

LIEBHERR

Crawler crane with lattice mast

LR 1400/2

LR 1400-2-010

Operating instructions

BAL-No.: 14709-02-02

Pages: 1860

Works-Number	
Date	

ORIGINAL OPERATING MANUAL

The operating manual is part of the crane!

It must always be available within reach!

The regulations for crane operation must be observed!

Liebherr-Werk Ehingen GmbH

Postfach 1361

D-89582 Ehingen / Donau

☎: +49 (0) 7391 502-0

Fax: +49 (0) 7391 502-3399

✉: info.lwe@liebherr.com

www.liebherr.com

Foreword

General

This crane was built according to the state of technology and recognized safety technical regulations. Despite that, dangers to body and life for the user and / or third persons or damage to the crane and / or other material assets can occur.

This crane may only be used in flawless technical condition and according to its mission as well as with constant awareness of safety and dangers. Any problems, which could affect safety must be fixed immediately.



Modifications on the crane may only be made with written approval by Liebherr-Werk Ehingen GmbH. This crane is equipped with a data recording device. The following data is recorded:

- Date, time
- Selected configuration (boom configuration, ballast, outrigger extension, reeving, hook block)
- Actual load
- Percentage of loading the crane
- Working radius
- Main boom angle, luffing jib angle
- Total length of tele boom, length of each tele section
- All bridging devices

The recorded data can be read with the respective software.

Warning notes

The terms **DANGER**, **WARNING**, **CAUTION** and **ATTENTION** used in these operating instructions are intended to point out certain rules of conduct to all persons working with the crane.

Warning signs	Signal word	Explanation
	DANGER	Designates a dangerous situation which will lead to death or serious injury if it is not prevented.
	WARNING	Designates a dangerous situation, which can lead to death or serious injury if it is not prevented.
	CAUTION	Designates a dangerous situation, which can lead to slight or medium-grade injuries if it is not prevented.
	ATTENTION	Designates a dangerous situation, which can lead to property damage if it is not prevented.

Additional notes

The term **Note** is used in these operating instructions to indicate useful information and tips to all persons working with the crane.

Sign	Signal word	Explanation
	Note	Designates useful information and tips.

Operating instructions

These operating instructions are intended to put you in a position to operate the crane safely and utilize the reliable usage options that it provides. The instructions also provide information about the function of important components and systems.

Certain expressions are used in these operating instructions. In order to avoid misunderstandings, the same expressions should always be used.

These operating instructions have been translated to be best of one's knowledge. Liebherr-Werk Ehingen GmbH assumes no liability for translation errors. The German version of these operating instructions is solely applicable for factual accuracy. If you find any errors or if any misunderstandings arise when reading these operating instructions, please contact Liebherr-Werk Ehingen GmbH immediately.



DANGER

Risk of fatal injury if operated incorrectly!

Incorrect operation of the crane can result in death or serious injuries!

► Only authorised and trained expert personnel are permitted to work on the crane!

The operating instructions and on-site regulations and specifications (such as accident prevention regulations) must be followed.

The use of these operating instructions:

- **makes it easier** to become familiar with the crane
- **avoids** problems due to improper operation

Observing these operating instructions:

- **increases** reliability in use
- **extends** the service life of your crane
- **reduces** repair costs and downtime

Always keep these operating instructions handy in the driver's or crane cab.

The operating manual is part of the crane!

Only operate the crane if you are well familiarized with the equipment, and always follow these operating instructions.



Note

► If you have received additional information about the crane from us, such as technical information bulletins, instructions and/or supplements to these operating instructions, then this information must also be followed and kept with the operating instructions.

If there is anything in the operating instructions or the individual chapters that you do not understand, please contact us before starting the relevant work.

The information and illustrations contained in these operating instructions may not be copied or distributed, nor used for the purposes of competition. All rights are expressly reserved in accordance with copyright laws.

All accident prevention guidelines, operating instructions, etc. are based on destined use of the crane.

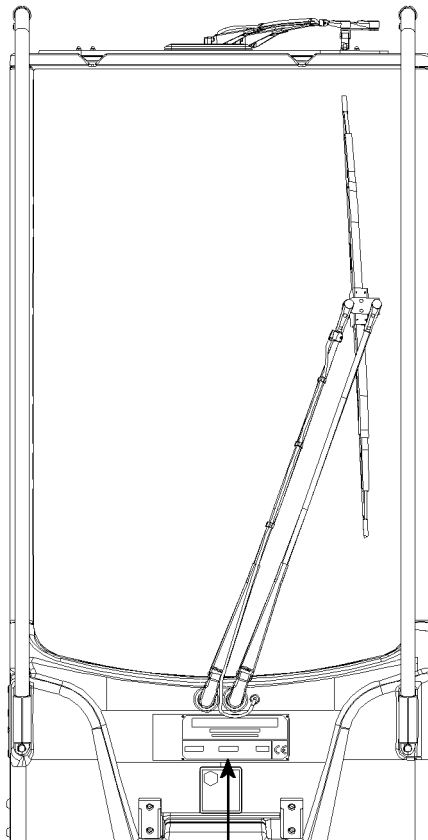

1

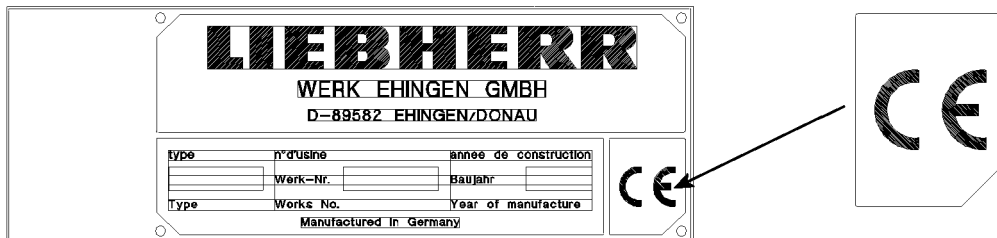

2



Destined use

The destined use of the crane consists solely in vertical lifting and lowering of free and non-adhered loads, whose weight and center of gravity are known.

To do so, a hook or hook block approved by Liebherr must be reeved on the hoist rope and it may only be operated within the permissible crane configurations.

Driving with the crane, with or without an attached load is only permissible if a corresponding driving or load chart is available. The crane configurations intended for it and the safety conditions must be observed according to the corresponding operating instructions.

Any other use or any other exceeding utilization is **not** destined use.

Part of destined use is also adherence of required safety regulations, conditions, preconditions, crane configurations and working steps as noted in the crane documentation (operating instructions, load chart, job planner).

The manufacturer is **not** liable for damages, which are caused by non-destined use or improper use of the crane. Any associated risk it is carried solely by the owner, the operator and the user of the crane.

**Note**

- ▶ Crane with “CE-mark” according to the European machinery directive 2006/42/EC and the EN 13000! Illustration 1
 - ▶ It is prohibited to bring the crane into service and to operate it within the European Union without a “CE-mark”! Illustration 2
 - ▶ It is prohibited to operate cranes with a tipping load utilization of 85% which are programmed according to ASME B30.5 within the European Union or in countries which permit a lower stationary stability utilization (for example according to ISO 4305)! These cranes may not have a “CE-mark”! Illustration 2
-

Non-destined use

Non -destined use is:

- Working outside the permissible crane configurations according to the load chart
- Working outside the permissible projection radii and slewing ranges according to the load chart
- Selecting load values, which do not correspond to the actual crane configuration
- Selecting LMB-Codes, which do not match the actual crane configuration
- Working with bypassed load moment limiter or bypassed hoist limit switch
- Increasing the projection radius of the lifted load after a LMB shut off, for example by diagonally pulling the load
- Using the support pressure display as a safety function against tipping over
- Using equipment or attachment parts which are not approved for the crane
- Using the crane at sports and recreational events, especially for 'Bungee' jumps
- Driving on a public road in non-permissible driving condition (axle load, dimension)
- Driving with the equipment in place in a non-permissible driving condition
- Pushing, pulling or lifting loads with the leveling regulation, the sliding beams or the support cylinders
- Pushing, pulling or lifting loads by actuating the slewing gear, the luffing gear or the telescoping gear
- Ripping stuck objects loose with the crane
- Utilizing the crane for a longer period of time for material handling tasks
- Releasing the crane suddenly (grapple or dumping operation)
- Utilizing the crane when the weight of the load, which is suspended load on the crane, is changed, for example by filling a container suspended on the load hook, except:
 - The load moment limiter was checked before for function with a known load.
 - The crane operator's cab is occupied and the crane is operational.
 - The container size is selected in such a way that an overload of the crane with full load is eliminated within the valid used load chart.

The crane may **not** be used for:

- Aattaching a stuck load for which the weight and center of gravity are not known and which is released first, for example with a cutting torch
- Letting persons drive along outside the driver's cab
- Transporting personnel in the crane cab while driving
- Transporting personnel with the lifting equipment and on the load
- Transporting of persons with work baskets (cherry pickers), if the national regulations of the responsible work safety organization are not observed
- Transporting loads on the chassis
- Two hook operation without auxiliary equipment
- Extended material handling operation
- Crane operation on a barge if the conditions are not determined and the written release by **Liebherr Werk Ehingen GmbH** is not present

The operating instructions must be read and used by all persons who are involved in the usage, operation, assembly and maintenance of the crane.

Safety systems

Special attention must be paid to the safety equipment built into the crane. The functionality of the safety equipment must be monitored at all times. The crane may not be operated if the safety equipment is not working or not working correctly.



Note

Your motto must always be:

► **Safety first!**

The crane had been built in accordance with the applicable crane operating and driving regulations and have been approved by the relevant authorities.

Attachment and spare parts

**DANGER**

Danger to life if original attachment parts are **not** used!

If the crane is operated with attachment parts, which are **not** original, then the crane can fail and cause fatal accidents!

Crane components can be damaged!

- ▶ Operate the crane only with original attachment parts!
- ▶ Crane operation with attachment parts, which do **not** belong to the crane is prohibited!

**DANGER**

The crane permit and the manufacturer's warranty will become void!

If any original installed parts are modified, manipulated or replaced (e.g. removal of parts, installation of non-original Liebherr parts), both the crane permit and the manufacturer's warranty will become void.

- ▶ Leave installed original parts unchanged!
- ▶ Do not remove original parts!
- ▶ Use only original Liebherr spare parts!

Definition of directional data

Forward driving means driving with the driver's cab on the front.

Reverse driving means driving with the tail lights of the chassis on the front.

Front, rear, right, left on the **crane** refer to the condition, that the driver's cab and the boom point in the same direction. Front is always in direction of the driver's cab.

Front, rear, right, left in the **driver's cab** refer to the crane chassis. The driver's cab is always in the front.

Front, rear, right, left in the **crane operator's cab** refer to the superstructure. Front is always in direction of the boom.

Optional

Customer-specific equipment is marked with *.

Contents

1.00 Description of crane	21
1.01 Terminology	22
1 Component overview	23
2 Component overview "narrow crawler"	25
3 Boom systems	27
1.02 Product description	34
1 Crawler travel gear	35
2 Crane superstructure	35
1.03 Technical data	37
1 Dimensions and weights	39
2 Lifting equipment	62
3 Ground pressure	62
4 Workplace-related emission value	62
5 Vibrations	62
6 Crane speeds	62
7 Ropes	63
2.00 Safety	65
2.03 Job planning	66
1 Crane operation planning	67
2.04 General safety technical guidelines	68
1 General	69
2 Emergency exit	75
3 Checking the rigging and fastening points	77
4 Personal protective equipment	79
5 Use of single-stranded height safety equipment, illustration 1	83
6 Use of double-stranded height safety equipment, illustration 2	83
7 Securing the assembly personnel against falling	83
8 Rescuing the assembly personnel	85
9 Documentation	85

10 Identification	85
11 Requirements for the crane operator	85
12 Selecting the location, illustrations 1 to 3	91
13 Slopes and excavations, illustrations 4 and 5	94
14 Permissible ground pressures	94
15 Supporting	99
16 Checking the safety measures	100
17 Endangering air traffic	100
18 Grounding	101
19 Consideration of wind conditions	101
20 Working in the vicinity of transmitters	109
21 Dangers when working together with several cranes	111
22 Hand signals for guidance	112
23 Crane operation with a load	119
24 Lifting of personnel	122
25 Crane operation in case of thunderstorms	123
26 Safety instructions for external power supply (230 V AC)	124
27 Welding work on the load	124
28 Interruption of crane operation	125
29 Resuming crane operation	125
30 Ending crane operation	126
31 Turning / driving in reverse	126
32 Parking the vehicle	126
33 Safety guidelines for ladders	129
2.05 Signs on the crane	135
1 Warning signs	137
2 Command and prohibition signs	141
3 Notice signs	143
2.15 General safety technical notes for operation with ballast trailer	146
1 Safety guidelines	147
2 Inspection of tires and disk wheels	148
3.00 Crane assembly	151
3.01 Crawler carrier assembly	152

1	Dimensions, weights and centers of gravity	153
2	Assembling the crawler travel gear with SA-bracket	155
3	Disassembling the crawler travel gear with SA-bracket	179
3.02	Turntable assembly	196
1	Assembly of turntable with Quick Connection*	197
2	Installing the turntable	197
3	Disassembly of the turntable with Quick Connection*	203
3.03	Central ballast	204
1	General	205
2	Assembly of central ballast	205
3	Installing the central ballast 43 t	207
4	Installing the central ballast 11 t	213
5	Removing the central ballast	217
3.04	Mechanical auxiliary support	218
1	General	219
2	Assembly	219
4.00	Operation of crane superstructure	223
4.01	Operating and monitoring instruments on the crane superstructure	224
1	Operating and control instruments	225
4.02	LICCON computer system	240
1	General	241
2	LICCON computer system boot up	245
3	Operating elements of the LICCON computer system on monitor 0	249
4	The set up program	253
5	The Crane operation program on monitor 0	279
6	Operating elements of the LICCON computer system on monitor 1	333
7	The Crane operation program on monitor 1	335
8	The Control parameter program	377
4.03	Crane start up and taking the crane out of service	384
1	Checks before start up	385
2	Crane operator's cab	387
3	Starting and stopping the engine	395
4	Swinging the crane operator's cab into operating / transport position	405

5	LICCON computer system after engine start	409
6	Operating winch 6* with the supply lines of winch 5 (actuation with master switch MS2y)	415
4.04	Safety equipment	422
1	General	423
2	Quick test Crane geometry	423
3	Quick test Overload protection	423
4	LICCON computer system	424
5	Safety devices on the crane	429
4.05	Crane operation	442
1	General	443
2	LICCON computer system	449
3	Winch and master switch assignment to operating modes	449
4	Lifting / lowering	451
5	Luffing	463
6	Turning	467
4.06	Rope reeving	472
1	Wire ropes and rope end connections	473
2	Reeving the hook block in and out	475
3	Securing and removing the load hook*	483
4	Attaching / removing the hoist limit switch weight	487
5	Assembling / disassembling the wedge lock	491
6	Rope reeving	491
4.07	Counterweight	492
1	Components	493
2	Counterweight combinations	495
3	Permissible counterweight assemblies	497
4	Installing the counterweight	499
5	Removing the counterweight	515
4.08	Working with a load	530
1	Technical safety instructions for working with a load	531
2	Checks before starting to work with the crane	532
3	Crane movement - Telescoping	533
4	Taking on a load	535

5	Crane operation	539
4.10	Driving from the crane operator's cab	541
1	Prerequisites for crawler operation	543
2	Driving the crawler crane	557
4.12	Two hook operation	568
1	General	569
4.15	Reeving plans	574
1	Reeving plans	575
4.20	Procedure for shut off of crane movements	576
1	General	577
2	Instructions for resuming crane movements for cranes with CE mark	581
3	Instructions for resuming crane movements for cranes without CE mark	629
5.00	Equipment	677
5.01	Safety technical guidelines for assembly and disassembly	678
1	Checking the retaining elements	679
2	Rope pulleys	679
3	Checking the ropes	679
4	Inspection procedures	680
5	Dangerous conditions without shut off	682
6	Transporting components	682
7	Pneumatic springs for assembly support of components	683
8	Manual rope winches for assembly support of components	683
9	Weights	684
10	Guy rods	684
11	Exceeding the overload protection	687
12	Assembly / disassembly	689
13	Erection / take down	718
5.02	SA-bracket	720
1	SA-bracket	721
5.03	Boom systems	730
1	Boom components	731
2	Arrangement of intermediate sections on the boom	731
3	Auxiliary guying	735

5.05 D-boom	738
1 Component overview D-boom	739
2 Fastening points D-components	739
3 Assembly	741
4 Disassembly	767
5.06 LN/SLN-boom	782
1 Component overview of assembly unit	783
2 Assembly	785
3 Crane operation	809
4 Disassembly	811
5.07 SW/SDW boom combination	828
1 General	829
2 Assembly	833
3 Crane operation	861
4 Disassembly	863
5.10 Boom nose lattice boom	878
1 Safety guidelines	879
2 Boom nose 36 t (H)	881
3 Boom nose 48 t (H2)	899
4 Boom nose 60 t (H)	913
5 Boom nose 72 t (H)	925
5.13 SF-boom combination	936
1 Component overview	937
2 Assembling F-lattice jib	941
3 Operating the crane	963
4 Disassembling the F-lattice jib	965
5.19 Hook blocks	976
1 Minimum required hook block weight	977
2 Procedure in case of slack rope	980
3 Hook block overview	983
4 Installing a double hook block for single operation	985
5 Installing a double hook block for parallel operation	995
6 Single hook blocks	1007
5.30 Pin pulling device	1014

1	Pinning and unpinning with pin pulling device	1015
5.35	Derrick ballast - Ballast trailer	1018
1	Component description and general notes	1021
2	Permissible ballast assemblies	1027
3	Assembling the ballast trailer	1029
4	Setting the ballast trailer radii	1055
5	Steering programs	1057
6	Driving the crane with the ballast trailer	1075
7	Crane operation with derrick ballast	1087
8	Disassembling the ballast trailer	1105
9	Emergency operation	1123
10	Maintenance intervals for the ballast trailer	1127
11	Maintenance	1129
5.36	Derrick ballast - Suspended ballast	1134
1	Suspended ballast	1135
5.37	L/LL-boom	1212
1	Component overview L-/LL-boom	1213
2	Fastening points L-/LL-components	1213
3	Assembling the L/LL-boom	1215
4	Erecting the L - boom	1241
5	Crane operation	1249
6	Disassembling the L/LL-boom	1251
5.38	S/SL-boom	1270
1	Component overview S-/SL-boom	1271
2	Fastening points S/SL-components	1271
3	Assembling the S/SL boom	1273
4	Erecting the S-boom	1305
5	Crane operation	1311
6	Disassembling the S/SL boom	1313
5.39	LD/SLD/SD-boom combination	1332
1	Component overview LD/SLD/SD boom	1333
2	Fastening points LD/SLD/SD-components	1333
3	Assembling the LD/SLD/SD-boom	1335
4	Erecting the S-boom	1367

5	Crane operation with derrick boom combination	1375
6	Disassembling the LD/SLD/SD-boom	1377
5.40	Sw-boom	1396
1	Component overview S-pivot section	1397
2	Sw-assembly	1399
3	Crane operation	1431
4	Sw-disassembly	1433
5.41	SwD-boom combination	1448
1	SwD-boom combination	1449
2	SwD-assembly	1451
3	Crane operation with derrick boom combination	1485
4	Disassembling the SwD-boom combination	1487
5.61	Pulley cart	1500
1	Components of pulley cart	1501
6.00	Additional equipment	1505
6.01	Heater / engine pre-heating	1506
1	Heating the crane operator's cab	1507
6.05	Emergency take-down	1514
1	Emergency operation	1515
2	Emergency operation with assembly plate Variation 1 (V1)	1521
3	Emergency operation of slewing gear(s) with assembly plate Variation 1 (V1)	1527
4	Emergency operation with assembly plate(s) Variation 2 (V2)	1531
5	Emergency operation slewing gear(s) with assembly plate(s) Variation 2 (V2)	1541
6	Emergency operation of winch 4 (W IV) on the LR1600/2 and LR1600/2-W	1545
7	Ending emergency operation	1549
7.00	Service and maintenance	1551
7.01	Maintenance and service - General	1552
1	General	1553
2	Cleaning and care of the crane	1554
3	Measures for work interruption or transport	1555
4	Maintenance work on the crane superstructure or boom	1556
5	Maintenance and inspection guidelines	1556
7.02	Maintenance intervals Crawler chassis, ballast trailer	1560

1	Crane chassis maintenance and inspection schedule	1561
2	Ballast trailer maintenance and inspection schedule	1565
7.03	Maintenance intervals - Crane superstructure	1566
1	Crane superstructure maintenance and inspection schedule	1567
7.04	Maintenance guidelines - Crane chassis	1576
1	Servicing the travel gear	1577
2	Servicing the central lubrication system of the crawler carrier	1585
3	Servicing the track chain	1593
7.05	Maintenance guidelines - Crane superstructure	1604
1	Diesel engine	1605
2	Pump distributor gear	1613
3	Hydraulic system	1615
4	Central lubrication system	1623
5	Slewing ring connection	1628
6	Winches	1631
7	Slewing gear	1639
8	Air dryer of the compressed air system of the crane superstructure	1641
9	Electrical system - Lighting	1641
7.06	Fill quantities, lubrication chart	1644
1	Fill quantities	1645
2	Lubrication schedule	1649
7.07	Service fluids and lubricants	1664
1	Specified service items and lubricants for Liebherr cranes	1665
7.15	Procedure in case of problems	1673
1	Procedure to follow in case of a problem	1675
2	Carrying out error diagnostics	1681
3	Measures in clear problem cases	1687
4	Measures for defective components	1693
8.00	Inspections of cranes	1701
8.01	Periodic crane inspections	1702
1	General	1703
2	Inspection of carrying crane structures, especially steel structures	1704
3	Inspection of tires and disk wheels	1769

4	Inspecting the hoist and luffing winches	1771
5	Inspecting load hooks	1783
6	Inspecting the rope feed mechanics in the telescopic boom	1783
7	Inspection of locking system of telescopic boom	1785
8	Inspection of membrane accumulator	1785
9	Inspection of relapse cylinders	1785
10	Inspection of the safety controls on the relapse cylinders	1786
11	Inspecting the cable pulleys	1786
12	Inspecting the function of the overload protection	1786
13	Inspecting the roller ring connection	1786
14	Inspecting the mounting of the load bearing equipment	1786
15	Inspection of the tele extension with eccentric, illustration 1	1789
16	Inspection of change over pulleys, illustration 2	1789
17	Inspecting the oil and fuel reservoirs	1789
18	Inspection of the auxiliary reeving winch, towing winch and spare wheel winch	1789
19	Appendix	1790
8.04	Inspection of crane wire ropes	1800
1	Introduction	1801
2	Wire rope	1801
3	Operating behavior of steel ropes	1807
4	Condition of equipment that is functionally associated with the rope	1807
5	Rope inspection log	1807
6	Rope storage and marking	1807
7	Wire ropes and rope end connections	1807
8	Twisting caused by stretching in rotation-resistant ropes and its remedy	1811
9	Appendix 1	1815
10	Appendix 2	1817
11	Appendix 3	1819
12	Appendix 4	1819
8.12	Inspection of safety switching on the relapse supports	1822
1	Boom relapse retainer	1823
2	Derrick relapse retainer	1825
3	N-lattice jib	1827
4	W-lattice jib	1831

8.14 Inspection of accumulator pressure in relapse cylinder	1834
1 Checking the accumulator pressure in the relapse cylinders	1835
2 N-lattice jib	1835
3 W-lattice jib	1837
8.15 Inspection and maintenance of guy rods	1838
1 General	1839
2 Repeat inspection of guy rods	1839
9.00 General notes	1841
9.02 Supplementary service work	1842
1 Checks before start up	1843
2 Repair and maintenance tasks	1843
3 Important servicing	1843
4 Maintenance notes for replacement parts	1844
5 Recommendations for travel operation	1844
6 Disposal of fuels and greases	1844
90.00 Appendix	1845
90.01 Foreword to appendix	1846
1 Preface	1847
90.05 Update confirmation	1848
1 Update confirmation	1849
Index	1851

1.00 Description of crane

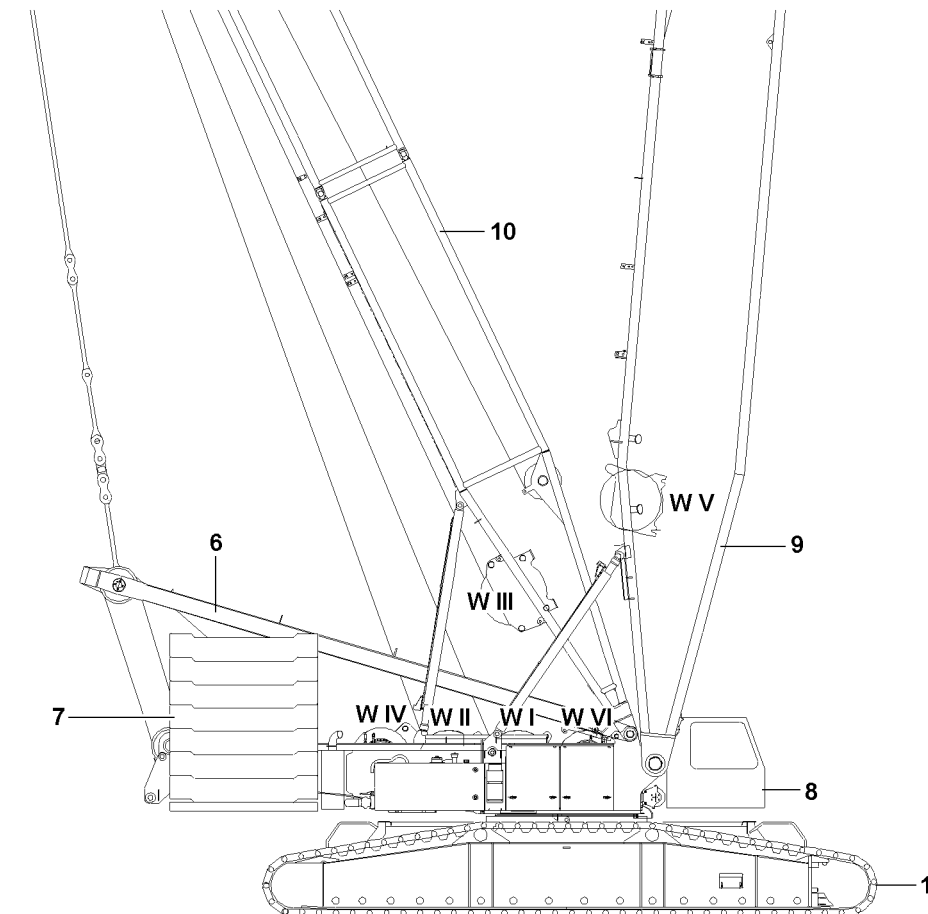
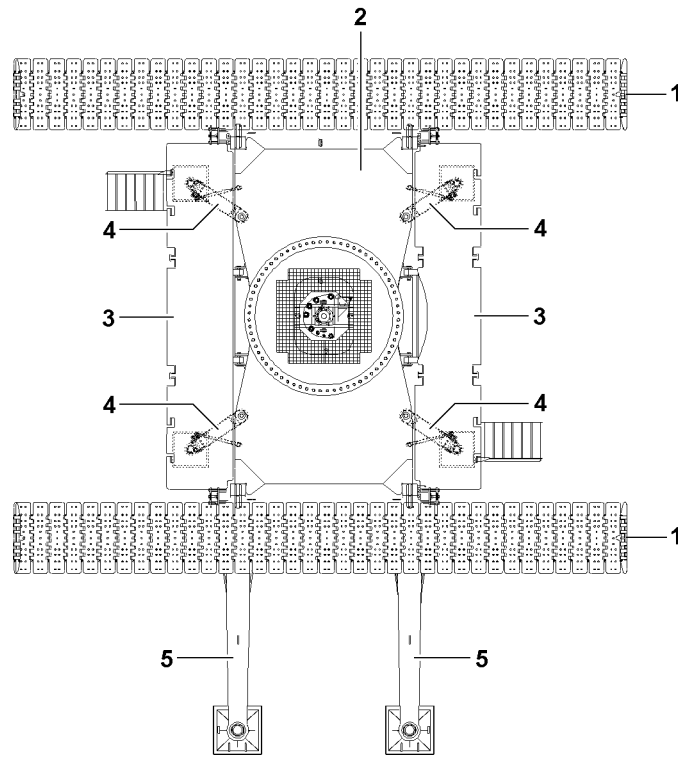

B109122

1 Component overview

1.1 Crawler track

- 1 Crawler carrier
- 2 Crawler center section
- 3 Central ballast
- 4 Hydraulic assembly support
- 5 Mechanical auxiliary support

1.2 Turntable

- 6 SA-frame
- 7 Counterweight
- 8 Crane operator's cab

- WI** Winch 1
- WII** Winch 2
- WIII** Winch 3
- WIV** Winch 4
- WV** Winch 5
- WVI** Winch 6

1.3 Boom

- 9 S/L-pivot section
- 10 D-pivot section

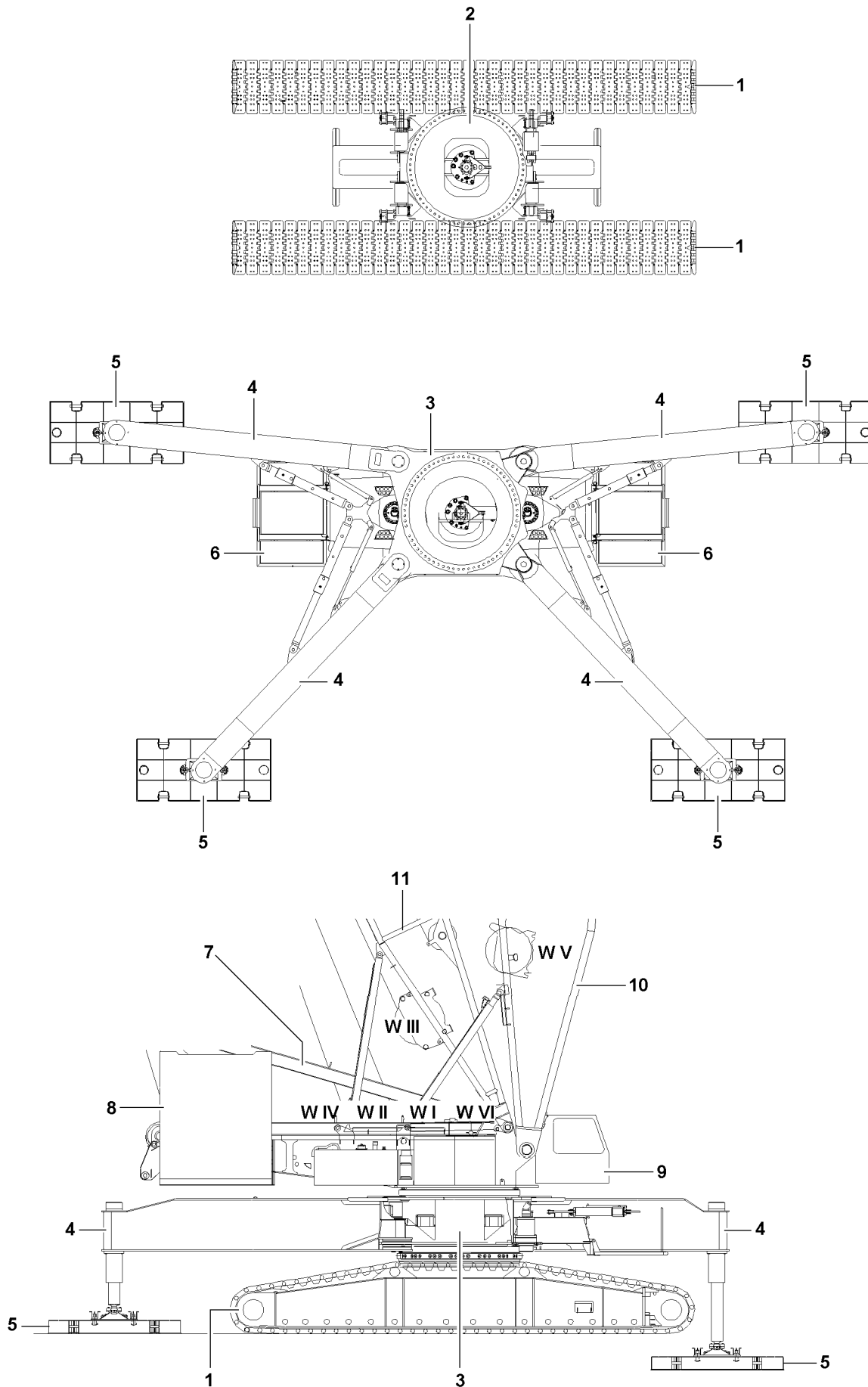

B109185

2 Component overview “narrow crawler”

2.1 Crawler track

- 1 Crawler carrier
- 2 Crawler center section

2.2 Crane support

- 3 Mid section crane support
- 4 Folding beam
- 5 Support pad
- 6 Platform

2.3 Turntable

- 7 SA-frame
- 8 Counterweight
- 9 Crane operator's cab
- WI** Winch 1
- WII** Winch 2
- WIII** Winch 3
- WIV** Winch 4
- WV** Winch 5
- WVI** Winch 6

2.4 Boom

- 10 S/L-pivot section
- 11 D-pivot section

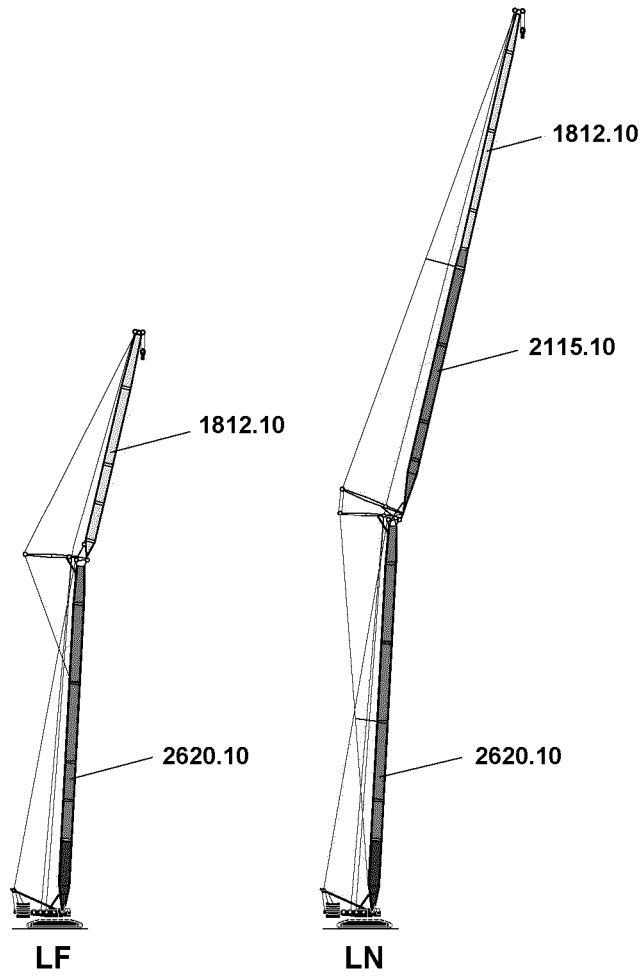
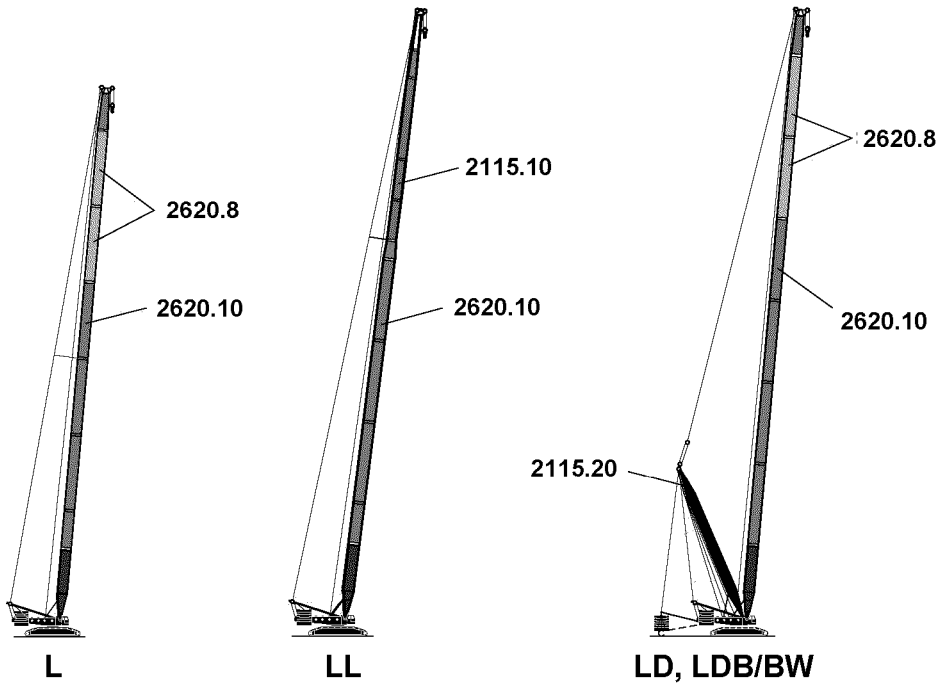

3 Boom systems

3.1 Abbreviations

L = Lattice boom, light

LL = Lattice boom, light L-version

N = Jib boom, light

F = Fixed jib

D = Derrick

B = Derrick ballast, suspended ballast

BW = Derrick ballast, ballast trailer

3.1.1 Boom combinations

Abbreviation	System lengths
L	L = 21.0 m - 98.0 m
LL	LL = 49.0 m - 105.0 m
LD	L = 28.0 m - 105.0 m
LDB	D = 21.0 m - 28.0 m
LDBW	
LN	L = 21.0 m - 70.0 m N = 21.0 m - 91.0 m
LF	L = 35.0 m - 70.0 m F = 10.5 m - 38.5 m

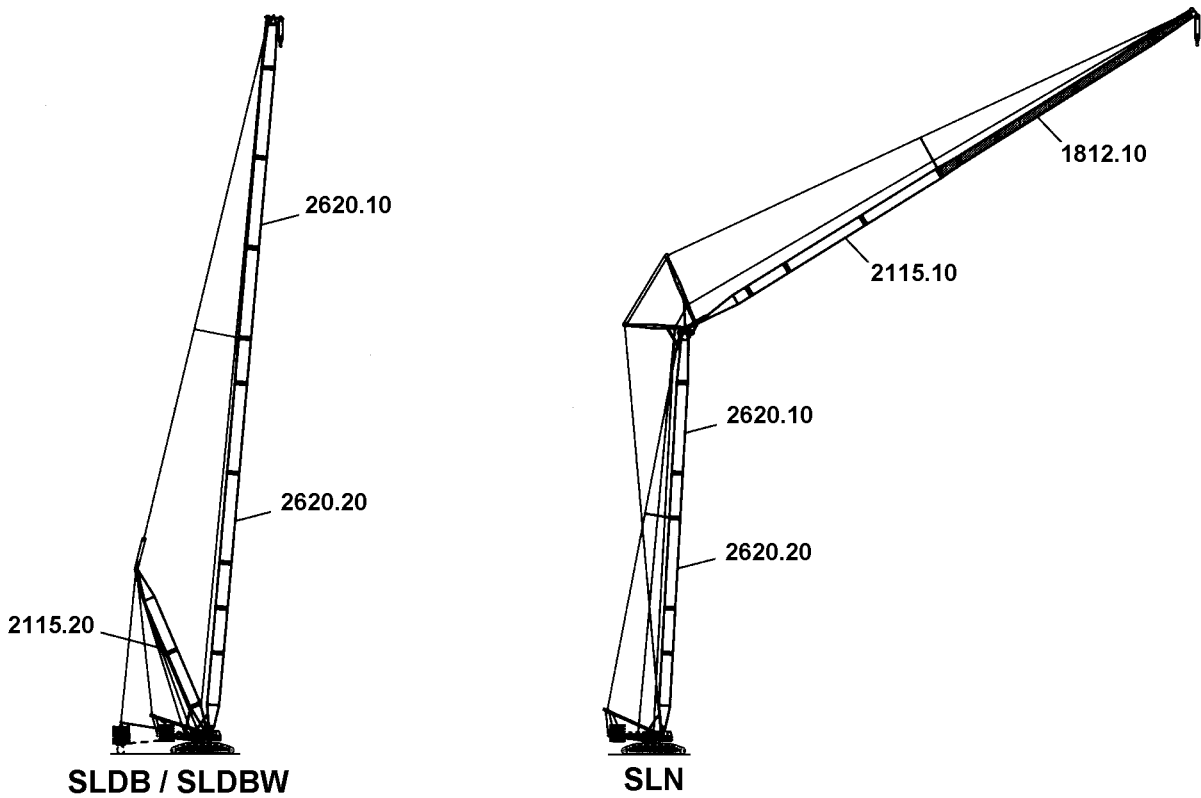
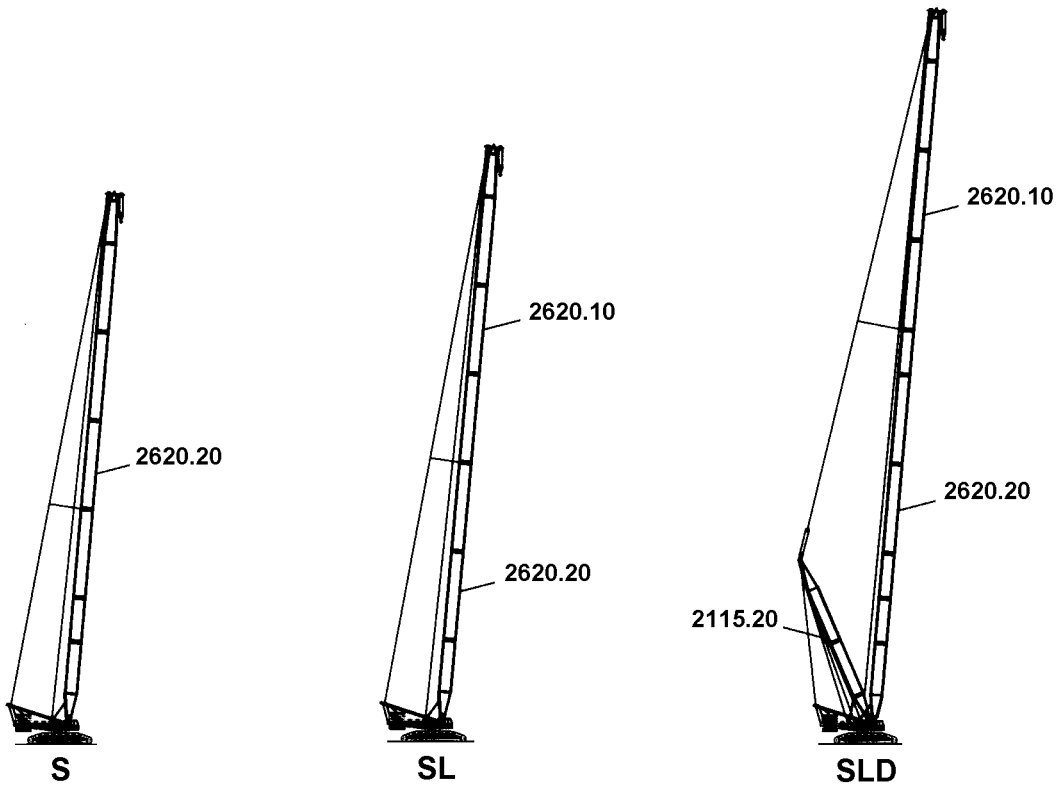

3.2 Abbreviations

S = Lattice boom, heavy

L = Lattice boom, light

N = Jib boom, light

D = Derrick

B = Derrick ballast, suspended ballast

BW = Derrick ballast, ballast trailer

3.2.1 Boom combinations

Abbreviation	System lengths
S	S = 21.0 m - 84.0 m
SL	SL = 21.0 m - 91.0 m
SLD	SL = 28.0 m - 112.0 m
	D = 21.0 m - 28.0 m
SLN	SL = 21.0 m - 70.0 m
	N = 21.0 m - 91.0 m
SLDB	SL = 28.0 m - 112.0 m
SLDBW	D = 21.0 m - 28.0 m

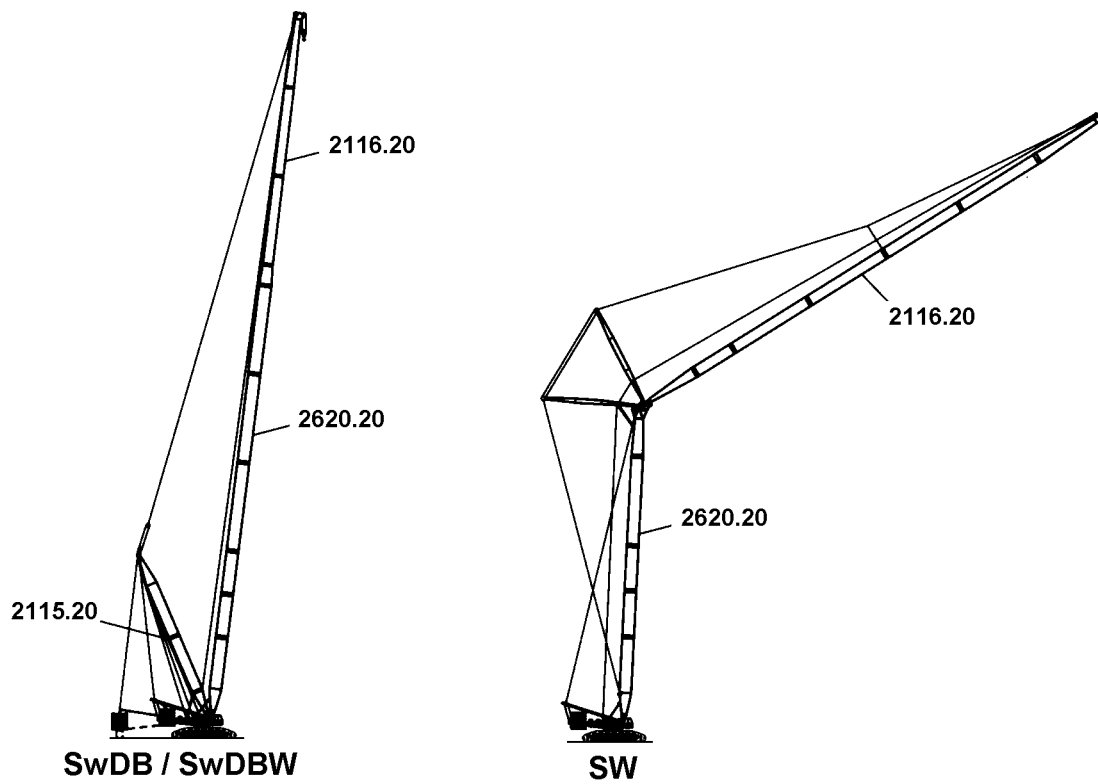
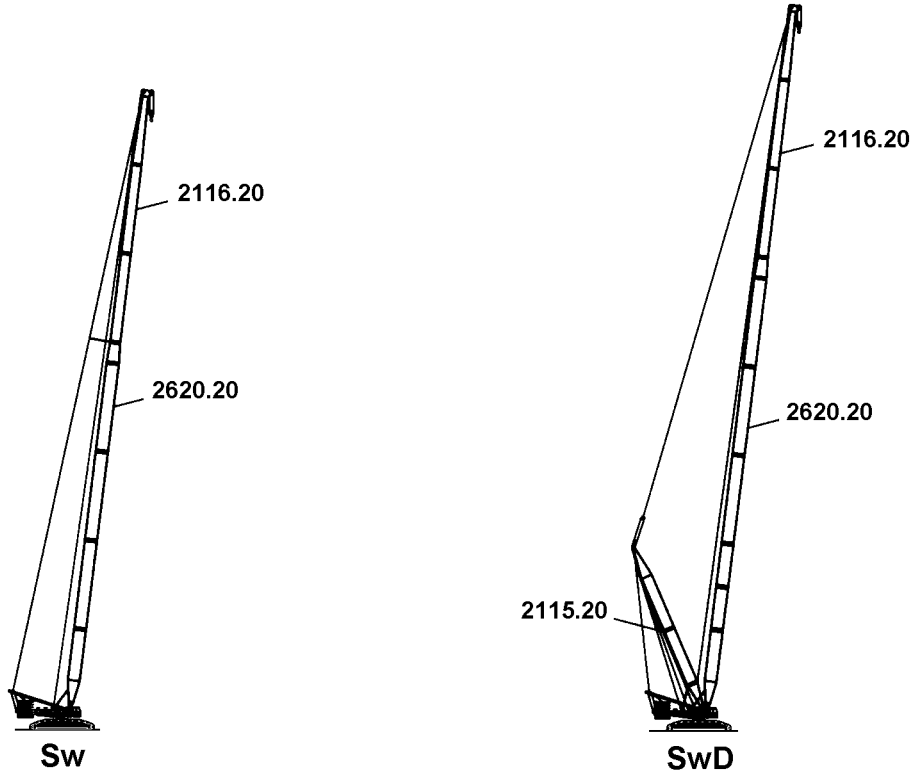

3.3 Abbreviations

S = Lattice boom, heavy

Sw = Lattice boom, mixed version

N = Jib boom, heavy

D = Derrick

B = Derrick ballast, suspended ballast

BW = Derrick ballast, ballast trailer

3.3.1 Boom combinations

Abbreviation	System lengths
Sw	Sw = 28.0 m - 98.0 m
SwD	Sw = 35.0 m - 112.0 m D = 21.0 m - 28.0 m
SwDB	Sw = 35.0 m - 112.0 m
SwDBW	D = 21.0 m - 28.0 m
SW	S = 21.0 m - 56.0 m W = 28.0 m - 91.0 m

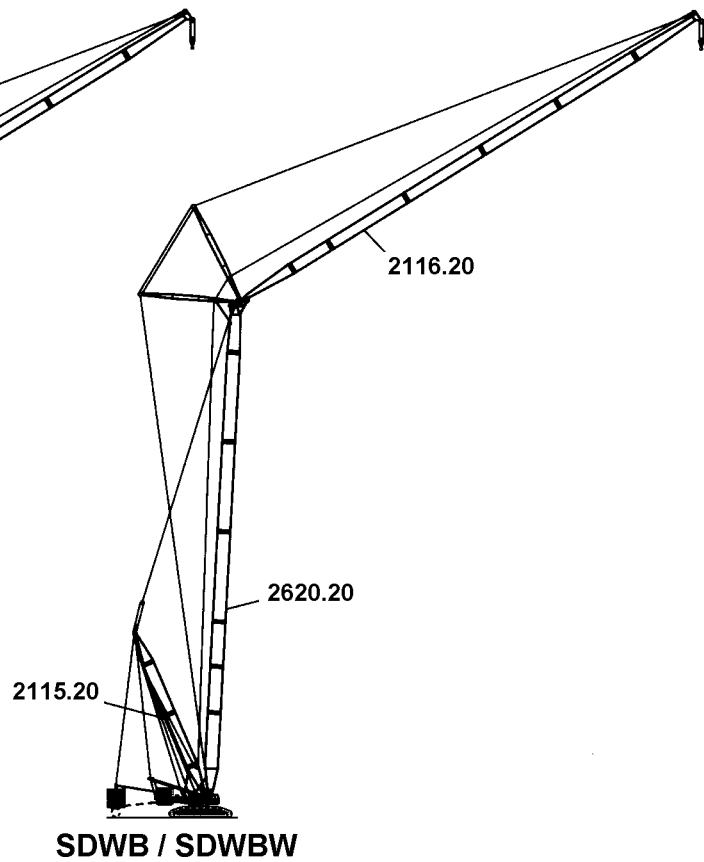
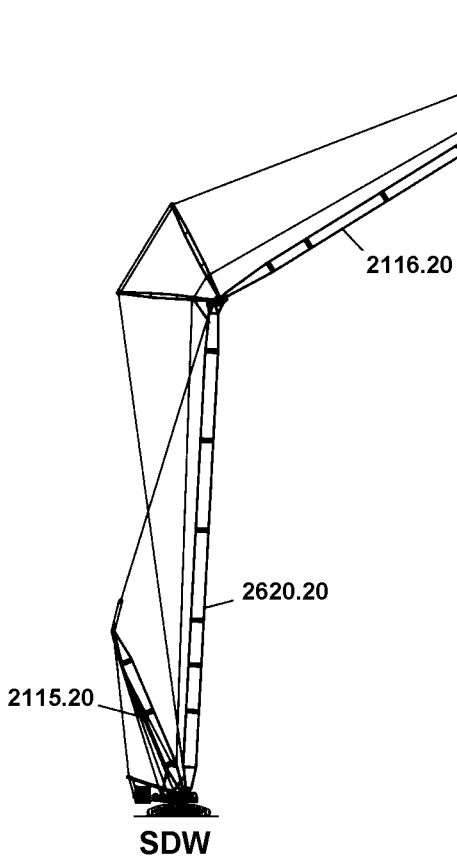
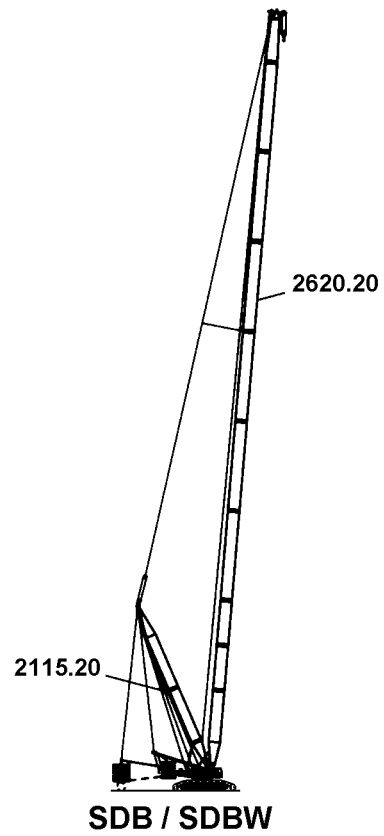
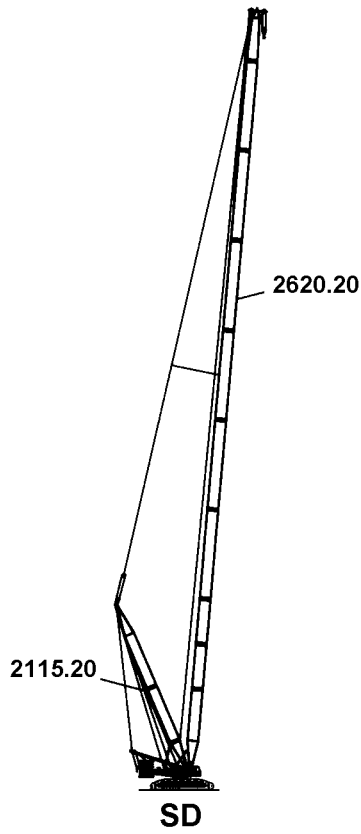

3.4 Abbreviations

S = Lattice boom, heavy

W = Jib boom, heavy

D = Derrick

B = Derrick ballast, suspended ballast

BW = Derrick ballast, ballast trailer

3.4.1 Boom combinations

Abbreviation	System lengths
SD	S = 28.0 m - 119.0 m
	D = 21.0 m - 28.0 m
SDB	S = 28.0 m - 119.0 m
SDBW	D = 21.0 m - 28.0 m
SDW	S = 35.0 m - 84.0 m
	D = 21.0 m - 28.0 m
	W = 28.0 m - 91.0 m
SDWB	S = 35.0 m - 84.0 m
SDWBW	D = 21.0 m - 28.0 m
	W = 28.0 m - 91.0 m

B195219

1 Crawler travel gear

1.1 Frame

In-house manufactured, distortion-resistant welded structure made from high-strength, close-grained structural steel.

The crawler carriers can be removed and can be installed / removed by the crane itself.

1.2 Tracks

Maintenance free, dirt protected crawler track with flat track pads.

Pad width: 1.2 m

Track width: 7.5 m

1.3 Drive

Hydraulic travel drives with planetary gears.

The crawler chains can be controlled independently and in the opposite direction.

There is no preferred travel direction.

1.4 Travel power

Stepless speed from 0 km/h to 1.8 km/h.

2 Crane superstructure

2.1 Frame

In-house manufactured, distortion-resistant welded structure made from high-strength, close-grained structural steel.

Connection to crawler travel gear via 3-row roller rotary connection, slewable by 360°.

2.2 Crane engine

6-cylinder Diesel, manufactured by Liebherr, model D 936L A6, water-cooled.

Performance: 270 KW at 1800 rpm

Maximum torque: 1720 Nm at 1300 rpm

Exhaust emissions according to guidelines per 97/68/EG Stage 3 and EPA / CARB Tier 3.

Fuel tank: 700 l

2.3 Crane drive

Hydraulic via pump distributor gear with four axial piston pumps with power regulation, closed oil circuits.

Axial piston pumps in open circuit for luffing and telescoping

2.4 Crane control

Servo control with electronic synchronous run device, energy recycling when lowering the load.

All movements are carried out independently of each other via joysticks.

2.5 Winches

Two winches as hoist and intake gear hydraulically driven via axial piston pumps and planetary gears.

Disk brakes spring loaded and hydraulically vented.

2.6 Slewing gear

Hydraulically driven via axial piston pumps and planetary gears.
Disk brakes spring loaded and hydraulically vented.
Slewing speed steplessly regulated from 0 rpm to 1.2 rpm.

2.7 Crane operator's cab

Steel plate design with safety glass, can be swung out to the side and inclined to the rear with operating and control instruments.

2.8 Counterweight

155.0 t, consists of: two consoles and counterweight plates of 10.0 t and 5.0 t.

2.9 Safety systems

LICCON overload system, hoist limitation, electronic incline display, safety valves against pipe and hose bursts.

2.10 Electrical system

24 Volt direct current, 2 batteries with 143 Ah each.

blank page!

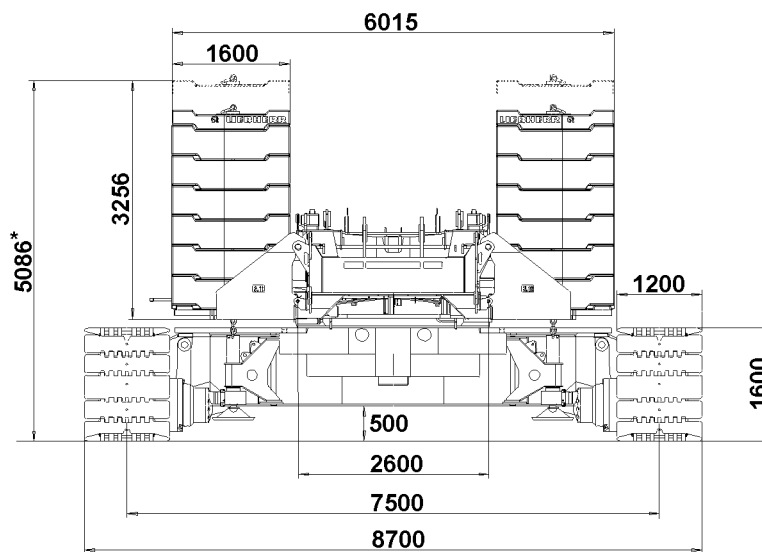
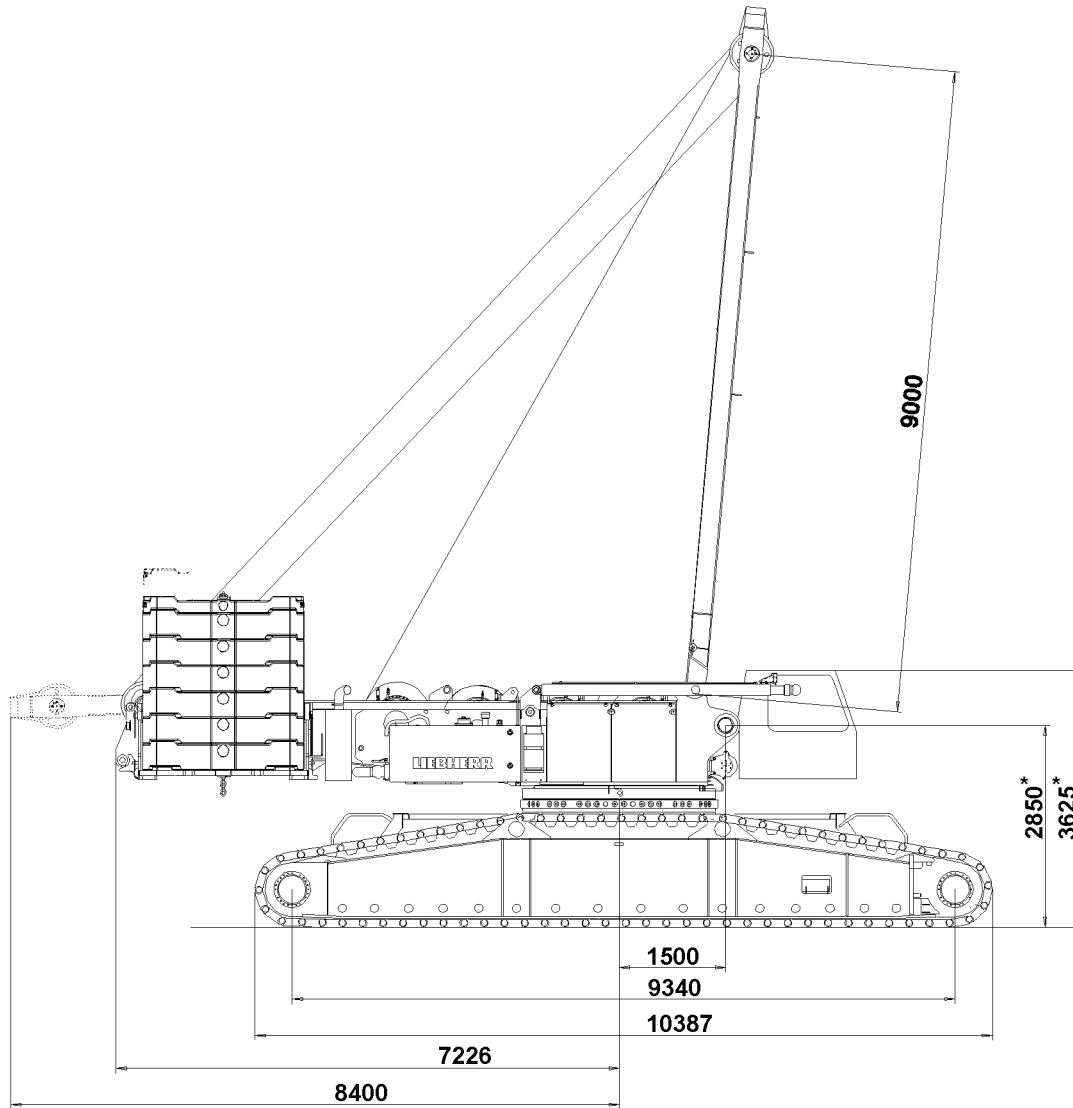

B104969

1 Dimensions and weights

1.1 Transport weights



Note

▶ Crawler travel gear with superstructure, see adjoining illustrations!

With Quick Connection*

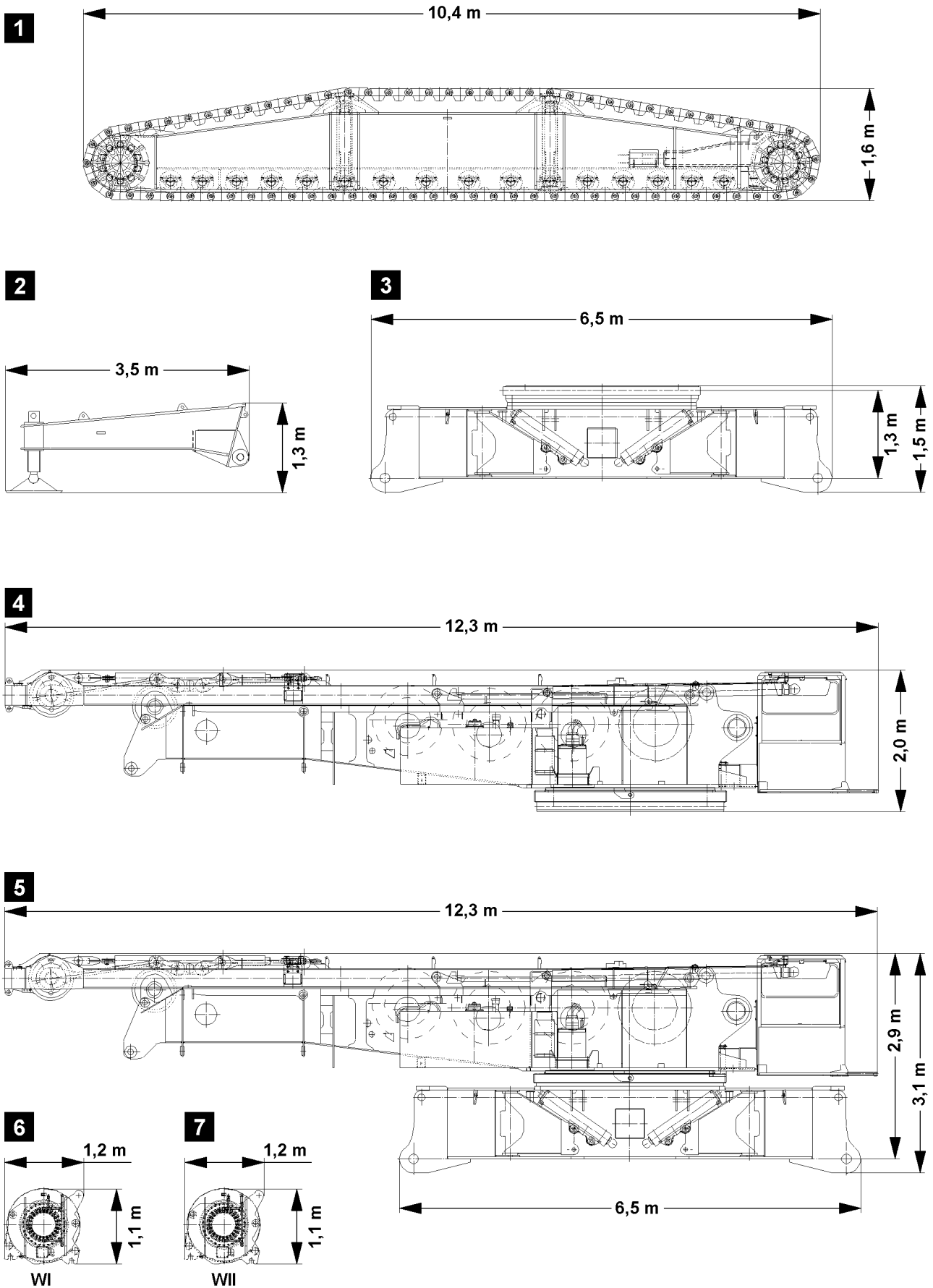

B104497

1.2 Crawler carrier

See illustration 1.

Crawler carrier	Weight	Width
1 Travel drive	25.2 t	1.6 m
2 Travel drives	27.7 t	1.6 m

1.3 Mechanical auxiliary support

See illustration 2.

Weight	Width
1.3 t	0.8 m

1.4 Crawler center section

See illustration 3.

Weight	Width
17.5 t	3.0 m

1.5 Turntable

See illustration 4.

Weight with winch 1 and winch 2	Weight without winch 1 and winch 2	Width
41.5 t	33.1 t	3.0 m

1.6 Turntable and crawler center section

See illustration 5.

Weight with winch 1, winch 2 and winch 4	Weight without winch 1 and winch 2	Width
56.6 t	48.2 t	3.0 m

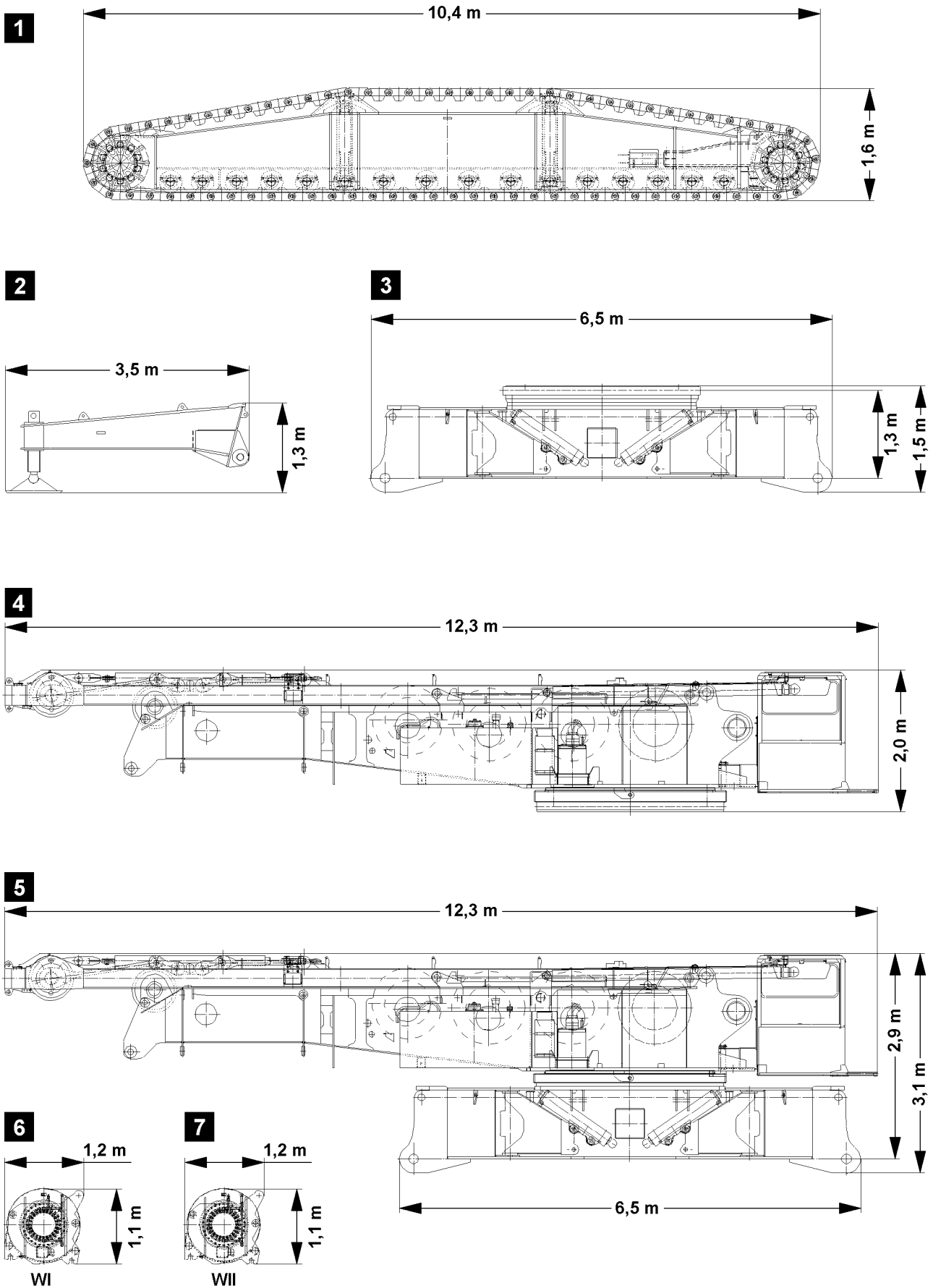

B104497

1.7 Winch 1

See illustration 6.

Weight	Width
4.2 t	1.5 m

1.8 Winch 2

See illustration 7.

Weight	Width
4.2 t	1.5 m

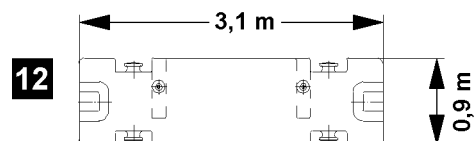
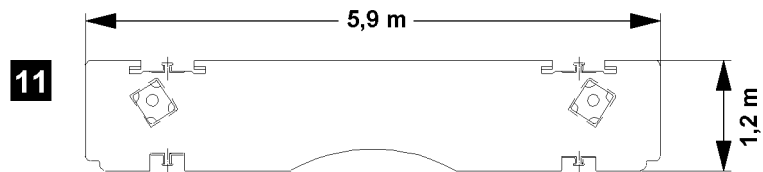
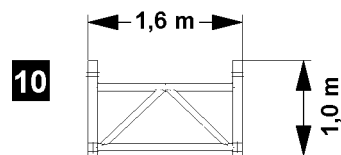
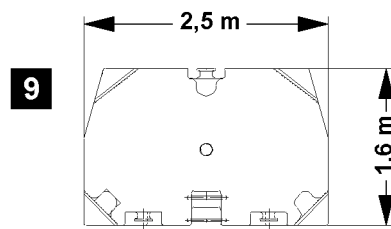
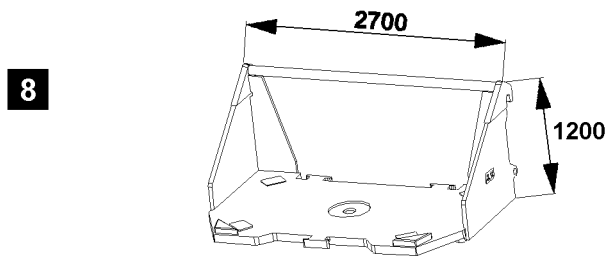

1.9 Console

See illustration 8.

Weight	Width
3.1 t	1.8 m

1.10 Counterweights for turntable / suspended ballast / ballast trailer

See illustration 9.

Weight	Thickness
10.0 t	0.46 m
5.0 t	0.26 m

1.11 Ballast frame for central ballast

See illustration 10.

Weight	Width
0.4 t	0.9 m

1.12 Central ballast 1

See illustration 11.

Weight	Thickness
5.7 t	0.16 m

1.13 Central ballast 2

See illustration 12.

Weight	Thickness
8.0 t	0.5 m

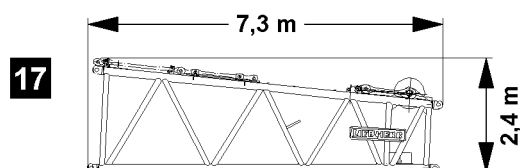
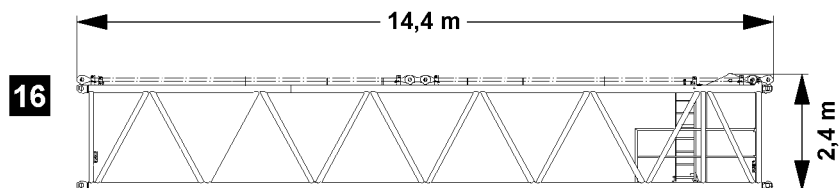
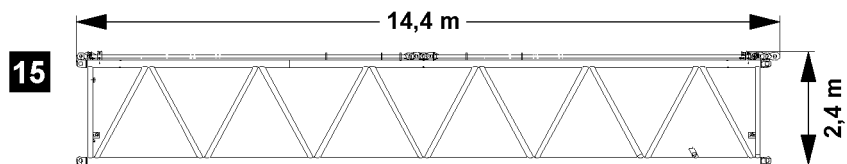
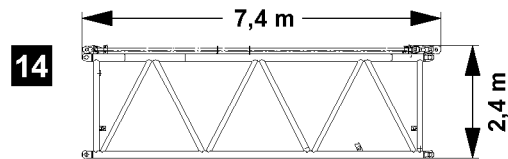
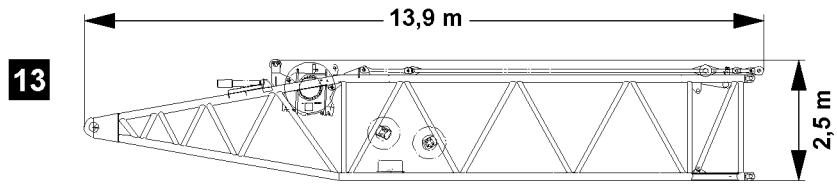

1.14 S-pivot section 13.4 m

See illustration 13.

Weight with winch 5	Weight without winch 5	Width
14.0 t	9.5 t	2.8 m

1.15 S-intermediate section 7.0 m, 2620.20

See illustration 14.

Weight	Width
3.7 t	2.8 m

1.16 S-intermediate section 14.0 m, 2620.20

See illustration 15.

Weight	Width
6.9 t	2.8 m

1.17 S-intermediate section 14.0 m for flying assembly, 2620.20

See illustration 16.

Weight	Width
7.9 t	2.8 m

1.18 S-adapter 7.0 m

See illustration 17.

Weight	Width
3.6 t	2.8 m

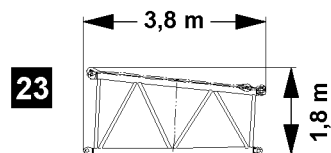
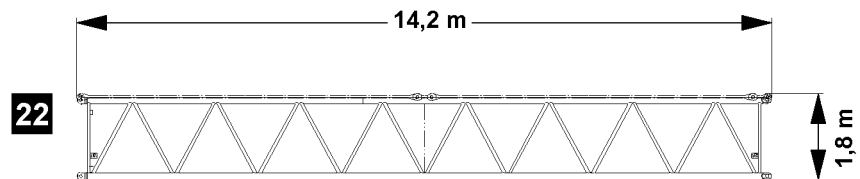
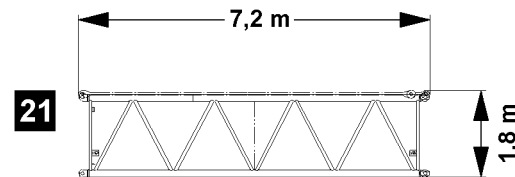
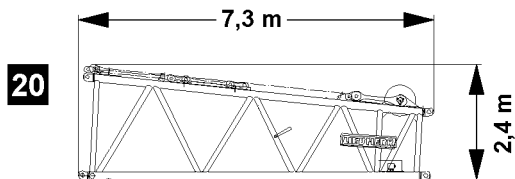
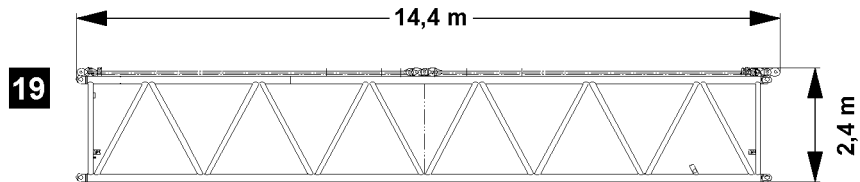
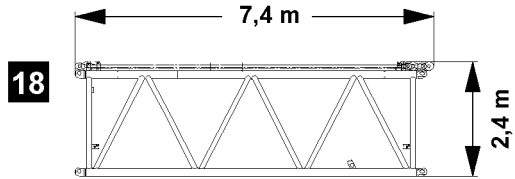

1.19 L-intermediate section 7.0 m, 2620.10

See illustration 18.

Weight	Width
2.9 t	2.8 m

1.20 L-intermediate section 14.0 m, 2620.10

See illustration 19.

Weight	Width
5.4 t	2.8 m

1.21 L-adapter 7.0 m

See illustration 20.

Weight	Width
3.1 t	2.8 m

1.22 NA-intermediate section 7.0 m

See illustration 21.

Weight	Width
1.5 t	2.3 m

1.23 NA-intermediate section 14.0 m

See illustration 22.

Weight	Width
2.8 t	2.3 m

1.24 NI-reducer section 3.5 m

See illustration 23.

Weight	Width
0.8 t	2.3 m

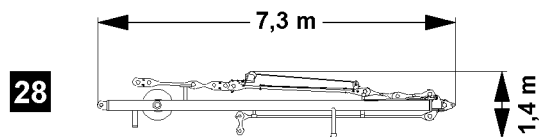
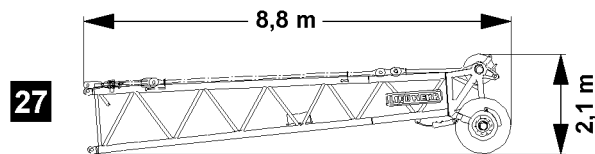
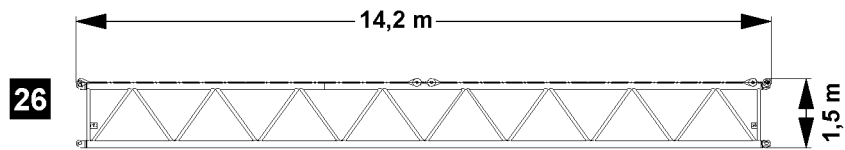
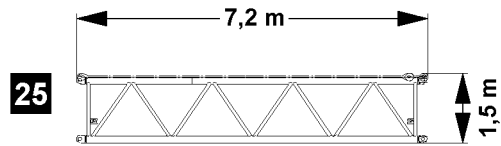
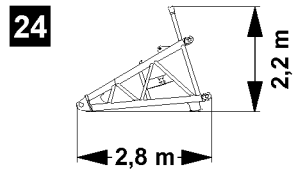

1.25 F-pivot section 2.5 m

See illustration 24.

Weight	Width
0.7 t	2.2 m

1.26 NI-intermediate section 7.0 m

See illustration 25.

Weight	Width
1.4 t	2.0 m

1.27 NI-intermediate section 14.0 m

See illustration 26.

Weight	Width
2.5 t	2.0 m

1.28 F-end section 8.0 m

See illustration 27.

Weight	Width
3.3 t	2.0 m

1.29 FA-frame 7.0 m

See illustration 28.

Weight	Width
2.4 t	2.4 m

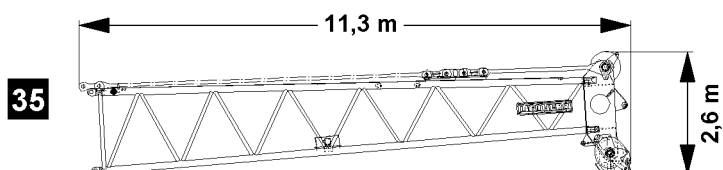
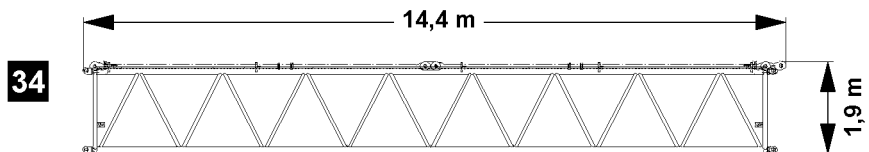
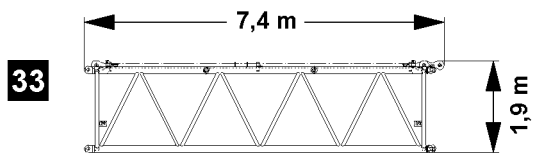
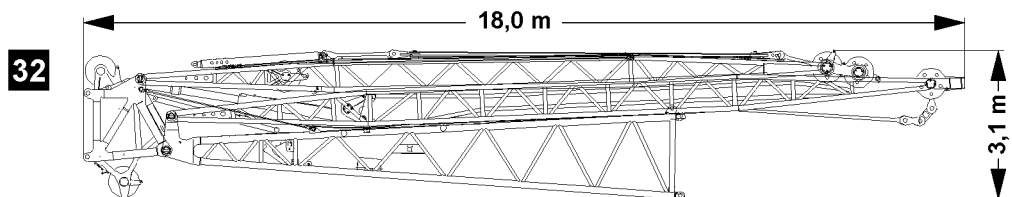
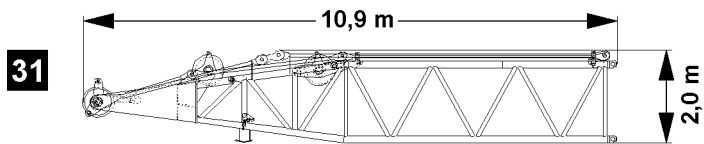
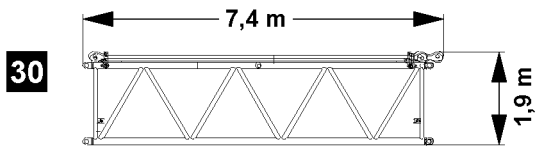
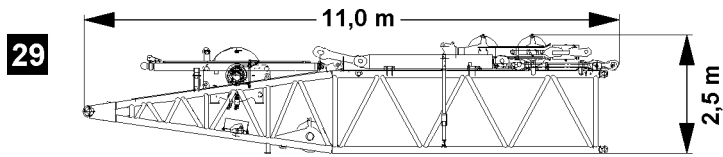

B104500

1.30 D-pivot section 10.5 m

See illustration 29.

Weight	Width
14.5 t	2.7 m

1.31 D-intermediate section 7.0 m

See illustration 30.

Weight	Width
2.7 t	2.5 m

1.32 D-end section 10.5 m

See illustration 31.

Weight	Width
5.4 t	2.5 m

1.33 W-assembly unit

See illustration 32.

Weight	Width
14.1 t	2.4 m

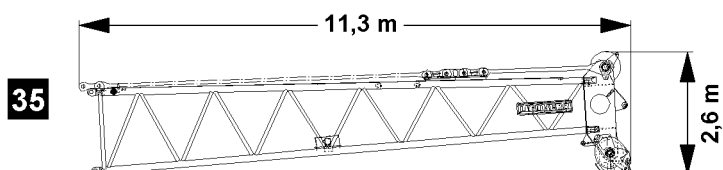
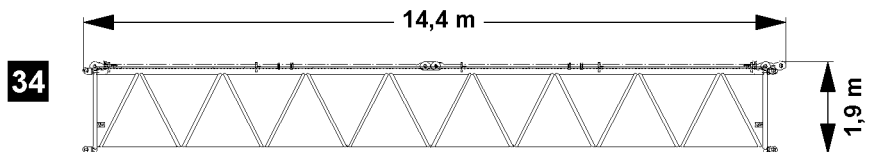
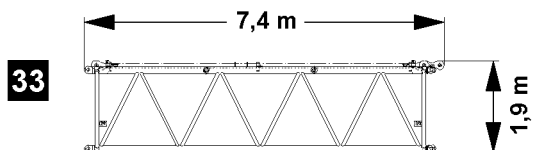
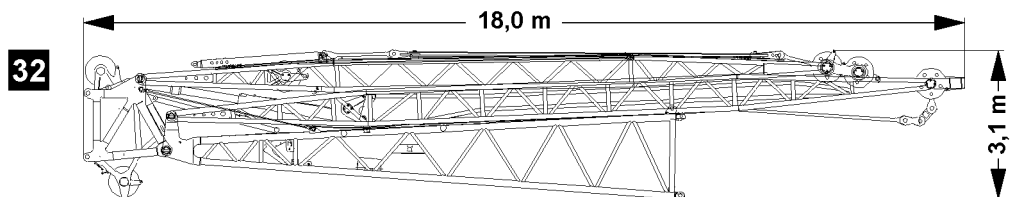
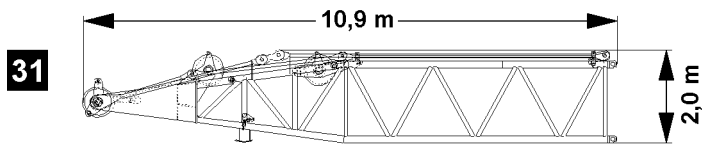
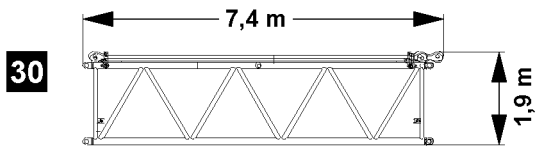
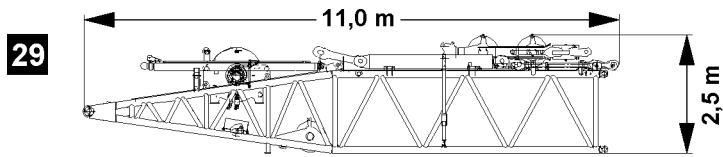

B104500

1.34 W-intermediate section 7.0 m, 2116.20

See illustration 33.

Weight	Width
1.7 t	2.4 m

1.35 W-intermediate section 14.0 m, 2116.20

See illustration 34.

Weight	Width
3.0 t	2.4 m

1.36 W-end section 10.5 m

See illustration 35.

Weight	Width
3.3 t	2.3 m

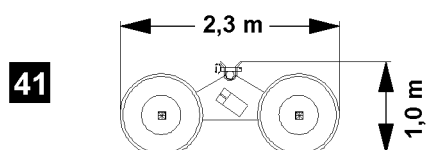
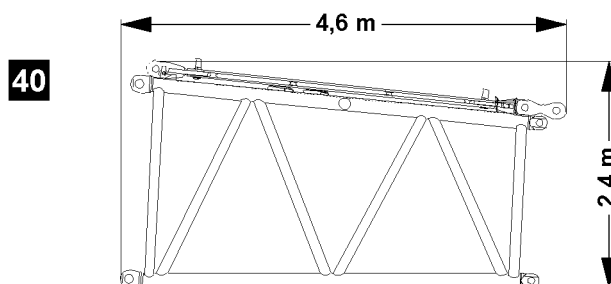
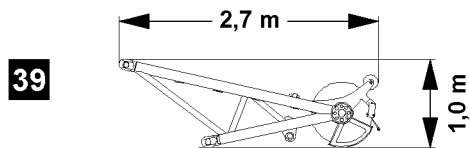
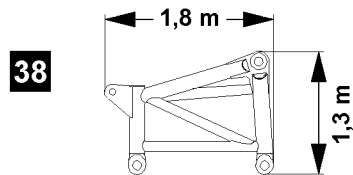
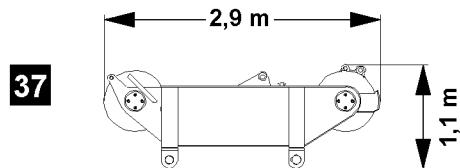
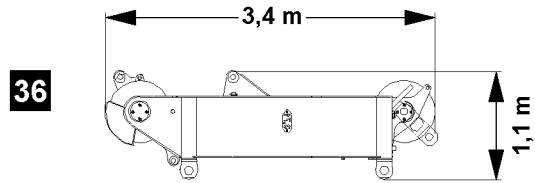

1.37 S-end section 400 t

See illustration 36.

Weight	Width
3.8 t	2.8 m

1.38 L-end section 350 t

See illustration 37.

Weight	Width
2.2 t	2.3 m

1.39 L-end section

See illustration 38.

Weight	Width
0.7 t	2.4 m

1.40 Boom nose

See illustration 39.

Weight	Width
0.5 t	1.2 m

1.41 Sw-reducer section

See illustration 40.

Weight	Width
1.8 t	2.8 m

1.42 Erection cart

See illustration 41.

Weight	Width
0.5 t	1.7 m

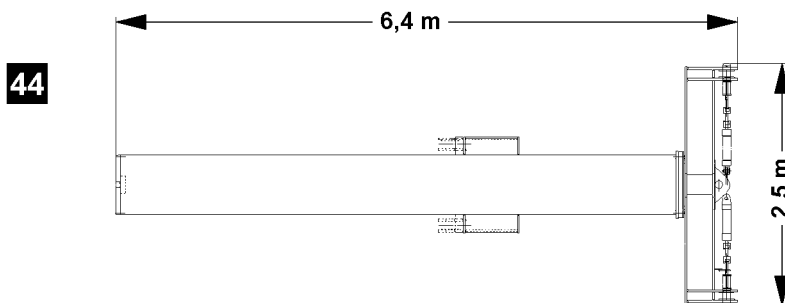
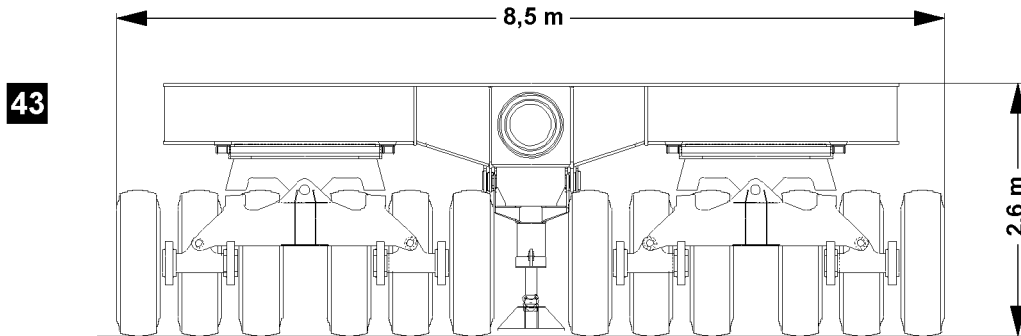
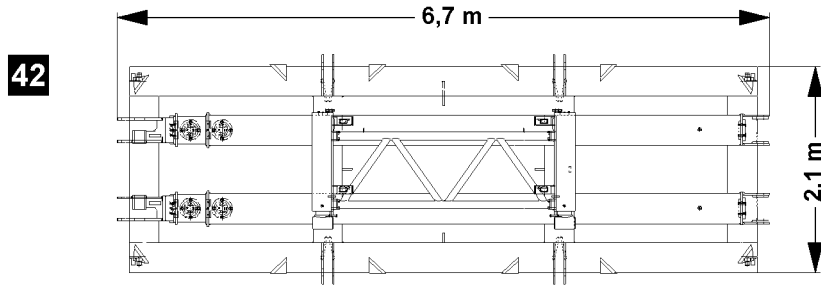

1.43 Suspended ballast with guide

See illustration 42.

Weight	Height
11.3 t	1.5 m

1.44 Ballast trailer

See illustration 43.

Weight	Width
26.8 t	2.5 m

1.45 Ballast trailer guide

See illustration 44.

Weight	Width
9.6 t	1.0 m

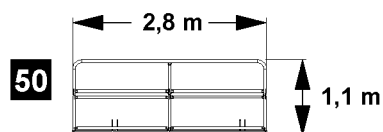
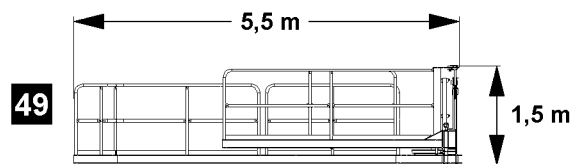
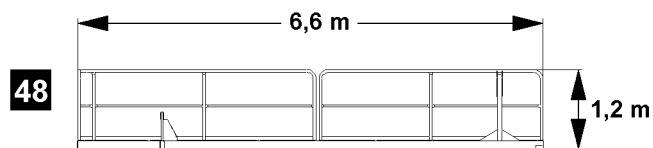
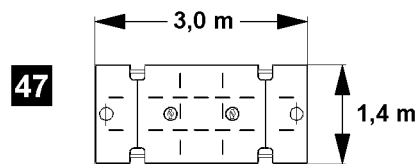
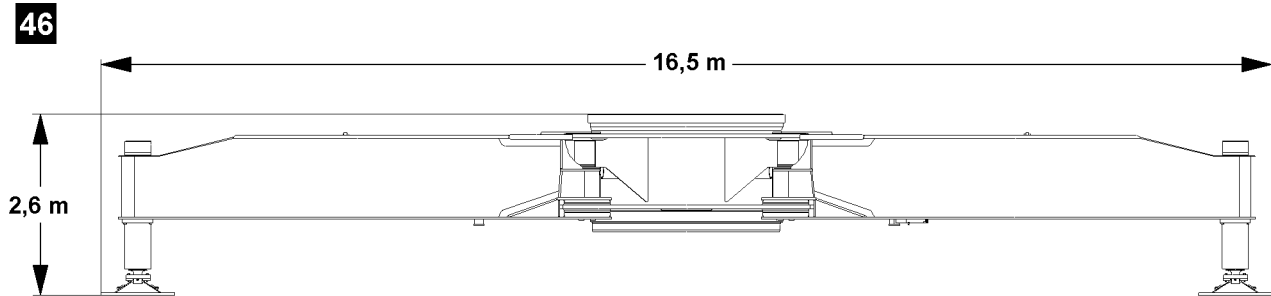
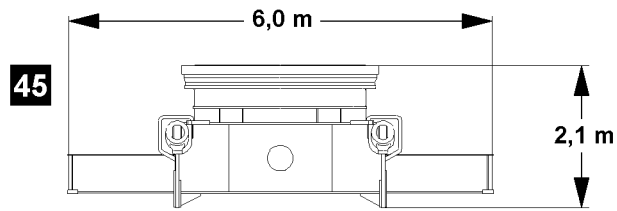

1.46 “Narrow” crawler center section

See illustration 45.

Weight	Width
12.8 t	2.8 m

1.47 Crane support

See illustration 46.

Weight	Width
44.1 t	3.0 m

1.48 Support plate

See illustration 47.

Weight	Thickness
1.3 t	0.3 m

1.49 Footbridge

See illustration 48.

Weight	Width
0.7 t	1.6 m

1.50 Footbridge

See illustration 49.

Weight	Width
1.2 t	2.2 m

1.51 Footbridge

See illustration 50.

Weight	Width
0.2 t	1.2 m

2 Lifting equipment



Note

► For lifting equipment, see separate load chart manual!

3 Ground pressure

Maximum ground pressure at nominal load	2000 kN/m ²
---	------------------------

4 Workplace-related emission value

Sound pressure level at nominal engine rpm	Stationary noise L _{pAeq}	
	Left ear	Right ear
Crane operator's cab	73 db(A)	

5 Vibrations

Vibrations transferred to the operator	Value
Total vibration value to which the upper body parts are exposed	not more than 2.5 m/s ²
Effective value of weighted acceleration to which the entire body is exposed	not more than 0.5 m/s ²

6 Crane speeds



Note

► The crane speeds refer to an engine rpm of 1900 min⁻¹!

Drives	Infinitely variable
Winch 1, 2	0 m/min to 150 m/min for single strand
Winch 3	0 m/min to 145 m/min for single strand
Winch 5	0 m/min to 130 m/min for single strand
Winch 6	0 m/min to 150 m/min for single strand
Winch 4	2 × 65 m/min for single strand

Drives	Infinitely variable
Slewing gear	0 rpm to 1.2 rpm

7 Ropes

7.1 Hoist ropes

	Rope diameter
Winch 1	25 mm
Winch 2	25 mm
Winch 5	25 mm
Winch 6	25 mm

7.2 Control ropes

	Rope diameter
Winch 3	25 mm
Winch 4	25 mm
Winch 5	25 mm

7.3 Guy ropes

	Rope diameter
Auxiliary guying	22 mm

7.4 Assembly ropes

	Rope diameter
Assembly winch	8 mm

2.00 Safety

1 Crane operation planning

In addition to a perfectly working crane and a well-trained crew, **crane operation planning** is an important principle of safe crane operation.



DANGER

Missing information increases the risk of accidents!

Crane operation may not be possible or improvisation can result if a crane operator does not have all the required data.

► A crane operator must have exact data before starting any work!

The crane operator must obtain or receive the necessary information in a timely fashion before driving to the work site. In particular:

- type of crane operation
- height and width clearance measurements
- electrical transmission lines (including voltages)
- space restrictions at the work site
- movement restrictions caused by buildings
- weight and dimensions of the load(s) to be hoisted
- required hoisting height and boom projection
- ground bearing capacity at the work site

Based on the above information, the crane operator must assemble the equipment required to operate the crane:

- hook block / load hook
- auxiliary boom
- fastening equipment
- counterweight

1 General



Note

- ▶ The illustrations in this chapter are only examples. The illustrations may differ depending on the crane model.

1.1 Danger zone of crane

The danger zone of the crane is made up of the areas which are accessed during crane operation by the load or by movements of the crane or the crane components.



WARNING

Do not stay in danger zone!

Personnel within the danger zone can be hit by falling loads or components!

Personnel in the danger zone can be caught by moving crane components or loads!

Fatal or severe injuries can be the result!

- ▶ Warn any personnel within the danger zone with the warning device of the crane!
- ▶ After the warning is issued, wait and ensure that no personnel remains within the danger zone!
- ▶ If required, block off the danger zone with a safety distance!

1.2 Danger of crushing when closing the windows



WARNING

Danger of crushing!

Never close the windows carelessly or uncontrolled. Significant crushing injuries can occur!

- ▶ During closing, watch the windows as it moves up!
- ▶ Make sure that no personnel or objects are wedged in!

1.3 Exhaust systems and other crane components with high temperatures



WARNING

Danger of burns!

You can get severely burnt on the surfaces of hot components!

This applies especially to exhaust systems, the engines and the respective gears in the crane chassis and in the crane superstructure!

- ▶ Let the components cool off before touching them!
- ▶ Proceed with special caution near heated crane components!

1.4 Movement on the crane



WARNING

Risk of accident!

No not step or place a load on areas, which are not approved, there is a danger of accidents!

Personnel can be severely injured or killed!

The crane can be damaged!

- ▶ Observe the signage!
- ▶ Replace damaged safety signs (warning signs) immediately!

**WARNING**

Danger of slipping / falling!

The traction of steps, walkways and hand rails changes due to effects of the weather, such as wetness, snow, frost and dirt!

Danger of slipping / falling!

Personnel can be severely injured or killed!

▶ Always move on the crane depending on the respective circumstances!

blank page!

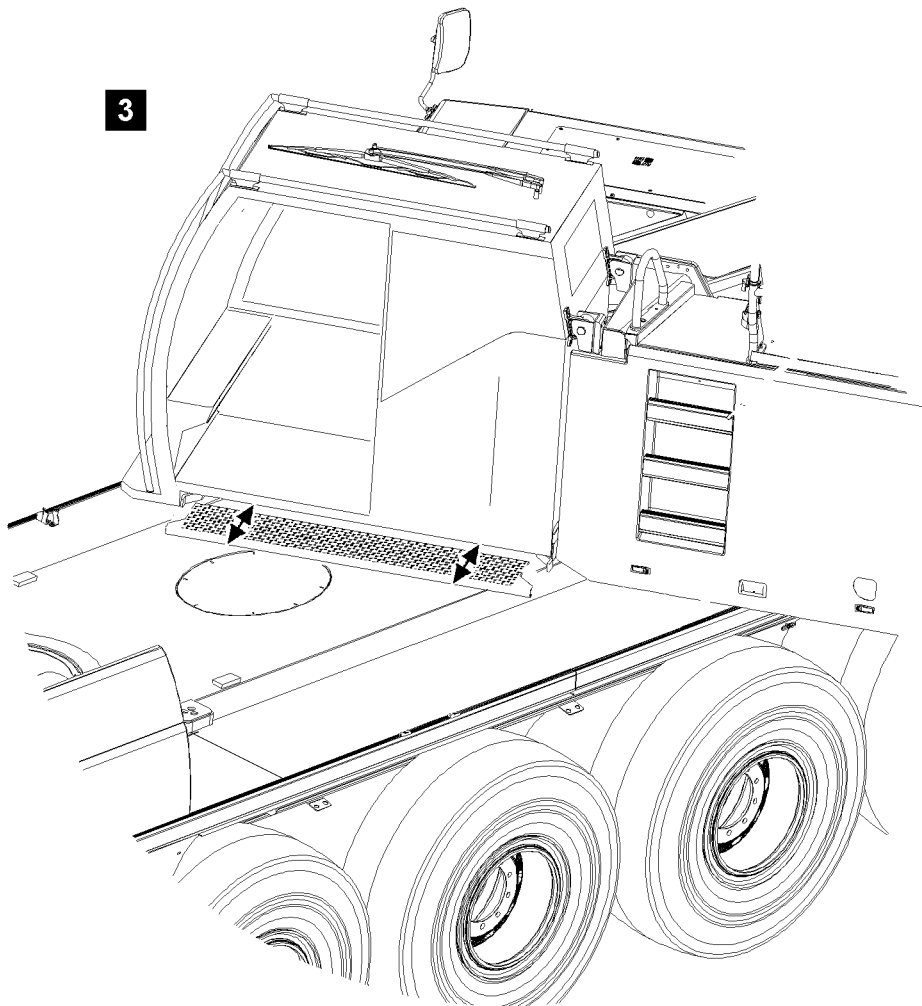
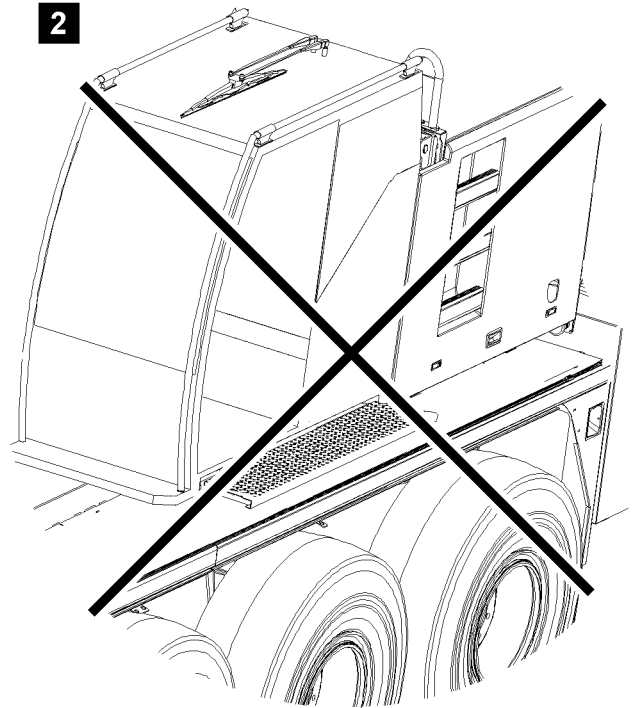
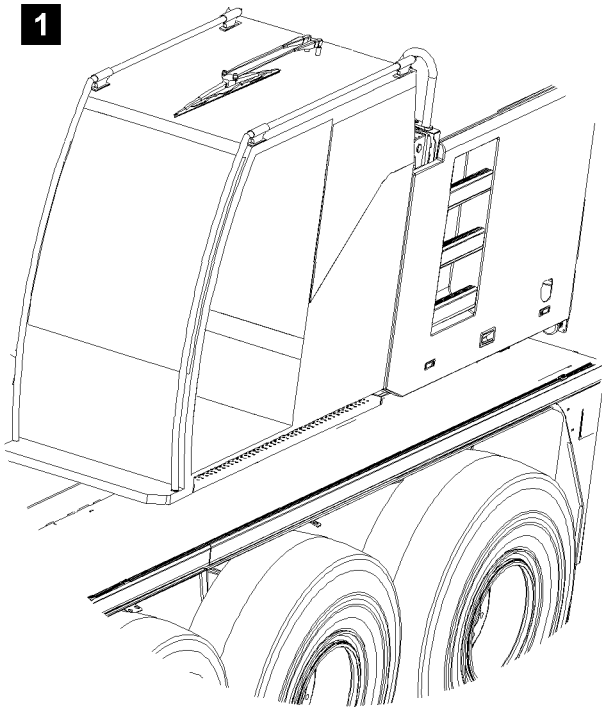

B109287

1.5 Crane operator's cab with retractable / extendable step

1.5.1 Entering / exiting of crane superstructure alignment length axis crane chassis

See illustration 1.

Before entering / exiting the crane operator's cab, the following prerequisites must be met:

- The crane superstructure is aligned in length axis of the crane chassis.
- The step under the crane operator's cab is moved in.
- The crane operator's cab with incline adjustment is in 0° position.



WARNING

Risk of falling!

If the crane superstructure is aligned in length axis of the crane chassis and the step is moved out, see illustration 2, then there is a danger of falling when entering / exiting!

Personnel can be severely injured or killed!

- ▶ Set up a suitable access, such as a ladder or pedestal, to ensure safe entry into the crane operator's cab!
- ▶ When exiting the crane operator's cab in position crane superstructure in length axis crane chassis, always move the step in completely!

1.5.2 Entering / exiting a swung crane superstructure

See illustration 3.

Before entering / exiting the crane operator's cab, the following prerequisites must be met:

- The crane superstructure is swung to the point where a safe access to the crane chassis is ensured.
- For the crane operator's cab with incline adjustment, the crane operator's cab is in 0° position.



Note

- ▶ Use extendable step!
- ▶ The extended step allows comfortable entry into the crane operator's cab as well as safe exit from the crane operator's cab to the crane chassis!

1.6 Crane operator's cab with incline adjustment



WARNING

Risk of falling!

If the crane operator's cab cannot be swung from an inclined position (for example 20° position) to the 0° position, for example due to a problem, then utmost caution must be used when entering / exiting the crane operator's cab!

There is a danger of falling, personnel can be severely injured or killed!

- ▶ For safety reasons, we recommend to take advantage of outside help!
- ▶ If necessary, have appropriate pedestals or other suitable entry aids set up to ensure safe exit from the crane operator's cab!



WARNING

Risk of accident!

If the door of the crane operator's cab is opened in inclined position, then the door can move back suddenly!

Hands can be crushed or injured!

- ▶ When the operator's cab is in inclined position, open the door carefully!

1

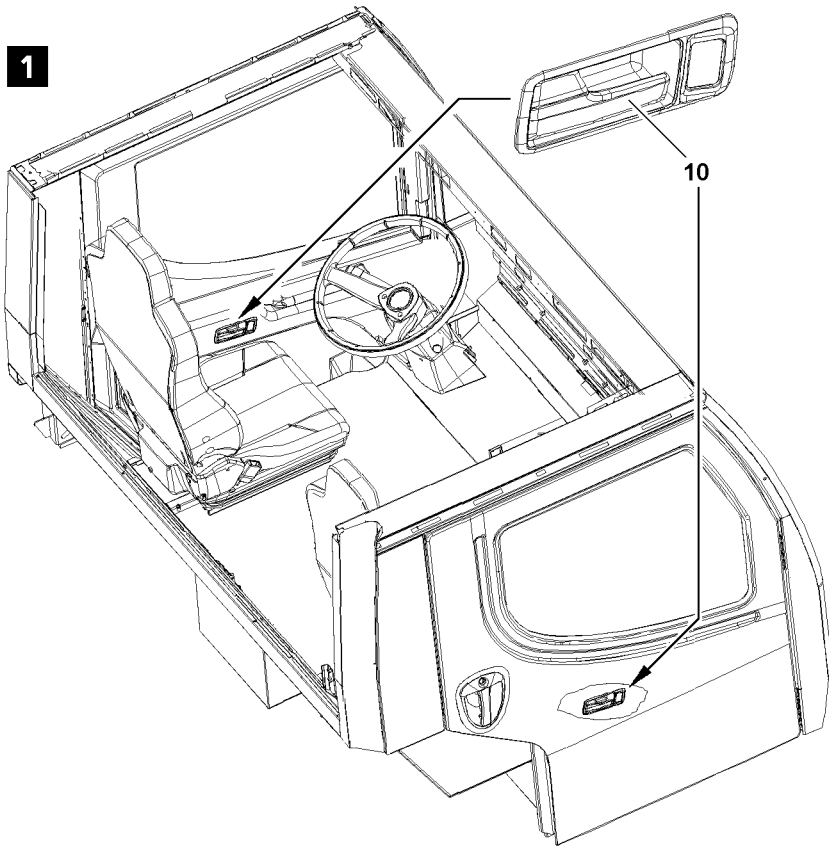

2

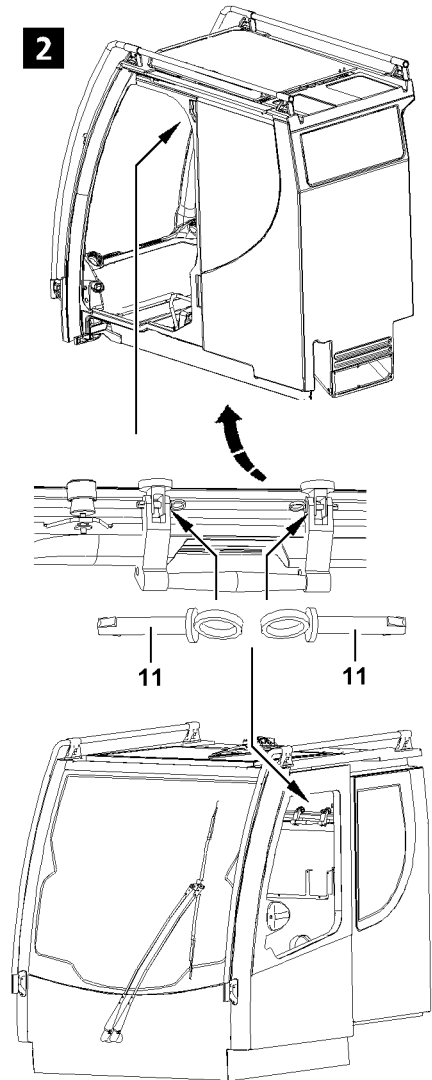

3

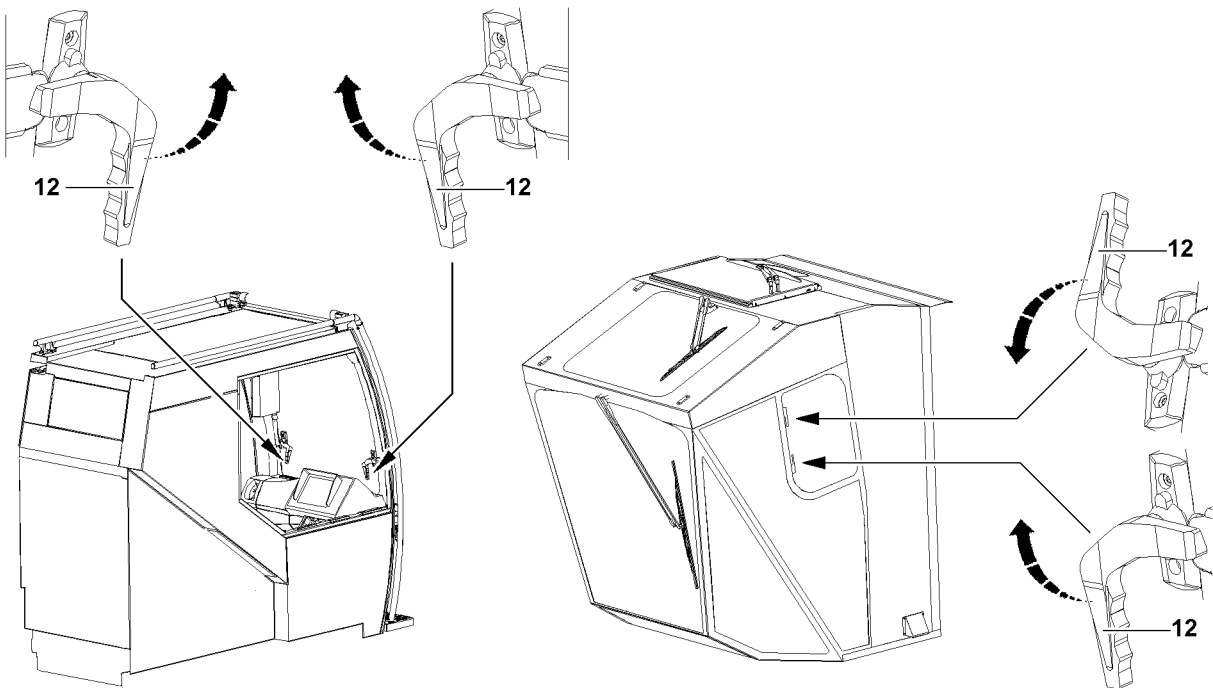

B109261

2 Emergency exit

2.1 Emergency exit - driver's cab

The driver's cab can be exited through the "Left driver's door" or the "Right passenger door", see illustration 1.

**Note**

- ▶ Exit the driver's cab through the "Left driver's door" or the "Right passenger door", see illustration 1: Pull and open the door handle **10** on the "Left driver's door" or the "Right passenger door".

2.2 Emergency exit - crane operator's cab

**WARNING**

Risk of falling!

If it is not possible to safely leave the crane operator's cab through the door or to reset the crane operator's cab from inclined position to horizontal position, then the crane operator can fall from the crane operator's cab during the emergency exit and be severely injured!

- ▶ Be especially careful when exiting at emergency exit!
- ▶ If the crane operator's cab cannot be exited safely, use outside aid!

In case of an emergency, if it is not possible to leave the crane operator's cab through the door, the crane operator's cab can be exited through one of the following openings, depending on the model:

- **Roof window**, see illustration 2: Pull the pins **11** on the left and right and open the roof window upward.
- **Rear window**, see illustration 2: Pull the pins **11** on the left and right and open the rear window upward.
- **Front window**, see illustration 3: Unlock the left and right handles **12** and open the front window.
- **Side window**, see illustration 3: Unlock the top and bottom handles **12** and open the side window.

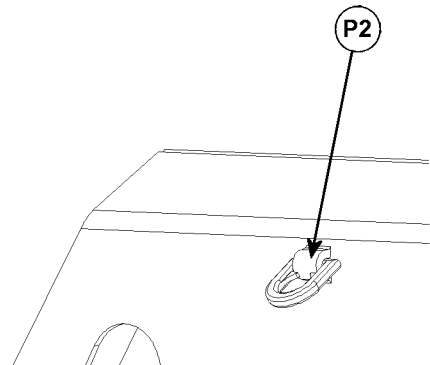
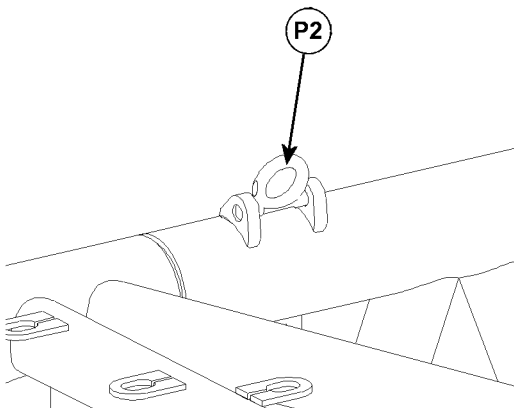
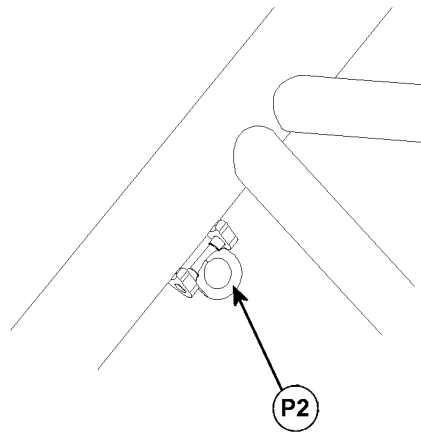
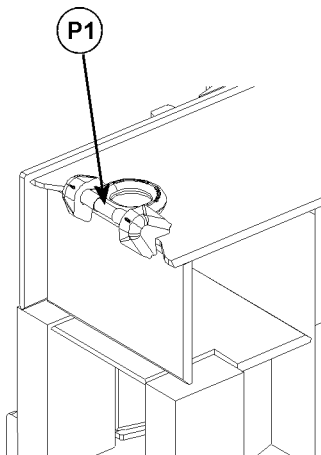
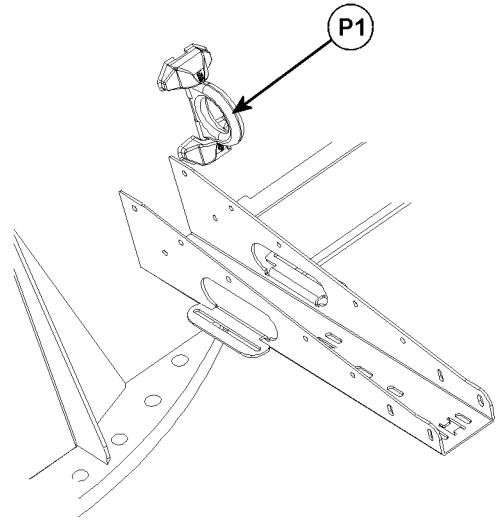
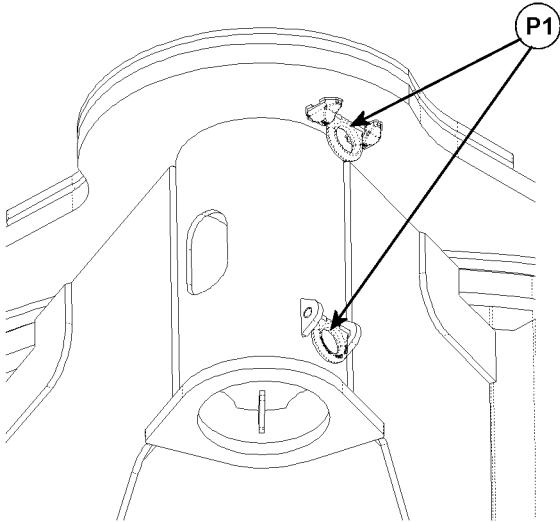

B111681

3 Checking the rigging and fastening points

Before every operation and at regular intervals, check the rigging points **P1** and the fastening points **P2** for cracks of the welding seam, significant corrosion, wear and distortion.

The inspection criteria are:

- Completeness of rigging points **P1** and fastening points **P2**.
- Distortion of carrying parts.
- Mechanical damage such as severe nicks.
- Changes in diameter due to wear.
- Significant corrosion (pitting).
- Cracks on carrying parts.
- Cracks or other damage on the welding seam.



WARNING

Risk of accident!

When using rigging and fastening points which are not operationally safe, severe personnel damage and property damage can occur!

- ▶ Have rigging and fastening points, which are not operationally safe replaced with new rigging and fastening points by authorized and trained expert personnel!
 - ▶ When hooking and unhooking the rigging and fastening equipment, handle carefully to avoid crushing, sheering, catch and impact points!
 - ▶ Eliminate damage of rigging and fastening equipment due to sharp edged stress loads!
-

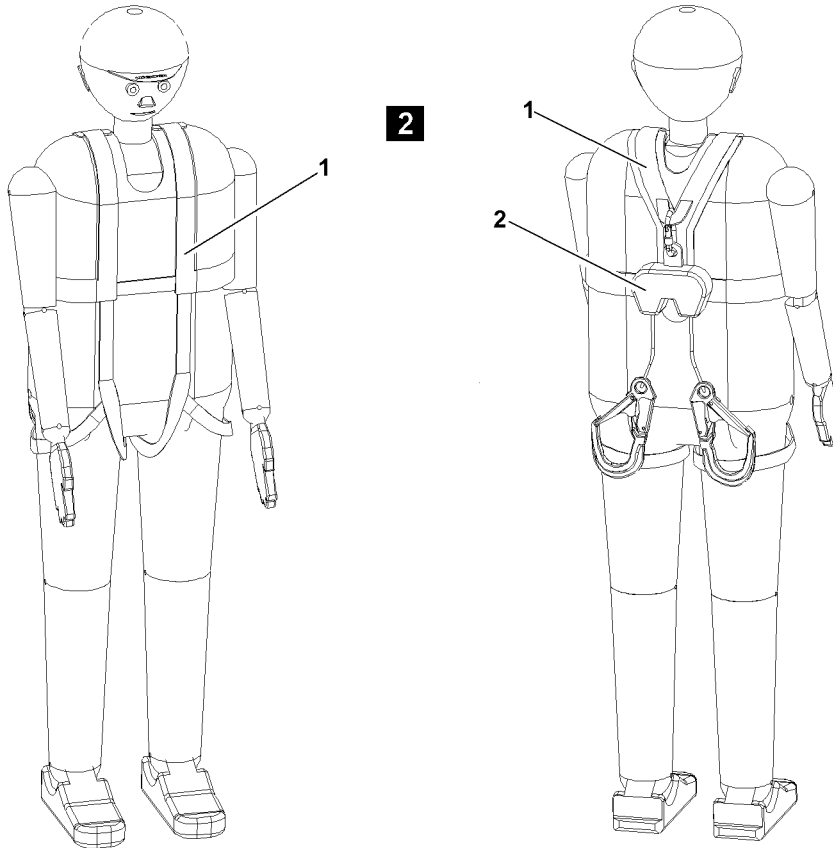
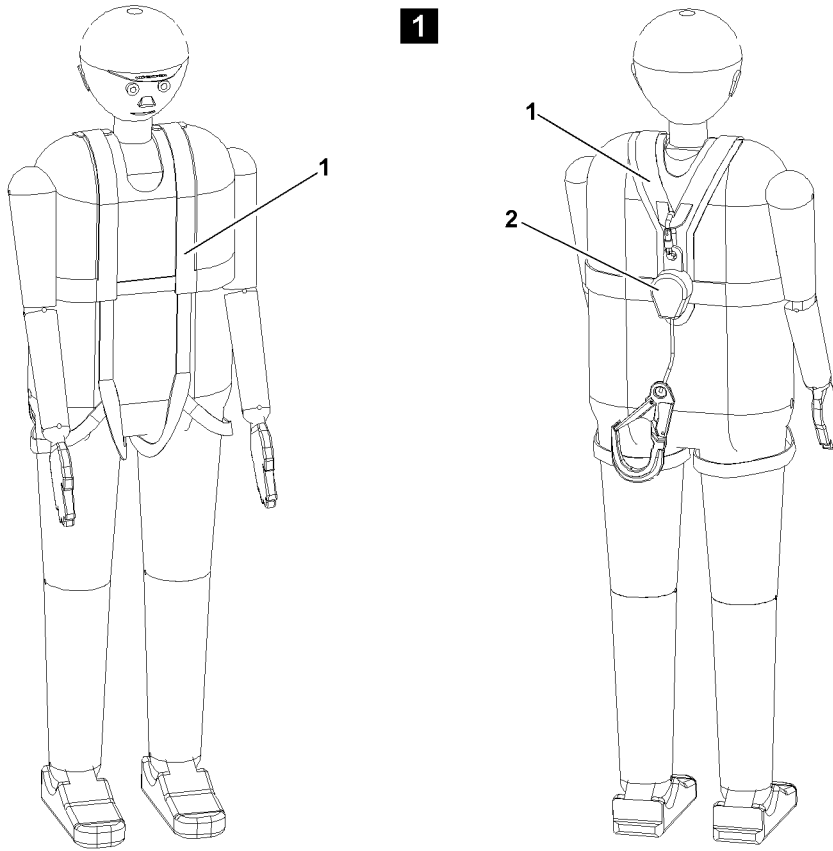

B111691

4 Personal protective equipment



WARNING

Risk of falling!

If personnel protective equipment is not worn during assembly or maintenance work, then the assembly personnel can be killed or severely injured!

- ▶ The operating instructions of the manufacturer for the personal protective equipment must be observed and adhered to!
- ▶ Through regular inspections it must be ensured that the product identification is not damaged!
- ▶ The crane operator must make personal protective equipment available for the assembly personnel!
- ▶ The crane operator must ensure that the personal protective equipment is worn by the assembly personnel!
- ▶ The assembly personnel is obligated to carry the personal protective equipment and to wear it!
- ▶ Replace defective or damaged personal protective equipment!

The personal protective equipment includes the following equipment:

- Head protection with chin strap: Protection from falling parts at assembly and disassembly. Hitting the head at assembly and disassembly of lattice mast equipment.
- Safety gloves: As a rule, when working with ropes, penetration safe safety gloves must be used.
- Supplied fall arrest systems (safety harness **1** and height safety equipment **2**).
- Safety shoes: Protection from falling parts at assembly and disassembly.
- Warning apparel



WARNING

Risk of fatal injury!

Even personal protective equipment does not provide 100 % protection!

A helmet can protect against small falling objects, but not against falling loads!

Personnel can be killed or seriously injured!

- ▶ Always remain aware of your surroundings and behave in a safe manner!
- ▶ Standing under suspended loads is prohibited!



WARNING

Risk of accident!

If the following measures are not carried out, personnel can be killed or severely injured!

- ▶ A plan for rescue actions, taking all possible emergencies into account, must be on hand!
- ▶ The following points can endanger the safe function of the personal protective equipment: For example extreme temperatures, routing of connecting devices, routing over or around sharp edges, chemical influences, electrical effects, cuts, abrasion, climatic influences or swing movements during falls!
- ▶ For that reason, appropriate safety preparations must be made!



WARNING

Important for the safety of the user!

- ▶ If the personal protective equipment is sold to another country, then the purchaser must make the manufacturer's operating instructions as well as the inspection and maintenance documents available in the language of the user country!

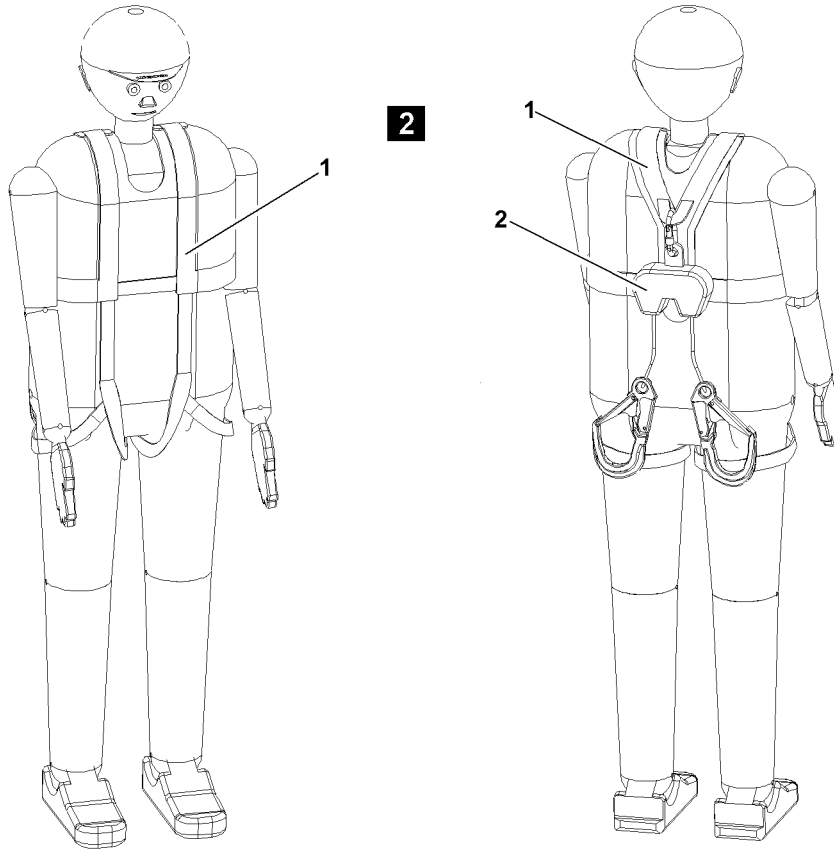
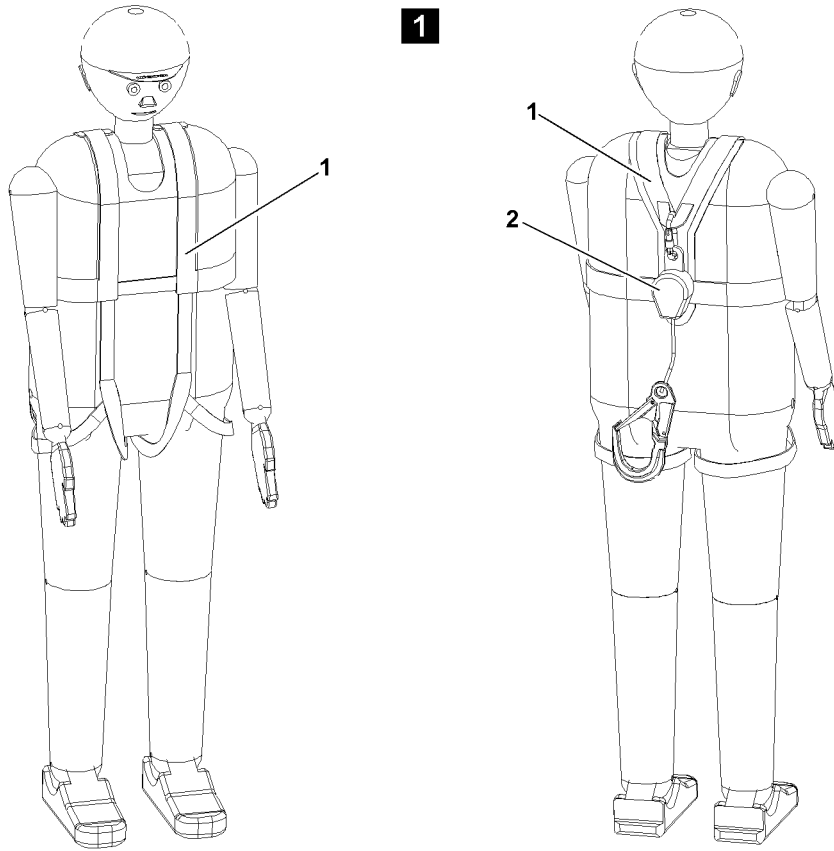

B111691

4.1 Supplied fall arrest system (safety harness and height safety equipment)

The supplied fall arrest system, consisting of safety harness **1** and height safety equipment **2** must be worn where no other fall protection equipment, such as railings, can be installed for technical reasons. In these cases, marked fastening and hook points for the fall arrest systems are provided on the components.



Note

- ▶ For cranes, which do not include the fall arrest system and the height rescue system as part of the scope of delivery can purchase the fall arrest system, consisting of safety harness **1** and height safety equipment **2** as well as the height rescue system at the Liebherr-Werk Ehingen.

Part of the category “Aids for working aloft” are, for example:

- Lifting platforms
- Scaffolding
- Auxiliary cranes



WARNING

Risk of falling!

If the fall arrest system is not worn during assembly or maintenance work, then the assembly personnel can fall down and be killed or severely injured!

- ▶ All work aloft, where there is a danger of falling must be carried out with suitable aids!
- ▶ If fall protection equipment is available, then it must be used, see Crane operating instructions, chapter 2.06!
- ▶ If aids are not available and work cannot be carried out from the ground, then the assembly personnel must secure themselves with the supplied fall arrest system to prevent falling!
- ▶ The supplied fall arrest system must be fastened on the fastening and hook points as well as on the safety ropes. For safety points, see Crane operating instructions, chapter 2.06!
- ▶ The assembly personnel must be instructed in practice on how to wear the supplied fall arrest system (safety harness **1** and height safety equipment **2**)! Annual practice instructions and drills must be carried out!
- ▶ The fall arrest system, which was supplied by the manufacturer must be used!
- ▶ The fall arrest system consists of a safety harness **1**, approved according to **EN 361** and a height safety equipment **2**, approved according to **EN 360** (for horizontal application and sharp edges)!
- ▶ The operating instructions of the manufacturer for the supplied fall arrest systems (safety harnesses **1** and height safety equipment **2**) must be observed and adhered to!
- ▶ Only step on the aids, ladders and catwalks with clean shoes!
- ▶ Keep aids, ladders and catwalks free of heavy dirt, snow and ice!
- ▶ The safety harness **1** and the height safety equipment **2** must be inspected annually according to the specifications by authorized and trained expert personnel and the results must be documented in the inspection log book!
- ▶ After every fall, the safety harness **1** and the height safety equipment **2** must be removed and inspected by an authorized and trained expert and the results must be documented in the inspection log book!

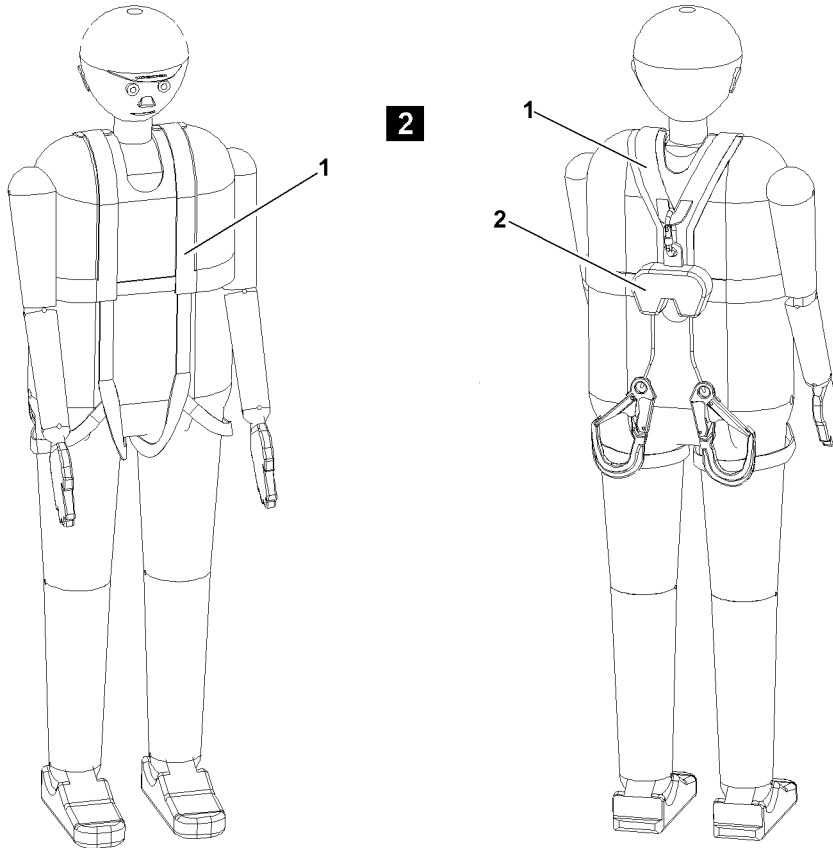
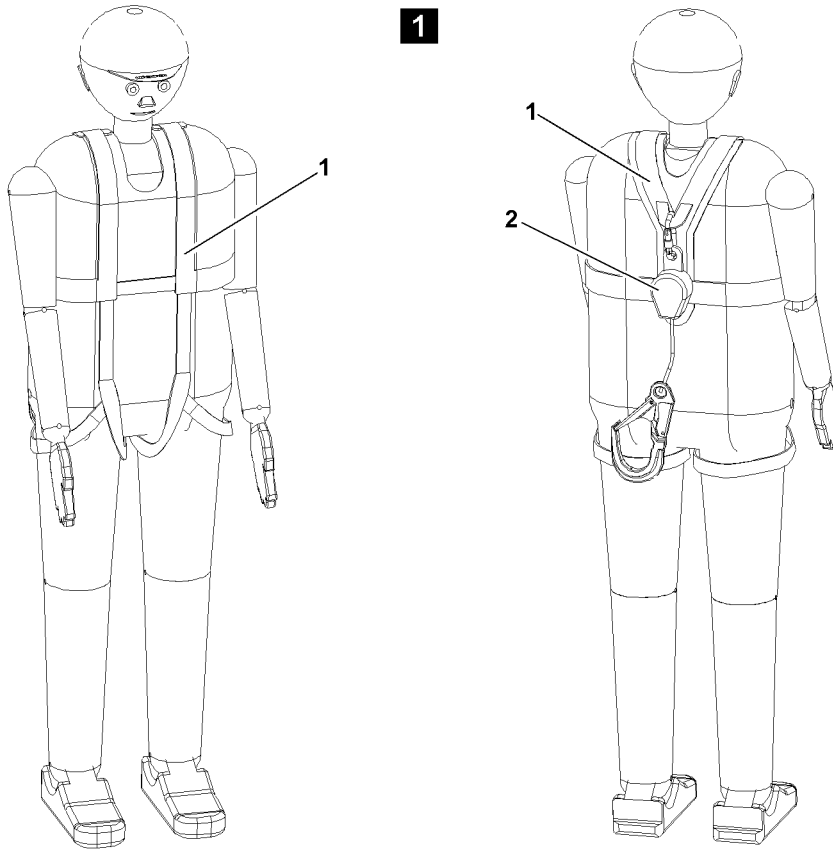

B111691

5 Use of single-stranded height safety equipment, illustration 1

Height safety equipment with a belt strap is intended for all cranes which have no catwalks with safety ropes. Use the supplied height safety equipment with extendable belt strap and snap hook (EN 362 Class A) with link.

6 Use of double-stranded height safety equipment, illustration 2

Height safety equipment with two belt straps are intended for cranes with catwalks, which are equipped with two ropes as fastening device on the left and right hand side of the catwalk. For example lattice sections, lattice booms, possibly telescopic booms or assembly units. Use the supplied height safety equipment with two extendable belt straps and snap hooks (EN 362 Class A) with links.



WARNING

Risk of falling!

- ▶ If two safety ropes are installed on the booms, lattice sections and other components, then the height safety equipment with two belt straps must always be used and one belt strap per safety rope must be hooked!

7 Securing the assembly personnel against falling

Make sure that that assembly personnel is wearing the supplied fall arrest systems (safety harnesses and height safety equipment) correctly.

7.1 Working on the telescopic boom head

Reeve the hoist rope in or out on the pulley head

- When working on a ladder, always use the supplied ladder with hook device. The fastening and hook points are noted in the Crane operating instructions, chapter 2.06.
- When ascending, the assembly personnel must ensure a 3-point support.
- When working on the ladder, the assembly personnel must hook themselves with the snap hooks of the fall arrest system on the fastening points and secure themselves against falling.

7.2 Working on the auxiliary boom

Assembling or disassembling the auxiliary boom

- When working on a ladder, always use the supplied ladder with hook device. The fastening and hook points are noted in the Crane operating instructions, chapter 2.06.
- When ascending, the assembly personnel must ensure a 3-point support.
- When working on the ladder, the assembly personnel must hook themselves with the snap hooks of the fall arrest system on the fastening points and secure themselves against falling.

7.3 Walking on the telescopic boom



WARNING

Risk of falling!

The assembly personnel can fall down by slipping on the telescopic boom and be killed or severely injured!

- ▶ The telescopic boom may only be accessed if the assembly personnel is protected with suitable safety measures to prevent them from falling!
- ▶ If safety ropes are present on the telescopic boom, then the assembly personnel must hook themselves with the supplied fall arrest system on the safety ropes of the telescopic boom on the left and right with both snap hooks and secure themselves against falling!
- ▶ Without appropriate safety measures, it is **strictly** prohibited to step on the telescopic boom!

Assembly of the hoist rope or the TY-guying

- During assembly, the assembly personnel must hook themselves on the fastening devices on the left and right with both snap hooks of the fall arrest system and secure themselves against falling.

7.4 Access to lattice sections or booms

Climbing the ladder:

- When ascending, the assembly personnel must ensure a 3-point support.

Changing from ladder to catwalk:

- Before changing over, the assembly personnel must hook at least one snap hook of the fall arrest system on a safety rope and secure themselves against falling.

7.5 Walking on lattice sections or booms

Walking on catwalks:

- When walking on catwalks, the assembly personnel must hook themselves on the safety ropes on the left and right with both snap hooks of the fall arrest system and secure themselves against falling.
- When changing the fall arrest system over to a new lattice section, the assembly personnel must be hooked with at least one snap hook of the fall arrest system on one safety device.

7.6 Working on lattice sections or booms

Pinning, unpinning the lattice sections of pull rods:

- During pinning, unpinning of lattice sections or pull rods, the assembly personnel must hook themselves on the safety ropes on the left and right with both snap hooks of the fall arrest system and secure themselves against falling.

Attaching the lattice sections:

- When attaching the lattice sections, the assembly personnel must hook themselves on the safety ropes on the left and right with both snap hooks of the fall arrest system and secure themselves against falling.

7.7 Descending from lattice sections or booms

Stepping on the ladder:

- Before stepping on the ladder, the assembly personnel must hook at least one snap hook of the fall arrest system on a safety rope and secure themselves against falling.
- When stepping on the ladder, the assembly personnel must ensure a 3-point support.
- The snap hook of the fall arrest system may only be unhooked after standing safely on the ladder (3-point support).

Climbing down the ladder:

- When descending, the assembly personnel must ensure a 3-point support.

8 Rescuing the assembly personnel



WARNING

Risk of falling!

- ▶ The assembly personnel must be instructed and trained properly in the correct handling of the height rescue system! Annual practice instructions and drills must be carried out!
 - ▶ The supplied height rescue system must be kept available!
 - ▶ The operating instructions of the manufacturer for the height rescue system must be observed and adhered to!
 - ▶ The height rescue system must be inspected annually by authorized and trained expert personnel according to the specifications and documented in the inspection log book!
-

8.1 First aid measures after rescue



WARNING

Risk of fatal injury!

- ▶ After the rescue, the patient must be positioned with the upper body raised (in seated or squatting position)!
 - ▶ Immediate flat position or even shock position can be fatal!
-

9 Documentation



Note

- ▶ The documentation of the fall arrest systems (safety harnesses and height safety equipment) and the height rescue system must be carried out according to the operating instructions of the respective manufacturer.
 - ▶ The crane operator, who employs the user, is responsible for the creation of documentation and entry of the required data.
-

10 Identification

Every personal protective equipment or other equipment must be marked clearly and permanently in the language of the user country.

If the identification is no longer legible, then the personal protective equipment must be handed to an expert for inspection.

11 Requirements for the crane operator

11.1 General

The crane operator's primary responsibility is to use and operate the crane in a manner that is safe for both himself and others.

The following important safety guidelines will help you achieve this.

Many crane accidents are caused by incorrect crane operation.

**WARNING**

Danger due to operating error!

- ▶ In the interest of both yourself and others, make sure you understand how your crane operates and familiarize yourself with all the risks associated with the work to be done.

The main **operating errors**, which are made again and again while operating or driving a crane, are as follows:

- Not paying careful attention while working, for example:
 - Slewing too quickly
 - Stopping the load too quickly
 - Angular pulling
 - Slack ropes
- Overloading
- Driving too fast with a load or equipment on an uneven roadway
- Attaching the load incorrectly
- Unsuitable operation; especially angular pulling, breaking away stuck loads
- Wind action on suspended loads
- Mistakes when driving on a road, for example:
 - Overspeeding the engine when driving downhill
 - Driving with turned on differential lock
- Crashing into bridges, roofs or high voltage wires due to insufficient headroom
- Inadequate support; support base, support under the support plates
- Mistakes during assembly or disassembly of booms

In many cases, crane damage is caused by improper maintenance:

- Insufficient oil, grease or antifreeze
- Contamination
- Broken cable wires, defective tires, worn parts
- Emergency limit switch or load torque limiter (LMB) not operating properly
- Brake and clutch failure
- Hydraulic defects; for example cracked hoses
- Loose bolts

11.2 Working on the crane superstructure or boom

**WARNING**

Risk of falling!

When working on the crane superstructure or boom, personnel must be secured with appropriate safety measures to prevent them from falling! If this is not observed, working personnel can fall and be killed or severely injured!

- ▶ For all work on the crane where there is a danger of falling, suitable safety measures must be taken!
- ▶ The crane superstructure or boom may not be accessed without suitable aids!
- ▶ Suitable aids are, for example: Lifting platforms, scaffoldings, ladders, assembly platforms, auxiliary crane.
- ▶ If railings are present on the crane superstructure, then they must be swung into operating position and secured for all work, see Crane operating instructions, chapter 2.06!
- ▶ Only step on such aids with clean shoes!
- ▶ Keep aids clean and free of snow and ice!
- ▶ If the work cannot be carried out with such aids nor from the ground, then the assembly personnel must secure themselves with approved fall arrest systems to avoid falling, see section "Personal protective equipment"!
- ▶ It is prohibited to step on the driver's cab or cab roof and specially marked surfaces, see Crane operating instructions, chapter 2.05!

11.3 Obligations of the crane operator

- 1.) Before starting to work, the crane operator must check the brake function and the emergency shut off devices. He must monitor the condition of the crane for obvious defects. On wireless controlled cranes, he must check the assignment of control unit and crane.
- 2.) The crane operator must cease crane operation in case of defects, which would endanger the safety.
- 3.) The crane operator must report all defects on the crane to the appropriate supervisor, also to his replacement in case of crane change.
- 4.) The crane operator must make sure that:
 - All control devices are set to neutral or idle position before release of the energy supply to the drive components.
 - The control devices are set to neutral or idle position and the energy supply is shut off before leaving the control platform.
 - When taking down the control unit for wireless control, it is secured to prevent unauthorized operation.
- 5.) The crane operator must ensure that cranes subjected to wind are not operated past the limits which were set by the crane manufacturer, and that the boom is taken down at least when the critical wind speeds for the crane are reached and at the end of the work.
- 6.) The crane operator must monitor the load at all crane movements or the load tackle devices when moving the crane without a load, if they could cause a dangerous situation. If observation is not possible, then the crane operator may move the crane only with the aid of a guide.
- 7.) The crane operator must give warning signs when necessary.
- 8.) The crane operator may not move loads over personnel.
- 9.) Any loads attached by hand may only be moved by the crane operator after he received a clear sign from the person who attached the load, the guide or any other responsible party which was assigned to that task by the contractor. If signals must be used to communicate with the crane operator, then they must be agreed upon before use between the responsible party and the crane operator. If the crane operator determines that the loads are not properly attached, then he may not move them.
- 10.) As long as a load is suspended on the crane, the crane operator must keep the control devices within reach. This does not apply for towing of vehicles with towing cranes.
- 11.) The crane operator may not run up to end positions operationally, if they are limited by the emergency limit switches.
- 12.) After a load moment limiter was triggered, the crane operator may not take on an overload by pulling in / raising the boom.
- 13.) The crane operator may **not** bypass the overload protection to increase the hoisting power of the crane.

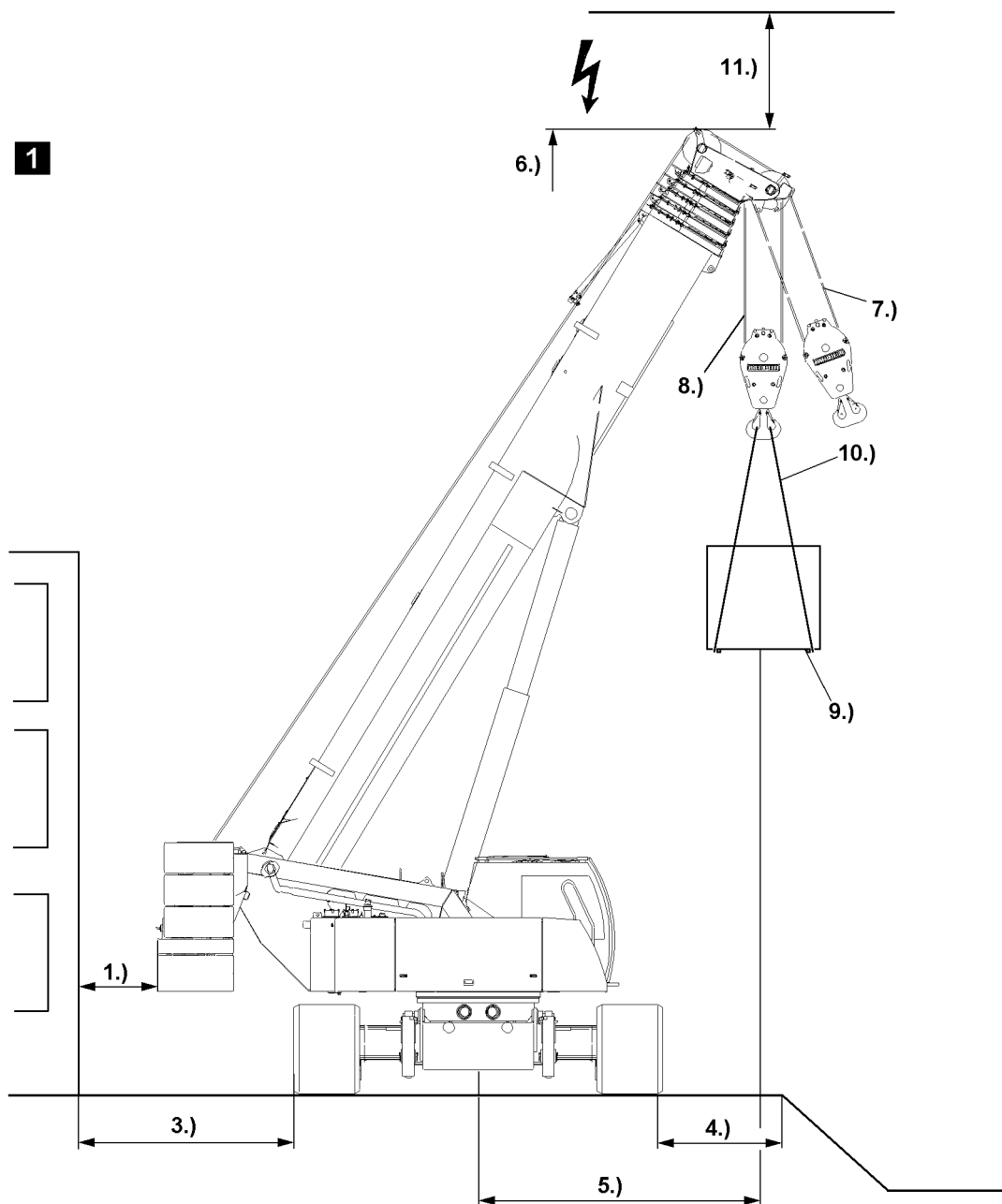

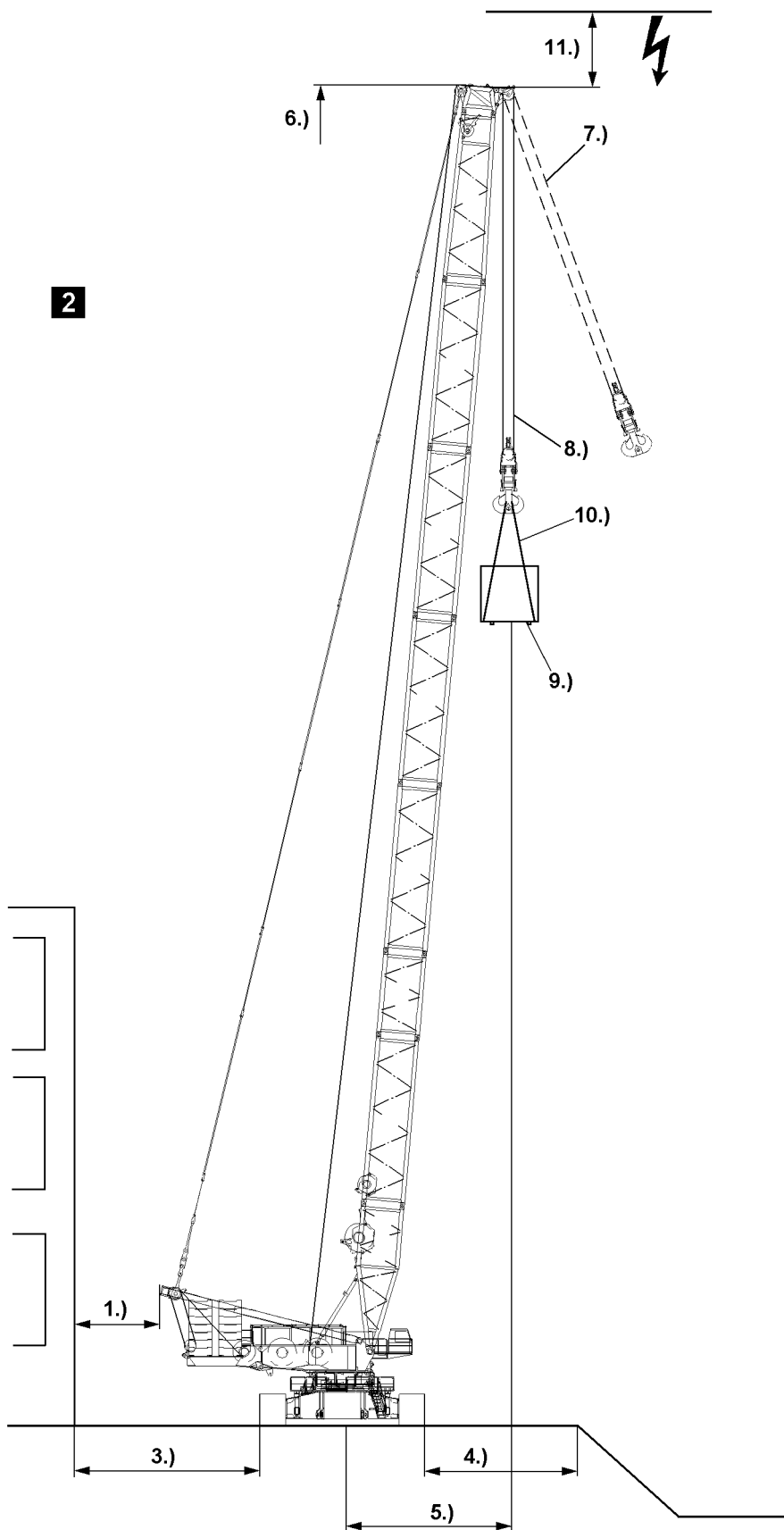

B104102

Example for crawler crane with lattice mast boom

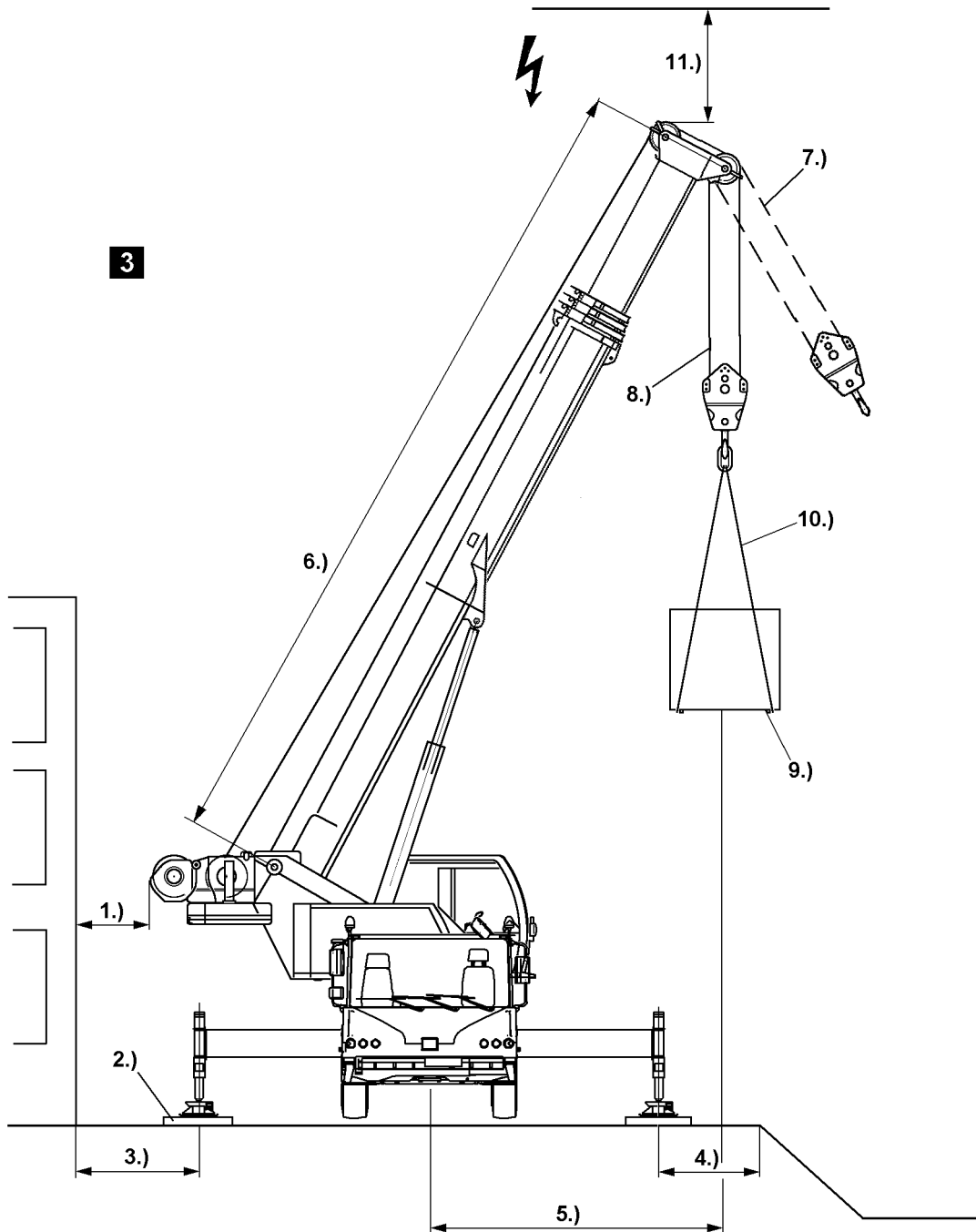

B104103

Example for mobile cranes

12 Selecting the location, illustrations 1 to 3

It is very important to choose an appropriate location for crane operation in order to minimize accident risks.



DANGER

Risk of accidents due to ground with **insufficient** load bearing capacity!

If the crane is supported or driven on ground with **insufficient** load bearing capacity, then the crane can topple over and kill personnel!

- ▶ Only support or drive the crane on ground with the required load-bearing capacity!
 - ▶ Act responsibly when planning and selecting the crane location and route.
 - ▶ Note the following points!
-

When selecting the location for the crane, observe the following:

- 1.) Select the placement location in such a way that crane movements can be carried out without collision, and that the outrigger supports can be extended to the support base stipulated in the load charts.
Make sure that no personnel is injured or killed!
Always keep a safety distance of 0.5 m. If this is not possible, secure the danger zone.
- 2.) On mobile cranes:
Support the crane correctly and support the support plates according to the load bearing capacity of the ground on the placement location.
- 3.) Keep a safety distance to basements or similar.
- 4.) Keep a safety distance to slopes or similar.
- 5.) Keep the radius to as low as possible.
- 6.) Select the correct boom length to the load case.
- 7.) Angular pull is prohibited!
- 8.) Select the correct reeving of the hoist rope to the load case.
- 9.) Bear in mind the weight and the wind exposure surface of the load.
- 10.) Select tackle according to the weight of the load, the type of attachment and the incline angle.
- 11.) Keep sufficient distance to electrical overhead wiring.

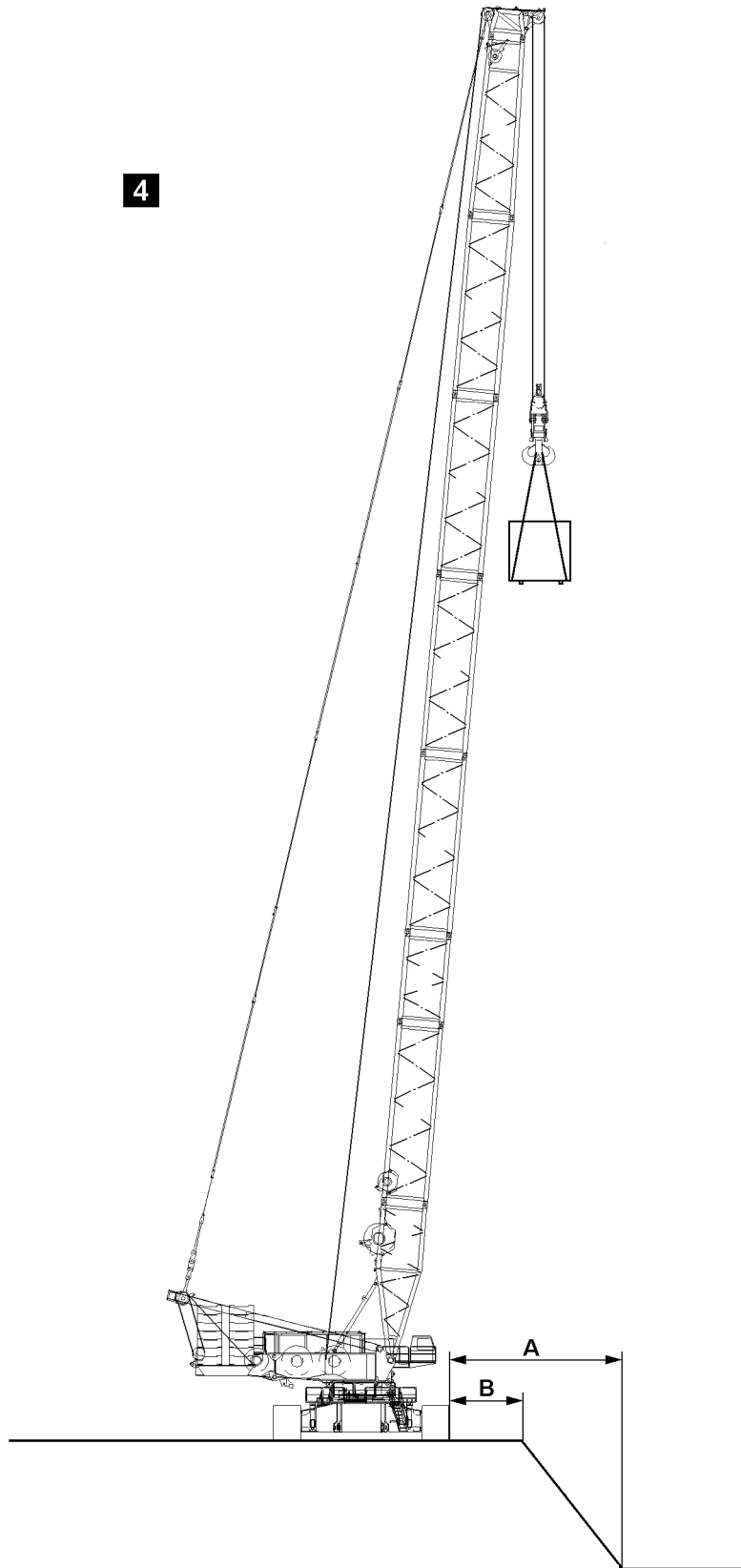

B108387

Example for crawler cranes

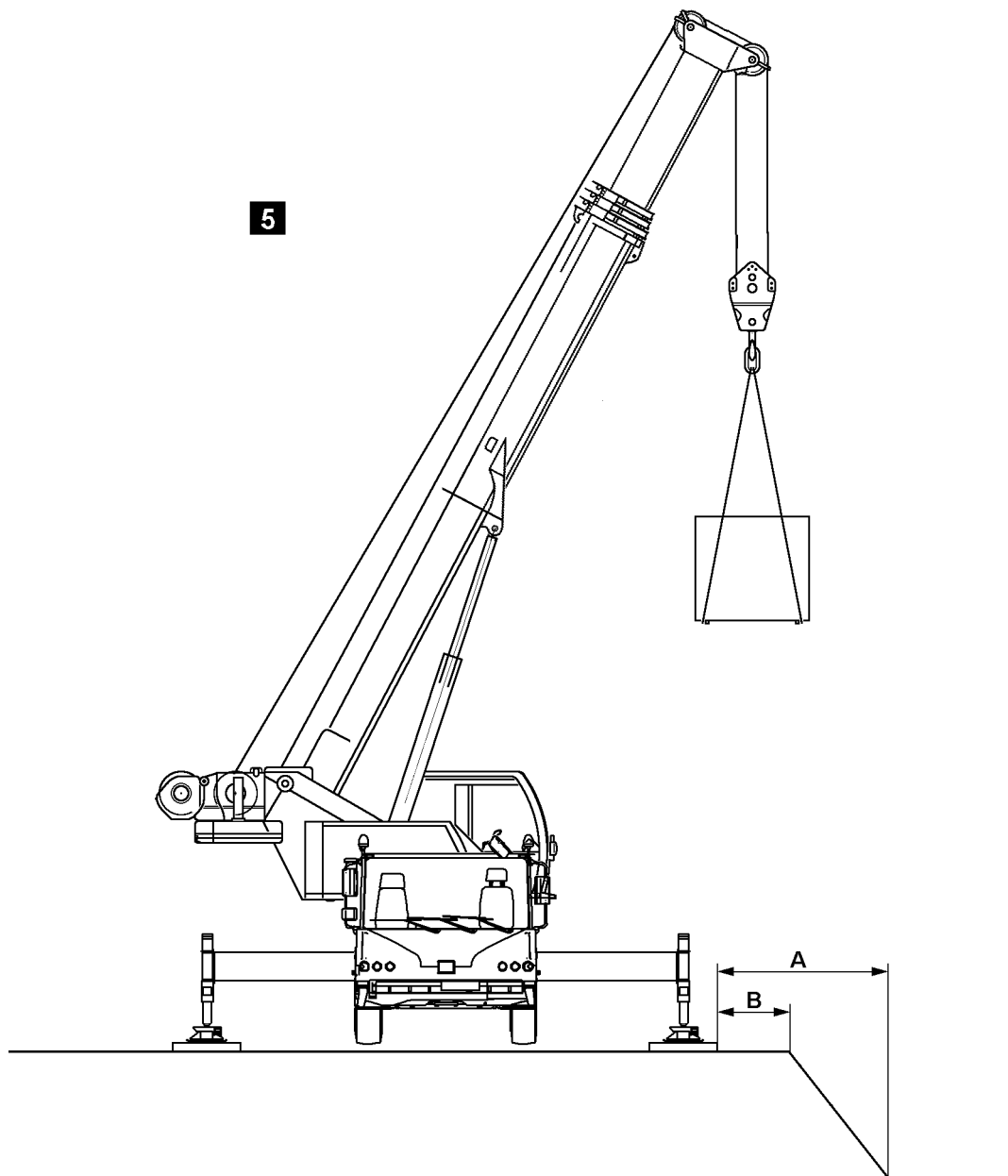

B108388

Example for mobile cranes

13 Slopes and excavations, illustrations 4 and 5

The crane may not be set up too close to slopes or excavations. Maintain adequate safety distance **A** and safety distance **B** in accordance with the type of soil.



WARNING

The crane can topple over!

The edge of the slope or excavation can break in if safety distance **A** or safety distance **B** is too small. If the edge of the slope or excavation breaks in, the crane can topple over and kill personnel!

► Always maintain the required safety distance **A** and safety distance **B**!

Abbreviation	Term
A	Distance to bottom of excavation
B	Distance to excavation

14 Permissible ground pressures

Permissible ground pressures		
Soil type		[N/cm ²]
1.	Organic ground: Peat, sludge, muck	0
2.	Uncompacted fill: Construction debris	0 to 10
3.	Non-cohesive ground: Sand, gravel, rocks and mix	20
4.	Cohesive soil: a) Clayed silt, mixed with topsoil b) Silt, consisting of poor clay and coarse clay c) Plastic clay, consisting of potter's clay and fill Stiff Semi-solid Solid d) Mixed granular ground, clay to sand, gravel and rocky areas Stiff Semi-solid Solid	12 13 9 14 20 15 22 33
5.	Rock in evenly solid condition:	

Permissible ground pressures		
Soil type		[N/cm ²]
	a) Brittle, with traces of decomposition	150
	b) Not brittle	400

If there is any doubt about the load bearing capability of the ground at the site, soil tests should be carried out by specialists using, for example, a penetrometer.

14.1 Permitted ground pressure for crawler cranes

During crane operation, significant forces are transferred to the ground. The ground must be able to safely withstand the pressure. If the crawler area is inadequate, then it must be supported from below according to the load bearing capacity of the ground.



WARNING

The crane can topple over!

If the crane is not properly supported, the crane can topple over and fatally injure personnel!

- ▶ The foundation support must be large enough for the ground conditions and constructed from solid materials, such as wood or steel plates!

14.2 Permitted ground pressure for mobile cranes

When the crane is supported, the support cylinders transmit significant forces to the ground. The ground must be able to safely withstand this pressure. If the support plate area is inadequate, then it must be supported from below according to the load bearing capacity of the ground. The required support area can be calculated from the load bearing capacity of the ground and the crane support force.



Note

- ▶ Consider that the support force, due to the counterweight, can be higher without a load than with a load.



WARNING

The crane can topple over!

If the crane is not properly supported, the crane can topple over and fatally injure personnel!

- ▶ Only strong materials may be used for the support pad bases; for example properly dimensioned wooden timbers!
- ▶ In order to ensure that pressure is evenly distributed over the base surface, the support plates must be positioned in the center of the support base!



Note

- ▶ The following are general calculation examples. The values are used only to explain the calculation steps. The crane specific values are in chapter 1.03 of the crane operating instructions.

Example: Calculation of specific support pressure	
Maximum support force according to crane operating instructions, chapter 1.03 for example: 720 kN	720000 N
Surface of square support plate with 550 mm side length according to chapter 1.03, for example: 302500 mm ²	3025 cm ²
80 % as carrying surface of support plate: 302500 mm ² x 0.8 = 242000 mm ²	2420 cm ²
Specific support pressure = Support force / surface support plate	720000 N / 2420 cm ² = 297.52 N/cm ²
Specific support pressure:	298 N/cm²

The value of the specific support pressure is far above the permissible ground pressure for all types of granular soil. If this crane is utilized on bedrock, type of ground gravel, permissible ground pressure 20 N/cm², then the support surface must be increased.

Example: Calculation of required support surface	
Maximum support force according to crane operating instructions, chapter 1.03 for example: 720 kN	720000 N
Permissible ground pressure, for example: 20 N/cm ²	20 N/cm ²
Required support surface = Support force / permissible ground pressure	720000 N / 20 N/cm ² = 36000 cm ²
Required support surface:	36000 cm ² = 3.6 m²

The surface of the support for each support plate must be at least **3.6 m²** .



Note

► The corresponding support forces can be determined with the crane job planer.

blank page!

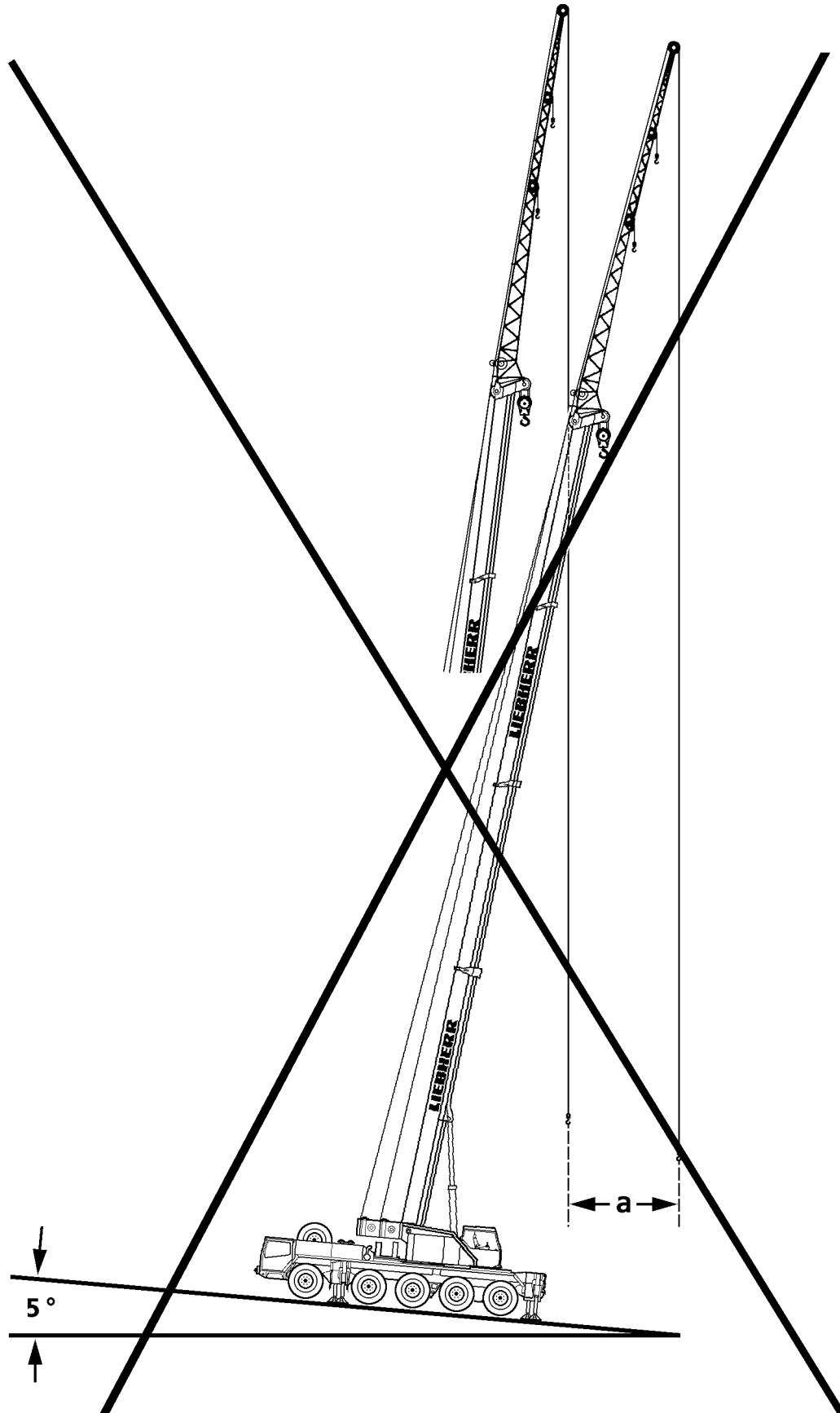

B180001

General example

15 Supporting



DANGER

The crane can topple over!

When actuating the supports with attached load and / or at loaded derrick ballast guying, the incline and the force conditions of the entire boom system change!

There is **no** shut off by the LICCON overload system!

The crane can topple over!

Personnel can be severely injured or killed!

- ▶ When a load is suspended, it is prohibited to actuate the support!
- ▶ When the derrick ballast guying is loaded, it is prohibited to actuate the support!

It is absolutely essential that the crane is supported exactly in accordance with the load charts to ensure safe operation.

The match of the sliding beams placement surfaces must be observed to ensure proper force transfer between the sliding beams.

The crane may only be supported in these extension conditions.



WARNING

Danger of tipping over!

If only the load side sliding beams are extended, the crane can tip over when turning or setting down the load!

- ▶ Move all 4 sliding beams and support cylinders out according to the data in the load chart!
- ▶ In intermediate positions between the support bases supporting is prohibited!
- ▶ Pin sliding beams to support base according to the load chart!
- ▶ Fully insert and secure the pins!



WARNING

Risk of tipping the crane due to incorrectly extending the sliding beams!

The load suspended on the hook causes tension and deformation of the hoist rope and telescopic boom. The same applies for operation with lattice jib and guy ropes. If the load is dropped from the fastening ropes or if the fastening or hoist rope breaks in this situation, a sudden relief occurs. The boom snaps back quickly. This can cause the crane to topple over.

Despite previous assumption, it might become necessary to swing the load to the opposite side. This can cause the crane to topple over.

When turning from the vehicle longitudinal direction, the crane can topple over due to the boom or counterweight momentum.

- ▶ It is imperative that all 4 sliding beams and support cylinders be extended according to the data in the load chart!

15.1 Crane alignment

In addition to the proper foundation for the supports, the horizontal alignment of the crane is of utmost importance for safe crane operation.



DANGER

The crane can topple over due to the incline position!

If the crane is positioned at an incline and if the boom is turned towards the slope, then the boom radius is increased as a result!

It is possible that the slewing gear can no longer hold the crane superstructure and, in extreme cases, the crane can topple over!

Personnel can be severely injured or killed!

► It is imperative to align the crane horizontally before starting crane operation!

If the horizontal alignment of the crane has to be readjusted:

► Set the load down on the ground before readjusting the crane!

Example: At a boom length of 50 m, a side incline of the crane by only 5° at a radius of 10 m causes an increase of the radius of $a = 4$ m.

16 Checking the safety measures

- The placement location has been selected in such a way that the crane can be operated with the least possible boom radius.
- The load bearing capacity of the ground is adequate.
- There is sufficient distance to excavations and slopes.
- It has been ensured that there are no live electrical wires within the working range of the crane.
- There are no obstacles which will hinder required crane movements.
- The crane is horizontally aligned.
- On mobile cranes:
 - The axle suspension is blocked.
 - All four sliding beams and support cylinders have been extended according to the support base given in the load chart.
 - The sliding beams are secured with pins to prevent them from moving.
 - The support plates are pinned and secured in the operating position.
 - The axles are relieved, which means the tires do not touch the ground.

17 Endangering air traffic

When working with cranes, heights are reached which could endanger air traffic. This applies especially to areas near airports.



WARNING

Endangering air traffic!

If no protective measures are taken, this can result in endangerment to air traffic!

► Get the approval from agency responsible for air traffic!

► Assemble the airplane warning light on the boom head and turn it on!

► If the airplane warning lights is operated for a longer period of time, with the engine turned off, then the battery can be discharged and as the result the airplane warning light turns off. To prevent the battery from discharging, an external electrical power supply must be established!

18 Grounding

18.1 Grounding the crane



WARNING

Danger of fatal injury due to electric shock!

There is a risk of electrical shock, if the crane is not properly grounded.

- ▶ Properly ground the crane!
- ▶ Make sure that there is a potential equalization between the crane and the ground!

The crane must be grounded before operation:

- Near transmitters (radio and TV transmitters, radio stations, etc.)
- Near high frequency switching stations
- In case of severe possibility of thunderstorms or potential thunderstorms

The crane can become electrostatically charged, especially if the crane is equipped with synthetic support mats or if the support mats are placed on insulating materials (such as wooden planks).

18.2 Grounding the load



WARNING

Danger of fatal injury due to electric shock!

There is a risk of electrical shock, if the load is not properly grounded!

- ▶ Properly ground the load!
- ▶ Make sure that there is a potential equalization between the load and the ground!

The load must be grounded before operation:

- Near transmitters (radio and TV transmitters, radio stations, etc.)
- Near high frequency switching stations
- In case of severe possibility of thunderstorms or potential thunderstorms

The load can become electrostatically charged, even if the crane is grounded. This applies in particular if a hook block with pulleys made of synthetic material and non-conductive fastening equipment (for example plastic or manila ropes) are used.

19 Consideration of wind conditions

It is imperative that the specifications regarding the permissible wind speeds are observed:

- For erection and take down of various boom configurations, see Wind speed chart.
- For crane operation, see Load chart.
- For the configured crane at “Crane not in service”, see Wind speed chart.



WARNING

The crane can topple over!

- ▶ It is prohibited to erect the crane to measure the wind speed!



Note

- ▶ The determining factor for all crane work in the actual wind speed at the job site of the crane!
- ▶ The current wind speed can be checked at the nearest weather bureau!
- ▶ Note the following: The wind speed on the boom may be higher than it is near the ground!
- ▶ Always observe the national valid regulations!

**WARNING**

Risk of accident!

The wind hitting the crane and the load can cause an increase of the support force! As a result, the permissible ground pressure can be exceeded!

- ▶ Make sure that the permissible ground pressure is not being exceeded!
-

blank page!

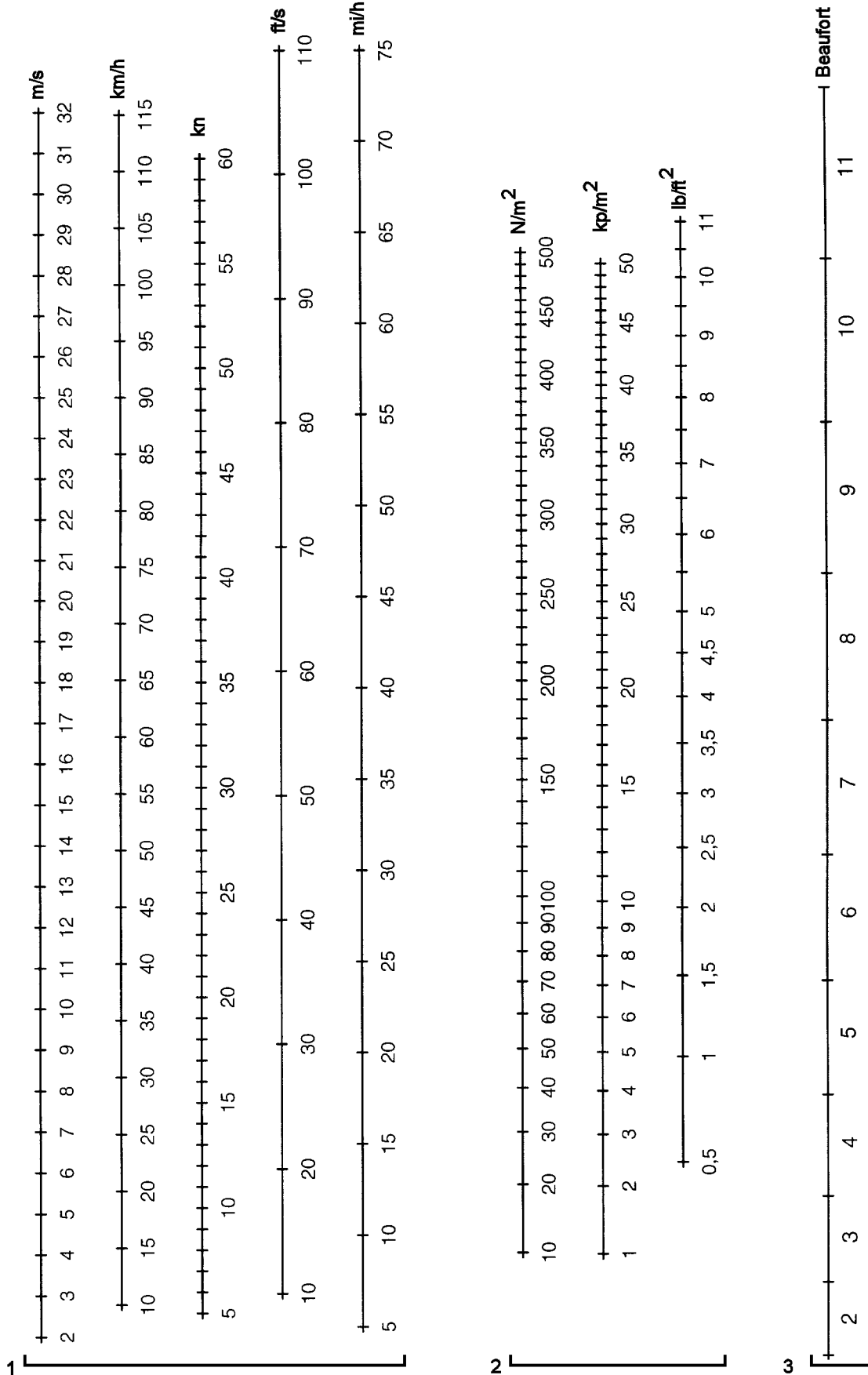

B106876

1 Wind speeds

2 Dynamic pressure

3 Wind velocity

19.1 Conversion chart for wind velocity and dynamic pressure



Note

► The wind scales for the following conversion charts are in the adjacent graphic!

Wind speed					Dynamic pressure		
[m/s]	[km/h]	[kn]	[ft/s]	[mi/h]	[N/m ²]	[kp/m ²]	[lb/ft ²]
2	7.2	3.9	6.6	4.5	2.5	0.25	0.05
4	14.4	7.8	13.1	8.9	9.8	1.00	0.20
6	21.6	11.7	19.7	13.4	22.1	2.25	0.46
8	28.8	15.6	26.2	17.9	39.2	4.00	0.82
10	36.0	19.4	32.8	22.4	61.3	6.25	1.28
12	43.2	23.3	39.4	26.8	88.3	9.00	1.84
14	50.4	27.2	45.9	31.3	120.2	12.25	2.51
16	57.6	31.1	52.5	35.8	157.0	16.00	3.28
18	64.8	35.0	59.1	40.3	198.7	20.25	4.15
20	72.0	38.9	65.6	44.7	245.3	25.00	5.12
22	79.2	42.8	72.2	49.2	296.8	30.25	6.20
24	86.4	46.7	78.7	53.7	353.2	36.00	7.37
26	93.6	50.5	85.3	58.2	414.5	42.25	8.65
28	100.8	54.4	91.9	62.6	480.7	49.00	10.04
30	108.0	58.3	98.4	67.1	551.8	56.25	11.52
32	115.2	62.2	105.0	71.6	627.8	64.00	13.11

19.2 Conversion chart for wind force



Note

► The influence of the wind onto the surrounding is described clearly in the Beaufort wind chart below to provide an orientation for the crane operator!

Wind force		Wind speed		Effect of the wind Inland
Beaufort	Description	[m/s]	[km/h]	
0	Calm	0 to 0.2	1	Calm, smoke rises vertically
1	Slight air movement (draft)	0.3 to 1.5	1 to 5	Wind direction is shown only by observing the trail of smoke, not by the wind sock
2	Light breeze	1.6 to 3.3	6 to 11	Wind can be felt on the face, the leaves rustle, wind sock moves slightly
3	Gentle breeze	3.4 to 5.4	12 to 19	Leaves and small twigs in constant motion Wind extends a flag

Wind force		Wind speed		Effect of the wind Inland
Beaufort	Description	[m/s]	[km/h]	
4	Moderate breeze	5.5 to 7.9	20 to 28	Swirls up dust and loose paper, moves twigs and thin branches
5	Fresh breeze	8.0 to 10.7	29 to 38	Small deciduous trees begin to sway, whitecaps form at sea
6	Strong breeze	10.8 to 13.8	39 to 49	Thicker branches move; telephone lines begin to whistle, umbrellas are difficult to use
7	Near gale	13.9 to 17.1	50 to 61	Entire trees swaying; difficult to walk into wind
8	Gale force wind	17.2 to 20.7	62 to 74	Breaks branches off trees, impedes walking in open areas considerably
9	Gale	20.8 to 24.4	75 to 88	Minor damage to property (chimney caps and roofing tile are blown off)
10	Severe storm	24.5 to 28.4	89 to 102	Trees are uprooted, significant damage to property
11	Violent storm	28.5 to 32.6	103 to 117	Extensive, widespread storm damage
12	Hurricane	32.7 and more	118 and more	Major destruction

19.3 Wind influences during erection and take down



WARNING

The crane can topple over!

If a boom or a boom system is erected or taken down and the expected wind speeds are larger than the maximum permissible wind speeds according to the wind speed chart, then the crane can topple over and fatally injure personnel!

- ▶ If wind speeds are expected which are larger than the maximum permissible wind speeds for erection, then erection of the boom or erection of the boom system is prohibited!
- ▶ If wind speeds are expected, which are larger than the maximum permissible wind speeds for take down, then the boom or the boom system must be taken down immediately!

19.4 Wind influences in crane operation



WARNING

The crane can topple over!

Unforeseeable factors, such as sudden gusts of wind onto the crane and the load cannot be considered exactly in advance!

- ▶ Carry out a professional job planning with authorized and trained expert personnel!
- ▶ The authorized and trained expert personnel must have sufficient knowledge in the area of "Wind influences in crane operation"!

**Note**

- ▶ Calculation examples are included in the load charts. If you need further information, contact Liebherr-Werk Ehingen GmbH.

Depending on crane application, for example:

- 1.) Lifting of large surfaced loads.
- 2.) Working with long boom combinations.
- 3.) Erection and take down of boom combinations.

The crane operator must check with appropriate information sources about the expected wind speeds, at:

- 1.) The start of crane operation.
- 2.) Interruption of crane operation.
- 3.) Resuming crane operation.

**WARNING**

The crane can topple over!

If the crane is operated at wind speeds which are larger than the maximum permissible wind speeds according to the load chart, then the crane can topple over and kill personnel!

- ▶ If wind speeds are expected which are larger than the maximum permissible wind speeds for the equipped crane, then the attachments and the boom must be taken down!
- ▶ If wind speeds are expected which are larger than the maximum permissible winds speeds for crane operation, then it is prohibited to lift a load!

19.5 Wind influences when the “Crane is not in service”

**WARNING**

The crane can topple over!

If the crane is taken out of service in configured condition and the expected wind speeds are larger than the maximum permissible wind speeds according to the wind chart, then the crane can topple over and fatally injure personnel!

- ▶ If wind speeds are expected which are larger than the maximum permissible wind speeds for “Taking the crane out of service”, then the attachments and the boom must be taken down!
- ▶ Always take the boom down for safety reasons if weather conditions are unclear, see Erection and take down charts!

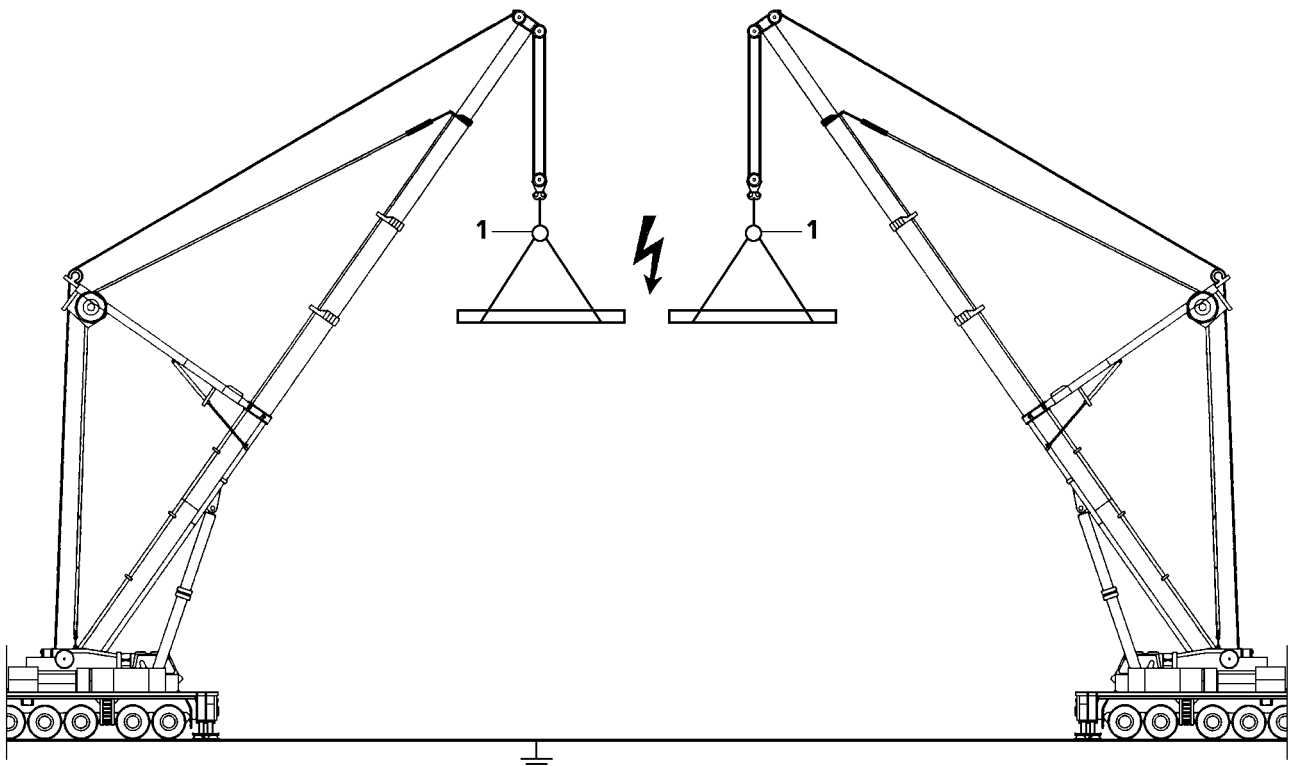
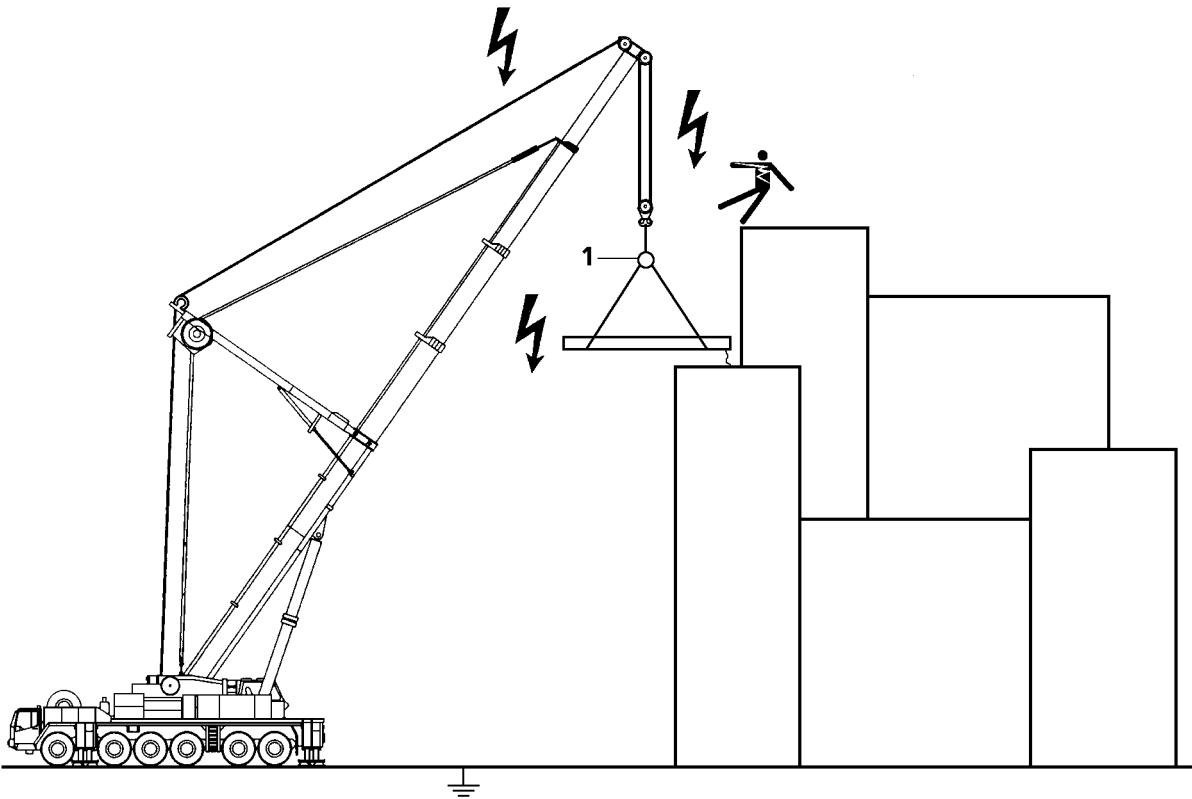

B189640

General example

20 Working in the vicinity of transmitters

Strong electromagnetic fields are likely to be present if the construction site is close to a transmitter. Electromagnetic fields can expose people and objects to direct and indirect risks, such as:

- Effect on human organs due to temperature increase.
- Combustion and ignition caused by temperature increases.
- Sparks or arcing.



DANGER

Risk due to electromagnetic fields!

- ▶ Before operating a crane in the vicinity of transmitters, be sure to consult with LIEBHERR!
- ▶ Also consult a high frequency specialist!

High frequency (HF) radiation from a transmitter requires supplementary work safety protection and special environmental specifications for crane operators and personnel:

- 1.) Each crane must be “fully” grounded. Check visually or with a simple tester to ensure that ladder, cab and cable pulleys are grounded.
- 2.) All personnel working on the crane or with large metal objects must protect themselves from burns by wearing non-conductive synthetic gloves and suitable clothing while working.
- 3.) There is no need to panic if you feel your hand warm up. Always work under the assumption that the respective workpiece, structural steel member or support is “hot”.
- 4.) The temperature of objects affected by high frequency radiation depends on their “size”. Cranes, carriers and coverings, for example, are “hotter”.
- 5.) Contact with other crane loads is not permitted when operating the crane (arcing). Since defects caused by burns considerably reduce rope carrying capacity, any such occurrences must be reported immediately to the machinery supervisor so that the ropes can be inspected.
- 6.) An insulator **1** is required at all times between the crane load hook and tackle. It is strictly prohibited to remove this insulator **1**.
- 7.) Do not touch the ropes above the insulator **1**.
- 8.) Loads that are attached to the crane may not be touched by any unprotected parts of the body after the load has been lifted or set down.
- 9.) Do not work with a bare upper torso or in short pants, this is prohibited.
- 10.) To minimize absorption of high-frequency radiation, larger loads should be transported horizontally if possible.
- 11.) Loads must be grounded, or additional insulation used (rubber material between the object and gloves) when manual work is required.
- 12.) Use a suitable measuring instrument to check the “Temperature” of the workpiece.
For example, if 500 V can be measured on a tool at a distance of 1 cm - 2 cm, then the tool may not be touched with bare hands.
The greater the distance, the higher is the voltage on the object:
At 10 cm distance, approx. 600 V are present, at 30 cm distance approx. 2000 V are present.
- 13.) When refueling the crane, it must be ensured that no sparks are created within a radius of 6 m, neither by handling larger metallic parts nor by other work.
- 14.) To avoid secondary accidents, use personal protective equipment when working on components that are high off the ground.
- 15.) Any accidents and unexpected events must immediately be reported to the local construction supervisor and the safety engineer.

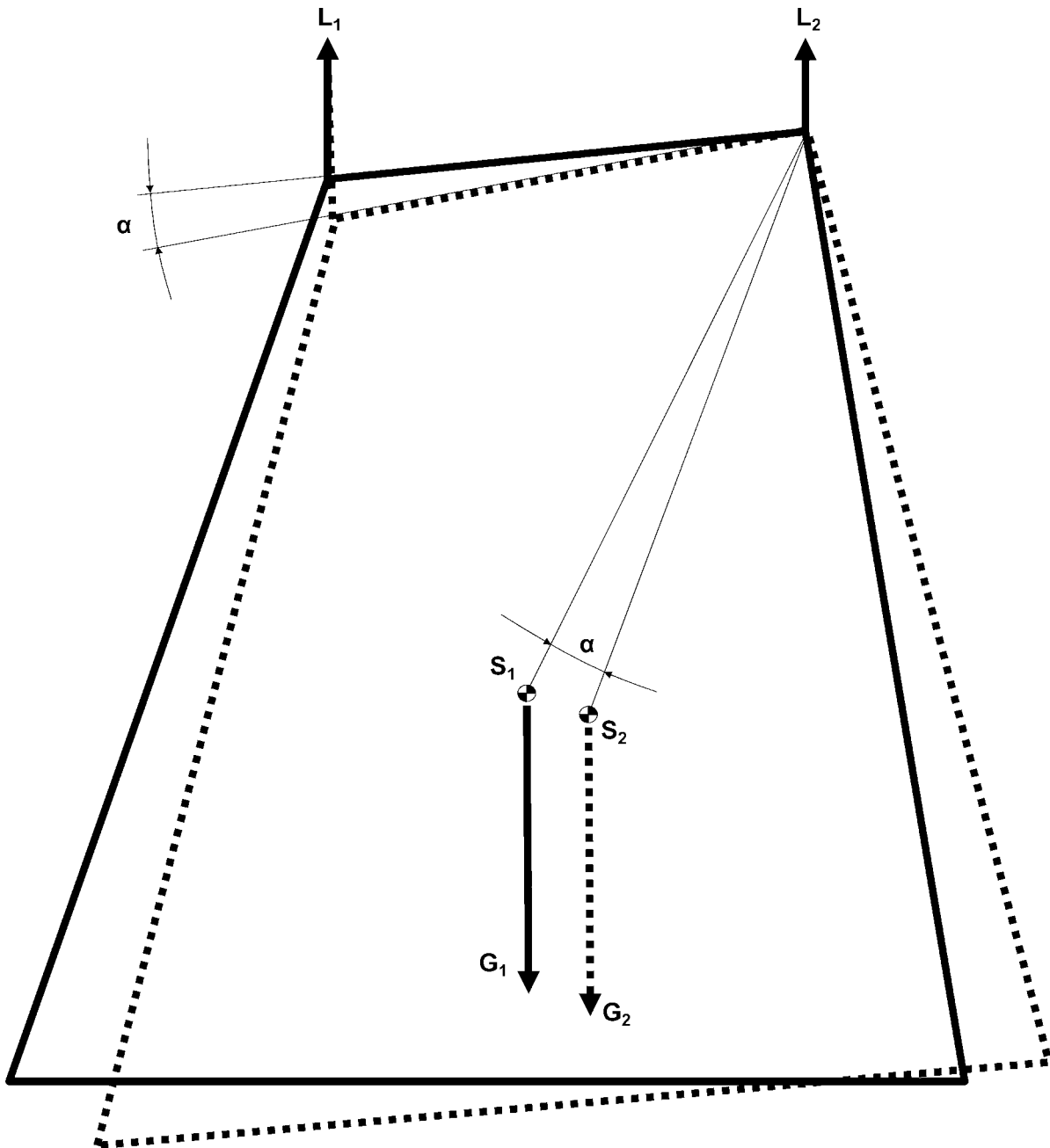

B111731

L_1 = Load on crane 1
 L_2 = Load on crane 2

α = Angle of incline position
 S_1 = Center of gravity of load

S_2 = Center of gravity of load at
 incline position

21 Dangers when working together with several cranes

21.1 Joint lifting of a load with two cranes

Before lifting a load jointly with two cranes, the operator of the cranes or a representative of the operator must determine the work sequence and assign a responsible supervisory person for the operation. The responsible supervisory person must monitor the operation.



Note

- ▶ The total weight and the center of gravity of the load must be known exactly!
- ▶ Carry out the job planning in detail and with care!

When the operational conditions or the work to be carried out require:

- ▶ Set up an assembly plan and operating instructions for the operation!



WARNING

Danger of tipping and overload of load carrying components!

If the load is not lifted or lowered exactly evenly by both cranes, then the center of gravity changes. One of the two cranes can be overloaded and topple over!

Personnel can be killed or seriously injured!

- ▶ Observe the national valid standards, regulations and accident prevention guidelines!
- ▶ Determine the utilization degree of the cranes in operation, depending on the complexity of the load lift!
- ▶ Plan for sufficient safety reserves!
- ▶ Utilize the load values given in the load chart manual for the used crane configuration to no more than the utilization degree of maximum 80 %!

In drawing is shown how the center of gravity for the load changes if the load is lifted or lowered unevenly. Even a slight incline of the load can cause the crane to be overloaded!

If the load on crane 1 (L_1) is lowered, the load on crane 2 (L_2) increases. As a result, crane 2 can be overloaded as a result of the load reduction of crane 1, without any action of its own!

21.2 Working ranges of several cranes overlap



WARNING

Risk of collision!

If the working ranges of several cranes overlap, there is a danger of collision!

Personnel can be injured or killed!

Significant property damages can result!

- ▶ The contractor or his representative must determine the work sequence in detail in advance!
- ▶ The contractor or his representative must ensure flawless communication between crane operators!
- ▶ The crane operators must ensure through calm operating mode, that no collisions occur due to uncontrolled movements! They must have been trained and instructed accordingly.

If the communication between the crane operators is not ensured by sound or visual connection, then suitable measures must be taken, such as using radio communication, guides or similar.



Note

- ▶ If guides are used, then the respective signals must be agreed upon between them and the crane operators. See Crane operating instructions, chapter 2.04 section "Hand signals for guidance"!

22 Hand signals for guidance

For all crane movements, the crane operator must always keep the load, as well as the crane hook or loading equipment when the crane is not loaded, in his field of vision.



WARNING

Risk of accident due to standing under swaying loads!

- ▶ Always keep loads in sight!
- ▶ Standing under swaying loads is not permissible!

If this is not possible, the crane operator may only operate the crane if he is signed by an assigned guide.

The operator may be guided by hand signals or a two-way radio. It must be ensured that there are no misunderstandings.



WARNING

Danger of accident caused by misunderstood hand signals!

- ▶ Hand signals must be mutually agreed upon and clearly executed!
- ▶ In any case, **national regulations** must be observed!

22.1 General hand signals

22.1.1 Start operation

(follow my instructions)

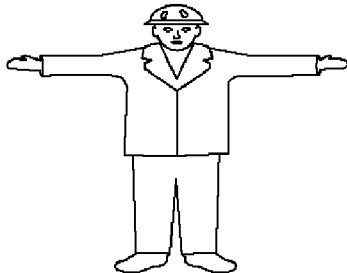

Both arms stretched out horizontally with hands open and palms directed to the front.

22.1.2 Stop

(normal stop)



Lift one arm overhead with open hand and palm directed to the front.

22.1.3 Emergency stop

(quick stop)

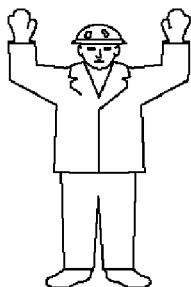

Lift both arms overhead with open hands and palms directed to the front.

22.1.4 End operation

(no longer follow my instructions)

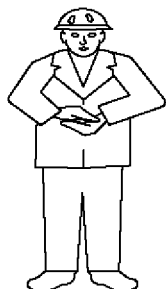

Fold hands together at chest height in front of body.

22.1.5 Inching gear or very slow movement

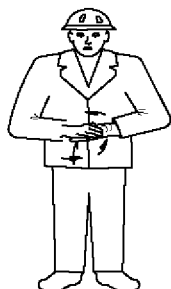

Rub palms together in circular motion. After this sign, all other applicable hand signals apply.

22.2 Vertical movements

22.2.1 Show the vertical distance

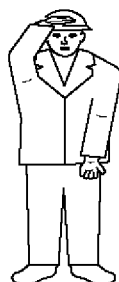

Both arms stretched out in front of the body one on top of the other, with opposing palms.

22.2.2 Lift / lower a load with even speed



Lift one arm overhead with closed hand and index finger pointing upward, with small horizontal circular movements with forearm.

22.2.3 Lift slowly



Give lift signal with one hand, the other palm is not moving and positioned over the hand, which gives the signal.

22.2.4 Lower the load while stationary

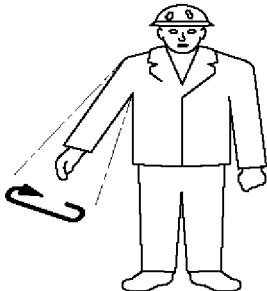

Point one arm away from the body, downward, with hand closed and index finger pointing down. Make small circular movements with forearm.

22.2.5 Lower slowly

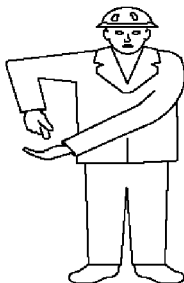

Give lowering signal with one hand, do not move the other palm and hold it under the hand, pointing to the hand which gives the signal.

22.3 Horizontal movements

22.3.1 Move / swing in given direction

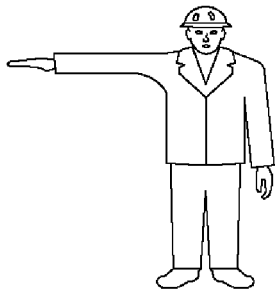

Hold stretched out arm horizontally into the desired direction, with the hand open and the palm pointing down.

22.3.2 Move away from me

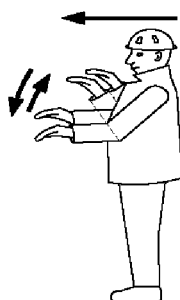

Stretch out both arms simultaneously with forearms in front, with both hands open and the palms pointing down. Move the forearms repeatedly between the horizontal and vertical position up and down.

22.3.3 Move toward me

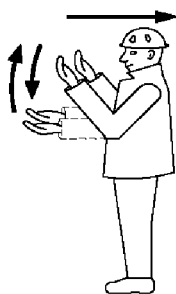

Stretch out both arms simultaneously with forearms vertically, with both hands open and the palms pointing to the rear. Move the forearms repeatedly up and down.

22.3.4 Move both track chains

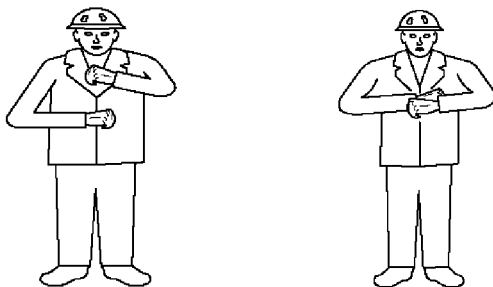

Turn both fists around each other in front of the body in direction of the movement (forward or reverse).

22.3.5 Move one track chain

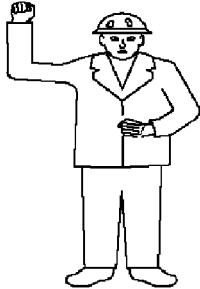

Lift one fist to show blockage of chain on one side. Turn the other fist vertically in front of the body to signal movement of the opposite chain.

22.3.6 Show the horizontal distance

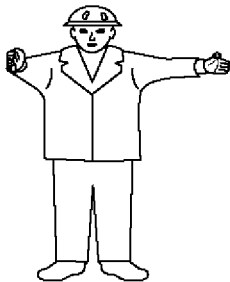

Keep both arms stretched out horizontally in front of the body with the palms opposite each other.

22.3.7 Transfer (between two cranes or two hooks)

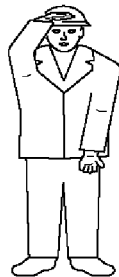
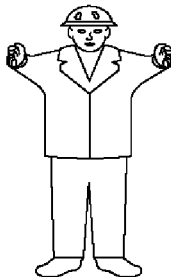

Hold both arms stretched out to the front, parallel and horizontally and turn by 90° in direction of the transfer.



WARNING

Danger of toppling the crane!

- ▶ Make sure that the load carrying capacity of the individual crane or hook is sufficient even if the transfer of the load is suddenly asymmetric!

22.4 Machine related movements

22.4.1 Lift with main winch

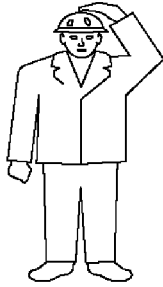

Place one hand on your head and hold the other arm on the side of the body.
After this signal all other hand signals apply only for the main winch.



Note

- ▶ If two or more main winches are present, then the signaller can show the number of the crane by pointing to it or signal with one finger.

22.4.2 Lift with auxiliary winch



Hold one forearm vertically with closed hand and touch the elbow of this arm with the other hand.
After this signal all other hand signals apply only for the auxiliary winch.

22.4.3 Lift the boom

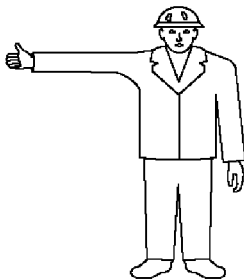

Hold one arm horizontally with thumb directed upward.

22.4.4 Lower the boom

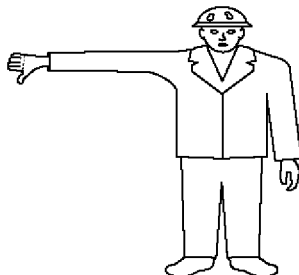

Hold one arm horizontally with thumb directed downward.

22.4.5 Extend the boom

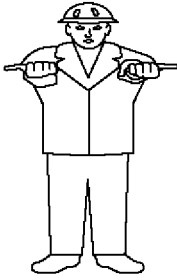

Hold both hands (with closed fists) stretched out to the front, with both thumbs directed away from each other.

22.4.6 Retract the boom

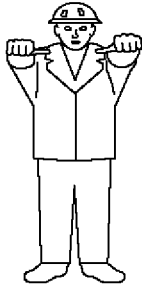

Hold both hands (with closed fists) stretched out to the front, with both thumbs directed toward each other.

22.4.7 Lift the boom and lower the load at the same time

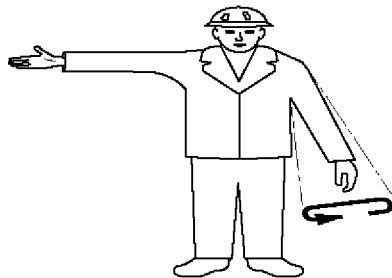

Hold one arm stretched out horizontally with thumb directed upward and stretch the other arm downward and away from the body, make small flat circles with the forearm.

22.4.8 Lower the boom and lift the load at the same time

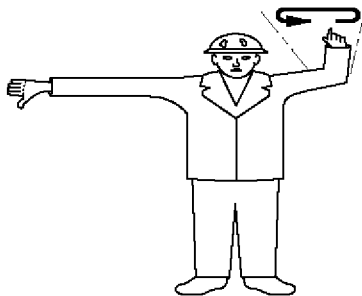

Hold one arm stretched out with thumb directed downward and close and open the fingers as long as the movement requires.

23 Crane operation with a load



WARNING

The crane can topple over!

If the crane is in condition which is **not** operationally safe, the crane can topple over or crane components can fall down!

Personnel can be severely injured or killed!

- ▶ Before starting to work, the crane operator must ensure that the crane is in operationally safe condition!
- ▶ If safe crane operation cannot be ensured by the crane operator, then crane operation is prohibited until an operationally safe condition for the crane is established!
- ▶ Safety devices, for example: Load moment limiter, hoist limit switch, brakes must be fully functioning, otherwise crane operation is prohibited!

Make sure that the following prerequisites are met:

- The load moment limiter must be set according to the current crane configuration.
- The loads given in the load chart may not be exceeded.
- The crane may never be subjected with a load which exceeds those specified in the load charts.
- The weight, center of gravity and dimensions of the load to be lifted must be known.
- Load carriers, lifting equipment and tackle must be in accordance with specified requirements.



Note

- ▶ Make sure that the weight of the hook block and the weight of the tackle is subtracted from the load given in the load chart, see the following chart!

Example:		
Maximum permissible load according to chart		30.000 t
Weight of the hook block	350 kg	- 0.350 t
Weight of the fastening rope	50 kg	- 0.050 t
Actual load capacity of the crane		= 29.600 t

The weight of the load to be lifted, in this example, may not exceed **29.6 t**.

23.1 Counterweight

The counterweight required depends on the weight of the load to be lifted and the radius required to do the work. The deciding factor for the selection of the counterweight is the data in the corresponding load chart.



WARNING

The crane can topple over!

If the counterweight is not attached in accordance with the load chart, the crane can topple over and fatally injure personnel!

- ▶ Install the counterweight in accordance with the load chart!

23.2 Hoist gear, hoist rope

The lifting capability of the crane depends on the pull force of the hoist gear and the number of possible hoist rope reevings. When working with a single strand, the crane can only lift as much of a load as the hoist gear is able to pull.

If the load to be lifted is heavier than the pull force of the hoist gear, then the hoist rope must be reeved as needed according to the principle of a pulley between the pulley head on the boom and the hook block.

When reeving, carefully observe the load chart specifications and the operating instructions.



WARNING

Hoist rope failure!

If the maximum pull force of the hoist gear is exceeded, the hoist rope can break or the hoist gear can be damaged!

The load can fall and kill personnel!

- ▶ Never exceed the rated pull force of the hoist gear!
-

23.3 Crane operation



DANGER

There is a high risk of accidents should the following points not be observed!

► It is imperative to comply with the following instructions.

High accident risk exists if:

- 1.) The load torque limiter is not set in accordance with the current crane configuration and is therefore not able to provide proper protection.
- 2.) The load torque limiter is defective or taken out of operation.
- 3.) The hoist limit switches are defective or not functioning.
- 4.) On crawler cranes:
The angle sensor and the force test brackets are not functioning.
- 5.) On mobile cranes:
The sliding beams of the hydraulic supports are not extended to the dimensions specified in the load chart.
- 6.) On crawler cranes:
The crawlers are not supported with stable base material sufficiently large for the ground conditions.
- 7.) On mobile cranes:
The support plates are not supported with stable base materials sufficiently large for the ground conditions.
- 8.) If the load is pulled at an angle.
Angular pulling to the side is particularly dangerous, because the boom has only minimal lateral moment of resistance.
It is prohibited to pull a load at an angle.
- 9.) Load attached during disassembly is too heavy and is freely suspended on the crane after release.
- 10.) The load hook is used to break away stuck loads.
Even if the weight of the load which is stuck is no greater than the permissible lifting load, the crane may topple over backwards if the load is suddenly freed since the tension created in the boom can cause it to jerk back violently.
- 11.) When working when the wind is excessively strong.
Observe the data given in the load chart.
- 12.) The crane is not aligned horizontally and the load is swung toward the slope.
- 13.) Improper crane movements cause the suspended load to swing like a pendulum.
- 14.) The loads and radii specified in the load charts are exceeded.
- 15.) When working in the vicinity of power cables which are not isolated by electricity engineers or if the hazardous area is not covered or fenced off.
If it is not possible to take such measures, a sufficient safety distance must be maintained:

Rated voltage	Minimum distance
Up to 1 kV	1 m
More than 1 kV to 110 kV	3 m
More than 110 kV to 220 kV	4 m
More than 220 kV to 380 kV	5 m
When rated voltage is not known	5 m

**WARNING**

Danger of current transfer!

If, despite all precautions having been taken, a flashover occurs, carry out the following procedure:

- ▶ Remain calm!
- ▶ Do not leave the crane operator's cab!
- ▶ Warn those around the crane not to move and not to touch the crane!
- ▶ Move the crane away from the danger area!

24 Lifting of personnel

24.1 Generally valid instructions:

**Note**

- ▶ The destined use of the crane is **lifting of loads!**
- ▶ **Lifting of personnel is not** considered to be destined use of the crane!
- ▶ The **national laws and regulations for lifting personnel** must be adhered to!

**DANGER**

Danger of accidents or falling!

When lifting personnel, the dangers of accidents and falls are significantly increased. Accidents which occur when lifting personnel often result in severe injuries or even death!

The company, the supervisor, the crane operator and auxiliary personnel must proceed especially carefully and safety conscious!

The following warning notes and safety regulations must be strictly observed!

- ▶ Lifting of persons with personal lifting devices is only permitted for the assembly, the use and the removal, if the user can prove that reaching the work area by conventional means, for example: Via elevator, ladder, steps, lift, aerial platform or scaffolding is dangerous or due to the structural design of the project or the work place condition is not possible!
- ▶ Lifting of persons is only permitted with personal lifting devices, which have been designed for lifting personnel and which were tested and approved!
- ▶ The personal lifting device may only be fastened on a hoist gear, which is equipped with a "Device for emergency operation"!
- ▶ When lifting personnel, the total load, including personal lifting devices, load lifting devices and load hook may only be 50 % of the nominal load for the respective condition of the valid load charts!
- ▶ The reeving must be handled in such a way that the rope pull with personal lifting devices, load lifting devices and load hook does not exceed 50 % of the maximum rope pull!
- ▶ The crane operator may not leave the crane operator's cab while lifting personnel with the crane!
- ▶ The person being lifted must be in radio contact with the crane operator!
- ▶ The rescue of person(s) in the personal lifting device must be planned in advance in case it is necessary in an emergency!
- ▶ As long as person are lifted, the crane may not be used for other purposes!
- ▶ The job planning for crane operation, where personnel is to be lifted must be made especially carefully!
- ▶ Check the load bearing capacity of the ground especially carefully!
- ▶ Lifting personnel may only be carried out by authorized and trained expert personnel!
- ▶ Unauthorized persons must remain outside the danger zone!
- ▶ Carry out all crane movements especially carefully and smoothly!
- ▶ The **persons to be moved** must secure themselves with personal protective equipment (for example safety harnesses) to protect them from falling from the movement devices!

- ▶ Do **not** step on lifted loads or lifted tackle!
- ▶ The **crane operator** may **not** move personnel with the load or the load tackle!
- ▶ Before using the safety devices of the crane, check them for proper function! This applies especially for the hoist limit switch and the load moment limitations! But all other crane functions must also be in proper condition!
- ▶ The crane must be equipped in such a way that personnel can exit the personnel lifting device without danger in case of a power failure or if the control of the personnel lifting device cannot be returned to the initial position!
- ▶ The national laws and regulations for lifting personnel must be adhered to!

24.2 In addition, the following applies for Germany:



Note

- ▶ In Germany, **lifting of personnel** under observation of the safety regulations for “Liftable personnel lifting devices” of the trade associations (Berufsgenossenschaften) BGR 159 is permissible!



DANGER

Danger of accidents or falling!

The following warning notes and safety regulations must be strictly observed!

Moving personnel and personnel lifting devices and working with these personnel lifting devices is approved and monitored by the national occupational health and safety agencies, in Germany the trade association (Berufsgenossenschaft)!

- ▶ Observe the safety regulations and guidelines of the national occupational health and safety agencies!

Additional obligations of the company:

- Report the operation of the lifting device to the appropriate trade association.
- Determination of supervisor.
- The operator of the lifting device must be familiar with the tasks.
- The contractor may not assign other tasks to the lifting device operator and the guide while personnel is being lifted.
- The contractor must make lifting devices with sufficient load carrying capacity available.
- The contractor must provide personal protective equipment (such as safety harnesses).
- Liftable personnel lifting devices must be inspected before the initial use and after significant changes by an expert before putting them back into service:
 - Carry out trial runs in the presence of the supervisor.
 - Regular inspections at least once a year.
 - Record and save proof of inspections.

25 Crane operation in case of thunderstorms

In weather conditions, which can include lightning:

- Stop work on the crane.
- If possible, place the load down.
- If possible, telescope the boom in or put it down and bring it into a safe condition.

If this is not possible, the crane operator's cab must remain occupied to keep the crane and the load always under control.



WARNING

Danger of accidents due to lightning strikes!

- ▶ Make sure that there are no persons near the immediate area of the crane.

26 Safety instructions for external power supply (230 V AC)

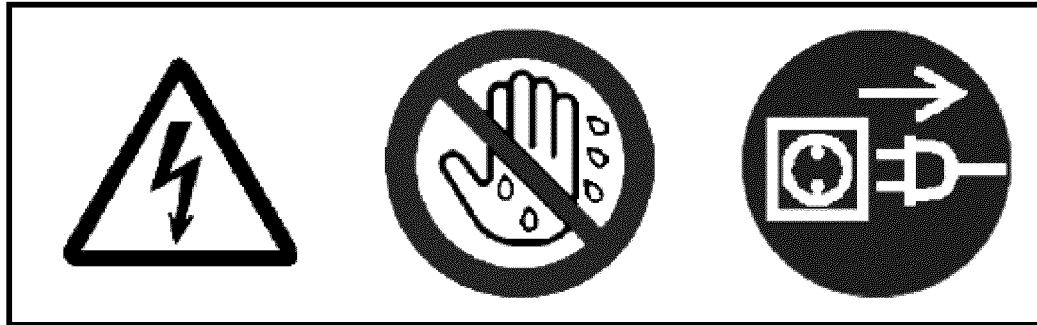

A potential hazard exists when supplying a crane with external power from a low voltage distribution system (230 V AC).

In particular, the following conditions pose an electrical hazard: touching a crane with open grounds (caused by the mechanical stress on flexible supply cables or the service connection), loose terminal connections, high wire or contact resistance, mixed up conductors, defective or missing protective equipment (fault interrupters) in combination with a body contact on the crane.



WARNING

Danger of fatal injury if the body conducts current!

Water and / or defective devices can cause hazardous stray voltages when touched. The person touching the crane is subject to lethal currents.

- ▶ The external supply cable must be in good working order!

Make sure that the external flexible supply cable is in good working order.

Where applicable, we recommend the use of an isolation transformer.

27 Welding work on the load



Note

- ▶ The load must additionally be grounded.

In case of welding work on the load, the screw clamp of the welding unit must be attached on the welding piece to avoid current flow via hoist rope, crane superstructure or crane chassis.

28 Interruption of crane operation

28.1 Interrupting crane operation

If the crane operator must leave an equipped crane, then it must be ensured that there is no danger for the crane or its surrounding area in case of an unforeseen event.



WARNING

Risk of fatal injury!

Situations may occur which could cause the crane to become unsafe if left unsupervised.

This could cause the crane to topple over, resulting in major personal injury and property damage.

► Always keep the crane under full control!

Incidents which could occur (for example):

- The ground giving way due to severe rain
- Melting ice under the supports
- Bad weather, storms, thunderstorms
- Landslides
- Wash outs
- On mobile cranes:
 - Support cylinder failure
- On cranes with telescopic boom:
 - Luffing cylinder failure
- Vandalism

Make sure that the following prerequisites are met:

- There is no load on the hook.
- The crane poses no traffic obstacle.



Note

► If crane work must be interrupted if the crane is equipped, then it must be ensured that measures are initiated in time by trained, qualified personnel, to bring the crane into a safe condition in case something happens.



DANGER

Risk of accident!

► If it is not possible to maintain full control over a rigged crane, the machinery and boom must be taken down.

29 Resuming crane operation

29.1 Resuming crane operation

When resuming crane operation, the crane operator is required to check the condition of the crane and the safety devices.



WARNING

Risk of accident!

► If the crane operator leaves the cab, even for a short time, the operating mode setting must be checked and reset, if necessary, before resuming crane operation.

► Check operating mode settings and reset, if necessary.

30 Ending crane operation

30.1 Ending crane operation

Before the crane operator may leave the crane, the following prerequisites must be met:

- ▶ Place the load fully on the ground and unhook from the crane hook.
- ▶ On cranes with telescopic boom:
Telescope the telescopic boom all the way in and place the boom down.
- ▶ On cranes with lattice mast boom:
Put down lattice mast boom and disassemble if necessary.
- ▶ Bring the control lever (master switch) to 0-position.
- ▶ Apply the parking brake on the crane chassis.
- ▶ Turn the engine off and pull the ignition key.
- ▶ On mobile cranes:
Secure the mobile crane to prevent unauthorized use. Make sure that the crane operator's cab and driver's cab are not occupied. Lock the crane operator's cab and driver's cab.
- ▶ On mobile cranes:
Secure the crane to prevent it from rolling off. See paragraph "Parking the vehicle".

31 Turning / driving in reverse



WARNING

Danger of accidents when turning or driving in reverse!

When turning or driving in reverse, personnel can be overlooked or killed!

Objects can be severely damaged!

- ▶ When turning or driving in reverse, the driver must act in such a way that he does not endanger other traffic participants!
- ▶ The driver may drive only in reverse or move back when it is ensured that persons or equipment are not endangered! If this cannot be ensured, then he must use a guide.
- ▶ An acoustical back up warning device will never replace the guide!
- ▶ Make sure that there are no persons or objects behind the vehicle when driving in reverse!
- ▶ Make sure that no personnel is injured or killed!
- ▶ Make sure that no objects are damaged!
- ▶ Driving in reverse is only permissible at slow driving speed (maneuvering speed)!
- ▶ Adhere to the national regulations!

32 Parking the vehicle



Note

- ▶ The "Parking the vehicle" section is only to be observed for mobile cranes!

**WARNING**

Danger of accidents if the vehicle rolls off!

If the following points are disregarded by the crane driver, then personnel can be fatally injured.

- ▶ It is prohibited to park the vehicle at a slope or an incline of more than 18 %.
- ▶ The parking brake must always be applied when parking the vehicle.
- ▶ The ground on which the vehicle is parked must be level and have adequate load-bearing capacity.

Make sure that the following prerequisites are met:

- The vehicle is standing on level ground with sufficient load bearing capacity.
- The parking brake is applied.

**WARNING**

The vehicle can roll off uncontrollably!

Under the following conditions, the vehicle must be secured against rolling away by using the specified number of wheel chocks or wedges - in addition to the parking brake:

- ▶ The vehicle is parked on a slope or an incline!
- ▶ The vehicle is defective, particularly if the brake system is defective!
- ▶ If all the specified wheel chocks are not placed directly behind the corresponding wheel, the vehicle may roll off uncontrollably and personnel can be fatally injured.
- ▶ All specified wheel chocks must be placed in such a way that they act against the downdrift force!
- ▶ Place all specified wheel chocks tightly directly under the wheel!
- ▶ Place all specified wheel chocks tightly so that they have an immediate braking action and keep the vehicle in parking position!

1

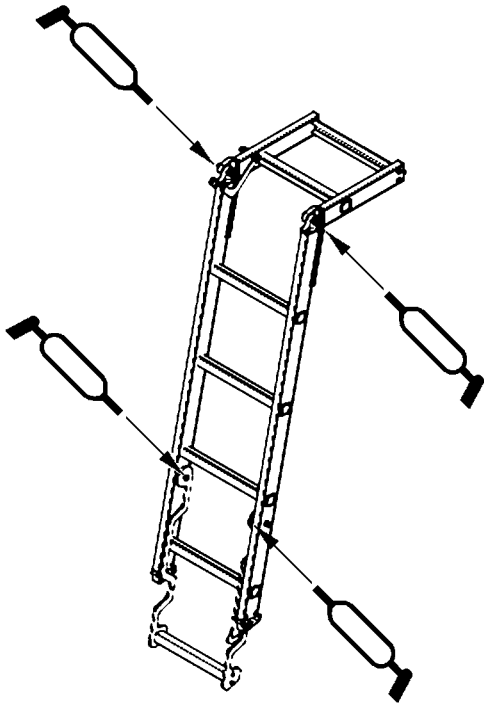

2

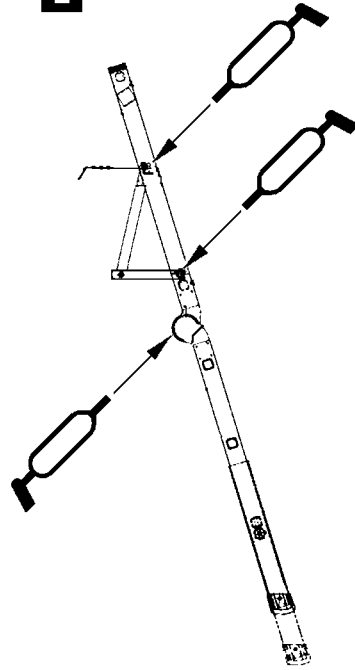

33 Safety guidelines for ladders

33.1 General

The ladders have been built according to the present level of technology and recognized safety technical regulations. Despite that, during their use dangers to life and physical condition of the user and / or third parties can occur. The ladders may only be used in a flawless technical condition and according to their missions as well as with constant awareness of safety and dangers. Changes on the structure may only be made with written approval of the manufacturer.

The ladders are exclusively designated for the entry and exit of personnel.

Any other use is not as intended.

The manufacturer is **not** liable for damages, which are caused by unintended use or improper usage.



WARNING

Risk of falling!

If the following safety guidelines are not observed, personnel can fall down and be killed or severely injured!

- ▶ Observe and adhere to the installation and safety guidelines for ladders!
- ▶ Observe and adhere to the safety signs on the ladders!
- ▶ Install and secure the ladders properly!
- ▶ Do not use damaged ladders and replace them immediately!
- ▶ Repairs on ladders may only be carried out by authorized expert workshops!

Before using the ladders, make sure that the following prerequisites are met:

- The ladders are hung and secured in the intended locations.
- The ladders are complete and not damaged (visual inspection).
- The legs of the ladders are not worn.
- Check the screws for tight seating and connection.
- The ladder may be subjected to a load of no more than one person or a maximum of 150 kg.

Before starting to drive / before transport, ensure that the following prerequisite is met:

- The ladders are tightly locked and secured in the intended transport retainers.

33.2 Maintenance



Note

- ▶ Grease joints and pivot points on the ladders regularly and check them for easy movement, see illustration 1 and illustration 2!
- ▶ Remove any dirt on the ladders!
- ▶ The ribbing on the rungs must be clear!

1

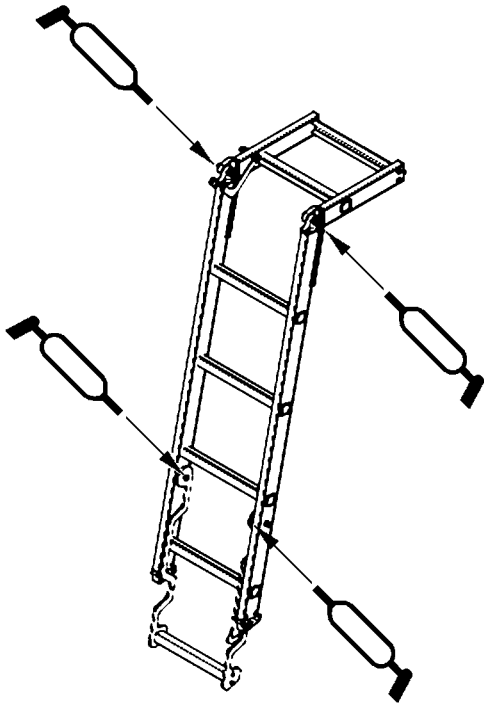

2

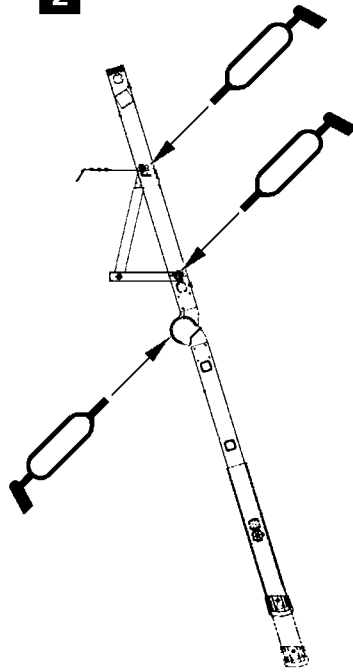











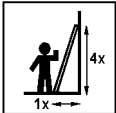



33.3 Safety signs on the ladders





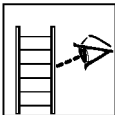



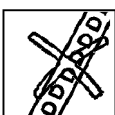

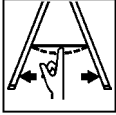

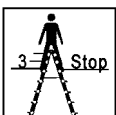

Note

- ▶ All safety signs on the ladders must be complete and always legible!
- ▶ The operating instructions of the manufacturer must be observed and adhered to.

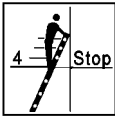
Signs	Explanation
	Read the operating instructions.
	Maximum load.
	Correct set up angle.
	Set up on level ground.
	Avoid leaning out to the side.
	Eliminate any contaminants on the ground.
	Set up on solid ground.

Signs	Explanation
	Ladder overhang over the set up point.
	It is not permitted to step off to the side from the ladder.
	Only one person on every accessible bracket.
	Visual inspection of the ladder before use.
	Do not use the ladder as a bypass.
	Do not stand on the top step.
	Check the legs of the ladder.
	When transporting the ladder, be aware of any danger due to overhead wires.
	Pay attention to correct set up direction.

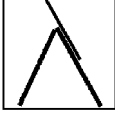
Signs	Explanation
	Face the ladder when climbing up or down the ladder.
	Before use, pay attention that the stepladder opens completely.
	Make sure the upper end of the ladder is placed correctly.
	Make sure that the safety strut engages.
	Maximum number of users on the ladder.
	Before use, make sure it is safely engaged.
	Correct access.
	When climbing the ladder, wear suitable shoes.
	Stepladders: Access the ladder to no more than the third step from the top - without railing.

Signs	Explanation
	<p>Leaning ladders: Access to no more than the fourth step from the top.</p>
	<p>Universal ladders: Access to no more than the fifth step from the top.</p>
	<p>Access the ladder only when sober.</p>
	<p>Eliminate damaged ladders immediately.</p>
	<p>Total weight of the ladder.</p>
	<p>Illustration of ladder type with maximum length.</p>
	<p>Secure the upper / lower end of the ladder.</p>

blank page!

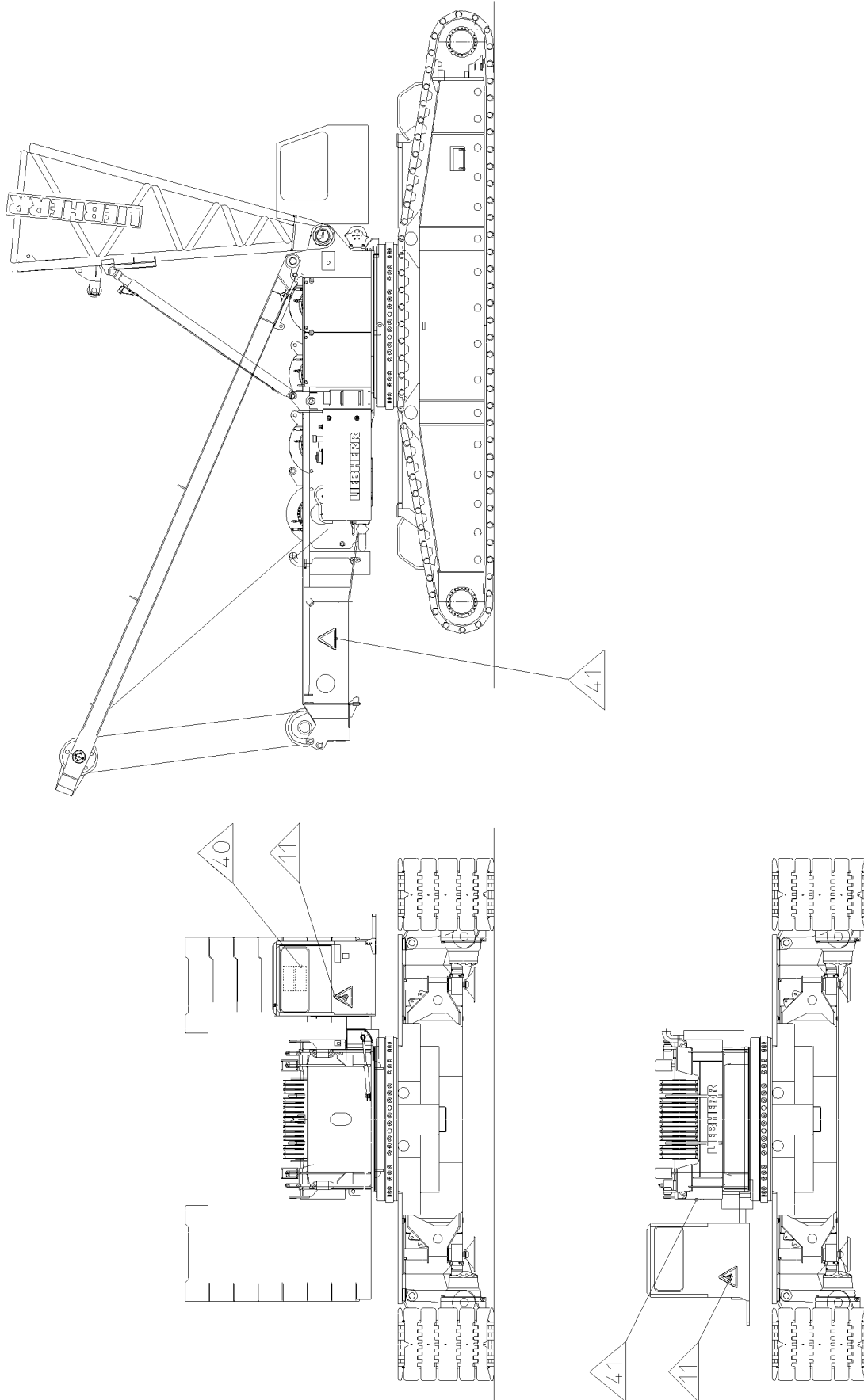

B108902

1 Warning signs

**Note**

- ▶ Warning signs are safety signs, which warn of a risk or danger!
- ▶ For that reason, all warning signs on the crane must be complete and always legible!
- ▶ Replace damaged warning signs immediately!

1.1 Warning of suspended load (position 11)

**DANGER**

Risk of fatal injury under suspended load!

- ▶ Standing under suspended loads is prohibited!
- ▶ Keep away from the working range of the machine!

1.2 Warning of high voltage (position 40)

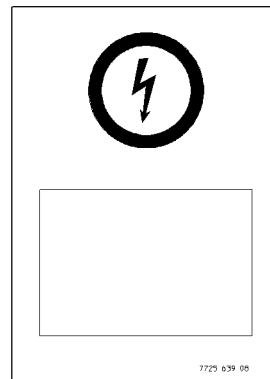
**Note**

- ▶ Only for certain countries!

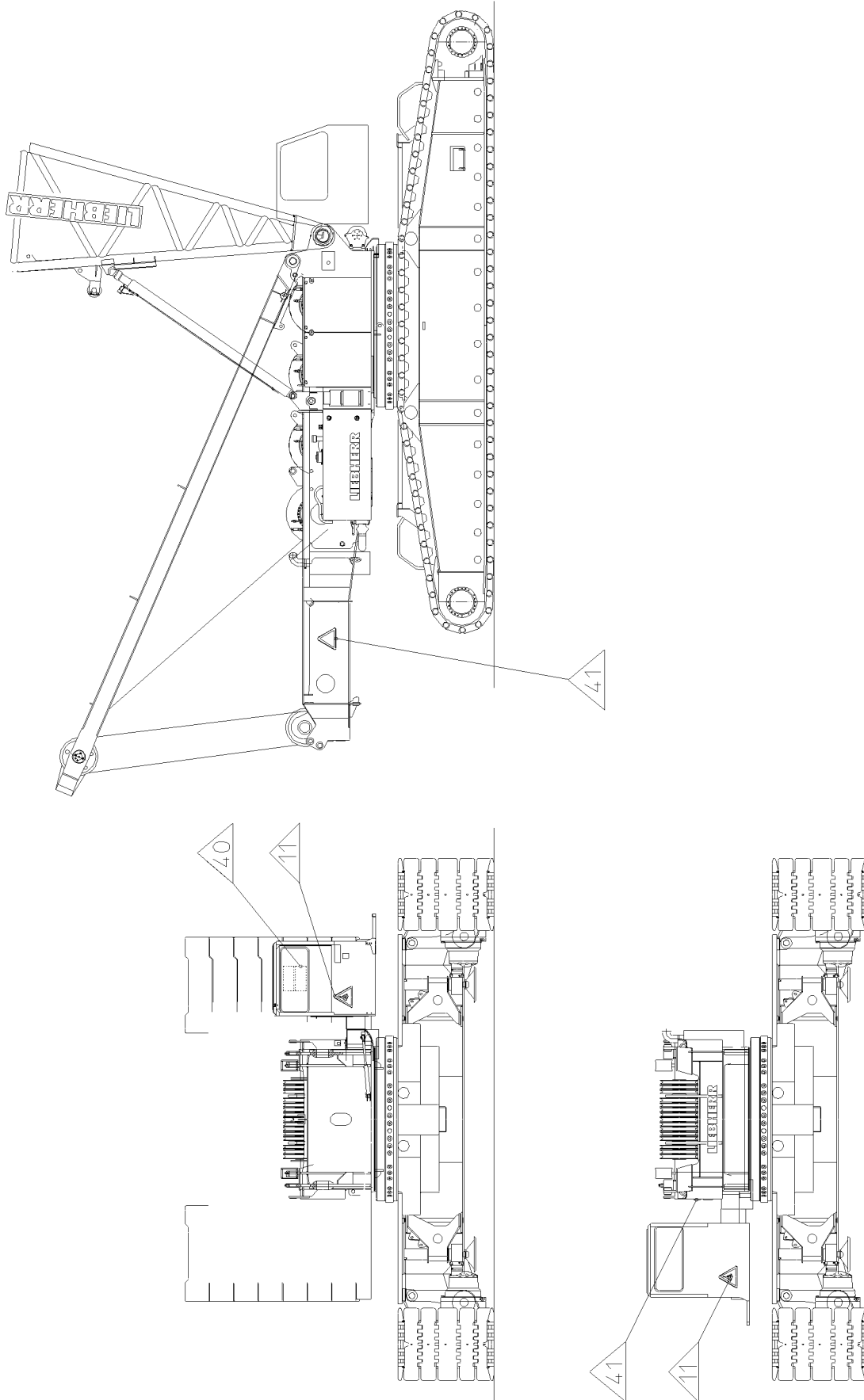

B108902

1.3 Slewing range (position 41)

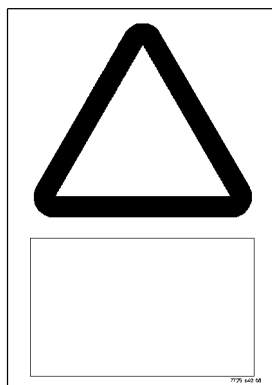

Note

▶ Only for certain countries!

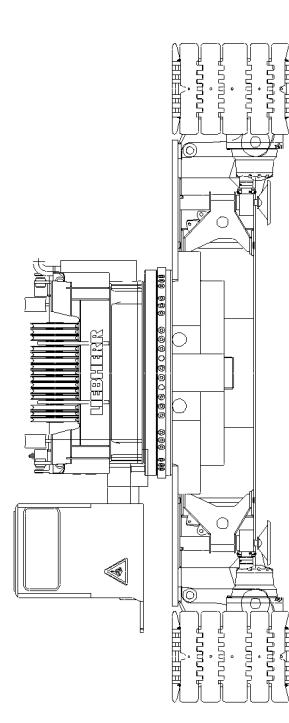
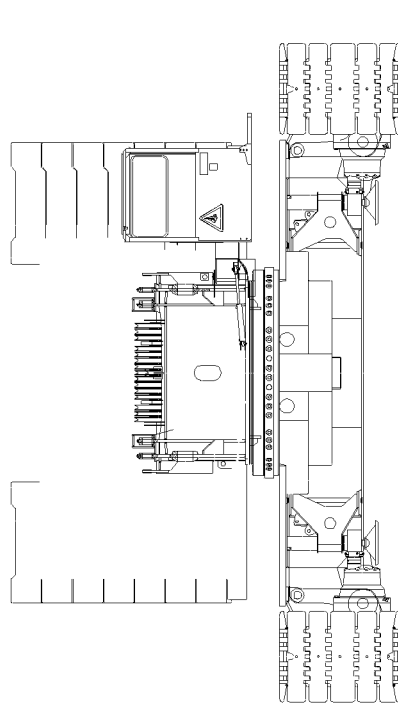
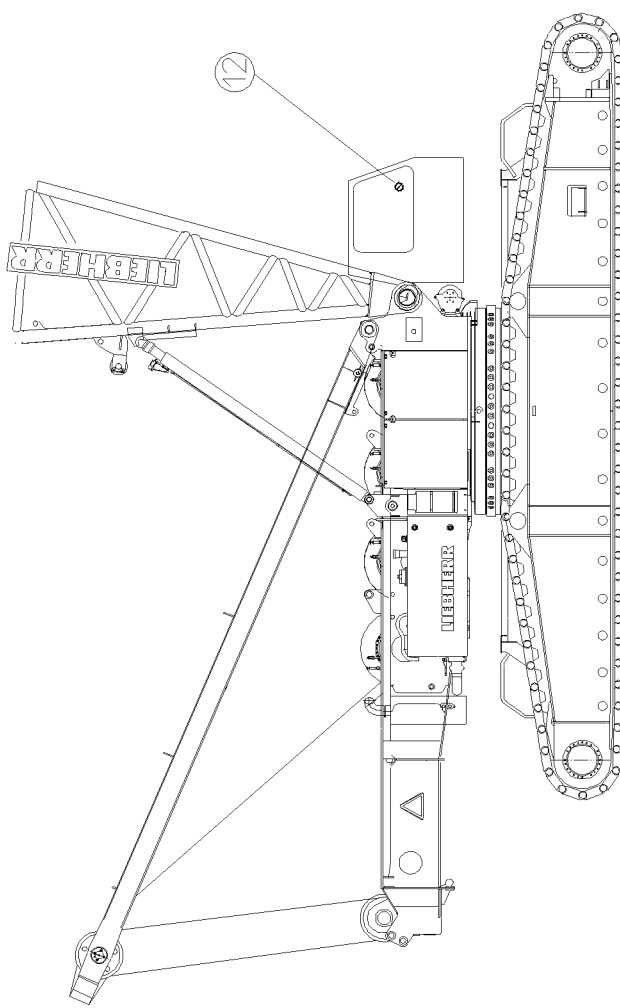

B108903

2 Command and prohibition signs

2.1 Prohibition signs

**Note**

- ▶ Prohibition signs are safety signs, which prohibit a behavior, which could result in danger!
- ▶ For that reason, all prohibition signs on the crane must be complete and always legible!
- ▶ Replace damaged prohibition signs immediately!

2.1.1 Access for unauthorized personnel prohibited (position 12)

**DANGER**

Risk of fatal injury!

If the crane is accessed by unauthorized personnel, life threatening injuries can occur!

- ▶ Access is strictly prohibited during crane operation!

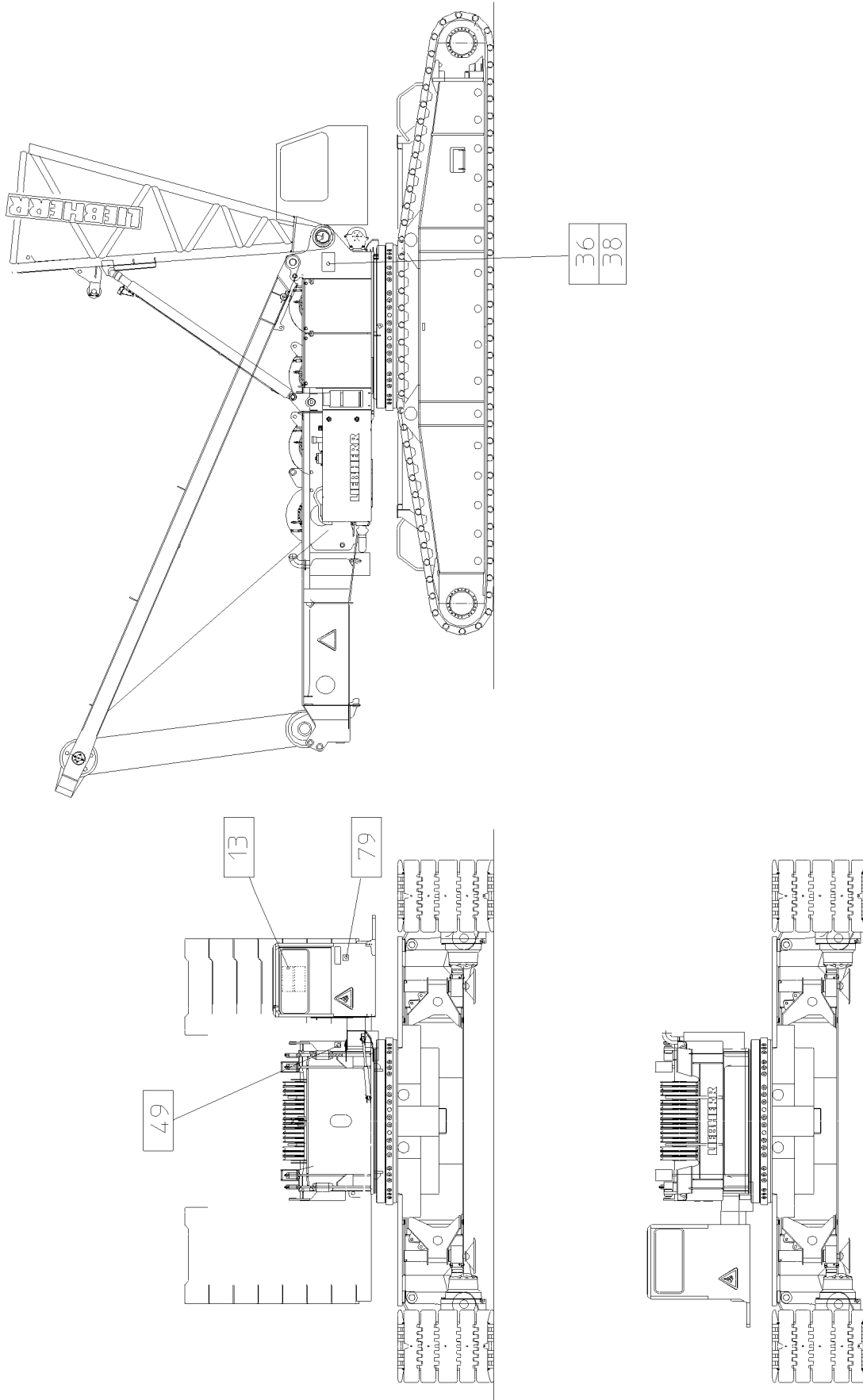

B108904

3 Notice signs



Note

- ▶ Notice signs are signs, which provide additional notes in text form and a pictogram!
- ▶ For that reason, all notice signs on the crane must be complete and always legible!
- ▶ Replace damaged notice signs immediately!

3.1 Operating instructions for cranes (position 13)



Note

- ▶ Only for certain countries!
- ▶ Read and observe the operating instructions before operating the crane!

3.2 Transport weights of components (Position 36)

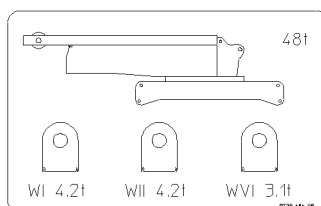

3.3 Transport weights of components (Position 38)

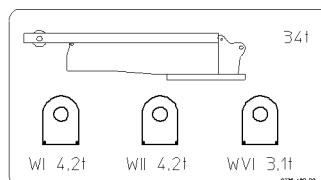

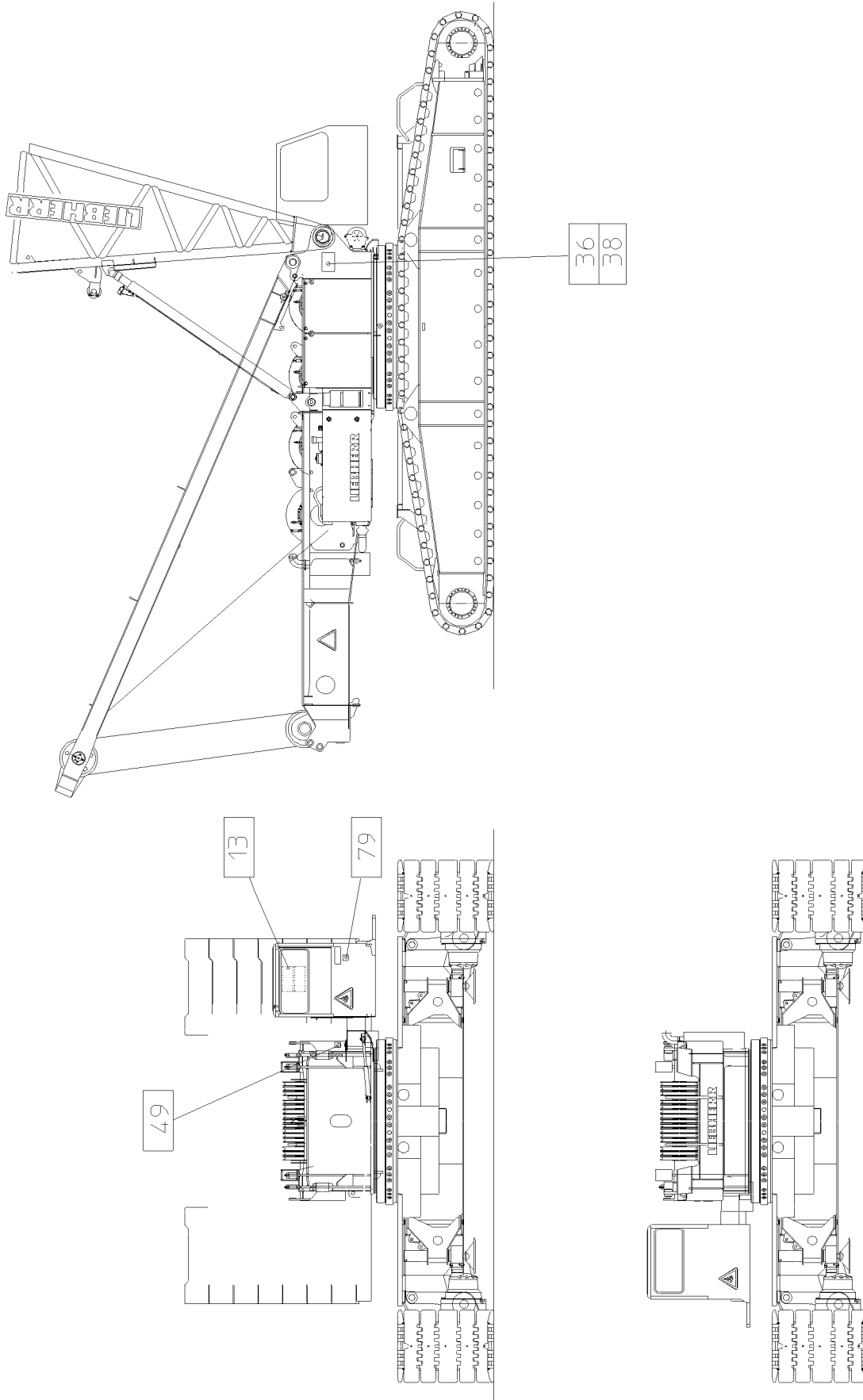

B108904

3.4 Notice sign for refueling (position 49)

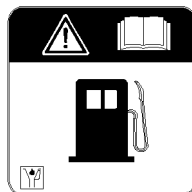

CAUTION

Property damage to the engine!

If the crane is refueled with fuel not specified in the operating instructions, then engine damage can occur!

► Observe the operating instructions!

3.5 Warranted maximum sound output level (position 79)

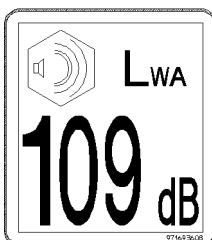

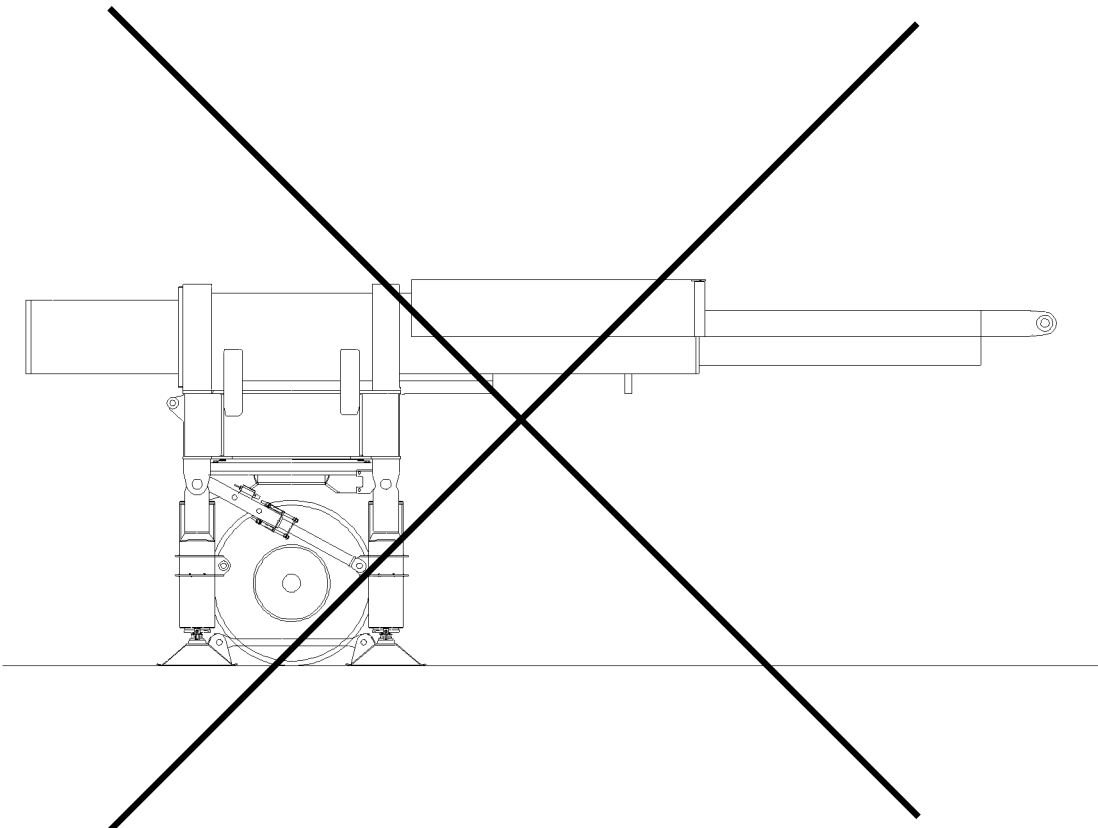
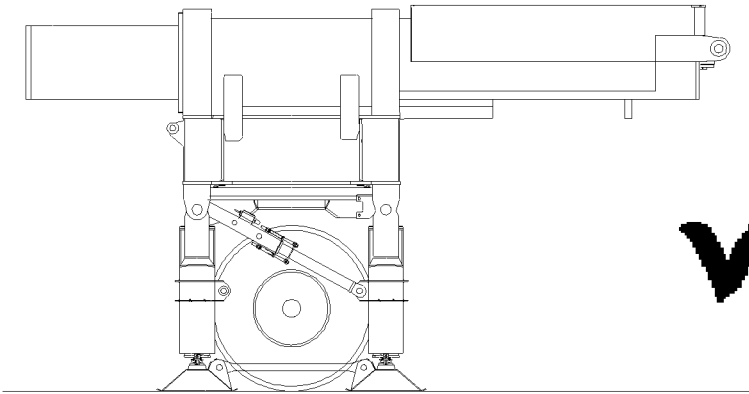

B107353

1 Safety guidelines



WARNING

Risk of falling!

- ▶ During assembly or disassembly work on the ballast trailer, assembly personnel must be secured with appropriate aids! If this is not observed, assembly personnel could fall and suffer life-threatening or fatal injuries!



WARNING

Danger of tipping the ballast trailer!

If the following notes are not observed, the freestanding ballast trailer or the ballast trailer which needs to be disassembled can tip over!

Personnel can be severely injured or killed!

- ▶ The ballast trailer may only be parked on level ground of sufficient load bearing capacity!
- ▶ The ballast trailer may only be unpinned from the crane and parked if the ballast trailer guide is fully retracted!
- ▶ The ballast trailer may only be unpinned from the crane and parked if the support cylinders are extended and the tires are relieved!
- ▶ The ballast trailer may only be unpinned from the crane and parked if the strut on the support cylinders is pinned and secured!



WARNING

Mortal danger if the permissible travel speed is exceeded!

If the permissible travel speed is exceeded, the tires can be damaged!

Personnel can be severely injured or killed!

As a result, significant property damage can occur on the crane and on the ballast trailer!

- ▶ The travel speed of the ballast trailer when during or driving with maximum ballast on the tires may be not more than maximum 1 km/h (0.28 m/s)!



WARNING

The crane can topple over if the level of the travel path differs!

Due to impermissible level differences between the ballast trailer route and the crane placement level, the entire crane system can be pulled back suddenly!

The relapse cylinders can run to block position. The relapse cylinders and the boom system can be damaged!

Personnel can be severely injured or killed!

- ▶ Do not exceed or fall below the permissible level difference between the ballast trailer travel path and the crane placement level!
- ▶ The travel path of the crane or the circular path of the ballast trailer must be level and of sufficient load bearing capacity!
- ▶ The permissible level difference of the ballast trailer travel path and crane travel path for "towing" and "parallel driving" may be no more than maximum 250 mm!
- ▶ The permissible level difference of the ballast trailer path and the crane travel path in relation to the crane travel path for circular driving may be no more than maximum 250 mm - based on a constant uphill incline or constant downhill incline on a 90° turning range!

**WARNING**

The crane can topple over!

If the following notes are not observed, the crane can topple over!

Personnel can be severely injured or killed!

- ▶ When lifting or lowering the ballast trailer, pay attention to the horizontal alignment of the ballast trailer!
- ▶ The assembly or disassembly work must be carried out according to the crane operating instructions, chapter 5.35 or chapter 5.11!

NOTICE

Danger of damage to the crane and the ballast trailer!

Due to steering movements on the crawler tracks while driving parallel, the crane and the ballast trailer can be significantly damaged!

- ▶ When driving parallel, steering the crawler tracks is prohibited!
- ▶ When driving parallel, the side tire distortion on the wheel sets must be observed by an instructed person over the entire travel route of the crane. If the tires distort by more than 100 mm, then the position of the wheel sets must be corrected!

**Note**

General safety technical guidelines!

- ▶ The ballast trailer guy rods must be assembled and secured according to the separately supplied assembly drawings. The numbering on the assembly drawings must be identical to the numbering on the guy rods!

2 Inspection of tires and disk wheels

**Note**

- ▶ See Crane operating instructions, chapter 8.01!

**WARNING**

Mortal danger when using non-approved tires!

Due to the use of tires, which are not explicitly approved by **LIEBHERR-Werk Ehingen GmbH**, uncontrollable operation conditions on the ballast trailer can occur due to the heavy load!

The tires can be destroyed and the ballast trailer as well as the crane can be significantly damaged!

Personnel can be severely injured or killed!

- ▶ Use only spare tires which have been approved in writing by **LIEBHERR-Werk Ehingen GmbH**!
- ▶ Using spare tires which have been not explicitly approved in writing by **LIEBHERR-Werk Ehingen GmbH** is prohibited!

NOTICE

Damage to tires!

Due to external environmental influences (for example: rain, wind, snow, frost, sun exposure) and the great weight load on the tires by the ballast trailer, the tires can become porous and the body can lose its original strength!

- ▶ The tires must be replaced according to the data of the tire manufacturer at least after 5 years, or if an expert representative of the tire manufacturer states in writing, after extensive inspection of the tires, that the tires can be utilized for an additional operation period stated by the expert representative!

**Note**

Tightening torque of ballast trailer tires!

- ▶ The tightening torque for the wheel lugs is 600 Nm!
- ▶ Check the wheel lugs according to the specified maintenance intervals for tight seating, see chapter 7.02 in the Crane operating instructions!

2.1 Tires with air inflation

It is imperative to comply with the following instructions:

- After extended downtime, the inflation pressure must be checked before using the ballast trailer.
- The tires must be protected against UV rays during extended downtimes with tarps or wooden boards.

**Note**

Inflation pressure of ballast trailer tires!

- ▶ The inflation pressure in all tires, which were approved in writing by **LIEBHERR-Werk Ehingen GmbH** is **10 bar** !
- ▶ Check the inflation pressure according to the specified maintenance intervals for tight seating, see chapter 7.02 in the Crane operating instructions!

**WARNING**

Risk of accident due to damaged ballast trailer tires!

Due to extended downtime of the crane, when the ballast trailer tires are not relieved with supports, the tires can get out of round!

As a result, the tires can be destroyed and the ballast trailer as well as the crane can be significantly damaged!

Personnel can be severely injured or killed!

- ▶ During extended downtimes, the ballast trailer tires must always be relieved by the outrigger supports!

**WARNING**

Risk of accident due to damaged ballast trailer tires!

When driving the crane on insufficiently prepared ground, the tires can become damaged or punctured by large rocks or other foreign matter!

As a result, the ballast trailer as well as the crane can be significantly damaged!

Personnel can be severely injured or killed!

- ▶ The travel route of the crane or the ballast trailer must be level, of sufficient load bearing capacity and free of rocks or other foreign matter!
- ▶ The travel route of the crane must be walked off personally in advance by the crane operator!
- ▶ Rocks and other foreign matter on the travel route must be removed before starting to travel!
- ▶ If the crane operator cannot ensure that the ballast trailer tires may not be damaged when moving the crane, then the ballast trailer tires must be foamed with a special foam approved by **LIEBHERR-Werk Ehingen GmbH**. Contact **LIEBHERR-Werk Ehingen GmbH** in this regard!
- ▶ If you decide to foam the ballast trailer tires, then ballast trailer operation is only permissible if all tires of the ballast trailer have been foamed according to the specifications of **LIEBHERR-Werk Ehingen GmbH**!

2.2 Tires foamed with special foam

The tires of the ballast trailer are foamed with a special, high quality foam.

It is imperative to comply with the following instructions:

- Relieve the tires on the ballast trailer if it is at a standstill for more than 2 h via the support cylinders.
- The tires must be protected against UV rays during extended downtimes with tarps or wooden boards.

**WARNING**

Mortal danger when using non-approved tire foams!

Due to the use of tire foams, which are not explicitly approved by **LIEBHERR-Werk Ehingen GmbH**, uncontrollable operation conditions on the ballast trailer can occur due to the heavy load!

The tires can be destroyed and the ballast trailer as well as the crane can be significantly damaged!

Personnel can be severely injured or killed!

- ▶ Use of spare tires filled with water, air or special foam of lower quality is prohibited!
 - ▶ Using spare tires which have been not explicitly approved in writing by **LIEBHERR-Werk Ehingen GmbH** is prohibited!
-

**WARNING**

Danger of accidents due to retreaded tires!

If tires foamed with the special foam are retreaded, the usage properties can be significantly changed negatively!

The tires can be destroyed and the ballast trailer as well as the crane can be significantly damaged!

Personnel can be severely injured or killed!

- ▶ Tires which are filled with special foam may not be retreaded, except if a written approval has been issued by the tire manufacturer!
-

3.00 Crane assembly

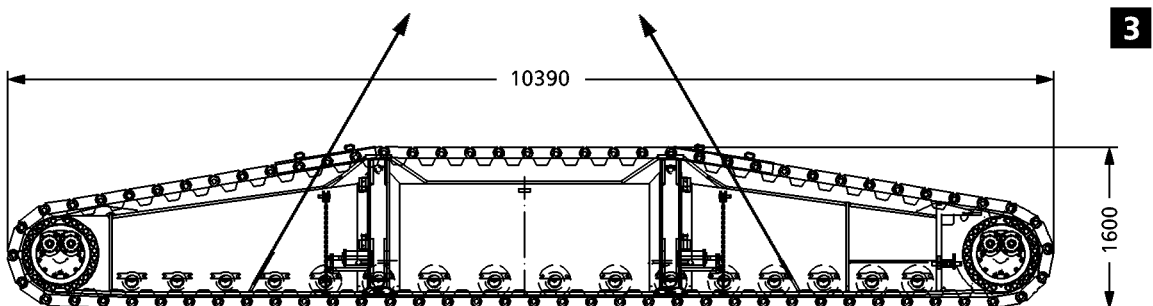
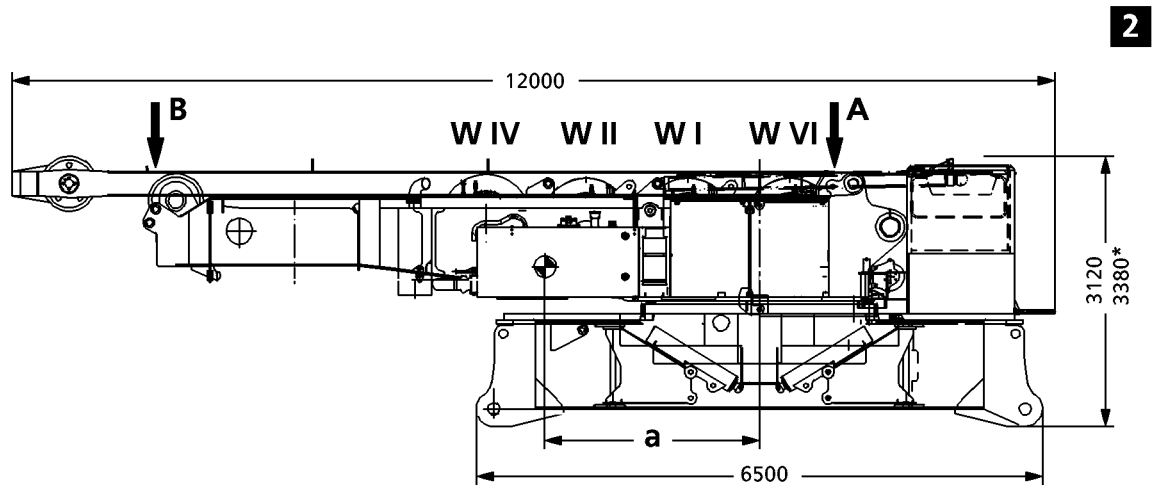
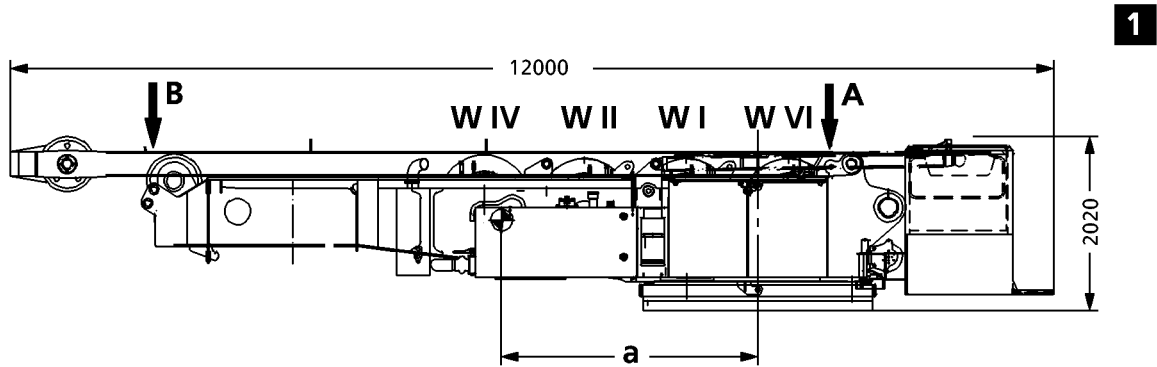

1 Dimensions, weights and centers of gravity

1.1 Turntable

See illustration 1

Width: 6.08 m

Condition with Quick connection*	Weight	Center of gravity a	A	B
With winch IV + rope	31.3 t	2672 mm	17.1 t	14.2 t
With winch I + IV + rope	35.5 t	2510 mm	20.1 t	15.4 t
With winch I, II + IV + rope	39.7 t	2456 mm	22.9 t	16.8 t
With winch VI, I, II + IV + rope	43.9 t	2180 mm	26.9 t	17.0 t

1.2 Turntable and crawler center section

See illustration 2

Width: 6.08 m

Condition with Quick connection*	Weight	Center of gravity a	A	B
With winch IV + rope	47.5 t	1761 mm	31.5 t	16.0 t
With winch I + IV + rope	51.7 t	1452 mm	36.4 t	15.3 t
With winch I, II + IV + rope	55.9 t	1745 mm	37.3 t	18.6 t
With winch VI, I, II + IV + rope	60.1 t	1598 mm	41.2 t	18.9 t

1.3 Crawler carrier

See illustration 3

Weight **with** track pads 1.2 m and two travel drives: 28 t

Width: 1.2 m

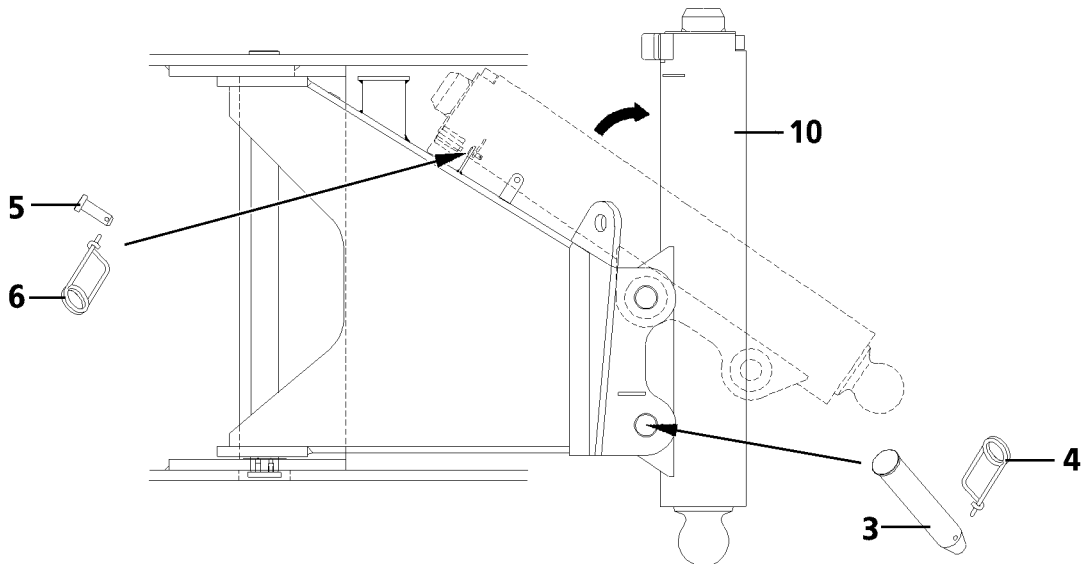
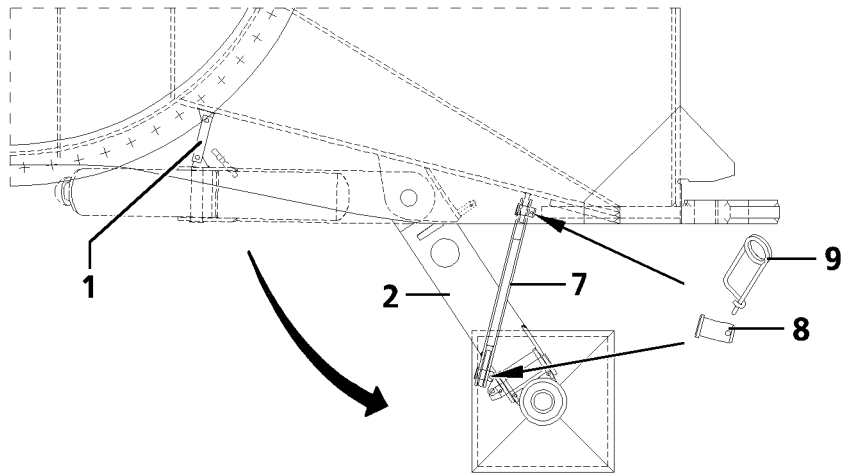
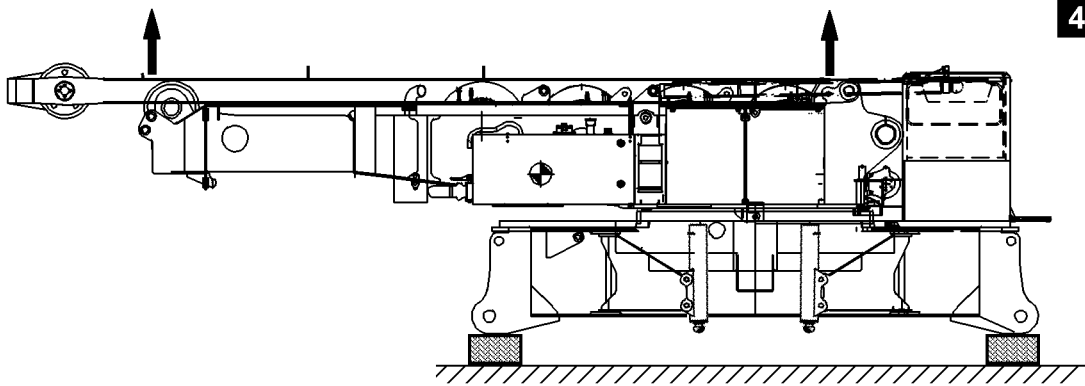

2 Assembling the crawler travel gear with SA-bracket



DANGER

Risk of accident!

During assembly and disassembly, personnel must be secured with appropriate aids to prevent them from falling. If this is not observed, assembly personnel could fall and suffer life-threatening injuries!

- ▶ All assembly work from a height of 2 m must normally be carried out using suitable aids (lifting platforms, scaffolding, ladders, auxiliary crane etc.)! The height above which assembly / disassembly work must be carried out with aids depends on national regulations. The national regulations must be adhered to!
- ▶ If work cannot be carried out on the ground or using such aids, then assembly personnel must be secured with suitable personal protective equipment (such as safety belts) to protect against falling!
- ▶ It is prohibited for anyone to remain within the complete danger zone during assembly and disassembly!



WARNING

Assembly with turned on set up key!

When the set up key is turned on, the LICCON overload protection is exceeded!

In the event of deliberate misuse, the crane can topple over!

Personnel can be killed!

This could result in high property damage!

- ▶ The set up key may only be actuated by persons who know the effects of a bypass!
- ▶ When the set up key is actuated, all crane movements must be carried out with utmost caution!
- ▶ Crane operation with the set up key turned on is strictly prohibited!

Make sure that the following prerequisites are met:

- An auxiliary crane is available.
- The placement location must be level and have adequate load bearing capacity.
- Suitable material must be available for the support of the crawler center section.

2.1 Short description of assembly procedure



Note

- ▶ The short description of the assembly procedure is only intended as an overview. In addition, the complete assembly description must be read and understood!
- ▶ Set the turntable and the crawler center section onto the support, see illustration 4.
- ▶ Swing the supports out, see illustration 5.
- ▶ Erecting the SA-bracket, see illustration 6.
- ▶ Lift the turntable and the crawler center section with the hydraulic support cylinders, see illustration 7.
- ▶ For assembly of crawler carrier with SA-bracket, see illustration 11, 12, 13.

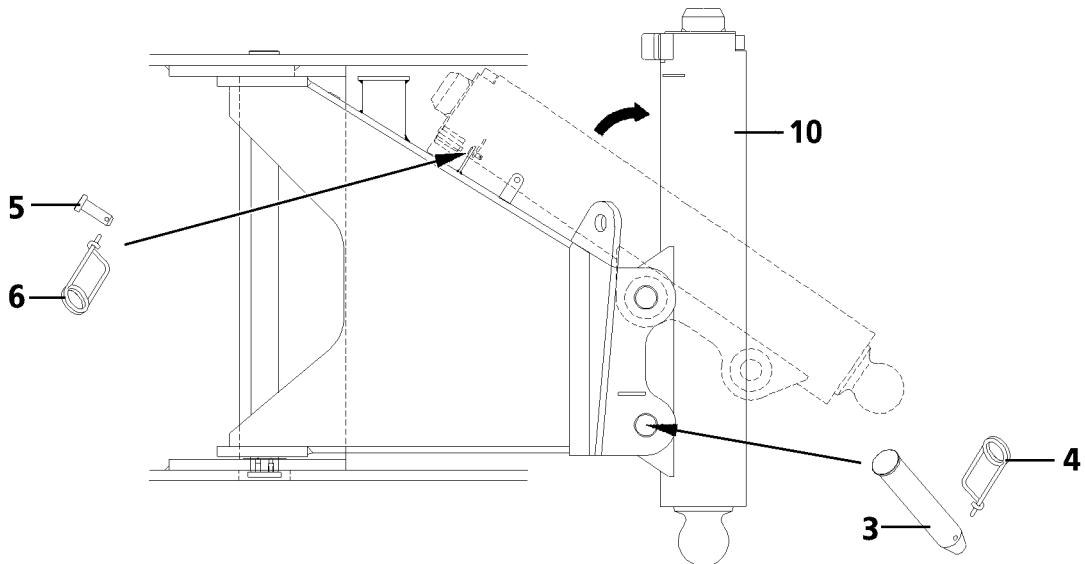
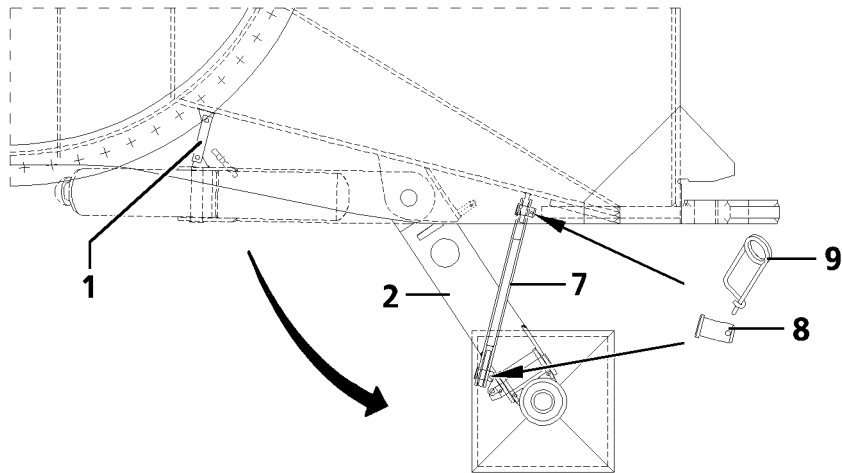
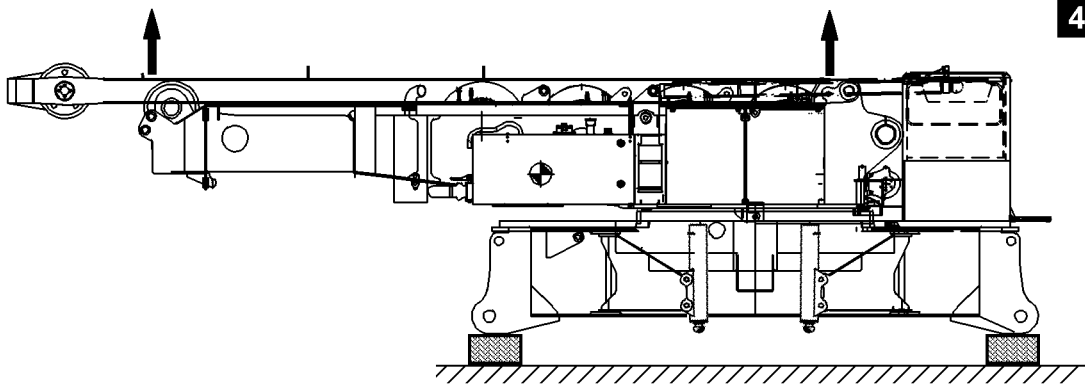

2.2 Setting the turntable and the crawler center section onto the support

For the following work, the turntable and the crawler center section must be lifted with an auxiliary crane from the transport vehicle and supported from below (hardwood timbers or other similar material).

Make sure that the following prerequisite is met:

- The placement location must be level and have adequate load bearing capacity.



DANGER

Risk of accident!

The crawler center section must be aligned horizontally. The foundation support must be made large enough for the ground conditions, with solid materials, such as wood, steel or concrete slabs, see Crane operating instructions, chapter 2.04!

- ▶ The foundation support must be able to safely take on the weight of the turntable and the crawler center section!

- ▶ Lift the turntable and the crawler center section with the auxiliary crane.
- ▶ Remove the transport vehicle.
- ▶ Set the turntable and the crawler center section onto the support, see illustration 4.

2.3 Swinging the hydraulic support out

For the crawler assembly, the turntable with the crawler center section must be hydraulically supported. To do so, the hydraulic supports **2** on the crawler center section must be swung out, see illustration 5.

- ▶ Loosen the transport retainer **1**.
- ▶ Swing the hydraulic supports **2** out.
- ▶ Remove pin **3** and spring retainer **4**.
- ▶ Loosen the pin **5** and spring retainer **6**.



DANGER

Danger of crushing!

The hydraulic support cylinder can fold down by itself due to its own weight when it is unlocked! This can crush fingers and hands, even cut off limbs!

- ▶ Before unlocking, hold the hydraulic support cylinder and fold it down slowly!

- ▶ Tilt the cylinder **10** into working position.
- ▶ To lock the cylinder, insert the pin **3** and secure with spring retainer **4**.
- ▶ Insert the pin **5** into the transport receptacle and secure with spring retainer **6**.
- ▶ Secure the bracket **7** by inserting the pin **8** with spring retainer **9**.

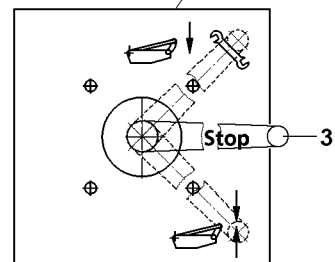
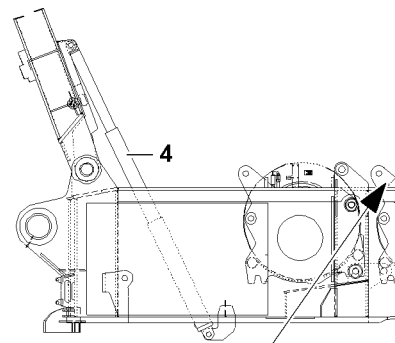
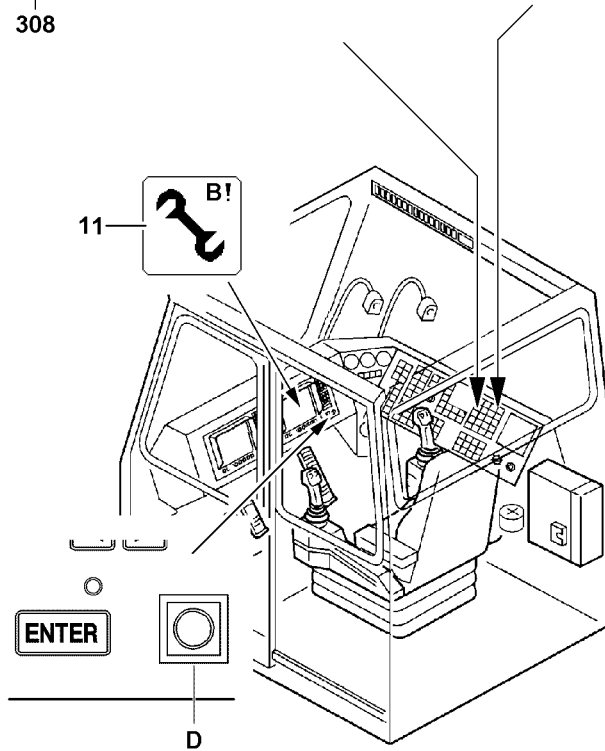
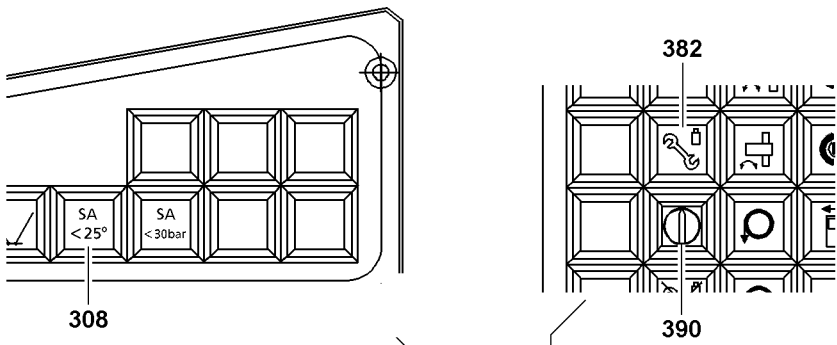
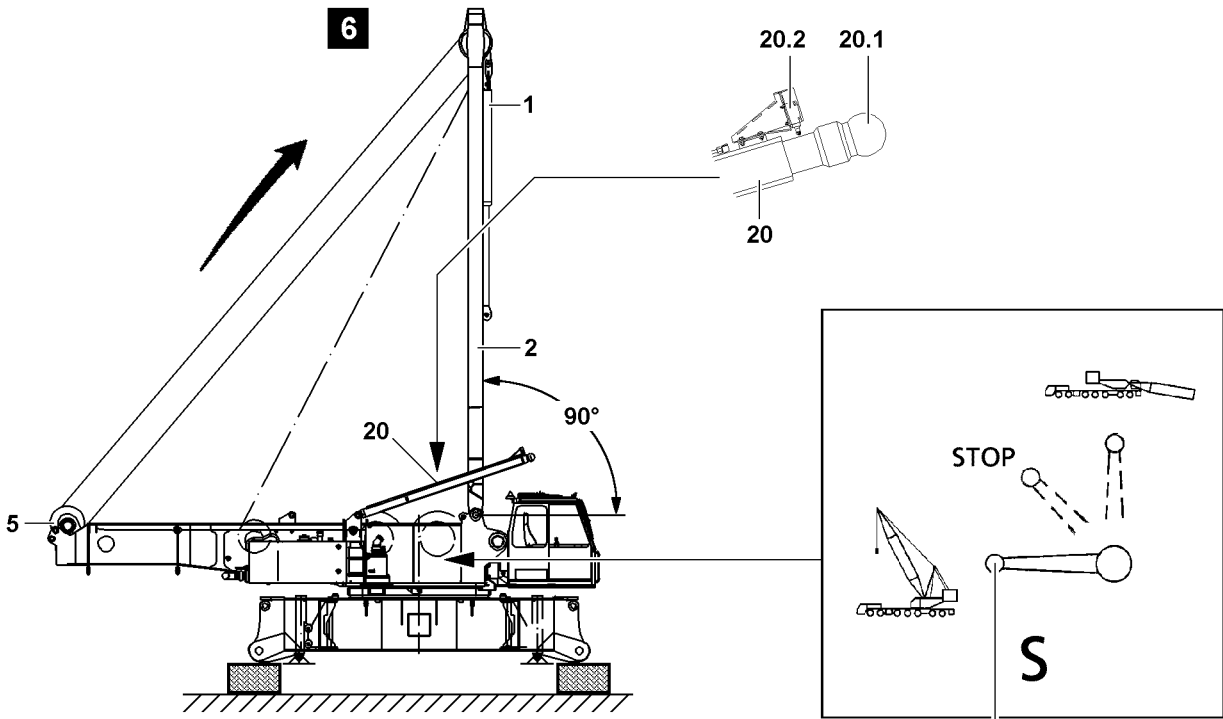

B112509

2.4 Erecting the SA-bracket



WARNING

Danger of toppling the crane!

- ▶ When the key button **390** "Crawler assembly" is turned on, there is no overload shut off for the assembly cylinder **1** as well as for the crane!



Note

- ▶ The piston rods **20.1** of the S-relapse cylinder **20** must be extended approx. 10 cm to approx. 15 cm so that the limit switches **20.2** on the relapse cylinders **20** are "cleared" and winch 4 can be "moved" with master switch 1 (MS1)!
- ▶ If this is not observed, winch 4 cannot be actuated and moved!

Make sure that the following prerequisites are met:

- The rope of winch 4 "Boom control" is reeved.
- The engine is running, see Crane operating instructions, chapter 4.03.
- The set up key **D** and the key button **390** "Crawler assembly" are actuated.
- The indicator light "Crawler assembly **382**" lights up.
- The assembly icon **11** is visible on the LICCON monitor.
- The piston rods **20.1** of the S-relapse cylinder **20** are extended approx. 10 cm to approx. 15 cm.
- The operating mode for the required configuration is set on the LICCON.



Note

- ▶ Pay attention to the master switch assignment for turned on key switches, see Crane operating instructions, chapter 4.05!

2.4.1 Extending the S-relapse cylinder

NOTICE

Destruction of the S-relapse cylinders **20**!

If the ball valve **23** is in "STOP" position (the S-relapse cylinders are thus blocked), the S-relapse cylinders **20** can be destroyed due to large temperature differences on the jobsite (for example between day and night)!

Expensive and extensive repairs can result!

- ▶ After completion of the crawler assembly, the ball valve **23** must always be set in position "retract" **or** in position "extend"!
- ▶ Never leave the ball valve **23** in "STOP" position for a longer period of time!

- ▶ Move the ball valve **23** into horizontal position.

Result:

- The piston rod **20.1** of the S-relapse cylinder **20** extends.
- The limit switch **20.2** is no longer actuated.
- Winch 4 can be "moved".

- ▶ When the piston rod **20.1** is extended approx. 10 cm to 15 cm:
Move the ball valve **23** into STOP position.

Result:

- The S-relapse cylinder **20** is blocked in the current position.

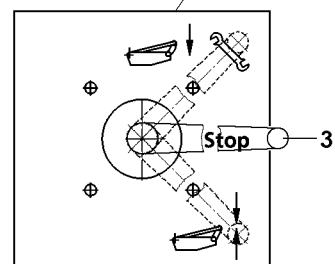
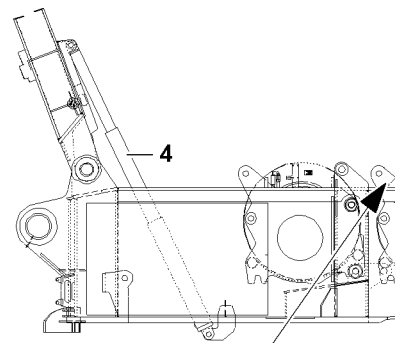
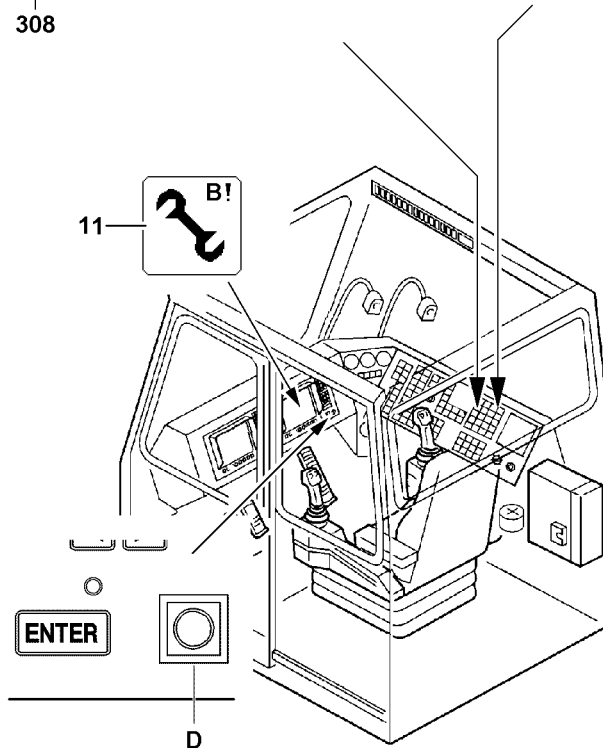
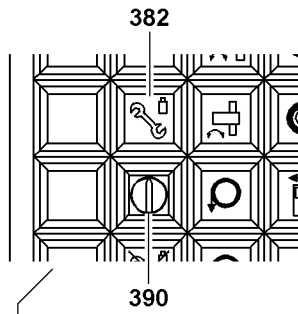
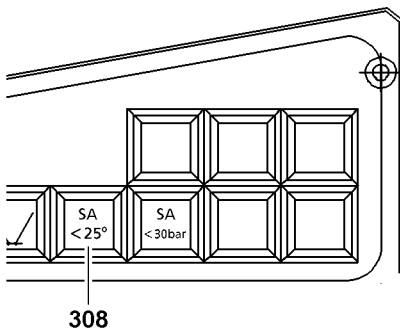
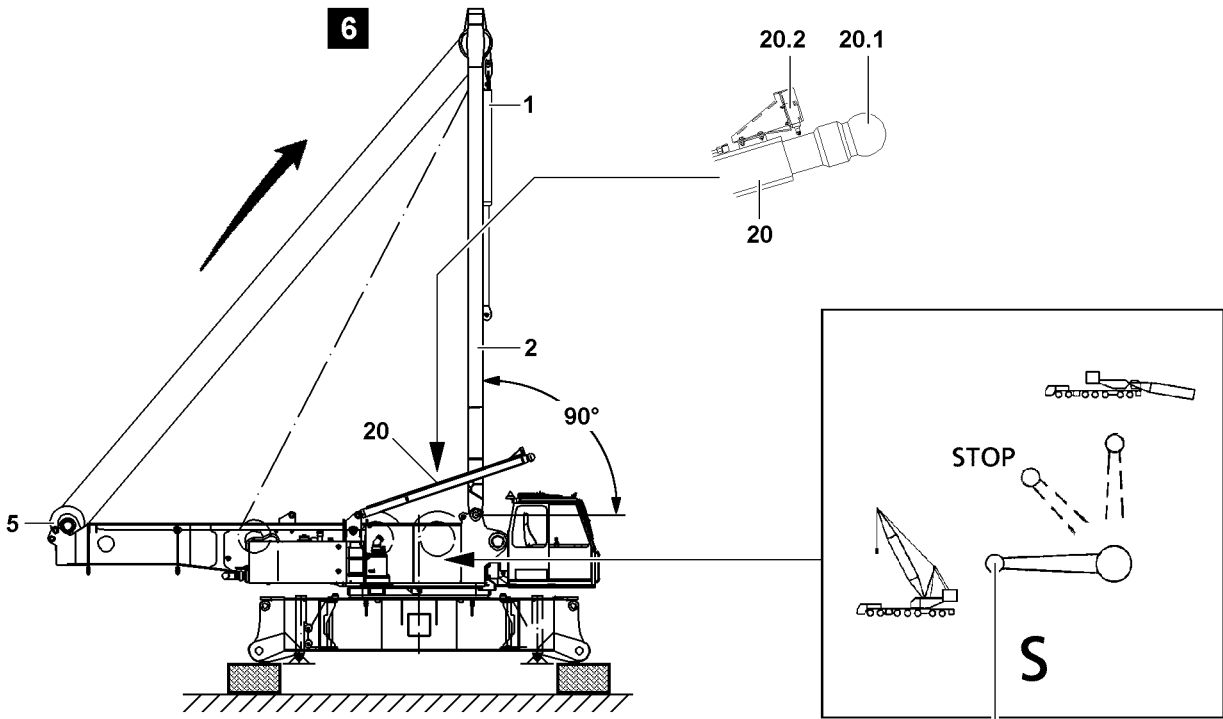

B112509

2.4.2 Erection procedure

- ▶ Move the ball valve **3** downward into operating position.

Result:

- The SA-bracket **2** is pushed upward by the erection cylinder **4** until the ropes are tensioned between the SA-bracket and the turntable - pulley block.

Positions of ball valve:	
Up	Lower the SA-bracket onto the turntable (transport position)
Horizontal	STOP, extension and retraction of piston rod is blocked
Down	Operation, extend the piston rod



WARNING

Danger of damaging the rope pulleys or ropes!

- ▶ Check visually if the ropes are placed correctly in the respective rope pulley!
-
- ▶ Spool out winch 4 by actuating the master switch 1 until the SA-bracket **2** is positioned at least at 90°!

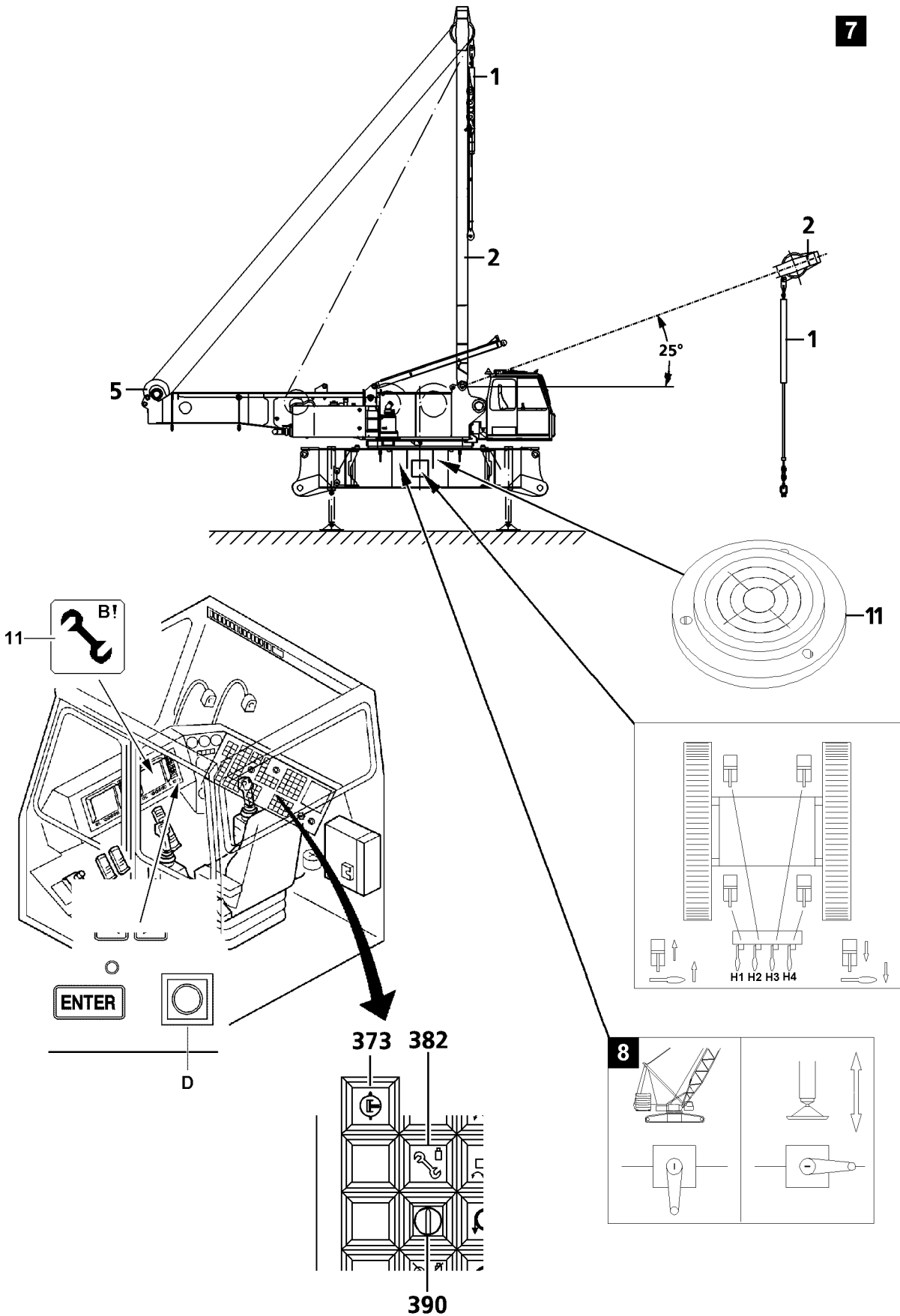

B112510

2.5 Lifting the turntable and the crawler center section with the hydraulic support cylinders

Make sure that the following prerequisites are met:

- The SA-bracket **2** is positioned at least at 90°.
- The set up key **D** and the key button **390** “Crawler assembly” are actuated.
- The indicator light “Crawler assembly **382**” lights up.
- The assembly icon **11** is visible on the LICCON monitor.
- The pressure change over switch **373** for the support cylinders in the cab is turned on.
- The ball valve is open (positioned vertically), see illustration **8**.

Function assignment of manual levers for the support cylinders	
H1	Manual lever for support cylinder, right front
H2	Manual lever for support cylinder, right rear
H3	Manual lever for support cylinder, left rear
H4	Manual lever for support cylinder, left front

2.5.1 Supporting

The support pads must be supported with large enough stable materials, such as wood, steel or concrete slabs, depending on the ground conditions.



Note

- ▶ Observe the safety guidelines and permissible ground pressures, see Crane operating instructions, chapter 2.04!



DANGER

Danger of toppling the crane!

- ▶ Only suitable materials may be used for the support!
- ▶ The support must be placed in the center underneath the support pads!
- ▶ The SA-bracket **2** must be erected at least to 90°!

- ▶ Support the support pads properly from underneath.
- ▶ Actuate the manual lever **H1**, **H2**, **H3**, **H4**.

Result:

- The support cylinders extend.



Note

- ▶ Lift the crane horizontally to approx. 1095 mm!

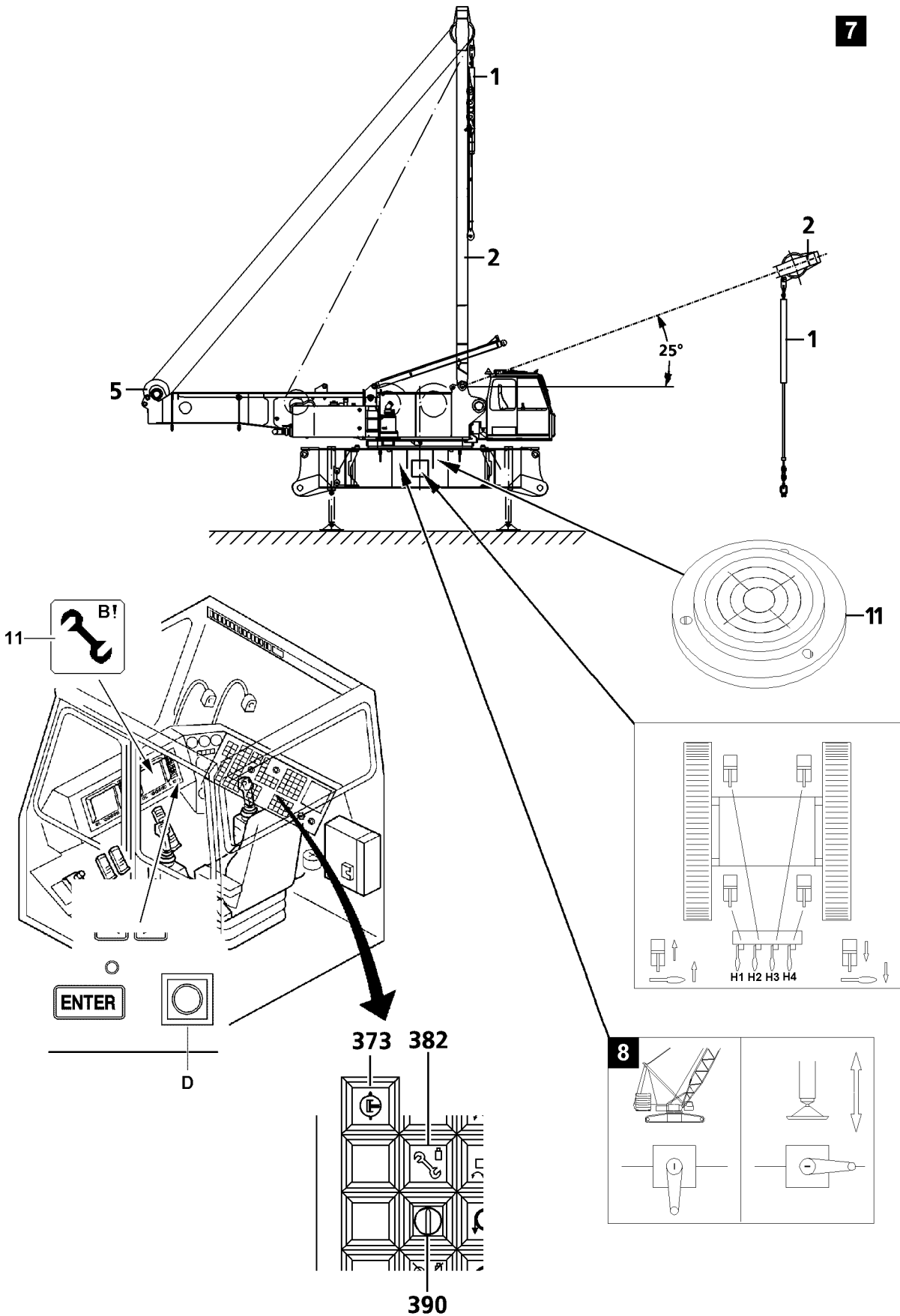

B112510

**DANGER**

Risk of accident!

- ▶ Pay attention to the horizontal position of the crane during the support procedure!
 - ▶ After supporting and aligning, the ball valve must be closed, see illustration 8!
 - ▶ The ball valve 3 for the SA-bracket must be in operating position “down” during assembly and crane operation, see illustration 6!
 - ▶ The ball valve positions “STOP” and “up” are only permissible when lowering the SA-bracket 2 to the turntable (transport position)!
 - ▶ When spooling out winch 4, watch for slack rope formation!
-
- ▶ Align the crane with the spirit level 11 in horizontal direction.
 - ▶ Close the ball valve, see illustration 8.

2.6 Lowering the SA-bracket to the front

- ▶ Spool out winch 4.

Result:

- The SA-bracket 2 is erected by the erection cylinder past the vertical position. Then it lowers to the front due to its own weight.

**Note**

- ▶ When the SA-bracket 2 is inclined to the front and the angle to the horizontal is less than 25°, the winch 4 “spool out” movement is shut off. The indicator light 308 lights up!
-
- ▶ Hang the tackle chains on the assembly cylinder 1.

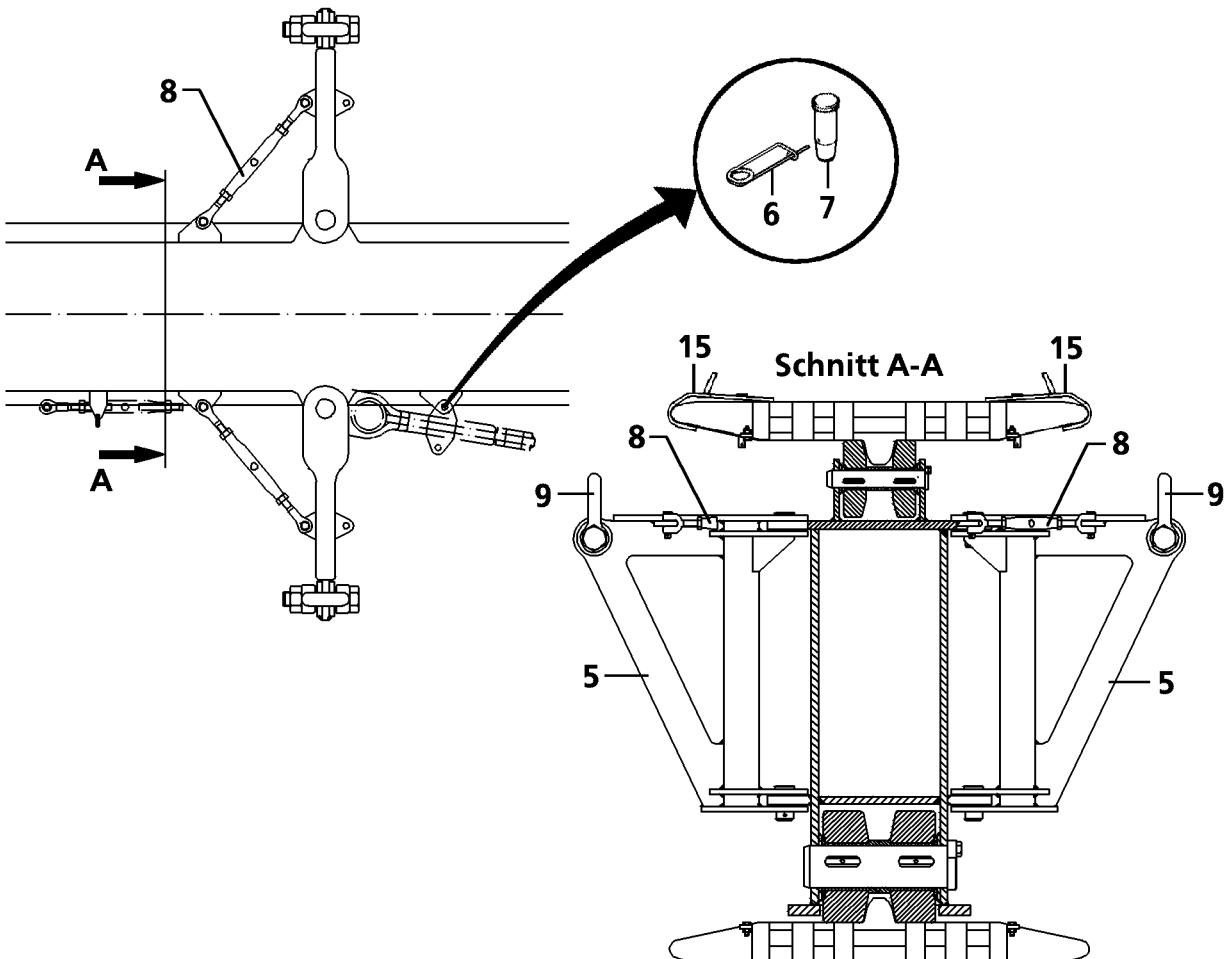
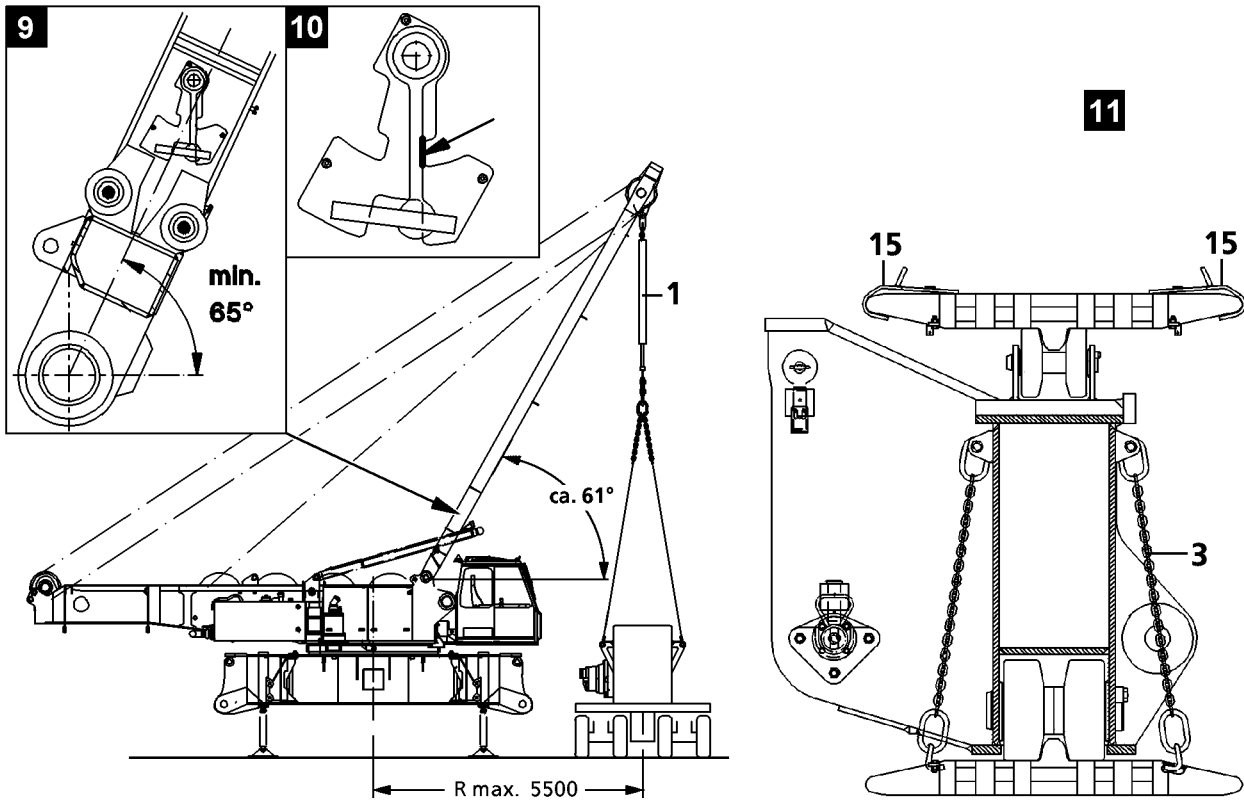

2.7 Assembly of crawler carrier with SA-bracket

2.7.1 Assembly preparation

- ▶ Move the transport vehicle with the crawler carrier as close as possible to the crawler center section.
- ▶ Luff the SA-bracket **2** up or down and turn the turntable if necessary until the assembly cylinder **1** is positioned over the crawler carrier.
- ▶ Remove the spring retainer **6**.
- ▶ Unpin the transport pin **7**.
- ▶ Swing the outer assembly console **5** out.
- ▶ Lock the turnbuckle **8** with the transport pin **7** and spring retainer **6** on the assembly console **5**.
- ▶ Extend the assembly cylinder **1**.
- ▶ Secure the crawler carrier plates with chains **3** on the respective two crawler plates on both sides to prevent them from sagging.



Note

- ▶ Attach 2 chains per crawler carrier side!
-
- ▶ Attach the rope guard **15** on the upper crawler plates.



DANGER

Risk of accident!

The rope guard must be used. If this is not observed, the attachment equipment can be damaged and rip!

- ▶ It is prohibited for anyone to remain under the crawler carrier as well as within the complete danger zone during assembly and disassembly!
-

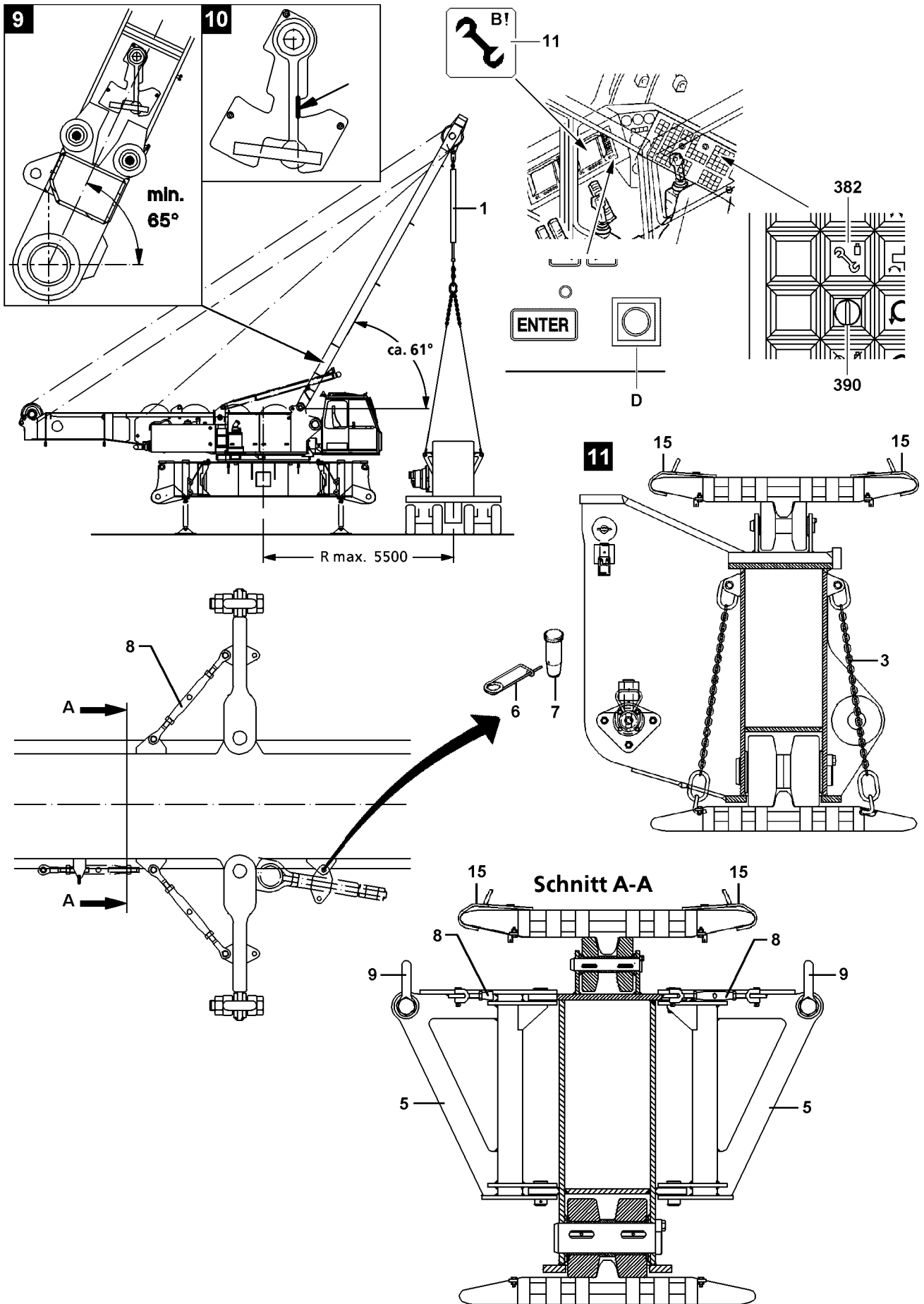

B112511

- ▶ Attach the attachment equipment to the shackles **9** of the assembly console **5** and guide it over the rope guard **15**.
- ▶ Lift the crawler carrier with the assembly cylinder **1** from the transport vehicle.
- ▶ Remove the transport vehicle.

**Note**

- ▶ The set up key **D** and the key button **390** "Crawler assembly" must be actuated!
- ▶ The indicator light "Crawler assembly **382**" lights up!
- ▶ The assembly icon **11** is visible on the LICCON monitor!
- ▶ Pay attention to the marking on the crawler carrier and the receptacle!

**DANGER**

Risk of accident!

- ▶ In this operating mode, when the key button "Crawler assembly" is turned on, there is no overload shut off for the assembly cylinder as well as for the crane!

**DANGER**

Risk of tipping the crane!

- ▶ The maximum radius of 5.5 m (approx. 61°) may not be exceeded when lifting the crawler carrier. The pendulum on the SA-bracket must remain in the green range (approx. 61° - 75°), see illustration **9**!

- ▶ Pay attention to the display of the pendulum on the SA-bracket, see illustration **10**.

12

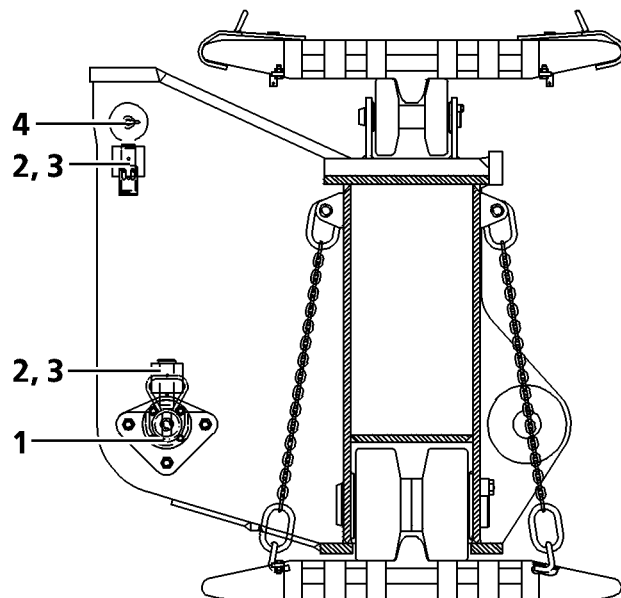
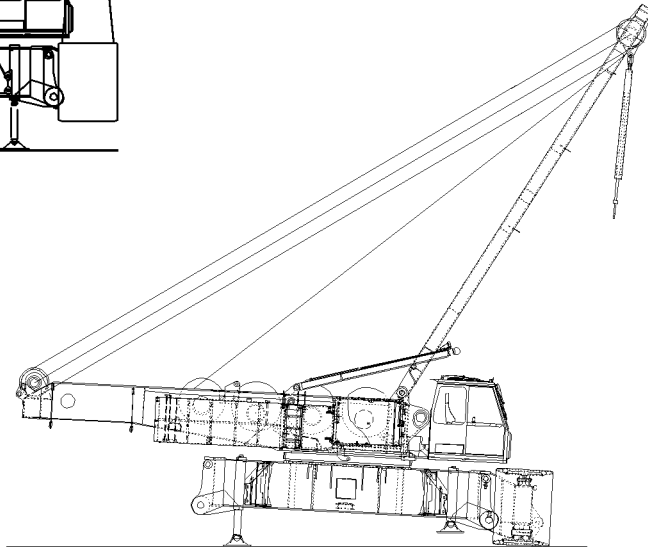
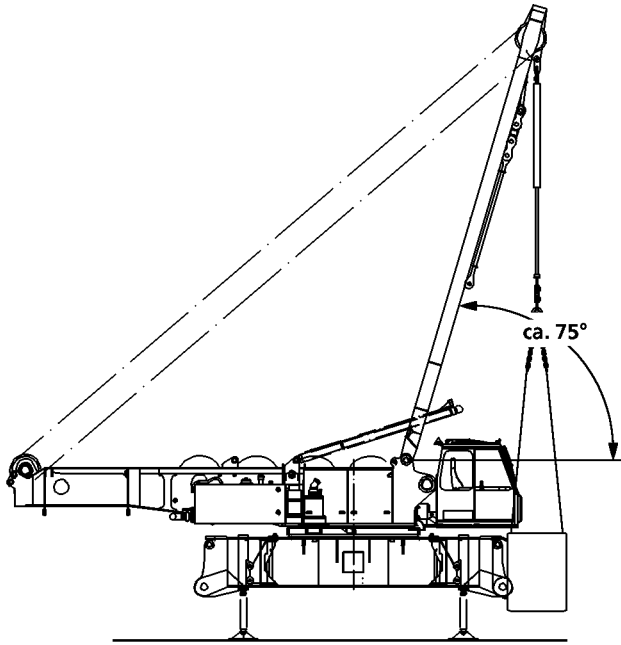

2.7.2 Assembling the first crawler carrier

Make sure that the following prerequisite is met:

- The preparations for crawler carrier assembly have been carried out, see section “Assembly preparation”.
- ▶ Swing the first crawler carrier to the receptacle on the crawler center section and insert it carefully to the stop and affix.



Note

- ▶ Note the marking on the crawler carrier and the crawler center section!



DANGER

Danger of crushing!

If the following point is not observed, life-threatening crushing injuries can occur!

- ▶ Do not stand between the crawler carrier and the crawler center section when the crawler carrier is placed!
- ▶ Pin and secure the crawler carrier on the crawler center section.
- ▶ Insert the pins **1** with the hydraulic pin pulling device and secure with retaining pins **2**.
- ▶ Secure the retaining pins **2** with spring retainers **3**.
- ▶ Insert the pin **4** by hand and secure with spring retainer **2**.
- ▶ Secure the retaining pins **2** with spring retainers **3**.
- ▶ Remove the attachment equipment and rope guard **15**.
- ▶ Disengage the chains **3** on the crawler pads.



DANGER

Risk of tipping the crane!

- ▶ Before turning the turntable, the first assembled crawler carrier must be positioned on the ground!
- ▶ Open the ball valve (vertical position), see illustration **7**.
- ▶ Retract the two hydraulic support cylinders on the side of the first assembled crawler carrier until it is standing on the ground, see illustration **13**.
- ▶ Actuate the manual lever **H1**, **H2**, **H3**, **H4**.

Result:

- The support cylinders retract.

13

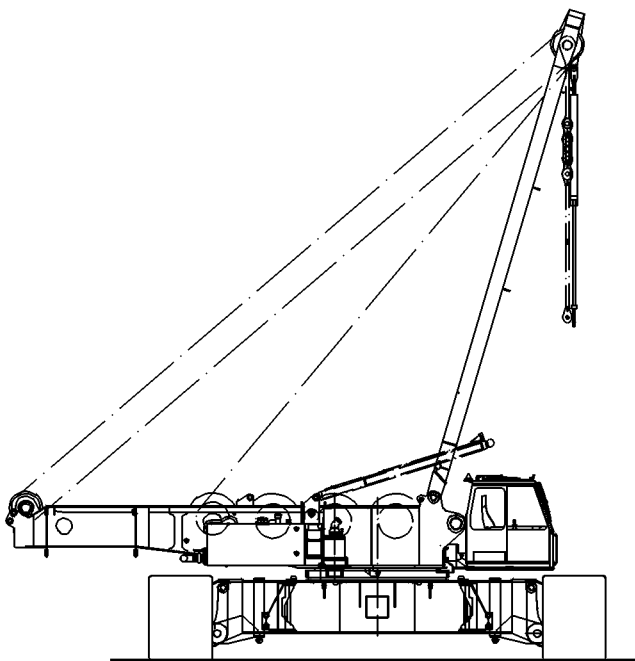
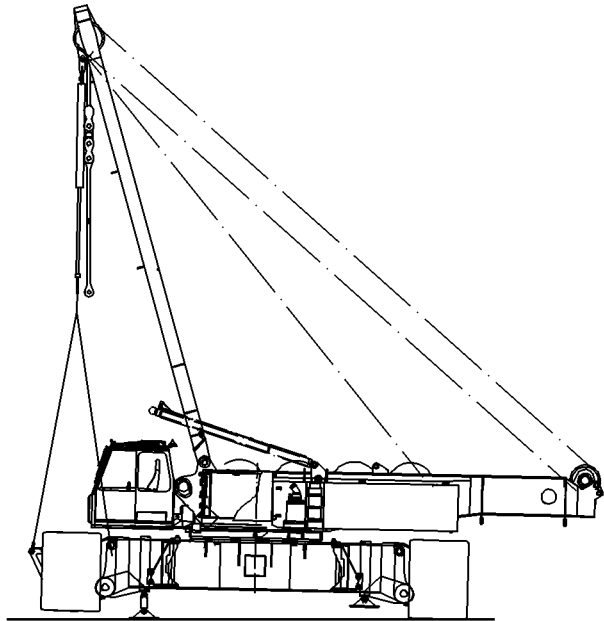
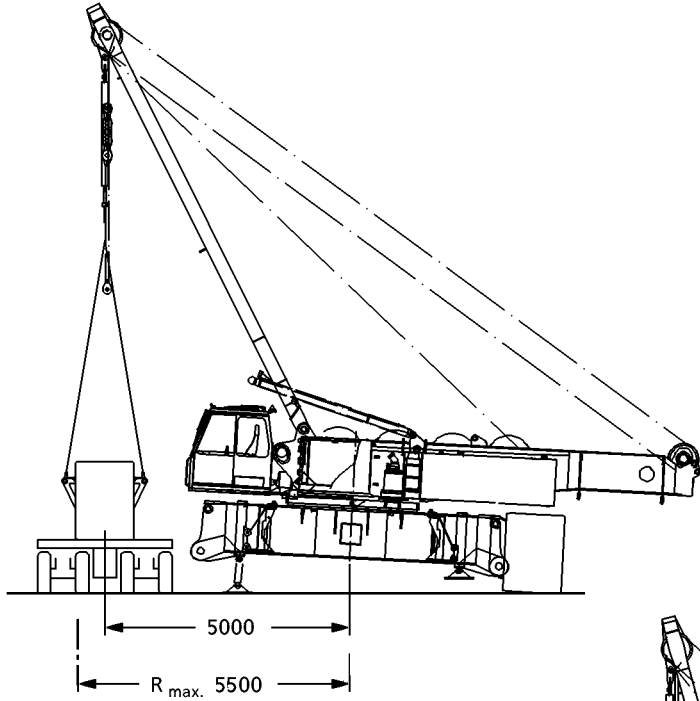

B104560

2.7.3 Assembling the second crawler carrier

Make sure that the following prerequisite is met:

- The preparations for crawler carrier assembly have been carried out, see section “Assembly preparation”.



DANGER

Risk of tipping the crane!

- ▶ Before turning the turntable, the first assembled crawler carrier must be positioned on the ground!
- ▶ The maximum radius of 5.5 m (approx. 61°) may not be exceeded when lifting the crawler carrier. The pendulum on the SA-bracket must remain in the green range (approx. 61° - 75°), see illustration 9!

-
- ▶ Pay attention to the display of the pendulum on the SA-bracket, see illustration 10.



DANGER

Risk of accident!

- ▶ In this operating mode, when the key button “Crawler assembly” is turned on, there is no overload shut off for the assembly cylinder as well as for the crane!

-
- ▶ Swing the second crawler carrier to the receptacle on the crawler center section and insert it carefully to the stop and affix.



Note

- ▶ Note the marking on the crawler carrier and the crawler center section!
-

13

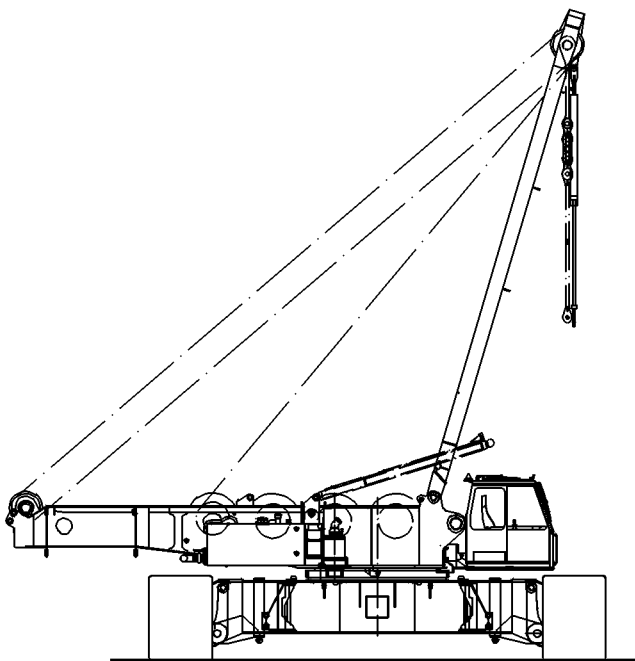
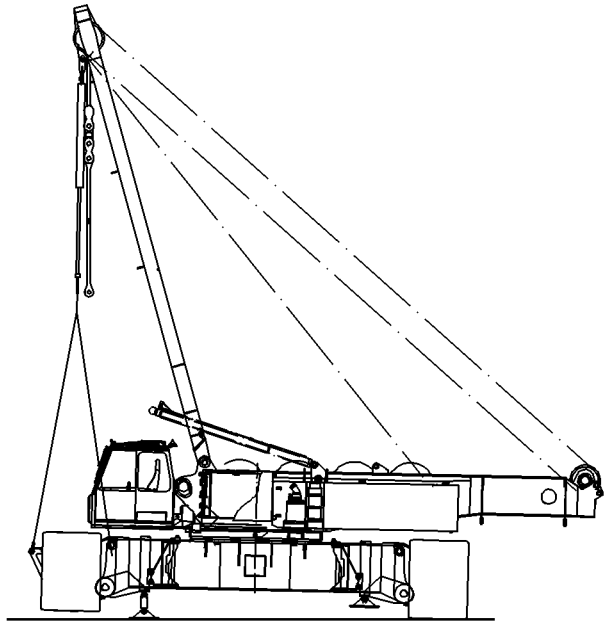
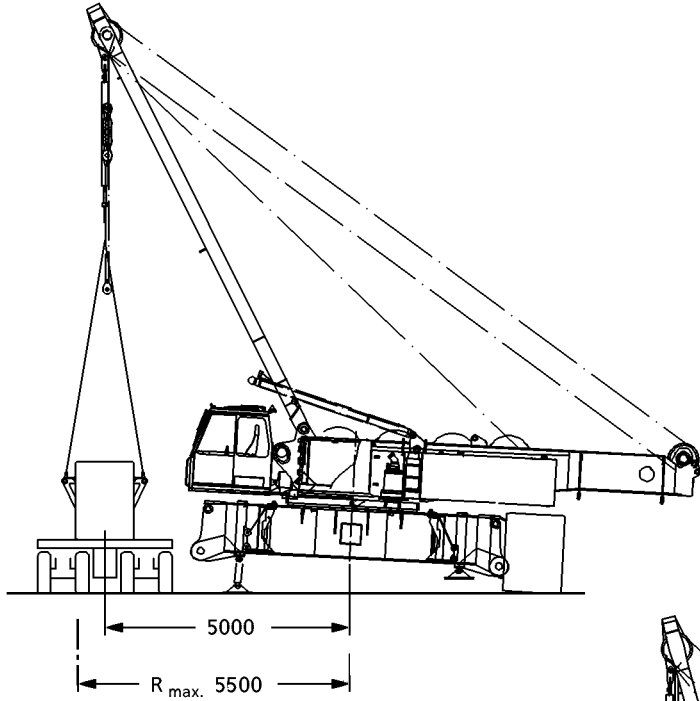

B104560

**DANGER**

Danger of crushing!

If the following point is not observed, life-threatening crushing injuries can occur!

- ▶ Do not stand between the crawler carrier and the crawler center section when the crawler carrier is placed!

-
- ▶ Pin and secure the crawler carrier on the crawler center section.
 - ▶ Insert the pins **1** with the hydraulic pin pulling device and secure with retaining pins **2**.
 - ▶ Secure the retaining pins **2** with spring retainers **3**.
 - ▶ Insert the pin **4** by hand and secure with spring retainer **2**.
 - ▶ Secure the retaining pins **2** with spring retainers **3**.
 - ▶ Remove the attachment equipment and rope guard **15**.
 - ▶ Disengage the chains **3** on the crawler pads.
 - ▶ Retract the two hydraulic support cylinders on the side of the second assembled crawler carrier until it is standing on the ground, see illustration **13**.
 - ▶ Retract the hydraulic support cylinders fully.
 - ▶ Swing the assembly consoles **5** and the turnbuckles **8** in on the crawler carriers and secure.
 - ▶ Close the ball valve (horizontal position), see illustration **8**.
 - ▶ Turn the pressure change over switch **373** off in the cab.
 - ▶ Retract the assembly cylinder **1** completely.
 - ▶ Turn the key button **390** "Crawler assembly" off.

Result:

- The indicator light **382** "Crawler assembly" turns off, see Crane operating instructions, chapter 4.01.

2.8 Establishing the hydraulic connection to the crawler travel gears

Make sure that the following prerequisite is met:

- Both crawler carriers are properly assembled.
- ▶ Establish the hydraulic connections.

**Note**

- ▶ To connect the hydraulic lines with quick couplers, see Crane operating instructions, chapter 5.01!

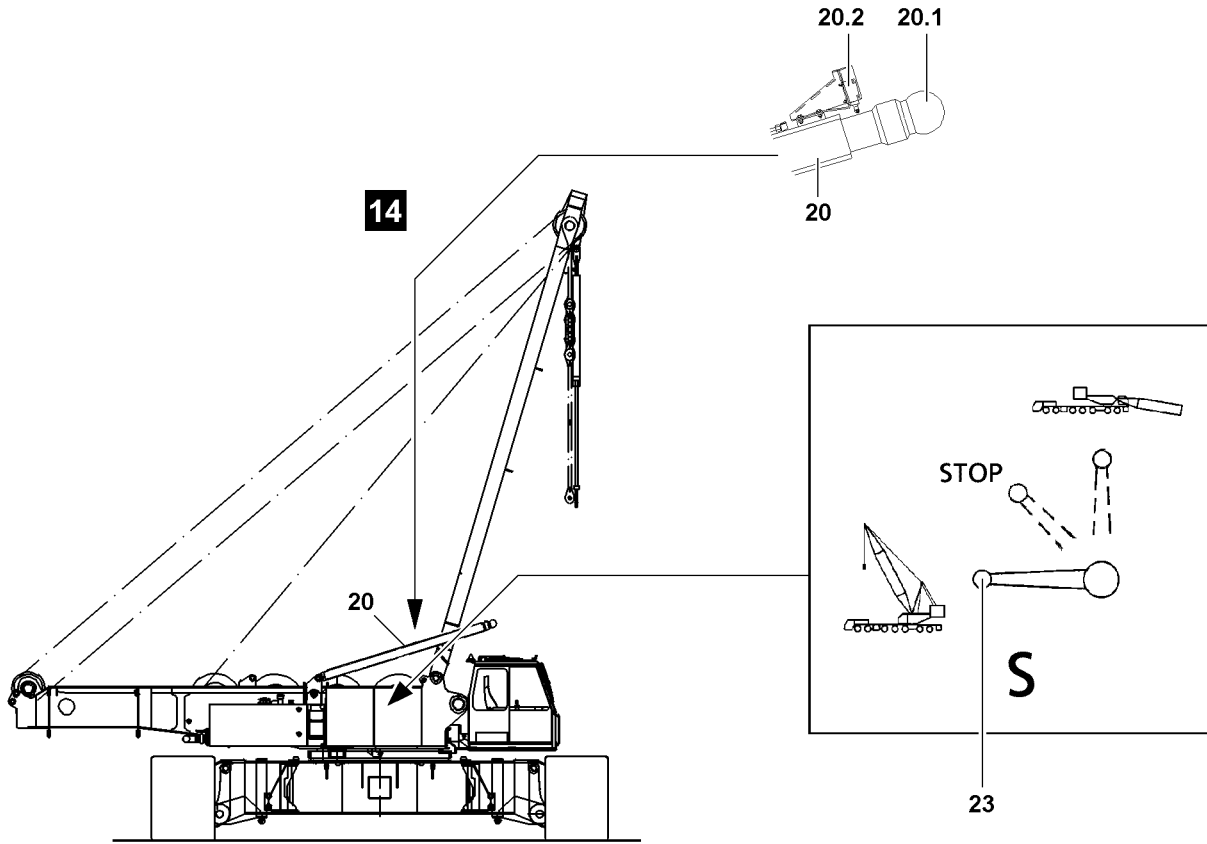

2.9 The S-relapse cylinders retract or extend

NOTICE

Destruction of the S-relapse cylinders **20**!

If the ball valve **23** is in "STOP" position (the S-relapse cylinders are thus blocked), the S-relapse cylinders **20** can be destroyed due to large temperature differences on the jobsite (for example between day and night)!

Expensive and extensive repairs can result!

- ▶ After completion of the crawler assembly, the ball valve **23** must always be set in position "retract" **or** in position "extend"!
 - ▶ Never leave the ball valve **23** in "STOP" position for a longer period of time!
-

Extending S-relapse cylinders:

- ▶ The assembly of the crawler carrier is completed:
Move the ball valve **23** into vertical position.

Result:

- The piston rod **20.1** of the S-relapse cylinder **20** extends.
- Winch 4 is blocked.



Note

- ▶ Alternatively, the S-relapse cylinders can also be extended after crawler assembly!
-

Extend the S-relapse cylinder:

- ▶ The assembly of the crawler carrier is completed:
Move the ball valve **23** into horizontal position.

Result:

- The piston rod **20.1** of the S-relapse cylinder **20** extends.

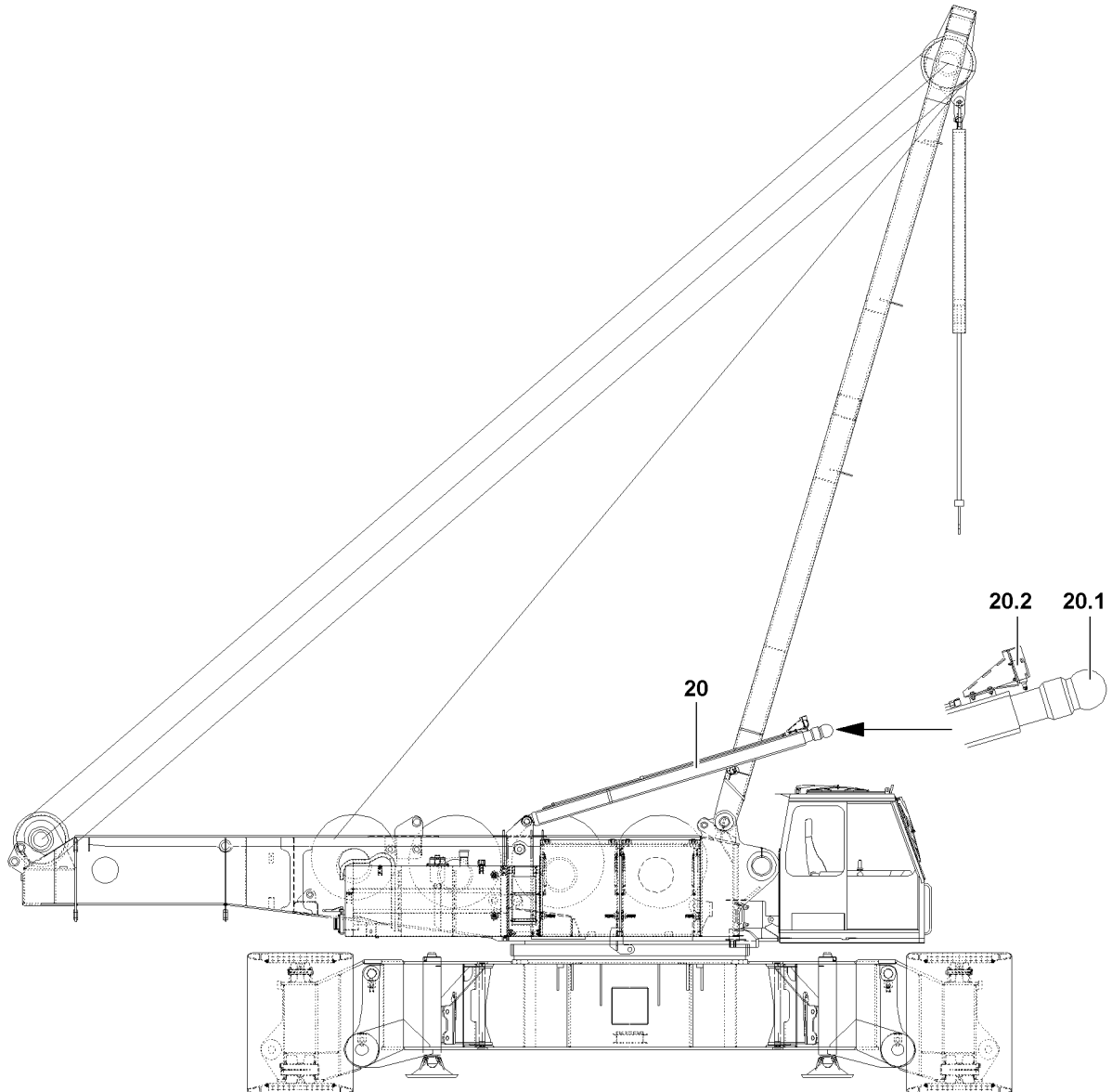

3 Disassembling the crawler travel gear with SA-bracket



DANGER

Risk of accident!

During assembly and disassembly, personnel must be secured with appropriate aids to prevent them from falling. If this is not observed, assembly personnel could fall and suffer life-threatening injuries!

- ▶ All assembly work from a height of 2 m must normally be carried out using suitable aids (lifting platforms, scaffolding, ladders, auxiliary crane etc.)! The height above which assembly / disassembly work must be carried out with aids depends on national regulations. The national regulations must be adhered to!
- ▶ If work cannot be carried out on the ground or using such aids, then assembly personnel must be secured with suitable personal protective equipment (such as safety belts) to protect against falling!
- ▶ It is prohibited for anyone to remain within the complete danger zone during assembly and disassembly!



WARNING

Disassembly with turned on set up key!

When the set up key is turned on, the LICCON overload protection is exceeded!

In the event of deliberate misuse, the crane can topple over!

Personnel can be killed!

This could result in high property damage!

- ▶ The set up key may only be actuated by persons who know the effects of a bypass!
- ▶ When the set up key is actuated, all crane movements must be carried out with utmost caution!
- ▶ Crane operation with the set up key turned on is strictly prohibited!

Make sure that the following prerequisites are met:

- An auxiliary crane is available.
- The placement location must be level and have adequate load bearing capacity.
- The piston rods **20.1** of the S-relapse cylinder **20** are extended approx. 10 cm to approx. 15 cm.
- The limit master switches **20.2** are **not** actuated.

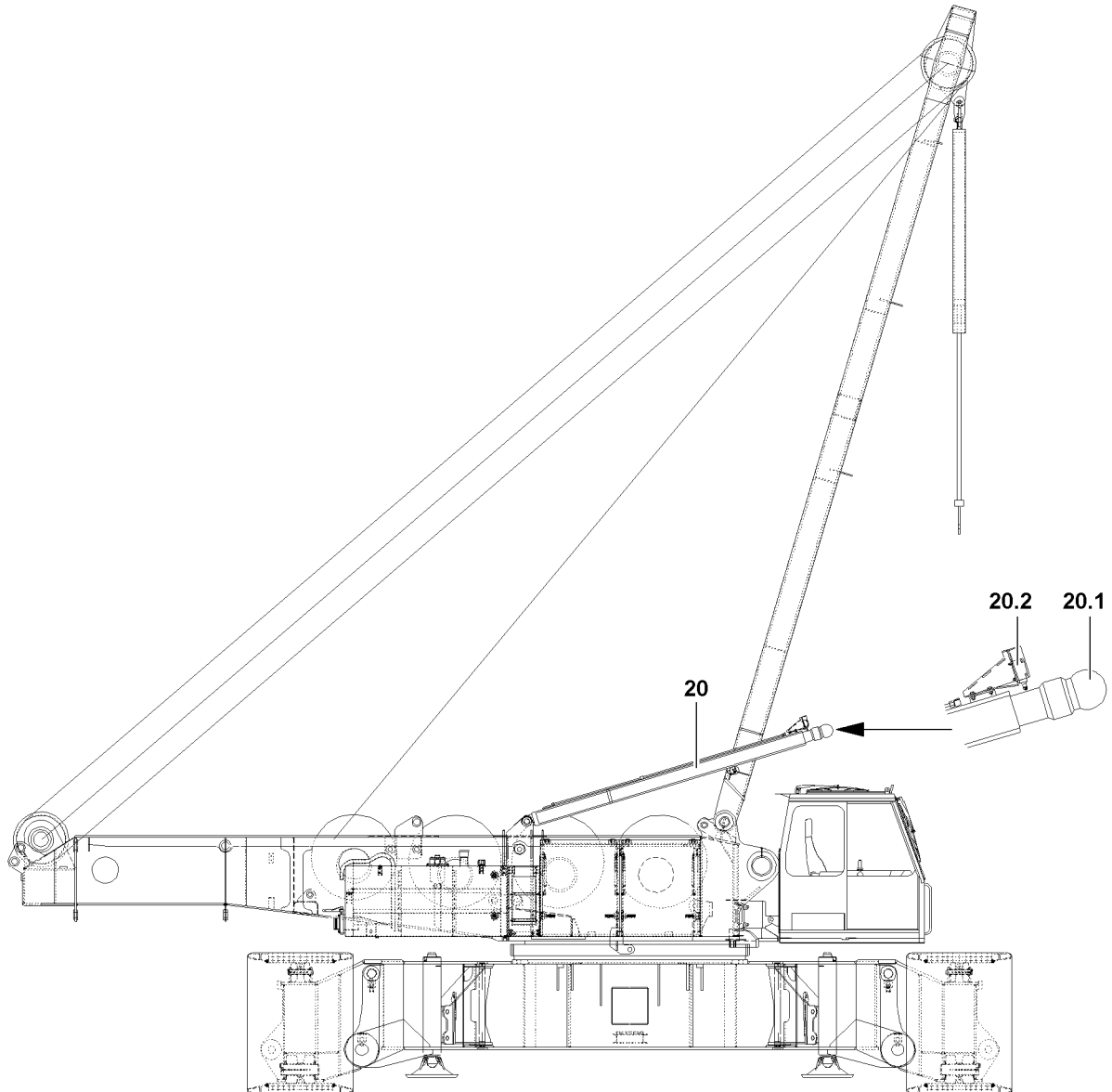

3.1 Short description of disassembly procedure

**Note**

- ▶ The short description of the disassembly procedure is only intended as an overview. In addition, the complete assembly description must be read and understood!
-
- ▶ For disassembly of crawler carrier with SA-bracket, see illustration 1, illustration 4, illustration 6.
 - ▶ Lower the turntable and the crawler center section with the hydraulic support cylinders on the support, see illustration 7.
 - ▶ Place the SA-bracket down, see illustration 8.
 - ▶ Swing the hydraulic supports in, see illustration 9.
 - ▶ Set the turntable and the crawler center section on the transport vehicle, see illustration 10.

3.2 Disconnecting the hydraulic connection to the crawler travel gears

Make sure that the following prerequisite is met:

- Both crawler carriers are assembled on the crawler center section.
- ▶ Disconnect the hydraulic connections

**Note**

- ▶ To release the hydraulic lines with quick couplers, see Crane operating instructions, chapter 5.01!

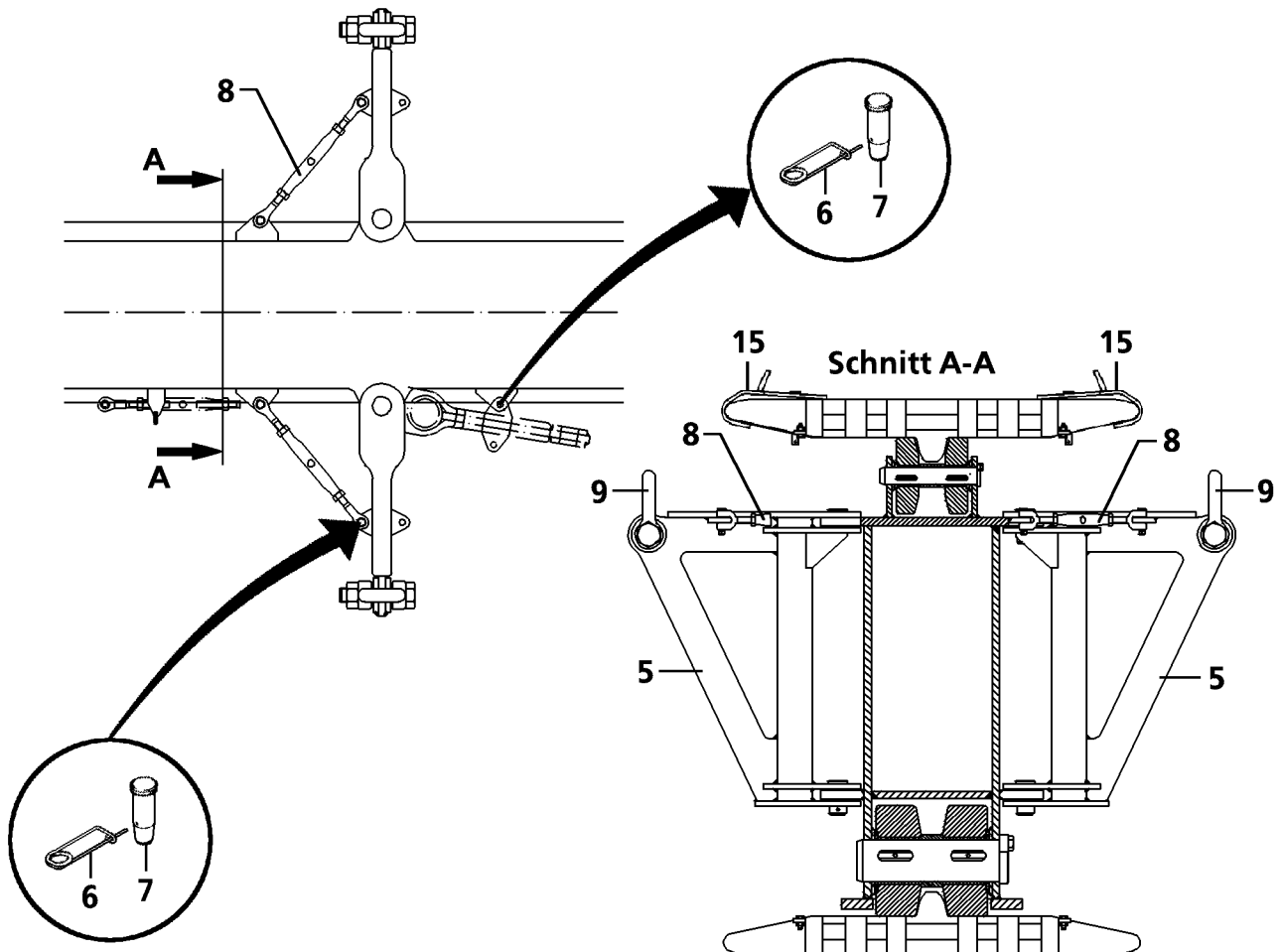
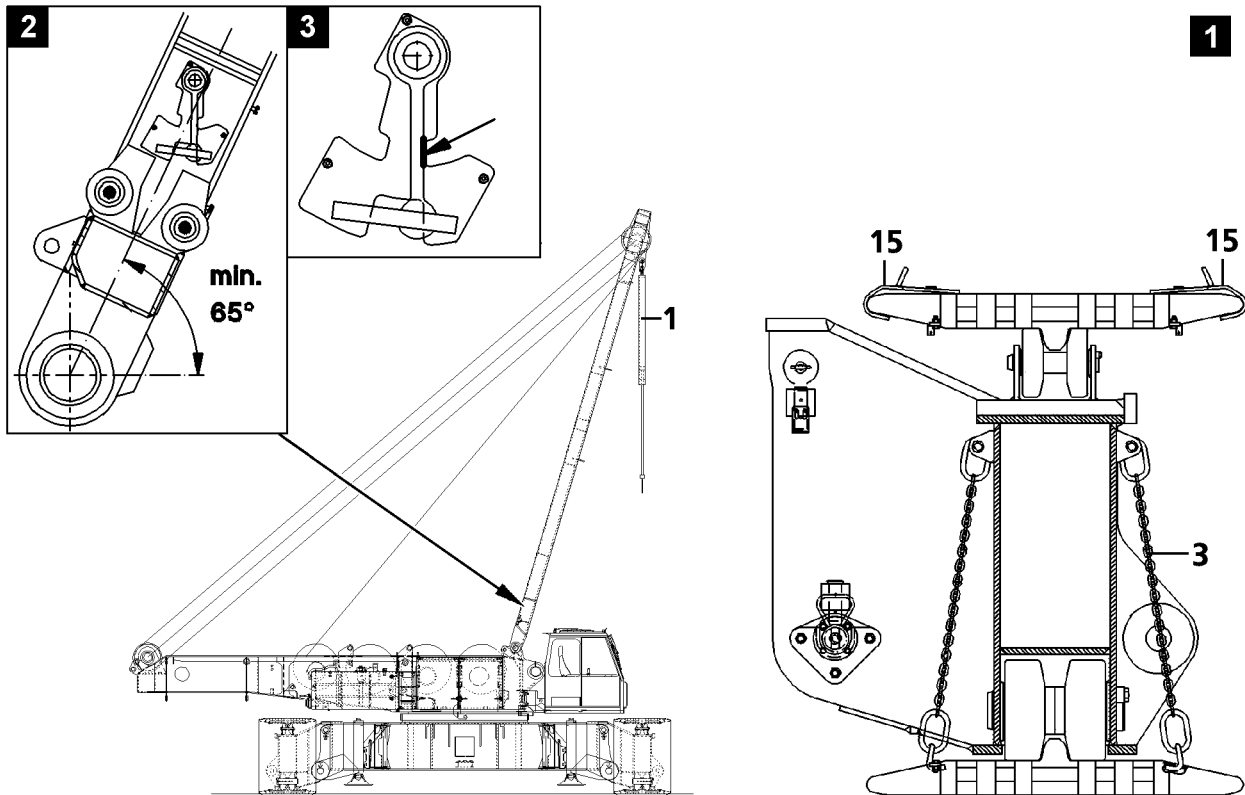

B104561

3.3 Disassembly of crawler carrier with SA-bracket

3.3.1 Disassembly preparation

- ▶ Luff the SA-bracket **2** up or down and turn the turntable if necessary until the assembly cylinder **1** is positioned over the crawler carrier.
- ▶ Remove the spring retainer **6**.
- ▶ Unpin the transport pin **7**.
- ▶ Swing the outer assembly console **5** out.
- ▶ Lock the turnbuckle **8** with the transport pin **7** and spring retainer **6** on the assembly console **5**.
- ▶ Extend the assembly cylinder **1** and hang in the tackle chains.
- ▶ Secure the crawler carrier plates with chains **3** on the respective two crawler plates on both sides to prevent them from sagging.



Note

- ▶ Attach 2 chains per crawler carrier side!

- ▶ Attach the rope guard **15** on the upper crawler plates.



DANGER

Risk of accident!

The rope guard must be used. If this is not observed, the attachment equipment can be damaged and rip!

- ▶ It is prohibited for anyone to remain under the crawler carrier as well as within the complete danger zone during assembly and disassembly!

- ▶ Attach the attachment equipment to the shackles **9** of the assembly console **5** and guide it over the rope guard **15**.



Note

- ▶ The set up key **D** and the key button **390** "Crawler assembly" must be actuated!
- ▶ The indicator light "Crawler assembly **382**" lights up!
- ▶ The assembly icon **11** is visible on the LICCON monitor!
- ▶ Pay attention to the master switch assignment for turned on key switches, see Crane operating instructions, chapter 4.05!



DANGER

Risk of accident!

- ▶ In this operating mode, when the key button "Crawler assembly" is turned on, there is no overload shut off for the assembly cylinder as well as for the crane!



DANGER

Risk of tipping the crane!

- ▶ The maximum radius of 5.5 m (approx. 61°) may not be exceeded when lifting the crawler carrier. The pendulum on the SA-bracket must remain in the green range (approx. 61° - 75°), see illustration **2**!

- ▶ Pay attention to the display of the pendulum on the SA-bracket, see illustration **3**.

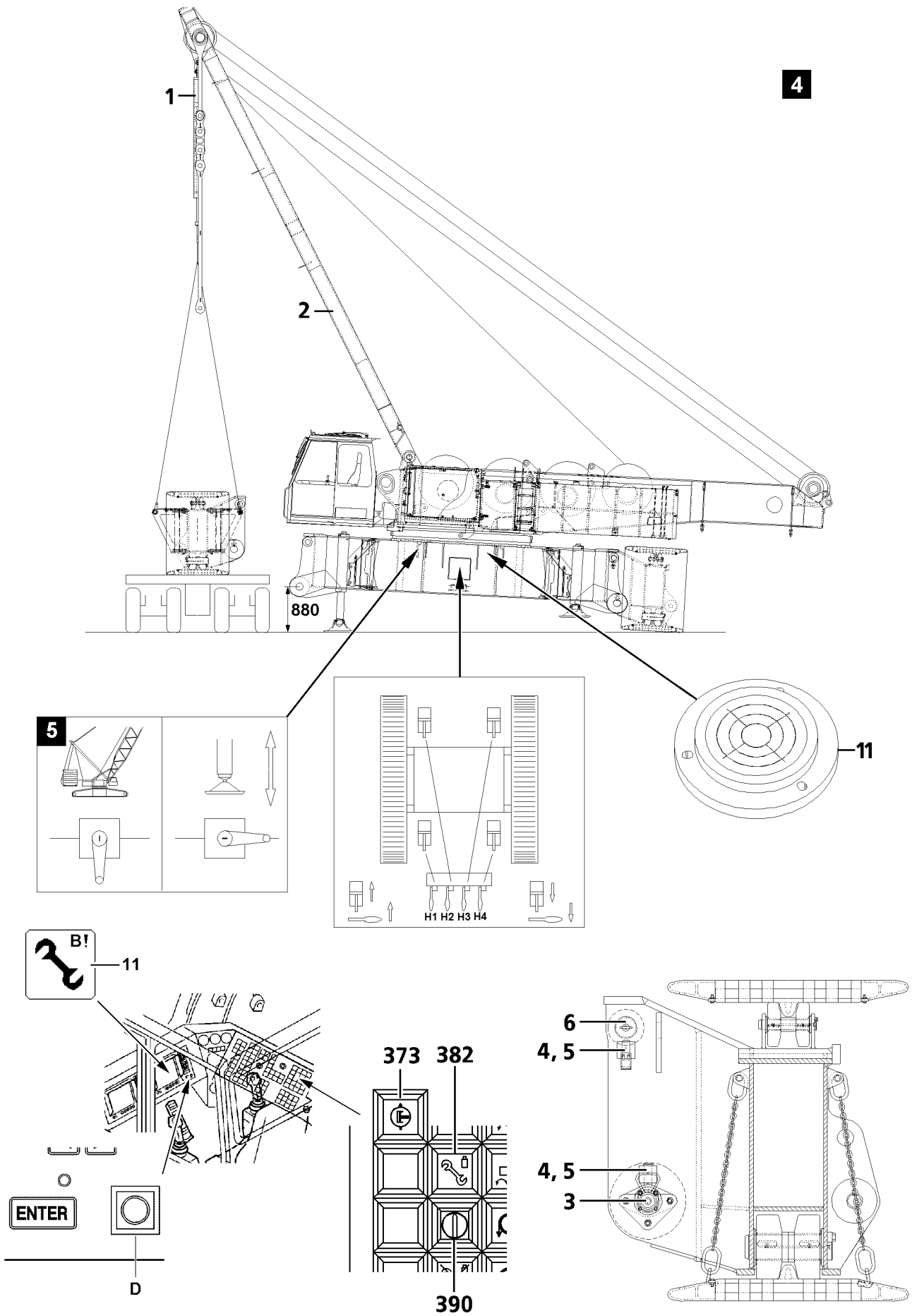

B112518

3.3.2 Disassembling the first crawler carrier

Make sure that the following prerequisite is met:

- The preparations for crawler carrier disassembly have been carried out, see section “Disassembly preparation”.
- The pressure change over switch **373** for the support cylinders in the cab is turned on.
- The engine is running, see Crane operating instructions, chapter 4.03.

For disassembly of the first crawler carrier, the hydraulic support cylinders must be extended on one side, so that one crawler carrier is still on the ground, see illustration 4.

- ▶ Open the ball valve (vertical position), see illustration 5.

Before supporting, the support pads must be supported from below with solid materials, such as wood, steel or concrete slabs, large enough for the ground conditions.



DANGER

Danger of toppling the crane!

- ▶ Only suitable materials may be used for the support!
 - ▶ The support must be placed in the center underneath the support pads!
-
- ▶ Support the support pads properly from underneath.



Note

- ▶ Observe the safety guidelines and permissible ground pressures, see Crane operating instructions, chapter 2.04!
-

- ▶ Actuate the manual lever **H1, H2, H3, H4**.

Result:

- The support cylinders extend.
- ▶ Extend the hydraulic support cylinders on the side of the crawler center section to approx. **880 mm**, see illustration 4.
 - ▶ Close the ball valve (horizontal position), see illustration 5.
 - ▶ Retract the assembly cylinders **1** until the pins **3** and **6** are relieved.
 - ▶ Loosen the retaining pin **4** and spring retainer **5**.
 - ▶ Pull the pin **6** out by hand.
 - ▶ Loosen the retaining pin **4** and spring retainer **5**.
 - ▶ Unpin the pin **3** with the hydraulic pin pulling device.
 - ▶ Move the transport vehicle as close as possible to the crawler carrier.
 - ▶ Carefully move the crawler carrier out from the stop and swing it on receptacle on the transport vehicle.
 - ▶ Remove the attachment equipment and rope guard **15**.

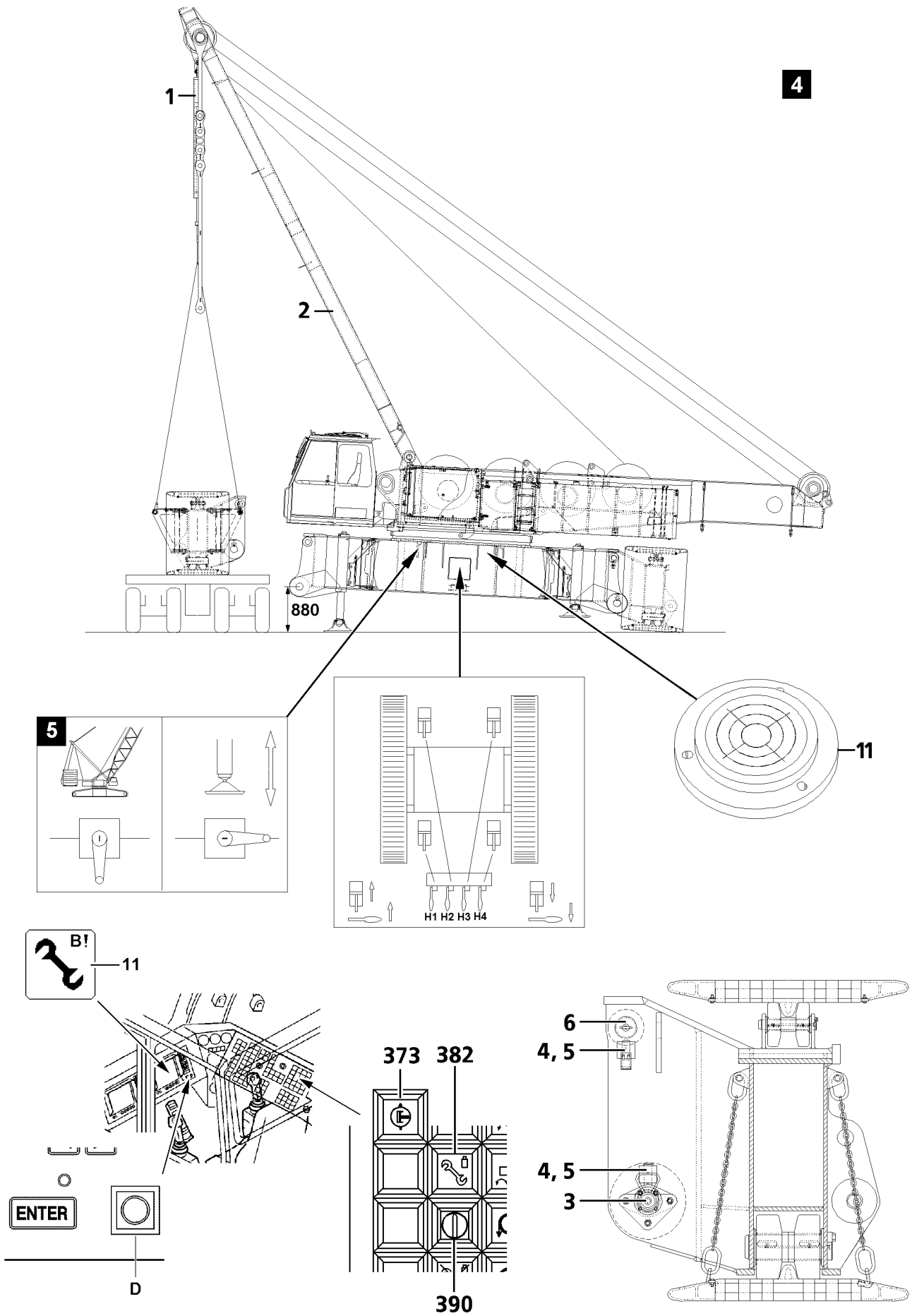

B112518

**DANGER**

Risk of tipping the crane!

- ▶ Before turning the turntable, the still assembled crawler carrier must be standing on the ground!
- ▶ Turn the turntable.

**DANGER**

Risk of tipping the crane!

- ▶ After turning the turntable, bring the crane into horizontal position with the hydraulic support cylinders!

For disassembly of the second crawler carrier, the hydraulic support cylinders must be extended on the other side, so that the crawler center section is in horizontal position, see illustration 6.

- ▶ Open the ball valve (vertical position), see illustration 5.

Before supporting, the support pads must be supported from below with solid materials, such as wood, steel or concrete slabs, large enough for the ground conditions.

**DANGER**

Danger of toppling the crane!

- ▶ Only suitable materials may be used for the support!
- ▶ The support must be placed in the center underneath the support pads!
- ▶ Support the support pads properly from underneath.

**Note**

- ▶ Observe the safety guidelines and permissible ground pressures, see Crane operating instructions, chapter 2.04!

- ▶ Actuate the manual lever **H1, H2, H3, H4**.

Result:

- The support cylinders extend.
- ▶ Extend the hydraulic support cylinders on the other side of the crawler center section until it is in horizontal position, see illustration 6.
- ▶ Check the horizontal position of the crane with the spirit level 11.
- ▶ Close the ball valve (horizontal position), see illustration 5.
- ▶ Turn the pressure change over switch **373** off in the cab.

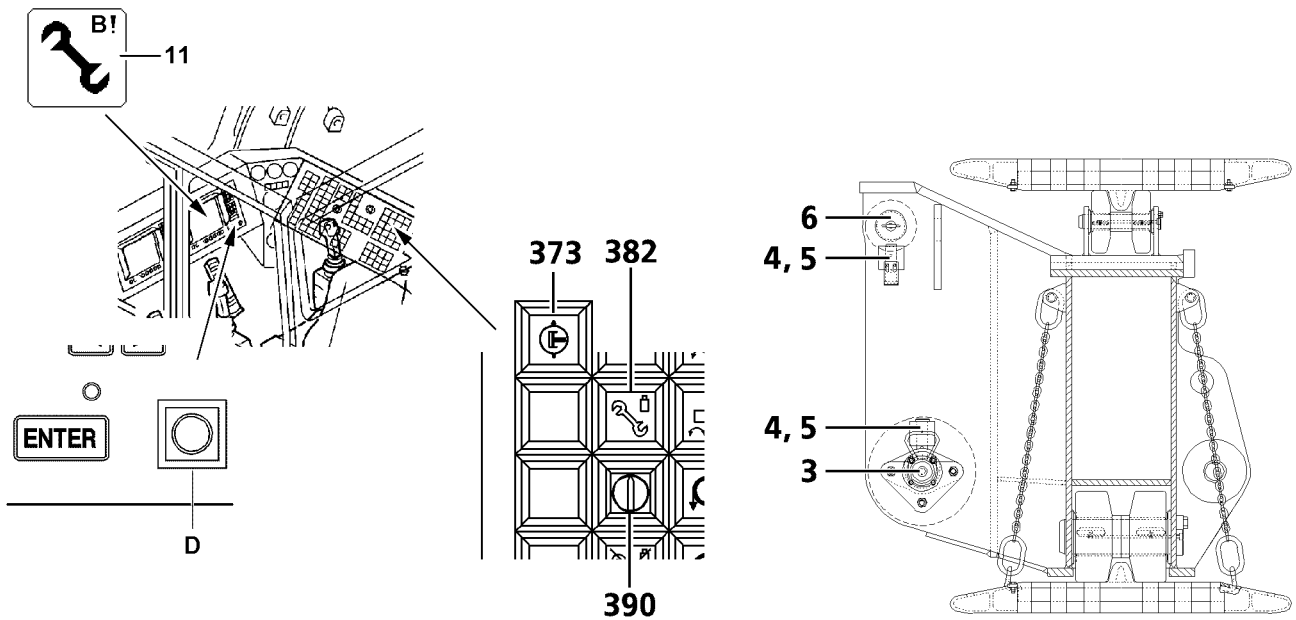
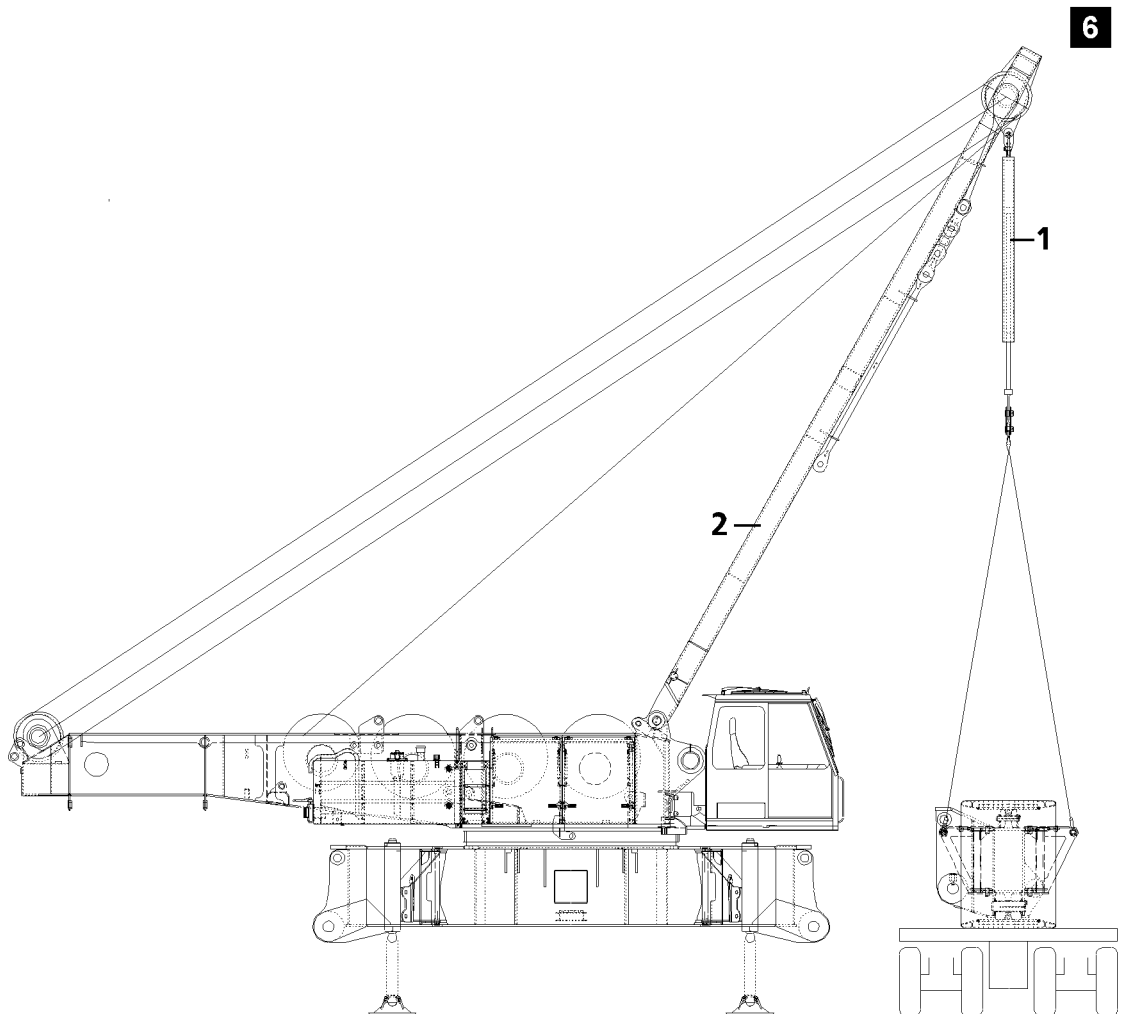

B112512

3.3.3 Disassembling the second crawler carrier

Make sure that the following prerequisite is met:

- The preparations for crawler carrier disassembly have been carried out, see section “Disassembly preparation”.
- The crane is supported horizontally.
- The engine is running, see Crane operating instructions, chapter 4.03.



DANGER

Risk of tipping the crane!

- ▶ The maximum radius of 5.5 m (approx. 61°) may not be exceeded when lifting the crawler carrier. The pendulum on the SA-bracket must remain in the green range (approx. 61° - 75°), see illustration 2!

- ▶ Pay attention to the display of the pendulum on the SA-bracket, see illustration 3.



WARNING

Risk of accident!

- ▶ When the key button **390** “Crawler assembly” is turned on, there is no overload shut off for the assembly cylinder **1** as well as for the crane!

- ▶ Retract the assembly cylinders **1** until the pins **3** and **6** are relieved.
- ▶ Loosen the retaining pin **4** and spring retainer **5**.
- ▶ Pull the pin **6** out by hand.
- ▶ Loosen the retaining pin **4** and spring retainer **5**.
- ▶ Unpin the pin **3** with the hydraulic pin pulling device.
- ▶ Move the transport vehicle as close as possible to the crawler carrier.
- ▶ Carefully move the crawler carrier out from the stop and swing it on receptacle on the transport vehicle.
- ▶ Remove the attachment equipment and rope guard.
- ▶ Retract the assembly cylinder **1** completely.
- ▶ Erect the SA-bracket **2** to 90°.

7

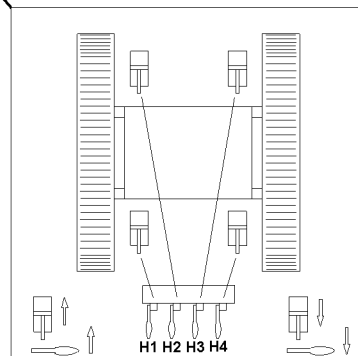
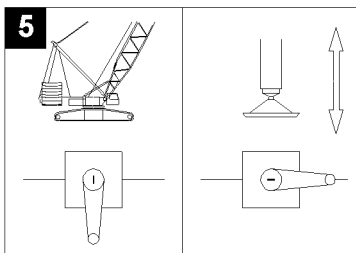
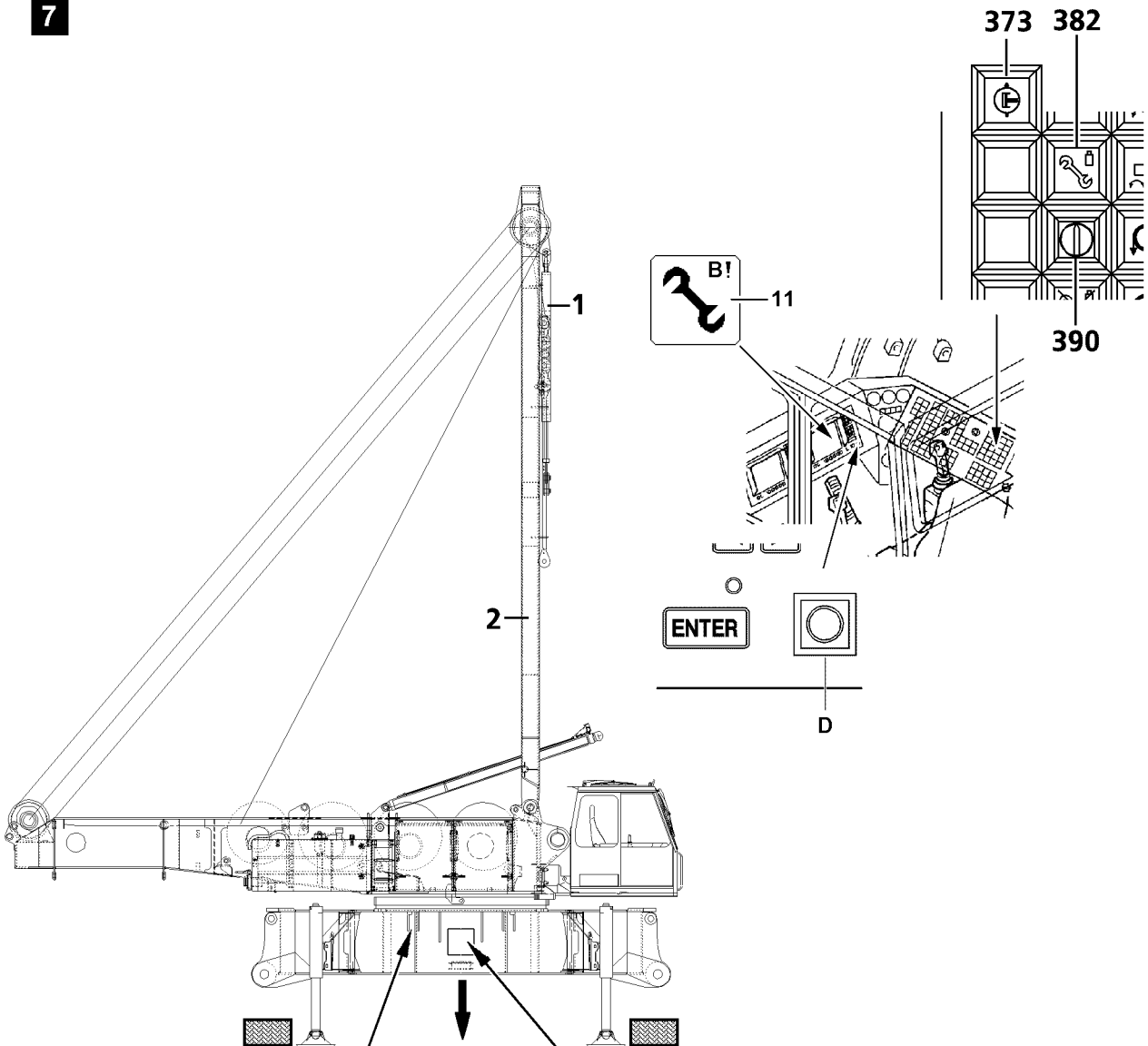

B112514

3.3.4 Lowering the turntable and the crawler center section with the hydraulic support cylinders on the support

Make sure that the following prerequisites are met:

- The SA-bracket **2** is positioned at least at 90°.
- The set up key **D** and the key button **390** “Crawler assembly” are actuated.
- The indicator light “Crawler assembly **382**” lights up.
- The assembly icon **11** is visible on the LICCON monitor.
- The pressure change over switch **373** for the support cylinders in the cab is turned on.
- The ball valve is open (positioned vertically), see illustration **5**.
- The engine is running, see Crane operating instructions, chapter 4.03.

Lowering

The support must be made with stable materials, large enough for the ground conditions.



Note

- ▶ Observe the safety guidelines and permissible ground pressures, see Crane operating instructions, chapter 2.04!



DANGER

Danger of toppling the crane!

- ▶ Only suitable materials may be used for the support!
- ▶ The SA-bracket must be erected at least to 90°!
- ▶ Support the turntable and the crawler section properly.
- ▶ Actuate the manual lever **H1, H2, H3, H4**.

Result:

- The support cylinders retract.



Note

- ▶ Lower the crane horizontally to the support!



DANGER

Risk of accident!

- ▶ Pay attention to the horizontal position of the crane during the lowering procedure!
- ▶ After lowering, the ball valve must be closed, see illustration **5**!
- ▶ The ball valve **3** for the SA-bracket must be in operating position “down” during assembly and crane operation, see illustration **8**!
- ▶ The ball valve position “STOP” and “up” are only permissible when lowering the SA-bracket onto the turntable (transport position)!
- ▶ Close the ball valve (horizontal position), see illustration **5**.
- ▶ Turn the pressure change over switch **373** off in the cab.

8

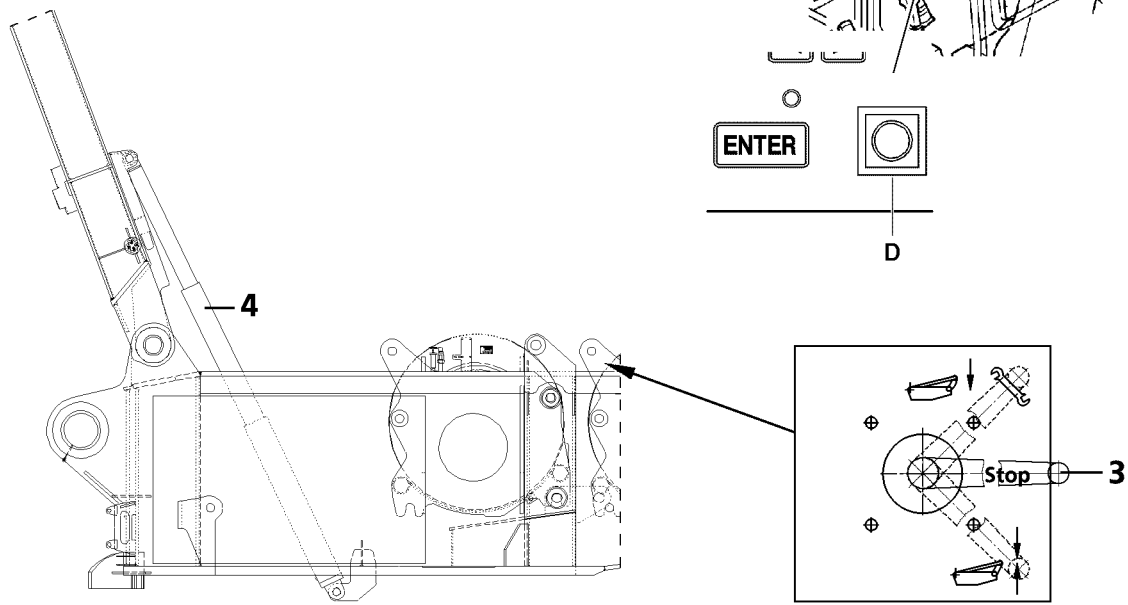
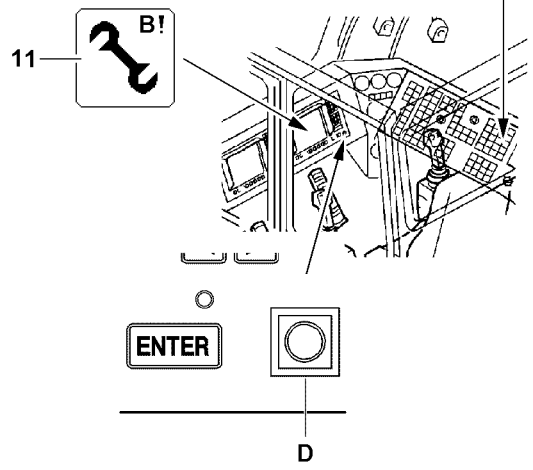
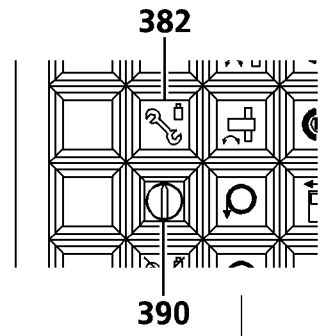
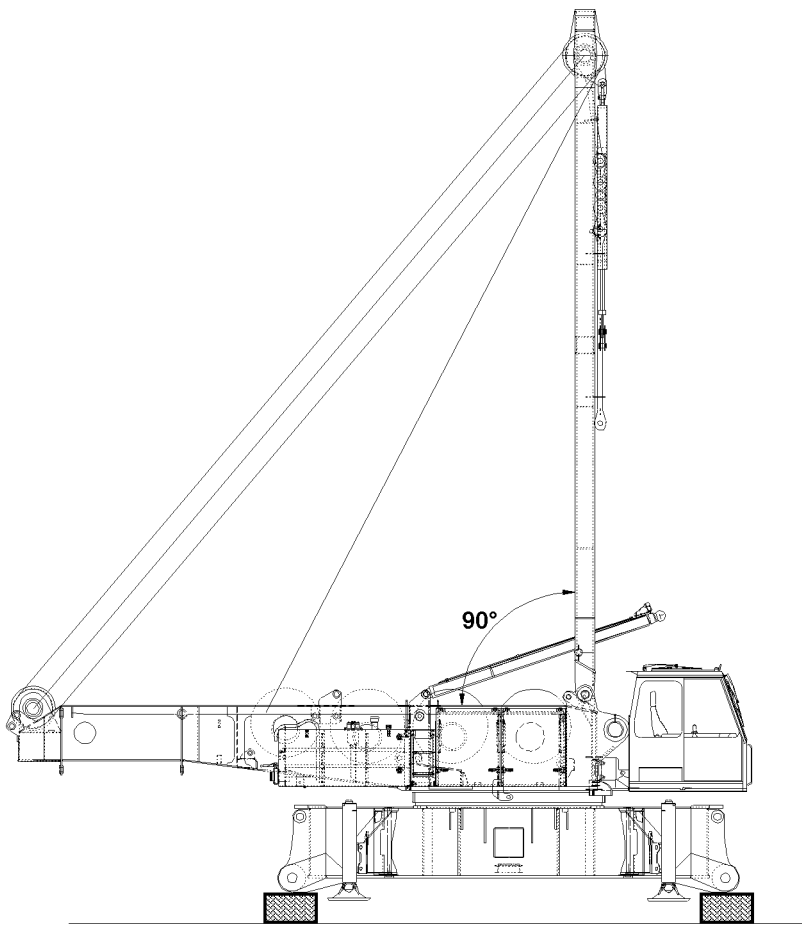

B112513

3.3.5 Placing the SA-bracket down

Make sure that the following prerequisites are met:

- The engine is running, see Crane operating instructions, chapter 4.03.
- The set up key **D** and the key button **390** "Crawler assembly" are actuated.
- The indicator light "Crawler assembly **382**" lights up.
- The assembly icon **11** is visible on the LICCON monitor.



Note

- ▶ Pay attention to the master switch assignment for turned on key switches, see Crane operating instructions, chapter 4.05!
-



DANGER

Danger of toppling the crane!

- ▶ When the key button "Crawler assembly" is turned on, there is no overload shut off for the assembly cylinder as well as for the crane!
-

Take down procedure

- ▶ Move the ball valve **3** into operating position **down**.

Result:

- The SA-bracket is pulled back against the erection cylinder **4** by spooling up winch 4.

- ▶ Spool up winch 4 by actuating the master switch "1" until the SA-bracket **2** is positioned approx. at 10°.

- ▶ Move the ball valve **3** into operating position **up**.

Result:

- The SA-bracket **2** is place down completely.

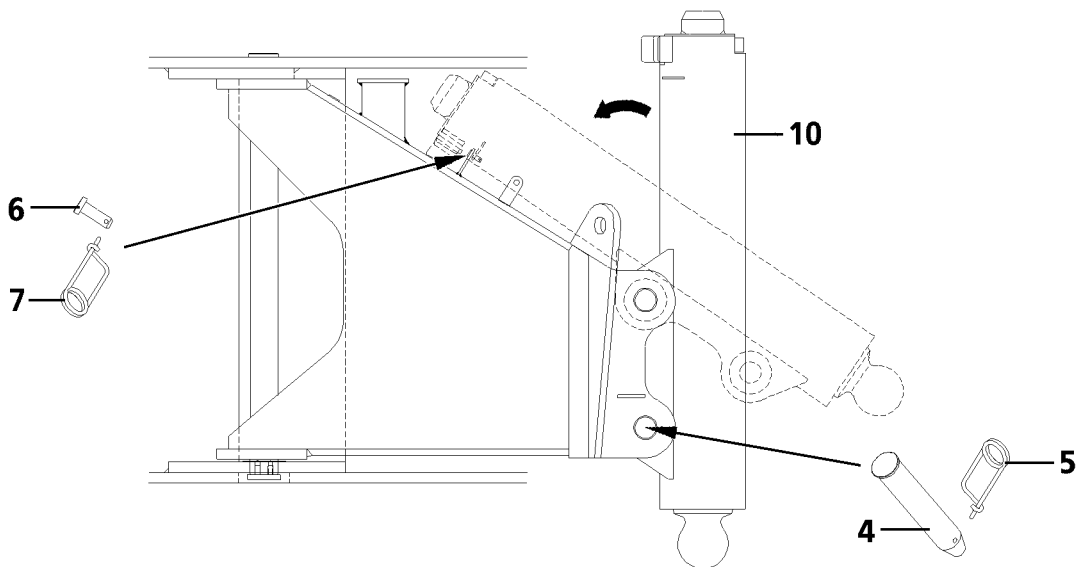
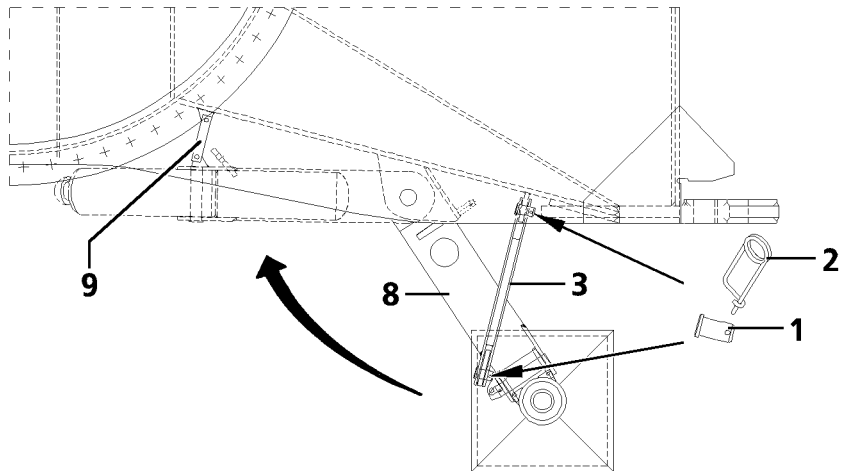
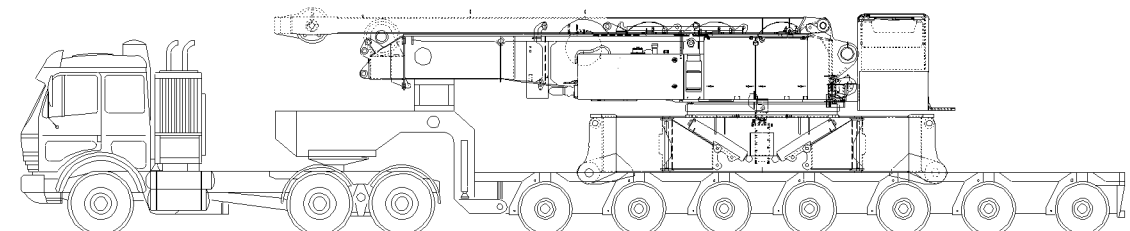
9**10**

3.3.6 Swinging the hydraulic support in

After crawler disassembly, the hydraulic supports on the crawler center section must be swung in for transport, see illustration 9.

- ▶ Loosen the pin 1 and spring retainer 2.
- ▶ Remove the bracket 3.
- ▶ Remove pin 4 and spring retainer 5.
- ▶ Loosen the pin 6 and spring retainer 7.
- ▶ Tilt the cylinder 10 into transport position.
- ▶ Insert the pin 6 to secure the cylinder 10 and secure with spring retainer 7.
- ▶ Insert the pin 4 and secure with spring retainer 5.
- ▶ Swing the hydraulic supports 8 in.
- ▶ Secure the hydraulic supports with the transport retainer 9.

3.3.7 Setting the turntable and the crawler center section onto the transport vehicle

For the following tasks, the turntable and the crawler center section must be lifted with an auxiliary crane from the support onto the transport vehicle.

Make sure that the following prerequisite is met:

- An auxiliary crane is available.
- ▶ Lift the turntable and the crawler center section with the auxiliary crane.
- ▶ Set the turntable and the crawler center section down on the transport vehicle, see illustration 10.

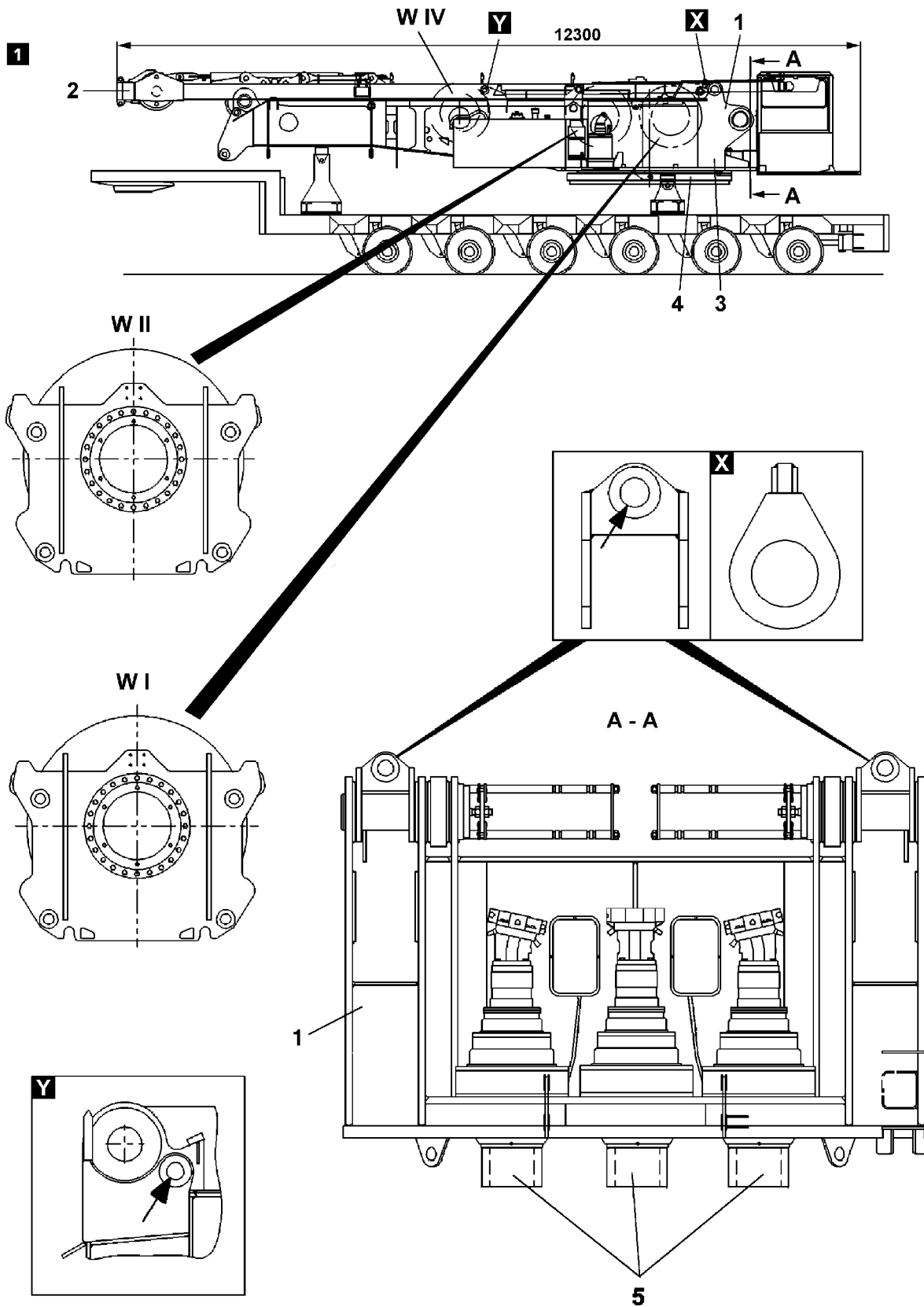

B194503

1 Assembly of turntable with Quick Connection*

To bypass height limitations at transport, the turntable can be separated from the crawler center section with the Quick Connection* device. In that case, the turntable as well as the crawler center section are each transported on a separate transport vehicle.

1.1 Transport weights and centers of gravity of the turntable

For parts installed on the turntable, see fig. 1 :

- Winch IV including rope
- SA-bracket 2 including pulley set
- Assembly winch 3 including rope
- Upper section 4 of the rotary connection with Quick Connection
- One to three slewing gears 5, depending on equipment

Weights turntable:

Turntable	Winch I including rope (4.2 t)	Winch II including rope (4.2 t)
Weight 33.1 t	---	---
Weight 37.3 t	---	X
Weight 41.5 t	X	X

Centers of gravity turntable:

For centers of gravity, see chapter 3.01.

2 Installing the turntable

2.1 Lift the turntable from transport vehicle

Ensure that the following preconditions are met:

- The brackets X are pinned on the receptacle points for the pivot section, see sectional view A-A.



DANGER

Risk of accident!

- ▶ Make sure that the brackets X are pinned correctly.
- ▶ Attach the tackle 14 to the receptacle points X and Y.
- ▶ Bring the tackle 14 to "tension".
- ▶ Release and remove the transport retainer on the turntable 1.
- ▶ Lift the turntable 1 with the auxiliary crane from the transport vehicle.



DANGER

Risk of accident!

- ▶ Make sure that the tackle is attached correctly and sufficiently secured to prevent it from loosing up.
- ▶ Attach the tackle 14 to the intended receptacle points X and Y.

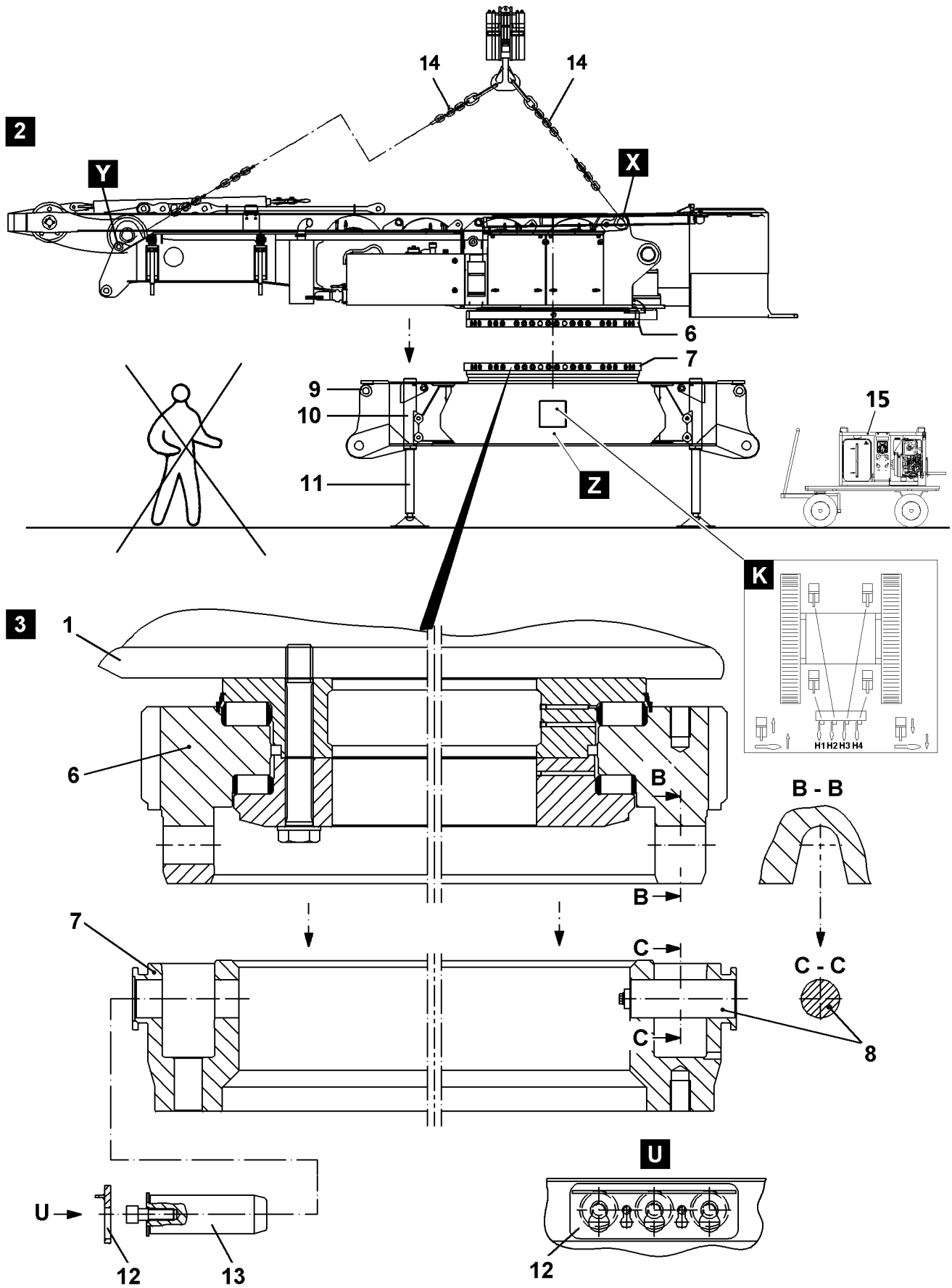

B104573

2.2 Installing the turntable

2.2.1 Cleaning the rotary connection

Before setting the turntable onto the crawler center section, the placement surfaces or the contact surfaces as well as the pin bores on the upper section **6** and the lower section **7** on the rotary connection must be cleaned.



WARNING

Property damage!

- ▶ If dirt on the rotary connection cannot be removed, then severe damage can occur, which even might require a replacement of the rotary connection.

2.2.2 Setting the turntable on the crawler center section with the auxiliary crane

Ensure that the following prerequisites are met:

- The hydraulic support **10** on the crawler center section **9** is swung out, locked and pinned.
- The hydraulic support cylinders **11** are extended with the pin pulling device **15** connected on point **Z** on the hydraulic lines and with the manual levers, see fig. **K**.
- The crawler center section **9** is horizontally aligned.
- The upper **6** and lower sections **7** of the rotary connection have been cleaned.
- The two centering pins **8** are installed and secured on the lower section of the rotary connection.
- The centering pins **8** are greased with water repellent grease.
- The tackle **14** is attached on the receptacle points **X** and **Y** of the turntable, see fig. **2**.



DANGER

Risk of accident!

- ▶ It is prohibited for anyone to remain within the slewing range of the auxiliary crane and under the turntable when swinging the turntable in and lowering it.
- ▶ Swing the turntable **1** with the auxiliary crane slowly over the supported and horizontally aligned crawler center section.



Note

- ▶ Pay attention to the precise alignment of the turntable or the receptacles to the centering pins **8**.
- ▶ Before lowering it, bring the turntable into position so that the centering pins **8** can be “paired” on the lower section **7** and the receptacles **B-B** on the upper section **6**. It is not possible to “incorrectly” set the turntable on the lower section **7** due to the arrangement design of the centering pins **8**.

- ▶ Lower the turntable **1** slowly.



DANGER

Risk of crushed limbs!

During the installation of the upper and lower section of the rotary connection, fingers and hands can be crushed and limbs can be severed.

- ▶ During the turntable installation, do not reach with your hands into the danger zone.
- ▶ Carefully place the turntable **1** on the crawler center section.
- ▶ Lower the turntable **1** on the lower section to the point where the tackle **14** is still “tensioned”.

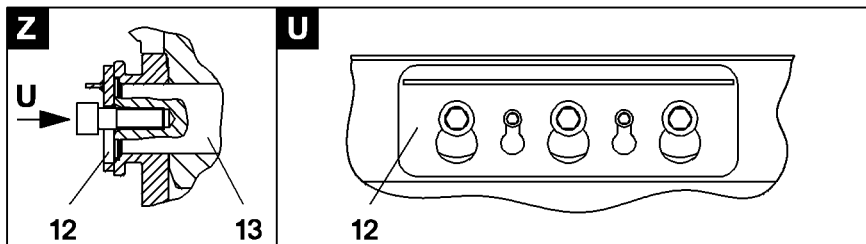
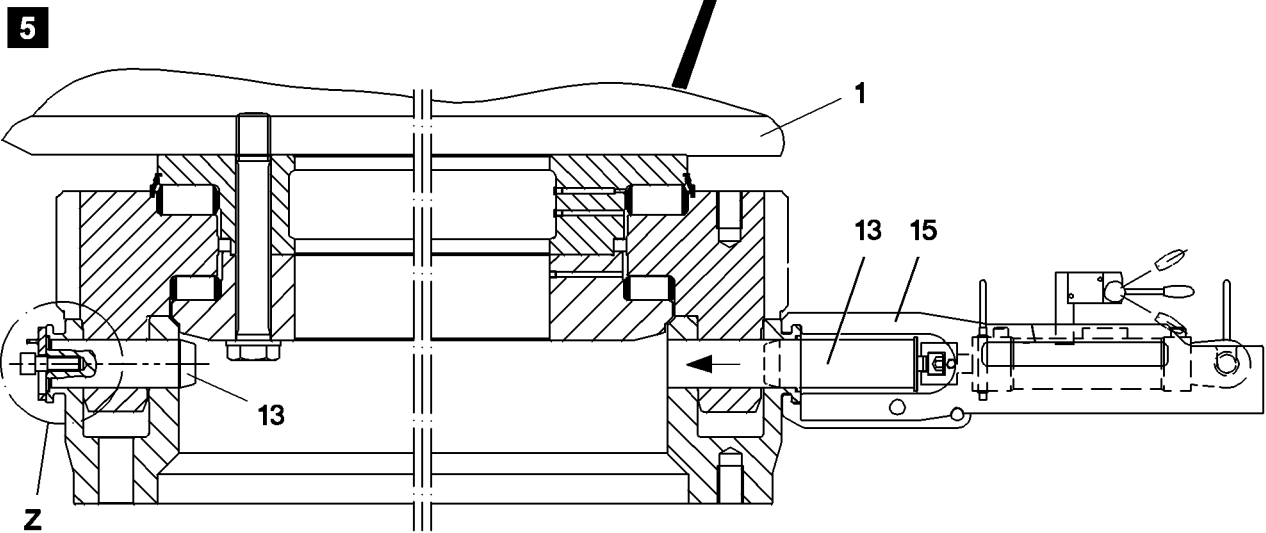
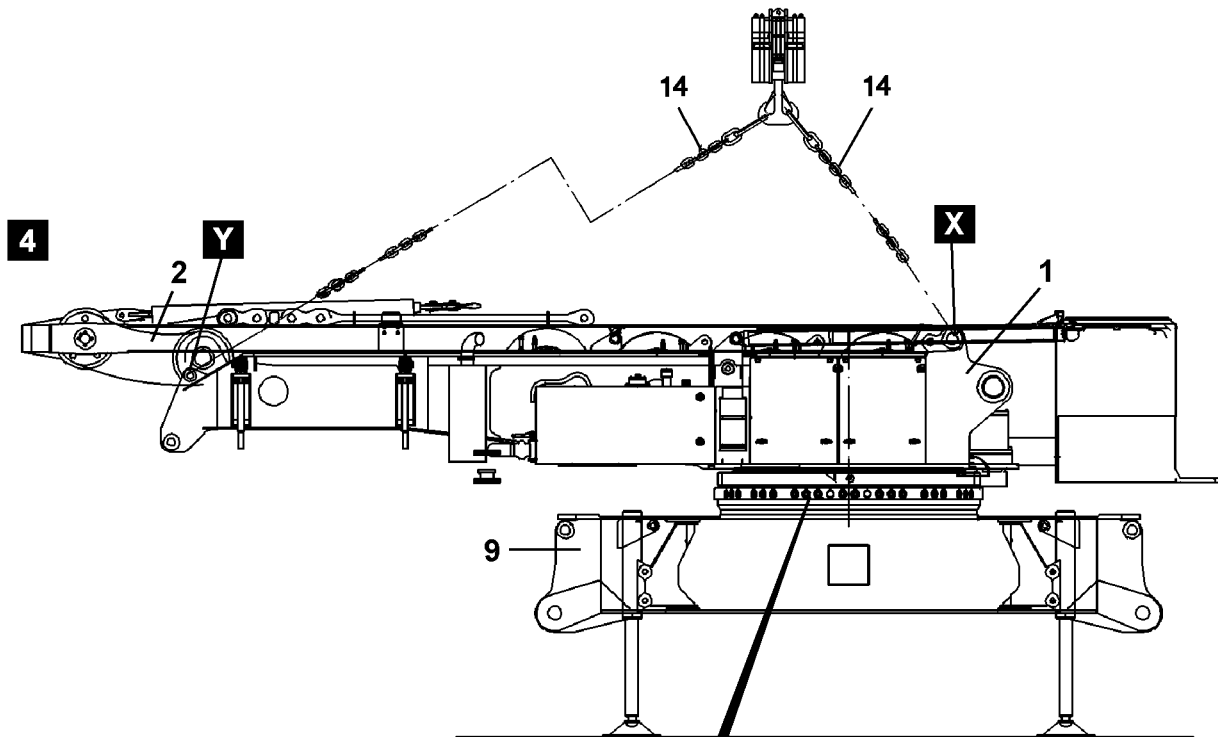

2.2.3 Pin the turntable with the quick-connection

Ensure that the following prerequisites are met:

- The turntable **1** is seated on the crawler center section **9**.
 - The tackle **14** between the turntable and the crawler center section is “tensioned”.
 - The pin bores are clear on the circumference of the rotary connection.
- ▶ Grease all connector pins **13** with water repellent grease.
 - ▶ Insert all connector pins **13** by hand to the stop, to pin the turntable with the crawler center section **9**, see fig. **5**.
 - ▶ If they are hard to pin, use the pin pulling device **15** for pinning.



DANGER

Risk of accident!

- ▶ The connector pins **13** must be secured immediately after pinning the turntable to the crawler center section **9**.
-
- ▶ Attach the retaining bars **12** and secure the connector pins **13**, see fig. **U**.
 - ▶ After pinning and securing the rotary connection, remove the tackle **14**.

2.2.4 Establishing the hydraulic connection to the turntable

Ensure that the following prerequisites are met:

- The turntable is pinned and secured on the rotary connection.

The hydraulic connection from the rotary connection in the crawler center section to the turntable is established with quick couplers.



Note

- ▶ The matching quick couplers are marked.
- ▶ Establish the hydraulic connections.



Note

- ▶ For connection or release of hydraulic lines with quick couplers, see chapter 5.01.

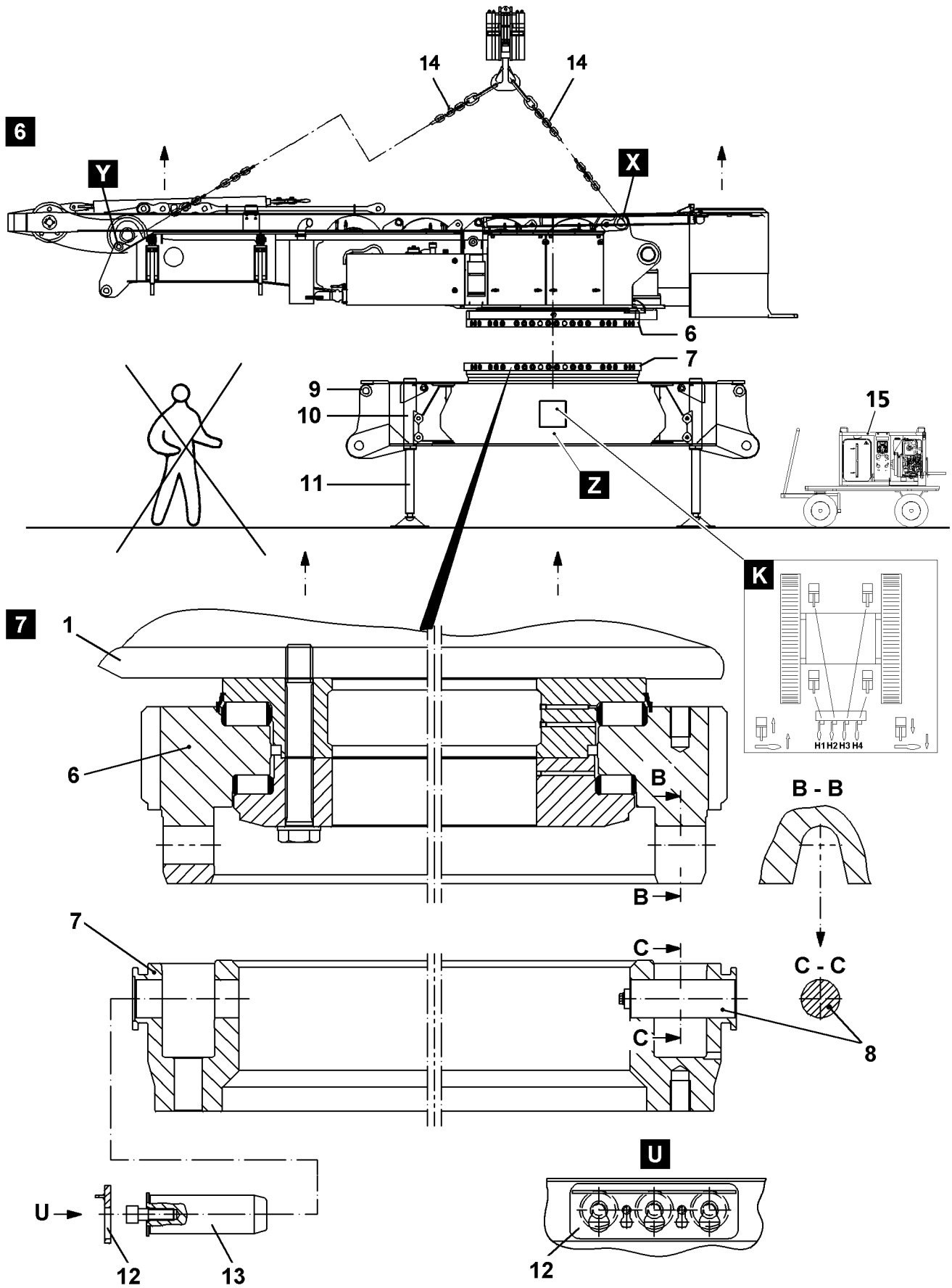

B104574

3 Disassembly of the turntable with Quick Connection*

3.1 Removing the turntable

Ensure that the following prerequisites are met:

- An auxiliary crane is available.
- The turntable ballast and the boom system are removed.
- The crawler carriers are removed.
- The hydraulic support **10** on the crawler center section **9** is swung out, locked and pinned.
- The hydraulic support cylinders **11** are extended with the pin pulling device **15** connected on point **Z** on the hydraulic lines and with the manual levers, see fig. **K**.
- The crawler center section **9** is horizontally aligned.
- The SA-bracket **2** is placed on the turntable **1**.
- The hydraulic connections on the rotary connection to the turntable are separated.
- The brackets are installed and pinned on point **X**.
- The tackle **14** is attached on the receptacle points **X** and **Y** of the turntable, see fig. **6**.



WARNING

Disconnect the hydraulic connection!

- ▶ Make sure that all hydraulic connections between the rotary connection and the turntable are separated.

- ▶ Bring the tackle **14** with the auxiliary crane to “tension”.
- ▶ Release and remove the retaining bars **12**, see fig. **U**.
- ▶ Unpin all connector pins **13**, using the pin pulling device **15**.



CAUTION

Remove the connector pins!

- ▶ Before lifting the turntable with the auxiliary crane, make sure that **all** connector pins **13** of the Quick connection have been removed.

- ▶ Carefully lift the turntable **1** with the auxiliary crane and set it on the transport vehicle.

1

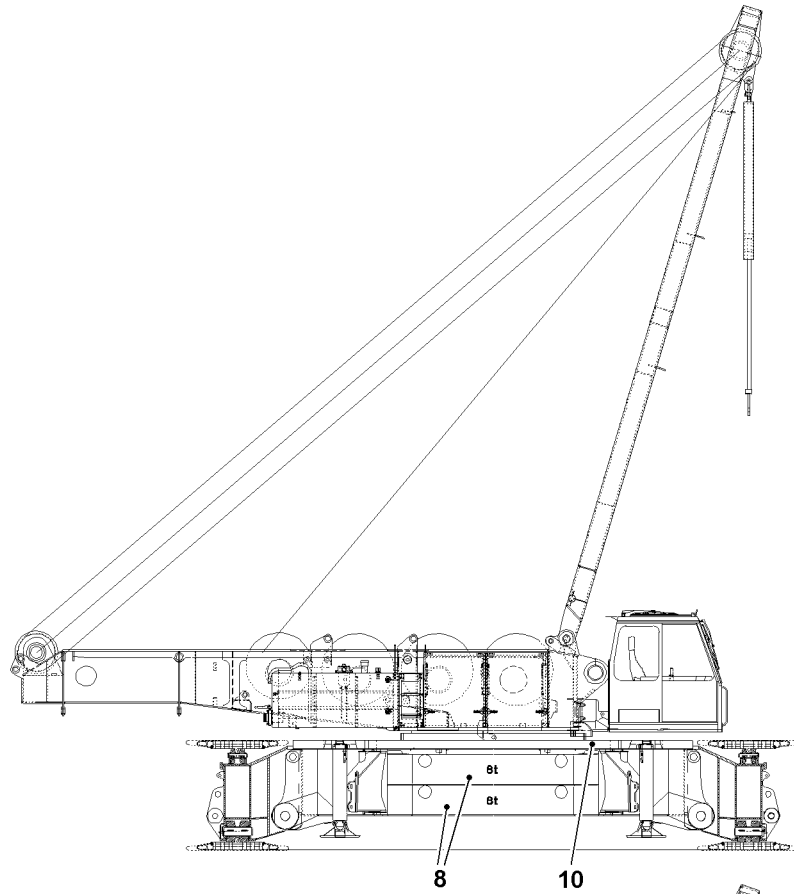

2

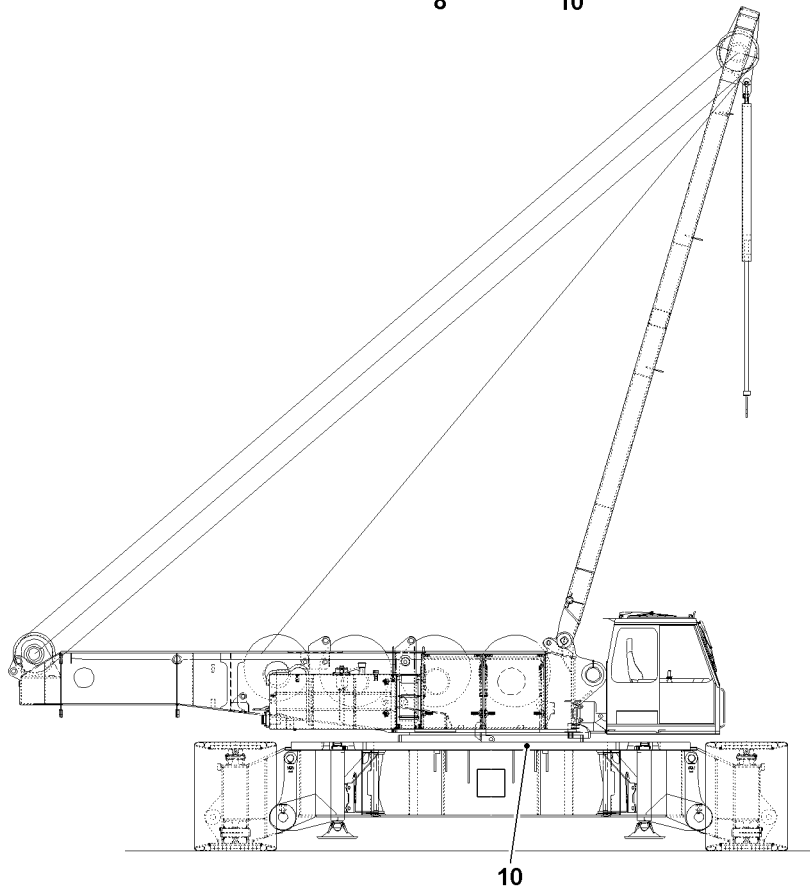

B104570

1 General

The crawler crane can be operated with two different central ballast versions:

- 1.) Central ballast 43 t, see fig. 1
- 2.) Central ballast 11 t, see fig. 2

2 Assembly of central ballast

Central ballast variation	Quantity	Description	Position	Illustration
43 t	2	Ballast frame		1
	4	Ballast plate 8.0 t	8	
11 t	2	Counterweight plate 5.5 t	10	
	2	Counterweight plate 5.5 t	10	2

The central ballast is installed with an auxiliary crane.



DANGER

Danger of impact and crushing!

Due to presence near the ballast assembly, there is an increased danger of impact and crushing when the ballast plates are "placed".

- ▶ Exercise extreme caution when lifting the ballast.
- ▶ Never allow people to stand under a suspended ballast.
- ▶ Exercise extreme caution when lowering the ballast. Danger of crushing people in the immediate area of the ballast being lowered.

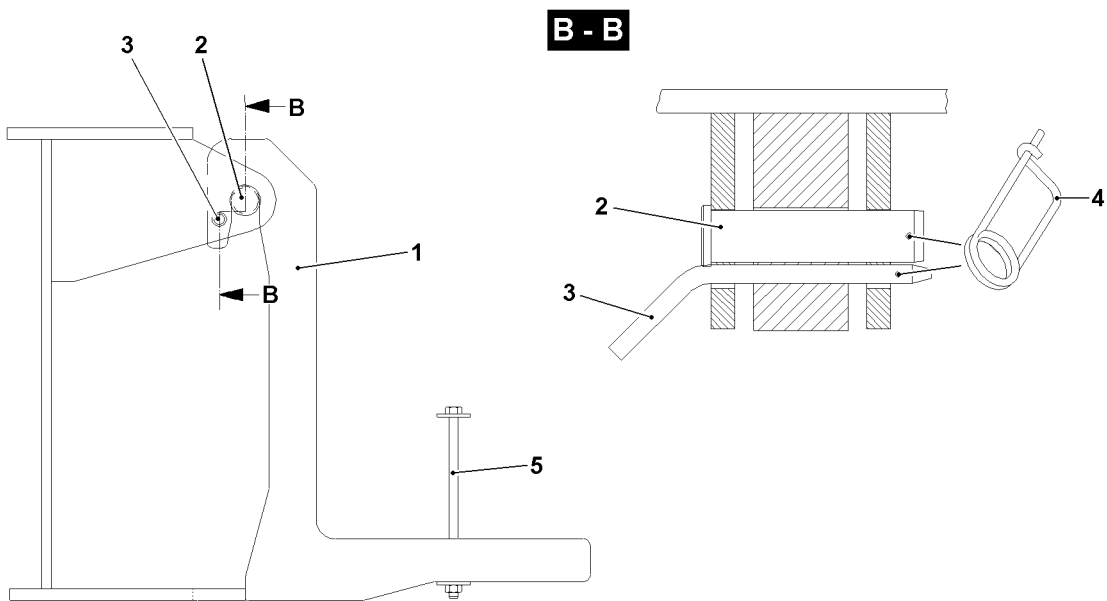
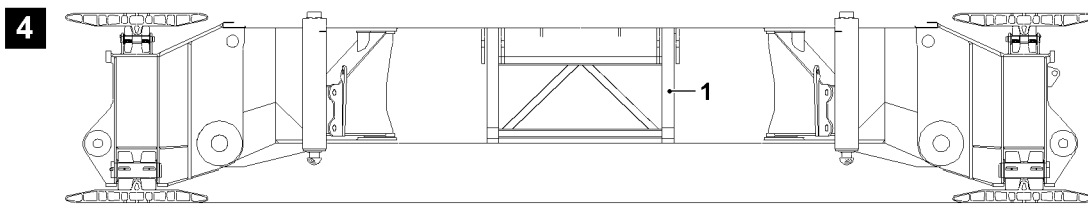
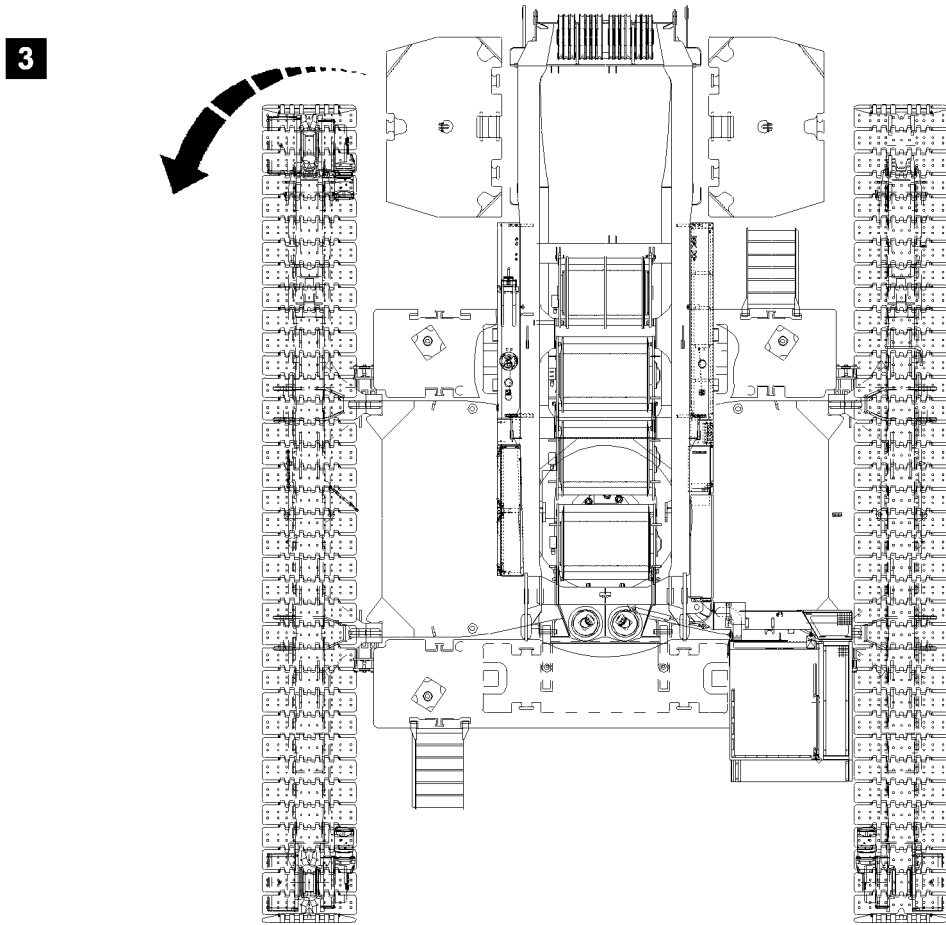

B104568

3 Installing the central ballast 43 t

Ensure that the following prerequisites are met:

- The installation of the crawler carrier is completed.
- All connections between the crawler center section and the crawler carrier are pinned and secured.
- The hydraulic support is swung out, locked and pinned.
- The hydraulic support cylinders are completely retracted.
- Both crawler carriers are standing on the ground.
- The turntable is turned by 90° in travel direction, see fig. 3.
- The pin 2 is inserted in the receptacle of the ballast frame and is secured with the spring retainer 4.
- An auxiliary crane is available.

3.1 Installing the ballast frame

The ballast frame is used to retain the ballast plates. It must be installed first on the crawler center section.

- ▶ Release the spring retainer 4 on the pin 3.
- ▶ Remove the pin 3.
- ▶ Hang the ballast frame 1 with the auxiliary crane on the pin 3.



WARNING

Risk of accident!

- ▶ Make sure that the ballast frame 1 is correctly hung on the crawler center section.
-
- ▶ Insert the pin 3 to secure the ballast frame 1 and secure with spring retainer 4.

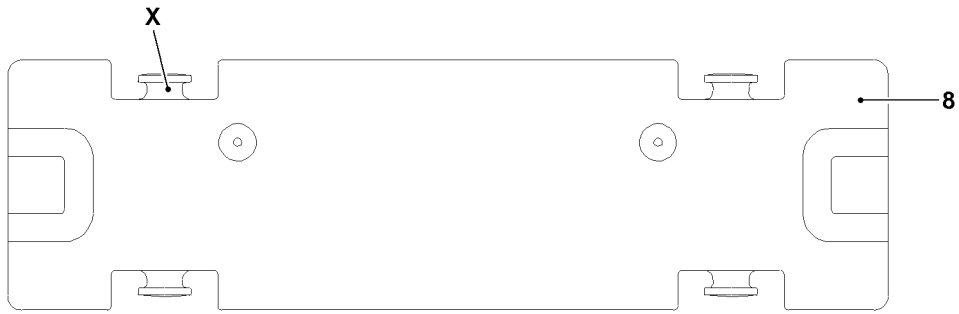

5

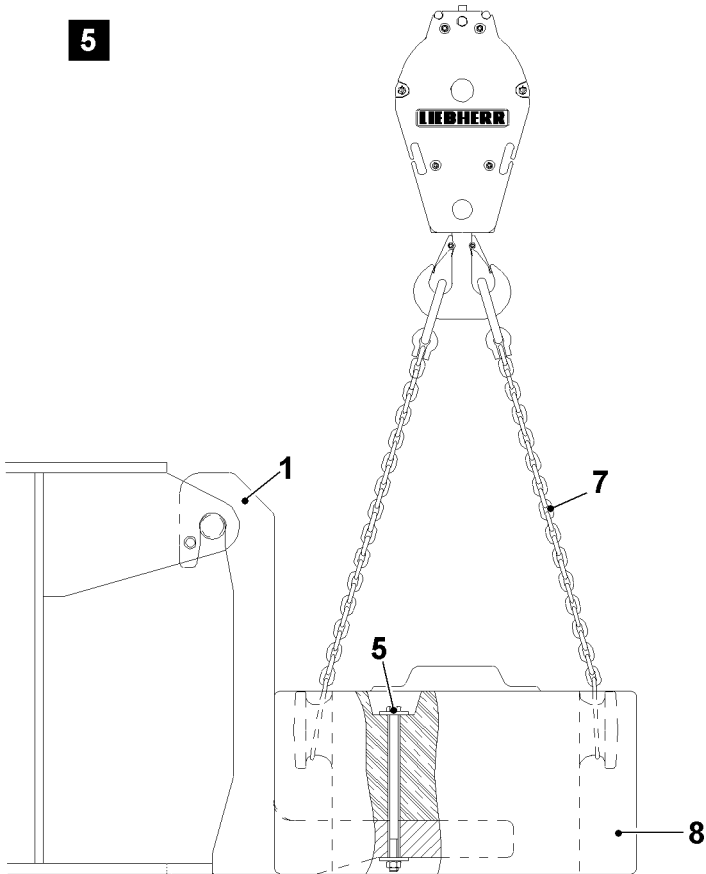

6

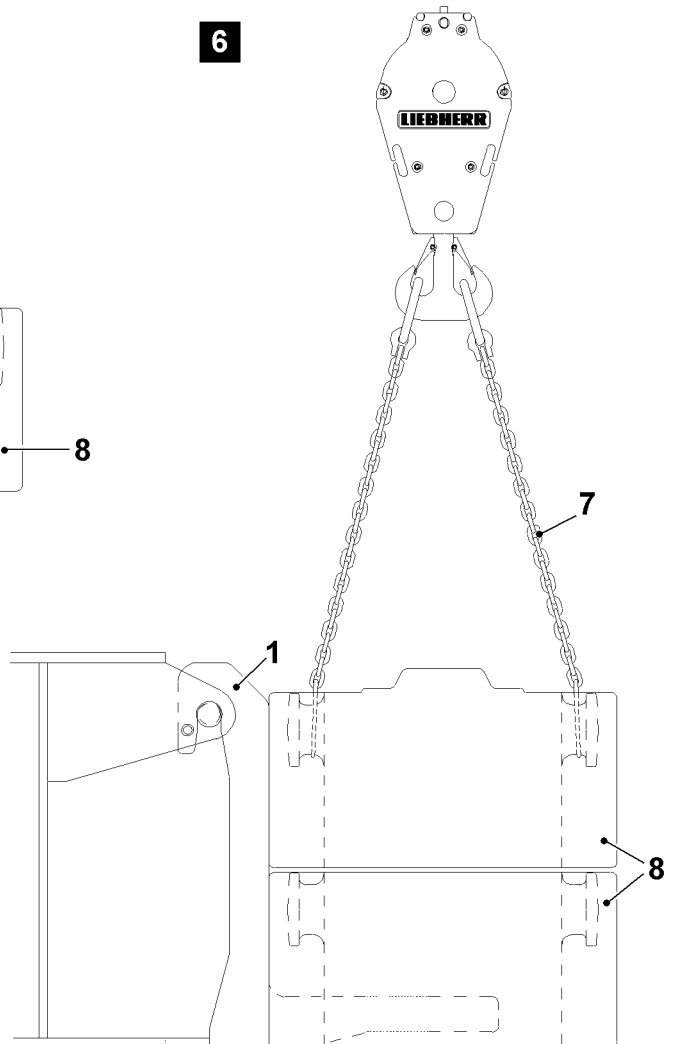

3.2 Place the ballast plates on the ballast frame



DANGER

Danger of crushing!

If the following note is not observed, severe injuries can occur.

- ▶ It is prohibited for anyone to remain between the ballast frame and the crawler carriers while the ballast plates are placed.



DANGER

Risk of accident!

If the following note is not observed, property damage on the crane can occur.

- ▶ Install the central ballast only according to the load chart.

3.2.1 Place the first ballast plate

Ensure that the following prerequisites are met:

- The ballast frame **1** is properly installed.
- ▶ Attach the tackle **7** to the bitts **X** of the ballast plate **8**.



WARNING

Risk of accident!

- ▶ Make sure that the tackle **7** is correctly attached on the bitts **X** and that it is secured sufficiently to prevent it from loosening up.
- ▶ Position the first ballast plate with the auxiliary crane and place it on the ballast frame **1**, see fig. **5**.
- ▶ Lower the ballast plate **8** all the way on the ballast frame **1** until the tackle **7** is relieved.



Note

- ▶ Do not loosen the tackle **7** on the ballast plate **8** until it is secured on the ballast frame **1** with the screw **5**.
- ▶ Secure the ballast plate **8** with the screw **5** on the ballast frame **1**.
- ▶ Loosen the tackle **7** on the ballast plate **8**.

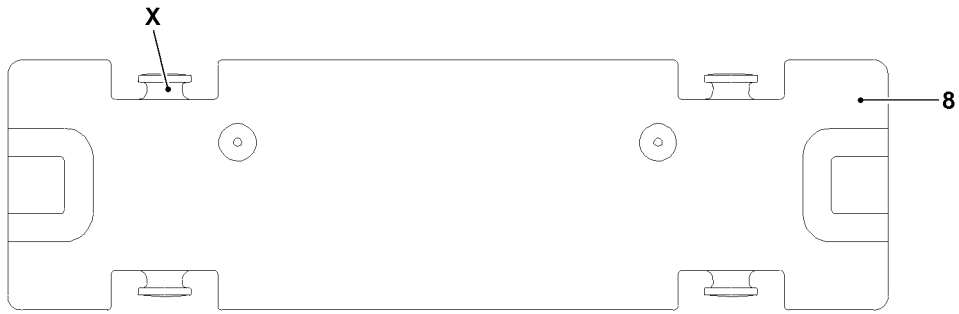

5

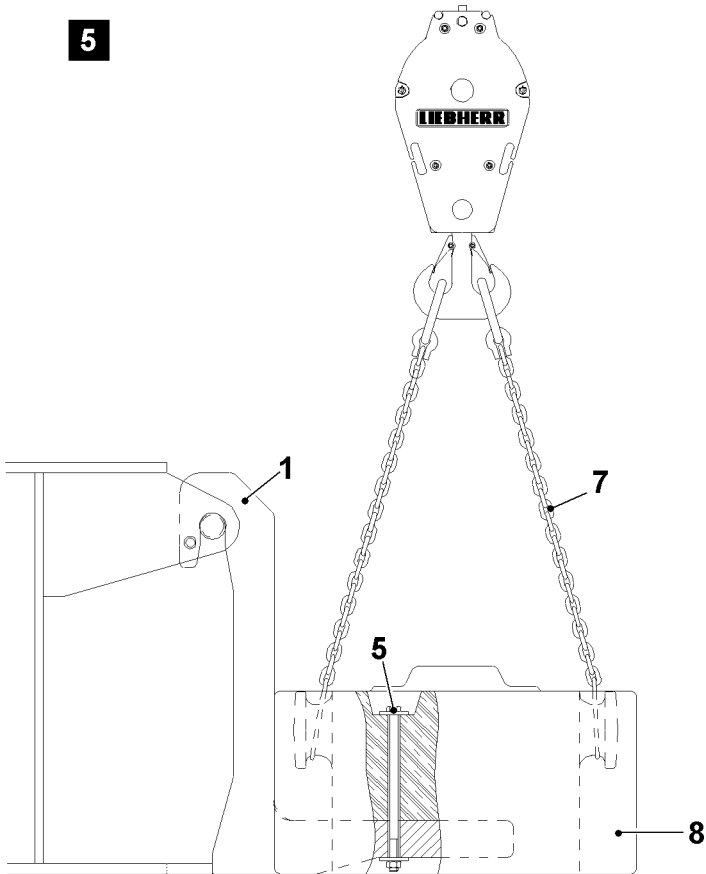

6

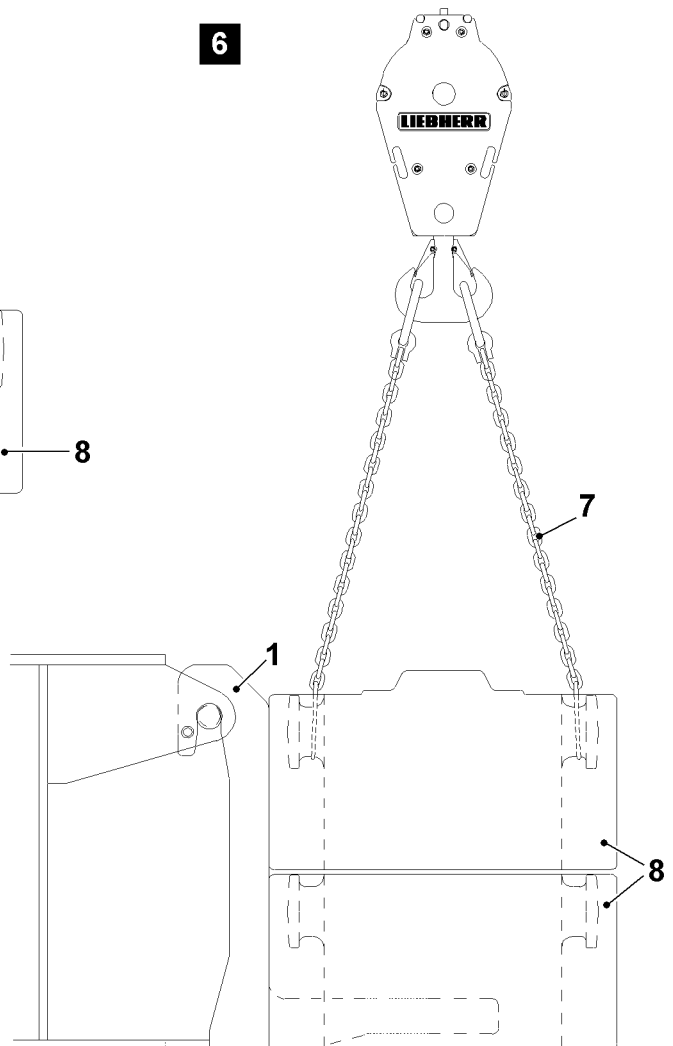

3.2.2 Place the second ballast plate

Ensure that the following prerequisites are met:

- The first ballast plate is laying on the ballast frame **1** and is secured with the screw **5**.
- ▶ Attach the tackle **7** to the bitts **X** of the ballast plate **8**.



WARNING

Risk of accident!

- ▶ Make sure that the tackle **7** is correctly attached on the bitts **X** and that it is secured sufficiently to prevent it from loosening up.
-
- ▶ Place the second ballast plate with the auxiliary crane on the first ballast plate, see fig. **6**.
 - ▶ Lower the ballast plate **8** all the way on the first ballast plate until the tackle **7** is relieved.
 - ▶ Loosen the tackle **7** on the ballast plate **8**.

3.3 Installing the counterweight plate



Note

- ▶ For assembly of counterweight plate, see section “Installing the central ballast 11 t”.
-

7

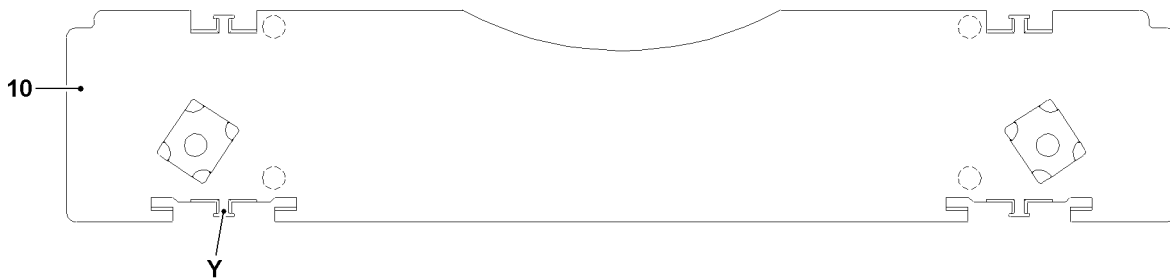
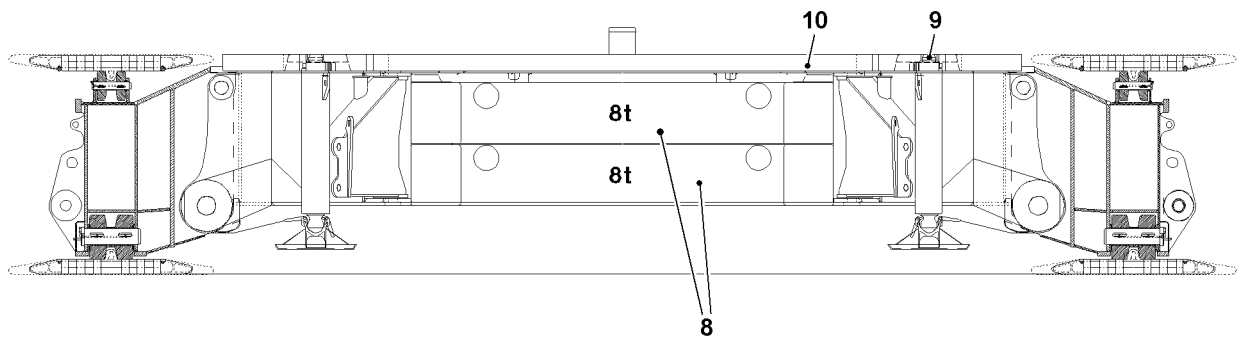

8

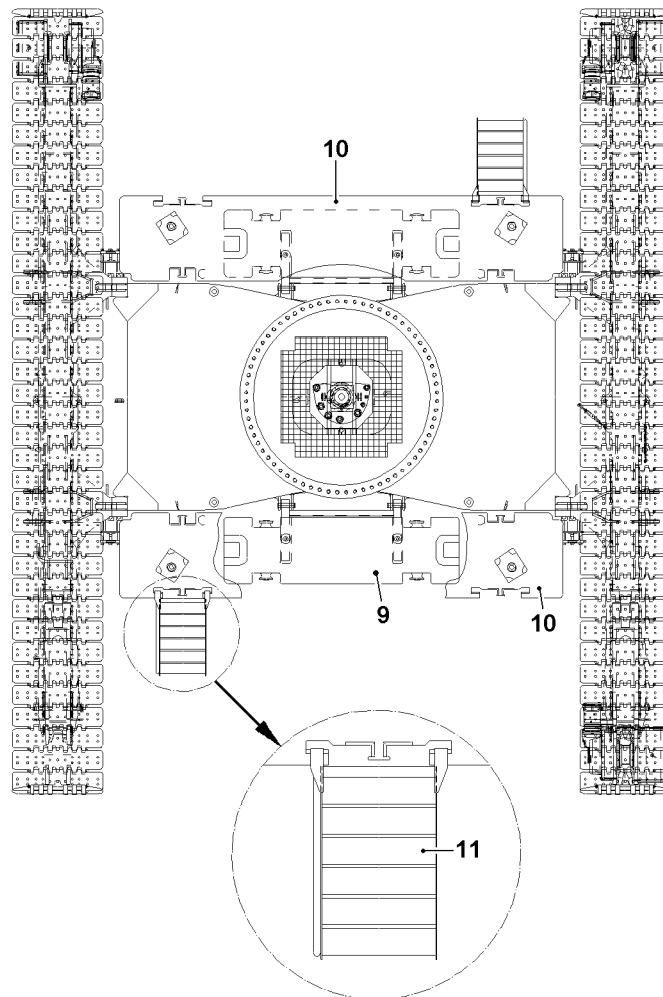

B104571

4 Installing the central ballast 11 t

The counterweight plate serves as the central ballast and when installed, the platform insures access the crane operator's cab in any slewing angle of the turntable, see illustration.

Ensure that the following prerequisites are met:

- The installation of the crawler carrier is completed.
- All connections between the crawler center section and the crawler carrier are pinned and secured.
- The hydraulic support is swung out, locked and pinned.
- The hydraulic support cylinders are completely retracted.
- Both crawler carriers are standing on the ground.
- The turntable is turned by 90° in travel direction, see fig. 3.
- An auxiliary crane is available.
- For the central ballast version 43 t, the two ballast plates are installed on the ballast frame.



DANGER

Danger of crushing!

If the following note is not observed, severe injuries can occur.

- ▶ It is prohibited for anyone to remain between the crawler center section and the crawler carriers while the counterweight plate is placed.



DANGER

Risk of accident!

If the following note is not observed, property damage on the crane can occur.

- ▶ Install the central ballast only according to the load chart.
-

7

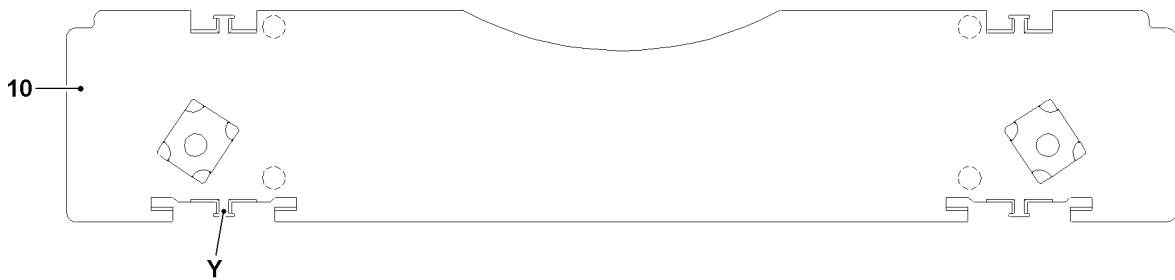
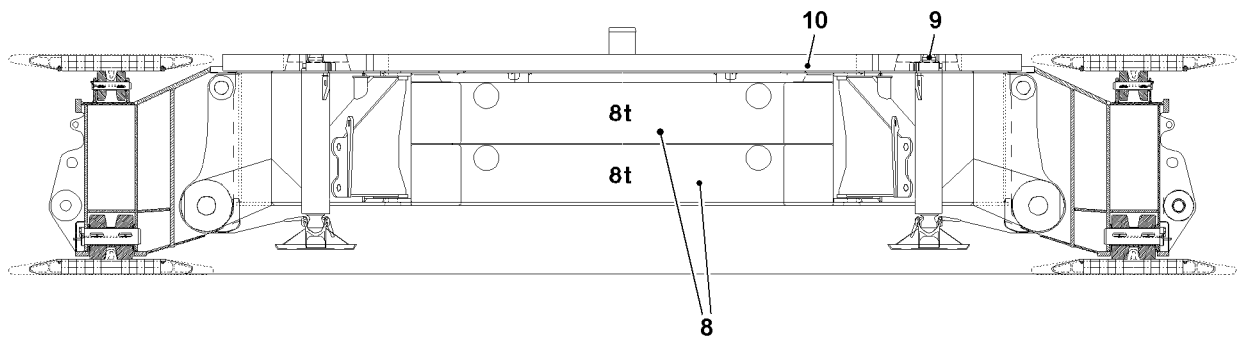

8

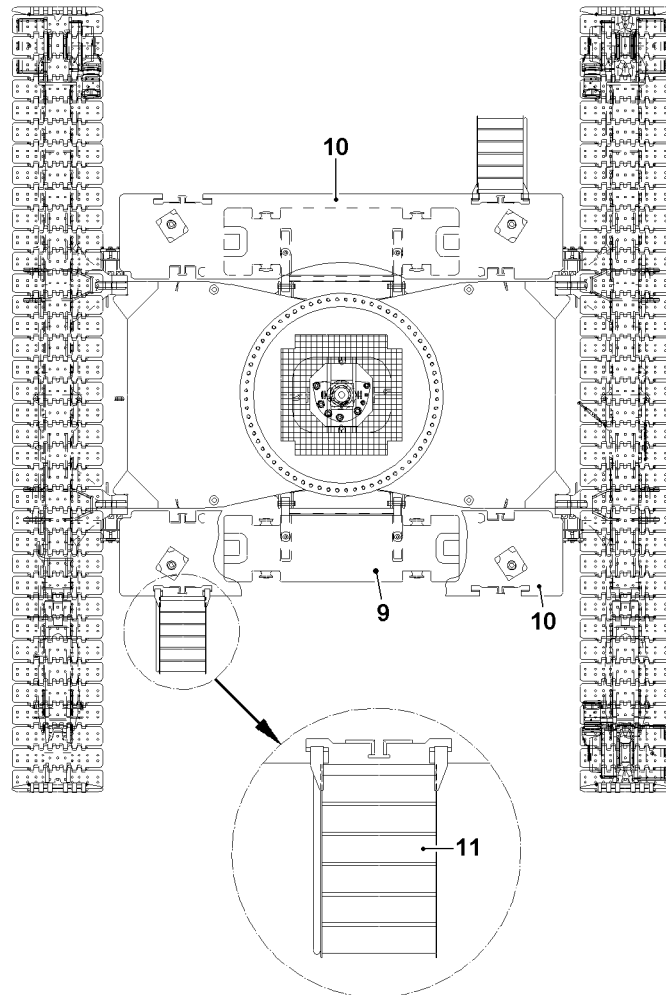

4.1 Installing the counterweight plate

- ▶ Attach the tackle on the bitts **Y** of the counterweight plate **10**.



WARNING

Risk of accident!

- ▶ Make sure that the tackle is correctly attached on the bitts **Y** and that it is secured sufficiently to prevent it from loosening up.
- ▶ Place the counterweight plate **10** with the auxiliary crane on the receptacle studs **9** of the hydraulic support cylinder, see fig. 7.
- ▶ Lower the counterweight plate **10** all the way on the hydraulic support cylinders until the tackle is relieved.



Note

- ▶ Do not loosen the tackle on the counterweight plate **10** until it is secured via the receptacle studs **9** of the hydraulic support cylinders.
- ▶ Loosen the tackle on the counterweight plate **10**.

4.2 Installing the access ladder

To ensure safe access for the crane operator and the assembly personnel, an access ladder is installed on each side.

- ▶ Hang the access ladder **11** on the notch of the counterweight plate **10**, see fig. 8.

9

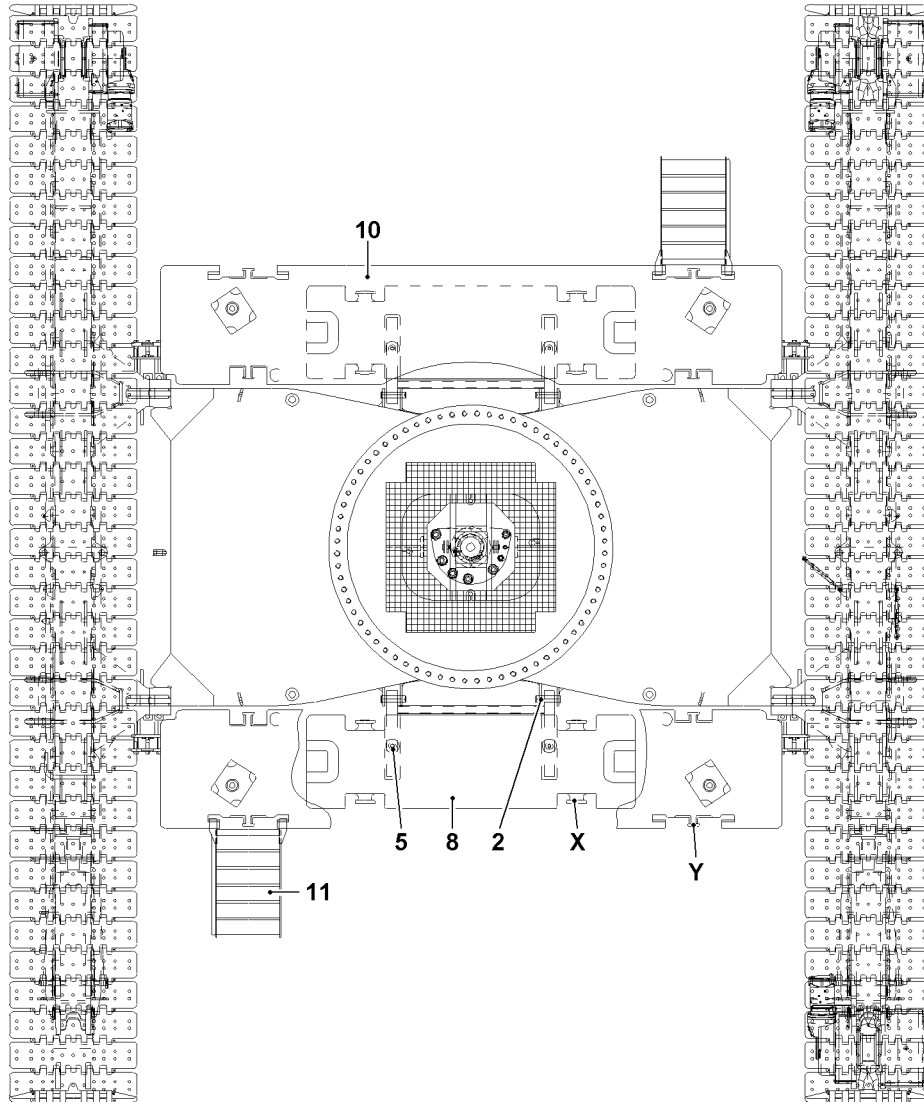

10

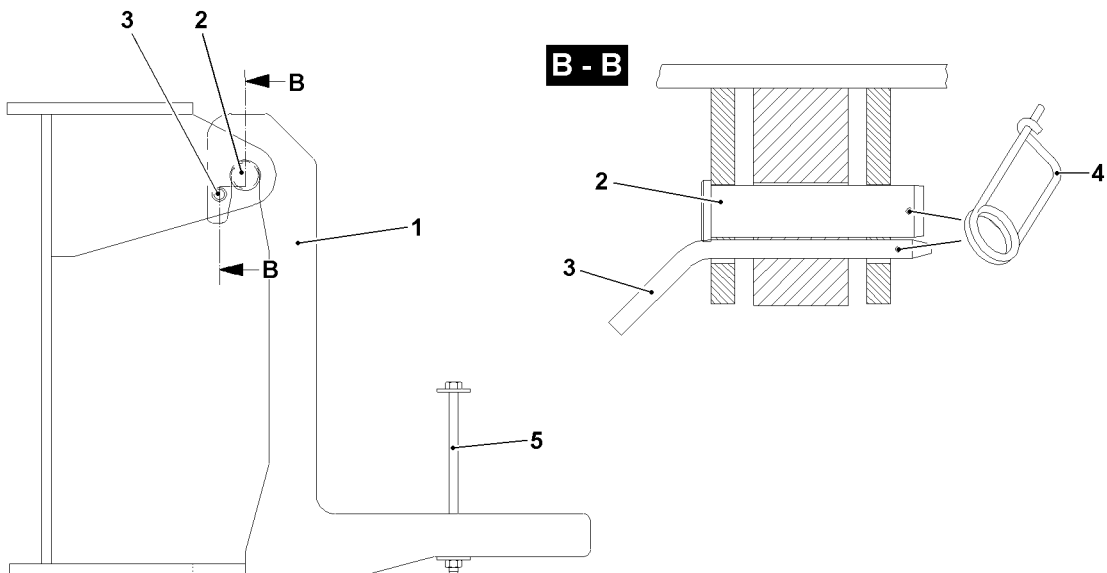

B104572

5 Removing the central ballast



DANGER

Danger of impact and crushing!

Due to presence near the ballast assembly, there is an increased danger of impact and crushing when the ballast plates are "removed".

- ▶ Exercise extreme caution when lifting the ballast.
- ▶ Never allow people to stand under a suspended ballast.
- ▶ Exercise extreme caution when lowering the ballast. Danger of crushing people in the immediate area of the ballast being lowered.

5.1 Removing the central ballast

Make sure that the following prerequisites are met:

- An auxiliary crane is available.
- The turntable is turned by 90° in travel direction, see fig. 3.
- Both crawler carriers are standing on the ground.
- ▶ Detach the access ladder **11** on the counterweight plate **10**.
- ▶ Attach the tackle on the bitts **Y** of the counterweight plate **10**.
- ▶ Lift the counterweight plate **10** with the auxiliary crane from the hydraulic support.
- ▶ Attach the tackle on the bitts **X** of the ballast plate **8**.
- ▶ Lift the first ballast plate **8** with the aid of the auxiliary crane from the ballast frame **1**.
- ▶ Attach the tackle on the bitts **X** of the ballast plate **8**.
- ▶ Loosen the retainer for the ballast plate **8** on the ballast frame **1** by removing the screw **5**.
- ▶ Lift the second ballast plate **8** with the aid of the auxiliary crane from the ballast frame **1**.
- ▶ Release the spring retainer **4** on the pin **3**, see fig. 10.
- ▶ Remove the pin **3**.
- ▶ Detach the ballast frame **1** with the auxiliary crane from the crawler center section.
- ▶ Insert the pin **3** on the retainer of the ballast frame and secure with spring retainer **4**.

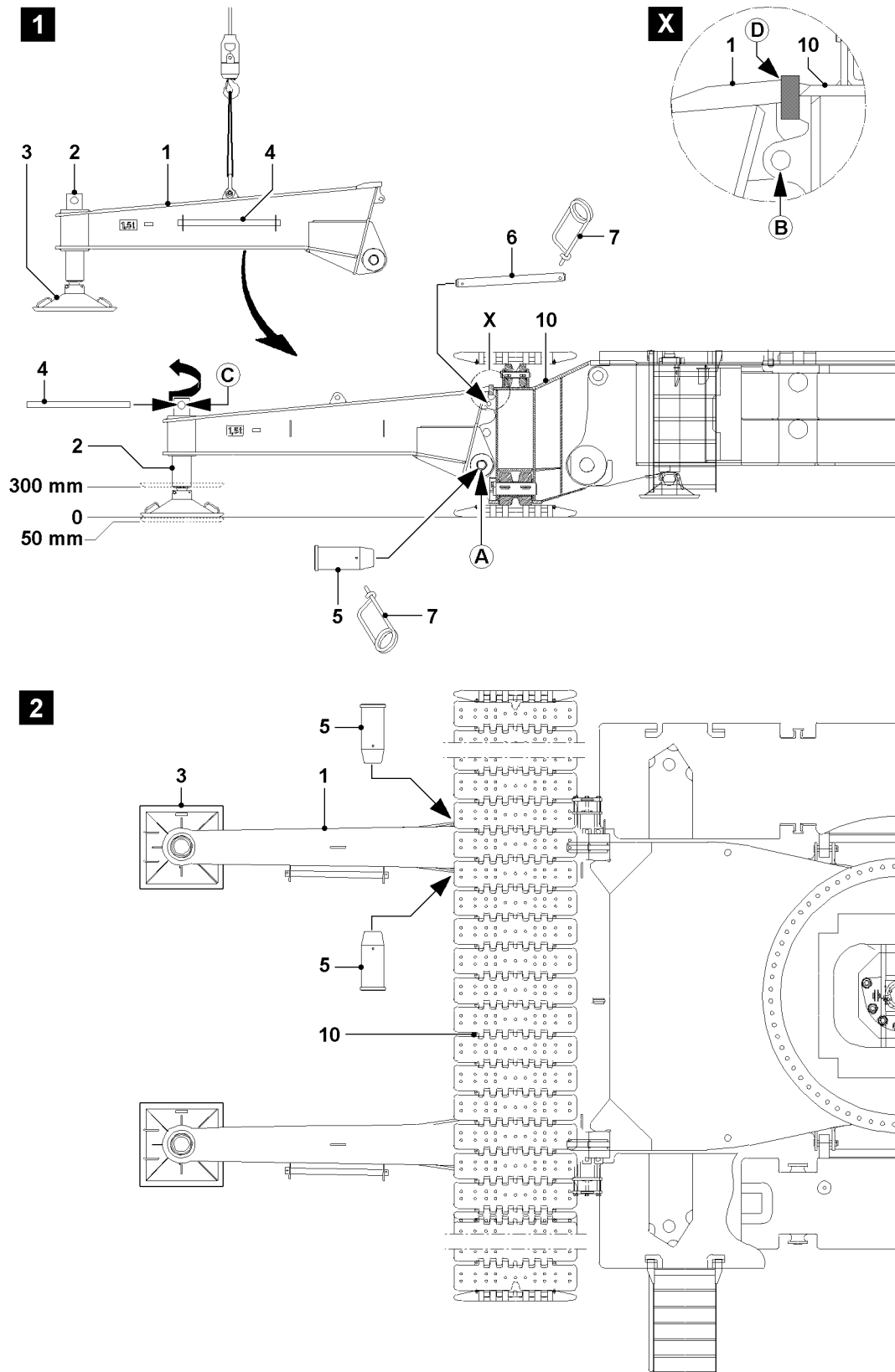

B104610

1 General

The mechanical auxiliary support is required to erect or take down long boom combinations and can be installed on the left or right crawler carrier.



Note

- ▶ The data in the erection and take down charts must be observed and adhered to!

2 Assembly



WARNING

Danger of fatal injury if crane topples over!

- ▶ If long boom combinations are erected or taken down without mechanical auxiliary support **1**, the crane can tip over and fatally injure personnel.
- ▶ Pin the mechanical auxiliary support **1** on the crawler carrier **10** and turn the spindle until the support pads lay on the ground.

Ensure that the following prerequisites are met:

- The crawler carriers are installed.
- The crane is aligned in horizontal direction.
- The ground has sufficient load bearing capacity in the area of the support pads.
- An auxiliary crane is available.

2.1 Assembly procedure



Note

- ▶ The installation of the mechanical auxiliary support **1** is the same for both support beams on the left and right hand side!
- ▶ Hang the mechanical auxiliary support **1** on the auxiliary crane and swing into pin position, fig. **1**.
- ▶ Align the mechanical auxiliary support **1** in such a way that the pin bores of the mechanical auxiliary support align with the pin bores on the crawler carrier **10**.
- ▶ Insert the pins **5** from the left and right at point **A** and secure each with spring retainer **7**, fig. **1** / fig. **2**.
- ▶ Insert the pin **6** at point **B** and secure with spring retainer **7** (fig. **X**).

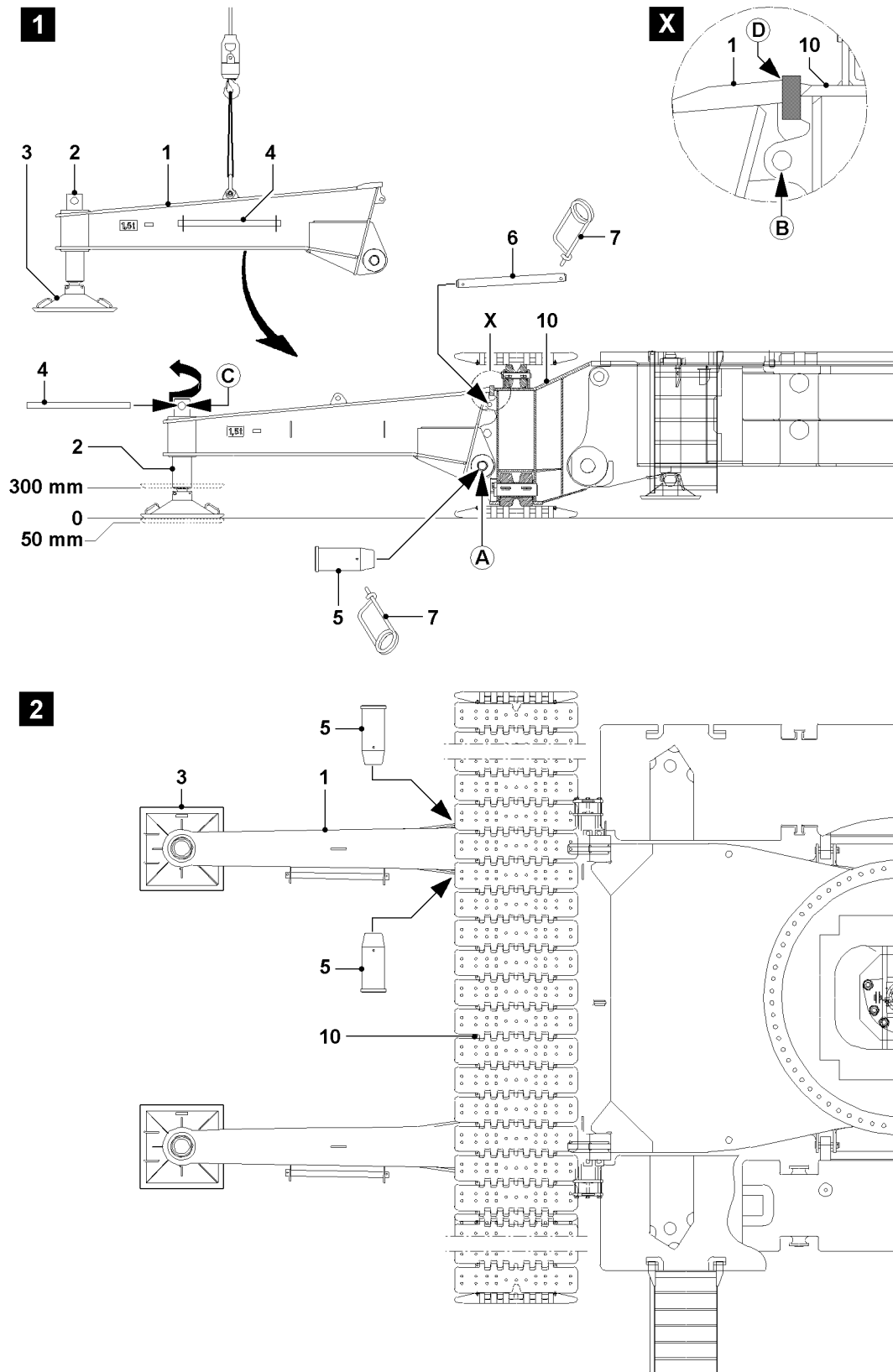

B104610

**DANGER**

Danger of fatal injury if crane topples over!

Due to the mechanical auxiliary support, the stability of the crane is increased towards the side, over which the boom system is to be erected or taken down. This may not be used to increase the load momentum. If this is not observed, the crane can topple over fatally injure personnel.

- ▶ The mechanical auxiliary support is only an erection and take down device.
- ▶ The support pads must be made large enough for the ground conditions, use solid materials, such as wood, steel or concrete slabs, see chapter 2.04.

- ▶ Remove the pipe **4** from the transport retainer on the mechanical auxiliary support.
- ▶ Insert the pipe **4** at point **C** into the bore on the spindle **2**.
- ▶ Turn the support pad **3** by turning the spindle **2** with the pipe **4** downward until it is "tensioned" and placed horizontally on the base support.

**DANGER**

Danger of accidents during erection and take down!

The mechanical auxiliary support **1** must touch on the crawler carrier **10** at point **D**, see fig. **X**. If this is not observed, the boom can move jerkily during erection and take down.

- ▶ Turn the support pad **3** with the spindle **2** until the mechanical auxiliary support **1** touches at point **D**.

**Note**

- ▶ Adjustment range of support pad: -50 mm to +300 mm.

- ▶ If the mechanical auxiliary support **1** has no contact at point **D** to the placement surface on the crawler carrier:
Turn the support pad **3** with the spindle **2**.

4.00 Operation of crane superstructure

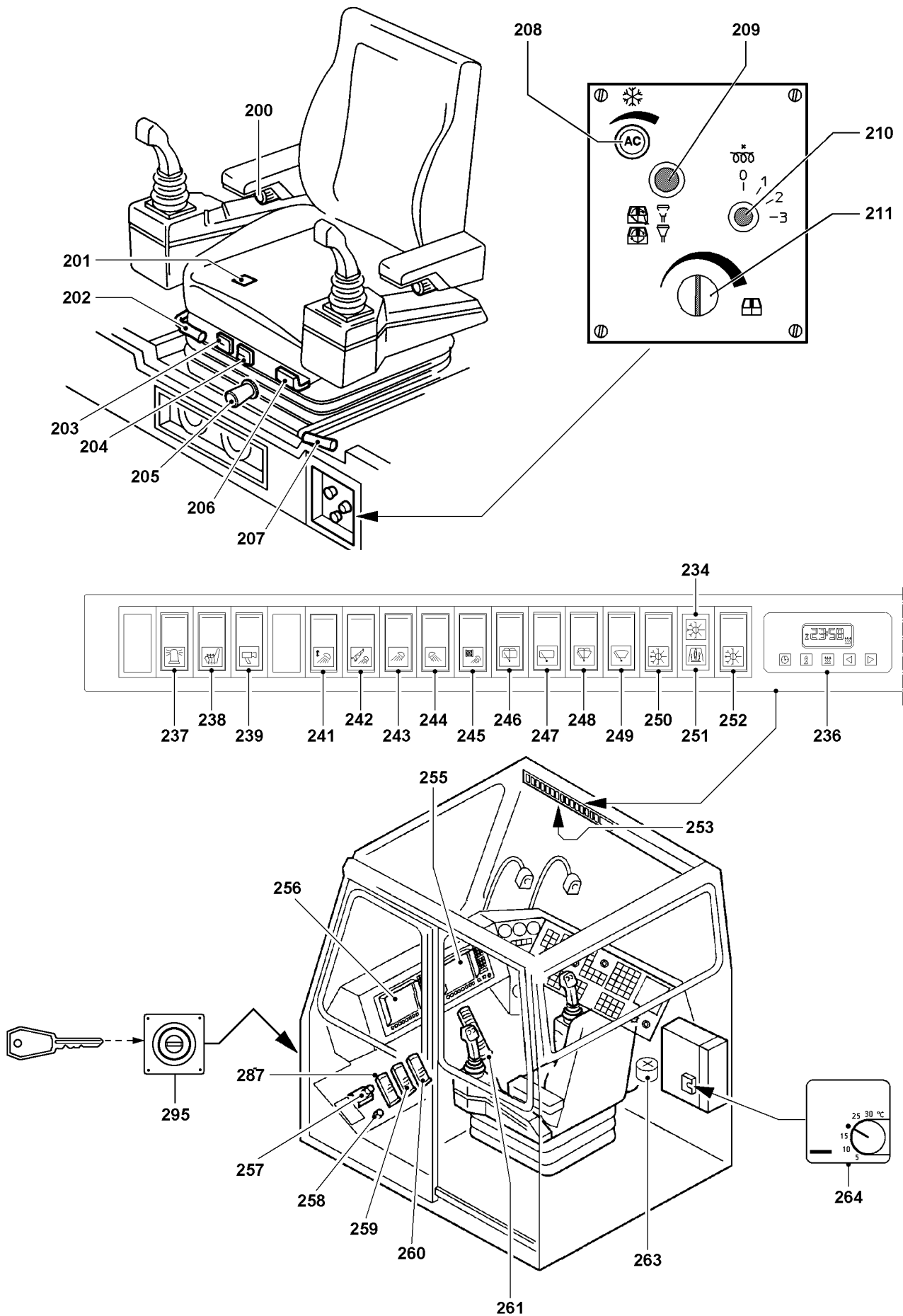

B110521

1 Operating and control instruments

1.1 Operating elements - Crane operator's seat / air conditioning system

200 Knob	• Adjustment of armrest incline
201 Seat contact button	
202 Hand lever	• Adjustment of seat cushion incline
203 Button	• Lumbar support in lower part of backrest
204 Button	• Lumbar support in upper part of backrest
205 Knob	• Adjustment of seat suspension for body weight
206 Hand lever	• Backrest incline adjustment
207 Hand lever	• Release for horizontal seat adjustment
208 Regulator knob*	• Climate control system
209 Switch	• Switching between fresh air / recirculated air
	• Air volume
210 Rotary switch	• Three stage blower
211 Regulator knob	• Temperature Cab heater

1.2 Control elements Roof console

234 Indicator light*	• Air conditioning system is turned on
236 Timer for auxiliary heater*	• With the following displays: <ul style="list-style-type: none"> • Time and day of the week • Fault in auxiliary heater • Air temperature • Preselection of heater operation
237 Switch	• Airplane warning light
238 Switch*	• Seat heater
239 Switch	• Camera illumination <ul style="list-style-type: none"> • Switch position I: Illumination winches 1 to 5 • Switch position II: Illumination winches 1 to 5 Illumination to the rear
241 Button*	• Height adjustment working floodlight, boom pivot section
242 Switch*	• Working floodlight on the boom pivot section
243 Switch*	• Working floodlight, cab pedestal
244 Switch*	• Working floodlight, cab roof, rear
245 Switch*	• Working floodlight winch illumination
246 Button	• Windshield wiper / washer, roof window
247 Switch	• Window wiper roof window, 2-stage
248 Button	• Windshield wiper / washer, front window
249 Switch	• Window wiper front window, 2-stage
250 Switch*	• Climate control system
251 Indicator light	• Auxiliary heater turned on
252 Switch*	• Auxiliary heater
253 Dome light with switch	

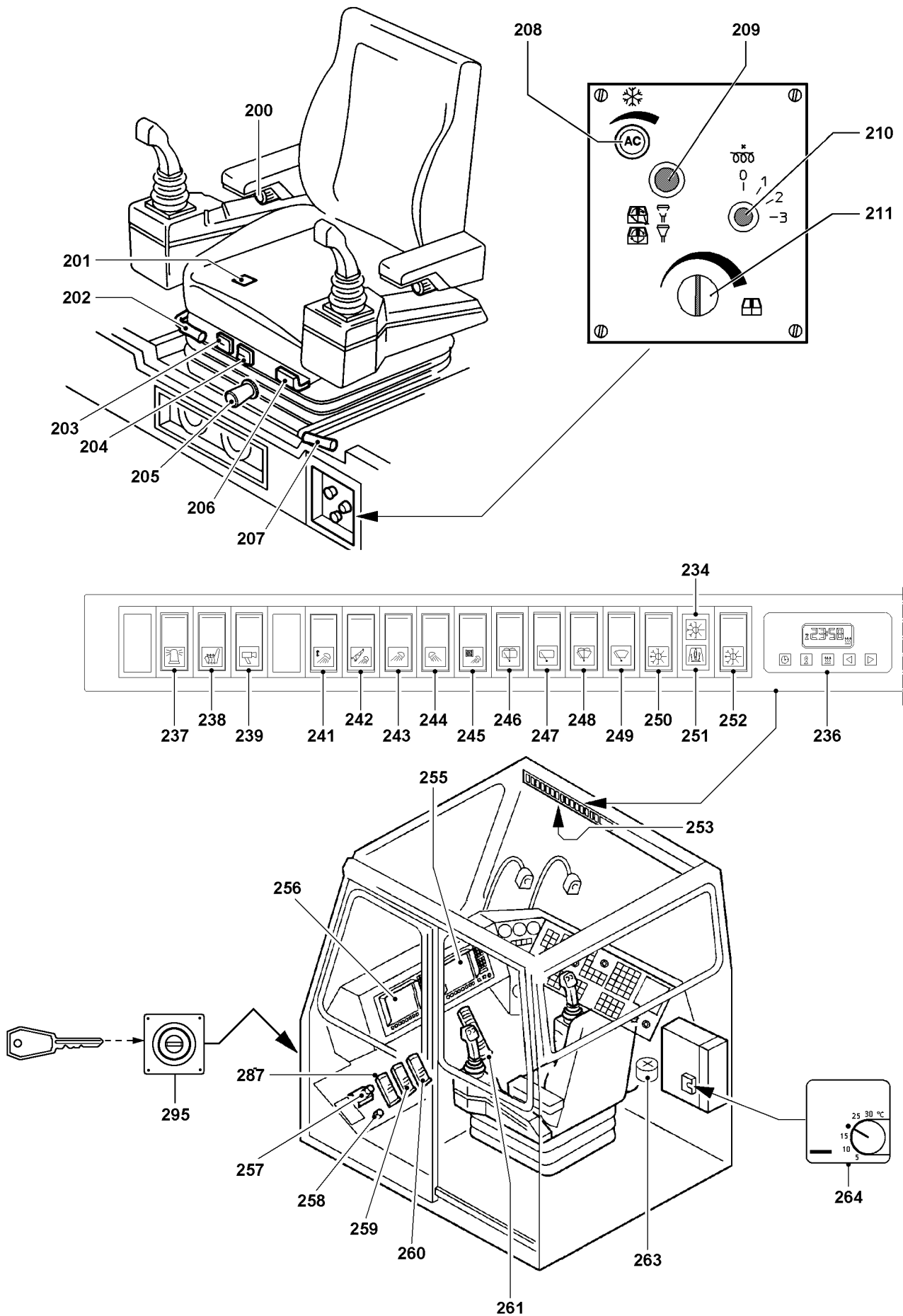

B110521

1.3 Operating elements, General

255 LICCON monitor 0

256 LICCON monitor 1

257 Foot button

258 Foot button

259 Foot rocker

260 Foot rocker

261 Pedal

263 Pressure gauge

264 Thermostat*

287 Pedal*

- Coasting slewing gear

- Horn

- Crawler track left

- Crawler track right

- Engine regulation

- Erection cylinder SA-bracket

- Auxiliary heater

- Slewing gear brake (block)

Note:

The slewing gear brake **287** (block) **may not be used** as operational slewing brake!

- Impact switch (outside of cab)

295 EMERGENCY OFF
switch*

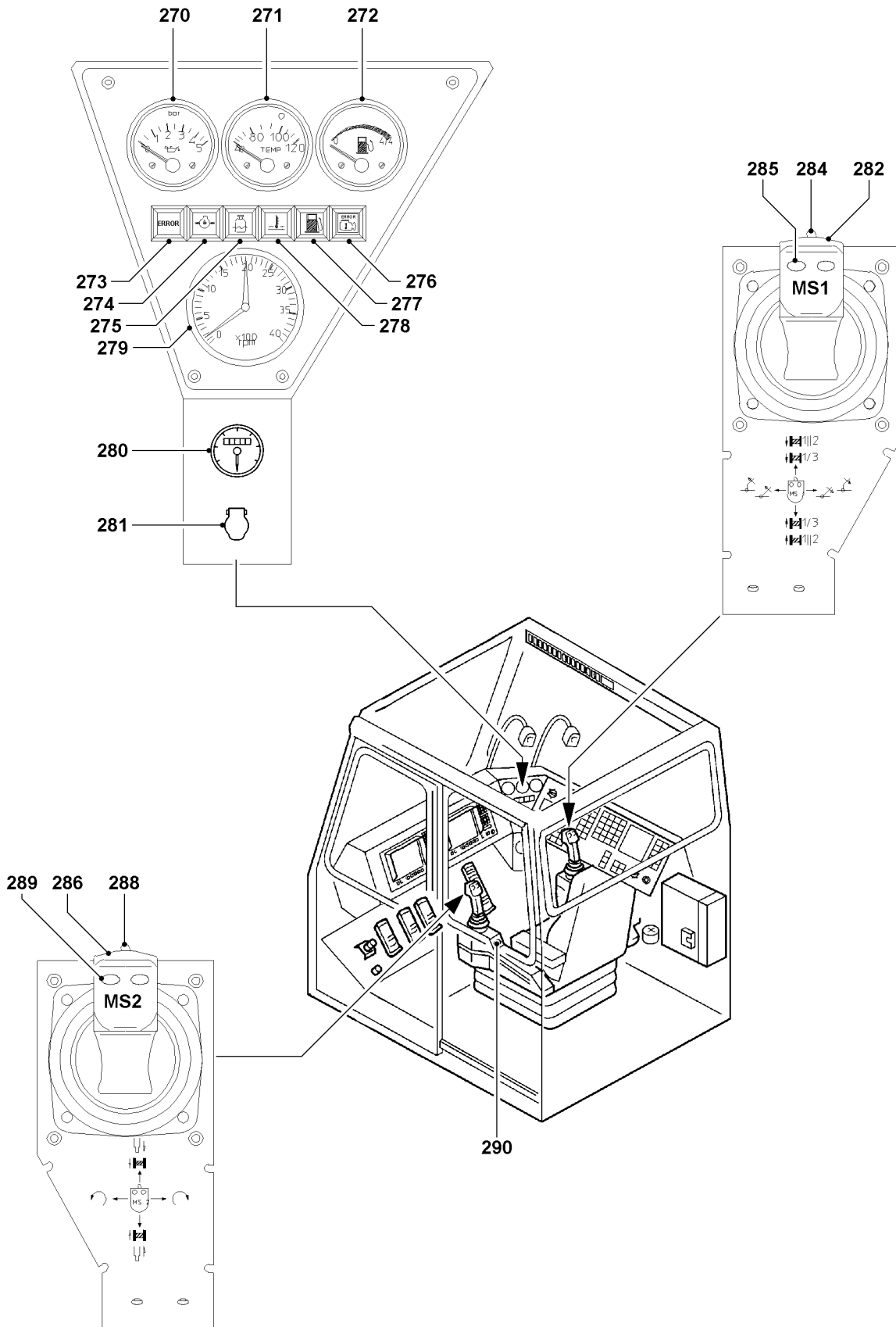

B104612

1.4 Indicator light instrument panel, right front

270 Oil pressure display	• Diesel engine
271 Temperature display	• Coolant temperature diesel engine
272 Fuel level display	• Diesel fuel tank
273 Warning light	• Rpm sensor or relay defective
274 Warning light	• Oil pressure diesel engine
275 Warning light	• Coolant level too low
276 Warning light	• Engine error: Error is issued via blinker code.
277 Warning light	• Fuel level too low
278 Warning light	• Coolant temperature too high
279 RPM gauge	• Diesel engine
280 Operating hour meter	• Recording of crane operating hours
281 Socket 24 V	

1.5 Operating elements on control panel

Control console, right:

282 Master switch - right (MS 1)	<ul style="list-style-type: none"> • Note: For assignment of master switch to operating modes, see chart, chapter 4.05.
284 Button	• Bypass of seat contact button
285 Button	• Lock engine regulation
	<ul style="list-style-type: none"> • Note: Pressing the button 285 will lock the engine regulation in the current position.

Control console, left:

286 Master switch left (MS 2)	<ul style="list-style-type: none"> • Note: For assignment of master switch to operating modes, see chart, chapter 4.05.
288 Button	• Bypass of seat contact button
289 Button	• Lock engine regulation
	<ul style="list-style-type: none"> • Note: Pressing the button 289 will lock the engine regulation in the current position.
290 Button	• Bypassing of overload protection, used to luff up at overload
	<ul style="list-style-type: none"> • Danger: The bypass may only be used if the overload was caused by luffing down at freely suspended load and the crane operator is absolutely certain that luffing up the load will take it out of the overload range.

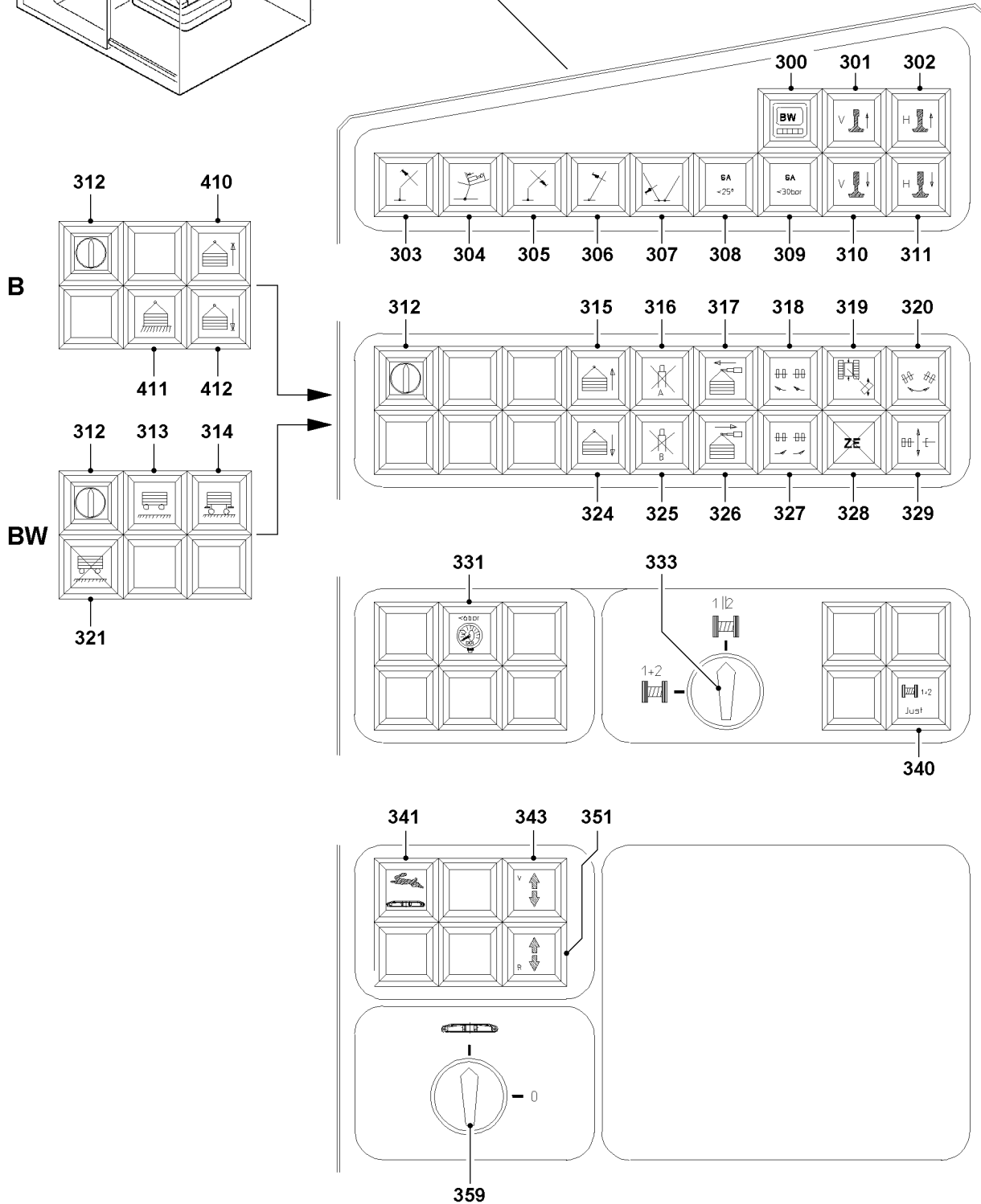
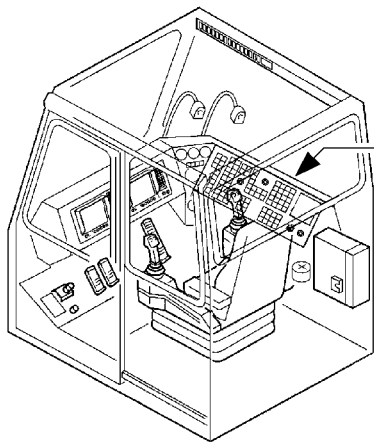

B104613

1.6 Operating elements - Instrument panel right

300 Switch*	• Change monitor 1 over to test system ballast trailer
	Note:
	The change over is only possible if the engine is turned off!
301 Button*	• Support cylinder ballast trailer front up
302 Button*	• Support cylinder ballast trailer rear up
303 Warning light	• Lattice jib “steepest” position, mechanical relapse retainer
304 Warning light	• Lattice jib, “steepest” position, relapse cylinder
305 Warning light	• Lattice jib “lowest” position
306 Warning light	• Boom “steepest” position, relapse cylinder
307 Indicator light*	• Derrick boom “bottom”
308 Warning light	• SA-bracket to the front, angle less than 25°
309 Warning light	• Shut off winch 4 when falling below the required pressure (at least 30 bar) in the SA-bracket relapse retainer
310 Button*	• Support cylinder ballast trailer front down
311 Button*	• Support cylinder ballast trailer rear down



DANGER

Danger of toppling the crane if the key button **312** is **not** actuated!

Dangerous situations can arise if the ballast trailer lifts off completely when driving the crane. The crane can topple over in extreme cases!

- ▶ When driving the crane with the ballast trailer, the crane operator must ensure by constantly checking visually that the ballast trailer has constant ground contact!
- ▶ If the ballast trailer should lift off the ground completely, then the crane operator is obligated to turn on the key button **312** “Ballast trailer lifted off”, see also chapter 5.11!

312 Key button “Ballast trailer lifted off” *	• Briefly pressing the key button will turn on the operating mode “ Ballast trailer lifted off ” (self retention)
	Note:
	“ Ballast trailer lifted off ” is shown by the blinking indicator light 313 as well as the red beacon assembled on the crane operator's cab. In addition, the ballast trailer icon on monitor 1 shows the suspended condition.
313 Warning light*	• Ballast trailer lifted off - blinks with turned on key button 312
314 Warning light*	• Support ballast trailer retracted
315 Button*	• Derrick ballast “UP”
316 Button*	• Block cylinder “A” on the derrick ballast
317 Button*	• Telescope derrick ballast out

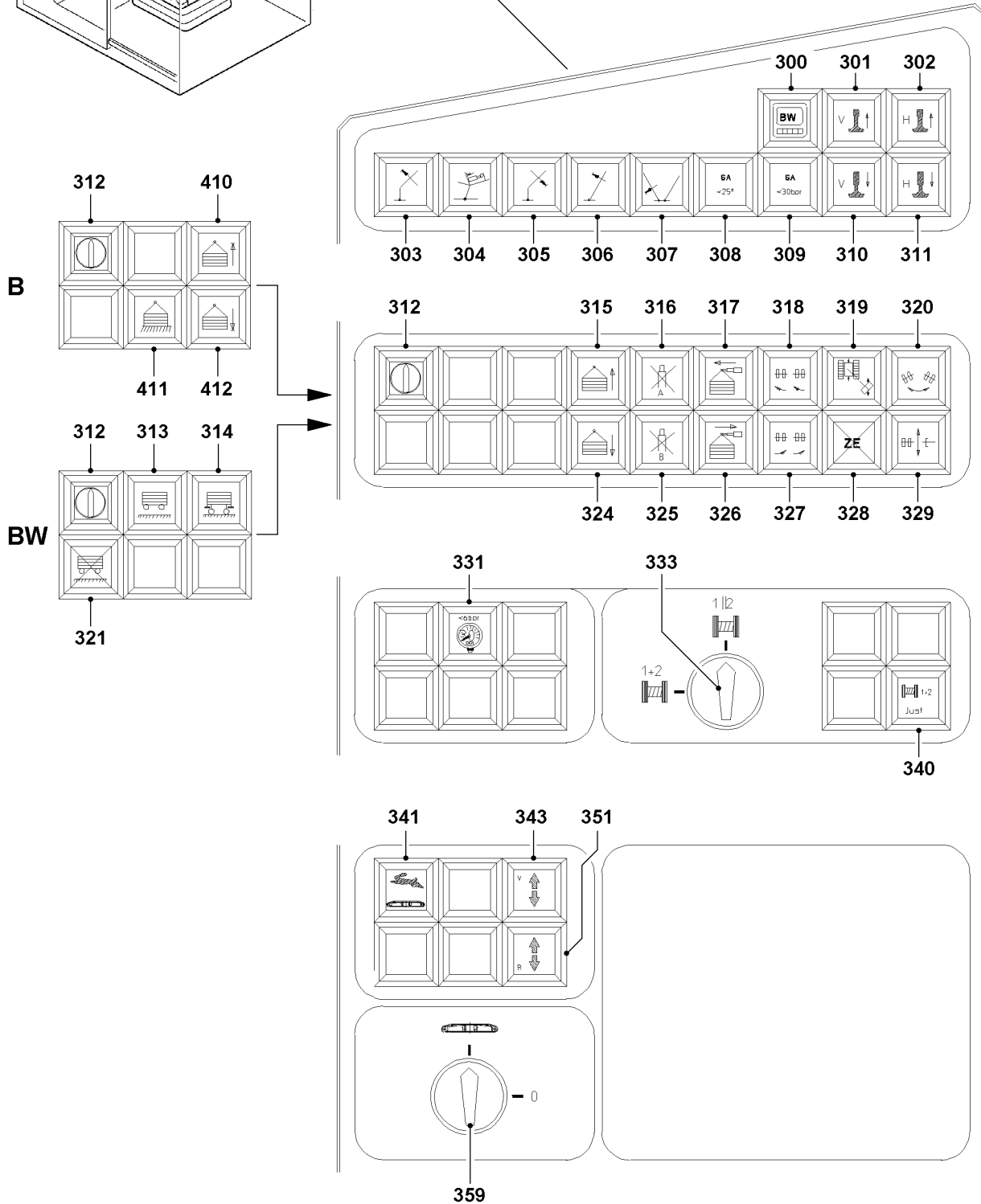
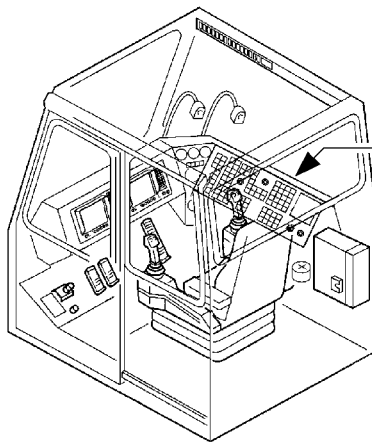

B104613

318 Button*	• Ballast trailer wheels turn to the right to drive on tight job sites - see also chapter 5.11
319 Button*	• Turn ballast trailer wheels into parallel travel position (crab walk) - the indicator light blinks • Ballast trailer wheels in parallel driving position - the indicator light lights up constantly - see also chapter 5.11
320 Button*	• Turn ballast trailer wheels into turning position - the indicator light blinks • Ballast trailer wheels in turning position - the indicator light lights up constantly - see also chapter 5.11
321 Button*	• Turn off self-retention of key button 312
324 Button*	• Derrick ballast "DOWN"
325 Button*	• Block cylinder "B" on the derrick ballast
326 Button*	• Telescope in derrick ballast or ballast trailer
327 Button*	• Ballast trailer wheels turn to the left to drive on tight job sites - see also chapter 5.11
328 Warning light*	• CPU ballast trailer is not "booting up" - see also chapter 5.11
329 Button*	• Set ballast trailer wheels into driving position - the indicator light blinks • Ballast trailer wheels in travel position - the indicator light lights up - see also chapter 5.11
331 Warning light	• Servo oil pressure in winches 1 to 4 < 10 bar Note: It can be determined in the LICCON test system for which winch this is the case.
333 Preselection switch	• Position 1 + 2: • Winch 1 and 2 • Individual operation • Separate master switches • Position 1 II 2: • Winch 1 II 2 • Parallel operation with one master switch
340 Button	• Adjusting parallel control of winch 1/2 Note: Adjust only if the hook blocks of winch 1II2 are parallel.
341 Switch	• Rapid gear for crawler track
343 Indicator light	• Position of turntable to crawler to the front (V)
351 Indicator light	• Position of turntable to crawler to the rear (R)
359 Preselection switch	• Crawler operation: • 0 = crawler operation "OFF" • 1 = crawler operation "ON"
410 Warning light	• Derrick ballast up
411 Warning light	• Derrick ballast on ground
412 Warning light	• Derrick ballast down

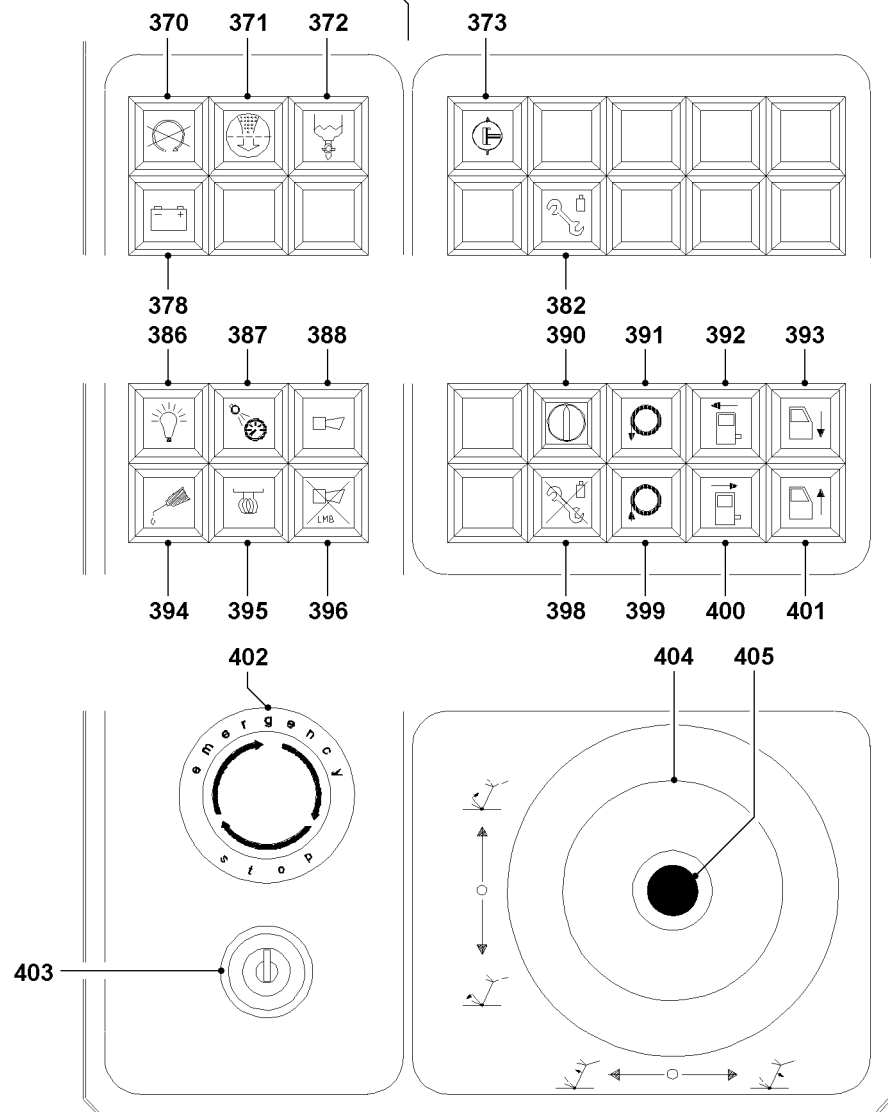
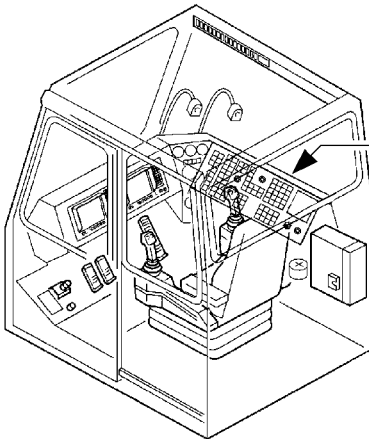

370 Indicator light	• Engine “STOP”
371 Warning light	• Air filter is dirty
372 Indicator light	• Fuel condensation drainage
373 Button	• Pressure change over switch, pump 9 is required for “erecting and lowering the SA-bracket” if the button is not pressed. By pressing the button, the pressure from pump 9 is forwarded to the following auxiliary users: <ul style="list-style-type: none"> • Adjust the cab • Boom pinning • Assembly winch • Assembly support
378 Warning light	• Charge monitoring
382 Indicator light	• Lights up at crawler assembly, key button 390 turned on
386 Button	• Bulb test
387 Switch	• Instrument illumination
388 Button	• Horn

**DANGER**

Overload of crane in case of actuated crawler assembly key button **390!**

If the following notes are not observed, an overload of the assembly cylinder as well as the entire crane can occur.

- ▶ The actuation of the crawler assembly key button is only permitted for crawler assembly tasks!
- ▶ The LICCON overload safety is bypassed and therefore ineffective if the crawler assembly key button is actuated, see also chapter 4.04!

390 Crawler assembly key button	• Briefly pressing the crawler assembly key button will preselect the “ Crawler assembly with assembly cylinder ” operating mode (self-retention) Note: Observe the safety notes in chapter 4.04! “ Crawler assembly key button ” turned on is shown by the indicator light 382 as well as a red beacon assembled on the crane operator’s cab. In addition, the assembly icon is shown on the LICCON monitor.
391 Button	• Spool the assembly winch out
392 Button	• Swing cab out
393 Button	• Cab adjustment “down”
394 Indicator light	• Central lubrication crane superstructure
395 Indicator light	• Engine preheating, heat flange
396 Button*	• Acoustical warning LMB “OFF”
398 Button	• Turn off self-retention of key button 390
399 Button	• Spool the assembly winch up
400 Button	• Swing cab in
401 Button	• Cab adjustment “up”
402 EMERGENCY OFF switch	• Impact switch
403 Ignition switch	
404 Master switch 3 (MS 3)	• Note: For assignment of master switches to operating modes, see chapter 4.05.
405 Button	• Bypass of the seat contact button

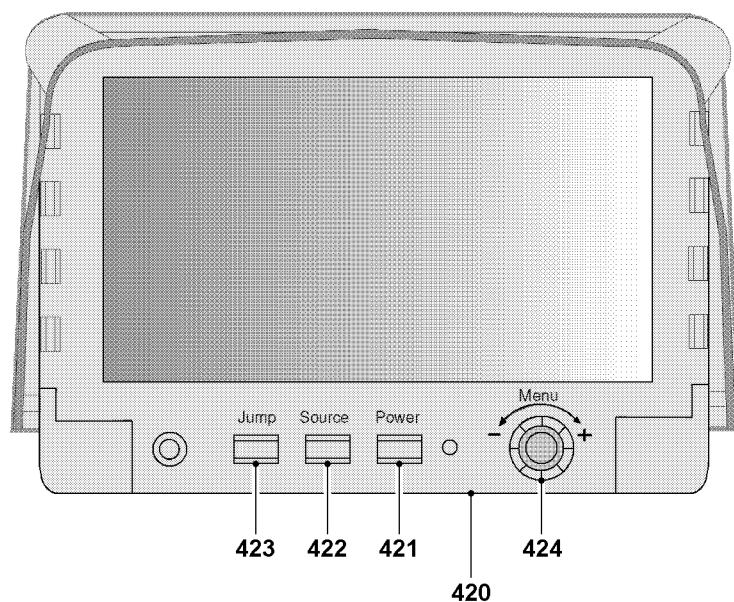

1.7 Camera monitoring

1.7.1 Monitor with rotary selection switch

420 TFT monitor

421 Key "Power"

422 Button "Source"

423 Button "Jump"

424 Selection knob / pressure switch

- Monitor On / Off
- By pressing the "Source" key in turned on condition, the view on the monitor is changed
- By pressing the "Jump" key, the preset camera inputs can be selected
- The selection menu on the monitor is activated by pressing the selection knob / pressure switch

Note:

If no adjustments are made after activation of selection on the monitor, then the selection turns off by itself after several seconds.

- When the selection menu is activated, a menu point can be selected by turning the selection knob / pressure switch. The selected menu point is highlighted in "yellow". Press the selection knob / pressure switch to change the color from "yellow" to "red". This selects the desired function.

Selection menu

• **Screen adjustments**

Note:

The following adjustments can be made in the menu "Screen adjustments".

- Brightness
- Contrast
- Color
- Hue
- Automatic brightness control
- Direction display
- Back

• **OSD settings**

Note:

The following adjustments can be made in the menu "OSD adjustments".

- Display
- Distance display
- Back

• **Camera adjustments**

Note:

The following adjustments can be made in the menu "Camera adjustments".

- Reflection
- Change over
- Video outlet
- Back

• **Reset**

- The display is reset to default settings

• **Output**

- OSD selection is ended

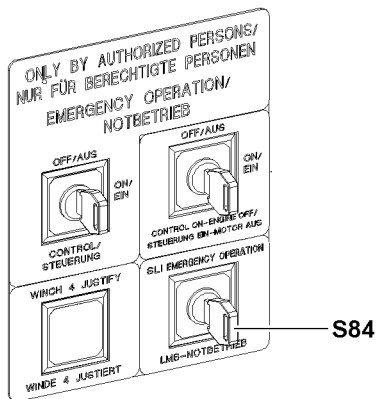
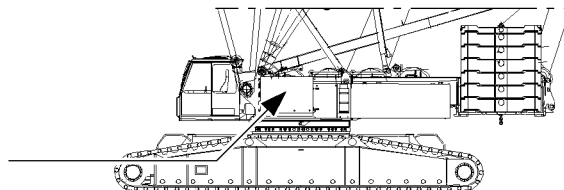
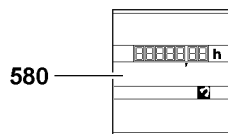
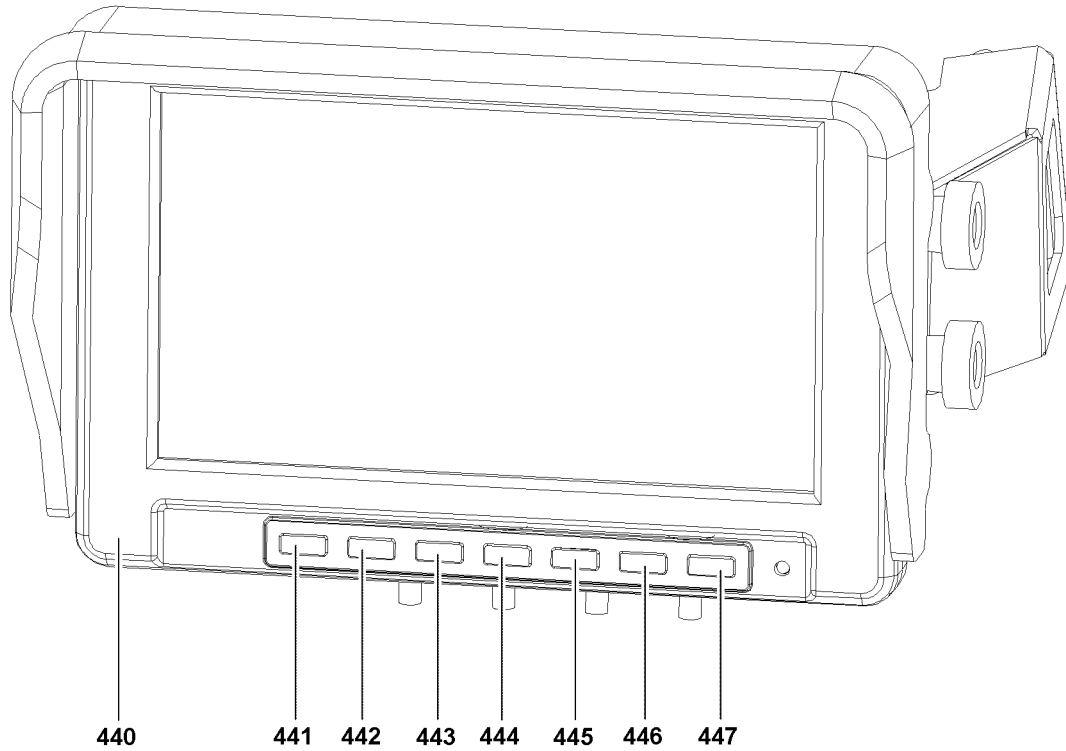

B113285

1.7.2 Monitor with keypad

- 440** TFT monitor
- 447** Button
- Monitor On / Off
- 441** Button "MODE"
- By pressing the button "MODE" the system changes between the individual display modes:
 - Single display mode
 - Split display mode
 - Display mode in thirds or quarters
- 442** Key "Camera selection"
- By pressing the button "camera selection" the system changes between the cameras:
 - Single display mode: Change between camera 1 and camera 2.
 - Split display mode: Change between cameras 1/2, 2/3, 3/4 and camera 4/1.
 - Display mode split in thirds or quarters: This button has no function.
- 443** Menu button
- By pressing the "Menu" button, menus for various adjustments are called up and changed over, in the following order:
 - Color: Adjustment of color saturation.
 - Brightness: Brightness adjustment.
 - Contrast: Contrast adjustment.
 - Standard: Reset to default settings.
 - Volume: Volume adjustment.
 - Language: Language adjustment (English, French, German, Spanish, Italian, Portuguese, Polish).
 - Reflection: Reflection of camera view. Return to the main menu with "Enter". End menu with "End".
- 444** "Minus" key
- By pressing the "Minus" key, the value of a setting is reduced
- 445** "Plus" key
- By pressing the "Plus" key, the value of a setting is increased
- 446** Button "Change between day / night"
- Press the button "Change over day / night" to match the brightness of the display to the time of day

1.8 Operating elements switch cabinet

- 580** Operating hour meter
- Recording of crawler operating hours
- S84** Key button
- LMB emergency operation

1 General



Note

- ▶ The monitor illustrations in this chapter are only examples!
 - ▶ The numerical values in the individual icons and charts do not have to necessarily match the crane exactly!
 - ▶ Numbers and letters can be replaced by place holders!
 - ▶ In addition, many of the illustrations show the maximum configuration of the LICCON monitor with icons!
 - ▶ In normal crane operation, an identical display will **not** appear on the LICCON monitor!
-

The LICCON computer system is a computer system for controlling and monitoring mobile and crawler cranes. In addition to the overload protection (Load moment limitation = **LMB**) there are a number of application programs that can be used for controlling and monitoring the crane movements. Currently the LICCON computer system includes the following application programs:

- Set up program
- Crane operation program
- Control parameter program

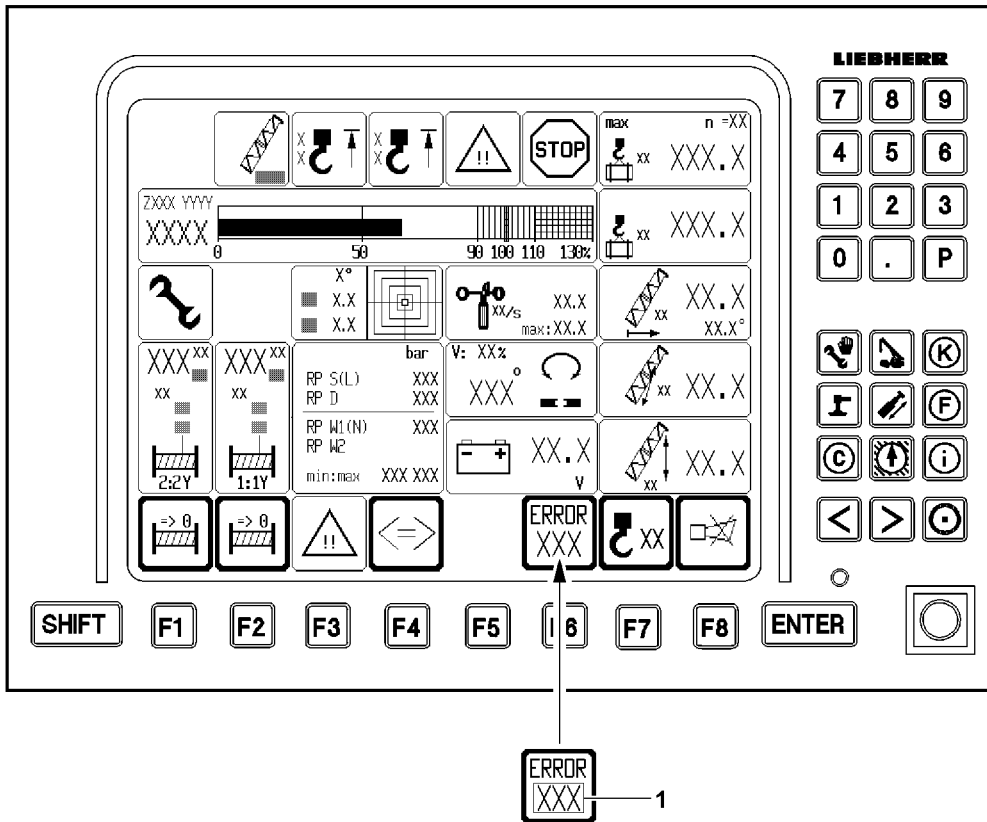

1.1 Overload protection (LMB)

The overload protection is implemented in microprocessor CPU 0 of base assembly 0. The LICCON computer system works on the principle of comparing the current / actual load with the “maximum permissible load according to the load chart and reeving”.

1.1.1 Actual load

The current load is determined by recording variable values.

The **load on the crane** results from the load momentum and the boom momentum together. It exerts a force in the boom guying, which is measured by force test sensors.

The **boom momentum** is calculated from angle sensor information (boom angle) and the crane data (boom weights) for the set operating mode.

The **radius** is calculated with data from the angle sensors (boom angle) and the geometric data for the set operating mode. This also takes into account the boom flexation due to its own weight and the weight of the load.

The actual load is calculated from the total load, the boom momentum and the boom radius.

1.1.2 Maximum load according to load chart and reeving

Crane data such as load charts, boom weights and geometry data are stored in the central data memory of the LICCON computer system.

The “maximum load according to the load chart and reeving” is constantly determined for the set crane configuration, for the set reeving and for the calculated radius, based on the load charts.

1.1.3 Comparison

The actual load and the “maximum load according to the loading chart and reeving” are compared. When they approach the specified limit, an advance warning is issued. If the specified limit is exceeded, a LMB STOP is triggered due to overload. When a LMB STOP is triggered, load moment increasing crane movements are shut off.

1.2 Error messages

The LICCON computer system monitors the crane permanently for operating / system errors. If an error occurs, an error message with a three digit error number **1** is issued.



Note

- ▶ Always pay attention to error messages **1**!
 - ▶ For procedure in case of error messages, see Diagnostics manual and the respective chapter in the Crane operating instructions!
-

1



2



3



2 LICCON computer system boot up

After it is turned on, the LICCON computer system performs a self test.

First the connections from the microprocessor CPU (ZE 0) to the monitor are checked. If no error is found during the test, the monitor shows this image:

```
=> DATA LINE CHECK PASSED -- O.K. !!
    SYSTEM CHECK .....
```

If the test finds no connection problems, there is a system test of all the microprocessor CPUs (ZE).

The incremental sequence of the self test can be monitored on the 7 segment displays of the CPUs. If no errors are found during the system test, the monitor shows this image:

```
=> DATA LINE CHECK PASSED -- O.K. !!
    SYSTEM CHECK .....PASSED -- O.K. !!
```

Shortly after that, this general initialisation screen appears on the monitor:

```
LIEBHERR-WERK      EHINGEN
```



Note

Errors during LICCON computer system boot up!

If an error is found while the LICCON computer system boots up, then the boot up procedure is interrupted!

- ▶ For procedure if an error occurs while the LICCON computer system boots up, see Diagnostics manual!

2.1 Operating mode preselection on the LICCON computer system



WARNING

Danger of accident due to deviating equipment set up configuration!

If the equipment set up configuration and the operating mode of the crane set on the LICCON computer system **does not** match, then the crane can be overloaded unnoticed and topple over! Personnel can be severely injured or killed!

- ▶ In the operating mode preselection, only the operating mode may be selected which actually corresponds to the equipment set up configuration of the crane!

When the starting procedure is completed successfully after a successful self test of the LICCON computer system, the following appears on:

- **LICCON monitor 0** for approx. 3 seconds the operating mode preselection screen.
- **LICCON monitor 1** the title screen with the words: “**LIEBHERR-WERK EHINGEN**”

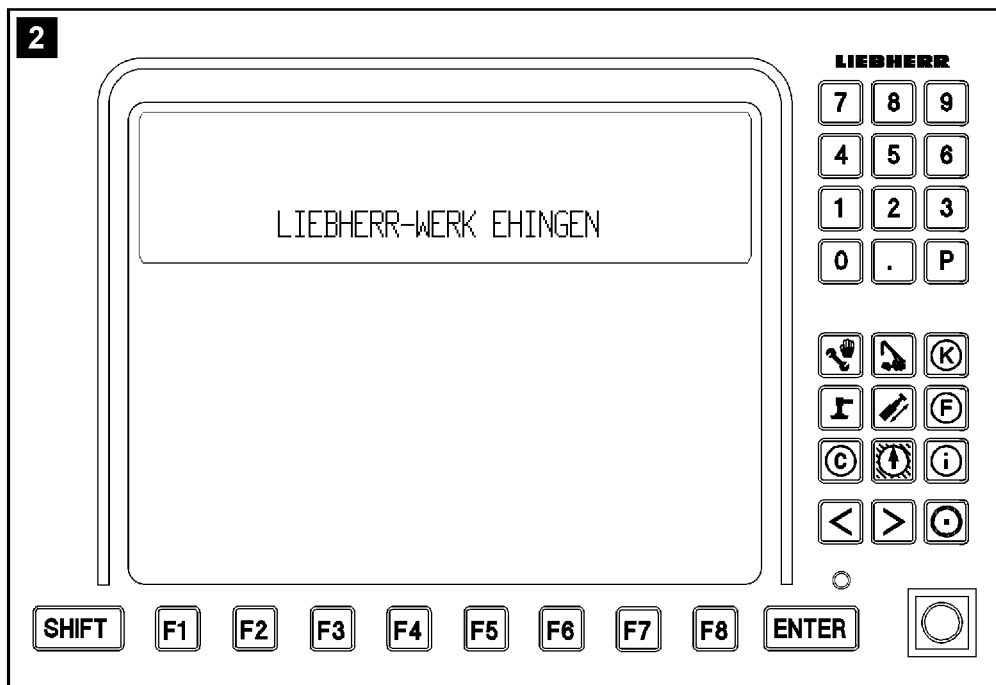
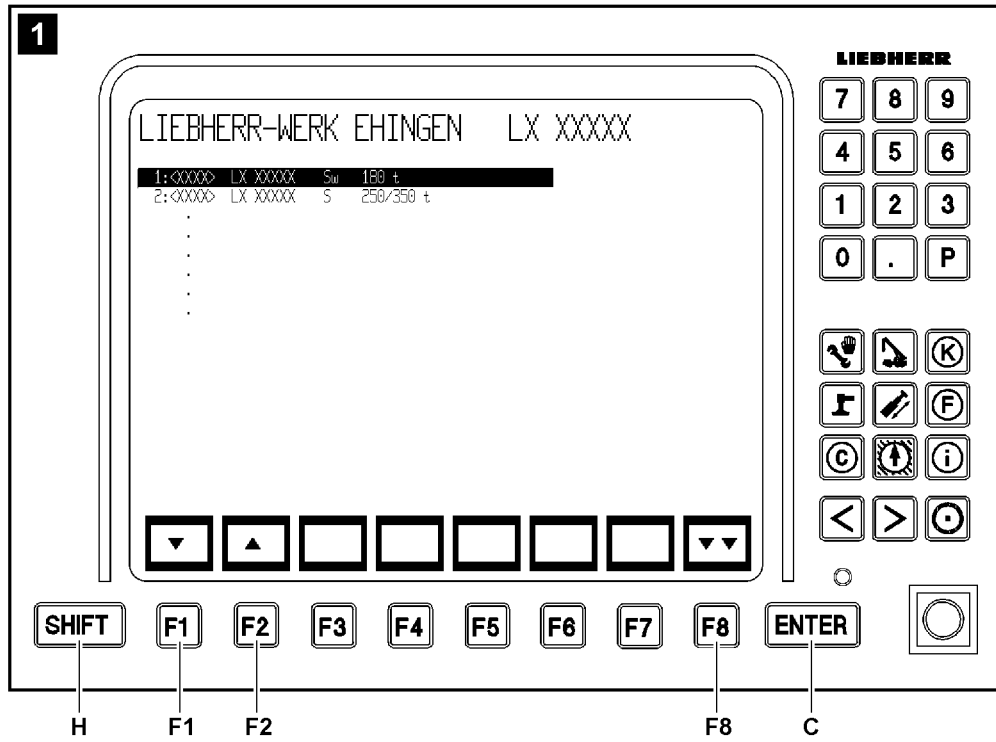

2.1.1 LICCON monitor 0

After successful starting procedure, the operating mode preselection screen appears on the **LICCON monitor 0** for approximately three seconds, see illustration 1.



Note

- ▶ The operating mode preselection screen is skipped if the crane only has one level! For example: The crane has only one S-boom (only S-operation possible)! In this case, the system changes directly into the set up screen for the only possible level!
- ▶ If the memory loses its data (for example as a result of a cold start) the previous operating mode is "rejected" and the first operating mode in the operating mode selection menu is activated! In this case, the corresponding set up screen appears!

The function key **F1** or the function key **F2** is pressed within three seconds when the operating mode preselection screen appears.

Result:

- The operating mode preselection screen is retained until the settings are confirmed by pressing the function key **F8** or the ENTER key **C**.



Note

- ▶ If neither the function key **F1** nor the function key **F2** are pressed within three seconds, then the last active operating mode remains set. The corresponding set up screen appears automatically!

To select the required operating mode group for crane operation, press the function key **F1** (cursor down) or function key **F2** (cursor up).



Note

- ▶ The selected operating mode group is highlighted in black in the operating mode preselection screen on the monitor!

Press the function key **F8** or the ENTER key **C**.

Result:

- The set operating mode group is taken over into the LICCON computer system and the set up program appears with the corresponding set up screen.

2.1.2 LICCON monitor 1

After successful starting procedure, the title screen with the words appears on the **LICCON monitor 1**: "LIEBHERR-WERK EHINGEN", see illustration 2.



Note

- ▶ Depending on the set up configuration of the crane, it is possible that a note for an operating mode appears!

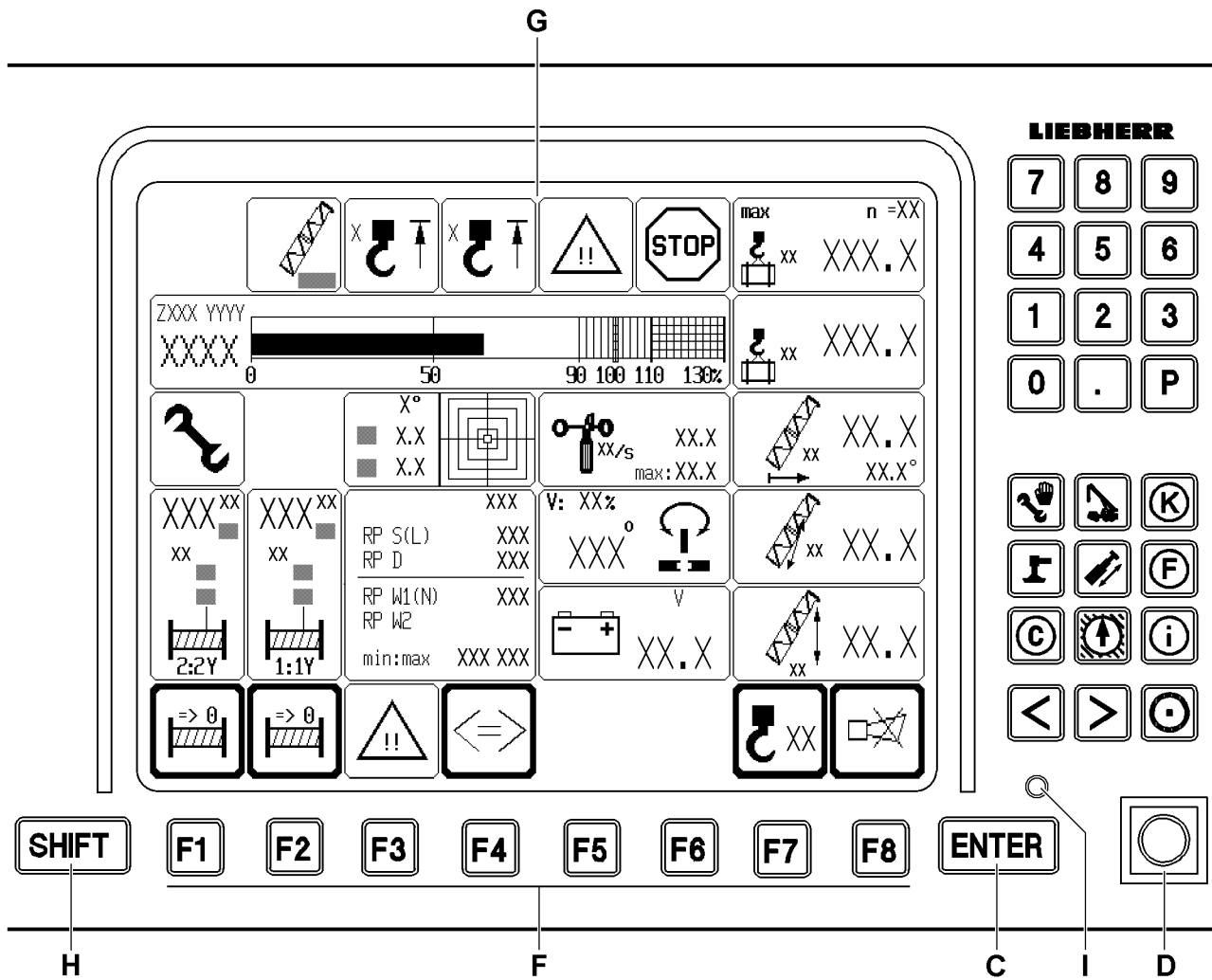

LIEBHERR

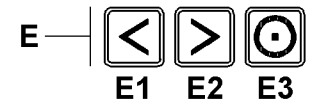
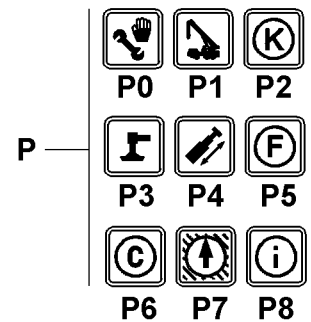
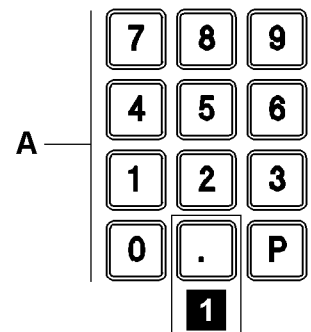
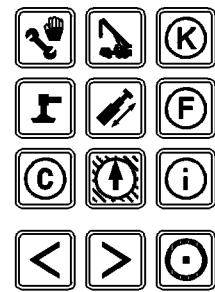
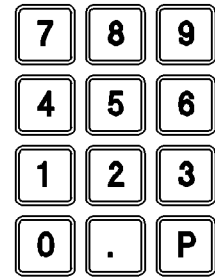

B112315

3 Operating elements of the LICCON computer system on monitor 0

The functions of the individual monitor operating elements are program-dependent and can differ, depending on the LICCON program which is currently running. This will be described in more detail in the description of the individual LICCON programs.

A Keypad	
P Program keys	• Selection of the individual LICCON programs
P0 Set up	• SHIFT and P0 : Engine monitoring.
P1 Crane operation	
P2 Crane acceptance	• Correction coefficients (program blocked - for LIEBHERR service personnel only)
P3 —	• Program key not assigned!
P4 —	• Program key not assigned!
P5 Input window hook block weight	
P6 Control parameter	
P7 —	• Program key not assigned!
P8 Test system	• Note: Description Test system, see Diagnostics manual!
C Input key ENTER	• Confirmation of changes
D Set up key	• Zero position (not actuated): Normal operation.
	• Touching: Function "Exceedance of shut off limits of LICCON overload protection" is released and / or the hoist limit switch is bypassed.



Note

Double function set up key!

If the crane has **no** CE-mark, when actuating the set up key **D**, the release for the "Emergency operation LICCON overload protection" is automatically engaged!

- ▶ Take into account, when actuating the set up key **D**, that the "Emergency operation LICCON overload protection" is automatically released!



Note

- ▶ By actuating the set up key **D**, all erection / take down procedures can be carried out within the erection / take down charts, for which no load charts are available!

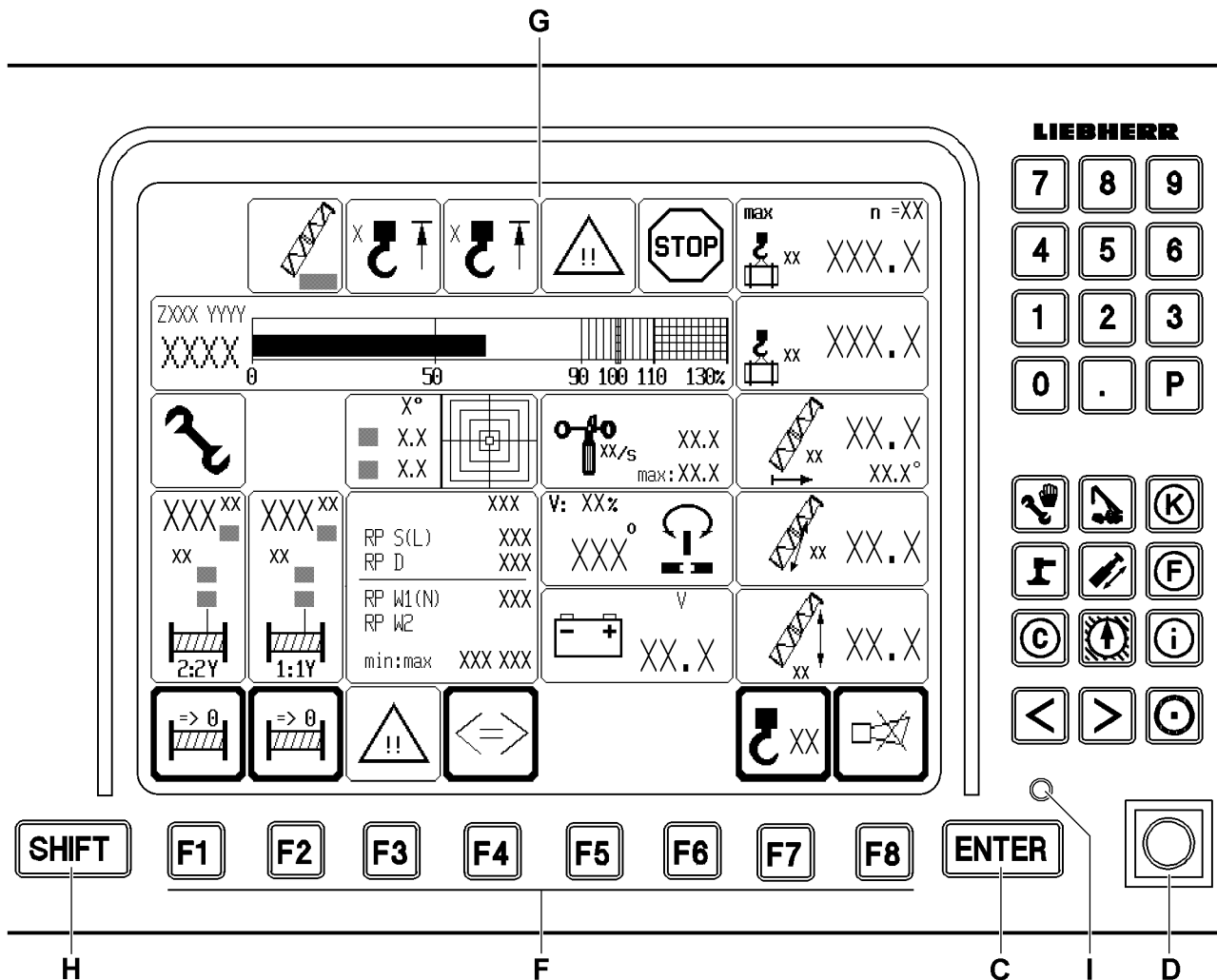

LIEBHERR

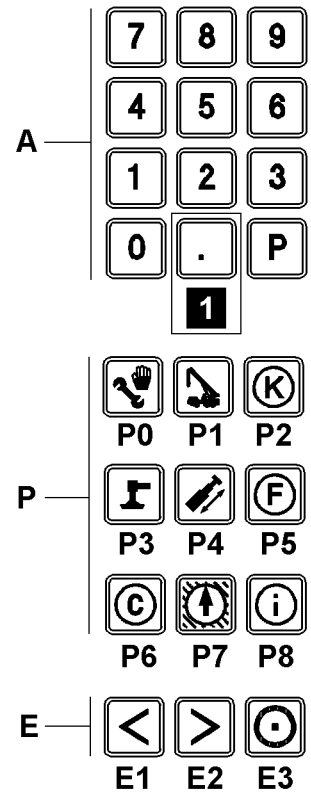

B112315

- E** Special function keys
 - Monitor brightness adjustment
 - Key combination **E3** and **E1**: Turn background illumination on / off.
 - Key combination **E3** and **E2**: Brightness adjustment in three stages.
 - **Note:**
Additional functions of the special function keys are program-dependent and are further explained in the descriptions of the individual LICCON programs!
- F** Function keys
 - The function keys should always be viewed in conjunction with the function key icon line displayed on the monitor
- G** Display
 - Display of the individual programs (example: Crane operation program)
- H** SHIFT key
 - Second-level key assignments, for example “Supervisory function”
- I** LED display
 - Monitor supply voltage present

4 The set up program

After the LICCON computer system boots up correctly, it changes automatically into the set up program.



Note

- ▶ All entries and settings, which are to be made by the crane operator in the set up program can only be carried out on **LICCON monitor 0!**



Note

Adjustment and display of set up configuration and reeving!

- ▶ Normally, the most recently run set up configuration and the reeving used at that time will be automatically set and displayed!
- ▶ If the computer system is started for the first time after set up of the crane, then the first valid set up configuration appears in the set up screen (first valid operating mode and reeving number "0")!
- ▶ After a new start of the computer system, due to a "cold start" (for example: battery or CPU change), the first valid configuration appears in the set up screen (first valid operating mode and reeving number "0")!

Using the set up program, the crane operator can set to the current operating mode, the current set up status of the crane and the reeving number of the hoist rope.

In addition, in the set up program he can also see all the load charts programmed into the LICCON computer system.

4.1 Setting the operating mode and set up configuration

The crane operator can select the operating mode and the set up configuration with the function keys **F** or by entering a 4-digit short code **1**.

4.1.1 Setting the operating mode and set up configuration via the function keys

The function keys **F** are explained in the section "Function key line" in this chapter.

- ▶ Select the respective function keys **F**.
- ▶ Press the ENTER key **C** to confirm and accept the settings.

Result:

- The data of the selected load chart can be viewed.

4.1.2 Setting the operating mode and set up configuration via the 4-digit short code

- ▶ Enter a 4-digit short code **1** with the keypad **A** on the **LICCON monitor 0**.
- ▶ Press the ENTER key **C** to confirm and accept the settings.

Result:

- The data of the selected load chart can be viewed.

4.2 Set up program areas



Note

- ▶ The monitor illustrations in this chapter are only examples!
- ▶ The numerical values in the individual icons and charts do not have to necessarily match the crane exactly!
- ▶ Numbers and letters can be replaced by place holders!
- ▶ The programmed load charts for the crane are binding!

The monitor is divided into three areas in the set up program:

- 1 General information line
- 2 Display area of load chart values
- 3 Function key line with assigned icons

4.2.1 General information line

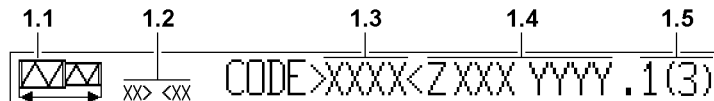

- 1.1 Main boom length icon
 1.2 Measuring unit
 1.3 4-digit short code

- The icon is identical for all operating modes.
- For the programmed length units (LE) and weight units (GE)
- It is located next to the text "CODE" inside angled brackets
- Each short code uniquely identifies a crane configuration. The valid set up configuration and their associated short code numbers for the crane can be found in the load chart manual of the crane.
- For internal Liebherr load chart administration
- Relates to the currently displayed part of the load chart
- Separated from the organization number with "."
- The total number of pages in this load chart is in parentheses

- 1.4 Organization number
 1.5 Page number

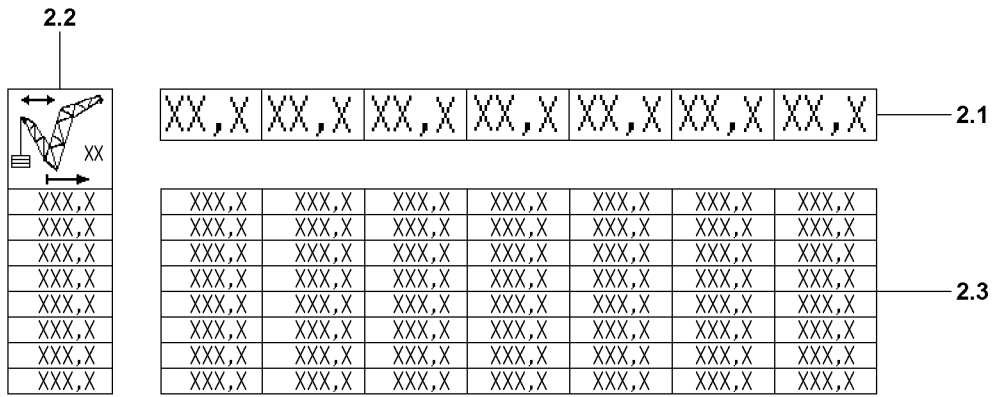

* n * * XX * * XX * * XX * * XX * * XX * * XX * * XX *

2.4

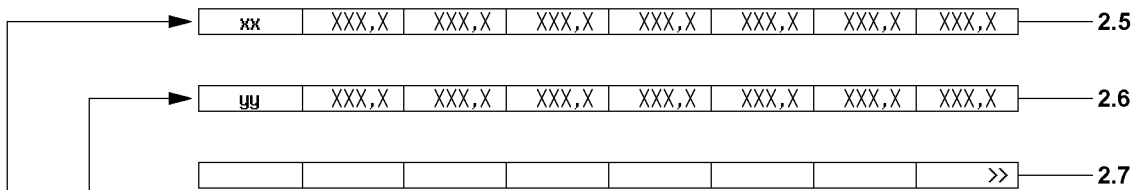

SHIFT



E1 E2

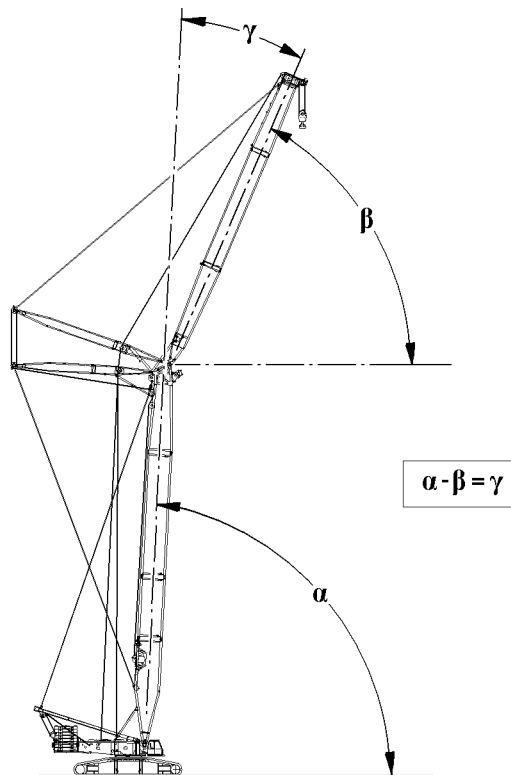
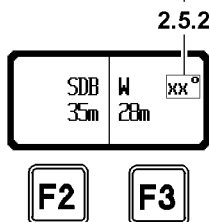
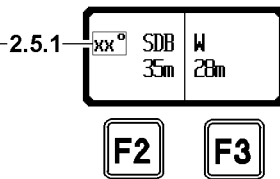

4.2.2 Display area of load chart values

- | | |
|-----------------------|---|
| 2.1 Main boom lengths | <ul style="list-style-type: none"> • In [m] or [ft] • Maximum of 7 columns per display page |
|-----------------------|---|



Note

View "Boom radius" icon 2.2!

- ▶ Depending on the operating mode of the crane, the view changes from the "Boom radius" icon 2.2!
- ▶ In the illustration, the "Boom radius" icon 2.2 shows an operating mode with luffing auxiliary boom / accessories, derrick boom and derrick ballast!

- | | |
|----------------------------------|---|
| 2.2 "Boom radius" icon | <ul style="list-style-type: none"> • In [m] or [ft] • Maximum 10 lines of radius values • Vertical axis of load value field |
| 2.3 Load value field | <ul style="list-style-type: none"> • Columns under the main boom lengths and in the lines to the right of radius values • Load values depending on boom length and radius |
| 2.4 Reeving number of hoist rope | <ul style="list-style-type: none"> • * n * n = Reeving number of the hoist rope between the boom head and hook block, in order to be able to lift the maximum load in the corresponding load chart column in single winch operation • Enter and confirm the reeving on the LICCON monitor 0, according to the reeving on the boom head |

NOTICE

Special equipment necessary!

- ▶ If a load value in the column exceeds that of a load that can be lifted with the maximum possible reeving, then there is an exclamation mark beside the reeving number ("!"). This exclamation mark indicates that special equipment is needed to lift this load!



Note

Parallel operation of hoist winches!

- ▶ For parallel operation of hoist winches (1|| 2), when reeving in the hoist rope, enter the total reeving of winch 1 and winch 2 on the LICCON computer system!
- ▶ **Example:** Winch 1 and winch 2 are each reeved 7ways, the total reeving is therefore n=14!
- ▶ The total reeving **must** always show an even number value in parallel operation!

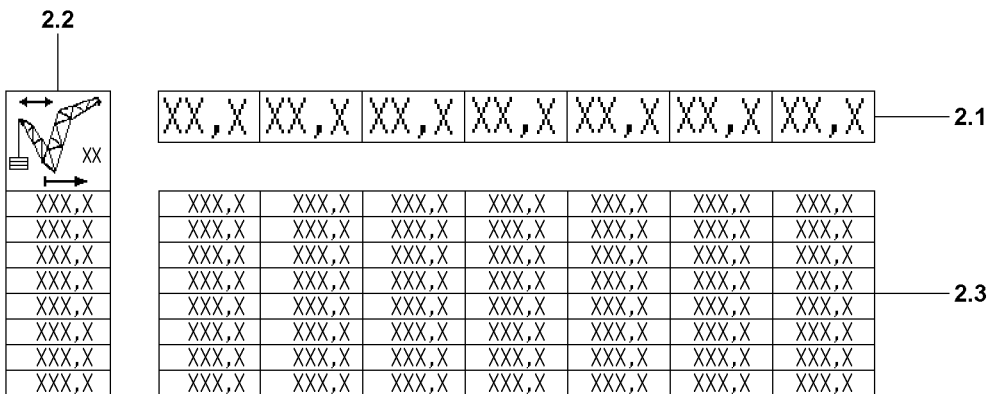

* n * * XX * * XX * * XX * * XX * * XX * * XX * * XX *

2.4

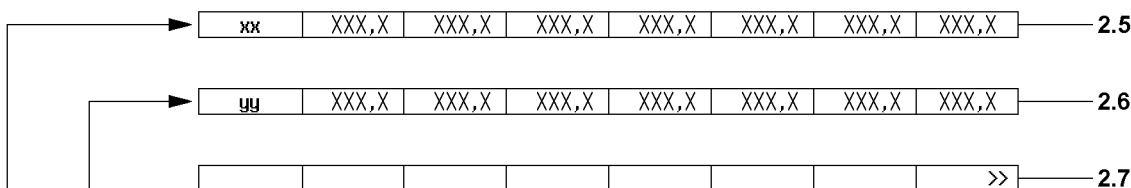

SHIFT



E1 E2

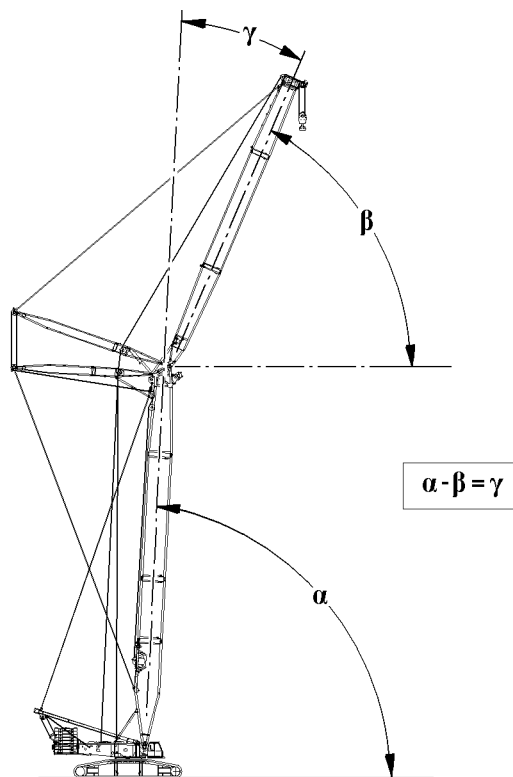
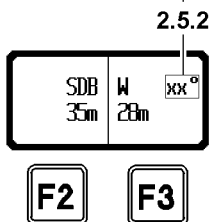
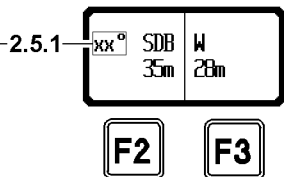

2.5 Boom angle

- Line **xx**
- In [°]
- **Note:**
Appears **only** in operating modes with luffing auxiliary boom / accessory!

2.5.1 Main geometry

- Appears "**xx**°" in main geometry status icon (for example: "**xx**° SDB") means "**xx**°" = main boom angle α in [°].
- In the line **xx** the main boom angles are listed, which must be set in order to be able to lift the load values in the corresponding load chart column

2.5.2 Auxiliary geometry

- Appears "**xx**°" in auxiliary geometry icon (for example: "**W**" "**xx**°") then means "**xx**°" = relative angle auxiliary boom / accessory γ in [°].
- In the load chart columns, the relative angles auxiliary boom / accessory, which must be set to be able to lift the load values in the corresponding load chart column are listed next to each other.

**Note**

- ▶ Main boom angle α : The angle of the main boom to the placement surface of the crane!
- ▶ Angle auxiliary boom / accessory β : The angle of the auxiliary boom / accessory to the placement surface of the crane!
- ▶ Relative angle auxiliary boom / accessory γ : The angle of the auxiliary boom / accessory is determined relative to the main boom!

2.6 Derrick ballast radius

- Line **yy**
- In [m] or [ft]
- **Note:**
Appears **only** in operating modes with derrick ballast!
- In the line **yy** the derrick ballast radii are listed, which must be set in order to be able to lift the load values in the corresponding load chart column.

2.7 Line for special displays

- If a load chart consists of more than seven columns, it cannot be fully displayed because of the size of the monitor. In that case, marking arrows in the first or the seventh field in this line indicate that there are additional chart columns to the left or right of the displayed chart. They can be shown by pressing the key **E1** or the key **E2**.
- **Note:**
Using the key combination **SHIFT** and **E1** or **SHIFT** and **E2**, you can, where possible, scroll left or right by 7 load chart columns (corresponds to 1 page)!

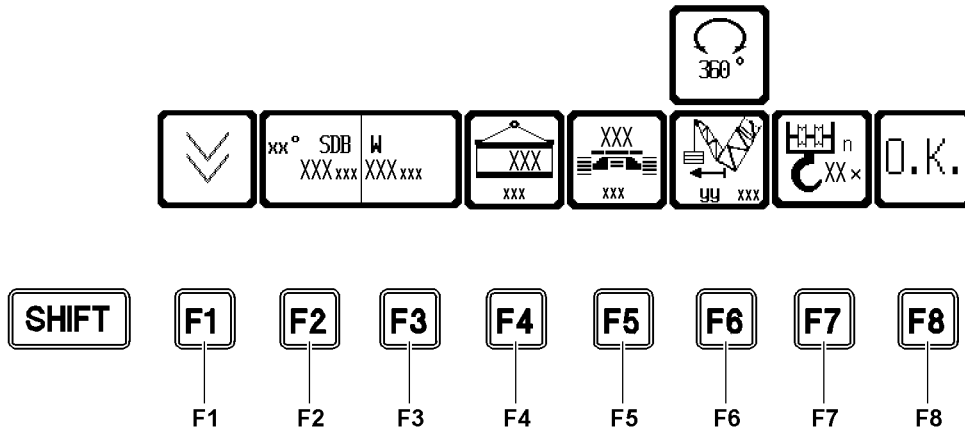

4.2.3 Function key line in the set up program

The function key line consists of function keys **F1** to **F8** and the function key icon bar above it. The function keys correspond to the various function key icons above them.

Various functions are indicated by the function key icons, or they may refer to changes of:

- Operating mode and
- set up configuration.

Not all function keys have to be assigned icons on the LICCON monitor. This depends on the program selection.

Pressing a function key changes the appearance of the icon above, its meaning, or its textual content.

- | | |
|------------------------------|--|
| F1 Vertical paging | <ul style="list-style-type: none">• Depending on the size of the monitor, up to 10 load chart lines can be displayed at once. If a chart consists of more than 10 lines, then the display is spread over several pages. When pressing a key, the next page of the load chart will be displayed, and the number of the current page in the “general information line” will be counted up by 1. When the last page is reached, page 1 will appear again after pressing the function key F1. |
| F2 Main boom geometry | <ul style="list-style-type: none">• Adjustment possibility of different main boom operating modes and main boom lengths of the crane (if available). The types are described by abbreviations (for example: SDB = heavy main boom, derrick boom and suspended ballast) and length data in the icon. |
| SHIFT and F2 | <ul style="list-style-type: none">• Previous main boom geometry (if available) |

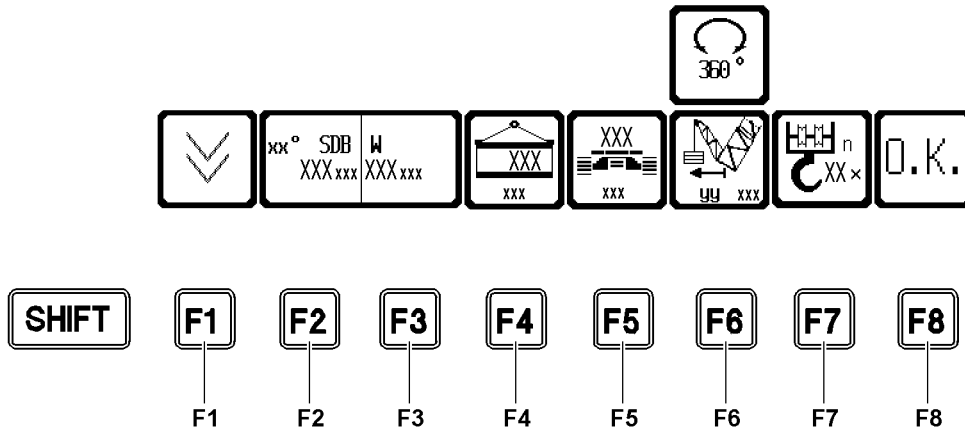

- F3** Boom geometry auxiliary boom / accessory
- Adjustment possibility of different auxiliary boom operating modes and auxiliary boom lengths of the crane (if available). The types are described by abbreviations (for example: **W** = luffing lattice jib) and length data in the icon. Possibly additional angle data is noted in the icon.
 - **Note:**
Pressing the function key **F2** and / or the function key **F3** removes all data (operating mode, set up configuration) from the monitor and sets the short code in the general information line to "CODE >????<".
 - **Operating mode data:**
 - Boom length icon in the general information line
 - Length units and weight units
 - Load chart organization number
 - Boom radius icon
 - Boom length data
 - **Set up dependent data:**
 - Numbering of current page number and total number of pages in load chart
 - Radius values in length units
 - Load values in weight units
- SHIFT and F3**
- F4** Counterweight
- Previous auxiliary boom geometry (if available)
 - Adjustment possibility for current counterweight, which must be on the turntable in order to obtain the values in the current chart. When pressing a key, the following icon appears with additional text in the counterweight icon.
 - Example:
"110 t" = total counterweight of 110 t
- F5** Crane chassis
- Adjustment possibility "Set up configuration crane chassis" (for example: crawler, support, central ballast)
 - In operating modes, where there are various crane chassis versions (for example: Ballast on crawler travel gear), this can be set with the function key **F5**.

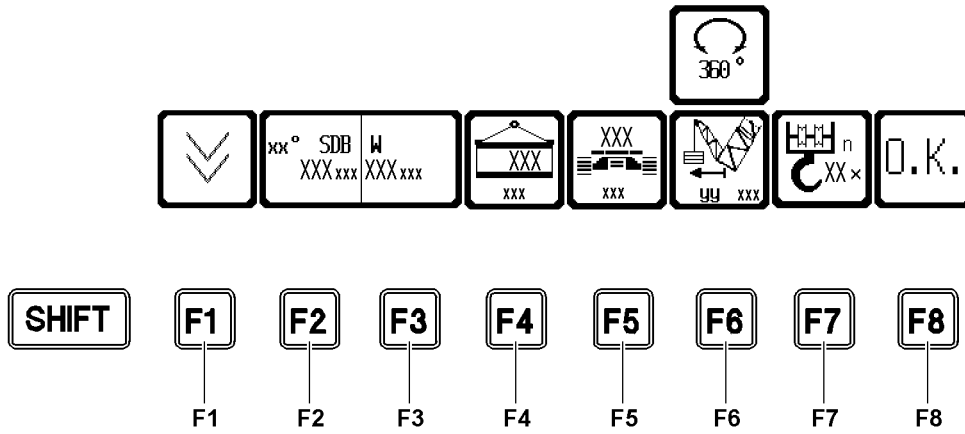

**Note**

- ▶ For crane operating modes without derrick ballast, the slewing range icon crane superstructure appears at **F6!**
- ▶ For crane operating modes with derrick ballast, the derrick ballast radius icon appears at **F6!**

F6 Slewing range crane superstructure

• “Slewing range icon 360°”

or

F6 Derrick ballast radius

• Set the set up configuration derrick ballast radius **yy** in [m] or [ft]

F7 Hoist rope reeving

- Adjustment possibility for the **number of hoist rope strands on the boom** to obtain a certain load carrying capacity
- Press the key: Reeving number on boom is increased by 1.
- Press the key: Reeving number on boom is reduced by 1.

SHIFT and **F7**

**Note**

Reeving boom nose!

- ▶ The reeving for the boom nose is not shown separately!
- ▶ When selecting a respective load chart for crane operation with boom nose, the respective reeving number must be entered in the icon Hoist rope reeving **F7!**

**Note**

- ▶ The displayed number of hoist rope strands (reeving) in the icon will be increased with every keystroke by one counter, up to a fixed maximum value (depending on operating mode)! If the maximum value is exceeded, the counter starts again at the minimum value!
- ▶ If the set value is still within the minimum and maximum values when switching to another operating mode, it remains valid! Otherwise it will be set to the minimum value for the new operating mode!
- ▶ After a “cold start” (for example loss of data in the memory), the display of the hoist rope reeving is at “0”!

**Note**

Parallel operation of hoist winches!

- ▶ For parallel operation of hoist winches (1|| 2), when reeving in the hoist rope, enter the total reeving of winch 1 and winch 2 on the LICCON computer system!
- ▶ **Example:** Winch 1 and winch 2 are each reeved 7ways, the total reeving is therefore n=14!
- ▶ The total reeving **must** always show an even number value in parallel operation!

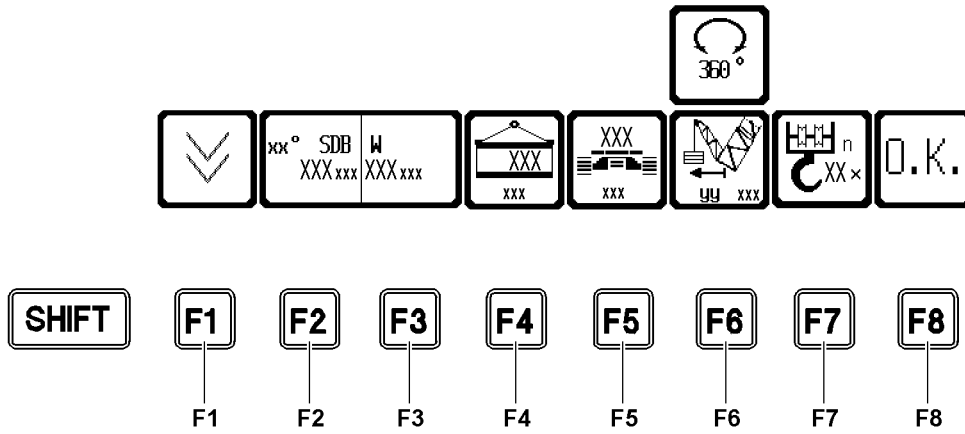

F8 Confirmation key

- For confirmation of selected set up configuration
- **Prerequisites:**
 - The entry of the set up configuration must be completed all the way. A valid short code is shown and in the chart field are load values.
 - The external conditions for this set up configuration, if stipulated, must be met.
 - The crane may not be utilized by more than 20 % in the previous set up configuration (applies only if the load suspended on the hook is heavier than 0.5 t). Switching to the crane operation program can otherwise only be done with the program key **P1**. In that case, the newly entered set up configuration is not accepted.

**Note**

- ▶ Make sure that the selected set up configuration (short code) and the hoist rope reevings are taken over after switching into the operating screen!

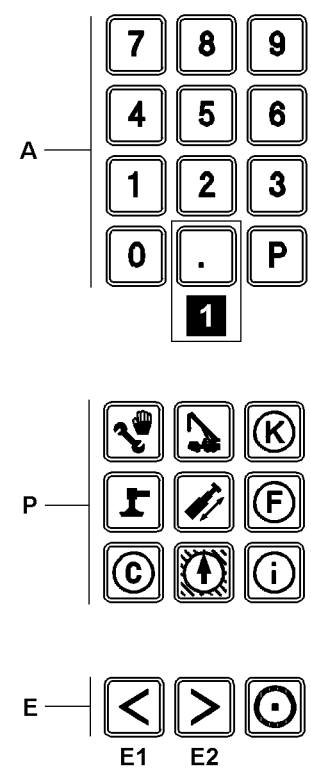
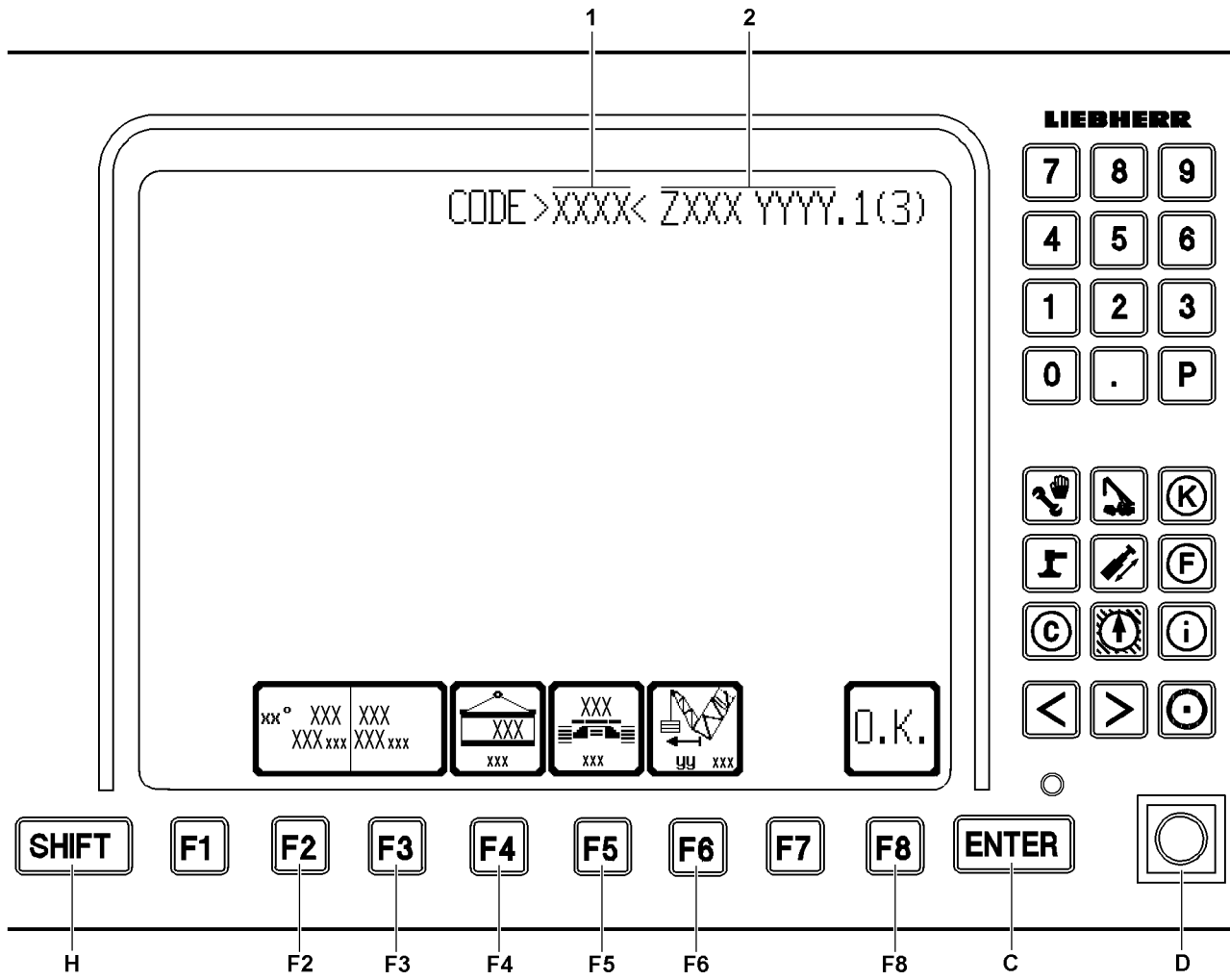

B112308

4.2.4 Operating errors in the set up program

- A Keypad**
- Pressing the keypad deletes all operating mode and set up configuration dependent data from the monitor
 - The keys **0** to **9** on the keypad can be used to enter the short code directly into the LICCON monitor
 - The key **P** and the key “. ” (illustration **1**) have no function in the set up program
- P Program keys**
- Selection of individual programs. The settings in the set up program are discarded and the set up configuration and reeving, which were last confirmed with the function key **F8** (OK) are continued to be used.
A program currently running **cannot** be called again using its program key.
- C Input key ENTER**
- Confirmation of input both for short codes **1** as well as for any change in the set up configuration via the function keys
 - **ENTER** after entering the short code, the short code **1** is searched for in all stored load charts. If the matching load chart has been programmed, it will be displayed in full. Otherwise there is an error message in the form of “????” in the second part of the organization number **2** and the acoustic signal “Horn” sounds.
 - **ENTER** after a changing the operating mode using the function key **F2** and the function key **F3** searches for this operating mode. If successful, sets its first set up configuration and displays the load chart and its short code **1**. In the event of an error, the short code **1** remains on “CODE ????”, the organization number **2** is displayed as “ZXXX????” and the acoustic signal “Horn” sounds.
 - **ENTER** after a change in the set up configuration with the function keys **F4** and **F5** as well as the function key **F6** this load chart (if the chart exists) displays with short code **1** on the monitor. In the event of error, the short code **1** remains on “CODE ????” and the acoustic signal “Horn” sounds.
- D Set up key**
- Has no function in the set up program

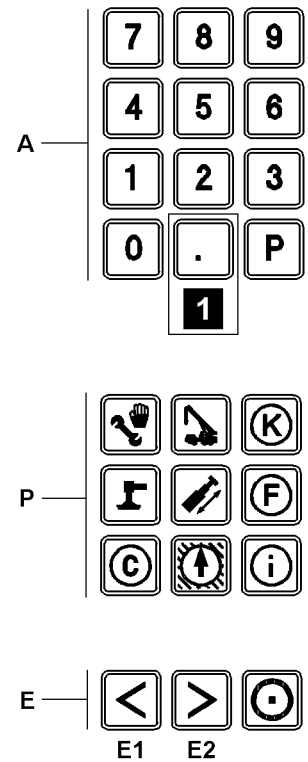
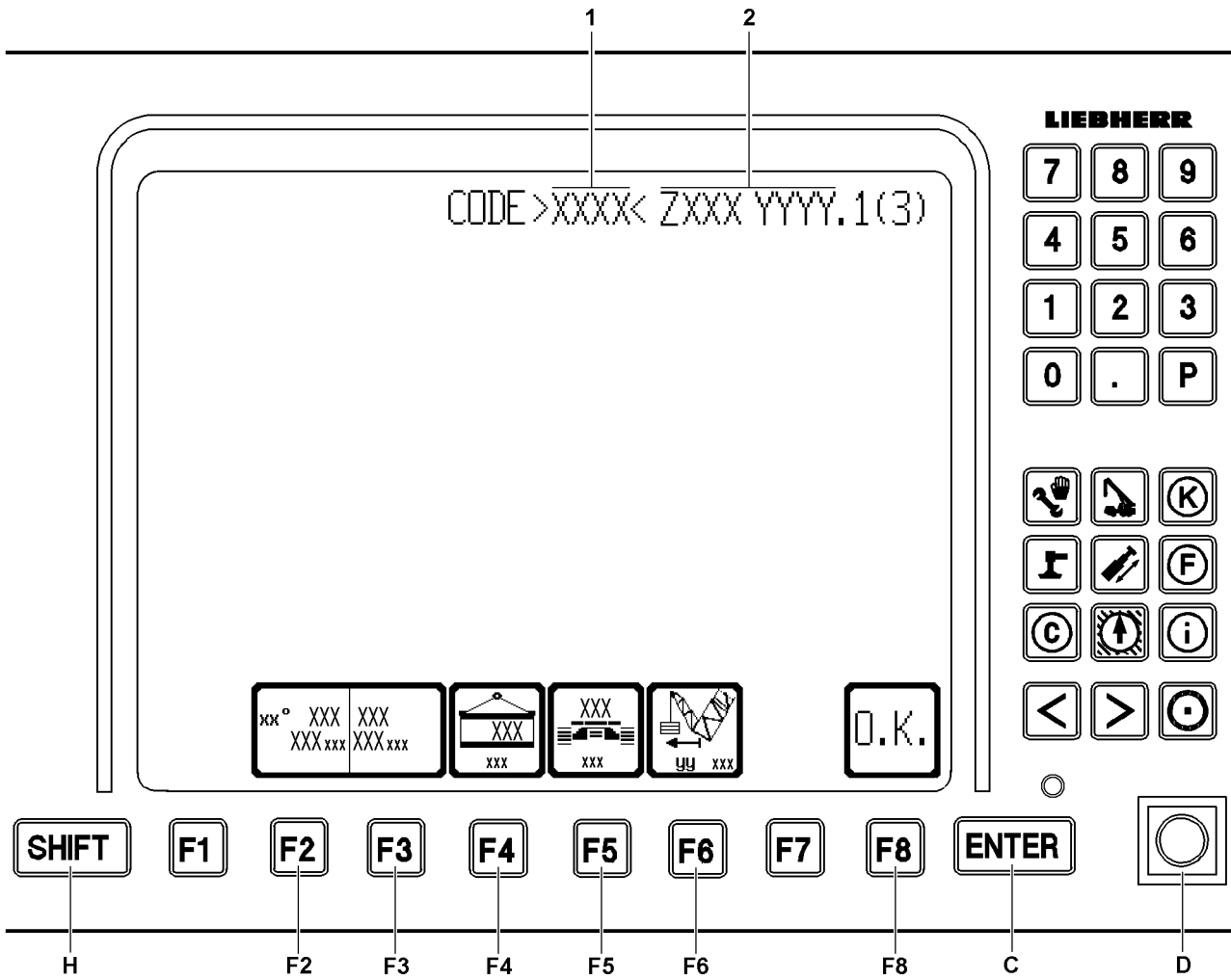

B112308

E Horizontal paging**• Note:**

The key **E1** and key **E2** only have a function if this is indicated in the "Line for special displays"!

- If a load chart consists of more than 7 columns, the first display of the set up configuration only shows columns 1 to 7
- Pay attention to the double arrow on the right (>>) and / or on the left (<<) edge of the line of the load chart! It points to additional columns in the respective direction!
- Press the key **E1** to display the next left chart column
- Press the key **E2** to display the next right chart column

• Note:

Using the key combination **SHIFT** and **E1** or **SHIFT** and **E2**, you can, where possible, scroll left or right by 7 load chart columns (corresponds to 1 page)!

H SHIFT key

- For example Supervisory function

- By pressing and holding down the **SHIFT** key and then pressing one of the function keys, which must correspond to the corresponding function, the previous main boom geometry, the auxiliary boom geometry and the previous reeving are reset

• Note:

See section "The function key line" in the set up program!

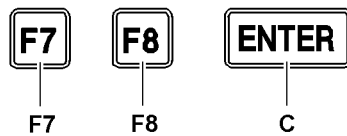
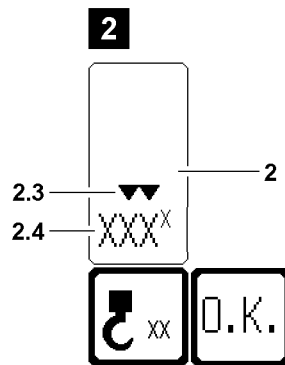
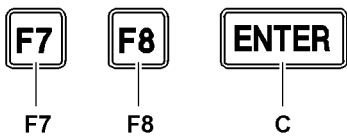
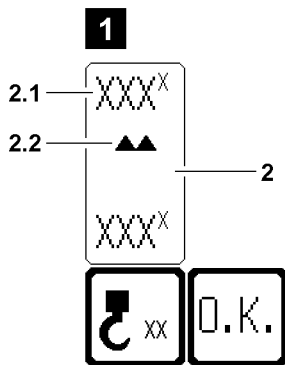
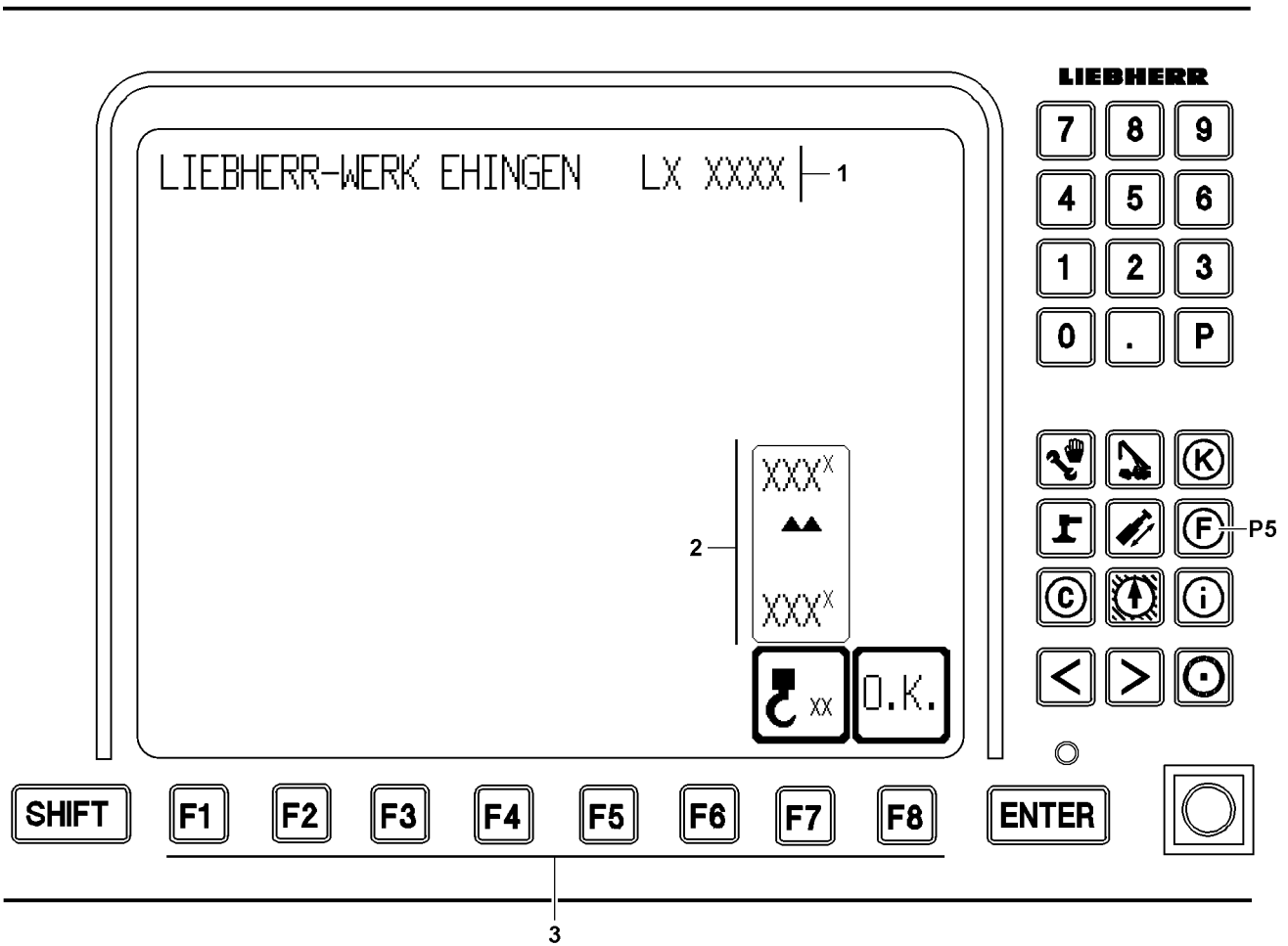

4.3 Input window hook block weight

After the selected set up configuration was confirmed in the set up program with the function key **F8**, the set up parameters are taken over by the LICCON computer system. Then the input window hook block weight **2** appears automatically.



WARNING

Deviation from specifications of erection and take down charts!

In case of a deviation from the specifications of the erection and take down charts, the crane can be overloaded and topple over!

Personnel can be severely injured or killed!

- ▶ The entered value must be taken from the erection and take down charts, depending on the selected set up configuration!
- ▶ If the actual weight of the hook block exceeds the permissible hook block weight, then the hook block must be carried along for erection / take down of the boom!
- ▶ The entered hook block weight is recorded with the data logger!

4.3.1 Starting the input window hook block weight

In the input window hook block weight, the crane operator must determine a hook block weight corresponding on the operating mode for erection / take down of the boom systems according to the erection / take down charts.

- ▶ Press the function key **F8** in the set up configuration screen.

or

- Press the program key **P5**.

Result:

- The input window hook block weight appears.

4.3.2 User interface

- 1 Crane type identification
- 2 Hook block weight icon
- 2.1 Input field for the hook block weight
- 2.2 Double arrow pointing up • Input field is active, illustration 1
- 2.3 Double arrow pointing down • Current input value is active, illustration 2
- 2.4 Current input value of hook block weight
- 3 Function key line

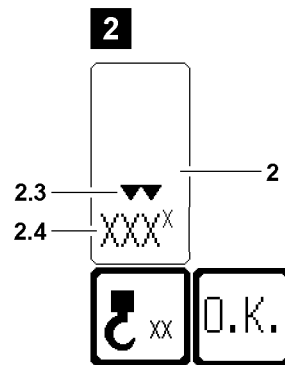
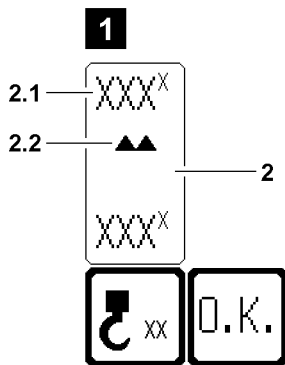
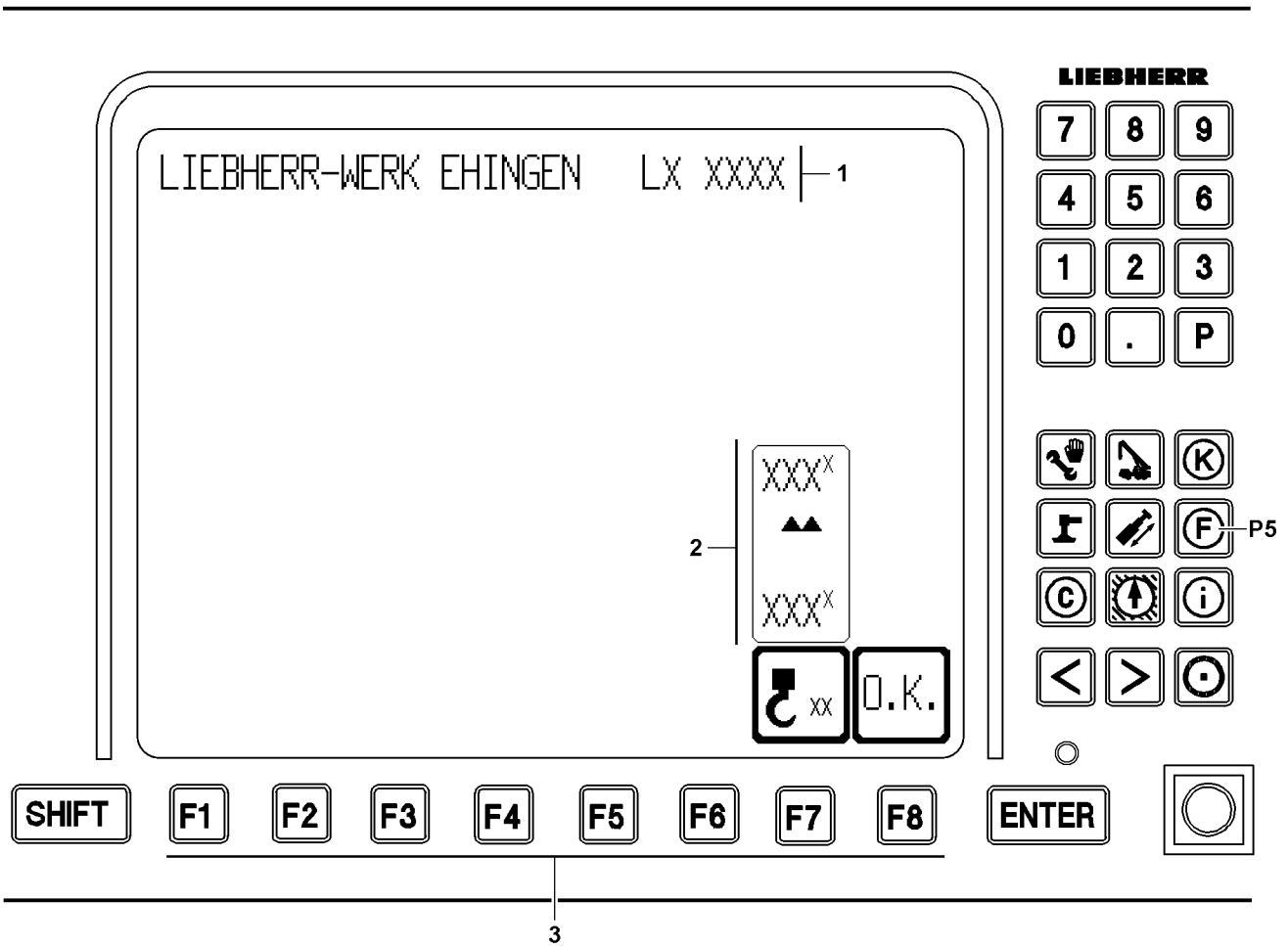

4.3.3 Enter the hook block weight

To be able to erect / take down a boom system, a valid hook block weight must first be entered in the input window hook block weight on the LICCON computer system and confirmed.

Take permissible weight of the hook block must be taken according to the selected set up configuration from the erection and take down charts.

Make sure that the following prerequisite is met:

- A valid set up configuration is entered and confirmed.
- ▶ Press the function key **F7**.
- ▶ Double arrow up **2.2** is shown, input field hook block weight **2.1** is active.
Enter the hook block weight via the keypad.
- ▶ When the entered hook block weight is shown in the input field hook block weight **2.1**:
Press the ENTER **C** key.

Result:

- The hook block weight is taken over as current input value hook block weight **2.4**, illustration 2.
- The input field hook block weight **2.1** is faded out.
- Double arrow down **2.3** is shown.



Note

- ▶ By pressing the function key **F7** again, the entered hook block weight can be changed!

- ▶ When the entered hook block weight has been accepted:
Press the function key **F8** (OK).

Result:

- The entered hook block weight is accepted into the LICCON computer system.
- The crane operating screen appears.

Troubleshooting

When luffing the boom up / down **with the hook block**, the maximum load according to the load chart and reeving is exceeded and a LML stop is triggered?

- ▶ Place the hook block down and carry it along.

Troubleshooting

When erecting / taking down the boom **with the hook block**, a higher value than the actual weight on the hook block is shown in the "Current load" icon (crane operating screen)?

- ▶ For further procedure, see section "Adapt the input value hook block weight".

Troubleshooting

When erecting / taking down the boom **without the hook block** (load weighting), a value of more than 0 t is shown in the "Current load" icon (crane operating screen)?

- ▶ For further procedure, see section "Adapt the input value hook block weight".
-

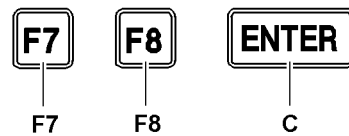
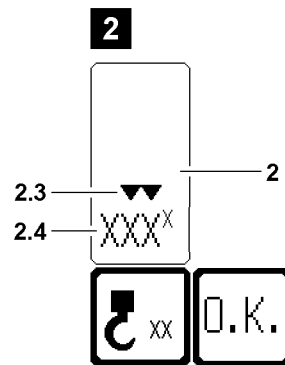
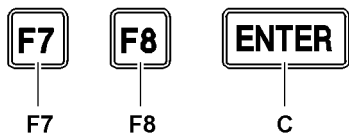
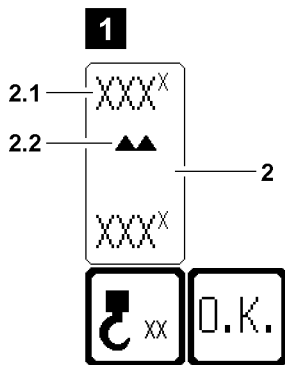
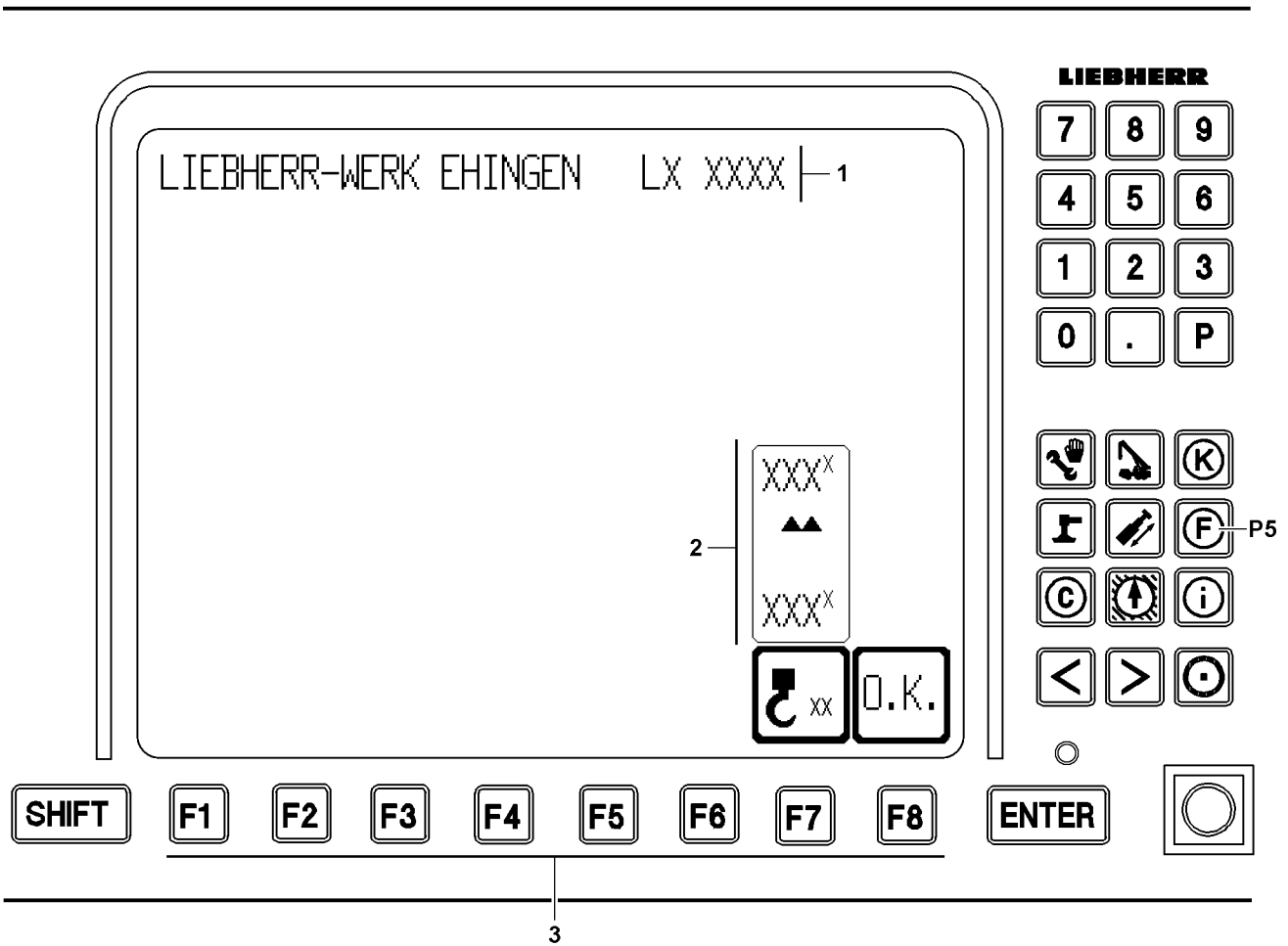

4.3.4 Adapting the input value hook block weight

It may be possible that the crane movement is shut off due to overload when trying to erect / take down the boom.

The reason for the shut off may be a weighing error.



Note

Weighing error!

- ▶ A weighing error is a combination of environmental influences, manufacturing and sensor tolerances!
- ▶ This combination can cause an increased display value in the "Current load" icon (crane operating screen)!

A weighing error can be compensated for by adapting the input value hook block weight.



WARNING

All-inclusive adaptation of the hook block weight!

If the input value hook block weight is adapted and no weighing error was determined, then the crane can be overloaded and topple over!

Personnel can be severely injured or killed!

- ▶ Before adapting the input value hook block weight, an existing weighing error must have been found!
- ▶ Only the determined weighing error may be added to the permissible hook block weight!

If a weighing error is suspected, then the crane operator must ensure, before carrying out additional steps, that:

- A valid set up configuration has been entered on the LICCON computer system!
- The assembled boom system matches the entered set up configuration of the crane!
- The boom system is assembled according to the rod plans!
- All attachment parts on the boom have been removed!
- No guy rods are on the boom!
- The boom is free of snow and ice!
- The wind influence onto the boom is not too great!
- The weighing error is plausible and comprehensible!

If it is ensured that the above listed prerequisites are adhered to, then the determined weighing error may be added to the permissible hook block weight and entered in the hook block weight icon.

- ▶ Enter the adapted hook block weight, see section "Entering the hook block weight".

Troubleshooting

The adapted value of the hook block weight is **not** taken over into the LICCON computer system, even though the weighing error is plausible and comprehensible?

- ▶ For erection of the boom system, carry the hook block along.

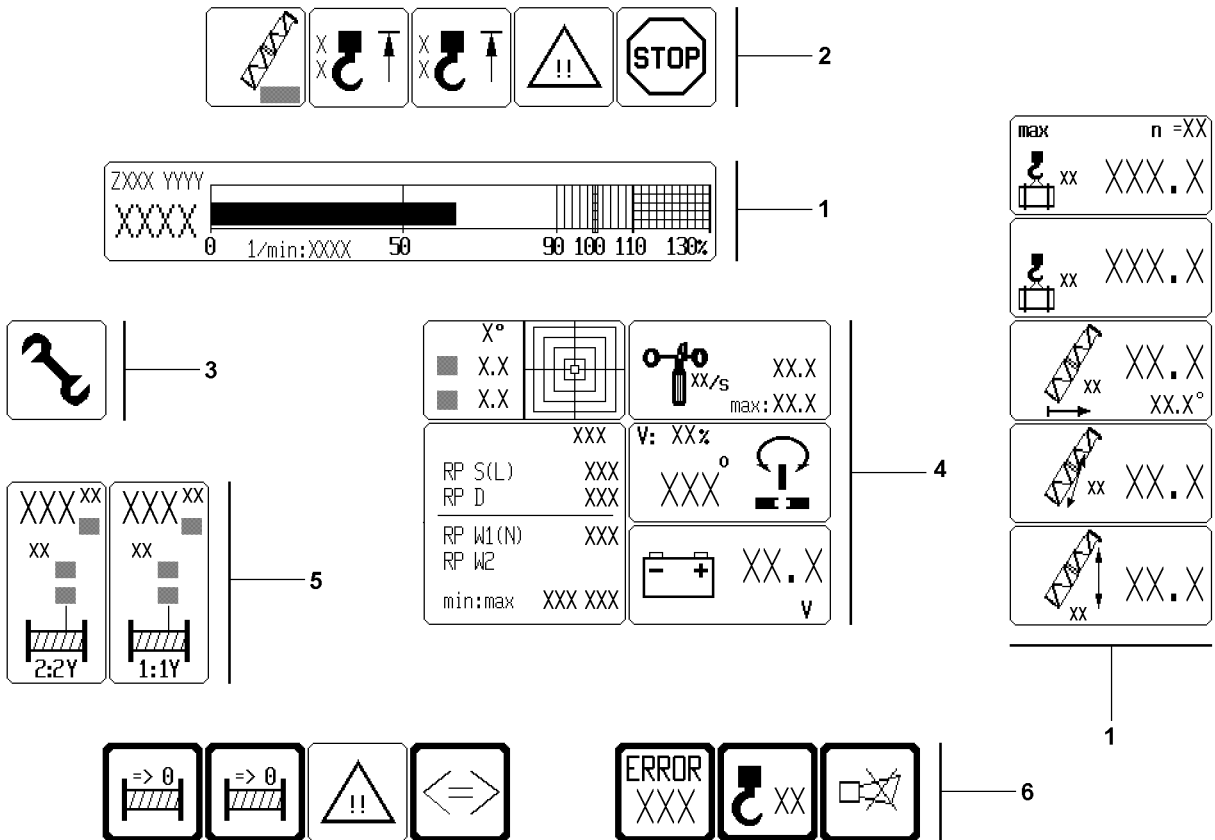
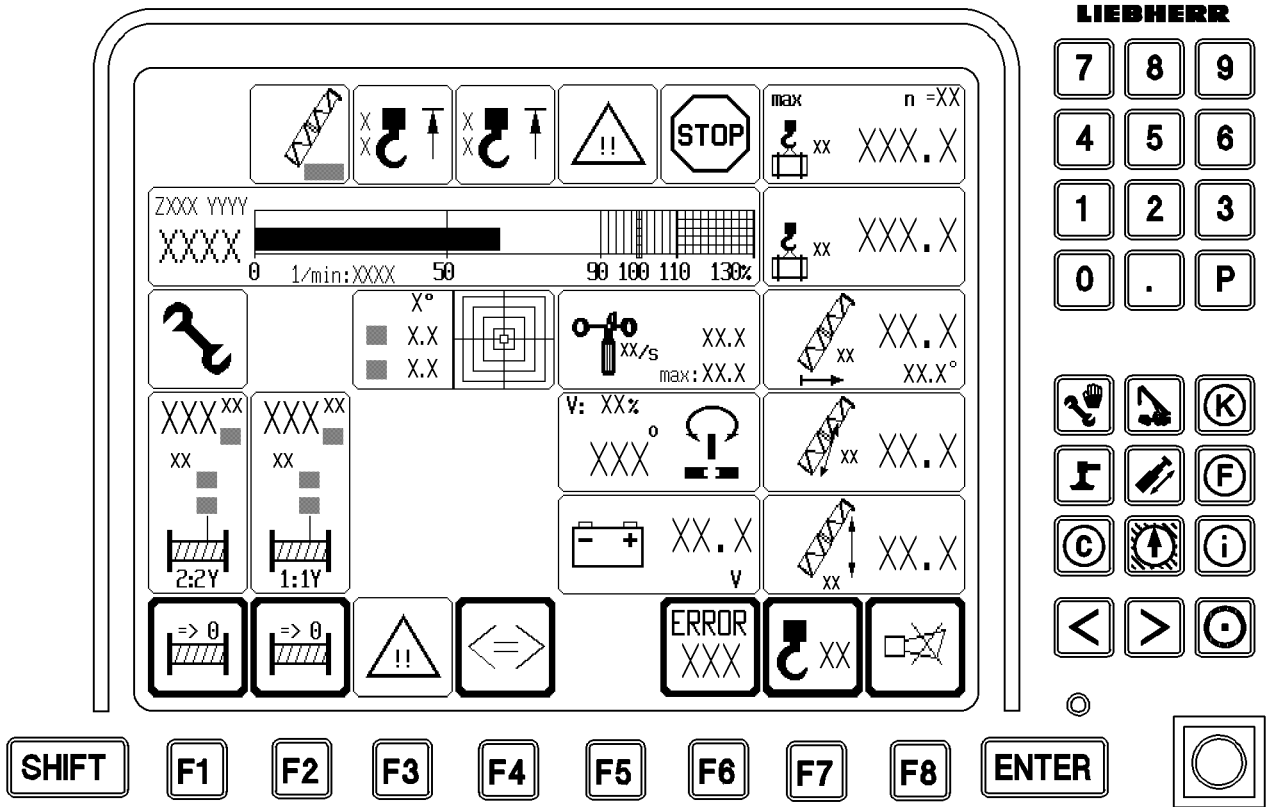

B112316

5 The Crane operation program on monitor 0

The LICCON program Crane operation assists the crane operator by displaying the data needed for operating the crane clearly on **monitor 0**. An acoustic signal accompanies all critical displays.

Depending on the equipment, a range of other icons may also be turned on as additional displays, either as required by the crane operator, or automatically in the event of a problem.

It also alerts the crane operator to imminent overload conditions. In the event of overload and many error conditions, which could be hazardous during crane operation, the system shuts off.

The LICCON monitor is divided into six areas in the Crane operation program:

- 1 Crane geometry and load information
- 2 Alarm functions
- 3 Special functions
- 4 Monitored auxiliary functions
- 5 Winch display • Winch 1 and winch 2
- 6 Function key line



Note

- ▶ The monitor illustrations in this chapter are only examples!
 - ▶ The numerical values in the individual icons and charts do not have to necessarily match the crane exactly!
 - ▶ The configuration of the LICCON monitor with icons is only descriptive!
 - ▶ An identical icon display will **not** appear during crane operation!
-

5.1 Crane geometry and load information



Note

- ▶ The crane illustrations in this section are only examples and are generalized!
 - ▶ They may differ from the crane type and equipment!
-

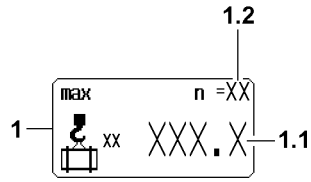

5.1.1 Maximum load

- 1 "Maximum load" icon
- 1.1 Maximum load on the boom
- In [t] or [lbs]
 - In [t] or [lbs]
 - The load capacity depends on:
 - The selected operating mode
 - The selected set up configuration (load chart)
 - The boom radius
 - The various boom angles
 - The derrick ballast radius*
 - The currently pulled derrick ballast*
 - The reeving of the hoist rope on the boom
 - **Note:**
The maximum load on the boom (also: Maximum load according to the load chart and the reeving on the boom) is the load, which the crane can lift in its current operating condition with the maximum utilized ballast / counterweight!
 - **Note:**
"???.?" is shown when no load chart value can be accessed!
An error message is issued, see Diagnostics manual!
 - Example:
The crane is not in the range of the load chart!
 - or**
The value cannot be calculated / determined!
- 1.2 Reeving number hoist rope
- n = reeving number of hoist rope on the pulley head selected via the load chart. The reeving number has been set first in the set up program.



Note

Reeving boom nose!

- ▶ The reeving for the boom nose is not shown separately!
 - ▶ If a load chart for crane operation with boom nose is selected, the reeving for the boom nose is shown in the "Maximum load" icon 1!
-

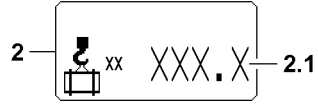

5.1.2 Current load

- 2 "Current load" icon
- 2.1 Current load on the boom

- In [t] or [lbs]
- Actual load display = current load in [t] or [lbs] on the selected boom
- Display of the calculated total load including the weights of the carrying equipment, the lifting equipment (hook block) and / or the fastening equipment, but **without** the nominal weight of the hoist rope
- **Note:**
 "???.?" is shown if the value cannot be calculated / determined!
 An error message is issued, see Diagnostics manual!



WARNING

Tolerances at actual load display!

Due to tolerances, there may be a deviation in the actual load display in the "Current load" icon 2!
 The current load display in the "Current load" icon 2 is no calibrated weighing device!

- ▶ Always observe the actual weight of the load in connection with the load charts and the set up configuration!



Note

Net load display in the "Current load" icon 2!

- ▶ By using the function "Tare" (see description of function key **F7** in section "Function key icon line") the display can be changed over to display the net load! In the icon appears additionally the word "Net"!



Note

Current load on the boom nose!

- ▶ The current load on the boom nose is not shown separately!
- ▶ If a load chart for crane operation with boom nose is selected, the current load on the boom nose is shown in the "Current load" icon 2!

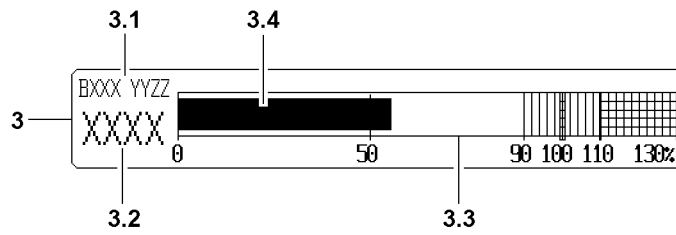

5.1.3 Dynamic utilization bar

- 3 “Dynamic utilization bar” icon
 - In percent [%]
- 3.1 Organization number
 - For internal Liebherr load chart administration
- 3.2 Short code
 - Identifies the selected set up configuration
- 3.3 Utilization scale
 - Marking from a utilization of 90 %: **Advance warning.**
 - Marking at a utilization of 100 %: **STOP shut off.**
- 3.4 Utilization bar
 - According to load chart and reeving
 - **Note:**
The utilization bar is the measurement for the current utilization of the crane!

Utilization of crane according to load chart and reeving	=	$\frac{\text{Current load on the boom head}}{\text{Maximum load according to load chart and reeving}}$
--	---	--

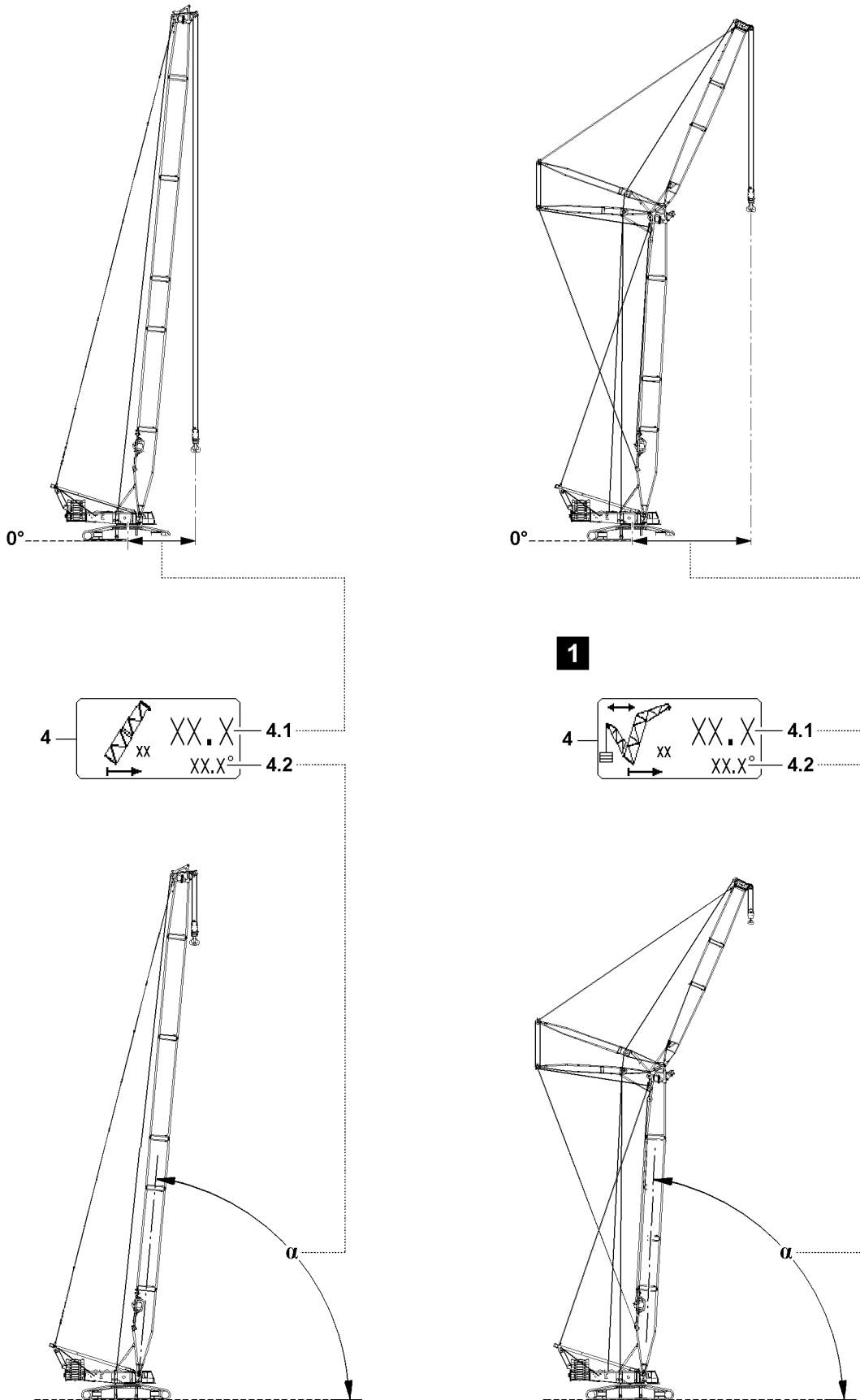

B112633

5.1.4 Radius

According to the set up configuration, the following changes:

- The illustration of the icon.
- The position of values in the icon, see sample illustration 1!

4 “Boom radius” icon

4.1 Radius

- In [m] or [ft]

Identifies the horizontal center of gravity distance of the load (on the load hook selected by the operating mode) from the center of rotation of the crane superstructure, measured on the ground! This also takes into account the boom flexation due to its own weight and the suspended weight of the load!

• **Note:**

“? ? ? . ?” is shown if the value cannot be calculated / determined!

An error message is issued, see Diagnostics manual!

4.2 Main boom angle

- In [°]

• Displayed is the medium value of the angle sensor in the main boom pivot section and the angle sensor in the main boom pulley head.

• **Note:**

“? ? ? . ?” is shown if the value cannot be calculated / determined!

An error message is issued, see Diagnostics manual!



Note

- Main boom angle α : The angle of the main boom to the placement surface of the crane!
-

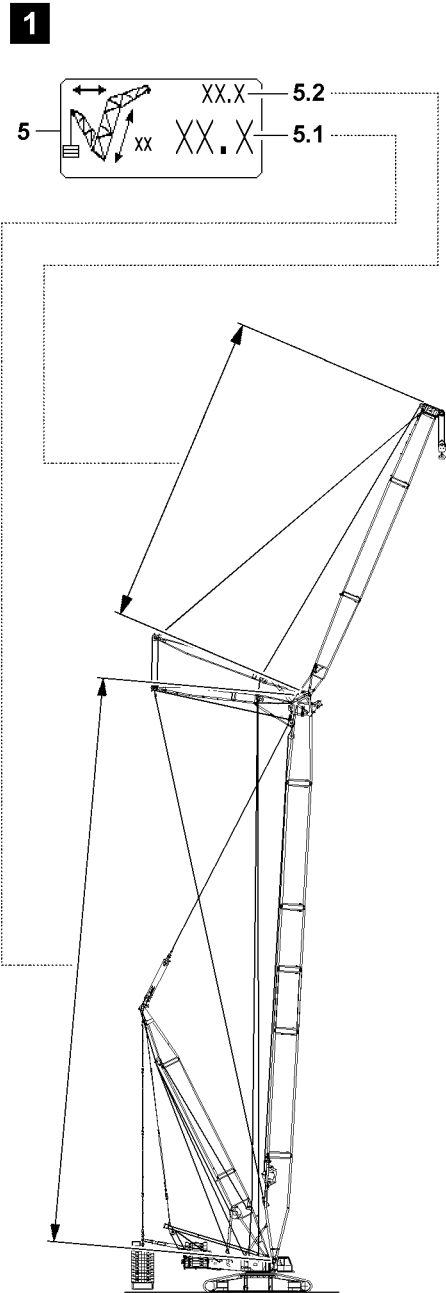
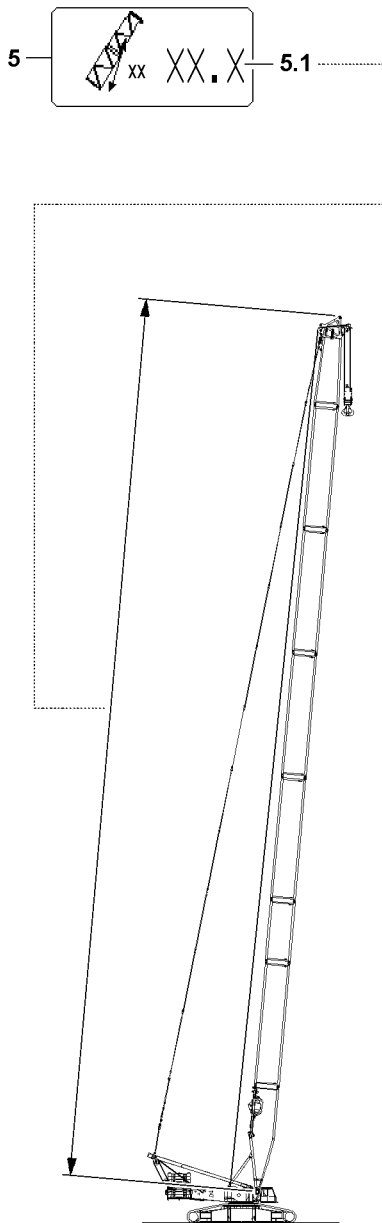

5.1.5 Boom length

According to the set up configuration, the following changes:

- The illustration of the icon.
- The position of values in the icon, see sample illustration 1!

5 “Boom length” icon

5.1 Length of main boom • In [m] or [ft]

5.2 Length of auxiliary boom / accessory • In [m] or [ft]

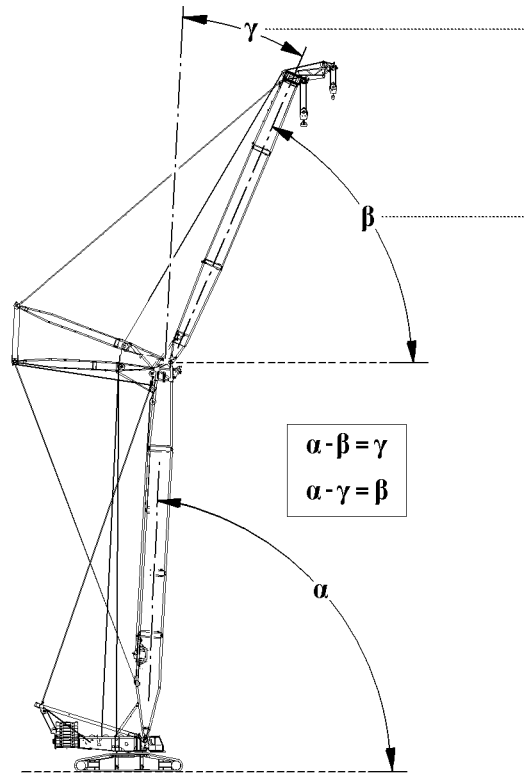

1

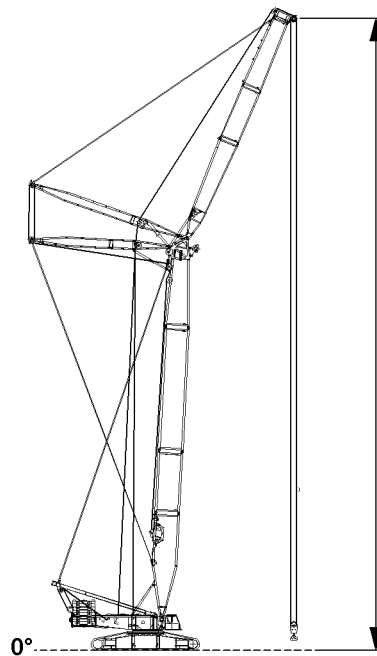
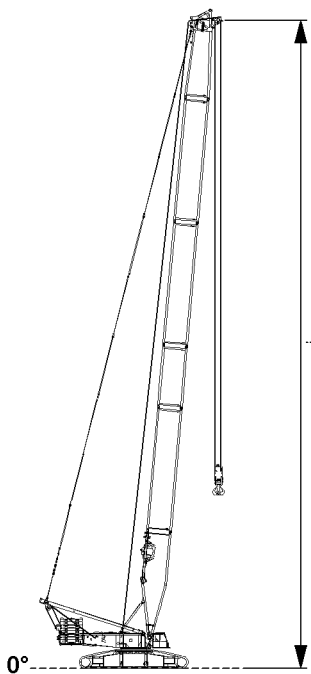
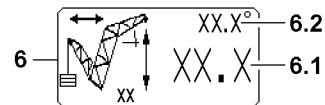
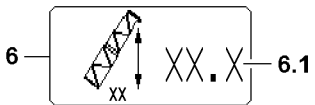

B112639

5.1.6 Pulley head height



Note

- ▶ Main boom angle α : The angle of the main boom to the placement surface of the crane!
- ▶ Angle auxiliary boom / accessory β : The angle of the auxiliary boom / accessory to the placement surface of the crane!
- ▶ Relative angle auxiliary boom / accessory γ : The angle of the auxiliary boom / accessory is determined relative to the main boom!

According to the set up configuration, the following changes:

- The illustration of the icon.
- The position of values in the icon, see sample illustration 1!

6 “Pulley head height” icon

- | | |
|---|---|
| 6.1 Pulley head height | <ul style="list-style-type: none"> • In [m] or [ft] • Identifies the vertical distance from the crane base to the selected pulley head axle, for which the displayed maximum load applies. • Note:
“? ? ? . ?” is shown if the value cannot be calculated / determined!
An error message is issued, see Diagnostics manual! |
| 6.2 Angle auxiliary boom / accessory | <ul style="list-style-type: none"> • In [°] • Note:
“? ? ? . ?” is shown if the value cannot be calculated / determined!
An error message is issued, see Diagnostics manual! |



Note

- ▶ Depending on the set up configuration and the load chart, a differentiation is made between an absolute angle display or a relative angle display!

- | | |
|--|---|
| β Absolute angle auxiliary boom / accessory | <ul style="list-style-type: none"> • The angle of the auxiliary boom / accessory to the horizontal (placement surface of the crane) in [°] • Display absolute angle: For operating modes with load chart for a fixed defined main boom angle! |
| or | |
| γ Relative angle auxiliary boom / accessory | <ul style="list-style-type: none"> • Angle between the main boom and the auxiliary boom / accessory in [°] • Display relative angle: For operating modes with load chart for a fixed defined angle auxiliary boom / accessory! |

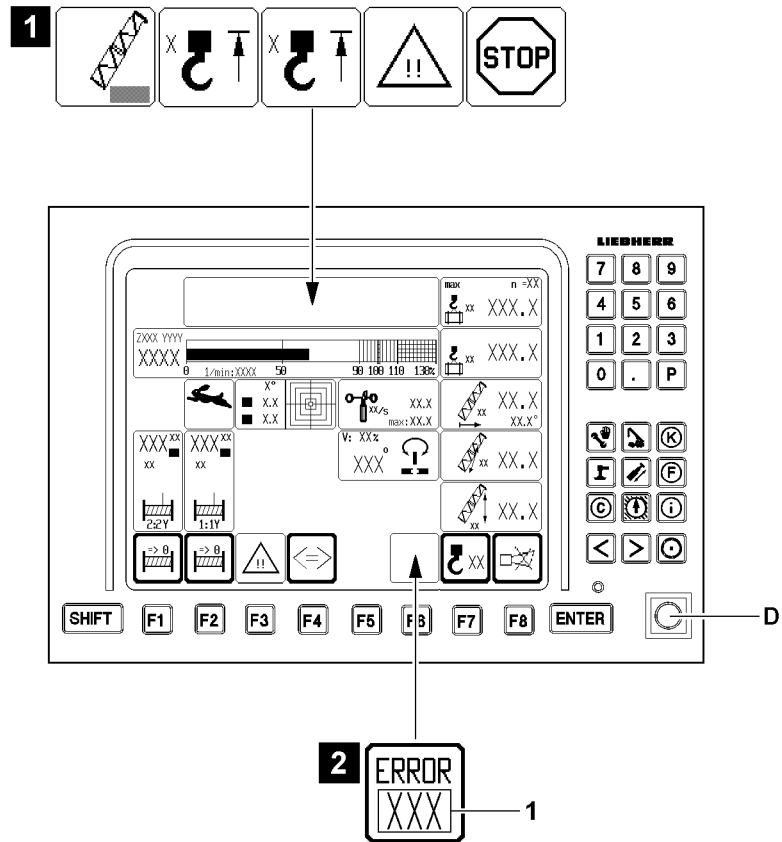

5.2 Alarm functions

NOTICE

Triggered alarm function!

If an alarm function is triggered (for example a advance warning occurrence or LMB Stop), the cause must be determined!

- ▶ Always pay attention to triggered alarm functions!
-

The limit ranges of the crane movements are monitored. When the limit ranges are reached, the crane operator is warned by the alarm functions.

The alarm functions are shown by the LICCON monitor:

- Optically with icons, see illustration 1.
- Acoustically by a warning sound "Horn".

Depending on the classification of an error, for example failure of relevant sensors / limit switches, special error messages 1 are added, see illustration 2.

5.2.1 Boom limitation

See illustration 3



Note

- ▶ Description of indicator lights for boom limitation in the instrument panel, see chapter 4.01 in the Crane operating instructions!
-

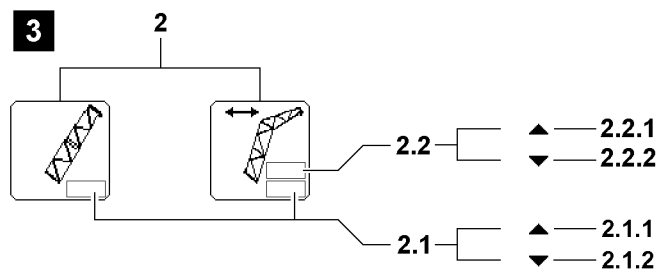
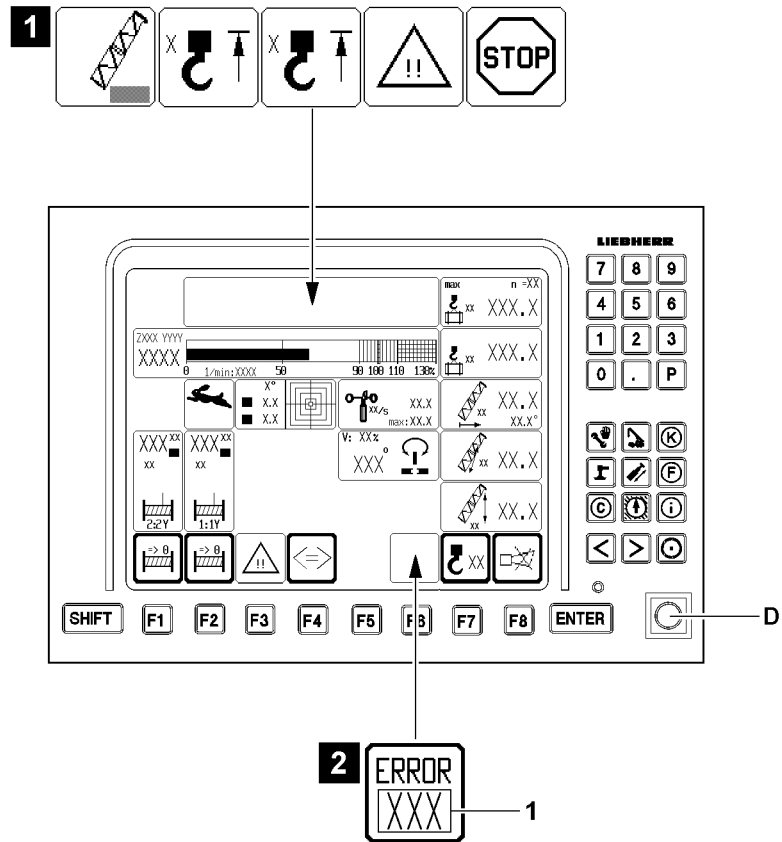

Limit signs main boom



Note

- ▶ The icon “Boom limitation” **2** can change in different operating modes, but it is shown always at the same position in the LICCON monitor!
- ▶ The field **2.1** “on the bottom” refers to the main boom!
- ▶ The field **2.2** “on the top” refers to the auxiliary boom / accessory!

2.1 “Boom limitation Main boom” icon

- The luffing range of the main boom is limited both upwards and downwards
- This icon appears if an end position determined by the load chart is reached when luffing the boom or when luffing the boom is disabled by a proximity switch
- Exclamation marks show when an associated sensor is defective

Position	Icon	Description
2.1.1	▲	The shut off “Luffing up the main boom” is made by running against the upper load chart limit or Utilization larger than 95 % and falling load carrying capacity when luffing up the main boom. Note: Luffing down the main boom is still possible!
2.1.2	▼	The shut off “Luffing down the main boom” is made by running against the lower load chart limit. Note: Luffing up the main boom is still possible!



WARNING

Alarm function deactivated!

When the set up key **D** is actuated, there is no shut off of crane movement via position **2.1.1** and position **2.1.2**!

- ▶ Observe the Crane operating instructions, chapter 4.20!

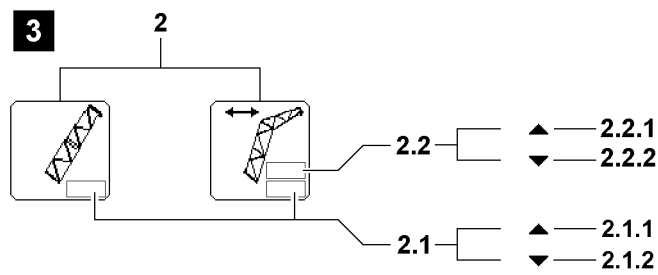
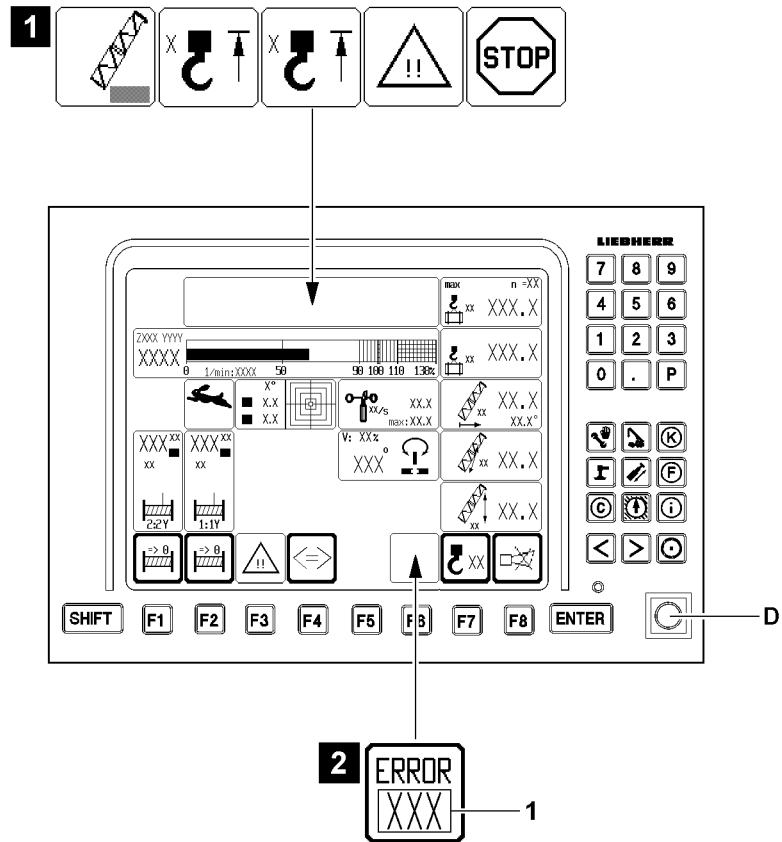

Limit sign auxiliary boom / accessory



Note

- ▶ The icon “Boom limitation” **2** can change in different operating modes, but it is shown always at the same position in the LICCON monitor!
- ▶ The field **2.1** “on the bottom” refers to the limit sign main boom!
- ▶ The field **2.2** “on the top” refers to the limit sign auxiliary boom / accessory!

2.2 “Boom limitation auxiliary boom / accessory” icon

- The luffing range of the auxiliary boom / accessory is limited both upwards and downwards.
- This icon appears if an end position determined by the load chart is reached when luffing the auxiliary boom / accessory or when luffing is disabled by a limit switch.
- Exclamation marks show when an associated sensor is defective.

Position	Icon	Description
2.2.1	▲	The shut off “Luffing up the auxiliary boom / accessory” is triggered by running against the upper load chart limit. Note: Luffing the auxiliary boom / accessory down remains possible!
2.2.2	▼	The shut off “Luffing down the auxiliary boom / accessory” is triggered by running against the lower load chart limit. Note: Luffing the auxiliary boom / accessory up remains possible!



WARNING

Alarm function deactivated!

When the set up key **D** is actuated, there is no shut off of crane movement via position **2.2.1** and position **2.2.2**!

- ▶ Observe the Crane operating instructions, chapter 4.20!

5.2.2 Failure of sensor / limit switch

NOTICE

Failure of sensor / limit switch!

Depending on the classification of the sensor / limit switch, the crane can continue to be operated with limitation or is shut off by the control!

An error message **1** is issued, see illustration **2**!

The error message **1** shows defective sensors / limit switches, see Diagnostics manual!

- ▶ The error must be remedied immediately!
- ▶ If the error cannot be remedied by yourself, contact Liebherr Service!
- ▶ Crane movements after a failure of a sensor / limit switch must be carried out anticipatorily and with extreme caution!

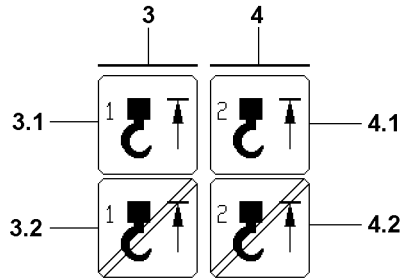

5.2.3 Hoist top limit switch

In order to prevent the crane from being operated without hoist limit switches (HES), the minimum hoist limit switch configuration is continuously monitored. If a hoist limit switch which is required for a certain operating mode is not plugged in, an error message is issued.

- | | |
|---|--|
| <p>3 “Hoist limit switch 1” icon</p> | <ul style="list-style-type: none"> • Note:
Is described as HES1. |
| <p>3.1 Hoist top on HES1</p> | <ul style="list-style-type: none"> • Appears if the hook block runs against the hoist limit switch on the main boom or on the auxiliary jib of the main boom |
| <p>3.2 “Hoist top on HES1 bypassed” icon</p> | <ul style="list-style-type: none"> • Note:
The crane movements “Spool up hoist winches”, “Luff boom down” and “Luff derrick boom down” are turned off. • The icon appears when the “Hoist top shut off” is bypassed |
| <p>4 “Hoist limit switch 2” icon</p> | <ul style="list-style-type: none"> • Note:
Is described as HES2. |
| <p>4.1 Hoist top on HES2</p> | <ul style="list-style-type: none"> • Appears if the hook block runs against the hoist limit switch on the auxiliary boom / accessory or on the auxiliary jib of the auxiliary boom / accessory |
| <p>4.2 “Hoist top on HES2 bypassed” icon</p> | <ul style="list-style-type: none"> • Note:
The crane movements “Spool up hoist winches”, “Luff boom down” and “Luff derrick boom down” are turned off. • The icon appears when the “Hoist top shut off” is bypassed |



5.2.4 Advance warning / LMB STOP

- 5 "Advance warning" icon
- The current load chart utilization is calculated from the "current load" and the "maximum load according to the load chart and the reeving".
 - The "Advance warning" icon appears if:
 - The current load chart utilization of the crane, according to the "Load chart and reeving" exceeds the programmed limit (**90 percent**) for the advance warning.
- 6 LMB STOP
- The "STOP" icon appears when the load chart utilization exceeds the **100 % mark**.
 - **Note:**
All crane movements are shut off!
 - **or**
 - The "STOP" icon appears when a sensor which is required to monitor the load chart has an error.
 - **Note:**
All crane movements are shut off!
 - **or**
 - The "STOP" icon appears if no load chart is available.
 - **Note:**
All crane movements are shut off!

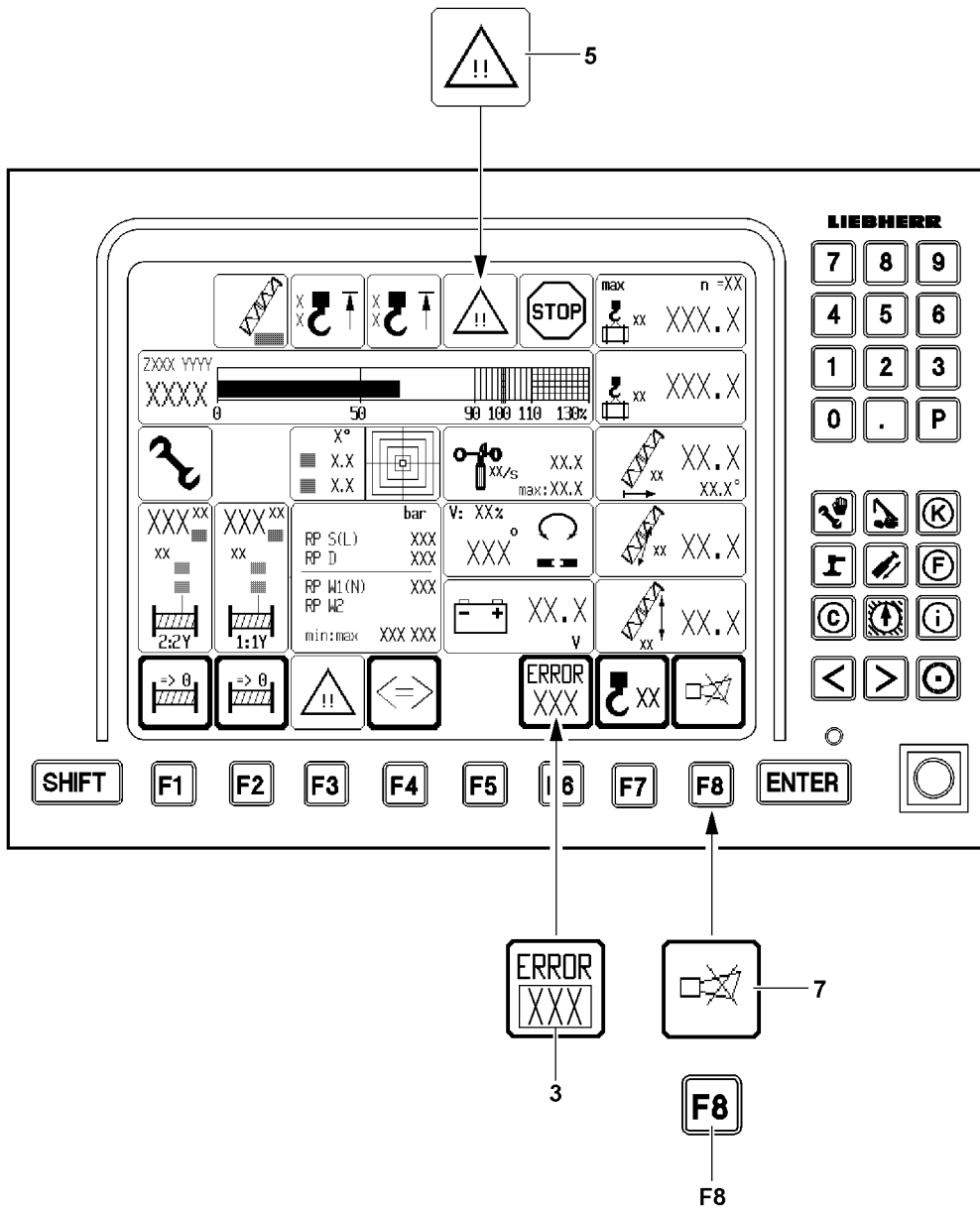

5.2.5 Acoustic warning on monitor 0

Acoustic warnings on monitor 0 are indicated by the warning sound "Horn".

The warning sound "Horn" is divided into two categories:

- "Horn" is a beeping sound of a duration of approximately 0.5 seconds, which is repeated in a second cycle.
- "Short horn" is a beeping sound of a duration of approximately 0.1 seconds, which is repeated in a second cycle.

7 Horn icon

- When the horn icon is shown in the LICCON monitor, any acoustic signals which will occur can be shut off by the LICCON monitor **0** by pressing the function key **F8**.
- If an operational error has the required classification, then, in addition to the acoustical warning, an error message with error number **3** is issued. Evaluating the error number **3**, see Diagnostics manual.

Acoustic signal "Horn"

- 1.) Sounds in addition to the optical display of an error message with field number **3** in case operational errors are found, which lead to a shut off of a crane movement.

Operational errors are:

- Overload
- Boom outside the angle range of the load chart
- Boom outside radius range of the load chart

- 2.) Application errors with error number **3**. For example sensor errors, which occur due to insufficient sensor signals or a defective sensor.

The following sensors are monitored:

- Hoist limit switch
- Angle sensors
- Pressure sensors
- Pull test brackets (force test boxes)
- Wind sensor
- Battery voltage

Acoustic signal "Short horn"

Sounds in addition to the visual display of error messages without an error number and which do not lead directly to crane movement shut off by the LICCON overload protection.

Monitored error messages are:

- Advance warning **5** triggered.
- Maximum permissible wind speed exceeded (only for activated wind sensor*).

Priority acoustic signal

- The "Horn" alarm has higher priority than the "Short horn" alarm, i.e. "Horn" takes preference over "Short horn".
- The "Horn", as well as the "Short horn" immediately become active again if an error recurs!

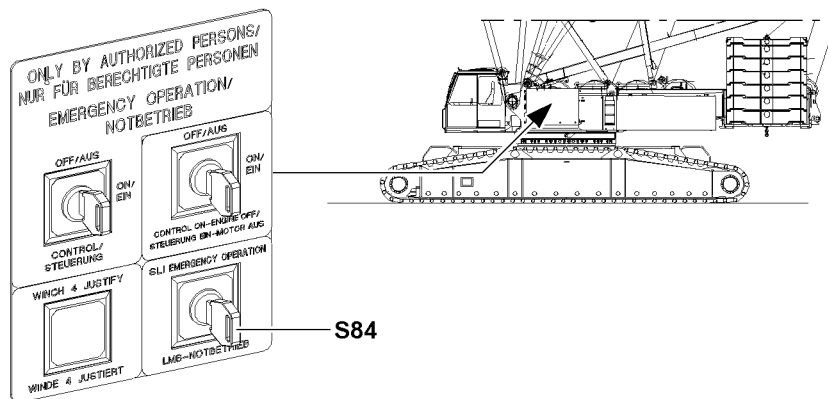
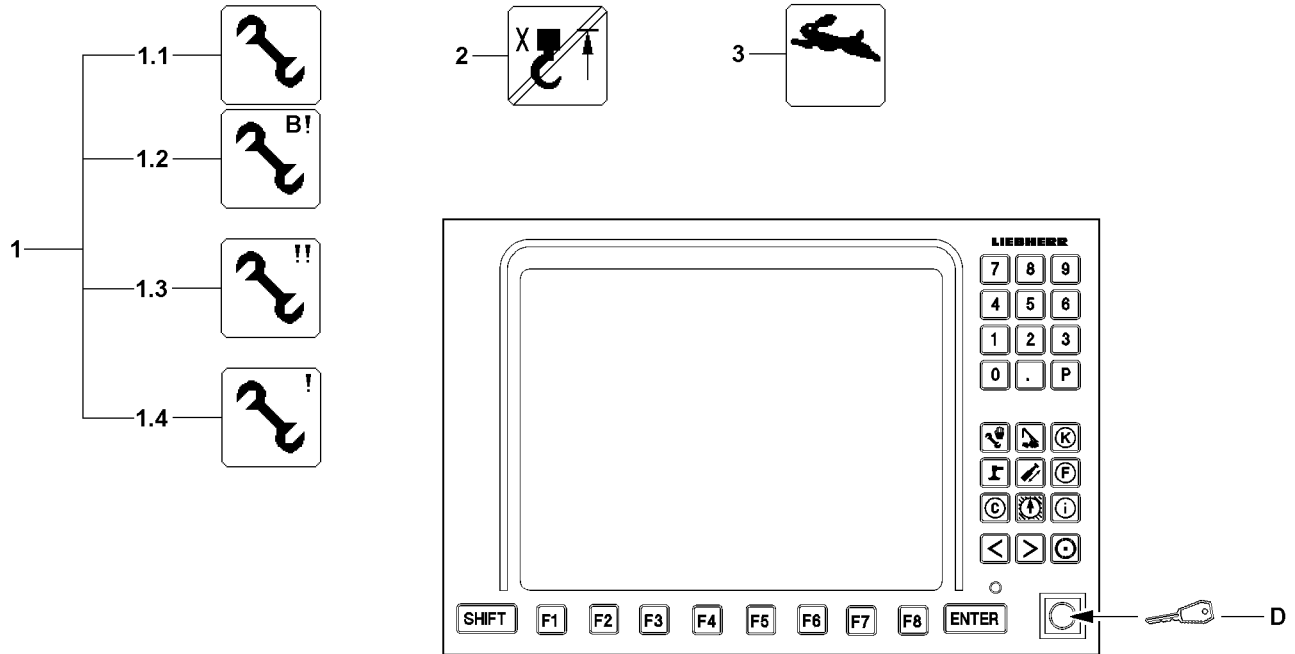

5.3 Special functions



Note

Double function set up key!

If the crane has **no** CE-mark, when actuating the set up key **D**, the release for the “Emergency operation LICCON overload protection” is automatically engaged!

- ▶ Take into account, when actuating the set up key **D**, that the “Emergency operation LICCON overload protection” is automatically released!



Note

- ▶ The various icons **1** are shown on the same position in the LICCON monitor, depending on the operating mode, illustration **2**.
- ▶ For operation and specifications for using the set up key **D** see Crane operating instructions, chapter 4.20 and 7.15.

5.3.1 Exceeding the shut off limits of the LICCON overload protection

1.1 Exceeding the shut off limits of the LICCON overload protection

- The icon appears:
 - When the shut off limits of the LICCON overload protection are bypassed via the set up key **D**.
 - **Note:**
The crane operation program is locked, meaning, no other program can be turned on via the program keys.

5.3.2 No load chart is available

1.2 No load chart is available

- The icon appears:
 - When the shut off limits of the LICCON overload protection are bypassed via the set up key **D** and no load chart is available.
 - **Note:**
By actuating the set up key **D**, all erection / take down procedures can be carried out within the erection / take down charts, for which no load charts are available!

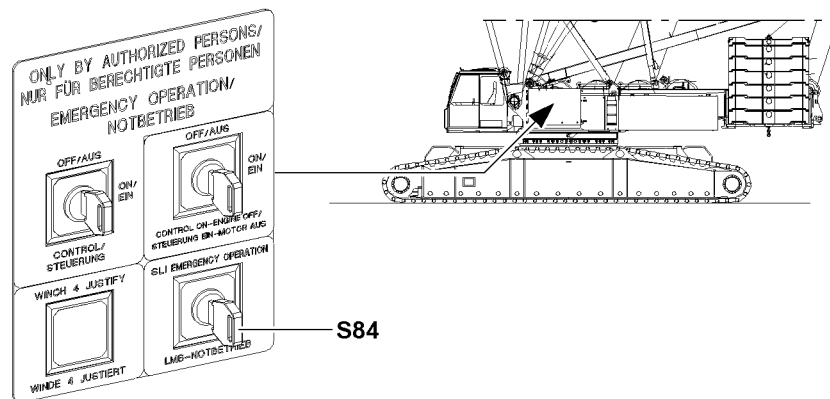
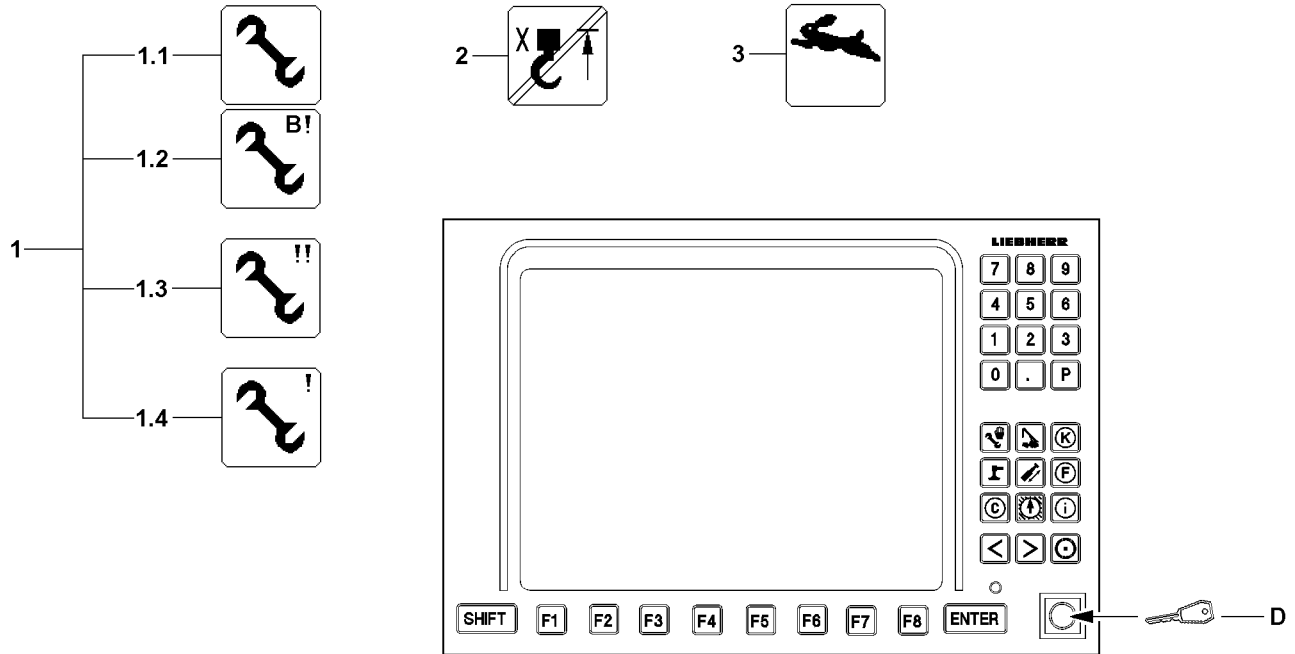

5.3.3 Emergency operation LICCON overload protection (according to EN 13000:2010)

1.3 LMB emergency operation activated

- The icon appears:
 - when the LMB-emergency operation is activated via the key button **S84**.
 - **Note:**
The crane operation program is locked, meaning, no other program can be turned on via the program keys.

5.3.4 Emergency operation LICCON overload protection (crane without CE mark)



Note

If the crane has **no** CE mark, then the functions of the “Emergency operation of the LICCON overload protection” are also engaged by the set up key **D!**

- ▶ Only crane without CE-mark: If the emergency operation LICCON overload protection is needed, actuate the key button **S84** or the set up key **D!**

1.3 LMB emergency operation activated

- Icon appears:
 - when the LMB emergency operation is activated by the keyed button **S84** or the set up key **D**.
 - **Note:**
Depending on the reason for the LMB emergency operation, the icon for no load chart available **1.2** can also appear.
 - **Note:**
The crane operation program is locked, meaning, no other program can be turned on via the program keys.

5.3.5 Additional emergency operating modes



WARNING

Erroneous operation of the crane!

If one of the icons for additional emergency operating modes **1.4** appears, then there is a risk of accidents due to erroneous operation of the crane!

Personnel can be killed or injured!

This could result in property damage!

- ▶ Deactivate additional operating modes **1.4** again or contact Liebherr Service and coordinate further procedure.

1.4 Additional emergency operating modes

- Icon **1.4** appears if additional emergency operating modes were activated.

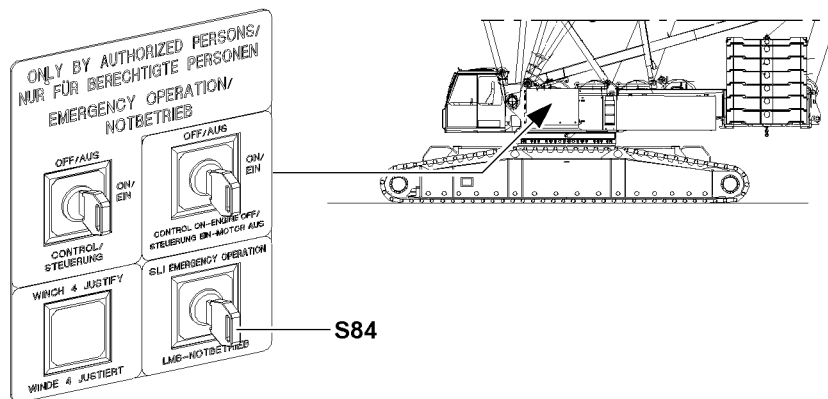
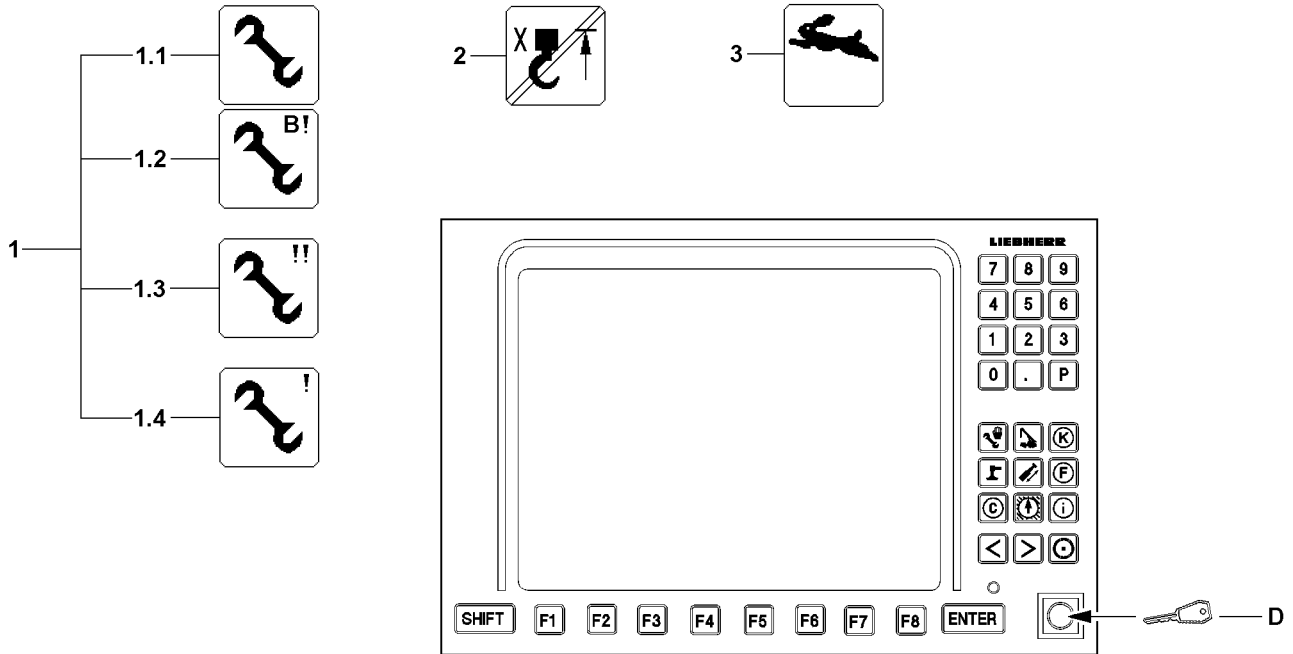

5.3.6 Bypass “Hoist top”

2 Bypass “Hoist top”

- The icon appears:
 - When the shut off “hoist top” is bypassed via the set up key **D**
 - **Note:**
The crane operation program is locked, meaning, no other program can be turned on via the program keys.

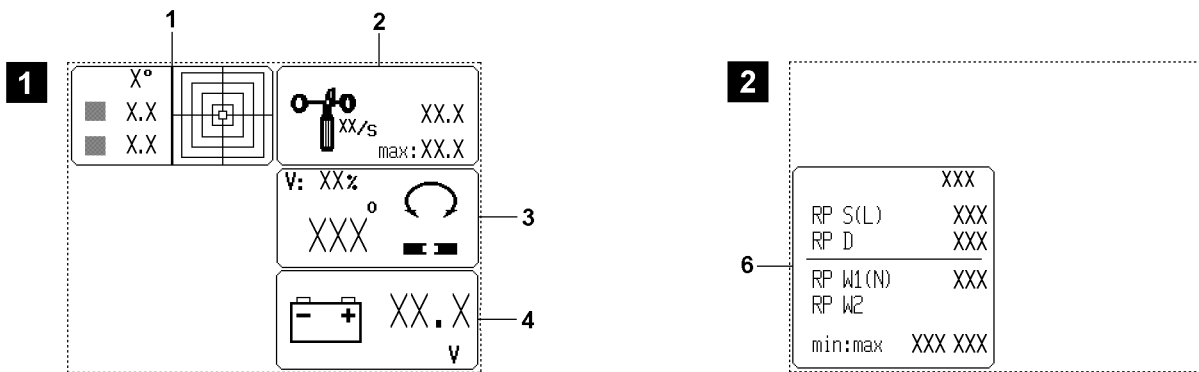
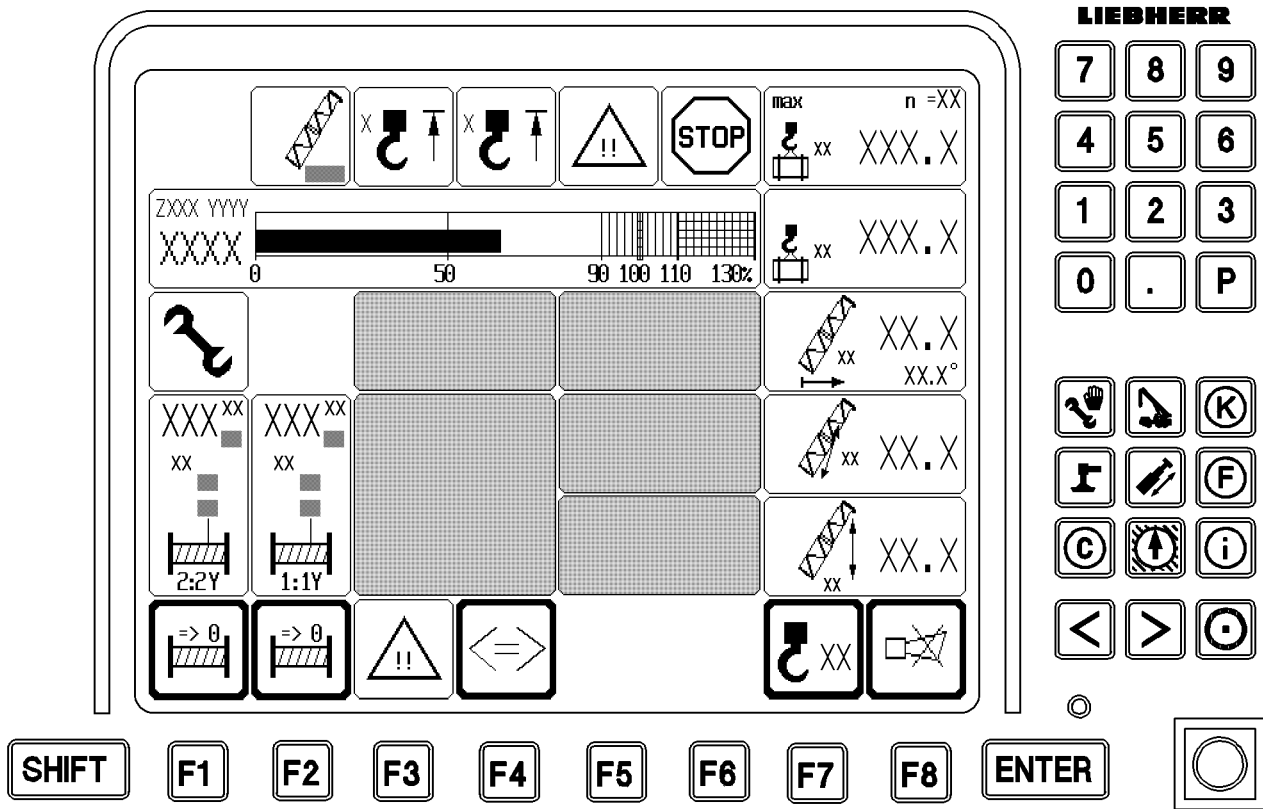

5.4 Monitored auxiliary functions for crane operation

There are several monitored auxiliary functions, which can be displayed when needed or automatically.

The monitoring of all auxiliary functions is always active, only the icons may be hidden. The icons of the monitored auxiliary functions have their fixed place on the LICCON monitor.



Note

- ▶ Using the function key **F3**, you can show the icons for the monitored auxiliary functions. Since not all icons of the auxiliary functions fit on one page (at maximum assignment), they are split over two pages. The icons on page 2 (if available) can be shown with the function key **F4**!

Page 1 (illustration 1):

Crane incline **1**

Wind speed **2**

Battery voltage **3**

Turning range **4**

Page 2 (illustration 2):

Monitoring relapse cylinder **6**



Note

- ▶ Depending if the monitored auxiliary functions are turned off or on, the illustration of the monitored auxiliary functions differs!
- ▶ The “Change page” icon can be actuated if it appears / blinks via the function key **F4**, see illustration 3!

Monitored auxiliary functions turned off:

- No error:
Icons are not shown.
- Only error in one function on page 1:
Icon is displayed on page 1.
- Only error in one function on page 2:
Icon is displayed on page 2.
- Error in one function on page 1 and 2:
Icon is displayed on page 1 and icon for “Change page” via function key **F4** blinks (= indicates an error in a function on page 2).

Monitored auxiliary functions turned on:

- No error:
Optional icons (customer request) are displayed.
If there are optional icons on page 2, the icon “Change page” via the function key **F4** is activated (= indication for change option).
- Error in one function on page 2:
Icon “Change page” blinks (= indication regarding an error of a function on the other page).
- Error in one function on page 1 and 2:
Icon is displayed on page 1.
Icon “Change page” blinks (= indication regarding an error of a function on the other page).

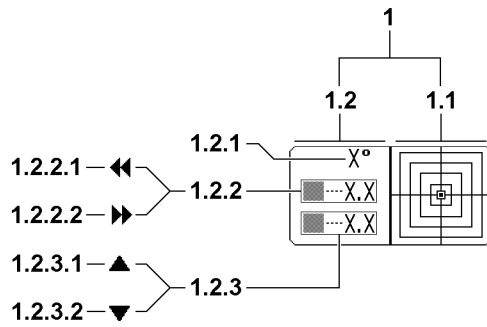

5.4.1 General



Note

“?” instead of display value!

- ▶ The value cannot be determined due to an error!
- ▶ If an error occurs and an error message is issued, see Diagnostics manual!
- ▶ Always pay attention to error messages!
- ▶ Remedy the error always as quick as possible!

5.4.2 Crane incline

- | | |
|---------------------|---|
| 1 “Incline” icon | <ul style="list-style-type: none"> • Display of the incline of the crane to the horizontal in longitudinal and lateral direction. The display is graphic as well as numeric. • The direction data refers to the driving direction of the crane chassis |
| 1.1 Graphic part | <ul style="list-style-type: none"> • The graphic display is in the form of a spirit level, with a moving dot (small square) representing the air bubble. The center of the dot shows the precise incline value. |
| 1.2 Numeric part | |
| 1.2.1 Incline range | <ul style="list-style-type: none"> • Value either 0.2° or 1°
This value describes the resolution of the graphic illustration and can only assume the two values “0.2°” or “1°”. If the incline is less than 1° in lateral direction and in longitudinal direction, the level moves within the 0.2° range. If at least one value reaches the 1° limit, it switches to the 1° range. The range change is automatic. |
| 1.2.2 Crane incline | <ul style="list-style-type: none"> • In [°] in lateral direction • Double arrow left 1.2.2.1 <ul style="list-style-type: none"> • The crane is inclined to the left • Double arrow right 1.2.2.2 <ul style="list-style-type: none"> • The crane is inclined to the right |
| 1.2.3 Crane incline | <ul style="list-style-type: none"> • In [°] in longitudinal direction • Arrow pointing up 1.2.3.1 <ul style="list-style-type: none"> • The crane is inclined to the rear • Arrow pointing down 1.2.3.2 <ul style="list-style-type: none"> • The crane is inclined to the front |

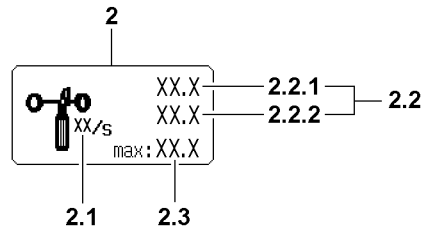

5.4.3 Wind speed

- | | |
|------------------------|--|
| 2 "Wind speed" icon | • The wind speeds are displayed in [m/sec.] or [ft/sec.] depending on the units of measurement shown in the load chart |
| 2.1 "Wind speed" unit | • [m/s] or [ft/s] |
| 2.2 Current wind speed | |



Note

- ▶ Depending on the set up configuration of the crane, a certain number of wind sensors must be present on the LSB bus!
- ▶ If no value can be determined for a wind sensor which must be present, then current wind speed **2.2** "???" appears in the display!
- ▶ If a wind sensor does not have to be present and is not plugged in, then the display value 0 appears in the "Wind speed" icon **2**!

2.2.1 Current wind speed

2.2.2 Current wind speed

- If several wind sensors are active, two values are shown



WARNING

Crane operation without display value of wind speed!

If the current wind speed **2.2** "???" appears in the display, then a wind sensor which must be present is missing or there is an error in the wind sensor!

- ▶ Remedy the error immediately!
- ▶ If an error cannot be remedied, then it must be ensured that the wind speed is monitored otherwise!

2.3 Maximum permissible wind speed

- The value depends on the operating mode and the set up configuration

• Note:

If access to a load chart is not possible, then the maximum value starts to blink and the acoustic alarm "Short horn" sounds!

If the current wind speed value exceeds the displayed maximum value, the maximum value starts to blink and the acoustic alarm "Short horn" sounds!



WARNING

Wind speed too high!

If the maximum permissible wind speed is exceeded with erected boom system, there is a danger of accidents!

Dangerous situations can arise, such as oscillating load or shaking crane!

The crane can topple over, personnel can be severely injured or killed!

- ▶ **The crane movements will not be shut off!**
- ▶ The danger notes, see Crane operating instructions, chapter 2.04 must be strictly observed and adhered to!

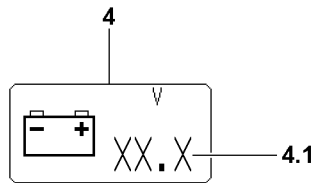
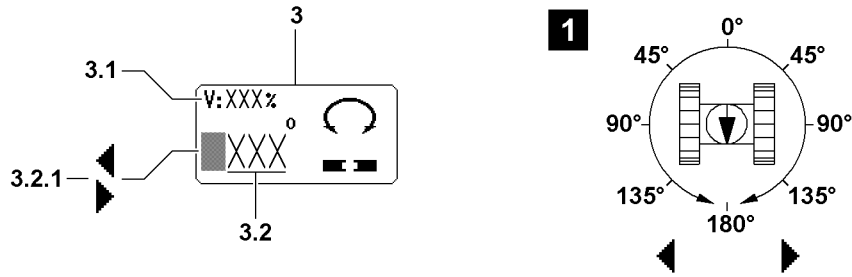

5.4.4 Turning range



DANGER

Danger of accidents in case of excessive rotation speed!

- ▶ Make the selection of the rotation speed according to the specifications in the load chart manual!

3 "Slewing range" icon

3.1 Maximum rotation speed

- V: [%]

- Identifies the current (selected) "Maximum rotation speed" of the slewing gear with a fully deflected master switch, relating to the maximum attainable rotation speed of the slewing gear. This value may be preselected in fixed percentage stages in the LICCON program control parameter.

3.2 Current position of the crane superstructure

3.2.1 Direction of deviation

- In relation to the main working direction (0 [°]) Increasing to the maximum value of 180°, see illustration 1
- The arrow in front of the value indicates the direction of the deviation.
 - Arrow to the right: Crane superstructure is turned to the right.
 - Arrow to the left: Crane superstructure is turned to the left

5.4.5 Battery voltage

4 Battery voltage icon

4.1 Value for battery voltage

- Current value of battery voltage with the unit [V]
- The accuracy of the display is $\pm 1/10$ V

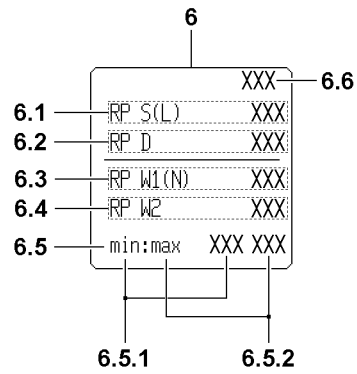

5.4.6 Monitoring relapse cylinder



Note

Display values pressure display!

- ▶ Pressure display = "0", if these relapse cylinder(s) are not present for the set operating mode!
- ▶ Pressure display = "???", if the pressure sensor signal is erroneous! There is an error display with error number!

6 "Monitoring relapse cylinder" icon

- | | |
|--------------------------------------|--|
| 6.1 Pressure display RP S(L) | • Relapse cylinder S-, SL- or L-boom |
| 6.2 Pressure display RP D | • Relapse cylinder derrick boom |
| 6.3 Pressure display RP W1(N) | • Pressure W1-relapse cylinder (= RP W1) at W-operation
or
• Pressure N-relapse cylinder (= RP N) at N-operation |
| 6.4 Pressure display RP W2 | • Pressure W2-relapse cylinder (= RP W2), if present |



Note

- ▶ In the N-lattice jib, only one N-relapse cylinder (RP N) is installed!
- ▶ In the W-lattice jib, two W-relapse cylinders are installed! W1-relapse cylinder (= RP W1) on the right and W2-relapse cylinder (= RP W2) on the left side.

6.5 Pressure limits

- Monitored pressure limits of relapse cylinders (W/N) Minimum / maximum pressure for RP W1(N) and RP W2

6.5.1 Minimum pressure (W/N)

- If a pressure limit value is being exceeded, then this is shown by a blinking pressure actual value and an additional error message
- This monitored minimum pressure is calculated from the angle of the main boom and the auxiliary boom / accessory. If one of the angles is invalid and is shown in the display with "???", then no monitoring of the minimum pressure can occur.

6.5.2 Maximum pressure (W/N)

- If a pressure limit value is being exceeded, then this is shown by a blinking pressure actual value and an additional error message

6.6 "Monitoring relapse cylinder" measuring unit

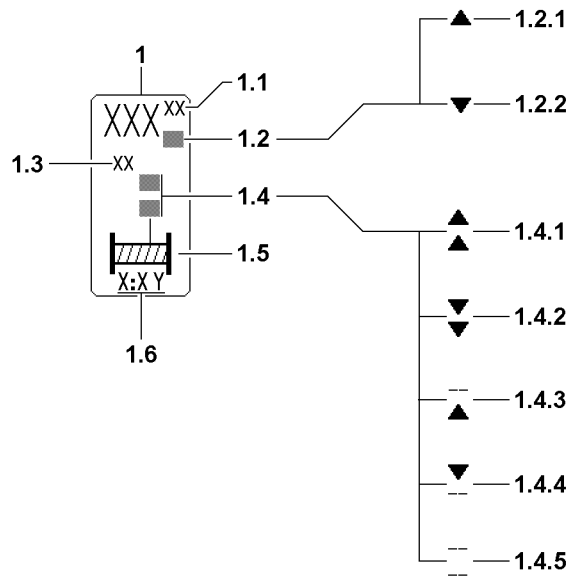

5.5 Winch display

1 Winch icon

- The winch 1 and winch 2 icons have the same meaning and are explained on one icon

- The icon for winch 1 or winch 2 is shown only on monitor 0, when the crane is equipped with the respective winch

1.1 Travelled distance

- In [m] or [ft]

From a zero point to be determined

- For single operation with the reeving setting made in the set up program: Completed hook path.

- For parallel operation with the set total reeving made in the set up program: Distance completed by hook block.

- The positions before the decimal point are displayed with a maximum of three large digits. The digits after the decimal point are displayed with small digits (Setting to zero point, see section "The function key line").

- A prerequisite for a correct display is that the reeving value entered equals the actual number of rope strands between the boom head and the hook block.



Note

Display area winch displays!

- ▶ The "completed path" display **1.1** has only three positions before the comma, any positions before that are cut off! The crane operator must evaluate for himself if, for example 200 m rope are spooled up on a winch or 1200 m. **The display in both cases would be identical with 200 m!**
- ▶ The hook path calculation only works accurately if the load is suspended freely and is not luffed during the lifting procedure! Not taken into account are flexation and rope expansion!
- ▶ The length display (hook path display) is only accurate and the layer jump is only taken into account correctly if the winch has been calibrated and no interruptions of the CPU power supply have occurred (cold start)!

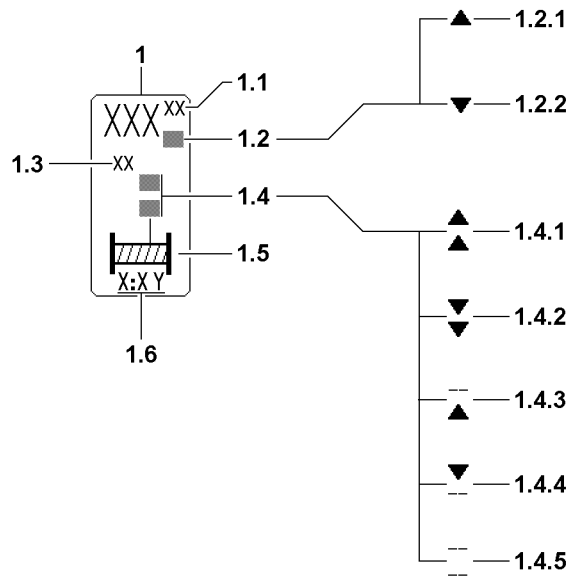

- 1.2** Direction of hook movement
- The arrows on the length value show the direction of the hook movement in relation to the zero point:
- Arrow up **1.2.1**: Hook moves upward from the zero point
 - Arrow down **1.2.2**: Hook moves downward from the zero point
- 1.3** Measuring unit hook path display
- 1.4** Winch status display
- There are five winch status icons (all blinking):
- 1.4.1** Spool out
- 1.4.2** Spool up
- 1.4.3** Spooled out
- 1.4.4** Spooled up
- 1.4.5** Winch is deactivated or unplugged
- Spooling out is blocked
 - Spooling up is blocked
 - Spooling up and spooling out are blocked (via Control parameter program)
- **Note:**
If no winch status icon appears, the activated winch is inactive and is neither spooled up nor out!
- (with rope end for winch status icon)
- Example: 1 : 1 Y.
First digit: Winch number.
Second digit: Master switch number.
Letter: Master switch operating direction.
- 1.5** Winch icon
- 1.6** Winch number with master switch number and master switch operating direction

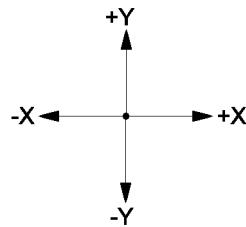

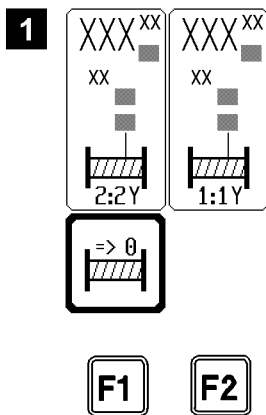
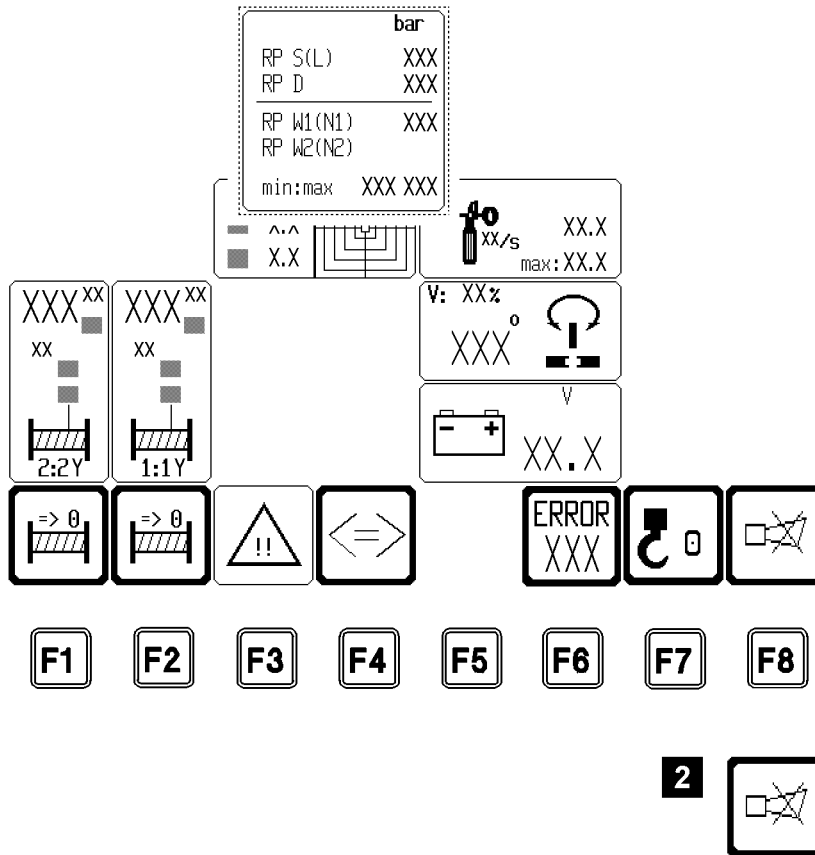

5.6 The function key line in the crane operation program

The function key line consists of function keys **F1** to **F8** and the function key icon bar above it. The function keys correspond to the various function key icons above them.

The function key icons may trigger a function or they change their appearance upon the push of a key (function keys) and thereby their definition.

Not all function keys must have assigned icons. This depends on the “active” program selection.

Pressing a function key changes the appearance of the icon above, its meaning, or its textual content.

- | | |
|------------------------|--|
| F1 Function key | <ul style="list-style-type: none"> • Zero point for hook path display, winch 2 • Pressing the function key F1 causes the “Set winch display to zero” icon to appear, i.e. the winch 2 hook path display in the winch icon above is set to “000.00” when the key is pressed. The path measurement begins here. |
| F2 Function key | <ul style="list-style-type: none"> • Zero point for hook path display, winch 1 • Pressing the function key F2 causes the “Set winch display to zero” icon to appear, i.e. the winch 1 hook path display in the winch icon above is set to “000.00” when the key is pressed. The path measurement begins here. • Note:
When winch 1 and winch 2 work in parallel operation, then the lengths displays of winch 1 and winch 2 can only be set together with the function key F1 to “000.00”!
Then the function key F2 has no function, see illustration 1! |
| F3 Function key | <ul style="list-style-type: none"> • Turn monitoring icons on / off • The function key F3 can be used to turn all the monitored auxiliary functions in the crane on or off • The appearance of the icon changes according to the status: <ul style="list-style-type: none"> • “Thick border” = auxiliary function icons turned off • “Thin border” = auxiliary function icons turned on • Note:
The monitoring of all auxiliary functions is always active, even if the monitoring icons are hidden!
When a monitored limit is exceeded, then an acoustic warning (horn) sounds and the respective icon is shown! |
| F4 Function key | <ul style="list-style-type: none"> • Change monitoring page (if present)
see also section “Monitored auxiliary functions for crane operation” |
| F5 Function key | <ul style="list-style-type: none"> • Not assigned |

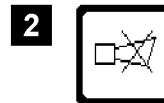
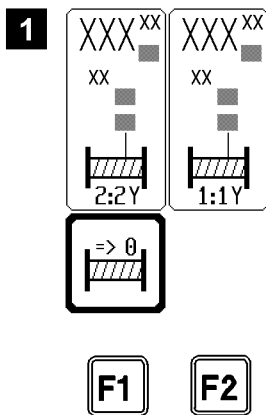
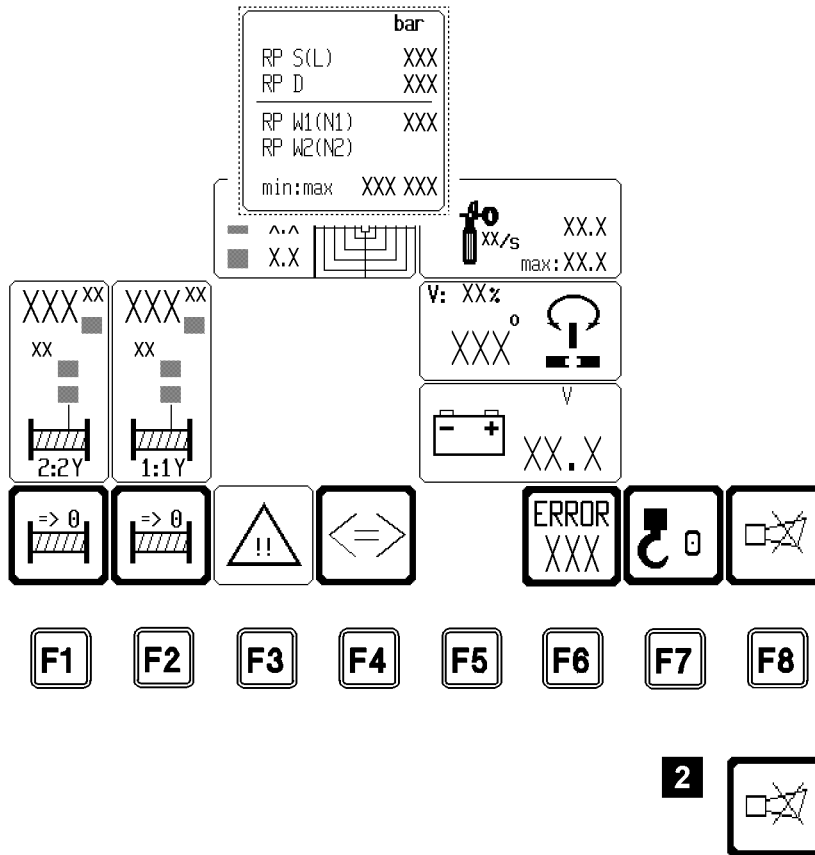

- F6** Function key
- Error
 - When an error occurs, then the text “**ERROR**” and a three digit error number describing the error appears in the function key icon. When the error is remedied, the error number disappears in the function key icon. Evaluating the error number, see Diagnostics manual.
 - **Note:**
The function key “F6” affects only a reactivation of the possible shut off acoustical warning.
- F7** Function key
- Taring
 - When the function key **F7** is pressed, the actual load display is set to “zero”. At the same time, the word “net” appears in the icon of the actual load display. This function, for example, makes it possible to eliminate the weights of the hoist rope, load carriers, lifting and fastening equipment and only display the weight of the load that must be lifted (net load). If the taring is cancelled, the word “net” disappears from the icon “Actual load display” and the gross load value is displayed.
 - Tare is cancelled by one of the following two actions:
 - Pressing the function key **F7** again.
 - By luffing by more than $\pm 4^\circ$.
- F8** Function key
- Turn off the acoustic warning
The “Horn” and “Short horn” acoustic warnings can be turned off by pressing the function key **F8**
 - **Note:**
A new error turns the acoustic warning on again!



WARNING

Malfunctions in the crane control!

A special program is available for LIEBHERR crane acceptance in the LICCON computer system!

This program is blocked after conclusion of the crane acceptance!

If an additional marking is displayed in the “Horn” icon (talons along the upper margin, see illustration 2), then the special program is activated!

- ▶ Contact LIEBHERR Service immediately!
 - ▶ In order to prevent error functions, access to the special program is only permitted for trained LIEBHERR personnel!
-

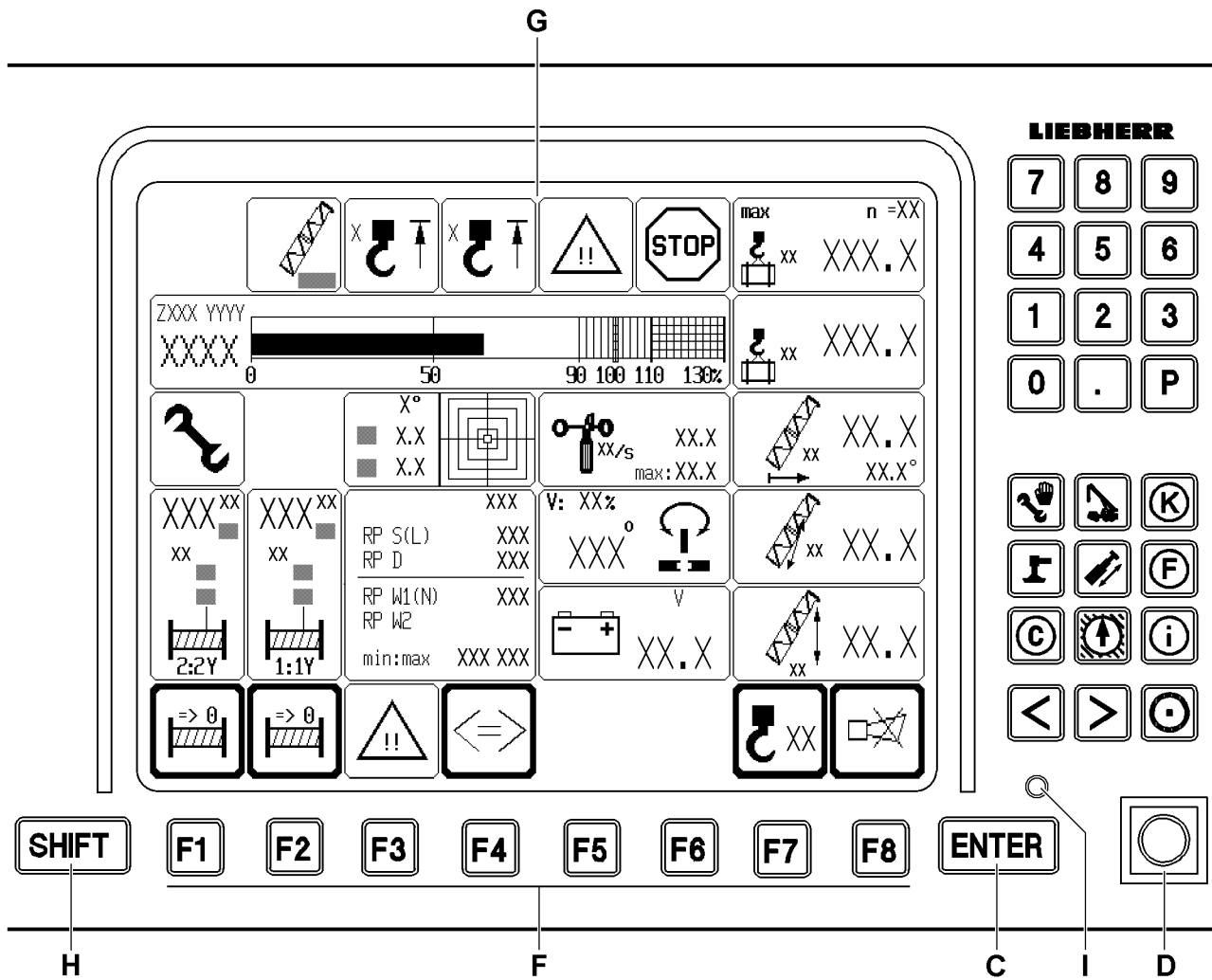

LIEBHERR

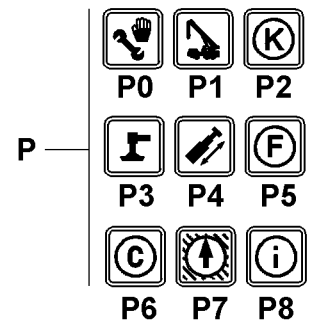
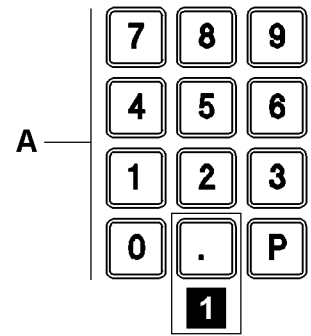
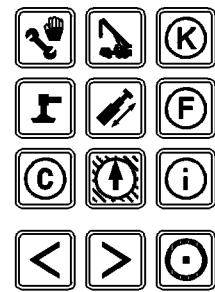
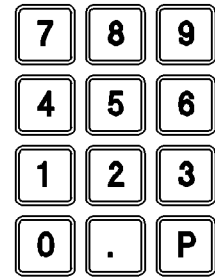

B112315

5.7 Other operating elements

The following functions are assigned to the other operating elements of the display and operating unit of the LICCON computer system in the crane operation program.

A Keypad

- Keys "0" to "9" and "P" have no function in the crane operation program

- Key ".", illustration 1

With the key ".", the so-called test screen function is turned on and off. All existing icons appear with a test value on the LICCON monitor.

- **Note:**

The monitored auxiliary functions must be opened in the desired page to appear in the test screen!

The test screen display can be held by pressing the SHIFT key **H** and the key "."!

By pressing the key "." again, the normal crane operating screen appears again!

If the test screen is not held, then the normal crane operating screen appears after 10 seconds!

P Program keys

- The program keys are used to select individual programs. However, the appropriate program-specific features (for example, switching from set up to crane operation once with "O.K.") must be noted.

- **Note:**

A program currently running **cannot** be called again using its program key!

The programs can only be called up with their program key when the set up key was not actuated before!

C Input key ENTER

- No function in crane operation program

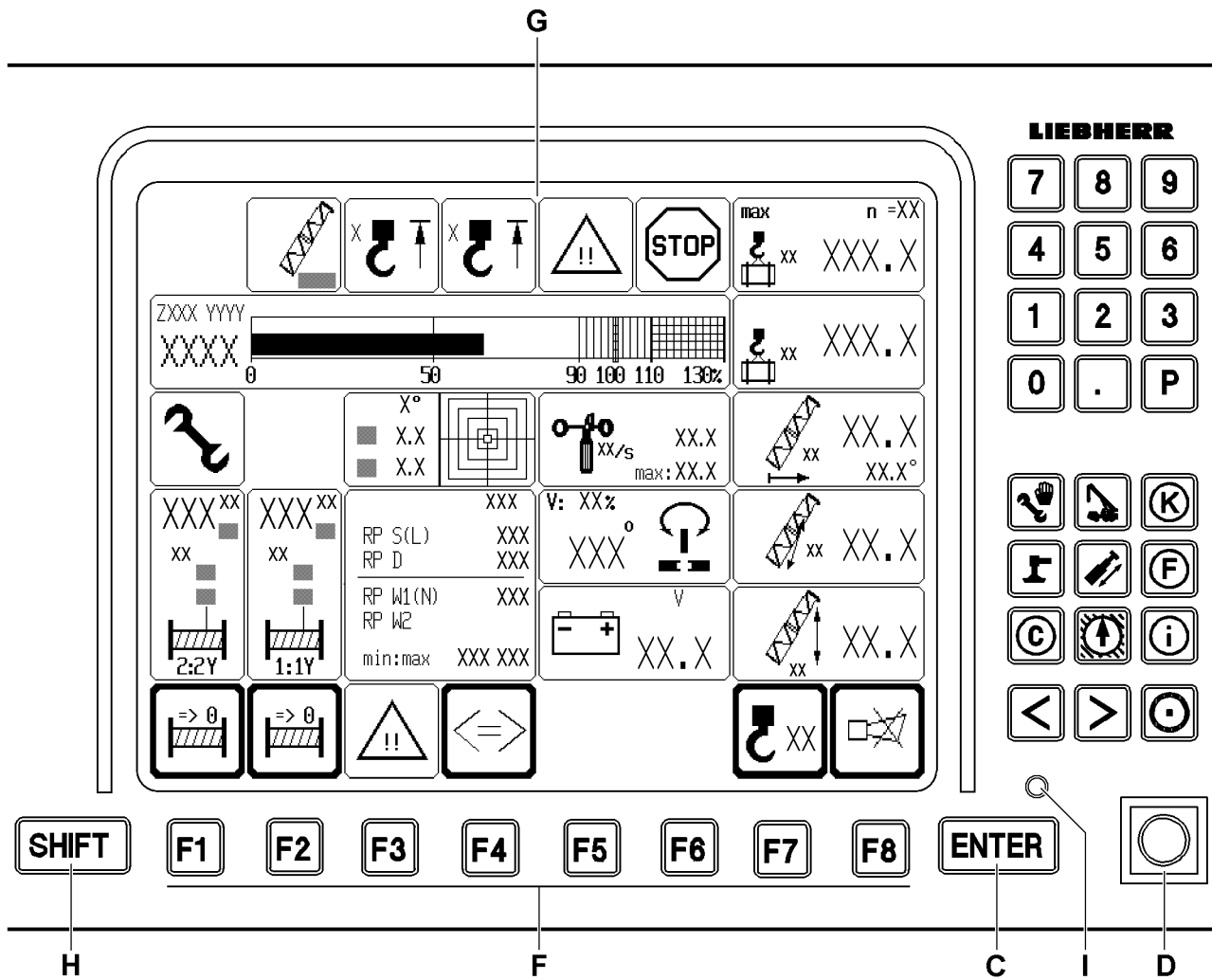

LIEBHERR

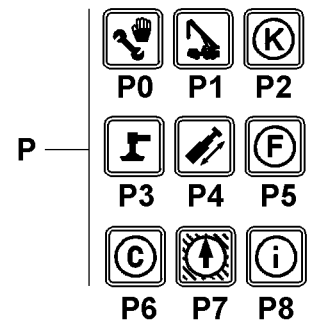
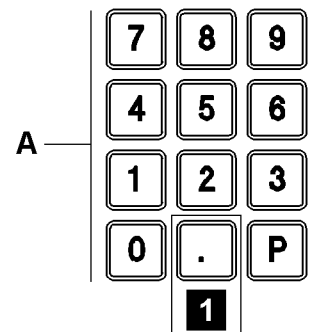
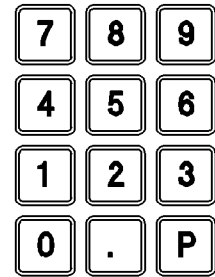

B112315

D Set up key

- Zero position (not actuated):
Normal operation.
- Touching:
Function "Exceedance of shut off limits of the LICCON overload protection" released.
- **Exceeding the shut off limits of the LICCON overload protection!**
If the shut off limits of the LICCON overload protection are exceeded, the LICCON overload protection shuts the crane movements off!
These shut offs can be exceeded by the set up key **D** in the "Right touching" position! To do so, chapter 4.20 in the Crane operating instructions must be observed!

**Note**

Double function set up key!

If the crane has **no** CE-mark, when actuating the set up key **D**, the release for the "Emergency operation LICCON overload protection" is automatically engaged!

- ▶ Take into account, when actuating the set up key **D**, that the "Emergency operation LICCON overload protection" is automatically released!

**Note**

Carry out the erection / take down procedures!

- ▶ By actuating the set up key **D**, all erection / take down procedures can be carried out within the erection / take down charts, for which no load charts are available!

E Special function keys

- **Bypass of the hoist top shut off**
If the hook block touches the hoist limit switch weight during the upward movement, the hoist limit switch reacts. The crane movement "spool up winches" and others are turned off. This shut off can be bypassed by the set up key **D** in the "right touching" position. To do so, chapter 4.20 in the Crane operating instructions must be observed!
- Monitor brightness adjustment
- Key combination **E3** and **E1**: Turn background illumination on / off.
- Key combination **E3** and **E2**: Brightness adjustment in three stages.

**Note**

- ▶ Additional functions of the special function keys **E** are program-dependent and are further explained in the description of the individual LICCON programs!

H SHIFT key

- Second level key assignments

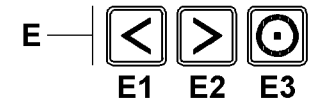
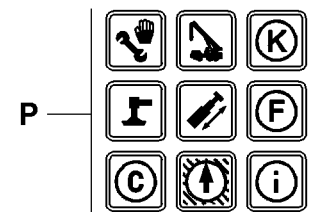
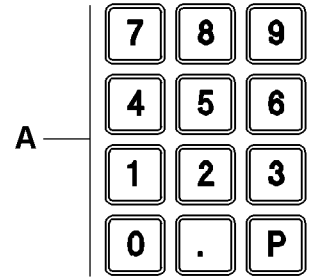
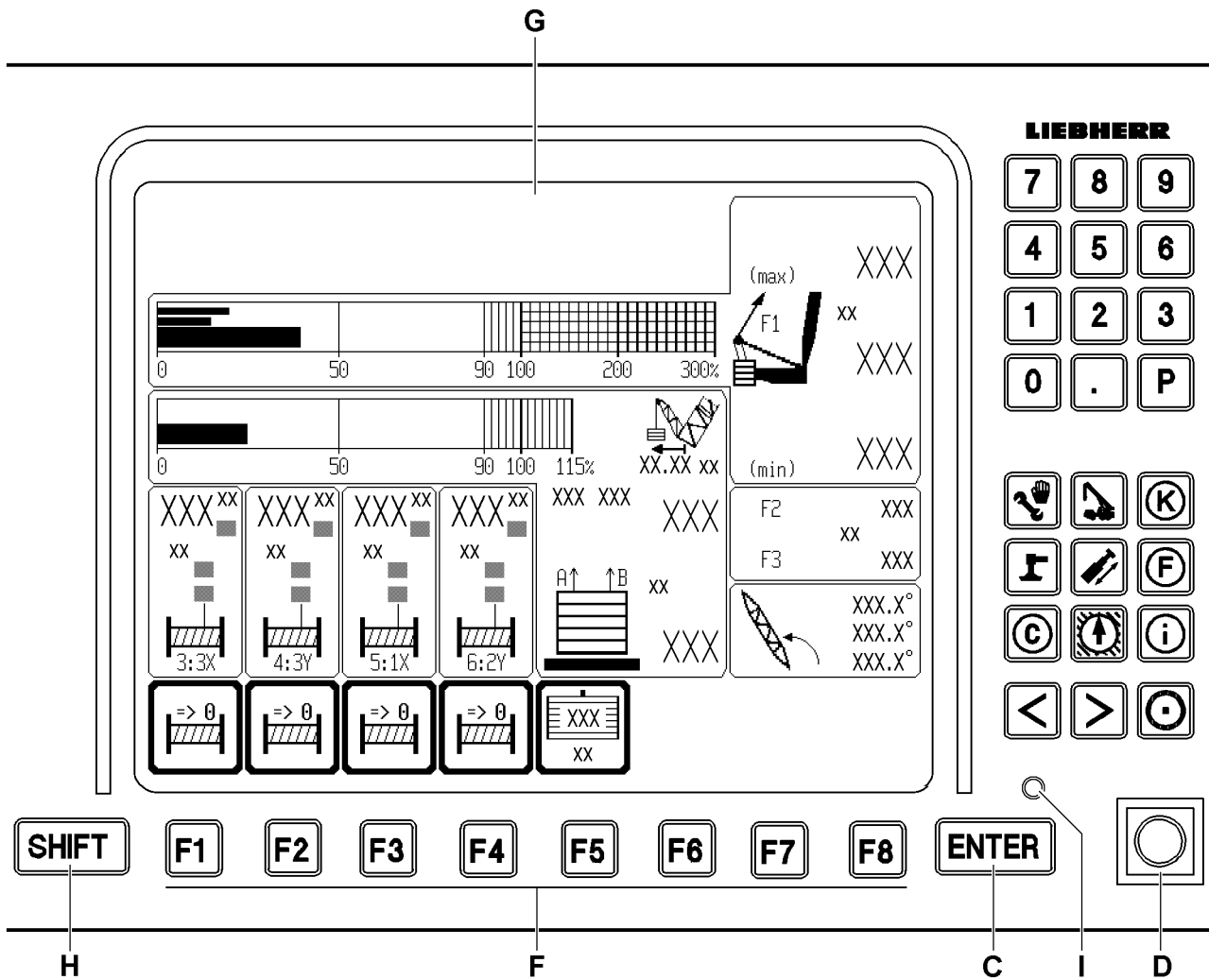

B111902

6 Operating elements of the LICCON computer system on monitor 1

A Keypad	• To edit the derrick ballast input values
P Program keys	• No function
C Input key ENTER	• Confirmation of changes
D Key button	• Acoustic signals which can be shut off of bell / horn turntable can be shut off
E Special function keys	• Monitor brightness adjustment
	• Key combination E3 and E1 : Turn background illumination on / off.
	• Key combination E3 and E2 : Brightness adjustment in three stages.



Note

- Additional functions of the special function keys **E** are program-dependent and are further explained in the description of the individual LICCON programs!
-

F Function keys	• The function keys should always be viewed in conjunction with the function key icon line displayed on the monitor
G Display	• In the display appears “normally” the crane operating screen of monitor 1
H SHIFT key	• No function
I LED display	• Monitor supply voltage present

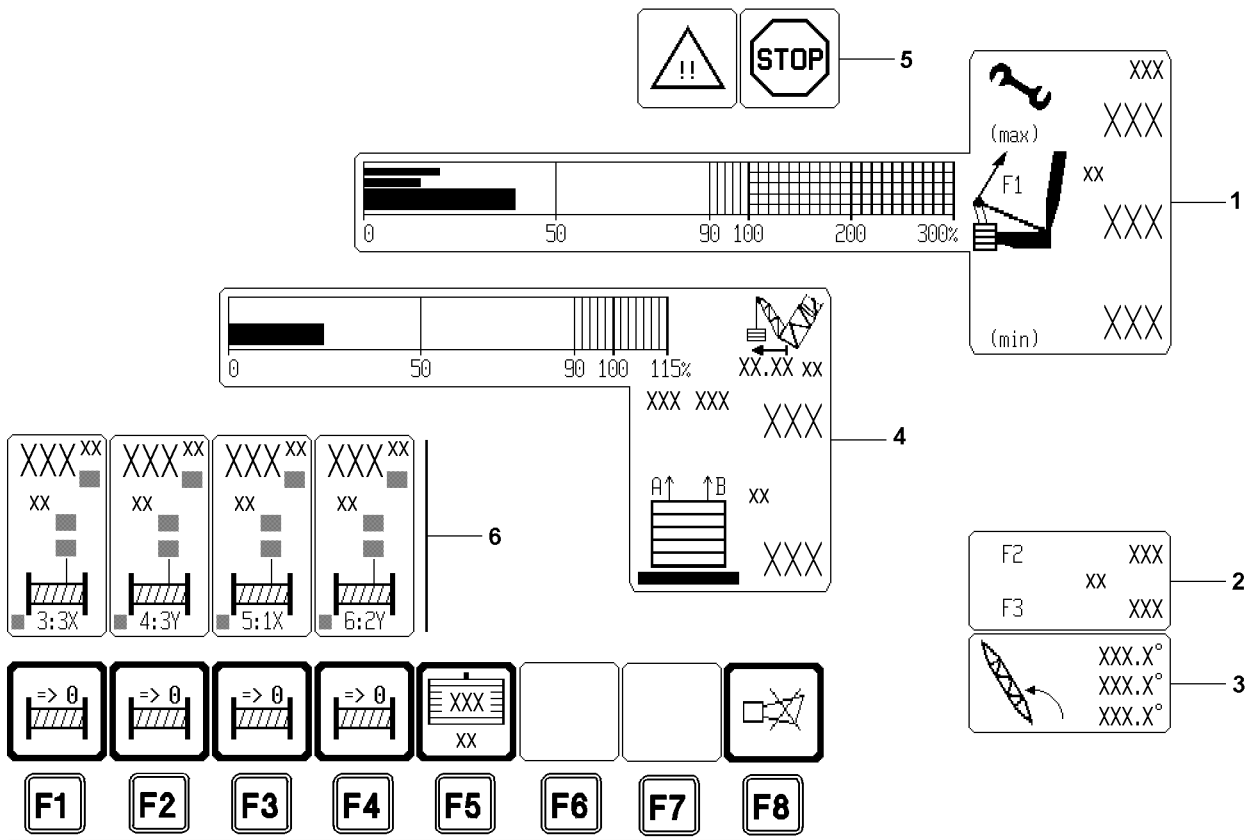
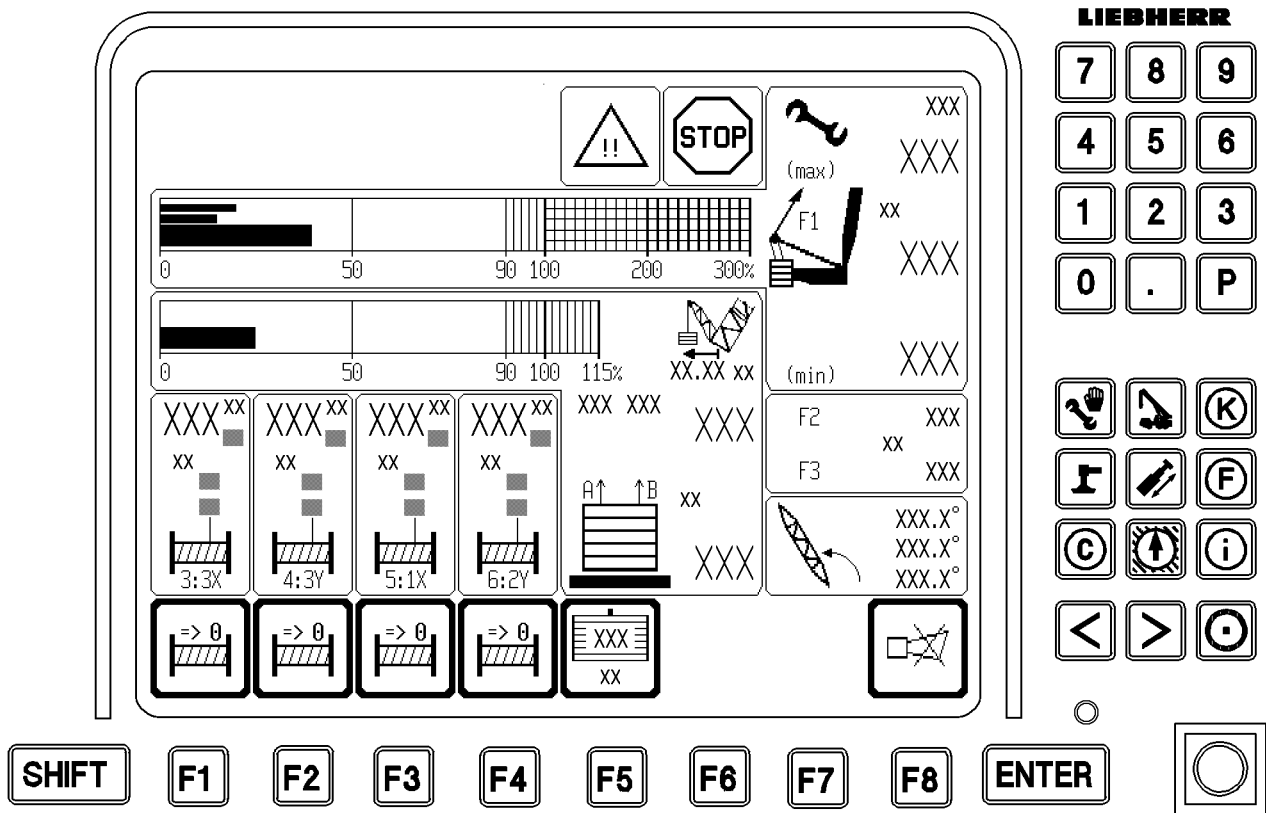

B111911

7 The Crane operation program on monitor 1



Note

- ▶ The suspended ballast and the ballast trailer* are generally described as **derrick ballast!**
- ▶ The fixed compensation weight which is assembled on the turntable is generally described as the **counterweight!**

In the crane operation program on monitor 1, the monitor is divided into eight areas:

- | | |
|---|--|
| 1 Test point 1 = F1 | <ul style="list-style-type: none"> • F1-load display • Pull test brackets on test points 1A and 1B in the SA-frame guying |
| 2 Test points 2/3 = F2/F3 | <ul style="list-style-type: none"> • Pull test brackets on test points 2A and 2B in the N/W guying • Pull test brackets on test points 3A and 3B in the S-guying in derrick operation |
| 3 Derrick boom angle | |
| 4 Derrick ballast, weight and utilization | <ul style="list-style-type: none"> • Derrick ballast, placed and pulled • Derrick ballast radius • Derrick ballast utilization |
| 5 Alarm functions | <ul style="list-style-type: none"> • “Advance warning” and “STOP” icons |
| 6 Winch displays | <ul style="list-style-type: none"> • Winch 3* • Winch 4 • Winch 5* • Winch 6* |
| 7 Function key line | <ul style="list-style-type: none"> • Function keys always refer to the icon shown directly above • Note:
If no icon is shown in the line directly above the function key, then no function is assigned in the program to the function key!
See for example function key F6 and function key F7! |

7.1 Test point 1 = F1



DANGER

Overload of crane in assembly operation!

If the crane is utilized in assembly operation past the assembly limit, then crane components can be overloaded!

The crane can topple over and personnel can be severely injured or killed!

- ▶ In assembly operation, the crane operator must make sure that the crane is not subjected to loads to the assembly limit!
- ▶ The crane may always only be erected / taken down **without load**, according to the data in the operating instructions and the erection and take down charts!

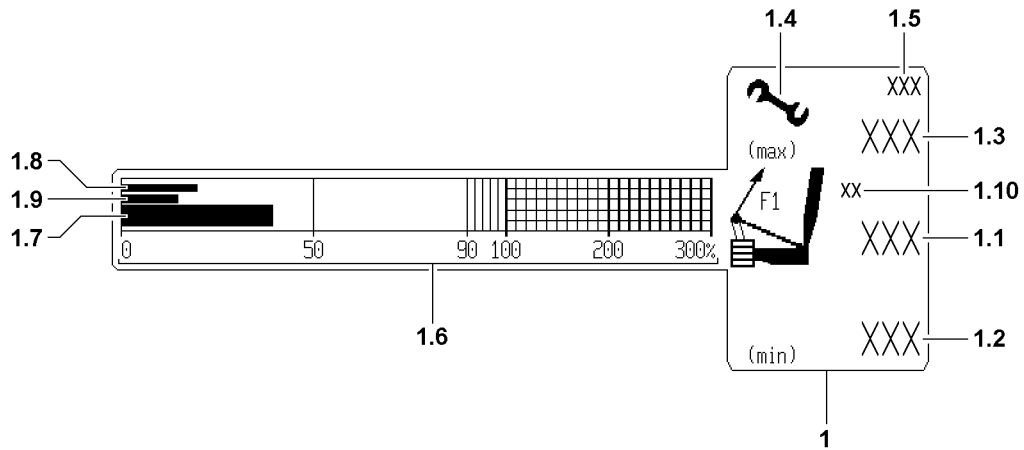

7.1.1 F1-assembly maximum force

The F1-assembly-maximum force is abbreviated in the chapter as $F1_{\text{max-assembly}}$.



Note

- ▶ A load chart is available in the operating range of the crane! Outside of the operating range, no load chart is available, the specifications for assembly operation apply!
- ▶ $F1_{\text{max-assembly}}$ **1.5** can be larger within the operating range for static reasons than $F1_{\text{max-assembly}}$ **1.5** outside the operating range!
- ▶ When luffing out of the operating range with load chart, the value $F1_{\text{max-assembly}}$ **1.5** can therefore be significantly reduced!



DANGER

Failure of angle sensor!

If angle sensor on the boom for the LMB are defective, then the LMB uses the highest permissible $F1_{\text{max-assembly}}$ **1.5** as the non-bypassable maximum value!

This ensures that the boom can always be taken down, even with a defective angle sensor!

If the crane is not taken down after a failure of the angle sensors exactly according to the data in the operating instructions and the erection / take down charts, then it can be overloaded!

The crane can topple over and personnel can be severely injured or killed!

- ▶ Take the crane down if needed exactly according to the data in the operating instructions and the erection / take down charts!

Operating modes without derrick boom

For operating modes without derrick boom, there is a unypassable F1-limit value:

- $F1_{\text{max-assembly}}$ **1.5**
as upper limit for erection / take down of the boom
and
for crane operation with load chart

Operating modes with derrick boom

For operating modes with derrick boom there are two F1-limit values

- $F1_{\text{max-assembly}}$ **1.5** outside the operating range
For erection and assembly of the crane (unypassable)
- $F1_{\text{max-operation}}$ **1.3**
As upper limit for crane operation with load chart (and a few angle degrees next to it)

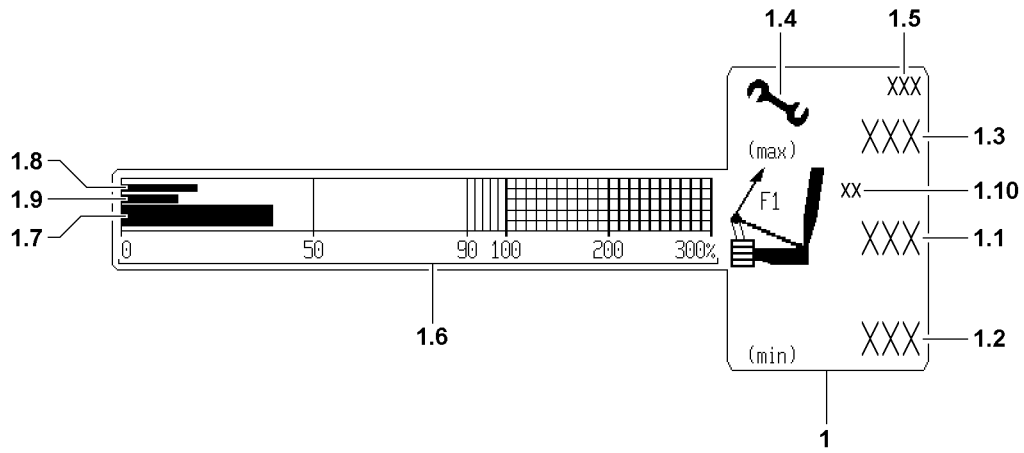

7.1.2 Test point 1 = F1 / icon description

Pull test brackets Test point 1A and 1B are in the SA-frame guying

Position	Icons / display values	Type of display	Is shown
1	Icon "Test point 1"	Static	Always
1.1	F1-actual force = $F1_{actual}$ $F1_{actual} = F1A_{actual} + F1B_{actual}$ $F1A_{actual} = F1$ -actual force test point 1A (SA-frame left) $F1B_{actual} = F1$ -actual force test point 1B (SA-frame right)	Static "???" blinking	For valid value For invalid value
1.2	F1-minimum force = $F1_{min}$	Static	Always when $F1_{min}$ is larger than 0 Note: A shut off occurs when falling below $F1_{min}$ If no value is shown $F1_{min} = 0!$
1.3	F1-operational maximum force = $F1_{max-operation}$	Static	Only in operating modes with derrick ballast (DB/DBW) Note: $F1_{max-operation}$ is the maximum value which may be reached in crane operation! In crane operation, the shut off occurs at $F1_{actual}$ larger than $F1_{max-operation}!$



Note

Shut off $F1_{min}$

- ▶ If the utilization of the derrick ballast is below 50 %, then there is no immediate shut off when falling below $F1_{min}$ **1.2!**
- ▶ The acoustical and optical warnings remain unaffected by the utilization of the derrick ballast!

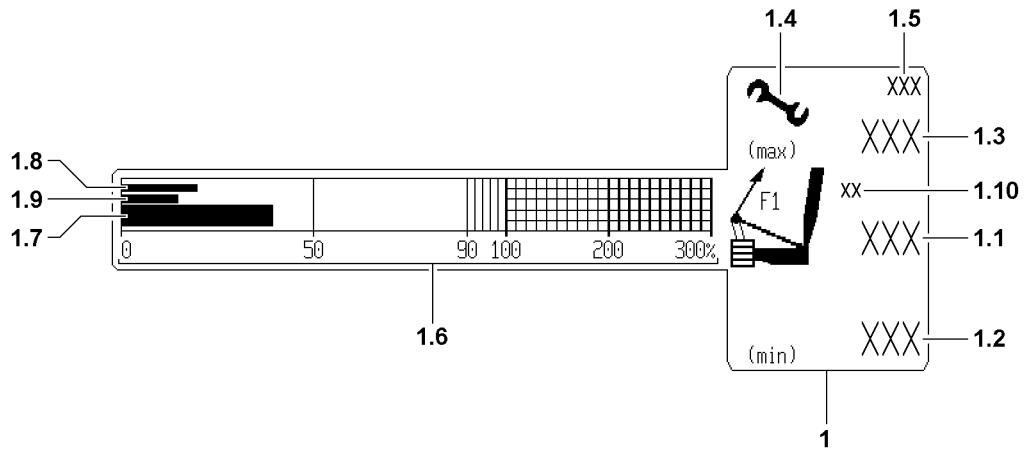

Position	Icons / display values	Type of display	Is shown
1.4	Assembly icon	Static / blinking	In "Assembly operation: Boom not in operating range" and / or Advance warning / shut off: Observe F1 limit values!
1.5	F1-assembly maximum force = $F1_{\text{max-assembly}}$	Static / blinking	In "Assembly operation: Boom not in operating range" and / or Advance warning / shut off: Observe F1 limit values! Note: Appears if $F1_{\text{actual}}$ is larger than 90 % of $F1_{\text{max-assembly}}$
1.6	F1-utilization scale in percent [%]	Static	Always
1.7	F1-utilization bar = Ratio $F1_{\text{actual}}$ to $F1_{\text{max-operation}}$ No display (0 percent) at: $F1_{\text{max-operation}} = 0$ or No value or $F1_{\text{min}} = \text{invalid}$	Dynamic	In operating modes with derrick ballast (DB/DBW)

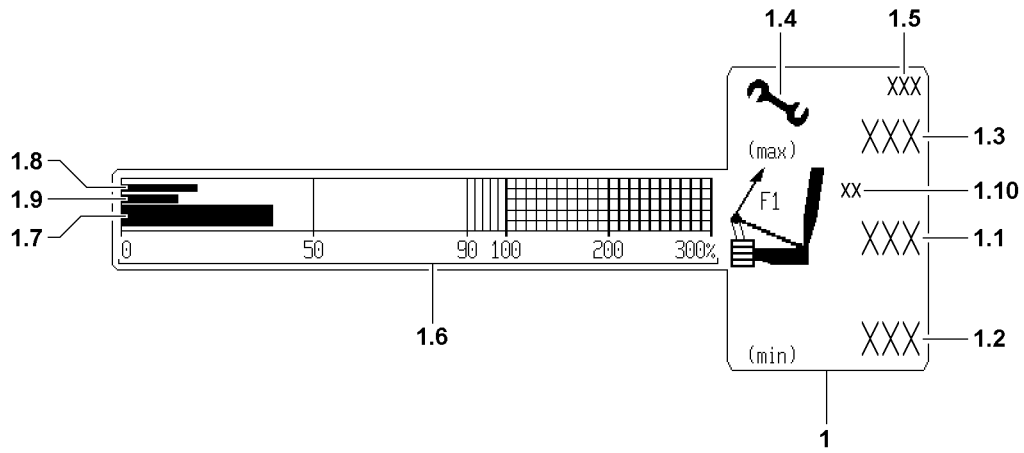

Position	Icons / display values	Type of display	Is shown
1.8	F1-Min-warning bar = Ratio $F1_{\text{min-warning value}}$ to $F1_{\text{max-operation}}$ No display (0 percent) at: $F1_{\text{max-operation}} = 0$ or No value or $F1_{\text{max-operation}} = \text{invalid}$	Dynamic	In operating modes with derrick ballast (DB/DBW)
1.9	F1-Min-Stop bar = Ratio $F1_{\text{min}}$ to $F1_{\text{max-operation}}$ 0 percent [%] for: $F1_{\text{max-operation}} = 0$ or No value or $F1_{\text{max-operation}} = \text{invalid}$	Dynamic	In operating modes with derrick ballast (DB/DBW)
1.10	Measuring unit icon	Static	Always

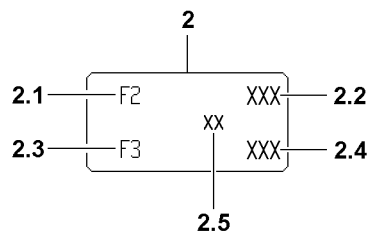

7.2 Test point 2 = F2 and test point 3 = F3

Pull test brackets test point 2A and 2B are in the N/W-guying

Pull test brackets test point 3A and 3B are in the guying derrick boom / main boom on the main boom head

Position	Icons / display values	Type of display	Is shown
2	Icon for N/W-guy force and main boom guy force in derrick operation	Static	In operating modes with auxiliary boom / accessory and / or derrick boom
2.1	Icon F2 for N/W-guy force test point 2	Static	In operating modes with auxiliary boom / accessory
2.2	$F2_{\text{actual}} = F2A_{\text{actual}} + F2B_{\text{actual}}$ Test point 2A = left Test point 2B = right	Static	In operating modes with auxiliary boom / accessory and valid F2-value
		"???" blinking	In operating modes with auxiliary boom / accessory and invalid F2-value
2.3	Icon F3 for main boom guy force test point 3	Static	In operating modes with derrick boom
2.4	$F3_{\text{actual}} = F3A_{\text{actual}} + F3B_{\text{actual}}$ Test point 3A = left Test point 3B = right	Static	In operating modes with derrick boom and valid F3-value
		"???" blinking	In operating modes with derrick boom and invalid F3-value
2.5	Measuring unit icon	Static	Always

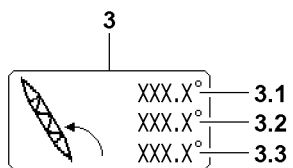

7.3 Derrick boom angle

Position	Icons / display values	Type of display	Is shown
3	Derrick boom angle icon	Static	In operating modes with derrick boom
3.1	Maximum derrick boom angle in crane operation = angle- D_{max} in [°]	Static	In operating modes with derrick boom and angle- $D_{current}$ smaller or same as angle- D_{max}
		Blinking	In operating modes with derrick boom and angle- $D_{current}$ larger than angle- D_{max}
3.2	Current derrick boom angle = angle- $D_{current}$ in [°]	Static	In operating modes with derrick boom and valid value
		"???" blinking	In operating modes with derrick boom and invalid value
3.3	Minimum derrick boom angle during crane operation = angle- D_{min} in [°]	Static	In operating modes with derrick boom and angle- $D_{current}$ larger or same as angle- D_{min}
		Blinking	In operating modes with derrick boom and angle- $D_{current}$ smaller than angle- D_{min}

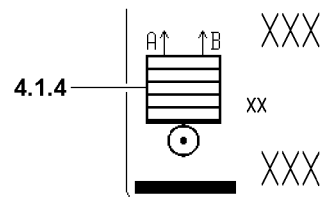
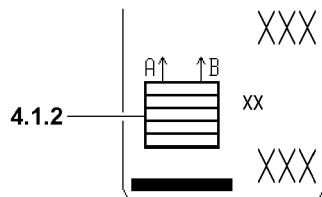
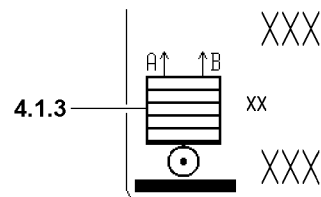
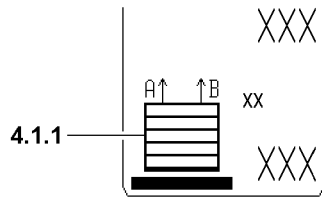
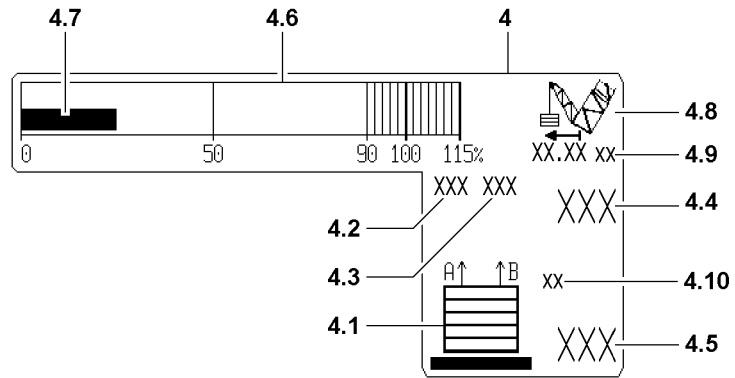

7.4 Derrick ballast, weight and utilization

Position	Icons / display values	Type of display	Is shown
4	“Derrick ballast, weight and utilization” icon	Static	In operating modes with derrick ballast
4.1	“Derrick ballast” icon	Static	In operating modes with derrick ballast, depending on the type and the condition of the derrick ballast (see 4.1.1 - 4.1.4)



Note

- ▶ The view of the “derrick ballast” 4.1 icon changes depending on if the derrick ballast is set up as a suspended ballast or as a ballast trailer!
- ▶ During crane operation observe the respective chapters for suspended ballast or ballast trailer in the Crane operating instructions!

Position	Icons / display values	Type of display	Is shown
4.1.1	“Suspended ballast on the ground” icon	Static	Ground contact sensor reports “Suspended ballast not suspended ”
4.1.2	“Suspended ballast suspended” icon	Static	Ground contact sensor reports “Suspended ballast suspended ”
4.1.3	“Ballast trailer on the ground” icon	Static	Key button ballast trailer in position “Ballast trailer not suspended ”
4.1.4	“Ballast trailer suspended” icon	Static	Key button ballast trailer in position “Ballast trailer suspended ”

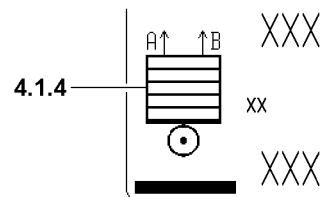
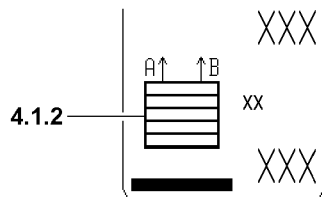
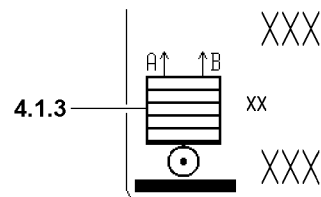
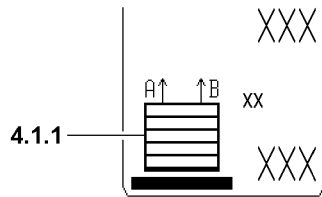
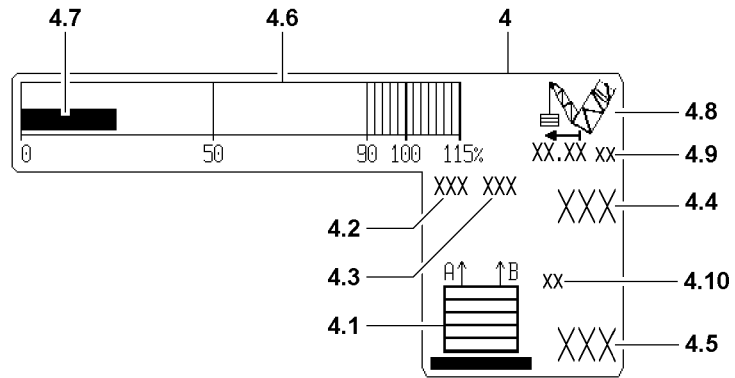

7.4.1 Hydraulically adjustable derrick ballast

Test points derrick ballast guying A are:

- Test point 4A = pressure sensor ring surface left F4A
- Test point 5A = pressure sensor piston surface left F5A

Test points derrick ballast guying B are:

- Test point 4B = pressure sensor ring surface right F4B
- Test point 5B = pressure sensor piston surface right F5B

Position	Icons / display values	Type of display	Is shown
4.2	Force Derrick ballast guying A (left) Test point 4A Test point 5A	Static	"Values test points" valid
		Blinking	"Values test points" valid and Difference between guy force A and B is larger than permissible
		"???" Blinking	At least one "Value test point" invalid
4.3	Force Derrick ballast guying B (left) Test point 4B Test point 5B	Static	"Values test points" valid
		Blinking	"Values test points" valid and Difference between guy force A and B is larger than permissible
		"???" Blinking	At least one "Value test point" invalid



Note

Failure of pressure sensor!

- ▶ If only one pressure sensor fails, for example F5A (test point 5A) invalid, then the LICCON computer system assumes F5A = F5B in the interim! An error message is issued!
- ▶ The error must be remedied immediately!

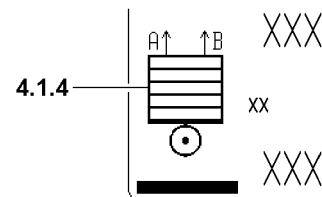
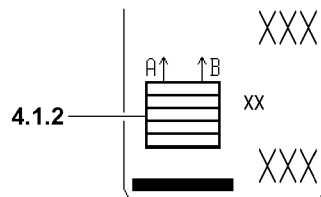
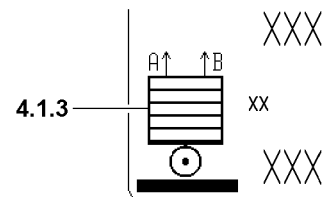
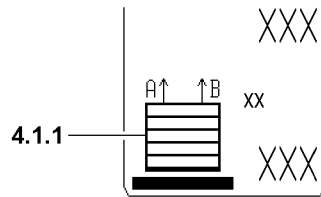
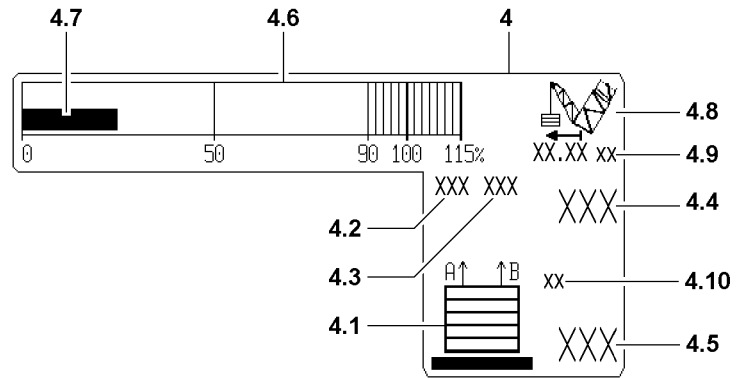

Position	Icons / display values	Type of display	Is shown
4.4	Pulled derrick ballast = BA_{pulled} = vertical force components in derrick ballast guying, calculated from test points 4A, 4B, 5A and 5B Note: The sum of forces in the derrick ballast guying A and B is larger or the same as the pulled derrick ballast (BA_{pulled})!	Static	If value BA_{pulled} valid
		"???" Blinking	If value BA_{pulled} invalid or Operating mode with BW and derrick ballast radius invalid
4.5	Placed derrick ballast = BA_{placed} Note: This value has been entered by hand and confirmed with the ENTER key! The value is saved when turning off and is valid again after turning on until it is changed with the function key " F5 " !	Static	If value BA_{placed} permissible
		Blinking	If value BA_{placed} questionable
		"???" blinking	If value BA_{placed} invalid

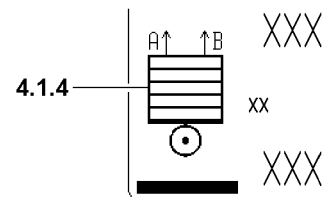
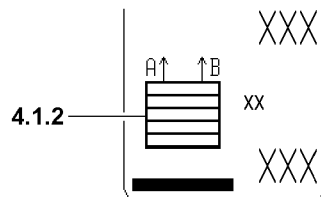
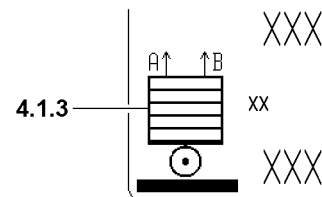
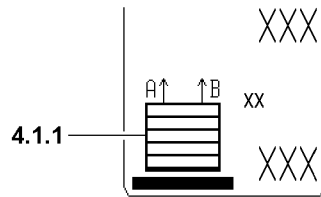
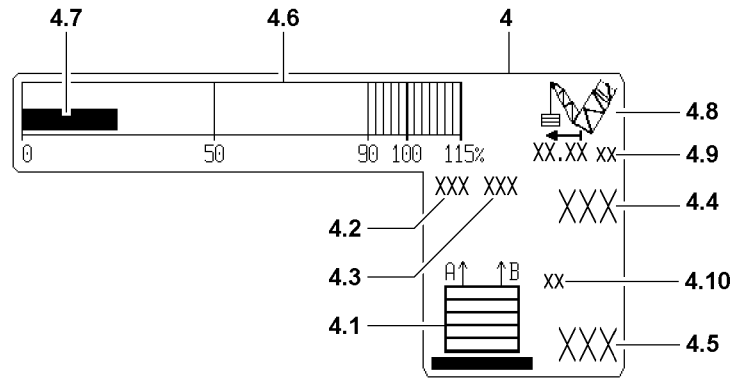

Position	Icons / display values	Type of display	Is shown
4.6	Ballast utilization scale	Static	Always
4.7	Derrick ballast utilization bar = Ratio BA_{pulled} to BA_{placed} in percent Derrick ballast utilization bar is 0 at: BA_{placed} smaller than BA_{placed_min} or BA_{pulled} = invalid	Dynamic	In operating modes with derrick ballast Note: The utilization bar can show max. 115 %!
4.8	“Derrick ballast radius” icon	Static	In operating modes with derrick ballast
4.9	Display of derrick ballast radius with measuring unit	Static	When value derrick ballast radius valid
		“???” blinking	When value derrick ballast radius invalid
4.10	Measuring unit Derrick ballast weight	Static	Always

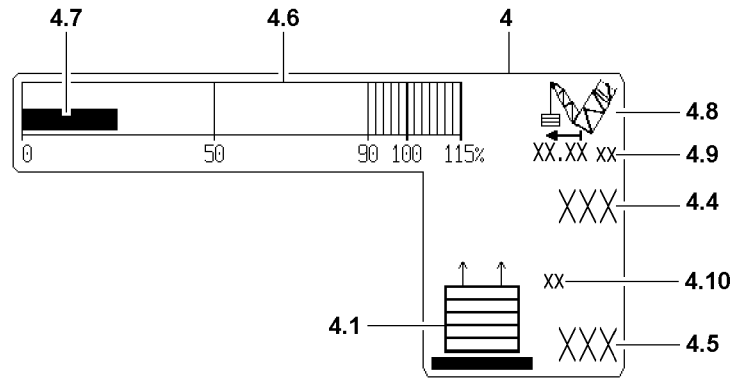

7.4.2 Mechanically adjustable suspended ballast

If a mechanically adjustable suspended ballast is installed, the values for:

- Theoretically pulled derrick ballast **4.4** = $BA_{\text{pulled theoretically}}$
- Derrick ballast utilization bar display **4.7** = $BA_{\text{pulled theoretically}}/BA_{\text{placed}}$ in percent

are calculated by the LICCON computer system. These values are described as “Theoretical values”.



WARNING

Deviation of theoretical values!

The “Theoretical pulled derrick ballast” ($BA_{\text{pulled theoretically}}$) can deviate from the actual pulled derrick ballast!

- ▶ The crane operator must check the displays $BA_{\text{pulled theoretically}}$ and the “Derrick ballast utilization bar” under 10 % and over 90 % utilization for plausibility! Derrick ballast suspended is at least 100 % utilization! Derrick ballast complete on the ground (guying loose) is approx. 0 %!
- ▶ When the limit ranges (displays $BA_{\text{pulled theoretically}}$ and “Derrick ballast utilization bar” under 10 % or over 90 %) are reached, then carry out the crane movements slowly and with utmost caution!

Position	Icons / display values	Type of display	Is shown
4.4	Theoretical pulled derrick ballast = $BA_{\text{pulled theoretically}}$	Static	For “Mechanical suspended ballast length sensor signal” and “Test point 1 (F1)” and “Test point 3 (F3)” ok
		“???” blinking	For “Mechanical suspended ballast length sensor signal” , or “Test point 1 (F1)” or “Test point 3 (F3)” erroneous
4.5	Placed derrick ballast = BA_{placed} Note: This value has been entered by hand and confirmed with the ENTER key! The value is saved when turning off and is valid again after turning on until it is changed with the function key “F5” !	Static	If value BA_{placed} permissible
		“???” blinking	If value BA_{placed} invalid

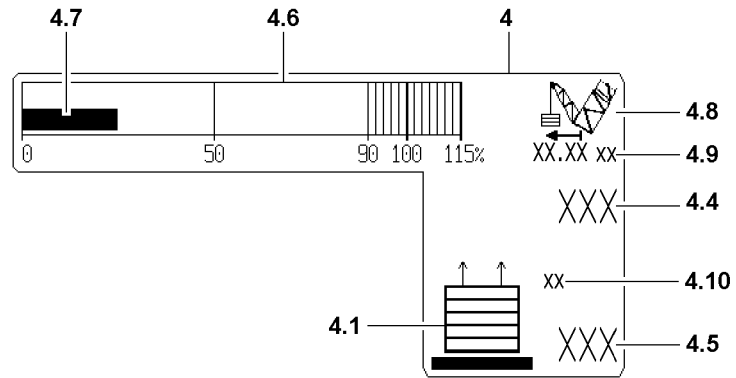

**Note**

- ▶ The change over of $F1_{\text{min-force threshold}}$ is not made depending on the theoretical pulled derrick ballast, rather than depending on the placed derrick ballast BA_{placed} !
- ▶ To reach the steepest boom position, it may be necessary to set the suspended ballast all the way down on the ground and to enter $BA_{\text{placed}} = 0$ t to maximum 4 t on the LICCON monitor !! The $F1_{\text{min threshold}}$ is thereby lowered!

Position	Icons / display values	Type of display	Is shown
4.6	Ballast utilization scale	Static	Always
4.7	Derrick ballast utilization bar = Relationship $BA_{\text{pulled theoretically}}$ to BA_{placed} in percent [%] Derrick ballast utilization bar is 0 at: BA_{placed} smaller than $BA_{\text{placed_min}}$ or $BA_{\text{pulled}} = \text{invalid}$		In operating modes with derrick ballast Note: The utilization bar can show max. 115 %!
4.8	“Derrick ballast radius” icon	Static	In operating modes with derrick ballast
4.9	Display of derrick ballast radius with measuring unit Note: Only the corresponding nominal value is shown, for example 11.0 m 13.0 m or 15.0 m .	Static	When value derrick ballast radius valid
		“???” Blinking	When value derrick ballast radius invalid
4.10	Measuring unit Derrick ballast weight	Static	Always



7.5 Alarm functions

NOTICE

Triggered alarm function!

If an alarm function is triggered (for example a advance warning occurrence or LMB Stop), the cause must be determined!

► Always pay attention to triggered alarm functions!

Position	Icons / display values	Type of display	Is shown
5	“Advance warning” icon	Blinking	If an advance warning occurs, for example: $F1_{\text{min-advance warning}}$: $F1_{\text{actual}}$ smaller than $F1_{\text{min-warning value}}$
6	“STOP” icon	Blinking	If an LMB stop occurrence results, for example: At $F1_{\text{min-stop}}$ ($F1_{\text{is}}$ smaller than $F1_{\text{min}}$) with shut off delay 3 s or At $F1_{\text{max-operation stop}}$ ($F1$ larger or same as $F1_{\text{max-operation shut off value}}$) with after run three seconds or $F1_{\text{max-assembly-stop}}$ ($F1_{\text{is}}$ larger or same as $F1_{\text{max-assembly}}$) with after run three seconds Note: $F1_{\text{max-operation shut off value}} = F1_{\text{max-operation}} + F1_{\text{addition for shut off!}}$



Note

Shut off delay LMB stop!

► An LMB stop with after run remains for a certain period of time! Possible fluctuating movements of the crane can be thereby minimized!

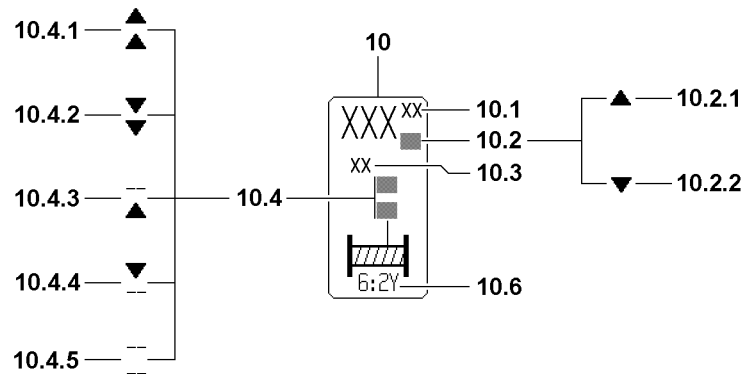
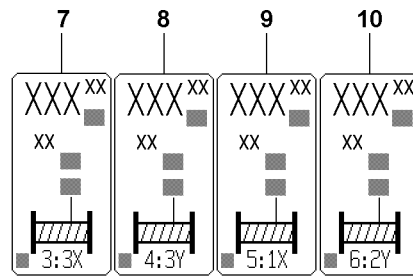

7.6 Winch displays

7.6.1 Winches 3 to 6

The icons for winch 3*, winch 4, winch 5* and winch 6* are only shown on monitor 1, if the crane is equipped with these winches.

The display of winches is the same as the display of winch 1 and 2 on LICCON monitor 0.



Note

- ▶ If one of the winches is used as hoist winch according to the set operating mode, then the **completed hook path** is shown in the winch icon. The value, which was tared by the corresponding function key is still shown unchanged, even after turning off and on or after an operating mode change!
- ▶ If one of the winches is used as a control winch, then the current **rope length on the winch drum** is shown, not the hook path. Then taring is possible, but after turning on and off again or after an operating mode change, the original value "Rope length on the rope drum" is shown again!

Position	Icons / display values	Type of display	Is shown
7	Winch display winch 3*	Static	For installed and plugged in winch 3*
8	Winch display winch 4	Static	For installed and plugged in winch 4
9	Winch display winch 5*	Static	For installed and plugged in winch 5*
10	Winch display winch 6*	Static	For installed and plugged in winch 6*



Note

- ▶ For winch 6, no master switch is assigned in single operation of winch I and winch III!
- ▶ If winch 1 and winch 2 are parallel operated, then winch 6 is assigned the master switch of winch 2, **MS2Y!**

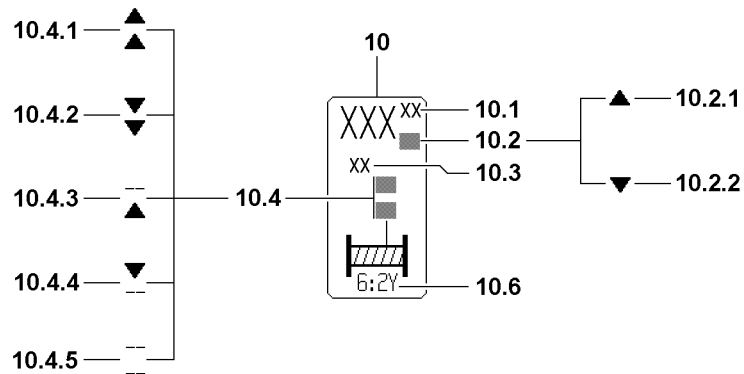
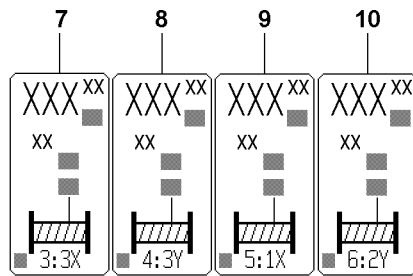

7.6.2 Winch display

The winch 3 to 6 icons have the same meaning, which are explained for the “Winch 6” **10** icon.



Note

Display area winch displays!

- ▶ The “completed path” display **1.1** has only three positions before the comma, any positions before that are cut off! The crane operator must evaluate for himself if, for example 200 m rope are spooled up on a winch or 1200 m. **The display in both cases would be identical with 200 m!**
- ▶ The hook path calculation only works accurately if the load is suspended freely and is not luffed during the lifting procedure! Not taken into account are flexation and rope expansion!
- ▶ The length display (hook path display) is only accurate and the layer jump is only taken into account correctly if the winch has been calibrated and no interruptions of the CPU power supply have occurred (cold start)!

10 “Winch 6” icon

10.1 Completed hook path

- In [m] or [ft]
From a zero point to be determined

• Note:

Is statically shown when the winch is calculated as **hoist winch** and a manually entered reeving must be assigned to this winch!

or

10.1 Rope length of the winch drum

- In [m] or [ft]

• Note:

Is statically shown when the winch is calculated as **control winch!**

• Note:

For winch 4 (intake gear), the rope length is valid equally for the left and the right half of the rope drum!



Note

Error in winch path measurement!

- ▶ In case of an error in the winch path measurement, blinking “???” appear as display value **10.1!**
- ▶ If an error occurs and an error message is issued, see Diagnostics manual!

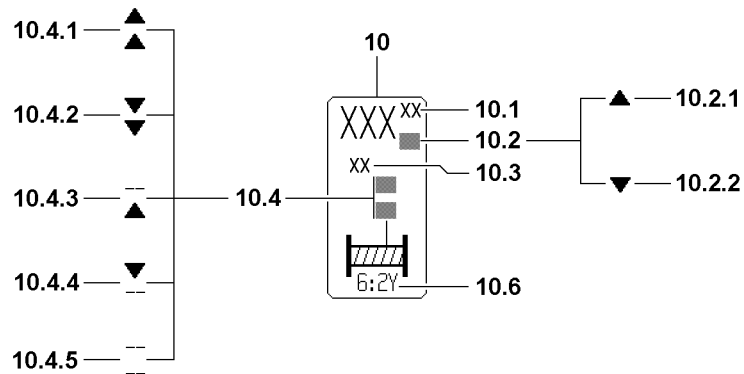
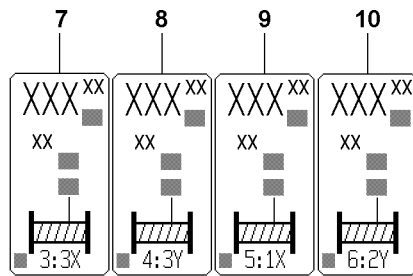

- 10.2** Direction of hook movement
- The arrows on the length value show the direction of the hook movement in relation to the zero point:
- Arrow up **10.2.1**: Hook has moved upward from the zero point.
 - Arrow down **10.2.2**: Hook has moved down from the zero point.
- 10.3** Length unit for hook path display
- In [m] or [ft]
- 10.4** Winch status display
- There are five winch status icons (all blinking):
- 10.4.1** Spool out
- 10.4.2** Spool up
- 10.4.3** Spooled out
- Spooling out is blocked
- 10.4.4** Spooled up
- Spooling up is blocked
- 10.4.5** Winch is deactivated
- Spooling up and spooling out are blocked (via Control parameter program)
 - **Note:**
If no winch status icon appears, the activated winch is inactive and is neither spooled up nor out!
- 10.5** Winch icon
- 10.6** Winch number with master switch number and master switch operating direction
- (with rope end for winch status icon)
 - Example: 6:2Y.
First digit: Winch number.
Second digit: Master switch number.
Letter: Master switch operating direction.

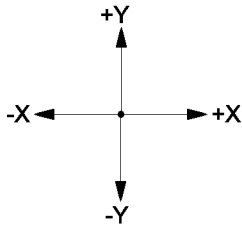

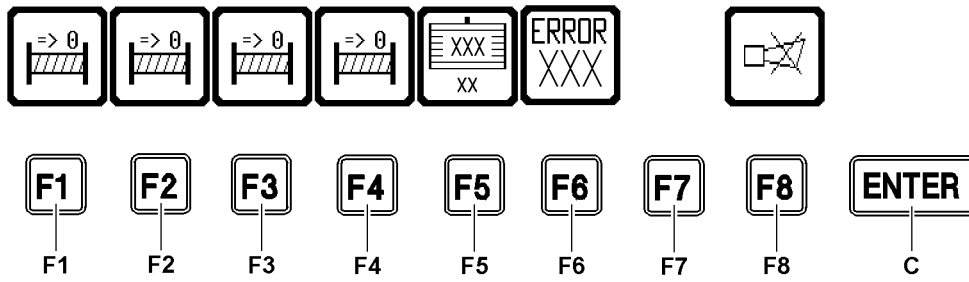

7.7 Function key line

Position	Function / function key line	Type of display	Is shown
F1	Tare length display of winch 3* Note: Tare = length display is set to 0 !	Static	If winch display for winch 3* is shown
F2	Tare the length display of winch 4 Note: Tare = length display is set to 0 !	Static	If winch display for winch 4 is shown
F3	Tare length display of winch 5* Note: Tare = length display is set to 0 !	Static	If winch display for winch 5* is shown
F4	Tare the length display of winch 6 Note: Tare = length display is set to 0 !	Static	If winch display for winch 6* is shown

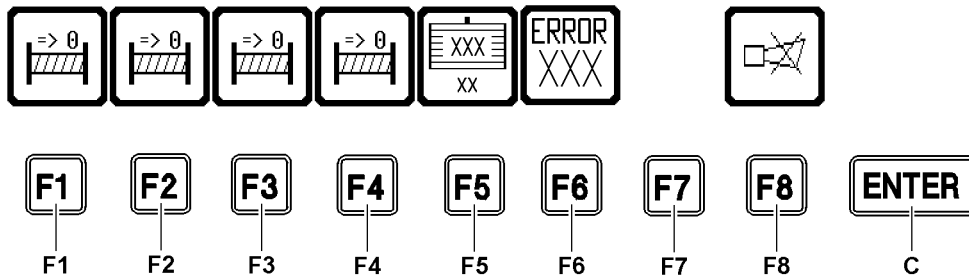

Position	Function / function key line	Type of display	Is shown
F5	<p>Ballast editing key*</p> <p>When pressing function key F5, the thick icon frame changes to a thin icon frame. A blinking cursor appears in the ballast editing field. The value for the placed ballast can only be entered in the displayed weight unit [t] or [kips] via the keypad on monitor 1.</p> <p>The ballast editing can be ended with:</p> <ul style="list-style-type: none"> - Pressing the ENTER key C = Take over value The entered value appears now as value for the placed ballast (BA_{placed}) in the ballast icon <p>or</p> <ul style="list-style-type: none"> - Pressing "F5" key = End editing. The change is discarded. The old value of BA_{placed} remains in the ballast icon. 	Static	In operating modes with derrick ballast

**Note**

- ▶ When editing the ballast, make sure to observe the respective section regarding the derrick ballast in the Crane operating instructions, chapter 4.03!

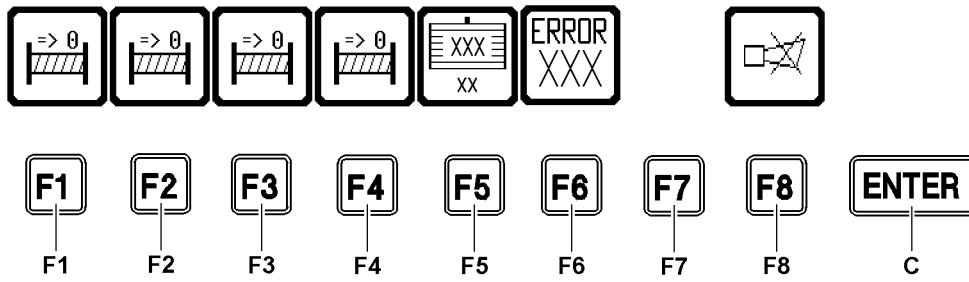

Position	Function / function key line	Type of display	Is shown
F5*	Ballast input value (BA _{edit})* = edited ballast value in function key icon of "F5"	Static	For valid ballast input value
		"???" blinking	For invalid ballast input value
F6	Error icon with frame and text "ERROR" and Error number of error Note: The F6 key has no function.	Static Blinking	If an application error is found on CPU1
F7	Not assigned		
F8	"Horn" icon - Turn off the acoustic signal "Horn" on monitor 1 by pressing the "F8" key.	Blinking	If the acoustical signal "Horn" sounds on monitor 1. See paragraph "Acoustical warning on monitor 1" .

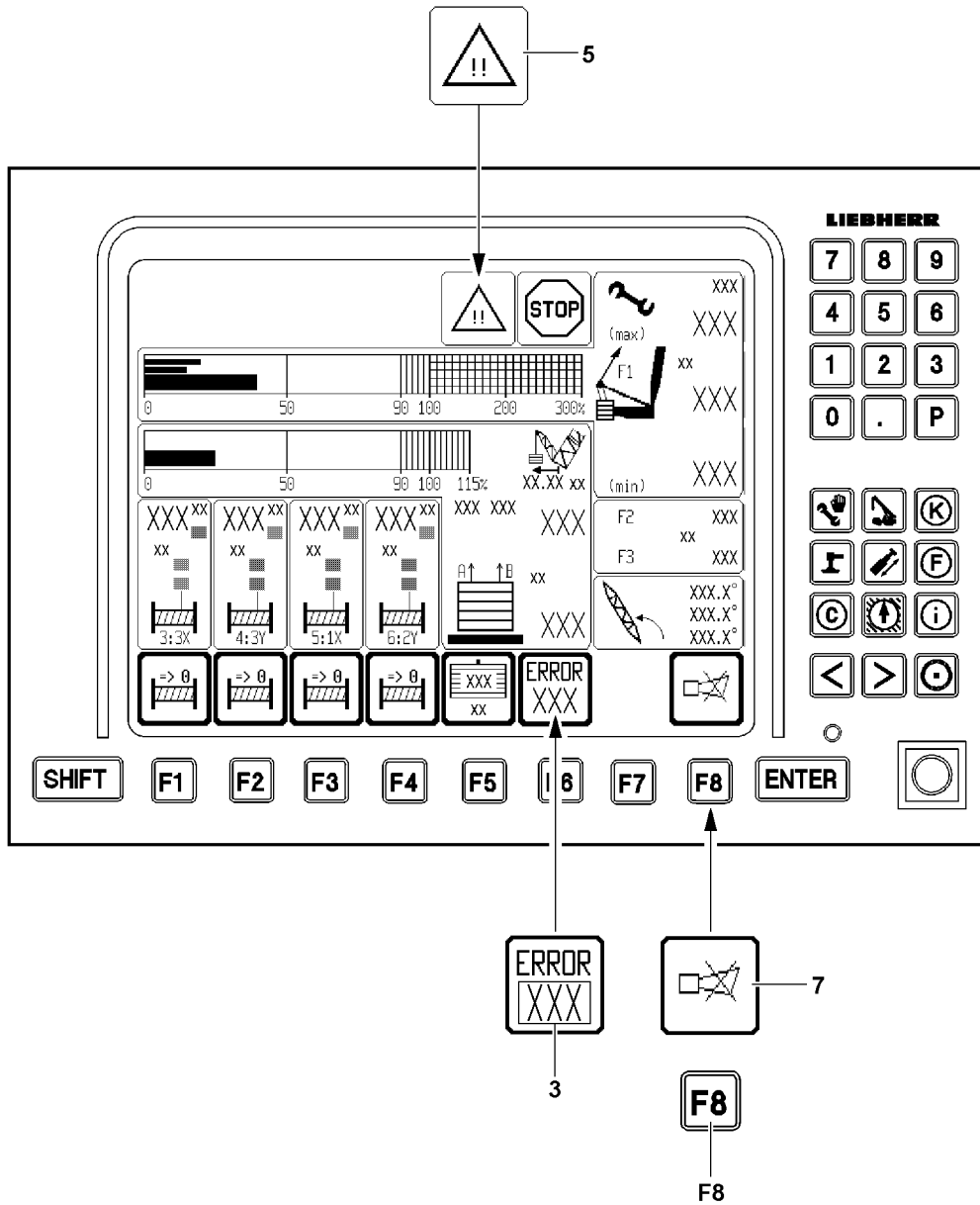

7.8 Acoustic warning on monitor 1

Acoustic warnings on monitor 1 are indicated by the warning sound "Horn".

The warning sound "Horn" is divided into two categories:

- "Horn" is a beeping sound of a duration of approximately 0.5 seconds, which is repeated in a second cycle.
- "Short horn" is a beeping sound of a duration of approximately 0.1 seconds, which is repeated in a second cycle.

F8 "Horn" icon

- When the horn icon is shown in the LICCON monitor, any acoustic signals which will occur can be shut off by the LICCON monitor 1 by pressing the function key **F8**.
- If an operational error has the required classification, then, in addition to the acoustical warning, an error message with error number **3** is issued. Evaluating the error number **3**, see Diagnostics manual.

7.8.1 Acoustic signal "Horn"

For some operational errors found on the CPU 1, which can lead to a shut off of a movement, it is important to check the operating screen on monitor 1. These errors are reported through the acoustical signal "Horn".

Operational errors are:

- Exceeding of test point 1 - Assembly maximum threshold
- Exceeding of test point 1 - Operation Max- shut off threshold
- Exceeding of test point 1 - Minimum threshold

Operational errors with error message are:

- For example sensor error at:
 - Pull test brackets (force test boxes)
 - Pressure sensors
 - Angle sensors

7.8.2 Acoustic signal "Short horn"

Sounds in addition to the visual display of error messages without an error number and which do not lead directly to crane movement shut off by the LICCON overload protection.

Monitored error messages are:

- Advance warning **5** triggered.

7.8.3 Priority acoustic signal

- The "Horn" alarm has higher priority than the "Short horn" alarm, i.e. "Horn" takes preference over "Short horn".
- The "Horn", as well as the "Short horn" immediately become active again if an error recurs!

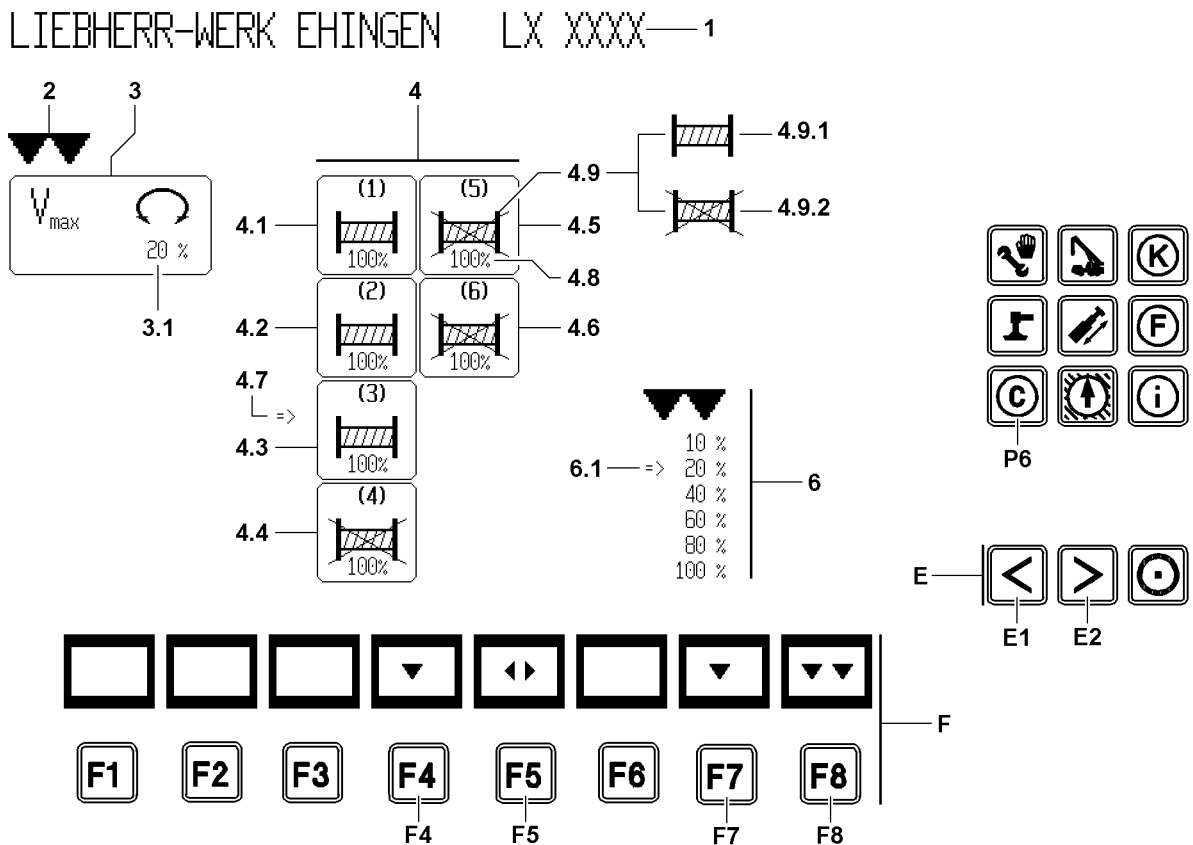
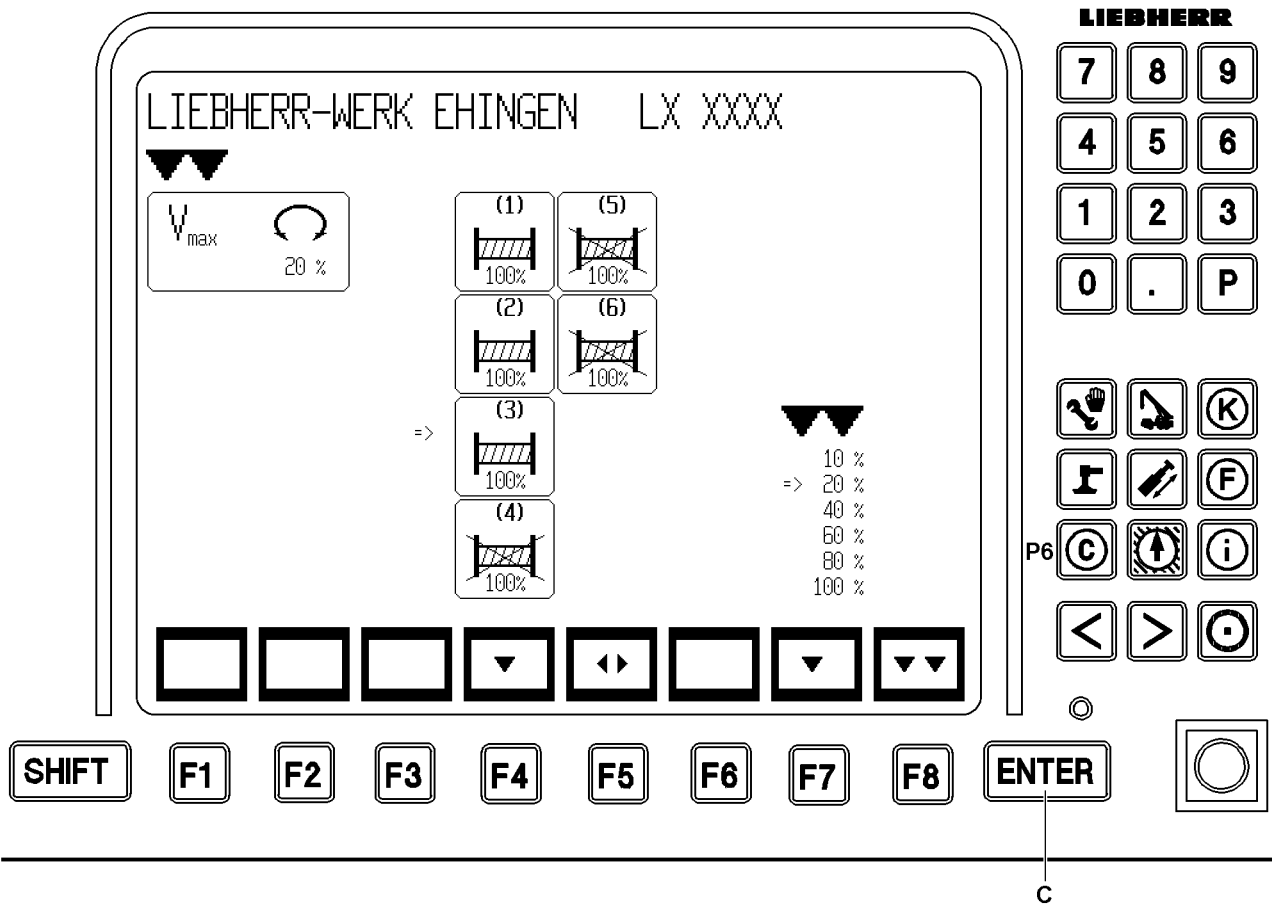

B112327

8 The Control parameter program

The Control parameter program offers the following possibilities:

- Preselection of maximum rotation speed of slewing gear.
- Preselection of maximum rotation speed of individual winches.
- Activation / deactivation of individual winches.

During the Control Parameter program, the exceedance of shut off limits of the LICCON overload protection may not / not be activated. Otherwise the system switches back immediately into the Crane operation program.



DANGER

Risk of accident!

- ▶ **Never** change the speeds or the activation / deactivation of the winches while actuating a crane movement!
-

8.1 Starting the program

- ▶ Press the program key **P6**.

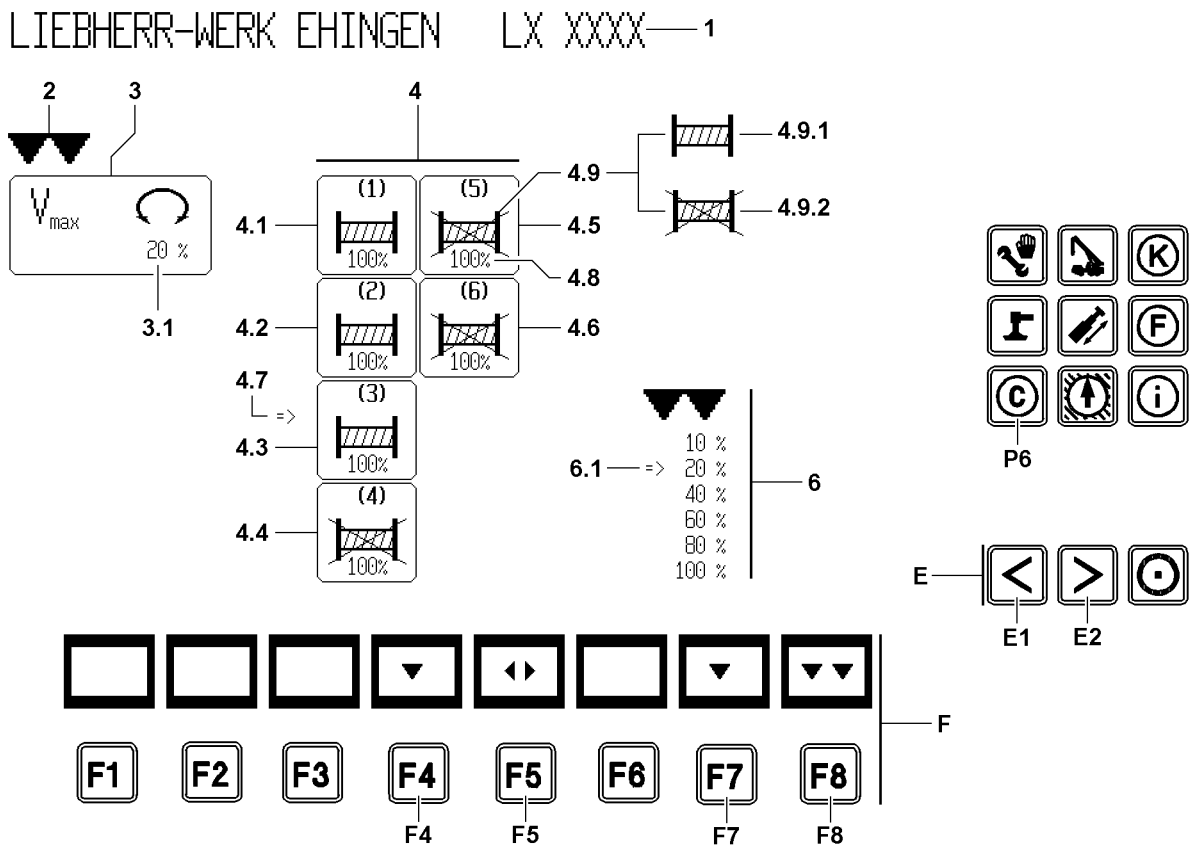
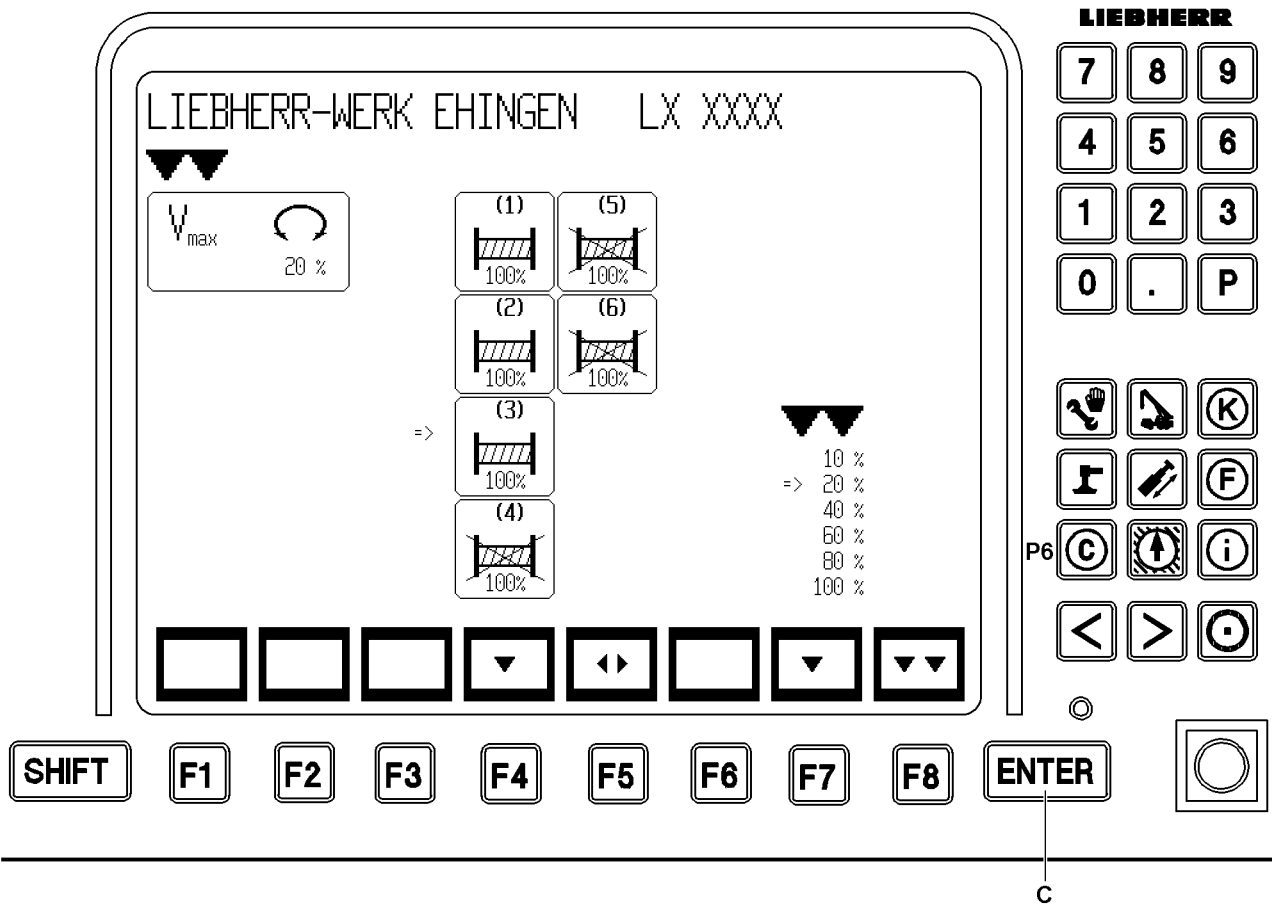

B112327

8.2 User interface

- 1 Crane type
- 2 Selector "Icon selection"
 - Double arrow pointing down
 - Select icon
- 3 "Slewing gear" icon
- 3.1 "Maximum rotation speed"
 - V_{\max} in percent [%]
- 4 "Winches" icon group
 - 4.1 Winch 1
 - 4.2 Winch 2
 - 4.3 Winch 3*
 - 4.4 Winch 4
 - 4.5 Winch 5*
 - 4.6 Winch 6*
 - 4.7 Winch selector
 - Arrow to the right
 - Select the winch, for which the "properties" are to be changed
 - In percent [%]
 - See value field with selector
 - 4.8 Speed
 - Arrow to the right
 - Select the winch, for which the "properties" are to be changed
 - In percent [%]
 - See value field with selector
 - 4.9 Winch icon
 - 4.9.1 Winch activated
 - 4.9.2 Winch deactivated
 - 6 Value field with selector
 - The percentage values relate to the speed with maximum deflection of the manual control lever, always in relation to the maximum achievable speed of the drive, with 100 % preselected speed. Six stages may be preselected.
 - Arrow to the right
 - Select percentage value(s) for speed stages
- 6.1 Speed selector
 - F Function key line
 - F4 Function key
 - Select winch
 - F5 Function key
 - Activate / deactivate selected winch(es)
 - F7 Function key
 - Select percentage value of corresponding speed in value field
 - F8 Function key
 - Return to the crane operation program and take over parameter.
 - C Input key ENTER
 - Take over the selected speed setting for the preset functions
 - E Special function keys
 - E1 Special function key
 - Move the selector 2 for selecting icons to the left
 - E2 Special function key
 - Move the selector 2 for selecting icons to the right

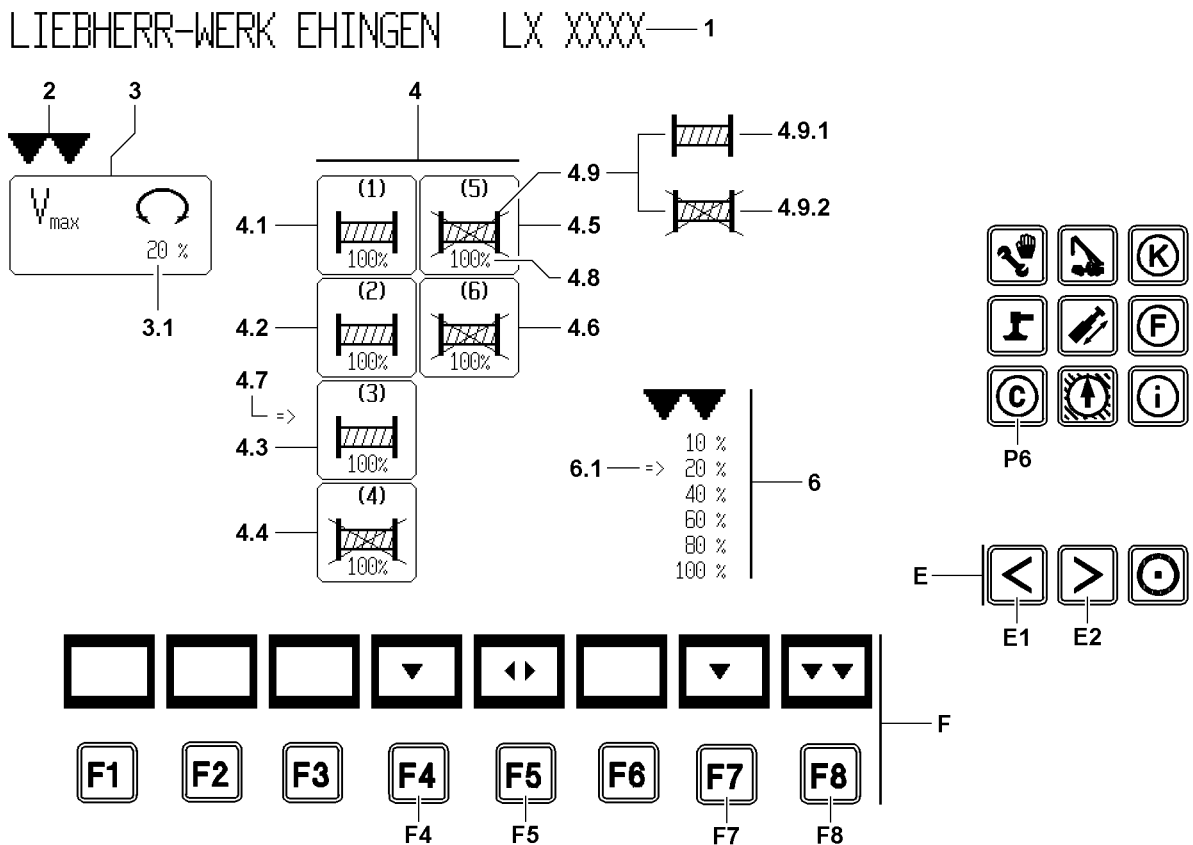
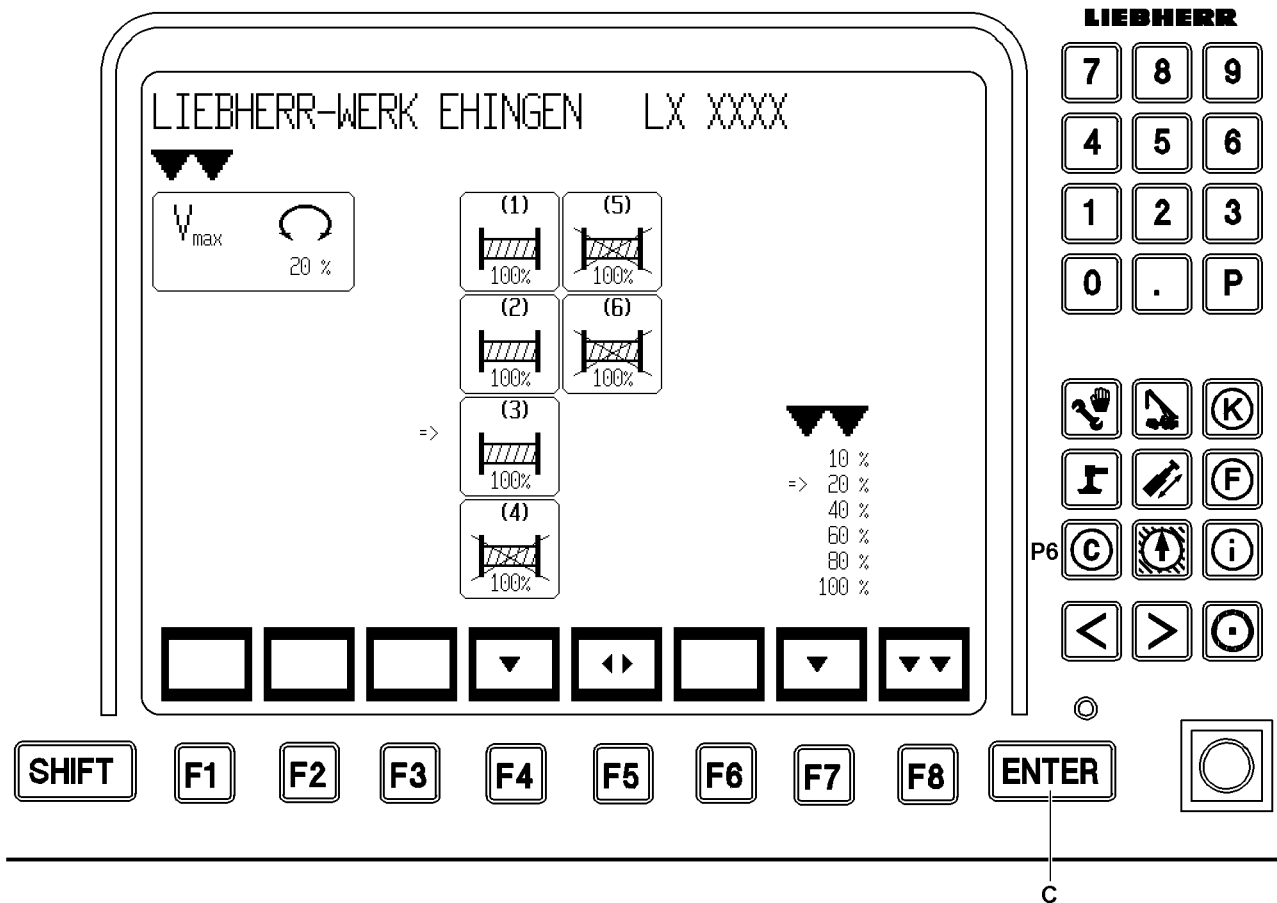

B112327

8.3 Changing the maximum rotation speed of slewing gear



DANGER

Risk of accident!

- ▶ Always adhere to the maximum speeds relative to the boom length and the operating modes during crane operations with loads (according to load charts)!
- ▶ The longer and heavier the boom is and the greater the load, the smaller the set "Maximum rotation speed" must be!
- ▶ **Never** deflect the master switch for the slewing gear to the stop at maximum load!

- ▶ Use the special function key **E1** or special function key **E2** to select the "slewing gear" icon **3**.

Result:

- Selector (double arrow down) **2** appears above the "Slewing gear" icon **3**.

- ▶ Select the maximum rotation speed in percent with function key **F7**.

Result:

- Selector (arrow to right) **6.1** shows the selected percentage value.

- ▶ Use the ENTER key **C** to confirm the selected "Maximum rotation speed".

Result:

- The value of the "maximum rotation speed" is shown in the icon and taken over into the control.

8.4 Winches

8.4.1 Changing maximum winch speed

- ▶ Using the special function key **E1** or special function key **E2**, select the icon group "Winches" **4**.

Result:

- Selector (double arrow down) **2** appears above the icon group "Winches".

- ▶ With the function key **F4**, select the icon for "Winch 1", or "Winch 2", or "Winch 3" *, or "Winch 4", or "Winch 5", * or "Winch 6" *.

Result:

- Selector (arrow to right) **4.7** shows the selected winch.

- ▶ Select the "maximum winch speed" in percent with function key **F7**.

Result:

- Selector (arrow to right) **6.1** shows the selected percentage value.

- ▶ Use the ENTER key **C** to confirm the selected "maximum winch speed".

Result:

- The value of the "maximum winch speed" is shown in the selected winch icon and taken over into the control.

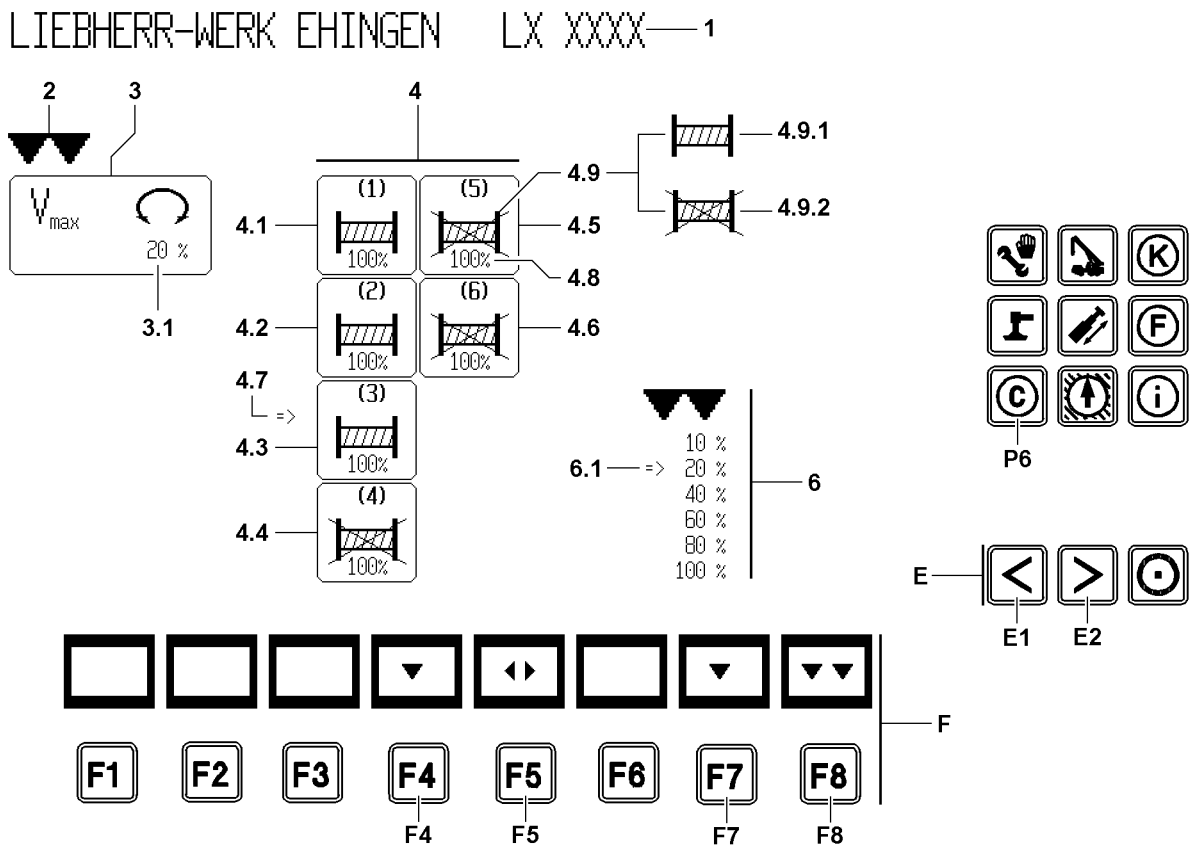
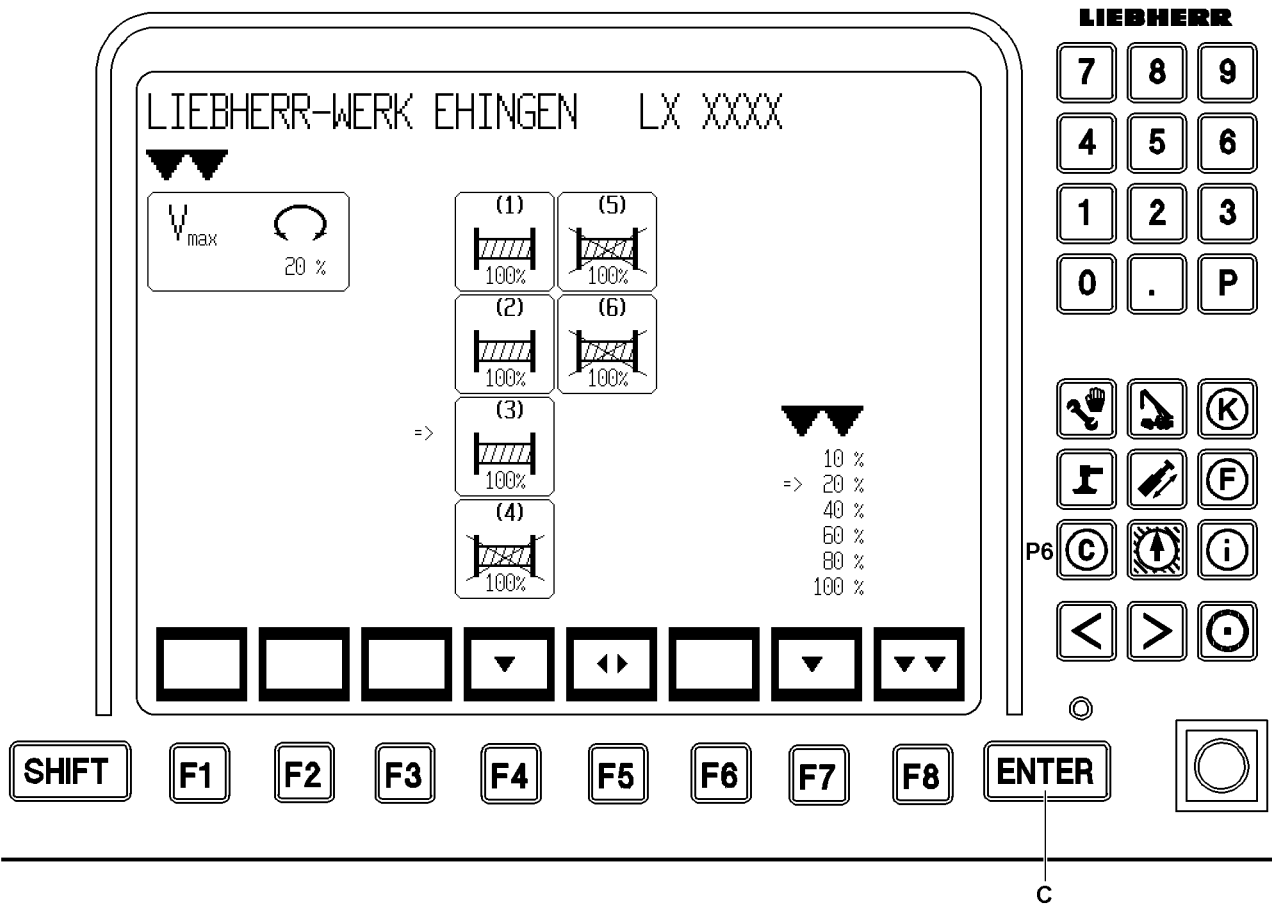

B112327

8.4.2 Activating / deactivating individual winches

In order to prevent unintentional activation of a winch that is currently not required, deactivate individual winches.

- ▶ Using the special function key **E1** or special function key **E2**, select the icon group “Winches” **4**.

Result:

- Selector (double arrow down) **2** appears above the icon group “Winches” **4**.

- ▶ With the function key **F4**, select the icon for “Winch 1”, or “Winch 2”, or “Winch 3” *, or “Winch 4”, or “Winch 5”, * or “Winch 6” *.

Result:

- Selector (arrow to right) **4.7** shows the selected winch.

- ▶ Using the function key **F5**, activate or deactivate the selected winch.

Result:

- The winch icon in the icon changes the appearance.
 - Winch icon not crossed out = winch activated **4.9.1**.
 - Winch icon crossed out = winch deactivated **4.9.2**.

8.5 Switching back to the crane operation program

- ▶ Press the function key **F8**.

Result:

- The parameters previously confirmed with the ENTER key **C** will be taken over into the control.

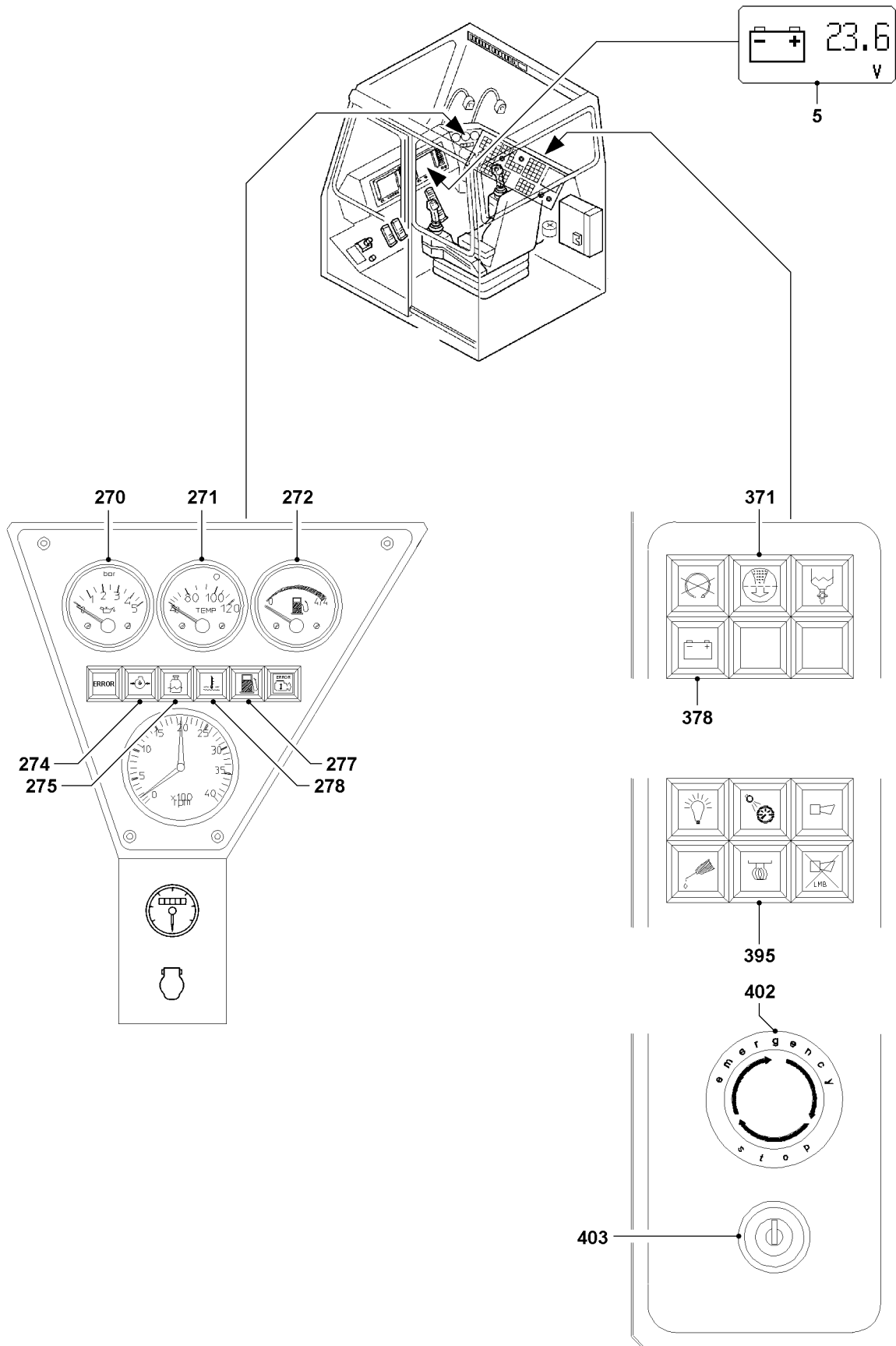

B104618

1 Checks before start up

Various checks must be performed before operating the crane.

1.1 Checking the oil level and filters

- ▶ Check the oil level on the engine.
- ▶ Check the oil level in the hydraulic tank.
- ▶ Check the filter on the hydraulic tank.

1.2 Checking the fuel level



Note

Bleed the fuel system!

If the fuel tank has been run dry, then the fuel system must be bled!

- ▶ Do not run the fuel tank dry!

The tank contents is shown on the fuel gauge **272** in the “instrument panel, on the right front”.

- ▶ Check the tank contents on the fuel gauge **272** and add diesel fuel, if necessary.
- ▶ If the warning light **277** lights up, then the fuel level in the tank is too low:
Add diesel fuel.

1.3 Checking the coolant level



WARNING

Danger of injury due to scalding of the skin!

- ▶ Check the coolant level only when the engine is cold!

The coolant expansion tank must be filled up to overflow on the filler neck.

- ▶ Check the coolant level.

1.4 Checking the battery voltage



Note

The battery voltage must be checked in regular intervals, especially if the crane has been “out of service” for a longer period of time and users, such as the airplane warning lights - must be checked and the battery must be recharged if necessary!

- ▶ Recharge the battery, see Crane operating instructions, chapter 7.05!



Note

Reduced battery performance requires greater power requirements!

- ▶ Ensure that batteries are well charged, particularly during the colder months!

- ▶ Check the battery voltage, see icon 5.

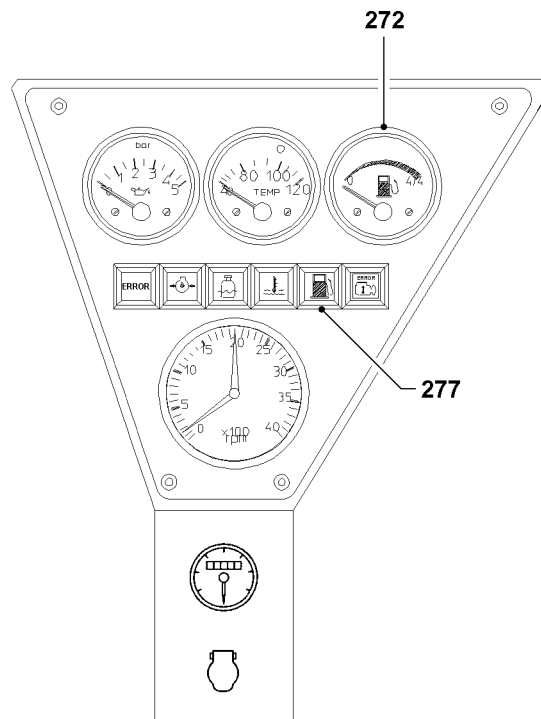
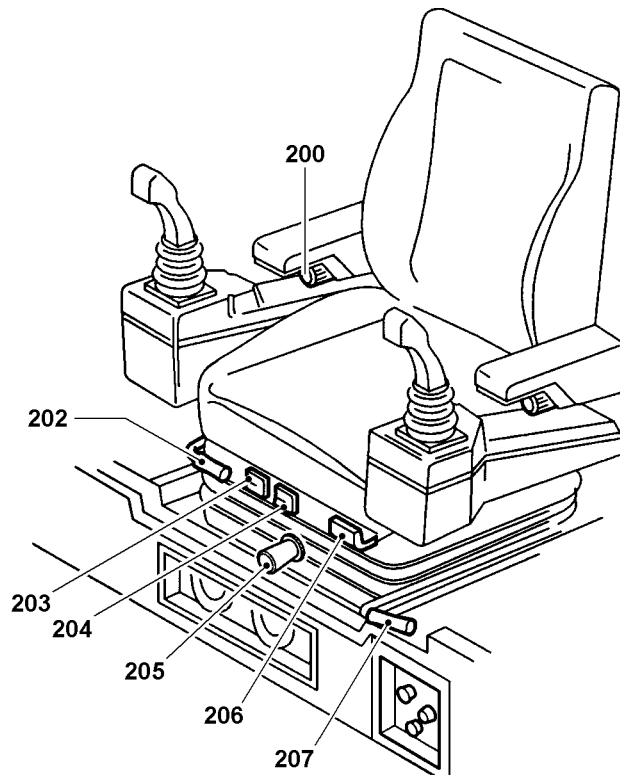

1.5 Checking the central lubrication system

The grease container must always be filled with grease as specified in the lubrication chart, see Crane operating instructions, chapter 7.07.

- ▶ Check the grease container.

1.6 Checking the general condition of the crane



DANGER

Danger of fatal injuries due to falling parts!

Loose parts on the boom can fall when the boom system is erected and kill or severely injure personnel!

- ▶ Before erecting the boom system, check to ensure that there are no loose parts on the boom system - such as pins, spring retainers or ice!

- ▶ Check if the crane is level.
- ▶ Check that the gear ring of the slewing ring connection is clean and greased.
- ▶ Check if the air supply to the oil and water cooler is clear.
- ▶ Check if the side covers are closed and locked.
- ▶ Ensure that there are no people or objects within the danger zone of the crane.
- ▶ Make sure that the cable / rope drum and the limit switches are free of snow and ice.
- ▶ Make sure that there are no loose parts on the superstructure and on the boom.

2 Crane operator's cab

2.1 Adjusting the crane operator's seat

The crane operator's seat can be adjusted to suit different body sizes.

- ▶ Adjust the incline of the armrests with the knob **200**.
- ▶ Adjust the incline of the seat surface with the manual lever **202**.
- ▶ Button **203** to adjust lumbar support in lower part of backrest.
- ▶ Button **204** to adjust lumbar support in upper part of backrest.
- ▶ Adjust the seat suspension to suit the body weight with the knob **205**.
- ▶ Adjust the backrest incline with the manual lever **206**.
- ▶ Adjust the horizontal seat adjustment with the manual lever **207**.

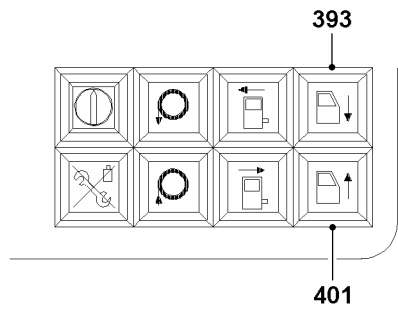
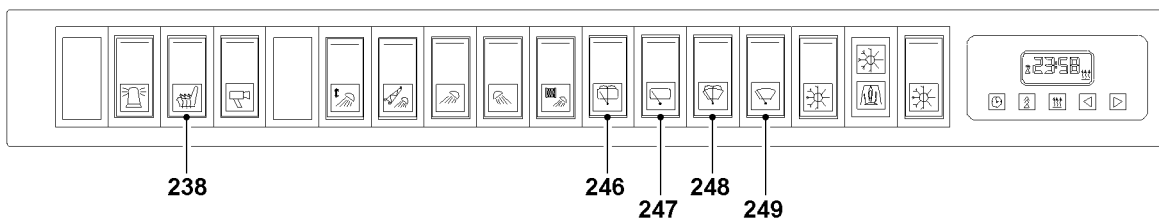

2.2 Turn the seat heater* on

- ▶ Actuate the switch **238** in the roof console.

Result:

- The crane operator's seat is heated.

2.3 Turning the heater / ventilation on

The cab can be heated or ventilated to the desired temperature. For a detailed description see Crane operating instructions, chapter 6.01.

2.4 Tilting the crane operator's cab

To provide a better field of vision for the crane operator during crane operation, the crane operator's cab can be tilted upward.



CAUTION

Danger of property damage!

When the crane operator's cab is tilted, the cab door moves back faster to the stop when it is opened and can be damaged!

- ▶ To open, hold the cab door by the handle and open it slowly!
-

After completion of working with the crane, return the crane operator's cab to horizontal position.

2.4.1 Tilting the crane operator's cab “up”

- ▶ Press the button **401** on the instrument panel “on the right”.

Result:

- Crane operator's cab moves upward.

2.4.2 Tilting the crane operator's cab “down”

- ▶ Press the button **393** on the instrument panel “on the right”.

Result:

- Crane operator's cab swivels downward.

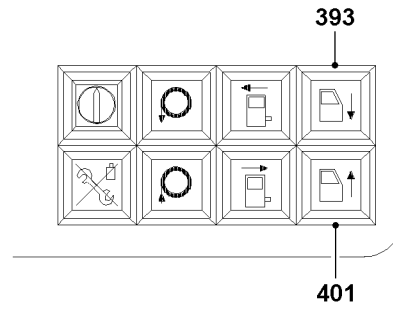
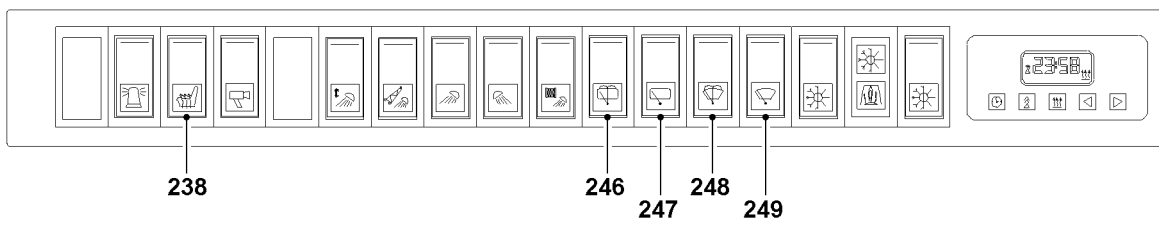

2.5 Operating the windshield wiper / windshield washer system

2.5.1 Operating the windshield wiper

The windshield wipers on the front and roof window can be actuated with the 2-stage switch:

- Switch position I: Intermittent
- Switch position II: Wipe
- ▶ To activate the windshield wiper on the front window:
Actuate the switch **249**.

or

To activate the windshield wiper on the roof window:

- Actuate the switch **247**.

2.5.2 Operating the windshield washer system

The windshield wipers on the front and roof windows can be assisted by a windshield washer system.



Note

- ▶ Before the start of the cold season, fill the container for the window washer fluid with standard antifreeze mix!

-
- ▶ To activate the windshield washer system for the front window:
Press the button **248**.

or

To activate the windshield washer system for the roof window:

- Press the button **246**.

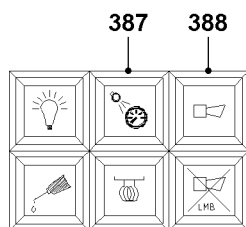

2.6 Opening the front window



WARNING

Danger of injuring hands if they become trapped!

- ▶ Be careful with your hands when closing the front window!

A pair of nitrogen gas cylinders provide help to lift the front window.

- ▶ To open from inside, just press on the front window.

or

If you only want to partly open the window:

- Use the attached strap to set the desired opening angle.

2.7 Checking the horn



Note

Use of horn!

- ▶ Use the horn only in dangerous situations to maintain its warning effect!

Before starting work, check that the horn is functioning.

- ▶ Press the button **388**.

2.8 Turning the instrument panel illumination on / off

- ▶ Actuate the switch **387**.

Result:

- The instrument panel illumination is turned on.

- ▶ When the instrument panel illumination is turned on:
Actuate the switch **387**.

Result:

- The instrument panel illumination is turned off.

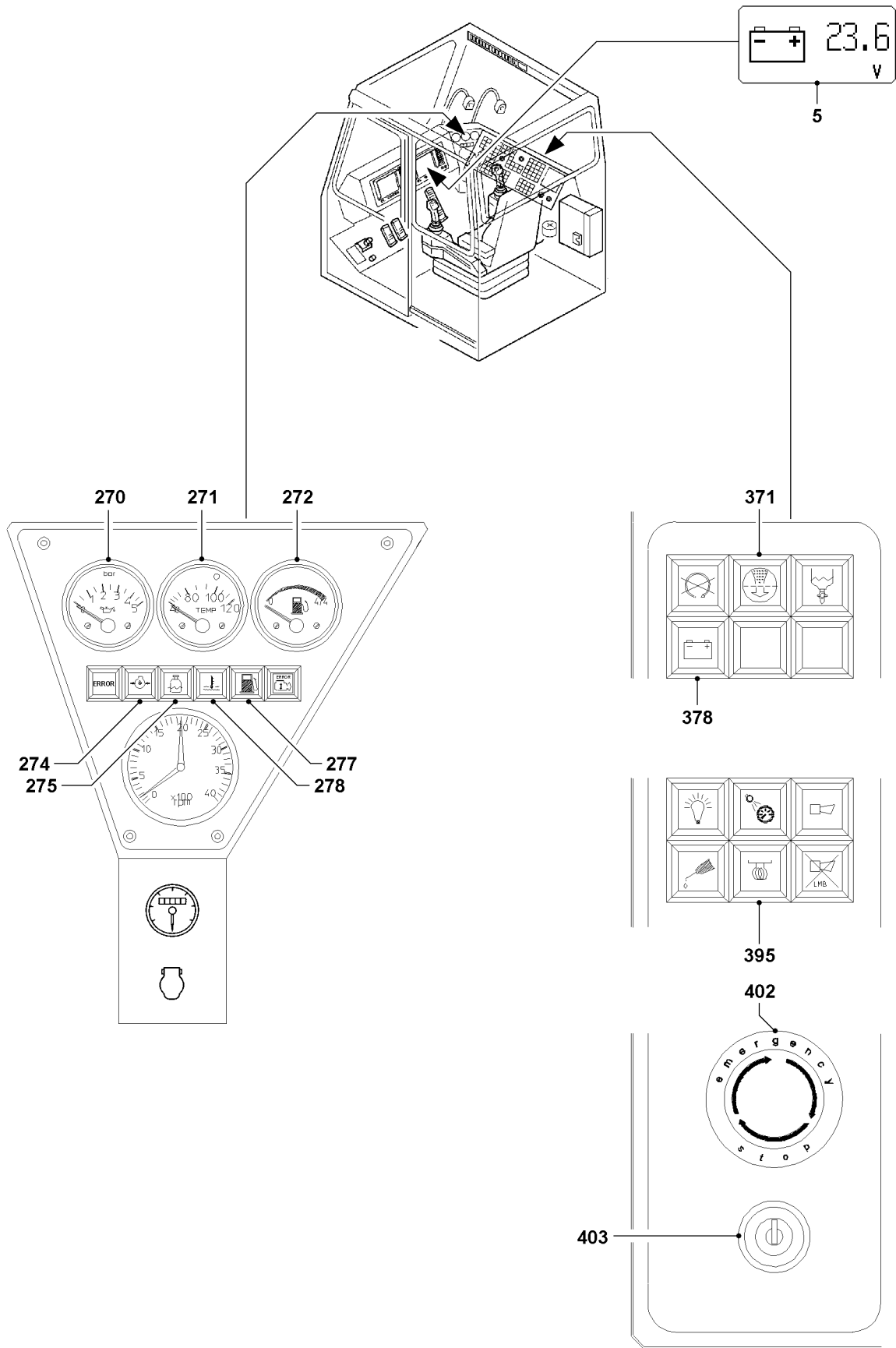

B104618

3 Starting and stopping the engine

The engine must be operated according to the separately supplied Engine operating instructions. Make sure that the following prerequisite is met:

- The battery master switch is turned on.

3.1 Starting the engine

- ▶ Turn the ignition switch **403** to position "I".

Result:

- The warning light **378** lights up.
- The indicator light **395** blinks.
The engine is ready to start.



CAUTION

Danger of property damage!

- ▶ Start the engine only when the warning light **378** lights up and the indicator light **395** blinks!

-
- ▶ Turn the ignition switch **403** to position "II".
 - ▶ Start the engine.

Troubleshooting

The engine does not start after a maximum of 10 seconds.

- ▶ Wait for 1 minute. The starter can be operated three times for 10 seconds per attempt with a pause in between of one minute each time.

-
- ▶ Check the instruments after starting the engine.

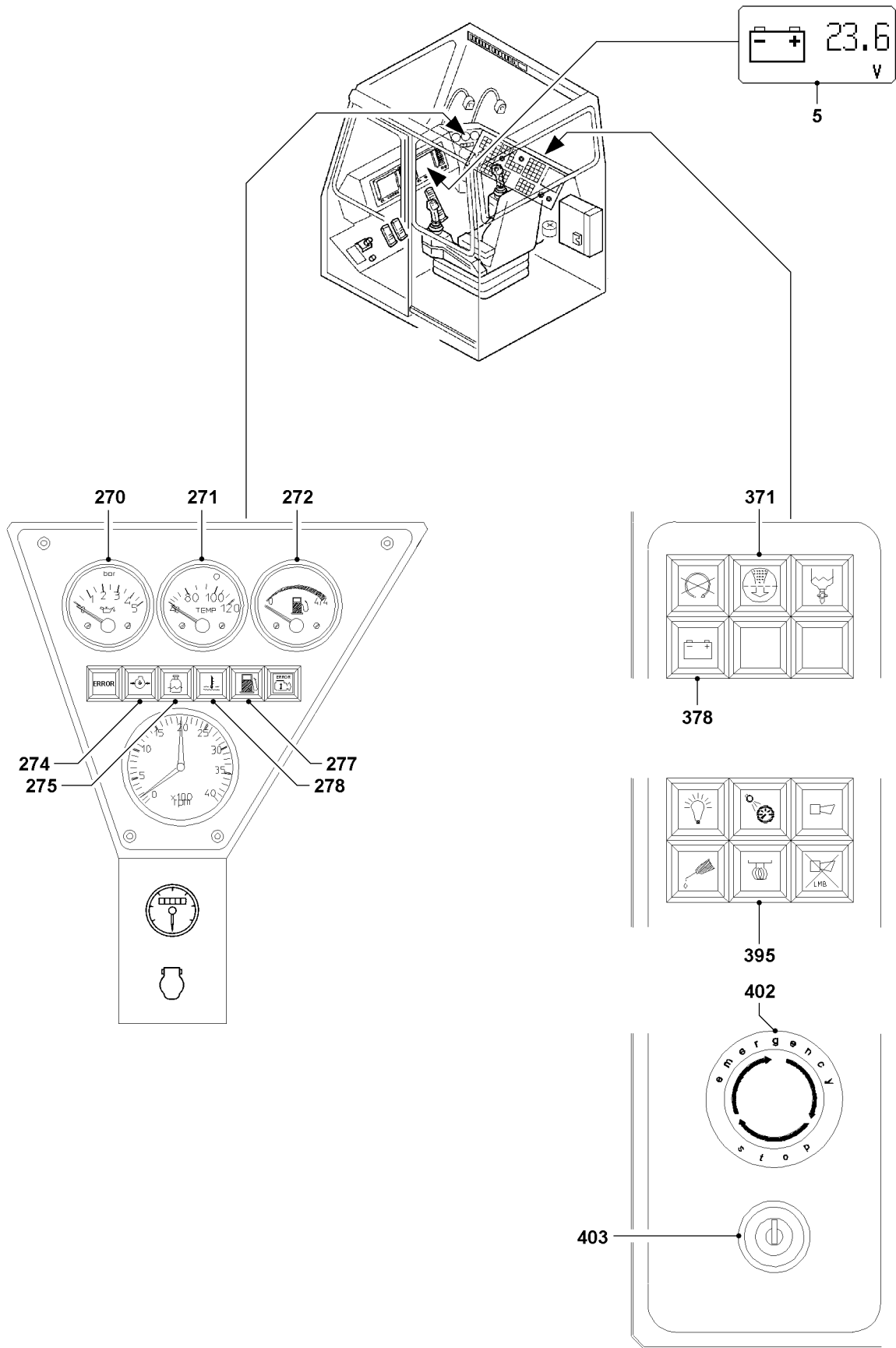

B104618

3.2 Starting the engine with heat flange control

To improve the cold start procedure, the engine is equipped with a heat flange. The heat flange control turns on at a coolant temperature below 10 °C. The heat flange control is also activated automatically at a coolant temperature above 25 °C and a charge air temperature of less than -10 °C. This turn on condition is required for a warm engine and very cold air.

When the engine is started with heat flange control, the idling speed is automatically increased to assist the battery.



WARNING

Functionality of the battery in the cold season!

The starting capacity of the battery is considerably reduced in cold temperatures: For example, at a temperature of -10 °C, the battery is at only 66 % of its normal capacity!

▶ Once the engine has been turned off, store batteries in a heated room, if possible!

▶ Turn the ignition switch **403** to position "I".

Result:

– The indicator light **395** lights up first and then starts to blink after a short time.
The engine is ready to start.

▶ Turn the ignition switch **403** to position "II".

▶ Start the engine.

Troubleshooting

Is the control light **395** flashing rapidly?

The control unit has identified a defect on the heat flange system.

▶ Remedy the problem.

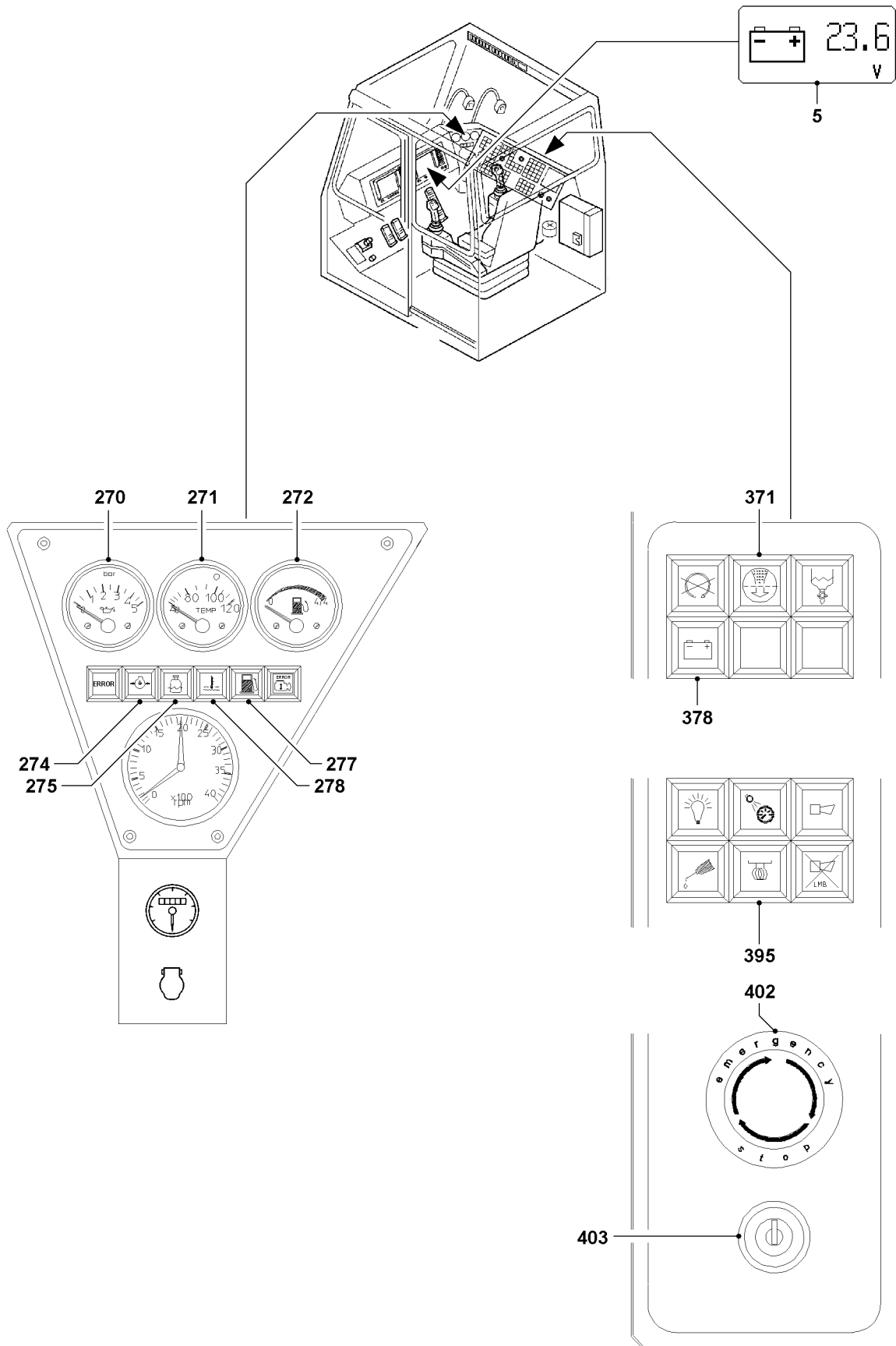

B104618

3.3 Checking the instruments after starting the engine

As soon as a stable voltage is present with the engine running, the electric crane control and the LICCON computer system are turned on automatically. A self-test of the microprocessor system follows and after a few seconds the set up screen appears on the monitor.

The following icons must turn off when the engine is running:

- Warning light **274** “Oil pressure diesel engine”
- Warning light **378** “Charge control”
- Indicator light **395** “Preheat engine / heat flange”

3.3.1 Checking the oil pressure - Diesel engine

- ▶ Check the oil pressure on the oil pressure display **270**.

Troubleshooting

The warning light **274** “Oil pressure diesel engine” does not turn off or lights up during crane operation?

The engine oil pressure is too low. The engine can be damaged as a result of insufficient oil pressure.

- ▶ Turn the engine off immediately and determine the cause.
-

3.3.2 Checking the coolant temperature

- ▶ Check the coolant temperature on the temperature display **271**.

Troubleshooting

The warning light **278** “Coolant temperature too high” lights up during crane operation?

The coolant temperature is too high. Excessive coolant temperature can lead to engine damage.

- ▶ Turn the engine off immediately.
-

3.3.3 Checking the tank contents

- ▶ Check the fuel gauge **272** “Tank contents”.

3.3.4 Checking the coolant level

- ▶ Check the warning light **275** “Coolant level too low”.

3.3.5 Checking the air filter

- ▶ Check the warning light **371** “Air filter dirty”.

3.3.6 Checking the battery voltage

- ▶ Check the “Battery voltage” icon **5** in the operating screen (monitored auxiliary functions) of the LICCON monitor 0, see Crane operating instructions, chapter 4.02.

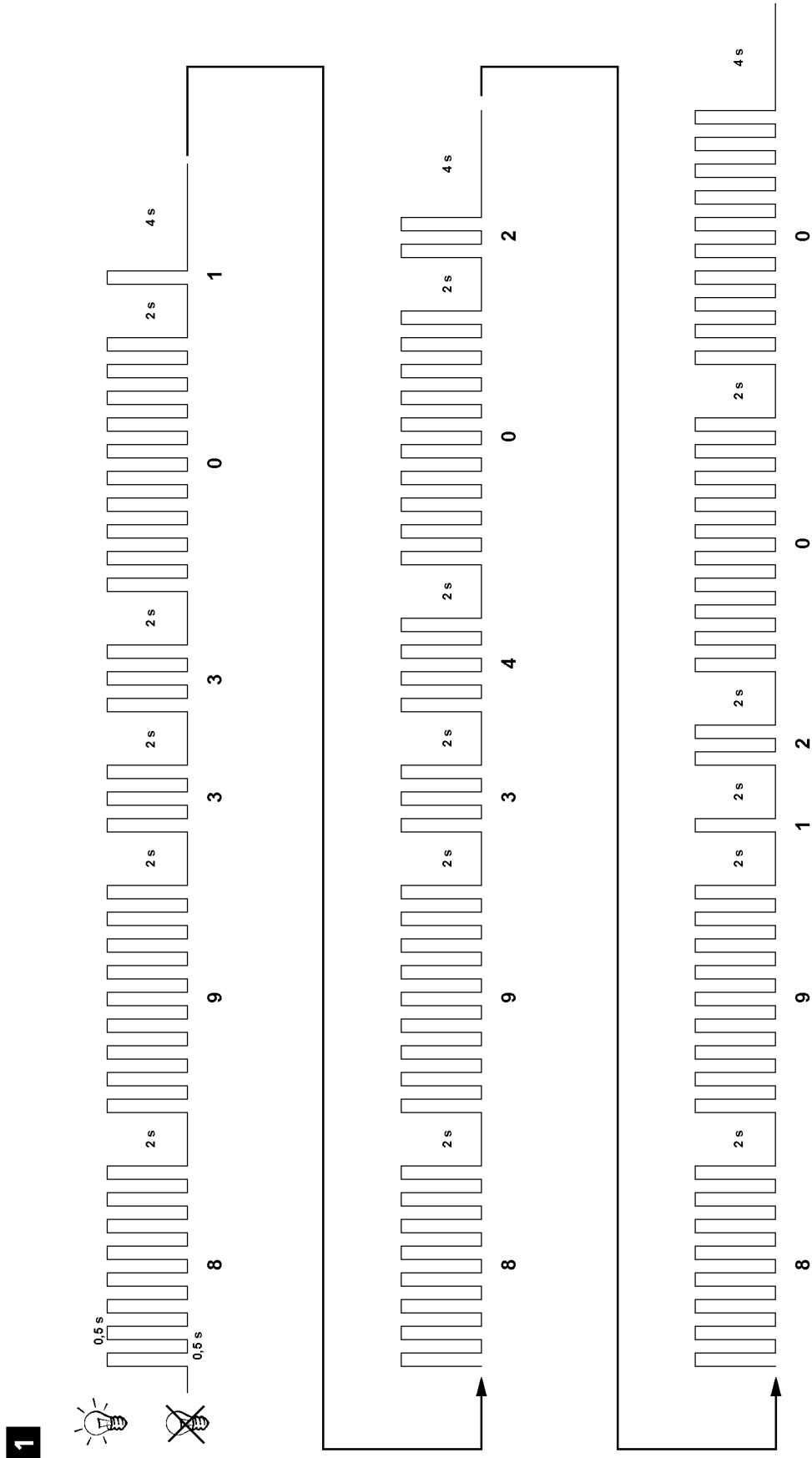

B104695

3.4 Engine monitoring

If an engine error is present, the error can be read out with the aid of a blinker code on the warning light **276**. The blinker code must be noted and checked in the separate error code chart (LICCON ERROR CODE), where the error is documented.

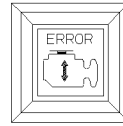

Warning light 276 "Engine error"

- ▶ Read the blinker code on the warning light **276**.

Design of blinker code

- Every number is shown with a blinker sequence in 0.5 second cycles. The number of blinker signs results in the value of the number, see illustration **1**.



Note

- ▶ The number **0** is shown with **10** blinker signs!
-
- There is a 2 second break between every number.
 - A break of 4 seconds is made after every error.
 - After all errors are shown, it starts again with the first error.
- ▶ Note the blinker code and check in the separate error code chart (LEC).

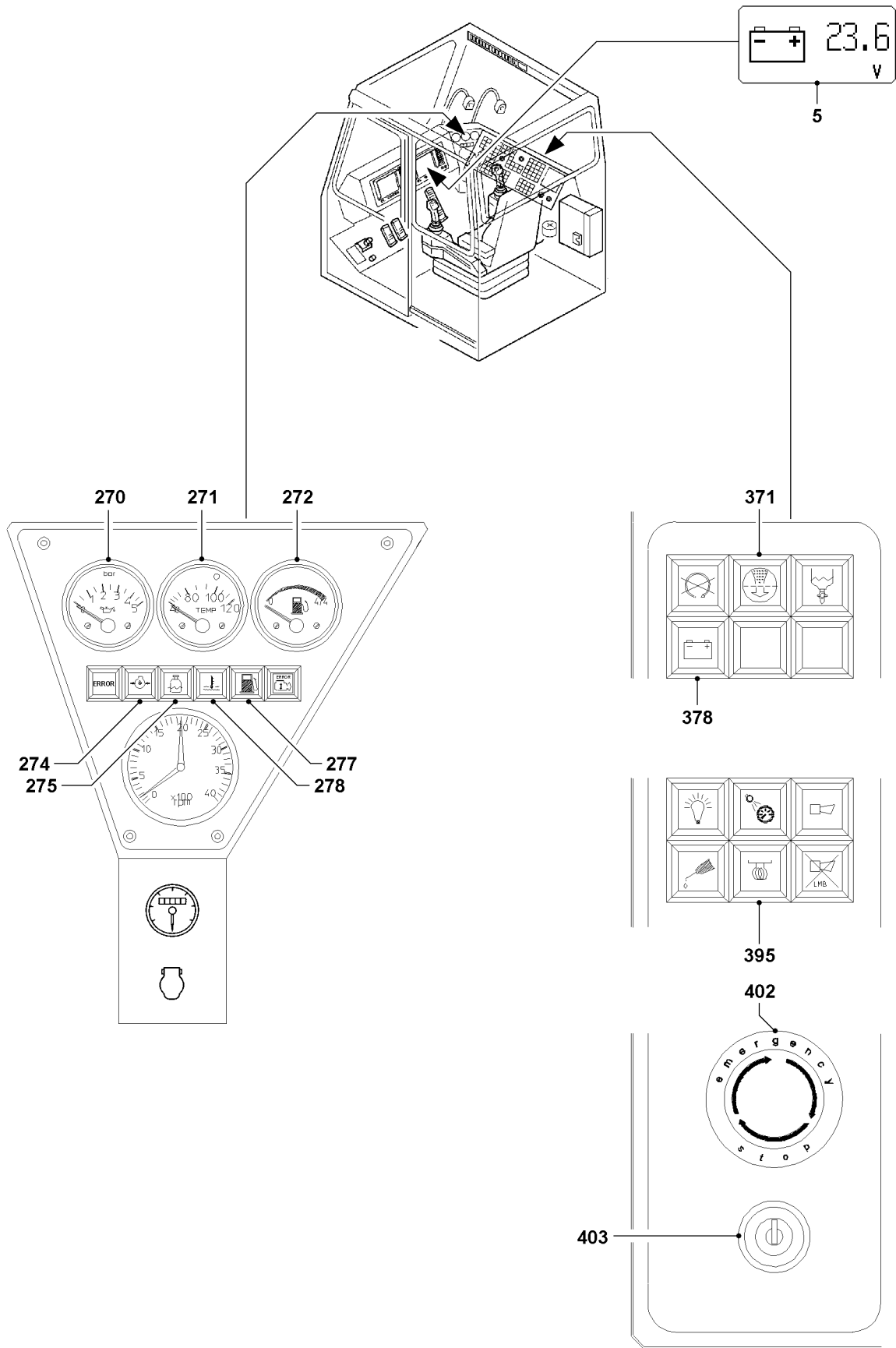

B104618

3.5 Turning the engine off

3.5.1 Turning the engine off

After operation at full engine output or with very high coolant temperature (above 95 °C), let the engine run without load for 1 - 2 minutes at low idle speed.

- ▶ Turn the ignition switch **403** back to the stop.
- ▶ Pull the ignition key and store it in a safe place.

3.5.2 Turning the engine off in the event of danger



CAUTION

Operation of the emergency off switch!

- ▶ Use the emergency off switch **402** only in absolute emergency situations!
 - ▶ Use of the emergency off switch **402** for normal operation is not permitted!
-

- ▶ Press the emergency off switch **402**.

Result:

- The crane will be turned off immediately.

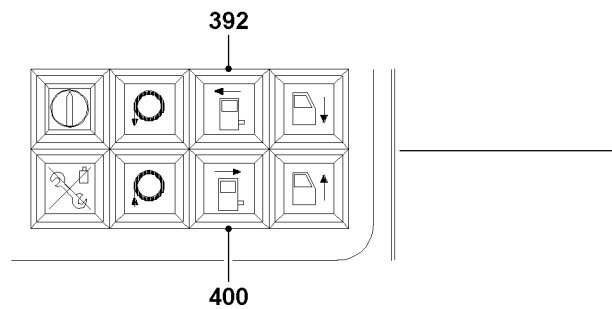
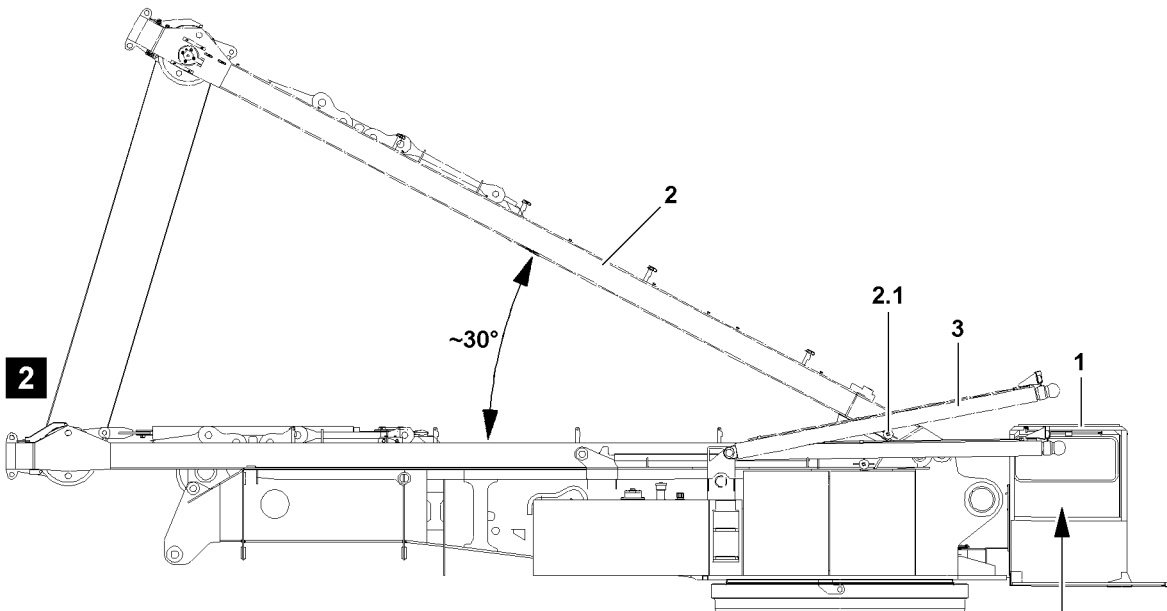
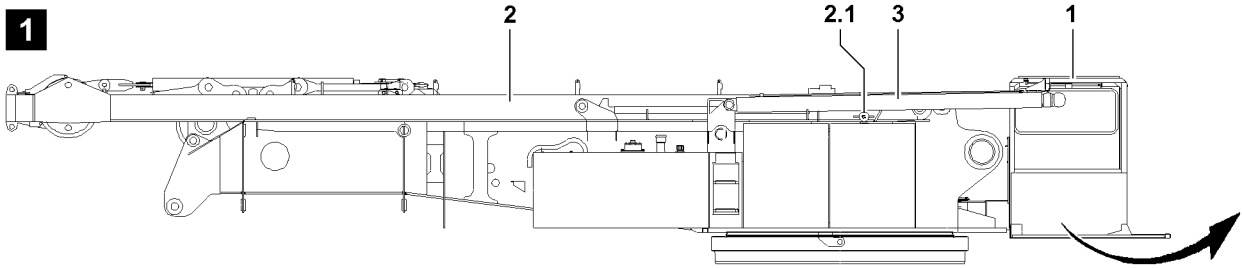

4 Swinging the crane operator's cab into operating / transport position

When in transport position, the crane operator's cab is in front of the turntable.

NOTICE

Damage to the crane operator's cab!

When the crane operator's cab is moved out at start up from transport to operating position, the crane operator's cab as well as the S-relapse cylinders **3** can be damaged severely!

When the crane operator's cab is moved in at shut down from operating to transport position, the crane operator's cab as well as the S-relapse cylinders **3** can be damaged severely!

- ▶ The crane operator's cab may only be swung out into operating position if the S-relapse cylinders **3** have been extended past the crane operator's cab, see illustration **2**!
- ▶ The crane operator's cab may only be swung into transport position if the S-relapse cylinders **3** have been extended past the crane operator's cab, see illustration **2**!
- ▶ The SA-frame must be erected to approx. 30° before swinging the crane operator's cab out of in!

Make sure that the following prerequisites are met:

- The crane is aligned in horizontal direction.
- The engine is running.

4.1 Erecting the SA-frame



Note

- ▶ See Crane operating instructions, chapter 3.01 and chapter 5.02!

- ▶ Move the ball valve **4** downward into operating position.

Result:

- The SA-frame **2** is pushed upward by the erection cylinder until the ropes are tensioned between the SA-frame and the turntable - pulley block.
- ▶ When the SA-frame **2** is erected to approx. 30°:
Move the ball valve **4** into operating position "STOP".

4.2 Swinging the crane operator's cab out into operating position

- ▶ When the SA-frame **2** has been erected to approx. 30° and the S-relapse cylinders **3** are above the crane operator's cab:
Press the button **392** and "hold".

Result:

- The crane operator's cab is swung out.
- ▶ When the end position "swung out" is reached:
Release the button **392**.

4.3 Swinging the crane operator's cab in into transport position



CAUTION

Damage to the crane operator's cab!

Disassemble the central ballast before swinging the crane operator's cab in into transport position, otherwise the crane operator's cab can be damaged!

- ▶ Remove the central ballast before swinging the crane operator's cab in!

- ▶ When the SA-frame **2** has been erected to approx. 30° and the S-relapse cylinders **3** are above the crane operator's cab:
Press the button **400** and "hold".

Result:

- The crane operator's cab is swung in.

- ▶ When the end position "swung in" is reached:
Release the button **400**.

blank page!

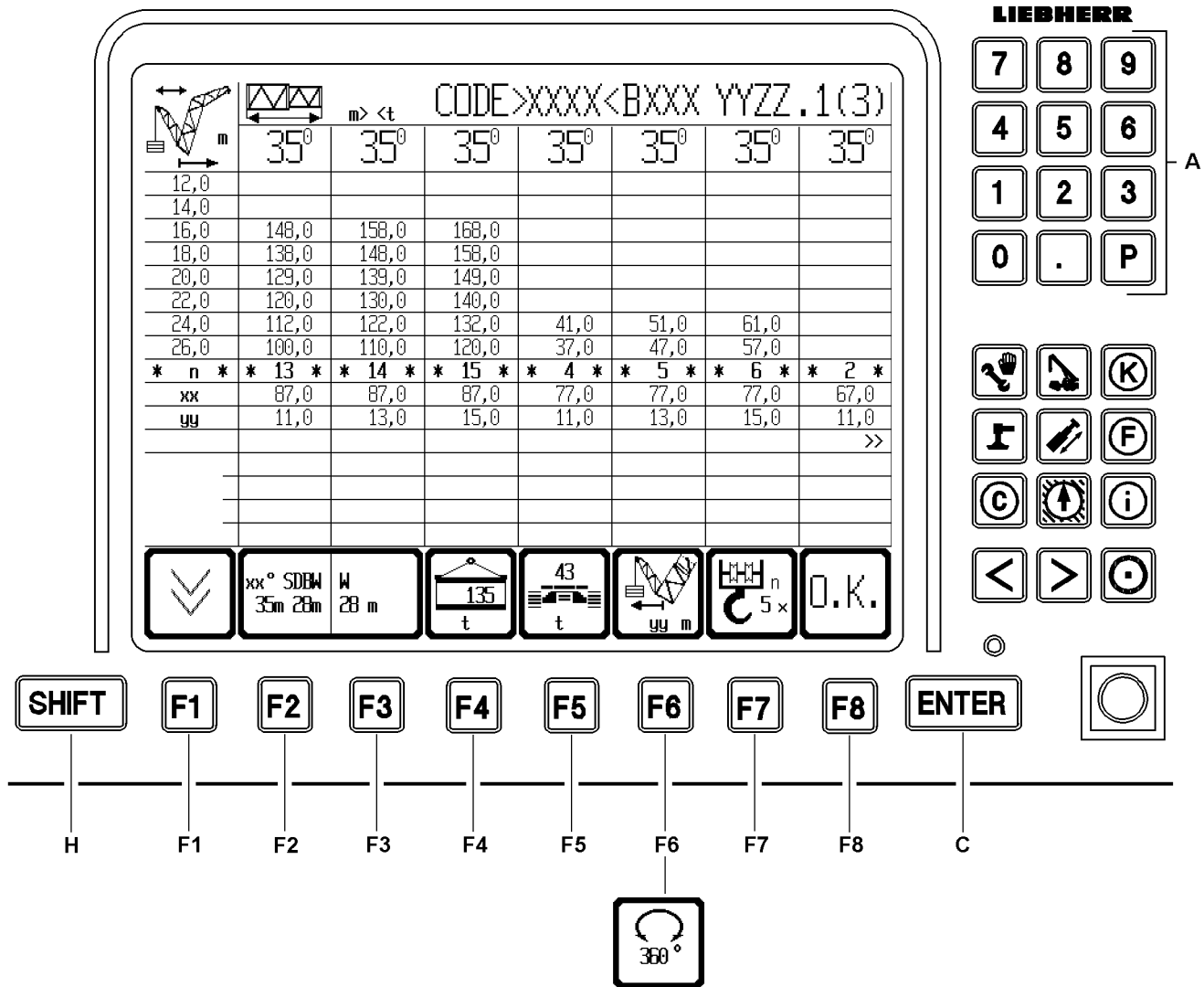

5 LICCON computer system after engine start

The LICCON computer system is only operational with the engine running.

5.1 Waiting for the boot up phase

After being turned on, the LICCON computer system boots up and carries out a self-test, see Crane operating instructions, chapter 4.02.

► Wait for the boot up phase.

Result:

- The operating mode preselection appears on the LICCON monitor, see Crane operating instructions, chapter 4.02.
- The set up screen appears on the LICCON monitor.

Normally, the most recently set configuration state and reeving number will be displayed.

If a master switch is moved away from the zero position during the boot up phase, the function circuit of the electrical safety chain is interrupted.

► In this case:
Turn the engine and the ignition off and restart.

Troubleshooting

An error message appears on the LICCON monitor?

- Turn the engine and the ignition off and restart.
 - The LICCON computer system automatically displays the troubleshooting display.
-

Troubleshooting

The LICCON monitor does not show the most recently set set up configuration and reeving number? If there has been a data loss in the memory (cold start), then the first valid set up configuration appears in the set up screen. The reeving number is set to "0".

► Set the set up configuration and reeving number again.

5.2 Taking over the previously selected set up configuration and hoist rope reeving

Check in the operating screen if the correct short code and the correct reeving number have been set, see Crane operating instructions, chapter 4.02.

► If the settings on the operating screen are correct:
Press function key.

Result:

- The "set up" program is terminated and the adjusted parameters are accepted for the newly started "Crane operation" program.

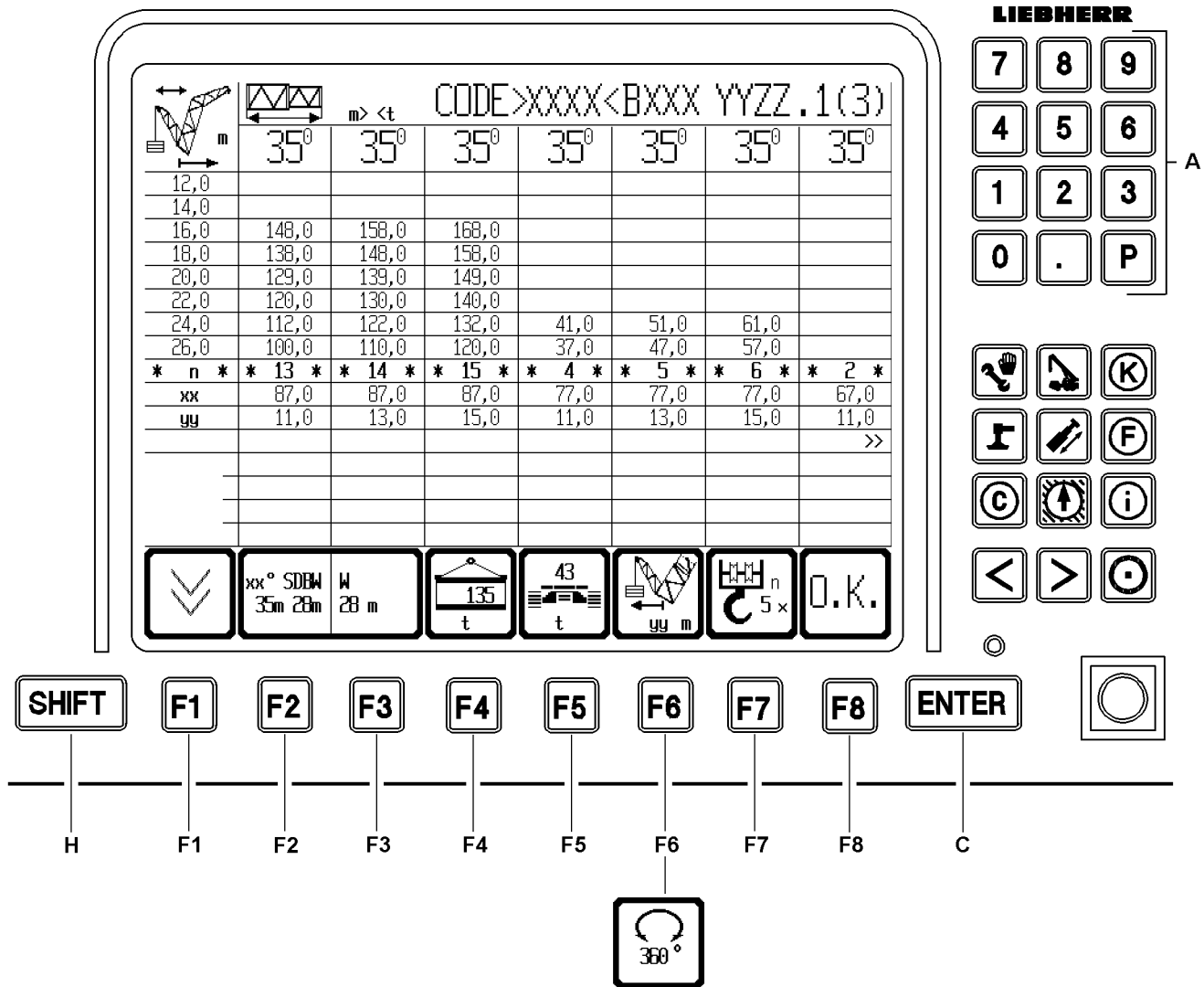

5.3 Setting a new set up configuration and new hoist rope reeving

The selected and displayed set up configuration can be changed with the function keys or by entering the short code.

5.3.1 Setting a new set up configuration with the function keys

- ▶ Press the function key **F2** until the desired main geometry status is selected.
- ▶ Press the function key **F3** until the desired accessory status is selected.
- ▶ Press the function key **F4** until the desired counterweight is selected.
- ▶ Press the function key **F5** until the desired central ballast is selected.
- ▶ Press the function key **F6** until the desired slewing range is selected for crane operation **without** derrick ballast.
- ▶ Press the function key **F6** until the desired derrick ballast range is selected for cranes **with** variable derrick ballast.
- ▶ Press the **ENTER C** key.
- ▶ Check the set load chart.

5.3.2 Setting a new set up configuration with short code

Take the short code from the load chart.

- ▶ Enter the 4-digit short code via the keyboard **A**.
- ▶ Confirm the entry with the **ENTER C** key.

Result:

- The data of the selected load chart can be viewed.

For a more detailed description of the “Configuration” program, see Crane operating instructions, chapter 4.02.

- ▶ Check the set load chart.

5.3.3 Setting a new hoist rope reeving

- ▶ Press the function key **F7** until the desired reeving number is selected.

or

- Press function keys **SHIFT** and **F7** until the desired reeving number is selected.

5.3.4 Checking and accepting the new set up configuration and hoist rope reeving

- ▶ If the settings on the set up screen are correct:
Press the function key **F8**.

Result:

- The “Configuration” program is terminated.
- The set parameters are accepted into the restarted “Crane operation” program.
- ▶ Check in the operating screen if the correct short code and the correct reeving number have been set, see Crane operating instructions, chapter 4.02.

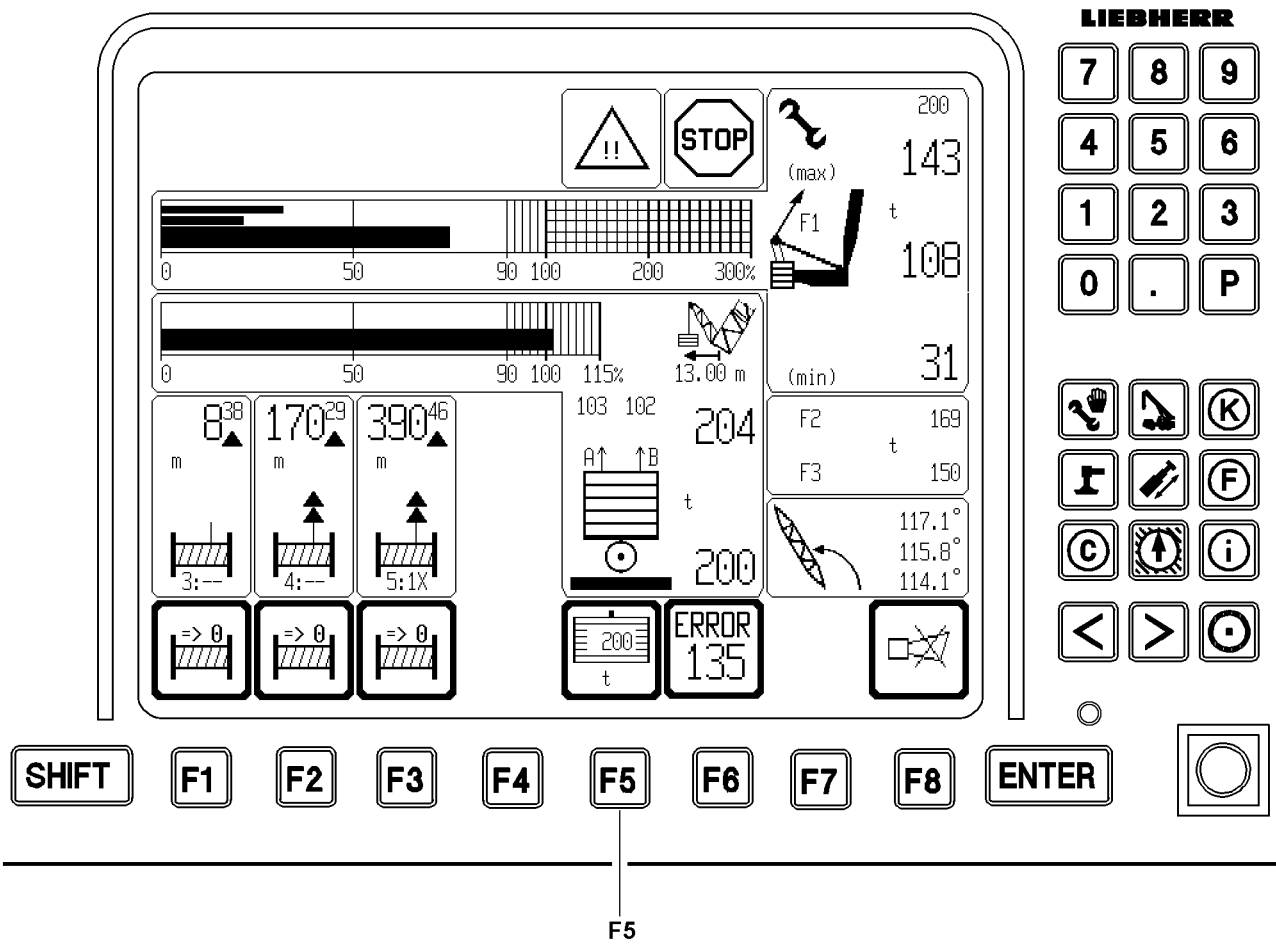

5.4 Setting the control parameters



Note

- ▶ For description to the control parameters and their settings, see Crane operating instructions, chapter 4.02!

5.5 Setting the derrick ballast



Note

- ▶ The entry of the derrick ballast is made on the LICCON monitor 1 with function key **F5**, see Crane operating instructions, chapter 4.02!



CAUTION

Danger of accident due to incorrect derrick weight entry!

- ▶ For operation with derrick ballast, always set the current size of the derrick ballast. This includes the weight of the empty ballast pallet or the empty ballast trailer and the weight of the placed derrick ballast plates!



DANGER

Danger of accident due to incorrect derrick ballast value!

The crane can topple over and personnel can be fatally or seriously injured due to incorrectly edited derrick ballast value!

- ▶ The set derrick ballast value **must** match the actually assembled derrick ballast weight!
- ▶ If a derrick ballast value is set, which is too low, then the derrick ballast utilization display is too large!
- ▶ If a derrick ballast value is set, which is too large, then the derrick ballast utilization display is too small and the ballast utilization dependent safety shut offs of test point 1 (F1min) are ineffective!



Note

- ▶ While the derrick ballast value is edited, the remaining monitor displays cannot be updated. The operating view on the monitor is frozen and can even show incorrect values. Therefore: Complete ballast editing quickly. If a master switch is actuated during ballast editing, then ballast editing is automatically aborted. The old value of the placed derrick ballast (BA_placed) remains in the derrick ballast icon!

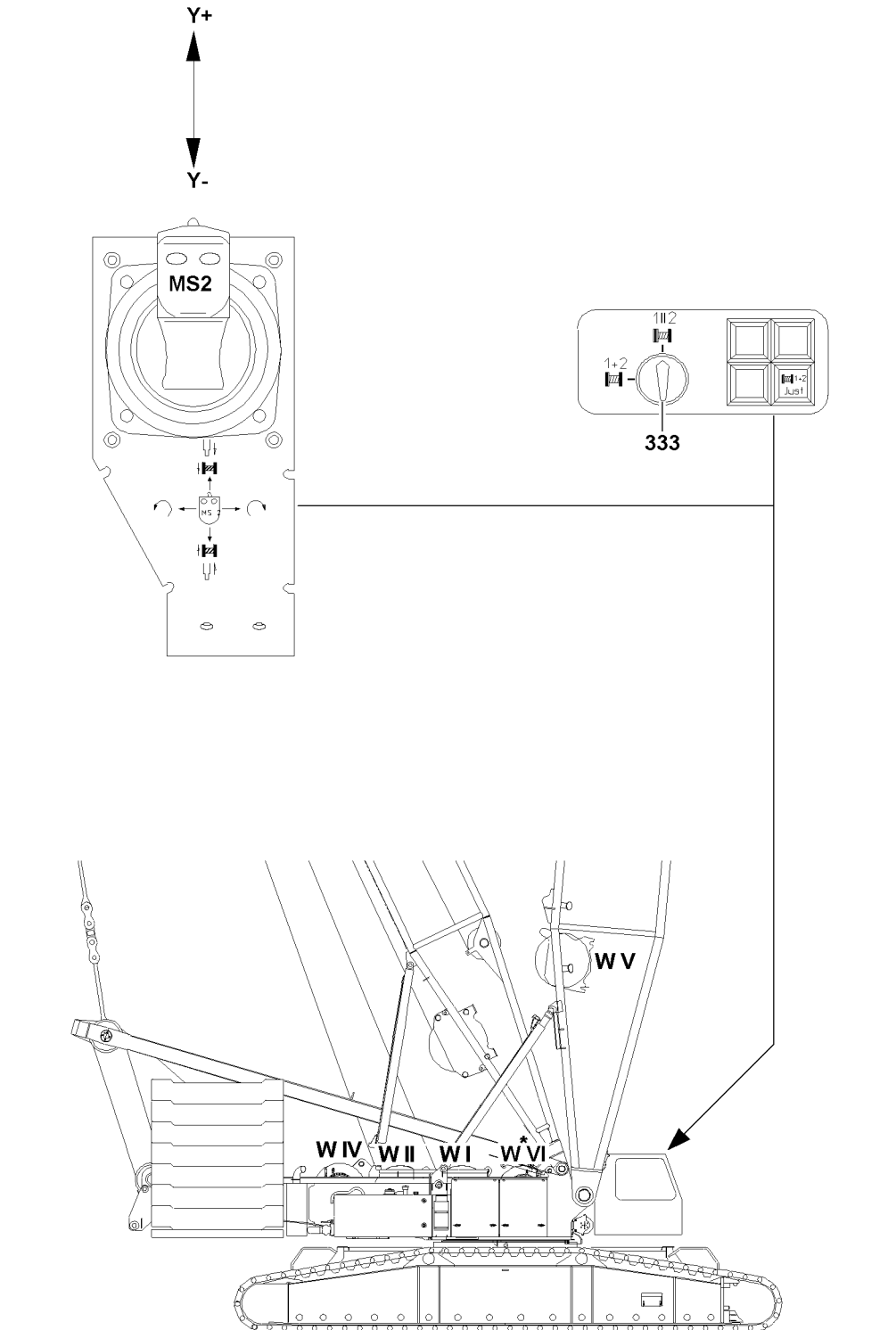

B113205

6 Operating winch 6* with the supply lines of winch 5 (actuation with master switch MS2y)



Note

- ▶ Deviating from the hydraulic standard supply of winch 6* **W VI** via hydraulic pump 4, winch 6* can also be operated with the hydraulic supply lines of winch 5 **W V** (hydraulic pump 5).
-

Make sure that the following prerequisites are met:

- Preselection switch **333** is in switch position 1II 2 (parallel operation winch 1 **W I** and winch 2 **W II**).
- The electric supply lines to winch 5 **W V** are not connected.
- The hydraulic supply lines to winch 5 **W V** are not connected.

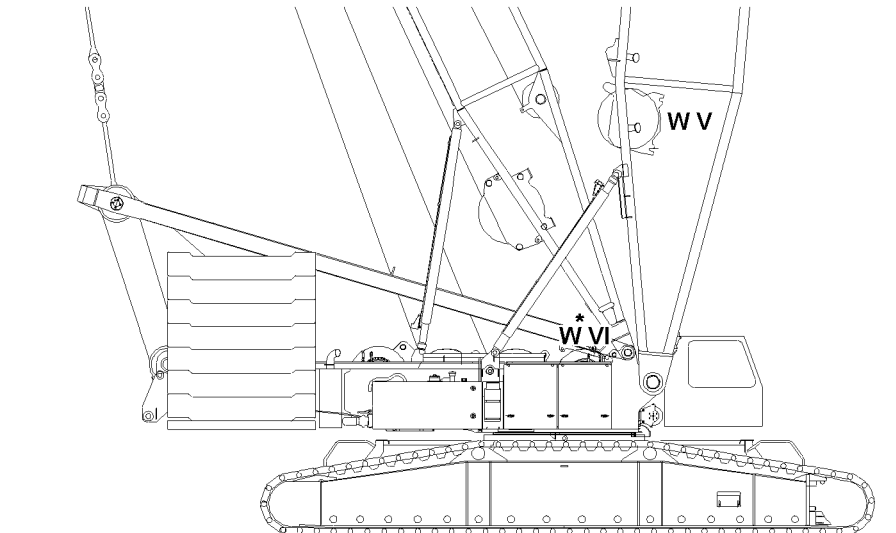
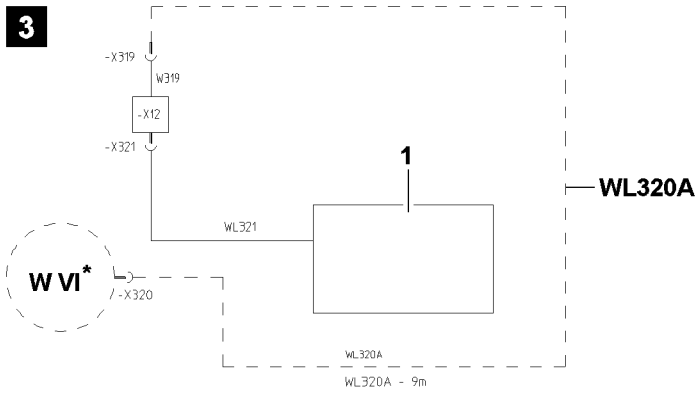
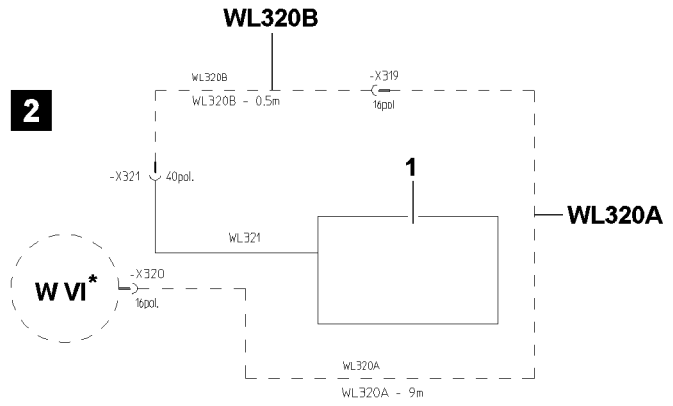
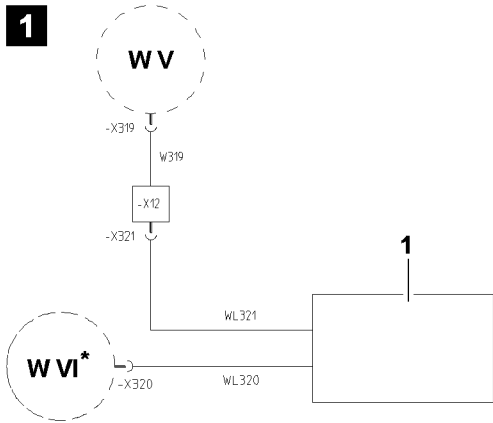

B113203

6.1 Establishing the electrical connections to winch 6*



Note

- ▶ To establish the electrical connections to winch 6* **W VI** use the Electric wiring diagram.

Assignment of switch schematics:

- Illustration 1
 - “Normal status” starting from Switch cabinet Electric 1
- Illustration 2
 - “Assembly status” starting from Switch cabinet Electric 1
- Illustration 3
 - Winch 6* **W VI** connected on the electrical connections of winch 5 **W V**, starting from Switch cabinet Electric 1.

Make sure that the following prerequisites are met:

- Winch 5 **W V** is not present or is not being used.
- The adapter line **W320A** (9 m) is present.
- The adapter line **W320B** (0.5 m) is present.
- ▶ Establish the electrical connections to winch 6* **W VI** according to the Electric wiring diagram.

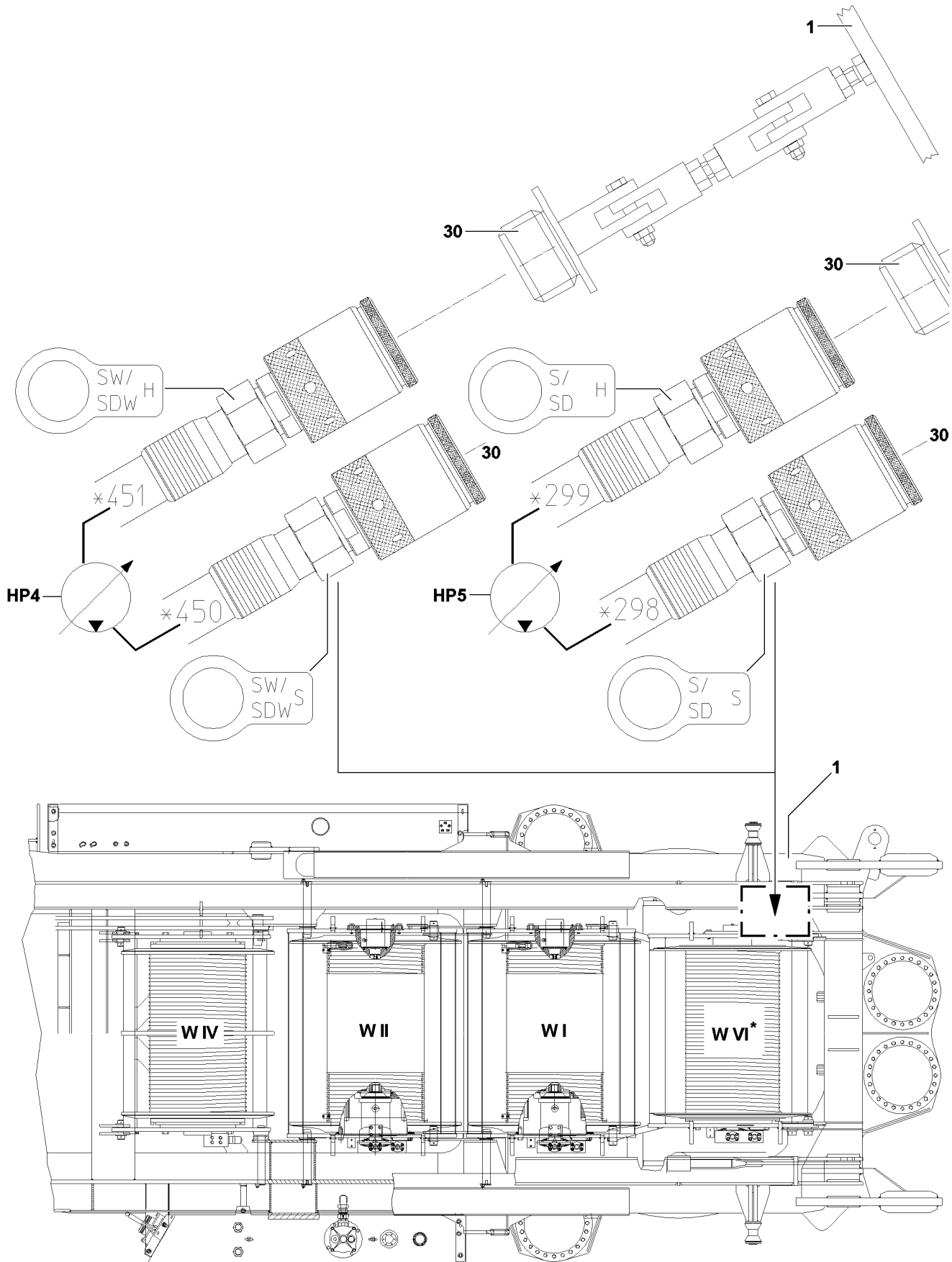

B113204

6.2 Establish the hydraulic connections to winch 6*



Note

- ▶ If winch 6* **W VI** is not installed on the turntable, the hydraulic supply lines (hydraulic line **450** and hydraulic line **451**, **as well as** hydraulic line **298** and hydraulic line **299**) are installed in "Parking position" on the plugs **30** on the turntable **1**.

Winch 6* **W VI**, if present on the crane, is supplied normally with hydraulic oil from the hydraulic pump **4 HP4** via the hydraulic line **450** and the hydraulic line **451**, see Hydraulic diagram.

If winch 6* **W VI** is to be operated with the hydraulic supply lines of winch 5 **W V**, then the hydraulic line **298** and the hydraulic line **299** must be used.

6.2.1 Releasing the hydraulic lines from parking position



WARNING

Pressure in the hydraulic lines!

If the pressure supply is not interrupted before connecting / releasing the hydraulic lines, the hydraulic oil can escape with high pressure!

Personnel can be severely injured or killed!

- ▶ Release the pressure in the hydraulic system before connecting / disconnecting: Interrupt the pressure supply and wait for a short time!

- ▶ Release the pressure in the hydraulic system.

- ▶ Take the hydraulic line **298** and hydraulic line **299** from the "parking position".

6.2.2 Establishing the hydraulic connections

The hydraulic connections are made with quick-release couplings.

When connecting hydraulic lines with quick-release couplings, make sure that the coupling procedure is carried out correctly.



WARNING

Pressure in the hydraulic lines!

If the pressure supply is not interrupted before connecting / releasing the hydraulic lines, the hydraulic oil can escape with high pressure!

Personnel can be severely injured or killed!

- ▶ Release the pressure in the hydraulic system before connecting / disconnecting: Interrupt the pressure supply and wait for a short time!

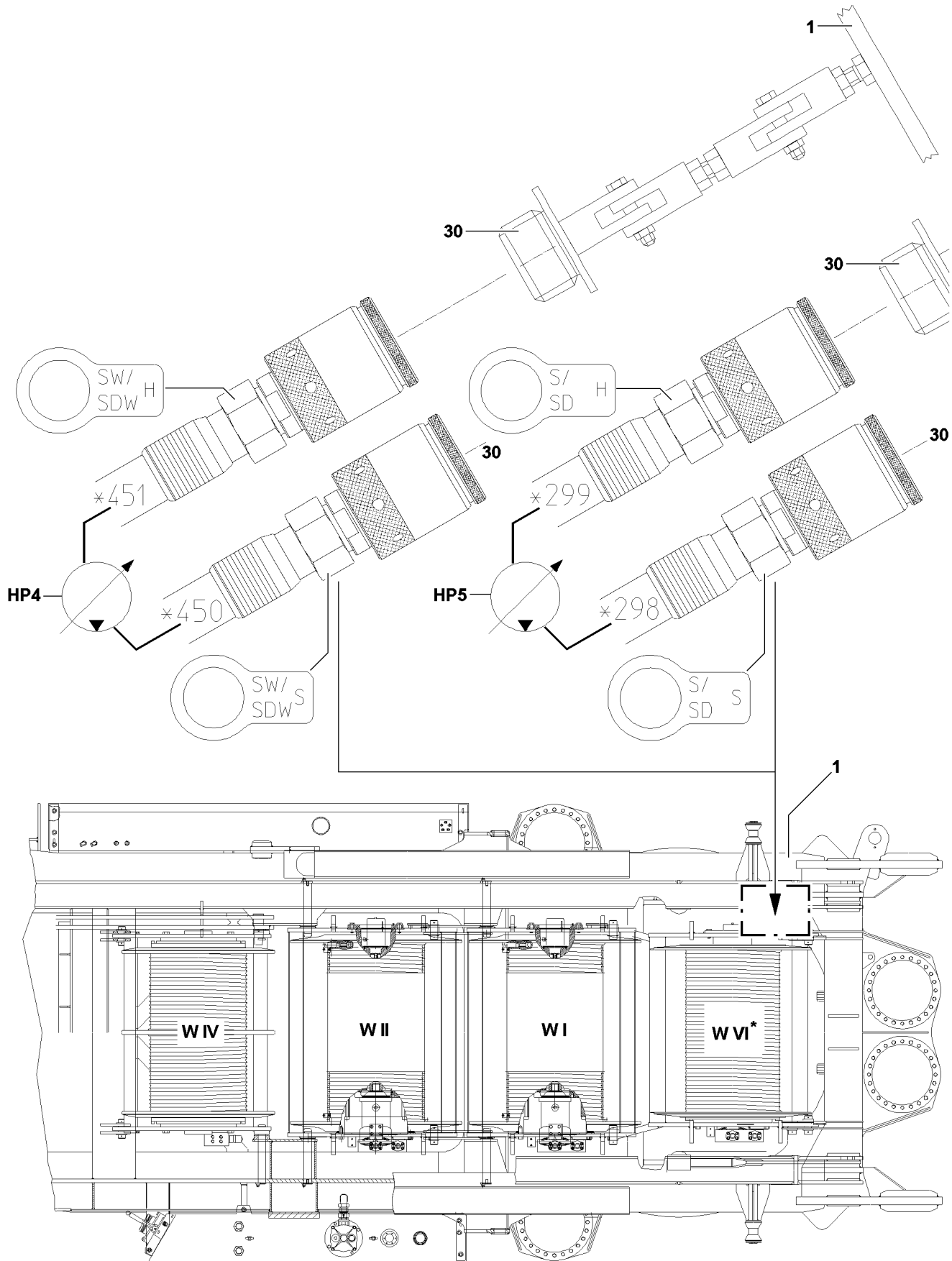

B113204

**WARNING**

Loss of pressure or leakage!

Incorrectly coupled or self-loosening quick-release couplings (particularly return lines) can result in serious accidents due to component failure!

- ▶ Check that the quick-release couplings have been properly connected before using the crane!
- ▶ Assemble coupling components (sleeve and connector) and screw together with the hand-tightened nut, pay attention to the identification of the coupling parts!
- ▶ Tighten hydraulic coupling by hand. Rotate the hand-tightened nut until it reaches a tangible, fixed stop position.
- ▶ Establish the hydraulic connections (hydraulic line **298** and hydraulic line **299**) to winch 6 **W VI**.

Result:

- Winch 6 **W VI** can be operated with the hydraulic supply of winch 5 **W V**.

6.3 Crane operation with winch 6* on the boom nose

Make sure that the following prerequisites are met:

- Depending on the intended operating mode (SW/SDW-operation or S/SD-operation), winch 6 **W VI** is connected with the appropriately marked supply lines on the hydraulic system.
- Depending on the intended operating mode (SW/SDW-operation or S/SD-operation), winch 6 **W VI** is connected on the crane electrical system.
- Preselection switch is in switch position 1|| 2 (parallel operation winch 1 **W I** and winch 2 **W II**).
- The corresponding operating mode is set and confirmed on the LICCON monitor.
- Winch 6 **W VI** is properly reeved in on the boom nose.

6.3.1 Using winch 6* in SW/SDW-operation as hoist winch boom nose

**Note**

- ▶ If winch 6* **W VI** is to be used in SW/SDW-operation, then hydraulic line **450** and hydraulic line **451** must be connected on winch 6* **W VI**.
- ▶ The electrical connections are established accordingly, see Electric wiring diagram.
- ▶ Operation of winch 6 **W VI**, see Crane operating instructions, chapter 4.05.

6.3.2 Using winch 6* in S/SD-operation as hoist winch boom nose

**Note**

- ▶ If winch 6* **W VI** is to be used in S/SD-operation, then hydraulic line **298** and hydraulic line **299** must be connected on winch 6* **W VI**.
- ▶ The electrical connections are established accordingly, see Electric wiring diagram.
- ▶ Operation of winch 6 **W VI**, see Crane operating instructions, chapter 4.05.

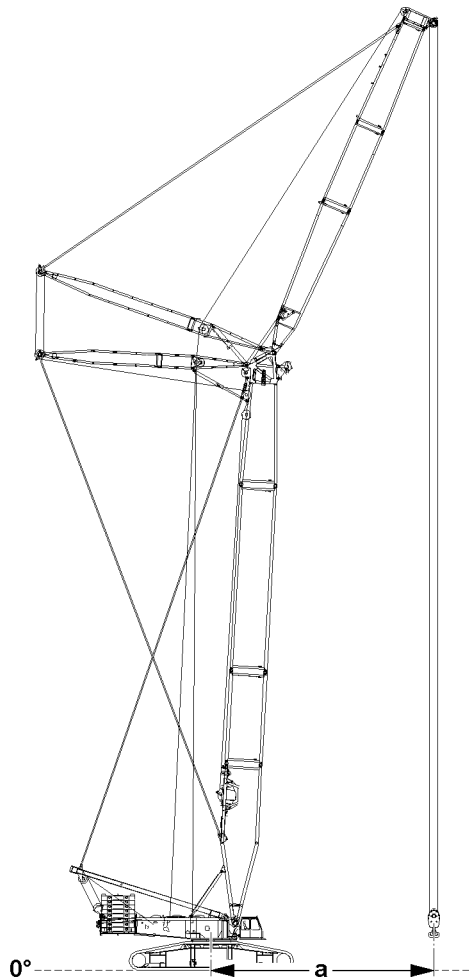
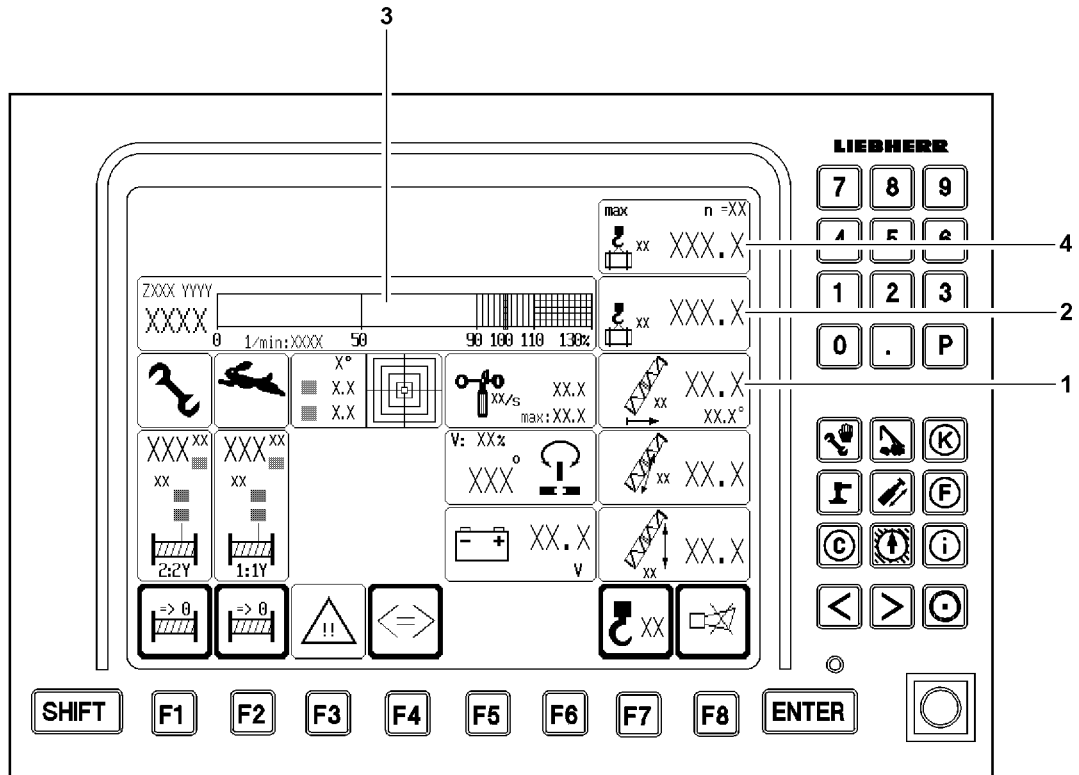

B112968

1 General

The crane operator is obligated before every crane operation to ensure that the warning and safety devices are functioning.



WARNING

Danger of accident due to defective warning and safety systems!

If the crane is operated with defective warning and safety devices, then there is a danger of accidents!

Personnel can be killed or seriously injured!

This could result in property damage!

- ▶ Make sure that all warning and safety devices are functioning.
 - ▶ Make sure that the overload protection is functioning.
-

2 Quick test Crane geometry

Make sure that the following prerequisites are met:

- The crane is aligned in horizontal direction.
- The set up status has been entered correctly into the LICCON computer system.
- There is no load on the hook.

Measure the horizontal distance of the load hook from the center of rotation of the crane superstructure on the ground:

- The value display radius **1** must match the measured value **a**.

3 Quick test Overload protection

Lift a known weight completely, such as the hook block or a counterweight plate and then set it down.

Make sure that the following prerequisite is met:

- The crane is aligned in horizontal direction.

The respective displayed values must be plausible:

- Actual load display **2**
- Utilization bar **3**: Ratio of value of Actual load display **2** to maximum load value **4**
- Example:
 - Value Actual load display **2** is 40 t.
 - Maximum load value **4** is 80 t.
 - Utilization bar **3** shows 50 %.

4 LICCON computer system

The LICCON computer system is a system for controlling and monitoring mobile cranes. In addition to the LICCON overload protection (Load torque limiter = LMB), there are a number of application programs that can be used for controlling and monitoring the crane movements. For a detailed description see Crane operating instructions, chapter 4.02 and chapter 4.20.

4.1 LICCON overload protection

The LICCON overload protection is programmed to **shut off** the crane movements if the permissible load moment is exceeded (LMB-STOP).

The LICCON overload protection may not be used as an operational shut off device for crane movements of any kind.

An overload protection cannot detect all occurring conditions by itself. Careful and diligent crane operation by the crane operator is important.

The basis for the calculation of the utilization of the crane are:

- The currently data and values recorded by the crane control.
- The set up configuration entered by the crane operator.

Direct influence has, for example:

- Failure of a test device (for example: Pull test brackets, angle sensor, pressure sensor).
- A set up configuration incorrectly entered by the crane operator.
- Environmental influences not considered (such as wind influence, ground with insufficient load bearing capability).
- Assembly and operating errors.



WARNING

Danger of accident due to assembly and operating errors!

Due to assembly and operating errors it is possible that the overload protection is not effective or shut off is delayed!

A set up configuration which deviates from the load chart cannot be detected by the overload protection!

Environmental influences which are not considered cannot be detected by the overload protection!

Dangerous situations and accidents can result!

Personnel can be killed or seriously injured!

This could result in property damage!

- ▶ Always assemble and operate the crane carefully!



WARNING

Operational utilization of the overload protection!

If the LICCON overload protection is utilized as an operational shut off device for crane movements, then there is a danger of accidents!

For example, crane movements can be shut off abruptly or uncontrolled!

The behavior of load and crane cannot be foreseen in such a case!

Personnel can be killed or seriously injured!

This could result in property damage!

- ▶ Do not use the LICCON overload protection as an operational shut off device for crane movements!



WARNING

Lifting of unknown loads!

The presence of the overload protection does not relieve the crane operator of his obligation for care and attention!

The crane may not only be operated according to the displays of the LICCON overload protection!

Lifting of loads with unknown weight and unknown properties can lead to accidents!

Personnel can be killed or seriously injured!

This could result in property damage!

- ▶ Before lifting a load, its weight and properties must be known to the crane operator!
- ▶ The crane operator must check with the load chart if the crane is able to carry out the work safely!

The LICCON computer system detects various values, which result in optical and acoustical warnings if exceeded:

Within the crane operator's cab:

- Acoustic warning “Horn / short horn” on the LICCON monitor
- Optical warning “blinking value / display” on the LICCON monitor

Outside the crane operator's cab:

- Acoustic warning via the horn on the slewing platform
- Optical warning via the warning light on the slewing platform

All warnings, even those which do not lead to an immediate shut off must be noted by the crane operator and personnel within the danger zone.

The overload protection can **not** detect (examples of cases):

- The hooking of the load or the load suspension equipment.
- Excessive retarding forces.
- Loads falling onto the rope.
- Angular pulling.
- Driving the crane on ground with large slope.
- Collapsing ground.

4.1.1 Failure of the overload protection



WARNING

Crane operation without overload protection!

If the LICCON overload protection is no longer functioning properly because of one or more errors, then there is a danger of accidents if crane operation is continued!

Due to operation of the crane with failed LICCON overload protection, the crane can be overloaded and collapse!

Personnel can be killed or seriously injured!

This could result in property damage!

- ▶ Crane operation without overload protection is prohibited!
- ▶ Do not take up crane operation again until the overload protection is functioning again!

A failed overload protection:

- Must be repaired before the crane can be operated again.
- May only be bypasses in emergency cases or emergency situations.

4.2 Bypass of overload protection

The overload protection can be bypassed in case of:

- Failure of the overload protection.
- In an emergency situation (according to EN 13000:2010).

4.2.1 Bypass of overload protection: Failure of the overload protection



Note

- ▶ Does **not** apply for cranes with CE-mark and configuration according to EN 13000:2010!

To bring the crane into safe condition after failure of a component required for the overload protection, it can be necessary that the overload protection has to be bypassed.

**WARNING**

Bypassed overload protection!

If the overload protection is bypassed, crane movements are no longer monitored!

The crane can be overloaded and collapse!

Personnel can be killed or seriously injured!

This could result in property damage!

- ▶ Only carry out crane movements within the range of the load chart as well as the erection / take down charts!

**Note**

- ▶ For procedure in case of problems, see Crane operating instructions, chapter 7.15.
- ▶ For procedure of shut off of crane movement, see Crane operating instructions, chapter 4.20.

4.2.2 Bypass of overload protection: Failure of overload protection (according to EN 13000:2010)

**Note**

- ▶ Applies **only** apply for cranes configuration according to EN 13000:2010!

To bring the crane into safe condition after failure of a component required for the overload protection, it can be necessary that the overload protection has to be bypassed.

With the specification that:

- The bypass is automatically reset at engine stop.
- The bypass is automatically reset after no later than 30 minutes.
- The bypass of the overload protection limits the working speed to no more than maximum 15%.

**WARNING**

Bypassed overload protection!

If the overload protection is bypassed, crane movements are no longer monitored!

The crane can be overloaded and collapse!

Personnel can be killed or seriously injured!

This could result in property damage!

- ▶ Only carry out crane movements within the range of the load chart as well as the erection / take down charts!

**Note**

- ▶ For procedure in case of problems, see Crane operating instructions, chapter 7.15.
- ▶ For procedure of shut off of crane movement, see Crane operating instructions, chapter 4.20.

4.2.3 Bypass of overload protection: Emergency situation (according to EN 13000:2010)

In an emergency situation, a bypass of the overload protection may become necessary.

With the specification that:

- The bypass is automatically reset at engine stop.
- The bypass is automatically reset after no later than 30 minutes.
- The bypass of the overload protection limits the working speed to no more than maximum 15%.

**DANGER**

Overload of crane!

After a bypass of the overload protection, the crane movements are no longer shut off in case of a danger of overload of the crane!

A bypass of the crane can result in severe damage or collapse!

Personnel can be killed or seriously injured!

This could result in property damage!

- ▶ Do not subject the crane to such a load that it collapses!
- ▶ Clear and secure the danger zone of the crane!

**Note**

- ▶ Location of bypass device, see Crane operating instructions, chapter 4.01 and chapter 4.02.

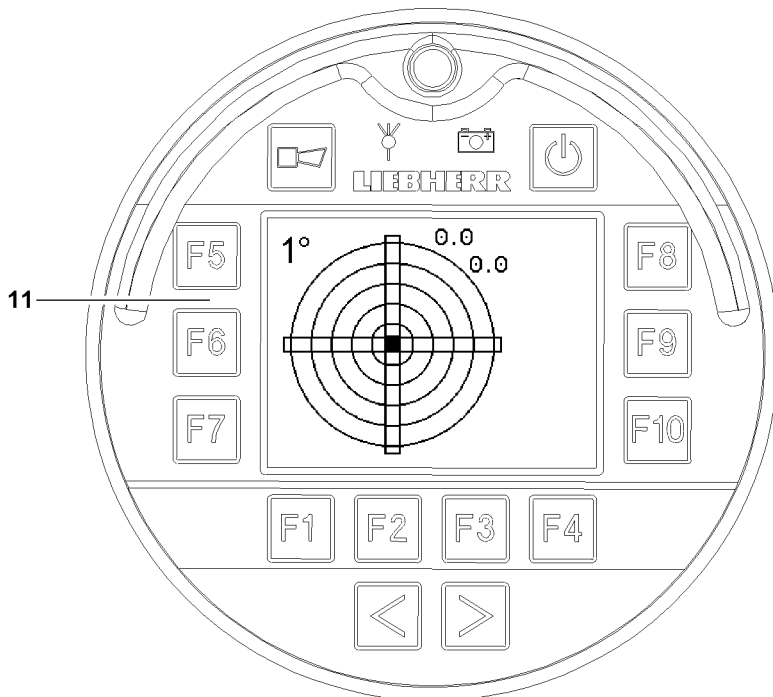
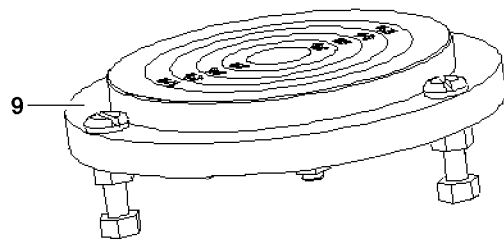
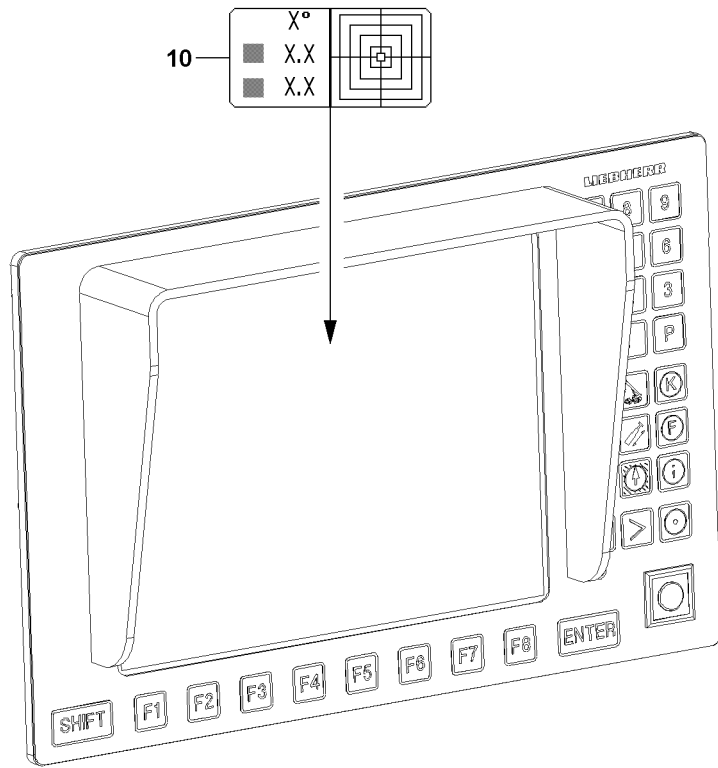

B112969

5 Safety devices on the crane

5.1 Leveling instruments

To ensure the working safety of the crane, the crane must be aligned on level ground with sufficient load bearing capacity according to the load chart.

The current values are continuously shown in the Incline icon **10**, see Crane operating instructions, chapter 4.02.

The incline is shown manually in the sight gauge **9** on the crawler travel gear.



WARNING

The crane can topple over!

If the leveling instruments are defective or incorrectly adjusted, there is a danger that the crane is not aligned according to the load chart!

A crane which is not aligned according to the load chart can topple over!

Personnel can be killed or seriously injured!

This could result in property damage!

► Make sure to align the crane according to the load chart!

5.1.1 Leveling instruments in the LICCON monitor

The incline of the crane is shown in the Incline icon **10** graphically as well as numerically, see Crane operating instructions, chapter 4.02.

5.1.2 Leveling instrument in the BTT

Only LR1600/2-W.

The incline of the crane is shown in the Incline display menu **11** graphically as well as numerically, see Crane operating instructions, chapter 3.10 and chapter 5.31.

5.1.3 Quick test Leveling instrument



Note

The horizontal alignment of the crane can be checked with a spirit level on the top of the slewing ring, for example.

► The alignment of the top of the slewing ring is the determining factor for the incline display.

Make sure that the following prerequisites are met:

- The crane is aligned in horizontal direction.
- There is no load on the hook.

For horizontally aligned crane:

- The sight gauge **9** on the crawler travel gear must show 0°.
- In the incline icon **10** 0° must be shown.

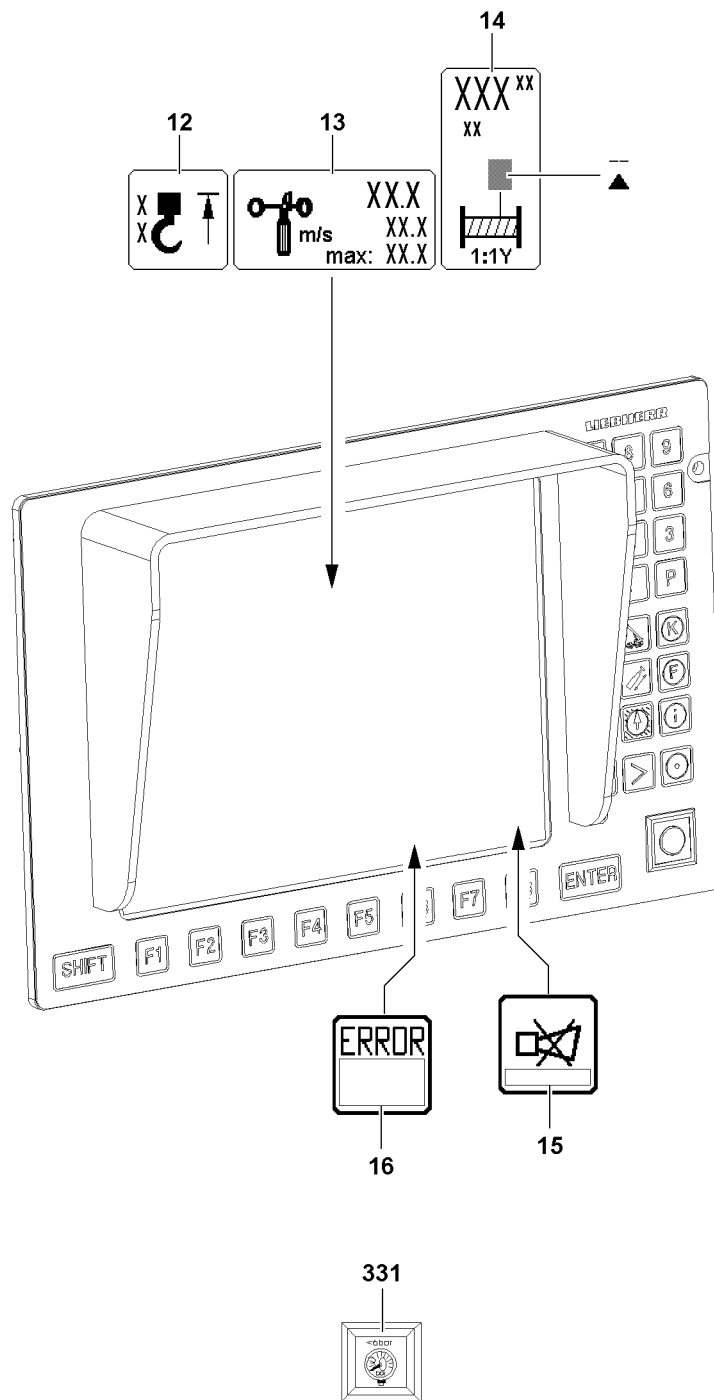

5.2 Acoustic and optical warning devices



Note

► Overview of acoustic and optical warnings, see Crane operating instructions, chapter 4.20.

- The acoustic and optical warning devices must be functioning and operational.
- Take care of any possible detriments in function, such as snow on the warning lights.

5.3 Hoist limit switch “Hoist top”

The hoist limit switch is intended to prevent the hook block from running against the boom head. Before every crane application, the function of the hoist limit switch must be checked by running against the switch weight with the hook block.

For installation purposes and in emergency cases, the hoist limit switch can be bypassed, see Crane operating instructions, chapter 4.20.



WARNING

Falling load and property damage!

If the hoist limit switch is defective, there is the danger that the hook block or the load hook is pulled against the pulley head!

Falling load and property damage can result!

Personnel can be severely injured or killed!

- Crane operation without or with defective hoist limit switch is prohibited!
- Repair or replace a defective hoist limit switch!

The hoist limit switch must actuate when the hoist limit switch weight is lifted by the load hook / hook block:

- When the hoist limit switch is actuated, the icon **12** “Hoist top” appears in the operating screen. The crane movement “Spool winch up” as well as other crane movements which have an influence on the hoist rope are shut off.

5.3.1 Quick test Hoist limit switch

When the hoist limit switch weight is lifted:

- The icon **12** “Hoist top” must appear in the operating screen.
- The actuated crane movement must be shut off.

5.4 Error messages by the LICCON computer system

Two types are differentiated (all crane types except LR1400/2):

- Operating errors
 - Displayed in field **15** by error number / LEC: B.....
- System errors in LICCON computer system
 - Displayed in field **15** by error number / LEC: E.....

Only LR1400/2:

- Error messages
 - Displayed in field **16**

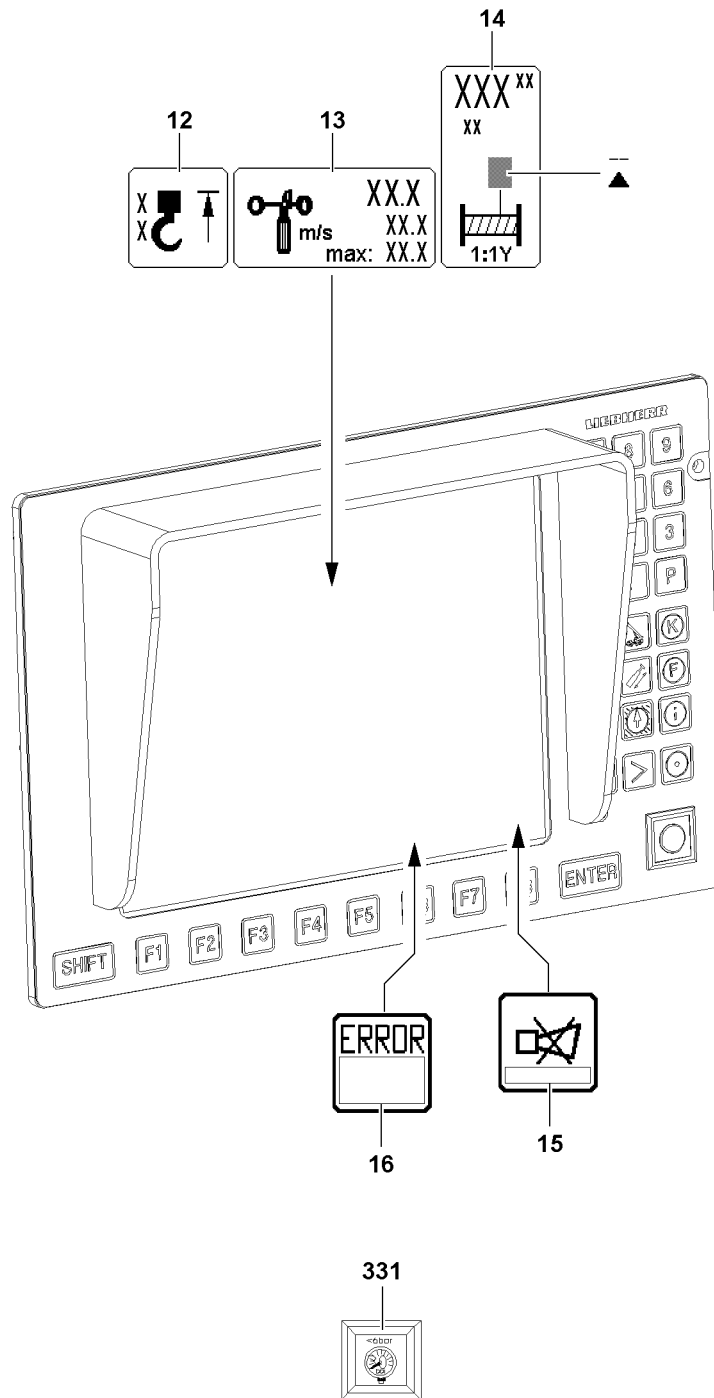

5.5 Wind speed sensor

The wind warning by the warning speed sensor appears in the operating screen of the LICCON computer system.



WARNING

The crane can topple over!

If the crane is operated with a defective wind speed sensor, then there is the danger that excessively high wind speeds are not recognized!

The crane can topple over!

Personnel can be killed or seriously injured!

This could result in property damage!

- ▶ Crane operation with a defective wind speed sensor is prohibited!
- ▶ Repair / replace a defective wind speed sensor!

If wind occurs, then the wind speed sensor must report it speed:

- If the actual wind speed value exceeds the displayed maximum value, the value in the icon 13 “Wind speed” starts to blink and the acoustic alarm “Short horn” sounds on the LICCON monitor. But there is **no shut off** of crane movements.

5.5.1 Quick test Wind speed sensor

When blowing in the cups:

- The wind speed sensor must start to move.
- An actual value must be shown in the icon 13 “Wind speed”.

5.6 Limit switch winch spooled out

The limit switches for the winches are adjusted at the factory. If used properly, the winches will not need readjustment.



Note

Minimum rope coils on the shut off point!

For the winches, a minimum of three rope coils are set for each drum.

- ▶ The shut off must occur **before** reaching the third minimum rope coil.



WARNING

The load can fall off!

If the limit switch “Winch spooled out” does not turn off **before** three minimum rope coils are reached, then there is the danger, when it is further spooled out, that the rope mounting locks are ripped out and the load falls down!

Falling load can cause the crane to sway and / or topple over!

Personnel can be severely injured or killed!

This could result in property damage!

- ▶ Crane operation with an incorrectly or non-adjusted winch is strictly prohibited!
- ▶ If the winch falls below the three minimum rope coils per winch, have it readjusted by **Liebherr Service!**

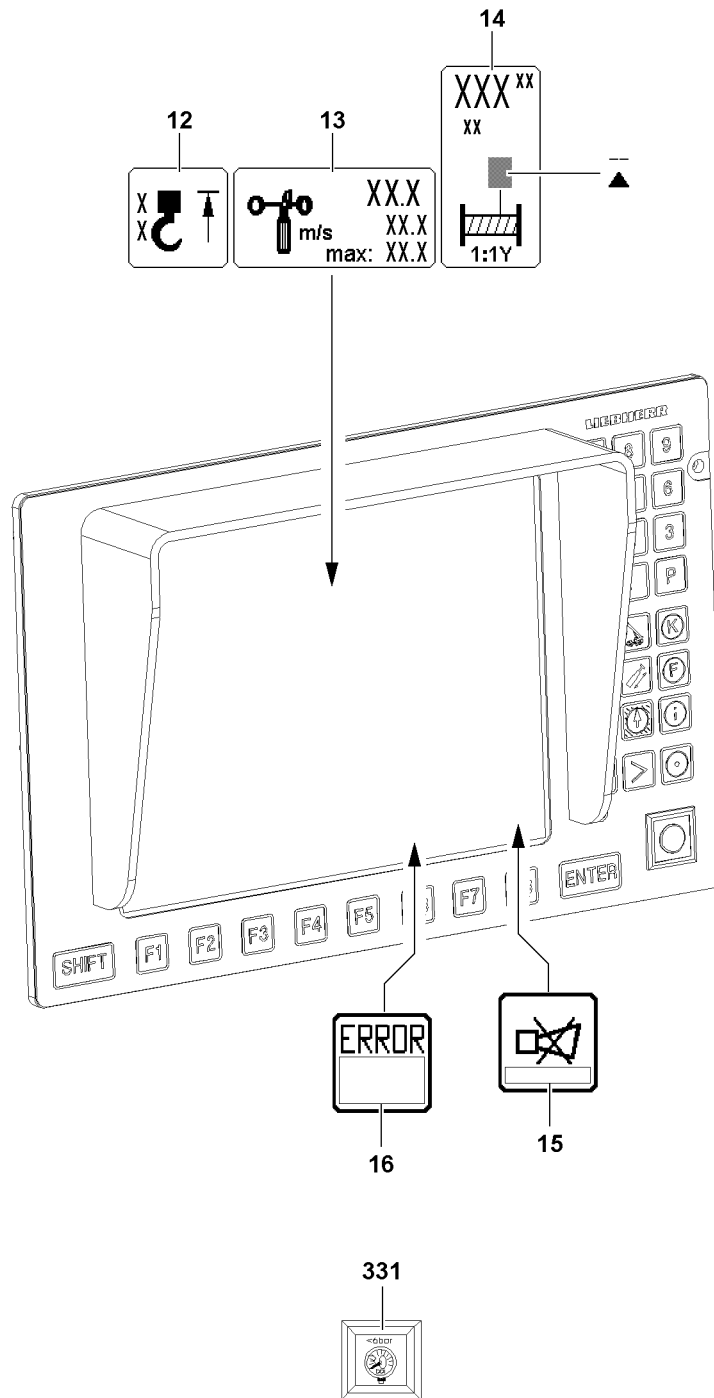

**WARNING**

The load can fall off!

If the rope is not spooled up or out properly, then the adjustment of the limit switch “Winch spooled out” is changed!

If the adjustment of the limit switch “Winch spooled out” has changed, then the minimum rope coils are fallen below!

The load can fall down!

Falling load can cause the crane to sway and / or topple over!

Personnel can be severely injured or killed!

This could result in property damage!

- ▶ **Never** pull the end of rope underneath the winch by spooling up the rope winch!
- ▶ **Never** pull the rope from the “stationary” winch!
- ▶ If you suspect that the limit switch “Winch spooled out” is not adjusted correctly: Check the shut off without a load on the hook!

The limit switch “Winch spooled out” must shut off when the minimum rope coils for the winch are reached:

- When the minimum rope coil for the winch is reached, then the display “Winch spooled out” appears in the Winch icon **14**, see illustration. The crane movement “Spool winch out” is shut off.

5.6.1 Quick test Limit switch winch

When the minimum rope coil is reached:

- The display “Winch spooled out” must appear in the Winch icon **14**.
- The crane movement “Spool winch out” must be shut off.

5.7 Servo oil pressure monitoring in the winches

All crane types except LR1400/2:

- If no servo oil pressure is present when the master switch is actuated, a corresponding error message appears in field **15**.

Only LR1400/2:

- If the servo oil pressure is too low, then the indicator light **331** in the right instrument panel appears.

5.8 Pressure monitoring in the relapse cylinders

Pressure sensors are installed in the hydraulic cylinders. The pressure measured with the pressure sensor is shown on the LICCON monitor, see Crane operating instructions, chapter 4.02.

**WARNING**

Risk of accident due to crane toppling over or destruction of the crane!

If the pressure drops, the relapse cylinder can no longer stabilize the boom!

The crane can topple over or be destroyed!

Personnel can be severely injured or killed!

- ▶ During crane operation: Constantly monitor the pressure in the relapse cylinders!

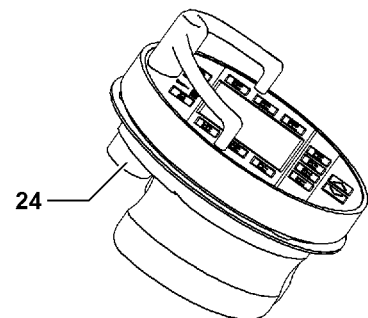
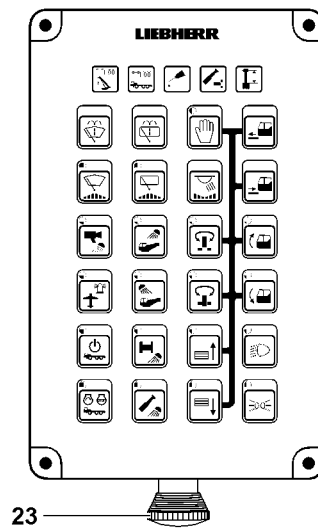
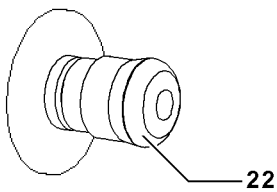
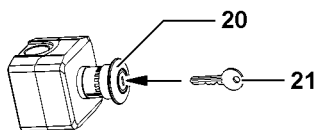
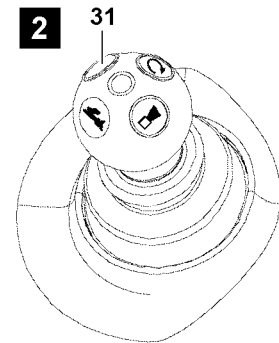
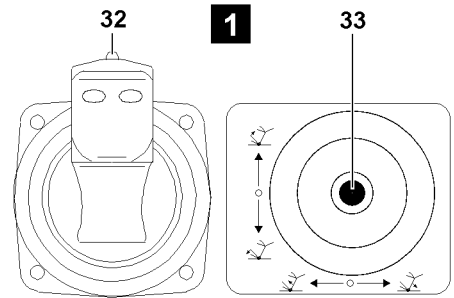
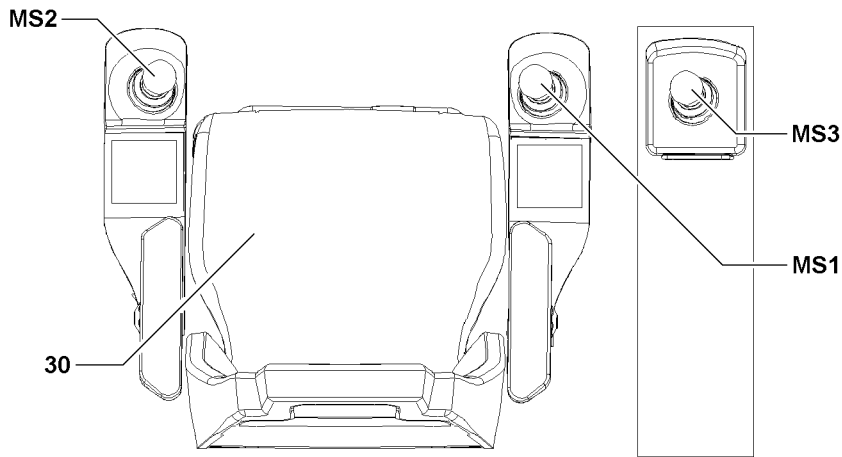

5.9 EMERGENCY STOP switch / EMERGENCY OFF switch

If an EMERGENCY STOP switch / EMERGENCY OFF switch is actuated, then the crane movement can be stopped with it.



WARNING

Defective EMERGENCY STOP switch / EMERGENCY OFF switch!

If the crane is operated with a defective EMERGENCY STOP switch / EMERGENCY OFF switch, then the crane movement cannot be stopped by actuating the EMERGENCY STOP switch!

This could result in accidents!

Personnel can be killed or seriously injured!

This could result in property damage!

- ▶ Crane operation with a defective EMERGENCY STOP switch / EMERGENCY OFF switch is prohibited!
- ▶ Repair or replace a defective EMERGENCY STOP switch / EMERGENCY OFF switch!

NOTICE

Operational actuation of the EMERGENCY STOP switch / EMERGENCY OFF switch

Actuation of the EMERGENCY STOP switch / EMERGENCY OFF switch causes the crane movement to stop abruptly!

Abruptly stopping the crane movement can cause the load to swing!

Swinging loads can cause accidents!

- ▶ Do not use the EMERGENCY STOP switch / EMERGENCY OFF switch operationally!
- ▶ Use the EMERGENCY STOP switch / EMERGENCY OFF switch only in emergency situations!

The EMERGENCY STOP switch / EMERGENCY OFF switch is available in various versions, depending on the crane type:

- After actuation of a switch of version* **20**, the release is only obtained by an authorized person with key **21** and by subsequently turning the ignition "Off - On" momentarily.
- After actuation of the switch of version* **22**, the release is obtained by turning and unlocking the knob and subsequently turning the ignition "Off - On" momentarily.
- After actuation of the switch of version* **23**, the release is obtained by turning and unlocking the knob and subsequently turning the ignition "Off - On" momentarily.
- After actuation of the switch of version* **24**, the release is obtained by turning and unlocking the knob and subsequently turning the ignition "Off - On" momentarily.



Note

- ▶ Which EMERGENCY STOP switch / EMERGENCY OFF switch is on the crane depends on the crane type.
- ▶ The switch **24** on the BTT is only activated when working with the BTT.

5.9.1 Quick test EMERGENCY STOP switch / EMERGENCY OFF switch

After actuation of the EMERGENCY STOP switch / EMERGENCY OFF switch:

- The crane movements must be stopped.
- No crane movements must be possible until the release was issued by turning and unlocking the knob and then turning the ignition "Off - On" momentarily.

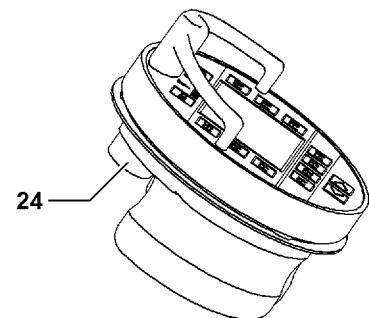
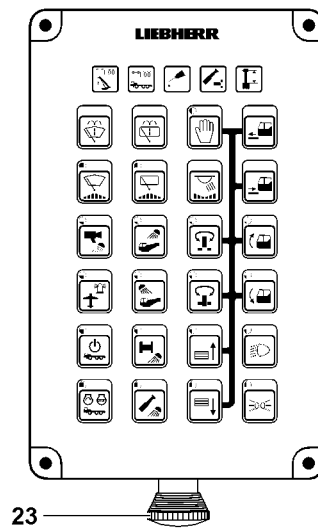
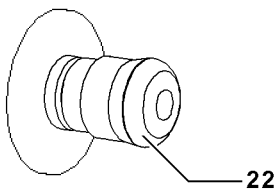
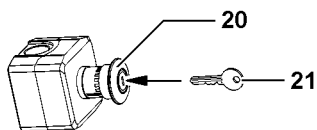
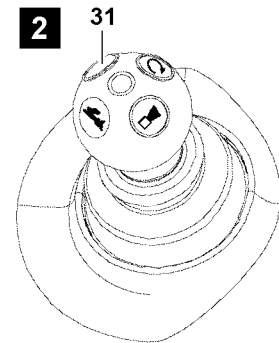
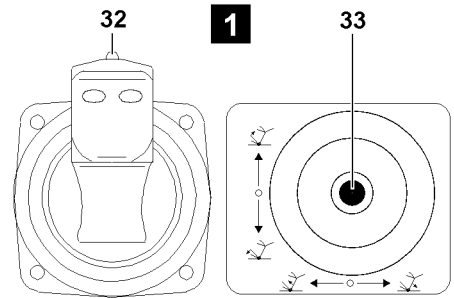
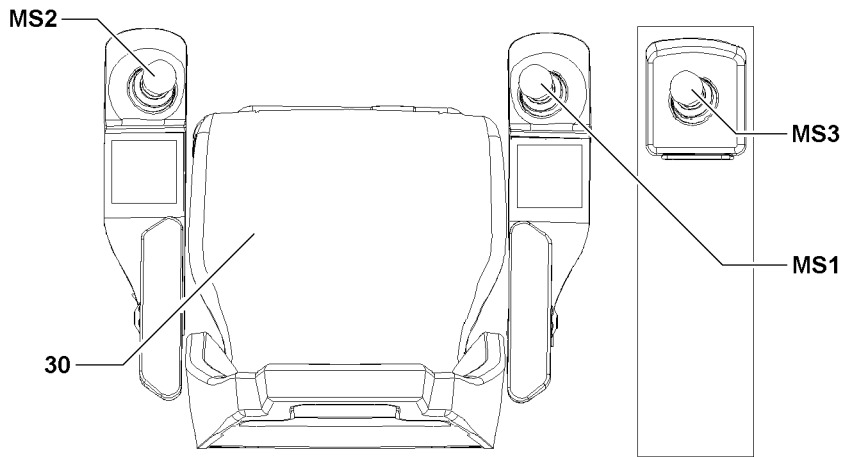

5.10 Control release

The control release can be made via three switches:

- Seat contact button **30**
- Button **31** on master switch **MS1** and **MS2** and **MS3**.
or
- Button **32** on master switch **MS1** and **MS2** (only LR1400/2)
- Button **33** on master switch **MS3** (only LR1400/2)

The seat contact button **30** shuts down the crane control as soon as the crane operator gets up from the seat.

This prevents unintended crane movements by accidentally touching the master switch, for example when getting in or out of the cab.

Button **31** or button **32** and the button **33** bypass the seat contact switch **30**, if necessary, for example, when work must be performed standing.

5.11 Hydraulic safety valves

A differentiation is made between three types:

- Pressure relief valves
 - Prevent pipe and hose bursts due to excessive pressure.
- Shut off valves
 - Control and secure the working cylinders.
- Check valves
 - Control and secure the flow direction.

5.12 Gravity actuated relapse retainer



Note

- ▶ Only for cranes with luffing accessories.

The gravity actuated relapse retainer (oscillation guard / flap / relapse support) prevent luffing accessory from tipping to the rear in “steepest position”.



WARNING

The crane can topple over!

If the gravity actuated relapse retainer (oscillation guard / flap / relapse support) is hard to move, then it will no longer function.

Shut off and limit functions can be set out of service!

The crane can be overloaded and topple over!

Personnel can be killed or seriously injured!

This could result in property damage!

- ▶ Before erecting the crane, check the relapse retainer for easy movement!
- ▶ Crane operation with hard to move relapse retainer is prohibited!

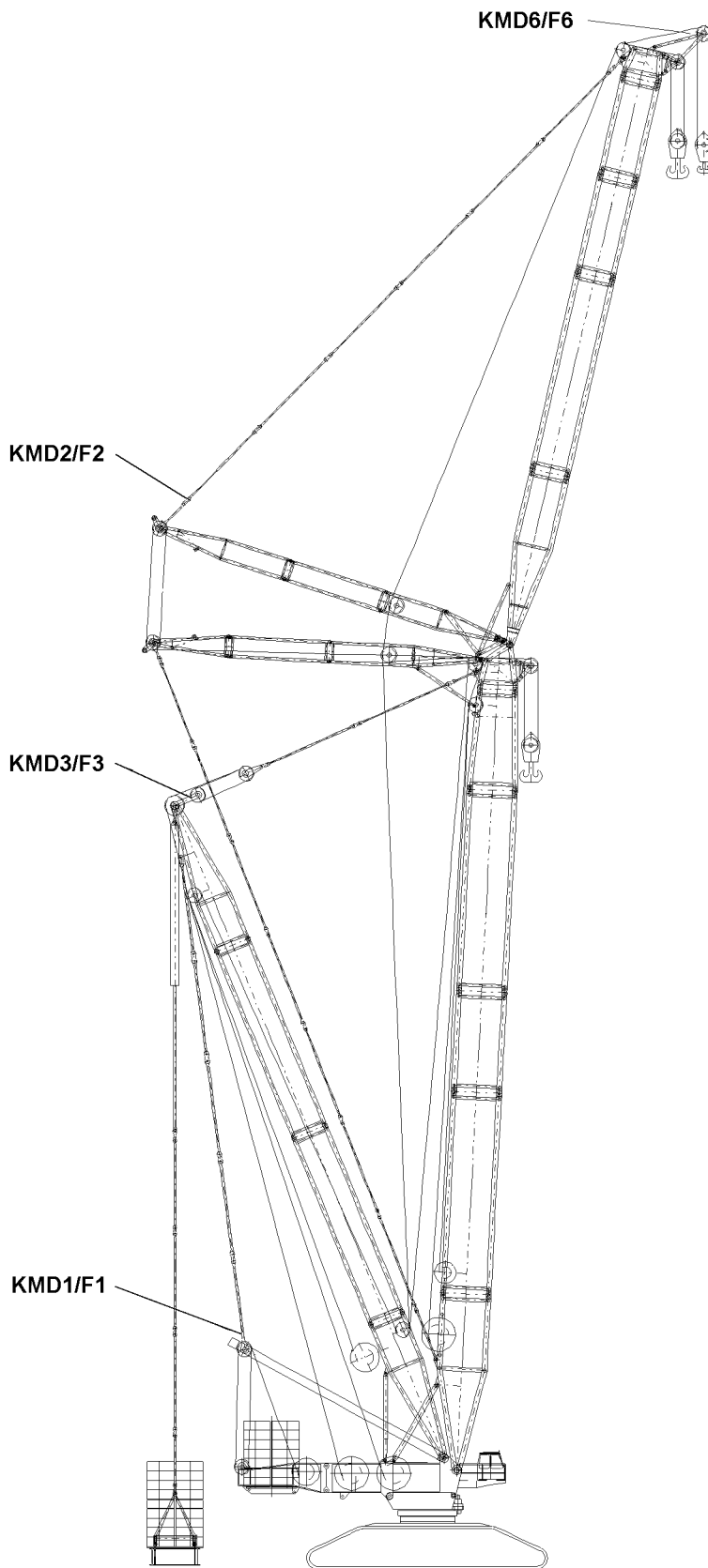

B112971

5.13 Angle sensors

Component	Description - Angle sensor (WG)
S-pivot section	Main boom bottom
S/W-end section, if used on boom	Main boom top
S/W-end section, if used on luffing jib	Luffing jib up
W-pivot section	Luffing jib bottom
W-connector head	Main boom top
D-pivot section	Derrick bottom
D-end section	Derrick top
SA-frame	SA-frame

5.14 Test brackets (KMD = force test box)

The test brackets measure the force in the guying, which results from the load and the boom momentum.

The test brackets are located:

- **KMD 1**, in the boom guying, SA-frame to boom for all operating modes **without** derrick
- **KMD 1**, in the derrick guying, SA-frame to derrick for all operating modes **with** derrick
- **KMD 2**, in the lattice jib guying, WA-frame 1 to lattice jib end section
- **KMD 3**, in the boom guying, derrick to boom for all operating modes **with** derrick
- **KMD 6**, in the boom nose (not LR1400/2)

5.15 Limit switch Boom system



WARNING

Danger of toppling or destroying the crane!

If the crane movement is stopped by the block limit switches, then the load forces cannot be absorbed and calculated by the control!

The crane can be overloaded and topple over!

Personnel can be hit and killed or seriously injured!

This could result in property damage!

- ▶ Do **not** use the hoist limit switch as an operational shut off device!
- ▶ Do not actuate the block limit switches!

1 General

1.1 General notes

Make sure that the following prerequisites are met:

- The crane is aligned in horizontal direction.
- The counterweight is attached and secured in accordance with the information in the load chart.
- The ground is able to carry the weight of the crane, including the load and the load tackle.
- The hook block is correctly reeved as shown in reeving plan.
- The crawler operation is turned off.
- The crane engine is running.
- All safety devices have been adjusted according to the data in the load chart.
- There are no persons or objects in the danger zone.
- The dummy plugs plugged in at assembly have been changed over to the corresponding connector sockets.



DANGER

Risk of accident!

- ▶ In order to protect the crane and reduce the danger of accidents always use the master switch slowly and sensitively.
 - ▶ Ensure that there are no obstacles in the working range of the crane and that there are no persons within the danger zone.
 - ▶ Give a warning signal before initiating a crane movement.
 - ▶ Observe the danger notes for crane operation in chapter 2.04 and 5.01.
-

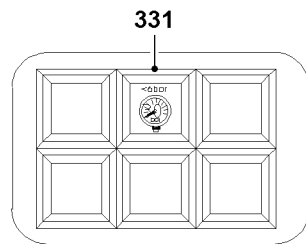
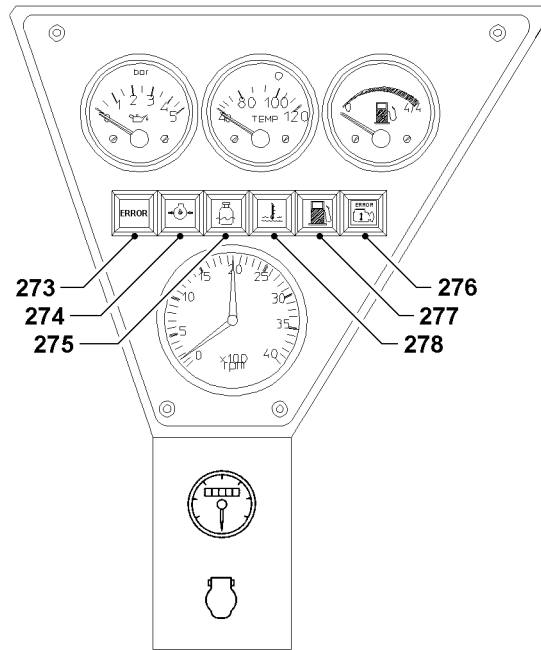

1.2 Observe the warning lights



CAUTION

Danger of damaging the engine!

If the warning light **274** and **278** are not observed, then severe engine damage can occur due to insufficient oil pressure or excessive coolant temperature.

- ▶ If the warning light **274** does not turn off after a short time after engine start, **turn the engine off immediately!**
- ▶ If the warning light **274** lights up during crane operation, **turn the engine off immediately!**
- ▶ If the warning light **278** lights up during crane operation, **turn the engine off immediately!**

During crane operation, the following warning lights must be regularly checked by the crane operator:

273 Warning light	• RPM sensor or relay defective
274 Warning light	• Oil pressure Diesel engine
275 Warning light	• Coolant level too low
276 Warning light	• Engine error: error is issued via blinker code
277 Warning light	• Fuel level too low
278 Warning light	• Coolant temperature too high
331 Warning light	• Servo oil pressure in winches I to VI is less than 10 bar

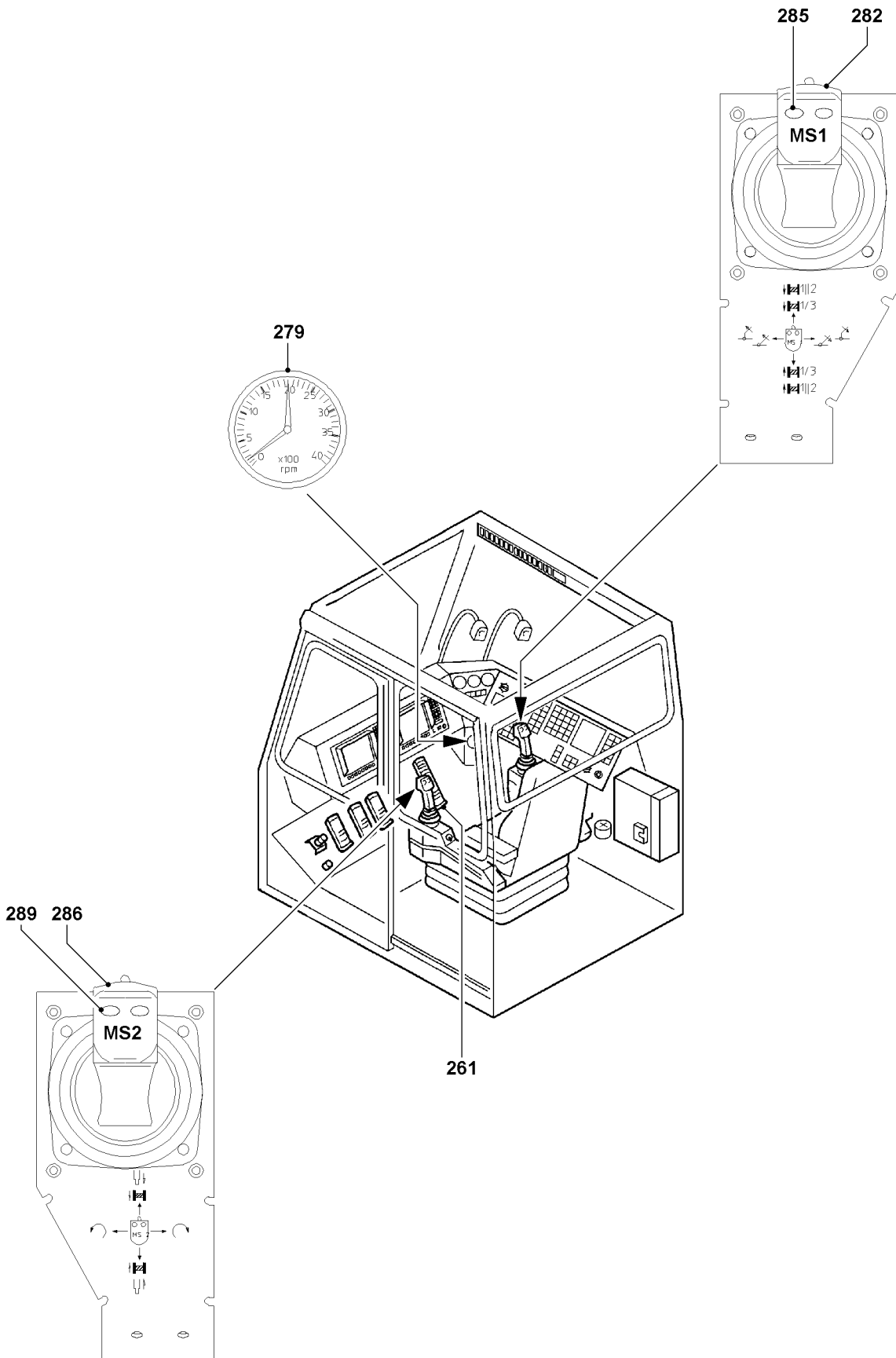

B104675

1.3 Engine RPM

The current engine RPM is shown on the RPM gauge **279**.

1.3.1 Locking the engine RPM

Locking engine RPM relieves the crane operator if he needs to work for an extended period with constant RPM. The engine control can be locked in any position.

- ▶ Press the pedal **261** for the engine regulation down until the desired engine RPM is reached.
- ▶ Press button **285**.

or

- Press button **289**.

Result:

- The engine RPM is locked.

1.3.2 Releasing the engine RPM lock

- ▶ If the engine RPM is locked:
Press button **285** again.

or

- Press button **289** again.

Result:

- The engine RPM lock is revoked.
- The engine RPM drops to the low idle speed.

2 LICCON computer system

See chapter 4.02.



WARNING

Risk of accident from overloading the crane!

- ▶ Constantly monitor the displays on the LICCON monitor - especially the utilization bar display.
 - ▶ Observe changing utilization conditions and forces.
-



Note

- ▶ The crane operator must evaluate constantly if the data shown in the operating view can even be correct. He may not rely blindly on the LICCON system but must think for himself and must recognize a possible error or overload conditions.
-

2.1 Crane engine running

Make sure that the following prerequisites are met:

- Batteries are charged by the generator.
- A stable voltage is present.

3 Winch and master switch assignment to operating modes

The assignment of the master switches to the winches is different, according to the operating modes. The assignments are shown and must be carried out as detailed in the separately supplied electric wiring diagram.



Note

- ▶ The crane operator must know and observe the assignments, in the separately supplied electric wiring diagram.
-

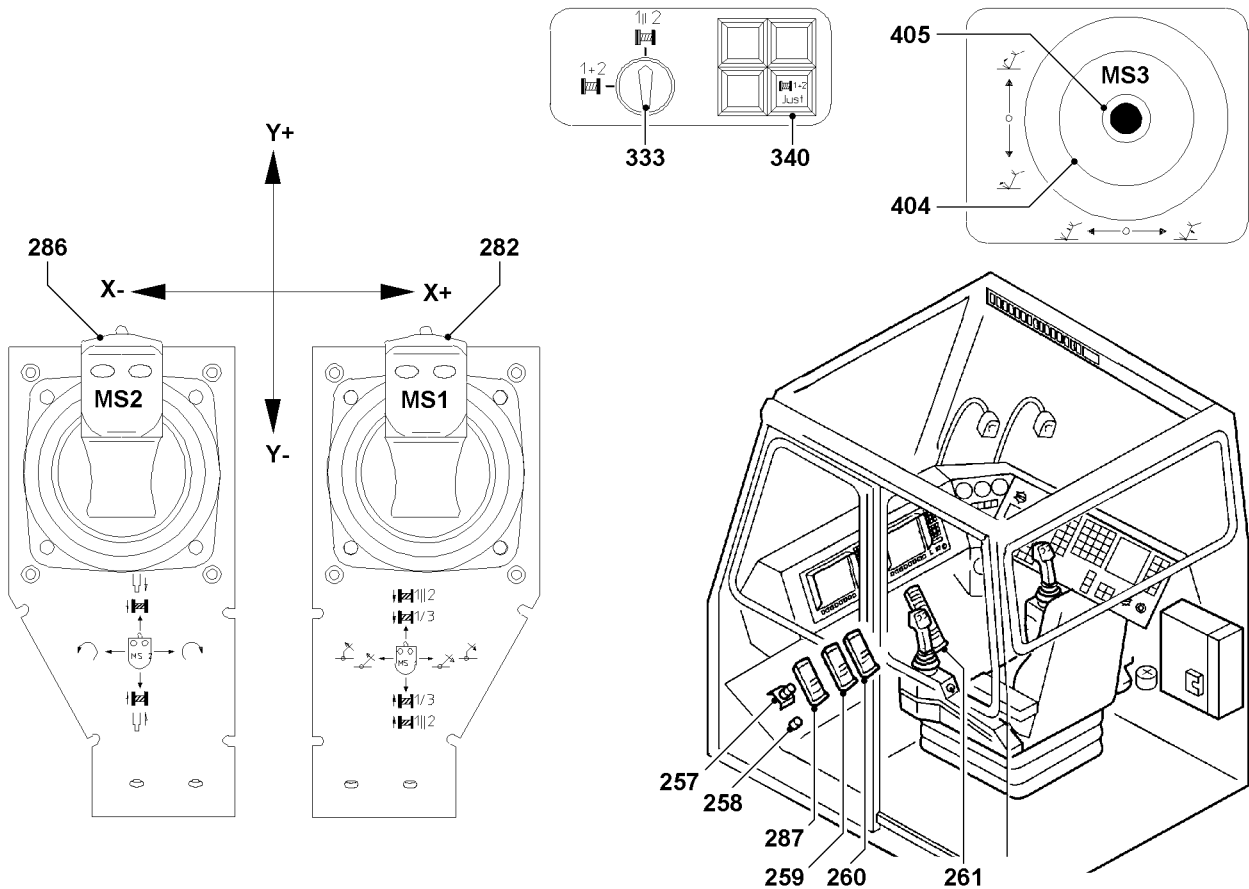
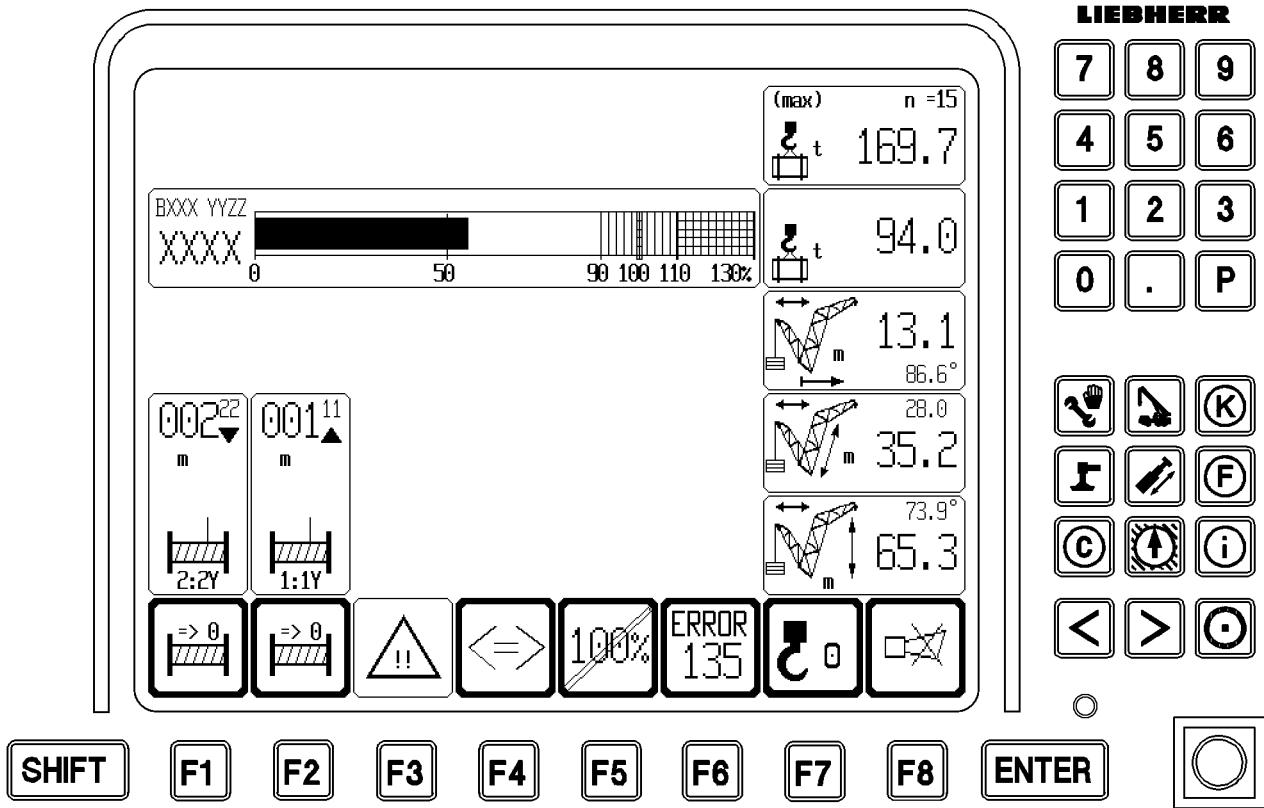

B104678

4 Lifting / lowering



CAUTION

Risk of rope damage!

- ▶ When spooling the winches up or out, make sure that no slack rope forms, especially for long booms and lattice jibs.
- ▶ Refer to the corresponding load charts for the required minimum hook block weights.

The speed of crane movement “lifting and lowering” is controlled via the deflection of the corresponding master switch and via the pedal **261** of the engine regulation.

In the “Control Parameter” program, the crane operator can assign a maximum winch speed to each individual winch. Individual winches can also be deactivated / activated by the crane operator.

See chapter 4.02, section “Control Parameter”.

4.1 Winch 1 - hoist winch

In the winch symbol is shown that the winch is turning, even if no hook movement is visible due to multiple reeving and low speed.

- ▶ Deflect master switch 1 **282** in direction Y+.

Result:

- Winch 1 spools out and the load is lowered.

- ▶ Deflect master switch 1 **282** in direction Y-.

Result:

- Winch 1 spools up, the load is raised.

4.2 Winch 2 - hoist winch

In the winch symbol is shown that the winch is turning, even if no hook movement is visible due to multiple reeving and low speed.

- ▶ Deflect master switch 2 **286** in direction Y+.

Result:

- Winch 2 spools out and the load is lowered.

- ▶ Deflect master switch 2 **286** in direction Y-.

Result:

- Winch 2 spools up and the load is lifted.

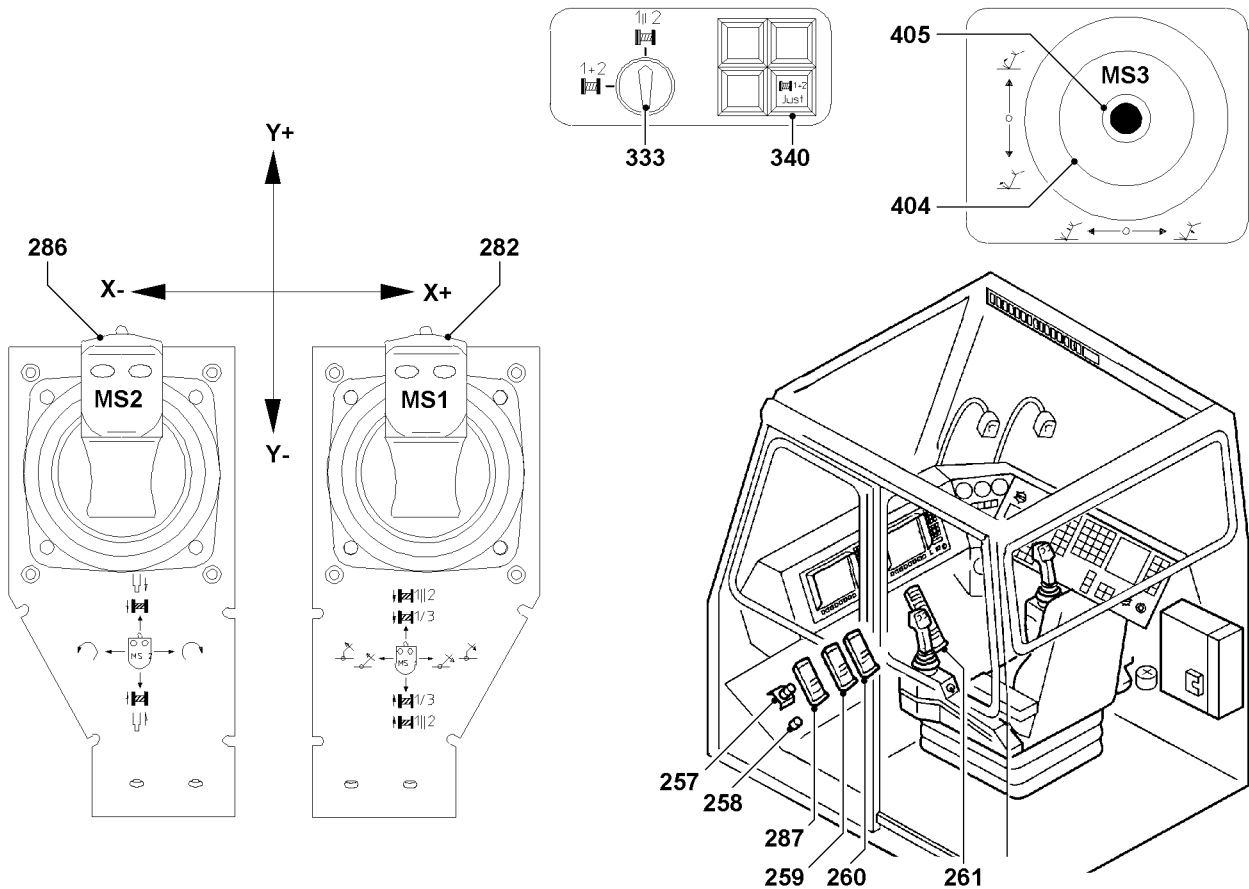
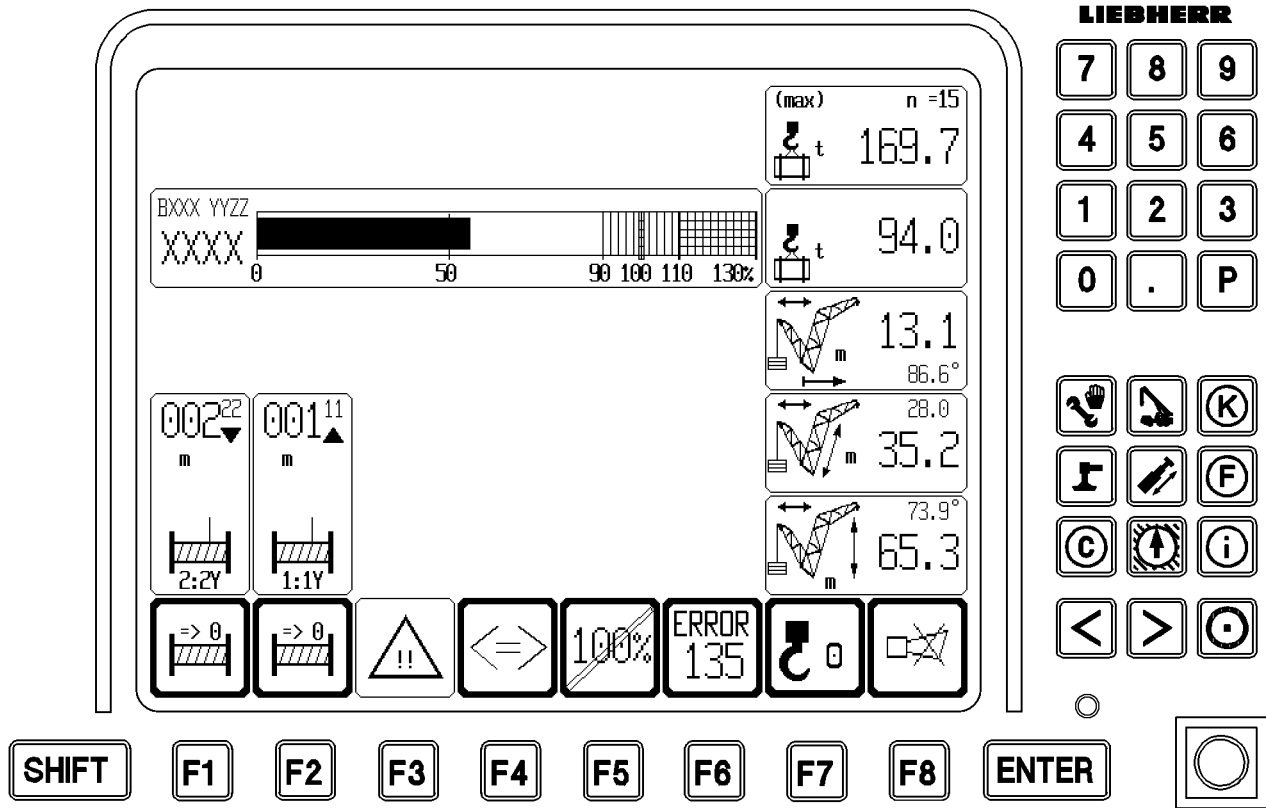

B104678

4.3 Winch 5

Winch 5 can be used for:

- The adjustment of the lattice jib.
- As hoist winch for the boom nose.

4.3.1 Winch 5 control winch

For adjustment movements of the lattice jib with winch 5 can be used:

- A torsion resistant hoist rope.
- A non-torsion resistant control rope.



WARNING

Damage of hoist rope!

If very frequent adjustment movements of the lattice jib are carried out with a torsion resistant hoist rope, then the rope will be damaged. Personnel can be severely injured or killed!

- ▶ For very frequent adjustment movements of the lattice jib, use a non-torsion resistant control rope!
- ▶ **Never** use non-rotation free ropes with a rotating rope end connections!



Note

- ▶ For a few adjustment movements of the lattice jib, a torsion resistant hoist rope may be used.

For operation, see section “Luffing the lattice jib in SW/SDW(B,BW) operation”.

4.3.2 Winch 5 hoist winch boom nose



WARNING

Rope breakage!

If a non-rotation free control rope is used as hoist rope for winch 5, then the rope will be overloaded and can break. Personnel can be severely injured or killed!

- ▶ A rotation-resistant rope must be used as hoist rope!
- ▶ Do not use a non-rotation free control rope as hoist rope!

In the winch symbol is shown that the winch is turning, even if no hook movement is visible due to multiple reeving and low speed.



Note

- ▶ In individual operation of winch 1 and winch 2, no master switch is assigned to winch 5.
- ▶ In parallel operation - switch **333** is in switch position parallel operation - winch 1 and winch 2 are actuated with the MS1y. The master switch MS2y is assigned to winch 5.

Operation with winch 5 with turned on parallel operation of winch 1 II 2

Ensure that the following prerequisite is met:

- Switch **333** is in switch position “Parallel operation”.

- ▶ Deflect master switch 2 **286** in direction Y+.

Result:

- Winch 5 spools out and the load is lowered.

- ▶ Deflect master switch 2 **286** in direction Y-.

Result:

- Winch 5 spools up and the load is raised.

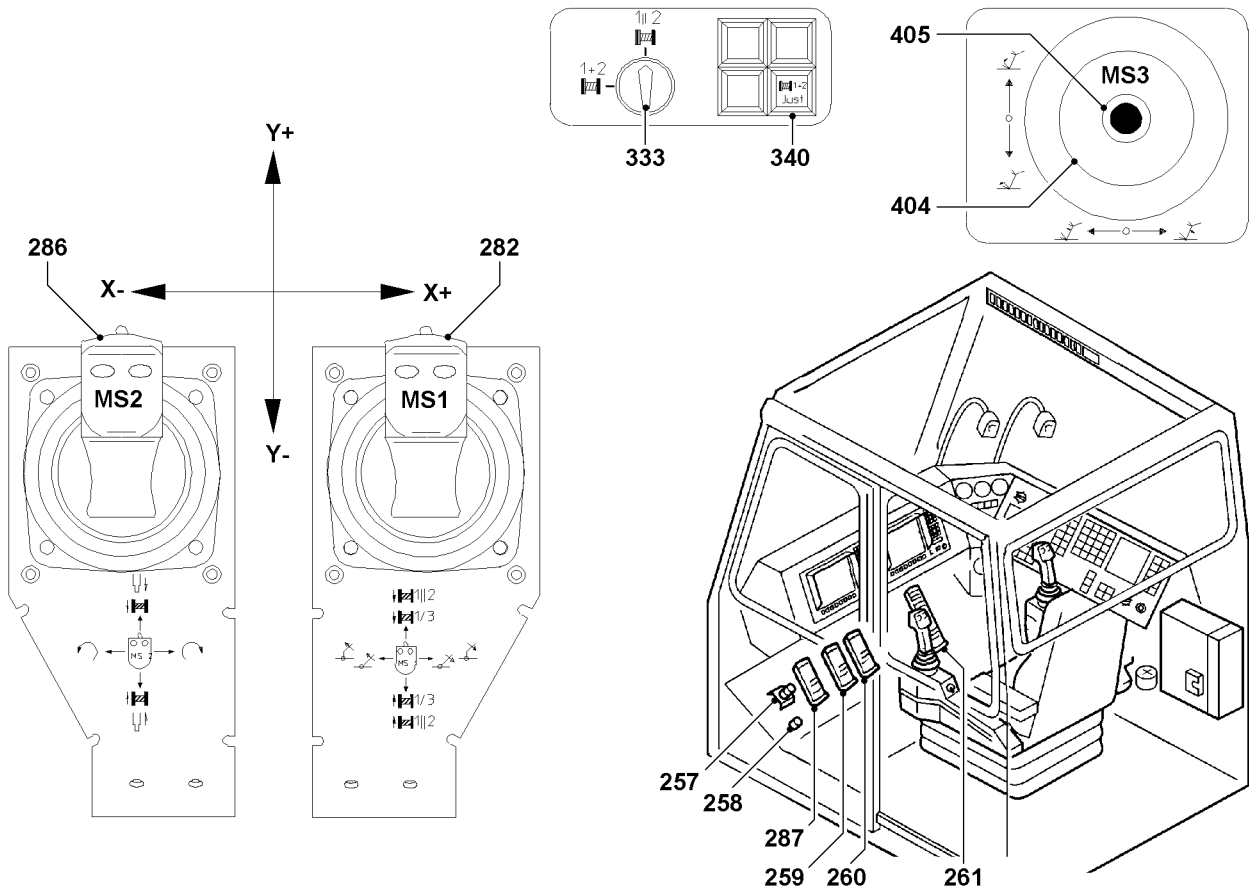
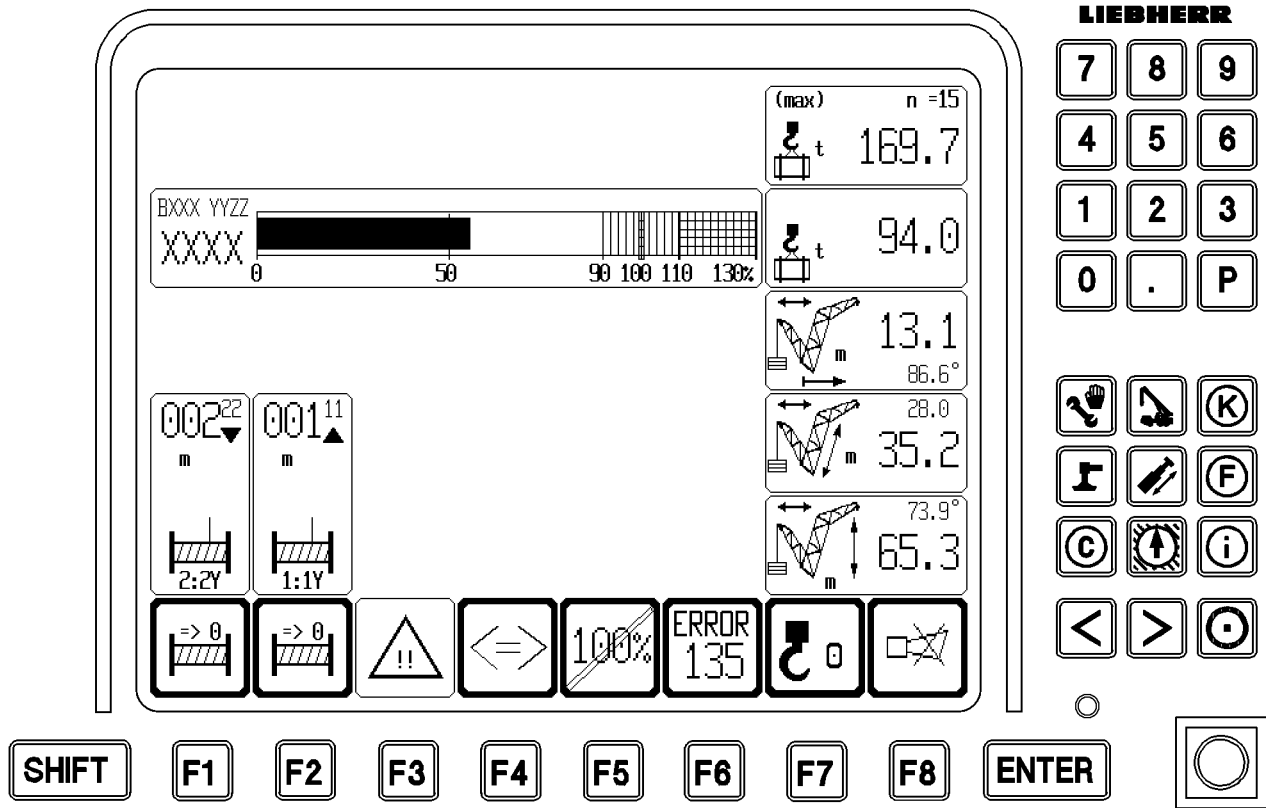

B104678

4.4 Winch 6 hoist winch boom nose

In the winch symbol is shown that the winch is turning, even if no hook movement is visible due to multiple reeving and low speed.



Note

- ▶ In individual operation of winch 1 and winch 2, no master switch is assigned to winch 6.
 - ▶ In parallel operation - switch **333** is in switch position parallel operation - winch 1 and winch 2 are actuated with the MS1y. The master switch MS2y is assigned to winch 6.
-

4.4.1 Operation with winch 6 with turned on parallel operation of winch 1 II 2

Ensure that the following prerequisite is met:

- Switch **333** is in switch position “Parallel operation”.

- ▶ Deflect master switch 2 **286** in direction Y+.

Result:

- Winch 6 spools out and the load is lowered.

- ▶ Deflect master switch 2 **286** in direction Y-.

Result:

- Winch 6 spools up and the load is raised.

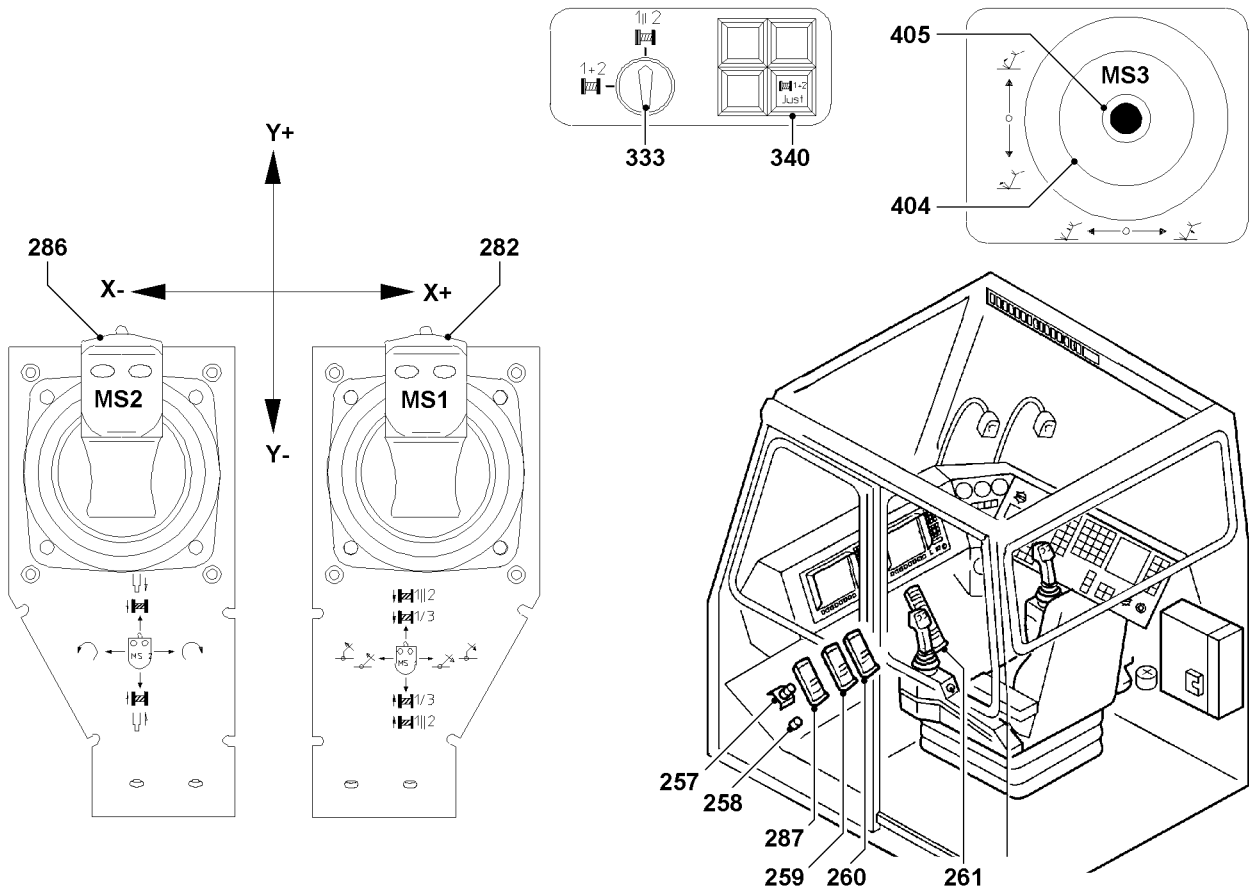
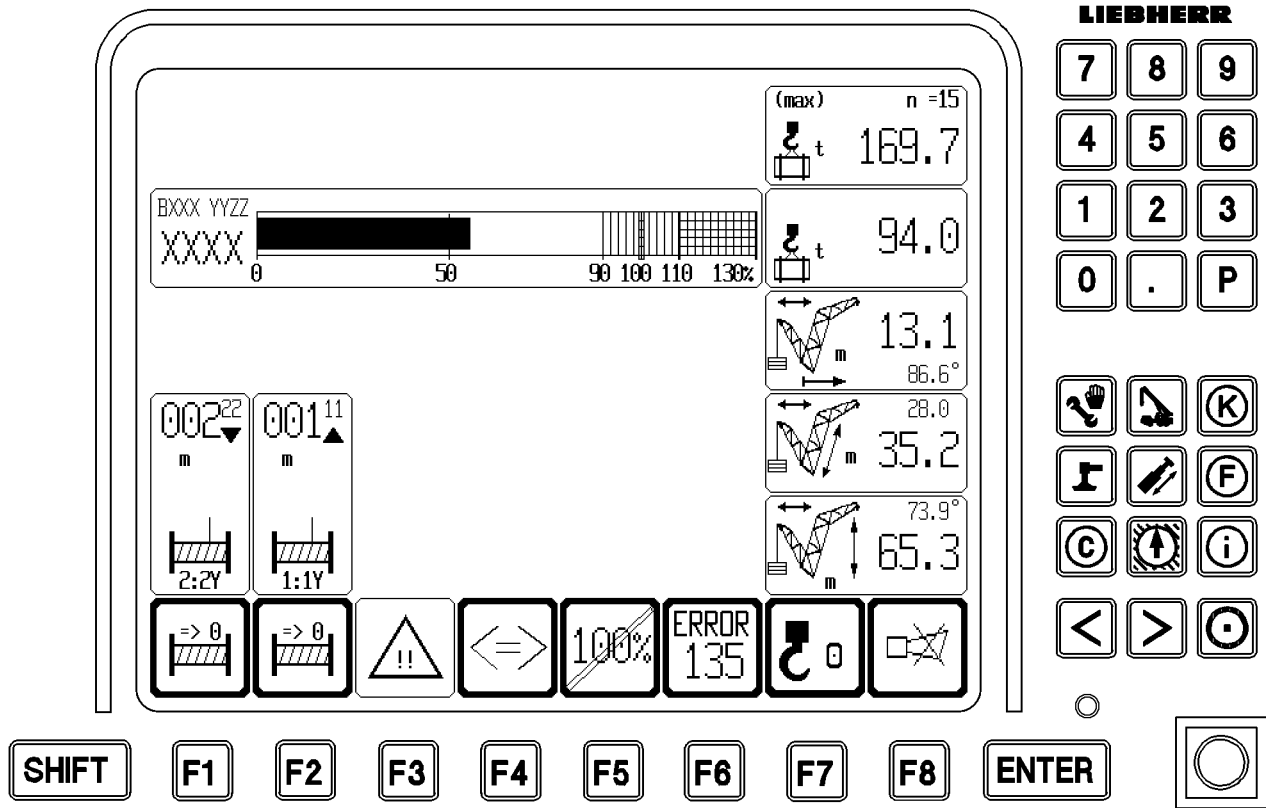

B104678

4.5 Parallel operation

For parallel operation, winch 1 and winch 2 are synchronized.

In parallel operation, winch 1 and 2 are actuated via the master switch MS1y.

Make sure that the following prerequisites are met:

- The double hook block is properly installed.
- The double hook blocks are reeved according to the load charts.
- The double hook block is correctly reeved as shown in reeving plan.
- The total reeving has been entered and confirmed on the LICCON monitor.
- The number of total reeving on the double hook block must be the same and even.



DANGER

Risk of accident!

- ▶ The number of total reeving on the double hook block in parallel operation must be the same and even. If the minimum value of the reeving is uneven, then - in parallel operation - the next higher, even reeving must be selected.
- ▶ The transport pins must be removed before horizontal alignment and before crane operation.
- ▶ Make sure that the danger zone of the double hook block is free of any personnel.

4.5.1 Horizontally aligning the double hook blocks

Ensure that the following prerequisite is met:

- The preselection switch **333** is in switch position individual operation for winch 1 and winch 2 (1+2).

The double hook blocks must be manually aligned in horizontally direction, check visually.

- ▶ Deflect master switch 1 **282** in direction Y.

or

- Deflect master switch 2 **286** in direction Y until the double hook blocks are horizontally aligned.

Result:

- Winch 1 or winch 2 spools up or out, check visually.
- ▶ When the double hook blocks are horizontally aligned, check visually:
Return master switch 1 **282** and/or master switch 1 **286** into zero position.

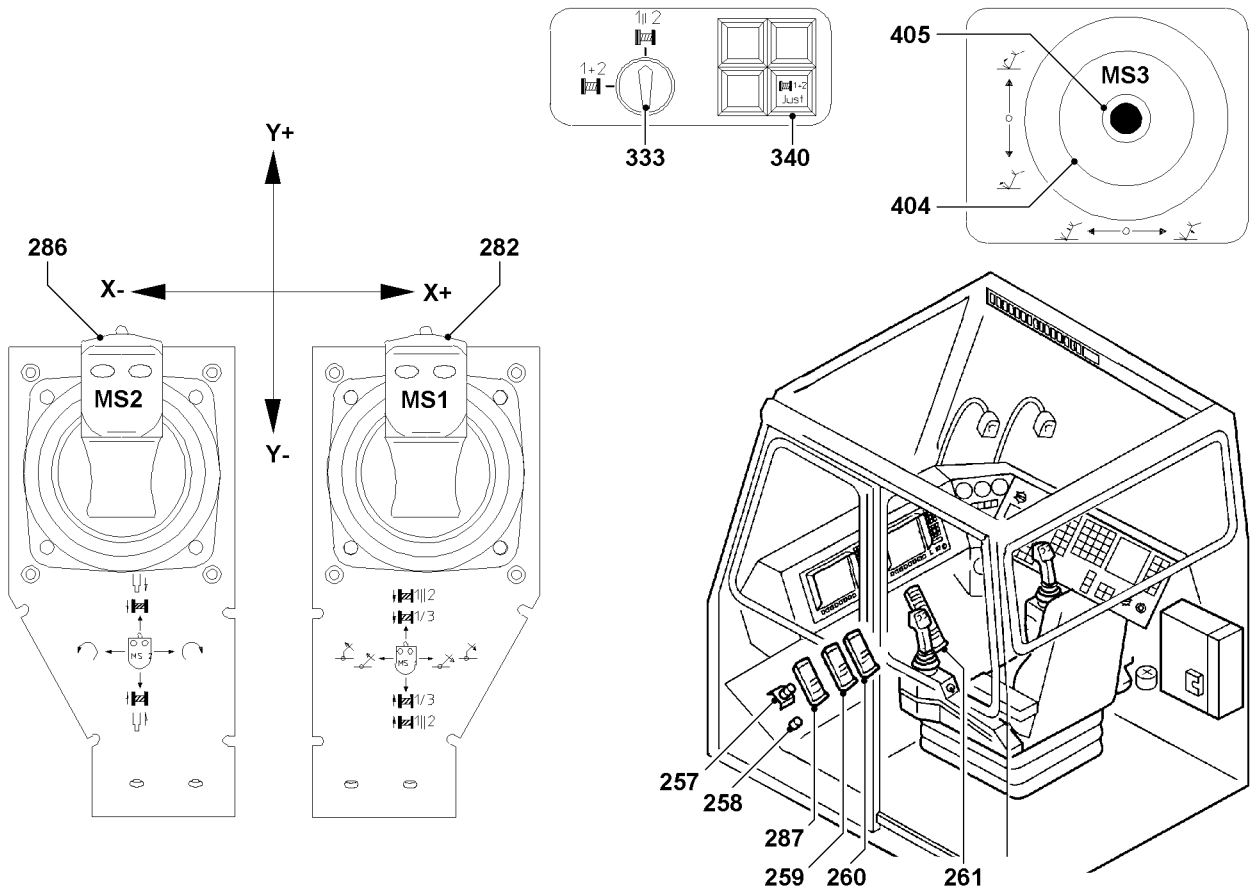
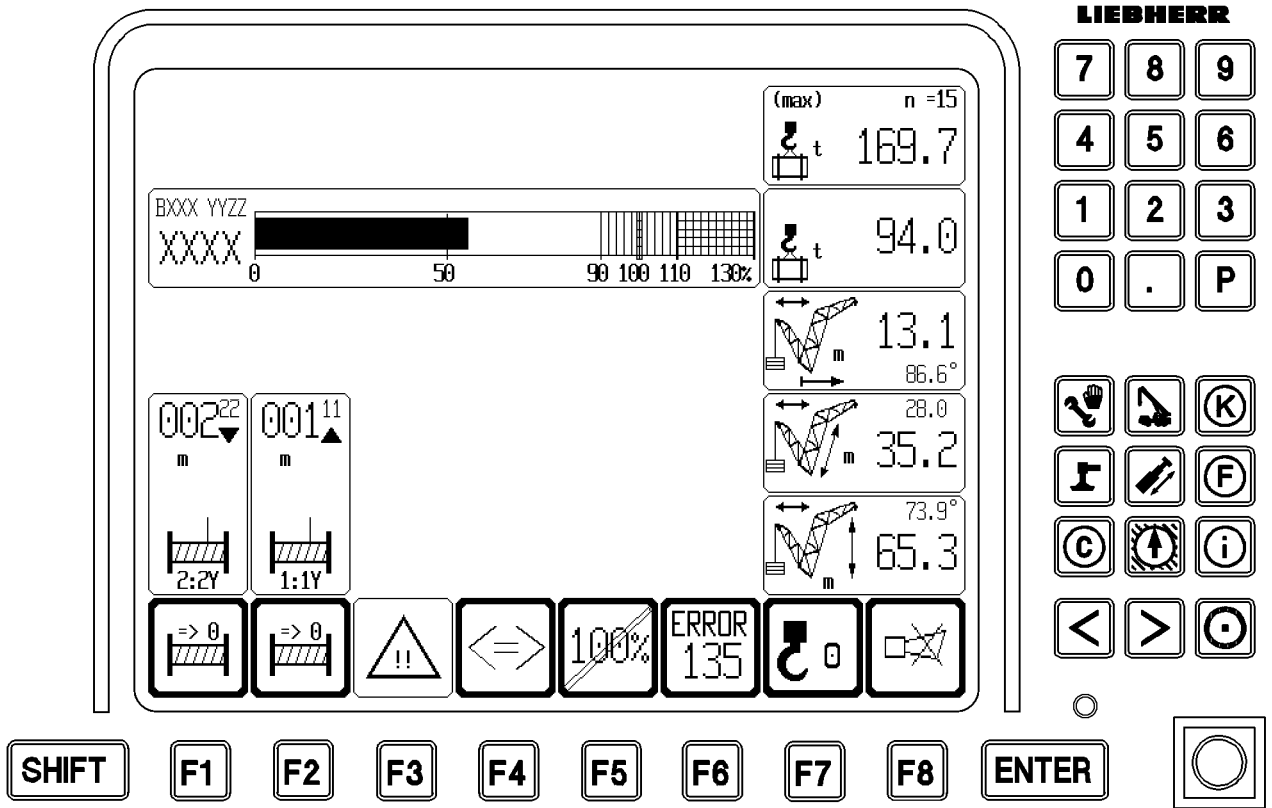

B104678

4.5.2 Adjust parallel control of winch 1 and winch 2

Make sure that the following prerequisites are met:

- The double hook blocks are horizontally aligned, check visually.
- There is no load on the hook.
- ▶ Switch the preselection switch **333** to parallel operation (**1II2**).
- ▶ Press button **340**.

Result:

- The parallel control of winch 1 and winch 2 is adjusted.

4.5.3 Adjusting zero point for hook path display



Note

- ▶ When winch 1 and 2 are working in parallel operation, then the hook path can be reset to zero for both winches by pressing the function key **F1**.

- ▶ Press the function key **F1**.

Result:

- The hook path display in the winch symbol of winch 1 is set to zero (000,00).
- The hook path display in the winch symbol of winch 2 is set to zero (000,00).



Note

- ▶ If the difference range for parallel control is exceeded in crane operation, then the winch movement is shut off. In that case, the winches must be again readjusted.
-

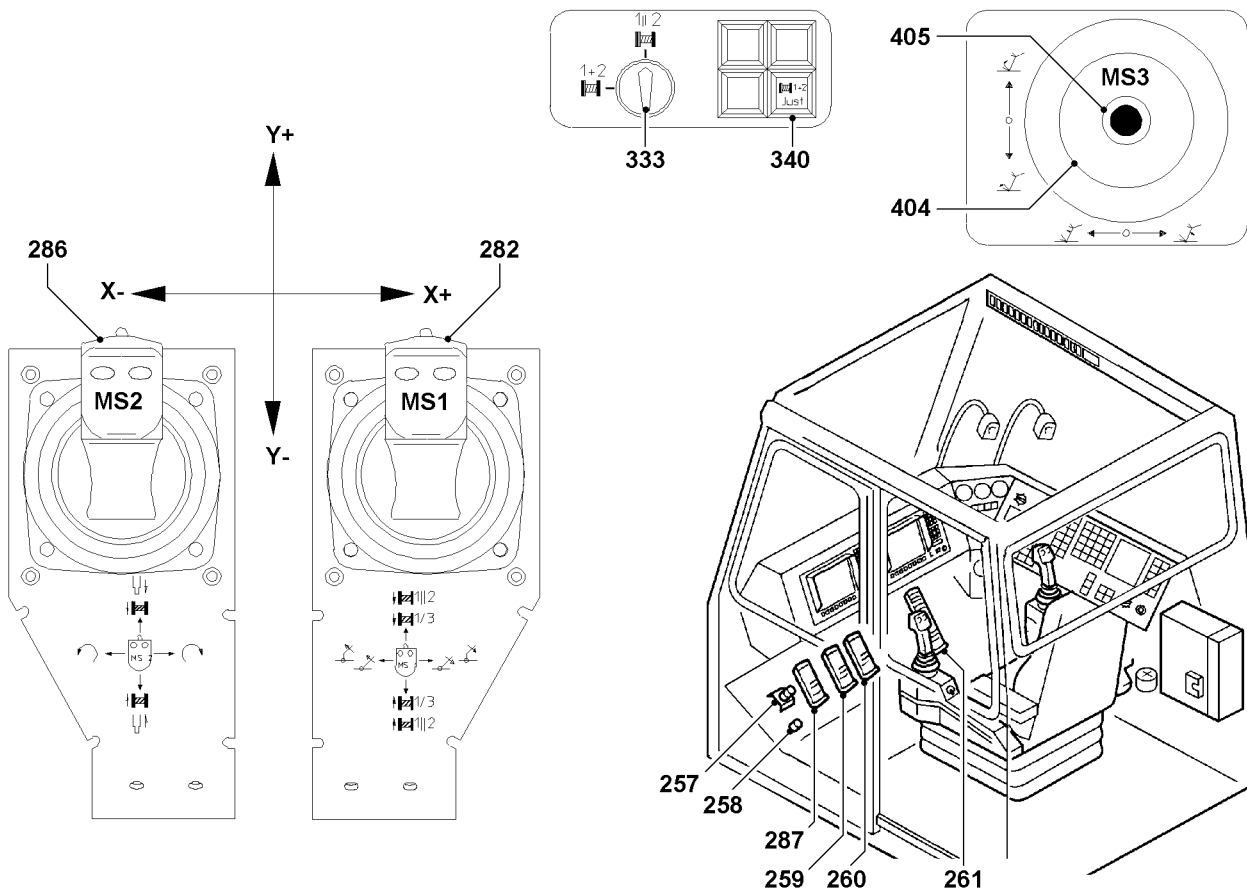
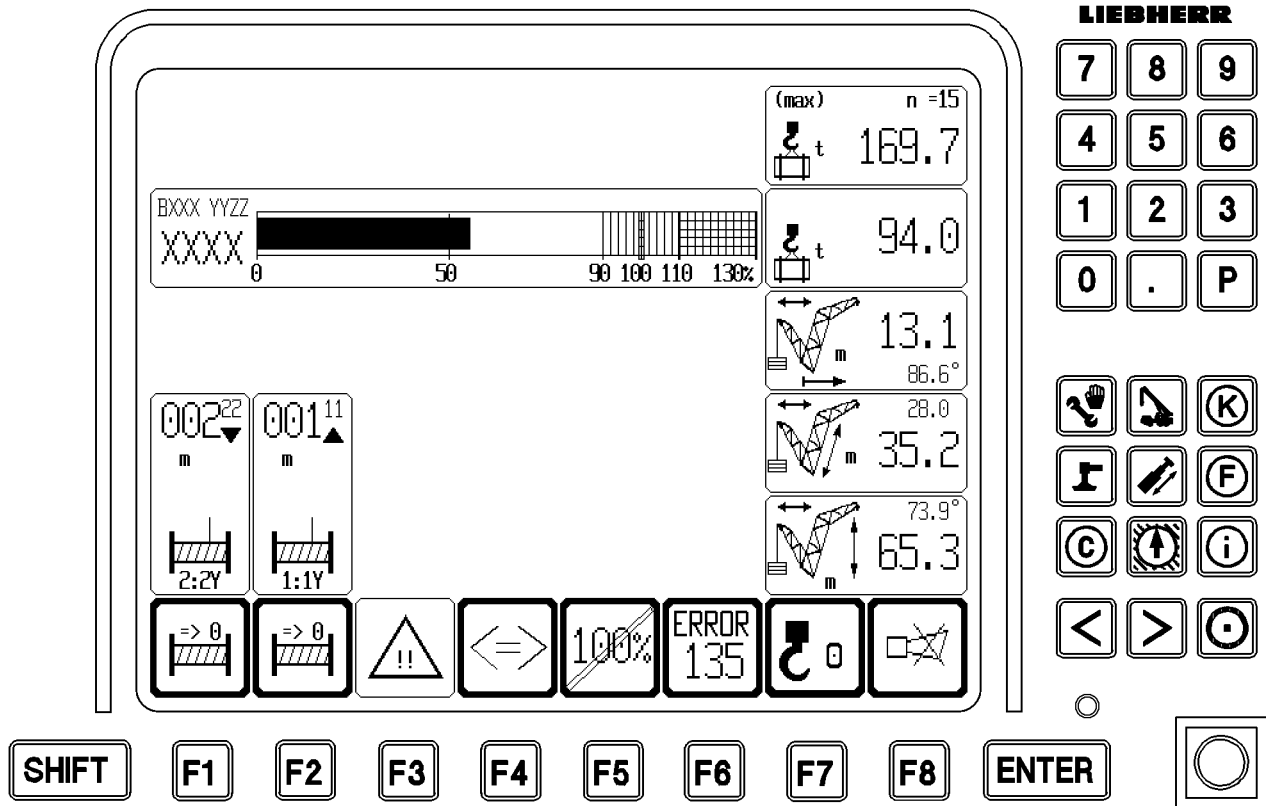

B104678

4.5.4 Parallel operation

**DANGER**

Risk of accident!

Due to errors in the set up of parallel operation, severe accidents can occur - despite the monitoring of the rotational speed of both winches by the electronic parallel control.

- ▶ Uneven rope lengths of winches 1 and 2 are prohibited in parallel operation!
 - ▶ Uneven reevings of winches 1 and 2 are prohibited!
 - ▶ The crane operator is obligated to check winches 1 and 2 during crane operation for their winding behavior!
 - ▶ The crane operator must ensure that the double hook blocks are always on the same level. If necessary, the winches must be readjusted!
-

**DANGER**

Risk of accident!

The compensating cross bar on the double hook blocks must always be horizontal.

If the compensation cross bar is inclined, then significant load increases will occur on the individual hook blocks.

If this is not observed, then the hook block, boom or ropes can be overloaded, resulting in property damage and personal injury.

- ▶ Make sure that the compensating cross bar is always horizontally aligned.
-

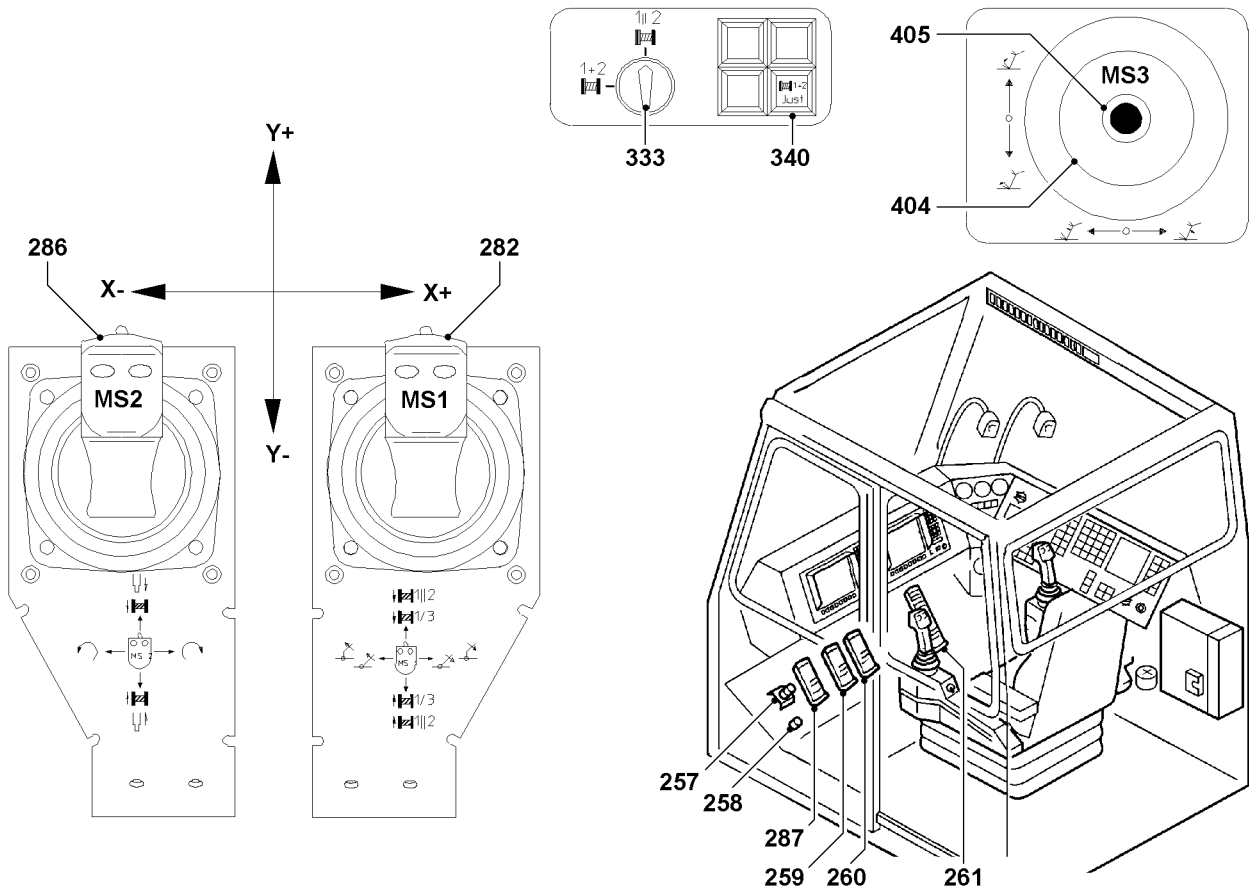
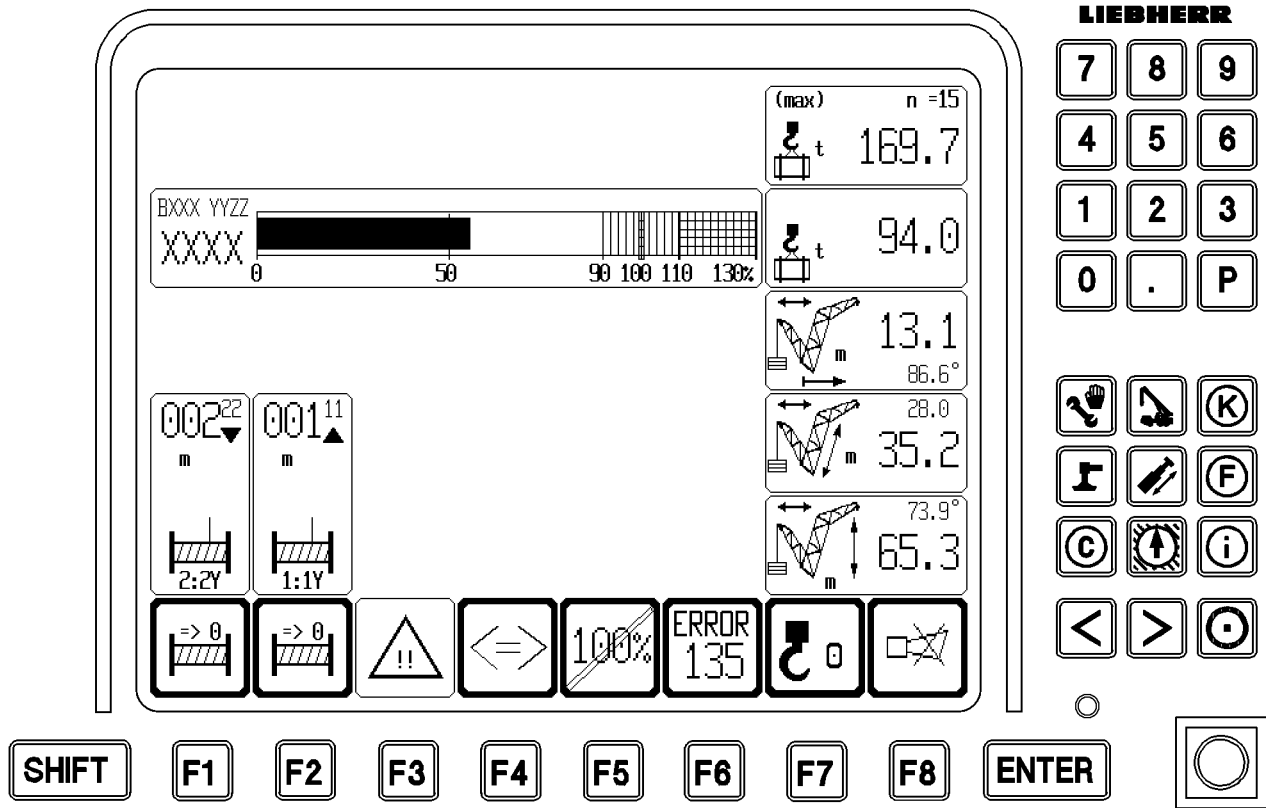

B104678

5 Luffing



DANGER

Crane can be damaged or topple over!

If the LICCON overload protection turns off when attempting to lift the load with the winch, do not luff up the boom.

- ▶ Do not lift the load by luffing up the boom, see chapter 4.04.

The speed of crane movement “luffing” is controlled by the deflection of the corresponding master switch and via the pedal **261** of the engine regulation.

5.1 Luffing the main boom at S/SL/SD/SLD/SDWV(B,BW) operation

- ▶ Deflect the master switch 1 **282** in direction X-.

Result:

- The main boom is luffed up.

- ▶ Deflect the master switch 1 **282** in direction X+.

Result:

- The main boom is luffed down.

5.2 Luffing the main boom in SW/SDW(B,BW)-operation

- ▶ Deflect the master switch 3 **404** in direction X-.

Result:

- The main boom is luffed up.

- ▶ Deflect the master switch 3 **404** in direction X+.

Result:

- The main boom is luffed down.

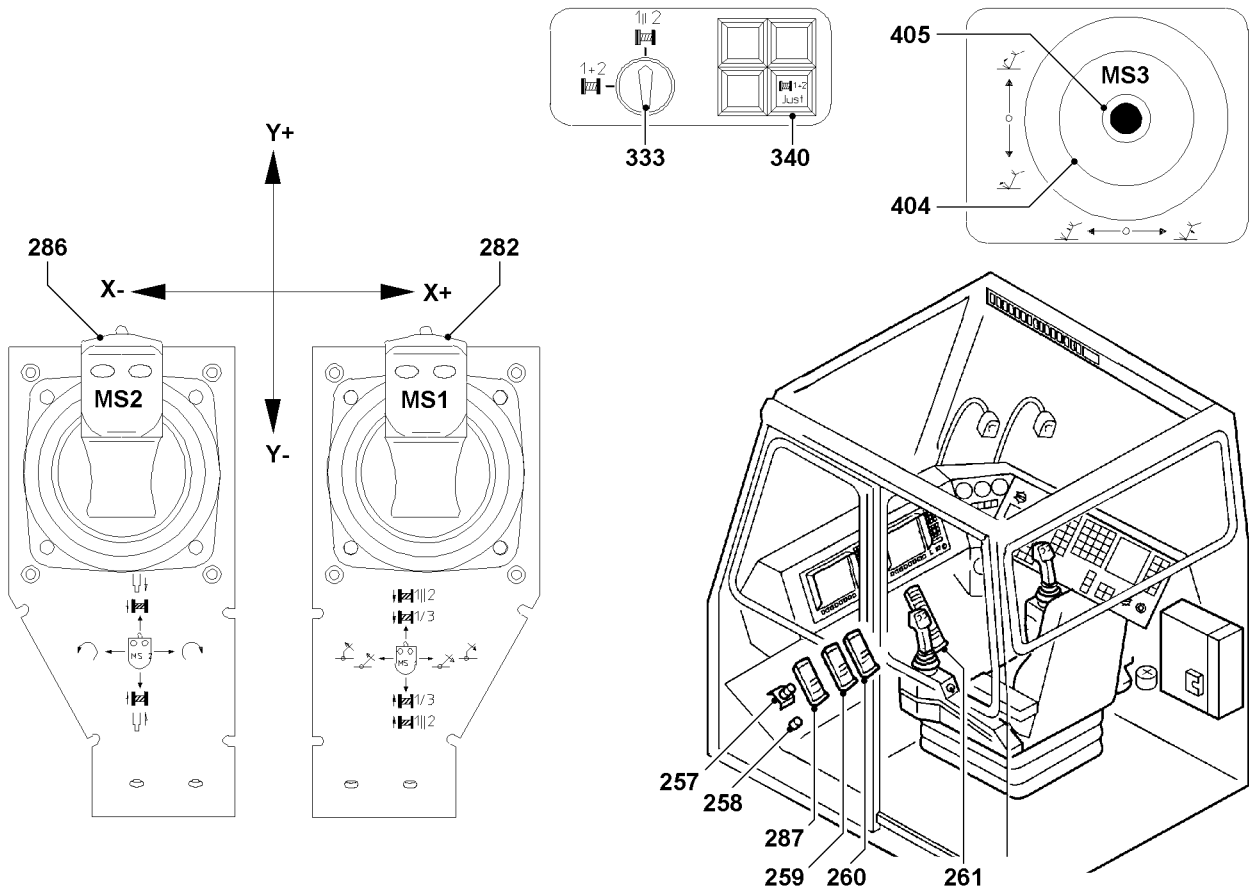
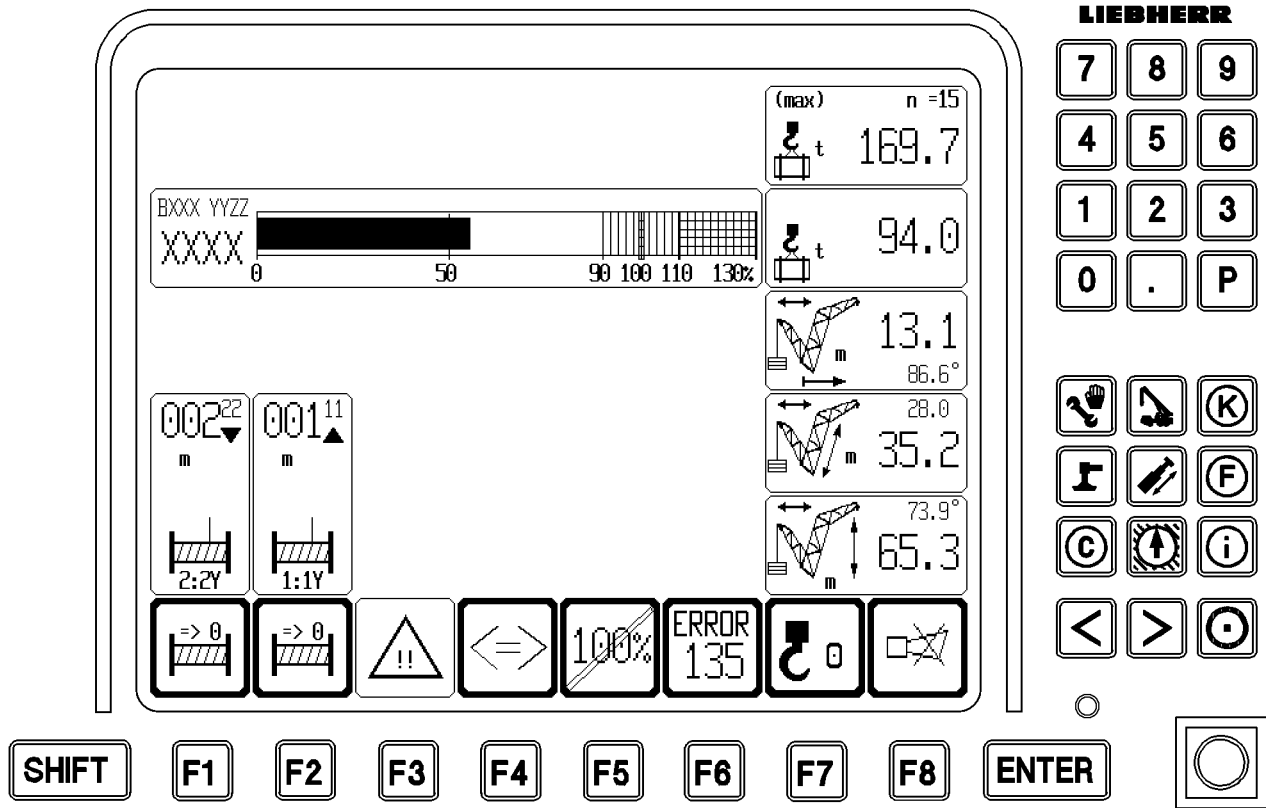

B104678

5.3 Luffing the lattice jib in SW/SDW(B,BW) operation

- ▶ Deflect the master switch 1 **282** in direction X-.

Result:

- The lattice jib is luffed up.

- ▶ Deflect the master switch 1 **282** in direction X+.

Result:

- The lattice jib is luffed down.

5.4 Luffing the derrick, for all D operating modes

- ▶ Deflect master switch 3 **404** in direction Y-.

Result:

- The derrick is luffed up.

- ▶ Deflect master switch 3 **404** in direction Y+.

Result:

- The derrick is luffed down.

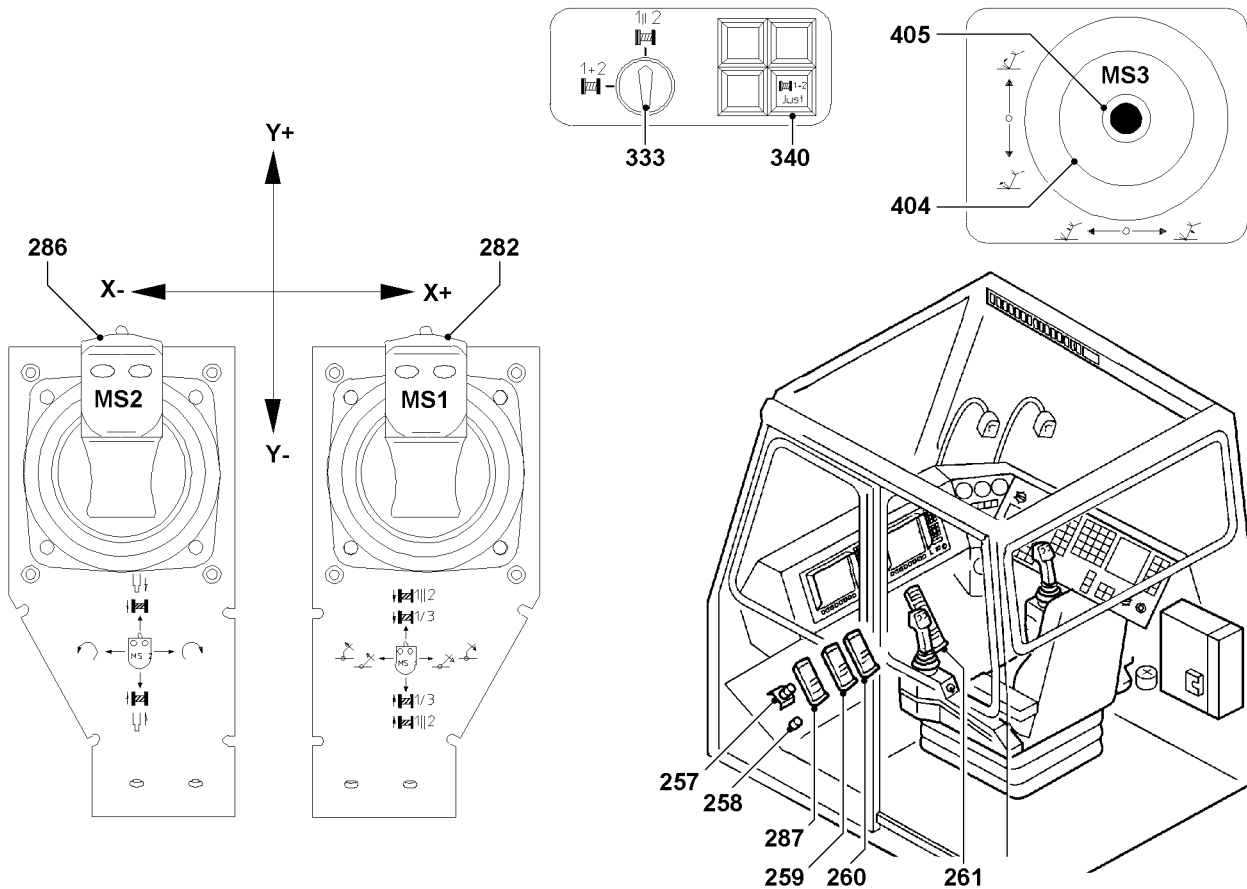
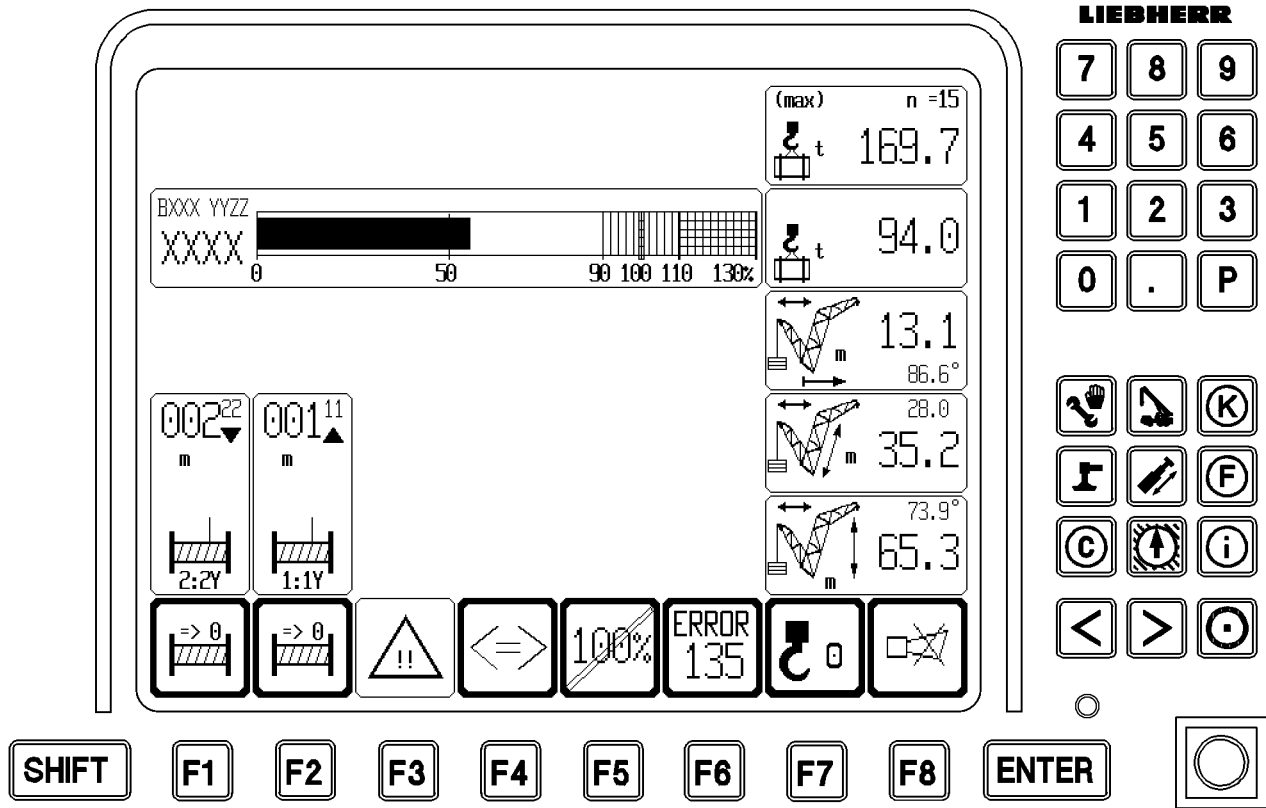

B104678

6 Turning

Speed of the “turning” crane movement is controlled via the deflection of master switch 2 **286** and via the pedal **261** of the engine regulation.



Note

- ▶ **The following applies:** the longer the boom and the larger the load, the lower is the rotational speed.

In the “Control Parameter” program, it is possible to preselect the maximum rotational speed. See chapter 4.02, section “Control Parameter”.

The load chart manual gives the maximum rotational speeds in percentages. These values depend on the boom length and the operating mode, and may not be exceeded under any circumstances.

6.1 Turning the crane superstructure



DANGER

Risk of fatal injury!

- ▶ Ensure that there are no obstacles in the crane working area and no persons in the danger zone.
- ▶ Give a short warning signal (horn) before starting a crane movement.



DANGER

Risk of fatal injury!

A swaying load can damage the crane and cause it to topple.

- ▶ The maximum permissible rotational speeds according to the load chart manual must be observed!
- ▶ When turning with a load, initiate and slow down the turning movement very sensitively.

- ▶ Deflect the master switch 2 **286** in direction X+.

Result:

- The crane superstructure turns to the right.

- ▶ Deflect the master switch 2 **286** in direction X-.

Result:

- The crane superstructure turns to the left.

6.2 Slewing gear, general

This crane is equipped with a “closed circuit slewing gear”.

With a “closed circuit slewing gear”, the braking effect starts as soon as master switch 2 **286** is moved towards the neutral position.

The parking brake is released as soon as master switch 2 **286** is moved away from the neutral position.

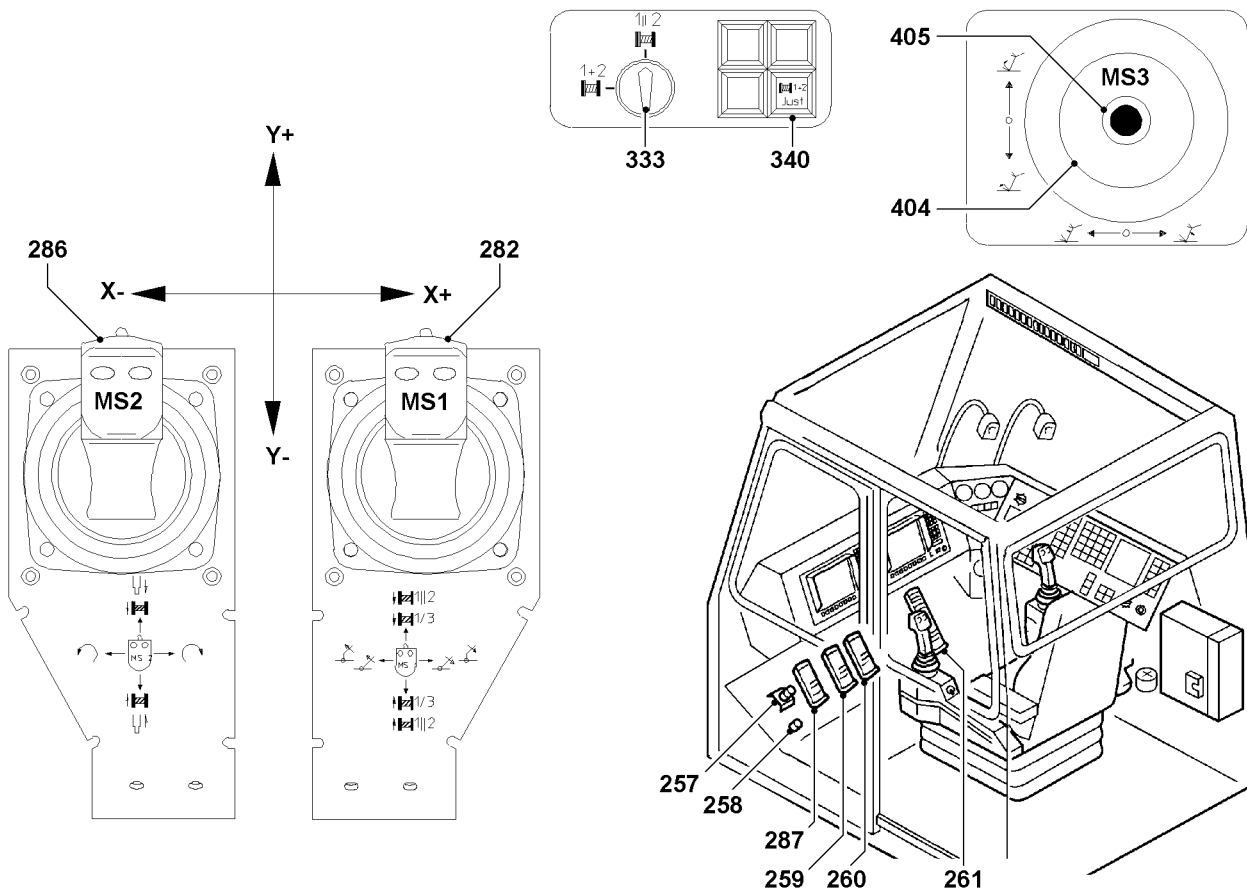
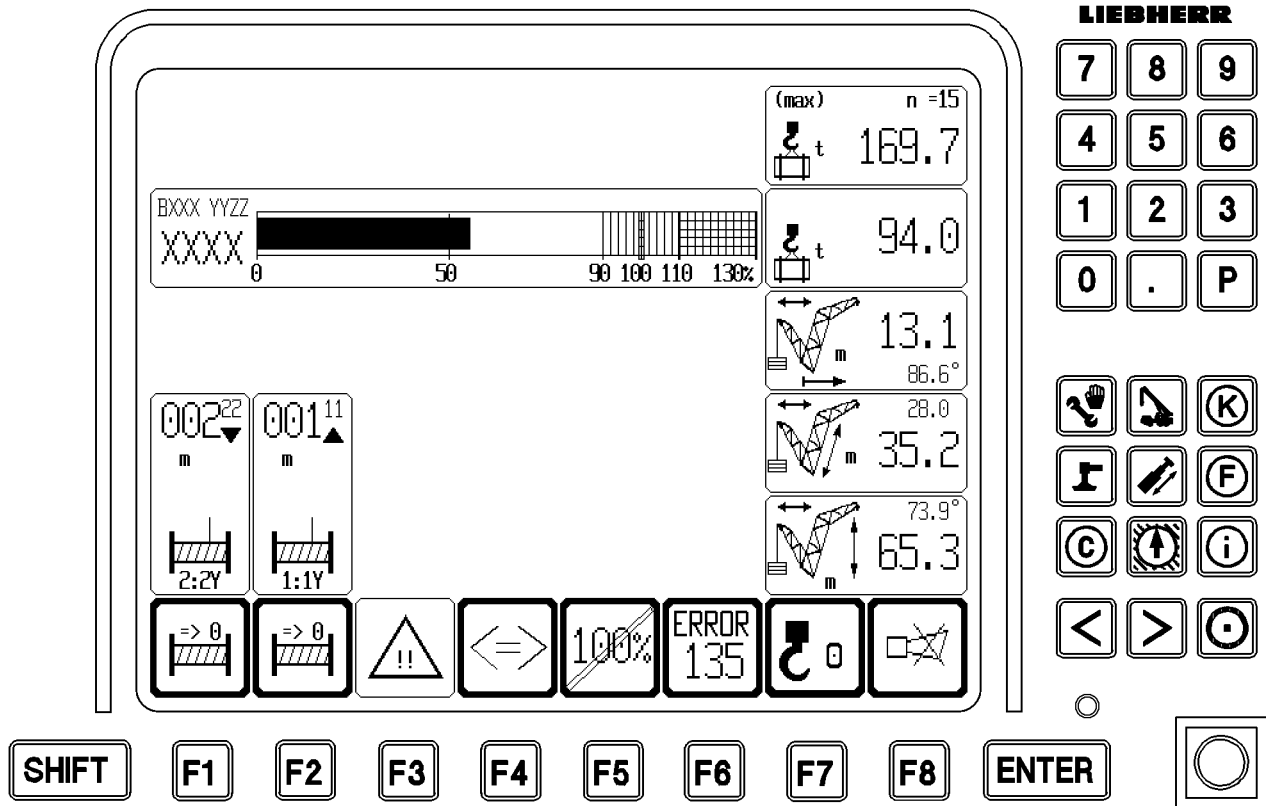

B104678

6.3 Switching the slewing gear to coasting

The slewing gear can be switched to coasting to be able to simply position the boom over the load to be lifted. The master switch 2 **286** must be in neutral position.

The slewing gear **cannot** be switched to coasting in these situations:

- Slewing gear shut off by the LICCON overload protection.
- Activated working range limitation.

▶ Press the foot button **257**.

Result:

- The slewing gear is switched to coasting.

Troubleshooting

With the slewing gear released, the superstructure turns unintentionally to the side (for example due to wind).

- ▶ Do not release the foot button **287**.
 - ▶ Deflect the master switch 2 **286** in slewing direction and then release the foot button **287**.
 - ▶ Slow down the slewing movement by slowly resetting the master switch 2 **286**.
-

6.4 Adding the slewing gear brake (block)



CAUTION

Destruction of the roller slewing ring connection or the slewing gear!

Due to improper use of the slewing gear brake **287**, the roller slewing ring and/or the slewing gear can be destroyed or heavily damaged!

- ▶ Do not use the slewing gear brake **287** as an operational slewing gear brake, since the slewing gear brake cannot slow down the full rotational momentum.
 - ▶ The slewing gear brake **287** may only be used at **minimum** rotational speeds, in other words with master switch 2 **286** almost in the neutral position.
 - ▶ Do not brake the turning movement of the crane by moving the master switch 2 **286** back to the neutral position and/or by abruptly applying the slewing gear brake **287**!
-

The slewing gear brake **287** is only to be used in the following situations:

- 1.) Starting out in strong side wind
- 2.) Stopping the slewing movement in strong side wind

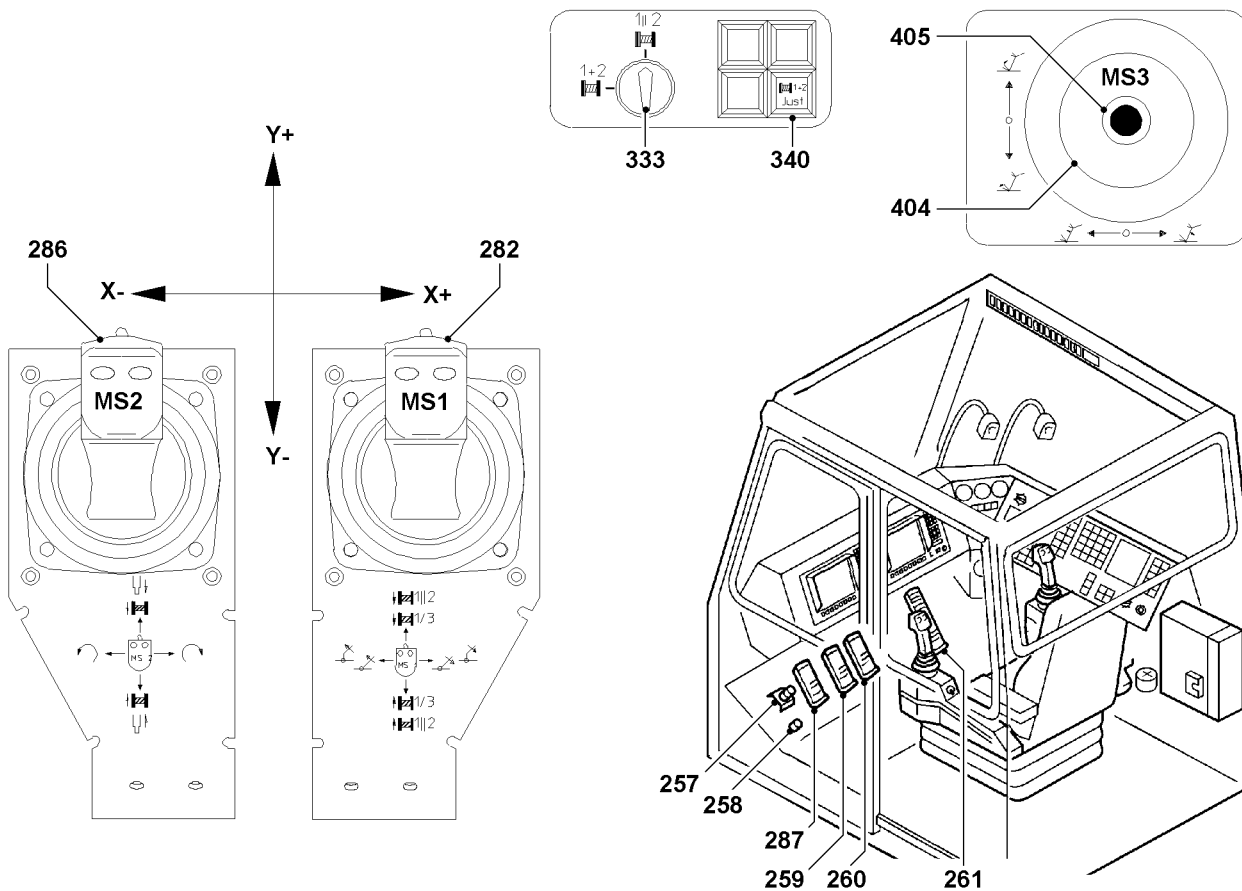
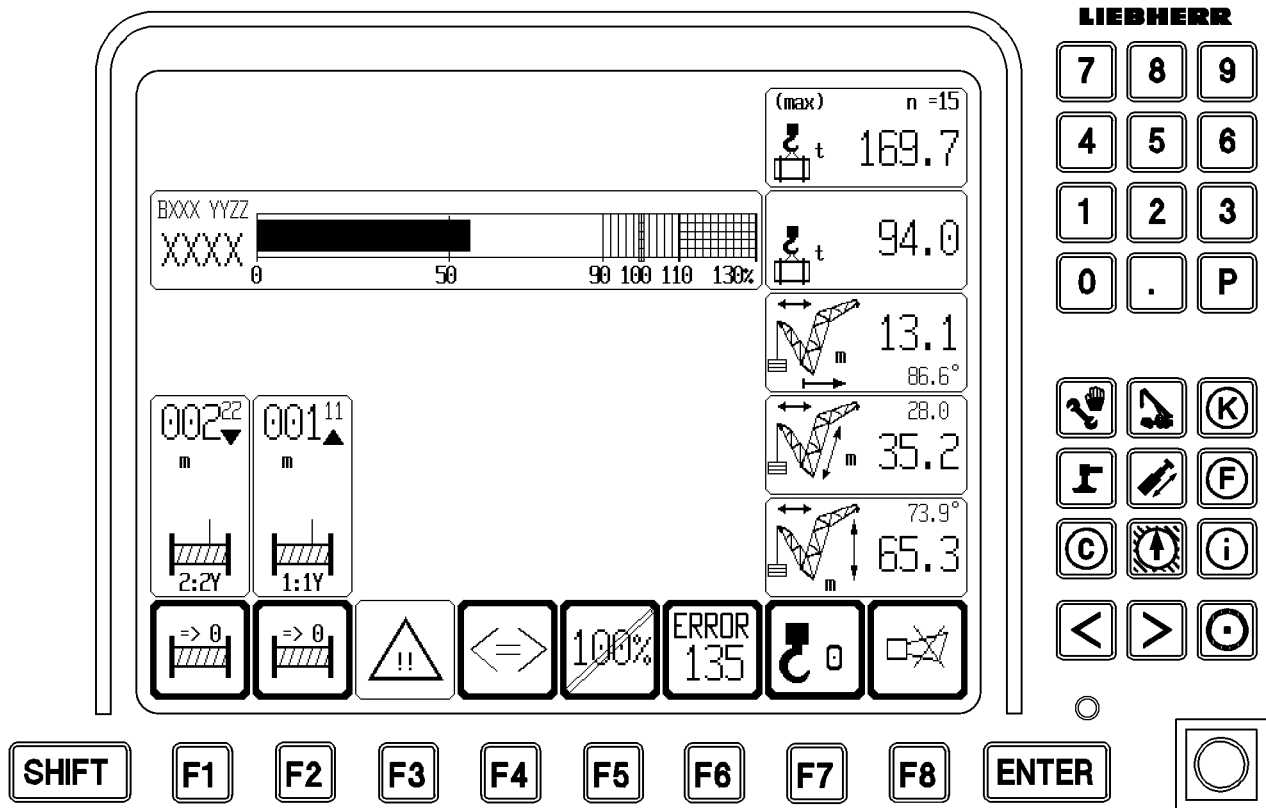

B104678

6.4.1 Starting out in strong side wind

When turning against the wind in strong side wind and with a long boom system, then the superstructure will turn into the opposite direction due to leakage in the hydraulic motor.

This can be avoided as follows:

- ▶ Actuate the slewing gear brake **287**.
- ▶ Deflect the master switch 2 **286** into the desired turning direction.
- ▶ Slowly release the slewing gear brake **287**.

Result:

- The crane superstructure turns into the desired direction.

6.4.2 Stopping the slewing movement in strong side wind

- ▶ Slow down the crane with master switch 2 **286** to minimum turning speed.
- ▶ Apply the slewing gear brake **287** carefully, until the crane superstructure has come to a standstill at the desired position.

1

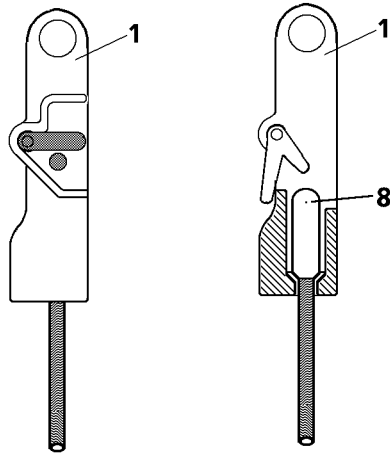

2

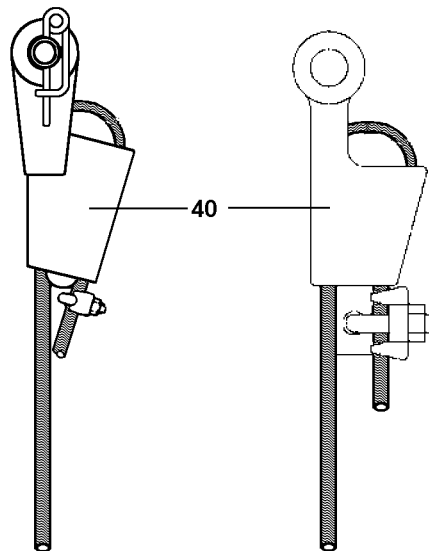

1 Wire ropes and rope end connections

1.1 Wire ropes

Please check if a **non-rotating** or a **rotation-resistant** rope is required for the application. The type of rope that is selected then determines the required type of rope end connections, see Crane operating instructions, chapter 8.04.



Note

- ▶ The correct choice and use of wire rope and rope end connections are decisive preconditions for proper and accident-free crane operation!



DANGER

Danger of serious personnel injury and equipment damage!

- ▶ **Never** use rotation-resistant ropes with a rotating rope end connection!
- ▶ **Never** install a twist compensator / swivel!

1.2 Rope end connections

Rope end connections are grouped into:

- Rope end connections with locking clamp **8**.
For that, use a rope lock **1**, see illustration **1**.
- Rope end connections without locking clamp.
For that, use a wedge lock **40**, see illustration **2**.

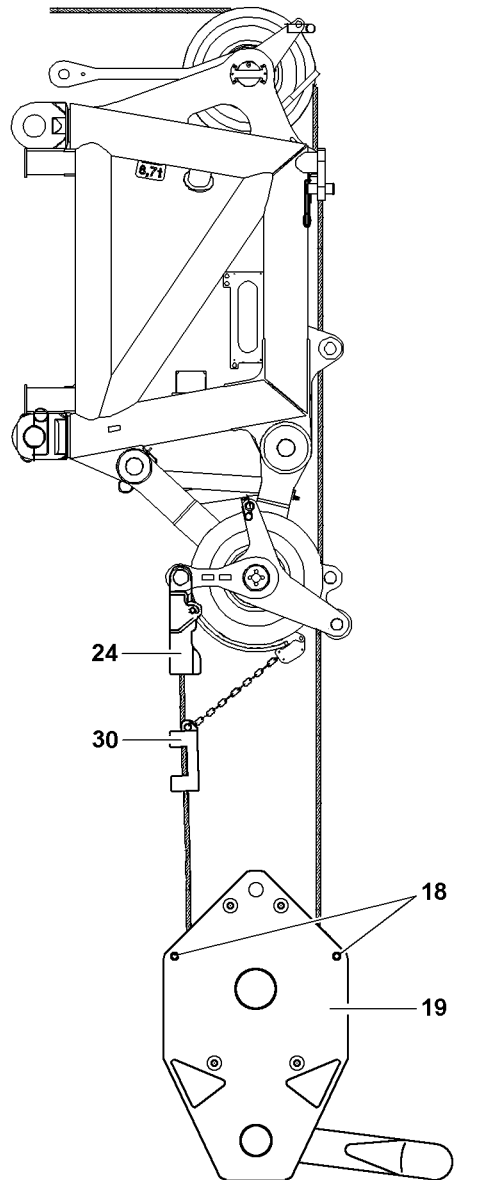
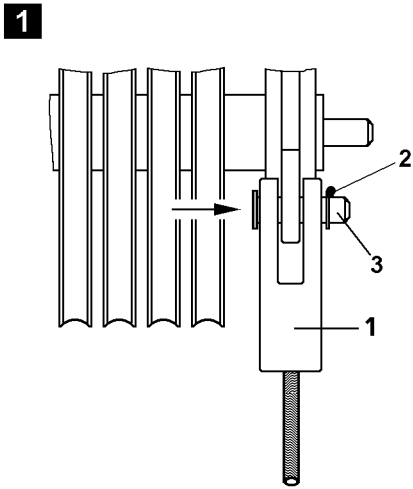
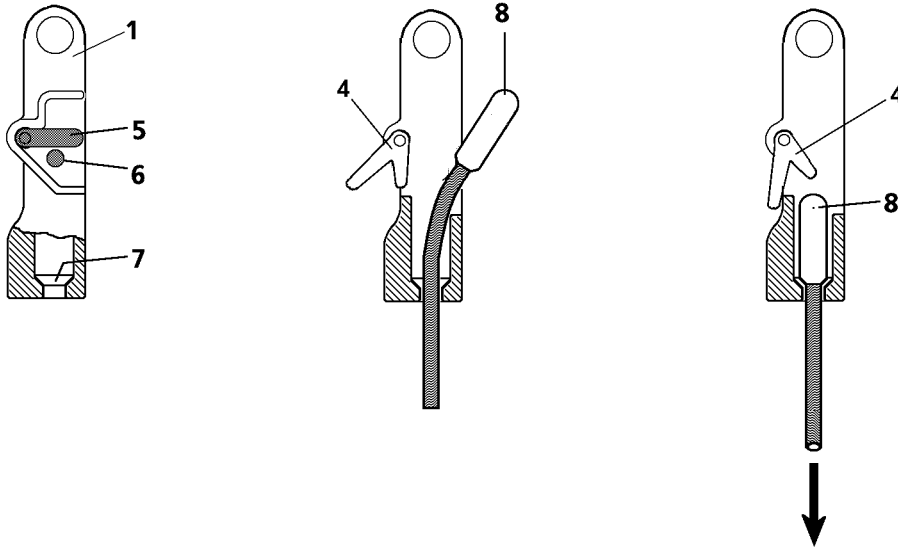

2 Reeving the hook block in and out



WARNING

Erroneous operation of crane function and danger of slipping on the boom!

If the following notes are not observed and adhered to, personnel can be severely injured or killed!

- ▶ Step on the boom only via the catwalks!
- ▶ The assembly personnel must secure themselves for all work on the lattice mast boom with approved antifall systems, on the safety ropes or on the lattice sections, with snap hook on both sides to prevent them from falling!
- ▶ Complete the assembly work from a stable location!
- ▶ Observe and adhere to the assembly guidelines in chapter 5.01 of the crane operating instructions!

2.1 Reeving in the hook block



WARNING

The hook block can fall over!

If the pins **2** are **not** inserted into the hook block before setting the hook block down, the hook block can fall over when unreeving the hoist rope!

Personnel can be severely injured or killed!

- ▶ Pin in the pin **2**, see chapter 5.19 of the crane operating instructions!



Note

- ▶ The reeving of the hoist rope can be carried out manually or with the aid of the assembly winch!
- ▶ Make sure that no slack rope forms during reeving!

NOTICE

Damage to the hoist rope!

An incorrectly reeved hoist rope or the incorrect selection of the rope fixed point can cause the hook block not to hang vertically and thus cause damage to the hoist rope!

- ▶ Always carry out the reeving of the hoist rope according to the reeving plan!
- ▶ The rope fixed point on the hook block is to be selected in such a way that the last strand runs parallel to the remaining rope strands, as much as possible!

Make sure that the following prerequisites are met:

- the crane is aligned in horizontal direction,
- the hook block is set down on the ground properly,
- the boom is luffed down to the point where the pulley head is above the hook block,
- an assistant is present to guide the hoist rope.

2.1.1 Procedure

- ▶ Release and unpin the rope retaining pipe on the hook block.
- ▶ Release and unpin the rope retaining pipes on the back pulley and on the pulley head.

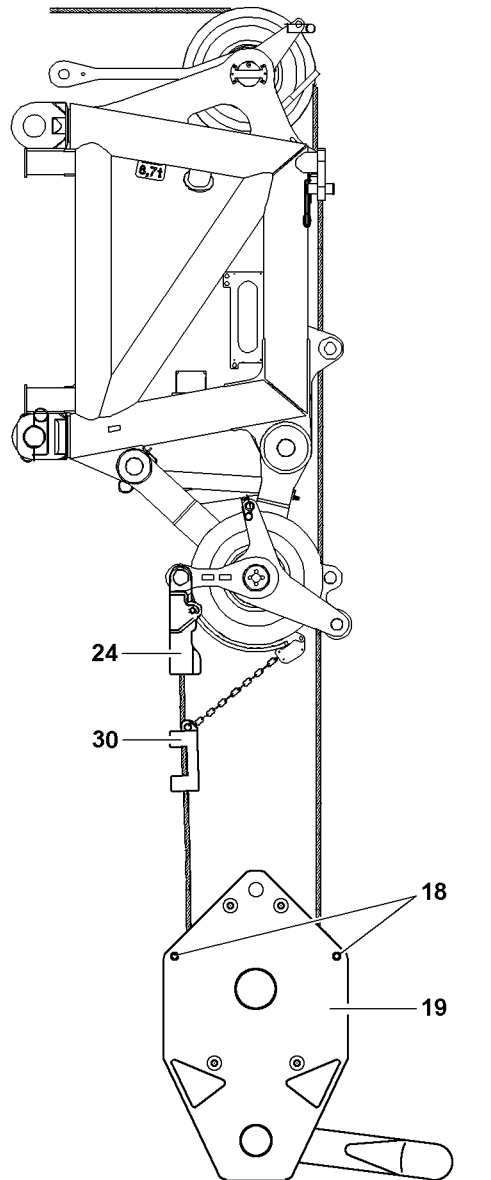
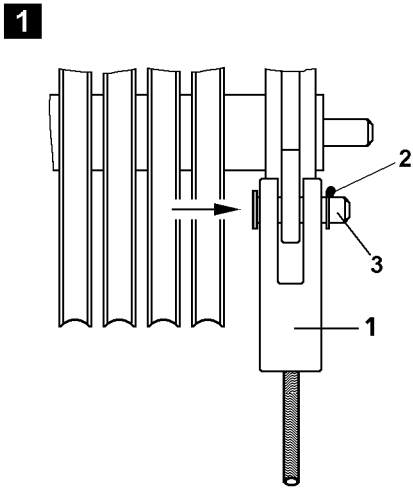
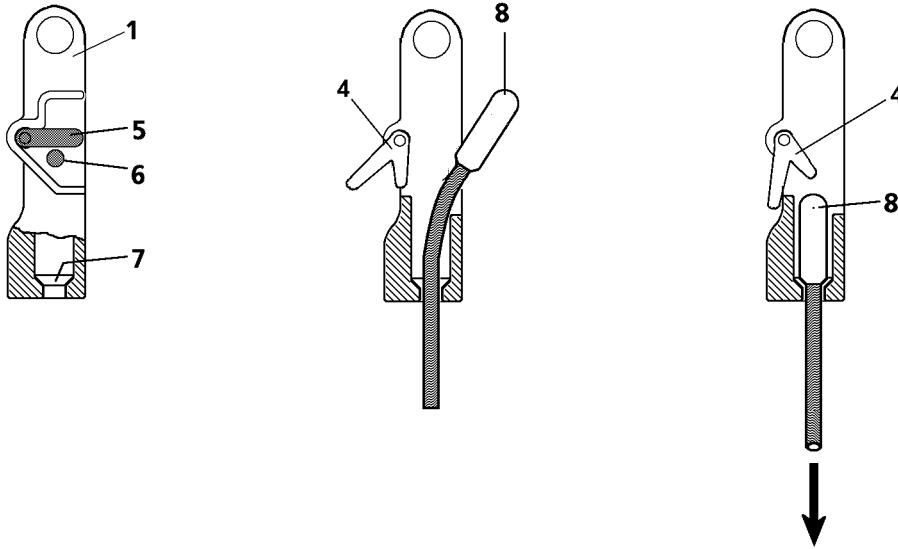

B108211

2.1.2 Manual reeving

- ▶ An assistant guides the hoist rope over the boom to the pulley head and at the same time, the crane operator spools the hoist winch out.
- ▶ Place the hoist rope of the back pulley and reeve in according to the reeving plan between the pulley head and the hook block.
- ▶ When the hook block is completely reeved in:
Insert the rope retaining pipes again and secure with spring retainers.

2.1.3 Reeving with assembly winch

- ▶ Reeve in the auxiliary rope in the reverse direction between the hook block and the pulley head.
- ▶ Connect the auxiliary rope with the hoist rope.
- ▶ Unwind the hoist rope from the hoisting winch and simultaneously wind up the auxiliary rope of the assembly winch.
- ▶ When the hook block is completely reeved in:
Insert the rope retaining pipes again and secure with spring retainers.

2.1.4 Hook the hoist rope on the rope lock

NOTICE

Scraping of hoist rope!

If the pin **3** has been assembled incorrectly, the hoist rope may rub against the pin **3** or on the linch pin **2**!

Hoist rope, pin **3** and linch pin **2** are damaged!

- ▶ Always insert pins **3** from “inside to outside” and secure them from the outside, see illustration **1**.

- ▶ The rope lock **1** must be pinned in either at the pulley head or on the hook block and secured with linch pins **2**, depending on reeving.
- ▶ On the rope lock **1**, push the retaining pin **6** in.
- ▶ Swing the lever **5** “down” and hold it in this position.

Result:

- The latch **4** will be swivelled “downward”.

- ▶ Attach the rope end with the locking clamp **8** in the rope lock **1** and pull “down” firmly (in direction of arrow), until the locking clamp **8** is touching in the cone **7**.

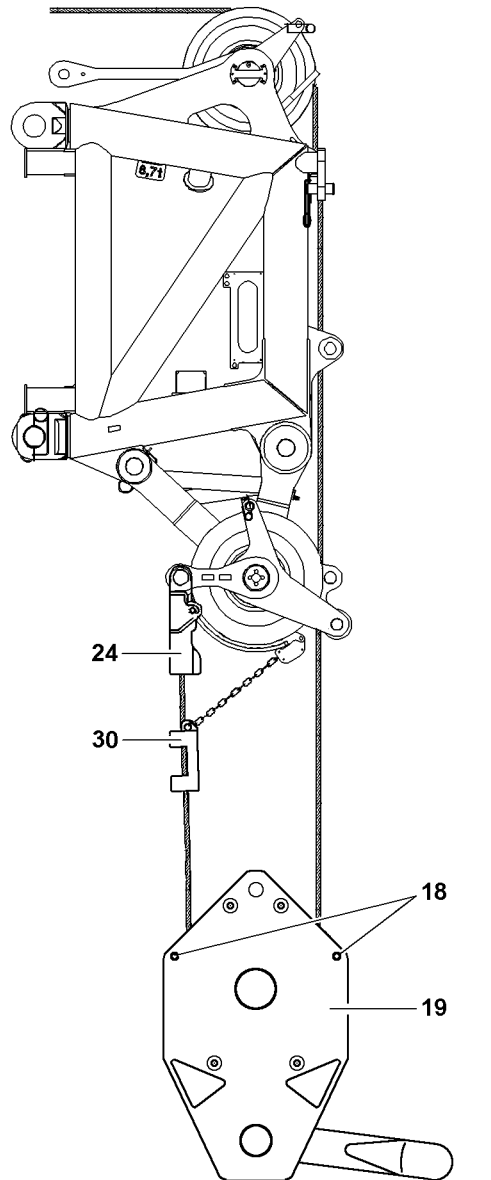
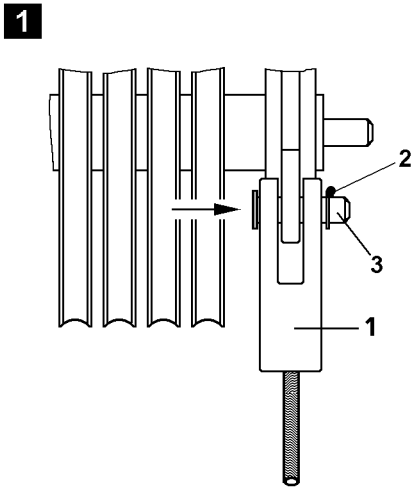
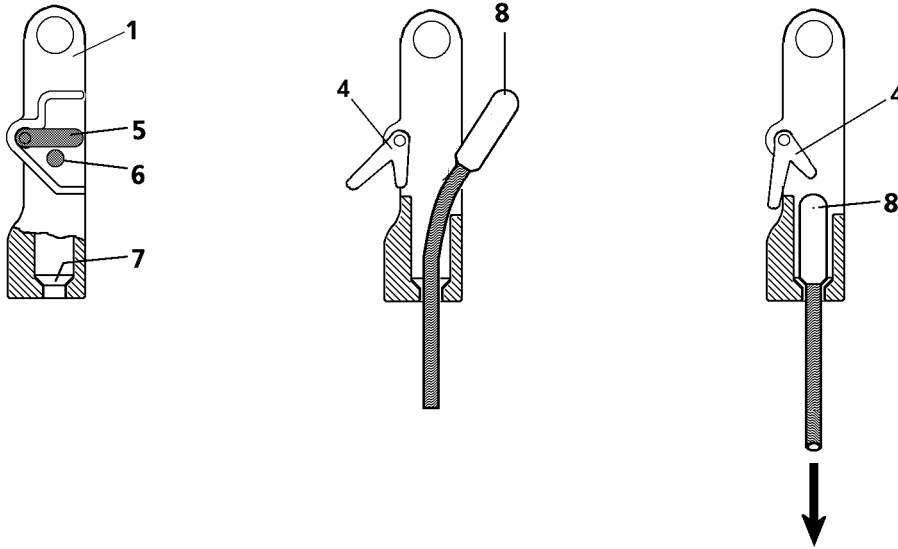

B108211

**WARNING**

Incorrectly secured locking clamp!

If the locking clamp **8** is hooked and secured incorrectly or insufficiently in the rope lock **1**, then the load and the hook block can fall down!

Personnel can be severely injured or killed!

- ▶ The locking clamp **8** must touch on the cone **7** after hanging it into the rope lock **1** and must be secured by the latch **4**!

- ▶ Release the lever **5**.

Result:

- The lever **5** returns to the initial position and is locked by the retaining pin **6**.

- ▶ Check the rope retainer. Check visually!

2.1.5 Preparing the hook block for crane operation

- ▶ Raise the boom or spool the hoist rope up until the hook block is completely lifted off the ground.

**Note**

- ▶ See chapter 5.19 of the crane operating instructions!

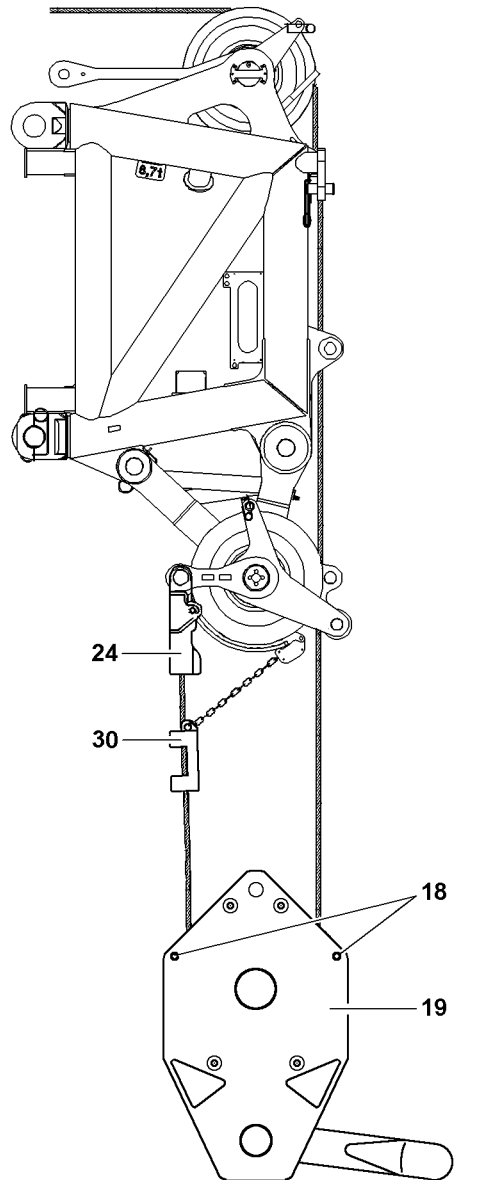
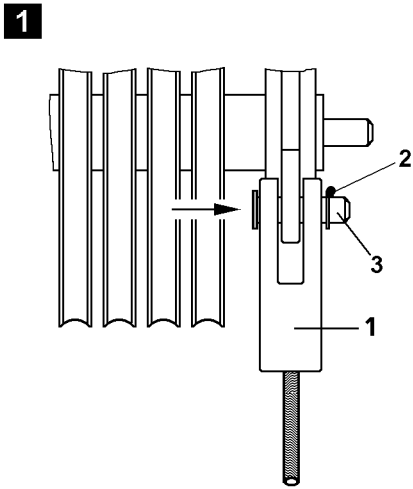
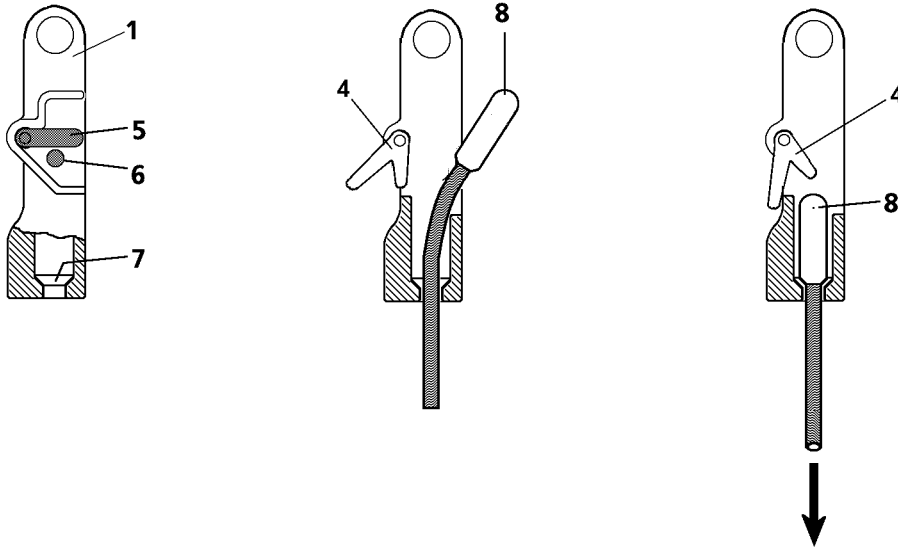

2.2 Unreeving the hook block

Make sure that the following prerequisites are met:

- the crane is aligned in horizontal direction,
- the ground is level and of sufficient load carrying capacity,
- the hook block is prepared for removal, see chapter 5.19 of the crane operating instructions,
- an assistant is present to guide the hoist rope.

2.2.1 Lowering the hook block



WARNING

Crushing of hands!

When guiding the hook block by hand, hands or fingers can be crushed!

When unreeving the hook block, it can topple over!

Personnel can be severely injured or killed!

- ▶ Use the handles in the safe area of the hook block!
- ▶ Make sure the hook block is safely positioned!

- ▶ Lower the hook block and set it on the ground.
- ▶ Remove the hoist limit switch weight, see section "Removing the hoist limit switch weight".

2.2.2 Detaching the hoist rope

- ▶ Push in retaining pin **6** on the rope lock **1** move the lever **5** downward and hold it in this position.

Result:

- The latch **4** is moved to the side and the locking clamp **8** is released.
- ▶ Push the hoist rope up and detach the locking clamp **8**.
- ▶ Release and unpin the rope retaining pipe on the hook block.
- ▶ Unreeve the hoist rope from the hook block and the pulley head.
- ▶ Insert the rope retaining pipes again and secure with spring retainers.

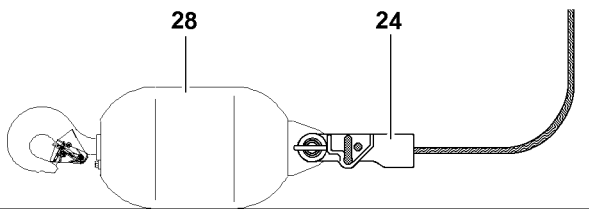
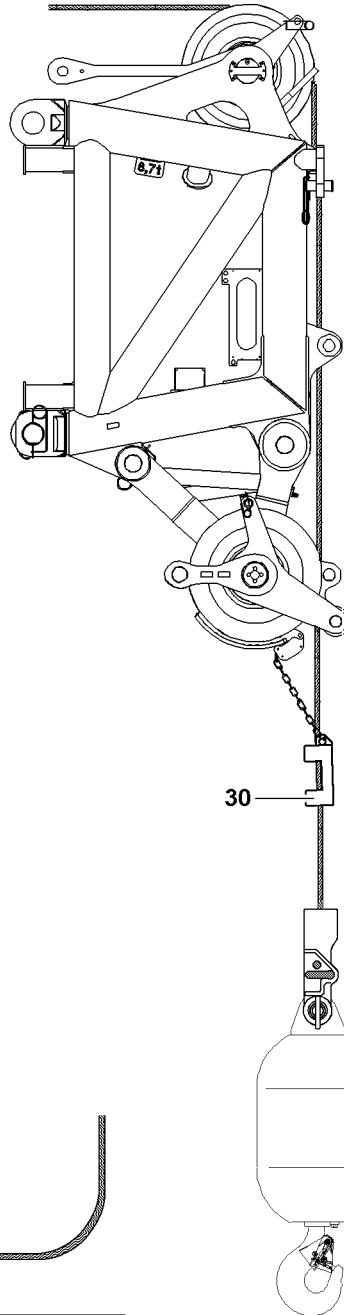
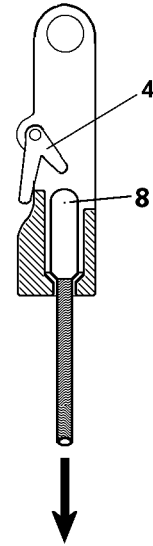
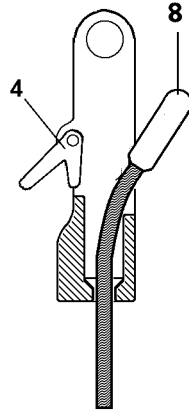
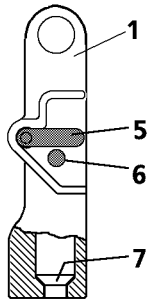

B108212

3 Securing and removing the load hook*

3.1 Securing the load hook*

3.1.1 Assembling the load hook*

- ▶ Place the load hook under the pulley head of the boom.
- ▶ Release and unpin the rope retaining pipes on the back pulley and on the pulley head.



WARNING

Erroneous operation of crane function and danger of slipping on the boom!

If the following notes are not observed and adhered to, personnel can be severely injured or killed!

- ▶ Step on the boom only via the catwalks!
- ▶ The assembly personnel must secure themselves for all work on the lattice mast boom with approved antifall systems, on the safety ropes or on the lattice sections, with snap hook on both sides to prevent them from falling!
- ▶ Complete the assembly work from a stable location!
- ▶ Observe and adhere to the assembly guidelines in chapter 5.01 of the crane operating instructions!

- ▶ An assistant guides the hoist rope over the boom to the pulley head and at the same time, the crane operator spools the hoist winch out.
- ▶ Place the hoist rope over the back pulley.
- ▶ Insert the rope retaining pipes again and secure with spring retainers.
- ▶ Pin the rope lock **1** in the load hook **26** and secure with spring retainers.

3.1.2 Fastening the hoist rope

- ▶ Push the retaining pin **6** in on the rope lock **1**, move the lever **5** to the side and hold it in this position.

Result:

- The latch **4** is moved to the side.

- ▶ Fasten the rope end with the locking clamp **8** in the rope lock and pull the rope firmly in the direction of the arrow, until the locking clamp **8** contacts the cone **7**.



WARNING

Incorrectly secured locking clamp!

If the locking clamp **8** is hooked and secured incorrectly or insufficiently in the rope lock **1**, then the load and the hook block can fall down!

Personnel can be severely injured or killed!

- ▶ The locking clamp **8** must touch on the cone **7** after hanging it into the rope lock **1** and must be secured by the latch **4**!

- ▶ Release the lever **5**.

Result:

- The lever **5** returns to the initial position and is locked by the retaining pin **6**.

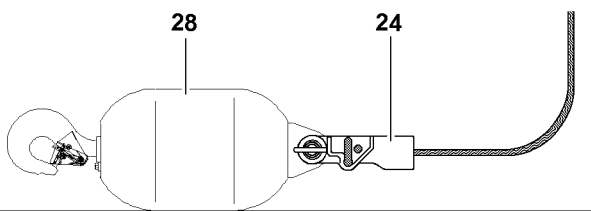
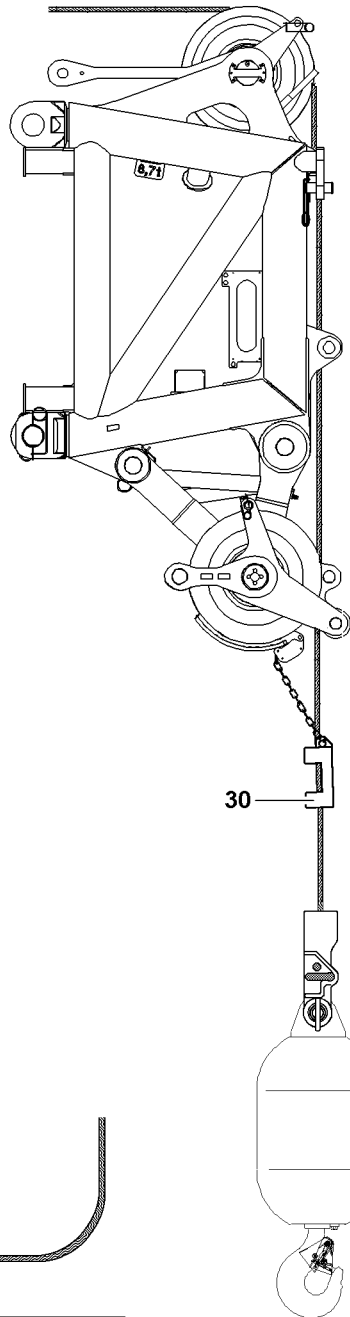
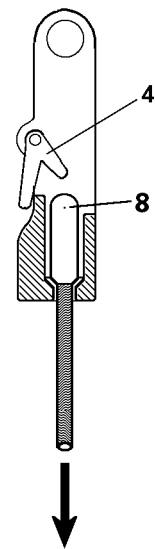
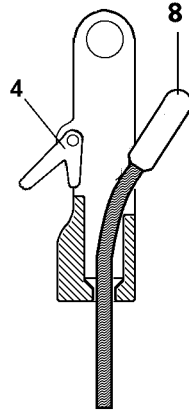
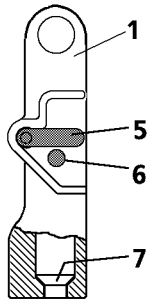

B108212

3.2 Removing the load hook*

Make sure that the following prerequisites are met:

- the crane is aligned in horizontal direction,
- an assistant is present to guide the hoist rope,
- the ground is level and of sufficient load carrying capacity.

3.2.1 Lowering the load hook



WARNING

Crushing of hands!

When guiding the load hook by hand, hands or fingers can be crushed!

The load hook could roll away!

▶ Make sure the load hook is safely positioned!

▶ Place the load hook **28** on the ground.

▶ Remove the hoist limit switch weight, see section "Removing the hoist limit switch weight".

3.2.2 Detaching the hoist rope

▶ Push the retaining pin **6** in on the rope lock **1**, move the lever **5** to the side and hold it in this position.

Result:

– The latch **4** is moved to the side and the locking clamp **8** is released.

▶ Push the hoist rope in the direction of the load hook and detach the locking clamp **8**.

▶ Remove the rope retaining pipes on the pulley head and on the back pulley.

▶ Lift the hoist rope from the rope pulleys.

▶ Insert the rope retaining pipes again and secure with spring retainers.

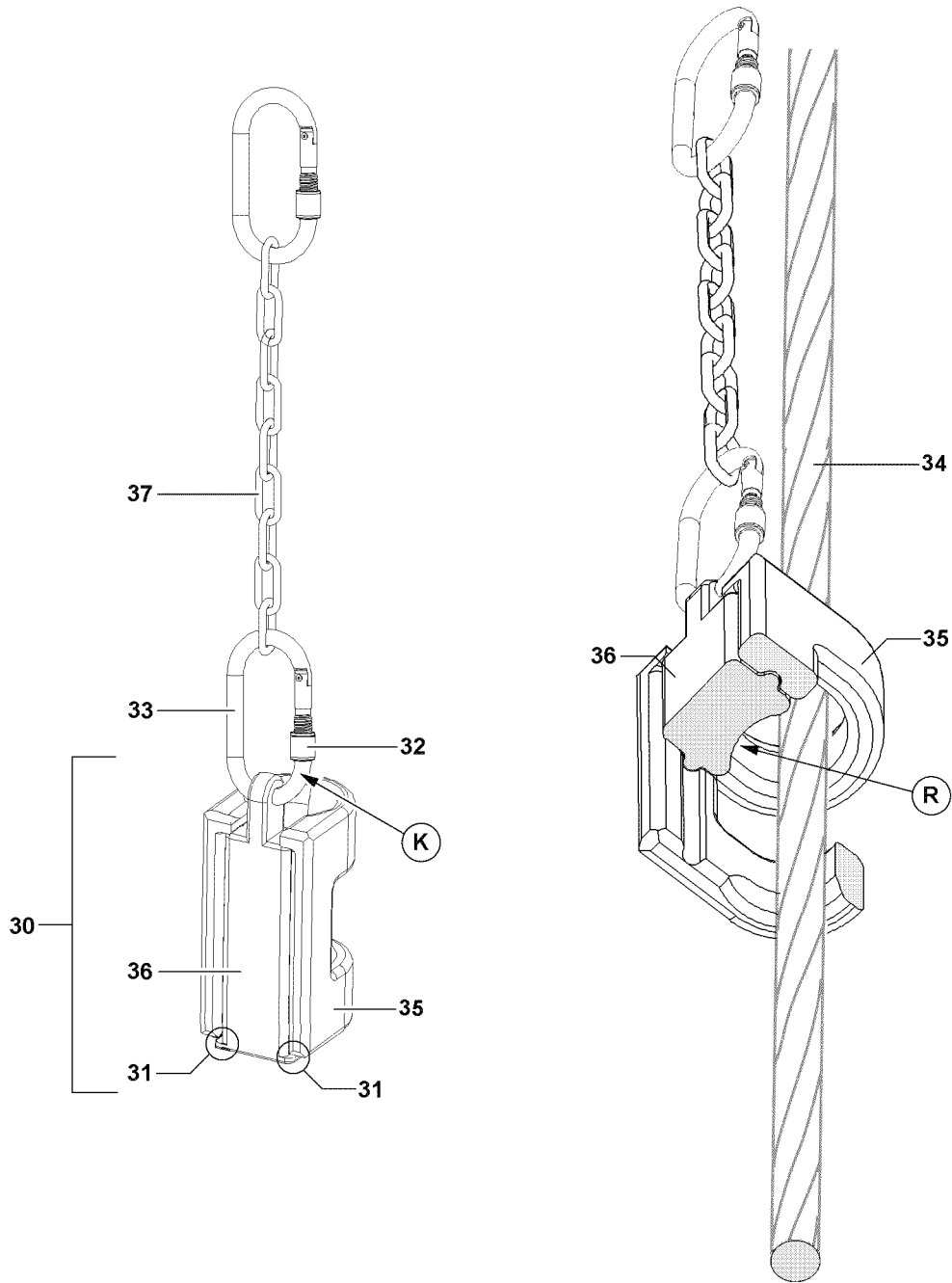

B106127

4 Attaching / removing the hoist limit switch weight

4.1 Attaching the hoist limit switch weight

The hoist limit switch weight **30** consists of 2 parts, which are pushed into each other:

- The weight **35**
- The carrier section **36**
- ▶ Loosen and open the screw retainer **32**.



WARNING

The hoist limit switch can fall down!

If the hoist limit switch weight is incorrectly assembled, components can fall down!

Personnel can be severely injured or killed!

- ▶ Do not replace the snap hook **33** with other parts, such as a shackle or similar!
- ▶ When detaching or fastening the hoist limit switch weight **30** make sure that the weight **35** and the carrier section **36** do not fall down!
- ▶ Make sure that the curvature **R** of the carrier section **36** points to the hoist rope **34**!
- ▶ Make sure that the stubs **31** of the carrier section **36** touch on the weight **35**!
- ▶ Make sure that the screw retainer **32** can be turned to be closed from top to bottom, point **K**!

The attachment of the hoist limit switch weight **30** depends on the position of the rope fixed point.

Rope fixed point on the pulley head:

- In the event of multiple hoist rope reeving, the hoist limit switch weight **30** must always be laid around the “stationary rope strand”, in other words around the rope strand that leads directly to the cable lock.

Rope fixed point on hook block:

- The hoist limit switch weight **30** is laid around the outer strand which shows the least diagonal pull, i.e. the one with the smallest angle between the hanging hoist limit switch weight and the hoist rope.



Note

- ▶ The chain **37** must be attached in full length during crane operation and may not be shortened.

- ▶ Push the weight **35** with one hand on the hoist rope **34** and hold.
- ▶ With the other hand, guide the carrier section **36** behind the hoist rope **34** and under the weight **35**. The curvature **R** of the carrier section **36** must point to the hoist rope **34**.
- ▶ Push the weight **35** on the carrier section **36**.
- ▶ Hang in the hoist limit switch weight **30** with the carrier section **36** in the snap hook **33**.

The snap hook **33** must be secured with the screw retainer **32**.

- ▶ Close the screw retainer **32** on the snap hook **33**.

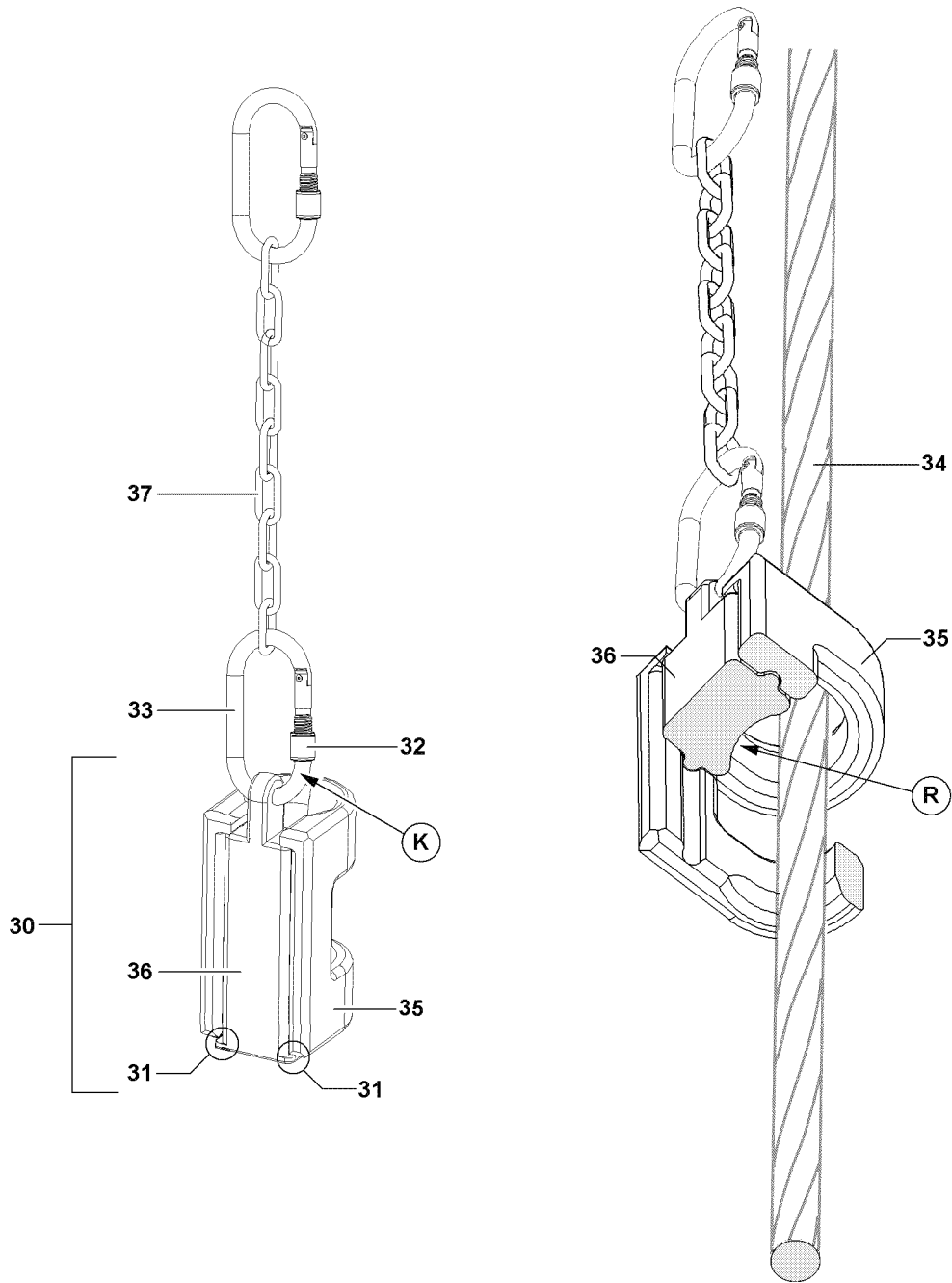

B106127

4.2 Removing the hoist limit switch weight



WARNING

The hoist limit switch can fall down!

If the hoist limit switch weight is incorrectly disassembled, components can fall down!

Personnel can be severely injured!

- ▶ When detaching or fastening the hoist limit switch weight **30** make sure that the weight **35** and the carrier section **36** do not fall down!
 - ▶ It is prohibited for anyone to remain in the danger zone!
-
- ▶ Release and open the screw retainer **32** on the snap hook **33**.
 - ▶ Detach the hoist limit switch weight **30** from the snap hook **33**.
 - ▶ Hold the weight **35** with one hand and with the other hand, push the carrier section **36** from the weight **35**.
 - ▶ Store the weight **35** and carrier section **36** safely.

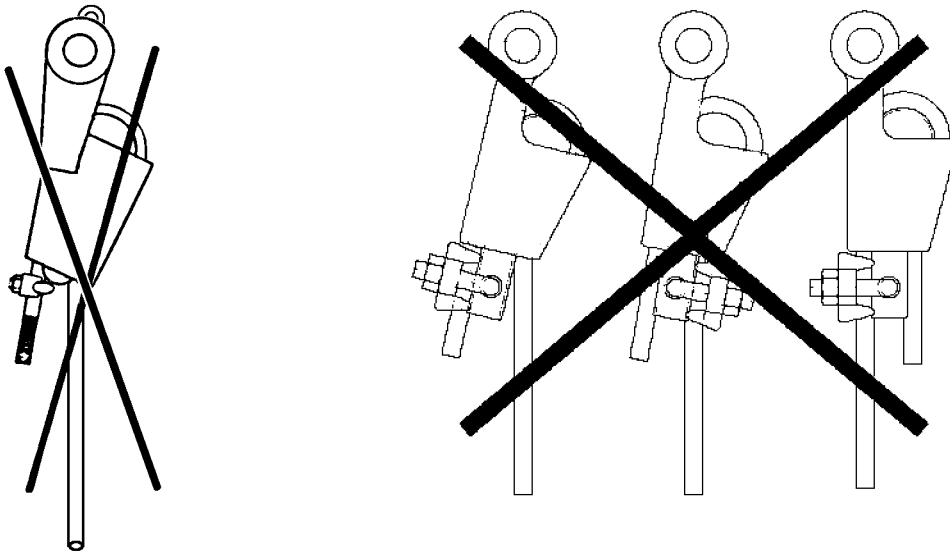
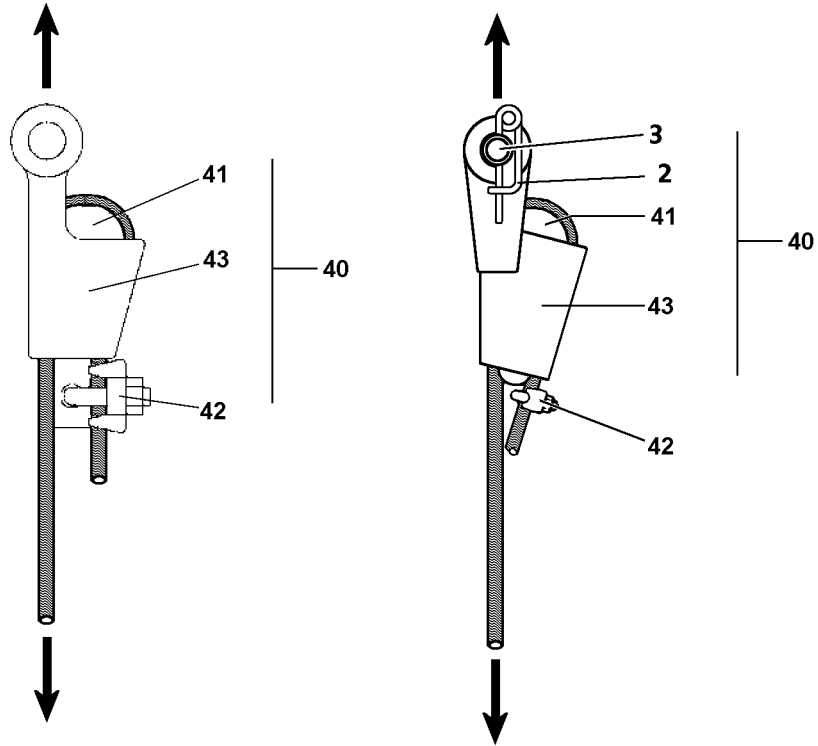

5 Assembling / disassembling the wedge lock

Make sure that the following prerequisites are met:

- the locking clamp is cut off on the hoist rope,
- the hook block or the load hook are ready for assembly.

5.1 Assembling the wedge lock



WARNING

Danger of fatal accidents due falling load!

If an incorrect wedge lock **40** is used or if the wedge lock **40** is incorrectly assembled, the hoist rope can rip off or the hoist rope can be pulled through the wedge lock **40**!

The hook block and the load can fall down and kill personnel!

- ▶ Use only a wedge lock **40** approved by **LIEBHERR-Werk Ehingen GmbH**!
 - ▶ Assembling the wedge lock **40** correctly!
 - ▶ Place the hoist rope with the wedge **41** into the housing **43** in such a way that the rope strand runs in the pull axle of the wedge lock **40**!
 - ▶ The dead end of the rope must be secured by the clamp **42** to prevent it from being pulled through!
 - ▶ It is prohibited for personnel to remain in the danger zone!
-
- ▶ Take a matching wedge lock **40** from the tool box.
 - ▶ Place the hoist rope with the wedge **41** into the housing **43**.
 - ▶ If possible, assemble the clamp **42** through the wedge **41** on the dead end of the rope.

NOTICE

Damage to the hoist rope!

If the pin **3** has been assembled incorrectly, the hoist rope may rub against the pin **3** or on the linch pin **2**.

- ▶ Always insert the pins **3** from “inside to outside” and secure from the outside.
-
- ▶ Pin and secure the wedge lock **40** on the fixed point of the pulley head or that of the hook block or on the load hook, depending on the reeving plan.

5.2 Disassembling the wedge lock

- ▶ Unpin the wedge lock **40** on the fixed point.
- ▶ Remove the clamp **42** and pull the hoist rope with the wedge from the housing.
- ▶ Store the wedge lock **40**.

6 Rope reeving



Note

- ▶ For reeving plans, see crane operating instructions, chapter 4.15!

1

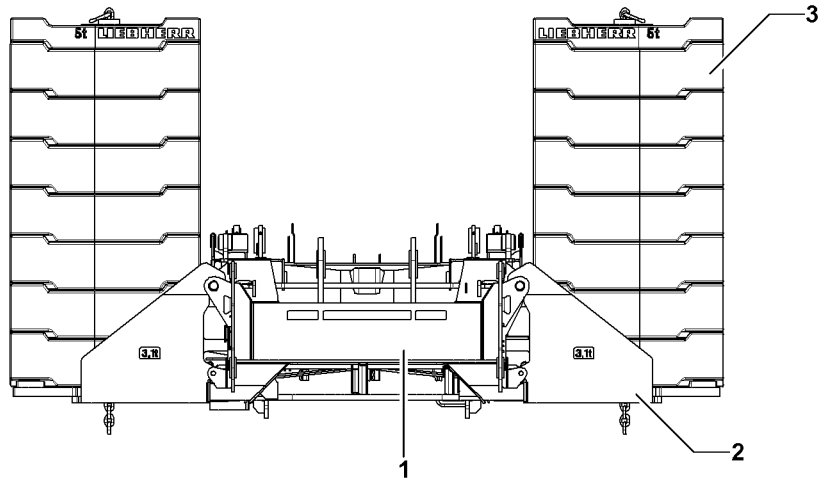

2

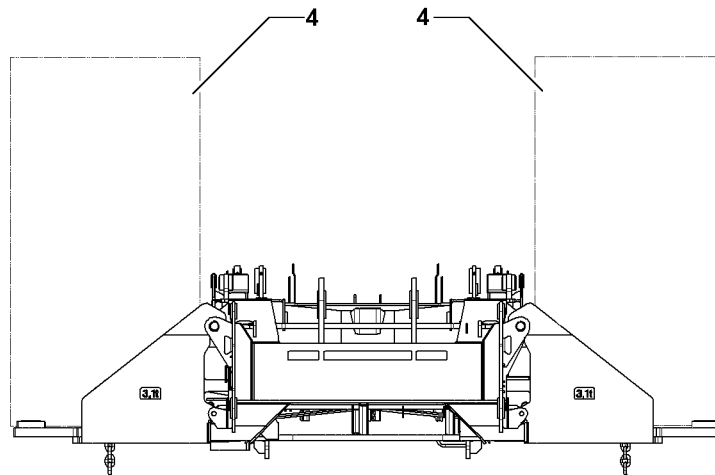

1 Components

The following components are required for the counterweight on the turntable **1**:

Counterweight plates **2**

Bracket counterweight **3**

1.1 Counterweight plates



WARNING

Damaged counterweight plates!

Damage on the counterweight plates **2** can cause the tackle to release!

The counterweight plates **2** and components can fall down!

Personnel can be severely injured or killed!

► Do not use damaged counterweight plates **2** and replace them immediately!

The counterweight plates **2** are placed down as the counterweight assembly **4**.

Component	Weight
Counterweight plate	5.0 t
	10.0 t

1

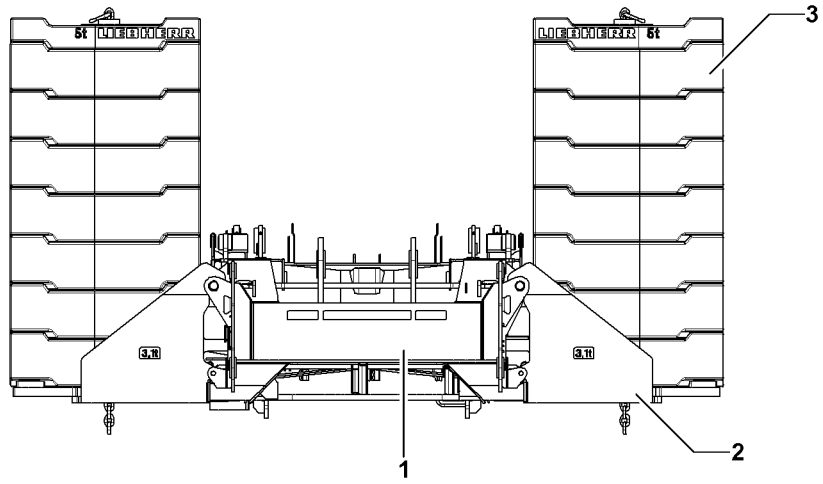

2

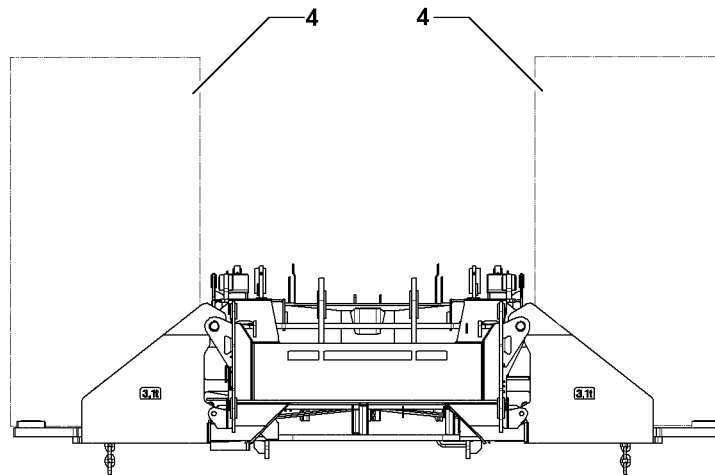

2 Counterweight combinations



WARNING

Incorrectly calculated counterweight!

The specified counterweight from the load charts also includes the own weight of the brackets **3**!
If the weight of the brackets **3** is not taken into account, too much counterweight has been placed!
The crane can be severely damaged or topple over!

Personnel can be severely injured or killed!

- ▶ Make sure that for the combination of the counterweight the weight of the brackets **3** has been taken into account!
- ▶ Observe the chart "Calculation example counterweight combination" in this chapter!

2.1 Counterweight combinations counterweight plates

Maximum counterweight	Combination	Individual weight
155.0 t	The counterweight can be assembled from the following counterweight plates:	5.0 t
	Bracket	10.0 t

2.2 Calculation example counterweight combination

Example: Specified counterweight from load chart 155.0 t		
14 x	Counterweight plate 10.0 t =	140.0 t
2 x	Counterweight plate 5.0 t =	10.0 t
2 x	Bracket =	5.0 t
Assembled counterweight:		155.0 t

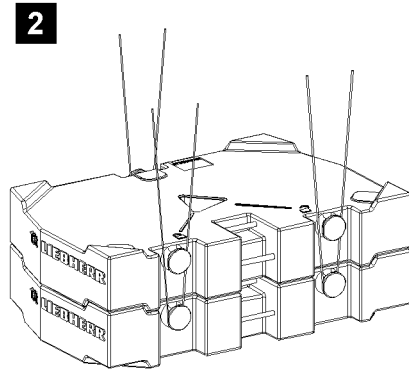
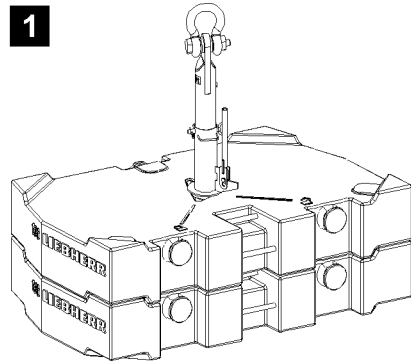

3 Permissible counterweight assemblies



WARNING

Overload fastening points counterweight plates!

If more than the permissible number of counterweight plates are lifted together, then the fastening points can be overloaded!

The counterweight plates and components can fall down!

Personnel can be severely injured or killed!

► Attach only the maximum permissible number of counterweight plates per lift!



WARNING

Incorrect set up of counterweight assemblies!

When lifting mixed weight counterweight assemblies, and the heavier counterweight plates are placed on top, the fastening points can be overloaded!

The counterweight plates and components can fall down!

Personnel can be severely injured or killed!

► Always stack the heavier counterweight plate on the bottom in the counterweight assembly!

For fastening systems with maximum permissible number of counterweight plates, see the following chart:

- “TwistLock”, see illustration 1
- Bits, see illustration 2

Individual weight Counterweight plate	Maximum number of same counterweight plates per lift over	
	Twist lock	Bitt
5.0 t	2	1
10.0 t	2	2

4 Installing the counterweight



WARNING

Risk of falling!

During assembly / disassembly work, personnel must be secured with appropriate aids to prevent them from falling. If this is not observed, assembly personnel can fall and suffer life-threatening or fatal injuries!

- ▶ Any assembly work, where there is a danger of falling must be carried out with suitable aids (for example lifting platform, scaffolding, ladder, auxiliary crane)!
- ▶ If the work cannot be carried out with such aids nor from the ground, then the assembly personnel must secure themselves with approved fall arrest systems to avoid falling, see crane operating instructions, Chapter 2.04!
- ▶ Approved fall arrest systems must be hung into the respective fastening points on the crane, see Crane operating instructions, chapter 2.06!
- ▶ If railings are present on the components, then they must be brought into the corresponding position and secured for assembly / disassembly work!
- ▶ Step on aids and fall arresters only with clean shoes!
- ▶ Keep aids and fall arresters clean and free from snow and ice!
- ▶ During all assembly and disassembly work, maintenance work and inspections, travel and crane operation is prohibited!



WARNING

Falling components and counterweight plates!

At assembly / disassembly, the components and counterweight plates can fall down! Personnel can be severely injured or killed!

- ▶ Make sure that no persons or objects are within the danger zone!



WARNING

Danger of impact / crushing!

When installing / removing counterweight components with the auxiliary crane, crane components can start to swing back and forth!

When lifting / lowering and positioning crane components, there is an increased danger of impacts / crushing!

Personnel can be caught and severely injured or killed!

- ▶ Make sure that personnel cannot be caught by components!
- ▶ When working in danger zones: Use aids to protect limbs!
- ▶ Guide components with suitable aids to minimize oscillation!

Make sure that the following prerequisite is met:

- The crane is aligned in horizontal direction.

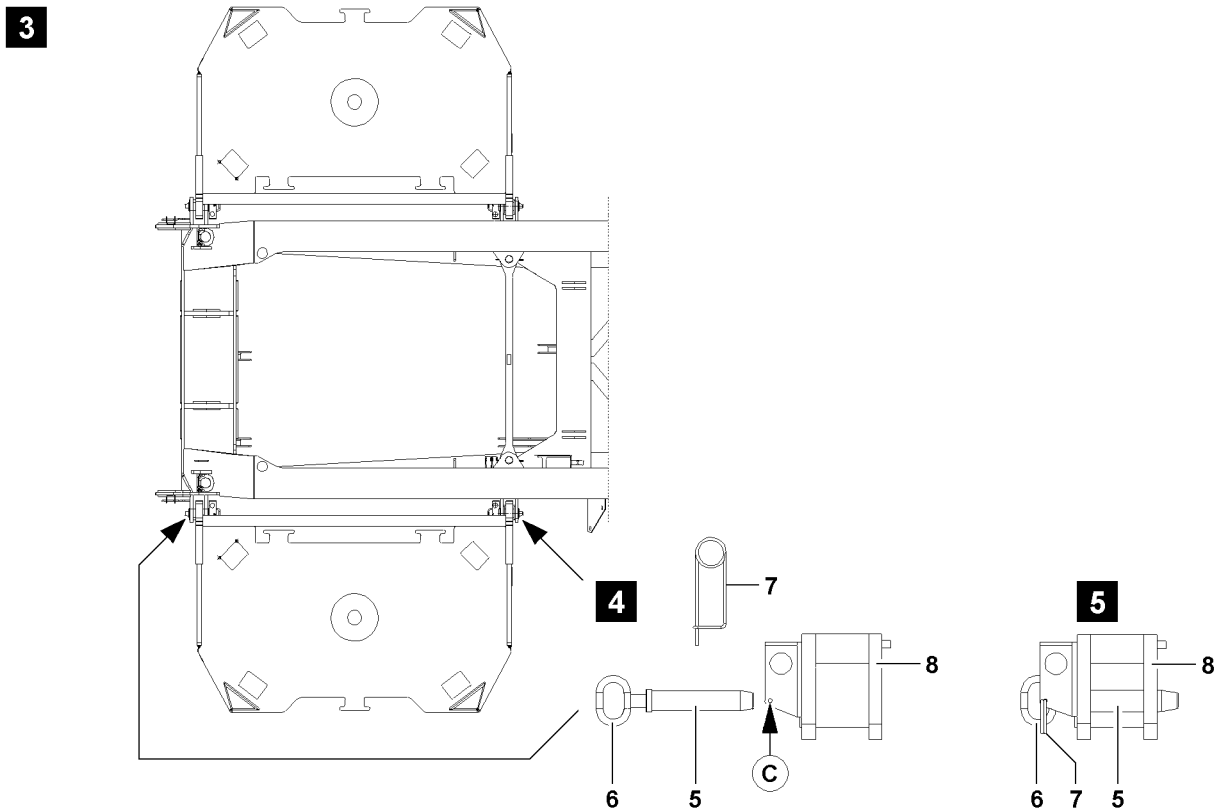
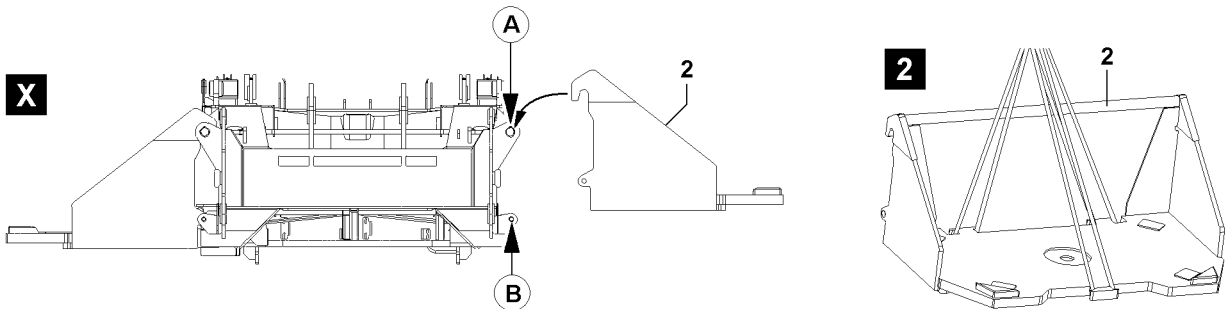
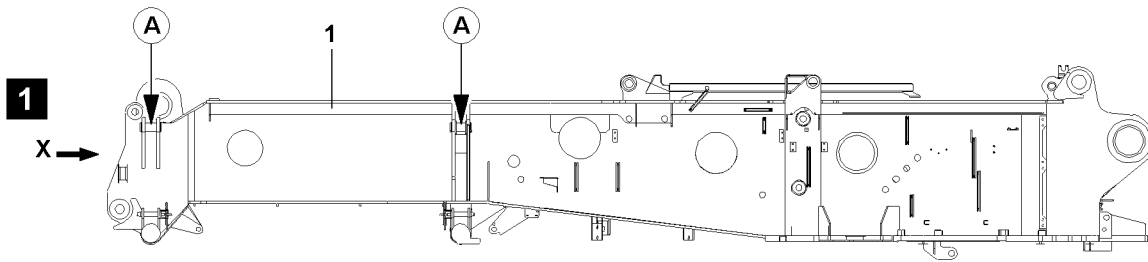

B104965

4.1 Installing the bracket

Make sure that the following prerequisite is met:

- the pin **5** is unbolted, see fig. **4**.



Note

- ▶ The weight of the bracket **2** is approximately 3 t. illustration **2**.
-

- ▶ Hang the bracket **2** onto the auxiliary crane, fig. **2**.
- ▶ Hang the bracket **2** with the auxiliary crane on the tackle points **A** on the turntable **1**, fig. **1**.
- ▶ Pin the bracket **2** on the turntable **1**: Insert the pin **5** on the left and right of the bracket **2** with handle bar **6**.

Secure the pin **5** with spring retainer **7** on point **C**.

- ▶ Insert the spring retainer **7** on point **C**.

Result:

- The pin **5** is secured.

6

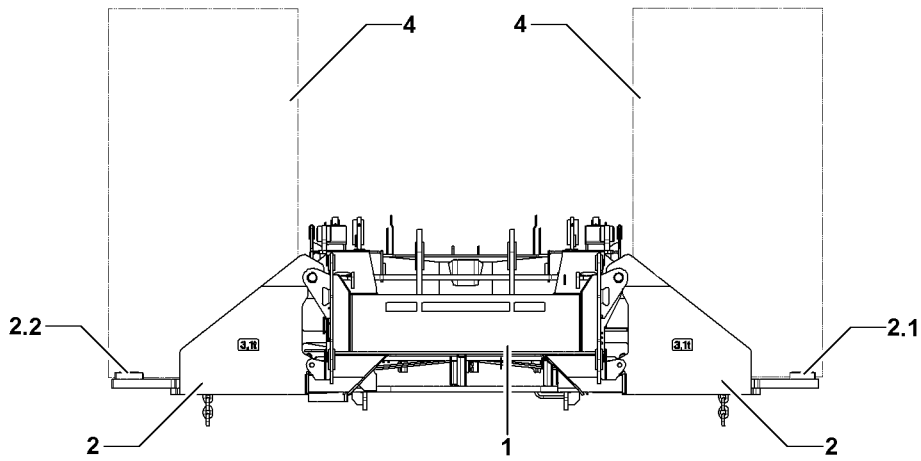

7

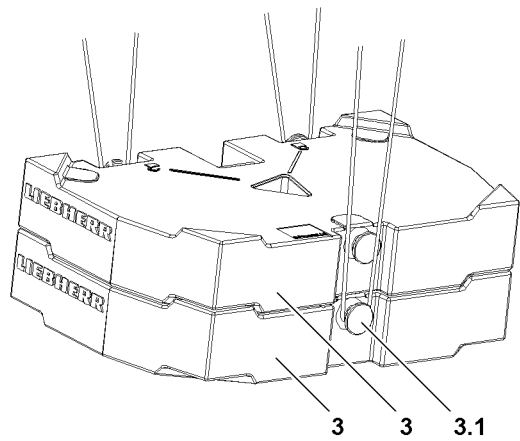

9

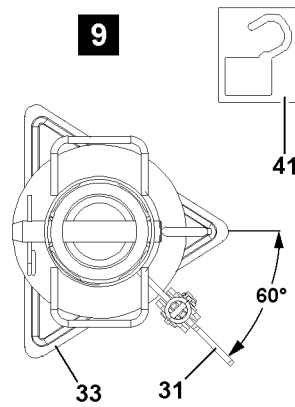

10

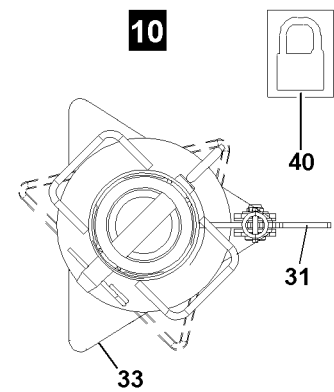

8

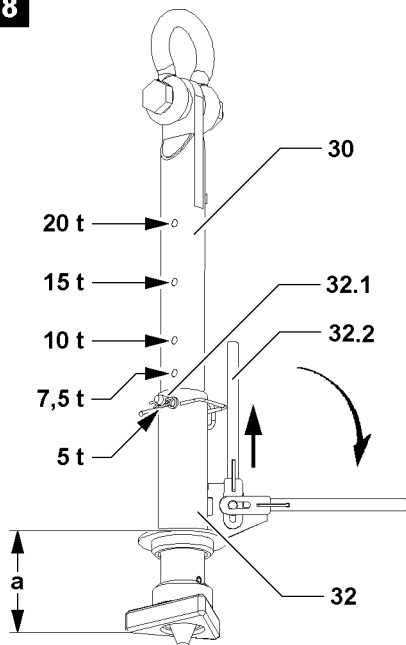

11

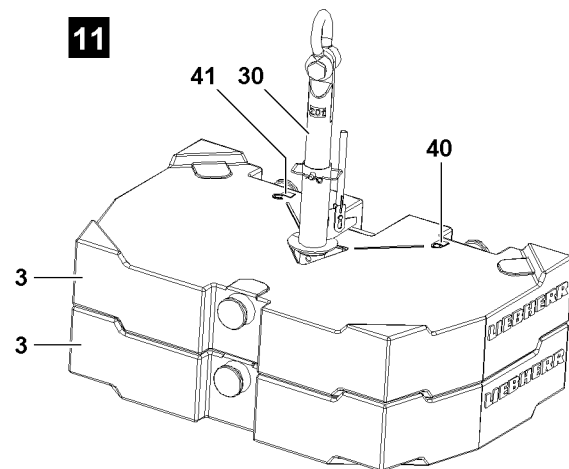

B110369

4.2 Placing the counterweight



DANGER

The crane can topple over!

If the following conditions are not met before turning the turntable - **without** installed boom, the crane can topple over!

Personnel can be severely injured or killed!

- ▶ Observe the data in the erection and take down charts!
- ▶ If no boom is installed on the turntable, max. 135 t counterweight may be installed and when turning the turntable by 360°, it must be ensured that the SA-bracket is erected to **more than 90°**!
- ▶ If the counterweight is increased to 155 t, then the boom must be installed and raised off the ground!

Maximum counterweight	Minimum central counter-weight	Equipment
55 t	11 t	Without equipment
95 t	11 t	
135 t	43 t	
155 t	43 t	Boom installed and raised off the ground



WARNING

Damaged counterweight plates!

Damage on the counterweight plates **2** can cause the tackle to release!

The counterweight plates **2** and components can fall down!

Personnel can be severely injured or killed!

- ▶ Do not use damaged counterweight plates **2** and replace them immediately!

Make sure that the following prerequisite is met:

- The brackets **2** are pinned and secured on the turntable.



WARNING

The crane can topple over!

If more than 20 t are placed with one lift on the bracket **2** or on the counterweight plates **3** or if the counterweight is placed asymmetrically, then the crane can topple over! Personnel can be severely injured or killed!

- ▶ A weight difference between the right and left counterweight stack of more than 20 t is prohibited!
- ▶ Alternately place no more than maximum 20 t counterweight assemblies on the counterweight stack, alternately symmetrically on the left and right!



WARNING

Counterweight too low / too high!

If the placed counterweight deviates from the specified data in the load charts or the assembly conditions, then the crane can be damaged or topple over!

Personnel can be severely injured or killed!

- ▶ Place the counterweight according to the data in the load chart!

6

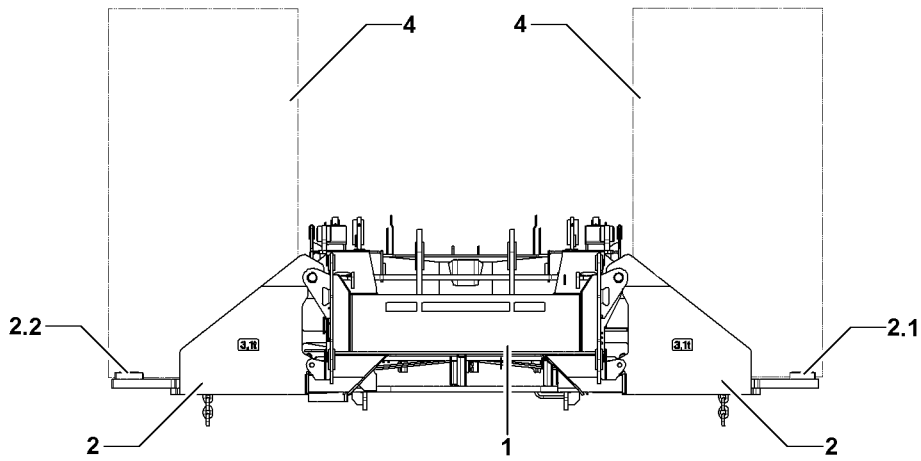

7

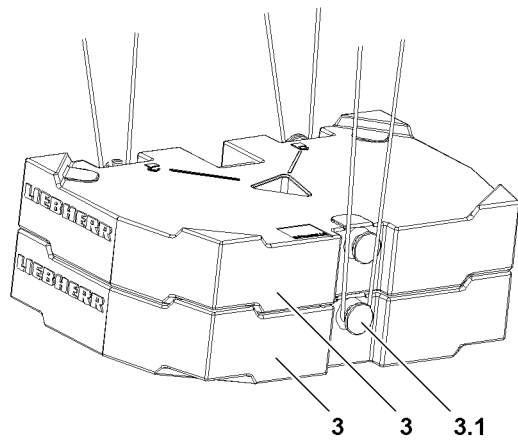

9

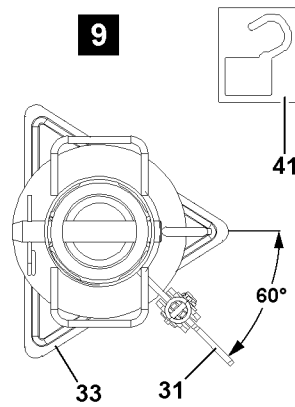

10

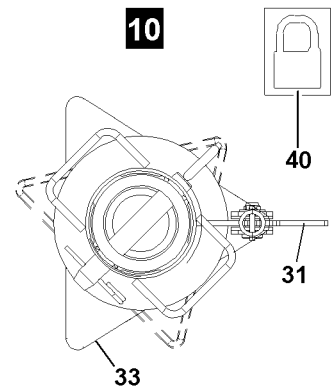

8

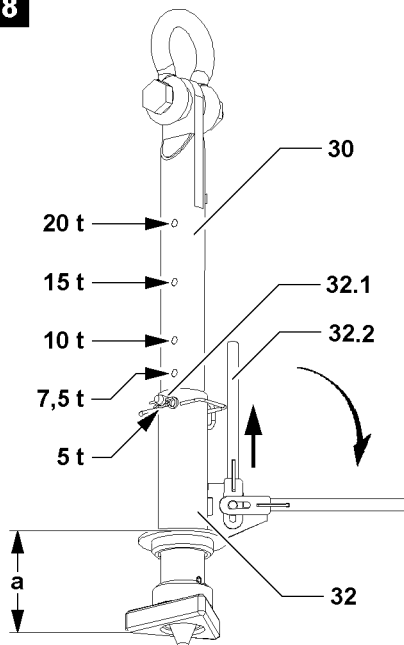

11

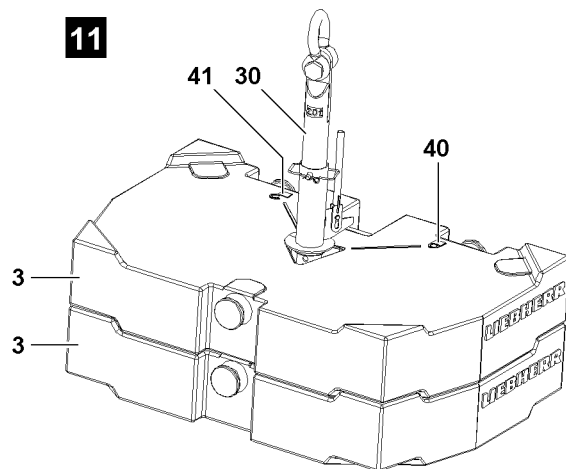

B110369

**WARNING**

Falling counterweight plates!

If more than the permissible loads are lifted, then the fastening points **8** are overloaded and the counterweight plates can fall down! Personnel can be severely injured or killed!

- ▶ Lift no more than maximum 20 t with the ropes, 3 fastening points.

**WARNING**

Incorrect handling of the fastening equipment!

If fastening equipment cannot be attached correctly and if it is not secured sufficiently to prevent it from loosening up, loads can fall down! Personnel can be severely injured or killed!

- ▶ Make sure that the tackle is correctly attached on the tackle points **8** and that it is secured sufficiently to prevent it from loosening up.

**WARNING**

Toppling counterweight assembly!

Lopsided stacked counterweight plates **3** create instability in the counterweight assembly **4**!

The counterweight plates **3** can tip from the brackets **2** and cause the crane to topple over!

Personnel can be severely injured or killed!

- ▶ Make sure that the counterweight plates **3** are placed correctly in the centerings!

**Note**

- ▶ The counterweight plates **2** are marked with their own weights!

6

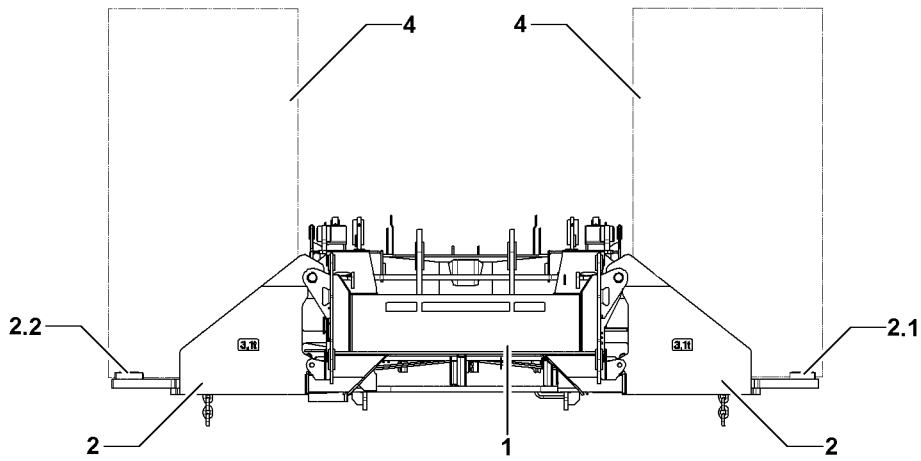

7

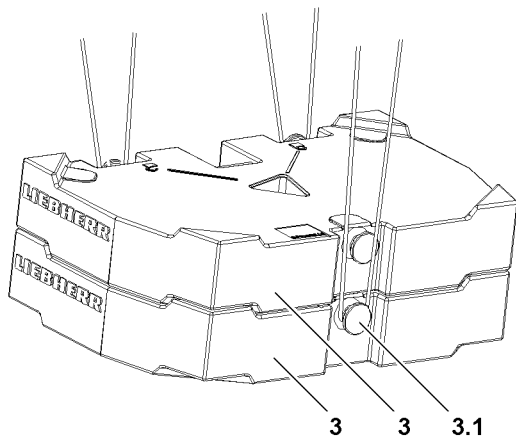

9

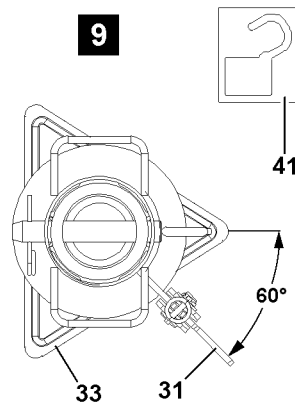

10

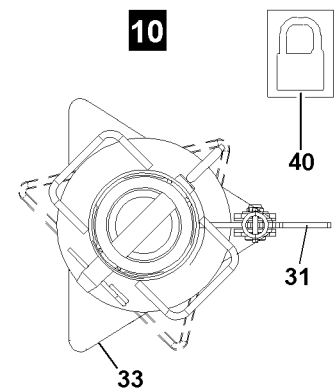

8

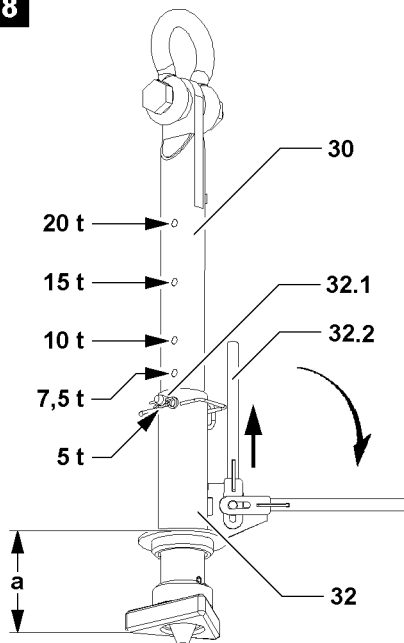

11

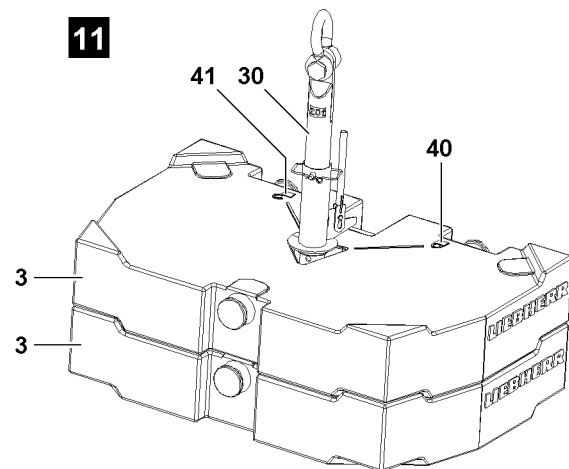

B110369

4.2.1 Placing the counterweight plates, fastening system: “Twist lock”

**WARNING**

Overload of receptacle stud and counterweight plates!

If more than the permissible number of counterweight plates are lifted with the receptacle stud **30**, the receptacle stud **30** and the counterweight plates can be overloaded and damaged!

Counterweight plates can fall down!

Personnel can be severely injured or killed!

- ▶ Observe the section “Permissible counterweight assemblies” in this chapter!
-

**WARNING**

Damage of receptacle stud and counterweight plates!

If two counterweight plates are lifted which do not lay correctly in their centerings, the receptacle stud **30** and the counterweight plates can be damaged!

Damage can cause the counterweight plates to fall down!

Personnel can be severely injured or killed!

- ▶ Make sure that the counterweight plates to be lifted are placed correctly in the centerings!
-

**WARNING**

The twist lock system opens by itself!

If the receptacle stud **30** is not correctly locked, the Twist lock system can open by itself!

Counterweight plates can fall down!

Personnel can be severely injured or killed!

- ▶ Make sure, when initiating a lift, that the lever **32.2** points directly on the symbol “Locked” **40** of the counterweight plates **3**, see illustration **10**!
-

**Note**

- ▶ During a lift, the locked Twist lock system cannot release by itself due to its gravitational retention!
 - ▶ During a lift, the locked Twist lock system cannot be released by hand due to its gravitational retention!
-

6

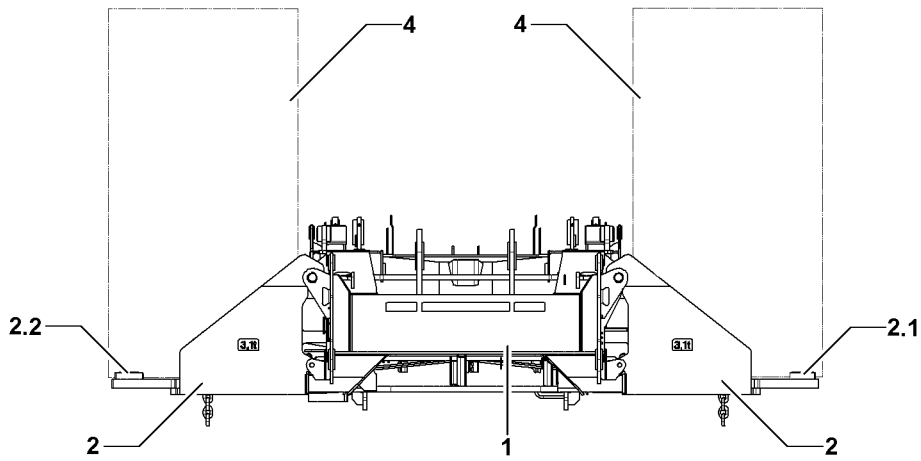

7

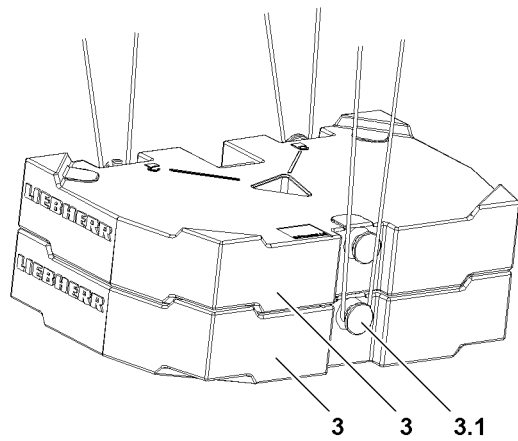

9

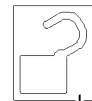

41

10



40

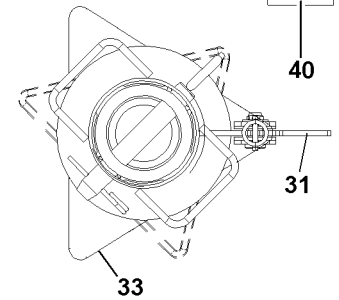
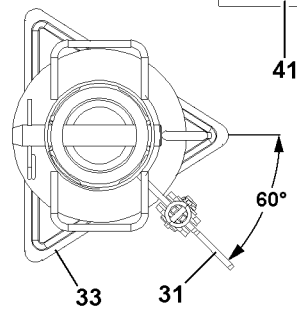

8

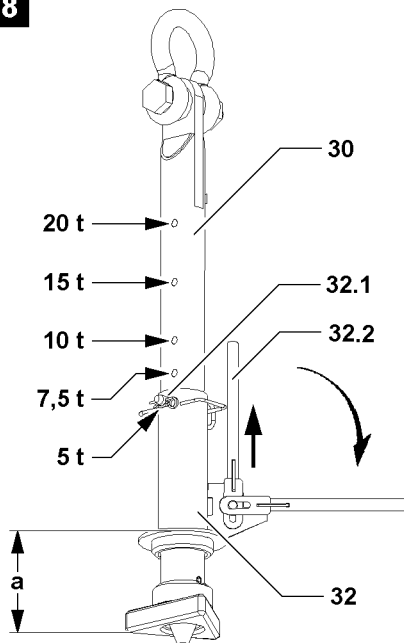

11

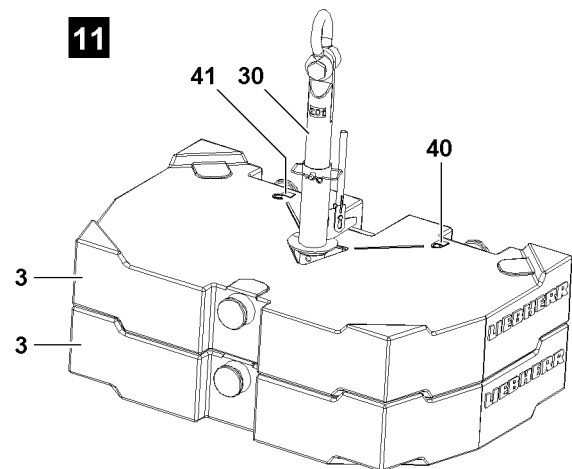

B110369

Before the receptacle stud **30** is guided into the counterweight plate(s), it must be ensured that the insertion length **a** of the receptacle stud **30** is set correctly.

The insertion length **a** of the receptacle stud can be adjusted by hand.

- ▶ If the insertion length **a** of the receptacle stud **30** is to be adjusted:
Release and unpin the pins **32.1**.
- ▶ Adjust the insertion length **a** by moving the guide sleeve **32** to the desired insertion length **a**, pay attention to the stages, see illustration **8**.
- ▶ Insert and secure pin **32.1**.

Result:

- The receptacle stud **30** is adjusted.

- ▶ Attach the receptacle stud **30** on the auxiliary crane and guide it into the counterweight plate(s).
- ▶ Pull the lever **32.2** up and fold it down.
- ▶ Turn the receptacle stud **30** with the lever **32.2** by 60° until it points to the symbol “Locked” **40** of the counterweight plate, see illustration **10**.
- ▶ Carefully lift the counterweight plate(s) or the counterweight assembly with the receptacle stud **30** and place them on the centerings of the counterweight pallet or another counterweight plate in the ballast stack, see illustration **6**.
- ▶ When the counterweight plates are placed down:
Turn the receptacle stud **30** with the lever **32.2** by 60° to the stop in direction of the symbol “unlocked” **41** of the counterweight plate, see illustration **9**.

Result:

- The receptacle stud **30** is unlocked.
- ▶ Carefully pull out the receptacle stud **30**.
- ▶ Secure all counterweight plates so they cannot move and fall down.

6

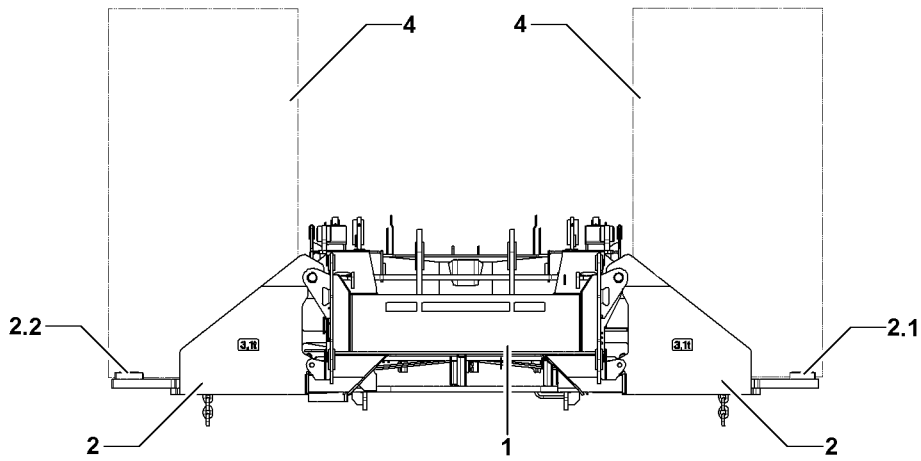

7

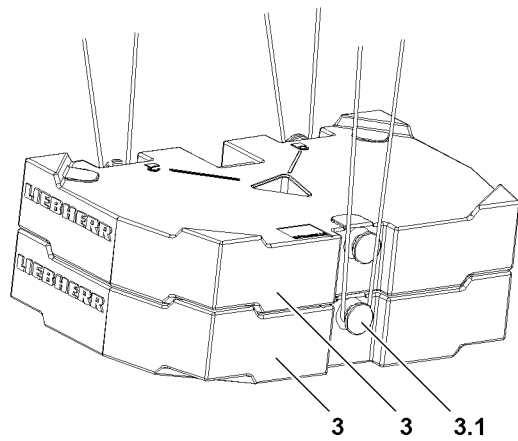

9

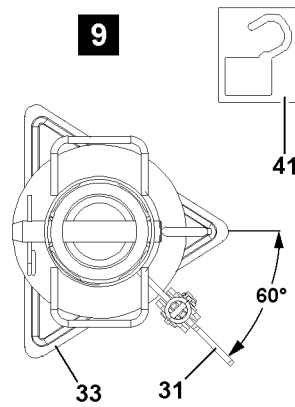

10

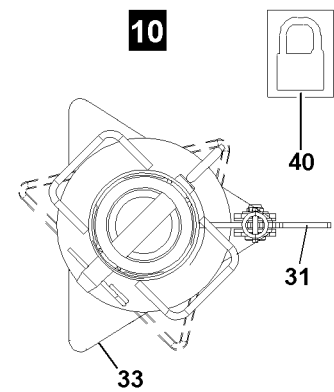

8

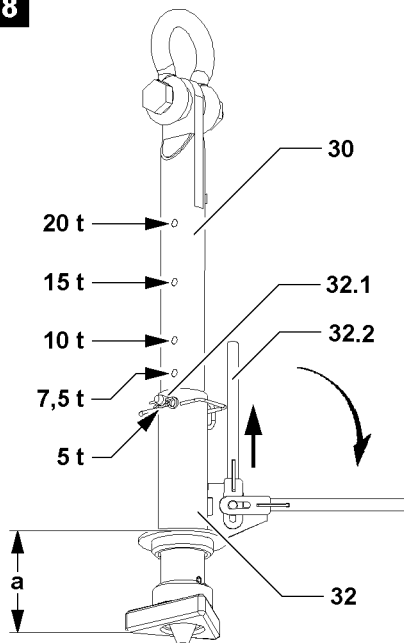

11

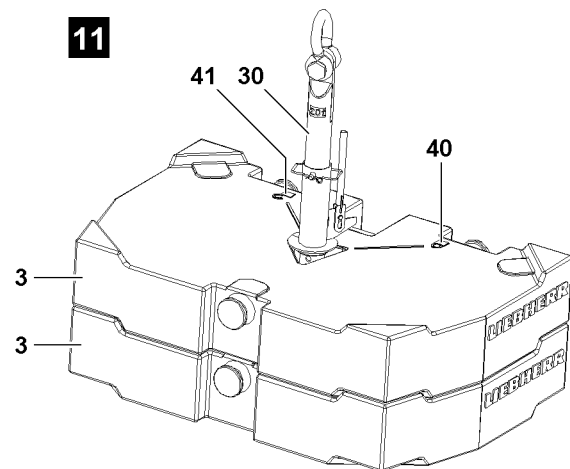

B110369

4.2.2 Placing the counterweight plates, fastening points: Bitt



WARNING

Overloaded counterweight plates!

If more than the permissible loads are lifted, the bitts **3.1** are overloaded!

The counterweight plates can be damaged and fall down!

Personnel can be severely injured or killed!

- ▶ Observe the section "Permissible counterweight assemblies" in this chapter!
-



WARNING

Incorrect handling of the fastening equipment!

If tackle cannot be attached correctly and / or if it is not secured sufficiently to prevent it from loosening up, the counterweight plates can fall down!

Personnel can be severely injured or killed!

- ▶ Make sure that the fastening equipment is correctly attached on the bitts **3.1** and that it is secured sufficiently to prevent it from loosening up, see illustration **7**!
-
- ▶ Attach the counterweight plates individually or as a counterweight assembly on the auxiliary crane.
 - ▶ Lift the counterweight plates or the counterweight assembly and place it carefully on the centerings of the counterweight pallet or on another counterweight plate in the counterweight stack.

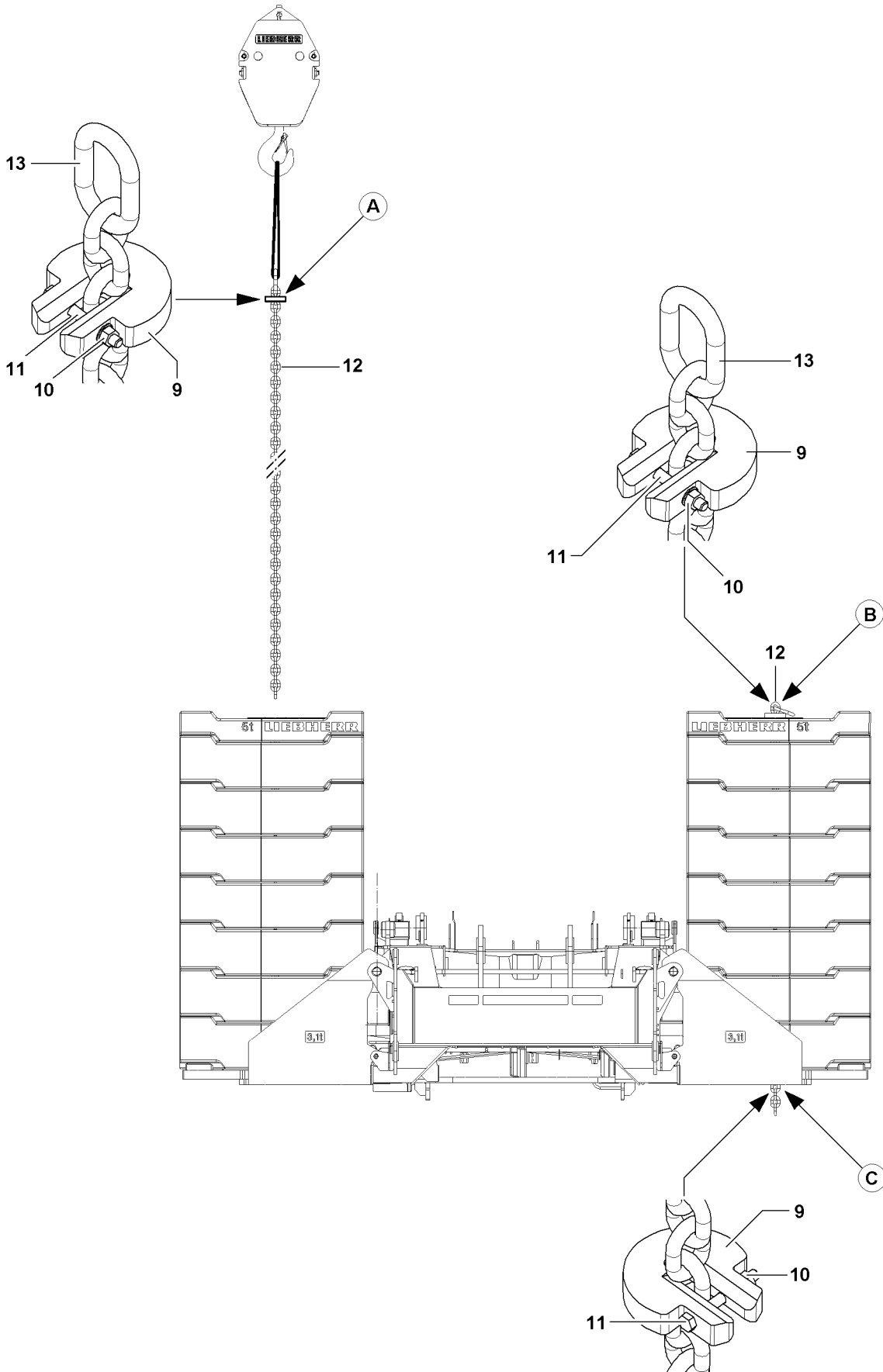

B104971

4.3 Securing the counterweight



WARNING

The counterweight can topple over!

Unsecured counterweights can slip from the counterweight stacks due to shocks during crane operation!

Personnel can be severely injured or killed!

- ▶ Before starting crane operation, secure the counterweights on both sides!
-

Repeat the following tasks for each other counterweight stack.

The retaining plate **9** is to be preassembled on the ground.

- ▶ Push the retaining plate **9** onto the retaining chain **12**, point **A**.
 - ▶ Attach the retaining plate **9**: Pin the screw **11** and secure with the nut **10**.
 - ▶ Attach the retaining chain **12** on the chain link **13** with tackle onto the auxiliary crane.
 - ▶ Guide the retaining chain **12** from top with the auxiliary crane into the counterweight stack until the retaining plate **9** is placed on the upper counterweight plate at point **B**.
 - ▶ Release the retaining chain **12** from the auxiliary crane.
 - ▶ Remove the auxiliary crane.
-



Note

- ▶ Attach the retaining plate **9** as close as possible on the underside of the bracket (point **C**).
 - ▶ Push the retaining plate **9** at point **C** onto the retaining chain **12**.
 - ▶ Attach the retaining plate **9**: Pin the screw **11** and secure with the nut **10**.
-

5 Removing the counterweight



WARNING

Risk of falling!

During assembly / disassembly work, personnel must be secured with appropriate aids to prevent them from falling. If this is not observed, assembly personnel can fall and suffer life-threatening or fatal injuries!

- ▶ Any assembly work, where there is a danger of falling must be carried out with suitable aids (for example lifting platform, scaffolding, ladder, auxiliary crane)!
- ▶ If the work cannot be carried out with such aids nor from the ground, then the assembly personnel must secure themselves with approved fall arrest systems to avoid falling, see crane operating instructions, Chapter 2.04!
- ▶ Approved fall arrest systems must be hung into the respective fastening points on the crane, see Crane operating instructions, chapter 2.06!
- ▶ If railings are present on the components, then they must be brought into the corresponding position and secured for assembly / disassembly work!
- ▶ Step on aids and fall arresters only with clean shoes!
- ▶ Keep aids and fall arresters clean and free from snow and ice!
- ▶ During all assembly and disassembly work, maintenance work and inspections, travel and crane operation is prohibited!



WARNING

Falling components and counterweight plates!

At assembly / disassembly, the components and counterweight plates can fall down! Personnel can be severely injured or killed!

- ▶ Make sure that no persons or objects are within the danger zone!



WARNING

Danger of impact / crushing!

When installing / removing counterweight components with the auxiliary crane, crane components can start to swing back and forth!

When lifting / lowering and positioning crane components, there is an increased danger of impacts / crushing!

Personnel can be caught and severely injured or killed!

- ▶ Make sure that personnel cannot be caught by components!
- ▶ When working in danger zones: Use aids to protect limbs!
- ▶ Guide components with suitable aids to minimize oscillation!

Make sure that the following prerequisite is met:

- The crane is horizontally aligned.

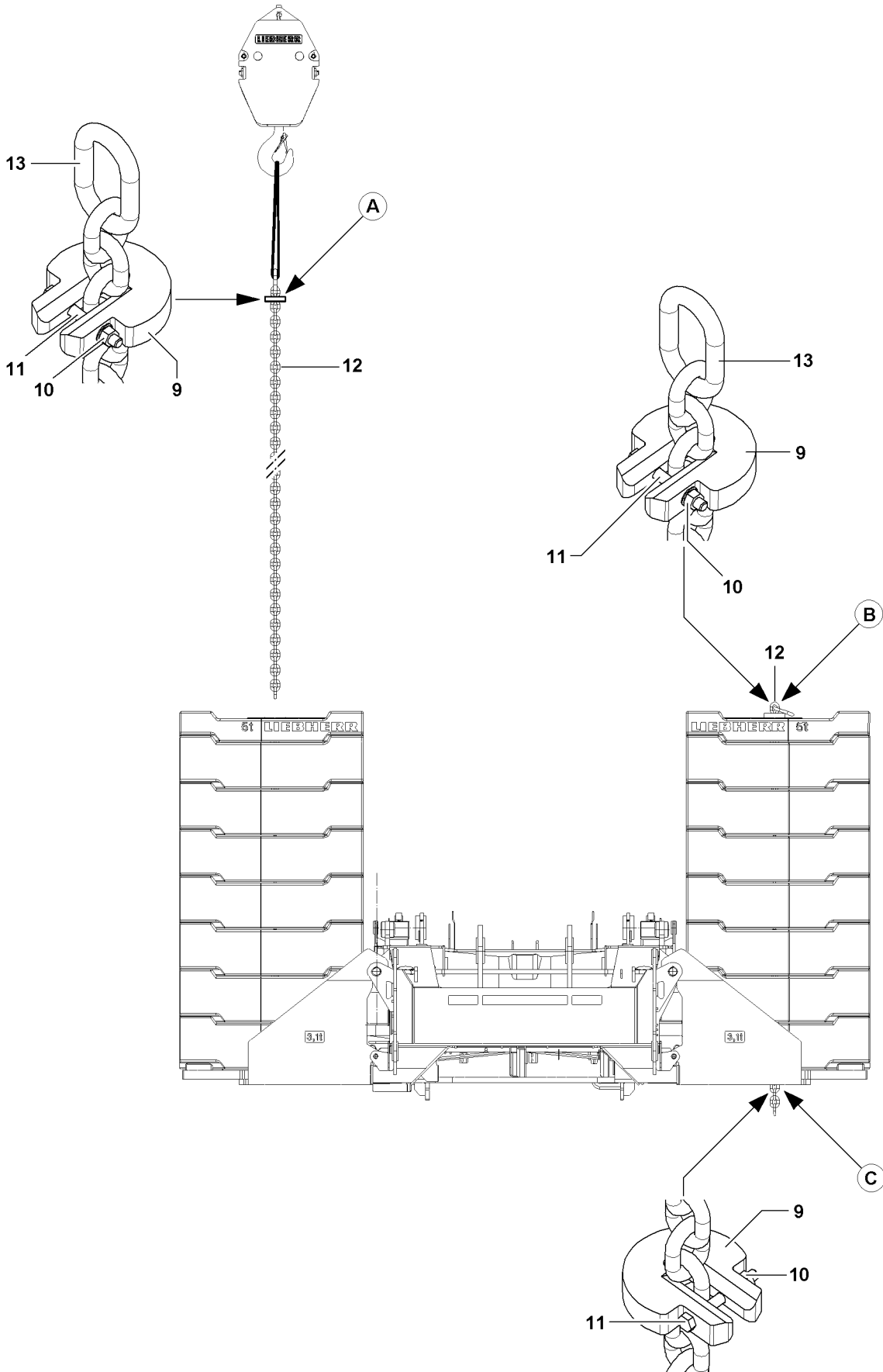

B104971

5.1 Releasing the counterweight

Repeat the following tasks for each other counterweight stack:

- ▶ Remove the retaining plate **9** on point **C**: Loosen the nut **10** and unpin the screw **11**.
- ▶ Remove the retaining plate **9**.
- ▶ Attach the retaining chain **12** on the chain link **13** with tackle onto the auxiliary crane.
- ▶ Pull the retaining chain **12** with the auxiliary crane upward from the counterweight stack and place on the ground.
- ▶ Release the retaining chain **12** from the auxiliary crane.
- ▶ Remove the auxiliary crane.
- ▶ Remove the retaining plate **9** on point **A**: Loosen the nut **10** and unpin the screw **11**.
- ▶ Remove the retaining plate **9**.

6

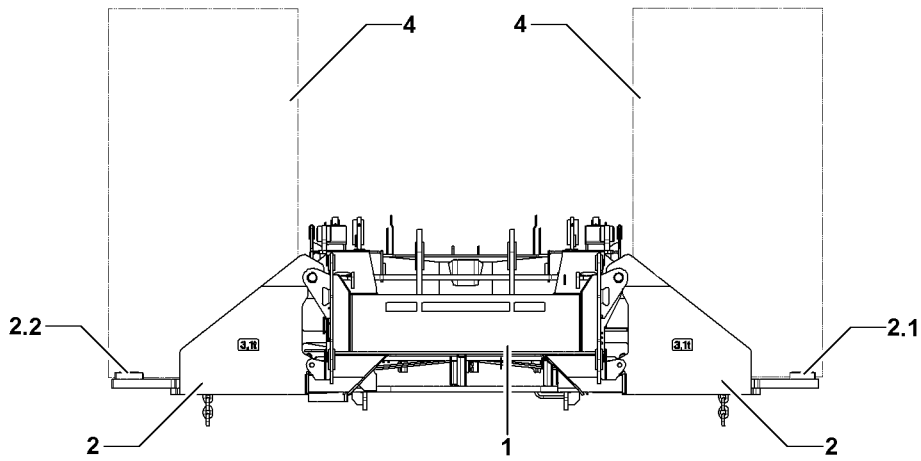

7

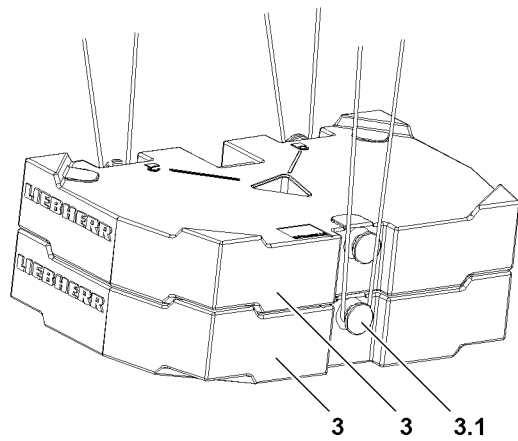

9

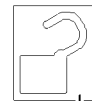

41

10



40

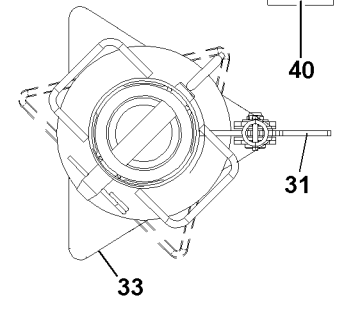
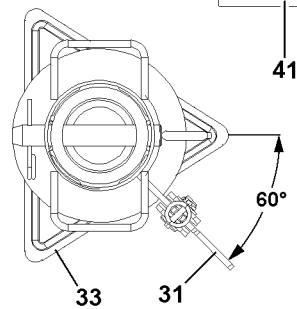

8

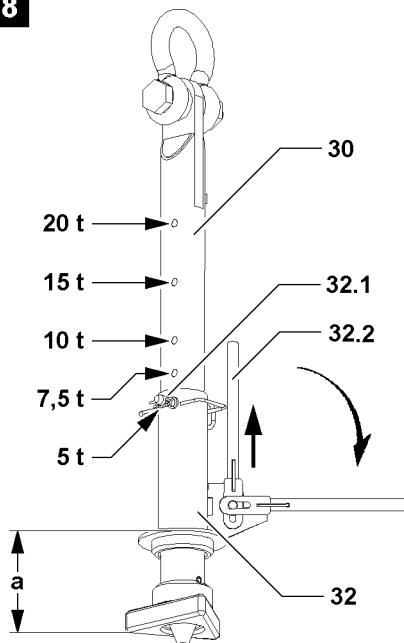

11

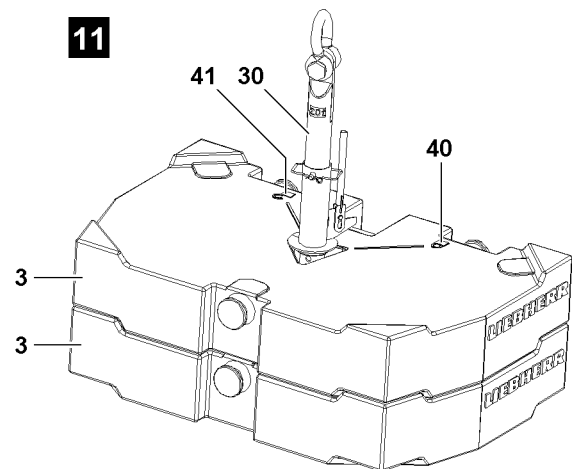

B110369

5.2 Removing the counterweight



DANGER

The crane can topple over!

If the following conditions are not met before turning the turntable - **without** installed boom, the crane can topple over!

Personnel can be severely injured or killed!

- ▶ Observe the data in the erection and take down charts!
- ▶ If no boom is installed on the turntable, max. 135 t counterweight may be installed and when turning the turntable by 360°, it must be ensured that the SA-bracket is erected to **more than 90°**!
- ▶ If the counterweight is increased to 155 t, then the boom must be installed and raised off the ground!

Maximum counterweight	Minimum central counter-weight	Equipment
55 t	11 t	Without equipment
95 t	11 t	
135 t	43 t	
155 t	43 t	Boom installed and raised off the ground

Make sure that the following prerequisite is met:

- The retaining chains are disassembled.



WARNING

Damaged counterweight plates!

Damage on the counterweight plates **2** can cause the tackle to release!

The counterweight plates **2** and components can fall down!

Personnel can be severely injured or killed!

- ▶ Do not use damaged counterweight plates **2** and replace them immediately!



WARNING

Asymmetrical counterweight distribution!

If more than 20 t are asymmetrically removed on the counterweight stacks **4**, the crane can topple over!

Personnel can be severely injured or killed!

- ▶ A weight difference between the right and left counterweight stack **4** of more than 20 t is prohibited!
- ▶ Alternately remove no more than maximum 20 t counterweight assemblies from the counterweight stack **4**, symmetrically on the left and right!



WARNING

Counterweight too low / too high!

If the placed counterweight deviates from the specified data in the load charts or the assembly conditions, then the crane can be damaged or topple over!

Personnel can be severely injured or killed!

- ▶ Place the counterweight according to the data in the load chart!

6

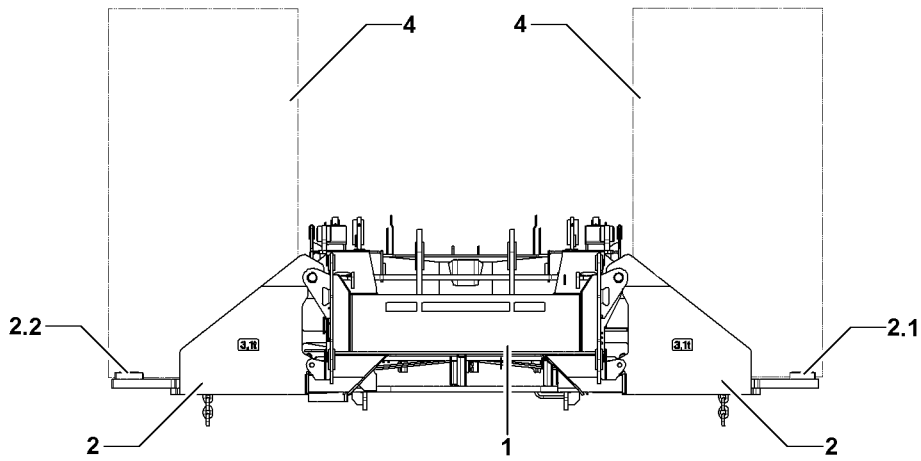

7

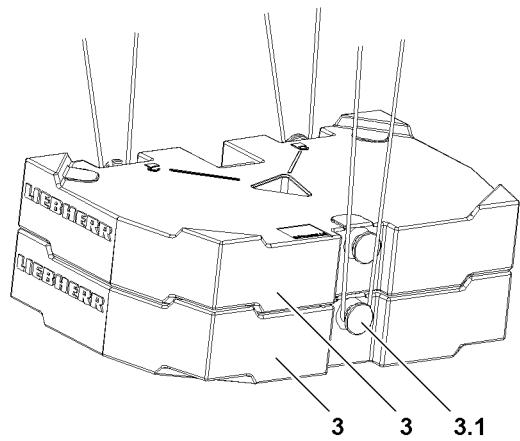

9

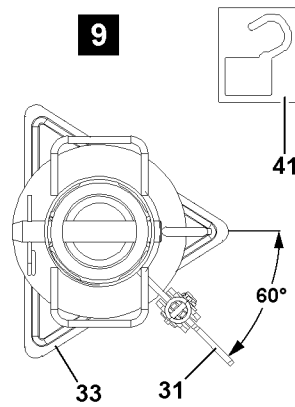

10

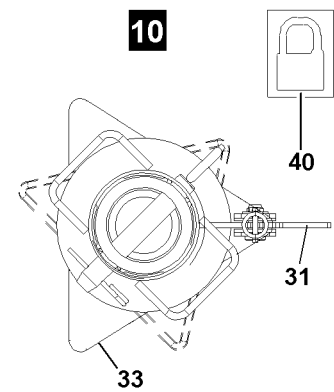

8

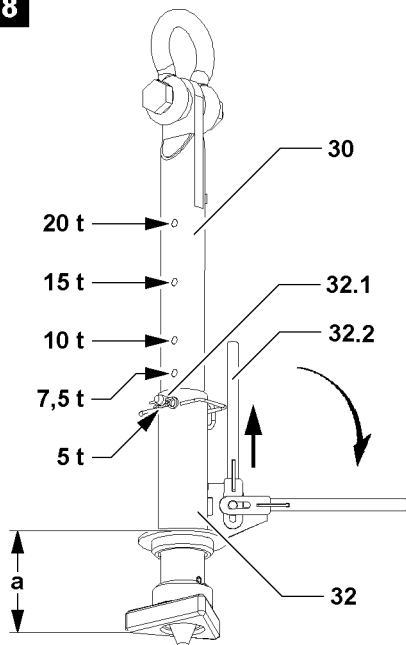

11

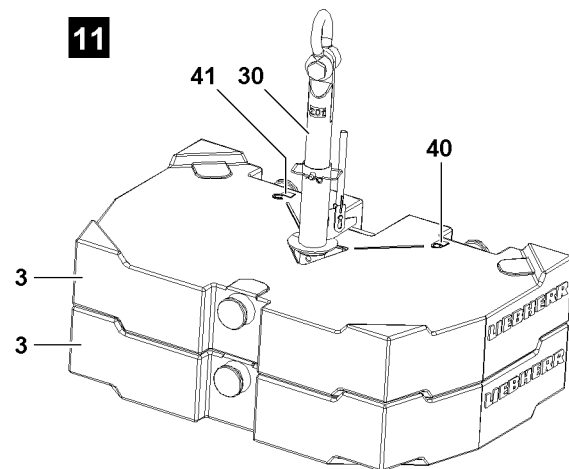

B110369

**WARNING**

Falling counterweight plates!

If more than the permissible loads are lifted, then the tackle points **8** are overloaded and the counterweight plates can fall down. Personnel can be severely injured or killed!

- ▶ Lift no more than maximum 20 t with the ropes, 3 fastening points.

**WARNING**

Incorrect handling of the fastening equipment!

If fastening equipment cannot be attached correctly and if it is not secured sufficiently to prevent it from loosening up, loads can fall down. Personnel can be severely injured or killed!

- ▶ Make sure that the tackle is correctly attached on the tackle points **8** and that it is secured sufficiently to prevent it from loosening up.

**Note**

- ▶ The counterweight plates **2** are marked with their own weights!

6

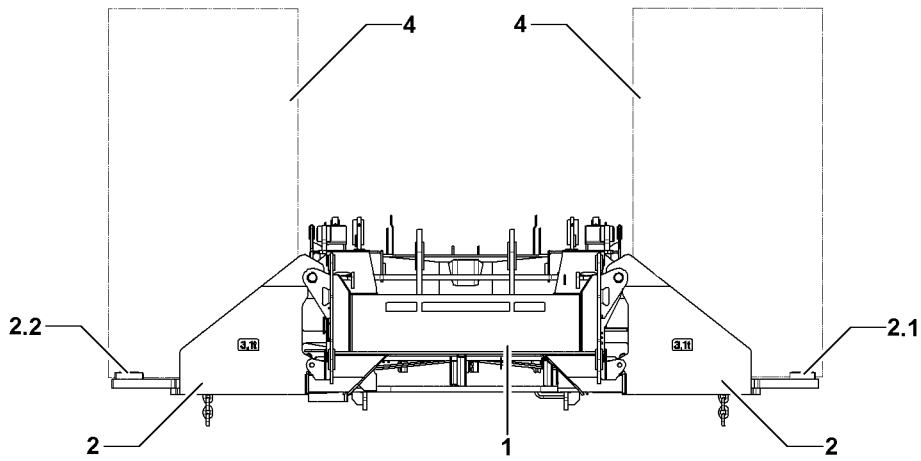

7

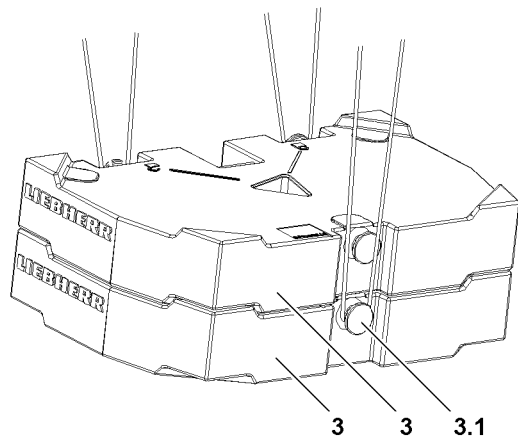

8

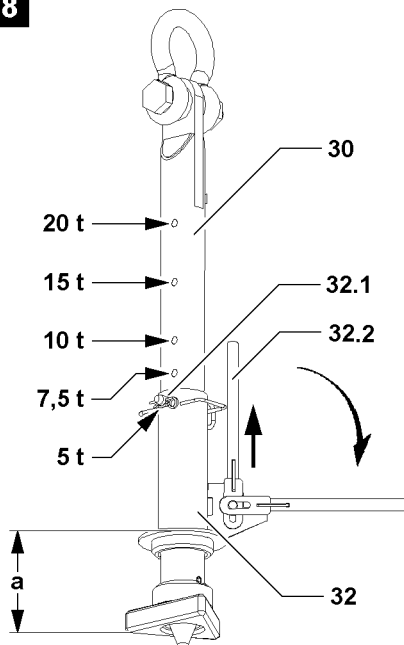

9

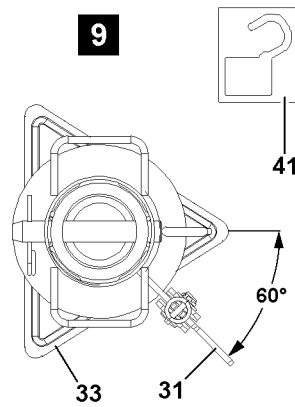

10

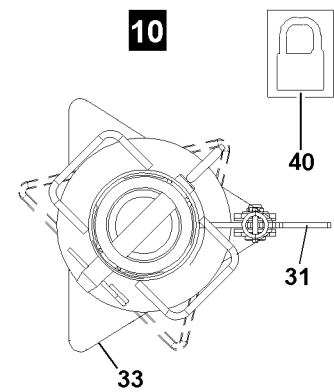

11

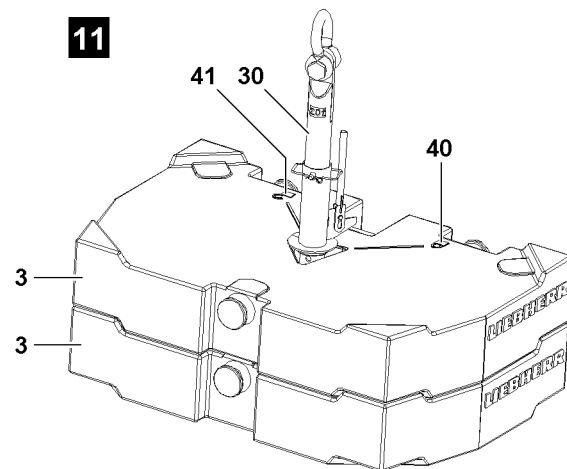

B110369

5.2.1 Removing the counterweight plates, fastening system: “Twist lock”

**WARNING**

Overload of receptacle stud and counterweight plates!

If more than the permissible number of counterweight plates are lifted with the receptacle stud **30**, the receptacle stud **30** and the counterweight plates can be overloaded and damaged!

Counterweight plates can fall down!

Personnel can be severely injured or killed!

- ▶ Observe the section “Permissible counterweight assemblies” in this chapter!
-

**WARNING**

Damage of receptacle stud and counterweight plates!

If two counterweight plates are lifted which do not lay correctly in their centerings, the receptacle stud **30** and the counterweight plates can be damaged!

Damage can cause the counterweight plates to fall down!

Personnel can be severely injured or killed!

- ▶ Make sure that the counterweight plates to be lifted are placed correctly in the centerings!
-

**WARNING**

The twist lock system opens by itself!

If the receptacle stud **30** is not correctly locked, the Twist lock system can open by itself!

Counterweight plates can fall down!

Personnel can be severely injured or killed!

- ▶ Make sure, when initiating a lift, that the lever **32.2** points directly on the symbol “Locked” **40** of the counterweight plates **3**, see illustration **10**!
-

**Note**

- ▶ During a lift, the locked Twist lock system cannot release by itself due to its gravitational retention!
 - ▶ During a lift, the locked Twist lock system cannot be released by hand due to its gravitational retention!
-

6

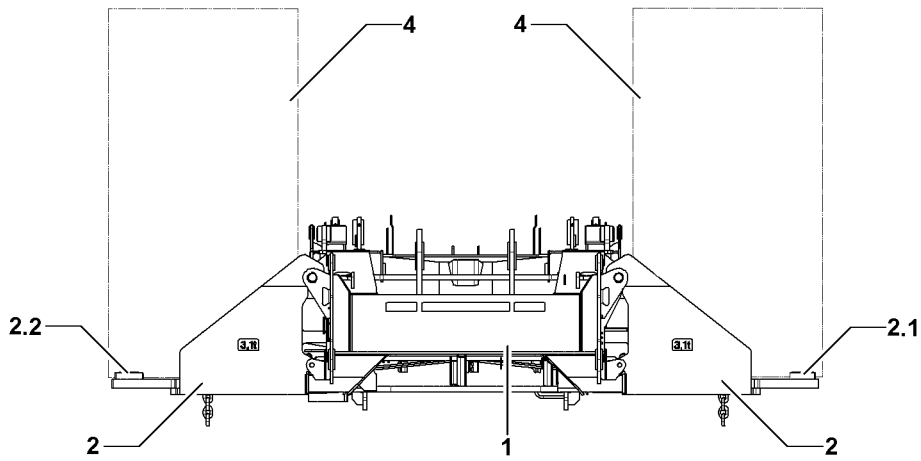

7

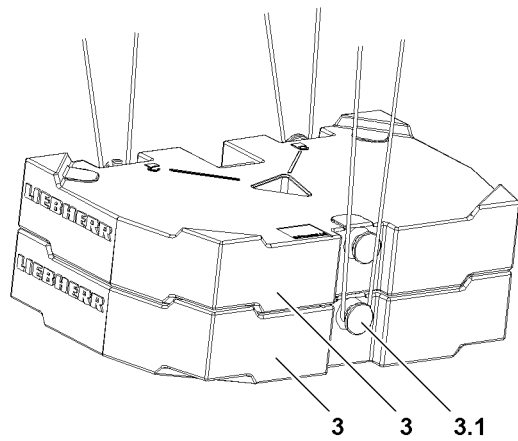

9

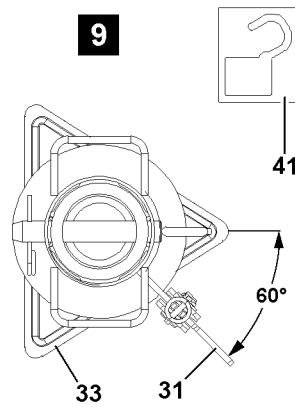

10

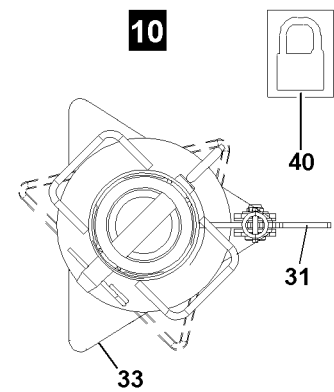

8

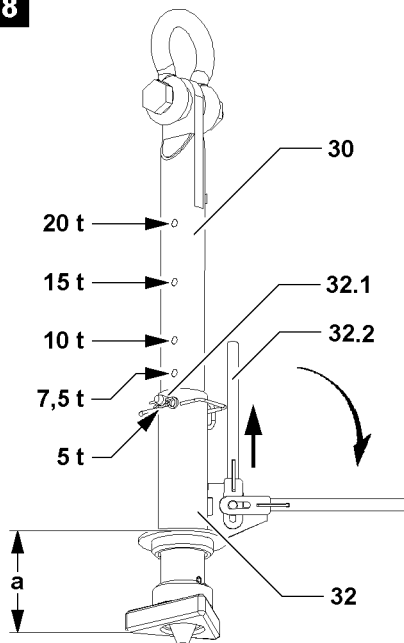

11

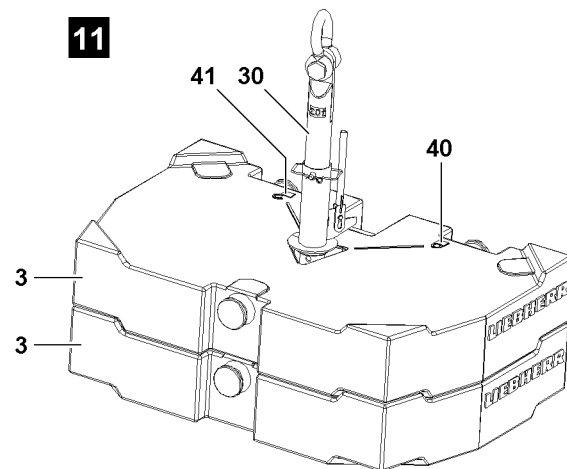

B110369

Before the receptacle stud **30** is guided into the counterweight plate(s), it must be ensured that the insertion length **a** of the receptacle stud **30** is set correctly.

The insertion length **a** of the receptacle stud can be adjusted by hand.

- ▶ If the insertion length **a** of the receptacle stud **30** is to be adjusted:
Release and unpin the pins **32.1**.
- ▶ Adjust the insertion length **a** by moving the guide sleeve **32** to the desired insertion length **a**, pay attention to the stages, see illustration **8**.
- ▶ Insert and secure pin **32.1**.

Result:

- The receptacle stud **30** is adjusted.

- ▶ Attach the receptacle stud **30** on the auxiliary crane and guide it into the counterweight plate(s).
- ▶ Pull the lever **32.2** up and fold it down.
- ▶ Turn the receptacle stud **30** with the lever **32.2** by 60° until it points to the symbol “Locked” **40** of the counterweight plate, see illustration **10**.
- ▶ Lift the counterweight plate(s) or counterweight assembly with the receptacle stud **30** and place down carefully.
- ▶ When the counterweight plates are placed down:
Turn the receptacle stud **30** with the lever **32.2** by 60° to the stop in direction of the symbol “unlocked” **41** of the counterweight plate, see illustration **9**.

Result:

- The receptacle stud **30** is unlocked.
- ▶ Carefully pull out the receptacle stud **30**.

6

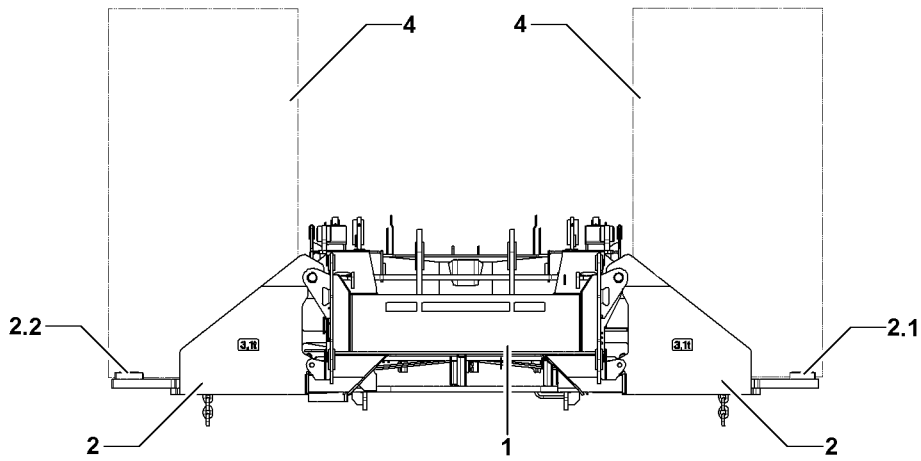

7

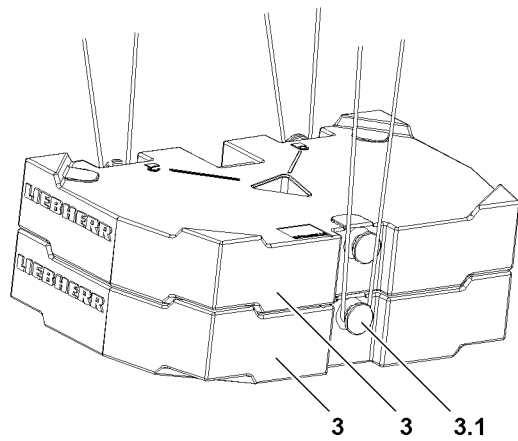

9

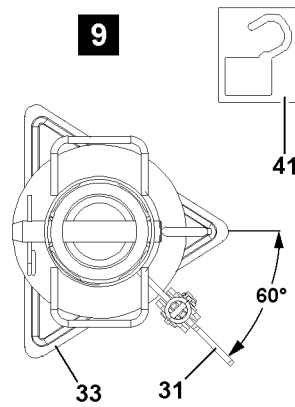

10

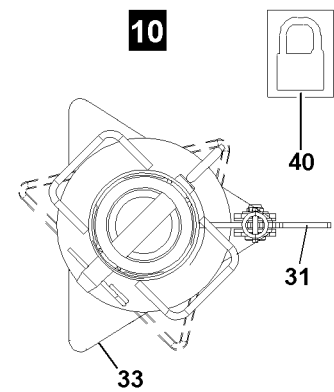

8

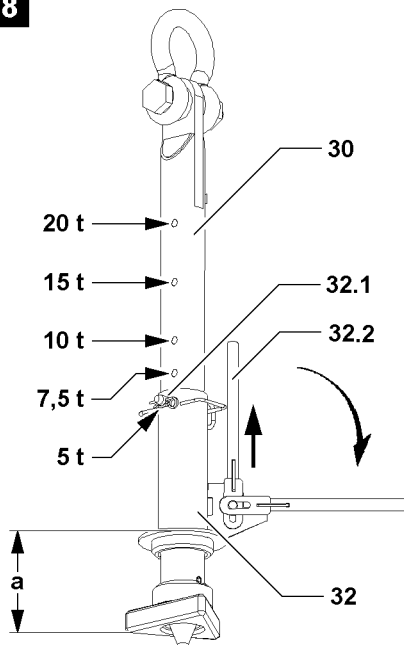

11

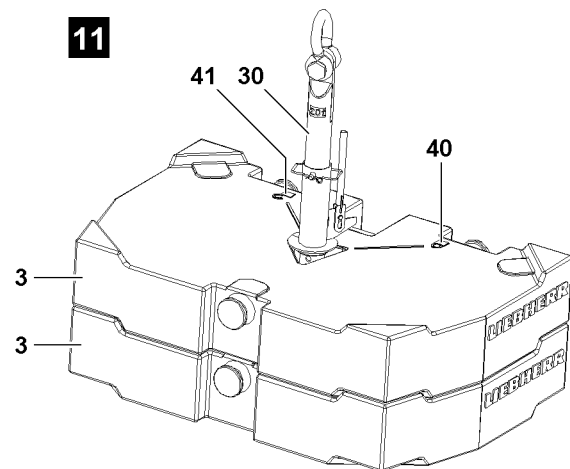

B110369

5.2.2 Removing the counterweight plates, fastening points: Bitt



WARNING

Overloaded counterweight plates!

If more than the permissible loads are lifted, the bitts **3.1** are overloaded!

The counterweight plates can be damaged and fall down!

Personnel can be severely injured or killed!

- ▶ Observe the section "Permissible counterweight assemblies" in this chapter!
-



WARNING

Incorrect handling of the fastening equipment!

If tackle cannot be attached correctly and / or if it is not secured sufficiently to prevent it from loosening up, the counterweight plates can fall down!

Personnel can be severely injured or killed!

- ▶ Make sure that the fastening equipment is correctly attached on the bitts **3.1** and that it is secured sufficiently to prevent it from loosening up, see illustration **7**!
-
- ▶ Attach the counterweight plates individually or as a counterweight assembly on the auxiliary crane.
 - ▶ Lift the counterweight plates or the counterweight assembly and place down carefully.

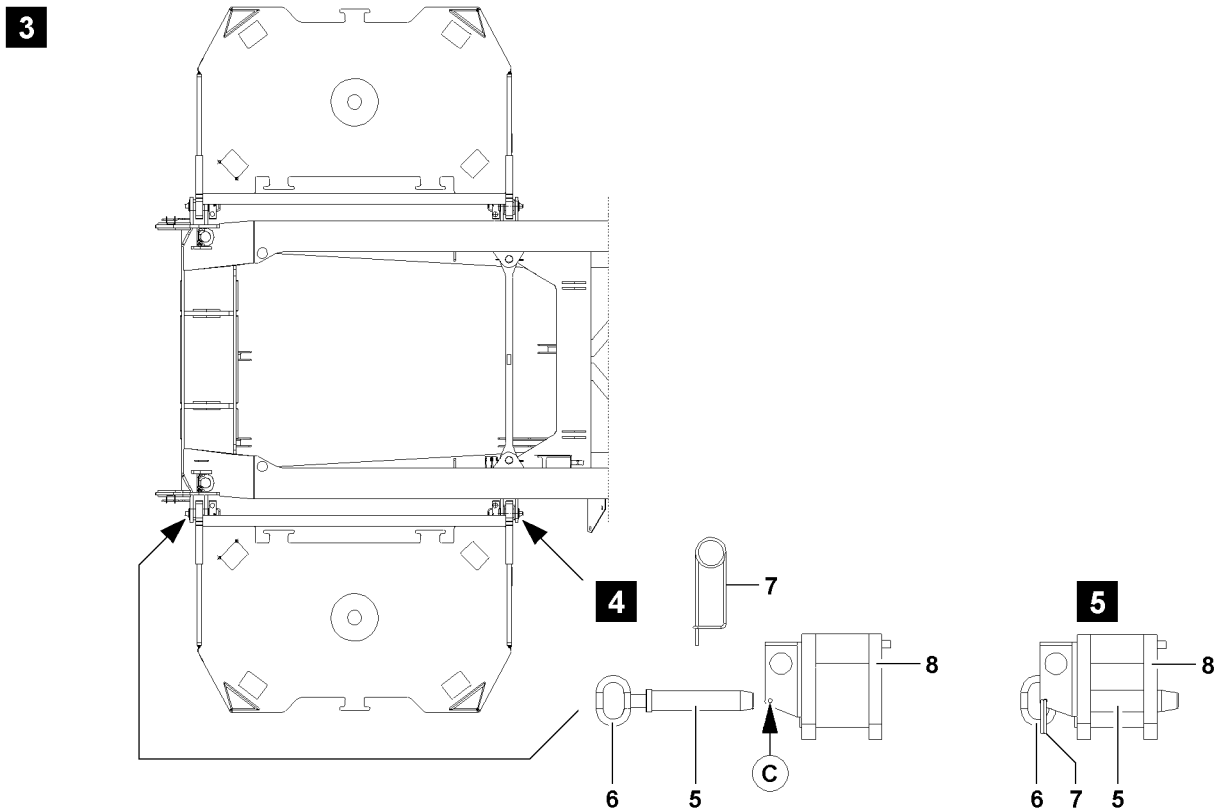
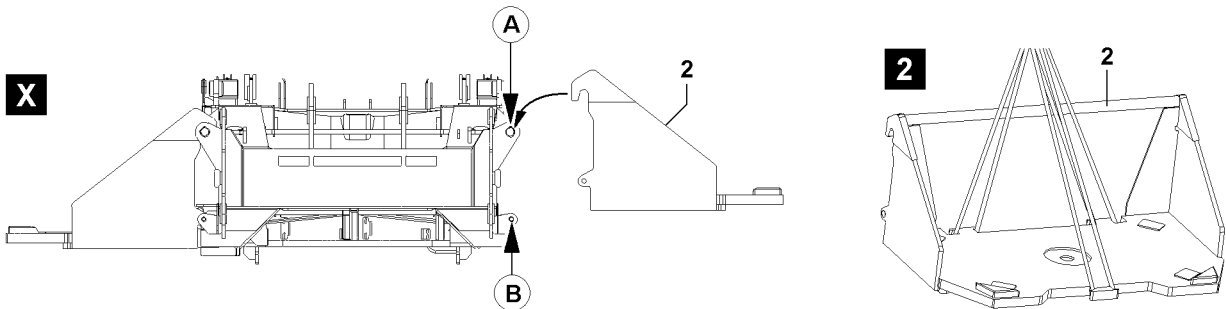
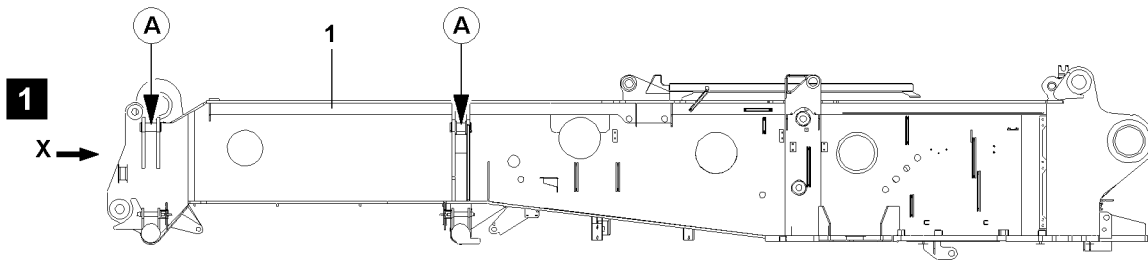

B104965

5.3 Removing the bracket



Note

- ▶ The weight of the bracket is approx. 3 t.
-
- ▶ Hang the bracket **2** onto the auxiliary crane, fig. **2**.
 - ▶ Unpin the bracket **2** on the turntable **1**:
Remove the spring retainer **7** and unpin the pin **5** on the left and right of the bracket **2** with the handle bar **6**, fig. **3**, fig. **4**.
 - ▶ Unhook the bracket **2** with the auxiliary crane from the turntable **1**.
 - ▶ When the bracket on the turntable is removed:
Insert the pin **5** on the left and right and secure with the spring retainer **7**, fig. **5**.

1 Technical safety instructions for working with a load

For more information, see chapter 2.04.



WARNING

The crane can topple over!

For steep boom positions, for which no loads are specified in the load charts there is a risk of the crane superstructure toppling when turning “backward”, i.e. towards the counterweight side! There is a particular danger if the support base has been reduced and supported with the sliding beams retracted!

Personnel can be severely injured or killed!

- ▶ The radii specified in the load chart must be observed!



WARNING

Danger of accident due to erroneous operation!

If the reeving number on the pulley head is less than the reeving number set on the LICCON computer system and if the load is lifted with the luffing gear, it can result in an overload of the hoist rope, as a result, the hoist rope can rip, causing the load to drop!

Personnel can be severely injured or killed!

- ▶ Always comply with the reeving numbers specified in the load chart for maximum loads!
- ▶ The reeving on the pulley head and the reeving set on the LICCON computer system must match, otherwise crane operation is prohibited!



DANGER

Danger of fatal accidents due falling load!

If the required number of three coils is fallen below (for example due to a technical defect), the hoist rope is ripped from the winch drum and the load falls down.

Personnel can be severely injured or killed!

- ▶ The crane operator must ensure that there are always at least three windings on the winch drum!

Always comply with the maximum loads specified in the load chart.

The weight of the hook block according the load chart must be taken into account.

For the lift, use the hook block which is suited best for the existing equipment configuration in connection with the load chart.

Initiate all crane movements carefully and also use the brakes carefully during crane movements.

That way you can avoid a swinging or pendulum motion in the suspended load.

2 Checks before starting to work with the crane

Before starting work with the crane, the crane operator must carry out a further inspection to satisfy himself about the crane's operational safety:

- Check that the crane is properly supported and level.
- Check that all values in the load chart that apply to the current equipment configuration have been entered and met.
- Ensure that there are no people or objects in the crane danger zone.



WARNING

Danger of accidents when turning the crane superstructure!

By turning the crane superstructure in restricted space conditions on the job site, especially in the rear area of the counterweight and towards the chassis, personnel can be crushed and severely injured or killed!

- ▶ Give a short warning signal (horn) before starting a slewing movement!
- ▶ Ensure before starting any slewing movement that there are no people or objects in the danger zone!

2.1 Visual check for damage



WARNING

Risk of accident!

If the crane is operated despite existing defects, personnel can be severely injured or killed!

- ▶ In the event of deficiencies that threaten operational safety, stop crane operation immediately!

The following deficiencies threaten the crane's operational safety:

- Damage to load-bearing parts of the crane design, such as booms, supports etc.
- Failure of the hoist gear brake and consequent slipping of the load
- Functional failures in the crane control system
- Functional failures in the indicator and warning lights
- Damage to the hoist ropes
- Functional failures in the safety devices
- Leakages on safety relevant components of the crane hydraulic

Inform the appropriate supervisor about the deficiencies on the crane and also inform your relief when crane operators are changed.

2.2 Telescopic boom distortion because of sunshine on one side

A temperature difference occurs between the side facing the sun and the side facing away from the sun for cranes with telescopic boom. This causes telescopic boom side distortion, which can reduce the load-bearing capacity of the telescopic boom. For example, a temperature difference between the two boom sides of 30 °C and a boom length of 60 m results in a length difference caused by the temperature difference between the two sides of the telescopic boom of approximately 22 mm.

Particularly with narrow boom parts, this causes the profiles to bend sideways!

If the maximum load carrying capacity is being fully utilized, particularly when a telescopic boom extension such as a lattice jib, luffing lattice jib or folding jib is being used, then it must be ensured through a visual inspection before picking up the load that the boom is not showing signs of side deformation due to one-sided sun exposure.



WARNING

Risk of accident because of component overloading!

If the telescopic boom has become distorted because of one-sided sun exposure this can cause component overload and therefore accidents!

- ▶ Turn crane so that both sides of the boom are brought to about the same temperature, therefore preventing side deformation due to temperature differences!

3 Crane movement - Telescoping

If the telescopic boom is telescoped, particularly with the auxiliary boom or telescopic boom extension, before the telescoping procedure, ensure that:

- The crane is properly supported and horizontally aligned.
- The telescopic boom is evenly warmed up by solar radiation.
- There is no strong side wind.



WARNING

Damage of the telescopic boom or the hoist rope!

If these 3 factors are not adhered to, damage of the telescopic boom or the hoist rope can occur and lead to accidents!

- ▶ Support the crane properly and align it horizontally!
 - ▶ Keep both sides of the boom at about the same temperature!
 - ▶ Telescope only to the permissible wind speed according to the load chart!
 - ▶ If the actual wind speed is higher than the permissible wind speed noted on the load chart, telescoping is prohibited!
-

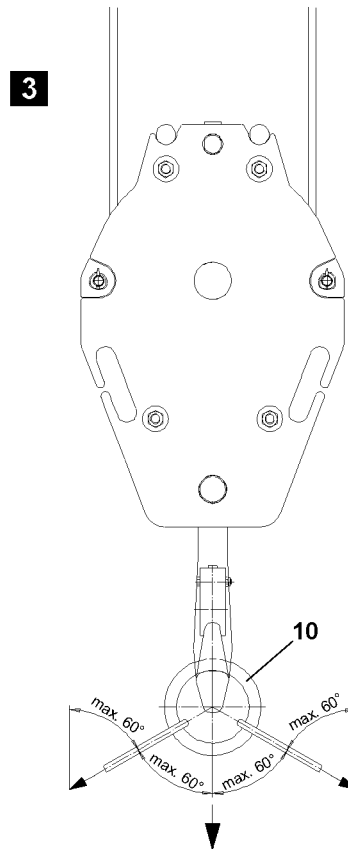
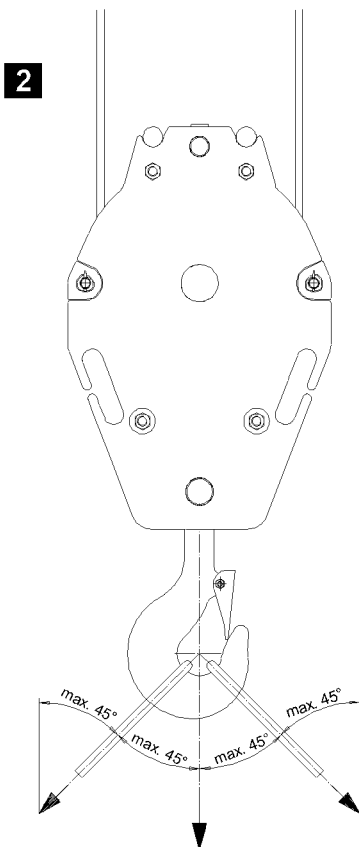
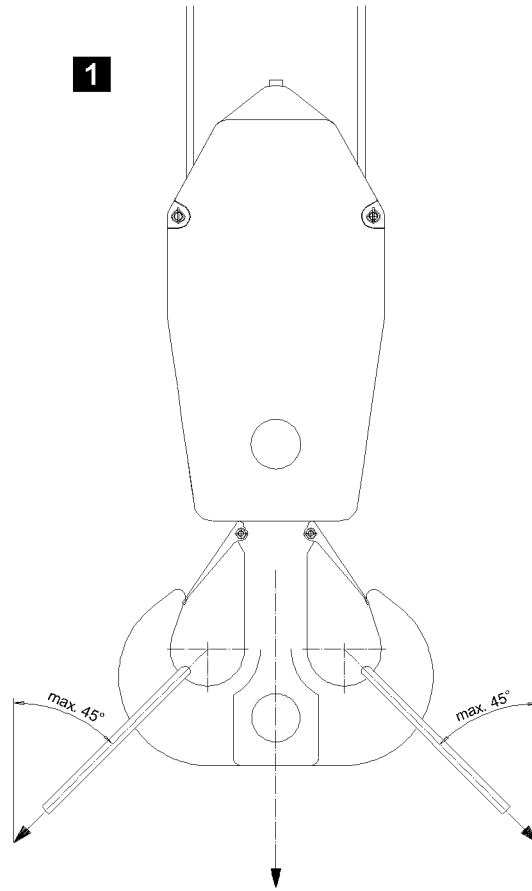

B112108

4 Taking on a load

The crane must always be operated in such a way that its load-bearing parts are not destroyed or damaged and its stability is ensured.

Make sure that the following prerequisites are met:

- The crane is supported and horizontally aligned.
- The LICCON overload protection has been set according to the load chart.
- The counterweight is installed according to the load chart.
- The hook block or the load hook is correctly reeved.

4.1 Attaching the load



WARNING

The crane can topple over!

If the following conditions are not met, the crane can topple over and cause fatal injuries!

This could result in high property damage!

- ▶ Observe own weight of the load tackle!
- ▶ Observe own weight of the load tackle!
- ▶ The maximum permissible incline of the strands fastened on single or double hooks in the hook jaws is 45°! See illustration 1 and illustration 2.

If necessary for the single hook:

- ▶ Use fastening equipment with a suspension link **10**! The maximum permissible incline in this case is 60°! See illustration 3.
- ▶ Load a single and double hook symmetrically! A maximum deviation of $\pm 3^\circ$ from the direction of the center of gravity is permissible!

If necessary:

- ▶ Use crossbars or two cranes for taking up the load!
-

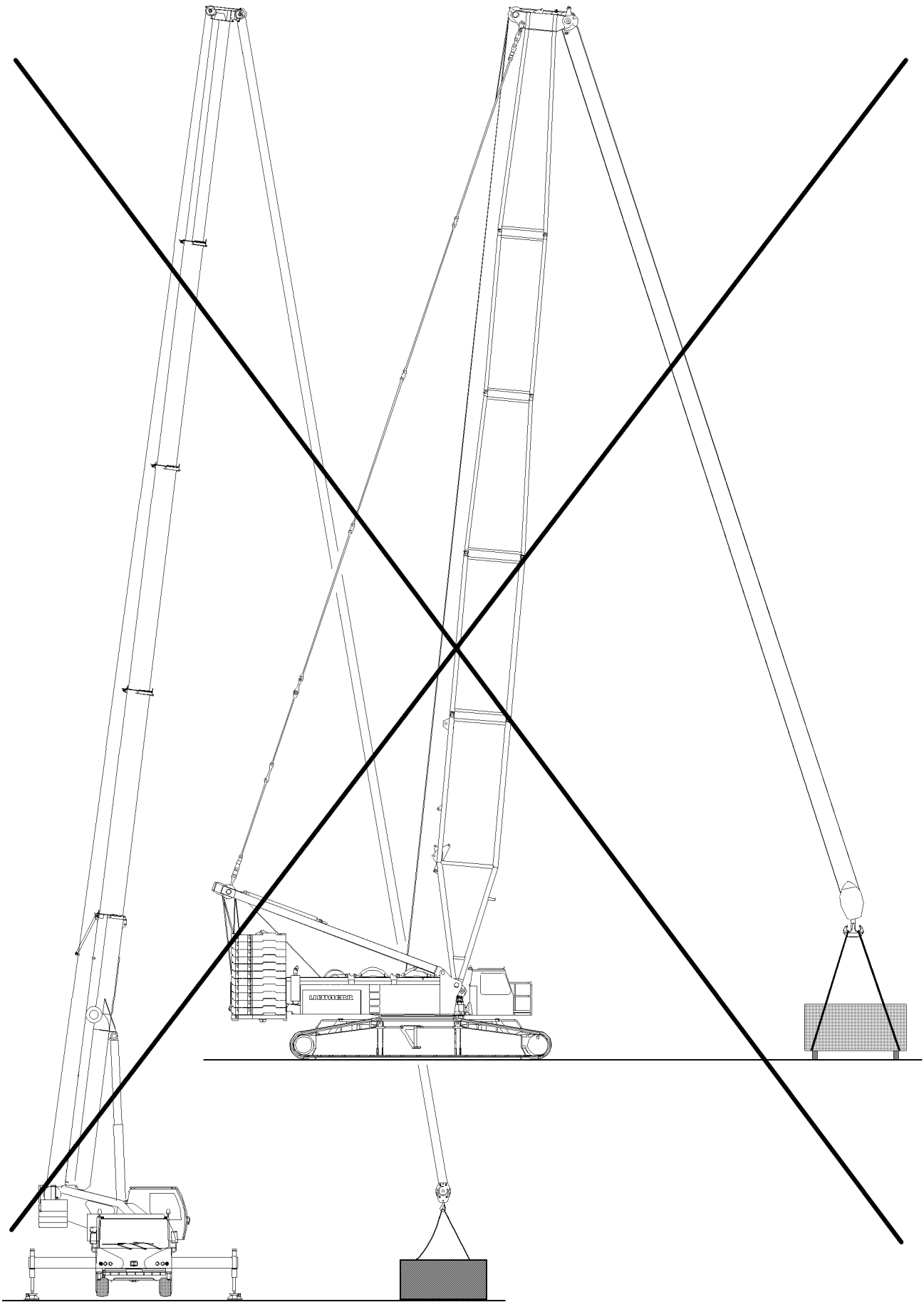

B102716

4.2 Lifting the load



WARNING

Danger of crushing for people in the load zone!

If personnel are located between the load to be lifted and a possible interfering edge (such as a wall of a building or similar) when the load is lifted, personnel can be severely injured or killed!

- ▶ Before lifting the load it must be ensured that there are no persons within the danger zone!
- ▶ It is prohibited for anyone to remain in the danger zone!
- ▶ It is prohibited for anyone to be under the load! Keep a safety distance!
- ▶ Swinging of the load is prohibited!
- ▶ Exercise extreme caution when lifting a load!



WARNING

The crane can topple over!

If an attempt to lift a load above the hoist gear causes the LICCON overload protection to turn off, then the load may not be lifted by luffing up the boom. This leads to overloading and toppling of the crane!

Personnel can be severely injured or killed!

- ▶ Do not lift the load by luffing up the boom from the ground!



Note

When using the assembly winch* observe the following:

- ▶ Use the assembly winch* only for assembly and not for lifting loads!
- ▶ Lifting of loads with the auxiliary winch is prohibited!

If the fastening rope is manually attached by an assistant to the load to be lifted:

- Make sure that the assistant's hands are not crushed by the tightened ropes between the load and the fastening rope.
- Make sure that the assistant's body parts (hands, legs etc.) are not crushed by a swaying movement of the load during lifting.

4.3 Angular pulling



WARNING

The crane can topple over!

Angular pulling can destroy the crane or cause it to topple over!

Personnel can be severely injured or killed!

- ▶ Attach (hang) the hook block always vertically over the center of gravity of the load to be lifted!
- ▶ Do not use the slewing gear to pull and set up loads!
- ▶ Angular pull is prohibited!

The crane is designed only to lift loads vertically. During angular pulling, regardless of whether this is done in the same direction as the boom or laterally, horizontal forces are generated in addition to the vertical forces, for which the boom is not designed.

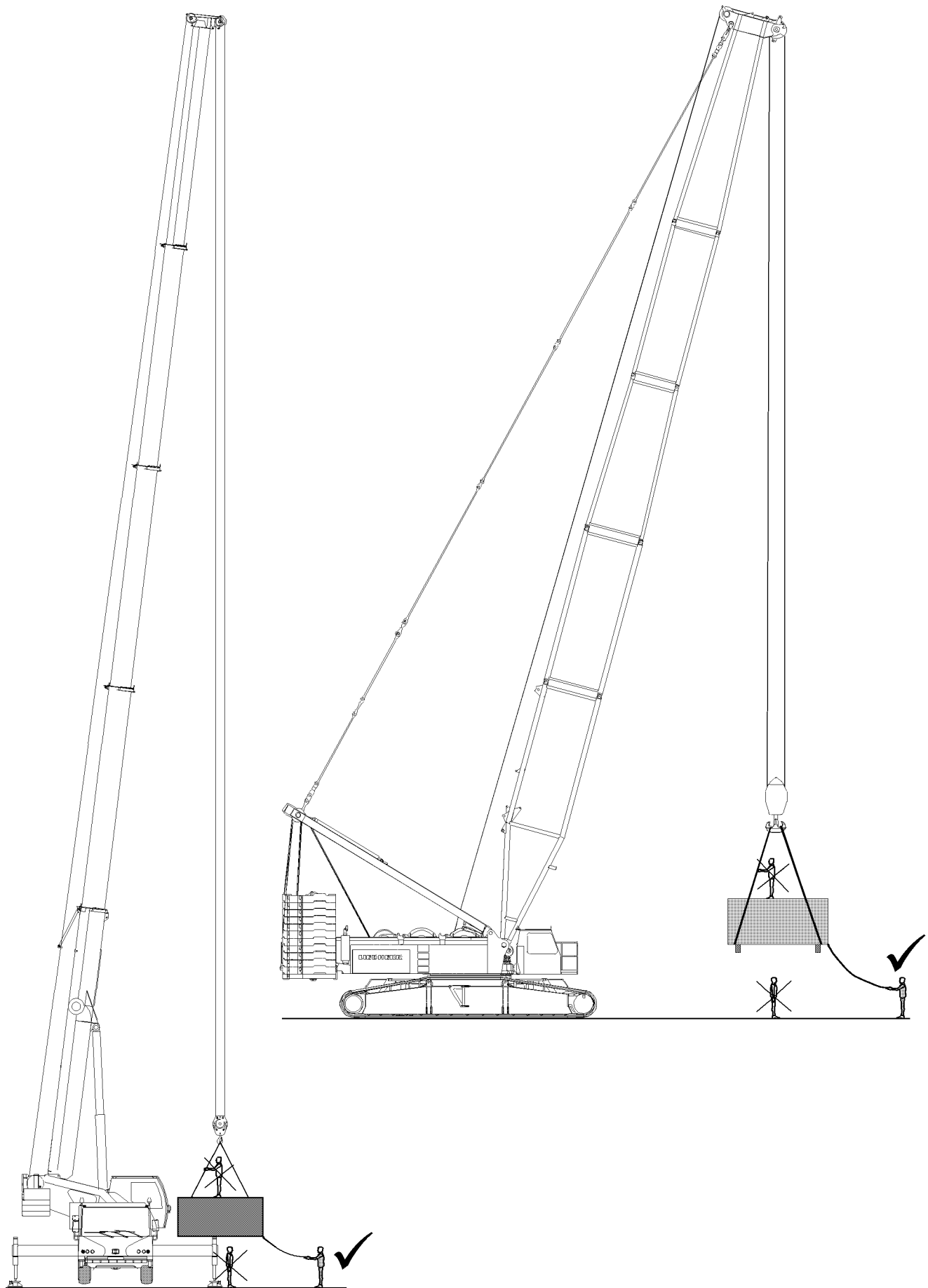

B102717

4.4 Breaking away fixed loads



WARNING

The crane can topple over!

Ripping stuck loads free can destroy the crane or cause it to topple over!

Personnel can be severely injured or killed!

- ▶ Ripping stuck loads free is prohibited!

5 Crane operation

The maximum load-bearing capacity is not just limited by stability, but in many cases a load-bearing component breaks when the crane is overloaded **before** the crane topples over. Particularly components that are susceptible to buckling such as the telescopic boom may fail suddenly **without showing signs of distortion beforehand** if the crane is overloaded.



WARNING

Danger of accidents for cranes with luffing cylinders!

When the luffing cylinder is on block position, the overload protection is not functioning!

- ▶ Crane operation at block position of luffing cylinders is prohibited!

5.1 General

A suspended load must always be kept under control. A fundamental requirement for this is the safe and delicate control of the crane's functions.



WARNING

Risk of accident due to swaying loads!

A swaying load can damage the crane and cause it to topple!

- ▶ All crane movements must be executed slowly and delicately!
- ▶ Initiate all crane movements slowly!
- ▶ Apply the brakes slowly in all crane movements!
- ▶ Crane operation with swaying loads is prohibited!

NOTICE

Damage of rope pulleys!

- ▶ Place down hook blocks, booms, folding jibs, auxiliary booms and boom noses in such a way that the rope pulleys do not lie on the ground and are damaged!

5.2 Guiding the load

The use of guide ropes is recommended to help the crane operator to manage the load more precisely and to prevent the load from swaying. This will prevent undesirable movements of the load and consequent damage.

5.3 Danger of being crushed!



WARNING

Risk of fatal injury!

Extreme care is needed when lowering a load! Mortal danger exists for personnel in the immediate area of the load being lowered!

Personnel can be severely injured or killed!

- ▶ Standing under a suspended loads is strictly prohibited!

5.4 Working in the vicinity of electricity transmission lines



DANGER

Risk of accident!

Failure to observe the following notes can lead to damage!

► Note the following points carefully!

If there are electricity transmission lines in the immediate vicinity of the building site, these must be switched off by qualified electricians. If this is not possible, the danger area must be covered over or cordoned off. If even these measures cannot be carried out, the following safety distances must be maintained:

Rated voltage	Minimum distance
Up to 1 kV	1 m
1 kV to 110 kV	3 m
110 kV to 220 kV	4 m
220 kV to 380 kV	5 m
Rated voltage not known	5 m

If the crane becomes electrified despite having taken all necessary precautions, proceed as follows:

- Remain calm!
- Stay inside the crane driver's cab!
- Warn anyone who is outside and advise them to remain stationary and not to touch the crane!
- Move the crane away from the danger zone!

5.5 Ram work or pulling sheet piles

Vibration can be transmitted to the supporting steel structure of the crane during ram work or when pulling sheet piles with the crane. This vibration can cause premature fatigue of the material and therefore cracks in the supporting steel structure.



DANGER

Important instructions for “ram work” or “pulling sheet piles”!

If the crane is used for ram work or pulling sheet piles, then the following instructions must be followed. Failure to follow the instructions can result in damage to the crane.

- The ramming equipment may not pass on vibrations into the boom!
- When pulling sheet piles, the maximum pull force of the crane is limited according to the load chart! Restricting the maximum pull force via the crane overload protection **only** is prohibited! The pull force must be additionally checked by measuring.

blank page!

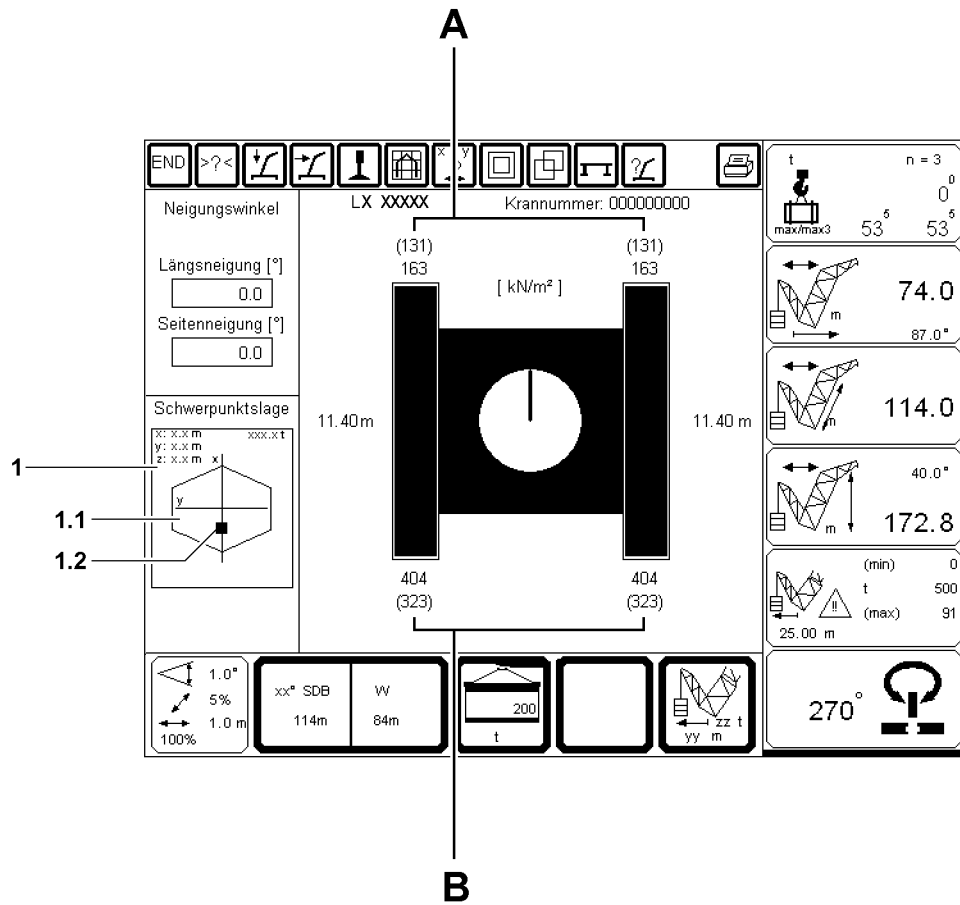

1 Prerequisites for crawler operation



WARNING

The crane can topple over!

If the following instructions are not observed, the crane can topple over!

Personnel can be severely injured or killed!

- ▶ Before driving the crane with the attachment, the optimum boom position must be determined with the aid of the job planner, to obtain as even a ground pressure as possible!
- ▶ The crane operator is responsible for the correct and complete data input on the job planner, for the respective equipment configuration of the crane and for the ground condition during crane application and while driving!
- ▶ When driving crawler cranes, it must be ensured that the ground can take on the ground pressures safely, which have been calculated with the job planner, over the entire intended travel route. If this cannot be ensured, the appropriate measured must be taken to be able to transfer the forced into the ground!
- ▶ An additional monitor, who is connected by radio contact with the crane operator must ensure that there are no persons or objects within the danger zone of the crane!



WARNING

Crane with narrow crawler track!

- ▶ When driving cranes with narrow tracks and corresponding equipment, special travel charts and danger notes must be observed and adhered to, see auxiliary chapter 6.02!

1.1 General prerequisites for driving of crawler cranes



WARNING

The crane can topple over!

If the turntable is not parallel to the crawler travel gear when driving the crane, the crawler crane can topple over!

- ▶ Make sure that the turntable is aligned parallel to the crawler travel gear in 0° or 180° position before driving the crawler crane!

Before driving on sloped terrain, it needs to be measured and a permissible equipment configuration on the crane must be established. If the display range of the inclinometer is not sufficient when driving uphill, then the actual incline can be determined with the aid of an angle spirit level. To determine the uphill angle, the angle spirit level must be placed in longitudinal direction on the slewing ring!



WARNING

The crane can topple over!

If the permissible inclines are exceeded, the crane can topple over!

Personnel can be severely injured or killed!

- ▶ Make sure that the permissible inclines are never exceeded!
- ▶ The crane operator is responsible for the adherence to the permissible inclines!

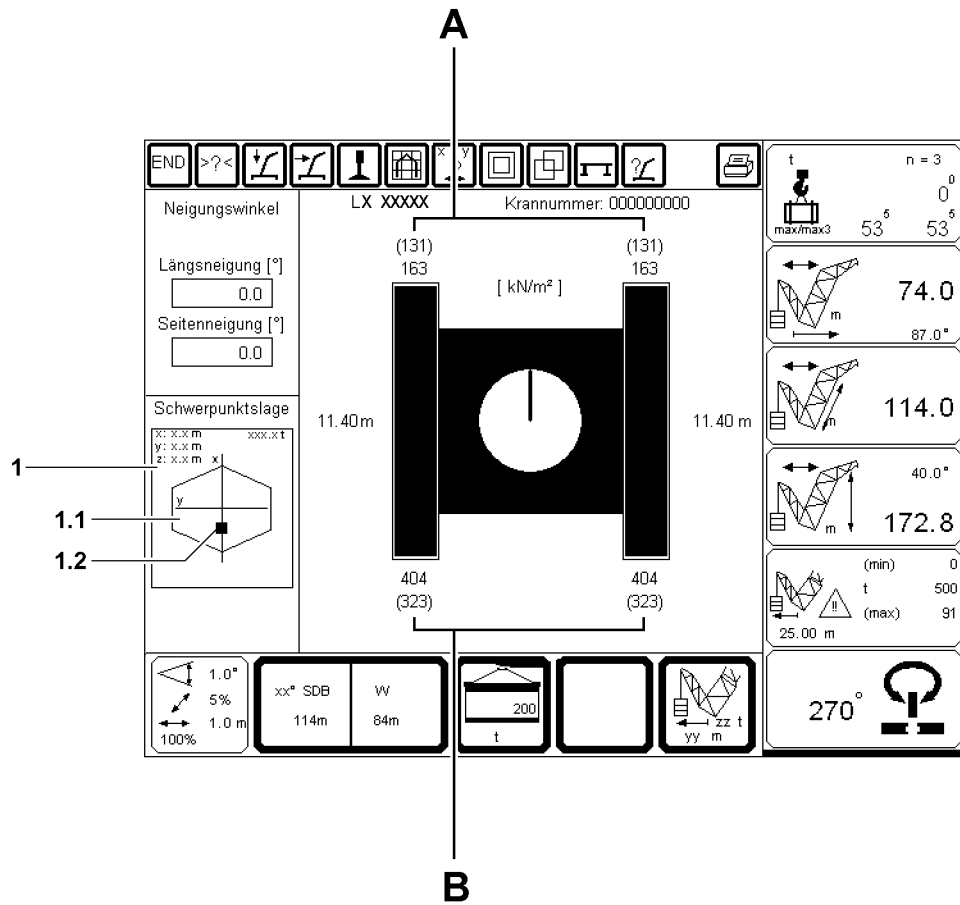

B109839

1.1.1 For Australia, the following applies for driving crawler cranes:

**Note**

- ▶ In Australia, driving crawler cranes is only permitted with 66 percent of the respective nominal load, for that reason, the loads in the respective load chart must be multiplied with a calculation factor of 0.88!
- ▶ The crane operator bears the sole and full responsibility for the observation of national regulations!

Driving crawler cranes with reduced load

Calculation formula

$$T_V^{1)} = T_{ISO\,DIN}^{2)} * 0.88^{3)}$$

1) T_V = maximum permissible, drivable load (= 66 percent of the nominal load) Valid only for Australia!

2) $T_{ISO\,DIN}$ = Standard load charts according to ISO DIN

3) **0.88** = Calculation factor

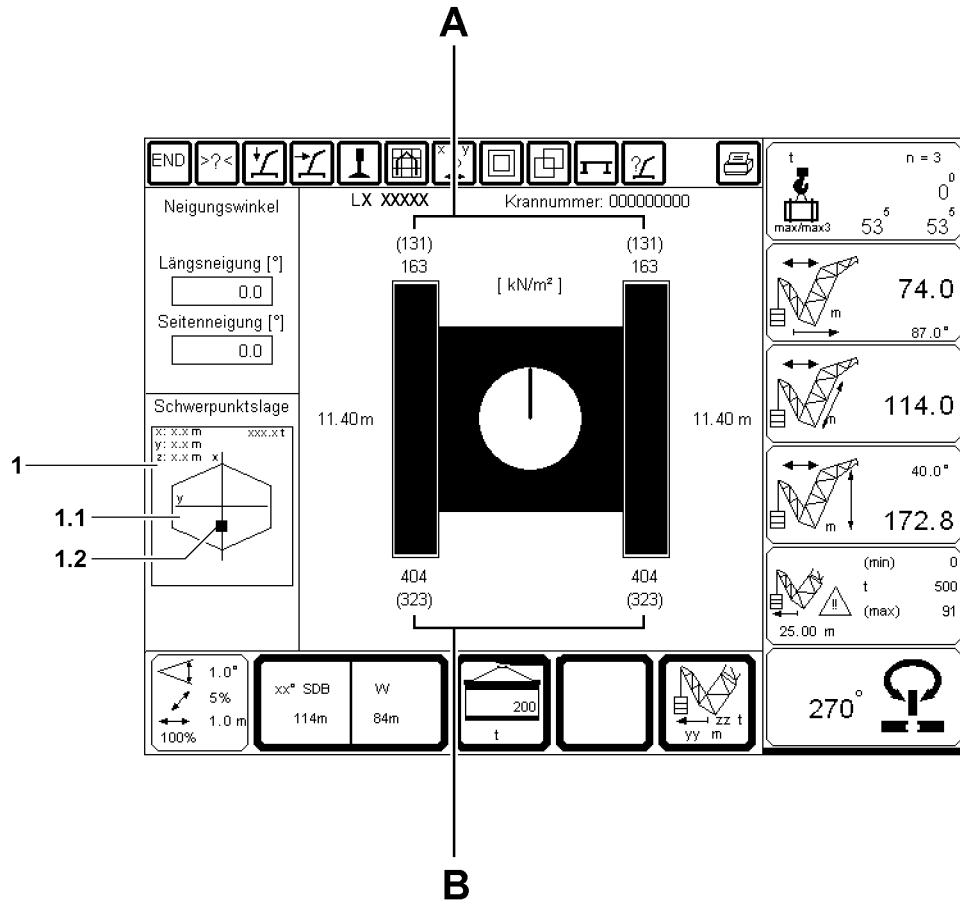

B109839

1.1.2 Center of gravity display

Position	Description
1	Center of gravity display
1.1	Core surface
1.2	Center of gravity



WARNING

Center of gravity of the crane is outside the core area!

If the center of gravity **1.2** of the crane is outside the core area **1.1**, then the crane can topple over!

Personnel can be severely injured or killed!

- ▶ To drive the crane, the center of gravity **1.2** must always be within the core area **1.1**!
- ▶ If the center of gravity is outside the core area, then it is prohibited to drive the crane!



Note

- ▶ If the center of gravity **1.2** of the crane is within the core area **1.1**, then the center of gravity **1.2** is shown in green!
- ▶ If the center of gravity **1.2** of the crane is outside the core area **1.1**, then the center of gravity **1.2** is shown in red!

1.1.3 Distribution of the ground pressure



Note

- ▶ The boom must be luffed down before driving until the load is even distributed on the tracks!
- ▶ If the counterweight on the turntable is large, then it is required to position the boom in such a way that a suitable distribution of ground pressure for driving is obtained!



Note

For all driving conditions, the ratio between the front and rear or the rear and the front ground pressures should be greater than 0.3!

- ▶ A : B should be greater than 0.3!

A = maximum ground pressure of the track which has the lower load of the two tracks

B = maximum ground pressure of the track which has the higher load of the two tracks

1.1.4 Steering ability

The steering ability depends on the following factors:

- Friction conditions under the chains
- Evenness of the ground:
 - Steering is not possible if the crawler track are only making contact with the ground at the front and rear.
- Load bearing capacity of the ground:
 - If the crawler tracks sink into the ground, then the steering ability is significantly restricted.
- Position of the total center of gravity:
 - If the total center of gravity - under consideration of the suspended load - is at the center of the crane, then steering is hard or not possible at all.

The steering ability can be improved by:

- Placing metal sheeting, sand, gravel, water underneath
- Through observation of the ground load bearing ability: Changing the position of the center of gravity by changing the radius

1.2 Prerequisites for driving with a load and / or derrick ballast



Note

- ▶ The permissible inclines from the load charts apply for driving with a load!
- ▶ Take the maximum permissible wind speed from the load charts!

Permissible inclines for driving with a load	
Overall incline	$\pm 0.3^\circ$



WARNING

The crane can topple over!

If the following conditions are not observed, the crane can topple over!

Personnel can be severely injured or killed!

- ▶ The ground must be level ($\pm 0.3^\circ$) and have adequate load bearing capacity!
- ▶ The ground must be able to safely take on the maximum occurring ground pressures!



WARNING

The crane can topple over!

If the crane is driven uphill with a load or derrick ballast, the crane can topple over!

Personnel can be severely injured or killed!

- ▶ Driving uphill with a load and / or derrick ballast is prohibited!



WARNING

The crane can topple over!

The crane can be driven with the given loads from the load charts, if the following prerequisites are met!

If the following prerequisites are not observed, the crane can topple over!

Personnel can be severely injured or killed!

- ▶ The maximum permissible travel speed of the crawler with load and / or derrick ballast may **not** exceed 0.05 m/s or 3 m/min or 0.18 km/h!

- ▶ Steering the crawler with suspended load and / or installed derrick ballast is prohibited!
- ▶ Avoid jerky driving movements!
- ▶ Secure the suspended load to avoid oscillation!
- ▶ Lift the suspended ballast no more than maximum 250 mm off the ground!
- ▶ Luff the main boom up or down until a medium utilization is obtained on test point 1 (MS1)!

1.3 Prerequisites for driving without a load and without derrick ballast

Make sure that the following prerequisites are met:

- The maximum permissible oil fill quantity in the motor is present.
- The oil level in the hydraulic oil tank is lowered from the cylinders to the extent that an overflow is not possible.
- The contents of the fuel tank must be reduced so that an overflow is not possible.
- The maximum permissible wind speed of 9 m/s is not being exceeded.
- the travel speed may not exceed 0.4 m/s **or** 24 m/min **or** 1.44 km/h
- The turntable is aligned parallel to the crawler track, 0° or 180° position.



Note

- ▶ The center of gravity for driving without a load must be constantly checked with the LICCON job planner!
- ▶ If the total center of gravity of the crane is within the core area **1.1** and the permissible inclines are observed, then the placement stability of the crane is ensured!
- ▶ By luffing the main boom up and down, the position of the center of gravity **1.2** must be corrected in such a way that the overall center of gravity remains within the core surface **1.1**!
- ▶ When driving the crane in terrain with a longitudinal and lateral slope, then the required boom position must be determined with the aid of the LICCON job planner via the position of the overall center of gravity, see section "Display of center of gravity"!



WARNING

Crane with narrow crawler track!

- ▶ When driving cranes with narrow tracks and corresponding equipment, special travel charts and danger notes must be observed and adhered to, see auxiliary chapter 6.02!

Permissible inclines for driving without a load	
Overall length of boom	Maximum permissible lateral incline
shorter/ equal to 96 m	± 3°
97 m to 150 m	± 2°



WARNING

The crane can topple over!

If the following conditions are not met when driving the crawler crane on a hill, then the crane can topple over!

Personnel can be severely injured or killed!

- ▶ The ground must be able to absorb the ground pressures which will occur!
- ▶ The friction coefficient between the roadway and the ground must be large enough to take on the occurring drive forces!
- ▶ Slippery ground can cause the crane to slip off to the side and therefore lead to an impermissible side slope position!
- ▶ The turntable must be parallel to the crawler carriers and secured to prevent it from turning!
- ▶ All movements and delay maneuvers must be initiated with extreme caution and at the least possible speed!

- ▶ The transfer from the horizontal into an uphill slope and from the uphill slope into the horizontal must be made evenly, i.e.: There may be no edges which can cause the crane to topple over! The incline change must be made continuously!
- ▶ The ground pressures which will occur should be determined with the job planner before travel!
- ▶ The ground must be sufficiently load bearing and have sufficient traction to prevent the crane from slipping!
- ▶ The counterweight on the turntable must be secured with a chain, see chapter 4.07 of the Crane operating instructions!
- ▶ The center of gravity of the crane must lie within the core area 1.1 of the crane! The appropriate and permissible boom position for the respective equipment configuration must be determined with the job planner!

1.4 Prerequisites for driving on uphill slopes

1.4.1 Maximum climbing ability

The maximum climbing ability of the crawler crane is limited by the following criteria:

- The location of the center of gravity for the complete crawler crane
- The friction coefficient between roadway and track pads
- The transit between the horizontal and the incline
- The maximum uphill incline of 10° to a boom length of 150 m

1.4.2 Calculation of required length for transfers



Note

- ▶ The required length **L** for transfers results from the existing uphill angle α and the length of the crawlers **LC**!

Abbreviation	Description
L	Required length of transfers
α	Angle of uphill slope in degrees
LC	Length of crawlers between drive wheels and steering wheels

Calculation example

Given:

$$\alpha = 10^\circ$$

$$LC = 12.6 \text{ m}$$

Wanted:

$$L = ?$$

Formula:

$$L = 0.5 \times \alpha \times LC$$

Result:

$$L = 0.5 \times 10 \times 12.6 \text{ m} = 63 \text{ m}$$

1.4.3 Prerequisites for driving under observation of the boom position



Note

- ▶ The illustrations in this section are only examples and may not match to your crane!
- ▶ The determining factor for driving uphill is the exact knowledge of the existing operational conditions on the jobsite and the ground pressures, permissible boom angles and inclines as well as the overall center of gravity which were determined from them with the job planner!

**WARNING**

The crane can topple over!

If the following note is not observed, the crane can topple over!

Personnel can be severely injured or killed!

▶ Driving uphill must always be anticipatory, with utmost caution and at the slowest speed!

There are two different possibilities to drive crawler cranes uphill (downhill):

- With main boom angle adjustment
- Without main boom angle adjustment

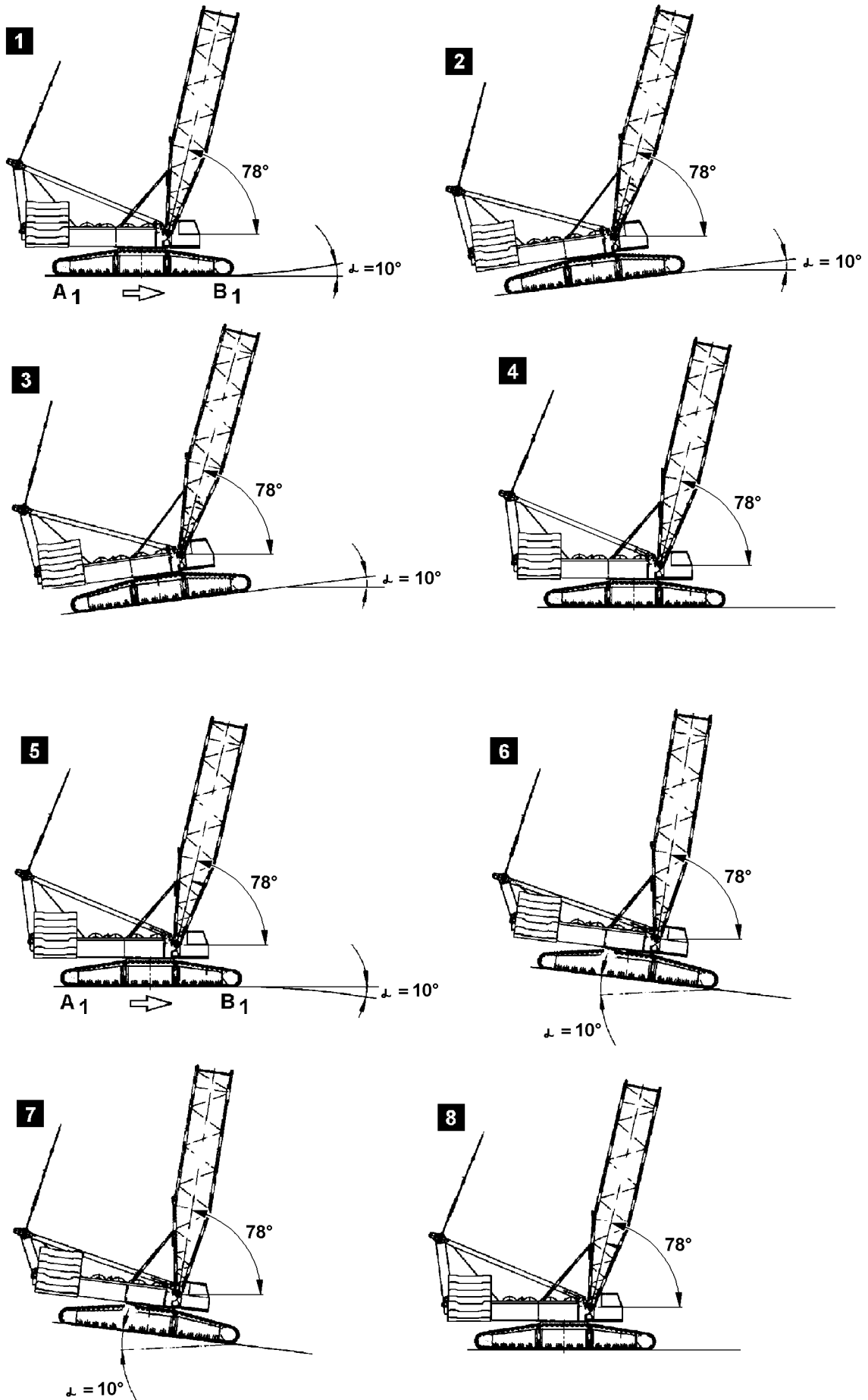

Examples

B109840

Prerequisites for driving on uphill slopes with boom angle adjustment



Note

- ▶ When driving into an uphill slope, during the transition between the horizontal into the incline, the original main boom angle must be changed continuously in such a way that the original main boom angle always remains between the main boom and the horizontal! This angle must be retained in the incline!
- ▶ When driving out of an uphill slope, during the transition between the incline into the horizontal, the original main boom angle must be changed continuously in such a way that the original main boom angle always remains between the main boom and the horizontal!
- ▶ In addition, the overall center of gravity of the crane must be observed!



WARNING

The crane can topple over!

If the crane is driven uphill with a load or derrick ballast, the crane can topple over!

If the main boom angle is not matched to the incline when driving the crane in uphill slopes, then the crane can topple over!

Personnel can be severely injured or killed!

- ▶ Driving uphill with a load and / or derrick ballast is prohibited!
- ▶ Match the main boom angle to the incline!

Positive length incline (illustration 1 to 4)



Note

- ▶ When driving in positive length inclines (uphill slopes), the main boom must be luffed down continuously - maximum by the **incline angle α** !

Illustration	State	Transition	Main boom angle
1	Driving on level ground (horizontal)	after uphill incline	match
2	Driving in uphill incline		
3	Driving in uphill incline	after horizontal	match
4	Driving on level ground (horizontal)		

Negative length incline (illustration 5 to 8)



Note

- ▶ When driving in negative length inclines (downhill slopes), the main boom must be luffed up continuously - maximum by the **incline angle α** !

Illustration	State	Transition	Main boom angle
5	Driving on level ground (horizontal)	after downhill slope	match
6	Driving downhill		
7	Driving downhill	after horizontal	match
8	Driving on level ground (horizontal)		

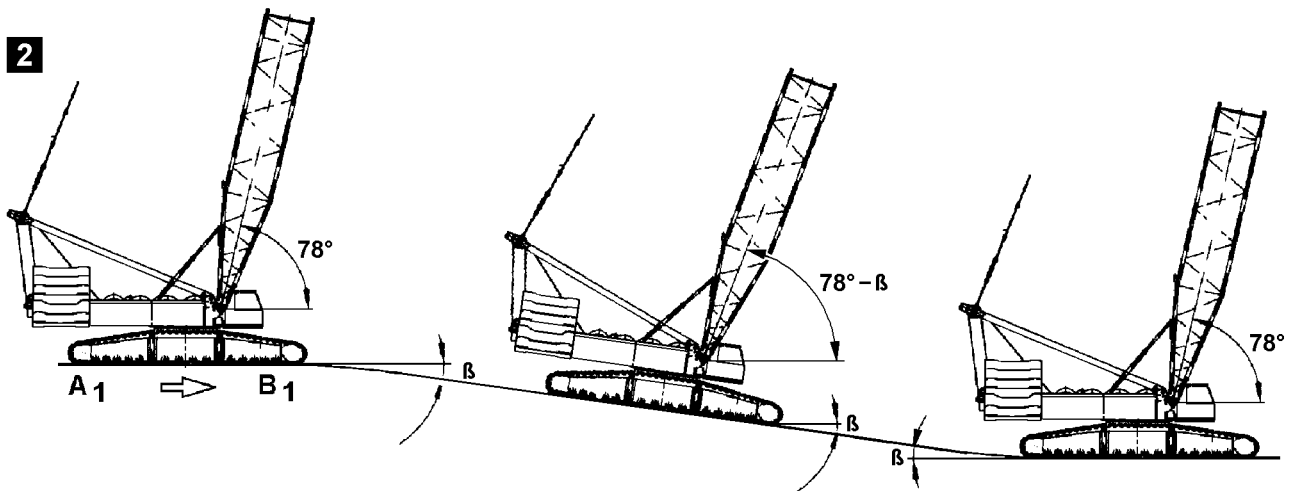
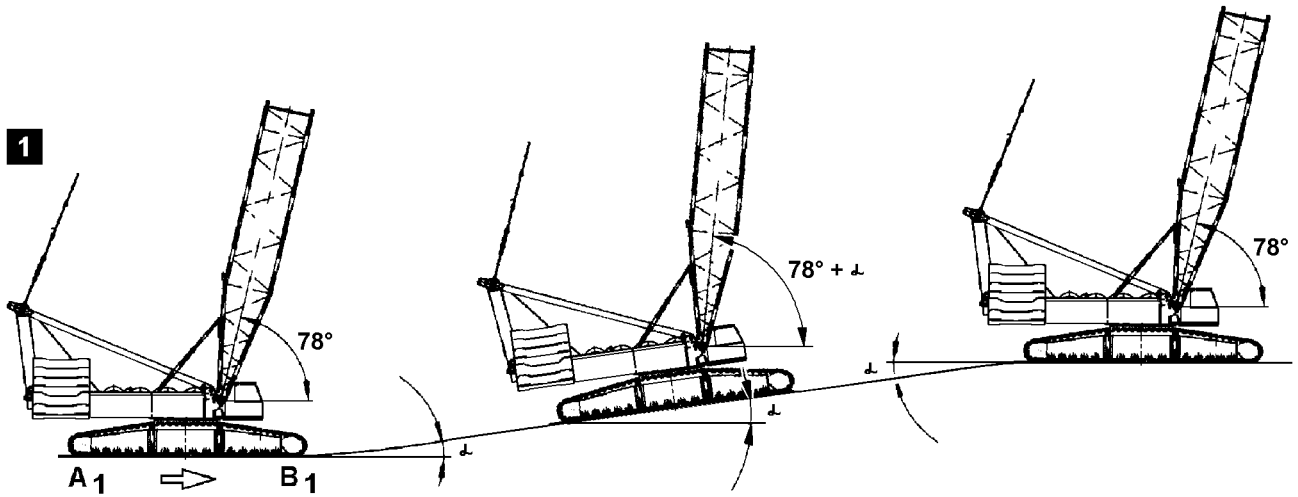

Prerequisites for driving on uphill slopes without boom angle adjustment



WARNING

The crane can topple over!

If the overall center of gravity of the crane is outside the core area when driving on inclines without main boom angle adjustment, then the crane can topple over!

Personnel can be severely injured or killed!

- ▶ Before driving into uphill or downhill slopes, check the change of the center of gravity with the job planner!
 - ▶ To be able to approximately determine the changes of the center of gravity in uphill slopes with the job planner, the main boom angle must be increased by the incline angle α when driving in inclines, illustration 1!
 - ▶ To be able to approximately determine the changes of the center of gravity in downhill slopes with the job planner, the main boom angle must be decreased by the incline angle β when driving in downhill slopes, illustration 2!
 - ▶ Before driving the crane, determine exactly with the job planner if the crane may drive on the intended route without changing the main boom angle!
 - ▶ If the intended incline cannot be driven without changing the main boom angle, then the main boom angle must be changed to be able to drive on the incline!
-

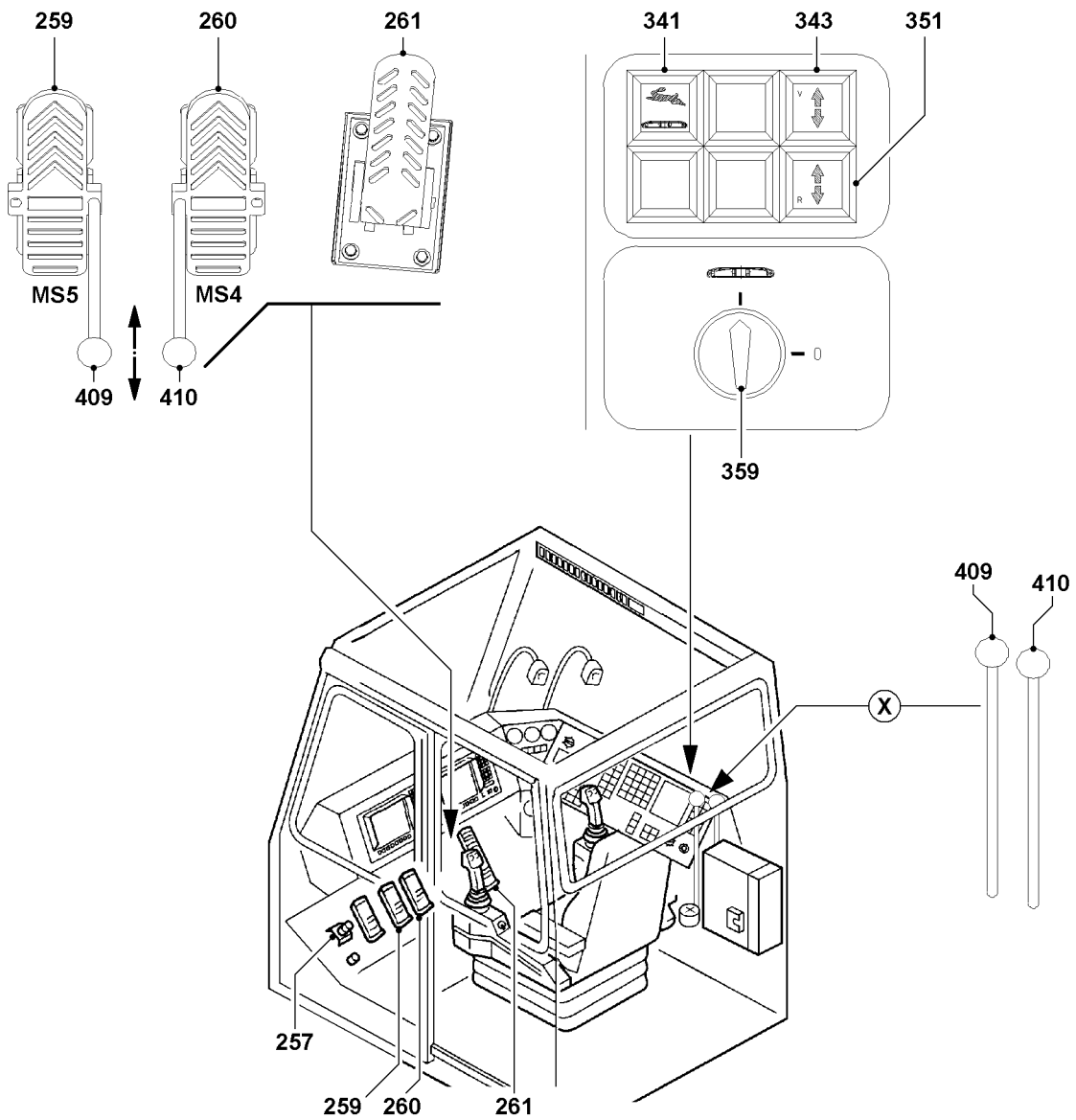
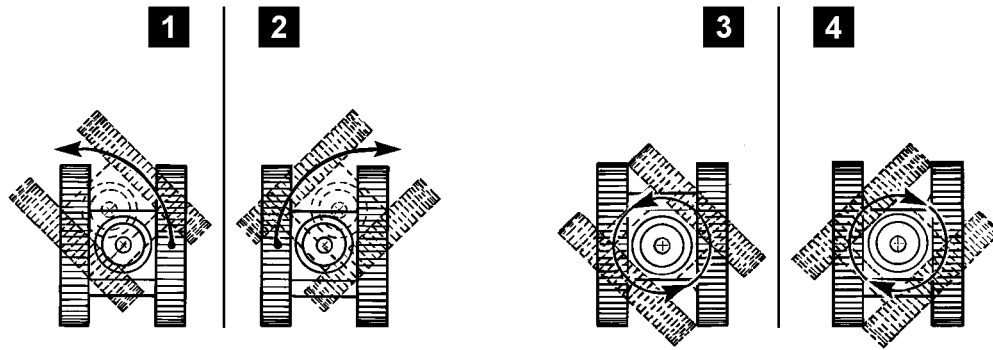

B104692

2 Driving the crawler crane



WARNING

The crane can topple over!

When driving the crane - this also applies for "circular travel" - and the ballast trailer is raised due to ground unevenness, the force on test point 1 **MS1** (F1) increases very quickly and the crane will be overloaded!

If the ballast trailer sinks while driving due ground unevenness, the force on test point 1 **MS1** (F1) drops and the ballast trailer lifts off the ground, or the entire boom system is pulled backward!

There is no LMB shut off!

The crane can topple over and personnel can be severely injured or killed!

- ▶ The crane operator must constantly observe the displays on the LICCON monitor while driving the crawler crane!
- ▶ The crane operator must correct the force changes on test point 1 **MS1** (F1) to a permissible operating range already when an advance warning occurrence on the LICCON monitor is issued by actuating the pull cylinder in the derrick ballast guying!



WARNING

The crane can topple over!

If the following instructions are not observed, the crane can topple over!

Personnel can be severely injured or killed!

- ▶ Before driving the crane with the attachment, the optimum boom position must be determined with the aid of the job planner, to obtain as even a ground pressure as possible!
- ▶ When driving crawler cranes, it must be ensured that the ground can take on the ground pressures, which have been calculated with the job planner, over the entire intended travel route. If this is not the case, appropriate measures must be taken to be able to discharge the forces into the ground!
- ▶ An additional monitor, who is connected by radio contact with the crane operator must ensure that there are no persons or objects within the danger zone of the crane!

Make sure that the following prerequisite is met:

- The crane engine is running.

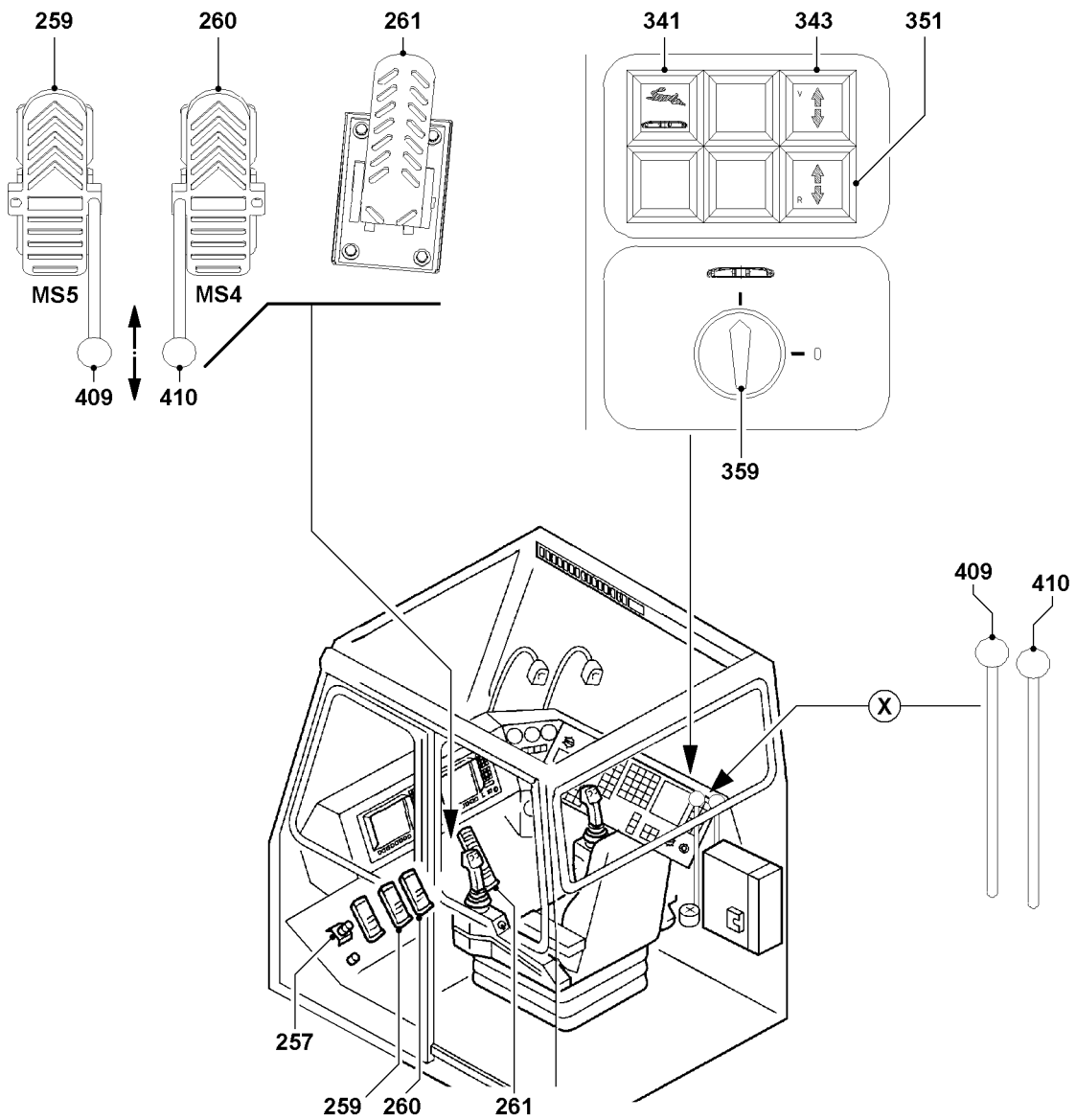
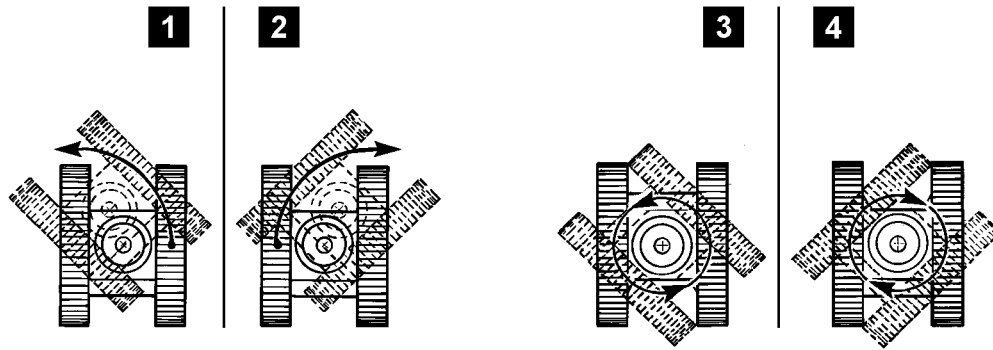

B104692

2.1 Activating crawler operation



Note

- ▶ For “normal” crane operation, the preselector switch **359** “Crawler operation OFF / ON” is in zero position!
- ▶ To activate crawler operation, the preselector switch **359** must be switched to position I, “Crawler operation ON”!

- ▶ Turn the preselector switch **359** to position I, to the left.

Result:

- Crawler operation is activated.
- The indicator light **343** or indicator light **351** lights up (depending on the turntable position).

- ▶ If the crawler operation is to be turned off:
Turn the preselector switch **359** to position 0, to the right.

Result:

- Crawler operation is turned off.
- Indicator light **343** or indicator light **351** turns off.

2.2 Selecting the travel speed

This crawler crane has 2 possible speeds:

- 1.) Speed stage 1:
Creeper gear
- 2.) Speed stage 2:
Fast mode (Rapid gear)

2.2.1 Activating the creeper gear

Make sure that the following prerequisites are met:

- The switch “Rapid gear” **341** is not actuated.
- The indicator light in the switch “Rapid gear” is off.

- ▶ Actuate the switch “Crawler operation” **359**.

Result:

- The creeper gear is active.

2.2.2 Turning the rapid gear on



WARNING

The crane can topple over!

If the crane is driven in rapid gear with a load or suspended ballast, then the crane can topple over!

Personnel can be severely injured or killed!

- ▶ Travel with a load or suspended ballast in rapid gear is prohibited!

Make sure that the following prerequisite is met:

- The creeper gear is active.

- ▶ To select speed stage 2:
Actuate the switch “Rapid gear” **341**.

Result:

- The rapid gear is activated.
- The indicator light in the switch “Rapid gear” lights up.

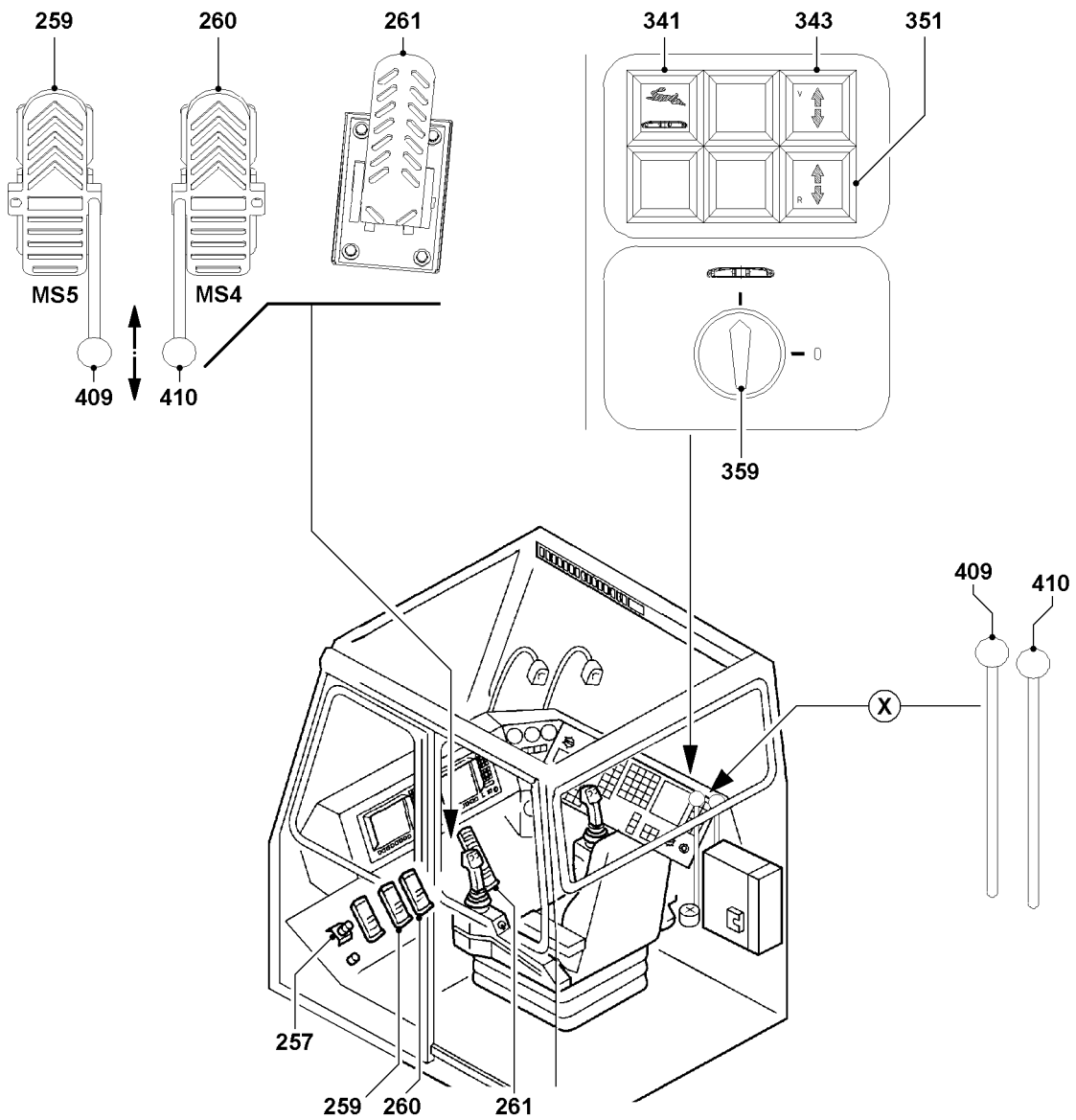
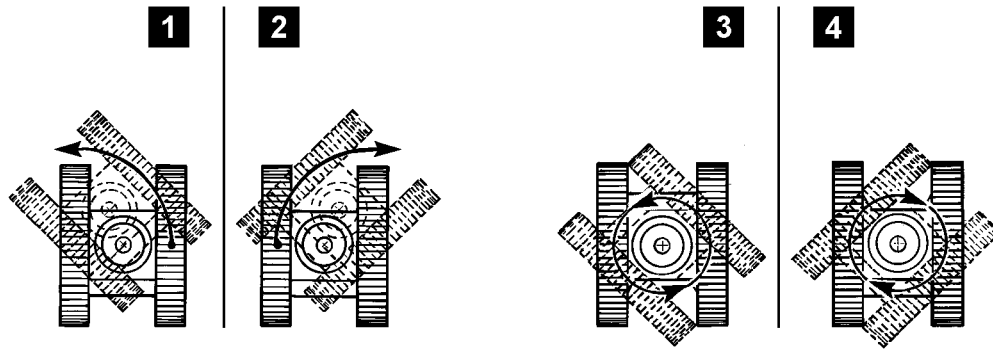

B104692

2.3 Driving the crawler



WARNING

The crane can topple over!

If the crane is driven in rapid gear with a load and / or suspended ballast, then it can topple over!

Personnel can be severely injured or killed!

- ▶ Travel with a load and / or suspended ballast in rapid gear is prohibited!
 - ▶ The maximum permissible travel speed of the crawler with load and / or suspended ballast may not exceed 3 m/min or 0.18 km/h!
 - ▶ Steering the crawler with attached load and / or installed suspended ballast is prohibited!
-



WARNING

Personnel present in danger zone!

Personnel within the danger zone of the crane can be severely injured or killed!

- ▶ An additional monitor, who is connected by radio contact with the crane operator must ensure that there are no persons or objects within the danger zone of the crane!
 - ▶ The observer may not remain in the crane danger zone!
-



Note

- ▶ Take the manual level from the transport retainer in the crane operator's cab!
 - ▶ The technical design of the manual lever is completely identical. The differentiation of the two manual levers is only in their assignment to the corresponding foot rockers in assembled (pushed on) condition!
-

Make sure that the following prerequisite is met:

- The switch “crawler operation” is actuated.

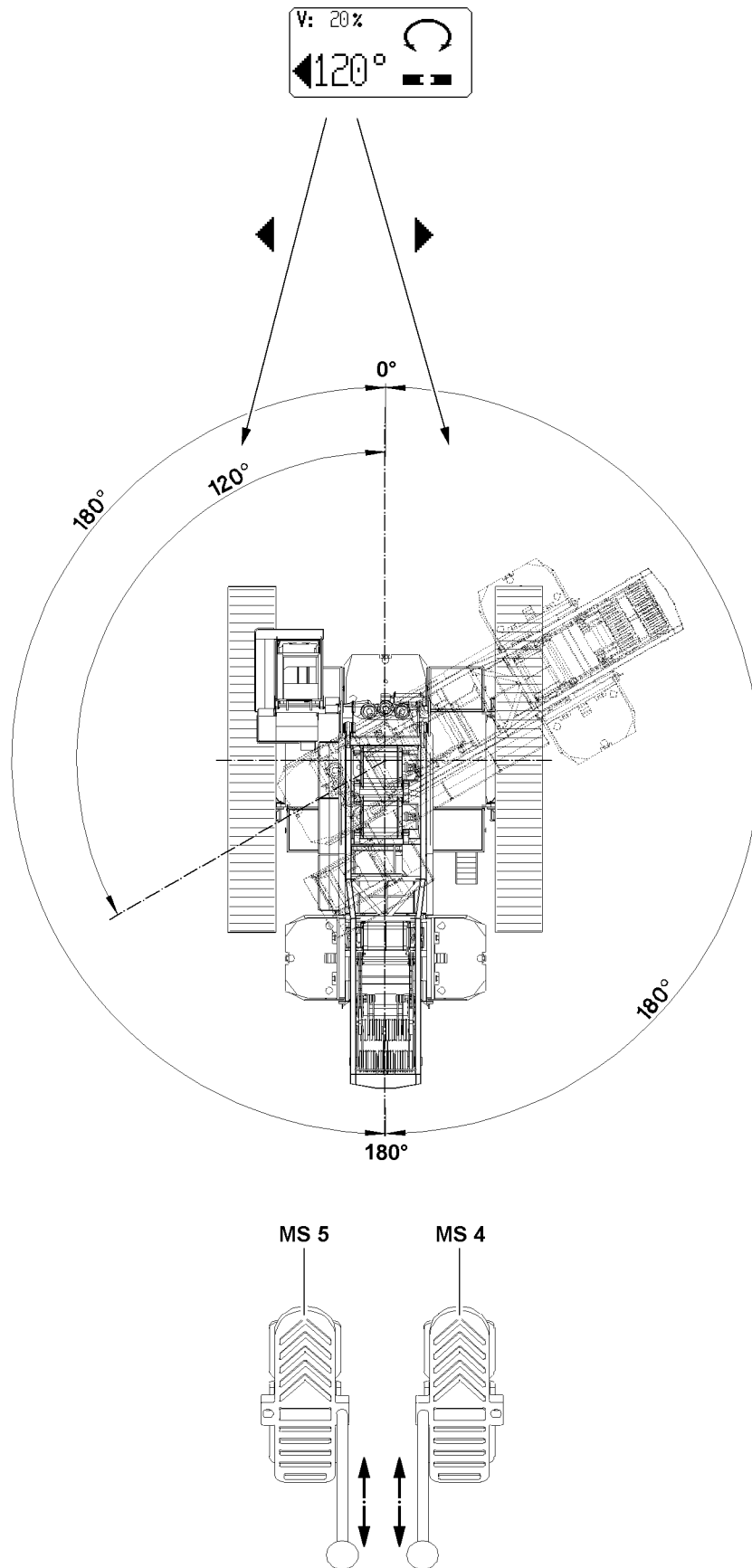

B109532

2.3.1 Changing the travel direction



Note

- ▶ At 0°, the crane superstructure is exactly in position “to the front”.
 - ▶ At 180°, the crane superstructure is exactly in position “to the rear”.
-

The travel direction relates to the position of the crane superstructure:

- If the crane superstructure is turned past 90°, then the “forward / reverse” travel direction changes.
- If the crane superstructure with actuated foot rocker **MS 4** or foot rocker **MS 5** is turned past 90°, then the travel direction remains until the corresponding foot rocker / manual control lever is “returned” to neutral position.

This means the new travel direction becomes active only if the corresponding foot rocker / manual control lever is no longer actuated.

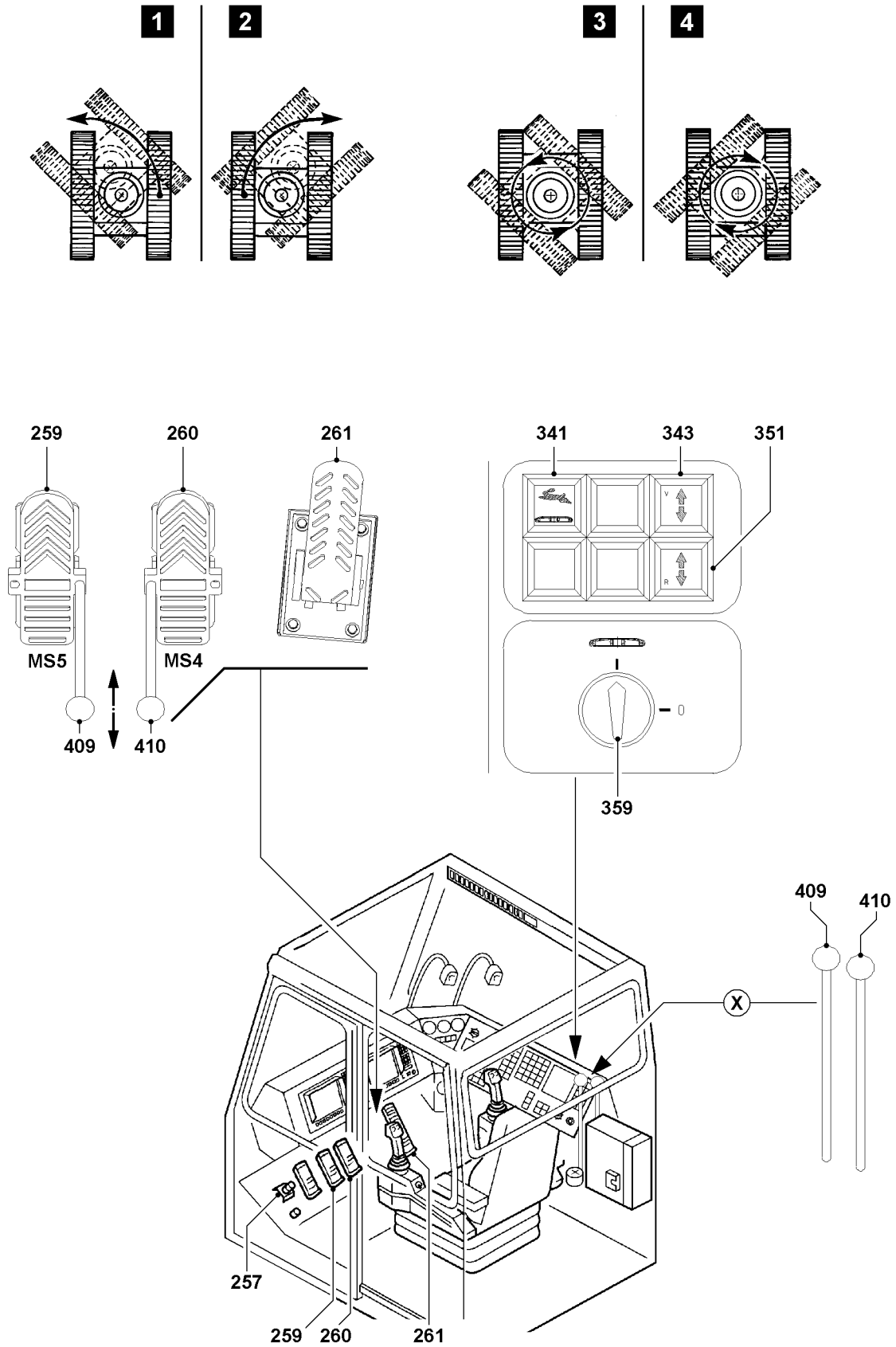

B104692

2.3.2 Driving the crawler forward and backward

The crawler tracks on the left and right can be operated with the foot pedals **259** and **260**.

Alternatively, the manual levers **409** and **410** can be installed (pushed in) on the foot pedal **259** and the foot pedal **260** for especially sensitive control of the travel movements of the crawler.

The travel direction of the crane refers to the position of the crane superstructure and is shown via the indicator lights **343** and **351**.

The tracks can be operated with the foot rockers:

- Crawler track left: Foot rocker **MS5**
- Crawler track right: Foot rocker **MS4**

Alternatively, a manual lever can be installed (inserted) on the foot rocker **MS4** and the foot rocker **MS5** in order to control the travel movements of the crawler precisely.

Drive the crawler forward

- ▶ Push the right foot rocker **MS4** forward.

or

- Move the manual lever on the foot rocker **MS4** forward.

Result:

- The right track moves forward.

- ▶ Push the left foot rocker **MS5** forward.

or

- Move the manual lever on the foot rocker **MS5** forward.

Result:

- The left track moves forward.

Move the crawler backward

- ▶ Push the right foot rocker **MS4** back.

or

- Move the manual lever on the foot rocker **MS4** backward.

Result:

- The right track moves backward.

- ▶ Push the left foot rocker **MS5** back.

or

- Move the manual lever on the foot rocker **MS5** backward.

Result:

- The left track moves backward.

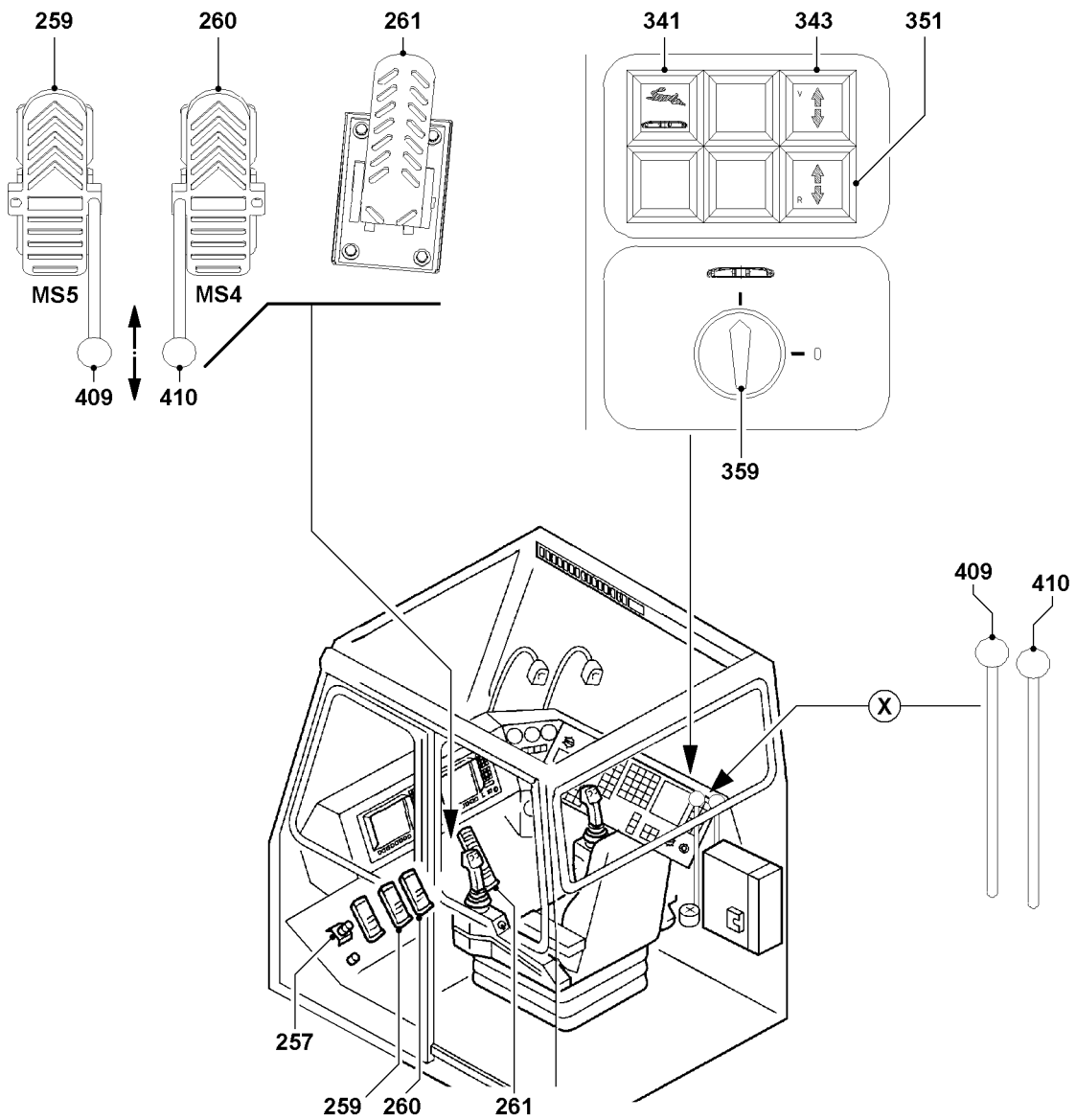
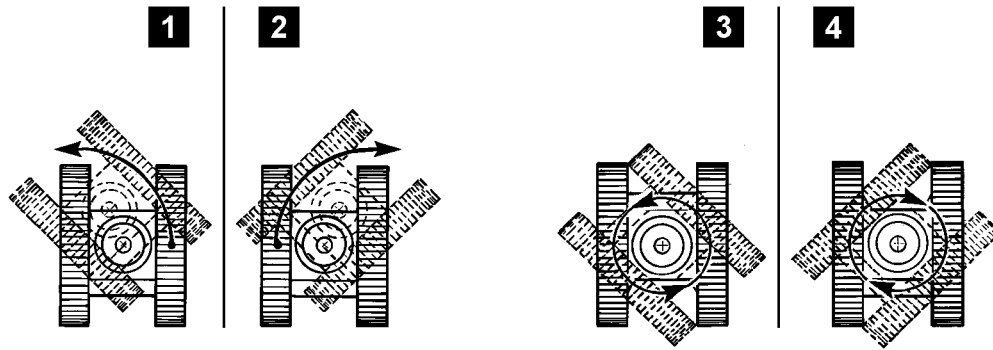

B104692

2.3.3 Steering the crane



WARNING

The crane can topple over!

If the crane is steered with closed slewing gear brake, then the boom system can be damaged due to high side acceleration!

Personnel can be severely injured or killed!

If the crane is steered with or without a load:

- ▶ When steering the crawler, always activate the slewing gear coasting!

NOTICE

The crane can topple over!

If the crawler chain sags on uneven ground, then the centering cams of the track pads can no longer be centered and guided sufficiently in the track rollers!

The centering cams will be damaged and the chain can jump out of its guide!

Personnel can be severely injured or killed!

- ▶ Stop steering movements immediately!
- ▶ Drive straight forward until all centering cams are centered again!
- ▶ When possible, retension the crawler chain, see chapter 7.04 of the Crane operating instructions!

NOTICE

High friction forces during steering!

When steering in small radii, high friction forces are created!

The track pads are heavily worn!

- ▶ Steer the tracks in as large a radius as possible!
- ▶ Avoid counter rotation!

Steering the tracks to the left

See illustration 1.

- ▶ Push the right foot rocker **MS4** forward.

or

- Move the manual lever on the foot rocker **MS4** forward.

Steering the tracks to the right

See illustration 2.

- ▶ Push the left foot rocker **MS5** forward.

or

- Move the manual lever on the foot rocker **MS5** forward.

Counter rotating the tracks to the left

See illustration 3.

- ▶ Push the right foot rocker **MS4** forward and the left foot rocker **MS5** backward.

or

- Move the manual lever on the foot rocker **MS4** forward and move the foot rocker **MS5** backward.

Counter rotating the tracks to the right

See illustration 4.

- ▶ Push the left foot rocker **MS5** forward and the right foot rocker **MS4** backward.

or

- Move the manual lever on the foot rocker **MS5** forward and move the foot rocker **MS4** backward.

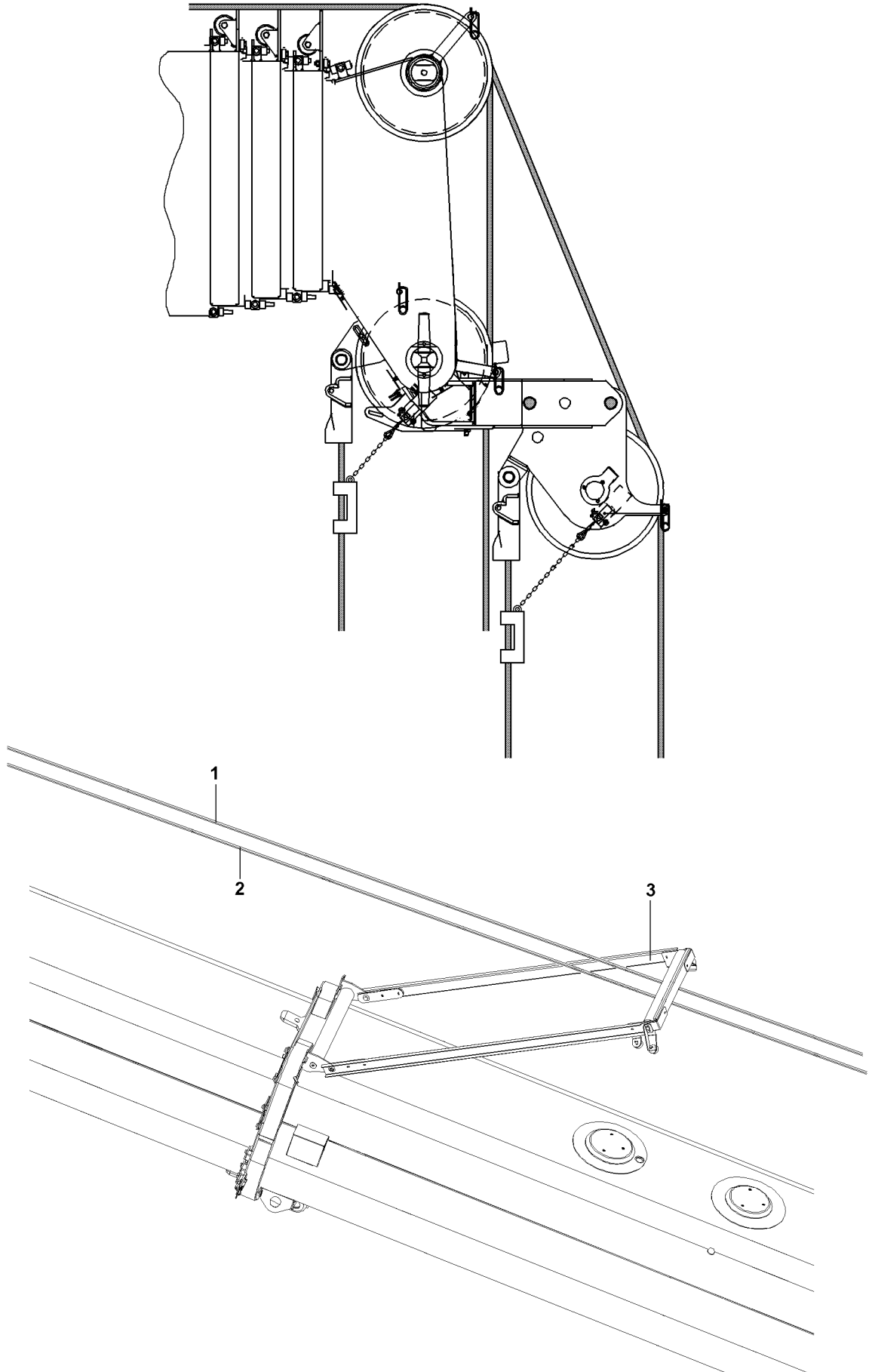

B108770

1 General

In 2-hook operations there is a difference between:

- 1.) Operations with a boom nose* on the telescopic boom
- 2.) Operations with a boom nose* on the lattice jib
- 3.) Operations with a boom extension (folding jib, auxiliary boom, luffing jib)

1.1 Operations with a boom nose* on the telescopic boom

NOTICE

Danger of damage on the hoist ropes!

When reeving in, the hoist rope **1** and hoist rope **2** must be guided through the bracket **3** on the telescopic boom!

- ▶ Guide the hoist rope **1** and hoist rope **2** through the bracket **3** on the telescopic boom.
-

This option is set up for rapid hoists over the boom nose, whereby the hook block reeved on the telescopic boom can remain reeved.

No special loading tables are available for boom nose operations. The boom nose is generally run in the telescopic boom operating mode.



DANGER

Danger of accidents because of imprecise radius and load displays.

- ▶ When operating with the boom nose, the overload protection radius and load display is not precise, because the boom nose is not taken into account in the boom geometry.
 - ▶ Set the operating mode of the telescopic boom to overload protection.
-



DANGER

Danger of accidents because of overloading the hoisting gear or the hoisting cable!

Overload protection is only achieved when the reeving on the telescopic boom is equal to, or greater than, the reeving on the mast boom.

- ▶ Set the overload protection to the smaller reeving of the two hooks.
-

The weight of the hook blocks (load hook), the boom nose and the lifting accessories must be added to the load to be lifted.

Setting this to the smaller reeving of the two hooks ensures that the crane cannot be overloaded.

- ▶ Enter the cable reeving that corresponds to the actual reeving on the mast nose.

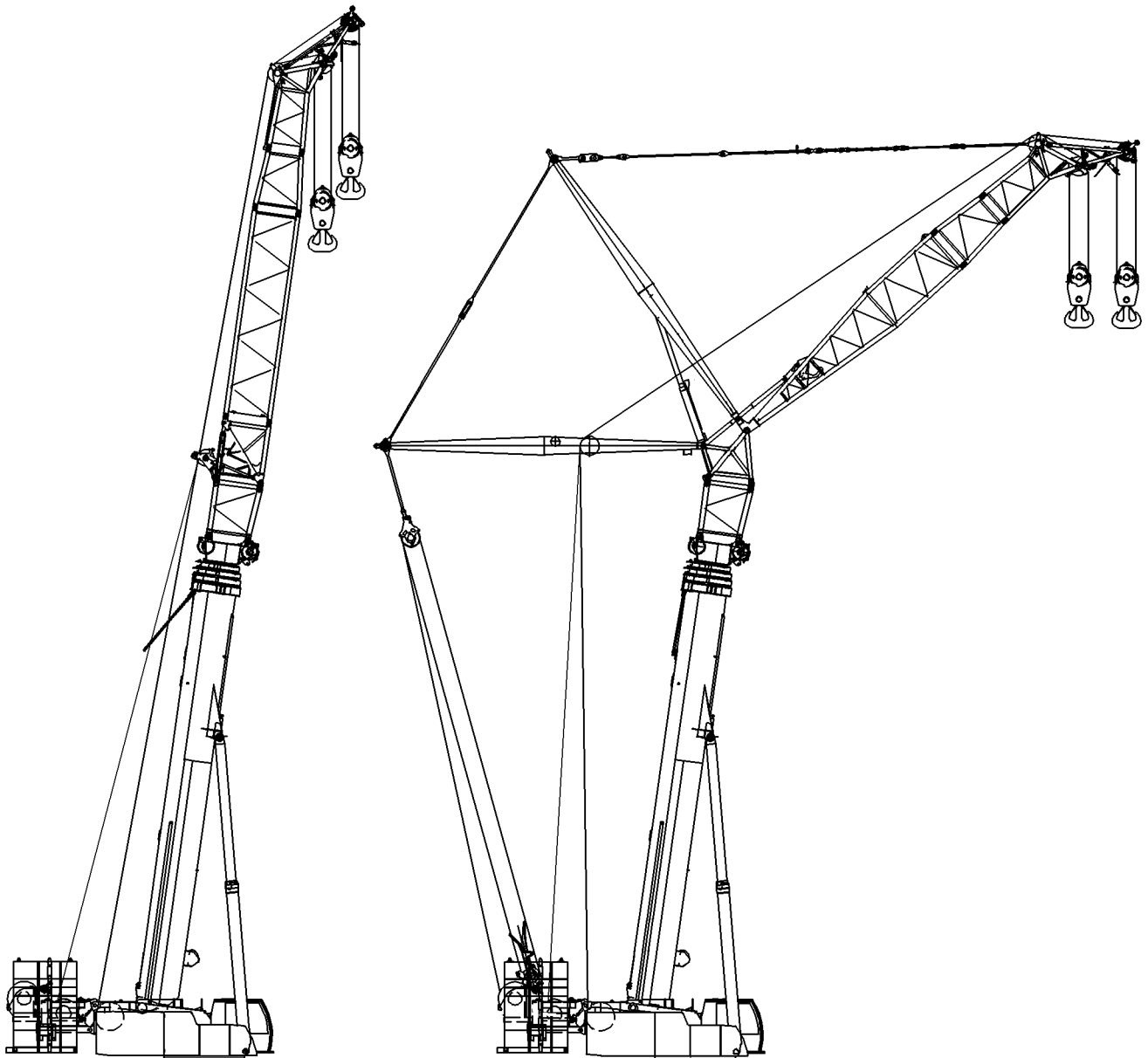

B195475

1.2 Operations with a boom nose* on the lattice jib

This option is set up for rapid hoists over the boom nose, whereby the hook block reeved on the lattice jib can remain reeved.

No special loading tables are available for boom nose operations. The boom nose is generally extended in the lattice jib operating mode.



DANGER

Danger of accidents because of imprecise radius and load displays.

- ▶ When operating with the boom nose, the overload protection radius and load display is not precise, because the boom nose is not taken into account in the boom geometry.

- ▶ Set the operating mode of the lattice jib to overload protection.



DANGER

Danger of accidents because of overloading the hoisting gear or the hoisting cable!

Overload protection is only achieved when the reeving on the lattice jib is equal to, or greater than, the reeving on the mast boom.

- ▶ Set the overload protection to the smaller reeving of the two hooks.

The weight of the hook blocks (load hook) and the lifting accessories must be added to the load to be lifted.

Setting this to the smaller reeving of the two hooks ensures that the crane cannot be overloaded.

- ▶ Enter the cable reeving that corresponds to the actual reeving on the mast nose.

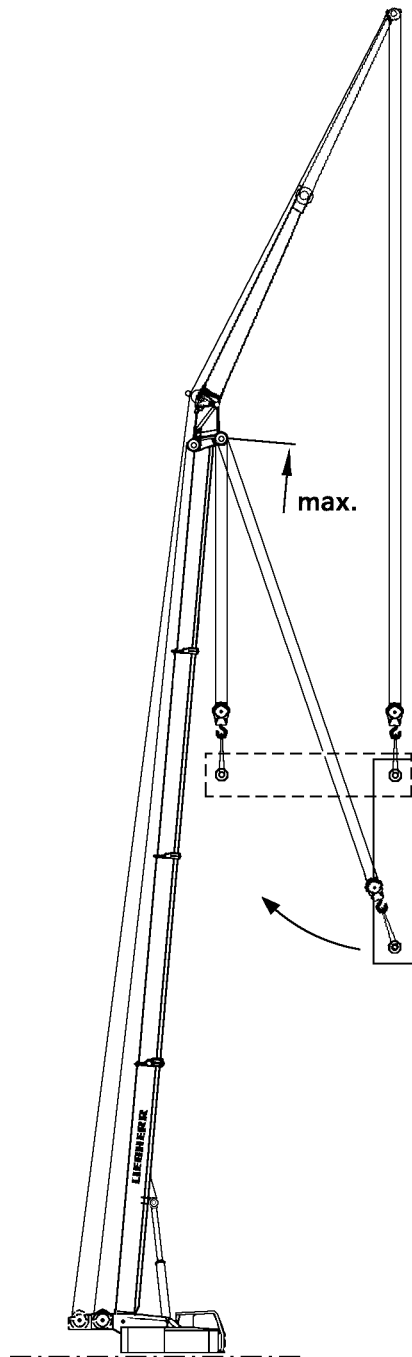

Va. 1

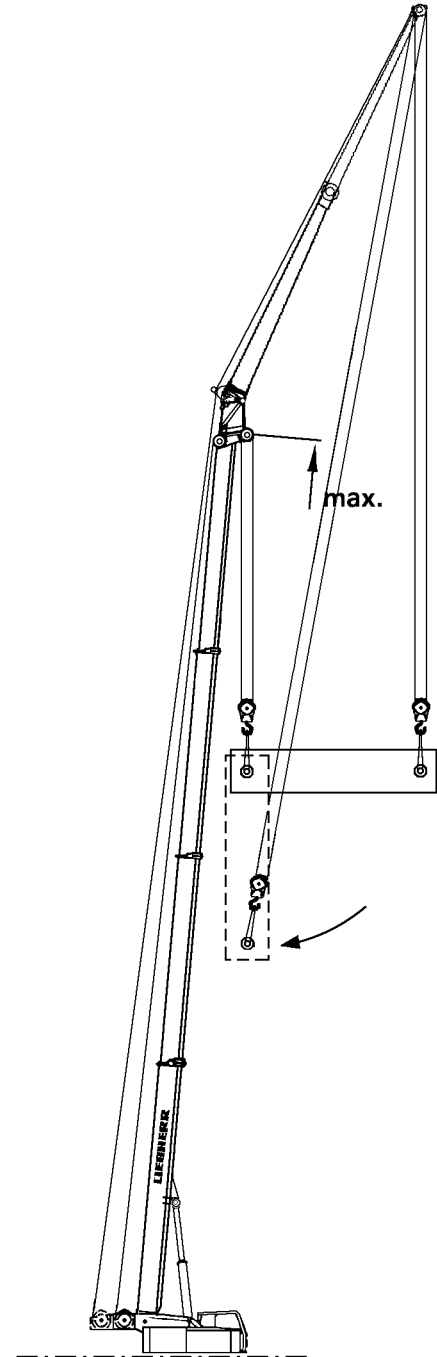

Va. 2

B180647

1.3 Operations with a boom extension (folding jib, auxiliary boom, luffing jib)

This option is set up for turning loads during the simultaneous operation of both sets of hoisting gear.



Note

Raising the load

- ▶ The load must always be raised or lowered using the weakest component (folding jib, auxiliary boom, luffing jib) initially at 100%

- ▶ In “2-hook operations” with a boom extension (folding jib, auxiliary boom, luffing jib), the overload protection must be set to the operating mode boom extension (folding jib, auxiliary boom, luffing jib).



DANGER

Risk of accident by overloading the hoisting gear or hoisting cable!

- ▶ The reeving on the boom must be equal to or greater than the reeving on the boom extension (folding jib, auxiliary boom, luffing jib).

- ▶ Enter the reeving that corresponds to the existing reeving on the boom extension (folding jib, auxiliary boom, luffing jib) into the overload protection.

In this case, the maximum permissible total load corresponds to the maximum permissible load in the corresponding loading table for operating with the boom extension (folding jib, auxiliary boom, luffing jib).

The weight of the hook blocks (load hook) and the lifting accessories must be added to the load to be lifted.



Note

Radius display

- ▶ The radius is displayed, depending on the boom extension (folding jib, auxiliary boom, luffing jib) entered.
- ▶ The load-bearing capacity for each hook in “2-hook operations” is the permissible load in the corresponding loading table for operating with a boom extension (folding jib, auxiliary boom, luffing jib).
- ▶ In 2-hook operations, the total load is the permissible load in the corresponding loading table for operating with a boom extension (folding jib, auxiliary boom, luffing jib).



DANGER

Risk of accident from overloading individual components on the crane!

- ▶ Lifting a load with two hooks is only permissible if done as shown in the illustrations Va. 1 and Va 2.



DANGER

Danger of accidents

- ▶ If both hooks are loaded, it is forbidden to lower the boom!
- ▶ In those circumstances, safety cover from the overload protection is not available.
- ▶ This is why the load must always be picked up at the maximum radius.

As soon as the inner hook is pulled, the overload protection load display is wrong!

- ▶ If a load is raised as shown in Va. 1, the load must first be fully lifted to 100% with the hook furthest away.

1 Reeving plans



Note

▶ See separate reeving plans!

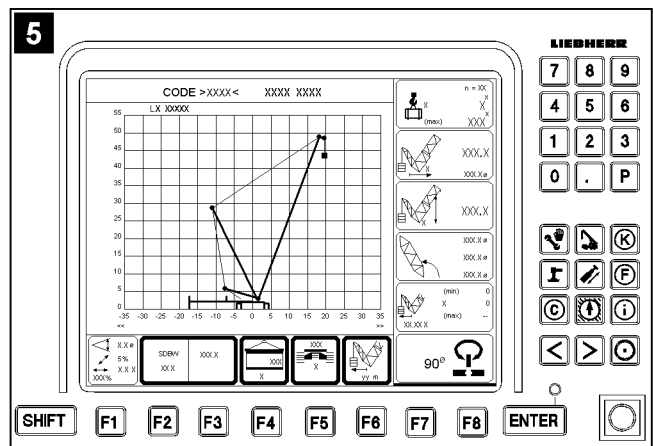
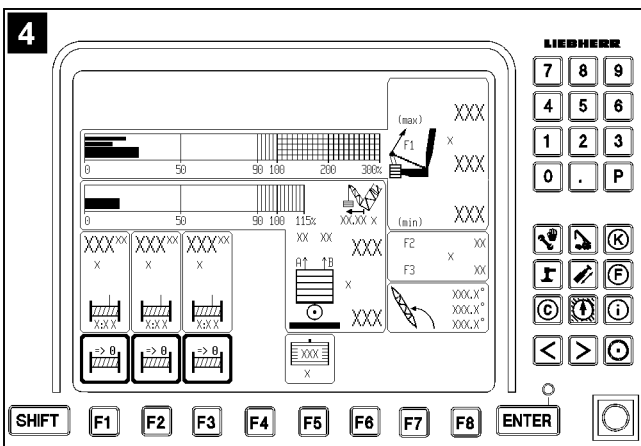
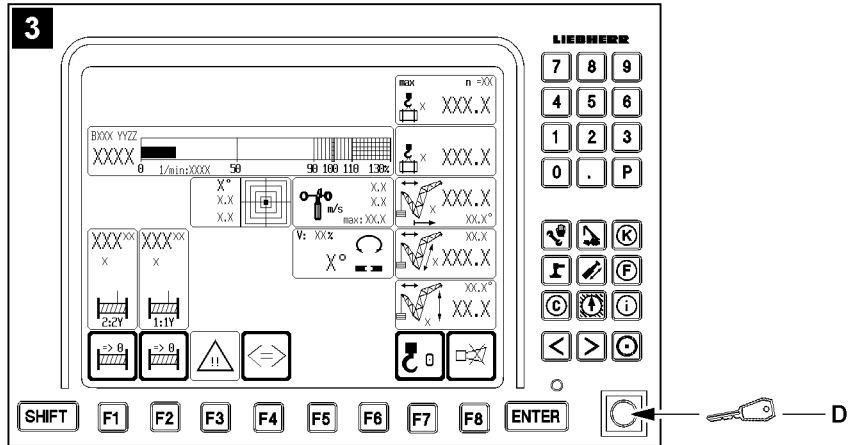
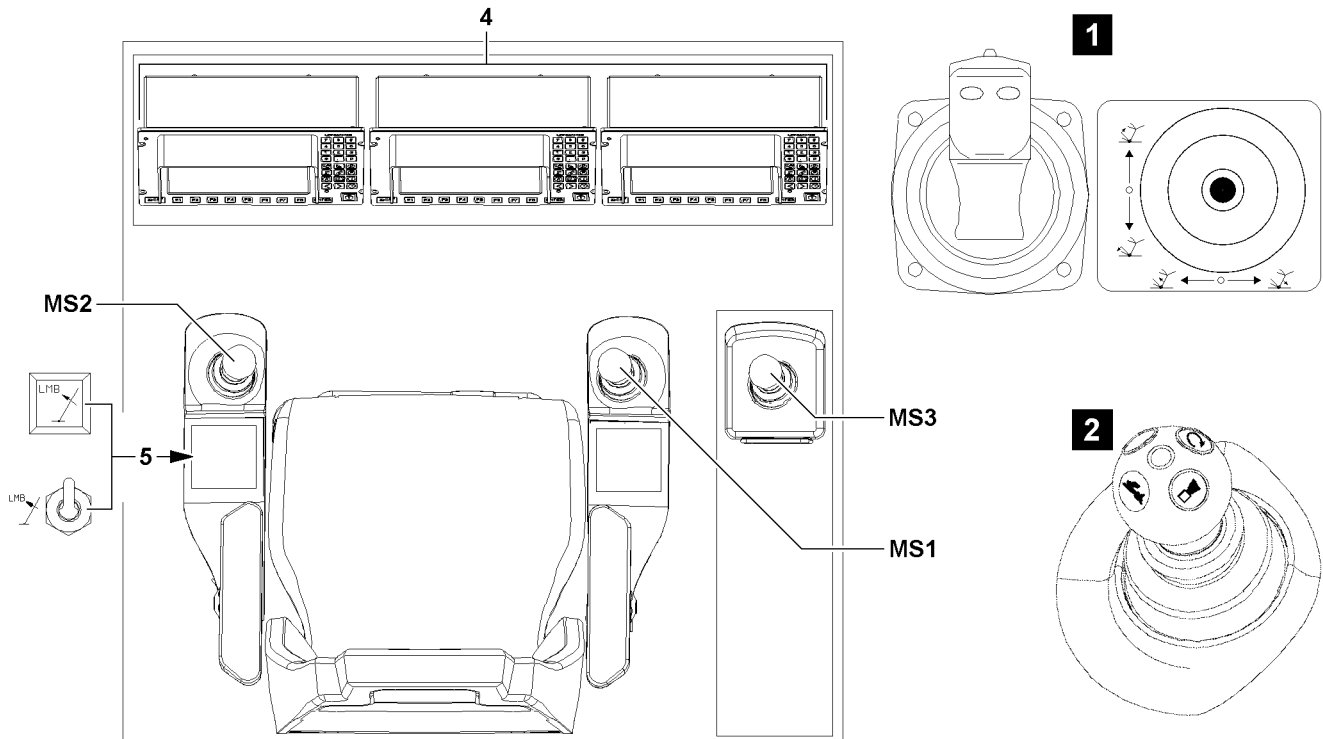

B112332

1 General

To operate the crane, three manually actuated master switches (MS1, MS2, MS3) are available.

- Master switch **MS1**
 - Right control console
- Master switch **MS2**
 - Left control console
- Master switch **MS3**
 - Right instrument panel

To monitor the crane, depending on the crane type, two or three LICCON monitors **4** are in the instrument panel.

- LICCON monitor, illustration **3**
 - User interface for entry of equipment configurations and for crane operation (crane operating screen), also described as LICCON monitor 0
- LICCON monitor, illustration **4**
 - User interface for operation with “Derrick” boom, also described as LICCON monitor 1
- LICCON monitor, illustration **5**
 - User interface for “LICCON job planner” (only for crane types with three monitors), also described as LICCON monitor 2

Equipment in the crane cab		
Crane type	Manually actuated master switches	LICCON monitors
LR 1350/1	Three (version illustration 2)	Two (three*)
LR 1400/2	Three (versions illustration 1)	Two
LR 1600/2	Three (version illustration 2)	Three
LR 1750	Three (version illustration 2)	Three
LG 1750	Three (version illustration 2)	Three
LR 11350	Three (version illustration 2)	Three

In the crane operator's cab, two buttons are installed to make it possible to bring the crane from an emergency situation after a shut off of the LICCON overload protection.

- Set up key **D** (Function “Exceeding the shut off limits for the LICCON overload protection”) on the LICCON monitor with crane operating screen, illustration **3**
- Button **5** “Luffing in with suspended load” in the left control console

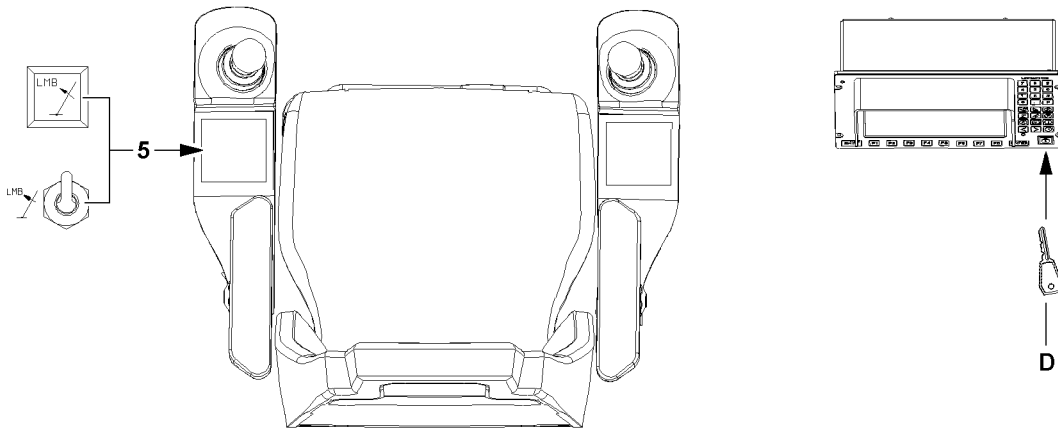

The function “Exceedance of shut off limits of the LICCON overload protection”, which is activated with the set up key **D** includes the following:

- Exceedance of the maximum permissible load moment
- Bypass of the hoist top shut off
- Exceedance of limit values from load charts
- Exceedance of maximum value test point 1 (force F1)
- Allowance of individual, limited crane movements after LMB STOP (error message)
- Completion of crane movements outside of load charts (erection / take down procedures)

NOTICE

Multi action function “Exceedance of shut off limits of the LICCON overload protection”

If the set up key **D** is actuated, then it is possible to exceed several shut off limits of the LICCON overload protection simultaneously!

The LICCON overload protection as a whole is deactivated or limited.

There is no additional protection against crane overload!

- ▶ When the set up key **D** is actuated, it must be taken into account that the LICCON overload protection as a whole is deactivated or limited.
-



Note

The set up key **D** has two functions, independent of each other:

- ▶ If no crane movement can be carried out due to the shut off of crane operation by the LICCON overload protection, then by pressing the set up key **D**, a 100 % utilization can be exceeded and / or an active shut off can be bypassed. The crane can thereby be controlled again in normal operating status (utilization below 100 % and no active shut off).
 - ▶ When the set up key **D** is actuated, all erection / take down procedures can be carried out within the erection / take down charts (assembly operation).
-



WARNING

Danger of accident due to function “Exceedance of shut off limits of the LICCON overload protection”! If the shut off limits of the LICCON overload protection are exceeded, there is no additional protection against crane overload!

Due to erroneous operation or deliberate misuse, the crane could collapse, the boom can break off or the crane can topple over!

Personnel can be severely injured or killed!

- ▶ The button **5** “Luffing in with suspended load” and the set up key **D** may only be actuated when it is ensured that no normal operating condition (utilization below 100 % and no active shut off) can be reached without the function “Exceedance of shut off limits of the LICCON overload protection”!
-

- ▶ Actuate the set up key **D** only when no normal operating condition (utilization below 100 % and no active shut off) can be reached with the button **5** "Luffing in with suspended load"!
 - ▶ The function "Exceedance of shut off limits of the LICCON overload protection" is only permissible in emergencies and for assembly purposes!
 - ▶ The set up key **D** may only be actuated by persons who are aware of the effects of their acts regarding the function "Exceedance of shut off limits of the LICCON overload protection"!
 - ▶ The function "Exceedance of shut off limits of the LICCON overload protection" requires the presence of an authorized person and must be performed with utmost caution!
 - ▶ Crane operation with activated function "Exceedance of shut off limits of the LICCON overload protection" is prohibited!
-

**WARNING**

Expanded working / danger zone of the crane!

Due to the function "Exceedance of shut off limits of the LICCON overload protection" it is possible that the working / danger zone of the crane is significantly expanded!

If these circumstances are not observed, collisions and accidents can occur!

Personnel can be severely injured or killed!

- ▶ With activated function "Exceedance of shut off limits of the LICCON overload protection" take an expanded working / danger zone of the crane into account and monitor it!
-

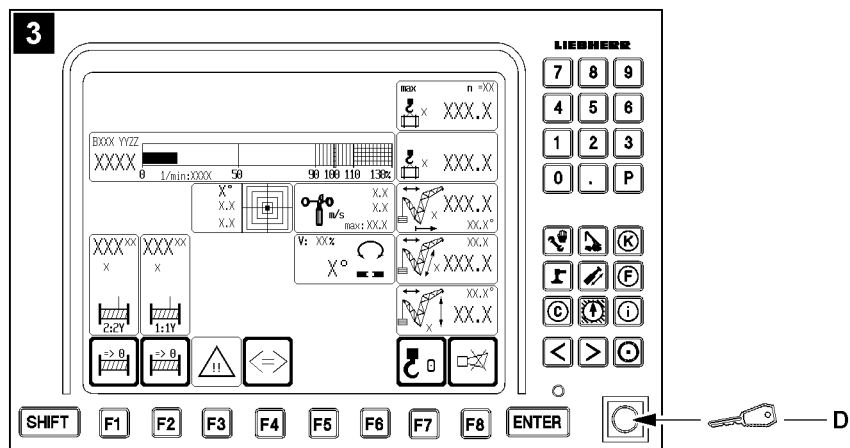
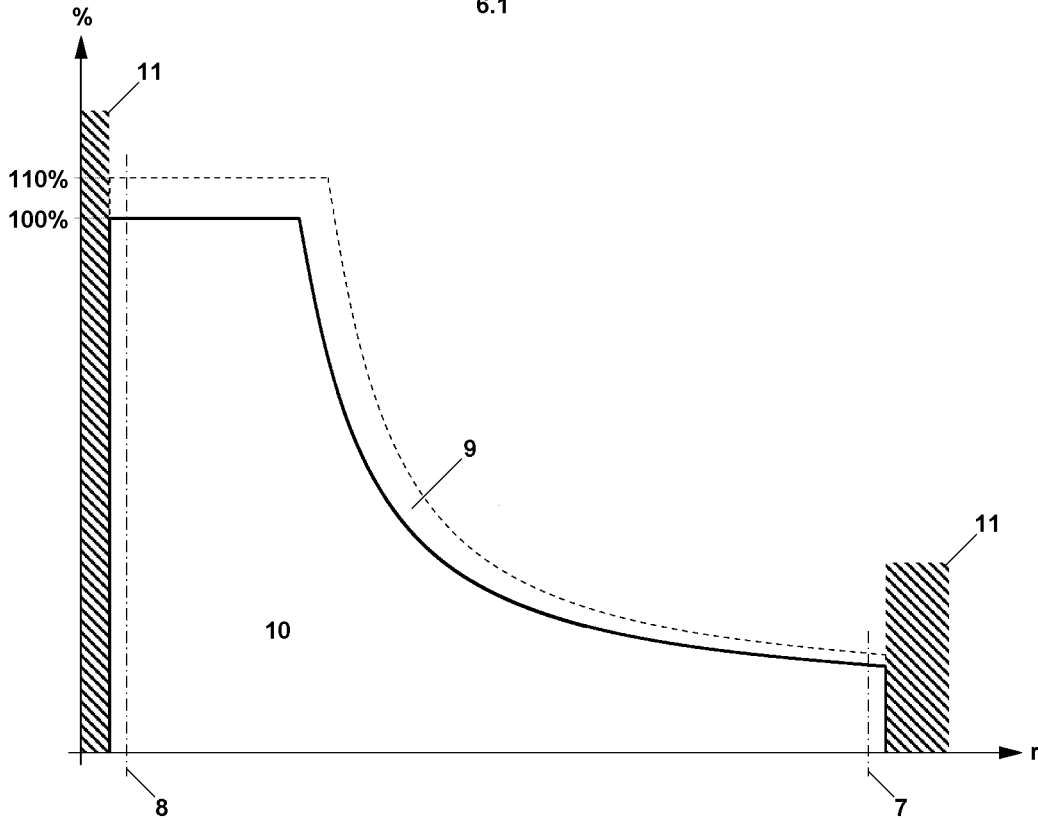
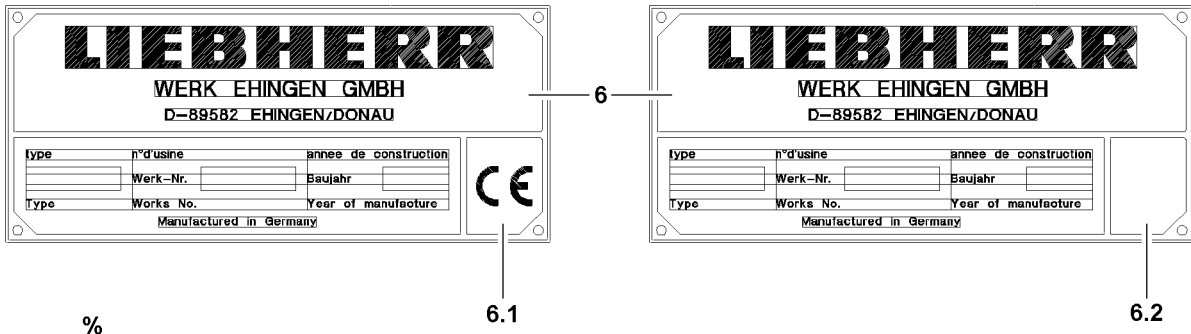

2 Instructions for resuming crane movements for cranes with CE mark



WARNING

Risk of accident!

If the following points are not observed, personnel can be severely injured or killed.

- ▶ The crane operator bears the sole and full responsibility for the adherence to measures to be taken in case of shut off of crane movement!
- ▶ The crane operator must make sure, before crane operation, that he is using the correct description for the current programming!



Note

- ▶ Check the data tag **6** to determine if your crane has a CE mark!
- ▶ The following section applies to a crane with CE mark, see data tag **6.1**!
- ▶ If your crane does not have a CE mark, see data tag **6.2**, then you must observe the description in section "Instructions for resuming a crane movement for cranes without CE mark"!

2.1 Overview load chart for cranes with CE mark

Axle	Description
r	Radius boom (working radius)
%	Utilization of the crane in percentages

Position	Description
7	Lower limit angle load chart
8	Upper limit angle load chart
9	Utilization up to 110 % with reduced working speed
10	Area "Load chart available"
11	Area "No load chart available"



Note

- ▶ If the set up key **D** (LICCON monitor with crane operating screen, illustration **3**) is actuated in the area "Load chart available", then the working speed is reduced and all displays of the LICCON overload protection remain functional!
- ▶ If the set up key **D** is actuated in the area "No load chart available", then the working speed is not reduced!

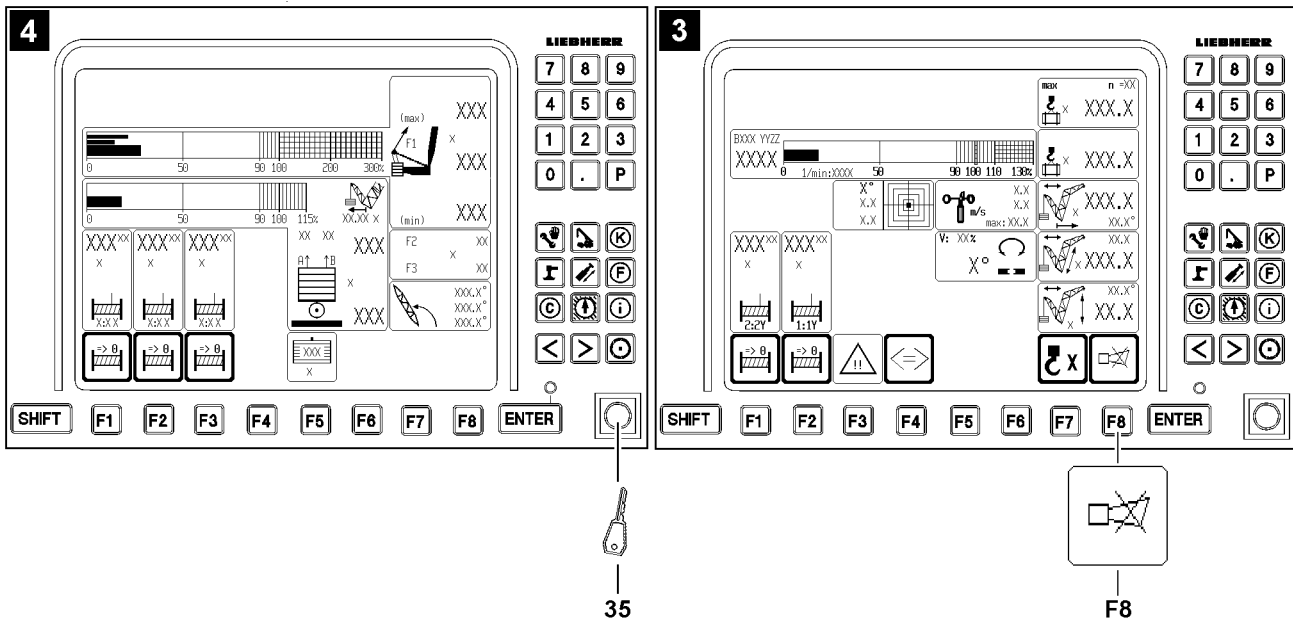
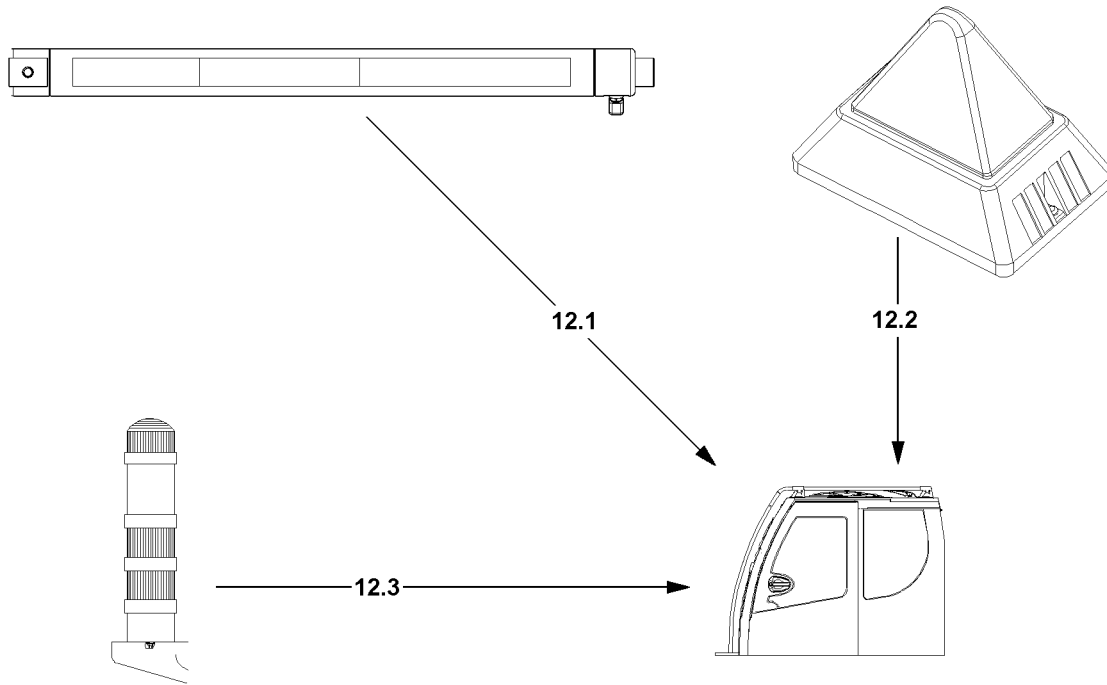

2.2 Overview of acoustic / visual warnings for cranes with CE mark

- Depending on the crane type, either a warning light **12.1** or a flashing beacon **12.2** or a combination of flashing beacon **12.2** and warning light* **12.3** are installed.
- The acoustic warnings within the crane operator's cab are turned off by pressing the button **F8** on the LICCON monitor with crane operating screen (illustration **3**).
- The acoustic warnings outside the crane operator's cab are turned off by actuating the key button **35** on the LICCON monitor with derrick operating screen (illustration **4**).

2.2.1 Description of acoustic / visual warnings

The case numbers from the chart "Overview of case numbers" are valid for the following charts in this chapter:

- "Acoustic / visual warnings on the LICCON monitor"
- "Warning light 12.1"
- "Flashing beacon 12.2"
- "Warning light 12.3"

Overview of case numbers	
Case number	Description Case
Case 001	Utilization of crane from 0 % to 89 %
Case 002	Utilization of crane from 90 % to 100 %
Case 003	Utilization of crane over 100 %
Case 004	Shut off of crane movements - LMB STOP
Case 005	Luffing in with suspended load
Case 006	Participating sensor (LMB) defective
Case 010	Exceeding the shut off limits of the LICCON overload protection
Case 011	Bypass of shut off hoist top
Case 016	Bypass of shut off luffing down the boom / auxiliary boom / accessories, "Load chart available"
Case 018	Bypass of shut off luffing down the boom / auxiliary boom / accessories, "No load chart available"
Case 020	Exceeding the shut off limits of the LICCON overload protection during erection / take down procedures, "No load chart available"

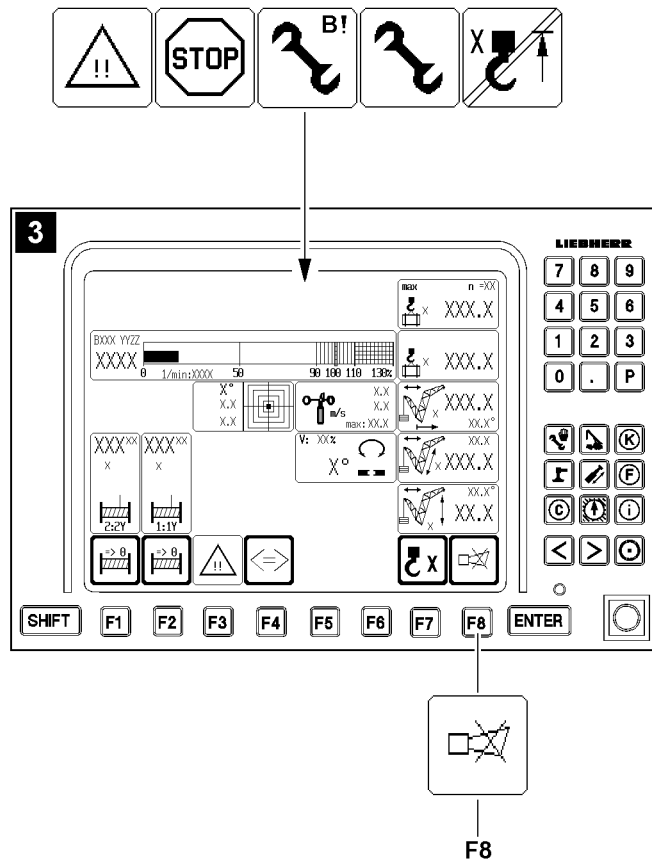

2.2.2 Acoustic / visual warnings within the crane operator's cab



Note

► Description of individual case numbers, see chart "Overview of case numbers"!

Acoustic / visual warnings on the LICCON monitor									
Case number	Acoustic warning LICCON monitor at utilization of crane			Visual warning LICCON monitor					
	Short sound	Long sound	Long sound	Utilization of crane		Occurrence			
	From 90 %	Above 100 %	Always	From 90 %	Above 100 %	LMB STOP	Appears if the set up key D is actuated		
Case 001							—	—	—
Case 002	X ²			○			—	—	—
Case 003		X ²		○	○		—	—	—
Case 004			X ²		○		—	—	—
Case 005	X ²	X ²		○	○		—	—	—
Case 006			X ²			○	Cannot be bypassed ⁵		
Case 010	X ²	X ²		○	○		○		
Case 011			X ²	○	○	○	○		○
Case 016	X ²	X ²		○	○		○		
Case 018			X ²			○		○	
Case 020			X ²			○		○	

○ = cannot be turned off

X² = can be turned off immediately on the LICCON monitor key **F8**

Cannot be bypassed⁵ = contact Liebherr Service

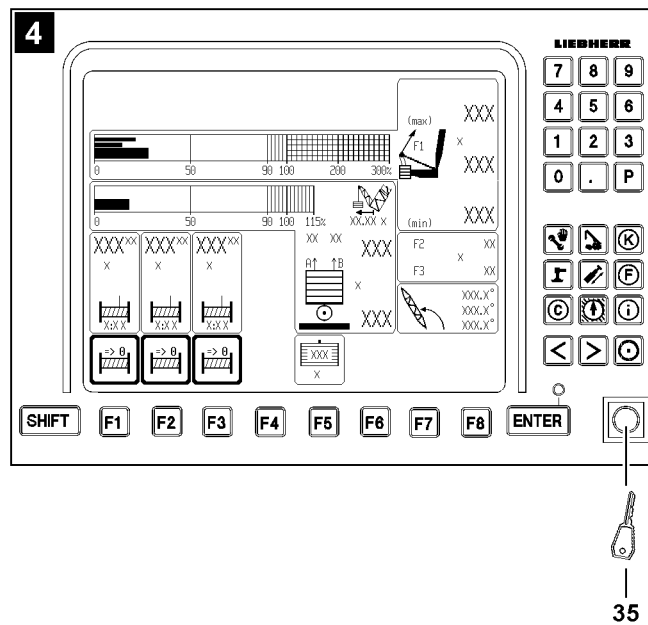
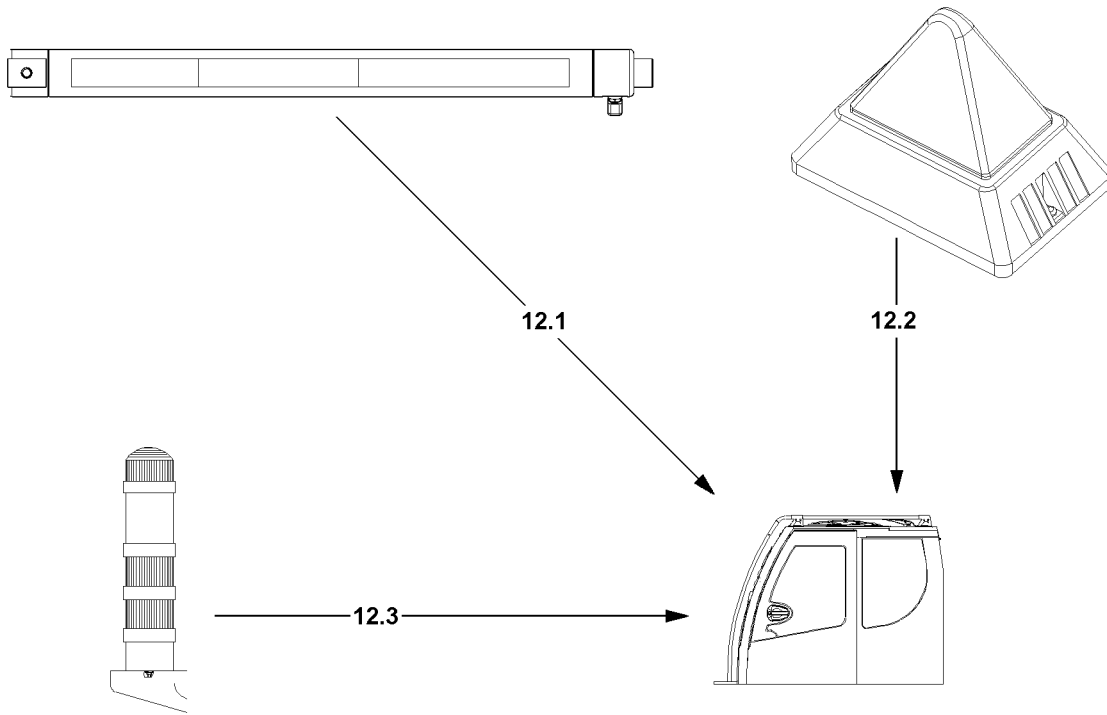

2.2.3 Acoustic / visual warnings outside the crane operator's cab



Note

► Description of individual case numbers, see chart "Overview of case numbers"!

Warning light 12.1					
Case number	At utilization of crane	Acoustic warning	Visual warning		
		Signal turntable	Green	Yellow	Red
Case 001	From 0 % to 89 %		O ¹		
Case 002	From 90 % to 100 %			O ¹	
Case 003	Above 100 %	X ¹			O ¹
Case 004	-				O ¹
Case 005	From 0 % to 89 %		O ¹		
Case 005	From 90 % to 100 %			O ¹	
Case 005	Above 100 %	X ¹			O ²
Case 006	-				O ¹
Case 010	From 0 % to 89 %		O ¹		
Case 010	From 90 % to 100 %			O ¹	
Case 010	Above 100 % to 110 %			O ²	
Case 010	Above 110 %	X ¹			O ¹
Case 011	Up to 110 %			O ²	
Case 011	Above 110 %	O			O ²
Case 016	From 0 % to 89 %		O ¹		
Case 016	From 90 % to 100 %			O ¹	
Case 016	Above 100 % to 110 %			O ²	
Case 016	Above 110 %	X ¹			O ¹
Case 018	No value available			O ²	
Case 020	No value available			O ²	

O = cannot be turned off

O¹ = warning light 12.1 lights up

O² = warning light 12.1 blinks

X¹ = can be turned off by actuating (right touching) the key button **35** on the LICCON monitor with the derrick operating screen (illustration 4), effective after at least 5 seconds

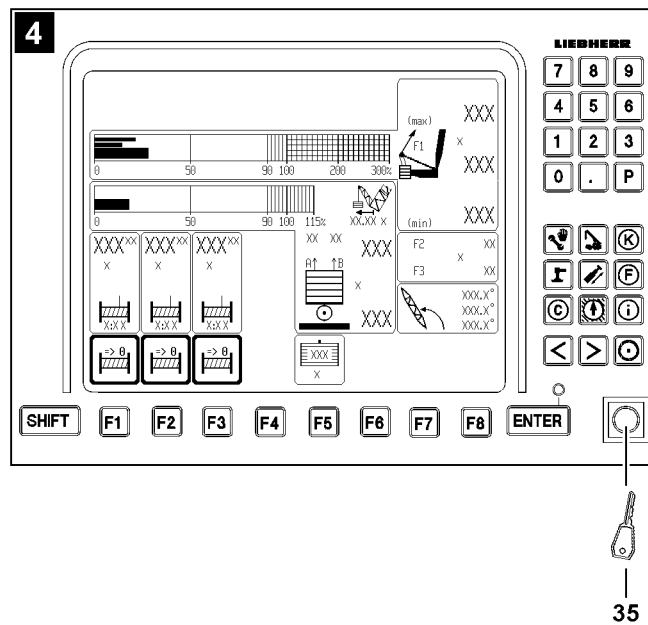
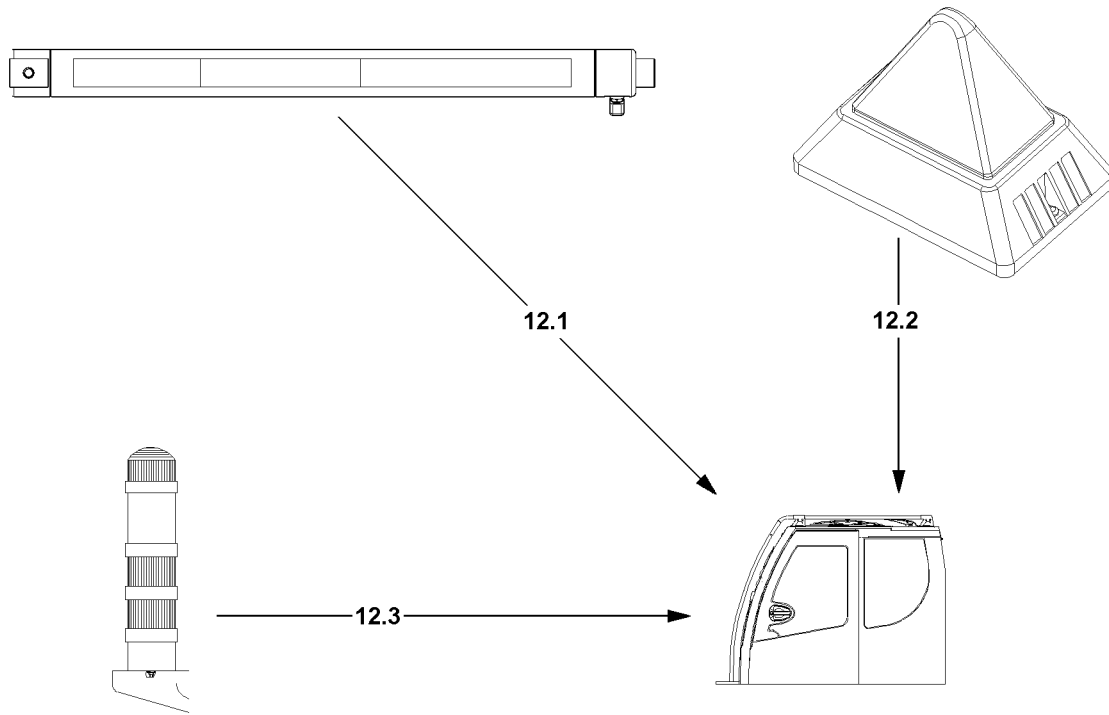

**Note**

► Description of individual case numbers, see chart "Overview of case numbers"!

Flashing beacon 12.2			
Case number	At utilization of crane	Acoustic warning	Visual warning
		Signal turntable	Red
Case 001	0 % up to 89 %	-	-
Case 002	90 % up to 100 %	-	-
Case 003	Above 100 %	X ¹	O ²
Case 004	-		O ²
Case 005	Above 100 %	X ¹	O ²
Case 006	-		O ²
Case 010	Above 110 %	X ¹	O ²
Case 011	Above 110 %	X ¹	O ²
Case 016	Above 110 %	X ¹	O ²
Case 018	No value available		O ²
Case 020	No value available		O ²

O = cannot be turned off

O² = flashing beacon **12.2** blinks

X¹ = can be turned off by actuating (right touching) the key button **35** on the LICCON monitor with the derrick operating screen (illustration **4**), effective after at least 5 seconds

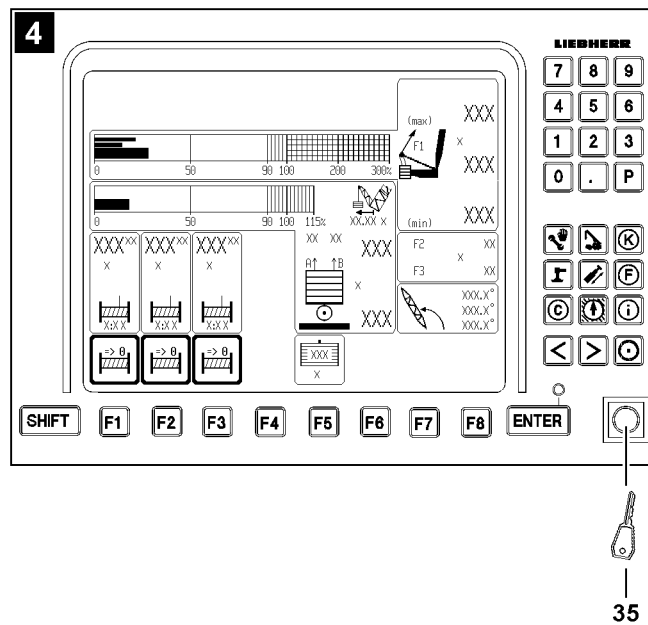
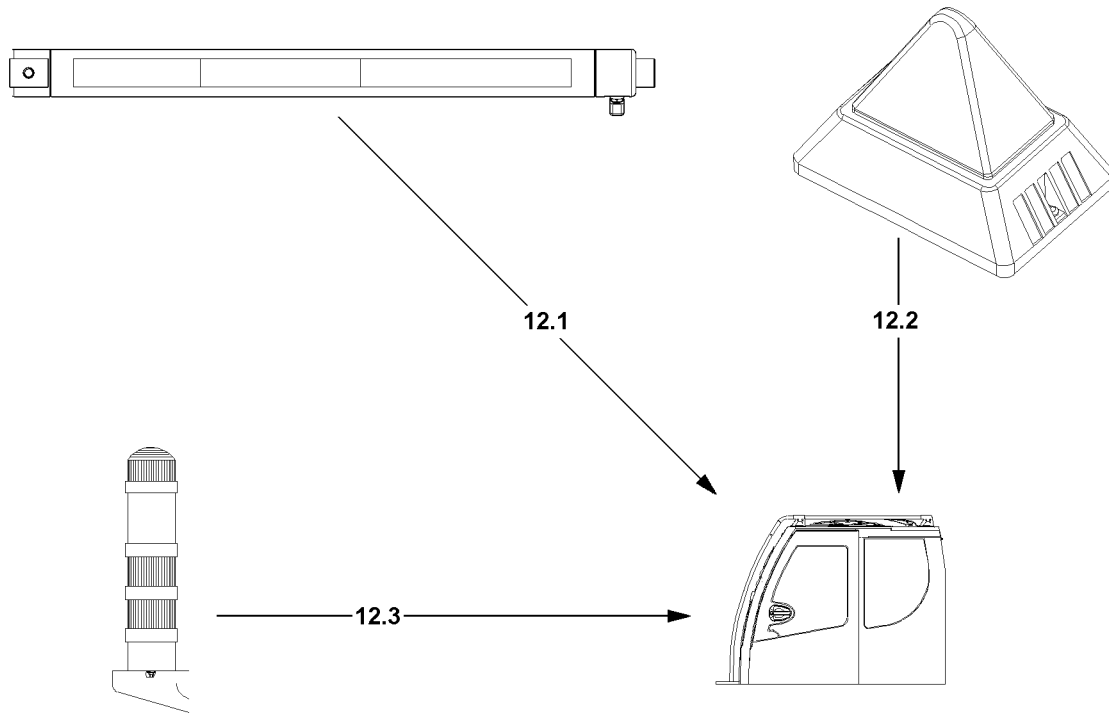

**Note**

► Description of individual case numbers, see chart "Overview of case numbers"!

Warning light 12.3					
Case number	At utilization of crane	Acoustic warning	Visual warning		
		Signal turntable	Green	Yellow	Red
Case 001	From 0 % to 89 %		O ¹		
Case 002	From 90 % to 100 %			O ¹	
Case 003	Above 100 %	X ¹			O ²
Case 004	-				O ²
Case 005	From 0 % to 89 %		O ¹		
Case 005	From 90 % to 100 %			O ¹	
Case 005	Above 100 %	X ¹			O ²
Case 006	-				O ²
Case 010	From 0 % to 89 %		O ¹		
Case 010	From 90 % to 110 %			O ¹	
Case 010	Above 110 %	X ¹			O ²
Case 011	Up to 110 %			O ¹	
Case 011	Above 110 %	X ¹			O ²
Case 016	From 0 % to 89 %		O ¹		
Case 016	From 90 % to 110 %			O ¹	
Case 016	Above 110 %	X ¹			O ²
Case 018	No value available				O ²
Case 020	No value available				O ²

O = cannot be turned off

O¹ = warning light **12.3** lights up

O² = warning light **12.3** blinks

X¹ = can be turned off by actuating (right touching) the key button **35** on the LICCON monitor with the derrick operating screen (illustration **4**), effective after at least 5 seconds

2.3 Monitoring of crane movement

**Note**

- If the LICCON overload protection turns the crane movement off, then the exact cause for the shut off must be determined first.
- As a first step, try to rescind the crane movement which has caused a shut off.
- If it is not possible to rescind the affected crane movement, then the additional steps are described in the following sections of the chapter.

**Note**

- For detailed description of the individually listed icons, see Crane operating instructions, chapter 4.02.

The LICCON overload protection carries out the following shut offs if a limit value is exceeded in crane operation:

- Shut off luffing the main boom up / down
- Shut off luffing the auxiliary boom / accessory up / down
- Shut off maximum / minimum value test point 1 (force F1)
- Shut off spooling the winch up / out
- Shut off hoist top
- Shut off due to error message

The LICCON overload protection warns if the limit values are exceeded, but does not turn off:

- Minimum / maximum support forces

2.3.1 Shut off luffing the main boom up / down

**Note**

- In crane operation with derrick boom, it is also shown in the icon!

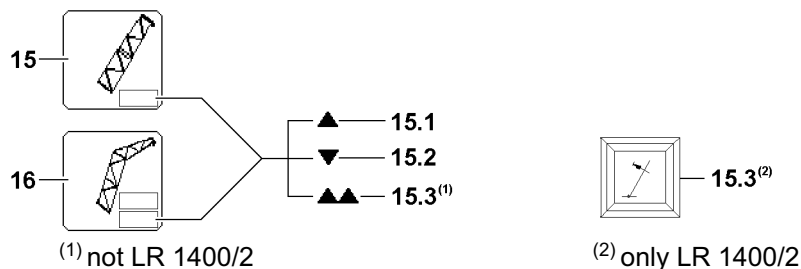

In icon **15** or icon **16** (lower field) arrow **15.1** or arrow **15.2** appear and the LICCON overload protection has shut off the crane movement.

“Luffing the main boom up” (arrow **15.1**) or “Luffing the main boom down” (arrow **15.2**) was shut off because the upper / lower limit angle of the selected load chart was exceeded / fallen below.

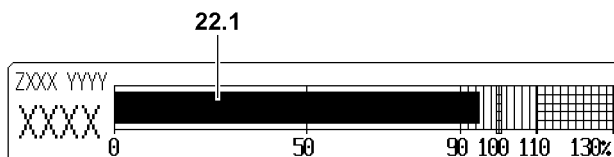
**Note**

- If the utilization of the crane is more than 95 % (utilization bar **22.1** exceeds 95 %) and the maximum load according to the load chart (falling load capacity) drops by continuing to luff up the boom, then the arrow **15.1** also appears and the crane movement “Luffing the main boom up” is turned off.

If the double arrow / warning light **15.3** appears, then:

- **either** it was luffed up to a limit switch or the limit switch has turned off the crane movement “Luffing the main boom up”
- **or** there is an error on one of the limit switches “Main boom top”

The arrow **15.1** appears and the crane movement “Luffing the main boom up” was turned off:

- Luff the main boom down.

Result:

- Crane operation is possible again.

The arrow **15.2** appears and the crane movement “Luffing the main boom down” was turned off:

- ▶ Luff the main boom up.

Result:

- Crane operation is possible again.

The double arrow / warning light **15.3** appears and the crane movement “Luffing the main boom up” was turned off:

- ▶ Luff the main boom down.

Result:

- Crane operation is possible again.

Troubleshooting

The double arrow / warning light **15.3** appears continuously?

If a double arrow / warning light **15.3** appears without having luffed the main boom up to a limit switch, then there may be an error in the limit switches “Main boom top”.

- ▶ Check if there is an error message from the LICCON computer system, see Diagnostics manual.
- ▶ If yes: Remedy the error immediately.

**WARNING**

Limited warning functions!

If one of the double version limit switches is not ok and the crane is continued to be operated, then the warning functions of the LICCON overload protection are limited!

- ▶ The crane can only be operated in an emergency after failure of a double version limit switch!
- ▶ Carry out crane movements in such a way that no repeated shut off by the LICCON overload protection occurs.

2.3.2 Shut off luffing the auxiliary boom / accessory up / down**Note**

- ▶ In crane operation with derrick boom, it is also shown in the icon!

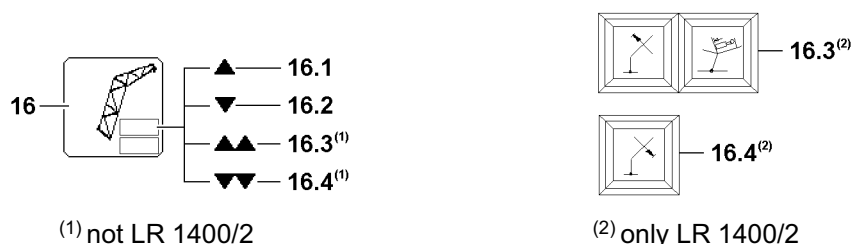

In the icon **16** (upper field) the arrow **16.1** or arrow **16.2** appear and the LICCON overload protection has shut off the crane movement.

“Luffing the auxiliary boom / accessory up” (arrow **16.1**) or “Luffing the auxiliary boom / accessory down” (arrow **16.2**) was shut off because the upper / lower limit angle of the selected load chart was exceeded / fallen below.

If the double arrow / warning light **16.3** appears, then:

- **either** it was luffed up to a limit switch or the limit switch has turned off the crane movement “Luffing the auxiliary boom / accessory up”
- **or** the mechanical relapse support has turned off the crane movement “Luffing the auxiliary boom / accessory up”
- **or** there is an error on one of the limit switches “Auxiliary boom / accessory top”.

If the double arrow / warning light **16.4** appears, then:

- **either** it was luffed down to a limit switch “Auxiliary boom / accessory bottom” and the limit switch has turned off the crane movement “Luffing the auxiliary boom / accessory up”
- **or** there is an error on one of the limit switches “Auxiliary boom / accessory bottom”

The arrow **16.1** appears and the crane movement “Luffing the auxiliary boom / accessory up” was turned off:

- ▶ Luff the auxiliary boom / accessory down.

Result:

- Crane operation is possible again.

The arrow **16.2** appears and the crane movement “Luffing the auxiliary boom / accessory down” was turned off:

- ▶ Luff the auxiliary boom / accessory up.

Result:

- Crane operation is possible again.

The double arrow / warning light **16.3** appears and the crane movement “Luffing the auxiliary boom / accessory up” was turned off:

- ▶ Luff the auxiliary boom / accessory down.

Result:

- Crane operation is possible again.

Troubleshooting

The double arrow / warning light **16.3** appears continuously?

If a double arrow / warning light **16.3** appears without having luffed up to a limit switch, then there may be an error in the limit switches “Auxiliary boom / accessory top”.

- ▶ Check if there is an error message from the LICCON computer system, see Diagnostics manual.
- ▶ If yes: Remedy the error immediately.

The double arrow / warning light **16.4** appears and the crane movement “Luffing the auxiliary boom / accessory down” was turned off:

- ▶ Luff the auxiliary boom / accessory up.

Result:

- Crane operation is possible again.

Troubleshooting

The double arrow / warning light **16.4** appears continuously?

If a double arrow / warning light **16.4** appears without having luffed down to a limit switch, then there may be an error in the limit switches “Auxiliary boom / accessory bottom”.

- ▶ Check if there is an error message from the LICCON computer system, see Diagnostics manual.
- ▶ If yes: Remedy the error immediately.

**WARNING**

Limited warning functions!

If one of the double version limit switches is not ok and the crane is continued to be operated, then the warning functions of the LICCON overload protection are limited!

- ▶ The crane can only be operated in an emergency after failure of a double version limit switch!
- ▶ Carry out crane movements in such a way that no repeated shut off by the LICCON overload protection occurs.

2.3.3 Shut off maximum / minimum value test point 1 (force F1)

**Note**

- ▶ The force determined on test point 1 is generally described as $F1_{\text{actual}}$ (actual value F1).
- ▶ In the icon 17 (F1-load display), the force relationship as well as the number values are shown in number values as well as a bar display (called F1-bar display).
- ▶ The value $F1_{\text{max-operation}}$ 17.3 corresponds to 100 % in the F1-bar display.
- ▶ The F1-utilization bar 17.1 shows the relationship $F1_{\text{actual}}$ 17.2 to $F1_{\text{max-operation}}$ 17.3.
- ▶ In crane operation without derrick ballast, fewer values may be shown in the icon 17 (F1-load display).

Shut off maximum value F1 in crane operation

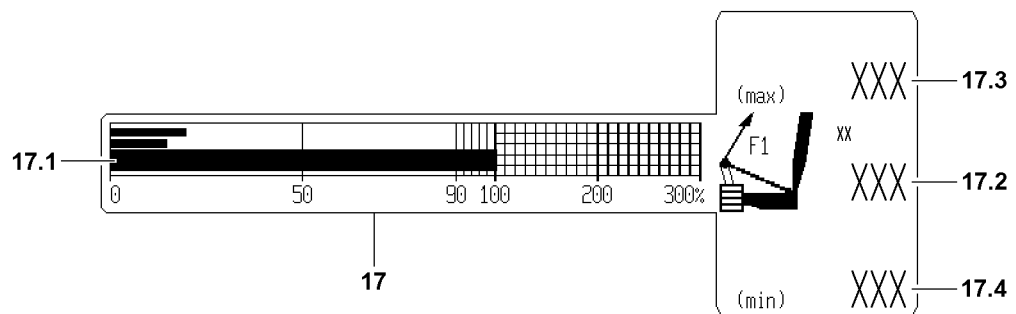

In the icon 17 (F1-load display) the F1-utilization bar 17.1 exceeds the 100 % mark and the LICCON overload protection has shut off the crane movement. The value $F1_{\text{actual}}$ 17.2 has exceeded the value $F1_{\text{max-operation}}$ 17.3.

All further movements, which lead to an increase of the force $F1$ (value $F1_{\text{actual}}$) are shut off.

- ▶ Reverse any crane movement which has caused the shut off.

or

- Initiate an alternative crane movement, which lowers the force $F1$ (value $F1_{\text{actual}}$).

Result:

- Crane operation is possible again.

Troubleshooting

The crane operation is limited because the value $F1_{\text{max-operation}}$ apparently is being reached too early?

- ▶ Make sure that a valid configuration status has been entered on the LICCON computer system!
- ▶ Make sure that the crane is assembled according to the assembly drawings!
- ▶ Make sure that the actual configuration status and the entered configuration status of the crane match.
- ▶ Make sure that all attachment parts and guy rods on the boom system, which are not needed, have been removed (weight)!
- ▶ Make sure that the boom system is free of snow and ice (weight)!
- ▶ Make sure that the wind influence onto the boom is not too great!
- ▶ If no irregularities can be found:
Contact LIEBHERR Service.

Shut off maximum value F1 in crane operation



Note

- ▶ A shut off minimum value F1 ($F1_{\min}$) only occurs in operating modes with derrick ballast. The status $F1_{\text{actual}} = F1_{\min}$ cannot be reached in all other operating modes.

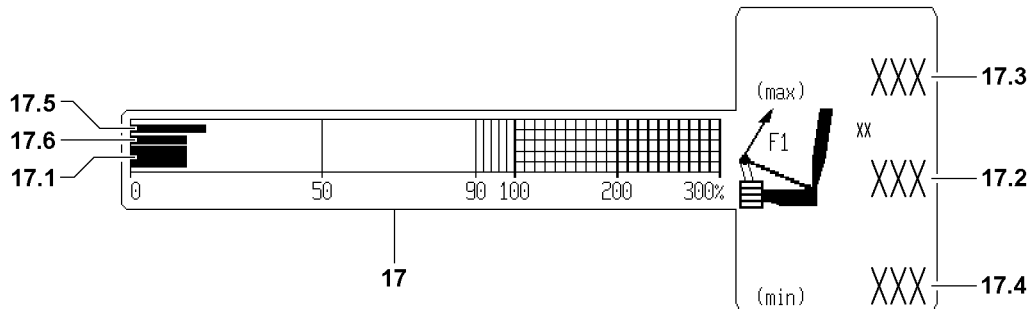

In the icon 17 (F1-load display), when falling below the $F1_{\min}$ advance warning bar 17.5, a warning of the upcoming shut off is issued by the F1-utilization bar 17.1.

If the F1-utilization bar 17.1 falls below the $F1_{\min}$ -STOP bar 17.6, then the LICCON overload protection shuts off the crane movement. The value $F1_{\text{actual}}$ 17.2 has fallen below the value $F1_{\min}$ 17.4.



Note

Shut off $F1_{\min}$

- ▶ If the utilization of the derrick ballast is below 50 %, then there is no immediate shut off when falling below value $F1_{\min}$!

All further movements, which lead to an decrease of the force F1 (value $F1_{\text{actual}}$) are shut off.

- ▶ Reverse any crane movement which has caused the shut off.

or

- Initiate an alternative crane movement, which increases the force F1 (value $F1_{\text{actual}}$).

Result:

- Crane operation is possible again.

Troubleshooting

The crane operation is limited because the value $F1_{\min}$ apparently is being reached too early?

- ▶ Make sure that a valid configuration status has been entered on the LICCON computer system!
- ▶ Make sure that the crane is assembled according to the assembly drawings!
- ▶ Make sure that the actual configuration status and the entered configuration status of the crane match.
- ▶ Make sure that all attachment parts and guy rods on the boom system, which are not needed, have been removed (weight)!
- ▶ Make sure that the boom system is free of snow and ice (weight)!
- ▶ Make sure that the wind influence onto the boom is not too great!
- ▶ If no irregularities can be found:
Contact LIEBHERR Service.

2.3.4 Shut off spooling the winch up / out

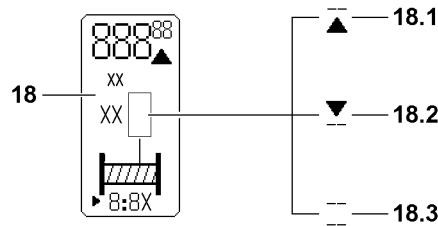

In the icon **18**, the line / arrow **18.1**, arrow / line **18.2** or line / line **18.3** appears and the LICCON overload protection has shut off the crane movement.

“Spooling the winch out” (line / arrow **18.1**) or “Spooling the winch up” (arrow / line **18.2**) was shut off because the upper / lower limit angle of the rope for the selected winch was exceeded or fallen below. If line / line **18.3** appears blinking in the icon **18**, then the affected winch is deactivated.

The line / arrow **18.1** appears and the crane movement “Spooling the winch out” was turned off:

- ▶ Spool the winch up.

Result:

- Crane operation is possible again.

The arrow / line **18.2** appears and the crane movement “Spooling the winch up” was turned off:

- ▶ Spool the winch out.

Result:

- Crane operation is possible again.

The line / line **18.3** appear and the winch is deactivated:

- ▶ Activate the winch, see Crane operating instructions, chapter 4.02.

Result:

- Crane operation is possible again.

2.3.5 Shut off hoist top

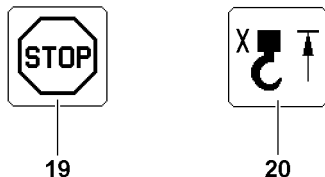

The icon **19** and hoist top icon **20** appear in the LICCON monitor and the LICCON overload protection has turned off crane movement.

Spooling the hoist winch up was turned off because the hook block or the load hook has run against a hoist limit weight during the upward movement and the affected hoist limit switch was triggered.



WARNING

Property damage / falling load!

- ▶ After shut off spool hoist winch up (hoist top), for every further crane movement, the distance between the hook block / load hook and the boom head must be checked!



Note

- ▶ After a hoist top shut off occurred, further crane movements, which affect the length of the hoist rope are also shut off!

- ▶ Spool the hoist winch out.

Result:

- Crane operation is possible again.

2.3.6 Shut off due to error message

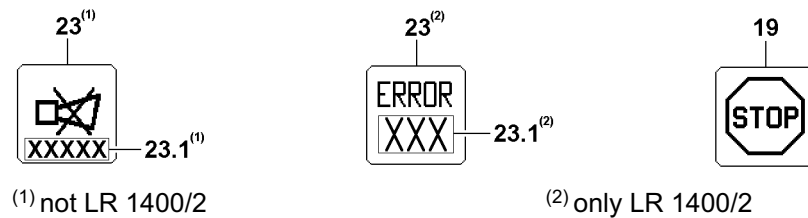

In the icon **23** appears an error message, the icon **19** appears in the LICCON monitor and the LICCON overload protection has turned off crane movement.

- ▶ Determine the existing error with the help of the error message from the error field **23.1** in icon **23**, see Diagnostics manual.
- ▶ Remedy the error.
- ▶ If the error cannot be remedied:
Contact LIEBHERR Service.

Troubleshooting

The erection of the crane, for example after assembly on a new job site or with another equipment configuration, is not possible due to an error message?

- ▶ Evaluate the error message.
- ▶ Make sure that all electrical connections are established correctly.
- ▶ Check if all sensors or dummy plugs with integrated electric have been connected properly.



Note

- ▶ If there is a defect on a participating sensor (LMB), then the crane can no longer be operated in normal operating condition. Contact Liebherr Service and fix / replace the sensors.

2.3.7 Minimum / maximum support forces



Note

- ▶ Applies only for cranes with support force monitoring*.
- ▶ Description of support force monitoring, see Crane operating instructions, chapter 4.02.

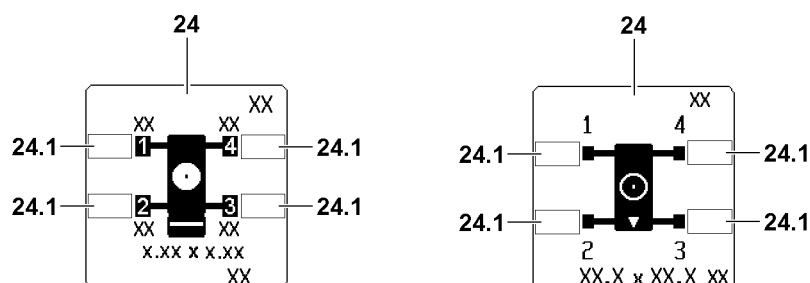

WARNING

The crane can topple over!

When reaching the programmed minimum / maximum support forces there is no automatic shut off of crane movements!

The displayed support force values are subjected to fluctuating influences, for example crane operation, surrounding and environmental influences!

The resulting tolerance field of the determined values may not be utilized by the support force display to determine the tipping limit of the crane!

If this is disregarded, then the crane can topple over!

Personnel can be severely injured or killed!

- ▶ The displayed support force values of the support force display may not be used to utilize the crane up to the tipping limit!
 - ▶ Make sure that all support force values are within the minimum / maximum support forces!
-

The icon **24** (depending on the crane, similar to the left or right illustration) is shown in the LICCON monitor with blinking value in one or several fields **24.1**. Blinking values in the fields **24.1** signal exceedance of the minimum / maximum support forces.

- ▶ Reverse the crane movements, which caused the support forces to be outside the minimum / maximum values.

Result:

- All values in the fields **24.1** are within the minimum / maximum support forces.
- ▶ Carry out crane movements in such a way that the support forces always remain within the minimum / maximum values.

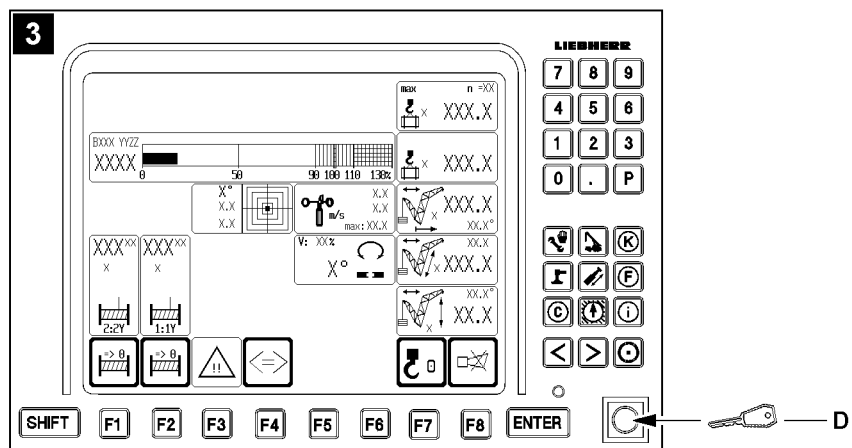
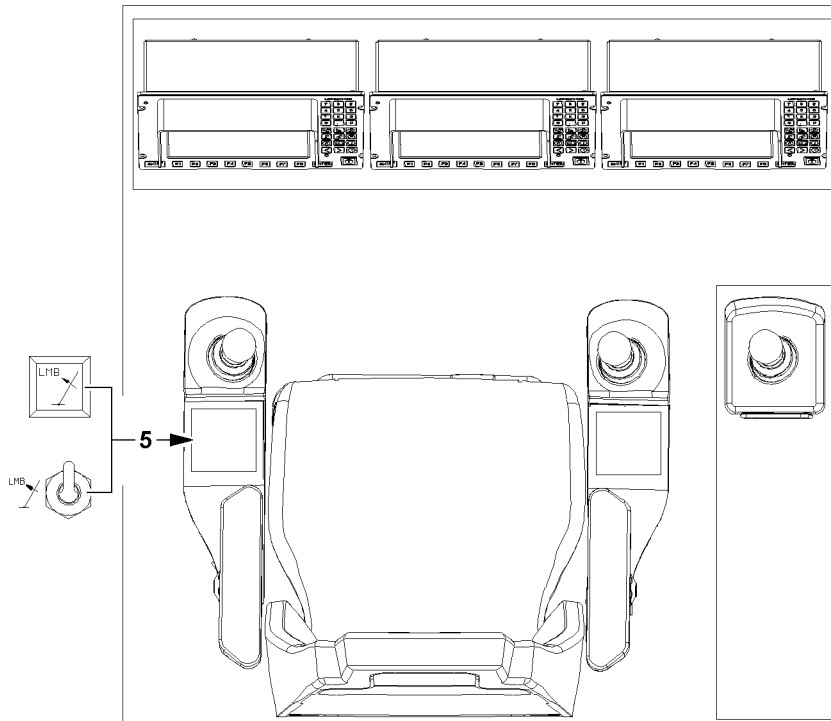

2.4 Shut off of crane movement: LMB STOP by LICCON overload protection



WARNING

Risk of overload and toppling the crane!

If the shut off limits of the LICCON overload protection are exceeded without knowing the exact cause for the shut off by the LICCON overload protection, then the crane can be overloaded and topple over! Personnel can be severely injured or killed!

- ▶ Before activating the function "Exceedance of shut off limits of the LICCON overload protection" determine the exact cause for the shut off!



WARNING

Danger of accident due to function "Exceedance of shut off limits of the LICCON overload protection"! If the shut off limits of the LICCON overload protection are exceeded, there is no additional protection against crane overload!

Due to erroneous operation or deliberate misuse, the crane could collapse, the boom can break off or the crane can topple over!

Personnel can be severely injured or killed!

- ▶ The button **5** "Luffing in with suspended load" and the set up key **D** may only be actuated when it is ensured that no normal operating condition (utilization below 100 % and no active shut off) can be reached without the function "Exceedance of shut off limits of the LICCON overload protection"!
- ▶ Actuate the set up key **D** only when no normal operating condition (utilization below 100 % and no active shut off) can be reached with the button **5** "Luffing in with suspended load"!
- ▶ The function "Exceedance of shut off limits of the LICCON overload protection" is only permissible in emergencies and for assembly purposes!
- ▶ The set up key **D** may only be actuated by persons who are aware of the effects of their acts regarding the function "Exceedance of shut off limits of the LICCON overload protection"!
- ▶ The function "Exceedance of shut off limits of the LICCON overload protection" requires the presence of an authorized person and must be performed with utmost caution!
- ▶ Crane operation with activated function "Exceedance of shut off limits of the LICCON overload protection" is prohibited!



WARNING

Expanded working / danger zone of the crane!

Due to the function "Exceedance of shut off limits of the LICCON overload protection" it is possible that the working / danger zone of the crane is significantly expanded!

If these circumstances are not observed, collisions and accidents can occur!

Personnel can be severely injured or killed!

- ▶ With activated function "Exceedance of shut off limits of the LICCON overload protection" take an expanded working / danger zone of the crane into account and monitor it!

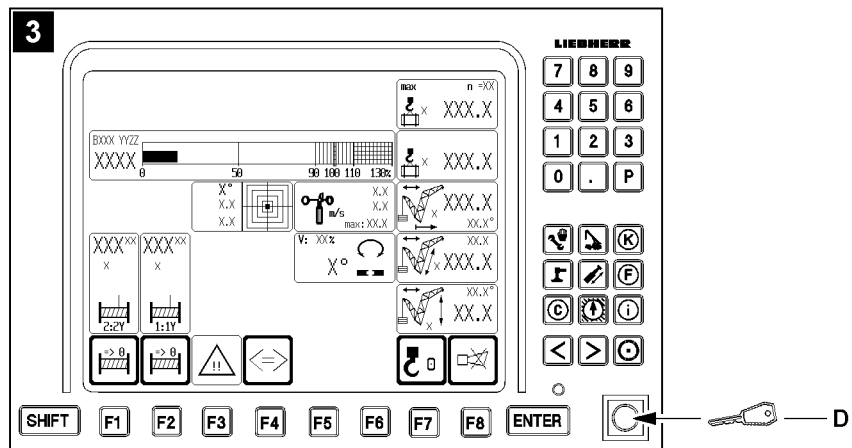
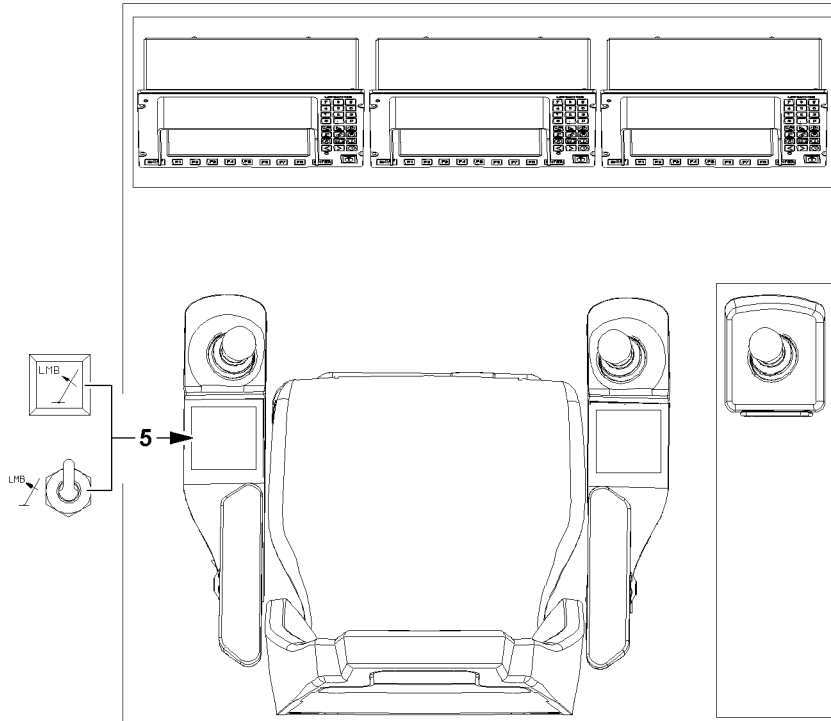

**WARNING**

Overload of crane!

When taking on a load by luffing the boom up, the crane can be overloaded!

This could result in serious accidents!

- ▶ Taking on load by luffing up the boom is prohibited!
- ▶ Take on a load only with the hoist gear!

**Note**

- ▶ If the set up key **D** is actuated in the area “Load chart available”, then the working speed is reduced!
- ▶ If the set up key **D** is actuated in the area “No load chart available”, then the working speed is not reduced!

There are two possibilities to exceed the shut off limits of the LICCON overload protection after LMB STOP:

- With button **5** “Luffing in with suspended load” in the left control console
- With the set up key **D** on the LICCON monitor with crane operating screen, see illustration **3**

NOTICE

Danger of mix up!

The function “Exceedance of shut off limits of LICCON overload protection” can only be activated with the set up key **D** on the LICCON monitor with crane operating screen, see illustration **3**!

The key buttons on the other monitors are not assigned with this function!

- ▶ Do not mix up the set up key **D** with the other key buttons!
- ▶ In case of mix up: Deactivate the activated function!

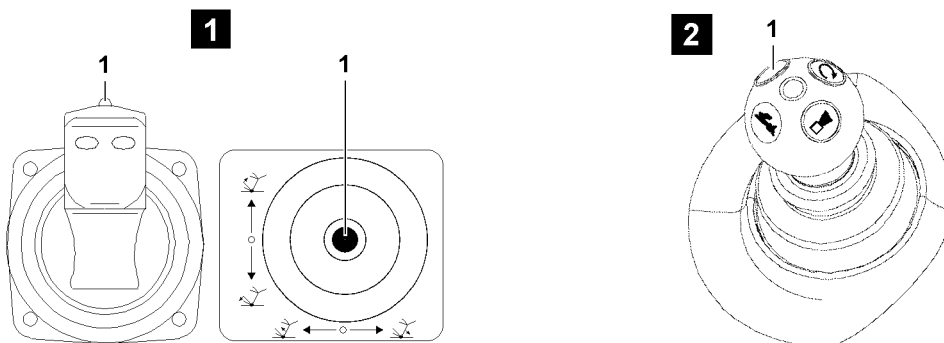
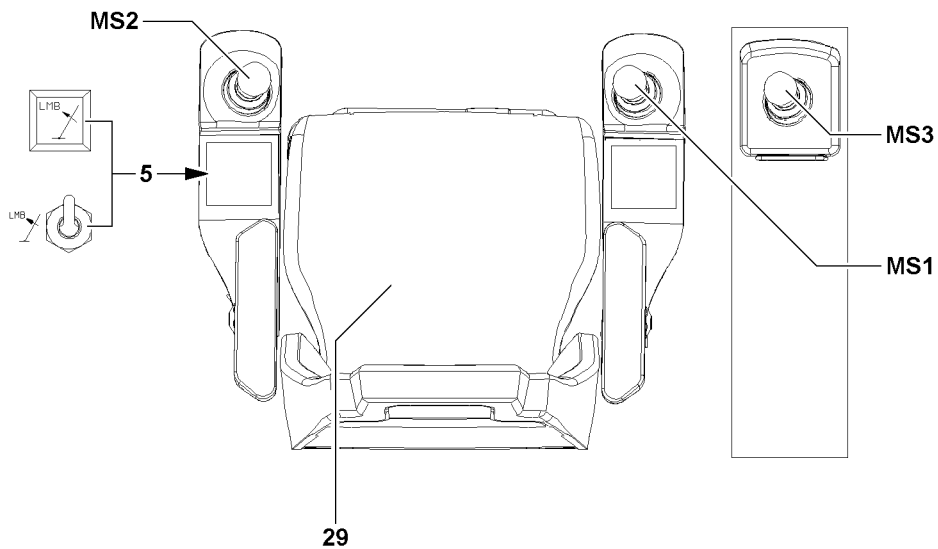
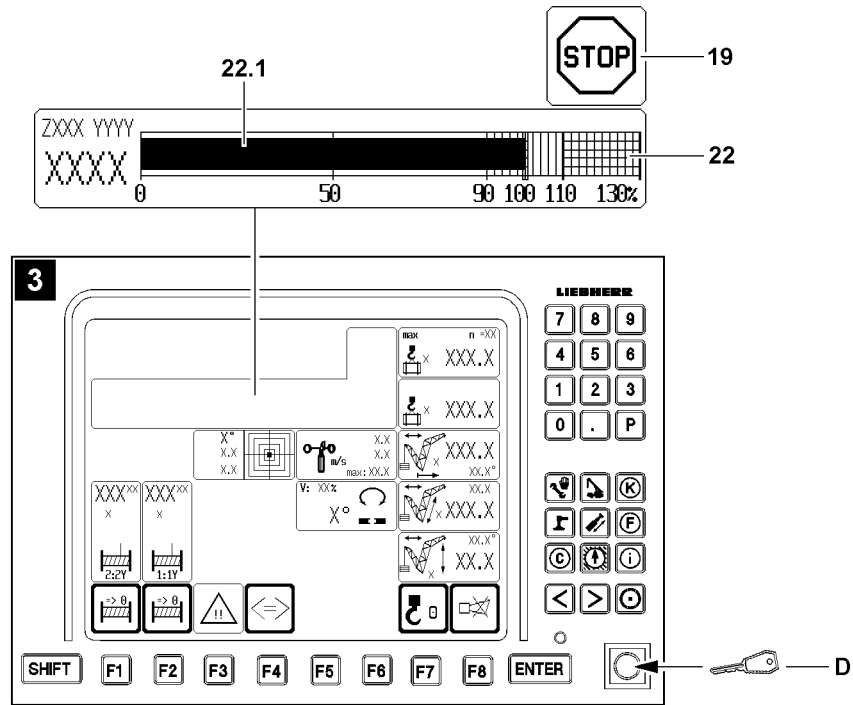

B112335

2.4.1 Luffing in with suspended load

If the maximum permissible load moment is exceeded, the LICCON overload protection turns off all crane movements that increase the load moment.

In the icon **22** (load moment display) the utilization bar **22.1** has exceeded the 100 % mark and in the LICCON monitor appears the icon **19**.

This shut off limit can be exceeded by actuating the button **5** "Luffing in with suspended load".

Make sure that the following prerequisite is met:

- Either the seat contact button **29** or one of the buttons **1** of the master switches (MS1, MS2, MS3) is actuated.



Note

- ▶ If the load is reduced by luffing up, then the button **5** "Luffing in with suspended load" is possibly not functioning.
 - ▶ For the procedure when the button **5** "Luffing in with suspended load" is not functioning, see section "Exceedance of maximum permissible load moment".
-

- ▶ Press the function key **5** "Luffing in with suspended load" and hold it.

Result:

- The LICCON overload protection is inactive.

- ▶ Luff the load in.

Result:

- If the crane reaches a normal operation status (utilization below 100 % and no active shut off) then the icon **19** turns off, normal crane operation is possible again.

The function "Luffing in with suspended load" is deactivated:

- When the function key **5** "Luffing in with suspended load" is not longer actuated.
- When neither the seat contact button **29** nor one of the buttons **1** of the master switches (MS1, MS2, MS3) is actuated.
- In case of defect of an associated sensor (LMB).
- At engine stop.

The function "Luffing in with suspended load" is deactivated:

- The LICCON overload protection is active.
- ▶ Carry out crane movements in such a way that no repeated shut off by the LICCON overload protection occurs.

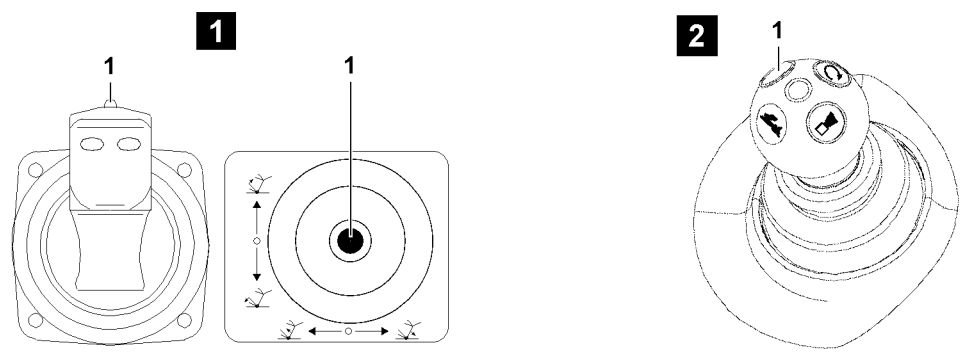
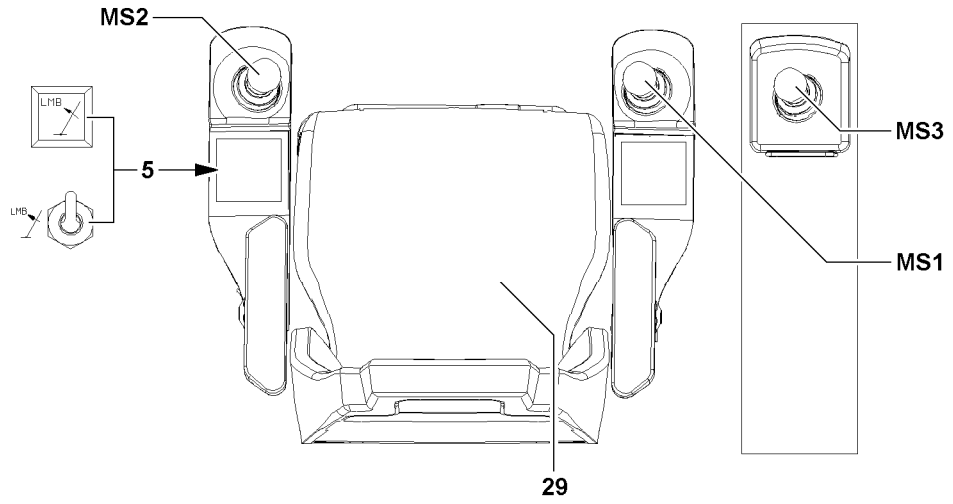
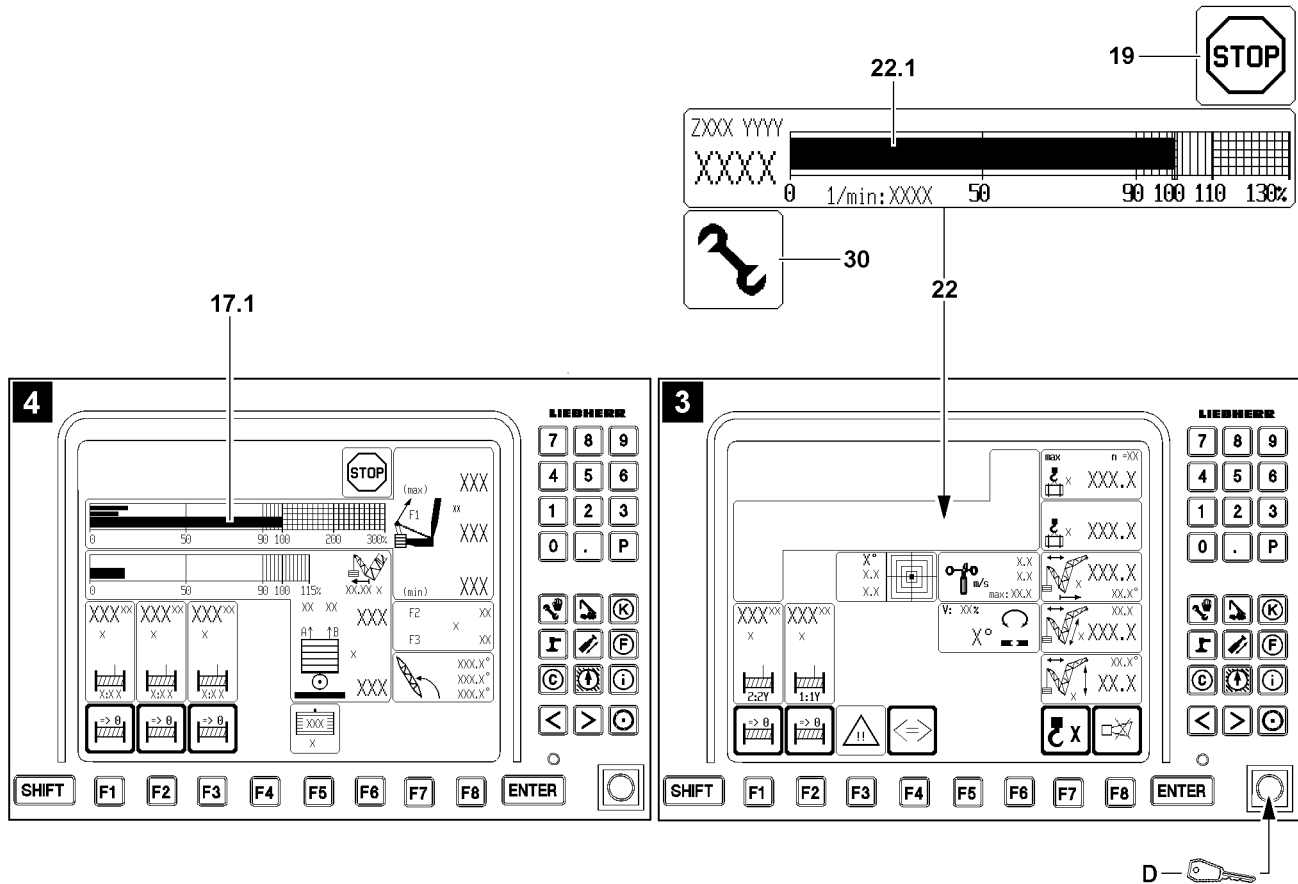

B112336

2.4.2 Exceedance of the maximum permissible load moment

If the maximum permissible load moment is exceeded, the LICCON overload protection turns off all crane movements that increase the load moment.

In the icon **22** (load moment display) the utilization bar **22.1** has exceeded the 100 % mark and in the LICCON monitor appears the icon **19**.

This shut off can be exceeded by the configuration button **D** in the “right touching” position.



WARNING

Shut off safety device!

If the function “Exceedance of shut off limits of LICCON overload protection” is activated by actuating the set up key **D** then it is possible to exceed the maximum permissible load moment! The function “Exceedance of maximum value test point 1” is automatically activated too. Thus there is no shut off when exceeding the maximum value test point 1!

- ▶ All notes regarding the function “Exceedance of shut off limits of LICCON overload protection” must be observed!
- ▶ The utilization bar $F1_{\text{actual}}$ **17.1** of the F1 load display must be observed!



Note

- ▶ In emergency situations, the function “Exceedance of shut off limits of the LICCON overload protection” can be activated with the set up key **D** and the maximum permissible load moment can be exceeded by 10 % to maximum 110 %.

The set up key **D** on the LICCON monitor has two positions:

- Operating position (not pressed): Crane is in normal operation.
- Position to right (touching): The function “Exceedance of shut off limits of the LICCON overload protection” is activated, the assembly icon **30** appears in the LICCON monitor.

Make sure that the following prerequisites are met:

- With the button **5** “Luffing in with suspended load” no normal operating condition (utilization below 100 % and no active shut off) can be reached.
- All master switches (MS1, MS2, MS3) are in zero position (not deflected).
- Either the seat contact button **29** or one of the buttons **1** of the master switches (MS1, MS2, MS3) is actuated.
- Radio operation* is not active.
- The load moment display 110 % has not been reached and a load chart is available.
- ▶ Turn the set up key **D** to the right (touching).

Result:

- The LICCON overload protection is inactive.
- The assembly icon **30** appears in the LICCON monitor.
- The working speed in the area “Load chart available” is reduced for all functions.

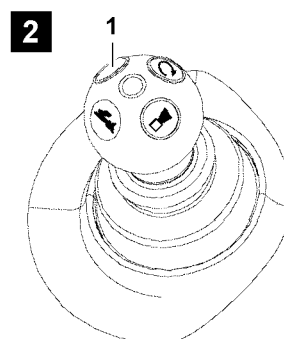
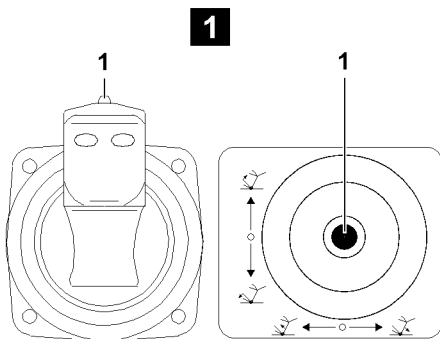
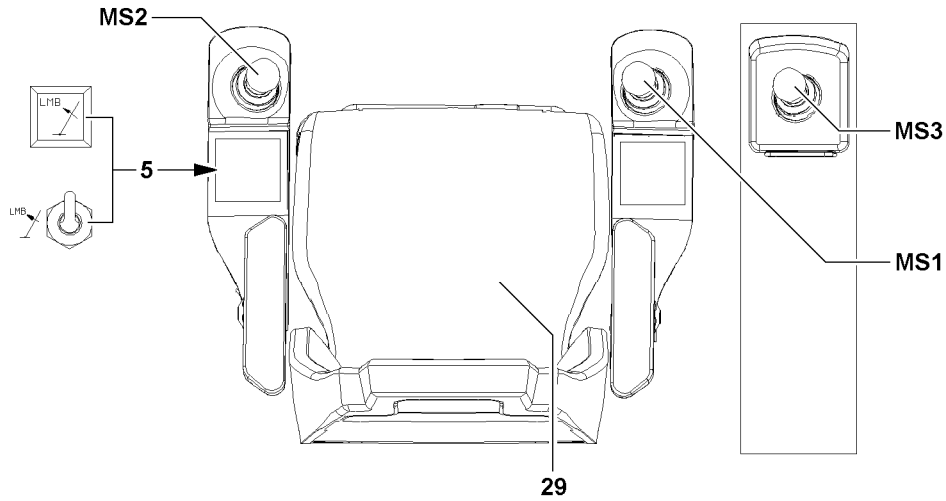
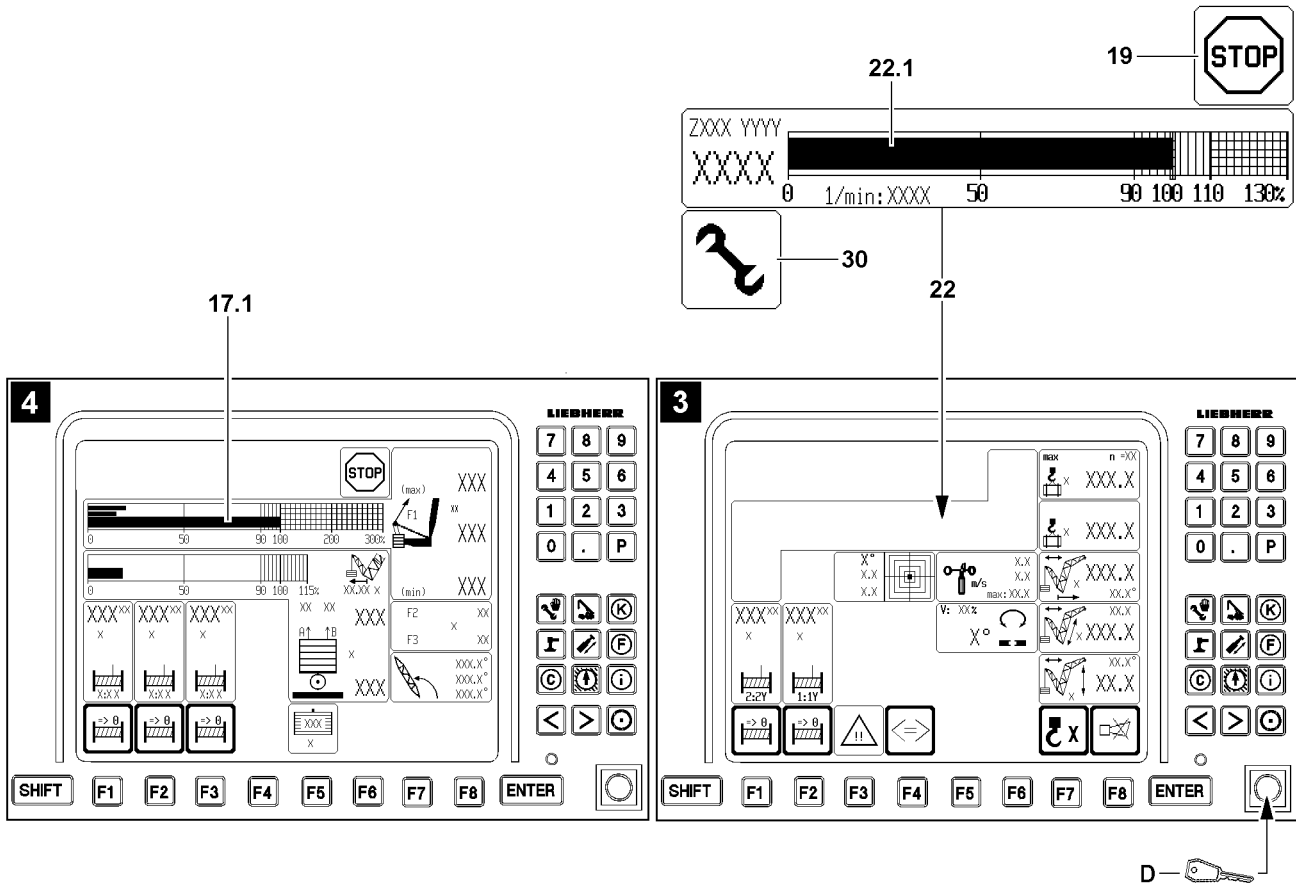

- ▶ Initiate crane movements which directly lead to a normal operating status (utilization below 100 % and no active shut off).

Result:

- If a crane reaches a normal operation status (utilization below 100 % and no active shut off), then the function “Exceedance of shut off limits of the LICCON overload protection” shuts off, the assembly icon **30** and icon **19** in the LICCON monitor turn off.

In addition, the function “Exceedance of shut off limits of LICCON overload protection” turns off immediately:

- If the set up key **D** is actuated again.
- If all master switches (MS1, MS2, MS3) are in neutral position for 10 seconds (with load chart available).
- When neither the seat contact button **29** nor one of the buttons **1** of the master switches (MS1, MS2, MS3) is actuated.
- If radio operation* is activated.
- At engine stop.
- At hoist top shut off.
- When leaving the angle range of the load chart.
- When the utilization bar **22.1** (load moment display) exceeds a utilization of 110 %.

**Note**

- ▶ The function “Exceedance of shut off limits of the LICCON overload protection” is only turned off when the assembly icon **30** in the LICCON monitor turns off.
- ▶ If the function “Exceedance of shut off limits of the LICCON overload protection” does not turn off after pressing the set up key **D** once, then press the set up key **D** again until the assembly icon **30** in the LICCON monitor turns off.

The function “Exceedance of shut off limits of the LICCON overload protection” has / was shut off:

- The assembly icon **30** in the LICCON monitor turns off.
- The working speed is reduced until all master switches (MS1, MS2, MS3) are in zero position at the same time.
- ▶ Make sure that the assembly icon **30** does no longer appear in the LICCON monitor.
- ▶ Carry out crane movements in such a way that no repeated shut off by the LICCON overload protection occurs.

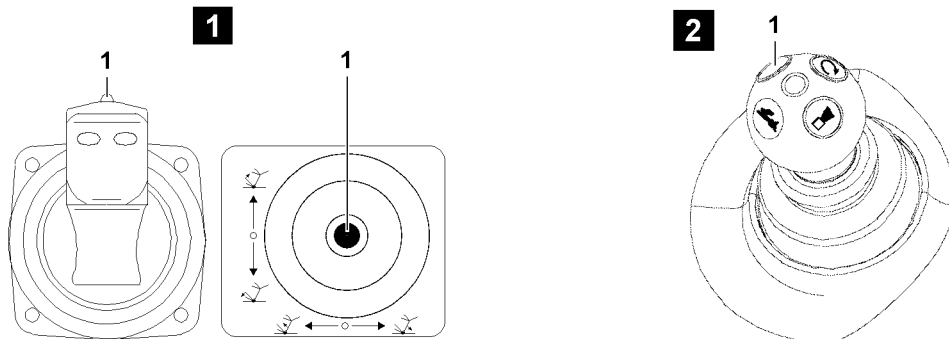
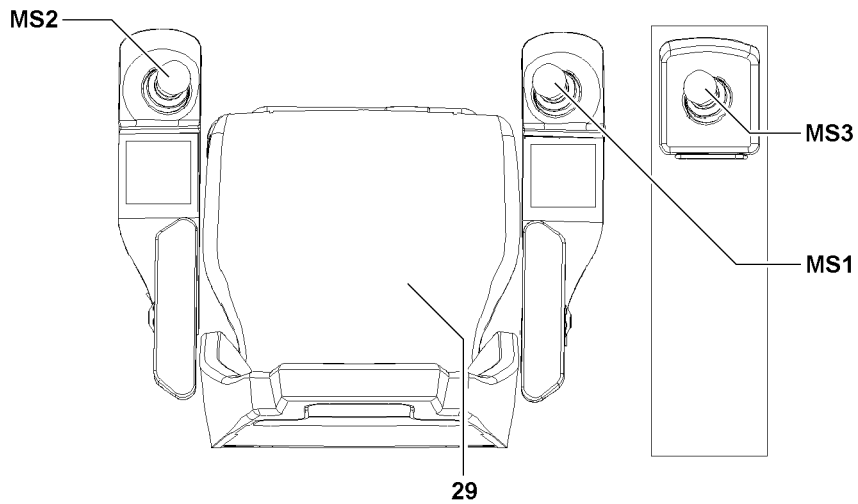
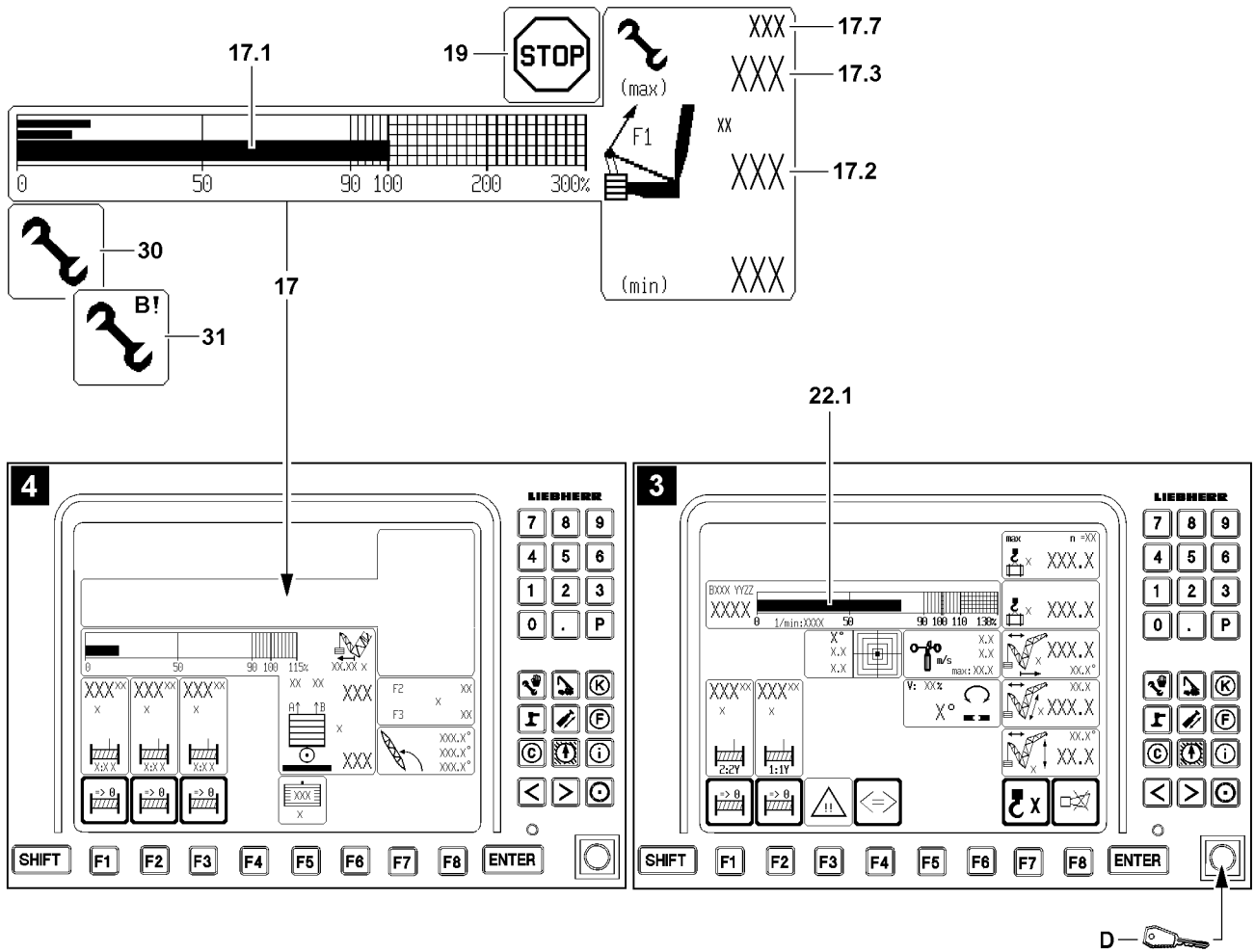

B112337

2.4.3 Exceedance of maximum value test point 1 (force F1) in crane operation



WARNING

Leaving the load chart with load on hook!

If, by actuating the set up key **D**, the shut off is bypassed by value $F1_{\text{max-operation}}$ **17.3** and exceeded by more than 110 %, then the crane is in assembly operation, the assembly icon **31** appears in the LICCON monitor!

There is no load chart available any longer and various display values may not be shown any longer in the crane operating screen!

The load on the hook is no longer monitored by the load chart!

Severe accidents due to crane overload can result!

Personnel can be severely injured or killed!

► In assembly operation, the data in the erection / take down charts is binding!



WARNING

Shut off safety device!

If, by actuating the set up key **D**, the function "Exceedance of maximum value test point 1" is activated, then the function "Exceedance of shut off limits of LICCON overload protection" is also activated automatically. Thus there is no shut off if the maximum permissible load moment is exceeded!

► All notes regarding the function "Exceedance of shut off limits of LICCON overload protection" must be observed!

► The utilization bar **22.1** of the load moment display must be observed!



Note

► The force determined on test point 1 is generally described as $F1_{\text{actual}}$ (actual value F1).

► In the icon **17** (F1-load display), the force relationship as well as the number values are shown in number values as well as a bar display (called F1-bar display).

► The value $F1_{\text{max-operation}}$ **17.3** corresponds to 100 % in the F1-bar display.

► The F1-utilization bar **17.1** shows the relationship $F1_{\text{actual}}$ **17.2** to $F1_{\text{max-operation}}$ **17.3**.

► In crane operation without derrick ballast, fewer values may be shown in the icon **17** (F1-load display).

► If the actual load is **larger** than the permissible hook block weight according to the erection / take down charts, then it can be exceeded up to maximum 110 % of $F1_{\text{max-operation}}$ **17.3**!

► If the actual load is **smaller** than the permissible hook block weight according to the erection / take down charts, then the assembly operation becomes active above 110 % of $F1_{\text{max-operation}}$ **17.3**. In assembly operation, there is no load chart available!

► The value $F1_{\text{max-assembly}}$ **17.7** appears in crane operation when 90 % of its nominal value is exceeded!

In the icon **17** (F1 load display) the utilization bar $F1_{\text{actual}}$ **17.1** exceeds the 100 % mark and the LICCON overload protection has shut off the crane movement. The value $F1_{\text{actual}}$ **17.2** has exceeded the value $F1_{\text{max-operation}}$ **17.3**.

All further movements, which lead to an increase of the force (value $F1_{\text{actual}}$) are shut off.

In the LICCON monitor with the derrick operating screen (illustration **4**) appears the icon **19**.

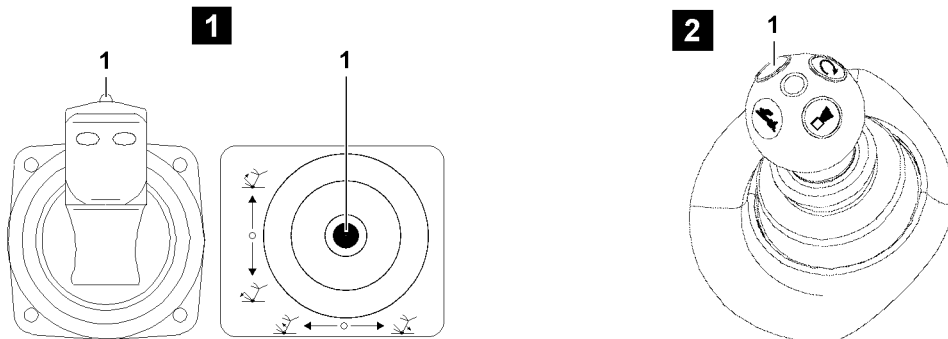
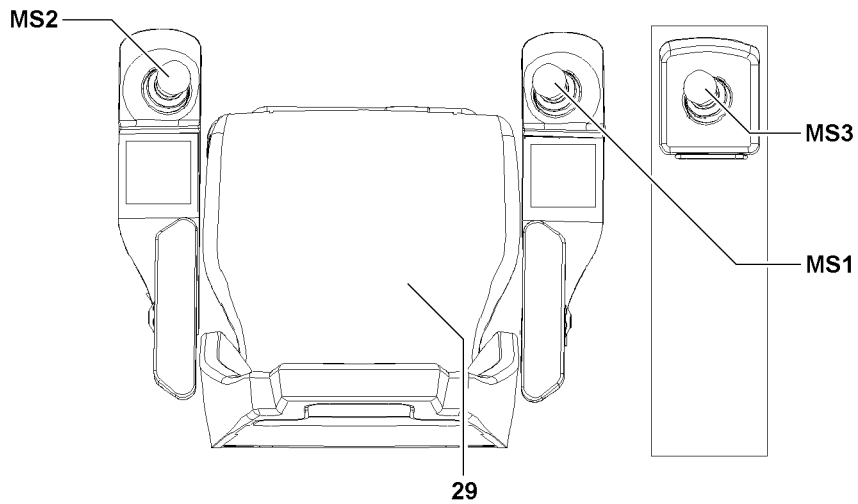
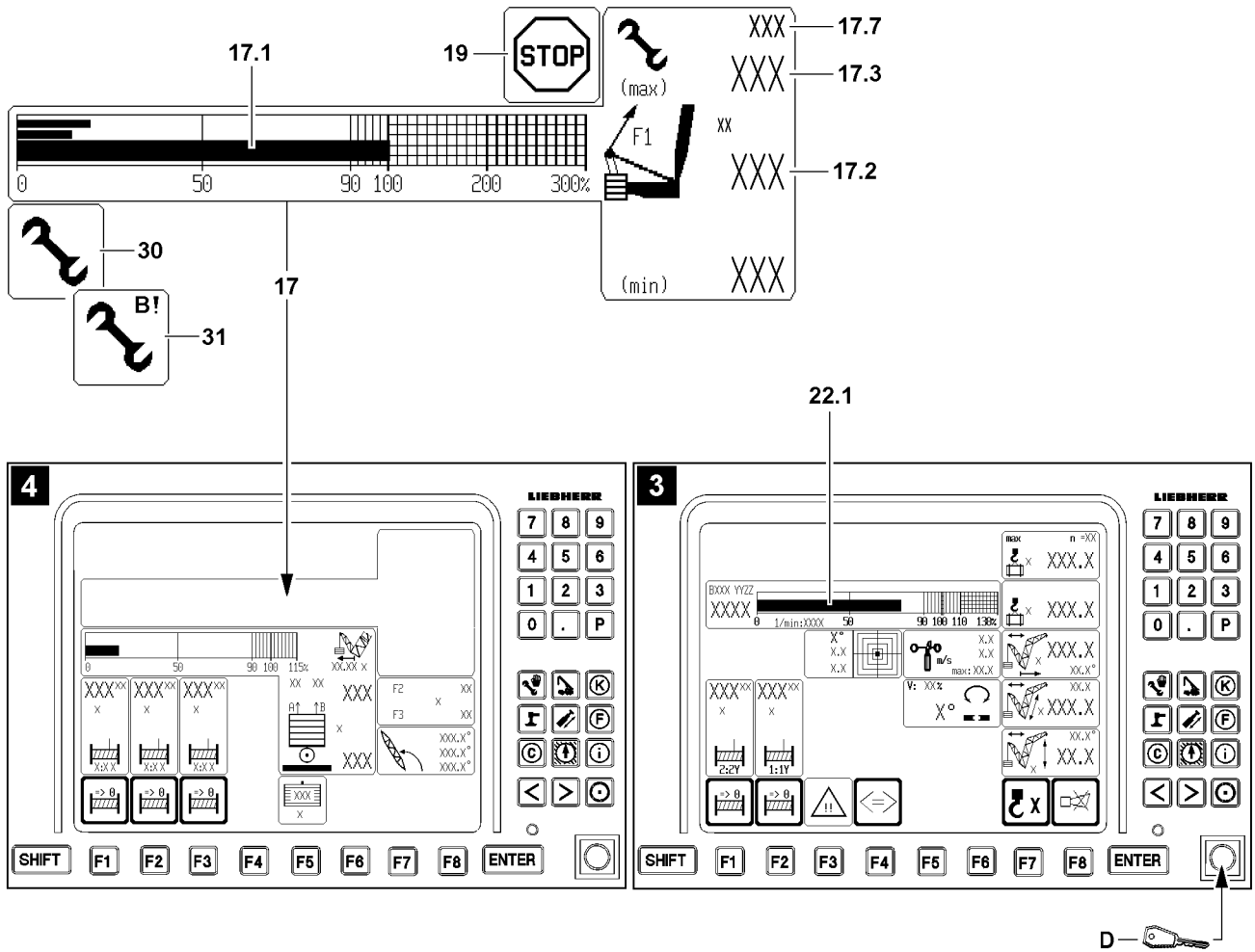

B112337

Make sure that the following prerequisites are met:

- All master switches (MS1, MS2, MS3) are in zero position (not deflected).
- Either the seat contact button **29** or one of the buttons **1** of the master switches (MS1, MS2, MS3) is actuated.
- Radio operation* is not active.
- The F1 load display 110 % has not been reached and a load chart is available.
- ▶ Turn the set up key **D** to the right (touching).

Result:

- The function “Exceedance of maximum value test point 1” is activated in connection with the function “Exceedance of the shut off limits of the LICCON overload protection”.
- $F1_{\text{max-operation}}$ **17.3** can be exceeded.

The function “Exceedance of shut off limits of the LICCON overload protection” in connection with the function “Exceedance of the maximum value test point 1” also shuts off immediately:

- If the set up key **D** is actuated again.
- If all master switches (MS1, MS2, MS3) are in neutral position for 10 seconds (with load chart available).
- When neither the seat contact button **29** nor one of the buttons **1** of the master switches (MS1, MS2, MS3) is actuated.
- If radio operation* is activated.
- At engine stop.
- At hoist top shut off.



Note

- ▶ The function “Exceedance of shut off limits of the LICCON overload protection” is only turned off when the assembly icon **30** in the LICCON monitor turns off.
- ▶ If the function “Exceedance of shut off limits of the LICCON overload protection” does not turn off after pressing the set up key **D** once, then press the set up key **D** again until the assembly icon **30** in the LICCON monitor turns off.

The function “Exceedance of shut off limits of the LICCON overload protection” has / was shut off:

- The assembly icon **30** in the LICCON monitor turns off.
- The working speed is reduced until all master switches (MS1, MS2, MS3) are in zero position at the same time.
- ▶ Make sure that the assembly icon **30** does no longer appear in the LICCON monitor.
- ▶ Carry out crane movements in such a way that no repeated shut off by the LICCON overload protection occurs.

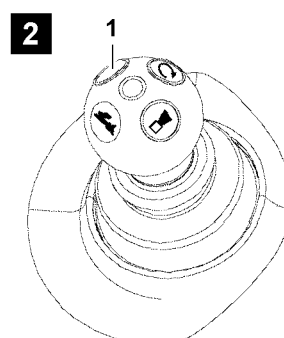
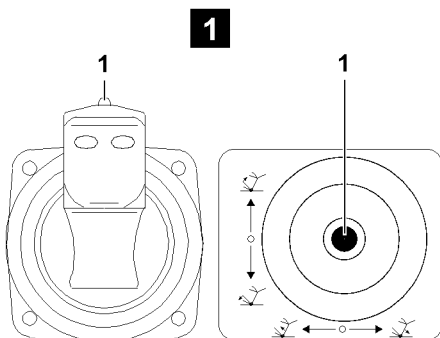
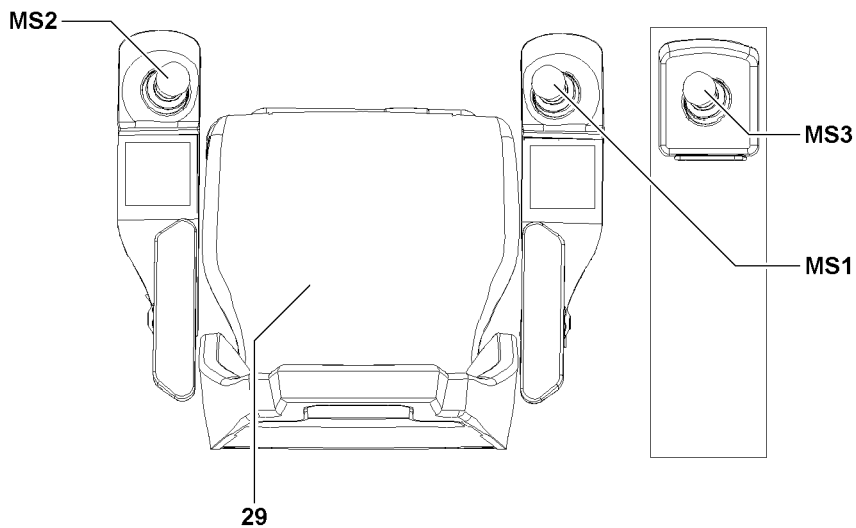
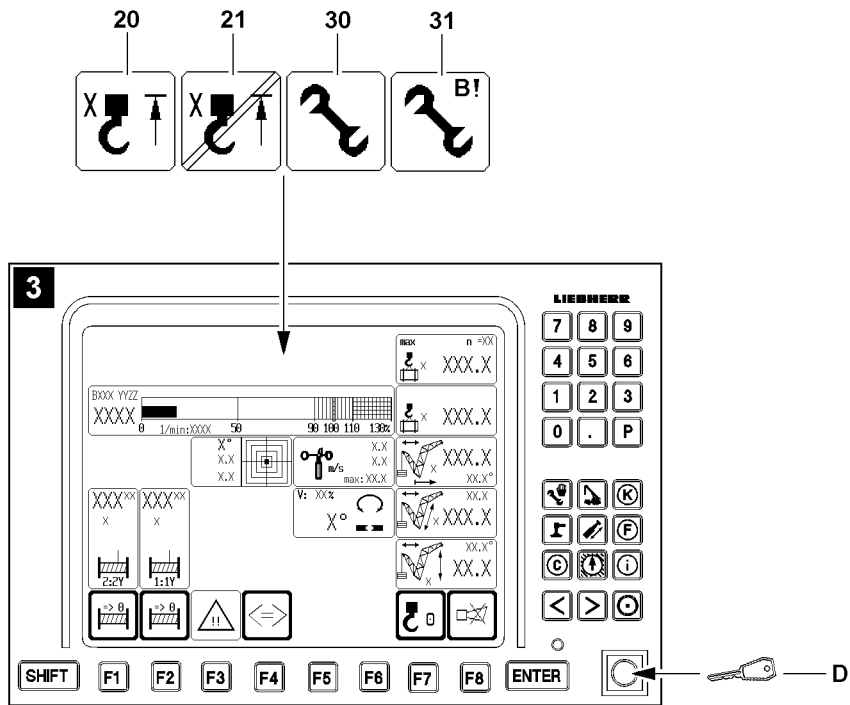

B111230

2.5 Bypass of the hoist top shut off



WARNING

Improper use of the function "Bypass of hoist top shut off"!

- ▶ The function "Bypass of hoist top shut off" may never be used to increase the lifting height during crane operation!



WARNING

Property damage and falling load!

If the function "Bypass of hoist top shut off" is activated, there is the danger that the hook block or the load hook is pulled against the pulley head!

This danger exists especially when the hoist winch is continued to be spooled up and for crane movements which have an influence on the hoist rope, for example luffing the boom, the auxiliary boom / accessory or the derrick boom!

Property damage and falling load can result!

Personnel can be severely injured or killed!

- ▶ The function "Bypass of hoist top shut off" may only be carried out by an authorized person, along with a guide. The guide must be in direct contact with the crane operator and must continually monitor the distance between the hook block / load hook and the boom head!
- ▶ Carry out all crane movements with utmost caution!



Note

- ▶ The activation of the function "Bypass of hoist top shut off" is only possible if the hoist limit switch was touched and the hoist top shut off has occurred.
- ▶ If the hoist limit switch is triggered when the set up key **D** is actuated (function "Exceedance of shut off limits of the LICCON overload protection" is active, the assembly icon **30** or the assembly icon **31** appear), then a hoist top shut off occurs and the function "Exceedance of shut off limits of the LICCON overload protection" is deactivated.
- ▶ For assembly purposes or in emergency cases, if the activation of the function "Bypass of hoist top shut off" **and** activation of the function "Exceedance of shut off limits of the LICCON overload protection" is necessary, then the set up key **D** must be actuated until the icon **21** and assembly icon **30** or assembly icon **31** (assembly operation) appear.

Make sure that the following prerequisites are met:

- A hoist top shut off has occurred, the hoist top icon **20** appears in the LICCON monitor.
- Either the seat contact button **29** or one of the buttons **1** of the master switches (MS1, MS2, MS3) is actuated.
- All master switches (MS1, MS2, MS3) are in zero position (not deflected).
- The radio operation* is not active.

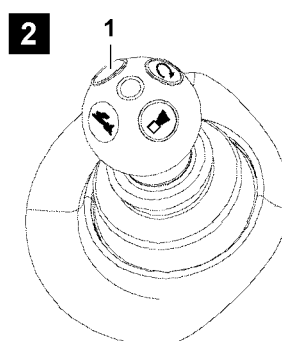
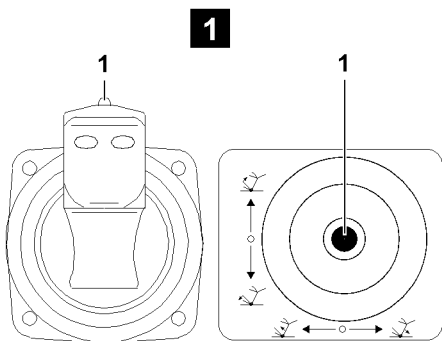
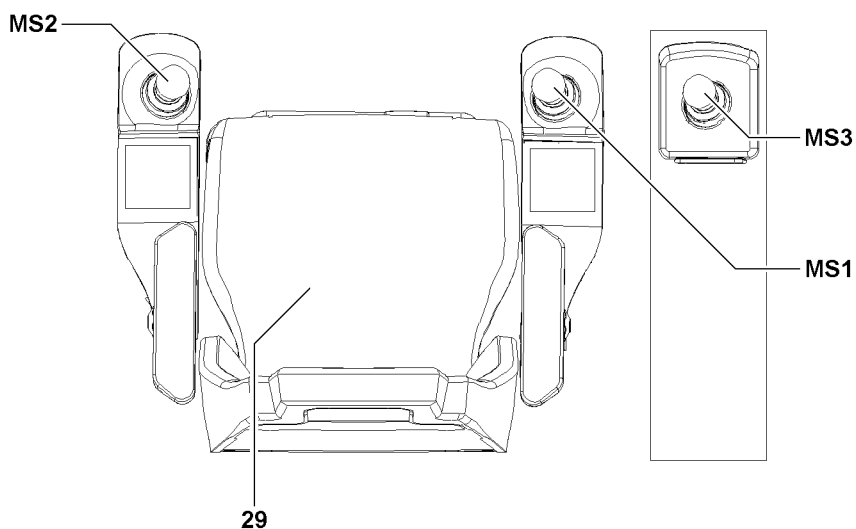
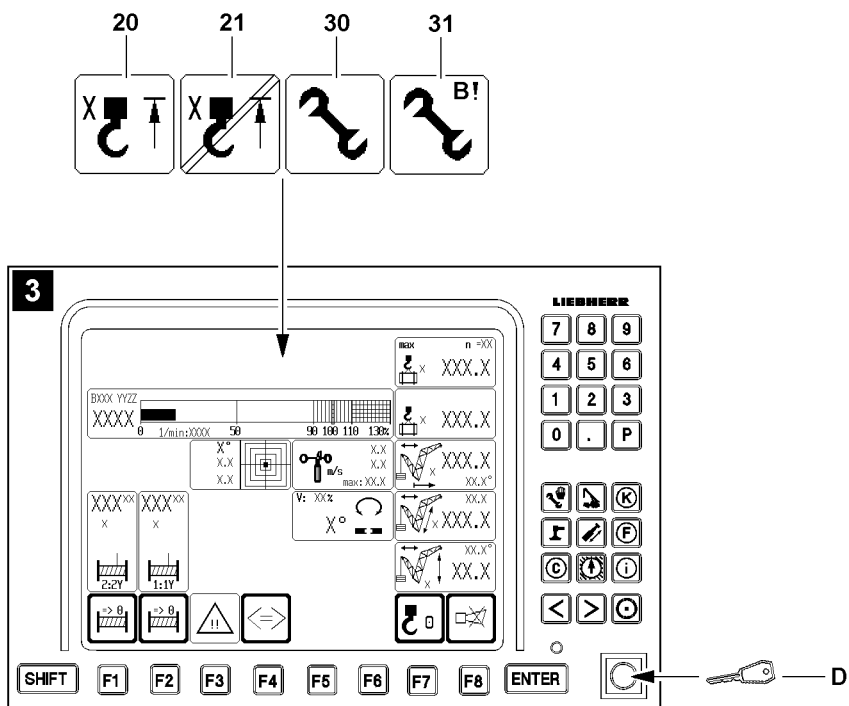

B111230

- ▶ Turn the set up key **D** to the right (touching).

Result:

- The assembly icon **30** or the assembly icon **31** (assembly operation) appear in the LICCON monitor.
 - The hoist top icon **20** in the LICCON monitor changes to the icon **21**.
 - The working speed is reduced for all functions (if load chart is available).
 - All hoist limit switches are bypassed.
- ▶ Carry out a crane movement with bypassed hoist limit switches with utmost caution and by taking the safety guidelines into account.

The function "Bypass of the hoist top shut off" turns off:

- If the set up key **D** is actuated again.
- When no master switch (MS1, MS2, MS3) was deflected for 10 seconds.
- When neither the seat contact button **29** nor one of the buttons **1** of the master switches (MS1, MS2, MS3) is actuated.
- If there is no longer a shut off of a hoist limit switch.
- If the radio operation* is active.
- At engine stop.

The function "Bypass of the hoist top shut off" has / was turned off:

- The assembly icon **30** or the assembly icon **31** (assembly operation) in the LICCON monitor turn off.
 - The icon **21** on the LICCON monitor turns off.
 - The working speed is reduced until all master switches (MS1, MS2, MS3) are in zero position at the same time.
- ▶ Make sure that the assembly icon **30** or the assembly icon **31** (assembly operation) as well as the icon **21** no longer appear in the LICCON monitor.
 - ▶ Carry out the crane movements in such a way that no repeated hoist top shut off occurs.

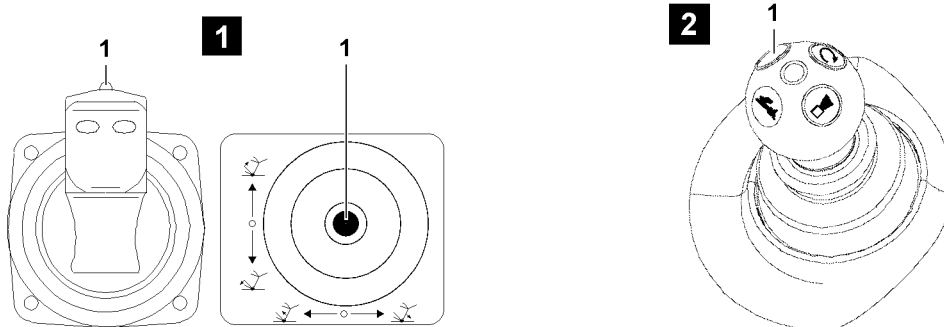
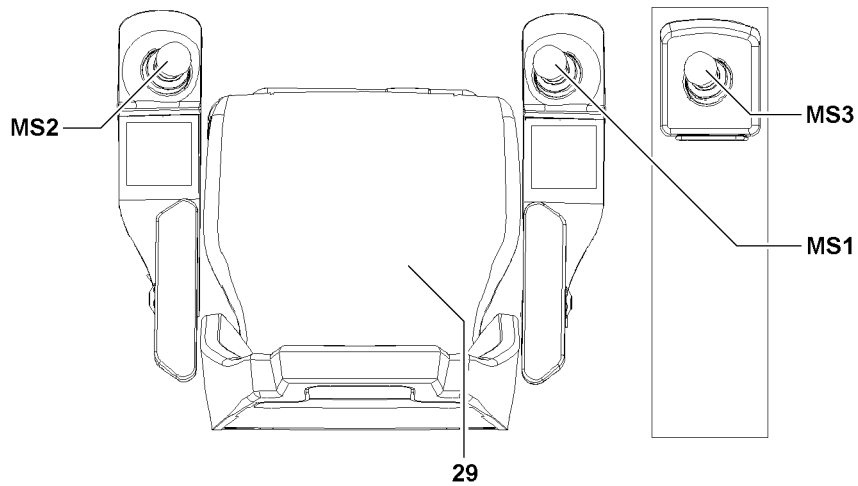
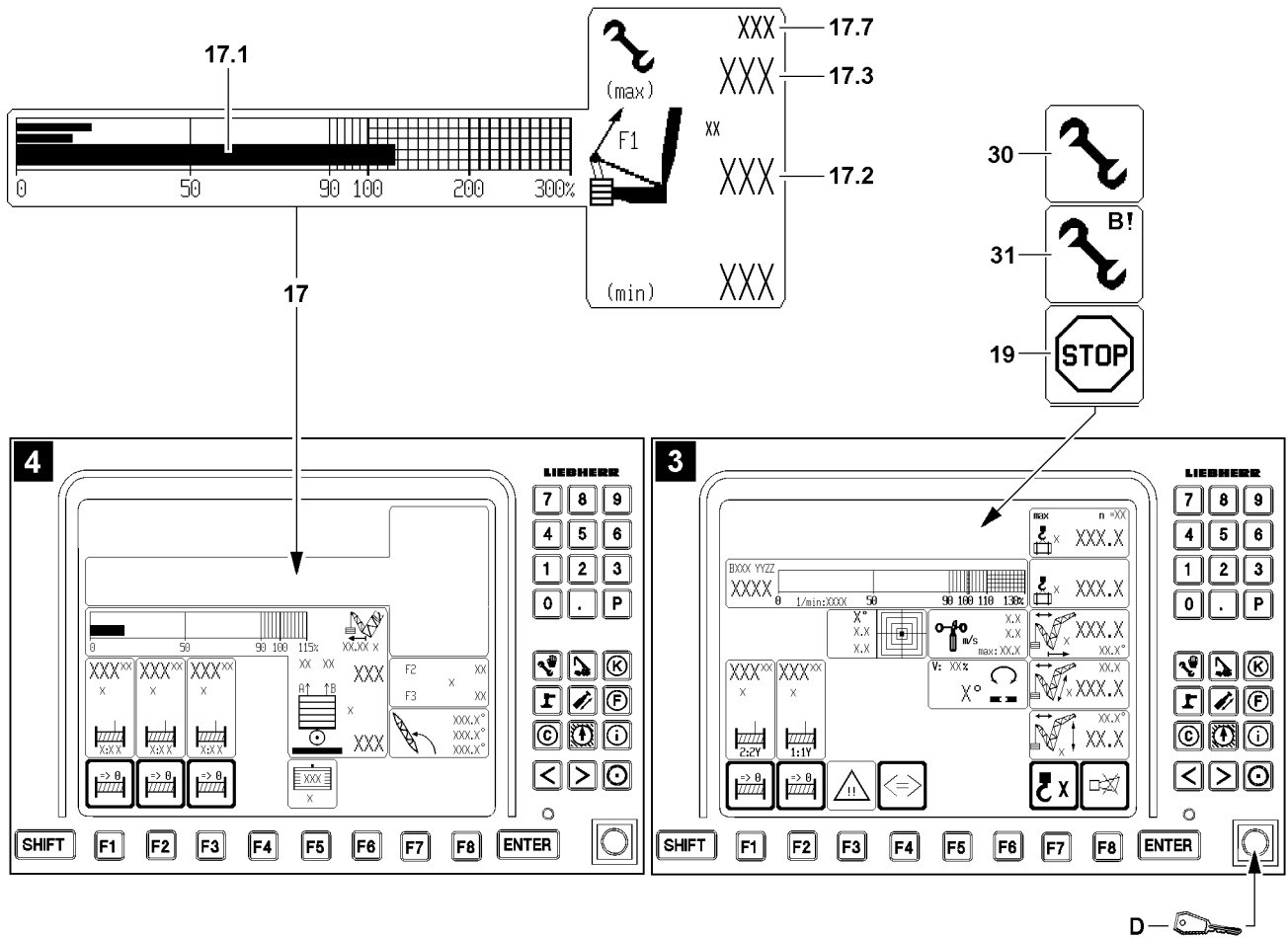

B112343

2.6 Exceeding the shut off limits of the LICCON overload protection during erection / take down procedures (assembly operation)



Note

- ▶ If the crane is in the area “No load chart available” then there is a shut off of the crane control by the LICCON overload protection. The icon **19** appears in the LICCON monitor.
- ▶ By an actuated set up key **D**, the function “Exceedance of shut off limits of the LICCON overload protection” can be activated, all erection / take down procedures can be carried out within the erection / take down charts, for which no load charts are available.



WARNING

Danger of accident during erection / take down procedures!

If the erection / take down charts are not observed, the crane could collapse, the boom can break off or the crane can topple over!

Personnel can be severely injured or killed!

- ▶ The erection / take down charts must be observed!
- ▶ Press the set up key **D** only when the configuration status has been entered correctly in the LICCON computer system and matches the actual situation!



Note

- ▶ The force determined on test point 1 is generally described as $F1_{\text{actual}}$ (actual value $F1$).
- ▶ In the icon **17** (F1-load display), the force relationship as well as the number values are shown in number values as well as a bar display (called F1-bar display).
- ▶ The value $F1_{\text{max-operation}}$ **17.3** corresponds to 100 % in the F1-bar display.
- ▶ The F1-utilization bar **17.1** shows the relationship $F1_{\text{actual}}$ **17.2** to $F1_{\text{max-operation}}$ **17.3**.
- ▶ In crane operation without derrick ballast, fewer values may be shown in the icon **17** (F1-load display).
- ▶ If a load chart is available, then the value $F1_{\text{max operation}}$ **17.3** is valid as the limit value for a shut off of crane operation.
- ▶ When leaving the area “Load chart available”, the assembly icon **30** turns off and the assembly icon **31** appears!
- ▶ When leaving the area “Load chart available” then $F1_{\text{max assembly}}$ **17.7** is valid as the upper limit value!
- ▶ $F1_{\text{max-assembly}}$ **17.7** might only appear when 90 % of its nominal value is exceeded!

2.6.1 Carrying out erection procedures (assembly operation)

Make sure that the following prerequisites are met:

- All master switches (MS1, MS2, MS3) are in zero position (not deflected).
- Either the seat contact button **29** or one of the buttons **1** of the master switches (MS1, MS2, MS3) is actuated.
- Radio operation* is not active.
- The set up configuration corresponds to the erection / take down charts.
- The set up configuration has been entered correctly into the LICCON computer system.

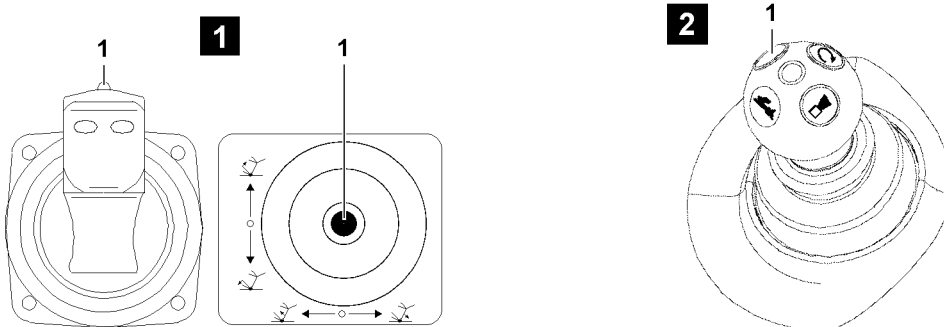
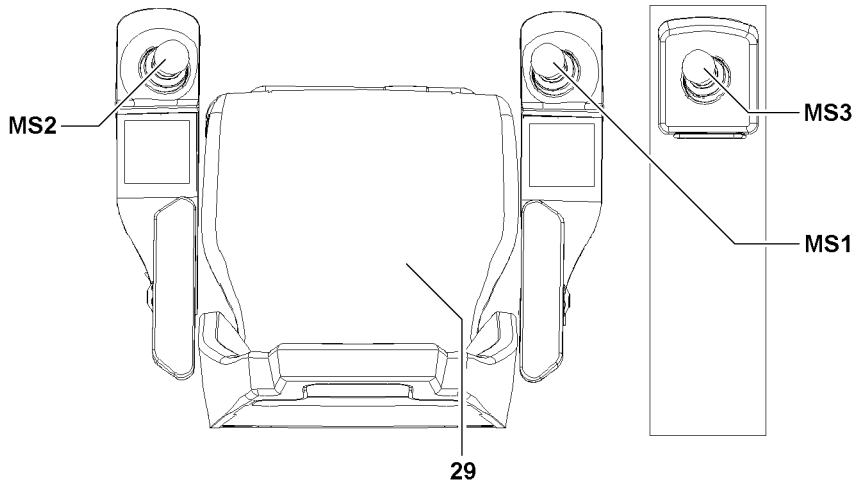
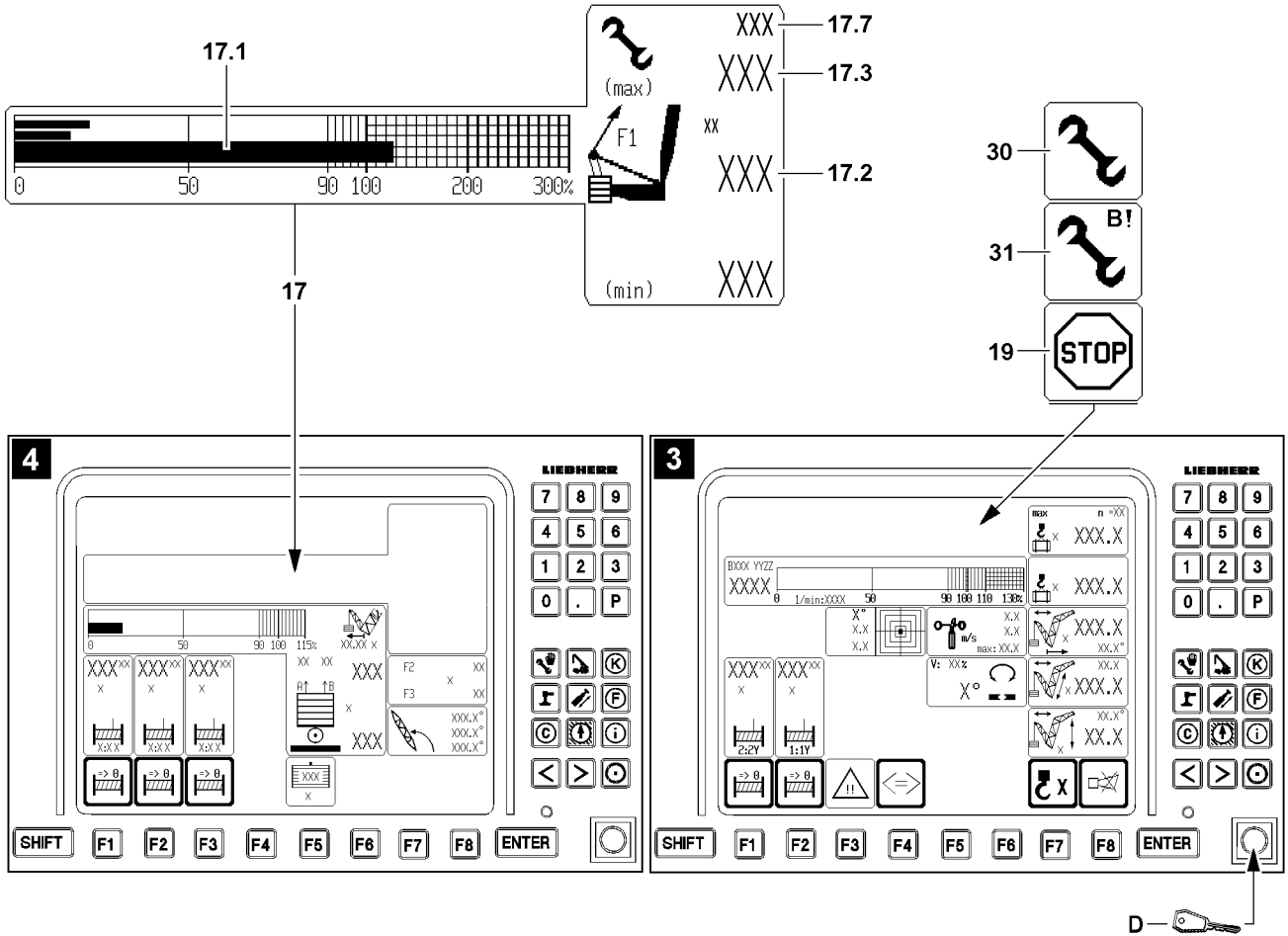

B112343

- ▶ Turn the set up key **D** to the right (touching).

Result:

- The assembly icon **31** appears in the area “No load chart available”.
 - The erection / take down procedures can be carried out.
- ▶ Watch the icon **17** (F1-load display), the value $F1_{\text{actual}}$ **17.2** may not exceed the value $F1_{\text{max-assembly}}$ **17.7**.

Troubleshooting

The erection / take down procedure cannot be carried out due to shut off “ $F1_{\text{max-assembly}}$ **17.7** exceeded”?

- ▶ See section “Danger of exceeding $F1_{\text{max assembly}}$ ”.

Troubleshooting

The function “Exceedance of shut off limits of the LICCON overload protection” can not be activated during erection / take down procedures?

- ▶ Check the error messages.
- ▶ Check the electrical connections.
- ▶ Check if all sensors or dummy plugs with integrated electric have been connected properly.

The function “Exceedance of shut off limits of the LICCON overload protection” turns off:

- If the set up key **D** is actuated again.
- When an area with existing load chart is reached (erection procedure).
- If all master switches (MS1, MS2, MS3) are in neutral position for 10 seconds (with “Load chart available”).
- When neither the seat contact button **29** nor one of the buttons **1** of the master switches (MS1, MS2, MS3) is actuated.
- At engine stop.

The function “Exceedance of shut off limits of the LICCON overload protection” has / was shut off:

- The assembly icon **30** or the assembly icon **31** in the LICCON monitor turns off.
- ▶ After completion of the erection / take down procedures, make sure that the assembly icon **30** or the assembly icon **31** no longer appear in the LICCON monitor.

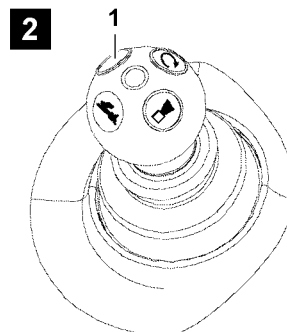
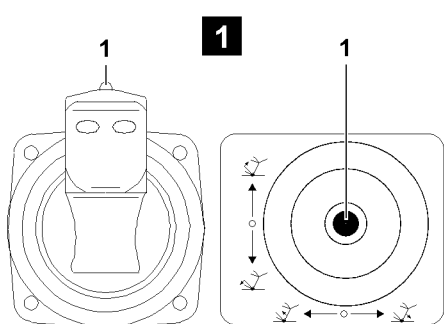
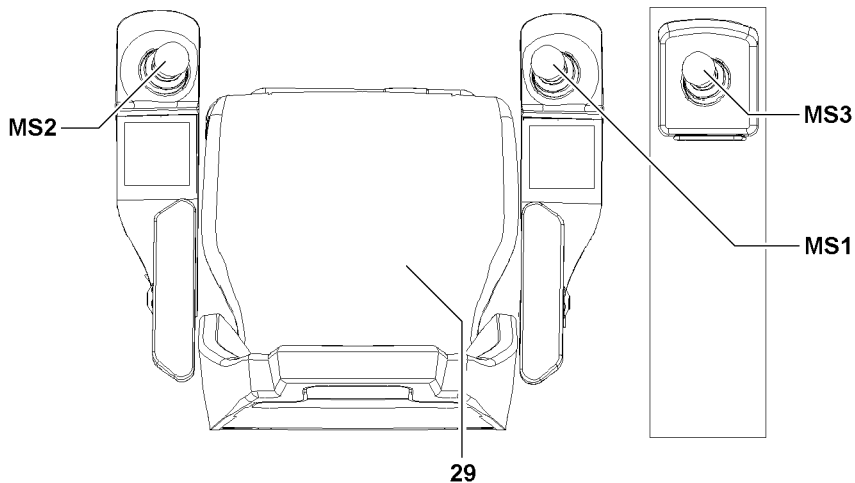
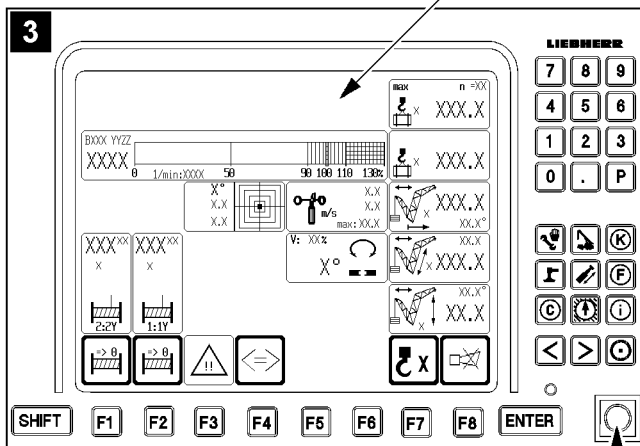
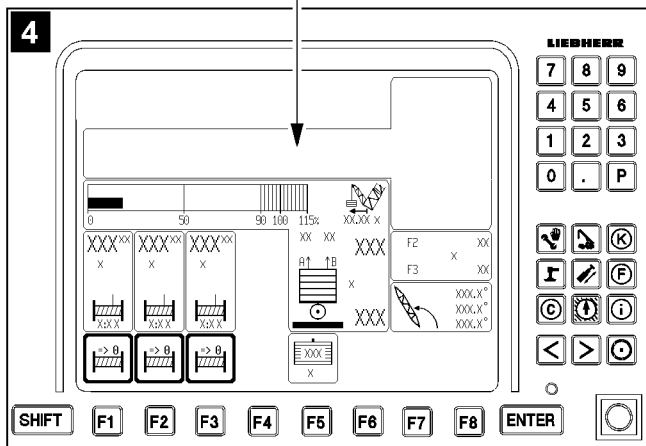
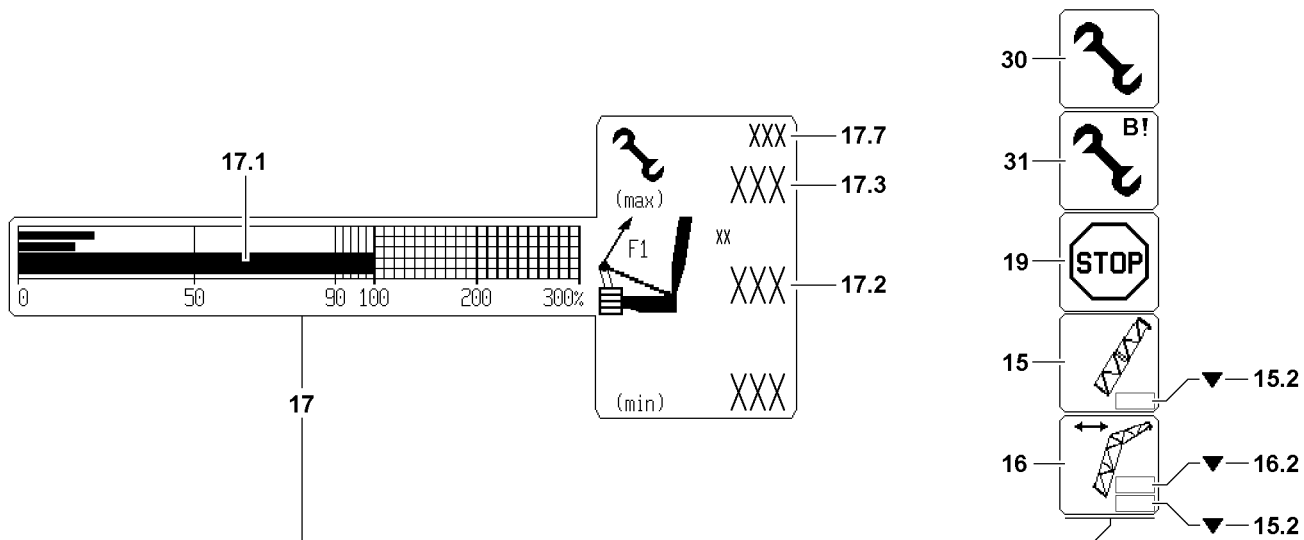

B112341

2.6.2 Carrying out take down procedures (assembly operation)



WARNING

Increased danger of accidents due to bypass of shut off of luffing the main boom / auxiliary boom / accessory down!

When the shut off luffing the main boom / auxiliary boom / accessory down is bypassed, then the LICCON overload protection as a whole is deactivated or limited.

When the shut off luffing the main boom / auxiliary boom / accessory down is bypassed and the main boom and / or the auxiliary boom / accessory is further luffed down, then there is no load chart available any longer!

Crane operation with bypassed shut off luffing the main boom / auxiliary boom / accessory down is prohibited, since severe accidents can result!

Personnel can be severely injured or killed!

- ▶ Activate the bypass of the shut off luffing the main boom / auxiliary boom / accessory down only in emergency cases or for erection / take down procedures with erection / take down charts!
- ▶ Carry out all crane movements with utmost caution!

Make sure that the following prerequisites are met:

- In icon **15** or icon **16** the arrow **15.2** or arrow **16.2** appear and the LICCON overload protection has shut off the crane movement.
- Either the seat contact button **29** or one of the buttons **1** of the master switches (MS1, MS2, MS3) is actuated.
- All master switches (MS1, MS2, MS3) are in zero position (not deflected).
- The radio operation* is not active.
- ▶ Turn the set up key **D** to the right (touching).

Result:

- The assembly icon **30** appears in the LICCON monitor.
- The function “Exceedance of shut off limits of the LICCON overload protection” is activated and has bypassed the shut off luffing the main boom / auxiliary boom / accessory down.



Note

- ▶ If a load chart is available, then the value $F1_{\text{max operation}}$ **17.3** is valid as the limit value for a shut off of crane operation.
- ▶ When leaving the area “Load chart available”, the assembly icon **30** turns off and the assembly icon **31** appears!
- ▶ When leaving the area “Load chart available” then $F1_{\text{max assembly}}$ **17.7** is valid as the upper limit value!
- ▶ If no derrick boom is installed, then the icon **17** only shows $F1_{\text{actual}}$ **17.1** and $F1_{\text{max-assembly}}$ **17.7**.
- ▶ $F1_{\text{max-assembly}}$ **17.7** might only appear when 90 % of its nominal value is exceeded!

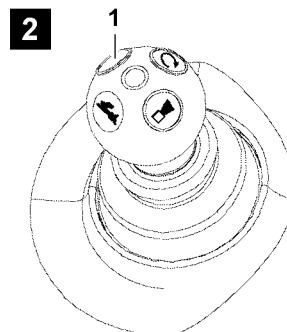
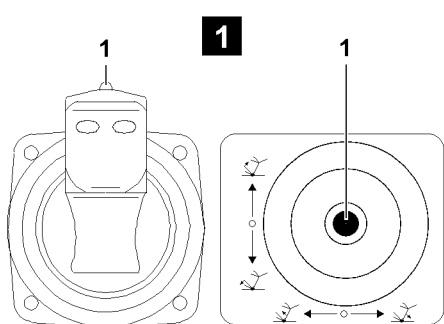
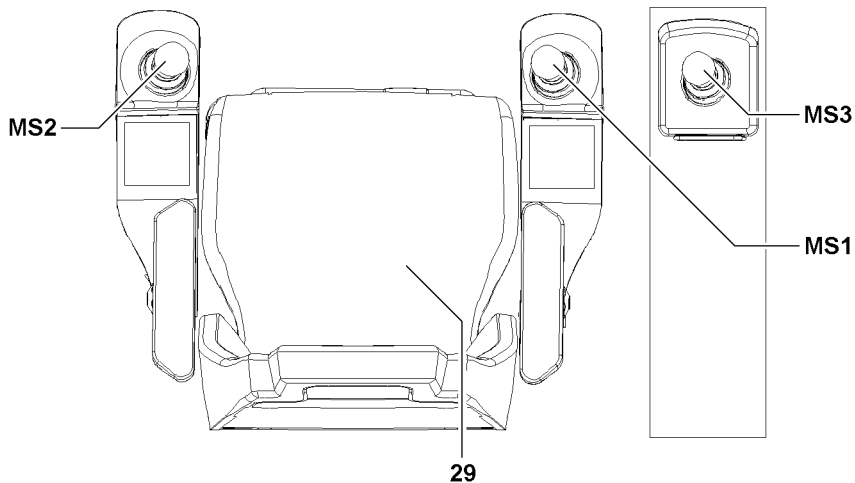
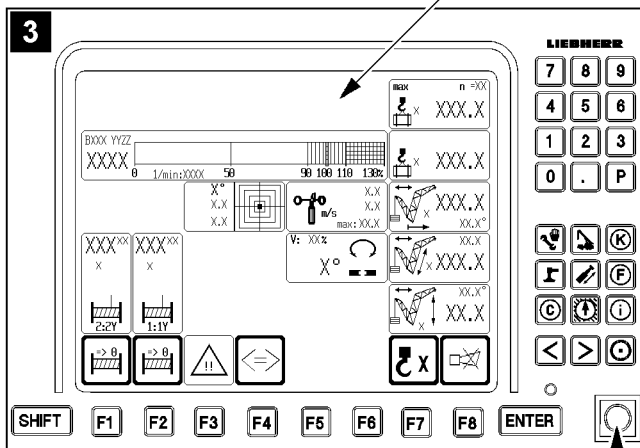
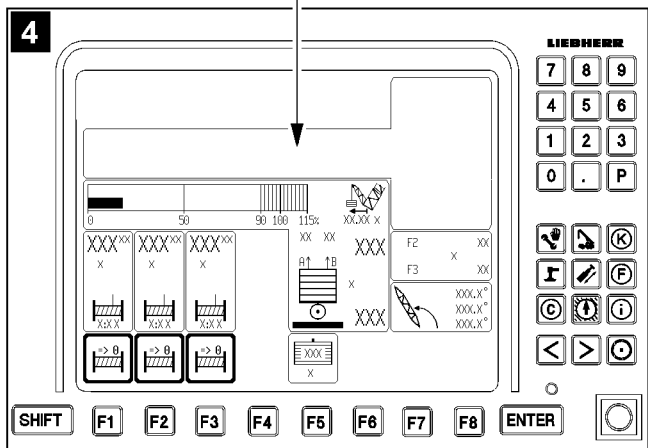
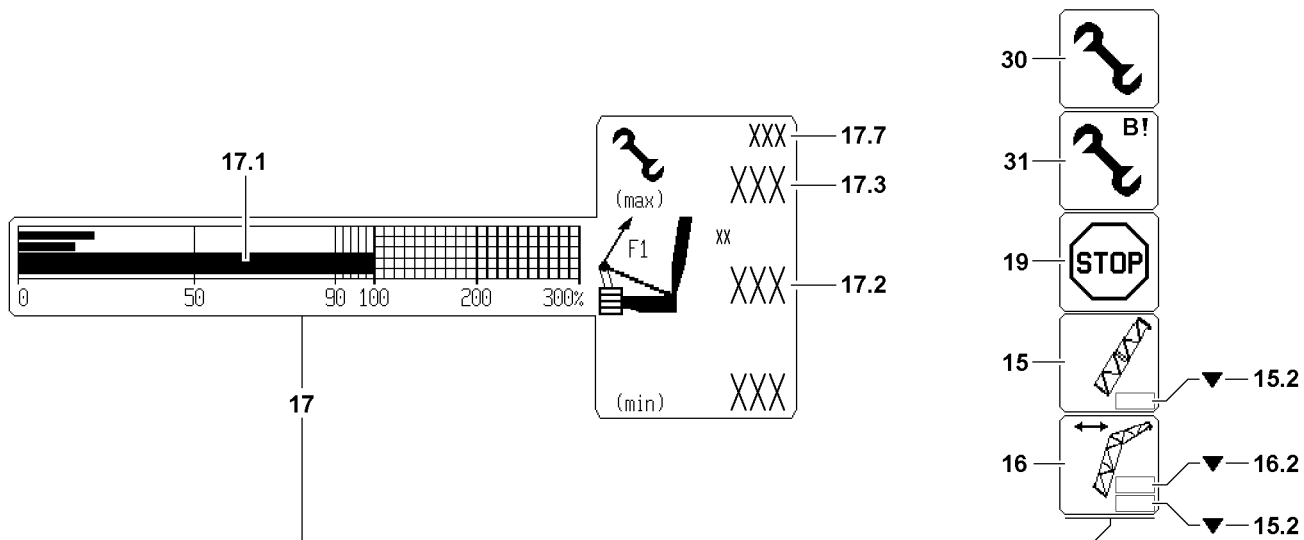

B112341

**DANGER**

The crane can topple over!

There is **no** shut off of the luff down movement after reaching the limit value $F1_{\text{max assembly}}$ **17.7!**

If the warnings by the LICCON overload protection are ignored, then the crane will be overloaded or topples over!

Personnel can be severely injured or killed!

- ▶ The icon **17** (F1-load display) must be watched permanently! It must be ensured that the value $F1_{\text{actual}}$ **17.2** is smaller than the value $F1_{\text{max assembly}}$ **17.7!**
- ▶ The luff down movement must be stopped before the value $F1_{\text{actual}}$ **17.2** exceeds the limit value $F1_{\text{max assembly}}$ **17.7!**

- ▶ During the take down procedure watch the icon **17** (F1-load display).

Troubleshooting

The take down procedure cannot be carried out due to danger of exceeding the $F1_{\text{max assembly}}$ **17.7?**

- ▶ See section "Danger of exceeding $F1_{\text{max assembly}}$ " .

The bypass of the shut off luffing the main boom / auxiliary boom / accessory down turns off:

- If the set up key **D** is actuated again.
- When neither the seat contact button **29** nor one of the buttons **1** of the master switches (MS1, MS2, MS3) is actuated.
- When an area with existing load chart is reached.
- If the radio operation* is active.
- At engine stop.

The bypass of the shut off luffing the main boom / auxiliary boom / accessory down has / was turned off:

- The assembly icon **31** or the assembly icon **30** in the LICCON monitor turns off.
- ▶ Make sure that the assembly icon **30** or the assembly icon **31** no longer appear in the LICCON monitor.

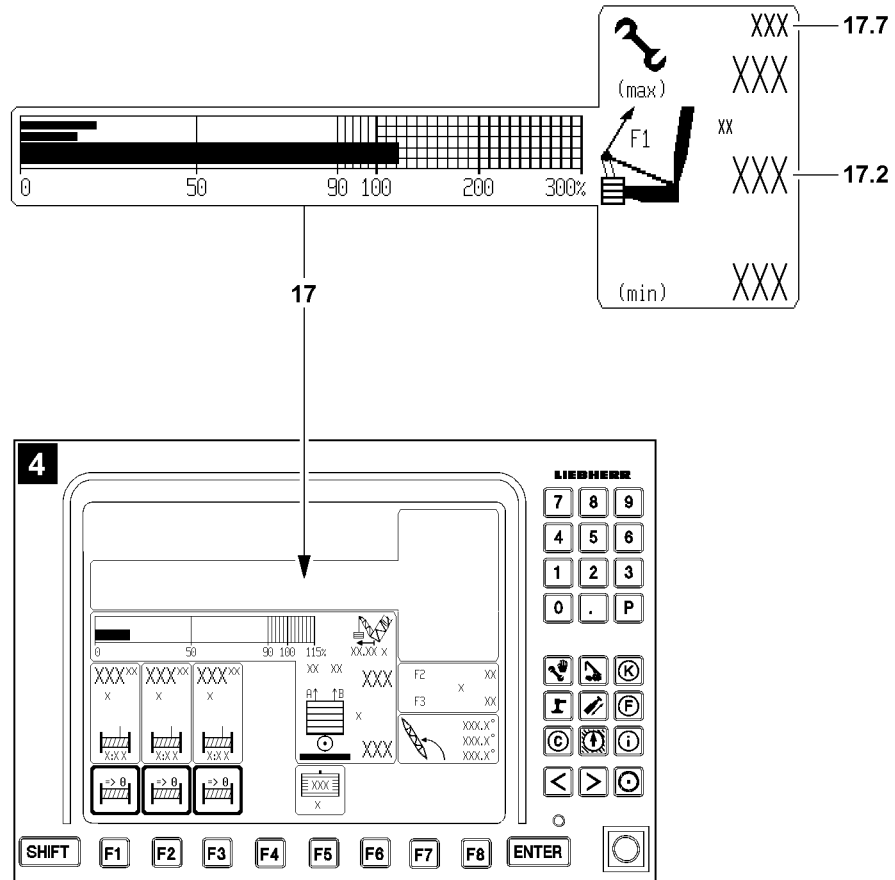

2.6.3 Danger of exceeding $F1_{\max \text{ assembly}}$



Note

- ▶ $F1_{\max \text{ assembly}}$ **17.7** might only appear when 90 % of its nominal value is exceeded!



DANGER

The crane can topple over!

There is **no** shut off of the luff down movement after reaching the limit value $F1_{\max \text{ assembly}}$ **17.7!**

If the warnings by the LICCON overload protection are ignored, then the crane will be overloaded or topples over!

Personnel can be severely injured or killed!

- ▶ The luff down movement must be stopped before the value $F1_{\text{actual}}$ **17.2** exceeds the limit value $F1_{\max \text{ assembly}}$ **17.7!**

In the icon **17** (F1-load display), the value $F1_{\text{actual}}$ **17.2** has reached the upper limit value $F1_{\max \text{ assembly}}$ **17.7**.

- ▶ Check if a crane movement, which can lower the force F1 (value $F1_{\text{actual}}$ **17.2**) can be initiated, for example setting down the hook block / load hook.
- ▶ Check if the correct set up configuration has been entered on the LICCON computer system.
- ▶ Check if the actual set up configuration matches the entered set up configuration.
- ▶ Check if the correct hook block weight has been entered.
- ▶ Check if the respective hook block / load hook is installed.
- ▶ Check if all attachment parts and guy rods on the boom system, which are not needed, have been removed.
- ▶ Check if environmental influences (wind, snow or ice) on the crane are not too great.



Note

- ▶ Hook block weight entry and correction of weighing errors, see Crane operating instructions, chapter 4.02.

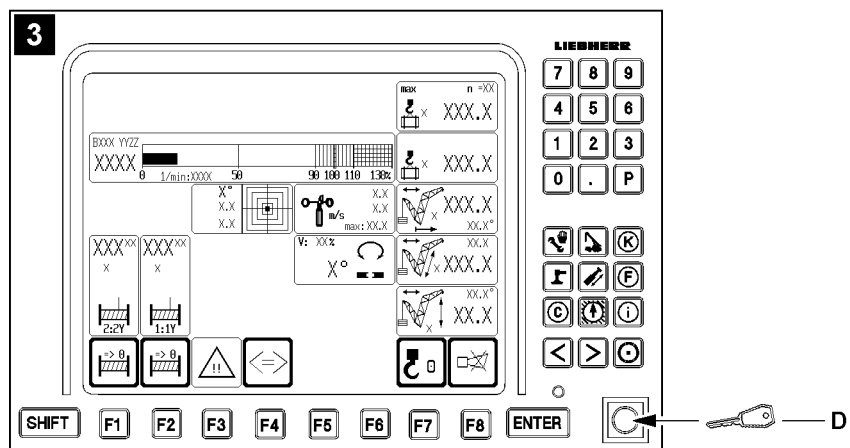
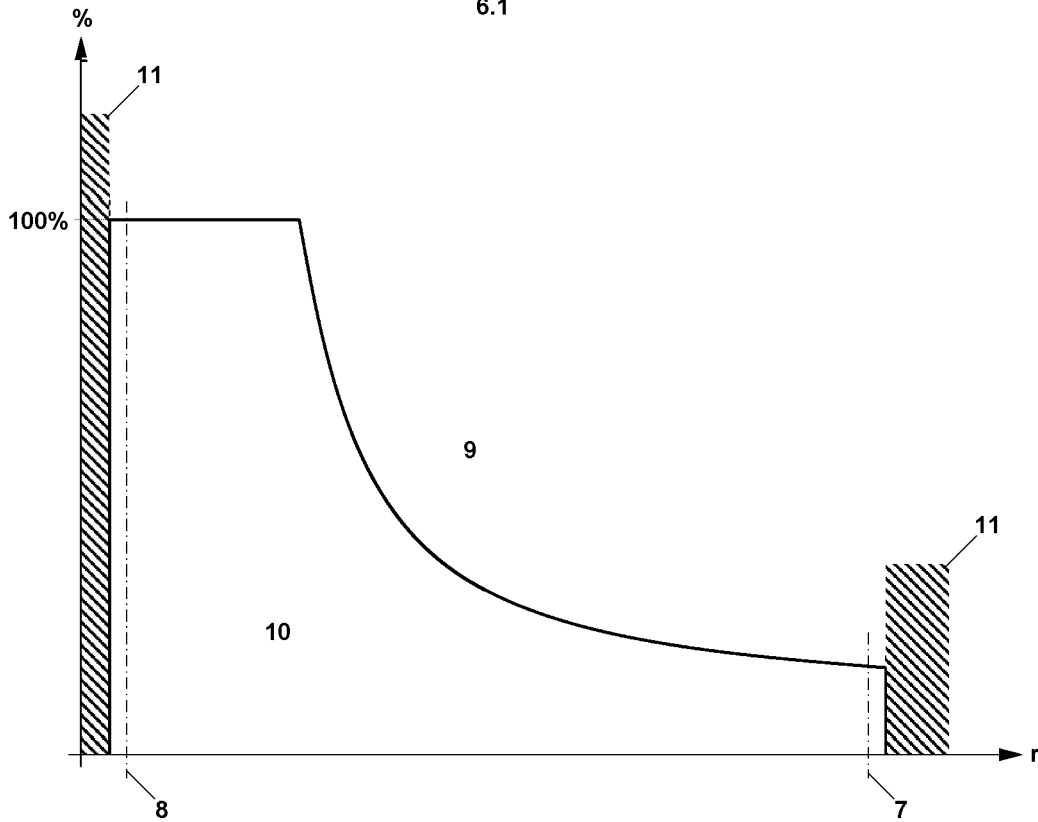
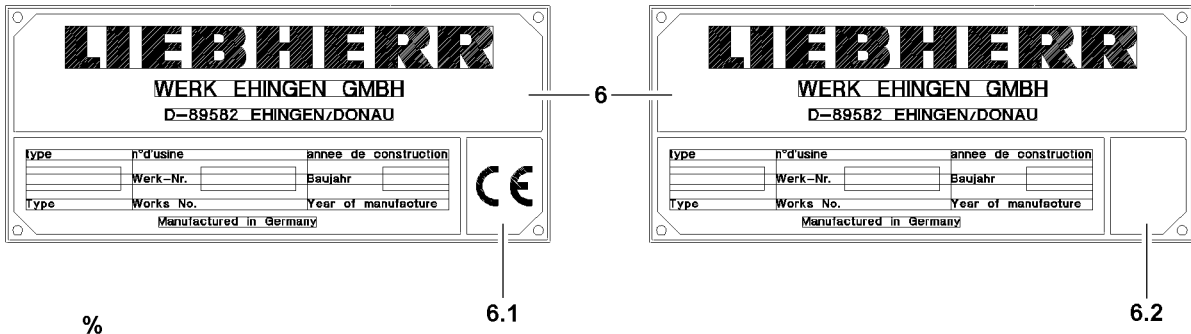

3 Instructions for resuming crane movements for cranes without CE mark



WARNING

Risk of accident!

If the following points are not observed, personnel can be severely injured or killed.

- ▶ The crane operator bears the sole and full responsibility for the adherence to measures to be taken in case of shut off of crane movement!
- ▶ The crane operator must make sure, before crane operation, that he is using the correct description for the current programming!



Note

- ▶ Check the data tag **6** to determine if your crane has a CE mark!
- ▶ The following section applies to a crane without CE mark, see data tag **6.2!**
- ▶ If your crane does have a CE mark, see data tag **6.1**, then you must observe the description in section "Instructions for resuming a crane movement for cranes with CE mark"!

3.1 Overview load chart for cranes without CE mark

Axle	Description
r	Radius boom (working radius)
%	Utilization of the crane in percentages

Position	Description
7	Lower limit angle load chart
8	Upper limit angle load chart
9	Area "Exceeding the overload protection"
10	Area "Load chart available"
11	Area "No load chart available"



Note

- ▶ If the set up key **D** (LICCON monitor with crane operating screen, illustration **3**) is actuated, the working speed is not reduced!

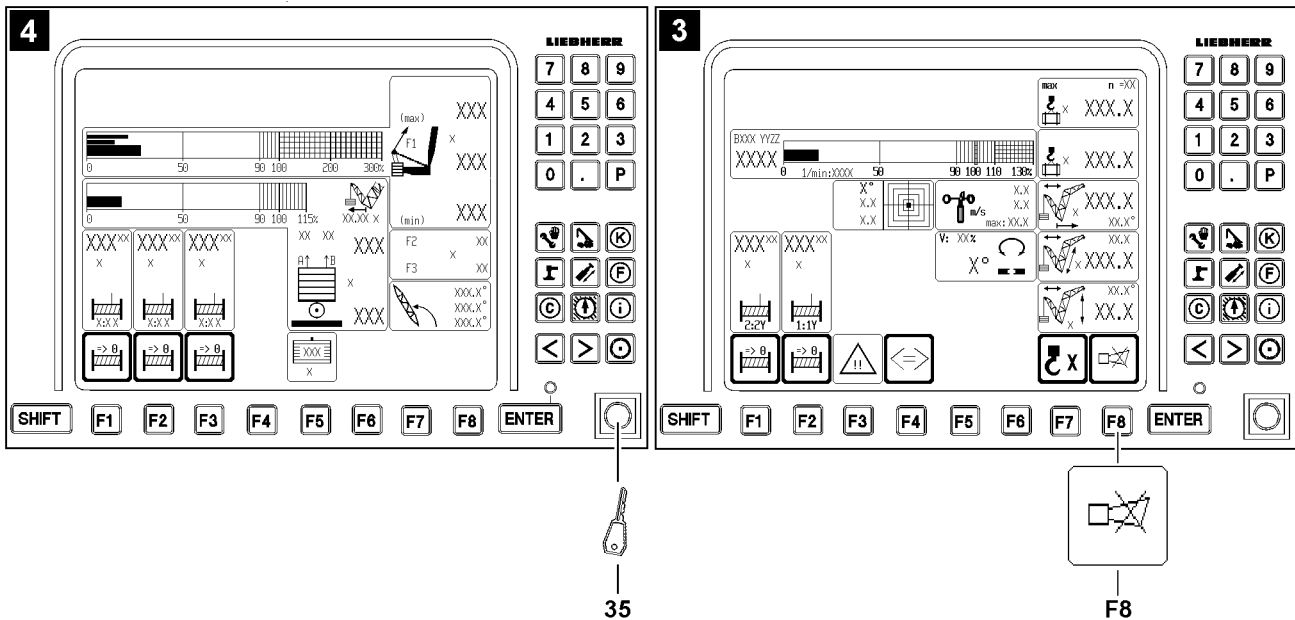
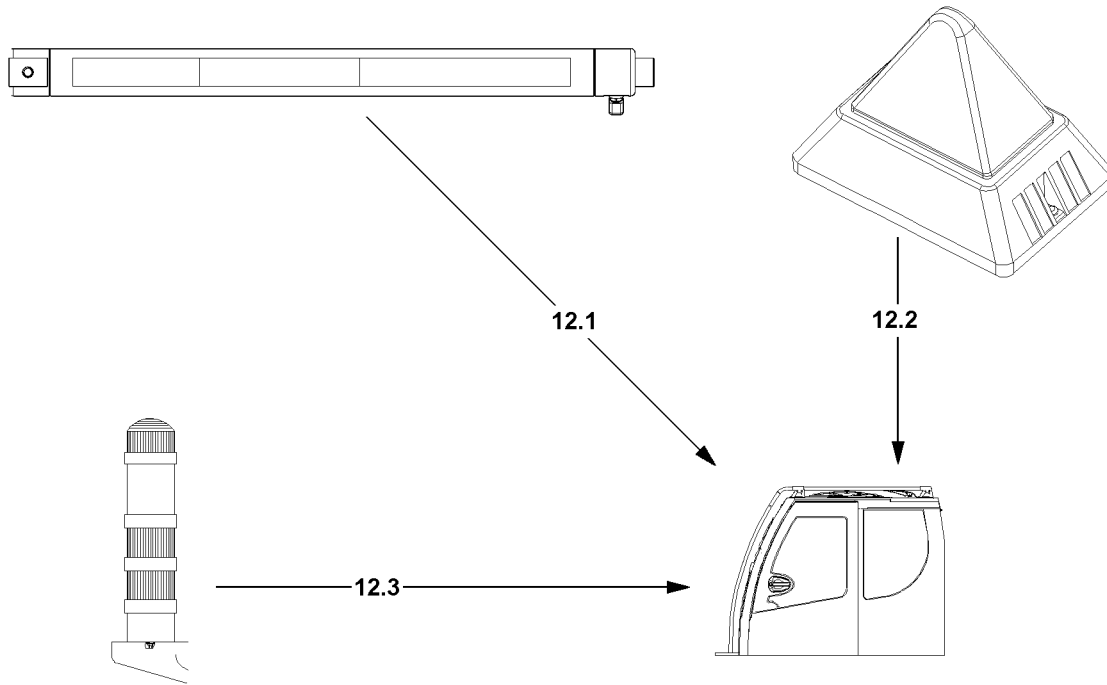

3.2 Overview of acoustic / visual warnings for cranes without CE mark

- Depending on the crane type, either a warning light **12.1** or a flashing beacon **12.2** or a combination of flashing beacon **12.2** and warning light* **12.3** are installed.
- The acoustic warnings within the crane operator's cab are turned off by pressing the button **F8** on the LICCON monitor with crane operating screen (illustration **3**).
- The acoustic warnings outside the crane operator's cab are turned off by actuating the key button **35** on the LICCON monitor with derrick operating screen (illustration **4**).

3.2.1 Description of acoustic / visual warnings

The case numbers from the chart "Overview of case numbers" are valid for the following charts in this chapter:

- "Acoustic / visual warnings on the LICCON monitor"
- "Warning light 12.1"
- "Flashing beacon 12.2"
- "Warning light 12.3"

Overview of case numbers	
Case number	Description Case
Case 001	Utilization of crane from 0 % to 89 %
Case 002	Utilization of crane from 90 % to 100 %
Case 003	Utilization of crane over 100 %
Case 004	Shut off of crane movements - LMB STOP
Case 005	Luffing in with suspended load
Case 006	Participating sensor (LMB) defective
Case 010	Exceeding the shut off limits of the LICCON overload protection
Case 011	Bypass of shut off hoist top
Case 016	Bypass of shut off luffing down the boom / auxiliary boom / accessories, "Load chart available"
Case 018	Bypass of shut off luffing down the boom / auxiliary boom / accessories, "No load chart available"
Case 020	Exceeding the shut off limits of the LICCON overload protection during erection / take down procedures, "No load chart available"

3.2.2 Acoustic / visual warnings within the crane operator's cab



Note

► Description of individual case numbers, see chart "Overview of case numbers"!

Acoustic / visual warnings on the LICCON monitor									
Case number	Acoustic warning LICCON monitor at utilization of crane			Visual warning LICCON monitor					
	Short sound	Long sound	Long sound	Utilization of crane		Occurrence			
	From 90 %	Above 100 %	Always	From 90 %	Above 100 %	LMB STOP	Appears if the set up key D is actuated		
Case 001							—	—	—
Case 002	X ²			○			—	—	—
Case 003		X ²		○	○		—	—	—
Case 004			X ²		○		—	—	—
Case 005	X ²	X ²		○	○		—	—	—
Case 006			X ²			○		○	
Case 010	X ²	X ²		○	○		○		
Case 011			X ²	○	○	○	○		○
Case 016	X ²	X ²		○	○		○		
Case 018			X ²			○		○	
Case 020			X ²			○		○	

○ = cannot be turned off

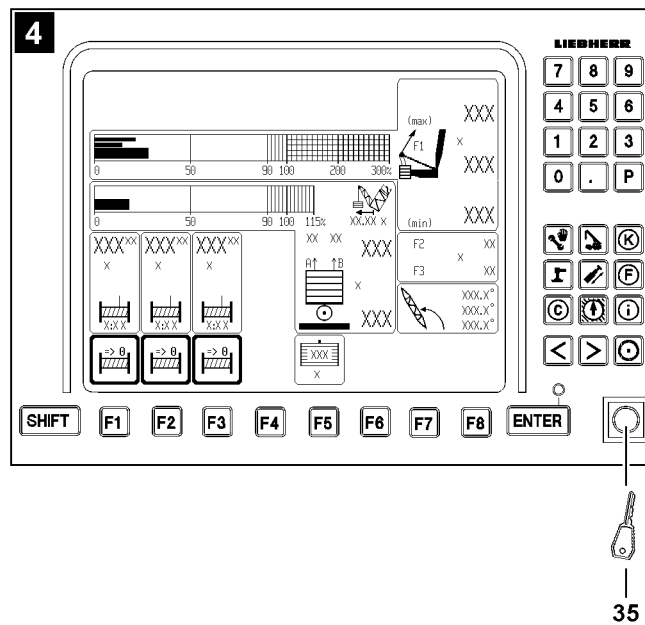
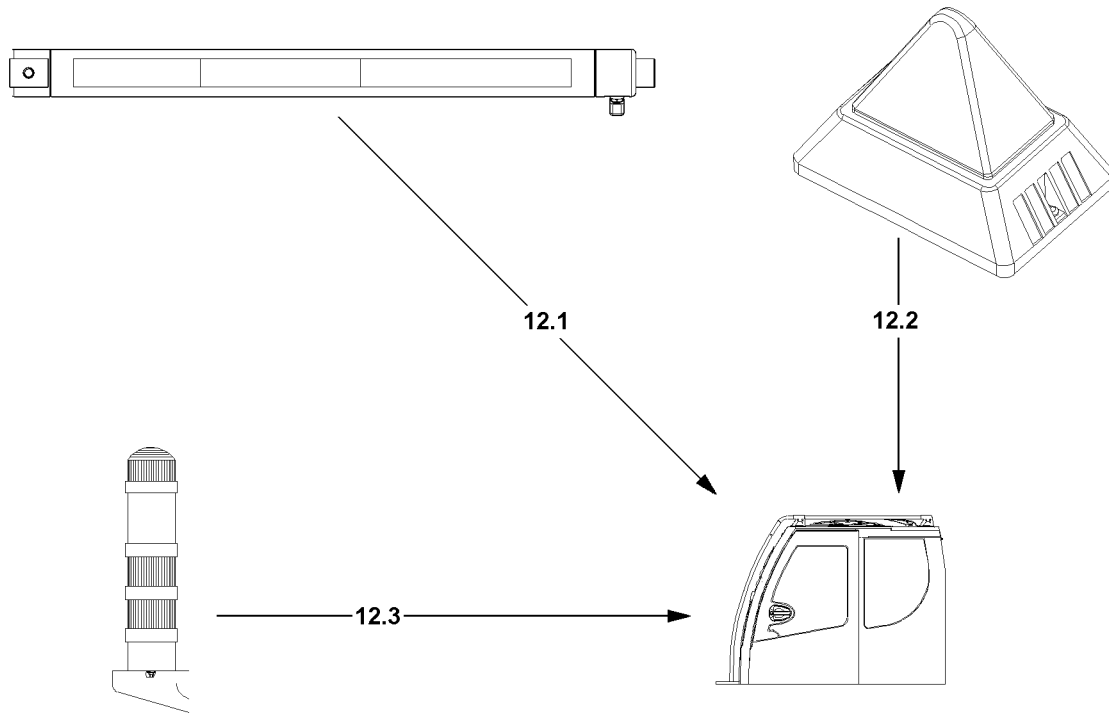
X² = can be turned off immediately on the LICCON monitor key **F8**



3.2.3 Acoustic / visual warnings outside the crane operator's cab



Note

► Description of individual case numbers, see chart "Overview of case numbers"!

Warning light 12.1					
Case number	At utilization of crane	Acoustic warning	Visual warning		
		Signal turntable	Green	Yellow	Red
Case 001	From 0 % to 89 %		O ¹		
Case 002	From 90 % to 100 %			O ¹	
Case 003	Above 100 %	X ¹			O ¹
Case 004	-				O ¹
Case 005	From 0 % to 89 %		O ¹		
Case 005	From 90 % to 100 %			O ¹	
Case 005	Above 100 %	X ¹			O ²
Case 006	-			O ²	
Case 010	From 0 % to 89 %		O ¹		
Case 010	From 90 % to 100 %			O ¹	
Case 010	Above 100 %	O			O ²
Case 011	From 0% to 100 %			O ²	
Case 011	Above 100 %	O			O ²
Case 016	Up to 90 %		O ¹		
Case 016	Above 90 % to 100 %			O ¹	
Case 016	Above 100 %	O			O ²
Case 018	No value available			O ²	
Case 020	No value available			O ²	

O = cannot be turned off

O¹ = warning light 12.1 lights up

O² = warning light 12.1 blinks

X¹ = can be turned off by actuating (right touching) the key button **35** on the LICCON monitor with the derrick operating screen (illustration **4**), effective after at least 5 seconds

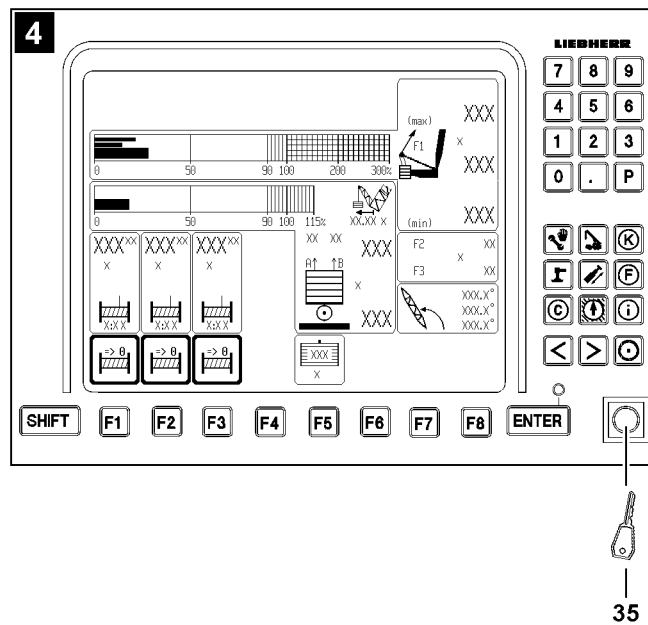
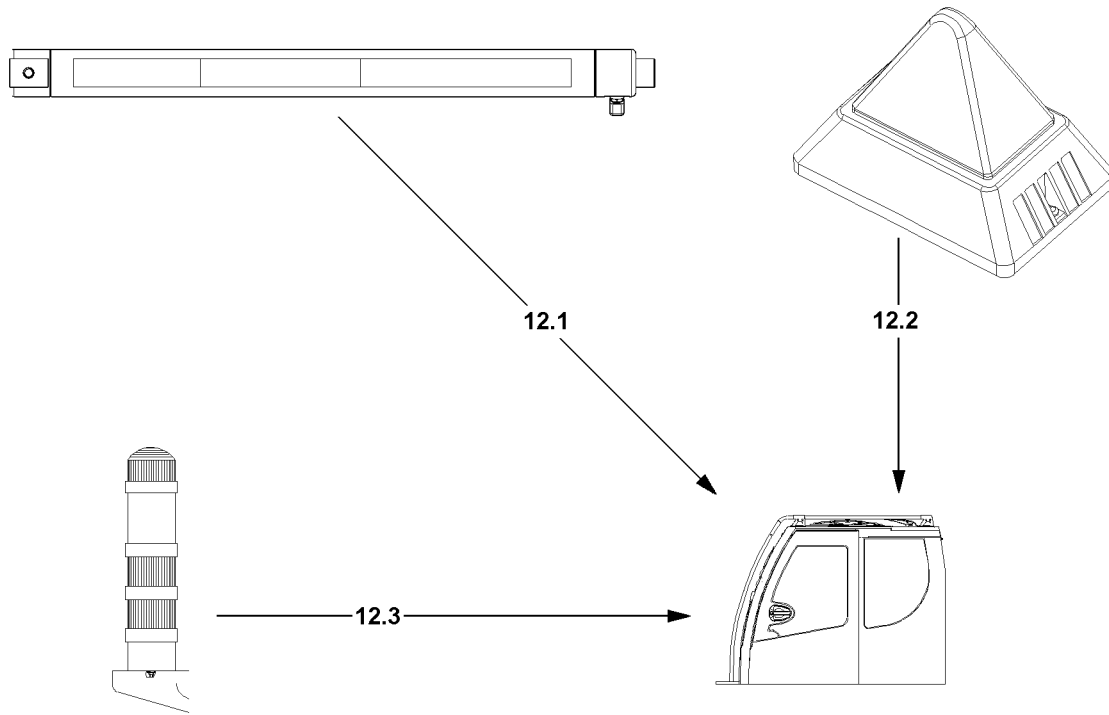

**Note**

► Description of individual case numbers, see chart "Overview of case numbers"!

Flashing beacon 12.2			
Case number	At utilization of crane	Acoustic warning	Visual warning
		Signal turntable	Red
Case 001	0 % up to 89 %	-	-
Case 002	90 % up to 100 %	-	-
Case 003	Above 100 %	X ¹	O ²
Case 004	-		O ²
Case 005	Above 100 %	X ¹	O ²
Case 006	-		O ²
Case 010	Above 100 %	O	O ²
Case 011	Above 100 %	O	O ²
Case 016	Above 100 %	O	O ²
Case 018	No value available		O ²
Case 020	No value available		O ²

O = cannot be turned off

O² = flashing beacon **12.2** blinks

X¹ = can be turned off by actuating (right touching) the key button **35** on the LICCON monitor with the derrick operating screen (illustration **4**), effective after at least 5 seconds

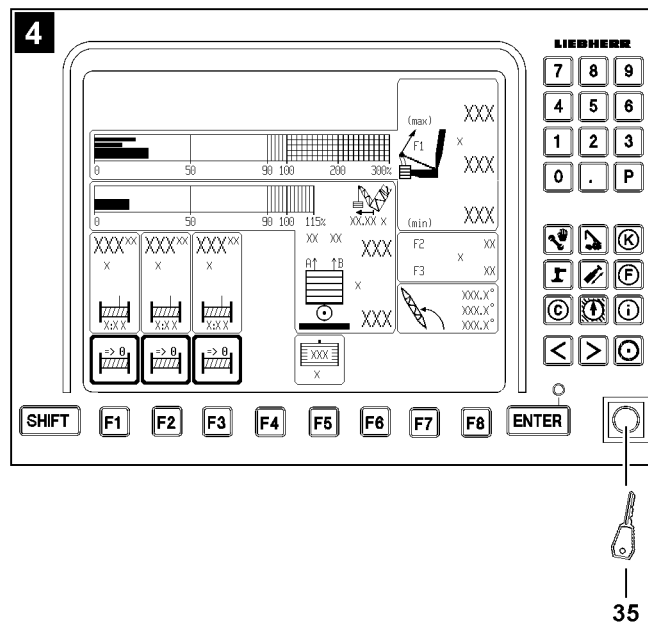
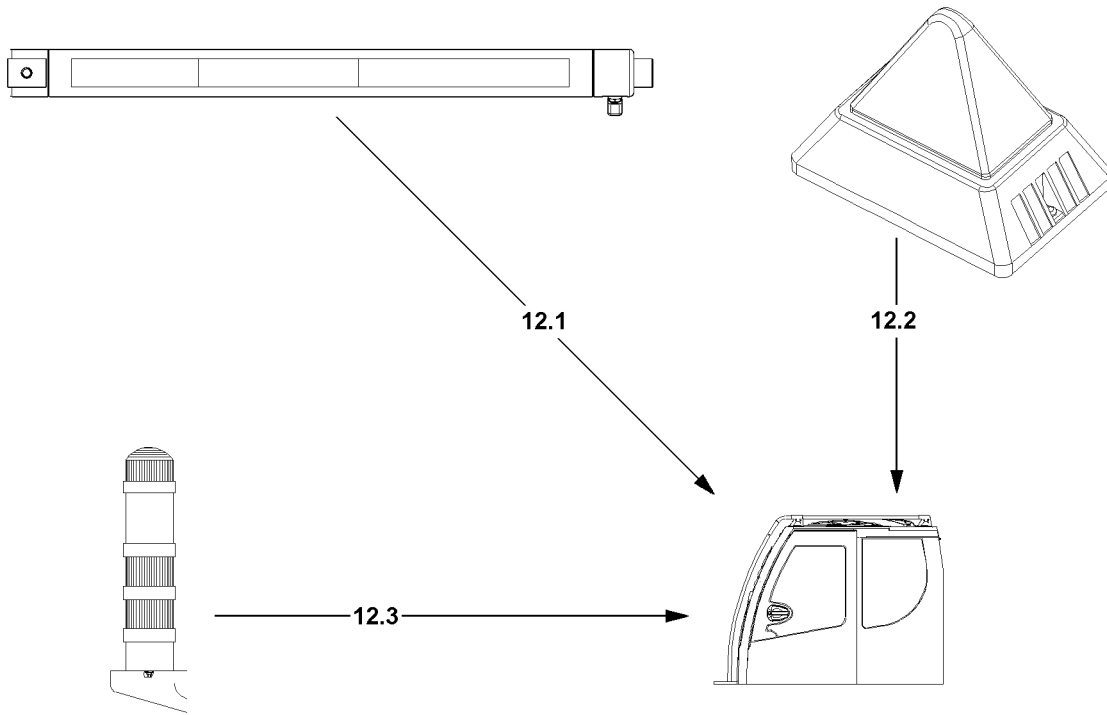

**Note**

► Description of individual case numbers, see chart "Overview of case numbers"!

Warning light 12.3					
Case number	At utilization of crane	Acoustic warning	Visual warning		
		Signal turntable	Green	Yellow	Red
Case 001	From 0 % to 89 %		O ¹		
Case 002	From 90 % to 100 %			O ¹	
Case 003	Above 100 %	X ¹			O ²
Case 004	-				O ²
Case 005	From 0 % to 89 %		O ¹		
Case 005	From 90 % to 100 %			O ¹	
Case 005	Above 100 %	X ¹			O ²
Case 006	-				O ²
Case 010	From 0 % to 89 %		O ¹		
Case 010	From 90 % to 100 %			O ¹	
Case 010	Above 100 %	O			O ²
Case 011	From 0% to 100 %			O ¹	
Case 011	Above 100 %	O			O ²
Case 016	From 0 % to 89 %		O ¹		
Case 016	From 90 % to 100 %			O ¹	
Case 016	Above 100 %	O			O ²
Case 018	No value available				O ²
Case 020	No value available				O ²

O = cannot be turned off

O¹ = warning light **12.3** lights up

O² = warning light **12.3** blinks

X¹ = can be turned off by actuating (right touching) the key button **35** on the LICCON monitor with the derrick operating screen (illustration **4**), effective after at least 5 seconds

3.3 Monitoring of crane movement

**Note**

- If the LICCON overload protection turns the crane movement off, then the exact cause for the shut off must be determined first.
- As a first step, try to rescind the crane movement which has caused a shut off.
- If it is not possible to rescind the affected crane movement, then the additional steps are described in the following sections of the chapter.

**Note**

- For detailed description of the individually listed icons, see Crane operating instructions, chapter 4.02.

The LICCON overload protection carries out the following shut offs if a limit value is exceeded in crane operation:

- Shut off luffing the main boom up / down
- Shut off luffing the auxiliary boom / accessory up / down
- Shut off maximum / minimum value test point 1 (force F1)
- Shut off spooling the winch up / out
- Shut off hoist top
- Shut off due to error message

The LICCON overload protection warns if the limit values are exceeded, but does not turn off:

- Minimum / maximum support forces

3.3.1 Shut off luffing the main boom up / down

**Note**

- In crane operation with derrick boom, it is also shown in the icon!

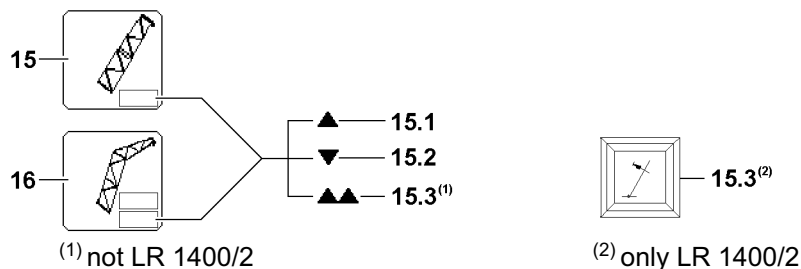

In icon **15** or icon **16** (lower field) arrow **15.1** or arrow **15.2** appear and the LICCON overload protection has shut off the crane movement.

“Luffing the main boom up” (arrow **15.1**) or “Luffing the main boom down” (arrow **15.2**) was shut off because the upper / lower limit angle of the selected load chart was exceeded / fallen below.

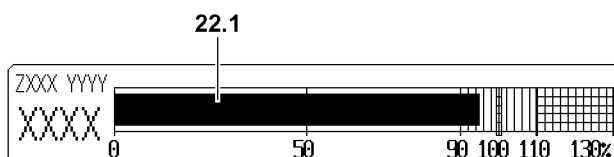
**Note**

- If the utilization of the crane is more than 95 % (utilization bar **22.1** exceeds 95 %) and the maximum load according to the load chart (falling load capacity) drops by continuing to luff up the boom, then the arrow **15.1** also appears and the crane movement “Luffing the main boom up” is turned off.

If the double arrow / warning light **15.3** appears, then:

- **either** it was luffed up to a limit switch or the limit switch has turned off the crane movement “Luffing the main boom up”
- **or** there is an error on one of the limit switches “Main boom top”

The arrow **15.1** appears and the crane movement “Luffing the main boom up” was turned off:

- Luff the main boom down.

Result:

- Crane operation is possible again.

The arrow **15.2** appears and the crane movement “Luffing the main boom down” was turned off:

- ▶ Luff the main boom up.

Result:

- Crane operation is possible again.

The double arrow / warning light **15.3** appears and the crane movement “Luffing the main boom up” was turned off:

- ▶ Luff the main boom down.

Result:

- Crane operation is possible again.

Troubleshooting

The double arrow / warning light **15.3** appears continuously?

If a double arrow / warning light **15.3** appears without having luffed the main boom up to a limit switch, then there may be an error in the limit switches “Main boom top”.

- ▶ Check if there is an error message from the LICCON computer system, see Diagnostics manual.
- ▶ If yes: Remedy the error immediately.

**WARNING**

Limited warning functions!

If one of the double version limit switches is not ok and the crane is continued to be operated, then the warning functions of the LICCON overload protection are limited!

- ▶ The crane can only be operated in an emergency after failure of a double version limit switch!
- ▶ Carry out crane movements in such a way that no repeated shut off by the LICCON overload protection occurs.

3.3.2 Shut off luffing the auxiliary boom / accessory up / down**Note**

- ▶ In crane operation with derrick boom, it is also shown in the icon!

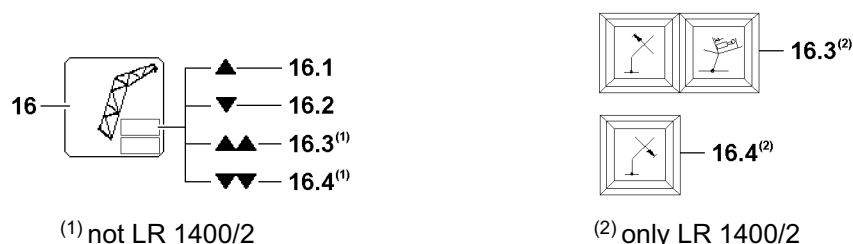

In the icon **16** (upper field) the arrow **16.1** or arrow **16.2** appear and the LICCON overload protection has shut off the crane movement.

“Luffing the auxiliary boom / accessory up” (arrow **16.1**) or “Luffing the auxiliary boom / accessory down” (arrow **16.2**) was shut off because the upper / lower limit angle of the selected load chart was exceeded / fallen below.

If the double arrow / warning light **16.3** appears, then:

- **either** it was luffed up to a limit switch or the limit switch has turned off the crane movement “Luffing the auxiliary boom / accessory up”
- **or** the mechanical relapse support has turned off the crane movement “Luffing the auxiliary boom / accessory up”
- **or** there is an error on one of the limit switches “Auxiliary boom / accessory top”.

If the double arrow / warning light **16.4** appears, then:

- **either** it was luffed down to a limit switch “Auxiliary boom / accessory bottom” and the limit switch has turned off the crane movement “Luffing the auxiliary boom / accessory up”
- **or** there is an error on one of the limit switches “Auxiliary boom / accessory bottom”

The arrow **16.1** appears and the crane movement “Luffing the auxiliary boom / accessory up” was turned off:

- ▶ Luff the auxiliary boom / accessory down.

Result:

- Crane operation is possible again.

The arrow **16.2** appears and the crane movement “Luffing the auxiliary boom / accessory down” was turned off:

- ▶ Luff the auxiliary boom / accessory up.

Result:

- Crane operation is possible again.

The double arrow / warning light **16.3** appears and the crane movement “Luffing the auxiliary boom / accessory up” was turned off:

- ▶ Luff the auxiliary boom / accessory down.

Result:

- Crane operation is possible again.

Troubleshooting

The double arrow / warning light **16.3** appears continuously?

If a double arrow / warning light **16.3** appears without having luffed up to a limit switch, then there may be an error in the limit switches “Auxiliary boom / accessory top”.

- ▶ Check if there is an error message from the LICCON computer system, see Diagnostics manual.
- ▶ If yes: Remedy the error immediately.

The double arrow / warning light **16.4** appears and the crane movement “Luffing the auxiliary boom / accessory down” was turned off:

- ▶ Luff the auxiliary boom / accessory up.

Result:

- Crane operation is possible again.

Troubleshooting

The double arrow / warning light **16.4** appears continuously?

If a double arrow / warning light **16.4** appears without having luffed down to a limit switch, then there may be an error in the limit switches “Auxiliary boom / accessory bottom”.

- ▶ Check if there is an error message from the LICCON computer system, see Diagnostics manual.
- ▶ If yes: Remedy the error immediately.

**WARNING**

Limited warning functions!

If one of the double version limit switches is not ok and the crane is continued to be operated, then the warning functions of the LICCON overload protection are limited!

- ▶ The crane can only be operated in an emergency after failure of a double version limit switch!
- ▶ Carry out crane movements in such a way that no repeated shut off by the LICCON overload protection occurs.

3.3.3 Shut off maximum / minimum value test point 1 (force F1)

**Note**

- ▶ The force determined on test point 1 is generally described as $F1_{\text{actual}}$ (actual value F1).
- ▶ In the icon 17 (F1-load display), the force relationship as well as the number values are shown in number values as well as a bar display (called F1-bar display).
- ▶ The value $F1_{\text{max-operation}}$ 17.3 corresponds to 100 % in the F1-bar display.
- ▶ The F1-utilization bar 17.1 shows the relationship $F1_{\text{actual}}$ 17.2 to $F1_{\text{max-operation}}$ 17.3.
- ▶ In crane operation without derrick ballast, fewer values may be shown in the icon 17 (F1-load display).

Shut off maximum value F1 in crane operation

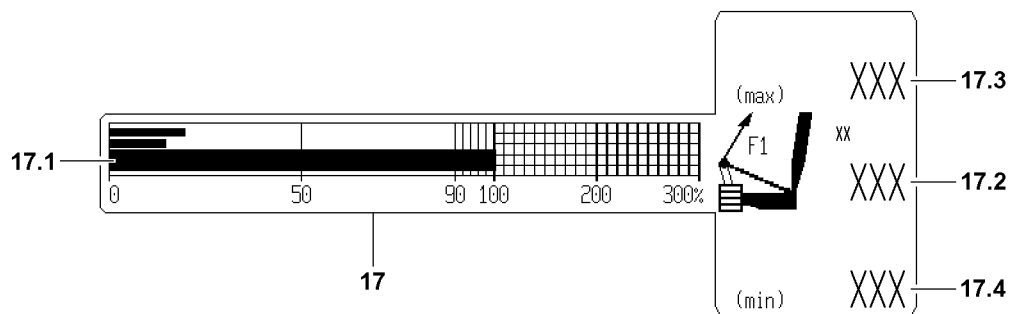

In the icon 17 (F1-load display) the F1-utilization bar 17.1 exceeds the 100 % mark and the LICCON overload protection has shut off the crane movement. The value $F1_{\text{actual}}$ 17.2 has exceeded the value $F1_{\text{max-operation}}$ 17.3.

All further movements, which lead to an increase of the force $F1$ (value $F1_{\text{actual}}$) are shut off.

- ▶ Reverse any crane movement which has caused the shut off.

or

- Initiate an alternative crane movement, which lowers the force $F1$ (value $F1_{\text{actual}}$).

Result:

- Crane operation is possible again.

Troubleshooting

The crane operation is limited because the value $F1_{\text{max-operation}}$ apparently is being reached too early?

- ▶ Make sure that a valid configuration status has been entered on the LICCON computer system!
- ▶ Make sure that the crane is assembled according to the assembly drawings!
- ▶ Make sure that the actual configuration status and the entered configuration status of the crane match.
- ▶ Make sure that all attachment parts and guy rods on the boom system, which are not needed, have been removed (weight)!
- ▶ Make sure that the boom system is free of snow and ice (weight)!
- ▶ Make sure that the wind influence onto the boom is not too great!
- ▶ If no irregularities can be found:
Contact LIEBHERR Service.

Shut off maximum value F1 in crane operation



Note

- ▶ A shut off minimum value F1 ($F1_{\min}$) only occurs in operating modes with derrick ballast. The status $F1_{\text{actual}} = F1_{\min}$ cannot be reached in all other operating modes.

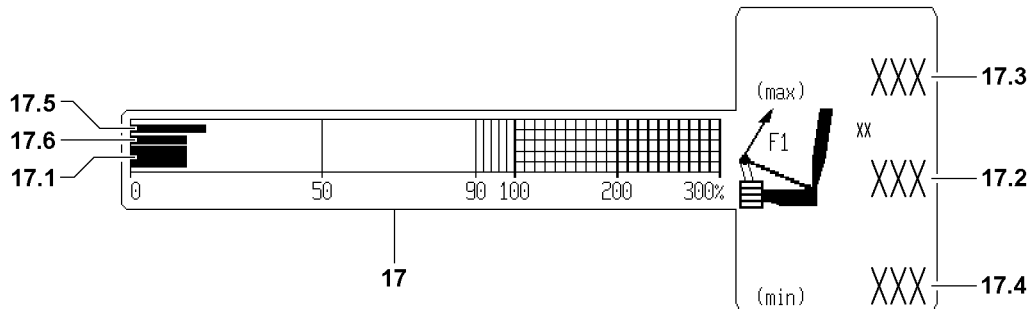

In the icon 17 (F1-load display), when falling below the $F1_{\min}$ advance warning bar 17.5, a warning of the upcoming shut off is issued by the F1-utilization bar 17.1.

If the F1-utilization bar 17.1 falls below the $F1_{\min}$ -STOP bar 17.6, then the LICCON overload protection shuts off the crane movement. The value $F1_{\text{actual}}$ 17.2 has fallen below the value $F1_{\min}$ 17.4.



Note

Shut off $F1_{\min}$

- ▶ If the utilization of the derrick ballast is below 50 %, then there is no immediate shut off when falling below value $F1_{\min}$ 17.4!

All further movements, which lead to an decrease of the force F1 (value $F1_{\text{actual}}$) are shut off.

- ▶ Reverse any crane movement which has caused the shut off.

or

- Initiate an alternative crane movement, which increases the force F1 (value $F1_{\text{actual}}$).

Result:

- Crane operation is possible again.

Troubleshooting

The crane operation is limited because the value $F1_{\min}$ apparently is being reached too early?

- ▶ Make sure that a valid configuration status has been entered on the LICCON computer system!
- ▶ Make sure that the crane is assembled according to the assembly drawings!
- ▶ Make sure that the actual configuration status and the entered configuration status of the crane match.
- ▶ Make sure that all attachment parts and guy rods on the boom system, which are not needed, have been removed (weight)!
- ▶ Make sure that the boom system is free of snow and ice (weight)!
- ▶ Make sure that the wind influence onto the boom is not too great!
- ▶ If no irregularities can be found:
Contact LIEBHERR Service.

3.3.4 Shut off spooling the winch up / out

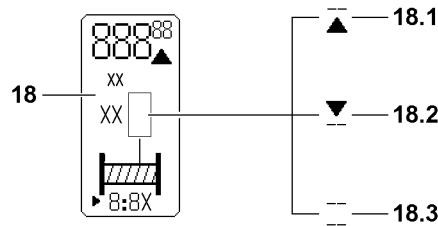

In the icon **18**, the line / arrow **18.1**, arrow / line **18.2** or line / line **18.3** appears and the LICCON overload protection has shut off the crane movement.

“Spooling the winch out” (line / arrow **18.1**) or “Spooling the winch up” (arrow / line **18.2**) was shut off because the upper / lower limit angle of the rope for the selected winch was exceeded or fallen below. If line / line **18.3** appears blinking in the icon **18**, then the affected winch is deactivated.

The line / arrow **18.1** appears and the crane movement “Spooling the winch out” was turned off:

- ▶ Spool the winch up.

Result:

- Crane operation is possible again.

The arrow / line **18.2** appears and the crane movement “Spooling the winch up” was turned off:

- ▶ Spool the winch out.

Result:

- Crane operation is possible again.

The line / line **18.3** appear and the winch is deactivated:

- ▶ Activate the winch, see Crane operating instructions, chapter 4.02.

Result:

- Crane operation is possible again.

3.3.5 Shut off hoist top

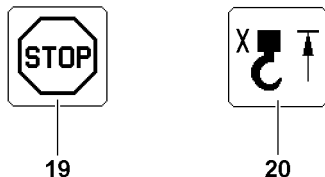

The icon **19** and hoist top icon **20** appear in the LICCON monitor and the LICCON overload protection has turned off crane movement.

Spooling the hoist winch up was turned off because the hook block or the load hook has run against a hoist limit weight during the upward movement and the affected hoist limit switch was triggered.



WARNING

Property damage / falling load!

- ▶ After shut off spool hoist winch up (hoist top), for every further crane movement, the distance between the hook block / load hook and the boom head must be checked!



Note

- ▶ After a hoist top shut off occurred, further crane movements, which affect the length of the hoist rope are also shut off!

- ▶ Spool the hoist winch out.

Result:

- Crane operation is possible again.

3.3.6 Shut off due to error message

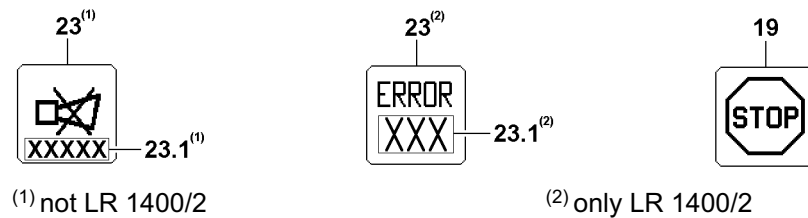

In the icon **23** appears an error message, the icon **19** appears in the LICCON monitor and the LICCON overload protection has turned off crane movement.



WARNING

Limited warning functions!

If there is a defect on a participating sensor (LMB) and the crane is continued to be operated by bypassing the sensor other otherwise, then the warning functions and the shut offs of the LICCON overload protection are deactivated!

- ▶ If there is a defect on a participating sensor (LMB), then the crane may be operated further only in emergency cases!
 - ▶ Fix / replace the sensor before starting crane operation again!
-
- ▶ Determine the existing error with the help of the error message from the error field **23.1** in icon **23**, see Diagnostics manual.
 - ▶ Remedy the error.

Troubleshooting

The erection of the crane, for example after assembly on a new job site or with another equipment configuration, is not possible due to an error message?

- ▶ Evaluate the error message.
- ▶ Make sure that all electrical connections are established correctly.
- ▶ Check if all sensors or dummy plugs with integrated electric have been connected properly.

- ▶ If the error cannot be remedied:
Contact LIEBHERR Service.

3.3.7 Minimum / maximum support forces



Note

- ▶ Applies only for cranes with support force monitoring*.
- ▶ Description of support force monitoring, see Crane operating instructions, chapter 4.02.

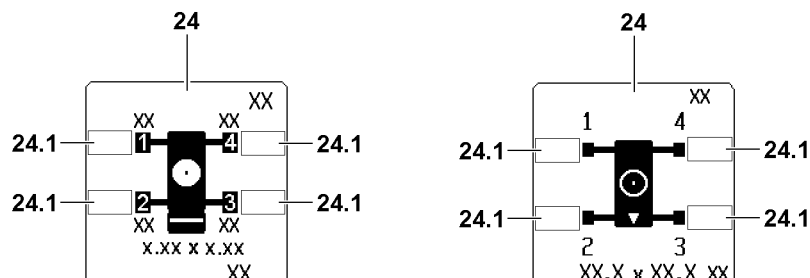

**WARNING**

The crane can topple over!

When reaching the programmed minimum / maximum support forces there is no automatic shut off of crane movements!

The displayed support force values are subjected to fluctuating influences, for example crane operation, surrounding and environmental influences!

The resulting tolerance field of the determined values may not be utilized by the support force display to determine the tipping limit of the crane!

If this is disregarded, then the crane can topple over!

Personnel can be severely injured or killed!

- ▶ The displayed support force values of the support force display may not be used to utilize the crane up to the tipping limit!
- ▶ Make sure that all support force values are within the minimum / maximum support forces!

The icon **24** (depending on the crane, similar to the left or right illustration) is shown in the LICCON monitor with blinking value in one or several fields **24.1**. Blinking values in the fields **24.1** signal exceedance of the minimum / maximum support forces.

- ▶ Reverse the crane movements, which caused the support forces to be outside the minimum / maximum values.

Result:

- All values in the fields **24.1** are within the minimum / maximum support forces.
- ▶ Carry out crane movements in such a way that the support forces always remain within the minimum / maximum values.

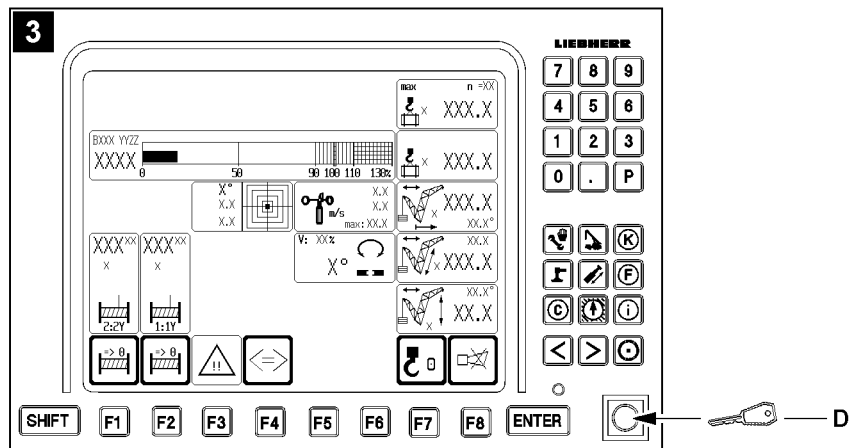
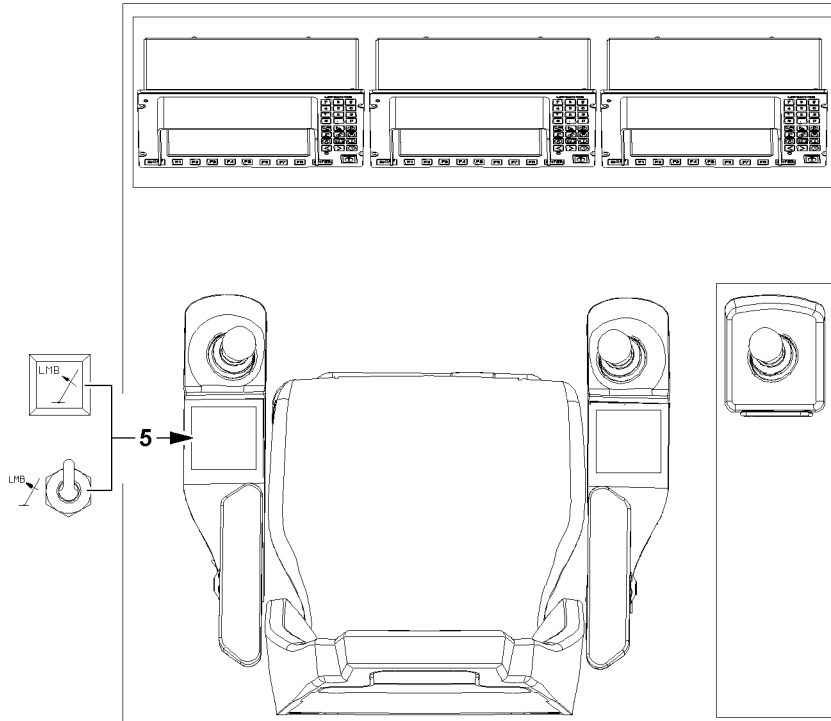

3.4 Shut off of crane movement: LMB STOP by LICCON overload protection



WARNING

Risk of overload and toppling the crane!

If the shut off limits of the LICCON overload protection are exceeded without knowing the exact cause for the shut off by the LICCON overload protection, then the crane can be overloaded and topple over! Personnel can be severely injured or killed!

- ▶ Before activating the function "Exceedance of shut off limits of the LICCON overload protection" determine the exact cause for the shut off!



WARNING

Danger of accident due to function "Exceedance of shut off limits of the LICCON overload protection"! If the shut off limits of the LICCON overload protection are exceeded, there is no additional protection against crane overload!

Due to erroneous operation or deliberate misuse, the crane could collapse, the boom can break off or the crane can topple over!

Personnel can be severely injured or killed!

- ▶ The button **5** "Luffing in with suspended load" and the set up key **D** may only be actuated when it is ensured that no normal operating condition (utilization below 100 % and no active shut off) can be reached without the function "Exceedance of shut off limits of the LICCON overload protection"!
- ▶ Actuate the set up key **D** only when no normal operating condition (utilization below 100 % and no active shut off) can be reached with the button **5** "Luffing in with suspended load"!
- ▶ The function "Exceedance of shut off limits of the LICCON overload protection" is only permissible in emergencies and for assembly purposes!
- ▶ The set up key **D** may only be actuated by persons who are aware of the effects of their acts regarding the function "Exceedance of shut off limits of the LICCON overload protection"!
- ▶ The function "Exceedance of shut off limits of the LICCON overload protection" requires the presence of an authorized person and must be performed with utmost caution!
- ▶ Crane operation with activated function "Exceedance of shut off limits of the LICCON overload protection" is prohibited!



WARNING

Expanded working / danger zone of the crane!

Due to the function "Exceedance of shut off limits of the LICCON overload protection" it is possible that the working / danger zone of the crane is significantly expanded!

If these circumstances are not observed, collisions and accidents can occur!

Personnel can be severely injured or killed!

- ▶ With activated function "Exceedance of shut off limits of the LICCON overload protection" take an expanded working / danger zone of the crane into account and monitor it!

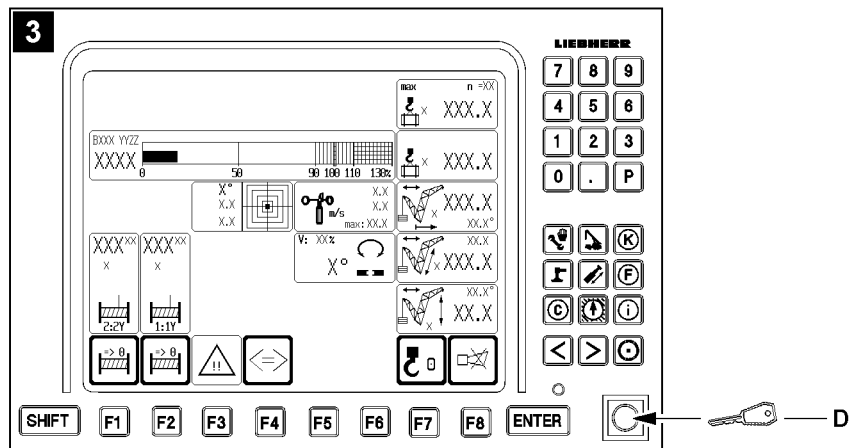
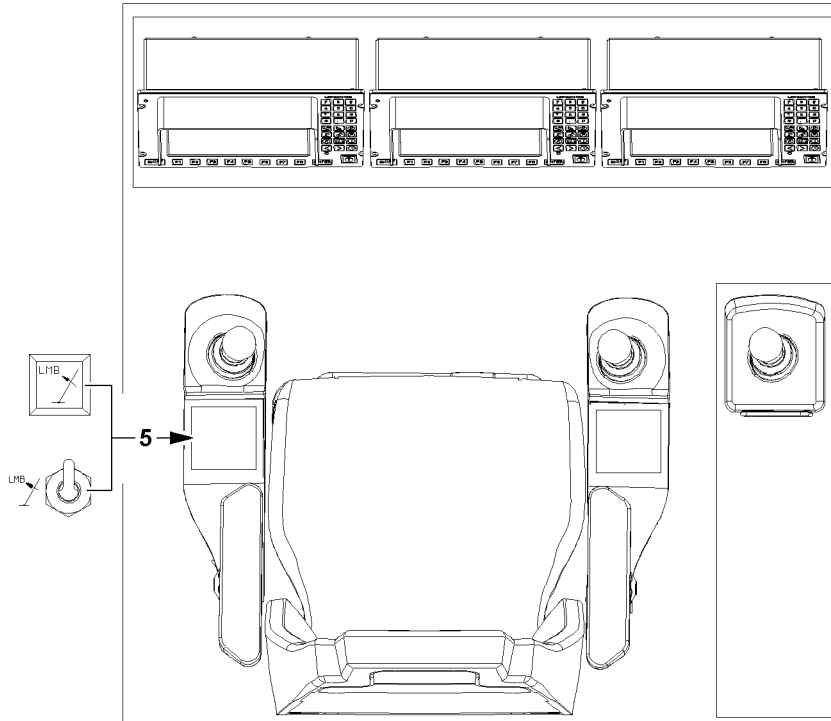

**WARNING**

Overload of crane!

When taking on a load by luffing the boom up, the crane can be overloaded!

This could result in serious accidents!

- ▶ Taking on load by luffing up the boom is prohibited!
- ▶ Take on a load only with the hoist gear!

There are two possibilities to exceed the shut off limits of the LICCON overload protection after LMB STOP:

- With button **5** “Luffing in with suspended load” in the left control console
- With the set up key **D** on the LICCON monitor with crane operating screen, see illustration **3**

NOTICE

Danger of mix up!

The function “Exceedance of shut off limits of LICCON overload protection” can only be activated with the set up key **D** on the LICCON monitor with crane operating screen, see illustration **3**!

The key buttons on the other monitors are not assigned with this function!

- ▶ Do not mix up the set up key **D** with the other key buttons!
 - ▶ In case of mix up: Deactivate the activated function!
-

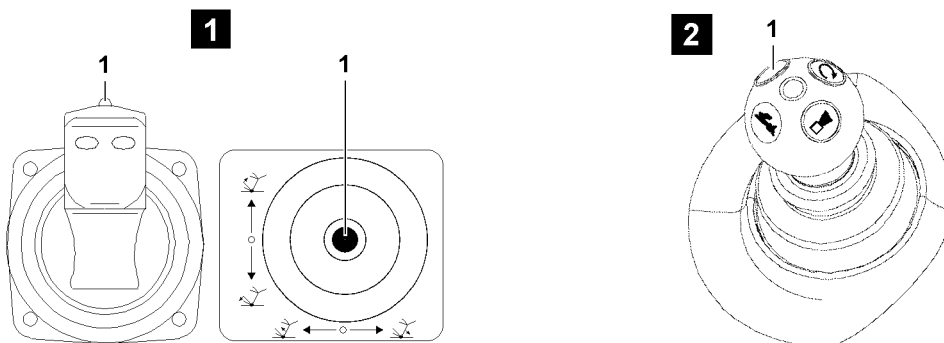
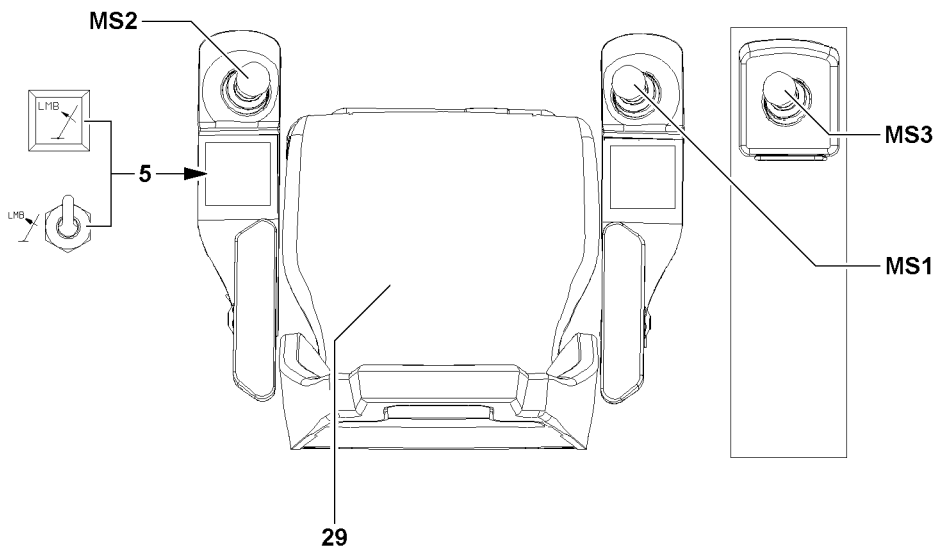
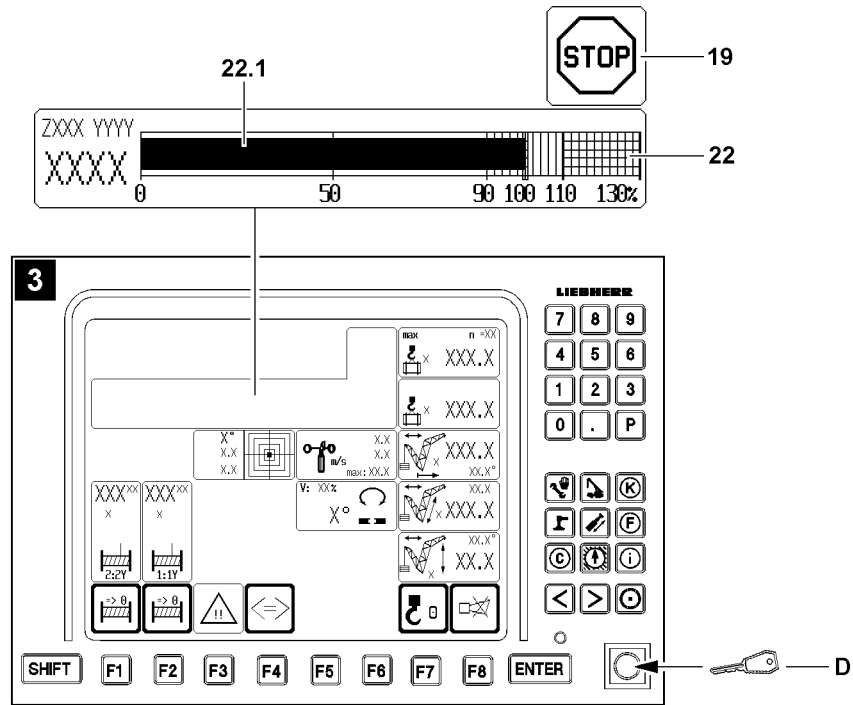

B112335

3.4.1 Luffing in with suspended load

If the maximum permissible load moment is exceeded, the LICCON overload protection turns off all crane movements that increase the load moment.

In the icon **22** (load moment display) the utilization bar **22.1** has exceeded the 100 % mark and in the LICCON monitor appears the icon **19**.

This shut off limit can be exceeded by actuating the button **5** "Luffing in with suspended load".

Make sure that the following prerequisite is met:

- Either the seat contact button **29** or one of the buttons **1** of the master switches (MS1, MS2, MS3) is actuated.



Note

- ▶ If the load is reduced by luffing up, then the button **5** "Luffing in with suspended load" is possibly not functioning.
 - ▶ For the procedure when the button **5** "Luffing in with suspended load" is not functioning, see section "Exceedance of maximum permissible load moment".
-

- ▶ Press the function key **5** "Luffing in with suspended load" and hold it.

Result:

- The LICCON overload protection is inactive.

- ▶ Luff the load in.

Result:

- If the crane reaches a normal operation status (utilization below 100 % and no active shut off) then the icon **19** turns off, normal crane operation is possible again.

The function "Luffing in with suspended load" is deactivated:

- When the function key **5** "Luffing in with suspended load" is not longer actuated.
- When neither the seat contact button **29** nor one of the buttons **1** of the master switches (MS1, MS2, MS3) is actuated.
- At engine stop.

The function "Luffing in with suspended load" is deactivated:

- The LICCON overload protection is active.
- ▶ Carry out crane movements in such a way that no repeated shut off by the LICCON overload protection occurs.

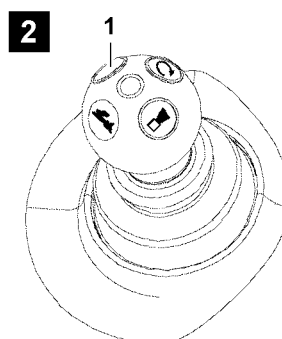
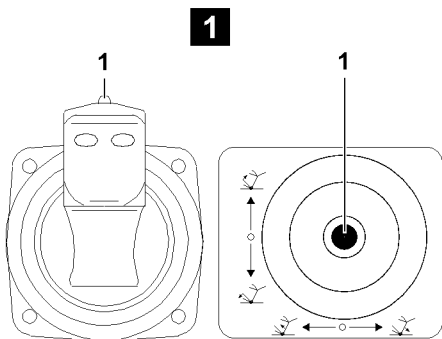
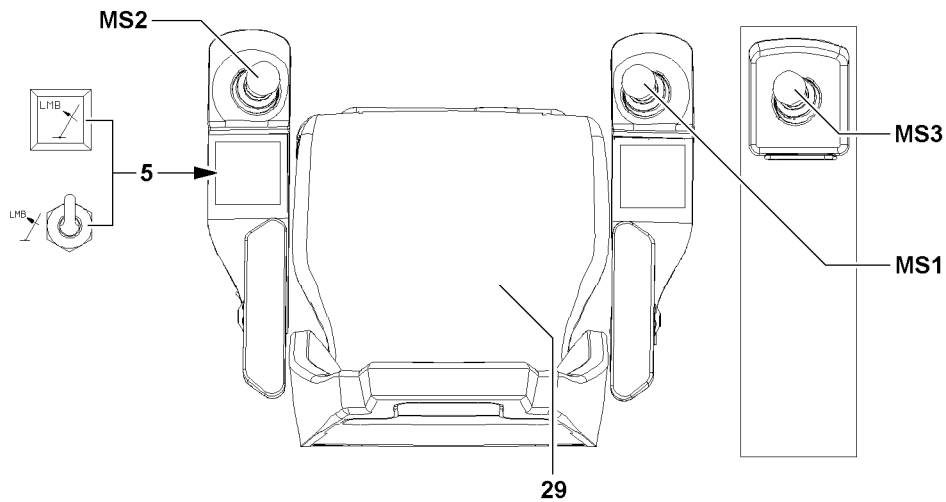
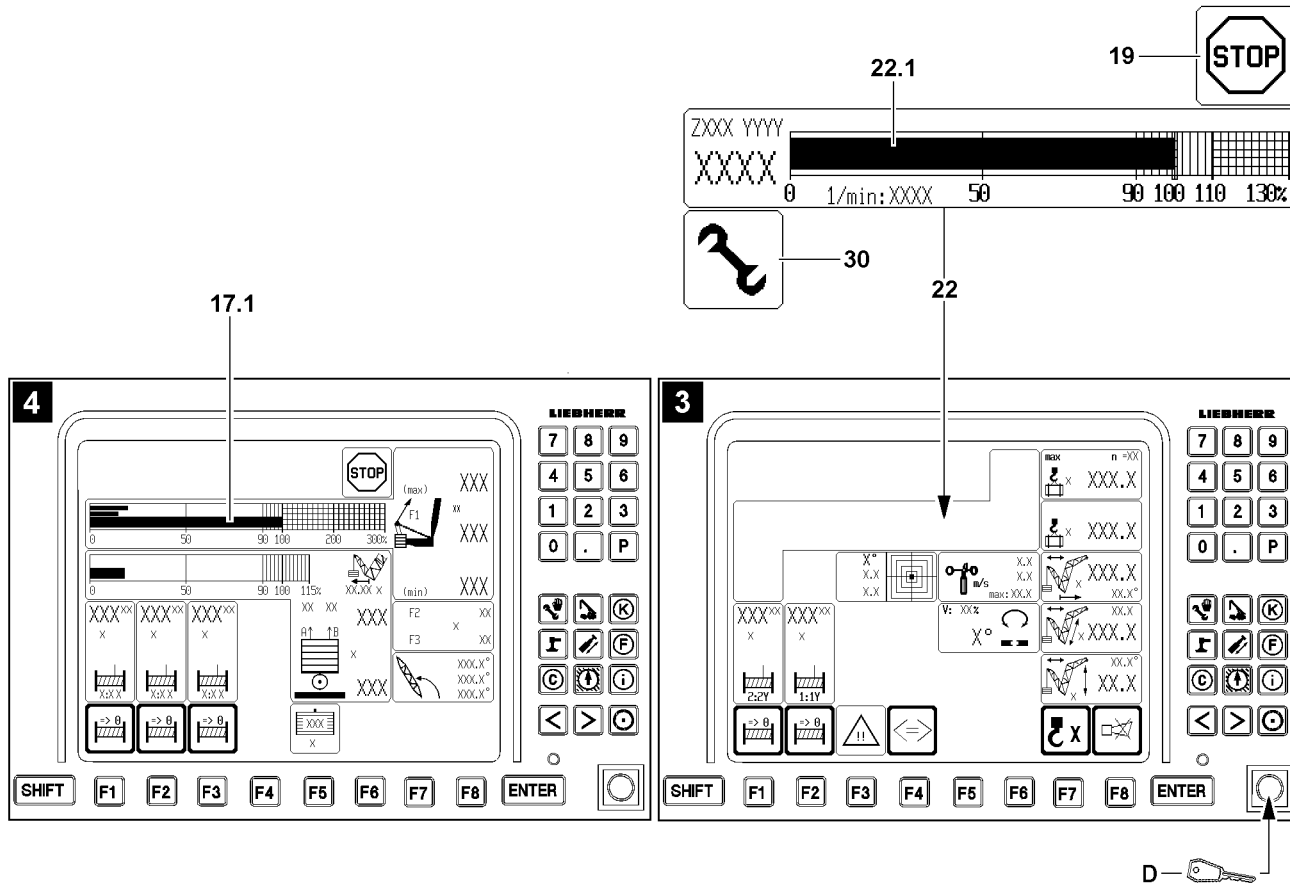

3.4.2 Exceedance of the maximum permissible load moment

If the maximum permissible load moment is exceeded, the LICCON overload protection turns off all crane movements that increase the load moment.

In the icon **22** (load moment display) the utilization bar **22.1** has exceeded the 100 % mark and in the LICCON monitor appears the icon **19**.

This shut off can be exceeded by the configuration button **D** in the “right touching” position.



WARNING

Shut off safety device!

If the function “Exceedance of shut off limits of LICCON overload protection” is activated by actuating the set up key **D** then it is possible to exceed the maximum permissible load moment! The function “Exceedance of maximum value test point 1” is automatically activated too. Thus there is no shut off when exceeding the maximum value test point 1!

- ▶ All notes regarding the function “Exceedance of shut off limits of LICCON overload protection” must be observed!
- ▶ The utilization bar $F1_{\text{actual}}$ **17.1** of the F1 load display must be observed!



Note

- ▶ In emergency situations, the function “Exceedance of shut off limits of the LICCON overload protection” can be activated with the set up key **D** and the maximum permissible load moment of 100 % can be exceeded.

The set up key **D** on the LICCON monitor has two positions:

- Operating position (not pressed): Crane is in normal operation.
- Position to right (touching): The function “Exceedance of shut off limits of the LICCON overload protection” is activated, the assembly icon **30** appears in the LICCON monitor.

Make sure that the following prerequisites are met:

- With the button **5** “Luffing in with suspended load” no normal operating condition (utilization below 100 % and no active shut off) can be reached.
- All master switches (MS1, MS2, MS3) are in zero position (not deflected).
- Either the seat contact button **29** or one of the buttons **1** of the master switches (MS1, MS2, MS3) is actuated.
- Radio operation* is not active.
- ▶ Turn the set up key **D** to the right (touching).

Result:

- The LICCON overload protection is inactive.
- The assembly icon **30** appears in the LICCON monitor.

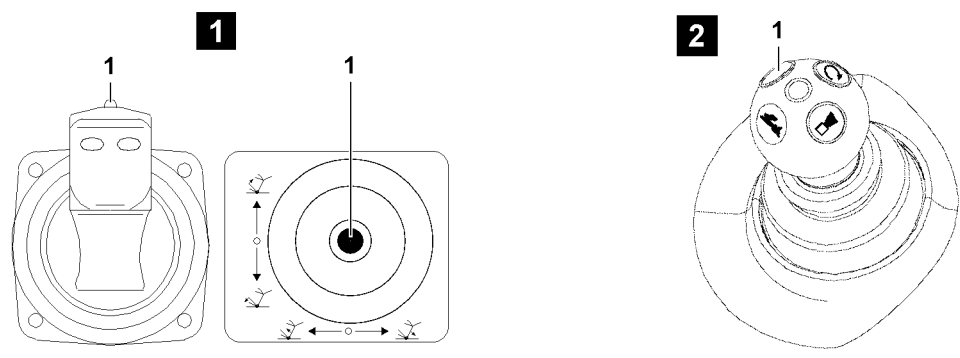
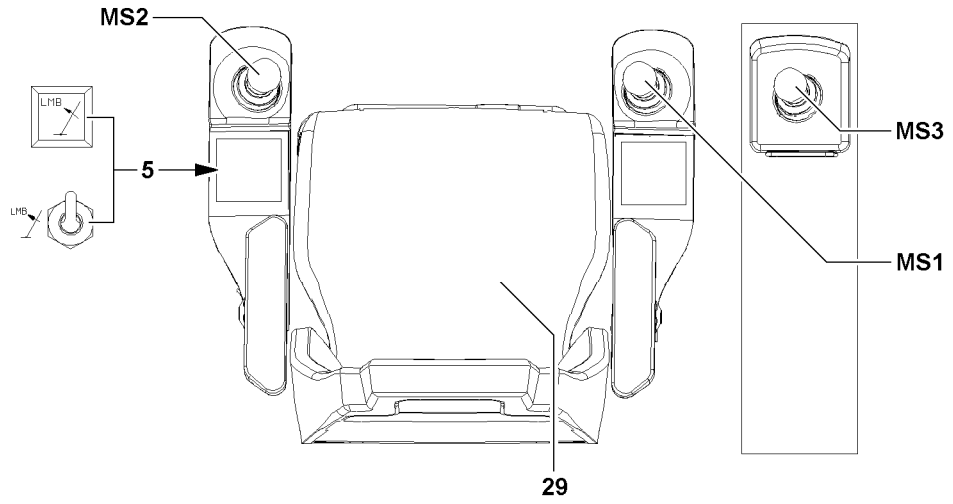
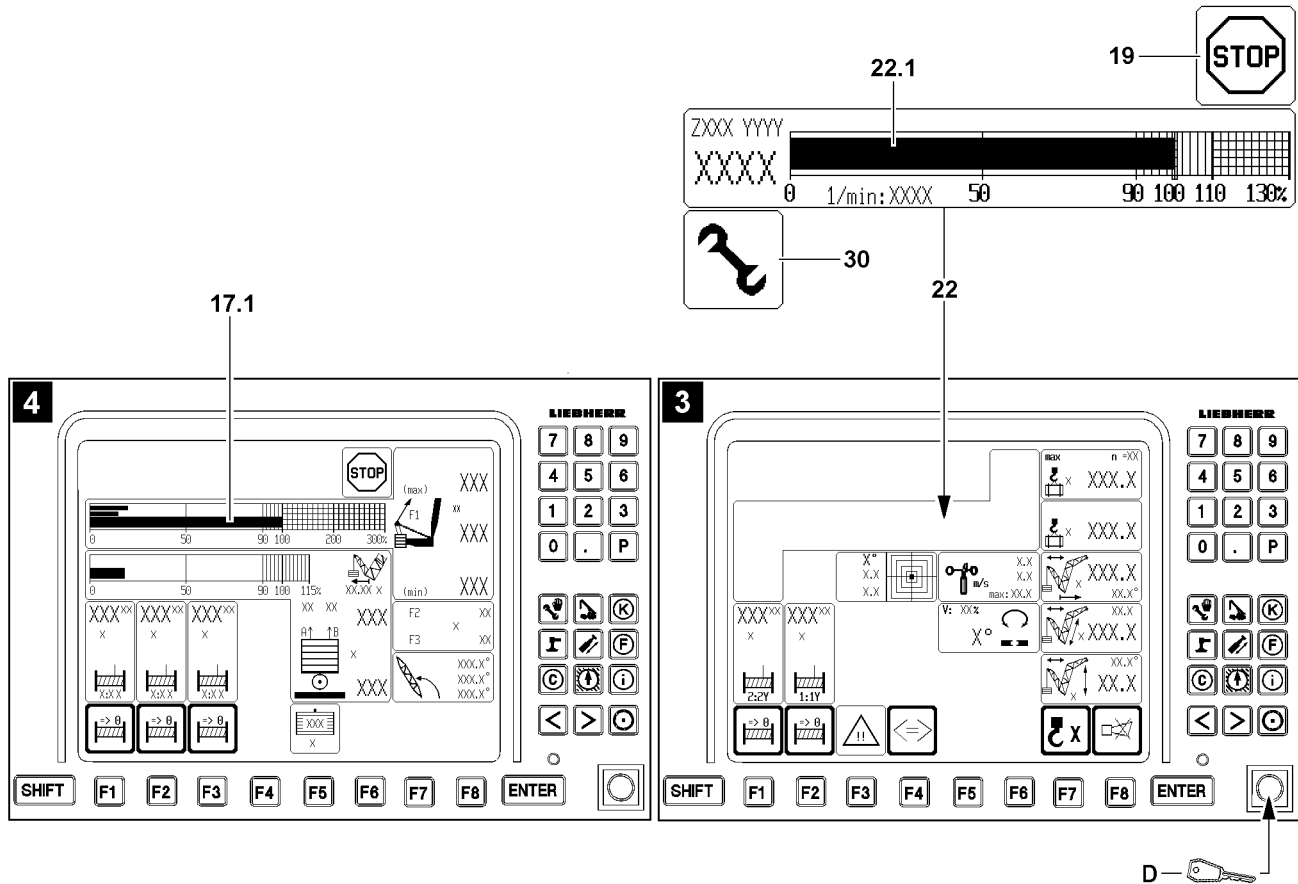

B112336

- ▶ Initiate crane movements which directly lead to a normal operating status (utilization below 100 % and no active shut off).

Result:

- If a crane reaches a normal operation status (utilization below 100 % and no active shut off), then the function “Exceedance of shut off limits of the LICCON overload protection” shuts off, the assembly icon **30** and icon **19** in the LICCON monitor turn off.

In addition, the function “Exceedance of shut off limits of LICCON overload protection” turns off immediately:

- If the set up key **D** is actuated again.
- If all master switches (MS1, MS2, MS3) are in neutral position for 10 seconds (with load chart available).
- When neither the seat contact button **29** nor one of the buttons **1** of the master switches (MS1, MS2, MS3) is actuated.
- If radio operation* is activated.
- At engine stop.
- At hoist top shut off.
- When leaving the angle range of the load chart.

**Note**

- ▶ The function “Exceedance of shut off limits of the LICCON overload protection” is only turned off when the assembly icon **30** in the LICCON monitor turns off.
- ▶ If the function “Exceedance of shut off limits of the LICCON overload protection” does not turn off after pressing the set up key **D** once, then press the set up key **D** again until the assembly icon **30** in the LICCON monitor turns off.

The function “Exceedance of shut off limits of the LICCON overload protection” has / was shut off:

- The assembly icon **30** in the LICCON monitor turns off.
- ▶ Make sure that the assembly icon **30** does no longer appear in the LICCON monitor.
- ▶ Carry out crane movements in such a way that no repeated shut off by the LICCON overload protection occurs.

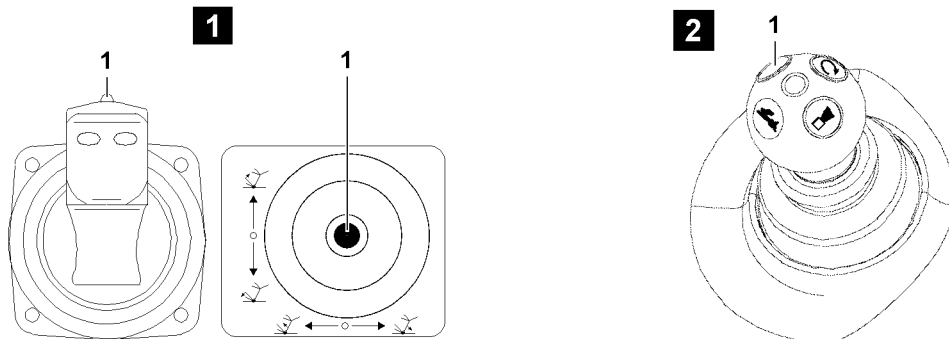
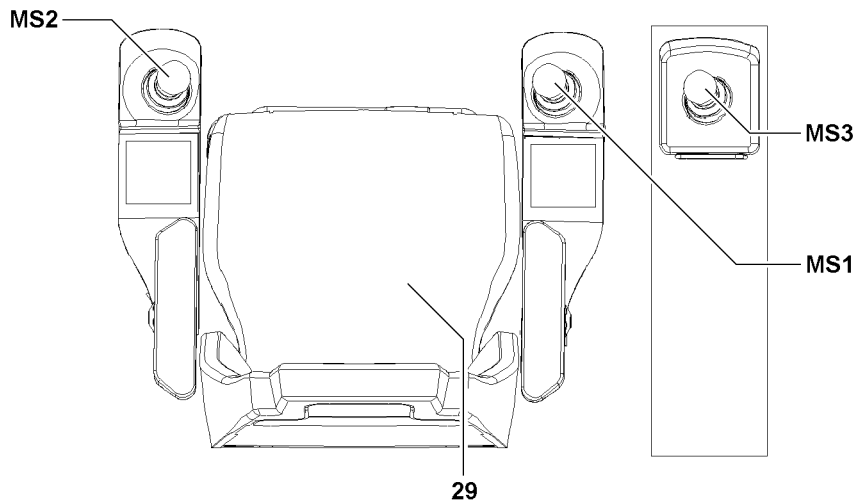
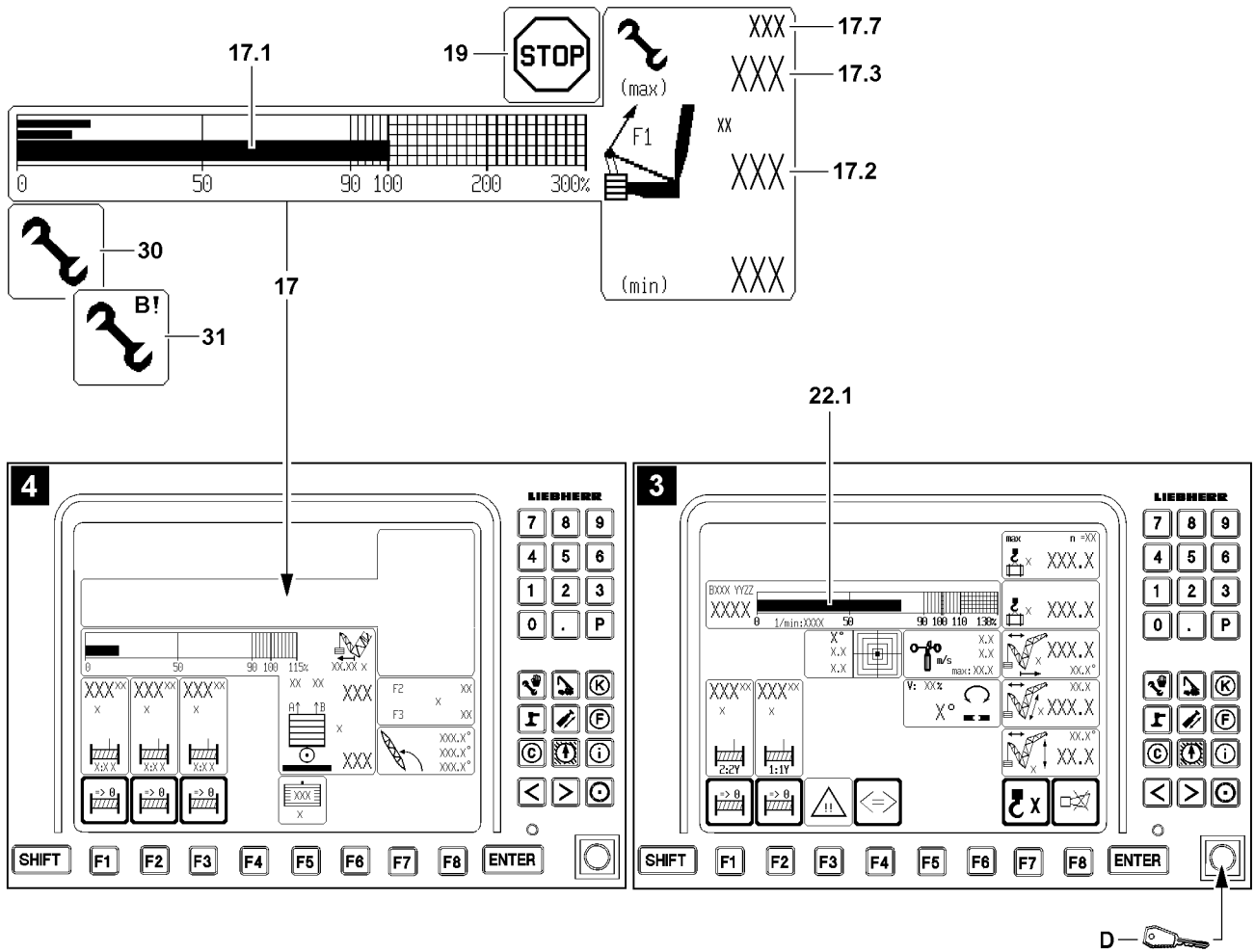

B112337

3.4.3 Exceedance of maximum value test point 1 (force F1) in crane operation



WARNING

Leaving the load chart with load on hook!

If, by actuating the set up key **D**, the shut off is bypassed by value $F1_{\text{max-operation}}$ **17.3** and exceeded by more than 110 %, then the crane is in assembly operation, the assembly icon **31** appears in the LICCON monitor!

There is no load chart available any longer and various display values may not be shown any longer in the crane operating screen!

The load on the hook is no longer monitored by the load chart!

Severe accidents due to crane overload can result!

Personnel can be severely injured or killed!

► In assembly operation, the data in the erection / take down charts is binding!



WARNING

Shut off safety device!

If, by actuating the set up key **D**, the function "Exceedance of maximum value test point 1" is activated, then the function "Exceedance of shut off limits of LICCON overload protection" is also activated automatically. Thus there is no shut off if the maximum permissible load moment is exceeded!

► All notes regarding the function "Exceedance of shut off limits of LICCON overload protection" must be observed!

► The utilization bar **22.1** of the load moment display must be observed!



Note

► The force determined on test point 1 is generally described as $F1_{\text{actual}}$ (actual value F1).

► In the icon **17** (F1-load display), the force relationship as well as the number values are shown in number values as well as a bar display (called F1-bar display).

► The value $F1_{\text{max-operation}}$ **17.3** corresponds to 100 % in the F1-bar display.

► The F1-utilization bar **17.1** shows the relationship $F1_{\text{actual}}$ **17.2** to $F1_{\text{max-operation}}$ **17.3**.

► In crane operation without derrick ballast, fewer values may be shown in the icon **17** (F1-load display).

► If the actual load is **larger** than the permissible hook block weight according to the erection / take down charts, then it can be exceeded up to maximum 110 % of $F1_{\text{max-operation}}$ **17.3**!

► If the actual load is **smaller** than the permissible hook block weight according to the erection / take down charts, then the assembly operation becomes active above 110 % of $F1_{\text{max-operation}}$ **17.3**. In assembly operation, there is no load chart available!

► The value $F1_{\text{max-assembly}}$ **17.7** appears in crane operation when 90 % of its nominal value is exceeded!

In the icon **17** (F1 load display) the utilization bar $F1_{\text{actual}}$ **17.1** exceeds the 100 % mark and the LICCON overload protection has shut off the crane movement. The value $F1_{\text{actual}}$ **17.2** has exceeded the value $F1_{\text{max-operation}}$ **17.3**.

All further movements, which lead to an increase of the force (value $F1_{\text{actual}}$) are shut off.

In the LICCON monitor with the derrick operating screen (illustration **4**) appears the icon **19**.

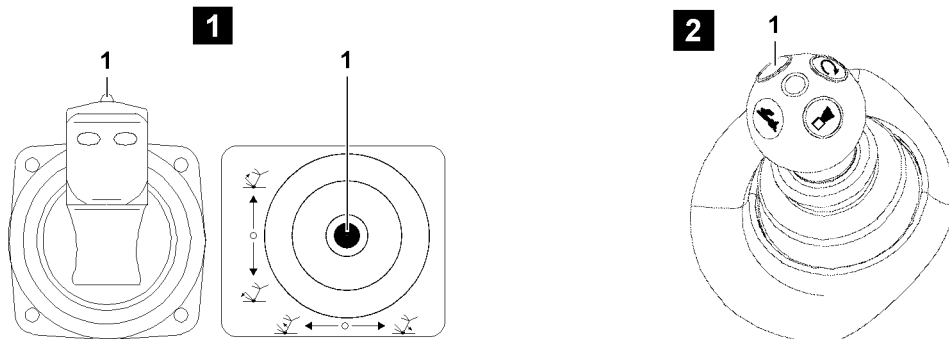
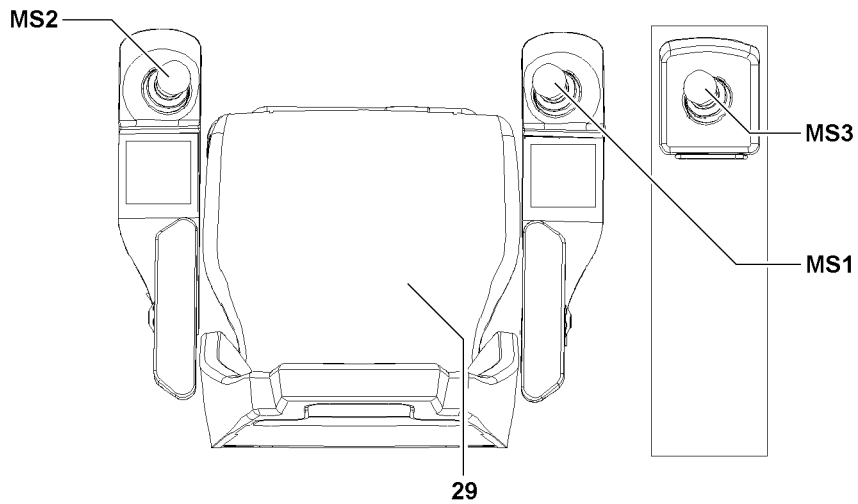
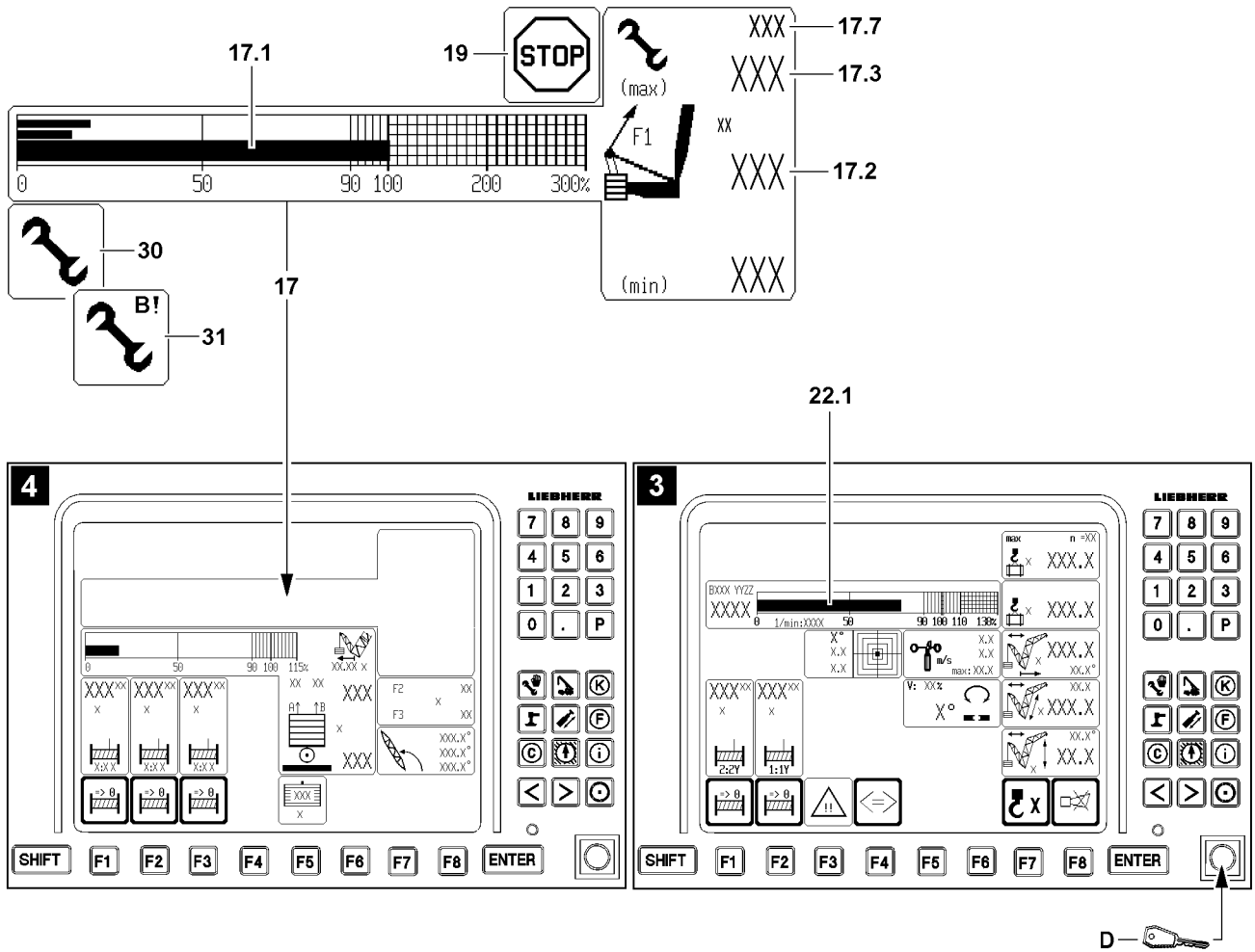

B112337

Make sure that the following prerequisites are met:

- All master switches (MS1, MS2, MS3) are in zero position (not deflected).
- Either the seat contact button **29** or one of the buttons **1** of the master switches (MS1, MS2, MS3) is actuated.
- Radio operation* is not active.
- The F1 load display 110 % has not been reached and a load chart is available.
- ▶ Turn the set up key **D** to the right (touching).

Result:

- The function “Exceedance of maximum value test point 1” is activated in connection with the function “Exceedance of the shut off limits of the LICCON overload protection”.
- $F1_{\text{max-operation}}$ **17.3** can be exceeded.

The function “Exceedance of shut off limits of the LICCON overload protection” in connection with the function “Exceedance of the maximum value test point 1” also shuts off immediately:

- If the set up key **D** is actuated again.
- If all master switches (MS1, MS2, MS3) are in neutral position for 10 seconds (with load chart available).
- When neither the seat contact button **29** nor one of the buttons **1** of the master switches (MS1, MS2, MS3) is actuated.
- If radio operation* is activated.
- At engine stop.
- At hoist top shut off.



Note

- ▶ The function “Exceedance of shut off limits of the LICCON overload protection” is only turned off when the assembly icon **30** in the LICCON monitor turns off.
- ▶ If the function “Exceedance of shut off limits of the LICCON overload protection” does not turn off after pressing the set up key **D** once, then press the set up key **D** again until the assembly icon **30** in the LICCON monitor turns off.

The function “Exceedance of shut off limits of the LICCON overload protection” has / was shut off:

- The assembly icon **30** in the LICCON monitor turns off.
- The working speed is reduced until all master switches (MS1, MS2, MS3) are in zero position at the same time.
- ▶ Make sure that the assembly icon **30** does no longer appear in the LICCON monitor.
- ▶ Carry out crane movements in such a way that no repeated shut off by the LICCON overload protection occurs.

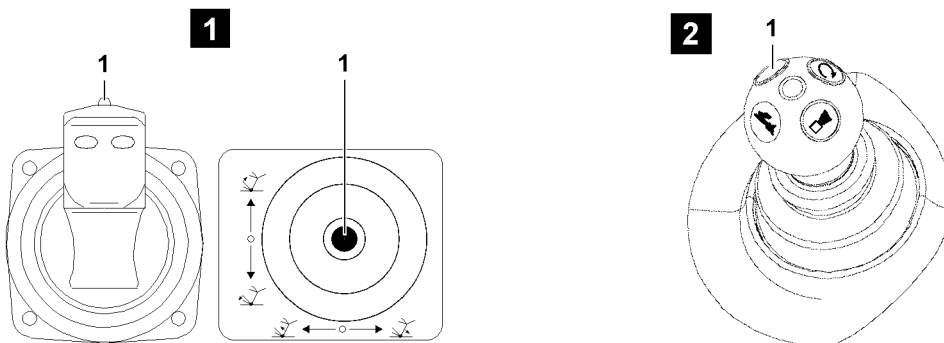
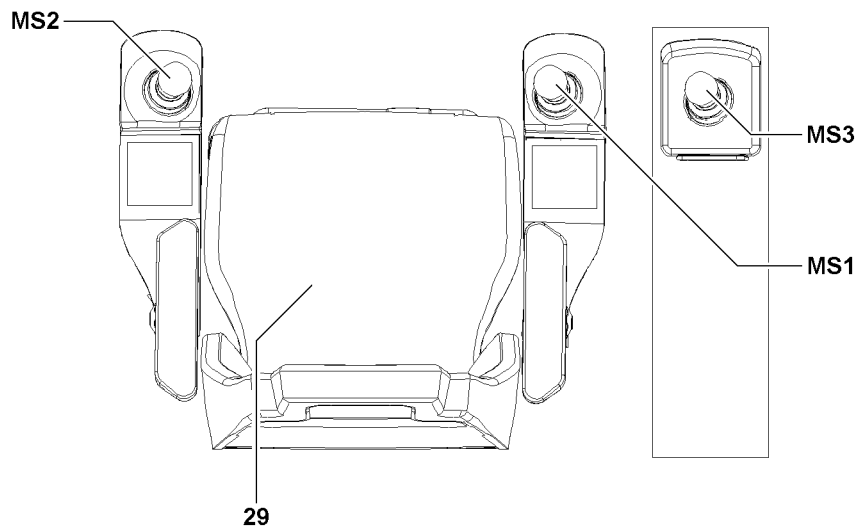
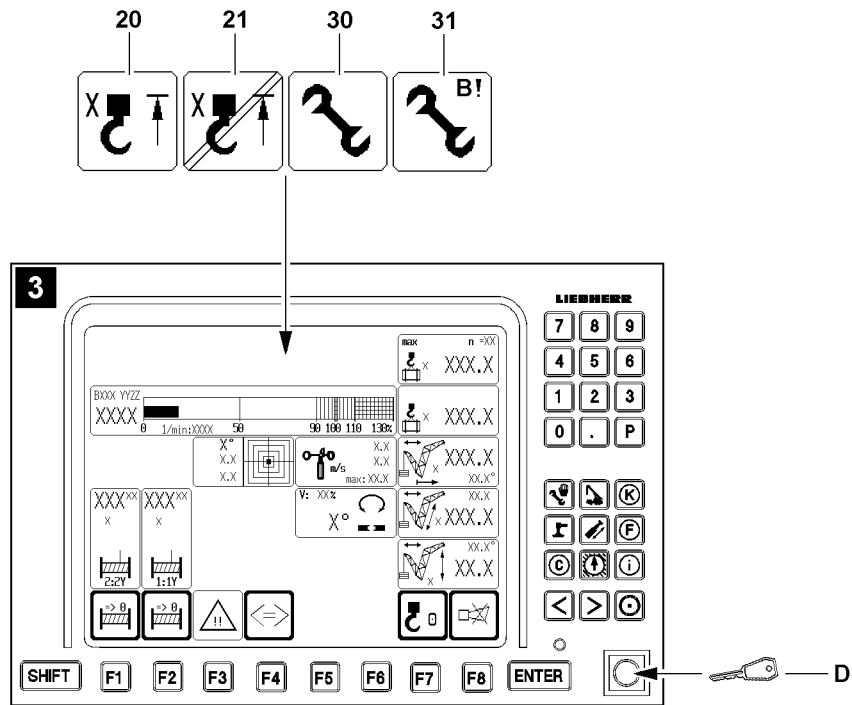

B111230

3.5 Bypass of the hoist top shut off



WARNING

Improper use of the function "Bypass of hoist top shut off"!

- ▶ The function "Bypass of hoist top shut off" may never be used to increase the lifting height during crane operation!



WARNING

Property damage and falling load!

If the function "Bypass of hoist top shut off" is activated, there is the danger that the hook block or the load hook is pulled against the pulley head!

This danger exists especially when the hoist winch is continued to be spooled up and for crane movements which have an influence on the hoist rope, for example luffing the boom, the auxiliary boom / accessory or the derrick boom!

Property damage and falling load can result!

Personnel can be severely injured or killed!

- ▶ The function "Bypass of hoist top shut off" may only be carried out by an authorized person, along with a guide. The guide must be in direct contact with the crane operator and must continually monitor the distance between the hook block / load hook and the boom head!
- ▶ Carry out all crane movements with utmost caution!



Note

- ▶ The activation of the function "Bypass of hoist top shut off" is only possible if the hoist limit switch was touched and the hoist top shut off has occurred.
- ▶ If the hoist limit switch is triggered when the set up key **D** is actuated (function "Exceedance of shut off limits of the LICCON overload protection" is active, the assembly icon **30** or the assembly icon **31** appear), then a hoist top shut off occurs and the function "Exceedance of shut off limits of the LICCON overload protection" is deactivated.
- ▶ For assembly purposes or in emergency cases, if the activation of the function "Bypass of hoist top shut off" **and** activation of the function "Exceedance of shut off limits of the LICCON overload protection" is necessary, then the set up key **D** must be actuated until the icon **21** and assembly icon **30** or assembly icon **31** (assembly operation) appear.

Make sure that the following prerequisites are met:

- A hoist top shut off has occurred, the hoist top icon **20** appears in the LICCON monitor.
- Either the seat contact button **29** or one of the buttons **1** of the master switches (MS1, MS2, MS3) is actuated.
- All master switches (MS1, MS2, MS3) are in zero position (not deflected).
- The radio operation* is not active.

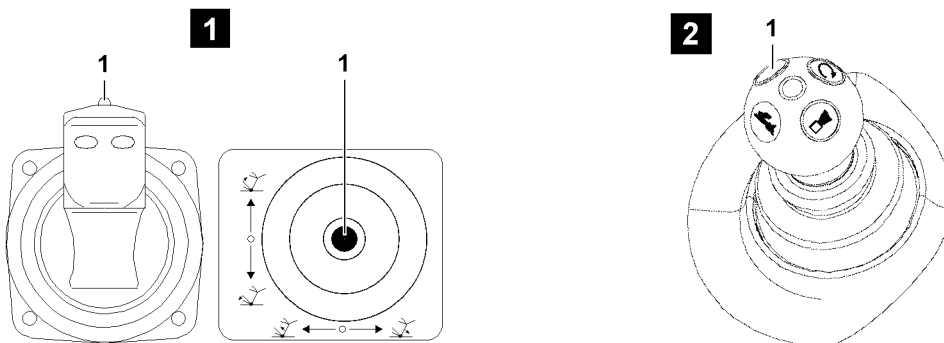
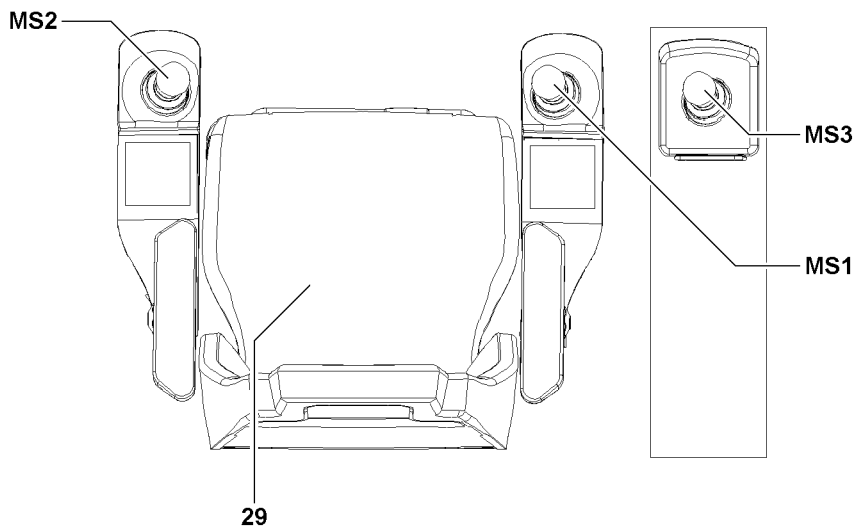
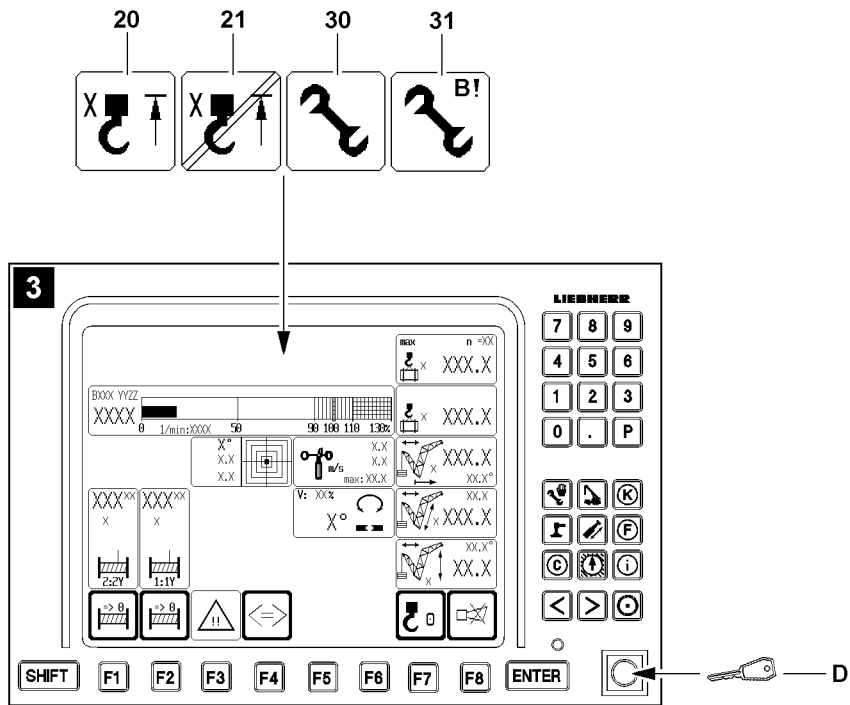

- ▶ Turn the set up key **D** to the right (touching).

Result:

- The assembly icon **30** or the assembly icon **31** (assembly operation) appear in the LICCON monitor.
 - The hoist top icon **20** in the LICCON monitor changes to the icon **21**.
 - All hoist limit switches are bypassed.
- ▶ Carry out a crane movement with bypassed hoist limit switches with utmost caution and by taking the safety guidelines into account.

The function "Bypass of the hoist top shut off" turns off:

- If the set up key **D** is actuated again.
- When no master switch (MS1, MS2, MS3) was deflected for 10 seconds.
- When neither the seat contact button **29** nor one of the buttons **1** of the master switches (MS1, MS2, MS3) is actuated.
- If there is no longer a shut off of a hoist limit switch.
- If the radio operation* is active.
- At engine stop.

The function "Bypass of the hoist top shut off" has / was turned off:

- The assembly icon **30** or the assembly icon **31** (assembly operation) in the LICCON monitor turn off.
 - The icon **21** on the LICCON monitor turns off.
- ▶ Make sure that the assembly icon **30** or the assembly icon **31** (assembly operation) as well as the icon **21** no longer appear in the LICCON monitor.
 - ▶ Carry out the crane movements in such a way that no repeated hoist top shut off occurs.

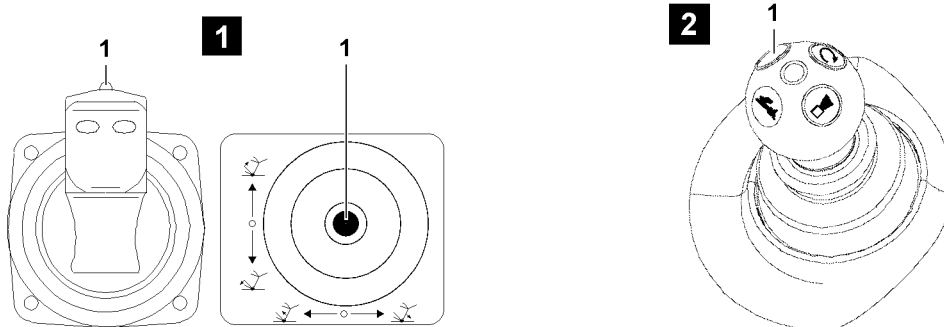
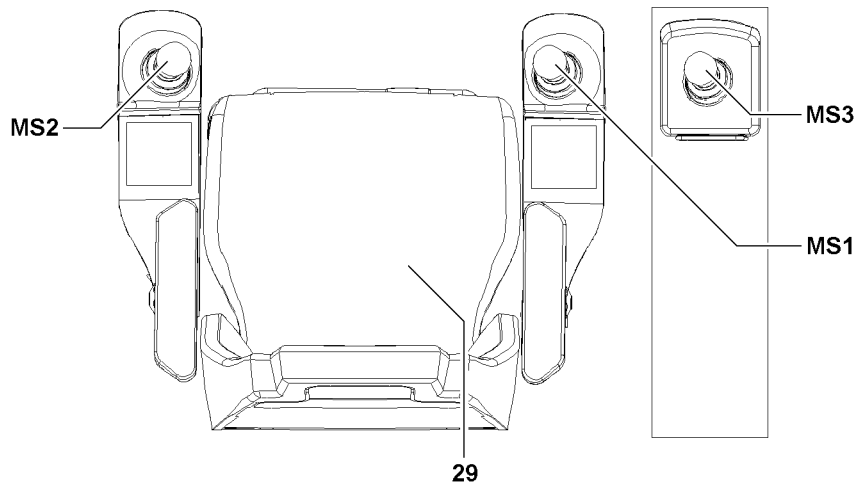
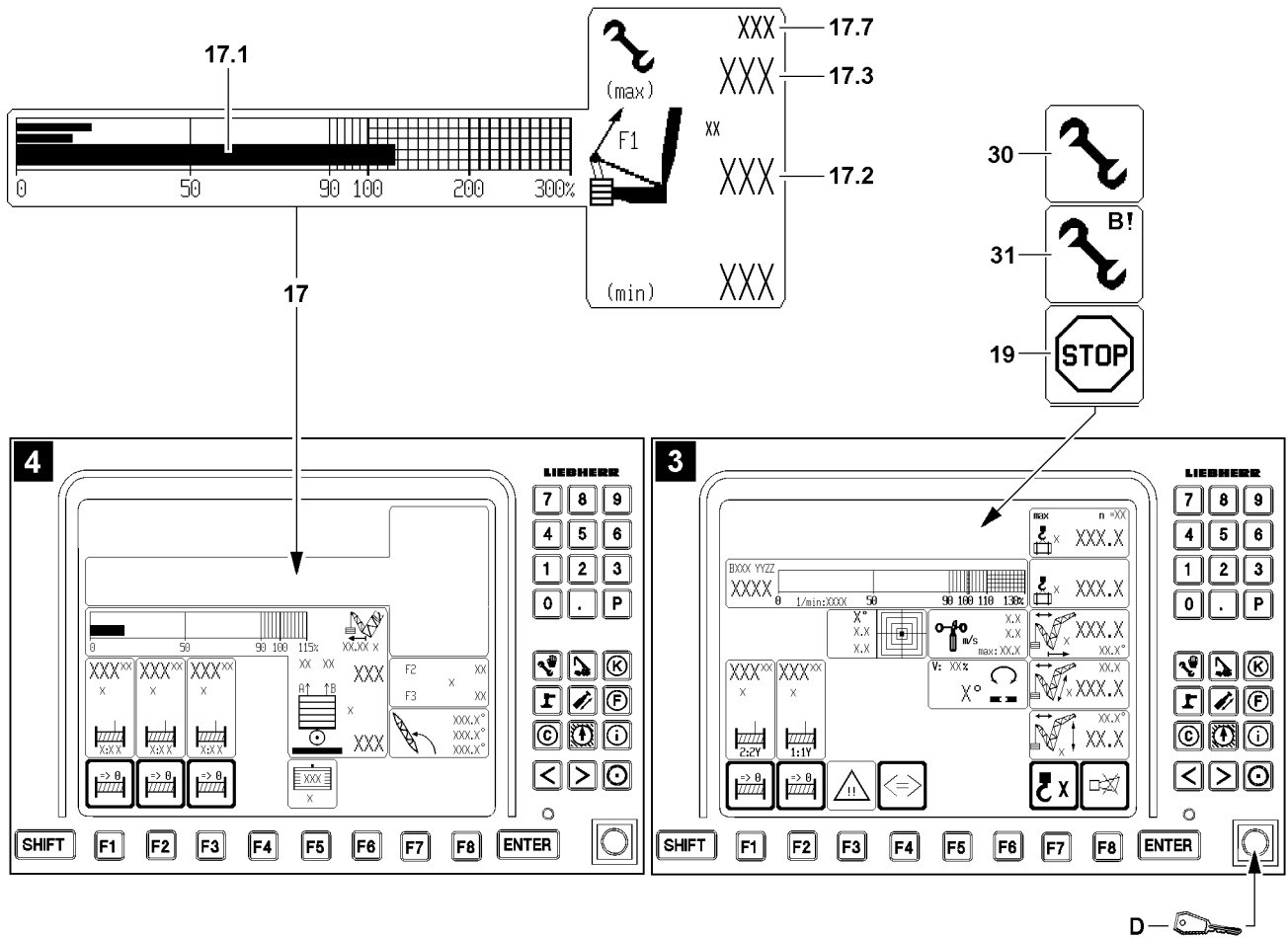

B112343

3.6 Exceeding the shut off limits of the LICCON overload protection during erection / take down procedures (assembly operation)



Note

- ▶ If the crane is in the area “No load chart available” then there is a shut off of the crane control by the LICCON overload protection. The icon **19** appears in the LICCON monitor.
- ▶ By an actuated set up key **D**, the function “Exceedance of shut off limits of the LICCON overload protection” can be activated, all erection / take down procedures can be carried out within the erection / take down charts, for which no load charts are available.



WARNING

Danger of accident during erection / take down procedures!

If the erection / take down charts are not observed, the crane could collapse, the boom can break off or the crane can topple over!

Personnel can be severely injured or killed!

- ▶ The erection / take down charts must be observed!
- ▶ Press the set up key **D** only when the configuration status has been entered correctly in the LICCON computer system and matches the actual situation!



Note

- ▶ The force determined on test point 1 is generally described as $F1_{\text{actual}}$ (actual value F1).
- ▶ In the icon **17** (F1-load display), the force relationship as well as the number values are shown in number values as well as a bar display (called F1-bar display).
- ▶ The value $F1_{\text{max-operation}}$ **17.3** corresponds to 100 % in the F1-bar display.
- ▶ The F1-utilization bar **17.1** shows the relationship $F1_{\text{actual}}$ **17.2** to $F1_{\text{max-operation}}$ **17.3**.
- ▶ In crane operation without derrick ballast, fewer values may be shown in the icon **17** (F1-load display).
- ▶ If a load chart is available, then the value $F1_{\text{max operation}}$ **17.3** is valid as the limit value for a shut off of crane operation.
- ▶ When leaving the area “Load chart available”, the assembly icon **30** turns off and the assembly icon **31** appears!
- ▶ When leaving the area “Load chart available” then $F1_{\text{max assembly}}$ **17.7** is valid as the upper limit value!
- ▶ $F1_{\text{max-assembly}}$ **17.7** might only appear when 90 % of its nominal value is exceeded!

3.6.1 Carrying out erection procedures (assembly operation)

Make sure that the following prerequisites are met:

- All master switches (MS1, MS2, MS3) are in zero position (not deflected).
- Either the seat contact button **29** or one of the buttons **1** of the master switches (MS1, MS2, MS3) is actuated.
- Radio operation* is not active.
- The set up configuration corresponds to the erection / take down charts.
- The set up configuration has been entered correctly into the LICCON computer system.

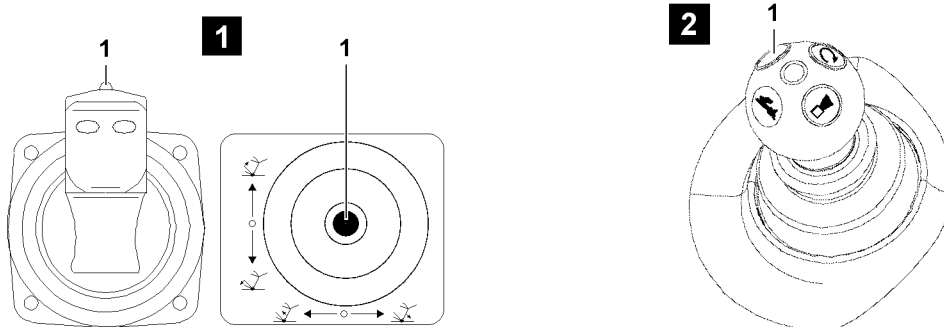
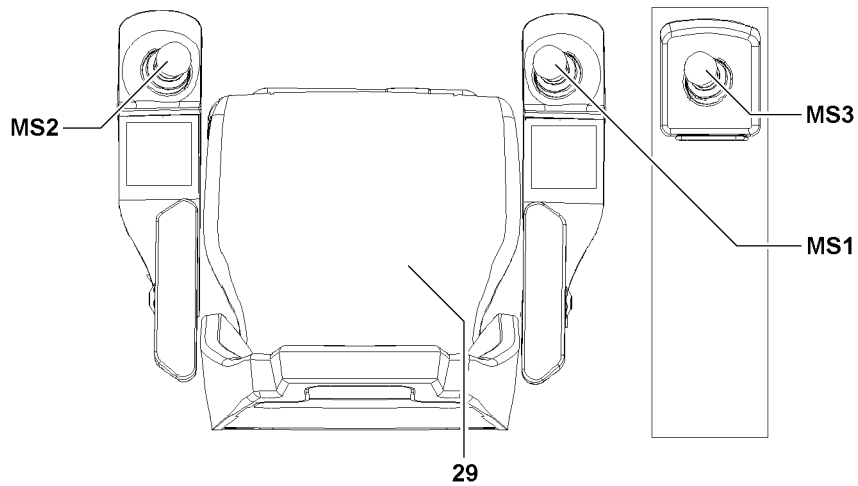
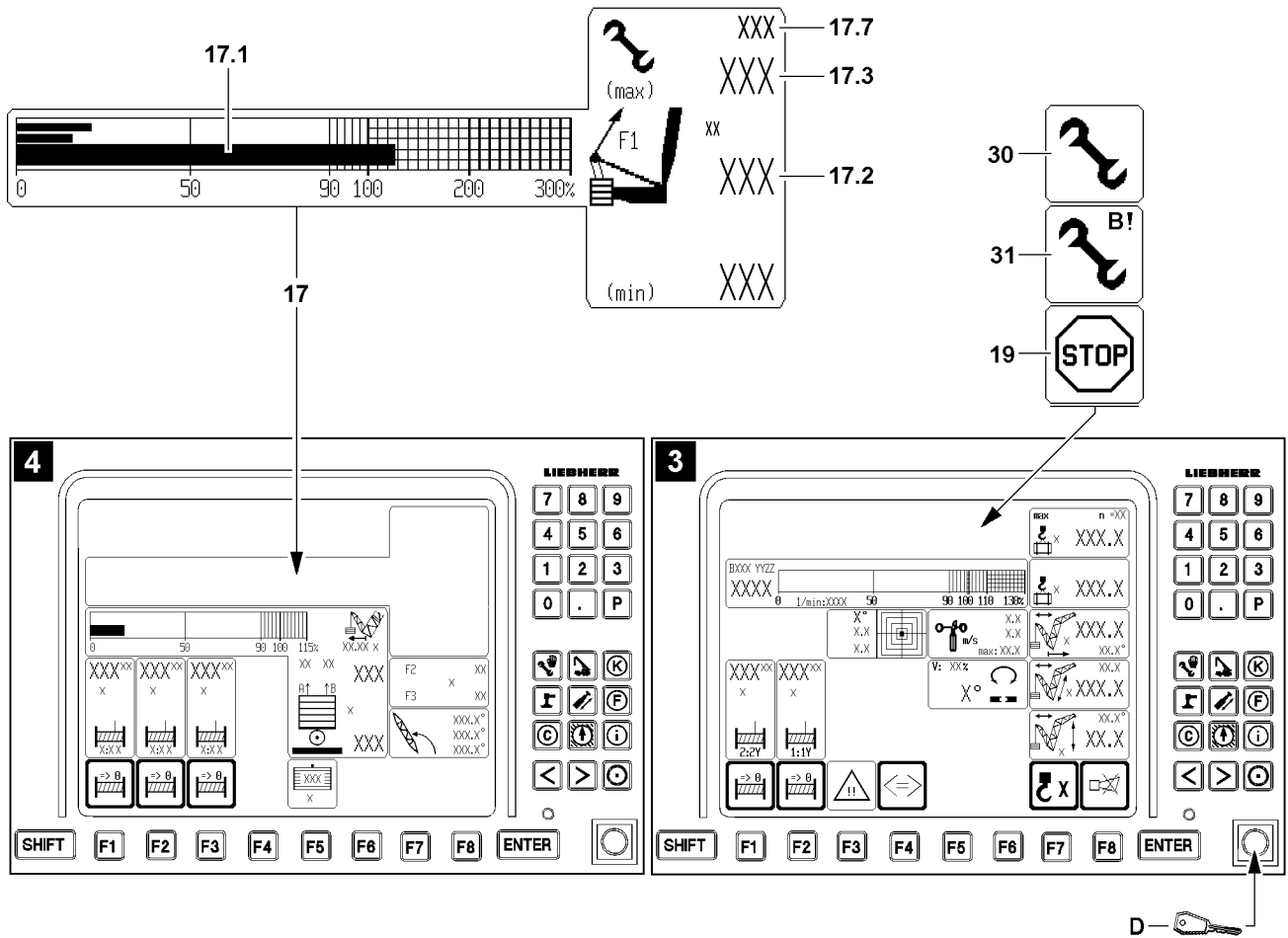

B112343

- ▶ Turn the set up key **D** to the right (touching).

Result:

- The assembly icon **31** appears in the area “No load chart available”.
 - The erection / take down procedures can be carried out.
- ▶ Watch the icon **17** (F1-load display), the value $F1_{\text{actual}}$ **17.2** may not exceed the value $F1_{\text{max-assembly}}$ **17.7**.

Troubleshooting

The erection / take down procedure cannot be carried out due to shut off “ $F1_{\text{max-assembly}}$ **17.7** exceeded”?

- ▶ See section “Danger of exceeding $F1_{\text{max assembly}}$ ”.

Troubleshooting

The function “Exceedance of shut off limits of the LICCON overload protection” can not be activated during erection / take down procedures?

- ▶ Check the error messages.
- ▶ Check the electrical connections.
- ▶ Check if all sensors or dummy plugs with integrated electric have been connected properly.

The function “Exceedance of shut off limits of the LICCON overload protection” turns off:

- If the set up key **D** is actuated again.
- When an area with existing load chart is reached (erection procedure).
- If all master switches (MS1, MS2, MS3) are in neutral position for 10 seconds (with “Load chart available”).
- When neither the seat contact button **29** nor one of the buttons **1** of the master switches (MS1, MS2, MS3) is actuated.
- At engine stop.

The function “Exceedance of shut off limits of the LICCON overload protection” has / was shut off:

- The assembly icon **30** or the assembly icon **31** in the LICCON monitor turns off.
- ▶ After completion of the erection / take down procedures, make sure that the assembly icon **30** or the assembly icon **31** no longer appear in the LICCON monitor.

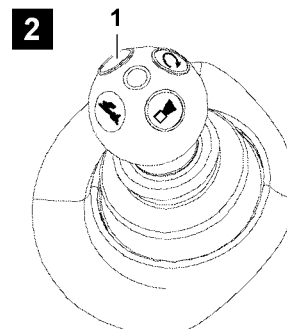
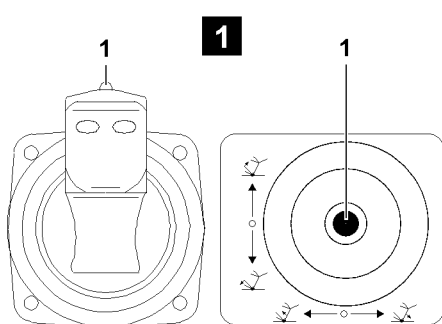
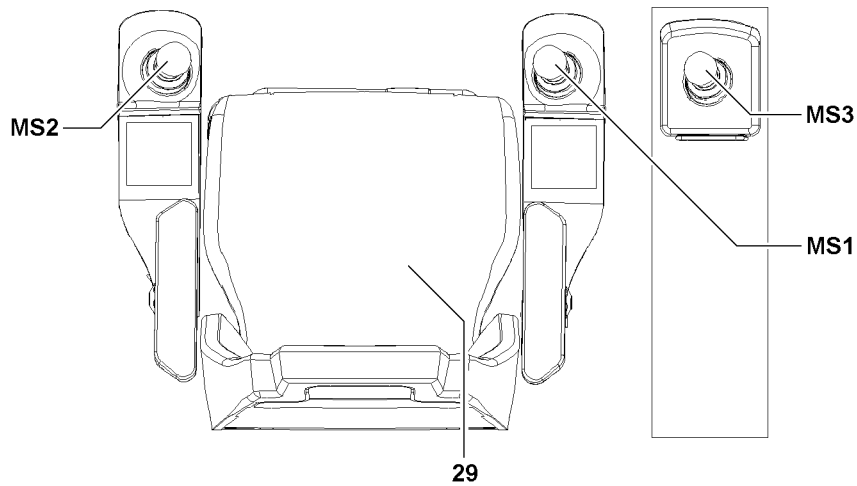
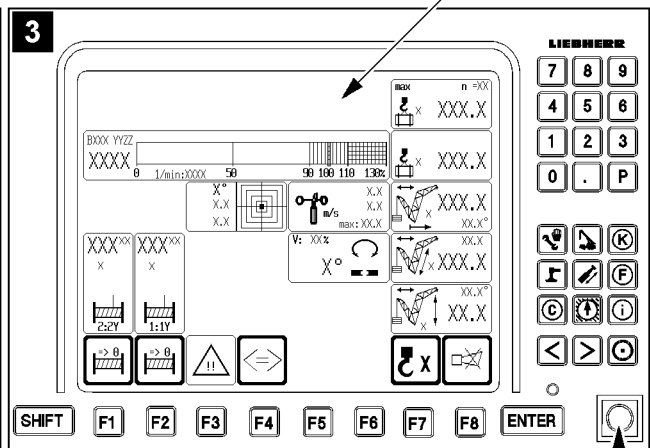
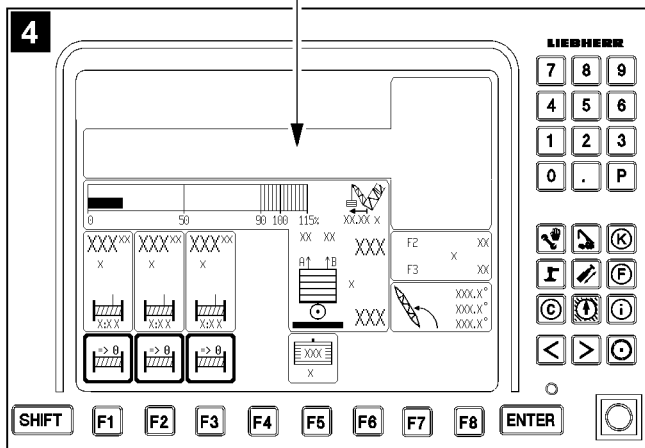
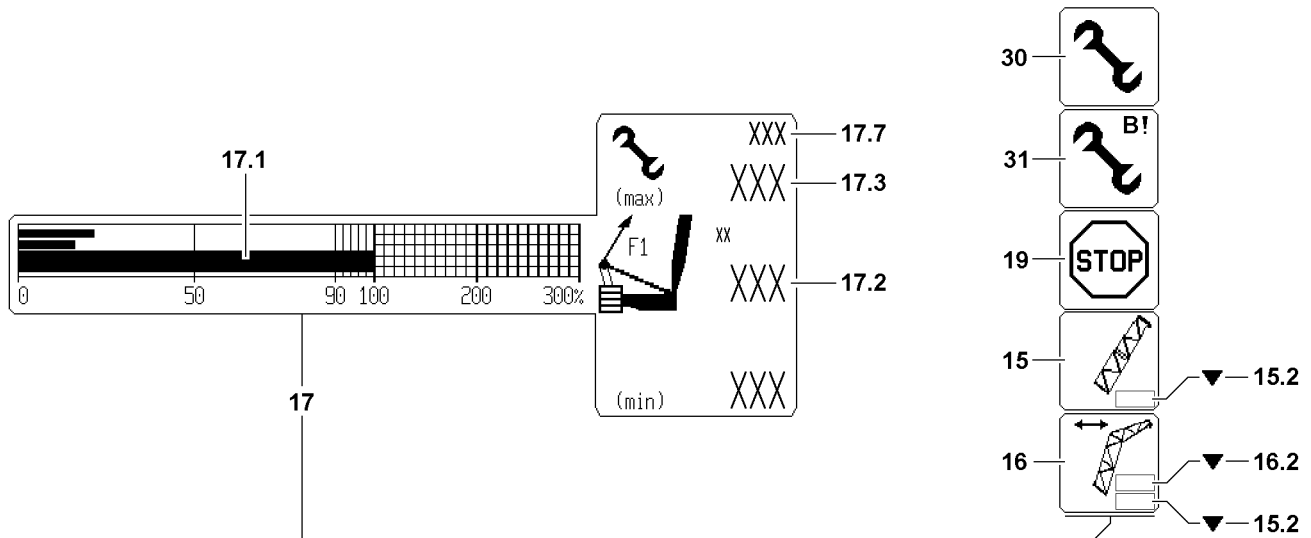

B112341

3.6.2 Carrying out take down procedures (assembly operation)



WARNING

Increased danger of accidents due to bypass of shut off of luffing the main boom / auxiliary boom / accessory down!

When the shut off luffing the main boom / auxiliary boom / accessory down is bypassed, then the LICCON overload protection as a whole is deactivated or limited.

When the shut off luffing the main boom / auxiliary boom / accessory down is bypassed and the main boom and / or the auxiliary boom / accessory is further luffed down, then there is no load chart available any longer!

Crane operation with bypassed shut off luffing the main boom / auxiliary boom / accessory down is prohibited, since severe accidents can result!

Personnel can be severely injured or killed!

- ▶ Activate the bypass of the shut off luffing the main boom / auxiliary boom / accessory down only in emergency cases or for erection / take down procedures with erection / take down charts!
- ▶ Carry out all crane movements with utmost caution!

Make sure that the following prerequisites are met:

- In icon **15** or icon **16** the arrow **15.2** or arrow **16.2** appear and the LICCON overload protection has shut off the crane movement.
- Either the seat contact button **29** or one of the buttons **1** of the master switches (MS1, MS2, MS3) is actuated.
- All master switches (MS1, MS2, MS3) are in zero position (not deflected).
- The radio operation* is not active.
- ▶ Turn the set up key **D** to the right (touching).

Result:

- The assembly icon **30** appears in the LICCON monitor.
- The function “Exceedance of shut off limits of the LICCON overload protection” is activated and has bypassed the shut off luffing the main boom / auxiliary boom / accessory down.



Note

- ▶ If a load chart is available, then the value $F1_{\text{max operation}}$ **17.3** is valid as the limit value for a shut off of crane operation.
- ▶ When leaving the area “Load chart available”, the assembly icon **30** turns off and the assembly icon **31** appears!
- ▶ When leaving the area “Load chart available” then $F1_{\text{max assembly}}$ **17.7** is valid as the upper limit value!
- ▶ If no derrick boom is installed, then the icon **17** only shows $F1_{\text{actual}}$ **17.1** and $F1_{\text{max-assembly}}$ **17.7**. $F1_{\text{max-assembly}}$ **17.7** might only appear when 90 % of its nominal value is exceeded!

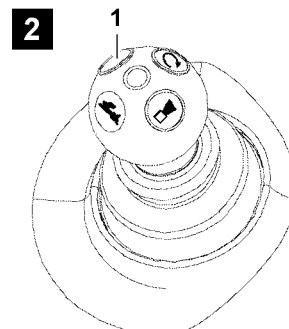
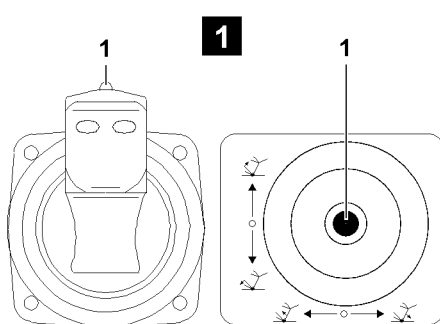
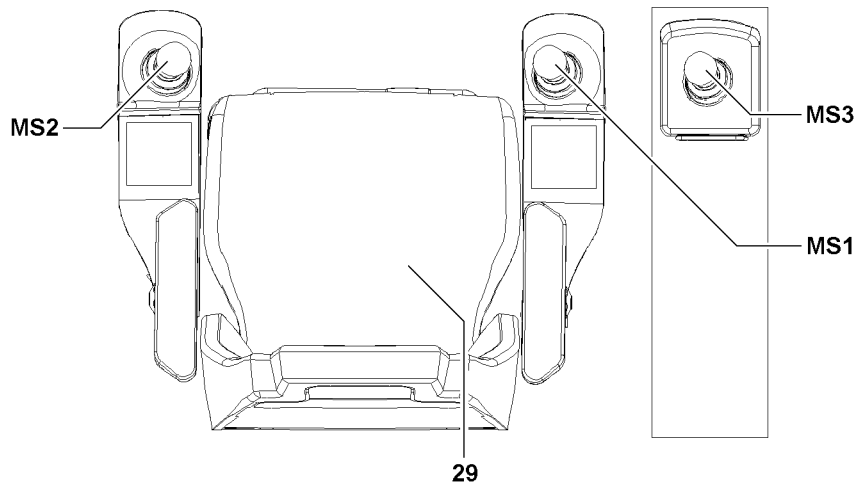
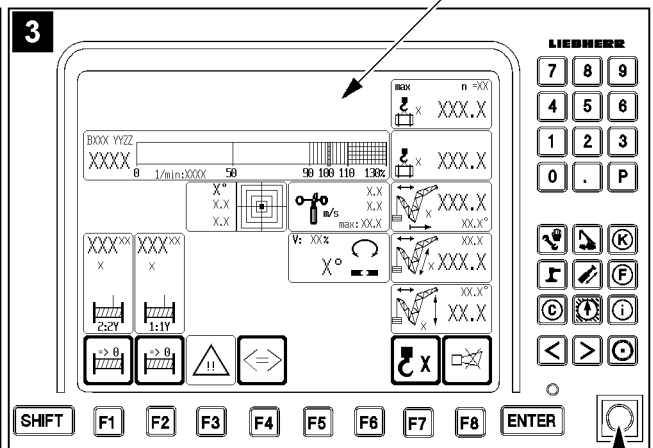
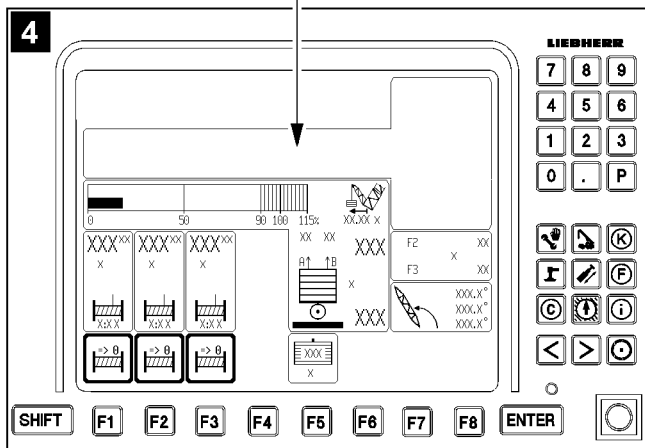
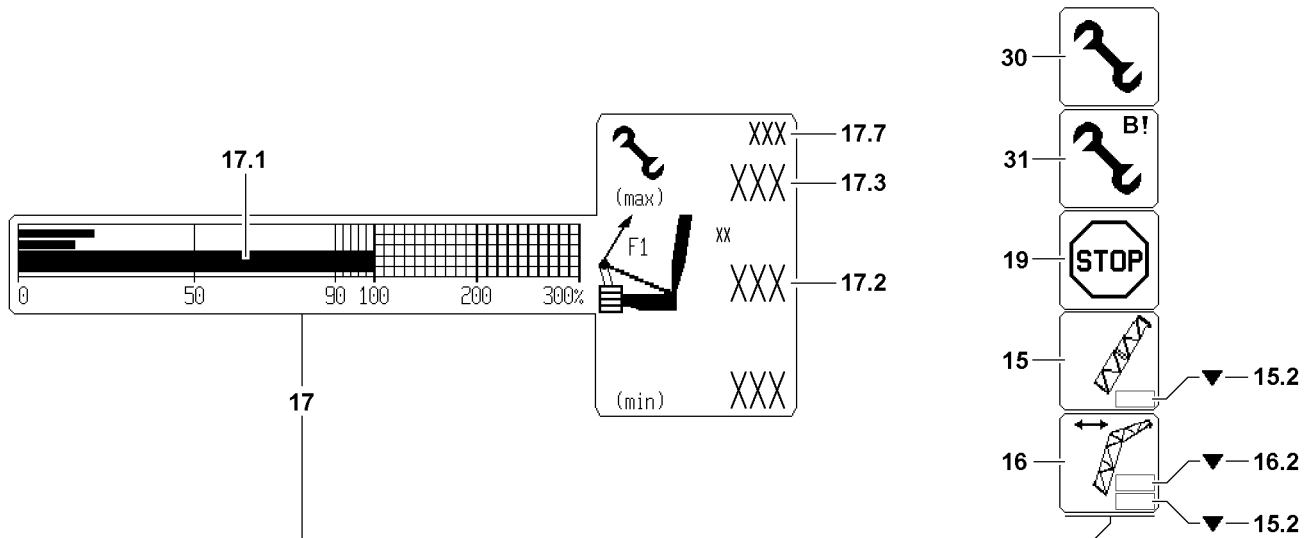

B112341

**DANGER**

The crane can topple over!

There is **no** shut off of the luff down movement after reaching the limit value $F1_{\text{max assembly}}$ **17.7!**

If the warnings by the LICCON overload protection are ignored, then the crane will be overloaded or topples over!

Personnel can be severely injured or killed!

- ▶ The icon **17** (F1-load display) must be watched permanently! It must be ensured that the value $F1_{\text{actual}}$ **17.2** is smaller than the value $F1_{\text{max assembly}}$ **17.7!**
- ▶ The luff down movement must be stopped before the value $F1_{\text{actual}}$ **17.2** exceeds the limit value $F1_{\text{max assembly}}$ **17.7!**

- ▶ During the take down procedure watch the icon **17** (F1-load display).

Troubleshooting

The take down procedure cannot be carried out due to danger of exceeding the $F1_{\text{max assembly}}$ **17.7?**

- ▶ See section "Danger of exceeding $F1_{\text{max assembly}}$ " .

The bypass of the shut off luffing the main boom / auxiliary boom / accessory down turns off:

- If the set up key **D** is actuated again.
- When neither the seat contact button **29** nor one of the buttons **1** of the master switches (MS1, MS2, MS3) is actuated.
- When an area with existing load chart is reached.
- If the radio operation* is active.
- At engine stop.

The bypass of the shut off luffing the main boom / auxiliary boom / accessory down has / was turned off:

- The assembly icon **31** or the assembly icon **30** in the LICCON monitor turns off.
- ▶ Make sure that the assembly icon **30** or the assembly icon **31** no longer appear in the LICCON monitor.

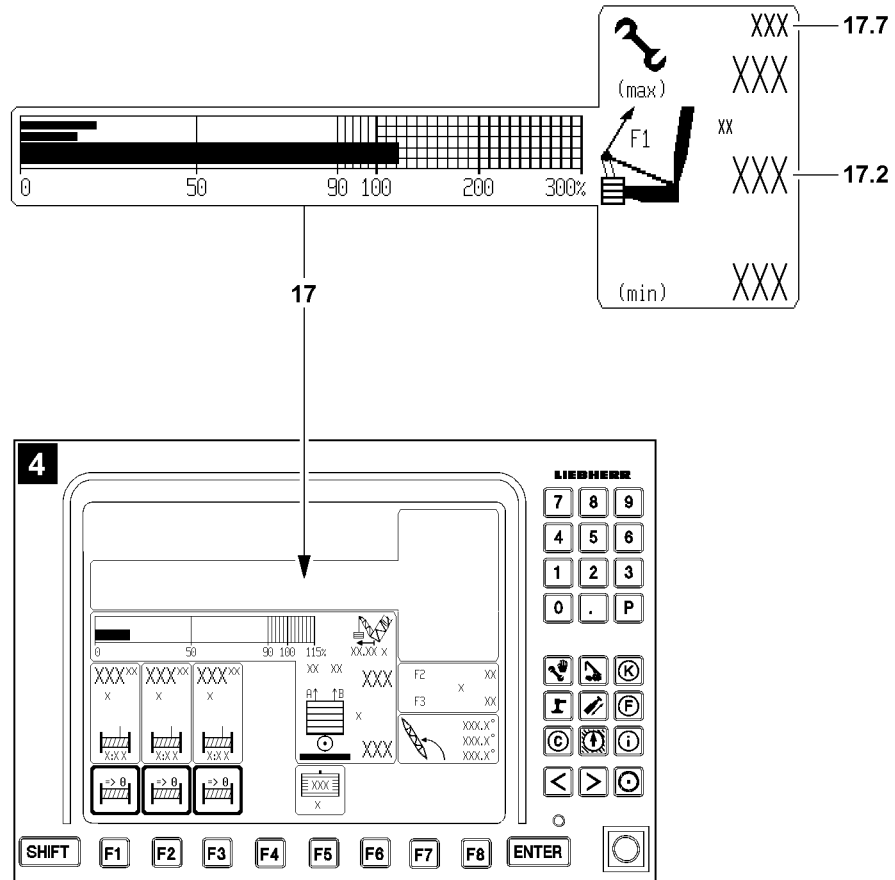

3.6.3 Danger of exceeding $F1_{\max \text{ assembly}}$



Note

- ▶ $F1_{\max \text{ assembly}}$ **17.7** might only appear when 90 % of its nominal value is exceeded!



DANGER

The crane can topple over!

There is **no** shut off of the luff down movement after reaching the limit value $F1_{\max \text{ assembly}}$ **17.7!**

If the warnings by the LICCON overload protection are ignored, then the crane will be overloaded or topples over!

Personnel can be severely injured or killed!

- ▶ The luff down movement must be stopped before the value $F1_{\text{actual}}$ **17.2** exceeds the limit value $F1_{\max \text{ assembly}}$ **17.7!**

In the icon **17** (F1-load display), the value $F1_{\text{actual}}$ **17.2** has reached the upper limit value $F1_{\max \text{ assembly}}$ **17.7**.

- ▶ Check if a crane movement, which can lower the force F1 (value $F1_{\text{actual}}$ **17.2**) can be initiated, for example setting down the hook block / load hook.
- ▶ Check if the correct set up configuration has been entered on the LICCON computer system.
- ▶ Check if the actual set up configuration matches the entered set up configuration.
- ▶ Check if the correct hook block weight has been entered.
- ▶ Check if the respective hook block / load hook is installed.
- ▶ Check if all attachment parts and guy rods on the boom system, which are not needed, have been removed.
- ▶ Check if environmental influences (wind, snow or ice) on the crane are not too great.



Note

- ▶ Hook block weight entry and correction of weighing errors, see Crane operating instructions, chapter 4.02.

5.00 Equipment

1 Checking the retaining elements

Retaining elements are used to secure the pins in the folding jibs and lattice sections. The spring force of the retaining elements may significantly reduce if they are mechanically damaged or distorted. Do not re-use retaining elements if there is insufficient spring force. The pins must be secured with correctly **functioning** retaining elements.



DANGER

Risk of accident if retaining element does not provide enough spring force!

It cannot be guaranteed that the pin is correctly secured if the retaining element does not provide sufficient spring force.

- ▶ Use retaining elements with sufficient spring force!

2 Rope pulleys



WARNING

Danger of crushing due to rotating rope pulleys!

Arms and legs can be crushed or severed between the rope pulley and the rope due to rotating rope pulleys!

- ▶ It is prohibited to touch the ropes or rope pulleys during operation!
- ▶ Adhere to the safety distance to ropes and rotating rope pulleys!

3 Checking the ropes

The ropes must be checked by an expert before assembly and checks must be performed at regular intervals in order to detect possible damage or wear and tear at an early stage. See Crane operating instructions, chapter 8.04.

The ropes must be removed immediately if any of the following damage is detected:

- Breakage of a strand
- Wire breaks
- Broken wire nests
- Reduction in the rope diameter by 10 % or more of the nominal size
- Rope deformations

3.1 Placing the hoist rope

In order to guarantee safety and operating characteristics, only original Liebherr replacement parts or parts approved by Liebherr may be used.

NOTICE

Damage to the hoist rope!

If a hoist rope is placed with worn rope pulleys, the hoist rope can be damaged!

- ▶ The rope pulleys must be checked before placing the hoist rope. See Crane operating instructions, chapter 8.01!
- ▶ Replace worn or damaged rope pulleys!

3.1.1 Cranes with cam limit switch

The cam limit switch is calibrated in the factory to switch off when only 3 hoist rope coils are left on the winch.



WARNING

Risk of accident due to falling load!

If the following instructions are not observed, the hoist rope end attachment may be torn out causing the load to topple.

- ▶ If a new hoist rope is used, the cam limit switch must be reset!
- ▶ The cam limit switch must be adjusted so that it turns off when only 3 hoist rope coils remain on the winch!
- ▶ If the hoist rope is wound up during the assembly, the hoist rope end must remain in front of the winch and may not be pulled over the winch, otherwise the cam limit switch must be reset!

3.1.2 Cranes with winch turn sensor

The winch turn sensor is calibrated in the factory to switch off when only 4 hoist rope coils are left on the winch. If used properly, the winch turn sensor will not need to be readjusted.



WARNING

Risk of accident due to falling load!

If the following instructions are not observed, the hoist rope end attachment may be torn out causing the load to topple.

- ▶ The winch turn sensor must be set to turn off when only 4 hoist rope coils remain on the winch!



Note

Avoid the following situations otherwise the winch speed sensor will need readjusting:

- ▶ Pulling the hoist rope ends under the winch by spooling up the winch!
- ▶ Pulling the hoist rope from the "Stationary" winch.
- ▶ The winch turn sensor must also be readjusted if it is established that the "Winch does not stop spooling out" when 4 rope coils are left on the winch. This applies during operation or when changing the hoist rope.

4 Inspection procedures



WARNING

The crane can topple over!

If the control measures are not carried out before crane operation, then the crane can topple over or be damaged!

Personnel can be killed or injured!

- ▶ Crane operation with safety devices which are **not** functioning correctly is strictly prohibited!
- ▶ Start crane operation only after all safety devices have been checked and are functioning correctly!
- ▶ Start crane operation only if the overload protection has been set according to the data in the load chart!
- ▶ Start crane operation only if the crane is properly supported and horizontally aligned!



Note

- ▶ If the crane operator leaves the cab, even for a short time, the operating mode setting must be checked and reset if necessary before resuming crane operation!

4.1 Control measures - mobile cranes

Perform the following checks before operating the crane:

- Check if the axle suspension is blocked.
- Check if the support pads are secured in the operating position.
- Check if the crane is sufficiently supported depending on the load case and the ground conditions.
- Check if there is adequate safety distance to excavations and embankments.
- Check if there are any live cables within the operating range of the crane.
- Ensure that the work can be carried out with minimum boom projection radius.
- Check that there are no obstacles that might hinder required crane movements.
- Check if the sliding beams are prevented from sliding by pins.
- Check if the crane is supported.
- Check if the crane is level.
- Check that the tires are not in contact with the ground.
- Check that the overload protection has been adjusted as per the information in the load chart.
- Check that the set up key is not active.
- Check the shut off of the overload protection by luffing the telescopic boom up.
- Check the shut off of the overload protection by running against the hoist limit switch.
- Check the easy movement and function of the wind speed sensor.
- Check the shut off of the limit switches - boom “Steepest position”. See Crane operating instructions, chapter 8.12.
- Check the easy movement of the pendulum for the mechanical relapse retainer over the total swing range of the pendulum.
- **On cranes with derrick boom:**
 - Check the shut off of the limit switches - derrick. See Crane operating instructions, chapter 8.12.
- **On cranes with lattice jib:**
 - Check the shut off of the limit switches - lattice jib “Steepest position”. See Crane operating instructions, chapter 8.12.
 - Check the shut off of the limit switches - lattice jib “Lowest position”. See Crane operating instructions, chapter 8.12.
 - Check the shut off of the limit switches – flap in position lattice jib “Steepest position”. See Crane operating instructions, chapter 8.12.

4.2 Control measures - crawler cranes

Perform the following checks before operating the crane:

- Check if the crane is sufficiently supported depending on the load case and the ground conditions.
- Check if there is adequate safety distance to excavations and embankments.
- Check if there are any live cables within the operating range of the crane.
- Ensure that the work can be carried out with minimum boom projection radius.
- Check that there are no obstacles that might hinder required crane movements.
- **For crawler cranes with crane support:**
 - Check if the support pads are secured in the operating position.
 - Check if the folding beams are prevented from sliding by pins.
 - Check if the crane is supported.
- Check if the crane is level.
- Check that the overload protection has been adjusted as per the information in the load chart.
- Check that the set up key is not active.
- **On certain crawler cranes:**
 - Check that the crawler assembly key button is turned off.
- Check the shut off of the overload protection by luffing the telescopic boom up.
- Check the shut off of the overload protection by running against the hoist limit switch.
- Check the easy movement and function of the wind speed sensor.
- Check the shut off of the limit switches - boom "Steepest position". See Crane operating instructions, chapter 8.12.
- Check the shut off of the limit switches - derrick. See Crane operating instructions, chapter 8.12.
- Check the shut off of the limit switches - lattice jib "Steepest position". See Crane operating instructions, chapter 8.12.
- Check the shut off of the limit switches - lattice jib "Lowest position". See Crane operating instructions, chapter 8.12.
- Check the shut off of the limit switches – flap in position lattice jib "Steepest position". See Crane operating instructions, chapter 8.12.
- Check the easy movement of the pendulum for the mechanical relapse retainer over the total swing range of the pendulum.

5 Dangerous conditions without shut off

5.1 Block position of relapse cylinders when setting down a load

NOTICE

Damage to boom or relapse cylinder!

If the block position of the relapse cylinders is triggered by the boom or the derrick with attached, freely suspended load, then there is a danger of damaging the boom or the relapse cylinders when setting down the load onto the ground! By setting down the load, the crane is relieved, which causes the boom system to move to the rear.

There is no shut off of the hoist gear down function!

- ▶ Actuate the opposite direction of movement which caused the block position and eliminate the block position!
-

6 Transporting components

If any components are transported on an auxiliary vehicle, then they must be properly secured. If necessary, transport these components on supports or using a special transport device.

6.1 Transporting lattice sections

If the lattice sections are pushed inside each other for transportation purposes, they must each be secured with 2 chains.

7 Pneumatic springs for assembly support of components

Pneumatic springs are installed on various components to simplify the installation or removal of these components.



WARNING

Danger of crushing!

Defective pneumatic springs no longer provide the supporting properties on the movable components! Due to falling components, personnel can be killed or severely injured!

High risk of accident!

- ▶ Always check pneumatic springs for external damage before actuating the corresponding components!
- ▶ Do not use components with defective pneumatic springs! Replace defective pneumatic springs!
- ▶ It is strictly prohibited for personnel or objects to remain within the movement range of the components, which are supported by the pneumatic spring!
- ▶ It is prohibited for personnel or objects to remain within the danger zone of the moveable components!

8 Manual rope winches for assembly support of components

Manual rope winches are installed on various components to simplify the installation or removal of these components.



WARNING

Danger of crushing!

Defective manual rope winches no longer provide the supporting action on the movable components! Due to falling components, personnel can be killed or severely injured!

High risk of accident!

- ▶ Always check manual rope winches for external and functional damage before actuating the respective components!
- ▶ Check the rope of the manual rope winch for damage!
- ▶ At least two rope coils must always remain on the drum!
- ▶ Do not use components with defective manual rope winches! Replace defective manual rope winches!
- ▶ It is strictly prohibited for personnel or objects to remain within the movement range of the components, which are supported by the manual rope winch!
- ▶ It is prohibited for personnel or objects to remain within the danger zone of the moveable components!

9 Weights



Note

Please note:

- ▶ The weight of each component is specified in the corresponding chapter of the Crane operating instructions or stated on the tag attached to the corresponding component!
 - ▶ Contact the Service department at **LIEBHERR-Werk Ehingen GmbH**, if the weight of the respective component is not stated on the tag or in the Crane operating instructions!
 - ▶ If components are pushed into one another (for example intermediate pieces) or folded together (for example the folding jib), then the total weight is given by the sum of the individual components!
 - ▶ Use an auxiliary crane with sufficient load carrying capacity!
-

10 Guy rods



WARNING

Unutilized guy rods on boom!

If guy rods are on the lattice sections which are not used for operation, then there is a risk of accidents!

Personnel can be severely injured or killed!

Guy rods can loosen up and fall down!

The load chart is invalid!

The load display of the LICCON computer system shows the incorrect value!

The weight of the boom is too large for erection!

- ▶ Disassembly and remove unutilized guy rods on the transport retainers before erecting the boom!
-



Note

- ▶ Inspection and maintenance of guy rods, see Crane operating instructions, chapter 8.15!
-

blank page!

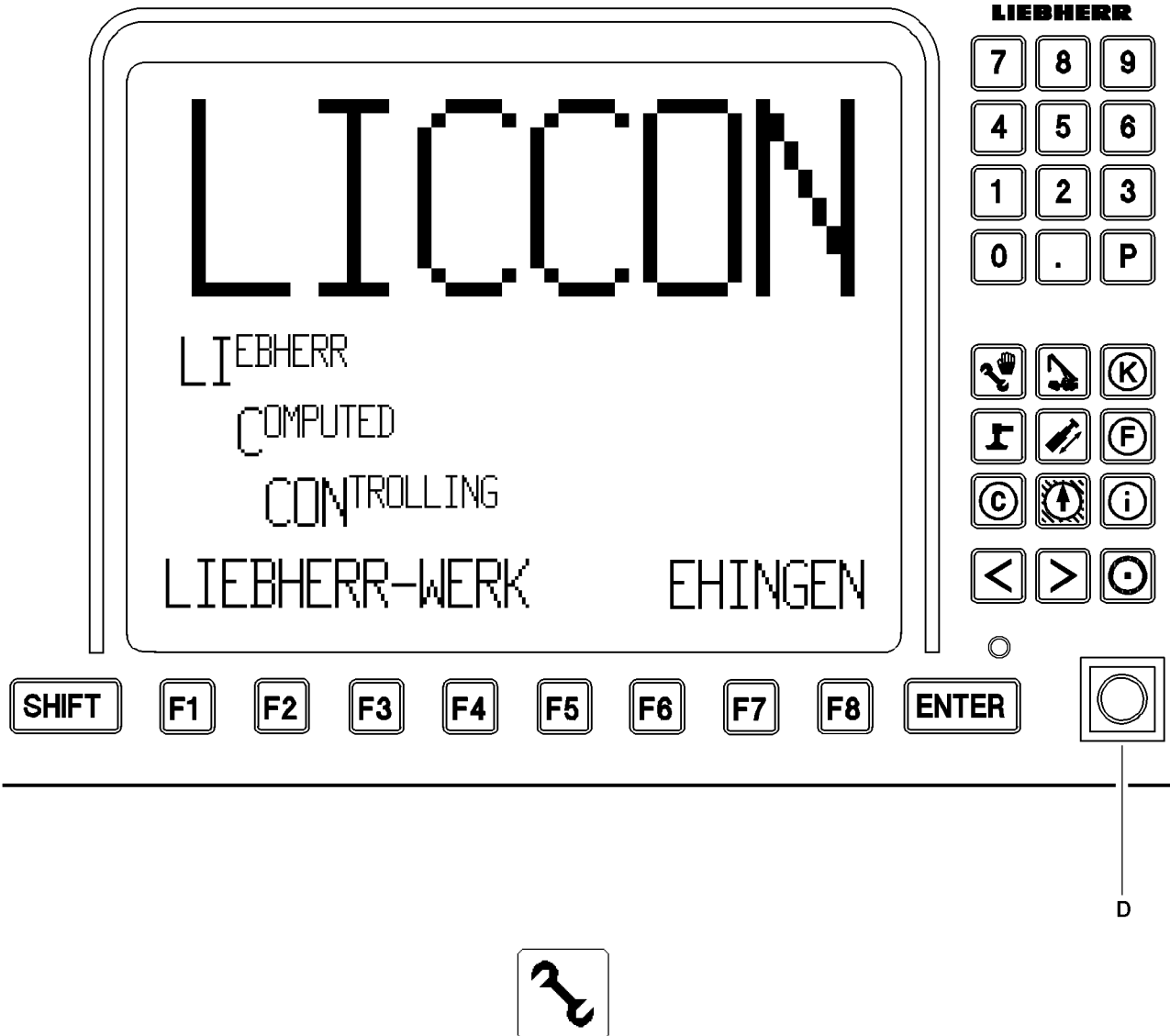

11 Exceeding the overload protection



DANGER

Increased accident risk when exceeding the overload protection!

As section 4.2.6.3.2 of EN 13000 does not put the requirements of appendix 1 of the EC machinery directive 89/37/EC into concrete terms, the overload protection has not been designed according to this definition.

Proper and destined use of the crane is ensured due to the construction of the overload protection system and observance of the information in the Crane operating instructions. All **sensibly foreseeable erroneous operations** of the crane have been taken into consideration.

Impermissible crane operation with exceeded overload protection – with the aim of increasing the maximum load-bearing capacity of the crane above the rated value in the load chart, or to extend the designated working range of the crane – does not constitute a **sensibly foreseeable erroneous operation**, rather a **deliberate improper use with high risk of accident!**

The possible risks and consequences of such deliberate improper use are detailed in the operating instructions.

Such deliberate improper use can neither be prevented by means of the constructive design, nor by means of information in the operating instructions!

- ▶ Actuate the set up key **D** only on according to the operating instructions!
 - ▶ Any other use of the set up key than that described in the operating instructions is prohibited!
-

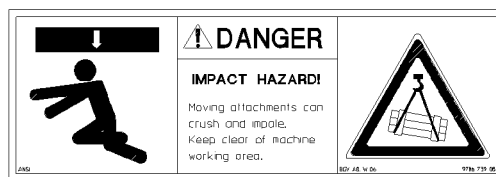
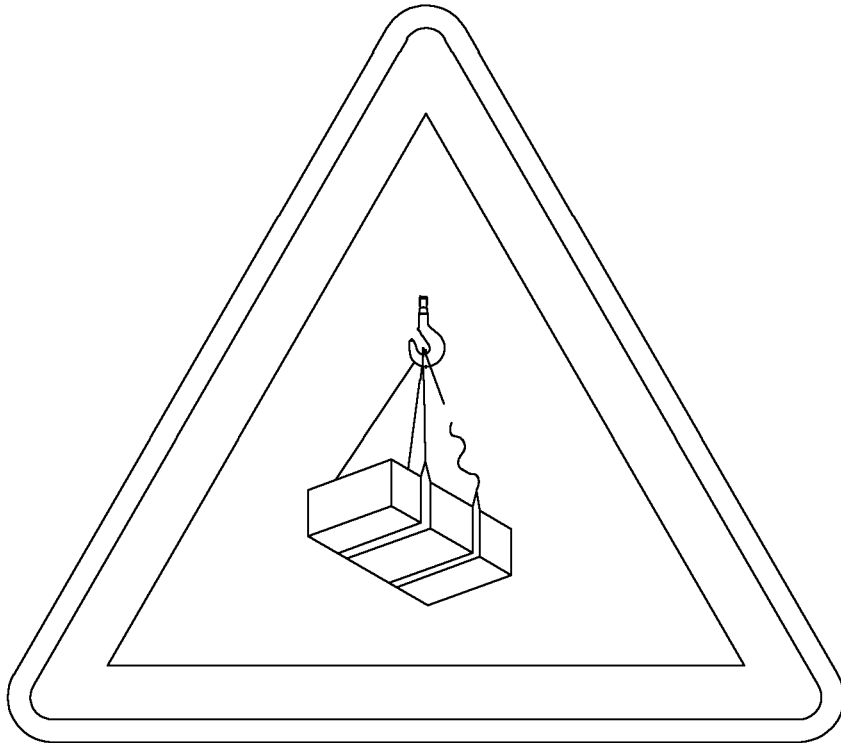

12 Assembly / disassembly



WARNING

Risk of fatal injury due to incorrect assembly or disassembly!

The assembly / disassembly of components may never be performed by untrained personnel.

Incorrect assembly / disassembly can result in death or severe injury!

- ▶ Assembly and disassembly may only be carried out by authorized and trained expert personnel!



Note

- ▶ For assembly / disassembly of individual components, also refer to the chapters relating to those components!
- ▶ Only use the auxiliary winch (installation or reeving winch) for installation and not to lift loads!
- ▶ Lifting of loads with the auxiliary winch is prohibited!

Normal assembly / disassembly procedures require all separately transported components to be transported close to the ground using appropriate auxiliary cranes and tackle and they must be safely (correctly) connected to the crane.



WARNING

Danger of impact and crushing!

There is a risk of impact and crushing when standing in the vicinity of suspended loads moving sideways.

- ▶ During assembly / disassembly no one may be in the dangerous area around or even underneath the suspended load before the load has been secured!

Part of the category "Aids for working aloft" are, for example:

- Lifting platforms
- Scaffolding
- Auxiliary cranes



WARNING

Risk of falling!

During assembly / disassembly, inspection and maintenance work, personnel must be secured with appropriate fall protection equipment to prevent them from falling! If this is not observed, assembly personnel could fall and suffer life-threatening or fatal injuries!

- ▶ All work aloft, where there is a danger of falling must be carried out with suitable aids!
- ▶ If fall protection equipment is available, then it must be used, see Crane operating instructions, chapter 2.06!
- ▶ If aids are not available and work cannot be carried out from the ground, then the assembly personnel must secure themselves with the approved fall arrest system to prevent falling, see Crane operating instructions, chapter 2.04!
- ▶ The fall arrest system must be fastened on the fastening and hook points as well as on the safety ropes. For safety points, see Crane operating instructions, chapter 2.06!
- ▶ Only step on the aids, ladders and catwalks with clean shoes!
- ▶ Keep aids, ladders and catwalks free of heavy dirt, snow and ice!
- ▶ It is prohibited to walk on the telescopic or an auxiliary boom without suitable protective devices!

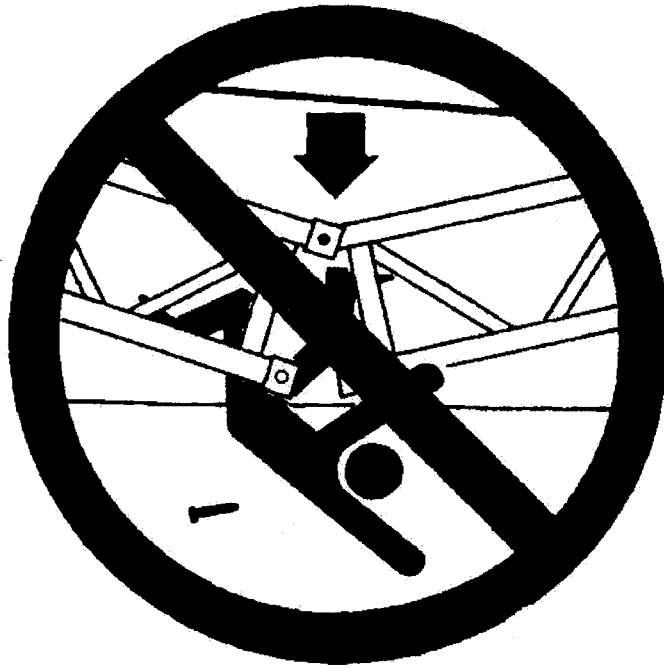

12.1 Assembly / disassembly of booms

If lattice sections are not in contact with the ground during assembly / disassembly, then they must be supported with suitable, stable materials. Adjust the height of the support so that the lattice sections are not in contact with the ground. Pay particular attention if the lattice sections are equipped with rope pulleys. Otherwise the rope pulleys could be damaged.

During disassembly it must be ensured that the auxiliary crane lifts the load vertically. The crane operator must ensure that the load bearing capacity of the auxiliary crane is sufficient to safely raise the dismantled component at the given radius. When attaching the auxiliary crane it must be ensured that the hook of the auxiliary crane is above the center of gravity of the disassembled component and the fastening ropes are attached to the load.



WARNING

The crane can topple over!

Angular pulling can destroy the crane or cause it to topple over.

- ▶ The hook block must always be attached vertically over the center of gravity of the load to be lifted!
- ▶ Angular pull is prohibited!



WARNING

Danger of accident at assembly / disassembly of booms!

The disassembling of unsecured or unsupported booms may result in fatal injury or mutilation.

- ▶ Never unpin the pins under unsecured or unsupported booms!
- ▶ Never unpin the connecting pins under unsecured or unsupported booms!
- ▶ Do not stand under the booms or within the complete danger zone during the pinning and unpinning procedure of the booms!
- ▶ Safely secure the pins in the bearing points as well as receptacles!
- ▶ Do not lean the ladder against the component being disassembled!



WARNING

Risk of accident from distorted pins!

Angular pulling or excessive / low hoisting force of the auxiliary crane may result in distortion of the pins.

Distorted parts can suddenly detach themselves when the pins are unpinned. This represents a fatal injury risk to assembly personnel.

- ▶ When the pins are unpinned, the "Lifting force" of the crane must be adapted to the "Weight" of the parts being lifted!
- ▶ Do **not** remove difficult to remove pins by force!
- ▶ Remove the reason for the distortion!



Note

Instructions for pinning and unpinning:

- ▶ Pin or unpin both pins at the same horizontal level, i.e. **left and right!**
- ▶ Pin the lower collar pins **from the inside to the outside** and unpin from the **outside to inside!**
- ▶ Insert and unpin horizontally installable double cone pins from the **outside to inside!**
- ▶ Insert and unpin vertically installable double cone pins from **top to bottom!**

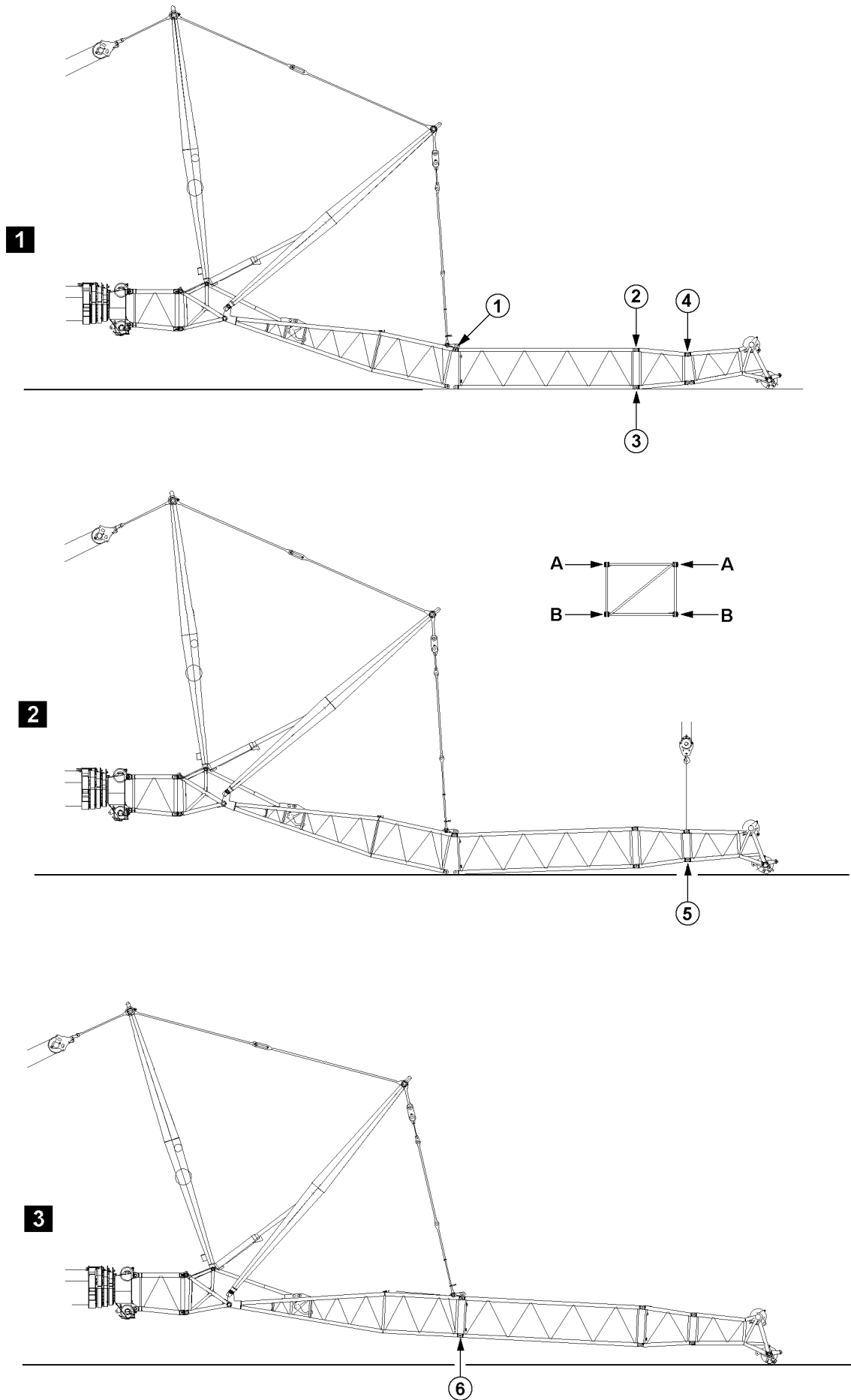

B197718

12.2 Assembly of lattice sections for telescopic cranes

12.2.1 Assembly of lattice sections for guyed auxiliary boom with an auxiliary crane

The illustrations serve as examples. The illustrations may differ depending on the crane.



WARNING

Risk of fatal injury when assembling auxiliary booms!

If the pins are not pinned in the given sequence, then lattice sections may suddenly fold down or even fall down. This can result in life-threatening injuries to personnel.

▶ Pins must be pinned in the order specified!

- ▶ Pin in and secure pins at both sides (level **A**) at point **1**, illustration 1.
- ▶ Pin in and secure pins at both sides (level **A**) at point **2**, illustration 1.
- ▶ Pin in and secure pins at both sides (level **B**) at point **3**, illustration 1.
- ▶ Pin in and secure pins at both sides (level **A**) at point **4**, illustration 1.
- ▶ Lift the end section with the auxiliary crane, illustration 2.
- ▶ Pin in and secure pins at both sides (level **B**) at point **5**, illustration 2.
- ▶ Lift the lattice sections, illustration 3.
- ▶ Pin in and secure pins at both sides (level **B**) at point **6**, illustration 3.

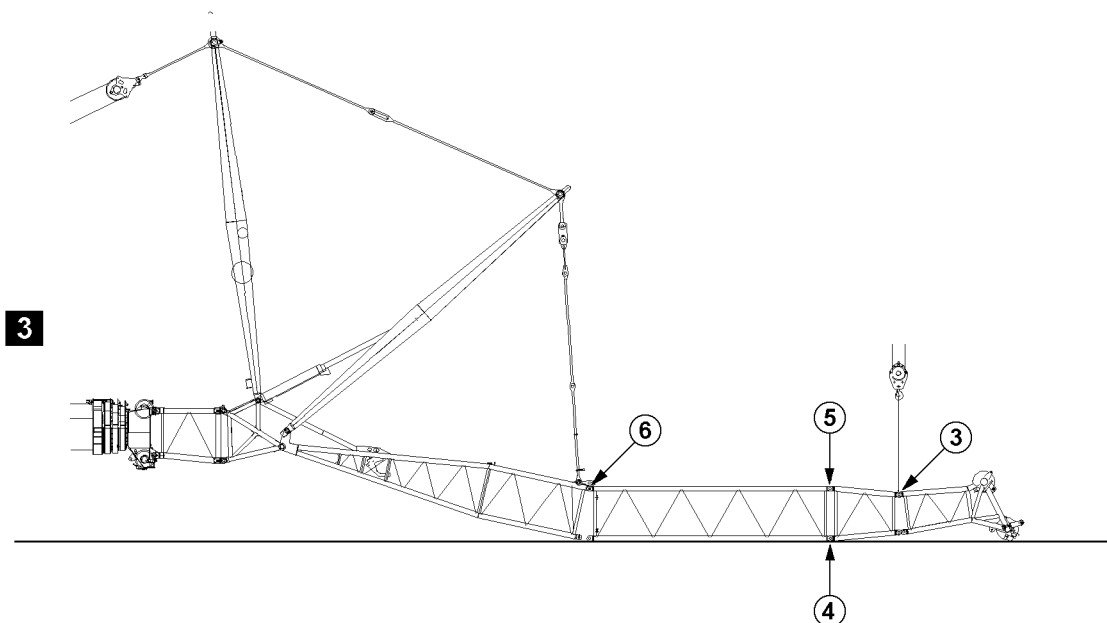
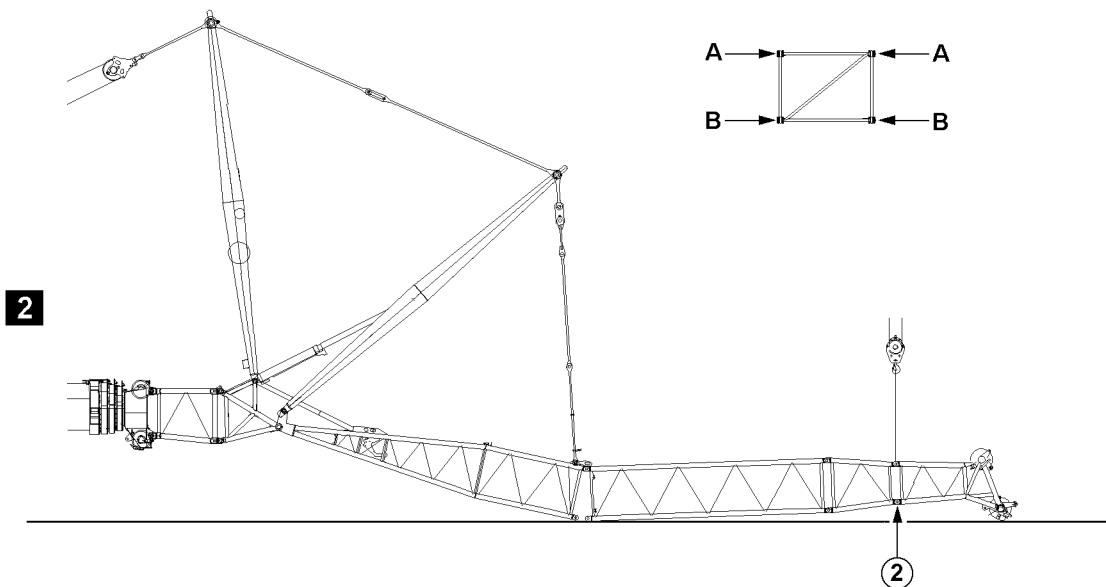
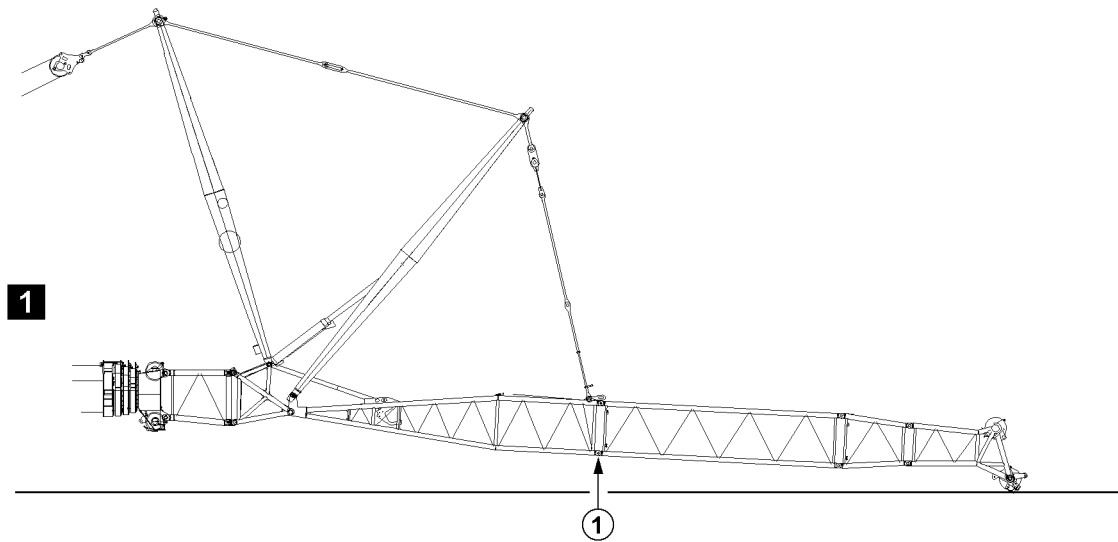

B197719

Example for cranes with telescopic boom

12.2.2 Disassembly of lattice sections for guyed auxiliary boom with an auxiliary crane

The illustrations serve as examples. The illustrations may differ depending on the crane.



WARNING

Risk of fatal injury when disassembling auxiliary booms!

If the pins are not unpinned in the given sequence, lattice sections may suddenly fold down or even fall down. This can result in life-threatening injuries to personnel.

▶ Pins must be unpinned in the order specified!

- ▶ Luff the auxiliary boom down until the end section is lightly touching the ground, illustration 1.
- ▶ Release and unpin pins at both sides (level **B**) at point **1**, illustration 1.
- ▶ Completely remove the lattice sections, illustration 2.
- ▶ Lift the end section with the auxiliary crane, illustration 2.
- ▶ Release and unpin pins at both sides (level **B**) at point **2**, illustration 2.
- ▶ Release and unpin pins at both sides (level **A**) at point **3**, illustration 3.
- ▶ Release and unpin pins at both sides (level **B**) at point **4**, illustration 3.
- ▶ Release and unpin pins at both sides (level **A**) at point **5**, illustration 3.
- ▶ Release and unpin pins at both sides (level **A**) at point **6**, illustration 3.

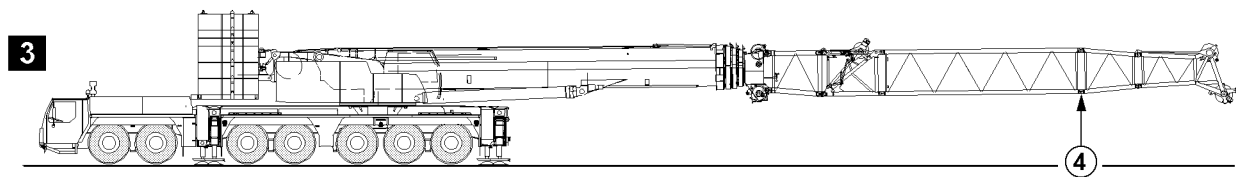
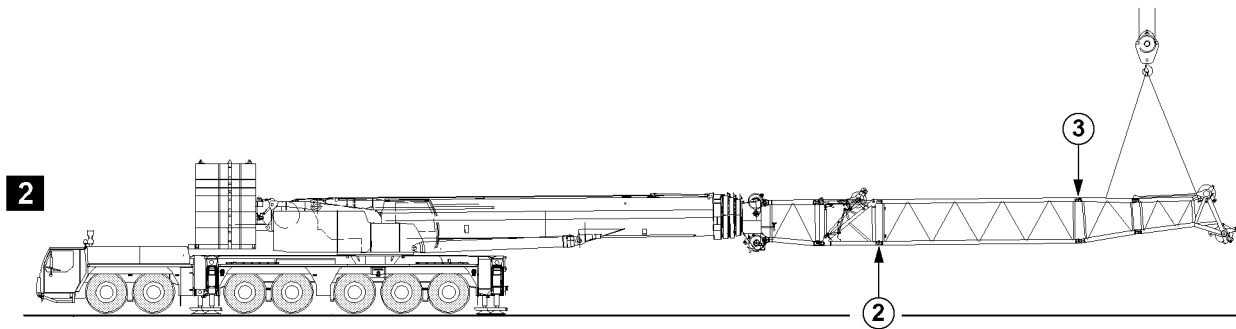
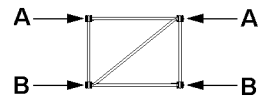
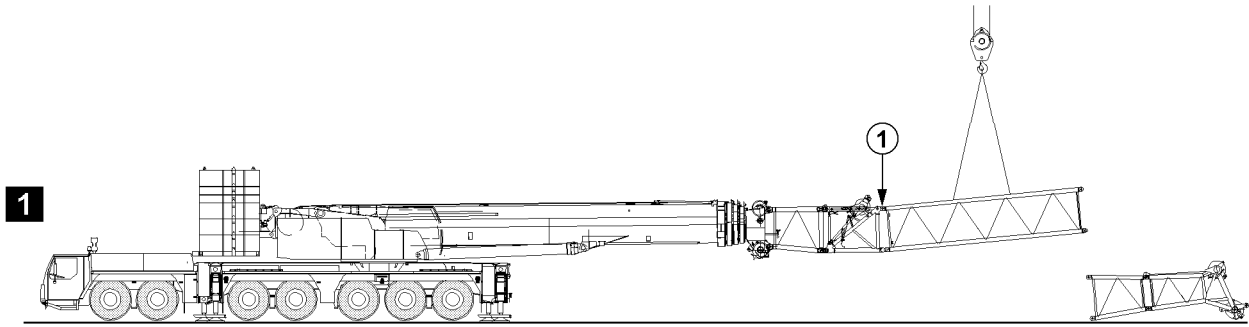

12.2.3 Assembly of lattice sections on self-supporting auxiliary booms using an auxiliary crane

The illustrations serve as examples. The illustrations may differ depending on the crane.



WARNING

Risk of fatal injury when assembling auxiliary booms!

If the pins are not pinned in the given sequence, then lattice sections may suddenly fold down or even fall down. This can result in life-threatening injuries to personnel.

▶ Pins must be pinned in the order specified!

- ▶ Pin in and secure pins at both sides (level **A**) at point **1**, illustration 1.
- ▶ Pin in and secure pins at both sides (level **B**) at point **2**, illustration 2.
- ▶ Pin in and secure pins at both sides (level **A**) at point **3**, illustration 2.
- ▶ Pin in and secure pins at both sides (level **B**) at point **4**, illustration 3.

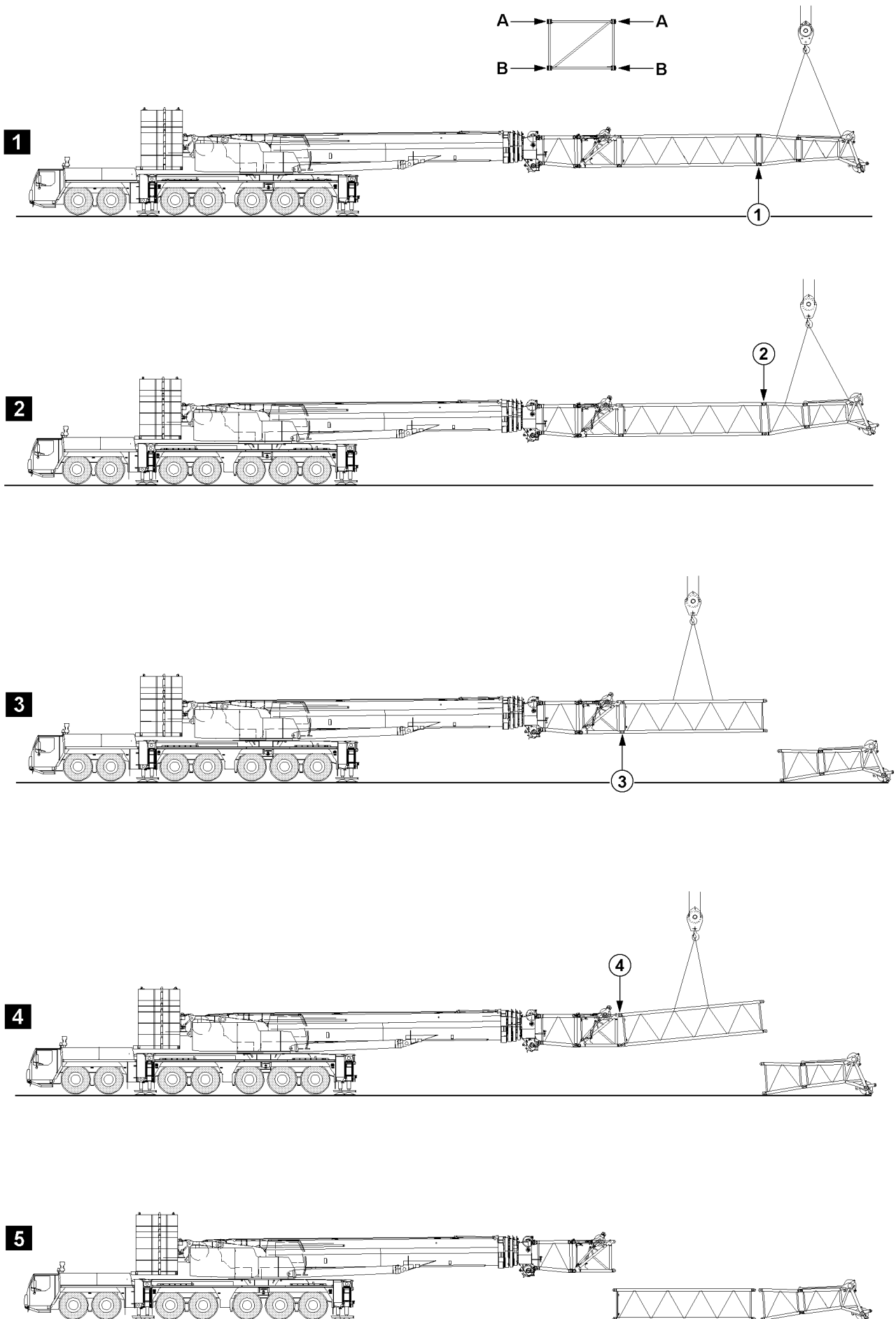

B105510

Example for cranes with telescopic boom

12.2.4 Disassembly of lattice sections on self-supporting auxiliary booms using an auxiliary crane

The illustrations serve as examples. The illustrations may differ depending on the crane.



WARNING

Risk of fatal injury when disassembling auxiliary booms!

If the pins are not unpinned in the given sequence, lattice sections may suddenly fold down or even fall down. This can result in life-threatening injuries to personnel.

▶ Pins must be unpinned in the order specified!

- ▶ Release and unpin pins at both sides (level **B**) at point **1**, illustration 1.
- ▶ Release and unpin pins at both sides (level **A**) at point **2**, illustration 2.
- ▶ Release and unpin pins at both sides (level **B**) at point **3**, illustration 3.
- ▶ Release and unpin pins at both sides (level **A**) at point **4**, illustration 4.

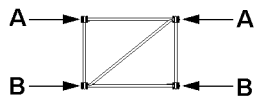
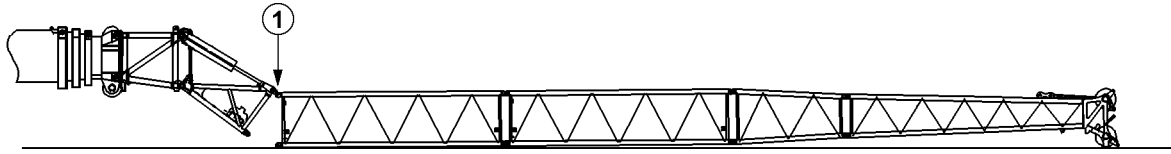
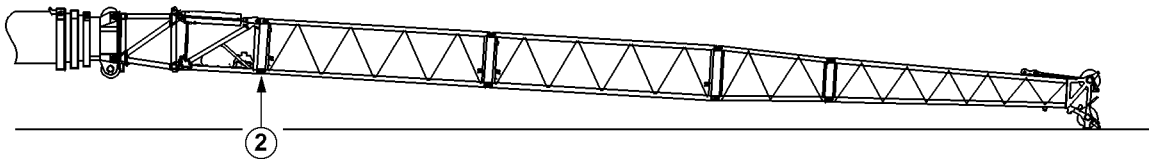
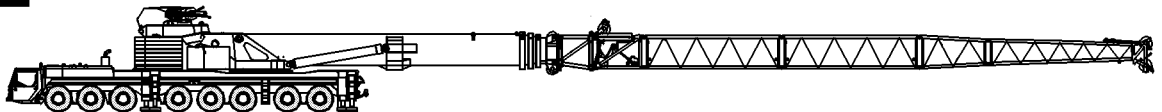
1**2****3**

12.2.5 Assembly of lattice sections on self-supporting auxiliary booms without using an auxiliary crane

The illustrations serve as examples. The illustrations may differ depending on the crane.



WARNING

Risk of fatal injury when assembling auxiliary booms!

If the pins are not pinned in the given sequence, then lattice sections may suddenly fold down or even fall down. This can result in life-threatening injuries to personnel.

- ▶ Pins must be pinned in the order specified!
-

For cranes with hydraulic angle adjustment and self-supporting auxiliary boom, the assembly / disassembly of additional lattice sections may be performed using the crane itself.

In order to do so, proceed as follows.

- ▶ Assemble the lattice sections to the required length.
- ▶ Pin in and secure pins at both sides (level **A**) at point **1**, illustration 1.
- ▶ Luff the auxiliary boom up until the pins can be pinned at point **2**, illustration 2.
- ▶ Pin in and secure pins at both sides (level **B**) at point **2**, illustration 2.

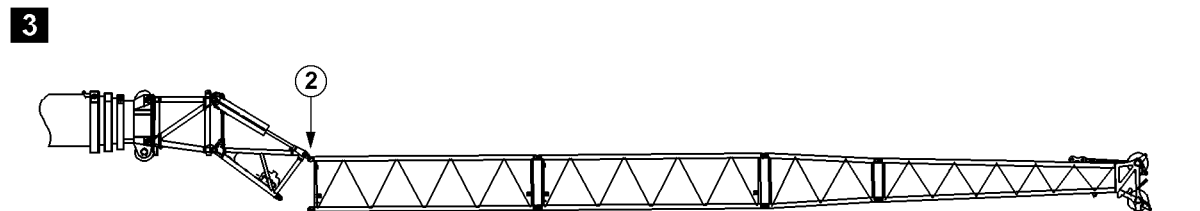
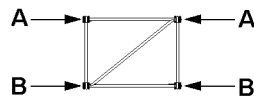
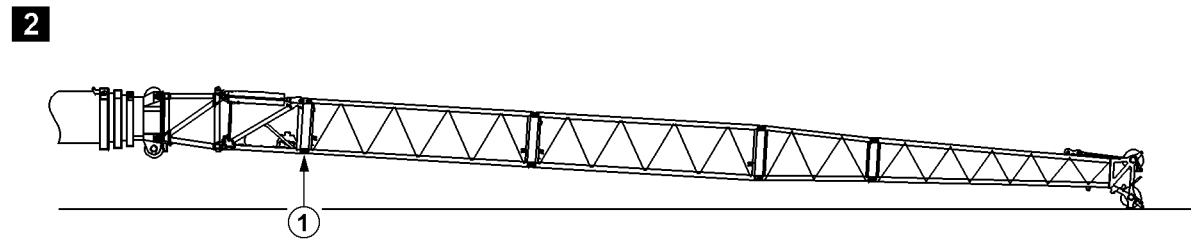
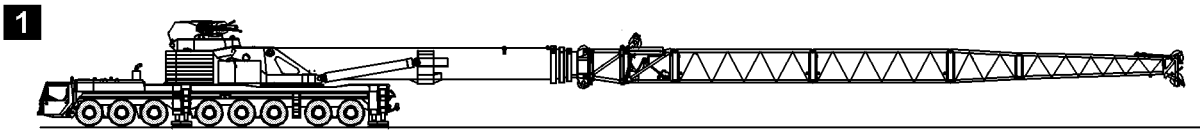

12.2.6 Disassembly of lattice sections on self-supporting auxiliary booms without using an auxiliary crane

The illustrations serve as examples. The illustrations may differ depending on the crane.



WARNING

Risk of fatal injury when disassembling auxiliary booms!

If the pins are not unpinned in the given sequence, lattice sections may suddenly fold down or even fall down. This can result in life-threatening injuries to personnel.

- ▶ Pins must be unpinned in the order specified!
-

For cranes with hydraulic angle adjustment and self-supporting auxiliary boom, the assembly / disassembly of additional lattice sections may be performed using the crane itself.

In order to do so, proceed as follows.

- ▶ Luff the auxiliary boom down until the end section is lightly touching the ground, illustration 2.
- ▶ Release and unpin pins at both sides (level **B**) at point **1**, illustration 2.
- ▶ Luff the auxiliary boom down until the lattice section to be disassembled are completely laying on the ground, illustration 3.
- ▶ Release and unpin pins at both sides (level **A**) at point **2**, illustration 3.
- ▶ Completely remove the auxiliary boom.

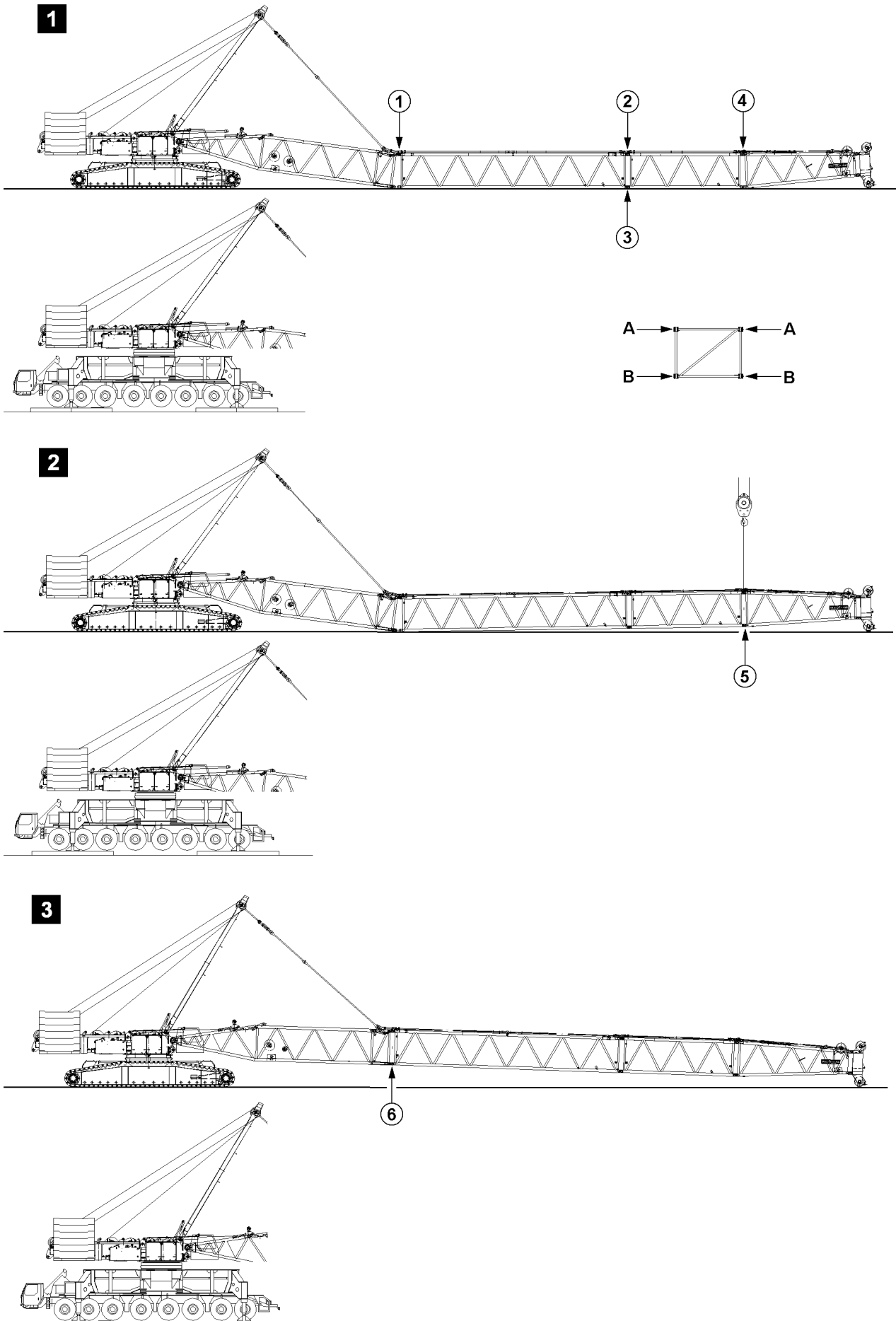

B197710

Example for cranes with lattice mast booms

12.3 Assembly of lattice sections for lattice mast cranes

12.3.1 Assembly of lattice sections

The illustrations serve as examples. The illustrations may differ depending on the crane.



WARNING

Risk of fatal injury when assembling booms!

If the pins are not pinned in the given sequence, then lattice sections may suddenly fold down or even fall down. This can result in life-threatening injuries to personnel.

▶ Pins must be pinned in the order specified!

- ▶ Pin in and secure pins at both sides (level **A**) at point **1**, illustration 1.
- ▶ Pin in and secure pins at both sides (level **A**) at point **2**, illustration 1.
- ▶ Pin in and secure pins at both sides (level **B**) at point **3**, illustration 1.
- ▶ Pin in and secure pins at both sides (level **A**) at point **4**, illustration 1.
- ▶ Lift the end section with the auxiliary crane, illustration 2.
- ▶ Pin in and secure pins at both sides (level **B**) at point **5**, illustration 2.
- ▶ Lift the lattice sections, illustration 3.
- ▶ Pin in and secure pins at both sides (level **B**) at point **6**, illustration 3.

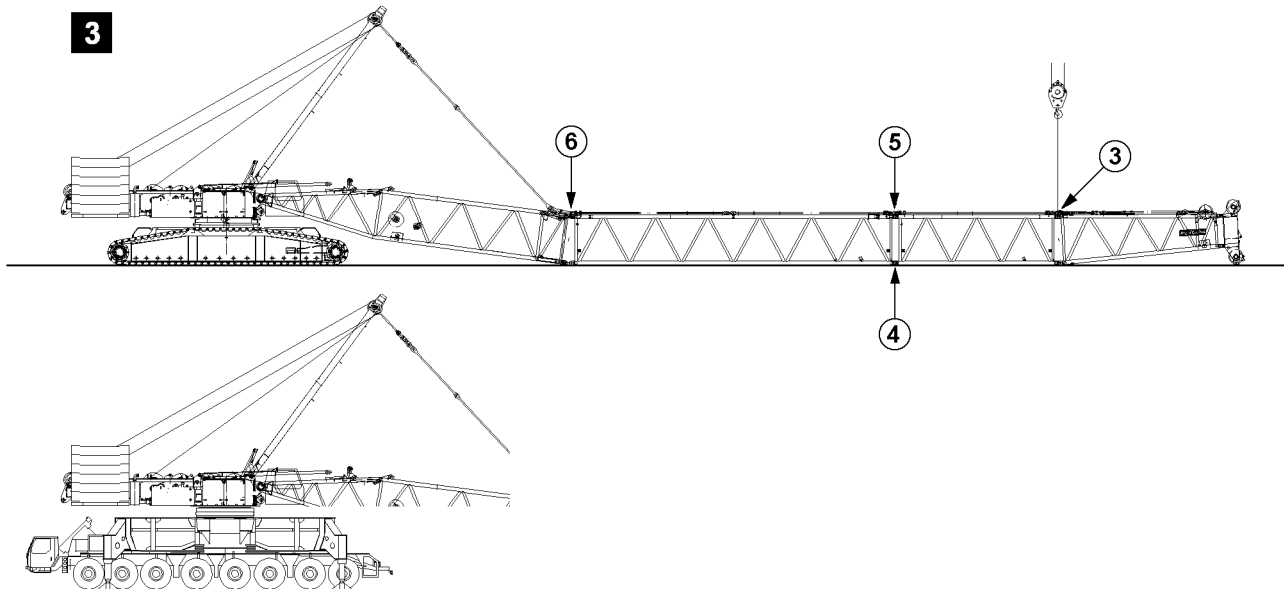
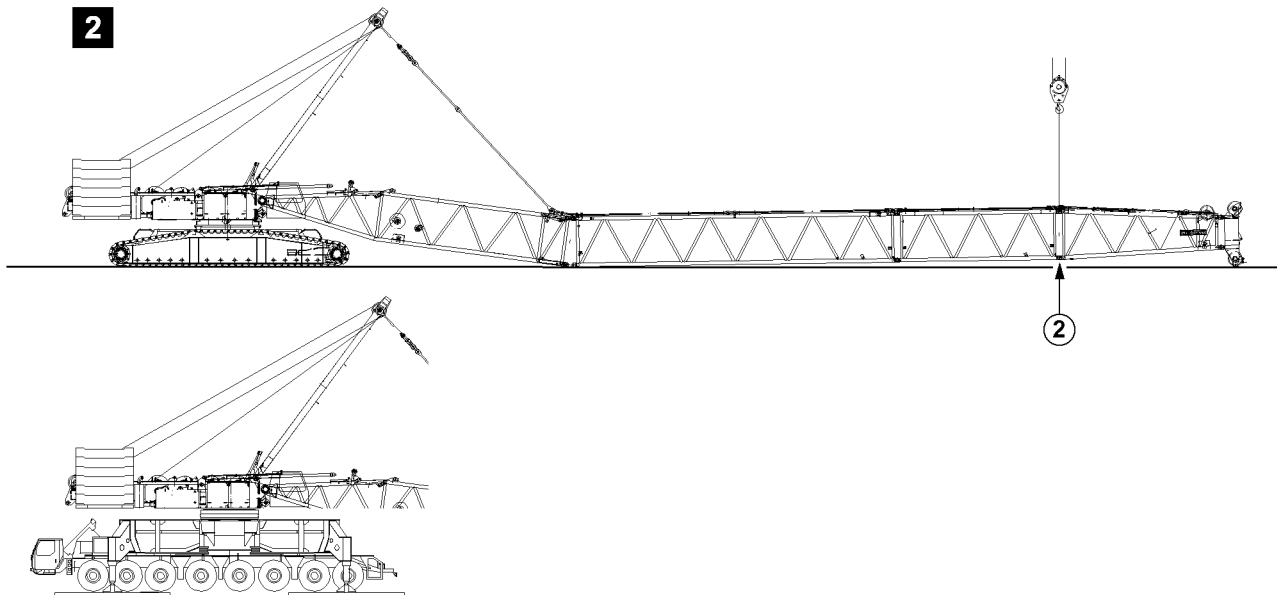
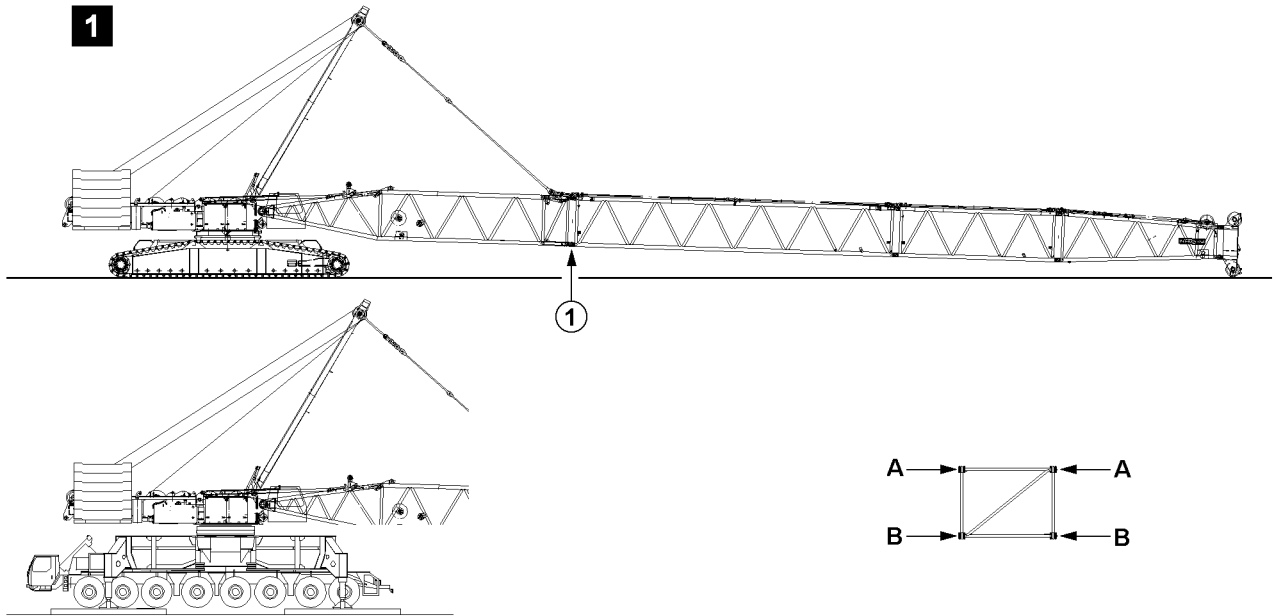

B197711

Example for cranes with lattice mast booms

12.3.2 Disassembly of lattice sections

The illustrations serve as examples. The illustrations may differ depending on the crane.



WARNING

Risk of fatal injury when disassembling booms!

If the pins are not unpinned in the given sequence, lattice sections may suddenly fold down or even fall down. This can result in life-threatening injuries to personnel.

▶ Pins must be unpinned in the order specified!

- ▶ Luff the boom down until the end section is lightly touching the ground, illustration 1.
- ▶ Release and unpin pins at both sides (level **B**) at point **1**, illustration 1.
- ▶ Completely remove the lattice sections, illustration 2.
- ▶ Lift the end section with the auxiliary crane, illustration 2.
- ▶ Release and unpin pins at both sides (level **B**) at point **2**, illustration 2.
- ▶ Release and unpin pins at both sides (level **A**) at point **3**, illustration 3.
- ▶ Release and unpin pins at both sides (level **B**) at point **4**, illustration 3.
- ▶ Release and unpin pins at both sides (level **A**) at point **5**, illustration 3.
- ▶ Release and unpin pins at both sides (level **A**) at point **6**, illustration 3.

1

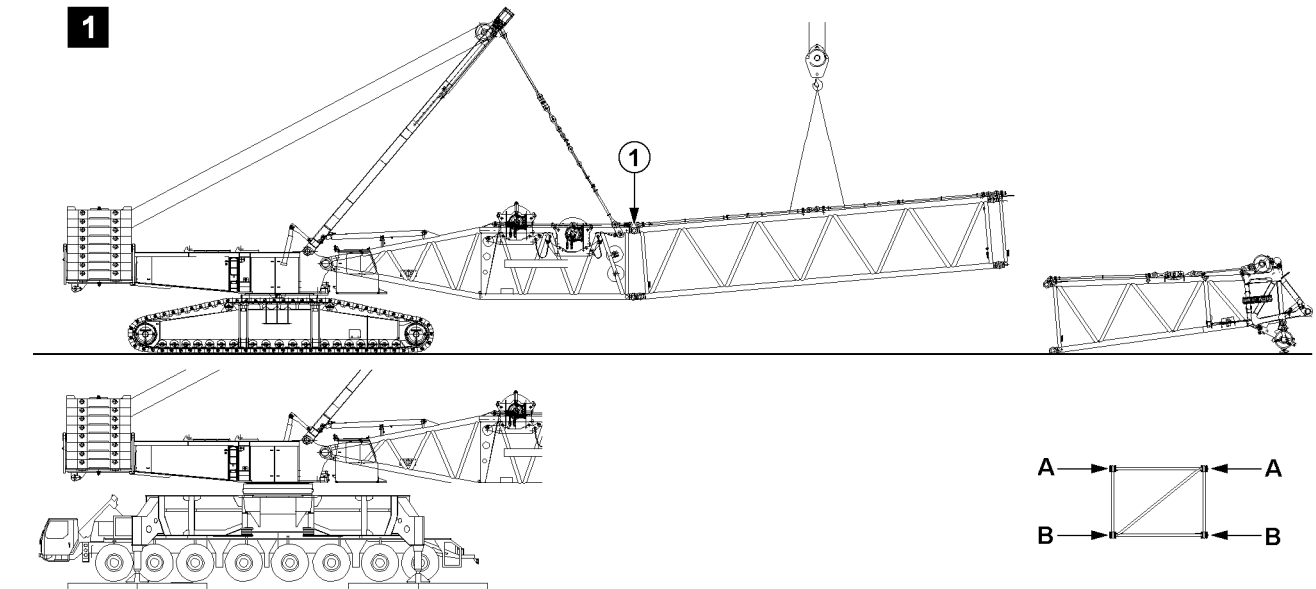

2

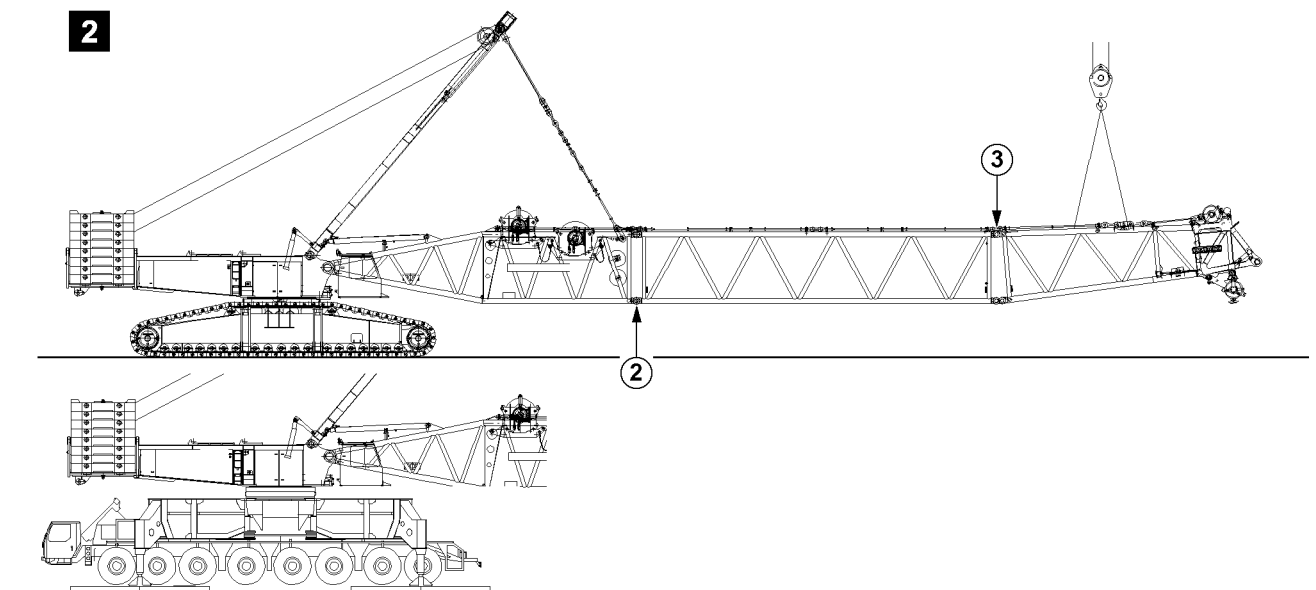

3

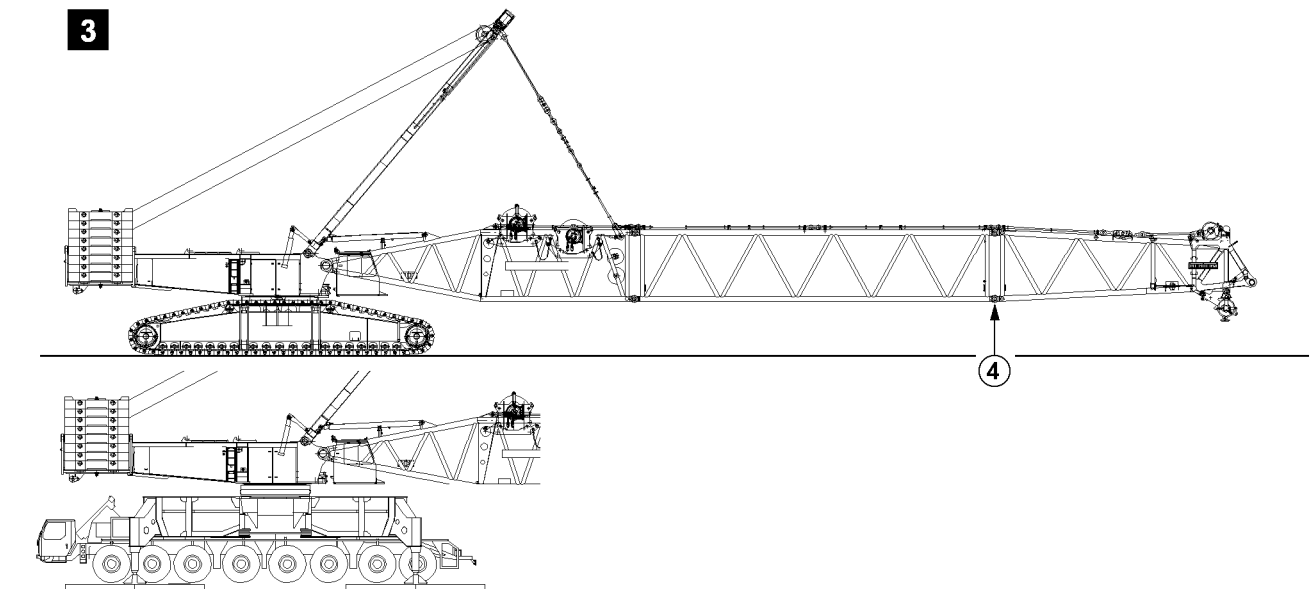

B198182

Example for cranes with lattice mast booms

12.3.3 Flying assembly of lattice sections

The illustrations serve as examples. The illustrations may differ depending on the crane.



WARNING

Risk of fatal injury when assembling booms!

If the pins are not pinned in the given sequence, then lattice sections may suddenly fold down or even fall down. This can result in life-threatening injuries to personnel.

▶ Pins must be pinned in the order specified!

- ▶ Pin in and secure pins at both sides (level **A**) at point **1**, illustration 1.
- ▶ Pin in and secure pins at both sides (level **B**) at point **2**, illustration 2.
- ▶ Pin in and secure pins at both sides (level **A**) at point **3**, illustration 2.
- ▶ Pin in and secure pins at both sides (level **B**) at point **4**, illustration 3.

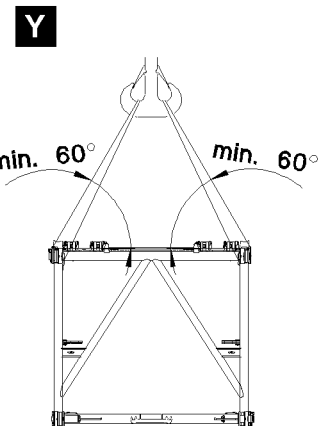
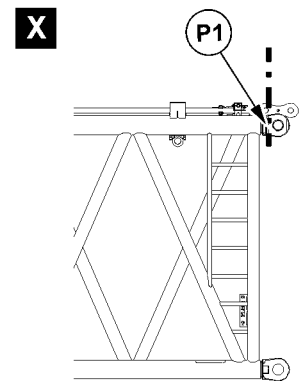
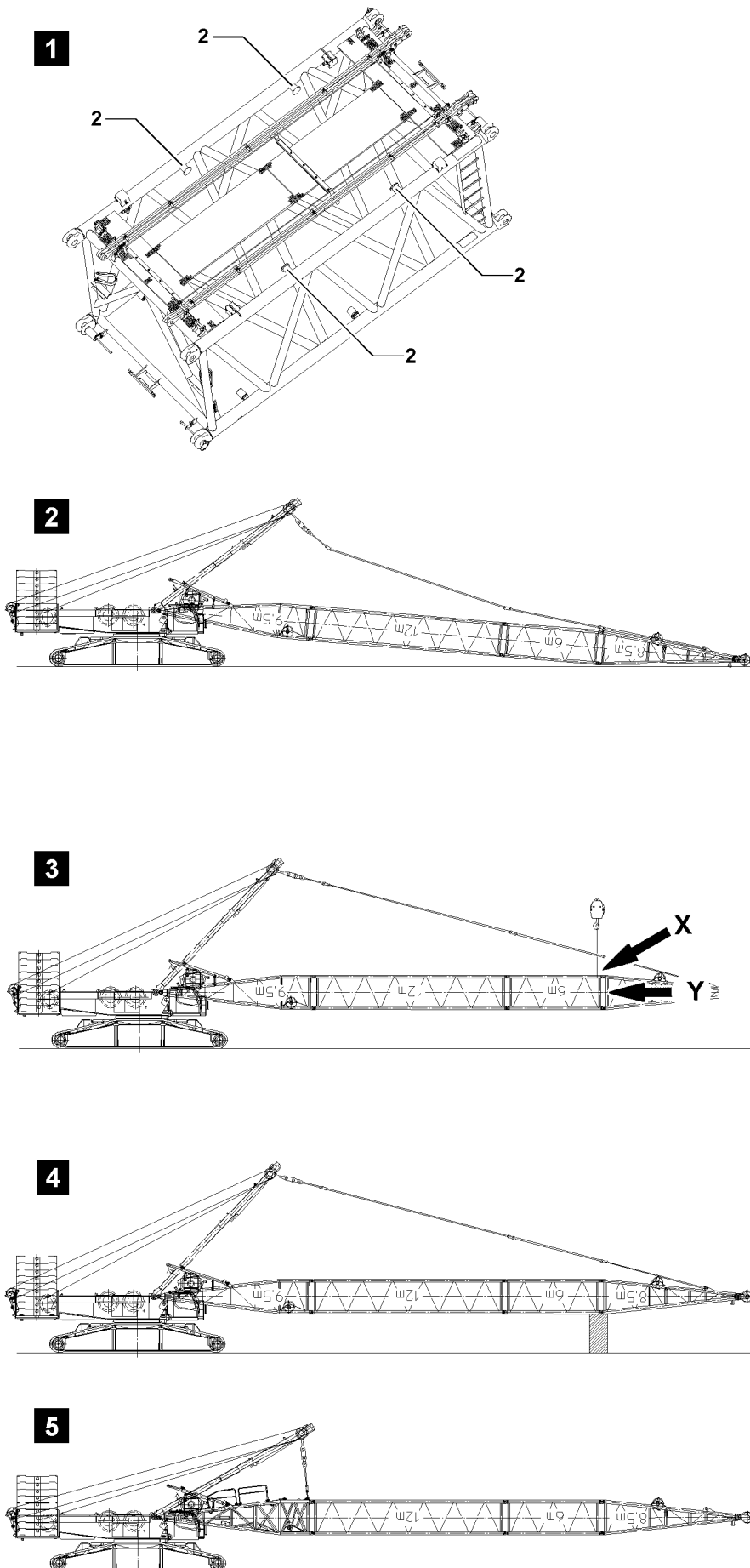

B111448

Guying the pivot section with the SA-frame

12.3.4 Flying disassembly of lattice sections

The illustrations serve as examples. The illustrations may differ depending on the crane.
The flying disassembly of lattice sections can be used on:

- Derrick boom
- Main boom



Note

- ▶ Before guying the pivot section, the boom is secured to prevent it from falling down!
- ▶ There are various possibilities to secure the boom to prevent it from falling down!

Guying the pivot section in flying mode with the SA-frame

- ▶ Place the boom on the ground, see illustration 2.

or



WARNING

Lattice section incorrectly attached!

If the fastening equipment is attached on the bits **2** when securing the boom, then the bits will be overloaded! The lattice section will be damaged and the boom can fall down! Personnel can be severely injured or killed!

If the auxiliary crane is used to secure the boom for flying disassembly:

- ▶ Do **not** fasten the lattice section on the bits **2**, see illustration 1!
- ▶ Attach the fastening equipment in the area of point **P1** on both sides on the lattice section, see detail **X!**
- ▶ Make sure that the long fastening equipment is used, so that the angle between the cross section of lattice section and guyed fastening equipment is at least 60°, see detail **Y!**

- Secure the boom with the auxiliary crane, see illustration 3.

or



WARNING

Falling boom!

If the boom is not properly and securely supported from below, then the boom can fall down!

- ▶ Support the boom properly and safely with suitable material!

- Support the boom, see illustration 4.

Result:

- The guy rods can be disassembled.

- ▶ Place down, secure and disassemble the guy rods.
- ▶ Pin and secure the guy rods SA-frame on the pivot section.
- ▶ Tighten the guy rods SA-frame until the boom is in horizontal position.

Result:

- Pivot section is guyed in flying mode with the SA-frame, see illustration 5.
- The lattice sections can be disassembled in flying mode.

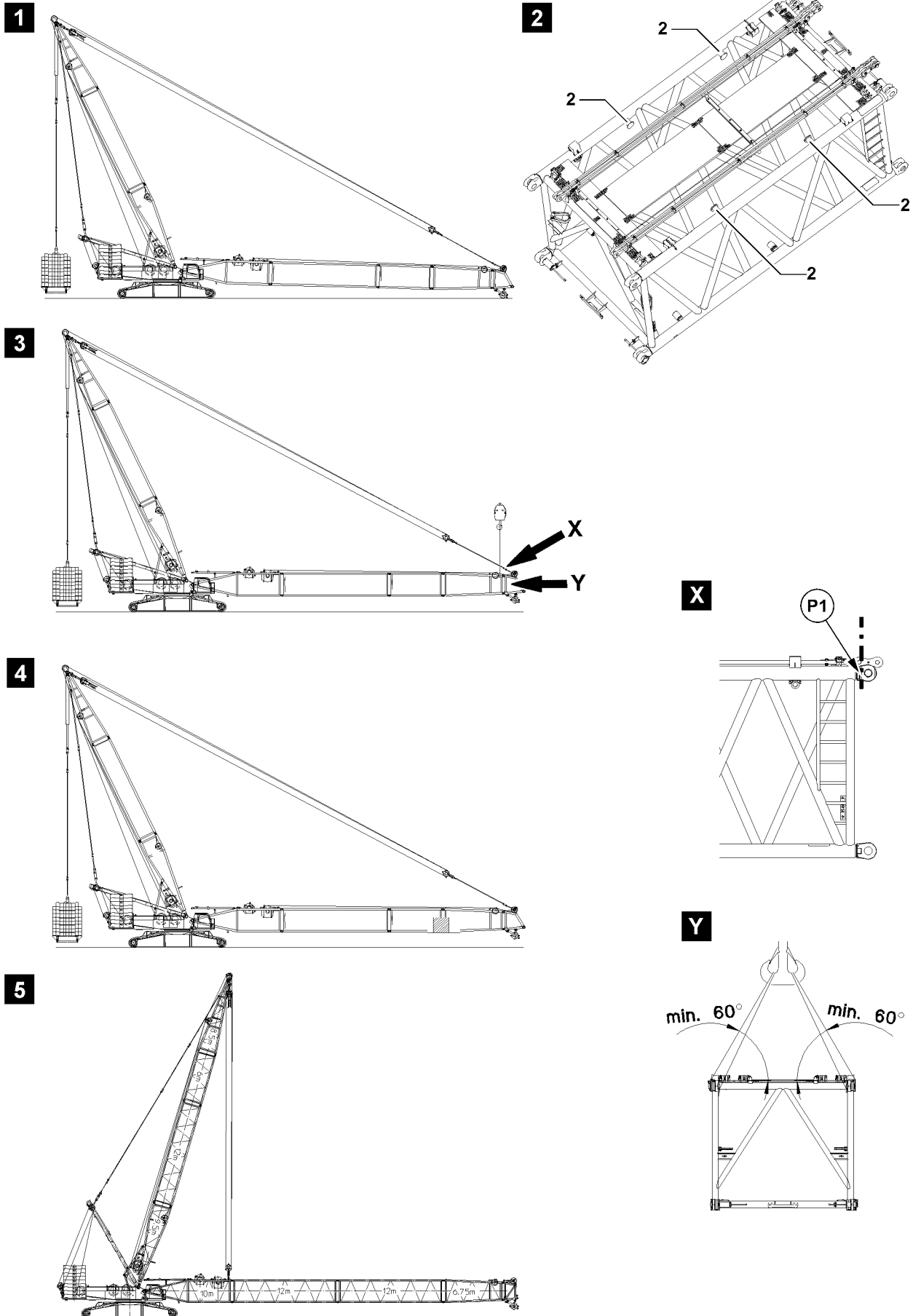

B111449

Guying the pivot section with the derrick boom

Guying the pivot section in flying mode with the derrick boom

- ▶ Place the boom on the ground, see illustration 1.

or

**WARNING**

Lattice section incorrectly attached!

If the fastening equipment is attached on the bits **2** when securing the boom, then the bits will be overloaded! The lattice section will be damaged and the boom can fall down! Personnel can be severely injured or killed!

If the auxiliary crane is used to secure the boom for flying disassembly:

- ▶ Do **not** fasten the lattice section on the bits **2**, see illustration **2**!
- ▶ Attach the fastening equipment in the area of point **P1** on both sides on the lattice section, see detail **X**!
- ▶ Make sure that the long fastening equipment is used, so that the angle between the cross section of lattice section and guyed fastening equipment is at least 60°, see detail **Y**!

- Secure the boom with the auxiliary crane, see illustration **3**.

or

**WARNING**

Falling boom!

If the boom is not properly supported from below, then the boom can fall down!

- ▶ Support the boom properly and safely with suitable material!

- Support the boom, see illustration **4**.

Result:

- The guy rods can be disassembled.

- ▶ Place down, secure and disassemble the guy rods.
- ▶ Pin and secure the pulley block on the pivot section.
- ▶ Tighten the control rope until the boom is in horizontal position.

Result:

- Pivot section is guyed in flying mode with the SA-frame, see illustration **5**.
- The lattice sections can be disassembled in flying mode.

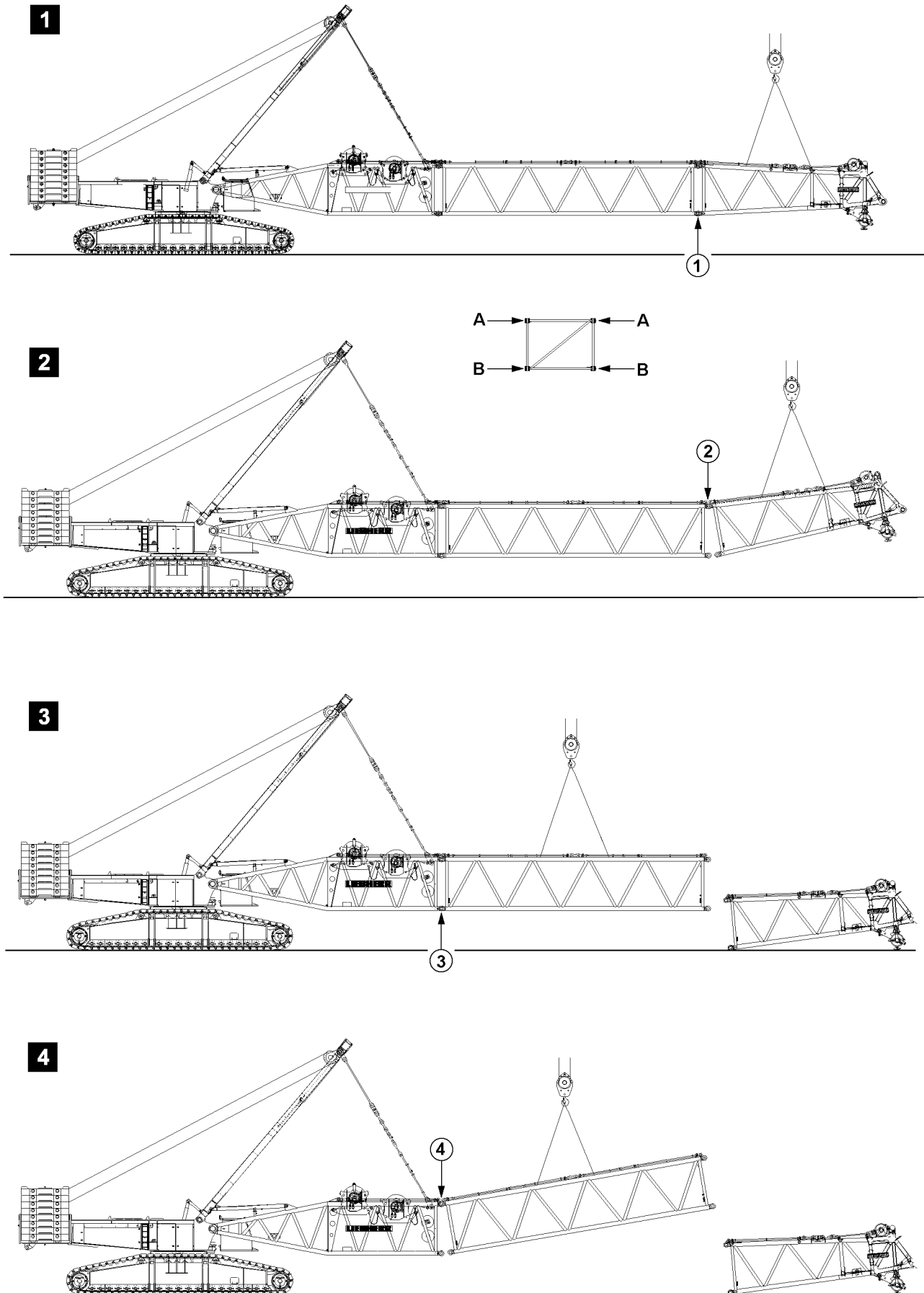

B105511

Example for cranes with lattice mast booms

Unpinning the lattice components



WARNING

Risk of fatal injury when disassembling booms!

If the pins are not unpinned in the given sequence, lattice sections may suddenly fold down or even fall down. This can result in life-threatening injuries to personnel.

▶ Pins must be unpinned in the order specified!

- ▶ Release and unpin pins at both sides (level **B**) at point **1**, illustration 1.
- ▶ Release and unpin pins at both sides (level **A**) at point **2**, illustration 2.
- ▶ Release and unpin pins at both sides (level **B**) at point **3**, illustration 3.
- ▶ Release and unpin pins at both sides (level **A**) at point **4**, illustration 4.

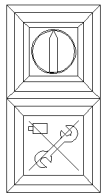
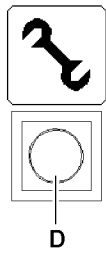

12.4 Bypassing during crawler assembly



Note

- ▶ The crawler assembly key button is only installed on certain cranes.



D

Make sure that the following prerequisites are met:

- The set up key is pressed.
- The assembly icon on the LICCON monitor lights up.



WARNING

High risk of injury in case of actuated crawler assembly key button!

Operating the crawler assembly key button bypasses the overload protection! No shut off at overload will occur in assembly mode or in crane operations!

In the event of deliberate misuse, the crane can topple over!

Personnel can be killed!

This could result in high property damage!

- ▶ The crawler assembly key button may only be actuated for assembly tasks!
- ▶ All other usage of the crawler assembly key button other than as described in the operating instructions is prohibited!
- ▶ Operating the crane with the crawler assembly key button enabled is strictly prohibited!

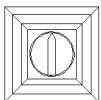

- ▶ Actuate the crawler assembly key button.

Result:

- The LICCON overload protection is inactive.
- The indicator light in the button lights up.

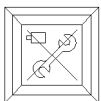

- ▶ To turn the crawler assembly key button off:
Turn off the crawler assembly key button by pressing the button.

Result:

- The indicator light in the button turns off.

12.5 Assembling / disassembly of hydraulic lines

When hydraulic lines are connected and disconnected with quick-release couplings, make ensure that the coupling procedure is being performed correctly.



WARNING

Risk of accident due to pressure loss or leakage!

Incorrectly coupled or self-loosening quick-release couplings (particularly return lines) can result in serious accidents due to component failure!

Personnel can be severely injured or killed!

- ▶ Check the quick-release couplings after installation for correct connection.

**WARNING**

Pressure in the hydraulic lines!

If the pressure supply is not interrupted before releasing the hydraulic lines, the hydraulic oil can escape with high pressure!

Personnel can be severely injured or killed!

- ▶ Release the pressure in the hydraulic system before releasing. Interrupt the pressure supply and wait for a short time.
-
- ▶ Release the pressure in the hydraulic system before connecting and disconnecting. Turn the engine off and wait for short time.
 - ▶ Connect the coupling components (sleeve and connector) and screw together with the hand-tightened nut.
 - ▶ Tighten the hydraulic coupling by hand. Rotate the hand-tightened nut until it reaches a tangible, fixed stop position.

13 Erection / take down

**WARNING**

The crane can topple over!

Due to an unforeseen occurrence, for example: sudden strong wind or storm, dangers operating situations can occur, up to toppling the crane!

Personnel can be severely injured or killed!

- ▶ The boom must be able to be placed down at any time with its current equipment!
- ▶ The required counterweight must always be in direct vicinity of the crane!
- ▶ The crane operator must ensure that the required counterweight is carried along when driving the crane with the equipment in place and that the boom can be placed down at any time!

**WARNING**

Risk of fatal injury!

- ▶ Incorrectly assembled or non-operational limit switches and falling parts (pins, spring retainers, ice etc.) can cause accidents!

13.1 Erection / take down for mobile cranes

Make sure that the following prerequisites are met:

- The crane is properly supported.
- The crane is aligned in horizontal direction.
- The counterweight has been installed on the turntable according to the load chart.
- The telescopic boom is fully telescoped in.
- The boom has been installed according to the load chart specifications and the operating instructions.
- All limit switches have been correctly installed and are fully functional.
- All pin connections have been secured.
- The hoist rope has been correctly placed in the rope pulleys and prevented from jumping out with the rope retaining pins.
- No personnel is within the danger zone.
- There are no loose parts on the boom or the auxiliary boom.
- In winter, the telescopic boom, the auxiliary boom and their associated components (limit switches, cable drum, flashing beacon, wind speed sensor etc.) must be kept free of ice and snow.

13.2 Erection / take down for crawler cranes

Make sure that the following prerequisites are met:

- The crane is aligned in horizontal direction.
- The counterweight has been installed on the turntable according to the load chart.
- The central ballast has been attached according to the load chart.
- The counterweight is stacked on the suspended ballast or on the ballast trailer according to the load chart.
- The boom has been installed according to the load chart specifications and the operating instructions.
- All limit switches have been correctly installed and are fully functional.
- All pin connections have been secured.
- The hoist rope has been correctly placed in the rope pulleys and prevented from jumping out with the rope retaining pins.
- No personnel is within the danger zone.
- There are no loose parts on the boom or the auxiliary boom.
- In winter, the boom, the auxiliary boom and their associated components (limit switches, cable drum, flashing beacon, wind speed sensor etc.) must be kept free of ice and snow.

13.3 Checking the prerequisites

- ▶ Check if all prerequisites have been met.

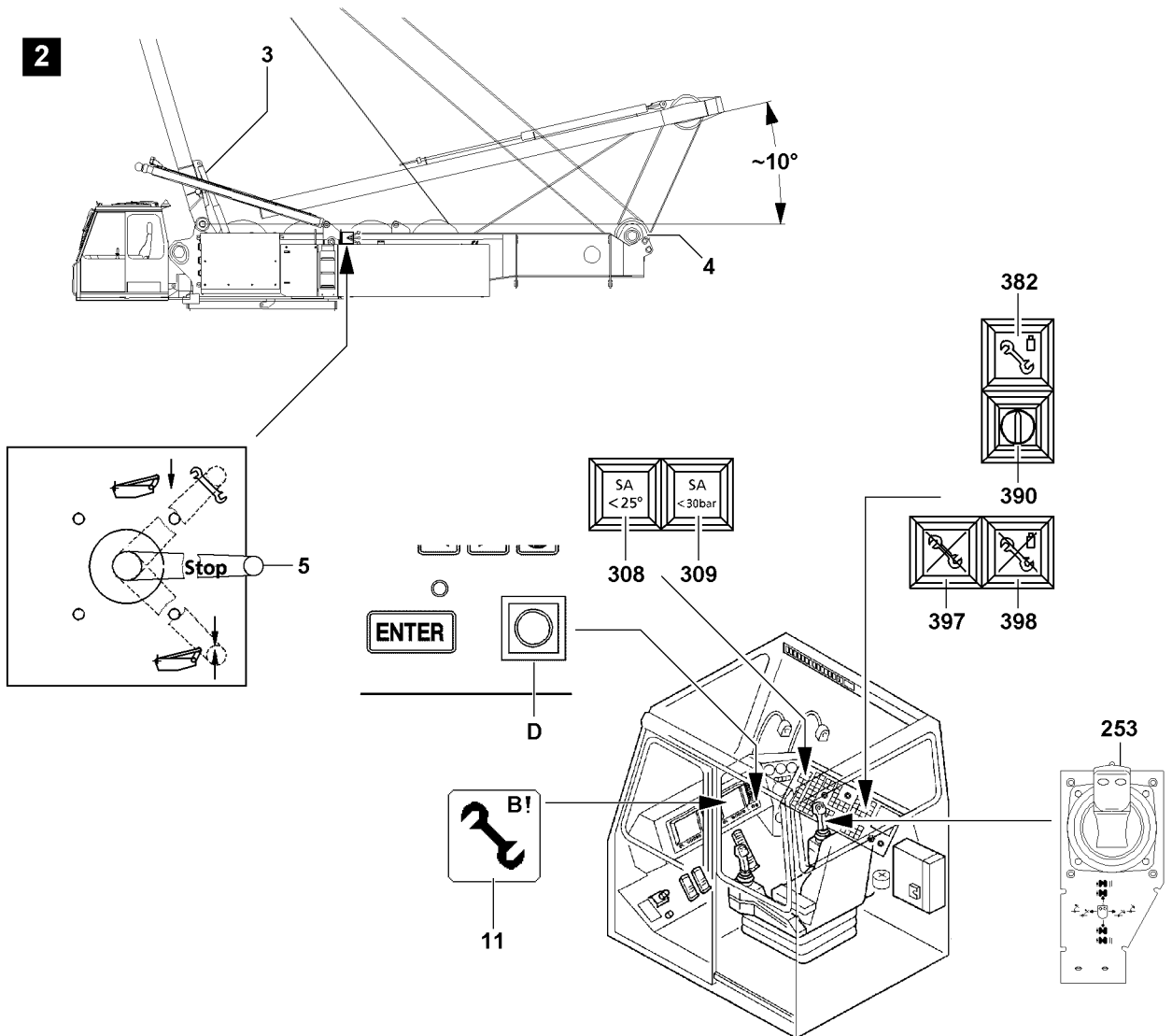
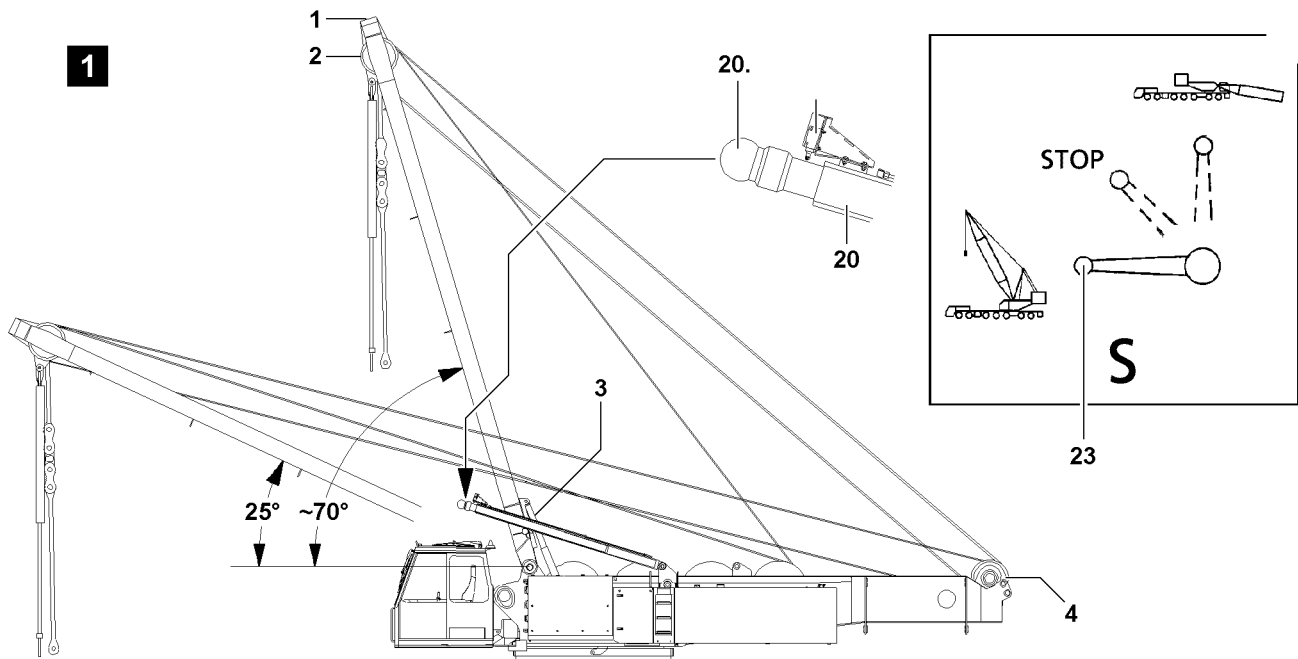

B111426

1 SA-bracket



Note

- ▶ The SA-bracket is used in assembly operation to install the crawler travel gear, see Crane operating instructions, chapter 3.01!



WARNING

Assembly with turned on set up key!

When the set up key is engaged, the LICCON overload protection is exceeded!

In the event of deliberate improper use, the crane could collapse, the boom can break off or the crane can topple over!

Personnel can be killed!

This could result in high property damage!

- ▶ The set up key **D** may only be actuated by persons who know the effects of a bypass!
- ▶ Press the set up key **D** only when the set up status was correctly entered into the LICCON computer system!
- ▶ Observe the erection / take down charts!
- ▶ Crane operation with the set up key **D** turned on is strictly prohibited!



Note

- ▶ Master switch assignment in case of exceeded LICCON overload protection, see Crane operating instructions, chapter 4.05!

Make sure that the following prerequisites are met:

- The SA-bracket has been placed on the turntable (transport position).
- The engine is running, see Crane operating instructions, chapter 4.03.
- **No** counterweight is installed on the turntable.
- The rope of winch 4 “Boom control” is reeved.
- The LICCON overload protection is exceeded.
- The assembly icon **11** is visible on the LICCON monitor.
- The key button **390** “Crawler and boom assembly” is actuated.
- The indicator light **382** Crawler assembly lights up.
- The piston rods **20.1** of the S-relapse cylinder **20** are extended approx. 10 cm to approx. 15 cm.

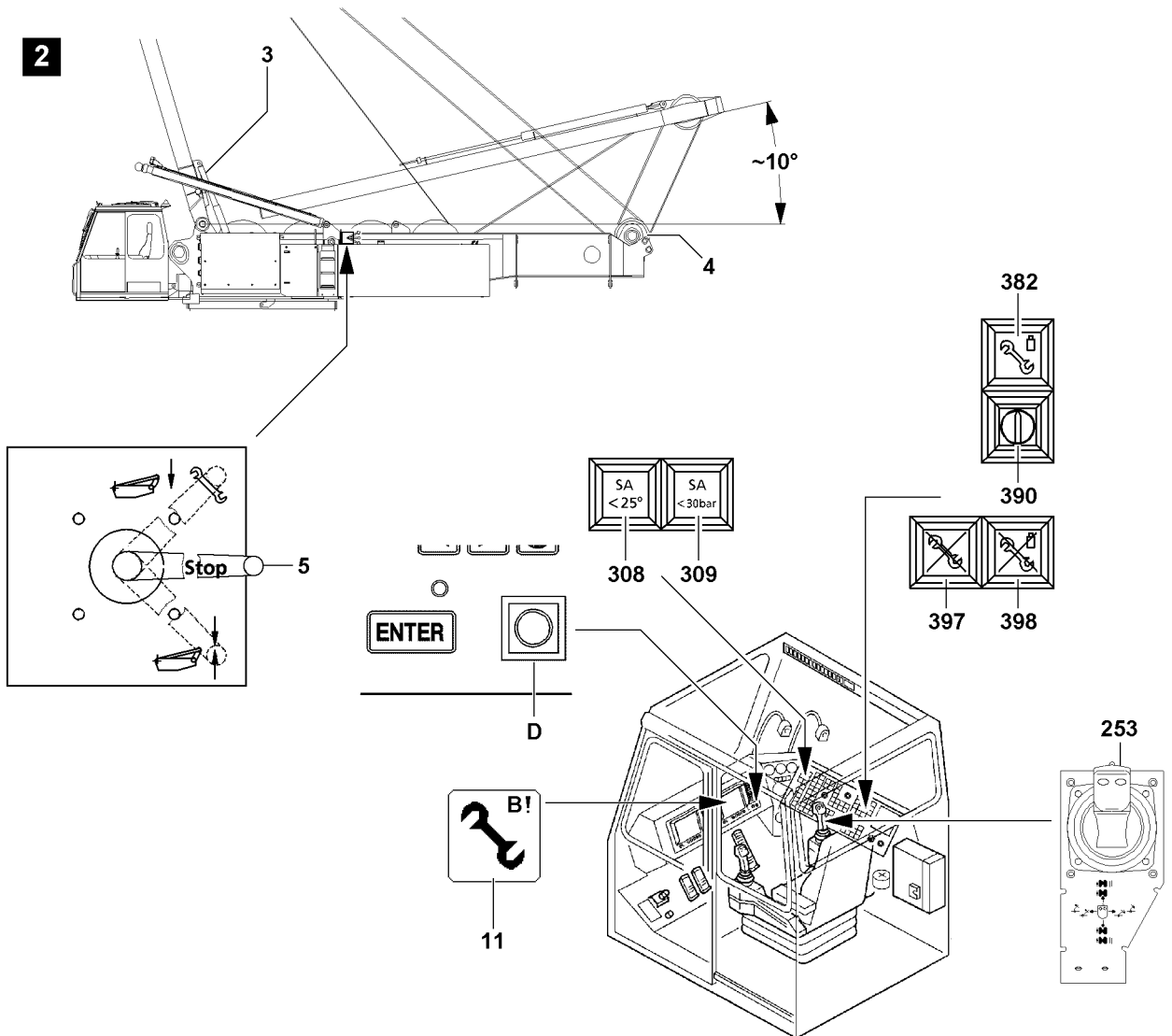
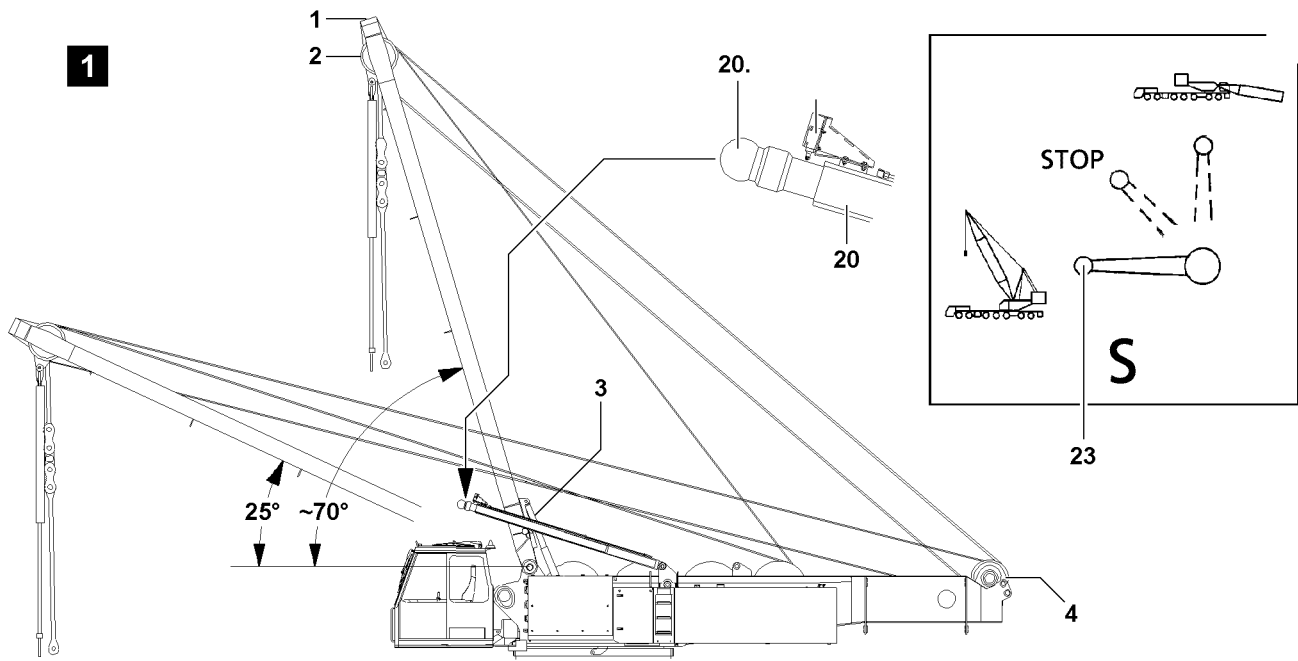

B111426

1.1 Erecting the SA-bracket



Note

- ▶ The piston rods **20.1** of the S-relapse cylinder **20** must be extended approx. 10 cm to approx. 15 cm so that the limit switches **20.2** on the relapse cylinders **20** are “cleared” and winch 4 can be “moved” with master switch 1 (MS1)!
- ▶ If this is not observed, winch 4 cannot be actuated and moved!



WARNING

Mortal danger due to unsecured ball valve **5**!

Due to an unsecured ball valve **5** in “down” position, the SA-bracket can “fall to the rear” uncontrolled in assembly operation, due to unauthorized change of the ball valve position!

Personnel can be severely injured or killed!

- ▶ If the SA-bracket is erected to operating range (approx. 70° to the front, illustration **1**), secure the ball valve in “down” position with a safety lock to prevent unauthorized access!
- ▶ The ball valve position “STOP” and “up” are only permissible when lowering the SA-bracket onto the turntable!

1.1.1 Extending the S-relapse cylinder

NOTICE

Destruction of the S-relapse cylinders **20**!

If the ball valve **23** is in “STOP” position (the S-relapse cylinders are thus blocked), the S-relapse cylinders **20** can be destroyed due to large temperature differences on the jobsite (for example between day and night)!

Expensive and extensive repairs can result!

- ▶ After erection of the SA-bracket, the ball valve **23** must always be set in position “retract” or in position “extend”!
- ▶ Never leave the ball valve **23** in “STOP” position for a longer period of time!

- ▶ Move the ball valve **23** into horizontal position.

Result:

- The piston rod **20.1** of the S-relapse cylinder **20** extends.
- The limit switch **20.2** is no longer actuated.
- Winch 4 can be “moved”.

- ▶ When the piston rod **20.1** is extended approx. 10 cm to 15 cm:
Move the ball valve **23** into STOP position.

Result:

- The S-relapse cylinder **20** is blocked in the current position.

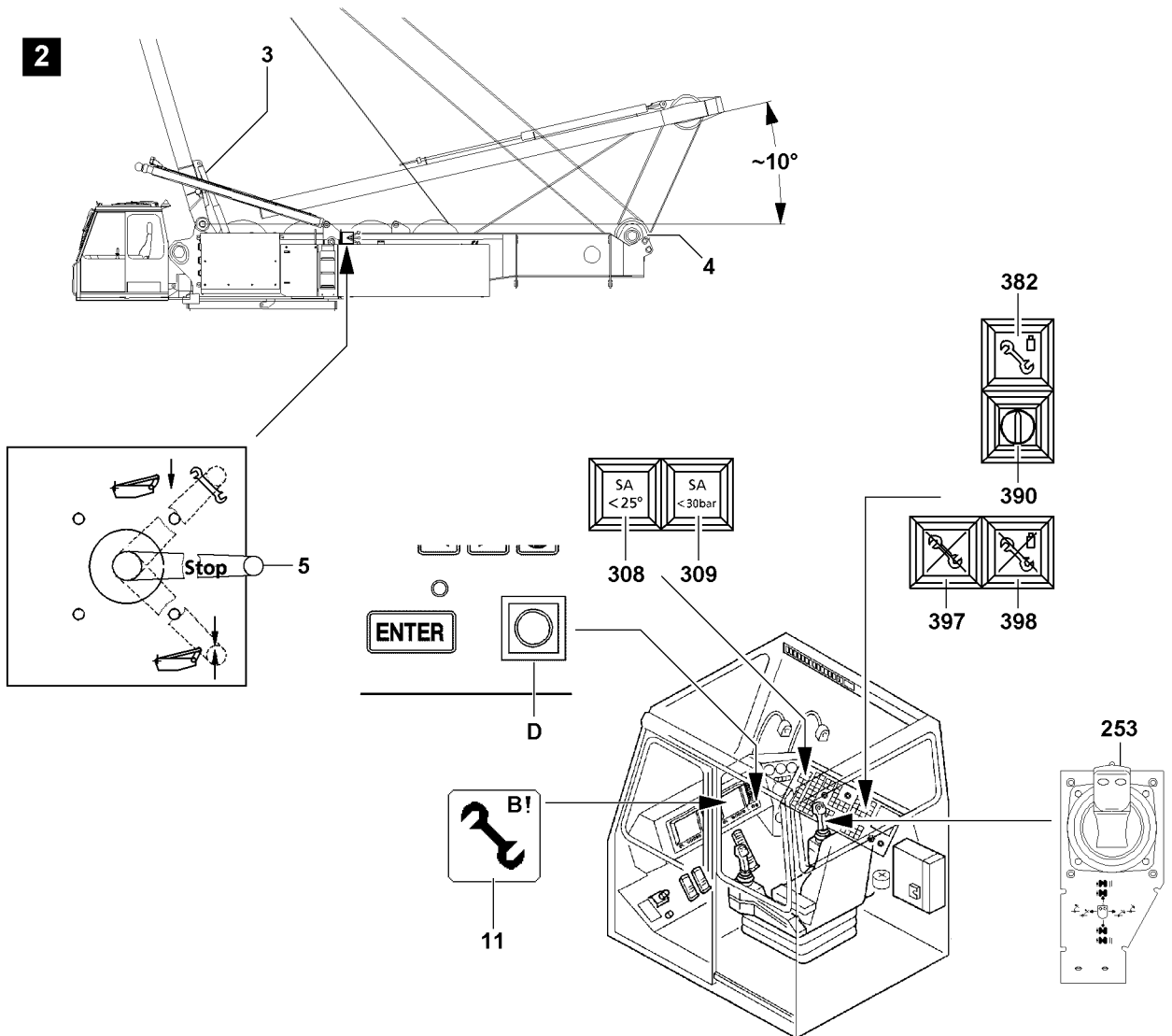
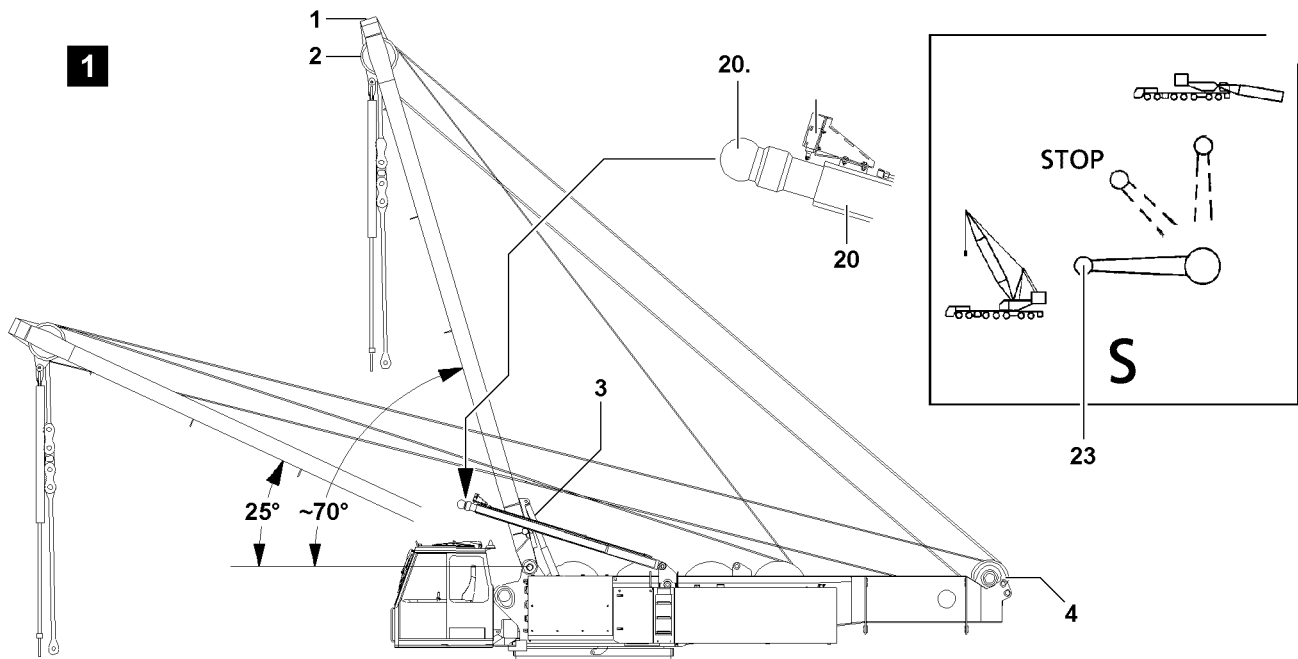

B111426

1.1.2 Erection procedure

NOTICE

Damage to the intake ropes!

By actuating winch 4 significant property damage can occur if the intake ropes are not placed correctly in the rope pulleys!

- ▶ Inspect the intake ropes visually!
- ▶ The intake ropes must be laying correctly in the corresponding rope pulleys!
- ▶ If the intake ropes are not in the rope pulleys, winch 4 may not be actuated!

- ▶ Move the ball valve 5 “down” to the stop.

Result:

- The SA-bracket 1 is pushed upward by the erection cylinders 3 until the intake ropes are tensioned between the rope pulleys 2 of the SA-bracket and the rope pulleys 4 of the turntable pulley block.

Positions of ball valve:	
Up	Lower the SA-bracket onto the turntable (transport position)
Horizontal	STOP , piston rods of the erection cylinder are blocked
Down	Erecting the SA-bracket to operating position

NOTICE

Danger of slack rope formation!

If winch 4 is spooled out too quickly during the erection procedure of the SA-bracket, slack rope can form!

- ▶ The intake rope of winch 4 must be tensioned during the entire erection procedure!
- ▶ The spool out speed of winch 4 must be matched to the erection speed of the erection cylinders!

- ▶ Deflect the master switch MS1 253 in direction X Plus.

Result:

- Winch 4 is spooled out.
- The SA-bracket 1 is erected by the erection cylinders 3 to approx. 70° (block position of the erection cylinders) to the horizontal - to the front, see illustration 1.



Note

- ▶ When the SA-assembly range is reached, the SA-bracket lowers itself to the front, due to its own weight - when spooling out winch 4!

- ▶ When the SA-bracket is erected to approx. 70°:
Set the master switch MS1 253 to zero position.

Result:

- Winch 4 is turned off.
- The SA-bracket is in the SA-assembly range.
- ▶ Secure the ball valve 5 with a safety lock to prevent unauthorized access.

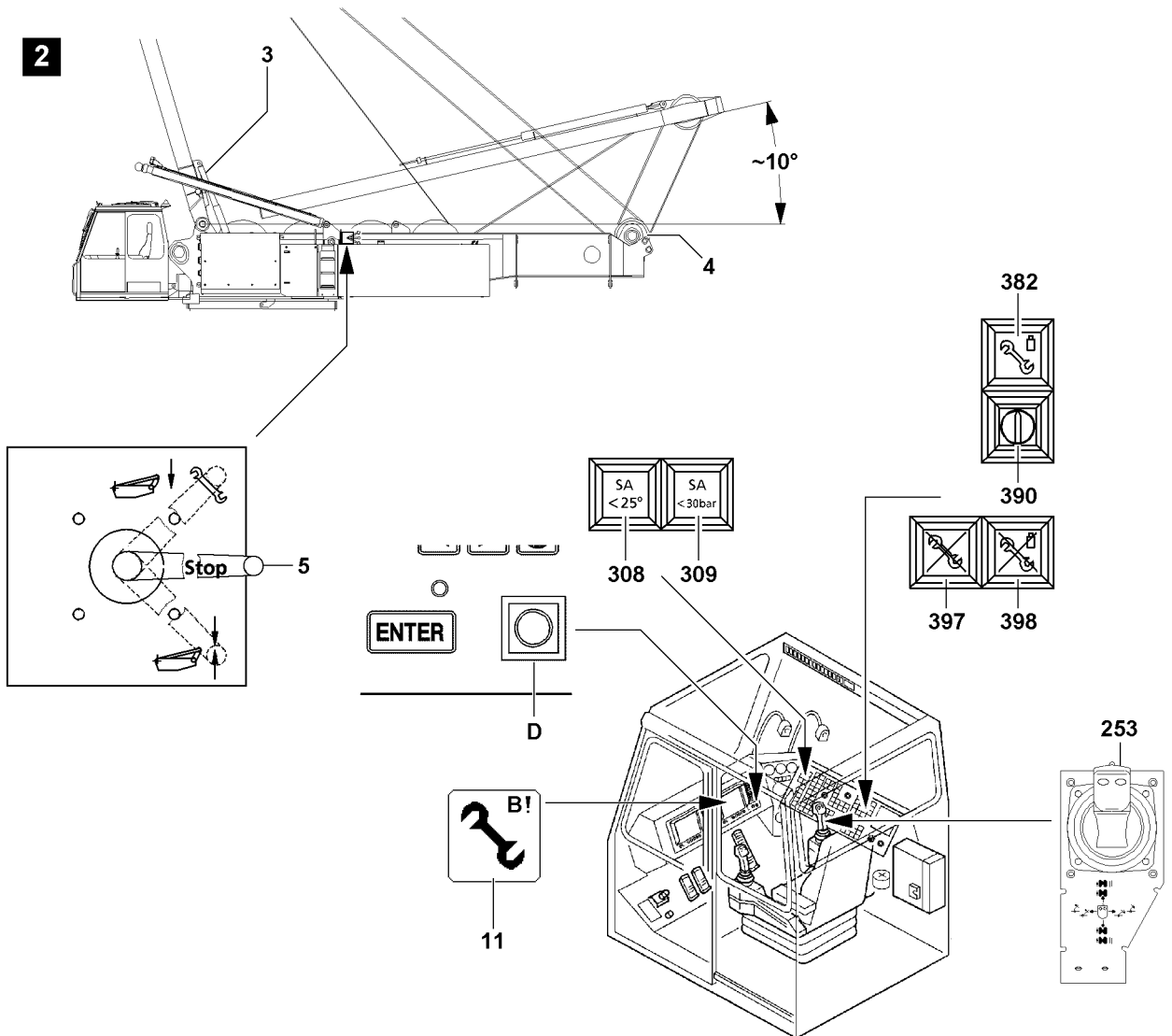
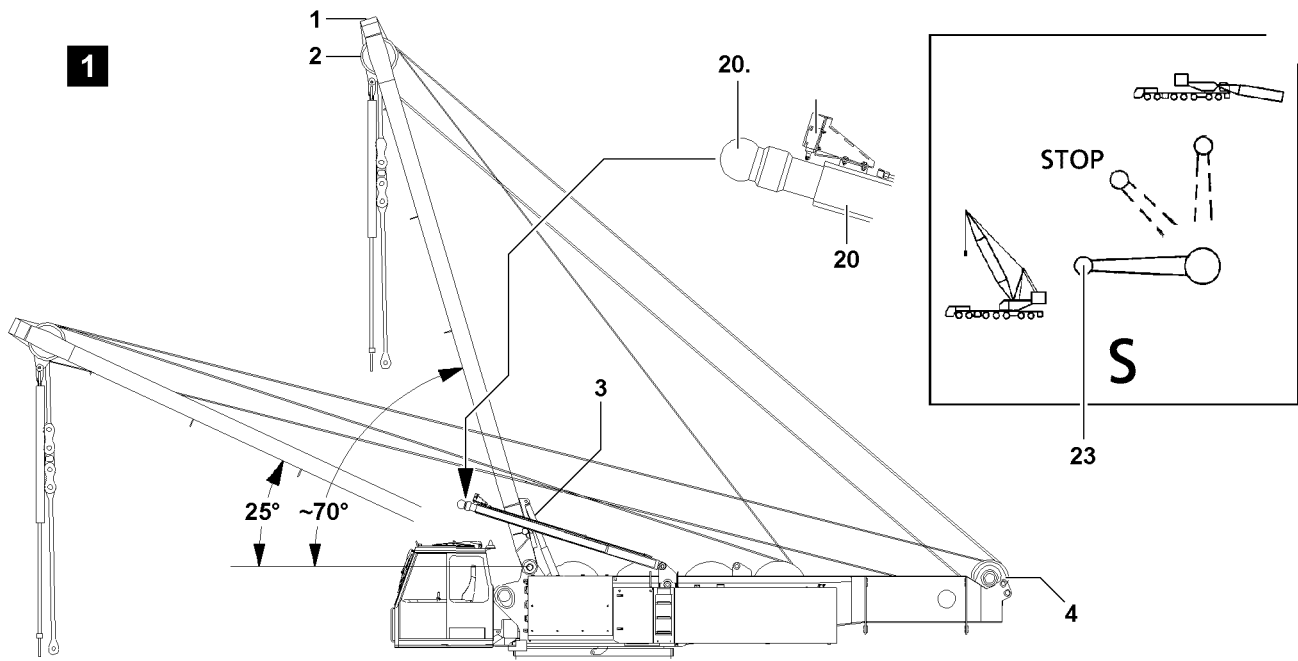

B111426

1.2 SA-bracket in assembly operation



DANGER

Risk of accident!

The ball valve **5** must be in “down” position during assembly operation and must be secured with a safety lock to prevent unauthorized access!

- ▶ After erecting the SA-bracket, secure the ball valve immediately with a safety lock!



Note

- ▶ The luffing up and down of the SA-bracket is realized by spooling winch 4 up or out. The SA-bracket lowers itself to the front due to its own weight when spooling out winch 4!

1.2.1 Luffing the SA-bracket up

- ▶ Deflect the master switch (MS1) **253** in direction X Minus.

Result:

- Winch 4 spools up.
- The SA-bracket is luffed up.

1.2.2 Luffing the SA-bracket down

- ▶ Deflect the master switch (MS1) **253** in direction X Plus.

Result:

- Winch 4 spools out.
- The SA-bracket is lowered to the front.

1.3 Shut offs in SA-assembly operation

Condition SA-bracket	Shut off / reaction
SA-bracket angle to the horizontal is smaller than 25°	Shut off Winch 4
	The indicator light 308 lights up.
Pressure in erection cylinders smaller than 30 bar	Shut off Winch 4
	The indicator light 309 lights up.

1.4 Placing the SA-bracket onto the turntable

Make sure that the following prerequisites are met:

- The LICCON overload protection is exceeded; indicator light “Assembly” **381** lights up.
- The assembly icon **11** is visible on the LICCON monitor.
- The key button **390** “Crawler and boom assembly” is actuated; the indicator light “Crawler and boom assembly” **382** lights up.
- The erection cylinders **3** are completely extended.
- The SA-bracket is in the assembly area.

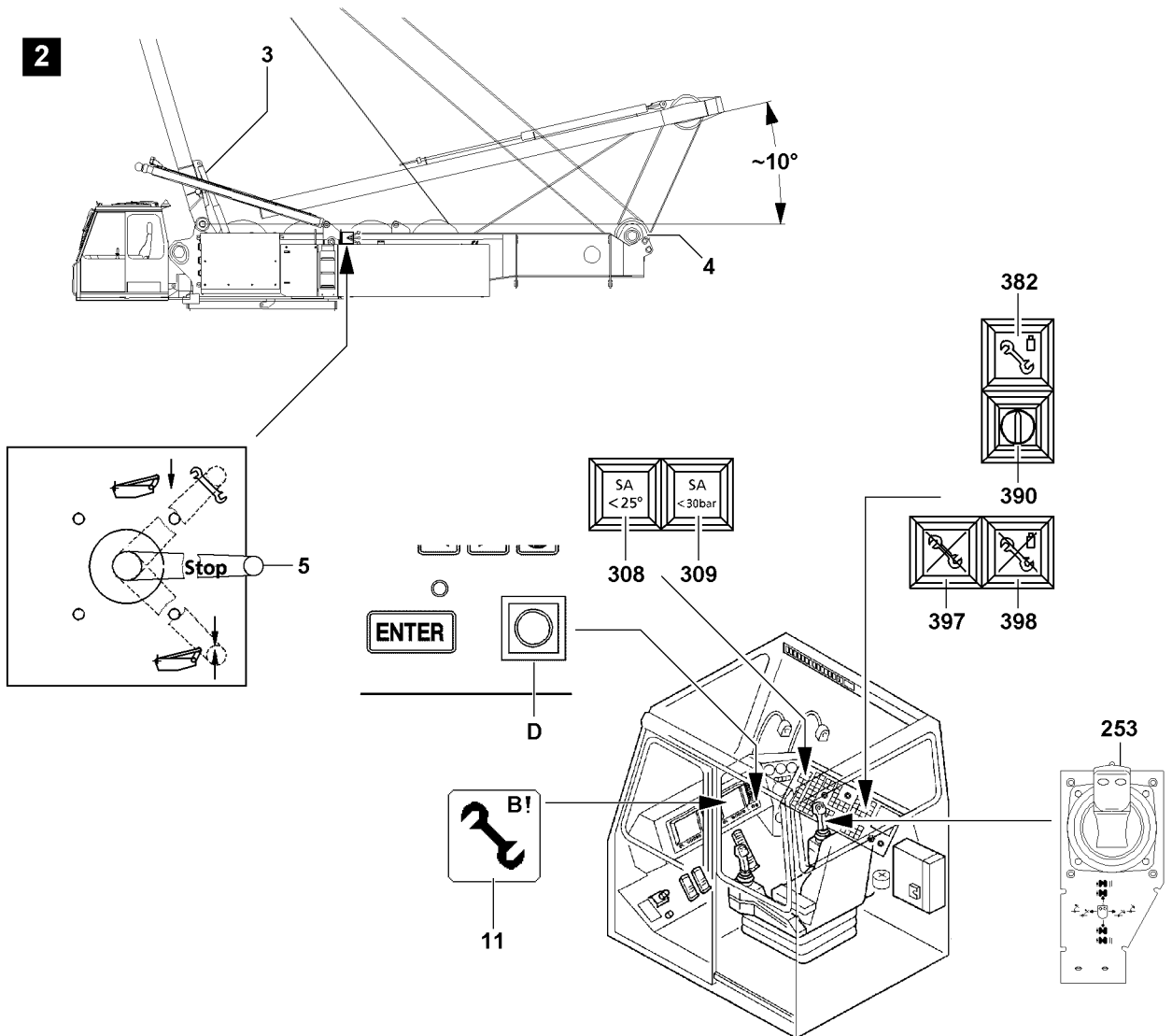
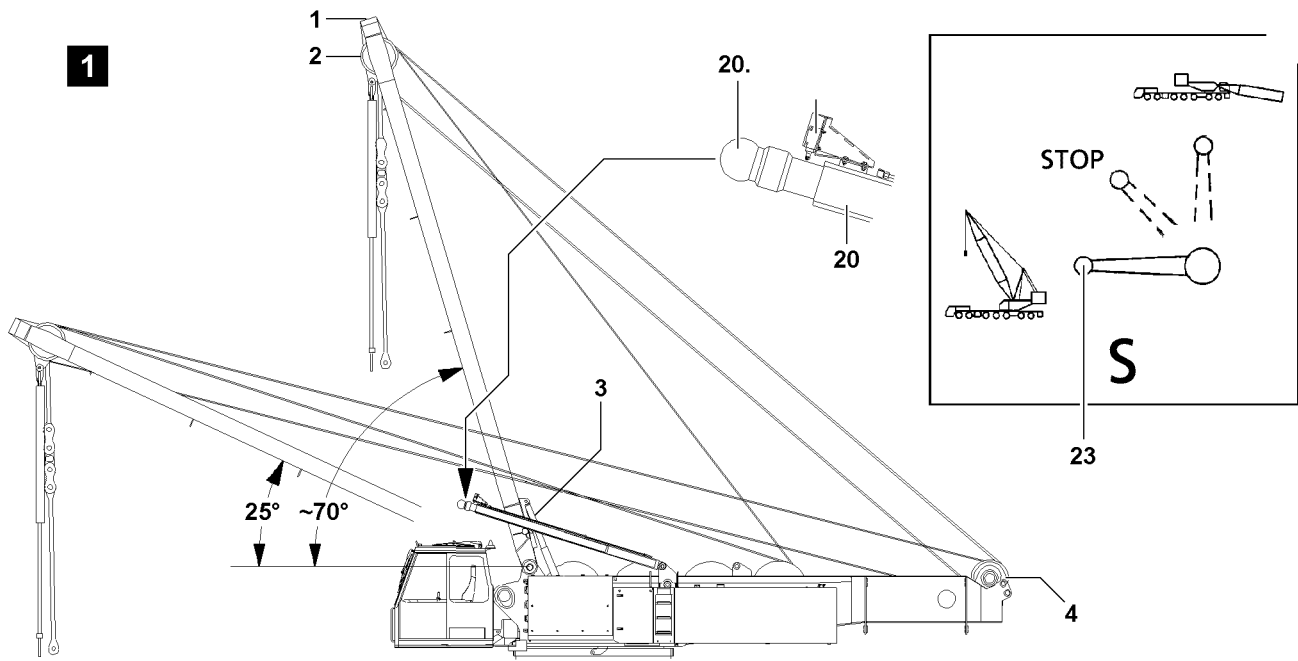

B111426

1.4.1 Take down procedure

- ▶ Deflect the master switch MS1 **253** in direction X-Minus.

Result:

- Winch 4 spools up.
- The SA-bracket **1** is pulled back against the pressure in the erection cylinders **3**.

- ▶ When the SA-bracket **1** has reached the 10° position “to the rear”, see illustration **2**:
Set the master switch MS1 **253** to zero position.

Result:

- Winch 4 is turned off.



WARNING

Risk of accident!

When lowering the SA-bracket, personnel within the danger zone can be severely injured or killed!

- ▶ The crane operator must ensure, before lowering the SA-bracket, that there are no persons or objects within the danger zone!

- ▶ Remove the safety lock on the ball valve **5**.

NOTICE

Danger of slack rope formation!

- ▶ When lowering the SA-bracket on the turntable, winch 4 must be spooled up simultaneously to avoid slack rope formation!

- ▶ Move the ball valve **5** “up”.

Result:

- The SA-bracket **1** lowers itself slowly on the turntable.

- ▶ Deflect the master switch MS1 **253** carefully in direction X Minus.

Result:

- Winch 4 spools up.

- ▶ When the SA-bracket **1** is laying completely on the turntable:
Set the master switch MS1 **253** to zero position.

Result:

- Winch 4 is turned off.

- ▶ Turn the set up key **D** to the right.

Result:

- The LICCON overload protection is activated.
- The assembly icon **11** on the LICCON monitor turns off.

- ▶ Press the button **397**.

Result:

- The self-retention of the key button **390** is turned off.
- The indicator light **382** turns off.

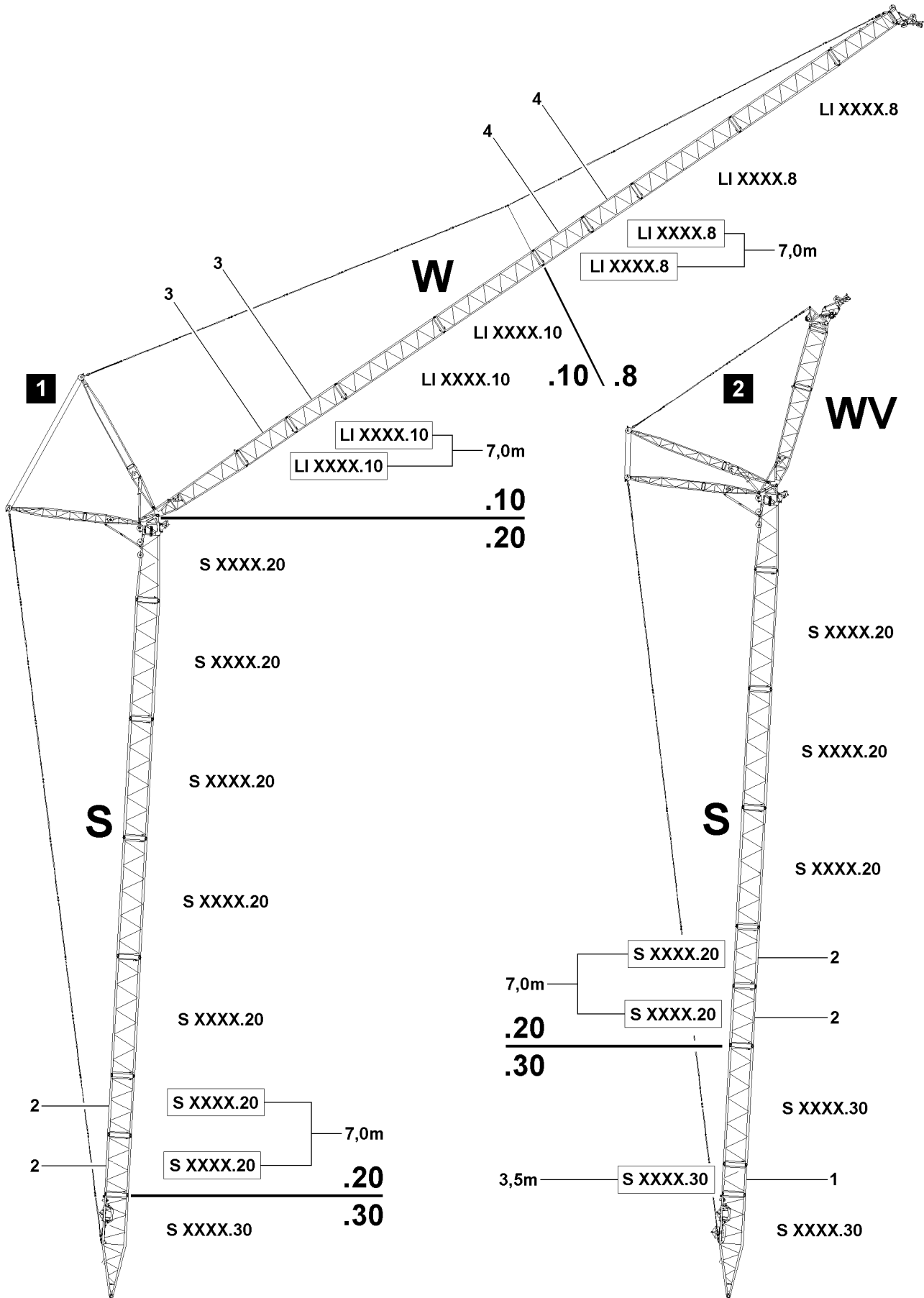

B112065

1 Boom components



Note

- ▶ For boom components including associated system dimensions, lengths and component weights refer to the Crane operating instructions, chapter 1.03!

2 Arrangement of intermediate sections on the boom



Note

- ▶ The following description is an example and may not exactly match to your crane!
- ▶ Lengths, weights and system dimensions of the intermediate sections are examples and may differ from the data on your crane!
- ▶ For exact crane data refer to the respective rod plan!
- ▶ For dimensions and weights of crane components, see Crane operating instructions, chapter 1.03!



WARNING

Boom can break off!

The arrangement of the intermediate sections on booms or boom systems are based on extensive static calculations! If the arrangement of the intermediate sections according to the rod plan is not observed, the crane can collapse, the boom can break off or the crane can topple over!

Personnel can be severely injured or killed!

- ▶ Always carry out the arrangement of the intermediate sections according to the rod plan!
- ▶ If an auxiliary guying is required for a certain boom length, then it must always be installed according to the rod plan on the position defined in the rod plan!

General specifications for the configuration of booms or boom systems:

- With the same system dimension, two short intermediate sections with a length of 3.5 m are heavier than one single intermediate section with a length of 7.0 m!
- With the same system dimension, two short intermediate sections with a length of 7.0 m are heavier than one single intermediate section with a length of 14.0 m!
- With the same system dimension, two short intermediate sections with a length of 3.5 m can be replaced by one single intermediate section with a length of 7.0 m!
- With the same system dimension, two short intermediate sections with a length of 7.0 m can be replaced by one single intermediate section with a length of 14.0 m!
- For intermediate sections with the same system dimension but different lengths, always install the short intermediate sections on the bottom in the boom, due to their weight, in direction of the slewing ring, see also illustration 1 and illustration 2!
- The heavier one intermediate section is, the higher is the value of the last two digits on the system dimension tag!

System dimensions and assignment			
Position	System	Heavy	Light
1	S XXXX .30	X	
2	S XXXX .20		X
3	LI XXXX .10	X	
4	LI XXXX .8		X

2.1 Arrangement of intermediate sections



WARNING

Danger of accidents due to incorrectly assembled intermediate sections!

- ▶ Any other arrangement of the intermediate sections and guy rods than specified in the operating instructions or the rod plans is prohibited!
- ▶ There is the danger that intermediate sections are mixed up, they are differently sized and do not differ externally!
- ▶ The intermediate sections differ externally only by the welded on plates (.8, .10, .12, .16, .20, .25, .30)!
- ▶ When assembling the boom, it must be ensured that the intermediate sections are arranged and installed according to their description as stated on the rod plan!



WARNING

Arrangement of intermediate sections!

If the arrangement of the intermediate sections is not carried out according to the rod plan, then the boom can be overloaded, bend down and break off!

Personnel can be severely injured or killed!

This could result in high property damage!

- ▶ For intermediate sections with the same system dimension but different length, always install the shorter intermediate sections on the bottom in the boom, in direction of the slewing ring!

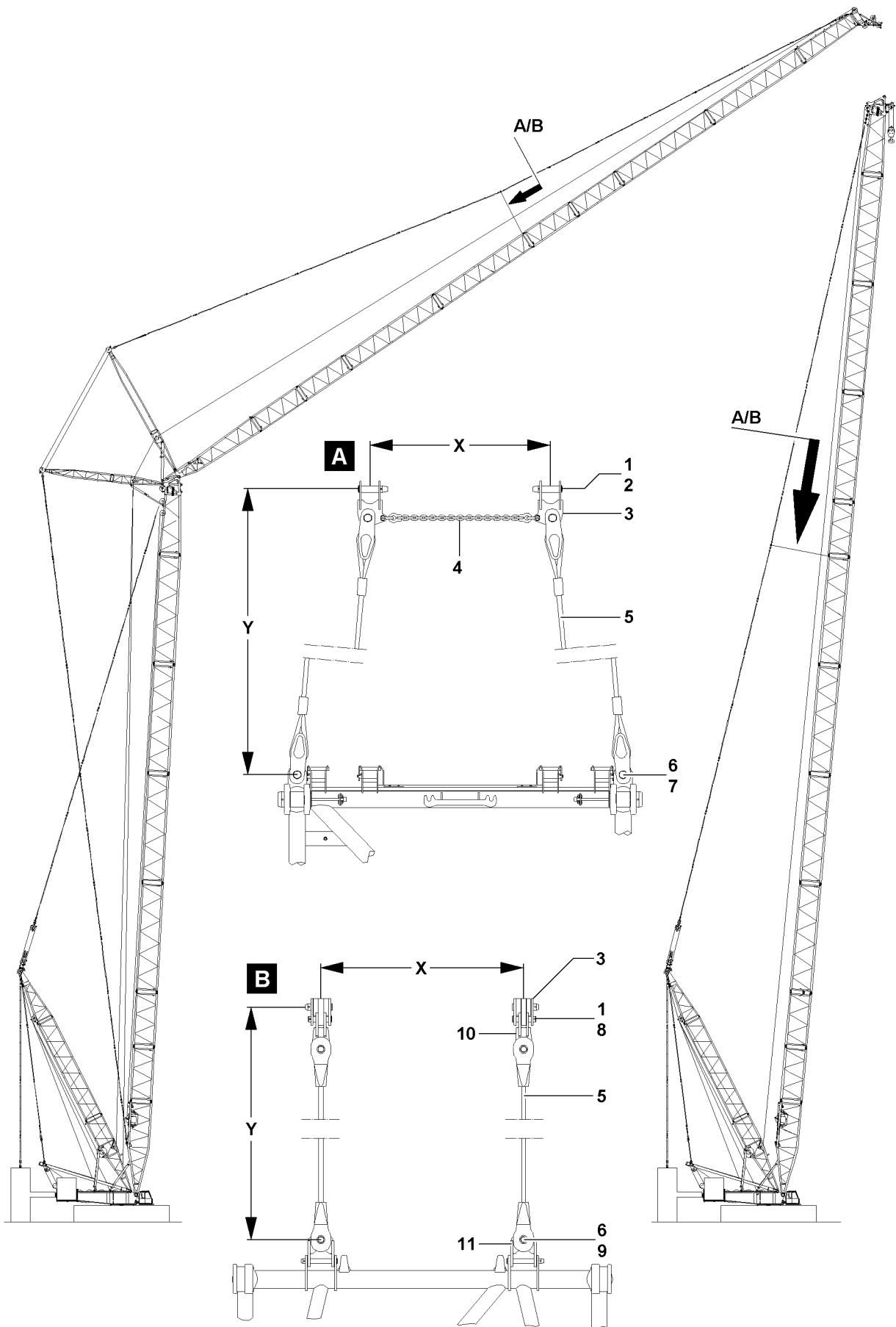

B112270

3 Auxiliary guying



Note

- ▶ The following description is an example and may not exactly match to your crane!
- ▶ For exact crane data refer to the respective rod plan!

3.1 Installing the auxiliary guying

The auxiliary guying, in regards to safe crane operation - especially for long boom systems - is of vital importance.

The auxiliary guying is a deciding factor in relieving the boom, or the boom system during erection and take down as well as during crane operation.



WARNING

The crane can topple over!

If the auxiliary guying is not installed or not installed on the position specified in the rod plan, then the crane can collapse, the boom can break off or the crane can topple over!

- ▶ If an auxiliary guying is specified in the rod plan for the required boom length, then it must be installed on the respective position!
- ▶ Make sure that the auxiliary guying is always completely installed and that all pins are properly pinned and secured!



Note

- ▶ The boom lengths, for which an auxiliary guying is required, can be seen in the rod plan!
- ▶ Depending on the crane type: To install the auxiliary guying, remove the standard lugs and install the "Lugs for the auxiliary guying"!

Components of auxiliary guying, illustration A	
Position	Designation
1	Pin
2	Spring retainer
3	Lug
4	Chain
5	Rope
6	Pin
7	Spring retainer

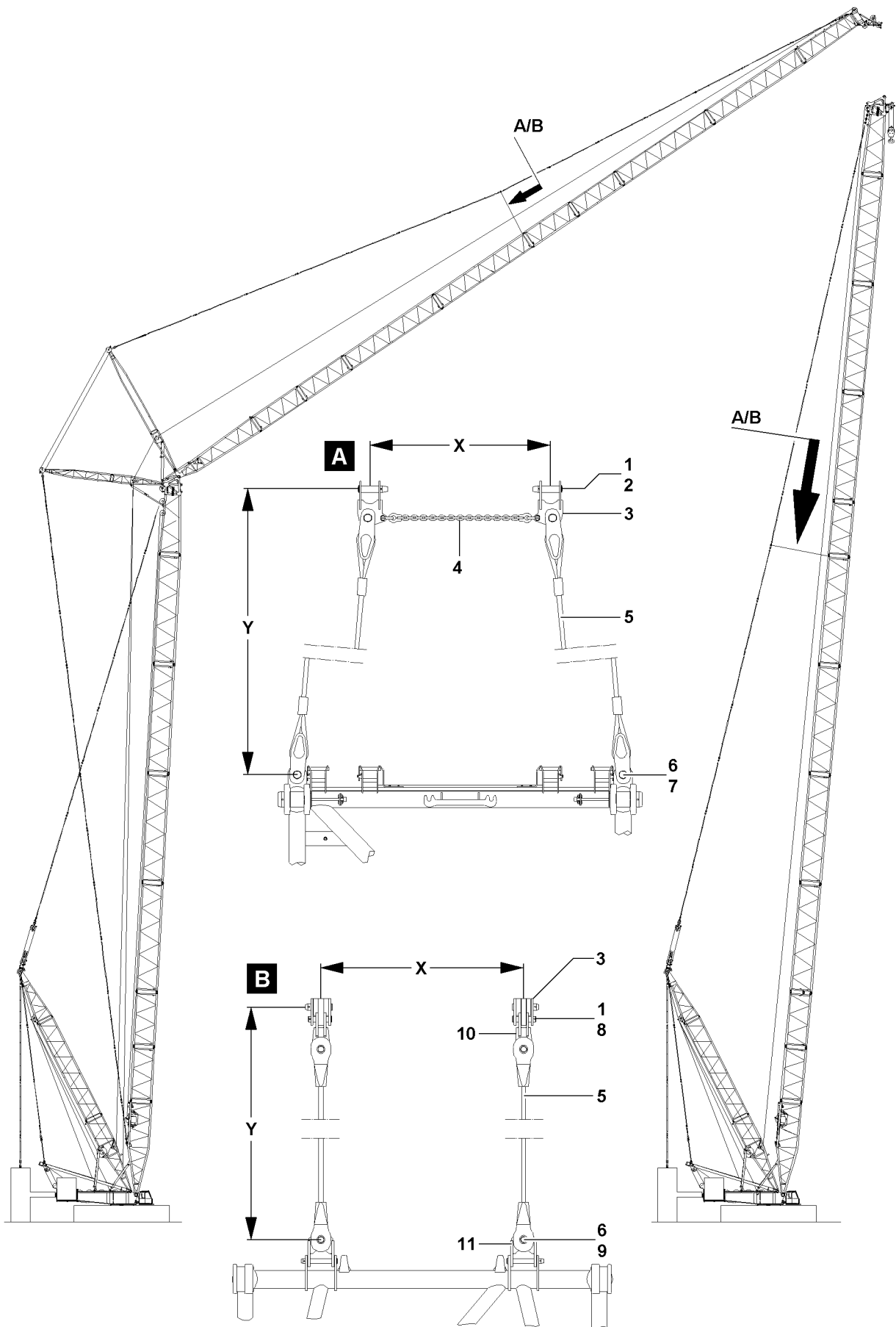

B112270

Components of auxiliary guying, illustration B	
Position	Designation
1	Pin
3	Lug
5	Rope
6	Pin
8	Linch pin
9	Linch pin
10	Cross-shaped lug
11	Cross-shaped lug

The lugs **3** must be installed in the guying instead of the standard lugs. The auxiliary guying is installed on the lugs **3**.

The guy ropes **5** are pinned on top on the lugs **3** of the guying or on the cross-shaped lugs **10**. The guy ropes **5** are pinned on the bottom on the lugs / connector points on the boom, see illustration **A** or on the cross-shaped lugs **11**, see illustration **B**.

► Install the guy ropes: Pin the guy ropes on top on the guying with pin **1** and secure with spring retainer **2**, see illustration **A**.

or

■ Install the guy ropes: Pin the guy ropes on top on the guying with pin **1** and secure with linch pin **8**, see illustration **B**.

► When the guy ropes **5** are pinned and secured on the lugs **3** of the guying or on the cross-shaped lugs **10**:

Pin the guy ropes **5** on the lugs / connection points on the boom, see illustration **A** with pin **6** and secure with locking spring **7**.

or

■ Pin the guy ropes **5** on the cross-shaped lugs **11** on the boom, see illustration **B** with pin **6** and secure with linch pin **9**.



WARNING

The crane can topple over!

If the chain **4** is not installed in connection with the auxiliary guying, then the guying can be damaged, the boom can break off and the crane can topple over!

Personnel can be severely injured or killed!

► The auxiliary guying must be installed according to the rod plans!

► If a chain **4** is specified in the rod plan, then it must always be installed in connection with the auxiliary guying, otherwise the guy rods will be pulled apart!

► Recheck the proper and complete assembly of the auxiliary guying before erecting the boom / boom system.

1

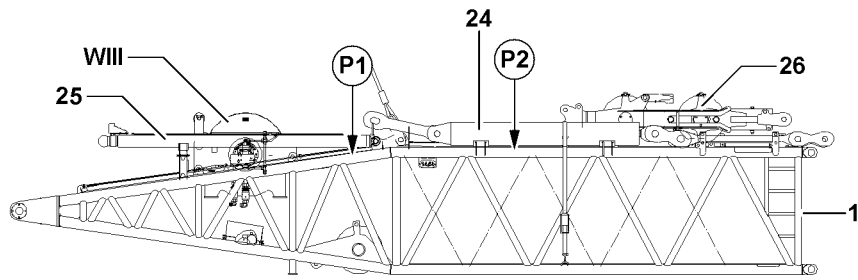

2

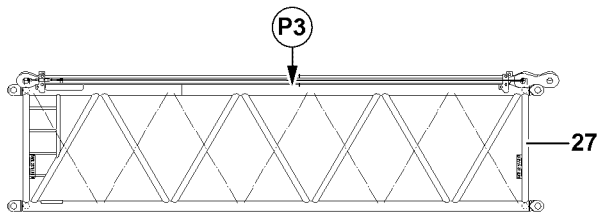

3

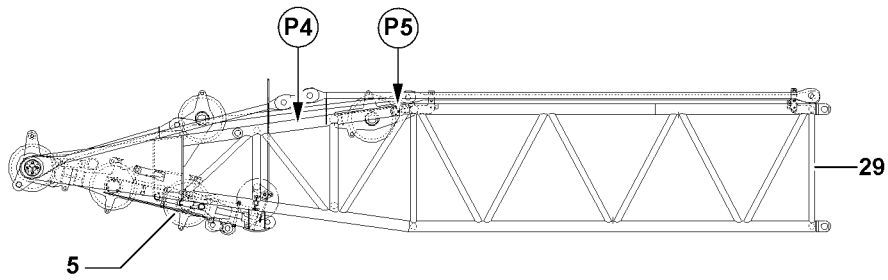

1 Component overview D-boom

Examples for components of D-boom:

- | | |
|--|--|
| <p>1 D-pivot section</p> <p>25 D-relapse cylinder</p> <p>26 Pulley block</p> <p>27 D-intermediate section
2115.20</p> <p>29 D-end section</p> | <ul style="list-style-type: none"> • Pivot section with winch 3 WIII and with pull cylinder 24 for B-operation and BW-operation, see illustration 1 • See illustration 1 • See illustration 1 • Intermediate section 7 m, see illustration 2 • See illustration 3 |
|--|--|

2 Fastening points D-components



WARNING

Component incorrectly attached!

Life-threatening situations can arise due to improper or incorrect attachment of the corresponding components!

Personnel can be severely injured or killed!

- ▶ Attach the components only on the intended fastening points on both sides!
- ▶ Attachment of components and description of fastening points, see Crane operating instructions, chapter 5.01!

Component	Fastening point	Illustration
D-pivot section	P1 and P2	1
D-intermediate section	P3	2
D-end section	P4 and P5	3

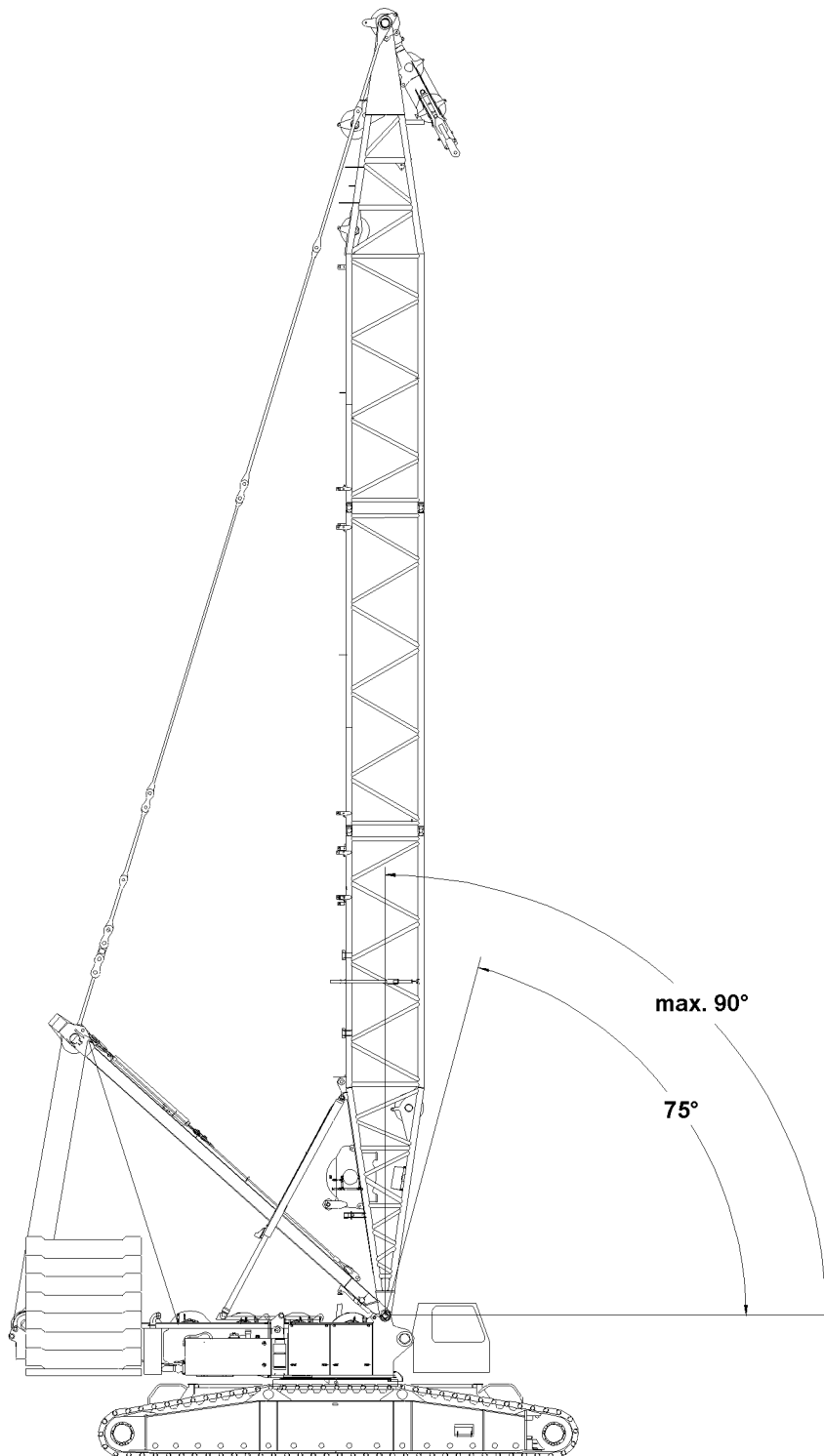

B111427

3 Assembly



WARNING

Risk of falling!

During assembly / disassembly, inspection and maintenance work, personnel must be secured with appropriate aids to prevent them from falling! If this is not observed, assembly personnel could fall and suffer life-threatening or fatal injuries!

- ▶ All work aloft, where there is a danger of falling must be carried out with suitable aids!
- ▶ If fall protection equipment is available, then it must be used, see Crane operating instructions, chapter 2.06!
- ▶ If aids are not available and work cannot be carried out from the ground, then the assembly personnel must secure themselves with the permissible fall arrest system to prevent falling, see Crane operating instructions, chapter 2.04!
- ▶ The fall arrest system must be fastened on the fastening and hook points as well as on the safety ropes. For safety points, see Crane operating instructions, chapter 2.06!
- ▶ Only step on the aids, ladders and catwalks with clean shoes!
- ▶ Keep aids, ladders and catwalks free of heavy dirt, snow and ice!
- ▶ It is prohibited to walk on the telescopic or an auxiliary boom without suitable protective devices!



WARNING

The lattice sections can fall down!

If the lattice sections are not pinned and secured correctly, then they can fall down and fatally injure personnel!

- ▶ Pin or unpin both pins at the same horizontal level, i.e. **left and right!**
- ▶ Do not stand under the booms or within the entire danger zone during the boom pinning and unpinning procedure!
- ▶ Secure the pins in the bearing points and the receptacles!
- ▶ It is prohibited to lean the ladder against the components being disassembled!
- ▶ Do not remove the fastening equipment and the auxiliary crane until each component is pinned on and secured!



WARNING

Danger of impact / crushing!

When installing / removing counterweight components with the auxiliary crane, crane components can start to swing back and forth!

When lifting / lowering and positioning crane components, there is an increased danger of impacts / crushing!

Personnel can be caught and severely injured or killed!

- ▶ Make sure that personnel cannot be caught by components!
- ▶ Make sure that the crane is aligned in horizontal position to avoid the support beams from swinging by themselves!
- ▶ When working in danger zones: Use aids to protect limbs!
- ▶ Guide components with suitable aids to minimize oscillation!

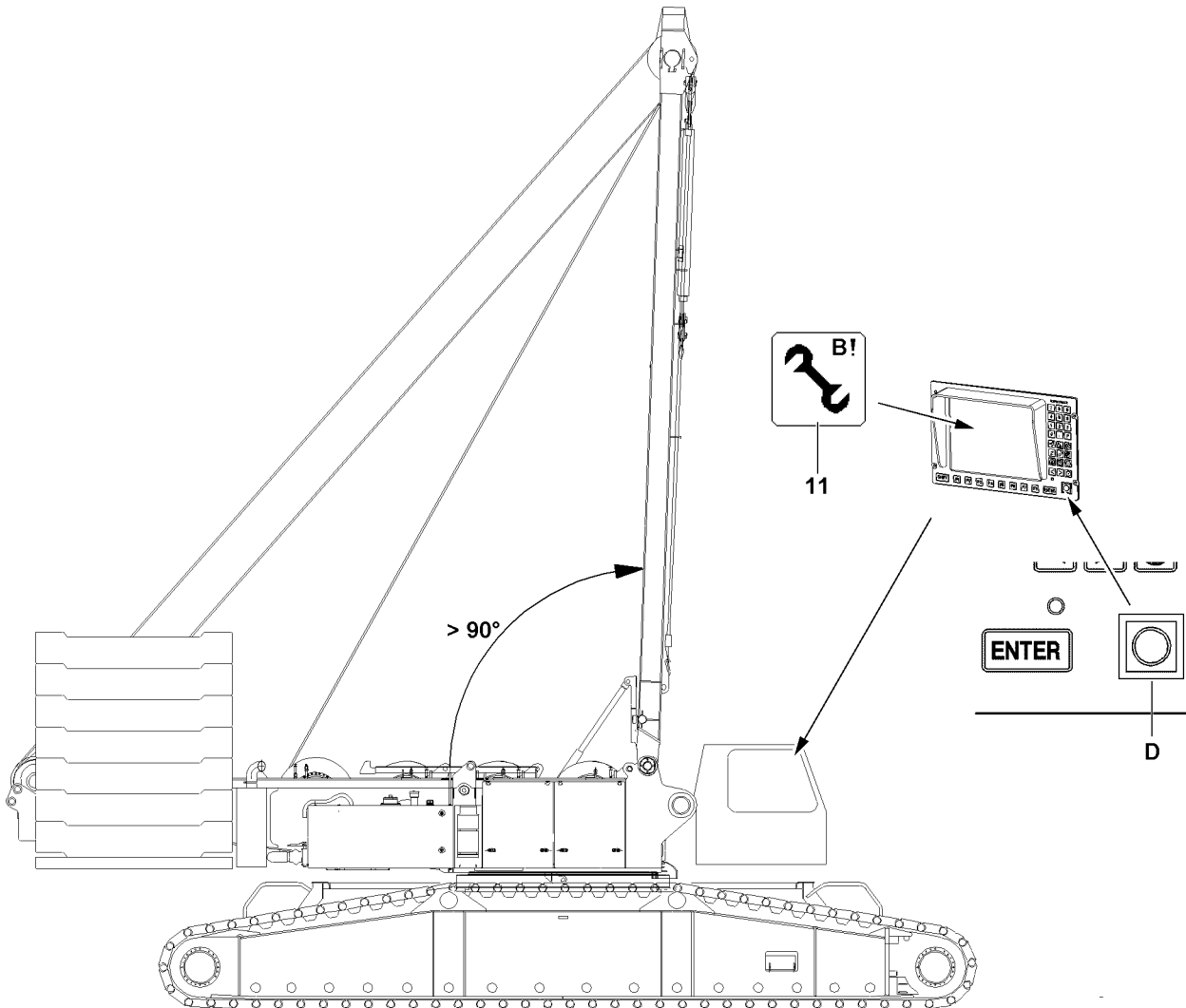

B111428

3.1 Assembling the D-boom



WARNING

The crane can topple over!

If the turntable is turned during the assembly of the boom, then the crane can topple over and be severely damaged! Personnel can be severely injured or killed!

- ▶ The turntable may not be turned during the assembly of the boom!



WARNING

Risk of accident!

If the following instructions are not observed, personnel can be severely injured or killed!

- ▶ Arrangement of lattice sections of boom combinations, see Rod plan!
- ▶ Depending on the condition of the ground, the boom and the lattice sections must be supported from below for the assembly of the boom!
- ▶ Observe the safety technical notes, see Crane operating instructions, chapter 5.01!

Make sure that the following prerequisites are met:

- The crane is aligned in horizontal direction.
- An auxiliary crane is available.
- An assembly scaffolding / work platform is available.
- The counterweight has been installed on the turntable according to the load chart.
- The LICCON overload protection has been set according to the data in the load chart.
- No main boom is assembled on the turntable.

3.1.1 Turning the turntable into assembly position



WARNING

The crane can topple over!

If the following conditions are not met before turning the turntable - **without** installed D-boom, the crane can topple over!

Personnel can be severely injured or killed!

- ▶ Observe the data in the erection and take down charts!
- ▶ If no D-boom is installed on the turntable, max. 135 t counterweight may be installed and when turning the turntable by 360°, it must be ensured that the SA-bracket is erected to **more than 90°**!
- ▶ If the counterweight is increased to 155 t, then the D-boom must be installed and raised off the ground!

Maximum counterweight	Minimum central ballast	Equipment
55 t	11 t	Without equipment
95 t	11 t	
135 t	43 t	
155 t	43 t	D-boom installed and raised off the ground

- ▶ Turn the turntable in longitudinal direction of the crawler travel gear or vertical to the crawler travel gear, see Erection and take down chart.

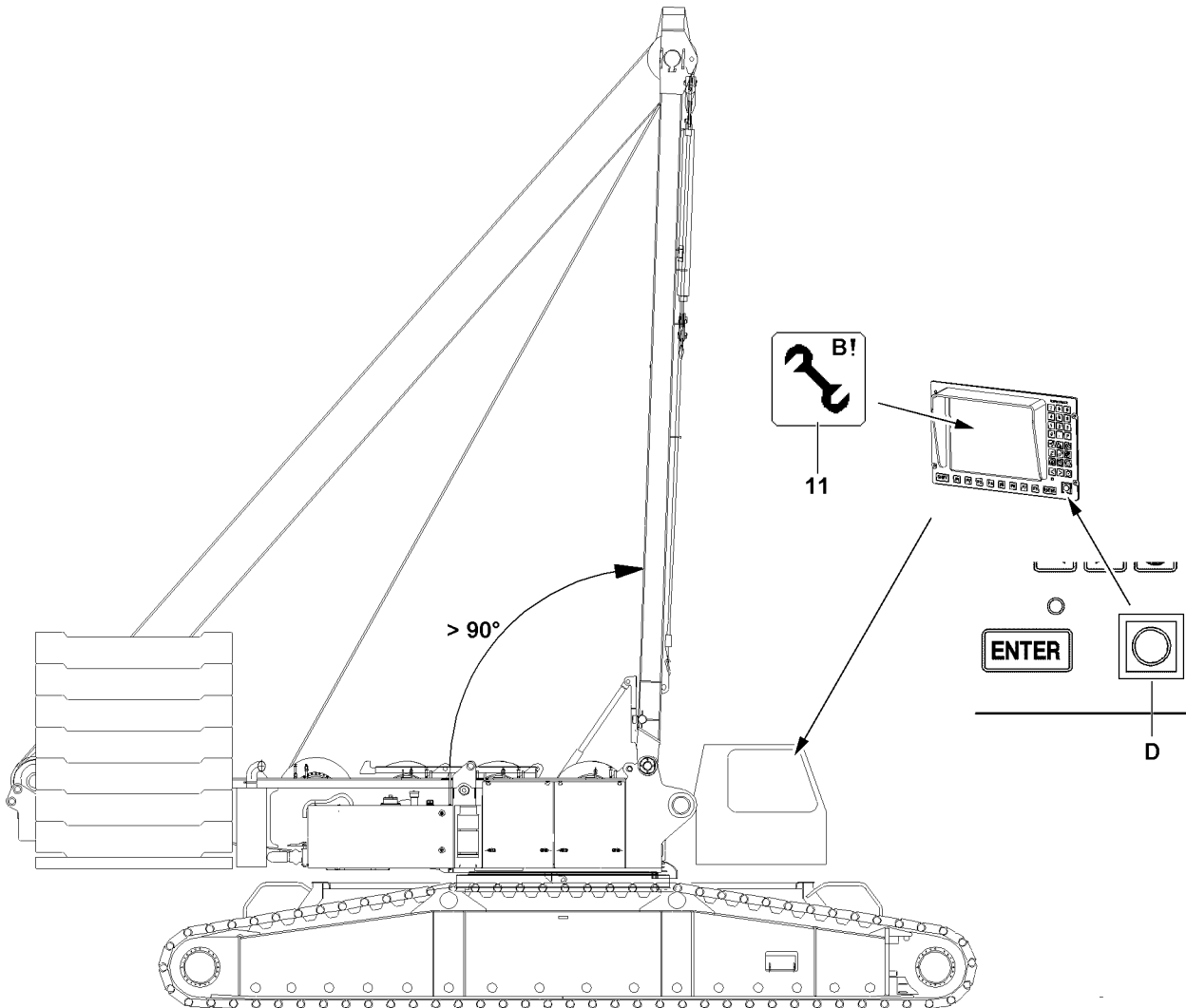

B111428

3.1.2 Exceeding the LICCON overload protection for assembly



WARNING

Assembly with turned on set up key!

When the set up key is engaged, the LICCON overload protection is exceeded!

In the event of deliberate improper use, the crane could collapse, the boom can break off or the crane can topple over!

Personnel can be killed!

This could result in high property damage!

- ▶ The set up key **D** may only be actuated by persons who know the effects of a bypass!
 - ▶ Press the set up key **D** only when the set up status was correctly entered into the LICCON computer system!
 - ▶ Observe the erection / take down charts!
 - ▶ Crane operation with the set up key **D** turned on is strictly prohibited!
-

- ▶ Turn the set up key **D** to the right.

Result:

- The LICCON overload protection is exceeded.
- The assembly icon **11** is visible on the LICCON monitor.

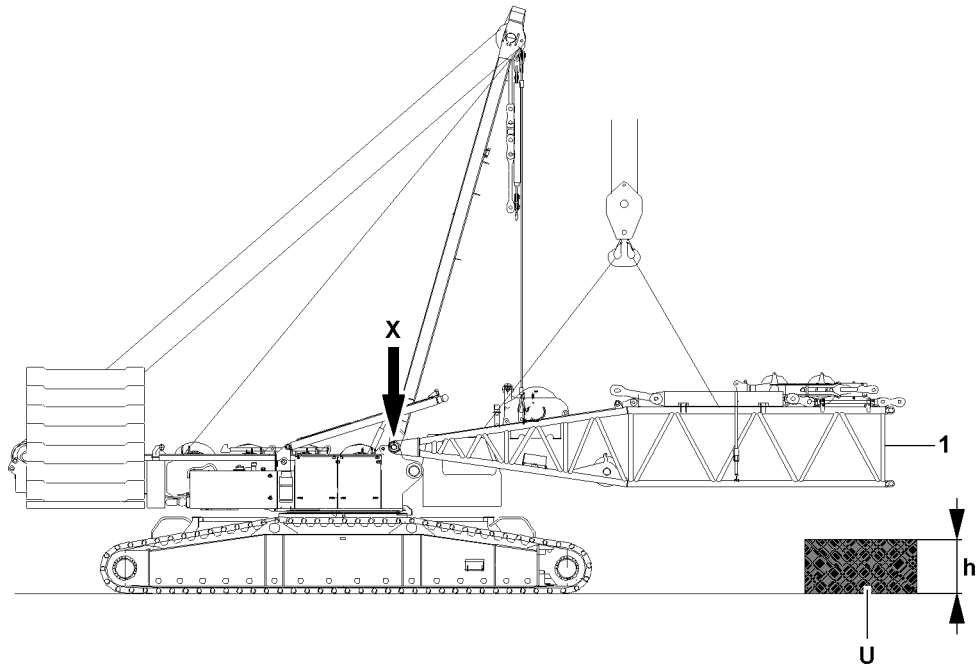

X

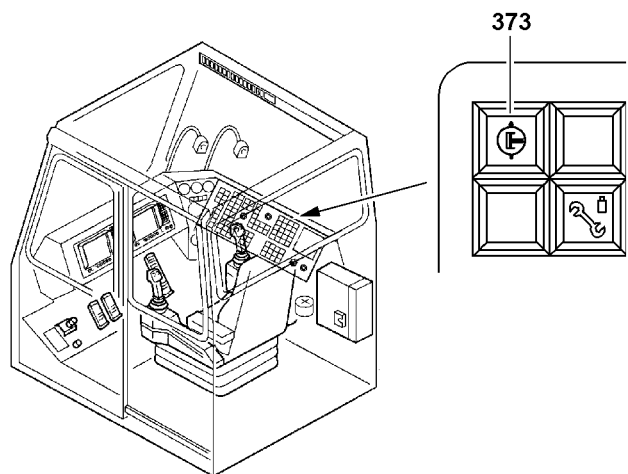
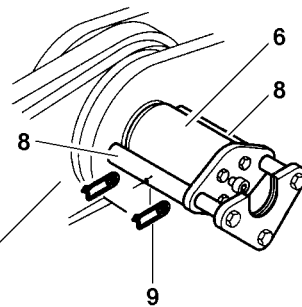
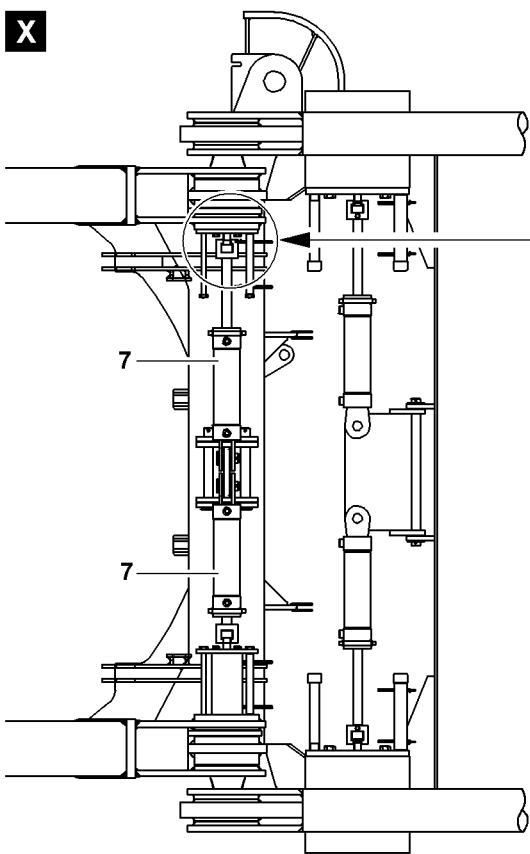

B111429

3.1.3 Pinning the D-pivot section on the turntable



WARNING

General danger notes!

- ▶ Support the D-boom during assembly with suitable materials!
- ▶ All pins are to be secured after assembly with the intended safety elements!
- ▶ The guy rods must be checked regularly, see Crane operating instructions, chapter 8.15!

- ▶ Hang the D-pivot section **1** onto the auxiliary crane and swing in to the pin points on the turntable.

Establish the hydraulic connection to the pin pulling device via two quick couplers.

Pin the D-pivot section **1** on the turntable and secure.

- ▶ Establish the hydraulic connection to the pin pulling device.
- ▶ Turn the pressure change over switch **373** on.



WARNING

Risk of fatal injury!

Due to unsecured or insufficiently secured connector pins, the D-boom can fall down and fatally injure personnel!

- ▶ Secure the connector pins **6** between the D-pivot section **1** and the turntable after the pin procedure with the retaining plates **8**!

- ▶ Insert the connector pins **6** with the hydraulic pin pulling device **7**.
- ▶ Secure the connector pin **6** on the left and right with the retaining plate **8** and the spring retainer **9**.
- ▶ Turn the pressure change over switch **373** off.

NOTICE

Damage of the D-pivot section and the turntable!

By placing the installed D-pivot section on the ground, significant property damage can occur on the pivot section and on the turntable!

- ▶ The D-pivot section may not be placed directly on the ground!
- ▶ When placing the D-pivot section down, always use a sufficiently load bearing and large enough base support!
- ▶ The support **U** may not fall below the specified minimum height **h**!

Minimum height of support U on D-pivot section	
Without Quick connection	400 mm
With Quick connection	760 mm

- ▶ Place the D-pivot section carefully with the auxiliary crane on the support **U**.
- ▶ Remove the auxiliary crane.

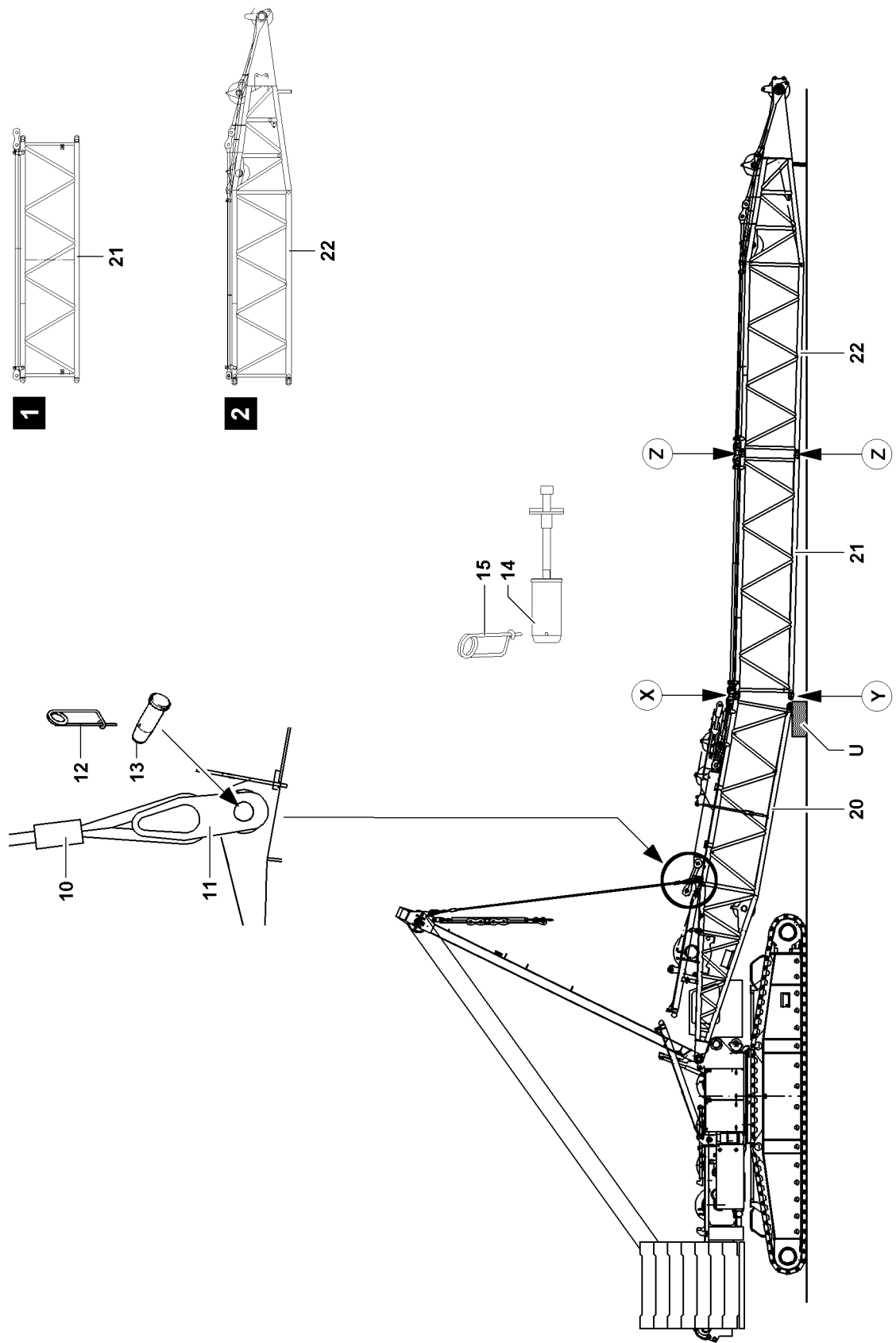

B104939

3.1.4 Installing the D-lattice components on the D-pivot section

Make sure that the following prerequisites are met:

- The D-pivot section is pinned and secured on the turntable.
- The D-pivot section is placed on the support **U**.



WARNING

General danger notes!

- ▶ Support the D-boom during assembly with suitable materials!
- ▶ All pins must be secured after assembly!
- ▶ The guy rods must be checked regularly, see Crane operating instructions, chapter 8.15!

To be able to install the D-lattice sections on the D-pivot section, the SA-bracket and the assembly rope **10** must be used.

- ▶ Lower the SA-bracket to the front, see Crane operating instructions, chapter 5.02.

Pin the assembly rope on the assembly bracket on the D-pivot section.

- ▶ Loosen the assembly rope **10** on the transport receptacle on the SA-bracket.
- ▶ Pull the assembly rope **10** to the assembly bracket **11** on the D-pivot section **20**.
- ▶ Pin the assembly rope **10** on the assembly bracket **11** with pins **12** and secure with spring retainer **13**.

Pin the D-intermediate section **21** on the D-pivot section **20** on top:

- ▶ Attach the D-intermediate section **21** on the auxiliary crane and align on the D-pivot section **20**.
- ▶ When the pin bores on the D-pivot section **20** and on the D-intermediate section **21** “on top” (point **X**) align:
Insert the pin **14** from the inside to the outside and secure with spring retainer **15**.
- ▶ Lift the D-pivot section **20** with the SA-bracket until the pin bores on the “bottom” align at point **Y**.
- ▶ When the pin bores on the D-pivot section **20** and on the D-intermediate section **21** “on the bottom” (point **Y**) align:
Insert the pin **14** from the inside to the outside and secure with spring retainer **15**.
- ▶ Attach the D-end section **22** on the auxiliary crane and align on the D-intermediate section **21**.
- ▶ When the pin bores on the D-intermediate section **21** and on the D-end section **22** “on top” (point **Z**) align:
Insert the pin **14** from the inside to the outside and secure with spring retainer **15**.
- ▶ Erect the SA-bracket until the pin bores on the D-intermediate section **21** and on the D-end section **22** “on the bottom” (point **Z**) align:
- ▶ When the pin bores on the D-intermediate section **21** and on the D-end section **22** “on the bottom” (point **Z**) align:
Insert the pin **14** from the inside to the outside and secure with spring retainer **15**.
- ▶ When the pins are properly pinned and secured on all D-lattice sections:
Luff the SA-bracket down until the assembly rope **10** is relieved.

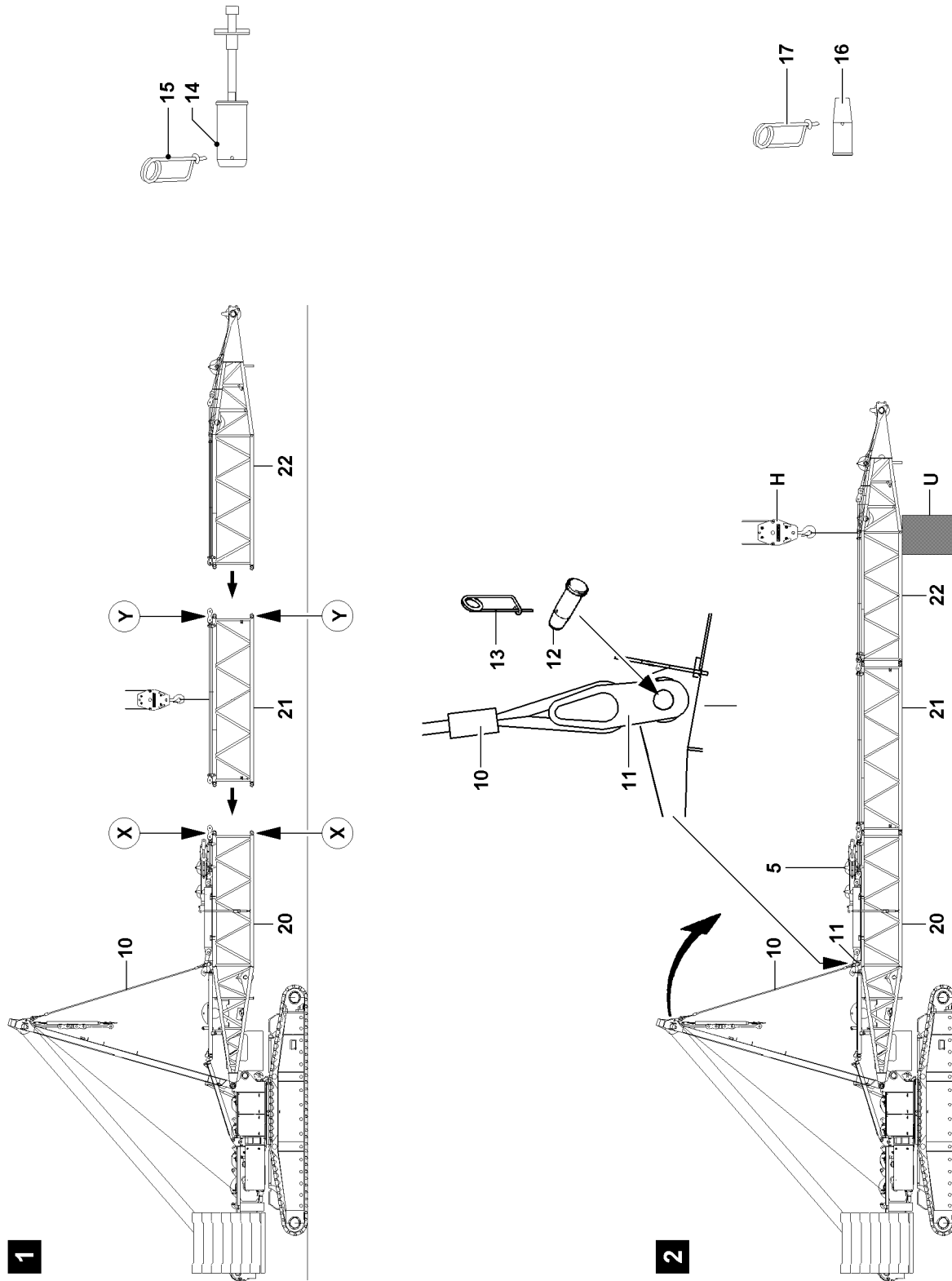

B104941

3.2 Flying assembly of the D-boom

If spatial prerequisites on the job site are limited for the assembly of the derrick boom, or if they are limited by buildings or similar, then the derrick boom can be installed in flying mode.



WARNING

Risk of accident!

If the following instructions are not observed, personnel can be severely injured or killed!

- ▶ Assembly of boom combinations, see rod plan and assembly plan!
- ▶ Depending on the condition of the ground, the boom and the lattice sections must be supported from below for the assembly of the boom!
- ▶ Observe the safety technical notes, see Crane operating instructions, chapter 5.01!

Make sure that the following prerequisites are met:

- The D-pivot section is pinned and secured on the turntable.
- The D-pivot section hangs horizontally on the assembly rope **10**, see illustration **1**.



WARNING

General danger notes!

- ▶ Support the D-boom during assembly with suitable materials!
 - ▶ All pins must be secured after assembly!
 - ▶ The guy rods must be checked regularly, see Crane operating instructions, chapter 8.15!
-
- ▶ Attach the D-intermediate section **21** on the auxiliary crane.
 - ▶ Lift the D-intermediate section **21** with the auxiliary crane and swing in to the pin points on the D-pivot section **20**.
 - ▶ When the pin bores on the D-pivot section **20** and on the D-intermediate section **21** “on top” and “bottom” align:
Insert the pins **14** “on top” and “bottom” at point **X** from the inside to the outside and secure with spring retainer **15**, see illustration **1**.
 - ▶ When the pins are properly inserted “on top” and “bottom” between the D-pivot section **20** and the D-intermediate section **21**:
Remove the auxiliary crane.
 - ▶ Attach the D-end section **22** on the auxiliary crane.
 - ▶ Lift the D-end section **22** with the auxiliary crane and swing in to the pin points on the D-intermediate section **21**.
 - ▶ When the pin bores on the D-intermediate section **21** and on the D-end section **22** “on top” and “bottom” align:
Insert the pins **14** “on top” and “bottom” at point **Y** from the inside to the outside and secure with spring retainers **15**, see illustration **1**.
 - ▶ When the pins are properly inserted “on top” and “bottom” between the D-intermediate section **21** and the D-end section **22**:
Remove the auxiliary crane.

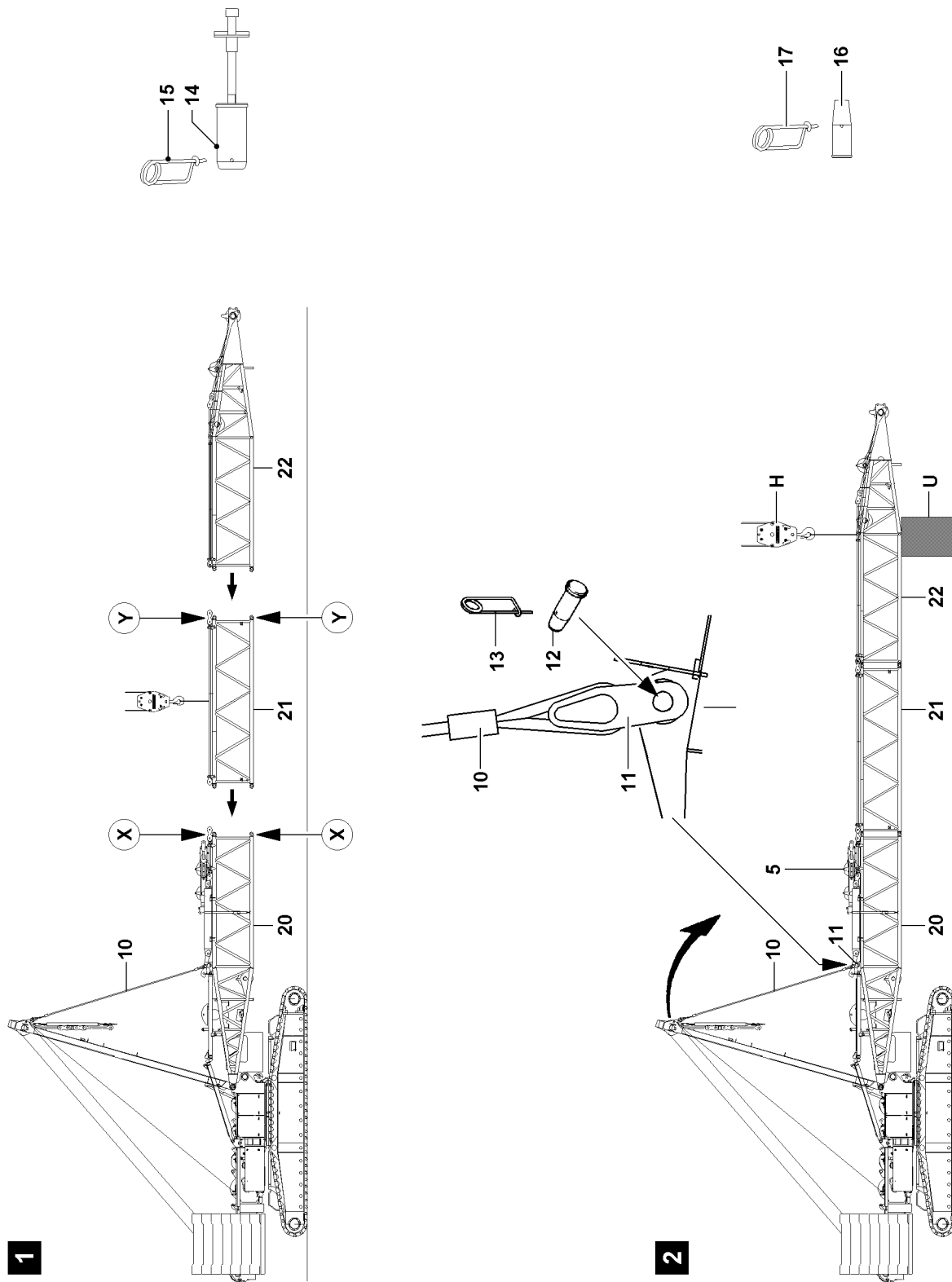

B104941

3.3 Assembling the D-guy rods



WARNING

Neglected inspection and maintenance on guy rods!

If the regular inspection and maintenance of the guy rods is not carried out or is carried out only in irregular intervals, then severe accidents can occur due to existing and unrecognized damage to the guy rods!

Personnel can be severely injured or killed!

- ▶ Check the guy rods before every assembly, see Crane operating instructions, chapter 8.15!



Note

- ▶ The S-guy rods must be assembled and secured, see Rod plan. The numbering in the rod plan must be identical to the numbering on the guy rods!

Make sure that the following prerequisites are met:

- The derrick boom is properly installed and all pin connections are secured.
- The derrick boom is laying on the ground with tensioned guy rods, see illustration 15.
- The installed derrick boom is horizontally aligned for flying assembly and placed on a support **U** or it is held by an auxiliary crane **H**, see illustration 2.



WARNING

Falling components!

If the intermediate sections are incompletely pinned or secured, then components can fall down!

Personnel can be severely injured or killed!

- ▶ Make sure that the intermediate sections or preassembled boom unit are pinned and secured on the S-pivot section!
- ▶ Make sure that the intermediate sections or preassembled boom unit is supported with suitable materials, secured with the auxiliary crane or the boom is placed on the ground!



WARNING

Risk of fatal injury!

If the following danger notes are not observed, the derrick boom can suddenly fold down.

Personnel can be severely injured or killed!

- ▶ The assembly rope may only be unpinned on the assembly bracket **11** on the D-pivot section **20** when it is ensured that the D-lattice sections are properly pinned and secured on all pin points.
- ▶ It is prohibited for anyone to remain under the installed D-lattice sections during the unpinning procedure on the assembly bracket.
- ▶ When the boom is **not** laying on the ground:
Support the boom and secure it with the auxiliary crane.
- ▶ Relieve the guy rods: Lower the SA-bracket somewhat to the front.

The D-guy rods are placed and secured for transport on the D-lattice components. Before assembly, the transport retainers must be released.

- ▶ Release the transport retainers on the guy rods.
- ▶ Carefully lower the SA-bracket until the assembly rope **10** is relieved.

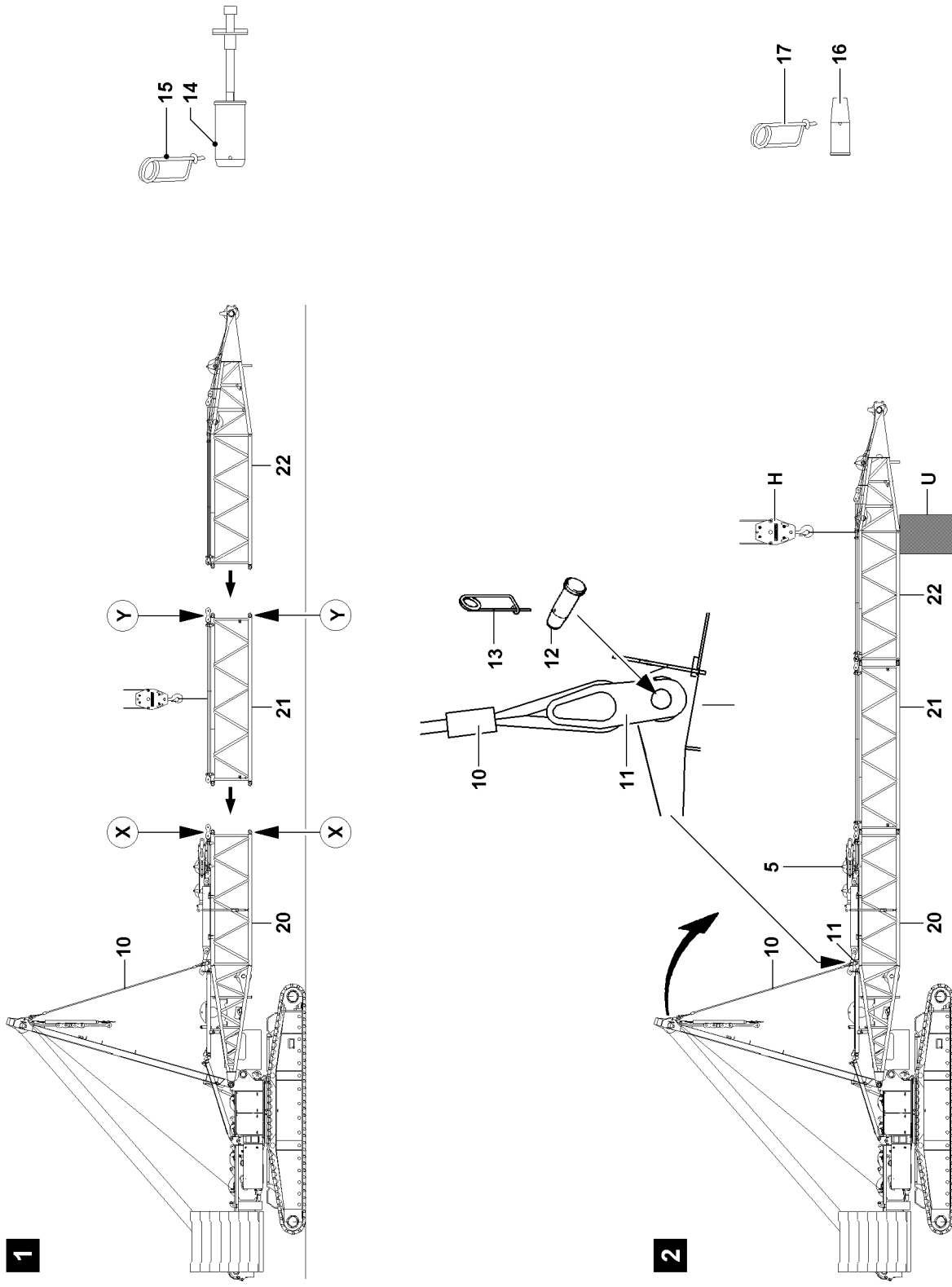

B104941

Unpin the assembly rope **10** on the assembly bracket **11**, see illustration **2**.

- ▶ Remove the spring retainer **13** and unpin the pin **12**.
- ▶ Secure the assembly rope **10** in the transport receptacle on the SA-bracket.
- ▶ Lower the SA-bracket further to the front, see Crane operating instructions, chapter 5.02.

NOTICE

Property damage!

If the pins of the guy rods are not pinned from the “inside” to the “outside”, the hoist rope can scrape on the pin and be damaged!

- ▶ Always insert the pins of the guy rods from the “inside” to the “outside”, see Rod plan and illustration **14**!

Pin the guy rods of the SA-bracket with the guy rods on the D-pivot section.

- ▶ Insert the pin **16** and secure with spring retainer **17**.

Pin the guy rods of the D-intermediate section with the guy rods on the D-pivot section.

- ▶ Insert the pin **16** and secure with spring retainer **17**.

Pin the guy rods of the D-intermediate section with the guy rods on the D-end section.

- ▶ Insert the pin **16** and secure with spring retainer **17**.
- ▶ Actuate winch 4 until the guy rods are tensioned between the SA-bracket and the D-end section.



DANGER

Mortal danger due to folding down of derrick boom!

- ▶ Before removing the auxiliary crane, the crane operator must ensure that the derrick boom is safely held by the guy rods!
-
- ▶ When the guy rods are tensioned between the SA-bracket and the D-end section:
Remove the auxiliary crane.

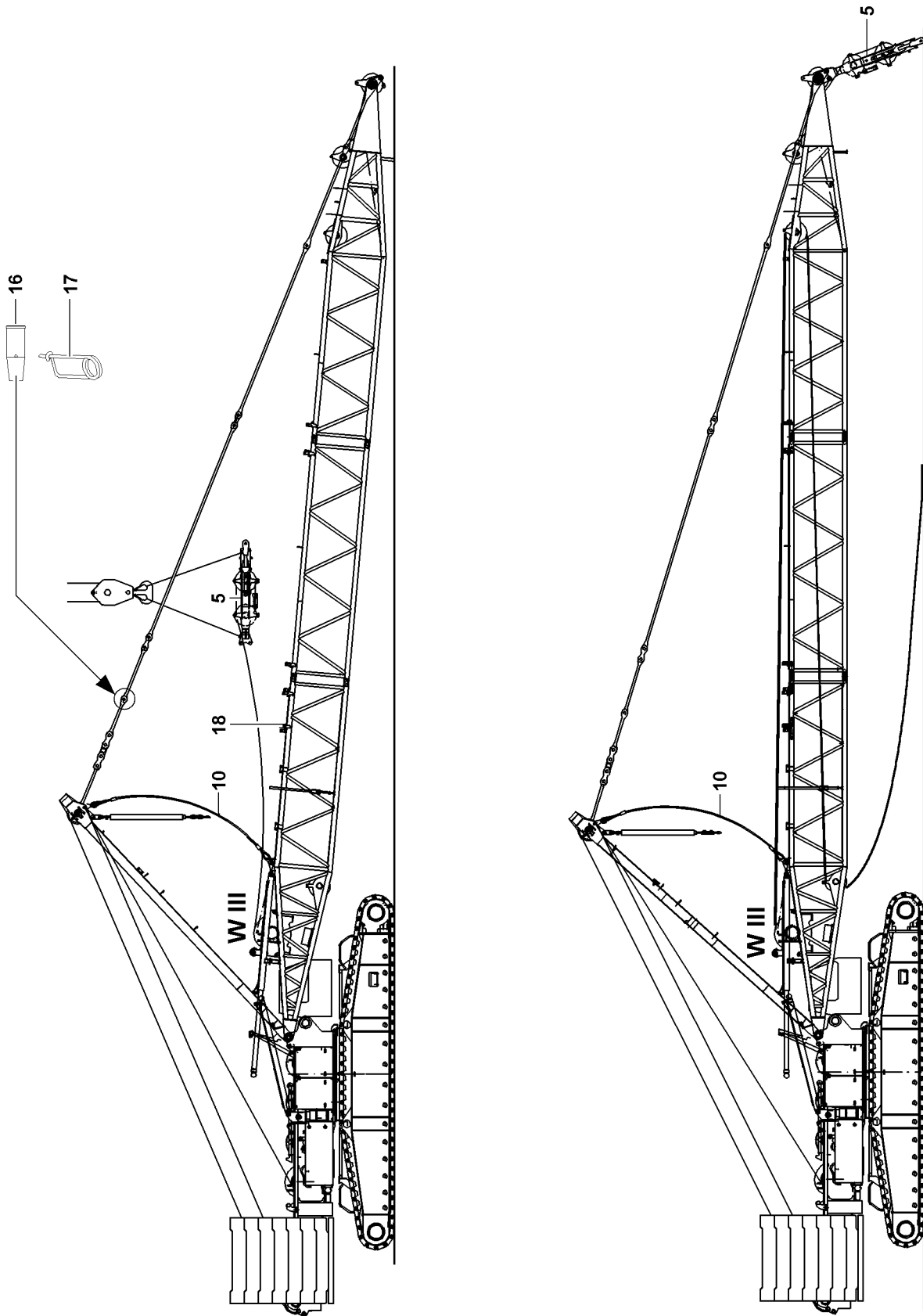

B104940

3.4 Assembling the pulley block

- ▶ Hang the pulley block **5** onto the auxiliary crane.
- ▶ Release and unpin the retaining pins on the transport receptacle **18** of the D-pivot section.
- ▶ Pull the pulley block **5** with the auxiliary crane to the D-end section while spooling out winch 3 at the same time.
- ▶ Pin and secure the pulley block **5** on the D-end section.
- ▶ Remove the auxiliary crane.



Note

- ▶ Hoist rope reevings, see Crane operating instructions, chapter 4.06 and Reeving plan!
-



WARNING

General danger notes!

If the following conditions are not met before erecting the derrick boom, the hoist rope can fall down and fatally injure personnel!

- ▶ Enough hoist rope must be guided over the rope pulleys to prevent the hoist rope from being pulled back and fall down due to its own weight when erecting the D-boom!
-
- ▶ Pull the hoist rope over the rope pulleys on the D-end section and the D-pivot section.
 - ▶ Luff up the derrick boom until the pulley block **5** hangs freely.

3.5 Establishing the electrical connections to the D-boom



Note

- ▶ To establish the electrical connections on the D-boom, see Electric wiring diagram!

Make sure that the following prerequisite is met:

- The D-boom is completely assembled.
- ▶ Establish the electrical connections.
- ▶ Make sure that all electrical connections on the boom are established.

3.6 Establishing the hydraulic connections to the D-boom

When connecting hydraulic lines with quick-release couplings, make sure that the coupling procedure is carried out correctly.



WARNING

Pressure in the hydraulic lines!

If the pressure supply is not interrupted before connecting / releasing the hydraulic lines, the hydraulic oil can escape with high pressure!

Personnel can be severely injured or killed!

- ▶ Release the pressure in the hydraulic system before connecting / disconnecting: Interrupt the pressure supply and wait for a short time!



WARNING

Loss of pressure or leakage!

Incorrectly coupled or self-loosening quick-release couplings (particularly return lines) can result in serious accidents due to component failure!

- ▶ Check that the quick-release couplings have been properly connected before using the crane!
- ▶ Connect the coupling components (sleeve and connector) and screw together with the hand-tightened nut.
- ▶ Tighten the hydraulic coupling by hand. Rotate the hand-tightened nut until it reaches a tangible, fixed stop position.
- ▶ Establish the hydraulic connections.

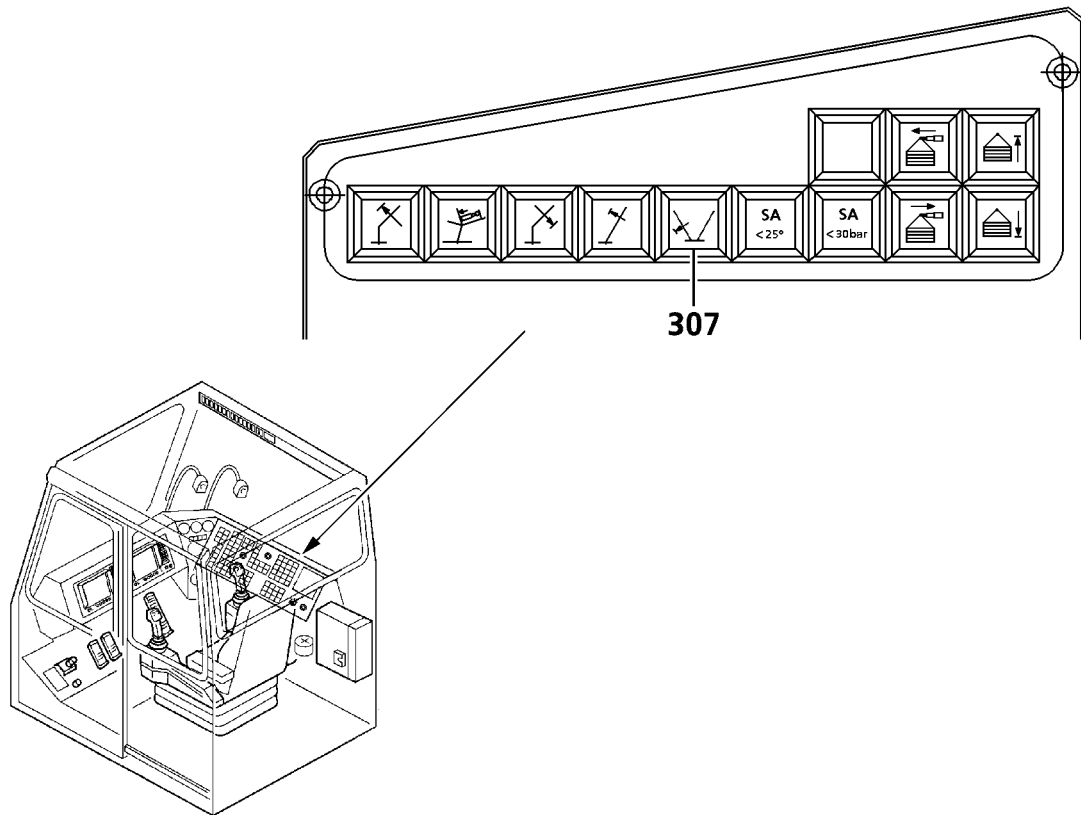

3.7 Function check

Make sure that the following prerequisites are met:

- All electrical and hydraulic connections have been established.
- The crane engine is running.
- The appropriate operating mode is set.
- The actuator levers of the limit switches have been checked for easy movement and are lubricated.

3.7.1 Limit switch - General

**Note**

- ▶ The limit switch functions have to be checked individually before erection!
-

- ▶ Manually actuate the individual limit switches on the D-relapse cylinders.

Result:

- Winch 4 (D-control winch) turns off in upward movement.
- The indicator light **307** lights up.

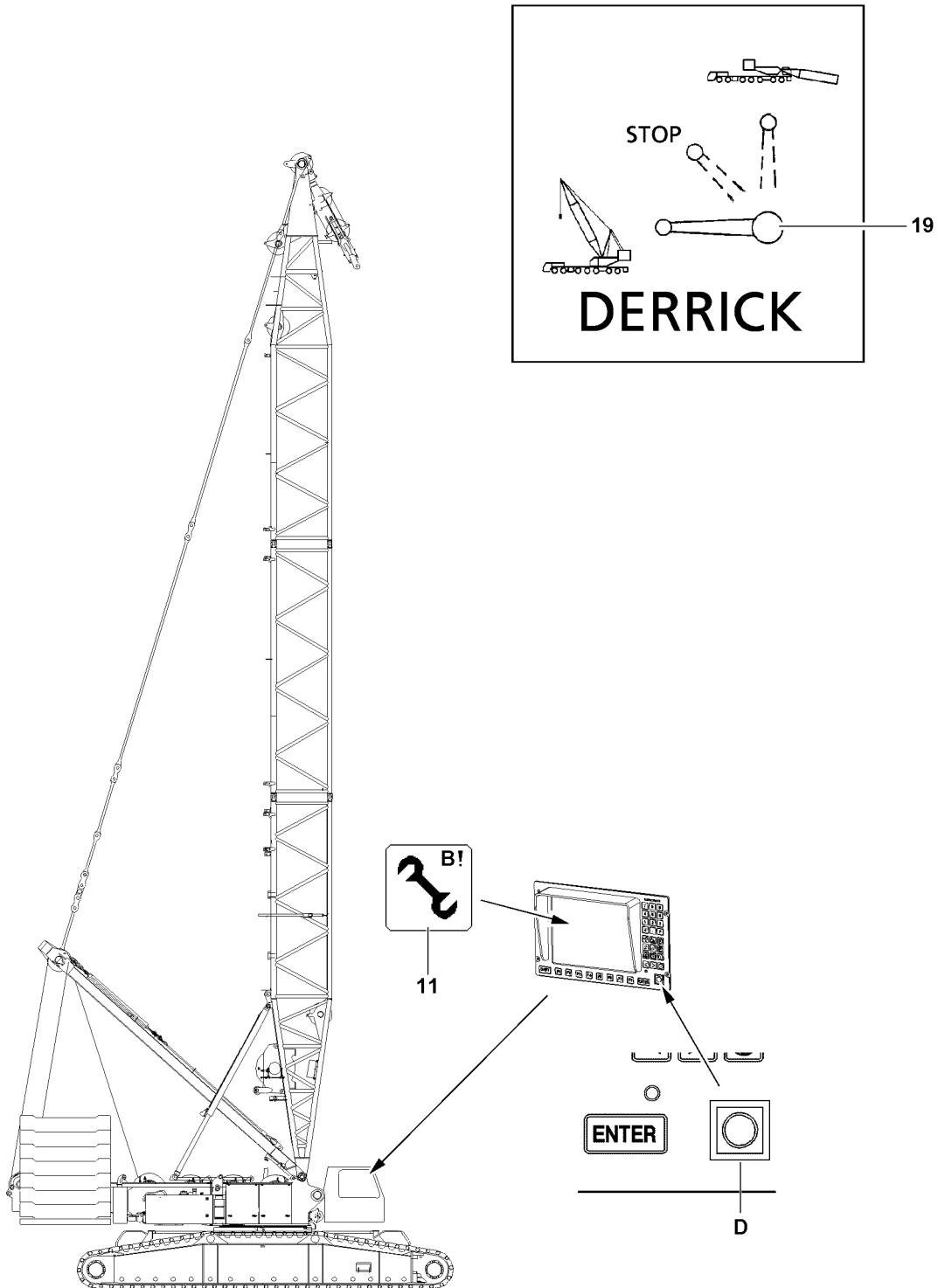

B111430

3.8 Erecting the D-boom



DANGER

The crane can topple over!

If the following conditions are not met before erecting the boom, the crane can topple over!

Personnel can be severely injured or killed!

- ▶ Observe the safety technical guidelines in chapter 5.01!
- ▶ Observe the data in the erection and take down charts!
- ▶ Extend the relapse cylinder before erection!

Make sure that the following prerequisites are met:

- The crane is aligned in horizontal direction.
- All electrical and hydraulic connections have been established.
- All limit switches are functioning.
- The counterweight has been installed on the turntable according to the load chart.
- All pin connections have been secured.
- The relapse cylinders on the D-pivot section are extended.
- The hoist rope has been correctly placed in the rope pulleys and is prevented from jumping out with the rope retaining pins.
- The LICCON overload protection has been set according to the data in the load chart.
- The LICCON overload protection settings have been compared with the actual crane configuration.
- The assembly icon **11** is visible on the LICCON monitor.
- No personnel is within the danger zone.

3.8.1 Extending the D-relapse cylinder



WARNING

Mortal danger due to derrick boom!

If the D-relapse cylinders are not extended before erecting the derrick boom, then the derrick boom can fall backward!

Personnel can be severely injured or killed!

- ▶ The D-relapse cylinders must be extended before erection of the derrick boom!
- ▶ The ball valve must be secured during crane operation to prevent unintended actuation!

The piston rod on the D-relapse cylinder must be extended by actuating the ball valve **19**.

Ball valve positions	
Horizontal	Crane operation, extend the piston rod
Vertical	Assembly, retract the piston rod
45°	STOP (the piston rod cannot be moved in / moved out)

1

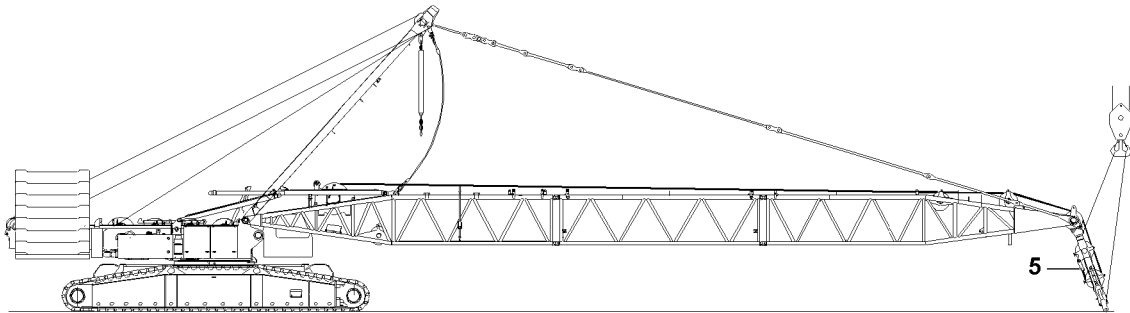

2

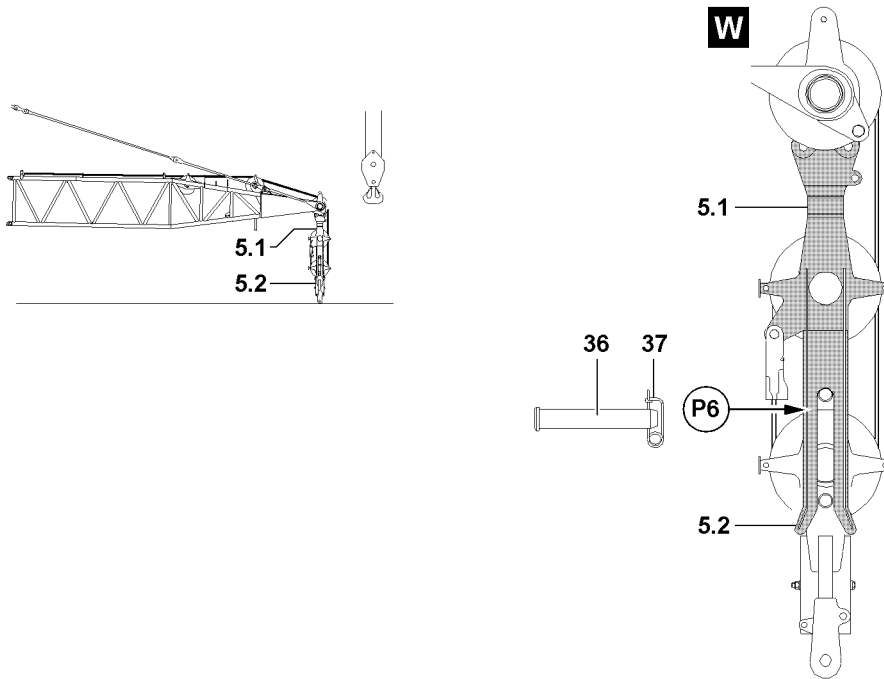

3.8.2 Unpinning the upper pulley block on the lower pulley block

NOTICE

Slack rope formation!

If winch 3 is spooled out as long as the upper pulley block and the lower pulley block are pinned, slack rope formation can occur!

- ▶ Before erecting the D-boom, unpin the upper pulley block **5.2** on the lower pulley block **5.1**!
-

Make sure that the following prerequisite is met:

- The pulley block **5** hangs down vertically, see illustration **2**.
- ▶ Unpin the upper pulley block **5.2** on the lower pulley block **5.1**: Remove the spring retainer **37** on point **P6** and unpin the pin **36**, see detail **W**.

3.8.3 Erecting the D-boom



DANGER

The crane can topple over!

- ▶ It is not permitted to turn the crane superstructure during erection procedure!
 - ▶ Do not allow slack cable to build up on the control winch (winch 3)!
 - ▶ The derrick boom may not be erected further than maximum 90° to the horizontal!
-
- ▶ Actuate winch 4 and erect the derrick boom to an angle range of 80° to 85°.

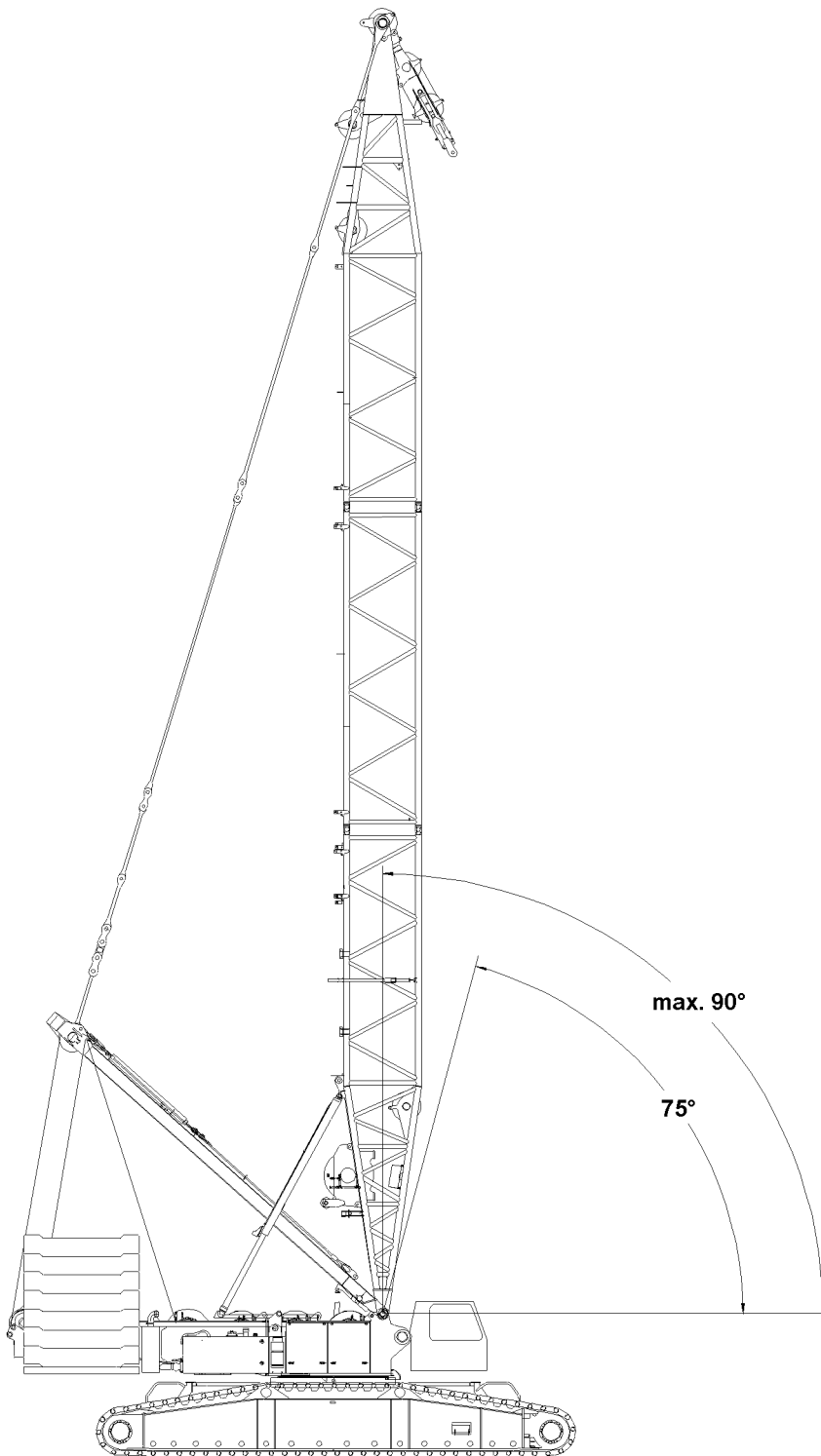

B111427

4 Disassembly



WARNING

Risk of falling!

During assembly / disassembly, inspection and maintenance work, personnel must be secured with appropriate aids to prevent them from falling! If this is not observed, assembly personnel could fall and suffer life-threatening or fatal injuries!

- ▶ All work aloft, where there is a danger of falling must be carried out with suitable aids!
- ▶ If fall protection equipment is available, then it must be used, see Crane operating instructions, chapter 2.06!
- ▶ If aids are not available and work cannot be carried out from the ground, then the assembly personnel must secure themselves with the permissible fall arrest system to prevent falling, see Crane operating instructions, chapter 2.04!
- ▶ The fall arrest system must be fastened on the fastening and hook points as well as on the safety ropes. For safety points, see Crane operating instructions, chapter 2.06!
- ▶ Only step on the aids, ladders and catwalks with clean shoes!
- ▶ Keep aids, ladders and catwalks free of heavy dirt, snow and ice!
- ▶ It is prohibited to walk on the telescopic or an auxiliary boom without suitable protective devices!



WARNING

The lattice sections can fall down!

If the lattice sections are not pinned and secured correctly, then they can fall down and fatally injure personnel!

- ▶ Pin or unpin both pins at the same horizontal level, i.e. **left and right!**
- ▶ Do not stand under the booms or within the entire danger zone during the boom pinning and unpinning procedure!
- ▶ Secure the pins in the bearing points and the receptacles!
- ▶ It is prohibited to lean the ladder against the components being disassembled!
- ▶ Do not remove the fastening equipment and the auxiliary crane until each component is pinned on and secured!



WARNING

Danger of impact / crushing!

When installing / removing counterweight components with the auxiliary crane, crane components can start to swing back and forth!

When lifting / lowering and positioning crane components, there is an increased danger of impacts / crushing!

Personnel can be caught and severely injured or killed!

- ▶ Make sure that personnel cannot be caught by components!
- ▶ Make sure that the crane is aligned in horizontal position to avoid the support beams from swinging by themselves!
- ▶ When working in danger zones: Use aids to protect limbs!
- ▶ Guide components with suitable aids to minimize oscillation!

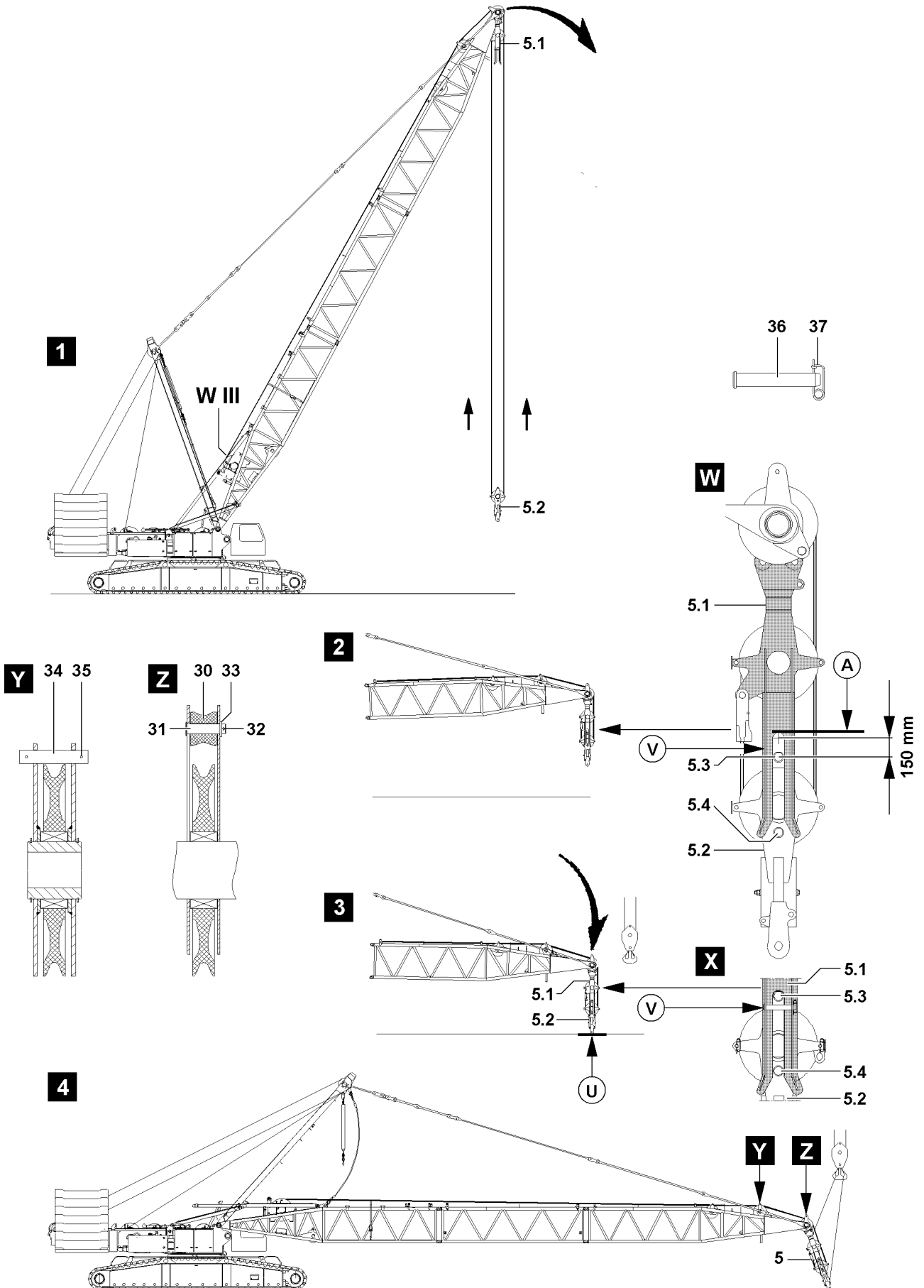

B105268

4.1 Disassembling the D-boom



WARNING

Falling boom!

If the D-boom is not properly supported before disassembly or held with an auxiliary crane, then the D-boom can fall down when it is unpinned!

Personnel can be severely injured or killed!

- ▶ Before supporting the D-boom, the ground condition must be checked regarding load bearing capability and level!

If the ground condition is not classified as sufficient:

- ▶ Support the D-boom properly and safely with suitable material!
 - ▶ Observe the safety technical notes, see Crane operating instructions, chapter 5.01!
-

Make sure that the following prerequisites are met:

- The crane is properly supported and horizontally aligned.
- An auxiliary crane is available.
- An assembly scaffolding / work platform is available.
- The counterweight has been installed to the turntable according to the erection chart.
- The LICCON overload protection has been set according to the data in the load chart.
- The main boom is disassembled.

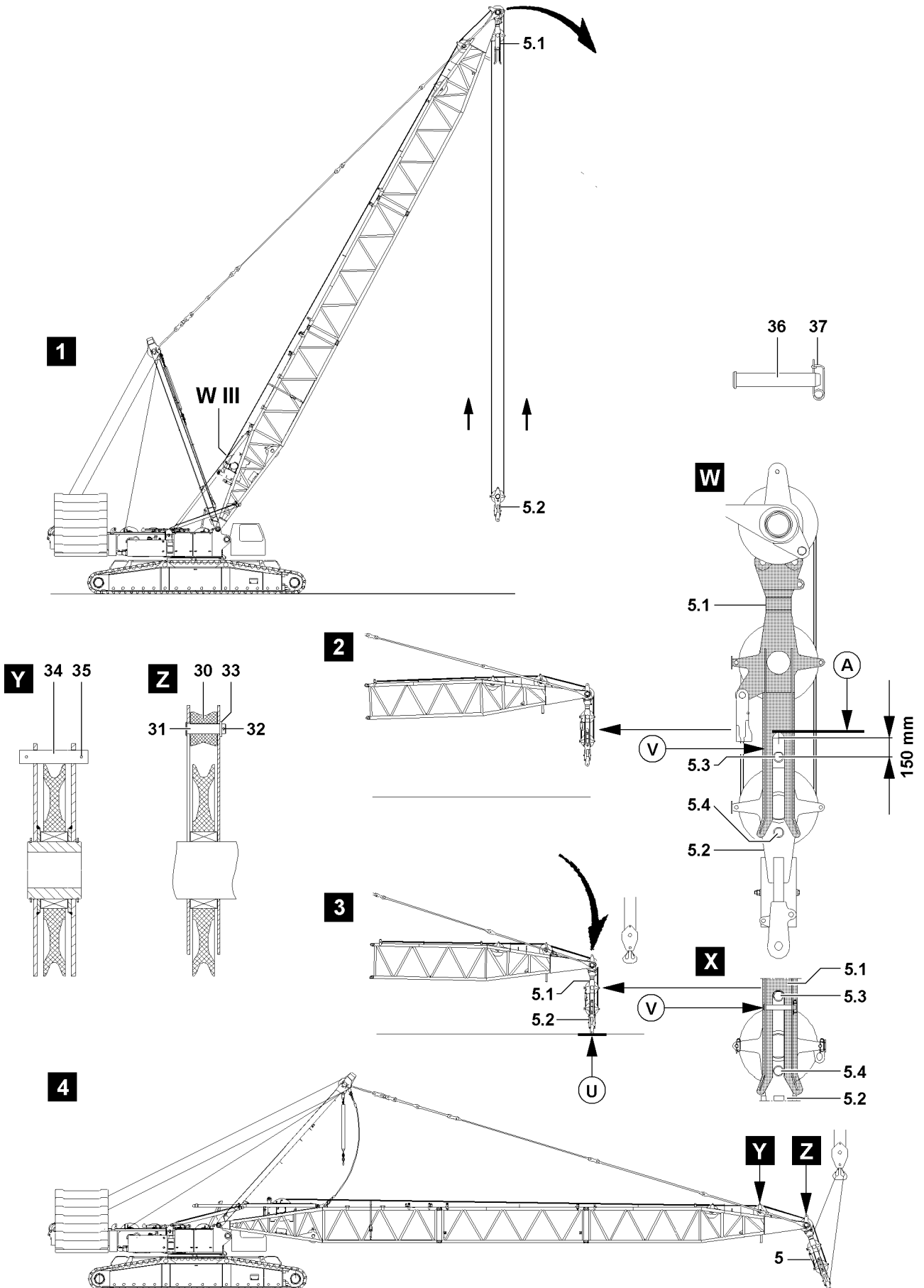

B105268

4.1.1 Pinning the upper pulley block with the lower pulley block

Make sure that the following prerequisites are met:

- The main boom is completely disassembled.
- The upper pulley block **5.2** hangs in reeved condition above the ground level, see illustration **1**.
- The retaining pin **36** on the bracket of the lower pulley block **5.1** is unpinned on point **V**, see illustration **W**.

The upper pulley block **5.2** must be pinned with the lower pulley block **5.1** before the complete pulley block **5** can be placed in the transport receptacle on the D-pivot section.

NOTICE

Damage to the pulley block!

If the D-boom is luffed down too quickly, significant damage can occur on the pulley block and on the D-end section!

- ▶ Luff the D-boom down carefully!
 - ▶ Make sure that the upper pulley block is moved slowly into the lower pulley block!
-
- ▶ Luff the D-boom down slowly and spool up winch **3** **WIII** simultaneously until the upper pulley block **5.2** is moved together with the guide pin **5.3** in the bracket to approx. 150 mm on the stop of the point **A**, the lower pulley block **5.1**, see illustration **2** and illustration **W**.
 - ▶ When the upper pulley block is approx. 150 mm before the stop of the lower pulley block **5.1**, point **A**:
Slowly and carefully luff the D-boom down until the upper pulley block **5.2** is in contact with the ground (point **U**), see illustration **3**.

NOTICE

Danger of property damage on the pulley block!

If the D-boom is luffed down too quickly, then significant property damage can occur on the upper as well as the lower pulley block.

- ▶ Always use a guide when connecting the upper and lower pulley block.
 - ▶ Carry out all crane movements slowly and with utmost caution.
 - ▶ When the guide pin **5.3** reaches the stop at point **A**, stop the luff down movement of the D-boom immediately.
-
- ▶ When the upper pulley block **5.2** is in contact with the ground at point **U**, illustration **3**:
Luff the D-boom down slowly and carefully until the guide pin **5.3** is entered to the stop at point **A**.
 - ▶ When the guide pin **5.3** touches on stop point **A** of the lower pulley block **5.1**, illustration **X**:
Stop the luff down movement immediately.
 - ▶ Insert the retaining pins **36** on both sides on the bracket of the lower pulley block **5.1** at point **V** and secure with spring retainer **37**.

Result:

- The upper pulley block **5.2** is connected with the lower pulley block **5.1** and now forms the "Transport unit" pulley block **5**, illustration **4**.

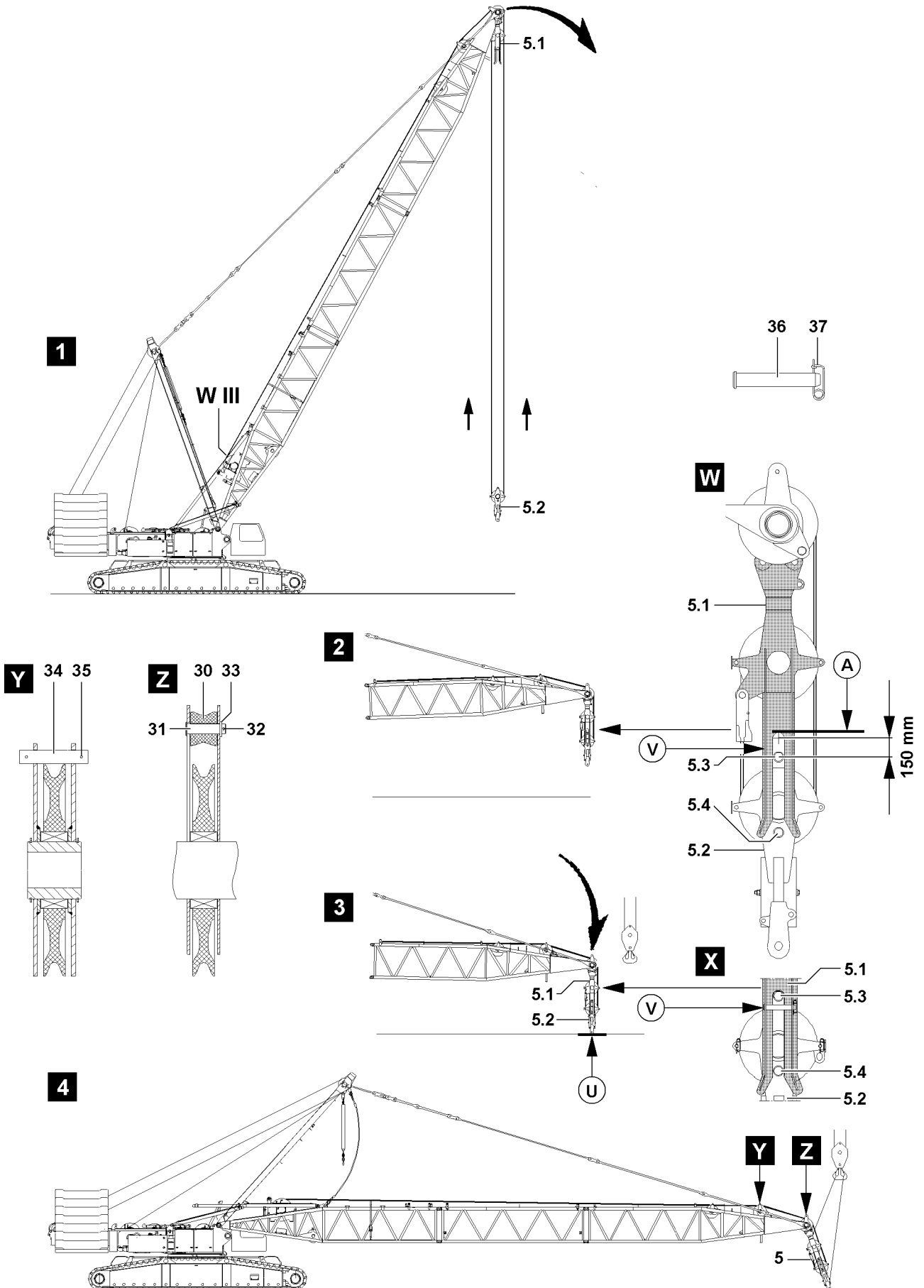

B105268

Before the pulley block **5** can be placed in the transport receptacle on the D-pivot section, the rope retaining pin **34**, see illustration **Y** and the rope retaining pin **31**, see illustration **Z** must be removed, illustration **4**.



Note

Loss of rope retaining elements

- ▶ After disassembly, store the rope retaining pipes and pins, spring retainers and linch pins in a safe location.
-
- ▶ Remove the spring retainer **35** on the rope retaining pipe **34**.
 - ▶ Unpin the rope retaining pipe **34**, illustration **Y**.
 - ▶ Remove the linch pin **32** on the rope retaining pin **31**.
 - ▶ Remove the washer **33**.
 - ▶ Hold the roller **30** and unpin the rope retaining pin **31**.

B195219

4.1.2 Disconnecting the electrical connections to the D-boom

Make sure that the following prerequisite is met:

- The D-boom has been placed down.

NOTICE

Damage to cable drum or cable!

If the cable of the cable drum is not properly spooled up on the cable drum after unplugging the D-end section, then the cable drum or the cable can be significantly damaged!

- ▶ Spool the cable drum up after unplugging!
-
- ▶ Disconnect the electrical connections.
 - ▶ Spool the cable drum up and secure it to prevent inadvertent spooling out.
 - ▶ Make sure that all electrical connections on the D-boom have been disconnected.

4.1.3 Disconnecting the hydraulic connections to the D-boom

When releasing hydraulic lines with quick-release couplings, make sure that the coupling procedure is carried out correctly.



WARNING

Pressure in the hydraulic lines!

If the pressure supply is not interrupted before connecting / releasing the hydraulic lines, the hydraulic oil can escape with high pressure!

Personnel can be severely injured or killed!

- ▶ Release the pressure in the hydraulic system before connecting / disconnecting: Interrupt the pressure supply and wait for a short time!
-
- ▶ Install the coupling components (sleeve and connector) with the hand-tightened nut.
 - ▶ Disconnect the hydraulic connections.
 - ▶ Install dust caps on the quick-release couplings.

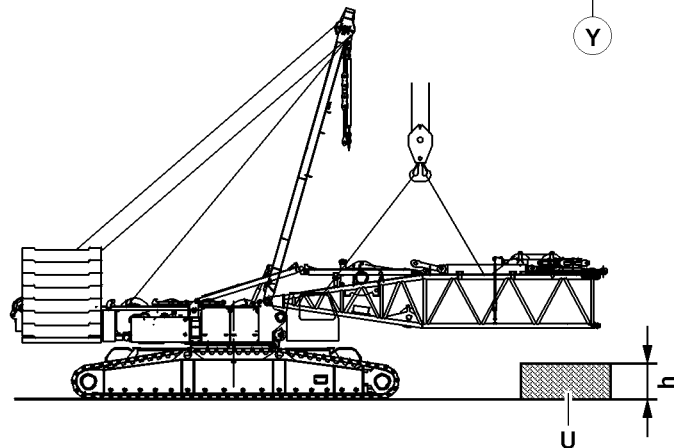
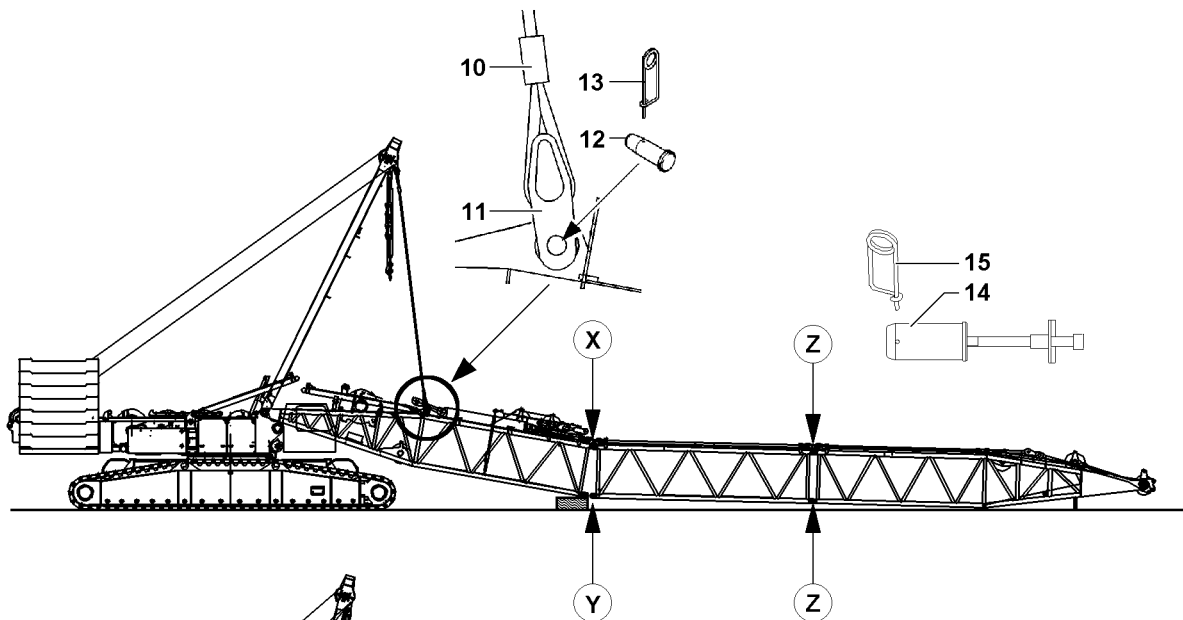
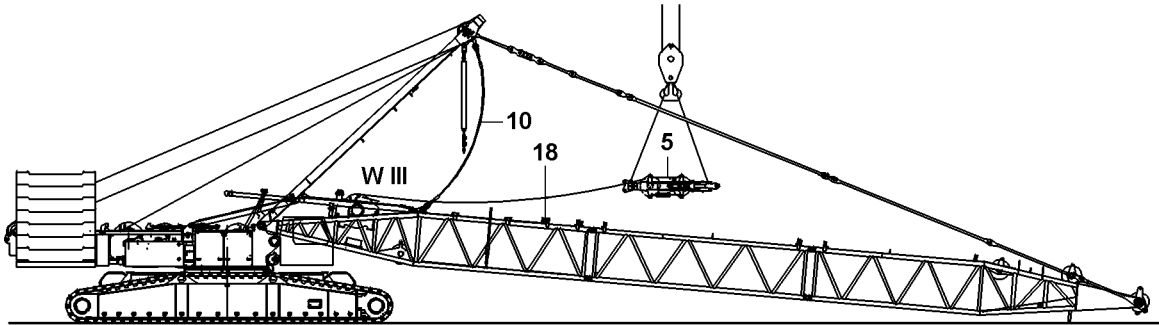
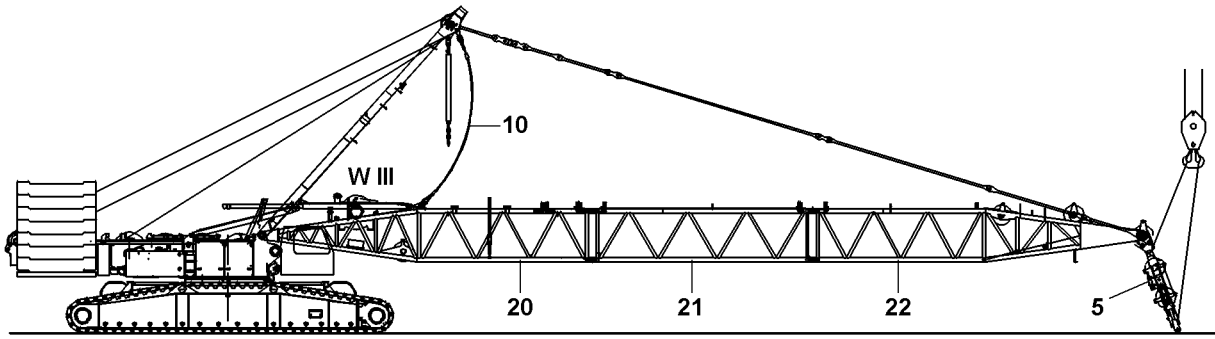

B104944

4.1.4 Placing the pulley block in the transport receptacle

Make sure that the following prerequisites are met:

- The lower and the upper pulley block are pinned together as a “Transport unit” pulley block **5**.
- The rope retaining pipes and pins are released and unpinned.
- ▶ Attach the pulley block **5** onto the auxiliary crane.
- ▶ Tension the tackle between the pulley block and the hook block of the auxiliary crane.



WARNING

Swinging pulley block!

If the pulley block is not properly attached on the auxiliary crane for disassembly, then the pulley block can start to swing back and forth during the unpinning procedure!

Personnel can be severely injured or killed!

- ▶ Before the unpinning procedure of the pulley block, the crane operator must ensure that it is held safely.
- ▶ It is prohibited to remain in the danger zone.
- ▶ Unpin the pulley block on the D-end section.
- ▶ Pull the pulley block **5** with the auxiliary crane to the D-pivot section while spooling out winch 3 at the same time.
- ▶ Place the pulley block **5** in the transport receptacle **18**.
- ▶ Pin and secure the pulley block **5** in the transport receptacle **18**.

4.1.5 Disassembling the D-guy rods

Make sure that the following prerequisite is met:

- The pulley block **5** is placed in the transport receptacle **18** on the D-pivot section **20**, pinned and secured.
- ▶ Carefully luff the derrick boom down until the D-end section is laying on the ground or on the support.
- ▶ Lower the SA-bracket to the front.
- ▶ Remove the guy rods and place them in the corresponding transport retainers on the D-lattice sections.
- ▶ Secure the guy rods in the transport retainers.

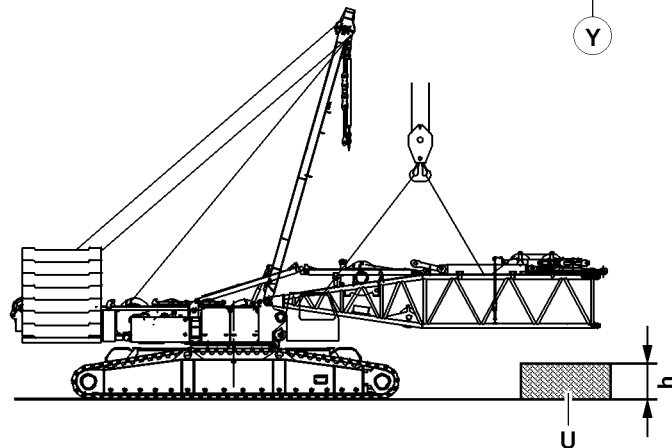
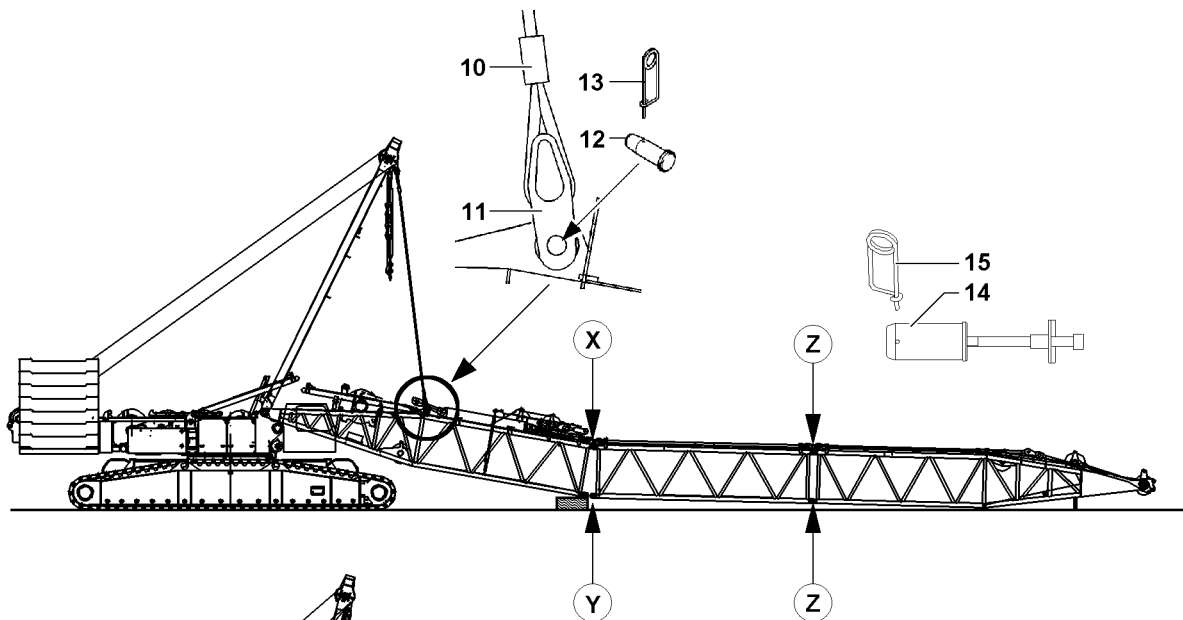
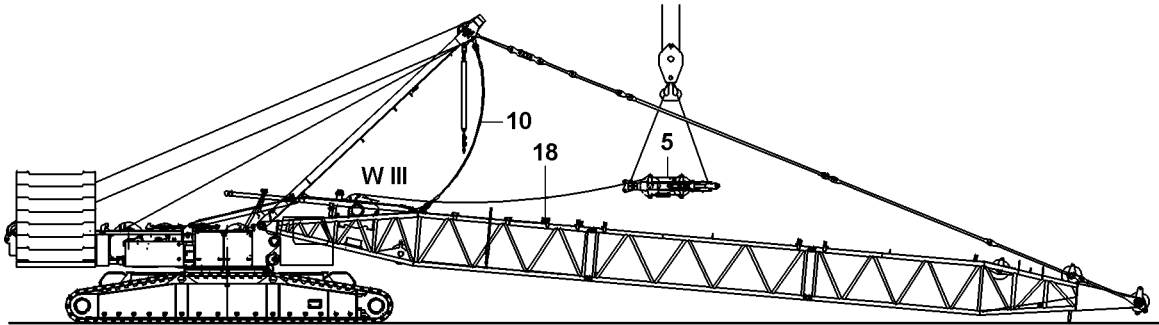
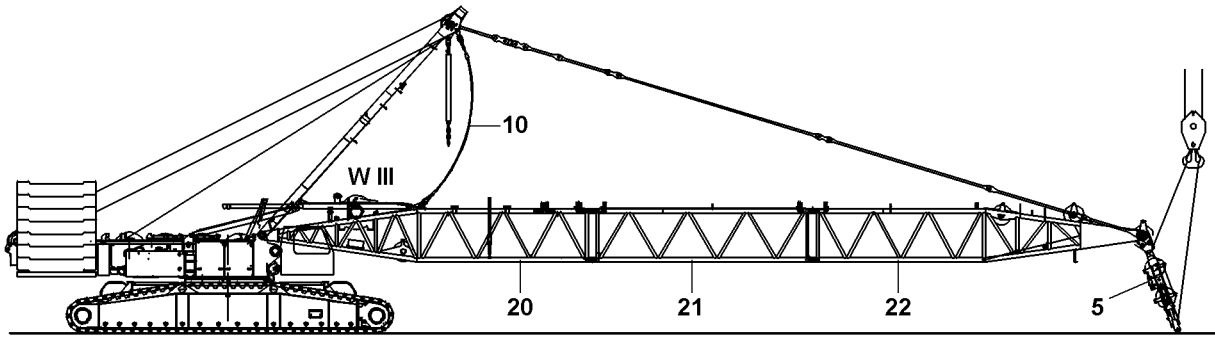

B104944

4.1.6 Removing the D-lattice sections on the D-pivot section

Pin the assembly rope on the assembly bracket on the D-pivot section.

- ▶ Loosen the assembly rope **10** on the transport receptacle on the SA-bracket.
- ▶ Pull the assembly rope **10** to the assembly bracket **11** on the D-pivot section.
- ▶ Pin the assembly rope **10** on the assembly bracket **11** with pins **12** and secure with spring retainer **13**.
- ▶ Luff the SA-bracket up until the assembly rope **10** is tensioned on the D-pivot section.



DANGER

Risk of fatal injury!

- ▶ Before unpinning the D-end section “on the bottom” at point **Z**, the assembly rope **10** must be pinned and tensioned on the assembly bracket **11**.
- ▶ It is prohibited for anyone to remain under the derrick boom during the entire disassembly procedure.

Release and unpin the pin **14** “at the bottom” at point **Z**.

- ▶ Remove the spring retainer **15** “on the bottom” at point **Z** on pin **14**.
- ▶ Unpin the pin **14** “at the bottom” at point **Z**.
- ▶ Hang the D-end section on the auxiliary crane.



DANGER

Risk of fatal injury!

The D-end section can fall down during the unpinning procedure and severely injure or kill personnel.

- ▶ The crane operator must make sure before the unpinning procedure, that the D-end section is being held completely by the auxiliary crane.
- ▶ When the D-end section is being held by the auxiliary crane:
Release and unpin the pin **14** “on top” at point **Z**.
- ▶ Remove the D-end section with the auxiliary crane.
- ▶ Carefully luff the derrick boom down until the D-intermediate section is laying on the ground or on the support.
- ▶ Release and unpin the D-intermediate section at the “bottom” at point **Y**.
- ▶ Hang the D-intermediate section on the auxiliary crane.



DANGER

Risk of fatal injury!

The D-intermediate section can fall down during the unpinning procedure and severely injure or kill personnel.

- ▶ The crane operator must make sure before the unpinning procedure, that the D-intermediate section is being held completely by the auxiliary crane.
- ▶ When the D-intermediate section is being held by the auxiliary crane:
Release and unpin the pin **14** “on top” at point **X**.
- ▶ Remove the D-intermediate section with the auxiliary crane.

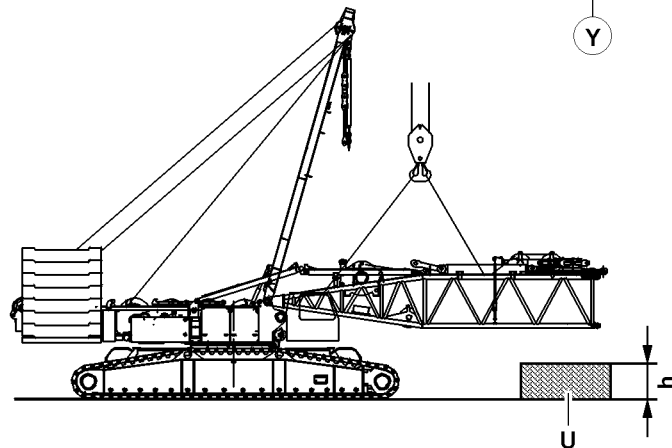
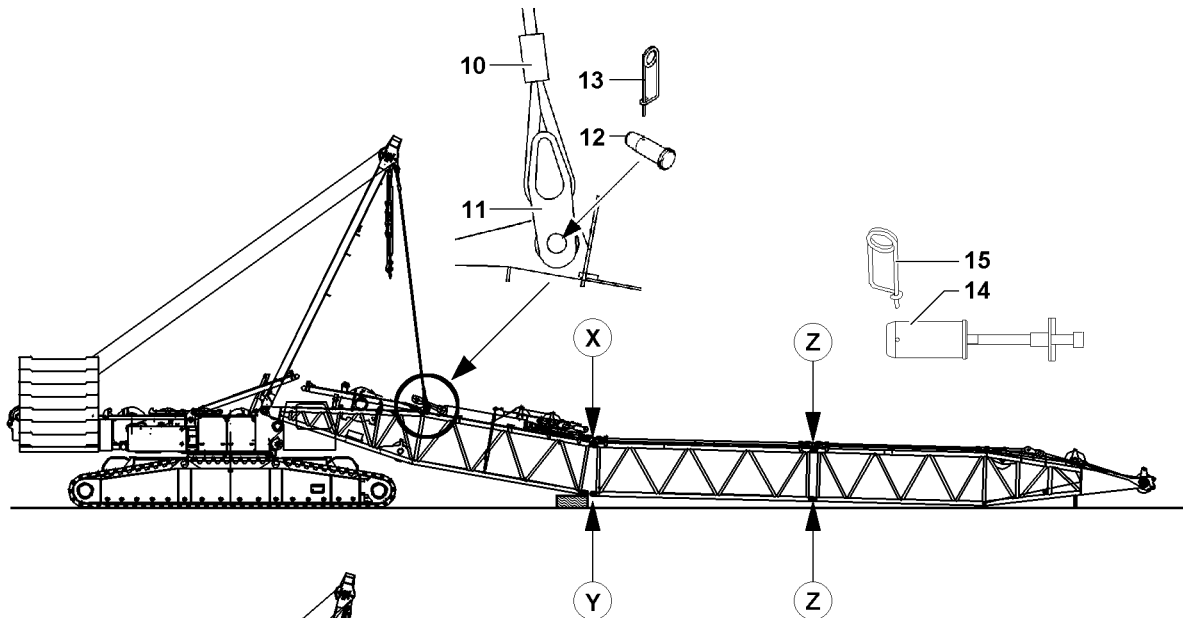
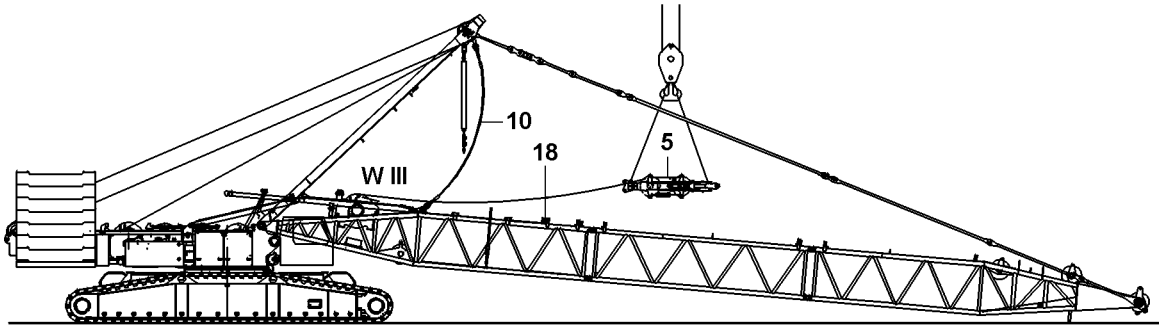
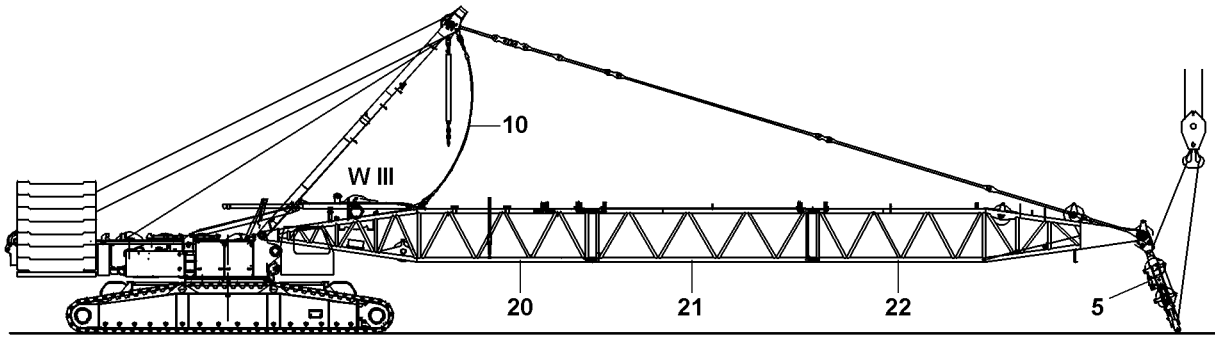

B104944

**CAUTION**

Damage of the D-pivot section and the turntable!

By placing the installed D-pivot section on the ground, significant property damage can occur on the D-pivot section and on the turntable.

- ▶ The D-pivot section may not be placed directly on the ground.
- ▶ When placing the D-pivot section down, always use a sufficiently load bearing and large enough support.
- ▶ The support **U** may not fall below the specified minimum height **h**.

Minimum height of support U on D-pivot section	
Without Quick connection	400 mm
With Quick connection	760 mm

- ▶ Place the D-pivot section on the support **U**.
- ▶ Hang the D-pivot section on the auxiliary crane.

Remove the assembly rope **10** on the D-pivot section.

- ▶ Release and unpin the pin **12** on the assembly bracket **11** on the D-pivot section.
- ▶ Secure the assembly rope **10** on the transport retainers on the SA-bracket.
- ▶ Turn the pressure change over switch **373** on.

Establish the hydraulic connection to the pin pulling device via two quick couplers.

Unpin the D-pivot section on the turntable.

- ▶ Release and remove the retaining plates of the connector pins.
- ▶ Unpin the connector pins with the hydraulic pin pulling device.
- ▶ When the connector pins are unpinned:
Release the electrical and hydraulic connections from the turntable to the D-pivot section.
- ▶ Remove the D-pivot section with the auxiliary crane.
- ▶ Turn the pressure change over switch **373** off.

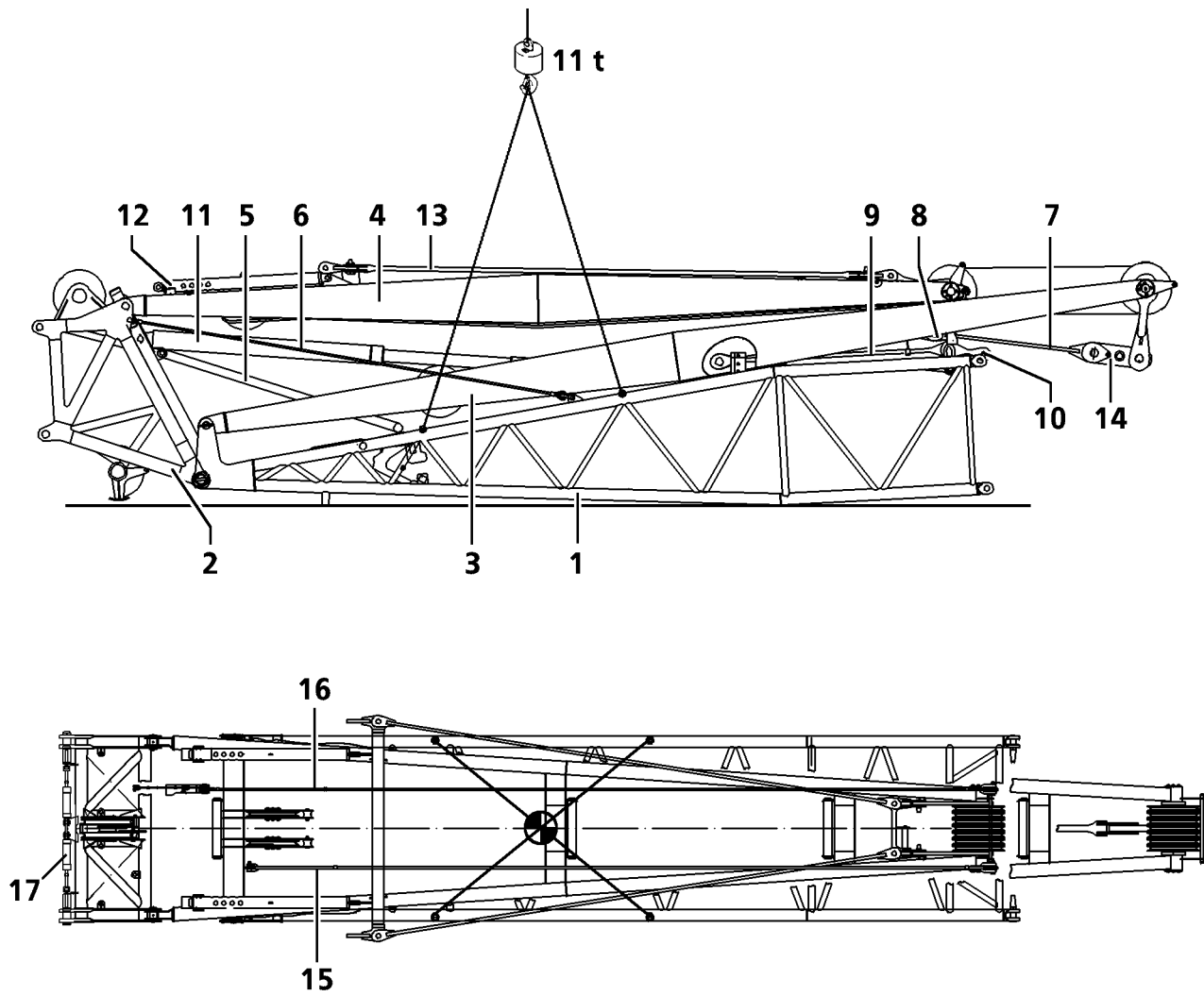

1 Component overview of assembly unit



Note

► The total weight of the N-assembly unit is approx. 11 t!

Component overview	
Position	Description
1	N-pivot section
2	Fold in head
3	NA-bracket I
4	NA-bracket II
5	Mechanical relapse support
6	Retaining rope
7	Guy rod 2010 mm
8	Guy rod 2630 mm
9	Guy rod 2790 mm
10	Connector bracket 420 mm
11	Relapse accumulator cylinder

Component overview	
Position	Description
12	NA-bracket II, relapse support
13	Guy rods
14	Test bracket
15	Assembly rope for NA-bracket II
16	Assembly rope
17	Pin pulling device

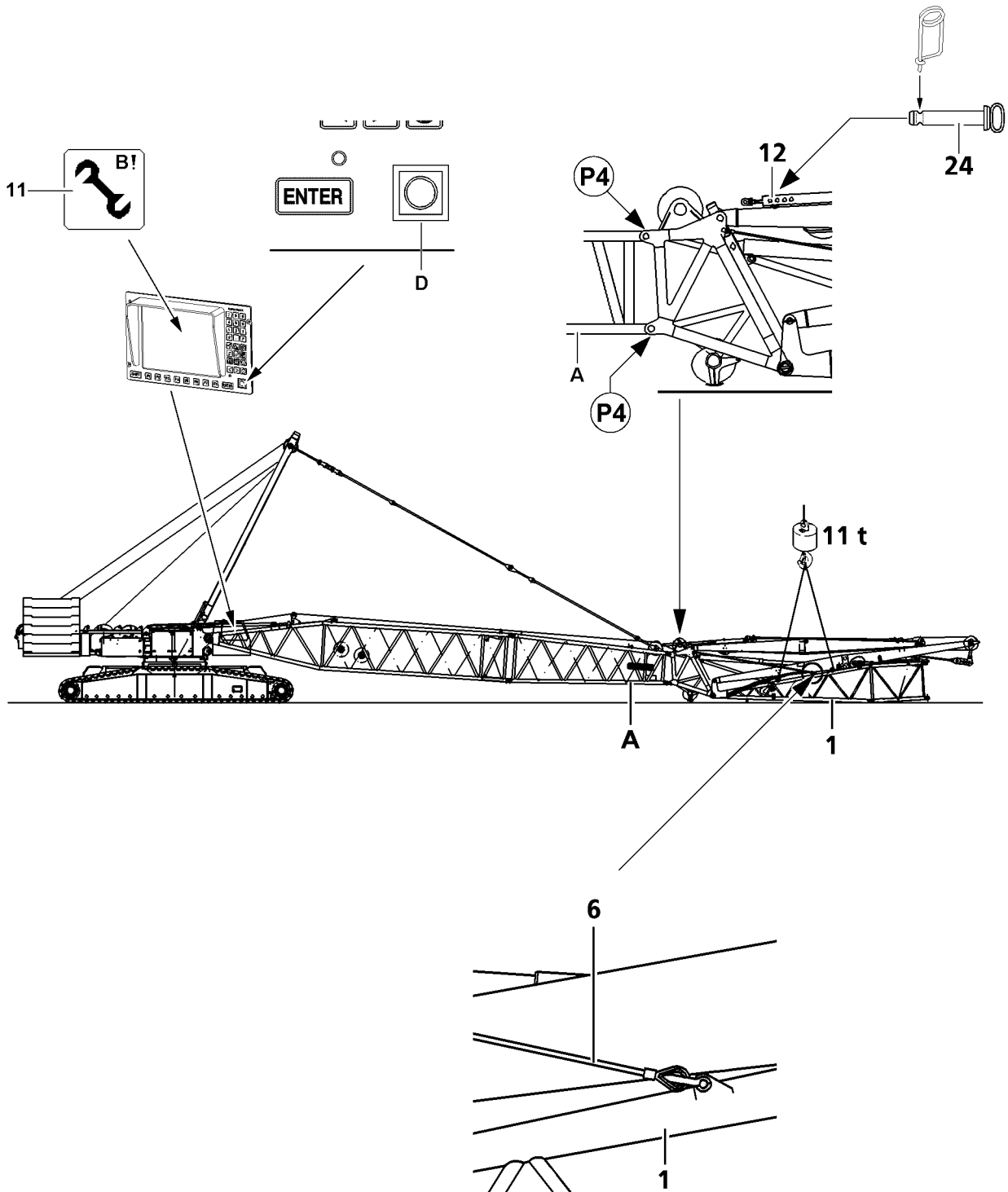

B111432

2 Assembly



WARNING

Risk of falling!

During assembly and disassembly, personnel must be secured with appropriate aids to prevent them from falling! If this is not observed, assembly personnel can fall and suffer life-threatening or fatal injuries!

- ▶ Any work, where there is a danger of falling must be carried out with suitable aids (for example: lifting platforms, scaffoldings, ladders, auxiliary crane)!
- ▶ If the work cannot be carried out with such aids nor from the ground, then the assembly personnel must secure themselves with approved fall arrest systems to avoid falling, see Crane operating instructions chapter 2.04!
- ▶ If railings are present on the components, then they must be brought into the corresponding position and secured for assembly / disassembly work!
- ▶ Step on aids and fall protection equipment only with clean shoes!
- ▶ Keep aids and fall protection equipment clean and free from snow and ice!
- ▶ During all assembly and disassembly work, maintenance work and inspections, travel or crane operation is prohibited!



WARNING

The lattice sections can fall down!

If the lattice sections are not pinned and secured correctly, then they can fall down and fatally injure personnel!

- ▶ Pin or unpin both pins at the same horizontal level, i.e. **left and right!**
- ▶ Do not stand under the booms or within the entire danger zone during the boom pinning and unpinning procedure!
- ▶ Secure the pins in the bearing points and the receptacles!
- ▶ It is prohibited to lean the ladder against the components being disassembled!
- ▶ Do not remove the fastening equipment and the auxiliary crane until each component is pinned on and secured!



WARNING

Danger of impact / crushing!

When installing / removing counterweight components with the auxiliary crane, crane components can start to swing back and forth!

When lifting / lowering and positioning crane components, there is an increased danger of impacts / crushing!

Personnel can be caught and severely injured or killed!

- ▶ Make sure that personnel cannot be caught by components!
- ▶ Make sure that the crane is aligned in horizontal position to avoid the support beams from swinging by themselves!
- ▶ When working in danger zones: Use aids to protect limbs!
- ▶ Guide components with suitable aids to minimize oscillation!

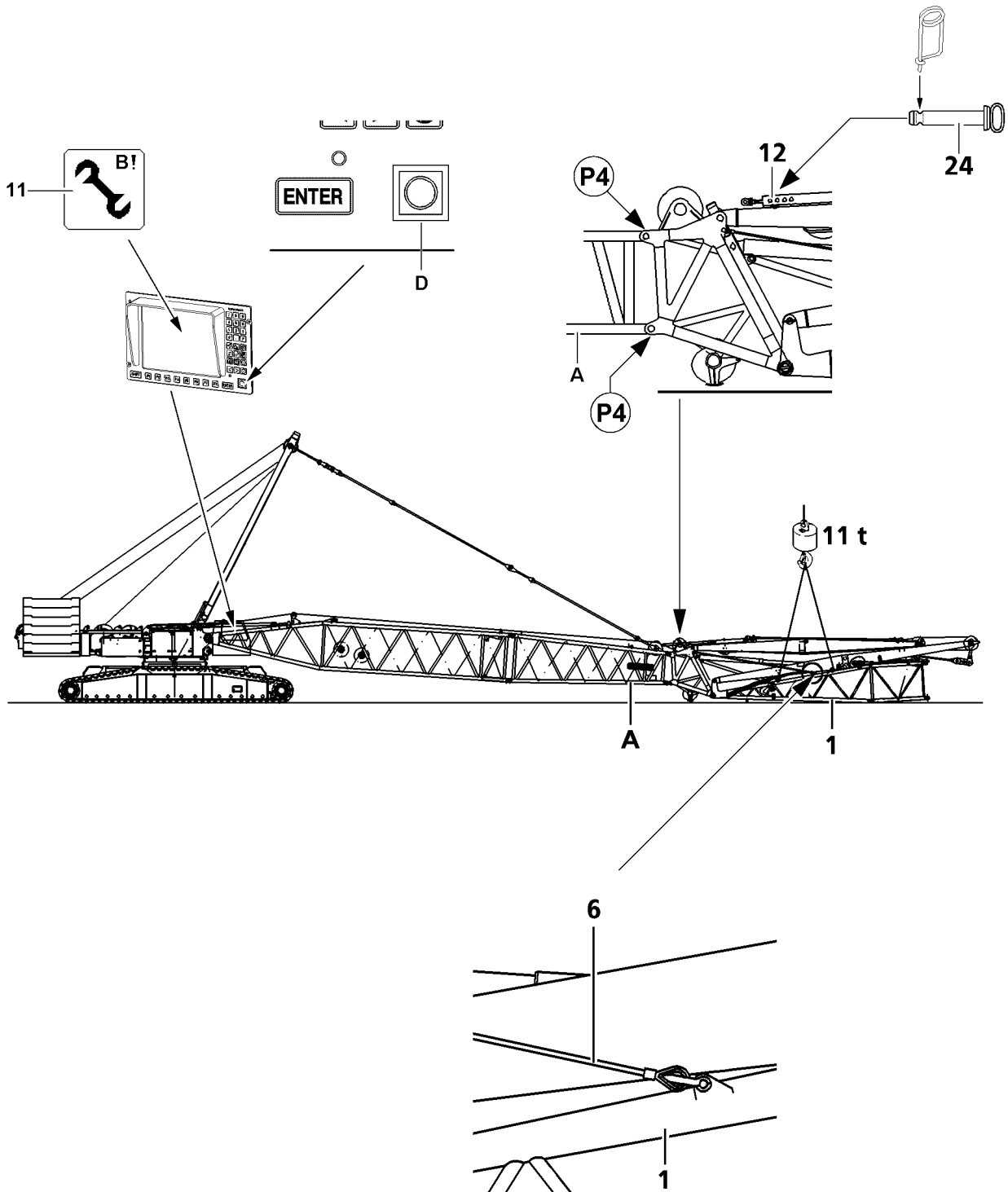

B111432

**WARNING**

Risk of accident!

If the following instructions are not observed, personnel can be severely injured or killed!

- ▶ Assembly of boom combinations, see rod plan and assembly plan!
- ▶ Depending on the condition of the ground, the boom and the lattice sections must be supported from below for the assembly of the boom!
- ▶ Observe the safety technical notes, see Crane operating instructions, chapter 5.01!

Make sure that the following prerequisites are met:

- The crane is aligned in horizontal direction.
- The S/SL-boom is assembled.
- The counterweight is attached to the turntable according to the erection chart and placed on the suspended ballast pallet / ballast trailer.
- The turntable is turned in longitudinal axle of the crawler travel gear against the travel direction or is vertically to the crawler travel gear, see Erection and take down chart.
- The LICCON overload protection has been set according to the data in the load chart.
- The LICCON overload protection settings have been compared with the actual crane configuration.
- The LICCON overload protection is exceeded.
- The assembly icon **11** is visible on the LICCON monitor.
- An auxiliary crane is available.

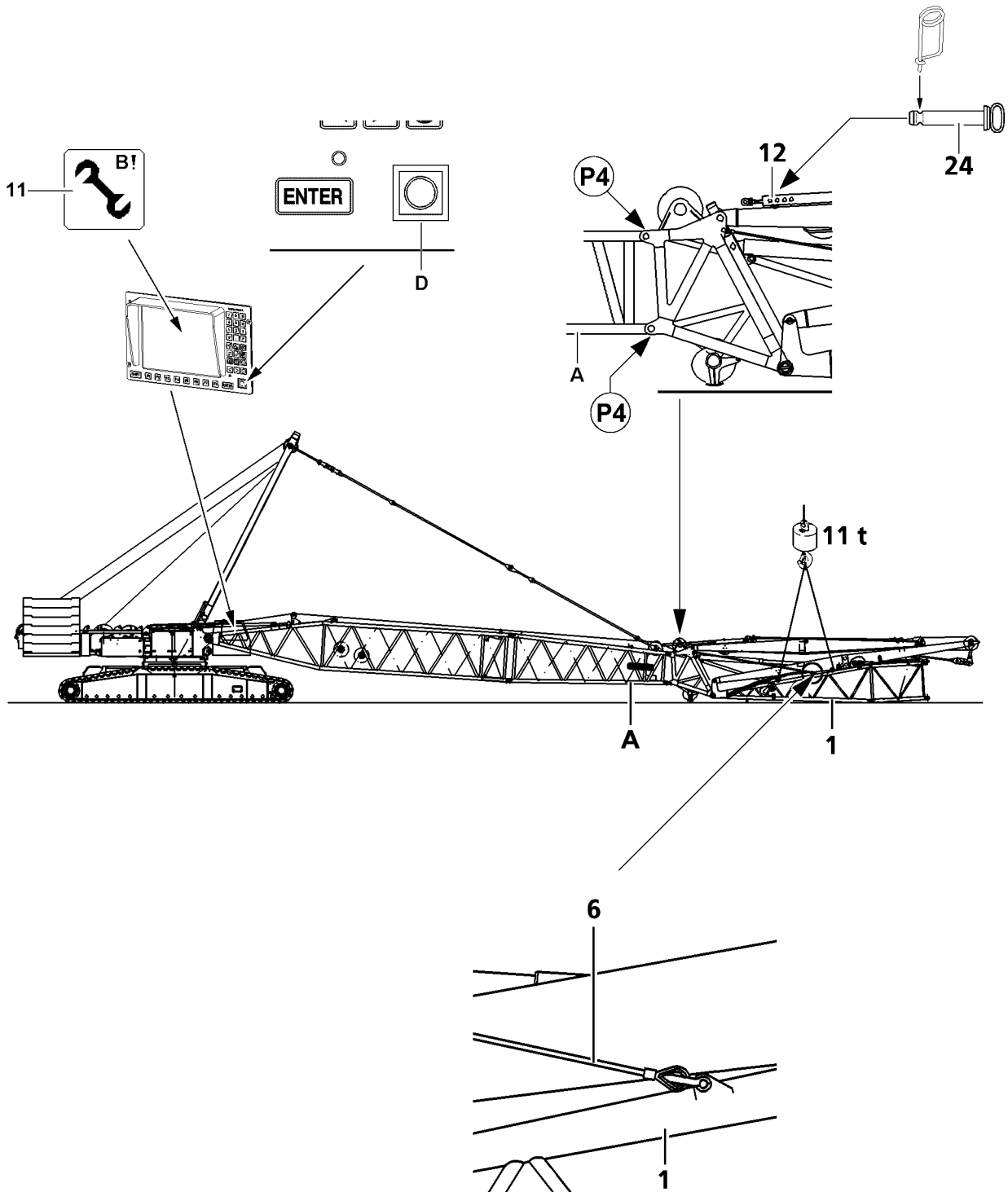

B111432

2.1 Installing the N-assembly unit on the L-/SL-boom

2.1.1 Pinning the N-assembly unit on the L-/SL-boom

Take on the N-assembly unit with the auxiliary crane on the attachment points on the N-pivot section **1**.

- ▶ Pin the N-assembly unit on the L-adapter **A** with the pin pulling device on top and bottom on points **P4** and secure with spring retainer, see Crane operating instructions, chapter 5.30.



DANGER

Mortal danger due to folding down pivot section!

The pivot section folds down by itself when the retaining rope **6** is removed!

Personnel can be severely injured!

- ▶ The N-assembly unit must be secured with the auxiliary crane before removing the retaining rope **6**!
-
- ▶ Remove the retaining rope **6**.
 - ▶ Lower the N-assembly unit with the auxiliary crane until it is laying on the ground.
 - ▶ Support the N pivot section **1**.
 - ▶ Release the socket pin **24** on the NA-bracket II relapse support **12**.
 - ▶ Unpin the socket pin **24** on the NA-bracket II relapse support **12**.
 - ▶ Pull the NA-bracket II relapse support **12** apart to the last hole.
 - ▶ Insert socket pin **24** and secure with spring retainer.

2.2 Reeving in the N-control rope between the NA-bracket I and the NA-bracket II

- ▶ Pull the auxiliary rope **Z** of the auxiliary winch over the change over pulleys to the turntable.
- ▶ Connect the auxiliary rope **Z** with the N-control rope **X** of winch 5 **WV**.
- ▶ Spool the auxiliary winch up and spool winch 5 **WV** out simultaneously and pull the N-control rope **X** to the NA-bracket II - watch the rope run, see illustration 1.
- ▶ Connect the N-control rope **X** and the auxiliary rope **Z** with the reeving rope **W** which is already reeved in between the NA-bracket I and the NA-bracket II - watch the rope run, see illustration 2.
- ▶ Spool the auxiliary winch up and simultaneously spool winch 5 **WV** out.
- ▶ Reeve in the N-control rope between the NA-bracket I and the NA-bracket II, for reeving, see Crane operating instructions, chapter 4.06.



Note

- ▶ To prevent the NA-bracket II from pulling up, the N-control winch winch 5 **WV** must be spooled out at the same time at erection!
-
- ▶ Attach the NA-bracket II on the assembly rope **15** to the auxiliary crane, see illustration 3.
 - ▶ Erect the NA-bracket II with the auxiliary crane to approx. 45°.
 - ▶ Hang the hoist rope of winch 1 / winch 2 **WI/II** on the lock **22** of the assembly rope **16**.

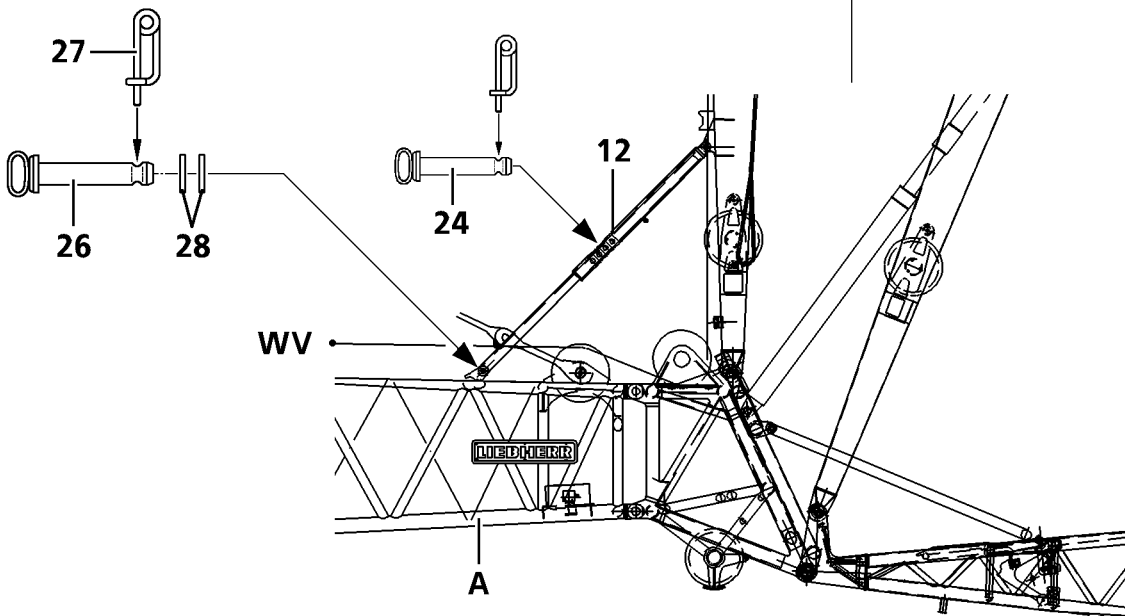
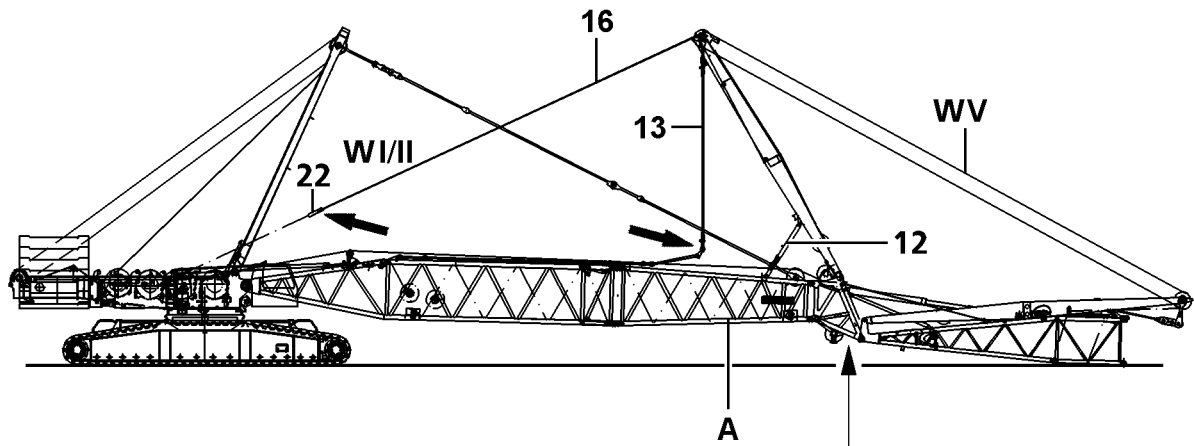

2.3 Assembling the guy rods between the NA-bracket II and the L-/SL-pivot section

- ▶ Continue to erect the NA-bracket II from approx. 45° with the hoist rope and the assembly rope **16** until the mechanical relapse support **12** can be pinned and secured on the L-adapter **A** with pin **26**, spring retainer **27** and two washers **28**.

NOTICE

Danger of property damage on NA-bracket II!

If the socket pin **24** is not unpinned after pinning the relapse support **12** on the L-adapter, the NA-bracket II can be significantly damaged when "pulling it to the rear"!

- ▶ Make sure to unpin the socket pin **24**!
 - ▶ Make sure that the socket pin **24** is unpinned!
-
- ▶ Unpin the socket pin **24** on the mechanical relapse support **12**.
 - ▶ **Spool up** the hoist winch and simultaneously **spool out** the N-control winch **WV**.

Result:

- The NA-bracket II is pulled to the rear.

Pull the NA-bracket II to the rear until the guy rods **13** of the NA-bracket II with the guy rods of the L-/SL-pivot section can be pinned and secured.



WARNING

Danger of accidents due to incorrect pin connection(s)!

Due to incorrect pin connections, the pins can loosen up by themselves and dangerous situations can arise!

Personnel can be severely injured or killed!

- ▶ The pins on the guy rods must be pinned from the inside to the outside!
 - ▶ Secure the pins from the outside!
-
- ▶ When the NA-bracket II has been pulled back far enough:
Pin the guy rods of the NA-bracket II with the guy rods on the L-/SL-pivot section.
 - ▶ Secure the pin connections.

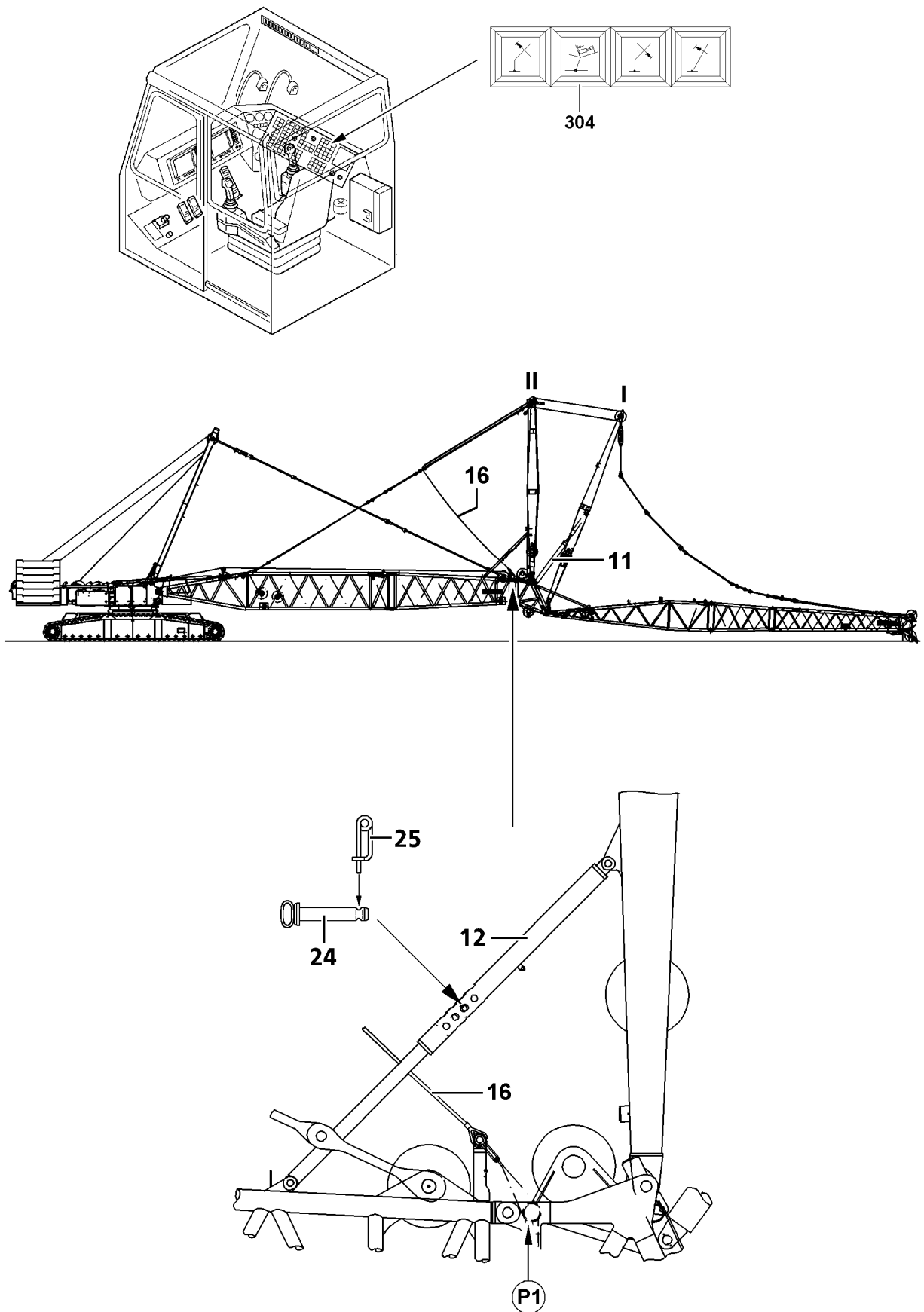

B111435

2.4 Checking the limit switch relapse cylinder

NOTICE

Damage to the N-relapse accumulator cylinder!

Before erecting the NA-bracket I, the electrical connections for the limit switches of the relapse accumulator cylinder **11** must have been established and manually actuated! If this is not the case, the NA-bracket I can be pulled back to the mechanical stop of the relapse accumulator cylinder **11** and be significantly damaged!

▶ Check the shut off with the limit switches of the relapse accumulator cylinder **11**!

▶ Establish the electrical connections to the limit switches of the relapse accumulator cylinder **11**.

▶ Manually actuate the limit switches individually.

Result:

- The indicator light **304** lights up.
- The boom limitation icon appears on the LICCON monitor.
- The spool up function of the N-control winch (winch 5) turns off.

2.5 Erecting the NA-bracket II

Make sure that the following prerequisites are met:

- The limit switches on the relapse accumulator cylinder **11** have been checked manually for function.
- The NA-bracket II guy rods are pinned.



Note

▶ The guying between the NA-bracket II and the L-/SL-pivot section is tensioned by spooling out the hoist winch and simultaneously spooling up the N-control winch, due to the pressure in the relapse accumulator cylinder **11**!

▶ Spool out the hoist winch and at the same time, spool up the N-control winch (winch 5) until the guying between the NA-bracket II and the L-/SL-pivot section is tensioned.

▶ Insert the socket pin **24** in maximum possible length on the next bore of the NA-bracket II relapse support **12** and secure with spring retainer **25**.

▶ Continue to spool out the hoist winch.

▶ Disengage the hoist rope on the lock.

▶ Attach the assembly rope **16** on the NA-bracket II on point **P1**.

▶ Loosen the tackle on the guy rods.

▶ Erect the NA-bracket I by spooling up the N-control winch (winch 5) until the spool up function of the N-control winch (winch 5) shuts off.

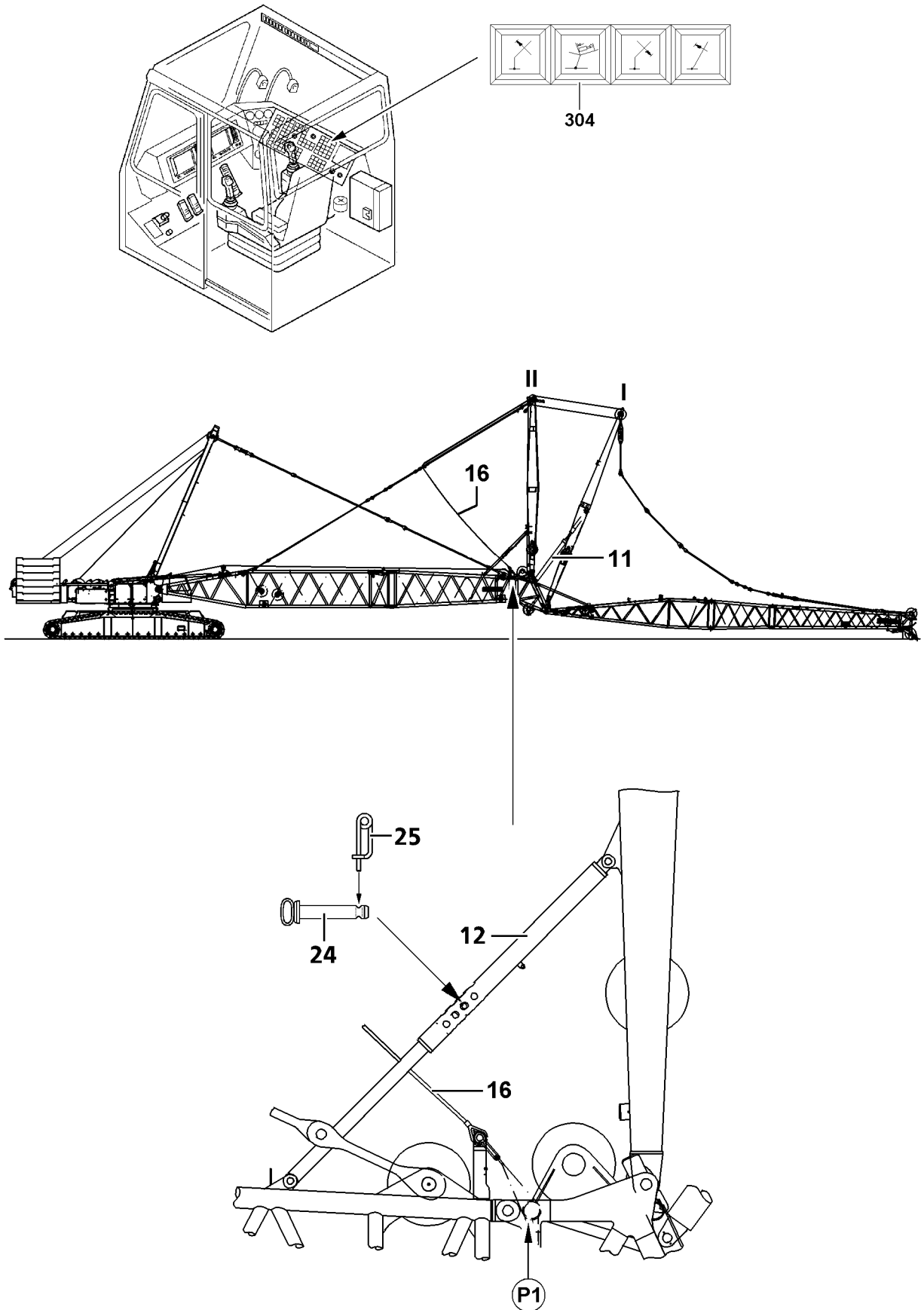

B111435

2.6 Assembling the N-lattice jib

2.6.1 Assembly of the N-lattice jib on the N-pivot section

Make sure that the following prerequisite is met:

- The N-end section has been placed in the pulley cart at assembly of the N-lattice jib, see Crane operating instructions, chapter 5.15.



WARNING

General danger notes!

If the following notes are not observed, severe accidents can occur due to tipping or falling components!

Personnel can be severely injured or killed!

- ▶ Support the lattice sections at lattice jib assembly / disassembly with suitable materials!
- ▶ During assembly of the N-lattice jib, adhere to the pinning sequence, see Crane operating instructions, chapter 5.01!
- ▶ All pins are to be secured after assembly of the lattice sections with spring retainers!
- ▶ Check the guy rods in regular intervals!
- ▶ It is prohibited for anyone to remain under the lattice sections during the pinning / unpinning procedure!

- ▶ Assemble the N-lattice jib to the required length.
- ▶ Spool the hoist rope out and pull it to the N-end section and attach it there.

The guy rods are placed and secured for transport on the lattice sections. The transport retainers must be release prior to the assembly of the guy rods.

- ▶ Release the transport retainers on the guy rods.



Note

- ▶ Always pin the pins from the “inside” to the “outside”!
 - ▶ The numbering on the assembly drawings must be identical to the numbering on the guy rods!
-
- ▶ Pin the guy rods of the N-end section to the guy rods of the NA-bracket I and secure.
 - ▶ Tension the guy rods.

2.7 Establishing the electrical connections

NOTICE

Damage to the electrical connection on the cable drum!

If the electrical connection from the cable drum to the terminal box on the L-pivot section is established first before the connection to the terminal box on the L-end section, the electrical connection can be damaged when spooling out the cable drum!

- ▶ Make the electrical connection from the cable drum in the L-pivot section to the terminal box on the L-end section first and then the electrical connection from the terminal box in the L-pivot section to the cable drum!
-



Note

- ▶ To establish the electrical connections on the boom, see Electric wiring diagram!
-

Make sure that the following prerequisites are met:

- The N-boom is completely assembled.
- The airplane warning light and the wind speed sensor are assembled.
- ▶ Establish the electrical connections.
- ▶ Make sure that all electrical connections on the boom are established.

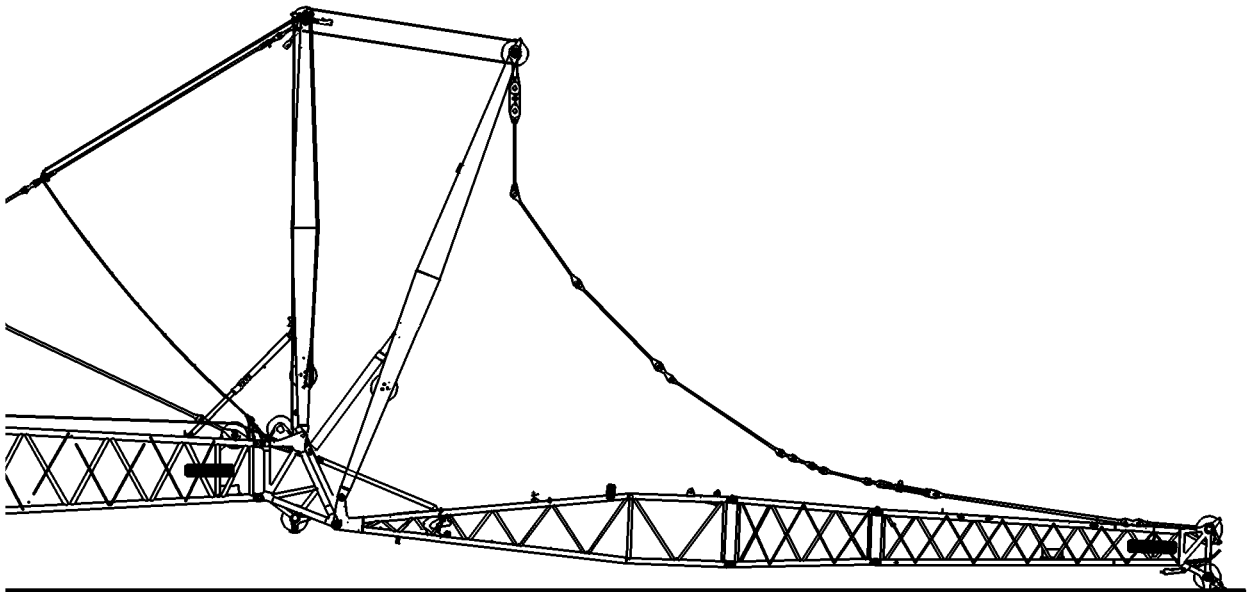
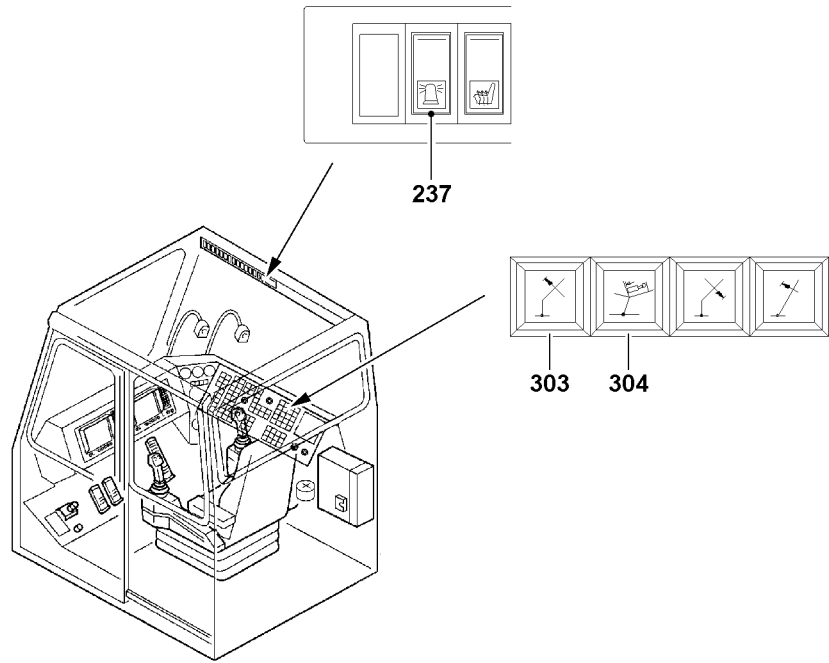

2.8 Function check

Make sure that the following prerequisites are met:

- All electrical connections have been made.
- The engine is running.
- The appropriate operating mode is set.
- The actuator levers of the limit switches have been checked for easy movement and are lubricated.

2.8.1 Airplane warning light*

- ▶ Turn the airplane warning light on with switch **237** and visually check the function.

2.8.2 Wind speed sensor*

- ▶ Check the movement and the function of the wind speed sensor.

2.8.3 Hoist limit switch

- ▶ Actuate the hoist limit switch manually on the pulley head.

Result:

- The hoist top icon appears on the LICCON monitor.
- The **spool up function** of the hoist winch turns off.

2.8.4 Limit switch lattice jib, “steepest” position, relapse cylinder



Note

- ▶ The switch point of the limit switches on the relapse cylinder must be checked before erection, see Crane operating instructions, chapter 8.12!

- ▶ Manually actuate the limit switches on the relapse cylinder individually.

Result:

- The N-control winch movement “spooling up” turns off.
- The indicator light **304** lights up.

2.8.5 Limit switch lattice jib, “steepest” position, mechanical relapse support

- ▶ Manually actuate the limit switches on the pendulum individually.

Result:

- The N-control winch movement “spooling up” turns off.
- The indicator light **303** lights up.

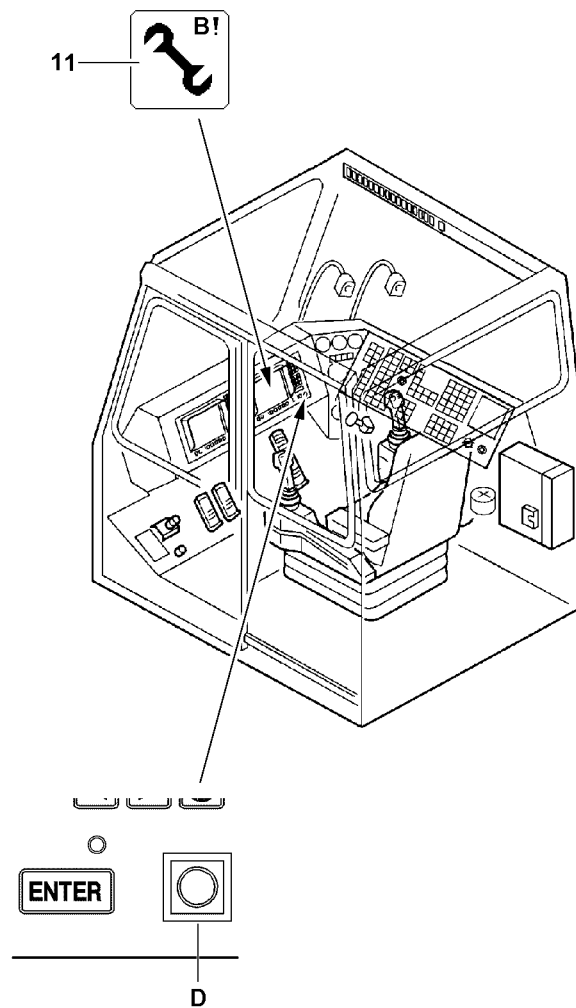

B111434

2.9 Erecting the boom



DANGER

The crane can topple over!

If the following conditions are not met before erecting the boom, the crane can topple over and fatally injure personnel!

- ▶ Observe the safety technical guidelines in chapter 5.01!
- ▶ Observe the data in the erection and take down charts!
- ▶ Extend the relapse cylinder before erection!

Make sure that the following prerequisites are met:

- The crane is aligned in horizontal direction.
- All electrical connections have been made.
- All limit switches have been correctly installed and are fully functional.
- The counterweight is installed on the turntable and on the derrick according to the load chart and the erection chart.
- The lattice jib has been assembled according to the load chart and the operating instructions.
- The easy movement of the pendulum on the mechanical relapse support must be checked over the entire swing range.
- All pin connections have been secured.
- There are no loose parts on the boom or the lattice jib.
- The hoist rope has been correctly placed in the rope pulleys and is prevented from jumping out with the corresponding rope retaining pins.
- In winter, the boom, the lattice jib and their components (limit switches, cable drum, airplane warning light, wind speed sensor) must be kept free of ice and snow.
- The LICCON overload protection settings have been compared with the actual crane configuration.
- The LICCON overload protection has been set according to the data in the load chart.
- The LICCON overload protection is exceeded.
- The assembly icon **11** is visible on the LICCON monitor.
- The hoist rope is attached to the end section.
- No personnel is within the danger zone.



WARNING

Falling components!

When erecting the N-boom combination, loose or incorrectly installed components can fall down!

Personnel can be severely injured or killed!

- ▶ It is prohibited for anyone to remain in the danger zone!



DANGER

Tipping lattice jib!

If the easy movement on the pendulum of the mechanical relapse support is **not** checked before erection or **not** reestablished, if necessary, then the mechanical relapse support will not engage in steep lattice jib position! As a result, the lattice jib can tip to the rear!

Personnel can be severely injured or killed!

- ▶ Check the easy movement on the pendulum of the mechanical relapse support before erection!
- ▶ If the pendulum does not move easily: Make the pendulum easy to move!

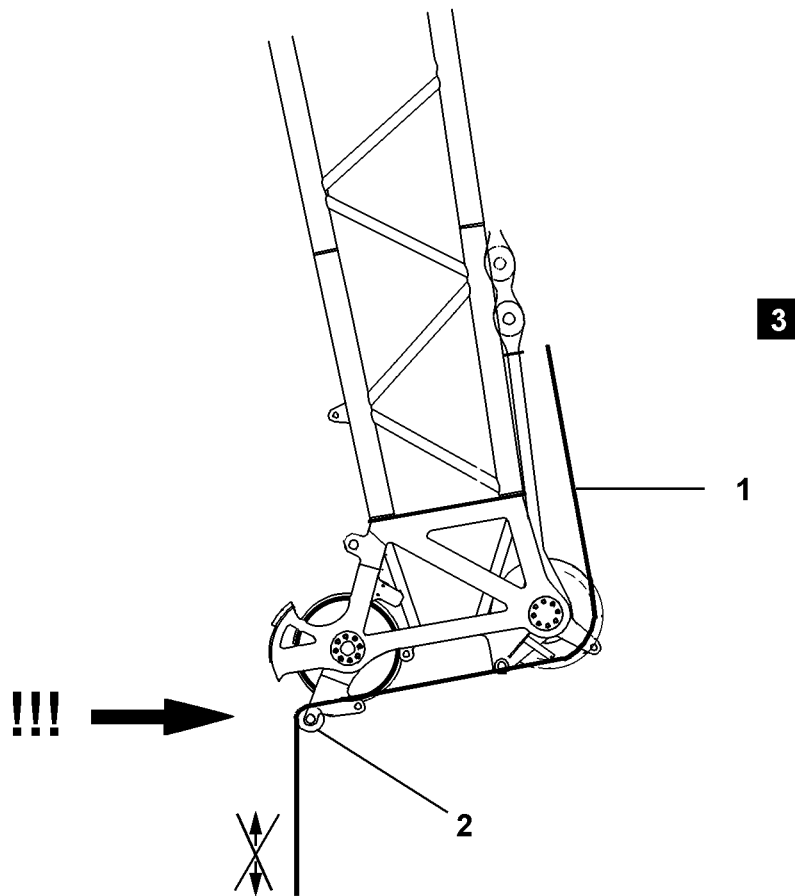
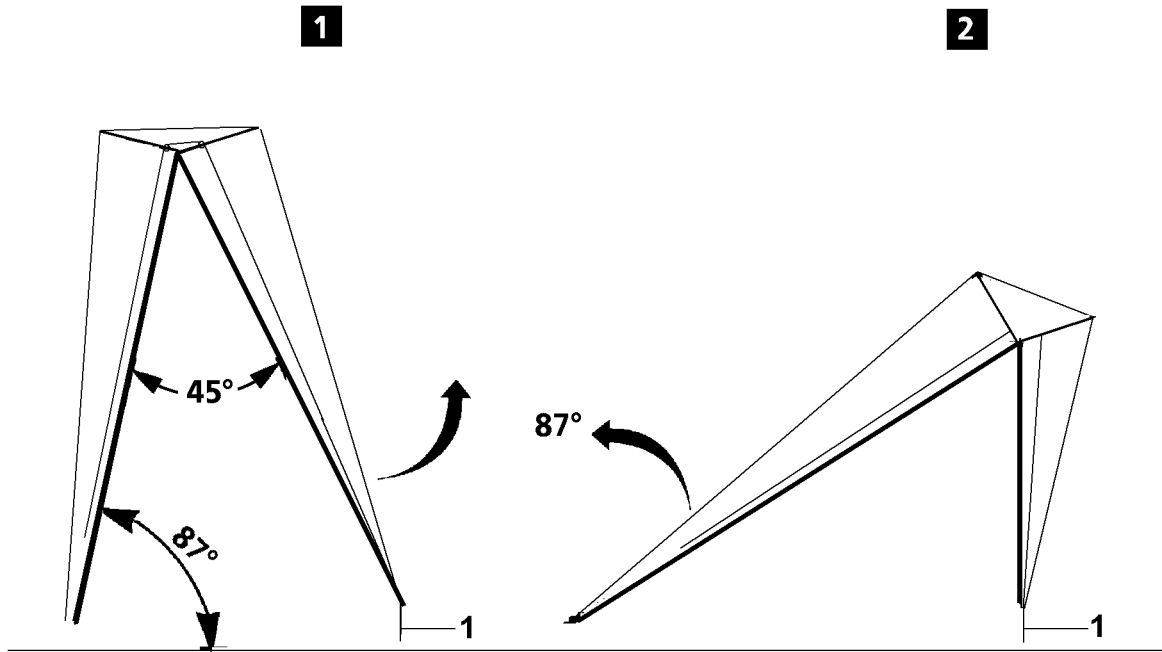

2.9.1 Erection procedure



WARNING

The crane can topple over!

- ▶ Observe the data in the erection and take down charts!
 - ▶ It is not permitted to turn the crane during erection!
 - ▶ The lattice jib must roll on the ground with its entire weight!
 - ▶ Spool the lattice jib control out so that the guy rods sag slightly!
 - ▶ Do not allow slack cable to build up on the control winch!
-



WARNING

Falling hoist rope!

If the hoist rope is not properly attached on the end section before the erection procedure, then it can fall down backward due to its own weight!

Personnel can be severely injured or killed!

- ▶ Attach the hoist rope properly on the end section before the erection procedure!
-
- ▶ Luff up the L-/SL-boom and simultaneously spool out the N-control winch to keep the lattice jib with the N-end section placed on the roller cart on the ground. Carry out this procedure until the boom and the N-lattice jib form an angle of more / equal to 45° or until the lattice jib has lifted off the ground first, illustration 1, illustration 2.
 - ▶ Remove the roller cart on the N-end section, see Crane operating instructions, chapter 5.15.
 - ▶ Luff up the N-lattice jib to the **lowest** operating position.
 - ▶ Luff up the L-/SL-boom until the N-end section lifts off the roller cart.
-

NOTICE

Damage to the hoist rope!

If the hoist rope is reeved on the hook block and changed over the “small guard rollers 2”, then the hoist gear may not be moved any longer, since the hoist rope can be damaged by spooling up or out, see illustration 3!

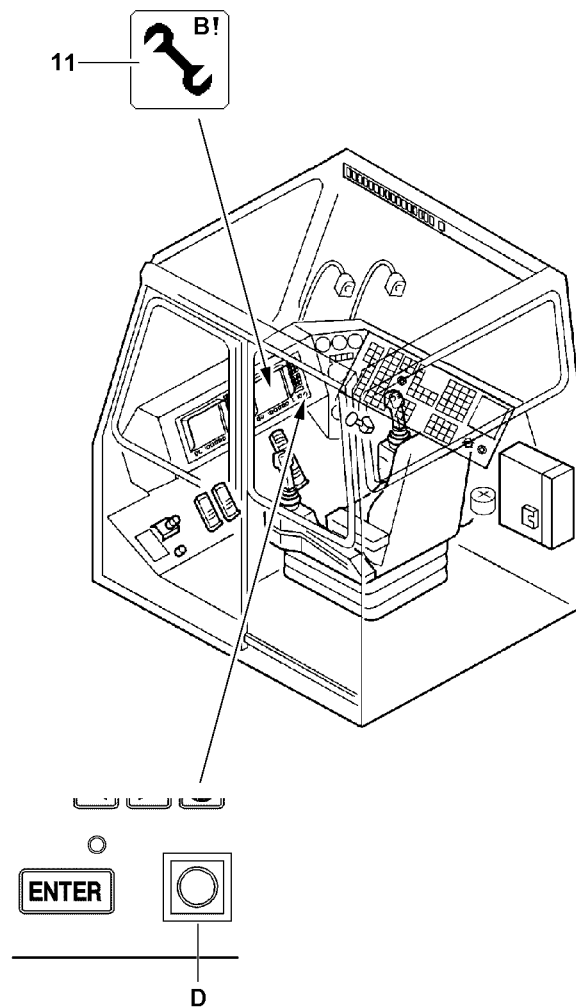

- ▶ Do not spool the hoist rope up or out!
-
- ▶ Loosen the hoist rope on the N-end section and reeve it in properly between the pulley head on the end section and the hook block and secure on the fixed point, see Reeving plan.
 - ▶ Attach the hoist limit switch weight.



B111434

**Note**

- ▶ During the erection procedure - outside the operating area - the alarm functions listed in the chart are displayed as blinking on the crane operating screen!

Displays on the LICCON monitor during the erection procedure	
 "STOP" icon blinks	
 "ERROR 150" icon blinks	Note: Error description, see Diagnostics manual
 Horn icon blinks	Note: In addition to the horn icon, an acoustic warning sounds

- ▶ Luff the L-/SL-boom up to the lowest operating position.
- ▶ When the operating range of the boom is reached:
Luff up the L-/SL-boom to the steepest boom position (87°).
- ▶ Luff up the N-lattice jib to the lowest operating position.

**DANGER**

The crane can topple over!

In crane operation with bypassed safety devices, the crane can topple over! Personnel can be severely injured or killed!

- ▶ The radii listed in the load chart may not be exceeded or fallen below, even if there is no load on the hook!

**Note**

- ▶ When the lowest operating position is reached, the LICCON overload protection is activated!
- ▶ In the maximum load icon appears a load number in "t" instead of the display "???"!

- ▶ Luff the boom up to the lowest operating position.
- ▶ When the boom has reached the lowest operating position:
Make sure that the assembly icon **11** on the LICCON monitor turns off.

Result:

- The LICCON overload protection is active.

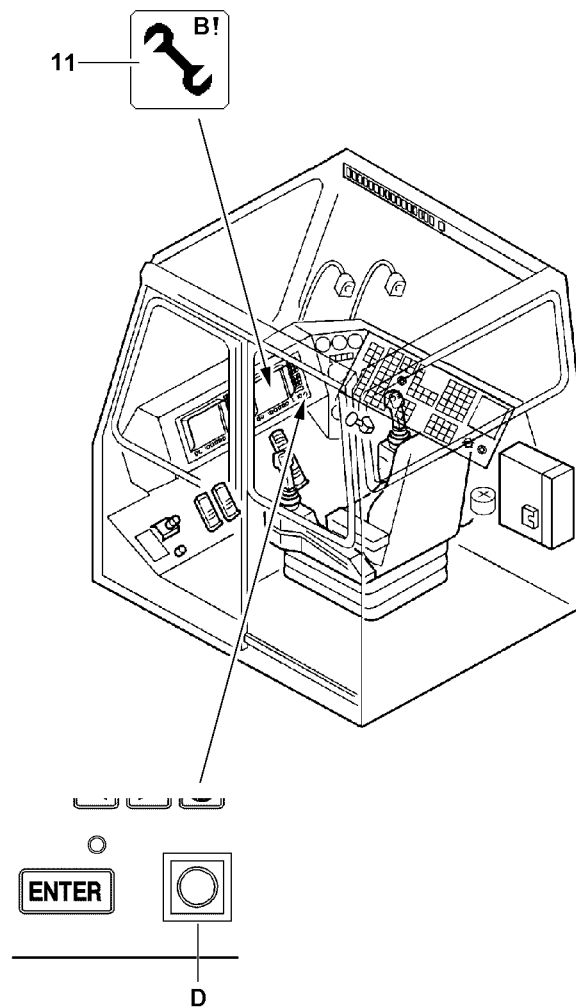

B111434

3 Crane operation



Note

- ▶ Observe the notes, see Crane operating instructions, chapter 4.05, chapter 4.08 and chapter 5.01!
-

Make sure that the following prerequisites are met:

- The LICCON overload protection is active.
 - The LICCON overload protection has been set according to the data in the load chart.
-

**DANGER**

The crane can topple over!

- ▶ Check the horizontal position of the crane before and during operation!
 - ▶ If the crane operator leaves the cab, even for a short time, the operating mode setting must be checked and reset if necessary before resuming crane operation!
-

3.1 Checking the settings

- ▶ Check the function of the overload protection by running against the operating positions “on top” and “bottom”.
- ▶ Check the hoist limit switch by running against the hoist limit switch weight.
- ▶ Check the function of the limit switches “Lattice jib steep” on the relapse cylinders.

3.2 Setting the boom to 67°/77°



Note

- ▶ **Before adjusting the boom to 67° or 77°**, the boom must be erected to the steepest boom position (87°) and the lattice jib to the steepest operation position!
-

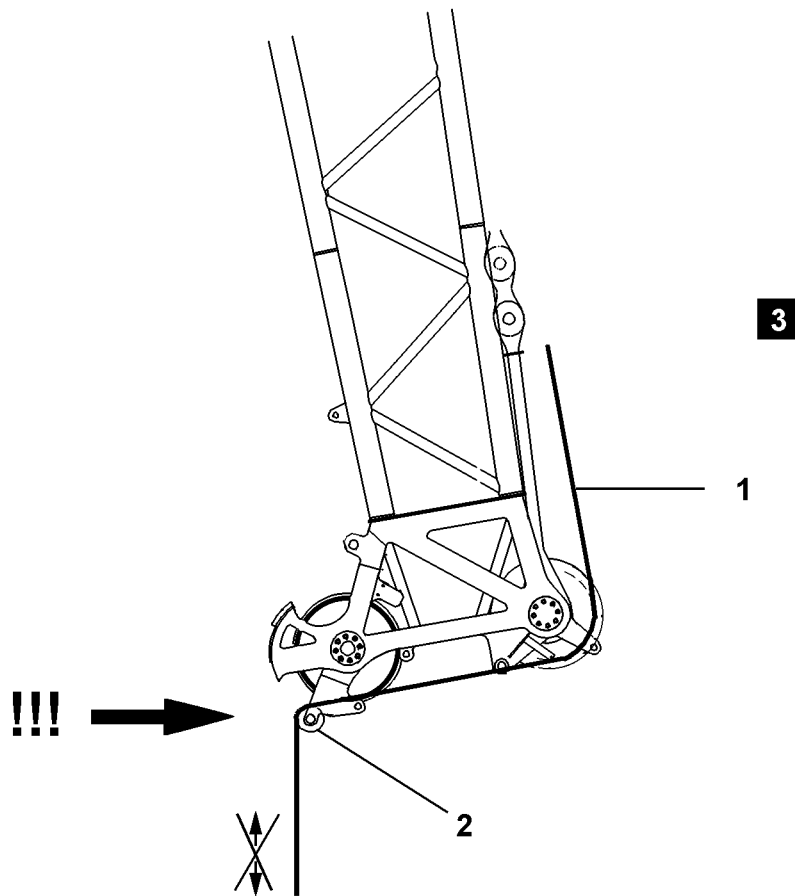
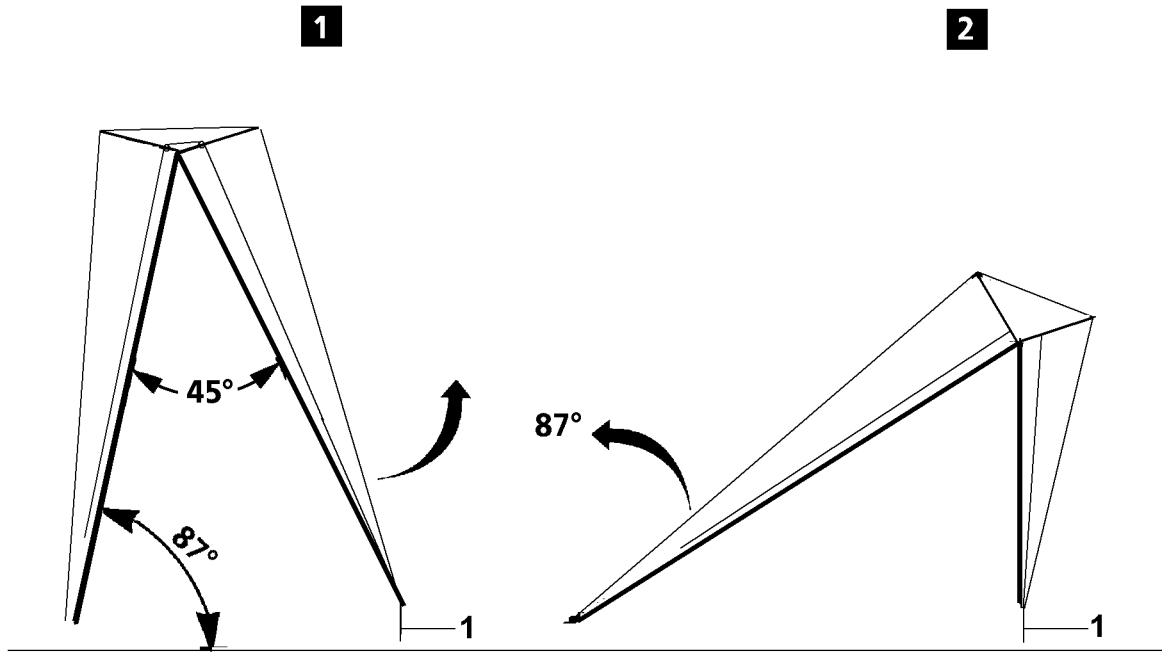

4 Disassembly



WARNING

Risk of falling!

During assembly and disassembly, personnel must be secured with appropriate aids to prevent them from falling! If this is not observed, assembly personnel can fall and suffer life-threatening or fatal injuries!

- ▶ Any work, where there is a danger of falling must be carried out with suitable aids (for example: lifting platforms, scaffoldings, ladders, auxiliary crane)!
- ▶ If the work cannot be carried out with such aids nor from the ground, then the assembly personnel must secure themselves with approved fall arrest systems to avoid falling, see Crane operating instructions chapter 2.04!
- ▶ If railings are present on the components, then they must be brought into the corresponding position and secured for assembly / disassembly work!
- ▶ Step on aids and fall protection equipment only with clean shoes!
- ▶ Keep aids and fall protection equipment clean and free from snow and ice!
- ▶ During all assembly and disassembly work, maintenance work and inspections, travel or crane operation is prohibited!



WARNING

The lattice sections can fall down!

If the lattice sections are not pinned and secured correctly, then they can fall down and fatally injure personnel!

- ▶ Pin or unpin both pins at the same horizontal level, i.e. **left and right!**
- ▶ Do not stand under the booms or within the entire danger zone during the boom pinning and unpinning procedure!
- ▶ Secure the pins in the bearing points and the receptacles!
- ▶ It is prohibited to lean the ladder against the components being disassembled!
- ▶ Do not remove the fastening equipment and the auxiliary crane until each component is pinned on and secured!



WARNING

Danger of impact / crushing!

When installing / removing counterweight components with the auxiliary crane, crane components can start to swing back and forth!

When lifting / lowering and positioning crane components, there is an increased danger of impacts / crushing!

Personnel can be caught and severely injured or killed!

- ▶ Make sure that personnel cannot be caught by components!
- ▶ Make sure that the crane is aligned in horizontal position to avoid the support beams from swinging by themselves!
- ▶ When working in danger zones: Use aids to protect limbs!
- ▶ Guide components with suitable aids to minimize oscillation!

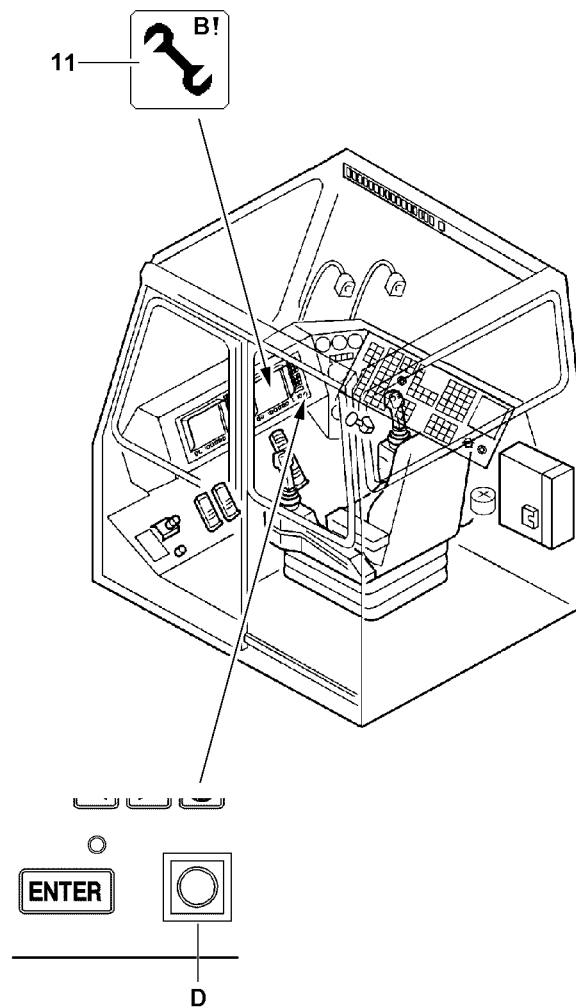

B111434

4.1 Placing the boom down



DANGER

The crane can topple over!

If the following conditions are not met before taking down the boom, the crane can topple over and fatally injure personnel!



- ▶ The turntable may not be turned during the assembly of the boom!
- ▶ Observe the safety technical notes, see the Crane operating instructions, chapter 5.01!
- ▶ Observe the data in the erection and take down charts!

Make sure that the following prerequisites are met:

- The L-/SL-boom is in the steepest position, 87°.
 - The hook block is approx. 5 m below the pulley head of the lattice jib.
 - The counterweight has been installed to the turntable according to the erection chart.
 - The turntable is turned in longitudinal axle of the crawler travel gear against the travel direction or is vertically to the crawler travel gear, see Erection and take down chart.
 - The LICCON overload protection has been set according to the data in the load chart.
 - The auxiliary crane is available.
- ▶ Luff the N-lattice jib down to the **lowest** operating position until the shut off of the luffing movement occurs.

The load value in the maximum load icon disappears and question marks are displayed (????).

The following alarm functions become active:

Display on the LICCON monitor after reaching the “lowest” operating position	
 Icon: “STOP” blinks	
 Horn icon blinks	Note: In addition to the horn icon, an acoustic warning sounds

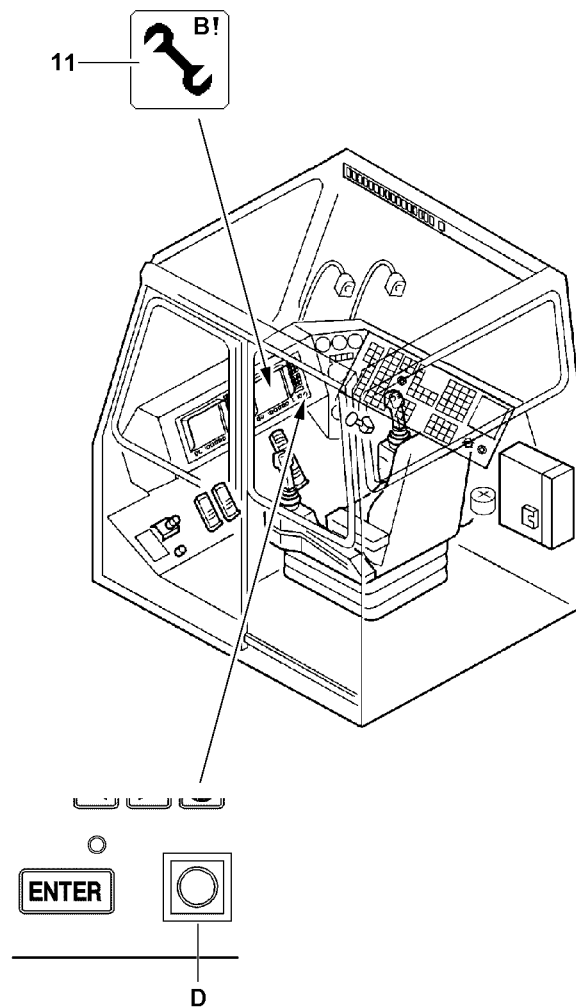

B111434

**WARNING**

Assembly with turned on set up key!

When the set up key is engaged, the LICCON overload protection is exceeded!

In the event of deliberate improper use, the crane could collapse, the boom can break off or the crane can topple over!

Personnel can be killed!

This could result in high property damage!

- ▶ The set up key **D** may only be actuated by persons who know the effects of a bypass!
- ▶ Press the set up key **D** only when the set up status was correctly entered into the LICCON computer system!
- ▶ Observe the erection / take down charts!
- ▶ Crane operation with the set up key **D** turned on is strictly prohibited!

- ▶ When the boom has reached the lowest operating position:
Turn the set up key **D** to the right.

Result:

- The LICCON overload protection is deactivated.
- The assembly icon **11** appears on the LICCON monitor.

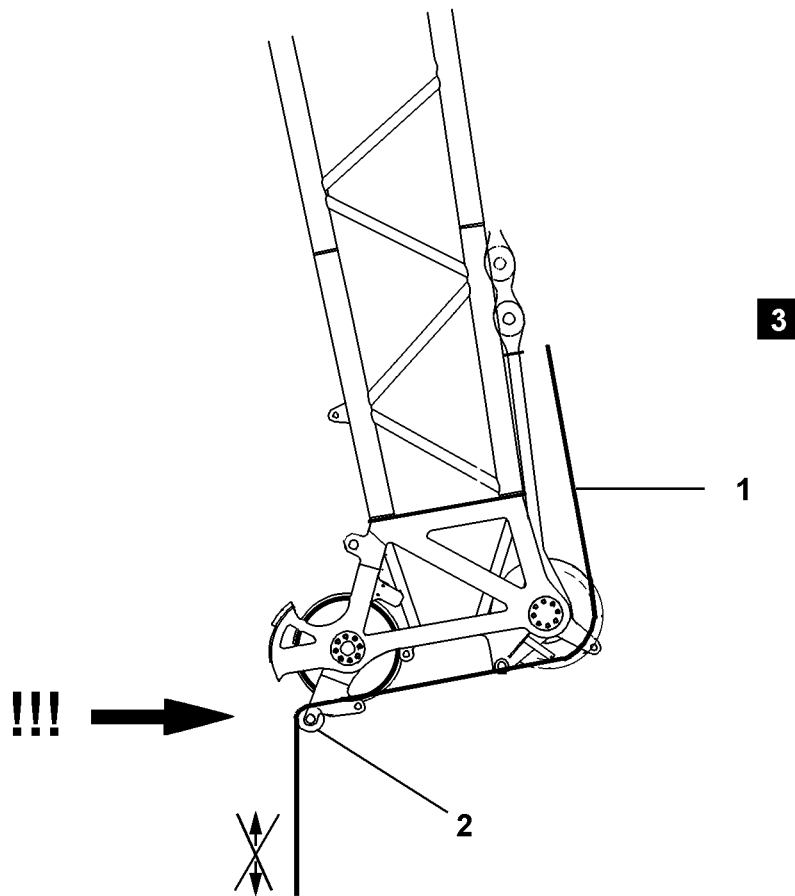
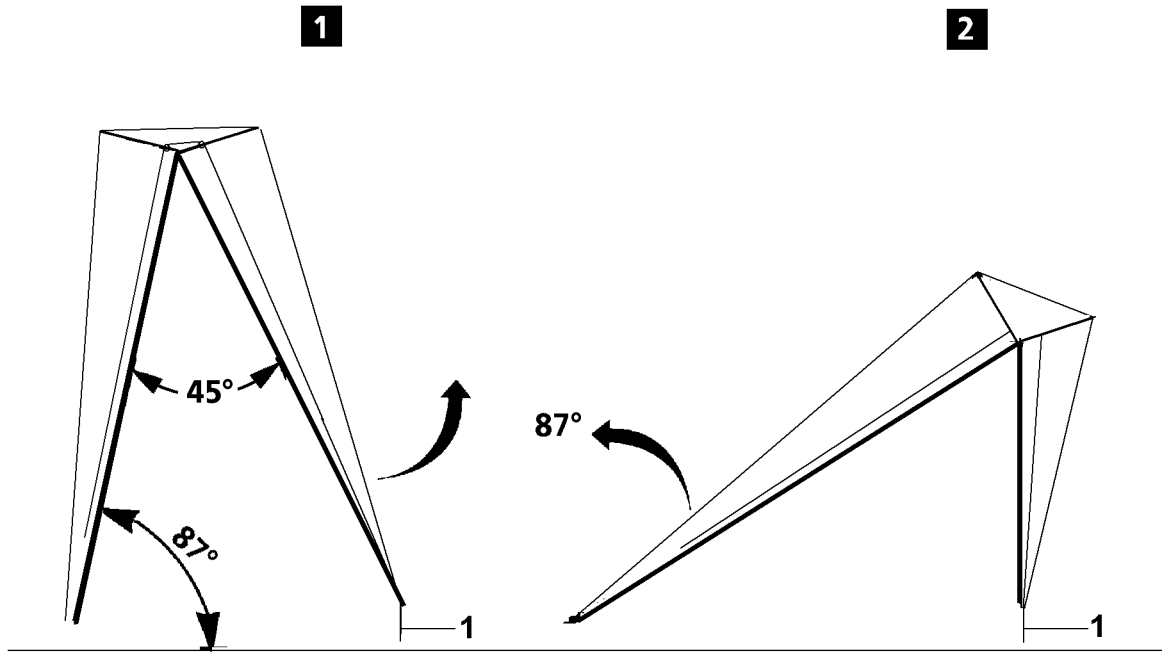

- ▶ Continue to luff the N-lattice jib down until an angle of approximately 45° is reached between the boom and the N-lattice jib.

When the angle is reached, "lattice jib bottom" is shut off, the indicator light lights up.

- ▶ Luff down the boom.

NOTICE

Damage of boom components!

Taking down the boom system can lead to a collision between the hook block and the pulley head!

The boom components can be severely damaged!

- ▶ Luff the L-/SL-boom down and simultaneously spool the hoist winch out to prevent a collision between the hook block and the N-end section!

- ▶ Luff the L-/SL-boom down until the hook block touches the ground.
- ▶ Remove the hoist limit switch weight and unreeve the hook block.
- ▶ Luff the L-/SL-boom down until the N-end section is laying with the receptacle studs in the receptacles on the pulley cart.

NOTICE

Damage to the hoist rope!

If the hoist rope is reeved on the hook block and changed over the "small guard rollers 2", then the hoist gear may be moved any longer, since the hoist rope can be damaged by spooling up or out, see illustration 3!

- ▶ Do not spool the hoist rope up or out!
- ▶ Assemble the N-end section on pulley cart, see Crane operating instructions, chapter 5.15.



DANGER

The crane can topple over!

- ▶ Do not pull the hook block along on the ground!
- ▶ The lattice jib must roll on the ground with its entire weight!
- ▶ Do not allow slack cable to build up on the control winch!
- ▶ Continue to luff down the L-/SL-boom and simultaneously spool the N-lattice jib control out so that the guy rods sag slightly.
- ▶ Luff down the L-/SL-boom until the boom head is resting on the base support on the ground.



DANGER

Risk of accident!

- ▶ Make sure that no personnel is within the danger zone!
- ▶ Secure the hoist rope with the auxiliary rope and pull it back slowly over the rope pulleys in the NA-brackets and lower it toward the end section!
- ▶ Remove the hoist rope.

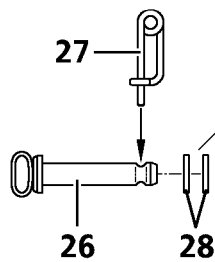
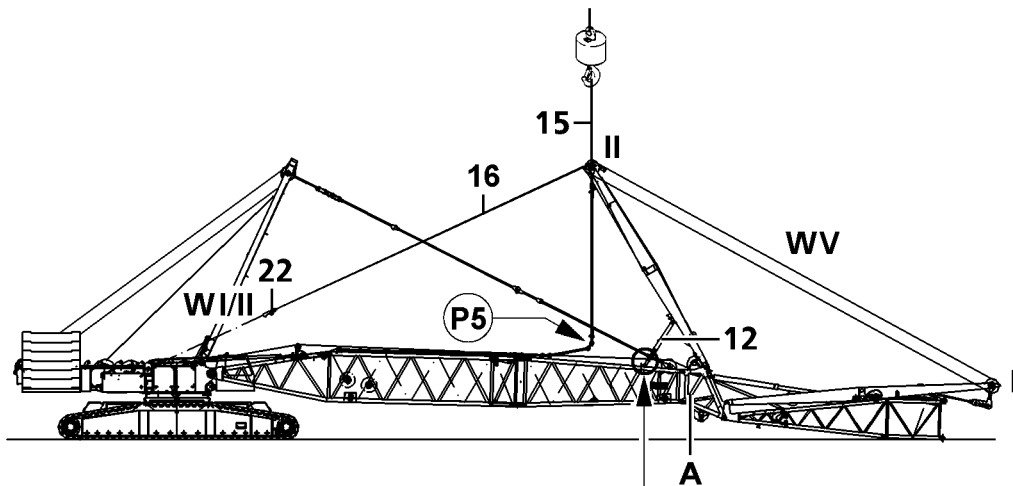
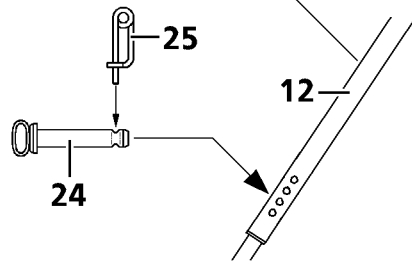
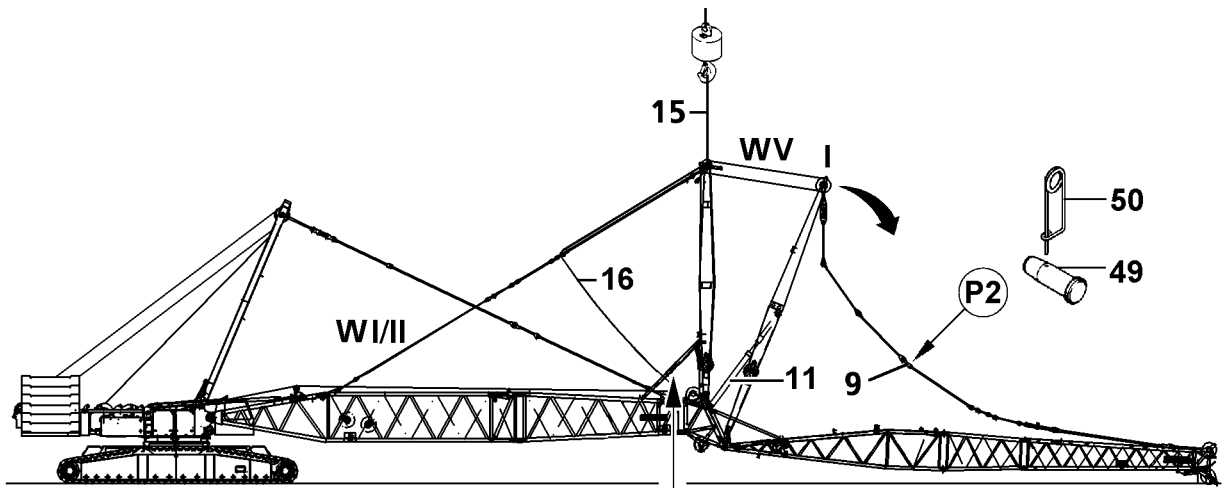

4.2 Disassembling the guy rods

- ▶ Lower the NA-bracket I to the front: Spool the N-control winch **WV** out.
- ▶ Unpin the guy rods at the connector brackets **9** on point **P2**: Remove the spring retainer **50** and unpin the pin **49**.
- ▶ Place the guy rods from the NA-bracket I down and secure.
- ▶ Place the remaining guy rods on the lattice sections and secure.

4.3 Disconnecting the electrical connections on the N-lattice jib

Make sure that the following prerequisite is met:

- The N-lattice jib is placed down.

NOTICE

Damage to the electrical connection on the cable drum!

If the electrical connection between the L-end section and the N-pivot section is not separated before spooling up the cable drum, the electrical connection will be damaged!

If the cable of the cable drum is not properly spooled up on the cable drum after unplugging it on the N-end section, then the cable drum or the cable can be significantly damaged!

- ▶ Disconnect the electrical connection from the cable drum on the N-pivot section to the terminal box on the L-end section first and then the electrical connection from the terminal box on the N-end section to the cable drum!
 - ▶ After unplugging, spool the cable onto the cable drum!
-

NOTICE

Damage of the relapse accumulator cylinder!

By pulling the NA-bracket II up, significant damage can occur due on the relapse accumulator cylinder **11** to a defective or not connected limit switch - due to the block position!

- ▶ Make sure that the electrical connections to the limit switches on the relapse accumulator cylinders have been established!
 - ▶ Make sure that "spool up winch 5" turns off when the limit switches on the relapse accumulator cylinders are actuated!
-

- ▶ Disconnect the electrical connections.
- ▶ After unplugging, spool the cable onto the cable drum and secure it to prevent it from spooling out inadvertently.
- ▶ Make sure that all electrical connections on the N-boom have been disconnected.

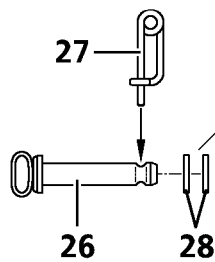
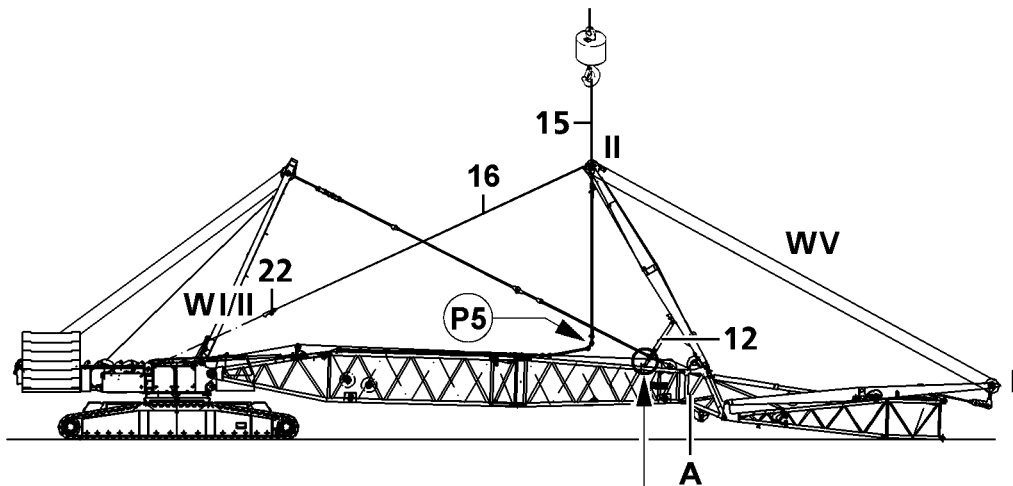
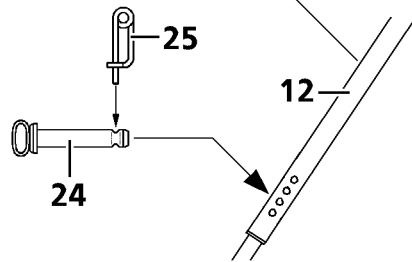
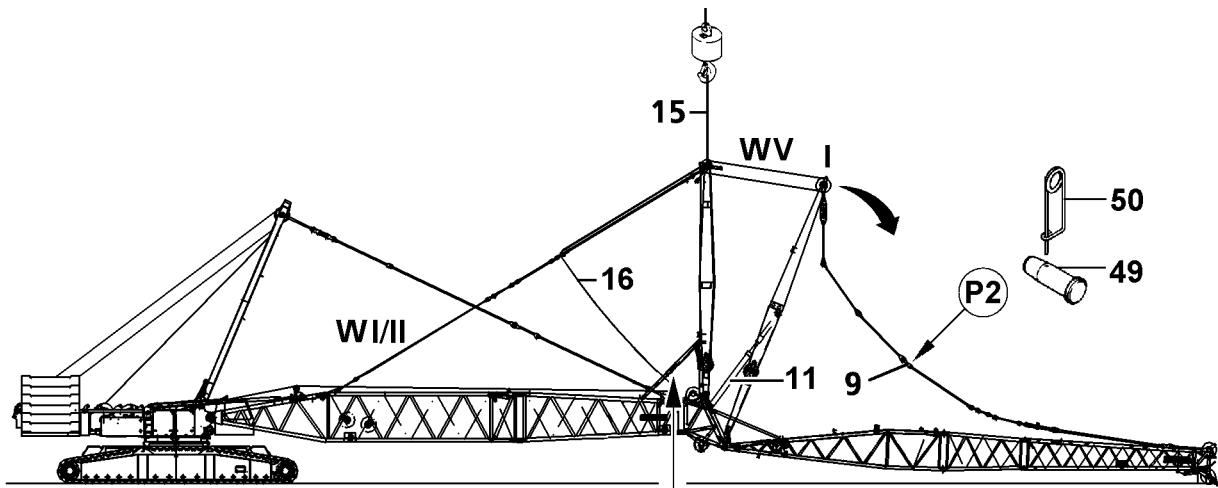

4.4 Disassembling the N-lattice section



WARNING

General danger notes!

If the following notes are not observed, severe accidents can occur due to tipping or falling components!

Personnel can be severely injured or killed!

- ▶ Support the lattice sections at lattice jib assembly / disassembly with suitable materials!
 - ▶ During assembly of the N-lattice jib, adhere to the pinning sequence, see Crane operating instructions, chapter 5.01!
 - ▶ It is prohibited for anyone to remain under the lattice sections during the pinning / unpinning procedure!
-



WARNING

The lattice jib can fold down!

If the following notes are not observed, the lattice jib can suddenly fold down during unpinning!

Personnel can be severely injured or killed!

- ▶ The pivot section must be held by an auxiliary crane before unpinning the connector pins or it must be supported with suitable and stable materials!
 - ▶ It is prohibited for anyone to remain under the lattice jib which is to be disassembled!
-
- ▶ Disassemble the N-end section and the N-lattice sections.

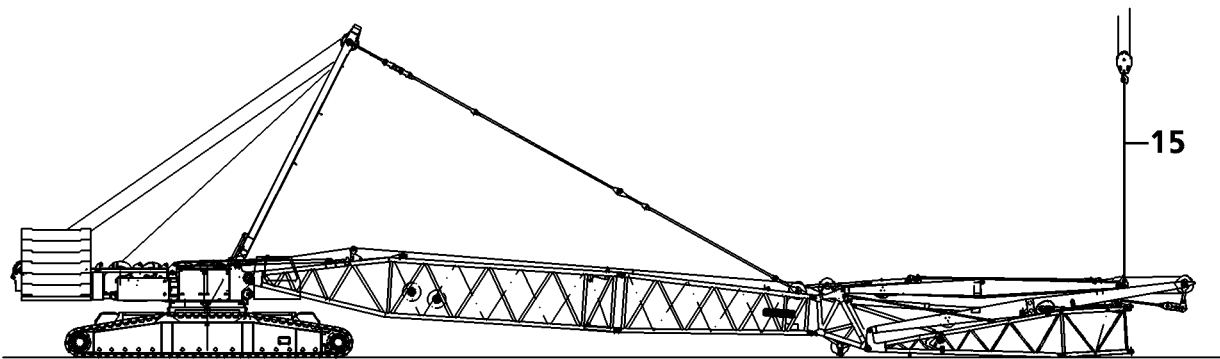
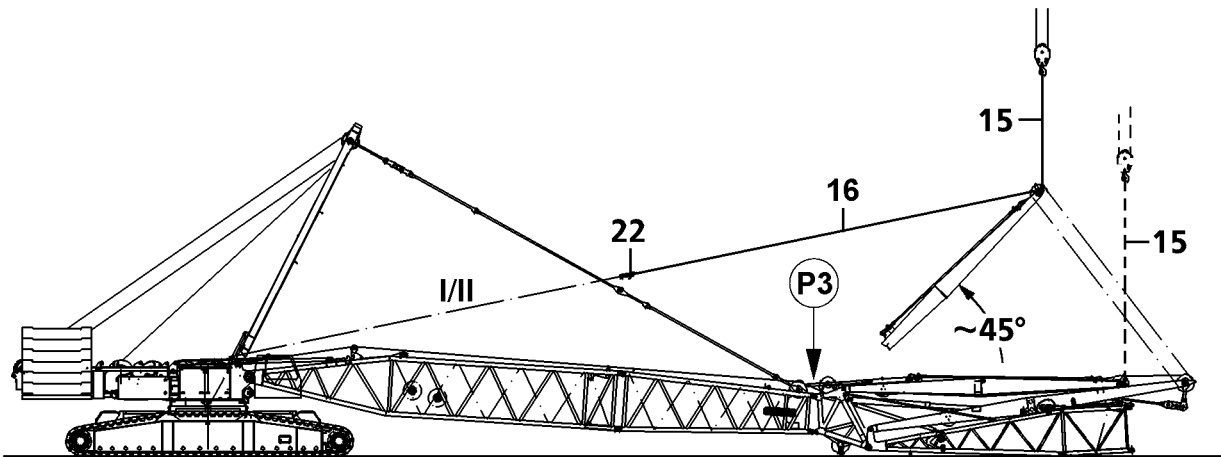

4.5 Placing the NA-brackets down

NOTICE

Damage of the relapse accumulator cylinder!

By pulling the NA-bracket II up, significant damage can occur due on the relapse accumulator cylinder **11** to a defective or not connected limit switch - due to the block position!

- ▶ Make sure that the electrical connections to the limit switches on the relapse accumulator cylinders have been established!
- ▶ Make sure that "spool up winch 5" turns off when the limit switches on the relapse accumulator cylinders are actuated!

- ▶ Disengage the assembly rope **16** on the NA-bracket and hang the hoist rope of winch 1 / winch 2 **WI/II** into the lock **22**.
- ▶ Spool the N-control winch **WV** up and pull the NA-bracket I up until the guying from the NA-bracket II to the pivot section is tensioned due to the counterpressure of the relapse accumulator cylinder **11**.

Result:

- The relapse support **12** can be unpinned.
- ▶ Remove spring retainer **25** and socket pin **24**.
- ▶ Lower the NA-bracket I until it rests on the N-pivot section.
- ▶ Pull the NA-bracket II back by spooling up the hoist winch and spooling the N-control winch **WV** out simultaneously and unpin the guy rods from the NA-bracket II to the pivot section on point **P5**.
- ▶ Place the guy rods on the lattice sections and secure.

NOTICE

Damage of socket pins **24** and the NA-bracket III!

If the NA-bracket II is "pulled to the rear", the socket pin **24** can be cut off and components of the NA-bracket II can be damaged!

- ▶ Make sure to unpin socket pins **24** before the NA-bracket II is "pulled to the rear"!

- ▶ Spool out the hoist winch and simultaneously spool up the N-control winch **WV**.

Result:

- The NA-bracket II is pulled up.
- ▶ Attach the assembly rope **15** on the NA-bracket II.
- ▶ Spool out the hoist winch and spool up the N-control winch **WV** until the NA-bracket II is in vertical position.
- ▶ Unpin the relapse support **12** on the L-adapter **A**.
- ▶ Remove the pin **26**, spring retainer **27** and washers **28**.
- ▶ Attach the assembly rope **15** on the NA-bracket II.

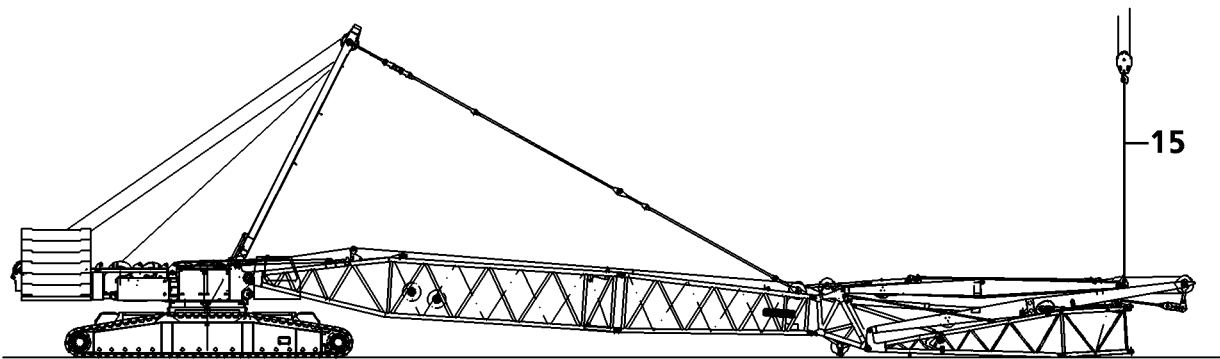
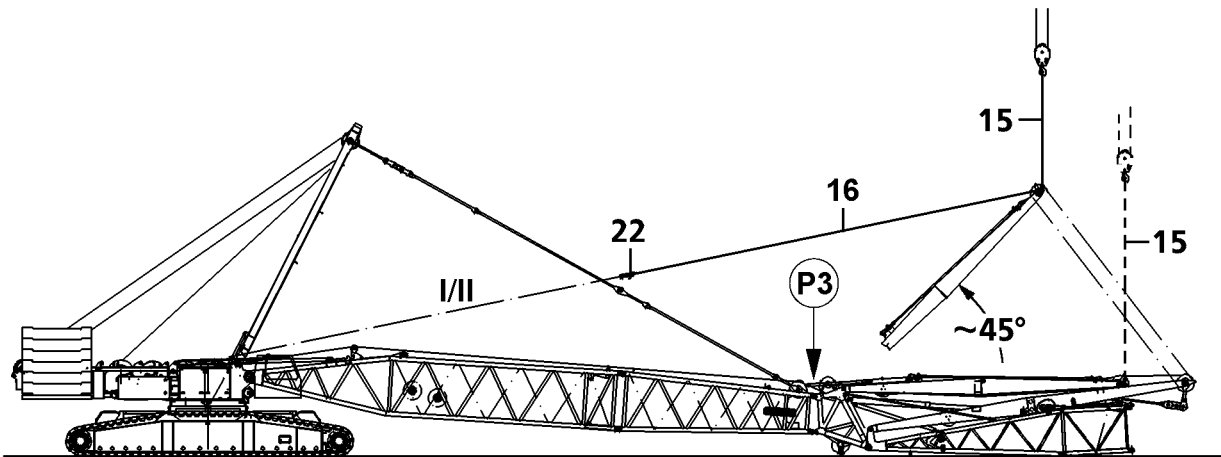

**WARNING**

The NA-bracket can fold down!

If the NA-bracket II is not held with the auxiliary crane during take down, from approx. 45° to the horizontal, then the NA-bracket can fold forward by itself!

Personnel can be severely injured or killed!

- ▶ Attach the NA-bracket II on the auxiliary crane (assembly rope **15**)!
- ▶ Lower the NA-bracket II slowly!

- ▶ Pull the NA-bracket II forward by spooling up winch 5 and simultaneously spooling out the hoist winch until approx. 45° to the horizontal.

NOTICE

Danger of slack rope formation!

- ▶ Slowly spool up the control rope when placing the NA-bracket II down!
- ▶ Hold the control rope tight when spooling up!

- ▶ Lower the NA-bracket II until it is placed on the NA-bracket I.
- ▶ Disengage the hoist rope on the lock **22** of the assembly rope **16** and engage the assembly rope **16** on the L-adapter at point **P3**.
- ▶ Remove the assembly rope **16** on the auxiliary crane and attach on the NA-bracket II.
- ▶ Unreeve the control rope and reeve in the auxiliary rope for the reeving at the same time.

4.6 Disconnecting the electrical connections to the N-lattice section

Make sure that the following prerequisite is met:

- The NA-brackets are placed down.
- ▶ Disconnect the electrical connections between the L-end section and the N-pivot section.

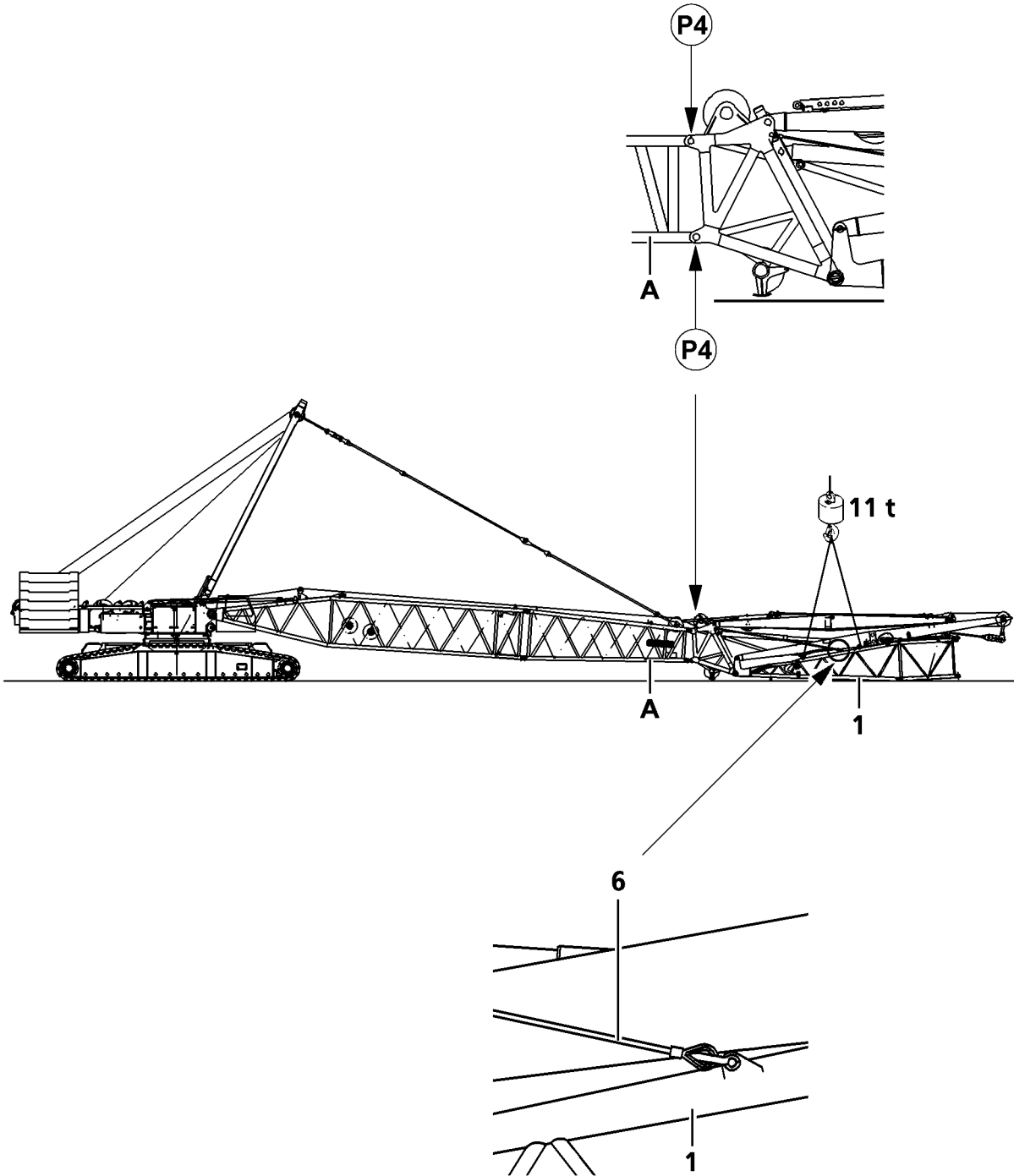

4.7 Unpinning the assembly unit on the L-/SL-boom

- ▶ Pin and secure the retaining rope **6** on the N-pivot section.
- ▶ Take on the N-assembly unit with the auxiliary crane on the attachment points on the N-pivot section.



Note

- ▶ The total weight of the assembly unit is approx. 11.0 t!
-



WARNING

Mortal danger if the fold in head folds away!

If the following notes are not observed, the fold in head can fold away with the NA-bracket I and the NA-bracket II!

Personnel can be severely injured or killed!

- ▶ Before unpinning the assembly unit, it must be held with the auxiliary crane!
 - ▶ The retaining rope **6** must be pinned and secured on the N-pivot section **1**!
 - ▶ It is prohibited for anyone to remain under the assembly unit!
-
- ▶ Unpin the N-assembly unit on the L-adapter **A** with the pin pulling device on top and bottom on points **P4**, see Crane operating instructions, chapter 5.30.
 - ▶ Remove the N-assembly unit with the auxiliary crane and place it down.

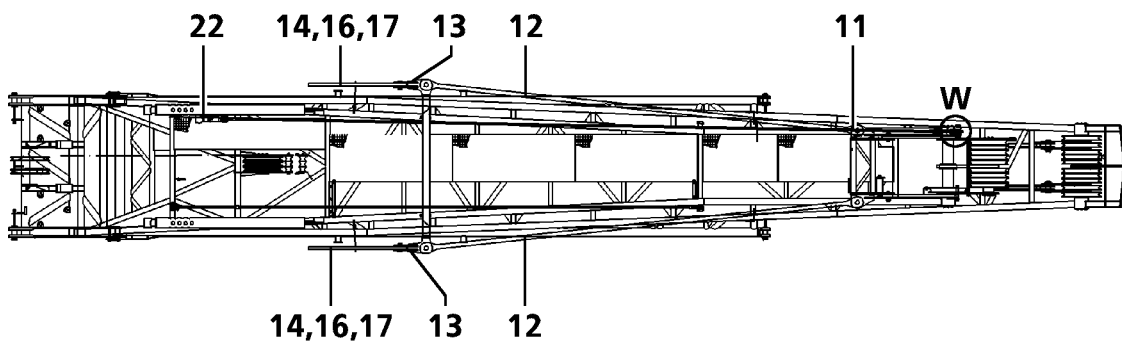
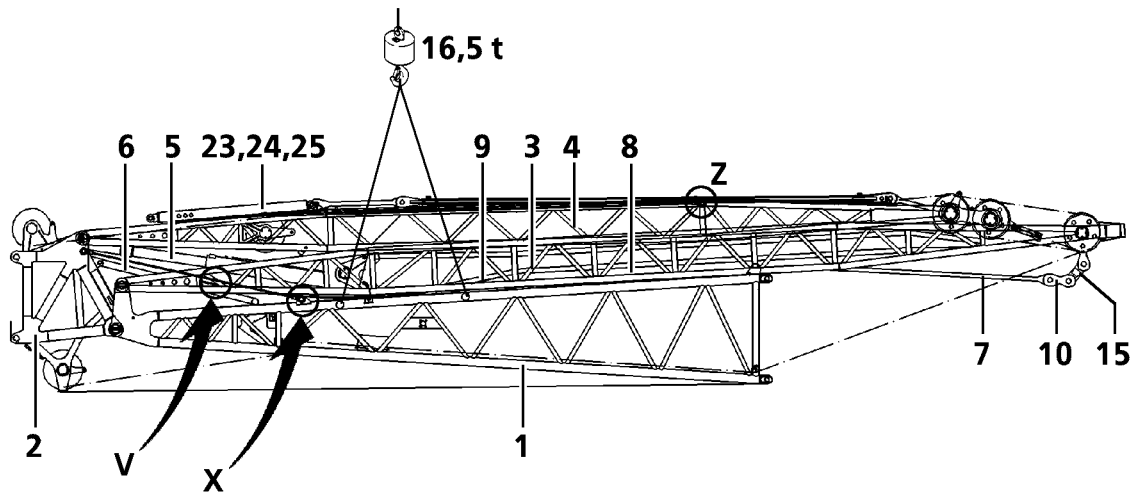

V

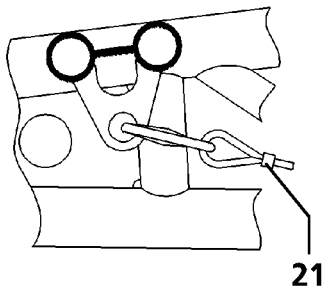

W

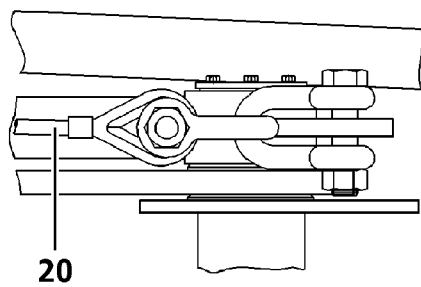

X

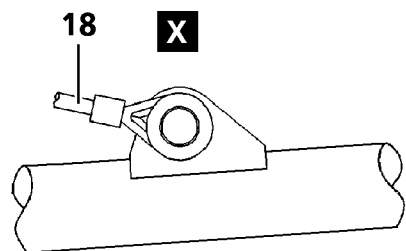

Z

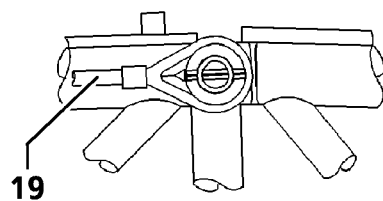

1 General



WARNING

When working aloft, there is a danger of falling!

If the following notes are not observed, the assembly personnel could fall and suffer life-threatening injuries!

- ▶ During all assembly / disassembly work, maintenance work and inspections, travel or crane operation is prohibited!
- ▶ Before any assembly / disassembly work and maintenance work on the crane and lattice mast boom, assembly personnel must wear the **approved fall arrest systems and protective equipment**, see Crane operating instructions, chapter 2.04!



DANGER

Danger of accident at assembly / disassembly of booms!

When you disassemble unsecured or unsupported booms, they can fall down!

Personnel can be severely injured or killed!

- ▶ Never unpin the pins under unsecured or unsupported booms!
- ▶ Never unpin the connecting pins under unsecured or unsupported booms!
- ▶ Do not stand under the booms or within the complete danger zone during the pinning and unpinning procedure of the booms!
- ▶ Safely secure the pins in the bearing points as well as receptacles!
- ▶ It is prohibited to lean the ladder against the component being assembled / disassembled!

1.1 Component overview of assembly unit

Component overview	
Position	Description
1	W-pivot section
2	S-end section 100 t
3	WA-bracket I
4	WA-bracket II
5	W-relapse cylinder
6	Mechanical relapse support
7	Guy rod 4200 mm
8	Guy rod 4730 mm
9	Connector bracket 320 mm
10	Connector bracket 300 mm
11	Cross beam
12	Guy rod 6990 mm
13	Cross beam
14	Guy rod 1380 mm

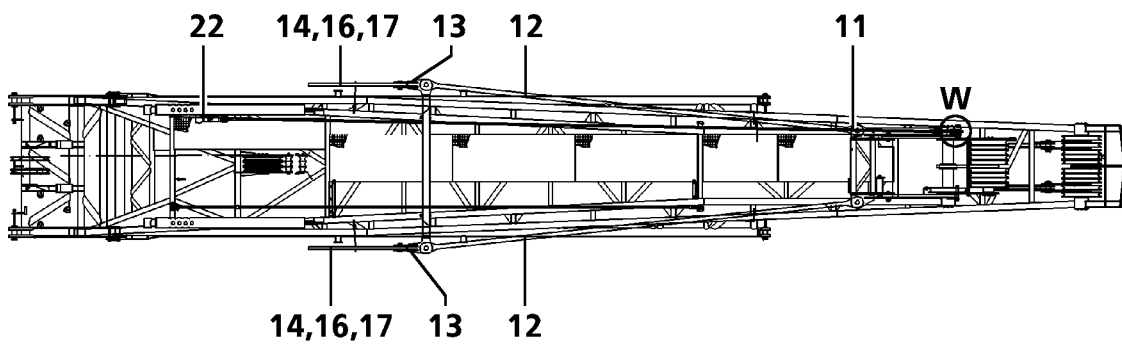
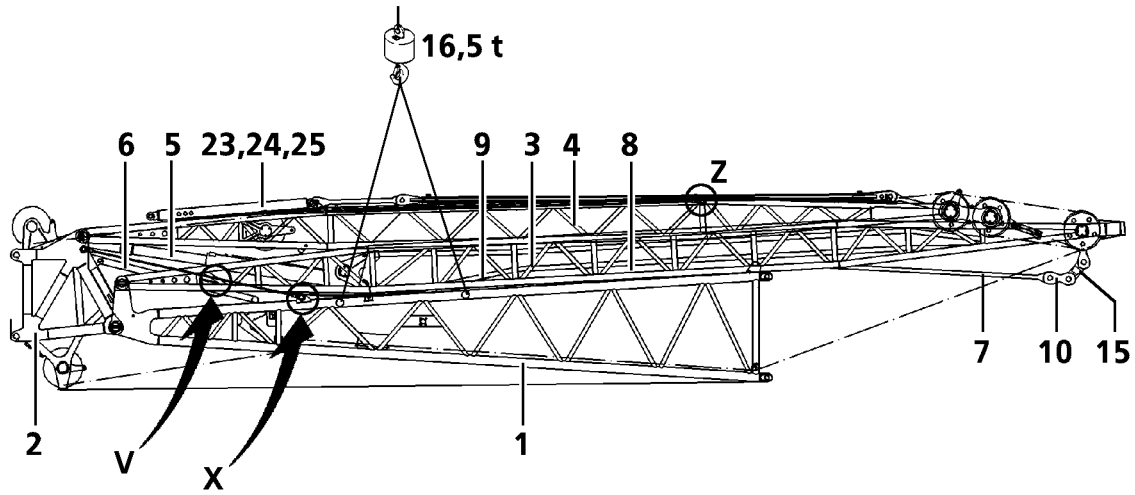

V

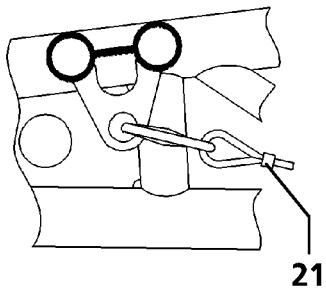

W

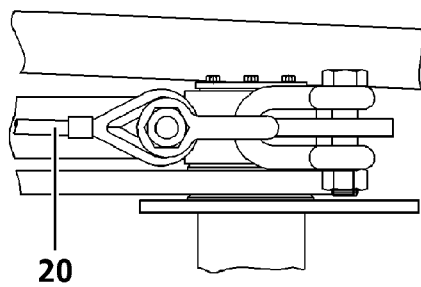

X

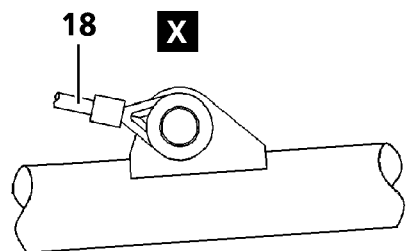

Z

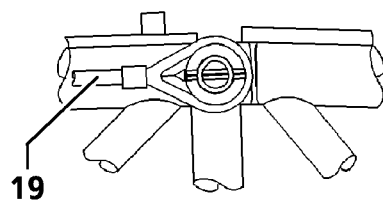

Component overview	
Position	Description
15	Test bracket
16	Spring retainer
17	Pin
18	Retaining rope
19	Assembly rope
20	Assembly rope
21	Fastening rope
22	Lock
23	WA-bracket II -Relapse support
24	Socket pin
25	Spring retainer

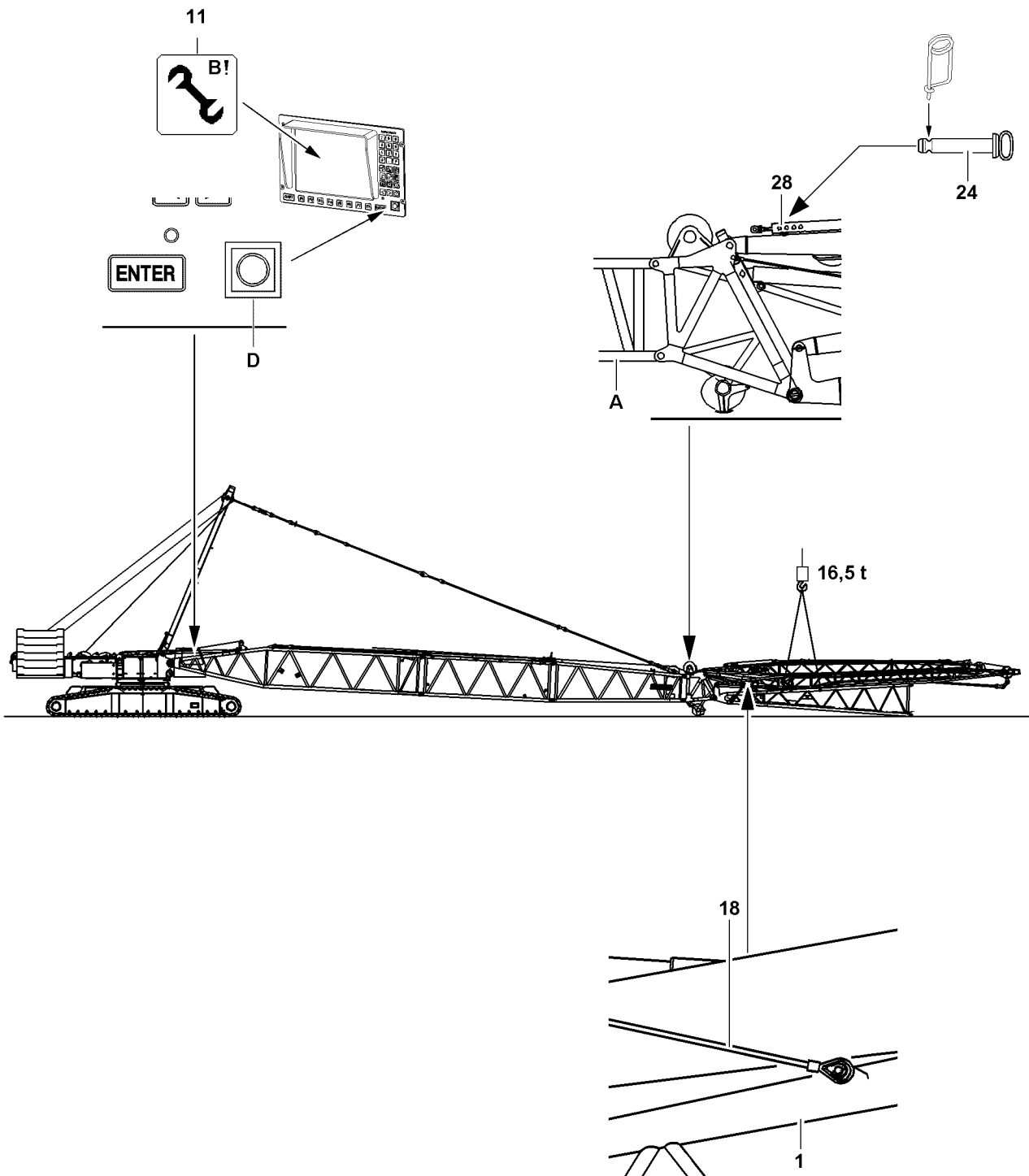

B111367

2 Assembly



WARNING

Risk of falling!

During assembly and disassembly, personnel must be secured with appropriate aids to prevent them from falling! If this is not observed, assembly personnel can fall and suffer life-threatening or fatal injuries!

- ▶ Any work, where there is a danger of falling must be carried out with suitable aids (for example: lifting platforms, scaffoldings, ladders, auxiliary crane)!
- ▶ If the work cannot be carried out with such aids nor from the ground, then the assembly personnel must secure themselves with approved fall arrest systems to avoid falling, see Crane operating instructions chapter 2.04!
- ▶ If railings are present on the components, then they must be brought into the corresponding position and secured for assembly / disassembly work!
- ▶ Step on aids and fall protection equipment only with clean shoes!
- ▶ Keep aids and fall protection equipment clean and free from snow and ice!
- ▶ During all assembly and disassembly work, maintenance work and inspections, travel or crane operation is prohibited!



WARNING

Falling components!

If unsecured or non-supported components are assembled or disassembled, they can fall down. Personnel can be killed or seriously injured!

- ▶ During pinning and unpinning of the lattice sections, it is prohibited for anyone to remain **under** or **on** the components as well as within the entire danger zone!
- ▶ Support the boom and components before pinning / unpinning!
- ▶ Pin or unpin both pins laying in a horizontal, i.e. **left** and **right**!
- ▶ Secure the pins in the bearing points and in the receptacles!
- ▶ Do not disengage the auxiliary crane until each component is pinned on and secured!
- ▶ It is prohibited to lean a ladder against the component being disassembled!



WARNING

Danger of impact / crushing!

When installing / removing counterweight components with the auxiliary crane, crane components can start to swing back and forth!

When lifting / lowering and positioning crane components, there is an increased danger of impacts / crushing!

Personnel can be caught and severely injured or killed!

- ▶ Make sure that personnel cannot be caught by components!
- ▶ Make sure that the crane is aligned in horizontal position to avoid the support beams from swinging by themselves!
- ▶ When working in danger zones: Use aids to protect limbs!
- ▶ Guide components with suitable aids to minimize oscillation!

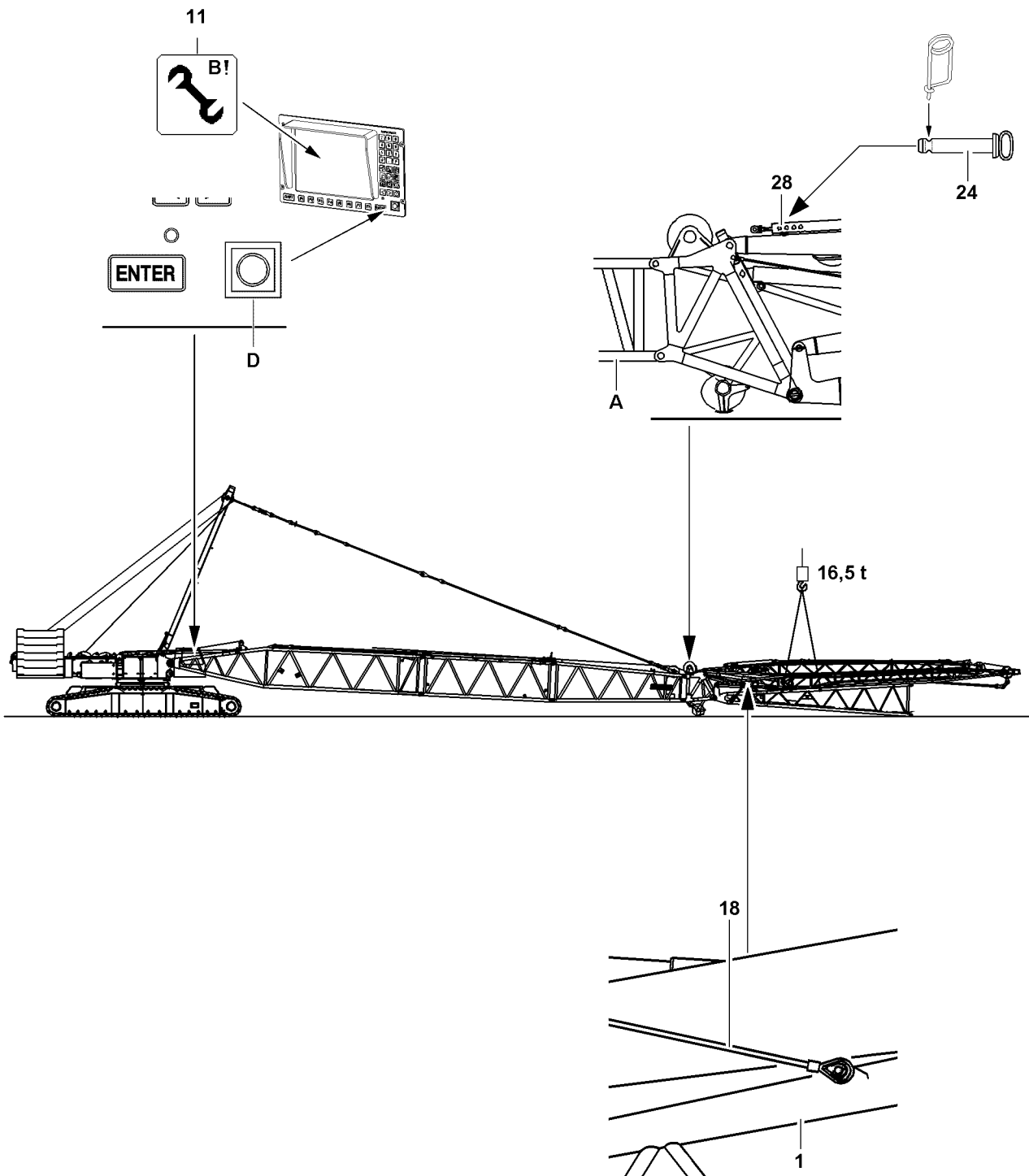

B111367

**WARNING**

Risk of accident!

If the following instructions are not observed, personnel can be severely injured or killed!

- ▶ The boom combinations must be assembled according to the separately supplied rod and assembly plans!
- ▶ Depending on the condition of the ground, the boom and the lattice sections must be supported from below for the assembly of the boom!
- ▶ Observe the safety technical notes, see Crane operating instructions, chapter 5.01!

Make sure that the following prerequisites are met:

- The crane is aligned in horizontal direction.
- The S-boom is assembled.
- The counterweight is attached to the turntable according to the load chart and placed on the suspended ballast pallet / ballast trailer.
- The LICCON overload protection has been set according to the data in the load chart.
- The LICCON overload protection is exceeded.
- The assembly icon **11** is visible on the LICCON monitor.
- An auxiliary crane is available.

2.1 Attaching the W-assembly unit to the S-boom

2.1.1 Adding the operating mode “Assembly”

**WARNING**

Assembly with turned on set up key!

When the set up key is engaged, the LICCON overload protection is exceeded!

In the event of deliberate improper use, the crane could collapse, the boom can break off or the crane can topple over!

Personnel can be killed!

This could result in high property damage!

- ▶ The set up key **D** may only be actuated by persons who know the effects of a bypass!
- ▶ Press the set up key **D** only when the set up status was correctly entered into the LICCON computer system!
- ▶ Observe the erection / take down charts!
- ▶ Crane operation with the set up key **D** turned on is strictly prohibited!

- ▶ Turn the set up key **D** to the right.

Result:

- The LICCON overload protection is deactivated.
- The assembly icon **11** appears on the LICCON monitor.

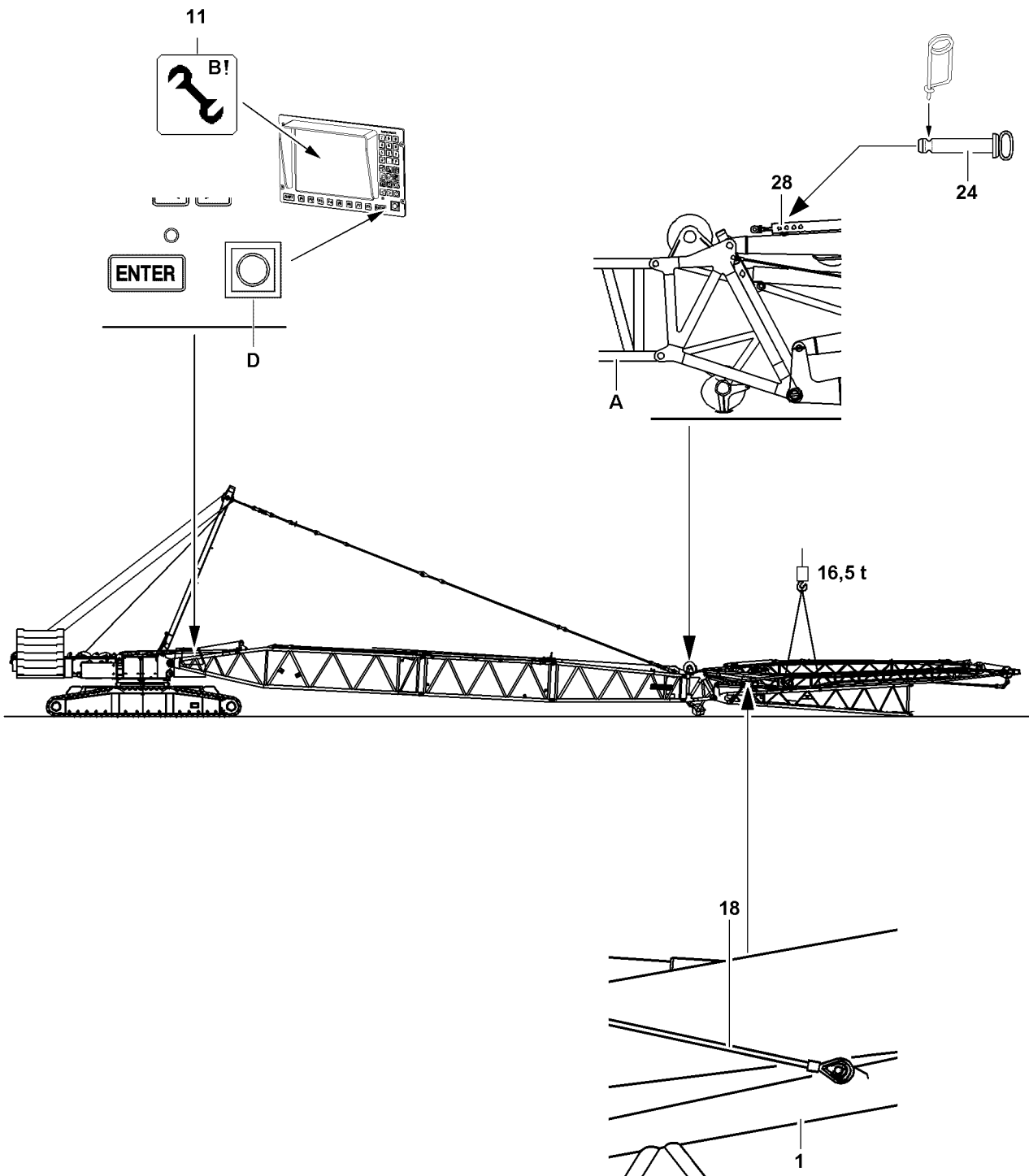

B111367

2.1.2 Pinning the W-assembly unit to the S-boom

Take on the W-assembly unit with the auxiliary crane on the attachment points on the W-pivot section 1.



Note

- ▶ The total weight of the W-assembly unit is 16.5 t!
-

- ▶ Pin the W-assembly unit on the S-adapter **A** with the pin pulling device on top and bottom and secure with spring retainer.
-



DANGER

Mortal danger due to folding down pivot section!

The pivot section folds down by itself when the retaining rope is removed!

Personnel can be severely injured!

- ▶ The W-assembly unit must be secured with the auxiliary crane before removing the retaining rope!
-

- ▶ Remove the retaining rope **18**.
- ▶ Lower the W-assembly unit with the auxiliary crane until it is laying on the ground.
- ▶ Support the W-pivot section **1**.
- ▶ Release the socket pin **24** on the WA-bracket II relapse support.
- ▶ Unpin the socket pin **24** on the WA-bracket II relapse support.
- ▶ Pull the relapse support apart to the last bore.
- ▶ Pin and secure the socket pin **24**.

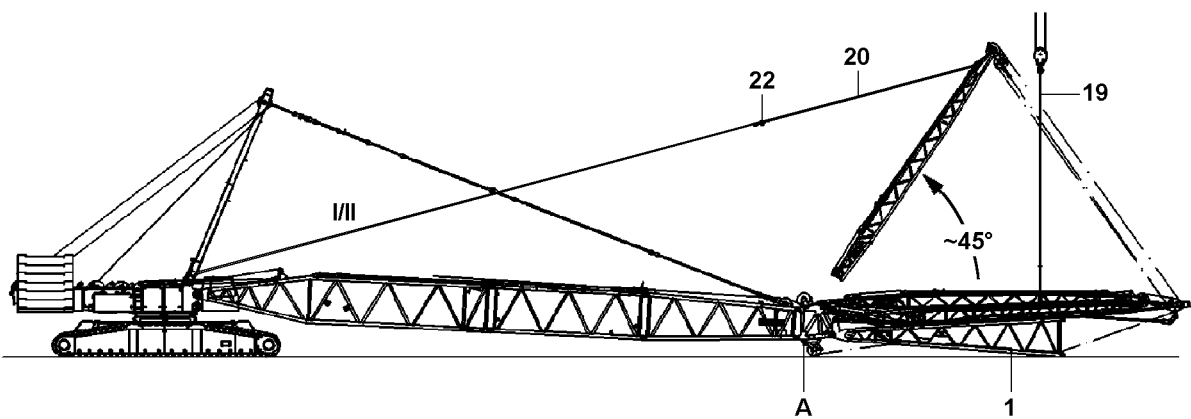
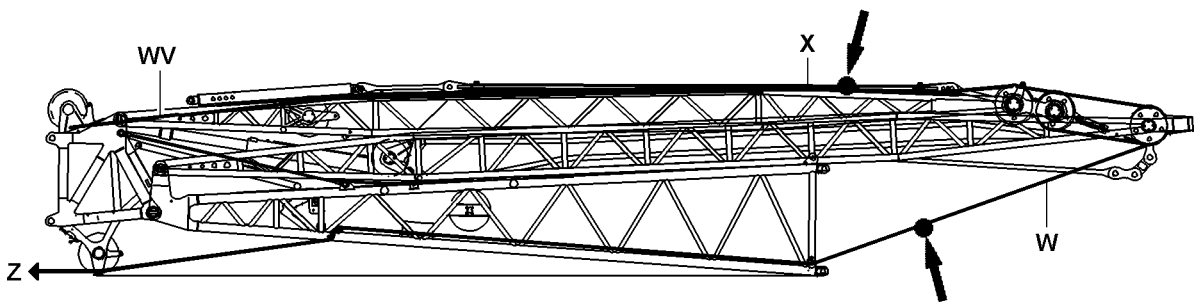
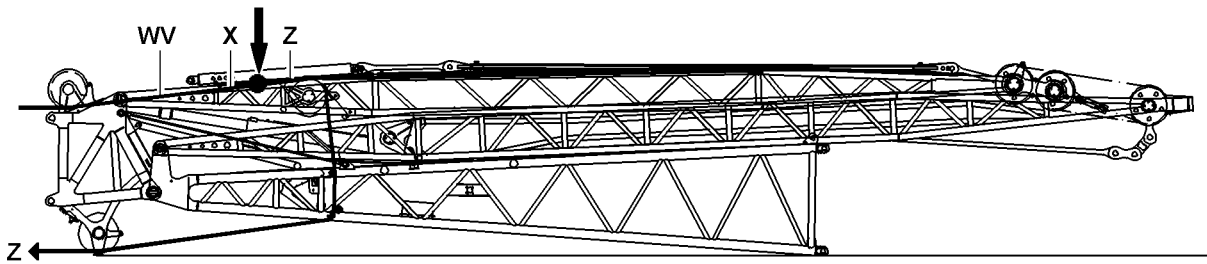

B105616

2.2 Reeving in the W-control rope between the WA-bracket I and the WA-bracket II

- ▶ Pull the auxiliary rope **Z** of the auxiliary winch over the change over pulleys to the turntable.
- ▶ Connect the auxiliary rope **Z** with the W-control rope **X** from winch 5.
- ▶ Spool the auxiliary winch up and spool winch 5 out simultaneously and pull the W-control rope to the WA-bracket II - watch the rope run, see illustration .
- ▶ Connect the W-control rope **X** and the auxiliary rope **Z** with the reeving rope **W** which is already reeved in between the WA-bracket I and the WA-bracket II - watch the rope run, see illustration .
- ▶ Spool the auxiliary winch up and simultaneously spool winch 5 out.
- ▶ Reeve in the W-control rope between the WA-bracket I and the WA-bracket II.



Note

- ▶ To prevent the WA-bracket II from pulling up, the control winch (winch 5) must be spooled out at the same time at erection!
-
- ▶ Attach the WA-bracket II on the assembly rope **19** to the auxiliary crane.
 - ▶ Erect the WA-bracket II with the auxiliary crane to approx. 45 °.
 - ▶ Hang the hoist rope of winch 1 / winch 2 on the lock **22** of the assembly rope **20**.

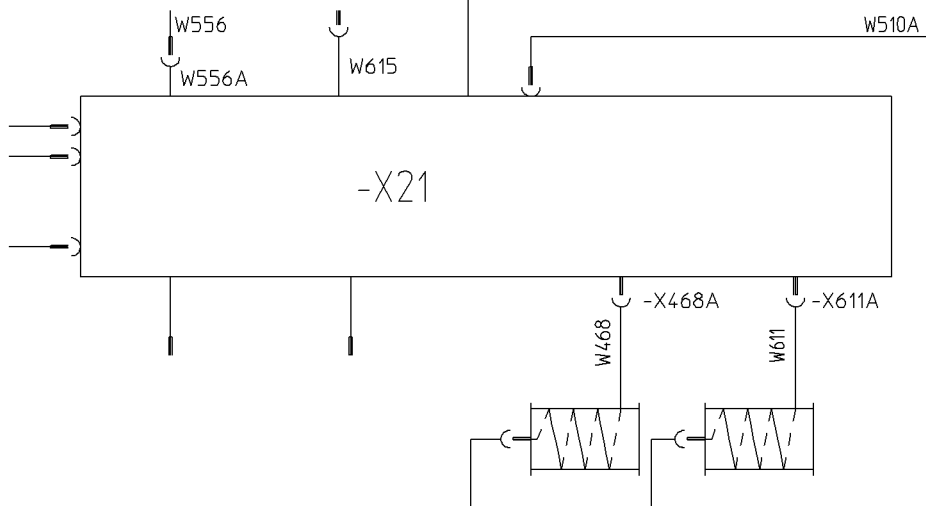
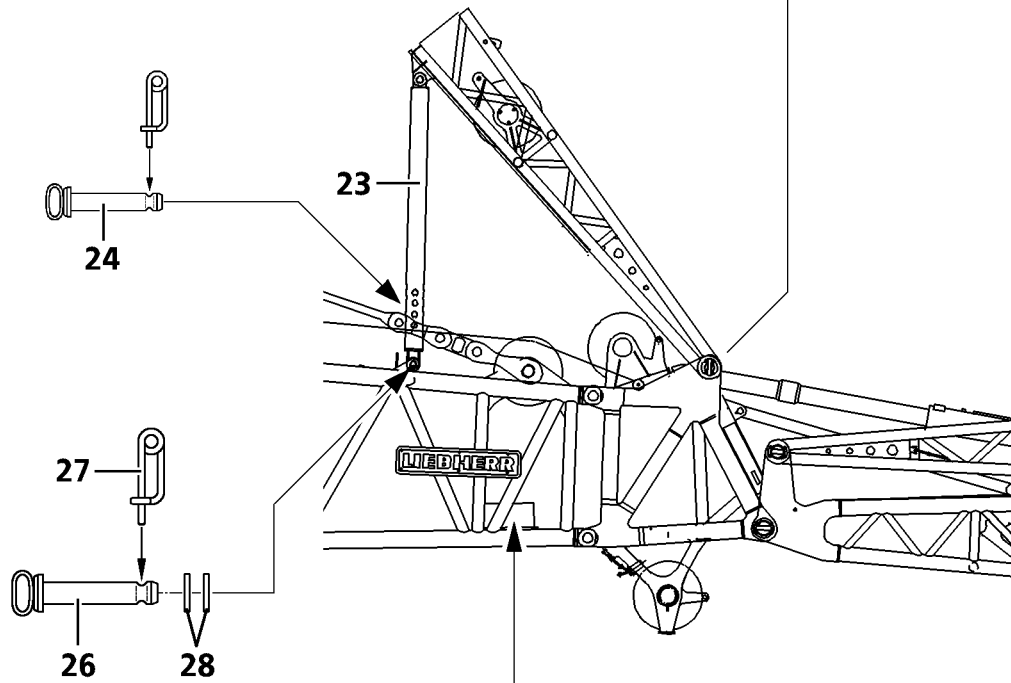
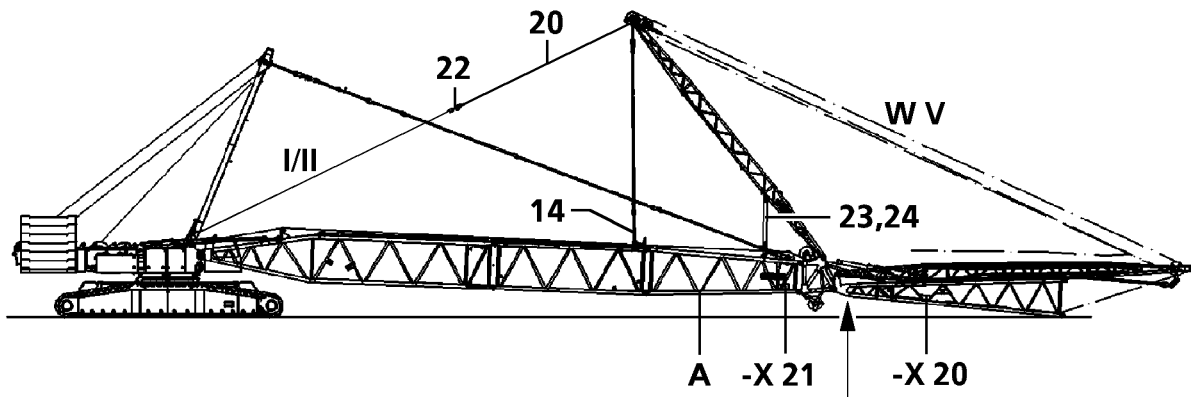

B105617

2.3 Assembling the guy rods between the WA-bracket II and the S-pivot section

Establish the electrical connections from the cable drums in the S-pivot section to the connector box -X21 in the S-adapter.

- ▶ Plug in the cable **W468** on the cable plug **-X468A** of the connector box **-X21**.
- ▶ Plug in the cable **W611** on the cable plug **-X611A** of the connector box **-X21**.
- ▶ Continue to erect the WA-bracket II from approx. 45° with the hoist rope and the assembly rope **20** until the mechanical relapse support **23** can be pinned and secured on the S-adapter **A** with pin **26**, spring retainer **27** and two washers **28**.

NOTICE

Danger of property damage on WA-bracket II!

If the socket pin **24** is not unpinned after pinning the relapse support on the S-adapter, the WA-bracket II can be significantly damaged when "pulling it to the rear"!

- ▶ Make sure to unpin the socket pin **24**!
 - ▶ Make sure that the socket pin **24** is unpinned!
-
- ▶ Unpin the socket pin **24** on the mechanical relapse support **23**.
 - ▶ **Spool up** the hoist winch and simultaneously **spool out** the W-control winch.

Result:

- The WA-bracket II is pulled to the rear.

Pull the WA-bracket II to the rear until the guy rods of the WA-bracket II with the guy rods of the S-pivot section can be pinned and secured.



WARNING

Danger of accidents due to incorrect pin connection(s)!

Due to incorrect pin connections, the pins can loosen up by themselves and dangerous situations can arise!

Personnel can be severely injured or killed!

- ▶ The pins on the guy rods must be pinned from the inside to the outside!
 - ▶ Secure the pins from the outside!
-
- ▶ When the WA-bracket II has been pulled back far enough:
Pin the guy rods of the WA-bracket II with the guy rods on the S-pivot section.
 - ▶ Secure the pin connection.

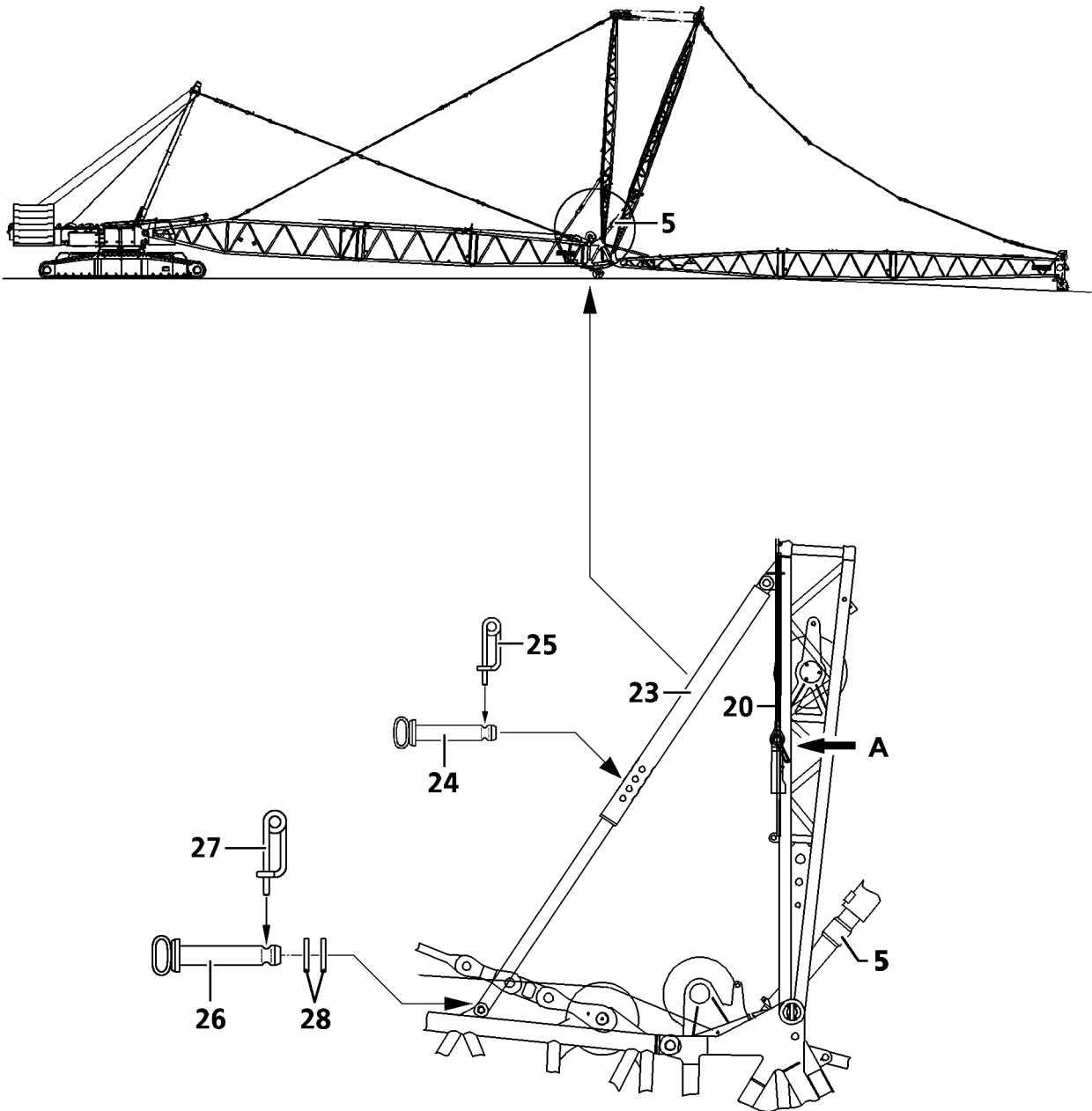

B188564

2.4 Erect the WA-bracket II

Make sure that the following prerequisites are met:

- The limit switches on the W-relapse accumulator cylinder **5** have been checked manually for function.
- The WA-bracket II guy rods are pinned.

NOTICE

Damage to the W-relapse accumulator cylinder!

Before erecting the WA-bracket I, the electrical connections for the limit switches of the W-relapse accumulator cylinder **5** must have been established and manually actuated. If this is not the case, the WA-bracket I can be pulled back to the mechanical stop of the W-relapse accumulator cylinder **5** and be significantly damaged!

▶ Check the shut off with the limit switches of the W-relapse accumulator cylinder **5**!

- ▶ Establish the electrical connections to the limit switches of the W-relapse accumulator cylinder **5**.
- ▶ Manually actuate the limit switches individually.

Result:

- The icon appears on the LICCON monitor.
 - The spool up function of the W-control winch (winch 5) turns off.
-



Note

- ▶ The guying between the WA-bracket II and the S-pivot section is tensioned by spooling out the hoist winch and simultaneously spooling up the W-control winch, due to the pressure in the W-relapse accumulator cylinder **5**!
-
- ▶ Spool out the hoist winch and at the same time, spool up the W-control winch (winch 5) until the guying between the WA-bracket II and the S-pivot section is tensioned.
 - ▶ Insert the socket pin **24** in maximum possible length on the next bore of the WA-bracket II relapse support **23** and secure with spring retainer **25**.
 - ▶ Continue to spool out the hoist winch.
 - ▶ Disengage the hoist rope on the lock.
 - ▶ Attach the assembly rope **20** on A of the WA-bracket II.
 - ▶ Loosen the tackle on the guy rods.
 - ▶ Erect the WA-bracket I by spooling up the W-control winch (winch 5) until the limit switch is actuated on the W-relapse cylinder **5**.

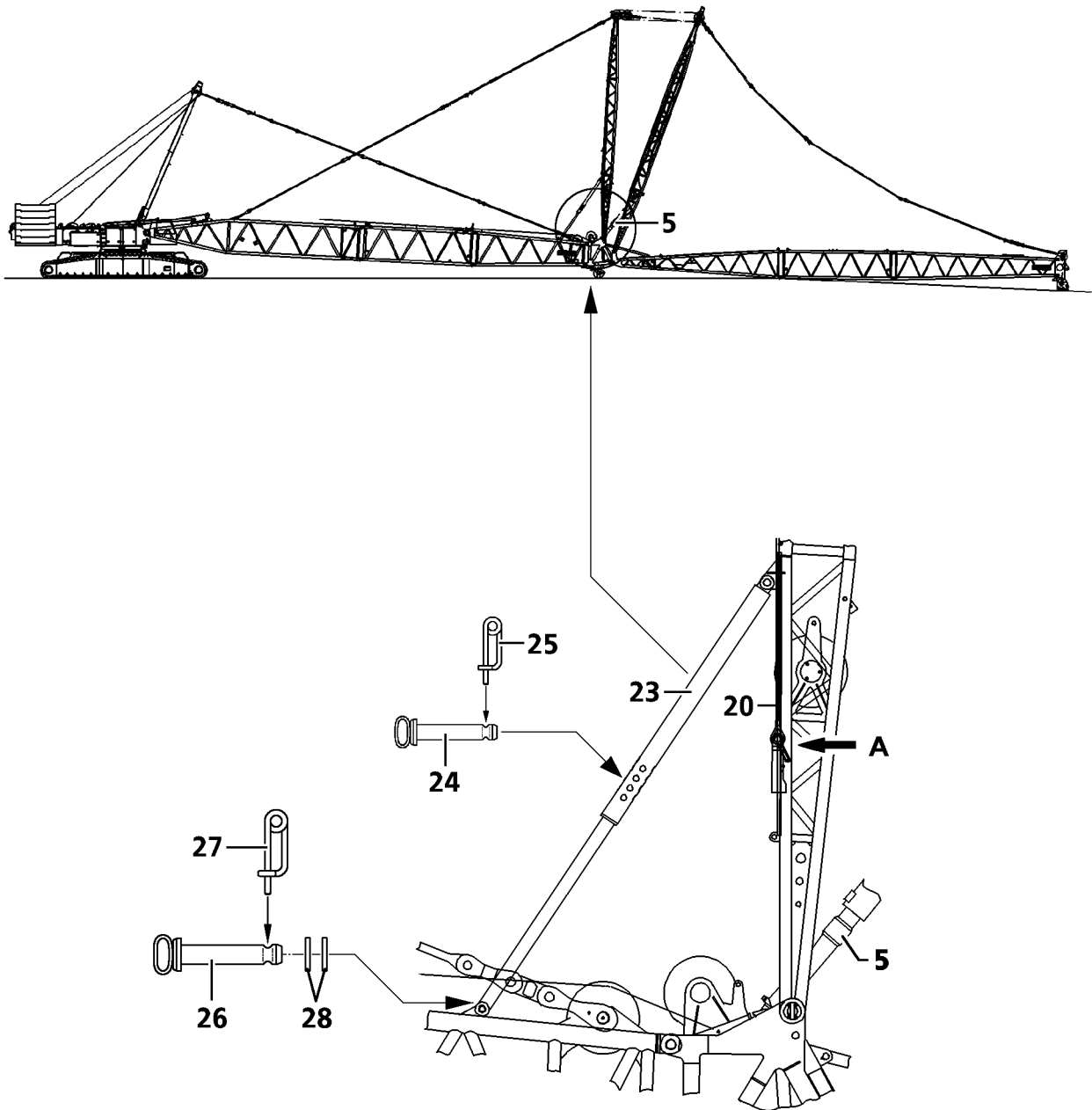

2.5 Assembling the W-lattice jib

2.5.1 Assembly of the W-lattice jib on the W-pivot section



Note

- ▶ During assembly of the W-lattice jib, adhere to the specified pin sequence, see Crane operating instructions, chapter 5.01!
-

Make sure that the following prerequisite is met:

- The SW-end section has been placed in the pulley cart at assembly of the W-lattice jib, see Crane operating instructions, chapter 5.15.
-



Note

- ▶ The air pressure in the tires of the pulley cart must be 9 bar!
-



WARNING

General danger notes!

If the following notes are not observed, severe accidents can occur due to tipping or falling components.

Personnel can be severely injured or killed!

- ▶ Support the lattice sections at lattice jib assembly / disassembly with suitable materials!
 - ▶ All pins are to be secured after assembly of the lattice sections with spring retainers!
 - ▶ Check the guy rods in regular intervals!
 - ▶ It is prohibited for anyone to remain under the lattice sections during the pinning / unpinning procedure!
-

- ▶ Assemble the W-lattice jib to the required length.
- ▶ Spool the hoist rope out and pull it to the SW-end section and attach it there.

The W-guy rods are placed and secured for transport on the W-lattice sections. Before assembly of the W-guy rods, the transport retainers must be released.

- ▶ Release the transport retainers of the W-guy rods.
-



Note

- ▶ Always pin the guy rods from the “inside” to the “outside”!
 - ▶ The numbering on the assembly drawings must match the numbering on the W-guy rods!
-
- ▶ Pin the W-guy rods of the W-end section with the W-guy rods of the WA-bracket I and secure.
 - ▶ Tension the W-guy rods.
-

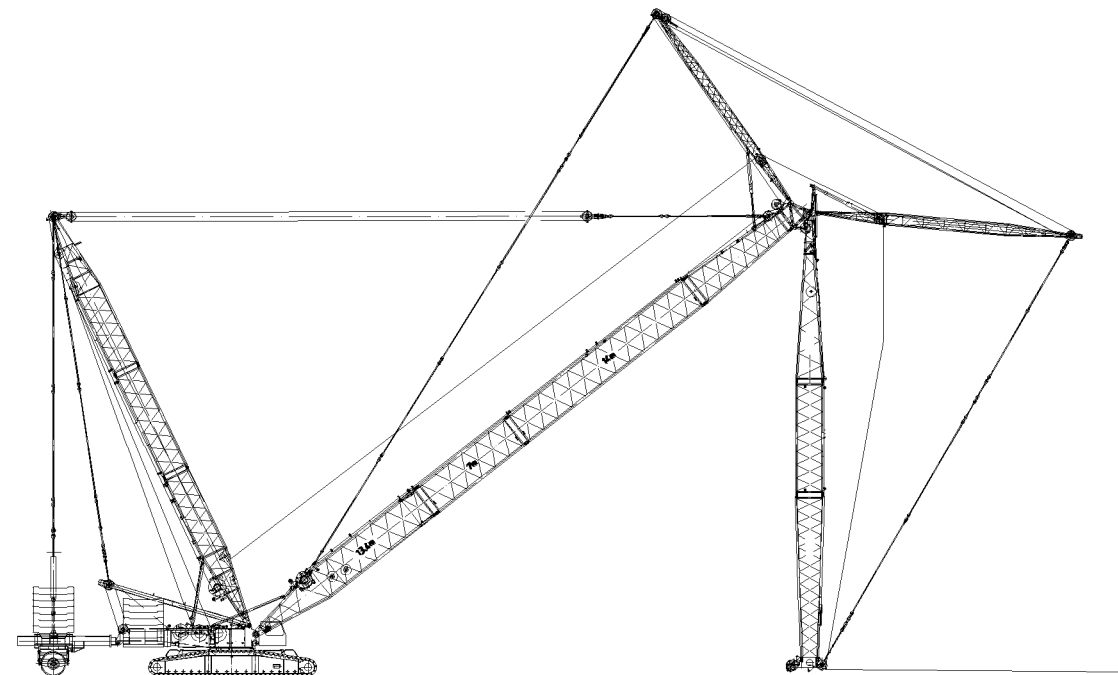
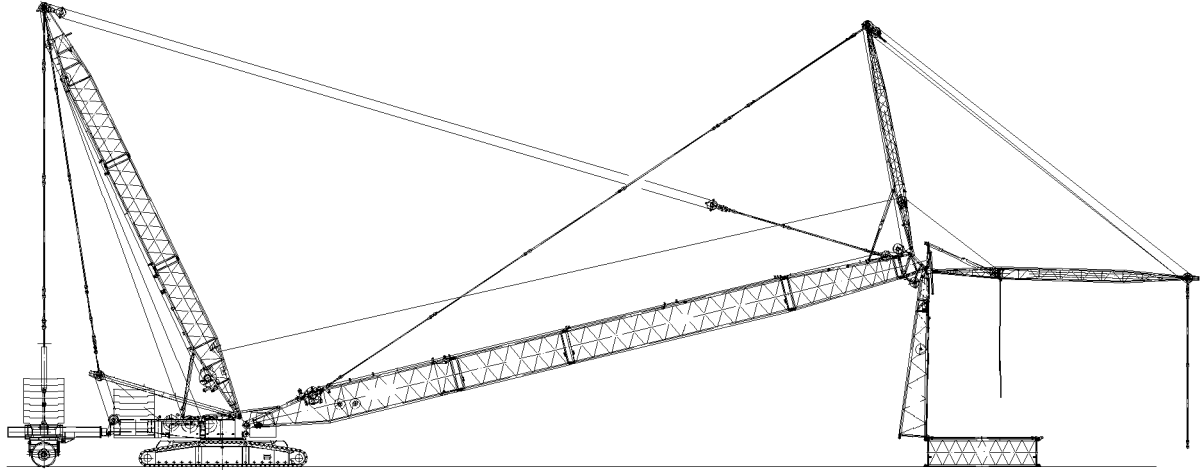

B195939

2.5.2 Flying assembly of the W-lattice jib on the W-pivot section

If spatial prerequisites on the job site are limited for the assembly of the W-lattice jib or if they are limited by buildings or similar, then the W-lattice jib can be installed in flying mode up to the following maximum lengths.

Flying assembly: hanging	
S-boom	W-lattice jib
S 42 m	W 28 m
S 49 m	W 35 m
S 56 m	W 42 m
S 63 m	W 42 m
S 70 m	W 49 m
S 77 m	W 56 m
S 84 m	W 56 m



WARNING

Danger of toppling the crane!

If the data on the LICCON monitor does not match the actual crane condition, then the crane can topple over!

Personnel can be severely injured or killed!

- ▶ Counterweight, central ballast and derrick ballast are installed according to the data in the load charts!
- ▶ Counterweight, central ballast and derrick ballast match with the settings on the LICCON monitor!



Note

- ▶ Observe the individual weights of the individual lattice sections, see Crane operating instructions, chapter 5.03!

Make sure that the following prerequisites are met:

- The S-boom is assembled to the required length.
- The W-assembly unit is installed.
- The WA-bracket I and WA-bracket II are erected.
- The hoist rope is placed and pulled off over the rope pulleys of the WA-brackets.
- The cable from the cable drum to the end section is pulled off.

NOTICE

Danger of damage of the W-pivot section!

- ▶ The W-pivot section must be guided along with the auxiliary crane to prevent it from sliding on the ground and being damaged!

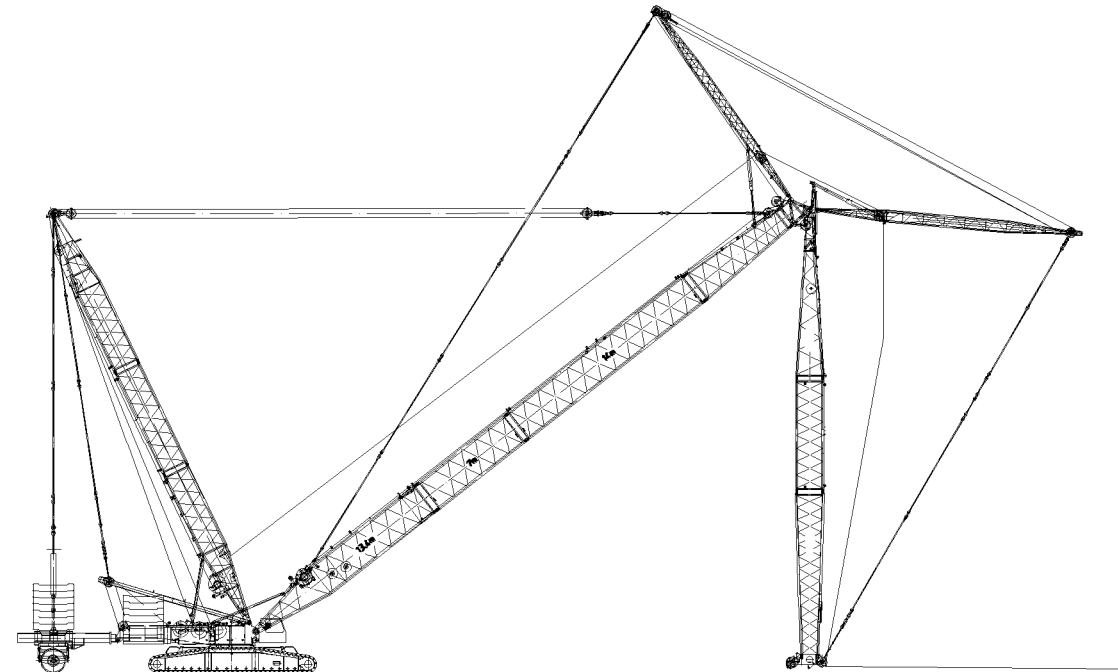
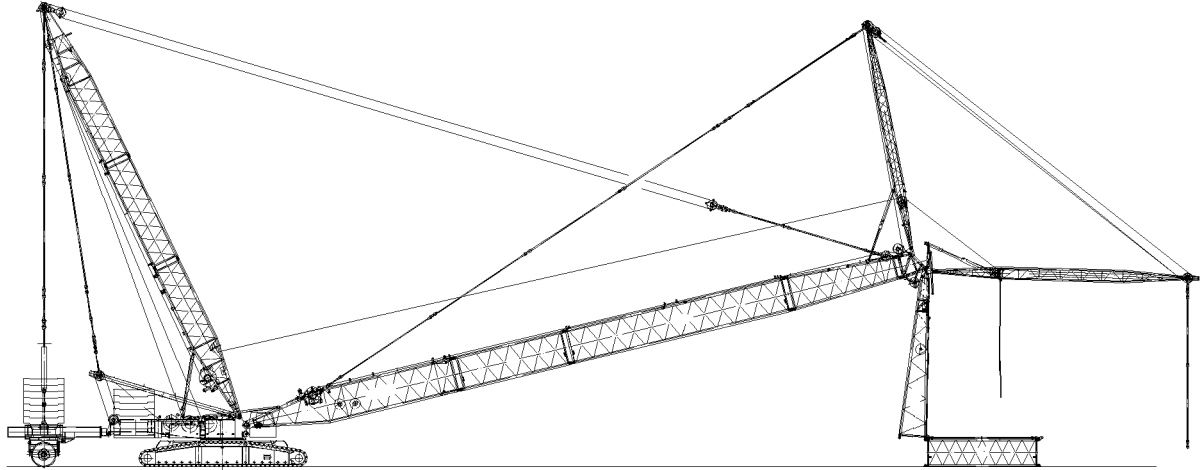

B195939

**WARNING**

Risk of fatal injury!

Severe accidents can occur if the following notes are not observed.

Personnel can be severely injured or killed!

- ▶ The maximum permissible W-lattice jib lengths may not be exceeded!
- ▶ The specifications in the load charts must be observed!
- ▶ It is prohibited for anyone to remain under the lattice sections during the unpinning / pinning procedure!

-
- ▶ Pull the S-boom up until the W-pivot section hangs vertically.

or

- Pull the S-boom up until the angle between the S-boom and the W-pivot section is at least 45°.
- ▶ Lower the WA-bracket I to the front.
- ▶ Pin and secure the guy rods of the intermediate section to be installed first on the guy rods of the WA-bracket I.
- ▶ Pin and secure the first intermediate section on the pin bores on the W-pivot section "on top".
- ▶ Continue to luff the S-boom up until the W-intermediate section hangs freely on the W-pivot section.
- ▶ Carefully luff the S-boom down until the W-intermediate section is standing upright on the ground.
- ▶ When the "lower" pin bores of the W-intermediate section align with the pin bores on the W-pivot section:
Pin and secure the W-intermediate section with the W-pivot section "on the bottom".
- ▶ Assemble additional W-intermediate sections and the W-end section the same way individually and one after the other to the required length.
- ▶ Disassemble the guy rods of the additional W-intermediate sections on the intermediate section and pin and secure continuously on the guy rods on the WA-bracket I.

**Note**

- ▶ For the W-lattice jib lengths to 49 m, corresponding, additional guy rods must be installed, see Rod plan!

-
- ▶ Plug the cable of the cable drum in on the W-end section.

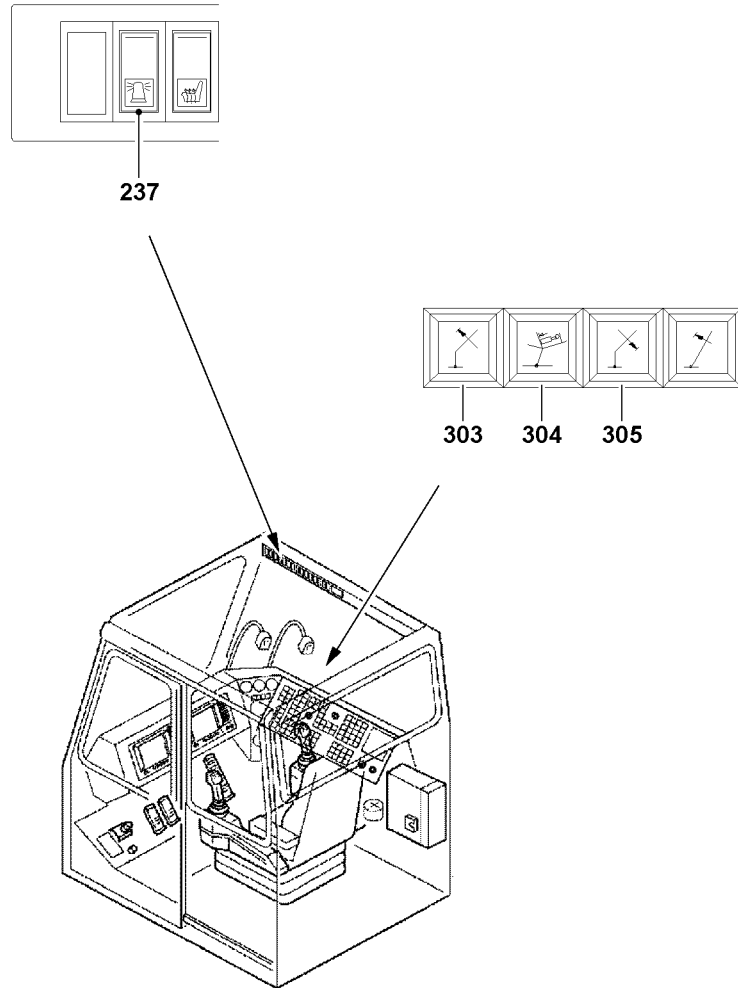

B111370

2.6 Establishing the electrical connections



Note

- ▶ To establish the electrical connections, see Electric wiring diagram!
-

NOTICE

Damage to the electrical connection on the cable drum!

If the electrical connection from the cable drum to the terminal box is made in incorrect sequence, then the electrical connection can be damaged when spooling the cable drum out!

- ▶ When establishing the electrical connections, pay attention to the sequence, see Electric wiring diagram!
-

Make sure that the following prerequisite is met:

- The W-boom is fully assembled.
- ▶ Establish the electrical connections.
- ▶ Make sure that all electrical connections on the boom are established.

2.7 Function check

Make sure that the following prerequisites are met:

- All electrical connections have been established.
- The engine is running.
- The appropriate operating mode is set.
- The actuator levers of the limit switches have been checked for easy movement and are lubricated.

2.7.1 Airplane warning light*

- ▶ Turn the airplane warning light on and visually check the function.

2.7.2 Wind speed sensor*

- ▶ Test the movement and the function of the wind speed sensor.

2.7.3 Hoist limit switch

- ▶ Actuate the hoist limit switch manually on the pulley head.

Result:

- The “Hoist top” icon on the LICCON monitor blinks.
- The **spool up function** of the hoist winch turns off.

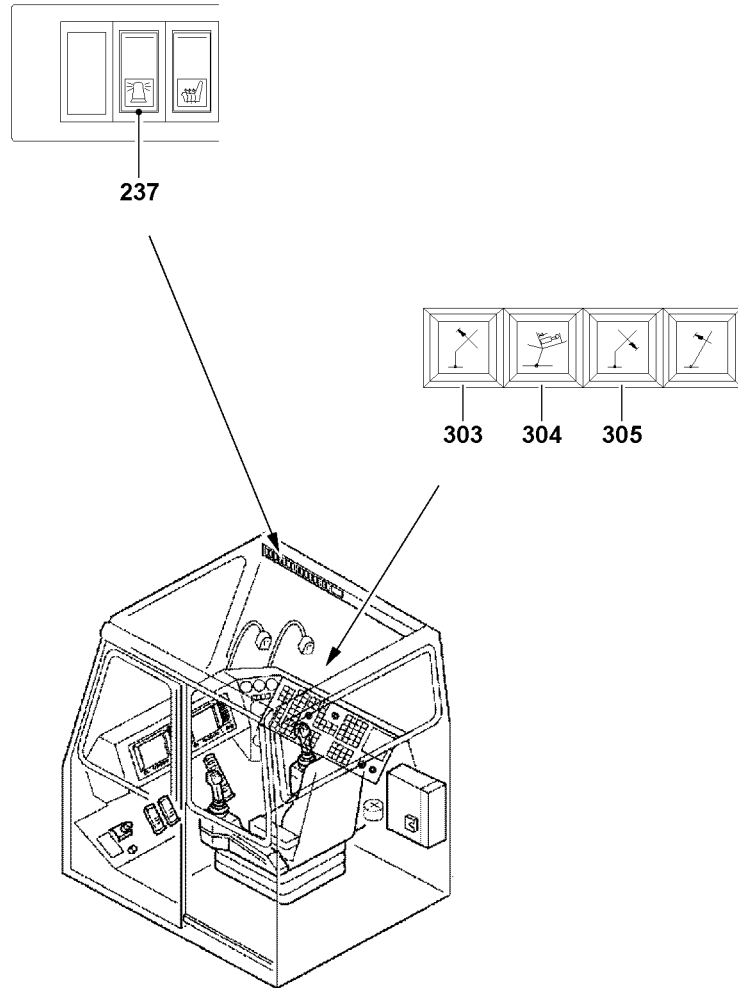

B111370

2.7.4 Limit switch lattice jib, “steepest” position, relapse cylinder



Note

- ▶ The switch point of the limit switches on the relapse cylinder must be checked before erection, see Crane operating instructions, chapter 8.13!
-

- ▶ Manually actuate the limit switches on the relapse cylinder individually.

Result:

- The W-control winch movement “spool up” turns off.
- The indicator light **304** lights up.

2.7.5 Limit switch lattice jib, “steepest” position, mechanical relapse support

- ▶ Manually actuate the limit switches on the pendulum individually.

Result:

- The W-control winch movement “spool up” turns off.
- The indicator light **303** lights up.

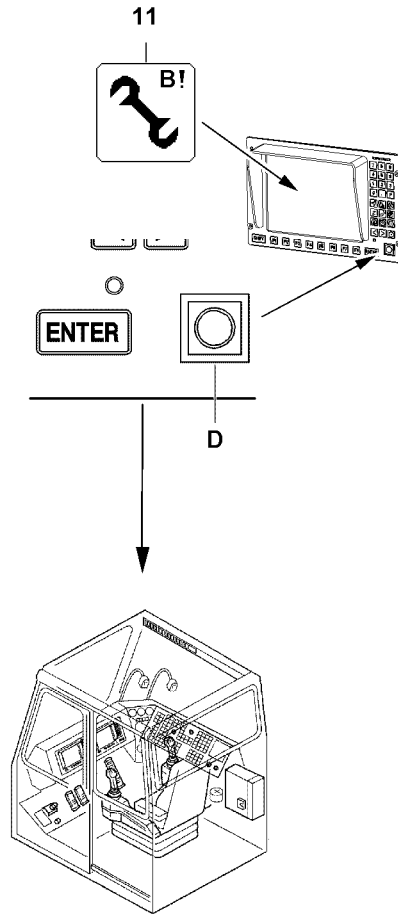

2.8 Erecting the boom



DANGER

The crane can topple over!

If the following conditions are not met before erecting the boom, the crane can topple over and fatally injure personnel!

- ▶ Observe the safety technical notes, see Crane operating instructions, chapter 5.01!
- ▶ Observe the data in the erection and take down charts!
- ▶ Extend the relapse cylinder before erection!

Make sure that the following prerequisites are met:

- The crane is aligned in horizontal direction.
- All electrical connections have been established.
- All limit switches have been correctly installed and are fully functional.
- The counterweight is installed on the turntable and on the derrick according to the load chart and the erection chart.
- The lattice jib has been assembled according to the load chart and the operating instructions.
- The easy movement of the pendulum on the mechanical relapse support must be checked over the entire swing range.
- All pin connections have been secured.
- No personnel is within the danger zone.
- There are no loose parts on the boom or the lattice jib.
- The hoist rope has been correctly placed in the rope pulleys and is prevented from jumping out with the corresponding rope retaining pins.
- The LICCON overload protection has been set according to the data in the load chart.
- The LICCON overload protection settings have been compared with the current crane configuration.
- In winter, the boom, the lattice jib and their components (limit switches, cable drum, airplane warning light, wind speed sensor,) must be kept free of snow a ice.
- The LICCON overload protection is exceeded.
- The assembly icon **11** is visible on the LICCON monitor.
- The hoist rope is attached to the end section.



WARNING

Falling components!

When erecting the W-boom combination, loose or incorrectly installed components can fall down!

Personnel can be severely injured or killed!

- ▶ It is prohibited for anyone to remain in the danger zone!



DANGER

Tipping lattice jib!

If the easy movement on the pendulum of the mechanical relapse support is **not** checked before erection or **not** reestablished, if necessary, then the mechanical relapse support will not engage in steep lattice jib position. As a result, the lattice jib can tip to the rear!

Personnel can be severely injured or killed!

- ▶ Check the easy movement on the pendulum of the mechanical relapse support before erection!
- ▶ If the pendulum does not move easily: Make the pendulum easy to move!

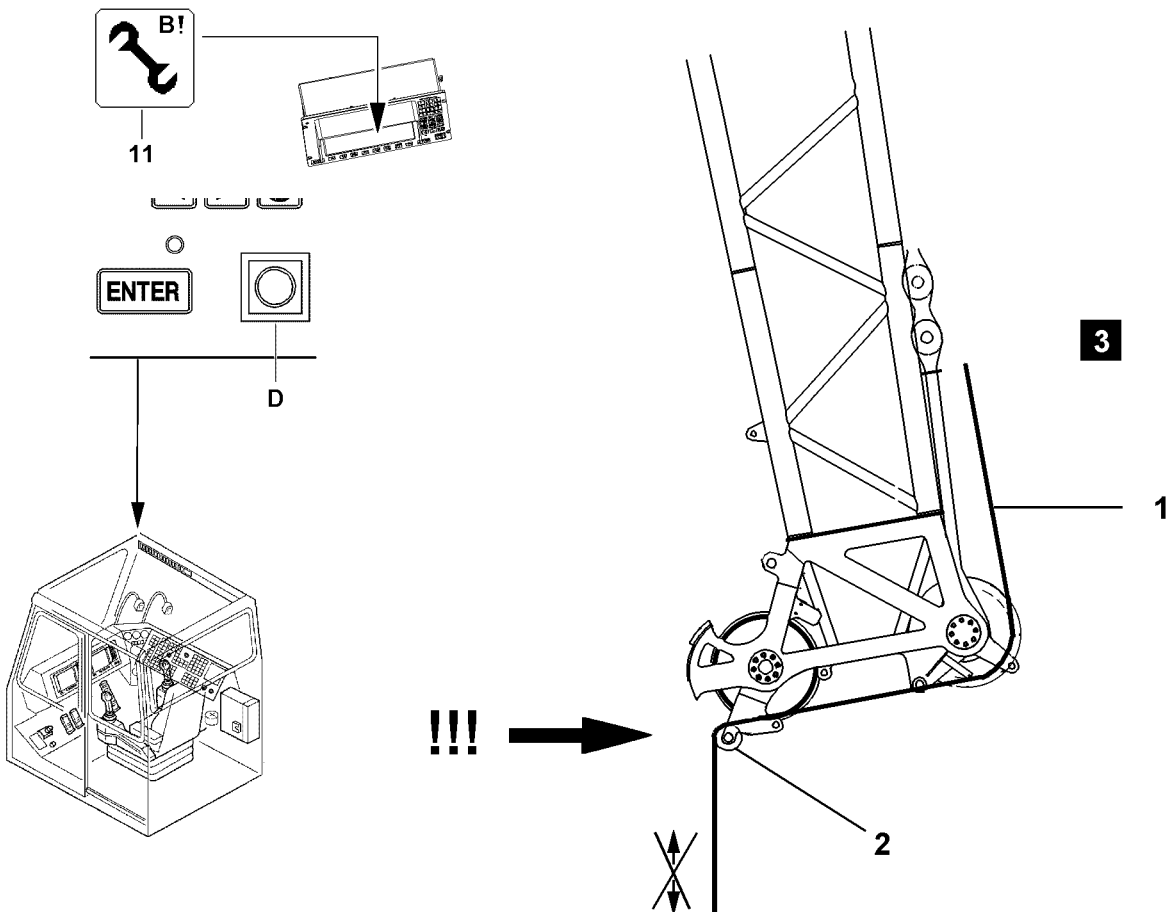
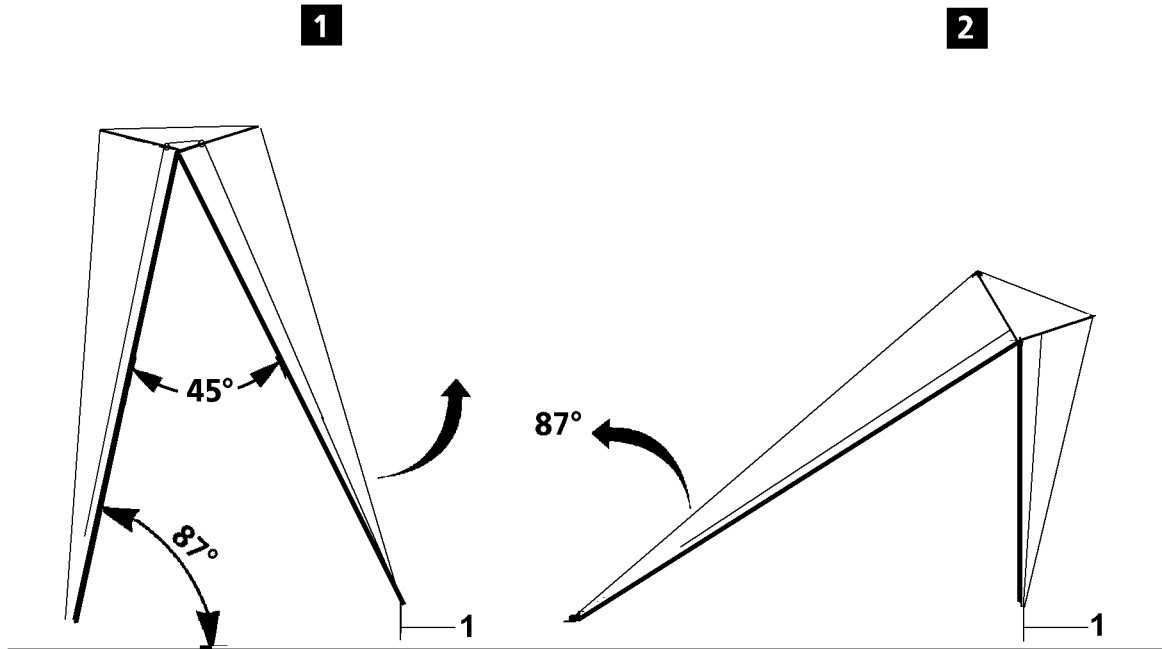

2.8.1 Erection procedure



WARNING

The crane can topple over!

- ▶ Observe the data in the erection and take down charts!
 - ▶ It is not permitted to turn the crane during erection!
 - ▶ The lattice jib must roll on the ground with its entire weight!
 - ▶ Spool the lattice jib control out so that the guy rods sag slightly!
 - ▶ Do not allow slack cable to build up on the control winch!
-



WARNING

Falling hoist rope!

If the hoist rope is not properly attached on the end section before the erection procedure, then it can fall down backward due to its own weight!

Personnel can be severely injured or killed!

- ▶ Attach the hoist rope properly on the end section before the erection procedure!
-
- ▶ Luff up the S-boom and simultaneously spool out the W-control winch to keep the lattice jib with the W-end section placed on the roller cart on the ground. Carry out this procedure until the S-boom and the W-lattice jib form an angle of more / equal to 45° or until the lattice jib has lifted off the ground first, illustration 1, illustration 2.
 - ▶ Remove the roller cart on the W-end section, see Crane operating instructions, chapter 5.15.
 - ▶ Luff the W-lattice jib up to the **lowest** operating position.
 - ▶ Luff up the S-boom until the W-end section lifts off the roller cart.
-

NOTICE

Damage to the hoist rope!

If the hoist rope is reeved on the hook block and changed over the “small guard rollers 2”, then the hoist gear may be moved any longer, since the hoist rope can be damaged by spooling up or out, see illustration 3!

- ▶ Do not spool the hoist rope up or out!
-
- ▶ Loosen the hoist rope on the W-end section and reeve it in properly between the pulley head on the end section and the hook block and secure on the fixed point, see Reeving plan.
 - ▶ Attach the hoist limit switch weight.

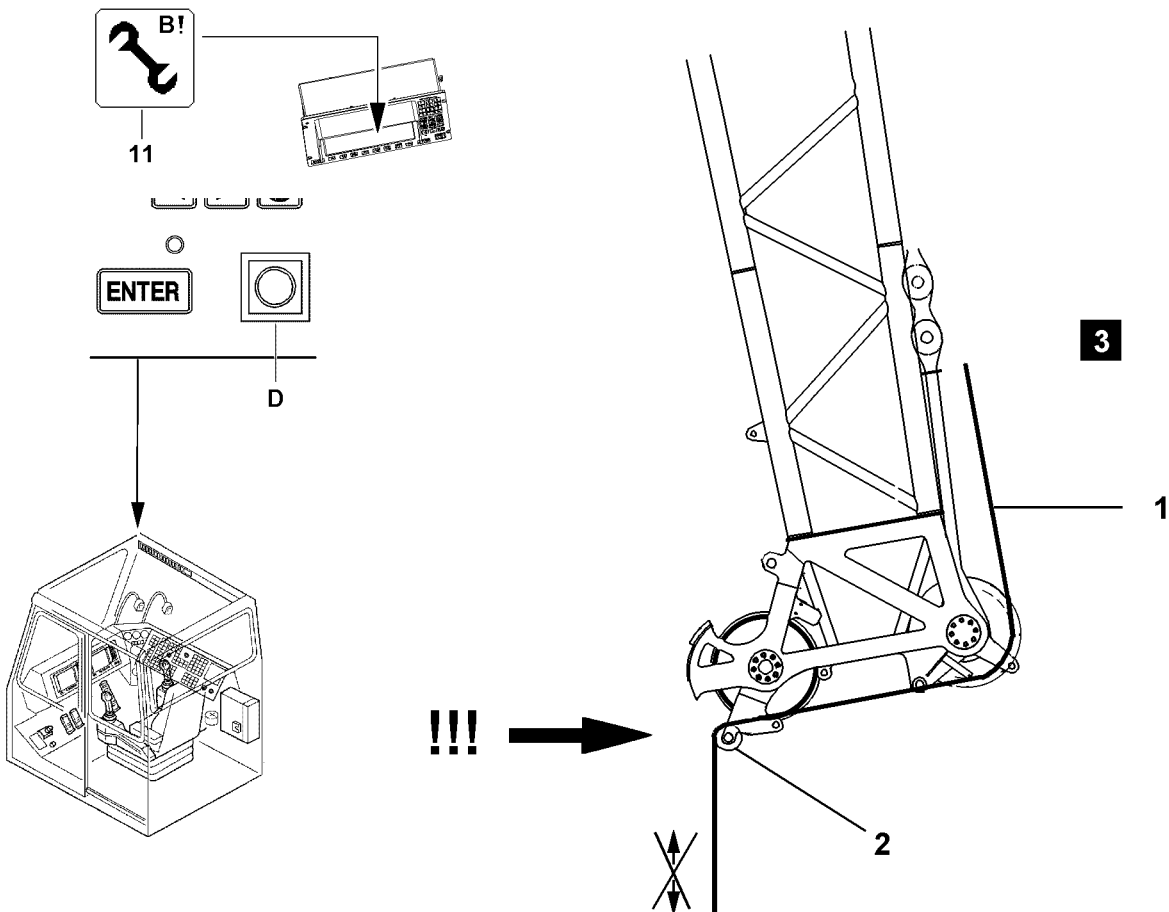
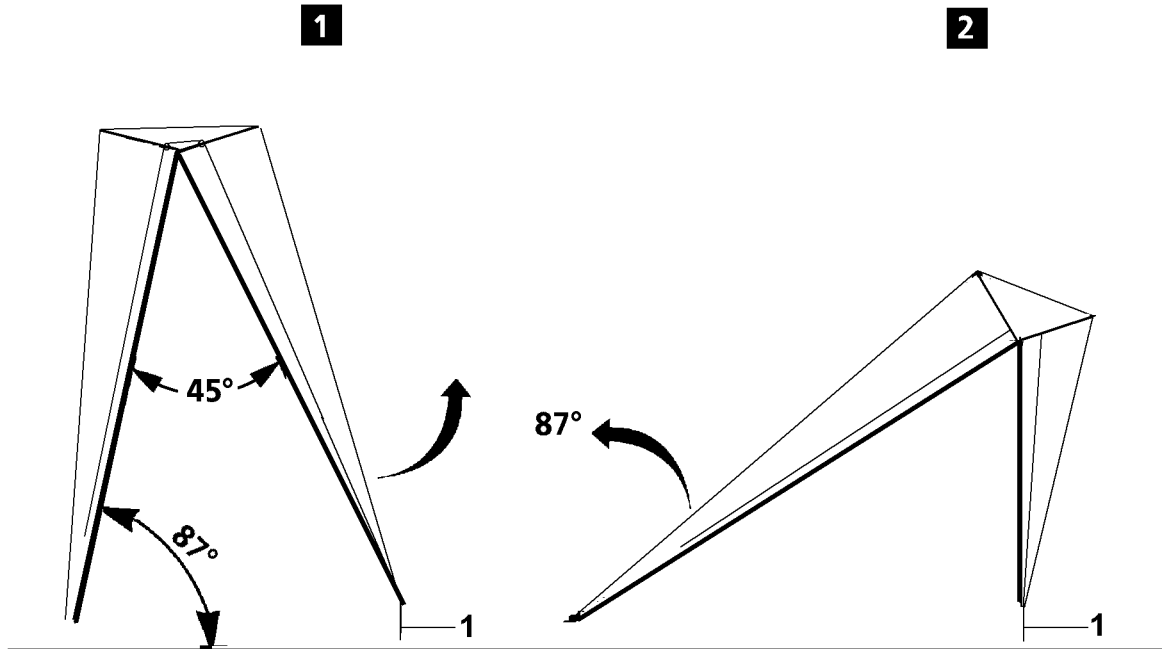

**DANGER**

The crane can topple over!

In crane operation with exceeded LICCON overload protection, the crane can topple over.

- ▶ Personnel can be severely injured or killed!
- ▶ The radii listed in the load chart may not be exceeded or fallen below, even if there is no load on the hook!

**Note**

- ▶ When the lowest operating position of the W-lattice jib is reached, the LICCON overload protection is activated!
- ▶ In the maximum load icon appears a load number in "t" instead of the display "???"!

- ▶ Luff the S-boom up to the lowest operating position.
- ▶ When the operating range of the S-boom is reached:
Luff the S-boom up to the steepest boom position (87 °).
- ▶ Luff the W-lattice jib up to the lowest operating position.
- ▶ When the W-lattice jib has reached the lowest operating position:
Make sure that the assembly icon **11** on the LICCON monitor turns off.

Result:

- The LICCON overload protection is active.

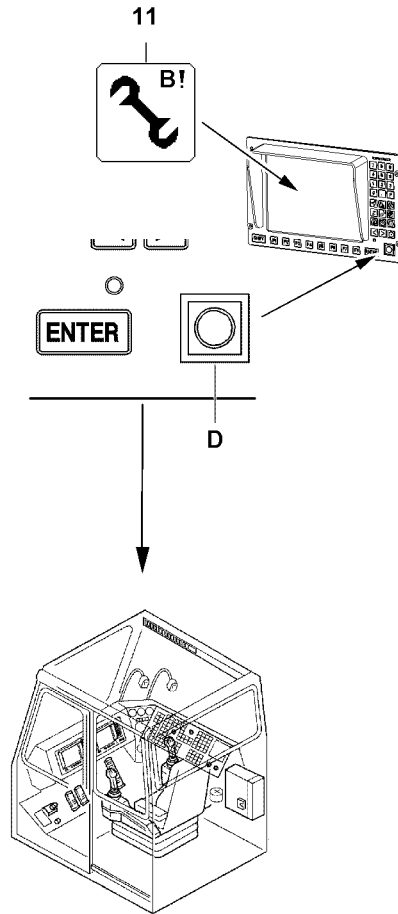

3 Crane operation

Observe the notes for crane operation, see Crane operating instructions, chapter 4.05, chapter 4.08 and chapter 5.01.

Make sure that the following prerequisites are met:

- The LICCON overload protection is active.
- The LICCON overload protection has been set according to the data in the load chart.



DANGER

The crane can topple over!

- ▶ Check the horizontal position of the crane before and during operation!
- ▶ If the crane operator leaves the cab, even for a short time, the operating mode setting must be checked and reset if necessary before resuming crane operation!

3.1 Checking the settings

- ▶ Check the function of the overload protection by running against the operating positions “on top” and “bottom”.
- ▶ Check the hoist limit switch by running against the hoist limit switch weight.
- ▶ Check the function of the limit switches “Lattice jib steep” on the relapse cylinders.

3.2 Setting the boom to 67 °/77 °



Note

- ▶ **Before adjusting the boom to 67 ° or 77 °**, the boom must be erected to the steepest boom position (87 °) and the lattice jib to the steepest operation position!



WARNING

Configuration of the crane!

- ▶ When adjusting the boom to 67 ° and in SDWB-operation, it may be required that the derrick ballast is installed, even without a load on the hook!

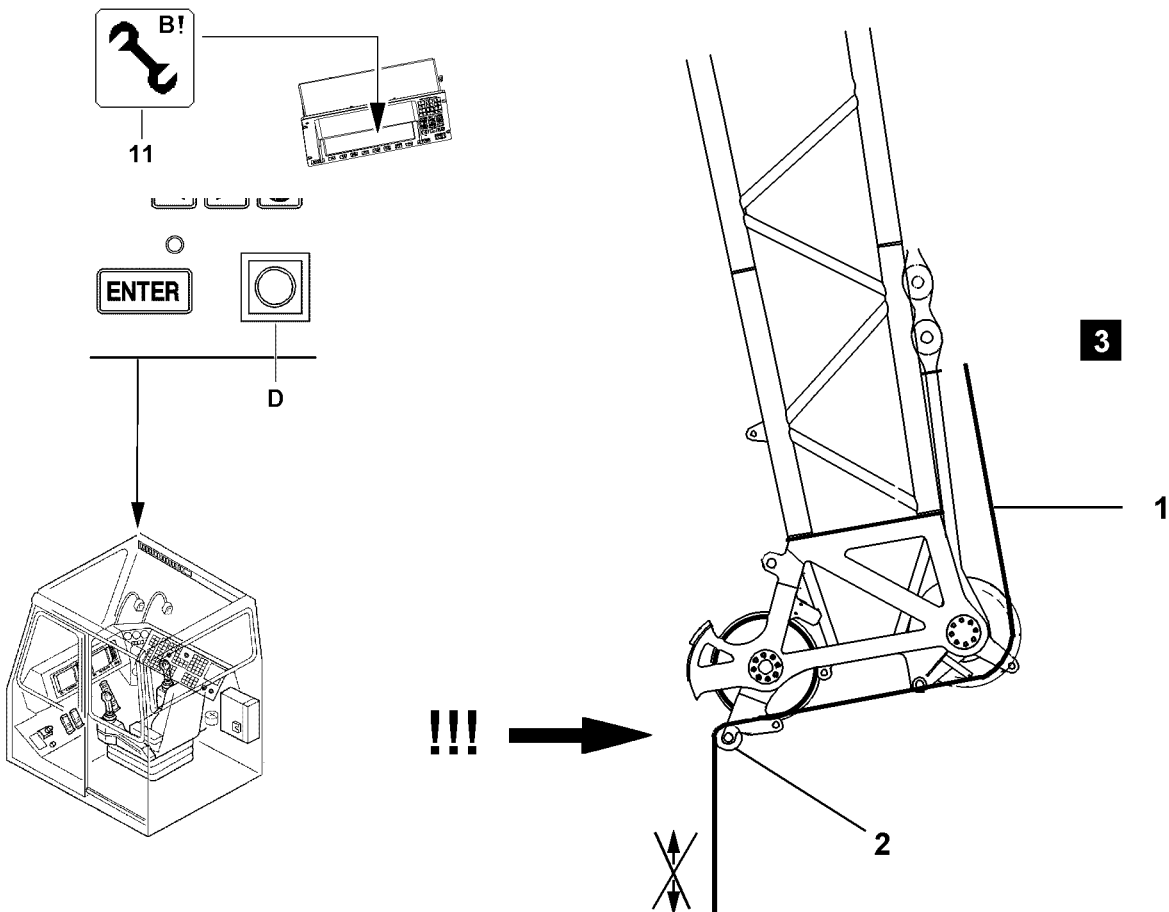
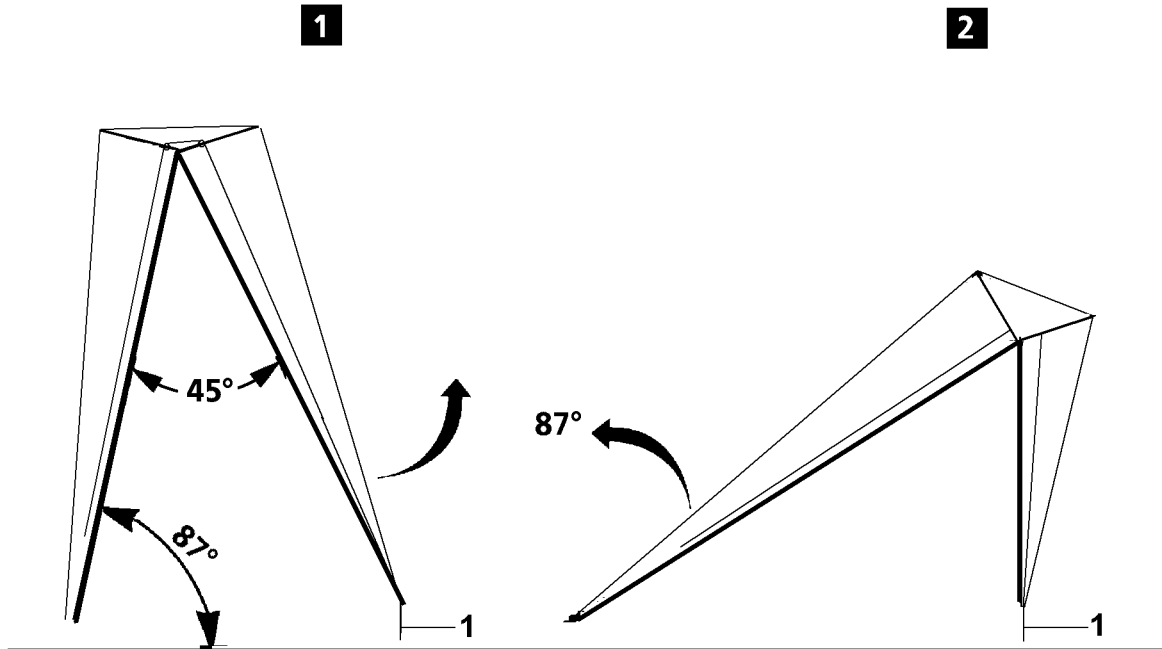

4 Disassembly



WARNING

Risk of falling!

During assembly and disassembly, personnel must be secured with appropriate aids to prevent them from falling! If this is not observed, assembly personnel can fall and suffer life-threatening or fatal injuries!

- ▶ Any work, where there is a danger of falling must be carried out with suitable aids (for example: lifting platforms, scaffoldings, ladders, auxiliary crane)!
- ▶ If the work cannot be carried out with such aids nor from the ground, then the assembly personnel must secure themselves with approved fall arrest systems to avoid falling, see Crane operating instructions chapter 2.04!
- ▶ If railings are present on the components, then they must be brought into the corresponding position and secured for assembly / disassembly work!
- ▶ Step on aids and fall protection equipment only with clean shoes!
- ▶ Keep aids and fall protection equipment clean and free from snow and ice!
- ▶ During all assembly and disassembly work, maintenance work and inspections, travel or crane operation is prohibited!



WARNING

Falling components!

If unsecured or non-supported components are assembled or disassembled, they can fall down. Personnel can be killed or seriously injured!

- ▶ During pinning and unpinning of the lattice sections, it is prohibited for anyone to remain **under** or **on** the components as well as within the entire danger zone!
- ▶ Support the boom and components before pinning / unpinning!
- ▶ Pin or unpin both pins laying in a horizontal, i.e. **left** and **right**!
- ▶ Secure the pins in the bearing points and in the receptacles!
- ▶ Do not disengage the auxiliary crane until each component is pinned on and secured!
- ▶ It is prohibited to lean a ladder against the component being disassembled!



WARNING

Danger of impact / crushing!

When installing / removing counterweight components with the auxiliary crane, crane components can start to swing back and forth!

When lifting / lowering and positioning crane components, there is an increased danger of impacts / crushing!

Personnel can be caught and severely injured or killed!

- ▶ Make sure that personnel cannot be caught by components!
- ▶ Make sure that the crane is aligned in horizontal position to avoid the support beams from swinging by themselves!
- ▶ When working in danger zones: Use aids to protect limbs!
- ▶ Guide components with suitable aids to minimize oscillation!

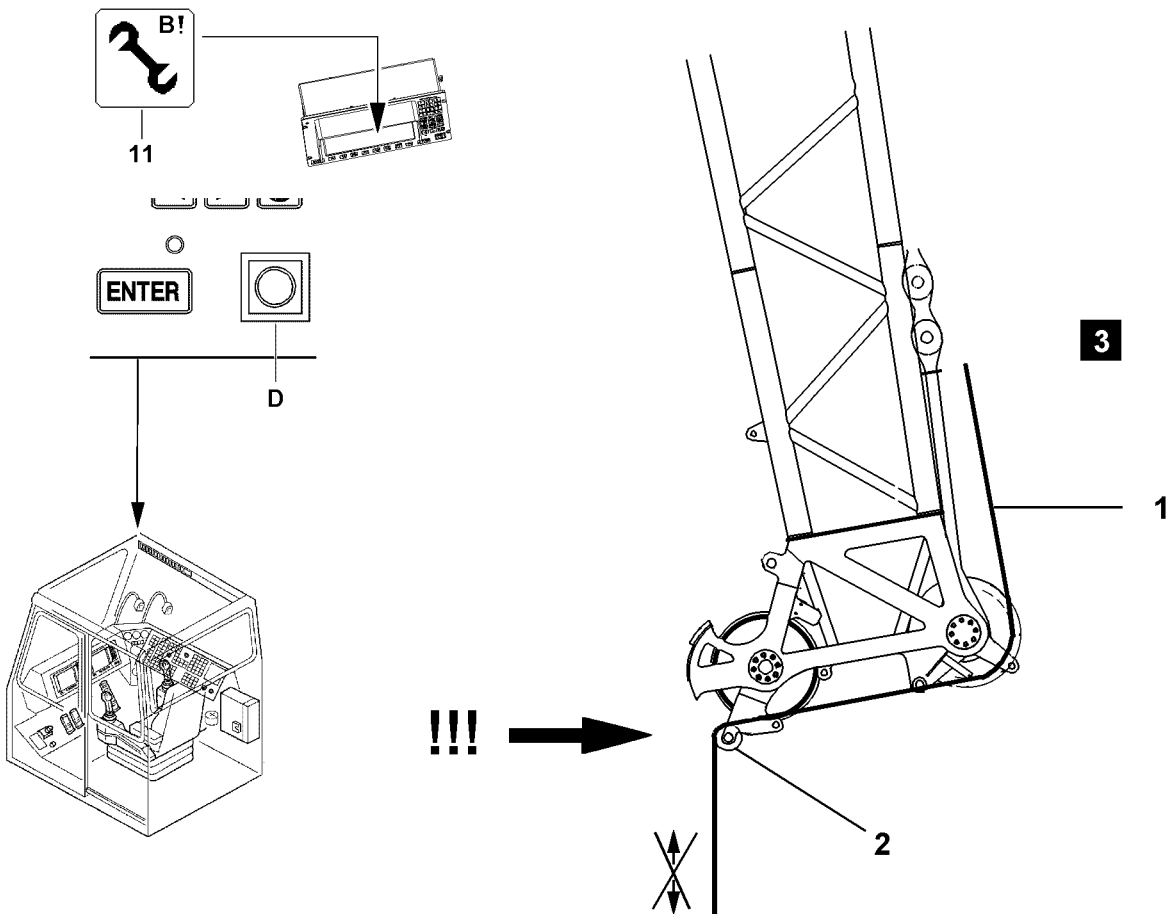
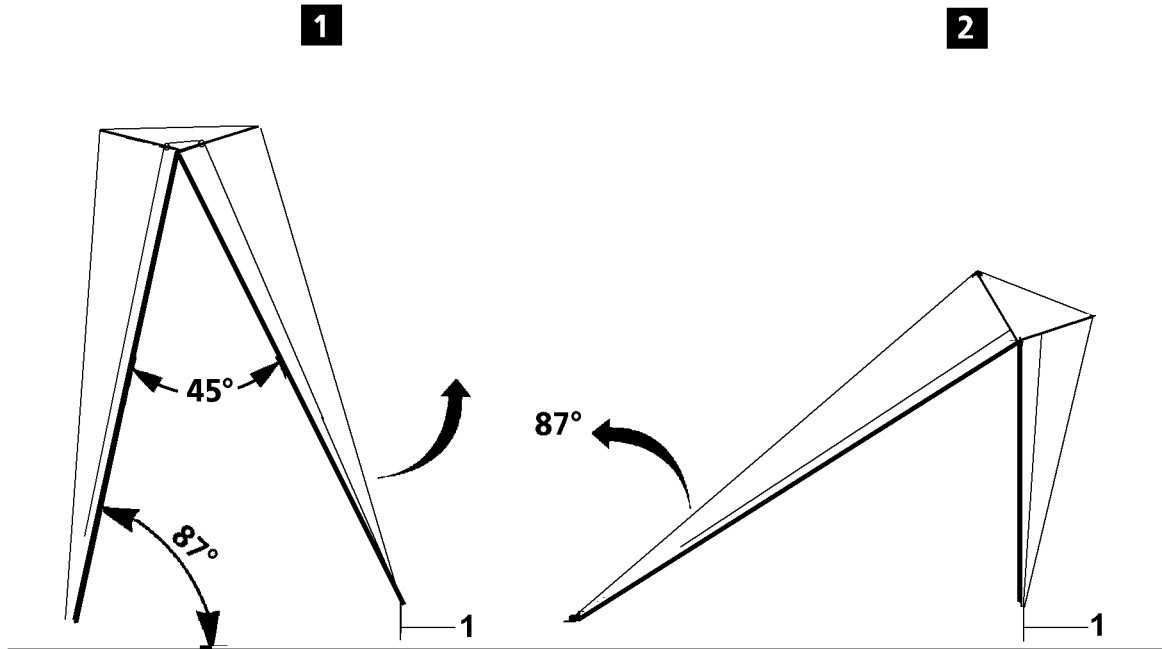

4.1 Placing the boom down



WARNING

Risk of accident!

If the following instructions are not observed, personnel can be severely injured or killed!

- ▶ The boom combinations must be assembled according to the separately supplied rod and assembly plans!
- ▶ Depending on the condition of the ground, the boom and the lattice sections must be supported from below for the assembly of the boom!
- ▶ Observe the safety technical notes, see Crane operating instructions, chapter 5.01!
- ▶ Observe the data in the erection and take down charts!

Make sure that the following prerequisites are met:

- The S-boom is in the steepest position, 87 °.
- The hook block is approx. 5 m below the pulley head of the lattice jib.



Note

- ▶ The luff down movement is turned off as soon as the lowest operating position is reached!
- ▶ When the lowest operating position of the W-lattice jib is reached, the load display in the maximum load icon turns off and instead of the load display appears the display “???”!
- ▶ In the crane operating screen appear alarm functions!

- ▶ Luff the W-lattice jib down to the “lowest” operating position.

Result:

- The luff down movement is turned off.
- The “STOP” icon appears on the LICCON monitor.
- The horn icon appears on the LICCON monitor.



WARNING

Assembly with turned on set up key!

When the set up key is engaged, the LICCON overload protection is exceeded!

In the event of deliberate improper use, the crane could collapse, the boom can break off or the crane can topple over!

Personnel can be killed!

This could result in high property damage!

- ▶ The set up key **D** may only be actuated by persons who know the effects of a bypass!
- ▶ Press the set up key **D** only when the set up status was correctly entered into the LICCON computer system!
- ▶ Observe the erection / take down charts!
- ▶ Crane operation with the set up key **D** turned on is strictly prohibited!

- ▶ When the W-lattice jib has reached the “lowest” operating position:
Turn the set up key **D** to the right.

Result:

- The LICCON overload protection is deactivated.
- The assembly icon **11** appears on the LICCON monitor.

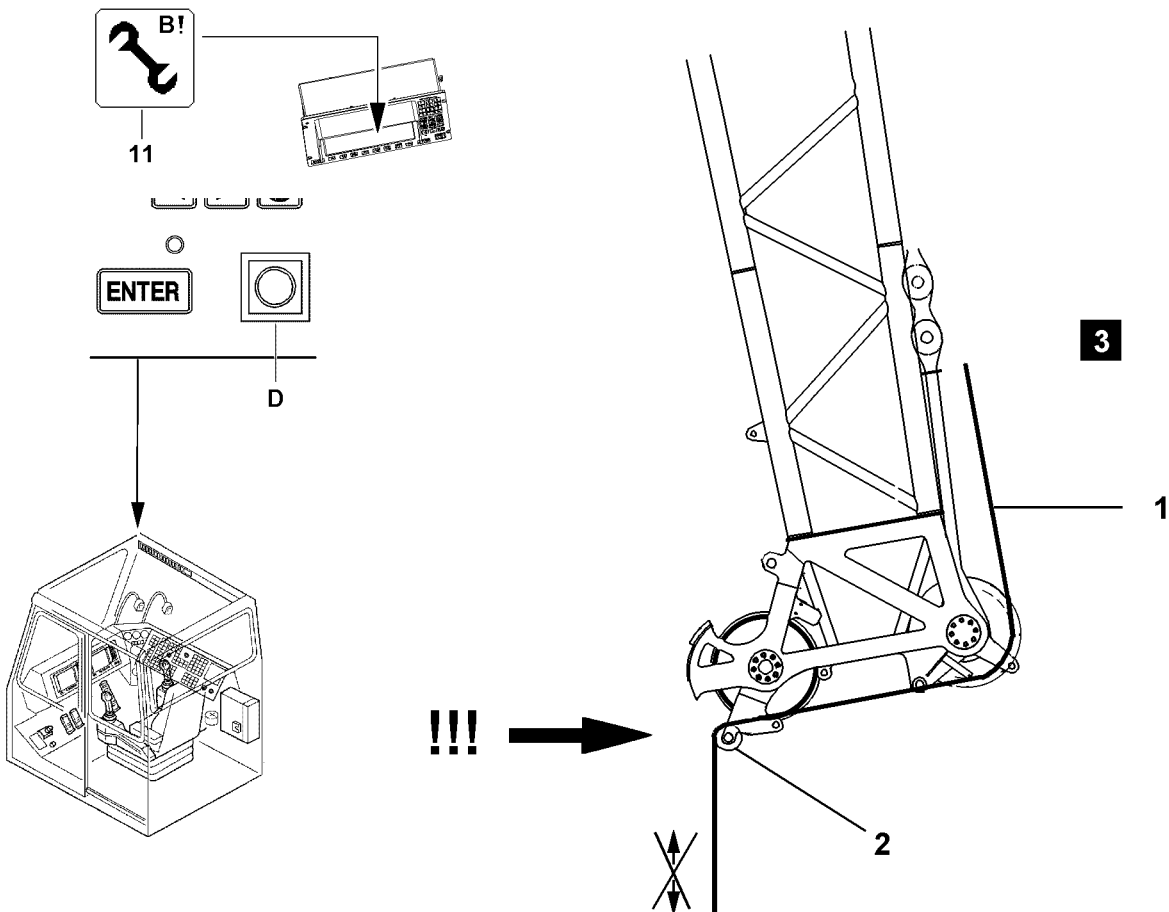
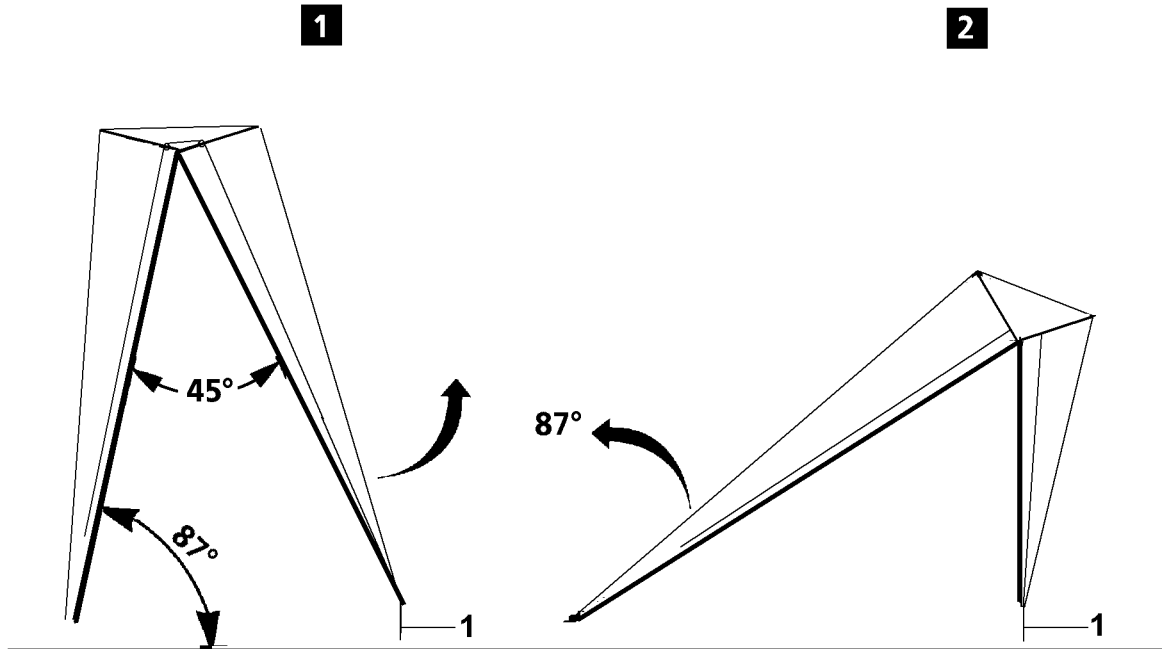

B111368

- ▶ Continue to luff down the W-lattice jib until an angle of approximately 45 ° is reached between the S-boom and the W-lattice jib.

When the angle is reached, "Lattice jib bottom" is shut off, the indicator light lights up.

- ▶ Luff the S-boom down.



CAUTION

Damage to crane!

- ▶ Luff the S-boom down and simultaneously spool the hoist winch out to prevent a collision between the hook block and the W-end section!

- ▶ Luff the S-boom down until the hook block touches the ground.
- ▶ Remove the hoist limit switch weight and unreeve the hook block.
- ▶ Luff the S-boom down until the W-end section is laying with the receptacle studs in the receptacles on the pulley cart.

NOTICE

Damage to the hoist rope!

If the hoist rope is reeved on the hook block and changed over the "small guard rollers 2", then the hoist gear may be moved any longer, since the hoist rope can be damaged by spooling up or out, see illustration 3!

- ▶ Do not spool the hoist rope up or out!
- ▶ Assemble the W-end section on pulley cart, see Crane operating instructions, chapter 5.15.



DANGER

The crane can topple over!

- ▶ Do not pull the hook block along on the ground!
- ▶ The lattice jib must roll on the ground with its entire weight!
- ▶ Do not allow slack cable to build up on the control winch!
- ▶ Continue to luff down the S-boom and simultaneously spool the W-lattice jib control out so that the guy rods sag slightly.
- ▶ Luff the S-boom down until the S-boom head is laying on the support on the ground.



DANGER

Risk of accident!

- ▶ Make sure that no personnel is within the danger zone!
- ▶ Secure the hoist rope with the auxiliary rope and pull it back slowly over the rope pulleys in the WA-brackets and lower it toward the S-end section!
- ▶ Remove the hoist rope.

4.2 Disconnecting the electrical connections on the D-boom

Make sure that the following prerequisite is met:

- The boom has been placed down.
- ▶ Disconnect the electrical connections.

NOTICE

Damage to cable drum or cable!

If the cable of the cable drum is not properly spooled up on the cable drum after unplugging, then the cable drum or the cable can be significantly damaged!

- ▶ Spool the cable drum up after unplugging!
-
- ▶ Spool the cable drum up and secure it to prevent inadvertent spooling out.
 - ▶ Make sure that all electrical connections on the boom have been disconnected.

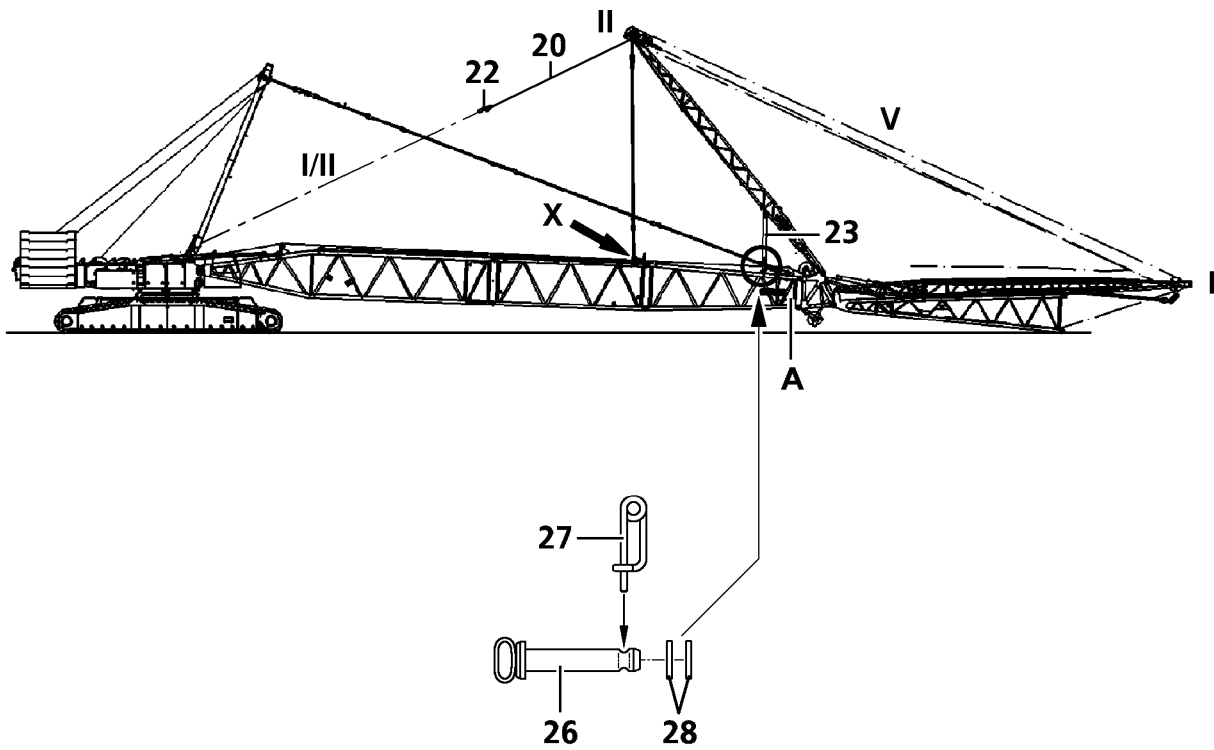
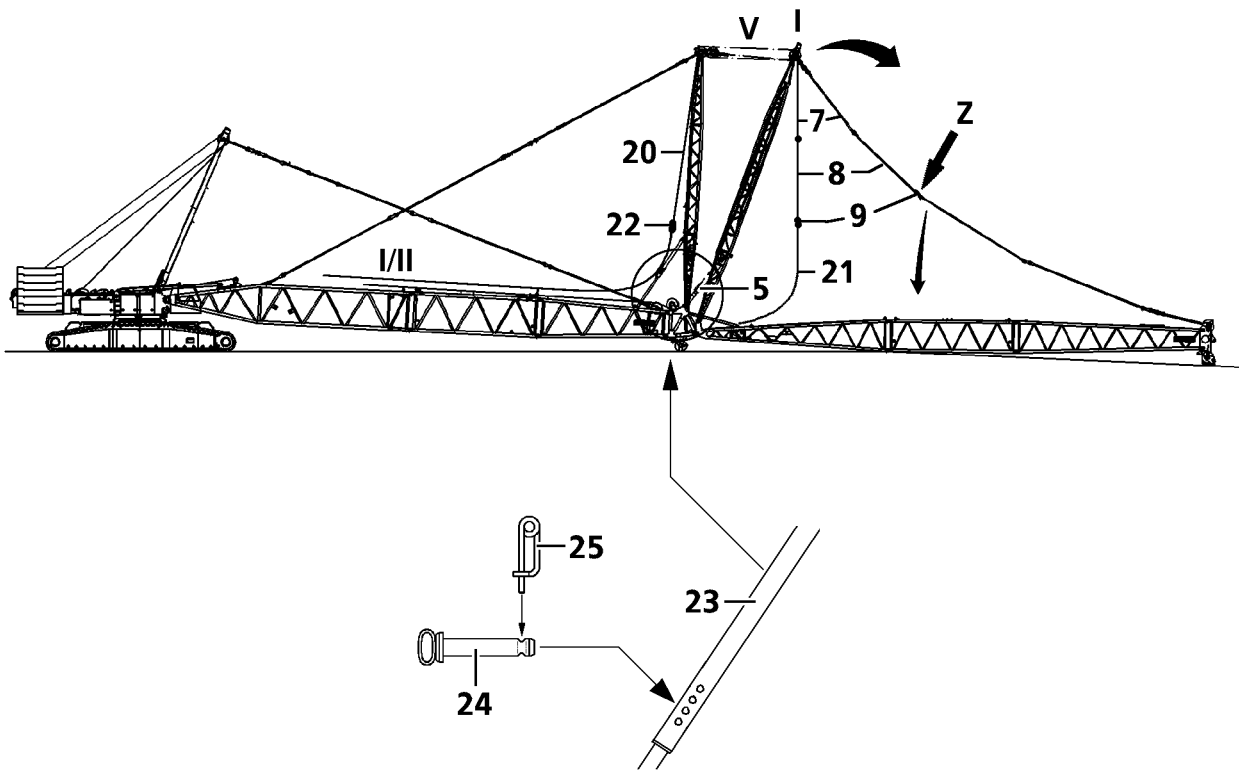

4.3 Disassembling the guy rods

- ▶ Lower the WA-bracket I to the front: Spool the W-control winch **V** out.
- ▶ Unpin the guy rods at the connector brackets **9**: Remove the spring retainer **50** and unpin the pin **49**, point **Z**.
- ▶ Attach the guy rods from the WA-bracket I on the tackle ropes **21** and place the remaining guy rods on the lattice sections and secure.



WARNING

Lattice jib can fold down!

If the following notes are not observed, the lattice jib can suddenly fold down during unpinning!

Personnel can be severely injured or killed!

- ▶ The pivot section must be held by an auxiliary crane before unpinning the connector pins or it must be supported with suitable and stable materials!
- ▶ It is prohibited for anyone to remain under the lattice jib which is to be disassembled!

- ▶ Disassembling the W-lattice jib.
- ▶ Unpin the pin between the pivot section and the intermediate section.

NOTICE

Damage of relapse supports!

By pulling the WA-bracket II up, significant damage can occur due on the W-relapse support **5** to a defective or not connected limit switch- due to the block position!

- ▶ The electrical connections to the limit switches on the W-relapse supports have been established!
- ▶ "Spool up winch 5" must turn off when the limit switches on the W-relapse supports are actuated!
- ▶ Disengage the assembly rope **20** on the WA-bracket and hang the hoist rope of winch 1 / winch 2 into the lock **22**.
- ▶ Spool the W-control winch **V** up and pull the WA-bracket I up until the guying from the WA-bracket II to the S-pivot section is tensioned due to the counterpressure of the relapse cylinder **5**.

Result:

- The relapse support **23** can be unpinned.
- ▶ Remove spring retainer **25** and socket pin **24**.
- ▶ Lower the WA-bracket I until it rests on the W-pivot section.
- ▶ Pull the WA-bracket II back by spooling up the hoist winch and spooling the W-control winch (winch 5) out simultaneously and unpin the guy rods from the WA-bracket II to the S-pivot section on point **X**.
- ▶ Place the guy rods on the lattice sections and secure.

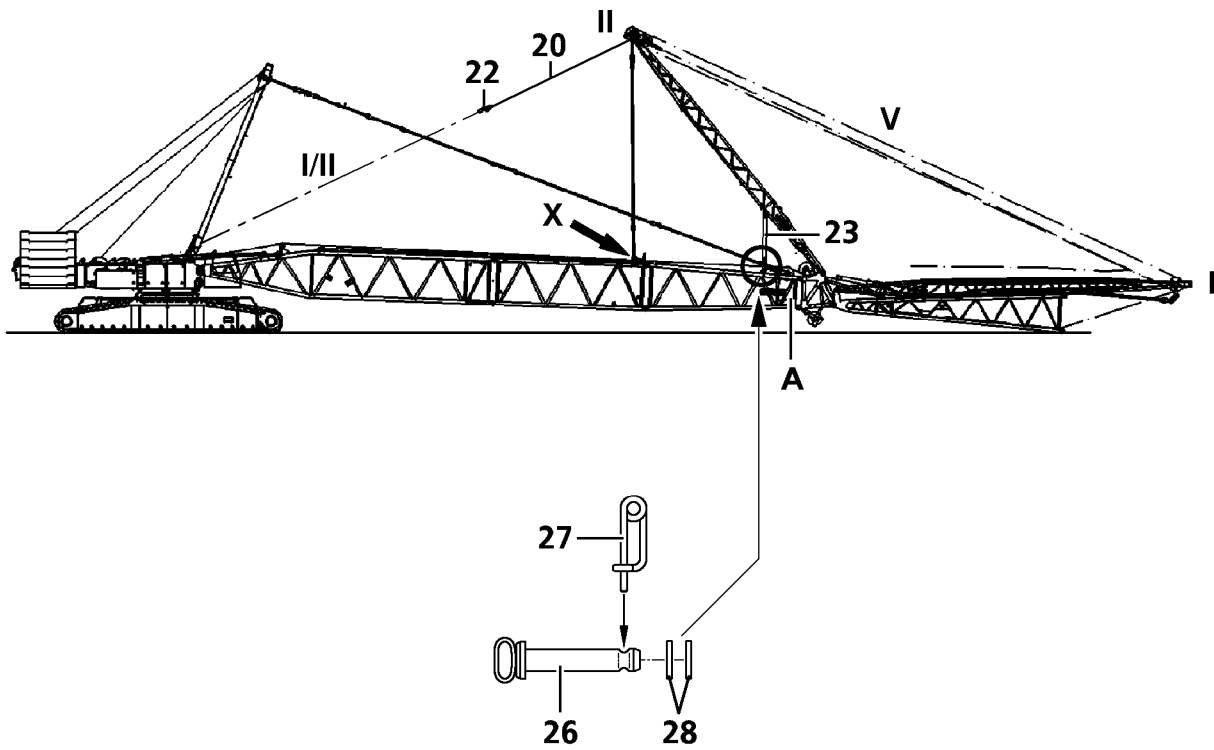
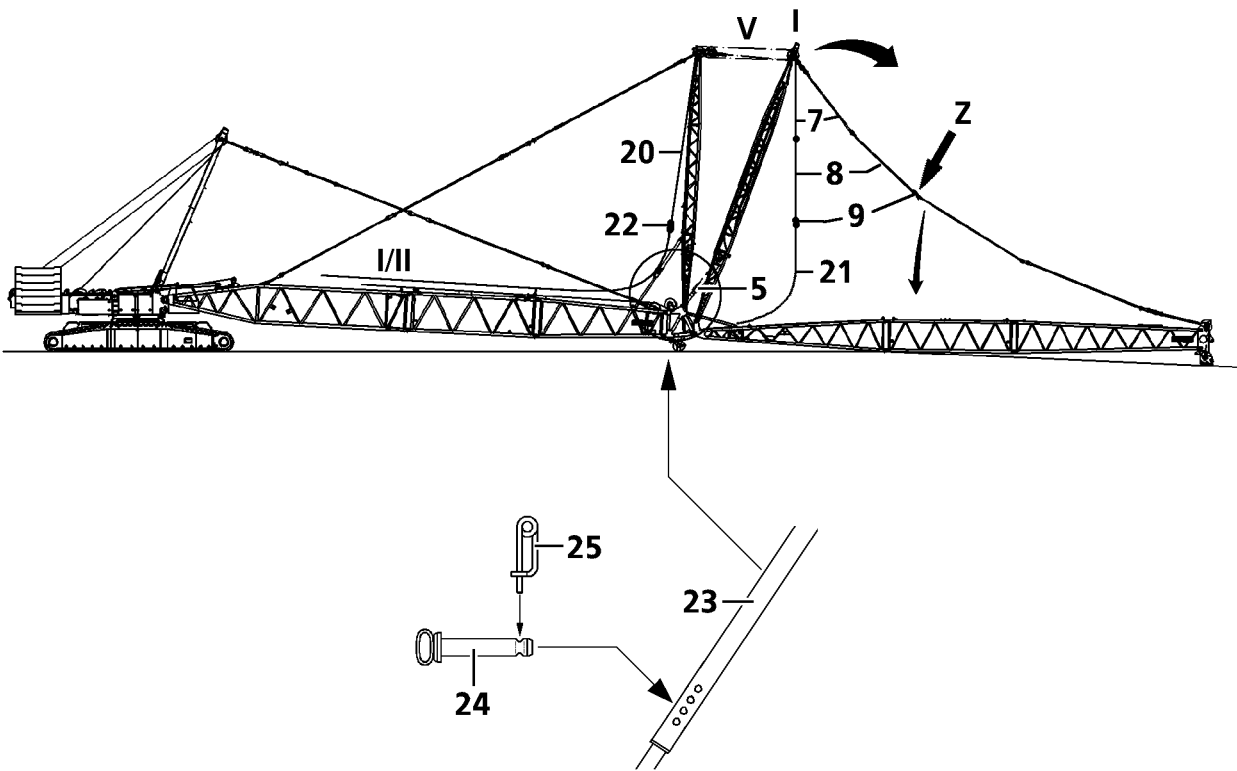

NOTICE

Damage of socket pins **24** and the WA-bracket II!

By “pulling the WA bracket II to the rear”, the socket pin **24** can be sheared off and the components of the WA-bracket II can be damaged!

▶ Unpin the socket pin **24** before “pulling the WA-bracket II back”!

▶ Spool out the hoist winch and spool the W-control winch (winch 5) up at the same time.

Result:

– The WA-bracket II is pulled up.

▶ Actuate the spool out hoist winch and spool up the W-control winch (winch 5) until the WA-bracket II is in vertical position.

▶ Unpin the WA-relapse support **23** on the S-adapter **A**.

▶ Remove the pin **26**, spring retainer **27** and washers **28**.

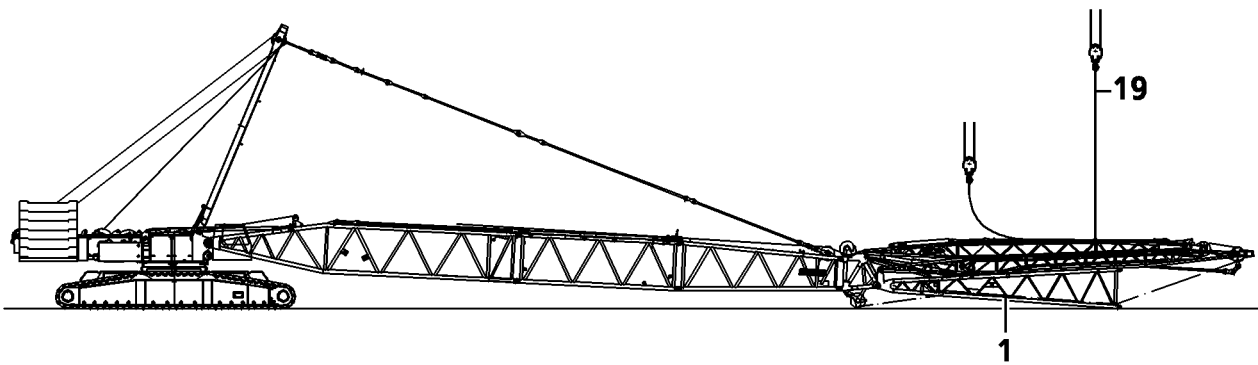
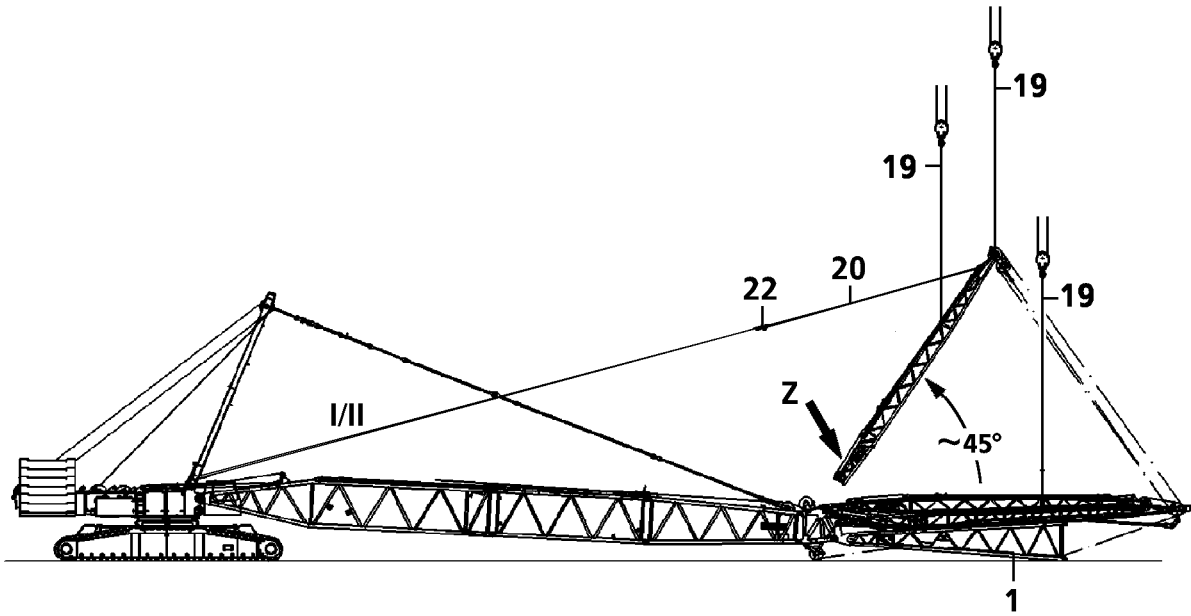

4.4 Placing the WA-bracket II down

- ▶ Attach the assembly rope **19** on the WA-bracket II.



WARNING

Danger due to folding down of the WA-bracket!

If the WA-bracket II is not held with the auxiliary crane during take down, from approx. 45 ° to the horizontal, then the WA-bracket can fold forward by itself!

Personnel can be severely injured or killed!

- ▶ Attach the WA-bracket II on the auxiliary crane (assembly rope **19**)!
 - ▶ Lower the WA-bracket II slowly!
-
- ▶ Pull the WA-bracket II forward by spooling up winch 5 and simultaneously spooling out the hoist winch until approx. 45 ° to the horizontal.

NOTICE

Danger of slack rope formation!

- ▶ Slowly spool up the control rope when placing the WA-bracket II down!
 - ▶ Hold the control rope tight when spooling up!
-
- ▶ Lower the WA-bracket II until it is placed on the WA-bracket I.
 - ▶ Disengage the hoist rope on the lock **22** of the assembly rope **20** and engage the assembly rope **20** on the WA-bracket II at point **Z**.
 - ▶ Remove the assembly rope **19** on the auxiliary crane and attach on the WA-bracket II.
 - ▶ Unreeve the control rope and reeve in the auxiliary rope for the reeving at the same time.

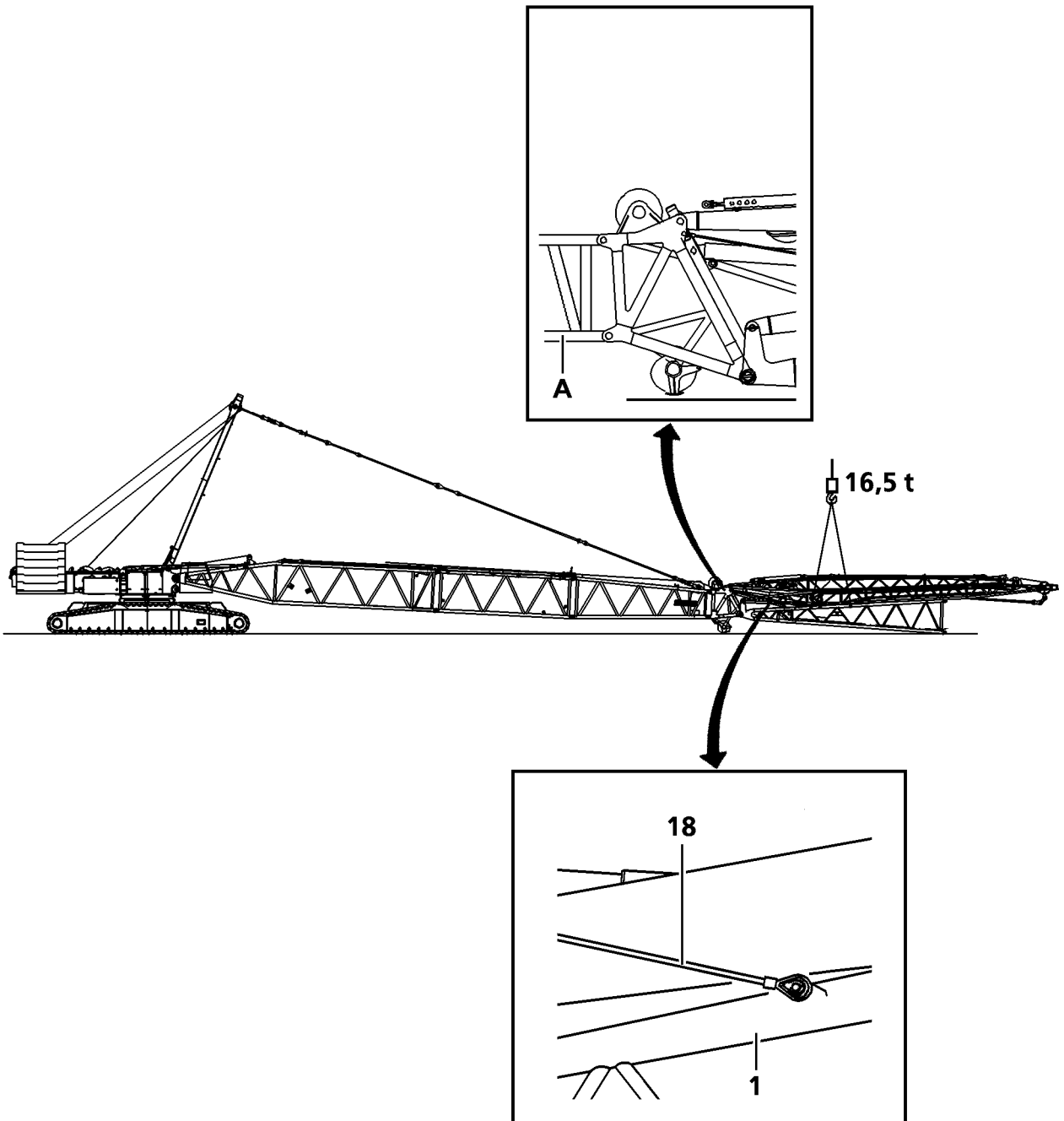

4.5 Unpinning the assembly unit on the S-boom

- ▶ Pin and secure the retaining rope **18** on the W-pivot section.
- ▶ Take on the W-assembly unit with the auxiliary crane on the attachment points on the W-pivot section.



Note

- ▶ The total weight of the assembly unit is approx. 16.5 t!
-



WARNING

Mortal danger if the fold in head folds away!

If the following notes are not observed, the fold in head can fold away with the WA-bracket I and the WA-bracket II!

Personnel can be severely injured or killed!

- ▶ Before unpinning the assembly unit, it must be held with the auxiliary crane!
 - ▶ The retaining rope **18** must be pinned and secured on the pivot section!
 - ▶ It is prohibited for anyone to remain under the assembly unit!
-

- ▶ Unpin the W-assembly unit on the S-adapter **A** with the pin pulling device on top and bottom.

1 Safety guidelines



WARNING

Risk of falling!

During assembly / disassembly work, personnel must be secured with appropriate aids to prevent them from falling. If this is not observed, assembly personnel can fall and suffer life-threatening or fatal injuries!

- ▶ Any work, where there is a danger of falling must be carried out with suitable aids (for example lifting platform, scaffolding, ladder, auxiliary crane)!
- ▶ If the work cannot be carried out with such aids nor from the ground, then the assembly personnel must secure themselves with approved fall arrest systems to avoid falling, see Crane operating instructions, chapter 2.04!
- ▶ Approved fall arrest systems must be hung into the respective fastening points on the crane, see Crane operating instructions, chapter 2.06!
- ▶ If railings are present on the components, then they must be brought into the corresponding position and secured for assembly / disassembly work!
- ▶ Step on aids and fall protection equipment only with clean shoes!
- ▶ Keep aids and fall protection equipment clean and free from snow and ice!
- ▶ During all assembly and disassembly work, maintenance work and inspections, travel and crane operation is prohibited!



WARNING

Falling components!

If unsecured or non-supported components are installed or removed, they can fall down!

Personnel can be severely injured or killed!

- ▶ During pinning and unpinning of the lattice sections, it is prohibited for anyone to remain **under** or **on** the components as well as within the entire danger zone!
- ▶ Support the boom and components before pinning / unpinning!
- ▶ Pin or unpin both pins that lie in one horizontal level, i.e. **left** and **right**!
- ▶ Secure the pins in the bearing points and in the receptacles!
- ▶ Do not disengage the auxiliary crane until each component is pinned on and secured!
- ▶ It is prohibited to lean a ladder against the component being disassembled!



WARNING

Danger of impact / crushing!

When installing / removing crane components with the auxiliary crane, crane components can start to swing back and forth!

When lifting / lowering and positioning crane components, there is an increased danger of impacts / crushing!

Personnel can be caught and severely injured or killed as a result!

- ▶ Make sure that personnel cannot be caught by components!
- ▶ When working in danger zones: Use aids to protect limbs!
- ▶ Guide components with suitable aids to minimize oscillation!

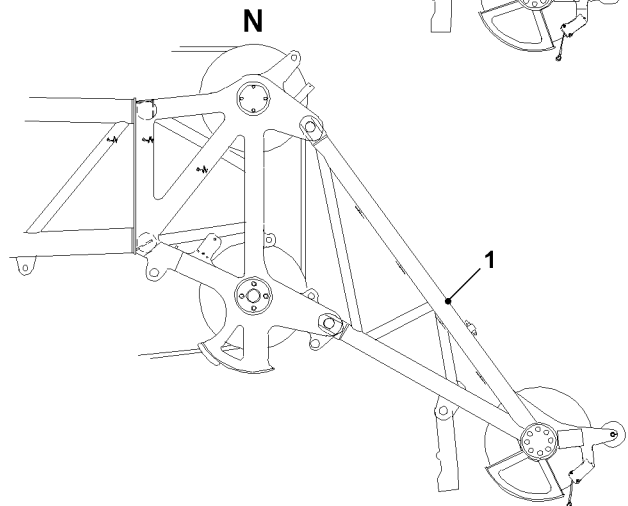
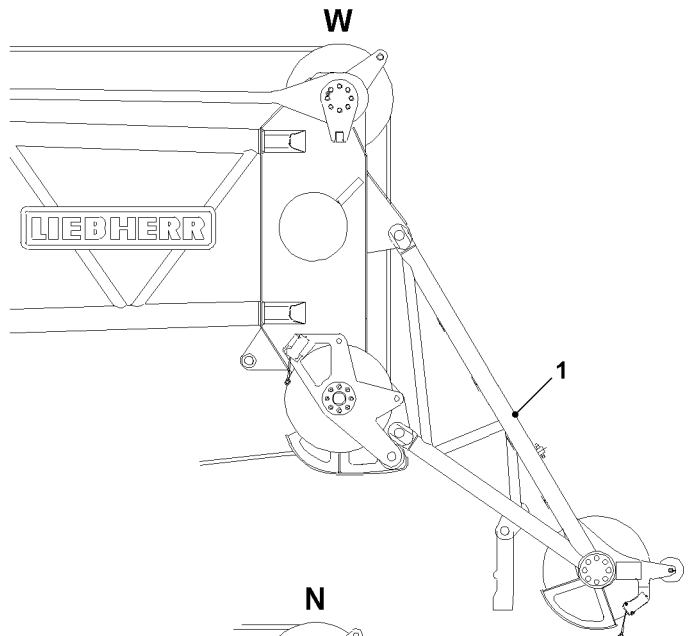
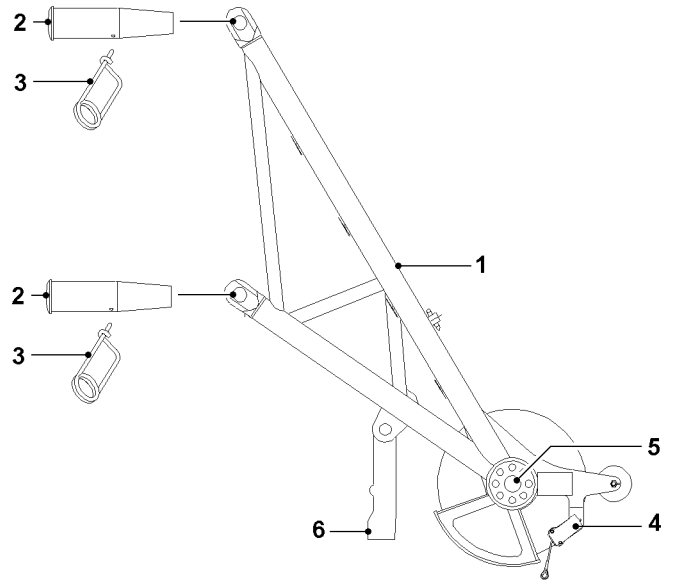
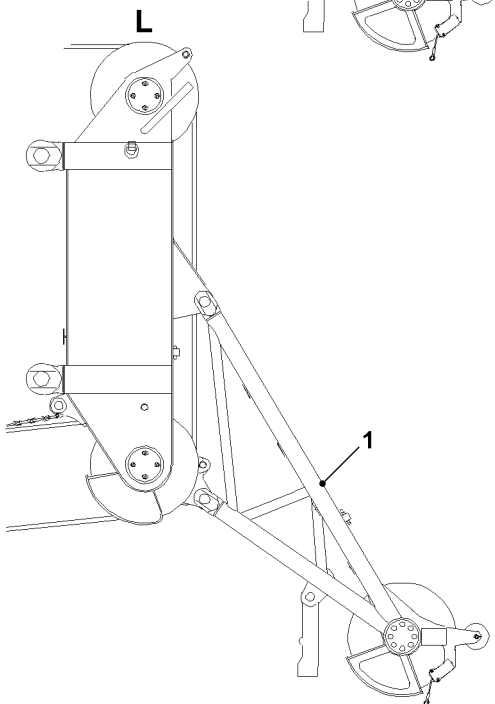
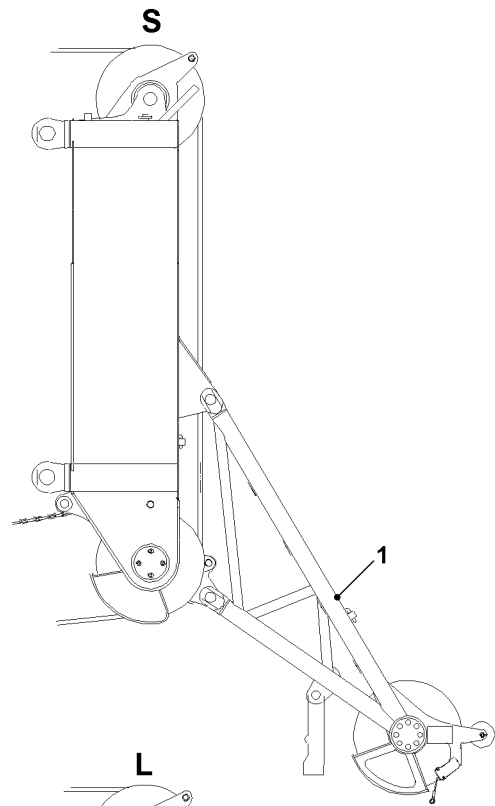

B104694

2 Boom nose 36 t (H)

2.1 Component overview boom nose

The 36 t boom nose (H) 1 can be installed and operated on various boom end sections (S-, L-, W- and N-), see illustration.

Position	Description	Weight
1	Boom nose, 36 t (H)	0.45 t
2	Pin	
3	Spring retainer	
4	Hoist limit switch	
5	Axle for erection roller cart	
6	Rope fixed point (rope lock)	

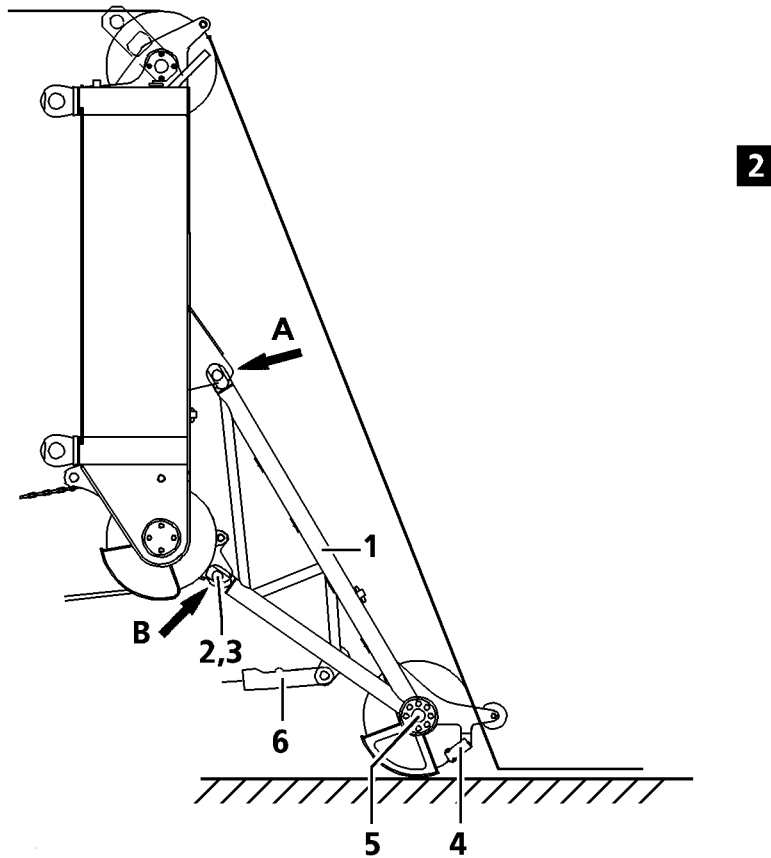
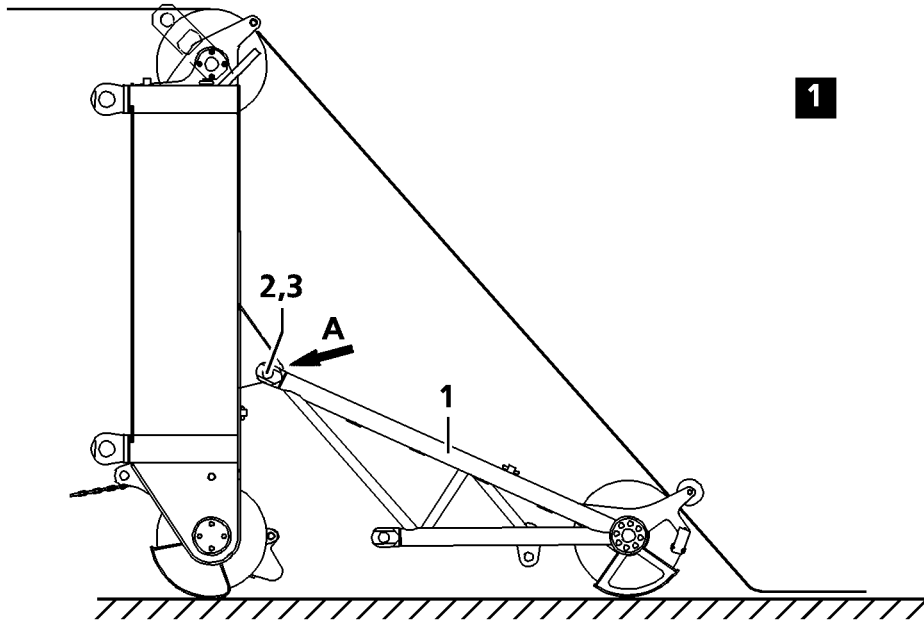

2.2 Assembling the boom nose 36 t (H)

Make sure that the following prerequisites are met:

- The crane is aligned in horizontal direction.
- The counterweight has been installed on the turntable according to the load chart.
- The derrick ballast is placed on the suspended ballast or the ballast trailer according to the load chart.
- The LICCON overload protection has been set according to the data in the load chart.
- The mechanical auxiliary support is installed on the crane.
- An auxiliary crane is available.

2.2.1 Assembling the boom nose 36 t (H) on the S-/L-boom head



Note

- ▶ The assembly procedure is described on the example of the S-boom head.
-

Make sure that the following prerequisite is met:

- The S-end section is laying on the ground.
- ▶ Hang the boom nose **1** onto the auxiliary crane.
- ▶ Position the boom nose **1** with the auxiliary crane on the S-end section in such a way that the pin bores align “on top” (point **A**), see illustration 1.
- ▶ When the pin bores align “on top”:
Insert the pin **2** on the end section “on top” and secure with spring retainer **3**.
- ▶ Lower the boom nose **1** to the ground with the auxiliary crane.
- ▶ Remove the auxiliary crane.
- ▶ Luff the boom up until the boom nose **1** touches the S-end section “on the bottom”, see illustration 2.
- ▶ When the pin bores align “on the bottom”:
Insert the pin **2** on the S-end section “on the bottom” (point **B**) and secure with spring retainer **3**.

NOTICE

Damage of boom nose!

By placing the boom system down with fully installed boom nose, significant damage can occur on the boom nose due to the weight of the boom.

- ▶ Luff the boom with installed boom nose down only to the point where the boom nose **1** does not touch the ground.
-



Note

- ▶ The hoist rope must be pulled over the rope pulleys and reeved, see Reeving plan!
 - ▶ Reeve the hook block properly and attach the hoist limit switch weight.
-

1

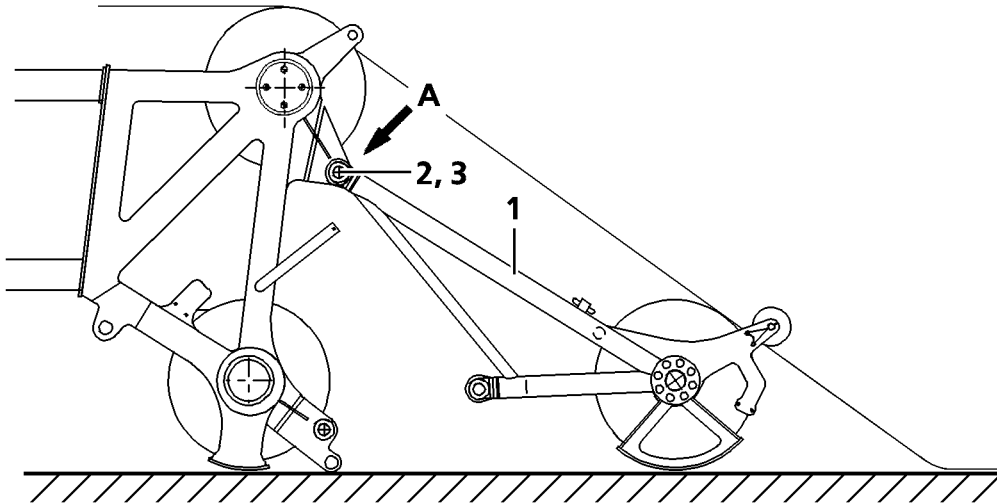

2

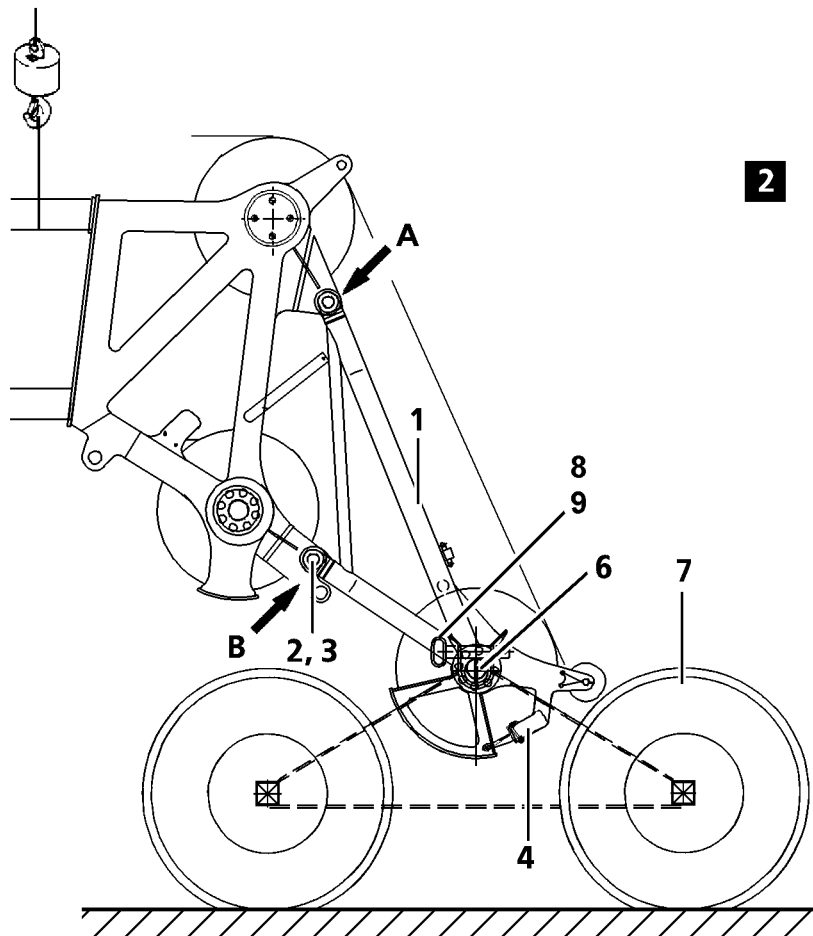

2.2.2 Assembling the boom nose 36 t (H) on the W-/N-boom head



Note

- ▶ The assembly procedure is described on the example of the W-boom head.

Make sure that the following prerequisite is met:

- The W-end section is laying on the ground.
- ▶ Hang the boom nose **1** onto the auxiliary crane.
- ▶ Position the boom nose **1** with the auxiliary crane on the W-end section in such a way that the pin bores align “on top” (point **A**), see illustration **1**.
- ▶ When the pin bores align “on top”:
Insert the pin **2** on the W-end section “on top” and secure with spring retainer **3**.
- ▶ Lower the boom nose **1** to the ground with the auxiliary crane.
- ▶ Remove the auxiliary crane.
- ▶ Lift the W-end section with the auxiliary crane until the boom nose touches the end section “on the bottom”, see illustration **2**.
- ▶ When the pin bores align “on the bottom”:
Insert the pin **2** on the W-end section “on the bottom” (point **B**) and secure with spring retainer **3**.
- ▶ Continue to lift the W-end section until the erection roller cart can be pushed under the boom nose.
- ▶ When the erection roller cart is positioned under the boom nose:
Slowly lower the W-end section with the auxiliary crane and place the boom nose with the studs **8** into the receptacles on the erection roller cart.
- ▶ Insert the pins **9** into the retainers on the erection roller cart and secure.



Note

- ▶ The hoist rope must be pulled over the rope pulleys and reeved, see Reeving plan!
- ▶ Reeve the hook block properly and attach the hoist limit switch weight.

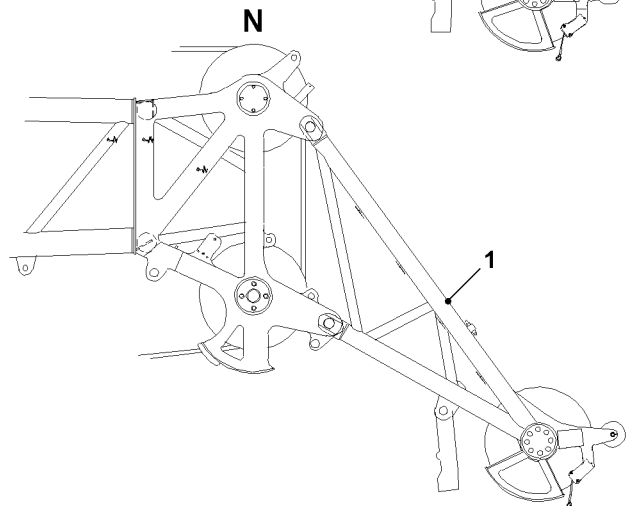
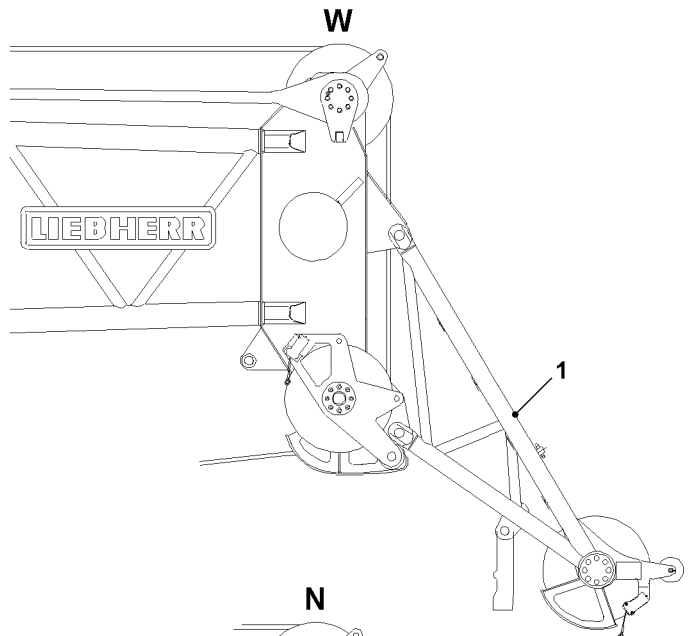
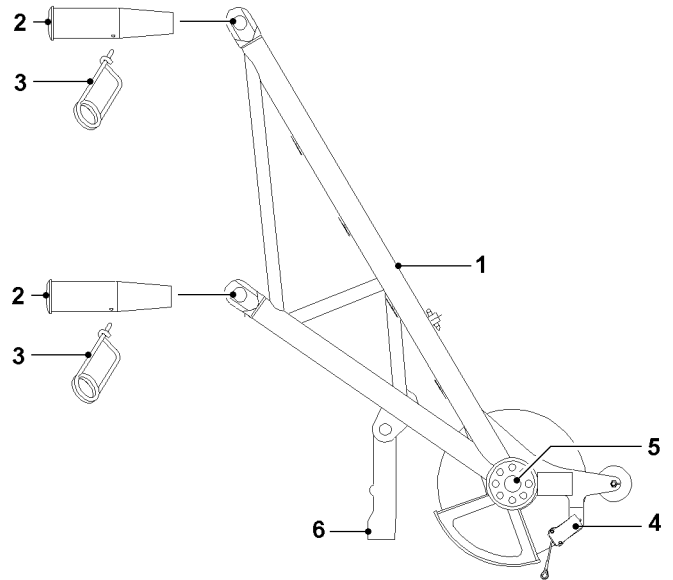
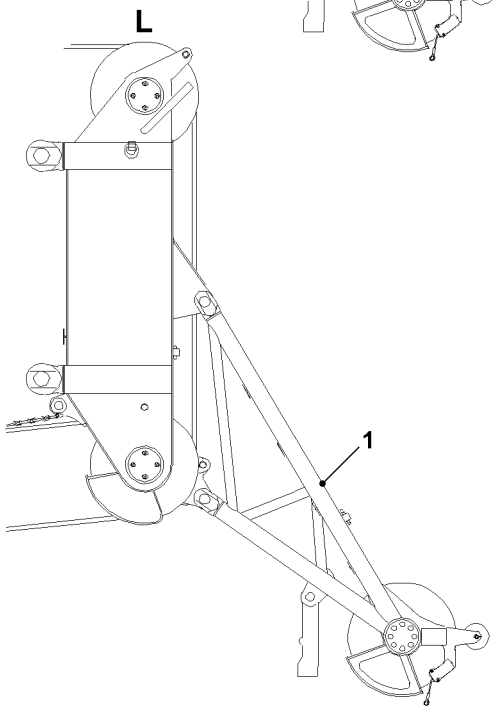
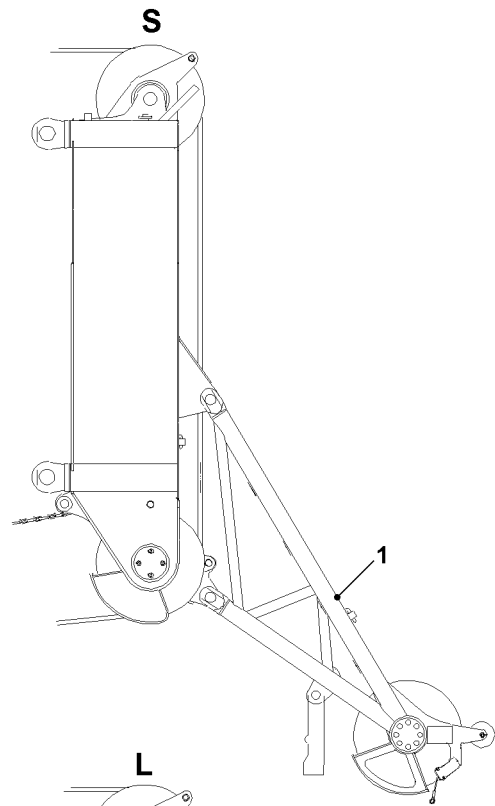

B104694

2.2.3 Establishing the electrical connections

Make sure that the following prerequisite is met:

- The boom nose is completely assembled.
- ▶ Establish the electrical connection from the terminal box of the “S-end section ” or the “L-end section ”, or the “W-end section ” or the “N-end section ” to the terminal box “Boom nose”.
- ▶ Establish the electrical connection from the terminal box of the “Boom nose” to the hoist limit switch.

2.2.4 Function check

Make sure that the following prerequisites are met:

- All electrical connections have been established.
- The corresponding operating mode is set in the LICCON computer system.

Limit switch - General



Note

- ▶ The limit switch functions have to be checked individually before erection!
-

Hoist limit switch

- ▶ Manually actuate the hoist limit switch.

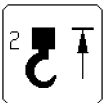

Result:

- The icon appears on the LICCON monitor.
- The **spool up function** of the hoist winch turns off.

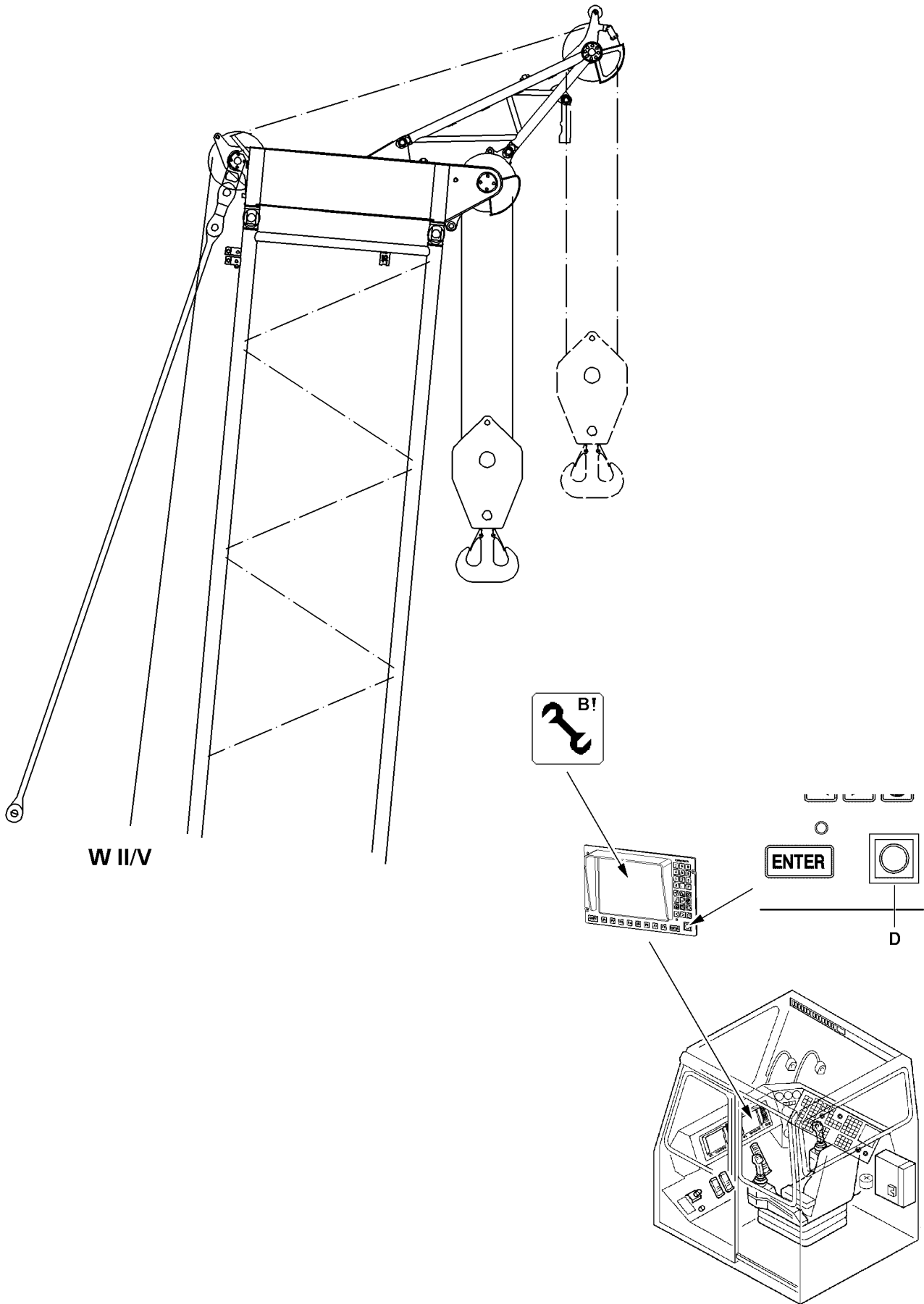

B112256

2.2.5 Erecting the boom



WARNING

Assembly with turned on set up key!

When the set up key is turned on, the LICCON overload protection is exceeded!

In the event of deliberate improper use, the crane could collapse, the boom can break off or the crane can topple over!

Personnel can be severely injured or killed!

This could result in high property damage!

- ▶ The set up key **D** may only be actuated by persons who know the effects of a bypass!
- ▶ Press the set up key **D** only when the set up status was correctly entered into the LICCON computer system!
- ▶ Observe the erection / take down charts!
- ▶ Crane operation with the set up key **D** turned on is strictly prohibited!

NOTICE

Danger of property damage on the boom nose!

- ▶ When erecting the boom systems, it must be ensured that the hoist rope does not get stuck in the boom nose!
- ▶ Reeve in the hoist rope according to the reeving plans on the hook block!



Note

- ▶ Erect the S-boom, see Crane operating instructions, chapter 5.38!
- ▶ Erect the SW-boom, see Crane operating instructions, chapter 5.07!

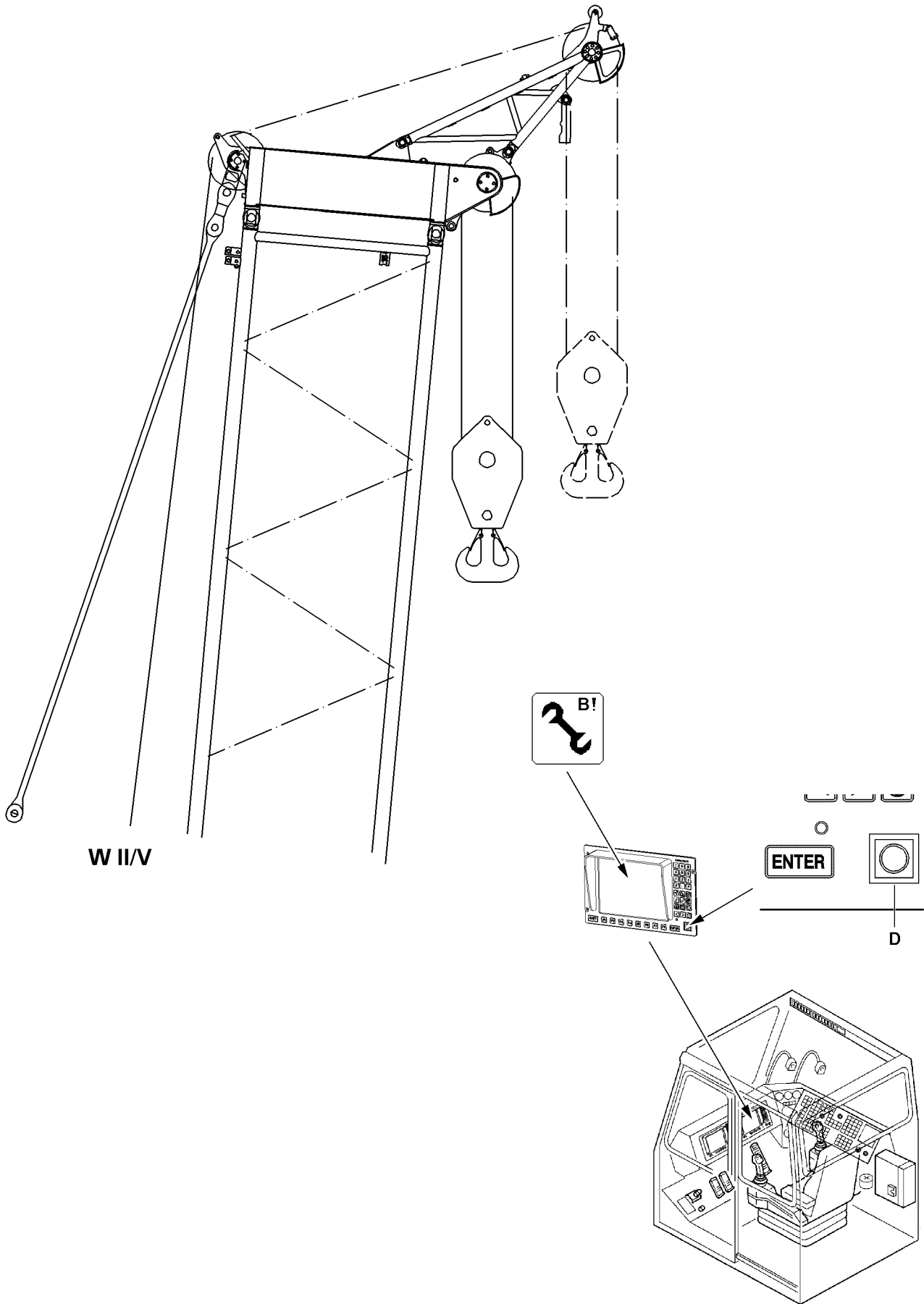

B112256

2.3 Crane operation

The possibility to operate the crane with the boom nose is intended for quick lifts with winch V in S/L-operation and winch II in W/N-operation.

The hook block can remain reeved on the boom head.



DANGER

Risk of accident!

- ▶ Two hook operation is prohibited for the 36 t boom nose!
- ▶ Maximum 3-way reeving is permissible, otherwise the boom nose will be overloaded!



Note

- ▶ Observe the notes, see Crane operating instructions, chapter 4.05, chapter 4.08 and chapter 5.01!

Make sure that the following prerequisites are met:

- The LICCON overload protection is active.
- The LICCON overload protection has been set according to the data in the load chart.



WARNING

The crane can topple over!

- ▶ Check the horizontal position of the crane before and during operation!
- ▶ If the crane operator leaves the cab, even for a short time, the operating mode setting must be checked and reset if necessary before resuming crane operation!

2.3.1 Checking the settings

- ▶ Check the function of the LICCON overload protection by running against the operating positions “on top” and “bottom”.
- ▶ Check the hoist limit switch by running against the hoist limit switch weight.
- ▶ Check the function of the limit switches “Boom steep” on the relapse cylinders.

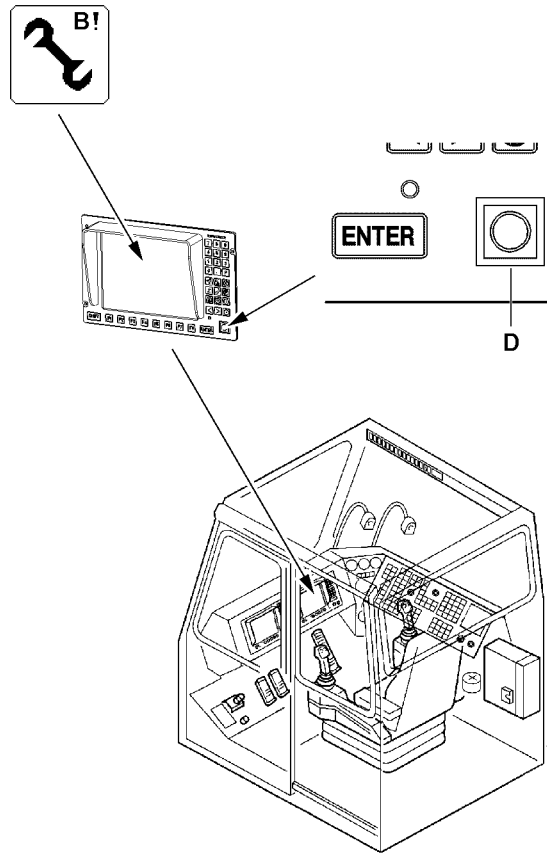

2.4 Disassembling the boom nose 36 t (H)

2.4.1 Placing the boom down



WARNING

Assembly with turned on set up key!

When the set up key is turned on, the LICCON overload protection is exceeded!

In the event of deliberate improper use, the crane could collapse, the boom can break off or the crane can topple over!

Personnel can be severely injured or killed!

This could result in high property damage!

- ▶ The set up key **D** may only be actuated by persons who know the effects of a bypass!
- ▶ Press the set up key **D** only when the set up status was correctly entered into the LICCON computer system!
- ▶ Observe the erection / take down charts!
- ▶ Crane operation with the set up key **D** turned on is strictly prohibited!



Note

- ▶ Take down the S-boom, see Crane operating instructions, chapter 5.38!
- ▶ Take down the SW-boom, see Crane operating instructions, chapter 5.07!

Make sure that the following prerequisites are met:

- The boom with boom nose is above the ground.
- The hook block is unreeved and removed.
- The LICCON overload protection is exceeded.

NOTICE

Damage of boom nose!

- ▶ If the boom nose is pinned on top and bottom on the end section, then the boom may be luffed down only to the point where the boom nose is not laying on the ground!
- ▶ Luff the boom down until the boom nose just above the ground.
- ▶ Remove the hoist rope.
- ▶ Unplug the hoist limit switch.
- ▶ Disconnect the electrical connections to the terminal boxes.

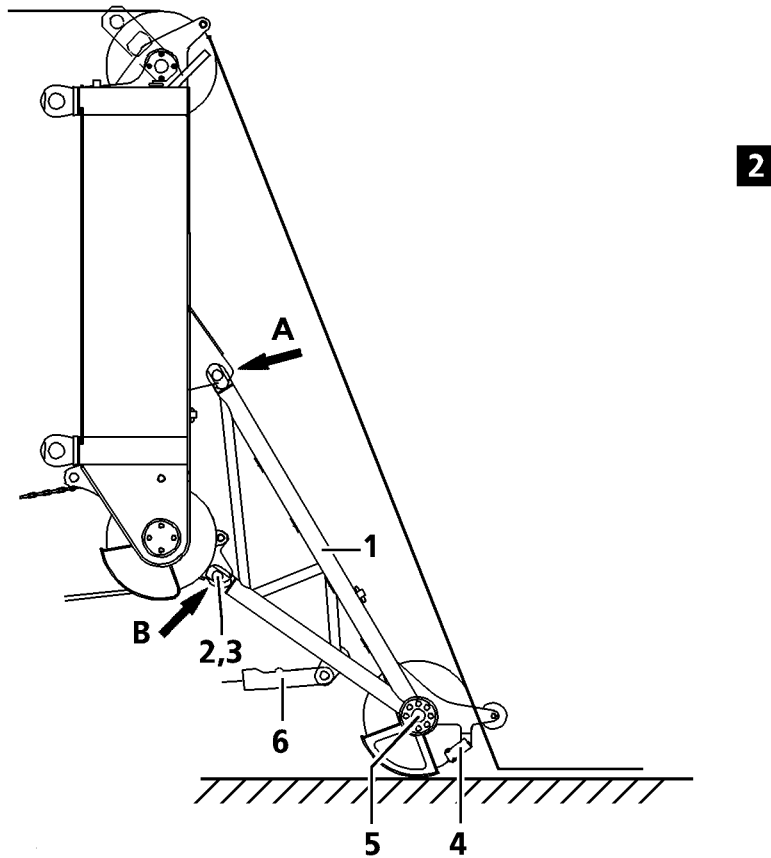
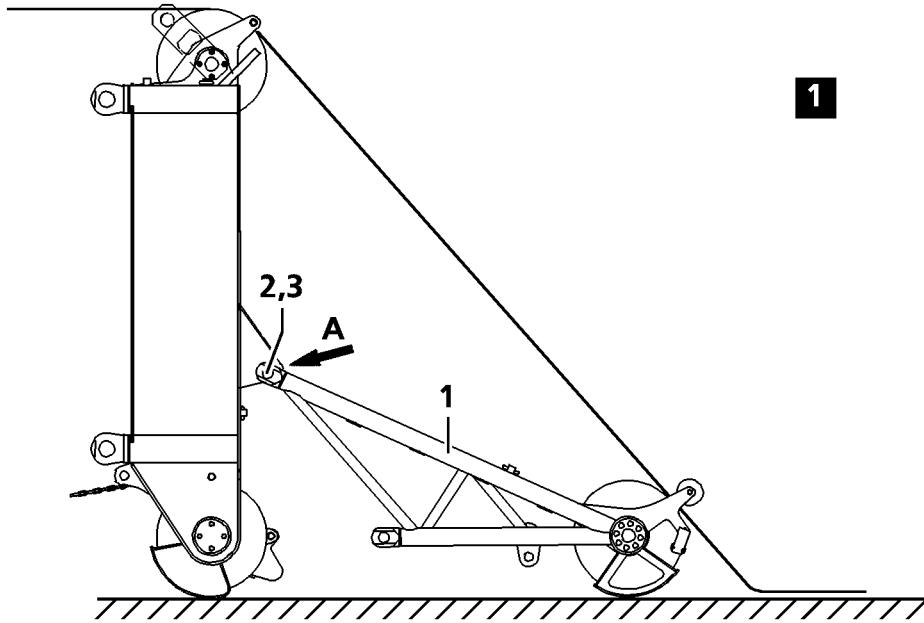

2.4.2 Disassembling the boom nose 36 t (H) on the S-/L-boom head



Note

- ▶ The disassembly procedure of the boom nose is described on the example of the S-boom head.

Make sure that the following prerequisite is met:

- The boom nose is just above the ground.
- ▶ Disengage the hoist limit switch weight with chain and shackle on the boom nose.
- ▶ Unreeve the hoist rope.
- ▶ Disconnect the electrical connections to the boom nose.
- ▶ Release and unpin the pin **2** on the end section “on the bottom” (point **B**).
- ▶ Hang the boom nose **1** onto the auxiliary crane.
- ▶ Lift the boom nose **1** with the auxiliary crane.



Note

- ▶ Make sure that the boom nose does not hit the ground when placing the S-boom down.
- ▶ Luff down the S-boom until the S-boom head is laying on the ground.
- ▶ When the S-boom head is laying on the ground:
Carefully lower the boom nose to the ground with the auxiliary crane.
- ▶ Disconnect the electrical connections to the boom nose.
- ▶ Release and unpin the pin **2** on the end section “on top” (point **A**).
- ▶ Remove the boom nose with the auxiliary crane and place it down outside the working range.
- ▶ Remove the auxiliary crane from the boom nose.

1

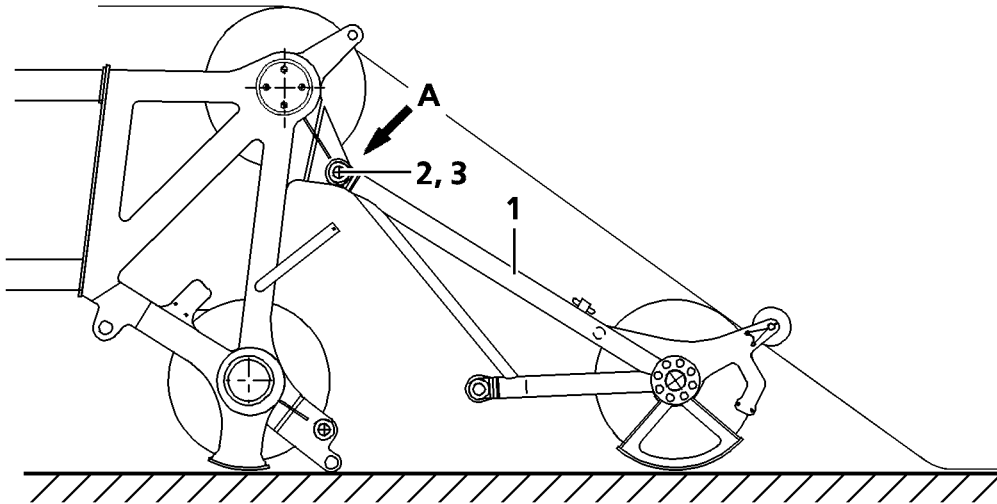

2

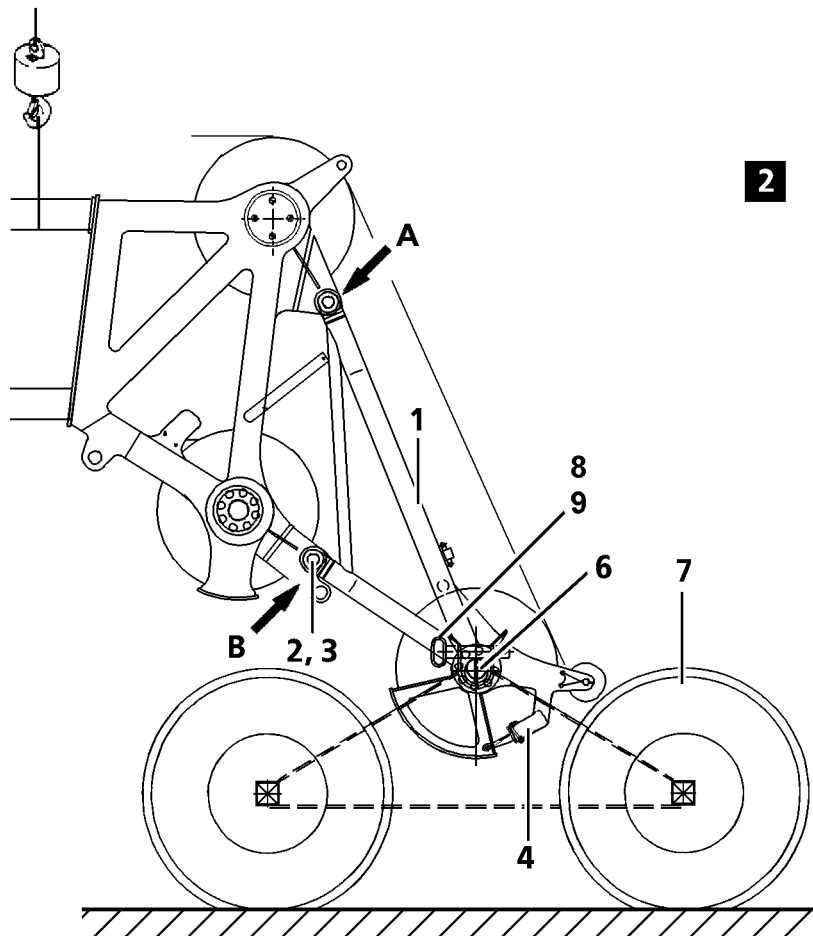

2.4.3 Disassembling the boom nose 36 t (H) on the W-/N-boom head



Note

- ▶ The disassembly procedure of the boom nose is described on the example of the W-boom head.

Make sure that the following prerequisite is met:

- The boom nose is just above the ground.
- ▶ Disengage the hoist limit switch weight with chain and shackle on the boom nose.
- ▶ Unreeve the hoist rope.
- ▶ Disconnect the electrical connections to the boom nose.

For disassembly of the boom nose on the W-boom head, use the erection roller cart.

- ▶ Position the erection roller cart under the boom nose.
- ▶ When the erection roller cart is positioned under the boom nose:
Luff down the boom and place the boom nose with the studs **8** into the receptacles on the erection roller cart.
- ▶ When the boom nose is placed properly in the receptacles of the erection roller cart:
Insert and secure pins **9** in the receptacles.
- ▶ Luff the boom down slowly.

Result:

- The boom moves on the erection roller cart toward the “outside” (away from the crane).

When the boom is taken down fully, lift the W-end section with the auxiliary crane, remove the erection roller cart and unpin the boom nose “on the bottom”.

- ▶ When the boom is completely placed down:
Hang the W-end section on the auxiliary crane and bring the fastening equipment to “tension”.
- ▶ Release and unpin the pin **9** on the erection roller cart.
- ▶ Lift the W-end section with the auxiliary crane until the erection roller cart can be removed on the boom nose.
- ▶ Release and unpin the pin **2** on the end section “on the bottom” (point **B**).
- ▶ Disconnect the electrical connections to the boom nose.



Note

- ▶ When placing the W-end section down, it must be ensured that the boom nose is not being damaged.

- ▶ Place the W-end section slowly to the ground with the auxiliary crane.
- ▶ Release and unpin the pin **2** on the end section “on top” (point **A**).
- ▶ Attach the boom nose on the intended fastening points with the auxiliary crane.
- ▶ Place the boom nose with the auxiliary crane down outside the working range.
- ▶ Remove the auxiliary crane from the boom nose.

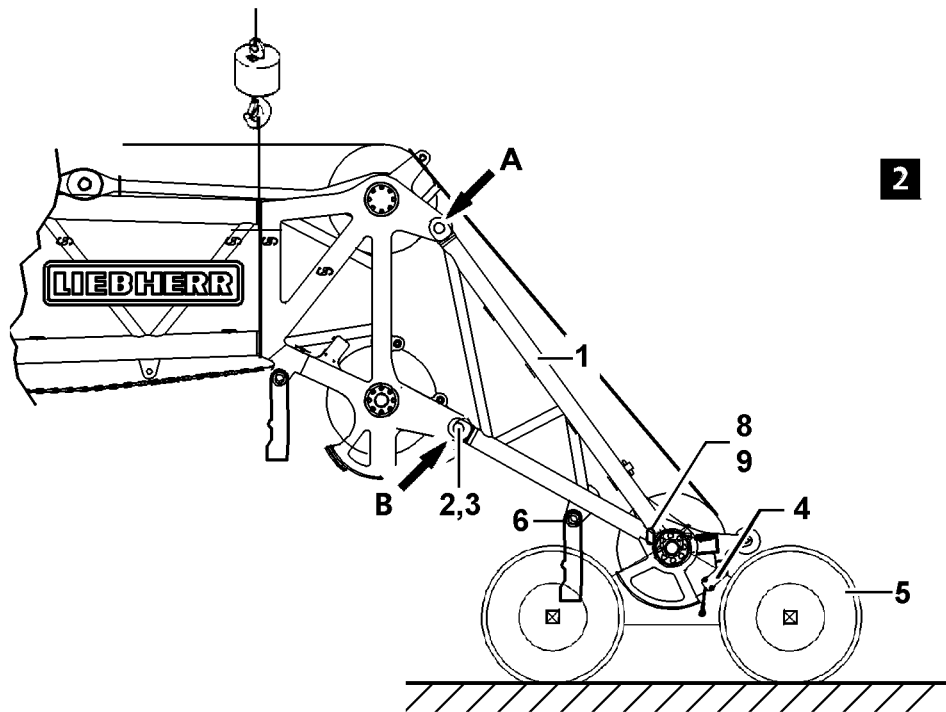
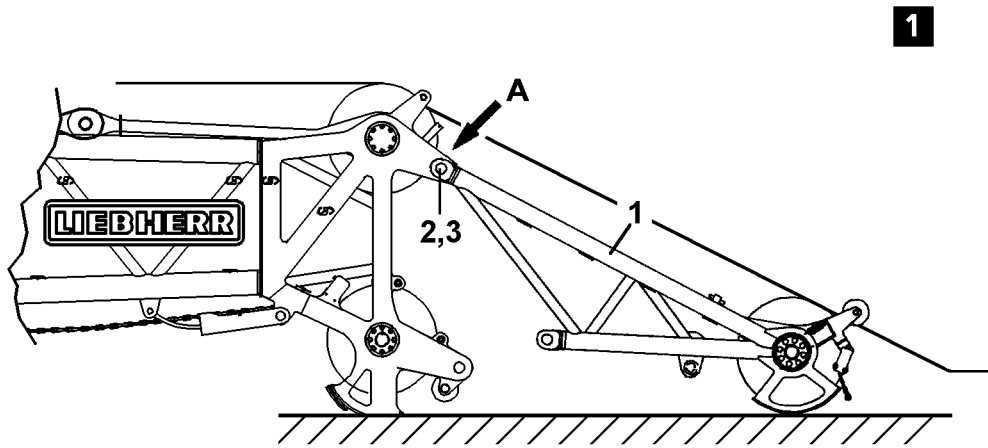

3 Boom nose 48 t (H2)

3.1 Component overview boom nose

The 48 t boom nose (H2) 1 can be installed and operated on various boom end sections (S-, L-, W- and N-), see illustration.

Position	Description	Weight
1	Boom nose, 48 t (H2)	0.61 t
2	Pin	
3	Spring retainer	
4	Hoist limit switch	
5	Axle for erection roller cart	
6	Rope fixed point (rope lock)	

3.2 Assembling the boom nose 48 t (H2)

Make sure that the following prerequisites are met:

- The crane is aligned in horizontal direction.
- The counterweight has been installed on the turntable according to the load chart.
- The derrick ballast is placed on the suspended ballast or the ballast trailer according to the load chart.
- The LICCON overload protection has been set according to the data in the load chart.
- The mechanical auxiliary support is installed on the crane.
- An auxiliary crane is available.

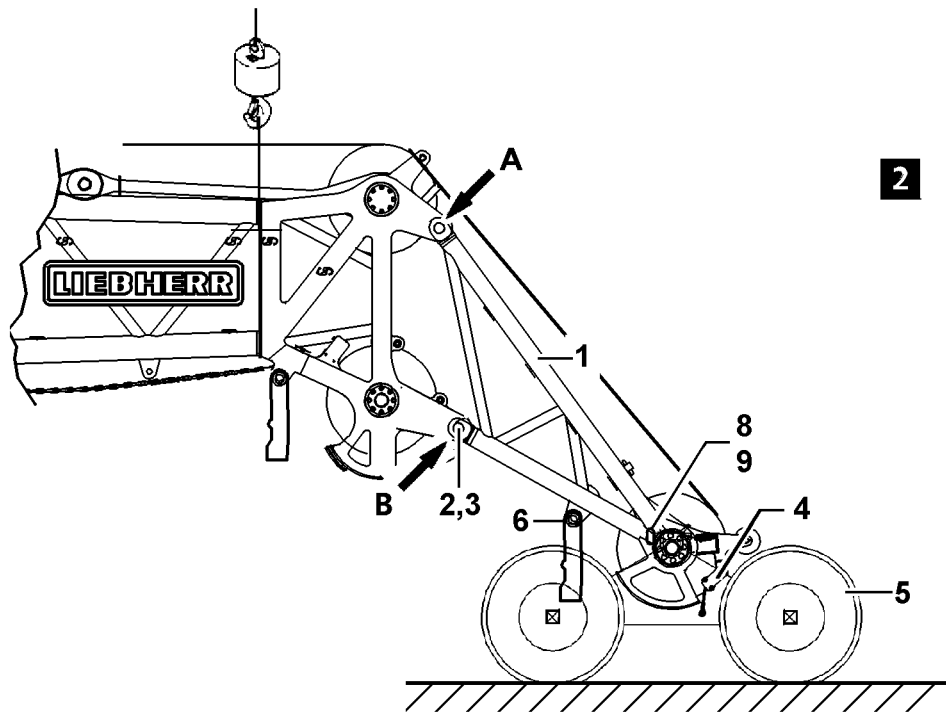
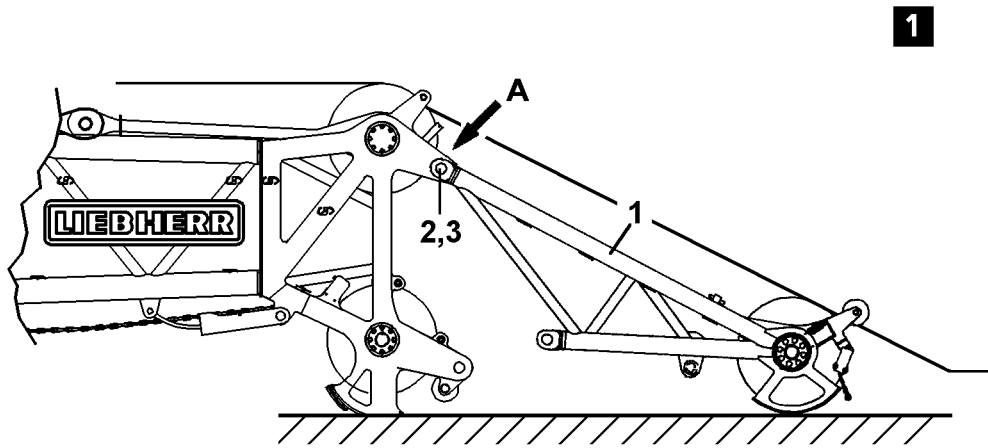

3.2.1 Assembling the boom nose 48 t (H2) on the N-boom head

Make sure that the following prerequisite is met:

- The N-end section is laying on the ground.
- ▶ Hang the boom nose **1** onto the auxiliary crane.
- ▶ Position the boom nose **1** with the auxiliary crane on the N-end section in such a way that the pin bores align “on top” (point **A**), see illustration **1**.
- ▶ When the pin bores align “on top”:
Insert the pin **2** on the N-end section “on top” and secure with spring retainer **3**.
- ▶ Lower the boom nose **1** to the ground with the auxiliary crane.
- ▶ Remove the auxiliary crane.
- ▶ Lift the N-end section with the auxiliary crane until the boom nose touches the end section “on the bottom”, see illustration **2**.
- ▶ When the pin bores align “on the bottom”:
Insert the pin **2** on the N-end section “on the bottom” (point **B**) and secure with spring retainer **3**.
- ▶ Continue to lift the N-end section until the erection roller cart can be pushed under the boom nose.
- ▶ When the erection roller cart is positioned under the boom nose:
Swing the folding roller to the rear and hold.
- ▶ Slowly lower the N-end section with the auxiliary crane and place the boom nose with the studs **8** into the receptacles on the erection roller cart.
- ▶ Insert the pins **9** into the retainers on the erection roller cart and secure.



Note

- ▶ The hoist rope must be pulled over the rope pulleys and reeved, see Reeving plan!
 - ▶ Reeve the hook block properly and attach the hoist limit switch weight.
-

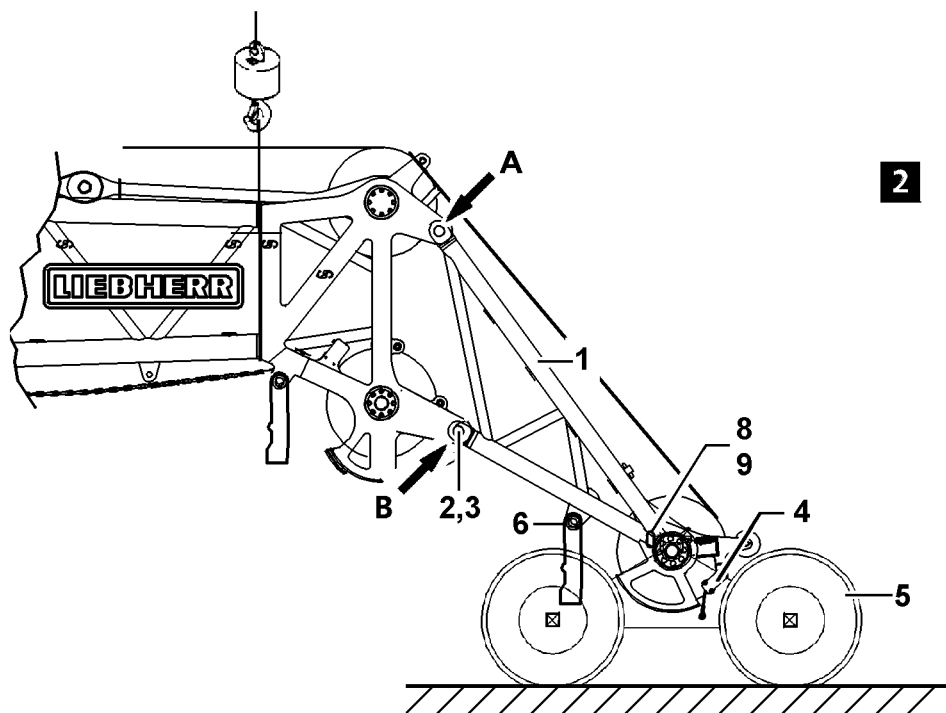
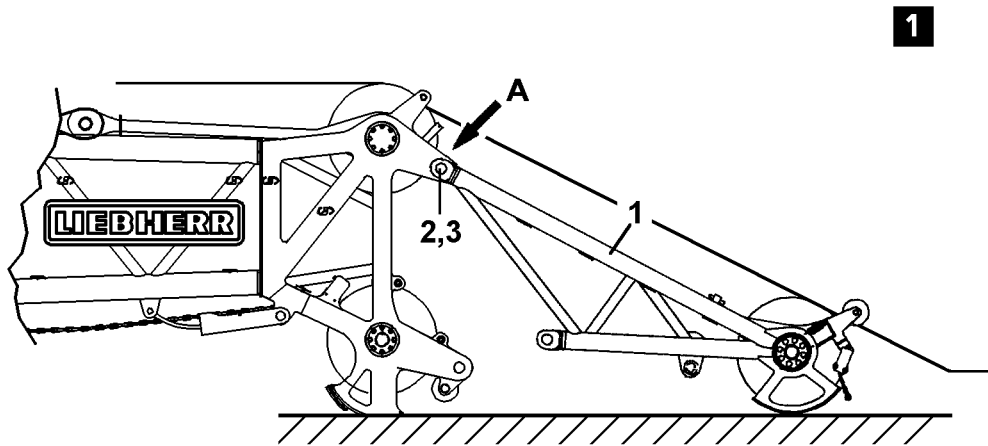

3.2.2 Establishing the electrical connections

Make sure that the following prerequisite is met:

- The boom nose is completely assembled.
- ▶ Establish the electrical connection from the terminal box of the “N-end section” to the terminal box “Boom nose”.
- ▶ Establish the electrical connection from the terminal box of the “Boom nose” to the hoist limit switch.

3.2.3 Function check

Make sure that the following prerequisites are met:

- All electrical connections have been established.
- The corresponding operating mode is set in the LICCON computer system.

Limit switch - General



Note

- ▶ The limit switch functions have to be checked individually before erection!
-

Hoist limit switch

- ▶ Manually actuate the hoist limit switch.

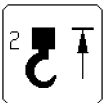

Result:

- The icon appears on the LICCON monitor.
- The **spool up function** of the hoist winch turns off.

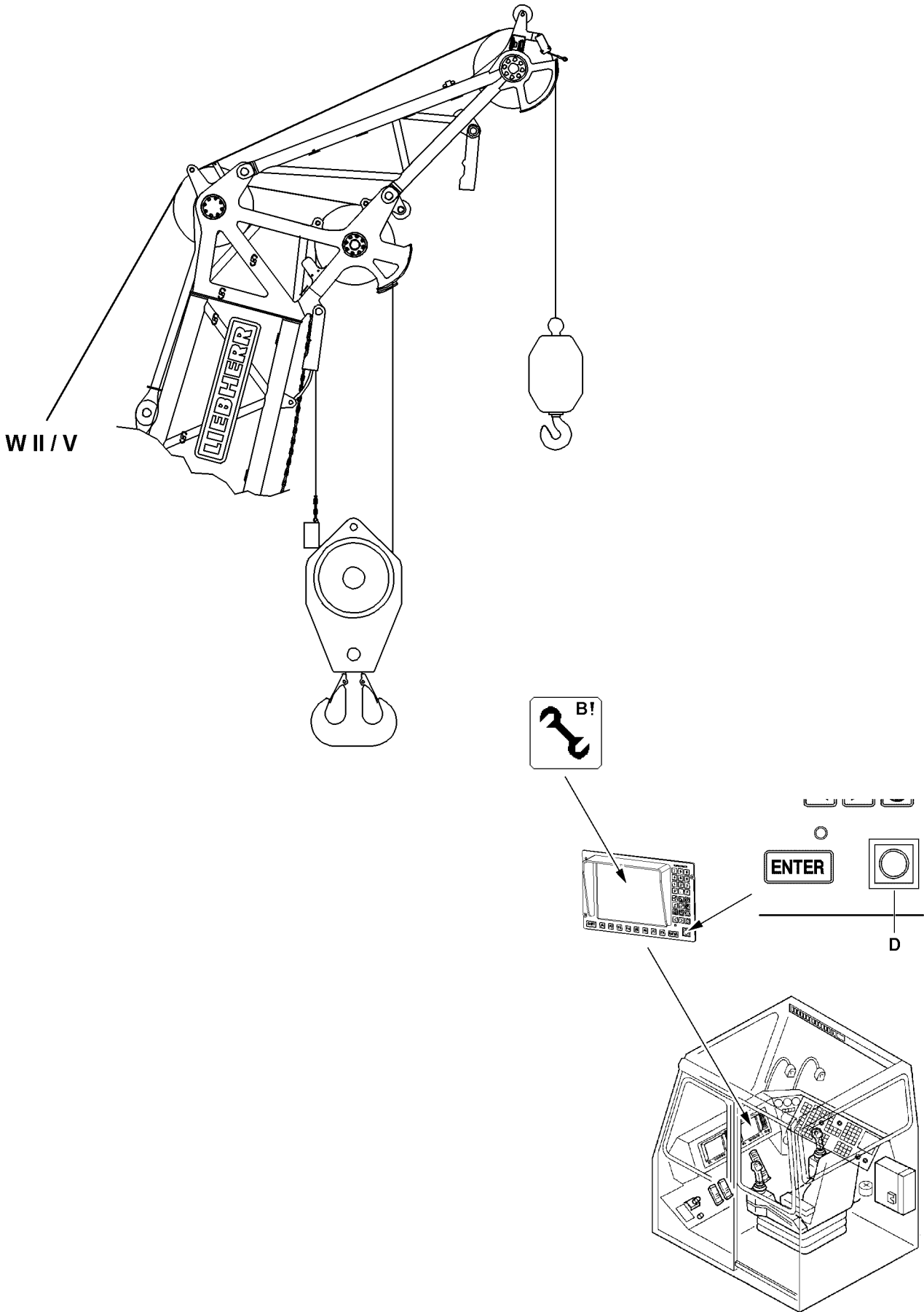

B112257

3.2.4 Erecting the boom



WARNING

Assembly with turned on set up key!

When the set up key is turned on, the LICCON overload protection is exceeded!

In the event of deliberate improper use, the crane could collapse, the boom can break off or the crane can topple over!

Personnel can be severely injured or killed!

This could result in high property damage!

- ▶ The set up key **D** may only be actuated by persons who know the effects of a bypass!
 - ▶ Press the set up key **D** only when the set up status was correctly entered into the LICCON computer system!
 - ▶ Observe the erection / take down charts!
 - ▶ Crane operation with the set up key **D** turned on is strictly prohibited!
-

NOTICE

Danger of property damage on the boom nose!

- ▶ When erecting the boom systems, it must be ensured that the hoist rope does not get stuck in the boom nose!
 - ▶ Reeve in the hoist rope according to the reeving plans on the hook block!
-



Note

- ▶ Erect the S-boom, see Crane operating instructions, chapter 5.38!
 - ▶ Erect the SW-boom, see Crane operating instructions, chapter 5.07!
-

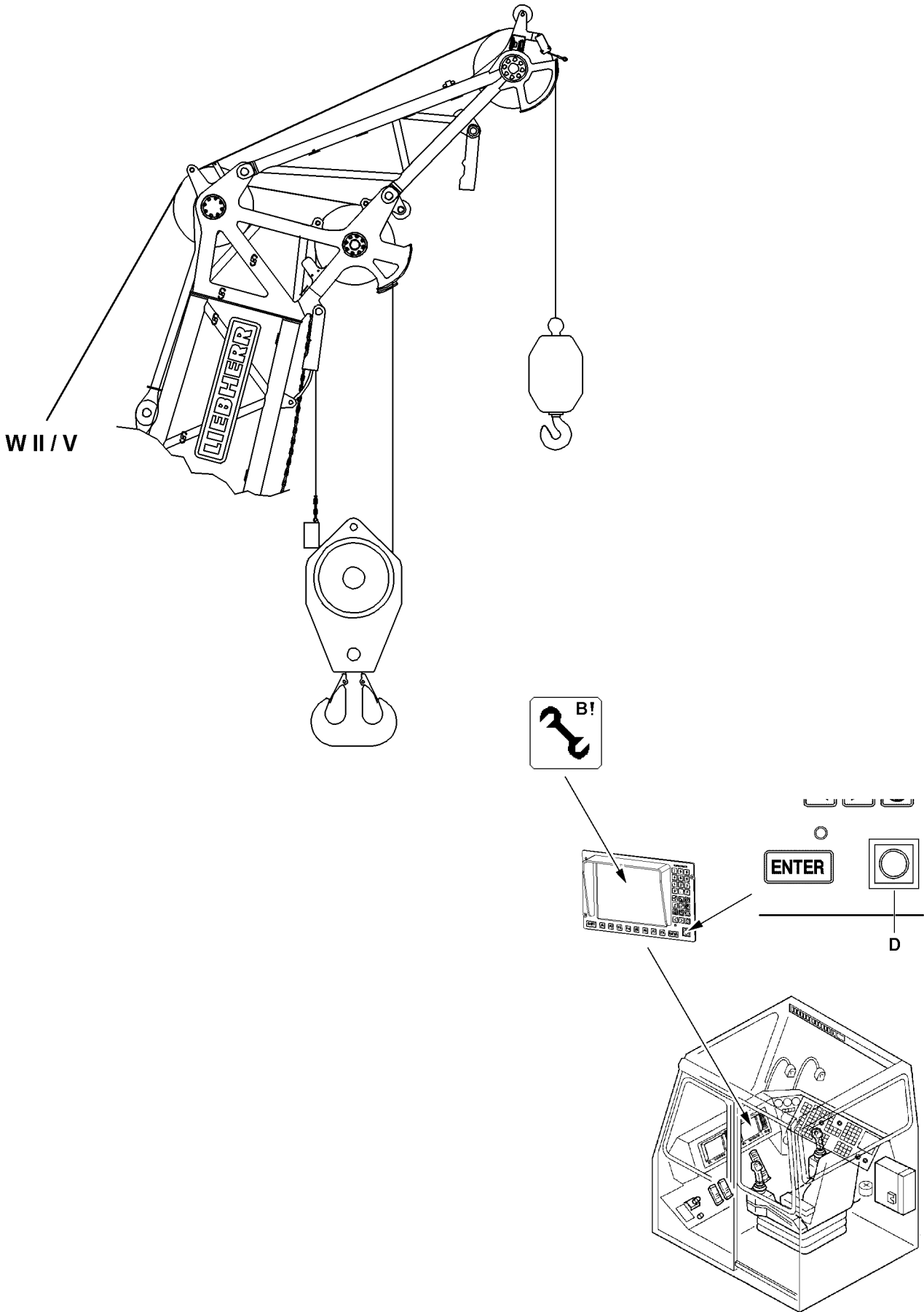

B112257

3.3 Crane operation

The possibility to operate the crane with the boom nose is intended for quick lifts with winch V in S/L-operation and winch II in N/W-operation.

The hook block can remain reeved on the boom head.



DANGER

Risk of accident!

- ▶ Two hook operation is prohibited for the 48 t boom nose!
- ▶ Maximum 4-way reeving is permissible, otherwise the boom nose will be overloaded!



Note

- ▶ Observe the notes, see Crane operating instructions, chapter 4.05, chapter 4.08 and chapter 5.01!

Make sure that the following prerequisites are met:

- The LICCON overload protection is active.
- The LICCON overload protection has been set according to the data in the load chart.



WARNING

The crane can topple over!

- ▶ Check the horizontal position of the crane before and during operation!
- ▶ If the crane operator leaves the cab, even for a short time, the operating mode setting must be checked and reset if necessary before resuming crane operation!

3.3.1 Checking the settings

- ▶ Check the function of the LICCON overload protection by running against the operating positions “on top” and “bottom”.
- ▶ Check the hoist limit switch by running against the hoist limit switch weight.
- ▶ Check the function of the limit switches “Boom steep” on the relapse cylinders.

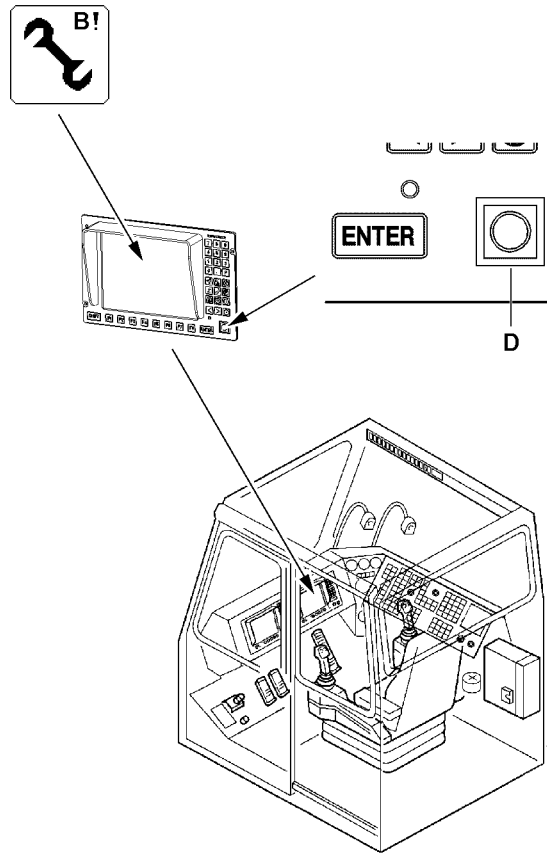

3.4 Disassembling the boom nose 48 t (H2)

3.4.1 Placing the boom down



WARNING

Assembly with turned on set up key!

When the set up key is turned on, the LICCON overload protection is exceeded!

In the event of deliberate improper use, the crane could collapse, the boom can break off or the crane can topple over!

Personnel can be severely injured or killed!

This could result in high property damage!

- ▶ The set up key **D** may only be actuated by persons who know the effects of a bypass!
- ▶ Press the set up key **D** only when the set up status was correctly entered into the LICCON computer system!
- ▶ Observe the erection / take down charts!
- ▶ Crane operation with the set up key **D** turned on is strictly prohibited!



Note

- ▶ Take down the S-boom, see Crane operating instructions, chapter 5.38!
- ▶ Take down the SW-boom, see Crane operating instructions, chapter 5.07!

Make sure that the following prerequisites are met:

- The boom with boom nose is above the ground.
- The hook block is unreeved and removed.
- The LICCON overload protection is exceeded.

NOTICE

Damage of boom nose!

- ▶ If the boom nose is pinned on top and bottom on the end section, then the boom may be luffed down only to the point where the boom nose is not laying on the ground!
- ▶ Luff the boom down until the boom nose just above the ground.
- ▶ Remove the hoist rope.
- ▶ Unplug the hoist limit switch.
- ▶ Disconnect the electrical connections to the terminal boxes.

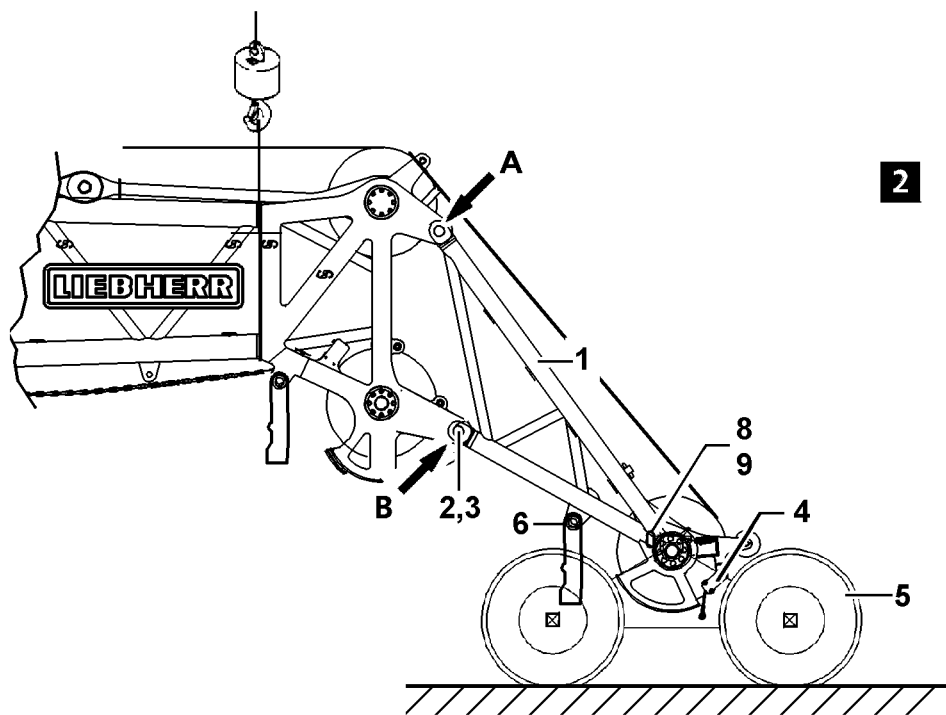
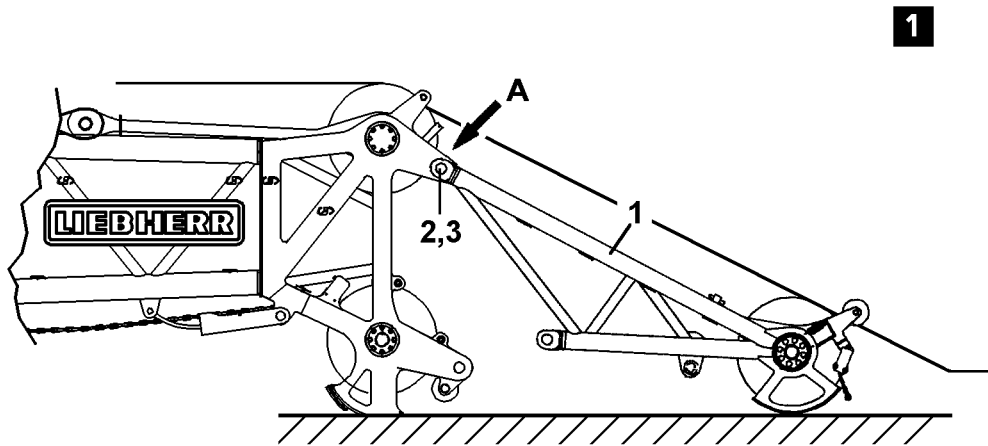

3.4.2 Disassembling the boom nose 48 t (H2) on the N-boom head

Make sure that the following prerequisite is met:

- The boom nose is just above the ground.
- ▶ Disengage the hoist limit switch weight with chain and shackle on the boom nose.
- ▶ Unreeve the hoist rope.
- ▶ Disconnect the electrical connections to the boom nose.

For disassembly of the boom nose on the N-boom head, use the erection roller cart.

- ▶ Position the erection roller cart under the boom nose.
- ▶ When the erection roller cart is positioned under the boom nose:
Luff down the boom and place the boom nose with the studs **8** into the receptacles on the erection roller cart.
- ▶ When the boom nose is placed properly in the receptacles of the erection roller cart:
Insert and secure pins **9** in the receptacles.
- ▶ Luff the boom down slowly.

Result:

- The boom moves on the erection roller cart toward the “outside” (away from the crane).

When the boom is taken down fully, lift the N-end section with the auxiliary crane, remove the erection roller cart and unpin the boom nose “on the bottom”.

- ▶ When the boom is completely placed down:
Hang the N-end section on the auxiliary crane and bring the fastening equipment to “tension”.
- ▶ Disconnect the electrical connections to the boom nose.
- ▶ Release and unpin the pin **9** on the erection roller cart.
- ▶ Lift the N-end section with the auxiliary crane until the erection roller cart can be removed on the boom nose.
- ▶ Release and unpin the pin **2** on the end section “on the bottom” (point **B**).



Note

- ▶ When taking the N-end section down, it must be ensured that the boom nose is not being damaged.

-
- ▶ Place the N-end section slowly to the ground with the auxiliary crane.
 - ▶ Release and unpin the pin **2** on the end section “on top” (point **A**).
 - ▶ Attach the boom nose on the intended fastening points with the auxiliary crane.
 - ▶ Place the boom nose with the auxiliary crane down outside the working range.
 - ▶ Remove the auxiliary crane from the boom nose.

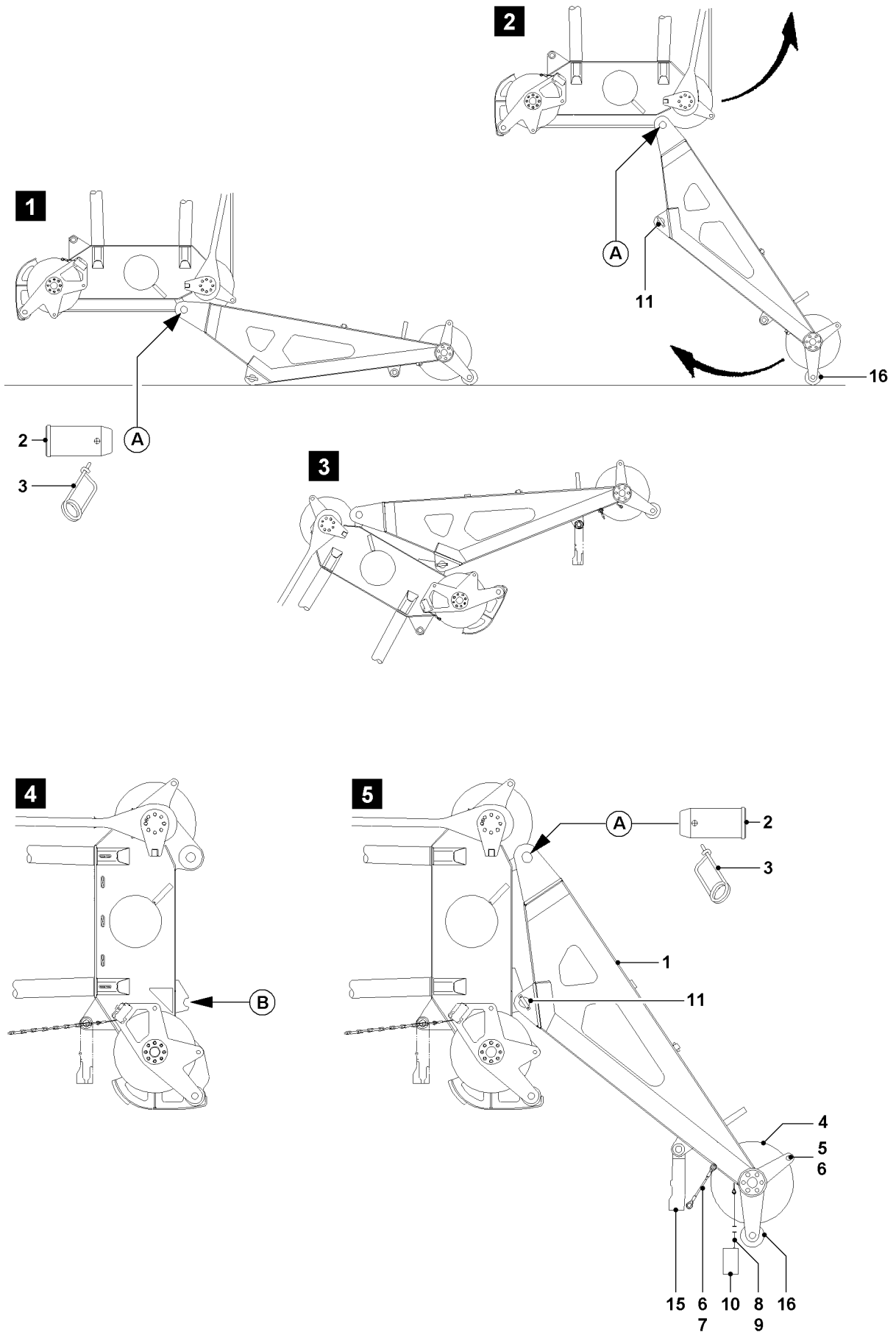

B104697

4 Boom nose 60 t (H)

4.1 Component overview boom nose

The 60 t boom nose (H) 1 can be installed and operated on the W-end section.

Position	Description	Weight
1	Boom nose, 60 t (H)	0.78 t
2	Pin	
3	Spring retainer	
4	Rope pulley	
5	Rope retaining pipe	
6	Spring retainer	
7	Rope	
8	Shackle	
9	Chain	
10	Hoist limit switch weight	
11	Pin	
12	Flat steel bar	
13	Spring ring A8	
14	Screw	
15	Twist compensator	
16	Roller	

4.2 Assembling the boom nose 60 t (H)

Make sure that the following prerequisites are met:

- The crane is aligned in horizontal direction.
- The counterweight has been installed on the turntable according to the load chart.
- The derrick ballast is placed on the suspended ballast or the ballast trailer according to the load chart.
- The LICCON overload protection has been set according to the data in the load chart.
- The mechanical auxiliary support is installed on the crane.
- An auxiliary crane is available.

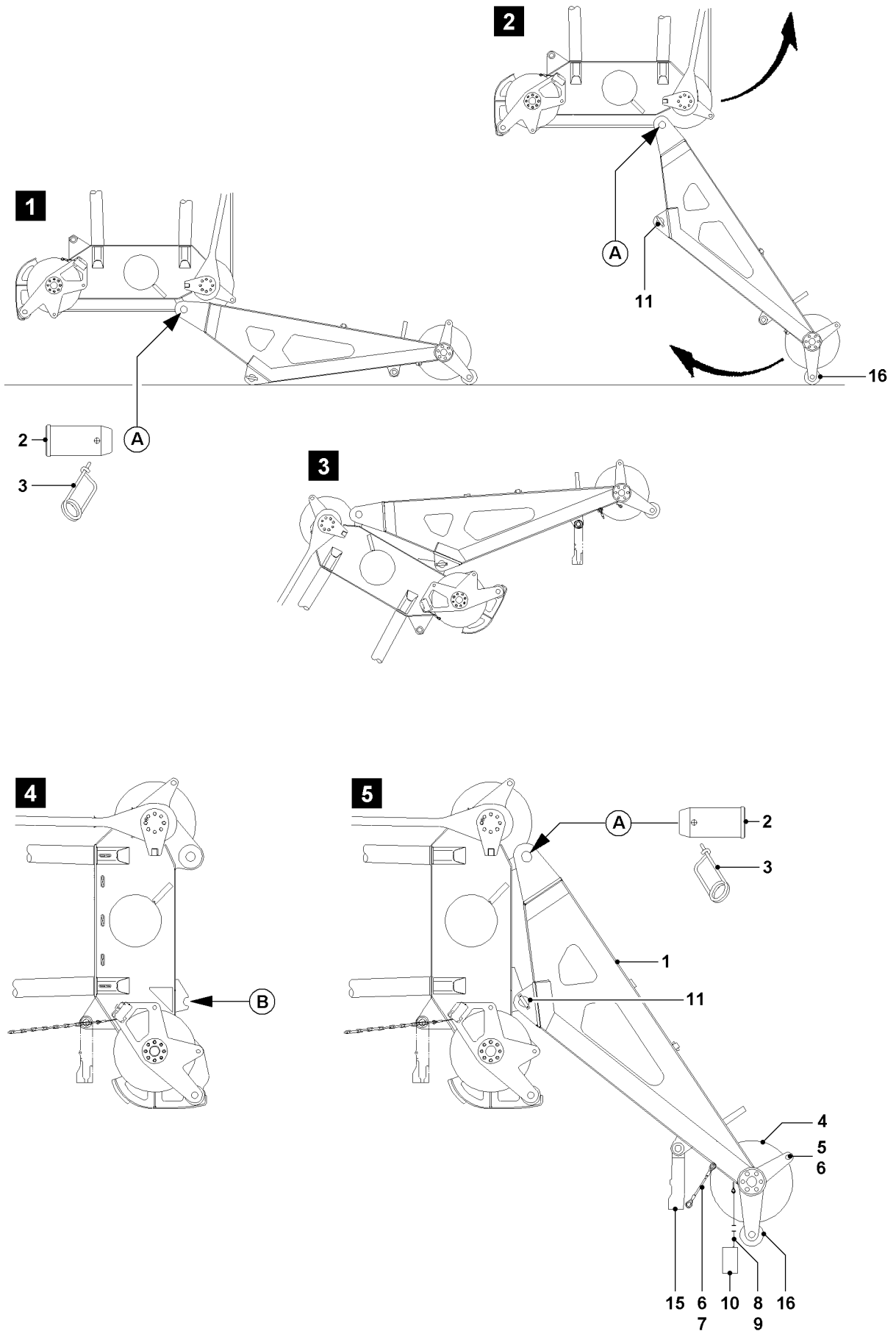

B104697

4.2.1 Assembling the boom nose 60 t (H) on the W-boom head

Make sure that the following prerequisite is met:

- The W-boom is in folded down position, see illustration 1.
- ▶ The boom nose 1 is laying on the ground, see illustration 1.
- ▶ Position the boom nose 1 in such a way that the pin bores align at point A.
- ▶ When the pin bores align at point A:
Insert the pin 2 on the W-end section at point A and secure with spring retainer 3.
- ▶ Release and unpin the rope retaining pipe 5.
- ▶ Pull the hoist rope over the rope pulley 4.
- ▶ Insert the rope retaining pipe 5 and secure with spring retainer 6.

Result:

- The hoist rope is secured to prevent it from jumping out of the rope pulley 4.
- ▶ Release the twist compensator by releasing it from the rope 7.
- ▶ Luff the W-boom up until the stop pins 11 touch the W-end section “on the bottom” (point B), see illustration 4.



Note

- ▶ The hoist rope must be pulled over the rope pulleys and reeved, see Reeving plan!
- ▶ Reeve the hook block properly and attach the hoist limit switch weight 10.

4.2.2 Establishing the electrical connections

Make sure that the following prerequisite is met:

- The boom nose is completely assembled.
- ▶ Establish the electrical connection from the terminal box of the “W-end section” to the terminal box “Boom nose”.
- ▶ Establish the electrical connection from the terminal box of the “Boom nose” to the hoist limit switch.

4.2.3 Function check

Make sure that the following prerequisites are met:

- All electrical connections have been established.
- The corresponding operating mode is set in the LICCON computer system.

Limit switch - General



Note

- ▶ The limit switch functions have to be checked individually before erection!

Hoist limit switch

- ▶ Manually actuate the hoist limit switch.

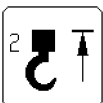

Result:

- The icon appears on the LICCON monitor.
- The **spool up function** of the hoist winch turns off.

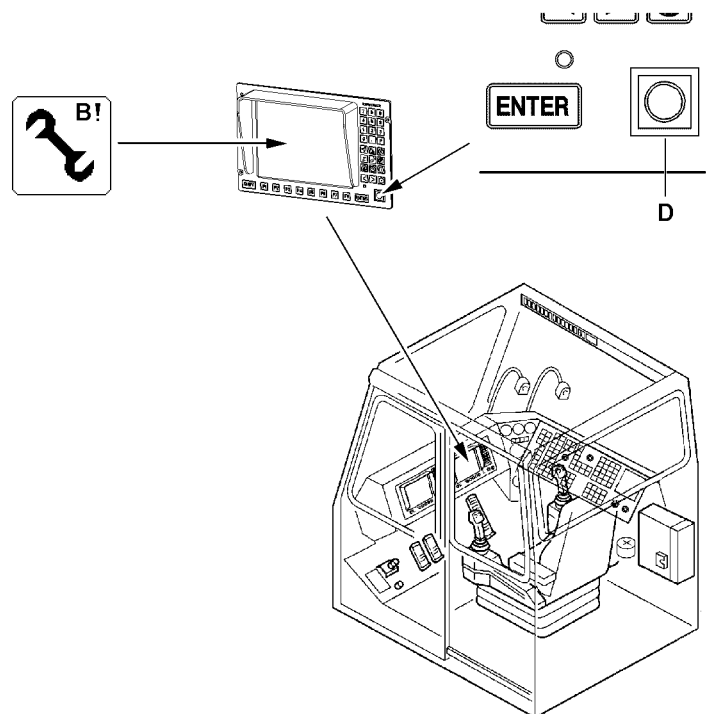
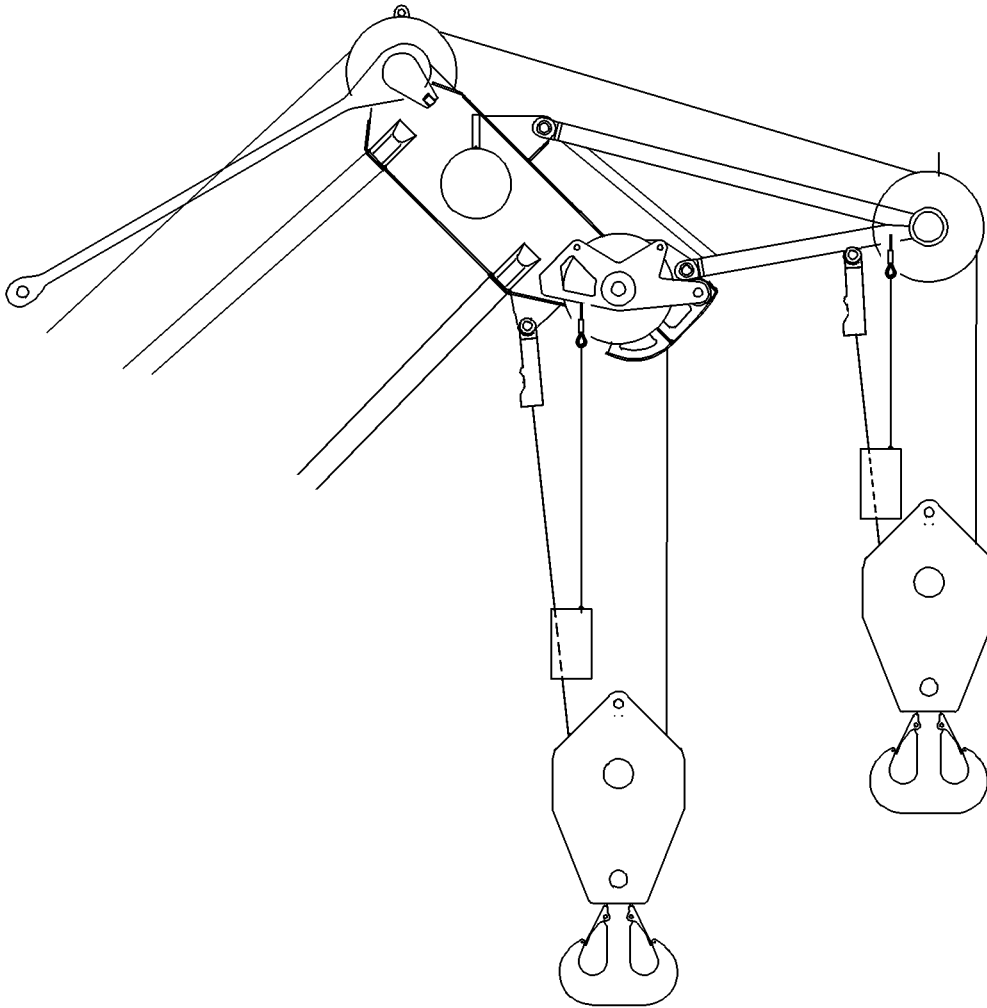

B112258

4.2.4 Erecting the boom



WARNING

Assembly with turned on set up key!

When the set up key is turned on, the LICCON overload protection is exceeded!

In the event of deliberate improper use, the crane could collapse, the boom can break off or the crane can topple over!

Personnel can be severely injured or killed!

This could result in high property damage!

- ▶ The set up key **D** may only be actuated by persons who know the effects of a bypass!
 - ▶ Press the set up key **D** only when the set up status was correctly entered into the LICCON computer system!
 - ▶ Observe the erection / take down charts!
 - ▶ Crane operation with the set up key **D** turned on is strictly prohibited!
-

NOTICE

Danger of property damage on the boom nose!

- ▶ When erecting the boom systems, it must be ensured that the hoist rope does not get stuck in the boom nose!
 - ▶ Reeve in the hoist rope according to the reeving plans on the hook block!
-

**Note**

- ▶ Erect the S-boom, see Crane operating instructions, chapter 5.38!
 - ▶ Erect the SW-boom, see Crane operating instructions, chapter 5.07!
-

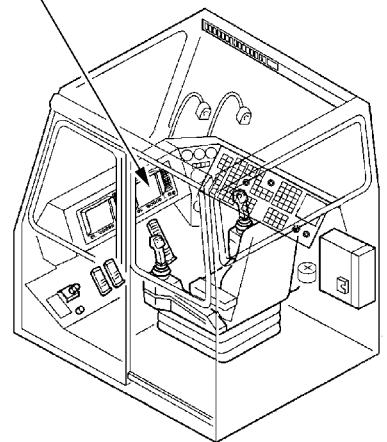
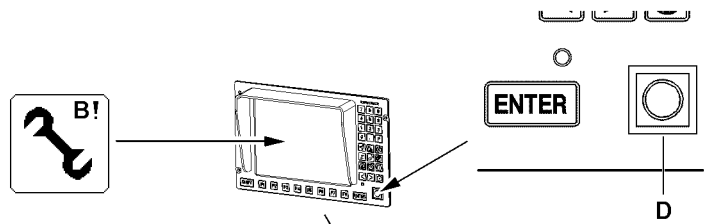
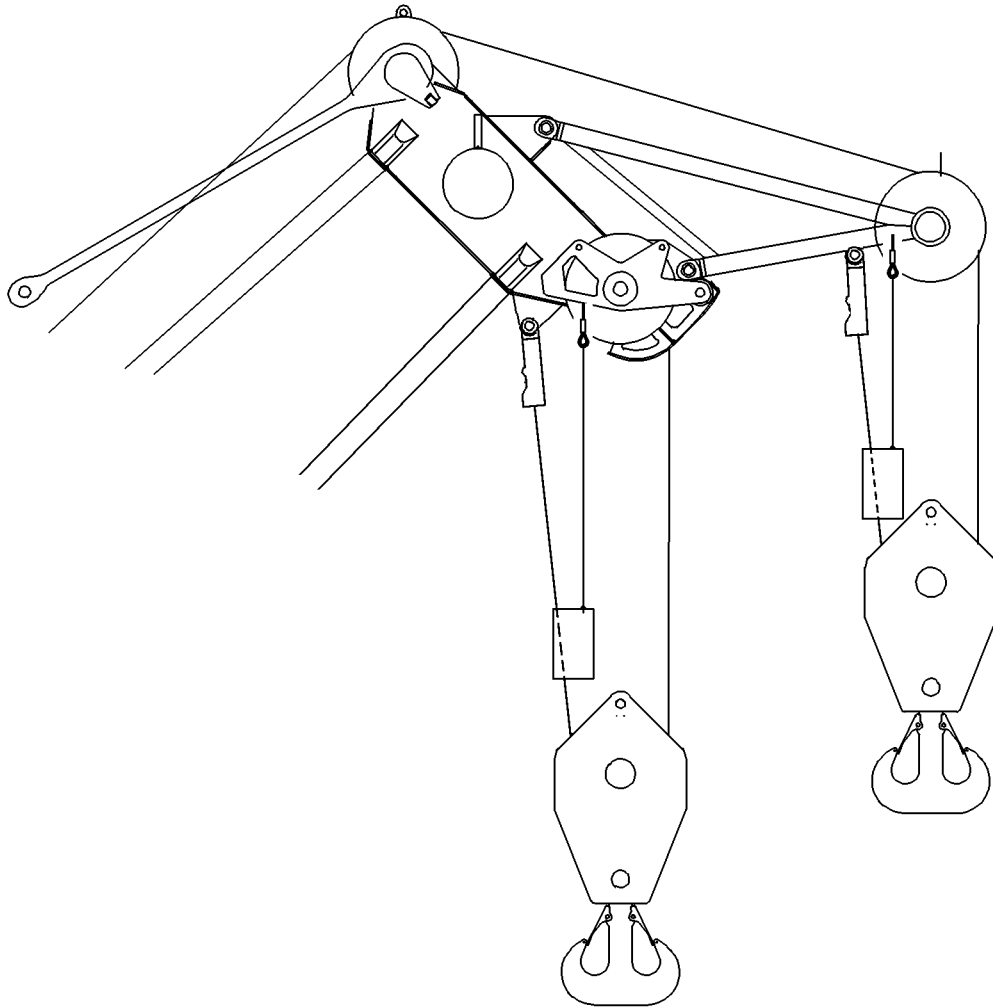

B112258

4.3 Crane operation

The possibility to operate the crane with this boom nose is intended for turning loads at simultaneous operation of both hoist gears over the 400 t end section and the boom nose.



DANGER

The crane can topple over!

- ▶ It is only permitted to turn a load in two hook operation towards the main hook!
- ▶ The setting of the LICCON overload protection to the smaller reeving of the two hook blocks ensures that the crane is not overloaded!
- ▶ Loads up to a maximum of 60 t are permissible on the boom nose!



Note

- ▶ Observe the notes, see Crane operating instructions, chapter 4.05, chapter 4.08 and chapter 5.01!

Make sure that the following prerequisites are met:

- The LICCON overload protection is active.
- The LICCON overload protection has been set according to the data in the load chart.



WARNING

The crane can topple over!

- ▶ Check the horizontal position of the crane before and during operation!
- ▶ If the crane operator leaves the cab, even for a short time, the operating mode setting must be checked and reset if necessary before resuming crane operation!

4.3.1 Checking the settings

- ▶ Check the function of the LICCON overload protection by running against the operating positions “on top” and “bottom”.
- ▶ Check the hoist limit switch by running against the hoist limit switch weight.
- ▶ Check the function of the limit switches “Boom steep” on the relapse cylinders.

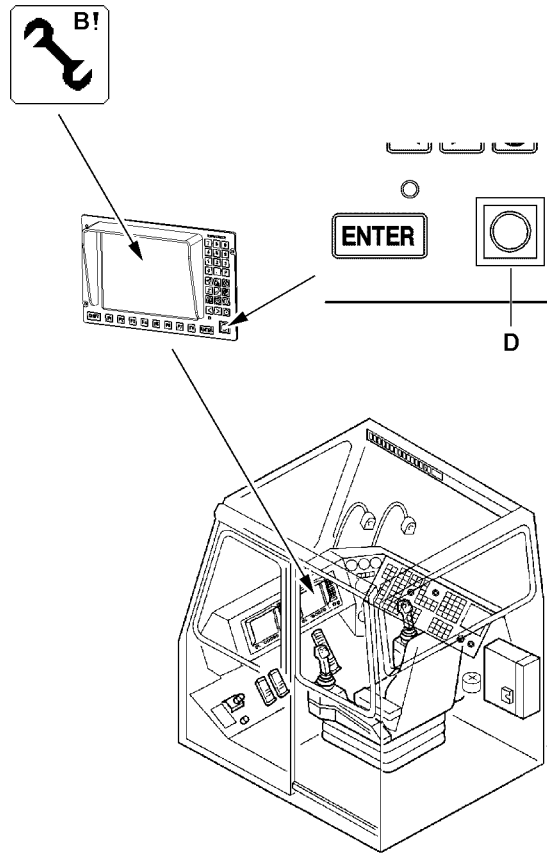

B112255

4.4 Disassembling the boom nose 60 t (H)

4.4.1 Placing the boom down



WARNING

Assembly with turned on set up key!

When the set up key is turned on, the LICCON overload protection is exceeded!

In the event of deliberate improper use, the crane could collapse, the boom can break off or the crane can topple over!

Personnel can be severely injured or killed!

This could result in high property damage!

- ▶ The set up key **D** may only be actuated by persons who know the effects of a bypass!
- ▶ Press the set up key **D** only when the set up status was correctly entered into the LICCON computer system!
- ▶ Observe the erection / take down charts!
- ▶ Crane operation with the set up key **D** turned on is strictly prohibited!



Note

- ▶ Take down the S-boom, see Crane operating instructions, chapter 5.38!
- ▶ Take down the SW-boom, see Crane operating instructions, chapter 5.07!

Make sure that the following prerequisites are met:

- The boom with boom nose is above the ground.
- The hook block is unreeved and removed.
- The LICCON overload protection is exceeded.

NOTICE

Damage of boom nose!

- ▶ If the boom nose is pinned on top and bottom on the end section, then the boom may be luffed down only to the point where the boom nose is not laying on the ground!
- ▶ Luff the boom down until the boom nose just above the ground.
- ▶ Remove the hoist rope.
- ▶ Unplug the hoist limit switch.
- ▶ Disconnect the electrical connections to the terminal boxes.

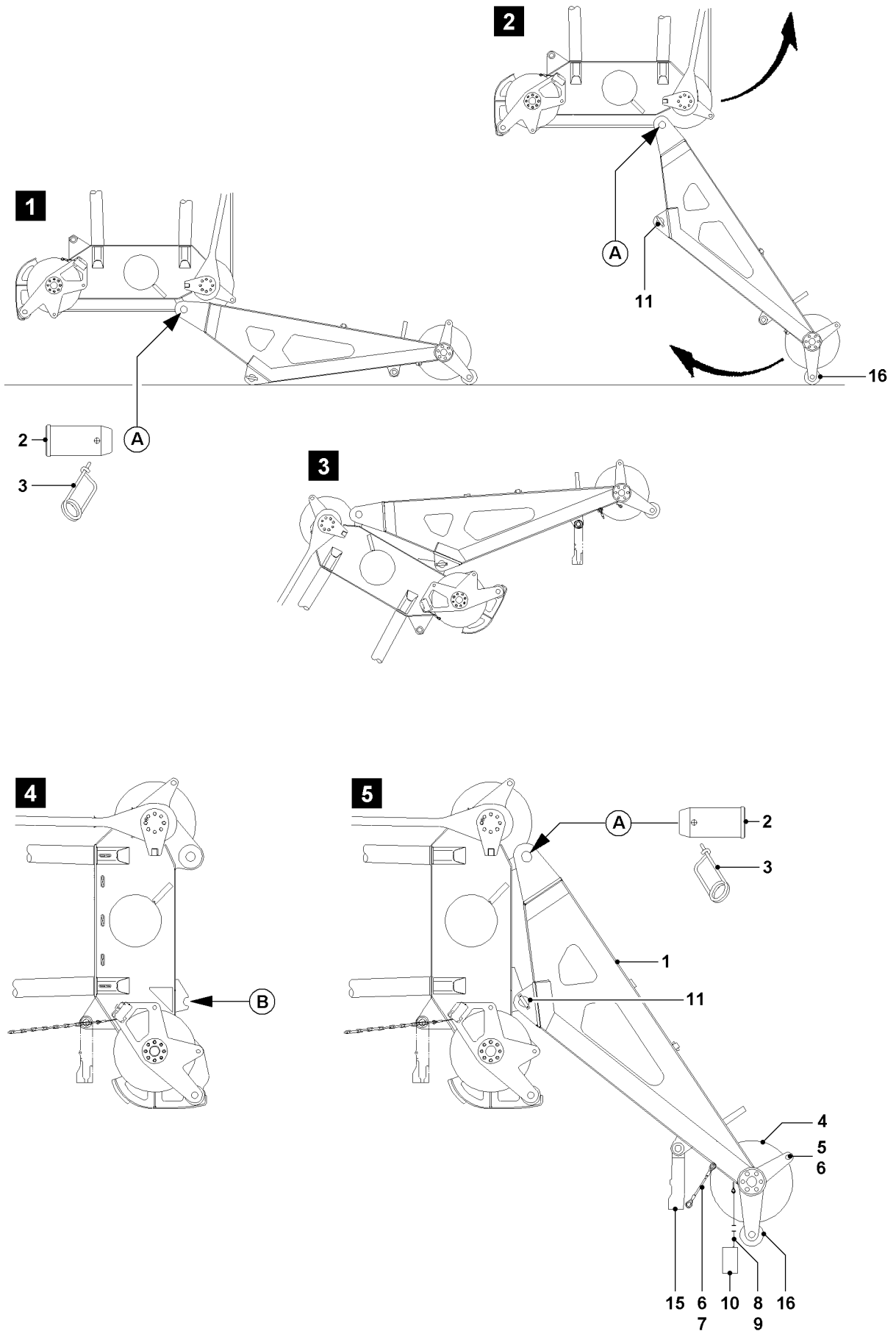

B104697

4.4.2 Disassembling the boom nose 60 t (H) on the W-boom head

Make sure that the following prerequisite is met:

- The boom nose is just above the ground.
- ▶ Disengage the hoist limit switch weight with chain and shackle on the boom nose.
- ▶ Release and unpin the rope retaining pipe **5**.
- ▶ Unreeve the hoist rope.
- ▶ Pin the rope retaining pipe **5** in again and secure.
- ▶ Disconnect the electrical connections to the boom nose.

NOTICE

Damage to the twist compensator!

If the twist compensator **15** is not secured on the boom nose in transport position before placing the boom all the way down, then it can be destroyed when it hits the ground!

- ▶ Secure the twist compensator **15** on the boom nose with the rope **7** and spring retainer **6** before placing the boom down.

-
- ▶ Carefully luff down the W-boom until the boom nose touches the ground with the “Roller”.
 - ▶ Continue to luff down the W-boom carefully until the boom nose folds automatically outward.
 - ▶ Place the W-boom all the way down.

Result:

- The boom nose runs on the roller by itself toward the “outside” (away from the crane).
- ▶ When the boom and the boom nose are laying completely on the ground:
Attach the boom nose on the auxiliary crane.
- ▶ Release and unpin the pin **2** on the end section “on top”, point **A**.
- ▶ Remove the boom nose with the auxiliary crane and place it down outside the working range.
- ▶ Remove the auxiliary crane from the boom nose.

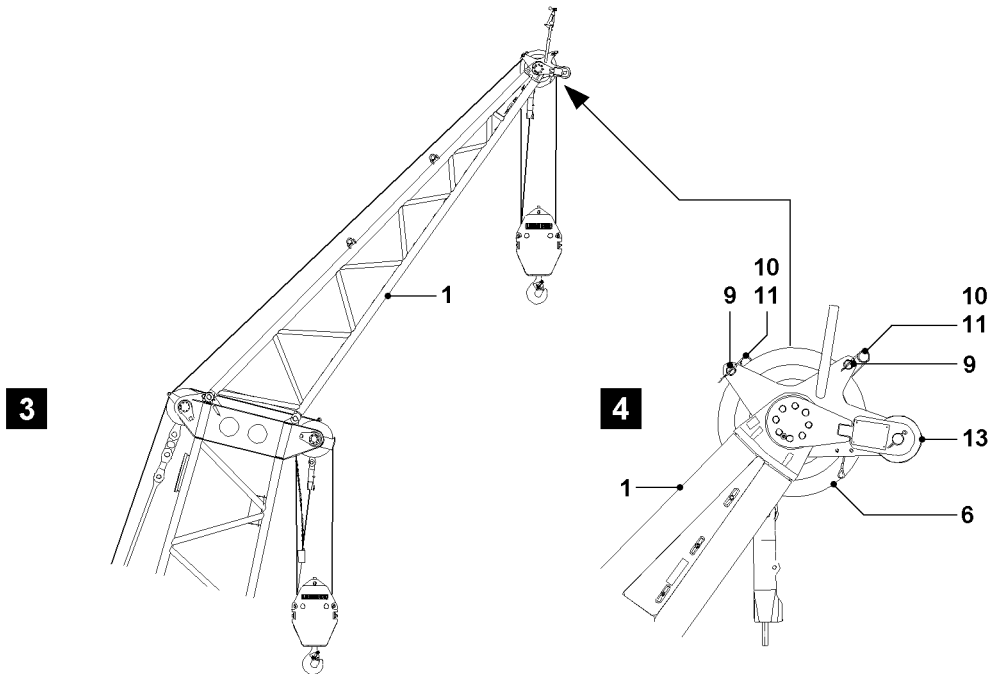
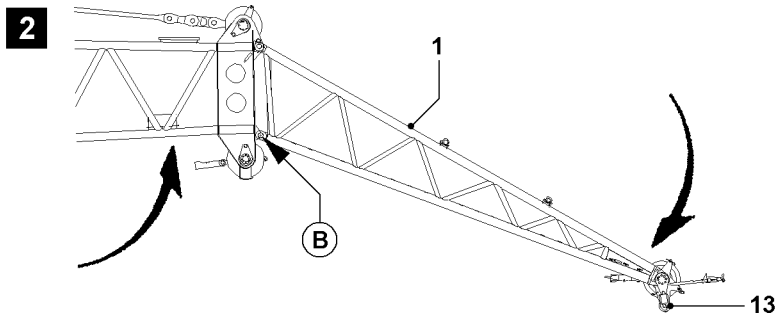
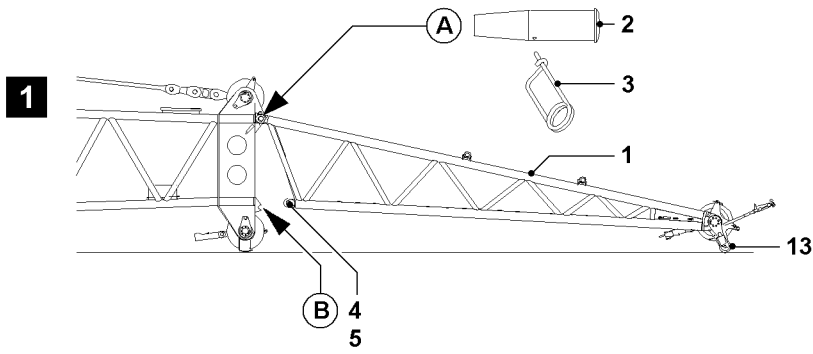

5 Boom nose 72 t (H)

5.1 Component overview boom nose

The 72 t boom nose 1 can be installed and operated on the SL-end section, see illustration.

Position	Description	Weight
1	Boom nose, 72 t (H)	1.75 t
2	Pin	
3	Spring retainer	
4	Pin	
5	Cotter pin	
6	Rope pulley	
9	Rope retaining pipe	
10	Cotter pin (on rope retaining pipe)	
11	Spring retainer	
13	Roller	

5.2 Assembling the boom nose 72 t (H)

Make sure that the following prerequisites are met:

- The crane is aligned in horizontal direction.
- The counterweight has been installed on the turntable according to the load chart.
- The derrick ballast is placed on the suspended ballast or the ballast trailer according to the load chart.
- The LICCON overload protection has been set according to the data in the load chart.
- The mechanical auxiliary support is installed on the crane.
- An auxiliary crane is available.

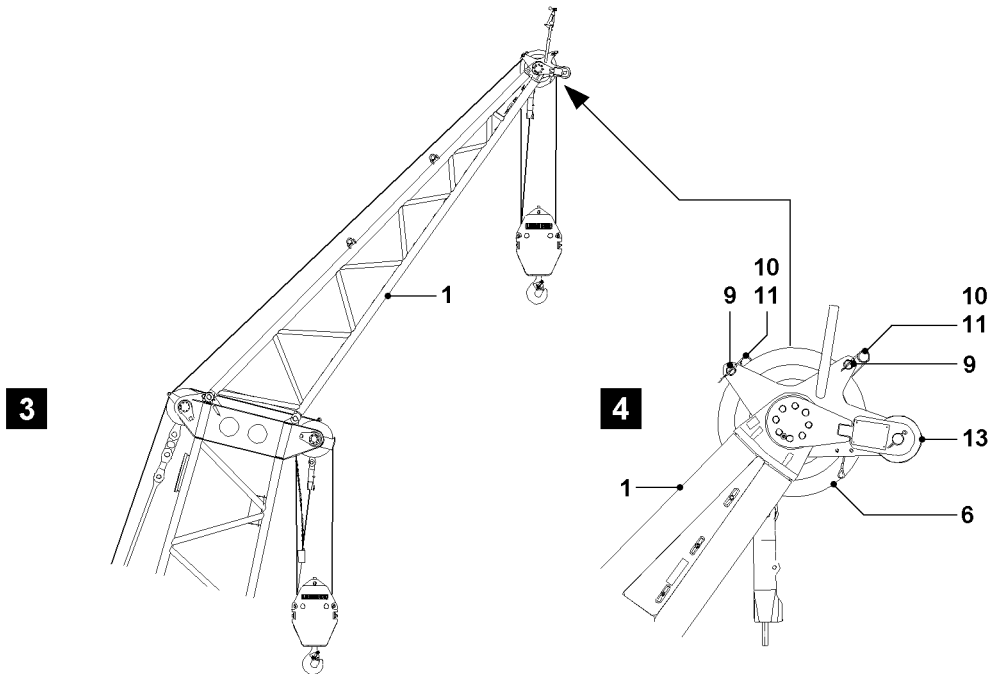
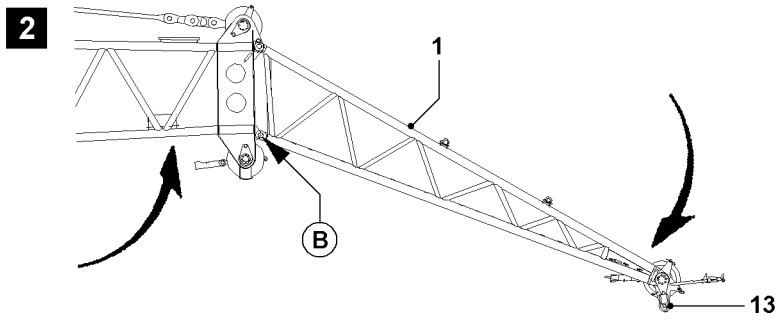
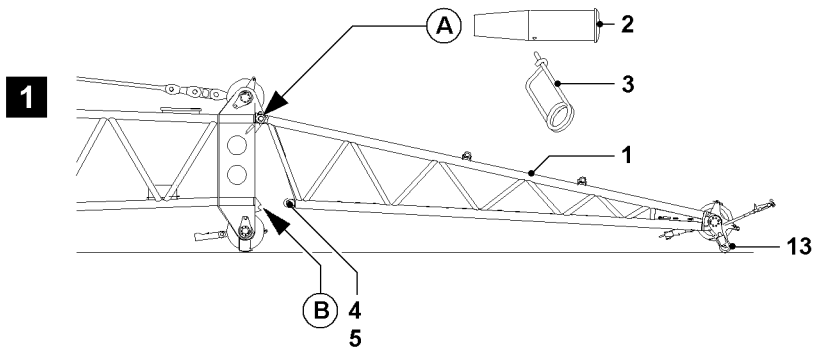

5.2.1 Assembly procedure on SL-boom head

Make sure that the following prerequisite is met:

- The SL-end section is laying on the ground.
- ▶ Hang the boom nose **1** onto the auxiliary crane.
- ▶ Position the boom nose **1** with the auxiliary crane on the SL-end section in such a way that the pin bores align “on top” (point **A**), see illustration 1.
- ▶ When the pin bores align “on top”:
Insert the pin **2** on the SL-end section “on top” from the outside to the inside and secure with spring retainer **3**.
- ▶ Lower the boom nose **1** to the ground with the auxiliary crane.
- ▶ Remove the auxiliary crane.
- ▶ Luff the SL-boom up until the stop pins **4** touch the SL-end section “on the bottom” (point **B**), see illustration 2.



Note

- ▶ The hoist rope must be pulled over the rope pulleys and reeved, see Reeving plan!
 - ▶ Reeve the hook block properly and attach the hoist limit switch weight.
-

5.2.2 Establishing the electrical connections

Make sure that the following prerequisite is met:

- The boom nose is completely assembled.
- ▶ Establish the electrical connection from the terminal box of the “SL-end section” to the terminal box “Boom nose”.
- ▶ Establish the electrical connection from the terminal box of the “Boom nose” to the hoist limit switch.

5.2.3 Function check

Make sure that the following prerequisites are met:

- All electrical connections have been established.
- The corresponding operating mode is set in the LICCON computer system.

Limit switch - General



Note

- ▶ The limit switch functions have to be checked individually before erection!
-

Hoist limit switch

- ▶ Manually actuate the hoist limit switch.

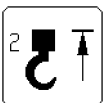

Result:

- The icon appears on the LICCON monitor.
- The **spool up function** of the hoist winch turns off.

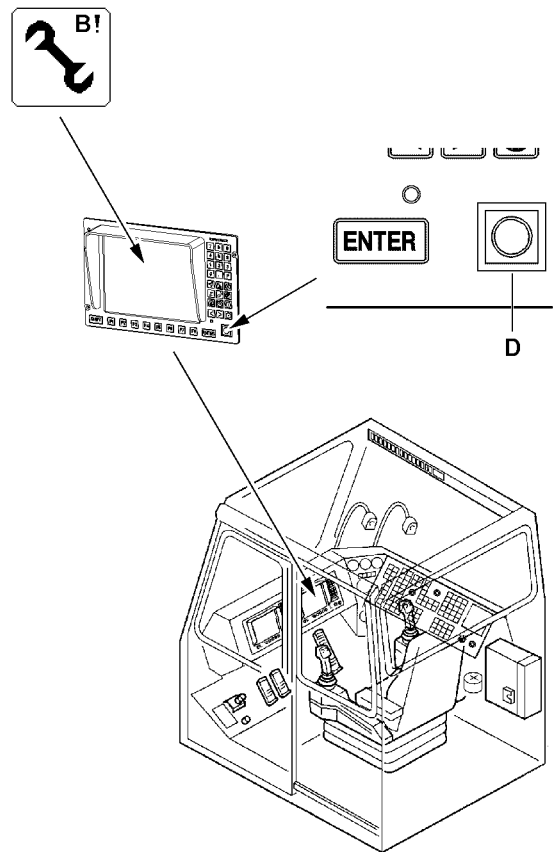
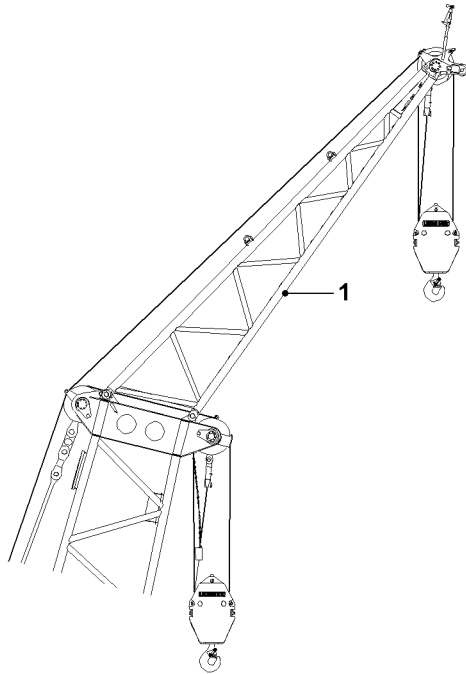

B112259

5.2.4 Erecting the boom



WARNING

Assembly with turned on set up key!

When the set up key is turned on, the LICCON overload protection is exceeded!

In the event of deliberate improper use, the crane could collapse, the boom can break off or the crane can topple over!

Personnel can be severely injured or killed!

This could result in high property damage!

- ▶ The set up key **D** may only be actuated by persons who know the effects of a bypass!
- ▶ Press the set up key **D** only when the set up status was correctly entered into the LICCON computer system!
- ▶ Observe the erection / take down charts!
- ▶ Crane operation with the set up key **D** turned on is strictly prohibited!

NOTICE

Danger of property damage on the boom nose!

- ▶ When erecting the boom systems, it must be ensured that the hoist rope does not get stuck in the boom nose!
- ▶ Reeve in the hoist rope according to the reeving plans on the hook block!



Note

- ▶ Erect the S-boom, see Crane operating instructions, chapter 5.38!
- ▶ Erect the SW-boom, see Crane operating instructions, chapter 5.07!

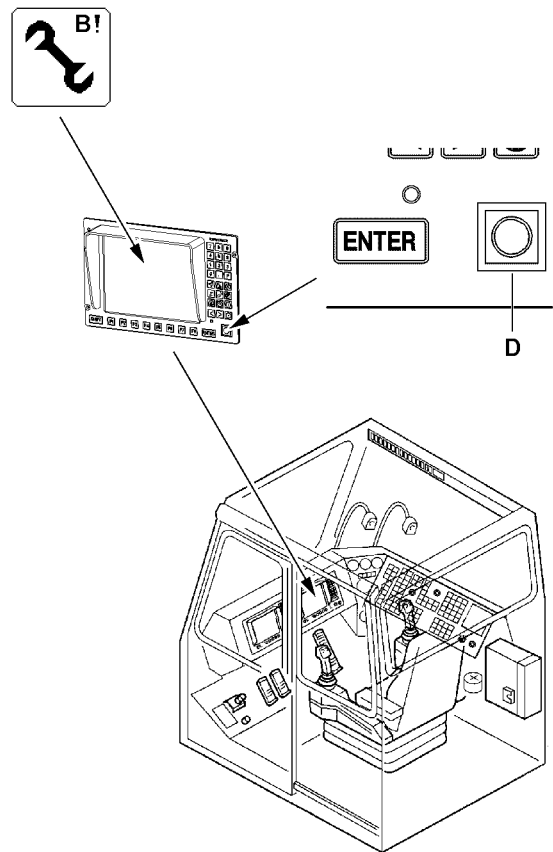
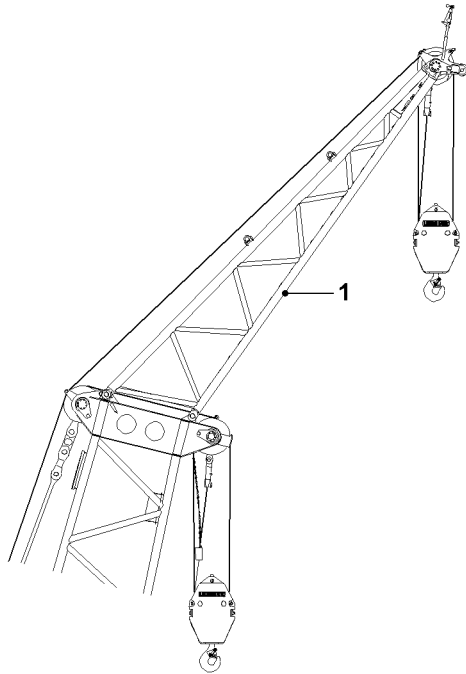

B112259

5.3 Crane operation

The possibility to operate the crane with this boom nose is intended for turning loads at simultaneous operation of both hoist gears over the 100 t head (SL-end section) and the boom nose.



DANGER

The crane can topple over!

- ▶ It is only permitted to turn a load in two hook operation towards the main hook!
- ▶ The setting of the LICCON overload protection to the smaller reeving of the two hook blocks ensures that the crane is not overloaded!
- ▶ Loads up to a maximum of 72 t are permissible on the boom nose!



Note

- ▶ Observe the notes, see Crane operating instructions, chapter 4.05, chapter 4.08 and chapter 5.01!

Make sure that the following prerequisites are met:

- The LICCON overload protection is active.
- The LICCON overload protection has been set according to the data in the load chart.



WARNING

The crane can topple over!

- ▶ Check the horizontal position of the crane before and during operation!
- ▶ If the crane operator leaves the cab, even for a short time, the operating mode setting must be checked and reset if necessary before resuming crane operation!

5.3.1 Checking the settings

- ▶ Check the function of the LICCON overload protection by running against the operating positions “on top” and “bottom”.
- ▶ Check the hoist limit switch by running against the hoist limit switch weight.
- ▶ Check the function of the limit switches “Boom steep” on the relapse cylinders.

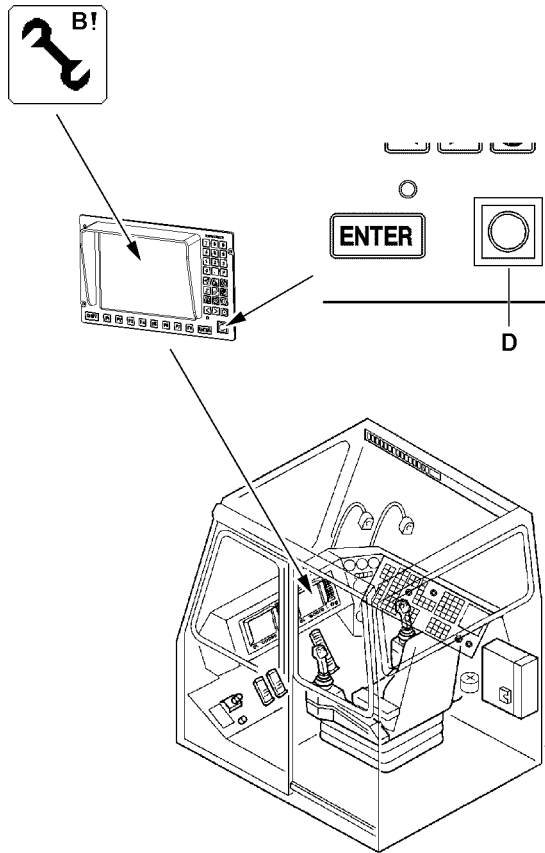

5.4 Disassembling the boom nose 72 t (H)

5.4.1 Placing the boom down



WARNING

Assembly with turned on set up key!

When the set up key is turned on, the LICCON overload protection is exceeded!

In the event of deliberate improper use, the crane could collapse, the boom can break off or the crane can topple over!

Personnel can be severely injured or killed!

This could result in high property damage!

- ▶ The set up key **D** may only be actuated by persons who know the effects of a bypass!
- ▶ Press the set up key **D** only when the set up status was correctly entered into the LICCON computer system!
- ▶ Observe the erection / take down charts!
- ▶ Crane operation with the set up key **D** turned on is strictly prohibited!



Note

- ▶ Take down the S-boom, see Crane operating instructions, chapter 5.38!
- ▶ Take down the SW-boom, see Crane operating instructions, chapter 5.07!

Make sure that the following prerequisites are met:

- The boom with boom nose is above the ground.
- The hook block is unreeved and removed.
- The LICCON overload protection is exceeded.

NOTICE

Damage of boom nose!

- ▶ If the boom nose is pinned on top and bottom on the end section, then the boom may be luffed down only to the point where the boom nose is not laying on the ground!
- ▶ Luff the boom down until the boom nose just above the ground.
- ▶ Remove the hoist rope.
- ▶ Unplug the hoist limit switch.
- ▶ Disconnect the electrical connections to the terminal boxes.

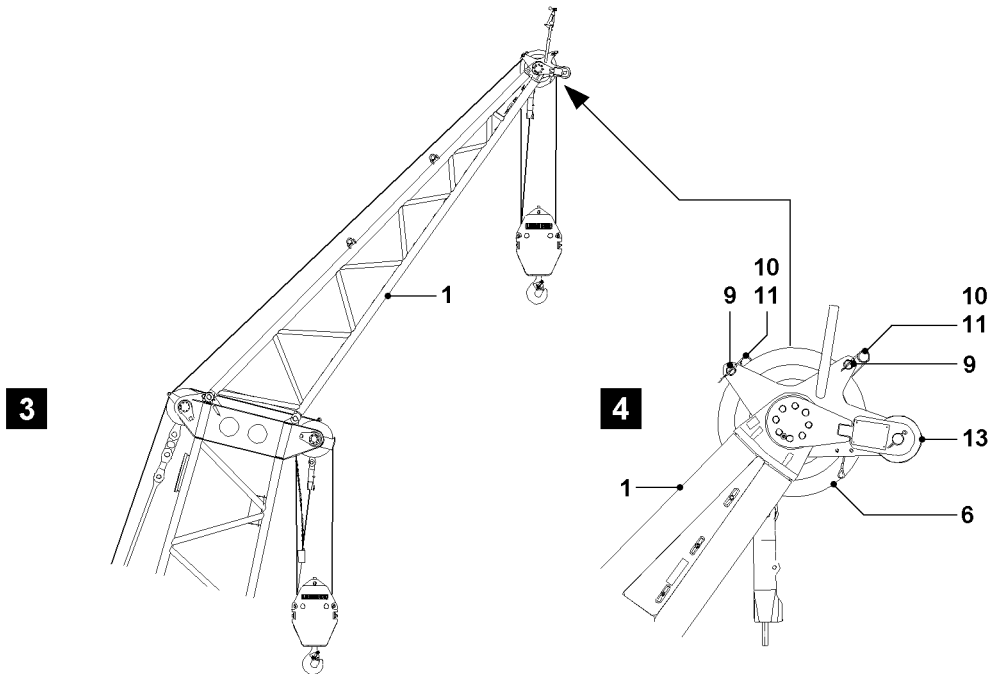
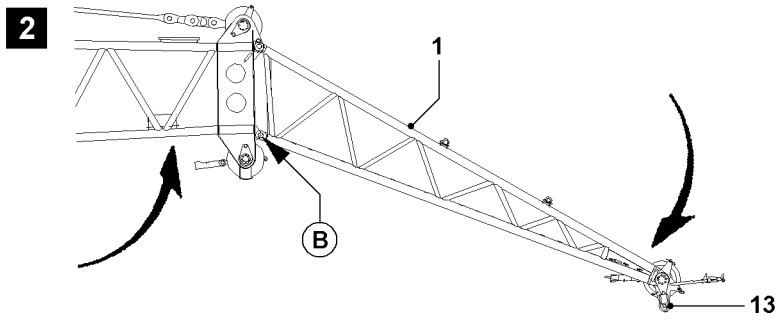
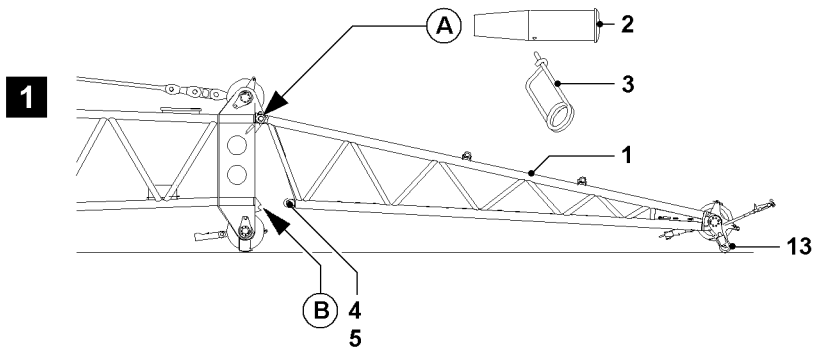

5.4.2 Disassembling the boom nose 72 t (H) on the SL-boom head

Make sure that the following prerequisite is met:

- The boom nose is just above the ground.
- ▶ Disengage the hoist limit switch weight with chain and shackle on the boom nose.
- ▶ Release and unpin the rope retaining pipes **9**.
- ▶ Unreeve the hoist rope.
- ▶ Pin the rope retaining pipe **9** in again and secure.
- ▶ Disconnect the electrical connections to the boom nose.
- ▶ Carefully lower the SL-boom until the boom nose **1** touches the ground with the “Roller **13**”.
- ▶ Continue to luff down the SL-boom carefully until the boom nose folds automatically outward.
- ▶ Place the SL-boom all the way down.

Result:

- The boom nose runs on the roller **13** by itself toward the “outside” (away from the crane).
- ▶ When the boom and the boom nose are laying completely on the ground:
Attach the boom nose on the auxiliary crane.
- ▶ Release and unpin the pin **2** on the end section “on top”, point **A**.
- ▶ Remove the boom nose with the auxiliary crane and place it down outside the working range.
- ▶ Remove the auxiliary crane from the boom nose.

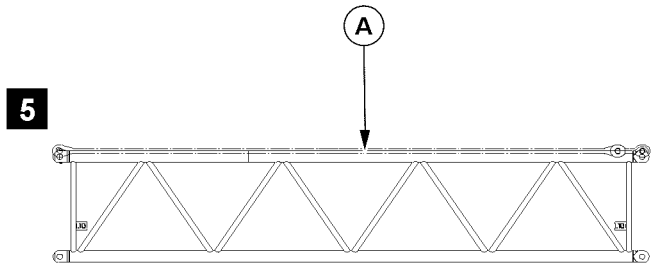
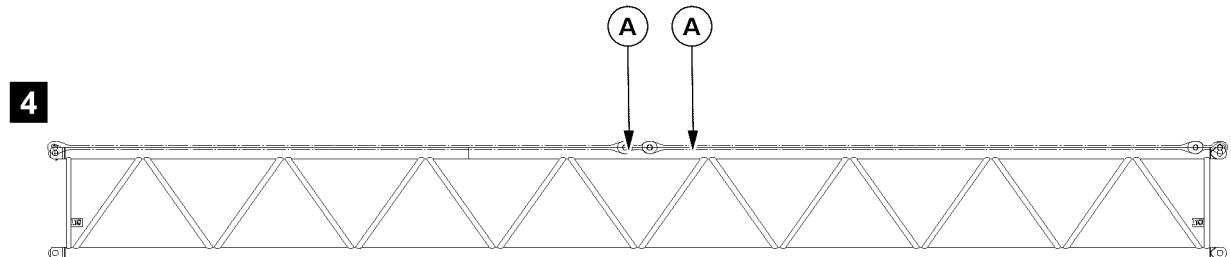
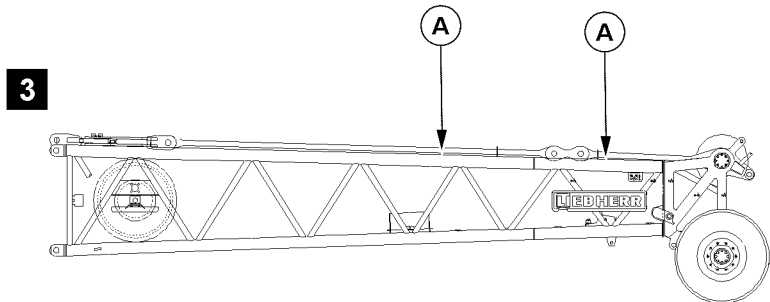
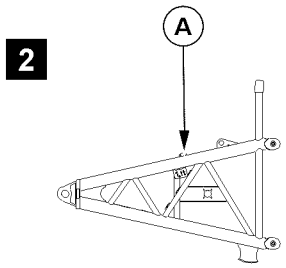
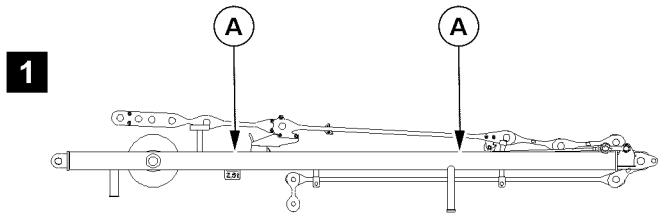

B105939

1 Component overview

1.1 Fastening points



WARNING

Falling components!

Components can fall due to incorrect or improper attachment. Personnel can be severely injured or killed!

► The corresponding components must be attached on the intended points **A!**



Note

► For assembly or disassembly, tackle with a strand length of at least **4 m** must be used!

1.2 FA-bracket

See illustration 1

Component	Abbreviation	Weight
FA-bracket	—	2.4 t

1.3 F-pivot section

See illustration 2

Component	Abbreviation	Weight
F-pivot section	—	0.7 t

1.4 F-end section

See illustration 3

Component	Abbreviation	Weight
F-end section	—	3.3 t

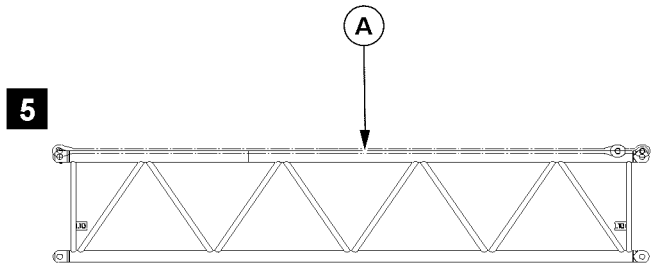
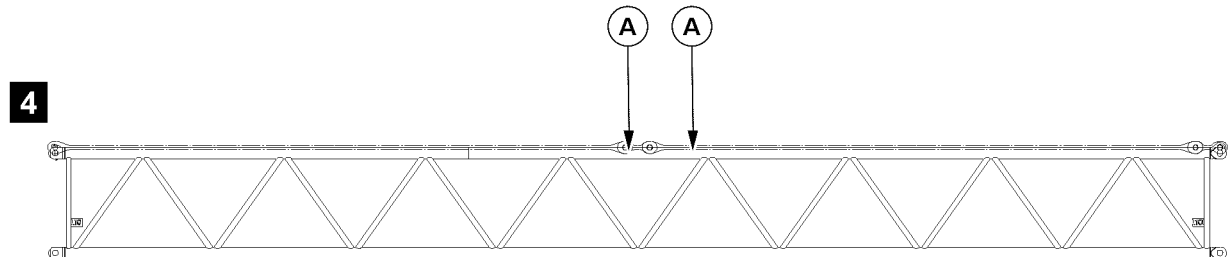
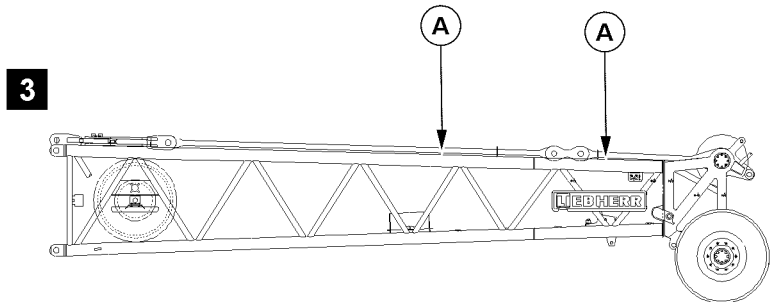
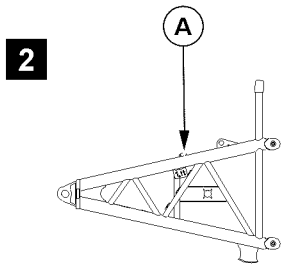
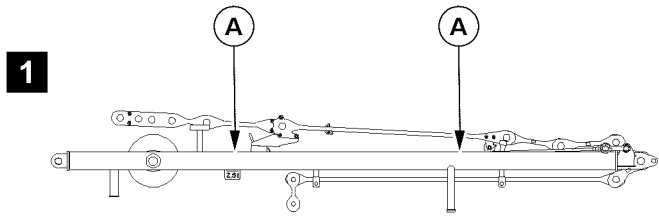

B105939

1.5 NI-intermediate section 14 m

See illustration 4

For the combination of the lattice sections with the same system number and the same grade, the following rules apply:

- Two intermediate sections 7 m can be replaced with one intermediate section 14 m.

Component	Abbreviation	Weight
NI-intermediate section (14 m) with guy rods	NI 1812.10	2.5 t

1.6 NI-intermediate section 7 m

See illustration 5

For the combination of the lattice sections with the same system number and the same grade, the following rules apply:

- Two intermediate sections 7 m can be replaced with one intermediate section 14 m.

Component	Abbreviation	Weight
NI-intermediate section (7 m) with guy rods	NI 1812.10	1.4 t

2 Assembling F-lattice jib



WARNING

Risk of falling!

During assembly and disassembly, personnel must be secured with appropriate aids to prevent them from falling! If this is not observed, assembly personnel can fall and suffer life-threatening or fatal injuries!

- ▶ Any work, where there is a danger of falling must be carried out with suitable aids (for example: lifting platforms, scaffoldings, ladders, auxiliary crane)!
- ▶ If the work cannot be carried out with such aids nor from the ground, then the assembly personnel must secure themselves with approved fall arrest systems to avoid falling, see Crane operating instructions chapter 2.04!
- ▶ If railings are present on the components, then they must be brought into the corresponding position and secured for assembly / disassembly work!
- ▶ Step on aids and fall protection equipment only with clean shoes!
- ▶ Keep aids and fall protection equipment clean and free from snow and ice!
- ▶ During all assembly and disassembly work, maintenance work and inspections, travel or crane operation is prohibited!



WARNING

Falling components!

If unsecured or non-supported components are assembled or disassembled, they can fall down. Personnel can be killed or seriously injured!

- ▶ During pinning and unpinning of the lattice sections, it is prohibited for anyone to remain **under** or **on** the components as well as within the entire danger zone!
- ▶ Support the boom and components before pinning / unpinning!
- ▶ Pin or unpin both pins laying in a horizontal, i.e. **left** and **right**!
- ▶ Secure the pins in the bearing points and in the receptacles!
- ▶ Do not disengage the auxiliary crane until each component is pinned on and secured!
- ▶ It is prohibited to lean a ladder against the component being disassembled!



WARNING

Danger of impact / crushing!

When installing / removing crane components with the auxiliary crane, crane components can start to swing back and forth!

When lifting / lowering and positioning crane components, there is an increased danger of impacts / crushing!

Personnel can be caught and severely injured or killed!

- ▶ Make sure that personnel cannot be caught by components!
- ▶ Make sure that the crane is aligned in horizontal position to avoid the support beams from swinging by themselves!
- ▶ When working in danger zones: Use aids to protect limbs!
- ▶ Guide components with suitable aids to minimize oscillation!

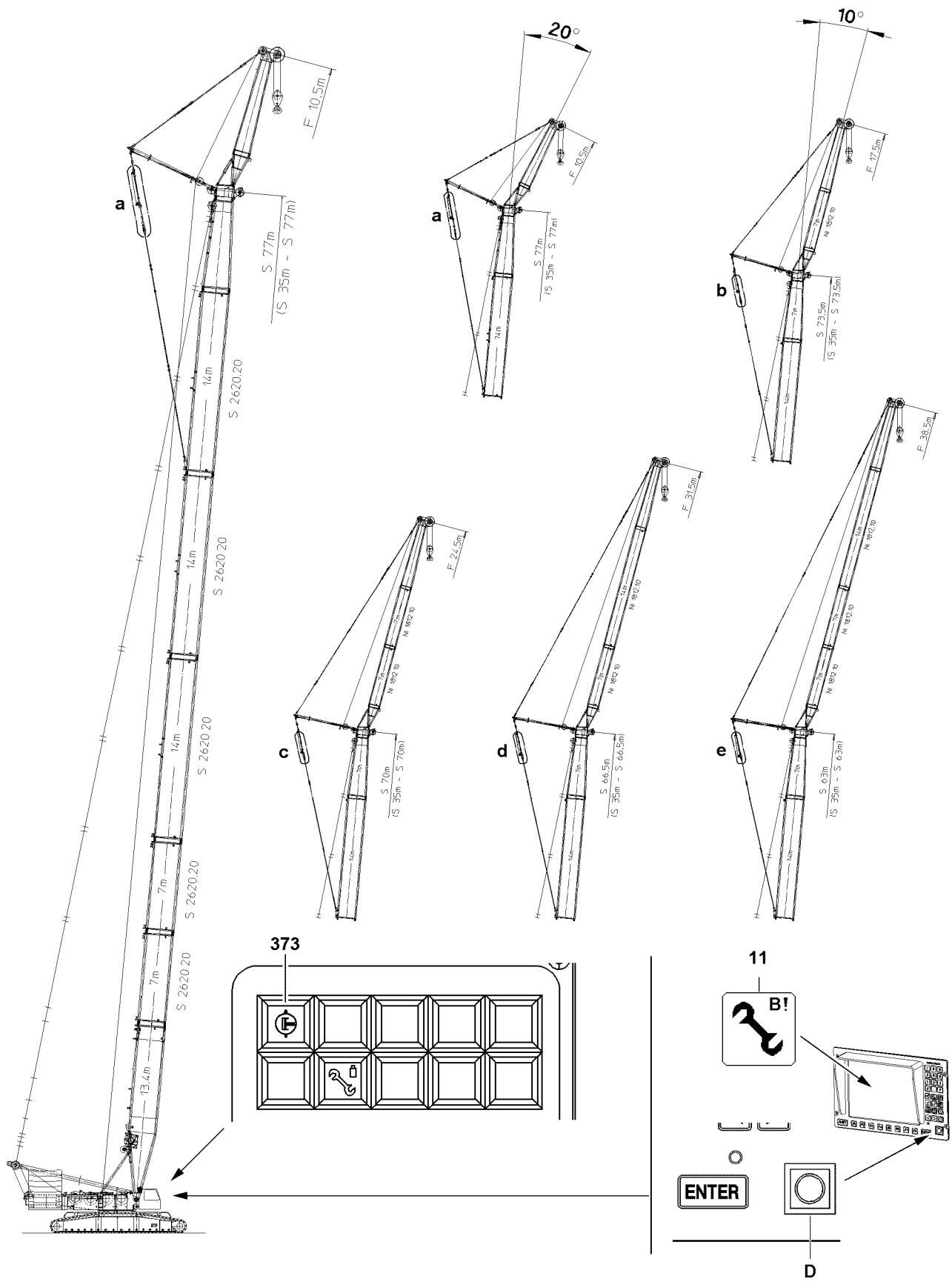

B111467

This crane can be equipped with an F-lattice jib.

The F-lattice jib can be assembled in the following angles for the S-boom, see illustration:

- 10 °
- 20 °

**Note**

- ▶ The F-lattice jib is **not** adjustable in crane operation!
-

**Note**

- ▶ In S2F2 operation, no pulley head is assembled on the L-end section!
-

Make sure that the following prerequisites are met:

- On the crane, the “mechanical auxiliary supports” are assembled properly, see **Erection and take down charts**.
- The SL-boom is installed and luffed down “to the side” over the “mechanical auxiliary supports”.
- The S-intermediate section with “guy brackets for the F-guying” is assembled on the S-boom, pinned and secured.
- The guy rods are placed on the S-intermediate section and are pinned and secured with the guy brackets.
- The L-end section is pinned and secured on the S-adapter.
- The F-assembly unit is properly hung and secured on the auxiliary crane.
- The F-assembly unit is pinned on the L-end section with double cone pins on top and bottom and secured with spring retainers.
- The LICCON overload protection has been set according to the data in the load chart.
- The LICCON overload protection is exceeded.
- The assembly icon **11** is visible on the LICCON monitor.
- The button **373** is actuated for the manual pressure supply.
- An auxiliary crane is available.

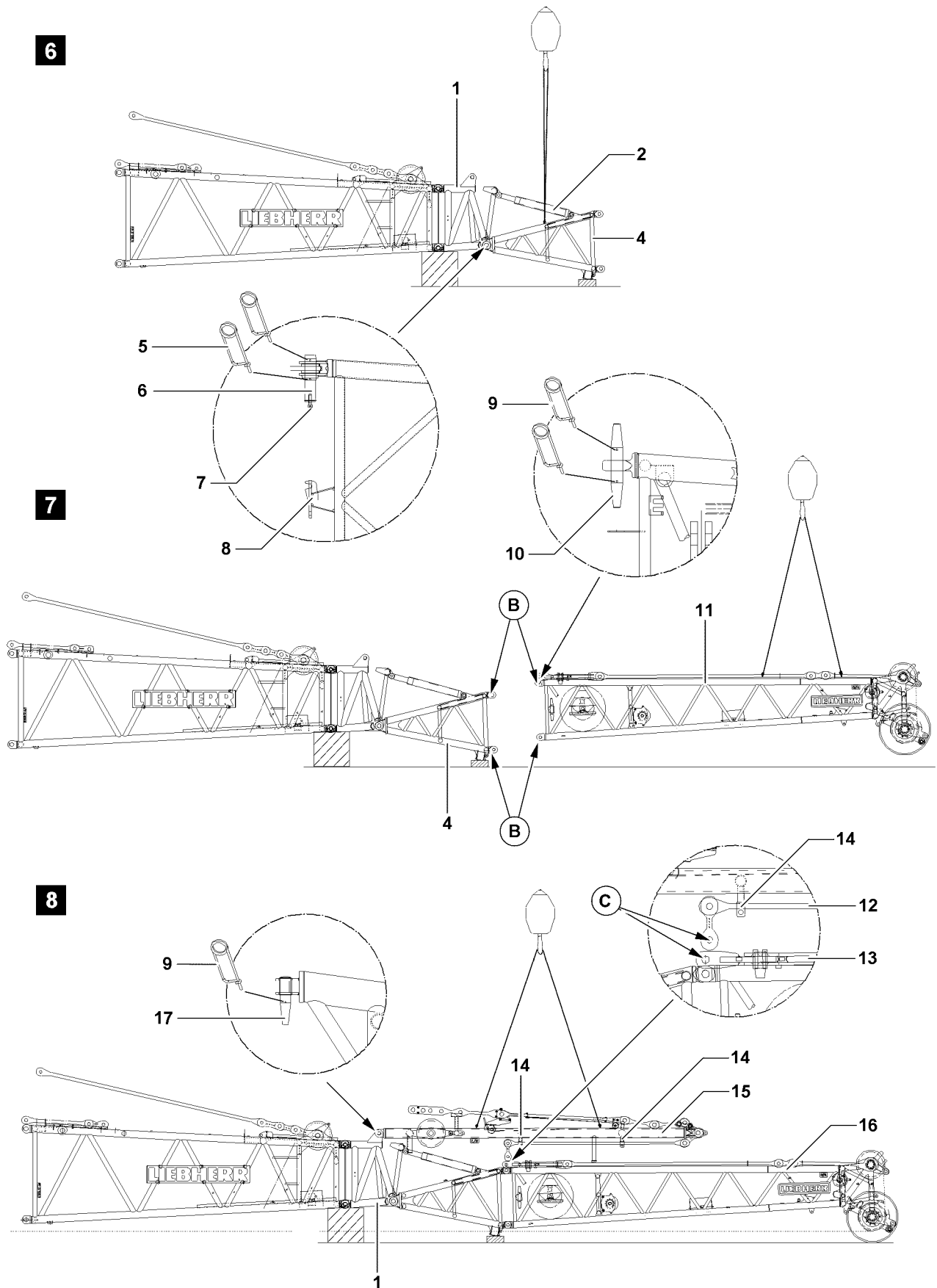

B105941

2.1 Assembling the F-pivot section

See illustration 6

Make sure that the following prerequisites are met:

- The hydraulic relapse cylinder is retracted.
- The boom lays on the ground with the pulley set or is supported.



Note

- ▶ Pin pulling device, see Crane operating instructions, chapter 5.30!
-

- ▶ Release and unpin the pins 6 on the F-pivot section 4.
- ▶ Lift the F-pivot section 4 with the auxiliary crane.
- ▶ Hang the hydraulic pin pulling cylinder on the screw 7 and retainer 8.
- ▶ Pin and secure the F-pivot section 4 with pins 6 and with spring retainers 5 on the L-end section 1 with pin pulling device.
- ▶ Unhook the hydraulic pin pulling cylinder on the F-pivot section 4 and remove.
- ▶ Support the F-pivot section 4 and place it down.
- ▶ Remove the auxiliary crane.

2.2 Assembling F-lattice jib

See illustration 7

Assemble the F-lattice jib with the NI-lattice sections and the F-pivot section 4 to the required length. Lift the components with the auxiliary crane.

- ▶ Support the NI-lattice sections and F-end section 11 and pin with pins 10 and secure with spring retainers 9.
- ▶ Pin the F-lattice jib on the F-pivot section 4 in the points B with pins 10 and secure with spring retainers 9.

2.3 Assembling the FA-bracket

See illustration 8

Make sure that the following prerequisite is met:

- The main boom is raised or the end section is supported.

- ▶ Lift the FA-bracket 15 with the auxiliary crane on the L-end section 1 and pin with pin 17 and secure with spring retainer 9.
- ▶ Place the FA-bracket 15 down on the lattice jib 16.
- ▶ Release and unpin the transport retainers 14.
- ▶ Pin the guy rods FA-bracket 12 with guy rods F-lattice jib 16 in point C.

9

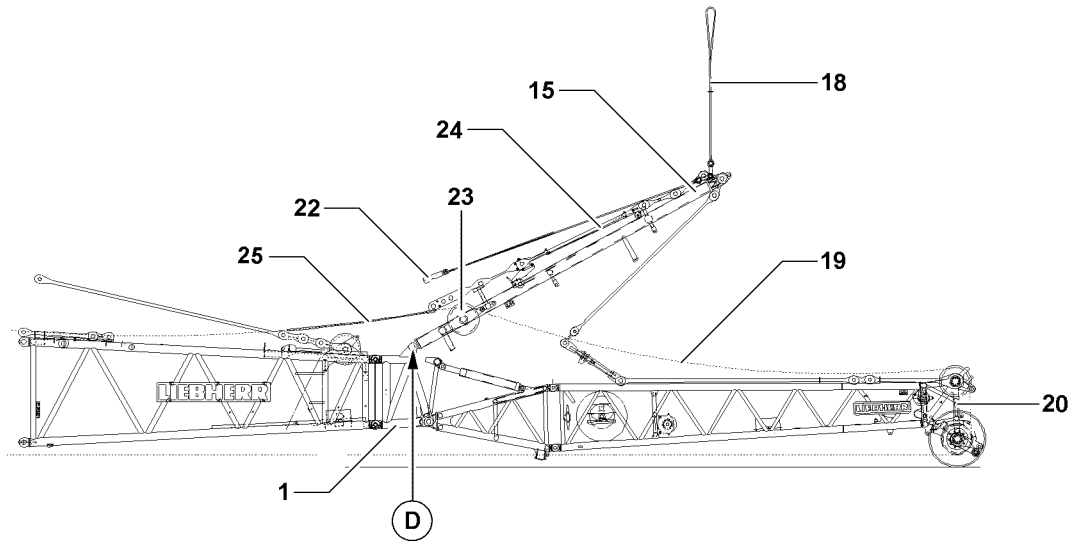

10

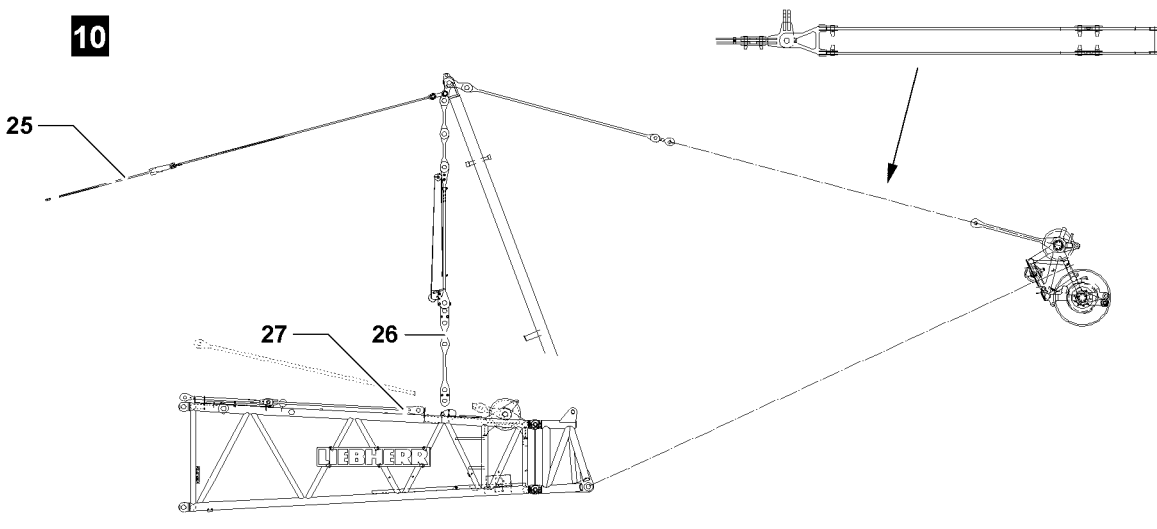

11

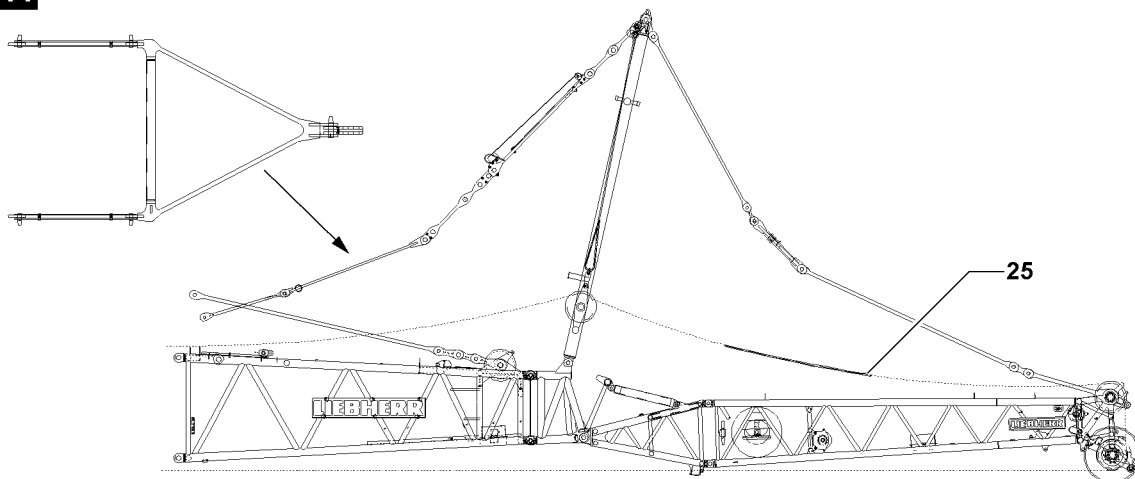

B105942

2.4 Assembling the guy rods

2.4.1 Erecting the FA-bracket



WARNING

Risk of accident!

If the following instructions are not observed, personnel can be severely injured or killed!

- ▶ The boom combinations must be assembled according to the separately supplied rod and assembly plans!
 - ▶ Depending on the condition of the ground, the boom and the lattice sections must be supported from below for the assembly of the boom!
 - ▶ Observe the safety technical notes, see Crane operating instructions, chapter 5.01!
-
- ▶ Pull the assembly rope **19** over the pulley set **20** on the F-end section and over the pulley **23** on the FA-bracket.
 - ▶ Hang the fastening equipment **18** of the FA-bracket on the auxiliary crane.
 - ▶ Lift the FA-bracket **15**.
 - ▶ Pull the hoist rope **25** with the assembly winch forward to the L-end section **1** and place it in the lock **22** on the FA-bracket **15**.
 - ▶ Lift the FA-bracket **15** with the auxiliary crane until the FA-bracket **15** is over the pivot point **D**, see illustration **9**.
 - ▶ Tension the hoist rope **25** and remove the auxiliary crane.
 - ▶ Pull the FA-bracket **15** up with the hoist rope until the guy rods FA-bracket **26** hang down vertically.

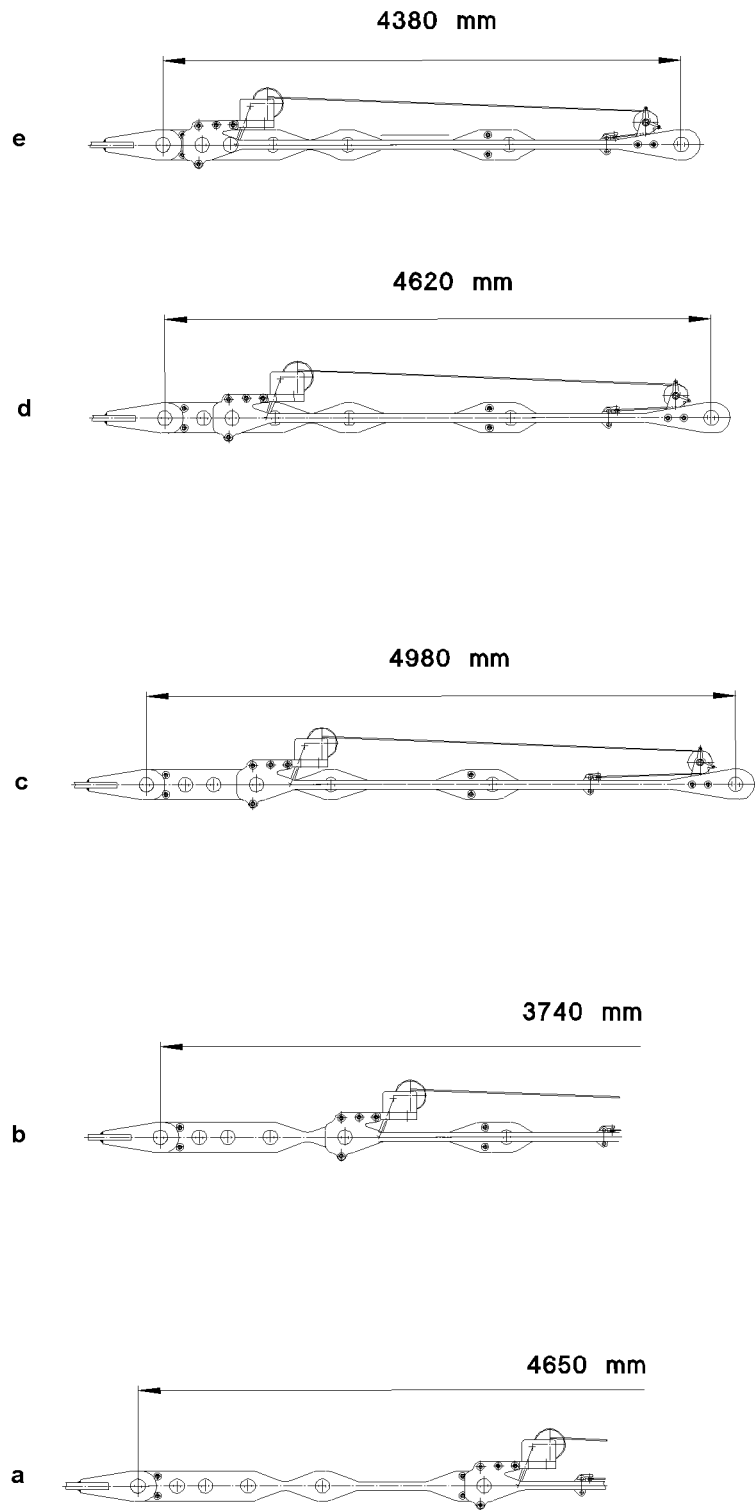
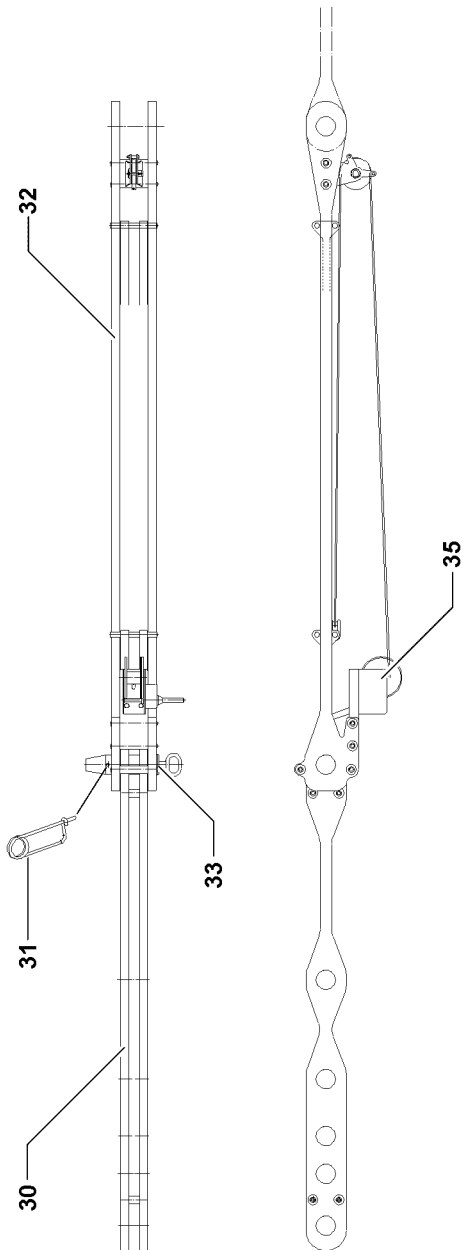

B105940

2.4.2 Adjusting the length of the guy rods

The guy rods of the FA-bracket are adjusted according to the lattice jib lengths.

Lattice jib length F	Illustration
10.5 m	a
17.5 m	b
24.5 m	c
31.5 m	d
38.5 m	e

- ▶ Determine the necessary lengths for the guy rods.



Note

- ▶ If the pins **33** are unpinned, the self-retention of the rope winch **35**, prevents the guy rods **30** from falling down!
- ▶ Remove the spring retainer **31** and unpin the pin **33**.
- ▶ Adjust the guy rods **26** with the rope winch **35** to the required lengths.
- ▶ Secure the guy rods **32** and guy rods **33** with pin **33** and spring retainer **31**.

9

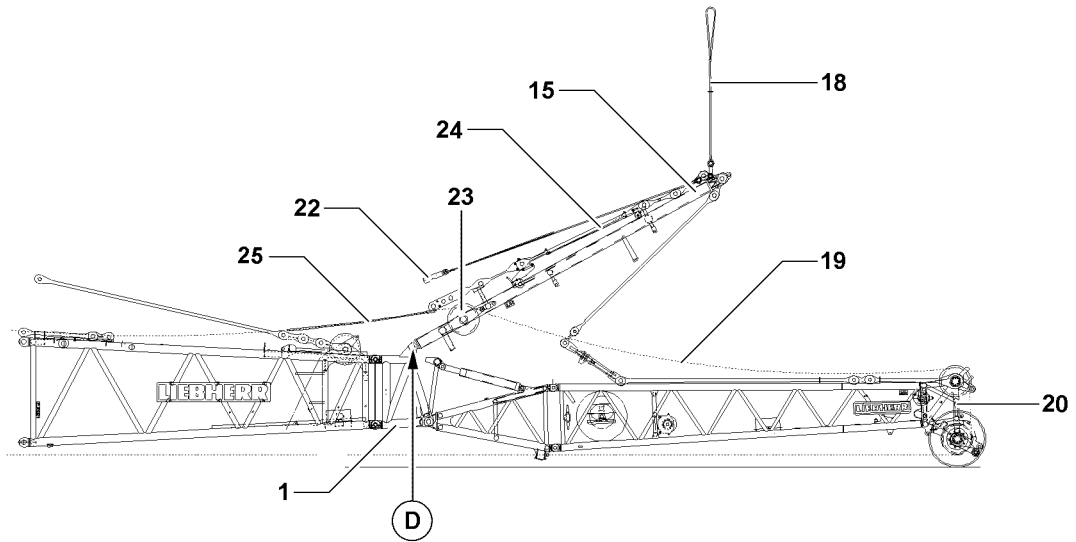

10

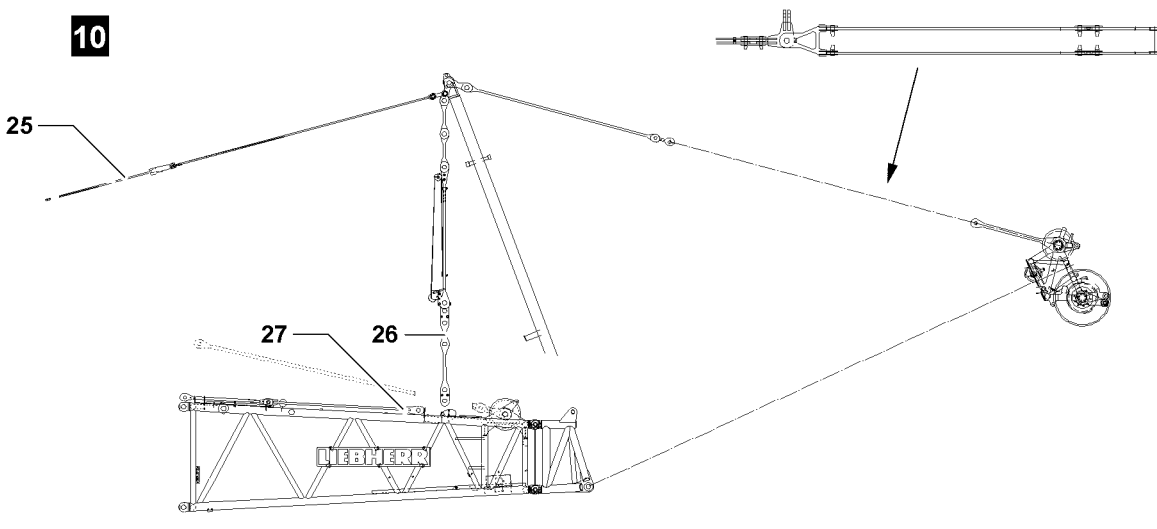

11

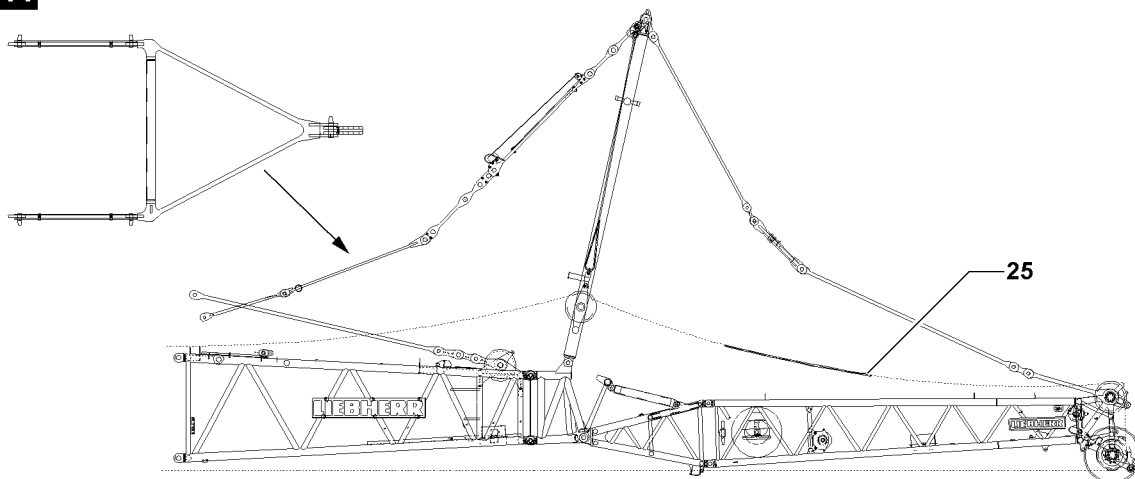

B105942

2.4.3 Pinning the guy rods

- ▶ Pin and secure the guy rods **26** FA-bracket with the guy rods **27** for the main boom.
- ▶ Relieve the hoist rope **25** and remove it from the lock **22**.
- ▶ Attach the hoist rope **25** on the assembly rope **19** and pull it over the pulley set **20** so that there is sufficient rope available for the erection procedure.
- ▶ Remove the assembly rope and spool it on the assembly winch.

12

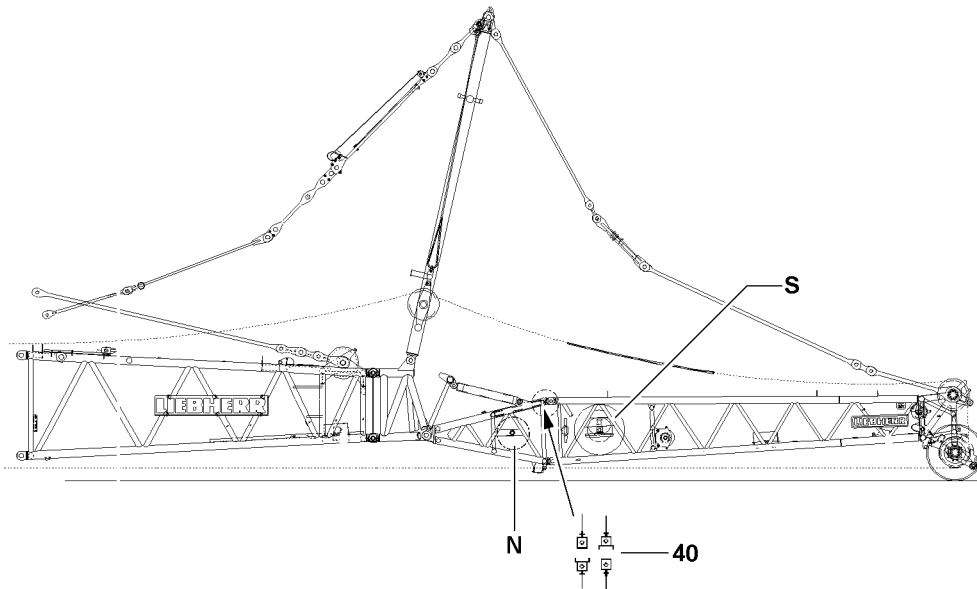

13

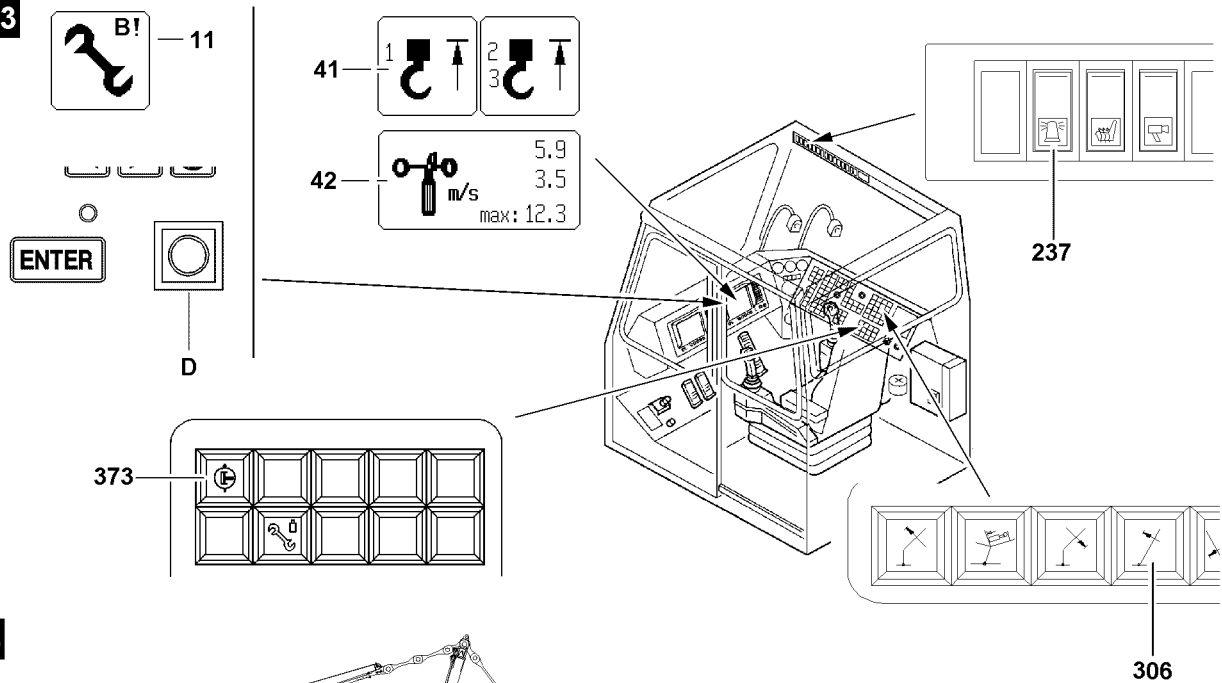

14

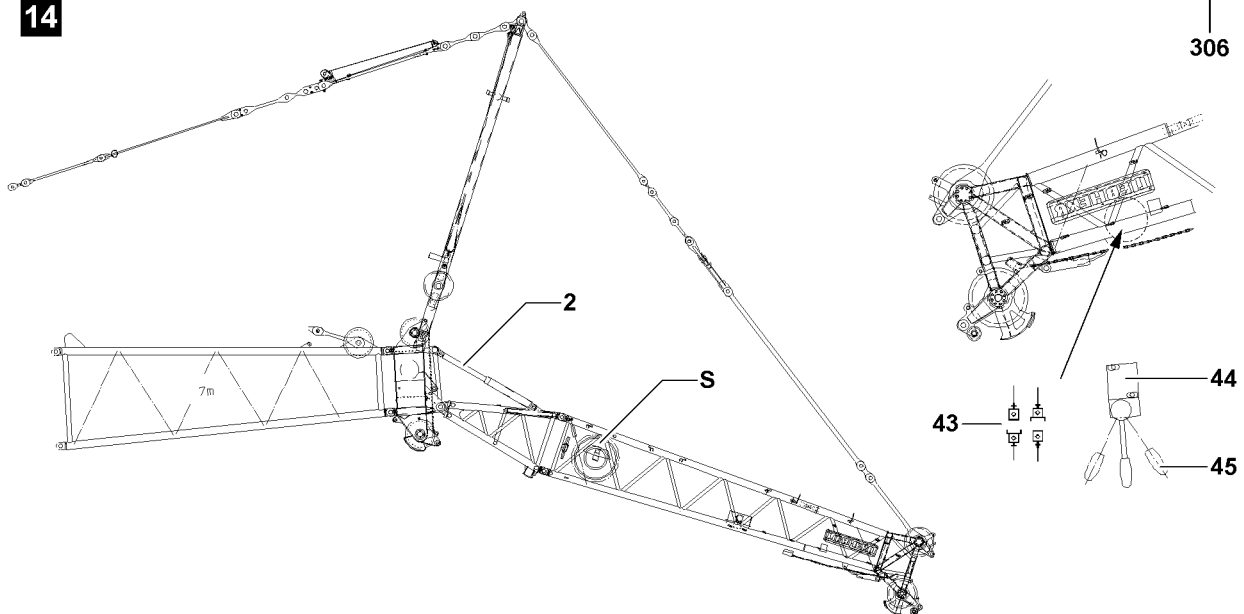

B111468

2.5 Establishing the electrical connections



Note

- ▶ To establish the electrical connections, see Electric wiring diagram!

NOTICE

Damage to the electrical connection on the cable drum!

If the electrical connection from the cable drum to the terminal box is made in incorrect sequence, then the electrical connection can be damaged when spooling the cable drum out!

- ▶ When establishing the electrical connections, pay attention to the sequence, see Electric wiring diagram!

Make sure that the following prerequisite is met:

- The F-lattice jib is completely assembled.
- ▶ Establish the electrical connections.
- ▶ Make sure that all electrical connections on the boom are established.

2.6 Checking the function of the safety devices



WARNING

Non-functioning safety devices!

If the function of the safety devices is defective, personnel can be severely injured or killed!

- ▶ Crane operation with non-functioning safety devices is **prohibited!**



Note

- ▶ The function of the individual limit switches must be checked before erection!
- ▶ The function of the limit switch initiators must be checked in the test system, see Diagnostics manual!



Note

- ▶ If a function check on the limit switches or on the safety devices does not lead to the desired shut offs, then the plug connections on the connector boxes or the components themselves must be checked! If no visible connection errors or component defects can be found, contact LIEBHERR Service!

12

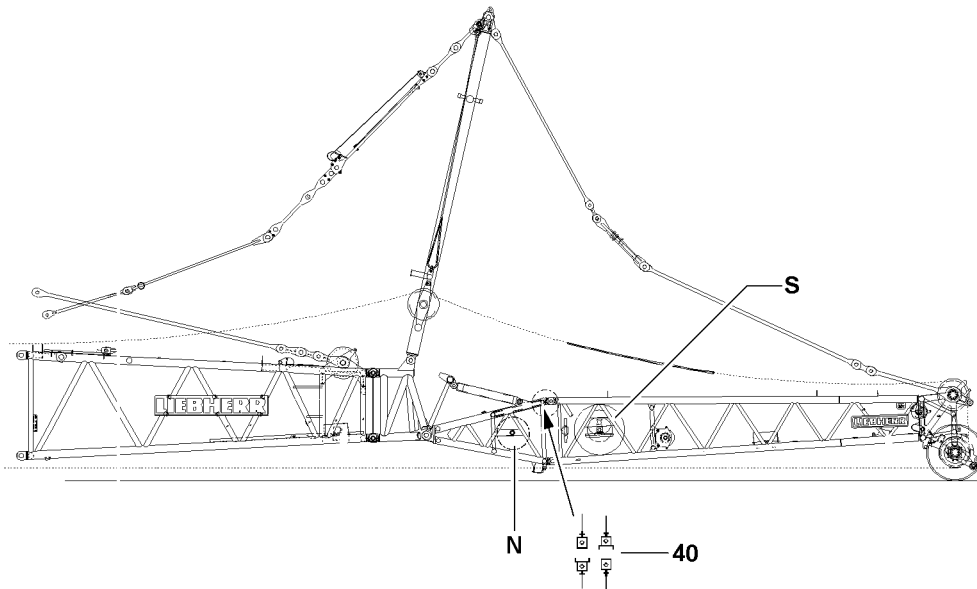

13

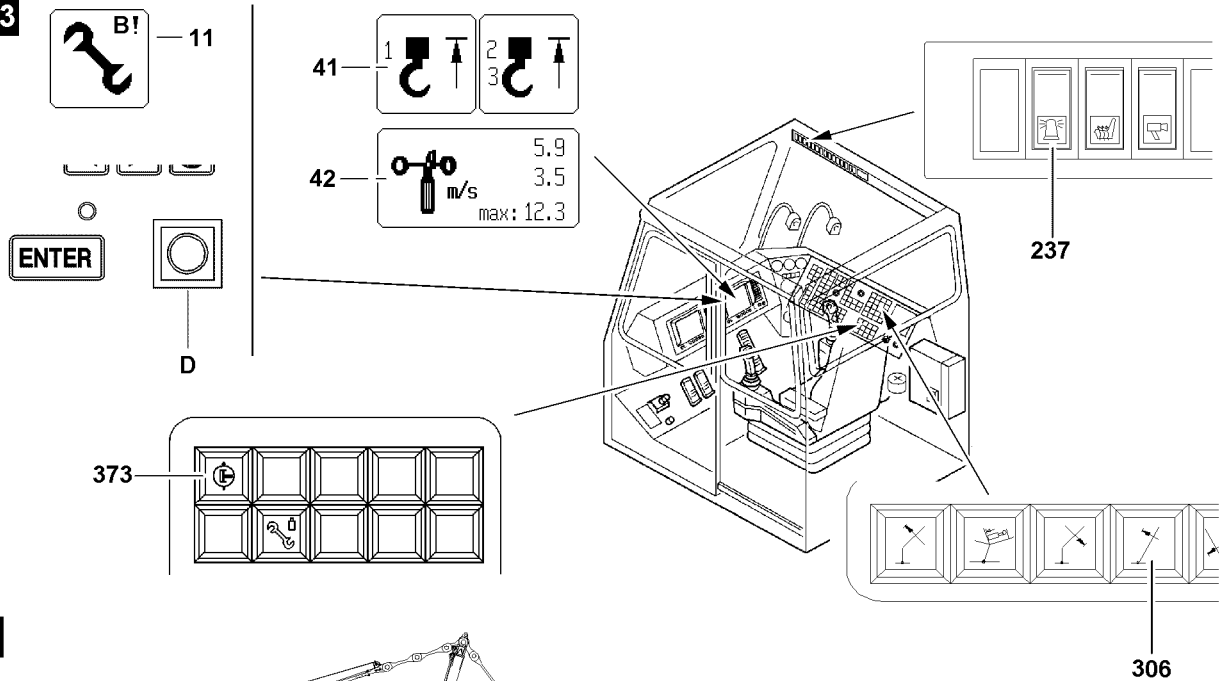

14

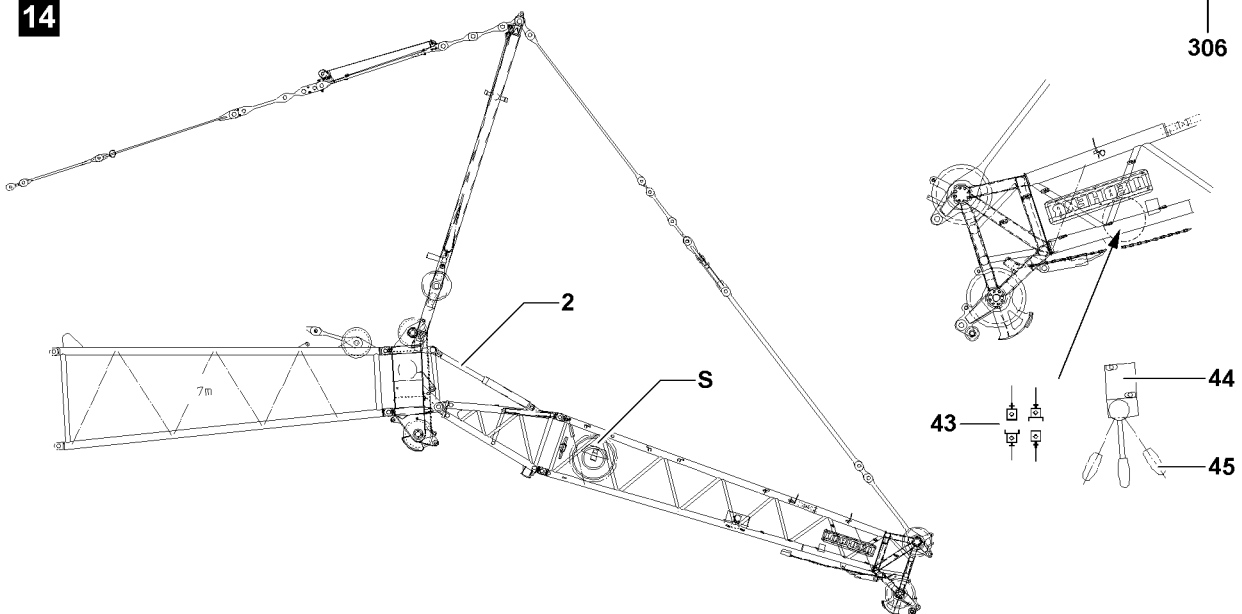

B111468

Make sure that the following prerequisites are met:

- All electrical connections have been made.
- The crane engine is running.
- The corresponding operating mode is set on the LICCON monitor.
- The actuator levers of the limit switches have been checked for easy movement and are lubricated.

2.6.1 Checking the wind speed sensor

- ▶ Check the movement and the function of the wind speed sensor.

Result:

- The “wind speed” icon **42** appears on the LICCON monitor 0.

2.6.2 Checking the airplane warning light

- ▶ Turn the airplane warning light on with the switch **237**.
- ▶ Check the function visually.

2.6.3 Checking the hoist limit switch on the pulley head



Note

- ▶ When replacing or changing a hoist limit switch (HES), the corresponding hoist limit switch must have the correct bus address and the correct software version in order to be detected again by the bus system (LSB)!

- ▶ Actuate the hoist limit switch manually on the pulley head.

Result:

- The spool up function of the hoist winch turns off.
- The “Hoist top” icon **41** appears on the LICCON monitor 0.
- The limit switch is functioning.

2.6.4 Checking the limit switch S-boom “Steepest position”



Note

- ▶ The limit switch functions have to be checked individually before erection!

- ▶ Cover the limit switch initiators on the S-relapse cylinders individually with a metal plate.

Result:

- The limit switch is actuated manually.
- The spool up function of winch 4 (control winch) turns off.
- The indicator light **306** lights up.
- The limit switch is functioning.

12

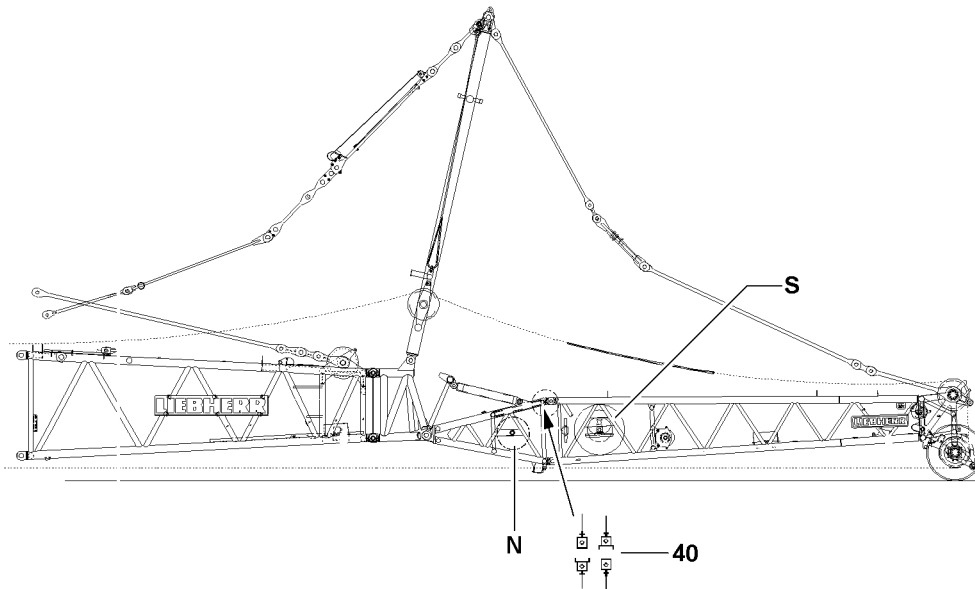

13

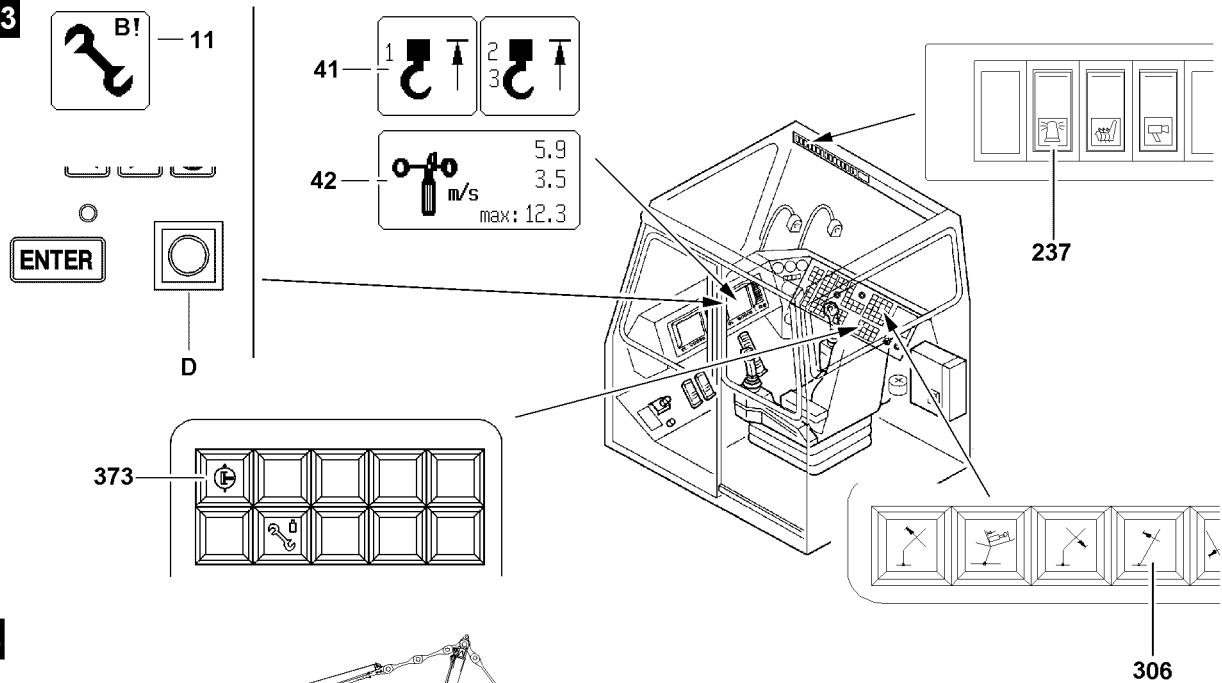

14

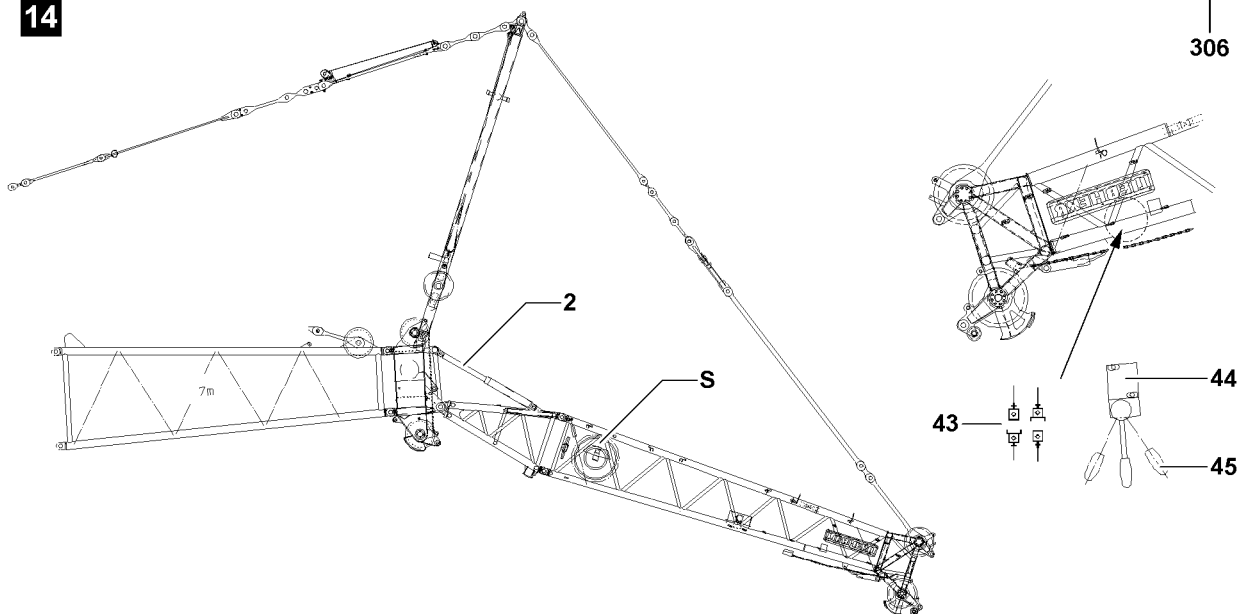

B111468

2.7 Erecting the SF-boom



DANGER

The crane can topple over!

If the following conditions are not met before erecting the boom, the crane can topple over and fatally injure personnel!

- ▶ Observe the safety technical notes, see Crane operating instructions, chapter 5.01!
- ▶ Observe the data in the erection and take down charts!
- ▶ Extend the relapse cylinder before erection!
- ▶ It is not permitted to turn the crane during erection!
- ▶ Make sure that no slack rope forms on the control winch!



WARNING

The crane can topple over!

For certain boom lengths, the mechanical auxiliary supports must be assembled, see Erection and take down charts!

- ▶ The boom must be erected or taken down “to the side” “in the direction” of the mechanical auxiliary supports!
- ▶ Always erect or take down according to the data in the **erection and take down charts!**



WARNING

Falling hoist rope!

If the hoist rope is not properly attached on the end section before the erection procedure, then it can fall down backward due to its own weight!

Personnel can be severely injured or killed!

- ▶ Attach the hoist rope properly on the end section before the erection procedure!

Make sure that the following prerequisites are met:

- The crane is aligned in horizontal direction.
- All electrical connections have been made.
- All limit switches are functioning.
- The counterweight has been installed on the turntable according to the load chart.
- All pin connections have been secured.
- The hoist rope has been correctly placed in the rope pulleys and is prevented from jumping out with the rope retaining pins.
- There are no loose parts on the boom.
- The LICCON overload protection has been set according to the data in the load chart.
- The LICCON overload protection settings have been compared with the actual crane configuration.
- The LICCON overload protection is exceeded.
- The assembly icon **11** is visible on the LICCON monitor.

12

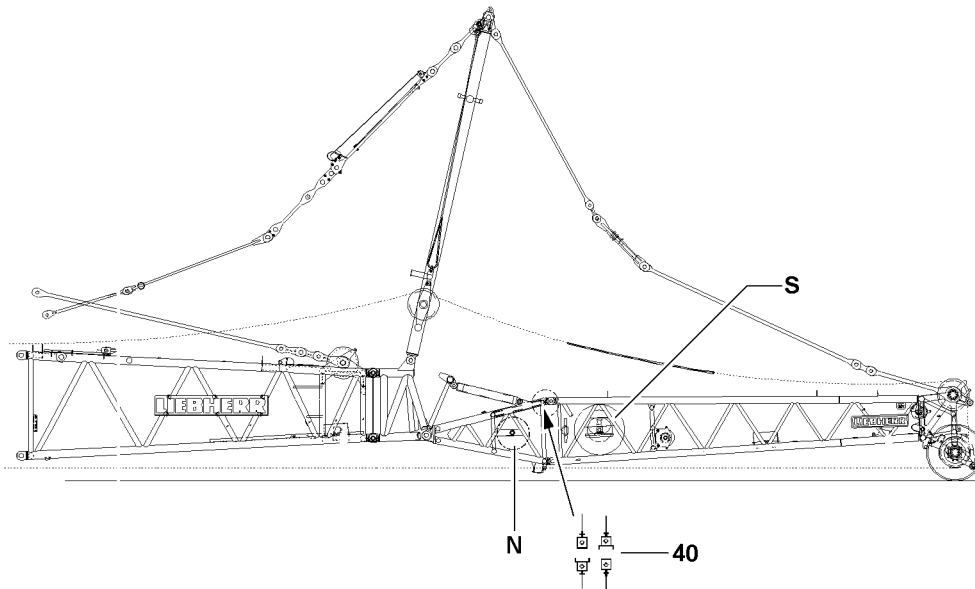

13

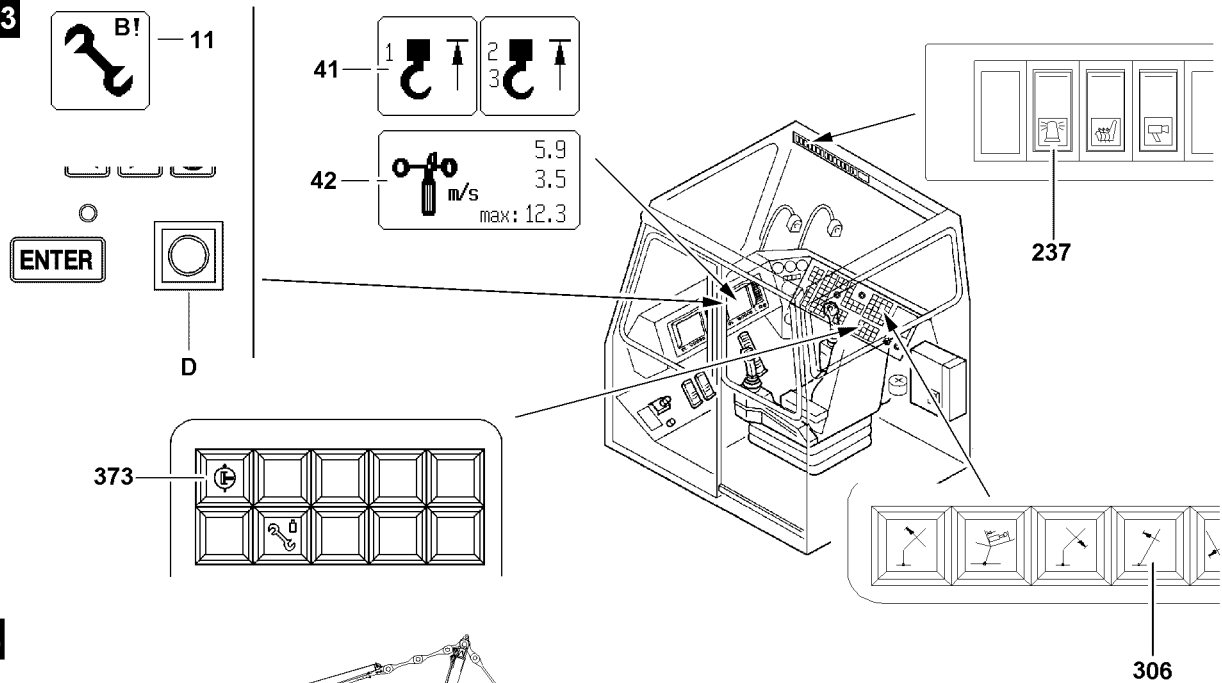

14

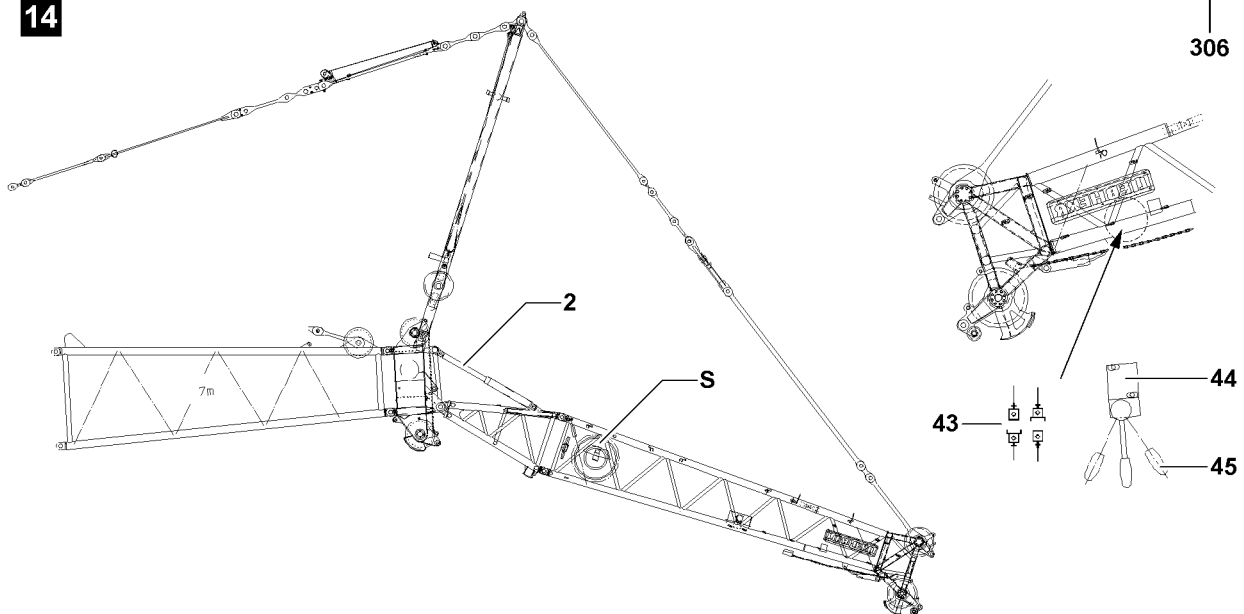

B111468

2.7.1 Pretensioning the relapse cylinder

See illustration 14

NOTICE

Damage to the boom system!

If the relapse cylinder is pretensioned when the F-end section is laying on the ground, then the boom system will be damaged!

- ▶ Lift the F-end section off the ground before pretensioning the relapse cylinder **2**!
-
- ▶ Spool the hydraulic hose from the hose drum **S** and close the quick-release couplings **40** for the relapse cylinder on the F-pivot section.
 - ▶ Luff the SF-boom up until the F-lattice jib (10 ° or 20 °) hangs in the guy rods and the F-end section lifts off the ground.
 - ▶ Connect the hydraulic aggregate for the pin pulling device on the quick-release couplings **43** on the F-end section.



Note

- ▶ In order to pretension the relapse cylinder, the operating pressure on the pin pulling device must be at least 180 bar!
 - ▶ Pin pulling device, see Crane operating instructions, chapter 5.30!
-
- ▶ Pretension the hydraulic relapse cylinder **2**: Actuate the lever **45** on the valve **44** until the piston rod is extended.
 - ▶ Disconnect the hydraulic aggregate from the quick-release couplings **43**.

12

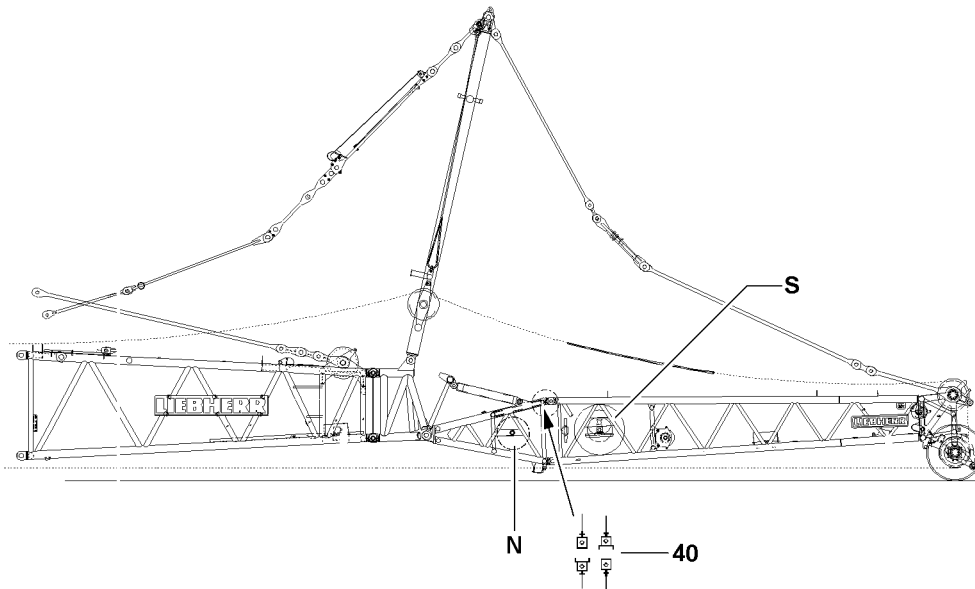

13

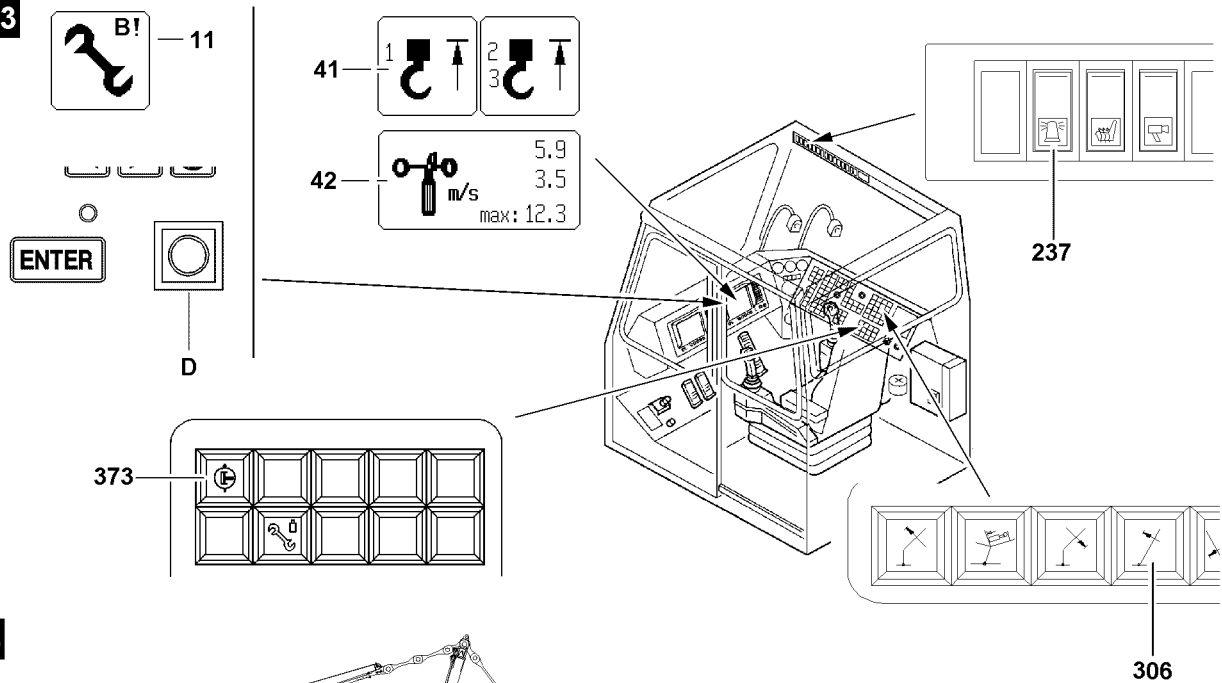

14

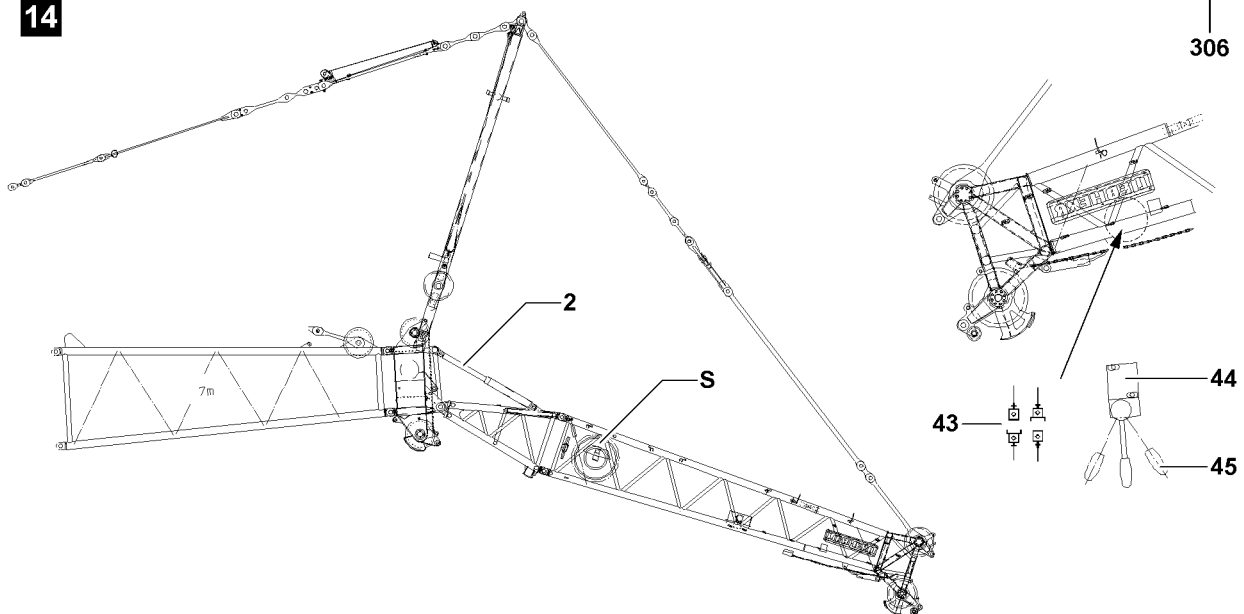

B111468

2.7.2 Erection procedure



DANGER

The crane can topple over!

- ▶ It is not permitted to turn the crane superstructure during erection procedure!
 - ▶ Observe the data in the erection and take down charts!
-

- ▶ Reeve in the hoist rope properly and secure on the rope fixed point, for reeving, see Reeving plans.
 - ▶ Attach the hoist limit switch weight.
-



DANGER

The crane can topple over!

In crane operation with exceeded LICCON overload protection, the crane can topple over!

- ▶ Personnel can be severely injured or killed!
 - ▶ The radii listed in the load chart may not be exceeded or fallen below, even if there is no load on the hook!
-



Note

- ▶ When the lowest operating position of the boom is reached, the LICCON overload protection is activated!
 - ▶ In the maximum load icon appears a load number in "t" instead of the display "???"!
-

- ▶ Luff the boom up to the lowest operating position.
- ▶ When the boom has reached the lowest operating position:
Make sure that the assembly icon **11** on the LICCON monitor turns off.

Result:

- The LICCON overload protection is active.

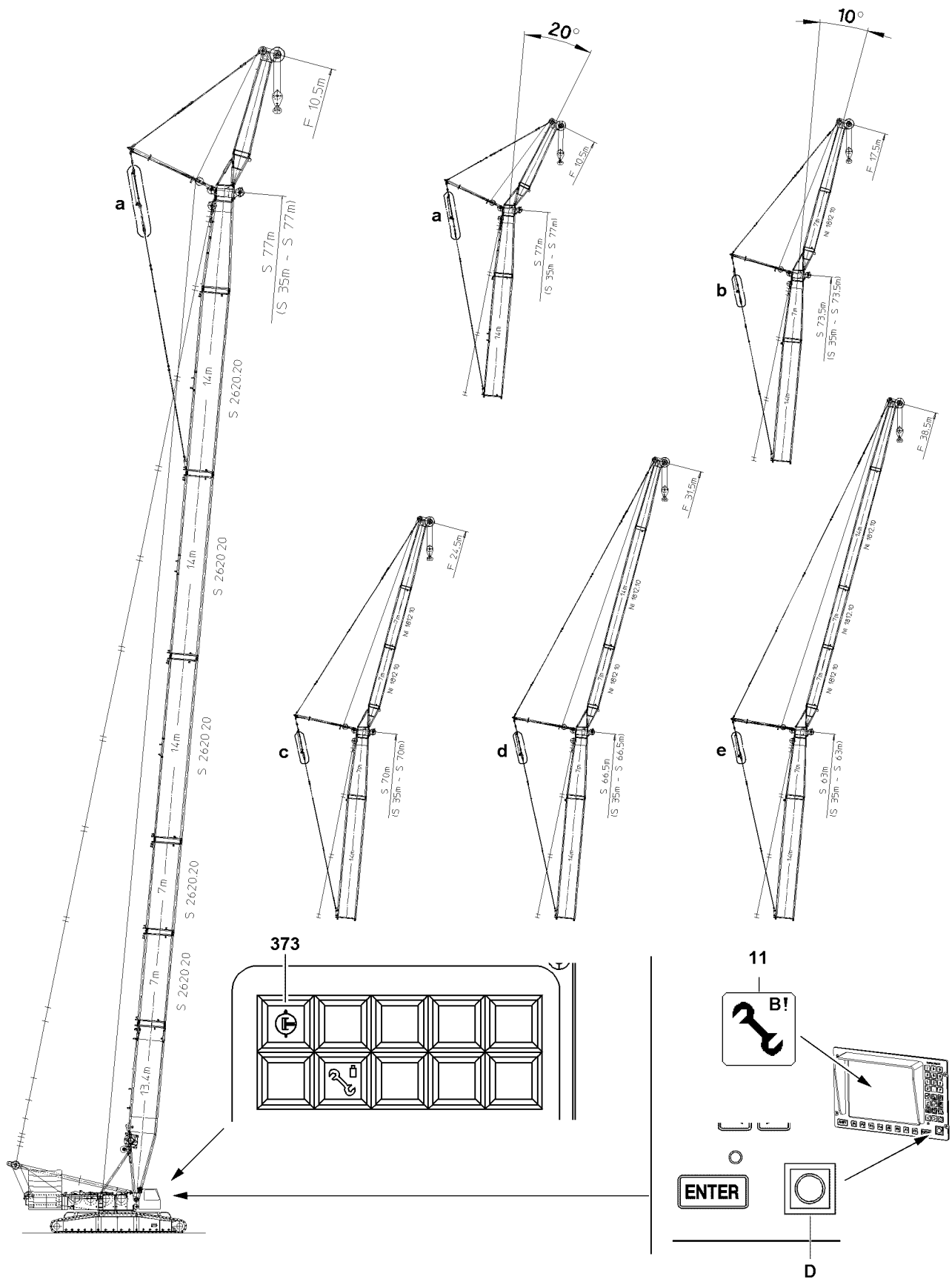

B111467

3 Operating the crane

3.1 Preparing for crane operation

**Note**

- ▶ Observe the notes, see Crane operating instructions, chapter 4.05, chapter 4.08 and chapter 5.01!

Make sure that the following prerequisites are met:

- The LICCON overload protection is active.
- The LICCON overload protection has been set according to the data in the load chart.

**WARNING**

The crane can topple over!

- ▶ Check the horizontal position of the crane before and during operation!
- ▶ If the crane operator leaves the cab, even for a short time, then he is obligated to check the operating mode setting before resuming crane operation and reset it, if necessary!

3.2 Checking the settings

- ▶ Check the function of the LICCON overload protection by running against the operating positions “on top” and “bottom”.
- ▶ Check the hoist limit switch by running against the hoist limit switch weight.
- ▶ Check the function of the limit switches on the relapse cylinders.

4 Disassembling the F-lattice jib



WARNING

Risk of falling!

During assembly and disassembly, personnel must be secured with appropriate aids to prevent them from falling! If this is not observed, assembly personnel can fall and suffer life-threatening or fatal injuries!

- ▶ Any work, where there is a danger of falling must be carried out with suitable aids (for example: lifting platforms, scaffoldings, ladders, auxiliary crane)!
- ▶ If the work cannot be carried out with such aids nor from the ground, then the assembly personnel must secure themselves with approved fall arrest systems to avoid falling, see Crane operating instructions chapter 2.04!
- ▶ If railings are present on the components, then they must be brought into the corresponding position and secured for assembly / disassembly work!
- ▶ Step on aids and fall protection equipment only with clean shoes!
- ▶ Keep aids and fall protection equipment clean and free from snow and ice!
- ▶ During all assembly and disassembly work, maintenance work and inspections, travel or crane operation is prohibited!



WARNING

Falling components!

If unsecured or non-supported components are assembled or disassembled, they can fall down. Personnel can be killed or seriously injured!

- ▶ During pinning and unpinning of the lattice sections, it is prohibited for anyone to remain **under** or **on** the components as well as within the entire danger zone!
- ▶ Support the boom and components before pinning / unpinning!
- ▶ Pin or unpin both pins laying in a horizontal, i.e. **left** and **right**!
- ▶ Secure the pins in the bearing points and in the receptacles!
- ▶ Do not disengage the auxiliary crane until each component is pinned on and secured!
- ▶ It is prohibited to lean a ladder against the component being disassembled!



WARNING

Danger of impact / crushing!

When installing / removing crane components with the auxiliary crane, crane components can start to swing back and forth!

When lifting / lowering and positioning crane components, there is an increased danger of impacts / crushing!

Personnel can be caught and severely injured or killed!

- ▶ Make sure that personnel cannot be caught by components!
- ▶ Make sure that the crane is aligned in horizontal position to avoid the support beams from swinging by themselves!
- ▶ When working in danger zones: Use aids to protect limbs!
- ▶ Guide components with suitable aids to minimize oscillation!

15

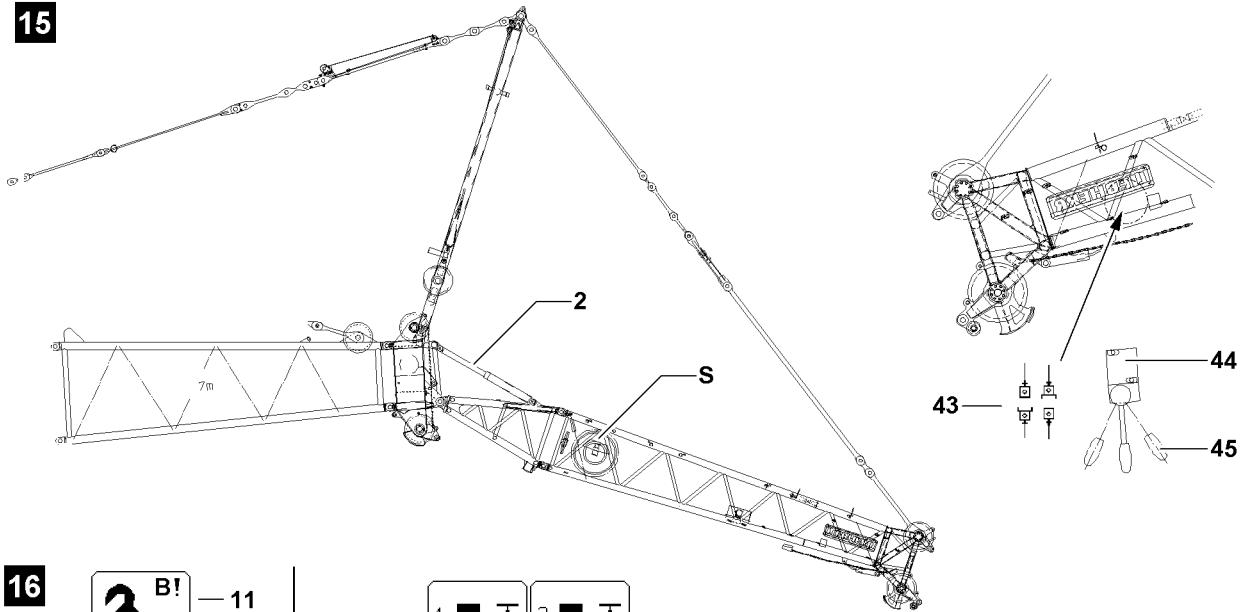

16

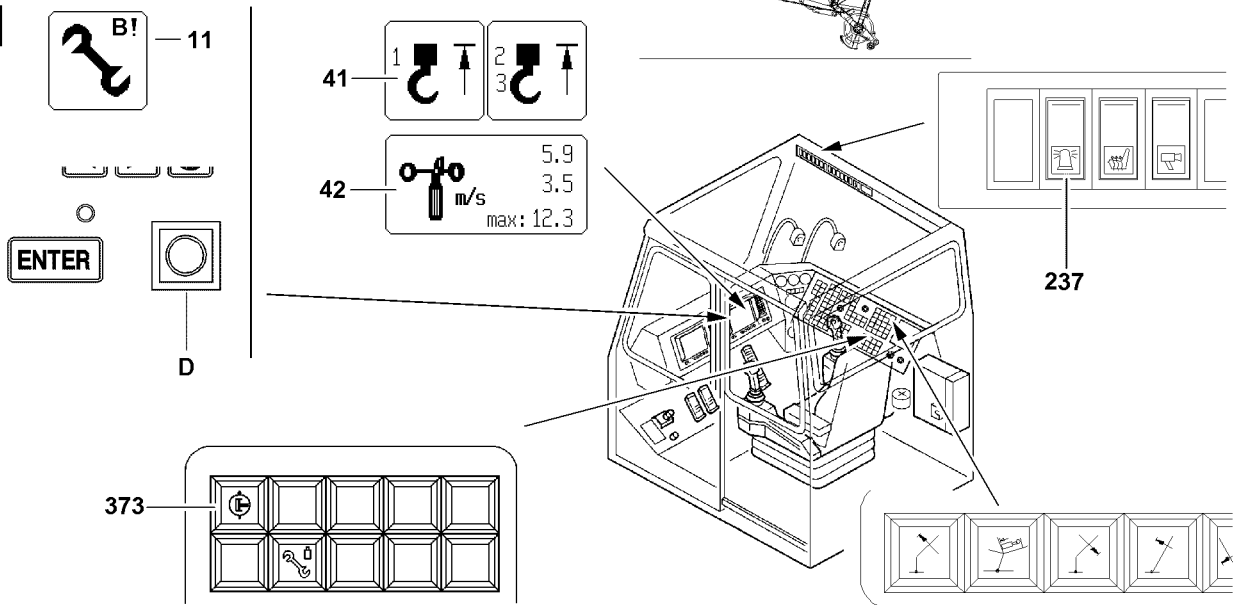

17

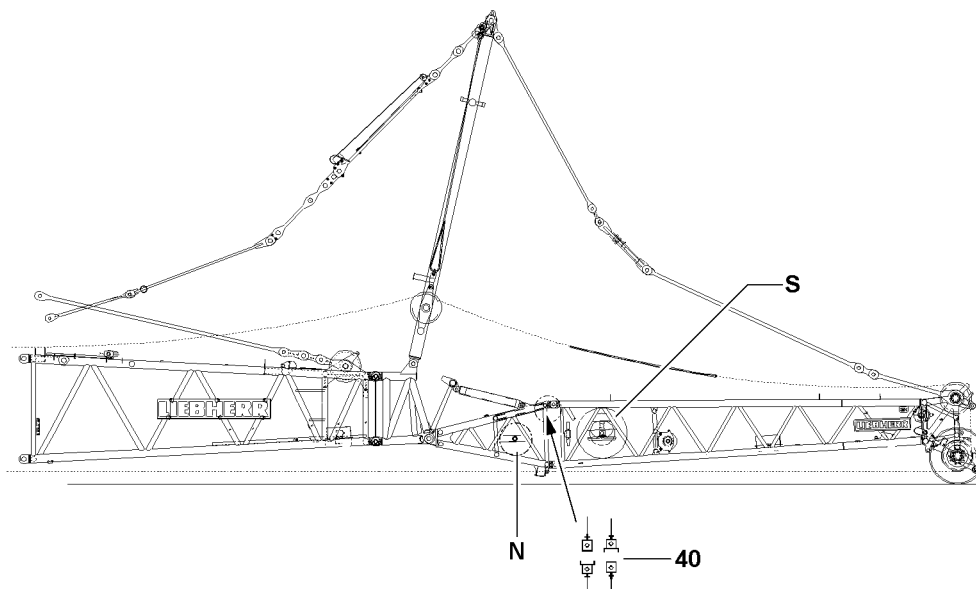

Make sure that the following prerequisites are met:

- The “mechanical auxiliary supports” are properly installed on the crane, see also **Erection and take down charts**.
- The SF-boom is luffed down “to the side” over the “mechanical auxiliary supports” and to the “lowest” operating position.
- The LICCON overload protection has been set according to the data in the load chart.
- The LICCON overload protection is exceeded.
- The assembly icon **11** is visible on the LICCON monitor.
- The button **373** is actuated for the manual pressure supply.
- The auxiliary crane is available.

4.1 Taking the SF-boom down



DANGER

The crane can topple over!

If the following conditions are not met before taking down the boom, the crane can topple over and fatally injure personnel!

- ▶ Observe the safety technical notes, see Crane operating instructions, chapter 5.01!
- ▶ Observe the data in the erection and take down charts!



WARNING

The crane can topple over!

For certain boom lengths, the mechanical auxiliary supports must be assembled, see Erection and take down charts!

- ▶ The boom must be erected or taken down “to the side” “in the direction” of the mechanical auxiliary supports!
- ▶ Always erect or take down according to the data in the **erection and take down charts**!

NOTICE

Damage of boom components!

Taking down the boom system can lead to a collision between the hook block and the pulley head. There is the danger that boom components may be significantly damaged!

- ▶ When taking down the boom system, always spool out the hoist winch at the same time!

15

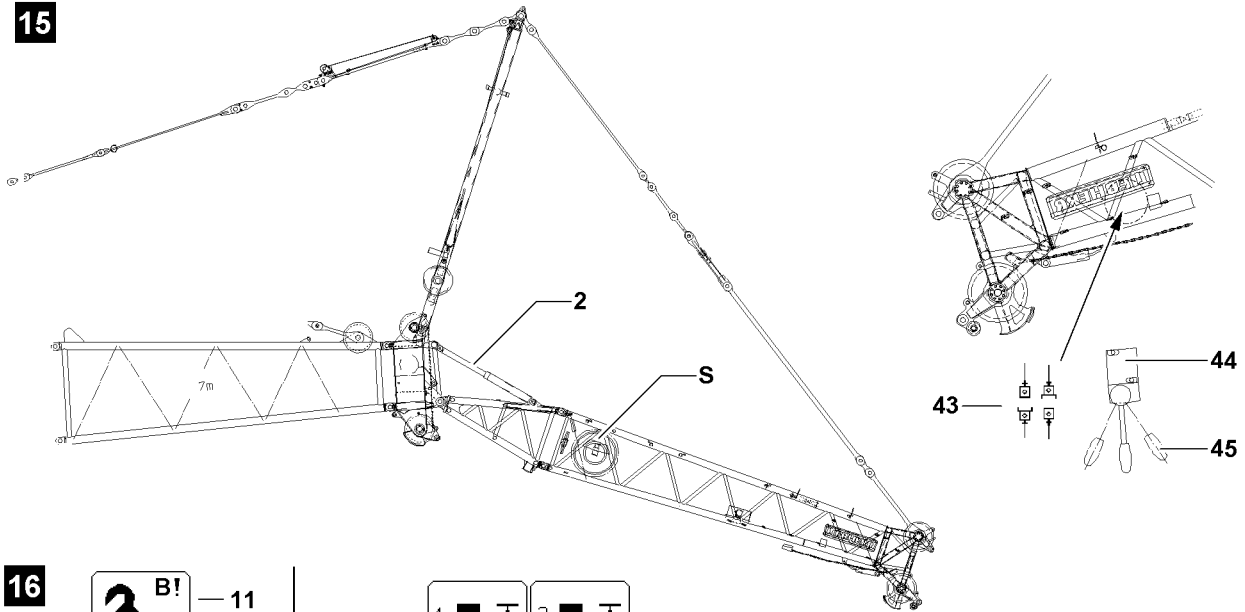

16

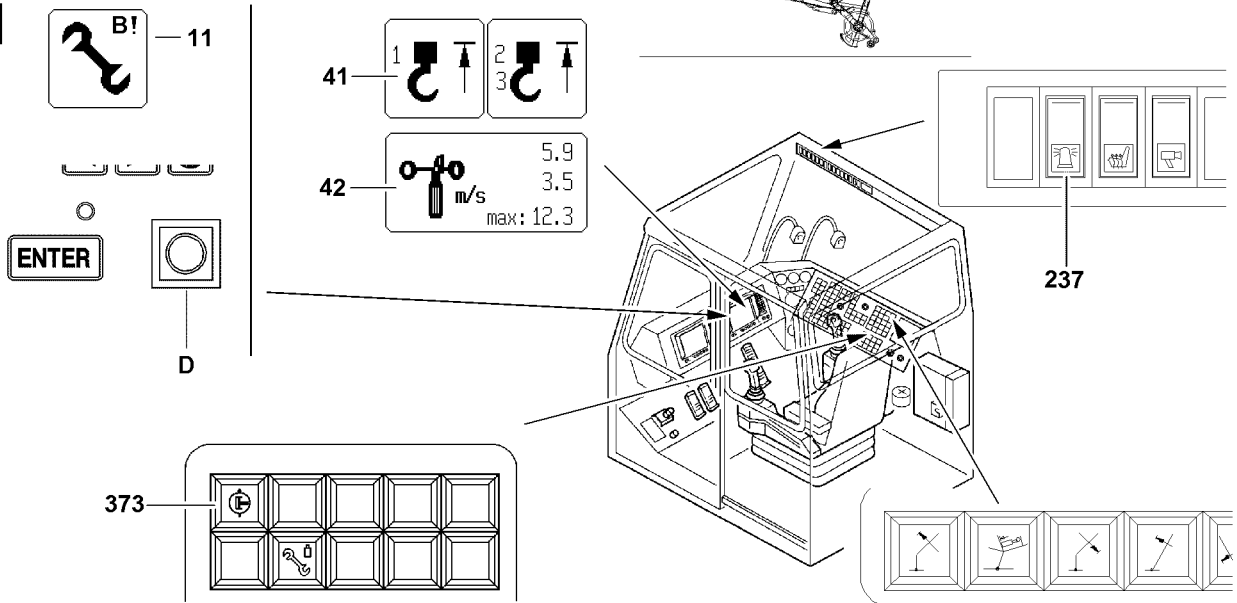

17

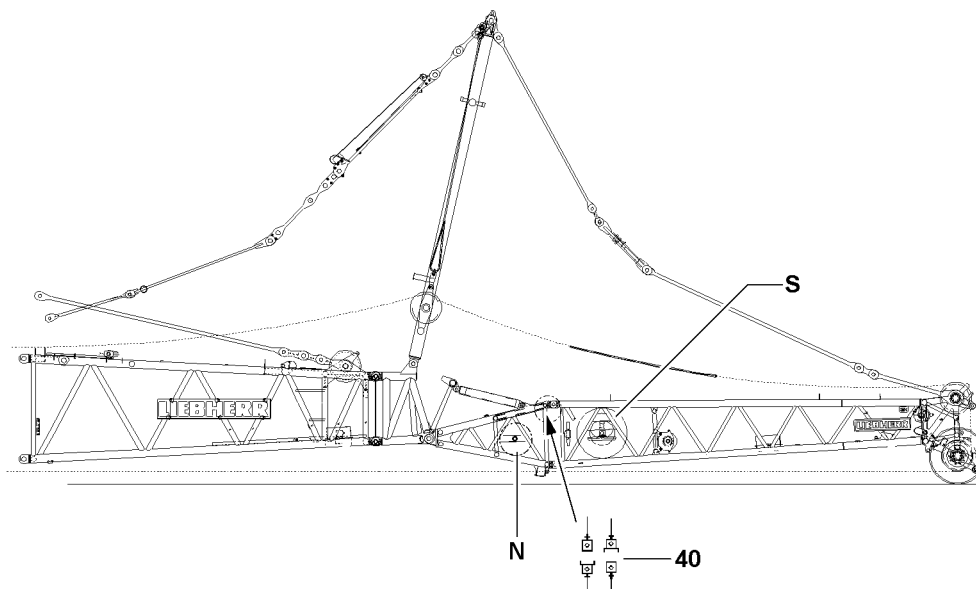

4.1.1 Luffing the SF-boom down



WARNING

Risk of accident!

If the following instructions are not observed, personnel can be severely injured or killed!

- ▶ The boom combinations must be assembled according to the separately supplied rod and assembly plans!
- ▶ Depending on the condition of the ground, the boom and the lattice sections must be supported from below for the assembly of the boom!
- ▶ Observe the safety technical notes, see Crane operating instructions, chapter 5.01!
- ▶ Observe the data in the erection and take down charts!



Note

- ▶ The luff down movement is turned off as soon as the lowest operating position is reached!
- ▶ When the lowest operating position of the boom is reached, the load display in the maximum load icon turns off and instead of the load display appears the display “???”!
- ▶ In the crane operating screen appear alarm functions!

- ▶ Luff the SF-boom down to the “lowest” operating position.

Result:

- The luff down movement is turned off.
- The “STOP” icon appears on the LICCON monitor.
- The horn icon appears on the LICCON monitor.



WARNING

Assembly with turned on set up key!

When the set up key is turned on, the LICCON overload protection is exceeded!

In the event of deliberate improper use, the crane could collapse, the boom can break off or the crane can topple over!

Personnel can be killed!

This could result in high property damage!

- ▶ The set up key **D** may only be actuated by persons who know the effects of a bypass!
- ▶ Press the set up key **D** only when the set up status was correctly entered into the LICCON computer system!
- ▶ Observe the erection / take down charts!
- ▶ Crane operation with the set up key **D** turned on is strictly prohibited!

- ▶ When the SF-boom has reached the “lowest” operating position:
Turn the set up key **D** to the right.

Result:

- The LICCON overload protection is deactivated.
- The assembly icon **11** appears on the LICCON monitor.

15

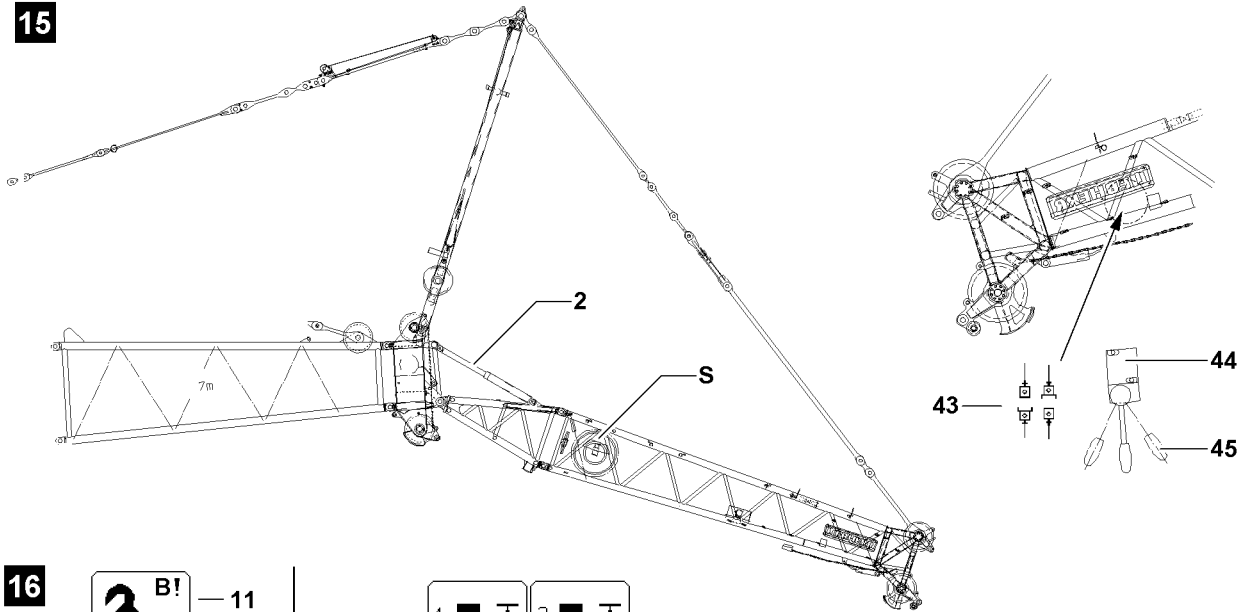

16

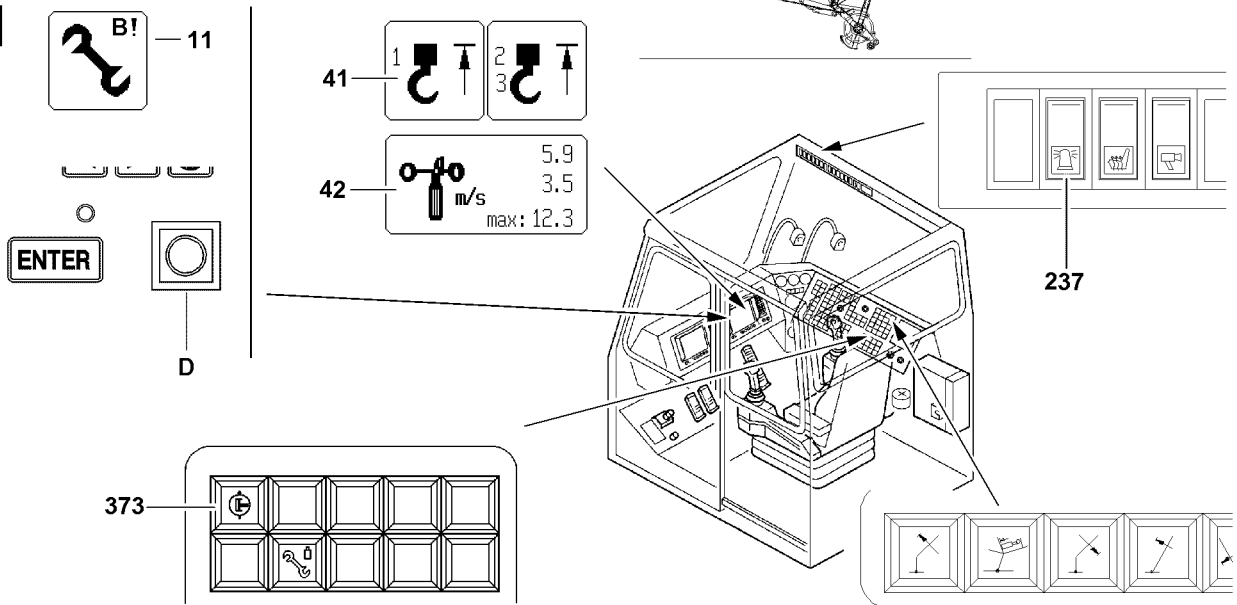

17

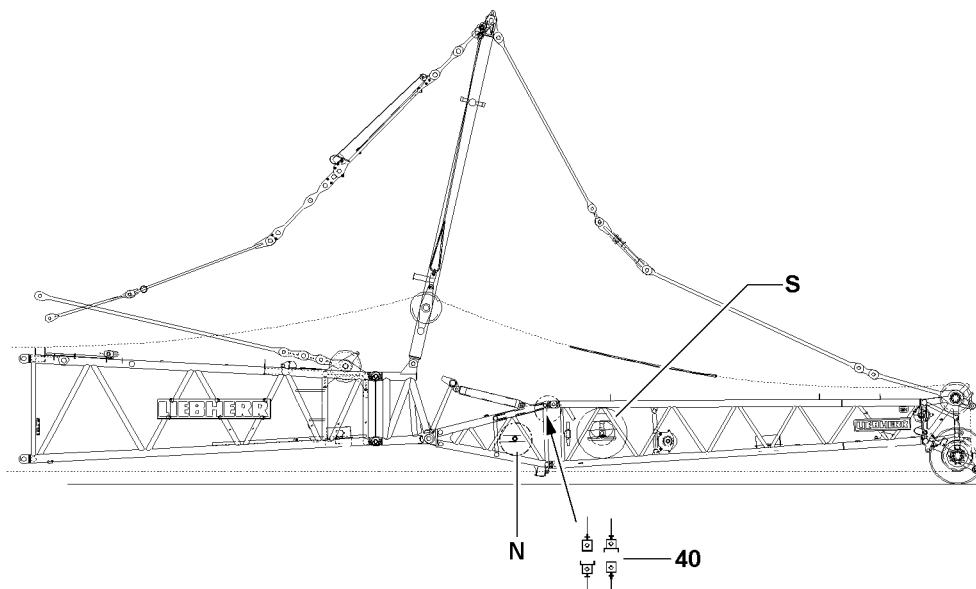

B111469

4.1.2 Relieving the relapse cylinder

See illustration 15

NOTICE

Damage to the boom system!

If the SF-boom is placed on the ground when the relapse cylinder is tensioned, the boom system will be damaged!

- ▶ Relieve the relapse cylinder **2** before the SF-boom is placed on the ground!
-
- ▶ Luff the SF-boom down until the F-end section is just above the ground.
 - ▶ Connect the hydraulic aggregate for the pin pulling device on the quick-release couplings **43** on the F-end section.



Note

- ▶ To relieve the relapse cylinder, the operating pressure on the pin pulling device must be at least 180 bar!
 - ▶ Pin pulling device, see Crane operating instructions, chapter 5.30!
-
- ▶ Pretension the hydraulic relapse cylinder: Actuate the lever **45** on the valve **44** until the cylinder is retracted.
 - ▶ Disconnect the hydraulic aggregate from the quick-release couplings **43**.

4.1.3 Taking the SF-boom down

See illustration 17

Make sure that the following prerequisite is met:

- The relapse cylinder is relieved.
- ▶ Spool the hoist winch out and luff the S-boom down further until the hook block touches the ground.
 - ▶ Remove the hoist limit switch weight and unreeve the hook block.
 - ▶ Luff the SF-boom down until the F-lattice jib is horizontally placed on the support.
 - ▶ Disconnect the hydraulic hose from the quick-release couplings **40** for the relapse cylinder on the F-pivot section and spool it up on the hose drum **S**.

4.2 Disconnecting the electrical connections

Make sure that the following prerequisite is met:

- The F-lattice jib is placed down.
- ▶ Disconnect the electrical connections.

NOTICE

Damage to cable drum or cable!

If the cable of the cable drum is not properly spooled up on the cable drum after unplugging, then the cable drum or the cable can be significantly damaged!

- ▶ Spool the cable drum up after unplugging!
-
- ▶ Spool the cable drum up and secure it to prevent inadvertent spooling out.
 - ▶ Make sure that all electrical connections on the SF-lattice jib have been disconnected.

18

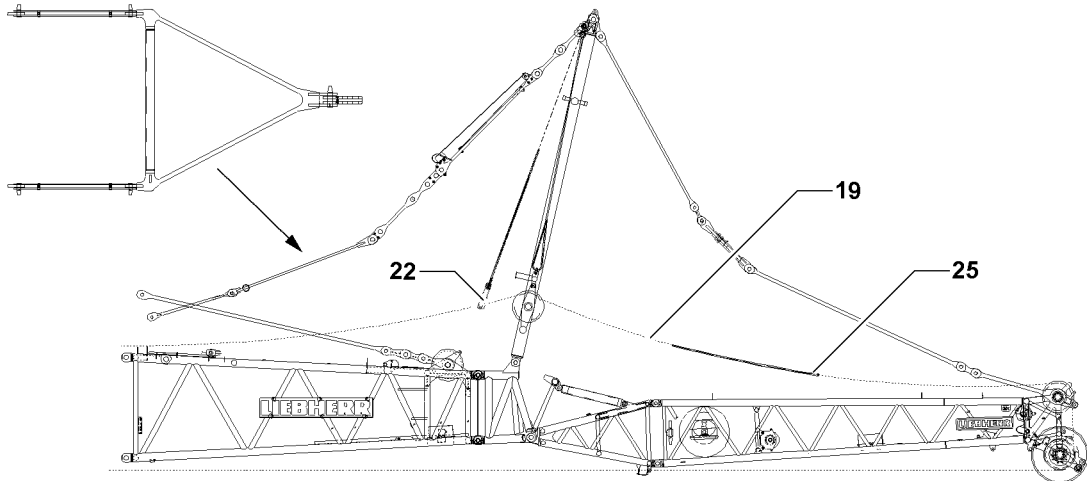

19

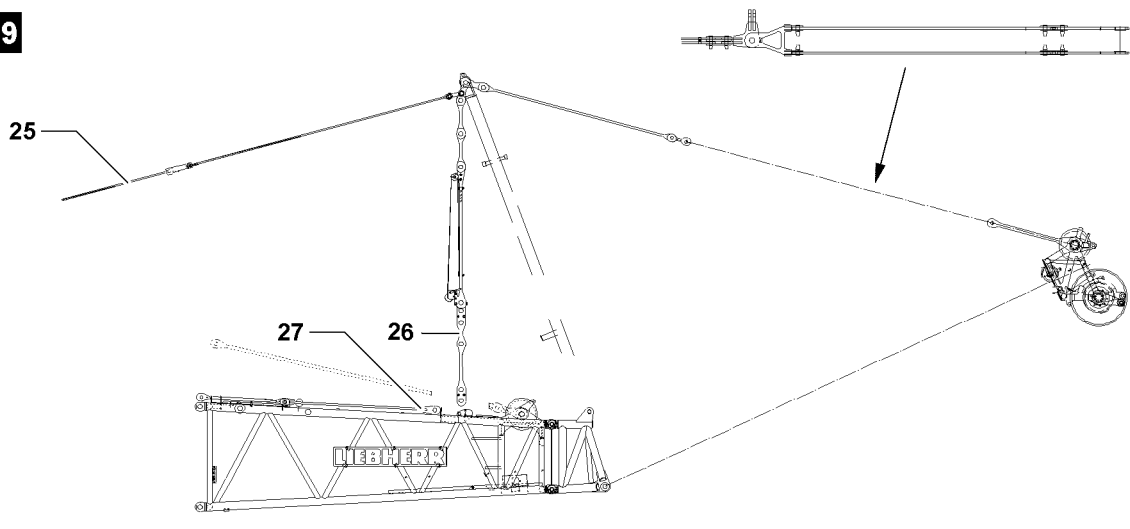

20

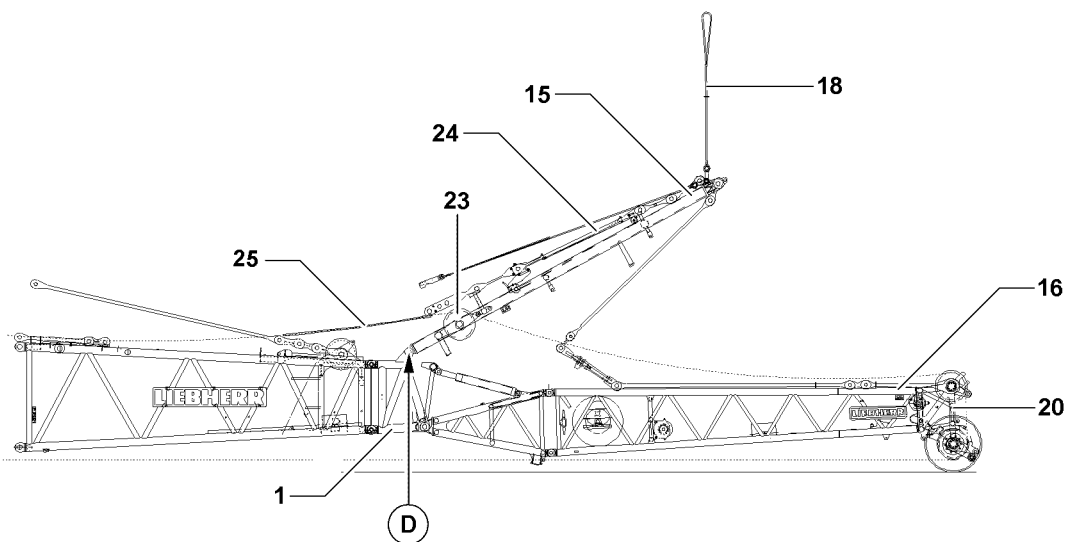

B106125

4.3 Disassembling the guy rods

4.3.1 Unpinning the guy rods

- ▶ Attach the hoist rope **25** on the assembly rope **19** and pull it to the FA-bracket.
- ▶ Place the hoist rope **25** in the lock **22**.
- ▶ Erect the FA-bracket with the hoist rope **25** until the guy rods FA-bracket **27** hang down vertically, see illustration **19**.
- ▶ Disconnect the guy rods **26** FA-bracket from the guy rods **27** main boom: Release and unpin the pins.

4.3.2 Placing the FA-bracket down

- ▶ Relieve the hoist rope **25** until the FA-bracket **27** is located on the right hand side over the pivot point, see illustration **20**.
- ▶ Hang the fastening equipment **18** of the FA-bracket on the auxiliary crane.
- ▶ Relieve the hoist rope **25** and remove it from the lock **22**.
- ▶ Place the FA-bracket **14** down on F-lattice jib **16**.
- ▶ Remove the auxiliary crane.

21

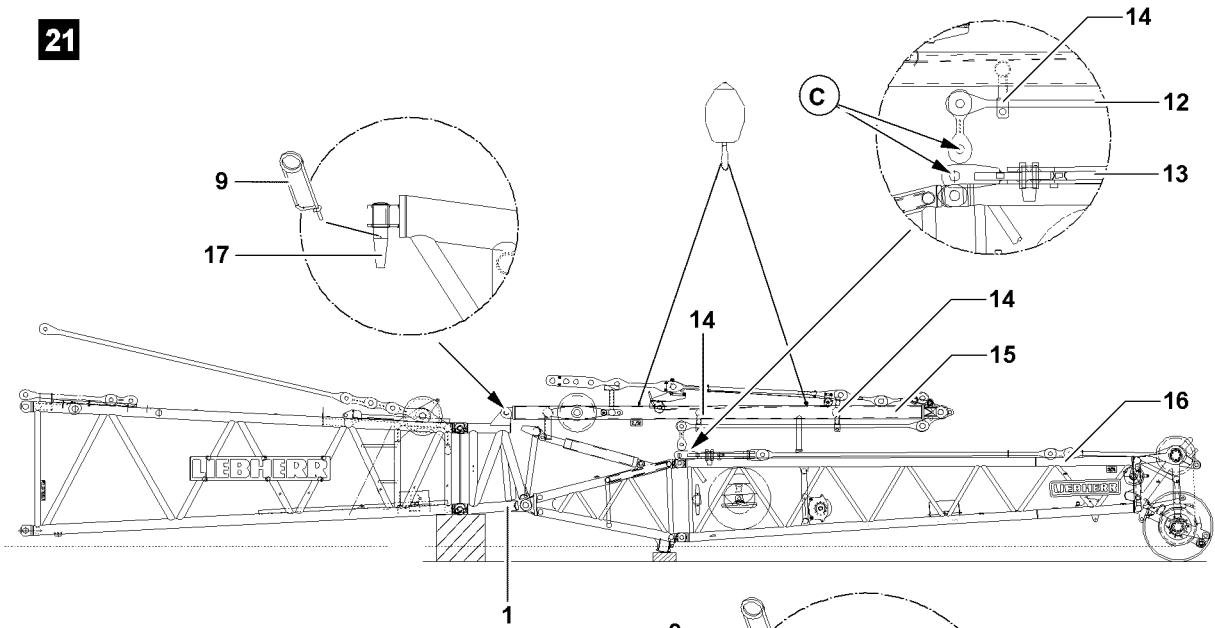

22

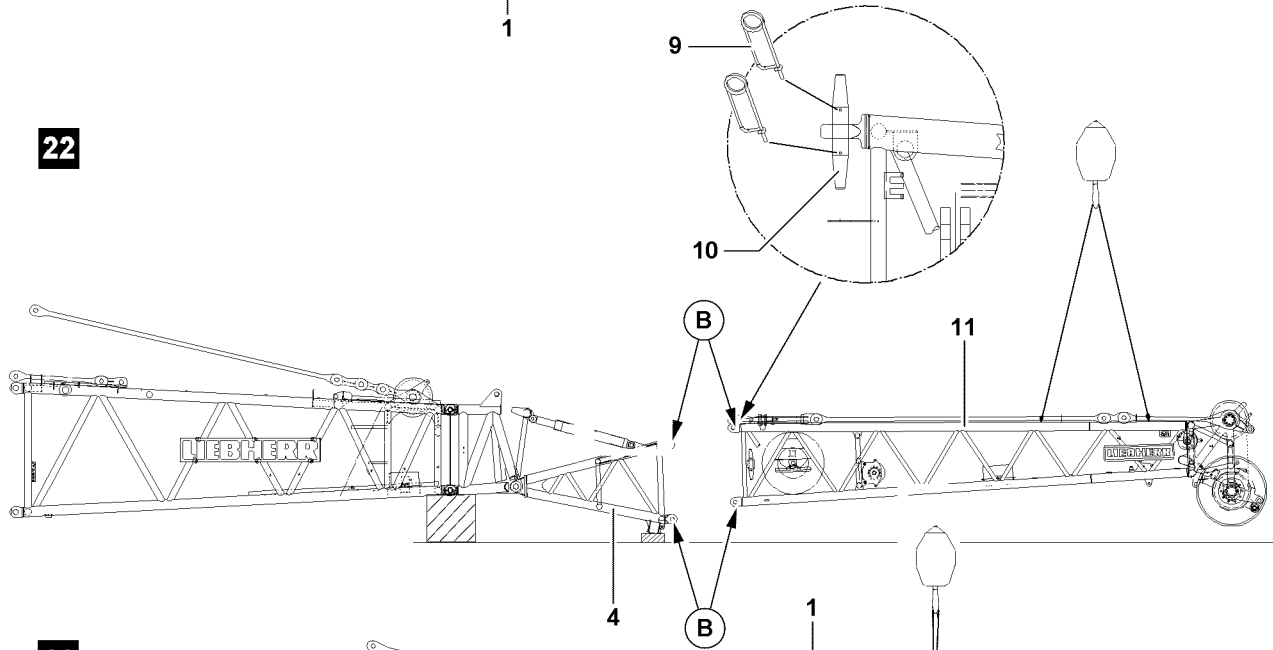

23

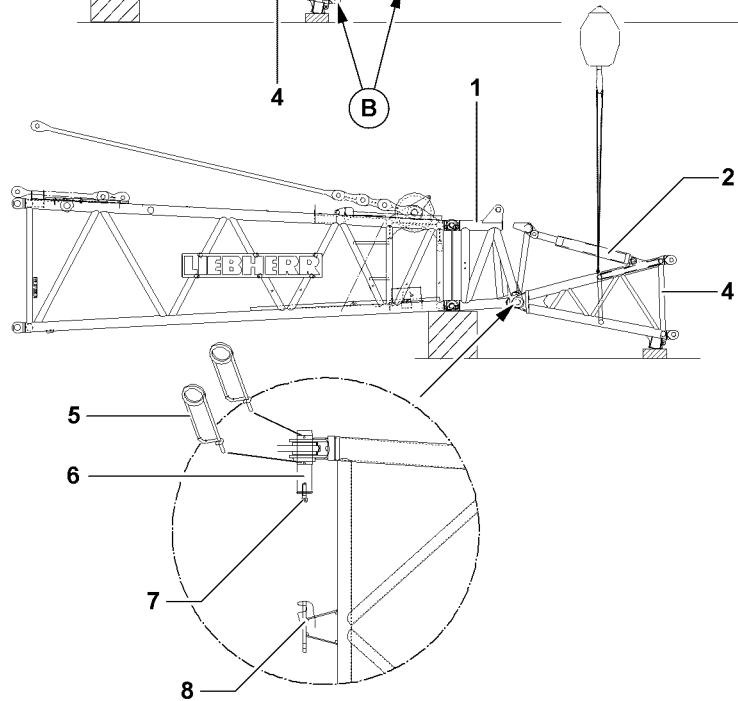

B106126

4.4 Disassembling the FA-bracket

See illustration 21

- ▶ Disconnect the guy rods FA-bracket **12** from the guy rods F-lattice jib **16** in point **C**: Release and unpin the pins.
- ▶ Pin and secure the guy rods FA-bracket **12** in the transport retainer **14**.
- ▶ Secure the FA-bracket **15** with the auxiliary crane.
- ▶ Disconnect the FA-bracket **15** from the L-end section **1**: Remove the spring retainer **9** and unpin the pin **17**.
- ▶ Lift and remove the FA-bracket **15** with auxiliary crane.

4.5 Disassembling the F-lattice jib

See illustration 22

- ▶ Support the F-pivot section **4**.
- ▶ Disconnect the F-lattice jib **16** from the F-pivot section **4** in points **B**: Remove the spring retainers **9** and unpin the pins **10**.
- ▶ Lift the F-lattice jib **16** with auxiliary crane and remove.
- ▶ Support the NI-lattice sections and the F-end section **11** and disconnect: Remove the spring retainers **9** and unpin the pins **10**.

4.6 Disassembling the F-pivot section

See illustration 23



Note

- ▶ Pin pulling device, see Crane operating instructions, chapter 5.30!
-
- ▶ Secure the F-pivot section **4** with the auxiliary crane.
 - ▶ Hang the hydraulic pin pulling cylinder on the screw **7** and the retainer **8** on the F-pivot section **4**.
 - ▶ Disconnect the F-pivot section **4** from the L-end section **1**: Remove the spring retainers **5** and unpin the pins **6** with the pin pulling cylinder.
 - ▶ Unhook the hydraulic pin pulling cylinder on the F-pivot section **4** and remove.
 - ▶ Lift the F-pivot section **4** and remove.

B195219

1 Minimum required hook block weight



WARNING

Falling components and hook block!

If the chosen hook block weight is not large enough, then the hoist rope pulls the hook block between the boom head and the winch from a certain hoisting height suddenly upward. As a result, the boom head and the hook block can be damaged. Damaged components and the hoist rope between the boom head and the winch can fall down.

If slack rope forms between the winch and the boom head when spooling the winch out, then the hook block can suddenly fall down.

Personnel can be severely injured or killed!

- ▶ Calculate the minimum required hook block weight before lifting the load!
- ▶ Select the weight of the hook block depending on the calculation!

If the weight of the hook block is not sufficient:

- ▶ Select a heavier hook block or increase the weight of the hook block with fastening items, load tackle, auxiliary weights or modification kits!

NOTICE

Rope damage due to insufficient weight of the hook block!

If the hook block is operated with a higher reeving than is required by the load on the respective boom length, the minimum required hook block weight increases.

If the hook block weight is too low to tighten the hoist rope sufficiently, spooling problems may occur on the winches when lowering and lifting the hook block due to slack rope formation. Rope damage can result.

If no minimum system-related hoist reeving is required for the operating mode:

- ▶ Reeve the hook block at the minimum depending on the maximum rope pull and the weight of the load to be lifted!

If the weight of the hook block is not sufficient:

- ▶ Select a heavier hook block or increase the weight of the hook block with fastening items, load tackle, auxiliary weights or modification kits!



Note

Recommendation for selection of hook block weight!

If the maximum load capacity for the respective boom configuration is not exceeded by an additional weight increase of the hook block:

- ▶ Increase the minimum required hook block weight additionally by at least 10%!

If an additional weight increase of the hook block due to the maximum load capacity for the respective boom configuration is not possible:

- ▶ Lower the hook block only with utmost caution!



Note

Observe the permissible hook block weights for erection and take down of the boom system!

If the permissible hook block weight for erection and take down of the boom system is exceeded due to the own weight increase of the hook block, then the boom system cannot be erected or taken down with this hook block weight.

- ▶ Observe the permissible hook block weights for erection and take down in the erection and take down charts!

If the permissible hook block weight for erection and take down is exceeded:

- ▶ Remove auxiliary weights for the erection and take down of the boom system!

1.1 Calculating the minimum required hook block weight

$$G = L \times M \times N \times F$$

Formula to determine the minimum required hook block weight

Abbreviation	Description	Unit
G	Minimum required hook block weight	kg
L	Overall boom length	m
M	Rope weight	kg/m
N	Reeving	-
F	Factor	-

Explanation of variables to calculate the minimum required hook block weight

1.2 Determining the rope weight for the rope diameter

Rope diameter	Rope weight M
13 mm	0.85 kg/m
15 mm	1.12 kg/m
17 mm	1.45 kg/m
19 mm	1.81 kg/m
21 mm	2.24 kg/m
23 mm	2.67 kg/m
25 mm	3.09 kg/m
28 mm	3.94 kg/m
30 mm	4.46 kg/m
32 mm	5.09 kg/m
38 mm	7.21 kg/m
40 mm	7.99 kg/m
52 mm	13.50 kg/m

Rope diameter and rope weight

1.3 Determining the factor for reeving

Reeving N	Factor F
1	1,31
2	1,34
3	1,36
4	1,39
5	1,41
6	1,44
7	1,46

Reeving N	Factor F
8	1,49
9	1,52
10	1,54
11	1,57
12	1,60
13	1,63
14	1,65
15	1,68
16	1,71
17	1,74
18	1,77
19	1,80
20	1,83
21	1,87
22	1,90
23	1,93
24	1,96
25	2,00
26	2,03
27	2,06
28	2,10
29	2,13
30	2,17

Reeving and factor

1.4 Calculation examples

1.4.1 Calculating the required hook block weight for crane operation with 1 hoist rope winch in single operation with single hook block

Crane configuration:

- Length of main boom: 70 m
- Length of auxiliary boom: 28 m
- Rope diameter: 28 mm
- Reeving: 12 rope strands

Variables for calculation:

L = overall boom length = 98 m

M = rope weight for rope diameter 28 mm = 3.94 kg/m

N = reeving = 12

F = Factor for 12 rope strands = 1.60

Calculation:

$$G = L \times M \times N \times F$$

$$G = 98 \text{ m} \times 3.94 \text{ kg/m} \times 12 \times 1.60$$

$$G = 7414 \text{ kg}$$

The minimum required hook block weight must be 7414 kg and must be increased additionally by at least 10 % (741 kg) to 8155 kg. The maximum load capacity for the respective boom configuration may not be exceeded by the additional weight increase of the hook block.

1.4.2 Calculating the required hook block weight for crane operation with 2 hoist rope winches in parallel operation with double hook block

Crane configuration:

- Length of main boom: 70 m
- Length of auxiliary boom: 28 m
- Rope diameter: 28 mm
- Reeving: 2 x 8 rope strands

Variables for calculation:

L = overall boom length = 98 m

M = rope weight for rope diameter 28 mm = 3.94 kg/m

N = reeving = (2 x 8)

F = Factor for 8 rope strands = 1.49

Calculation:

$$G = L \times M \times (2 \times N) \times F$$

$$G = 98 \text{ m} \times 3.94 \text{ kg/m} \times (2 \times 8) \times 1.49$$

$$G = 9205 \text{ kg}$$

The minimum required hook block weight must be 9205 kg and must be increased additionally by at least 10 % (921 kg) to 10126 kg. The maximum load capacity for the respective boom configuration may not be exceeded by the additional weight increase of the hook block.

2 Procedure in case of slack rope

2.1 Lowering the hook block if slack rope forms

If the hook block can no longer be lowered due to slack rope formation, then the following steps must be carried out.

2.1.1 Spooling up loose hoist rope

- ▶ Spool up loose hoist rope between the boom head and the winch carefully onto the winch.



Note

- ▶ A slight rope slack must remain between the boom head and the winch!
-

2.1.2 Luffing the boom down

NOTICE

Risk of collision!

When luffing the boom down, the hoist rope length can shorten and pull the hook block against the boom head.

- ▶ Monitor the distance of the hook block to the boom head!
-

- ▶ Luff the boom down carefully.

Result:

- The hoist rope between the boom head and the winch is tensioned.

2.1.3 Lowering the hook block

- ▶ Lower the hook block carefully with the hoist gear.

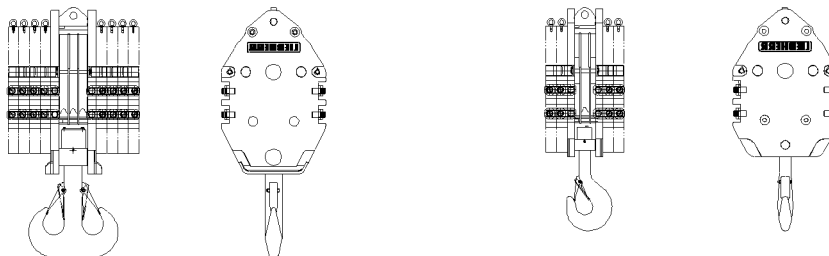
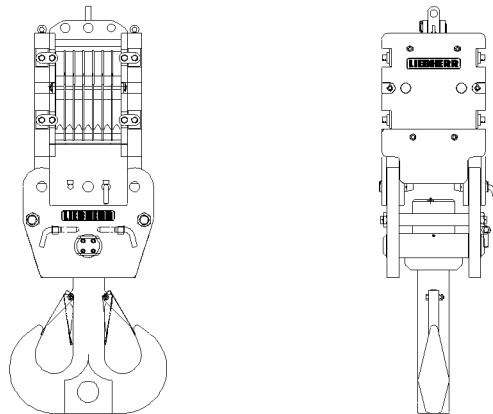
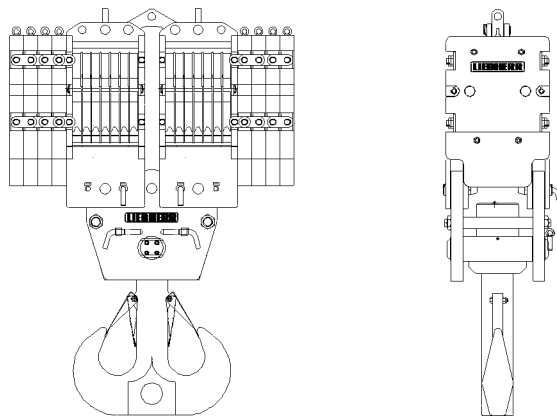
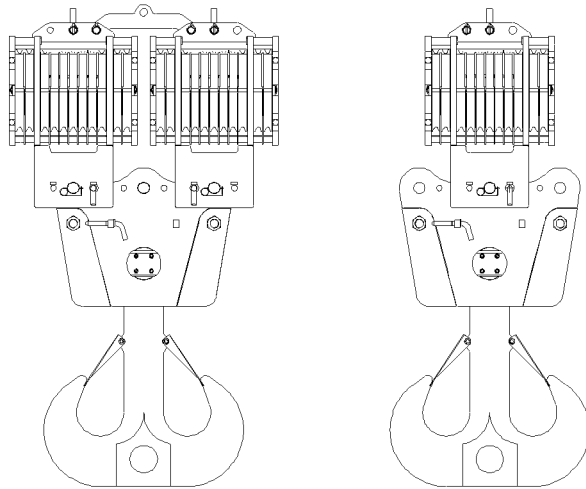

B108122

3 Hook block overview

3.1 Handling of hook blocks

**Note**

- ▶ For the load hooks and hook blocks approved for this crane type refer to the separate load chart manual!
- ▶ The hook blocks shown in this chapter are only examples and can differ from your hook block in type and number of rope pulleys. The different assembly and disassembly procedures are therefore only an example of the description for a number of different hook blocks!

**DANGER**

Hook block weights!

If the data in the erection and take down charts as well as the load charts are not observed, dangerous situations up to toppling of the crane can occur!

Personnel can be severely injured or killed, in addition, high property damage can result!

- ▶ Observe the data in the erection and take down charts!
- ▶ The specifications in the load charts must be adhered to!
- ▶ The crane operator bears the sole and full responsibility for the adherence to the data in the erection and take down charts as well as the load charts!

Differently sized hook blocks can be used for various loads.

NOTICE

Rope damage due to insufficient hook block weight!

If the hook block weight is too low to tighten the hoist rope sufficiently, spooling problems may occur on the winches when lowering and lifting the hook block due to slack rope formation!

The hoist rope can be damaged!

- ▶ In order to prevent spooling problems on the winches, the hook block weight may be increased with auxiliary weights, if necessary!
- ▶ If problems develop in the assembly and set up conditions due to the weight increase of the hook block, auxiliary weights must be removed again!

4 Installing a double hook block for single operation

4.1 Installing the hook block

If the hook blocks are to be used in single operation, then the pulley block **4** must be installed centered on the cross brace **8**.

4.1.1 Installing the pulley block on cross brace

Make sure that the following prerequisites are met:

- The ground is sufficiently load bearing to take on the weight of the hook block safely.
- The ground is level and horizontal.
- The cross brace **8** is placed on the ground, see illustration **1**.



DANGER

Risk of tipping the pulley block!

If the retaining pins **7**, during assembly of the pulley block **4** are not pinned on the cross brace, then the pulley block tips to the side when the auxiliary crane is removed!

Personnel remaining in the danger zone can be severely injured or killed!

- ▶ Insert the retaining pins **7** into the bores **U** on the hook block!
- ▶ Make sure before removing the auxiliary crane that the pulley block is properly pinned and secured!

-
- ▶ Attach the pulley block **4** onto the auxiliary crane, illustration **1**.
 - ▶ Position pulley block **4** on the cross brace **8** and align the pin bore **V**.
 - ▶ Insert the pin **5** on point **V** and secure with spring retainer **6**.
 - ▶ Unpin the retaining pin **7** from the transport receptacle (point **X**).
 - ▶ Insert the retaining pins **7** into one of the bores (point **U**) on the cross brace **8**, illustration **1**.
 - ▶ When the pulley block **4** is secured by the retaining pins **7** at point **U**:
Remove the auxiliary crane.

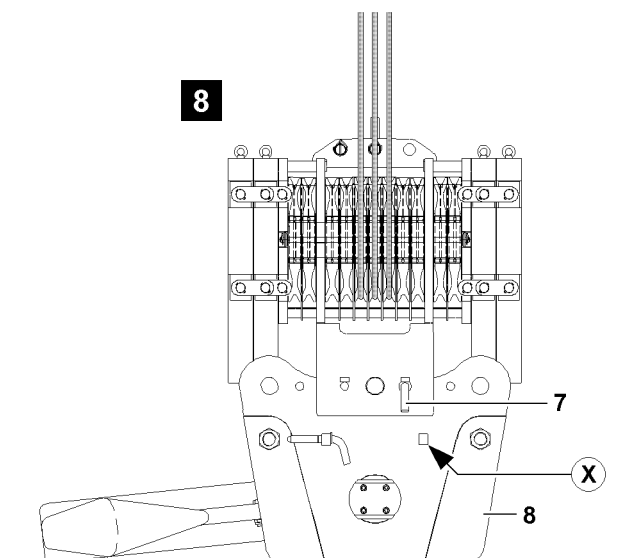
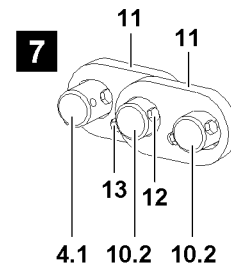
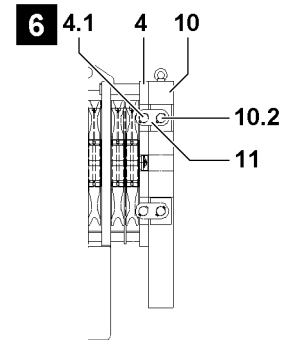
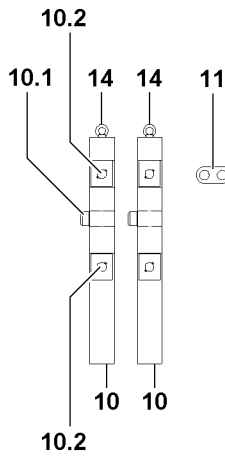
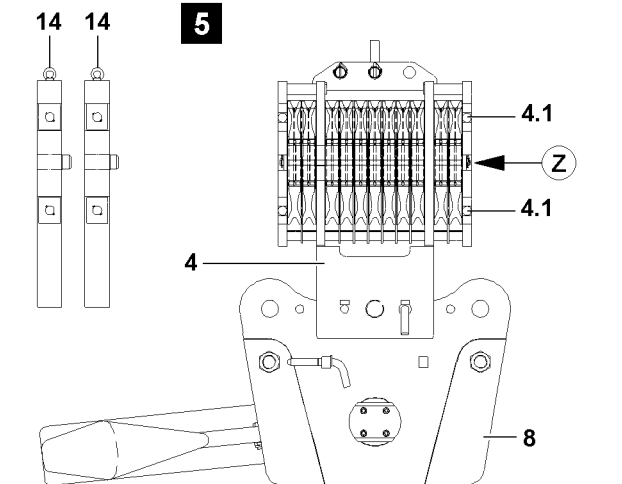
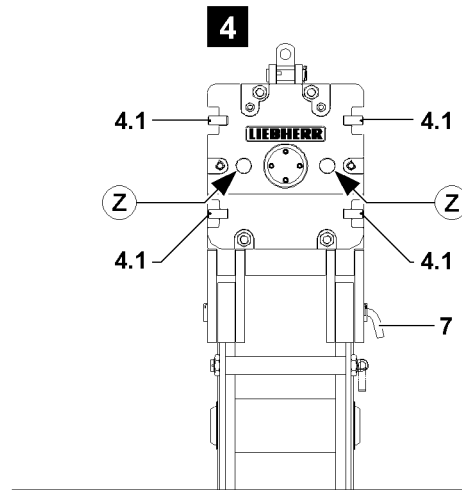
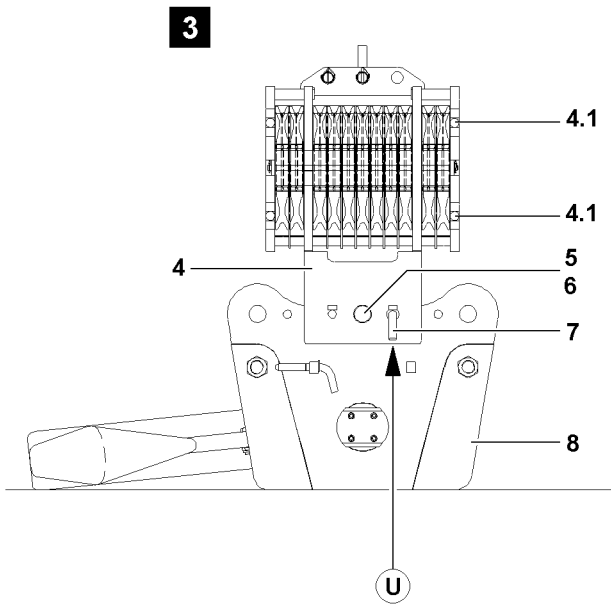

B108141

4.1.2 Installing the auxiliary weights



Note

- ▶ Each auxiliary weight's own weight is marked on the auxiliary weight!



WARNING

Toppling of hook block!

If the auxiliary weights are installed one-sided, the hook block can topple over!

Personnel can be severely injured or killed!

- ▶ The auxiliary weights may only be installed **individually** and alternating left and right on the pulley block!
- ▶ When the required auxiliary weight is installed on the hook block, the difference between the left and right side may never be more than one auxiliary weight!
- ▶ Asymmetrical installation of auxiliary weights is prohibited!
- ▶ Do not exceed the maximum permissible own weight of the hook block! The maximum permissible own weight is engraved on ballastable hook blocks. See "Engraving WT max."

Make sure that the following prerequisites are met:

- The hook block is placed on the ground.
- The pulley block **4** is properly installed and secured.
- The retaining pin **7** is pinned and secured at point **U**.



WARNING

Falling auxiliary weights!

If the auxiliary weights are not properly installed on the pulley block, then they can fall down during installation or in crane operation!

Personnel can be severely injured or killed!

- ▶ Standing under a suspended auxiliary weight is prohibited!
- ▶ Make sure that the auxiliary weights are properly installed and secured!
- ▶ Crane operation with insufficiently secured auxiliary weights is prohibited!

- ▶ Attach the auxiliary weight **10** on the ring screw **14** on the auxiliary crane, illustration **5**.



WARNING

Danger of crushing!

When swinging the auxiliary weights to the pulley block, personnel can be severely injured or killed!

Fingers, hands and arms can be crushed or severed!

- ▶ It is prohibited for anyone to remain between the pulley block and the auxiliary weight!
- ▶ Swing auxiliary weights in to the pulley block with utmost caution and at the least possible speed!

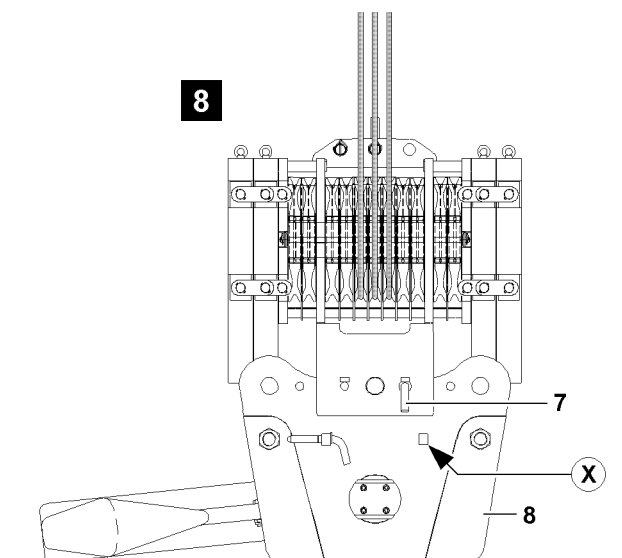
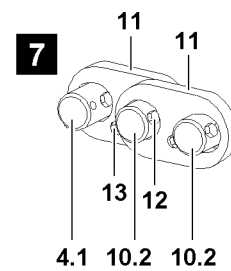
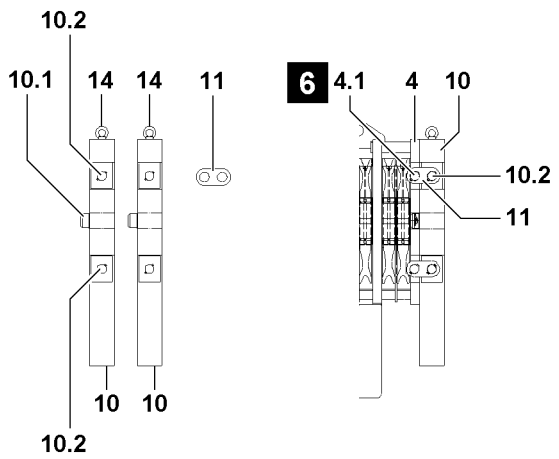
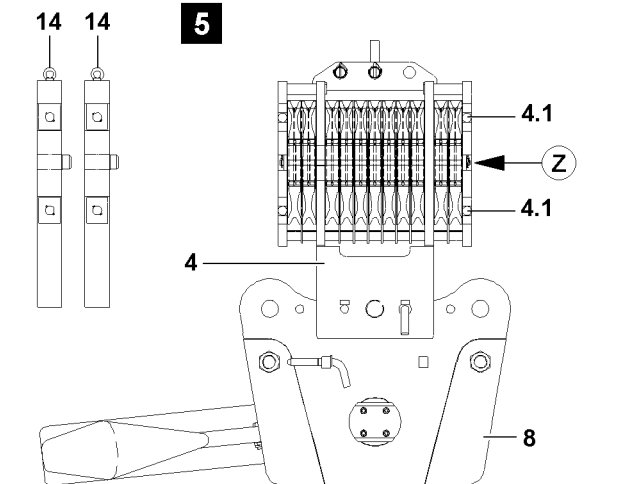
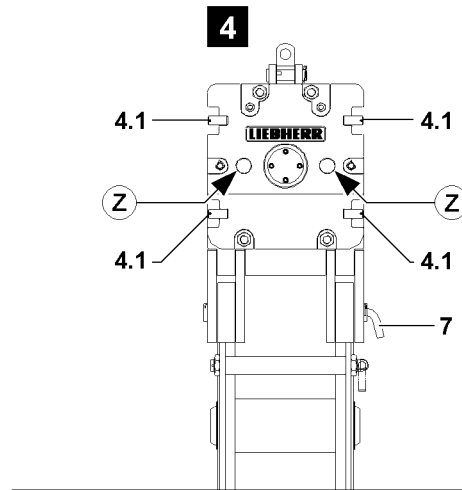
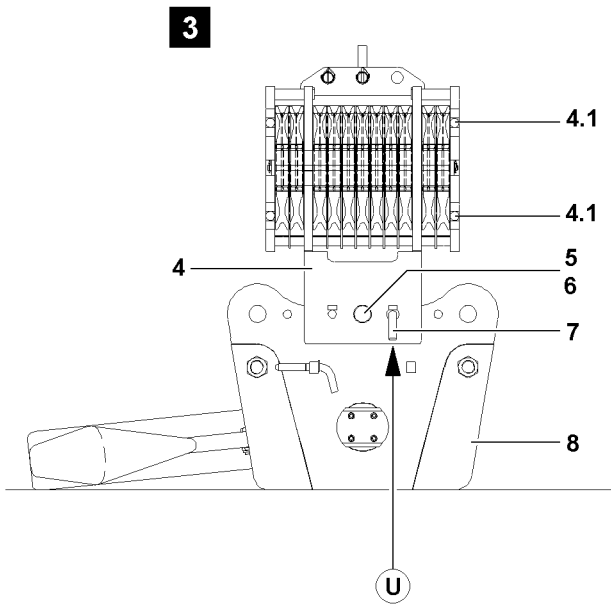

B108141

- ▶ Align the auxiliary weight **10** on the pulley block **4**.
- ▶ Move the centering pin **10.1** of the auxiliary weight into the centering bores **Z** on the pulley block **4**, illustration **6**.

**WARNING**

Falling auxiliary weights!

If all mounting brackets **11** are removed simultaneously on an unsecured auxiliary weight, then the auxiliary weight can fall down!

Personnel can be severely injured or killed!

- ▶ Never remove all mounting brackets **11** of an unsecured auxiliary weight at the same time!
- ▶ Always install or remove the mounting brackets **11** alternately!

- ▶ Install the mounting brackets **11** on the side and connect the pulley block **4** with the auxiliary weight **10**, illustration **7**.
- ▶ Secure the mounting brackets **11** with screws **12** and lock nuts **13**, illustration **7**.

**Note**

- ▶ Additional auxiliary weights must be connected with the mounting brackets **11**!

**WARNING**

Falling auxiliary weights!

The auxiliary weights can fall down by removing the auxiliary crane!

Personnel can be severely injured or killed!

- ▶ Remove the auxiliary crane only when it is ensured that the auxiliary weight **10** is properly secured with the mounting brackets **11**!

- ▶ When the respective auxiliary weight is properly installed and secured:
Remove the auxiliary crane.

4.1.3 Preparing the hook block for crane operation

**Note**

- ▶ The reeving of the hook blocks is described in chapter 4.06 of the Crane operating instructions!
- ▶ Observe the “permissible hook block weights” in the erection and take down charts!

- ▶ Reeve the hoist rope according to the instructions in chapter 4.06 of the Crane operating instructions and the reeving plans!

NOTICE

Retaining pins **7** pinned when lifting the load!

If the retaining pin **7** is not unpinned before crane operation, then the retaining pin **7** may be shorn off when lifting the load!

- ▶ Unpin the retaining pin **7** from the hook block before crane operation!

- ▶ When the hook block is properly reeved and has been lifted off the ground:
Unpin the retaining pin **7** and pin and secure into the transport receptacle (point **X**), illustration **8**.

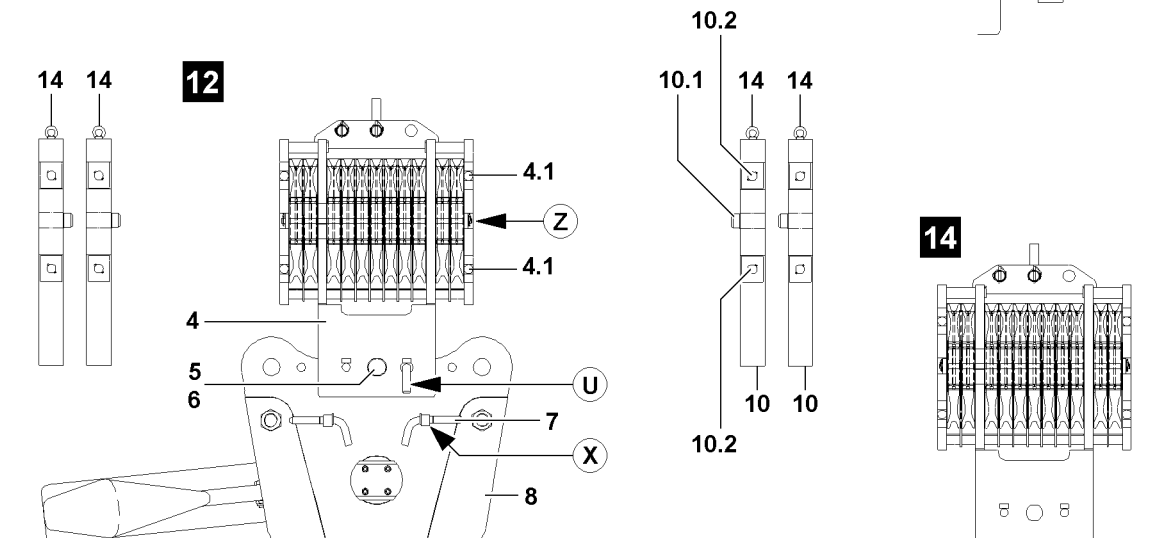
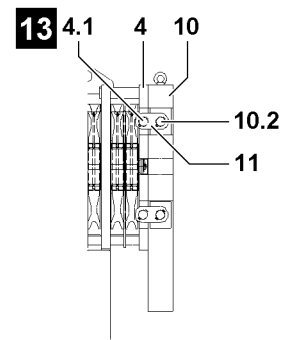
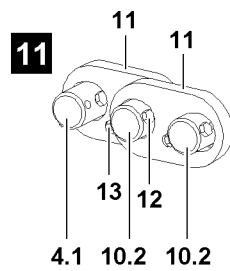
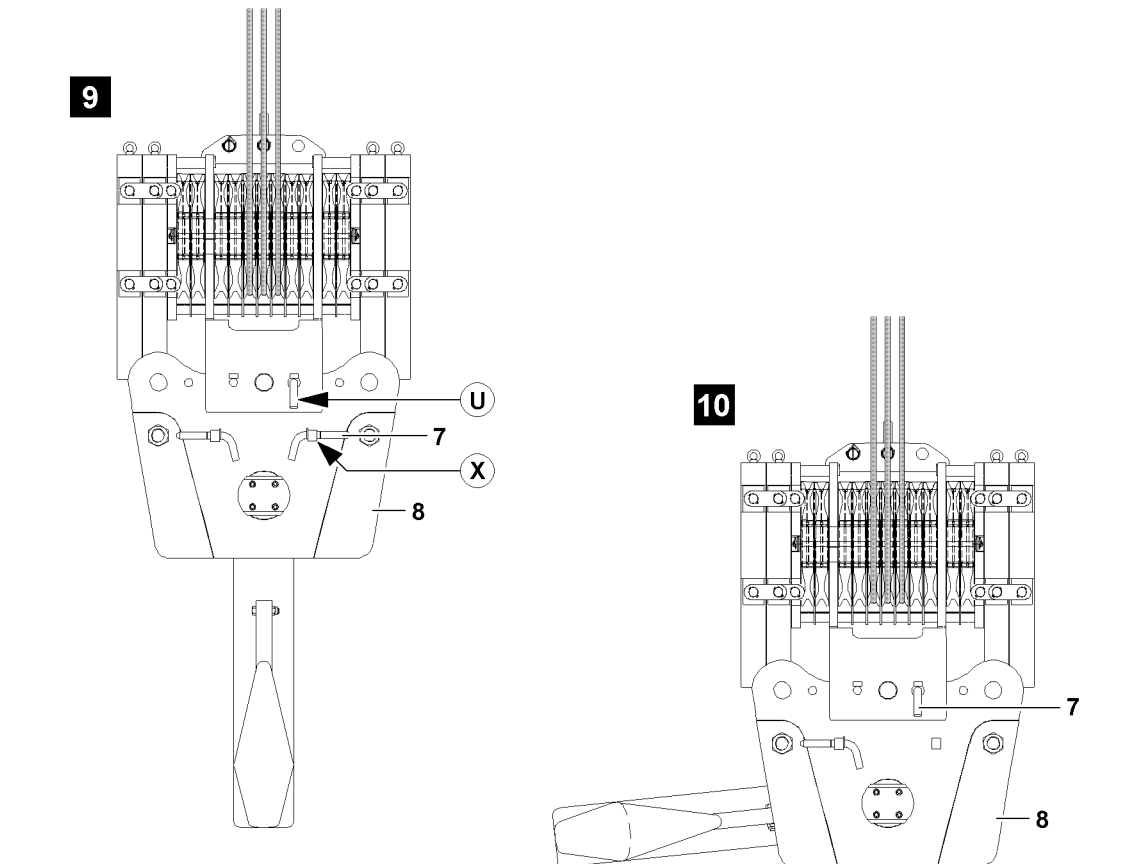

B108142

4.2 Removing the hook block

4.2.1 Preparing the hook block for removal



Note

- ▶ The unreeving of the hook blocks is described in chapter 4.06 of the Crane operating instructions!
- ▶ Observe the “permissible hook block weights” in the erection and take down charts!

NOTICE

Retaining pin 7 unpinned when setting down the hook block!

If the retaining pin 7 - before setting the hook block on the ground - is not pinned, then the pulley block tips away to the side when it is set down!

Personnel can be severely injured or killed!

- ▶ Insert and secure the retaining pin 7, before setting the hook block on the ground, at point **U**!

Make sure that the following prerequisites are met:

- The ground is sufficiently load bearing to take on the weight of the hook block and the auxiliary weights safely.
- The ground is level and horizontal.
- ▶ Lower the hook block completely to the ground.
- ▶ When the hook block was placed down on the ground properly:
Unreeve the hoist rope according to chapter 4.06 of the Crane operating instructions!

4.2.2 Removing the auxiliary weights



Note

- ▶ Each auxiliary weight's own weight is marked on the auxiliary weight!



WARNING

Toppling of hook block!

If the auxiliary weights are removed one-sided, the hook block can topple over!

Personnel can be severely injured or killed!

- ▶ The auxiliary weights may only be removed **individually** and alternating left and right on the pulley block!
- ▶ The difference between the left and the right side at removal of the auxiliary weights may never be more than one auxiliary weight!
- ▶ Asymmetrical removal of auxiliary weights is prohibited!

Make sure that the following prerequisite is met:

- The retaining pin 7 is pinned and secured at point **U**.



WARNING

Falling auxiliary weights!

If the auxiliary weights on the pulley block are not properly removed, then they can fall down at removal!

Personnel can be severely injured or killed!

- ▶ Standing under a suspended auxiliary weight is prohibited!
- ▶ Attach the auxiliary weight **10** on the ring screw **14** on the auxiliary crane.
- ▶ Tension the tackle carefully.

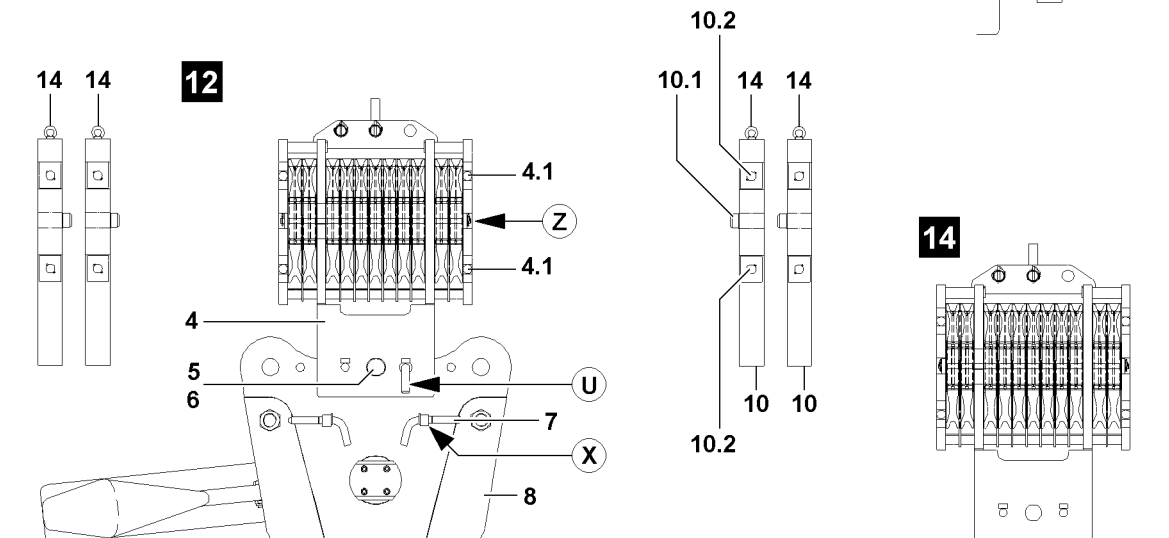
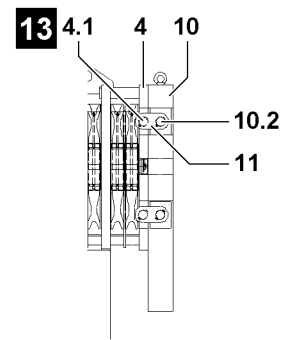
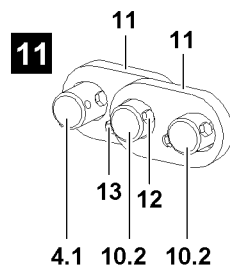
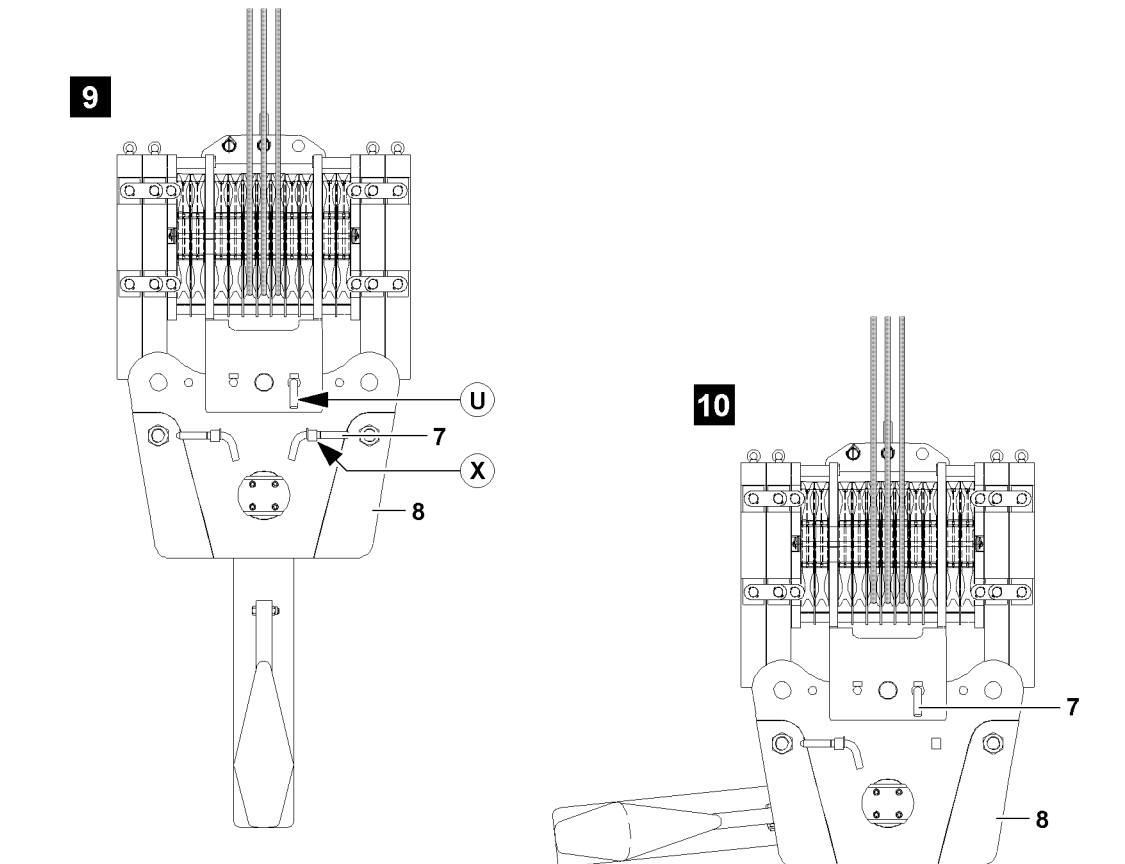

B108142

**WARNING**

Oscillating auxiliary weights!

During the removal of the auxiliary weights, the auxiliary weights can start to swing back and forth! Personnel can be severely injured or killed!

- ▶ It is prohibited for anyone to remain in the danger zone!
- ▶ Make sure that the auxiliary weight which is being removed is properly attached on the auxiliary crane before releasing the mounting brackets!
- ▶ Angular pull is prohibited!

- ▶ When the tackle is tensioned on the auxiliary weight:
Release the screw connection on the mounting brackets of the outermost auxiliary weight and remove the screws.

**WARNING**

Falling auxiliary weights!

If all mounting brackets **11** are removed simultaneously on an unsecured auxiliary weight, then the auxiliary weight can fall down!

Personnel can be severely injured or killed!

- ▶ Never remove all mounting brackets **11** of an unsecured auxiliary weight at the same time!
- ▶ Always install or remove the mounting brackets **11** alternately!

- ▶ Pull the mounting brackets **11** off to the side.

**WARNING**

Falling auxiliary weights!

If additional auxiliary weights which are being removed are released, then these auxiliary weights can fall down!

Personnel can be severely injured or killed!

- ▶ Make sure, before removing the outermost auxiliary weight, that the other auxiliary weights are secured with the mounting brackets!

- ▶ If additional mounting brackets must be removed to release the outermost auxiliary weight:
Reinstall the mounting brackets again immediately, so that only the auxiliary weight which is being removed is released.
- ▶ Lift the auxiliary weight with the auxiliary crane from the pulley block.
- ▶ Place the auxiliary weight onto the ground.
- ▶ Remove the auxiliary crane.
- ▶ Remove additional auxiliary weights as described above.

4.2.3 Removing the pulley block on cross brace

Make sure that the following prerequisite is met:

- The auxiliary weights have been removed.

- ▶ Attach the pulley block **4** on the auxiliary crane.
- ▶ Tension the tackle carefully.
- ▶ Unpin the retaining pin **7** at point **U** and pin into the transport receptacle on the cross brace, point **X**, illustration **12**.
- ▶ Release and unpin the pin **5**.
- ▶ Swing the pulley block **4** out with auxiliary crane.
- ▶ Place the pulley block **4** on the ground, illustration **14**.
- ▶ Remove the auxiliary crane.

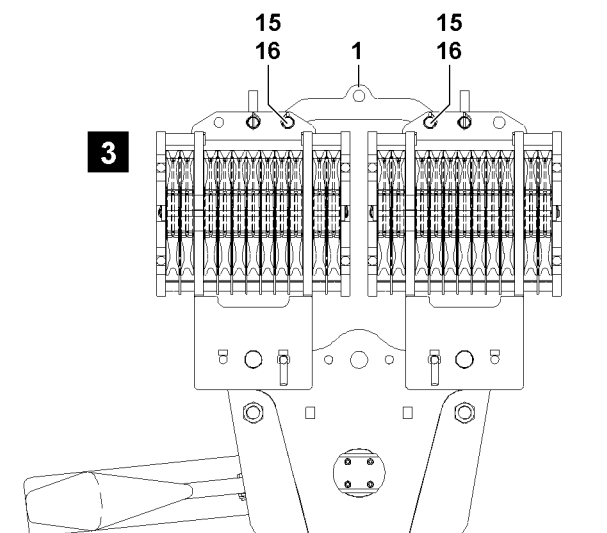
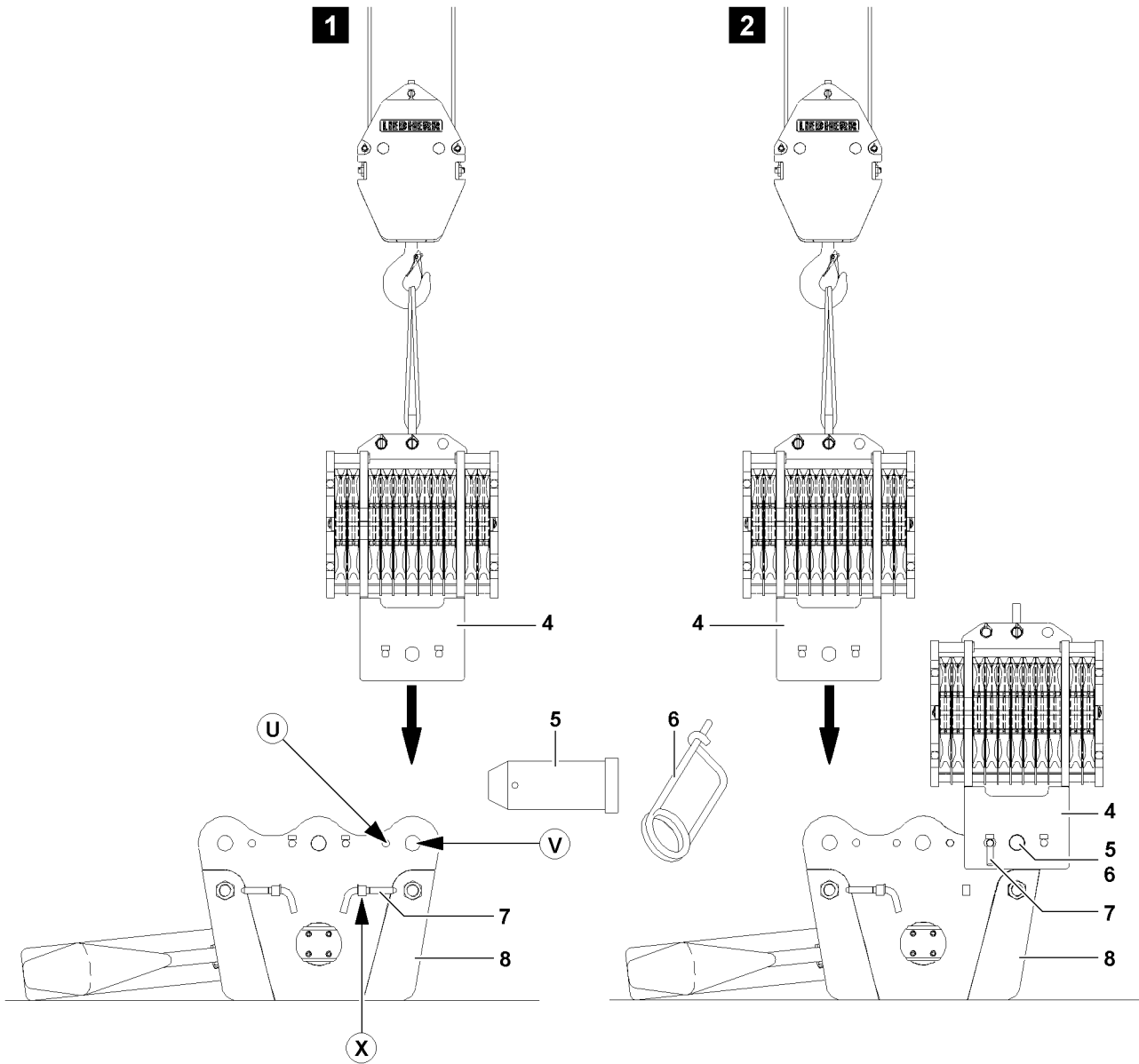

B108121

5 Installing a double hook block for parallel operation

5.1 Installing the hook block

If the hook blocks are to be used in parallel operation, then the pulley blocks **4** must be installed on the left and right on the cross brace **8**.

5.1.1 Installing the pulley blocks on the cross brace

Make sure that the following prerequisites are met:

- The ground is sufficiently load bearing to take on the weight of the hook block safely.
- The ground is level and horizontal.
- The cross brace **8** is placed on the ground, see illustration **1**.



DANGER

Risk of tipping the pulley blocks!

If the retaining pins **7**, during assembly of the pulley blocks **4** are not pinned on the cross brace, then the pulley blocks tip to the side when the auxiliary crane is removed!

Personnel remaining in the danger zone can be severely injured or killed!

- ▶ Insert the retaining pins **7** into the bores **U** on the hook block!
- ▶ Make sure before removing the auxiliary crane that the pulley blocks are properly pinned and secured!



Note

- ▶ The installation of two pulley blocks **4** is identical and is described on the example of one pulley block!

- ▶ Attach the pulley block **4** onto the auxiliary crane, illustration **1**.
- ▶ Position pulley block **4** on the cross brace **8** and align the pin bore **V**.
- ▶ Insert the pin **5** on point **V** and secure with spring retainer **6**.
- ▶ Unpin the retaining pin **7** from the transport receptacle (point **X**).
- ▶ Insert the retaining pins **7** into the bores (point **U**) on the cross brace **8**, illustration **1**.
- ▶ When the pulley block **4** is secured by the retaining pins **7** at point **U**:
Remove the auxiliary crane, illustration **2**.
- ▶ Install the second pulley block.

5.1.2 Installing the block connector

Make sure that the following prerequisite is met:

- The two pulley blocks **4** are installed and secured on the cross brace **8**.

Both pulley blocks **4** are pinned with the block connector **1**.

- ▶ Attach the block connector **1** on the auxiliary crane.
- ▶ Position the block connector **1** with auxiliary crane in pin position, illustration **3**.
- ▶ Insert the pins **15** on both sides on the pulley blocks **4** and secure with linch pin **16**, illustration **3**.
- ▶ When the block connector **1** is pinned and secured properly:
Remove the auxiliary crane.

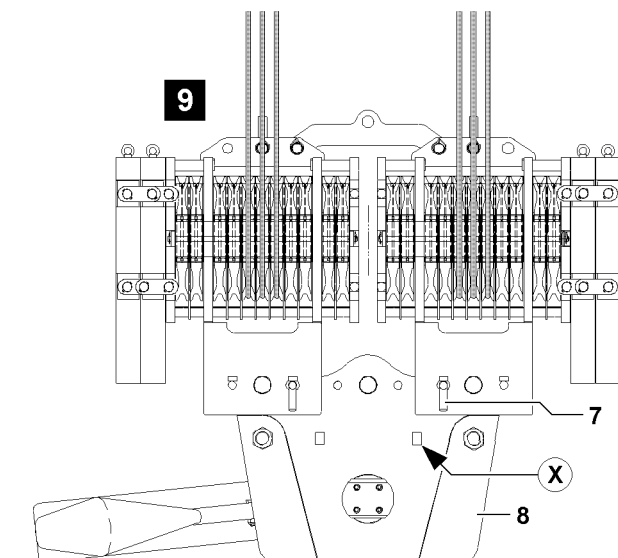
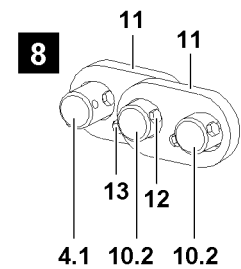
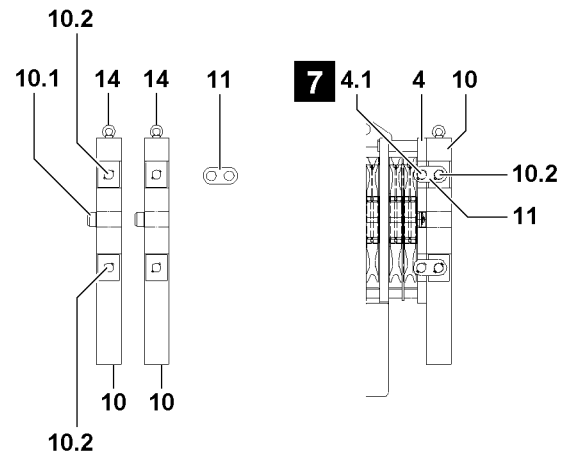
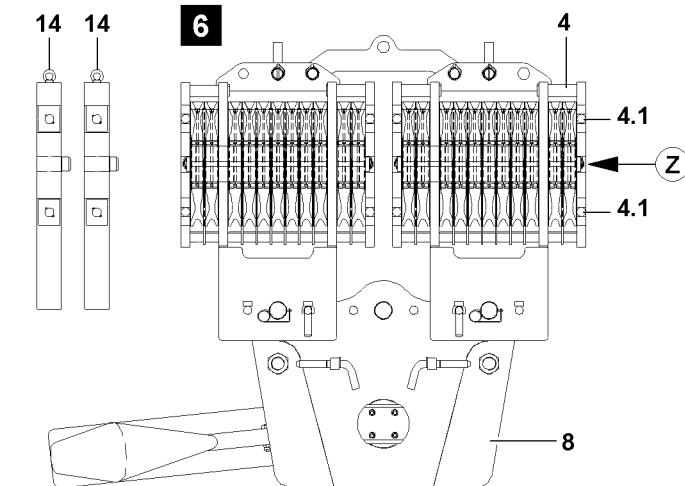
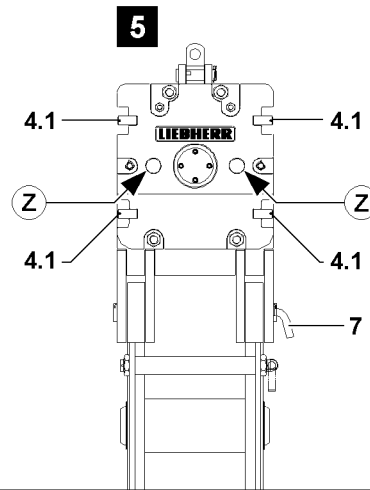
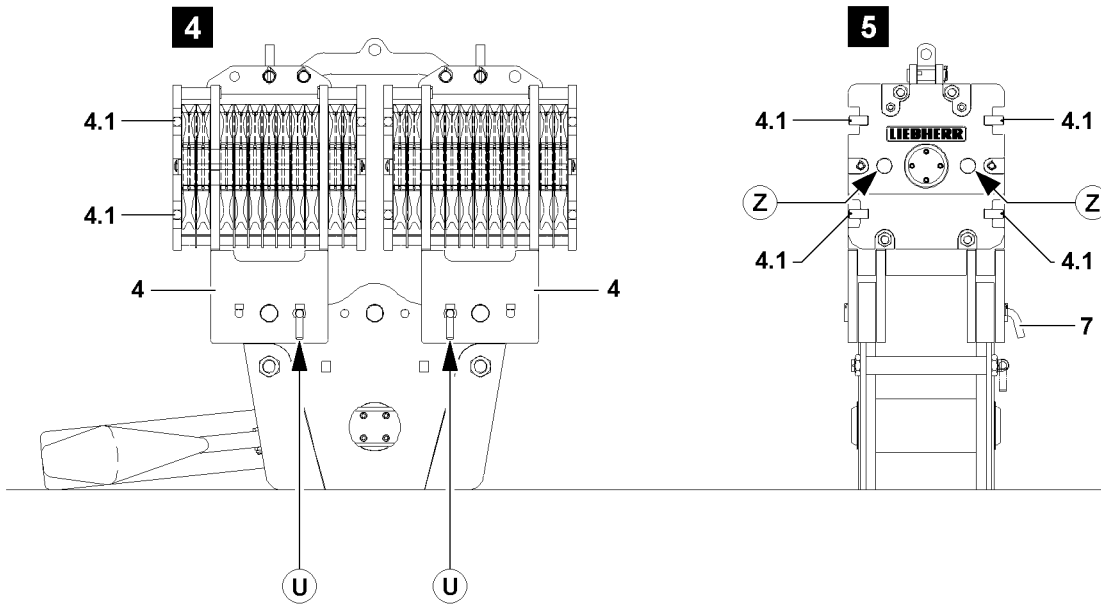

B108120

5.1.3 Installing the auxiliary weights



Note

- ▶ Each auxiliary weight's own weight is marked on the auxiliary weight!



WARNING

Toppling of hook block!

If the auxiliary weights are installed one-sided, the hook block can topple over!

Personnel can be severely injured or killed!

- ▶ The auxiliary weights may only be placed **individually** and alternating left and right on the pulley blocks of the hook block!
- ▶ When the required auxiliary weight is installed on the hook block, the difference between the left and right side may never be more than one auxiliary weight!
- ▶ Asymmetrical installation of auxiliary weights is prohibited!
- ▶ Do not exceed the maximum permissible own weight of the hook block! The maximum permissible own weight is engraved on ballastable hook blocks. See "Engraving WT max."

Make sure that the following prerequisites are met:

- The hook block is placed on the ground.
- The pulley blocks **4** are properly installed and secured.
- The retaining pins **7** are pinned in and secured at point **U**.
- The block connector **1** is properly installed and secured.



WARNING

Falling auxiliary weights!

If the auxiliary weights on the pulley blocks are not properly installed, then they can fall down during installation or during crane operation!

Personnel can be severely injured or killed!

- ▶ Standing under a suspended auxiliary weight is prohibited!
- ▶ Make sure that the auxiliary weights are properly installed and secured!
- ▶ Crane operation with insufficiently secured auxiliary weights is prohibited!

- ▶ Attach the auxiliary weight **10** on the ring screw **14** on the auxiliary crane.



WARNING

Danger of crushing!

When swinging the auxiliary weights to the pulley block, personnel can be severely injured or killed!

Fingers, hands and arms can be crushed or severed!

- ▶ It is prohibited for anyone to remain between the pulley blocks and the auxiliary weight!
- ▶ Swing auxiliary weights in to the pulley block with utmost caution and at the least possible speed!

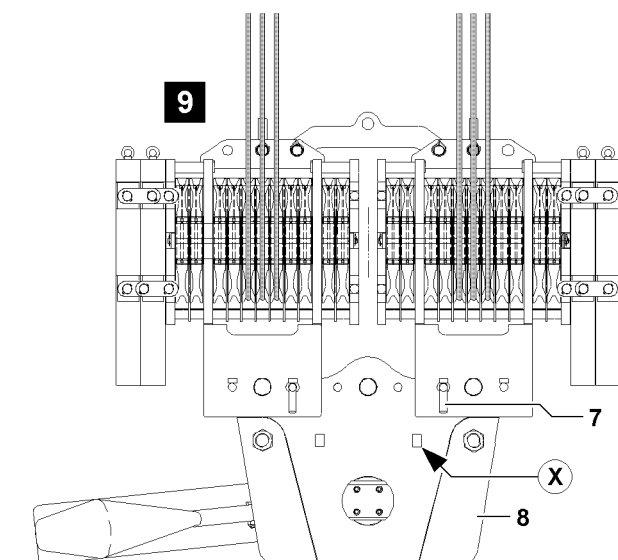
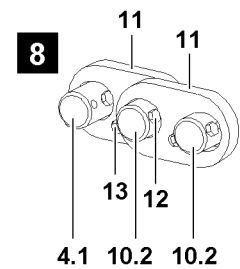
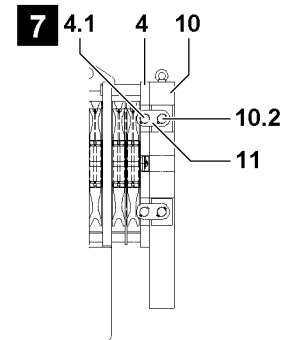
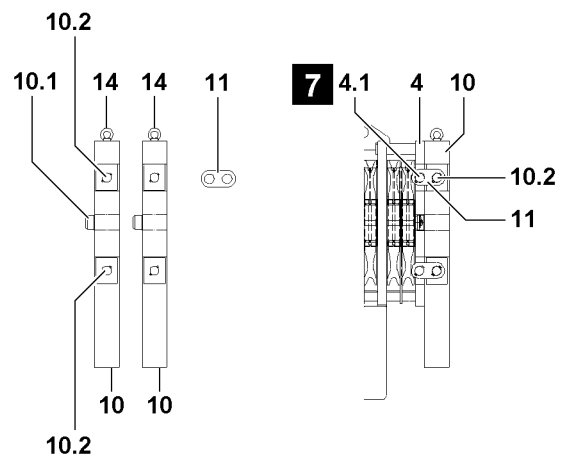
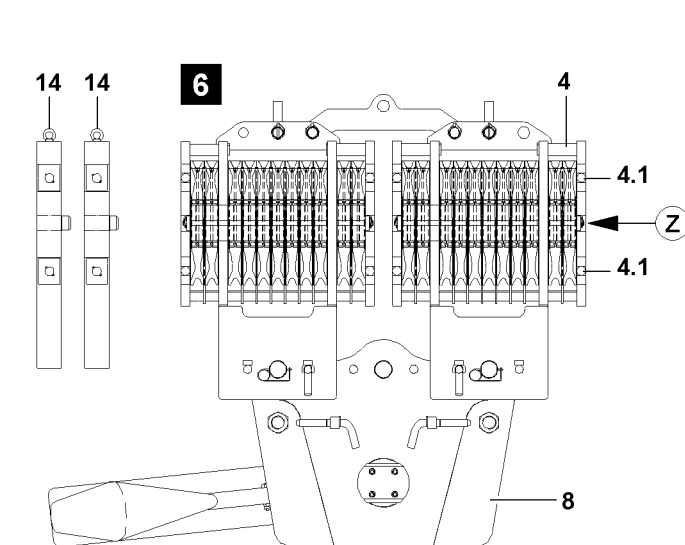
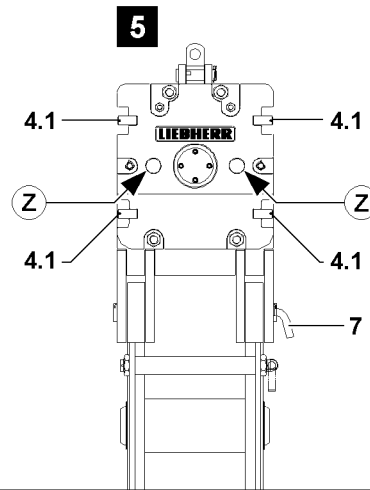
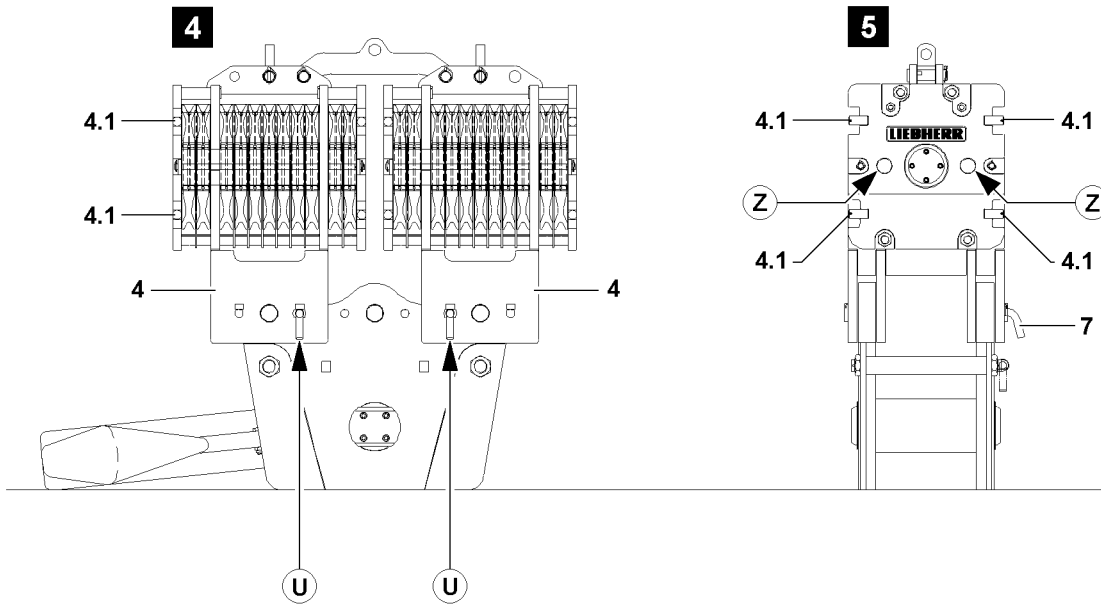

B108120

- ▶ Align the auxiliary weight **10** on the pulley block **4**.
- ▶ Move the centering pin **10.1** of the auxiliary weight into the centering bores **Z** on the pulley block **4**, illustration **7**.

**WARNING**

Falling auxiliary weights!

If all mounting brackets **11** are removed simultaneously on an unsecured auxiliary weight, then the auxiliary weight can fall down!

Personnel can be severely injured or killed!

- ▶ Never remove all mounting brackets **11** of an unsecured auxiliary weight at the same time!
- ▶ Always install or remove the mounting brackets **11** alternately!

- ▶ Install the mounting brackets **11** on the side and connect the pulley block **4** with the auxiliary weight **10**, illustration **8**.
- ▶ Secure the mounting brackets **11** with screws **12** and lock nuts **13**, illustration **8**.

**Note**

- ▶ Additional auxiliary weights must be connected with the mounting brackets **11**!

**WARNING**

Falling auxiliary weights!

The auxiliary weights can fall down to the side when the auxiliary crane is removed!

Personnel can be severely injured or killed!

- ▶ Remove the auxiliary crane only when it is ensured that the auxiliary weight **10** is properly secured with the mounting brackets **11**!

- ▶ When the respective auxiliary weight is properly installed and secured:
Remove the auxiliary crane.

5.1.4 Preparing the hook block for crane operation

**Note**

- ▶ The reeving of the hook blocks is described in chapter 4.06 of the Crane operating instructions!
- ▶ Observe the “permissible hook block weights” in the erection and take down charts!

- ▶ Reeve the hoist rope according to the instructions in chapter 4.06 of the Crane operating instructions and the reeving plans!

NOTICE

Retaining pins **7** pinned when lifting the load!

If the retaining pins **7** are not unpinned before the crane operation, then the retaining pins **7** may be shorn off when lifting the load!

- ▶ Unpin the retaining pin **7** from the hook block before crane operation!

- ▶ When the hook block is properly reeved and has been lifted off the ground:
Unpin the retaining pin **7** and pin and secure into the transport receptacle (point **X**), illustration **9**.

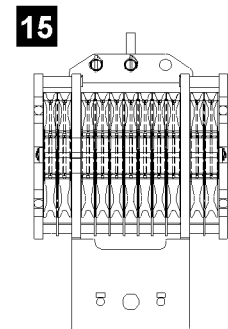
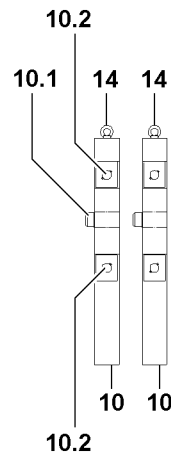
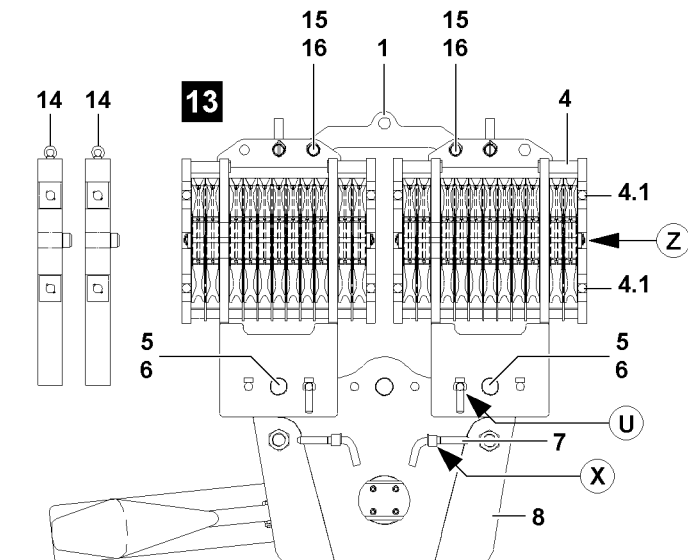
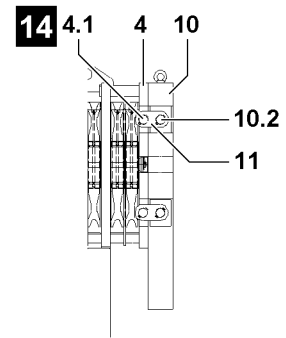
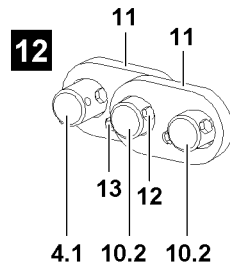
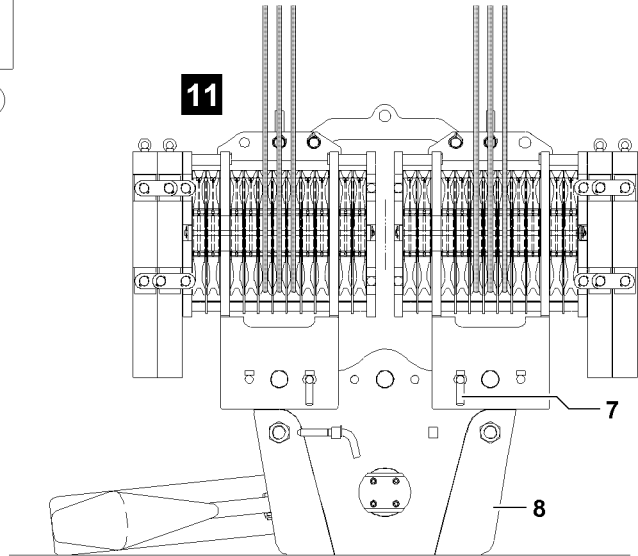
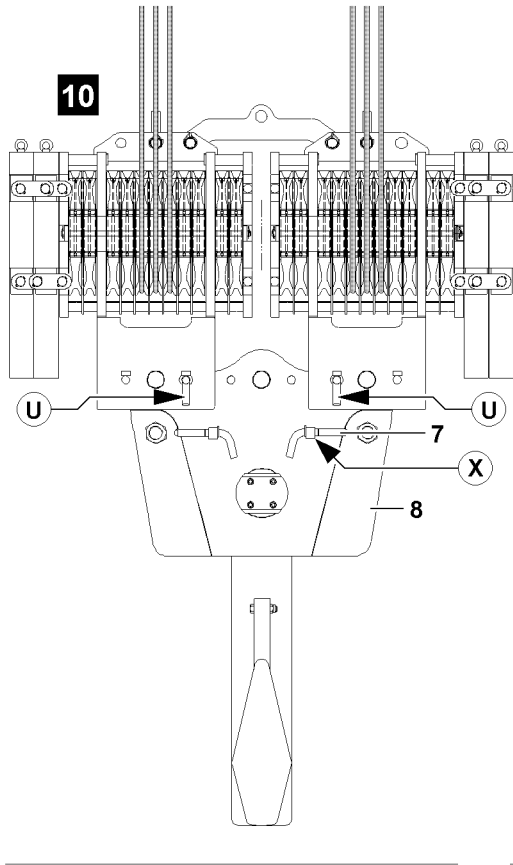

B108143

5.2 Removing the hook block

5.2.1 Preparing the hook block for removal



Note

- ▶ The unreeving of the hook blocks is described in chapter 4.06 of the Crane operating instructions!
- ▶ Observe the “permissible hook block weights” in the erection and take down charts!

NOTICE

Retaining pin 7 unpinned when setting down the hook block!

If the retaining pin 7 - before setting the hook block on the ground - is not pinned, then the pulley blocks tip away to the side when the hoist rope is unreeved!

Personnel can be severely injured or killed!

- ▶ Before setting the hook block on the ground, insert and secure the retaining pins 7 on both pulley blocks at point **U**!

Make sure that the following prerequisites are met:

- The ground is sufficiently load bearing to take on the weight of the hook block and the auxiliary weights safely.
- The ground is level and horizontal.
- ▶ Lower the hook block completely to the ground.
- ▶ When the hook block was placed down on the ground properly:
Unreeve the hoist rope(s) according to chapter 4.06 of the Crane operating instructions!

5.2.2 Removing the auxiliary weights



Note

- ▶ Each auxiliary weight's own weight is marked on the auxiliary weight!



WARNING

Toppling of hook block!

If the auxiliary weights are removed one-sided, the hook block can topple over!

Personnel can be severely injured or killed!

- ▶ The auxiliary weights may only be removed **individually** and alternating left and right on the pulley blocks of the hook block!
- ▶ The difference between the left and the right side at removal of the auxiliary weights may never be more than one auxiliary weight!
- ▶ Asymmetrical removal of auxiliary weights is prohibited!

Make sure that the following prerequisites are met:

- The retaining pins 7 are pinned and secured on both sides at point **U**.
- The block connector 1 has been removed.

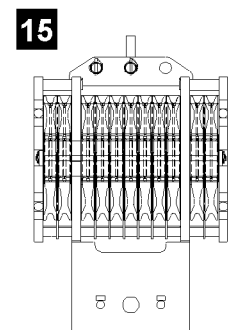
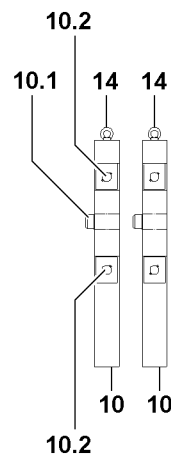
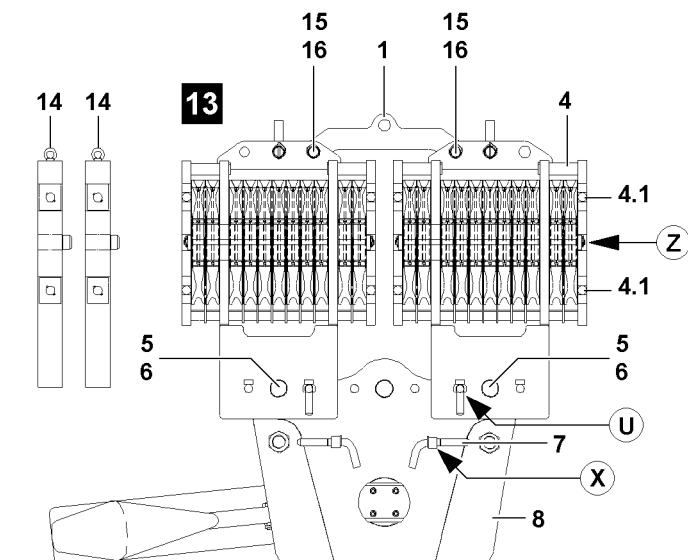
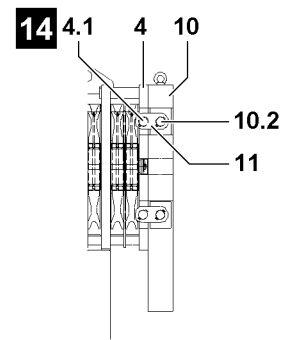
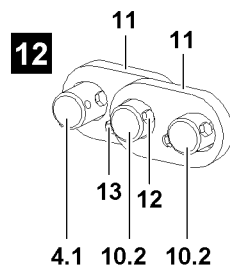
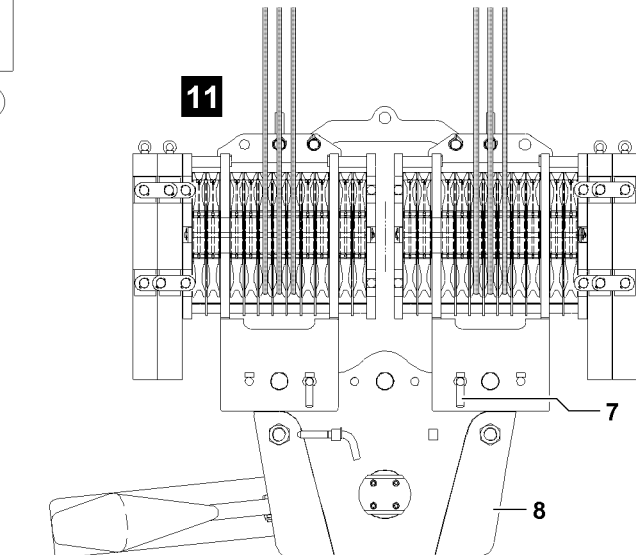
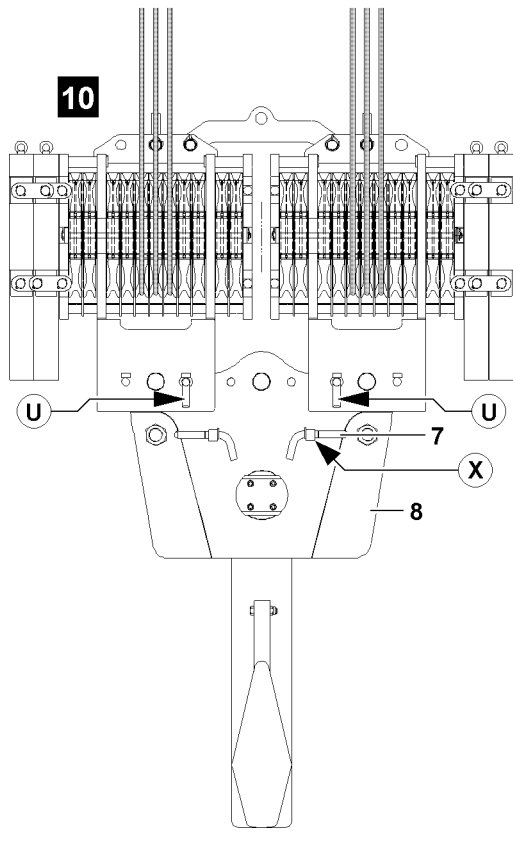

B108143

**WARNING**

Falling auxiliary weights!

If the auxiliary weights on the pulley blocks are not properly removed, then they can fall down at removal!

Personnel can be severely injured or killed!

▶ Standing under a suspended auxiliary weight is prohibited!

▶ Attach the auxiliary weight **10** on the ring screw **14** on the auxiliary crane.

▶ Tension the tackle carefully.

**WARNING**

Oscillating auxiliary weights!

During the removal of the auxiliary weights, the auxiliary weights can start to swing back and forth!

Personnel can be severely injured or killed!

▶ It is prohibited for anyone to remain in the danger zone!

▶ Make sure that the auxiliary weight which is being removed is properly attached on the auxiliary crane before releasing the mounting brackets!

▶ Angular pull is prohibited!

▶ When the tackle is tensioned on the auxiliary weight:

Release the screw connection on the mounting brackets of the outermost auxiliary weight and remove the screws.

**WARNING**

Falling auxiliary weights!

If all mounting brackets **11** are removed simultaneously on an unsecured auxiliary weight, then the auxiliary weight can fall down!

Personnel can be severely injured or killed!

▶ Never remove all mounting brackets **11** of an unsecured auxiliary weight at the same time!

▶ Always install or remove the mounting brackets **11** alternately!

▶ Pull the mounting brackets **11** off to the side.

**WARNING**

Falling auxiliary weights!

If additional auxiliary weights which are being removed are released, then these auxiliary weights can fall down!

Personnel can be severely injured or killed!

▶ Make sure, before removing the outermost auxiliary weight, that the other auxiliary weights are secured with the mounting brackets **11**!

▶ If additional mounting brackets **11** must be removed to release the outermost auxiliary weight:

Reinstall the mounting brackets again immediately, so that only the auxiliary weight which is being removed is released.

▶ Lift the auxiliary weight with the auxiliary crane from the pulley block.

▶ Place the auxiliary weight onto the ground.

▶ Remove the auxiliary crane.

▶ Remove additional auxiliary weights as described above.

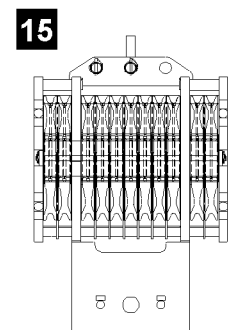
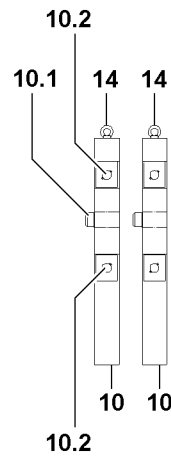
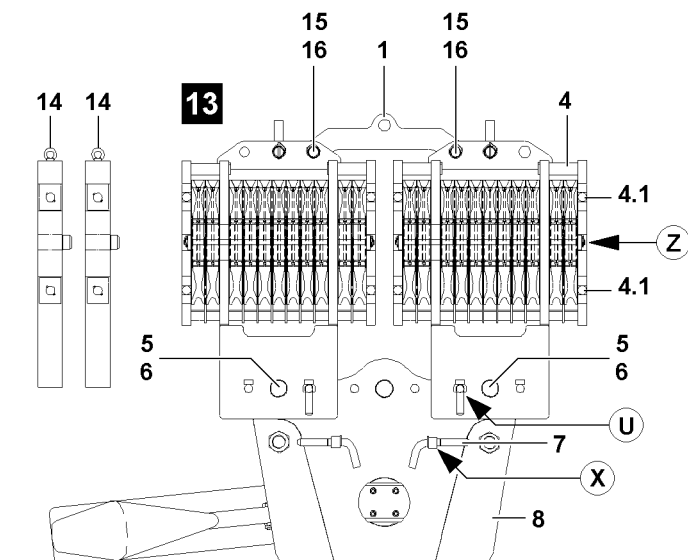
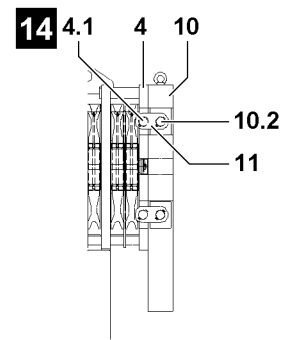
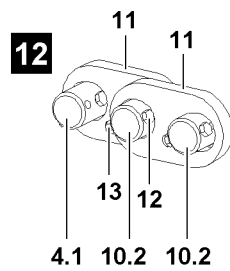
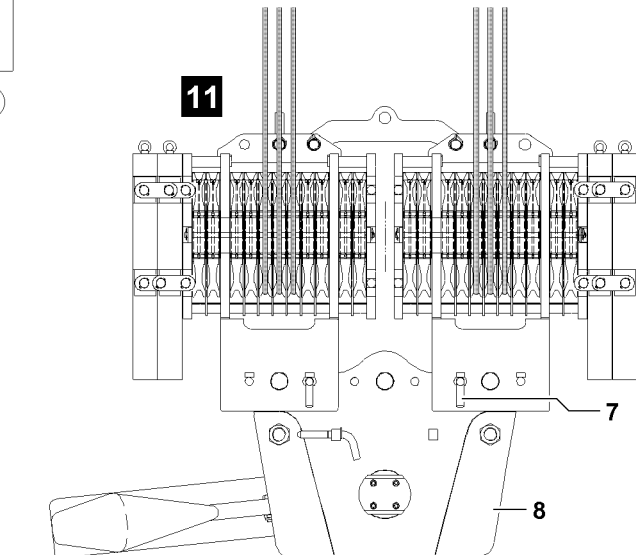
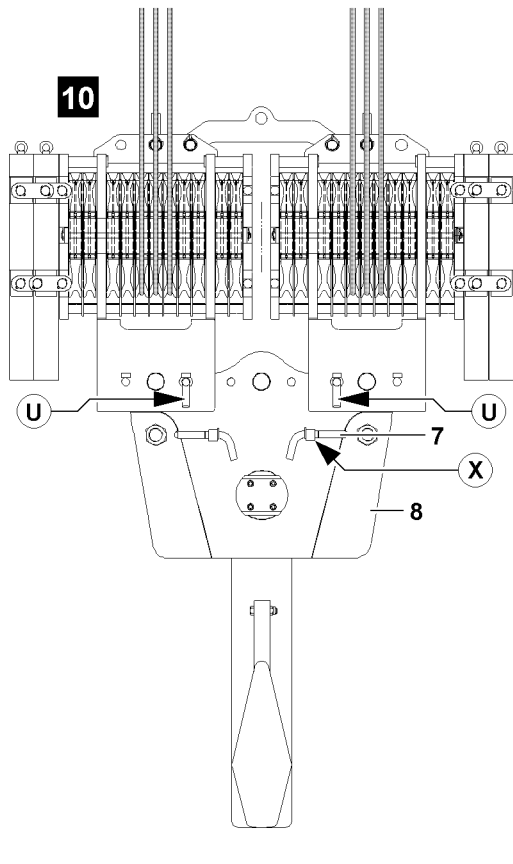

B108143

5.2.3 Removing the block connector

- ▶ Attach the block connector **1** on the auxiliary crane.



DANGER

Risk of tipping the pulley blocks!

If the retaining pins **7**, during removal of the block connector **1** are not pinned on the pulley blocks, then the pulley blocks tip to the side when the block connector is removed!

Personnel remaining in the danger zone can be severely injured or killed!

- ▶ Insert the retaining pins **7** into the bores **U** on the hook block!
- ▶ Make sure before removing the block connector that the pulley blocks are properly pinned and secured!

- ▶ Release and unpin the pins **15** on both sides on the pulley blocks **4**.
- ▶ Remove the block connector **1** on the auxiliary crane.
- ▶ Place the block connector **1** onto the ground.
- ▶ Remove the auxiliary crane.

5.2.4 Removing the pulley blocks on the cross brace



Note

- ▶ The removal of two pulley blocks is identical and is described on the example of one pulley block!

Make sure that the following prerequisites are met:

- The auxiliary weights have been removed.
- The block connector has been removed.
- ▶ Attach the pulley block **4** on the auxiliary crane.
- ▶ Tension the tackle carefully.
- ▶ Unpin the retaining pin **7** at point **U** and pin into the transport receptacle on the cross brace, point **X**, illustration **13**.
- ▶ Release and unpin the pin **5**.
- ▶ Swing the pulley block **4** out with auxiliary crane.
- ▶ Place the pulley block **4** on the ground.
- ▶ Remove the auxiliary crane.
- ▶ Remove the second pulley block.

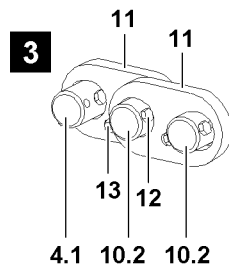
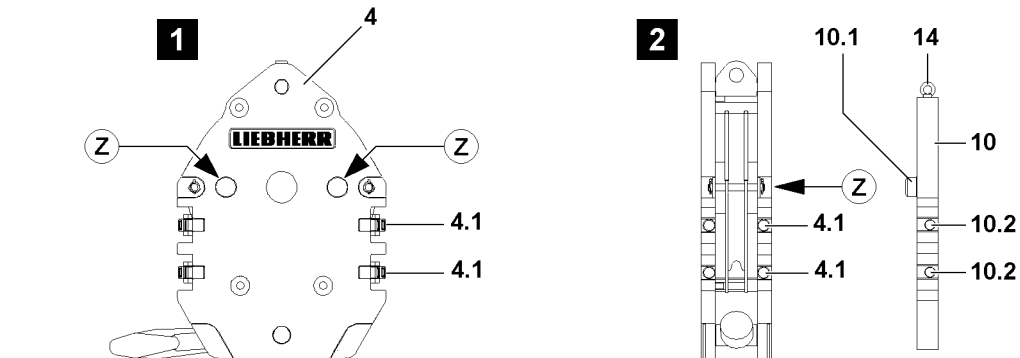

6 Single hook blocks

6.1 Installing the single blocks

6.1.1 Installing the auxiliary weights



Note

- ▶ Each auxiliary weight's own weight is marked on the auxiliary weight!



WARNING

Toppling of hook block!

If the auxiliary weights are installed one-sided, the hook block can topple over!

Personnel can be severely injured or killed!

- ▶ The auxiliary weights may only be installed **individually** and alternately on the left and right on the hook block!
- ▶ When the required auxiliary weight is installed on the hook block, the difference between the left and right side may never be more than one auxiliary weight!
- ▶ Asymmetrical installation of auxiliary weights is prohibited!
- ▶ Do not exceed the maximum permissible own weight of the hook block! The maximum permissible own weight is engraved on ballastable hook blocks. See "Engraving WT max."

Make sure that the following prerequisite is met:

- The hook block is placed on the ground.



WARNING

Falling auxiliary weights!

If the auxiliary weights are not properly installed on the hook block, then they can fall down during installation or in crane operation!

Personnel can be severely injured or killed!

- ▶ Standing under a suspended auxiliary weight is prohibited!
- ▶ Make sure that the auxiliary weights are properly installed and secured!
- ▶ Crane operation with insufficiently secured auxiliary weights is prohibited!

- ▶ Attach the auxiliary weight **10** on the ring screw **14** on the auxiliary crane.



WARNING

Danger of crushing!

When swinging the auxiliary weights to the hook block, personnel can be severely injured or killed!

Fingers, hands and arms can be crushed or severed!

- ▶ It is prohibited for anyone to remain between the hook block and the auxiliary weight!
- ▶ Swing auxiliary weights in to the hook block with utmost caution and at the least possible speed!

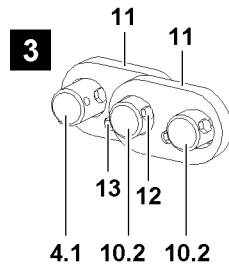
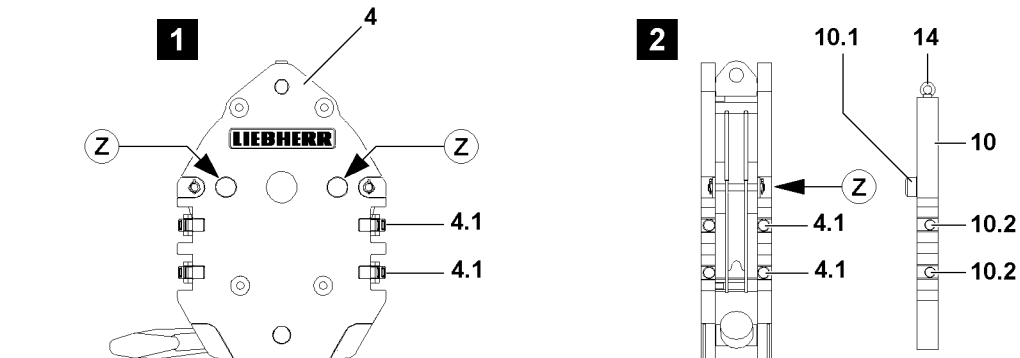

- ▶ Align the auxiliary weight **10** on the hook block.
- ▶ Move the centering pin **10.1** of the auxiliary weight into the centering bores **Z** on the hook block.

**WARNING**

Falling auxiliary weights!

If all mounting brackets **11** are removed simultaneously on an unsecured auxiliary weight, then the auxiliary weight can fall down!

Personnel can be severely injured or killed!

- ▶ Never remove all mounting brackets **11** of an unsecured auxiliary weight at the same time!
- ▶ Always install or remove the mounting brackets **11** alternately!

▶ Install the mounting brackets **11** on the side and connect the hook block with the auxiliary weight **10**, illustration **3**.

▶ Secure the mounting brackets **11** with screws **12** and lock nuts **13**, illustration **3**.

**Note**

- ▶ Additional auxiliary weights must be connected with the mounting brackets **11**!

**WARNING**

Falling auxiliary weights!

The auxiliary weights can fall down by removing the auxiliary crane!

Personnel can be severely injured or killed!

- ▶ Remove the auxiliary crane only when it is ensured that the auxiliary weight **10** is properly secured with the mounting brackets **11**!

▶ When the respective auxiliary weight is properly installed and secured:
Remove the auxiliary crane.

6.1.2 Preparing the hook block for crane operation

**Note**

- ▶ The reeving of the hook blocks is described in chapter 4.06 of the Crane operating instructions!
- ▶ Observe the “permissible hook block weights” in the erection and take down charts!

▶ Reeve the hoist rope according to the instructions in chapter 4.06 of the Crane operating instructions and the reeving plans!

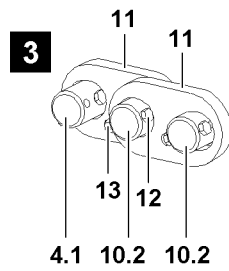
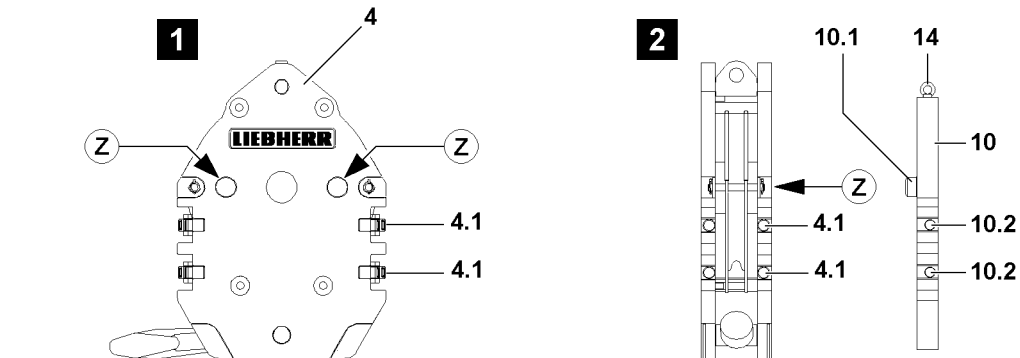

6.2 Removing the single blocks

6.2.1 Preparing the hook block for removal



Note

- ▶ The unreeving of the hook blocks is described in chapter 4.06 of the Crane operating instructions!
- ▶ Observe the “permissible hook block weights” in the erection and take down charts!

Make sure that the following prerequisites are met:

- The ground is sufficiently load bearing to take on the weight of the hook block and the auxiliary weights safely.
- The ground is level and horizontal.
- ▶ Lower the hook block completely to the ground.
- ▶ When the hook block was placed down on the ground properly:
Unreeve the hoist rope according to chapter 4.06 of the Crane operating instructions!

6.2.2 Removing the auxiliary weights



Note

- ▶ Each auxiliary weight's own weight is marked on the auxiliary weight!



WARNING

Toppling of hook block!

If the auxiliary weights are removed one-sided, the hook block can topple over!

Personnel can be severely injured or killed!

- ▶ The auxiliary weights may only be removed **individually** and alternately on the left and right on the hook block!
- ▶ The difference between the left and the right side at removal of the auxiliary weights may never be more than one auxiliary weight!
- ▶ Asymmetrical removal of auxiliary weights is prohibited!



WARNING

Falling auxiliary weights!

If the auxiliary weights on the pulley block are not properly removed, then they can fall down at removal!

Personnel can be severely injured or killed!

- ▶ Standing under a suspended auxiliary weight is prohibited!
- ▶ Attach the auxiliary weight **10** on the ring screw **14** on the auxiliary crane.
- ▶ Tension the tackle carefully.

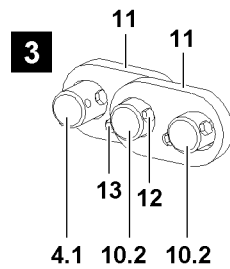
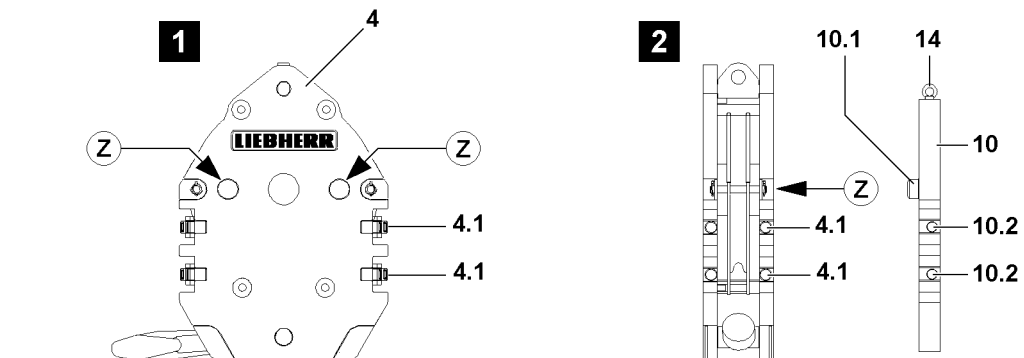

**WARNING**

Oscillating auxiliary weights!

During the removal of the auxiliary weights, the auxiliary weights can start to swing back and forth!
Personnel can be severely injured or killed!

- ▶ It is prohibited for anyone to remain in the danger zone!
- ▶ Make sure that the auxiliary weight which is being removed is properly attached on the auxiliary crane before releasing the mounting brackets!
- ▶ Angular pull is prohibited!

- ▶ When the tackle is tensioned on the auxiliary weight:
Release the screw connection on the mounting brackets of the outermost auxiliary weight and remove the screws.

**WARNING**

Falling auxiliary weights!

If all mounting brackets **11** are removed simultaneously on an unsecured auxiliary weight, then the auxiliary weight can fall down!

Personnel can be severely injured or killed!

- ▶ Never remove all mounting brackets **11** of an unsecured auxiliary weight at the same time!
- ▶ Always install or remove the mounting brackets **11** alternately!

- ▶ Pull the mounting brackets **11** off to the side.

**WARNING**

Falling auxiliary weights!

If additional auxiliary weights which are being removed are released, then these auxiliary weights can fall down!

Personnel can be severely injured or killed!

- ▶ Make sure, before removing the outermost auxiliary weight, that the other auxiliary weights are secured with the mounting brackets!

- ▶ If additional mounting brackets must be removed to release the outermost auxiliary weight:
Reinstall the mounting brackets **11** again immediately, so that only the auxiliary weight which is being removed is released.
- ▶ Lift the auxiliary weight with the auxiliary crane from the hook block.
- ▶ Place the auxiliary weight onto the ground.
- ▶ Remove the auxiliary crane.
- ▶ Remove additional auxiliary weights as described above.

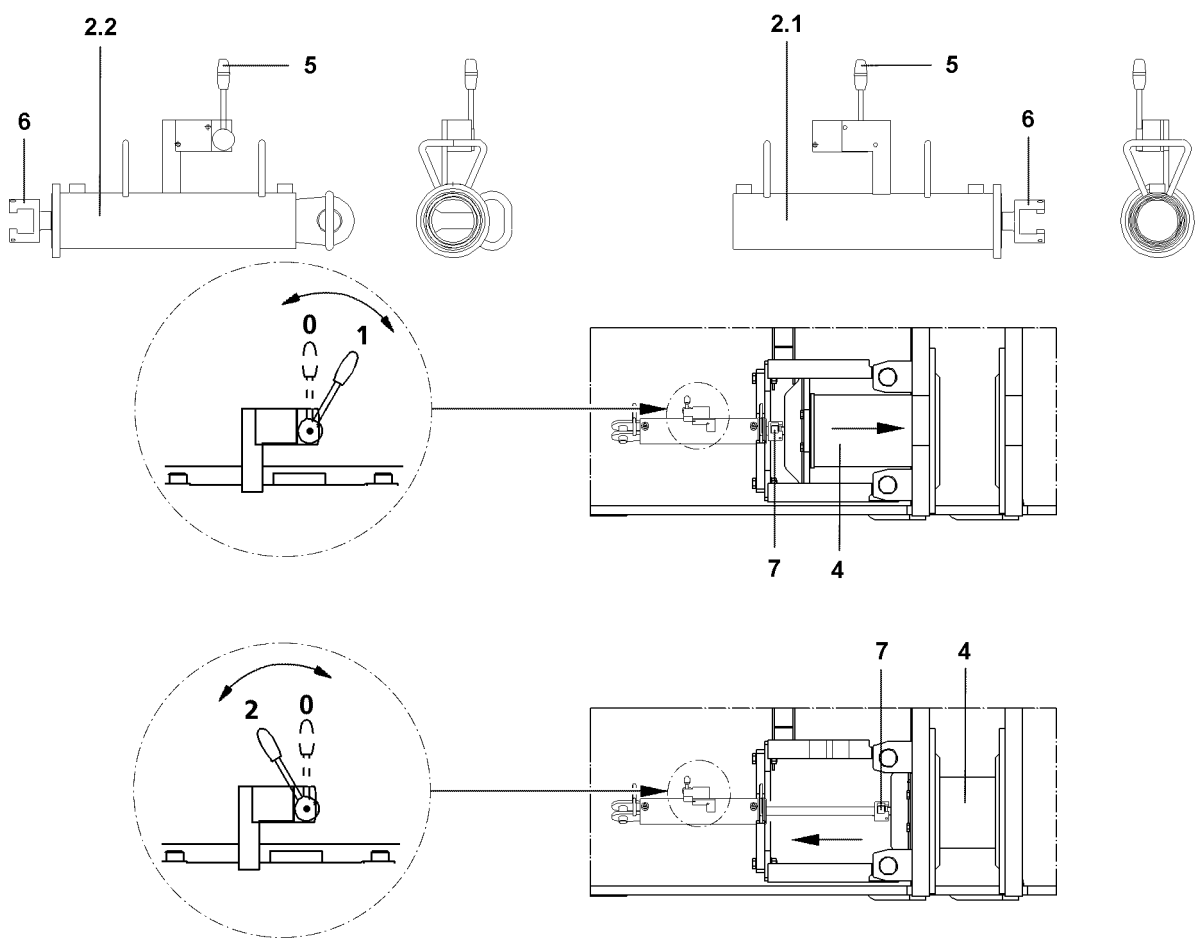
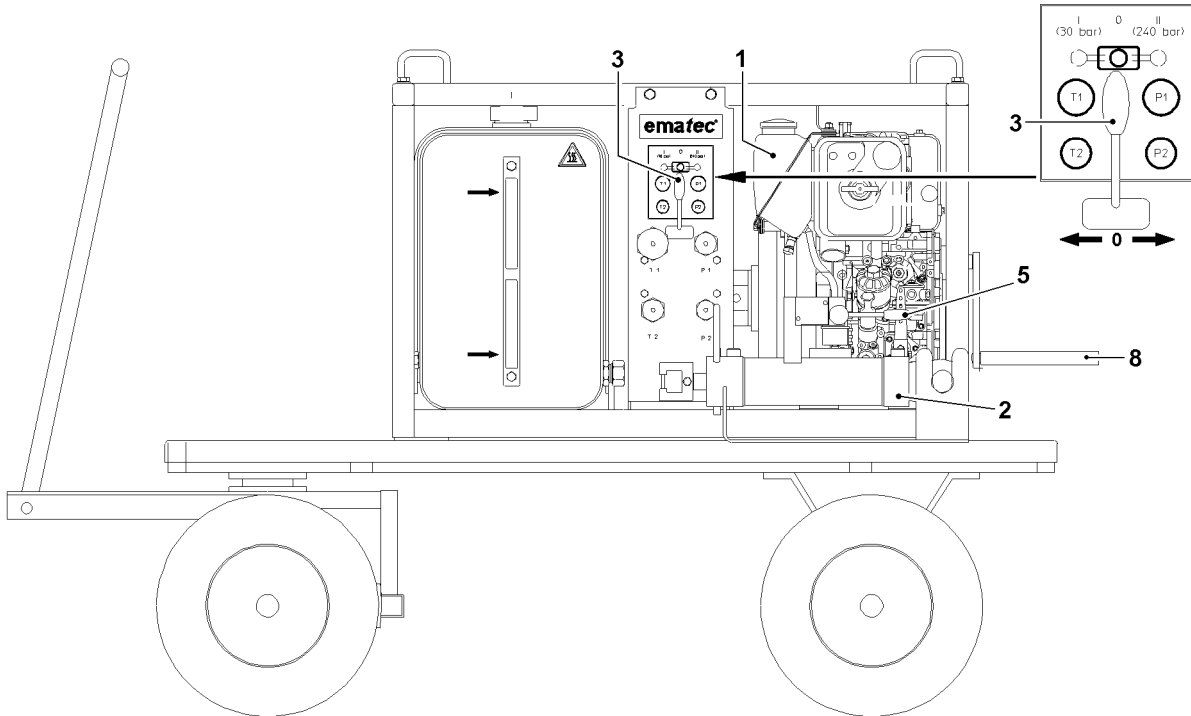

B104575

1 Pinning and unpinning with pin pulling device

The pin pulling device consists of the aggregate **1** and the pin pulling cylinders **2.1** und **2.2**. The connector pins on the crawler crane and on the lattice sections are pinned and unpinned with these cylinders.

The cylinder **2.1** is used to pin and unpin the connector pins on the crawler.

The cylinder **2.2** is used to pin and unpin the connector pins on the boom lattice sections and on the ballast trailer.



Note

- ▶ Before pinning and unpinning the lattice sections, engage the lever **5** in position **1** or **2**. For safety reasons, the cylinder **2.2** is actuated on the aggregate.

The cylinder **2.1** is actuated directly with the lever on the cylinder.

Make sure that the following prerequisites are met:

- The aggregate **1** is not yet started.
- The change over lever **3** is in **0-position**.



DANGER

Risk of accident!

When you disassemble unsecured or unsupported crane parts, they can fall down and kill or severely injure personnel.

- ▶ Never stand **under** unsecured or unsupported crane parts and unpin the pins!
- ▶ Never unpin the connecting pins under unsecured or unsupported booms!
- ▶ Do not stand under the crane parts or within the complete danger zone during the pinning and unpinning procedure!
- ▶ Do not lean the ladder against the crane part being disassembled!

1.1 Preparatory work

- ▶ Connect hydraulic hoses of the required cylinder on the pin pulling device **1**.
- ▶ Hang or pin the cylinder into the retainer on the crawler or lattice section.
- ▶ Connect the piston rod head **8** with the screw **7** on the pin **4**.



Note

- ▶ Pin the cylinder **2.2** additionally on the lattice section.

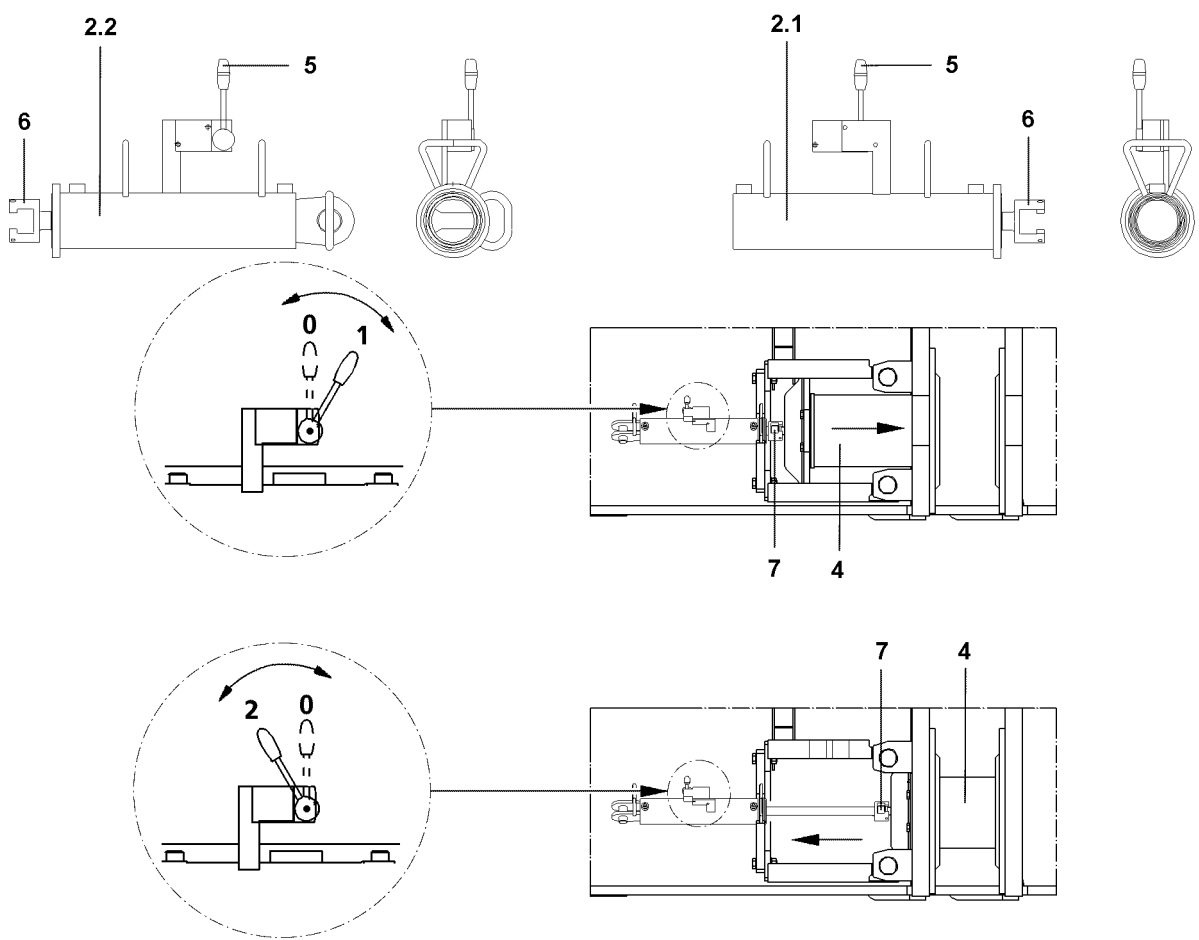
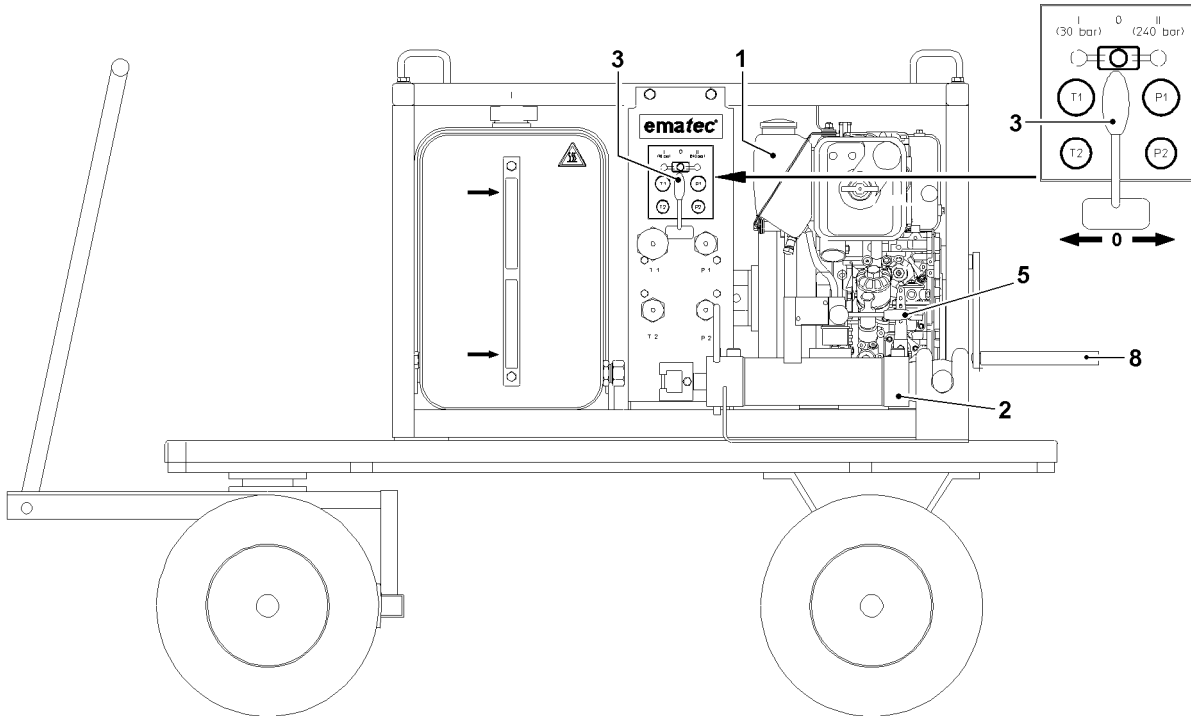

B104575

1.2 Pinning and unpinning the pins on the boom lattice sections or on the ballast trailer

- ▶ Engage the lever **5** on the cylinder **2.2**.



Note

- ▶ Position 1, insert pin **4**.
- ▶ Position 2, unpin pin **4**.

-
- ▶ Set the change over lever **3** in 0-position.
 - ▶ Start the aggregate **1** with the hand crank **8**.
 - ▶ Move the change over lever **3** to the **left** (30 bar) and unpin or pin the pin **4**.



Note

- ▶ The change over lever **3** to the **right** (240 bar) is only needed if the pin **4** is tight or hard to move.
- ▶ Set the engine RPM on the aggregate **1**.

1.3 Pinning and unpinning pins on the cross carriers or the crawler carriers

- ▶ Set the change over lever **3** to the **left** (30 bar).



Note

- ▶ The change over lever **3** to the **right** (240 bar) is only needed if the pin **4** is tight or hard to move.
- ▶ Start the aggregate **1** with the hand crank **8**.
- ▶ Set the engine RPM on the aggregate **1**.
- ▶ Actuate the lever **6** on the cylinder **2.1**.
- ▶ Pin or unpin the pin **4**.

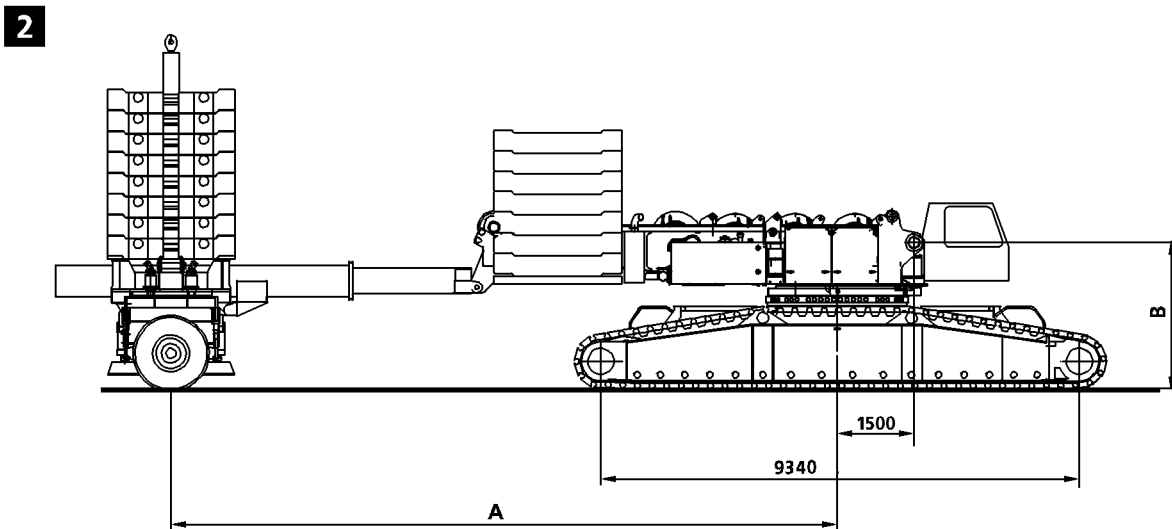
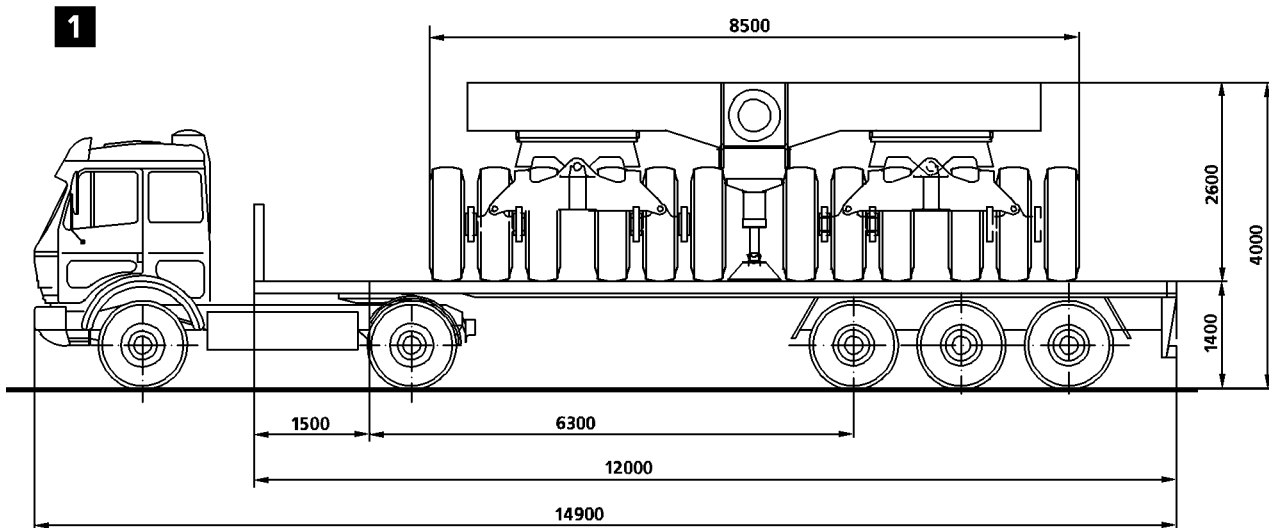

3

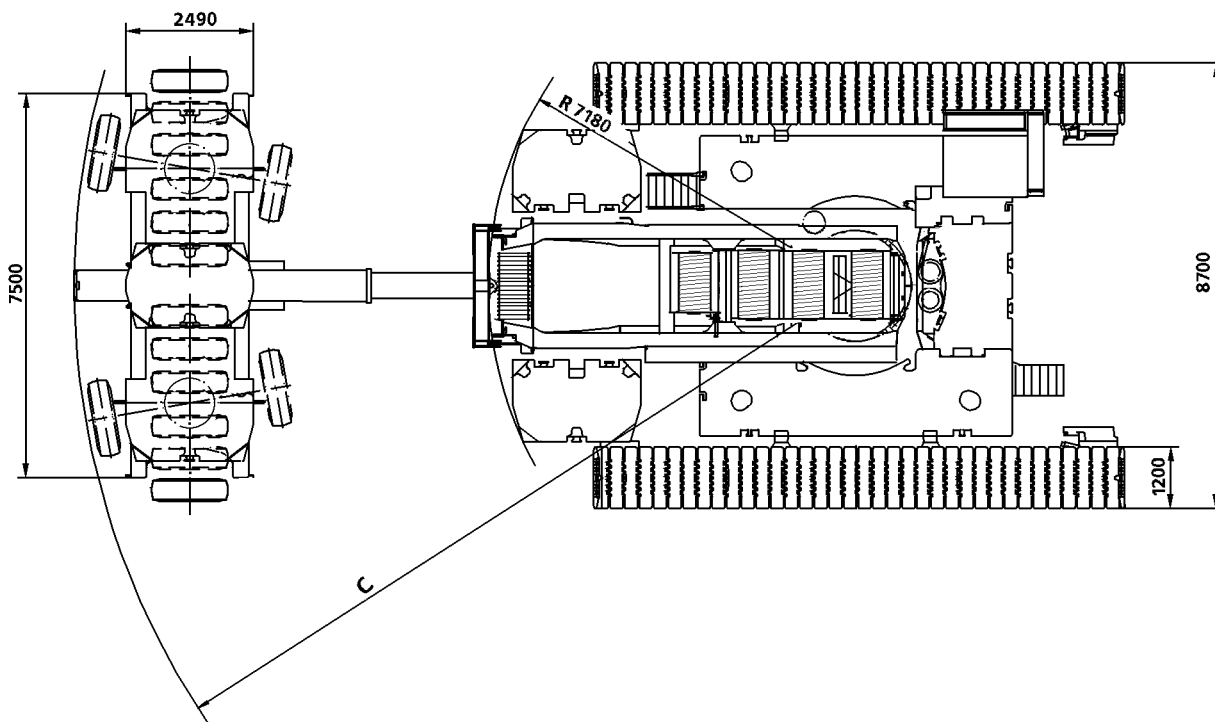

4

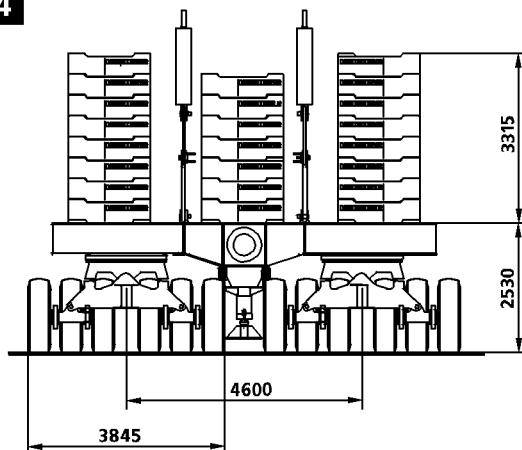

B188653

5

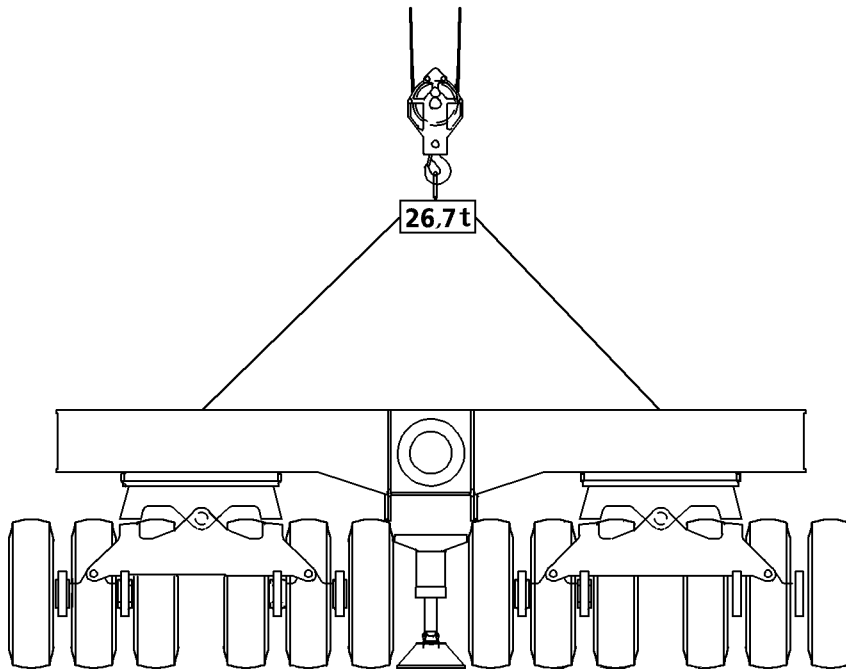

6

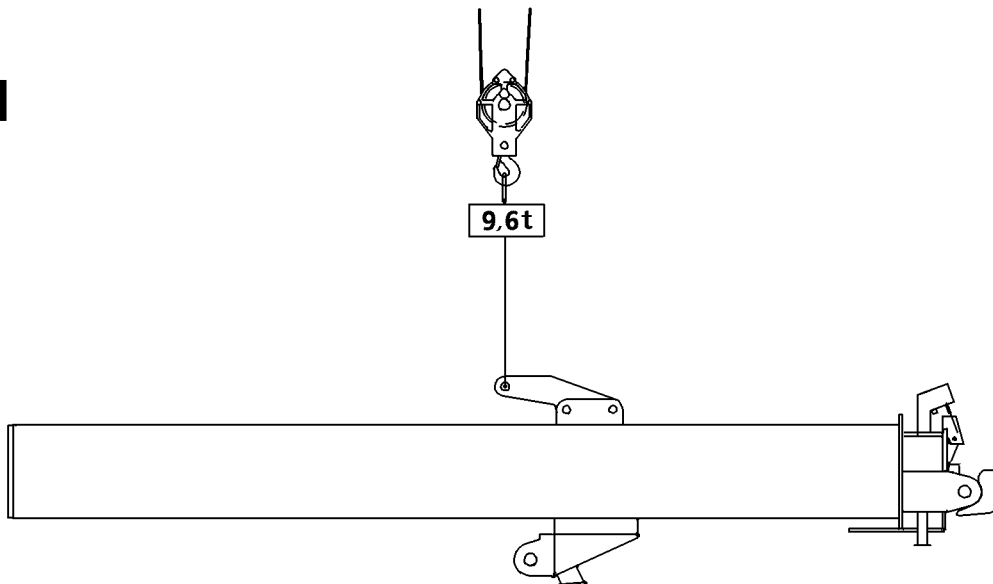

1 Component description and general notes

The ballast trailer consists of:

- 2 wheel sets, oscillating mounted
- Ballast frame
- Guide tube

Hydraulic, telescopic guide for ballast trailer radii of R13.26 m - R17.26 m. The pull cylinders for the ballast trailer are installed directly and can be actuated under load.

Hydraulic, mechanical steering, electronically adjustable for:

- Towing
- Circular driving
- Parallel driving
- Manual corrective steering

1.1 Dimensions

Illustration 1, 2, 3, 4

Length A	Turning radius C
11.00 m	13.40 m
13.00 m	15.35 m
15.00 m	17.30 m

	With Quick connection	Without Quick connection
Length B	2.85 m	2.59 m

1.2 Components, weights

Illustration 5 and 6

Component	Weight
Ballast trailer	26.7 t
Guide	9.6 t

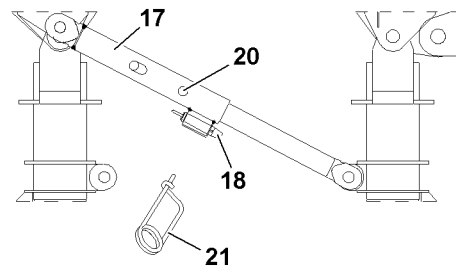
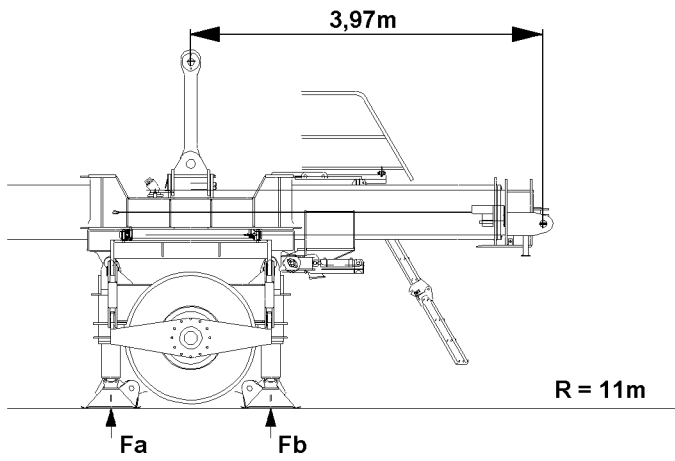

1.3 Stability and tipping safety in case of non-installed ballast trailer on the turntable

Make sure that the following prerequisites are met:

- The ballast trailer guide is hydraulically fully retracted.
- The ballast trailer is supported and aligned in horizontal direction.



WARNING

Danger of tipping the ballast trailer!

If the ballast trailer is not installed on the turntable and the ballast trailer guide is not fully retracted, then the ballast trailer can tip over!

Personnel can be severely injured or killed!

- ▶ Before removal of the ballast trailer on the turntable, the locking pin **18** must be pinned on the strut of the ballast trailer and secured with the spring retainer **21**!
- ▶ The ballast trailer guide must be fully retracted before removal of the ballast trailer on the turntable!

Illustration	Ballast trailer radius	Ballast	Fa	Fb
1	R = 11 m	0 t	12.6 t	23.0 t

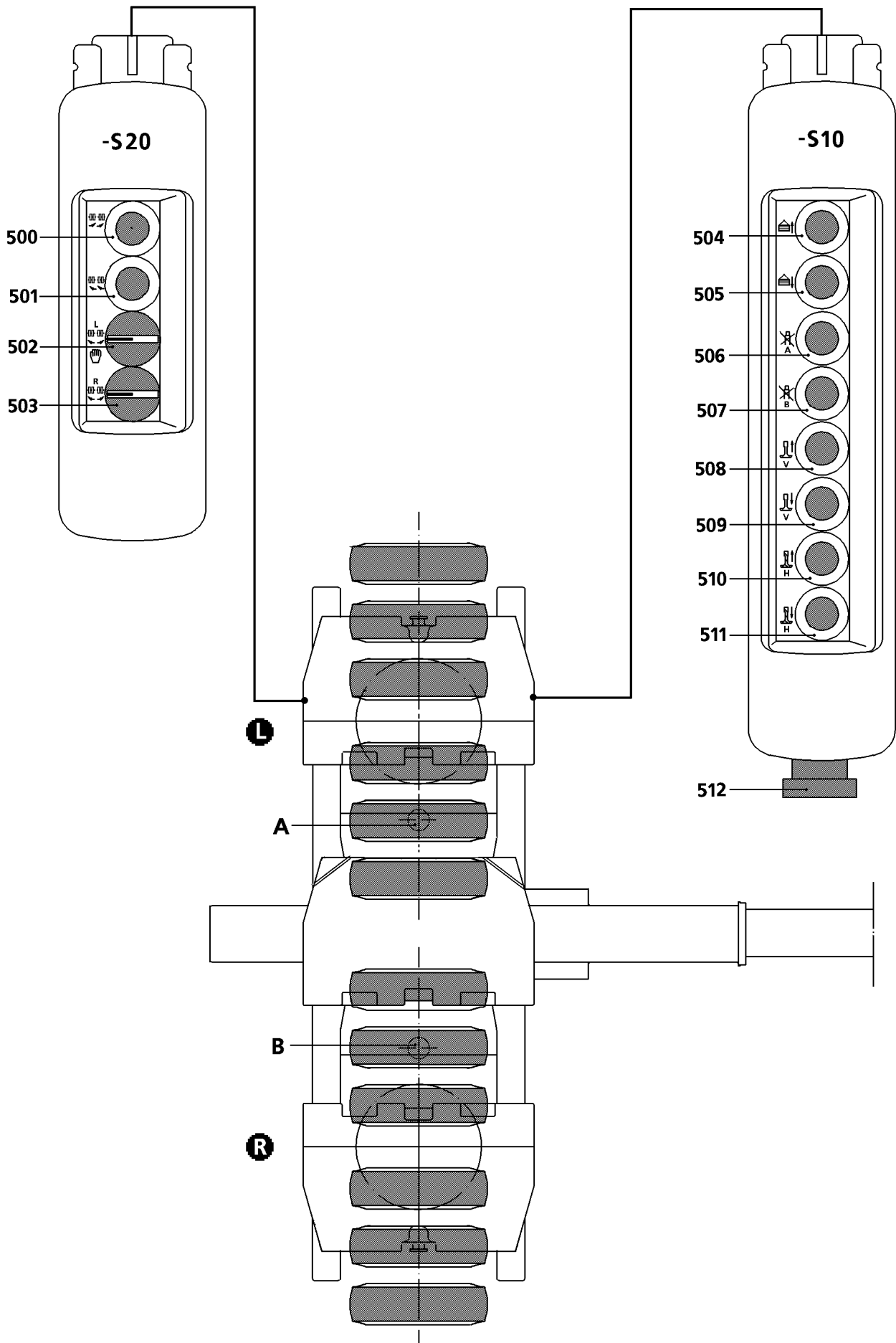

B104576

1.4 Control elements on the control panels

1.4.1 Control panel - S20

Position	Control element	Function
500	Button	• Manual corrective steering, turn the wheel sets to the left
501	Button	• Manual corrective steering, turn the wheel sets to the right
502	Rotary switch	• Turn wheel set on the left side L to right or left, manual operation during assembly or emergency operation
503	Rotary switch	• Turn wheel set on the right side R to right or left, manual operation during assembly or emergency operation

1.4.2 Control panel - S10

Position	Control element	Function
504	Button	• Derrick ballast "UP" - retract both cylinders
505	Button	• Derrick ballast "DOWN" - extend both cylinders
506	Button	• Block cylinder "A" on the derrick ballast
507	Button	• Block cylinder "B" on the derrick ballast
508	Button	• Retract the support cylinder on the front
509	Button	• Extend the support cylinder on the front
510	Button	• Retract the support cylinder on the front
511	Button	• Extend the support cylinder on the rear
512	Switch	• EMERGENCY OFF

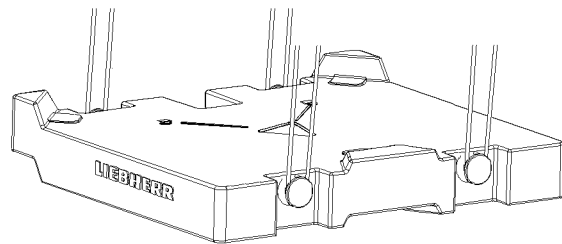
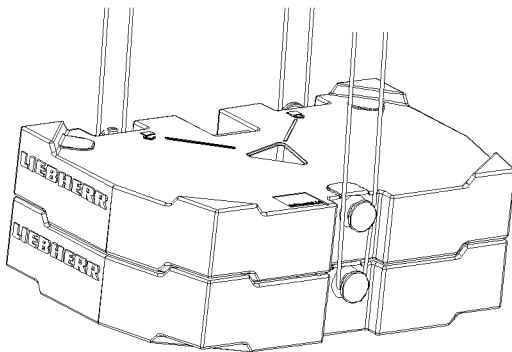
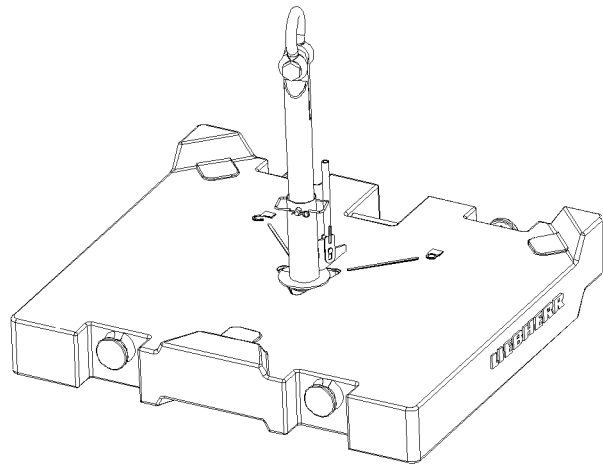
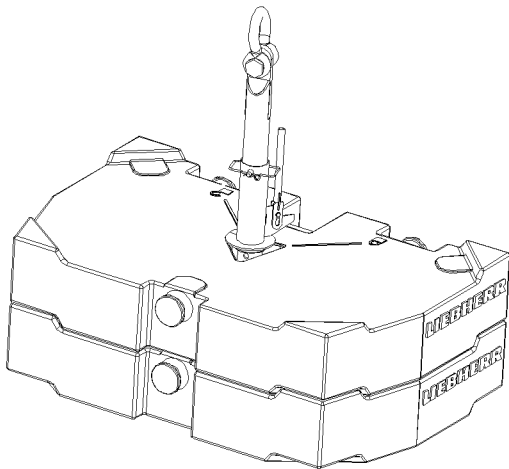

B109263

2 Permissible ballast assemblies



WARNING

Overload fastening points ballast plates!

If more than the permissible number of ballast plates are lifted together, then the fastening points can be overloaded!

The ballast plates and components can fall down!

Personnel can be severely injured or killed!

- ▶ Attach only the maximum permissible number of ballast plates per lift!



WARNING

Incorrect set up of ballast assemblies!

When lifting mixed weight ballast assemblies and the heavier ballast plates are placed on top, the fastening points can be overloaded!

The ballast plates and components can fall down!

Personnel can be severely injured or killed!

- ▶ Always stack the heavier ballast plate on the bottom in the ballast assembly!

Individual weight Ballast plate	Maximum number of same ballast plates per lift over	
	Twistlock	Bitt
5.0 t	2	1
10.0 t	2	2
12.5 t	1	2

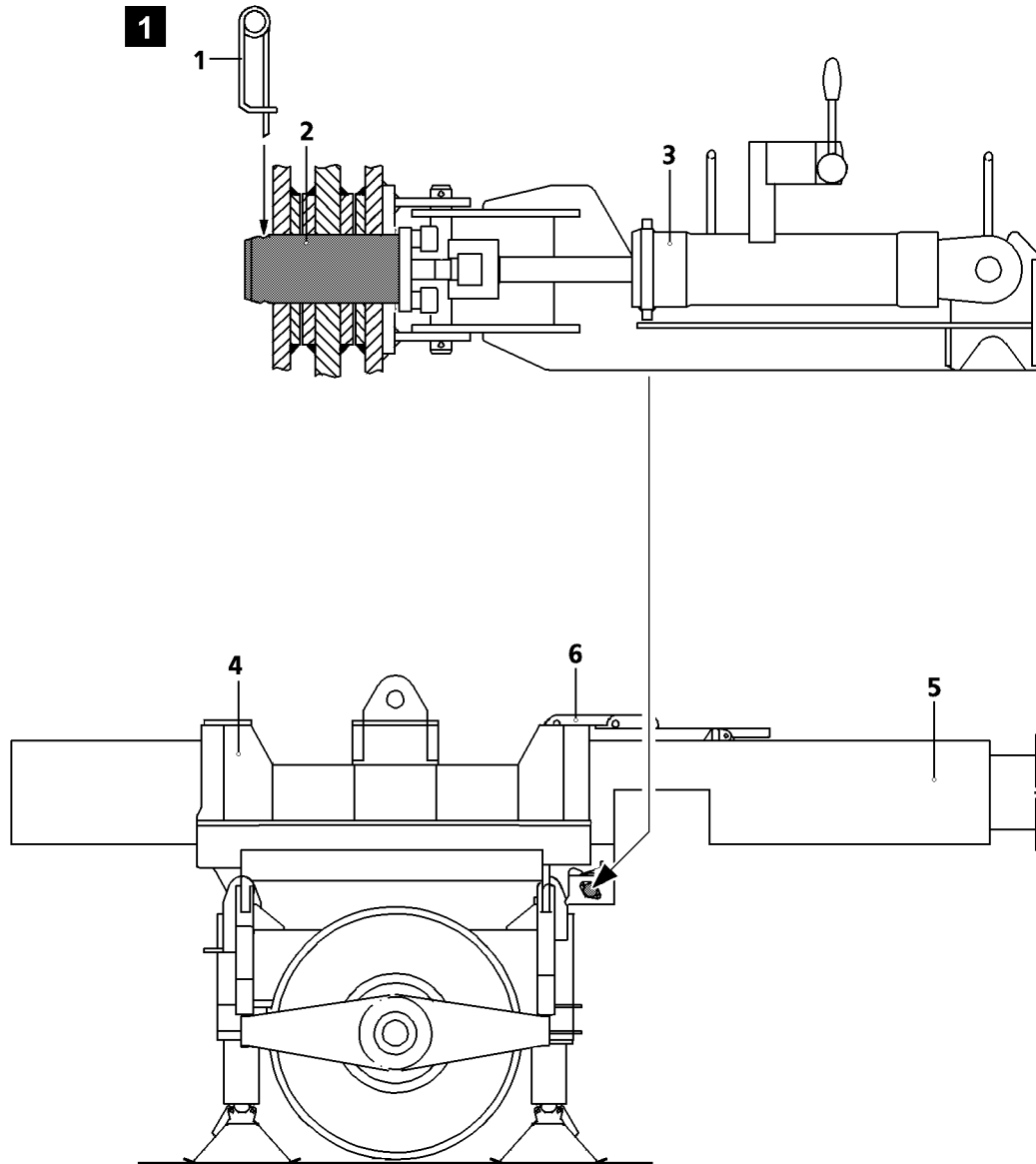

B109264

3 Assembling the ballast trailer



WARNING

Risk of falling!

During assembly / disassembly work, personnel must be secured with appropriate aids to prevent them from falling. If this is not observed, assembly personnel can fall and suffer life-threatening or fatal injuries!

- ▶ Any assembly work, where there is a danger of falling must be carried out with suitable aids (for example lifting platform, scaffolding, ladder, auxiliary crane)!
- ▶ If the work cannot be carried out with such aids nor from the ground, then the assembly personnel must secure themselves with approved fall arrest systems to avoid falling, see Crane operating instructions, chapter 2.04!
- ▶ Approved fall arrest systems must be hung into the respective fastening points on the crane, see Crane operating instructions, chapter 2.06!
- ▶ If railings are present on the components, then they must be brought into the corresponding position and secured for assembly / disassembly work!
- ▶ Step on aids and fall protection equipment only with clean shoes!
- ▶ Keep aids and fall protection equipment clean and free from snow and ice!
- ▶ During all assembly and disassembly work, maintenance work and inspections, travel and crane operation is prohibited!



WARNING

Components not pinned and secured!

If a component is released from the auxiliary crane before having been pinned and secured, the component will fall down! Personnel can be severely injured or killed!

- ▶ Do not disengage the auxiliary crane until the corresponding component is pinned and secured!



WARNING

Danger of impact / crushing!

When installing / removing crane components with the auxiliary crane, crane components can start to swing back and forth!

When lifting / lowering and positioning crane components, there is an increased danger of impacts / crushing!

Personnel can be caught and severely injured or killed!

- ▶ Make sure that personnel cannot be caught by components!
- ▶ When working in danger zones: Use aids to protect limbs!
- ▶ Guide components with suitable aids to minimize oscillation!

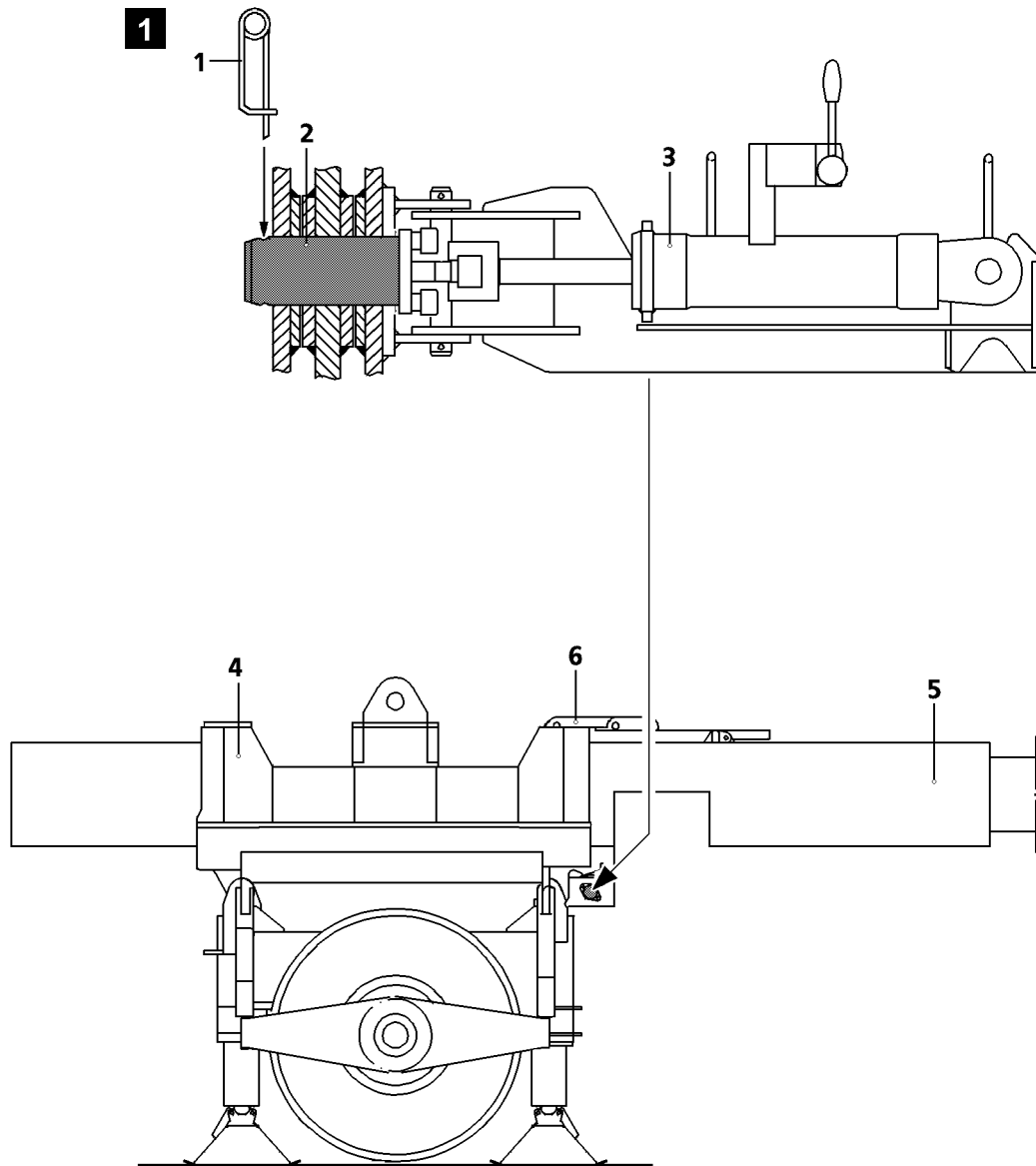

B109264

**DANGER**

Risk of accident!

The assembly of the ballast trailer may only be carried out on level and load bearing ground and only by authorized personnel!

- ▶ The ballast trailer is not equipped with a brake system. It is therefore essential that it rests on the support cylinders when it is not pinned to the turntable!

Make sure that the following prerequisites are met:

- The placement location must be level and have adequate load bearing capacity.
- An auxiliary crane is available.

3.1 Installing the guide on the ballast frame

Illustration 1

Make sure that the following prerequisites are met:

- The wheel sets are relieved.
- The ballast trailer **4** is supported on the support cylinders and horizontally aligned.

**WARNING**

Danger of tipping the ballast trailer!

If the stability and tipping safety guidelines are not observed, there is a danger of tipping over! Personnel can be severely injured or killed!

- ▶ Observe Crane operating instructions, chapter 2.15 as well as section "Stability and tipping resistance when ballast trailer is not installed on the turntable"!

- ▶ Lift the ballast trailer **4** with the auxiliary crane from the transport vehicle.
- ▶ Use the auxiliary crane to lift the guide **5** on the lifting strap **6** from the transport vehicle and swing in to the pin points on the ballast trailer **4** and affix.

**Note**

- ▶ The guide **5** must be held with the auxiliary crane until it is pinned and secured!

- ▶ Connect the pin pulling device **3** with the hydraulic aggregate.
- ▶ Insert the pins **2** on both sides with the pin pulling device **3**.
- ▶ Secure the pin **2** with spring retainer **1**.
- ▶ Unpin the lifting strap **6** and tilt forward.

B195219

3.2 Pinning the guide on the turntable

Make sure that the following prerequisites are met:

- Move the crane as close as possible to the ballast trailer.
- The engine is turned off.
- The ballast trailer is supported.

3.2.1 Establishing the electrical connection



Note

- ▶ For assembly, the electrical connection can be established to be able to move the support cylinders as well as the pull cylinders, if necessary. The "Ballast UP / DOWN" release is independent of whether the ballast trailer is attached, providing the conditions in the shut off diagram are fulfilled. The "Ballast UP" release allows the retraction of the pull and support cylinders. The "Ballast DOWN" release allows the extension of the pull and support cylinders. This means the support cylinders and the pull cylinders can be moved, even if the "Ballast trailer assembled" signal is not yet present!



Note

- ▶ To establish the electrical connections, Electric wiring diagram!
- ▶ Establish the electrical connections.

3.2.2 Establishing the hydraulic connection

When hydraulic lines are connected and disconnected with quick release couplings, make ensure that the coupling procedure is being performed correctly.



Note

- ▶ The matching quick release hydraulic couplings are marked!



DANGER

Risk of accident due to loss of pressure or leakage!

Incorrectly coupled or self-loosening quick release couplings (particularly return lines) can result in serious injury due to component failure!

- ▶ Check that the quick release couplings have been properly connected before using the crane!
- ▶ Release the pressure in the hydraulic system before connecting and disconnecting. Turn the engine off and wait for short time.
- ▶ Connect the coupling components (sleeve and connector) and screw together with the hand-tightened nut.
- ▶ Tighten the hydraulic coupling by hand. Rotate the hand-tightened nut until it reaches a tangible, fixed stop position.

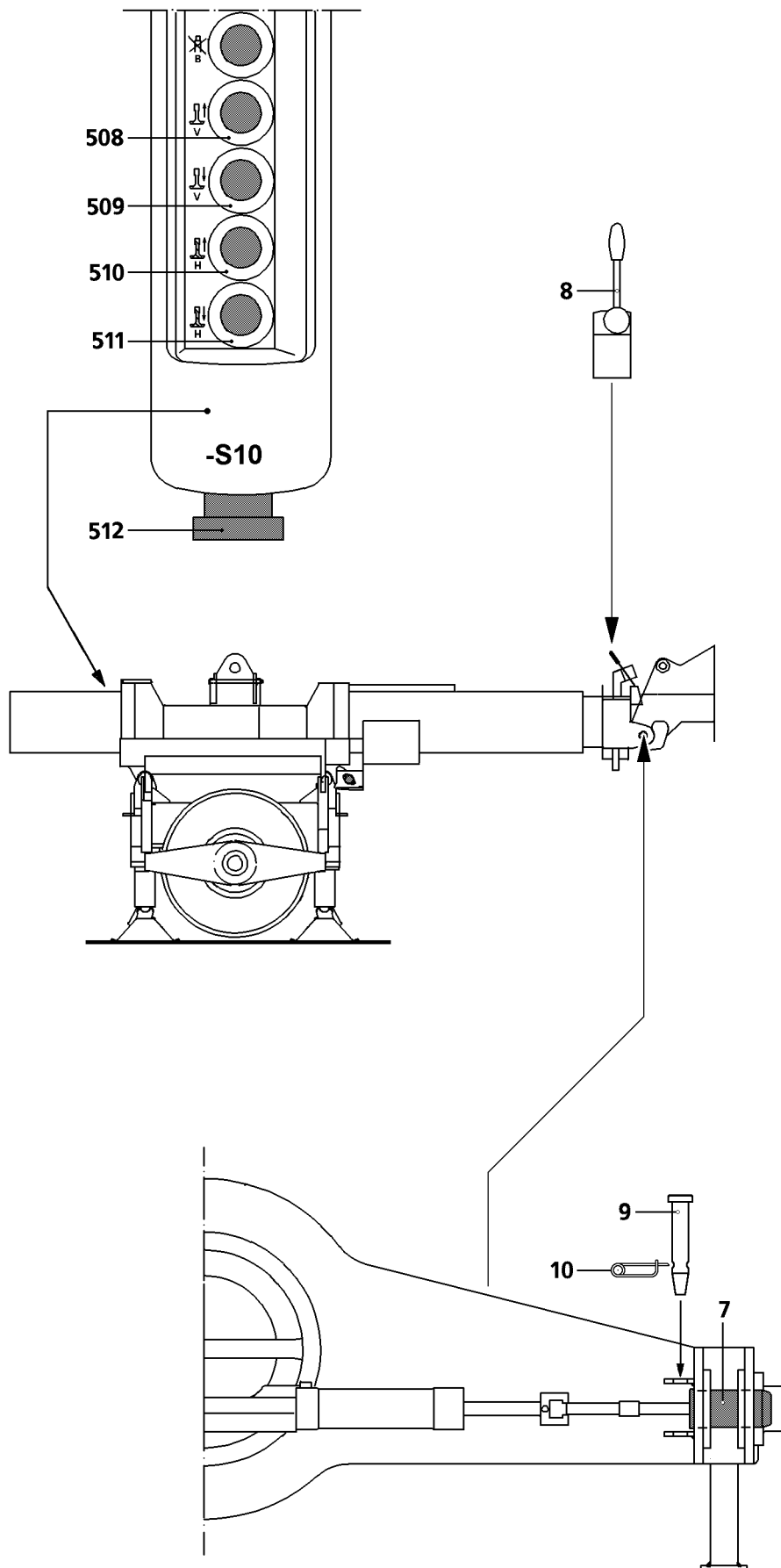

B109265

3.2.3 Aligning the ballast trailer

Make sure that the following prerequisites are met:

- The electrical and hydraulic connections have been established.
- The crane has been moved to the pin points on the guide of the ballast trailer.
- ▶ Align the ballast trailer by raising or lowering the two support cylinders until the pins 7 can be inserted on both sides.

Control panel - S10:

Position	Control element	Function
508	Button	• Retract the support cylinder on the front
509	Button	• Extend the support cylinder on the front
510	Button	• Retract the support cylinder on the front
511	Button	• Extend the support cylinder on the rear
512	Switch	• EMERGENCY OFF



Note

- ▶ To align the pin bores on top of each other, the turntable might have to be turned a little. Check visually!

NOTICE

Damage of ballast trailer!

If the following notes are not observed, the crane or the ballast trailer can be damaged!

- ▶ Always carry out the lifting or lowering movements with utmost caution!
- ▶ If necessary, swing the turntable carefully.

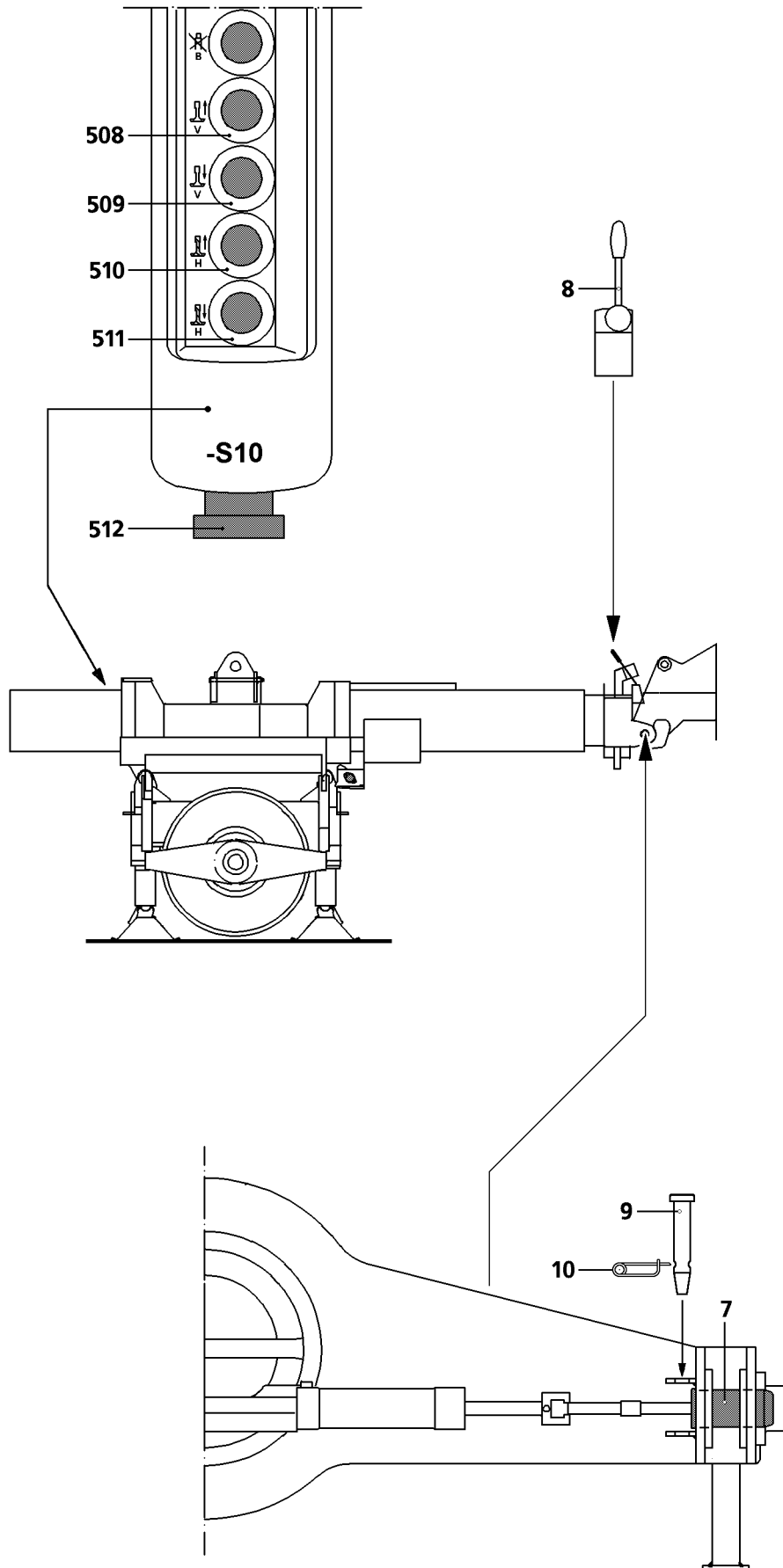

B109265

3.2.4 Pinning procedure

- ▶ Operate the lever **8**.

Result:

- The guide is pinned to the turntable by pins **7**.

- ▶ Insert the retaining pins **10** on both sides and secure with spring retainers **9**.



Note

- ▶ The crane control recognizes via the limit switch initiators on the left and right on the pin points if the pins are fully inserted on the turntable!
- ▶ After pinning, it must be rechecked if both pins are properly pinned and secured and if the connector lines are correctly and completely connected!
- ▶ If the two pins are pinned completely and correctly, then the crane control receives the message "Ballast trailer pinned", which means the turntable cannot be turned and the crawler cannot be driven!
- ▶ The release is issued only when the ballast trailer wheels are in the required position for circular, towing or parallel travel!

NOTICE

Damage of ballast trailer!

If the following notes are not observed, the crane or the ballast trailer can be damaged!

- ▶ Always carry out the lifting or lowering movements with utmost caution!
 - ▶ As long as only one pin is pinned, the crane control does not receive the message "Ballast trailer pinned", which means that the turntable can be turned and the crawler can be driven to be able to pin the second pin!
- ▶ Retract the front and rear support cylinders.

Control panel -

S10:

Position	Control element	Function
508	Button	• Retract the support cylinder on the front
510	Button	• Retract the support cylinder on the rear
512	Switch	• EMERGENCY OFF



Note

- ▶ The support cylinders can also be retracted via the corresponding buttons on the instrument panel in the crane operator's cab!
- ▶ Retract the support cylinders completely.

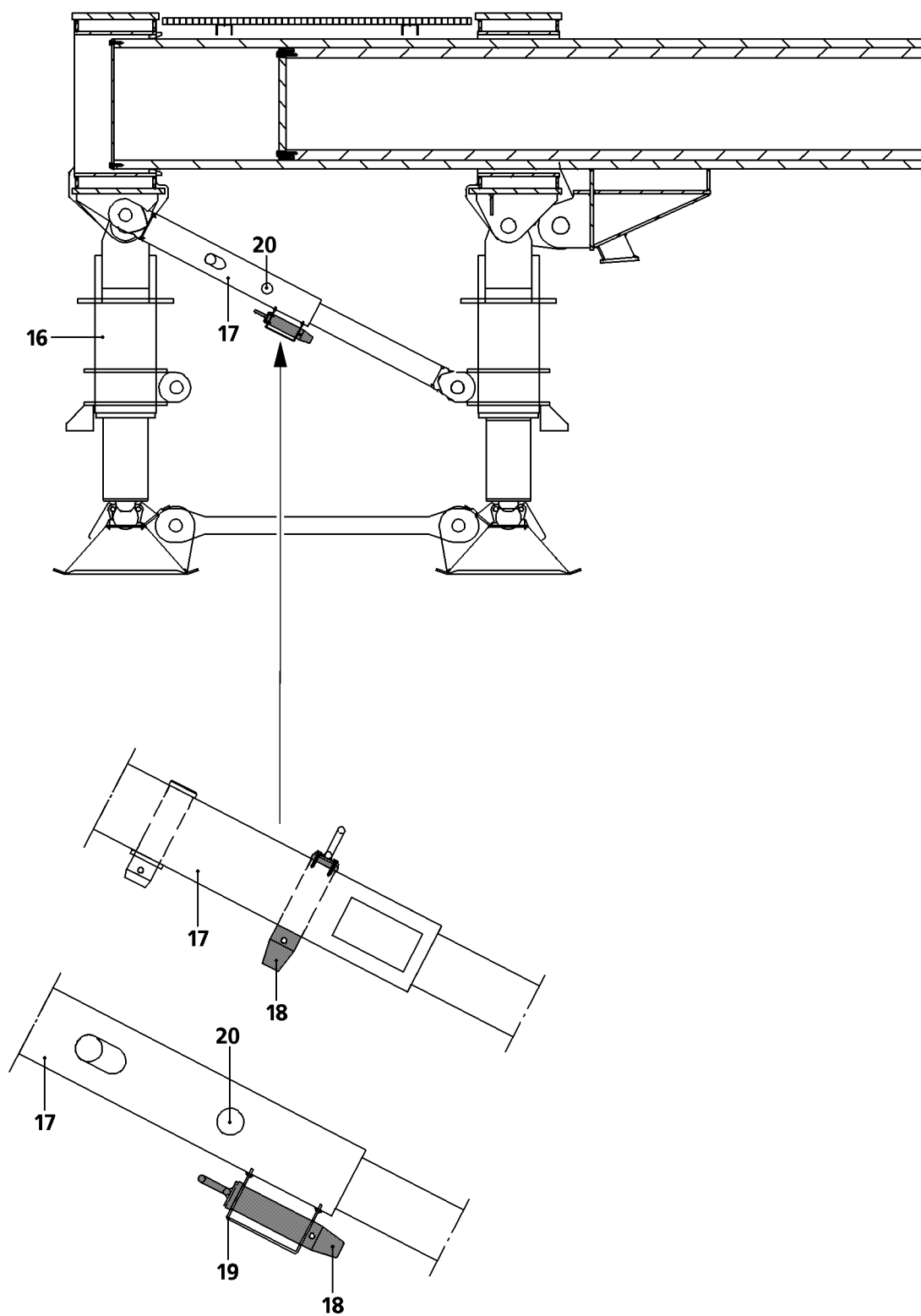

B109266

3.3 Retracting the support cylinder

When the pin procedure between the ballast trailer and the turntable is completed, retract the support cylinders **16**.

Make sure that the following prerequisites are met:

- The ballast trailer is pinned and secured to the turntable.
- The electrical and hydraulic connections are connected.

Retract the support cylinders 16 on the front and rear:

Position	Control element	Function
508	Button	• Retract the support cylinder on the front
510	Button	• Retract the support cylinder on the rear
512	Switch	• EMERGENCY OFF

- ▶ Remove the spring retainer on the locking pin **18**.
- ▶ Unpin the locking pin **18** on the strut **17**.
- ▶ Insert the locking pin **18** into the transport receptacle **19** and secure with spring retainer.



Note

- ▶ The locking pin **18** can only be unpinned if the support cylinders **16** are relieved!



CAUTION

Danger of property damage!

- ▶ Before placing the ballast plates on the ballast trailer attached to the crane, it must be ensured that the support cylinders **16** are retracted and the locking pin **18** on the strut **17** is unpinned!
 - ▶ The locking pin **18** must be unpinned before supporting the mounted ballast trailer, for example when changing the wheel position!
 - ▶ This is necessary to allow a level adjustment between the strut **17** and the support cylinders **16** with supported and ballasted ballast trailer!
 - ▶ If this is not observed, the ballast trailer may be damaged!
-
- ▶ Retract the support cylinders completely.



WARNING

Risk of accident!

- ▶ It is prohibited to operate the supports on crawler cranes when a load is suspended or the stay ropes to the ballast trailer or the suspended ballast are under tension. Changing the support will alter the slope of the boom system, resulting in a significant shift of the relative forces. Under these conditions, the relapse cylinders could also go to the block position. An LMB shut off will not occur!
-
- ▶ Do not operate the crane supports when performing a lift.

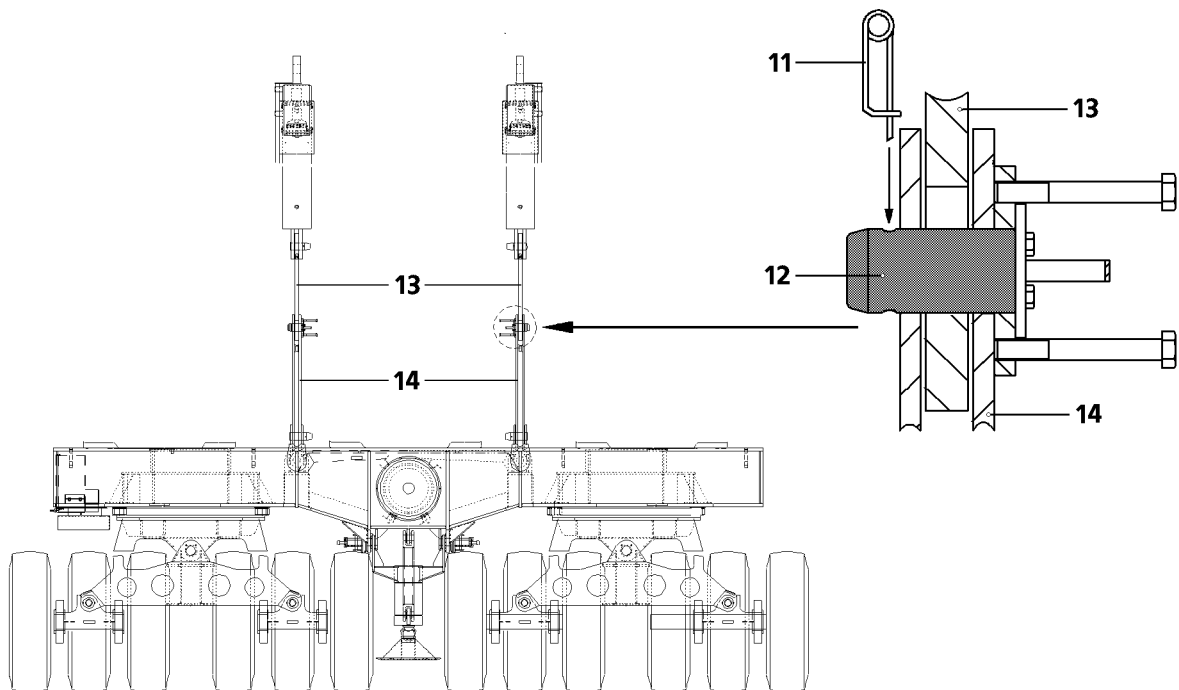
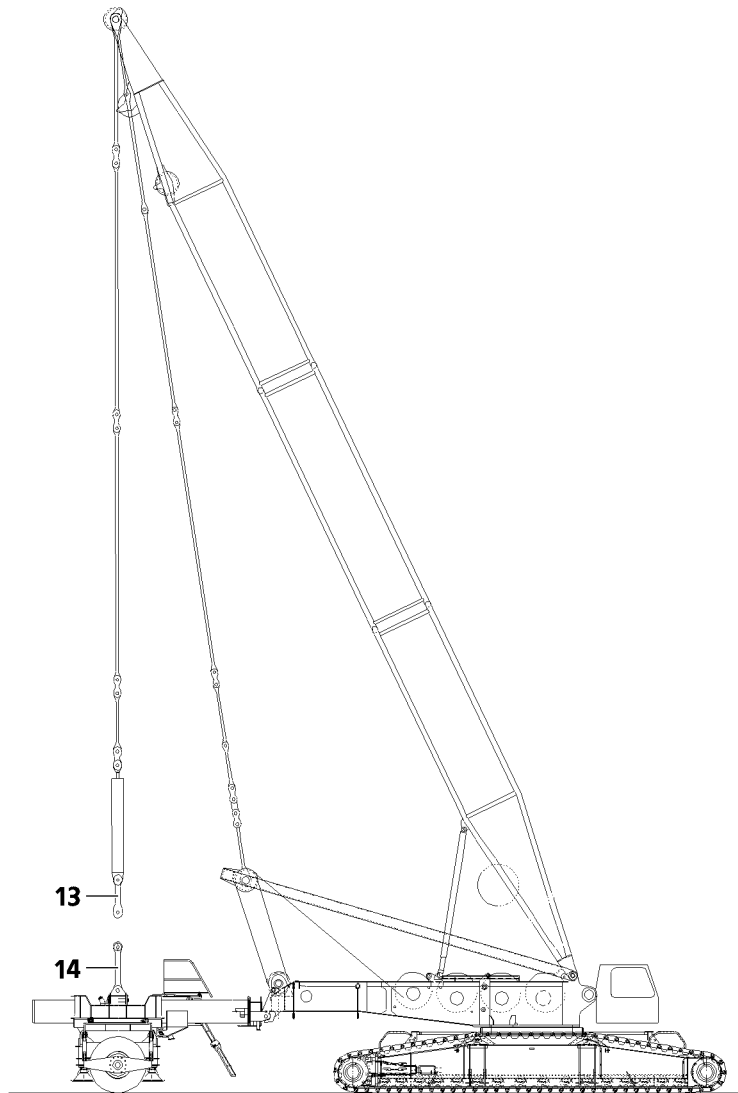

B104577

3.4 Assembling the ballast guy rods

Make sure that the following prerequisites are met:

- The turntable is turned in the lengthwise direction of the ballast trailer.
- The transport retainers for the ballast guy rods on the derrick boom have been released.
- The ballast trailer radius is R 11.00 m.
- The derrick is erected.



DANGER

Risk of accident!

- ▶ The ballast guy rods and pull cylinders swing out by themselves as soon as the derrick boom is lowered to the rear beyond the vertical!
- ▶ It is prohibited for anyone to remain on the ballast trailer when lowering the derrick boom!

-
- ▶ Fold the connector rods **14** up.
 - ▶ Use auxiliary ropes to secure the pull cylinders and ballast guy rods **13** of the derrick boom.
 - ▶ Use the auxiliary rope to pull the ballast guy rods **13** to the con-rods **14**.
 - ▶ Pin the ballast guy rods **13** with the pins **12**.
 - ▶ Secure the pins **12** with spring retainers **11**.
 - ▶ Connect the supply line from the ballast trailer to the turntable.

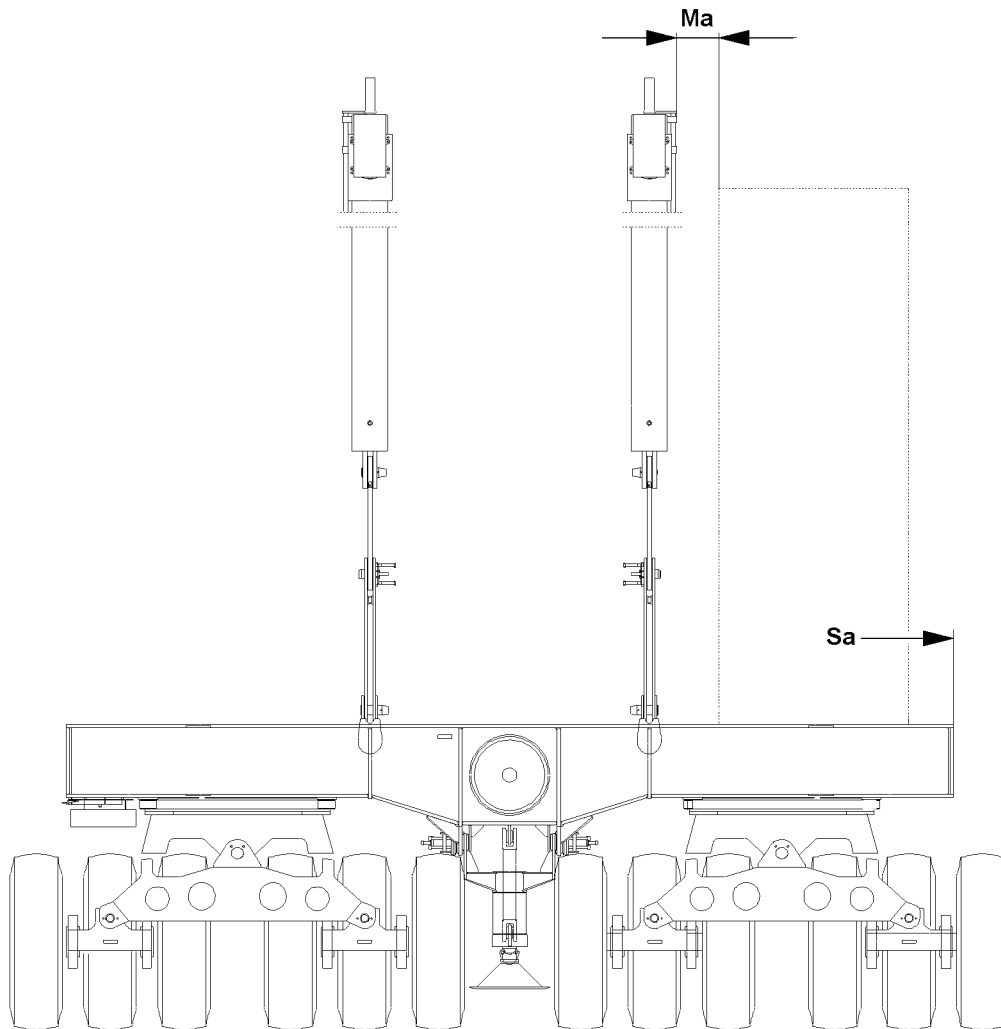

B108504

3.5 Ballasting the ballast trailer



WARNING

The crane can topple over!

If the following danger notes are not observed, the ballast plates or the ballast stack can slip on the ballast trailer and fall down!

The crane can topple over and personnel can be severely injured or killed!

- ▶ The ground on which the ballast trailer is ballasted must be level and have adequate load-bearing capacity!
- ▶ Place the ballast plates always symmetrically, in reference to the longitudinal axis!
- ▶ The outer ballast stacks must always weigh the same after ballasting!
- ▶ The ballast stacks may only be stacked to three times the height of the ballast plate width!
- ▶ When ballasting on and off in **suspended condition**, the weight difference between the left and right ballast stack may be no more than maximum 12.5 t!
- ▶ The maximum permissible weight of the ballast plates of 230 t may not be exceeded!
- ▶ The ballast plates must be secured to prevent them from moving or falling down!
- ▶ At a center of gravity distance **Sa** of 800 mm - measured from the outer edge of the ballast trailer - the maximum permissible ballast weight of 110 t per side may not be exceeded. The center of gravity distance **Sa** must be identical between the left and right stack!
- ▶ Replace damaged ballast plates immediately with new ballast plates!

NOTICE

Damage to the pull cylinder!

If the minimum clearance of the ballast stacks to the pull cylinders is exceeded, the pull cylinders can be substantially damaged!

- ▶ The minimum distance **Ma** of the ballast stacks to the pull cylinders must be at least 300 mm!



WARNING

Damaged ballast plates!

Damage on the ballast plates can cause the fastening equipment to release!

The ballast plates and components can fall down!

Personnel can be severely injured or killed!

- ▶ Do not use damaged ballast plates and replace them immediately!

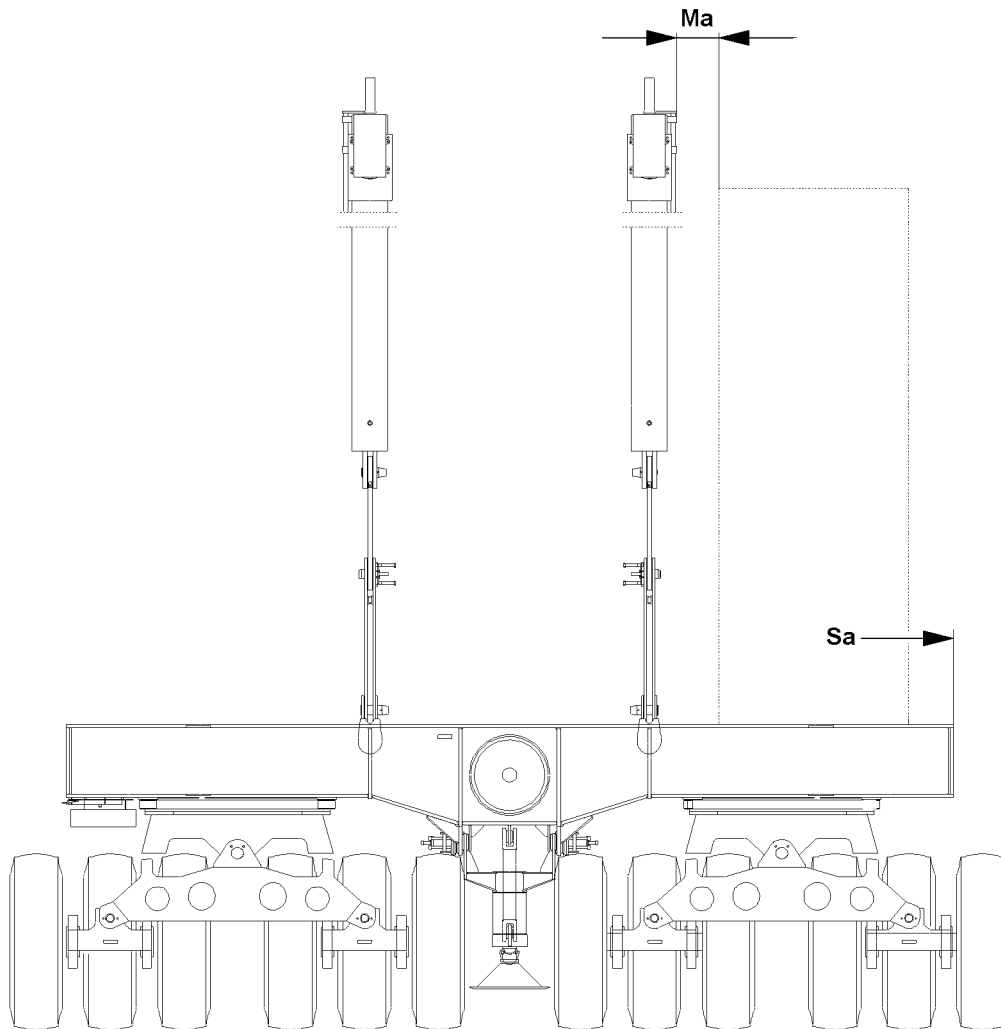

B108504

**WARNING**

Excessive ballast weight!

If the placed ballast weight deviates from the specified data in the load charts or the assembly conditions, then the crane can be damaged or topple over!

Personnel can be severely injured or killed!

- ▶ Place the ballast weight according to the data in the load chart!
- ▶ Observe the data in the erection and take down charts!

**WARNING**

Toppling ballast stack!

Lopsided stacked ballast plates create instability in the ballast stack!

The ballast plates can tip over and cause the crane to topple over!

Personnel can be severely injured or killed!

- ▶ Make sure that the ballast plates are placed correctly in the centerings!

Make sure that the following prerequisites are met:

- The ballast trailer is pinned and secured to the turntable.
- The ballast guy rods are pinned and secured on both sides.
- The support cylinders must be retracted and the locking pins on the strut unpinned.

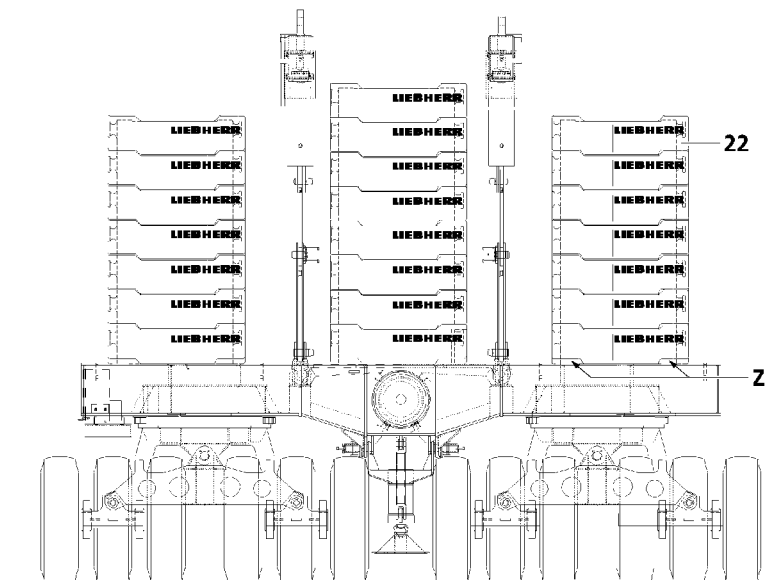
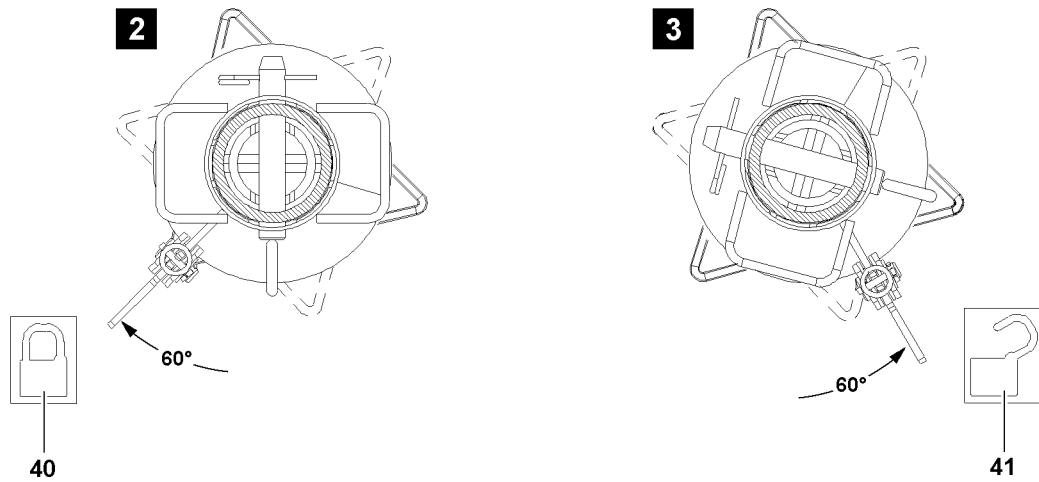
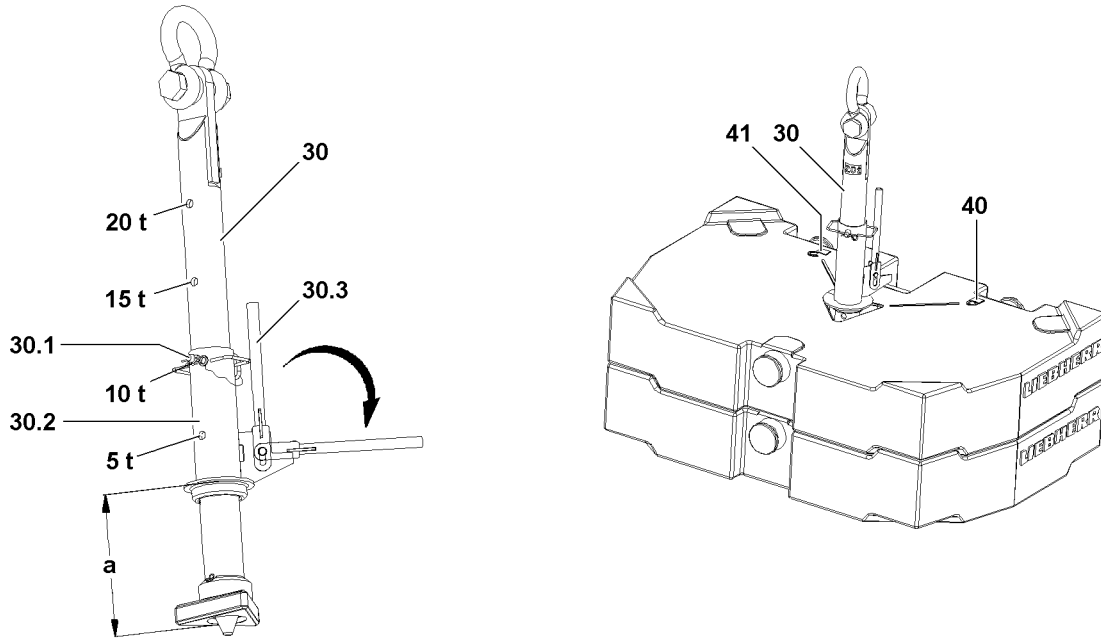

B109267

3.5.1 Stacking the ballast plates on the ballast trailer, fastening system: Twistlock



WARNING

Overload of receptacle stud and ballast plates!

If more than the permissible number of ballast plates are lifted with the receptacle stud **30**, the receptacle stud **30** and the ballast plates can be overloaded and damaged!

The ballast plates can fall down!

Personnel can be severely injured or killed!

- ▶ Observe the chart "Permissible ballast assemblies" in this chapter!



WARNING

Damage of receptacle stud and ballast plates!

If two ballast plates are lifted which do not lay correctly in their centerings, the receptacle stud **30** and the ballast plates can be damaged!

Damage can cause the ballast plates to fall down!

Personnel can be severely injured or killed!

- ▶ Make sure that the ballast plates to be lifted are placed correctly in the centerings!



WARNING

The Twistlock system opens by itself!

If the receptacle stud **30** is not correctly locked, the Twistlock system can open by itself!

The ballast plates **22** can fall down!

Personnel can be severely injured or killed!

- ▶ Make sure, when initiating a lift, that the lever **30.3** points directly on the locked symbol **40**!



WARNING

The Twistlock system opens by itself!

If the receptacle stud **30** is not correctly locked, the Twistlock system can open by itself!

The ballast plates can fall down!

Personnel can be severely injured or killed!

- ▶ Make sure, when initiating a lift, that the lever **30.3** points directly on the locked symbol **40**!



Note

- ▶ During a lift, the locked Twistlock system cannot release by itself due to its gravitational retention!
- ▶ During a lift, the locked Twistlock system cannot be released by hand due to its gravitational retention!



Note

- ▶ The ballast plates are marked with their own weights!

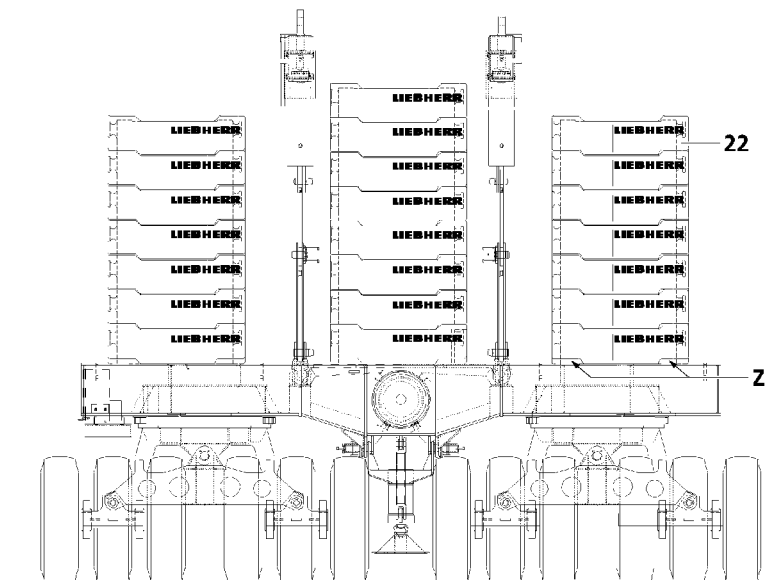
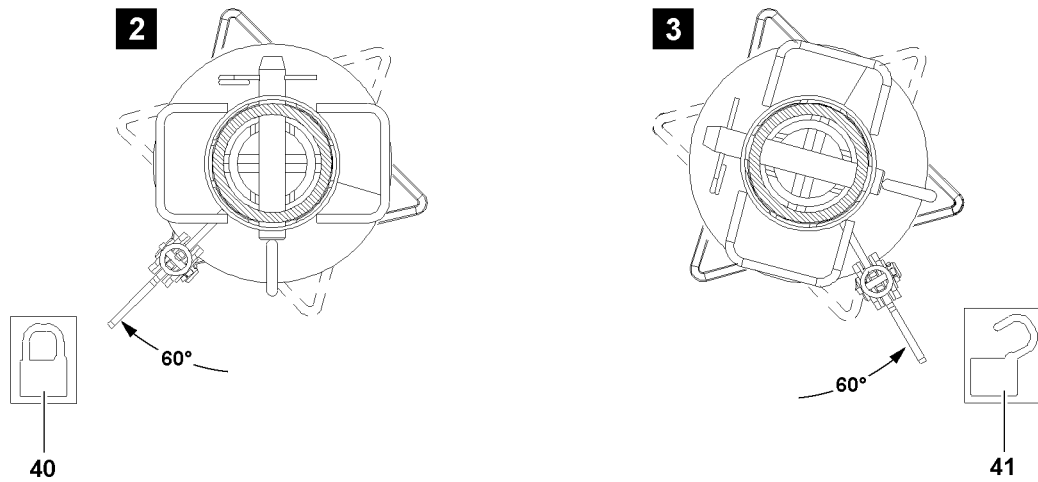
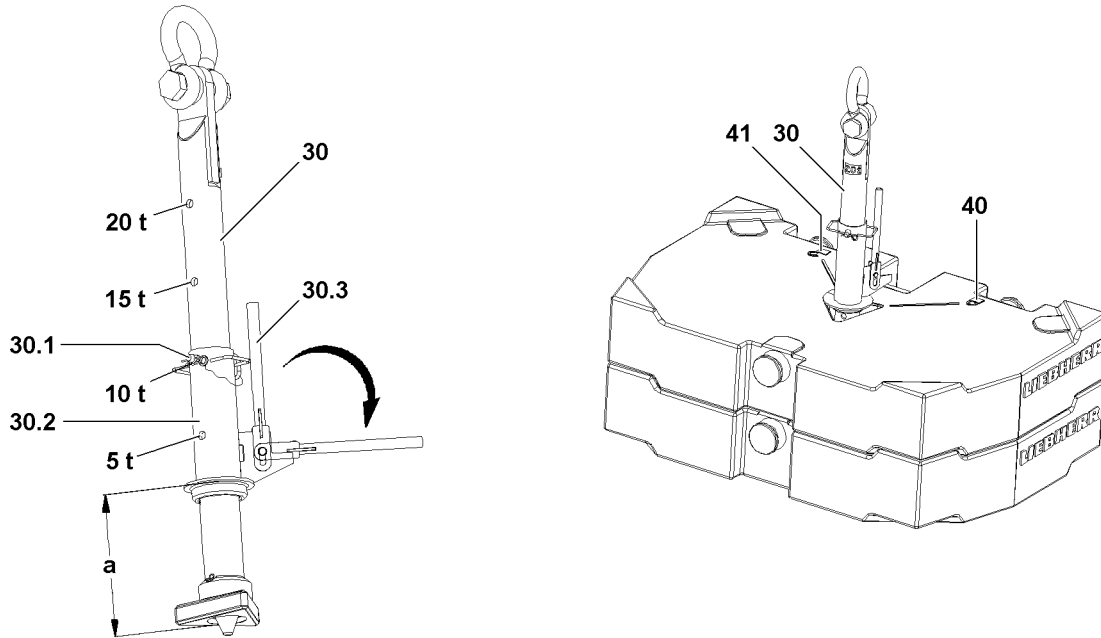

B109267

To stack the ballast plate(s) **22**, use the receptacle stud **30**.

Before the receptacle stud **30** is guided into the ballast plates, it must be ensured that the insertion length **a** of the receptacle stud **30** is set correctly. The insertion length **a** of the receptacle stud **30** can be adjusted via the pin **30.1**.

- ▶ If the insertion length **a** of the receptacle stud **30** is to be adjusted:
Release and unpin the pin **30.1**.
- ▶ Adjust the receptacle stud **30** by moving the guide sleeve **30.2** to the desired insertion length **a**, pay attention to the staging.
- ▶ Insert the pin **30.1** and secure with spring retainer.

Result:

- The receptacle stud **30** is adjusted.

- ▶ Attach the receptacle stud **30** on the auxiliary crane and guide it into the ballast plate(s) **22**.
- ▶ Pull the lever **30.3** up and fold it down.
- ▶ Turn the receptacle stud **30** with the lever **30.3** by 60° until it points to the symbol **40** on the ballast plate(s) **22**, illustration 2.



Note

- ▶ The receptacle stud **30** is locked by lifting the ballast plate(s) **22**!
-

- ▶ Lift the ballast plate(s) **22** or the ballast assembly with the receptacle stud **30** and place it carefully on the centerings on the ballast trailer or on another ballast plate in the ballast stack.
- ▶ When the ballast plate(s) **22** or the ballast assembly are placed down:
Turn the lever **30.3** by 60° to the stop in direction of the unlocked symbol **41**, illustration 3.

Result:

- The receptacle stud **30** is unlocked.
- ▶ Carefully pull the receptacle stud **30** from the ballast plate.
- ▶ Place additional ballast plate(s) **22** according to the load chart.

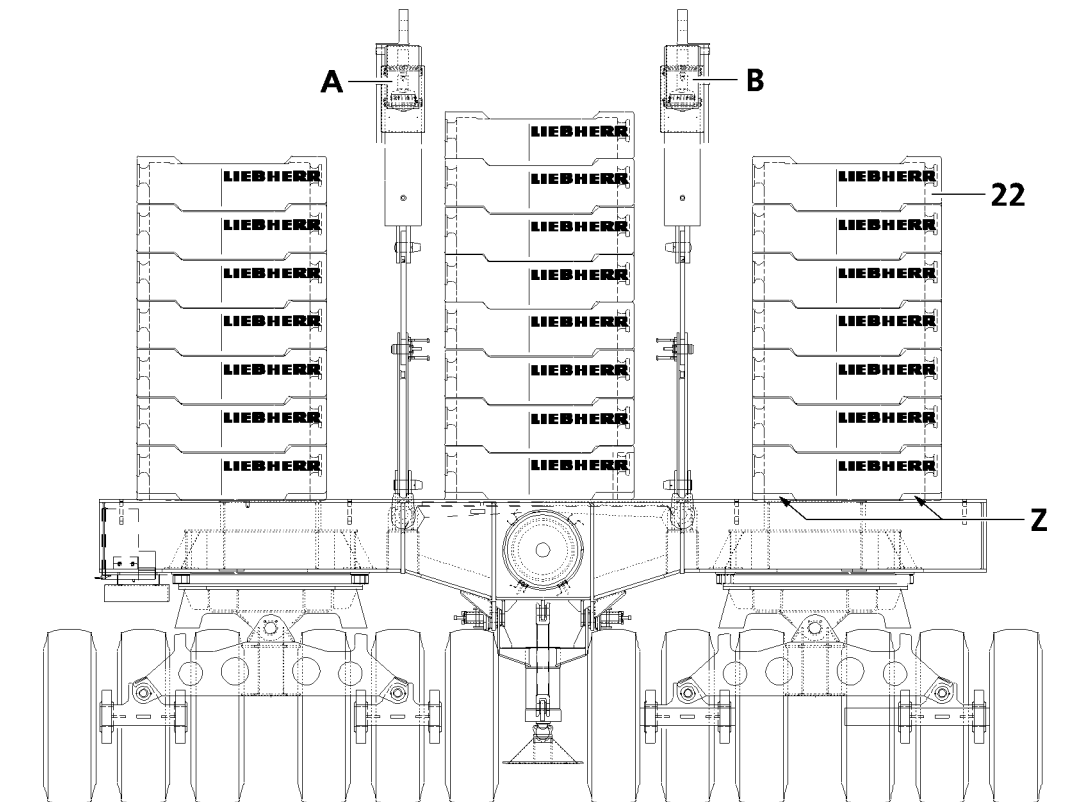
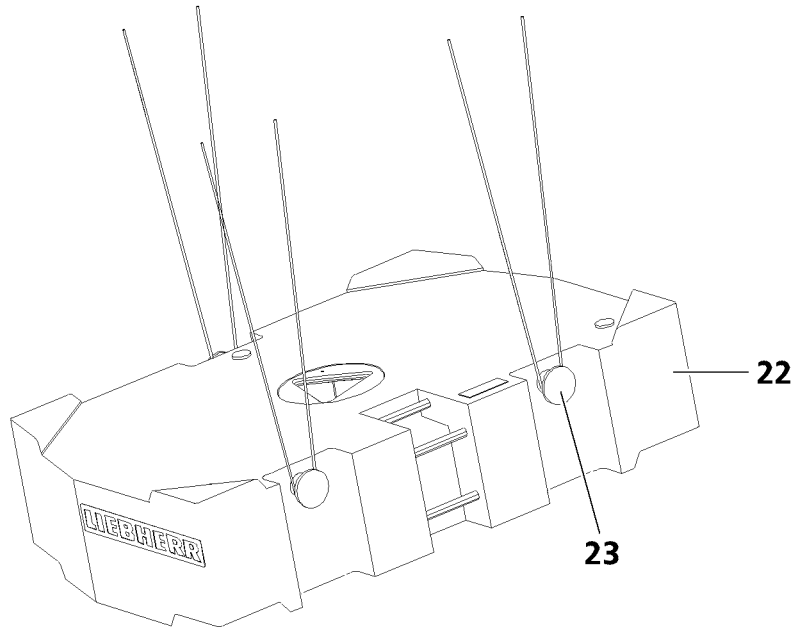

B108499

3.5.2 Stacking the ballast plates on the ballast trailer, fastening points: Bitt

**Note**

- ▶ The ballast plates are marked with their own weights!

**WARNING**

Overload of the ballast plates!

If more than the permissible loads are lifted, the bitts **23** are overloaded!

The ballast plates **22** can fall down!

Personnel can be severely injured or killed!

- ▶ Observe the chart "Permissible ballast plates" in this chapter!
- ▶ Replace damaged ballast plates!

**WARNING**

Incorrect handling of the fastening equipment!

If tackle is not attached correctly and / or if it is not secured sufficiently to prevent it from loosening up, the ballast plates **22** can fall down!

Personnel can be severely injured or killed!

- ▶ Make sure that the fastening equipment is correctly attached on the bitts **23** and that it is secured sufficiently to prevent it from loosening up!
- ▶ Use the auxiliary crane to evenly distribute the ballast plates **22** on the ballast trailer and center them on the centering plates **Z**.
- ▶ Lift a maximum of two ballast plates **22** together and place them on the ballast trailer.

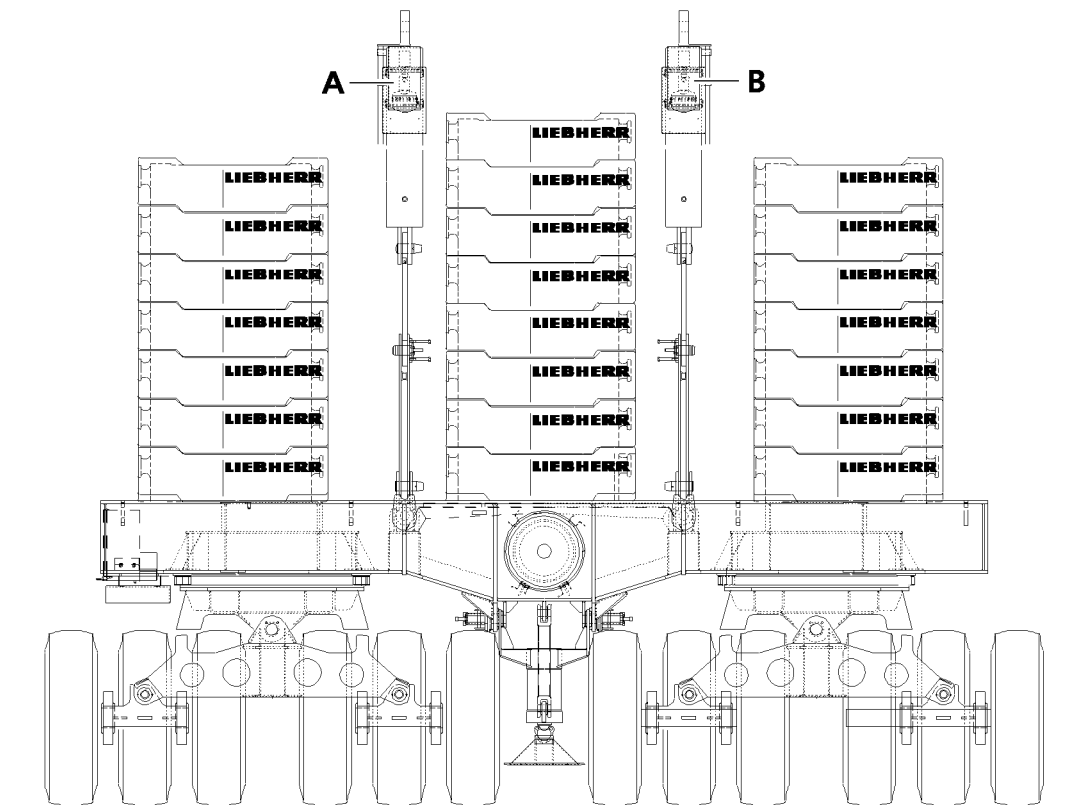

3.6 Lifting and lowering the ballast trailer at installation with the pull cylinders

From the control panel:

- Press the button **504**, the ballast trailer is lifted with the pull cylinders.
- Press the button **505**, the ballast trailer is lowered with the pull cylinders.



DANGER

Risk of accident!

If this is not observed, there is an increased danger of accidents!

- ▶ When the ballast trailer is lifted or lowered, pay attention to the horizontal position of the ballast trailer!
- ▶ If the ballast trailer is at an angle, block the appropriate pull cylinder until the ballast trailer is horizontally aligned again!
- ▶ The control panel on the ballast trailer may only be used during assembly!
- ▶ During crane operation, the crane operator may **not** lift or lower the ballast trailer with the control panel on the ballast trailer, because the LICCON monitors cannot be seen from there!
- ▶ Lifting or lowering during crane operation may **only** be carried out from the cab!
- ▶ When lifting and lowering the ballast trailer, it must be ensured that the difference of the forces in the ballast guying is not too large!
- ▶ The LICCON computer system shows both forces and issues a warning if the difference of the forces is too great, see section "Difference force monitoring of the ballast guying"!

- Press the button **506**, the ballast cylinder **A** left is locked.
- Press the button **507**, the ballast cylinder **B** right is locked.

3.7 Lifting and lowering the ballast trailer in crane operation with the pull cylinders

From the crane cab:

- Press button **315** in the cab, the ballast trailer is lifted with the pull cylinders.
- Press button **324** in the cab, the ballast trailer is lowered with the pull cylinders.



DANGER

Risk of accident!

- ▶ When the ballast trailer is lifted or lowered, pay attention to the horizontal position of the ballast trailer!
- ▶ If the ballast trailer is at an angle, block the appropriate pull cylinder until the ballast trailer is horizontally aligned again!
- ▶ The control panel on the ballast trailer may only be used during assembly!
- ▶ During crane operation, the crane operator may **not** lift or lower the ballast trailer with the control panel on the ballast trailer, because the LICCON monitors cannot be seen from there!
- ▶ Lifting or lowering during crane operation may **only** be carried out from the cab!
- ▶ When lifting and lowering the ballast trailer, it must be ensured that the difference of the forces in the ballast guying is not too large!
- ▶ The LICCON computer system shows both forces and issues a warning if the difference of the forces is too great, see section "Difference force monitoring of the ballast guying"!
- ▶ If this is not observed, there is an increased danger of accidents!

- Press button **316**, ballast cylinder **A** left is locked.
- Press button **325**, ballast cylinder **B** right is locked.

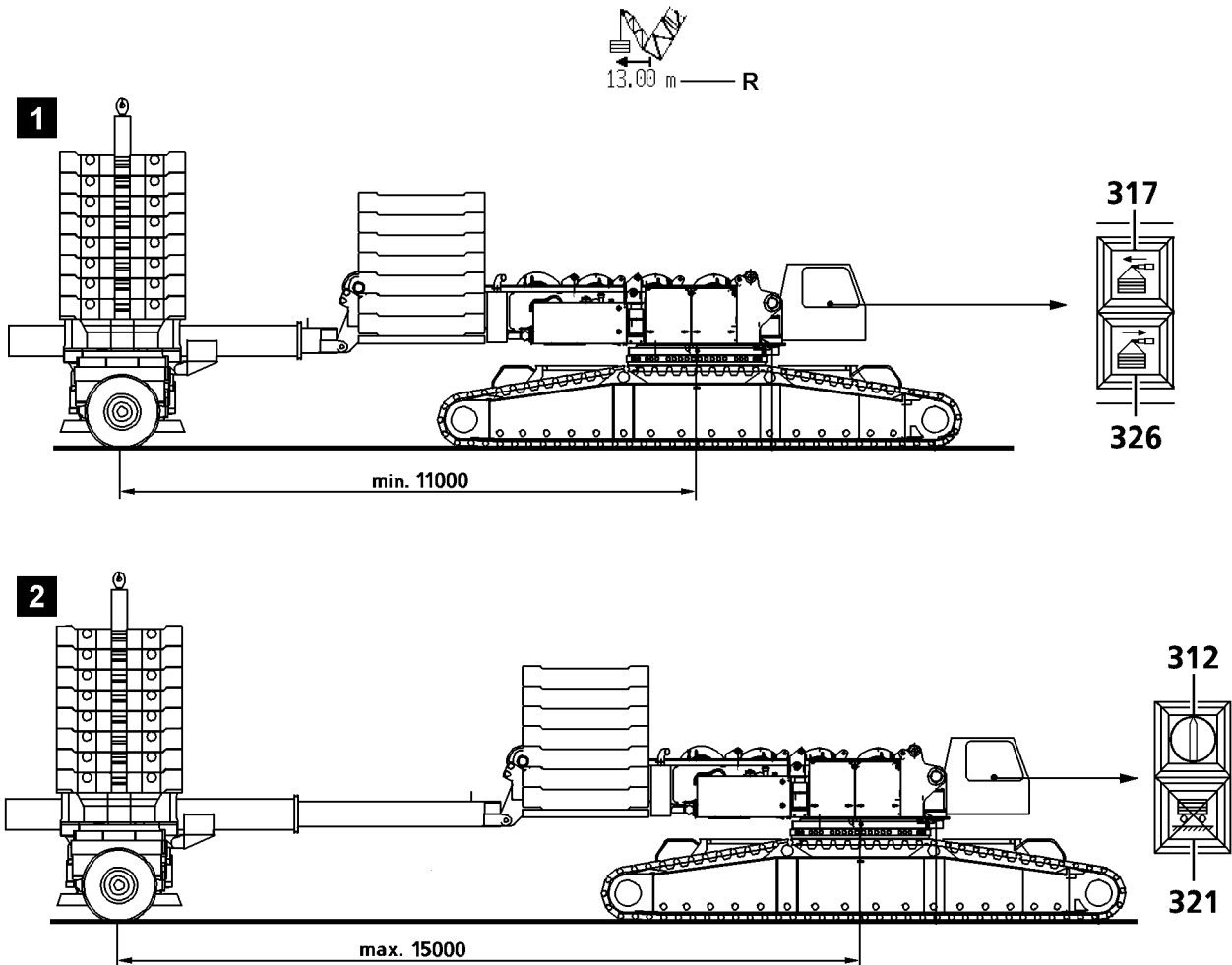
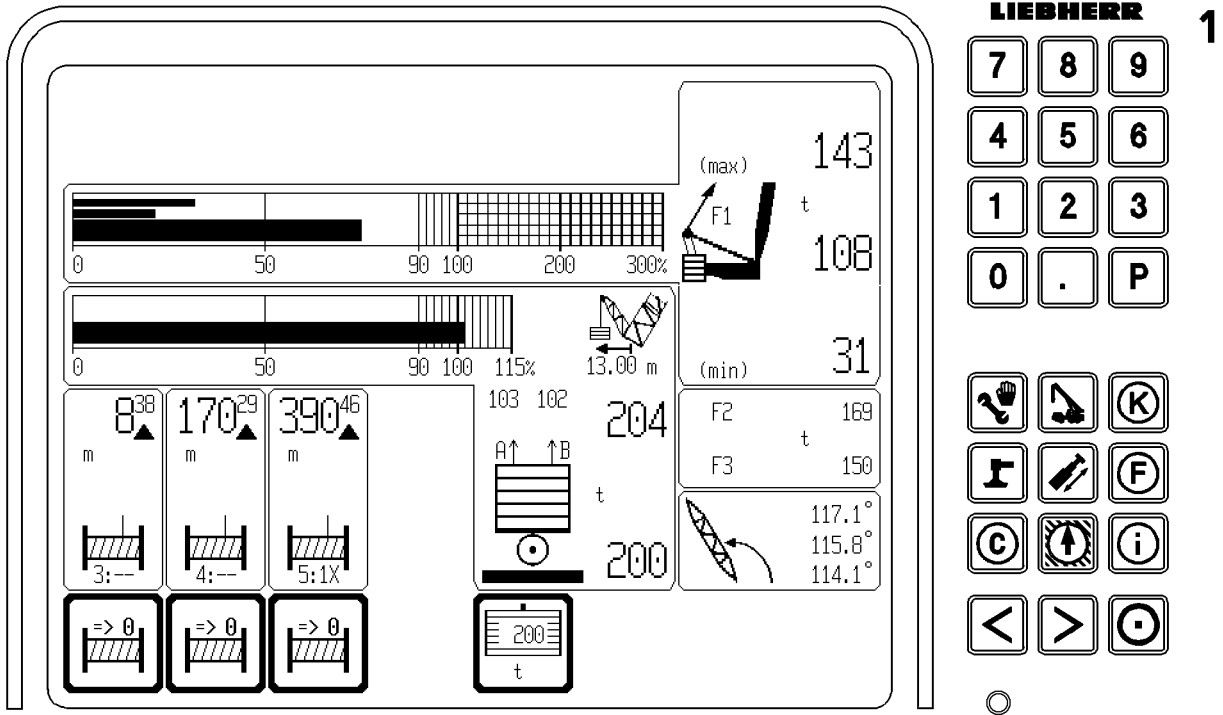

B109268

4 Setting the ballast trailer radii

The ballast trailer is equipped with a telescopic guide. This allows the ballast trailer length to be adjusted to suit the environment and type of lifting work. The maximum length of the telescoping guide is 15 m and the minimum length is 11 m see illustration 1 and illustration 2.

4.1 Telescoping the guide out and in



Note

- ▶ The release for telescoping the ballast trailer guide in/out is issued when the wheel sets are set to towing mode, or the ballast trailer is suspended and assembly condition “**Ballast trailer lifted off**” is turned on by operating key button **312**. The warning light **313** blinks when the key button **312** is turned on, section Key button “Ballast trailer lifted off”!



DANGER

Risk of accident!

The wheel sets must be set to towing mode when telescoping the ballast trailer guide in or out!

- ▶ If this is not observed, the crane or ballast trailer may be damaged!



Note

- ▶ When telescoping out, observe the actual length **R** displayed on the LICCON monitor!
- ▶ The crane operator may not blindly rely on the radius measurement, he must think for himself and check if the length sensor measure functions correctly!

4.1.1 Telescoping the guide from R 11 m to R 15 m

- ▶ Release the guy rods between the derrick head and the ballast trailer.
- ▶ Press the button **317** and telescope the ballast trailer out to the required radius R 13 m or R 15 m.

4.1.2 Telescoping the guide from R 15 m to R 11 m

- ▶ Release the guy rods between the derrick head and the ballast trailer.
- ▶ Press the button **326** and telescope the ballast trailer out to the required radius R 13 m or R 11 m.

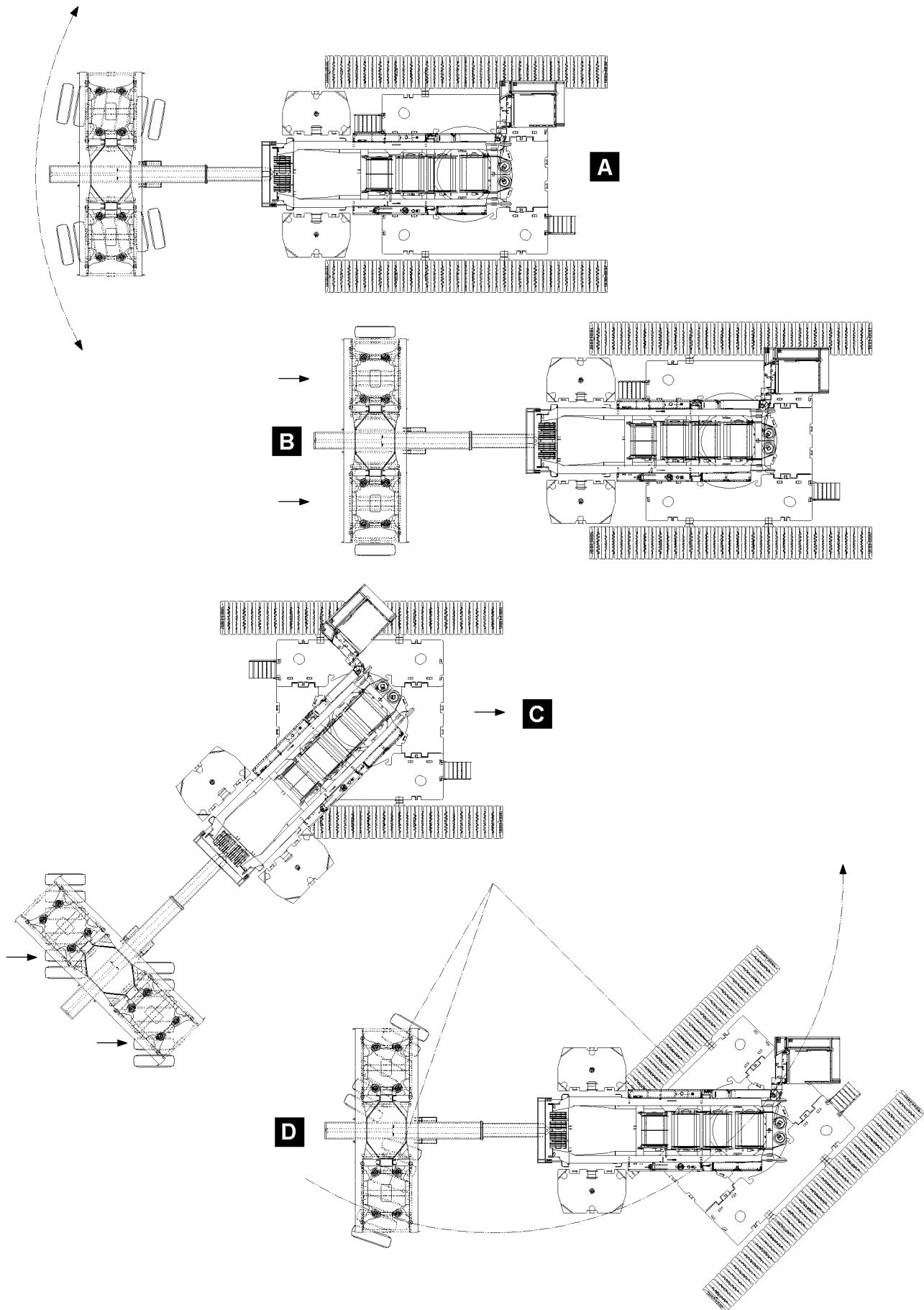

B104579

5 Steering programs

The ballast trailer is equipped with computer controlled steering programs.

- **Circular driving**, illustration **A**
- **Towing**, illustration **B**
- **Parallel driving**, illustration **C**
- **Manual corrective steering**, illustration **D**

The computer controlled steering programs circular driving, towing and parallel driving can only be actuated from the cab.

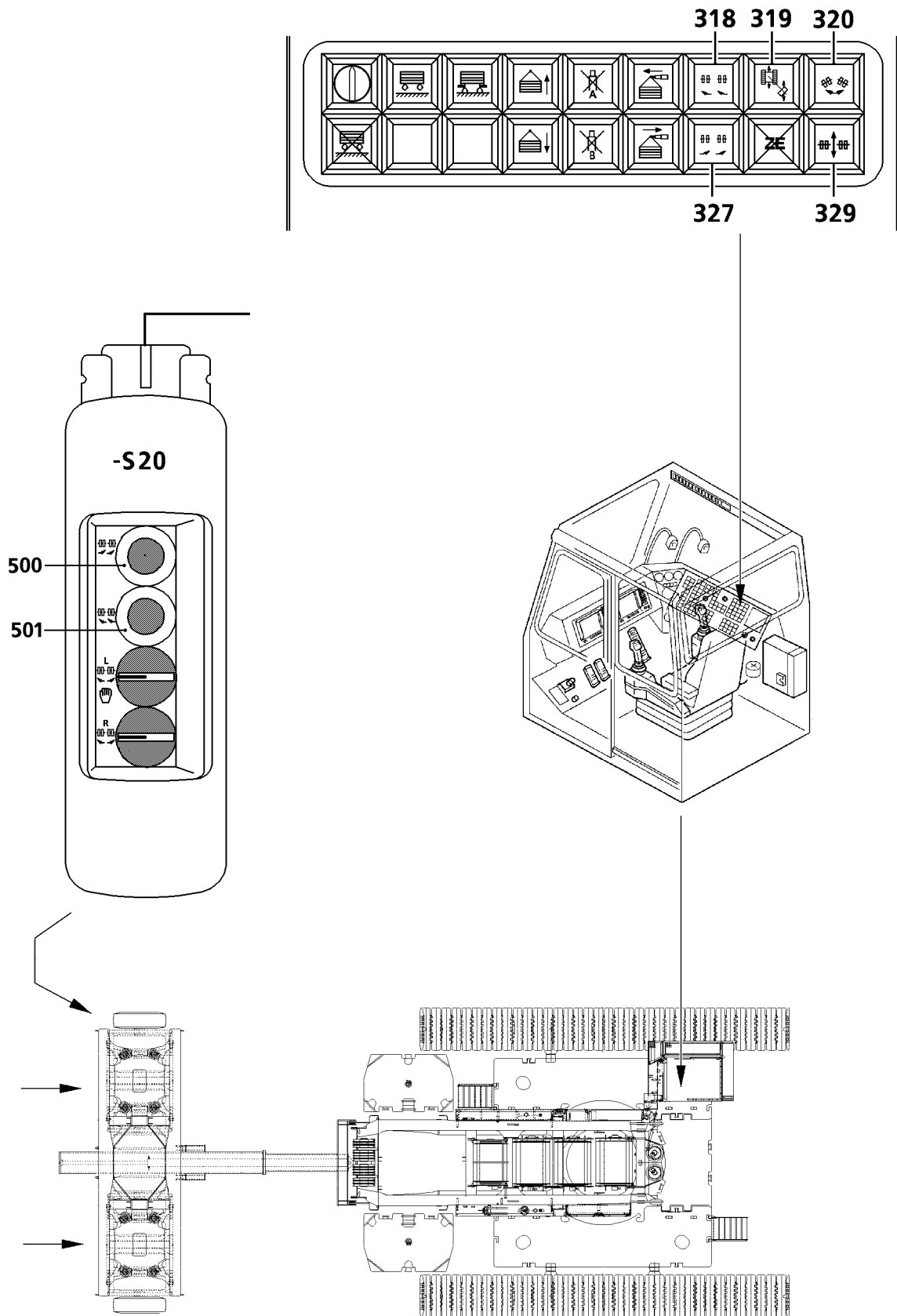

5.1 Notes to change the wheel sets

The change of the wheel sets for circular driving **320**, towing **329** and parallel driving **319** is only possible with buttons **320**, **329** and **319** in the cab.

Manual corrective steering can be performed using buttons **318** and **327** in the cab or buttons **500** and **501** on the ballast trailer control panel **-S20**.

The manual change of the wheel sets for assembly purposes is only possible with the buttons on the control panel **-S20** on the ballast trailer.



Note

- ▶ During crane operation, the wheel sets must be set to the circular driving steering program. If the ballast trailer is operated on the ground, the wheel sets must be in the circular driving position. If the ballast trailer is suspended, the wheel sets can be positioned in any mode, if the key button **312** "Ballast trailer lifted off" was turned on. In this case, the crane driver must monitor that the wheels do not scrape on the ground!



DANGER

Risk of accident!

- ▶ If the ballast trailer is resting on the ground during crane operation, the wheel sets must be set to the circular driving otherwise the ballast trailer and crane will be damaged!

5.2 Changing the wheel sets

The change procedure is the same for all steering programs.



Note

- ▶ If the ballast trailer is not loaded, the wheel sets can be changed without relieving the tires!
- ▶ If the ballast trailer is loaded, lift the ballast trailer with the support cylinders first until the load on the tires is relieved!



DANGER

Risk of accident!

- ▶ By raising the ballast trailer with the support cylinders, the force at test point 1 = F 1 can increase to its maximum value. The extension of the support cylinders is then turned off. However it should not reach the shut-off position; instead it should stop first!

- ▶ Actuate the support cylinders in the cab and watch the monitor display at the same time.

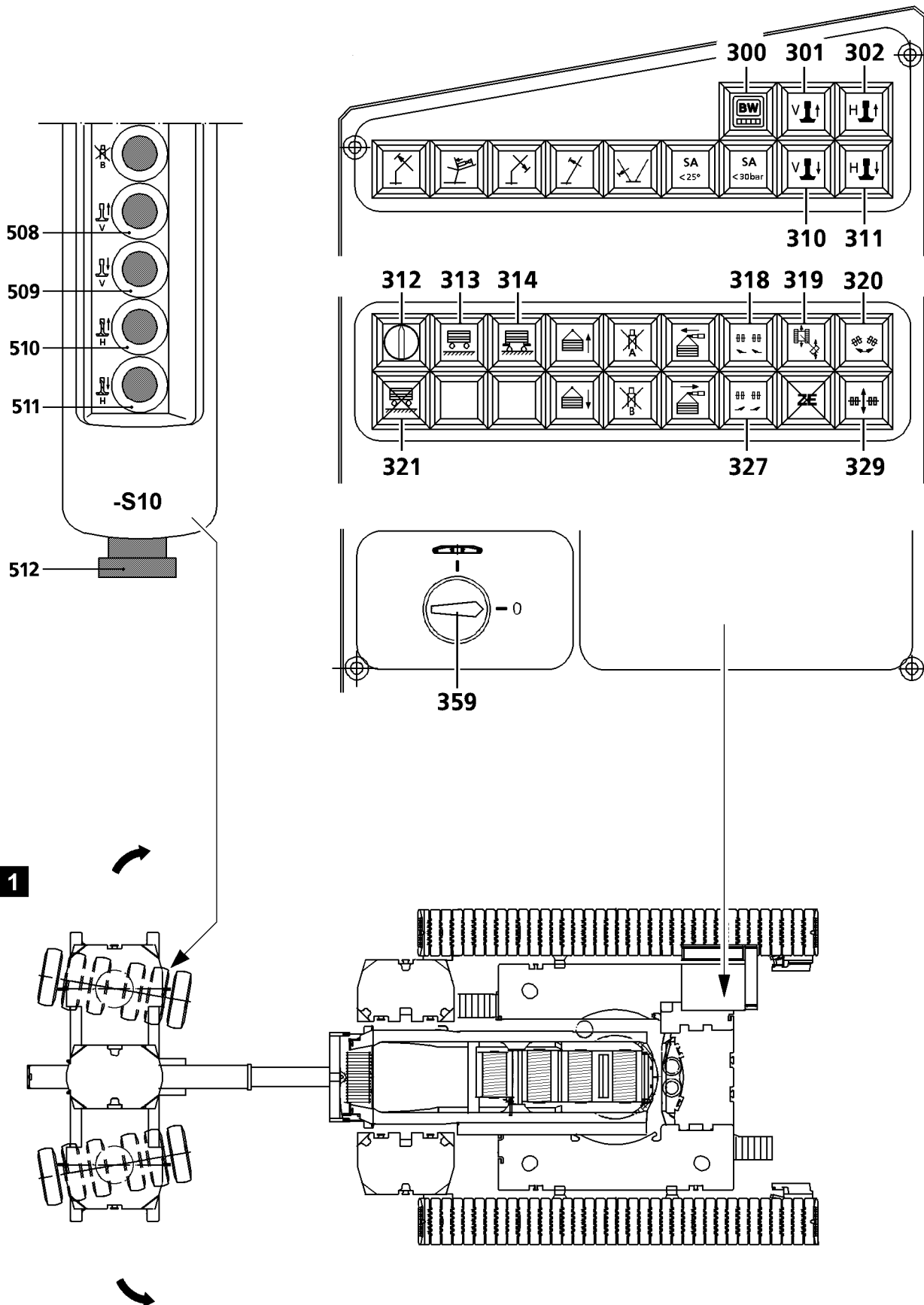

B109269

5.3 Circular driving

Illustration 1

Make sure that the following prerequisites are met:

- The ballast trailer guide is telescoped out to the required radius.



Note

- ▶ If the ballast trailer is operated on the ground, the wheels must be in the correct driving position!
- ▶ If the ballast trailer is suspended, the wheel sets can be set to any position providing key button **312** "Ballast trailer lifted off" has been turned on. In this case, the crane driver must monitor that the wheels do not scrape!



WARNING

Damage to tires!

- ▶ If the ballast trailer is resting on the ground in an incorrect wheel position and key button **312** "Ballast trailer lifted off" is turned on, the ballast trailer wheels may become damaged as they turn!

5.3.1 Lifting the ballast trailer with the support cylinders

- ▶ Press button **310** and **311** or button **509** and **511** and extend the front / rear support cylinders.
- ▶ Raise the ballast trailer until the tires are relieved.

5.3.2 Aligning the axles to the circular driving position

- ▶ Press button **320**, the wheel sets are turned to the circular driving position.

Result:

- The indicator light in the button will blink until the circular driving position is reached. The indicator light in the button remains permanently lit when the circular driving position is reached.



Note

- ▶ If one of the wheel sets deviates from the specified angle, the indicator light in button **320** blinks and the axles must be reset as described above!

- ▶ Press the button **320** again.

5.3.3 Lowering the ballast trailer with the support cylinders

- ▶ Press button **301** and **302** or button **508** and **510** and fully retract the front / rear support cylinders.

Result:

- Indicator light **314** lights up, the support cylinders are retracted.



Note

- ▶ The release for "turning the turntable" is only given when both axles are in the turning position and the support cylinders are retracted!

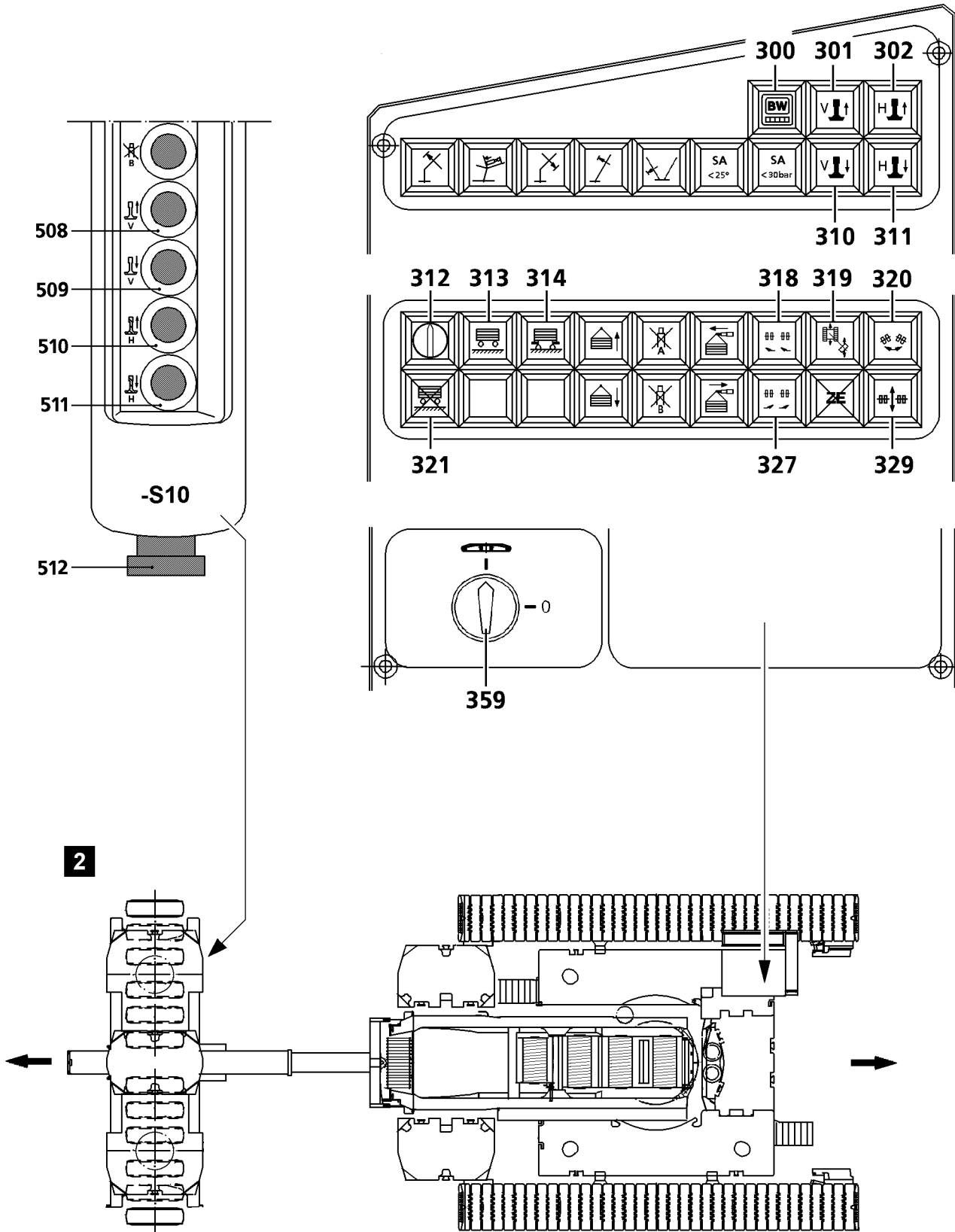

B109270

5.4 Towing

Illustration 2

Make sure that the following prerequisite is met:

- The rotary switch **359** is set to crawler operation (vertical position).



Note

- ▶ If the ballast trailer is operated on the ground, the wheels must be in the correct driving position!
- ▶ If the ballast trailer is suspended, the wheel sets can be set to any position providing key button **312** "Ballast trailer lifted off" has been turned on. In this case, the crane driver must monitor that the wheels do not scrape!



WARNING

Damage to tires!

- ▶ If the ballast trailer is resting on the ground in an incorrect wheel position and key button **312** "Ballast trailer lifted off" is turned on, the ballast trailer wheels may become damaged as they turn!

5.4.1 Lifting the ballast trailer with the support cylinders

- ▶ Press button **310** and **311** or button **509** and **511** and extend the front / rear support cylinders.
- ▶ Raise the ballast trailer until the tires are relieved.

5.4.2 Aligning the axles to the towing position

- ▶ Press button **329**, the axles are turned to the towing position.

Result:

- The indicator light in the button will blink until the towing position is reached. The indicator light in the button remains permanently lit when the towing position is reached.

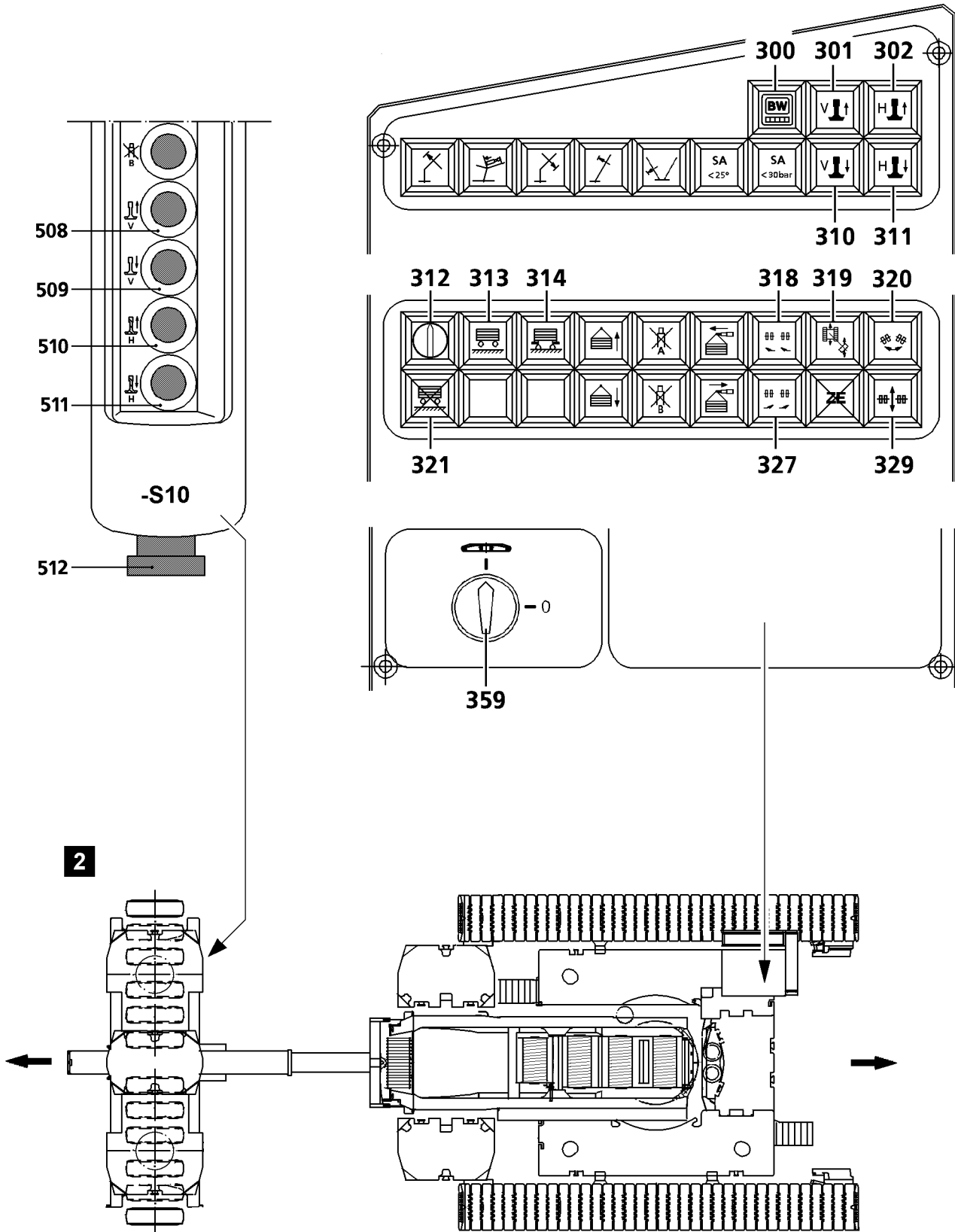

B109270

5.4.3 Lowering the ballast trailer with the support cylinders

- ▶ Press button **301** and **302** or button **508** and **510** and fully retract the front / rear support cylinders.

Result:

- Indicator light **314** is lit, the support cylinders are retracted.



Note

- ▶ The release for "Towing" is only made when both wheel sets are in driving position (neutral position) and the support cylinders are completely retracted!

- ▶ Check the setting of the wheel sets and the support cylinders.

5.4.4 Changing from manual corrective steering to the towing position and vice-versa



Note

- ▶ Changing from operating mode towing to manual corrective steering (and back) is possible while moving the crawler. If one of the wheel sets deviates from the specified angle, the indicator light in button **329** blinks and the axles must be reset as described above. If towing is selected when currently in manual corrective steering mode, the indicator light in button **329** blinks until the towing position is reached. The general rule is that the wheel sets can only move if button **318** or **327** or **329** are pressed when in a particular operating mode or the crawler is being driven!
-

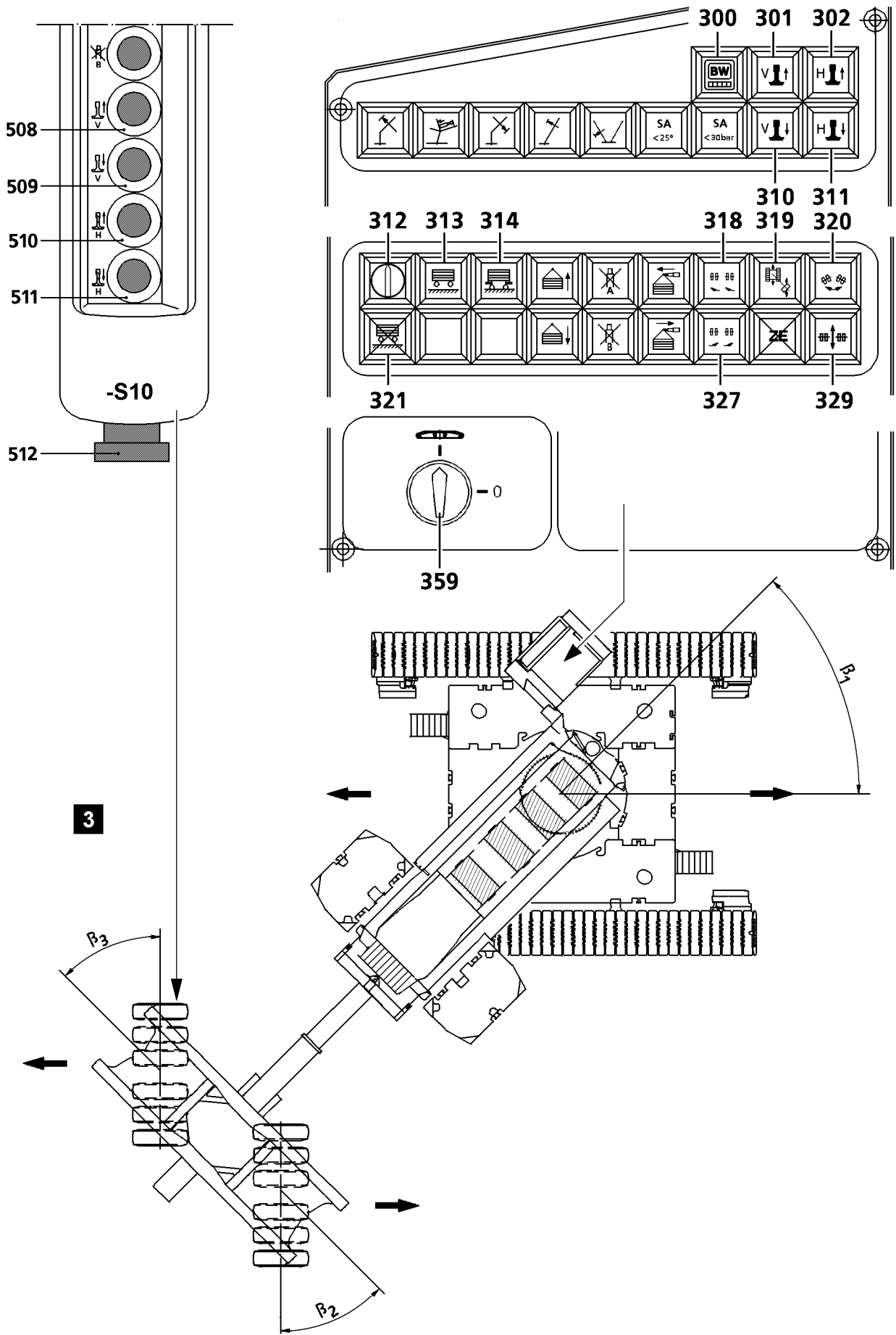

B109271

5.5 Parallel driving

Illustration 3

Make sure that the following prerequisite is met:

- The rotary switch **359** is set to crawler operation (vertical position).



Note

- ▶ The wheel sets must be in parallel driving position, regardless if the “Ballast trailer is on the ground” or if the “Ballast trailer is suspended”. For other wheel set positions, the control system reverts to the same shut off functions as for towing!
-



WARNING

Damage to tires!

- ▶ If the ballast trailer is resting on the ground in an incorrect wheel position and key button **312** “Ballast trailer lifted off” is turned on, the ballast trailer wheels may become damaged as they turn!
-

5.5.1 Lifting the ballast trailer with the support cylinders

- ▶ Press button **310** and **311** or button **509** and **511** and extend the front / rear support cylinders.

5.5.2 Aligning the axles to the parallel driving position

- ▶ Press the button **319**, the axles are turned to parallel position.

Result:

- The control light in the button will blink until the parallel position is reached. The indicator light in the button is lit when the parallel position is reached.



Note

- ▶ If one of the wheel sets deviates from the specified angle, the indicator light in button **319** blinks and the wheel sets must be reset as described above!
-

- ▶ Check the parallel position.

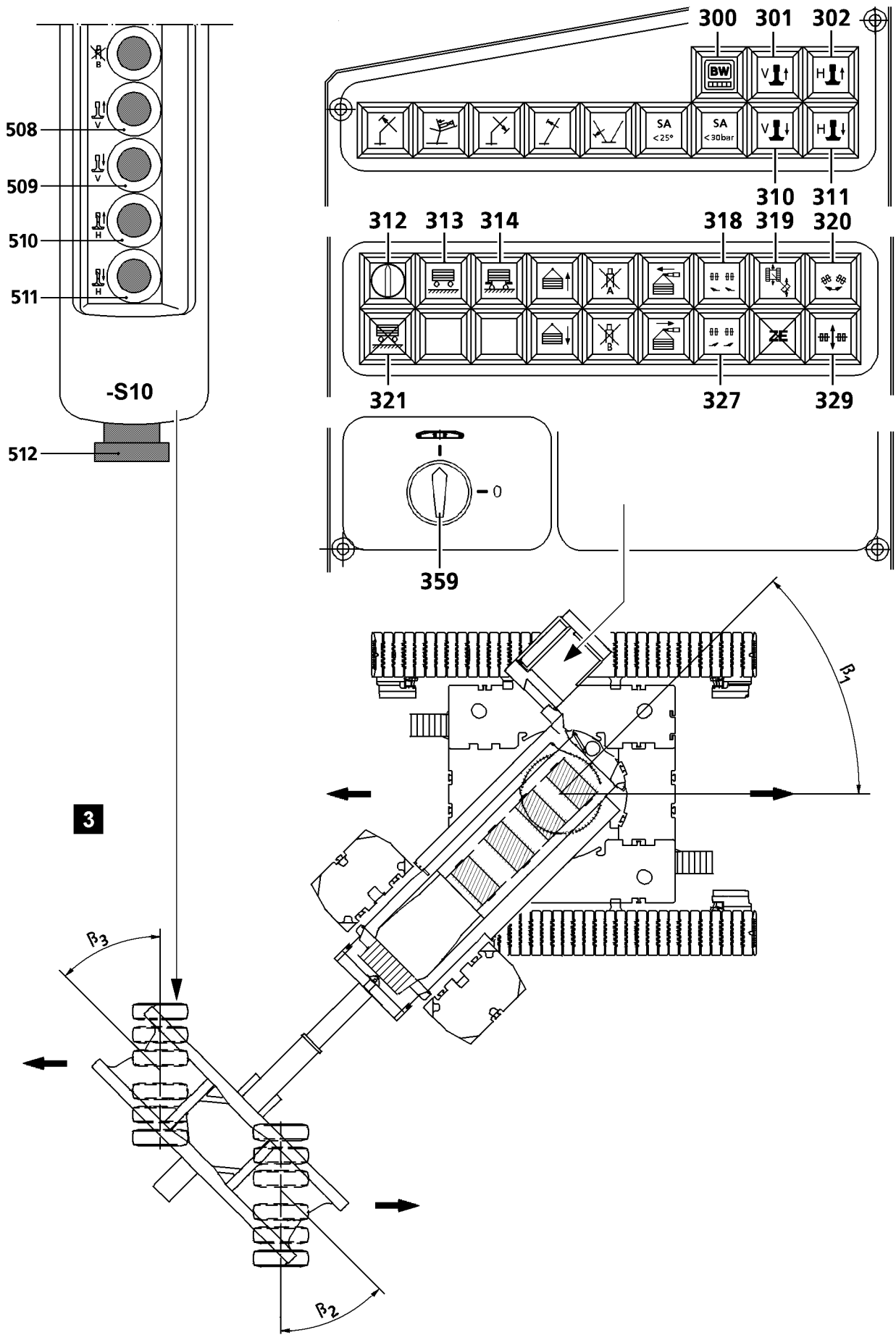

B109271

5.5.3 Lowering the ballast trailer with the support cylinders

- ▶ Press button **301** and **302** or button **508** and **510** and fully retract the front / rear support cylinders.

Result:

- Indicator light **314** lights up, the support cylinders are retracted.



Note

- ▶ The travel drive of the crawler is locked until the axles are in parallel position. During "drive crawler", the slewing gear brake on the crane remains engaged and the hydraulic concentric run is opened!
 - ▶ If the angles β_2 , β_3 in relation to β_1 deviate by more than the permissible limit value, then the crawler track is stopped. The indicator light **319** blinks!
 - ▶ The crawler track is only released again by turning the axles to the specified angle, as described above!
-



CAUTION

Property damage!

- ▶ In parallel driving mode, steering the crawlers is prohibited, but not shut off. If they are steered anyway, the mechanical slewing brake can slip until the crawler track is stopped, due to the angle deviation!
 - ▶ In parallel driving mode, a person must monitor the side tire distortion. In case of a distortion of more than 100 mm, the position of the axles must be corrected!
-
- ▶ Check the settings.

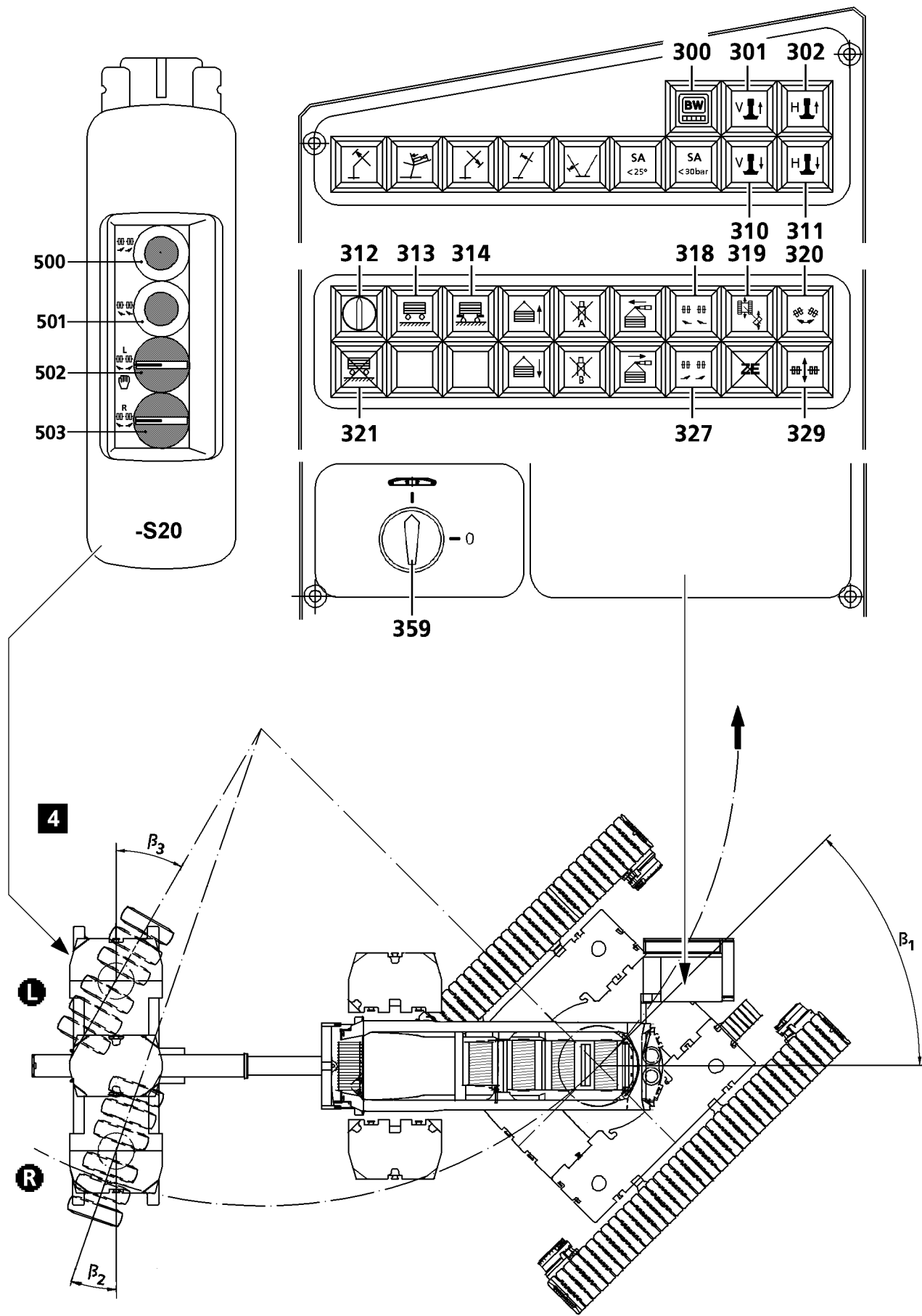

B109272

5.6 Manual corrective steering

Make sure that the following prerequisite is met:

- The rotary switch **359** is set to crawler operation (vertical position).

5.6.1 Steering and correcting steering of the axles

Make sure that the following prerequisites are met:

- Operating mode towing was selected **and** the ballast trailer axles have reached the towing position.
 - ▶ Press button **318** or **501**, the ballast trailer wheels turn to the right.
 - ▶ Press button **327** or **500**, the ballast trailer wheels turn to the left.

The right wheels set is regulated by the computer controlled steering program in such a way that a steering center is always present. Angles β_1 is determined by the driving of the crawler and angle β_3 by the operator steering, whereby angle β_2 is continually corrected. It is possible to switch between manual corrective steering and towing modes when driving the crawler once the towing position has been reached. If manual corrective steering is selected when currently in towing mode, the indicator lights in buttons **318** and **327** light up.



Note

- ▶ The left wheel set can be steered up to a specified angle β_3 . It is not possible to steer beyond this limit. The right wheel set is reregulated according to the steering center. If the right correctively steered wheel set cannot follow the left wheel set, then the left wheel set is stopped until the right correctively steered wheel set has caught up. If the right wheel set still deviates from the specified angle, the indicator lights in buttons **318** and **327** blink and towing has to be restarted. If angle β_1 of the turntable exceeds the specified value, an automatic switch is made to towing mode. The indicator lights in buttons **318** and **327** and **329** blink. When the towing position is reached, manual corrective steering can continue. Indicator light in buttons **318** and **327** lights up. The general rule is that the wheel sets only move during manual corrective steering if button **318** or **327** or **329** or **500** or **501** on the control panel are pressed in the respective operating mode or the crawler is being driven!

-
- ▶ Check the settings.

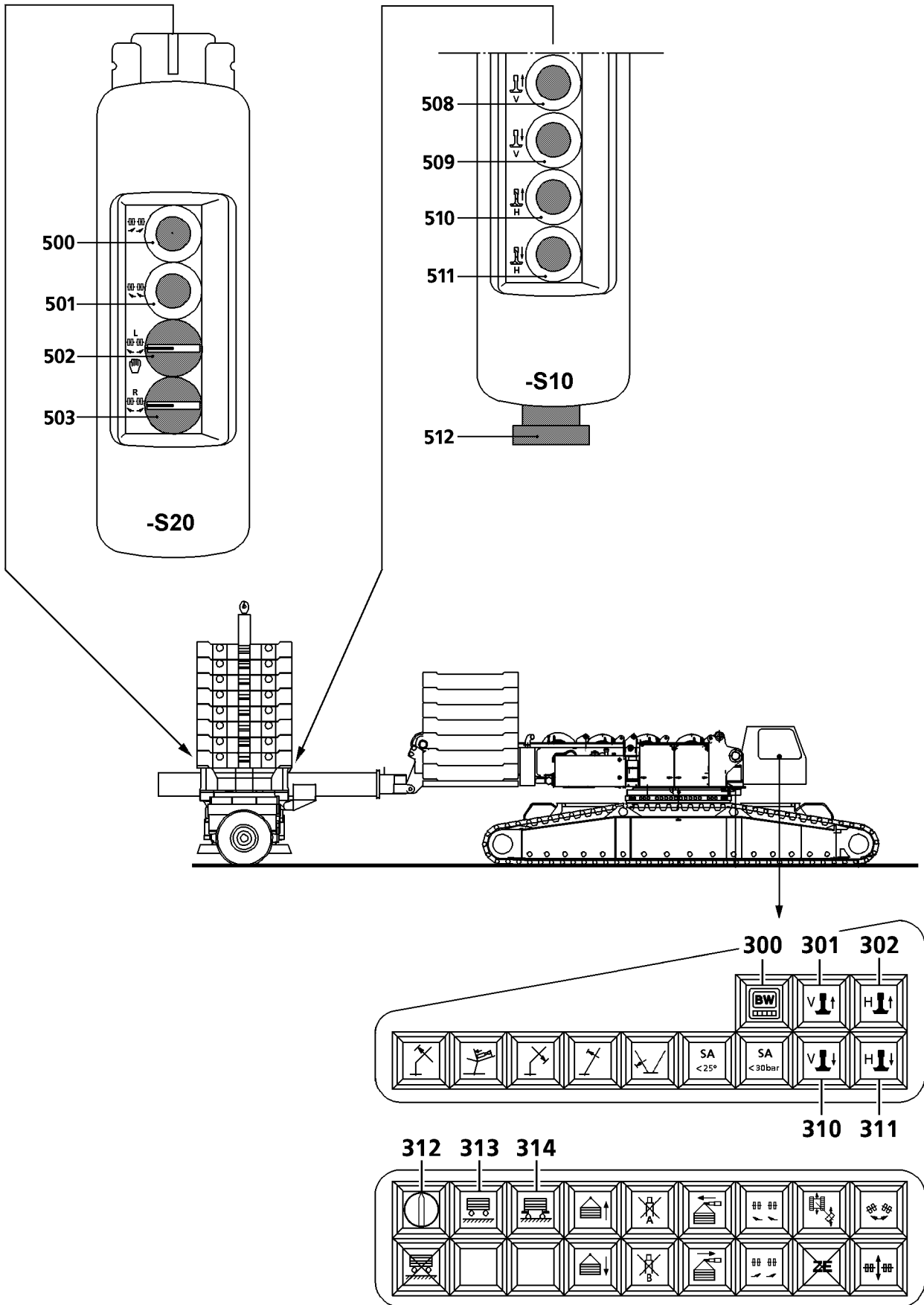

B109273

5.7 Manual operation for assembly

The ballast trailer is equipped with a program which allows for each wheel set to be turned individually at assembly.

5.7.1 Lifting the ballast trailer with the support cylinders

- ▶ Press button **310** and **311** or button **509** and **511** and extend the front / rear support cylinders.

5.7.2 Setting the axles

- ▶ Turn the rotary switch **502** to the right, the left axle turns to the right.
- ▶ Turn the rotary switch **502** to the left, the left axle turns to the left.
- ▶ Turn the rotary switch **503** to the right, the right axle turns to the right.
- ▶ Turn the rotary switch **503** to the left, the right axle turns to the left.

5.7.3 Lowering the ballast trailer with the support cylinders

- ▶ Press button **301** and **302** or button **508** and **510** and fully retract the front / rear support cylinders.

Result:

- Indicator light **314** lights up, the support cylinders are retracted.

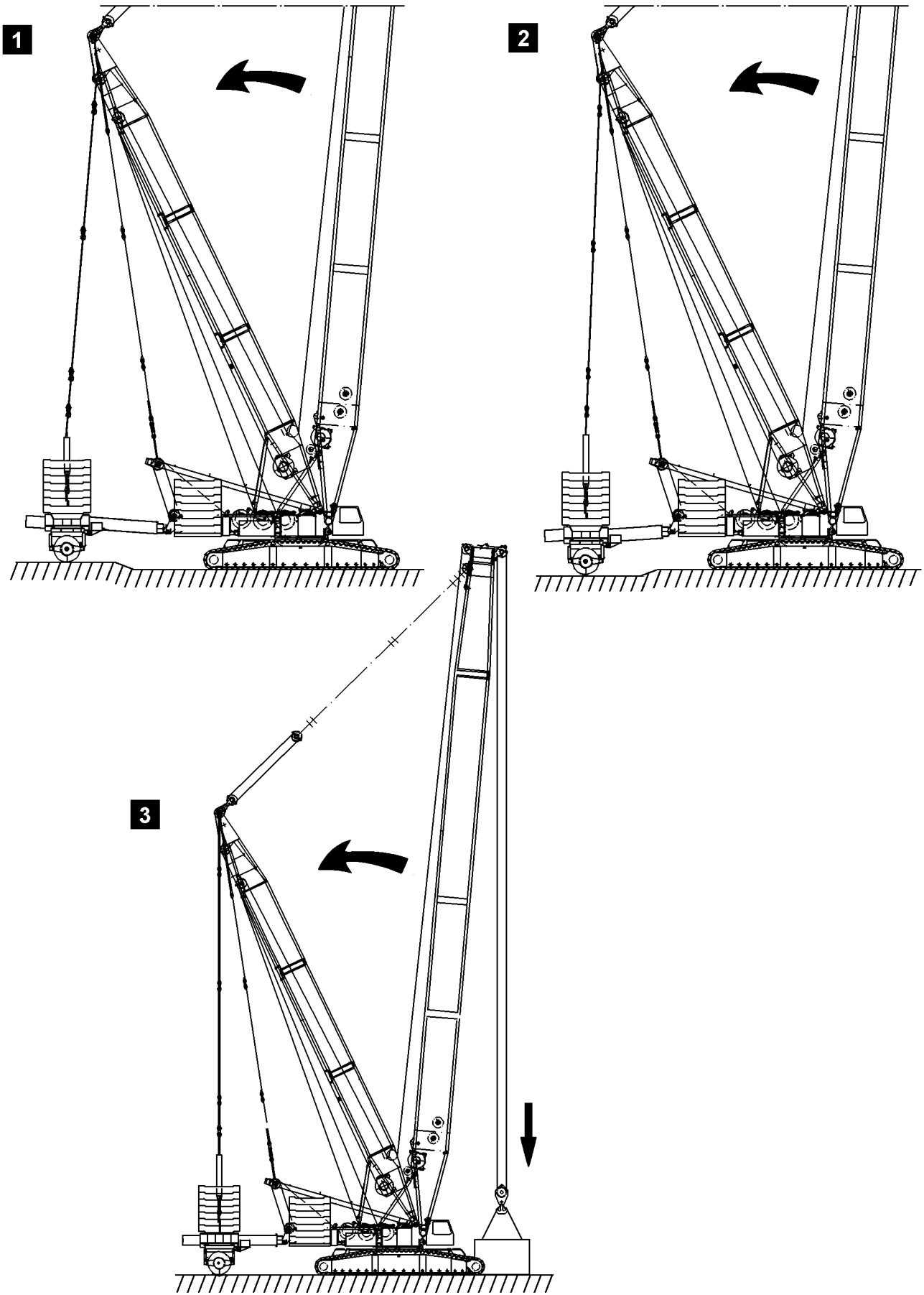

B109274

6 Driving the crane with the ballast trailer



WARNING

Ground not suitable for driving with ballast trailer!

The guide on the ballast trailer could be overloaded or damaged when driving forwards / reversing the trailer on unsuitable ground!

Personnel can be severely injured or killed!

- ▶ It is only permitted to drive the ballast trailer on level ground capable of supporting the load!
- ▶ It is prohibited to drive over obstacles!

If the ballast trailer sinks into soft ground or when driving up / down slopes:

- ▶ Unload the ballast trailer!
-

6.1 Safety guidelines for travel operation

6.1.1 Relapse cylinder

When the steepest operating position of the main boom is reached, luffing up is turned off by the overload protection in all operating modes.



Note

- ▶ However, there are cases when the relapse cylinders move mechanically to stop position, due to a movement of the entire crane system to the rear!
-

6.1.2 Block position relapse cylinders

In normal crane operation without bypass of the overload protection, a block position is not possible. Should a block position occur anyway, the movement is shut off and an indicator light on the instrument panel lights up.

This indicator light in the crane cab is used to determine which limit switch on which relapse cylinder has been actuated. Reverse the last movement which was carried out until the corresponding limit switch is released again.

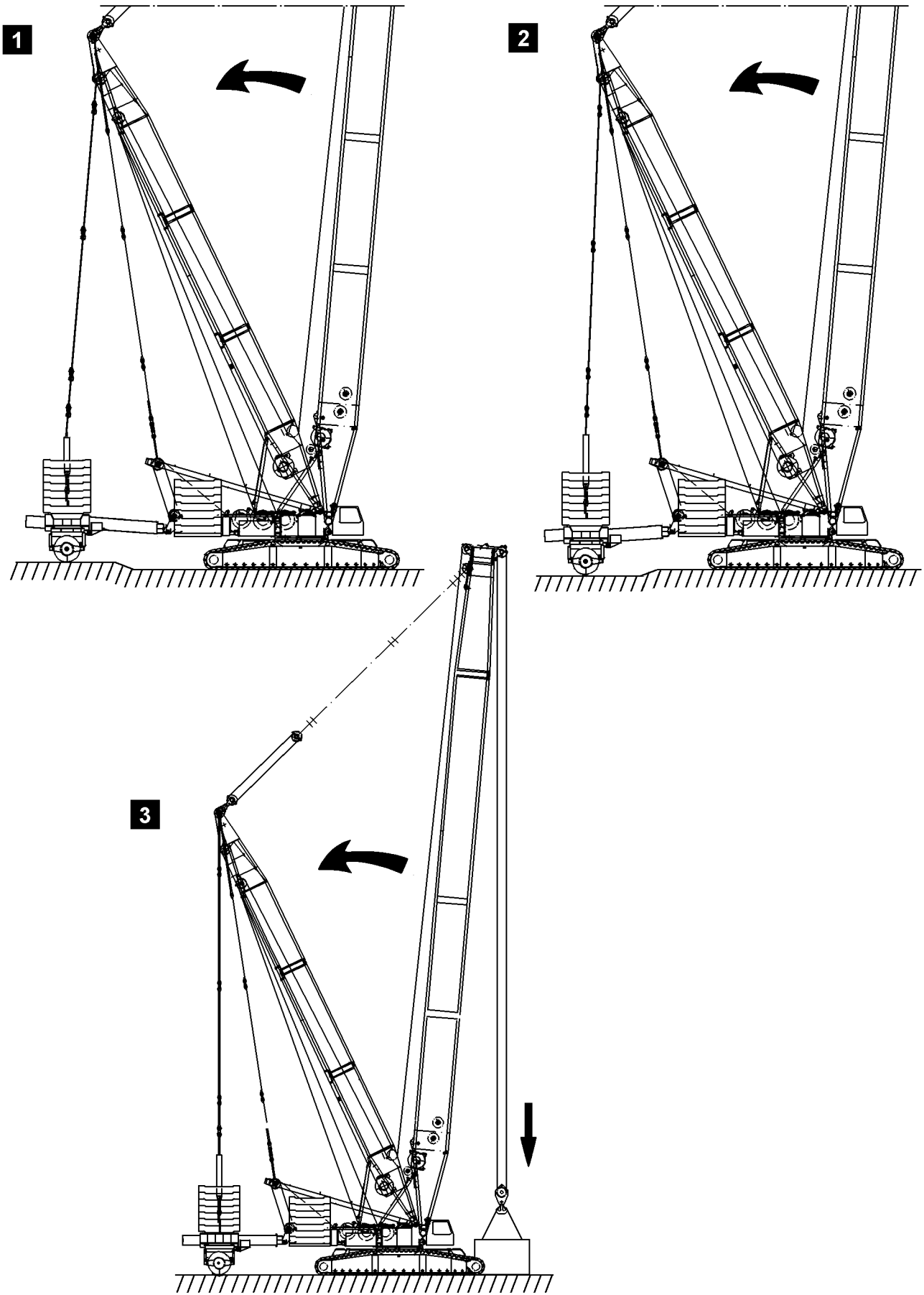

B109274

6.1.3 Case 1, illustration 1

When driving or turning the crane with steeply positioned boom, the ballast trailer can be lowered, due to the level differences. This causes the whole boom system to be pulled backward and there is a risk of reaching the block position in the relapse cylinders. The same risk applies when turning if the ballast trailer sinks due to level differences.

**Note**

- ▶ Due to the signals "Main boom relapse cylinder on block" or "Derrick relapse cylinder on block", the drive and turn movements of the crawler are automatically turned off during crane operation with the ballast trailer!
-

6.1.4 Case 2, illustration 2

If the level under the crane increases, the boom system is also pulled back. There is a risk that the relapse cylinders reach the block position.

**Note**

- ▶ Due to the signals "Main boom relapse cylinder on block" or "Derrick relapse cylinder on block", the drive and turn movements of the crawler are automatically turned off during crane operation with the ballast trailer!
-

6.1.5 Case 3, illustration 3

When the load is set down with the hoist gear, the crane is relieved. This causes the booms to move to the rear. The hoist gear is not shut off.

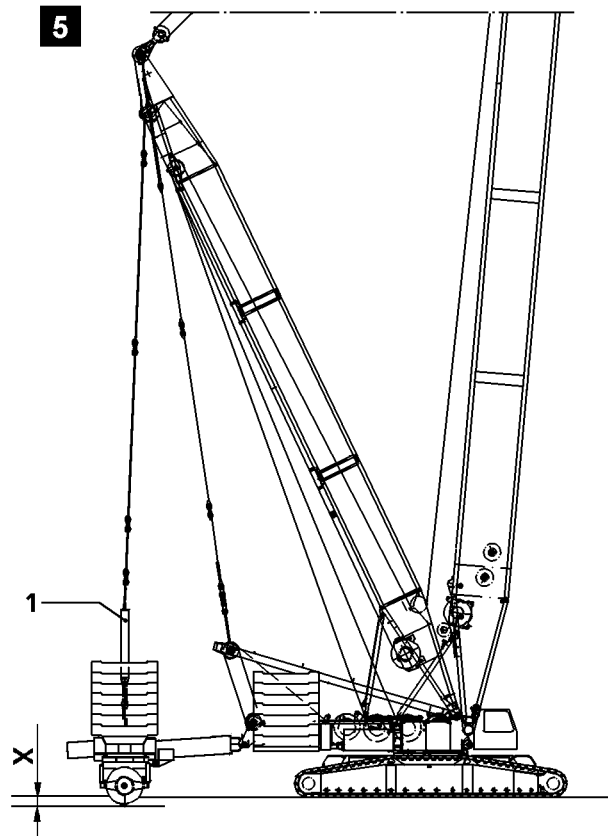
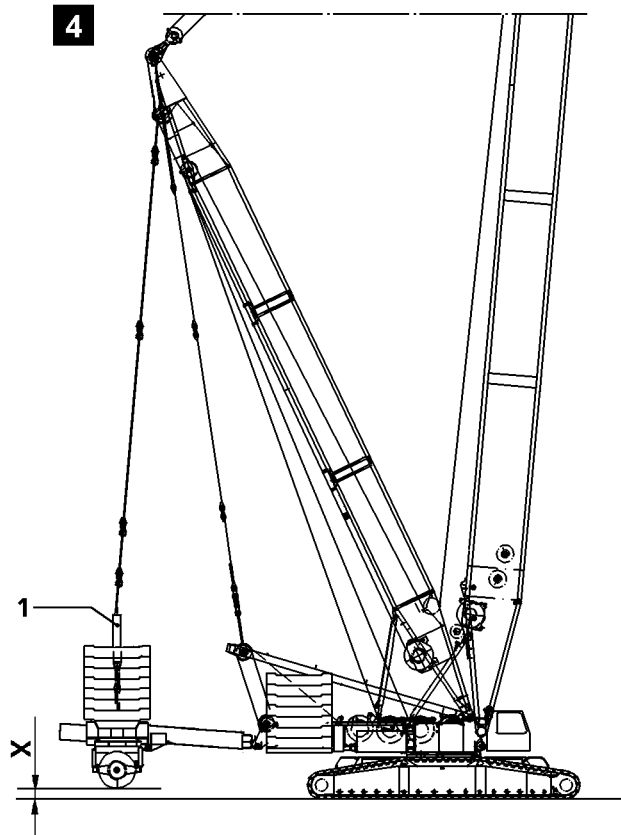

B109275

6.2 Maximum permitted level difference

Level changes between the crane footprint and ballast trailer while driving or turning.



DANGER

Risk of accident!

- ▶ The level difference of the ballast trailer route in relation to the crane route must be a maximum of 250 mm for towing and parallel driving. The level difference between the ballast trailer route and the base of the crane should be maximum of 250 mm for circular driving (constant uphill or downhill slope)!

6.2.1 Compensation of the maximum permitted level difference by the pull cylinders, illustrations 4 and illustration 5

The permitted ground unevenness can be compensated by raising or lowering the pull cylinders.

Ballast trailer radius R 11 m				
	With Quick connection		Without Quick connection	
	Cylinder stroke	Dimension X	Cylinder stroke	Dimension X
Maximum permitted level difference		± 250 mm		± 250 mm
Pull cylinder retracted	0	+ 1440 mm	0	+ 1140 mm
Nominal position of pull cylinder	1320 mm	0	1060 mm	0
Pull cylinder extended	2180 mm	- 810 mm	2180 mm	- 1040 mm

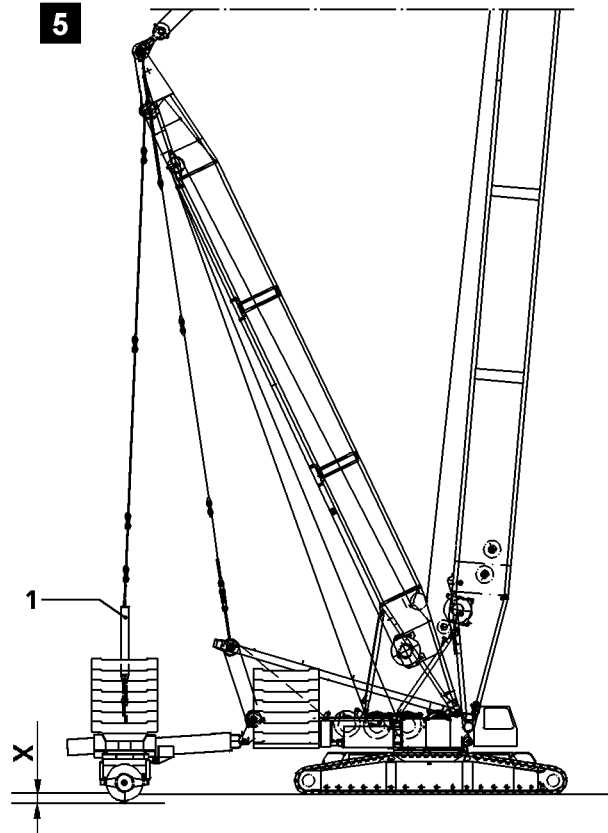
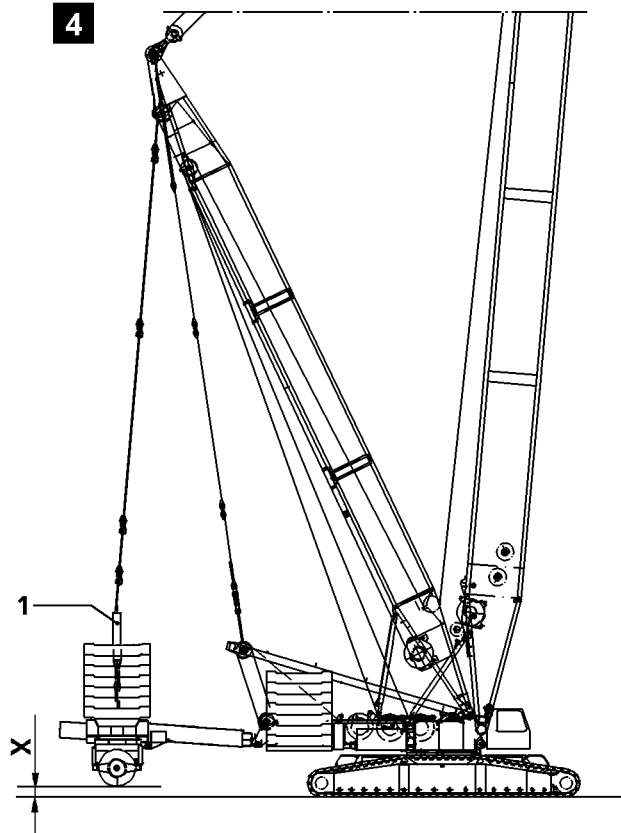

B109275

Ballast trailer radius R 13 m				
	With Quick connection		Without Quick connection	
	Cylinder stroke	Dimension X	Cylinder stroke	Dimension X
Maximum permitted level difference		± 250 mm		± 250 mm
Pull cylinder retracted	0	+ 1440 mm	0	+ 1160 mm
Nominal position of pull cylinder	1400 mm	0	1140 mm	0
Pull cylinder extended	2180 mm	- 760 mm	2180 mm	- 1010 mm

Ballast trailer radius R 15 m				
	With Quick connection		Without Quick connection	
	Cylinder stroke	Dimension X	Cylinder stroke	Dimension X
Maximum permitted level difference		± 250 mm		± 250 mm
Pull cylinder retracted	0	+ 1660 mm	0	+ 1390 mm
Nominal position of pull cylinder	1630 mm	0	1370 mm	0
Pull cylinder extended	2180 mm	- 550 mm	2180 mm	- 810 mm

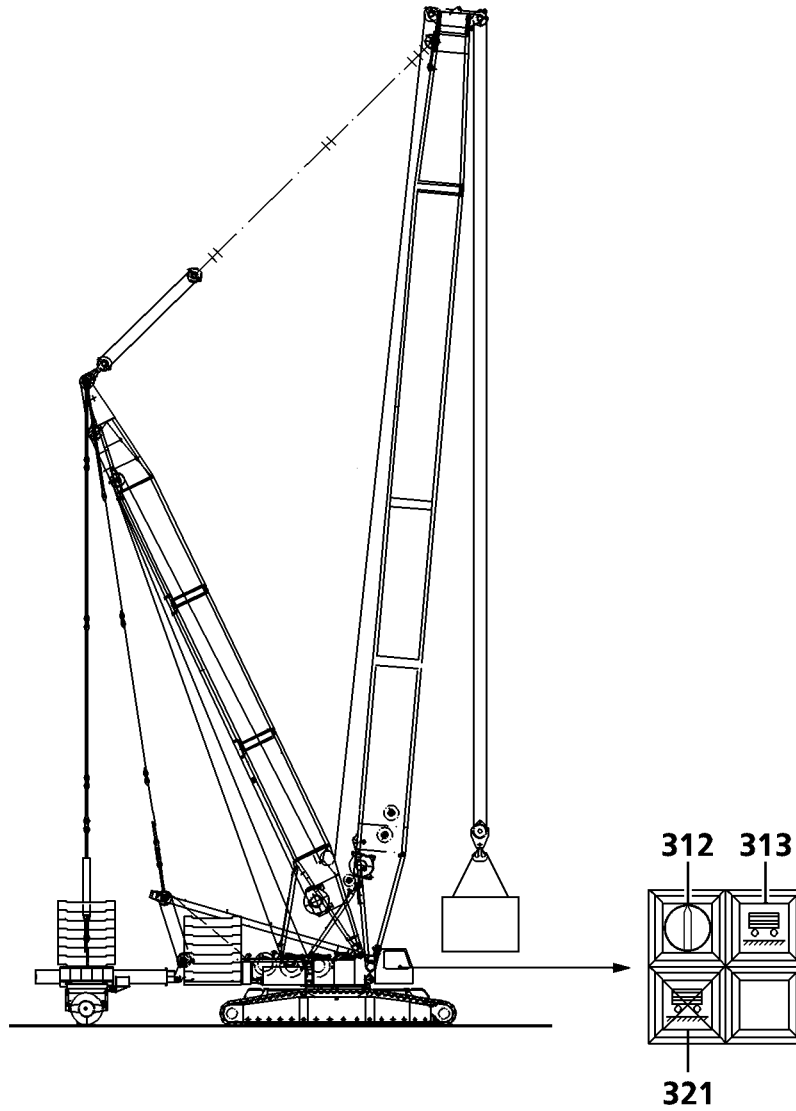

6.3 Key button “Ballast trailer lifted off”

When “Crawler driving” and key button **312** is not operated, i.e. “Ballast trailer not lifted off”, the slewing gear brake and hydraulic concentric running of the slewing gear are opened. When driving the “Drive crawler” with lifted off ballast trailer (constant visual check), the key button **312** “Ballast trailer lifted off” must be turned on.



DANGER

Risk of accident!

If the ballast trailer is lifted off the ground (constant visual check), there is the danger that the wind turns the turntable when “Driving the crawler”; the key button **312** “Ballast trailer lifted off” must be therefore be turned on!

- ▶ Therefore, when “Driving the crawler”, the slewing brake remains applied, but the hydraulic slewing gear coasting remains open. If, when “Driving the crawler”, the ballast trailer scrapes on the ground or gets stuck on the ground, so that the turntable twists with the ballast trailer against the crawler track, the slewing brake can slip. The slewing gear will not be damaged. However, if the wheels of the ballast trailer are not in towing position, the ballast trailer or the crane will be damaged!
-



Note

- ▶ When the function “Ballast trailer lifted off” is turned on, the indicator light **313** blinks, it is possible to turn the crane superstructure or to move the crane even though the wheels of the ballast trailer are not on circular driving, towing or parallel driving!
-

If the key button **312** is turned to “Ballast trailer lifted off”, this is indicated by the blinking indicator light **313**, as well as the red flashing beacon on the crane cab. In addition, the ballast trailer icon is shown on the LICCON monitor 1 is suspended condition.

To turn “Ballast trailer lifted off” off, the button **321** must be pressed. The indicator light **313** turns off. The LICCON monitor shows the derrick ballast icon on the ground.

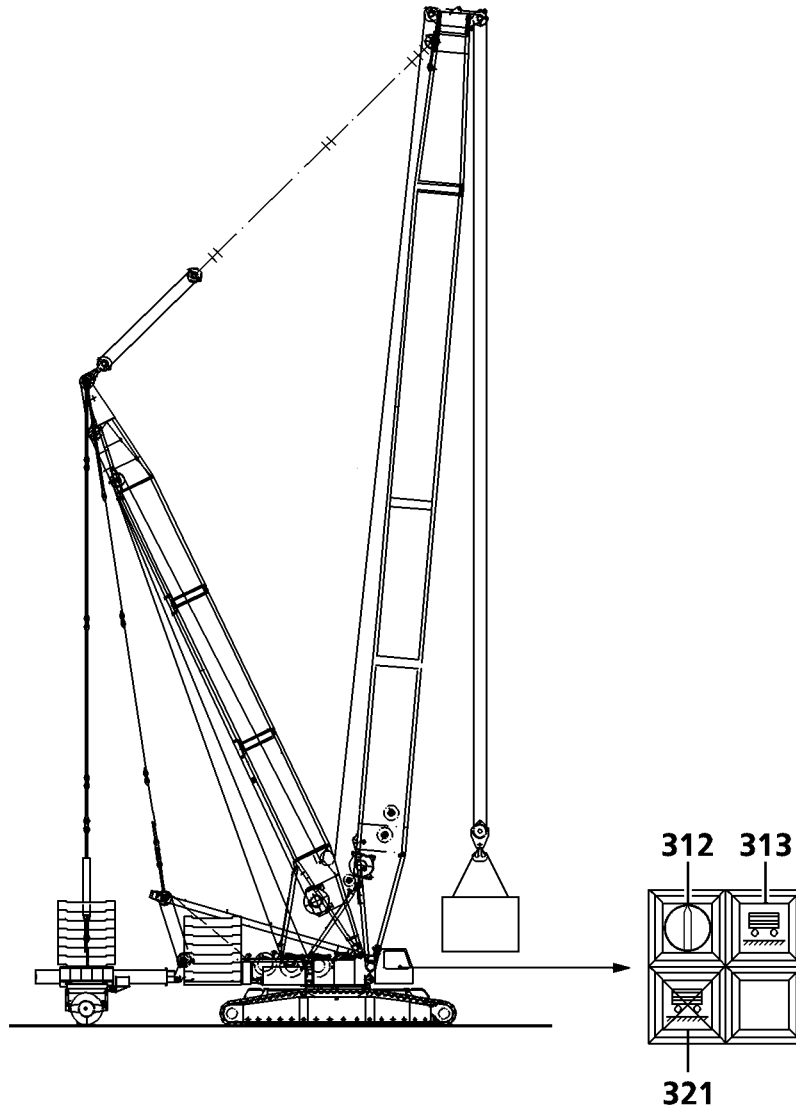

6.4 Defined ballast trailer operation

The ballast trailer may not be lifted off or set down while driving, it must be lifted off or set down before starting to drive.

1. The ballast trailer should be either

defined as set on the ground key button **312** not actuated "**Ballast trailer not lifted off**". This means that the ballast trailer and its residual load are resting on the ballast trailer tires. This residual load is large enough to prevent the wind from turning the crane superstructure even though the slewing gear brake opens when the crawler is actuated.

or

2. defined as lifted off the ground, key button **312** actuated "**Ballast trailer lifted off**". This means that the slewing gear brake does not open when crawler is being driven. The wind can therefore not turn the superstructure when the crawler is driven.



DANGER

Risk of accident!

- ▶ The ballast trailer must always be operated, as defined, either freely suspended or solidly on the ground. Operation of the ballast trailer in an undefined state is prohibited. There is an increased accident risk if the ballast trailer is not in a defined set down or raised state!

6.5 Non-defined ballast trailer operation



DANGER

Risk of accident!

- ▶ The ballast trailer must always be operated in a defined mode!

Ballasted ballast trailer is still standing on the ground with 1 t.

1. If key button **312** is not actuated "**Ballast trailer not lifted off**". The slewing gear brake opens when driving the crawler. The wind can turn the superstructure and the load starts to swing.



DANGER

Risk of accident!

- ▶ There is an increased danger of accidents due to collision!

or

2. If key button **312** is actuated "**Ballast trailer lifted off**". The slewing gear brake remains closed when driving the crawler. When driving the crawler around a curve, the ballast trailer tires or the slewing brake will slip.

0

LIEBHERR

7 8 9
4 5 6
1 2 3
0 . P

SHIFT F1 F2 F3 F4 F5 F6 F7 F8 ENTER

D

1

LIEBHERR

7 8 9
4 5 6
1 2 3
0 . P

SHIFT F1 F2 F3 F4 F5 F6 F7 F8 ENTER

B111436

7 Crane operation with derrick ballast

7.1 Safety guidelines



WARNING

Danger of accident when exceeding the shut off limits of the LICCON overload protection!

If the shut off limits of the LICCON overload protection are exceeded, there is no additional protection against crane overload!

Due to erroneous operation or deliberate misuse, the crane could collapse, the boom can break off or the crane can topple over!

Personnel can be severely injured or killed!

- ▶ The button "Luffing in with suspended load" and the set up key **D** may only be used when it is ensured that no normal operating condition (utilization below 100 % and no active shut off) can be reached without exceeding the shut off limits of the LICCON overload protection!
- ▶ Use the set up key **D** only when no normal operating condition (utilization below 100 % and no active shut off) can be reached with the button "Luffing in with suspended load"!
- ▶ It is only permitted to exceed the shut off limits of the LICCON overload protection in emergencies and for assembly purposes!
- ▶ The set up key **D** may only be actuated by persons who are aware of the effects of their acts regarding the exceeding of the LICCON overload protection!
- ▶ Exceeding the shut off limits of the LICCON overload protection requires the presence of an authorized person and must be performed with utmost caution!
- ▶ Crane operation with exceeded shut off limits of the LICCON overload protection is prohibited!
- ▶ For procedure of shut off of crane movements, see Crane operating instructions, chapter 4.20!



WARNING

The crane can topple over!

If the derrick ballast is lifted off the ground past the **maximum permissible** 250 mm then the crane can topple to the rear if the load rips off!

If the following notes are not observed, personnel can be severely injured or killed!

- ▶ There may be no personnel, objects or obstacles within the entire slewing range of the crane, derrick ballast and the load!
- ▶ Do not lift the derrick ballast more than 250 mm off the ground!
- ▶ The ground in the entire working area of the crane - including the derrick ballast and the load - must be even and of sufficient load carrying capacity in order to be able to securely accept the encountered ground pressures and weight loads!



Note

- ▶ The test points must be checked for function before crane operation. The crane must be horizontally aligned on the set up location. The weight of the load to be lifted must be known. The placement surface of the derrick ballast should not be no more than maximum 0.25 m above - or 0.25 m below the level of the crane base. The placement location on which the derrick ballast is placed after the load lift has been completed must be level, horizontal and of sufficient load bearing capacity in order to be able to safely support the weight!

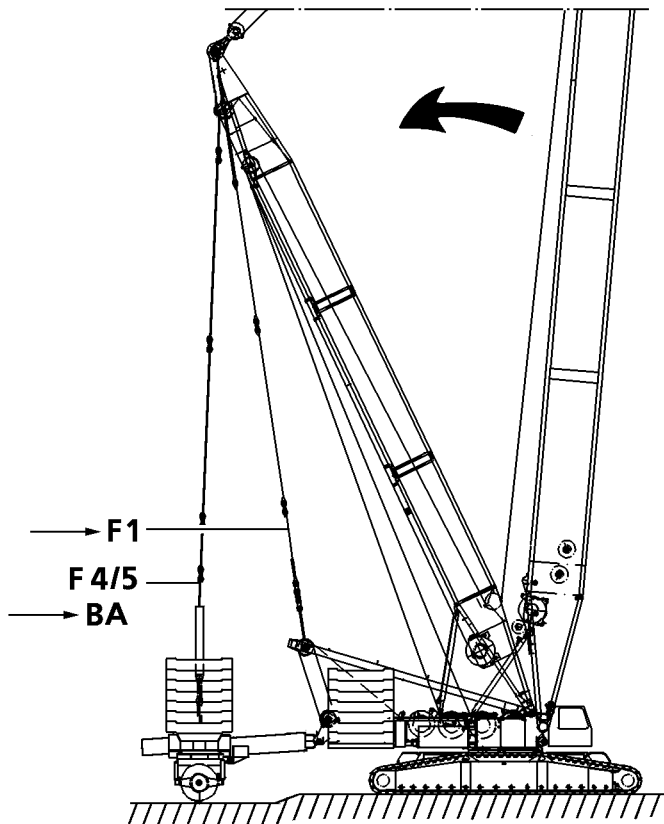
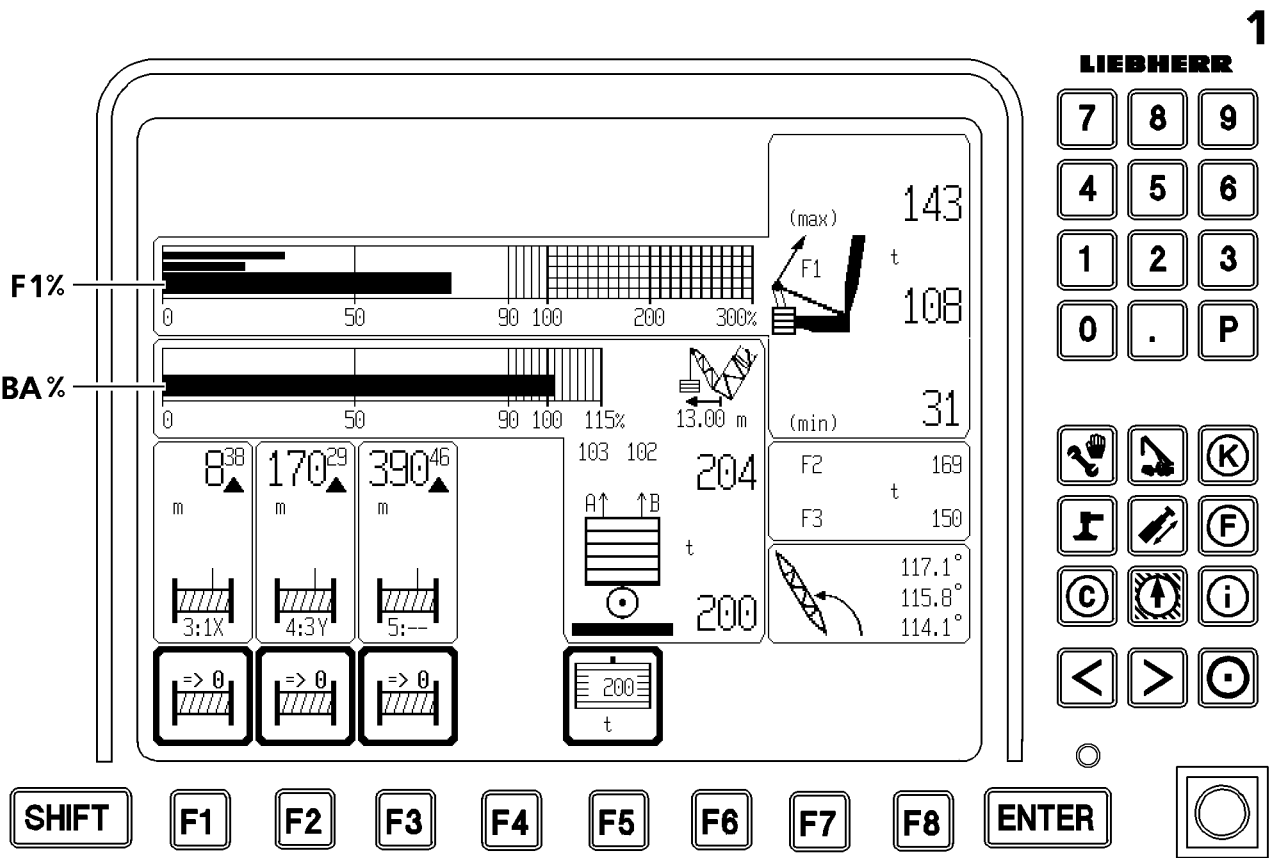

B108502

**WARNING**

Risk of accident!

If the following points are not observed, there is a risk of tipping when lifting with placed ballast plates and this could cause the crane to topple over! Personnel can be severely injured or killed!

- ▶ There may be no obstacles within the slewing range of the crane, and the derrick ballast and the load!
- ▶ When the derrick ballast is raised, it must be observed by a guide or the crane operator!
- ▶ When taking on the load, diagonal pull must be avoided, which means the derrick ballast, the center of rotation of the turntable and the load must be on one line! To ensure this, operate the pull cylinder to lift and set down the derrick ballast before adding any ballast plates!

**WARNING**

Risk of accident!

- ▶ The guying between the SA-bracket and the derrick end section, test point 1, may never be force-free!
- ▶ This can lead to uncontrolled movements of the boom system and cause an accident!

**CAUTION**

Risk of accident!

- ▶ Before setting down the load and the suspended derrick ballast, the crane operator must make sure that a safe placement is ensured!

When lifting the load, the guying between the derrick ballast and derrick end section must be relieved to the point where the actual force at test point 1 is larger than the F1-minimum force (F1-min).

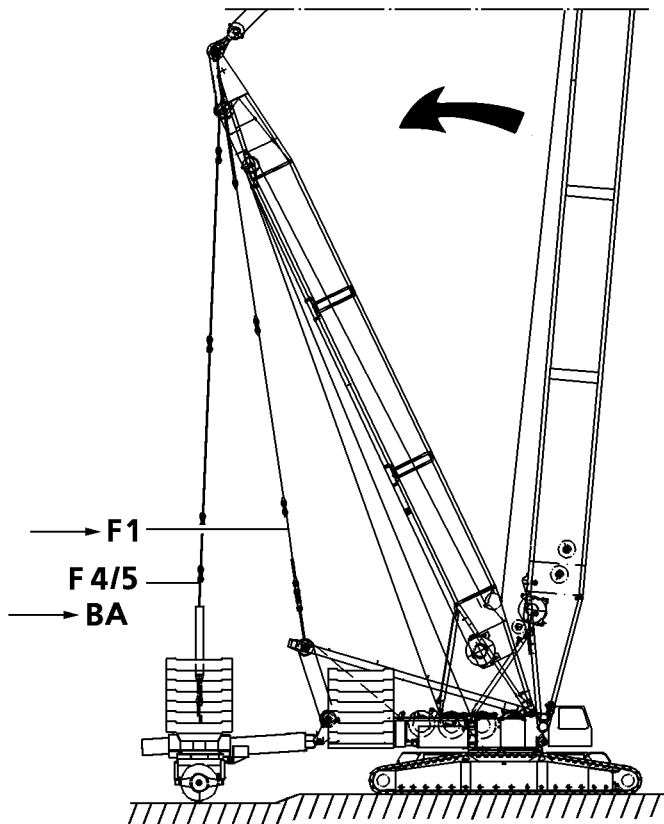
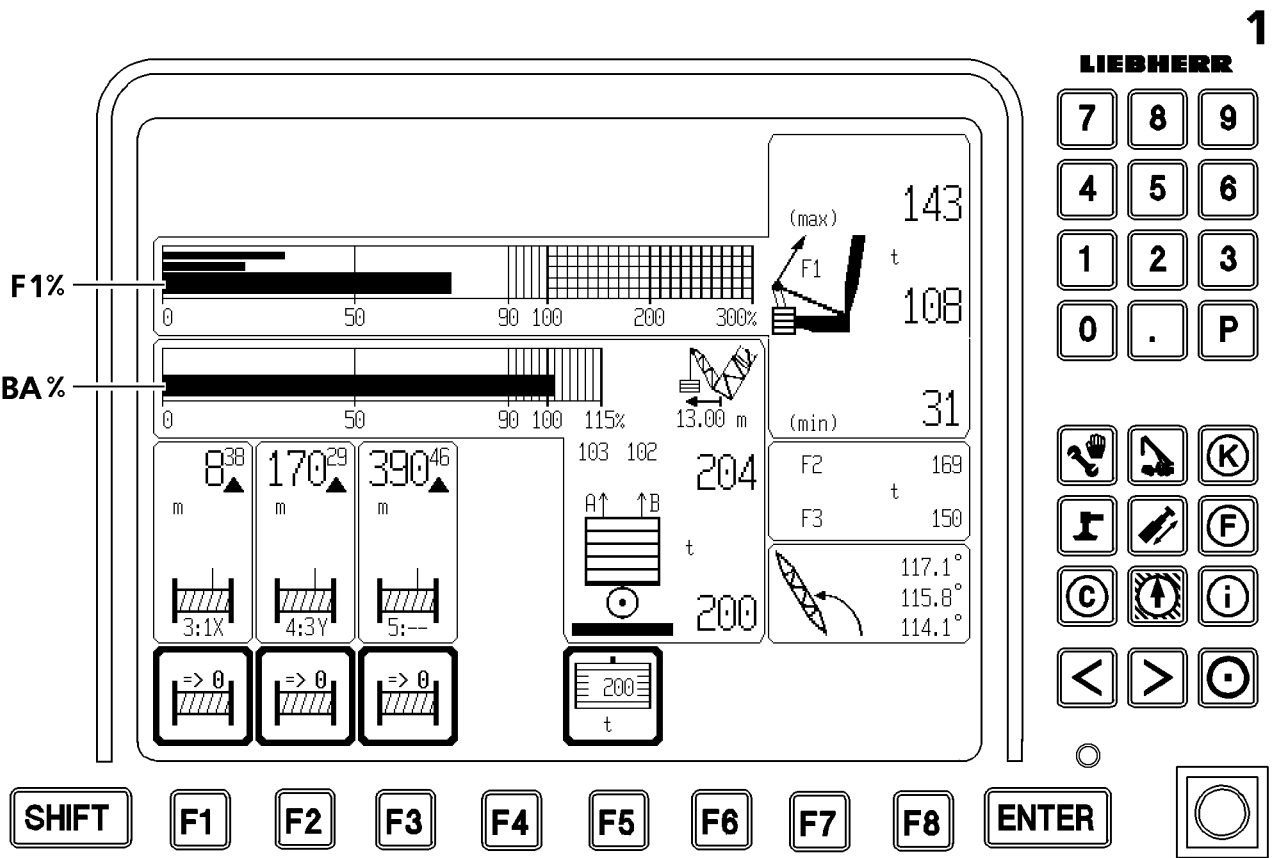

B108502

7.2 LICCON overload protection

Make sure that the following prerequisites are met:

- The required derrick ballast according the load chart is placed and exactly entered and confirmed in the LICCON overload protection.
- The derrick is in operating position.

7.2.1 Presettings

- ▶ Set and confirm the load chart for the upcoming crane operation in the LICCON computer system.



Note

- ▶ Enter the actually present derrick ballast weight in the LICCON computer system!
- ▶ Enter the actual present reeving in the LICCON computer system!

To set the derrick ballast, see Crane operating instructions, chapter 4.03.



DANGER

Risk of accident!

The set derrick ballast value must correspond to the actual derrick ballast weight added!

- ▶ Incorrect entry of the ballast weight can result in dangerous operational situations!
- ▶ Check the set derrick ballast against the actual derrick ballast!

7.2.2 Crane operation

For crane operation with derrick ballast the data must be observed, see Crane operating instructions, chapter 4.02.



DANGER

Risk of accident!

There may be no persons or obstacles within the turning range of the derrick ballast!

During the turn, a guide must monitor the boom, derrick boom and derrick ballast for any danger of collision.

When turning with a load and suspended derrick ballast, the turning movement must be initiated or slowed down extremely carefully!

- ▶ The jerky initiation / slowing down of a turning movement can cause the load or suspended derrick ballast to swing!
- ▶ This can cause the boom to break off or the crane to topple over!



Note

- ▶ Observe section “Lifting and lowering with pull cylinders” and “Differential force monitoring for ballast guying”!
- ▶ Monitor the extension condition of the pull cylinders and the incline of the ballast trailer.

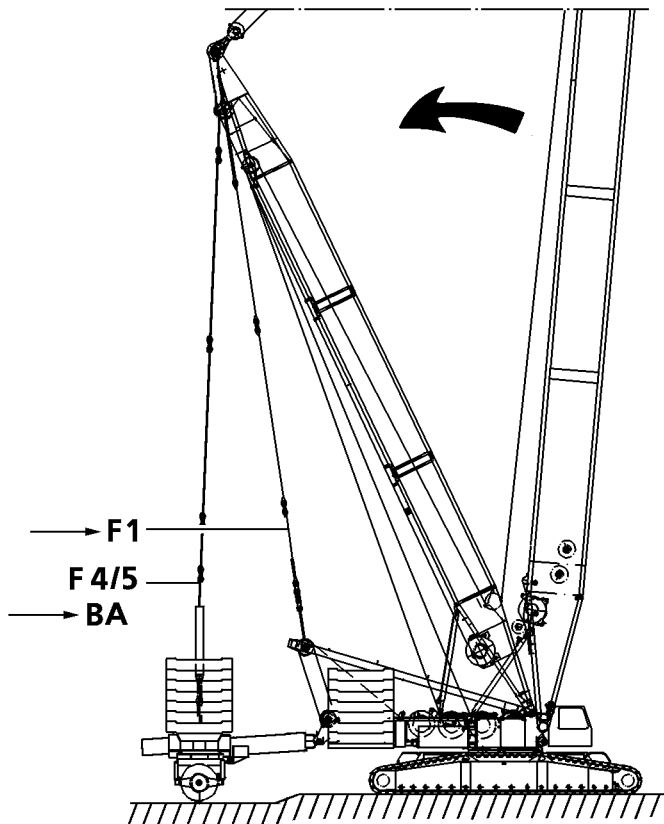
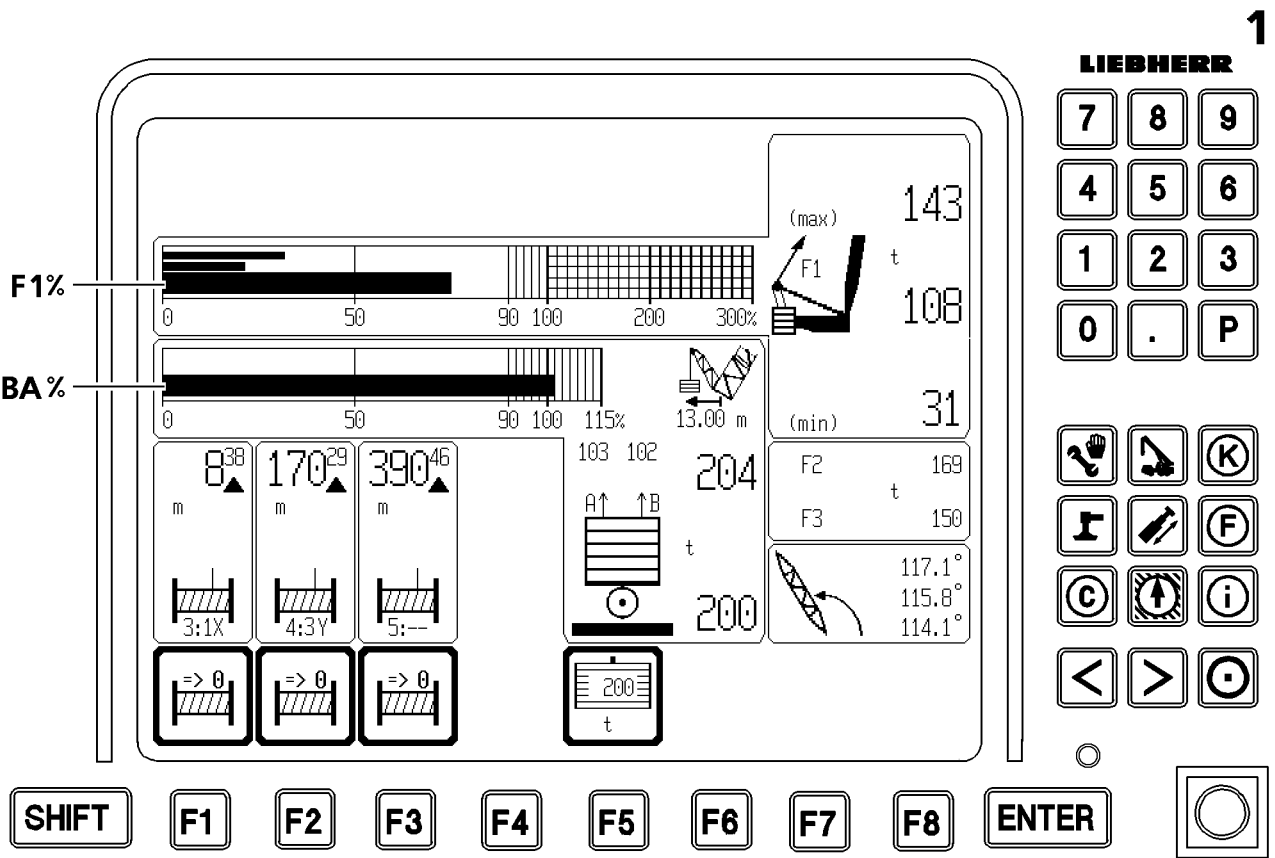

B108502

7.3 Determination of forces in operating mode with derrick ballast

In all operating modes with derrick ballast, the load is divided between the guy rods from the derrick head to the SA-bracket (F1) and the derrick ballast (F4/5).



Note

► For a detailed description, see Crane operating instructions, chapter 4.02!

7.3.1 Force F1 (test point 1) between guying SA-bracket - Derrick end section

The force F1 (test point 1) is determined in the guy rods from the SA-bracket to the derrick head by 2 force test boxes and is shown on the LICCON monitor as total force of the guying.

From the operating force F1 and the force F1-operational maximum force results the F1 utilization. This is shown on the LICCON monitor in a utilization bar (F1 in %).

7.3.2 Force F4/5 (test point 4/5) guying derrick ballast - derrick end section

The forces F4/5 (test point 4/5) are effective in the guy rods from the derrick ballast to the derrick head.

The actual forces in the guy rods (A = left and B = right) are calculated from three pressure sensors installed on the pull cylinders and displayed on the LICCON monitor as individual forces.

The pulled ballast is calculated from the forces of the individual guyings, which means the part of the ballast pulled up by the guying. The remaining part is on the ground. The derrick ballast utilization results from the pulled ballast and the placed ballast. This is shown on the LICCON monitor in a utilization bar (BA in %).

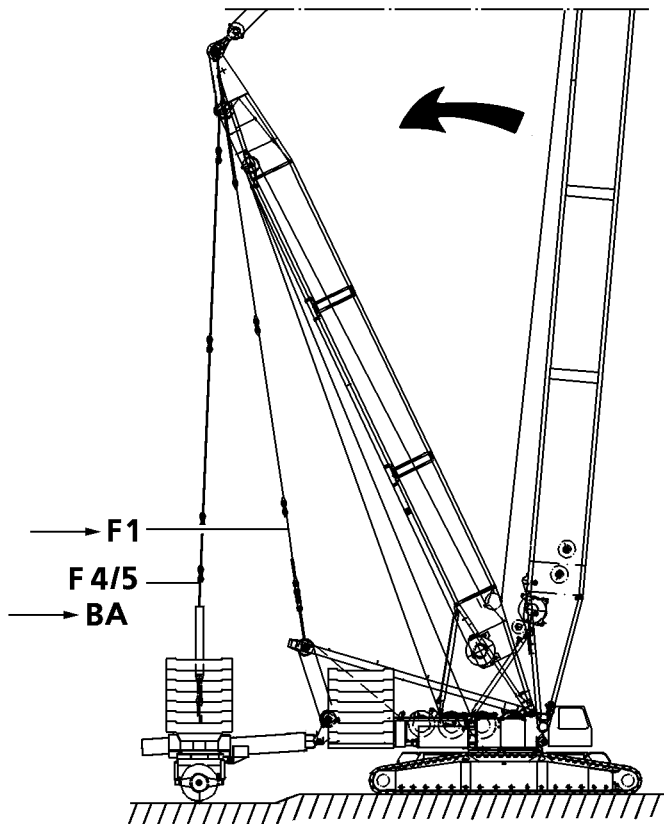
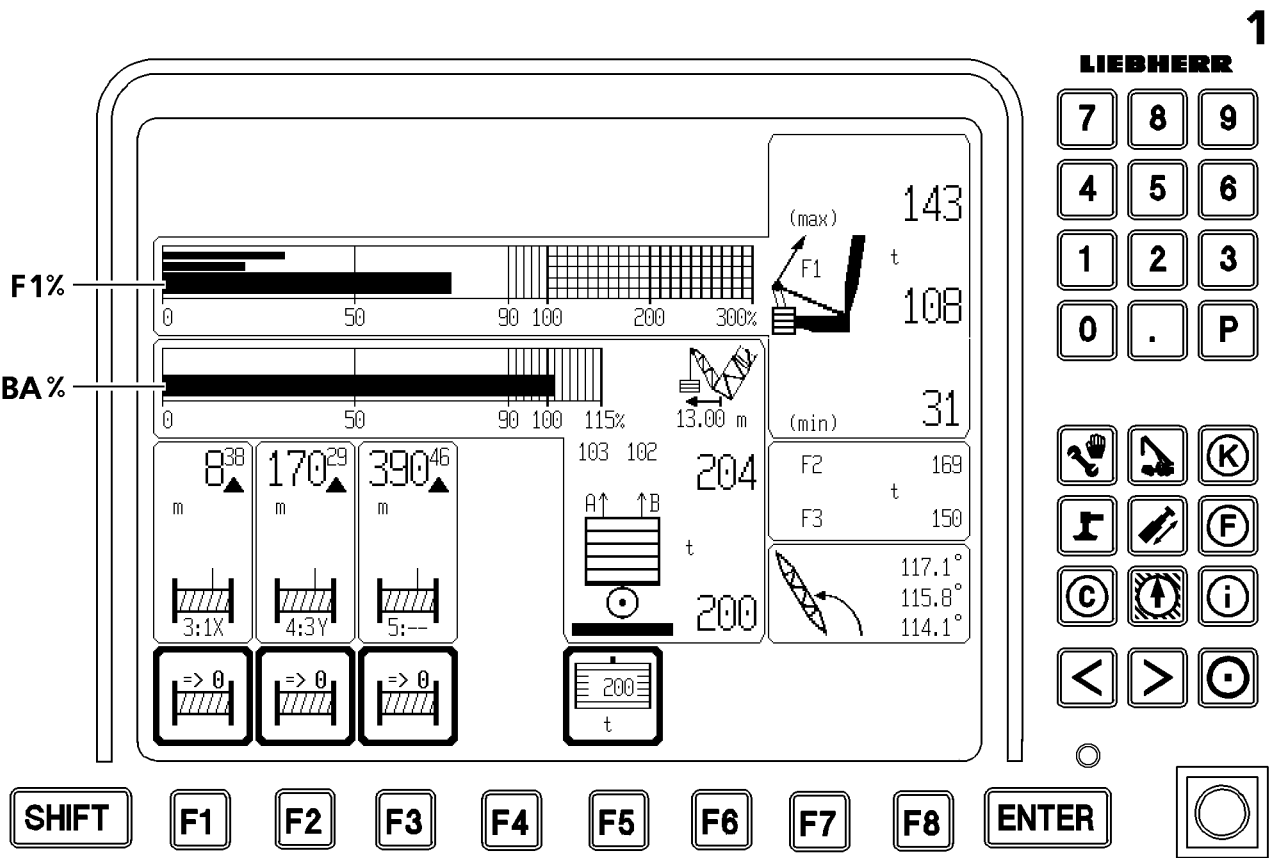

B108502

7.3.3 Monitoring of minimum force F1



WARNING

Danger of accident when exceeding the shut off limits of the LICCON overload protection!

- ▶ For procedure of shut off of crane movements, see Crane operating instructions, chapter 4.20!



Note

- ▶ If the minimum force- $F_{1\min}$ (test point 1) is fallen below, then the LICCON overload protection shuts the crane movement off!
- ▶ A shut off of crane movements can be avoided when F1 remains larger than $F_{1\min}$!



Note

- ▶ Graphic illustration and description of the shut off functions, see section "Shut off during crane operation with derrick ballast"!

If more than 50 % of the entered derrick ballast is pulled (ballast utilization bar more than 50 %), and the force falls below the minimum force $F1_{\min}$ (test point 1), all load moment increasing crane movements are turned off.



DANGER

Risk of accident!

- ▶ It is prohibited to fall below the minimum force $F1_{\min}$ (test point 1) if more than 50 % of the derrick ballast is pulled. If this is not observed, in case of loose tension from test point 1 ($F1$) and derrick ballast on the ground, the derrick ballast can suddenly lift off the ground due to the increased load moment and the boom system suddenly moves forward! This will result in the load swinging violently and could damage the boom and cab!

If more than 90 % of the entered derrick ballast is pulled (ballast utilization bar at more than 90 %), and the force falls below the minimum force $F1_{\min}$ (test point 1), all load moment increasing and all load moment decreasing crane movements are turned off. The hoist gear "down" movement is also turned off.



DANGER

Risk of accident!

It is prohibited to fall below the minimum force $F1_{\min}$ (test point 1) if more than 90 % of the derrick ballast is pulled. If this is not observed and the guying on test point 1 ($F1$) is slack and the suspended derrick ballast is suddenly set down on the ground and the boom system suddenly moves back by the reduction of the load moment of the derrick ballast! Thereby the relapse cylinders can be pressed on block and be overloaded. There is a danger of damage to the relapse cylinders for boom and derrick!

- ▶ This also causes significant oscillation of the load, which can damage the boom and the crane!

1
0

Icons: Crane, Hook 1, Hook 2, Warning, STOP, (max) n=15, t=169.7

0380, 0-130% scale, t=94.0

0.2°, 0.2, 0.1, 7.0, 6.4, max: 9.0, 13.1, 86.6°

002²² m, 001¹¹ m, bar, V: 10%, 120°, 28.0, 35.2

RP S(L) 66, RP D 70, RP W1(N) 170, RP W2 176, min:max 125:380, 23.6 v, 73.9°, 65.3

Icons: => 0, => 0, Warning, <=>, 100%, ERROR 135, Hook, Crane

LIEBHERR

7	8	9
4	5	6
1	2	3
0	.	P
Hand	Crane	(K)
Truck	Crane	(F)
(C)	Warning	(i)
<	>	Home

SHIFT

F1

F2

F3

F4

F5

F6

F7

F8

ENTER

○

2
3
1

0-300% scale, (max) 143, t=108

0-115% scale, 13.00 m, (min) 31

8³⁸ m, 170²⁹ m, 390⁴⁶ m, 103, 102, 204, F2 t=169, F3 t=150

3:1X, 4:3Y, 5:--

A↑ B↑, t=200, 117.1°, 115.8°, 114.1°

Icons: => 0, => 0, => 0, t=200

LIEBHERR

7	8	9
4	5	6
1	2	3
0	.	P
Hand	Crane	(K)
Truck	Crane	(F)
(C)	Warning	(i)
<	>	Home

SHIFT

F1

F2

F3

F4

F5

F6

F7

F8

ENTER

○

7.4 Overload monitoring in operating mode with derrick ballast



Note

- ▶ Explanation of description in quotes (" "), see Crane operating instructions, chapter 4.02!
- ▶ Graphic illustration, see section "Shut offs during crane operation with derrick ballast"!

In operating modes with derrick ballast, the "Maximum load for the current crane condition" is monitored two ways:

- 1.) Monitoring of maximum load by the LMB overload protection.
- 2.) Monitoring of test point 1 - operational maximum force by derrick ballast overload protection.

7.4.1 The LMB overload protection

It monitors the "Maximum load according to load chart and reeving".

In operating modes with derrick ballast, this is the maximum load of the current crane condition with optimum derrick ballast. It is shown on LICCON monitor 0. The current utilization of the crane with optimum derrick ballast results from the load utilization bar **1** on the LICCON monitor 0.

If the load utilization bar reaches 90 %, an advance warning is given in the form of a caution icon and a "SHORT HORN" on the LICCON monitor 0.

At 100 % on the load utilization bar, the shut off of all load moment increasing movements with the "STOP" icon and the acoustical warning "HORN" occurs on LICCON monitor 0.

It may then be possible to further increase the "Maximum load for the current crane condition".

7.4.2 Monitoring of test point 1-operational maximum force (= F1 max)

It is shown on LICCON monitor 1.

If the F1 max- utilization **2** reaches 90 %, an advance warning is given in the form of a caution icon and a "SHORT HORN" on the LICCON monitor 1.

At 100 % F1 max utilization, the shut off of all load moment increasing movements with the "STOP" icon and the acoustical warning "HORN" occurs on the LICCON monitor 1.

When the maximum load according to the load chart and the reeving is not reached (utilization bar **1**), then the maximum load of the current crane condition can still be increased by:

- Lifting the derrick ballast if it is not already suspended.
- Telescoping out the derrick ballast if the added ballast is still lower than the optimum ballast.
- Increasing the derrick ballast by adding additional ballast plates if the placed ballast is still smaller than the optimum ballast.

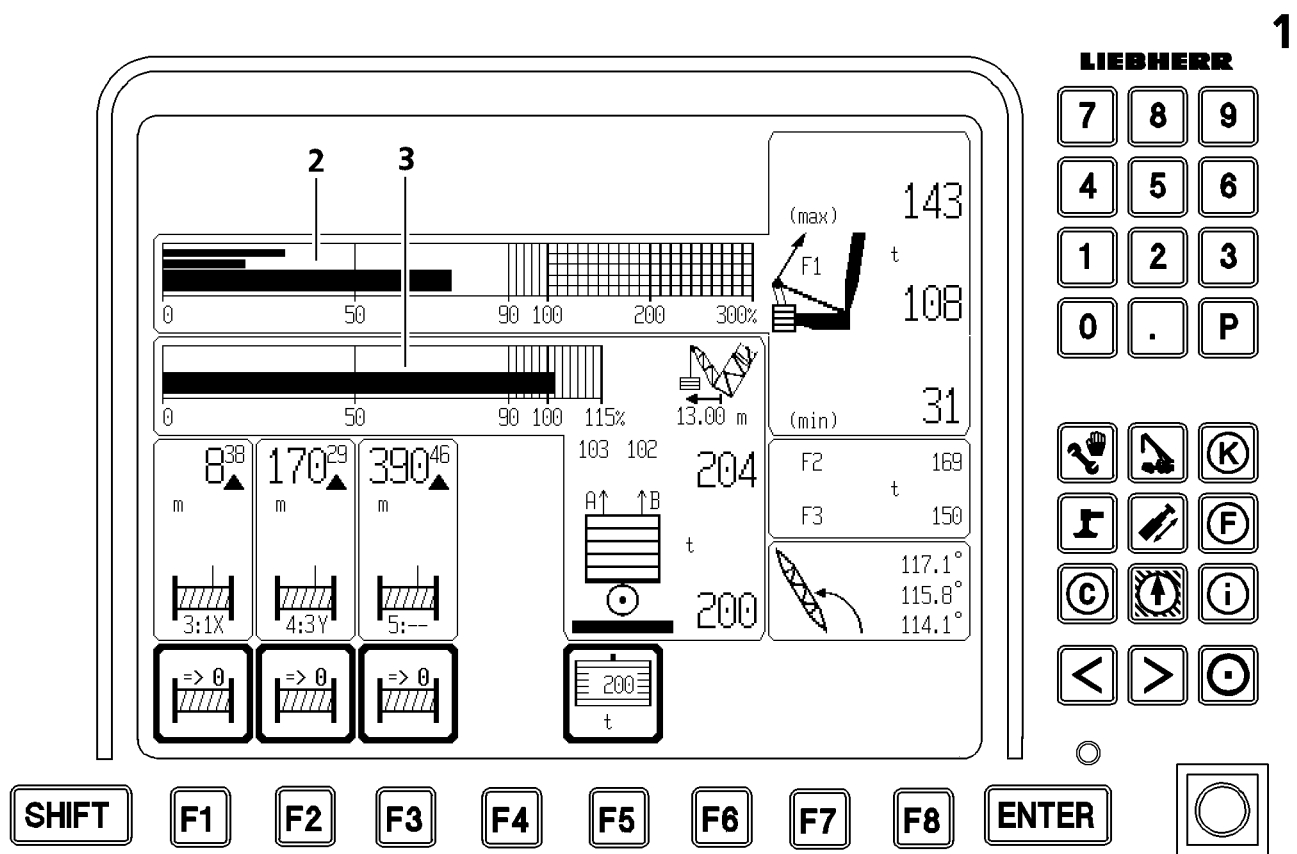
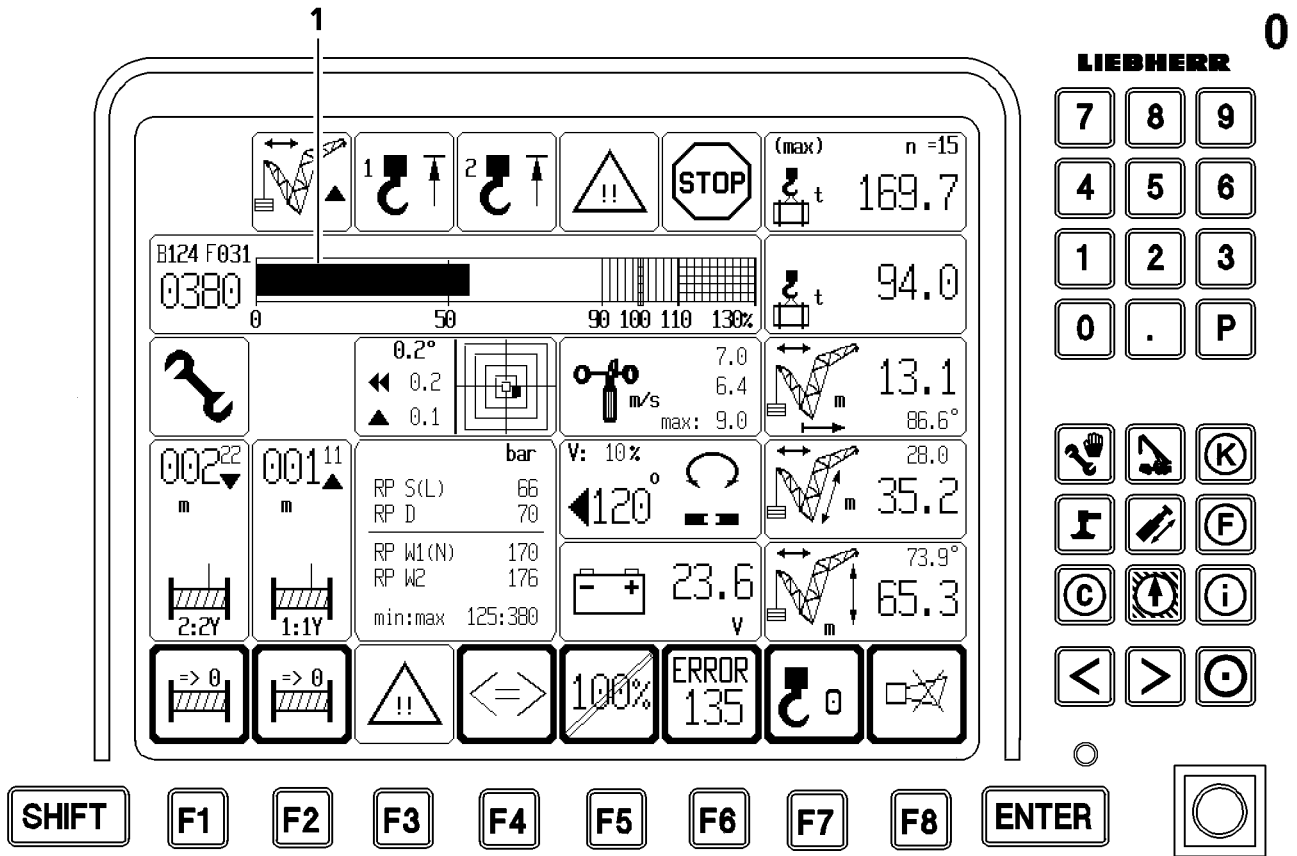

7.4.3 Utilization conditions

The current utilization of the crane results from the load utilization bar **1** on monitor 0 and the F1-utilization bar **2** on the LICCON monitor 1.

The "Maximum load of the current **crane condition**" is reached when the load utilization bar **1** has reached 100 % or when the F1 - utilization bar **2** has reached 100 %.

The "Maximum load of the current **crane equipment**" is reached when the load utilization bar **1** has reached 100 % or when the F1 - utilization bar **2** has reached 100 % and the derrick ballast is suspended (ballast utilization bar **3** at 100 %, if the ballast input value and the ballast weighing are correct).

The "Maximum load according to the load chart and the reeving" (100 % limit of load utilization bar) and the maximum load according to F1 max-operation (100 % limit of the F1 utilization bar) can be bypassed by the following measures:

1.) Holding the key button D_0 on LICCON monitor 0 in position "right touching" (after corresponding preselection with function key $F5_0$) bypasses only the maximum load according to the load chart and reeving, see Crane operating instructions, chapter 4.02.

2.) Assembly key button on instrument panel.

This bypasses the maximum load according to the load chart and reeving, the test point 1-operation - maximum force (= F1max-operation) and a number of other limit values and limit switches.

Test point 1-assembly-maximum force (= F1max-assembly) cannot be bypassed (see Crane operating instructions, chapter 4.04).



DANGER

The crane can topple over!

When the set up key D on the LICCON monitor 0 is turned on, then the LICCON overload protection is exceeded and no longer effective!

The crane can be overloaded unnoticed and topple over!

Personnel can be severely injured or killed!

- ▶ When the set up key D is turned on, only load moment reducing crane movements may be carried out until a permissible operating and load range!
- ▶ The set up key D must be turned off immediately after reaching the permissible load range!
- ▶ The crane operator carries complete and sole responsibility for his actions if the LICCON overload protection is exceeded!

The movement "Ballast up" or "Ballast down" requires utmost attention. When 90 % of the placed ballast is pulled, the warning "Upcoming lift off of derrick ballast" is issued. The warning is indicated by a "Short horn" and blinking "Pulled ballast" value. The warning is turned off when the operator confirms that he has recognized the warning by pressing the function key $F8_1$ (= horn off on LICCON monitor 1).

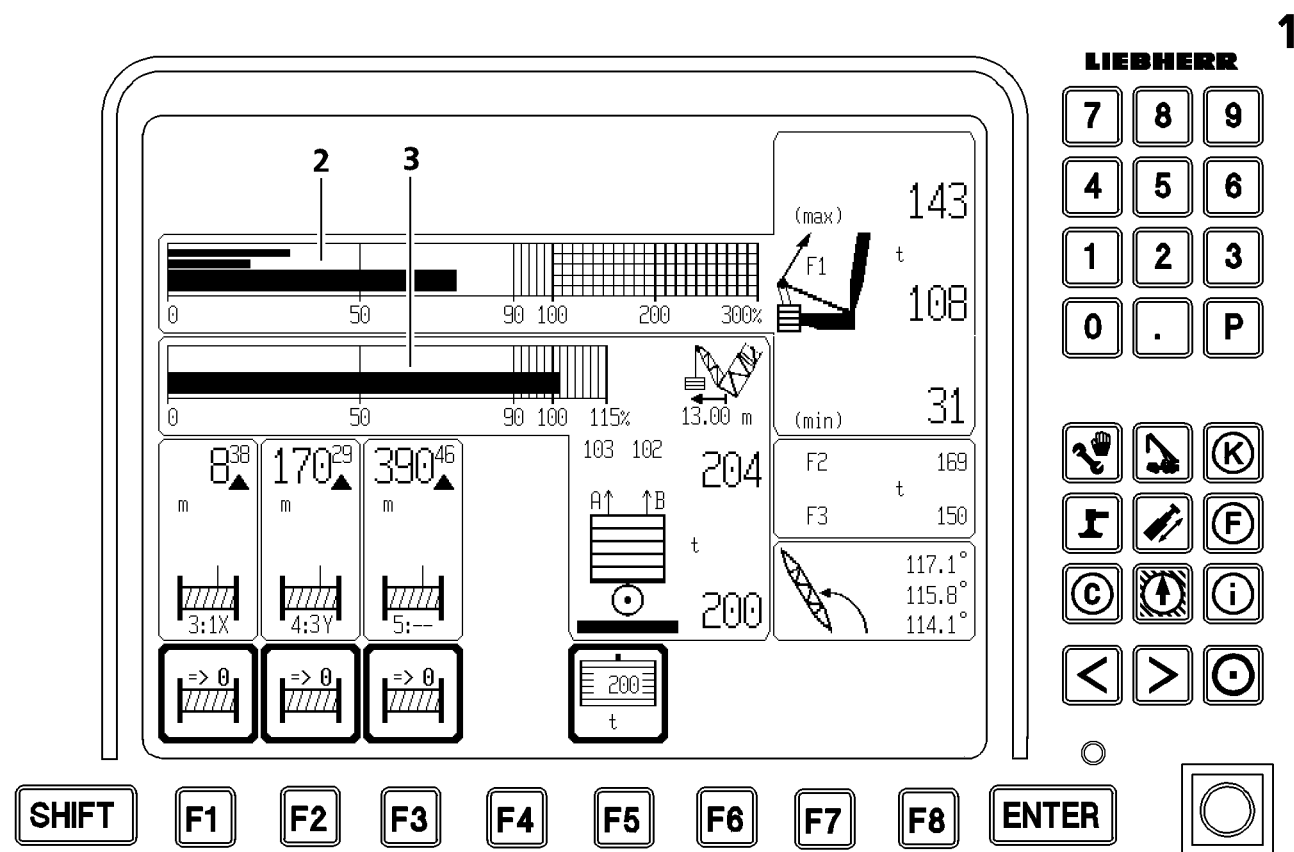
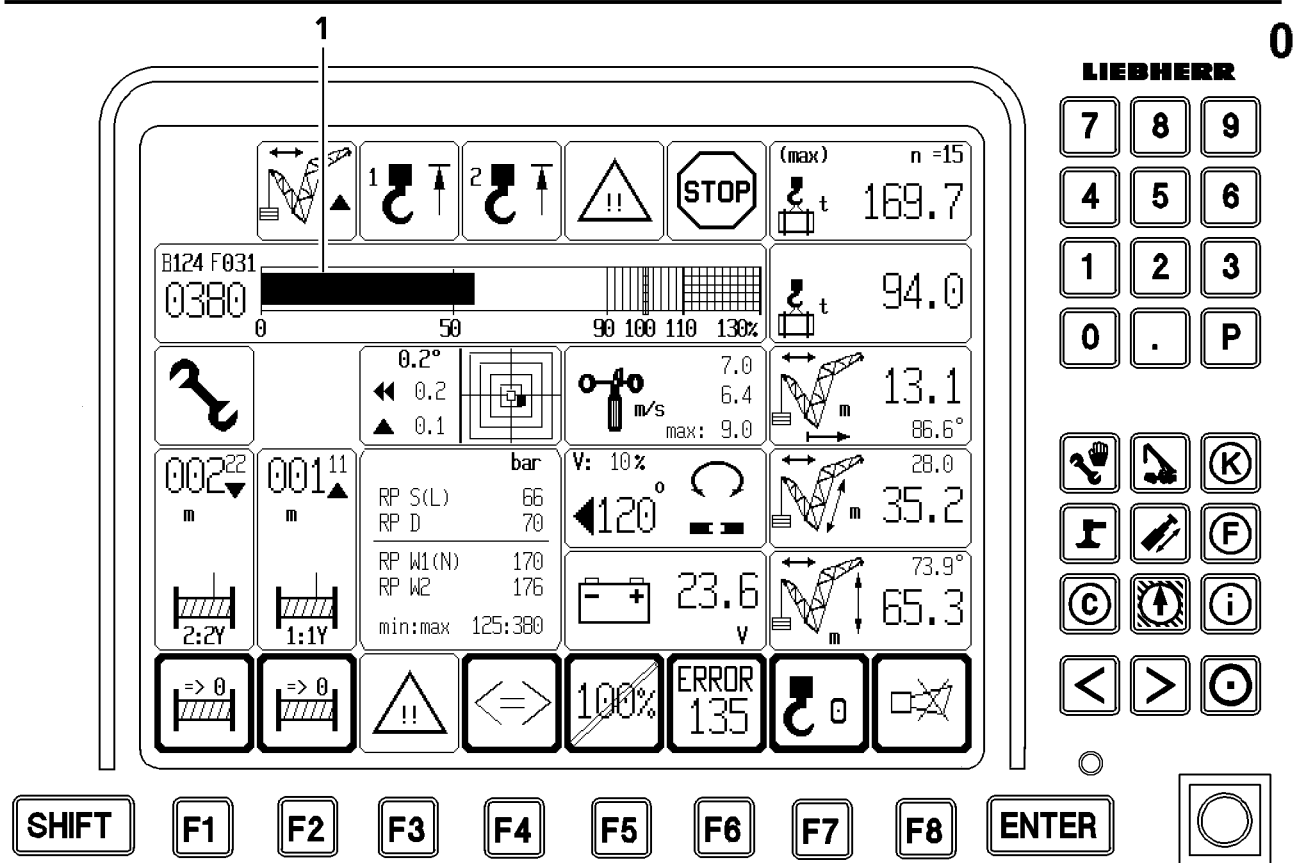

7.5 Checking the length sensor value on the ballast trailer

When telescoping the derrick ballast in and out, the derrick ballast radius display must be monitored carefully.

When telescoping the derrick ballast, the display must change according to the movement. This allows the crane operator to immediately notice if the length sensor rope drum jams when spooling in or out.

When the derrick ballast is extended or retracted all the way, the derrick ballast display must show almost the exact end position, for example Radius = 11 m or 15 m.

The crane operator may not rely blindly on the derrick ballast radius measurement, but he must think for himself and check, if the measurement is still working correctly.



DANGER

Risk of accident!

If the derrick ballast radius is measured incorrectly, the false radius value will result in the calculated maximum lifted load and test point 1-operation-max-force being too high!

- ▶ The crane will be overloaded although this is not apparent!
-

1

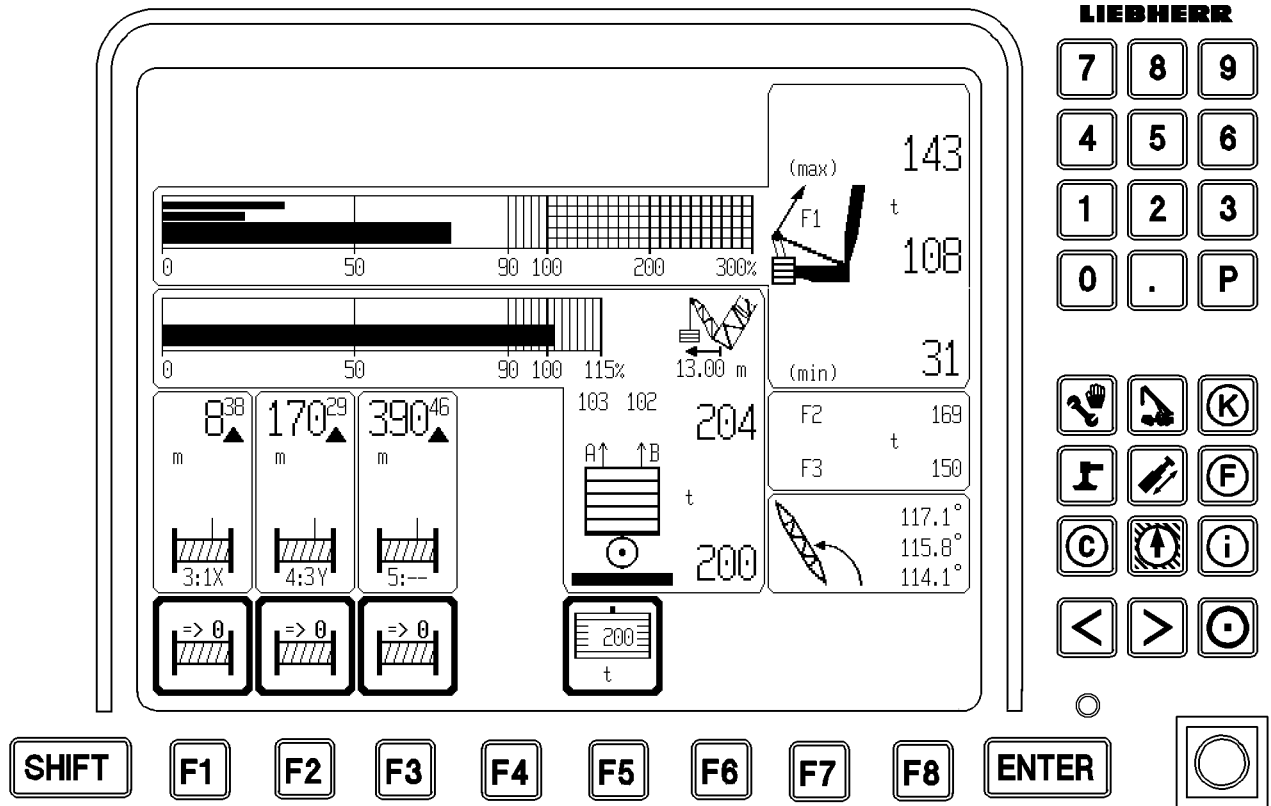

7.6 Difference force monitoring of ballast guying

In operating modes with derrick ballast, the difference of the forces of derrick ballast guying A and B is monitored on LICCON monitor 1.



DANGER

Risk of accident!

If the difference of these forces is too high, it will damage the derrick head or other crane components!

► Risk of accident!

The forces in the derrick ballast guyings A and B are shown and compared on the LICCON monitor 1. If the difference exceeds a permissible value, an acoustical warning is issued and the two force values blink. However **none** of the movements are turned off.

If the difference of the forces of the derrick ballast guyings A and B exceeds the specified limit value, then this can have various causes:

- Taking up the load by relieving the load on the ballast trailer tires or flexing the turntable.
- The ground under the derrick ballast is uneven.
- The crane is leaning to one side.
- The derrick ballast has been loaded one-sided.
- By raising or lowering the derrick ballast using the pull cylinders.
- The force measurement in one guying is incorrect.

The crane driver must recognize the correct cause and take countermeasures:

- 1.) The error, which caused the one-sided force, must be remedied.
- 2.) In case of small ground unevenness only, the following measure is permissible:
Lock one ballasting cylinder and use the other ballasting cylinder to "Raise the ballast" or "Lower the ballast" until the difference between the forces reduces. It must be ensured that the derrick ballast is not tilted at an inadmissible angle with respect to the crane, otherwise the derrick ballast guide and attachments will be damaged.
- 3.) In case of implausible sensor values: Check whether the ballast weighing pressure sensors or inputs are faulty. If necessary, detach the sensor or replace the CPU.



DANGER

Risk of accident!

► Derrick ballast cylinder A should be extended by a maximum of approx. 40 mm more or less than cylinder B!

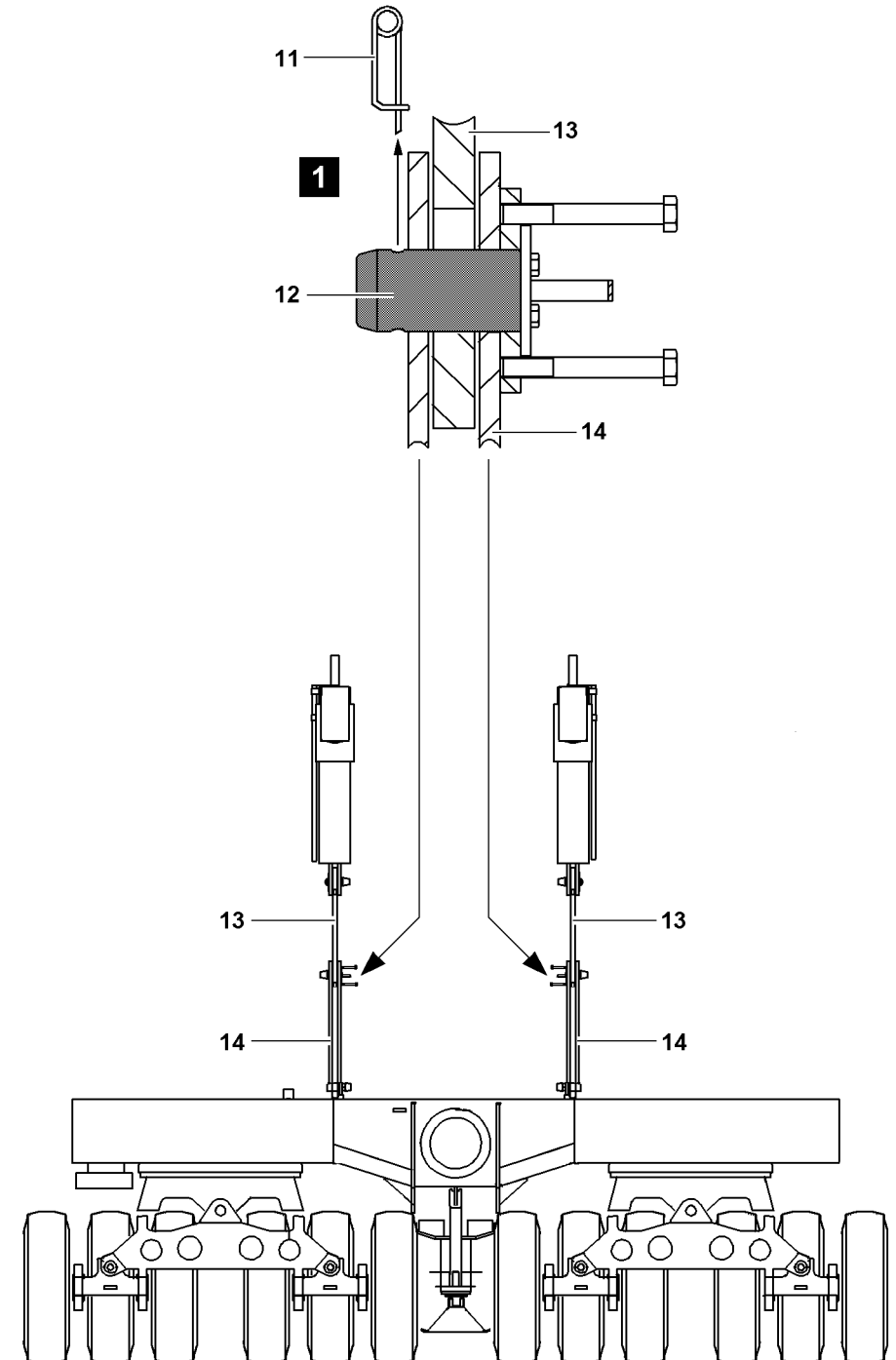

B109276

8 Disassembling the ballast trailer



WARNING

Risk of falling!

During assembly / disassembly work, personnel must be secured with appropriate aids to prevent them from falling. If this is not observed, assembly personnel can fall and suffer life-threatening or fatal injuries!

- ▶ Any assembly work, where there is a danger of falling must be carried out with suitable aids (for example lifting platform, scaffolding, ladder, auxiliary crane)!
- ▶ If the work cannot be carried out with such aids nor from the ground, then the assembly personnel must secure themselves with approved fall arrest systems to avoid falling, see Crane operating instructions, chapter 2.04!
- ▶ Approved fall arrest systems must be hung into the respective fastening points on the crane, see Crane operating instructions, chapter 2.06!
- ▶ If railings are present on the components, then they must be brought into the corresponding position and secured for assembly / disassembly work!
- ▶ Step on aids and fall protection equipment only with clean shoes!
- ▶ Keep aids and fall protection equipment clean and free from snow and ice!
- ▶ During all assembly and disassembly work, maintenance work and inspections, travel and crane operation is prohibited!



WARNING

Components not pinned and secured!

If a component is released from the auxiliary crane before having been pinned and secured, the component will fall down! Personnel can be severely injured or killed!

- ▶ Do not disengage the auxiliary crane until the corresponding component is pinned and secured!



WARNING

Danger of impact / crushing!

When installing / removing crane components with the auxiliary crane, crane components can start to swing back and forth!

When lifting / lowering and positioning crane components, there is an increased danger of impacts / crushing!

Personnel can be caught and severely injured or killed!

- ▶ Make sure that personnel cannot be caught by components!
- ▶ When working in danger zones: Use aids to protect limbs!
- ▶ Guide components with suitable aids to minimize oscillation!

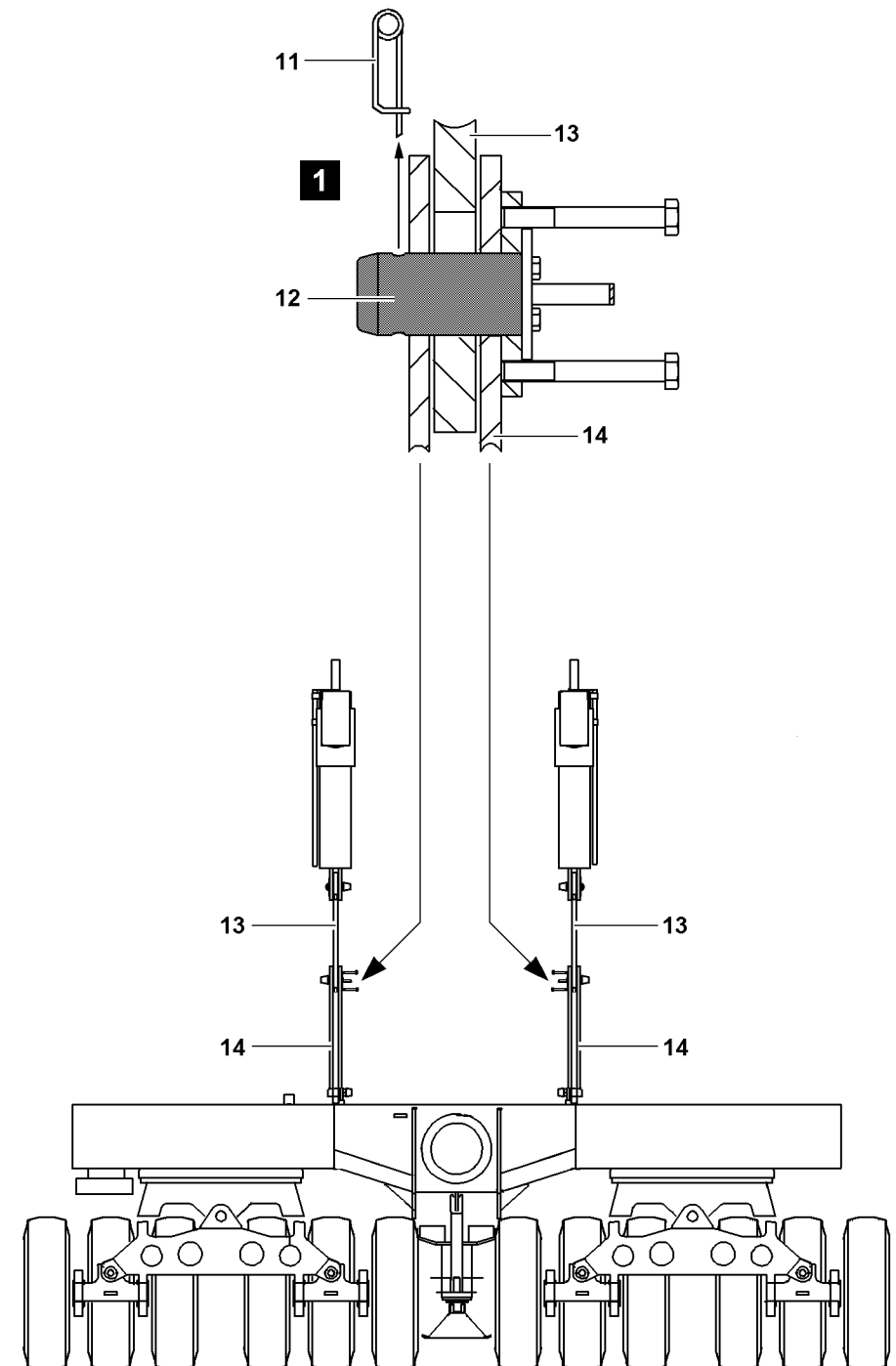

**DANGER**

Risk of accident!

- ▶ The disassembly of the ballast trailer may only be carried out on level and load bearing ground and only by authorized personnel.
- ▶ The ballast trailer is not equipped with a brake system. It is therefore essential that it rests on the support cylinders when it is not pinned to the turntable!

Make sure that the following prerequisites are met:

- The crane is aligned in horizontal direction.
- The boom and the derrick are assembled on the turntable.
- The derrick is erected.
- The placement location must be level and have adequate load bearing capacity.
- An auxiliary crane is available.

8.1 Taking the ballast trailer down

**WARNING**

The crane can topple over!

If the following danger notes are not observed, the ballast plates or the ballast stack can slip on the ballast trailer and fall down!

The crane can topple over and personnel can be severely injured or killed!

- ▶ The ground on which the ballast trailer is ballasted off must be level and have adequate load-bearing capacity!
- ▶ Lift the ballast plates off always symmetrically, in reference to the longitudinal axis!
- ▶ When ballasting on and off in **suspended condition**, the weight difference between the left and right ballast stack may be no more than maximum 12.5 t!
- ▶ Replace damaged ballast plates immediately with new ballast plates!

**WARNING**

Damaged ballast plates!

Damage on the ballast plates can cause the fastening equipment to release!

The ballast plates and components can fall down!

Personnel can be severely injured or killed!

- ▶ Do not use damaged ballast plates and replace them immediately!

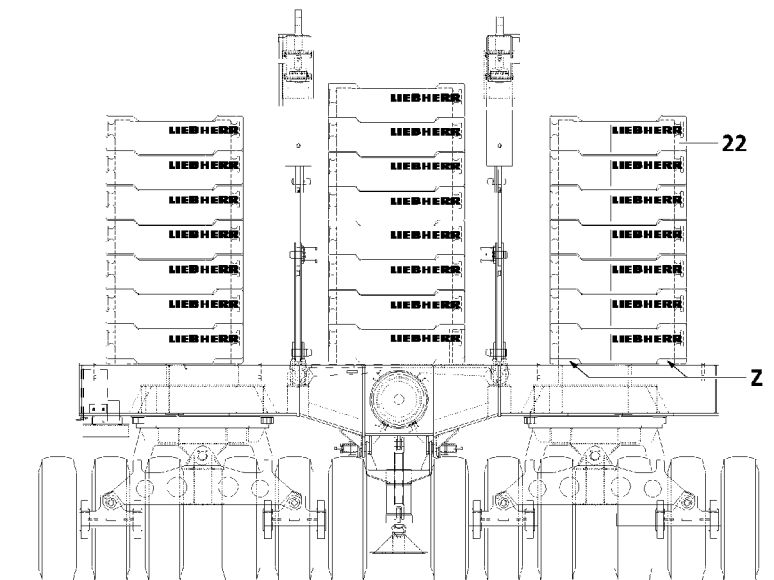
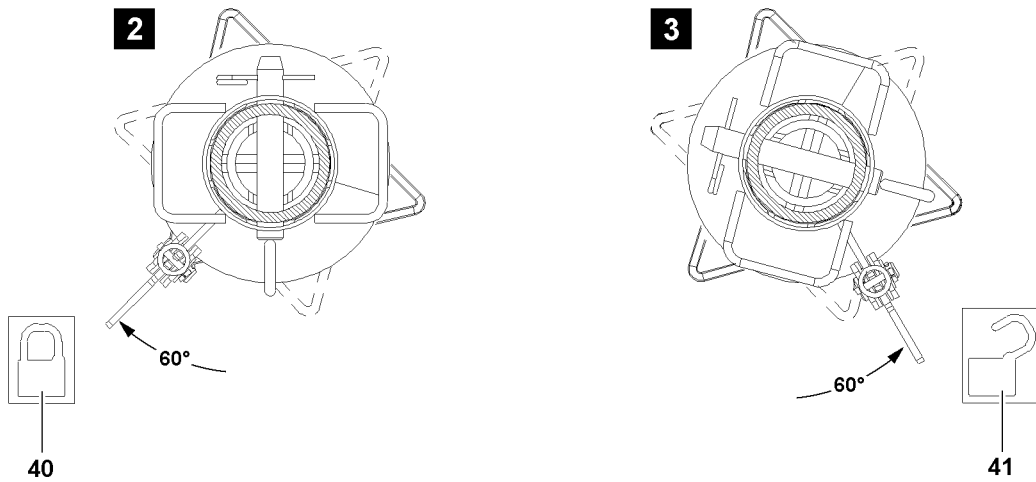
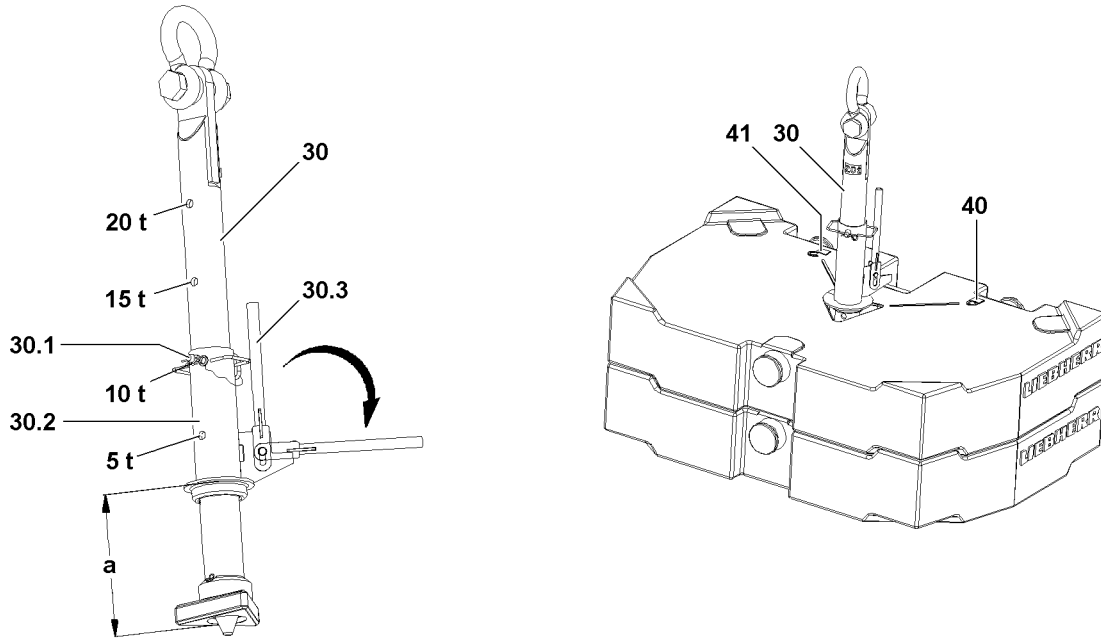

B109267

8.1.1 Removing the ballast plates, fastening system: Twistlock

**WARNING**

Overload of receptacle stud and ballast plates!

If more than the permissible number of ballast plates are lifted with the receptacle stud **30**, the receptacle stud **30** and the ballast plates can be overloaded and damaged!

The ballast plates can fall down!

Personnel can be severely injured or killed!

- ▶ Observe the chart "Permissible ballast assemblies" in this chapter!
-

**WARNING**

Damage of receptacle stud and ballast plates!

If two ballast plates are lifted which do not lay correctly in their centerings, the receptacle stud **30** and the ballast plates can be damaged!

Damage can cause the ballast plates to fall down!

Personnel can be severely injured or killed!

- ▶ Make sure that the ballast plates to be lifted are placed correctly in the centerings!
-

**WARNING**

The Twistlock system opens by itself!

If the receptacle stud **30** is not correctly locked, the Twistlock system can open by itself!

The ballast plates **22** can fall down!

Personnel can be severely injured or killed!

- ▶ Make sure, when initiating a lift, that the lever **30.3** points directly on the locked symbol **40**!
-

**Note**

- ▶ During a lift, the locked Twistlock system cannot release by itself due to its gravitational retention!
 - ▶ During a lift, the locked Twistlock system cannot be released by hand due to its gravitational retention!
-

**Note**

- ▶ The ballast plates **22** are marked with their own weights!
-

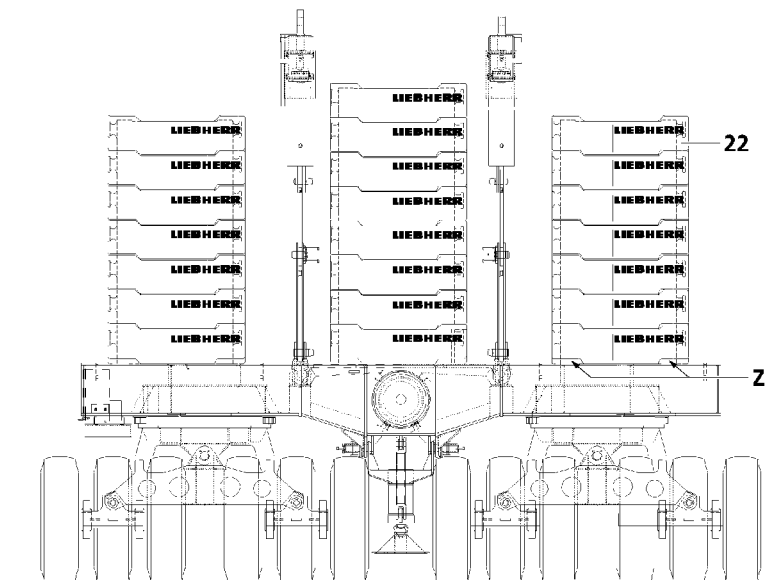
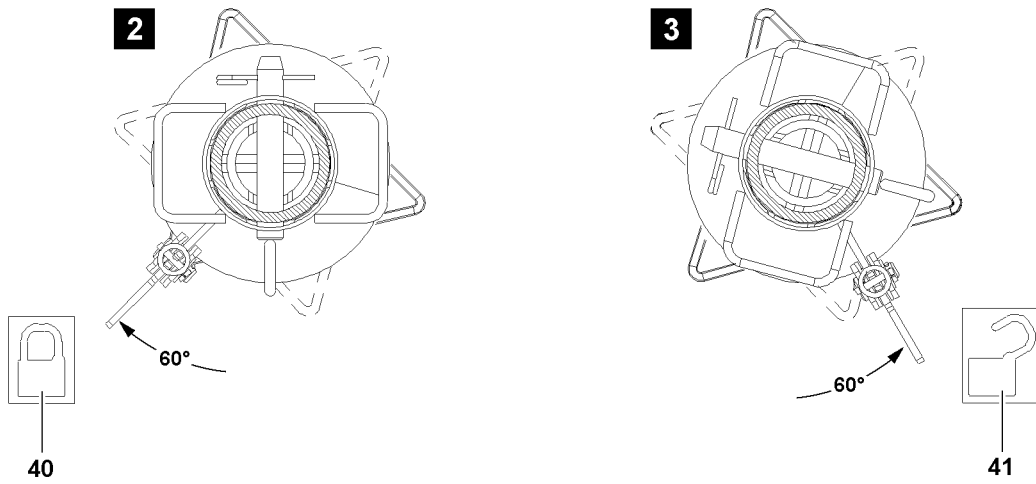
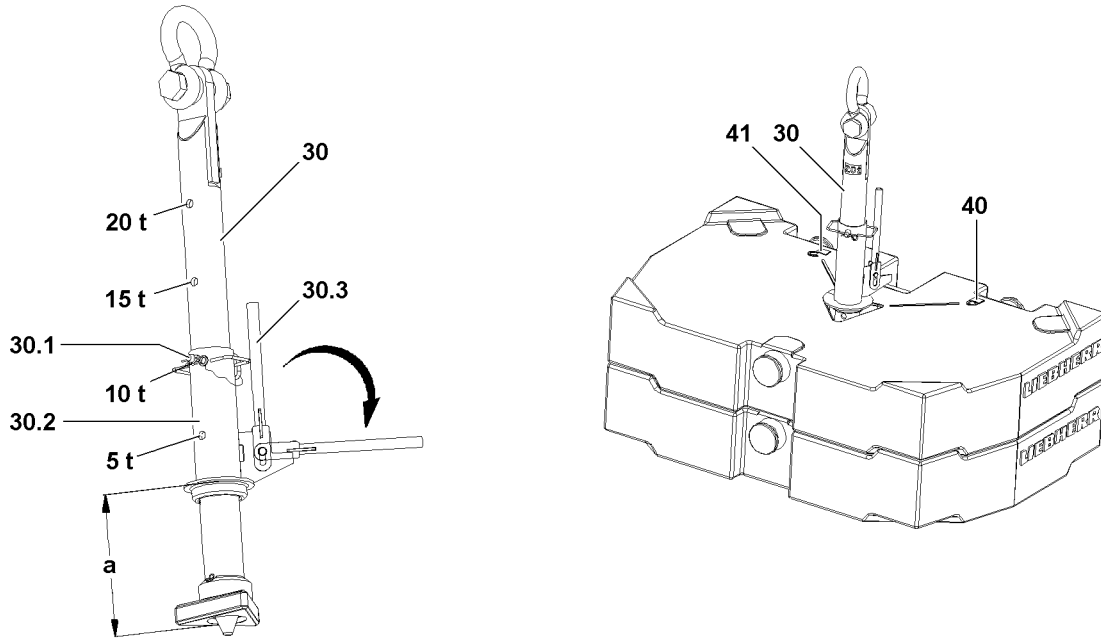

B109267

To lift the ballast plate(s) **22** from the ballast trailer, use the receptacle stud **30**.

Before the receptacle stud **30** is guided into the ballast plates, it must be ensured that the insertion length **a** of the receptacle stud **30** is set correctly. The insertion length **a** of the receptacle stud **30** can be adjusted via the pin **30.1**.

- ▶ If the insertion length **a** of the receptacle stud **30** is to be adjusted:
Release and unpin the pin **30.1**.
- ▶ Adjust the receptacle stud **30** by moving the guide sleeve **30.2** to the desired insertion length **a**, pay attention to the staging.
- ▶ Insert the pin **30.1** and secure with spring retainer.

Result:

- The receptacle stud **30** is adjusted.

- ▶ Attach the receptacle stud **30** on the auxiliary crane and guide it into the ballast plate(s) **22**.
- ▶ Pull the lever **30.3** up and fold it down.
- ▶ Turn the receptacle stud **30** with the lever **30.3** by 60° until it points to the symbol **40** on the ballast plate(s) **22**, illustration 2.



Note

- ▶ The receptacle stud **30** is locked by lifting the ballast plate(s) **22**!

- ▶ Lift the ballast plate(s) **22** or the ballast assembly with the receptacle stud **30** and from the ballast trailer of another ballast plate in the ballast stack.
- ▶ Place the ballast plate(s) **22** on a suitable base support.
- ▶ When the ballast plate(s) **22** or the ballast assembly are placed down:
Turn the lever **30.3** by 60° to the stop in direction of the symbol "Unlocked" **41**, illustration 3.

Result:

- The receptacle stud **30** is unlocked.

- ▶ Carefully pull the receptacle stud **30** from the ballast plate.
- ▶ Remove additional ballast plate(s) **22** and place them down according to the above description.

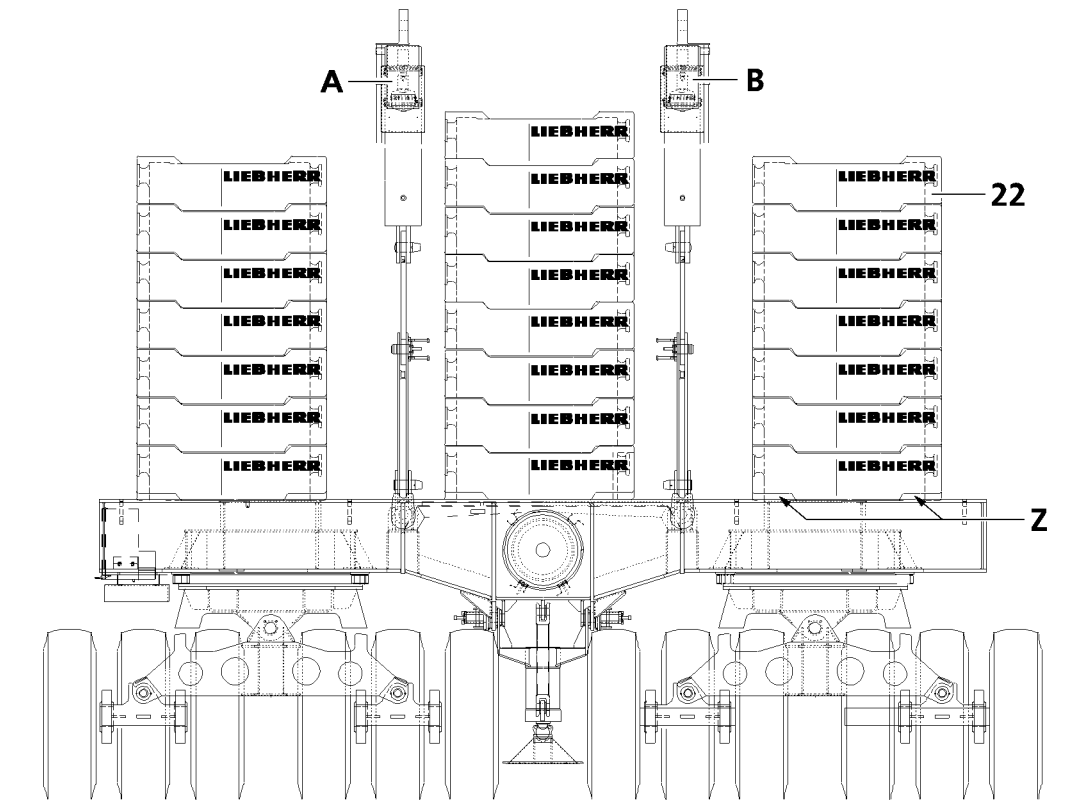
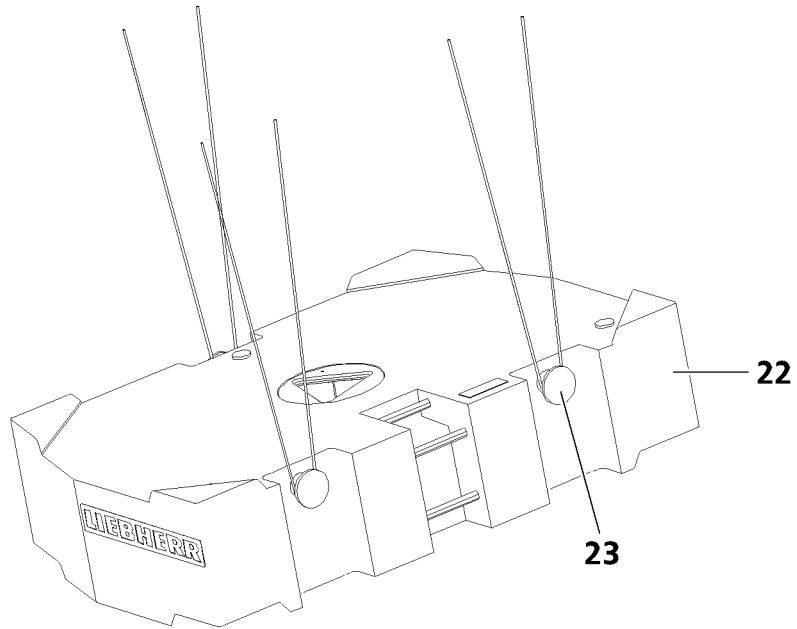

8.1.2 Removing the ballast plates, fastening points: Bitt



Note

- ▶ The ballast plates are marked with their own weights!



WARNING

Overload of the ballast plates!

If more than the permissible loads are lifted, the bitts **23** are overloaded!

The ballast plates **22** can fall down!

Personnel can be severely injured or killed!

- ▶ Observe the chart "Permissible ballast plates" in this chapter!
- ▶ Replace damaged ballast plates!



WARNING

Incorrect handling of the fastening equipment!

If tackle is not attached correctly and / or if it is not secured sufficiently to prevent it from loosening up, the ballast plates **22** can fall down!

Personnel can be severely injured or killed!

- ▶ Make sure that the fastening equipment is correctly attached on the bitts **23** and that it is secured sufficiently to prevent it from loosening up!
- ▶ Use the auxiliary crane to remove the ballast plates **22** evenly distributed from the ballast trailer.
- ▶ Do not remove more than maximum two ballast plates **22** together from the ballast trailer and place them on a suitable support.

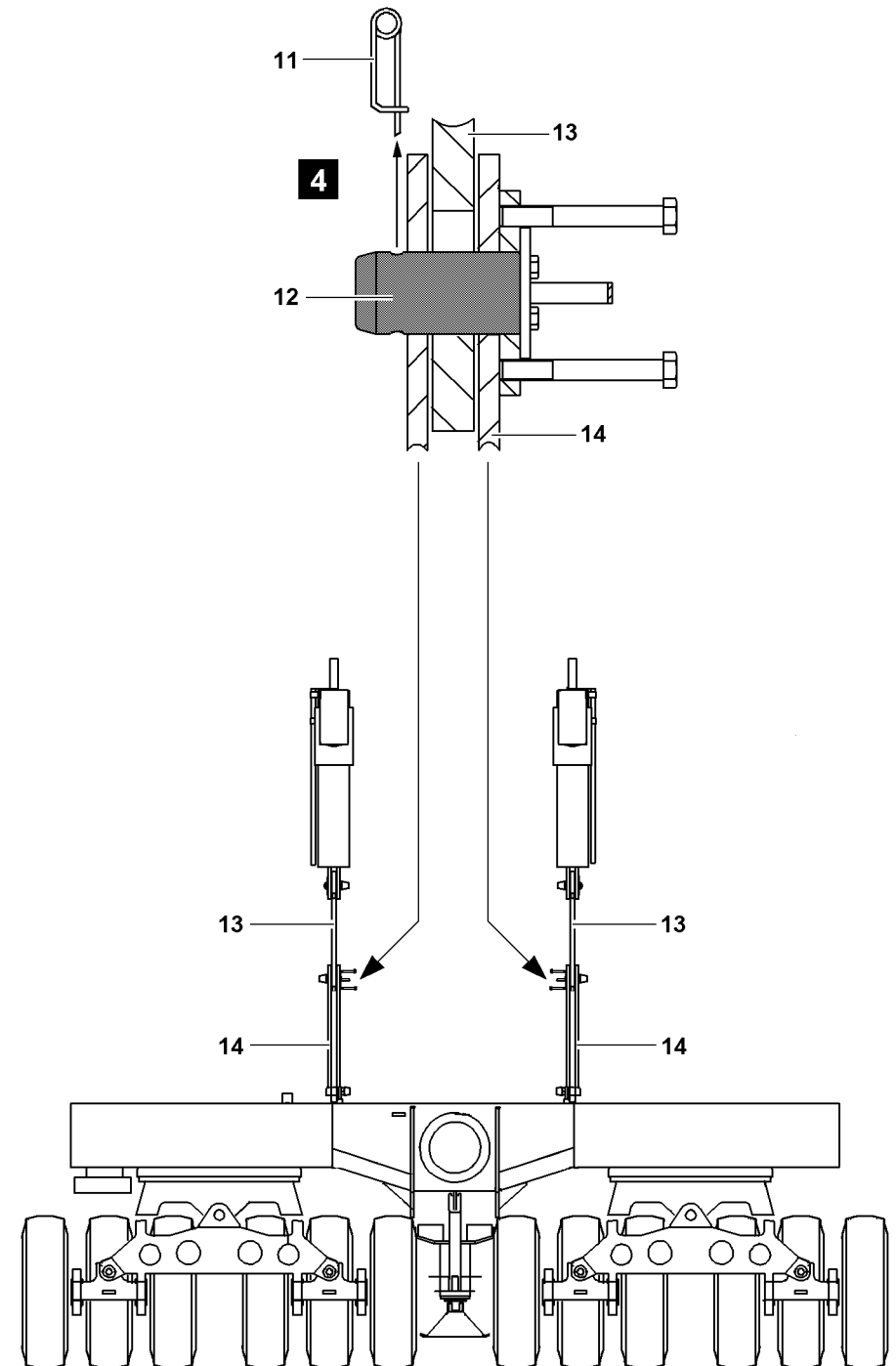

B109278

8.2 Disassembling the ballast guy rods

Illustration 4

- ▶ Detach the supply lines from the turntable to the ballast trailer.
- ▶ Remove the spring retainer **11** on pin **12**.
- ▶ Unpin the pins **12** on both sides.
- ▶ Fold down the con-rods **14**.

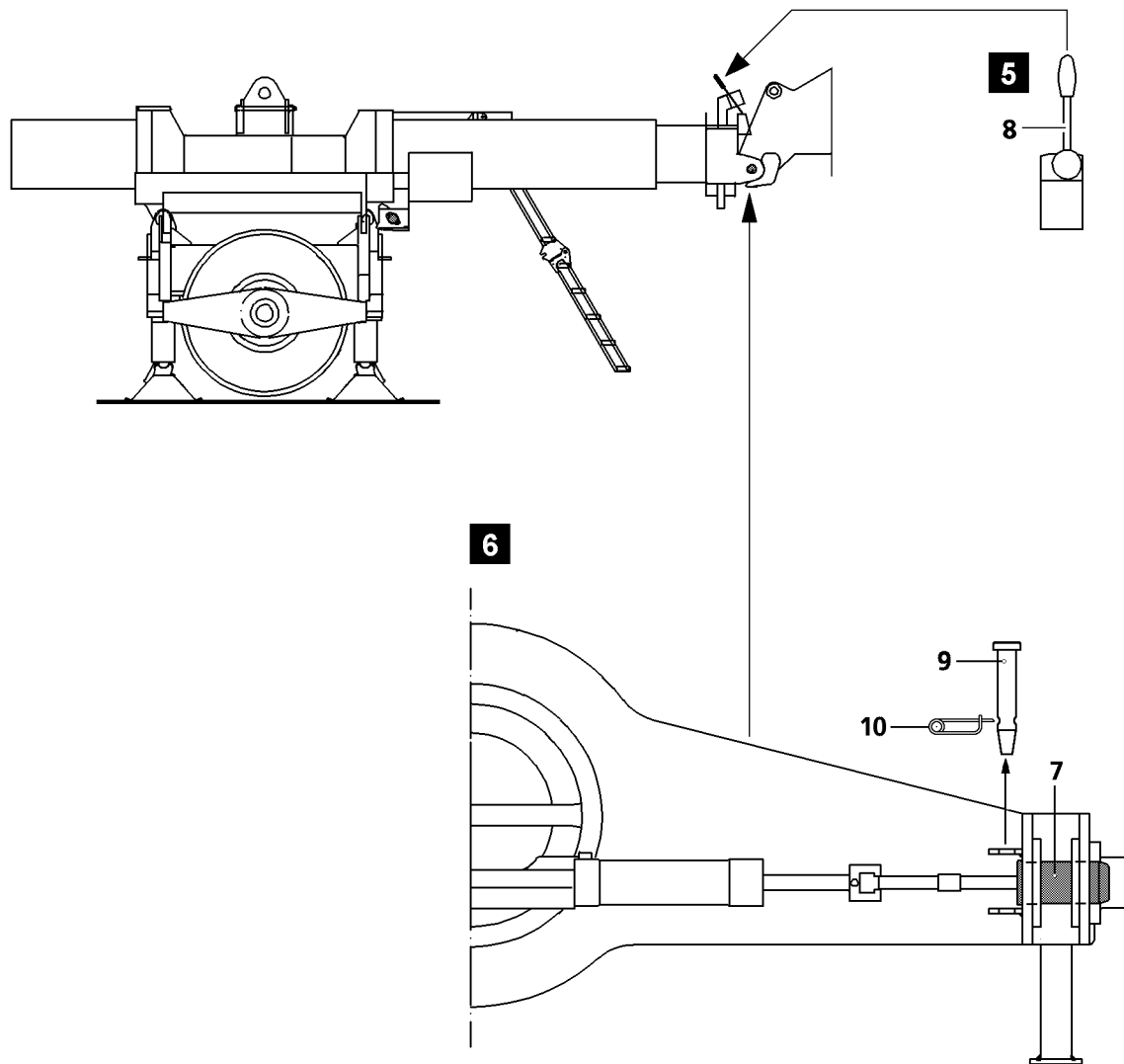
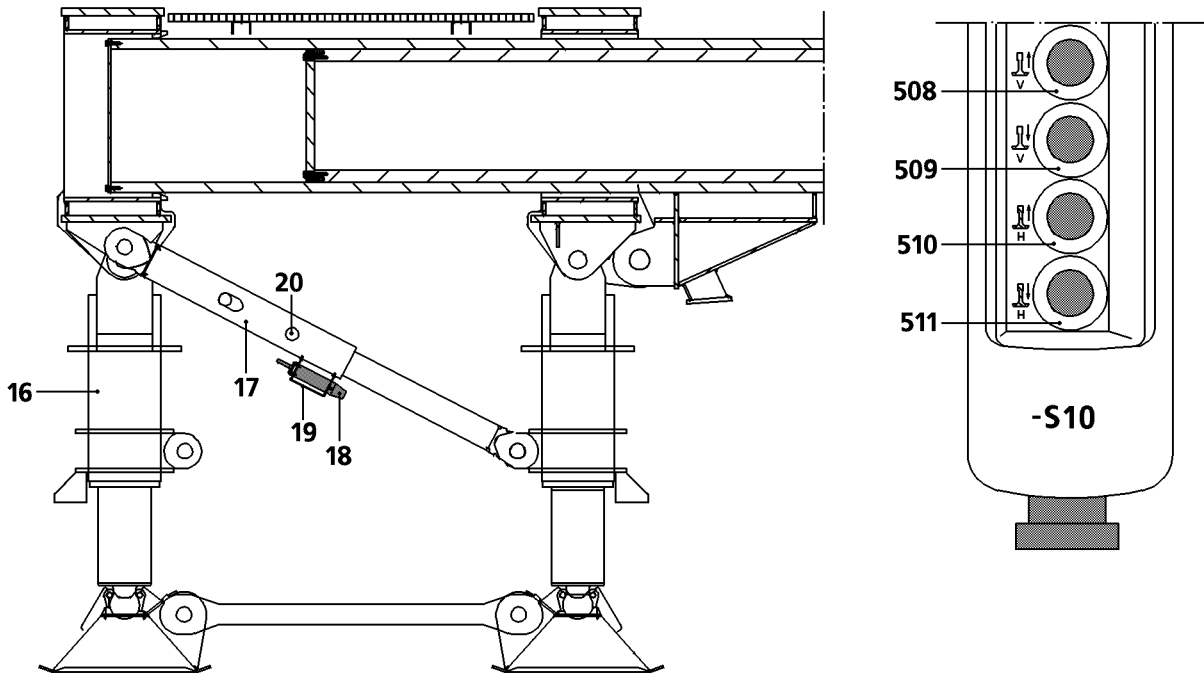

B109279

8.3 Moving the support cylinders out

If the ballast plates and guy rods have been disassembled, extend the support cylinders. Make sure that the following prerequisite is met:

- The crane is aligned in horizontal direction.



Note

- ▶ The locking pin **18** can only be pinned if the support cylinders **16** are relieved!
-

- ▶ Remove the spring retainer on the locking pin **18**.
- ▶ Unpin the locking pin **18** from the transport receptacle **19**.
- ▶ Insert the locking pin **18** into hole **20** on the strut **17** and secure with a spring retainer.

Extend the support cylinders **16**:

- Press button **509**, front support cylinder extends.
- Press button **511**, rear support cylinder extends.
- ▶ Check the moved out support cylinder visually.

8.4 Unpinning the guide from the turntable

8.4.1 Unpinning procedure

Illustration **5** and illustration **6**

- ▶ Remove spring retainer **10** on the retaining pin **9**.
- ▶ Operate the lever **8**.

Result:

- The pins **7** are unpinned on both sides of the pinning point between the guide and the turntable.

8.4.2 Disconnecting the hydraulic connections

Make sure that the following prerequisite is met:

- The engine is not running.

When hydraulic lines are connected and disconnected with quick release couplings, make ensure that the coupling procedure is being performed correctly.



DANGER

Risk of accident due to loss of pressure or leakage!

Incorrectly coupled or self-loosening quick release couplings (particularly return lines) can result in serious injury due to component failure!

- ▶ Check that the quick release couplings have been properly connected before using the crane!

- ▶ Release the pressure in the hydraulic system before connecting and disconnecting. Turn the engine off and wait for short time.
- ▶ Connect the coupling components (sleeve and connector) and screw together with the hand-tightened nut.
- ▶ Tighten the hydraulic coupling by hand. Rotate the hand-tightened nut until it reaches a tangible, fixed stop position.
- ▶ Fit dummy plugs to the couplings after they are opened.

8.4.3 Releasing the electrical connection



DANGER

Damage to crane!

- ▶ Only detach the electrical connections and insert them in the dummy plug when the ballast trailer guide on the crane is completely unpinned. As soon as one of the two pins is unpinned from the guide frame, the crane control recognizes that the ballast trailer is not longer assembled. The crane can be still turned and driven, despite the attached ballast trailer (ballast trailer is connected to the turntable using one pin). There is a danger of damage to the ballast trailer or crane, if the crawler is driven or the turntable is turned!



Note

- ▶ To disconnect the electrical connections, Electric wiring diagram!
- ▶ Disconnect the electrical connections.
- ▶ Properly store the connector cable in the intended receptacles.

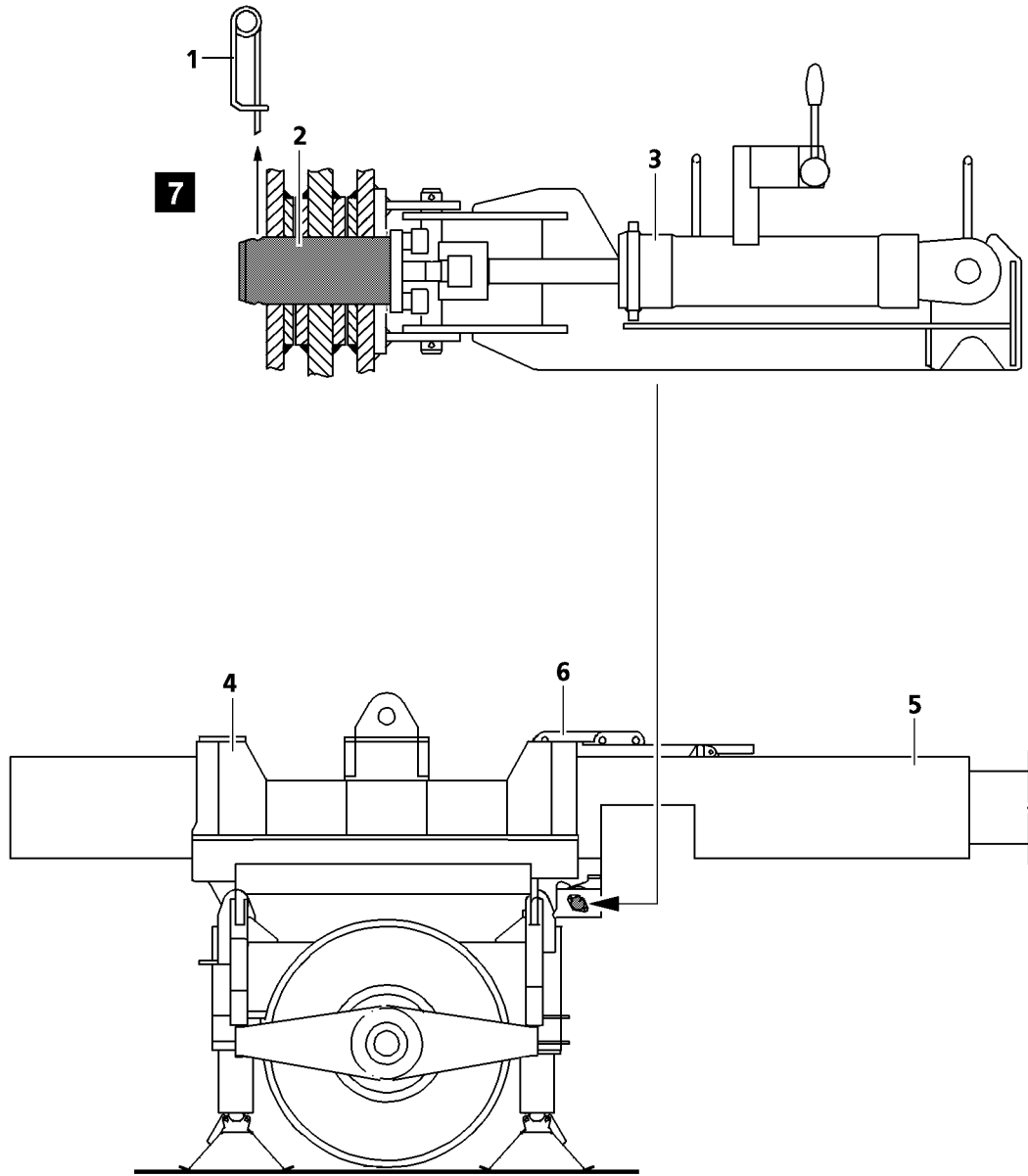

B109280

8.5 Disassembling the guide from the ballast frame

Illustration 7

Make sure that the following prerequisites are met:

- The ballast trailer **4** is supported on the support cylinders and horizontally aligned.
- The wheel sets are relieved.
- The locking pin is pinned in the strut.
- An auxiliary crane is on hand.
- The crane has been driven away from the ballast trailer.



DANGER

Danger of tipping over!

If the safety guidelines for the stability and tipping safety are not observed and the strut is not pinned with the locking pin, there is a danger of tipping over! Personnel can be severely injured or killed!

- ▶ See section "Observe the stability and tipping resistance when ballast trailer is not fitted to the turntable".
- ▶ The strut must be pinned with the locking pin!

8.5.1 Disassembling the guide

- ▶ Unpin the lifting strap **6**, tilt backwards and pin.
- ▶ Secure the ballast trailer guide **5** using the auxiliary crane.
- ▶ Connect the pin pulling device **3** to the hydraulic aggregate.
- ▶ Release the pins **2** and unpin on both sides with the pin pulling device **3**.
- ▶ Use the auxiliary crane to place the ballast trailer guide **5** onto the transport vehicle.
- ▶ Use the auxiliary crane to set the ballast trailer **4** down on the transport vehicle.



DANGER

Risk of accident!

- ▶ The ballast trailer **4** and ballast trailer guide **5** must be properly secured for transportation. The ballast trailer must be supported so that the tires are slightly pushed in!
- ▶ The ballast trailer is not equipped with its own brake system. It must therefore be supported after it has been disassembled!

- ▶ Secure the ballast trailer for transport on the transportation vehicle.

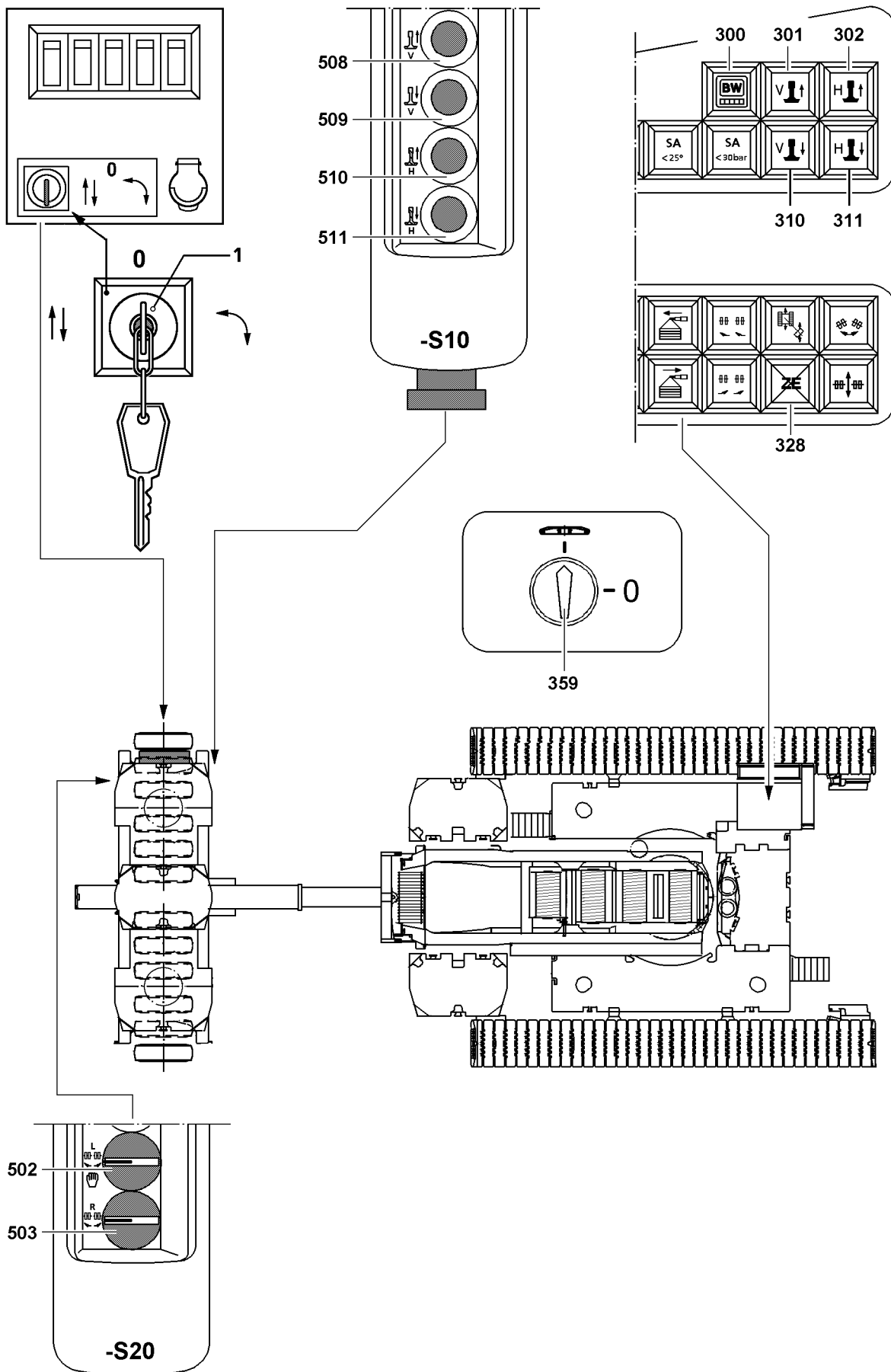

B109281

9 Emergency operation

9.1 Emergency operation of ballast trailer

In case of a failure or defect of the central unit on the ballast trailer (warning light **328** lit), the electronic steering of the ballast trailer can no longer be actuated.

The signals towing and circular driving can no longer be sent from the ballast trailer control to the crane control.

By actuating the key switch **1** in the switch box on the ballast trailer, the central unit can be bypassed.

Key switch positions

- 0 (center) = no emergency operation
- I (left) = emergency operation towing
- II (right) = emergency operation circular driving



DANGER

Risk of accident!

- ▶ Emergency operation should only be carried out by authorized personnel!
 - ▶ Make sure that no persons are within the danger zone of the ballast trailer!
 - ▶ Perform each driving maneuver with utmost caution, minimum acceleration and careful braking!
 - ▶ Only actuate the key switch **1** if the electronic has failed!
 - ▶ The signal "Towing" and "Circular driving" is released to the crane, even though the wheels might be positioned incorrectly!
 - ▶ The wheel position must be manually monitored. Observe the angle scale on the ballast trailer!
-



Note

- ▶ During crane operation (no emergency operation), the key switch **1** must be set to position 0 (center position)!
-

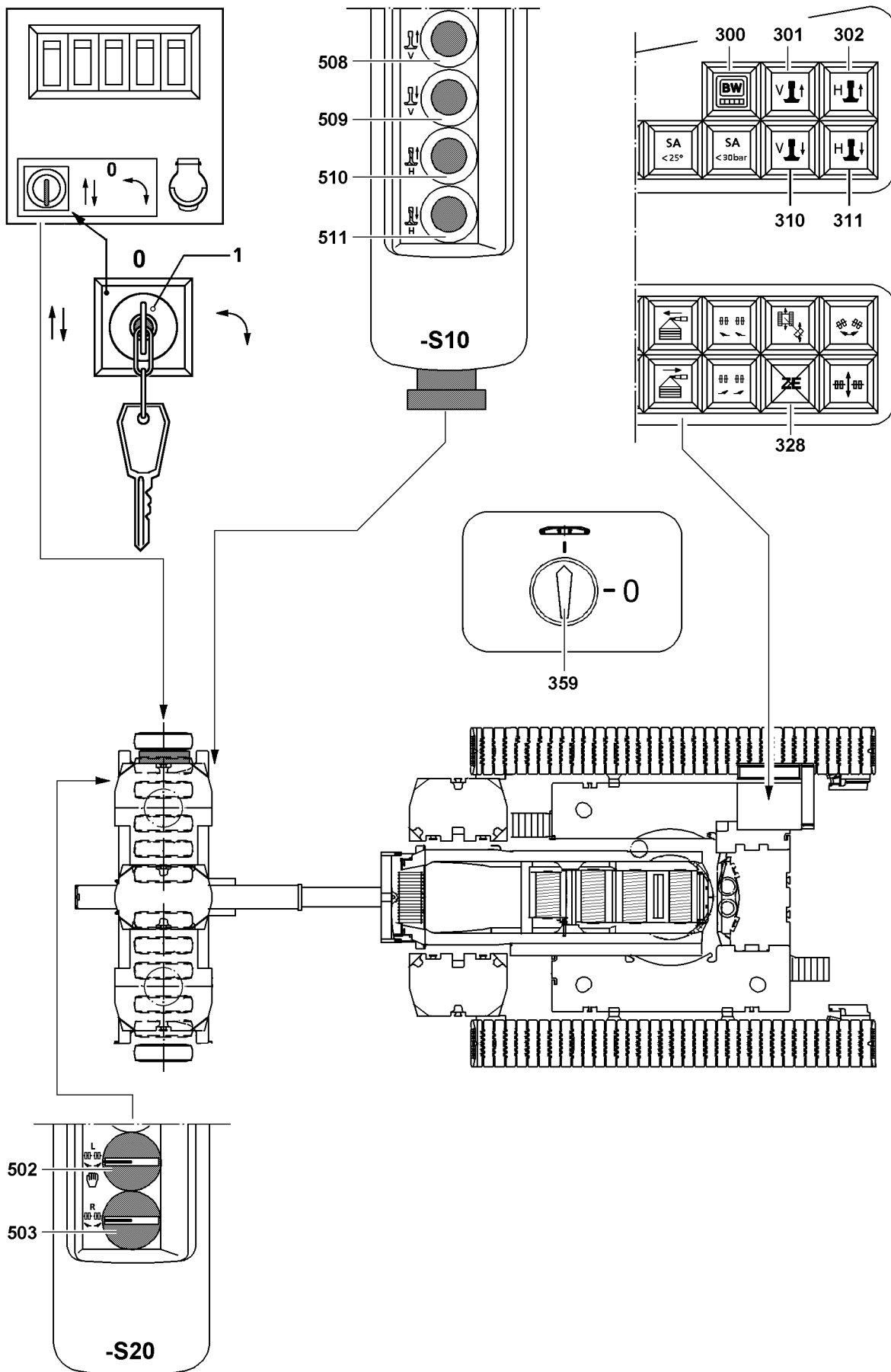

B109281

9.2 Emergency operation of the ballast trailer - Towing

Make sure that the following prerequisites are met:

- The crane is standing.
- The ballast trailer is properly installed.
- The rotary switch **359** is set to crawler operation (vertical position).

9.2.1 Lifting the ballast trailer with the support cylinders

- ▶ Switch the key switch **1** on the ballast trailer to position I (left).



Note

- ▶ By turning the key switch **1** to position I, the “Towing” command is forwarded to the crane and emergency operation is turned on!
-
- ▶ Press button **310** and **311** or button **509** and **511**; extend the front / rear support cylinders.
 - ▶ In emergency operation, the support can only be moved using the control panel on the ballast trailer.

9.2.2 Aligning the axles to the towing position

- ▶ Switch the key switch **1** on the ballast trailer to position I (left).
- ▶ Actuate the rotary switch **502**, move the left wheel pair to the towing position.
- ▶ Actuate the rotary switch **503**, move the right wheel pair to the towing position.



DANGER

Risk of accident!

- ▶ Constantly monitor the wheel position of the wheel pairs when driving. Observe the angle scale on the ballast trailer. If the tires become excessively deformed, readjust the wheel position!
-
- ▶ If necessary, correct the wheel position.

9.2.3 Lowering the ballast trailer with the support cylinders

- ▶ Press button **301** and **302** or button **508** and **510**; retract the front / rear support cylinders.
- ▶ The indicator light **314**, indicating that the ballast trailer supports are retracted, is lit.

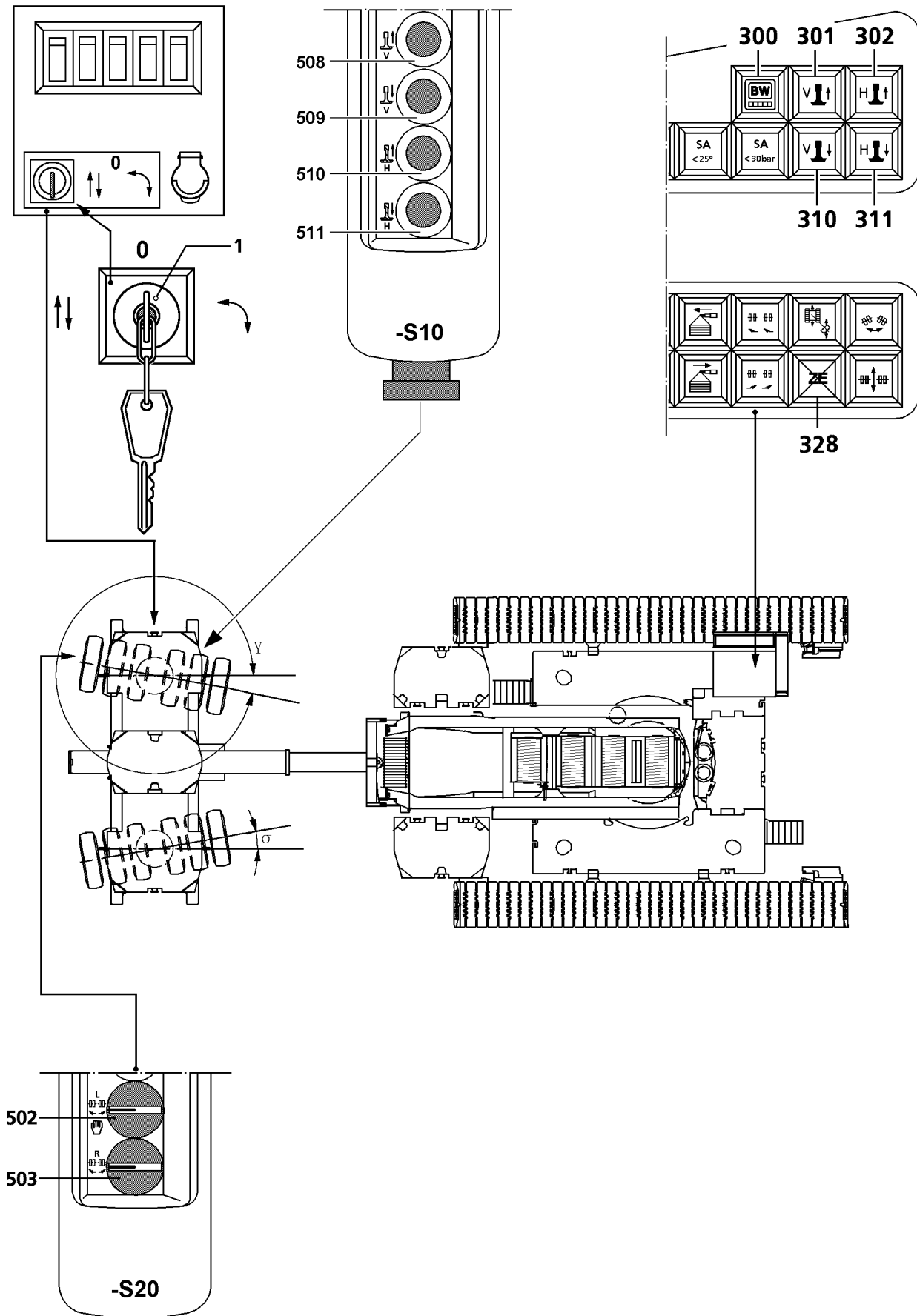

B109282

9.3 Emergency operation of the ballast trailer - Circular driving

Different turning radii are possible by telescoping the ballast trailer. Make sure that the following prerequisites are met:

- The crane is standing.
- The ballast trailer is properly installed.

9.3.1 Lifting the ballast trailer with the support cylinders

- ▶ Switch the key switch **1** on the ballast trailer to position II (right).



Note

- ▶ By turning the key switch **1** to position II, the command for "Circular driving" is forwarded to the crane and emergency operation is turned on!
- ▶ Press button **310** and button **311** or button **509** and button **511**, the support cylinders on the front and the rear extend.

9.3.2 Aligning the axles to the circular driving position

Ballast trailer radius [m]	Angle scale [°]	
	Left [γ]	Right [σ]
11 m	348.19	11.8
13 m	349.96	10.3
15 m	351.28	8.71

- ▶ Operate the knob **502** and turn the left wheel pair in the circular driving position until the marking pointer matches the ballast trailer radius.
- ▶ Operate the knob **503** and turn the right wheel pair in the circular driving position until the marking pointer matches the ballast trailer radius.



DANGER

Risk of accident!

- ▶ Constantly monitor the wheel position of the wheel pairs when driving. Observe the marking pointer on the ballast trailer. If the tires become excessively deformed, readjust the wheel position!
- ▶ If necessary, correct the wheel position.

9.3.3 Lowering the ballast trailer with the support cylinders

- ▶ Press button **301** and **302** or button **508** and **510**; retract the front / rear support cylinders.
- ▶ The indicator light **314**, indicating that the ballast trailer supports are retracted, is lit.

10 Maintenance intervals for the ballast trailer



Note

- ▶ Maintenance intervals on the ballast trailer, see Crane operating instructions, chapter 7.02!

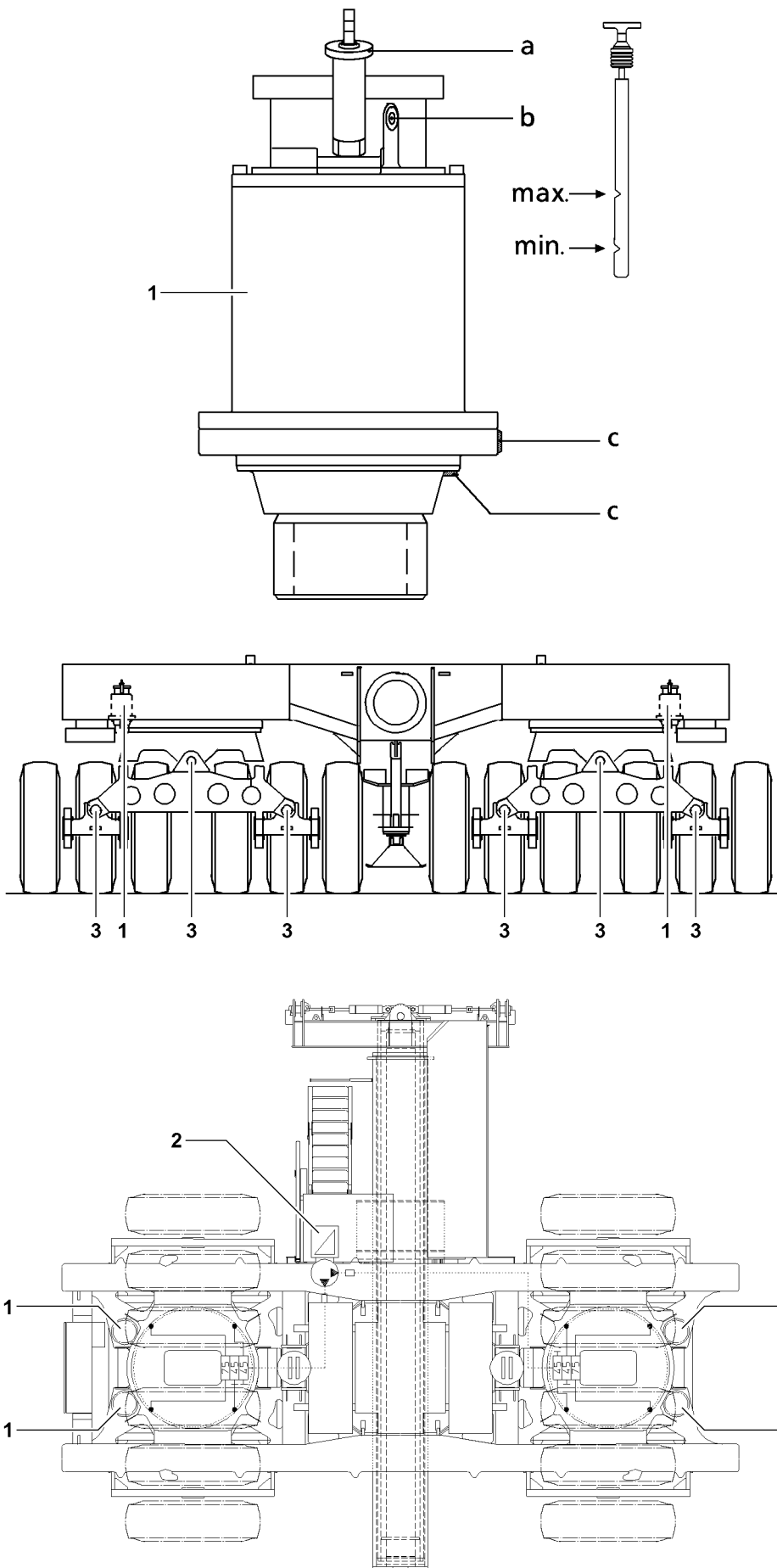

B108514

11 Maintenance

11.1 Ballast trailer tires

11.1.1 Ballast trailer tires

**Note**

- ▶ Maintain the ballast trailer tires, see Crane operating instructions, chapter 2.15!

11.1.2 Ballast trailer tires and disk wheels

**Note**

- ▶ Ballast trailer tires and disk wheels, see Crane operating instructions, chapter 8.01!

11.2 Hydraulic hose lines

**Note**

- ▶ Hydraulic hose lines, see Crane operating instructions, chapter 7.05!

11.3 Slewing gear

Please maintain utmost cleanliness during all work to prevent dirt from entering the interior of the gear system.

11.3.1 Checking the oil level

The oil level must be between the MIN and MAX marks on the dipstick.
Make sure that the following prerequisite is met:

- The crane is in horizontal position.
- ▶ Remove the dipstick, wipe clean, re-insert and pull out again.
- ▶ After the check has been completed, reinsert the dipstick tightly in the test point.
- ▶ If necessary, refill with oil as specified on the lubrication chart.

**Note**

- ▶ If the oil level has dropped below the MIN mark, add oil as shown in the lubrication chart until the oil level is between the MIN and MAX marks!
- ▶ If no oil is added, then there is a danger of gear damage!

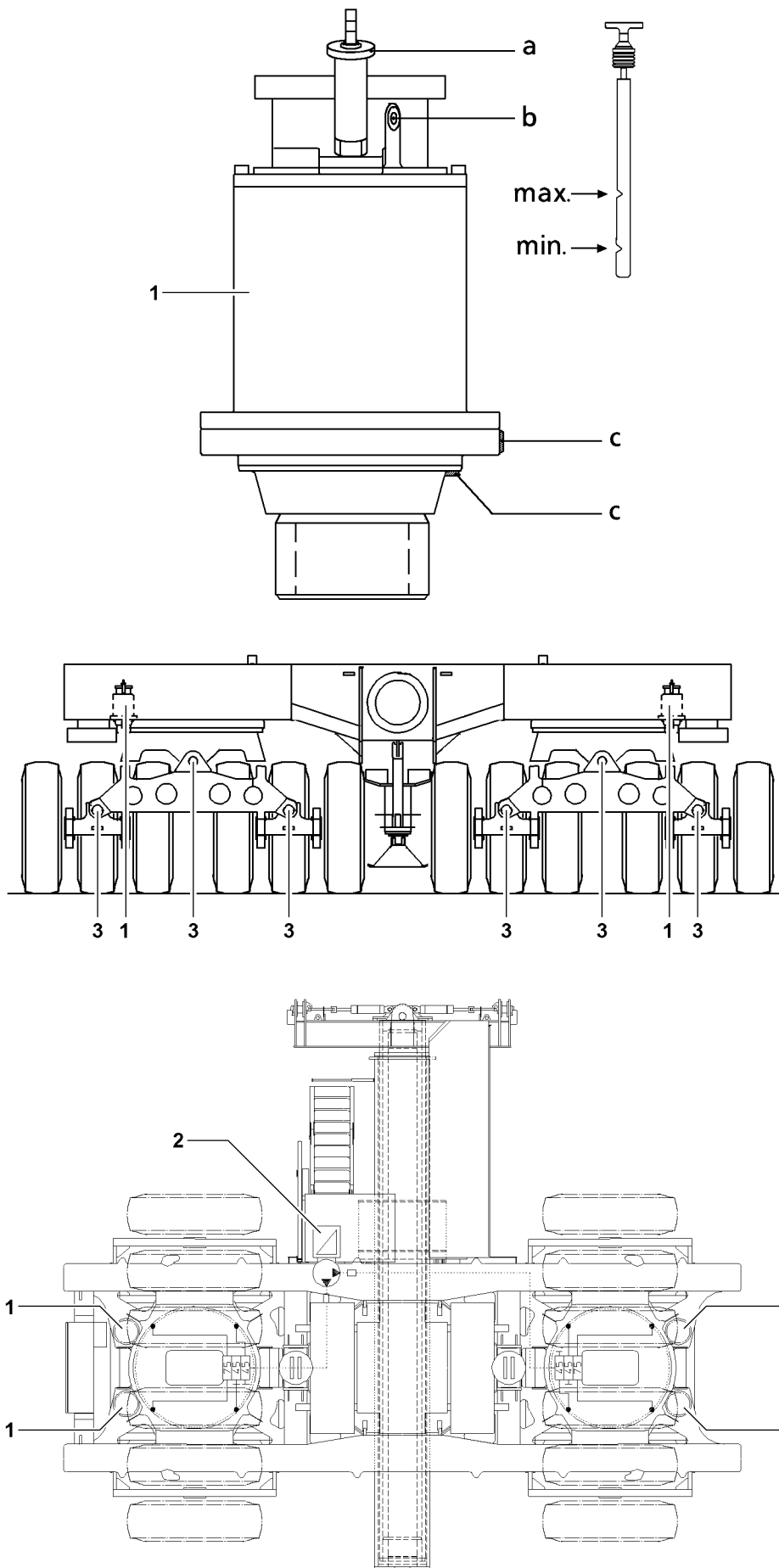

B108514

11.3.2 Changing the oil

- ▶ Pull the dipstick **a** out of the oil filler nozzle **a**.
- ▶ Unscrew the oil drain plug **c** and seal ring. Clean the sealing surface.
- ▶ Drain off the old oil.
- ▶ Install the oil drain plug **c** with new seal ring and tighten.
- ▶ Top up with oil as specified on the lubrication chart through the oil filler opening **b**.
- ▶ Wipe clean the dipstick, re-insert and pull out again.
- ▶ After the check has been completed, reinsert the dipstick tightly in the test point.
- ▶ If necessary, repeat this step.

11.4 Central lubrication system



Note

- ▶ Central lubrication system, see Crane operating instructions, chapter 7.05!

11.5 Lubrication and fill quantities

The specified fill quantities (change quantities) are orientation values. The markings on the dipsticks, inspection ports or sight gauges are decisive for filling.

NOTICE

Danger of property damage!

- ▶ Do not mix synthetic oils with mineral oils!

Position	Components	Fill quantity
1	Slewing gear	3.0 l
2	Central lubrication system	2.5 kg
3	Lube point, (see Crane operating instructions, chapter 7.06)	0.1 kg

¹ Before checking the oil level, retract all hydraulic cylinders and lower the vehicle all the way via the leveling regulation. The oil level must be in the center of the sight gauge.

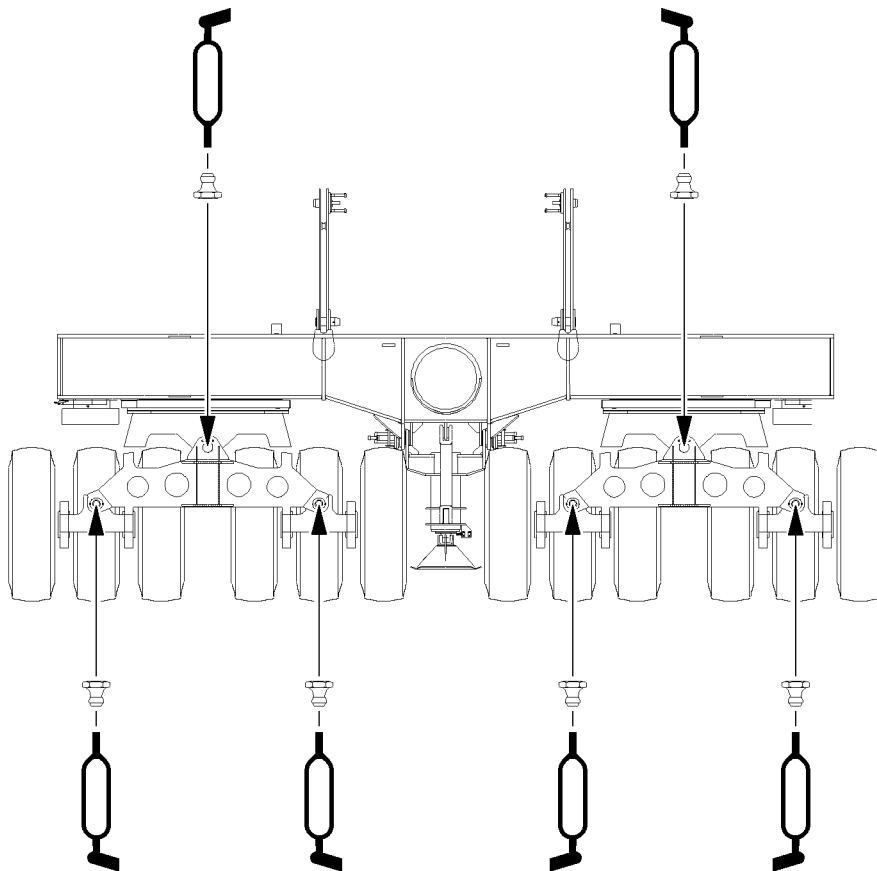

B108515

11.6 Lubrication chart

11.6.1 Lubrication chart Ballast trailer

Rocker

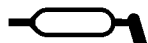

Note

▶ The lube points are marked with this icon!

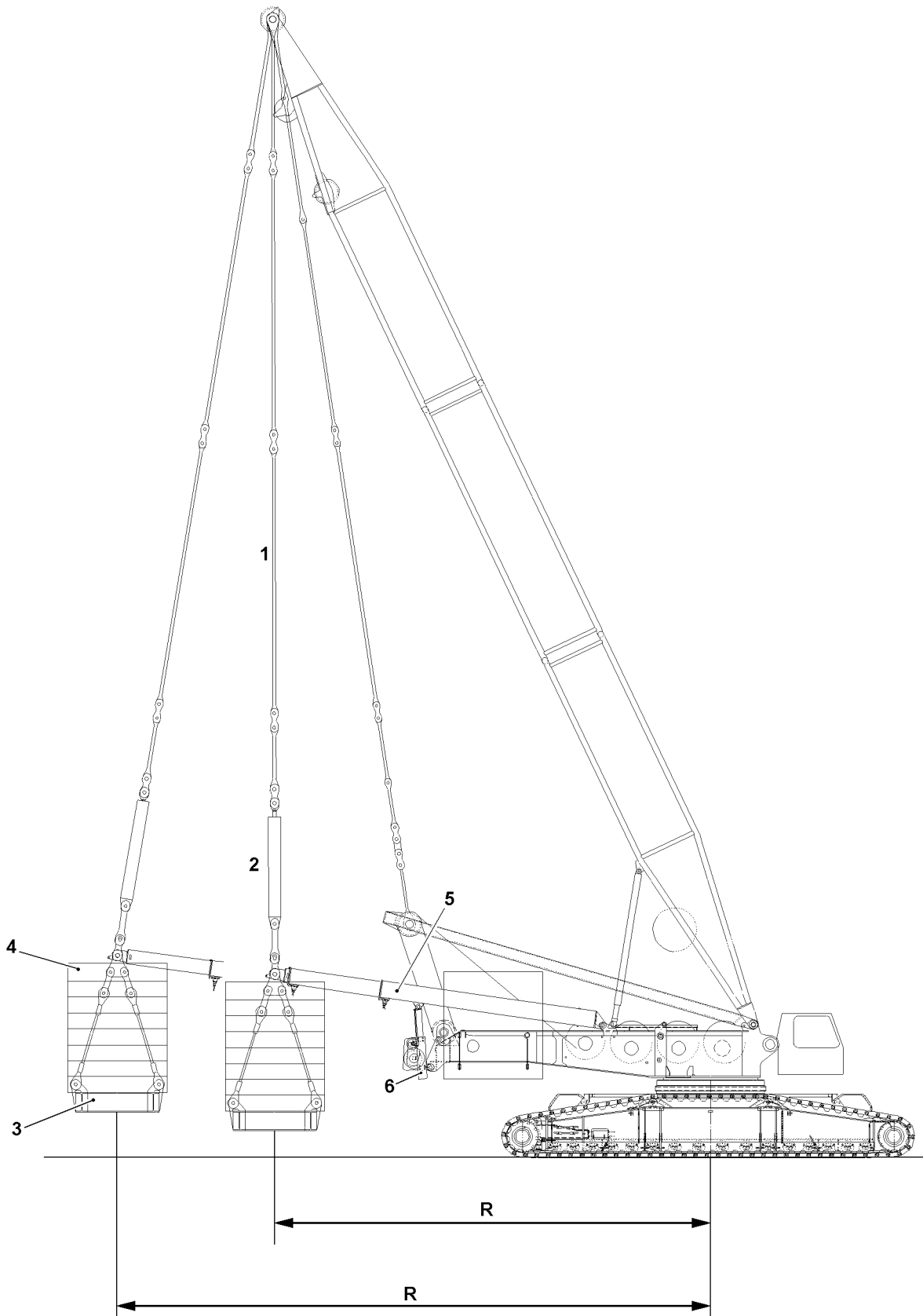

B104656

1 Suspended ballast

1.1 Description

The derrick ballast can be telescoped out steplessly via the hydraulically telescopeable ballast guides **5**, which are pinned on both sides of the turntable. The derrick boom angle, the derrick ballast, weight and utilization are shown on LICCON monitor 1.

After assembly on the ground, the derrick ballast is raised for crane operation using the pull cylinders **2** which are installed on the ballast guides **5**.

For crane operation with derrick ballast, see Crane operating instructions, chapter 4.02.

1.2 Component overview - Derrick ballast

The components for crane operation with derrick ballast are:

Components	
1	Guying
2	Pull cylinder
3	Ballast pallet
4	Ballast plates
5	Complete guide
6	Ballast guide

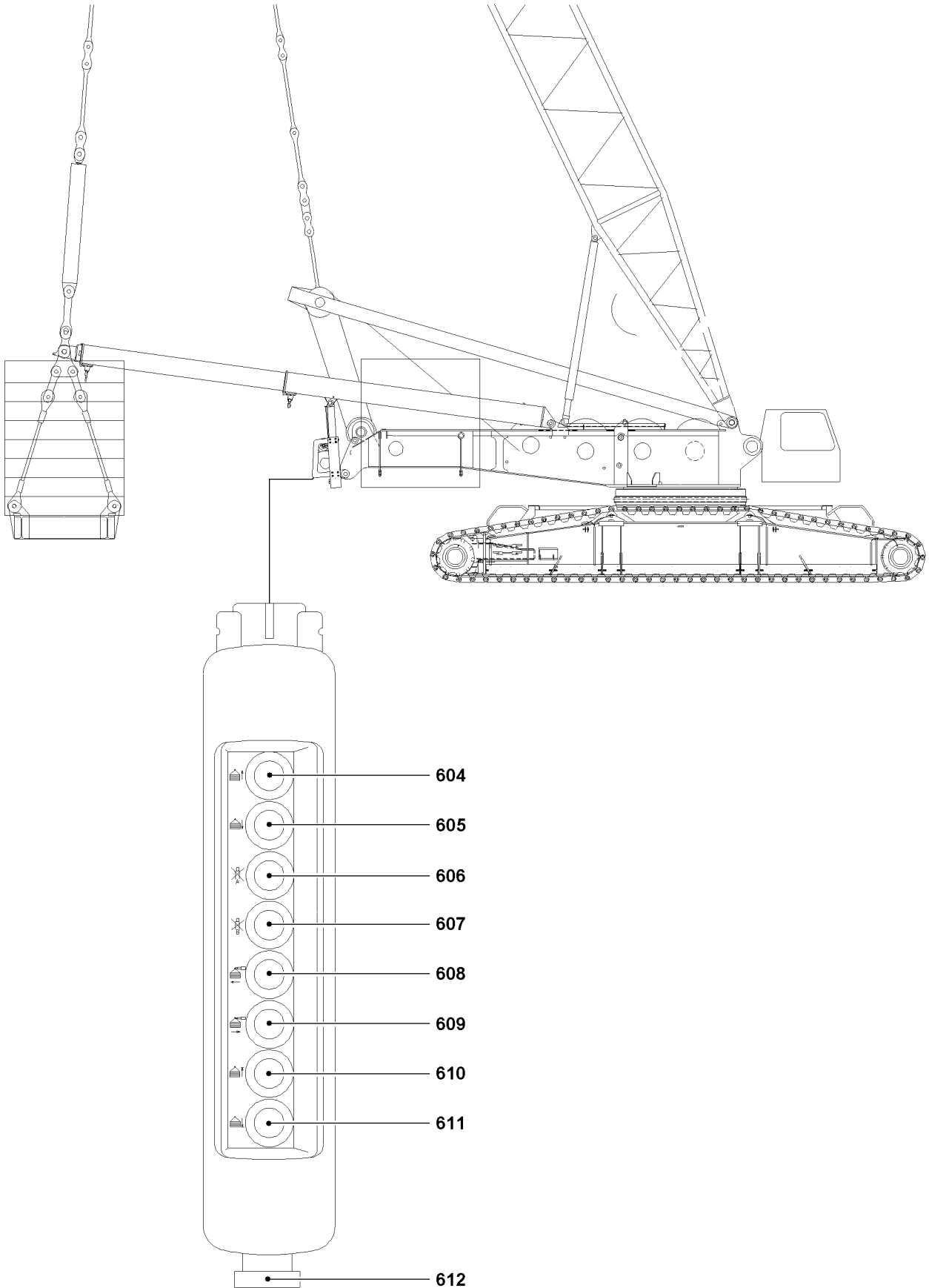

B104665

1.3 Control elements on the control panels

Control panel suspended ballast

604	Button	• Derrick ballast "UP" - retract both cylinders
605	Button	• Derrick ballast "DOWN" - extend both cylinders
606	Button	• Block cylinder "A" on the derrick ballast
607	Button	• Block cylinder "B" on the derrick ballast
608	Button	• Telescope derrick ballast out
609	Button	• Telescope derrick ballast in
610	Indicator light	• Indicator "Derrick ballast above ground level"
611	LED	• Indicator and bypass "Derrick ballast below ground level"
612	Switch	• EMERGENCY OFF

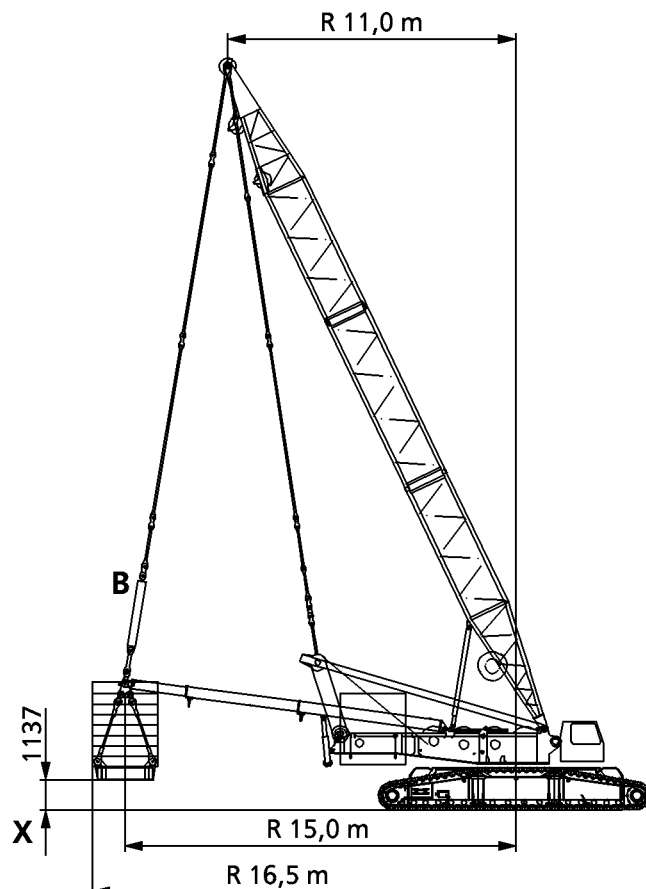
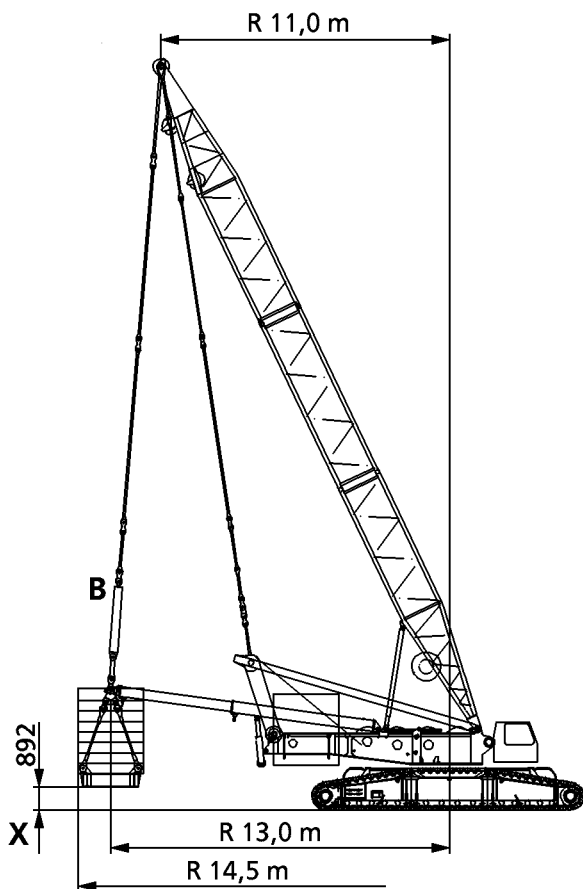
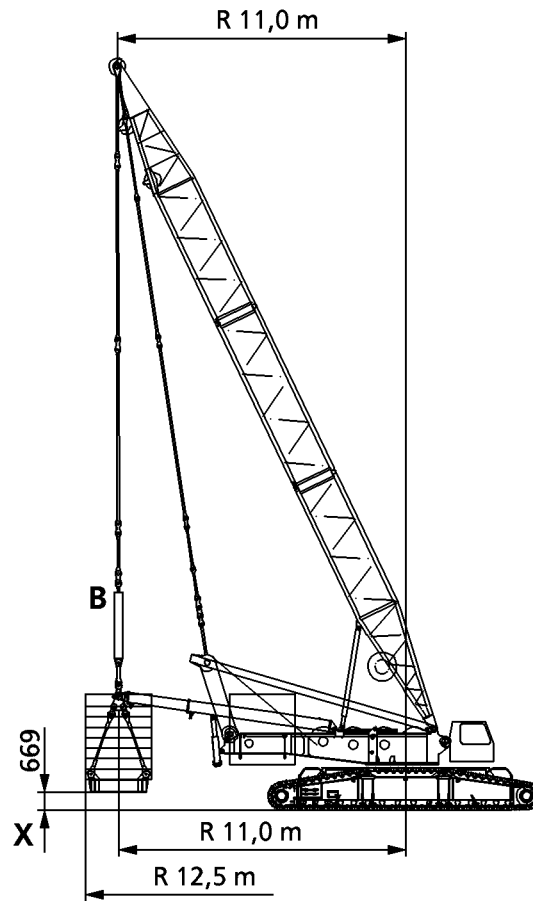
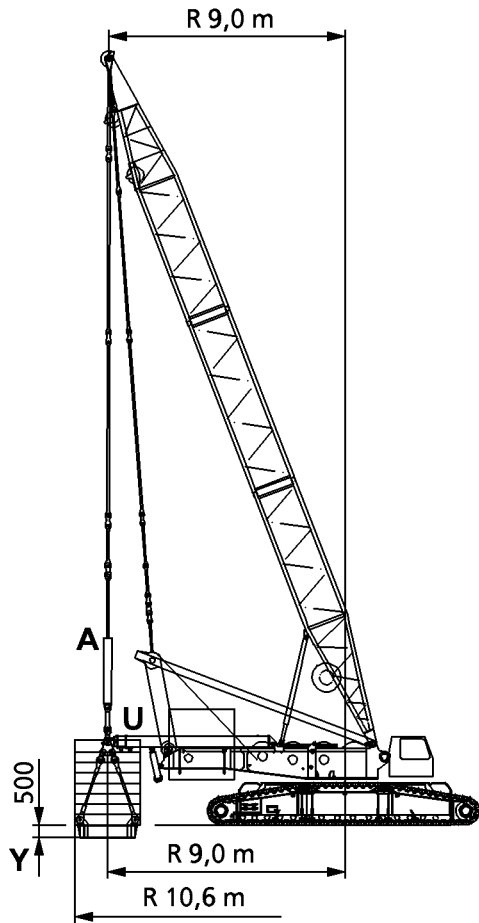

B104657

1.4 Derrick boom radii

1.4.1 Derrick boom radii for derrick 28 m

Configuration states, see illustrations	
A	= cylinder extended
B	= cylinder retracted
U	= lower shut-off
X	= maximum above level of base [mm]
Y	= maximum below level of base [mm]



Note

- ▶ The lower shut-off **U** applies to all radii!
- ▶ The dimension of 500 mm for “Maximum below level of base” applies to all radii!

1.4.2 Derrick boom radii for derrick 21 m

Configuration states, see illustrations	
A	= cylinder extended
B	= cylinder retracted
U	= lower shut-off
X	= maximum above level of base [mm]
Y	= maximum below level of base [mm]



Note

- ▶ The lower shut-off **U** applies to all radii!
- ▶ The dimension of 500 mm for “Maximum below level of base” applies to all radii!

1.5 Assembly



WARNING

Risk of falling!

During assembly / disassembly work, personnel must be secured with appropriate aids to prevent them from falling. If this is not observed, assembly personnel can fall and suffer life-threatening or fatal injuries!

- ▶ Any assembly work, where there is a danger of falling must be carried out with suitable aids (for example lifting platform, scaffolding, ladder, auxiliary crane)!
- ▶ If the work cannot be carried out with such aids nor from the ground, then the assembly personnel must secure themselves with approved fall arrest systems to avoid falling, see Crane operating instructions, chapter 2.04!
- ▶ Approved fall arrest systems must be hung into the respective fastening points on the crane, see Crane operating instructions, chapter 2.06!
- ▶ If railings are present on the components, then they must be brought into the corresponding position and secured for assembly / disassembly work!
- ▶ Step on aids and fall protection equipment only with clean shoes!
- ▶ Keep aids and fall protection equipment clean and free from snow and ice!
- ▶ During all assembly and disassembly work, maintenance work and inspections, travel and crane operation is prohibited!



WARNING

Components not pinned and secured!

If a component is released from the auxiliary crane before having been pinned and secured, the component will fall down! Personnel can be severely injured or killed!

- ▶ Do not disengage the auxiliary crane until the corresponding component is pinned and secured!



WARNING

Danger of impact / crushing!

When installing / removing crane components with the auxiliary crane, crane components can start to swing back and forth!

When lifting / lowering and positioning crane components, there is an increased danger of impacts / crushing!

Personnel can be caught and severely injured or killed!

- ▶ Make sure that personnel cannot be caught by components!
- ▶ When working in danger zones: Use aids to protect limbs!
- ▶ Guide components with suitable aids to minimize oscillation!

Make sure that the following prerequisites are met:

- The crane is aligned in horizontal direction.
- The boom and the derrick are assembled on the turntable.
- The derrick is erected.
- The counterweight has been installed on the turntable according to the load chart.
- An auxiliary crane is available.

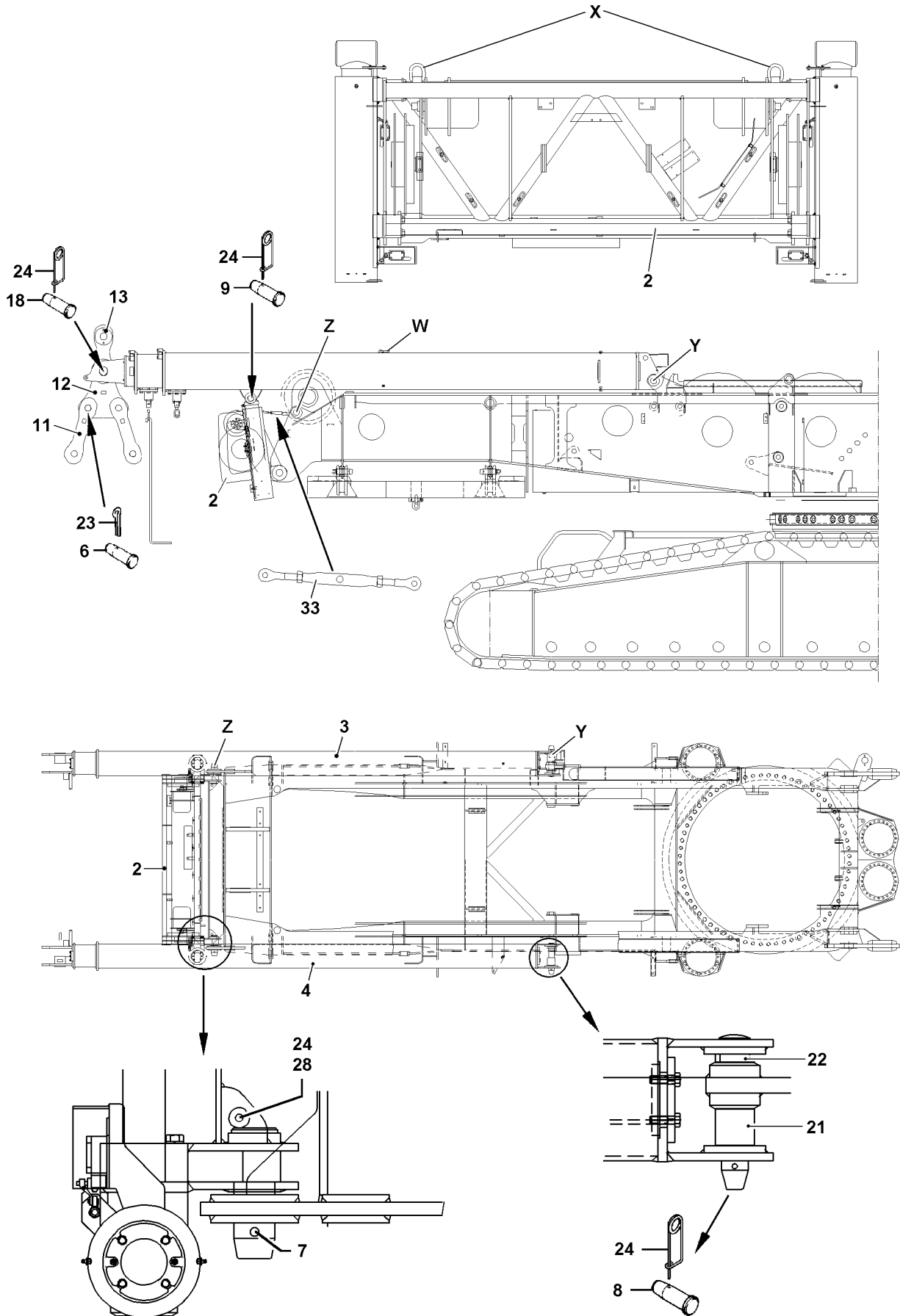

B104659

1.5.1 Installing the guide frame

- ▶ Secure the guide frame **2** to the lifting brackets **X** on the auxiliary crane.
- ▶ Use the auxiliary crane to swivel and fix the guide frame **2** to the pinning point **Z** on the turntable.
- ▶ Pin in the pins **7** at the pinning point **Z** and secure with spring retainers **28**.
- ▶ Secure the retaining pins **28** with spring retainers **24**.



Note

- ▶ The turnbuckle **33** only serves as an assembly support and **must** be disassembled after the ballast guide has been fitted!

-
- ▶ Attach the turnbuckle **33** between the guide frame **2** and the turntable.

1.5.2 Assembling the ballast guide

Before assembling the ballast guides, pin and secure the triangular brackets **12**, brackets **11** and ballast guy rods **13** to the end section on the ballast guide **3** and **4**.

- ▶ Pin triangular brackets **12** and ballast guy rods **13** to the end section using pins **18**.
- ▶ Secure the pin **18** with spring retainer **24**.
- ▶ Pin the brackets **11** to the triangular brackets **12** using pins **6**.
- ▶ Secure pins **6** with split pins **23**.
- ▶ Secure ballast guide right **3** and ballast guide left **4** to the auxiliary crane lifting brackets **W**.
- ▶ Use the auxiliary crane to swivel and fix the ballast guide **3** and **4** to the pinning point **Y** on the turntable.
- ▶ Insert the pins **8**.
- ▶ Install the spacer pipes **21** and **22**.
- ▶ Secure pins **8** and spacer pipes **21** and **22** with spring retainers **24**.

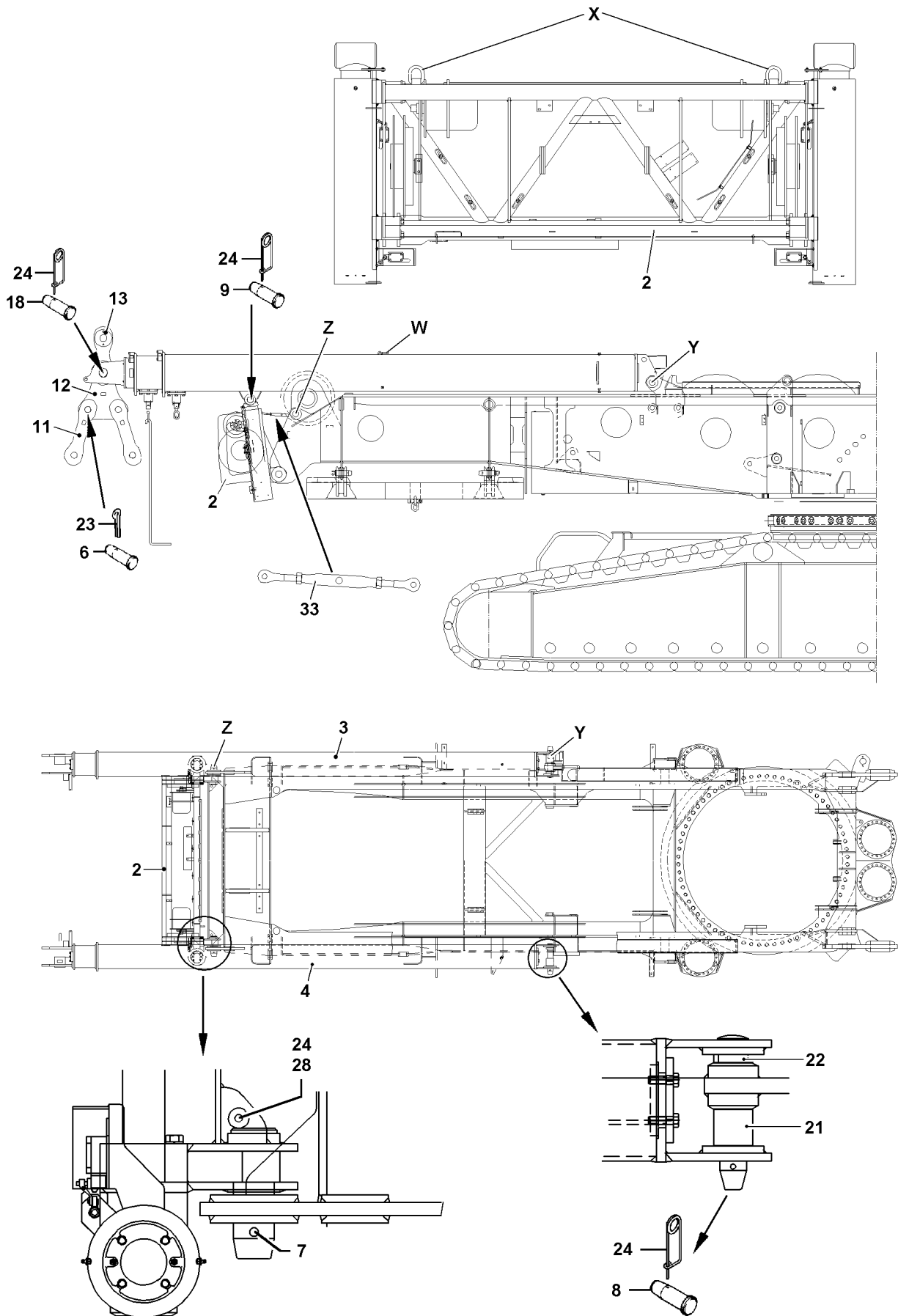

B104659

Once the ballast guides are pinned to the pinning point **Y**, also pin the ballast guides to the guide pipe on the guide frame **2**.

- ▶ Completely lower ballast guide right **3** and ballast guide left **4** onto the turntable using the auxiliary crane.
- ▶ Pin ballast guides **3** and **4** using pins **9** to the guide pipe on the guide frame **2**.
- ▶ Secure the pin **9** with spring retainer **24**.
- ▶ Remove the turnbuckle **33** between the guide frame **2** and the turntable.

**Note**

- ▶ The turnbuckle **33** only serves as an assembly support and **must** be disassembled after the ballast guide has been fitted!
-

**DANGER**

Risk of accident due to loss of pressure or leakage!

Incorrectly coupled or self-loosening quick release couplings (particularly return lines) can result in serious injury due to component failure!

- ▶ Check that the quick release couplings have been properly connected before using the crane!
-
- ▶ Connect the supply lines for the ballast guide to the turntable.

A

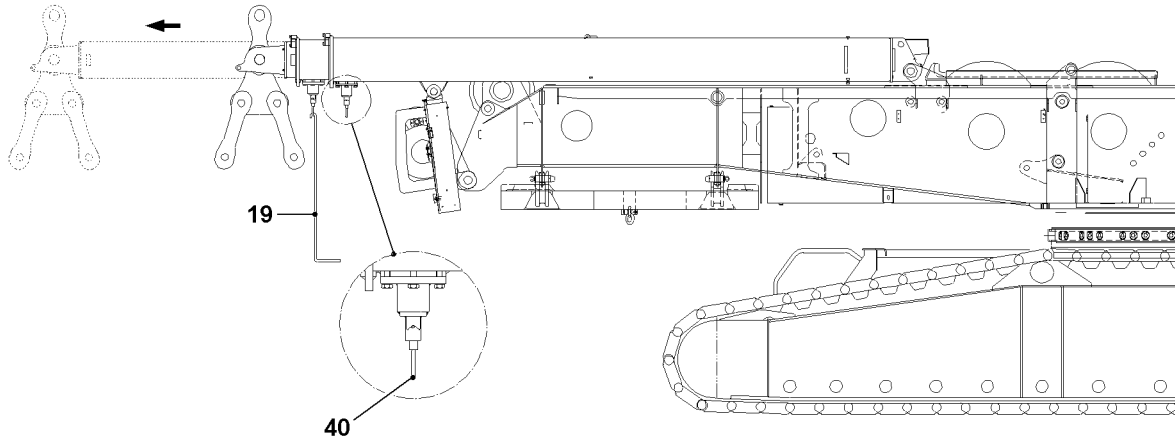

B

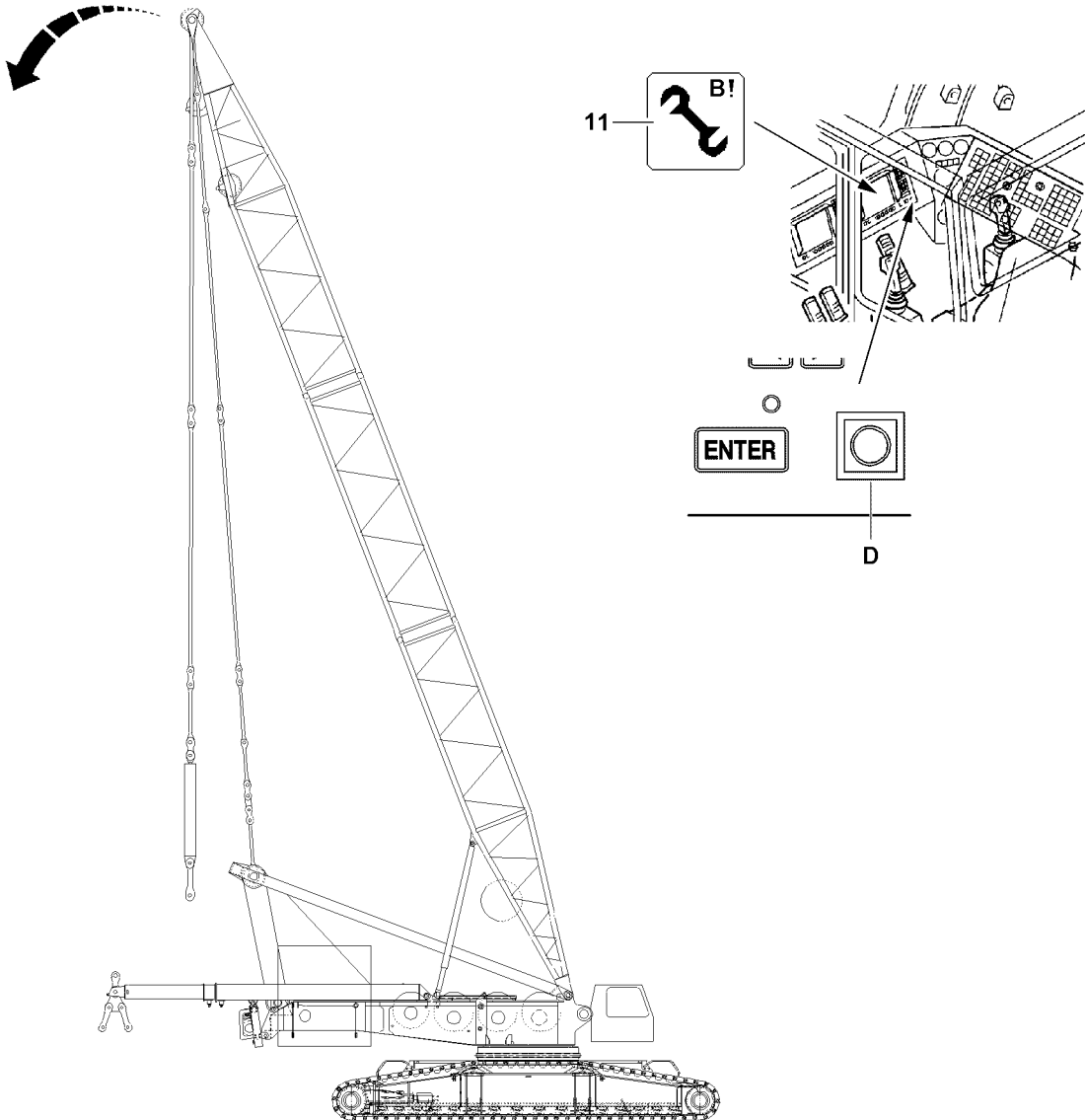

B112515

1.5.3 Mechanically telescoping the ballast guide

Make sure that the following prerequisites are met:

- The guide frame is assembled to the turntable.
- Both ballast guides are assembled to the turntable.

The ballast guide is equipped with a telescoping end section with a length of 2 m. It must be mechanically pulled using suitable equipment, see illustration **A**.



Note

- ▶ In order to mechanically pull the telescoping end section, **both** locking pins **40** must be released from the assembly rod **19**!
- ▶ After telescoping has been completed, **both** locking pins **40** must be pinned and secured with the assembly rod **19**!

1.5.4 Erecting the derrick boom



WARNING

Assembly with turned on set up key!

When the set up key is turned on, the LICCON overload protection is exceeded!

In the event of deliberate improper use, the crane could collapse, the boom can break off or the crane can topple over!

Personnel can be killed!

This could result in high property damage!

- ▶ The set up key **D** may only be actuated by persons who know the effects of a bypass!
- ▶ Press the set up key **D** only when the set up status was correctly entered into the LICCON computer system!
- ▶ Observe the erection / take down charts!
- ▶ Crane operation with the set up key **D** turned on is strictly prohibited!

- ▶ Turn the set up key **D** to the right.

Result:

- The LICCON overload protection is exceeded.
- The assembly icon **11** is visible on the LICCON monitor.

The derrick boom and ballast guide must be erected or telescoped to a radius of 11 m to allow the pull cylinders to be connected to the ballast guide, see illustration **B**.

- ▶ Erect derrick boom to a radius of 11 m with the master switch 1.

B195219

1.5.5 Establishing the electrical connection from the suspended ballast to the turntable



Note

- ▶ To establish the electrical connections, see Electric wiring diagram!
 - ▶ Establish the electrical connections.
-

1.5.6 Establishing the hydraulic connection from the suspended ballast to the turntable

When hydraulic lines are connected and disconnected with quick release couplings, make ensure that the coupling procedure is being performed correctly.



DANGER

Risk of accident due to loss of pressure or leakage!

Incorrectly coupled or self-loosening quick release couplings (particularly return lines) can result in serious accidents due to component failure!

- ▶ Check that the quick release couplings have been properly connected before using the crane!
- ▶ Release the pressure in the hydraulic system before connecting and disconnecting: Turn the engine off and wait for short time.
- ▶ Connect the coupling components (sleeve and connector) and screw together with the hand-tightened nut.
- ▶ Tighten hydraulic coupling by hand: Rotate hand-tightened nut until it reaches a tangible, fixed stop position.

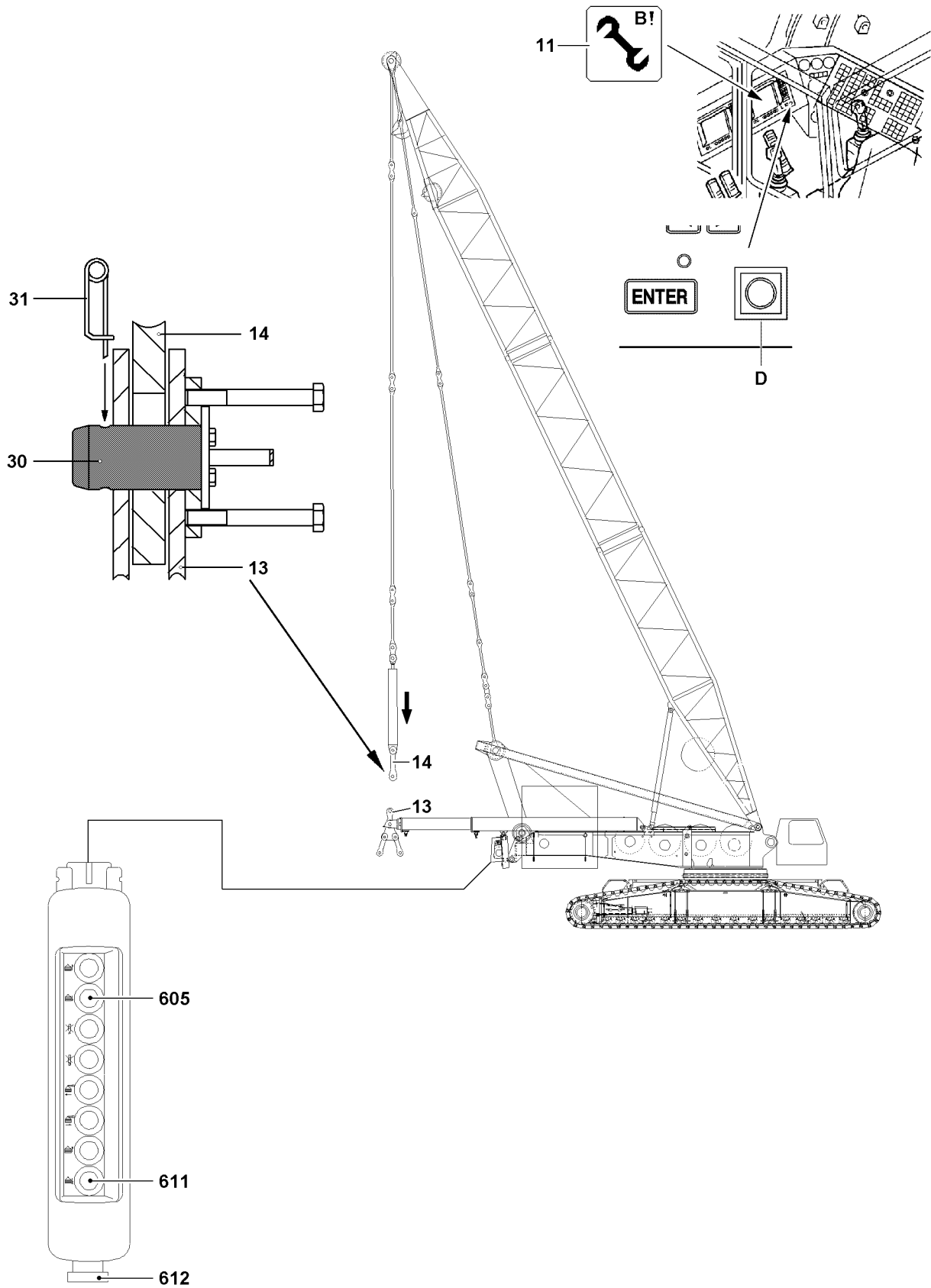

B112516

1.5.7 Pinning the pull cylinder to the end section on the guide

Make sure that the following prerequisites are met:

- The engine is running.
- The LICCON overload protection is exceeded.
- The assembly icon **11** is visible on the LICCON monitor.
- The turnbuckle between the guide frame and turntable has been disassembled.
- The derrick boom is erected to 11 m.
- The ballast guide is mechanically telescoped to 11 m, pinned and secured.
- ▶ Remove the control panel from the storage compartment in the guide frame.
- ▶ Press button **605** "Extend pull cylinders".

Troubleshooting

Pull cylinders do not extend when operating button **605**?

When assembling both ballast guides, these rest on the turntable frame. Consequently the limit switches for "Derrick ballast below ground level" are actuated and the pull cylinders cannot be extended. The illuminated button **611** lights up.

- ▶ The limit switches can be bypassed by operating the illuminated button **611**.

-
- ▶ Press button **605** and illuminated button **611** at the same time.

Result:

- Both pull cylinders extend.
- ▶ Extend the pull cylinders until the brackets **14** align with the ballast guy rods **13** on the end section.



WARNING

Risk of accident!

- ▶ The manual control panel should only be used to install or remove the derrick ballast. Once the pins have been inserted, the derrick ballast functions may only be driven from the crane operator's cab because the screen display on the LICCON monitor is required for derrick ballast operation!
- ▶ It is prohibited to raise the derrick ballast off the ground using the control panel!

-
- ▶ Pin the ballast guy rods **13** and brackets **14** with pins **30**.
 - ▶ Secure the pin **30** with spring retainer **31**.

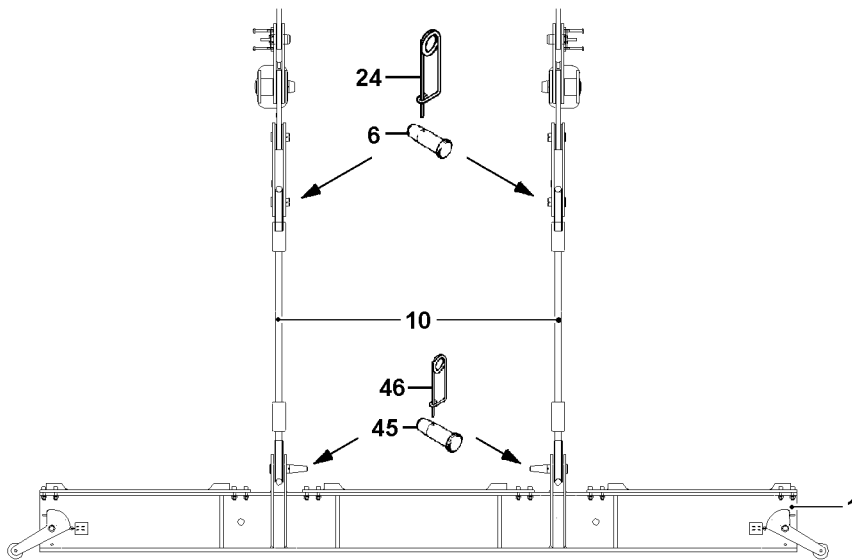
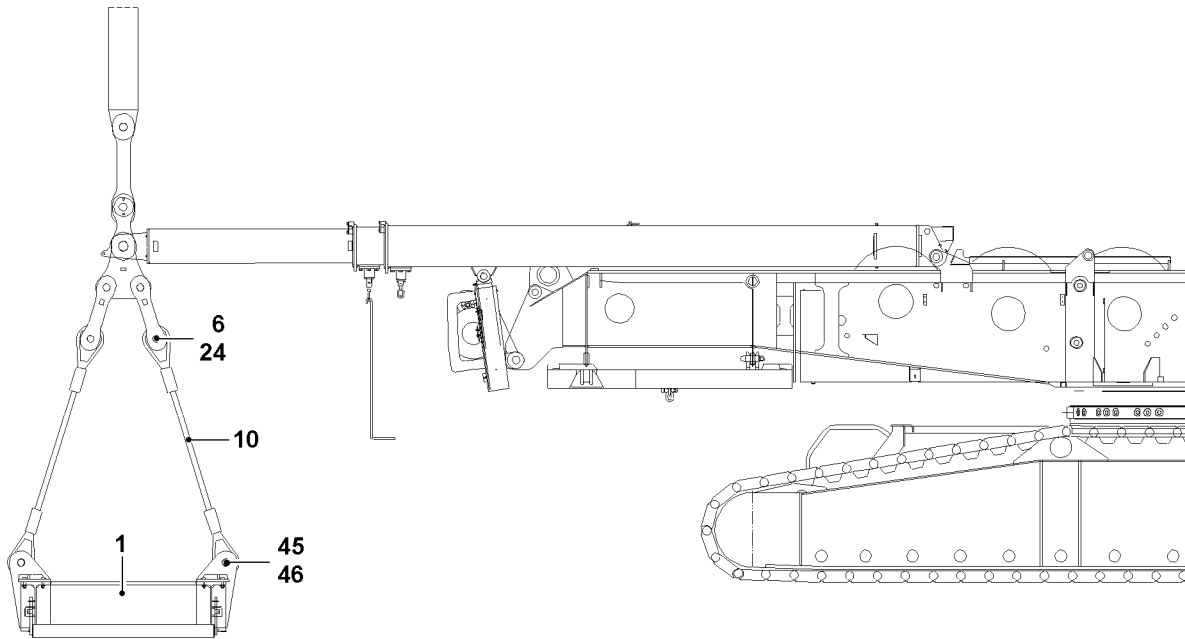

1.5.8 Installing the ballast pallet

Make sure that the following prerequisites are met:

- The ballast guides are pinned to the pull cylinders.
- An auxiliary crane is available.
- ▶ Set down and align the ballast pallet **1** to a radius of approx. 11 m relative to the crane's center of rotation.
- ▶ Pin the ropes **10** to the brackets of the end section of the ballast guide with the pins **6**.
- ▶ Secure the pin **6** with spring retainer **24**.
- ▶ Pin the ropes **10** to the ballast pallet **1** using pins **45**.
- ▶ Secure the pin **45** with spring retainer **46**.

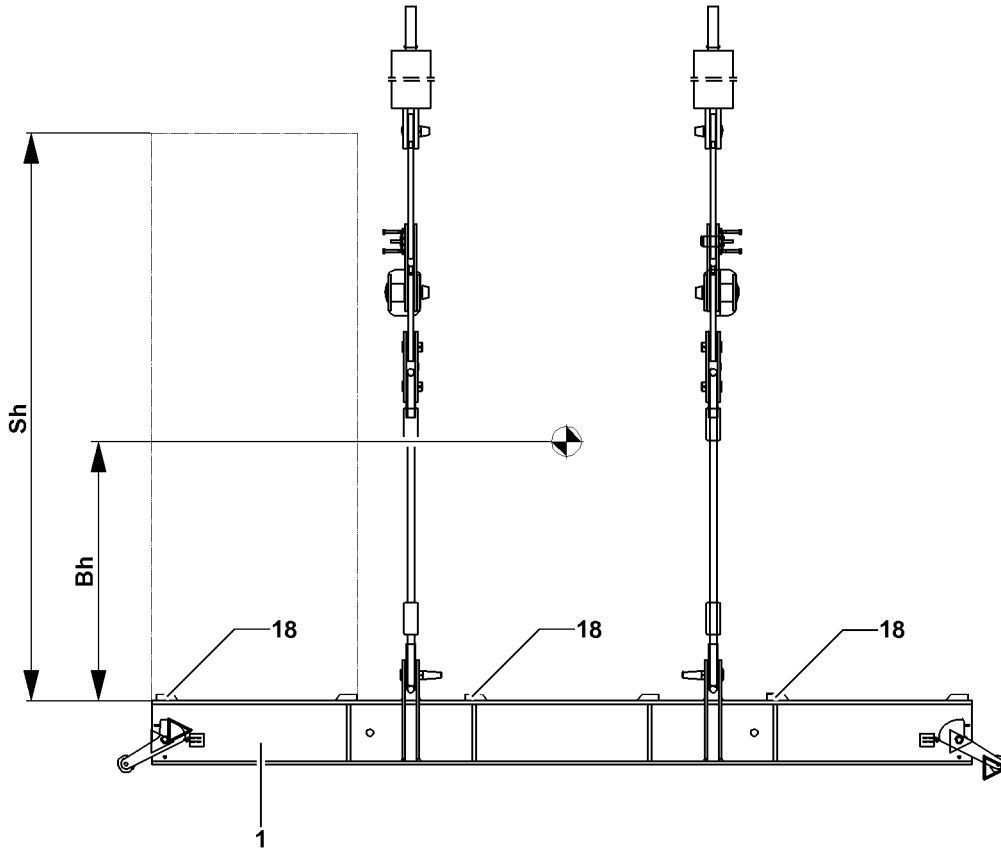

B110372

1.5.9 Ballasting the ballast pallet



WARNING

Danger of toppling the ballast stack!

Incorrect up or down ballasting of the ballast plates on the ballast pallet can cause the ballast stack to topple over!

Personnel can be severely injured or killed!

▶ The maximum permissible total weight of the suspended ballast is 260 t!

▶ The maximum permissible weight of the ballast plates is 250 t!

When the ballast pallet is in suspended condition:

▶ The permissible weight difference between the left and right ballast stack may not exceed 10 t for ballasting up or down!

▶ Place the ballast plates always symmetrically, in reference to the longitudinal axis!

▶ The ballast stacks on the left and right hand side must weigh the same and be the same height after ballasting or during crane operation!

▶ The maximum permissible height of the ballast center of gravity **Bh** of **2.05 m** may **not** be exceeded!

▶ The maximum permissible stack height of the ballast plates of **Sh** of 4.54 m - measured from the upper edge of the ballast pallet - may **not** be exceeded!

▶ The installed derrick ballast must correspond to the data in the load chart!

▶ Make sure that the ballast plates are laying in the centerings **18** on the ballast frame!

▶ The ballasts must be placed in such a way that the ballast pallet is always balanced!

▶ Secure all ballast plates so they cannot move and fall down!

Possible permissible distribution of the ballast plates, variation V1		
Description	Number of ballast plates	Total weight
Ballast stack left	8 x 10 t =	80 t
Ballast stack center	9 x 10 t =	90 t
Ballast stack right	8 x 10 t =	80 t
Maximum total weight of the ballast plates		250 t
Maximum total weight of the suspended ballast		260 t

Possible permissible distribution of the ballast plates, variation V2		
Description	Number of ballast plates	Total weight
Ballast stack left	11 x 10 t =	110 t
Ballast stack center	3 x 10 t =	30 t
Ballast stack right	11 x 10 t =	110 t
Maximum total weight of the ballast plates		250 t
Maximum total weight of the suspended ballast		260 t

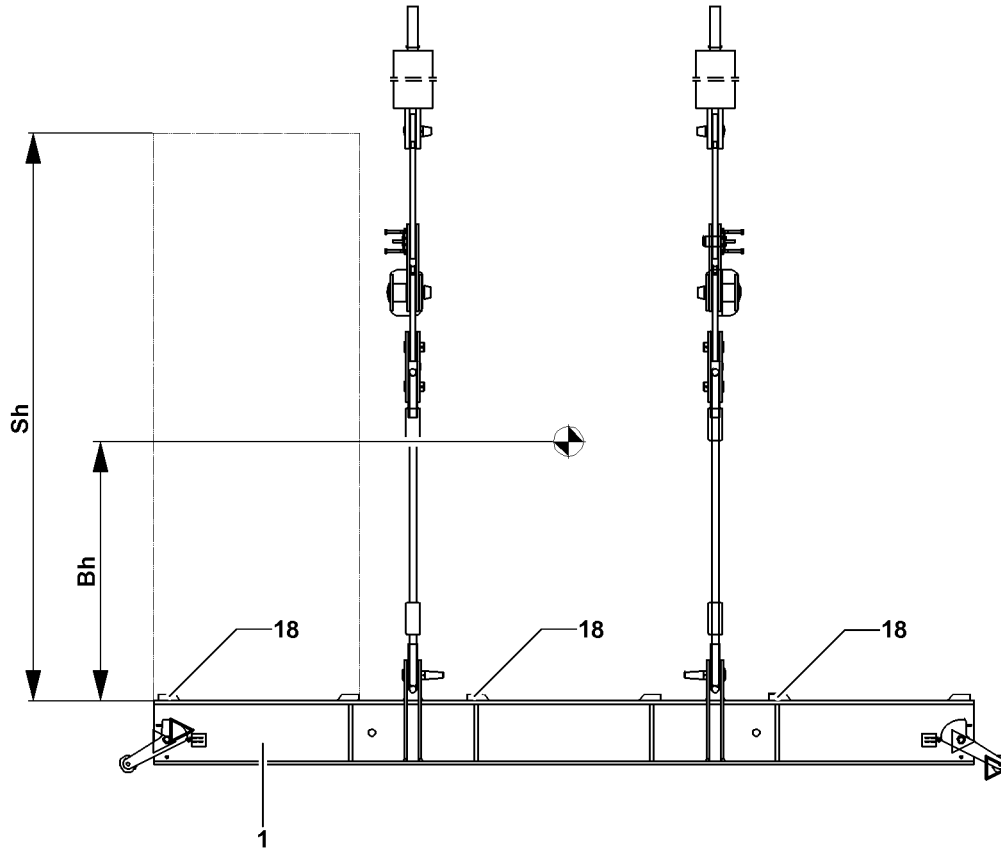

B110372

**WARNING**

Falling ballast plates!

If more than the permissible loads are lifted, then the studs on the ballast plates are overloaded and the ballast plates can fall down. Personnel can be severely injured or killed!

- ▶ Lift no more than maximum 10 t with the ropes, 3 fastening points!
- ▶ Replace damaged ballast plates!

**WARNING**

Incorrect handling of the fastening equipment!

If fastening equipment cannot be attached correctly and if it is not secured sufficiently to prevent it from loosening up, loads can fall down. Personnel can be severely injured or killed!

- ▶ Make sure that the fastening equipment is correctly attached on the fastening points and that it is secured sufficiently to prevent it from loosening up!

**Note**

- ▶ The ballast plates are marked with their own weights!

Make sure that the following prerequisites are met:

- The ballast pallet is assembled on the ballast guide.
- The pull cylinders are pinned and secured on both sides.
- An auxiliary crane is available.
- The LICCON overload protection is exceeded.
- The assembly icon is visible on the LICCON monitor.

**Note**

- ▶ Raise the empty ballast pallet **1** off the ground by luffing down the derrick boom to the front and using master switch 1. Subsequently place it back on the ground by erecting the derrick boom. This ensures that the ballast pallet **1** is aligned exactly vertically before the ballast plates are added!

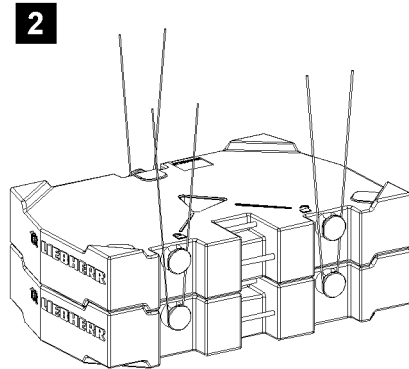
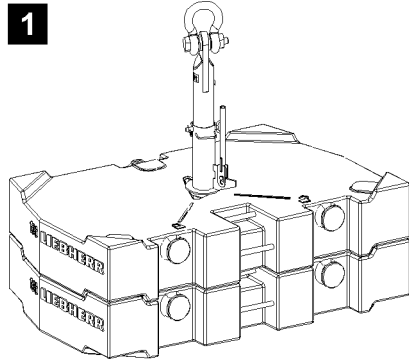

Permissible ballast assemblies



WARNING

Overload fastening points ballast plates!

If more than the permissible number of ballast plates are lifted together, then the fastening points can be overloaded!

The ballast plates and components can fall down!

Personnel can be severely injured or killed!

► Attach only the maximum permissible number of ballast plates per lift!



WARNING

Incorrect set up of ballast assemblies!

When lifting mixed weight ballast assemblies and the heavier ballast plates are placed on top, the fastening points can be overloaded!

The ballast plates and components can fall down!

Personnel can be severely injured or killed!

► Always stack the heavier ballast plate on the bottom in the ballast assembly!

For fastening systems with maximum permissible number of ballast plates, see the following chart:

- “TwistLock”, see illustration 1
- Bits, see illustration 2

Individual weight Ballast plate	Maximum number of same ballast plates per lift over	
	Twistlock	Bitt
5.0 t	2	1
7.5 t	2	2
10.0 t	2	2

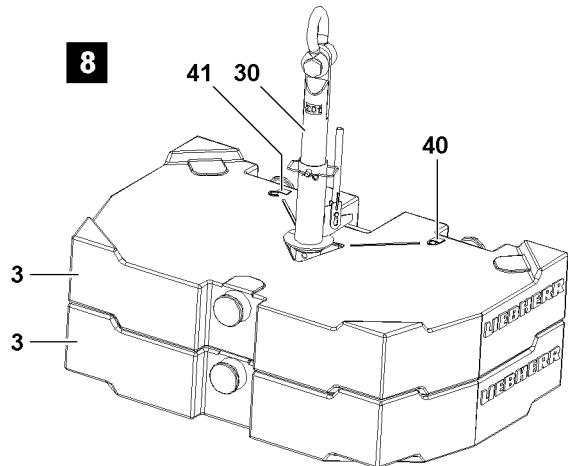
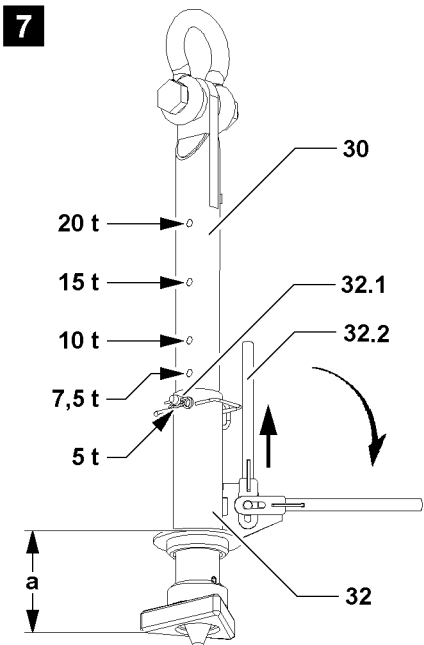
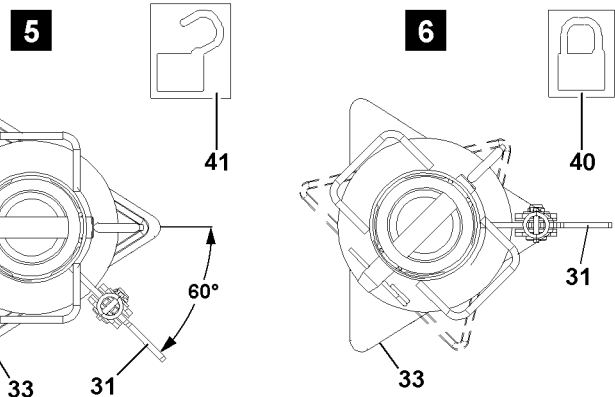
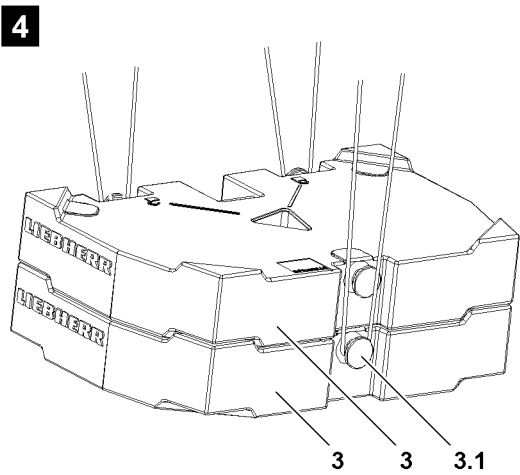
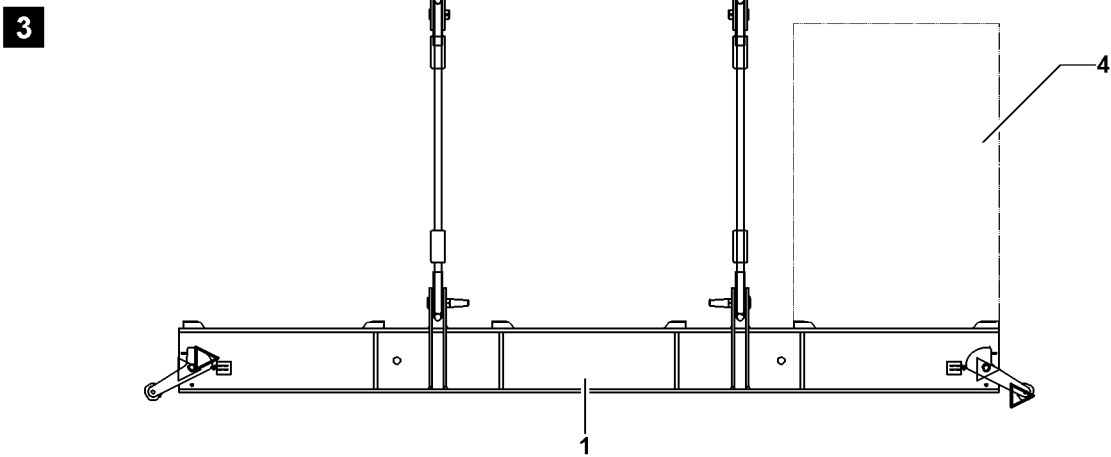

B110371

Placing the ballast plates, fastening system: "Twistlock"

**WARNING**

Overload of receptacle stud and ballast plates!

If more than the permissible number of ballast plates are lifted with the receptacle stud **30**, the receptacle stud **30** and the ballast plates can be overloaded and damaged!

The ballast plates can fall down!

Personnel can be severely injured or killed!

- ▶ Observe the section "Permissible ballast assemblies" in this chapter!
-

**WARNING**

Damage of receptacle stud and ballast plates!

If two ballast plates are lifted which do not lay correctly in their centerings, the receptacle stud **30** and the ballast plates can be damaged!

Damage can cause the ballast plates to fall down!

Personnel can be severely injured or killed!

- ▶ Make sure that the ballast plates to be lifted are placed correctly in the centerings!
-

**WARNING**

The Twistlock system opens by itself!

If the receptacle stud **30** is not correctly locked, the Twist lock system can open by itself!

The ballast plates can fall down!

Personnel can be severely injured or killed!

- ▶ Make sure, when initiating a lift, that the lever **32.2** points directly on the locked symbol **40** of the ballast plates **3**, see illustration **6**!
-

**Note**

- ▶ During a lift, the locked Twistlock system cannot release by itself due to its gravitational retention!
 - ▶ During a lift, the locked Twistlock system cannot be released by hand due to its gravitational retention!
-

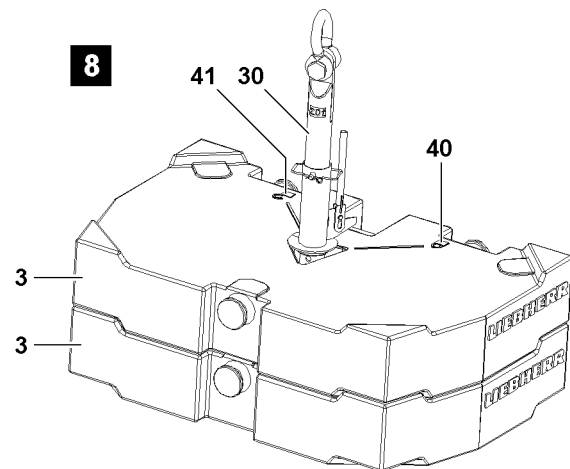
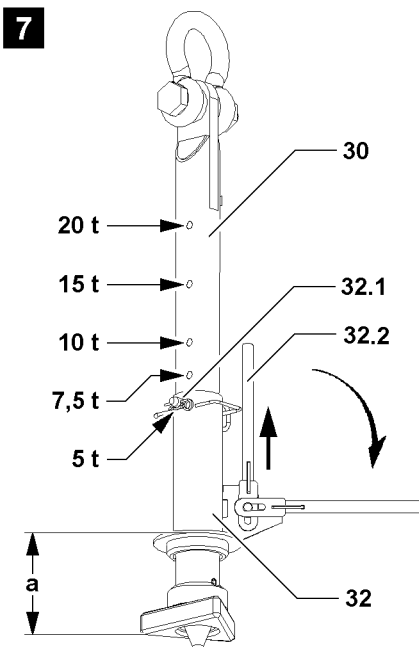
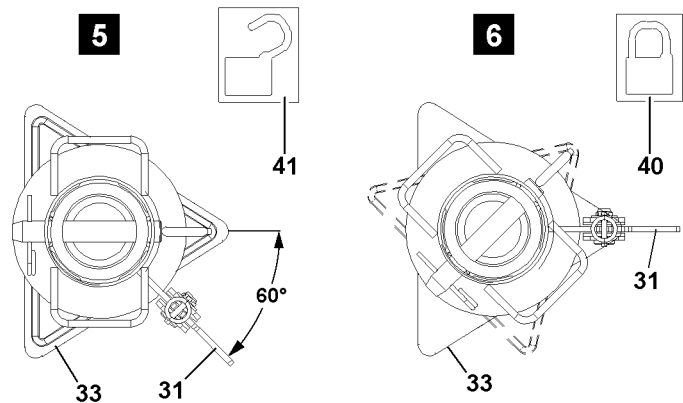
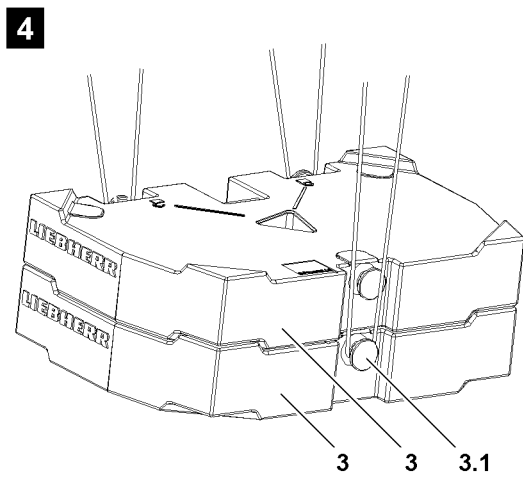
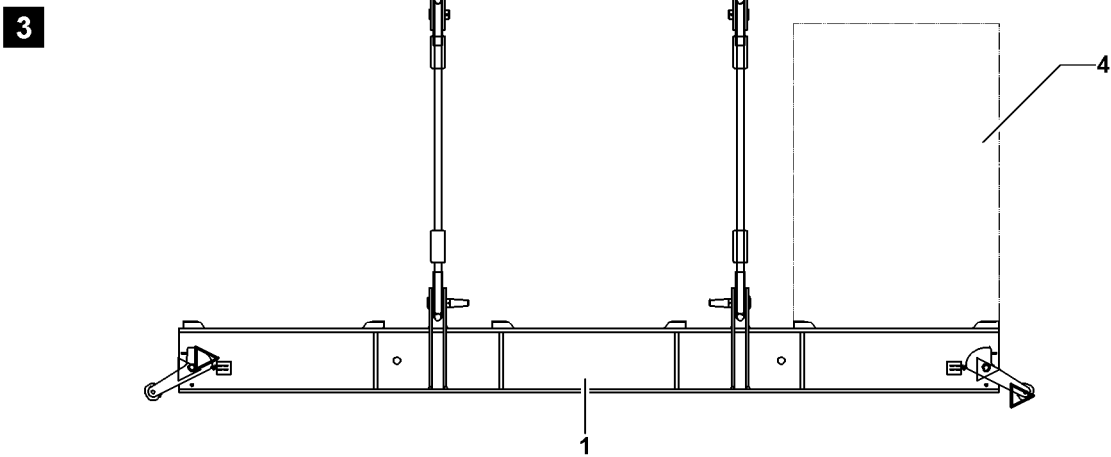

B110371

Before the receptacle stud **30** is guided into the ballast plate(s), it must be ensured that the insertion length **a** of the receptacle stud **30** is set correctly.

The insertion length **a** of the receptacle stud can be adjusted by hand.

- ▶ If the insertion length **a** of the receptacle stud **30** is to be adjusted:
Release and unpin the pin **32.1**.
- ▶ Adjust the insertion length **a** by moving the guide sleeve **32** to the desired insertion length **a**, pay attention to the stages, see illustration **11**.
- ▶ Insert and secure pin **32.1**.

Result:

- The receptacle stud **30** is adjusted.

- ▶ Attach the receptacle stud **30** on the auxiliary crane and guide it into the ballast plate(s).
- ▶ Pull the lever **32.2** up and fold it down.
- ▶ Turn the receptacle stud **30** with the lever **32.2** by 60° until it points to the locked symbol **40** of the ballast plate, see illustration **6**.
- ▶ Carefully lift the ballast plate(s) or the ballast assembly with the receptacle stud **30** and place them on the centerings of the ballast pallet or another ballast plate in the ballast stack **4**, see illustration **7**.
- ▶ When the ballast plates are placed down:
Turn the receptacle stud **30** with the lever **32.2** by 60° to the stop in direction of the unlocked symbol **41** of the ballast plate, see illustration **5**.

Result:

- The receptacle stud **30** is unlocked.
- ▶ Carefully pull out the receptacle stud **30**.
- ▶ Secure all ballast plates so they cannot move and fall down.

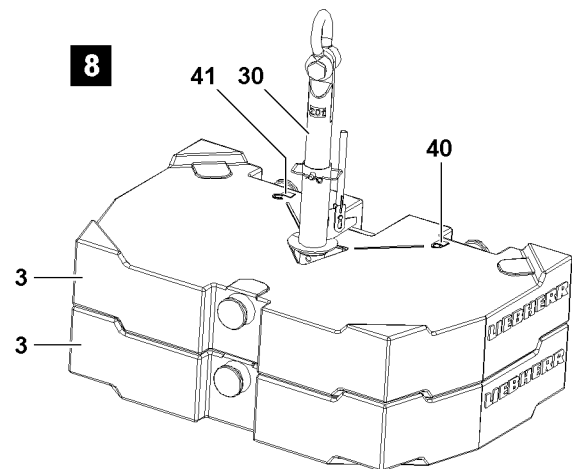
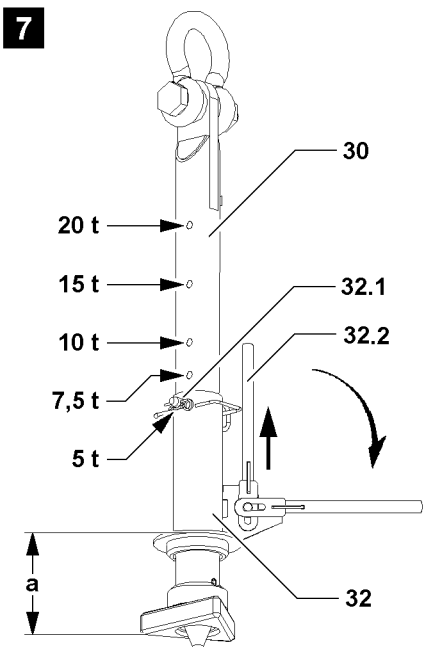
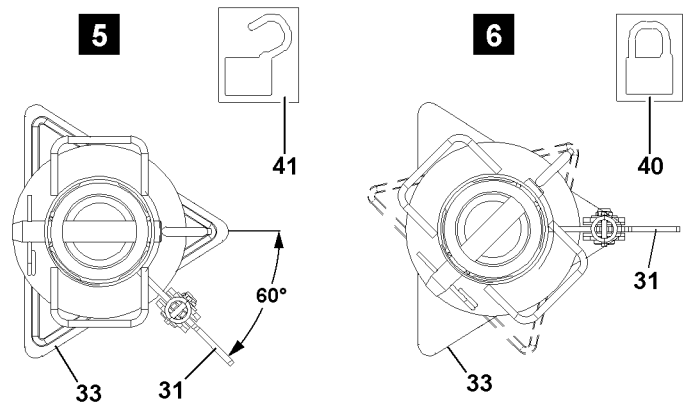
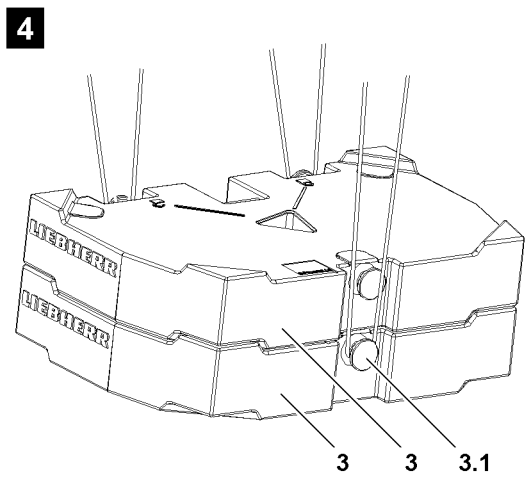
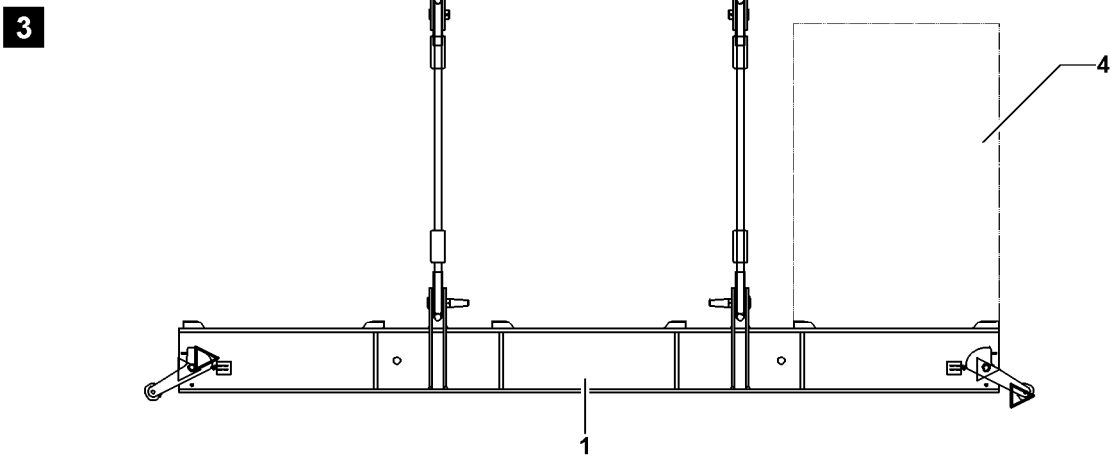

B110371

Placing the ballast plates, fastening points: Bitt

**WARNING**

Overloaded ballast plates!

If more than the permissible loads are lifted, the bitts **3.1** are overloaded!

The ballast plates can be damaged and fall down!

Personnel can be severely injured or killed!

- ▶ Observe the section "Permissible ballast assemblies" in this chapter!
-

**WARNING**

Incorrect handling of the fastening equipment!

If tackle cannot be attached correctly and / or if it is not secured sufficiently to prevent it from loosening up, the ballast plates can fall down!

Personnel can be severely injured or killed!

- ▶ Make sure that the fastening equipment is correctly attached on the bitts **3.1** and that it is secured sufficiently to prevent it from loosening up, see illustration **4**!
-
- ▶ Attach the ballast plates individually or as a ballast assembly on the auxiliary crane.
 - ▶ Lift the ballast plates or the ballast assembly and place it carefully on the centerings on the ballast pallet or on another ballast plate in the ballast stack **4**.

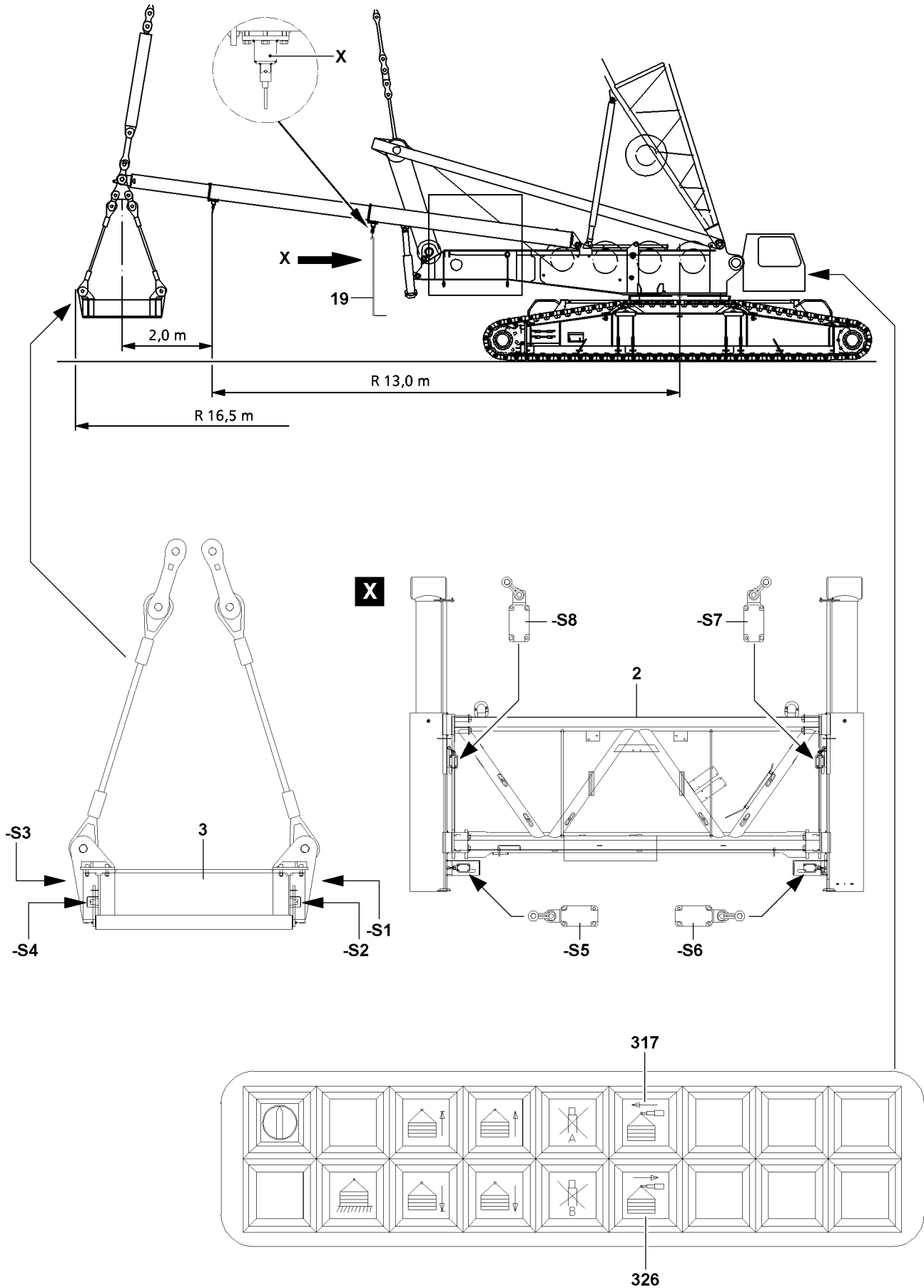

B104668

1.5.10 Function check

Make sure that the following prerequisites are met:

- All electrical connections have been made.
- The actuator levers of the limit switches on the guide and ballast pallet have been checked for ease of movement and have been lubricated.
- The actuator rollers on the ballast pallet have been checked for easy movement and are lubricated.

Limit switch “Derrick ballast on ground”

- ▶ Manually actuate limit switch **-S1**, limit switch **-S2**, limit switch **-S3** and limit switch **-S4** on the ballast pallet **3** individually.

Result:

- The slewing gear must turn off.
- The warning light **411** lights up.

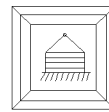

Warning light 411 “Derrick ballast on ground”

Limit switch “Derrick ballast up and down”

- ▶ Manually actuate limit switch **-S5**, limit switch **-S6**, limit switch **-S7** and limit switch **-S8** on the guide frame **2** individually, see view **X**.

Result:

- Extension and retraction of the pull cylinders is switched off.
- Warning light **410** or warning light **412** is lit.

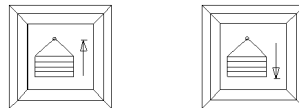

Warning light 410 “Derrick ballast up” and warning light 412 “Derrick ballast down”

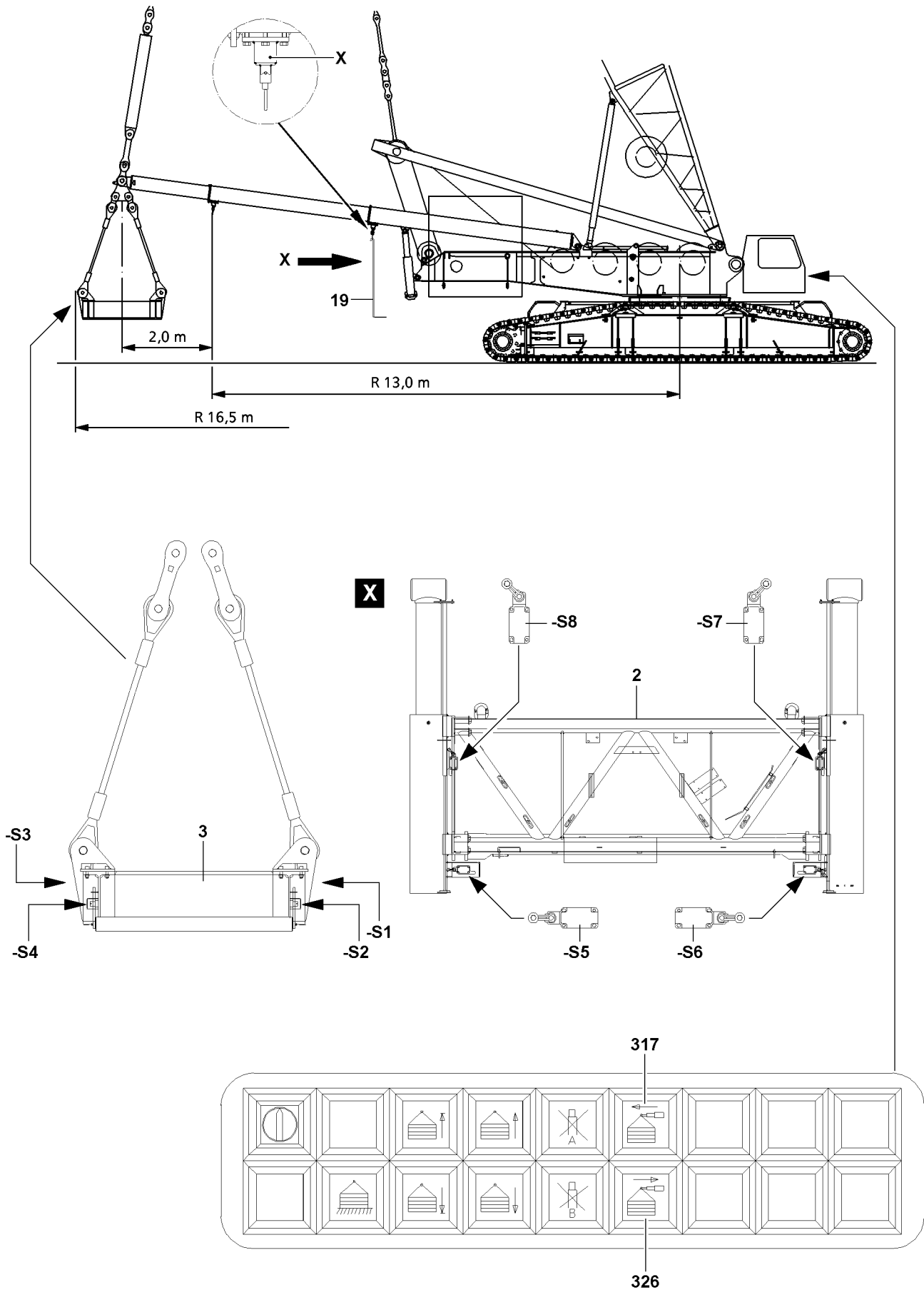

B104668

1.5.11 Telescoping the derrick ballast to the required radius

The ballast guide can be steplessly hydraulically telescoped. To achieve a radius of 15 m, the 2 m long end side must be mechanically pulled, see section "Mechanically telescoping the ballast guide".



WARNING

Risk of accident!

- ▶ The crane driver must ensure that both telescopic cylinders extend by the same amount, because only one side is equipped with a length sensor. If both telescopic cylinders diverge, briefly drive the extension mechanism against a stop until both telescopic cylinder are extended or retracted by the same amount!
-

Hydraulically telescoping out the ballast guide

- ▶ Press the button **317** in the crane operator's cab.

Result:

- The ballast guide extends.
- ▶ When the required derrick ballast radius is reached:
Do **not** press the button **317** in the crane operator's cab any longer.

Hydraulically telescoping in the ballast guide

- ▶ Press the button **326** in the crane operator's cab.

Result:

- The ballast guide retracts.
- ▶ When the required derrick ballast radius is reached:
Do **not** press the button **326** in the crane operator's cab any longer.

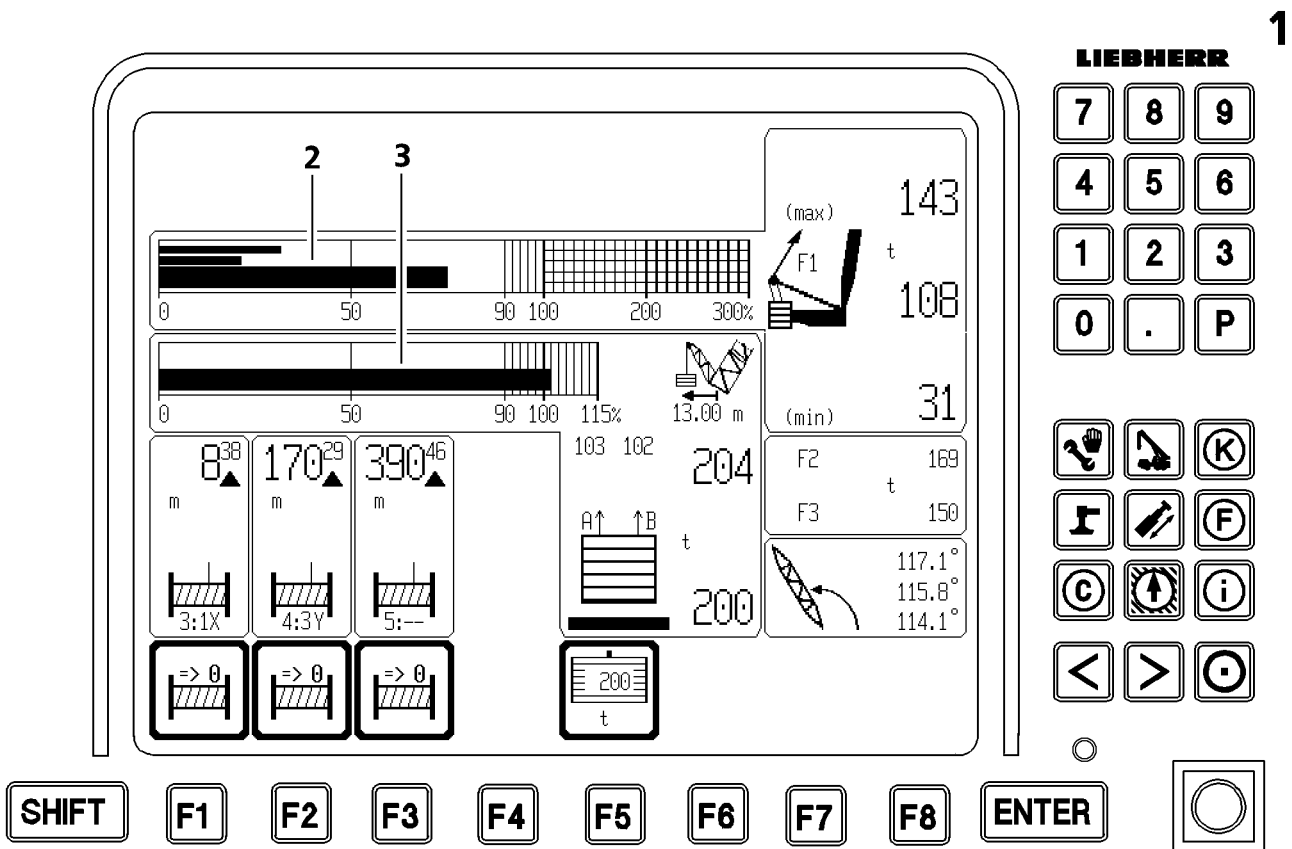
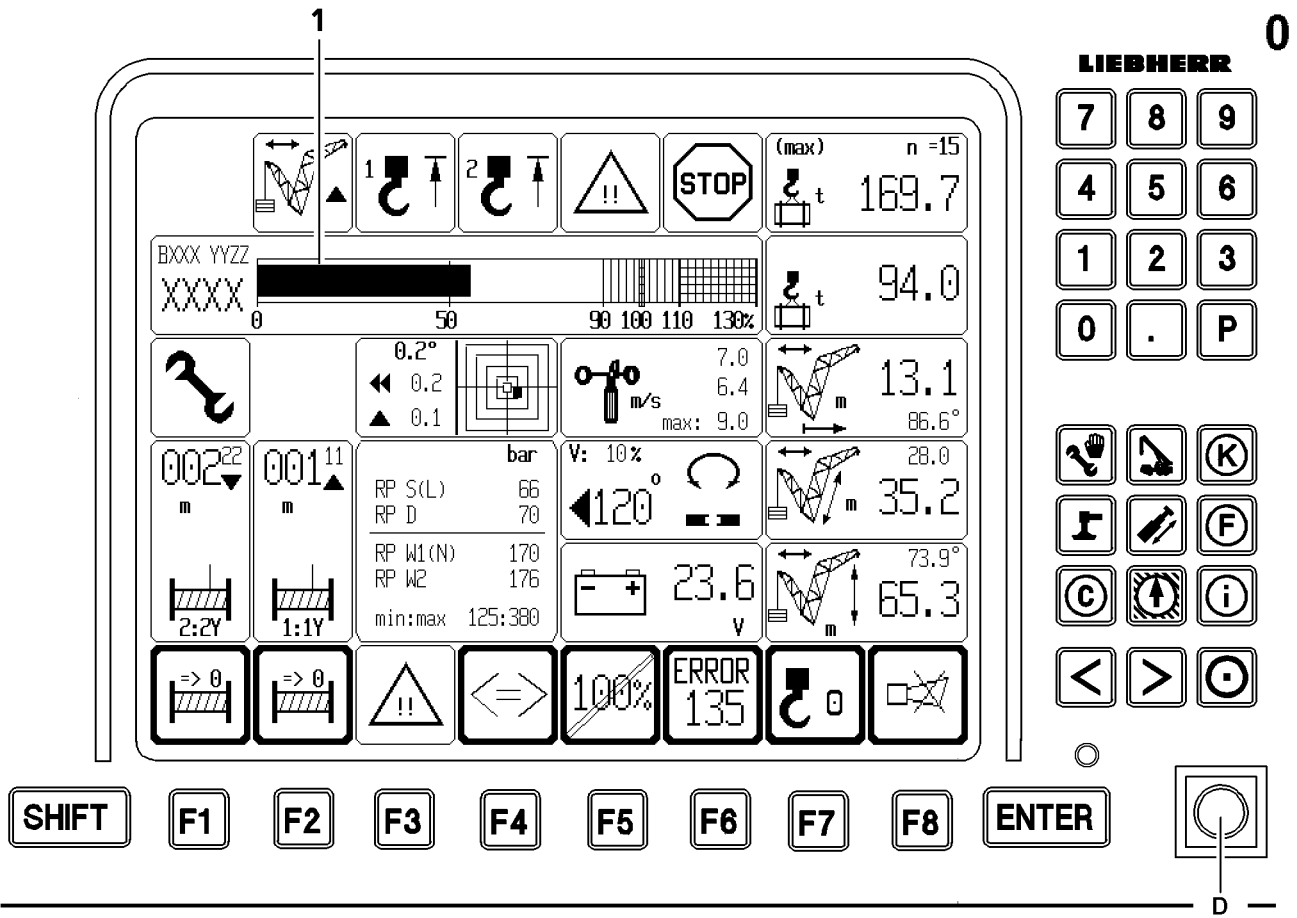

B111437

1.5.12 Crane operation with derrick ballast



WARNING

Danger of accident when exceeding the shut off limits of the LICCON overload protection!

If the shut off limits of the LICCON overload protection are exceeded, there is no additional protection against crane overload!

Due to erroneous operation or deliberate misuse, the crane could collapse, the boom can break off or the crane can topple over!

Personnel can be severely injured or killed!

- ▶ The button "Luffing in with suspended load" and the set up key **D** may only be used when it is ensured that no normal operating condition (utilization below 100 % and no active shut off) can be reached without exceeding the shut off limits of the LICCON overload protection!
- ▶ Use the set up key **D** only when no normal operating condition (utilization below 100 % and no active shut off) can be reached with the button "Luffing in with suspended load"!
- ▶ It is only permitted to exceed the shut off limits of the LICCON overload protection in emergencies and for assembly purposes!
- ▶ The set up key **D** may only be actuated by persons who are aware of the effects of their acts regarding the exceeding of the LICCON overload protection!
- ▶ Exceeding the shut off limits of the LICCON overload protection requires the presence of an authorized person and must be performed with utmost caution!
- ▶ Crane operation with exceeded shut off limits of the LICCON overload protection is prohibited!
- ▶ For procedure of shut off of crane movements, see Crane operating instructions, chapter 4.20!



WARNING

The crane can topple over!

If the derrick ballast is lifted off the ground past the **maximum permissible** 250 mm then the crane can topple to the rear if the load rips off!

If the following notes are not observed, personnel can be severely injured or killed!

- ▶ There may be no personnel, objects or obstacles within the entire slewing range of the crane, derrick ballast and the load!
- ▶ Do not lift the derrick ballast more than 250 mm off the ground!
- ▶ The ground in the entire working area of the crane - including the derrick ballast and the load - must be even and of sufficient load carrying capacity in order to be able to securely accept the encountered ground pressures and weight loads!



Note

- ▶ The suspended ballast and the ballast trailer are generally described as **derrick ballast!**
- ▶ The fixed compensation weight which is assembled on the turntable is generally described as the **counterweight!**

Make sure that the following prerequisites are met:

- The required derrick ballast is placed according to the load chart.
- The derrick boom is in the required operating position, radius **9 m or 11 m**.

1

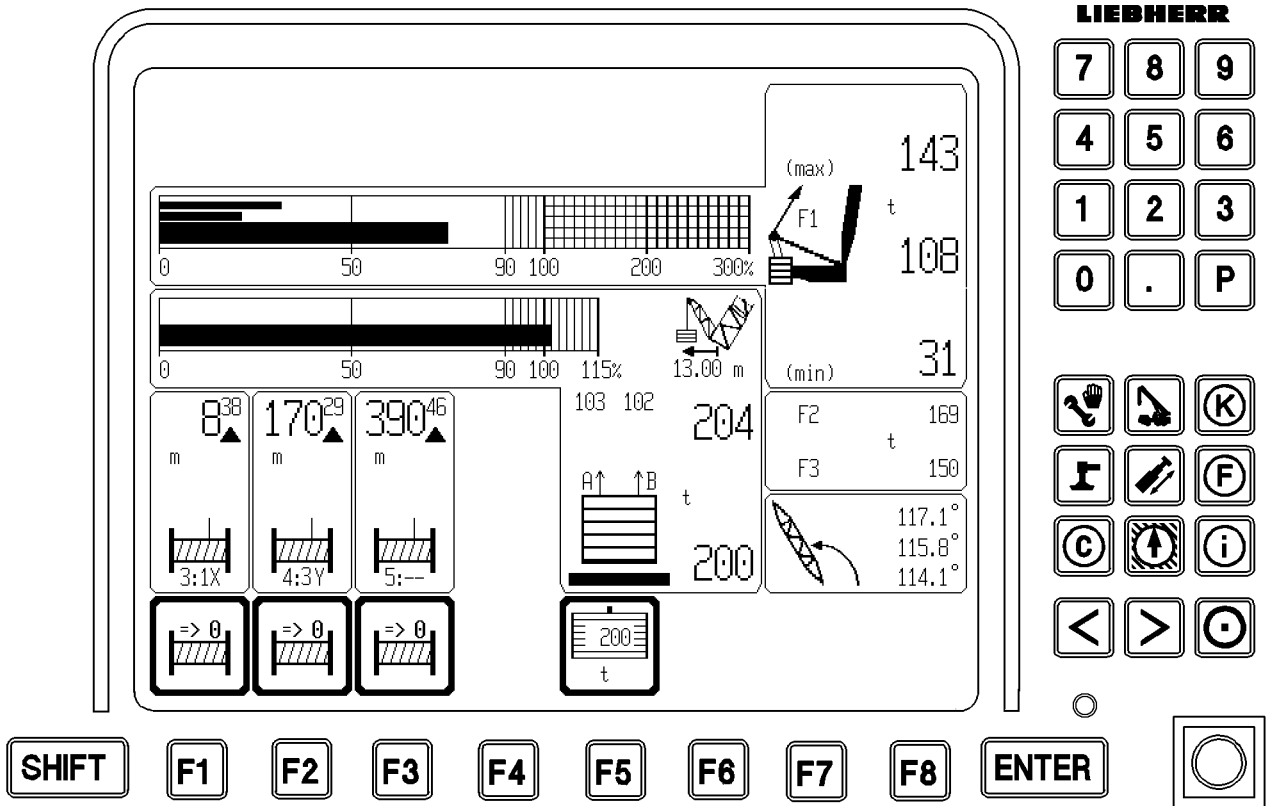

Settings

- ▶ Set and confirm the load chart for the upcoming crane operation in the LICCON computer system.
- ▶ Set the actually present derrick ballast weight in the LICCON computer system.

**Note**

- ▶ To set the derrick ballast, see Crane operating instructions, chapter 4.03!
- ▶ The required derrick ballast must be determined according to the data in the load chart!

**DANGER**

Risk of accident!

The set derrick ballast must match the actually placed derrick ballast!

- ▶ Incorrect ballast weight entry can lead to dangerous operating situations!

- ▶ Check the set derrick ballast against the actual derrick ballast!

Crane operation**DANGER**

Risk of accident!

There may be no persons or obstacles within the turning range of the derrick ballast.

During the turn, a guide must monitor the boom, derrick boom and derrick ballast for any danger of collision.

When turning with a load and suspended derrick ballast, the turning movement must be initiated or slowed down extremely carefully!

- ▶ The jerky initiation / slowing down of a turning movement can cause the load or suspended derrick ballast to swing!
- ▶ This can cause the boom to break off or the crane to topple over!
- ▶ For crane operation with derrick ballast, the data in chapter 4.02 of the Crane operating instructions must be observed!

**Note**

- ▶ If the suspended derrick ballast must be swung over any obstructions or be set down at a different level to the crane, it is possible to raise or lower the suspended derrick ballast using the pull cylinders. The pull cylinders are operated from the crane operator's cab!

**DANGER**

Danger of tipping over!

The derrick ballast functions may only be carried out from the crane operator's cab because the monitor display is required for derrick ballast operation!

- ▶ It is prohibited to raise the derrick ballast off the ground using the control panel!
- ▶ The derrick ballast must always be in horizontal position when it is raised or lowered with the pull cylinders!

- ▶ Monitor the extended state of the cylinder piston rod.

Crane operation with derrick ballast

In all operating modes with derrick ballast, the load on the guy rods from the derrick head to the SA-bracket (F1) and to the derrick ballast (F4/5) is distributed.

The load of the crane is monitored by test point 1 (F1), in the guying from the SA-bracket to the derrick head. If the force becomes too high, then all movements, which increase the load momentum are turned off.

The force distribution can change due to the following procedures:

- Taking on the load: By flexing of the turntable.
- By raising or lowering the derrick ballast using the pull cylinders.
- By ballasting derrick ballast plates on or off.

Safety guidelines

- The test points must be checked for function before crane operation.
- The crane must be horizontally aligned on the set up location.
- The weight of the load to be lifted must be known.
- Place the ballast plates according to the data in the load charts or the job planner.
- According to the information on the following illustrations, the contact surface of the derrick ballast may be above or below the level of the crane base.
- The placement surface on which the suspended derrick ballast is placed after completion of the load lift must be level, horizontal and able to safely support the weight.



WARNING

Risk of accident!

- ▶ Before setting down the load and suspended derrick ballast, the crane operator must make sure that it can be safely set down!

- There should not be any obstacles within the slewing range of the crane, ballast trailer, suspended derrick ballast and load.
- The suspended derrick ballast should be lifted off the ground by approx. 0.25 m. Lift off must be monitored by the crane operator or guide.
- When picking up the load, **make sure** to avoid diagonal pull, i.e. the derrick ballast, the center of rotation of the turntable and the load must be in one line! To ensure this, operate the cylinder to lift and set down the derrick ballast (ballast pallet) before adding any ballast plates.



DANGER

Danger of tipping over!

- ▶ If this is not observed, there is a risk of tipping when lifting with ballast plates. This could cause the crane to topple over!

- When taking on the load, the guying of the derrick ballast to the derrick end section must be without force or slightly tensioned, so that the **minimum force F1 min** on **test point 1 (F1)** is being exceeded.
- The guying between the SA-bracket and derrick head **test point 1 (F1)** should **never be untensioned!**



DANGER

Risk of accident!

- ▶ If the guying between the SA-bracket and the derrick head is not under tension, this may lead to uncontrolled movements of the boom system and cause an accident!

1

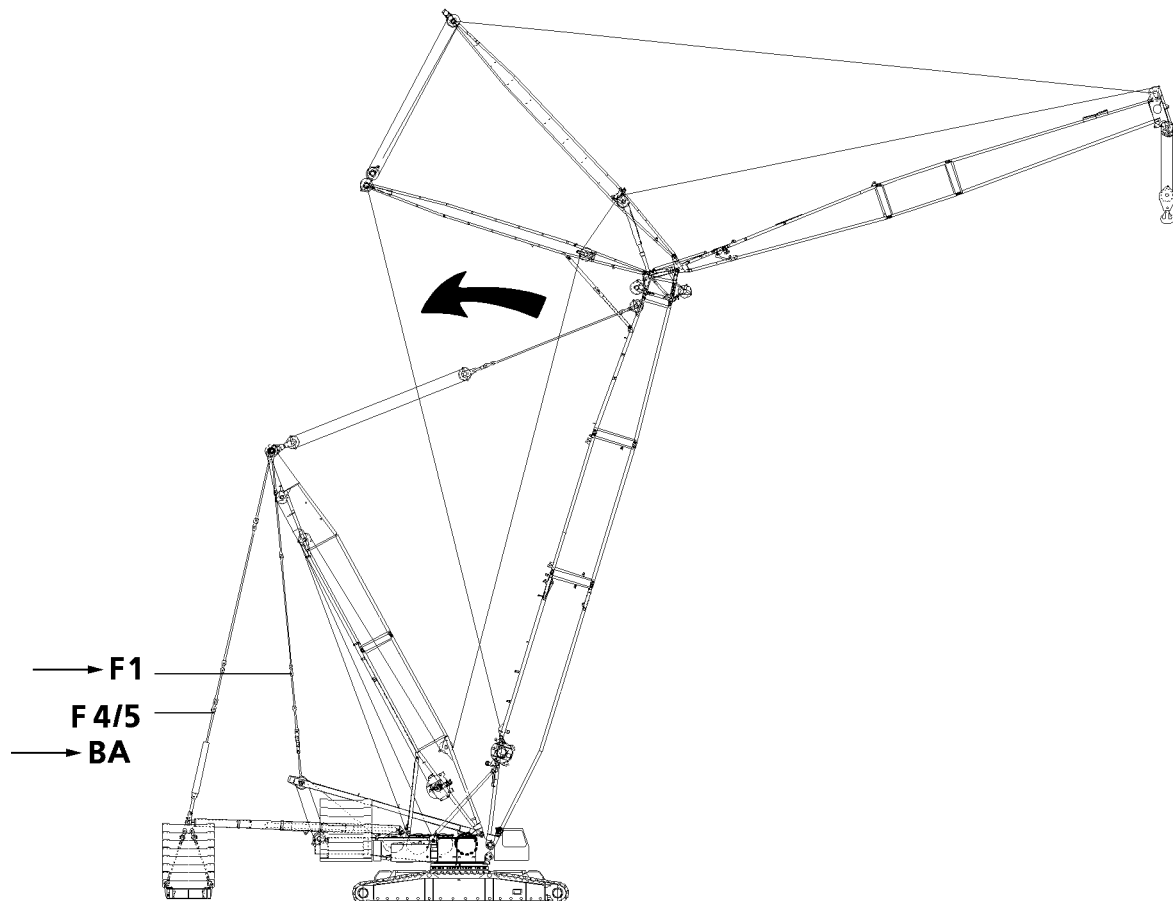
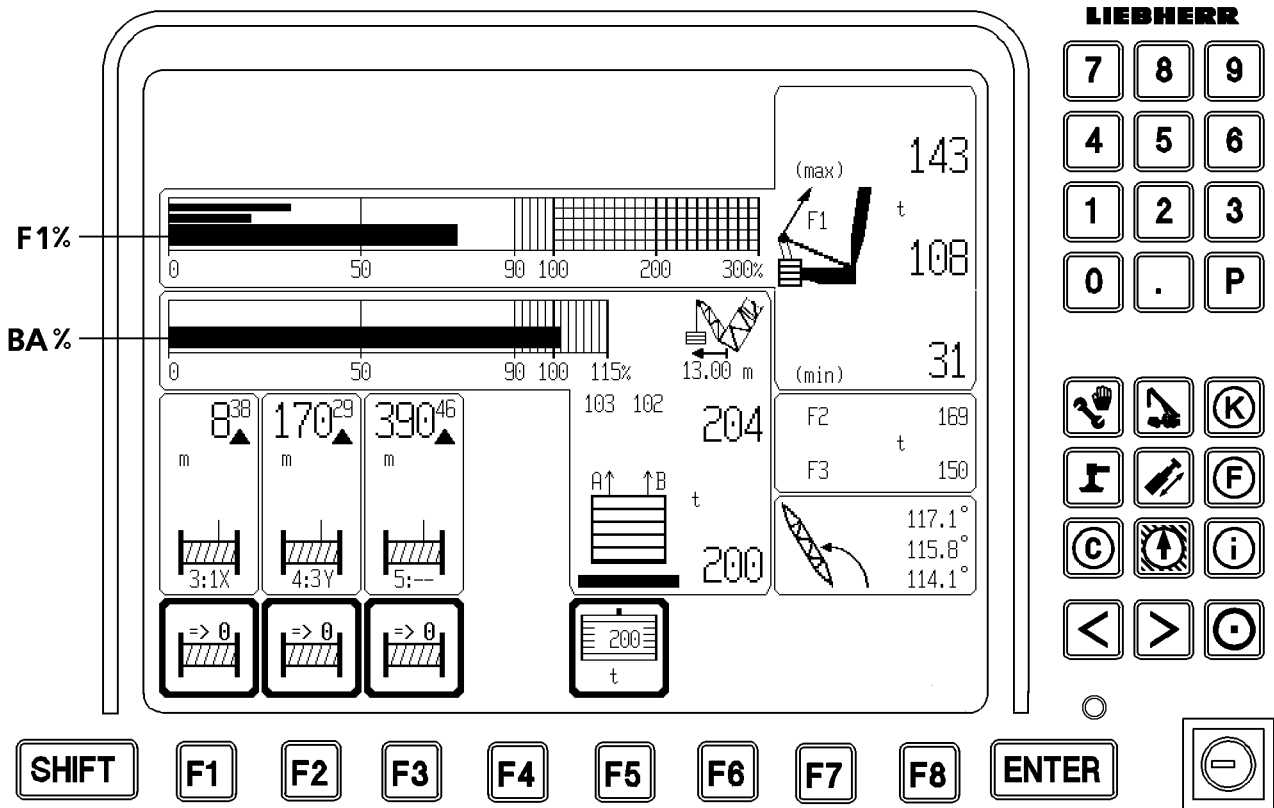

B110373

Force F4/5 (test point 4/5) guying derrick ballast - derrick end section

The forces F4/5 (test point 4/5) are effective in the guy rods from the derrick ballast to the derrick head.

The actual forces in the guy rods (A = left and B = right) are calculated from three pressure sensors installed on the pull cylinders and displayed on the LICCON monitor as individual forces.

The pulled ballast is calculated from the forces of the individual guying, which means the part of the ballast pulled up by the guying. The remaining part is on the ground. The derrick ballast utilization results from the pulled ballast and the placed ballast. This is shown on the LICCON monitor in a utilization bar (BA in %).

Force F1 (test point 1) between guying SA-bracket - Derrick end section

The force F1 (test point 1) is determined in the guy rods from the SA-bracket to the derrick head by 2 force test boxes and is shown on the LICCON monitor as total force of the guying.

From the operating force F1 and the force F1-operational maximum force results the F1 utilization. This is shown on the LICCON monitor in a utilization bar (F1 in %).

Monitoring of minimum force F1**WARNING**

Danger of accident when exceeding the shut off limits of the LICCON overload protection!

- ▶ For procedure of shut off of crane movements, see Crane operating instructions, chapter 4.20!

**Note**

- ▶ If the minimum force- $F_{1\min}$ (test point 1) is fallen below, then the LICCON overload protection shuts the crane movement off!
- ▶ A shut off of crane movements can be avoided when F1 remains larger than $F_{1\min}$!

If more than 50 % of the entered derrick ballast is pulled (ballast utilization bar more than 50 %), and the force falls below the minimum force F1 min (test point 1), all load moment increasing crane movements are turned off.

**DANGER**

Risk of accident!

- ▶ It is prohibited to fall below the minimum force F1 min (test point 1) if more than 50 % of the derrick ballast is pulled. If this is not observed, in case of loose tension from test point 1 (F1) and derrick ballast on the ground, the derrick ballast can suddenly lift off the ground due to the increased load moment and the boom system suddenly moves forward! This will result in the load swinging violently and could damage the boom and cab!

If more than 90 % of the entered derrick ballast is pulled (ballast utilization bar at more than 90 %), and the force falls below the minimum force F1 min (test point 1), all load moment increasing and all load moment reducing crane movements are turned off. The hoist gear "down" movement is also turned off.

1

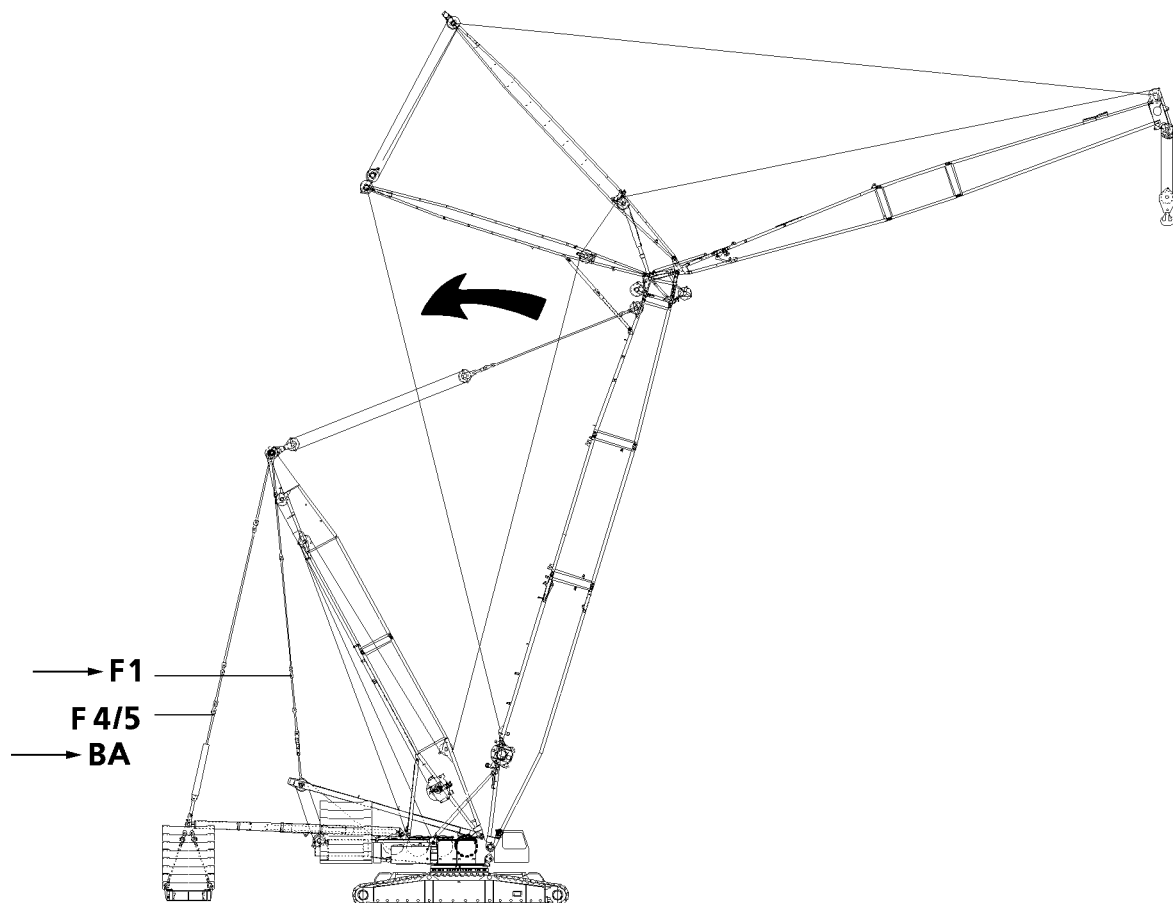
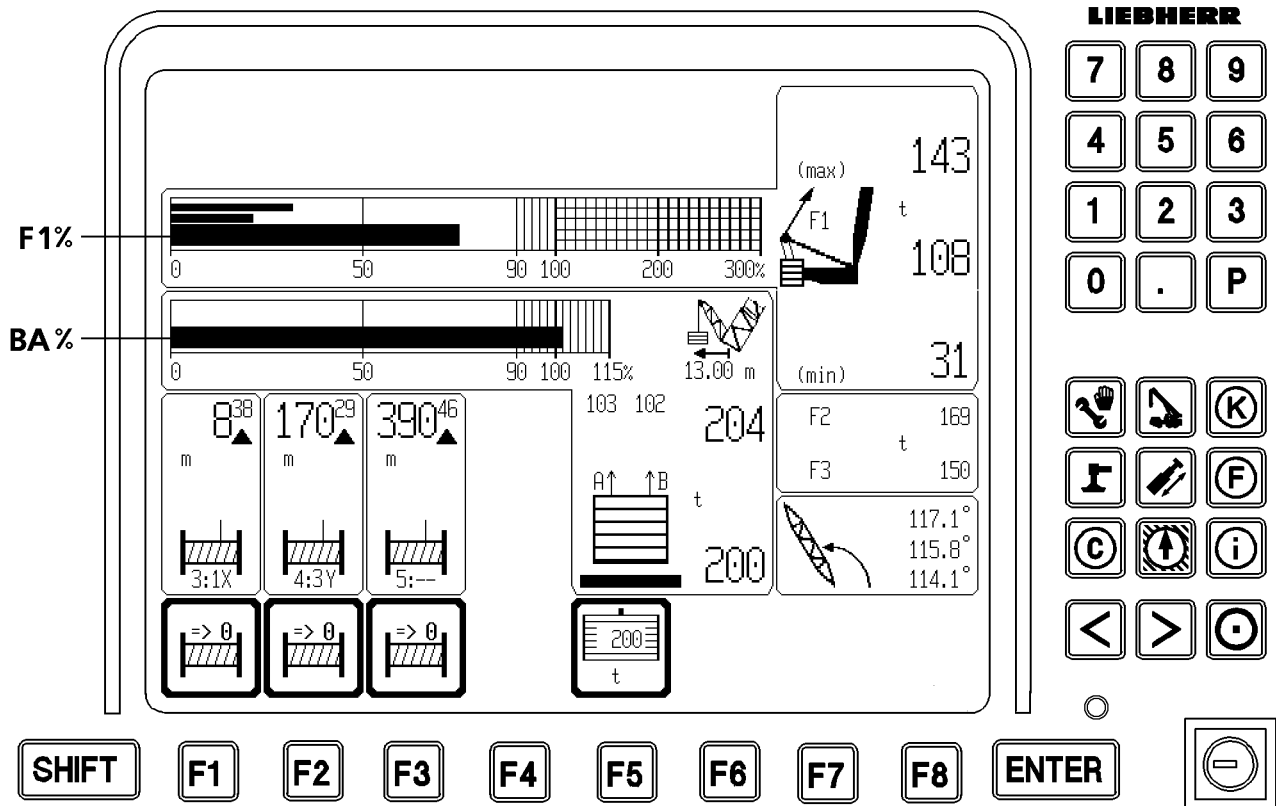

B110373

**DANGER**

Risk of accident!

It is prohibited to fall below the minimum force $F1_{min}$ (test point 1) if more than 90 % of the derrick ballast is pulled. If this is not observed and the guying on test point 1 ($F1$) is slack and the suspended derrick ballast is suddenly set down on the ground and the boom system suddenly moves back by the reduction of the load moment of the derrick ballast! Thereby the relapse cylinders can be pressed on block and be overloaded. There is a danger of damage to the relapse cylinders for boom and derrick!

► This also causes significant oscillation of the load, which can damage the boom and the crane!

This danger condition can only be overcome :

- By lowering the suspended derrick ballast to the ground using the pull cylinders,
- **or** ballast pallets are unloaded to reduced the derrick ballast utilisation and increase the load at test point 1 ($F1$).

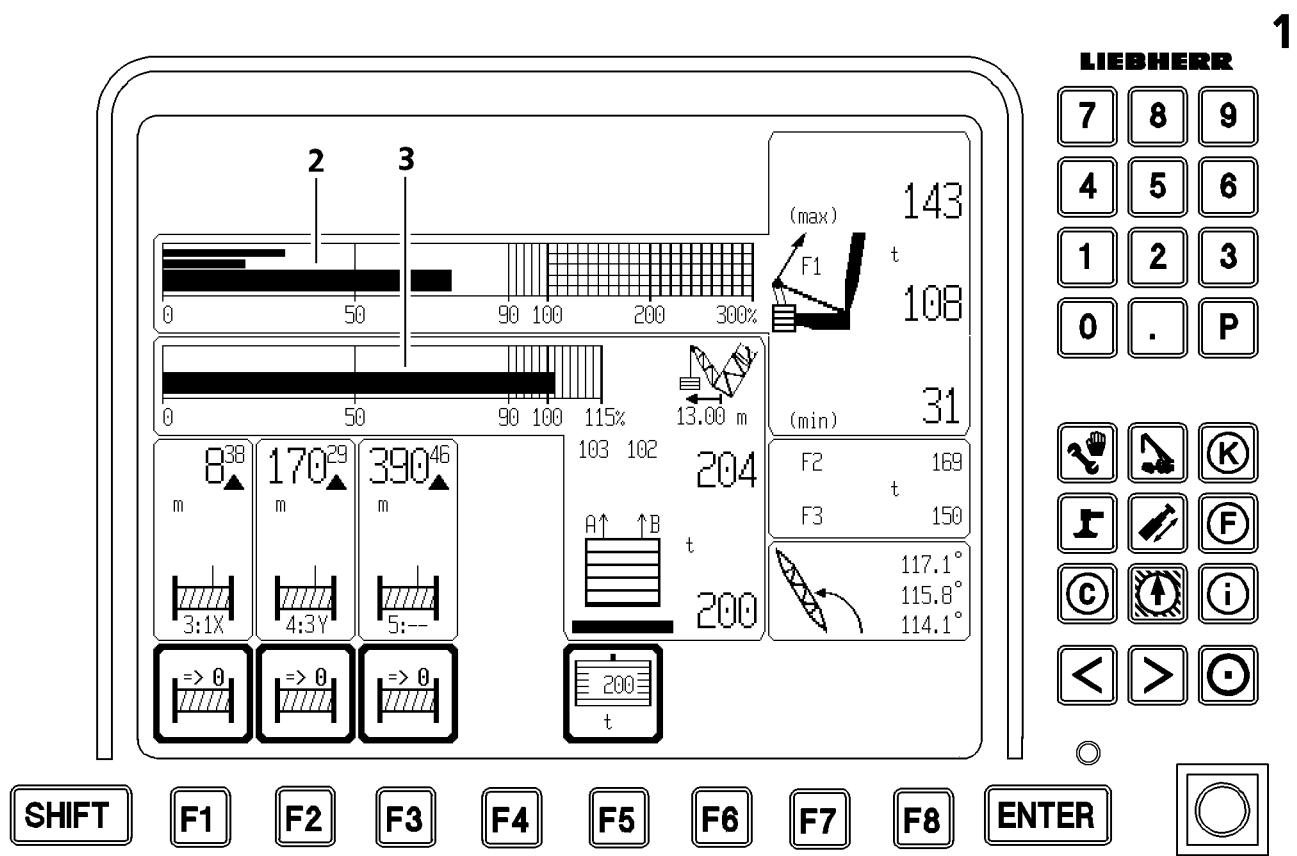
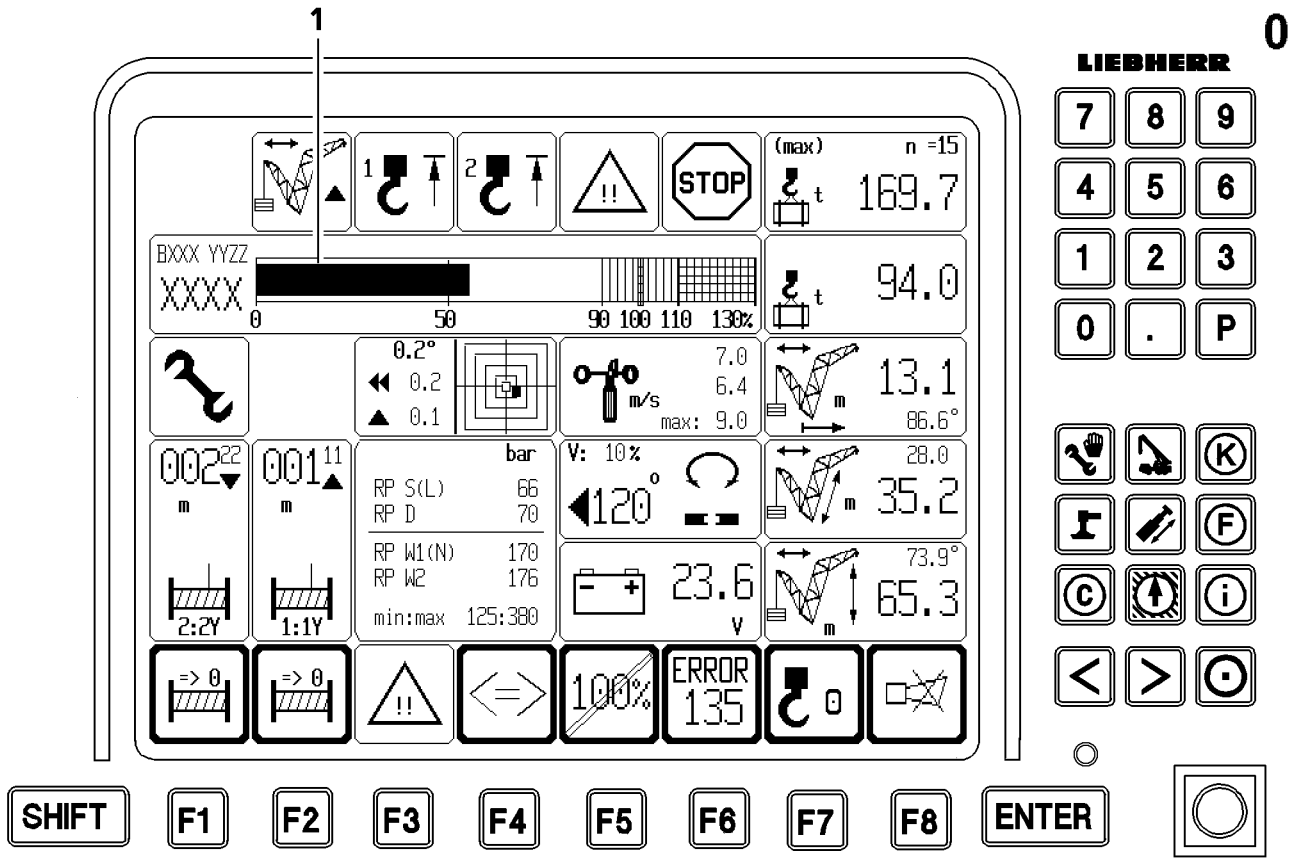

1.5.13 Overload monitoring in operating mode with derrick ballast

**Note**

► Explanation of description in quotes (" "), see Crane operating instructions, chapter 4.02!

In operating modes with derrick ballast, the "Maximum load for the current crane condition" is monitored two ways:

- 1.) Monitoring of maximum load by the LMB overload protection.
- 2.) Monitoring of test point 1 - operational maximum force by derrick ballast overload protection.

The LMB overload protection

It monitors the "Maximum load according to load chart and reeving".

In operating modes with derrick ballast, this is the maximum load of the current crane condition with optimum derrick ballast. It is shown on LICCON monitor 0. The current utilization of the crane with optimum derrick ballast results from the load utilization bar **1** on the LICCON monitor 0.

If the load utilization bar reaches 90 %, an advance warning is given in the form of a caution icon and a "SHORT HORN" on the LICCON monitor 0.

At 100 % on the load utilization bar, the shut off of all load moment increasing movements with the "STOP" icon and the acoustical warning "HORN" occurs on LICCON monitor 0.

The "Maximum load" can possibly be increased further by pulling the derrick ballast up or by placing additional ballast plates - within the specifications of the load charts.

Monitoring of test point 1-operational maximum force (= F1 max)

It is shown on LICCON monitor 1.

If the F1 max- utilization **2** reaches 90 %, an advance warning is given in the form of a caution icon and a "SHORT HORN" on the LICCON monitor 1.

At 100 % F1max utilization, the shut off of all load moment increasing movements with the "STOP" icon and the acoustical warning "HORN" occurs on the LICCON monitor 1.

When the maximum load according to the load chart and the reeving is not reached (utilization bar **1**), then the maximum load of the current crane condition can still be increased by:

- Lifting the derrick ballast if it is not already suspended.
- Telescoping out the derrick ballast if the added ballast is still lower than the optimum ballast.
- Increasing the derrick ballast by adding additional ballast plates if the placed ballast is still smaller than the optimum ballast.

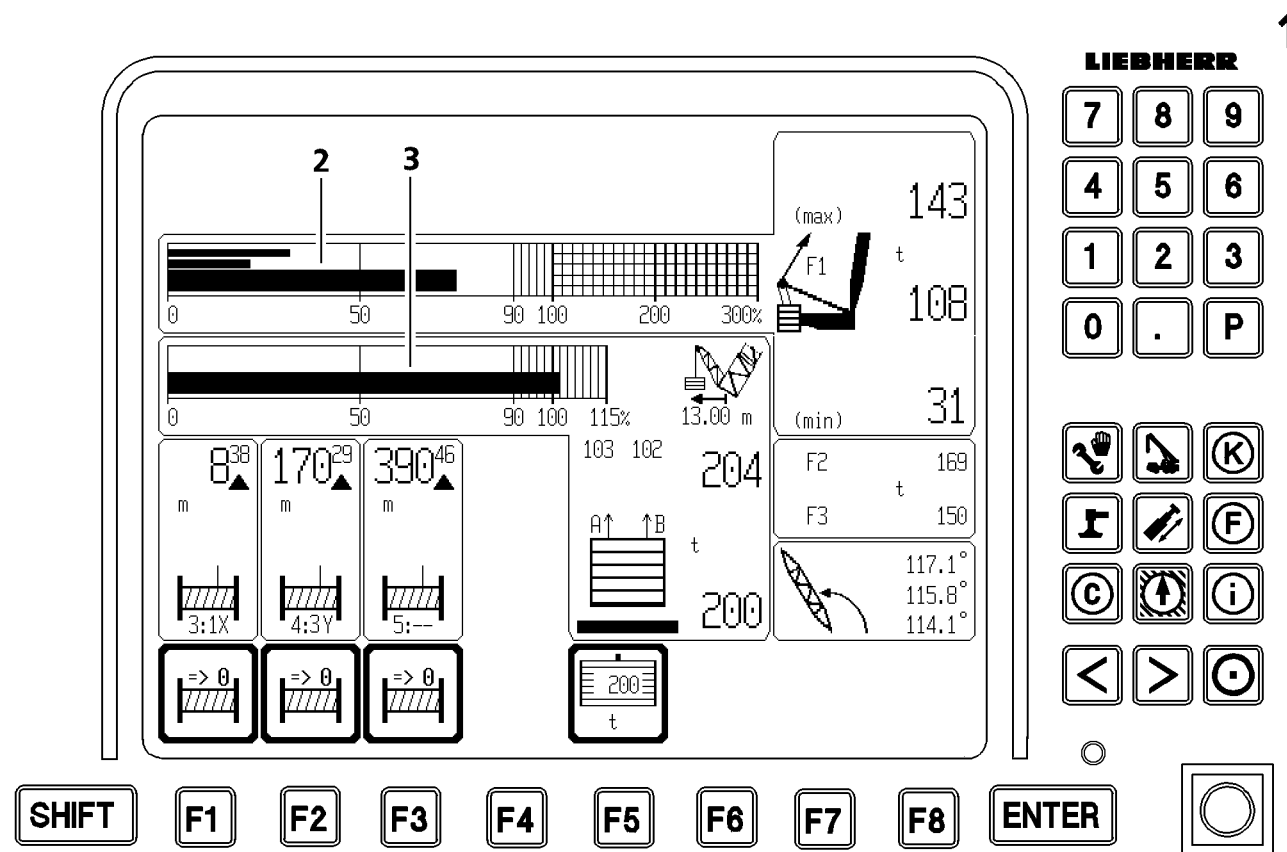
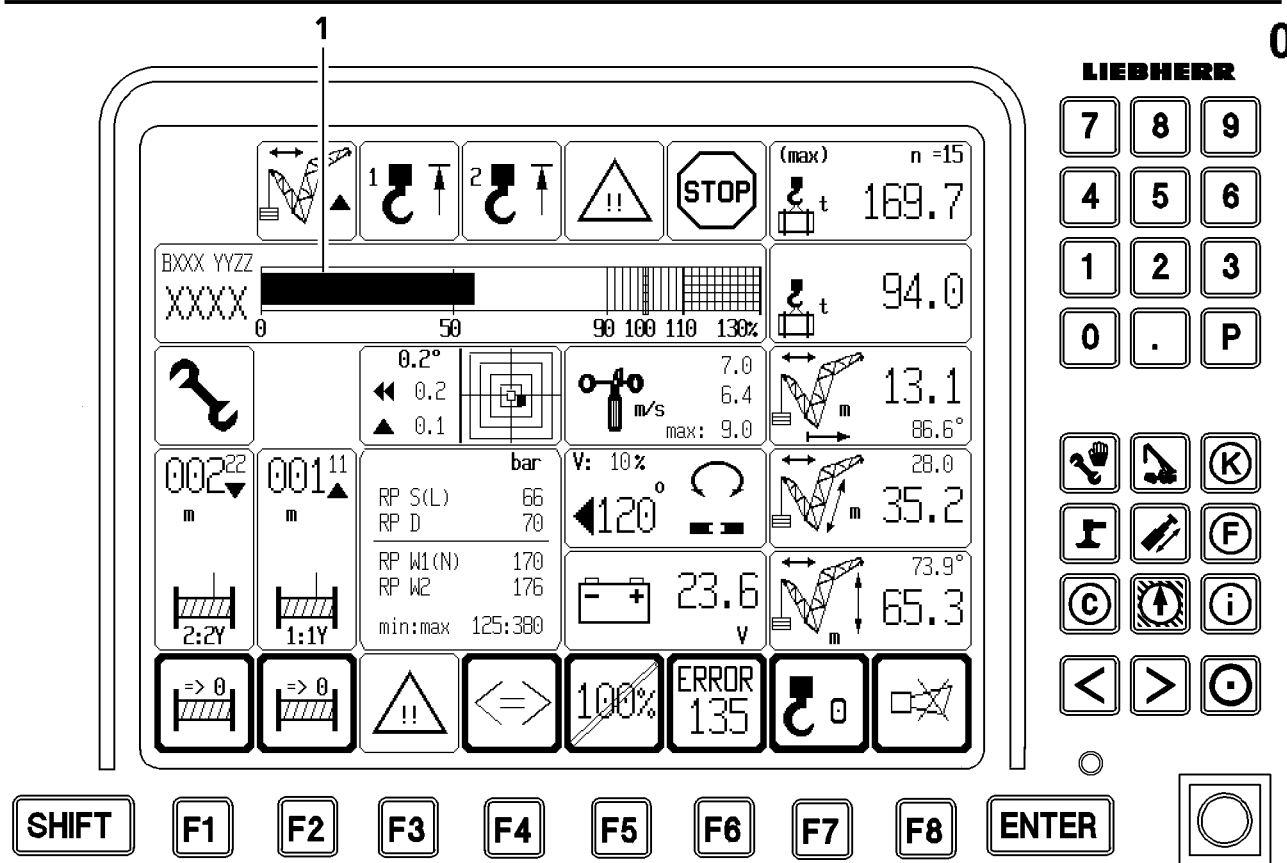

1.5.14 Utilization conditions



WARNING

Danger of accident when exceeding the shut off limits of the LICCON overload protection!

- ▶ For procedure of shut off of crane movements, see Crane operating instructions, chapter 4.20!



Note

- ▶ If the minimum force- $F_{1_{\min}}$ (test point 1) is fallen below, then the LICCON overload protection shuts the crane movement off!
- ▶ A shut off of crane movements can be avoided when F_1 remains larger than $F_{1_{\min}}$!

The current utilization of the crane results from the load utilization bar **1** on monitor 0 and the F1-utilization bar **2** on the LICCON monitor 1.

The "Maximum load of the current **crane condition**" is reached when the load utilization bar **1** has reached 100 % or when the F1 - utilization bar **2** has reached 100 %.

The "Maximum load of the current **crane equipment**" is reached when the load utilization bar **1** has reached 100 % or when the F1 - utilization bar **2** has reached 100 % and the derrick ballast is suspended (ballast utilization bar **3** at 100 %, if the ballast input value and the ballast weighing are correct).

The movement "Ballast up" or "Ballast down" requires utmost attention. When 90 % of the placed ballast is pulled, the warning "Upcoming lift off of derrick ballast" is issued. The warning is indicated by a "Short horn" and blinking "Pulled ballast" value. The warning is turned off when the operator confirms that he has recognized the warning by pressing the function key $F8_1$ (= horn off on LICCON monitor 1).

1

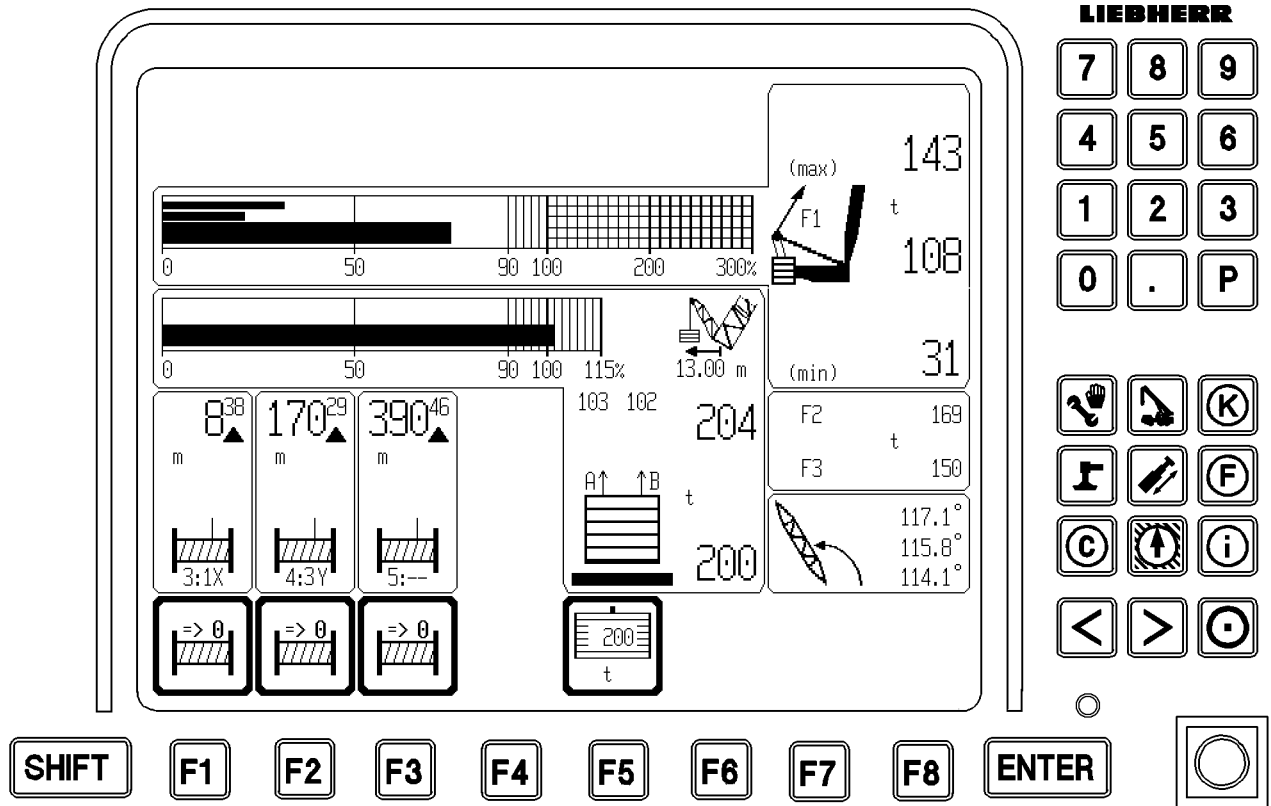

1.5.15 Accessing the load charts

Checking the length sensor value on the derrick ballast

When telescoping the derrick ballast in and out, the derrick ballast radius display must be monitored carefully.

When telescoping the derrick ballast, the display must change according to the movement. This allows the crane operator to immediately notice if the length sensor rope drum jams when spooling in or out.

When the derrick ballast is extended or retracted all the way, the derrick ballast display must show almost the exact end position, for example Radius = 11 m or 15 m.

The crane operator may not rely blindly on the derrick ballast radius measurement, but he must think for himself and check, if the measurement is still working correctly.



DANGER

Risk of accident!

If the derrick ballast radius is measured incorrectly, the false radius value will result in the calculated maximum lifted load and test point 1-operation-max-force being too high!

► The crane will be overloaded although this is not apparent!

Check with length sensor for derrick ballast radius

It must be ensured that both telescopic cylinders extend by the same amount, because only one side is equipped with a length sensor.

If both telescopic cylinders diverge, briefly drive the extension mechanism against a stop until both telescopic cylinder are extended or retracted by the same amount.

1

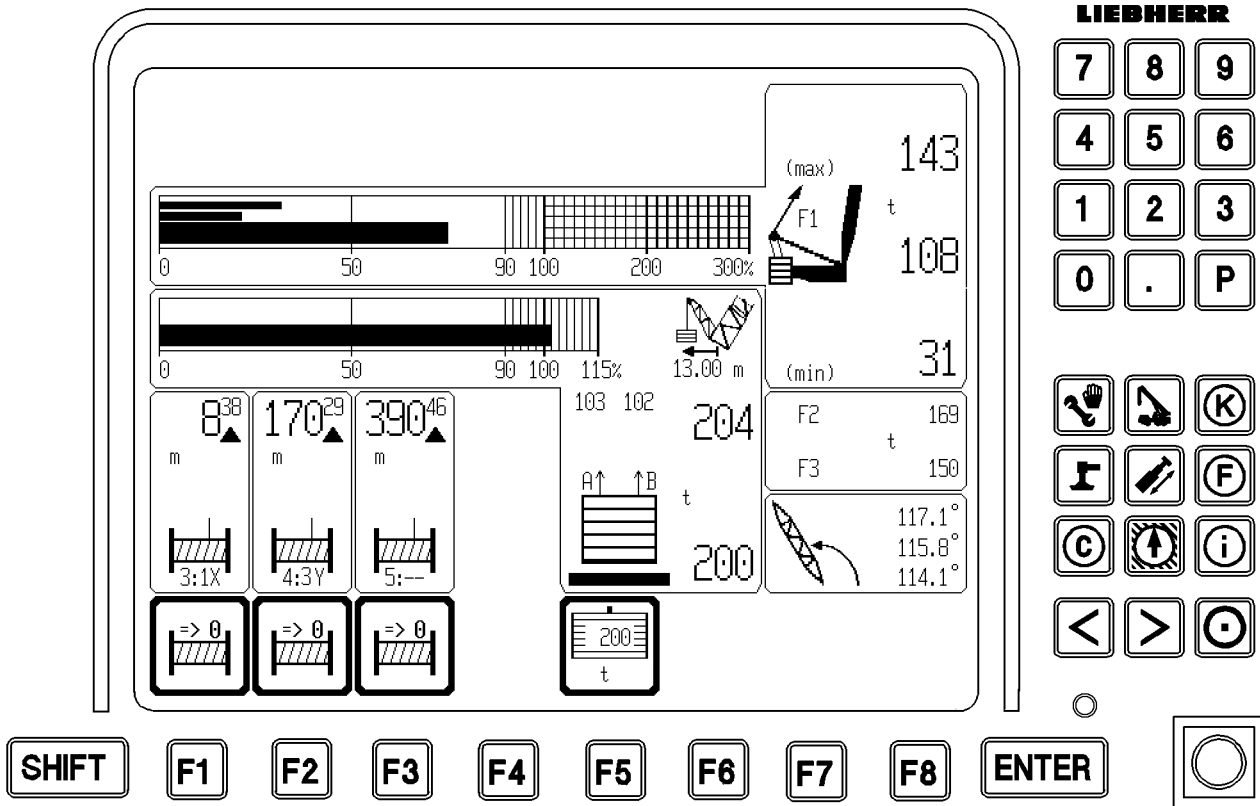

1.5.16 Difference force monitoring of ballast guying

In operating modes with derrick ballast, the difference of the forces of derrick ballast guyings A and B, LICCON monitor 1, are monitored.



DANGER

Risk of accident!

If the difference of these forces is too high, it will damage the derrick head or other crane components!

► Risk of accident!

The forces in the derrick ballast guyings A and B are shown and compared on the LICCON monitor 1. If the difference exceeds a permissible value, an acoustical warning is issued and the two force values blink. However **none** of the movements are turned off.

If the difference of the forces of the derrick ballast guyings A and B exceeds the specified limit value, then this can have various causes:

- Taking up the load by relieving the load on the ballast trailer tires or flexing the turntable.
- The ground under the derrick ballast is uneven.
- The crane is leaning to one side.
- The derrick ballast has been loaded one-sided.
- By raising or lowering the derrick ballast using the pull cylinders.
- The force measurement in one guying is incorrect.

The crane driver must recognize the correct cause and take countermeasures:

- 1.) The error, which caused the one-sided force, must be remedied.
- 2.) In case of small ground unevenness only, the following measure is permissible:
Lock one ballasting cylinder and use the other ballasting cylinder to “Raise the ballast” or “Lower the ballast” until the difference between the forces reduces. It must be ensured that the derrick ballast is not tilted at an inadmissible angle with respect to the crane, otherwise the derrick ballast guide and attachments will be damaged.
- 3.) In case of implausible sensor values: Check whether the ballast weighing pressure sensors or inputs are faulty. If necessary, detach the sensor or replace the CPU.

**DANGER**

Risk of accident!

► Derrick ballast cylinder A should be extended by a maximum of approx. 40 mm more or less than cylinder B!

1.6 Disassembly



WARNING

Risk of falling!

During assembly / disassembly work, personnel must be secured with appropriate aids to prevent them from falling. If this is not observed, assembly personnel can fall and suffer life-threatening or fatal injuries!

- ▶ Any assembly work, where there is a danger of falling must be carried out with suitable aids (for example lifting platform, scaffolding, ladder, auxiliary crane)!
- ▶ If the work cannot be carried out with such aids nor from the ground, then the assembly personnel must secure themselves with approved fall arrest systems to avoid falling, see Crane operating instructions, chapter 2.04!
- ▶ Approved fall arrest systems must be hung into the respective fastening points on the crane, see Crane operating instructions, chapter 2.06!
- ▶ If railings are present on the components, then they must be brought into the corresponding position and secured for assembly / disassembly work!
- ▶ Step on aids and fall protection equipment only with clean shoes!
- ▶ Keep aids and fall protection equipment clean and free from snow and ice!
- ▶ During all assembly and disassembly work, maintenance work and inspections, travel and crane operation is prohibited!



WARNING

Components not pinned and secured!

If a component is released from the auxiliary crane before having been pinned and secured, the component will fall down! Personnel can be severely injured or killed!

- ▶ Do not disengage the auxiliary crane until the corresponding component is pinned and secured!



WARNING

Danger of impact / crushing!

When installing / removing crane components with the auxiliary crane, crane components can start to swing back and forth!

When lifting / lowering and positioning crane components, there is an increased danger of impacts / crushing!

Personnel can be caught and severely injured or killed!

- ▶ Make sure that personnel cannot be caught by components!
- ▶ When working in danger zones: Use aids to protect limbs!
- ▶ Guide components with suitable aids to minimize oscillation!

Make sure that the following prerequisites are met:

- The placement surface for the derrick ballast must be level, horizontal and of sufficient load carrying capacity.
- The boom and the derrick boom are assembled on the turntable.
- An auxiliary crane is available.

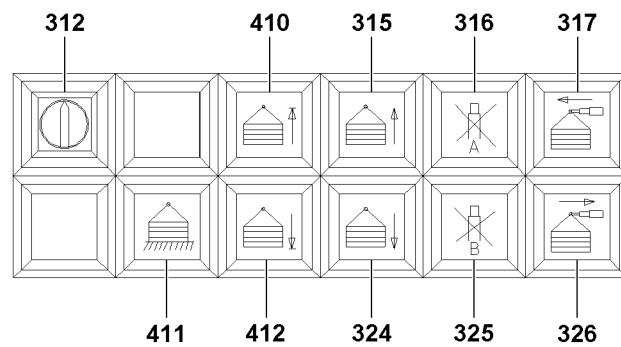
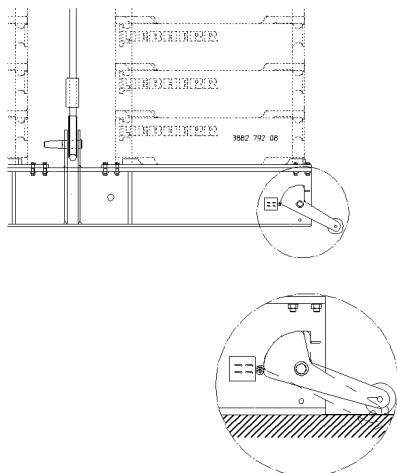
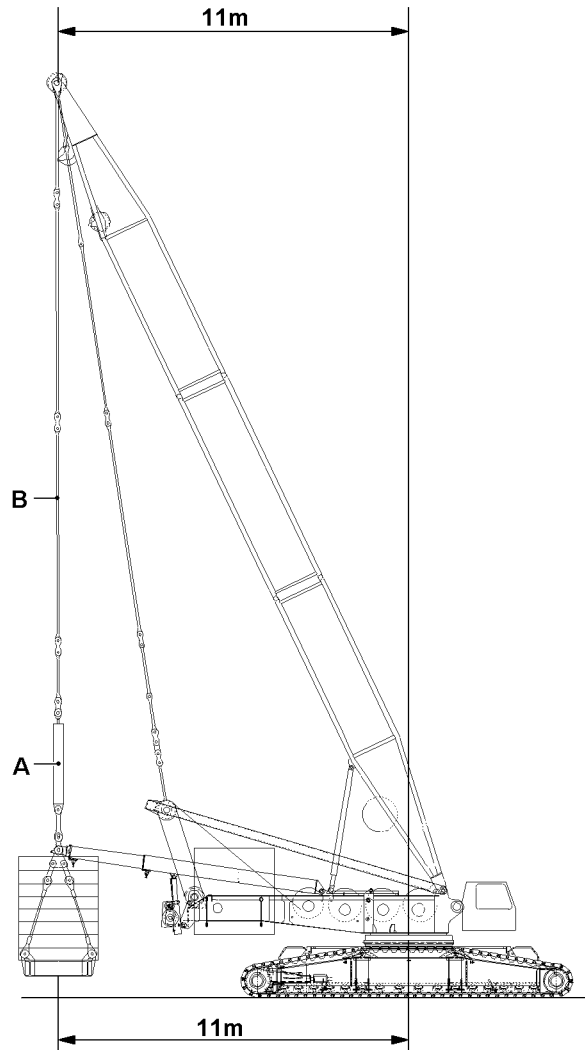

1.6.1 Setting the ballast pallet down



DANGER

Risk of accident!

The surface on which the derrick ballast is set down must be level, horizontal and of sufficient load bearing capacity, otherwise the derrick ballast can tip over and cause fatal injury!

- ▶ Check the horizontal position of the crane during the set down procedure!
- ▶ Check the horizontal position of the derrick ballast during the set down procedure!
- ▶ Constantly check the difference forces in the guying on the LICCON monitor!
- ▶ It is strictly prohibited for anyone to stand under the derrick ballast or in any part of the danger zone during the set down procedure!

Make sure that the following prerequisites are met:

- The derrick boom is erected to a radius of 11 m.
- The ballast guide is telescoped to a radius of 11 m.
- A guide or crane operator must monitor the setting down of the derrick ballast and the load.

- ▶ Press the button **324**.

Result:

- The piston rods of the pull cylinders **A** extend.
- The derrick ballast is lowered.



Note

- ▶ If the ballast pallet is at an angle and if there is a difference in the forces in the guying **B**, re-align the ballast pallet until it is horizontal!

- ▶ Block the left or right pull cylinder **A** by pressing button **316** or button **325**.
- ▶ Extend or retract the non-blocked pull cylinder **A** by pressing button **315** or button **324** until the ballast pallet is horizontal.
- ▶ When the ballast pallet touches the ground, the ground contact switches are actuated.

Result:

- The crane movements “**Turning the turntable**” and “**Driving the crawler**” turn off.

- ▶ Press button **324** until indicator light **412** is lit.

Result:

- The ballast guide is now fully resting on the turntable frame.
- The crane movement **Derrick ballast down** turns off.

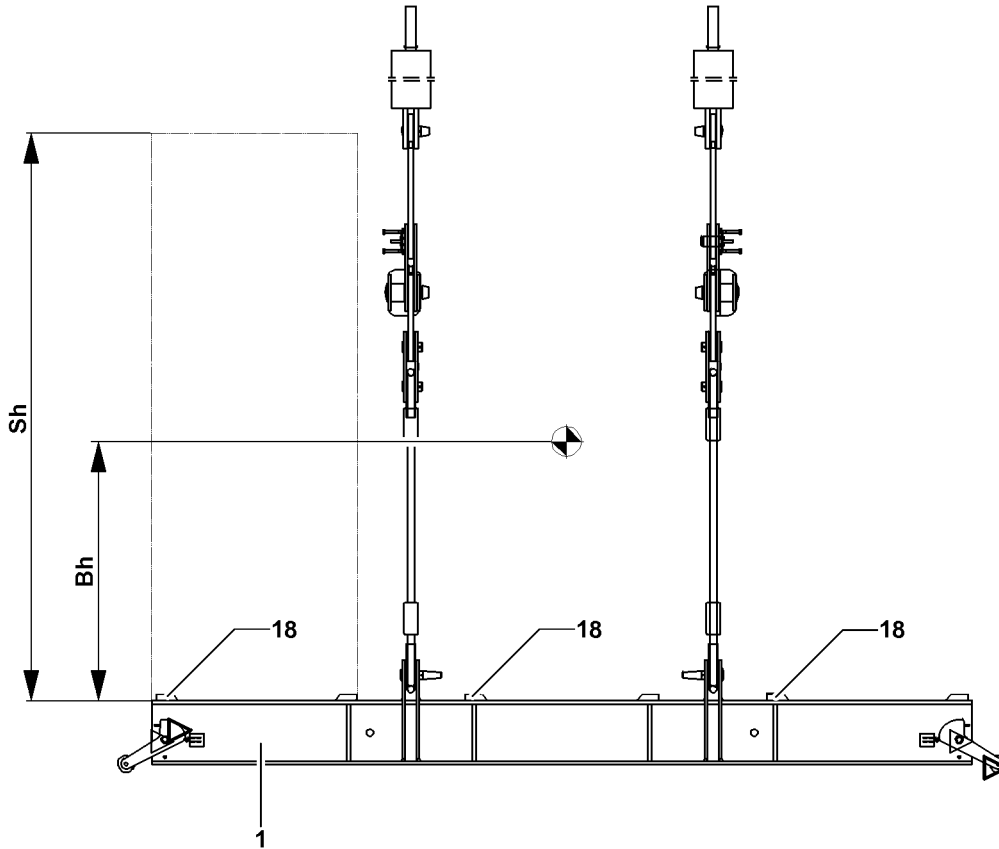

B110372

1.6.2 Taking the ballast pallet down



WARNING

Danger of toppling the ballast stack!

Incorrect up or down ballasting of the ballast plates on the ballast pallet can cause the ballast stack to topple over!

Personnel can be severely injured or killed!

When the ballast pallet is in suspended condition:

- ▶ The permissible weight difference between the left and right ballast stack may not exceed 10 t for ballasting up or down!
- ▶ Remove the ballast plates always symmetrically, in reference to the longitudinal axis!



WARNING

Falling ballast plates!

If more than the permissible loads are lifted, then the studs on the ballast plates are overloaded and the ballast plates can fall down. Personnel can be severely injured or killed!

- ▶ Lift no more than maximum 10 t with the ropes, 3 fastening points!
- ▶ Replace damaged ballast plates!



WARNING

Incorrect handling of the fastening equipment!

If fastening equipment cannot be attached correctly and if it is not secured sufficiently to prevent it from loosening up, loads can fall down. Personnel can be severely injured or killed!

- ▶ Make sure that the fastening equipment is correctly attached on the fastening points and that it is secured sufficiently to prevent it from loosening up!



Note

- ▶ The ballast plates are marked with their own weights!

Make sure that the following prerequisites are met:

- The suspended ballast is pinned and secured on the ballast guide.
- The ballast guyings are pinned and secured on both sides.

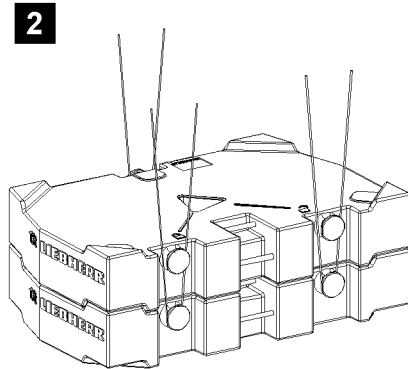
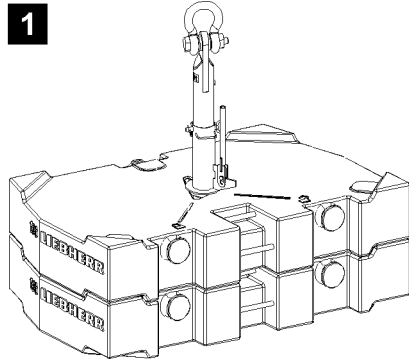

Permissible ballast assemblies



WARNING

Overload fastening points ballast plates!

If more than the permissible number of ballast plates are lifted together, then the fastening points can be overloaded!

The ballast plates and components can fall down!

Personnel can be severely injured or killed!

► Attach only the maximum permissible number of ballast plates per lift!



WARNING

Incorrect set up of ballast assemblies!

When lifting mixed weight ballast assemblies and the heavier ballast plates are placed on top, the fastening points can be overloaded!

The ballast plates and components can fall down!

Personnel can be severely injured or killed!

► Always stack the heavier ballast plate on the bottom in the ballast assembly!

For fastening systems with maximum permissible number of ballast plates, see the following chart:

- “TwistLock”, see illustration 1
- Bits, see illustration 2

Individual weight Ballast plate	Maximum number of same ballast plates per lift over	
	Twistlock	Bitt
5.0 t	2	1
7.5 t	2	2
10.0 t	2	2

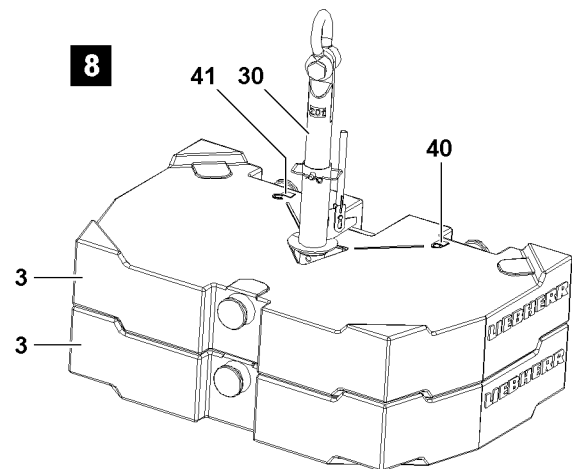
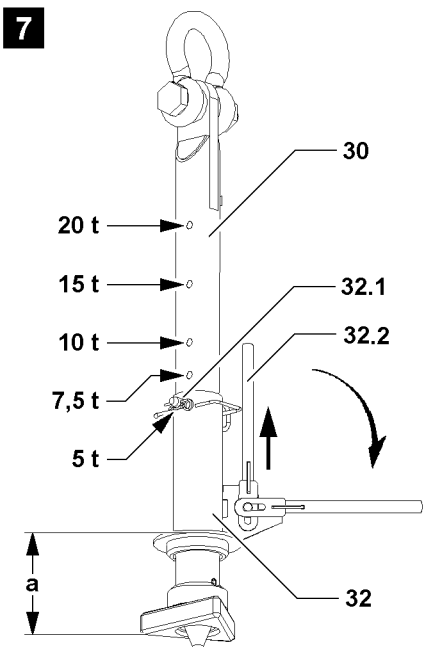
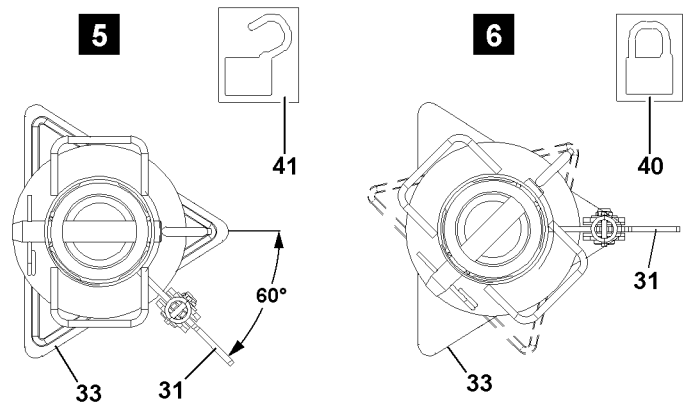
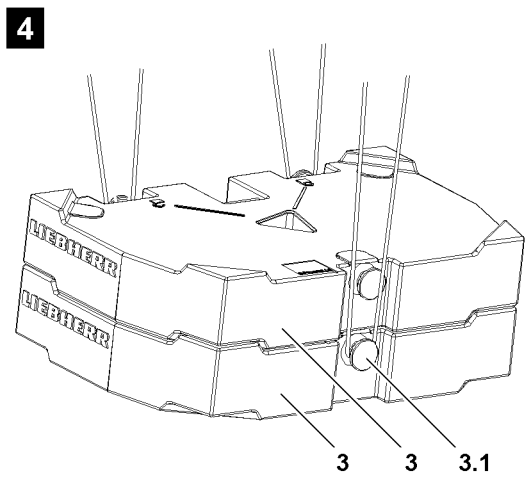
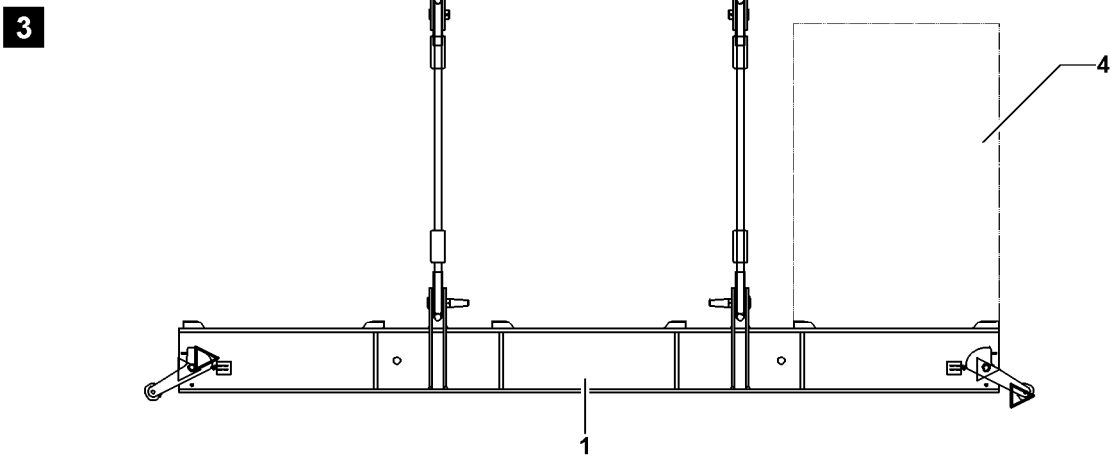

B110371

Removing the ballast plates, fastening system: "Twistlock"

**WARNING**

Overload of receptacle stud and ballast plates!

If more than the permissible number of ballast plates are lifted with the receptacle stud **30**, the receptacle stud **30** and the ballast plates can be overloaded and damaged!

The ballast plates can fall down!

Personnel can be severely injured or killed!

- ▶ Observe the section "Permissible ballast assemblies" in this chapter!
-

**WARNING**

Damage of receptacle stud and ballast plates!

If two ballast plates are lifted which do not lay correctly in their centerings, the receptacle stud **30** and the ballast plates can be damaged!

Damage can cause the ballast plates to fall down!

Personnel can be severely injured or killed!

- ▶ Make sure that the ballast plates to be lifted are placed correctly in the centerings!
-

**WARNING**

The Twistlock system opens by itself!

If the receptacle stud **30** is not correctly locked, the Twist lock system can open by itself!

The ballast plates can fall down!

Personnel can be severely injured or killed!

- ▶ Make sure, when initiating a lift, that the lever **32.2** points directly on the locked symbol **40** of the ballast plates **3**, see illustration **6**!
-

**Note**

- ▶ During a lift, the locked Twistlock system cannot release by itself due to its gravitational retention!
 - ▶ During a lift, the locked Twistlock system cannot be released by hand due to its gravitational retention!
-

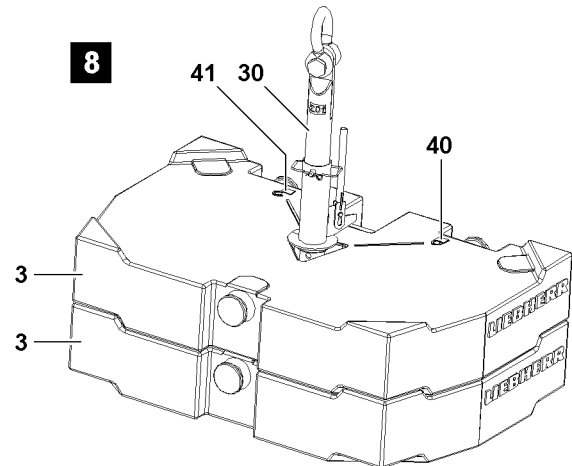
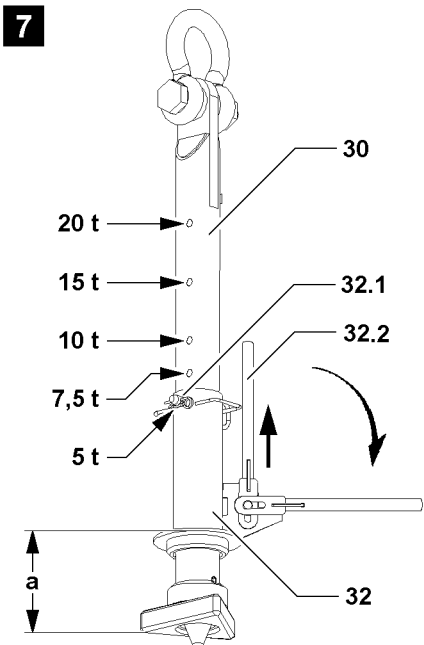
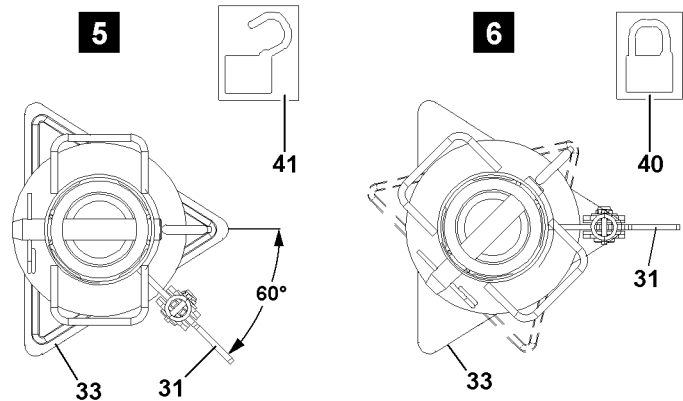
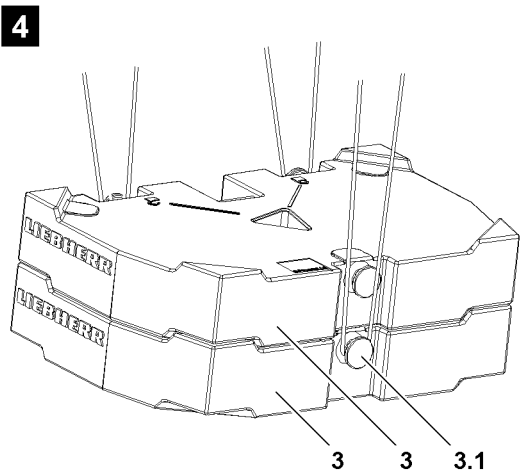
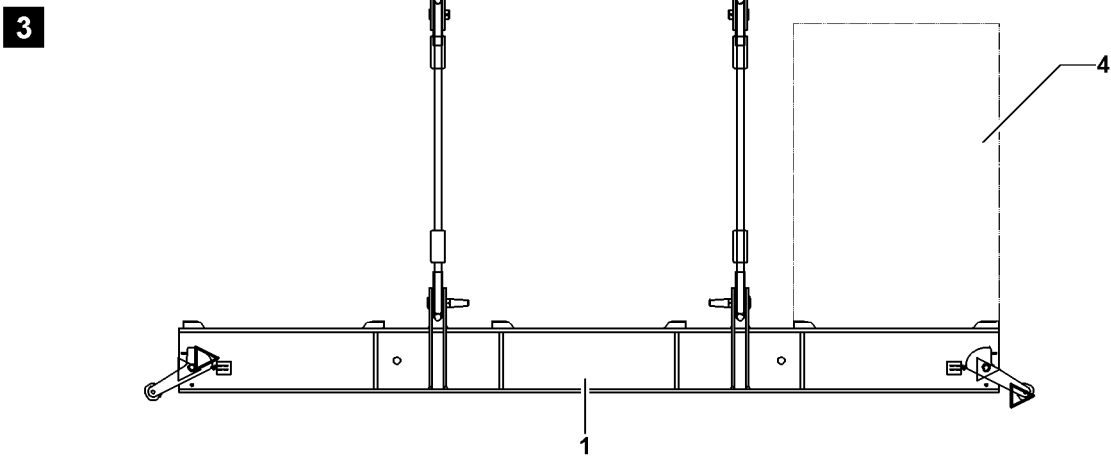

B110371

Before the receptacle stud **30** is guided into the ballast plate(s), it must be ensured that the insertion length **a** of the receptacle stud **30** is set correctly.

The insertion length **a** of the receptacle stud can be adjusted by hand.

- ▶ If the insertion length **a** of the receptacle stud **30** is to be adjusted:
Release and unpin the pin **32.1**.
- ▶ Adjust the insertion length **a** by moving the guide sleeve **32** to the desired insertion length **a**, pay attention to the stages, see illustration 7.
- ▶ Insert and secure pin **32.1**.

Result:

- The receptacle stud **30** is adjusted.

- ▶ Attach the receptacle stud **30** on the auxiliary crane and guide it into the ballast plate(s).
- ▶ Pull the lever **32.2** up and fold it down.
- ▶ Turn the receptacle stud **30** with the lever **32.2** by 60° until it points to the locked symbol **40** of the ballast plate, see illustration 6.
- ▶ Lift the ballast plate(s) or ballast assembly with the receptacle stud **30** and take them carefully from the ballast stack **4**.
- ▶ When the ballast plates are placed down:
Turn the receptacle stud **30** with the lever **32.2** by 60° to the stop in direction of the unlocked symbol **41** of the ballast plate, see illustration 5.

Result:

- The receptacle stud **30** is unlocked.
- ▶ Carefully pull out the receptacle stud **30**.
- ▶ Secure all ballast plates so they cannot move and fall down.

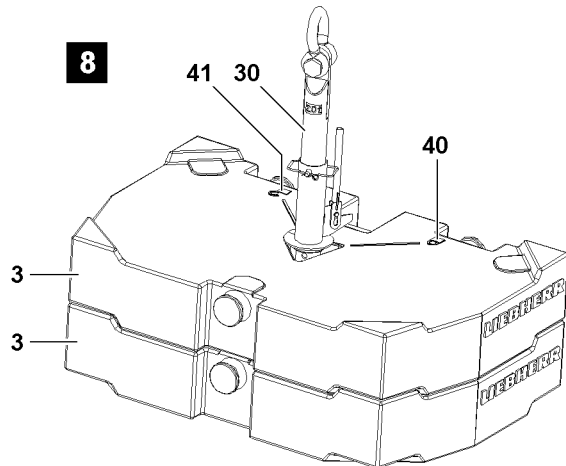
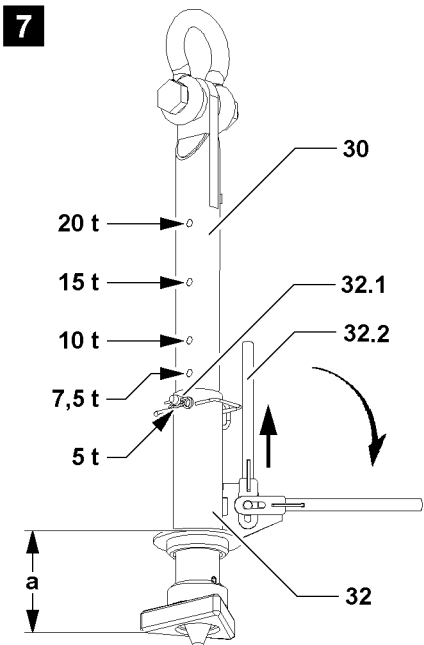
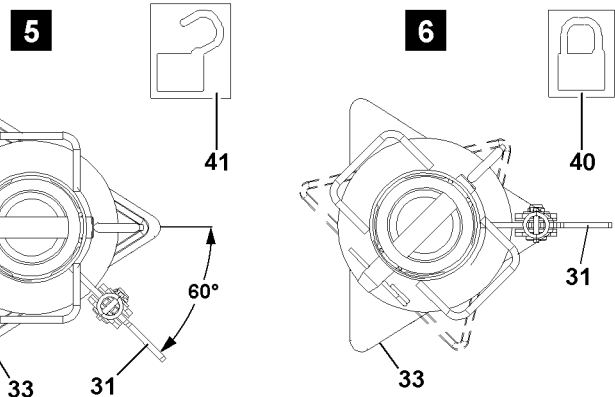
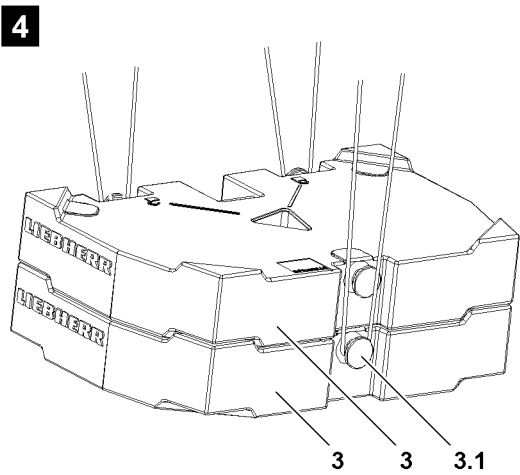
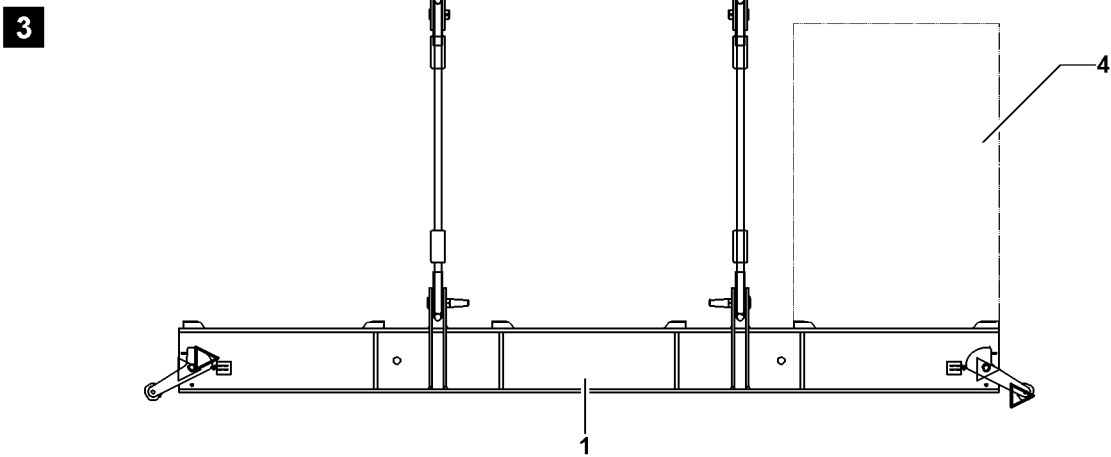

B110371

Removing the ballast plates, fastening points: Bitt

**WARNING**

Overloaded ballast plates!

If more than the permissible loads are lifted, the bitts **3.1** are overloaded!

The ballast plates can be damaged and fall down!

Personnel can be severely injured or killed!

- ▶ Observe the section "Permissible ballast assemblies" in this chapter!
-

**WARNING**

Incorrect handling of the fastening equipment!

If tackle cannot be attached correctly and / or if it is not secured sufficiently to prevent it from loosening up, the ballast plates can fall down!

Personnel can be severely injured or killed!

- ▶ Make sure that the fastening equipment is correctly attached on the bitts **3.1** and that it is secured sufficiently to prevent it from loosening up, see illustration **4**!
-
- ▶ Attach the ballast plates individually or as a ballast assembly on the auxiliary crane.
 - ▶ Lift the ballast plates or the ballast assembly and take it carefully from the ballast stack **4**.

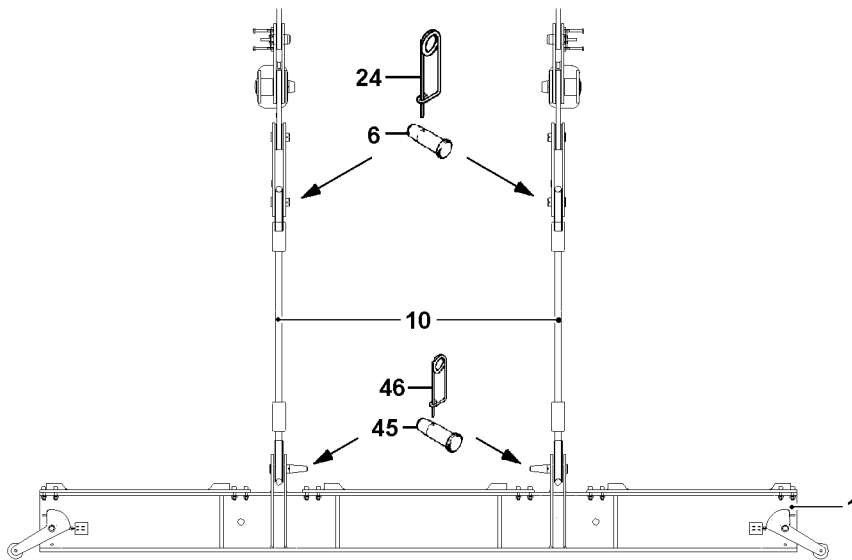
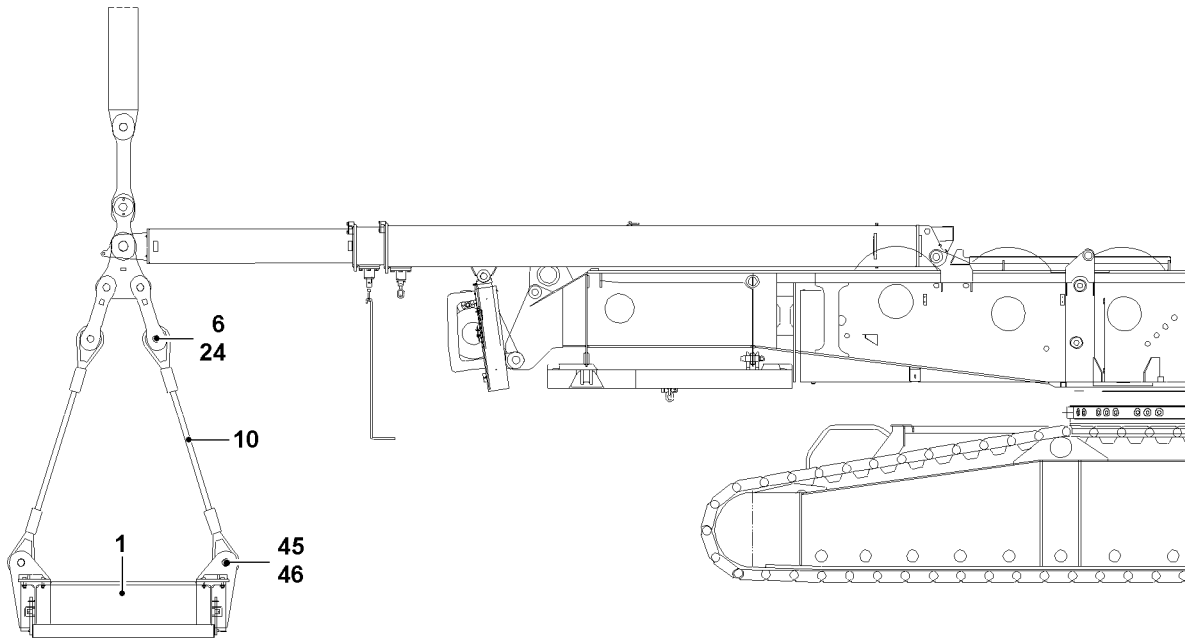

1.6.3 Removing the ballast pallet

Make sure that the following prerequisites are met:

- The ballast pallet is ballasted down.
 - The ballast pallet is placed on the ground.
 - The ballast guide is resting on the turntable frame.
 - An auxiliary crane is available.
- ▶ Remove the spring retainer **46** on pin **45**.
 - ▶ Unpin the pins **45** on the ropes **10** of the ballast pallet **1**.
 - ▶ Remove the spring retainer **24** on pin **6**.
 - ▶ Unpin the rope **10** from the ballast guide end section brackets using pins **6**.
 - ▶ Unplug cable **W 266** from socket **-X 266** and insert dummy plug **-X 266**.
 - ▶ Use the auxiliary crane to set the ballast pallet **1** down on the transport vehicle.

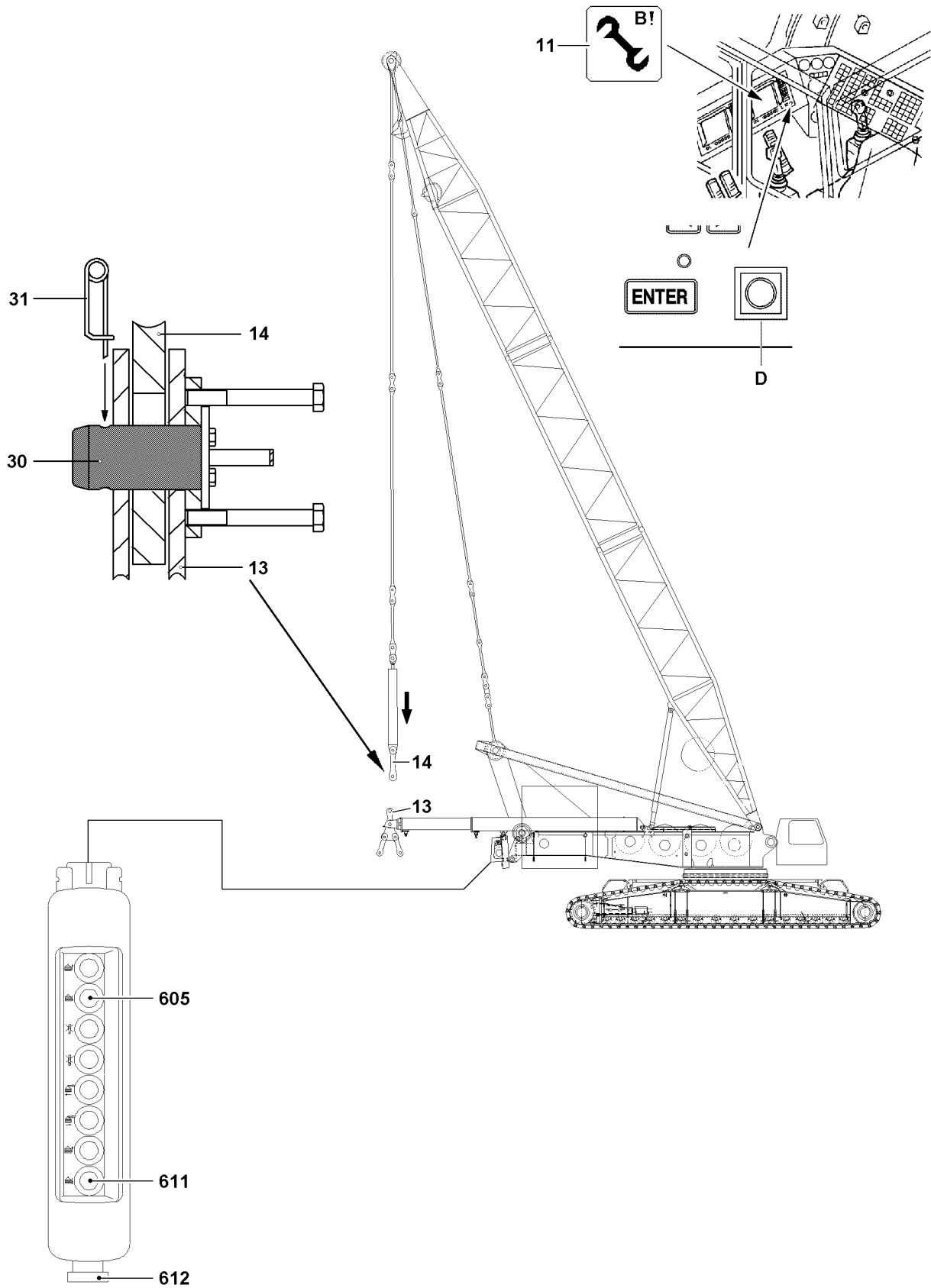

B112516

1.6.4 Unpinning the pull cylinder from the end section on the guide

Make sure that the following prerequisites are met:

- The engine is running.
- The LICCON overload protection is exceeded.
- The assembly icon **11** is visible on the LICCON monitor.
- The derrick boom is erected to 11 m.
- The ballast guide is mechanically telescoped to 11 m, pinned and secured.



WARNING

Risk of accident!

- ▶ The manual control panel should only be used to install or remove the derrick ballast. Once the pins have been inserted, the derrick ballast functions may only be driven from the crane operator's cab because the screen display on the LICCON monitor is required for derrick ballast operation!
- ▶ It is prohibited to raise the derrick ballast off the ground using the control panel!

- ▶ Remove the control panel from the storage compartment in the guide frame.
- ▶ Press button **605** "Extend pull cylinders".

Troubleshooting

Pull cylinders do not extend when operating button **605**?

When assembling both ballast guides, these rest on the turntable frame. Consequently the limit switches for "Derrick ballast below ground level" are actuated and the pull cylinders cannot be extended. The illuminated button **611** lights up.

- ▶ The limit switches can be bypassed by operating the illuminated button **611**.

- ▶ Press button **605** and illuminated button **611** at the same time.

Result:

- Both pull cylinders extend.
- ▶ Extend the pull cylinder until pins **30** on the end section are no longer under tension.
- ▶ Remove spring retainer **31** on the pins **30**.
- ▶ Unpin the pins **30** on both sides.
- ▶ After completing this procedure, fully retract the pull cylinder.

1.6.5 Disconnecting the electrical connection from the suspended ballast to the turntable

Make sure that the following prerequisite is met:

- The engine is not running.
- ▶ Disconnect the electrical connections and store properly.

1.6.6 Disconnecting the hydraulic connection from the suspended ballast to the turntable

When hydraulic lines are connected and disconnected with quick release couplings, make ensure that the coupling procedure is being performed correctly.



DANGER

Risk of accident due to loss of pressure or leakage!

Incorrectly coupled or self-loosening quick release couplings (particularly return lines) can result in serious injury due to component failure!

- ▶ Check that the quick release couplings have been properly connected before using the crane!
- ▶ Release the pressure in the hydraulic system before connecting and disconnecting. Turn the engine off and wait for short time.
- ▶ Install the coupling components (sleeve and connector) with the hand-tightened nut.
- ▶ Disconnect the coupling sections.
- ▶ Store the hydraulic hoses properly.
- ▶ Protect the coupling sections with caps to prevent contamination and damage.

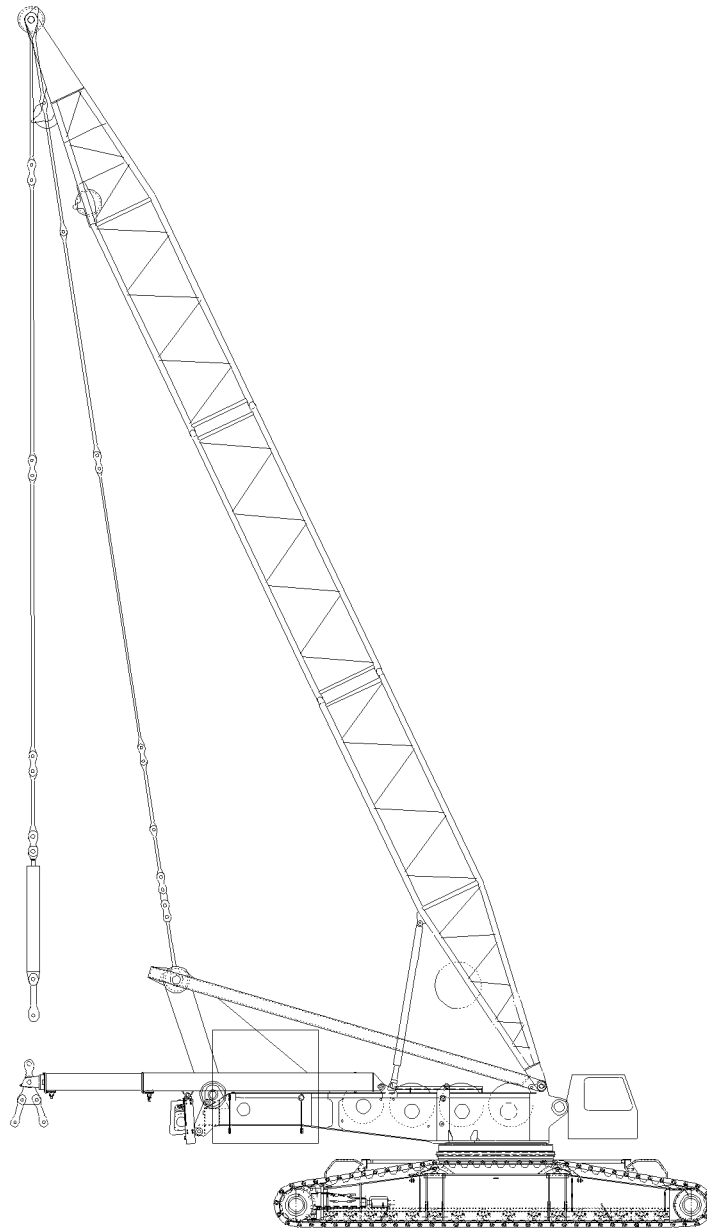
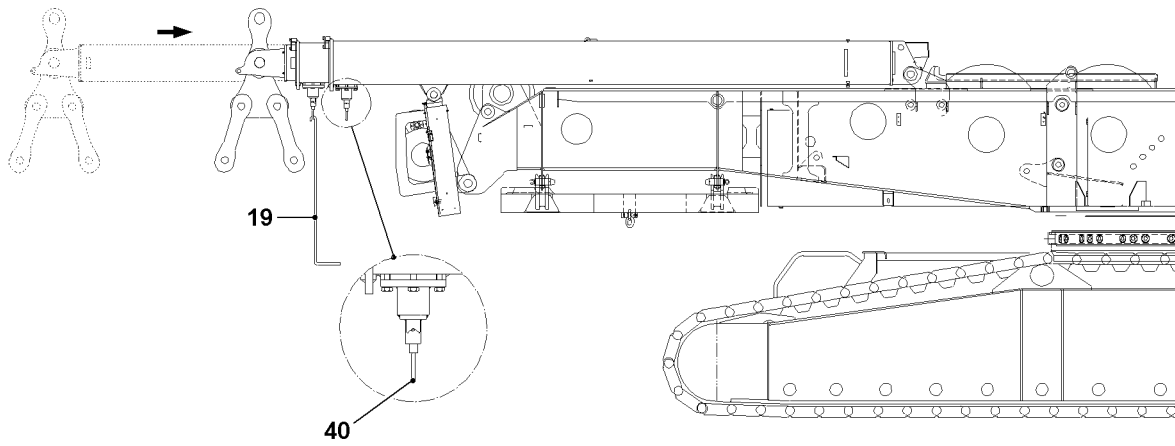

B104673

1.6.7 Mechanically telescoping in the ballast guide

Make sure that the following prerequisites are met:

- Both ballast guides are assembled to the turntable.
- The pull cylinder is detached from the ballast guide.

The 2 m long telescoping end section on the ballast guide must be mechanically telescoped in using suitable equipment.



Note

- ▶ In order to mechanically telescope in the telescoping end section, **both** locking pins **40** must be released from the assembly rod **19**!
 - ▶ After telescoping has been completed, **both** locking pins **40** must be pinned and secured with the assembly rod **19**!
-

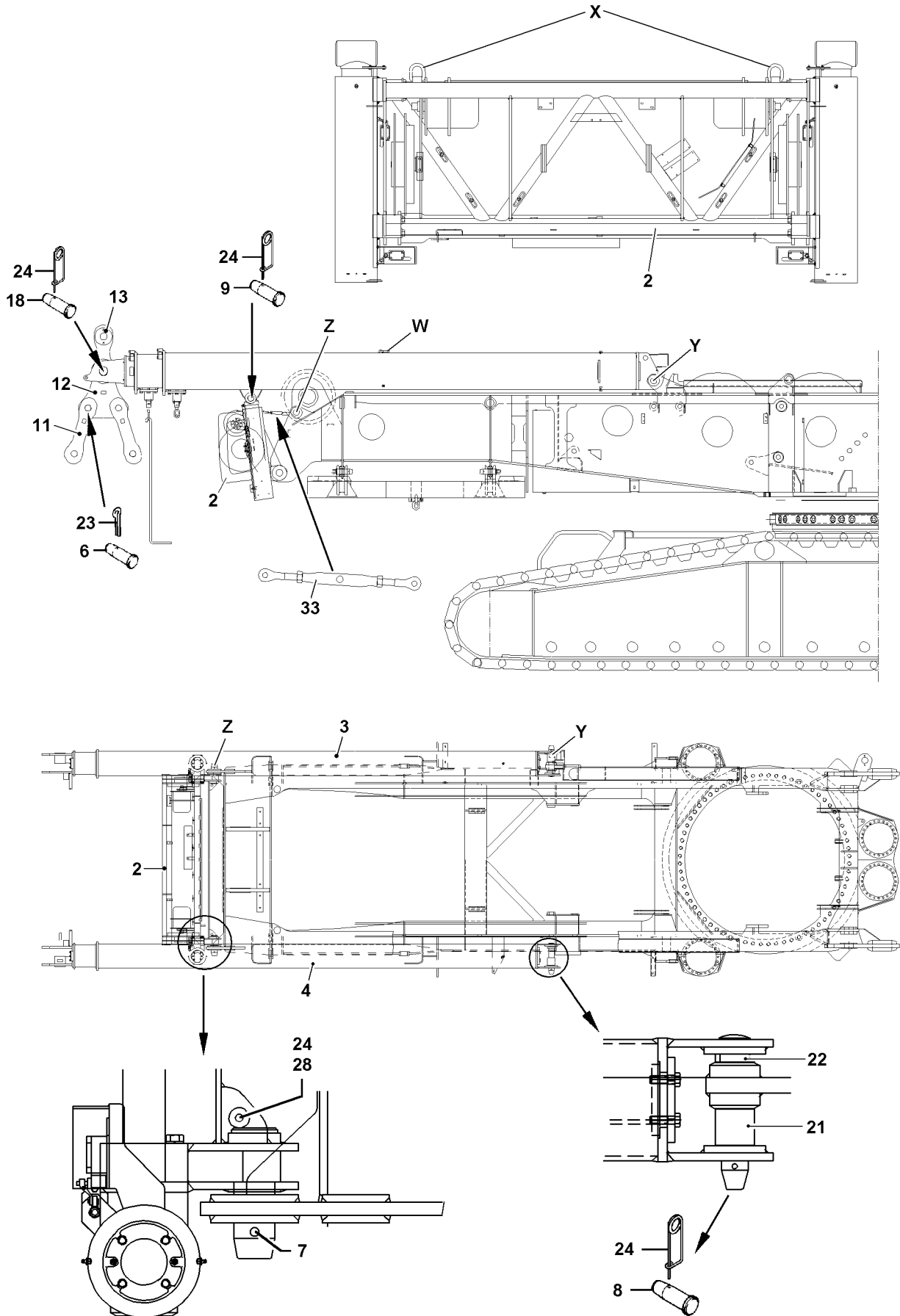

B104659

1.6.8 Removing the ballast guide

Before removing the ballast guide, fit the turnbuckle **33** between the guide frame **2** and turntable.

- ▶ Remove the spring retainer **24** on pin **9**.
- ▶ Unpin the pins **9** at the pinning point between the ballast guides **3** and **4** and the guide pipe on the guide frame **2**.
- ▶ Before releasing the pin **8**, hook an auxiliary crane into the lifting bracket **W** on the ballast guide.
- ▶ Remove the spring retainer **24** on pin **8**.
- ▶ Remove spacer pipes **21** and **22**.
- ▶ Unpin the pin **8**.
- ▶ Use the auxiliary crane to lift the ballast guides from the turntable onto the transportation vehicle.

Before removing the ballast guides, remove the triangular brackets **12**, brackets **11** and ballast guy rods **13** to the end section on the ballast guide **3** and **4**.

- ▶ Remove the split pin **23** from pin **6**.
- ▶ Unpin the pins **6** from the triangular brackets **12** and brackets **11**.
- ▶ Remove the spring retainer **24** on pin **18**.
- ▶ Unpin the pins **18** from the end section.

1.6.9 Disassembling the guide frame

- ▶ Secure the guide frame **2** to the lifting brackets **X** on the auxiliary crane.
- ▶ Release the turnbuckle **33** between the guide frame **2** and turntable.
- ▶ Release the spring retainer **24** on retaining pin **28**.
- ▶ Unpin the retaining pins **28**.
- ▶ Unpin the pin **7** on the pin point **Z**.
- ▶ Lift the guide frame **2** with the auxiliary crane onto the transport vehicle.

1

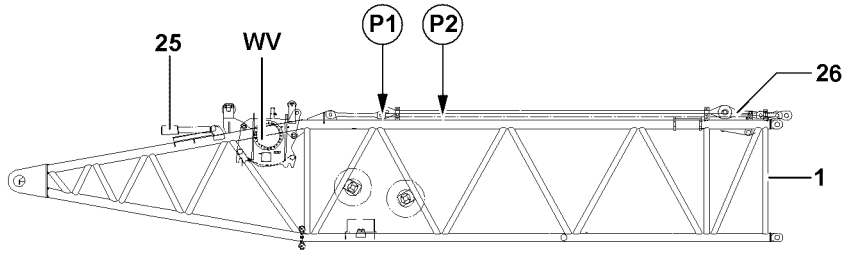

2

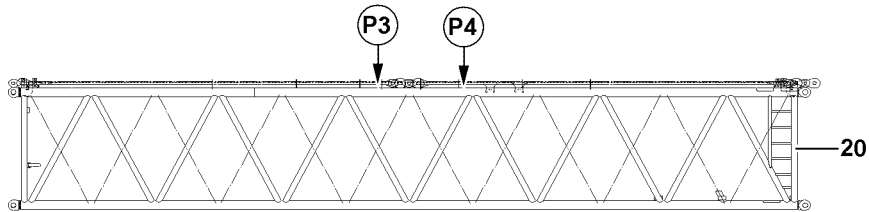

3

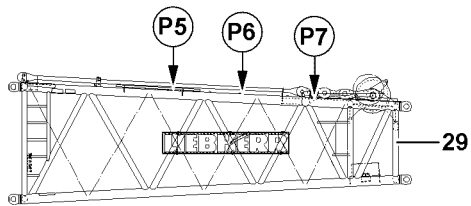

4

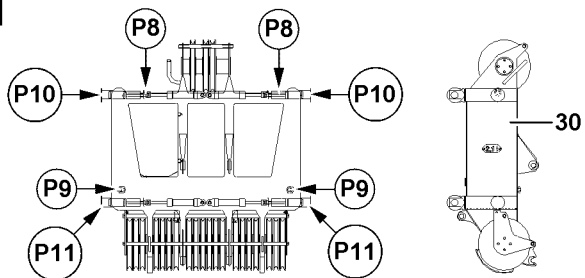

1 Component overview L-/LL-boom

Examples for components of S-/SL-boom:

1 L-pivot section	• Pivot section with winch 5 WV and W-guy rods 26 , see illustration 1.
25 L-relapse cylinder	• See illustration 1
20 L-intermediate section 2620.10	• Intermediate section 14 m, see illustration 2
29 L-adapter	• See illustration 3
30 L-end section	• See illustration 4

2 Fastening points L-/LL-components



WARNING

Component incorrectly attached!

Life-threatening situations can arise due to improper or incorrect attachment of the corresponding components!

Personnel can be severely injured or killed!

- ▶ Attach the components only on the intended fastening points on both sides!
- ▶ Attachment of components and description of fastening points, see Crane operating instructions, chapter 5.01!

Component	Fastening point	Illustration
L-pivot section	P1 and P2	1
L-intermediate section	P3 and P4	2
L-adapter, without L-end section	P5 and P7	3
L-adapter, with assembled L-end section	P6 and P8	3 and 4
L-end section	P8 and P9	4
L-end section, with bitt	P10 and P11 or P8 and P9	4

3 Assembling the L/LL-boom



Note

- ▶ The assembly is described on the example of the L-boom!



WARNING

Risk of falling!

During assembly / disassembly, inspection and maintenance work, personnel must be secured with appropriate aids to prevent them from falling! If this is not observed, assembly personnel could fall and suffer life-threatening or fatal injuries!

- ▶ All work aloft, where there is a danger of falling must be carried out with suitable aids!
- ▶ If fall protection equipment is available, then it must be used, see Crane operating instructions, chapter 2.06!
- ▶ If aids are not available and work cannot be carried out from the ground, then the assembly personnel must secure themselves with the permissible fall arrest system to prevent falling, see Crane operating instructions, chapter 2.04!
- ▶ The fall arrest system must be fastened on the fastening and hook points as well as on the safety ropes. For safety points, see Crane operating instructions, chapter 2.06!
- ▶ Only step on the aids, ladders and catwalks with clean shoes!
- ▶ Keep aids, ladders and catwalks free of heavy dirt, snow and ice!
- ▶ It is prohibited to walk on the telescopic or an auxiliary boom without suitable protective devices!



WARNING

Falling components!

If unsecured or non-supported components are installed or removed, they can fall down!

Personnel can be severely injured or killed!

- ▶ During pinning and unpinning of the lattice sections, it is prohibited for anyone to remain **under** or **on** the components as well as within the entire danger zone!
- ▶ Support the boom and components before pinning / unpinning!
- ▶ Pin or unpin both pins that lie in one horizontal level, i.e. **left** and **right**!
- ▶ Secure the pins in the bearing points and in the receptacles!
- ▶ Do not disengage the auxiliary crane until each component is pinned on and secured!
- ▶ It is prohibited to lean a ladder against the component being disassembled!



WARNING

Danger of impact / crushing!

When installing / removing crane components with the auxiliary crane, crane components can start to swing back and forth!

When lifting / lowering and positioning crane components, there is an increased danger of impacts / crushing!

Personnel can be caught and severely injured or killed as a result!

- ▶ Make sure that personnel cannot be caught by components!
- ▶ When working in danger zones: Use aids to protect limbs!
- ▶ Guide components with suitable aids to minimize oscillation!

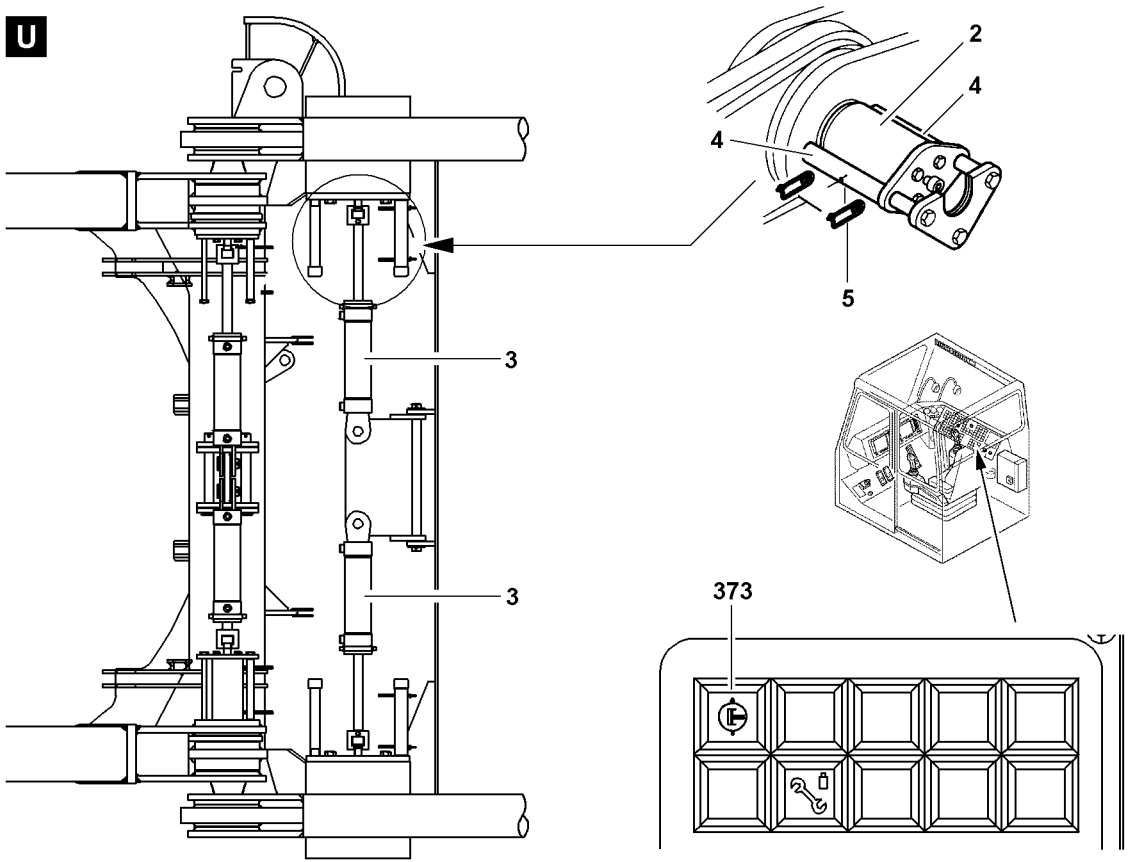
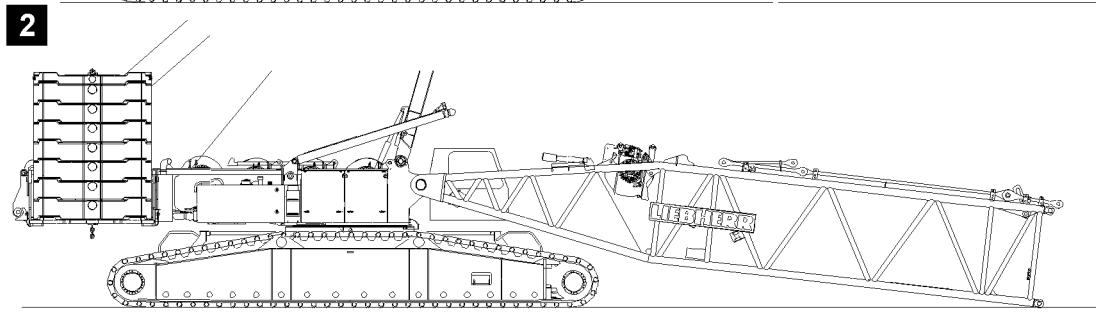
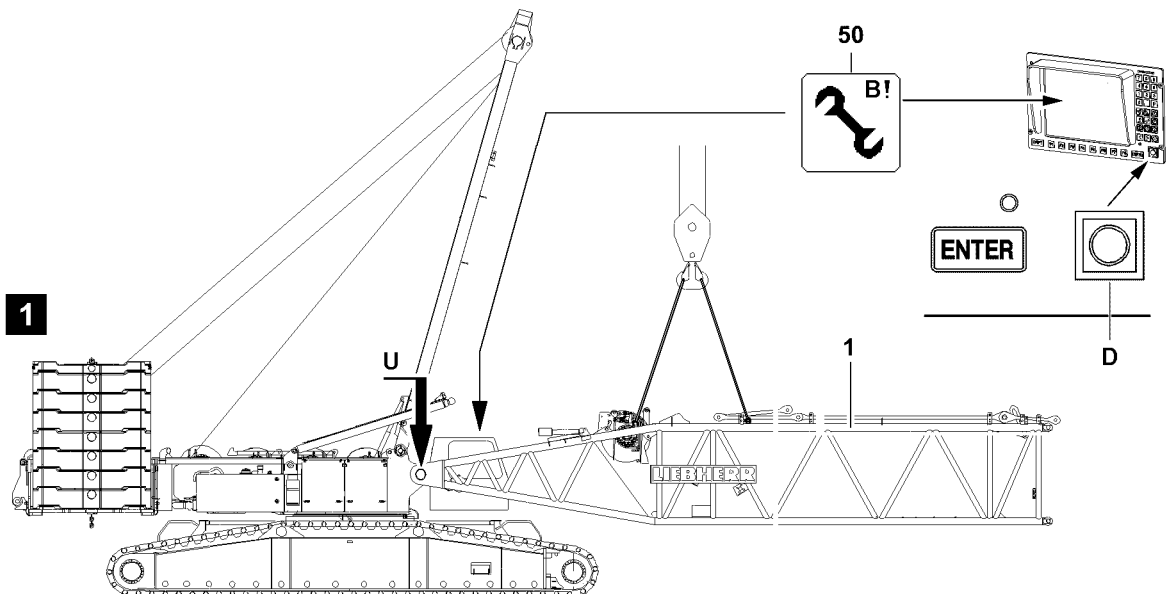

B111470

**WARNING**

The crane can topple over!

If the turntable is turned during the assembly of the boom, then the crane can topple over and be severely damaged! Personnel can be severely injured or killed!

- ▶ The turntable may not be turned during the assembly of the boom!

**WARNING**

Risk of accident!

If the following instructions are not observed, personnel can be severely injured or killed!

- ▶ Arrangement of lattice sections of boom combinations, see Rod plan!
- ▶ Depending on the condition of the ground, the boom and the lattice sections must be supported from below for the assembly of the boom!
- ▶ Observe the safety technical notes, see Crane operating instructions, chapter 5.01!

Make sure that the following prerequisites are met:

- The crane is aligned in horizontal direction.
- An auxiliary crane is available.
- An assembly scaffolding / work platform is available.
- The counterweight has been installed on the turntable according to the load chart.
- The LICCON overload protection has been set according to the data in the load chart.

3.1 Turning the turntable into assembly position

**DANGER**

The crane can topple over!

If the following conditions are not met before turning the turntable - **without** installed L-boom, the crane can topple over!

Personnel can be severely injured or killed!

- ▶ Observe the data in the erection and take down charts!
- ▶ If no L-boom is installed on the turntable, max. 135 t counterweight may be installed and when turning the turntable by 360°, it must be ensured that the SA-bracket is erected to **more than 90°**!
- ▶ If the counterweight is increased to 155 t, then the L-boom must be installed and raised off the ground!

Maximum counterweight	Minimum central ballast	Equipment
55 t	11 t	Without equipment
95 t	11 t	
135 t	43 t	
155 t	43 t	L-boom installed and raised off the ground

- ▶ Turn the turntable in longitudinal axle of the crawler travel gear or vertical to the crawler travel gear, see Erection and take down chart.

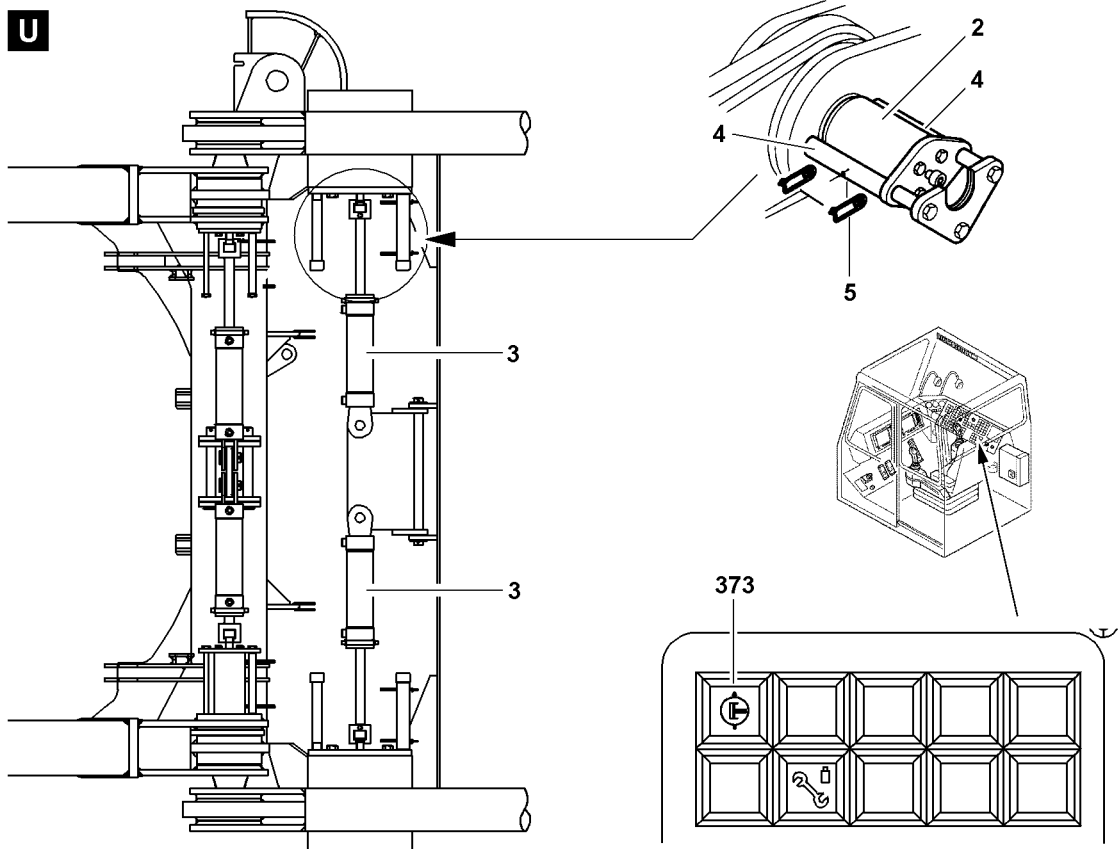
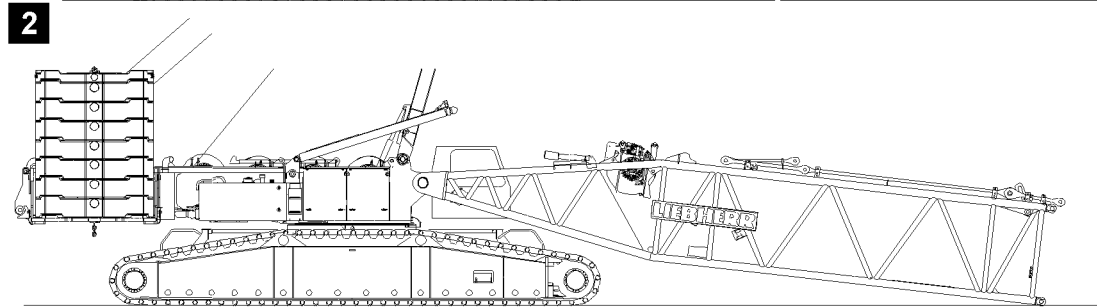
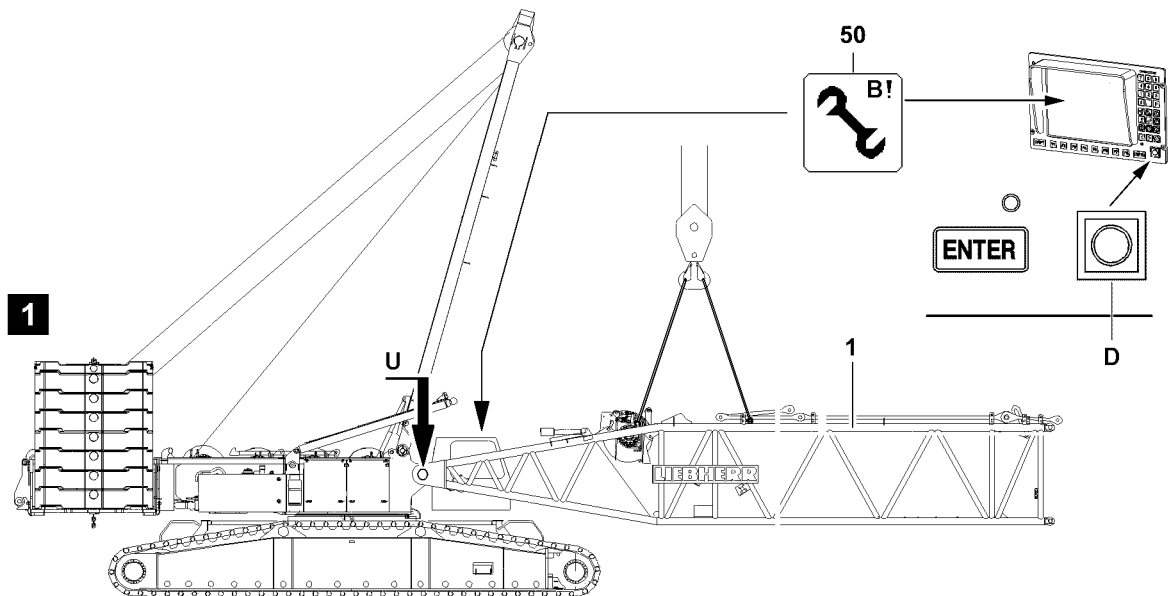

B111470

3.2 Exceeding the LICCON overload protection for assembly



WARNING

Assembly with turned on set up key!

When the set up key is turned on, the LICCON overload protection is exceeded!

In the event of deliberate improper use, the crane could collapse, the boom can break off or the crane can topple over!

Personnel can be severely injured or killed!

This could result in high property damage!

- ▶ The set up key **D** may only be actuated by persons who know the effects of a bypass!
 - ▶ Press the set up key **D** only when the set up status was correctly entered into the LICCON computer system!
 - ▶ Observe the erection / take down charts!
 - ▶ Crane operation with the set up key **D** turned on is strictly prohibited!
-

- ▶ Turn the set up key **D** to the right.

Result:

- The LICCON overload protection is deactivated.
- The assembly icon **50** appears on the LICCON monitor.

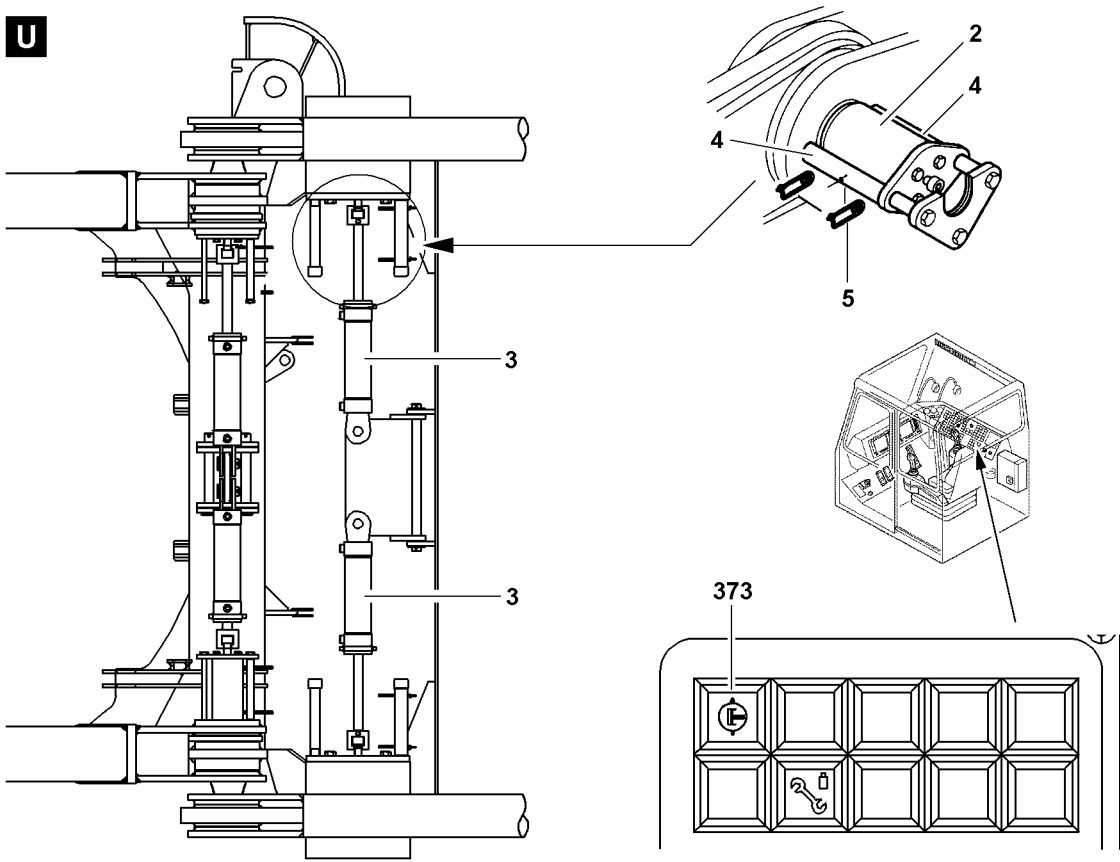
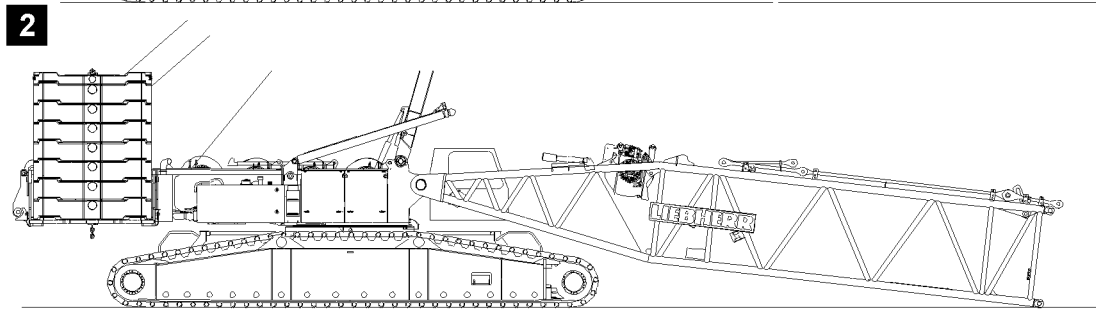
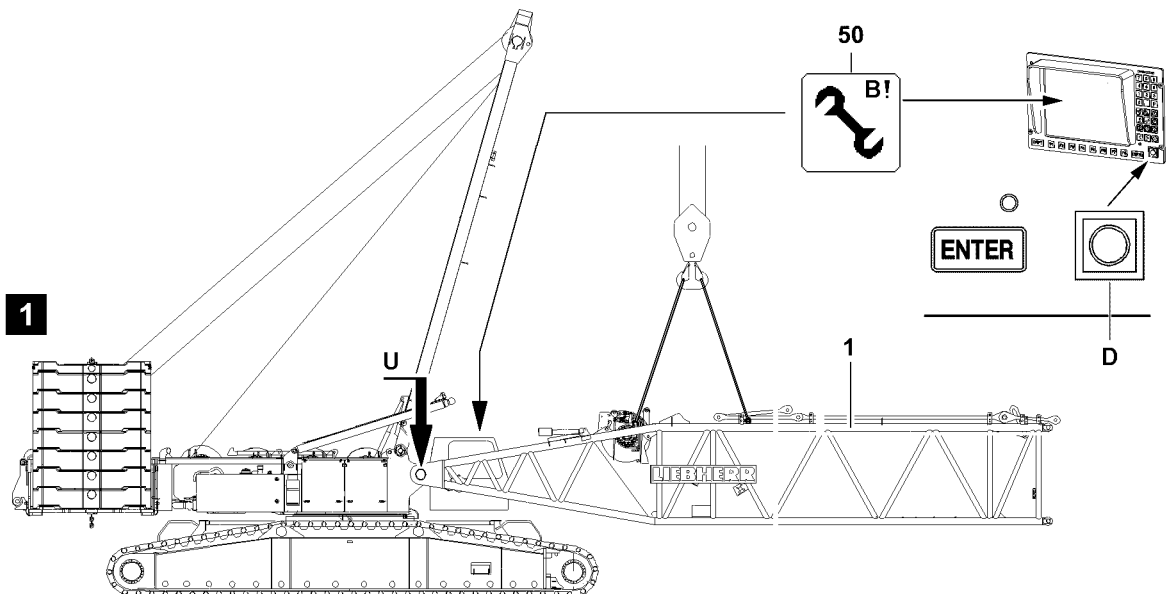

B111470

3.3 Pinning the L-pivot section on the turntable



WARNING

General danger notes!

- ▶ Support the L-boom during assembly with suitable materials!
- ▶ All pins are to be secured after assembly with the intended safety elements!
- ▶ The guy rods must be inspected regularly, see Crane operating instructions, chapter 8.15!

- ▶ Hang the L-pivot section **1** onto the auxiliary crane and swing in to the pin points on the turntable, illustration **1**.

Establish the hydraulic connection to the pin pulling device via two quick couplers.

Pin the L-pivot section **1** on the turntable and secure.

- ▶ Establish the hydraulic connection to the pin pulling device.
- ▶ Turn the pressure change over switch **373** on.



WARNING

The L-pivot section can fold downward!

Due to non-secured or insufficiently secured connector pins, the L-pivot section can fold down. Personnel can be severely injured or killed!

- ▶ Secure the connector pins **2** between the L-pivot section **1** and the turntable after the pin procedure with the retaining plates **4**!
- ▶ Insert the connector pins **2** with the hydraulic pin pulling device **3**.
- ▶ When the connector pins **2** are completely pinned on the left and right on the L-pivot section: Secure the connector pin **2** on the left and right with the retaining plate **4** and the spring retainer **5**.
- ▶ Turn the pressure change over switch **373** off.

NOTICE

Damage to the L-pivot section!

Property damage can occur on the L-pivot section by placing the assembled L-pivot section on the ground!

- ▶ Slowly place the L-pivot section with the auxiliary crane and at low speed on the ground!
- ▶ Before placing it on the ground, support the L-pivot section!

- ▶ Carefully place the L-pivot section down.
- ▶ Remove the auxiliary crane.

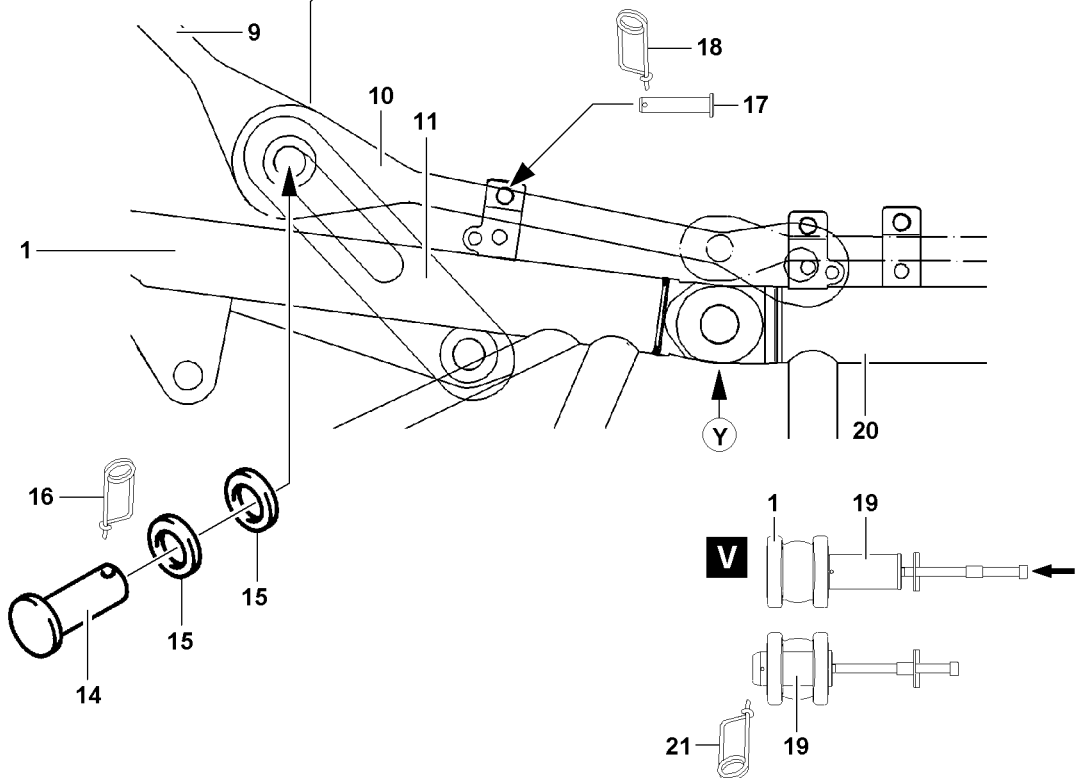
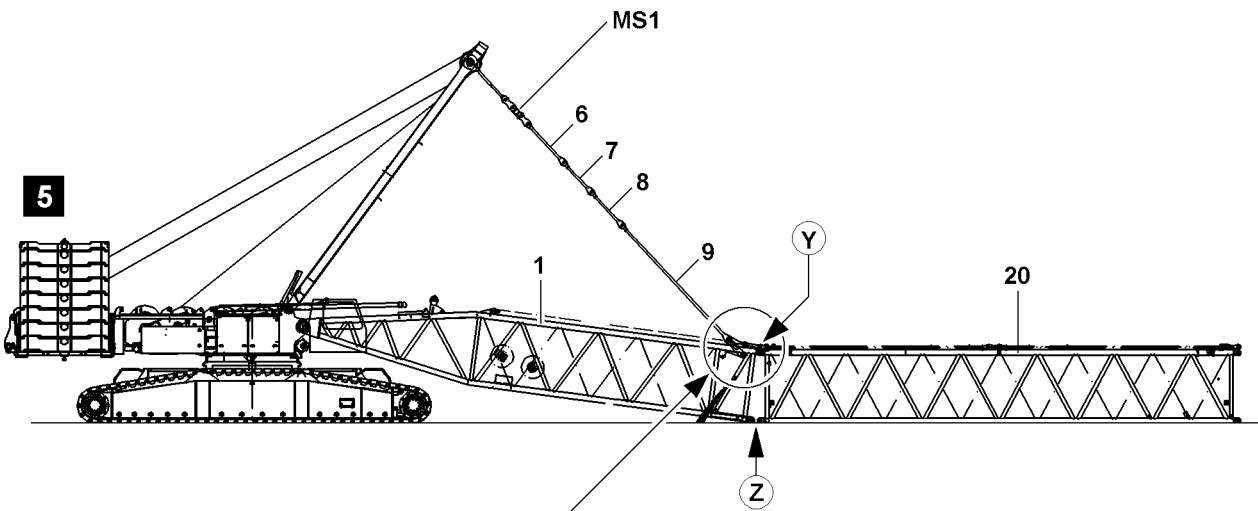
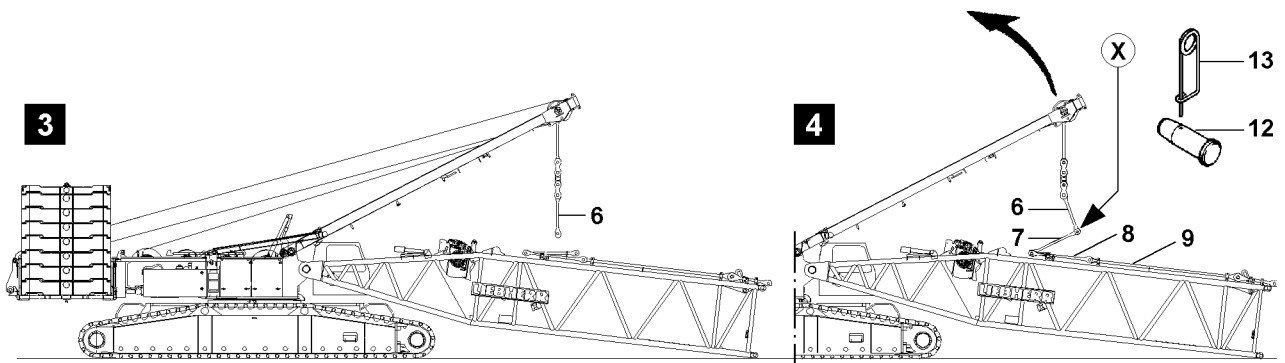

3.4 Assembling the L-lattice sections

The assembly of the lattice sections is carried out in various ways:

- “Closing” the boom.
- Assembling the lattice sections in “Flying mode”.



WARNING

General danger notes!

- ▶ Support the S-boom during assembly / disassembly with suitable materials!
- ▶ All pins are to be secured after assembly with the intended safety elements!
- ▶ The guy rods must be inspected regularly, see Crane operating instructions, chapter 8.15!
- ▶ Secure the boom with support or auxiliary crane, see Crane operating instructions, chapter 5.01!
- ▶ It is prohibited for anyone to remain under the booms or within the complete danger zone during the pinning and unpinning procedure of the lattice section!



Note

- ▶ For weights of intermediate sections with placed guy rods, see Crane operating instructions, chapter 1.03!
- ▶ The intermediate sections are pinned with the aid of the pin pulling device, see Crane operating instructions, chapter 5.30!

3.4.1 Assembling the L-lattice sections (by “closing” the boom)

Make sure that the following prerequisites are met:

- The L-pivot section is pinned and secured on the turntable.
- The L-pivot section is placed on the ground.
- The auxiliary crane is removed.

To be able to assemble the L-intermediate sections on the L-pivot section, the SA-bracket guy rods must be used.

- ▶ Remove the transport retainers for the guy rods on the SA-bracket.
- ▶ Remove the transport retainers for the guy rods on the L-pivot section.
- ▶ Lower the SA-bracket to the front until the guy rods **6** hang freely over the guy rods **7** of the L-pivot section **1**, see illustration **3**.

Pin the guy rods **6** of the SA-bracket with the guy rods **7** on the L-pivot section.

- ▶ Pin in the pins **12** at point **X** from the “inside” to the “outside” and secure with spring retainers **13**, see illustration **4**.

When pinning the pin **14**, you have to use the washers **15**, see illustration.

Pin and secure the assembly brackets **11** on the connector point of the guy rods **9** and guy rods **10**, use washers **15**.

- ▶ Insert the pins **14** into the hollow axle and secure with spring retainers **16**.
- ▶ Erect the SA-bracket until the guy rods are completely tensioned, see illustration **5**.

Pin the L-intermediate section **20** on the L-pivot section **1** “on top”:

- ▶ Attach the L-intermediate section **20** on the auxiliary crane and align on the L-pivot section **1**, see illustration **5**.
- ▶ When the pin bores on the L-pivot section **1** and on the L-intermediate section **20** “on top” (point **Y**) align, see illustration **5**:
Insert the pin **19** from the inside to the outside and secure with spring retainer **21**, see detail **V**.

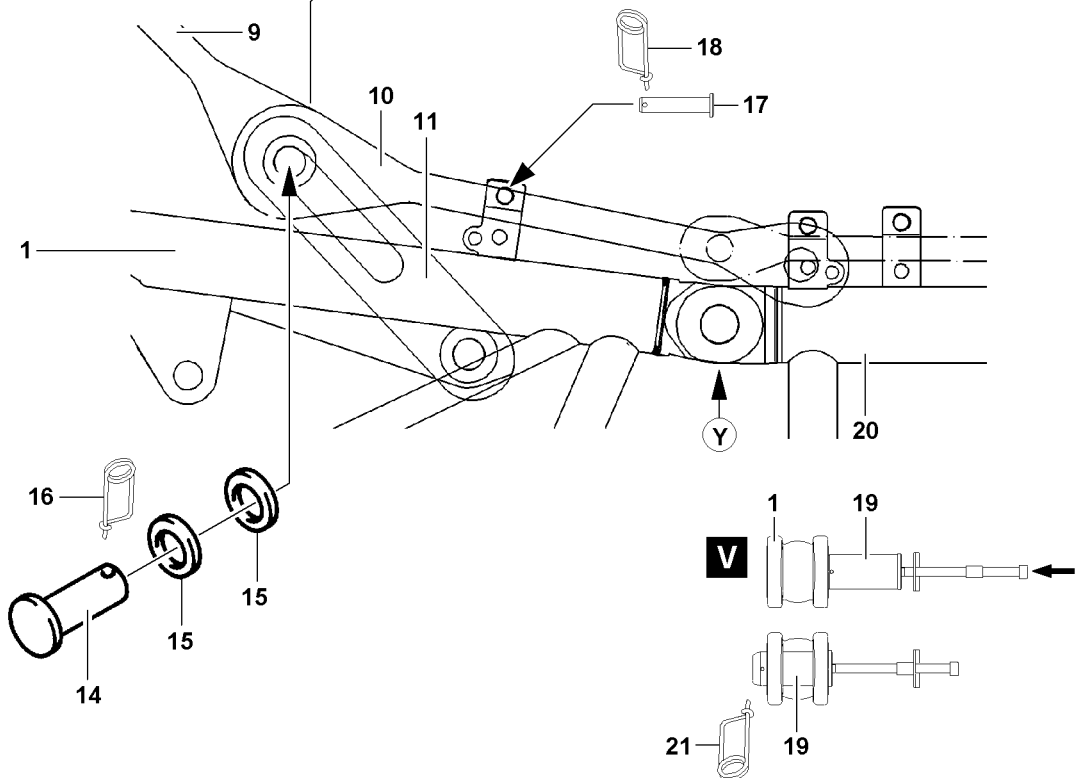
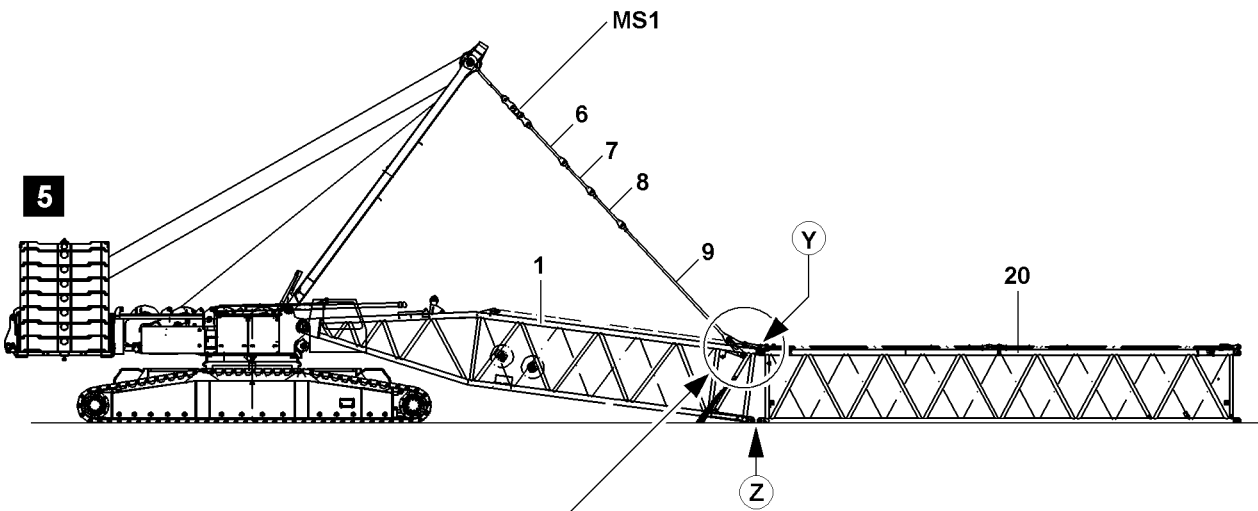
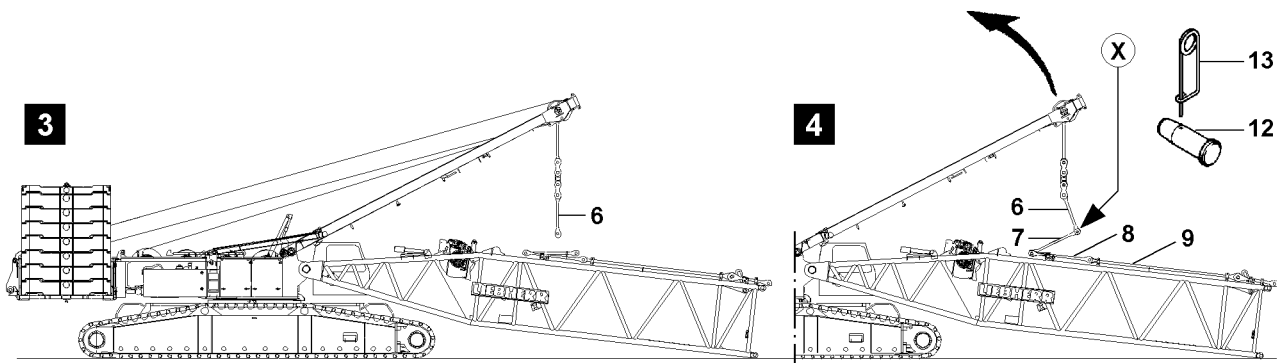

**WARNING**

The crane can topple over!

If the following conditions are not met, the crane can topple over or be significantly damaged!

Personnel can be severely injured or killed!

- ▶ During the “Closing procedure” of the L-intermediate sections, the maximum total force on test point **MS1** of 110 t may **not** be exceeded!
- ▶ The end section of the corresponding L/LL-boom combination during the “Closing procedure” may **not** lift off the ground!
- ▶ With the SA-bracket, L-boom combinations may be lifted / closed to maximum **L 105 m** !

**Note**

- ▶ The actual force on the test point MS1 - which is exerted during the closing procedure of the boom system - is shown on the LICCON monitor 1!
- ▶ Record the actual force and keep it ready for the disassembly of the boom system!
- ▶ During the boom disassembly, the guying is tensioned with the noted actual force (assembly) so that the connector pins of the intermediate sections can be unpinned!

The L-boom must be assembled to the required length before the L-boom can be closed. The assembly is described on the example of an intermediate section.

- ▶ Position the L-intermediate section with the auxiliary crane on the L-pivot section until the pin points align.
- ▶ Pin the L-lattice sections with each other: Insert the pin **19** on both sides “on top” and secure with spring retainer **21**.
- ▶ Pin the L-lattice sections with each other: Insert the pin **19** on both sides “on the bottom” and secure with spring retainer **21**.
- ▶ When the L/LL-boom combination is assembled to the desired length:
Lift the L-pivot section **1** with the SA-bracket until the pin bores on the “bottom” align at point **Z**, illustration **5**.
- ▶ Read the actual force of the test point **MS1** on the LICCON monitor and note.
- ▶ Insert the pin **19** on point **Z** from the inside to the outside and secure with spring retainer **21**.

12

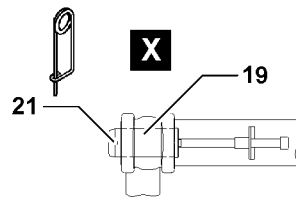
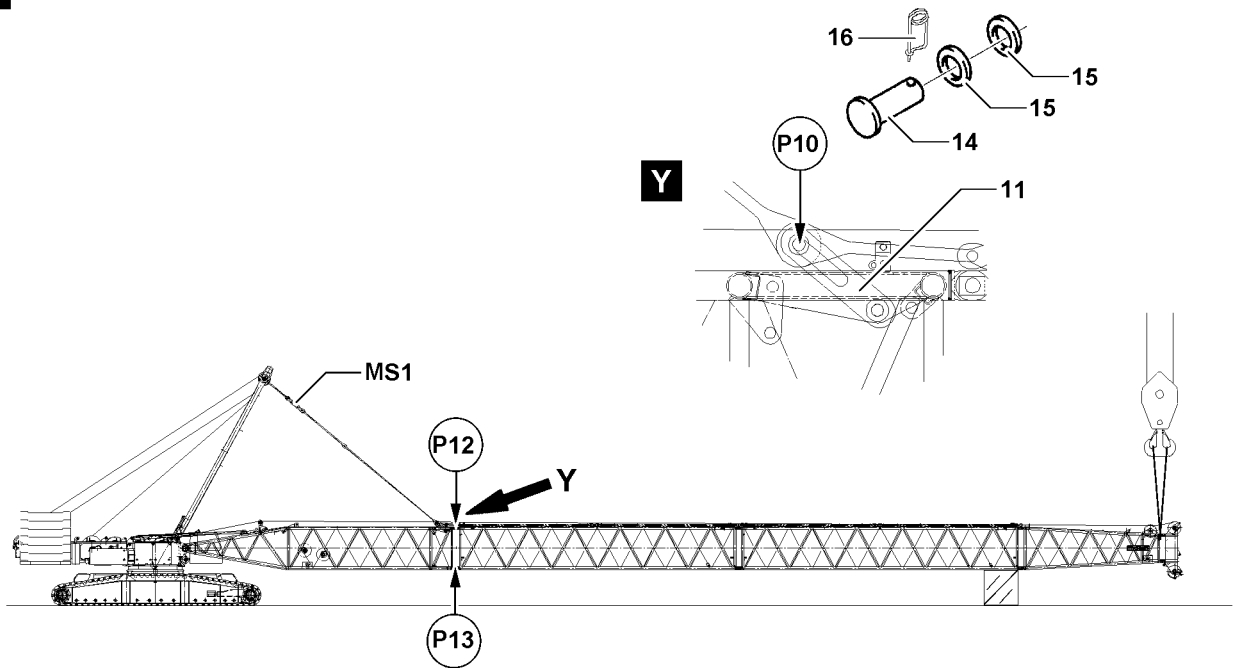

14

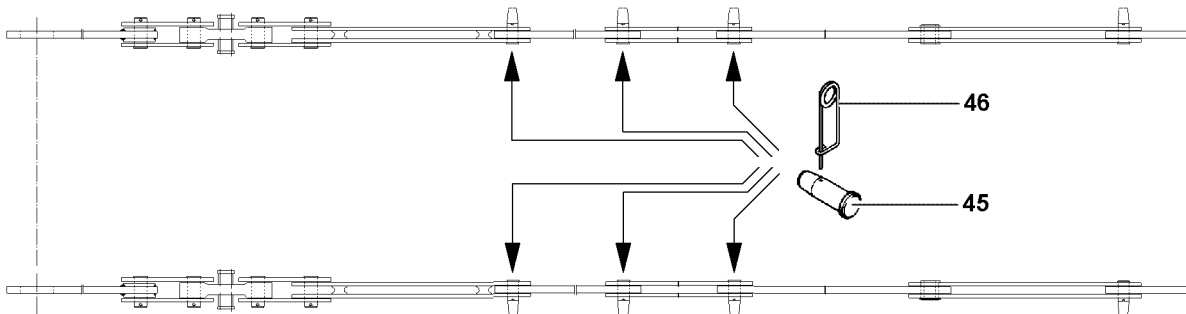

15

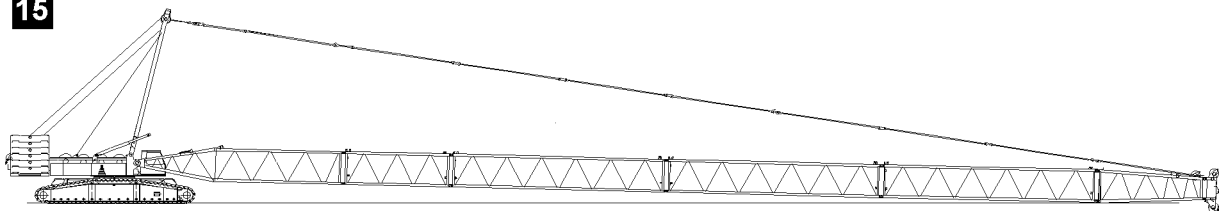

3.4.2 Assembling the L-intermediate section in “Flying mode” on the S-pivot section

If spatial prerequisites on the job site are limited for the assembly of the L-boom, or if they are limited by buildings or similar, then the L-boom can be assembled in flying mode.



WARNING

General danger notes!

- ▶ Support the L-boom during assembly / disassembly with suitable materials!
- ▶ All pins are to be secured after assembly with the intended safety elements!
- ▶ The guy rods must be inspected regularly, see Crane operating instructions, chapter 8.15!
- ▶ Secure the boom with support or auxiliary crane, see Crane operating instructions, chapter 5.01!



WARNING

Impermissible boom lengths!

If impermissible boom lengths are assembled on the crane, significant property damage can occur on the crane!

Personnel can be severely injured or killed!

- ▶ The maximum permissible boom lengths for the “Flying assembly” may not be exceeded!
- ▶ The data in the erection and take down charts as well as the load charts must be observed!



WARNING

The crane can topple over!

If the following conditions are not met, the crane can topple over or be significantly damaged!

Personnel can be severely injured or killed!

- ▶ For the “flying” boom assembly, the maximum permissible total force on the test point **MS1** may **not** be exceeded. The “Actual force” is shown on LICCON monitor 1!
- ▶ The “flying” boom assembly is only permissible up to a certain system length, observe the following charts!

Maximum permissible total force MS1 110 t				
Boom system	Maximum system length	Equipment	DB _{min} ¹⁾	ZB _{min} ²⁾
L	49.0 m	- with end section - without hook block	55 t	43 t
L	55.4 m	- without end section - without hook block	55 t	43 t

1) This counterweight must be at least installed on the turntable for “Flying assembly”.

2) This central ballast must be at least installed on the crawler center section for “Flying assembly”.

12

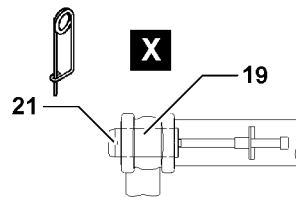
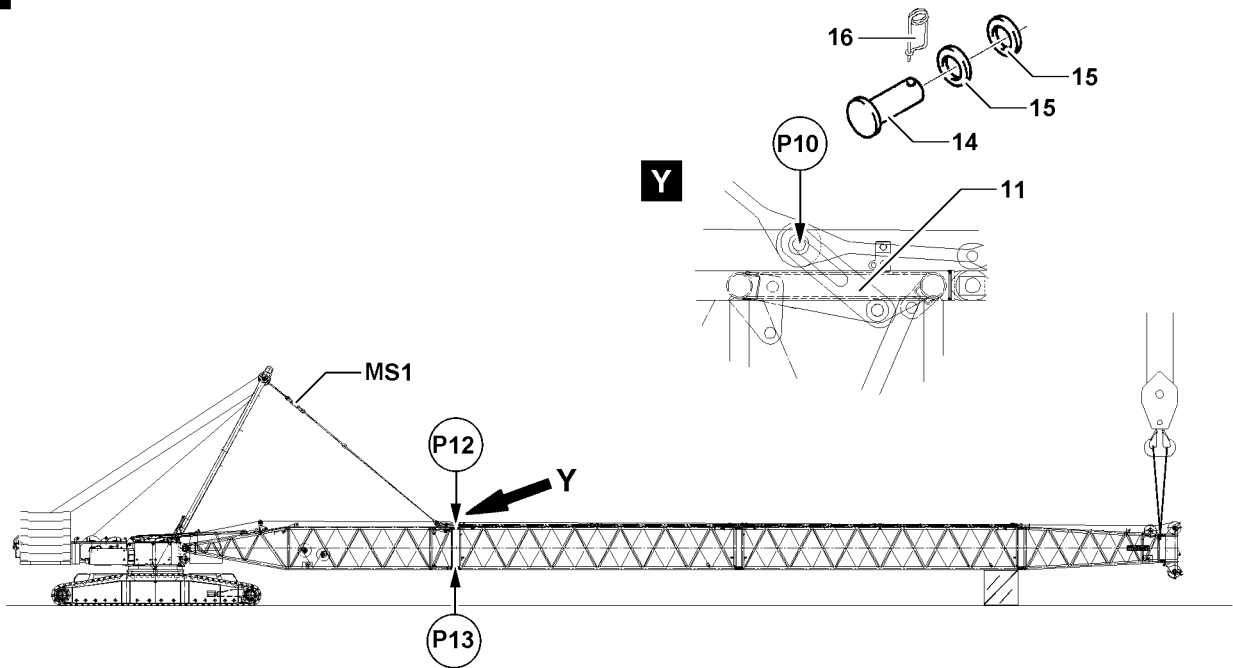

14

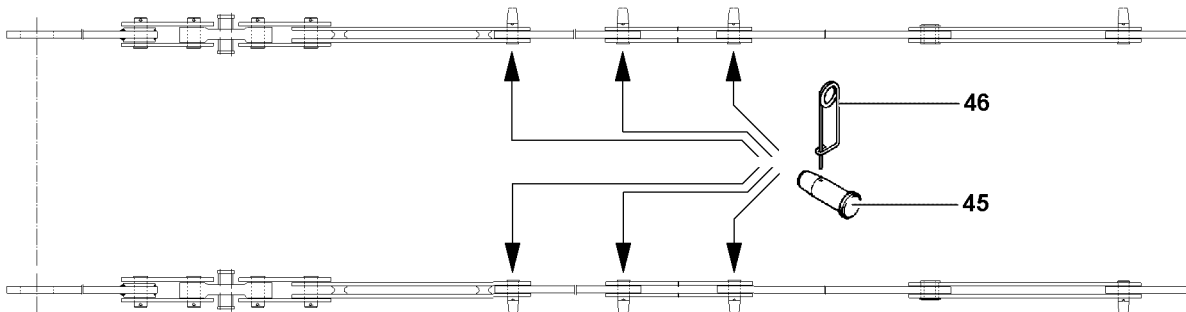

15

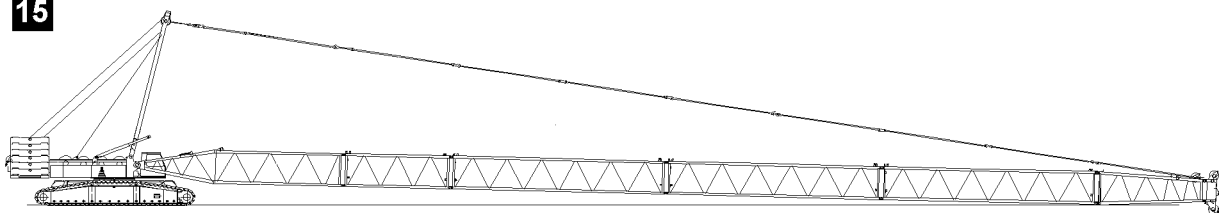

Make sure that the following prerequisites are met:

- The L-pivot section is pinned and secured on the turntable.
- The L-pivot section is horizontally tensioned.
- A minimum of 55 t counterweight is placed on the turntable.
- A minimum of 43 t central ballast is installed on the crawler center section.
- An auxiliary crane is available.



WARNING

Falling components!

If unsecured or non-supported components are installed or removed, they can fall down! Personnel can be killed or seriously injured!

- ▶ During pinning and unpinning of the intermediate sections, it is prohibited for anyone to remain **under or on** the components as well as within the entire danger zone!
- ▶ Before unpinning: Support crane components and boom!
- ▶ Secure the pins in the bearing points and in the receptacles!
- ▶ It is prohibited to lean a ladder against the crane section which is being disassembled!



Note

- ▶ The “Actual force” is shown on LICCON monitor!
- ▶ The flying assembly is made without the assembly of the hook block!
- ▶ For weights of intermediate sections with placed guy rods, see Crane operating instructions, chapter 5.03!



Note

- ▶ When pinning the pin **14**, you have to use the washers **15**, see detail **Y** and detail **Z**.
- ▶ For guying on the S-pivot section, the pin **14** is inserted on both sides on the assembly brackets **11** on point **P10** and secured with the spring retainer **16**!

For “flying” assembly of the intermediate sections, they can be installed individually or as preassembled boom unit on the S-pivot section.

- ▶ Fasten the intermediate sections or preassembled boom unit on the auxiliary crane.
- ▶ Lift the intermediate sections or preassembled boom unit with the auxiliary crane and position on the S-pivot section.
- ▶ When the pin points between the S-pivot section and the intermediate section or the preassembled boom unit align “on top” and “bottom”:
Pin the intermediate section “on top”: Insert the pin **19** on both sides at point **P12** and secure with spring retainer **21**, see illustration **X**.
- ▶ Pin the intermediate section “on the bottom”: Insert the pins on both sides on point **P13** and secure with spring retainer **21**, see detail **X**.
- ▶ When the pins are properly pinned and secured on “top” and “bottom” between the S-pivot section and the S-intermediate section or the preassembled boom unit:
Remove the auxiliary crane.
- ▶ If additional lattice sections are assembled:
Assemble additional lattice sections the same way as described in this section.

12

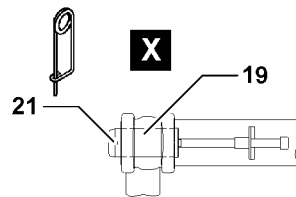
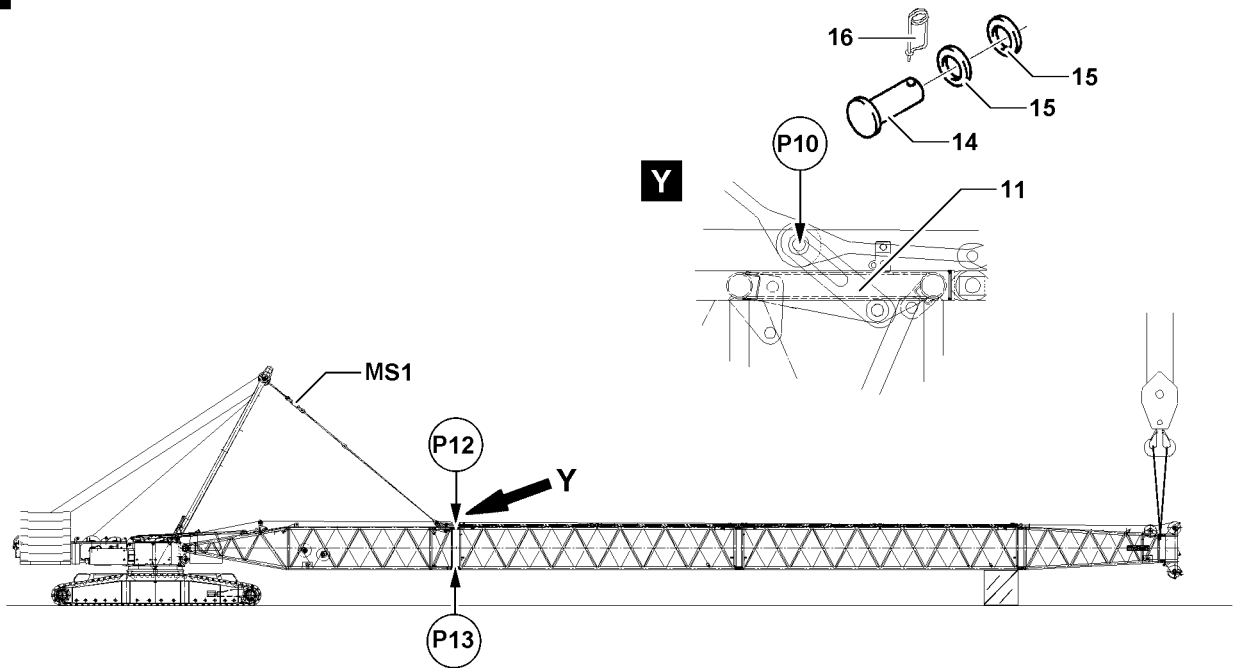

14

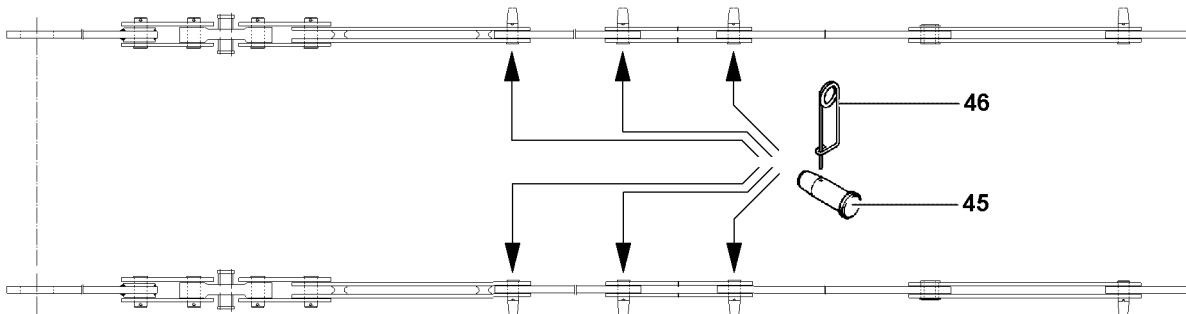

15

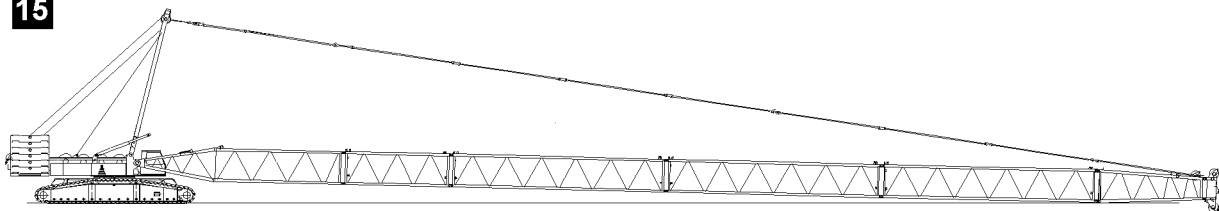

3.4.3 Assembling the L-guy rods



WARNING

Neglected inspection and maintenance on guy rods!

If the regular inspection and maintenance of the guy rods is not carried out or is carried out only in irregular intervals, then severe accidents can occur due to existing and unrecognized damage to the guy rods!

Personnel can be severely injured or killed!

- ▶ Check the guy rods before every assembly, see Crane operating instructions, chapter 8.15!
- ▶ The L-guy rods must be assembled and secured, see Rod plan. The numbering in the rod plan must be identical to the numbering on the guy rods!

Make sure that the following prerequisites are met:

- The boom is guyed on point **P10** on the S-pivot section, see illustration **12**, detail **Y**.
- **Or** the boom is laying on the ground with tensioned guy rods, see illustration **15**.



WARNING

Falling components!

If the intermediate sections are incompletely pinned or secured, then components can fall down!

Personnel can be severely injured or killed!

- ▶ Make sure that the intermediate sections or preassembled boom unit are pinned and secured on the L-pivot section!
- ▶ Make sure that the intermediate sections or preassembled boom unit is supported with suitable materials, secured with the auxiliary crane or the boom is placed on the ground!



WARNING

The boom can fold downward!

By unpinning the guy rods on the assembly brackets **11**, the boom can fold down!

Personnel can be severely injured or killed!

- ▶ Unpin the guy rods on the assembly brackets **11**, point **P10** when it is ensured that the intermediate sections are supported with suitable materials or are held by the auxiliary crane or the boom is placed on the ground!
- ▶ When the boom is **not** laying on the ground:
Support the boom or secure it with the auxiliary crane.
- ▶ Relieve the guy rods: Lower the SA-bracket somewhat to the front.

Result:

- The guy rods between the SA-bracket and the S-pivot section are relieved.

The guy rods are placed and secured for transport on the L-intermediate sections. Before assembly of the guy rods, you must remove the transport retainers.

- ▶ Release and unpin transport retainers for the guy rods.

12

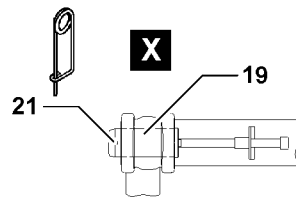
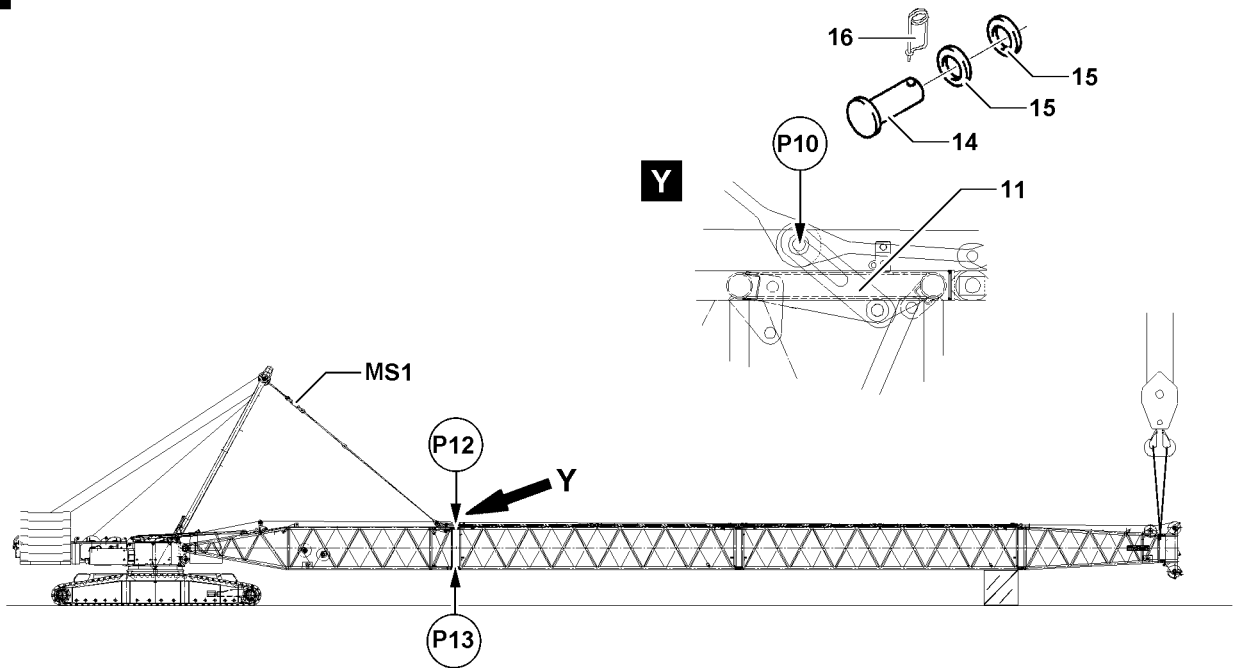

14

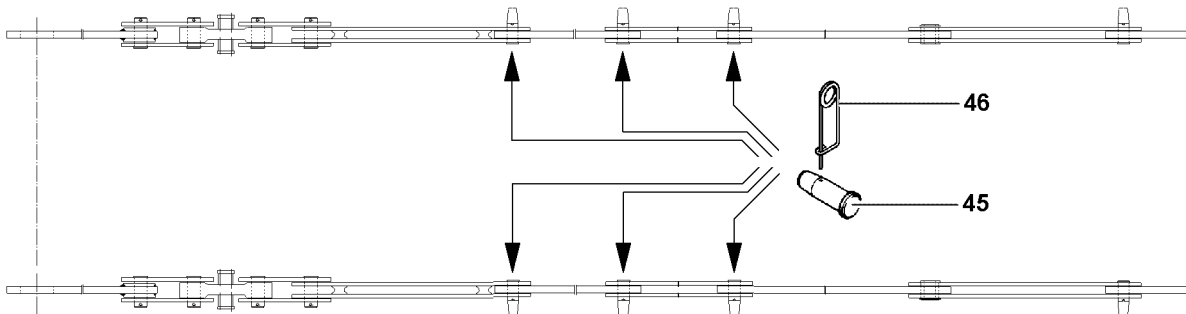

15

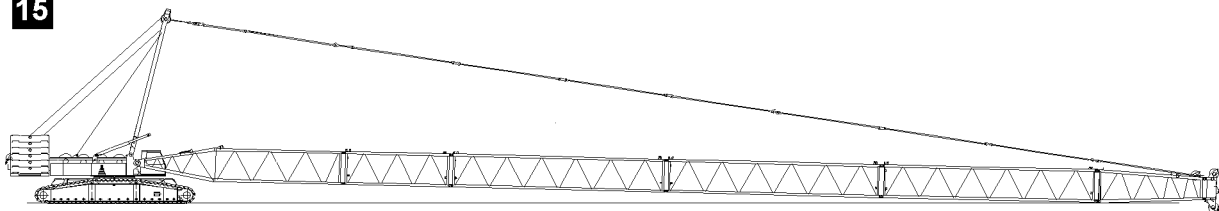

NOTICE

Property damage!

If the pins of the guy rods are not pinned from the “inside” to the “outside”, the hoist rope can scrape on the pin and be damaged!

- ▶ Always insert the pins of the guy rods from the “inside” to the “outside”, see Rod plan and illustration **14**!
-

**Note**

- ▶ The guy rods of the L-intermediate sections are pinned to each other starting from the fixed point on the end section of the boom!
-
- ▶ Pin the guy rods of all intermediate sections: Insert the pin **45** from the “inside” to the “outside”.
 - ▶ Secure the pin **45** with spring retainer **46**.
 - ▶ When all guy rods on the boom system are pinned and secured:
Release and unpin the pins on the assembly brackets **11** or the assembly brackets **23**.
 - ▶ Erect the SA-bracket until the guy rods between the SA-bracket and the L-end section tension.
 - ▶ Remove the auxiliary crane.

B195219

3.5 Establishing the electrical connections

NOTICE

Damage to the electrical connection on the cable drum!

If the electrical connection from the cable drum to the terminal box on the L-pivot section is established first before the connection to the terminal box on the L-end section, the electrical connection can be damaged when spooling out the cable drum!

- ▶ Make the electrical connection from the cable drum in the L-pivot section to the terminal box on the L-end section first and then the electrical connection from the terminal box in the L-pivot section to the cable drum!



Note

- ▶ To establish the electrical connections on the L-boom, see Electric wiring diagram!

Make sure that the following prerequisites are met:

- The L-boom is completely assembled.
- The airplane warning light and the wind speed sensor are assembled.
- ▶ Establish the electrical connections.
- ▶ Make sure that all electrical connections on the boom are established.

3.6 Establishing the hydraulic connections to the L-boom

When connecting hydraulic lines with quick release couplings, make sure that the coupling procedure is carried out correctly.



WARNING

Pressure in the hydraulic lines!

If the pressure supply is not interrupted before connecting / releasing the hydraulic lines, the hydraulic oil can escape with high pressure!

Personnel can be severely injured or killed!

- ▶ Release the pressure in the hydraulic system before connecting / disconnecting: Interrupt the pressure supply and wait for a short time!



WARNING

Loss of pressure or leakage!

Incorrectly coupled or self-loosening quick release couplings (particularly return lines) can result in serious accidents due to component failure!

- ▶ Check that the quick release couplings have been properly connected before using the crane!
- ▶ Connect the coupling components (sleeve and connector) and screw together with the hand-tightened nut.
- ▶ Tighten the hydraulic coupling by hand. Rotate the hand-tightened nut until it reaches a tangible, fixed stop position.
- ▶ Establish the hydraulic connections.

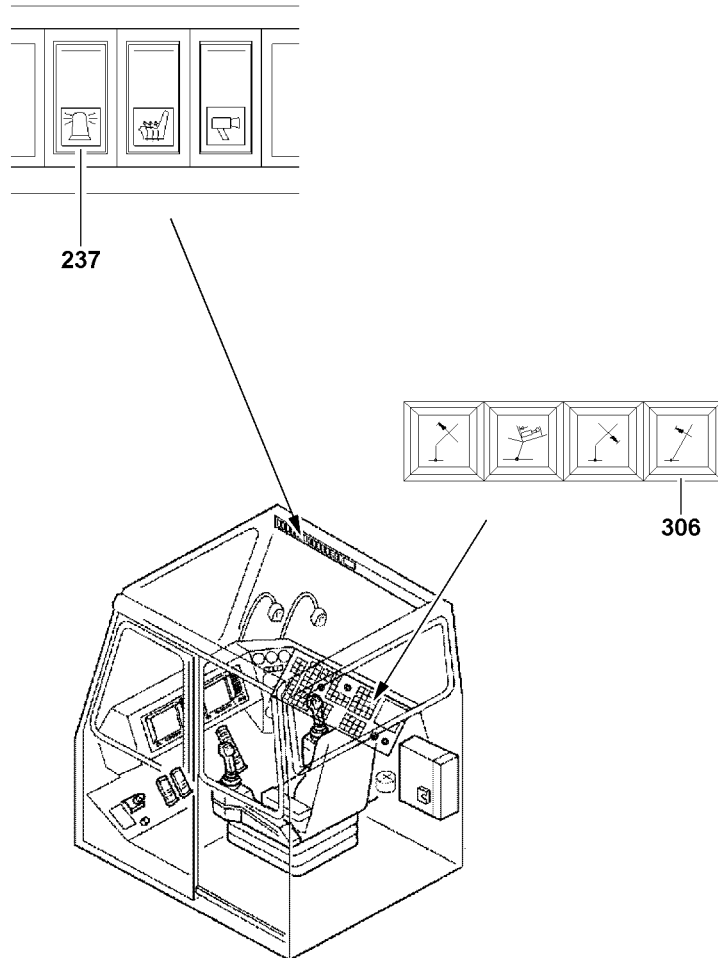

B111471

3.7 Checking the function of the safety devices



WARNING

Non-functioning safety devices!

If the function of the safety devices is defective, personnel can be severely injured or killed!

- ▶ Crane operation with non-functioning safety devices is **prohibited!**



Note

- ▶ The function of the individual limit switches must be checked before erection!
- ▶ The function of the limit switch initiators must be checked in the test system, see Diagnostics manual!



Note

- ▶ If a function check on the limit switches or on the safety devices does not lead to the desired shut offs, then the plug connections on the connector boxes or the components itself must be checked! If no visible connection errors or component defects can be found, contact LIEBHERR Service!

Make sure that the following prerequisites are met:

- All electrical connections have been made.
- The crane engine is running.
- The corresponding operating mode is set in the LICCON computer system.
- The actuator levers on the limit switches are greased.

3.7.1 Wind speed sensor*

- ▶ Check the movement and the function of the wind speed sensor.

3.7.2 Airplane warning light*

- ▶ Turn the airplane warning light on with the switch **237**.
- ▶ Check the function visually.

3.7.3 Hoist limit switch

- ▶ Actuate the limit switch on the pulley head manually.

Result:

- The hoist winch turns off in upward movement.
- The hoist top icon blinks on the LICCON monitor 0.
- The limit switch is functioning.

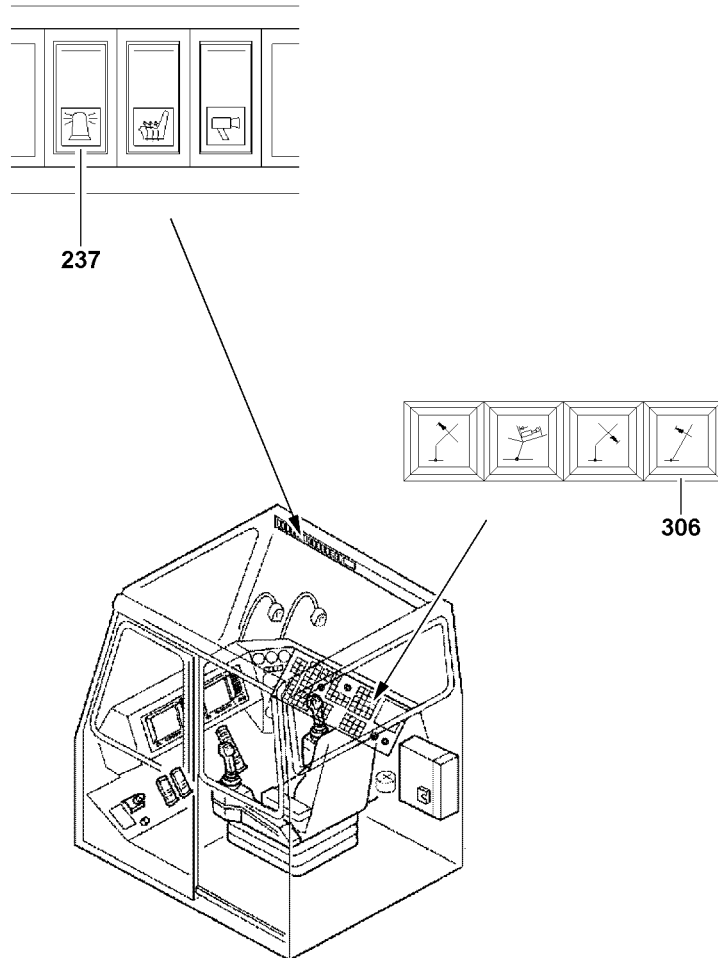

B111471

3.7.4 Limit switch boom “Steepest position”

**Note**

► The limit switch functions have to be checked individually before erection!

► Manually actuate the individual limit switches on the relapse cylinders.

Result:

- Winch 4 (control winch) turns off in upward movement.
- The indicator light **306** lights up.
- An acoustic signal sounds.
- The limit switch is functioning.

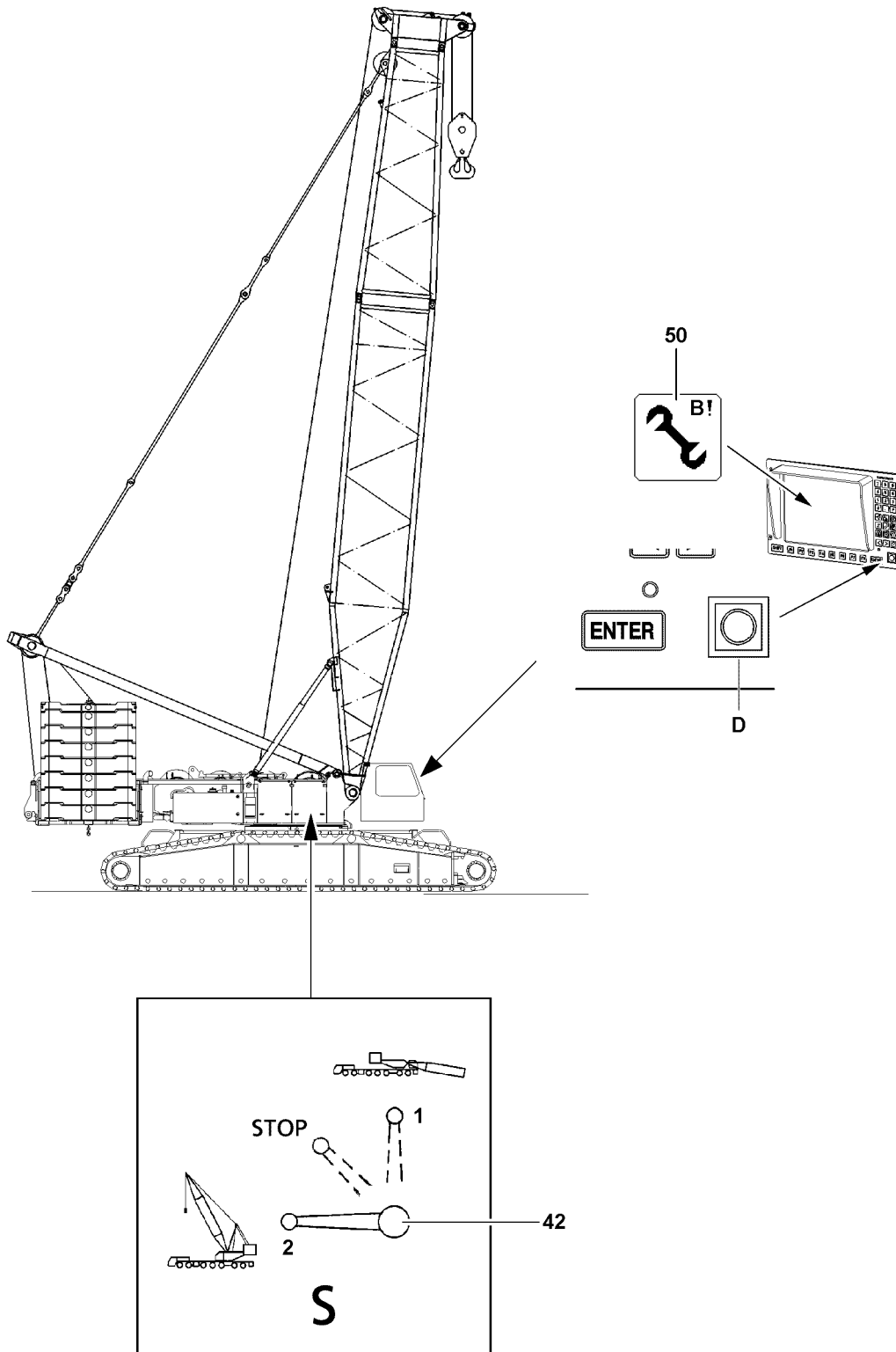

B111472

4 Erecting the L - boom



WARNING

The crane can topple over!

If the following conditions are not met before erecting the boom, the crane can topple over. Personnel can be severely injured or killed!

- ▶ It is not permitted to turn the crane during erection!
- ▶ Observe the data in the erection and take down charts!
- ▶ Observe the safety technical notes, see Crane operating instructions, chapter 5.01!
- ▶ Extend the L-relapse cylinder before erection!
- ▶ Do not allow slack cable to build up on the control winch!



WARNING

Unutilized guy rods on boom!

If guy rods are on the lattice sections which are not used for operation, then there is a risk of accidents!

Personnel can be severely injured or killed!

Guy rods can loosen up and fall down!

The load chart is invalid!

The load display of the LICCON computer system shows the incorrect value!

The weight of the boom is too large for erection!

- ▶ Disassembly and remove unutilized guy rods on the transport retainers before erecting the boom!

Make sure that the following prerequisites are met:

- The crane is aligned in horizontal direction.
- All electrical connections have been made.
- All limit switches are functioning.
- The counterweight has been installed on the turntable according to the load chart.
- All pin connections have been secured.
- The hoist rope has been correctly placed in the rope pulleys and is prevented from jumping out with the rope retaining pins.
- There are no loose parts on the boom.
- The LICCON overload protection has been set according to the data in the load chart.
- The LICCON overload protection settings have been compared with the actual crane configuration.
- The LICCON overload protection is exceeded.
- The assembly icon **50** is visible on the LICCON monitor.
- No personnel is within the danger zone.

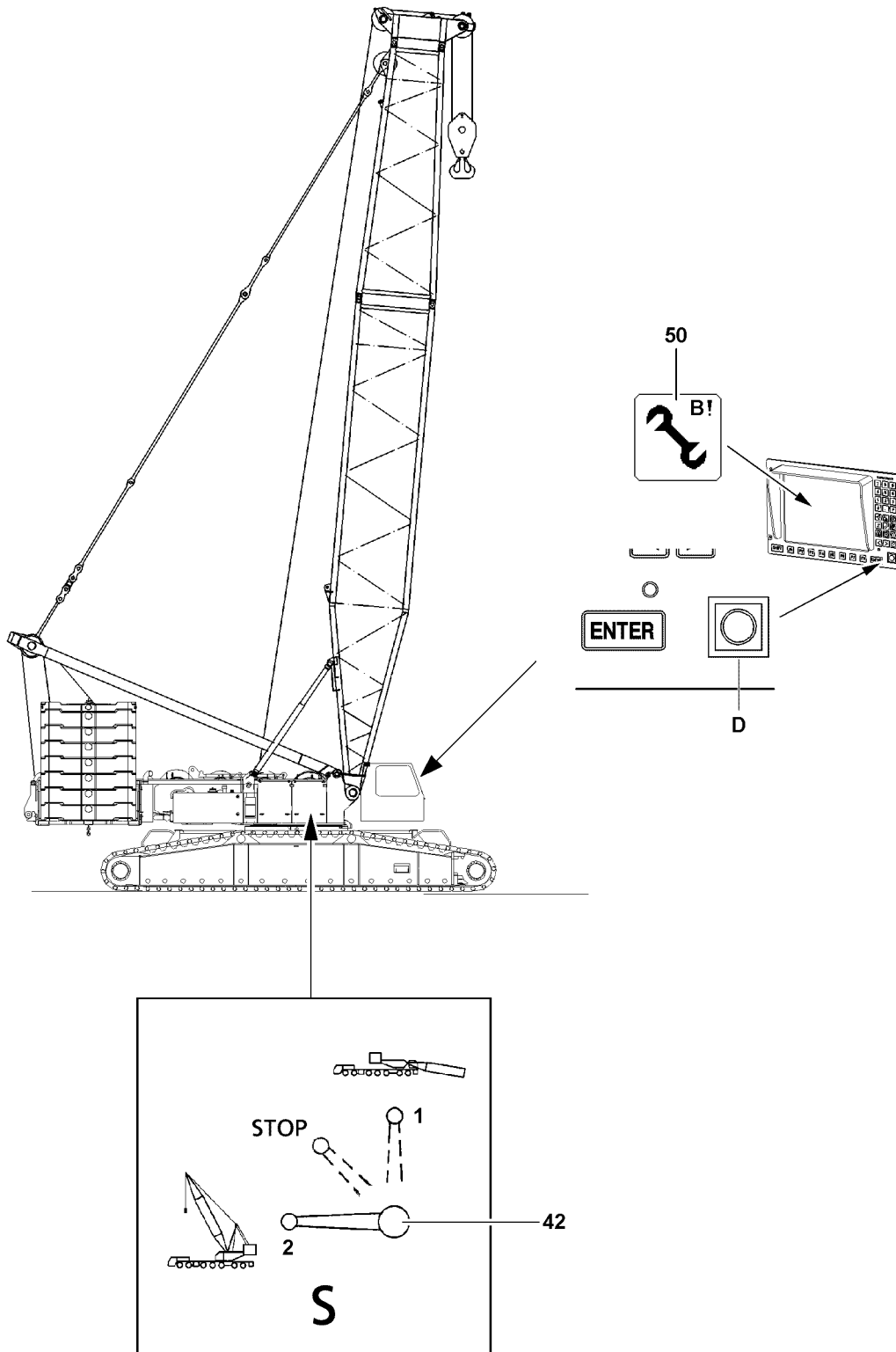

B111472

4.1 Extending the L-relapse cylinder



WARNING

The crane can topple over!

If the L-relapse cylinders are not extended before erecting the L-boom, then the L-boom can fall to the rear in crane operation and the crane can topple over!

Personnel can be severely injured or killed!

- ▶ Extend the L-relapse cylinders before erecting the L-boom!
- ▶ Secure the ball valve **42** during crane operation to prevent inadvertent actuation!

Ball valve positions	
2	Crane operation, extend the piston rod
1	Assembly, retract the piston rod
STOP	The piston rod cannot be retracted / extended

The piston rods on the L-relapse cylinders can be extended with the ball valve **42**.

- ▶ Set the ball valve **42** to **position 2**.

Result:

- The piston rods of the L-relapse cylinders extend.



Note

- ▶ The ball valve **42** is secured by closing the cabinet door and removing the key!
- ▶ Close the cabinet door and pull the key.
- ▶ Hand the key to an authorized person.

4.2 Reeving in the hook block

- ▶ Erect the boom until the end section lifts off the ground.
- ▶ Check the actual load on the LICCON monitor.

Troubleshooting

Actual load on the LICCON monitor is larger than 0.0 t!

- ▶ Observe the notes for input of hook block weight, see Crane operating instructions, chapter 4.02!



Note

- ▶ Hoist rope reevings, see Crane operating instructions, chapter 4.06 and Reeving plan!
- ▶ Reeve in the hook block properly and secure the hoist rope on the rope fixed point, for reeving, see reeving plan.
- ▶ Attach the hoist limit switch weight.
- ▶ Enter the weight of the hook block into the LICCON computer system!

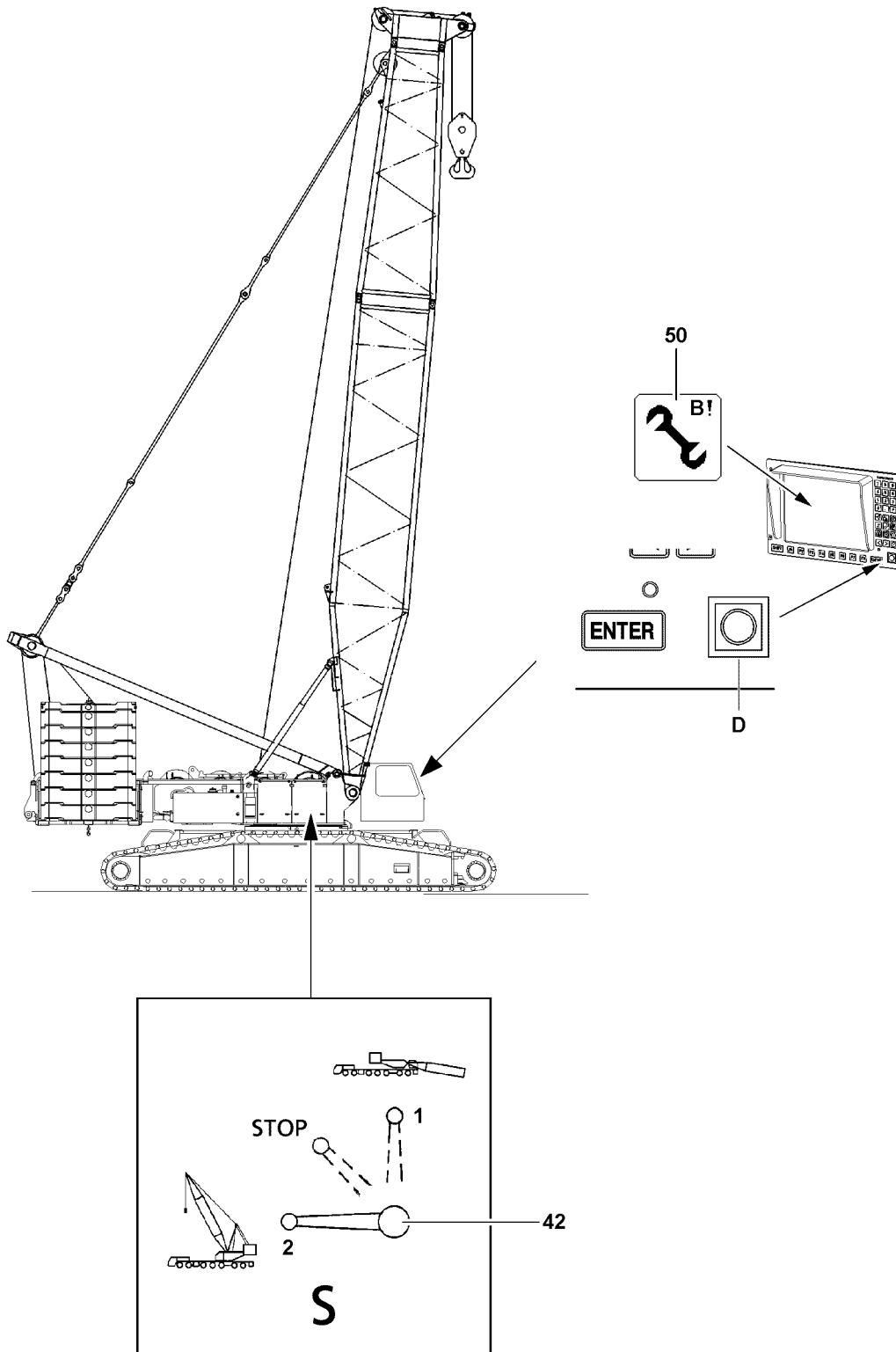

4.3 Erecting the L - boom



WARNING

Falling hoist rope!

If the hoist rope is not reeved with the respective length on the boom before the erection procedure, then it can fall backward due to its own weight.



Personnel can be severely injured or killed!

- ▶ Reeve in the hoist rope with sufficient length on the S-boom before the erection process!
- ▶ The hoist rope must be constantly monitored during erection!
- ▶ Do not step into the danger zone!



Note

- ▶ During the erection procedure - outside the operating area - the alarm functions listed in the chart are displayed as blinking on the crane operating screen!

Displays on the LICCON monitor during the erection procedure	
 "STOP" icon visible	
 "ERROR 150" icon visible	Note: Error description, see Crane operating instructions, chapter 20.05.
 Horn icon visible	Note: In addition to the horn icon, an acoustic warning sounds.

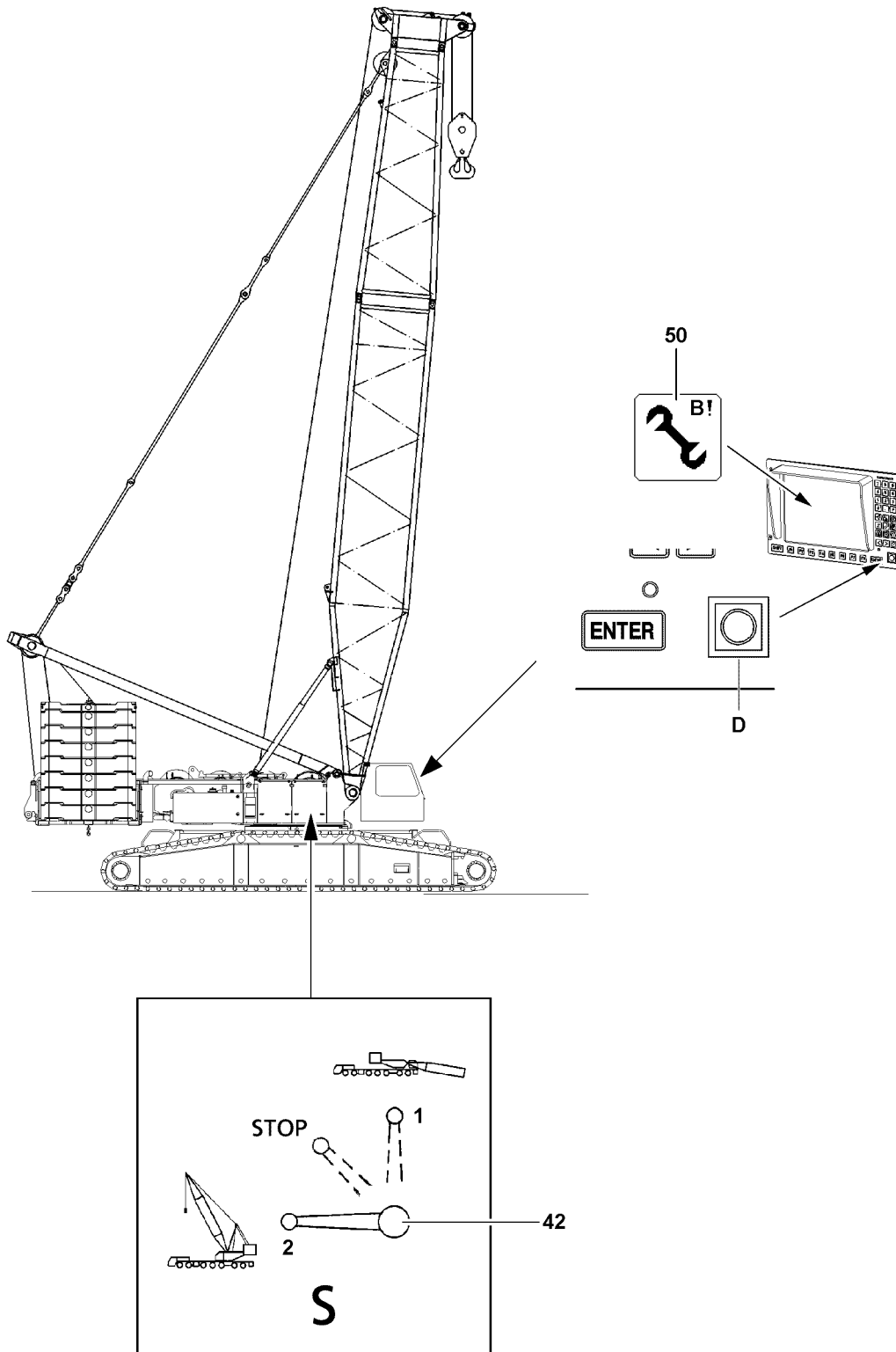

B111472

**WARNING**

The crane can topple over!

In crane operation with exceeded LICCON overload protection, the crane can topple over!

Personnel can be severely injured or killed!

- ▶ The radii listed in the load chart may not be exceeded or fallen below, even if there is no load on the hook!

**Note**

- ▶ When the lowest operating position of the boom is reached, the LICCON overload protection is activated!
- ▶ The displays on the LICCON monitor turn off!
- ▶ In the maximum load icon appears a load number in "t" instead of the display "???"!

- ▶ Luff the boom up to the lowest operating position.
- ▶ When the boom has reached the lowest operating position:
Make sure that the assembly icon **50** on the LICCON monitor turns off.

Result:

- The LICCON overload protection is active.

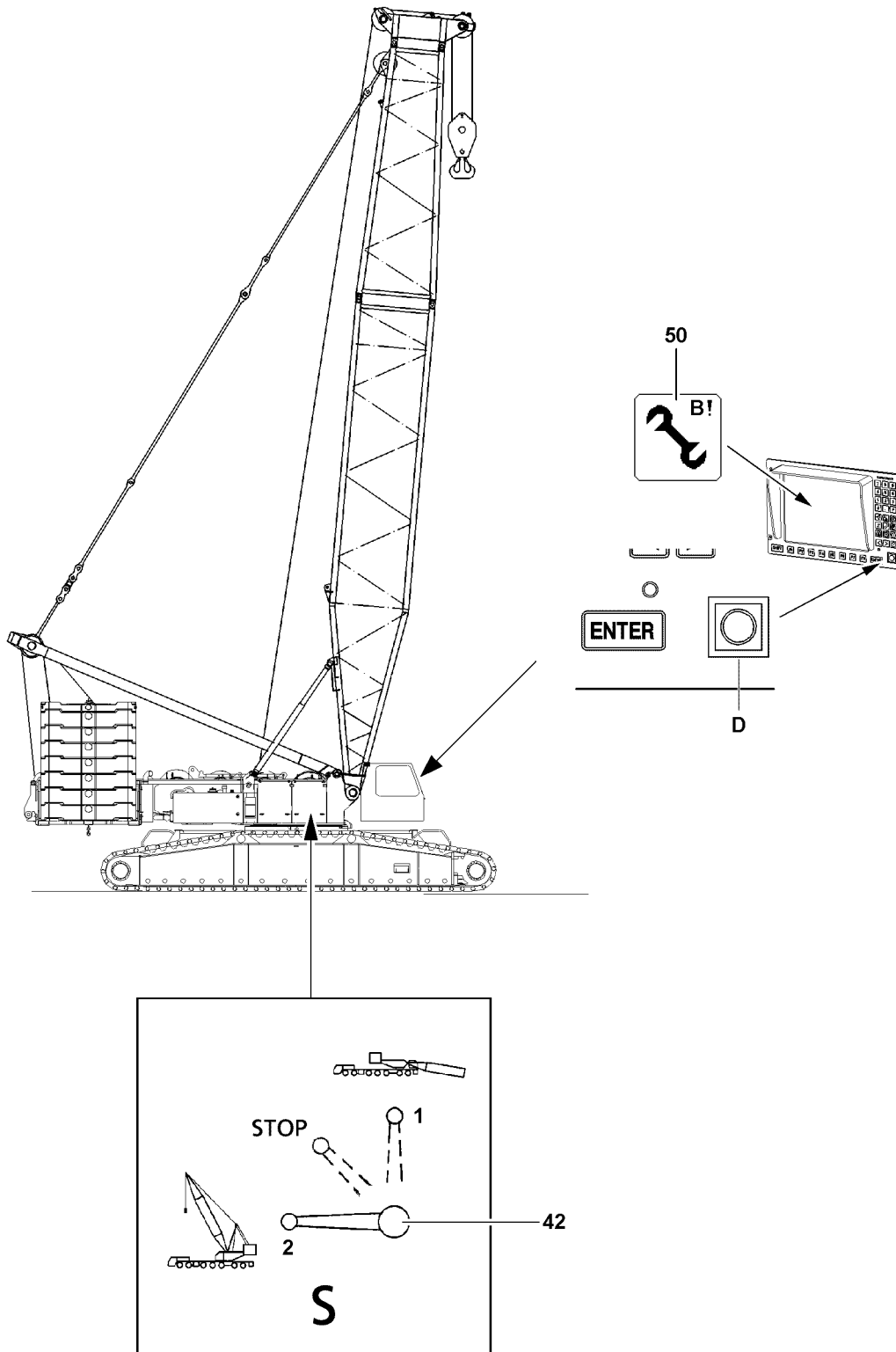

B111472

5 Crane operation

5.1 Preparing for crane operation

**Note**

- ▶ Observe the notes in the chapters, see Crane operating instructions, chapter 4.05, chapter 4.08 and chapter 5.01!

Make sure that the following prerequisites are met:

- The LICCON overload protection is active.
- The LICCON overload protection has been set according to the data in the load chart.

**WARNING**

The crane can topple over!

- ▶ Check the horizontal position of the crane before and during operation!
- ▶ If the crane operator leaves the cab, even for a short time, the operating mode setting must be checked and reset if necessary before resuming crane operation!

5.1.1 Checking the settings

- ▶ Check the function of the overload protection by running against the operating positions “on top” and “bottom”.
- ▶ Check the hoist limit switch by running against the hoist limit switch weight.
- ▶ Check the function of the limit switches “Boom steep” on the relapse cylinders.

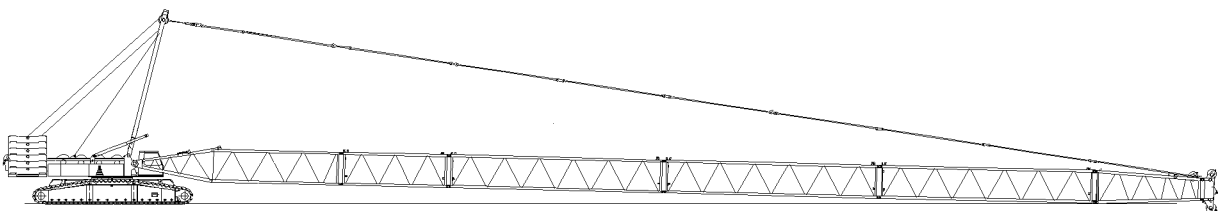
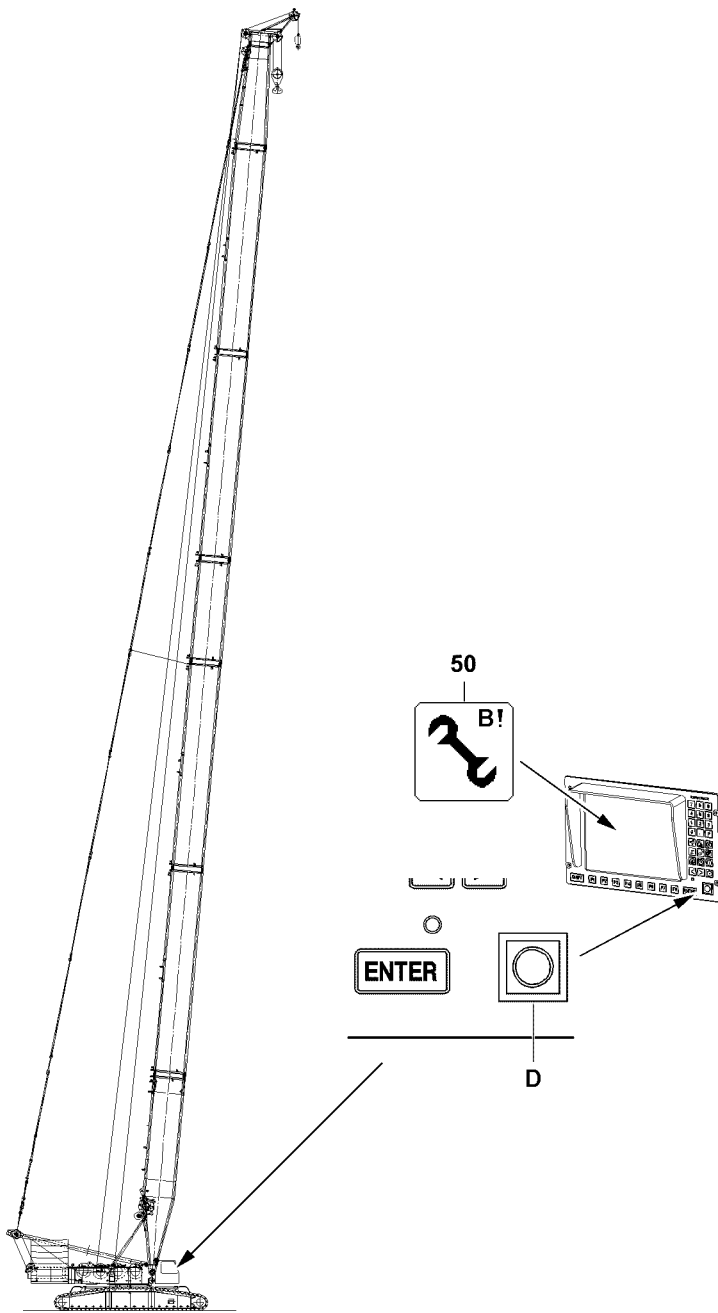

B112449

6 Disassembling the L/LL-boom



Note

- ▶ The assembly is described on the example of the L-boom!



WARNING

Risk of falling!

During assembly / disassembly, inspection and maintenance work, personnel must be secured with appropriate aids to prevent them from falling! If this is not observed, assembly personnel could fall and suffer life-threatening or fatal injuries!

- ▶ All work aloft, where there is a danger of falling must be carried out with suitable aids!
- ▶ If fall protection equipment is available, then it must be used, see Crane operating instructions, chapter 2.06!
- ▶ If aids are not available and work cannot be carried out from the ground, then the assembly personnel must secure themselves with the permissible fall arrest system to prevent falling, see Crane operating instructions, chapter 2.04!
- ▶ The fall arrest system must be fastened on the fastening and hook points as well as on the safety ropes. For safety points, see Crane operating instructions, chapter 2.06!
- ▶ Only step on the aids, ladders and catwalks with clean shoes!
- ▶ Keep aids, ladders and catwalks free of heavy dirt, snow and ice!
- ▶ It is prohibited to walk on the telescopic or an auxiliary boom without suitable protective devices!



WARNING

Falling components!

If unsecured or non-supported components are installed or removed, they can fall down!

Personnel can be severely injured or killed!

- ▶ During pinning and unpinning of the lattice sections, it is prohibited for anyone to remain **under** or **on** the components as well as within the entire danger zone!
- ▶ Support the boom and components before pinning / unpinning!
- ▶ Pin or unpin both pins that lie in one horizontal level, i.e. **left** and **right**!
- ▶ Secure the pins in the bearing points and in the receptacles!
- ▶ Do not disengage the auxiliary crane until each component is pinned on and secured!
- ▶ It is prohibited to lean a ladder against the component being disassembled!



WARNING

Danger of impact / crushing!

When installing / removing crane components with the auxiliary crane, crane components can start to swing back and forth!

When lifting / lowering and positioning crane components, there is an increased danger of impacts / crushing!

Personnel can be caught and severely injured or killed as a result!

- ▶ Make sure that personnel cannot be caught by components!
- ▶ When working in danger zones: Use aids to protect limbs!
- ▶ Guide components with suitable aids to minimize oscillation!

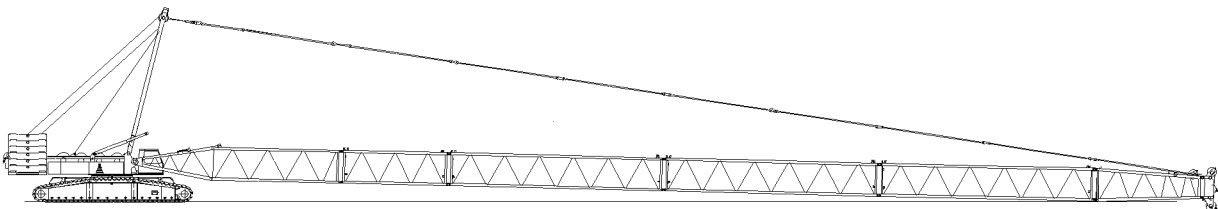
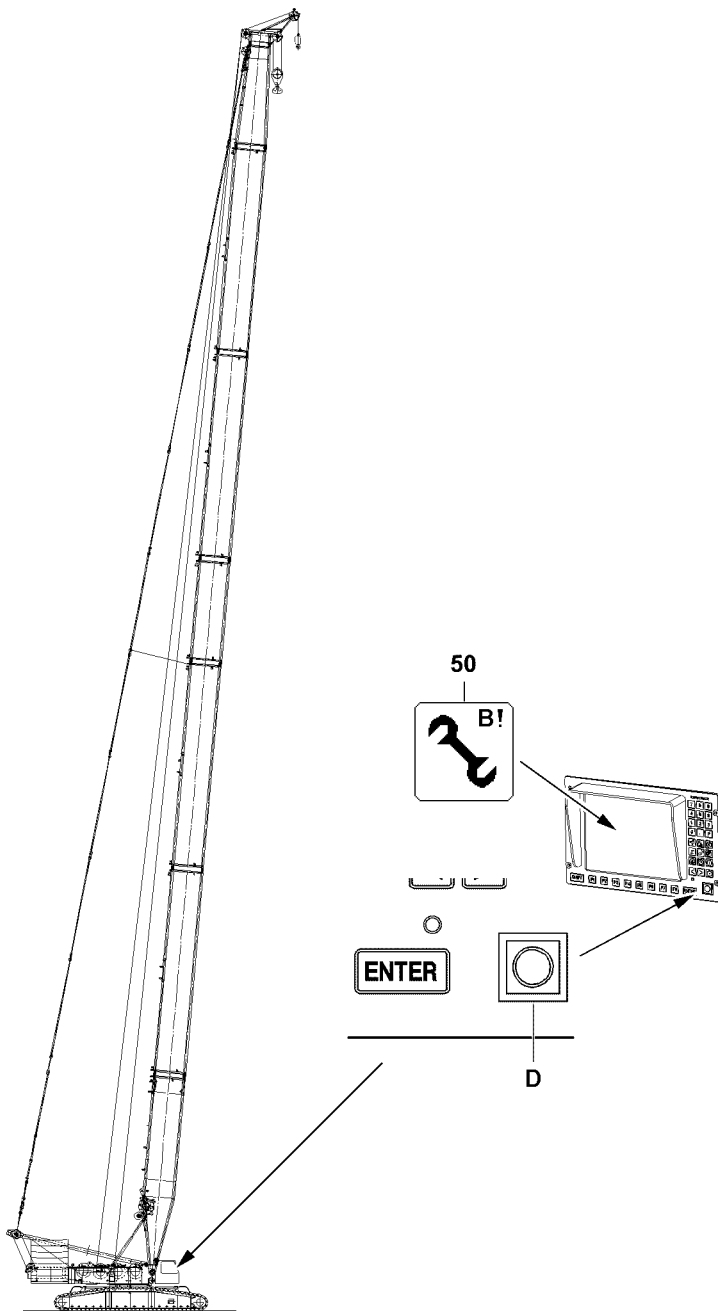

B112449

6.1 Placing the L-boom down



WARNING

Risk of accident!

If the following instructions are not observed, personnel can be severely injured or killed!

- ▶ The turntable may not be turned during the assembly of the boom!
 - ▶ Observe the safety technical notes, see Crane operating instructions, chapter 5.01!
 - ▶ Observe the data in the erection and take down charts!
-

NOTICE

Damage of boom components!

Taking down the boom system can lead to a collision between the hook block and the pulley head!

There is the danger that boom components may be significantly damaged!

- ▶ When taking down the boom system, always spool out the hoist winch at the same time!
-

Make sure that the following prerequisites are met:

- The crane is aligned in horizontal direction.
- An auxiliary crane is available.
- An assembly scaffolding / work platform is available.
- The counterweight has been installed to the turntable according to the erection chart.
- The LICCON overload protection has been set according to the data in the load chart.

6.1.1 Turning the turntable into disassembly position

- ▶ Turn the turntable in longitudinal axle of the crawler travel gear against the travel direction or vertically to the crawler travel gear, see Erection and take down chart.

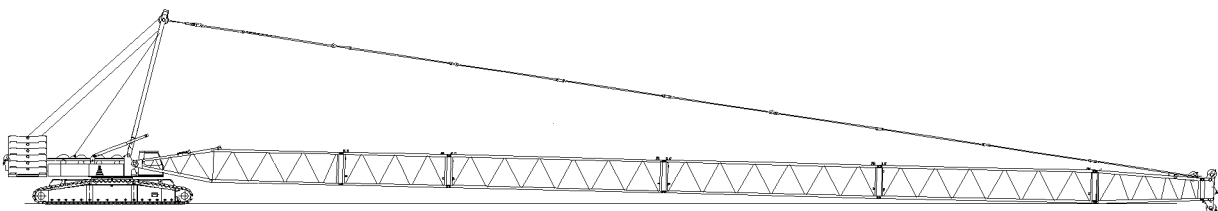
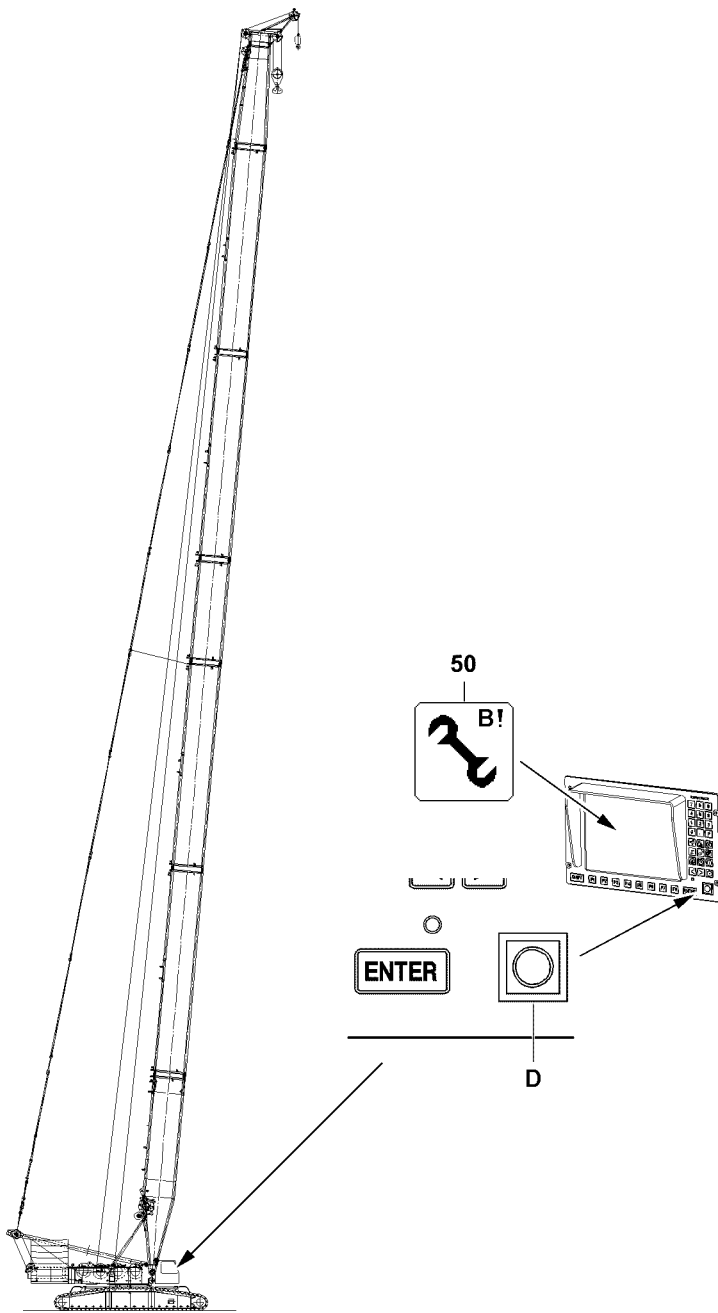

B112449

6.1.2 Luffing the L-boom down





Note

- ▶ The luff down movement is turned off as soon as the lowest operating position is reached!
- ▶ When the lowest operating position of the boom is reached, the load display in the maximum load icon turns off and instead of the load display appears the display “???”!



Note

- ▶ During the take down procedure - outside the operating range - alarm functions appear on the crane operating screen, see the following chart!

Display on the LICCON monitor 0 after reaching the “lowest” operating position	
 Icon: “STOP” visible	
 Icon: “ERROR 150” visible	<p>Note: Error description, see Diagnostics manual, chapter 20.05.</p>
 Icon: “Horn” visible	<p>Note: In addition to the “Horn” icon, an acoustic warning sounds.</p>

- ▶ Luff the S-boom down to the “lowest” operating position.

Result:

- The luff down movement is turned off.
- The “STOP” icon appears on the LICCON monitor.
- The horn icon appears on the LICCON monitor.

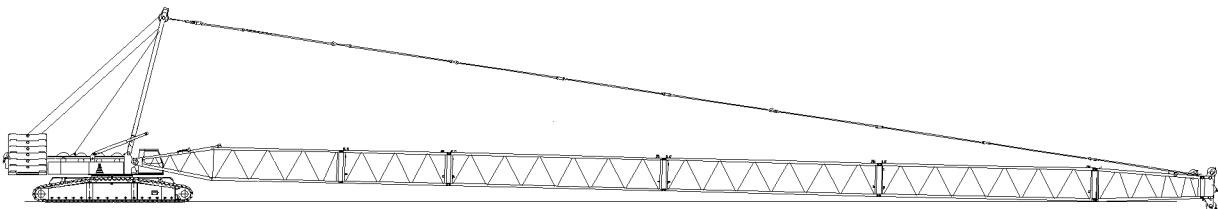
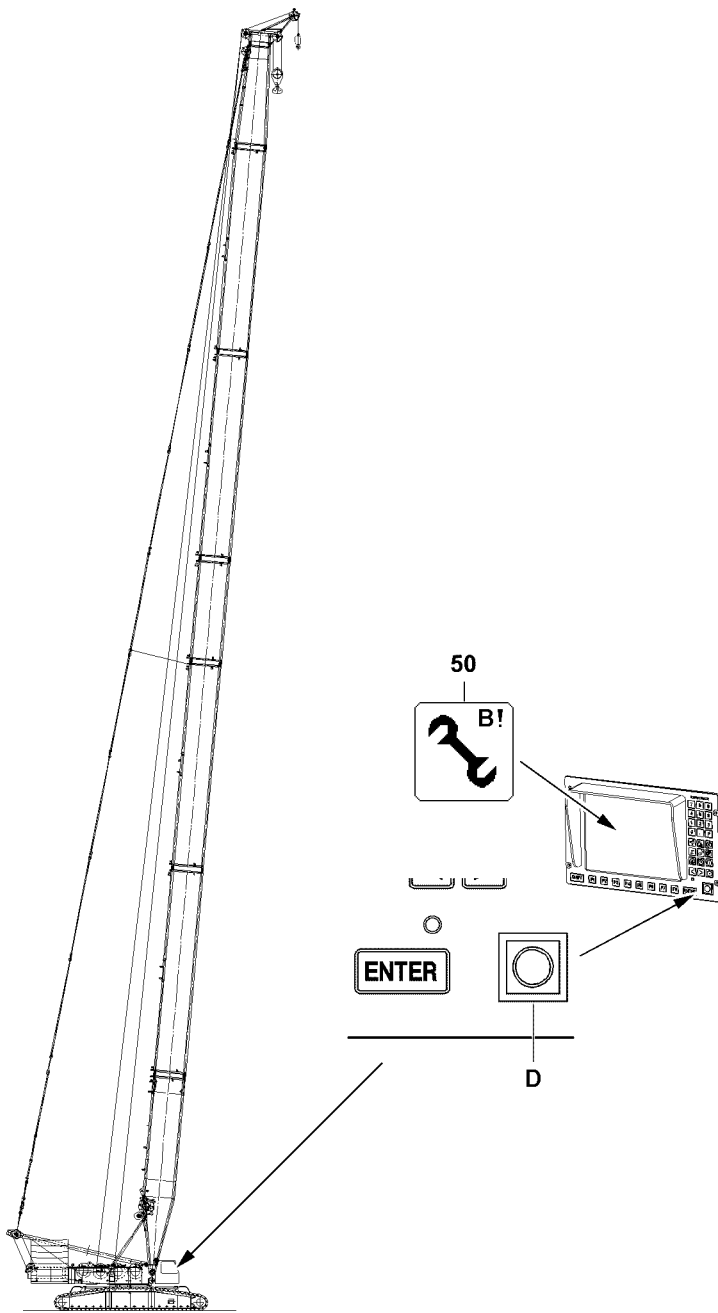

B112449

**WARNING**

Assembly with turned on set up key!

When the set up key is turned on, the LICCON overload protection is exceeded!

In the event of deliberate improper use, the crane could collapse, the boom can break off or the crane can topple over!

Personnel can be severely injured or killed!

This could result in high property damage!

- ▶ The set up key **D** may only be actuated by persons who know the effects of a bypass!
- ▶ Press the set up key **D** only when the set up status was correctly entered into the LICCON computer system!
- ▶ Observe the erection / take down charts!
- ▶ Crane operation with the set up key **D** turned on is strictly prohibited!

- ▶ When the L-boom has reached the “lowest” operating position:
Turn the set up key **D** to the right.

Result:

- The LICCON overload protection is deactivated.
- The assembly icon **50** appears on the LICCON monitor.
- ▶ At the same time, spool the hoist winch out and luff the S-boom down further until the hook block touches the ground.

6.1.3 Unreeving the hook block

- ▶ Remove the hoist limit switch weight and unreeve the hook block.

6.1.4 Spooling the hoist rope up

- ▶ Luff the boom down until the boom head is lying on the support on the ground.

NOTICE

Overspooled winch!

If the rope is pulled under the winch when spooling up, the settings of the cam limit switch are not longer correct and there is an increased danger of accidents!

As a result, extensive adjustment work on the cam limit switch is required!

- ▶ Slowly spool up the hoist rope over the rope pulleys back to the winch!
- ▶ Stop the winch in time, with sufficient rope reserve!
- ▶ Do not overspool the winch!

- ▶ Remove the hoist rope.

6.2 Disconnecting the electrical connections to the L-boom

Make sure that the following prerequisite is met:

- The L-boom has been placed down.
- ▶ Disconnect the electrical connections.

NOTICE

Damage to cable drum or cable!

If the cable of the cable drum is not properly spooled up on the cable drum after unplugging, then the cable drum or the cable can be significantly damaged!

- ▶ Spool the cable drum up after unplugging!
- ▶ Spool the cable drum up and secure it to prevent inadvertent spooling out.
- ▶ Make sure that all electrical connections on the L-boom have been disconnected.

6.3 Disconnecting the hydraulic connection on the L-boom

When releasing hydraulic lines with quick release couplings, make sure that the coupling procedure is carried out correctly.



WARNING

Pressure in the hydraulic lines!

If the pressure supply is not interrupted before connecting / releasing the hydraulic lines, the hydraulic oil can escape with high pressure!

Personnel can be severely injured or killed!

- ▶ Release the pressure in the hydraulic system before connecting / disconnecting: Interrupt the pressure supply and wait for a short time!
- ▶ Install the coupling components (sleeve and connector) with the hand-tightened nut.
- ▶ Disconnect the hydraulic connections.
- ▶ Install dust caps on the quick release couplings.

1

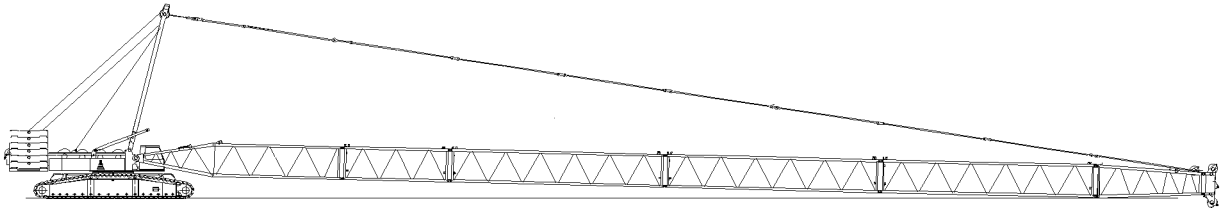

Y

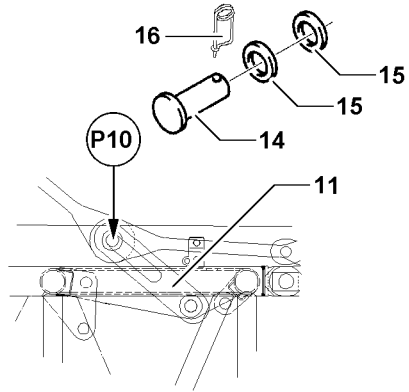

2

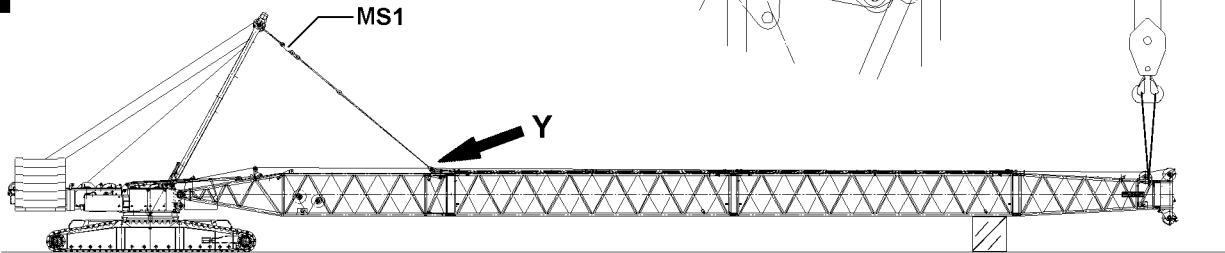

X

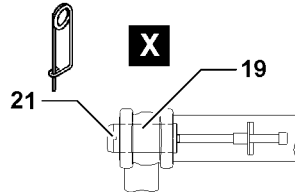

3

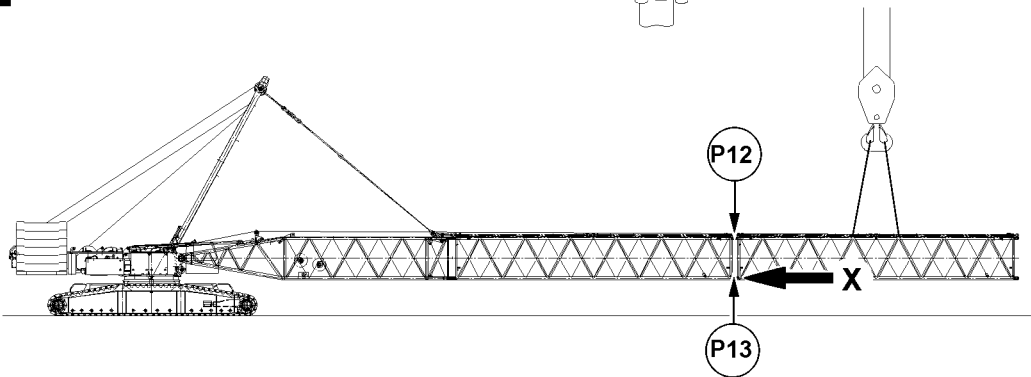

6.4 Disassembling the L-lattice sections

The disassembly of the lattice sections is carried out in various ways:

- Disassembling the lattice sections in “Flying mode”.
- “Opening” the boom.



WARNING

General danger notes!

- ▶ Support the S-boom during assembly / disassembly with suitable materials!
- ▶ All pins are to be secured after assembly with the intended safety elements!
- ▶ The guy rods must be inspected regularly, see Crane operating instructions, chapter 8.15!
- ▶ Secure the boom with support or auxiliary crane, see Crane operating instructions, chapter 5.01!
- ▶ It is prohibited for anyone to remain under the booms or within the complete danger zone during the pinning and unpinning procedure of the lattice section!



Note

- ▶ For weights of intermediate sections with placed guy rods, see Crane operating instructions, chapter 1.03!
- ▶ The intermediate sections are unpinned with the aid of the pin pulling device, see Crane operating instructions, chapter 5.30!

Make sure that the following prerequisite is met:

- All electrical and hydraulic connections are separated on the boom.

6.4.1 Disassembling the L-lattice section in “Flying mode” on the S-pivot section

If spatial prerequisites on the job site are limited for the disassembly of the S-boom, or if they are limited by buildings or similar, then the S-boom can be removed in flying mode.



WARNING

Impermissible boom lengths guyed in flying mode!

If impermissible boom lengths are guyed on the assembly brackets, then severe property damage can occur on the crane! Personnel can be severely injured or killed!

- ▶ The maximum permissible boom lengths for the “Flying assembly” may not be exceeded, see section “Assembling the S-lattice sections”!
- ▶ For the “flying” boom assembly, the maximum permissible total force on the test point **MS1** may **not** be exceeded, see section “Assembling the S-lattice sections in flying mode”!
- ▶ Pin the guy rods on the assembly brackets **11**, point **P10**!
- ▶ The data in the erection and take down charts as well as the load charts must be observed!



WARNING

The boom can fold downward!

By unpinning the guy rods on the assembly brackets **11**, the boom can fold down!

Personnel can be severely injured or killed!

- ▶ Unpin the guy rods on the assembly brackets **11**, point **P10** when it is ensured that the intermediate sections are supported with suitable materials or are secured by the auxiliary crane or the boom is placed on the ground!

1

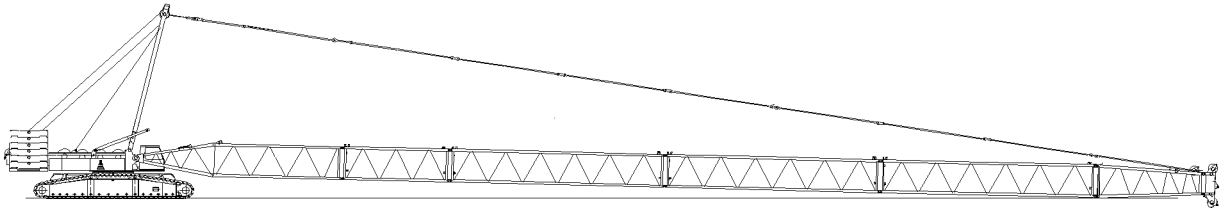

Y

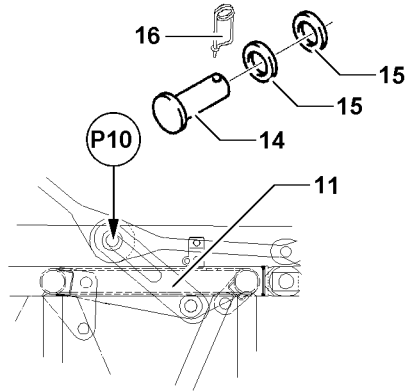

2

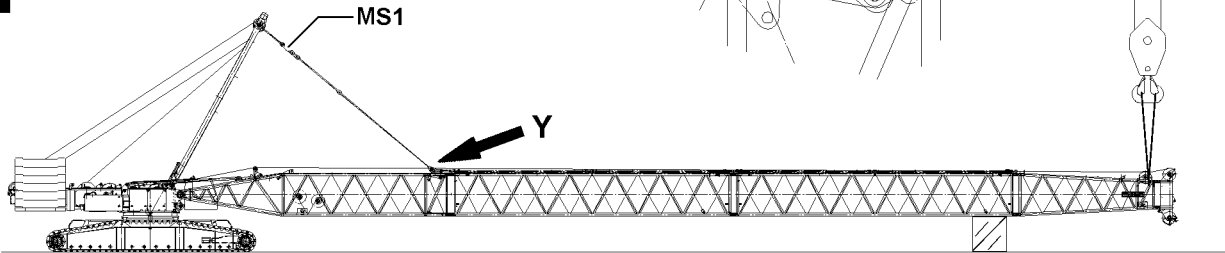

X

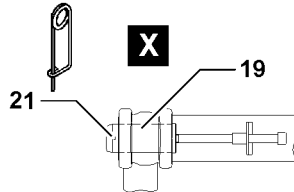

3

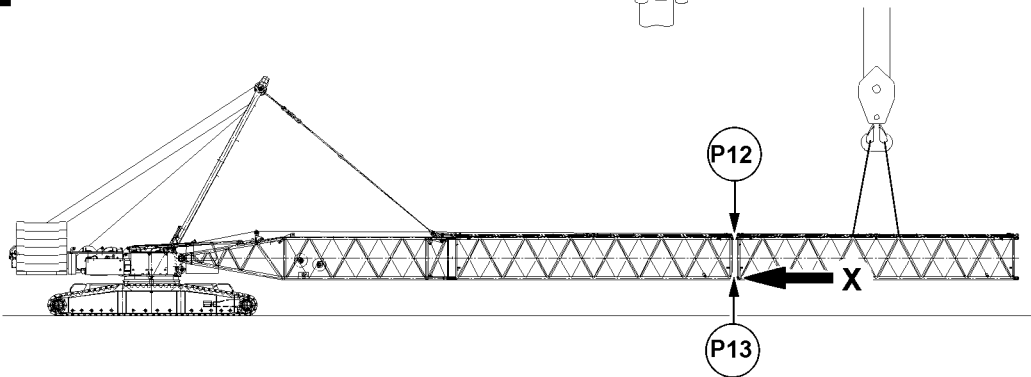

Make sure that the following prerequisites are met:

- The boom is in horizontal position.
- The guy rods are tensioned.
- Suitable materials to support the boom are available.
- An auxiliary crane is available.

Guying the S-boom in “Flying mode”

- ▶ Support the boom or secure it with the auxiliary crane.



Note

- ▶ The guy rods must be placed down to the point where the boom can be guyed on the assembly brackets **11** on point **P10**!

- ▶ Make sure that the transport retainers for the guy rods on the intermediate sections are unpinned.
- ▶ Luff the SA-bracket down and place the guy rods on the L-intermediate sections in the transport retainers.

When pinning the pin **14**, you have to use the washers **15**, see illustration.

- ▶ Pin the guy rods on the assembly brackets **11** on the S-pivot section: Insert the pin **14** on point **P10** and secure with spring retainer **16**.
- ▶ Disassemble the guy rods, which are laying on the boom and secure them in the transport retainers.

Result:

- The L-intermediate sections can be disassembled.

Disassembling the S-intermediate section

The “flying” disassembly is described on the example of one intermediate section, see illustration **3**.

- ▶ Secure the L-intermediate section with the auxiliary crane.
- ▶ Unpin the L-intermediate section on both sides “on the bottom” at point **P13**: Remove the spring retainer **21** and unpin the pin **19**.
- ▶ Unpin the L-intermediate section on both sides “on top” at point **P12**: Remove the spring retainer **21** and unpin the pin **19**.
- ▶ Remove the L-intermediate section.

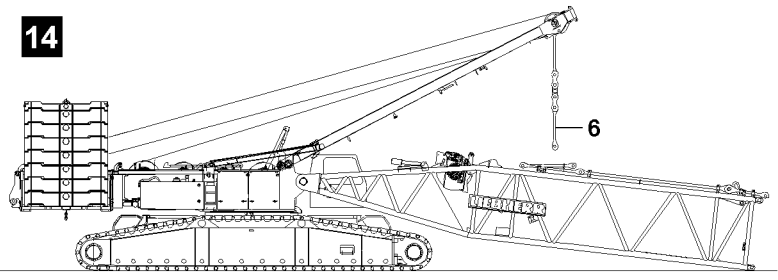
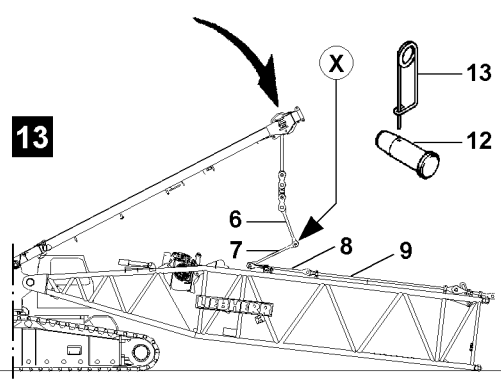
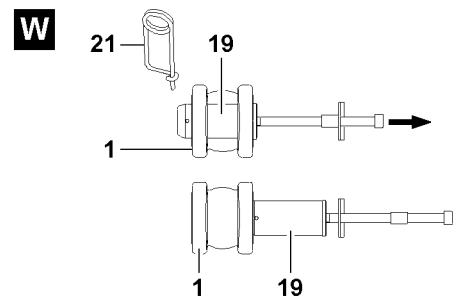
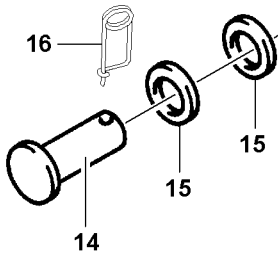
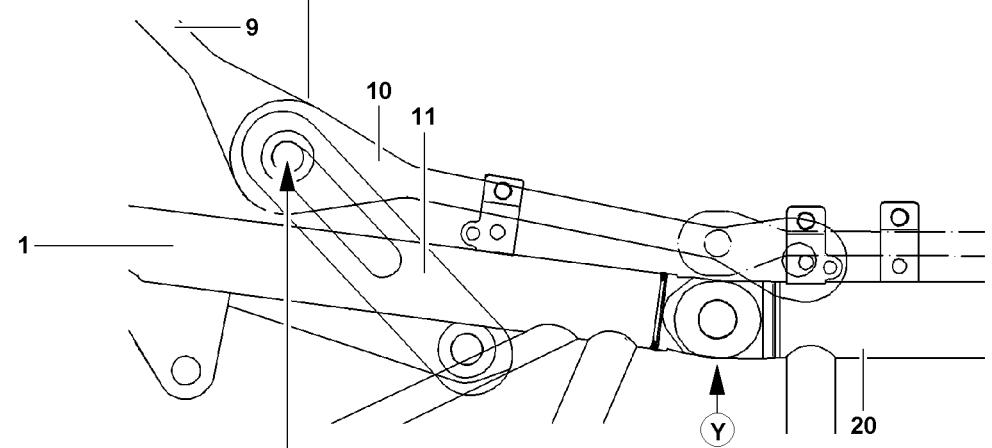
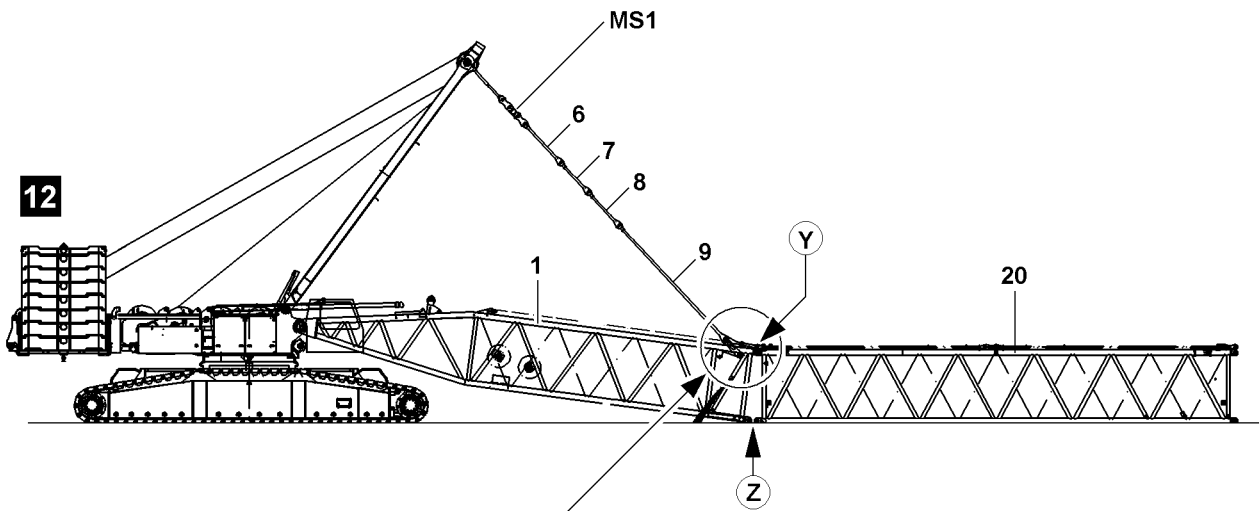

B105431

6.4.2 Disassembling the L-lattice sections (“open” boom)



WARNING

The crane can topple over!

If the following conditions are not met, the crane can topple over or be significantly damaged!

Personnel can be severely injured or killed!

- ▶ During the “Opening procedure” of the L-intermediate sections, the maximum total force on test point **MS1** of 110 t may **not** be exceeded!
- ▶ The end section of the corresponding L/LL-boom combination during the “Opening procedure” may **not** lift off the ground!
- ▶ With the SA-bracket, L-boom combinations may be lifted / closed to maximum **L 105 m** !

Make sure that the following prerequisites are met:

- The guy rods are tensioned.
- Suitable materials to support the boom are available.
- An auxiliary crane is available.



Note

- ▶ The guy rods must be placed down to the point where the guy rods can be pinned on the assembly brackets **11** on point **P10**!
 - ▶ Luff the SA-bracket down and place the boom on the support on the ground.
 - ▶ Make sure that the transport retainers for the guy rods on the intermediate sections are unpinned.
 - ▶ Luff the SA-bracket down and place the guy rods on the L-intermediate sections in the transport retainers.
- When pinning the pin **14**, you have to use the washers **15**, see illustration.
- ▶ Pin the guy rods on the assembly brackets **11** on the S-pivot section: Insert the pin **14** and secure with spring retainer **16**.
 - ▶ Disassemble the guy rods, which are laying on the boom and secure them in the transport retainers.

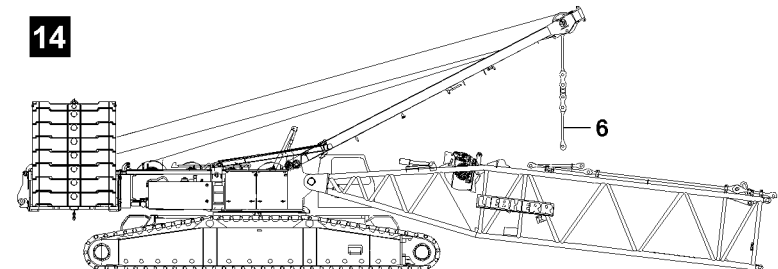
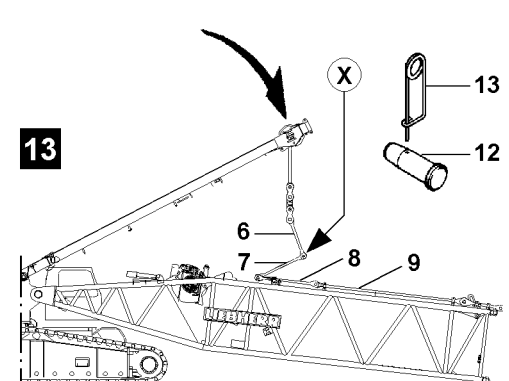
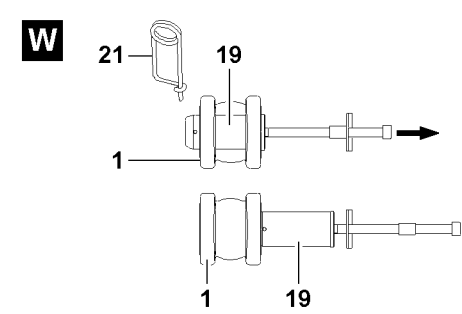
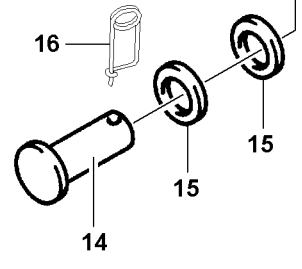
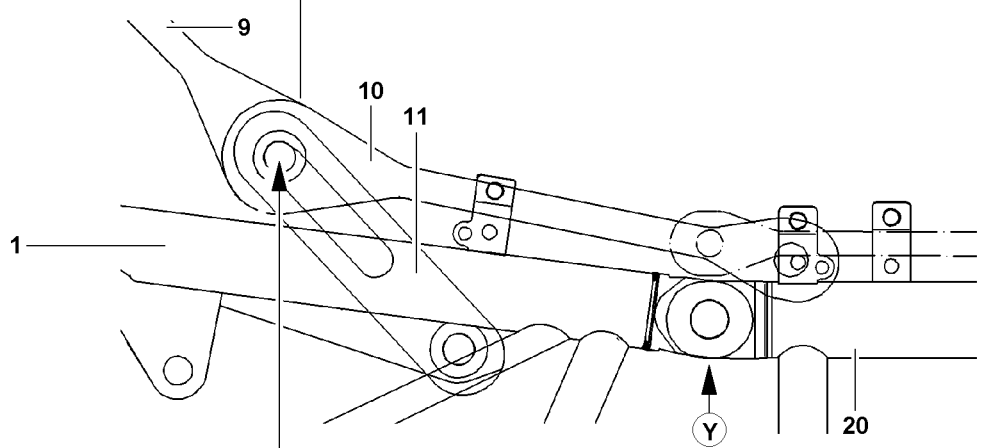
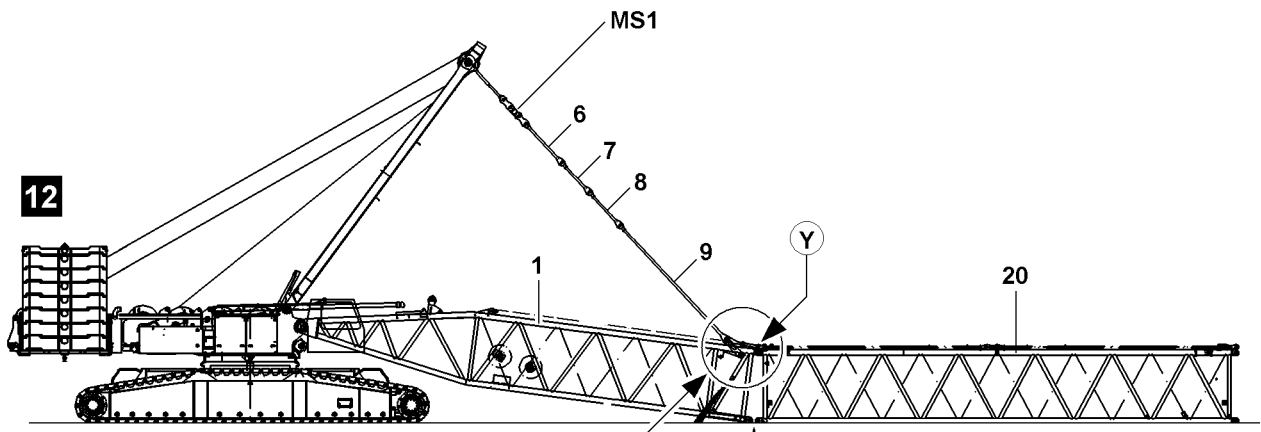

**Note**

- ▶ The actual force on the test point **MS1** is shown on monitor 1!
 - ▶ Tension the guying on the SA-bracket with the same force as for assembly, see the actual force which was measured and noted at assembly on test point (MS1)!
 - ▶ The pins can be pulled easier and the pins and lugs are therefore not damaged!
-
- ▶ Lift the SA-bracket and tension the guy rods until the force on test point **MS1** corresponds to the force at assembly.
 - ▶ Unpin the L-pivot section on both sides “on the bottom” at point **Z**: Remove the spring retainer **21** and unpin the pin **19**, see detail **W**.
 - ▶ Lower the L-boom until the intermediate sections and the S-pivot section is laying on the ground.
 - ▶ Unpin the L-pivot section on both sides “on top” at point **Y**: Remove the spring retainer **21** and unpin the pin **19**, see detail **W**.
 - ▶ Lower the SA-bracket and place the guy rods **7** on the L-pivot section in the transport retainers.
 - ▶ Unpin the guy rods **7** S-pivot section on the guy rods **6** SA-bracket, place them down and secure with transport retainers.

Result:

- The L-lattice sections can be disassembled.

The disassembly is described on the example of one intermediate section, see detail **W**.

- ▶ Unpin the S-intermediate section on both sides “on the bottom”: Remove the spring retainer **21** and unpin the pin **19**.
- ▶ Unpin the S-intermediate section on both sides “on top”: Remove the spring retainer **21** and unpin the pin **19**.
- ▶ Remove the S-intermediate section.

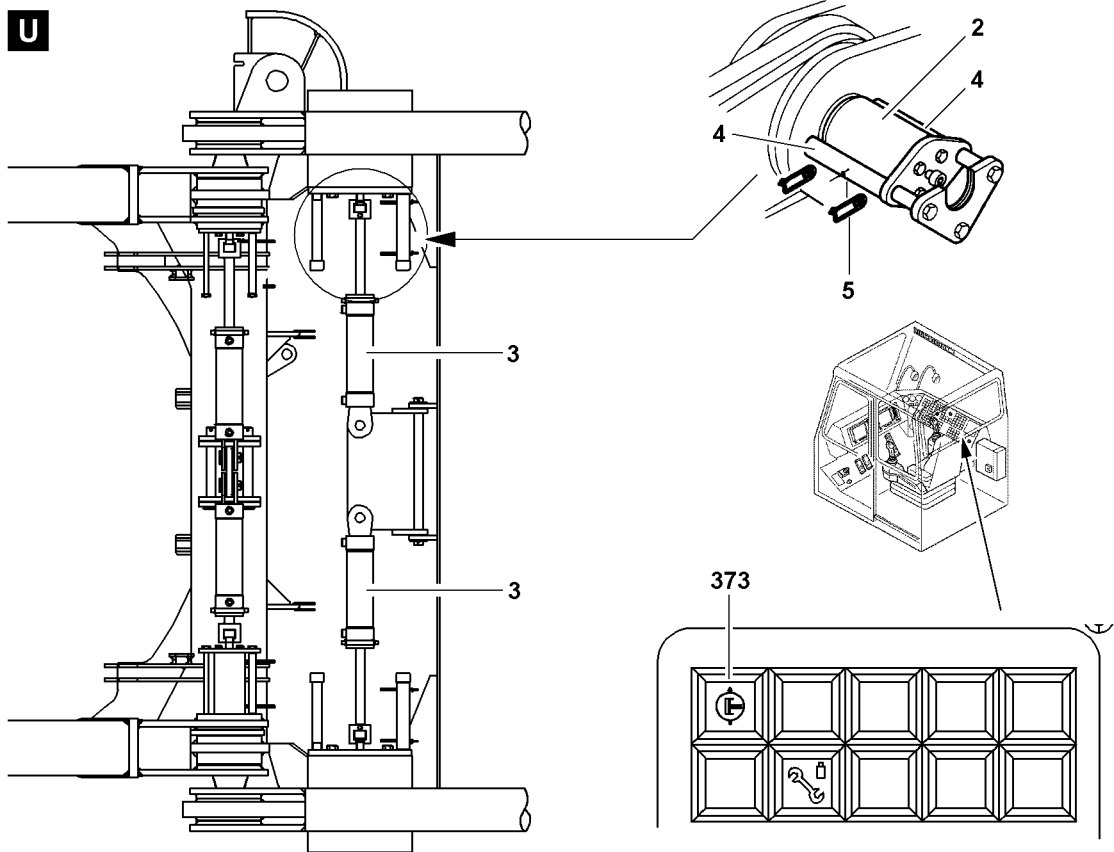
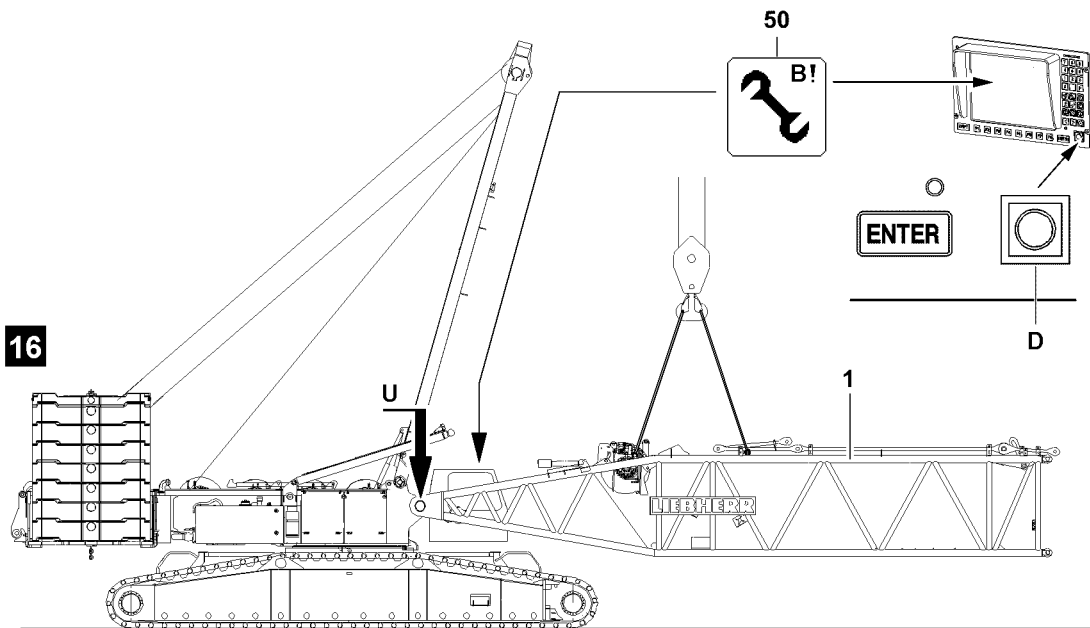
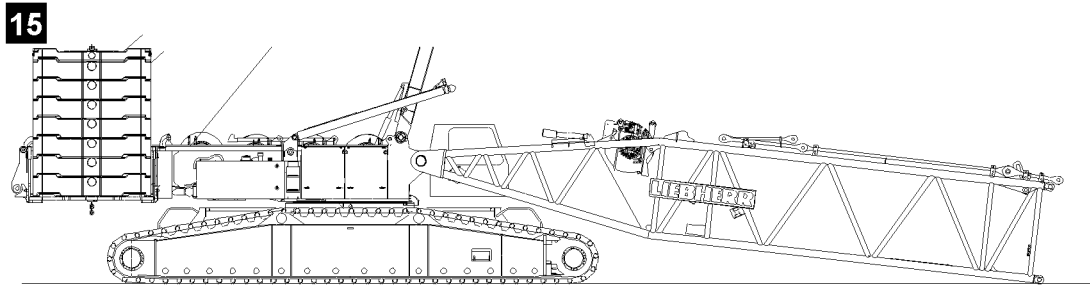

B111474

6.5 Disassembling the L-pivot section



WARNING

General danger notes!

- ▶ Support the L-pivot section during disassembly with suitable materials!
- ▶ Insert and secure all pins after disassembly in the intended transport receptacles!
- ▶ The guy rods must be inspected regularly, see Crane operating instructions, chapter 8.15!

Make sure that the following prerequisite is met:

- The SA-bracket is erected to the point where the L-pivot section can be disassembled without obstructions.

- ▶ Attach the L-pivot section **1** on the auxiliary crane.
- ▶ Lift the L-pivot section **1** with the auxiliary crane to the horizontal.

Establish the hydraulic connection to the pin pulling device via two quick couplers.

Release and unpin the L-pivot section **1** on the turntable.

- ▶ Establish the hydraulic connection to the pin pulling device.
- ▶ Turn the pressure change over switch **373** on.



WARNING

The L-pivot section can fold downward!

- ▶ Make sure that the L-pivot section is safely held by the auxiliary crane before unpinning the pins **2**!

- ▶ Remove the spring retainer **5** on the retaining plate **4** on the left and right.
- ▶ Remove the retaining plate **4** left and right.
- ▶ Unpin the connector pins **2** with the hydraulic pin pulling device **3**.
- ▶ Turn the pressure change over switch **373** off.

NOTICE

Property damage on the turntable and on the L-pivot section!

- ▶ Slowly swing the L-pivot section out with the auxiliary crane and at low speed on the turntable!

- ▶ Place the L-pivot section with the auxiliary crane on the support on the ground.
- ▶ Remove the pin pulling device.
- ▶ Remove the auxiliary crane.



Note

- ▶ Place the SA-bracket on the turntable, see Crane operating instructions, chapter 5.02!

1

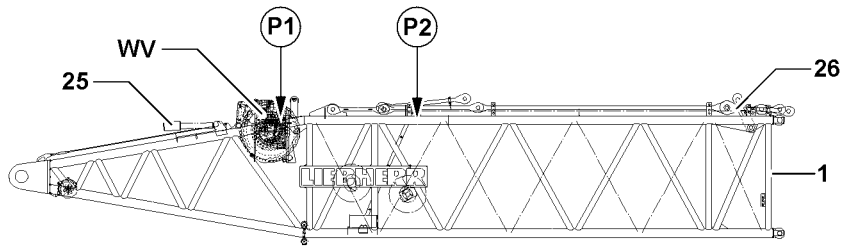

2

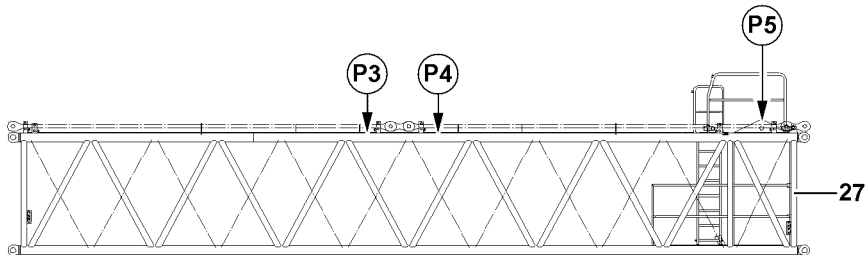

3

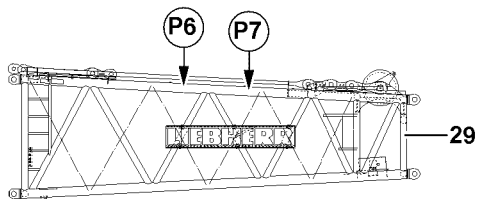

4

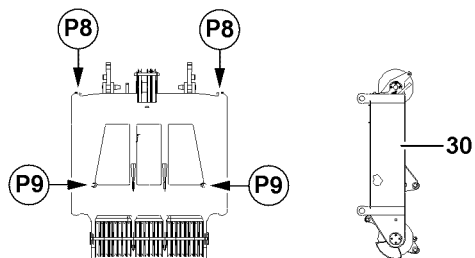

1 Component overview S-/SL-boom

Examples for components of S-/SL-boom:

- | | |
|---|---|
| 1 S-pivot section | • Pivot section with winch 5 WV and W-guy rods 26 , see illustration 1 |
| 25 S-relapse cylinder | • See illustration 1 |
| 27 S-intermediate section
2620.20 | • Intermediate section 14 m with guy bracket on point P5 for flying assembly, see illustration 2 |
| 29 S-adapter | • See illustration 3 |
| 30 S-end section | • See illustration 4 |

2 Fastening points S/SL-components



WARNING

Component incorrectly attached!

Life-threatening situations can arise due to improper or incorrect attachment of the corresponding components!

Personnel can be severely injured or killed!

- ▶ Attach the components only on the intended fastening points on both sides!
- ▶ Attachment of components and description of fastening points, see Crane operating instructions, chapter 5.01!

Component	Fastening point	Illustration
S-pivot section	P1 and P2	1
S-intermediate section	P3 and P4	2
S-adapter	P6 and P7	3
S-end section	P8 and P9	4

B195219

3 Assembling the S/SL boom



Note

- ▶ The assembly is described on the example of the S-boom!



WARNING

Risk of falling!

During assembly / disassembly, inspection and maintenance work, personnel must be secured with appropriate aids to prevent them from falling! If this is not observed, assembly personnel could fall and suffer life-threatening or fatal injuries!

- ▶ All work aloft, where there is a danger of falling must be carried out with suitable aids!
- ▶ If fall protection equipment is available, then it must be used, see Crane operating instructions, chapter 2.06!
- ▶ If aids are not available and work cannot be carried out from the ground, then the assembly personnel must secure themselves with the permissible fall arrest system to prevent falling, see Crane operating instructions, chapter 2.04!
- ▶ The fall arrest system must be fastened on the fastening and hook points as well as on the safety ropes. For safety points, see Crane operating instructions, chapter 2.06!
- ▶ Only step on the aids, ladders and catwalks with clean shoes!
- ▶ Keep aids, ladders and catwalks free of heavy dirt, snow and ice!
- ▶ It is prohibited to walk on the telescopic or an auxiliary boom without suitable protective devices!



WARNING

Falling components!

If unsecured or non-supported components are installed or removed, they can fall down!

Personnel can be severely injured or killed!

- ▶ During pinning and unpinning of the lattice sections, it is prohibited for anyone to remain **under** or **on** the components as well as within the entire danger zone!
- ▶ Support the boom and components before pinning / unpinning!
- ▶ Pin or unpin both pins that lie in one horizontal level, i.e. **left** and **right**!
- ▶ Secure the pins in the bearing points and in the receptacles!
- ▶ Do not disengage the auxiliary crane until each component is pinned on and secured!
- ▶ It is prohibited to lean a ladder against the component being disassembled!



WARNING

Danger of impact / crushing!

When installing / removing crane components with the auxiliary crane, crane components can start to swing back and forth!

When lifting / lowering and positioning crane components, there is an increased danger of impacts / crushing!

Personnel can be caught and severely injured or killed as a result!

- ▶ Make sure that personnel cannot be caught by components!
- ▶ When working in danger zones: Use aids to protect limbs!
- ▶ Guide components with suitable aids to minimize oscillation!

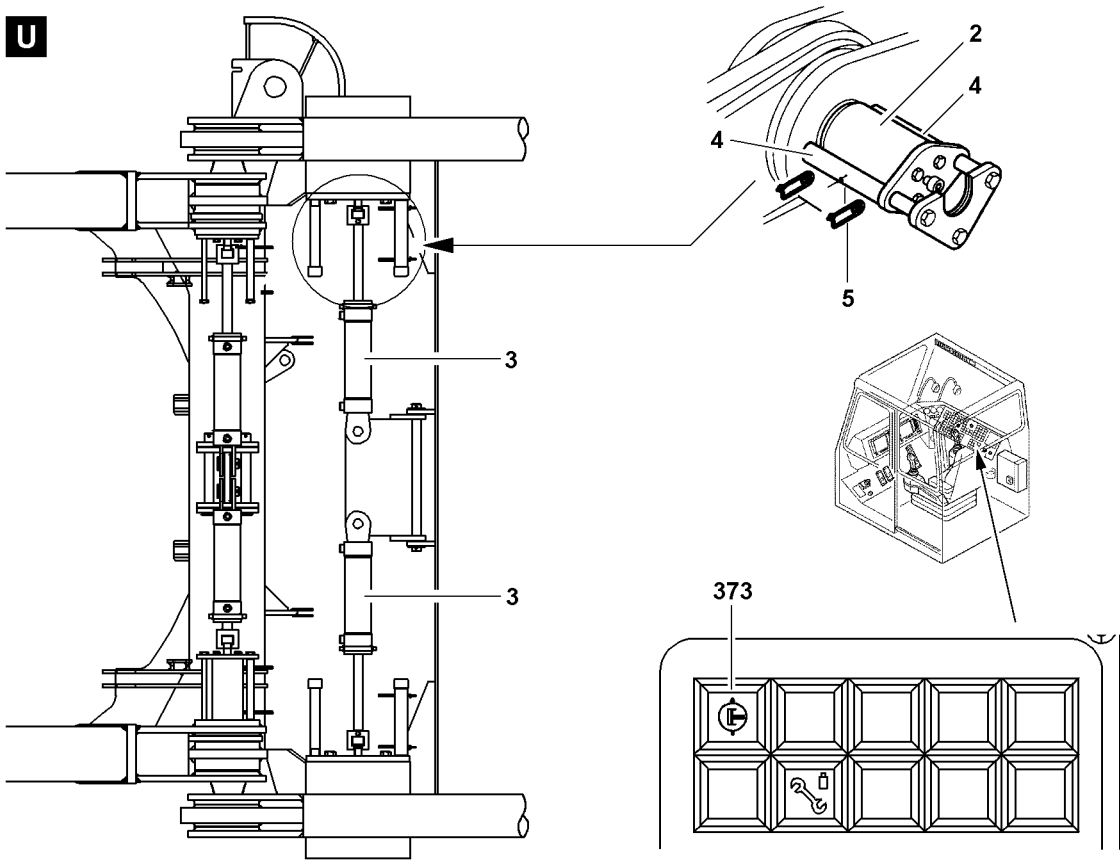
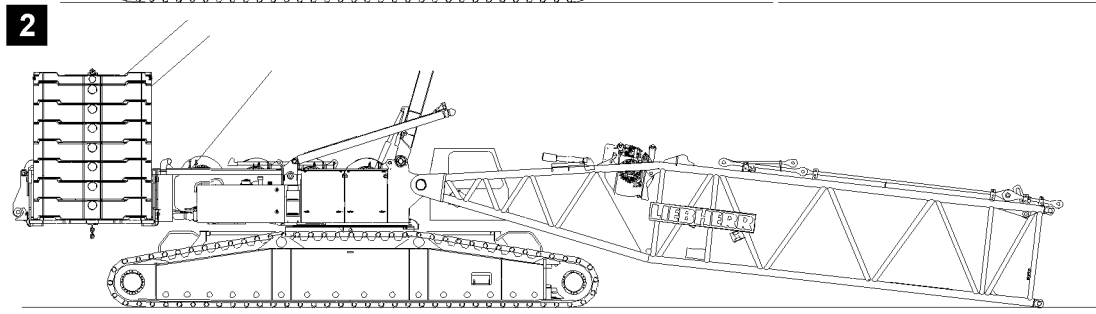
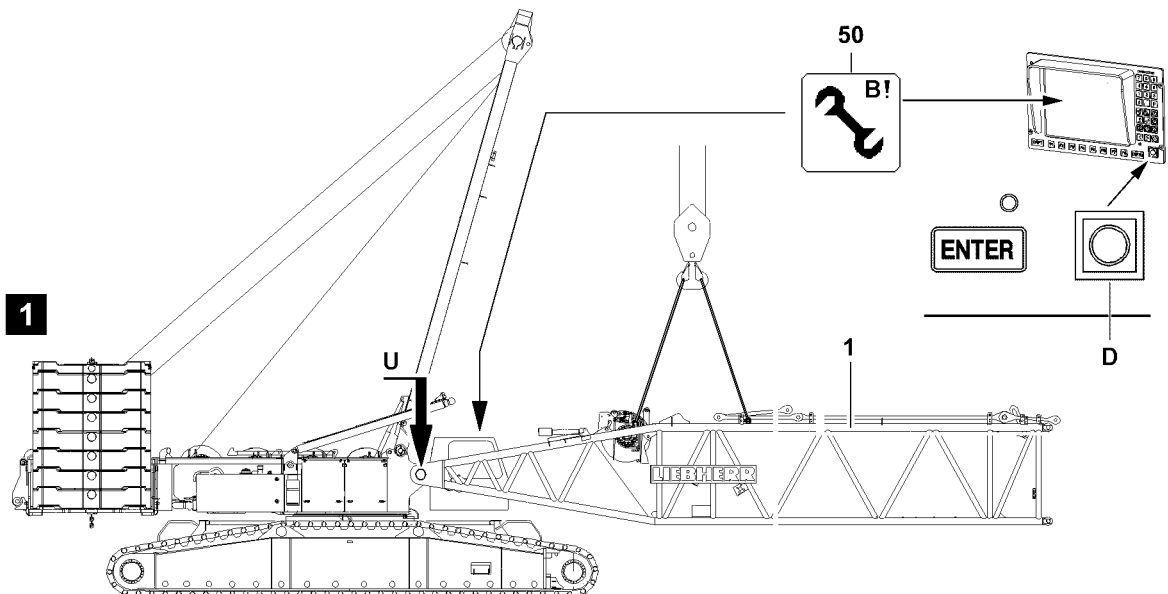

B111470

**WARNING**

The crane can topple over!

If the turntable is turned during the assembly of the boom, then the crane can topple over and be severely damaged! Personnel can be severely injured or killed!

- ▶ The turntable may not be turned during the assembly of the boom!

**WARNING**

Risk of accident!

If the following instructions are not observed, personnel can be severely injured or killed!

- ▶ Arrangement of lattice sections of boom combinations, see Rod plan!
- ▶ Depending on the condition of the ground, the boom and the lattice sections must be supported from below for the assembly of the boom!
- ▶ Observe the safety technical notes, see Crane operating instructions, chapter 5.01!

Make sure that the following prerequisites are met:

- The crane is aligned in horizontal direction.
- An auxiliary crane is available.
- An assembly scaffolding / work platform is available.
- The counterweight has been installed on the turntable according to the load chart.
- The LICCON overload protection has been set according to the data in the load chart.

3.1 Turning the turntable into assembly position

**DANGER**

The crane can topple over!

If the following conditions are not met before turning the turntable - **without** assembled S-boom, the crane can topple over!

Personnel can be severely injured or killed!

- ▶ Observe the data in the erection and take down charts!
- ▶ If no S-boom is installed on the turntable, max. 135 t counterweight may be installed and when turning the turntable by 360 °, it must be ensured that the SA-bracket is erected to **more than 90 °**!
- ▶ If the counterweight is increased to 155 t, then the S-boom must be installed and raised off the ground!

Maximum counterweight	Minimum central ballast	Equipment
55 t	11 t	Without equipment
95 t	11 t	
135 t	43 t	
155 t	43 t	S-boom installed and raised off the ground

- ▶ Turn the turntable in longitudinal axle of the crawler travel gear or vertical to the crawler travel gear, see Erection and take down chart.

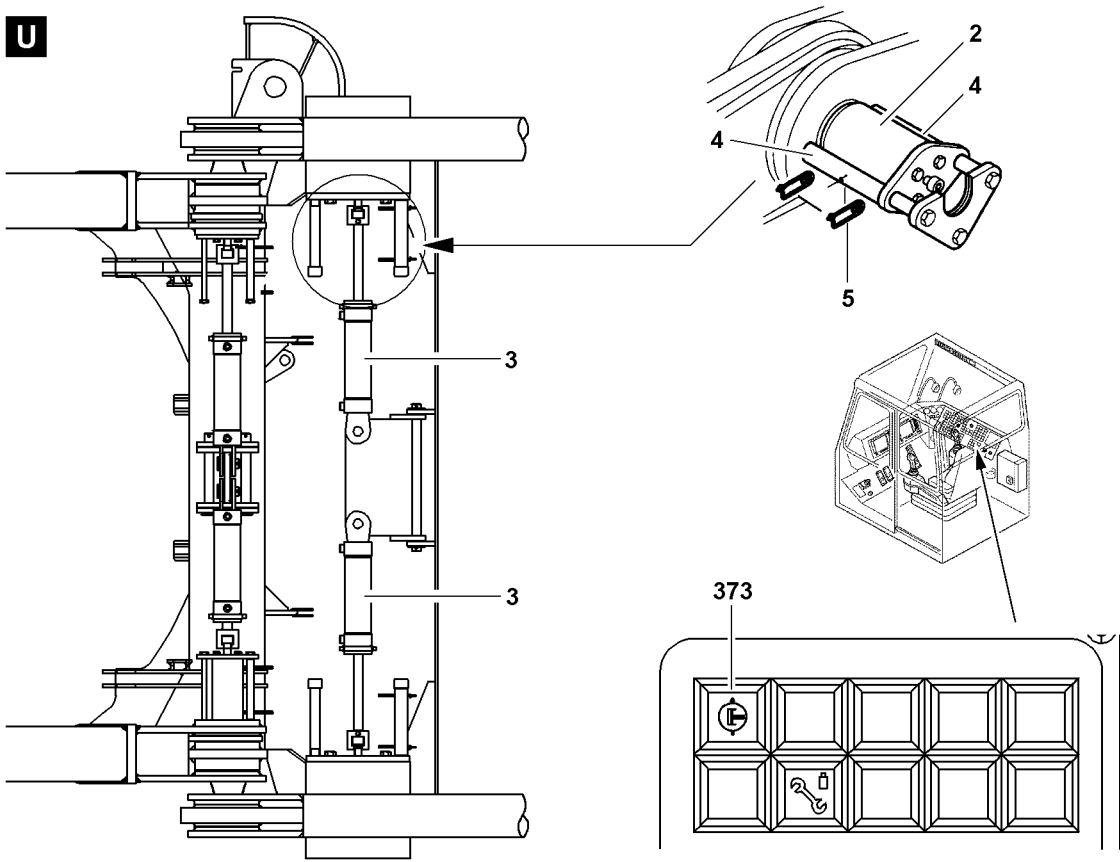
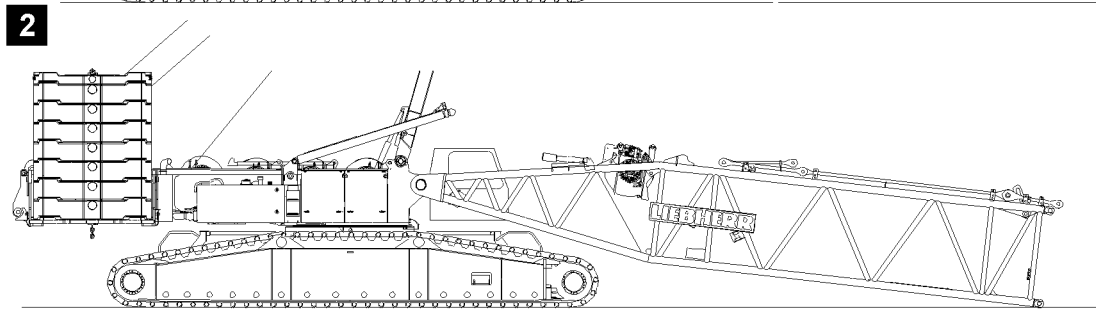
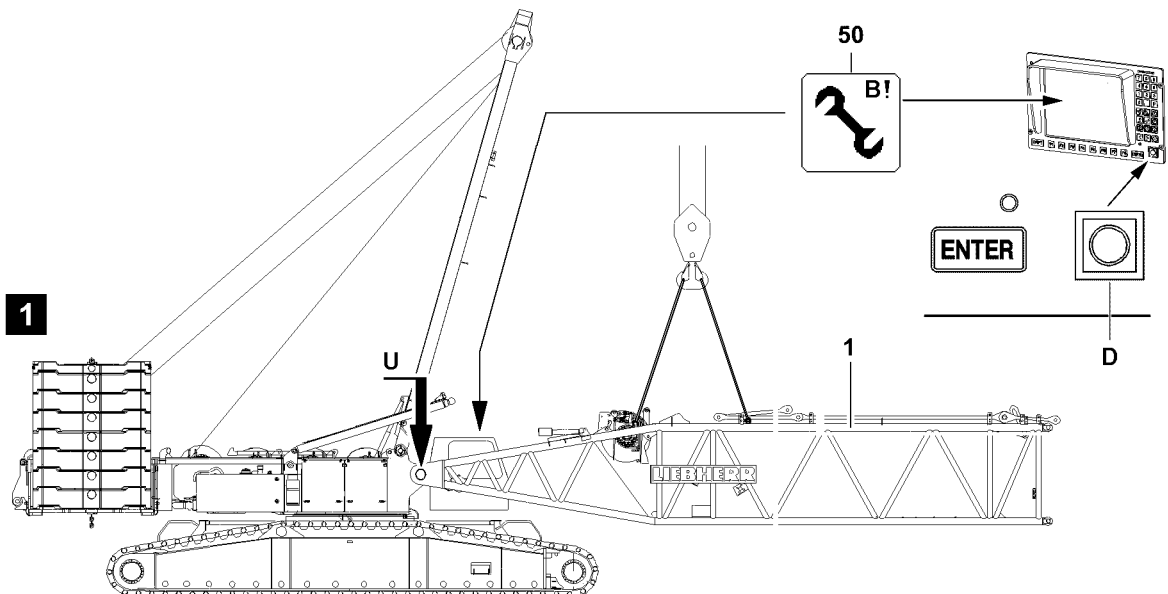

B111470

3.2 Exceeding the LICCON overload protection for assembly



WARNING

Assembly with turned on set up key!

When the set up key is turned on, the LICCON overload protection is exceeded!

In the event of deliberate improper use, the crane could collapse, the boom can break off or the crane can topple over!

Personnel can be severely injured or killed!

This could result in high property damage!

- ▶ The set up key **D** may only be actuated by persons who know the effects of a bypass!
 - ▶ Press the set up key **D** only when the set up status was correctly entered into the LICCON computer system!
 - ▶ Observe the erection / take down charts!
 - ▶ Crane operation with the set up key **D** turned on is strictly prohibited!
-

- ▶ Turn the set up key **D** to the right.

Result:

- The LICCON overload protection is deactivated.
- The assembly icon **50** appears on the LICCON monitor.

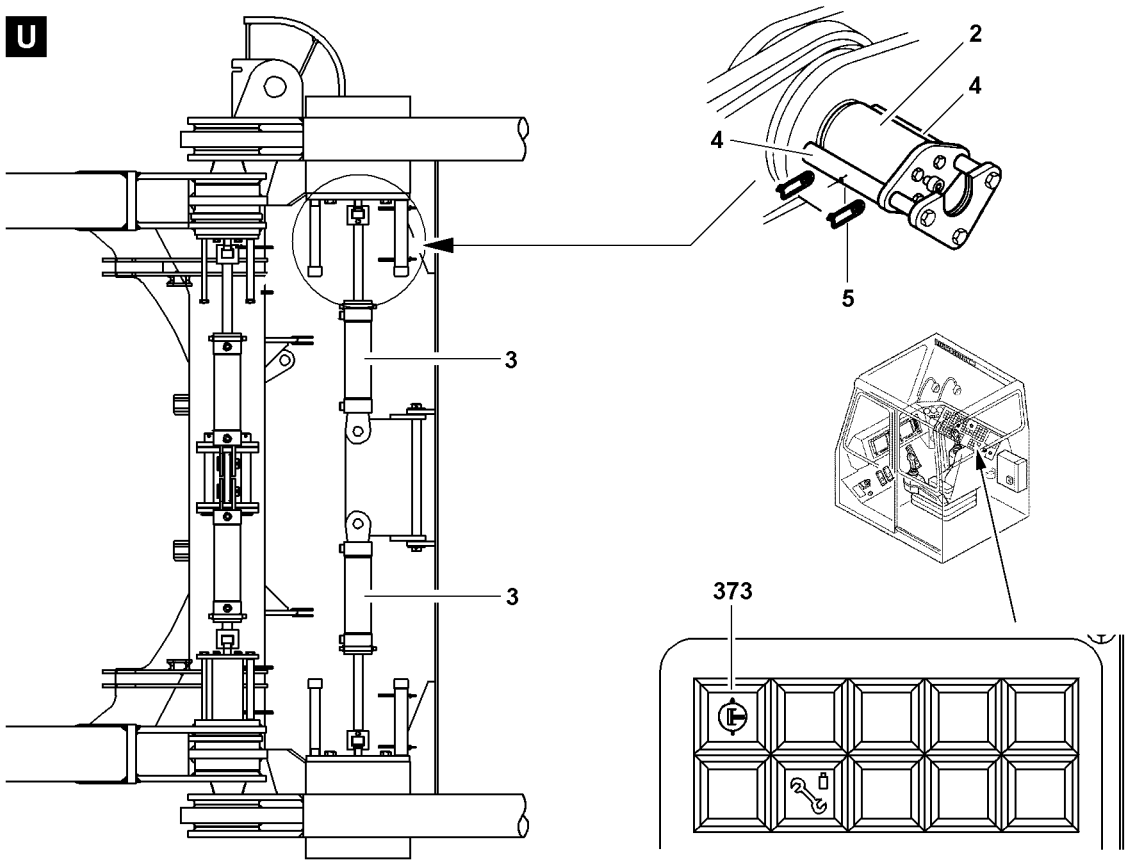
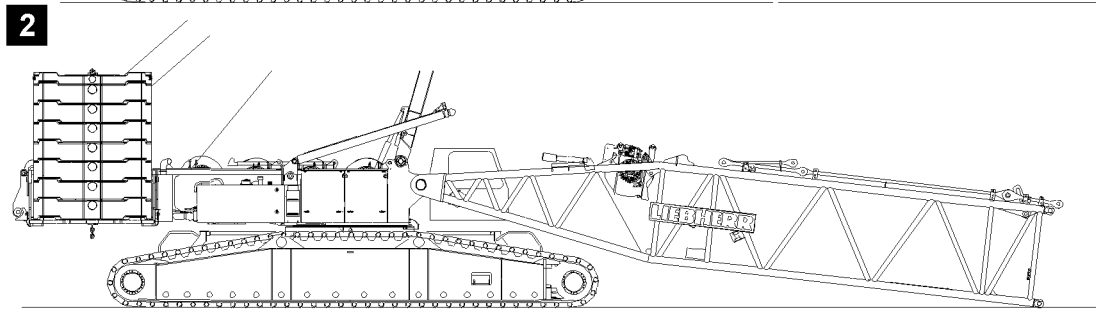
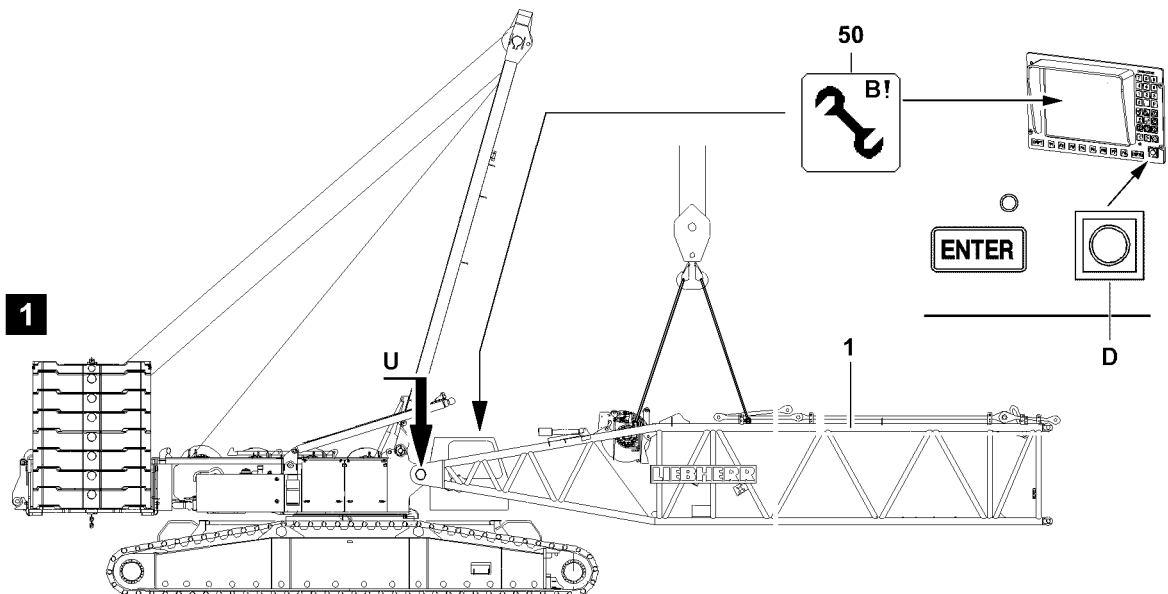

B111470

3.3 Assembling the S-pivot section on the turntable



WARNING

General danger notes!

- ▶ Support the S-boom during assembly with suitable materials!
- ▶ All pins are to be secured after assembly with the intended safety elements!
- ▶ The guy rods must be inspected regularly, see Crane operating instructions, chapter 8.15!

- ▶ Hang the S-pivot section **1** onto the auxiliary crane and swing in to the pin points on the turntable, illustration **1**.

Establish the hydraulic connection to the pin pulling device via two quick couplers.

Pin the S-pivot section **1** on the turntable and secure.

- ▶ Establish the hydraulic connection to the pin pulling device.
- ▶ Turn the pressure change over switch **373** on.



WARNING

The S-pivot section can fold downward!

Due to non-secured or insufficiently secured connector pins, the S-pivot section can fold down. Personnel can be severely injured or killed!

- ▶ The connector pins **2** between the S-pivot section **1** and the turntable must be secured after the pin procedure with the retaining plates **4**!

- ▶ Insert the connector pins **2** with the hydraulic pin pulling device **3**.
- ▶ When the connector pins **2** are completely pinned on the left and right on the S-pivot section: Secure the connector pin **2** on the left and right with the retaining plate **4** and the spring retainer **5**.
- ▶ Turn the pressure change over switch **373** off.

NOTICE

Damage to the S-pivot section!

Property damage can occur on the S-pivot section by placing the installed S-pivot section on the ground!

- ▶ Slowly place the S-pivot section with the auxiliary crane and at low speed on the ground!
- ▶ Before placing it on the ground, support the S-pivot section!

- ▶ Carefully place the S-pivot section down.
- ▶ Remove the auxiliary crane.

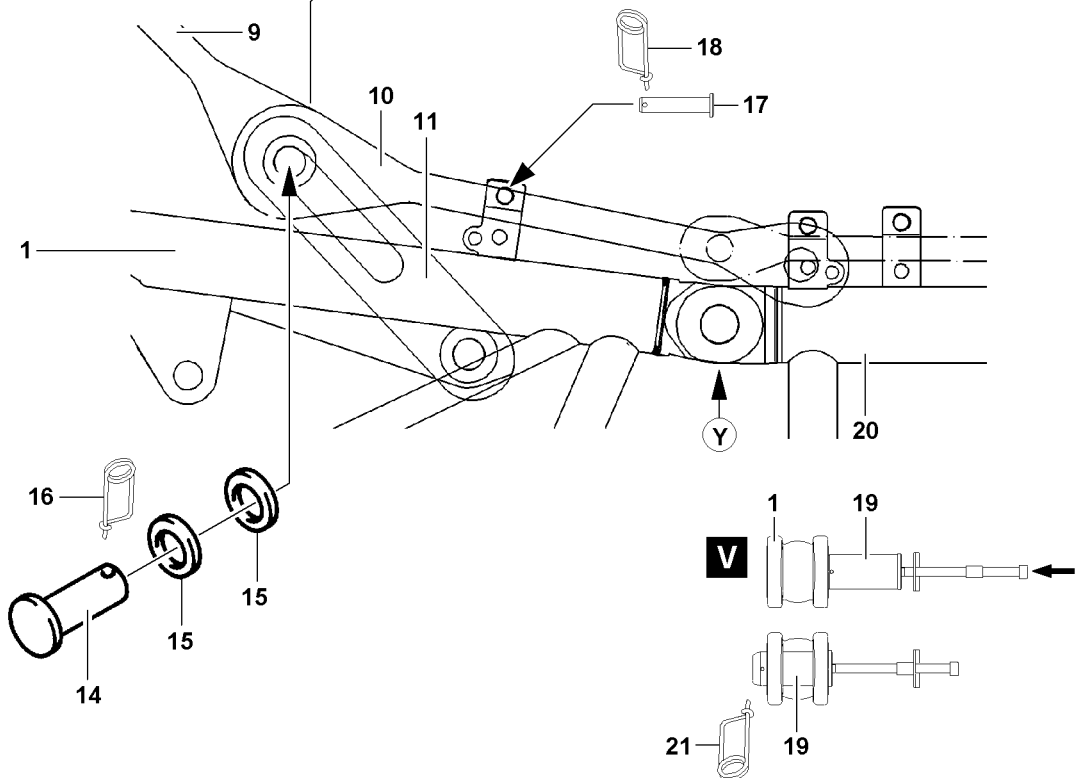
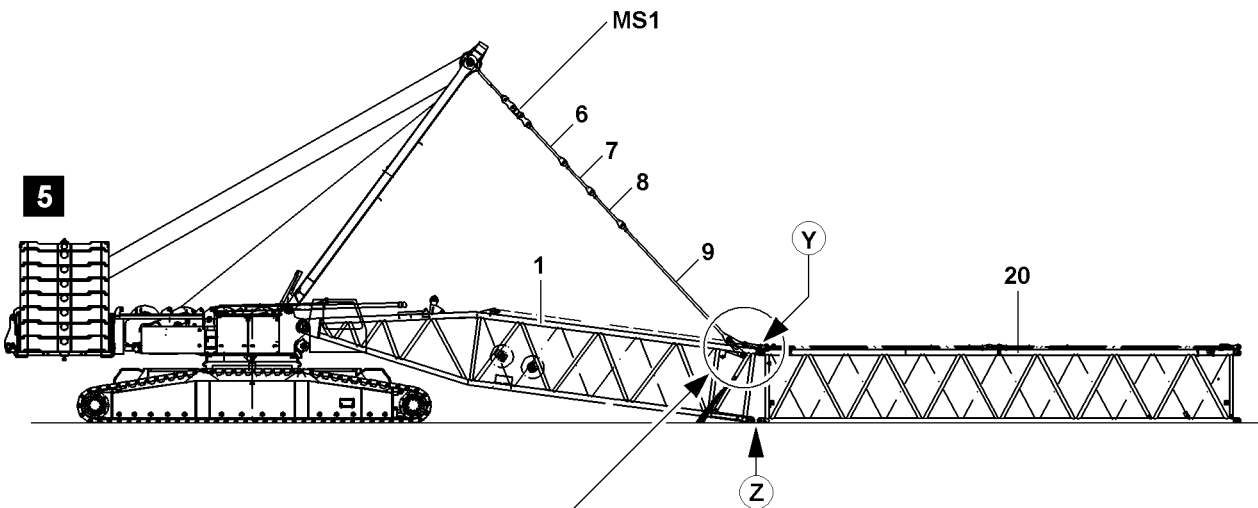
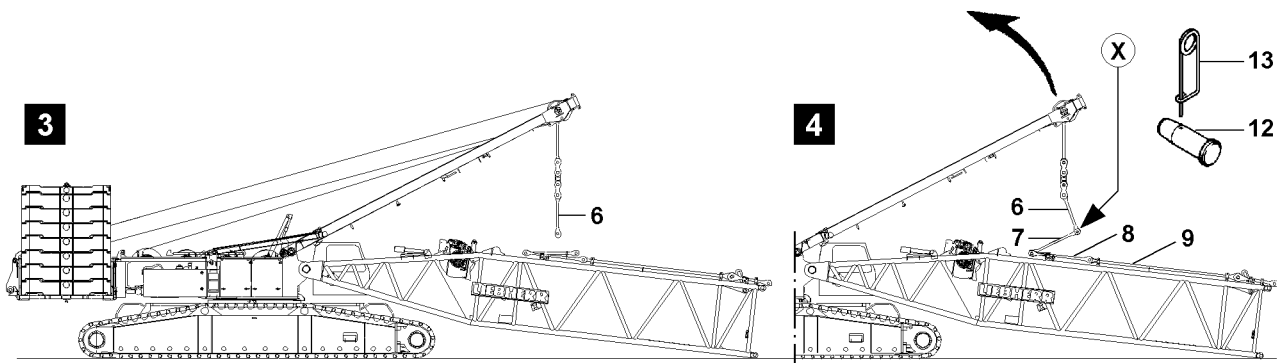

3.4 Assembling the S-lattice sections

The assembly of the lattice sections is carried out in various ways:

- “Closing” the boom.
- Assembling the lattice sections in “Flying mode”.



WARNING

General danger notes!

- ▶ Support the S-boom during assembly / disassembly with suitable materials!
- ▶ All pins are to be secured after assembly with the intended safety elements!
- ▶ The guy rods must be inspected regularly, see Crane operating instructions, chapter 8.15!
- ▶ Secure the boom with support or auxiliary crane, see Crane operating instructions, chapter 5.01!
- ▶ It is prohibited for anyone to remain under the booms or within the complete danger zone during the pinning and unpinning procedure of the lattice section!



Note

- ▶ For weights of intermediate sections with placed guy rods, see Crane operating instructions, chapter 1.03!
- ▶ The intermediate sections are pinned with the aid of the pin pulling device, see Crane operating instructions, chapter 5.30!

3.4.1 Assembling the S-lattice sections (by “closing” the boom)

Make sure that the following prerequisites are met:

- The S-pivot section is pinned and secured on the turntable.
- The S-pivot section is placed on the ground.
- The auxiliary crane is removed.

Connecting the guy rods SA-bracket with the guy rods S-pivot section

To be able to assemble the S-intermediate sections on the S-pivot section, the SA-bracket guy rods must be used.

- ▶ Remove the transport retainers for the guy rods on the SA-bracket.
- ▶ Remove the transport retainers for the guy rods on the S-pivot section.
- ▶ Lower the SA-bracket to the front until the guy rods **6** hang freely over the guy rods **7** of the S-pivot section **1**, illustration **3**.
- ▶ Pin the guy rods **6** of the SA-bracket with the guy rods **7** of the S-pivot section: Insert pin **12** at point **X** from the “inside” to the “outside” and secure with spring retainer **13**, illustration **4**.

When pinning the pin **14**, you have to use the washers **15**, see illustration.

- ▶ Pin the assembly brackets **11** on the connection point of the guy rods **9** and the guy rods **10** and pin the pin **14** in the hollow axle and secure with spring retainer **16**.
- ▶ Erect the SA-bracket until the guy rods are completely tensioned, illustration **5**.

Pinning the S-intermediate section with the S-pivot section “on top”

Pin the S-intermediate section **20** on the S-pivot section **1** “on top”.

- ▶ Fasten the S-intermediate section **20** on the auxiliary crane and align on the S-pivot section **1**, illustration **5**.
- ▶ When the pin bores on the S-pivot section **1** and on the S-intermediate section **20** “on top” (point **Y**) align, illustration **5**:
Insert the pin **19** from the inside to the outside and secure with spring retainer **21**, detail **V**.

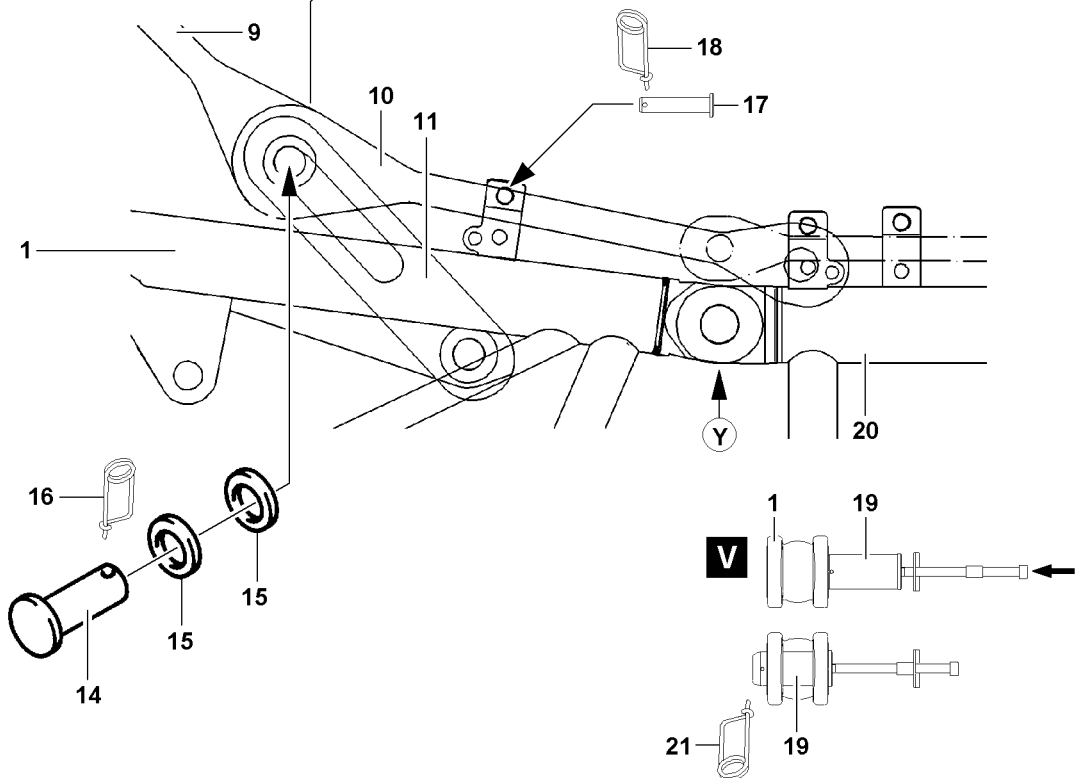
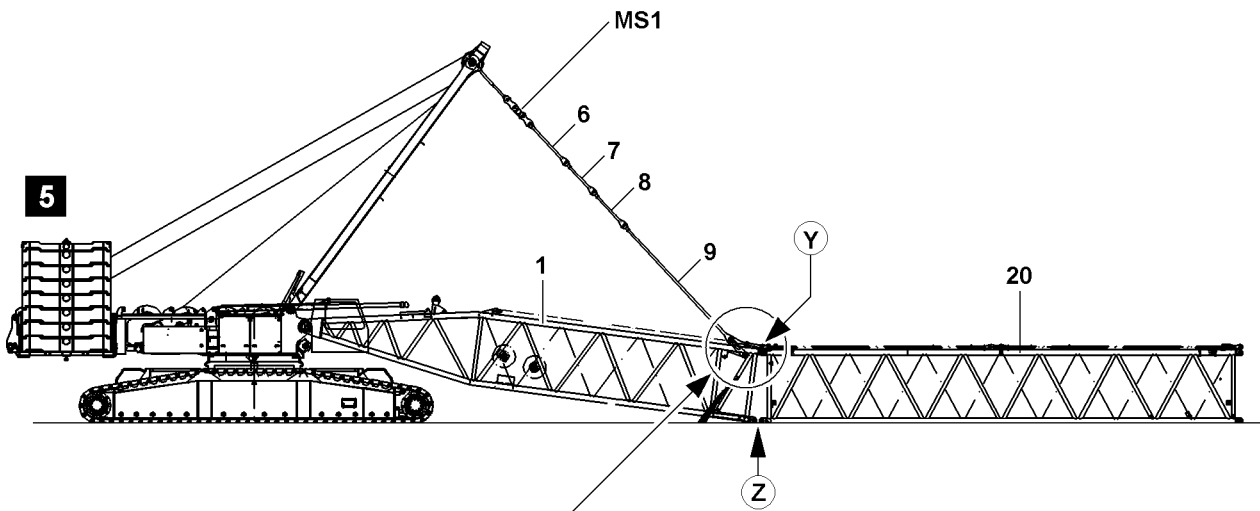
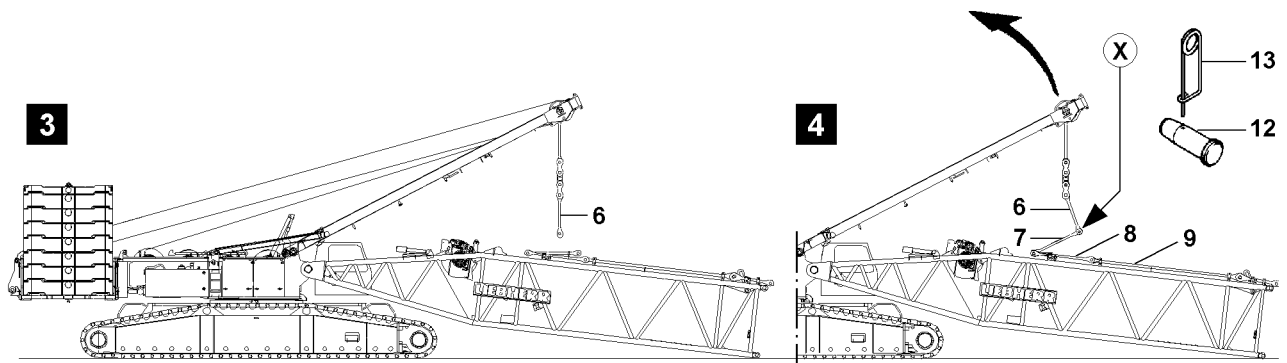

“Closing” the S-boom



WARNING

The crane can topple over!

If the following conditions are not met, the crane can topple over or be significantly damaged!

Personnel can be severely injured or killed!

- ▶ During the “Closing procedure” of the S-intermediate sections, the maximum total force on test point **MS1** of 110 t may **not** be exceeded!
- ▶ The end section of the corresponding S/SL-boom combination may **not** lift off the ground during the “Closing procedure”!
- ▶ With the SA-bracket, S-boom combinations to maximum **S 119 m** may be lifted / closed.
- ▶ With the SA-bracket, SL-boom combinations to maximum **SL 112 m** may be lifted / closed!



Note

- ▶ The actual force on the test point **MS1** - which is exerted during the closing procedure of the boom system - is shown on the LICCON monitor 1!
- ▶ Record the actual force and keep it ready for the disassembly of the boom system!
- ▶ During the boom disassembly, the guying is tensioned with the noted actual force (assembly) so that the connector pins of the intermediate sections can be unpinned!

The S-boom must be assembled to the required length before the S-boom can be closed. The assembly is described on the example of an intermediate section.

- ▶ Position the S-intermediate section with the auxiliary crane on the S-pivot section until the pin points align.
- ▶ Pin the S-lattice sections with each other: Insert the pin **19** on both sides “on top” and secure with spring retainer **21**.
- ▶ Pin the S-lattice sections with each other: Insert the pin **19** on both sides “on the bottom” and secure with spring retainer **21**.
- ▶ When the S/SL-boom combination is assembled to the desired length:
Lift the S-pivot section **1** with the SA-bracket until the pin bores on the “bottom” align at point **Z**, illustration **5**.
- ▶ Read the actual force of the test point **MS1** on the LICCON monitor and note.
- ▶ Insert the pin **19** on point **Z** from the inside to the outside and secure with spring retainer **21**.

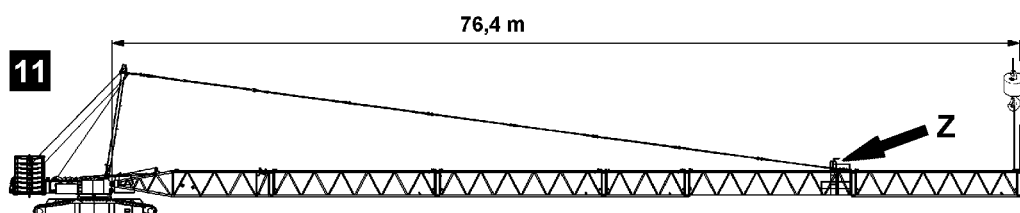
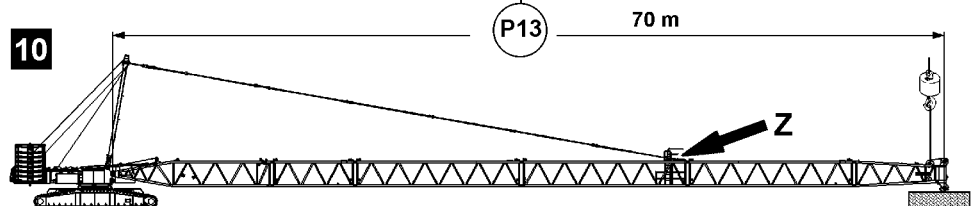
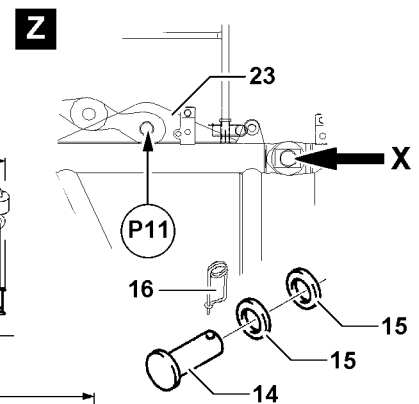
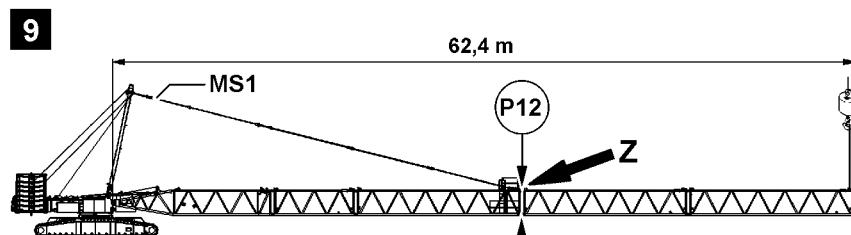
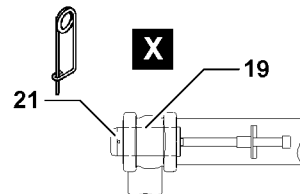
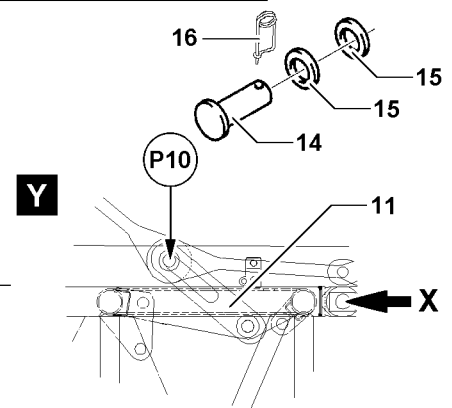
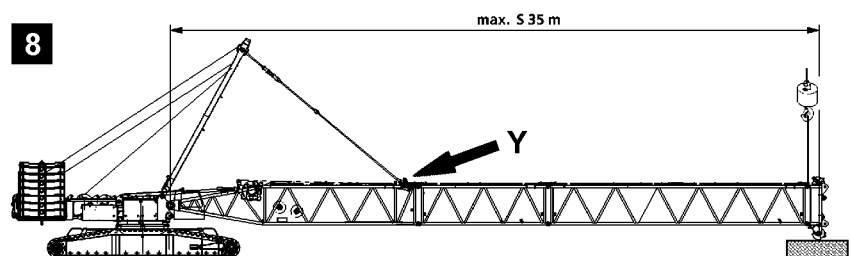
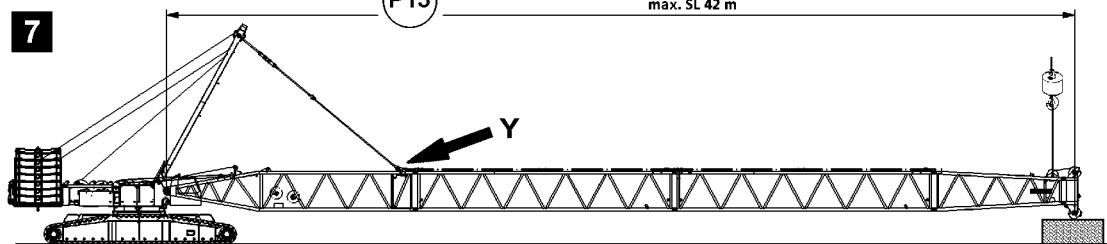
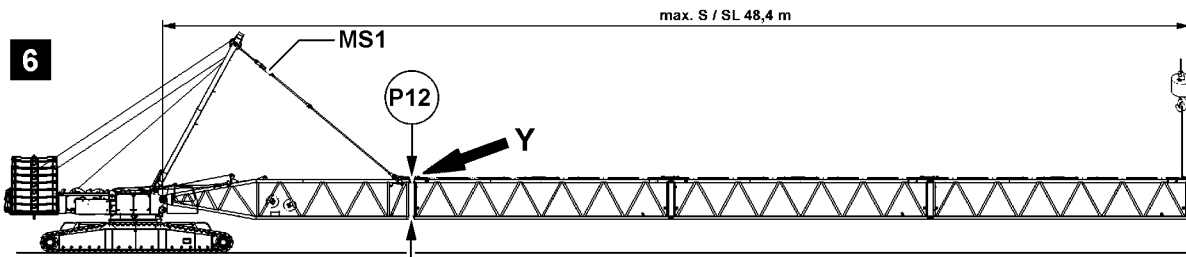

B112447

3.4.2 Assembling the S-lattice sections in “Flying mode”

If spatial prerequisites on the job site are limited for the assembly of the S-boom, or if they are limited by buildings or similar, then the S-boom can be installed in flying mode.

For the flying assembly, a differentiation is made between the guy points on the boom:

- Guying on the S-pivot section, see illustration 6, illustration 7 and illustration 8
- Guying on the S-intermediate section 14 m 2620.20 for flying assembly, see illustration 9, illustration 10 and illustration 11



WARNING

General danger notes!

- ▶ Support the S-boom during assembly / disassembly with suitable materials!
- ▶ All pins are to be secured after assembly with the intended safety elements!
- ▶ The guy rods must be inspected regularly, see Crane operating instructions, chapter 8.15!
- ▶ Secure the boom with support or auxiliary crane, see Crane operating instructions, chapter 5.01!



WARNING

Impermissible boom lengths!

If impermissible boom lengths are assembled on the crane, significant property damage can occur on the crane!

Personnel can be severely injured or killed!

- ▶ The maximum permissible boom lengths for the “Flying assembly” may not be exceeded!
- ▶ The data in the erection and take down charts as well as the load charts must be observed!



Note

- ▶ For weights of intermediate sections with placed guy rods, see Crane operating instructions, chapter 5.03!



Note

- ▶ When pinning the pin 14, you have to use the washers 15, see detail Y and detail Z.
- ▶ For guying on the S-pivot section, the pin 14 is inserted on both sides on the assembly brackets 11 on point P10 and secured with the spring retainer 16!
- ▶ For guying on the S-intermediate section 14 m 2620.20 for flying assembly, the pin 14 is inserted on both sides on the assembly brackets 23 on point P11 and secured with the spring retainer 16!

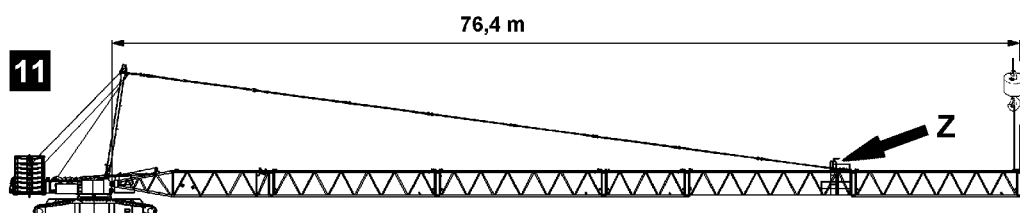
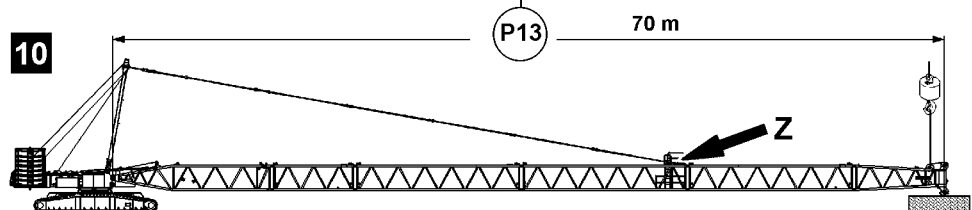
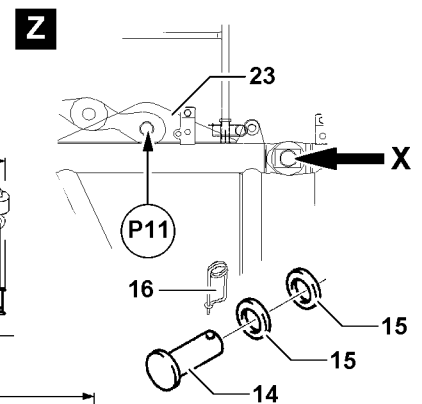
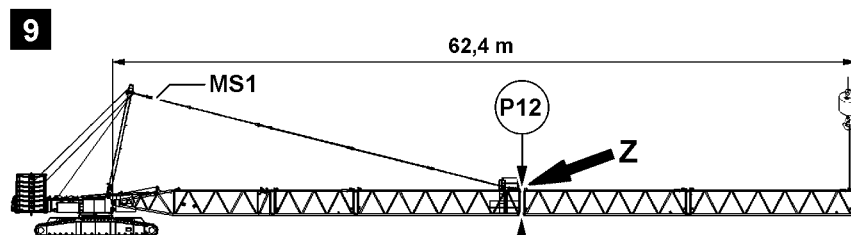
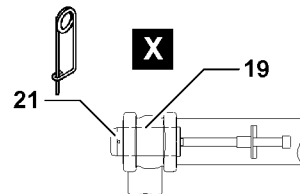
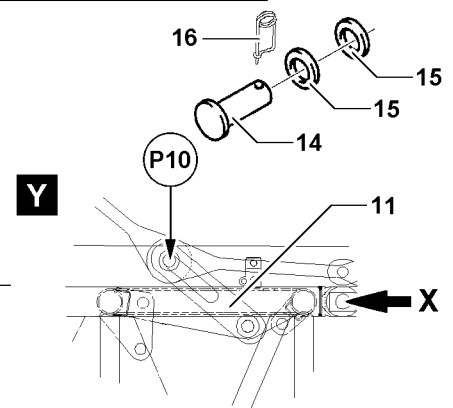
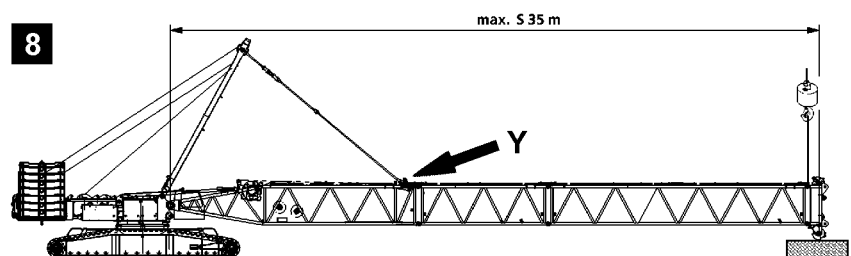
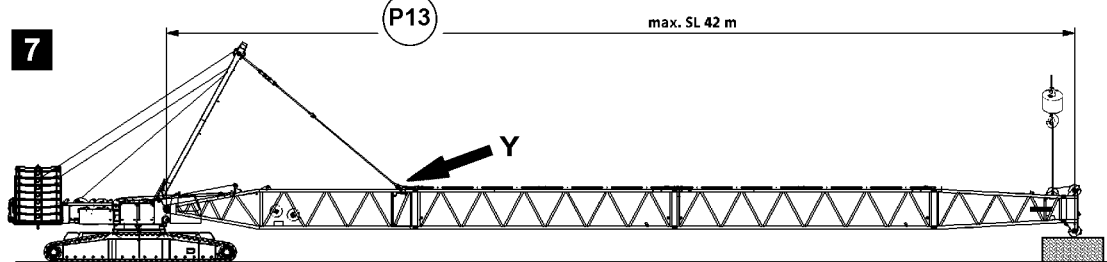
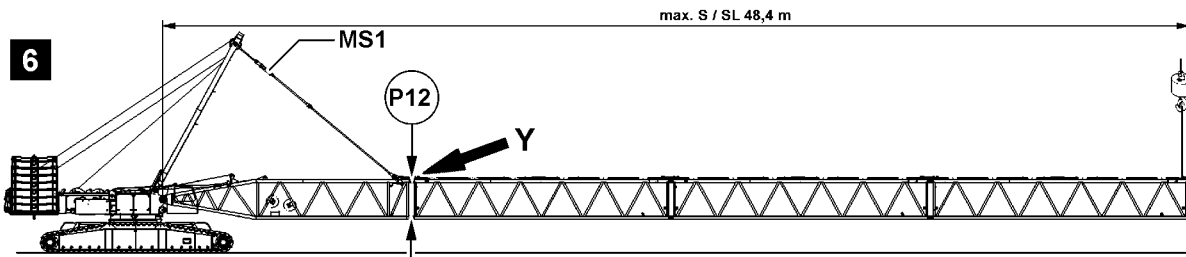

B112447

Assembling the intermediate sections in “Flying mode” on the S-pivot section



WARNING

The crane can topple over!

If the following conditions are not met, the crane can topple over or be significantly damaged!

Personnel can be severely injured or killed!

- ▶ For the “flying” boom assembly, the maximum permissible total force on the test point **MS1** may **not** be exceeded. The “Actual force” is shown on LICCON monitor 1!
- ▶ The “flying” boom assembly is only permissible up to a certain system length, observe the following charts!

Maximum permissible total force MS1 110 t				
Boom system	Maximum system length	Equipment	DB _{min} ¹⁾	ZB _{min} ²⁾
S	35.0 m	- with 400 t end section - without hook block	55 t	43 t
SL	42.0 m	- with 250 t end section - without hook block	55 t	43 t
S/SL	48.4 m	- without end section - without hook block	55 t	43 t

1) This counterweight must be at least installed on the turntable for “Flying assembly”.

2) This central ballast must be at least installed on the crawler center section for “Flying assembly”.

Make sure that the following prerequisites are met:

- The S-pivot section is pinned and secured on the turntable.
- The S-pivot section is pinned on the assembly brackets **11** on point **P10** with the SA-bracket guy rods and is in horizontal position, see illustration **6**, detail **Y**.
- A minimum of 55 t counterweight is placed on the turntable.
- A minimum of 43 t central ballast is installed on the crawler center section.
- An auxiliary crane is available.



WARNING

Falling components!

If unsecured or non-supported components are installed or removed, they can fall down! Personnel can be killed or seriously injured!

- ▶ During pinning and unpinning of the intermediate sections, it is prohibited for anyone to remain **under** or **on** the components as well as within the entire danger zone!
- ▶ Before unpinning: Support crane components and boom!
- ▶ Secure the pins in the bearing points and in the receptacles!
- ▶ It is prohibited to lean a ladder against the crane section which is being disassembled!

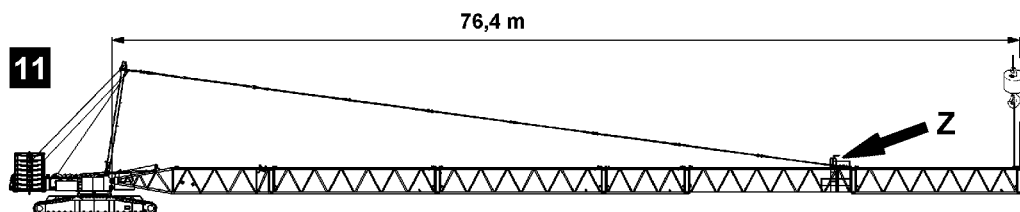
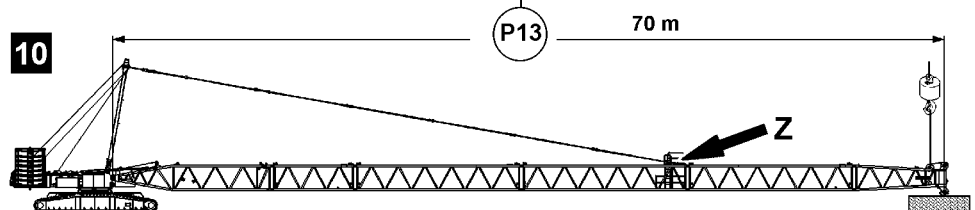
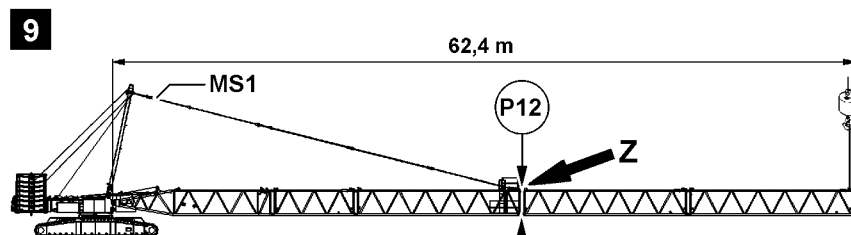
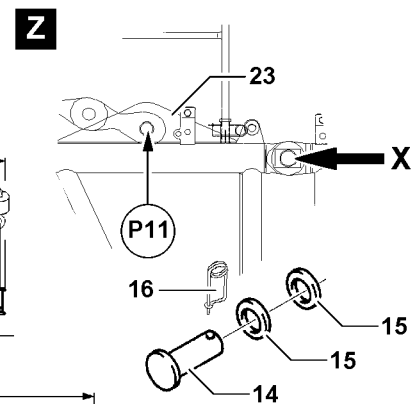
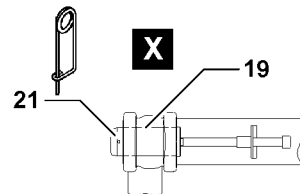
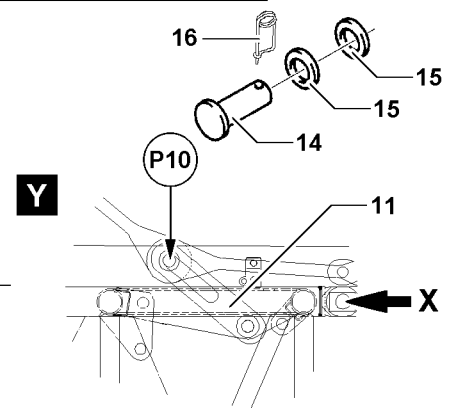
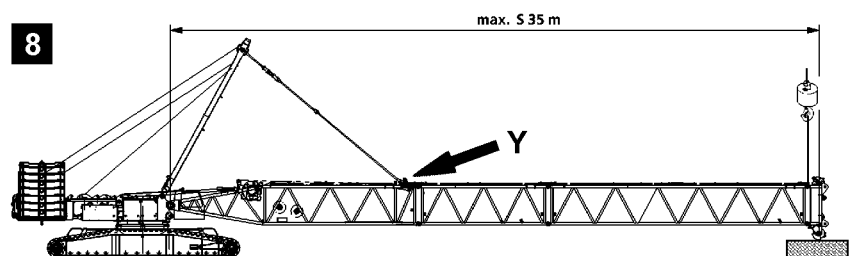
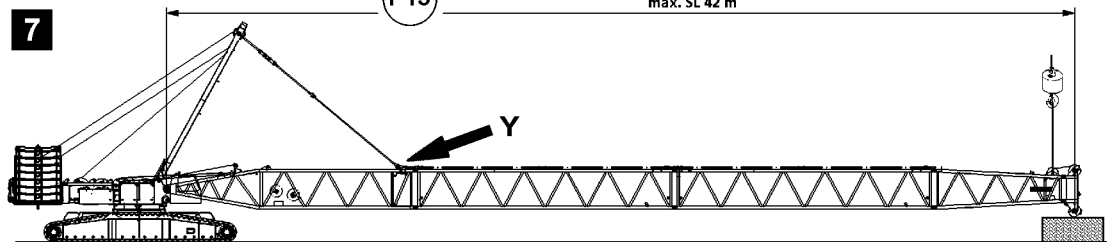
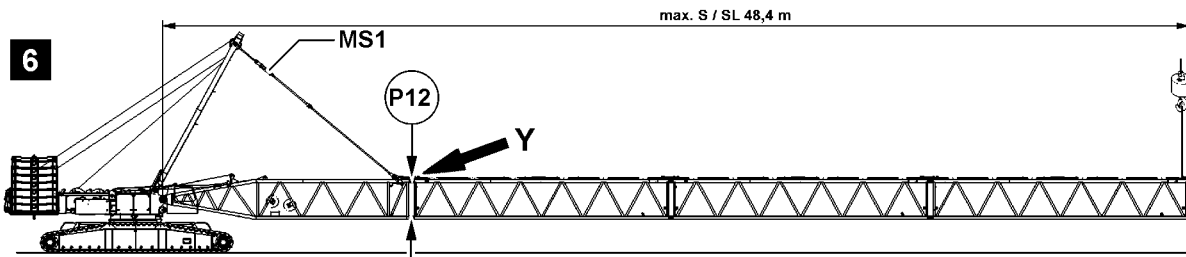

B112447

**Note**

- ▶ The “Actual force” is shown on LICCON monitor!
- ▶ The flying assembly is made without the assembly of the hook block!

For “flying” assembly of the intermediate sections, they can be installed individually or as preassembled boom unit on the S-pivot section.

- ▶ Fasten the intermediate sections or preassembled boom unit on the auxiliary crane.
- ▶ Lift the intermediate sections or preassembled boom unit with the auxiliary crane and position on the S-pivot section.
- ▶ When the pin points between the S-pivot section and the intermediate section or the preassembled boom unit align “on top” and “bottom”:
 - Pin the intermediate section “on top”: Insert the pin **19** on both sides on point **P12** and secure with spring retainer **21**, see detail **X**.
- ▶ Pin the intermediate section “on the bottom”: Insert the pin **19** on both sides on point **P13** and secure with spring retainer **21**, see detail **X**.
- ▶ When the pins are properly pinned and secured on “top” and “bottom” between the S-pivot section and the S-intermediate section or the preassembled boom unit:
 - Remove the auxiliary crane.
- ▶ If additional lattice sections are assembled:
 - Assemble additional lattice sections the same way as described in this section.

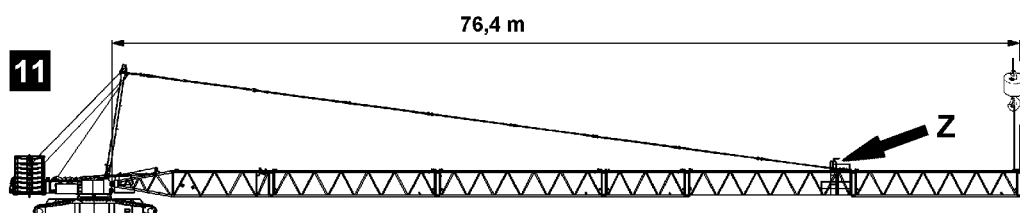
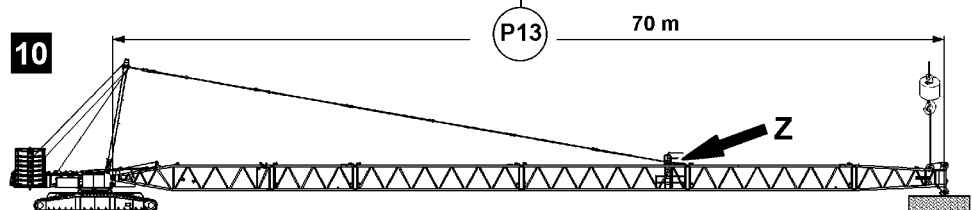
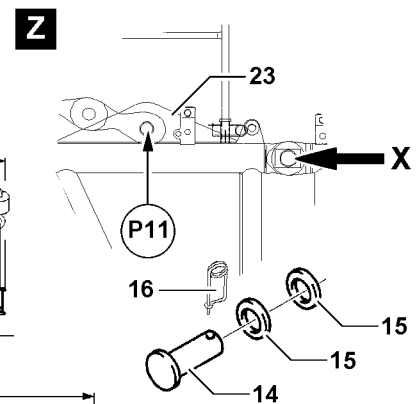
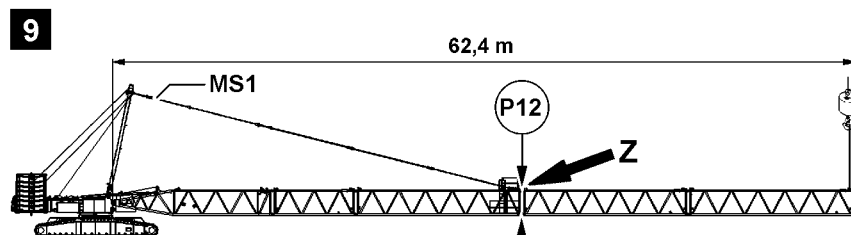
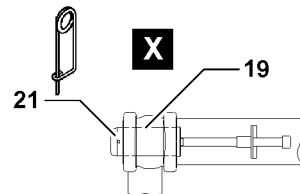
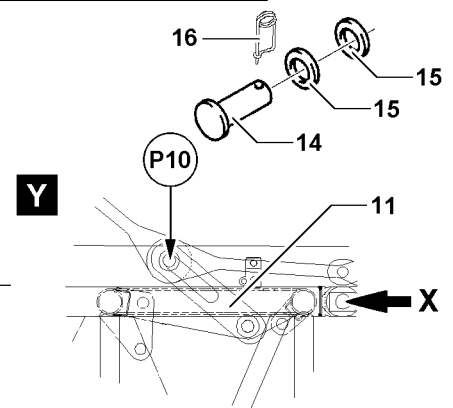
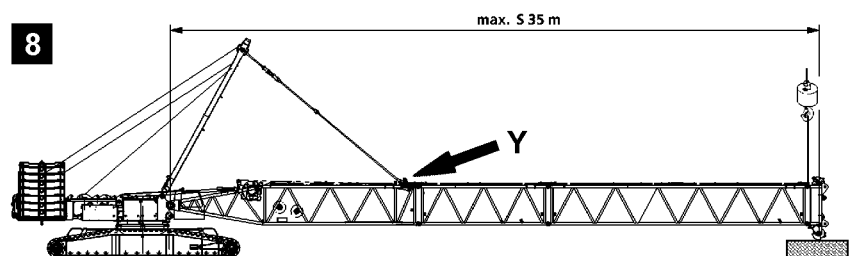
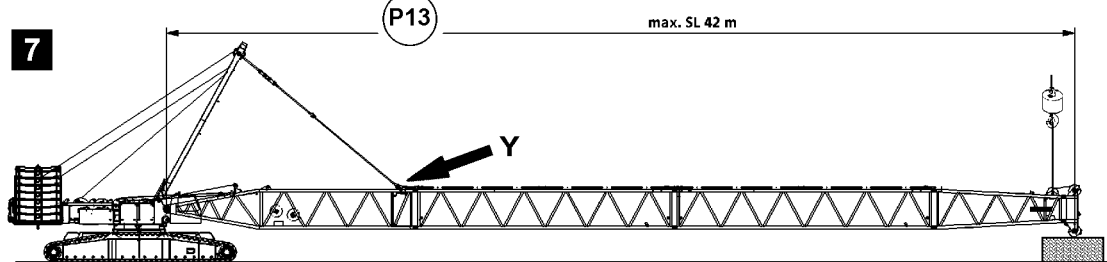
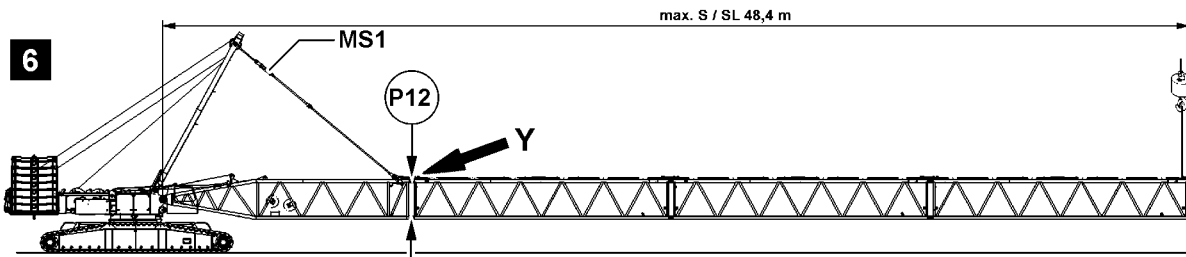

B112447

Assembling the intermediate sections in “Flying mode” on the intermediate section 14 m 2620.20



WARNING

The crane can topple over!

If the following conditions are not met, the crane can topple over or be significantly damaged!

Personnel can be severely injured or killed!

- ▶ For the “flying” boom assembly, the maximum permissible total force on the test point **MS1** may **not** be exceeded. The “Actual force” is shown on LICCON monitor 1!
- ▶ The “flying” boom assembly is only permissible up to a certain system length, observe the following charts!



Note

- ▶ The guy rods of the SA-bracket are installed on the intermediate section 2620.20 **13** with the guy brackets **30**!

Maximum permissible total force MS1 150 t				
Boom system	Maximum system length	Equipment	DB _{min} ¹⁾	ZB _{min} ²⁾
SL	62.4 m	- without S-end section - without adapter	55 t	43 t
SL	70.0 m	- without hook block	55 t	43 t
S/SL	76.4 m	- without S-end section - without adapter	55 t	43 t

1) This counterweight must be at least installed on the turntable for “Flying assembly”.

2) This central ballast must be at least installed on the crawler center section for “Flying assembly”.

Make sure that the following prerequisites are met:

- The S-pivot section is pinned and secured on the turntable.
- The intermediate section 14 m 2620.20 is pinned on the assembly brackets **23** on point **P11** with the SA-bracket guy rods and is in horizontal position, see illustration **9**, detail **Z**.
- A minimum of 55 t counterweight is placed on the turntable.
- A minimum of 43 t central ballast is installed on the crawler center section.
- An auxiliary crane is available.



WARNING

Falling components!

If unsecured or non-supported components are installed or removed, they can fall down! Personnel can be killed or seriously injured!

- ▶ During pinning and unpinning of the intermediate sections, it is prohibited for anyone to remain **under** or **on** the components as well as within the entire danger zone!
- ▶ Before unpinning: Support crane components and boom!
- ▶ Secure the pins in the bearing points and in the receptacles!
- ▶ It is prohibited to lean a ladder against the crane section which is being disassembled!

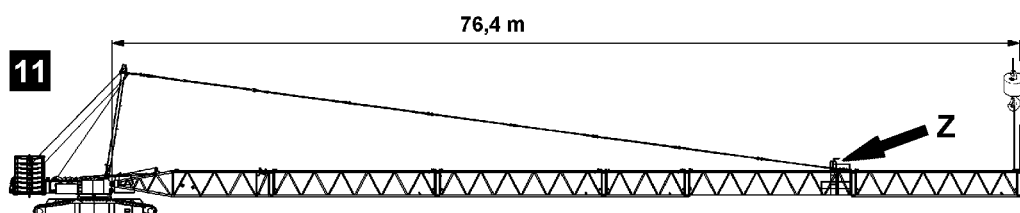
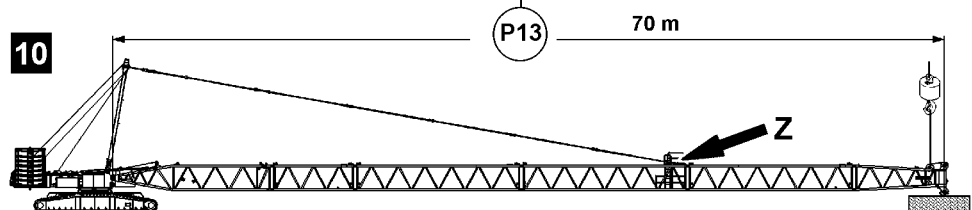
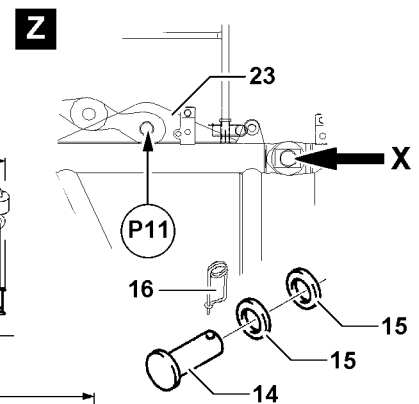
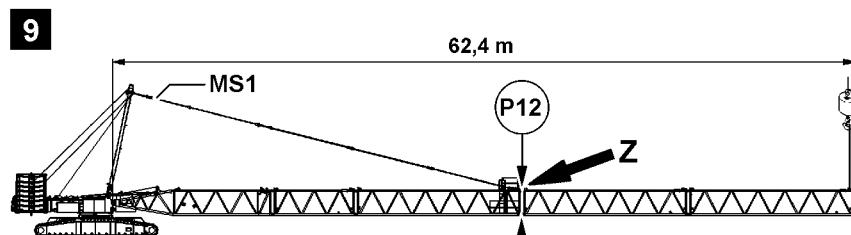
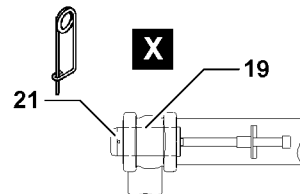
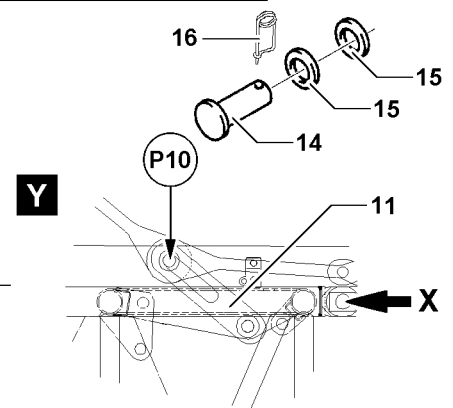
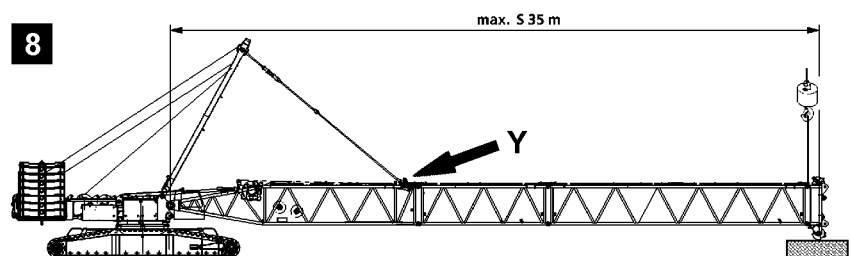
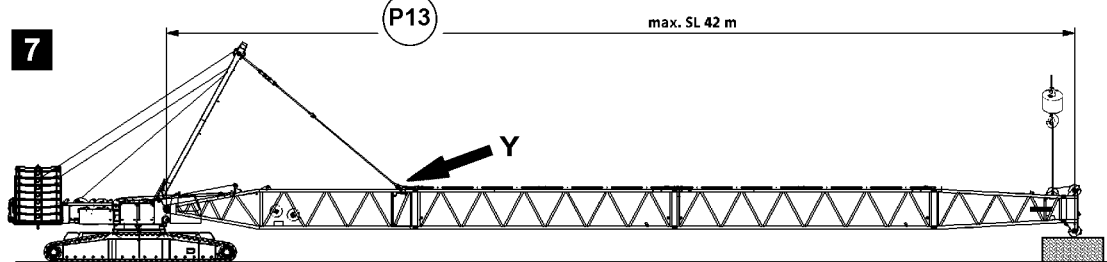
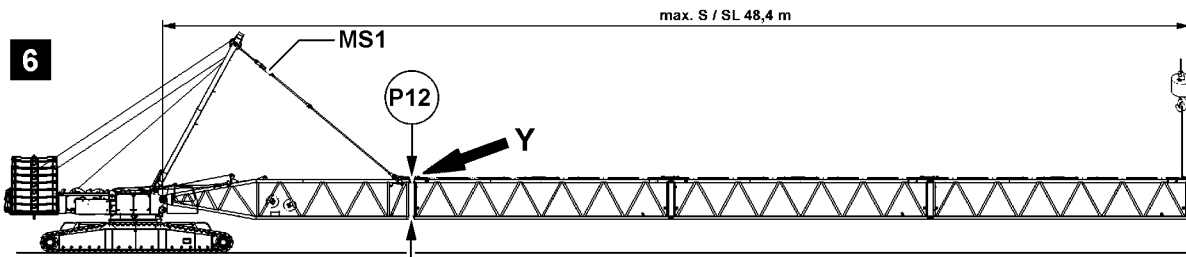

B112447

**Note**

- ▶ The “Actual force” is shown on LICCON monitor!
- ▶ The flying assembly is made without the assembly of the hook block!

For “flying” assembly of the intermediate sections, they can be installed individually or as preassembled boom unit on the S-pivot section.

- ▶ Fasten the intermediate sections or preassembled boom unit on the auxiliary crane.
- ▶ Lift the intermediate sections or preassembled boom unit with the auxiliary crane and position on the S-pivot section.
- ▶ When the pin points between the S-pivot section and on the S-intermediate section or the preassembled boom unit align “on top” and “bottom”:
Pin the intermediate section “on top”: Insert the pin **19** on both sides on point **P12** and secure with spring retainer **21**, see detail **X**.
- ▶ Pin the intermediate section “on the bottom”: Insert the pin **19** on both sides on point **P13** and secure with spring retainer **21**, see detail **X**.
- ▶ When the pins are properly pinned and secured on “top” and “bottom” between the S-pivot section and the S-intermediate section or the preassembled boom unit:
Remove the auxiliary crane.
- ▶ If additional lattice sections are assembled:
Assemble additional lattice sections the same way as described in this section.

12

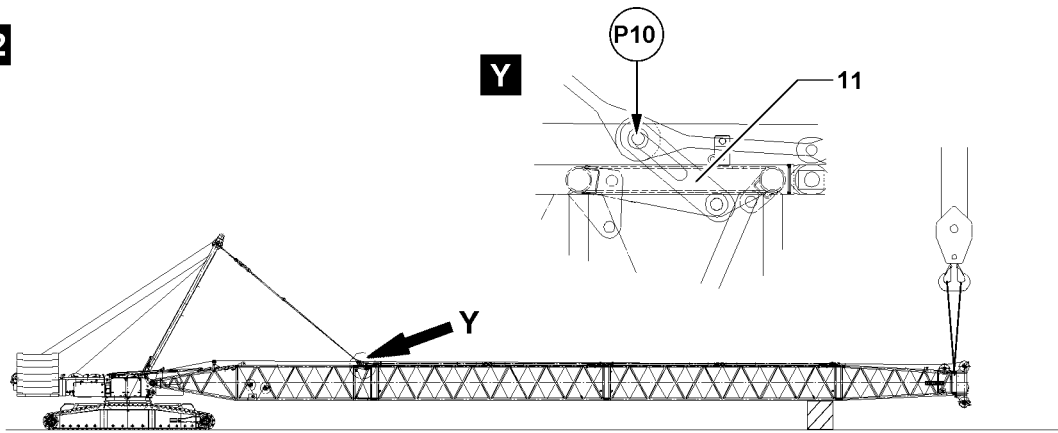

13

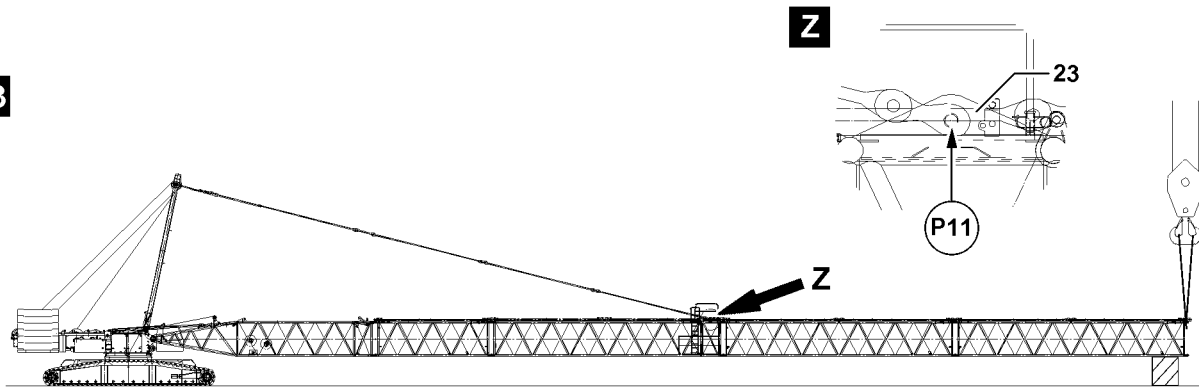

14

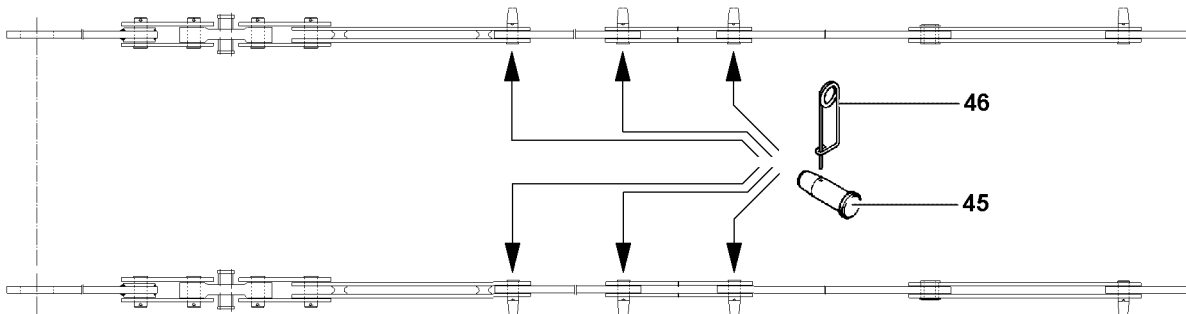

15

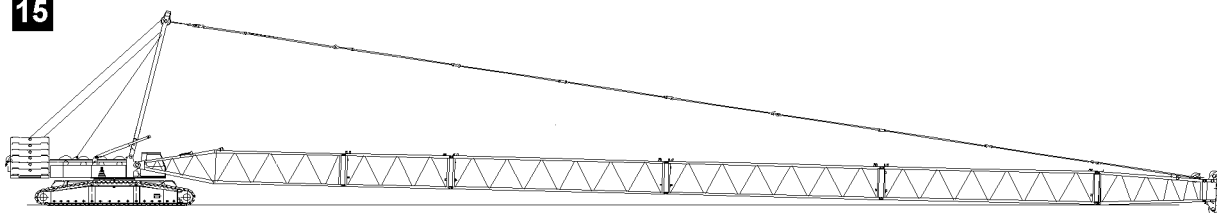

3.5 Assembling the S-guy rods



WARNING

Neglected inspection and maintenance on guy rods!

If the regular inspection and maintenance of the guy rods is not carried out or is carried out only in irregular intervals, then severe accidents can occur due to existing and unrecognized damage to the guy rods!

Personnel can be severely injured or killed!

- ▶ Check the guy rods before every assembly, see Crane operating instructions, chapter 8.15!
- ▶ The S-guy rods must be assembled and secured, see Rod plan. The numbering in the rod plan must be identical to the numbering on the guy rods!

Make sure that the following prerequisites are met:

- The boom is guyed on point **P10** on the S-pivot section, see illustration **12**, detail **Y**.
- **Or** the boom is guyed on point **P11** on the S-intermediate section 14 m 2620.20 for flying assembly, see illustration **13**, detail **Z**.
- **Or** the boom is laying on the ground with tensioned guy rods, see illustration **15**.



WARNING

Falling components!

If the intermediate sections are incompletely pinned or secured, then components can fall down!

Personnel can be severely injured or killed!

- ▶ Make sure that the intermediate sections or preassembled boom unit are pinned and secured on the S-pivot section!
- ▶ Make sure that the intermediate sections or preassembled boom unit is supported with suitable materials, secured with the auxiliary crane or the boom is placed on the ground!



WARNING

The boom can fold downward!

By unpinning the guy rods on the assembly brackets **11** or the assembly brackets **23**, the boom can fold down!

Personnel can be severely injured or killed!

- ▶ Unpin the guy rods on the assembly brackets **11**, point **P10** or the assembly brackets **23**, point **P11** when it is ensured that the intermediate sections are supported with suitable materials or are held by the auxiliary crane or the boom is placed on the ground!

- ▶ When the boom is **not** laying on the ground:
Support the boom or secure it with the auxiliary crane.
- ▶ Relieve the guy rods: Lower the SA-bracket somewhat to the front.

Result:

- The guy rods between the SA-bracket and the S-pivot section or the S-intermediate section for flying assembly are relieved.

The guy rods are placed and secured for transport on the S-intermediate sections. Before assembly of the guy rods, you must remove the transport retainers.

- ▶ Release and unpin transport retainers for the guy rods.

12

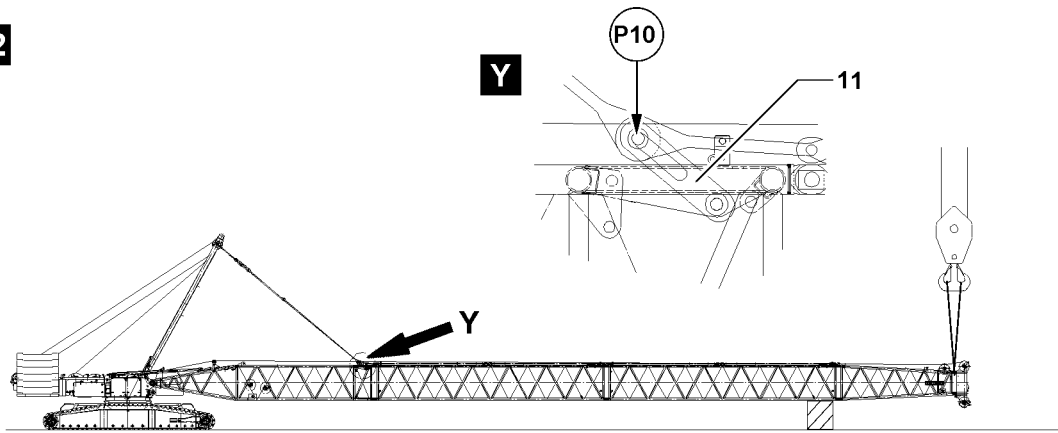

13

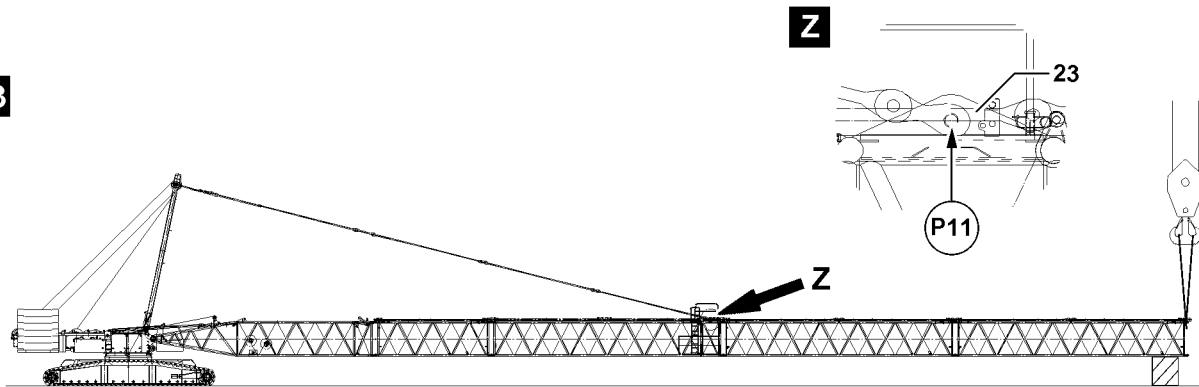

14

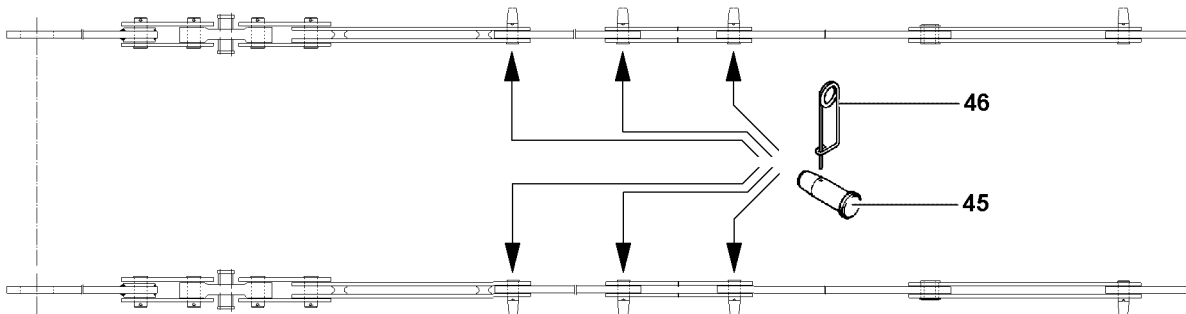

15

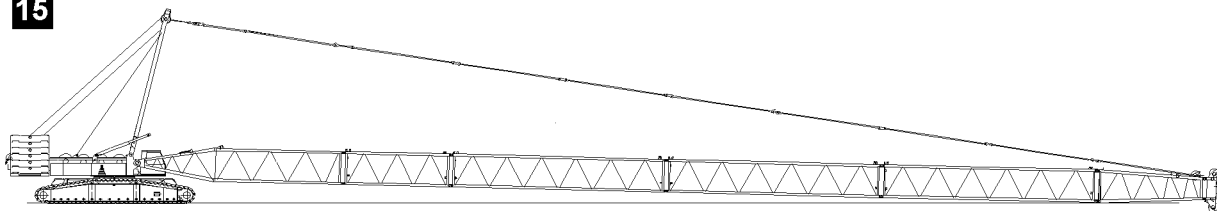

NOTICE

Property damage!

If the pins of the guy rods are not pinned from the “inside” to the “outside”, the hoist rope can scrape on the pin and be damaged!

- ▶ Always insert the pins of the guy rods from the “inside” to the “outside”, see Rod plan and illustration **14**!
-

**Note**

- ▶ The guy rods of the S-intermediate sections are pinned to each other starting from the fixed point on the end section of the boom!
-
- ▶ Pin the guy rods of all intermediate sections: Insert the pin **45** from the “inside” to the “outside”.
 - ▶ Secure the pin **45** with spring retainer **46**.
 - ▶ When all guy rods on the boom system are pinned and secured:
Release and unpin the pins on the assembly brackets **11** or the assembly brackets **23**.
 - ▶ Erect the SA-bracket until the guy rods between the SA-bracket and the S-end section tension.
 - ▶ Remove the auxiliary crane.

B195219

3.6 Establishing the electrical connections

NOTICE

Damage to the electrical connection on the cable drum!

If the electrical connection from the cable drum on the S-pivot section to the terminal box on the S-pivot section is established first before the connection to the terminal box on the S-end section, the electrical connection can be damaged when spooling out the cable drum!

- ▶ Establish first the electrical connection from the cable drum in the S-pivot section to the terminal box on the S-end section and then the electrical connection from the terminal box in the S-pivot section to the cable drum!



Note

- ▶ To establish the electrical connections on the boom, see Electric wiring diagram!

Make sure that the following prerequisite is met:

- The boom is fully assembled.
- ▶ Establish the electrical connections.
- ▶ Make sure that all electrical connections on the boom are established.

3.7 Establishing the hydraulic connections to the S-boom

When connecting hydraulic lines with quick release couplings, make sure that the coupling procedure is carried out correctly.



WARNING

Pressure in the hydraulic lines!

If the pressure supply is not interrupted before connecting / releasing the hydraulic lines, the hydraulic oil can escape with high pressure!

Personnel can be severely injured or killed!

- ▶ Release the pressure in the hydraulic system before connecting / disconnecting: Interrupt the pressure supply and wait for a short time!



WARNING

Loss of pressure or leakage!

Incorrectly coupled or self-loosening quick release couplings (particularly return lines) can result in serious accidents due to component failure!

- ▶ Check that the quick release couplings have been properly connected before using the crane!
- ▶ Connect the coupling components (sleeve and connector) and screw together with the hand-tightened nut.
- ▶ Tighten the hydraulic coupling by hand. Rotate the hand-tightened nut until it reaches a tangible, fixed stop position.
- ▶ Establish the hydraulic connections.

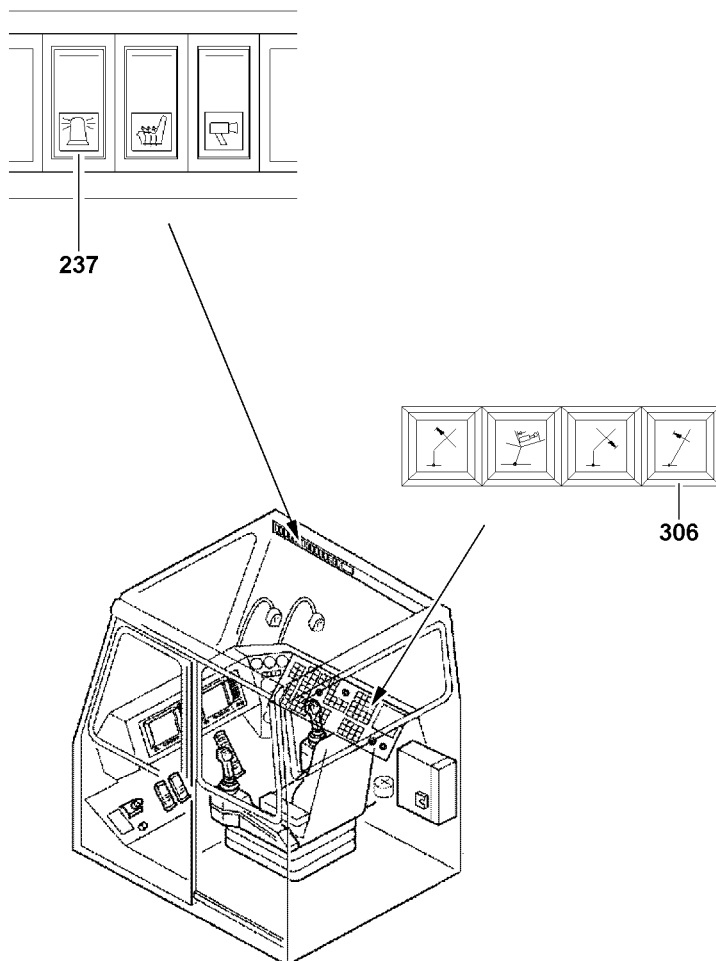

B111471

3.8 Checking the function of the safety devices



WARNING

Non-functioning safety devices!

If the function of the safety devices is defective, personnel can be severely injured or killed!

- ▶ Crane operation with non-functioning safety devices is **prohibited!**



Note

- ▶ The function of the individual limit switches must be checked before erection!
- ▶ The function of the limit switch initiators must be checked in the test system, see Diagnostics manual!



Note

- ▶ If a function check on the limit switches or on the safety devices does not lead to the desired shut offs, then the plug connections on the connector boxes or the components itself must be checked! If no visible connection errors or component defects can be found, contact LIEBHERR Service!

Make sure that the following prerequisites are met:

- All electrical connections have been made.
- The crane engine is running.
- The corresponding operating mode is set in the LICCON computer system.
- The actuator levers on the limit switches are greased.

3.8.1 Wind speed sensor*

- ▶ Check the movement and the function of the wind speed sensor.

3.8.2 Airplane warning light*

- ▶ Turn the airplane warning light on with the switch **237**.
- ▶ Check the function visually.

3.8.3 Hoist limit switch

- ▶ Actuate the limit switch on the pulley head manually.

Result:

- The hoist winch turns off in upward movement.
- The hoist top icon appears on the LICCON monitor 0.
- The limit switch is functioning.

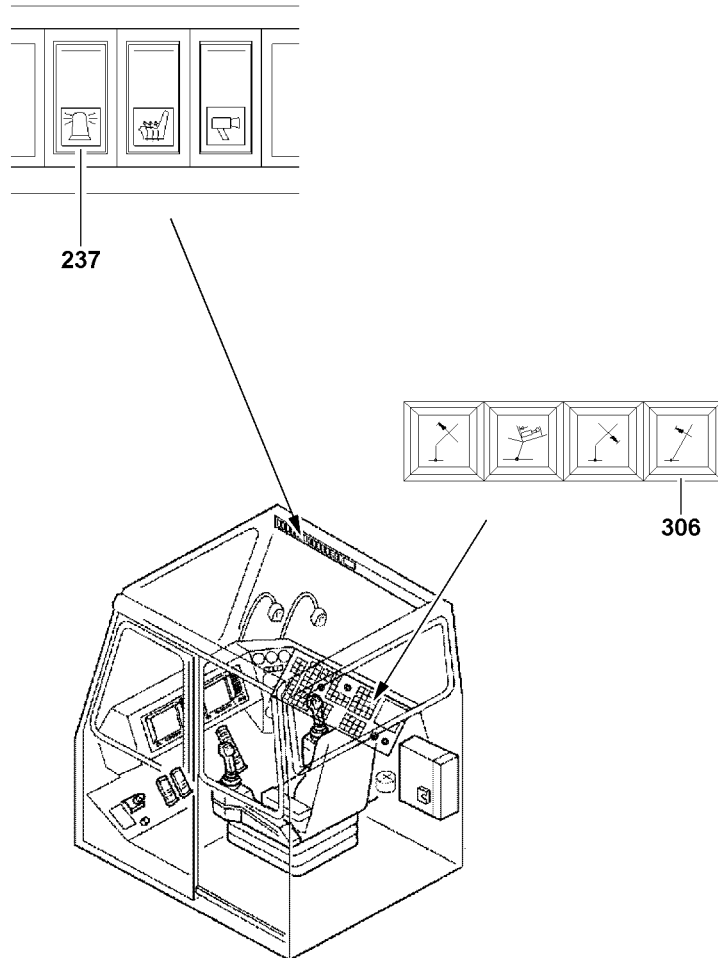

B111471

3.8.4 Limit switch boom “Steepest position”

**Note**

► The limit switch functions have to be checked individually before erection!

► Manually actuate the individual limit switches on the S-relapse cylinders.

Result:

- Winch 4 (control winch) turns off in upward movement.
- The indicator light **306** lights up.
- An acoustic signal sounds.
- The limit switch is functioning.

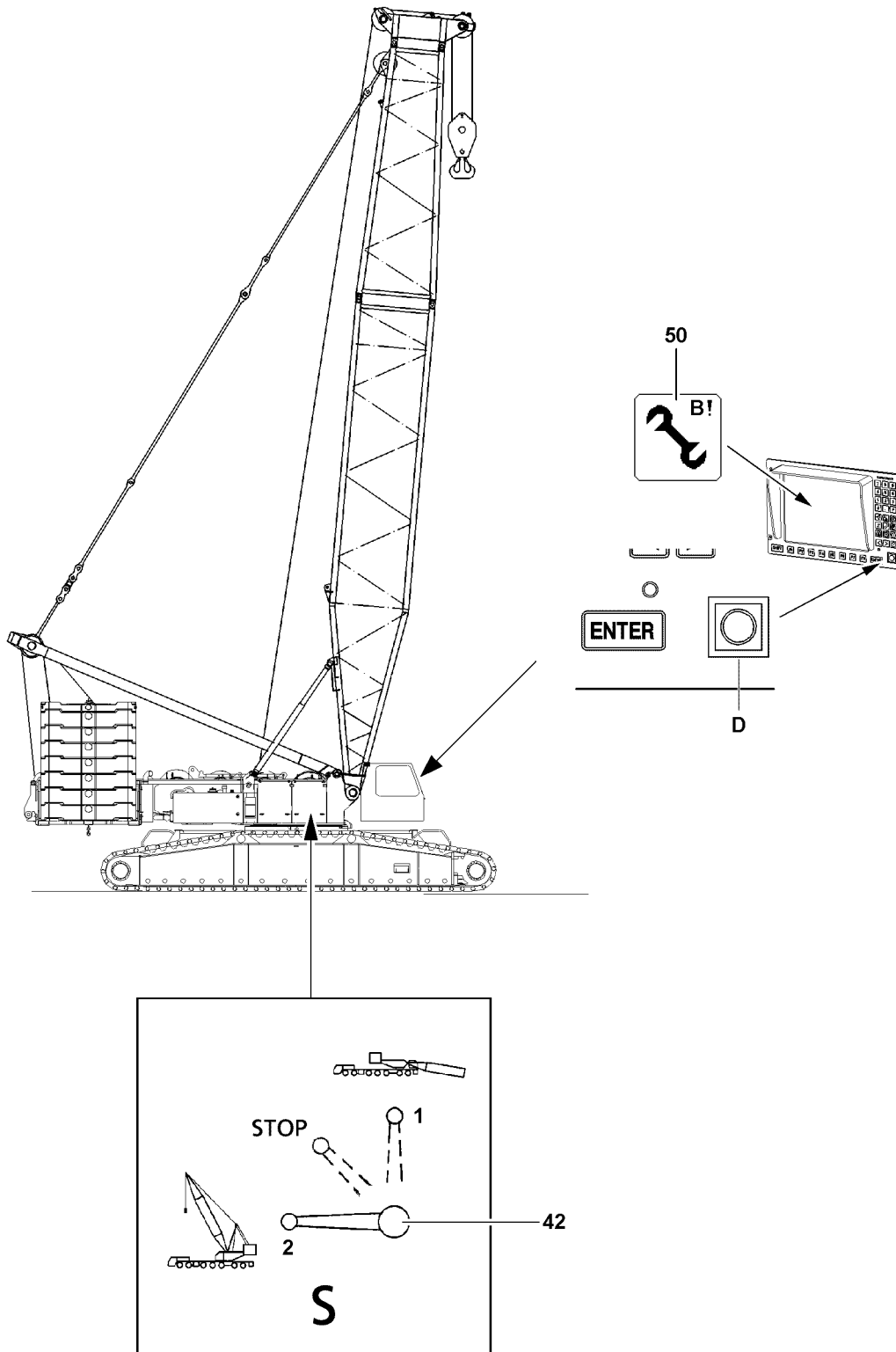

B111472

4 Erecting the S-boom



WARNING

The crane can topple over!

If the following conditions are not met before erecting the boom, the crane can topple over! Personnel can be severely injured or killed!

- ▶ It is not permitted to turn the crane during erection!
- ▶ Observe the data in the erection and take down charts!
- ▶ Observe the safety technical notes, see Crane operating instructions, chapter 5.01!
- ▶ Extend the S-relapse cylinder before erection!
- ▶ Do not allow slack cable to build up on the control winch!



WARNING

Unutilized guy rods on boom!

If guy rods are on the lattice sections which are not used for operation, then there is a risk of accidents!

Personnel can be severely injured or killed!

Guy rods can loosen up and fall down!

The load chart is invalid!

The load display of the LICCON computer system shows the incorrect value!

The weight of the boom is too large for erection!

- ▶ Disassembly and remove unutilized guy rods on the transport retainers before erecting the boom!

Make sure that the following prerequisites are met:

- The crane is aligned in horizontal direction.
- All electrical and hydraulic connections have been established.
- All limit switches are functioning.
- The counterweight has been installed on the turntable according to the load chart.
- All pin connections have been secured.
- The hoist rope has been correctly placed in the rope pulleys and is prevented from jumping out with the rope retaining pins.
- There are no loose parts on the boom.
- The LICCON overload protection has been set according to the data in the load chart.
- The LICCON overload protection settings have been compared with the actual crane configuration.
- The LICCON overload protection is exceeded.
- The assembly icon **50** is visible on the LICCON monitor.
- No personnel is within the danger zone.

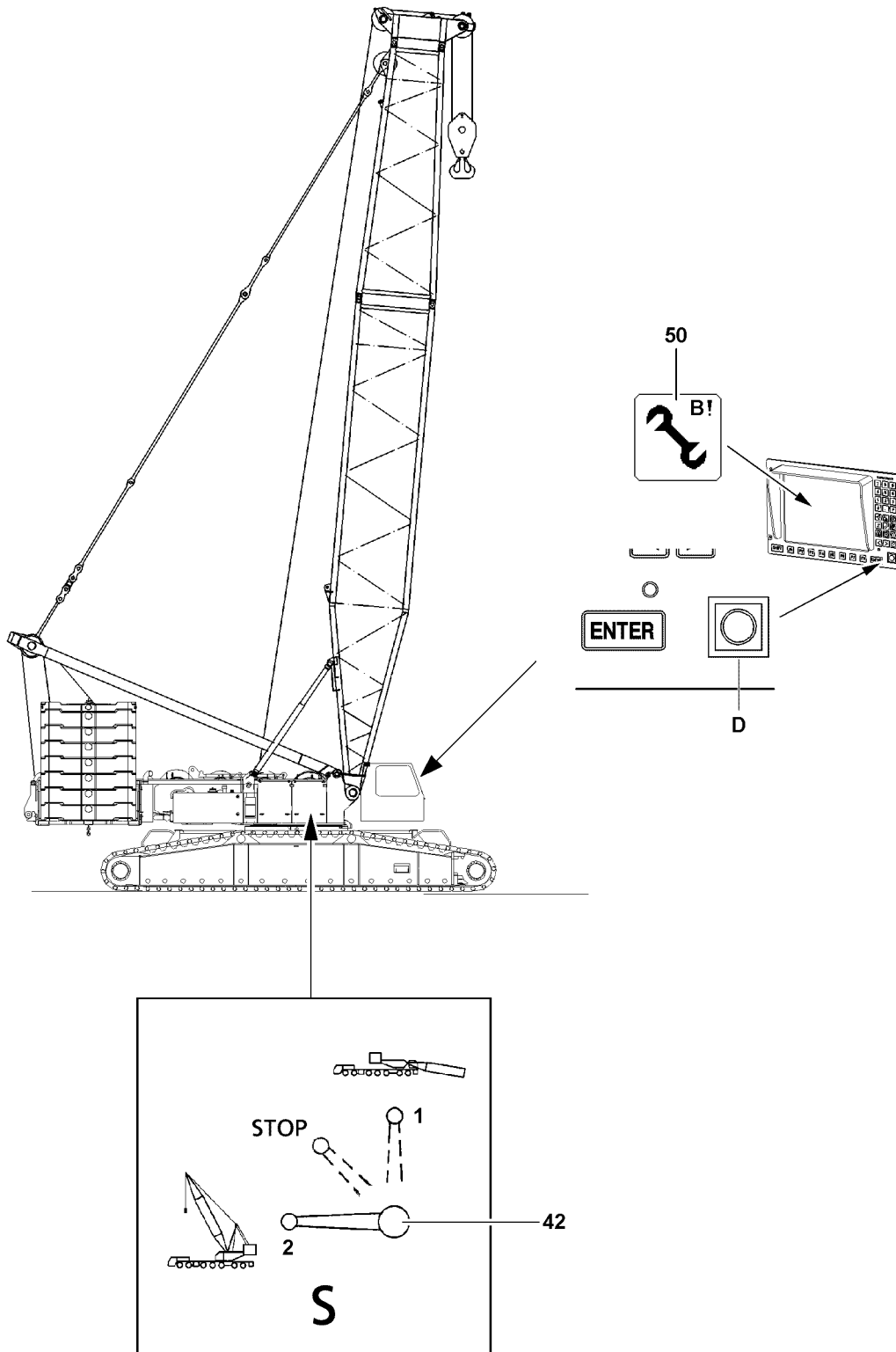

4.1 Extending the S-relapse cylinder



WARNING

The crane can topple over!

If the S-relapse cylinders are not extended before erecting the S-boom, then the S-boom can fall to the rear in crane operation and the crane can topple over!

Personnel can be severely injured or killed!

- ▶ Extend the S-relapse cylinders before erecting the S-boom!
- ▶ Secure the ball valve **42** during crane operation to prevent inadvertent actuation!

Ball valve positions	
2	Crane operation, extend the piston rod
1	Assembly, retract the piston rod
STOP	The piston rod cannot be retracted / extended

The piston rods on the S-relapse cylinders can be extended with the ball valve **42**.

- ▶ Set the ball valve **42** to **position 2**.

Result:

- The piston rods of the S-relapse cylinders extend.



Note

- ▶ The ball valve **42** is secured by closing the cabinet door and removing the key!
- ▶ Close the cabinet door and pull the key.
- ▶ Hand the key to an authorized person.

4.2 Reeving in the hook block

- ▶ Erect the boom until the end section lifts off the ground.
- ▶ Check the actual load on the LICCON monitor.

Troubleshooting

Actual load on the LICCON monitor is larger than 0.0 t!

- ▶ Observe the notes for input of hook block weight, see Crane operating instructions, chapter 4.02!



Note

- ▶ Hoist rope reevings, see Crane operating instructions, chapter 4.06 and Reeving plan!
- ▶ Reeve in the hook block properly and secure the hoist rope on the rope fixed point, for reeving, see reeving plan.
- ▶ Attach the hoist limit switch weight.
- ▶ Enter the weight of the hook block into the LICCON computer system!

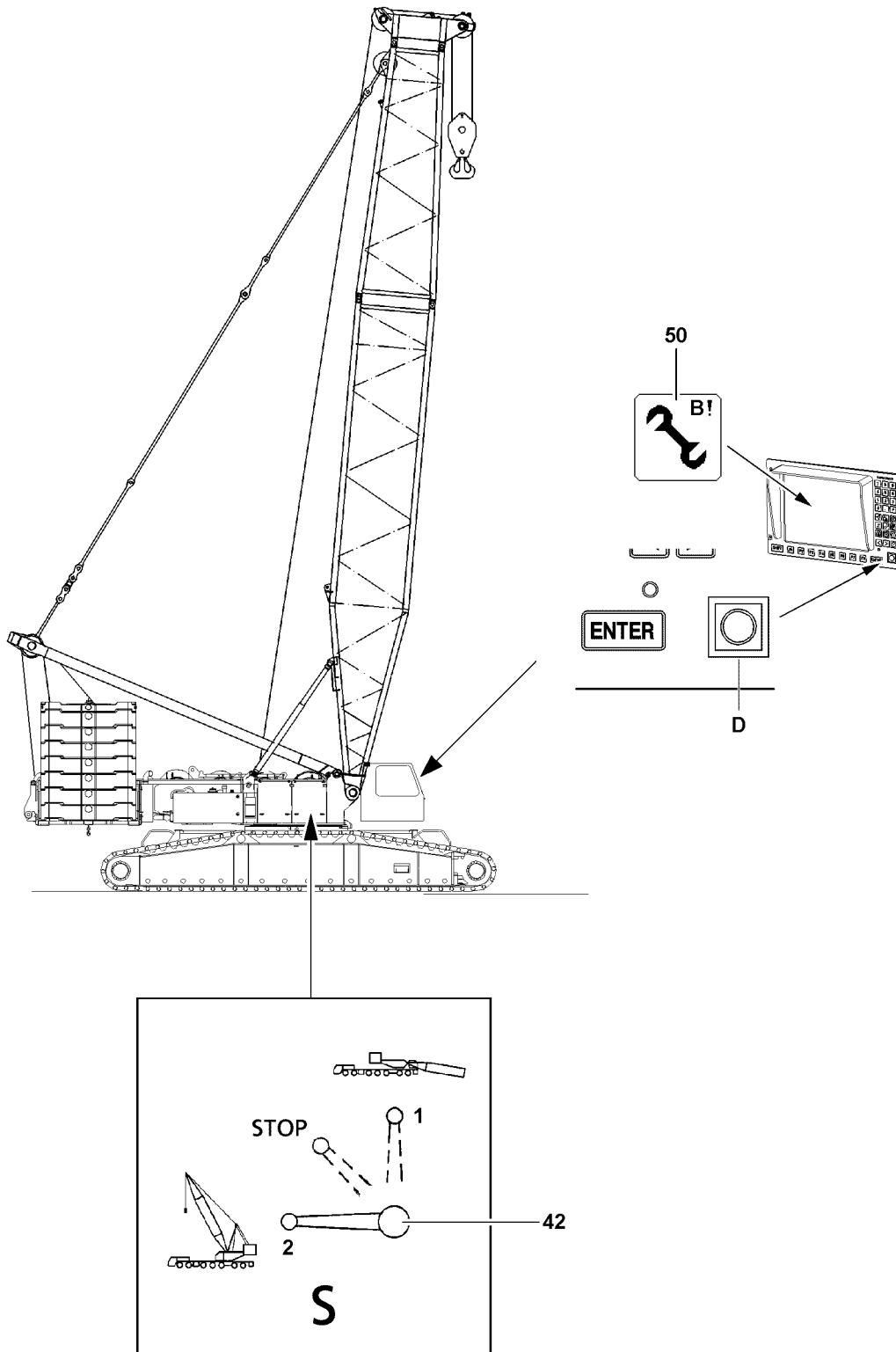



B111472

4.3 Erecting the S-boom



Note

- ▶ During the erection procedure - outside the operating range - alarm functions appear on the crane operating screen, see the following chart!

Displays on the LICCON monitor during the erection procedure	
 "STOP" icon visible	
 "ERROR 150" icon visible	Note: Error description, see Crane operating instructions, chapter 20.05.
 Horn icon visible	Note: In addition to the horn icon, an acoustic warning sounds.



WARNING

The crane can topple over!

In crane operation with exceeded LICCON overload protection, the crane can topple over!

Personnel can be severely injured or killed!

- ▶ The radii listed in the load chart may not be exceeded or fallen below, even if there is no load on the hook!



Note

- ▶ When the lowest operating position of the boom is reached, the LICCON overload protection is activated!
 - ▶ The displays on the LICCON monitor turn off!
 - ▶ In the maximum load icon appears a load number in "t" instead of the display "???"!
-
- ▶ Luff the boom up to the lowest operating position.
 - ▶ When the boom has reached the lowest operating position:
Make sure that the assembly icon **50** on the LICCON monitor turns off.

Result:

- The LICCON overload protection is active.

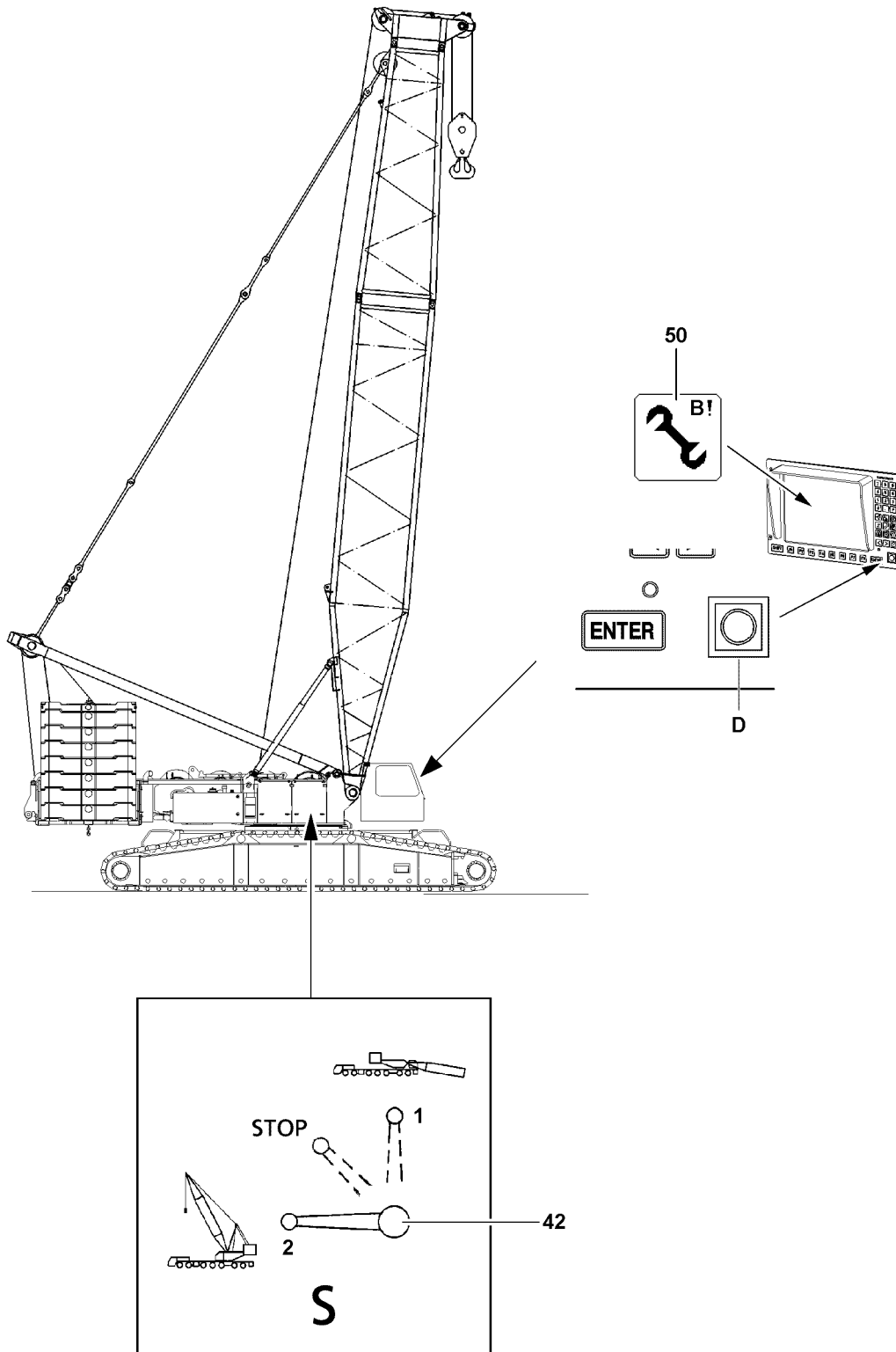

B111472

5 Crane operation

5.1 Preparing for crane operation

**Note**

- ▶ Observe the notes in the chapters, see Crane operating instructions, chapter 4.05, chapter 4.08 and chapter 5.01!

Make sure that the following prerequisites are met:

- The LICCON overload protection is active.
- The LICCON overload protection has been set according to the data in the load chart.

**WARNING**

The crane can topple over!

- ▶ Check the horizontal position of the crane before and during operation!
- ▶ If the crane operator leaves the cab, even for a short time, the operating mode setting must be checked and reset if necessary before resuming crane operation!

5.1.1 Checking the settings

- ▶ Check the function of the overload protection by running against the operating positions “on top” and “bottom”.
- ▶ Check the hoist limit switch by running against the hoist limit switch weight.
- ▶ Check the function of the limit switches “Boom steep” on the relapse cylinders.

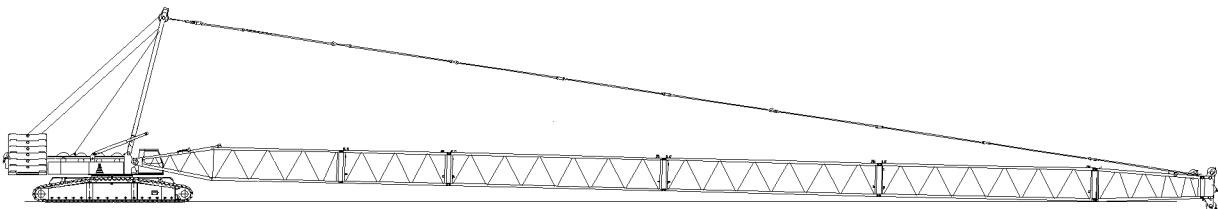
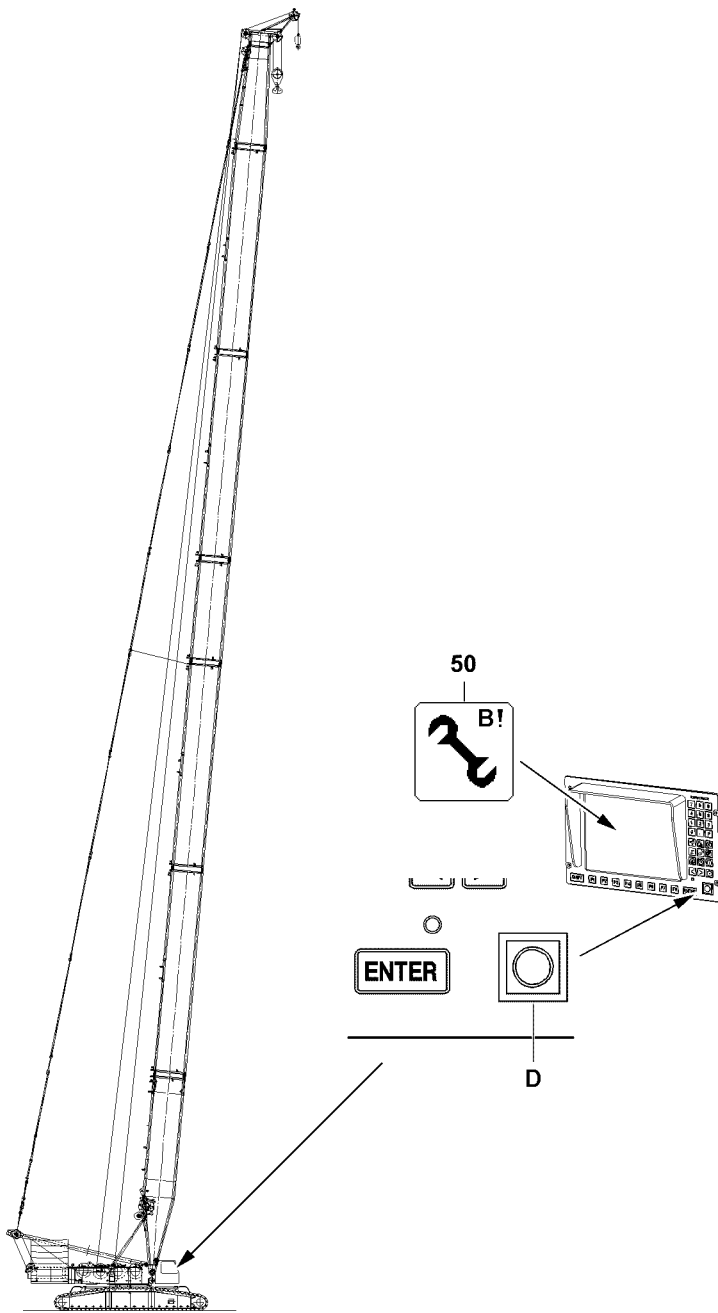

B112449

6 Disassembling the S/SL boom



Note

- ▶ The assembly is described on the example of the S-boom!



WARNING

Risk of falling!

During assembly / disassembly, inspection and maintenance work, personnel must be secured with appropriate aids to prevent them from falling! If this is not observed, assembly personnel could fall and suffer life-threatening or fatal injuries!

- ▶ All work aloft, where there is a danger of falling must be carried out with suitable aids!
- ▶ If fall protection equipment is available, then it must be used, see Crane operating instructions, chapter 2.06!
- ▶ If aids are not available and work cannot be carried out from the ground, then the assembly personnel must secure themselves with the permissible fall arrest system to prevent falling, see Crane operating instructions, chapter 2.04!
- ▶ The fall arrest system must be fastened on the fastening and hook points as well as on the safety ropes. For safety points, see Crane operating instructions, chapter 2.06!
- ▶ Only step on the aids, ladders and catwalks with clean shoes!
- ▶ Keep aids, ladders and catwalks free of heavy dirt, snow and ice!
- ▶ It is prohibited to walk on the telescopic or an auxiliary boom without suitable protective devices!



WARNING

Falling components!

If unsecured or non-supported components are installed or removed, they can fall down!

Personnel can be severely injured or killed!

- ▶ During pinning and unpinning of the lattice sections, it is prohibited for anyone to remain **under** or **on** the components as well as within the entire danger zone!
- ▶ Support the boom and components before pinning / unpinning!
- ▶ Pin or unpin both pins laying in a horizontal, i.e. **left** and **right**!
- ▶ Secure the pins in the bearing points and in the receptacles!
- ▶ Do not disengage the auxiliary crane until each component is pinned on and secured!
- ▶ It is prohibited to lean a ladder against the component being disassembled!



WARNING

Danger of impact / crushing!

When installing / removing crane components with the auxiliary crane, crane components can start to swing back and forth!

When lifting / lowering and positioning crane components, there is an increased danger of impacts / crushing!

Personnel can be caught and severely injured or killed as a result!

- ▶ Make sure that personnel cannot be caught by components!
- ▶ Make sure that the crane is aligned in horizontal position to avoid the support beams from swinging by themselves!
- ▶ When working in danger zones: Use aids to protect limbs!
- ▶ Guide components with suitable aids to minimize oscillation!

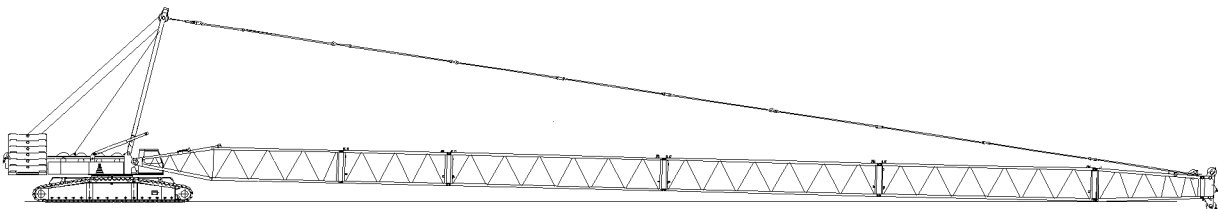
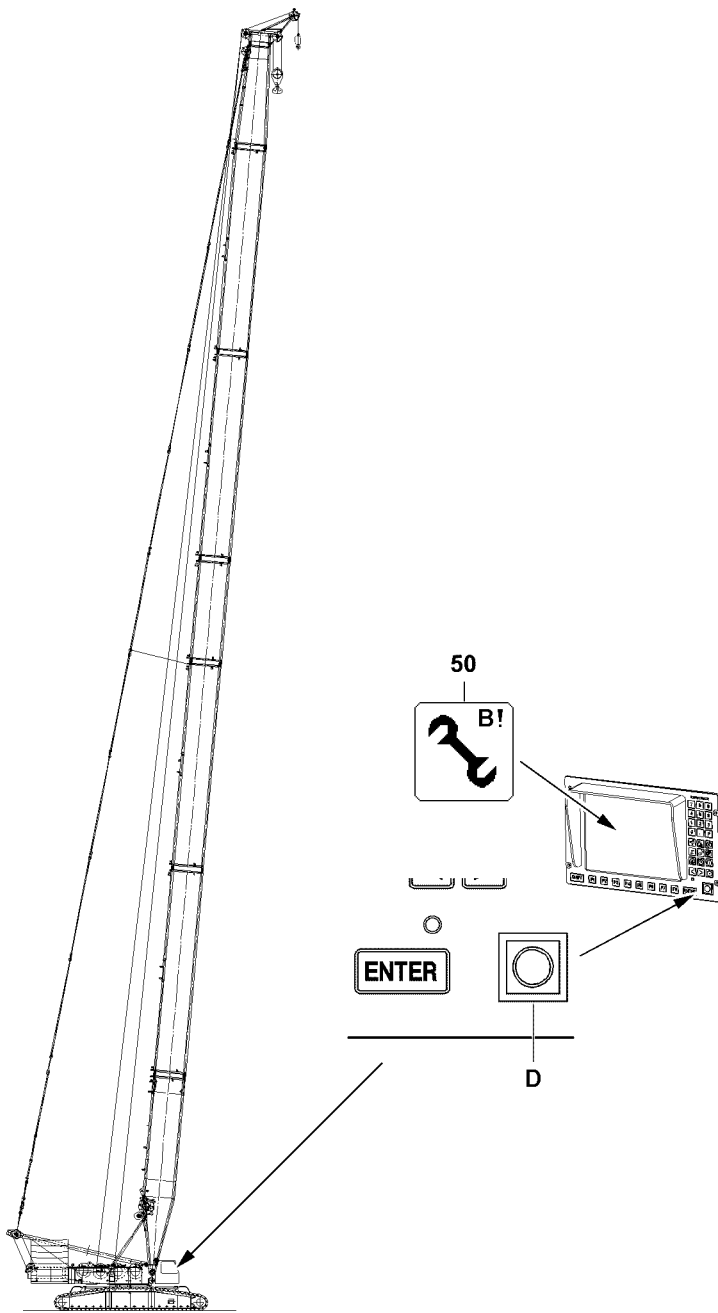

B112449

6.1 Taking the S-boom down



WARNING

Risk of accident!

If the following instructions are not observed, personnel can be severely injured or killed!

- ▶ The turntable may not be turned during the disassembly of the boom!
- ▶ Observe the safety technical notes, see Crane operating instructions, chapter 5.01!
- ▶ Observe the data in the erection and take down charts!

NOTICE

Damage of boom components!

Taking down the boom system can lead to a collision between the hook block and the pulley head!

The boom components can be severely damaged!

- ▶ Luff the boom system down at the same time and spool the hoist winch out!



Note

- ▶ Depending on the condition of the ground, the boom and the lattice sections must be supported from below for the disassembly of the boom!

Make sure that the following prerequisites are met:

- The crane is aligned in horizontal direction.
- An auxiliary crane is available.
- An assembly scaffolding / work platform is available.
- The counterweight has been installed to the turntable according to the erection chart.
- The LICCON overload protection has been set according to the data in the load chart.

6.2 Turning the turntable into disassembly position

- ▶ Turn the turntable in longitudinal axle of the crawler travel gear against the travel direction or vertically to the crawler travel gear, see Erection and take down chart.

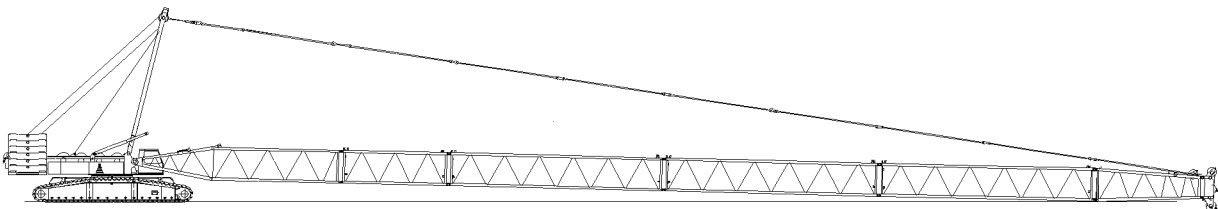
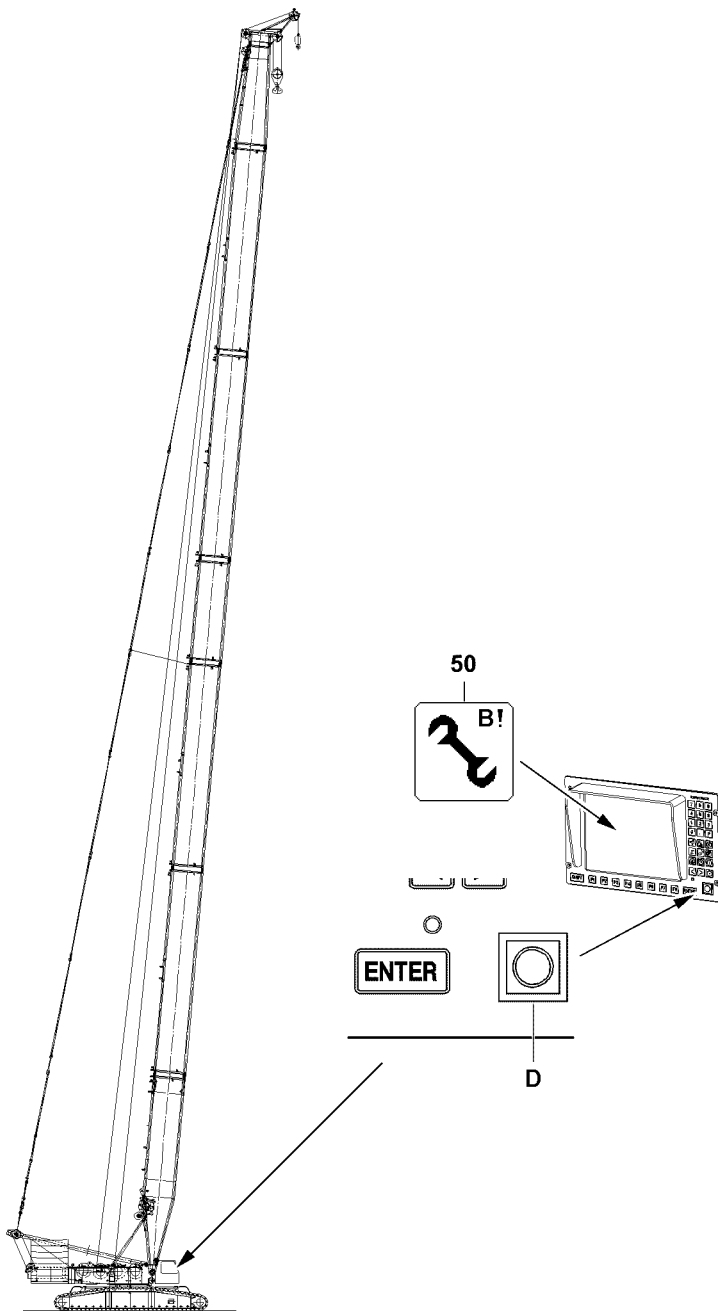

B112449

6.3 Luffing the S-boom down





Note

- ▶ The luff down movement is turned off as soon as the lowest operating position is reached!
- ▶ When the lowest operating position of the boom is reached, the load display in the maximum load icon turns off and instead of the load display appears the display “???”!



Note

- ▶ During the take down procedure - outside the operating range - alarm functions appear on the crane operating screen, see the following chart!

Display on the LICCON monitor 0 after reaching the “lowest” operating position	
 Icon: “STOP” visible	
 Icon: “ERROR 150” visible	<p>Note: Error description, see Diagnostics manual, chapter 20.05.</p>
 Icon: “Horn” visible	<p>Note: In addition to the “Horn” icon, an acoustic warning sounds.</p>

- ▶ Luff the S-boom down to the “lowest” operating position.

Result:

- The luff down movement is turned off.
- The “STOP” icon appears on the LICCON monitor.
- The horn icon appears on the LICCON monitor.

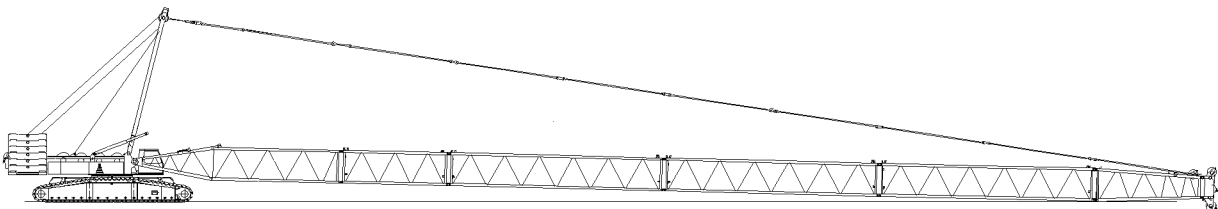
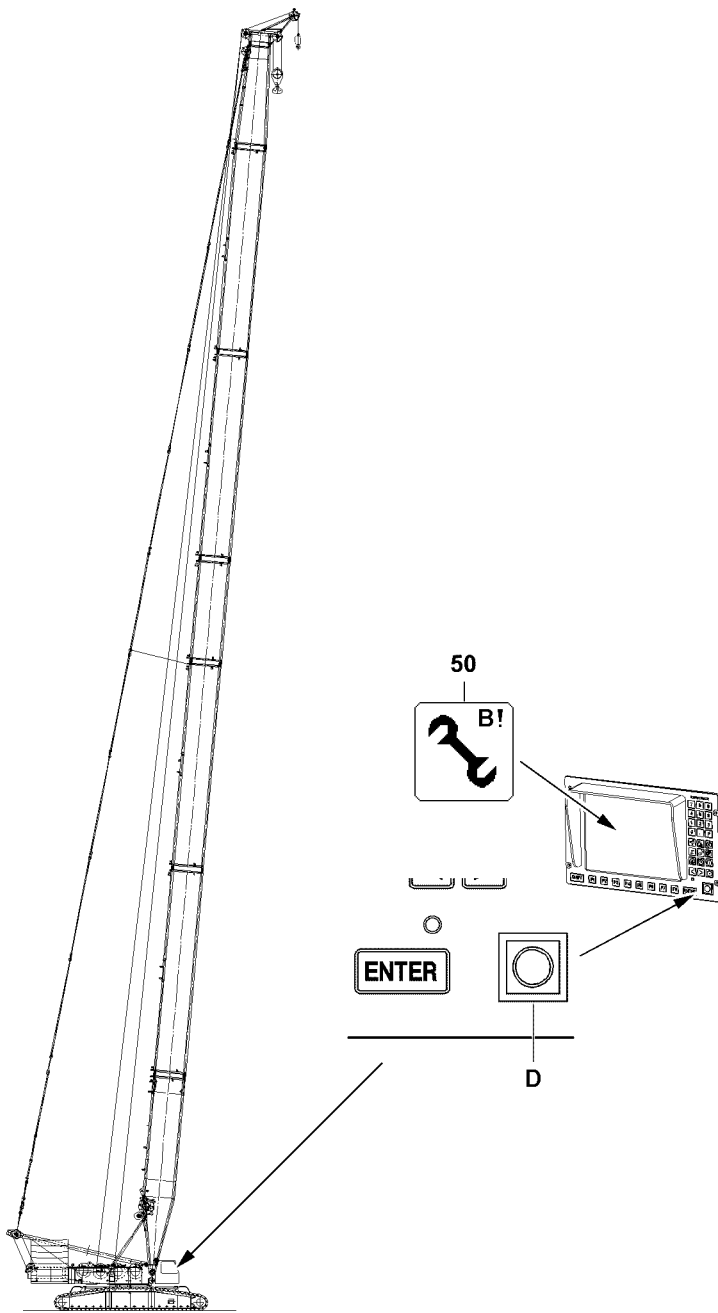

B112449

**WARNING**

Assembly with turned on set up key!

When the set up key is turned on, the LICCON overload protection is exceeded!

In the event of deliberate improper use, the crane could collapse, the boom can break off or the crane can topple over!

Personnel can be severely injured or killed!

This could result in high property damage!

- ▶ The set up key **D** may only be actuated by persons who know the effects of a bypass!
- ▶ Press the set up key **D** only when the set up status was correctly entered into the LICCON computer system!
- ▶ Observe the erection / take down charts!
- ▶ Crane operation with the set up key **D** turned on is strictly prohibited!

- ▶ When the S-boom has reached the “lowest” operating position:
Turn the set up key **D** to the right.

Result:

- The LICCON overload protection is deactivated.
- The assembly icon **50** appears on the LICCON monitor.
- ▶ At the same time, spool the hoist winch out and luff the S-boom down further until the hook block touches the ground.

6.4 Unreeving the hook block

- ▶ Remove the hoist limit switch weight and unreeve the hook block.

6.5 Spooling the hoist rope up

NOTICE

Overspooled winch!

If the rope is pulled under the winch when spooling up, the settings of the cam limit switch are not longer correct and there is an increased danger of accidents!

As a result, extensive adjustment work on the cam limit switch is required!

- ▶ All rope retaining pins / pipes on the S-boom are removed!
- ▶ Slowly spool up the hoist rope over the rope pulleys back to the winch!
- ▶ Stop the winch in time, with sufficient rope reserve!
- ▶ Do not overspool the winch!

- ▶ Spool up the hoist rope.

B195219

6.6 Disconnecting the electrical connections to the S-boom

Make sure that the following prerequisite is met:

- The S-boom is in horizontal position or placed on the ground.

- ▶ Disconnect the electrical connections.

NOTICE

Damage to cable drum or cable!

If the cable of the cable drum is not properly spooled up on the cable drum after unplugging, then the cable drum or the cable can be significantly damaged!

- ▶ Spool the cable drum up after unplugging!

-
- ▶ Spool the cable drum up and secure it to prevent inadvertent spooling out.
 - ▶ Make sure that all electrical connections on the S-boom have been disconnected.

6.7 Disconnecting the hydraulic connections to the S-boom

When releasing hydraulic lines with quick release couplings, make sure that the coupling procedure is carried out correctly.



WARNING

Pressure in the hydraulic lines!

If the pressure supply is not interrupted before connecting / releasing the hydraulic lines, the hydraulic oil can escape with high pressure!

Personnel can be severely injured or killed!

- ▶ Release the pressure in the hydraulic system before connecting / disconnecting: Interrupt the pressure supply and wait for a short time!
-
- ▶ Install the coupling components (sleeve and connector) with the hand-tightened nut.
 - ▶ Disconnect the hydraulic connections.
 - ▶ Install dust caps on the quick release couplings.

1

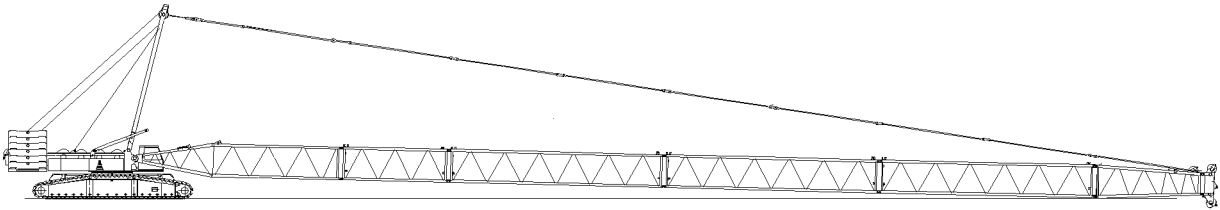

2

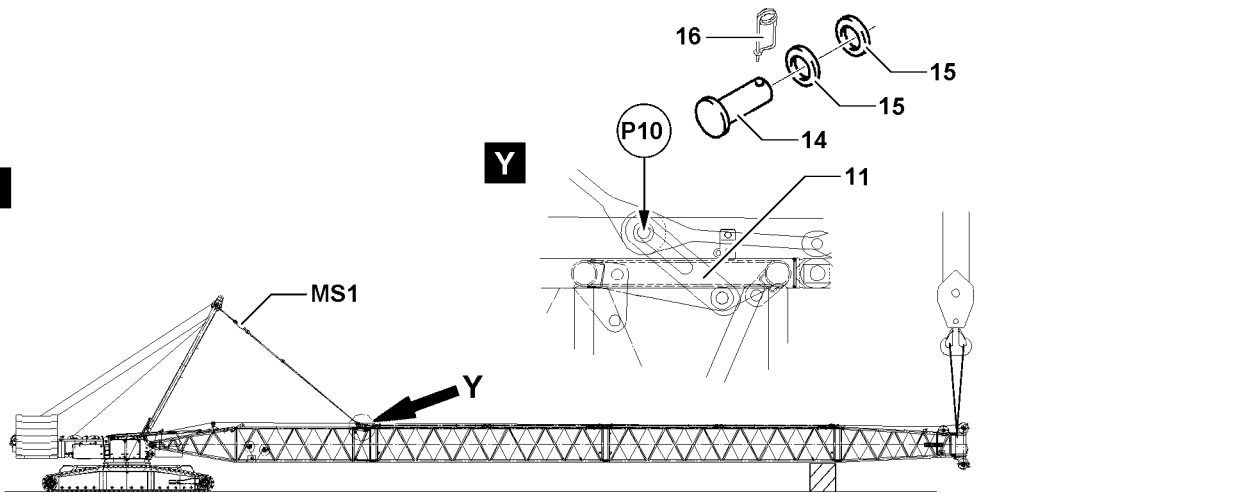

3

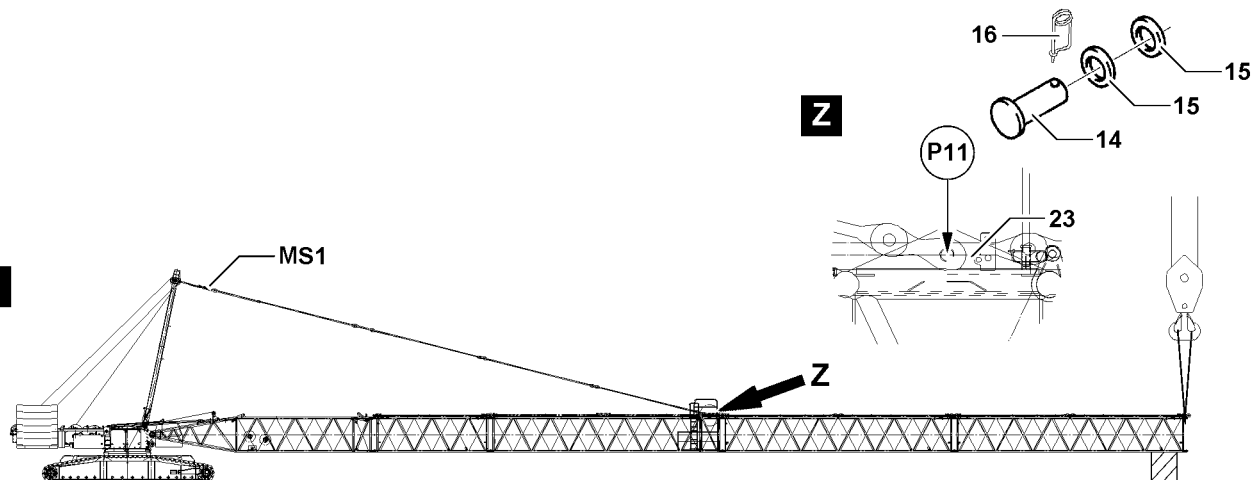

4

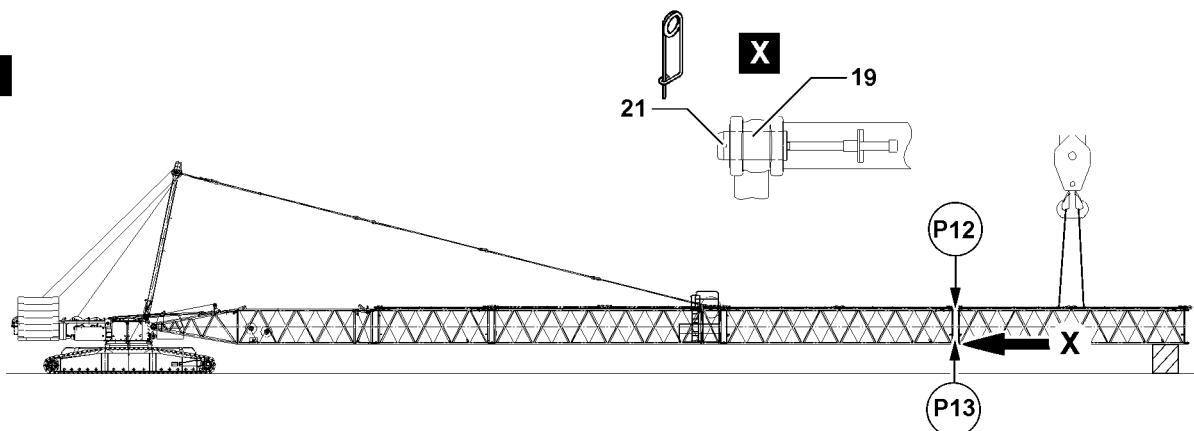

B112448

6.8 Disassembling the S-lattice sections

The disassembly of the lattice sections is carried out in various ways:

- Disassembling the lattice sections in “Flying mode”.
- “Opening” the boom.



WARNING

General danger notes!

- ▶ Support the S-boom during assembly / disassembly with suitable materials!
- ▶ All pins are to be secured after assembly with the intended safety elements!
- ▶ The guy rods must be inspected regularly, see Crane operating instructions, chapter 8.15!
- ▶ Secure the boom with support or auxiliary crane, see Crane operating instructions, chapter 5.01!
- ▶ It is prohibited for anyone to remain under the booms or within the complete danger zone during the pinning and unpinning procedure of the lattice section!



Note

- ▶ For weights of intermediate sections with placed guy rods, see Crane operating instructions, chapter 1.03!
- ▶ The intermediate sections are unpinned with the aid of the pin pulling device, see Crane operating instructions, chapter 5.30!

Make sure that the following prerequisite is met:

- All electrical and hydraulic connections are separated on the boom.

6.8.1 Disassembling the S-lattice sections in “Flying mode”

If spatial prerequisites on the job site are limited for the disassembly of the S-boom, or if they are limited by buildings or similar, then the S-boom can be removed in flying mode.

For the flying disassembly, a differentiation is made between the guy points on the boom:

- Guying on S-pivot section, see illustration 2.
- Guying on S-intermediate section for flying assembly, see illustration 3.



WARNING

Impermissible boom lengths guyed in flying mode!

If impermissible boom lengths are guyed on the assembly brackets, then severe property damage can occur on the crane! Personnel can be severely injured or killed!

- ▶ The maximum permissible boom lengths for the “Flying assembly” may not be exceeded, see section “Assembling the S-lattice sections”!
- ▶ For the “flying” boom assembly, the maximum permissible total force on the test point **MS1** may **not** be exceeded, see section “Assembling the S-lattice sections in flying mode”!
- ▶ Pin the guy rods either on the assembly brackets **11**, point **P10**, or the assembly brackets **23**, point **P11**!
- ▶ The data in the erection and take down charts as well as the load charts must be observed!



WARNING

The boom can fold downward!

By unpinning the guy rods on the assembly brackets **11** or the assembly brackets **23**, the boom can fold down!

Personnel can be severely injured or killed!

- ▶ Unpin the guy rods on the assembly brackets **11**, point **P10** or the assembly brackets **11**, point **P11** when it is ensured that the intermediate sections are supported with suitable materials or are secured with the auxiliary crane or the boom is placed on the ground!

1

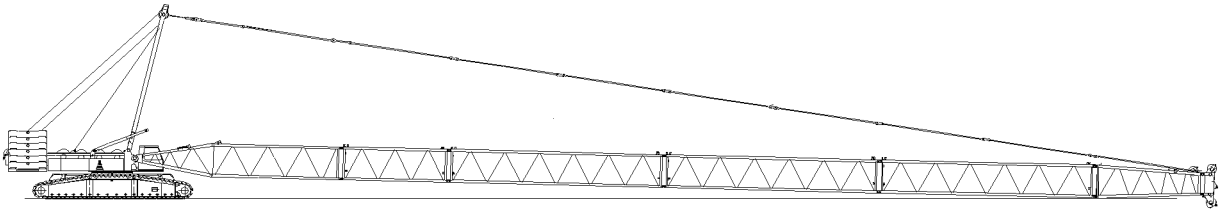

2

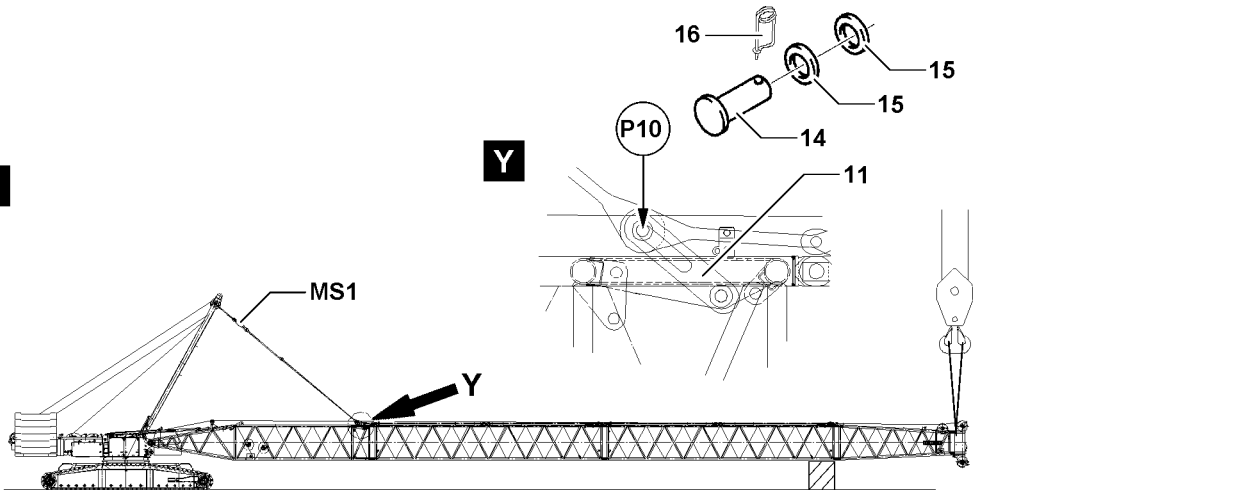

3

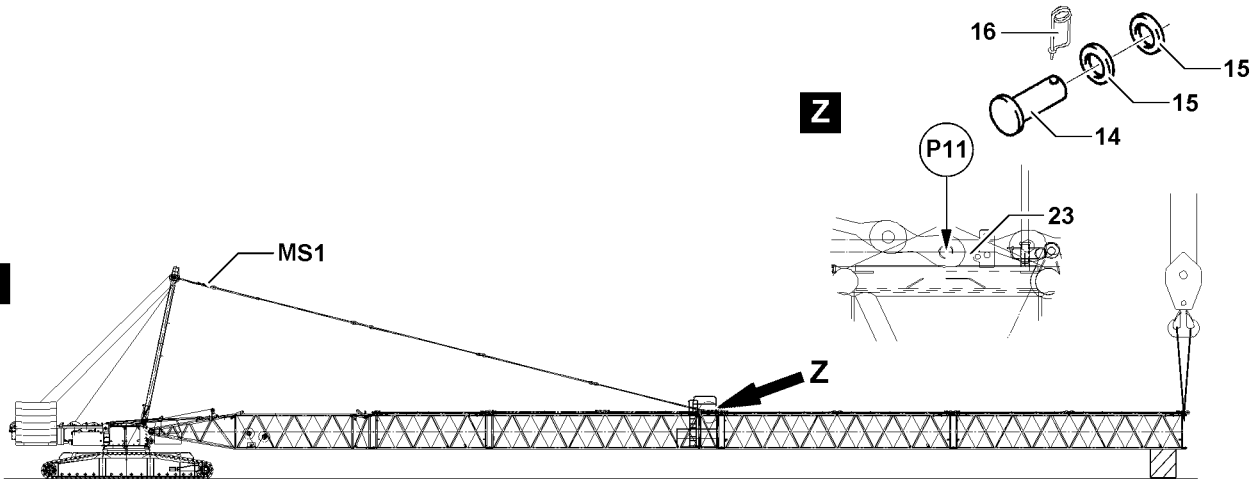

4

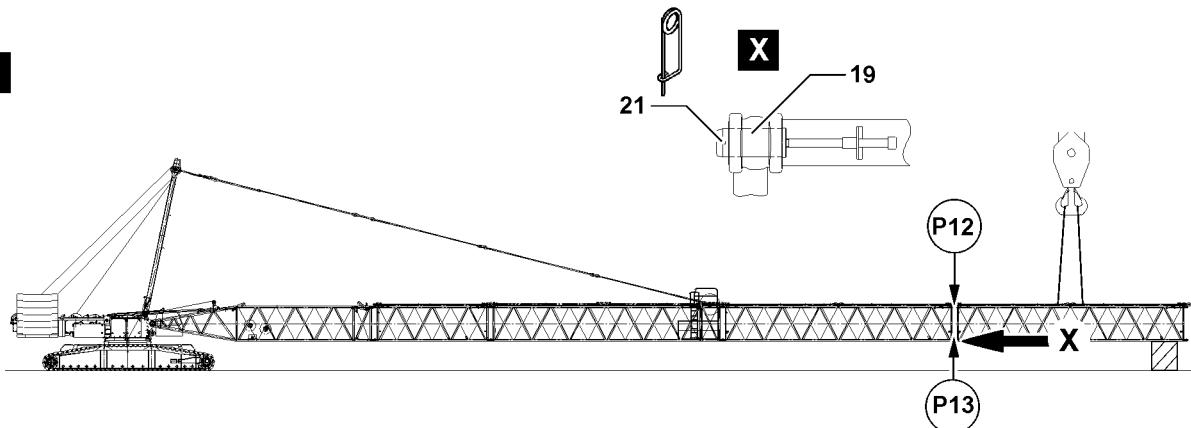

B112448

Make sure that the following prerequisites are met:

- The boom is in horizontal position.
- The guy rods are tensioned.
- Suitable materials to support the boom are available.
- An auxiliary crane is available.

Guying the S-boom in “Flying mode”

- ▶ Support the boom or secure it with the auxiliary crane.



Note

- ▶ The guy rods must be placed down to the point where the boom can be guyed on the assembly brackets **11** on point **P10** or the assembly brackets **23** on point **P11**!
-

- ▶ Make sure that the transport retainers for the guy rods on the intermediate sections are unpinned.
- ▶ Luff the SA-bracket down and place the guy rods on the S-intermediate sections in the transport retainers.

When pinning the pin **14**, you have to use the washers **15**, see illustration.

- ▶ When the boom is guyed on the S-pivot section:
Pin the guy rods on the assembly brackets **11**: Insert the pin **14** on point **P10** and secure with spring retainer **16**.
- ▶ When the boom is guyed on the S-intermediate section:
Pin the guy rods on the assembly brackets **23**: Insert the pin **14** on point **P11** and secure with spring retainer **16**.
- ▶ Disassemble the guy rods, which are laying on the boom and secure them in the transport retainers.

Result:

- The S-intermediate sections can be disassembled.

Disassembling the S-intermediate section

The “flying” disassembly is described on the example of one intermediate section, see illustration **4**.

- ▶ Secure the S-intermediate section with the auxiliary crane.
- ▶ Unpin the S-intermediate section on both sides “on the bottom” at point **P13**: Remove the spring retainer **21** and unpin the pin **19**.
- ▶ Unpin the S-intermediate section on both sides “on top” at point **P12**: Remove the spring retainer **21** and unpin the pin **19**.
- ▶ Remove the S-intermediate section.

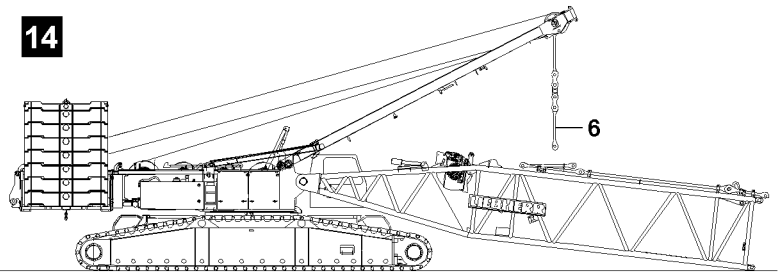
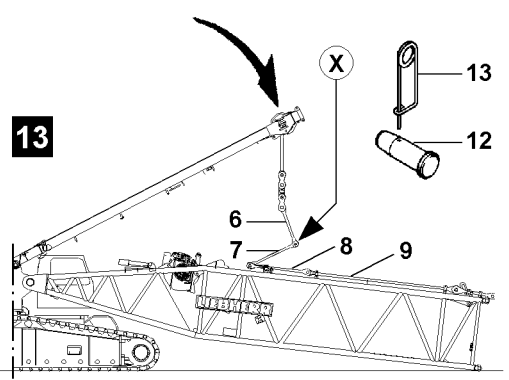
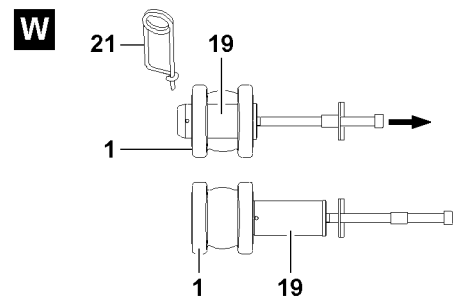
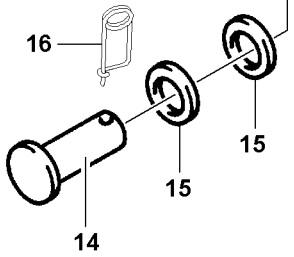
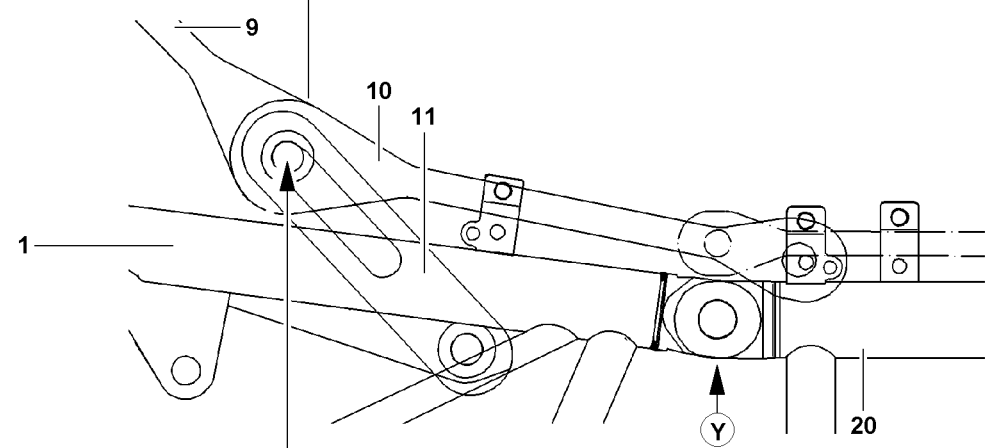
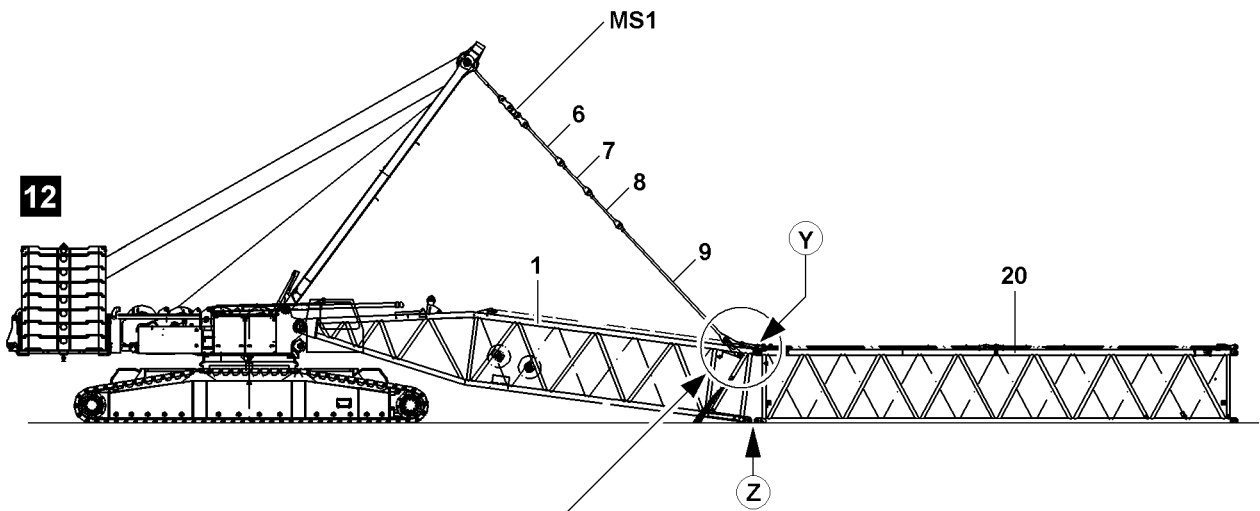

B105431

6.8.2 Disassembling the S-lattice sections (“open” boom)



WARNING

The crane can topple over!

If the following conditions are not met, the crane can topple over or be significantly damaged!

Personnel can be severely injured or killed!

- ▶ During the “Opening procedure” of the S-intermediate sections, the maximum total force on test point **MS1** of 110 t may **not** be exceeded!
- ▶ The end section of the corresponding S/SL-boom combination may **not** lift off the ground when “opening” the boom!
- ▶ With the SA-bracket, S-boom combinations to maximum **S 119 m** may be lifted / opened!
- ▶ With the SA-bracket, SL-boom combinations to maximum **SL 112 m** may be lifted / opened!

Make sure that the following prerequisites are met:

- The guy rods are tensioned.
- Suitable materials to support the boom are available.
- An auxiliary crane is available.

Pinning the guy rods on the S-pivot section



Note

- ▶ The guy rods must be placed down to the point where the guy rods can be pinned on the assembly brackets **11** on point **P10**!

- ▶ Luff the SA-bracket down and place the boom on the support on the ground.
- ▶ Make sure that the transport retainers for the guy rods on the intermediate sections are unpinned.
- ▶ Luff the SA-bracket down and place the guy rods on the S-intermediate sections in the transport retainers.

When pinning the pin **14**, you have to use the washers **15**, see illustration.

- ▶ Pin the guy rods on the assembly brackets **11** on the S-pivot section: Insert the pin **14** and secure with spring retainer **16**.
- ▶ Disassemble the guy rods, which are laying on the boom and secure them in the transport retainers.

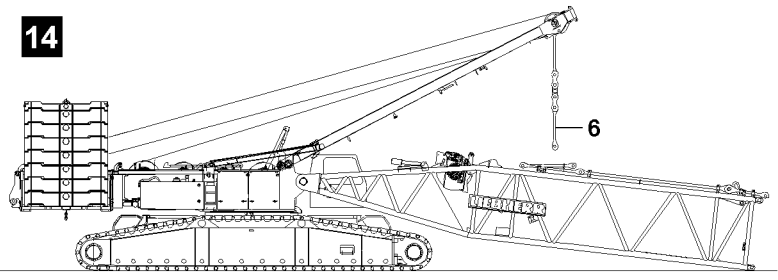
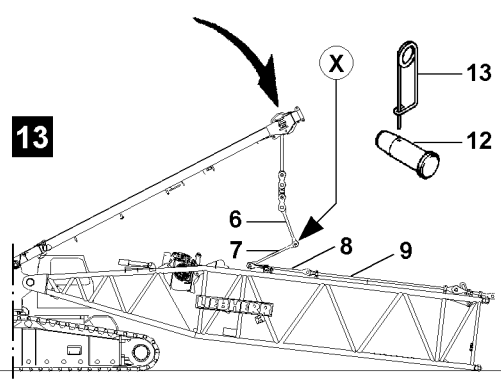
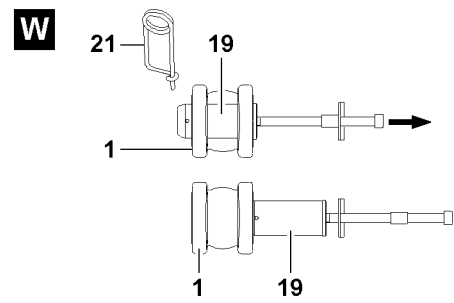
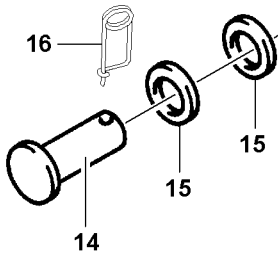
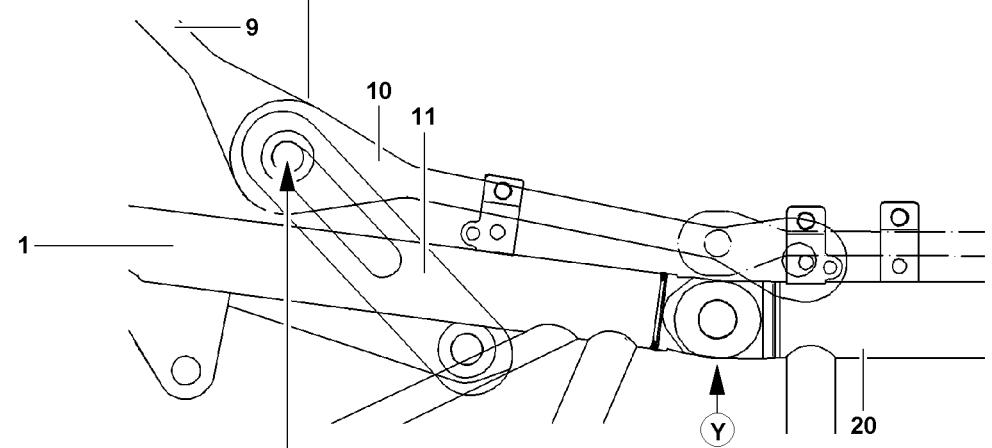
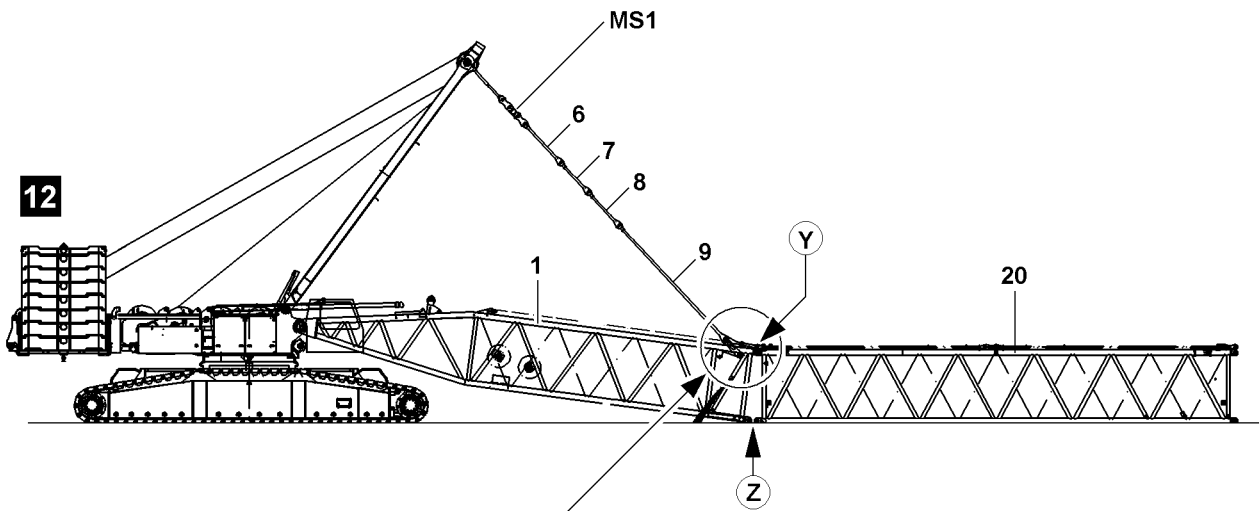

“Opening” the S-boom



Note

- ▶ The ACTUAL force on test point **MS1** is shown on LICCON monitor 1!
 - ▶ Tension the guying on the SA-bracket with the same force as for assembly, see the actual force which was measured and noted at assembly on test point **MS1**!
 - ▶ The pins can be pulled easier and the pins and lugs are therefore not damaged!
-
- ▶ Lift the SA-bracket and tension the guy rods until the force on test point **MS1** corresponds to the force at assembly.
 - ▶ Unpin the S-pivot section on both sides “on the bottom” at point **Z**: Remove the spring retainer **21** and unpin the pin **19**, see detail **W**.
 - ▶ Lower the S-boom until the intermediate sections and the S-pivot section is laying on the ground.
 - ▶ Unpin the S-pivot section on both sides “on top” at point **Y**: Remove the spring retainer **21** and unpin the pin **19**, see detail **W**.
 - ▶ Lower the SA-bracket and place the guy rods **7** on the S-pivot section in the transport retainers.
 - ▶ Unpin the guy rods **7** S-pivot section on the guy rods **6** SA-bracket, place them down and secure with transport retainers.

Result:

- The S-lattice sections can be disassembled.

Disassembling the S-intermediate section

The disassembly is described on the example of one intermediate section, see detail **W**.

- ▶ Unpin the S-intermediate section on both sides “on the bottom”: Remove the spring retainer **21** and unpin the pin **19**.
- ▶ Unpin the S-intermediate section on both sides “on top”: Remove the spring retainer **21** and unpin the pin **19**.
- ▶ Remove the S-intermediate section.

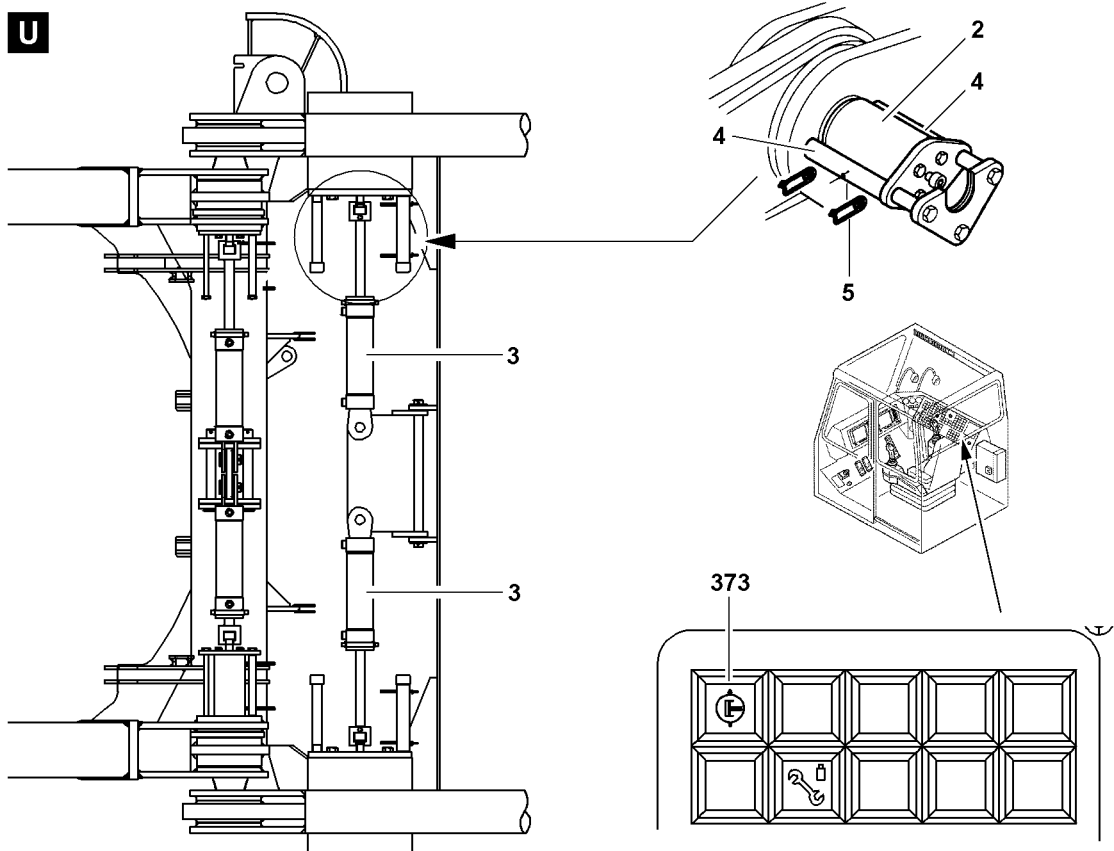
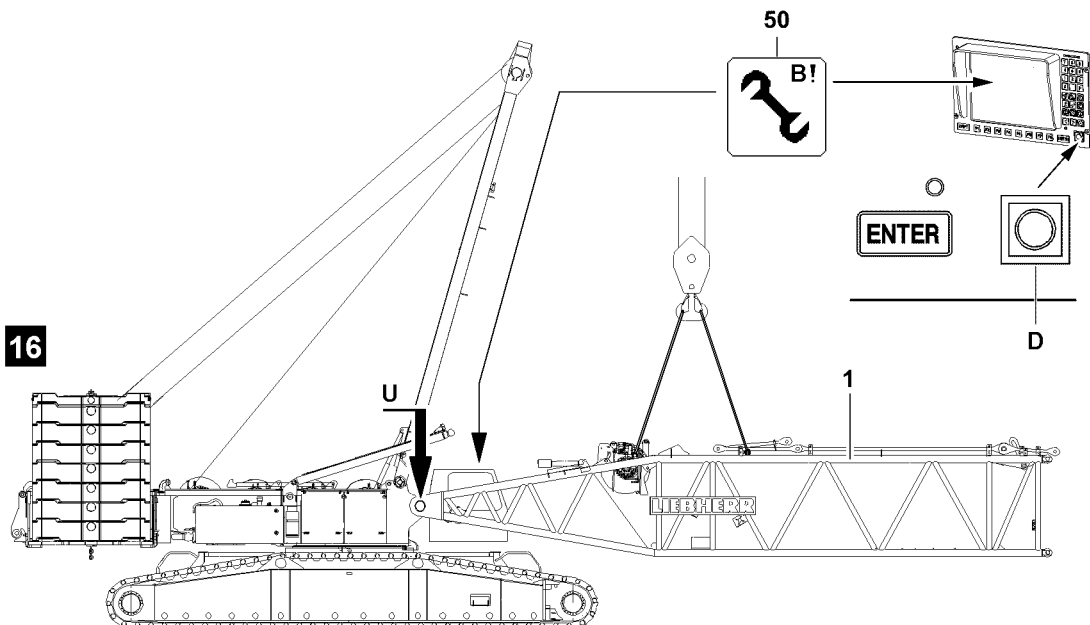
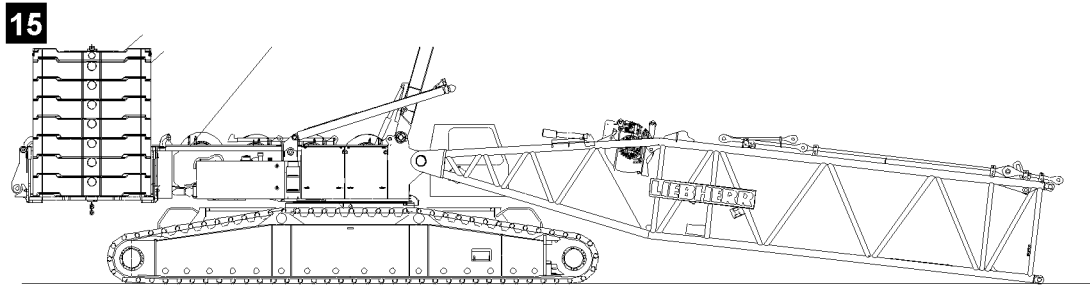

B111474

6.9 Disassembling the S-pivot section



WARNING

General danger notes!

- ▶ Support S-pivot section during disassembly with suitable materials!
- ▶ Insert and secure all pins after disassembly in the intended transport receptacles!
- ▶ The guy rods must be inspected regularly, see Crane operating instructions, chapter 8.15!

Make sure that the following prerequisite is met:

- The SA-bracket is erected to the point where the S-pivot section can be disassembled without obstructions.

- ▶ Attach the S-pivot section **1** on the auxiliary crane.
- ▶ Lift the S-pivot section **1** with the auxiliary crane to the horizontal.

Establish the hydraulic connection to the pin pulling device via two quick couplers.

Release and unpin the S-pivot section **1** on the turntable.

- ▶ Establish the hydraulic connection to the pin pulling device.
- ▶ Turn the pressure change over switch **373** on.



WARNING

The S-pivot section can fold downward!

- ▶ Make sure that the S-pivot section is safely held by the auxiliary crane before unpinning the pins **2**!
- ▶ Remove the spring retainer **5** on the retaining plate **4** on the left and right.
- ▶ Remove the retaining plate **4** left and right.
- ▶ Unpin the connector pins **2** with the hydraulic pin pulling device **3**.
- ▶ Turn the pressure change over switch **373** off.

NOTICE

Property damage on the turntable and on the S-pivot section!

- ▶ Slowly swing the S-pivot section out with the auxiliary crane and at low speed on the turntable!
- ▶ Place the S-pivot section with the auxiliary crane on the support on the ground.
- ▶ Remove the pin pulling device.
- ▶ Remove the auxiliary crane.



Note

- ▶ Place the SA-bracket on the turntable, see Crane operating instructions, chapter 5.02!

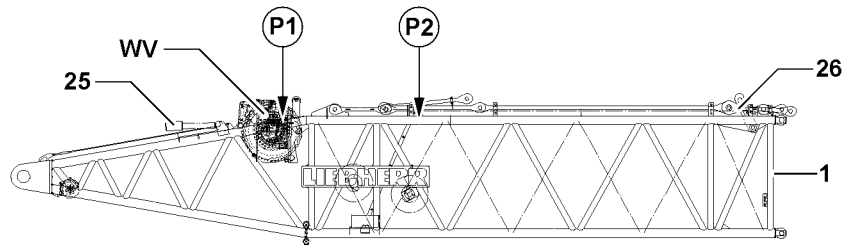
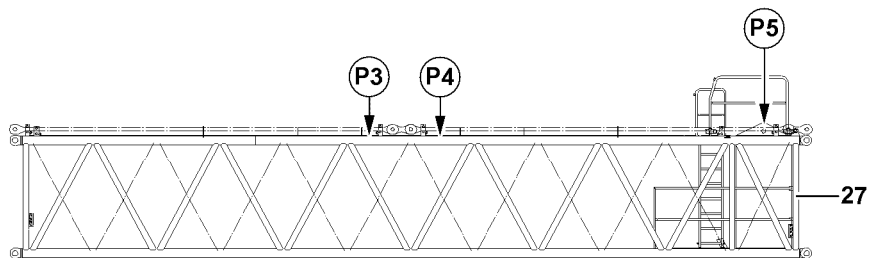
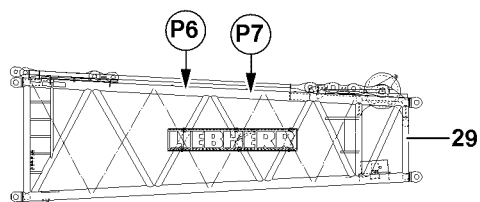
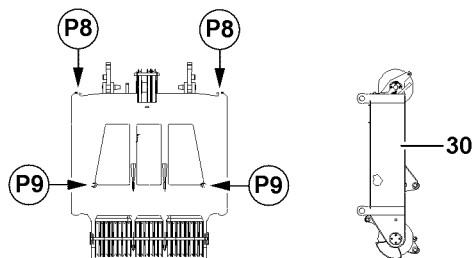
1**2****3****4**

1 Component overview LD/SLD/SD boom

Examples for components of S-/SL-boom:

- | | |
|---|--|
| 1 S-pivot section | • Pivot section with winch 5 WV and W-guy rods 26 , see illustration 1 |
| 25 S-relapse cylinder | • See illustration 1 |
| 27 S-intermediate section
2620.20 | • Intermediate section 14 m with guy bracket on point P5 for flying assembly, see illustration 2 |
| 29 S-adapter | • See illustration 3 |
| 30 S-end section | • See illustration 4 |

2 Fastening points LD/SLD/SD-components



WARNING

Component incorrectly attached!

Life-threatening situations can arise due to improper or incorrect attachment of the corresponding components!

Personnel can be severely injured or killed!

- ▶ Attach the components only on the intended fastening points on both sides!
- ▶ Attachment of components and description of fastening points, see Crane operating instructions, chapter 5.01!

Component	Fastening point	Illustration
S-pivot section	P1 and P2	1
S-intermediate section	P3 and P4	2
S-adapter	P6 and P7	3
S-end section	P8 and P9	4

B195219

3 Assembling the LD/SLD/SD-boom



Note

- ▶ The assembly is described on the example of the S-boom!



WARNING

Risk of falling!

During assembly / disassembly, inspection and maintenance work, personnel must be secured with appropriate aids to prevent them from falling! If this is not observed, assembly personnel could fall and suffer life-threatening or fatal injuries!

- ▶ All work aloft, where there is a danger of falling must be carried out with suitable aids!
- ▶ If fall protection equipment is available, then it must be used, see Crane operating instructions, chapter 2.06!
- ▶ If aids are not available and work cannot be carried out from the ground, then the assembly personnel must secure themselves with the permissible fall arrest system to prevent falling, see Crane operating instructions, chapter 2.04!
- ▶ The fall arrest system must be fastened on the fastening and hook points as well as on the safety ropes. For safety points, see Crane operating instructions, chapter 2.06!
- ▶ Only step on the aids, ladders and catwalks with clean shoes!
- ▶ Keep aids, ladders and catwalks free of heavy dirt, snow and ice!
- ▶ It is prohibited to walk on the telescopic or an auxiliary boom without suitable protective devices!



WARNING

The lattice sections can fall down!

If the lattice sections are not pinned and secured correctly, then they can fall down and fatally injure personnel!

- ▶ Pin or unpin both pins that lie in one horizontal level, i.e. **left and right!**
- ▶ Do not stand under the lattice sections or within the entire danger zone during the pinning and unpinning procedure of the boom!
- ▶ Secure the pins in the bearing points and the receptacles!
- ▶ It is prohibited to lean the ladder against the components being disassembled!
- ▶ Do not remove the fastening equipment and the auxiliary crane until each component is pinned on and secured!



WARNING

Danger of impact / crushing!

When installing / removing crane components with the auxiliary crane, crane components can start to swing back and forth!

When lifting / lowering and positioning crane components, there is an increased danger of impacts / crushing!

Personnel can be caught and severely injured or killed!

- ▶ Make sure that personnel cannot be caught by components!
- ▶ Make sure that the crane is aligned in horizontal position to avoid the support beams from swinging by themselves!
- ▶ When working in danger zones: Use aids to protect limbs!
- ▶ Guide components with suitable aids to minimize oscillation!

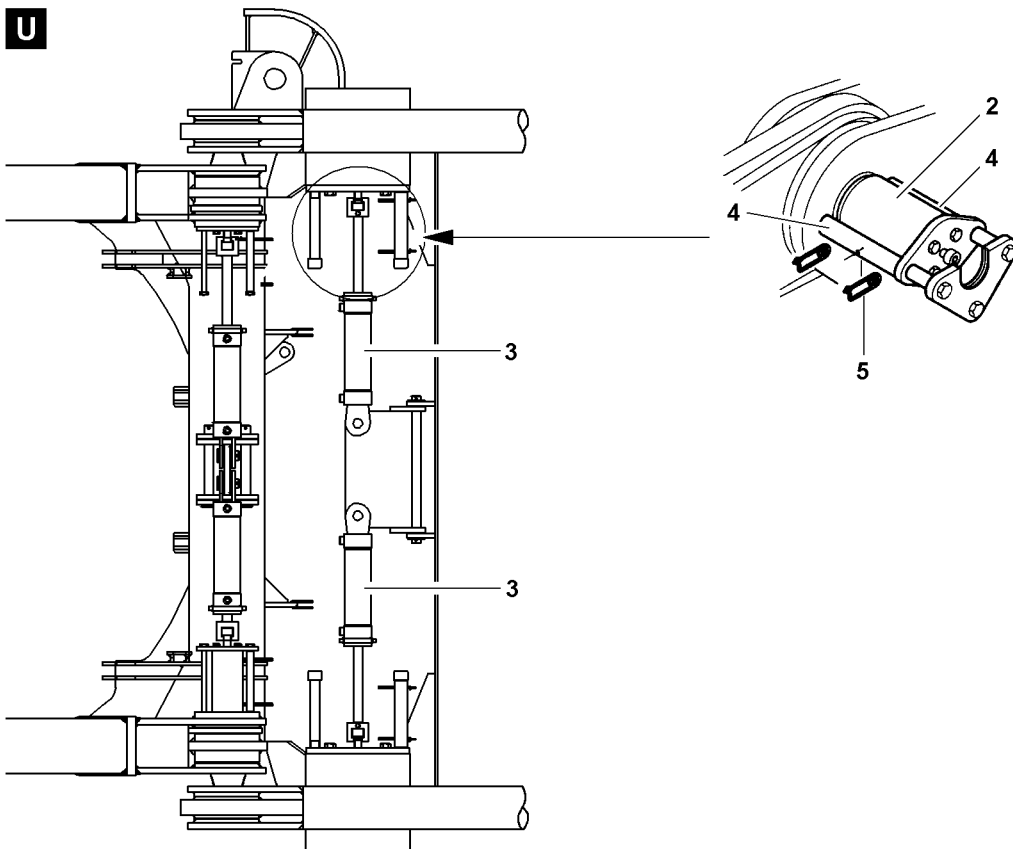
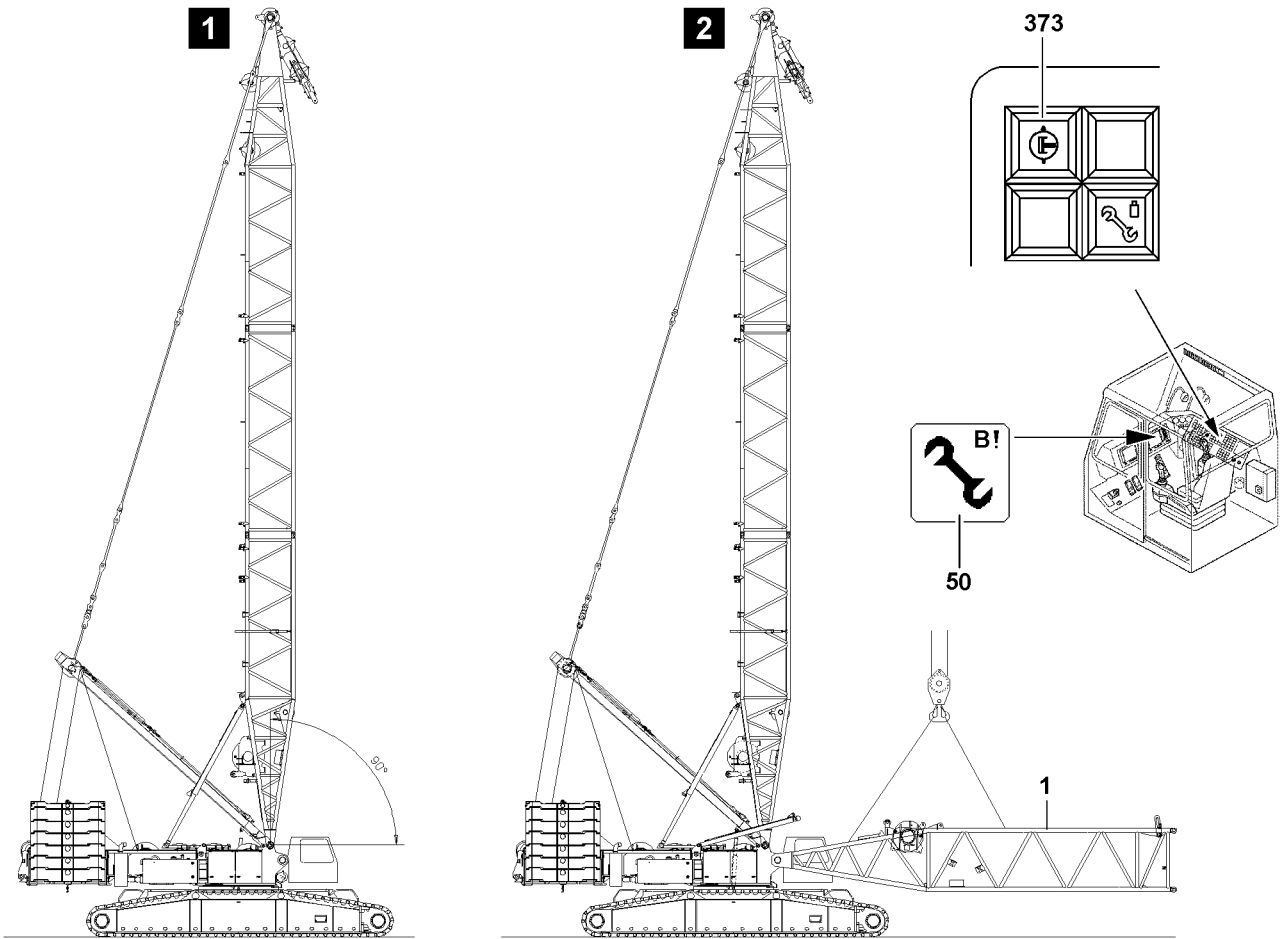

B112261

**WARNING**

The crane can topple over!

If the turntable is turned during the assembly of the boom, then the crane can topple over and be severely damaged! Personnel can be severely injured or killed!

- ▶ The turntable may not be turned during the assembly of the boom!

**WARNING**

Risk of accident!

If the following instructions are not observed, personnel can be severely injured or killed!

- ▶ Arrangement of lattice sections of boom combinations, see Rod plan!
- ▶ Depending on the condition of the ground, the boom and the lattice sections must be supported from below for the assembly of the boom!
- ▶ Observe the safety technical notes, see Crane operating instructions, chapter 5.01!

Make sure that the following prerequisites are met:

- The crane is in assembly position.
- The crane is aligned in horizontal direction.
- The turntable is in longitudinal direction of the crawler travel gear or turned vertical to the crawler travel gear, see Erection and take down chart.
- An assembly scaffolding / work platform is available.
- The counterweight has been installed on the turntable according to the load chart.
- The derrick boom is completely assembled and erected on the turntable, see Crane operating instructions, chapter 5.05.
- The LICCON overload protection has been set according to the data in the load chart.
- The LICCON overload protection is exceeded.
- The assembly icon **50** is visible on the LICCON monitor.
- An auxiliary crane is available.

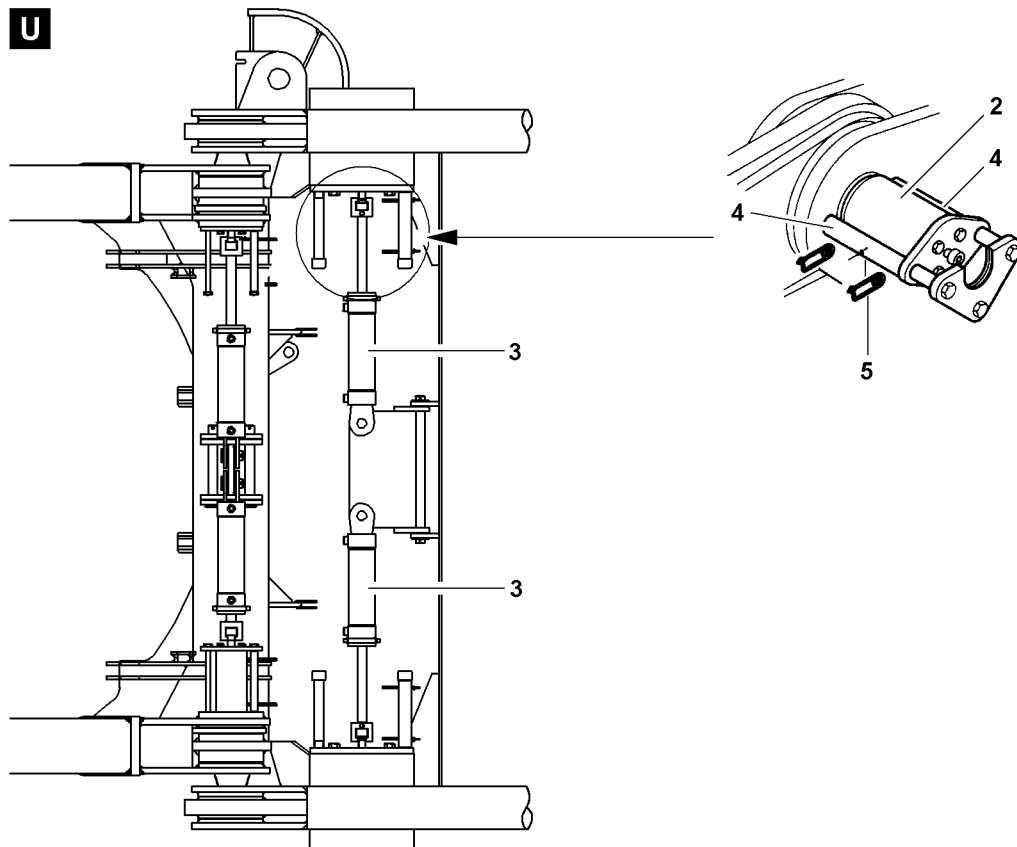
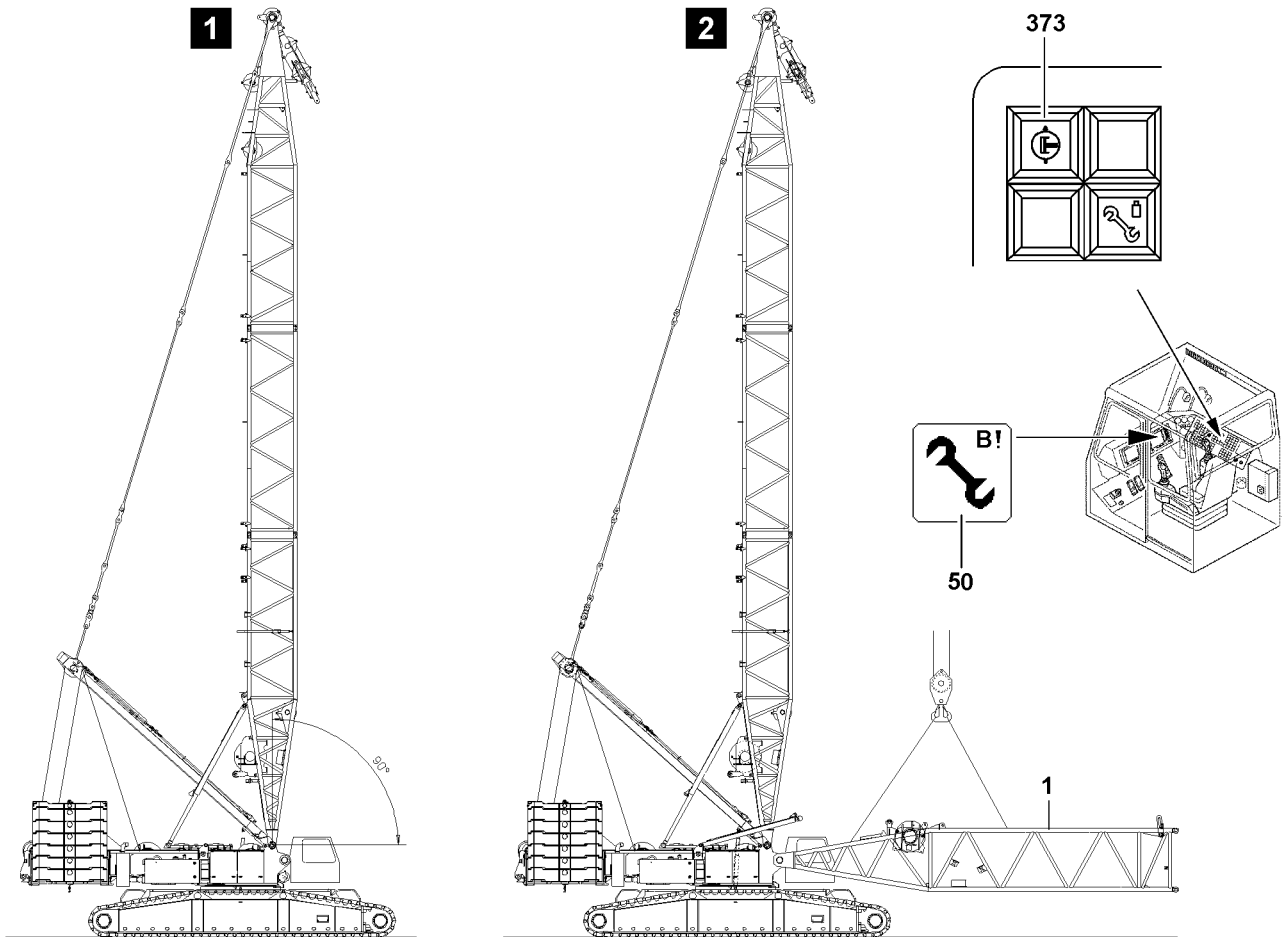

B112261

3.1 Assembling the S-pivot section on the turntable



WARNING

General danger notes!

- ▶ Support the S-boom during assembly with suitable materials!
- ▶ All pins are to be secured after assembly with the intended safety elements!
- ▶ The guy rods must be inspected regularly, see Crane operating instructions, chapter 8.15!

- ▶ Hang the S-pivot section **1** onto the auxiliary crane and swing in to the pin points on the turntable, illustration **1**, illustration **2**.

Establish the hydraulic connection to the pin pulling device via two quick couplers.

Pin the S-pivot section **1** on the turntable and secure.

- ▶ Establish the hydraulic connection to the pin pulling device.
- ▶ Turn the pressure change over switch **373** on.



WARNING

The S-pivot section can fold downward!

Due to non-secured or insufficiently secured connector pins, the S-pivot section can fold down. Personnel can be severely injured or killed!

- ▶ The connector pins **2** between the S-pivot section **1** and the turntable must be secured after the pin procedure with the retaining plates **4**!

- ▶ Insert the connector pins **2** with the hydraulic pin pulling device **3**.
- ▶ When the connector pins **2** are completely pinned on the left and right on the S-pivot section: Secure the connector pin **2** on the left and right with the retaining plate **4** and the spring retainer **5**.
- ▶ Turn the pressure change over switch **373** off.

NOTICE

Damage to the S-pivot section!

Property damage can occur on the S-pivot section by placing the installed S-pivot section on the ground!

- ▶ Slowly place the S-pivot section with the auxiliary crane and at low speed on the ground!

- ▶ Carefully place the S-pivot section down.
- ▶ Remove the auxiliary crane.

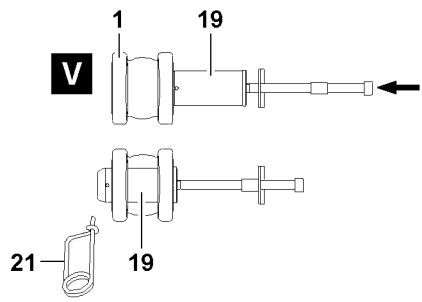
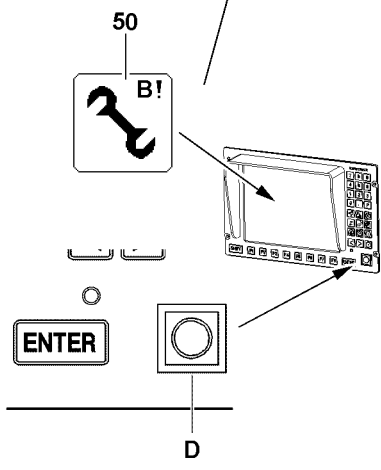
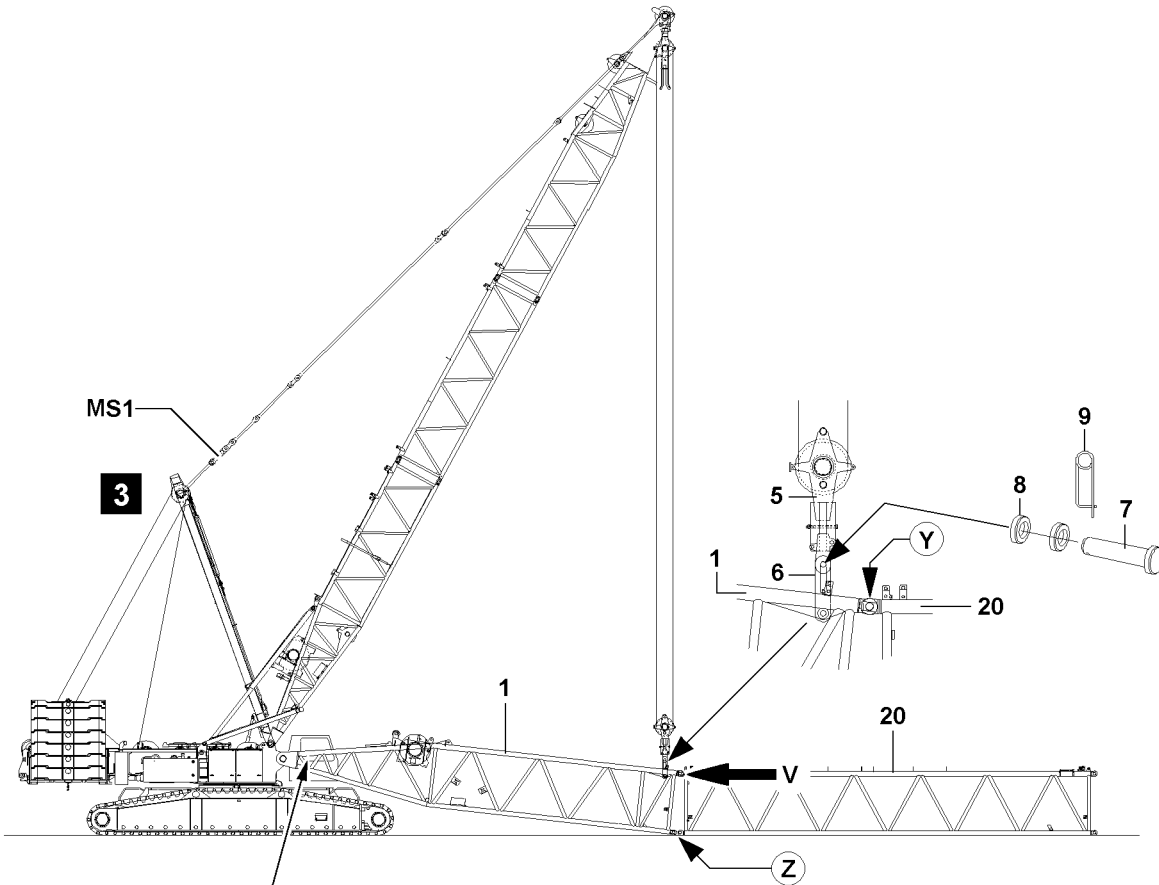

3.2 Assembling the S-lattice sections

The assembly of the lattice sections is carried out in various ways:

- “Closing” the boom.
- Assembling the lattice sections in “Flying mode”.



WARNING

General danger notes!

- ▶ Support the S-boom during assembly / disassembly with suitable materials!
- ▶ All pins are to be secured after assembly with the intended safety elements!
- ▶ The guy rods must be inspected regularly, see Crane operating instructions, chapter 8.15!
- ▶ Secure the boom with support or auxiliary crane, see Crane operating instructions, chapter 5.01!
- ▶ It is prohibited for anyone to remain under the booms or within the complete danger zone during the pinning and unpinning procedure of the lattice section!



Note

- ▶ For weights of intermediate sections with placed guy rods, see Crane operating instructions, chapter 1.03!
- ▶ The intermediate sections are pinned with the aid of the pin pulling device, see Crane operating instructions, chapter 5.30!

3.2.1 Assembling the S-lattice sections (by “closing” the boom)

Make sure that the following prerequisites are met:

- The S-pivot section is pinned and secured on the turntable.
- The S-pivot section is placed on the ground.
- The auxiliary crane is removed.

Pinning the upper pulley block on the S-pivot section

To be able to “close” the boom combination after assembly, it is necessary to luff the derrick boom down to the front and to lower the upper pulley block to the S-pivot section. Then pin and secure the upper pulley block with the S-pivot section.

- ▶ Luff the derrick down to the front until the upper pulley block **5** is positioned freely over the assembly bracket **6** of the S-pivot section **1**.
- ▶ Lower the upper pulley block **5** to the S-pivot section.
- ▶ Pin and secure the upper pulley block **5** with the assembly brackets **6**.
- ▶ Use pin **7**, washer **8** and spring retainer **9**.

Pinning the S-intermediate sections with the S-pivot section “on top”

Make sure that the following prerequisite is met:

- The upper pulley block **5** is pinned and secured with the assembly brackets **6**.
- ▶ Attach the intermediate section **20** to the auxiliary crane and align on the S-pivot section **1**.
- ▶ When the pin bores on the S-pivot section **1** and on the S-intermediate section **20** “on top” (point **Y**) align, illustration **3**:
Insert the pin **19** from the “inside” to the “outside” and secure with spring retainer **21**, illustration **V**.

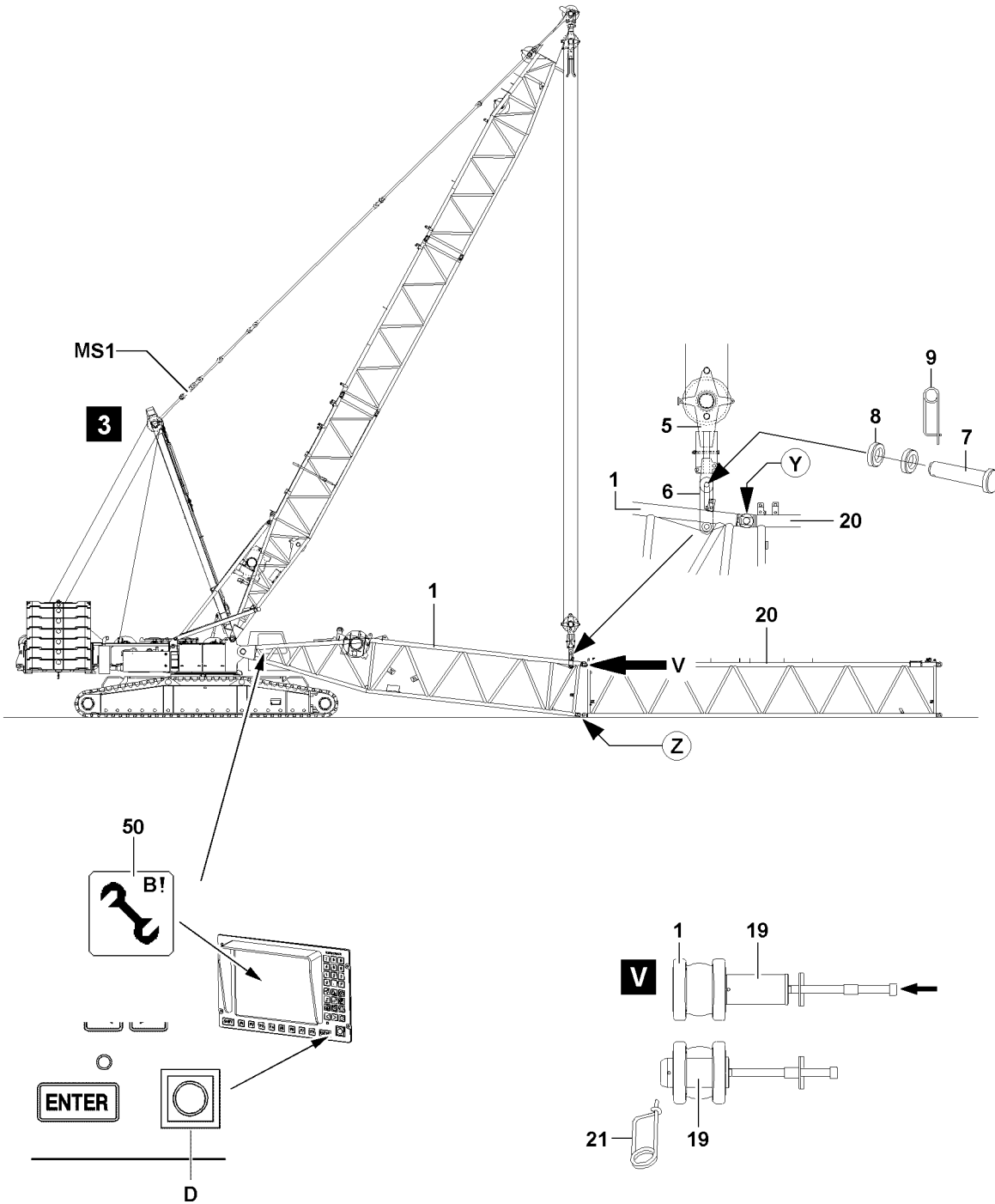

B112262

“Closing” the S-boom



WARNING

The crane can topple over!

If the following conditions are not met, the crane can topple over or be significantly damaged!

Personnel can be severely injured or killed!

- ▶ During the “Closing procedure” of the intermediate sections, the maximum permissible total force on the test point **MS1** must be **smaller** than **70 t** !
- ▶ The end section of the corresponding boom combination may **not** lift off the ground during the “Closing procedure”!
- ▶ With the upper pulley block, boom combinations to maximum **L 105 m** may be lifted / closed!
- ▶ With the upper pulley block, boom combinations to maximum **SL 112 m** may be lifted / closed!
- ▶ With the upper pulley block, boom combinations to maximum **Sw 112 m** may be lifted / closed!
- ▶ With the upper pulley block, boom combinations to maximum **S 119 m** may be lifted / closed!



Note

- ▶ The actual force on the test point **MS1** - which is exerted during the closing procedure of the boom system - is shown on the LICCON monitor 1!
- ▶ Record the actual force and keep it ready for the disassembly of the boom system!
- ▶ During the boom disassembly, the guying is tensioned with the noted actual force (assembly) so that the connector pins of the intermediate sections can be unpinned!

The S-boom must be assembled to the required length before the S-boom can be closed. The assembly is described on the example of an intermediate section.

- ▶ Position the S-intermediate section with the auxiliary crane on the S-intermediate section until the pin points align.
- ▶ Pin the S-intermediate sections with each other: Insert the pin **19** on both sides “on top” and secure with spring retainer **21**.
- ▶ Pin the S-intermediate sections with each other: Insert the pin **19** on both sides “on the bottom” and secure with spring retainer **21**.
- ▶ When the L/SL/S-boom combination is assembled to the desired length:
Lift the S-pivot section **1** with the upper pulley block until the pin bores on the “bottom” align at point **Z**, illustration **3**.
- ▶ Insert the pin **19** at point **Z** from the “inside” to the “outside” and secure with spring retainer **21**, illustration **V**.



WARNING

The boom can fold downward!

By unpinning the upper pulley block **5** on the assembly brackets **6**, the boom can suddenly fold down if the boom is not pinned at point **Z** “on the bottom”!

Personnel can be severely injured or killed!

- ▶ It is prohibited for anyone to remain under the raised lattice jib during the pinning / unpinning procedure!
- ▶ Unpin the upper pulley block **5** only when it is ensured that the S-pivot section **1** is pinned and secured “on top” and “bottom” with the intermediate section **20**!

Unpin the upper pulley block **5** on the assembly brackets **6**.

- ▶ Relieve the upper pulley block **5** by spooling out the control rope.
- ▶ Unpin the upper pulley block **5** on the assembly brackets **6**.

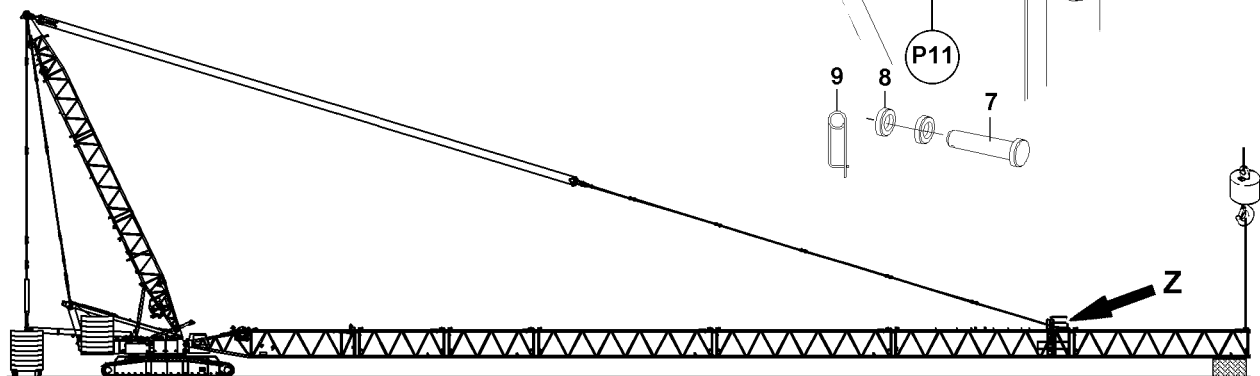
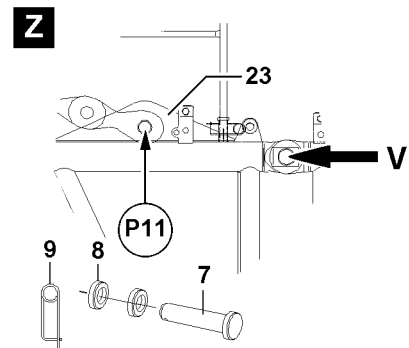
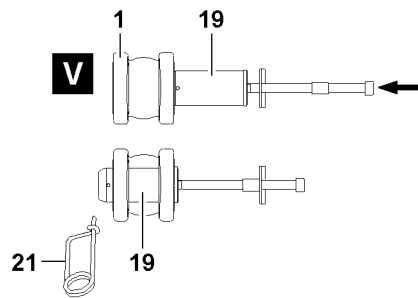
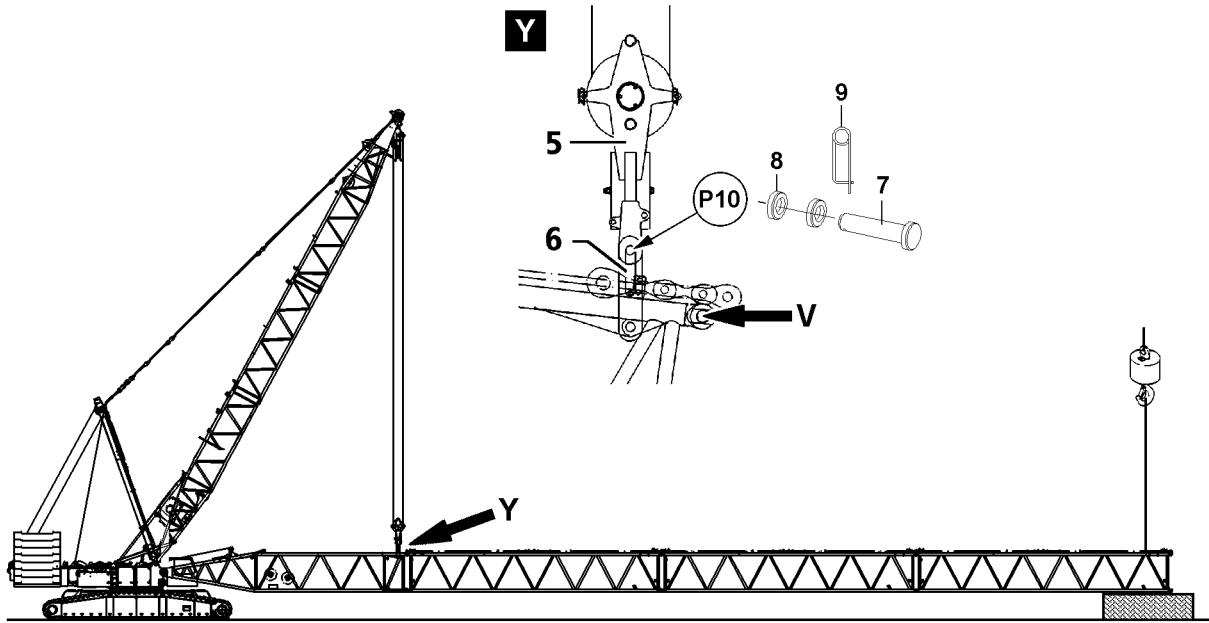

3.2.2 Assembling the S-lattice sections in “Flying mode”

If spatial prerequisites on the job site are limited for the assembly of the boom, or if they are limited by buildings or similar, then the boom can be installed in “Flying mode”.

For the flying assembly, a differentiation is made between the guy points on the boom:

- Guying on S-pivot section, see detail **Y**.
- Guying on the S-intermediate section 14 m 2620.20 for flying assembly, see detail **Z**.



WARNING

General danger notes!

- ▶ Support the boom during assembly / disassembly with suitable materials!
- ▶ All pins are to be secured after assembly with the intended safety elements!
- ▶ The guy rods must be inspected regularly, see Crane operating instructions, chapter 8.15!
- ▶ Secure the boom with support or auxiliary crane, see Crane operating instructions, chapter 5.01!



WARNING

Impermissible boom lengths!

If impermissible boom lengths are assembled on the crane, significant property damage can occur on the crane!

Personnel can be severely injured or killed!

- ▶ The maximum permissible boom lengths for the “Flying assembly” may not be exceeded!
- ▶ The data in the erection and take down charts as well as the load charts must be observed!



Note

- ▶ For weights of intermediate sections with placed guy rods, see Crane operating instructions, chapter 5.03!



Note

- ▶ When pinning the pin **7**, you have to use the washers **8**, see detail **Y**.
- ▶ For guying on the S-pivot section, the pin **7** is inserted on both sides on the assembly brackets **6** on point **P10** and secured with the spring retainer **9**!
- ▶ For guying on the S-intermediate section 14 m 2620.20 for flying assembly, the pin **7** is inserted on both sides on the assembly brackets **23** on point **P11** and secured with the spring retainer **16**!

4

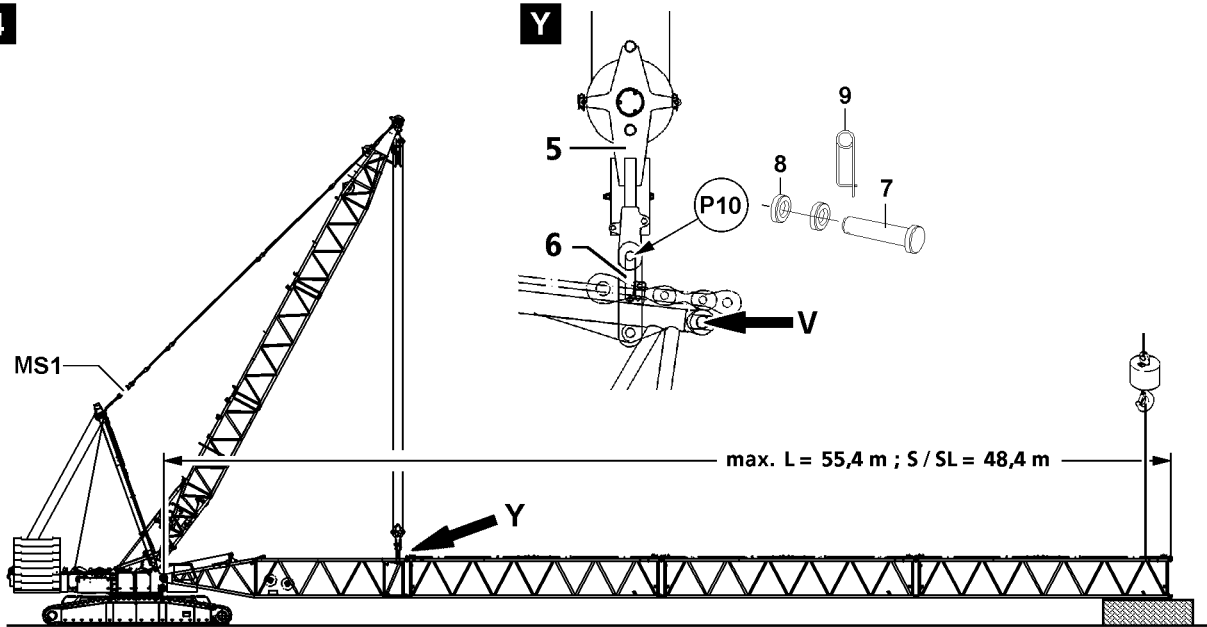

5

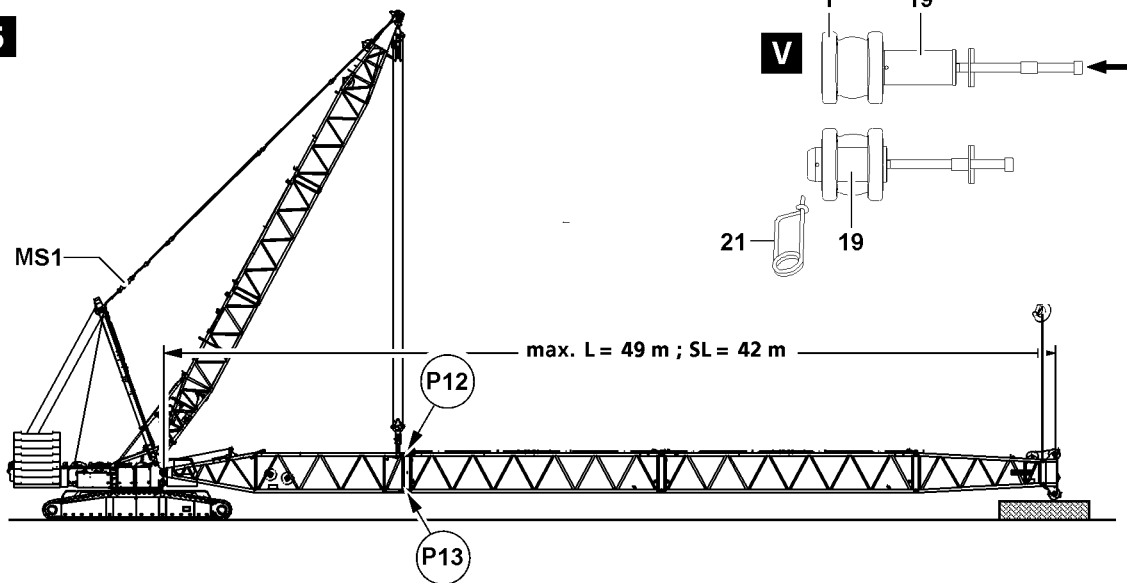

6

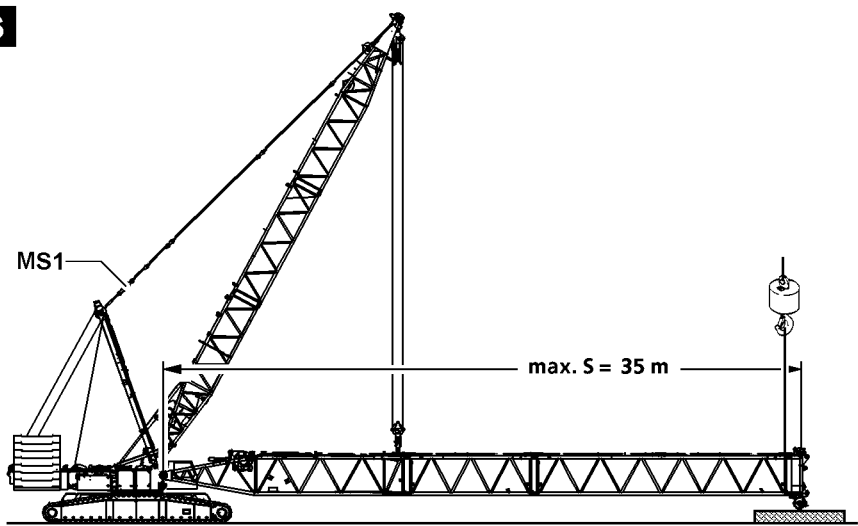

B112452

Assembling the S-boom in “Flying mode” on the S-pivot section



WARNING

The crane can topple over!

If the following conditions are not met, the crane can topple over or be significantly damaged!

Personnel can be severely injured or killed!

- ▶ For the “flying” boom assembly, the maximum permissible total force on the test point **MS1** may **not** be exceeded. The “Actual force” is shown on LICCON monitor 1!
- ▶ The “flying” boom assembly is only permissible up to a certain system length, observe the following charts!

Maximum permissible system length for a maximum total force MS1 110 t					
Boom system	Maximum system length	Equipment	DB _{min} ¹⁾	ZB _{min} ²⁾	Illustration
L(D)	55.4 m	- without end section - without hook block	95 t	43 t	4
	49.0 m	- with 250 t end section - without hook block	95 t	43 t	5
SL(D)	48.4 m	- without end section - without hook block	95 t	43 t	4
	42.0 m	- with 250 t end section - without hook block	95 t	43 t	5
S(D)	48.4 m	- without end section - without hook block	95 t	43 t	4
	35.0 m	with 400 t end section - without hook block	95 t	43 t	6

1) This counterweight must be at least installed on the turntable for “Flying assembly”.

2) This central ballast must be at least installed on the crawler center section for “Flying assembly”.

Make sure that the following prerequisites are met:

- The S-pivot section **1** is pinned and secured with the assembly lug **6** on point **P10** on the upper pulley block **5**, see detail **Y**.
- The S-pivot section **1** is lifted using the upper pulley block **5** and is in a horizontal position.



WARNING

Falling components!

If unsecured or non-supported components are installed or removed, they can fall down! Personnel can be killed or seriously injured!

- ▶ During pinning and unpinning of the intermediate sections, it is prohibited for anyone to remain **under** or **on** the components as well as within the entire danger zone!
- ▶ Before unpinning: Support crane components and boom!
- ▶ Secure the pins in the bearing points and in the receptacles!
- ▶ It is prohibited to lean a ladder against the crane section which is being disassembled!

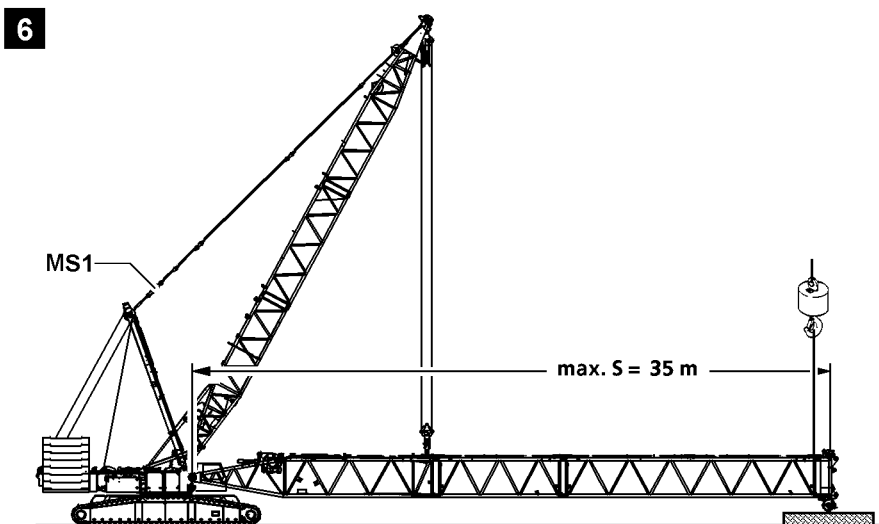
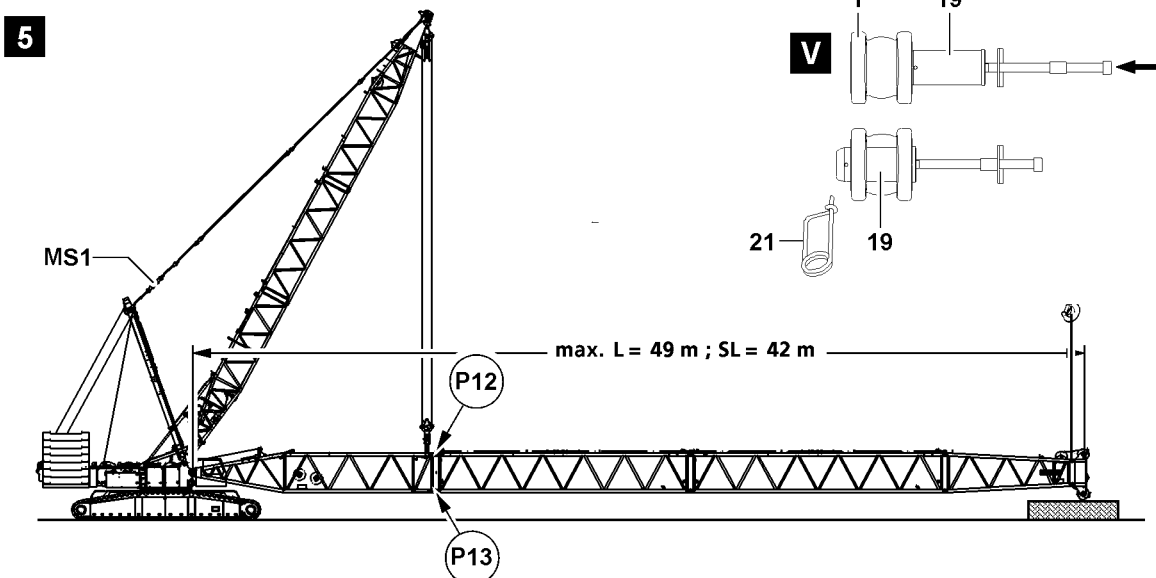
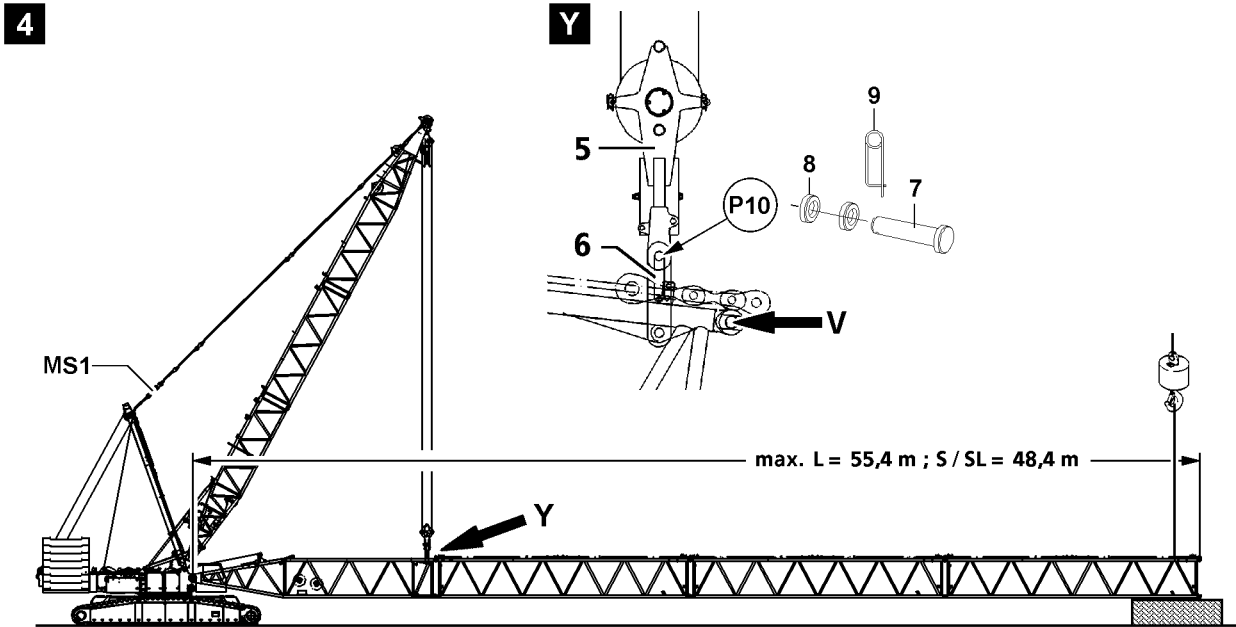

B112452

**Note**

- ▶ The “Actual force” is shown on LICCON monitor!
- ▶ The flying assembly is made without the assembly of the hook block!

For “flying” assembly of the intermediate sections, they can be installed individually or as preassembled boom unit on the S-pivot section.

- ▶ Fasten the intermediate sections or preassembled boom unit on the auxiliary crane.
- ▶ Lift the intermediate sections or preassembled boom unit with the auxiliary crane and position on the S-pivot section.
- ▶ When the pin points between the S-pivot section and the intermediate section or the preassembled boom unit align “on top” and “bottom”:
 - Pin the intermediate section “on top”: Insert the pin **19** on both sides at point **P12** and secure with spring retainer **21**, see illustration **V**.
- ▶ Pin the intermediate section “on the bottom”: Insert the pin **19** on both sides at point **P13** and secure with spring retainer **21**, see illustration **V**.
- ▶ When the pins are properly pinned and secured on “top” and “bottom” between the S-pivot section and the S-intermediate section or the preassembled boom unit:
 - Remove the auxiliary crane.
- ▶ If additional lattice sections are assembled:
 - Assemble additional lattice sections the same way as described in this section.

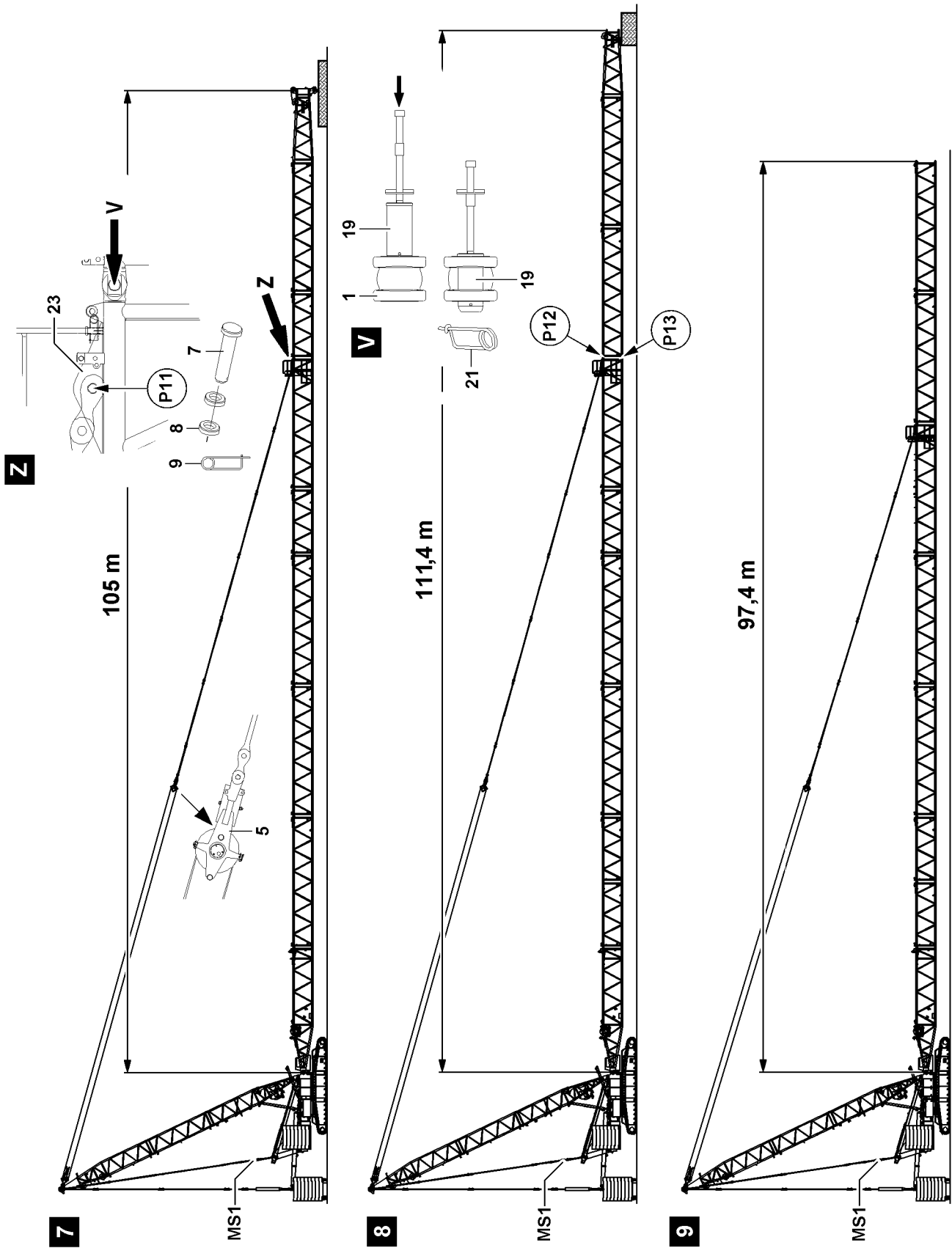

B112469

Assembling the S-boom in “Flying mode” on the intermediate section 14 m 2620.20**WARNING**

The crane can topple over!

If the following conditions are not met, the crane can topple over or be significantly damaged!

Personnel can be severely injured or killed!

- ▶ For the “flying” boom assembly, the maximum permissible total force on the test point **MS1** may **not** be exceeded. The “Actual force” is shown on LICCON monitor 1!
- ▶ The “flying” boom assembly is only permissible up to a certain system length, observe the following charts!

**WARNING**

The crane can topple over!

When erecting the below listed boom systems with the WA-bracket II, the crane can be overloaded or the crane can topple over!

Personnel can be severely injured or killed!

- ▶ When erecting the boom systems with the WA-bracket II, the maximum permissible system lengths must be reduced by a minimum of 7 m!

Maximum permissible system length for a maximum total force MS1 180 t					
Boom system	Maximum system length	Equipment	DB_{min}¹⁾	ZB_{min}²⁾	Illustration
SL(D)	105.0 m	- without WA-bracket II - without rods for WA-bracket II - without hook block	95 t	43 t	7
	111.4 m	- without L-end section - without WA-bracket II - without rods for WA-bracket II	95 t	43 t	8
S(D)	105.0 m	- without WA-bracket II - without rods for WA-bracket II - without hook block	95 t	43 t	7
	97.4 m	- without adapter and L-end section - without WA-bracket II - without rods for WA-bracket II	95 t	43 t	9

1) This counterweight must be at least installed on the turntable for “Flying assembly”.

2) This central ballast must be at least installed on the crawler center section for “Flying assembly”.

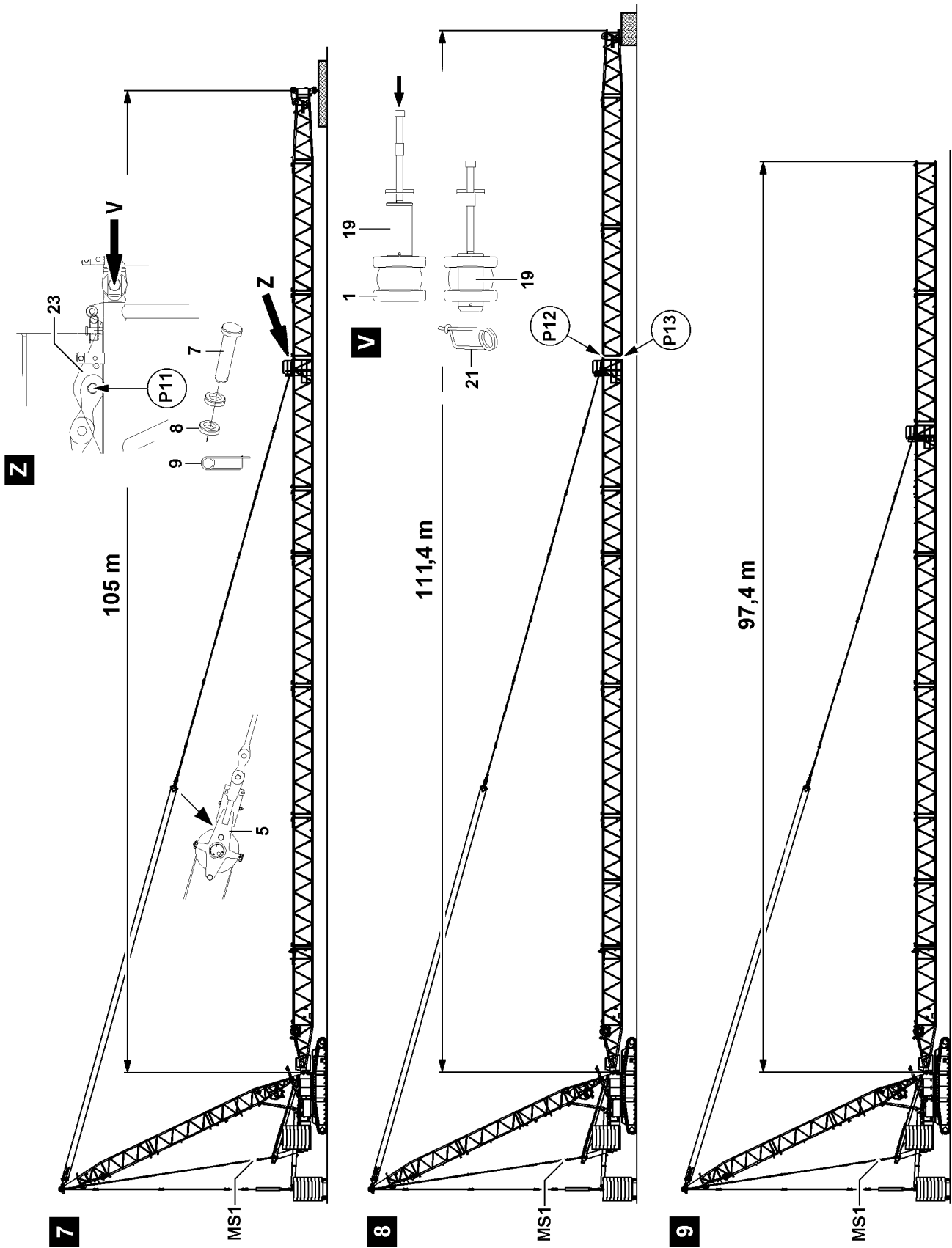

B112469

Make sure that the following prerequisites are met:

- The boom combination is preassembled to the “reinforced intermediate section”.
- The S-pivot section is pinned and secured on the turntable.
- The derrick boom is erected (between 75 ° and 90 °).



Note

- ▶ The S-pivot section and the intermediate sections must be preassembled at a suitable location. The reinforced intermediate section must be the end of the preassembled boom combination!
-

The boom combination must be attached after assembly on the turntable **or** it must be placed on a stable and solid support.

- ▶ When the boom combination is installed on the S-pivot section:
Fasten the boom combination on the auxiliary crane or place it on the support.
 - ▶ Lower the upper pulley block **5** to the S-pivot section **1** or the boom.
 - ▶ Pin the guy rods on the upper pulley block **5** and on the assembly brackets **23**.
-

NOTICE

Overload of crane!

By luffing the derrick boom into operating position, the crane can be overloaded!

The crane can be thereby damaged!

- ▶ If the derrick boom is luffed into operating position, it must be ensured that the guy rods and the control rope are **not** tensioned during the luffing procedure!
 - ▶ Spool the control rope out somewhat, if necessary!
-



Note

- ▶ The boom combination must be in horizontal position for “flying” assembly!
-

- ▶ Luff the derrick boom up to operating position.
- ▶ When the derrick boom is in operating position:
Spool the control winch up until the guying of the boom combination is tensioned.
- ▶ When the boom combination is tensioned:
Remove the auxiliary boom or support.

Result:

- The intermediate section 14 m 2620.20 is pinned and secured on the assembly brackets **23** on point **P11** on the upper pulley block **5**, see detail **Z**.

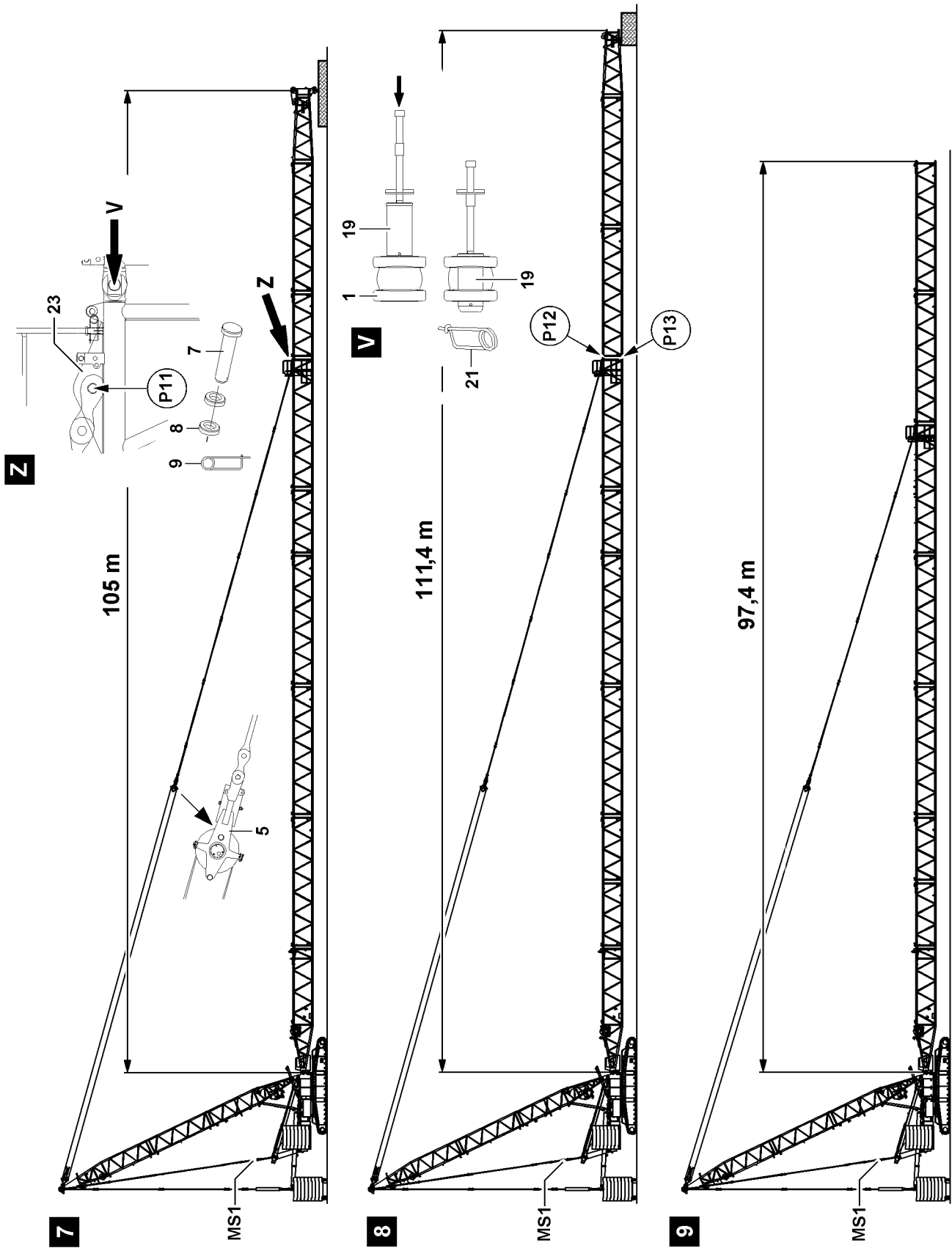

B112469

**WARNING**

Falling components!

If unsecured or non-supported components are installed or removed, they can fall down! Personnel can be killed or seriously injured!

- ▶ During pinning and unpinning of the intermediate sections, it is prohibited for anyone to remain **under** or **on** the components as well as within the entire danger zone!
- ▶ Before unpinning: Support crane components and boom!
- ▶ Secure the pins in the bearing points and in the receptacles!
- ▶ It is prohibited to lean a ladder against the crane section which is being disassembled!

**Note**

- ▶ The "Actual force" is shown on LICCON monitor!
- ▶ The flying assembly is made without the assembly of the hook block!

For "flying" assembly of the intermediate sections, they can be installed individually or as preassembled boom unit on the S-pivot section.

- ▶ Fasten the intermediate sections or preassembled boom unit on the auxiliary crane.
- ▶ Lift the intermediate sections or preassembled boom unit with the auxiliary crane and position on the S-pivot section.
- ▶ When the pin points between the S-pivot section and the intermediate section or the preassembled boom unit align "on top" and "bottom":
Pin the intermediate section "on top": Insert the pin **19** on both sides at point **P12** and secure with spring retainer **21**, see illustration **V**.
- ▶ Pin the intermediate section "on the bottom": Insert the pin **19** on both sides at point **P13** and secure with spring retainer **21**, see illustration **V**.
- ▶ When the pins are properly pinned and secured on "top" and "bottom" between the S-pivot section and the S-intermediate section or the preassembled boom unit:
Remove the auxiliary crane.
- ▶ If additional lattice sections are assembled:
Assemble additional lattice sections the same way as described in this section.

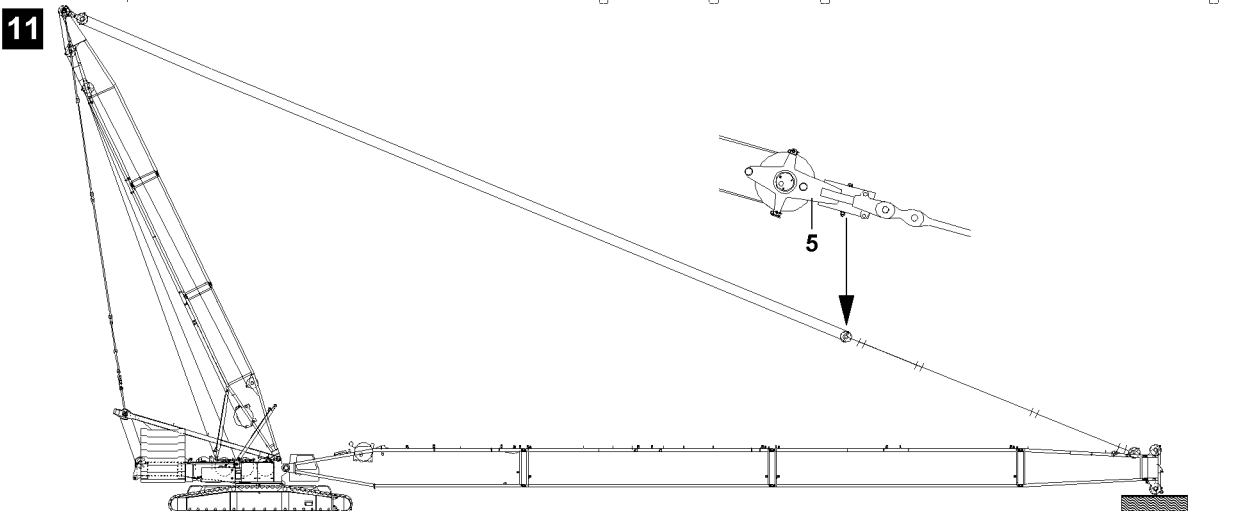
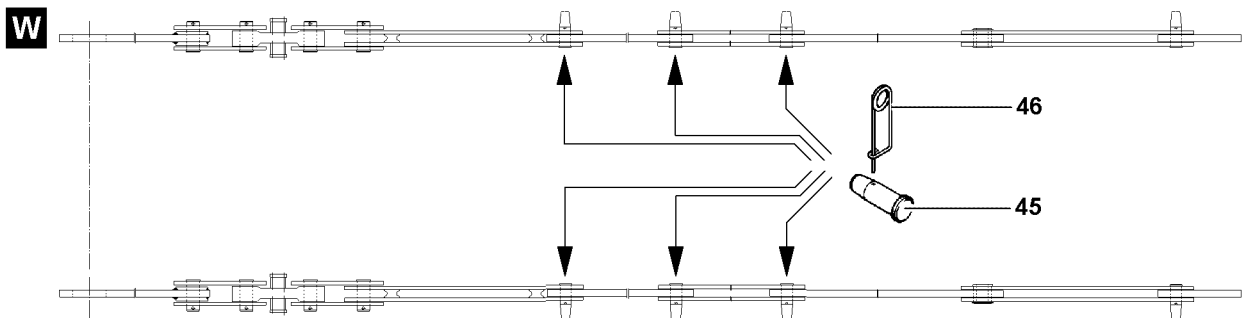
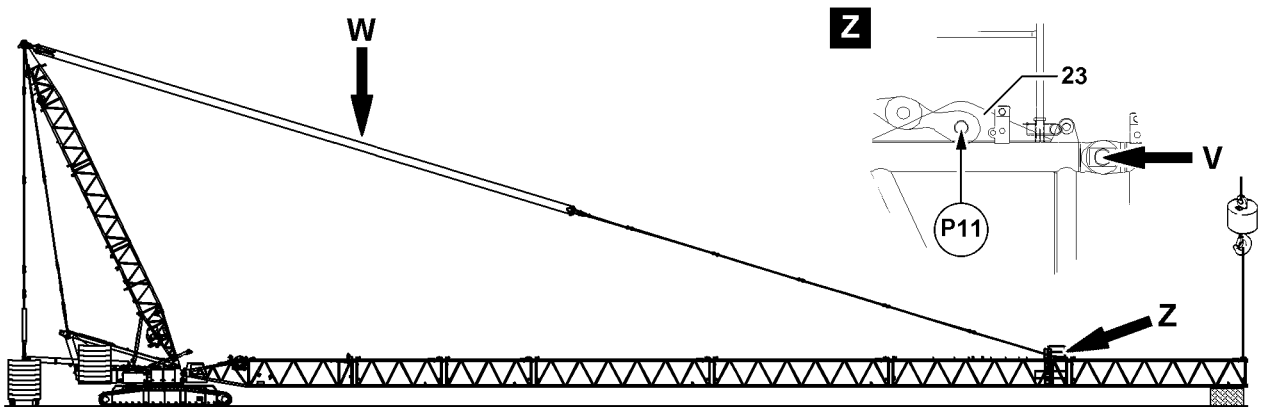
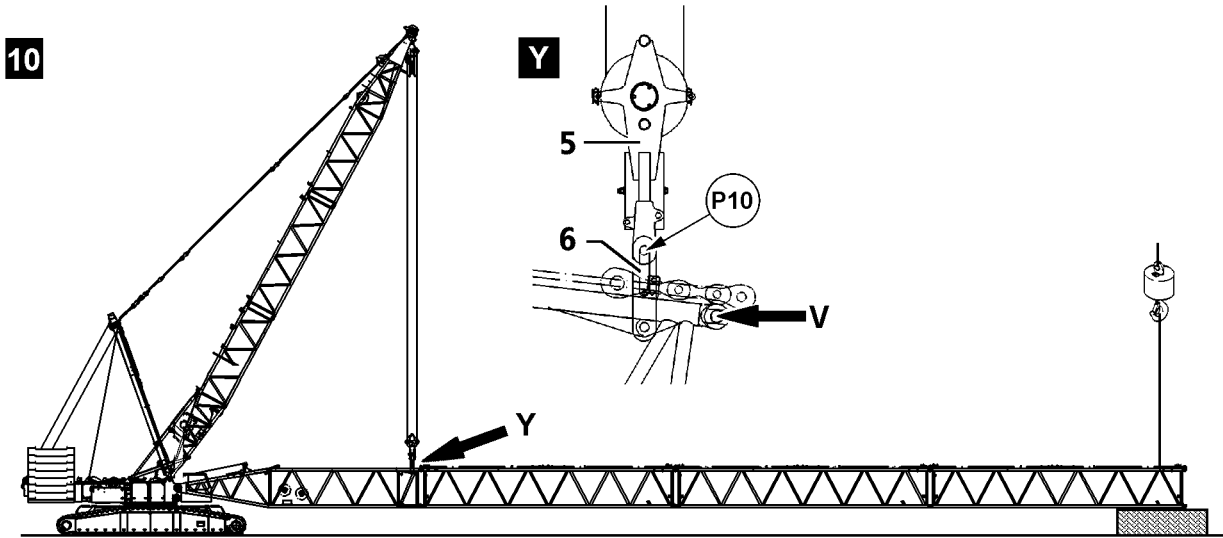

B112470

3.3 Assembling the S-guy rods



WARNING

Neglected inspection and maintenance on guy rods!

If the regular inspection and maintenance of the guy rods is not carried out or is carried out only in irregular intervals, then severe accidents can occur due to existing and unrecognized damage to the guy rods!

Personnel can be severely injured or killed!

- ▶ Check the guy rods before every assembly, see Crane operating instructions, chapter 8.15!
- ▶ The S-guy rods must be assembled and secured, see Rod plan. The numbering in the rod plan must be identical to the numbering on the guy rods!



Note

- ▶ The D-guy rods must be installed and secured, see Rod plan! The numbering in the rod plan must be identical to the numbering on the guy rods!

Make sure that the following prerequisite is met:

- The boom is guyed on point **P10** on the S-pivot section, see illustration **10**, detail **Y**.
- **Or** the boom is guyed on point **P11** on the S-intermediate section 14 m 2620.20 for flying assembly, see illustration **13**, detail **Z**.



WARNING

Falling components!

If the intermediate sections are incompletely pinned or secured, then components can fall down!

Personnel can be severely injured or killed!

- ▶ Make sure that the intermediate sections or preassembled boom unit are pinned and secured on the S-pivot section!
- ▶ Make sure that the intermediate sections or preassembled boom unit is supported with suitable materials, secured with the auxiliary crane or the boom is placed on the ground!



WARNING

The boom can fold downward!

By unpinning the guy rods on the assembly brackets **6** or the assembly brackets **23**, the boom can fold down!

Personnel can be severely injured or killed!

- ▶ Unpin the guy rods on the assembly brackets **6**, point **P10** or the assembly brackets **23**, point **P11** when it is ensured that the intermediate sections are supported with suitable materials or are secured by the auxiliary crane!
- ▶ Support the boom or secure it with the auxiliary crane.
- ▶ Luff the derrick boom down to the front.
- ▶ Lower the upper pulley to the boom: Spool out winch 3.

The guy rods are placed and secured for transport on the corresponding intermediate sections. Before assembly, the transport retainers must be released.

- ▶ Release and unpin transport retainers for the guy rods.

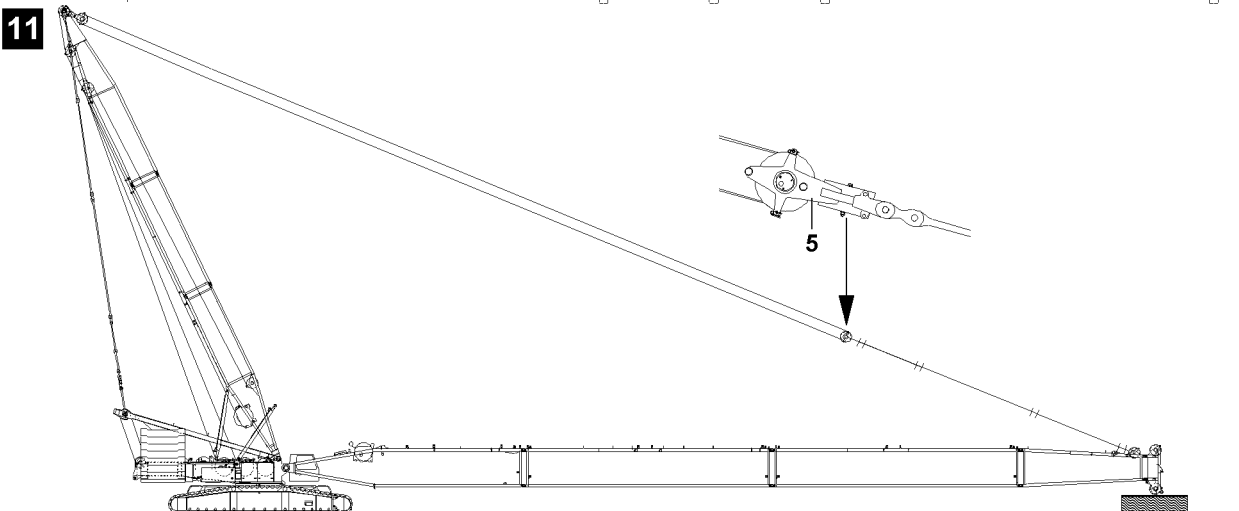
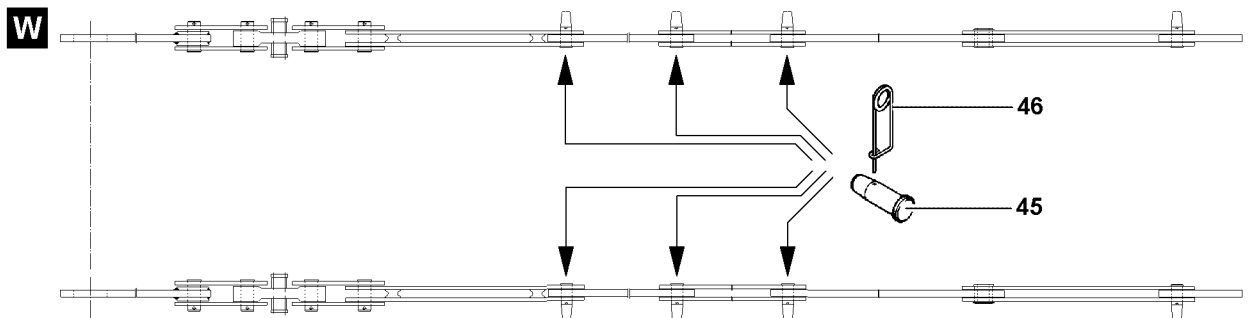
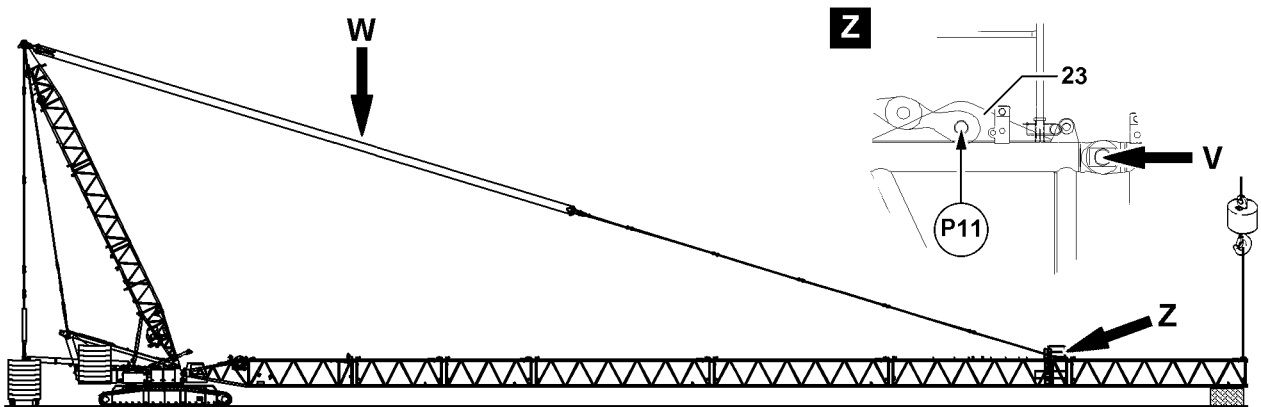
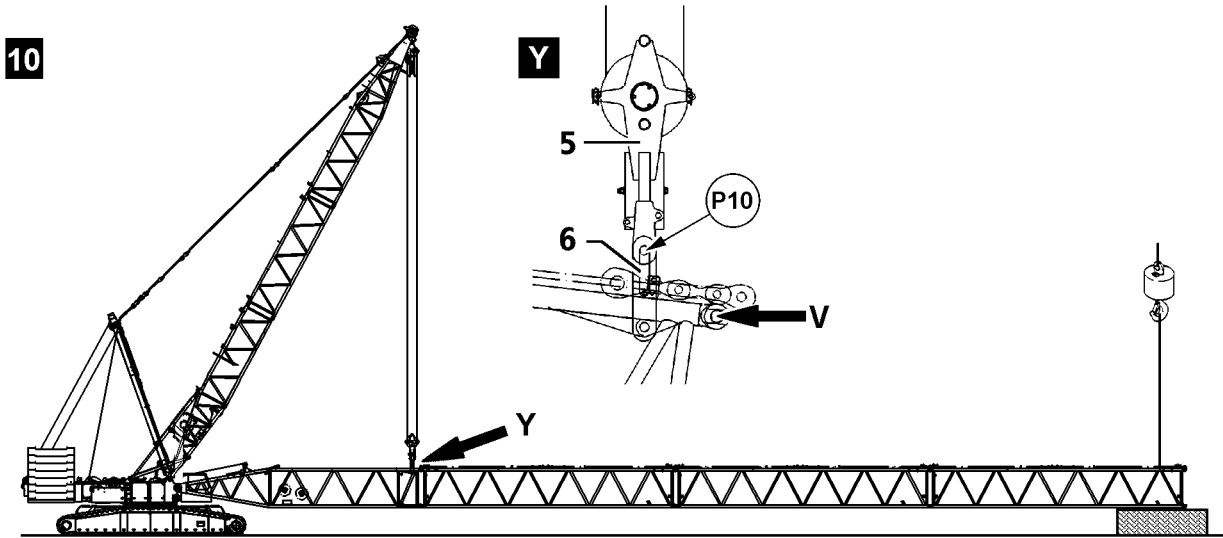

B112470

NOTICE

Property damage!

If the pins of the guy rods are not pinned from the “inside” to the “outside”, the hoist rope can scrape on the pin and be damaged!

- ▶ Always insert the pins of the guy rods from the “inside” to the “outside”, see Rod plan and detail **W!**
-

**Note**

- ▶ The guy rods of the S-intermediate sections are pinned to each other starting from the fixed point on the end section of the boom!
-
- ▶ Pin the guy rods of all intermediate sections: Insert the pin **45** from the “inside” to the “outside”.
 - ▶ Secure the pin **45** with spring retainer **46**.
 - ▶ When all guy rods on the boom system are pinned and secured:
Release and unpin the pins on the assembly brackets **6** or the assembly brackets **23**.
 - ▶ Erect the derrick to the operating position ($X = 111.1^\circ$ to 115.6°) and spool out winch 3 at the same time so that the boom is not pulled up.
 - ▶ When the derrick boom has reached the operating position:
Tension the guying between the derrick and the boom head.
 - ▶ Remove the auxiliary crane on the boom head and support.
 - ▶ Guide the hoist rope over the rope pulley on the end section.

B195219

3.4 Establishing the electrical connections to the boom

NOTICE

Damage to the electrical connection on the cable drum!

If the electrical connection from the cable drum on the S-pivot section to the terminal box on the S-pivot section is established first before the connection to the terminal box on the S-end section, the electrical connection can be damaged when spooling out the cable drum!

- ▶ Establish first the electrical connection from the cable drum in the S-pivot section to the terminal box on the S-end section and then the electrical connection from the terminal box in the S-pivot section to the cable drum!



Note

- ▶ To establish the electrical connections on the boom, see Electric wiring diagram!

Make sure that the following prerequisite is met:

- The boom is fully assembled.
- The airplane warning light and the wind speed sensor are assembled.
- ▶ Establish the electrical connections.
- ▶ Make sure that all electrical connections on the boom are established.

3.5 Establishing the hydraulic connections to the boom

When connecting hydraulic lines with quick release couplings, make sure that the coupling procedure is carried out correctly.



WARNING

Pressure in the hydraulic lines!

If the pressure supply is not interrupted before connecting / releasing the hydraulic lines, the hydraulic oil can escape with high pressure!

Personnel can be severely injured or killed!

- ▶ Release the pressure in the hydraulic system before connecting / disconnecting: Interrupt the pressure supply and wait for a short time!



WARNING

Loss of pressure or leakage!

Incorrectly coupled or self-loosening quick release couplings (particularly return lines) can result in serious accidents due to component failure!

- ▶ Check that the quick release couplings have been properly connected before using the crane!
- ▶ Connect the coupling components (sleeve and connector) and screw together with the hand-tightened nut.
- ▶ Tighten the hydraulic coupling by hand. Rotate the hand-tightened nut until it reaches a tangible, fixed stop position.
- ▶ Establish the hydraulic connections.

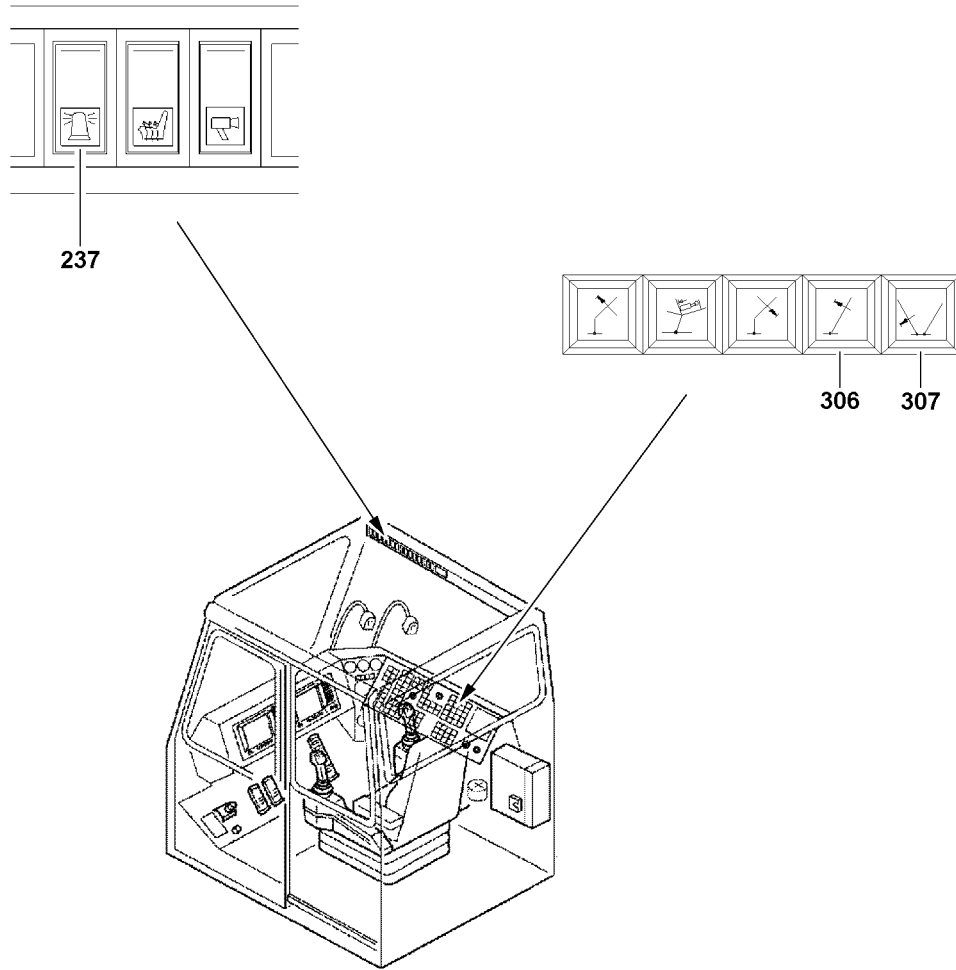

B111476

3.6 Checking the function of the safety devices



WARNING

Non-functioning safety devices!

If the function of the safety devices is defective, personnel can be severely injured or killed!

- ▶ Crane operation with non-functioning safety devices is prohibited!



Note

- ▶ The function of the individual limit switches must be checked before erection of the boom system!
- ▶ The function of the limit switch initiators must be checked in the test system, see Diagnostics manual.



Note

- ▶ If a function check on the limit switches or on the safety devices does not lead to the desired shut offs, then the plug connections on the connector boxes or the components itself must be checked. If no visible connection errors or component defects can be found, contact LIEBHERR Service.

Make sure that the following prerequisites are met:

- All electrical connections have been made.
- The crane engine is running.
- The appropriate operating mode is set.
- The actuator levers on the limit switches are greased.

3.6.1 Wind speed sensor*

- ▶ Check the movement and the function of the wind speed sensor.

3.6.2 Airplane warning light*

- ▶ Turn the airplane warning light on with the switch **237**.
- ▶ Check the function visually.

3.6.3 Hoist limit switch

- ▶ Actuate the limit switch on the pulley head manually.

Result:

- The hoist winch turns off in upward movement.
- The hoist top icon appears on the LICCON monitor 0.
- The limit switch is functioning.

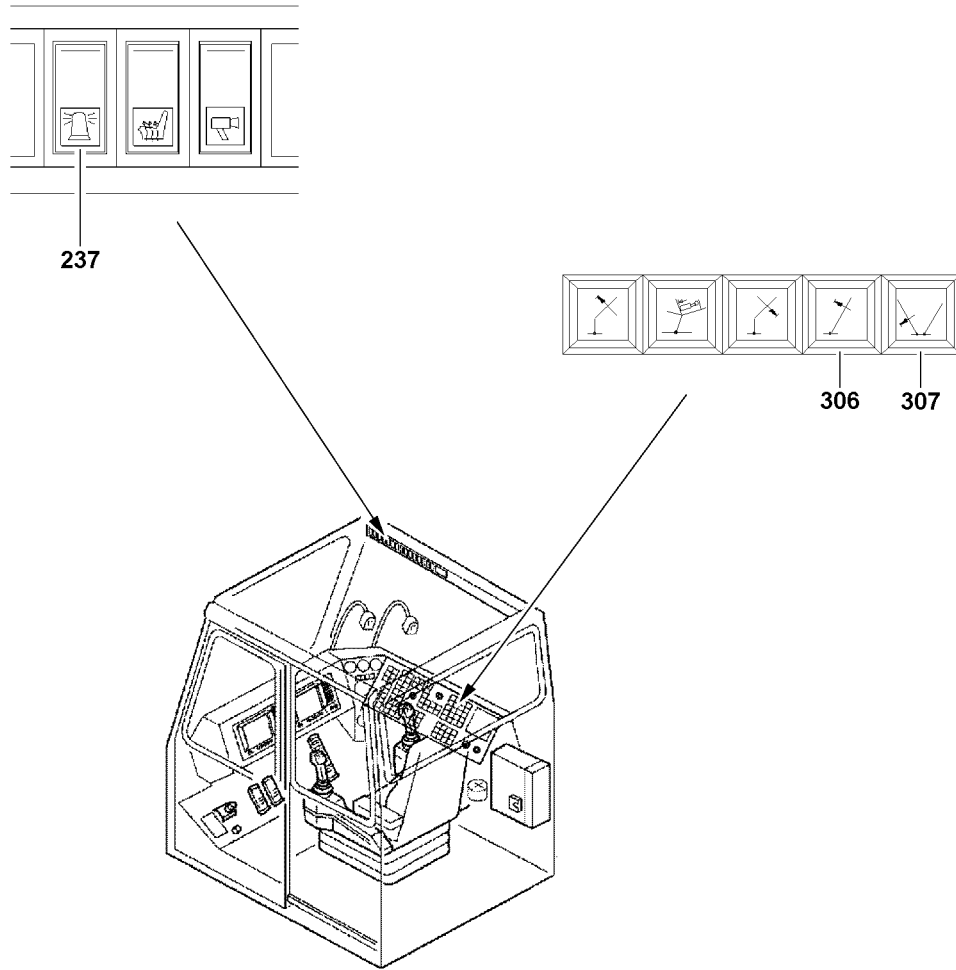

B111476

3.6.4 Limit switch boom “Steepest position”

**Note**

► The limit switch functions have to be checked individually before erection!

► Manually actuate the individual limit switches on the relapse cylinders.

Result:

- Winch 3 (control winch) turns off in upward movement.
- The indicator light **306** lights up.
- An acoustic signal sounds.
- The limit switch is functioning.

3.6.5 D-relapse cylinder

► Manually actuate the individual limit switches on the D-relapse cylinders.

Result:

- Winch 4 (control winch) turns off in upward movement.
- The indicator light **307** lights up.
- An acoustic signal sounds.

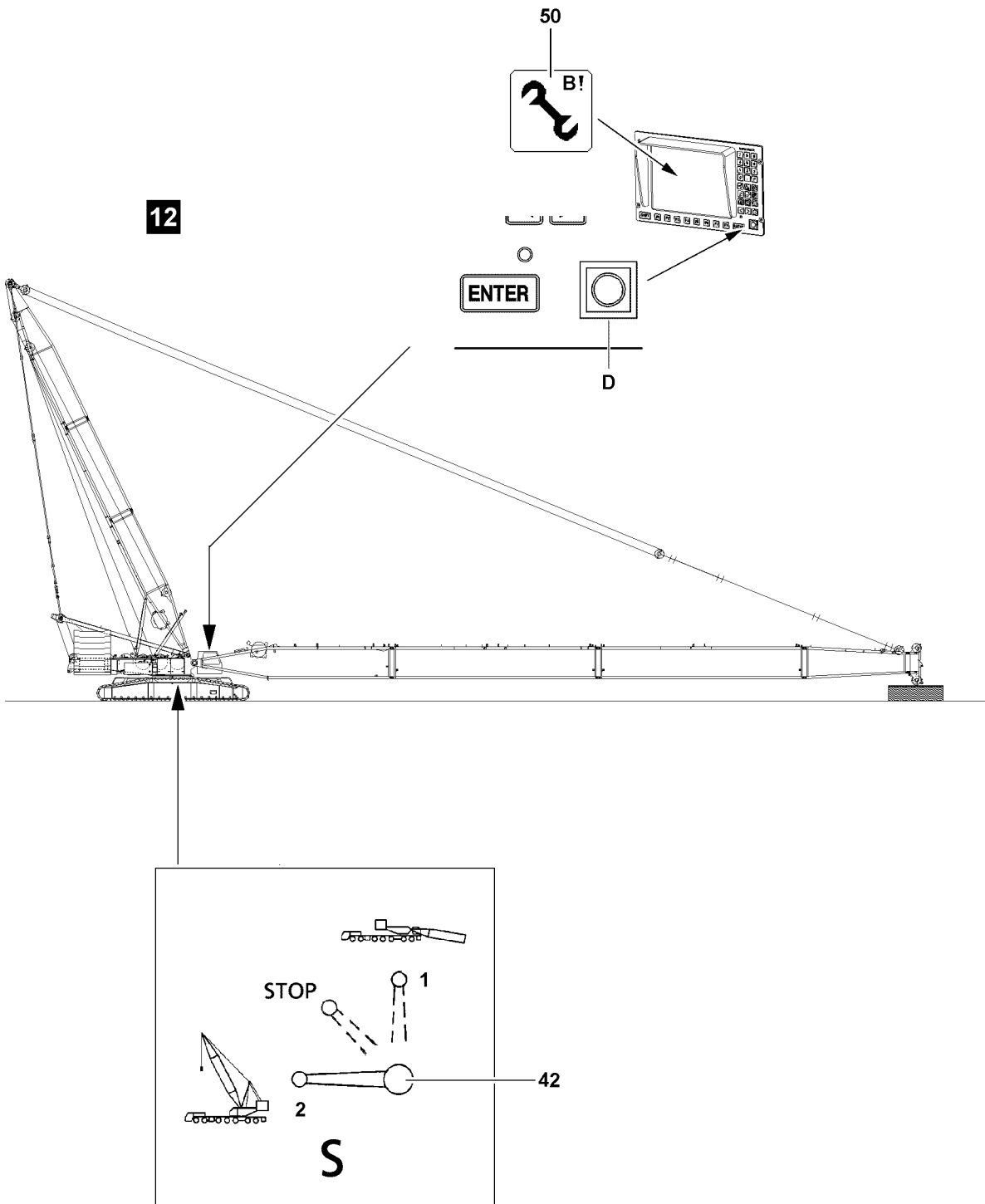

4 Erecting the S-boom



WARNING

The crane can topple over!

If the following conditions are not met before erecting the boom, the crane can topple over! Personnel can be severely injured or killed!

- ▶ It is not permitted to turn the crane during erection!
- ▶ Observe the data in the erection and take down charts!
- ▶ Observe the safety technical notes, see Crane operating instructions, chapter 5.01!
- ▶ Extend the S-relapse cylinder before erection!
- ▶ Do not allow slack cable to build up on the control winch!



WARNING

Unutilized guy rods on boom!

If guy rods are on the lattice sections which are not used for operation, then there is a risk of accidents!

Personnel can be severely injured or killed!

Guy rods can loosen up and fall down!

The load chart is invalid!

The load display of the LICCON computer system shows the incorrect value!

The weight of the boom is too large for erection!

- ▶ Disassembly and remove unutilized guy rods on the transport retainers before erecting the boom!

Make sure that the following prerequisites are met:

- The crane is aligned in horizontal direction.
- All electrical connections have been made.
- All limit switches are functioning.
- The counterweight has been installed on the turntable according to the load chart.
- All pin connections have been secured.
- The hoist rope has been correctly placed in the rope pulleys and is prevented from jumping out with the rope retaining pins.
- There are no loose parts on the boom.
- The LICCON overload protection has been set according to the data in the load chart.
- The LICCON overload protection settings have been compared with the actual crane configuration.
- The LICCON overload protection is exceeded.
- The assembly icon **50** is visible on the LICCON monitor.
- No personnel is within the danger zone.

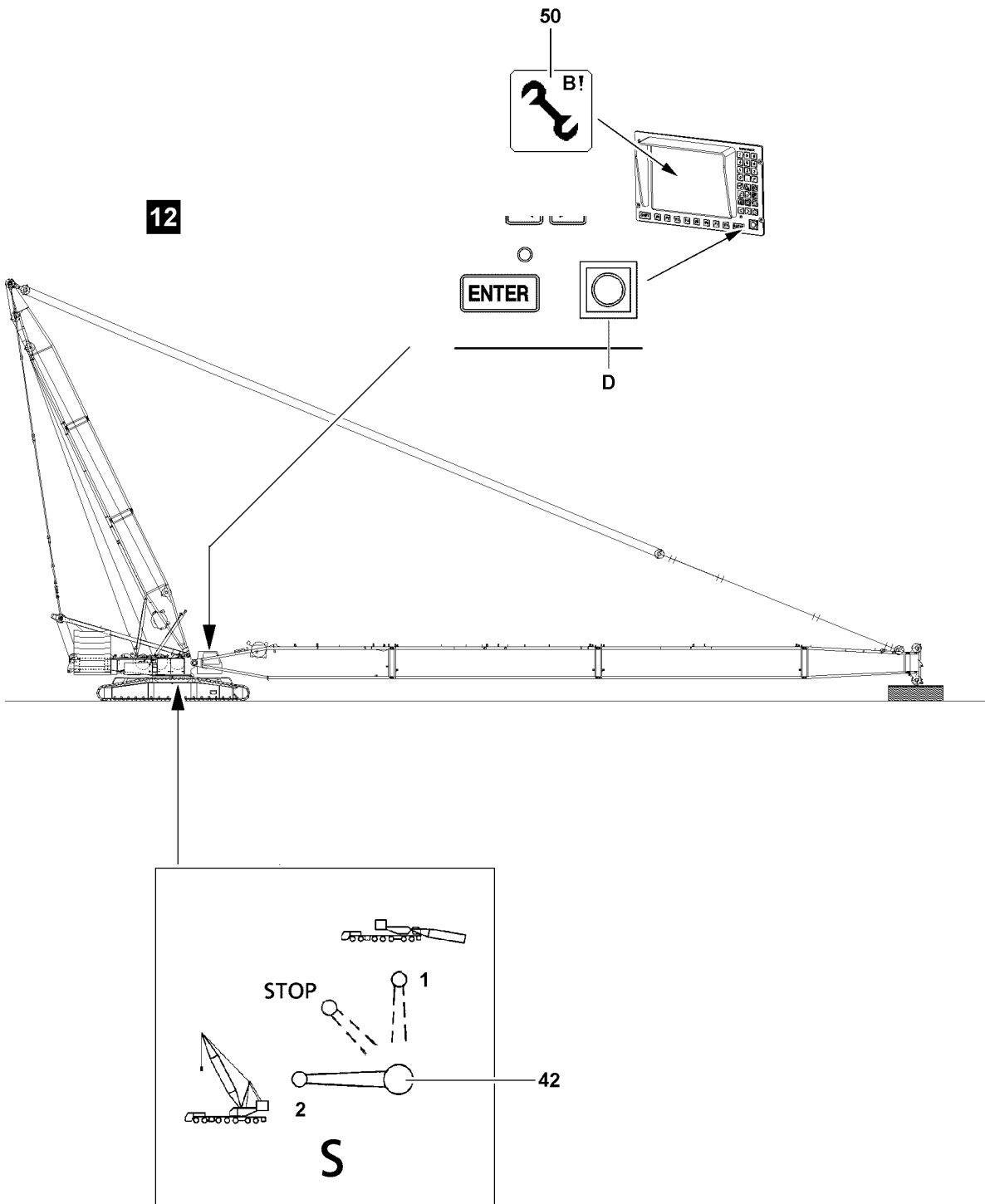

B111477

4.1 Extending the S-relapse cylinder



WARNING

The crane can topple over!

If the S-relapse cylinders are not extended before erecting the S-boom, then the S-boom can fall to the rear in crane operation and the crane can topple over!

Personnel can be severely injured or killed!

- ▶ Extend the S-relapse cylinders before erecting the S-boom!
- ▶ Secure the ball valve **42** during crane operation to prevent inadvertent actuation!

Ball valve positions	
2	Crane operation, extend the piston rod
1	Assembly, retract the piston rod
STOP	The piston rod cannot be retracted / extended

The piston rods on the S-relapse cylinders can be extended with the ball valve **42**.

- ▶ Set the ball valve **42** to **position 2**.

Result:

- The piston rods of the S-relapse cylinders extend.



Note

- ▶ The ball valve **42** is secured by closing the cabinet door and removing the key!
- ▶ Close the cabinet door and pull the key.
- ▶ Hand the key to an authorized person.

4.2 Reeving in the hook block

- ▶ Erect the boom until the end section lifts off the ground.
- ▶ Check the actual load on the LICCON monitor.

Troubleshooting

Actual load on the LICCON monitor is larger than 0.0 t!

- ▶ Observe the notes for input of hook block weight, see Crane operating instructions, chapter 4.02!



Note

- ▶ Hoist rope reevings, see Crane operating instructions, chapter 4.06 and Reeving plan!
- ▶ Reeve in the hook block properly and secure the hoist rope on the rope fixed point, for reeving, see reeving plan.
- ▶ Attach the hoist limit switch weight.
- ▶ Enter the weight of the hook block into the LICCON computer system!

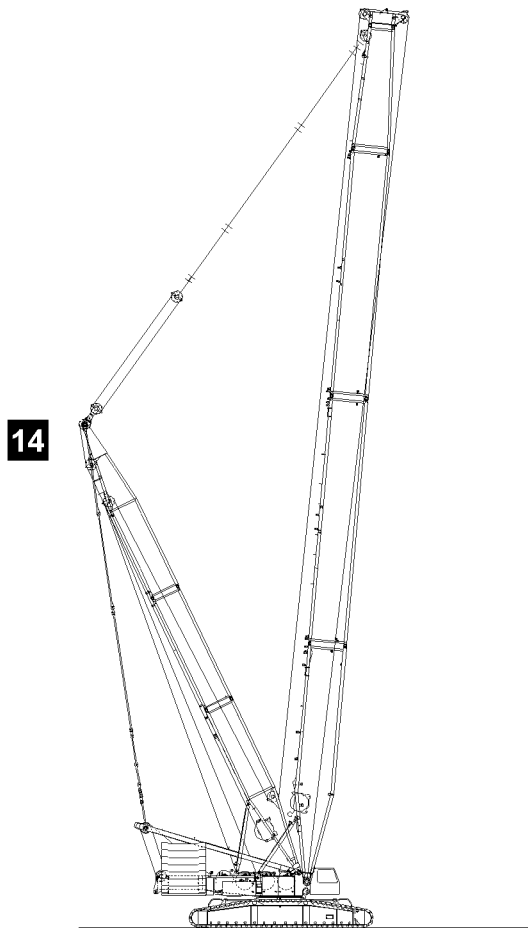
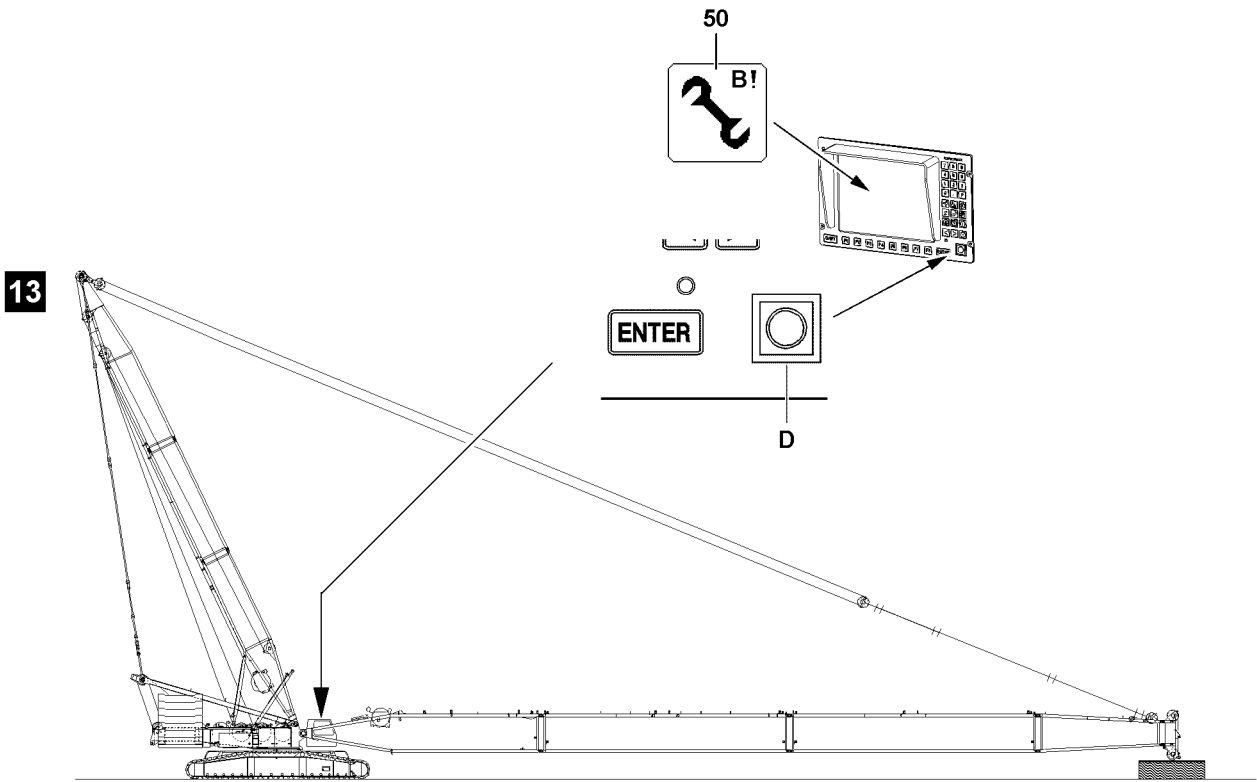

B111478

4.3 Erecting the S-boom



WARNING

Falling hoist rope!

If the hoist rope is not reeved with the respective length on the boom before the erection procedure, then it can fall backward due to its own weight.



Personnel can be severely injured or killed!

- ▶ Reeve in the hoist rope with sufficient length on the S-boom before the erection process!
- ▶ The hoist rope must be constantly monitored during erection!
- ▶ Do not step into the danger zone!



Note

- ▶ During the erection procedure - outside the operating area - the alarm functions listed in the chart are displayed as blinking on the crane operating screen!

Displays on the LICCON monitor during the erection procedure	
 "STOP" icon visible	
 "ERROR 150" icon visible	Note: Error description, see Crane operating instructions, chapter 20.05.
 Horn icon visible	Note: In addition to the horn icon, an acoustic warning sounds.

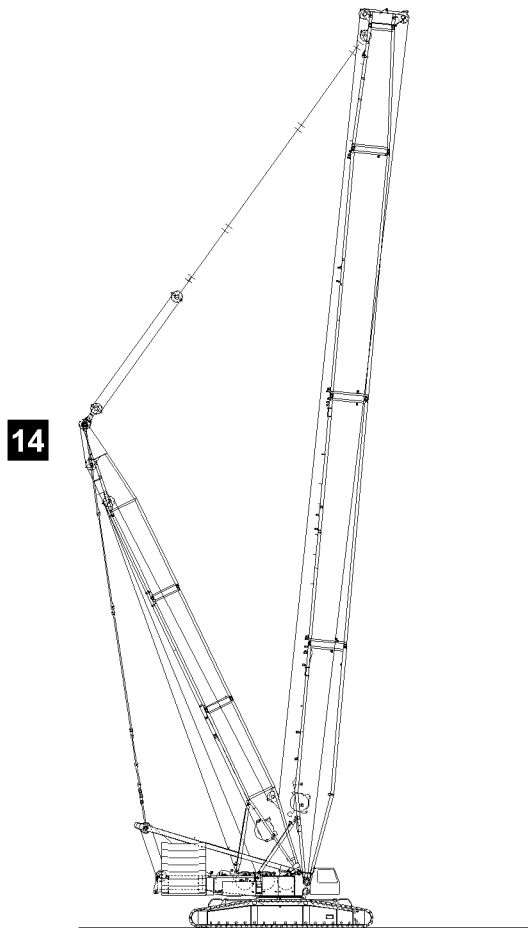
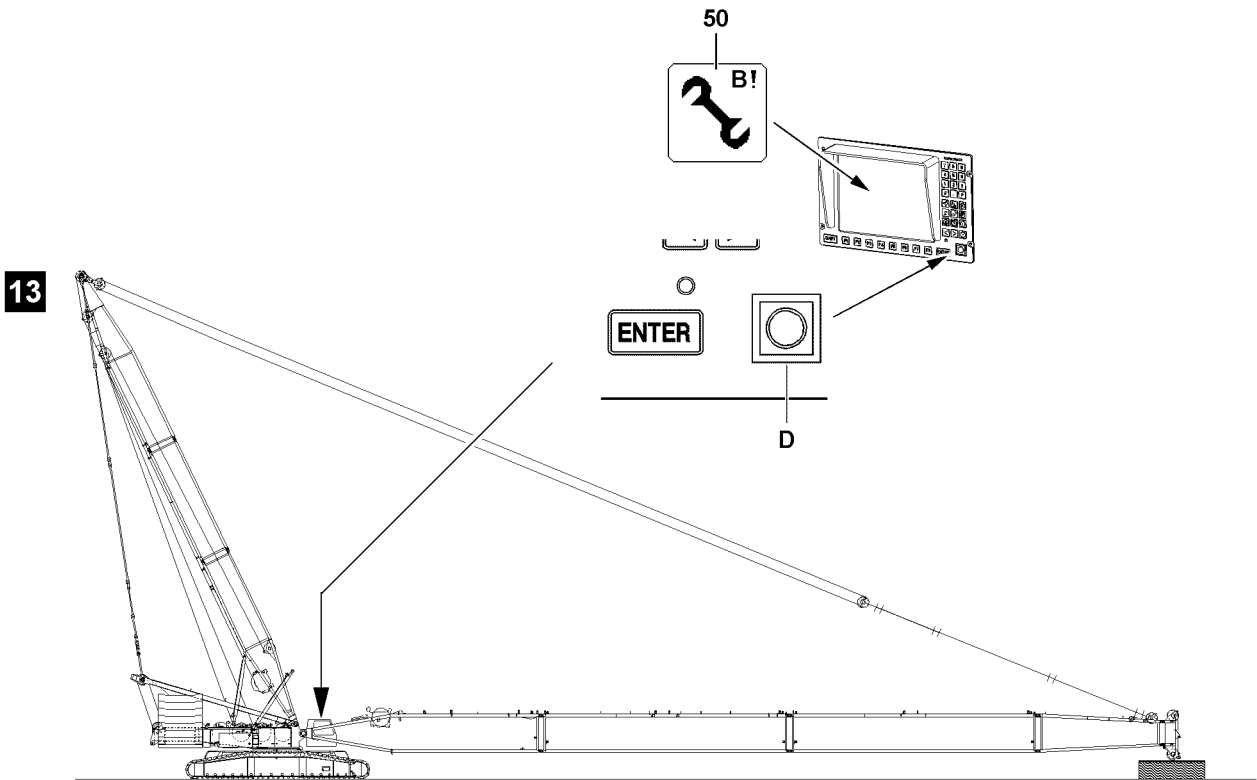

B111478

**WARNING**

The crane can topple over!

In crane operation with exceeded LICCON overload protection, the crane can topple over!

Personnel can be severely injured or killed!

- ▶ The radii listed in the load chart may not be exceeded or fallen below, even if there is no load on the hook!

**Note**

- ▶ When the lowest operating position of the boom is reached, the LICCON overload protection is activated!
- ▶ The displays on the LICCON monitor turn off!
- ▶ In the maximum load icon appears a load number in "t" instead of the display "???"!

- ▶ Luff the boom up to the lowest operating position.
- ▶ When the boom has reached the lowest operating position:
Make sure that the assembly icon **50** on the LICCON monitor turns off.

Result:

- The LICCON overload protection is active.

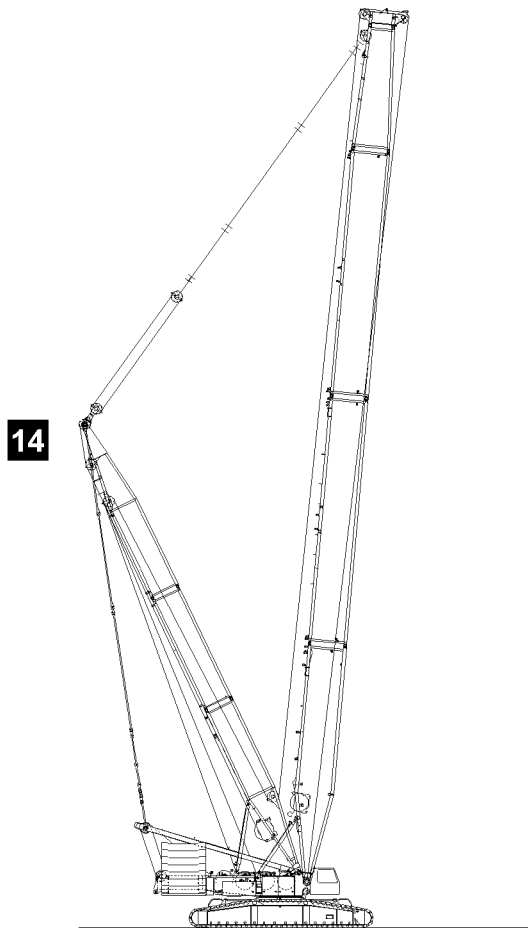
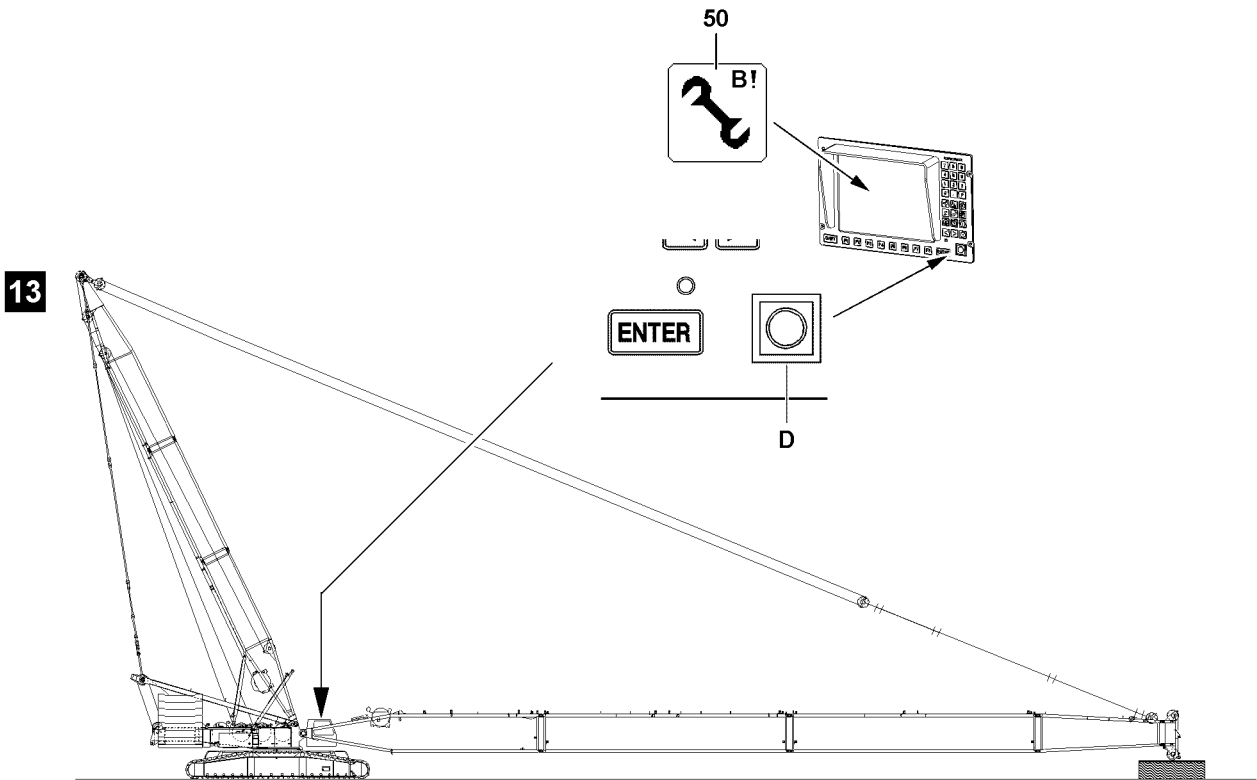

B111478

5 Crane operation with derrick boom combination

5.1 Preparing for crane operation

**Note**

- ▶ Observe the notes, see Crane operating instructions, chapter 4.02, chapter 4.05, chapter 4.08 and chapter 5.01!

Make sure that the following prerequisites are met:

- The LICCON overload protection is active.
- The LICCON overload protection has been set according to the data in the load chart.

**WARNING**

The crane can topple over!

- ▶ Check the horizontal position of the crane before and during operation!
- ▶ If the crane operator leaves the cab, even for a short time, the operating mode setting must be checked and reset if necessary before resuming crane operation!

5.1.1 Checking the settings

- ▶ Check the function of the overload protection by running against the operating positions “on top” and “bottom”.
- ▶ Check the hoist limit switch by running against the hoist limit switch weight.
- ▶ Check the function of the limit switches “Boom steep” on the relapse cylinders.

B195219

6 Disassembling the LD/SLD/SD-boom



Note

- ▶ The assembly is described on the example of the S-boom!



WARNING

Risk of falling!

During assembly / disassembly, inspection and maintenance work, personnel must be secured with appropriate aids to prevent them from falling! If this is not observed, assembly personnel could fall and suffer life-threatening or fatal injuries!

- ▶ All work aloft, where there is a danger of falling must be carried out with suitable aids!
- ▶ If fall protection equipment is available, then it must be used, see Crane operating instructions, chapter 2.06!
- ▶ If aids are not available and work cannot be carried out from the ground, then the assembly personnel must secure themselves with the permissible fall arrest system to prevent falling, see Crane operating instructions, chapter 2.04!
- ▶ The fall arrest system must be fastened on the fastening and hook points as well as on the safety ropes. For safety points, see Crane operating instructions, chapter 2.06!
- ▶ Only step on the aids, ladders and catwalks with clean shoes!
- ▶ Keep aids, ladders and catwalks free of heavy dirt, snow and ice!
- ▶ It is prohibited to walk on the telescopic or an auxiliary boom without suitable protective devices!



WARNING

Falling components!

If unsecured or non-supported components are installed or removed, they can fall down!

Personnel can be severely injured or killed!

- ▶ During pinning and unpinning of the lattice sections, it is prohibited for anyone to remain **under** or **on** the components as well as within the entire danger zone!
- ▶ Support the boom and components before pinning / unpinning!
- ▶ Pin or unpin both pins that lie in one horizontal level, i.e. **left** and **right**!
- ▶ Secure the pins in the bearing points and in the receptacles!
- ▶ Do not disengage the auxiliary crane until each component is pinned on and secured!
- ▶ It is prohibited to lean a ladder against the component being disassembled!



WARNING

Danger of impact / crushing!

When installing / removing crane components with the auxiliary crane, crane components can start to swing back and forth!

When lifting / lowering and positioning crane components, there is an increased danger of impacts / crushing!

Personnel can be caught and severely injured or killed!

- ▶ Make sure that personnel cannot be caught by components!
- ▶ When working in danger zones: Use aids to protect limbs!
- ▶ Guide components with suitable aids to minimize oscillation!

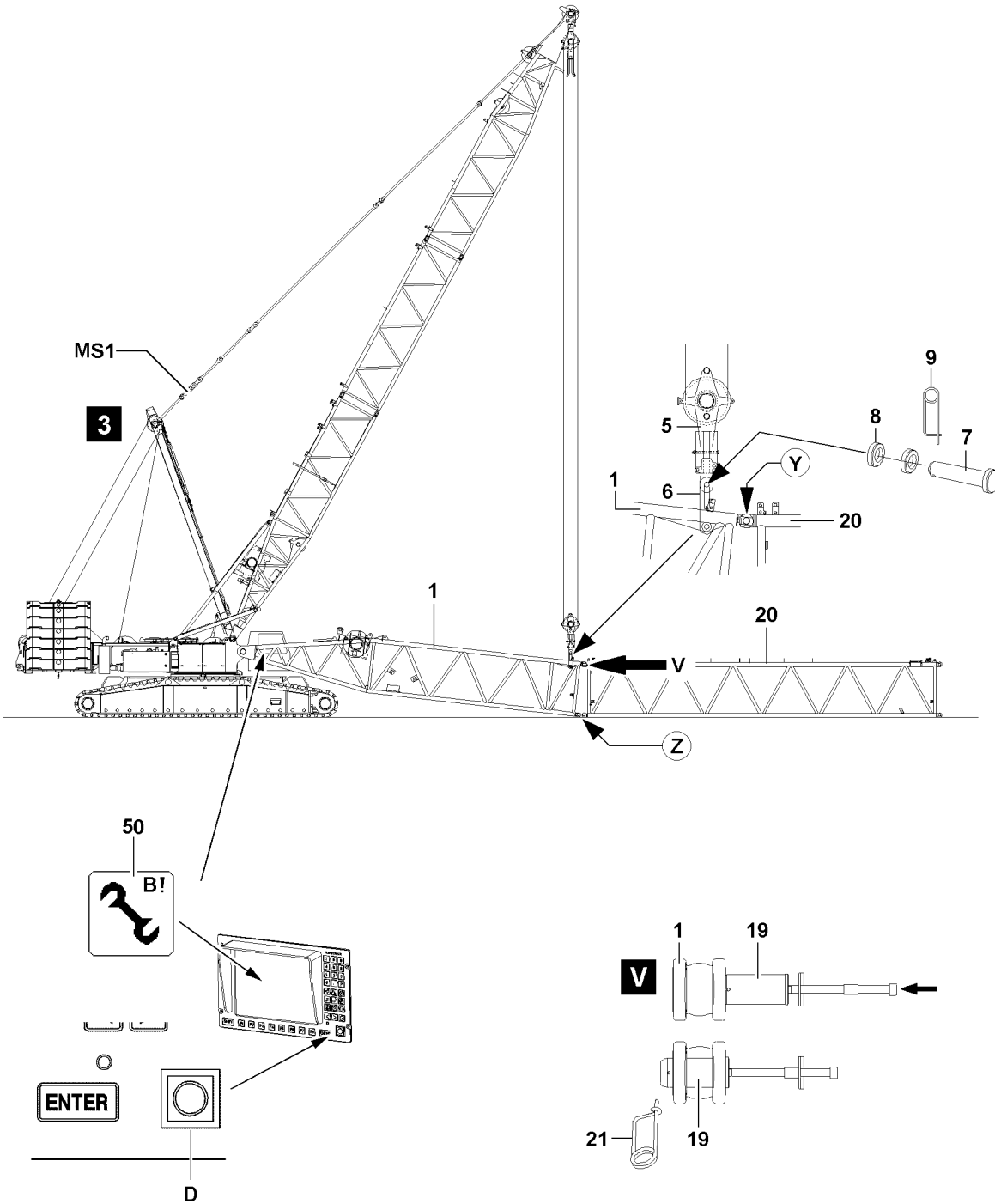

B112262

6.1 Taking the S-boom down



WARNING

Risk of accident!

If the following instructions are not observed, personnel can be severely injured or killed!

- ▶ The turntable may not be turned during the disassembly of the boom!
- ▶ Observe the safety technical notes, see Crane operating instructions, chapter 5.01!
- ▶ Observe the data in the erection and take down charts!

NOTICE

Damage of boom components!

Taking down the boom system can lead to a collision between the hook block and the pulley head.

There is the danger that boom components may be significantly damaged!

- ▶ When taking down the boom system, always spool out the hoist winch at the same time!
- ▶ When luffing the boom system down, the derrick boom must remain in operating position until the end section is laying on the ground!



Note

- ▶ Depending on the condition of the ground, the boom and the lattice sections must be supported from below for the disassembly of the boom!

Make sure that the following prerequisites are met:

- The crane is aligned in horizontal direction.
- An auxiliary crane is available.
- An assembly scaffolding / work platform is available.
- The counterweight has been installed to the turntable according to the erection chart.
- The LICCON overload protection has been set according to the data in the load chart.

6.1.1 Turning the turntable into disassembly position

- ▶ Turn the turntable in longitudinal axle of the crawler travel gear against the travel direction or vertically to the crawler travel gear, see Erection and take down chart.

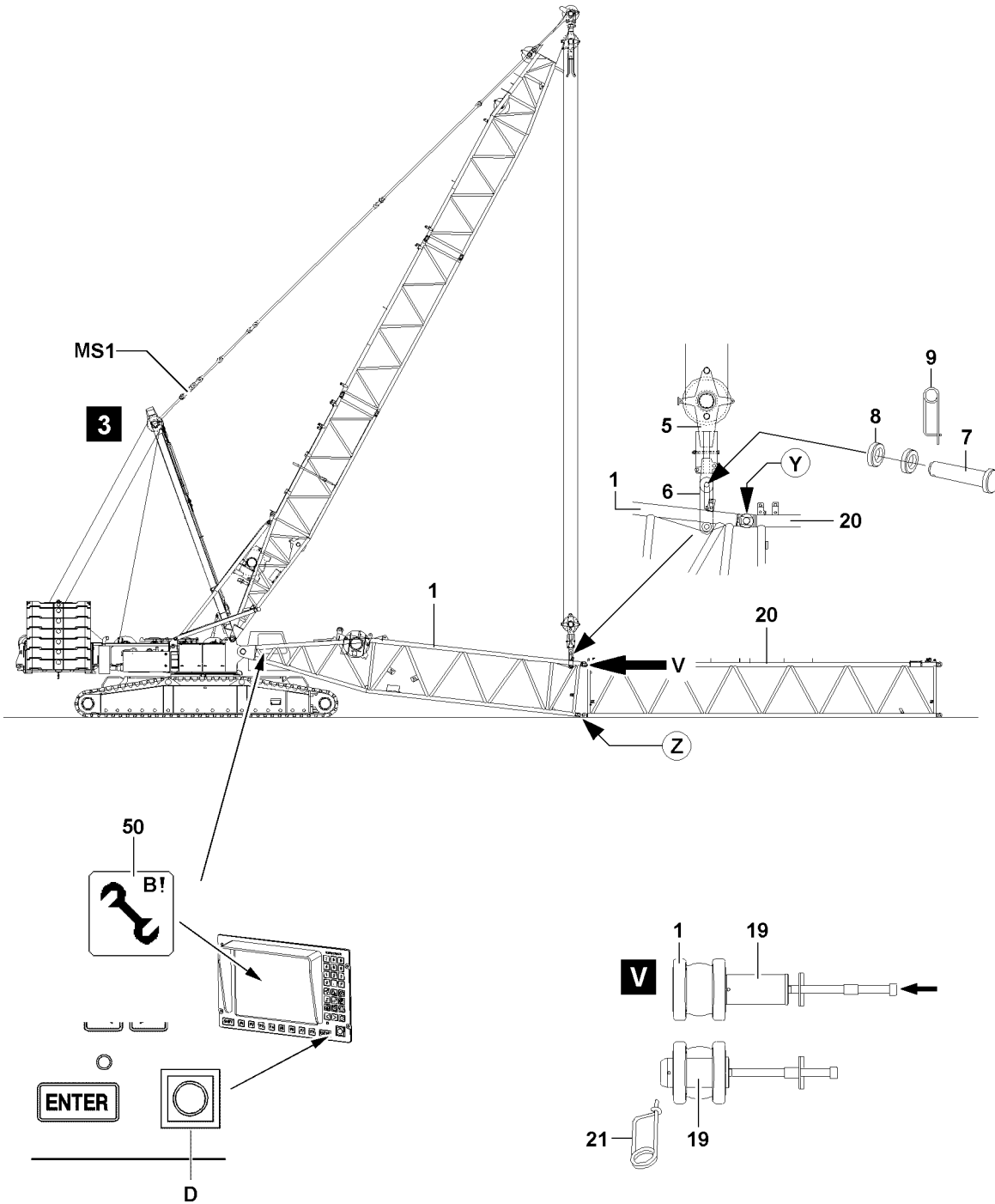

B112262

6.1.2 Luffing the S-boom down





Note

- ▶ The luff down movement is turned off as soon as the lowest operating position of the boom is reached!
- ▶ When the lowest operating position of the boom is reached, the load display in the maximum load icon turns off and instead of the load display appears the display “???”!
- ▶ In the crane operating screen appear alarm functions!



Note

- ▶ During the take down procedure - outside the operating range - alarm functions appear on the crane operating screen, see the following chart!

Display on the LICCON monitor 0 after reaching the “lowest” operating position	
 “STOP” icon visible	
 “ERROR 150” icon visible	Note: Error description, see Crane operating instructions, chapter 20.05.
 Horn icon visible	Note: In addition to the “Horn” icon, an acoustic warning sounds.

- ▶ Luff the S-boom down to the “lowest” operating position.

Result:

- The luff down movement is turned off.
- The “STOP” icon appears on the LICCON monitor.
- The horn icon appears on the LICCON monitor.

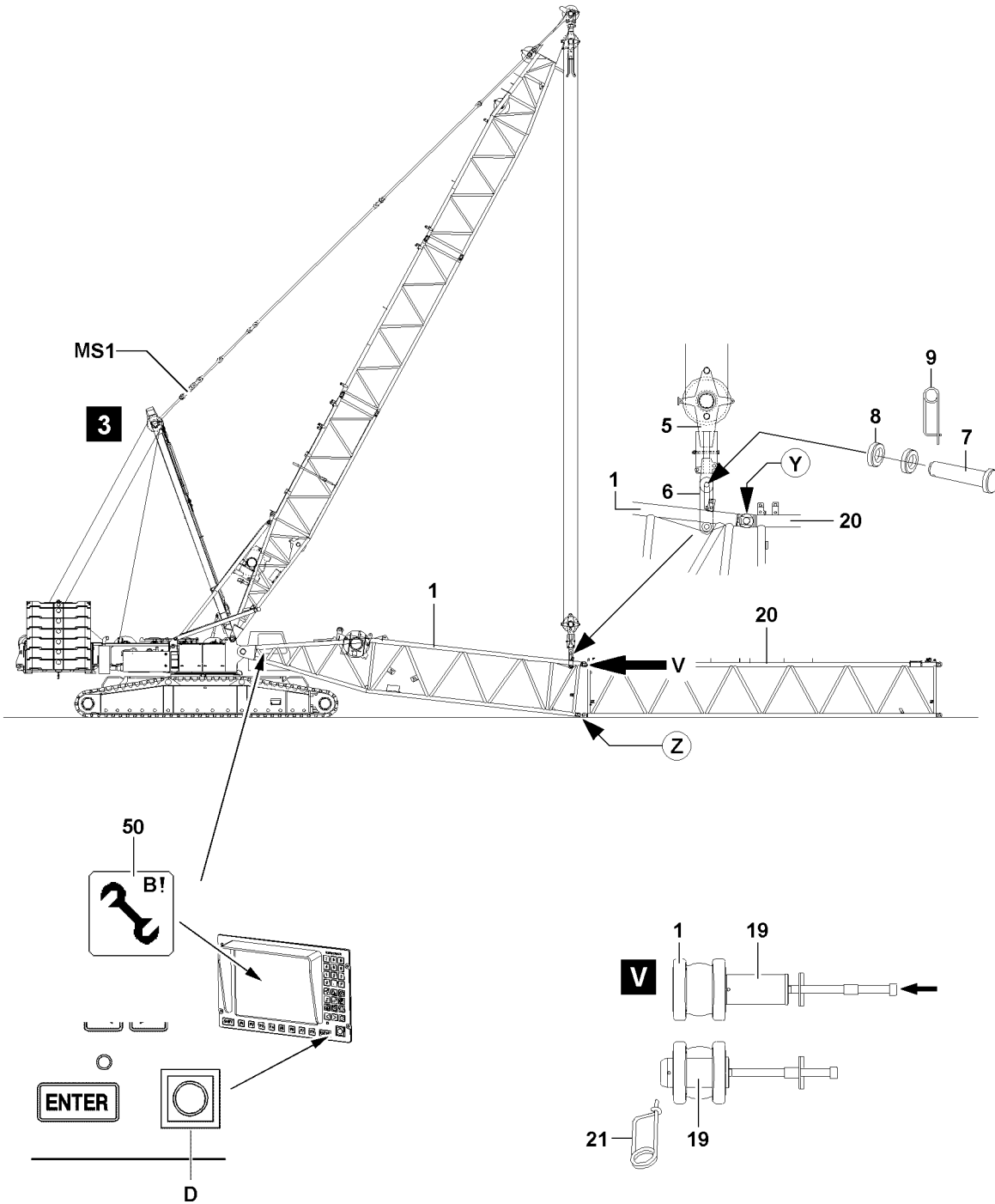

B112262

**WARNING**

Assembly with turned on set up key!

When the set up key is turned on, the LICCON overload protection is exceeded!

In the event of deliberate improper use, the crane could collapse, the boom can break off or the crane can topple over!

Personnel can be killed!

This could result in high property damage!

- ▶ The set up key **D** may only be actuated by persons who know the effects of a bypass!
- ▶ Press the set up key **D** only when the set up status was correctly entered into the LICCON computer system!
- ▶ Observe the erection / take down charts!
- ▶ Crane operation with the set up key **D** turned on is strictly prohibited!

- ▶ When the S-boom has reached the “lowest” operating position:
Turn the set up key **D** to the right.

Result:

- The LICCON overload protection is deactivated.
- The assembly icon **50** appears on the LICCON monitor.
- ▶ At the same time, spool the hoist winch out and luff the boom down further until the hook block touches the ground.

6.1.3 Unreeving the hook block

- ▶ Remove the hoist limit switch weight and unreeve the hook block.
- ▶ Luff the boom down until the boom head is lying on the support on the ground.

6.1.4 Spooling the hoist rope up**NOTICE**

Overspooled winch!

If the rope is pulled under the winch when spooling up, the settings of the cam limit switch are not longer correct and there is an increased danger of accidents!

As a result, extensive adjustment work on the cam limit switch is required!

- ▶ Slowly spool up the hoist rope over the rope pulleys back to the winch.
- ▶ Stop the winch in time, with sufficient rope reserve!
- ▶ Do not overspool the winch!

- ▶ Spool up the hoist rope.

B195219

6.2 Disconnecting the electrical connections to the S-boom

Make sure that the following prerequisite is met:

- The S-boom is in horizontal position or placed on the ground.

- ▶ Disconnect the electrical connections.

NOTICE

Damage to cable drum or cable!

If the cable of the cable drum is not properly spooled up on the cable drum after unplugging the end section, then the cable drum or the cable can be significantly damaged!

- ▶ Spool the cable drum up after unplugging!

-
- ▶ Spool the cable drum up and secure it to prevent inadvertent spooling out.

6.3 Disconnecting the hydraulic connections to the S-boom

When releasing hydraulic lines with quick release couplings, make sure that the coupling procedure is carried out correctly.



WARNING

Pressure in the hydraulic lines!

If the pressure supply is not interrupted before connecting / releasing the hydraulic lines, the hydraulic oil can escape with high pressure!

Personnel can be severely injured or killed!

- ▶ Release the pressure in the hydraulic system before connecting / disconnecting: Interrupt the pressure supply and wait for a short time!

-
- ▶ Install the coupling components (sleeve and connector) with the hand-tightened nut.
 - ▶ Disconnect the hydraulic connections.
 - ▶ Install dust caps on the quick release couplings.

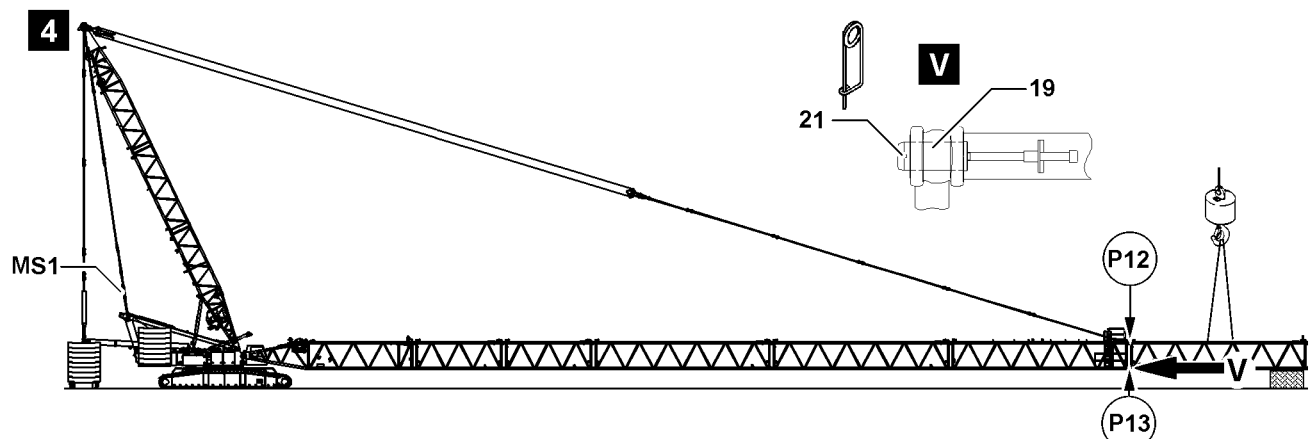
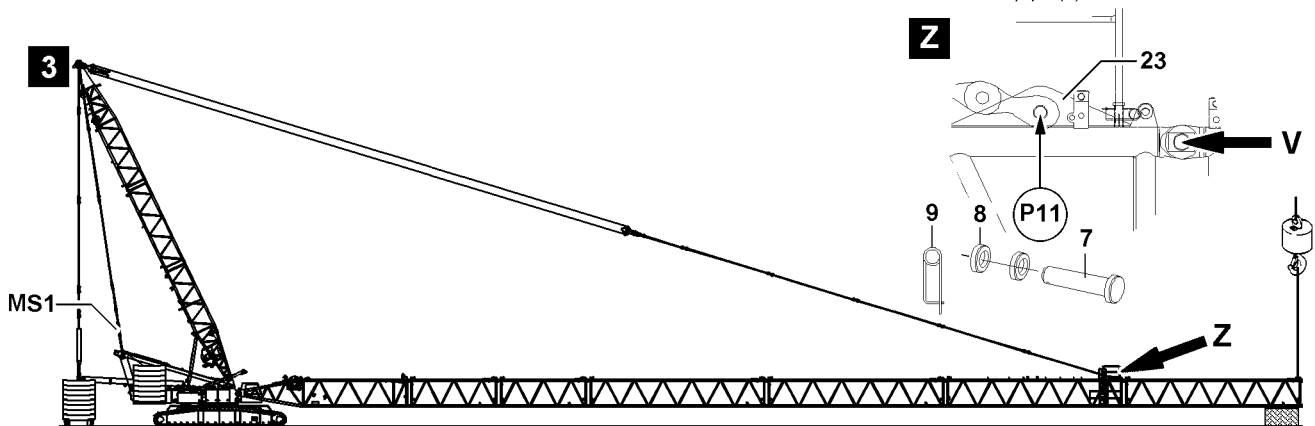
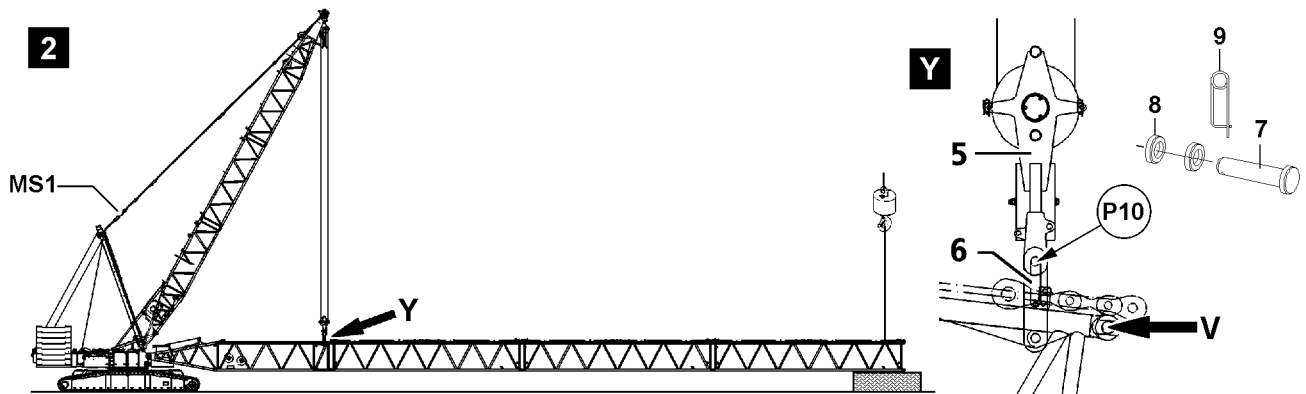
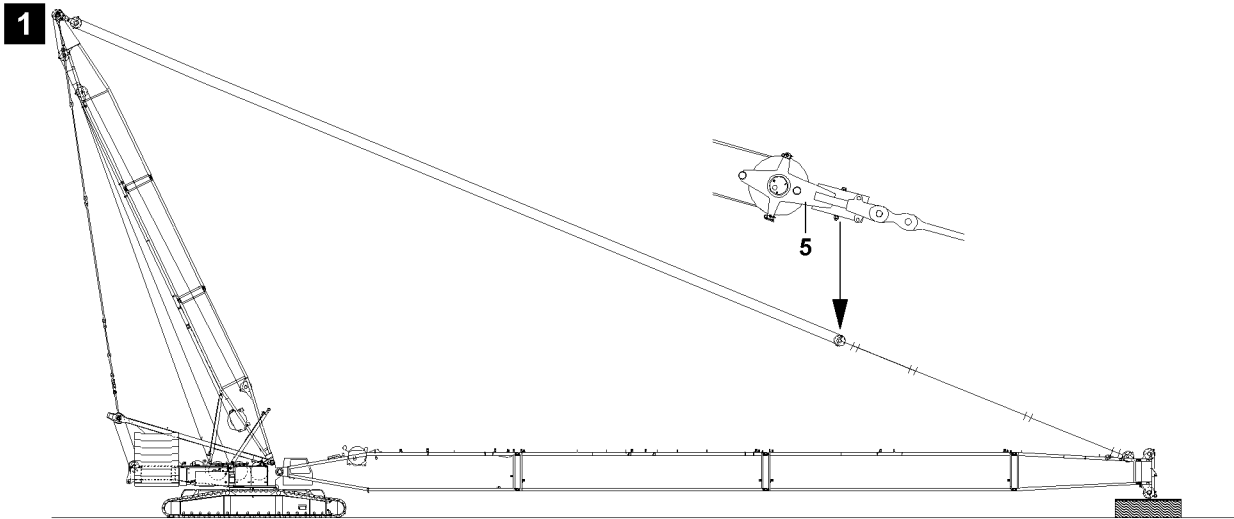

B112471

6.4 Disassembling the S-lattice sections

The disassembly of the lattice sections is carried out in various ways:

- Disassembling the lattice sections in “Flying mode”.
- “Opening” the boom.



WARNING

General danger notes!

- ▶ Support the S-boom during assembly / disassembly with suitable materials!
- ▶ All pins are to be secured after assembly with the intended safety elements!
- ▶ The guy rods must be inspected regularly, see Crane operating instructions, chapter 8.15!
- ▶ Secure the boom with support or auxiliary crane, see Crane operating instructions, chapter 5.01!
- ▶ It is prohibited for anyone to remain under the booms or within the complete danger zone during the pinning and unpinning procedure of the lattice section!



Note

- ▶ For weights of intermediate sections with placed guy rods, see Crane operating instructions, chapter 1.03!
- ▶ The intermediate sections are unpinned with the aid of the pin pulling device, see Crane operating instructions, chapter 5.30!

Make sure that the following prerequisite is met:

- All electrical and hydraulic connections on the boom are separated.

6.4.1 Disassembling the S-lattice sections in flying mode

If spatial prerequisites on the job site are limited for the disassembly of the S-boom, or if they are limited by buildings or similar, then the S-boom can be removed in flying mode.

For the flying disassembly, a differentiation is made between the guy points on the boom:

- Guying on S-pivot section, see detail **Y**.
- Guying on S-intermediate section for flying assembly, see detail **Z**.



WARNING

Impermissible boom lengths guyed in flying mode!

If impermissible boom lengths are guyed on the assembly brackets, then severe property damage can occur on the crane! The crane can topple over! Personnel can be severely injured or killed!

- ▶ The maximum permissible boom lengths for the “Flying assembly” may not be exceeded, see section “Assembling the S-lattice sections”!
- ▶ For the “flying” boom assembly, the maximum permissible total force on the test point **MS1** may **not** be exceeded, see section “Assembling the S-lattice sections in flying mode”!
- ▶ Pin the guy rods either on the assembly brackets **6**, point **P10**, or the assembly brackets **23**, point **P11**!
- ▶ The data in the erection and take down charts as well as the load charts must be observed!



WARNING

The boom can fold downward!

By unpinning the guy rods on the assembly brackets **6** or the assembly brackets **23**, the boom can fold down!

Personnel can be severely injured or killed!

- ▶ Unpin the guy rods on the assembly brackets **6**, point **P10** or the assembly brackets **23**, point **P11** when it is ensured that the intermediate sections are supported with suitable materials or are secured with the auxiliary crane or the boom is placed on the ground!

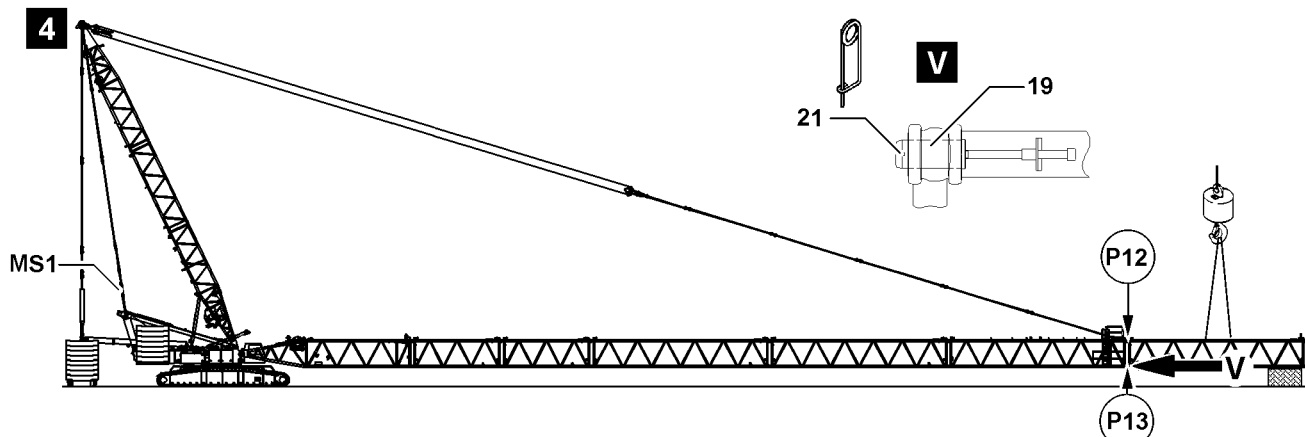
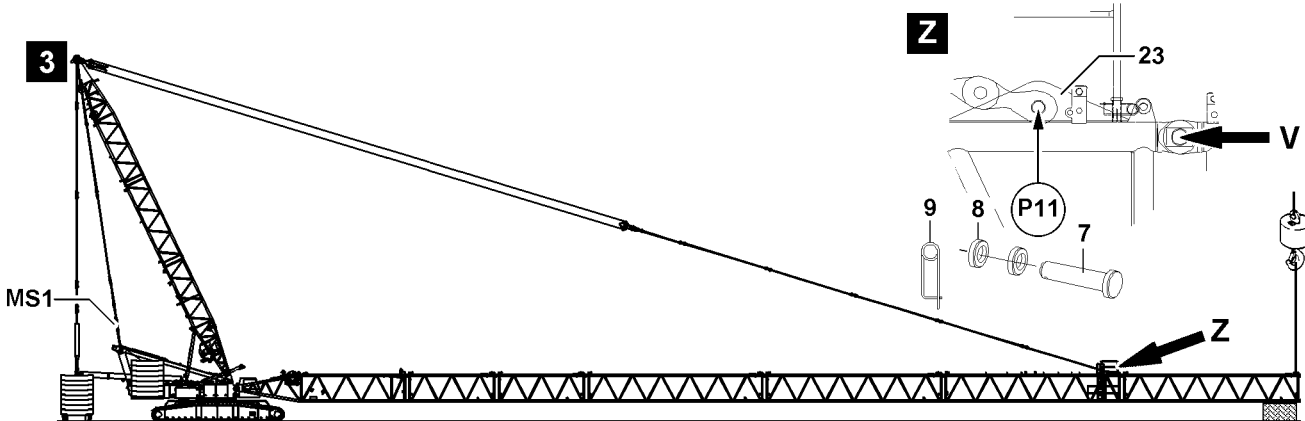
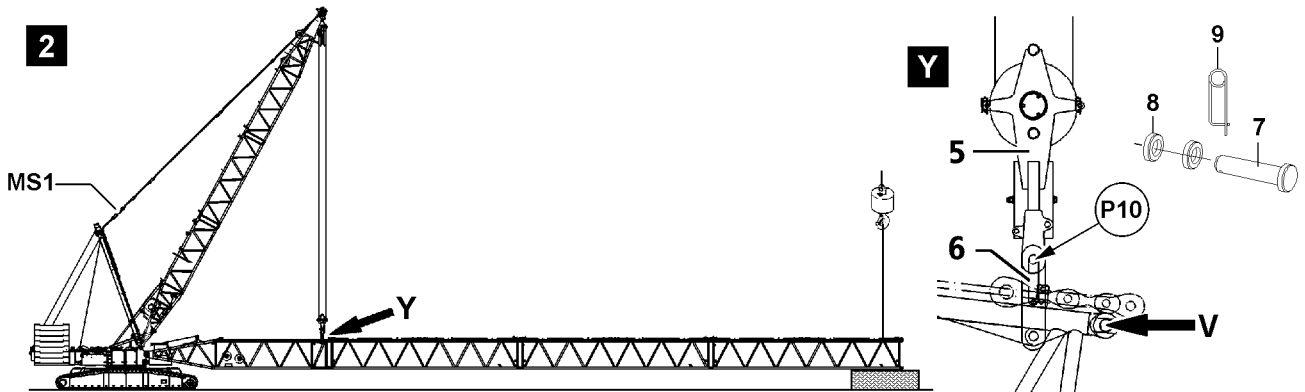
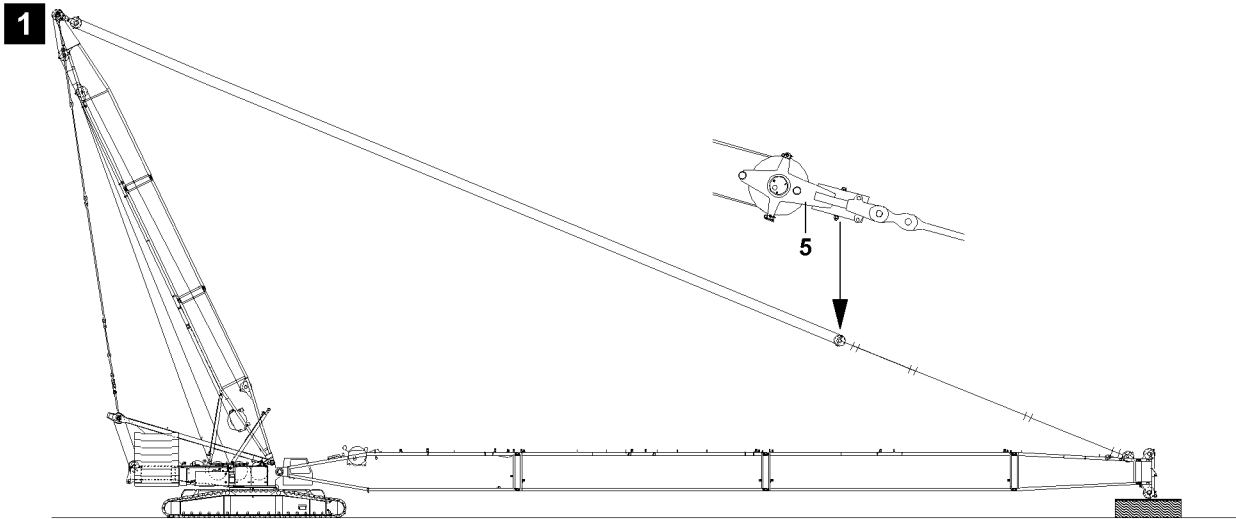

B112471

Make sure that the following prerequisites are met:

- The boom is in horizontal position.
- The guy rods are tensioned.
- Suitable materials to support the boom are available.
- An auxiliary crane is available.

Guying the S-boom in “Flying mode”

- ▶ Support the boom or secure it with the auxiliary crane.



Note

- ▶ The actual force on the test point **MS1** is shown on LICCON monitor 1!

The guy rods are placed on the S-intermediate sections in the transport retainers.

- ▶ Make sure that the transport retainers for the guy rods on the intermediate sections are unpinned.
- ▶ Luff the derrick boom down to the front until the upper pulley block can be unpinned on the guy rods.
- ▶ When the guying is relieved:
Unpin the upper pulley block **5** on the guy rods.
- ▶ Erect the derrick boom until the upper pulley block **5** hangs over the assembly bracket.
- ▶ Lower the upper pulley block **5** to the assembly brackets.

When pinning the pin **7**, you have to use the washers **8**, see illustration.

- ▶ When the boom is guyed on the S-pivot section:
Pin the upper pulley block on the assembly brackets **6**: Insert the pin **7** on point **P10** and secure with spring retainer **9**.
- ▶ When the boom is guyed on the S-intermediate section:
Pin the upper pulley block on the assembly brackets **23**: Insert the pin **7** on point **P11** and secure with spring retainer **9**.
- ▶ Disassemble the guy rods, which are laying on the boom and secure them in the transport retainers.

Result:

- The S-intermediate sections can be disassembled.

Disassembling the S-intermediate section

The “flying” disassembly is described on the example of one intermediate section, see illustration **4**.

- ▶ Secure the S-intermediate section with the auxiliary crane.
- ▶ Unpin the S-intermediate section on both sides “on the bottom” at point **P13**: Remove the spring retainer **21** and unpin the pin **19**.
- ▶ Unpin the S-intermediate section on both sides “on top” at point **P12**: Remove the spring retainer **21** and unpin the pin **19**.
- ▶ Remove the S-intermediate section.

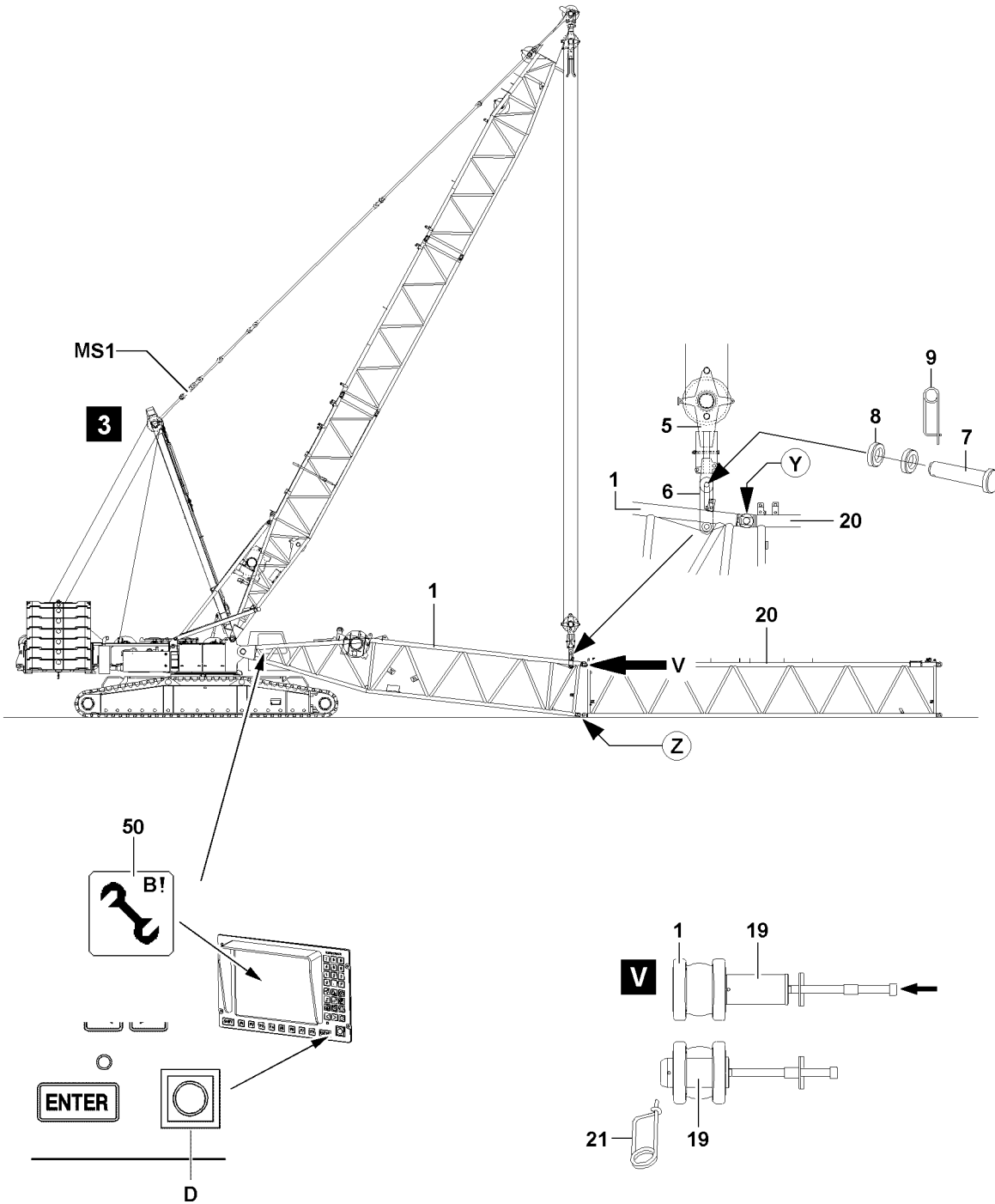

B112262

6.4.2 Disassembling the S-lattice sections (“open” boom)



WARNING

The crane can topple over!

If the following conditions are not met, the crane can topple over or be significantly damaged!

Personnel can be severely injured or killed!

- ▶ During the “Opening procedure” of the intermediate sections, the maximum permissible total force on the test point **MS1** must be **smaller** than **70 t** !
- ▶ The end section of the corresponding S/SL-boom combination may **not** lift off the ground when “opening” the boom!
- ▶ The end section of the corresponding boom combination may **not** lift off the ground during the “Opening procedure”!
- ▶ With the upper pulley block, boom combinations to maximum **L 105 m** may be lifted / closed!
- ▶ With the upper pulley block, boom combinations to maximum **SL 112 m** may be lifted / closed!
- ▶ With the upper pulley block, boom combinations to maximum **Sw 112 m** may be lifted / closed!
- ▶ With the upper pulley block, boom combinations to maximum **S 119 m** may be lifted / closed!

Make sure that the following prerequisites are met:

- The guy rods are tensioned.
- Suitable materials to support the boom are available.
- An auxiliary crane is available.

Pinning the upper pulley block on the S-pivot section

- ▶ Luff the derrick boom down and place the boom on the support on the ground.
- ▶ Make sure that the transport retainers for the guy rods on the intermediate sections are unpinned.
- ▶ Luff the derrick boom down to the front until the upper pulley block can be unpinned on the guy rods.
- ▶ When the guying is relieved:
Unpin the upper pulley block on the guy rods.
- ▶ Erect the derrick boom until the upper pulley block **5** hangs over the assembly brackets **6**.
- ▶ Lower the upper pulley block **5** to the assembly brackets **6**.

When pinning the pin **7**, you have to use the washers **8**, see illustration.

- ▶ Pin the upper pulley block **5** on the assembly brackets **6** on the S-pivot section **1**. Insert the pin **7** on point **P10** and secure with spring retainer **9**.
- ▶ Disassemble the guy rods, which are laying on the boom and secure them in the transport retainers.

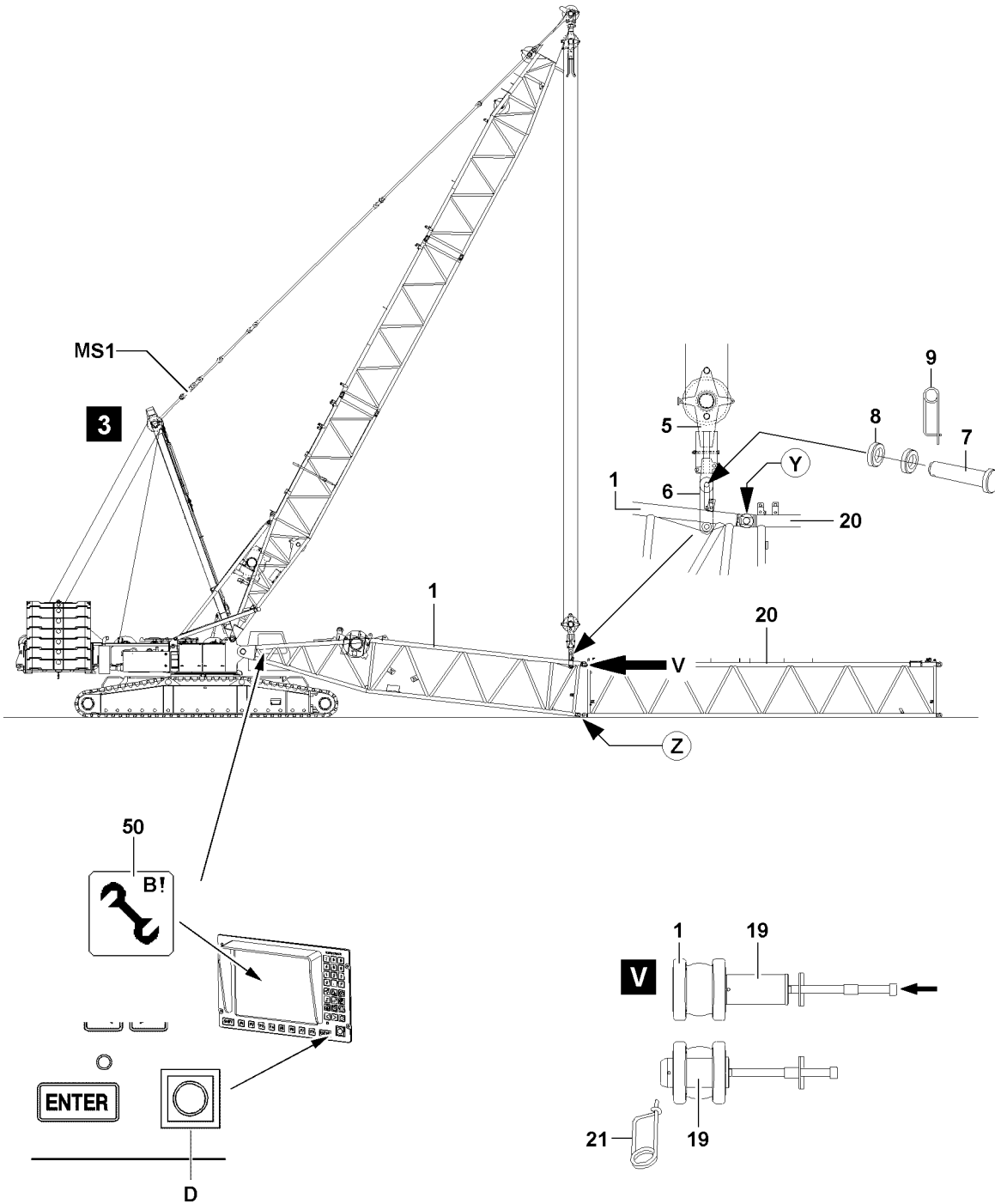

B112262

“Opening” the S-boom



Note

- ▶ The actual force on the test point **MS1** is shown on LICCON monitor 1!
 - ▶ Tension the guying on the SA-bracket with the same force as for assembly, see the actual force which was measured and noted at assembly on test point **MS1**!
 - ▶ The pins can be pulled easier and the pins and lugs are therefore not damaged!
-
- ▶ Lift the upper pulley block **5** and tension the guy rods until the force on test point **MS1** matches the force at assembly.
 - ▶ Unpin the S-pivot section on both sides “on the bottom” at point **Z**: Remove the spring retainer **21** and unpin the pin **19**, see detail **V**.
 - ▶ Lower the S-boom until the intermediate sections and the S-pivot section is laying on the ground.
 - ▶ Unpin the S-pivot section on both sides “on top” at point **Y**: Remove the spring retainer **21** and unpin the pin **19**, see detail **V**.
 - ▶ Make sure that the S-pivot section is laying on the ground.
 - ▶ Unpin the upper pulley block **5** on the assembly brackets **6**: Remove the spring retainer **9** and unpin the pin **7**.

Result:

- The S-lattice sections can be disassembled.

Disassembling the S-intermediate section

The disassembly is described on the example of one intermediate section, see detail **V**.

- ▶ Unpin the S-intermediate section on both sides “on the bottom”: Remove the spring retainer **21** and unpin the pin **19**.
- ▶ Unpin the S-intermediate section on both sides “on top”: Remove the spring retainer **21** and unpin the pin **19**.
- ▶ Remove the S-intermediate section.

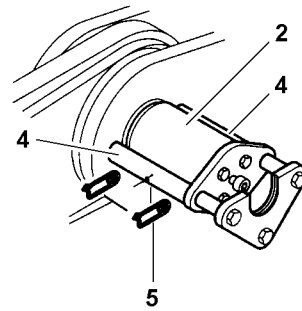
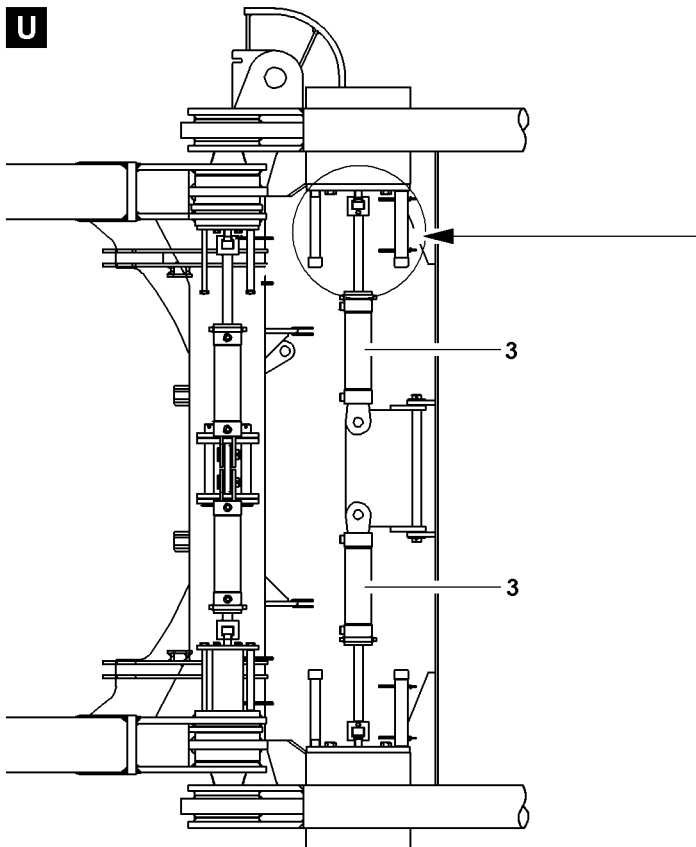
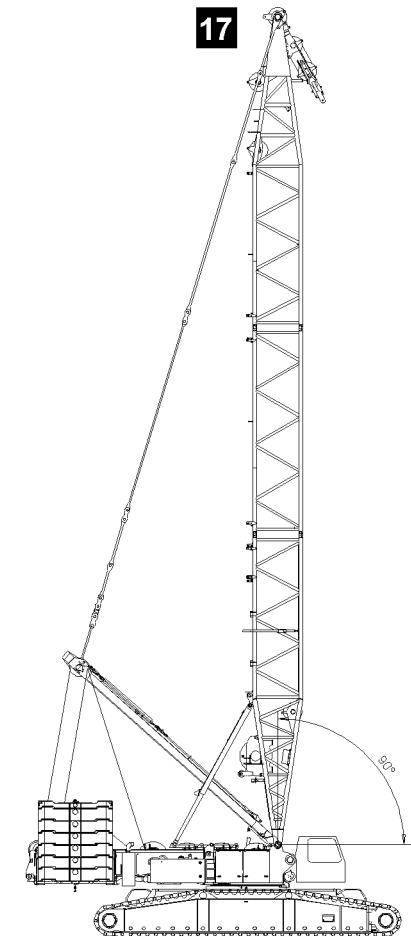
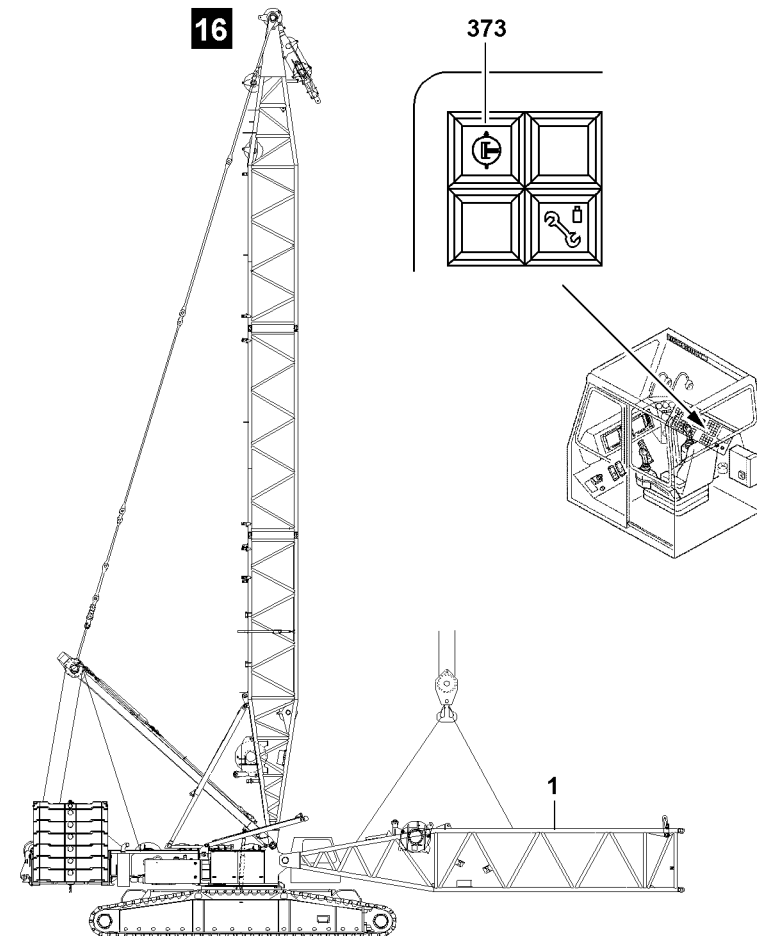

B111480

6.5 Unpinning the S-pivot section



WARNING

General danger notes!

- ▶ Support S-pivot section during disassembly with suitable materials!
- ▶ Insert and secure all pins after disassembly in the intended transport receptacles!
- ▶ The guy rods must be inspected regularly, see Crane operating instructions, chapter 8.15!

Make sure that the following prerequisite is met:

- The derrick boom is erected to the point where the S-pivot section can be disassembled without obstructions.
- ▶ Attach the S-pivot section **1** on the auxiliary crane.
- ▶ Lift the S-pivot section **1** with the auxiliary crane to the horizontal.

Establish the hydraulic connection to the pin pulling device via two quick couplers.

Release and unpin the S-pivot section **1** on the turntable.

- ▶ Establish the hydraulic connection to the pin pulling device.
- ▶ Turn the pressure change over switch **373** on.



WARNING

The S-pivot section can fold downward!

- ▶ Make sure that the S-pivot section is safely held by the auxiliary crane before unpinning the pins **2**!
- ▶ Remove the spring retainer **5** on the retaining plate **4** on the left and right.
- ▶ Remove the retaining plate **4** left and right.
- ▶ Unpin the connector pins **2** with the hydraulic pin pulling device **3**.
- ▶ Turn the pressure change over switch **373** off.

NOTICE

Property damage on the turntable and on the S-pivot section!

- ▶ Slowly swing the S-pivot section out with the auxiliary crane and at low speed on the turntable!
- ▶ Place the S-pivot section with the auxiliary crane on the support on the ground.
- ▶ Remove the pin pulling device.
- ▶ Remove the auxiliary crane.



Note

- ▶ Disassemble the derrick boom, see Crane operating instructions, chapter 5.05!

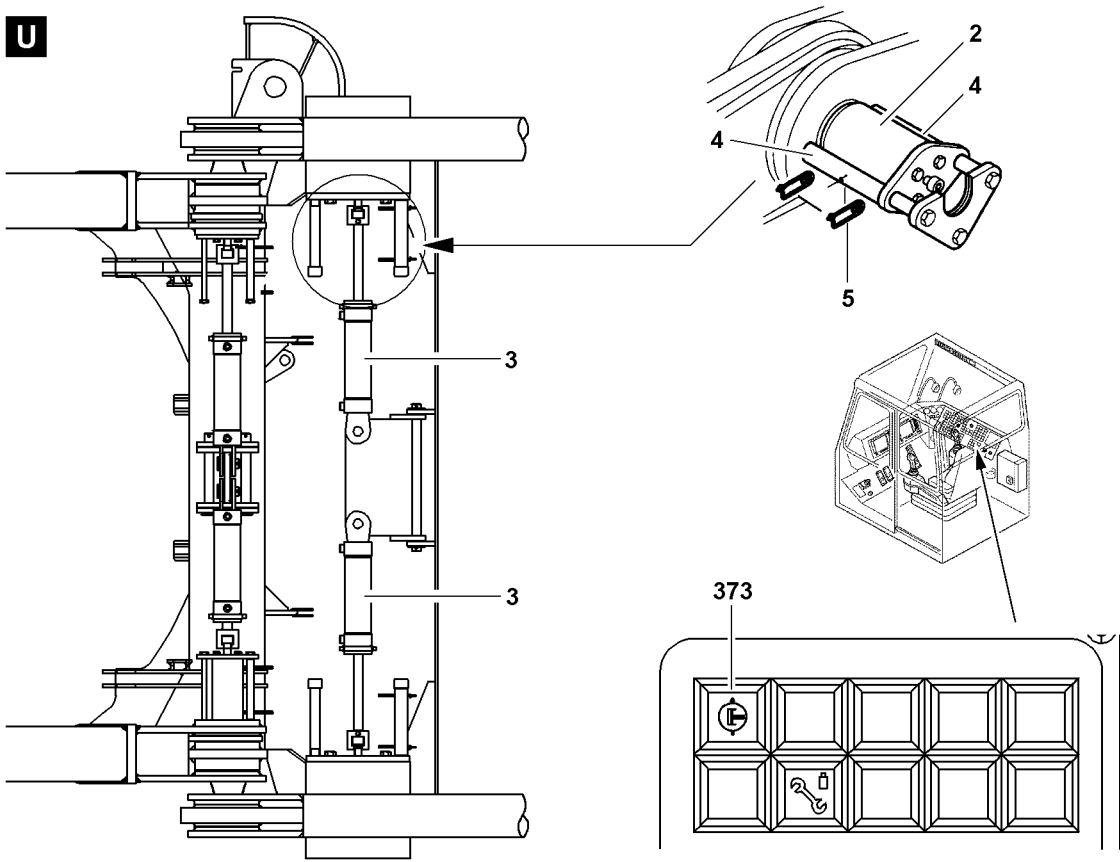
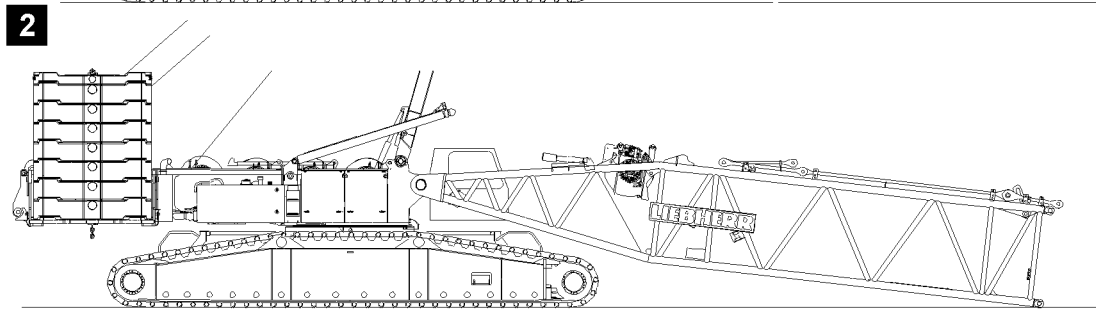
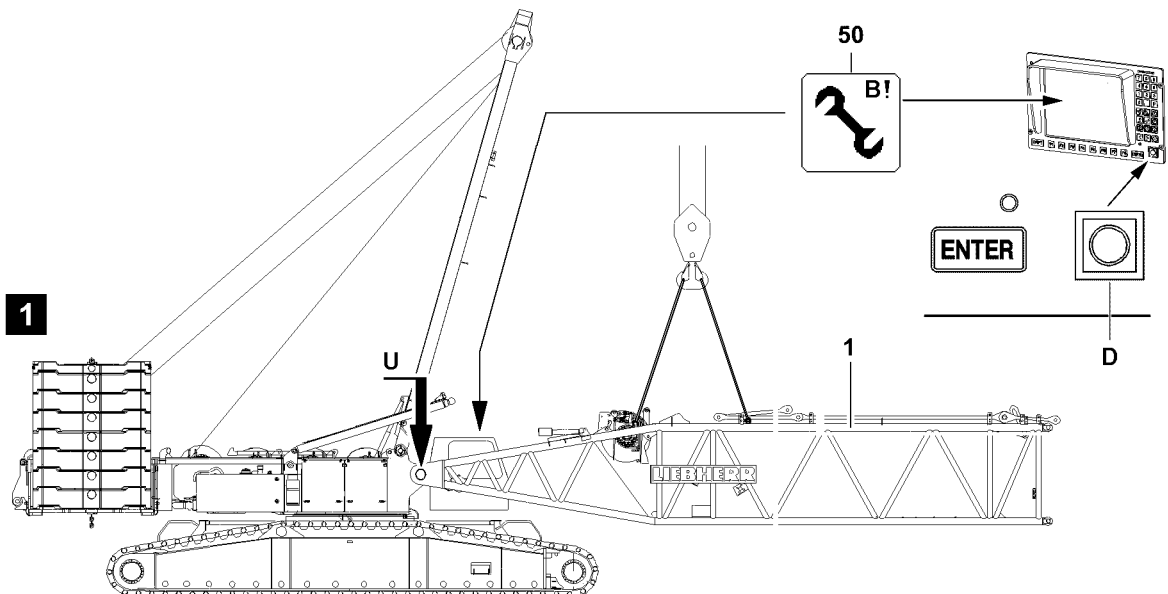

B111470

1 Component overview S-pivot section

Component	Weight
S-pivot section incl. guy rods	7.7 t
Winch 5 including rope	6.3 t
Total weight	14.0 t

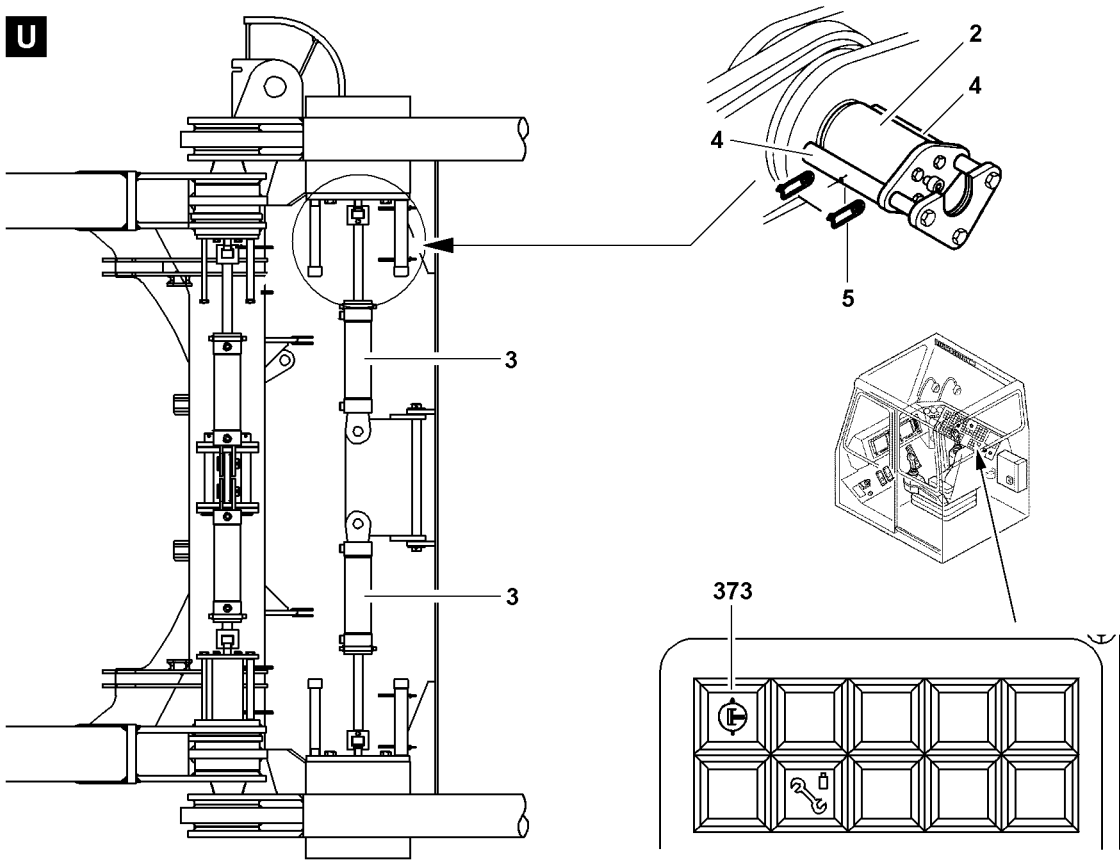
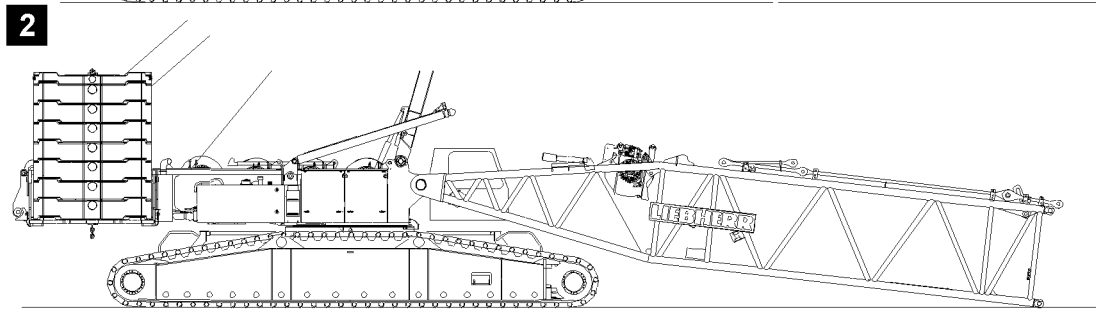
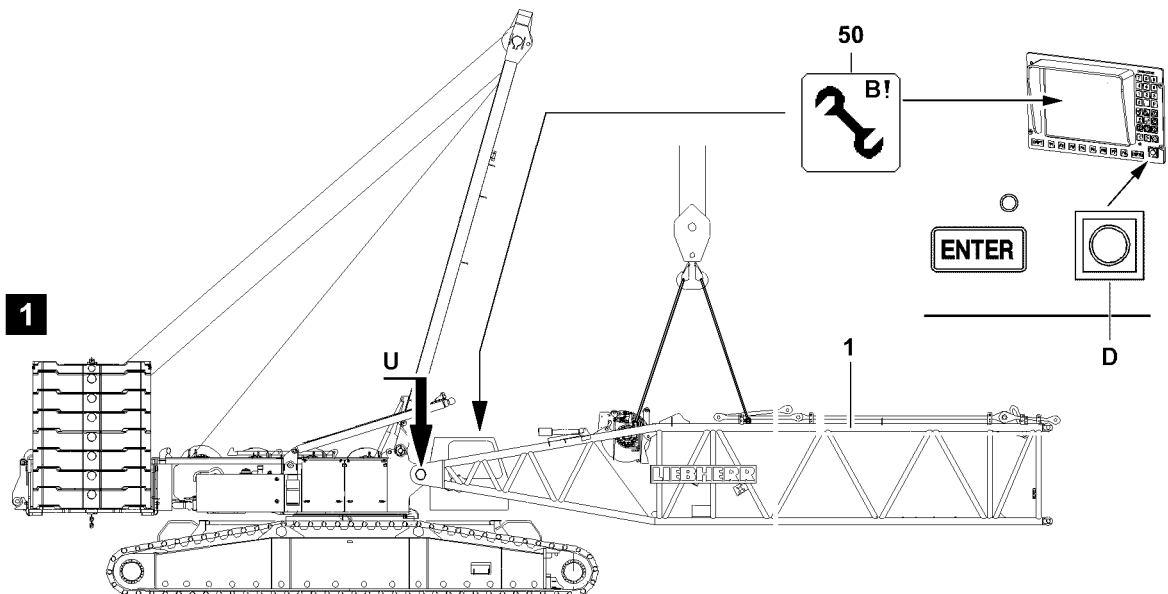

B111470

2 Sw-assembly

The **Sw** -boom comprises lattice sections from the S- and W-systems, as well as a SW-reducer section and W-end section.



WARNING

Risk of falling!

During assembly / disassembly work, personnel must be secured with appropriate aids to prevent them from falling. If this is not observed, assembly personnel can fall and suffer life-threatening or fatal injuries!

- ▶ Any work, where there is a danger of falling must be carried out with suitable aids (for example lifting platform, scaffolding, ladder, auxiliary crane)!
- ▶ If the work cannot be carried out with such aids nor from the ground, then the assembly personnel must secure themselves with approved fall arrest systems to avoid falling, see Crane operating instructions, chapter 2.04!
- ▶ Approved fall arrest systems must be hung into the respective fastening points on the crane, see Crane operating instructions, chapter 2.06!
- ▶ If railings are present on the components, then they must be brought into the corresponding position and secured for assembly / disassembly work!
- ▶ Step on aids and fall protection equipment only with clean shoes!
- ▶ Keep aids and fall protection equipment clean and free from snow and ice!
- ▶ During all assembly and disassembly work, maintenance work and inspections, travel and crane operation is prohibited!



WARNING

Falling components!

If unsecured or non-supported components are installed or removed, they can fall down!

Personnel can be severely injured or killed!

- ▶ During pinning and unpinning of the lattice sections, it is prohibited for anyone to remain **under or on** the components as well as within the entire danger zone!
- ▶ Support the boom and components before pinning / unpinning!
- ▶ Pin or unpin both pins that lie in one horizontal level, i.e. **left and right!**
- ▶ Secure the pins in the bearing points and in the receptacles!
- ▶ Do not disengage the auxiliary crane until each component is pinned on and secured!
- ▶ It is prohibited to lean a ladder against the component being disassembled!



WARNING

Danger of impact / crushing!

When installing / removing crane components with the auxiliary crane, crane components can start to swing back and forth!

When lifting / lowering and positioning crane components, there is an increased danger of impacts / crushing!

Personnel can be severely injured or killed!

- ▶ Make sure that personnel cannot be caught by components!
- ▶ When working in danger zones: Use aids to protect limbs!
- ▶ Guide components with suitable aids to minimize oscillation!

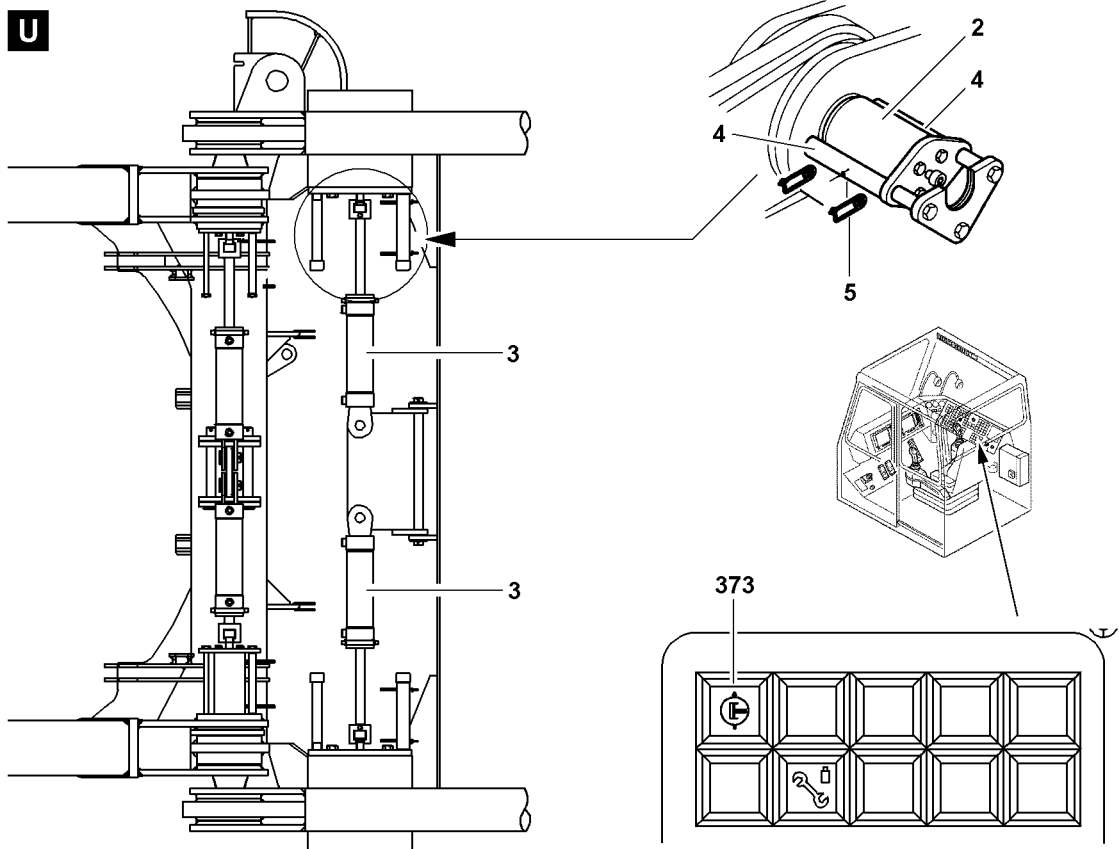
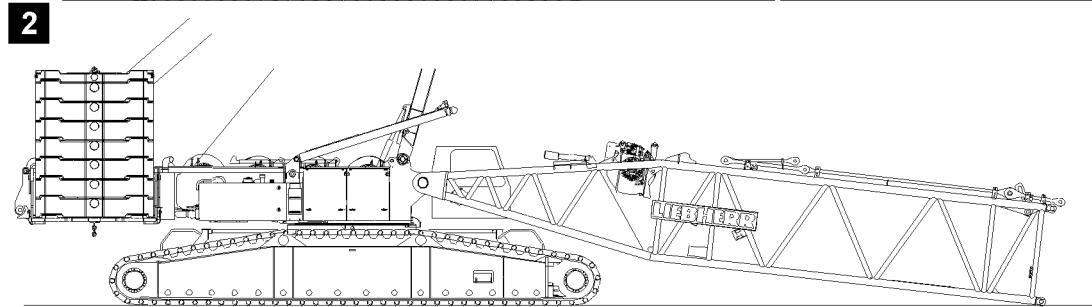
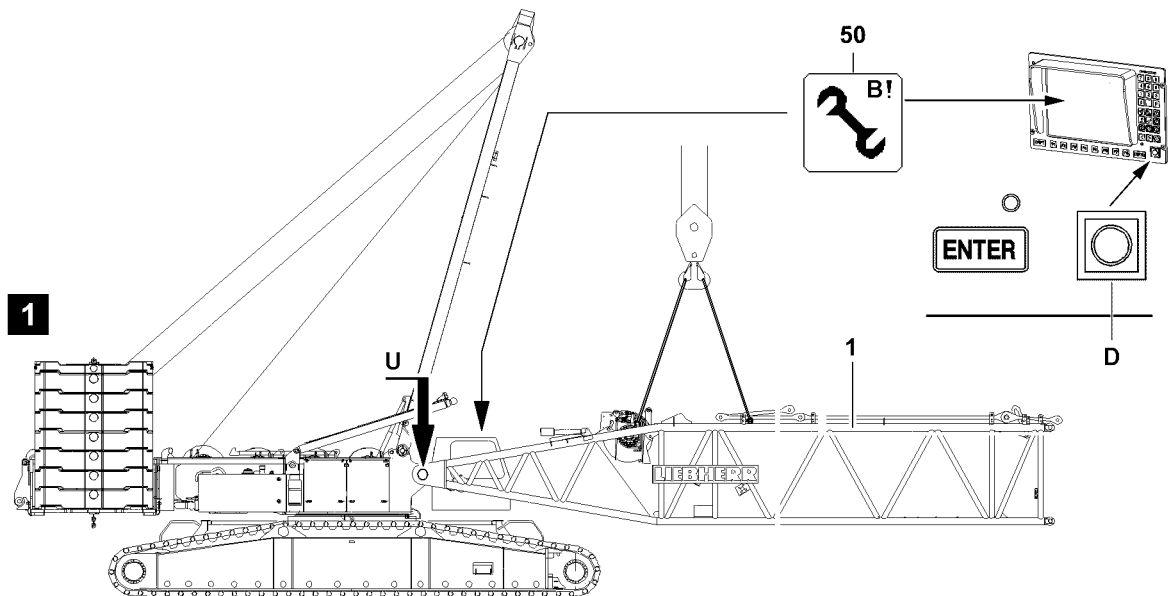

B111470

2.1 Assembling the Sw-boom



WARNING

The crane can topple over!

If the turntable is turned during the assembly of the boom, then the crane can topple over and be severely damaged! Personnel can be severely injured or killed!

- ▶ The turntable may not be turned during the assembly of the boom!



WARNING

Risk of accident!

If the following instructions are not observed, personnel can be severely injured or killed!

- ▶ Assembly of boom combinations, see Rod plan and Assembly plan!
- ▶ Depending on the condition of the ground, the boom and the lattice sections must be supported from below for the assembly of the boom!
- ▶ Observe the safety technical notes, see Crane operating instructions, chapter 5.01!

Make sure that the following prerequisites are met:

- The crane is aligned in horizontal direction.
- An auxiliary crane is available.
- An assembly scaffolding / work platform is available.
- The counterweight has been installed on the turntable according to the load chart.
- The LICCON overload protection has been set according to the data in the load chart.

2.1.1 Turning the turntable into assembly position



DANGER

The crane can topple over!

If the following conditions are not met before turning the turntable - **without** installed boom, the crane can topple over!

Personnel can be severely injured or killed!

- ▶ Observe the data in the erection and take down charts!
- ▶ If no boom is installed on the turntable, max. 135 t counterweight may be installed and when turning the turntable by 360 °, it must be ensured that the SA-bracket is erected to **more than 90 °** !
- ▶ If the counterweight is increased to 155 t, then the boom must be installed and raised off the ground!

Maximum counterweight	Minimum central ballast	Equipment
55 t	11 t	Without equipment
95 t	11 t	
135 t	43 t	
155 t	43 t	Boom installed and raised off the ground

- ▶ Turn the turntable in longitudinal axle of the crawler travel gear or vertical to the crawler travel gear, see Erection and take down chart.

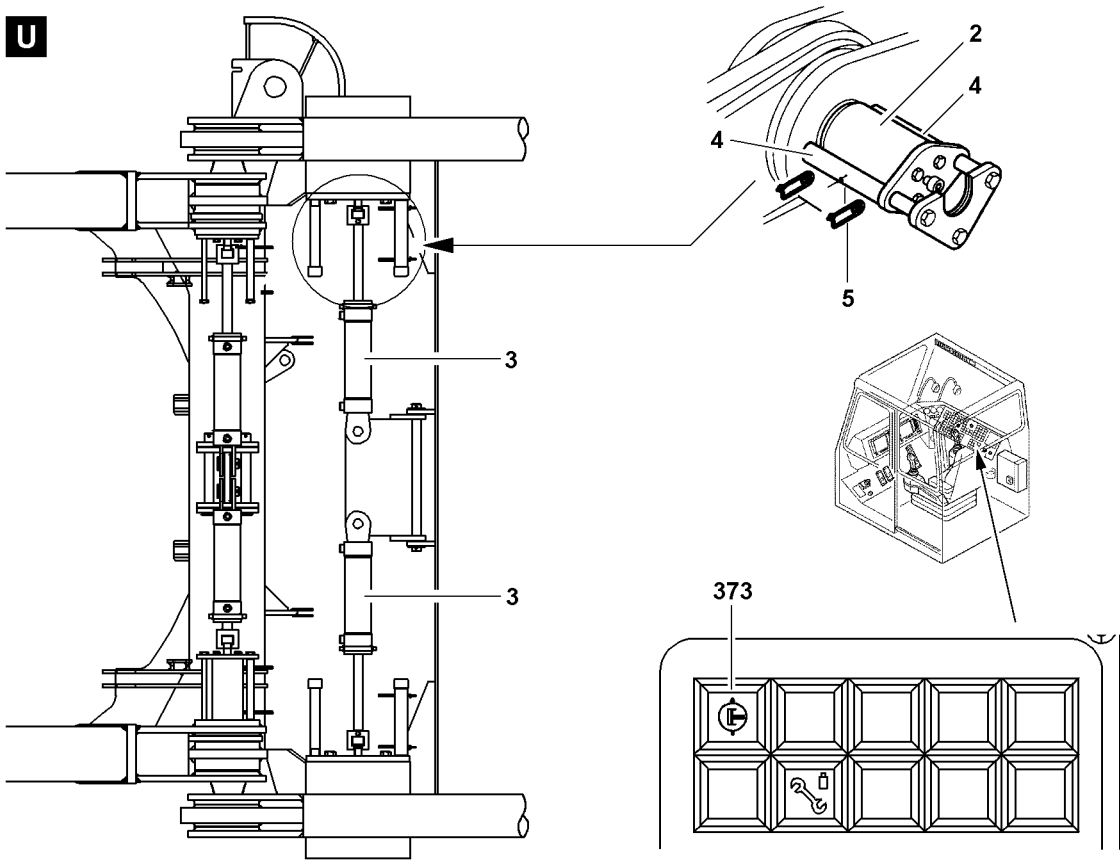
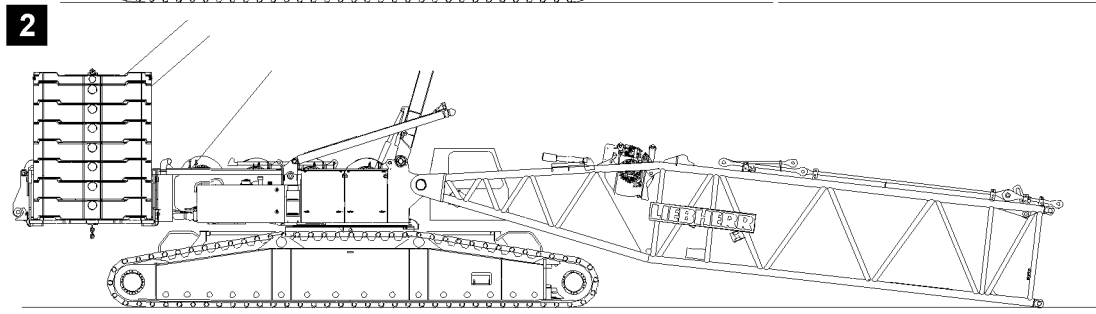
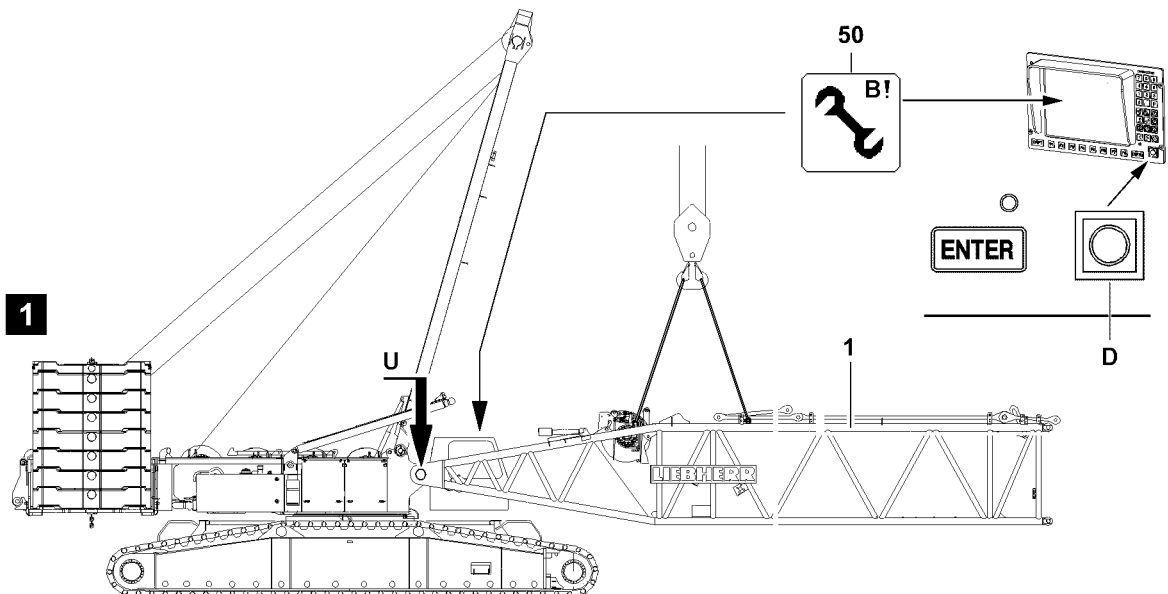

B111470

2.1.2 Exceeding the LICCON overload protection for assembly



WARNING

Assembly with turned on set up key!

When the set up key is turned on, the LICCON overload protection is exceeded!

In the event of deliberate improper use, the crane could collapse, the boom can break off or the crane can topple over!

Personnel can be severely injured or killed!

This could result in high property damage!

- ▶ The set up key **D** may only be actuated by persons who know the effects of a bypass!
 - ▶ Press the set up key **D** only when the set up status was correctly entered into the LICCON computer system!
 - ▶ Observe the erection / take down charts!
 - ▶ Crane operation with the set up key **D** turned on is strictly prohibited!
-

- ▶ Turn the set up key **D** to the right.

Result:

- The LICCON overload protection is deactivated.
- The assembly icon **50** appears on the LICCON monitor.

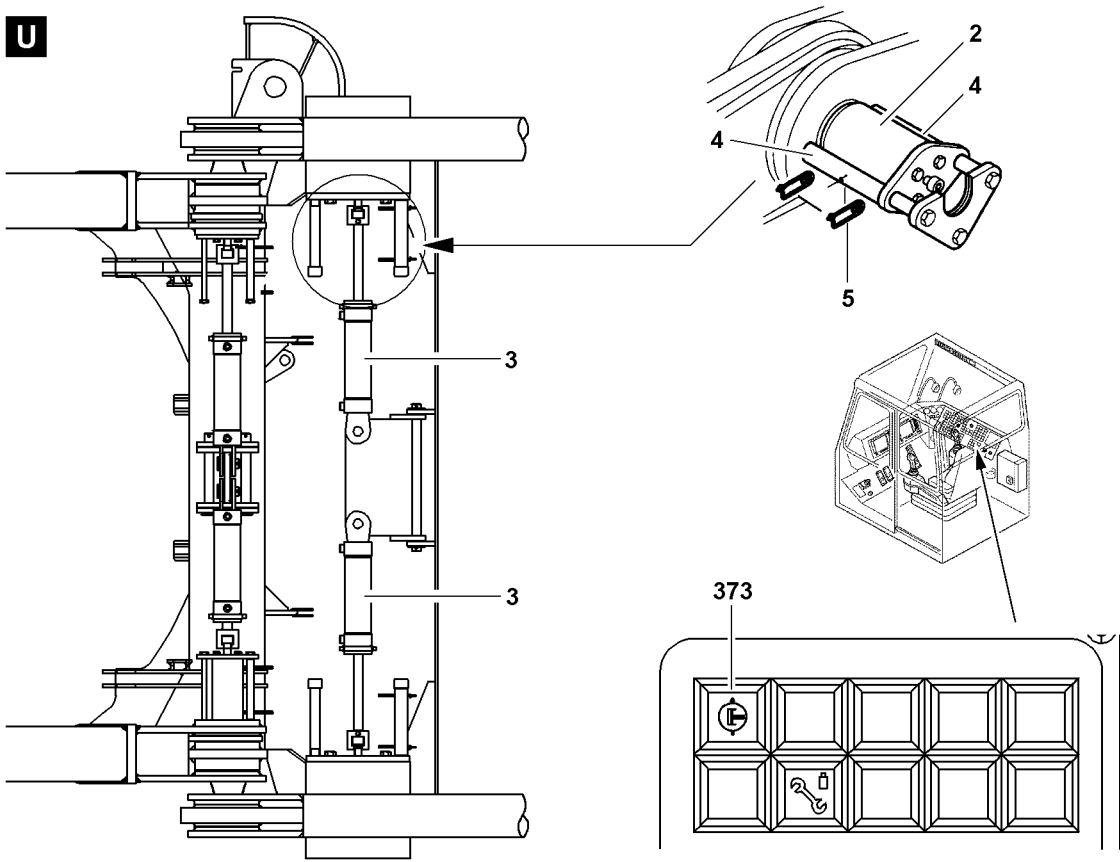
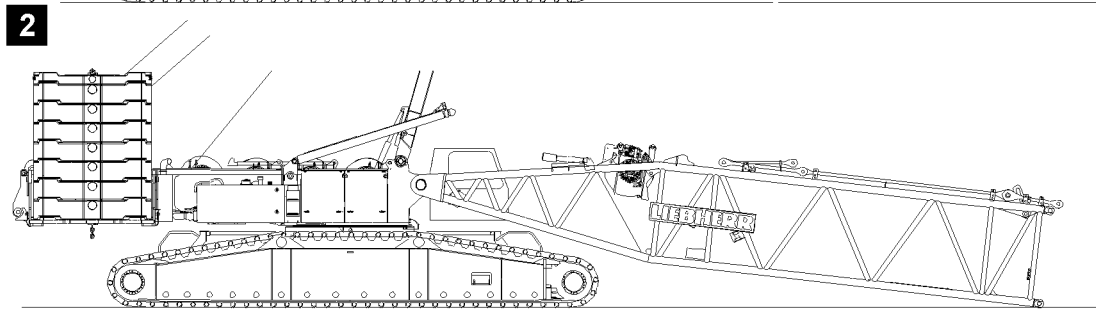
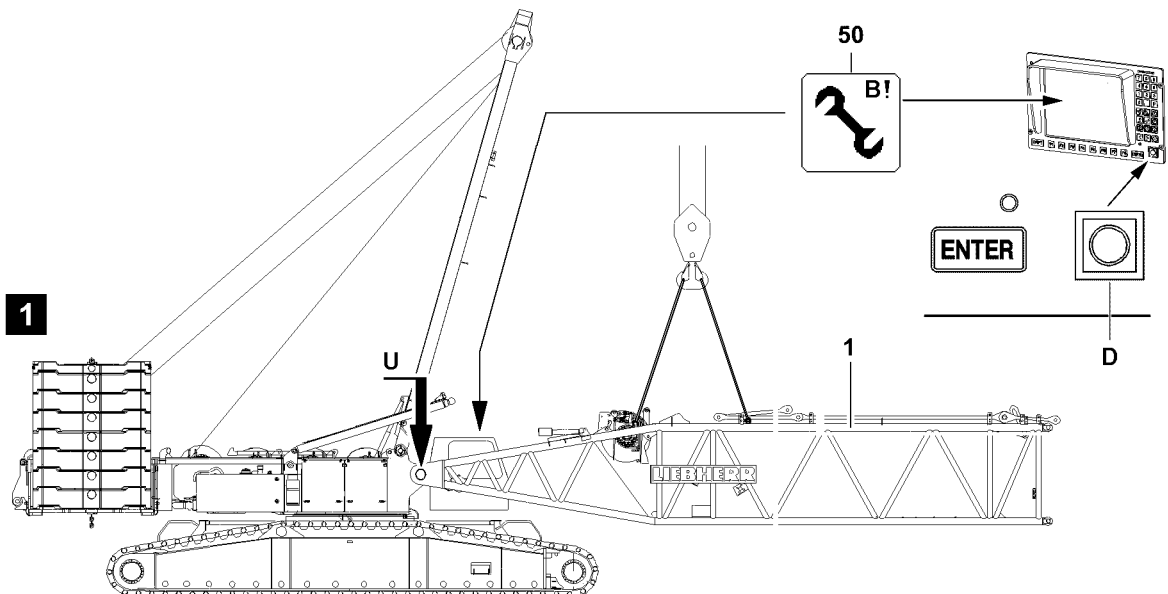

B111470

2.2 Pinning the S-pivot section on the turntable



WARNING

General danger notes!

- ▶ Support the Sw-boom during assembly with suitable materials!
- ▶ All pins are to be secured after assembly with the intended safety elements!
- ▶ The guy rods must be inspected regularly, see Crane operating instructions, chapter 8.15!

- ▶ Hang the S-pivot section **1** onto the auxiliary crane and swing in to the pin points on the turntable, illustration **1**.

Establish the hydraulic connection to the pin pulling device via two quick couplers.

Pin the S-pivot section **1** on the turntable and secure.

- ▶ Establish the hydraulic connection to the pin pulling device.
- ▶ Turn the pressure change over switch **373** on.



WARNING

Falling S-pivot section!

Due to non-secured or insufficiently secured connector pins, the S-pivot section can fall down!

Personnel can be severely injured or killed!

- ▶ The connector pins **2** between the S-pivot section **1** and the turntable must be secured after the pin procedure with the retaining plates **4**!

- ▶ Insert the connector pins **2** with the hydraulic pin pulling device **3**.
- ▶ When the connector pins **2** are completely pinned on the left and right on the S-pivot section:
Secure the connector pin **2** on the left and right with the retaining plate **4** and the spring retainer **5**.
- ▶ Turn the pressure change over switch **373** off.

NOTICE

Damage to the S-pivot section!

Property damage can occur on the S-pivot section by placing the installed S-pivot section on the ground!

- ▶ Slowly place the S-pivot section with the auxiliary crane and at low speed on the ground!
- ▶ Before placing it on the ground, support the S-pivot section!

- ▶ Carefully place the S-pivot section down.
- ▶ Remove the auxiliary crane.

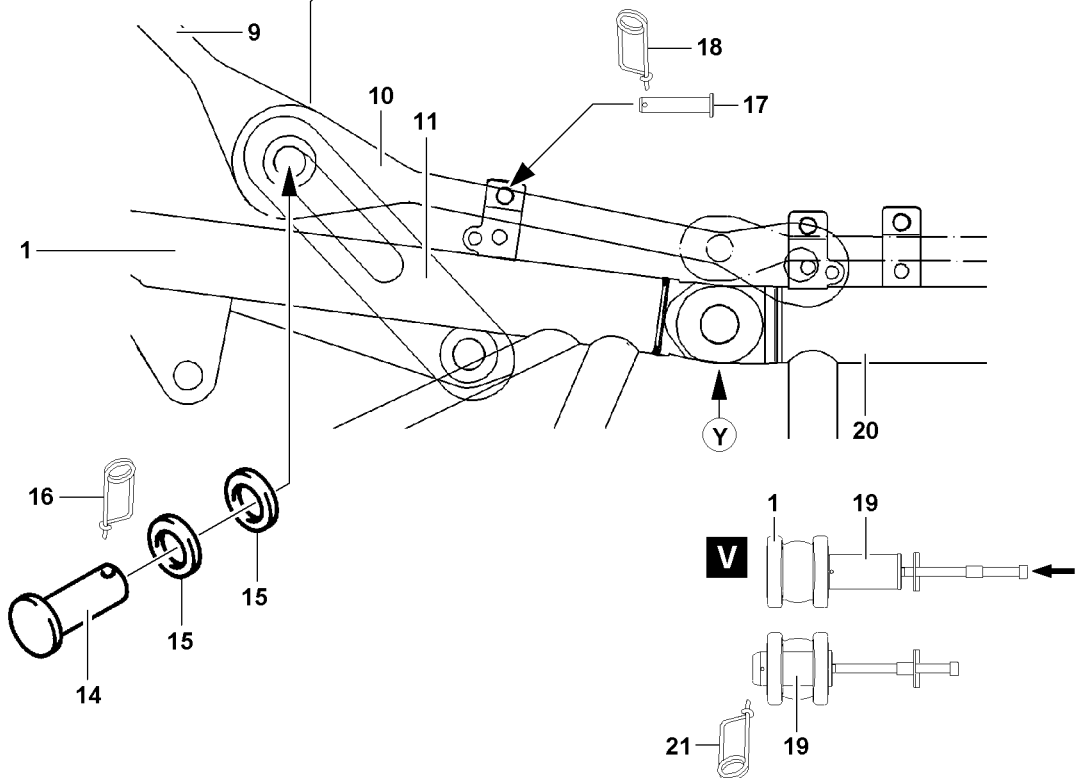
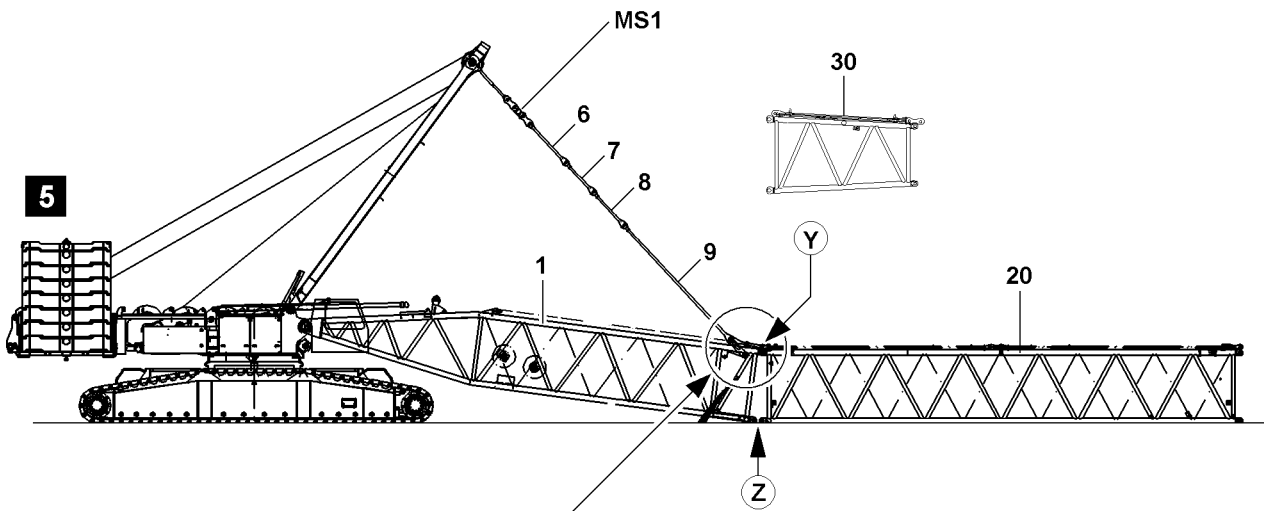
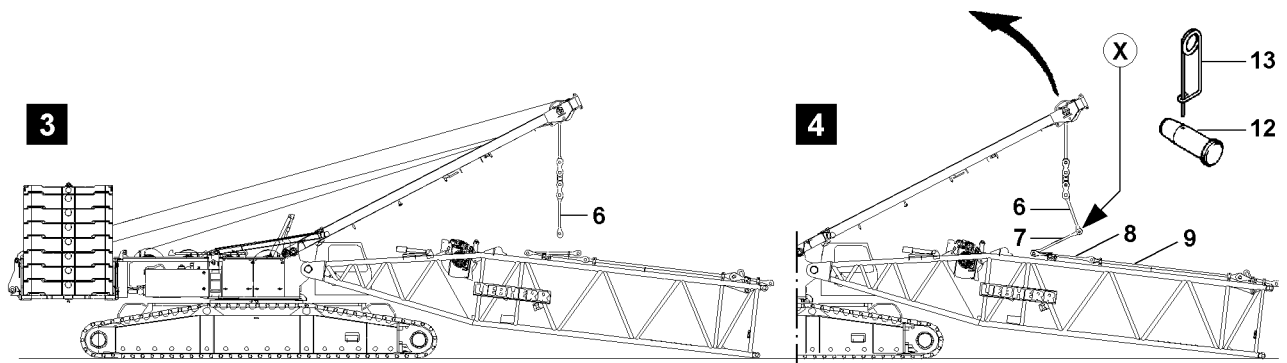

B105908

2.3 Fitting the S-intermediate sections, SW-reducer section and W-intermediate sections

2.3.1 Fitting the S-intermediate section(s) or SW-reducer section onto the S-pivot section

Make sure that the following prerequisites are met:

- The S-pivot section is pinned and secured on the turntable.
- The S-pivot section is placed on the ground.
- The auxiliary crane is removed.



WARNING

General danger notes!

- ▶ All pins are to be secured after assembly with the intended safety elements!
- ▶ The guy rods must be inspected regularly, see Crane operating instructions, chapter 8.15!



Note

- ▶ To pin the S- and W-intermediate sections, the pin pulling device can be used, see Crane operating instructions, chapter 5.30!

In order to fit the S-intermediate section or SW-reducer section onto the S-pivot section, use the SA-bracket guy rods.

- ▶ Remove the transport retainers for the guy rods on the SA-bracket.
- ▶ Remove the transport retainers for the guy rods on the S-pivot section.
- ▶ Lower the SA-bracket to the front until the guy rods **6** hang freely over the guy rods **7** of the S-intermediate section **20**, illustration **3**.

Pin the guy rods **6** of the SA-bracket with the guy rods **7** on the S-pivot section.

- ▶ Insert the pin **12** at point **X** from the “inside” to the “outside” and secure with spring retainer **13**, illustration **4**.

Pin and secure the assembly brackets **11** on the connector point of the guy rods **9** and guy rods **10**, use washers **15**.

- ▶ Insert the pins **14** into the hollow axle and secure with spring retainers **16**.
- ▶ Erect the SA-bracket until the guy rods are completely tensioned, illustration **5**.



Note

- ▶ The S-guy rods must be installed and secured, see Assembly drawings! The numbering on the assembly drawings must be identical to the numbering on the guy rods!

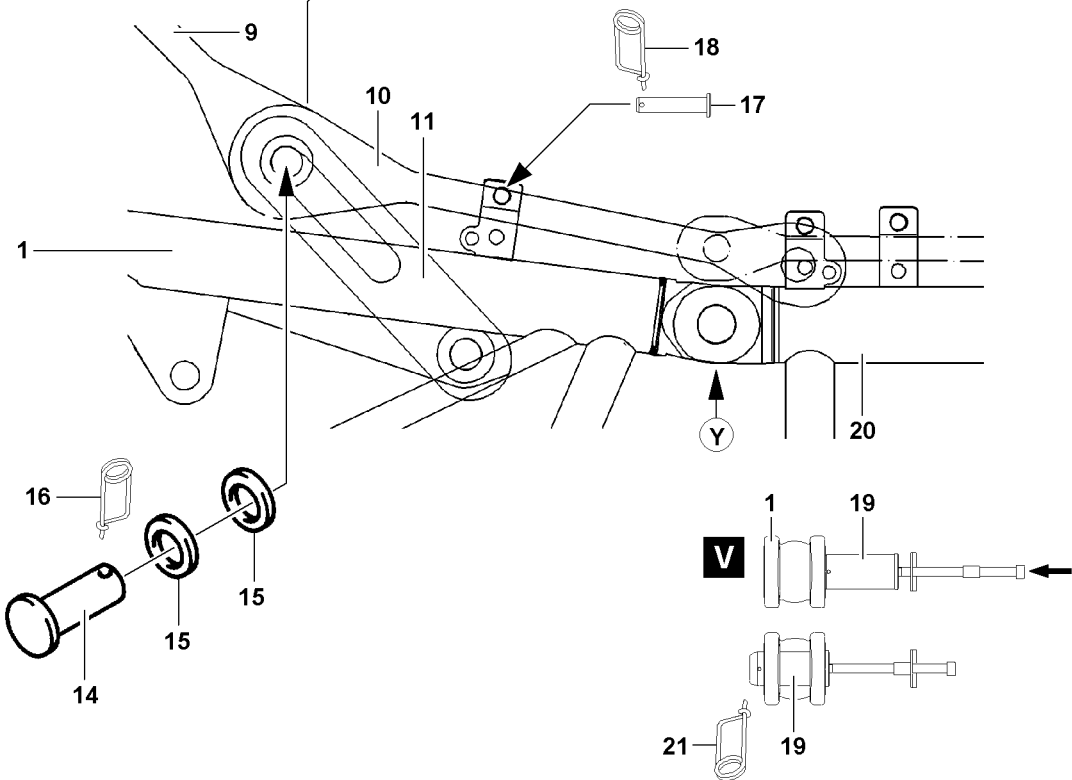
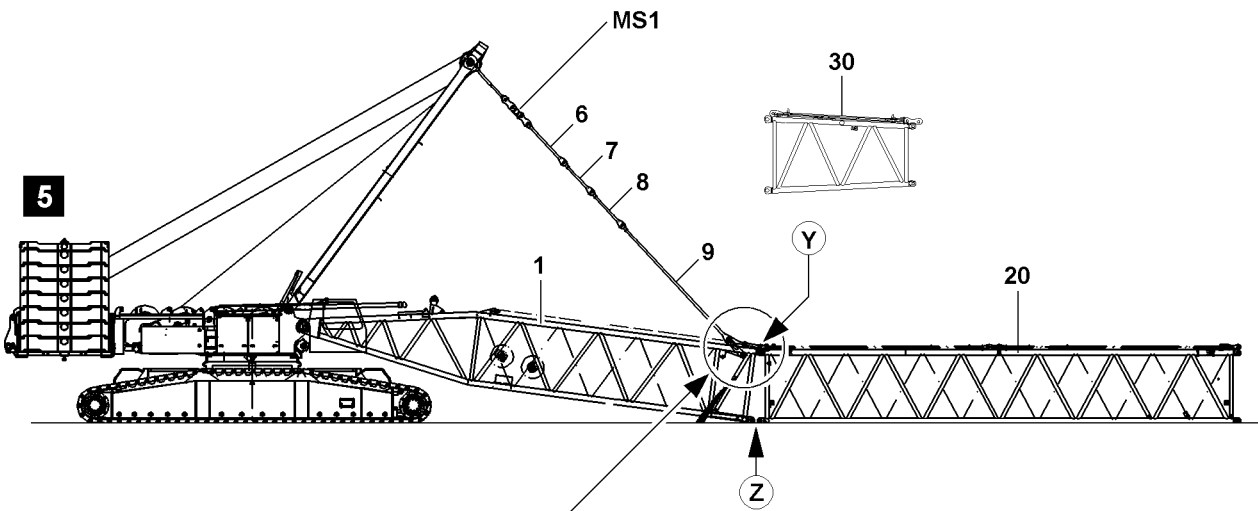
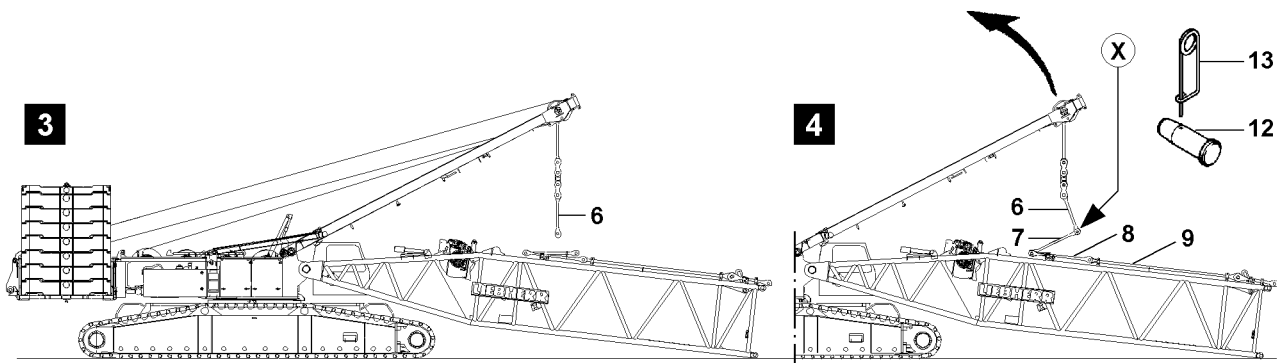

The guy rods are placed and secured for transport on the intermediate sections. The transport retainers must be removed before assembly of the guy rods.

- ▶ Release the transport retainers of the guy rods on the S-intermediate sections: Remove the spring retainer **18** and unpin the pin **17**.

Pin the S-intermediate section **20** or SW-reducer section **30** on the S-pivot section **1** "on top".

- ▶ Fasten the S-intermediate section **20** on the auxiliary crane and align on the S-pivot section **1**, illustration **5**.
- ▶ When the pin bores on the S-pivot section **1** and on the S-intermediate section **20** "on top" (point **Y**) align, illustration **5**:
Insert the pin **19** from the inside to the outside and secure with spring retainer **21**, illustration **5**.

or

- Attach the SW-reducer section **30** onto the auxiliary crane and align to the S-pivot section **1**.
- ▶ When the pin bores on the S-pivot section **1** and SW-reducer section **30** "on top" (point **Y**) align, illustration **5**:
Insert the pin **19** from the inside to the outside and secure with spring retainer **21**, illustration **5**.



WARNING

The crane can topple over!

If the following conditions are not met, the crane can topple over or be significantly damaged!

Personnel can be severely injured or killed!

- ▶ During the "Closing procedure" of the Sw-boom, the maximum permissible total force on test point **MS1** of 100 t may **not** be exceeded!
- ▶ The end section of the Sw-boom should **not** lift off the ground during "Closure"!
- ▶ With the SA-bracket, Sw-booms up to maximum **Sw 98 m** may be lifted / closed!



Note

- ▶ The actual force on the test point MS1 - which is exerted during the closing procedure of the boom system - is shown on the LICCON monitor 1!
- ▶ Record the actual force and keep it ready for the disassembly of the boom system!
- ▶ During the boom disassembly, the guying is tensioned with the noted actual force (assembly) so that the connector pins of the intermediate sections can be unpinned!

Assemble the Sw-boom to the required length and either pin and secure to the S-intermediate section **20** or the SW-reducer section **30** "top" and "bottom".

- ▶ Insert the pin **19** from the inside to the outside and secure with spring retainer **21**.
- ▶ When the Sw-boom is assembled to the desired length:
Lift the S-pivot section **1** with the SA-bracket until the pin bores on the "bottom" align at point **Z**, illustration **5**.
- ▶ Read the actual force of the test point 1 (MS1) on the LICCON monitor and record it.
- ▶ Insert the pin **19** on point **Z** from the inside to the outside and secure with spring retainer **21**.

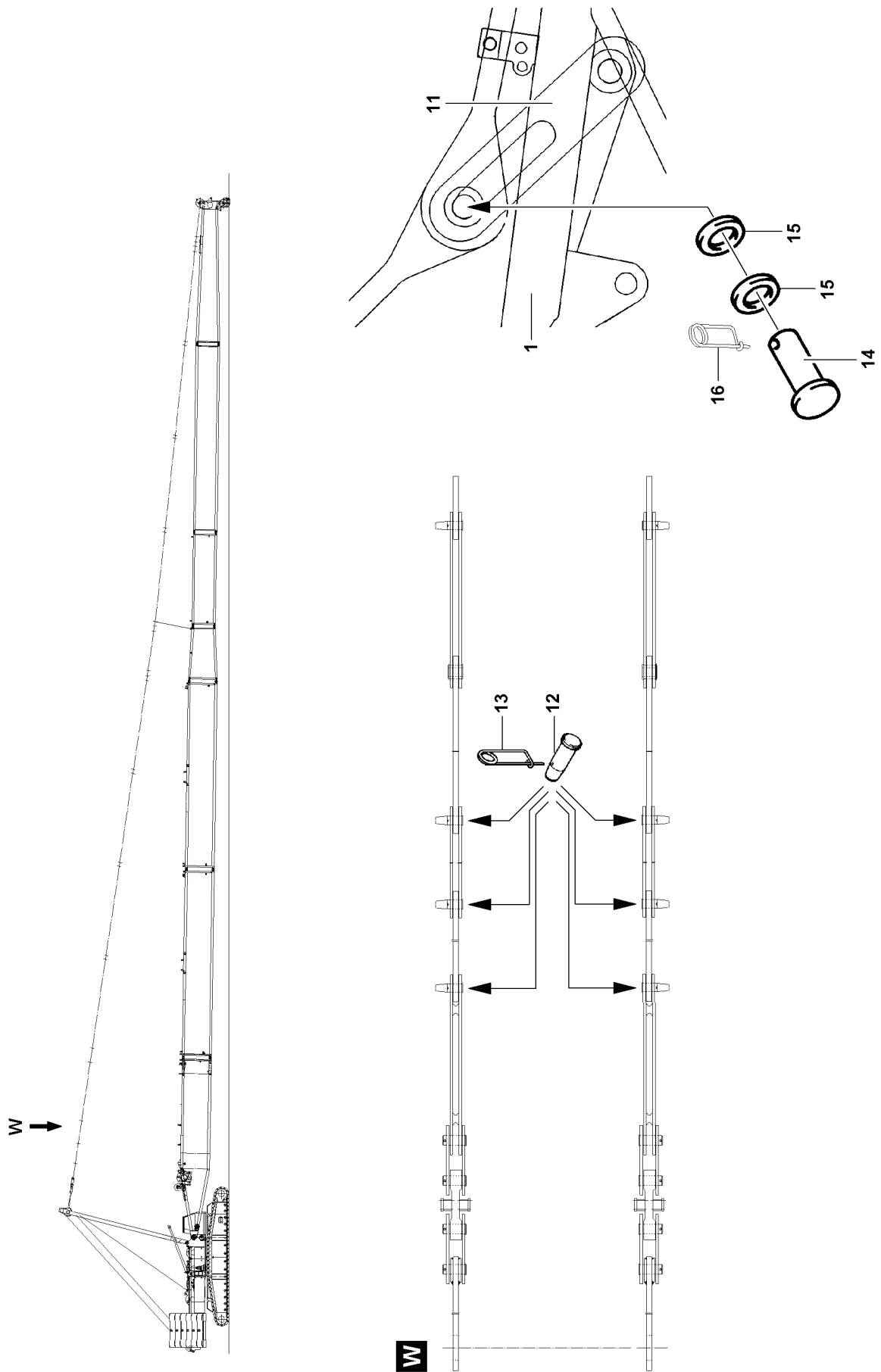

B105904

2.3.2 Assembling the guy rods



WARNING

Neglected inspection and maintenance on guy rods!

If the regular inspection and maintenance of the guy rods is not carried out or only in irregular intervals, then severe accidents can occur due to existing and unrecognized damage on the guy rods! Personnel can be severely injured or killed!

- ▶ The guy rods must be checked before every assembly, see Crane operating instructions, chapter 8.15!



Note

- ▶ The S-guy rods must be installed and secured, see Assembly drawings! The numbering on the assembly drawings must be identical to the numbering on the guy rods!

Make sure that the following prerequisite is met:

- The Sw-boom is pinned and secured to the S-pivot section.
- ▶ Relieve the guy rods between the SA-bracket and the S-pivot section: Lower the SA-bracket somewhat to the front.

Result:

- The guy rods between the SA-bracket and the S-pivot section are relieved.

The guy rods are placed and secured for transport on the corresponding intermediate sections. Before assembly, the transport retainers must be released.

- ▶ Release the transport retainers on the guy rods.

NOTICE

Danger of property damage!

If the pins of the guy rods are not pinned from the “inside” to the “outside”, the hoist rope can scrape on the pin and be damaged!

- ▶ Always insert the pins of the guy rods from the “inside” to the “outside”, see Rod plan!

- ▶ Pin and secure the guy rods for all intermediate sections.
- ▶ Pin the guy rods: Insert the pin **12** from the “inside” to the “outside”.
- ▶ Secure the pin **12** with spring retainer **13**.



WARNING

The boom can suddenly fold down!

If the pins **14** on the assembly bracket **11** are unpinned, then the boom can fold down!

Personnel can be severely injured or killed!

- ▶ Unpin the pins **14** on the assembly brackets **11** only when it is ensured that the intermediate sections are supported with suitable materials or if they are held by an auxiliary crane!
- ▶ When all guy rods on the boom system are pinned:
Release and unpin the pin **14** on the hollow axle of the assembly bracket **11**.
- ▶ Actuate winch 4 until the guy rods are tensioned between the SA-bracket and the W-end section.

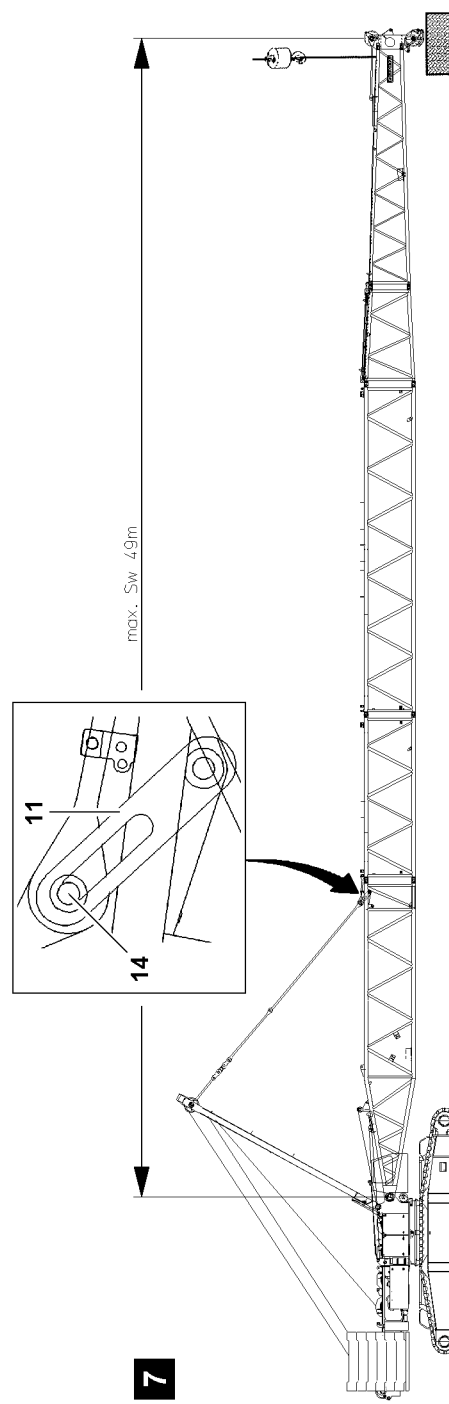
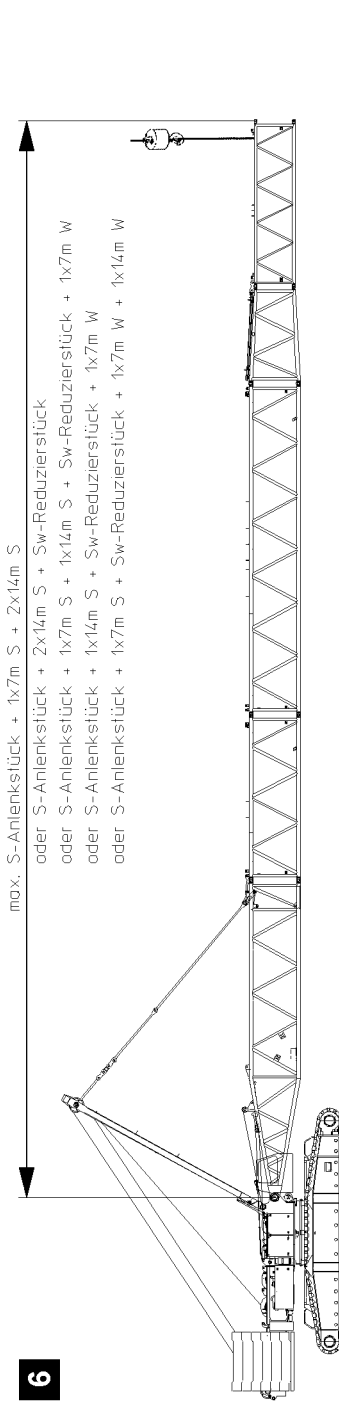

B111485

2.4 Flying assembly of the intermediate sections

If spatial prerequisites on the job site are limited for the assembly of the boom, or if they are limited by buildings or similar, then the boom can be installed in "Flying mode".



WARNING

General danger notes!

- ▶ Support the boom during assembly / disassembly with suitable materials!
- ▶ All pins are to be secured after assembly with the intended safety elements!
- ▶ The guy rods must be inspected regularly, see Crane operating instructions, chapter 8.15!
- ▶ Secure the boom with support or auxiliary crane, see Crane operating instructions, chapter 5.01!



WARNING

The crane can topple over!

If the following conditions are not met, the crane can topple over or be significantly damaged!

Personnel can be severely injured or killed!

- ▶ For the "flying" boom assembly, the maximum permissible total force on the test point **MS1** may **not** be exceeded. The "Actual force" is shown on LICCON monitor 1!
- ▶ The following system lengths may only be installed in "Flying mode" if it has been ensured that a counterweight of at least 55 t has been installed on the turntable and a 43 t central ballast is installed on the crawler center section!
- ▶ The maximum permissible system lengths may not be exceeded, refer to the following table!

	Maximum permissible system lengths for a maximum total force MS1 100 t					
	49.0 m	48.4 m	45.5 m	45.5 m	38.5 m	45.5 m
	DB _{min} ¹⁾ 55 t / ZB _{min} ²⁾ 43 t					
S-pivot section 13.4 m	1x	1x	1x	1x	1x	1x
S-intermediate section 7.0 m	1x	1x	—	1x	—	1x
S-intermediate section 14.0 m	—	2x	2x	1x	1x	—
SW-reducer section 4.1 m	1x	—	1x	1x	1x	1x
W-intermediate section 7.0 m	—	—	—	1x	1x	1x
W-intermediate section 14.0 m	1x	—	—	—	—	1x
W-end section 10.5 m	1x	—	—	—	—	—

1) This counterweight **must** be at least installed on the turntable for "Flying assembly".

2) This central ballast **must** be at least installed on the crawler center section for "Flying assembly".

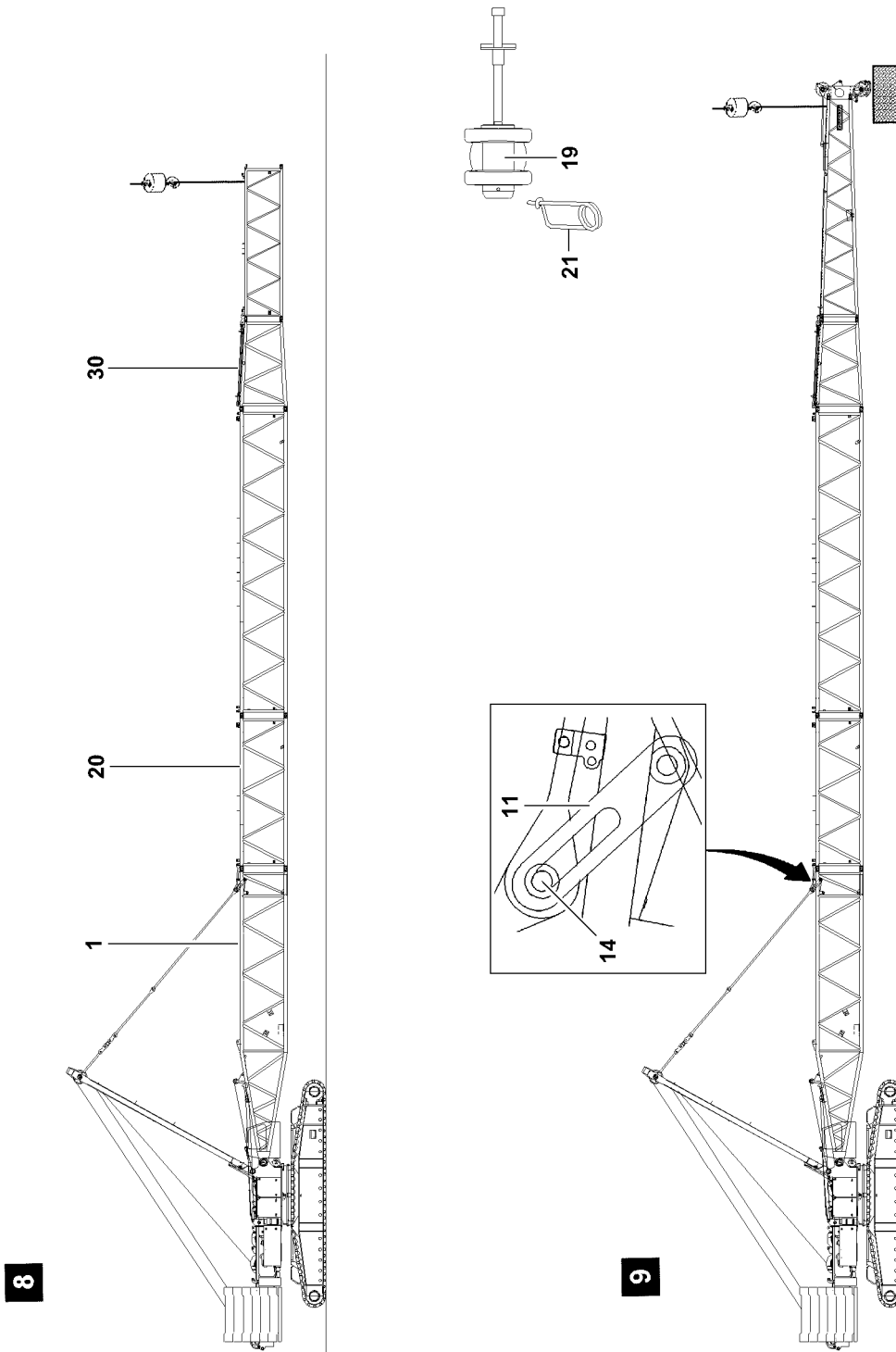

B111486

2.4.1 Assembling the intermediate sections in “Flying mode” on the S-pivot section



WARNING

Impermissible boom lengths!

If impermissible boom lengths are assembled on the crane, significant property damage can occur on the crane!

Personnel can be severely injured or killed!

- ▶ The maximum permissible boom lengths for the “Flying assembly” may not be exceeded!
- ▶ The data in the erection and take down charts as well as the load charts must be observed!



Note

- ▶ For weights of intermediate sections with placed guy rods, see Crane operating instructions, chapter 5.03!

Make sure that the following prerequisites are met:

- The S-pivot section is pinned and secured on the turntable.
- The S-pivot section is horizontally tensioned.
- A minimum of 55 t counterweight is placed on the turntable.
- A minimum of 43 t central ballast is installed on the crawler center section.
- An auxiliary crane is available.



WARNING

Falling components!

If unsecured or non-supported components are installed or removed, they can fall down! Personnel can be severely injured or killed!

- ▶ During pinning and unpinning of the intermediate sections, it is prohibited for anyone to remain **under** or **on** the components as well as within the entire danger zone!
- ▶ Before unpinning: Support crane components and boom!
- ▶ Secure the pins in the bearing points and in the receptacles!
- ▶ It is prohibited to lean a ladder against the crane section which is being disassembled!

For “flying” assembly of the intermediate sections, they can be installed individually or as preassembled boom unit on the S-pivot section.

- ▶ Fasten the intermediate sections or preassembled boom unit on the auxiliary crane.
- ▶ Lift the intermediate sections or preassembled boom unit with the auxiliary crane and position on the S-pivot section.
- ▶ When the pin points between the S-pivot section **1** and S-intermediate section **20** or the SW-reducer section **30** or pre-assembled boom unit align “top” and “bottom”:
Pin in the pin **19** on “top” and “bottom” from the inside to the outside and secure with spring retainer **21**.
- ▶ When the pins are properly pinned and secured at the “top” and “bottom” between the S-pivot section **1** and the S-intermediate section **20** or SW-reducer section **30** or the preassembled boom unit:
Remove the auxiliary crane.

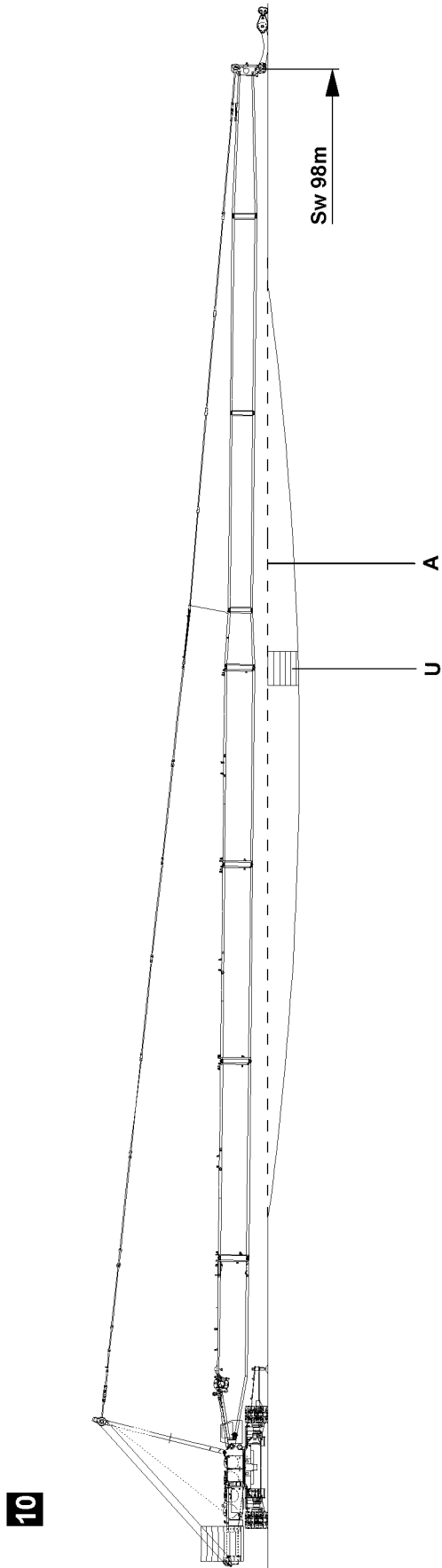

B111484

2.4.2 Assembling the SwD-boom combination with support

In order to assemble the Sw-boom combination on the crane on **uneven ground** without damaging the crane, the Sw-boom combination must be supported with suitable materials of sufficient load-bearing capacity.



Note

- ▶ For boom lengths longer than 98 m, a support must be used!
-

Make sure that the following prerequisite is met:

- The crane is in assembly position.

The S-boom combination - consisting of S-pivot section and S-intermediate sections - should be preassembled in a suitable location. The pre-assembled S-boom combination must be swung in towards the turntable with an auxiliary crane and pinned and secured.

- ▶ Preassemble the S-boom combination.
- ▶ Swing the preassembled S-boom combination in with the auxiliary crane to the turntable.
- ▶ Pin and secure the S-boom combination to the S-pivot section on the turntable.



Note

- ▶ The boom combination must be supported underneath in the area of the reducer section to a height of the alignment level **A**!
-
- ▶ Place the S-boom combination on the support **U** or hang it on the auxiliary crane.
 - ▶ Fully pre-assemble the W-boom combination including the W-end section and attach it to the S-boom combination with the auxiliary crane, or individually install each W-intermediate section and W-end section with the auxiliary crane, pin and secure.

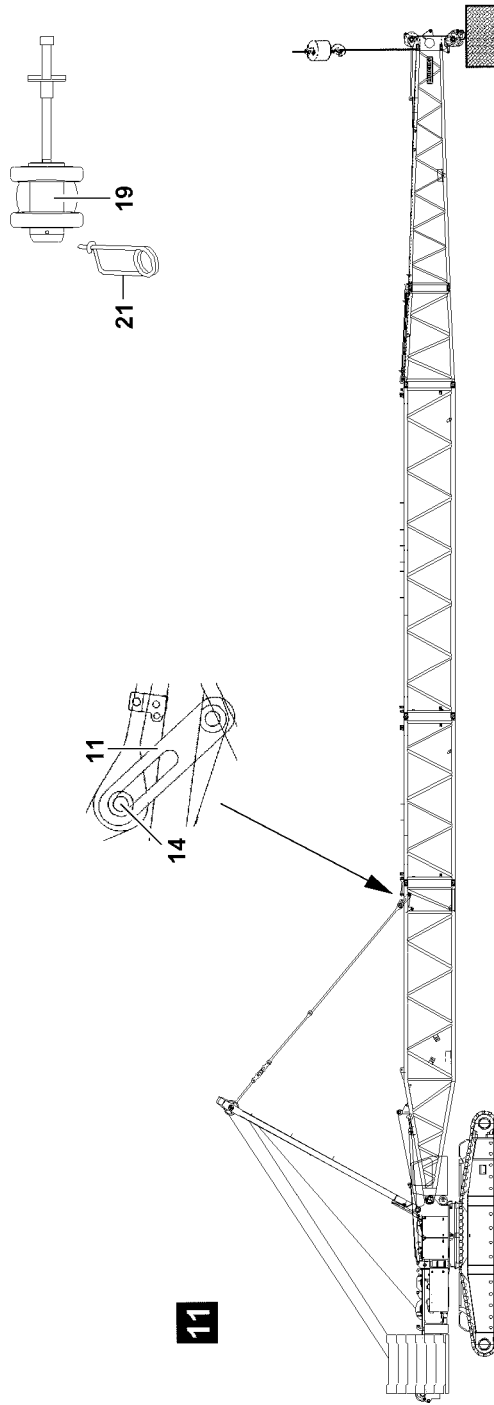

B111483

2.4.3 Assembling the guy rods



WARNING

Neglected inspection and maintenance on guy rods!

If the regular inspection and maintenance of the guy rods is not carried out or only in irregular intervals, then severe accidents can occur due to existing and unrecognized damage on the guy rods! Personnel can be severely injured or killed!

- ▶ The guy rods must be checked before every assembly, see Crane operating instructions, chapter 8.15!



Note

- ▶ The guy rods must be installed and secured according to the separately supplied assembly drawings! The numbering on the assembly drawings must be identical to the numbering on the guy rods!

Make sure that the following prerequisites are met:

- The S-intermediate sections **or** the SW-reducer section **or** the preassembled unit are pinned and secured to the S-pivot section.
- The S-intermediate sections **or** the SW-reducer section **or** the preassembled unit are supported by suitable materials or secured by the auxiliary crane.
- ▶ Relieve the guy rods: Lower the SA-bracket somewhat to the front.

Result:

- The guy rods between the SA-bracket and the S-pivot section are relieved.

The guy rods are placed and secured for transport on the corresponding intermediate sections. Before assembly, the transport retainers must be released.

- ▶ Release the transport retainers on the guy rods.

NOTICE

Danger of property damage!

- ▶ Always insert the pins of the guy rods from the “inside” to the “outside”!
- ▶ Pin and secure the guy rods for all lattice sections.



WARNING

The boom can suddenly fold down!

If the pins **14** on the assembly bracket **11** are unpinned, then the boom can fold down!

Personnel can be severely injured or killed!

- ▶ Unpin the pins **14** on the assembly brackets **11** only when it is ensured that the intermediate sections are supported with suitable materials or if they are held by an auxiliary crane!
- ▶ When all guy rods on the boom system are pinned:
Release and unpin the pin **14** on the hollow axle of the assembly bracket **11**.
- ▶ Actuate winch 4 until the guy rods are tensioned between the SA-bracket and the W-end section.

B195219

2.5 Establishing the electrical connections

NOTICE

Damage to the electrical connection on the cable drum!

If the electrical connection from the cable drum to the terminal box is made in incorrect sequence, then the electrical connection can be damaged when spooling the cable drum out!

- ▶ When establishing the electrical connections, pay attention to the sequence, see Electric wiring diagram!



Note

- ▶ To establish the electrical connections, see Electric wiring diagram!

Make sure that the following prerequisite is met:

- The boom is fully assembled.
- ▶ Establish the electrical connections.
- ▶ Make sure that all electrical connections on the boom are established.

2.6 Establishing the hydraulic connections

When connecting hydraulic lines with quick release couplings, make sure that the coupling procedure is carried out correctly.



WARNING

Pressure in the hydraulic lines!

If the pressure supply is not interrupted before connecting / releasing the hydraulic lines, the hydraulic oil can escape with high pressure!

Personnel can be severely injured or killed!

- ▶ Release the pressure in the hydraulic system before connecting / disconnecting: Interrupt the pressure supply and wait for a short time!



WARNING

Loss of pressure or leakage!

Incorrectly coupled or self-loosening quick release couplings (particularly return lines) can result in serious accidents due to component failure!

- ▶ Check that the quick release couplings have been properly connected before using the crane!
- ▶ Connect the coupling components (sleeve and connector) and screw together with the hand-tightened nut.
- ▶ Tighten the hydraulic coupling by hand. Rotate the hand-tightened nut until it reaches a tangible, fixed stop position.
- ▶ Establish the hydraulic connections.

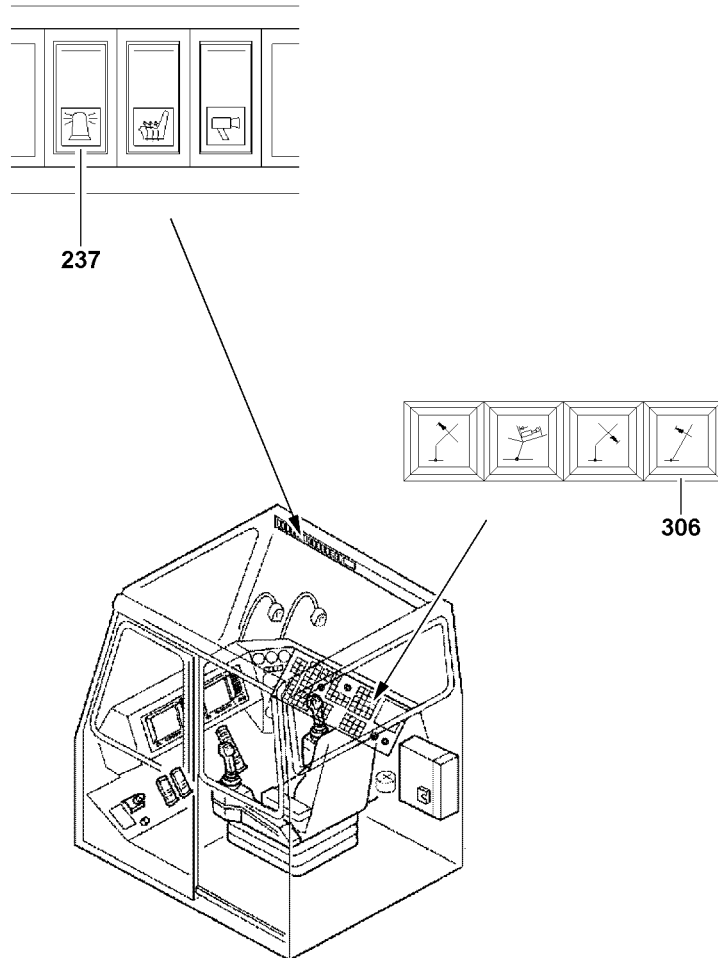

B111471

2.7 Function check



WARNING

Non-functioning safety devices!

If the function of the safety devices is defective, personnel can be severely injured or killed!

- ▶ Crane operation with non-functioning safety devices is **prohibited!**



Note

- ▶ The function of the individual limit switches must be checked before erection!
- ▶ The function of the limit switch initiators must be checked in the test system, see Diagnostics manual!



Note

- ▶ If a function check on the limit switches or on the safety devices does not lead to the desired shut offs, then the plug connections on the connector boxes or the components itself must be checked! If no visible connection errors or component defects can be found, contact LIEBHERR Service!

2.7.1 Wind speed sensor*

- ▶ Check the movement and the function of the wind speed sensor.

2.7.2 Airplane warning light*

- ▶ Turn the airplane warning light on with the switch **237**.
- ▶ Check the function visually.

2.7.3 Hoist limit switch

- ▶ Actuate the limit switch on the pulley head manually.

Result:

- The hoist winch turns off in upward movement.
- The hoist top icon appears on the LICCON monitor 0.
- The limit switch is functioning.

2.7.4 Limit switch boom “Steepest position”



Note

- ▶ The limit switch functions have to be checked individually before erection!

- ▶ Manually actuate the individual limit switches on the S-relapse cylinders.

Result:

- Winch 4 (control winch) turns off in upward movement.
- The indicator light **306** lights up.
- An acoustic signal sounds.
- The limit switch is functioning.

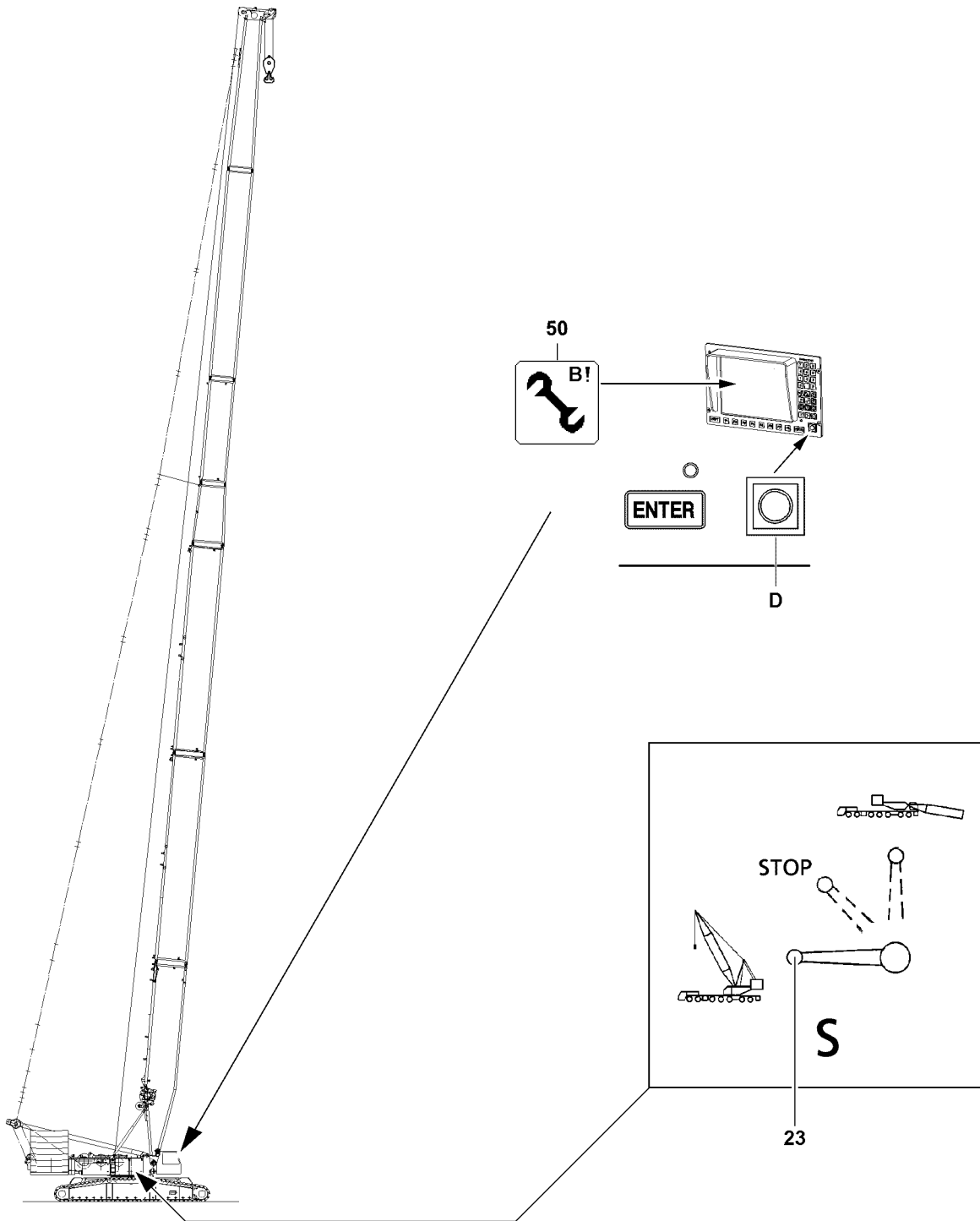

B111481

2.8 Erecting the boom



WARNING

The crane can topple over!

If the following conditions are not met before erecting the boom, the crane can topple over and fatally injure personnel!

- ▶ It is not permitted to turn the crane during erection!
- ▶ Observe the safety technical notes, see Crane operating instructions, chapter 5.01!
- ▶ Observe the data in the erection and take down charts!
- ▶ Extend the relapse cylinder before erection!
- ▶ Do not allow slack cable to build up on the control winch!
- ▶ The ball valve cabinet must be locked! Always pull the key and hand it to an authorized person!

Make sure that the following prerequisites are met:

- The crane is aligned in horizontal direction.
- All electrical connections have been made.
- All limit switches are functioning.
- The counterweight has been installed on the turntable according to the load chart.
- All pin connections have been secured.
- The hoist rope has been correctly placed in the rope pulleys and is prevented from jumping out with the rope retaining pins.
- There are no loose parts on the boom.
- The LICCON overload protection has been set according to the data in the load chart.
- The LICCON overload protection settings have been compared with the actual crane configuration.
- No personnel is within the danger zone.
- The LICCON overload protection is exceeded.
- The assembly icon **50** is visible on the LICCON monitor.

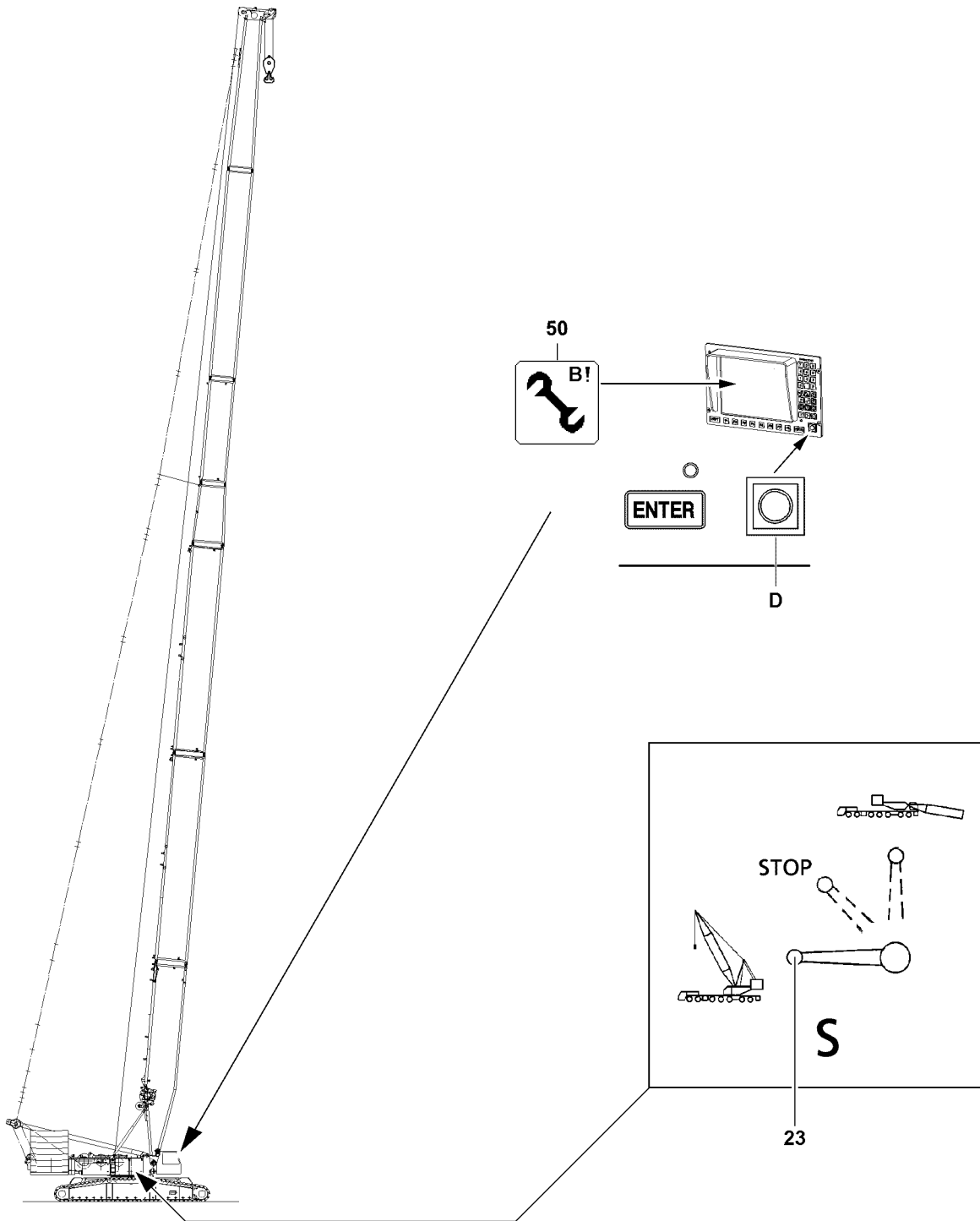

B111481

2.8.1 Extending the S-relapse cylinder



WARNING

The crane can topple over!

If the S-relapse cylinders are not extended before erecting the S-boom, then the S-boom can fall backward during crane operation.

Personnel can be severely injured or killed!

- ▶ The S-relapse cylinders must be extended before erection of the S-boom!
- ▶ The ball valve must be secured during crane operation to prevent unintended actuation!

The piston rod on the S-relapse cylinder must be extended by actuating the ball cock **23**.

Ball valve positions	
Horizontal	Crane operation, extend the piston rod
Vertical	Assembly, retract the piston rod
45 °	STOP (the piston rod cannot be retracted / extended)

Make sure that the following prerequisite is met:

- All hydraulic connections have been made.
- ▶ Move the ball valve **23** into horizontal position.

Result:

- The piston rod of the S-relapse cylinders extends.



Note

- ▶ The ball valve **23** is secured by closing the cabinet door and removing the key!
- ▶ Close the cabinet door and pull the key.
- ▶ Hand the key to an authorized person.

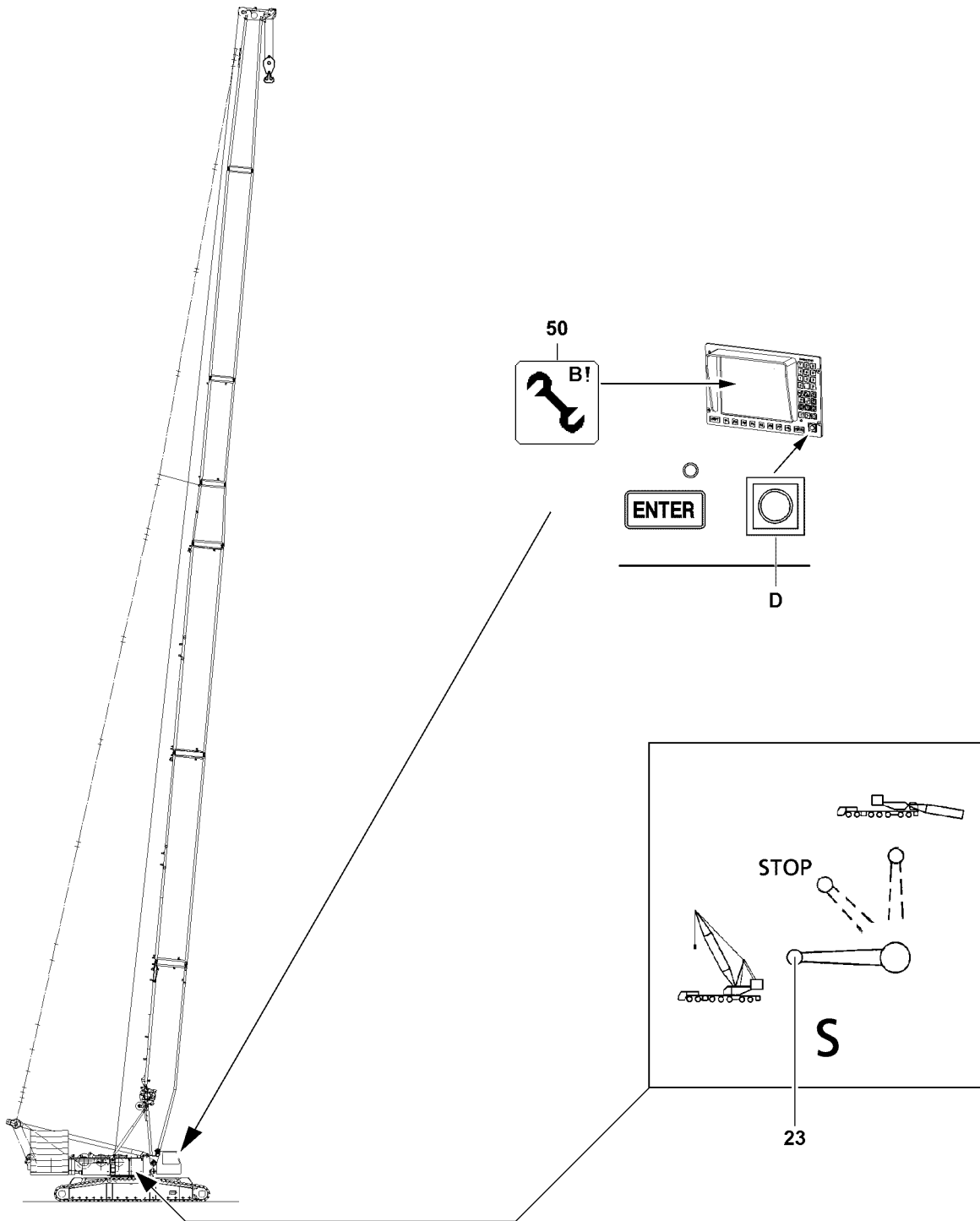

B111481

2.8.2 Erection procedure



DANGER

The crane can topple over!

- ▶ It is not permitted to turn the crane superstructure during erection procedure!
- ▶ Observe the data in the erection and take down charts!

- ▶ Erect the boom until the end section lifts off the ground.



Note

- ▶ Hoist rope reevings, see Crane operating instructions, chapter 4.06 and Reeving plan!

- ▶ Reeve the hook block properly and secure it on the rope fixed point.
- ▶ Attach the hoist limit switch weight.



DANGER

The crane can topple over!

In crane operation with exceeded LICCON overload protection, the crane can topple over! Personnel can be severely injured or killed!

- ▶ The radii listed in the load chart may not be exceeded or fallen below, even if there is no load on the hook!



Note

- ▶ When the lowest operating position of the boom is reached, the LICCON overload protection is activated!
- ▶ In the maximum load icon appears a load number in "t" instead of the display "???"!

- ▶ Luff the boom up to the lowest operating position.
- ▶ When the boom has reached the lowest operating position:
Make sure that the assembly icon **50** on the LICCON monitor turns off.

Result:

- The LICCON overload protection is active.

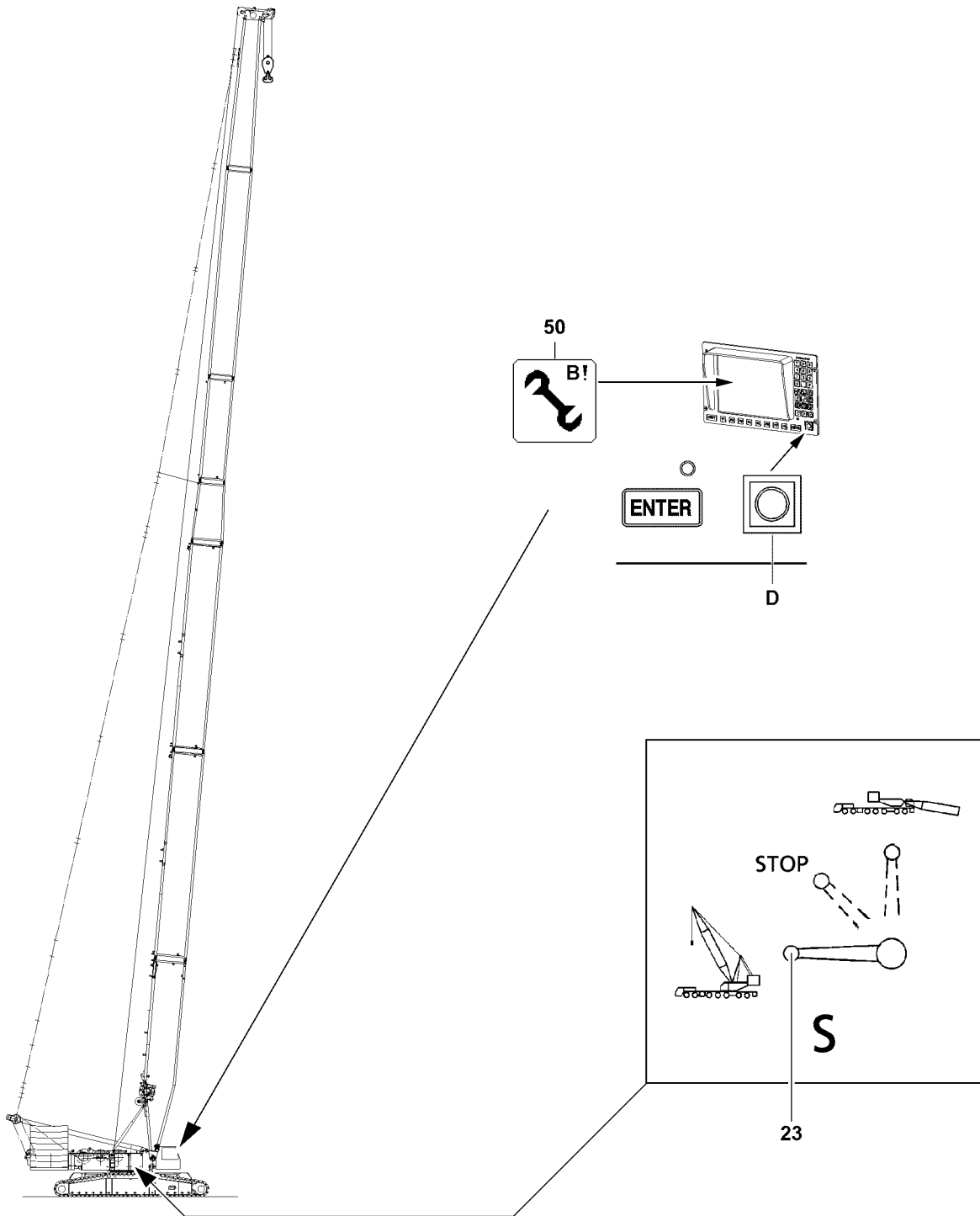

B111481

3 Crane operation

3.1 Preparing for crane operation

**Note**

- ▶ Observe the notes in the chapters, see Crane operating instructions, chapter 4.05, chapter 4.08 and chapter 5.01!

Make sure that the following prerequisites are met:

- The LICCON overload protection is active.
- The LICCON overload protection has been set according to the data in the load chart.

**WARNING**

The crane can topple over!

- ▶ Check the horizontal position of the crane before and during operation!
- ▶ If the crane operator leaves the cab, even for a short time, the operating mode setting must be checked and reset if necessary before resuming crane operation!

3.1.1 Checking the settings

- ▶ Check the function of the overload protection by running against the operating positions “on top” and “bottom”.
- ▶ Check the hoist limit switch by running against the hoist limit switch weight.
- ▶ Check the function of the limit switches “Boom steep” on the relapse cylinders.

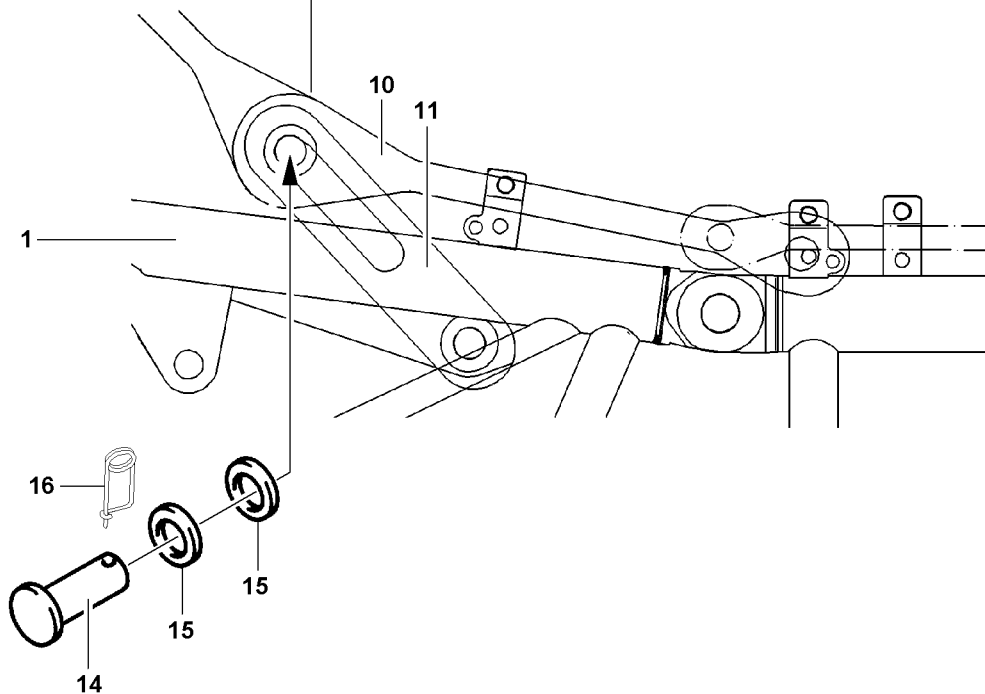
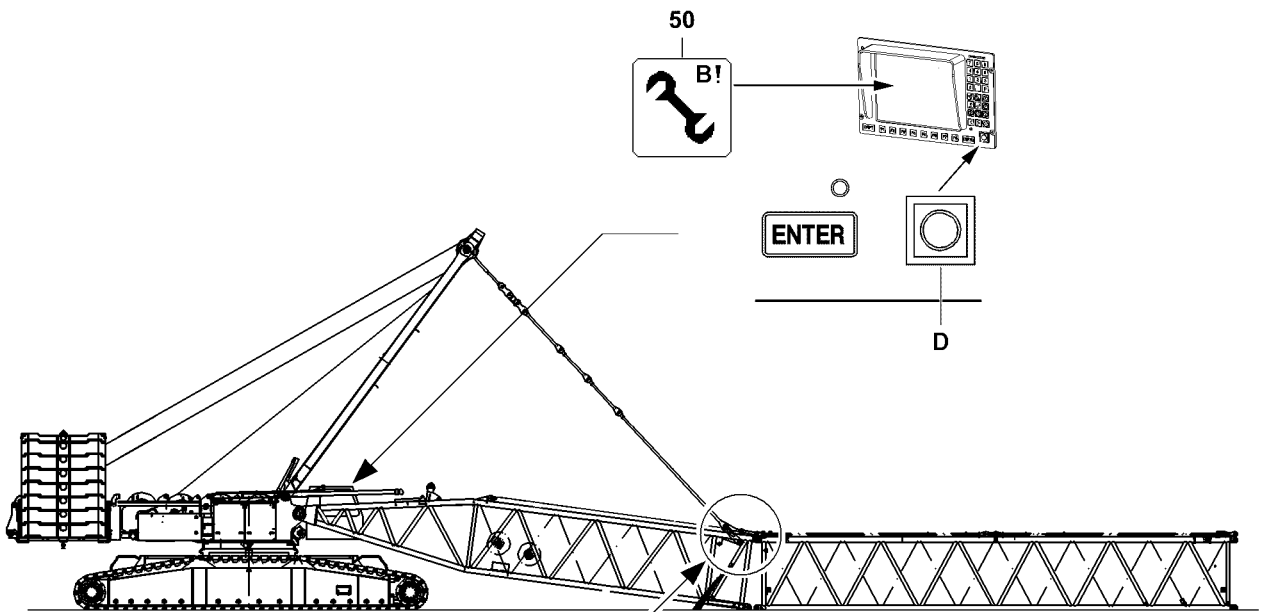
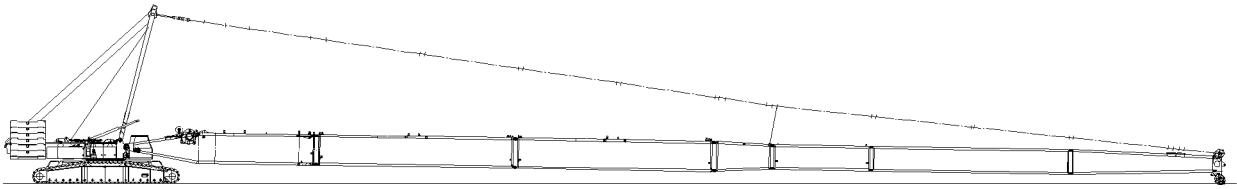

B111482

4 Sw-disassembly



WARNING

Risk of falling!

During assembly and disassembly, personnel must be secured with appropriate aids to prevent them from falling! If this is not observed, assembly personnel can fall and suffer life-threatening or fatal injuries!

- ▶ Any work, where there is a danger of falling must be carried out with suitable aids (for example: lifting platforms, scaffoldings, ladders, auxiliary crane)!
- ▶ If the work cannot be carried out with such aids nor from the ground, then the assembly personnel must secure themselves with approved fall arrest systems to avoid falling, see Crane operating instructions chapter 2.04!
- ▶ If railings are present on the components, then they must be brought into the corresponding position and secured for assembly / disassembly work!
- ▶ Step on aids and fall protection equipment only with clean shoes!
- ▶ Keep aids and fall protection equipment clean and free from snow and ice!
- ▶ During all assembly and disassembly work, maintenance work and inspections, travel or crane operation is prohibited!



WARNING

Falling components!

If unsecured or non-supported components are installed or removed, they can fall down!

Personnel can be severely injured or killed!

- ▶ During pinning and unpinning of the lattice sections, it is prohibited for anyone to remain **under** or **on** the components as well as within the entire danger zone!
- ▶ Support the boom and components before pinning / unpinning!
- ▶ Pin or unpin both pins laying in a horizontal, i.e. **left** and **right**!
- ▶ Secure the pins in the bearing points and in the receptacles!
- ▶ Do not disengage the auxiliary crane until each component is pinned on and secured!
- ▶ It is prohibited to lean a ladder against the component being disassembled!



WARNING

Danger of impact / crushing!

When installing / removing crane components with the auxiliary crane, crane components can start to swing back and forth!

When lifting / lowering and positioning crane components, there is an increased danger of impacts / crushing!

Personnel can be severely injured or killed!

- ▶ Make sure that personnel cannot be caught by components!
- ▶ Make sure that the crane is aligned in horizontal position to avoid the support beams from swinging by themselves!
- ▶ When working in danger zones: Use aids to protect limbs!
- ▶ Guide components with suitable aids to minimize oscillation!

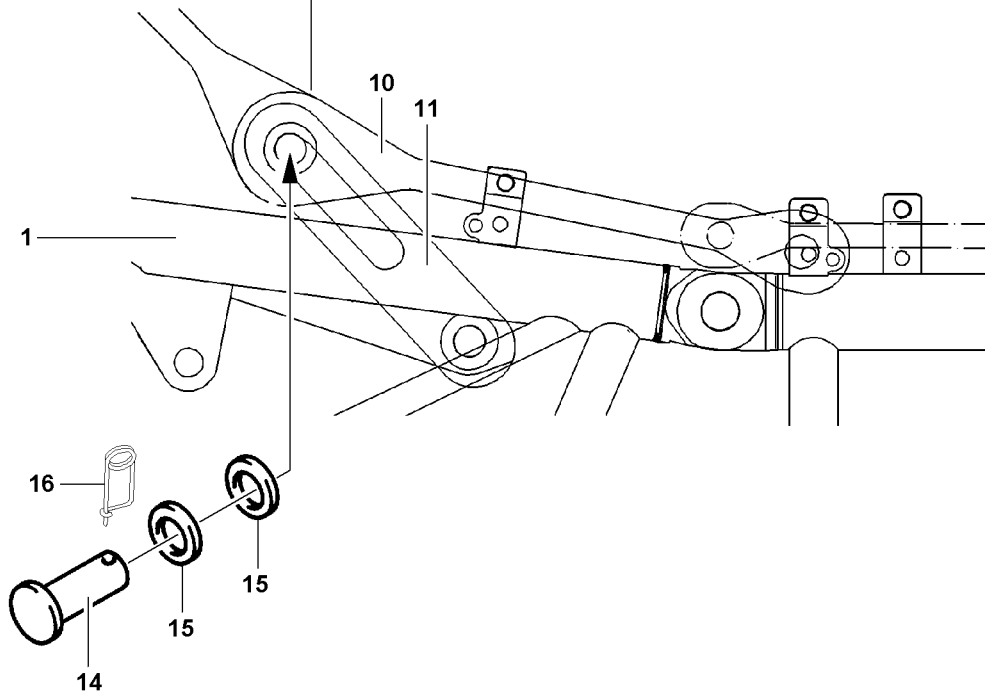
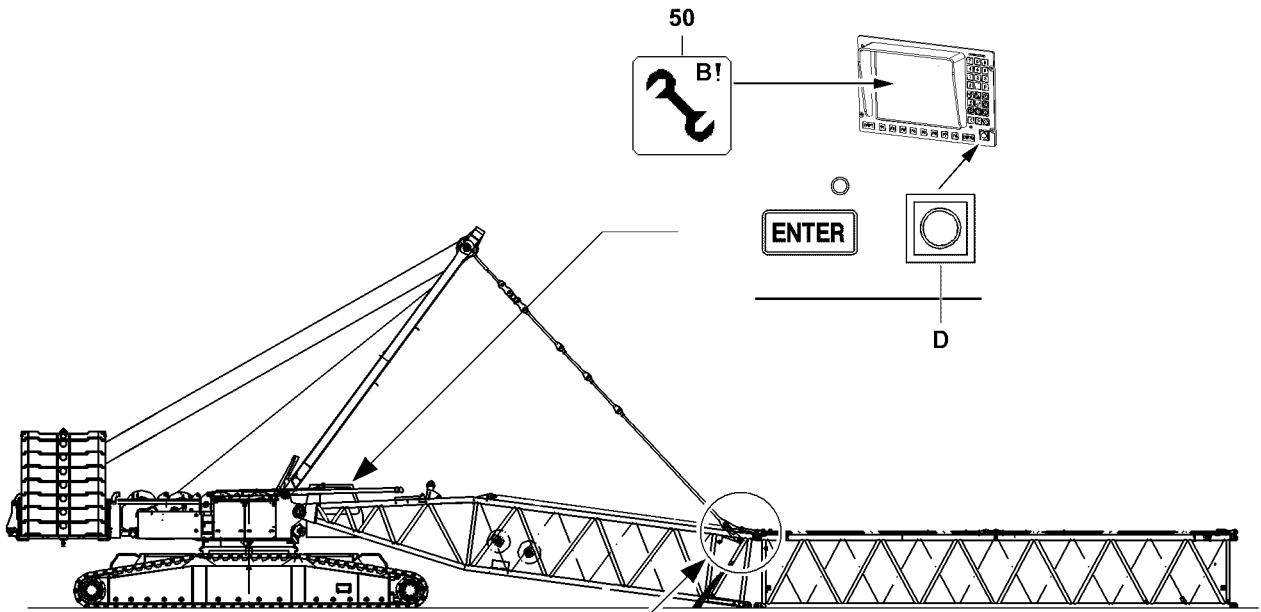
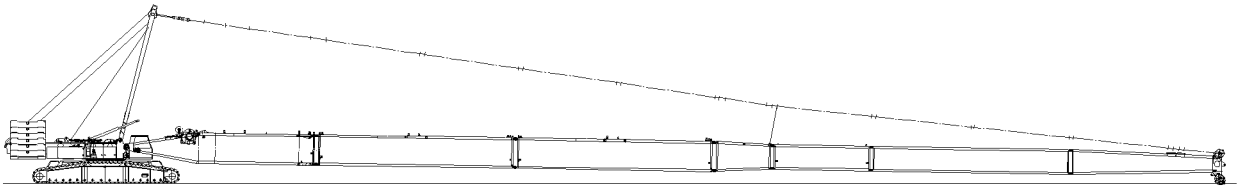

B111482

4.1 Taking the Sw-booms down



WARNING

Risk of accident!

If the following instructions are not observed, personnel can be severely injured or killed!

- ▶ The turntable may not be turned during the assembly of the boom!
- ▶ Observe the safety technical notes, see Crane operating instructions, chapter 5.01!
- ▶ Observe the data in the erection and take down charts!

NOTICE

Damage of boom components!

Taking down the boom system can lead to a collision between the hook block and the pulley head!

There is the danger that boom components may be significantly damaged!

- ▶ When taking down the boom system, always spool out the hoist winch at the same time!

Make sure that the following prerequisites are met:

- The crane is aligned in horizontal direction.
- An auxiliary crane is available.
- An assembly scaffolding / work platform is available.
- The counterweight has been installed to the turntable according to the erection chart.
- The LICCON overload protection has been set according to the data in the load chart.
- ▶ Turn the turntable in longitudinal axle of the crawler travel gear against the travel direction or vertically to the crawler travel gear, see Erection and take down chart.



Note

- ▶ The luff down movement is turned off as soon as the lowest operating position is reached!
- ▶ When the lowest operating position of the boom is reached, the load display in the maximum load icon turns off and instead of the load display appears the display “???”!
- ▶ In the crane operating screen appear alarm functions!
- ▶ Luff the S-boom down to the “lowest” operating position.

Result:

- The luff down movement is turned off.
- The “STOP” icon appears on the LICCON monitor.
- The horn icon appears on the LICCON monitor.

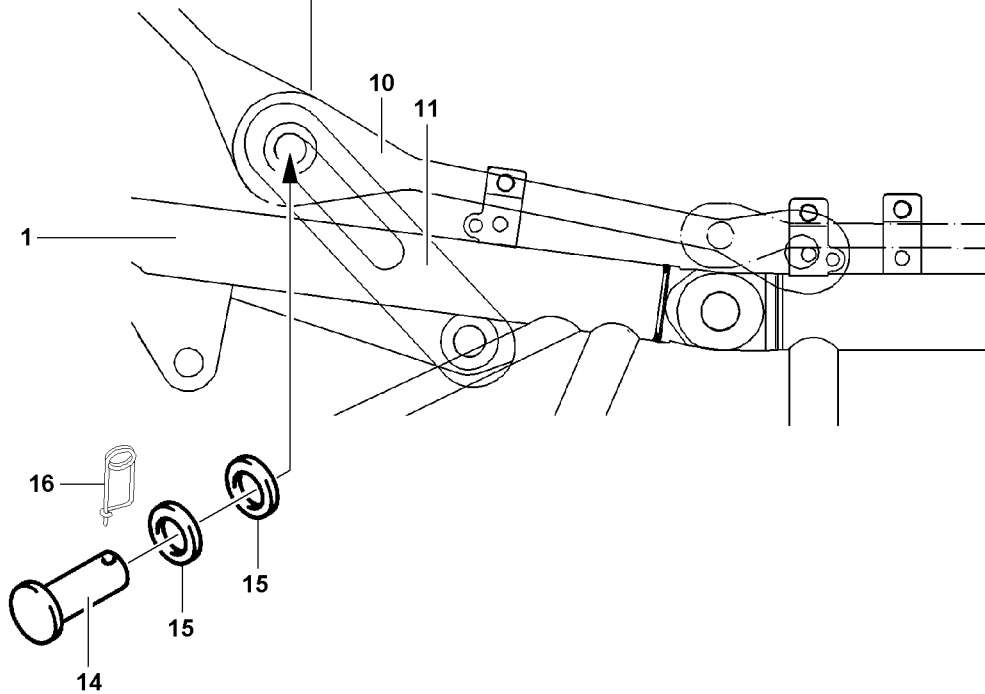
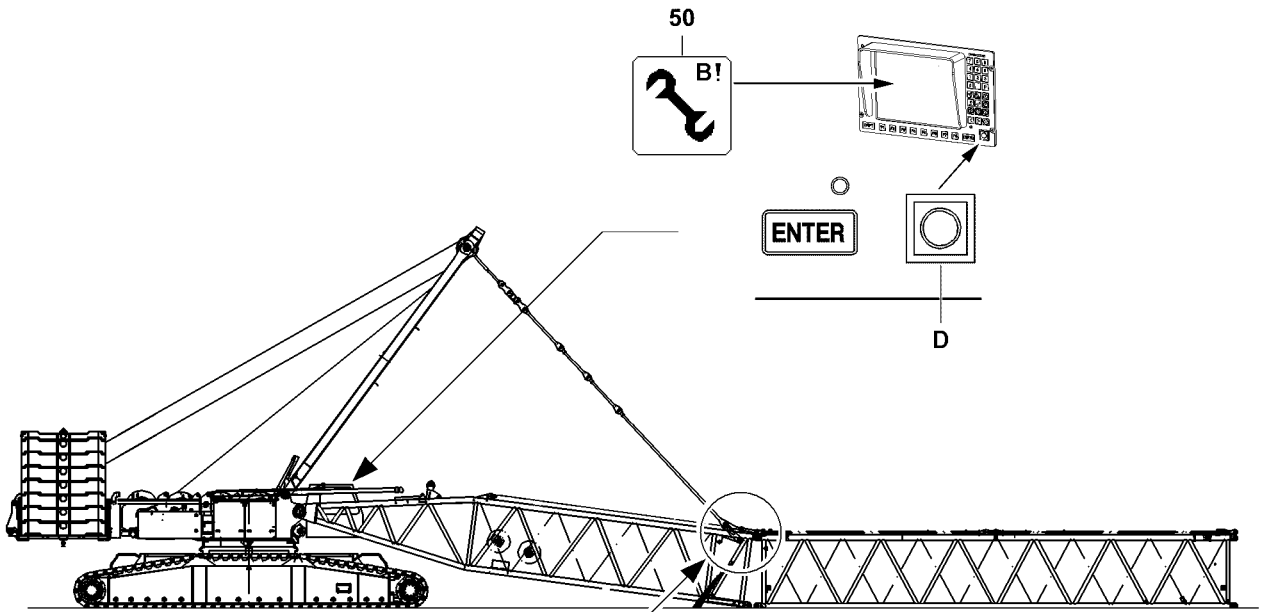
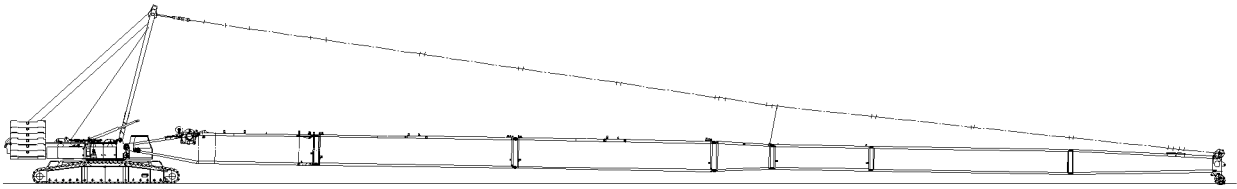

B111482

**WARNING**

Assembly with turned on set up key!

When the set up key is turned on, the LICCON overload protection is exceeded!

In the event of deliberate improper use, the crane could collapse, the boom can break off or the crane can topple over!

Personnel can be severely injured or killed!

This could result in high property damage!

- ▶ The set up key **D** may only be actuated by persons who know the effects of a bypass!
- ▶ Press the set up key **D** only when the set up status was correctly entered into the LICCON computer system!
- ▶ Observe the erection / take down charts!
- ▶ Crane operation with the set up key **D** turned on is strictly prohibited!

- ▶ When the S-boom has reached the “lowest” operating position:
Turn the set up key **D** to the right.

Result:

- The LICCON overload protection is deactivated.
- The assembly icon **50** appears on the LICCON monitor.
- ▶ At the same time, spool the hoist winch out and luff the S-boom down further until the hook block touches the ground.
- ▶ Remove the hoist limit switch weight and unreeve the hook block.
- ▶ Luff the boom down until the boom head is lying on the support on the ground.

NOTICE

Overspooled winch!

If the rope is pulled under the winch when spooling up, the settings of the cam limit switch are not longer correct and there is an increased danger of accidents!

As a result, extensive adjustment work on the cam limit switch is required!

- ▶ Slowly spool up the hoist rope over the rope pulleys back to the winch!
- ▶ Stop the winch in time, with sufficient rope reserve!
- ▶ Do not overspool the winch!
- ▶ Remove the hoist rope.

B195219

4.2 Disconnecting the electrical connections

Make sure that the following prerequisite is met:

- The boom has been placed down.
- ▶ Disconnect the electrical connections.

NOTICE

Damage to cable drum or cable!

If the cable of the cable drum is not properly spooled up on the cable drum after unplugging, then the cable drum or the cable can be significantly damaged!

- ▶ Spool the cable drum up after unplugging!
- ▶ Spool the cable drum up and secure it to prevent inadvertent spooling out.
- ▶ Make sure that all electrical connections on the boom have been disconnected.

4.3 Disconnecting the hydraulic connection

When releasing hydraulic lines with quick release couplings, make sure that the coupling procedure is carried out correctly.



WARNING

Pressure in the hydraulic lines!

If the pressure supply is not interrupted before connecting / releasing the hydraulic lines, the hydraulic oil can escape with high pressure!

Personnel can be severely injured or killed!

- ▶ Release the pressure in the hydraulic system before connecting / disconnecting: Interrupt the pressure supply and wait for a short time!
- ▶ Install the coupling components (sleeve and connector) with the hand-tightened nut.
- ▶ Disconnect the hydraulic connections.
- ▶ Install dust caps on the quick release couplings.

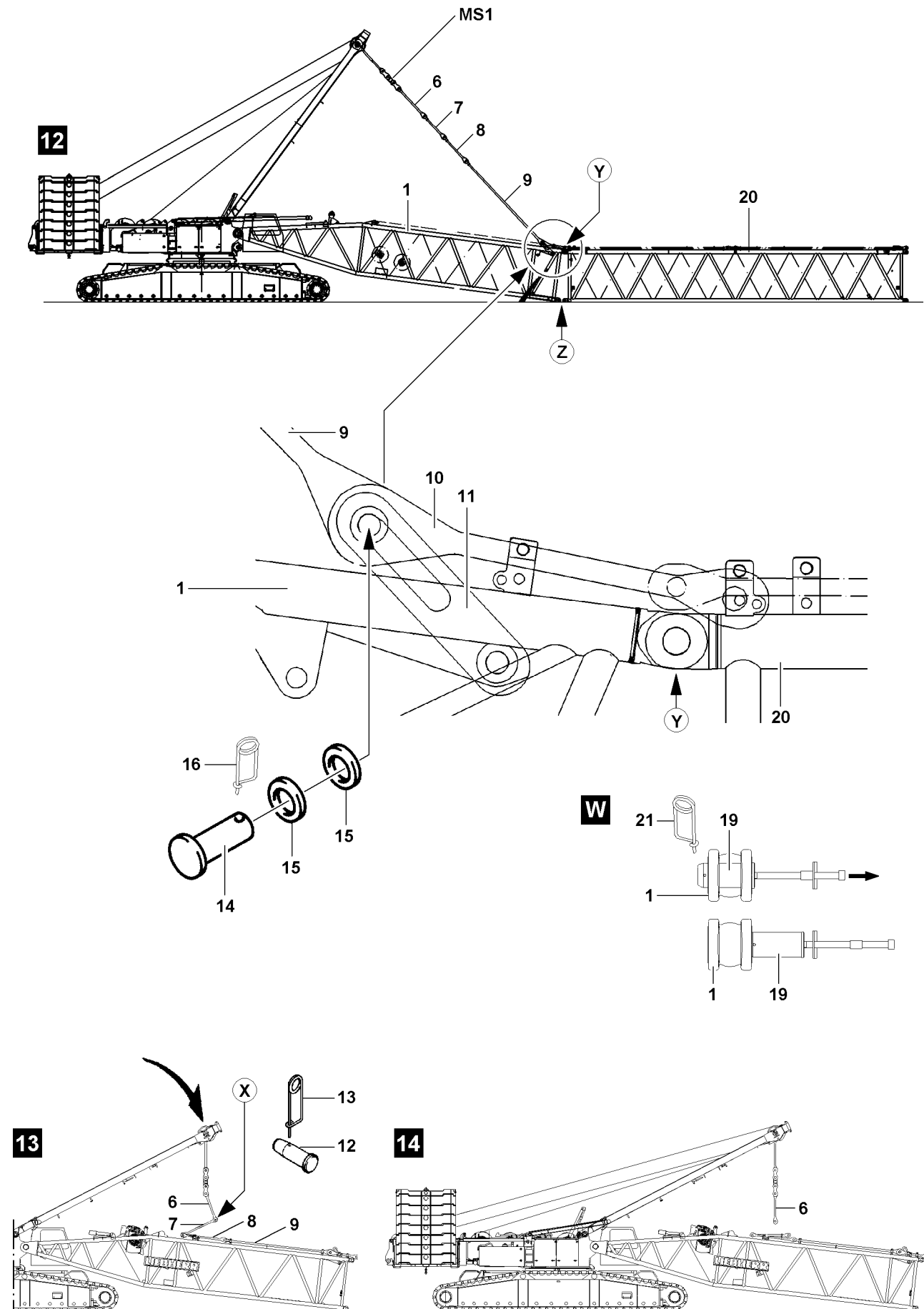

B105431

4.4 Dismantling the Sw-booms



WARNING

The boom can suddenly fold down!

If the following conditions are not met prior to dismantling the boom, the boom can fold down and fatally injure people!

- ▶ Support the Sw-boom during disassembly with suitable materials!
- ▶ Before unpinning the S-intermediate section **20** or the SW-reducer section, the guy rods **9** on the assembly brackets **11** must be pinned and secured!
- ▶ It is prohibited for anyone to remain under the booms or within the complete danger zone during the pinning and unpinning procedure of the booms!

Make sure that the following prerequisite is met:

- All electrical and hydraulic connections are separated on the boom.
- ▶ Relieve the guy rods by lowering the SA-bracket: Spool out winch 4.
- ▶ Unpin the guy rods at the intermediate sections: Remove the spring retainer **13** and unpin the pin **12**.
- ▶ Place the guy rods on the intermediate sections and secure with transport retainers.
- ▶ Pin the guy rods **9** on the assembly brackets **11**: Insert the pin **14** and secure with spring retainer **16**, see illustration **12**, point **Y**.



WARNING

The crane can topple over!

If the following conditions are not met, the crane can topple over or be significantly damaged!

Personnel can be severely injured or killed!

- ▶ The maximum permissible total force on test point **MS1** may **not** be exceeded!
- ▶ Lifting the following boom length is permissible if the maximum permissible total force on test point 1 (MS1) is noted, observe the following charts!



Note

- ▶ The ACTUAL force on test point **MS1** is shown on monitor 1!
- ▶ Tension the guy rods on the SA-bracket with the same force as during the assembly!
- ▶ For this, refer the ACTUAL force at the measuring point measured and recorded during the assembly (MS1)!
- ▶ The pins can be pulled easier and the pins and lugs are therefore not damaged!

	Maximum permissible system lengths for a maximum total force MS1 100 t					
	49.0 m	48.4 m	45.5 m	45.5 m	38.5 m	45.5 m
	DB _{min} ¹⁾ 55 t / ZB _{min} ²⁾ 43 t					
S-pivot section 13.4 m	1x	1x	1x	1x	1x	1x
S-intermediate section 7.0 m	1x	1x	—	1x	—	1x
S-intermediate section 14.0 m	—	2x	2x	1x	1x	—
SW-reducer section 4.1 m	1x	—	1x	1x	1x	1x

	Maximum permissible system lengths for a maximum total					
	force MS1 100 t					
W-intermediate section 7.0 m	—	—	—	1x	1x	1x
W-intermediate section 14.0 m	1x	—	—	—	—	1x
W-end section 10.5 m	1x	—	—	—	—	—

1) This counterweight **must** be at least installed on the turntable for "Flying assembly".

2) This central ballast **must** be at least installed on the crawler center section for "Flying assembly".

blank page!

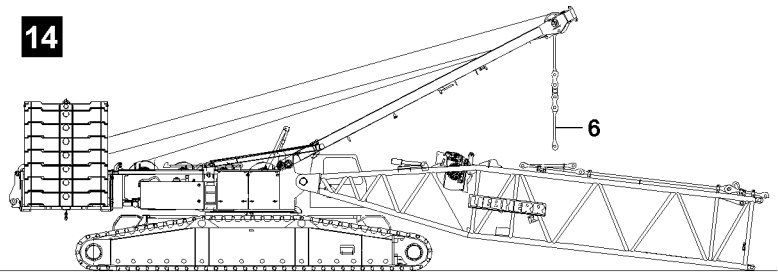
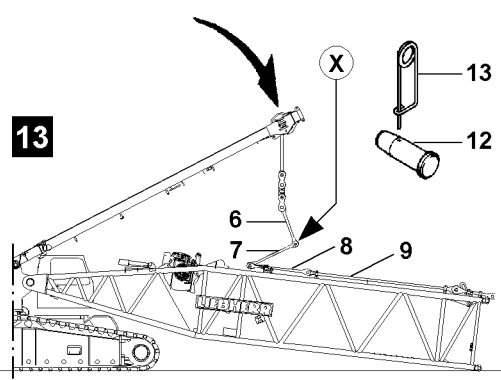
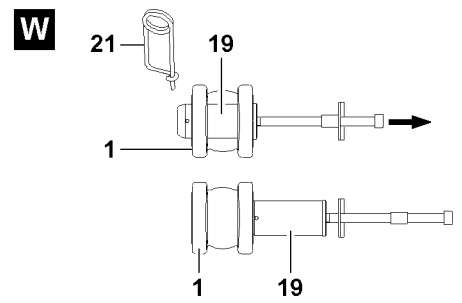
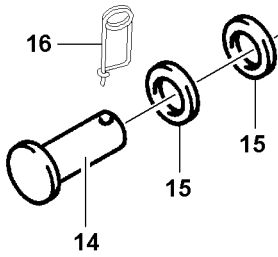
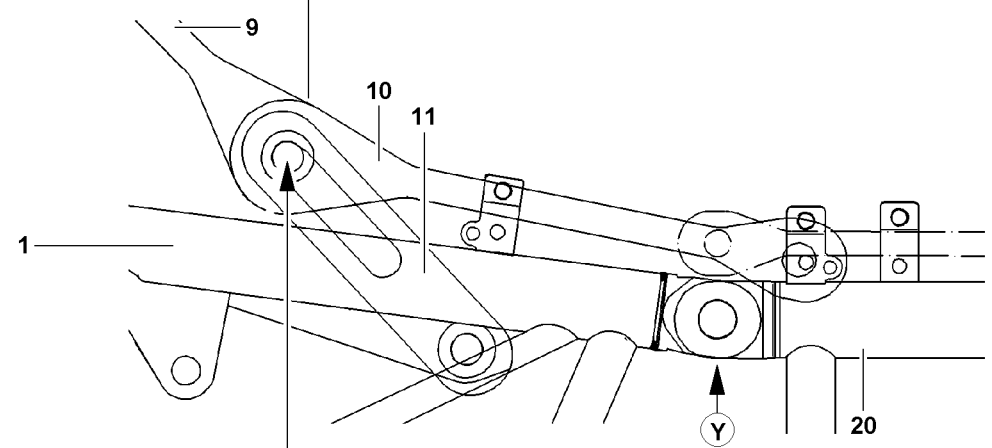
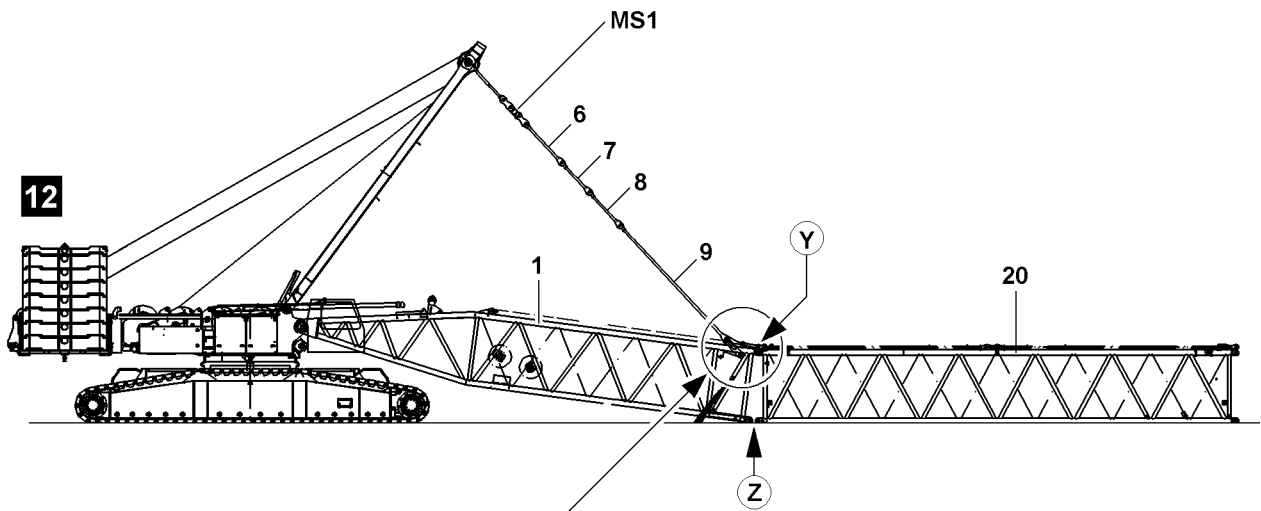

B105431

**Note**

- ▶ Unpin the intermediate sections with the pin pulling device, see Crane operating instructions, chapter 5.30!

NOTICE

Danger of property damage!

If the maximum permissible total force is not observed when lifting the boom for disassembly, then the crane components can be severely damaged!

- ▶ Do not exceed the maximum permissible total force!
- ▶ Disconnect the electrical connections and store the cables carefully.
- ▶ Spool the cable drum up and secure it to prevent inadvertent spooling out.
- ▶ Lift the S-pivot section **1** up with the SA-bracket and unpin on both sides at point **Z**: Remove the spring retainer **21** and unpin the pin **19**.
- ▶ Lower the S-pivot section on the support.
- ▶ Relieve the guy rods by lowering the SA-bracket.
- ▶ Unpin the guy rods at the assembly brackets **11**: Remove the spring retainer **16** and unpin the pin **14**.
- ▶ Unpin and disassemble the intermediate sections.

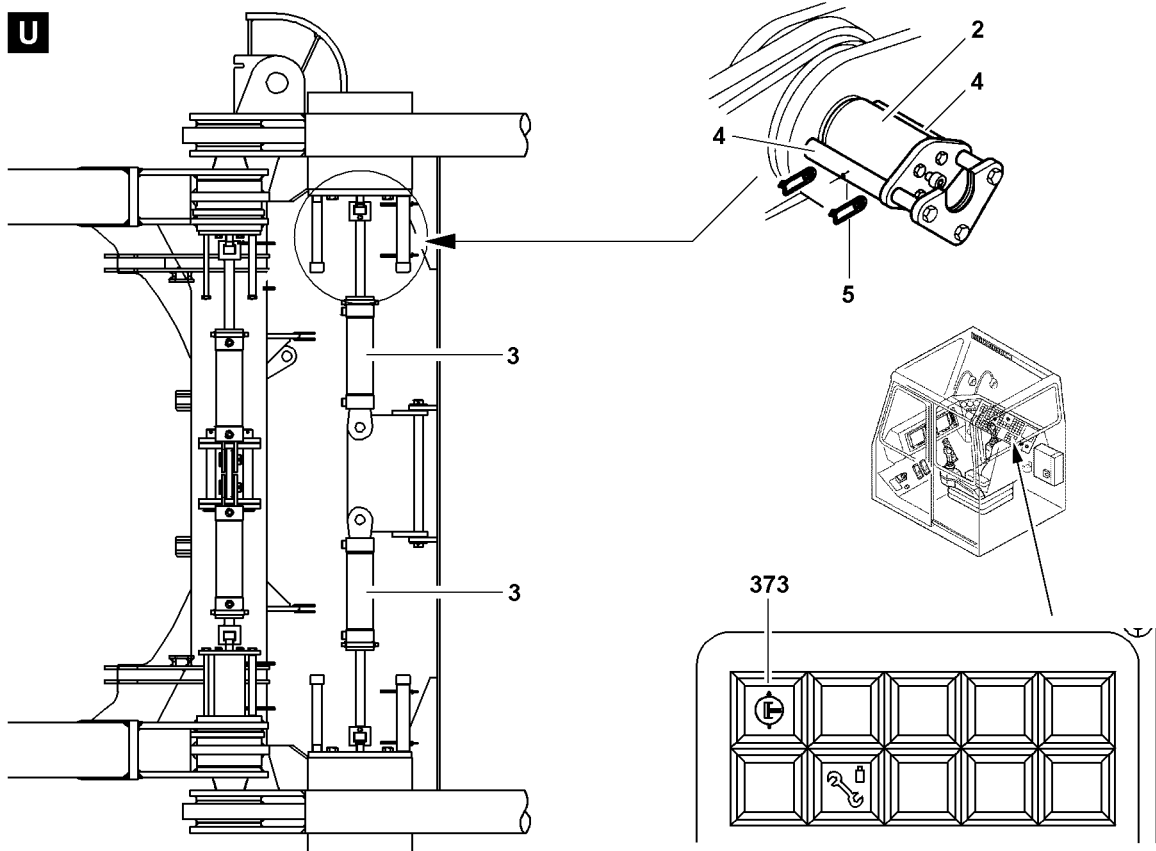
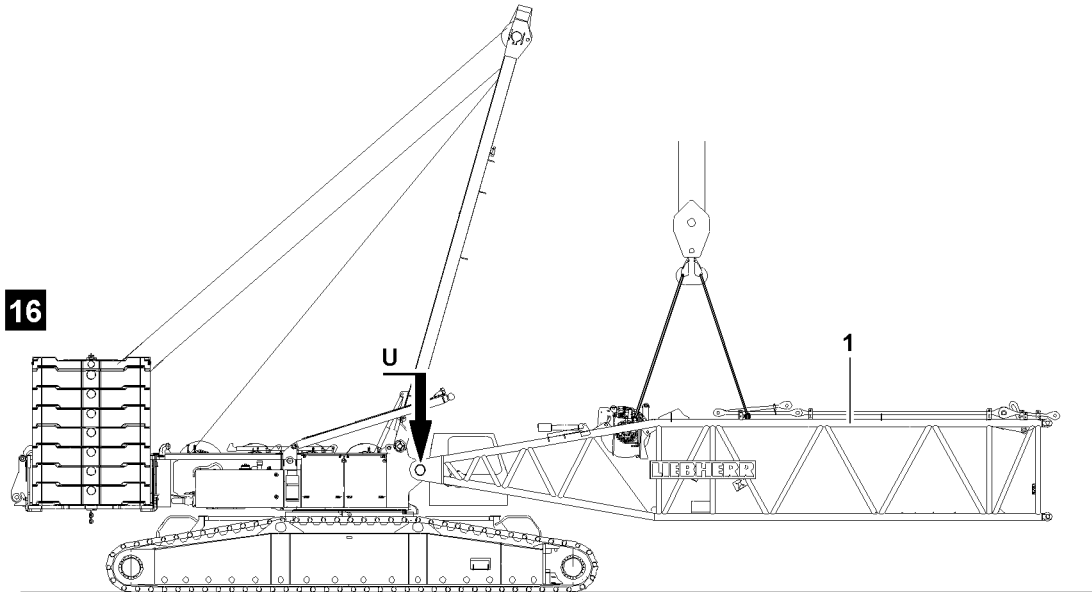
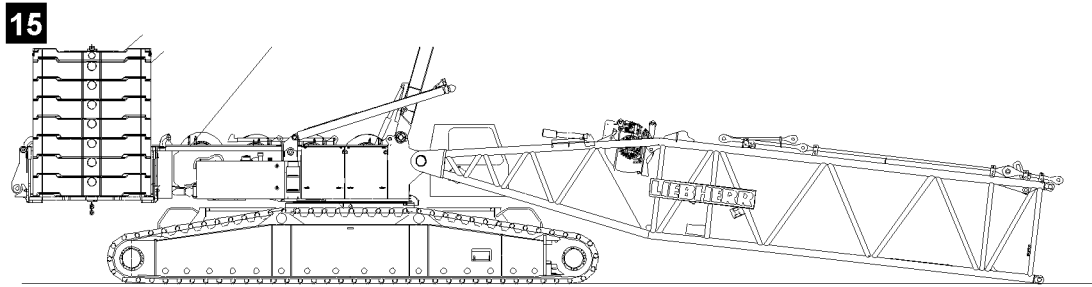

B112519

4.5 Unpinning the S-pivot section



WARNING

General danger notes!

- ▶ Support S-pivot section during disassembly with suitable materials!
- ▶ Insert and secure all pins after disassembly in the intended transport receptacles!

Make sure that the following prerequisite is met:

- The SA-bracket is erected to the point where the S-pivot section can be disassembled without obstructions.
- ▶ Attach the S-pivot section **1** on the auxiliary crane.
- ▶ Lift the S-pivot section **1** with the auxiliary crane to the horizontal.

Establish the hydraulic connection to the pin pulling device via two quick couplers.

Release and unpin the S-pivot section **1** on the turntable.

- ▶ Establish the hydraulic connection to the pin pulling device.
- ▶ Turn the pressure change over switch **373** on.



WARNING

Falling S-pivot section!

- ▶ Make sure that the S-pivot section is safely held by the auxiliary crane before unpinning the pins **2**!
- ▶ Remove the spring retainer **5** on the retaining plate **4** on the left and right.
- ▶ Remove the retaining plate **4** left and right.
- ▶ Unpin the connector pins **2** with the hydraulic pin pulling device **3**.
- ▶ Turn the pressure change over switch **373** off.

NOTICE

Danger of property damage on the turntable and on the S-pivot section!

- ▶ Slowly swing the S-pivot section out with the auxiliary crane and at low speed on the turntable!
- ▶ Place the S-pivot section with the auxiliary crane on the support on the ground.
- ▶ Remove the pin pulling device.
- ▶ Remove the auxiliary crane.
- ▶ Place the SA-bracket on the turntable, see Crane operating instructions, chapter 5.02.

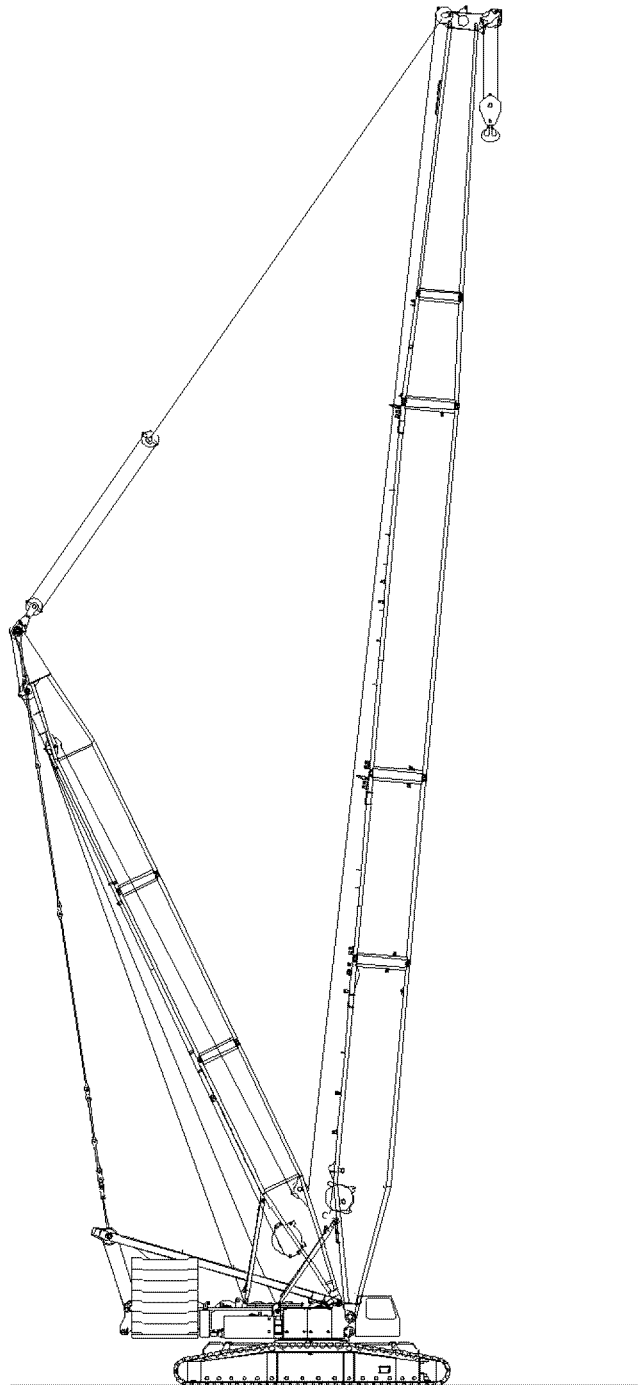

B111508

1 SwD-boom combination

The **SwD** -boom combination consists of a combination of lattice sections of the S-system and lattice sections of the W-system, as well as the SW-reducer section and W-end section. The boom system is expanded with the derrick boom D, see Crane operating instructions, chapter 5.05.

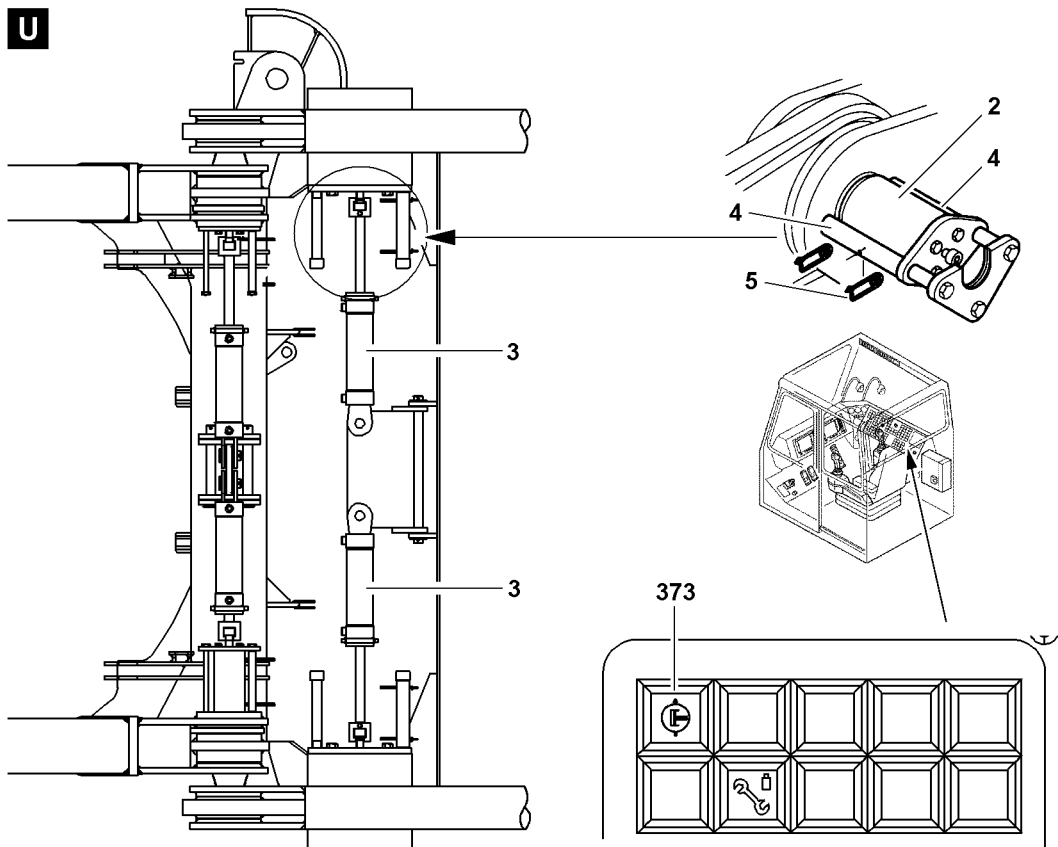
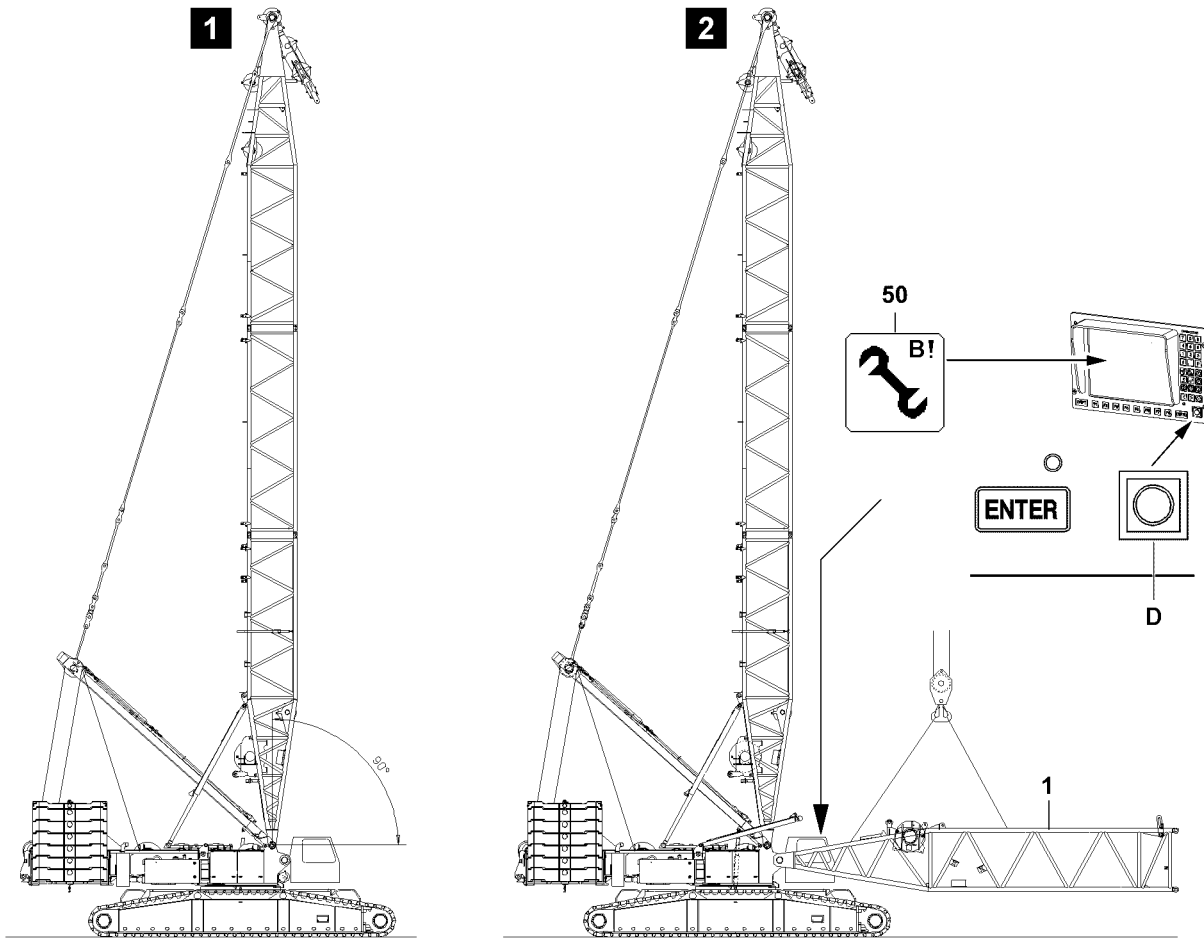

B111487

2 SwD-assembly



WARNING

Risk of falling!

During assembly / disassembly work, personnel must be secured with appropriate aids to prevent them from falling. If this is not observed, assembly personnel can fall and suffer life-threatening or fatal injuries!

- ▶ Any work, where there is a danger of falling must be carried out with suitable aids (for example lifting platform, scaffolding, ladder, auxiliary crane)!
- ▶ If the work cannot be carried out with such aids nor from the ground, then the assembly personnel must secure themselves with approved fall arrest systems to avoid falling, see Crane operating instructions, chapter 2.04!
- ▶ Approved fall arrest systems must be hung into the respective fastening points on the crane, see Crane operating instructions, chapter 2.06!
- ▶ If railings are present on the components, then they must be brought into the corresponding position and secured for assembly / disassembly work!
- ▶ Step on aids and fall protection equipment only with clean shoes!
- ▶ Keep aids and fall protection equipment clean and free from snow and ice!
- ▶ During all assembly and disassembly work, maintenance work and inspections, travel and crane operation is prohibited!



WARNING

Falling components!

If unsecured or non-supported components are installed or removed, they can fall down!

Personnel can be severely injured or killed!

- ▶ During pinning and unpinning of the lattice sections, it is prohibited for anyone to remain **under** or **on** the components as well as within the entire danger zone!
- ▶ Support the boom and components before pinning / unpinning!
- ▶ Pin or unpin both pins that lie in one horizontal level, i.e. **left** and **right**!
- ▶ Secure the pins in the bearing points and in the receptacles!
- ▶ Do not disengage the auxiliary crane until each component is pinned on and secured!
- ▶ It is prohibited to lean a ladder against the component being disassembled!



WARNING

Danger of impact / crushing!

When installing / removing crane components with the auxiliary crane, crane components can start to swing back and forth!

When lifting / lowering and positioning crane components, there is an increased danger of impacts / crushing!

Personnel can be severely injured or killed!

- ▶ Make sure that personnel cannot be caught by components!
- ▶ When working in danger zones: Use aids to protect limbs!
- ▶ Guide components with suitable aids to minimize oscillation!

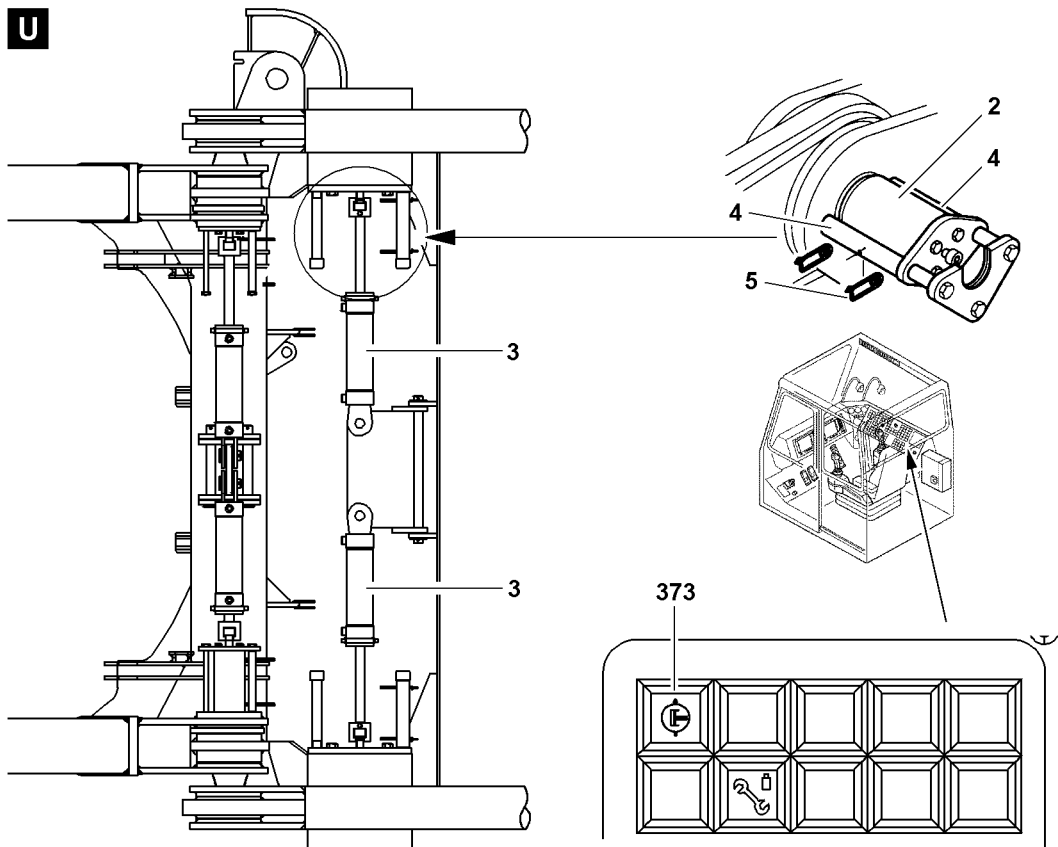
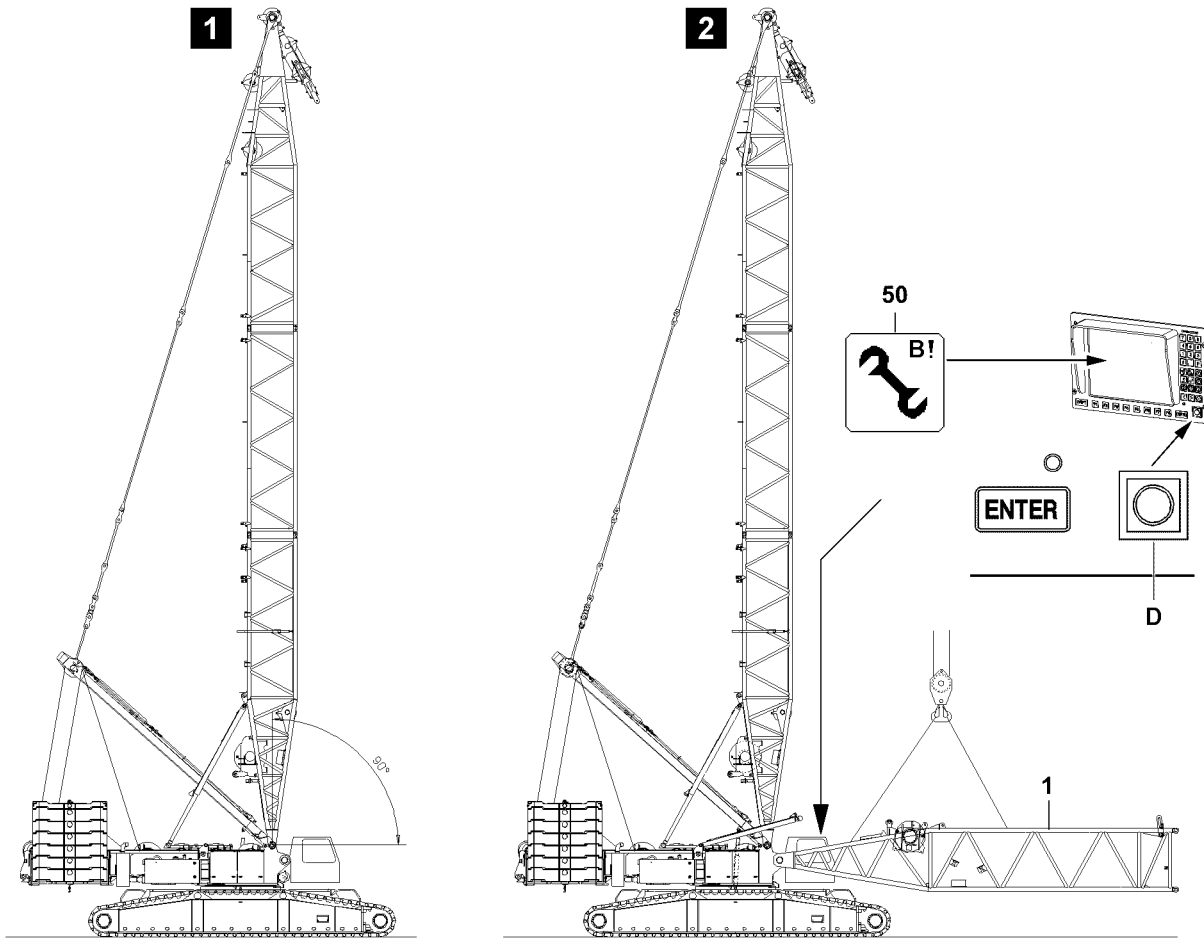

B111487

2.1 Assembling the SwD-boom combination



WARNING

The crane can topple over!

If the turntable is turned during the assembly of the boom, then the crane can topple over and be severely damaged! Personnel can be severely injured or killed!

- ▶ The turntable may not be turned during the assembly of the boom!



WARNING

Risk of accident!

If the following instructions are not observed, personnel can be severely injured or killed!

- ▶ Assembly of boom combinations, see Rod plan and Assembly plan!
- ▶ Depending on the condition of the ground, the boom and the lattice sections must be supported from below for the assembly of the boom!
- ▶ Observe the safety technical notes, see Crane operating instructions, chapter 5.01!

Make sure that the following prerequisites are met:

- The crane is aligned in horizontal direction.
- An auxiliary crane is available.
- An assembly scaffolding / work platform is available.
- The counterweight has been installed on the turntable according to the load chart.
- The LICCON overload protection has been set according to the data in the load chart.

2.2 Exceeding the LICCON overload protection for assembly



WARNING

Assembly with turned on set up key!

When the set up key is turned on, the LICCON overload protection is exceeded!

In the event of deliberate improper use, the crane could collapse, the boom can break off or the crane can topple over!

Personnel can be severely injured or killed!

This could result in high property damage!

- ▶ The set up key **D** may only be actuated by persons who know the effects of a bypass!
- ▶ Press the set up key **D** only when the set up status was correctly entered into the LICCON computer system!
- ▶ Observe the erection / take down charts!
- ▶ Crane operation with the set up key **D** turned on is strictly prohibited!

- ▶ Turn the set up key **D** to the right.

Result:

- The LICCON overload protection is deactivated.
- The assembly icon **50** appears on the LICCON monitor.

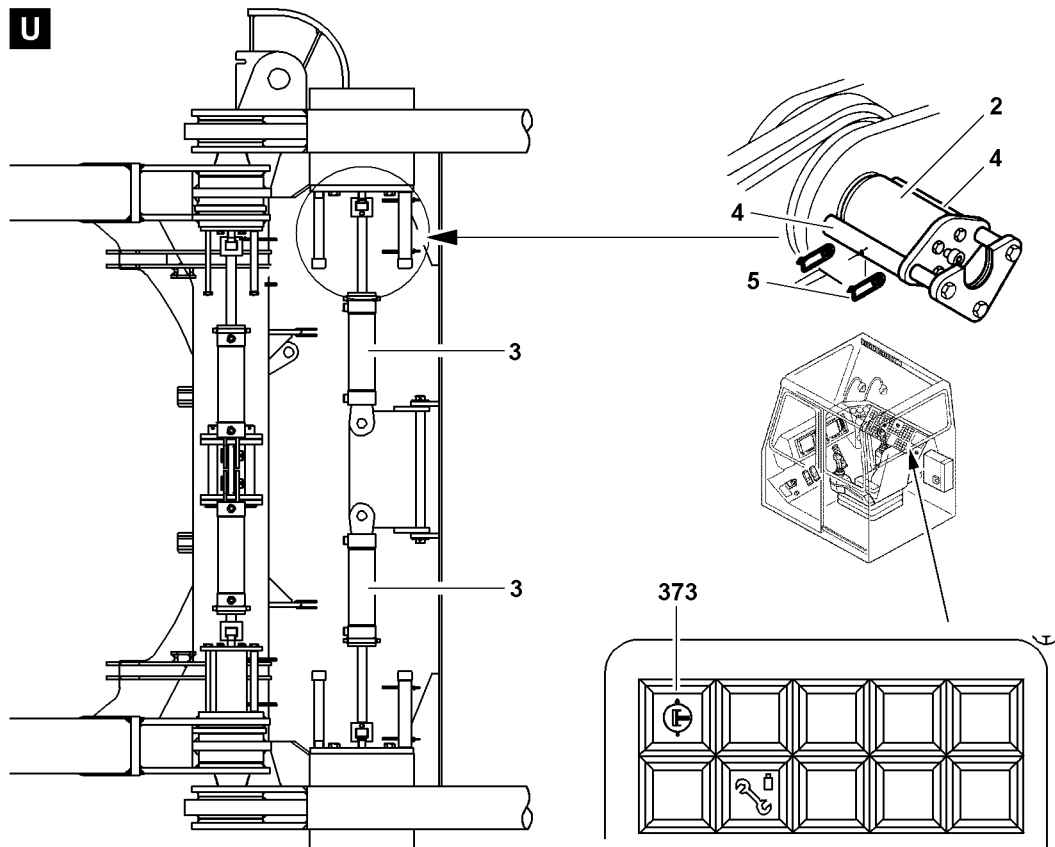
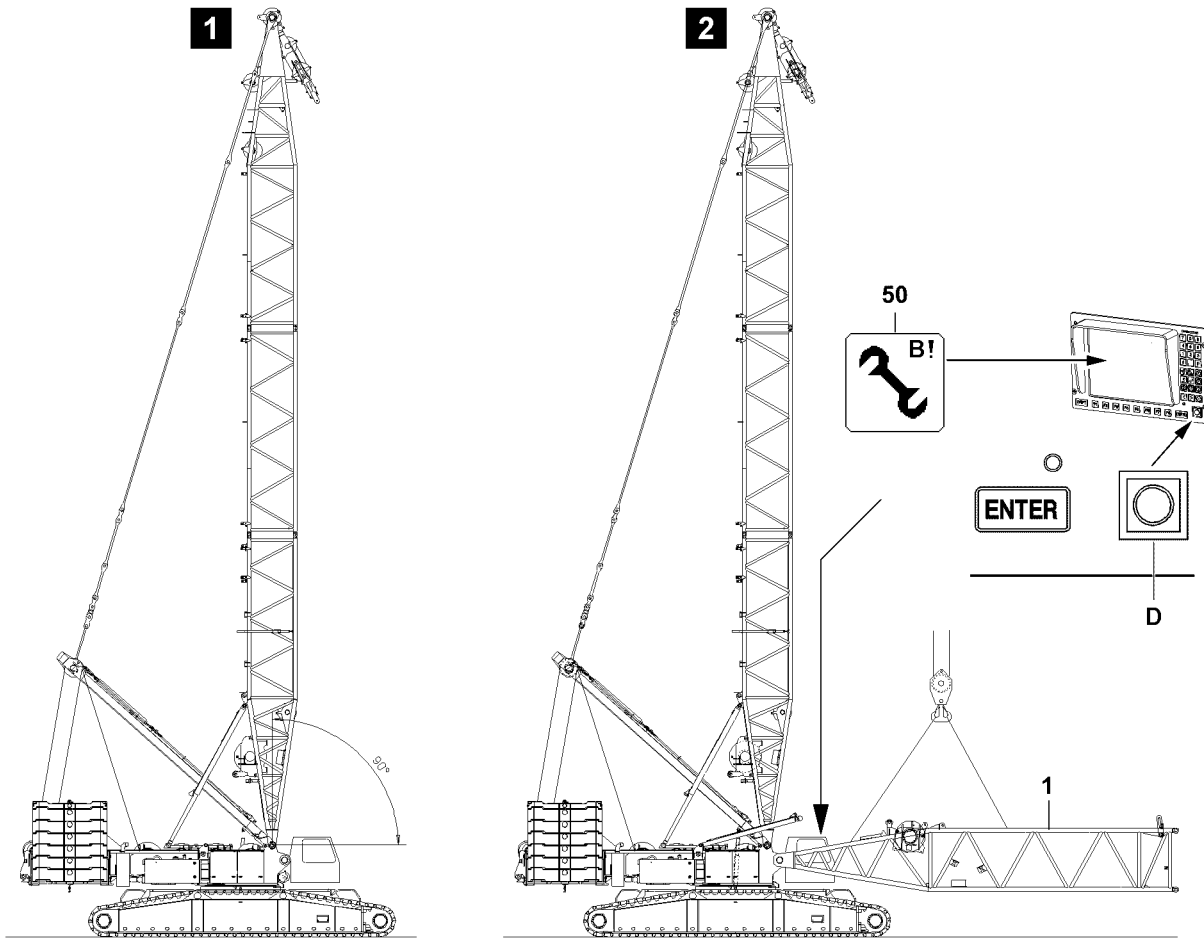

B111487

2.3 Pinning the S-pivot section on the turntable



WARNING

General danger notes!

- ▶ Support the boom during assembly with suitable materials!
- ▶ All pins are to be secured after assembly with the intended safety elements!
- ▶ The guy rods must be inspected regularly, see Crane operating instructions, chapter 8.15!

- ▶ Hang the S-pivot section **1** onto the auxiliary crane and swing in to the pin points on the turntable, illustration **1**, illustration **2**.

Establish the hydraulic connection to the pin pulling device via two quick couplers.

Pin the S-pivot section **1** on the turntable and secure.

- ▶ Establish the hydraulic connection to the pin pulling device.
- ▶ Turn the pressure change over switch **373** on.



WARNING

Falling S-pivot section!

Due to non-secured or insufficiently secured connector pins, the S-pivot section can fall down!

Personnel can be severely injured or killed!

- ▶ The connector pins **2** between the S-pivot section **1** and the turntable must be secured after the pin procedure with the retaining plates **4**!

- ▶ Insert the connector pins **2** with the hydraulic pin pulling device **3**.
- ▶ When the connector pins **2** are completely pinned on the left and right on the S-pivot section:
Secure the connector pin **2** on the left and right with the retaining plate **4** and the spring retainer **5**.
- ▶ Turn the pressure change over switch **373** off.

NOTICE

Damage to the S-pivot section!

Property damage can occur on the S-pivot section by placing the installed S-pivot section on the ground!

- ▶ Slowly place the S-pivot section with the auxiliary crane and at low speed on the ground!
- ▶ Before placing it on the ground, support the S-pivot section!

- ▶ Carefully place the S-pivot section down.
- ▶ Remove the auxiliary crane.

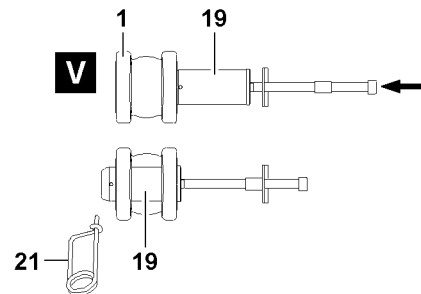
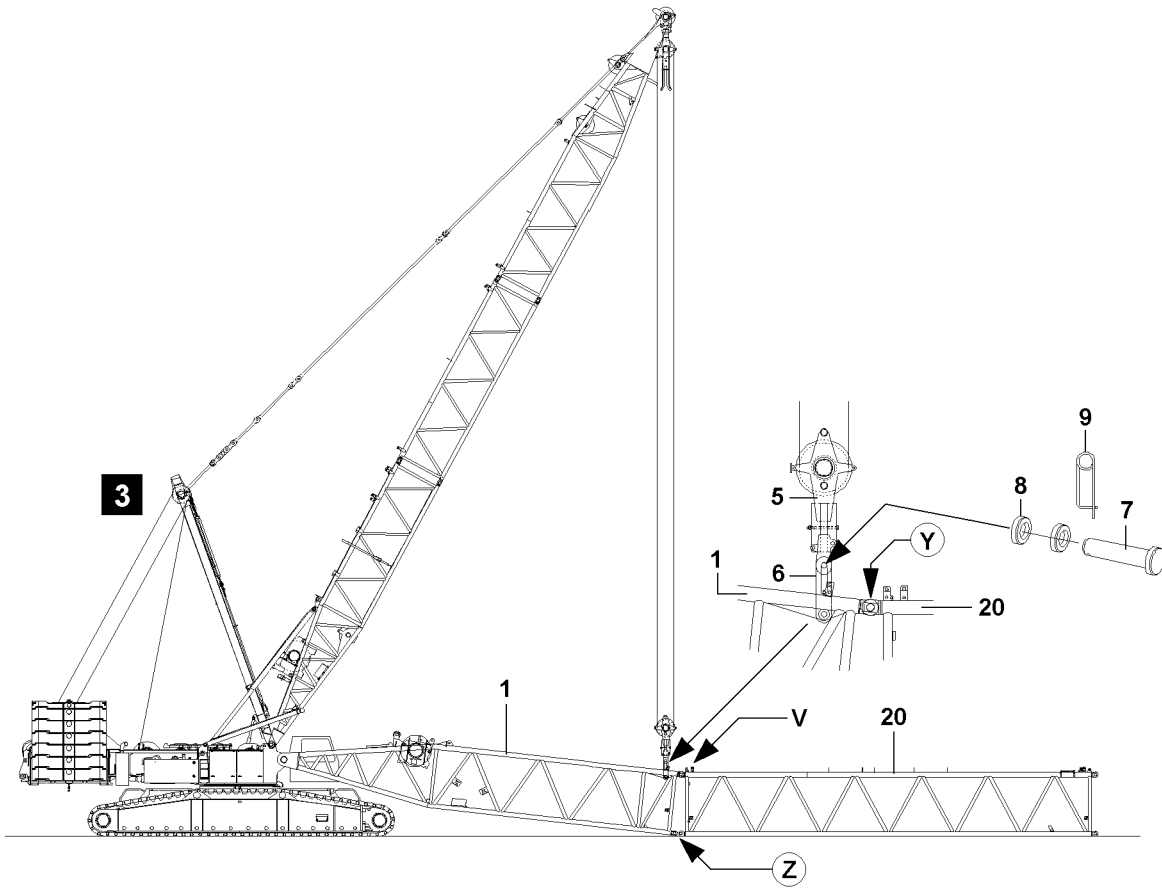

2.4 Pinning the upper pulley block on the S-pivot section

To be able to “close” the boom combination after assembly, it is necessary to luff the derrick boom down to the front and to lower the upper pulley block to the S-pivot section. Then pin and secure the upper pulley block with the S-pivot section.

Make sure that the following prerequisites are met:

- The S-pivot section is pinned and secured on the turntable.
- The S-pivot section is placed on the ground.
- The auxiliary crane is removed.
- ▶ Luff the derrick down to the front until the upper pulley block **5** is positioned freely over the assembly bracket **6** of the S-pivot section **1**.
- ▶ Lower the upper pulley block **5** to the S-pivot section.
- ▶ Pin and secure the upper pulley block **5** with the assembly brackets **6**.
- ▶ Use pin **7**, washer **8** and spring retainer **9**.

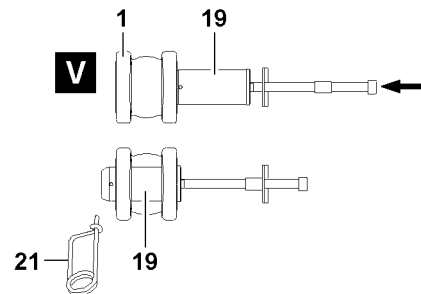
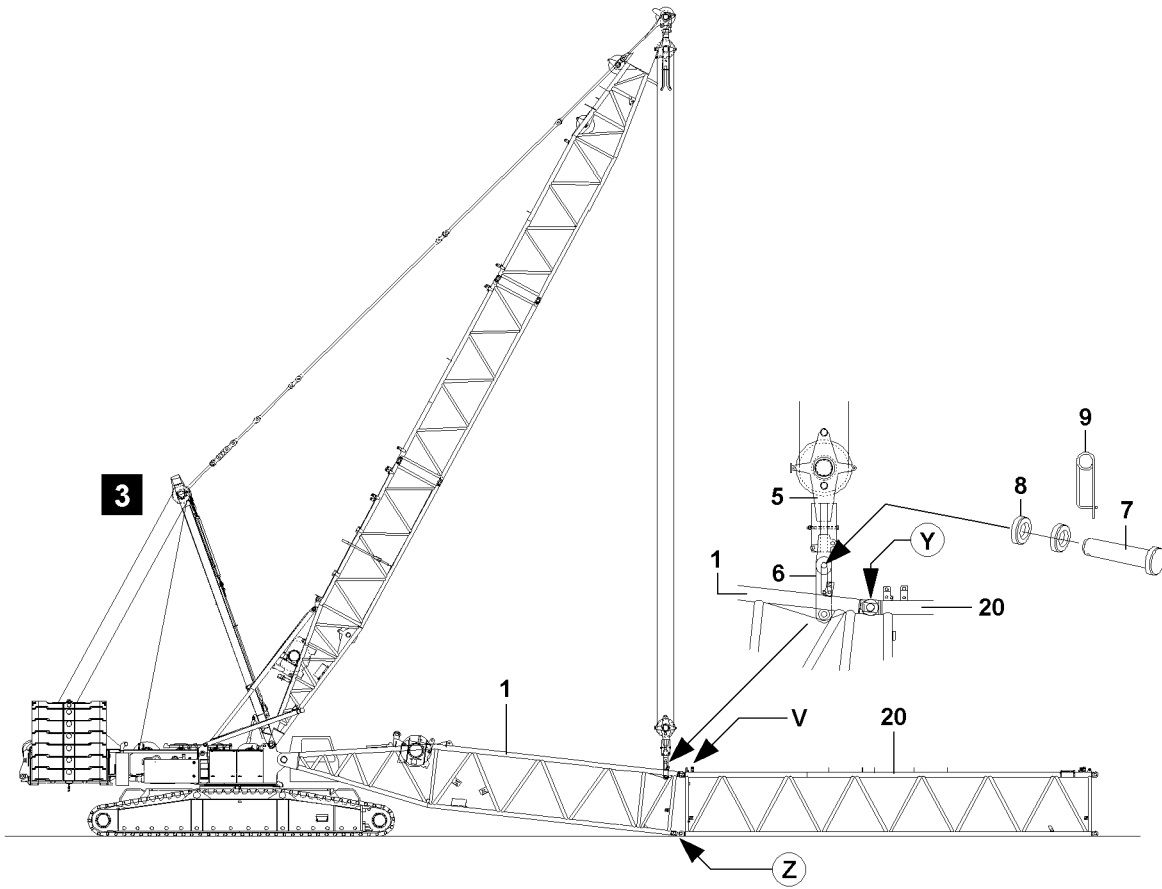

B105817

2.5 Fitting the S-intermediate sections, SW-reducer section and W-intermediate sections

The sectioning of the boom depends on the required boom length for a particular application.



Note

- ▶ For sectioning of the boom, see Assembly drawings and Rod plans!

2.5.1 Installing the S-intermediate section(s) on the S-pivot section

Make sure that the following prerequisites are met:

- The S-pivot section is pinned and secured on the turntable.
- The S-pivot section is placed on the ground.
- The auxiliary crane is removed.
- The upper pulley block **5** is pinned and secured with the assembly brackets **6**.



WARNING

General danger notes!

- ▶ All pins are to be secured after assembly with the intended safety elements!
- ▶ The guy rods must be inspected regularly, see Crane operating instructions, chapter 8.15!



Note

- ▶ To pin the S- and W-intermediate sections, the pin pulling device can be used, see Crane operating instructions, chapter 5.30!
- ▶ The guy rods must be checked regularly! See chapter 8.15!

To be able to assemble the S-intermediate sections on the S-pivot section, the derrick guy rods must be used.

- ▶ Attach the S-intermediate section **20** to the auxiliary crane and align on the S-pivot section **1**.
- ▶ When the pin bores on the S-pivot section **1** and on the S-intermediate section **20** “on top” (point **Y**) align, illustration **3**:
Insert the pin **19** from the “inside” to the “outside” and secure with spring retainer **21**, illustration **V**.

Assemble the Sw-boom to the required length and pin and secure on the S-intermediate section **20** “on top” and “bottom”.

- ▶ Insert the pin **19** from the “inside” to the “outside” and secure with spring retainer **21**.



WARNING

The crane can topple over!

If the following conditions are not met, the crane can topple over or be significantly damaged!

Personnel can be severely injured or killed!

- ▶ During the “Closing procedure” of the intermediate sections, the maximum permissible total force on the test point **MS1** must be **smaller** than **70 t** !
- ▶ The end section of the corresponding boom combination may **not** lift off the ground during the “Closing procedure”!
- ▶ With the upper pulley block, boom combinations to maximum **Sw 112 m** may be lifted / closed!

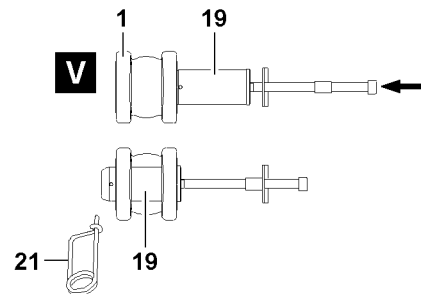
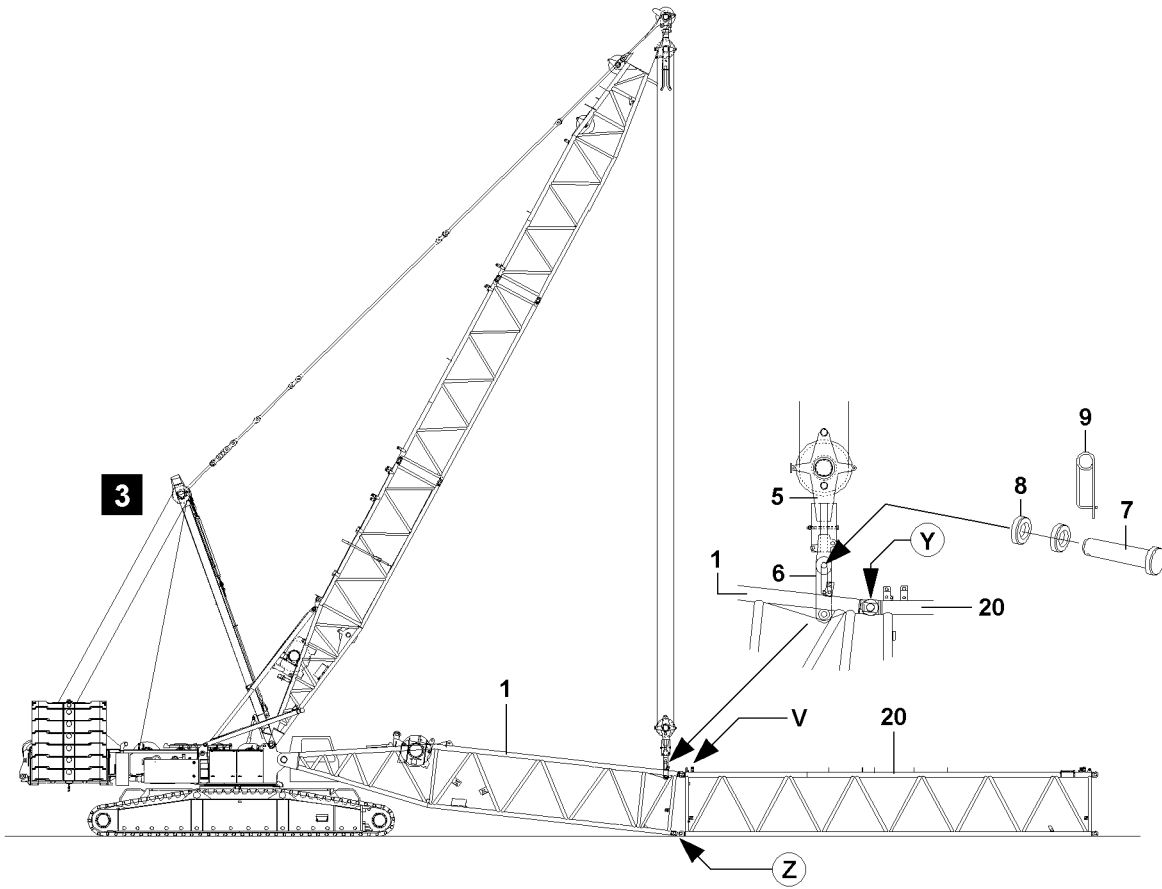

B105817

**Note**

- ▶ The actual force on the test point MS1 - which is exerted during the closing procedure of the boom system - is shown on the LICCON monitor 1!
 - ▶ Record the actual force and keep it ready for the disassembly of the boom system!
 - ▶ During the boom disassembly, the guying is tensioned with the noted actual force (assembly) so that the connector pins of the intermediate sections can be unpinned!
-
- ▶ When the Sw-boom combination is assembled to the desired length:
Lift the S-pivot section **1** with the upper pulley block until the pin bores on the “bottom” align at point **Z**, illustration **3**.
 - ▶ Insert the pin **19** at point **Z** from the “inside” to the “outside” and secure with spring retainer **21**, illustration **V**.

**WARNING**

Mortal danger due to folding down of boom!

By unpinning the upper pulley block **5** on the assembly brackets **6**, the boom can suddenly fold down if the boom is not pinned at point **Z** “on the bottom”!

Personnel can be severely injured or killed!

- ▶ It is prohibited for anyone to remain under the raised lattice jib during the pinning / unpinning procedure!
- ▶ Unpin the upper pulley block **5** only when it is ensured that the S-pivot section **1** is pinned and secured “on top” and “bottom” with the intermediate section **20**!

Unpin the upper pulley block **5** on the assembly brackets **6**.

- ▶ Relieve the upper pulley block **5** by spooling out the control rope.
- ▶ Unpin the upper pulley block **5** on the assembly brackets **6**.

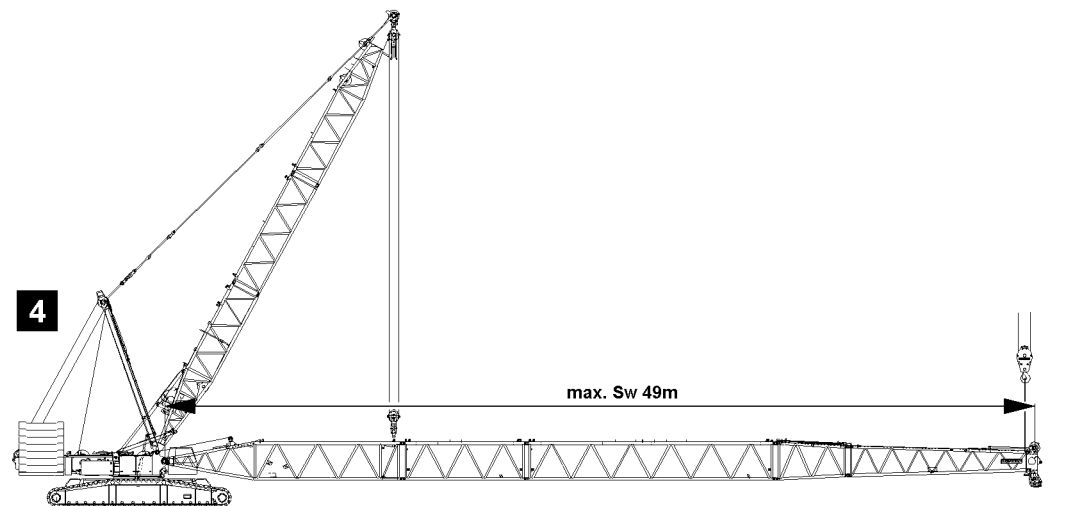

B105910

2.6 “Flying” assembly of the SwD-boom

If spatial prerequisites on the job site are limited for the assembly of the boom, or if they are limited by buildings or similar, then the boom can be installed in “Flying mode”.



WARNING

General danger notes!

- ▶ Support the boom during assembly / disassembly with suitable materials!
- ▶ All pins are to be secured after assembly with the intended safety elements!
- ▶ The guy rods must be inspected regularly, see Crane operating instructions, chapter 8.15!
- ▶ Secure the boom with support or auxiliary crane, see Crane operating instructions, chapter 5.01!



WARNING

The crane can topple over!

If the following conditions are not met, the crane can topple over or be significantly damaged!

Personnel can be severely injured or killed!

- ▶ For the “flying” boom assembly, the maximum permissible total force at test point **MS1** may **not** be exceeded. The “Actual force” is shown on LICCON monitor 1!
- ▶ The “flying” boom assembly is only permissible to certain system lengths!
- ▶ The maximum permissible system lengths may not be exceeded!



Note

- ▶ The total weights of the individual lattice sections, including the corresponding guy rods, see Crane operating instructions, chapter 5.03!



WARNING

The crane can topple over!

- ▶ The following system lengths may only be installed in “Flying mode” if it has been ensured that a counterweight of at least 95 t has been installed on the turntable and a 43 t central ballast is installed on the crawler center section!

	Maximum permissible system lengths for a maximum total					
	force MS1 110 t					
	49.0 m	48.4 m	45.5 m	45.5 m	38.5 m	45.5 m
	DB _{min} ¹⁾ 95 t / ZB _{min} ²⁾ 43 t					
S-pivot section 13.4 m	1x	1x	1x	1x	1x	1x
S-intermediate section 7.0 m	1x	1x	—	1x	—	1x
S-intermediate section 14.0 m	1x	2x	2x	1x	1x	—
SW-reducer section 4.1 m	1x	—	1x	1x	1x	1x
W-intermediate section 7.0 m	—	—	—	1x	1x	1x
W-intermediate section 14.0 m	—	—	—	—	—	1x
W-end section 10.5 m	1x	—	—	—	—	—

1) This counterweight **must** be at least installed on the turntable for “Flying assembly”.

2) This central ballast **must** be at least installed on the crawler center section for “Flying assembly”.

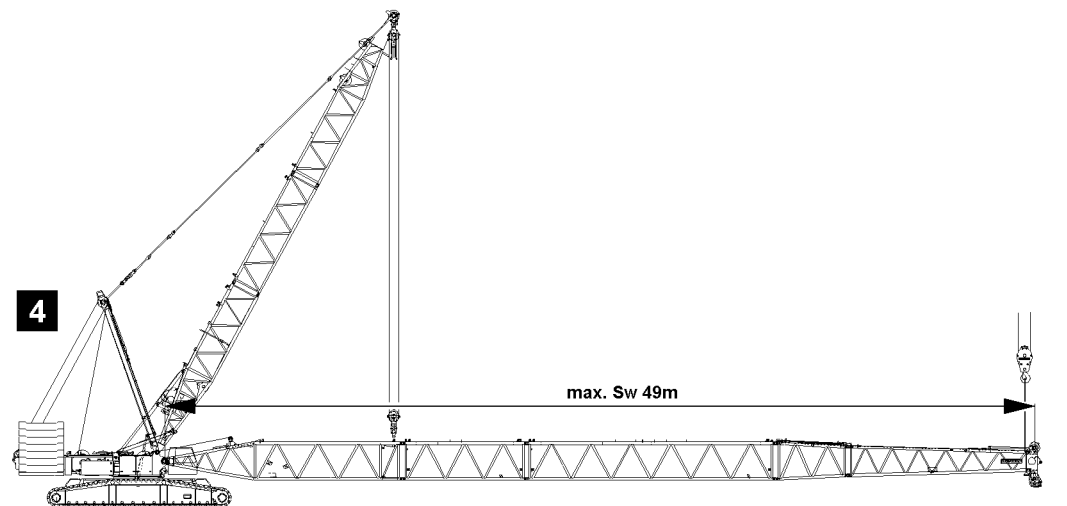

B105910

2.6.1 Assembling the intermediate sections in “Flying mode” on the S-pivot section



WARNING

Impermissible boom lengths!

If impermissible boom lengths are assembled on the crane, significant property damage can occur on the crane!

Personnel can be severely injured or killed!

- ▶ The maximum permissible boom lengths for the “Flying assembly” may not be exceeded!
- ▶ The data in the erection and take down charts as well as the load charts must be observed!



Note

- ▶ For weights of intermediate sections with placed guy rods, see Crane operating instructions, chapter 5.03!

Make sure that the following prerequisites are met:

- The S-pivot section **1** is pinned and secured with the assembly bracket **6** on the upper pulley block **5**.
- The S-pivot section **1** is lifted using the upper pulley block **5** and is in a horizontal position.
- A minimum ballast of 95 t is placed on the turntable.
- The central ballast of 43 t is placed.



WARNING

Falling components!

If unsecured or non-supported components are installed or removed, they can fall down!

Personnel can be severely injured or killed!

- ▶ During pinning and unpinning of the intermediate sections, it is prohibited for anyone to remain **under** or **on** the components as well as within the entire danger zone!
- ▶ Before unpinning: Support crane components and boom!
- ▶ Secure the pins in the bearing points and in the receptacles!
- ▶ It is prohibited to lean a ladder against the crane section which is being disassembled!

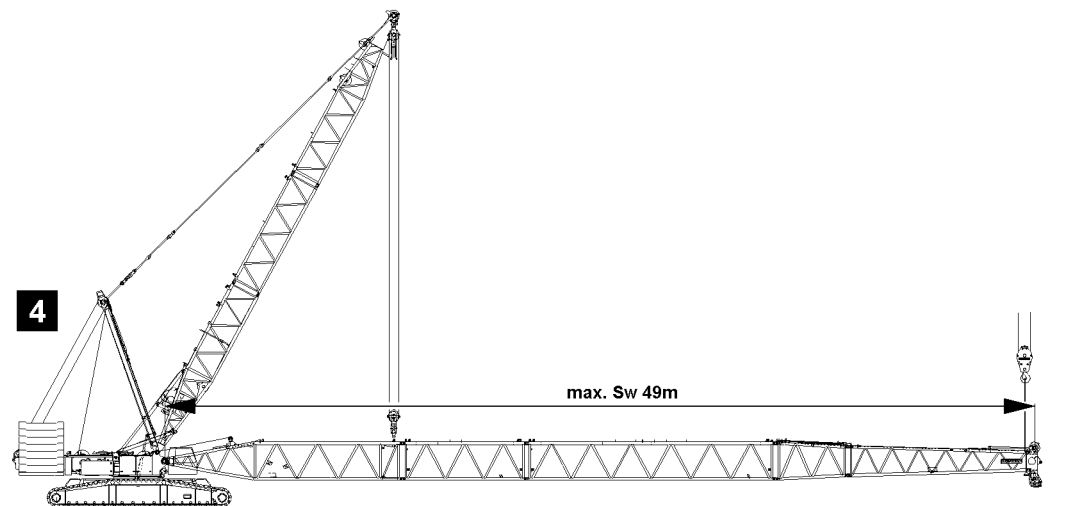

B105910

In “flying” assembly, the intermediate sections can be pinned and secured with the auxiliary crane individually or as a preassembled unit on the S-pivot section.

- ▶ Insert and secure the pin “on top” and “on the bottom”.
- ▶ When the intermediate sections on the S-pivot section are pinned and secured:
Attach the boom on the front on the auxiliary crane.

or

- Support the boom with stable materials.
- ▶ When the boom is attached on the auxiliary crane or properly supported:
Lower the upper pulley block **5**.

Result:

- The control rope is relieved.



WARNING

Mortal danger due to folding down of lattice jib!

When unpinning the upper pulley block from the assembly bracket, the derrick boom can suddenly fold down!

Personnel can be severely injured or killed!

- ▶ Before unpinning the upper pulley block **5**, the boom must be safely held by an auxiliary crane or it must be supported accordingly!
 - ▶ It is prohibited for anyone to remain under the lattice jib during the unpinning procedure!
-
- ▶ Unpin the upper pulley block **5** on the assembly bracket **6**.

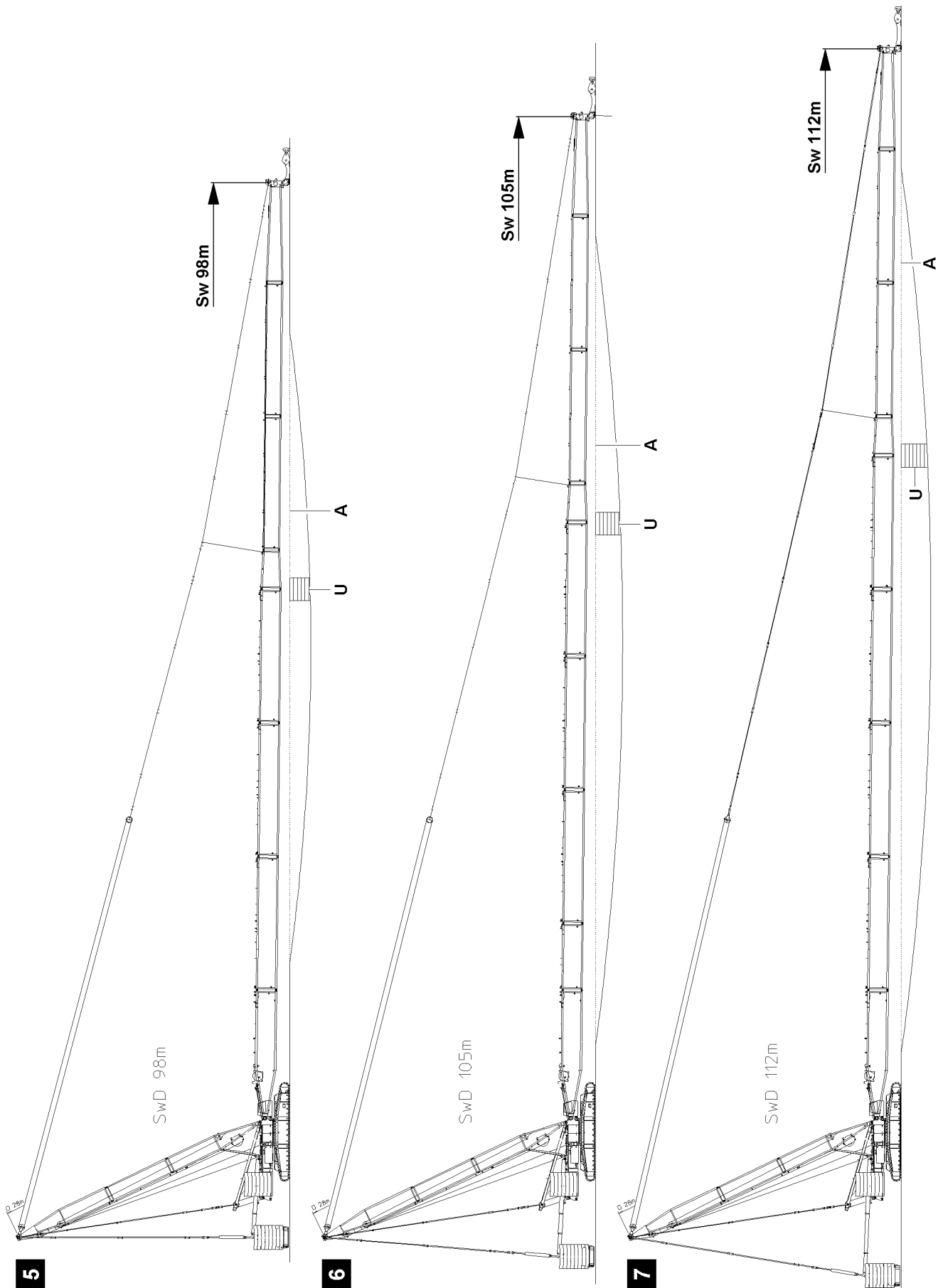

B106193

2.7 Assembling the SwD-boom combination with support

In order to mount the SwD-boom combination to the crane when on **uneven ground** without damaging the crane, the SwD-boom combination must be supported on suitable materials capable of bearing the load.



Note

- ▶ For boom lengths longer than 98 m, a support must be used!

Make sure that the following prerequisites are met:

- The derrick boom is assembled and erected to approx. 75 ° to 85 °.
- The crane is in assembly position.



WARNING

Danger of toppling the crane!

If the derrick boom is erected at an angle of more than 85 °, there is a risk of toppling the crane! Personnel could be severely injured or killed!

- ▶ The derrick boom may not be erected further than a maximum of 85 °!

The S-boom combination - consisting of S-pivot section and S-intermediate sections - should be preassembled in a suitable location. The pre-assembled S-boom combination must be swung in towards the turntable with an auxiliary crane and pinned and secured.

- ▶ Preassemble the S-boom combination.
- ▶ Swing the preassembled S-boom combination in with the auxiliary crane to the turntable.
- ▶ Pin and secure the S-boom combination to the S-pivot section on the turntable.



Note

- ▶ The boom combination must be supported underneath in the area of the reducer section to a height of the alignment level **A!**

- ▶ Place the S-boom combination on the support **U** or hang it on the auxiliary crane.
- ▶ Fully pre-assemble the W-boom combination including the W-end section and attach it to the S-boom combination with the auxiliary crane, or individually install each W-intermediate section and W-end section with the auxiliary crane, pin and secure.

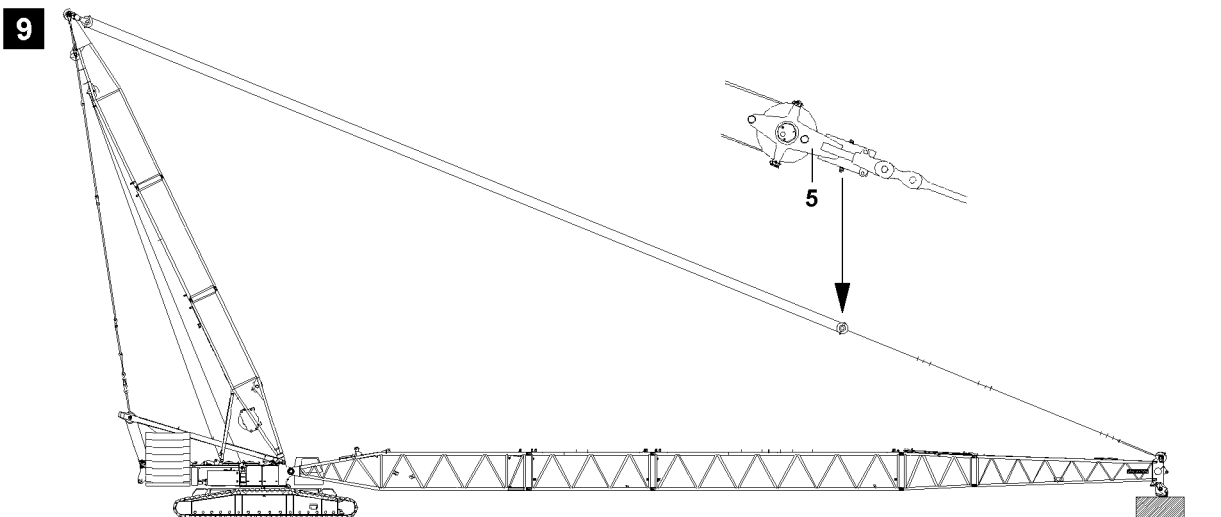
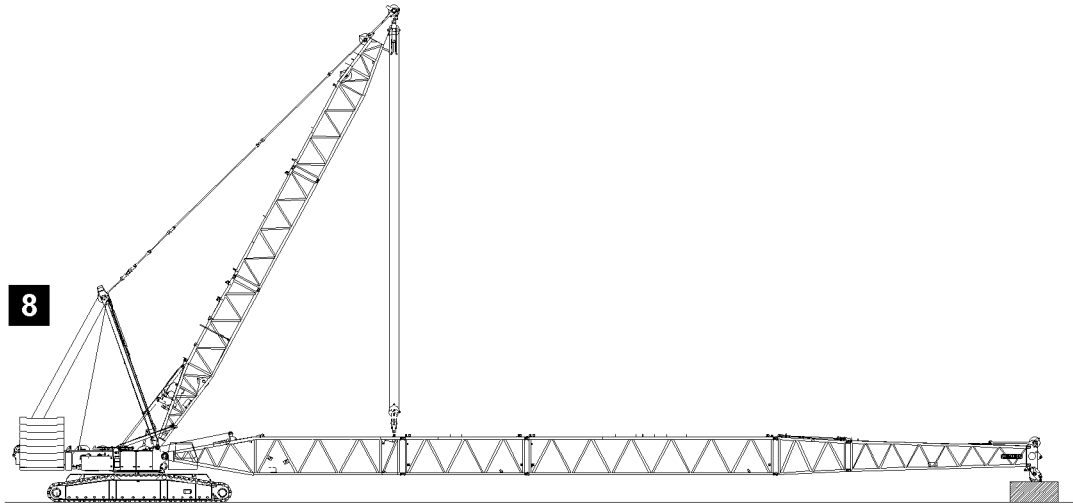

B106188

2.8 Assembling the guy rods



WARNING

Neglected inspection and maintenance on guy rods!

If the regular inspection and maintenance of the guy rods is not carried out or only in irregular intervals, then severe accidents can occur due to existing and not recognized damage on the guy rods!

Personnel can be severely injured or killed!

- ▶ The guy rods must be checked before every assembly, see Crane operating instructions, chapter 8.15!



Note

- ▶ The guy rods must be installed and secured according to the separately supplied assembly drawings! The numbering on the assembly drawings must be identical to the numbering on the guy rods!

Make sure that the following prerequisites are met:

- The boom is fully assembled.
- All lattice sections are properly pinned with each other.
- All pin connections have been secured.
- ▶ Luff the derrick boom down to the front.
- ▶ Lower the upper pulley to the boom: Spool out winch 3.

The guy rods are placed and secured for transport on the corresponding intermediate sections. Before assembly, the transport retainers must be released.

- ▶ Release the transport retainers on the guy rods.

NOTICE

Danger of property damage!

If the pins of the guy rods are not pinned from the “inside” to the “outside”, the hoist rope can scrape on the pin and be damaged!

- ▶ Always insert the pins of the guy rods from the “inside” to the “outside”!
- ▶ Pay attention to the special rod plan!

- ▶ Pin and secure the guy rods for the intermediate sections.
- ▶ Pin and secure the guy rods with the upper pulley block **5**.
- ▶ When the guy rods are pinned and secured:
Erect the derrick to the operating position ($X = 111.1^\circ$ to 115.6°) and spool out winch 3 at the same time so that the boom is not pulled up.
- ▶ When the derrick boom has reached the operating position:
Tension the guying between the derrick and the boom head.



WARNING

The boom can suddenly fold down!

If the following notes are not observed, the boom can suddenly fold down when the auxiliary boom or the support is removed!

Personnel can be severely injured or killed!

- ▶ Remove the auxiliary crane only when the derrick boom is in operating position and the guying between the derrick and the boom is tensioned!

- ▶ Remove the auxiliary crane on the boom head.

or

- Remove the support.
- ▶ Guide the hoist rope over the rope pulley on the end section.

B195219

2.9 Establishing the electrical connections

NOTICE

Damage to the electrical connection on the cable drum!

If the electrical connection from the cable drum to the terminal box is made in incorrect sequence, then the electrical connection can be damaged when spooling the cable drum out!

- ▶ When establishing the electrical connections, pay attention to the sequence, see Electric wiring diagram!



Note

- ▶ To establish the electrical connections, see Electric wiring diagram!

Make sure that the following prerequisite is met:

- The boom is fully assembled.
- ▶ Establish the electrical connections.
- ▶ Make sure that all electrical connections on the boom are established.

2.10 Establishing the hydraulic connections

When connecting hydraulic lines with quick release couplings, make sure that the coupling procedure is carried out correctly.



WARNING

Pressure in the hydraulic lines!

If the pressure supply is not interrupted before connecting / releasing the hydraulic lines, the hydraulic oil can escape with high pressure!

Personnel can be severely injured or killed!

- ▶ Release the pressure in the hydraulic system before connecting / disconnecting: Interrupt the pressure supply and wait for a short time!



WARNING

Loss of pressure or leakage!

Incorrectly coupled or self-loosening quick release couplings (particularly return lines) can result in serious accidents due to component failure!

- ▶ Check that the quick release couplings have been properly connected before using the crane!
- ▶ Connect the coupling components (sleeve and connector) and screw together with the hand-tightened nut.
- ▶ Tighten the hydraulic coupling by hand. Rotate the hand-tightened nut until it reaches a tangible, fixed stop position.
- ▶ Establish the hydraulic connections.

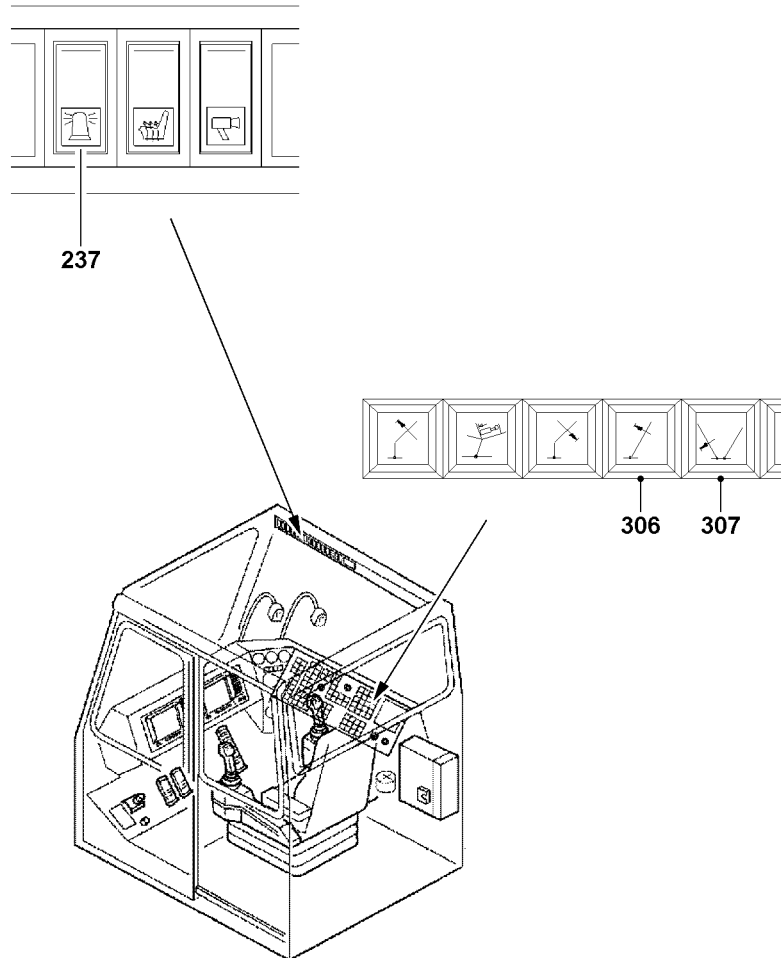

2.11 Function check



WARNING

Non-functioning safety devices!

If the function of the safety devices is defective, personnel can be severely injured or killed!

- ▶ Crane operation with non-functioning safety devices is **prohibited!**



Note

- ▶ The function of the individual limit switches must be checked before erection!
- ▶ The function of the limit switch initiators must be checked in the test system, see Diagnostics manual!



Note

- ▶ If a function check on the limit switches or on the safety devices does not lead to the desired shut offs, then the plug connections on the connector boxes or the components itself must be checked! If no visible connection errors or component defects can be found, contact LIEBHERR Service!

2.11.1 Wind speed sensor*

- ▶ Check the movement and the function of the wind speed sensor.

2.11.2 Airplane warning light*

- ▶ Turn the airplane warning light on with the switch **237**.
- ▶ Check the function visually.

2.11.3 Hoist limit switch

- ▶ Actuate the limit switch on the pulley head manually.

Result:

- The hoist winch turns off in upward movement.
- The hoist top icon appears on the LICCON monitor 0.
- The limit switch is functioning.

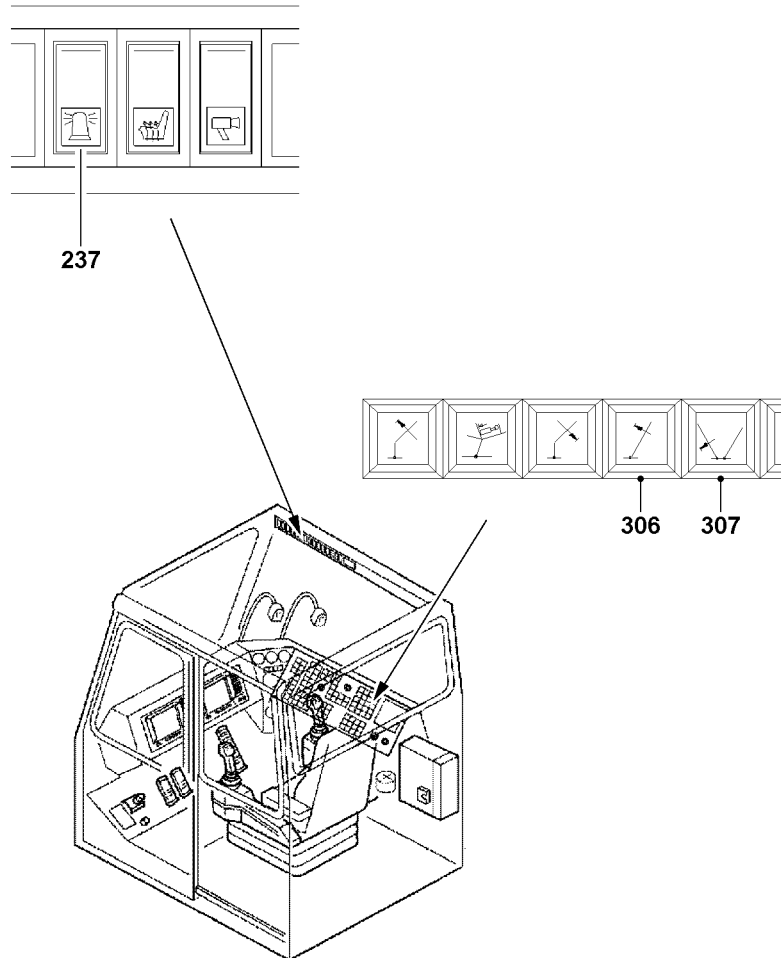

2.11.4 Limit switch boom “Steepest position”

**Note**

► The limit switch functions have to be checked individually before erection!

► Manually actuate the individual limit switches on the S-relapse cylinders.

Result:

- Winch 3 (control winch) turns off in upward movement.
- The indicator light **306** lights up.
- An acoustic signal sounds.
- The limit switch is functioning.

2.11.5 D-relapse cylinder

► Manually actuate the individual limit switches on the D-relapse cylinders.

Result:

- Winch 4 (control winch) turns off in upward movement.
- The indicator light **307** lights up.
- An acoustic signal sounds.
- The limit switch is functioning.

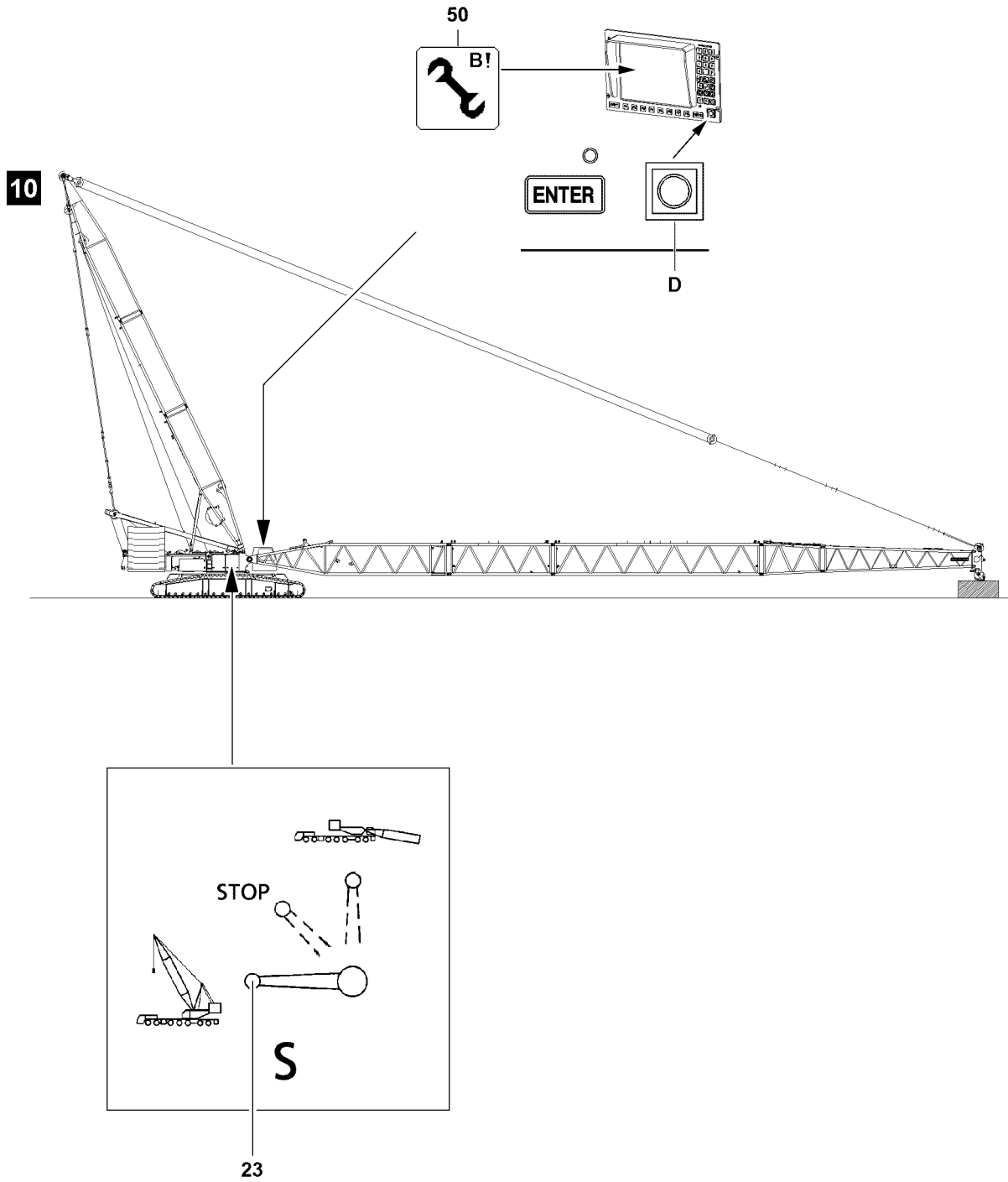

2.12 Erecting the boom



WARNING

The crane can topple over!

If the following conditions are not met before erecting the boom, the crane can topple over and fatally injure personnel!

- ▶ It is not permitted to turn the crane during erection!
- ▶ Observe the safety technical notes, see Crane operating instructions, chapter 5.01!
- ▶ Observe the data in the erection and take down charts!
- ▶ Extend the relapse cylinder before erection!
- ▶ Do not allow slack cable to build up on the control winch!
- ▶ The ball valve cabinet must be locked! Always pull the key and hand it to an authorized person!

Make sure that the following prerequisites are met:

- The crane is aligned in horizontal direction.
- All electrical connections have been made.
- All limit switches are functioning.
- The counterweight has been installed on the turntable according to the load chart.
- All pin connections have been secured.
- The hoist rope has been correctly placed in the rope pulleys and is prevented from jumping out with the rope retaining pins.
- There are no loose parts on the boom.
- The LICCON overload protection has been set according to the data in the load chart.
- The LICCON overload protection settings have been compared with the actual crane configuration.
- No personnel is within the danger zone.
- The LICCON overload protection is exceeded.
- The assembly icon **50** is visible on the LICCON monitor.

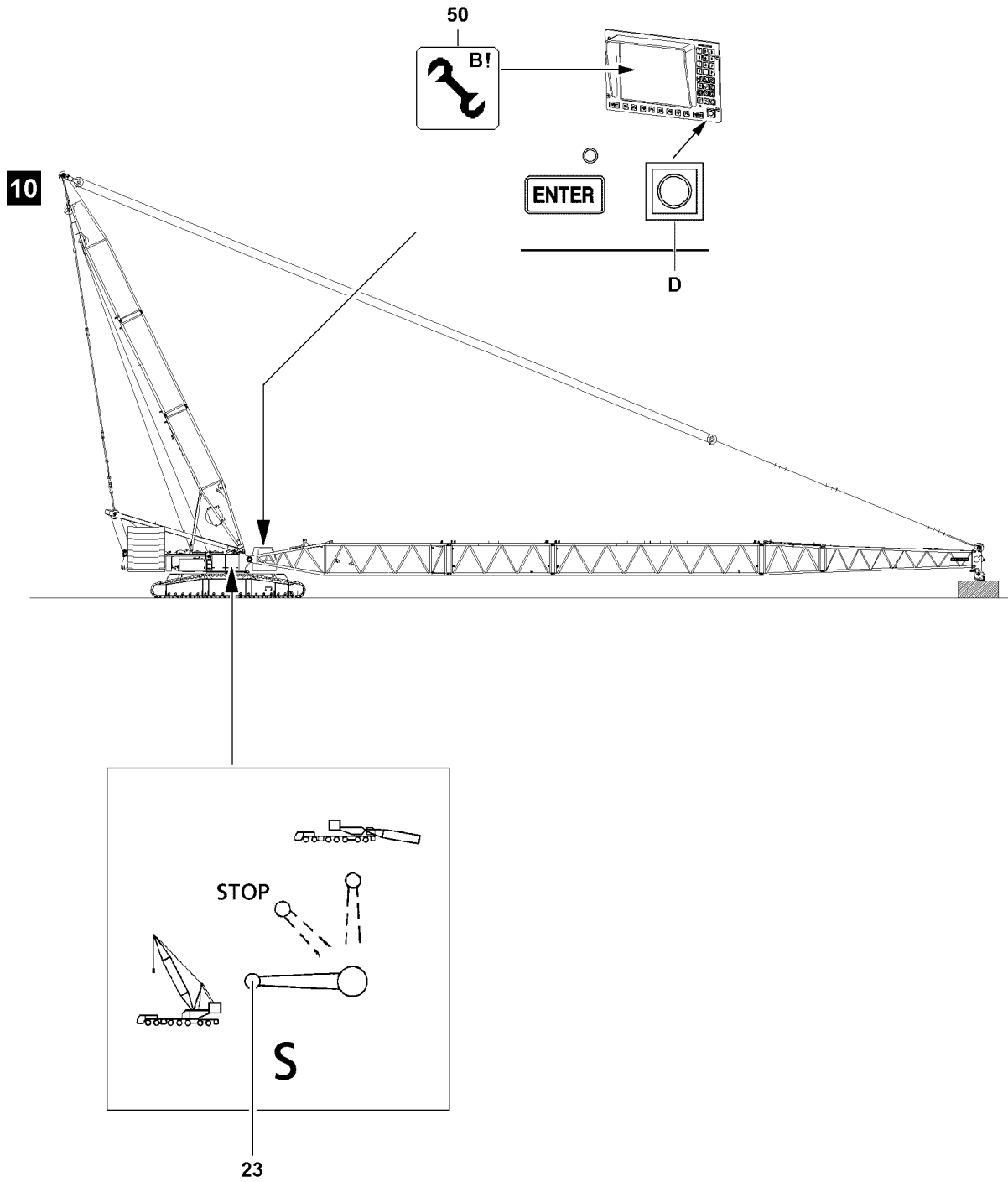

B111488

2.12.1 Extending the relapse cylinder

NOTICE

Damage of the relapse cylinder!

When extending the S-relapse cylinder on the Sw-boom, it must be ensured that the derrick boom is already in its operating position. Otherwise the S-relapse cylinders on the Sw-boom will collide with the D-relapse cylinders!

This can result in severe damage to the S-relapse cylinders!

- ▶ The relapse cylinders on the Sw-boom may only be extended when the derrick boom is in its operating position!



WARNING

The crane can topple over!

If the S-relapse cylinders are not extended before erecting the S-boom, then the S-boom can fall backward during crane operation!

Personnel can be severely injured or killed!

- ▶ The S-relapse cylinders must be extended before erection of the S-boom!
- ▶ The ball valve must be secured during crane operation to prevent unintended actuation!

The piston rod on the S-relapse cylinder must be extended by actuating the ball cock **23**.

Ball valve positions	
Horizontal	Crane operation, extend the piston rod
Vertical	Assembly, retract the piston rod
45 °	STOP (the piston rod cannot be retracted / extended)

Make sure that the following prerequisite is met:

- All hydraulic connections have been made.
- ▶ Move the ball valve **23** into horizontal position.

Result:

- The piston rod of the relapse cylinders extends.



Note

- ▶ The ball valve **23** is secured by closing the cabinet door and removing the key!
- ▶ Close the cabinet door and pull the key.
- ▶ Hand the key to an authorized person.

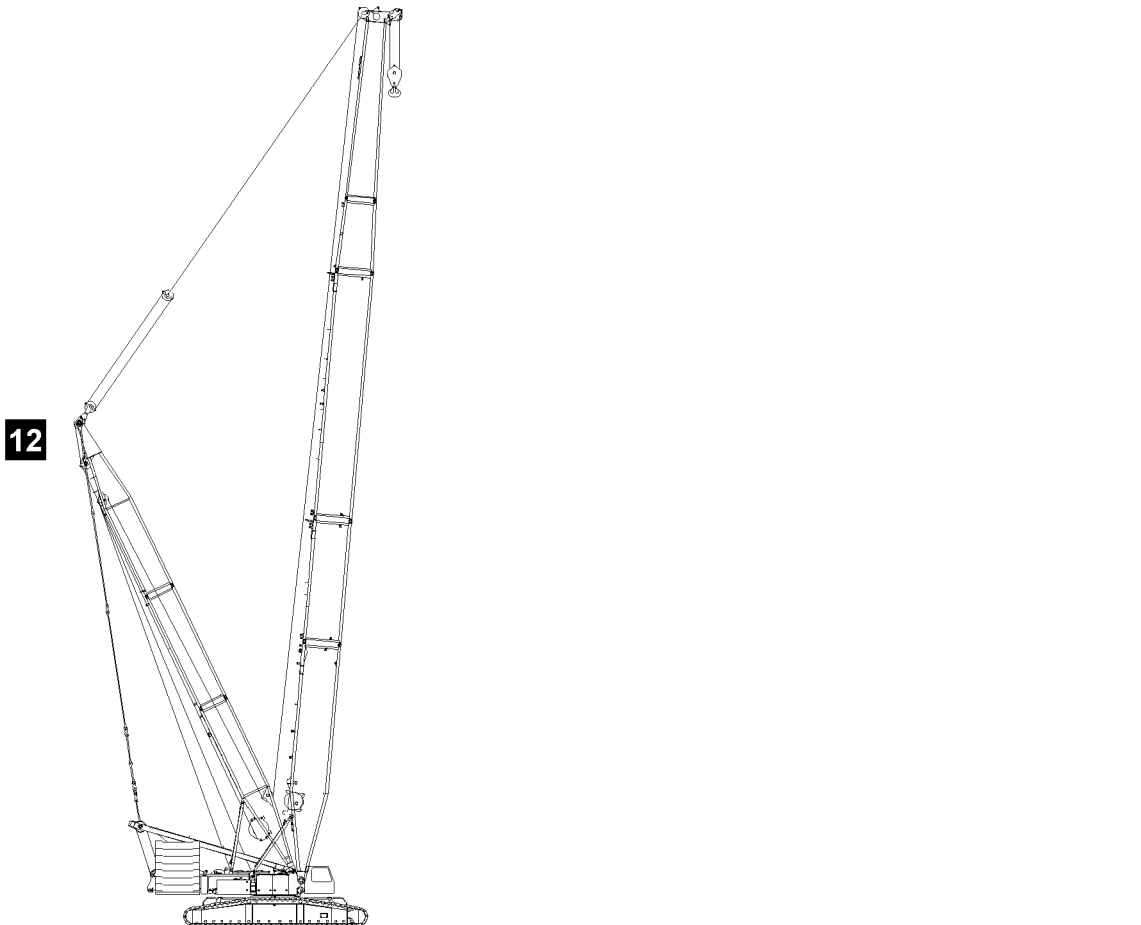
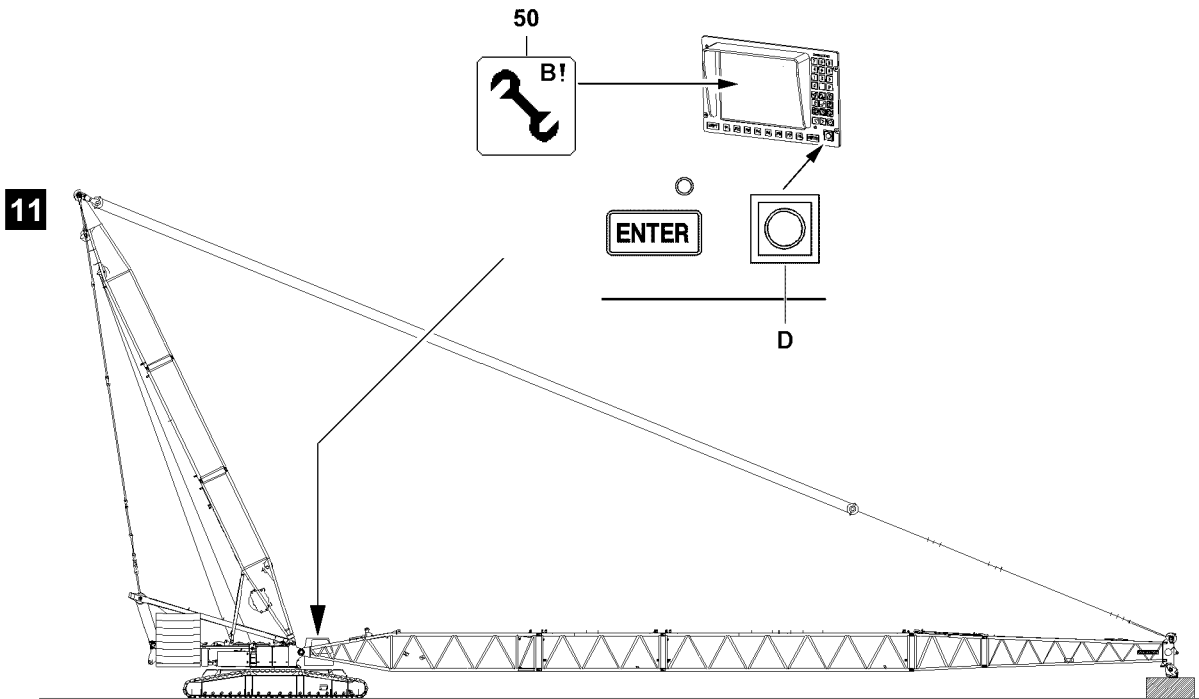

B111489

2.12.2 Erection procedure



DANGER

The crane can topple over!

- ▶ It is not permitted to turn the crane superstructure during erection procedure!
- ▶ Observe the data in the erection and take down charts!

- ▶ Erect the Sw-boom until the end section lifts off the ground.



Note

- ▶ Hoist rope reevings, see Crane operating instructions, chapter 4.06 and Reeving plan!

- ▶ Reeve in the hoist rope properly and secure on the rope fixed point, for reeving, see separate reeving plans.
- ▶ Attach the hoist limit switch weight.



DANGER

The crane can topple over!

In crane operation with exceeded LICCON overload protection, the crane can topple over! Personnel can be severely injured or killed!

- ▶ The radii listed in the load chart may not be exceeded or fallen below, even if there is no load on the hook!



Note

- ▶ When the lowest operating position of the boom is reached, the LICCON overload protection is activated!
- ▶ In the maximum load icon appears a load number in "t" instead of the display "???"!

- ▶ Luff up the Sw-boom to the lowest operating position.
- ▶ When the boom has reached the lowest operating position:
Make sure that the assembly icon **50** on the LICCON monitor turns off.

Result:

- The LICCON overload protection is active.

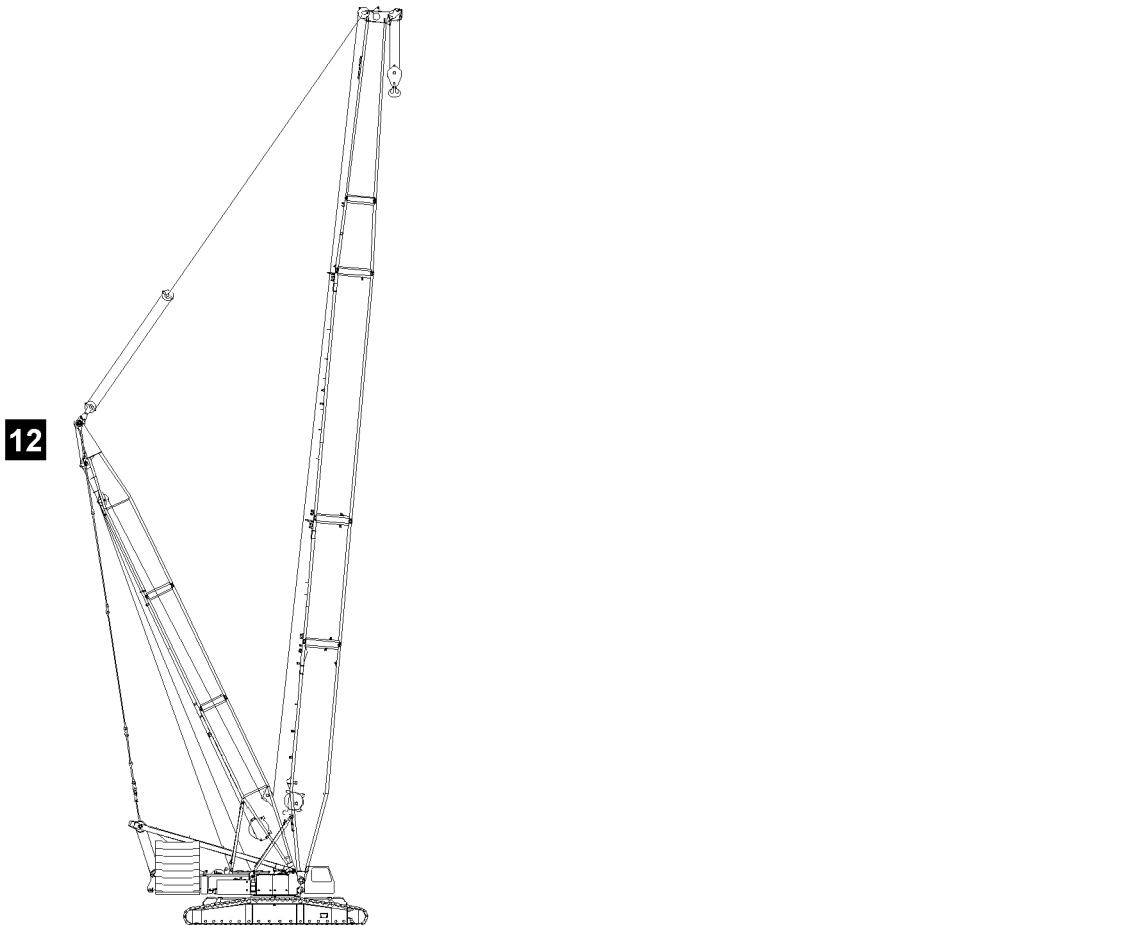
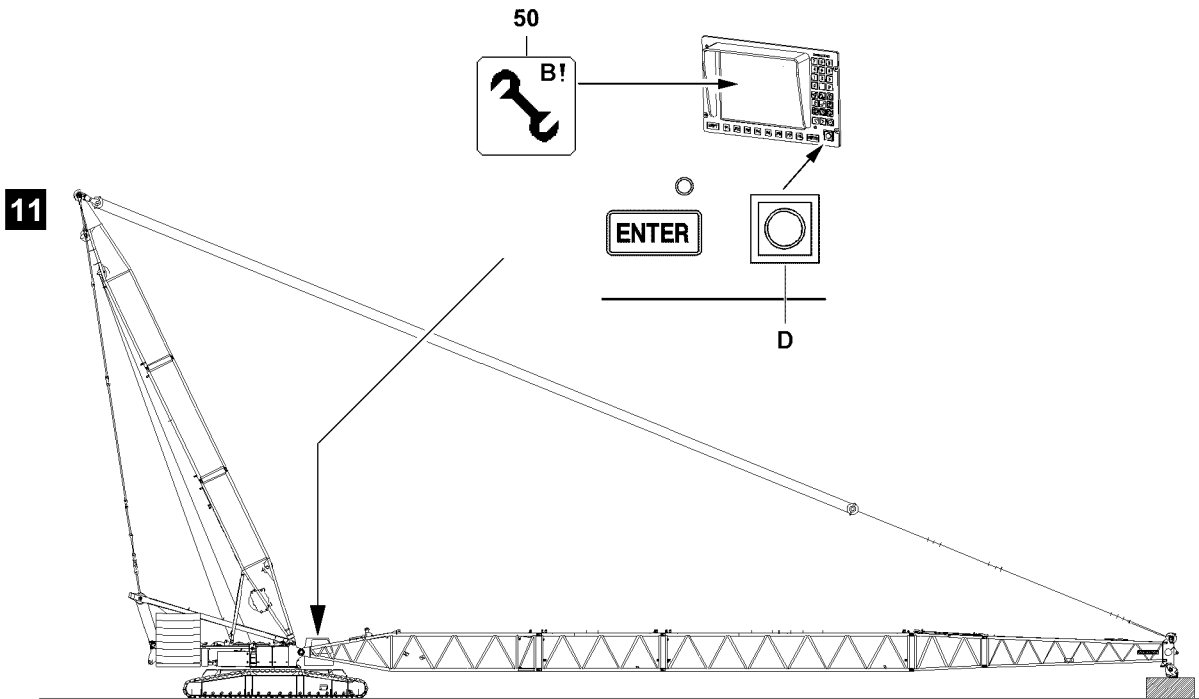

B111489

3 Crane operation with derrick boom combination

3.1 Preparing for crane operation

**Note**

- ▶ Observe the notes in the chapters, see Crane operating instructions, chapter 4.05, chapter 4.08 and chapter 5.01!

Make sure that the following prerequisites are met:

- The LICCON overload protection is active.
- The LICCON overload protection has been set according to the data in the load chart.

**WARNING**

The crane can topple over!

- ▶ Check the horizontal position of the crane before and during operation!
- ▶ If the crane operator leaves the cab, even for a short time, the operating mode setting must be checked and reset if necessary before resuming crane operation!

3.1.1 Checking the settings

- ▶ Check the function of the overload protection by running against the operating positions “on top” and “bottom”.
- ▶ Check the hoist limit switch by running against the hoist limit switch weight.
- ▶ Check the function of the limit switches “Boom steep” on the relapse cylinders.

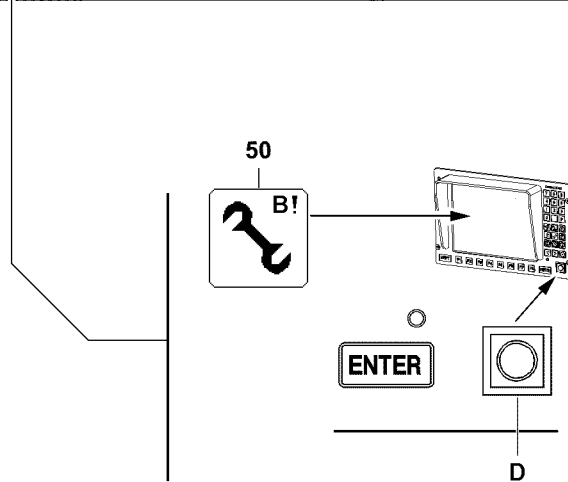
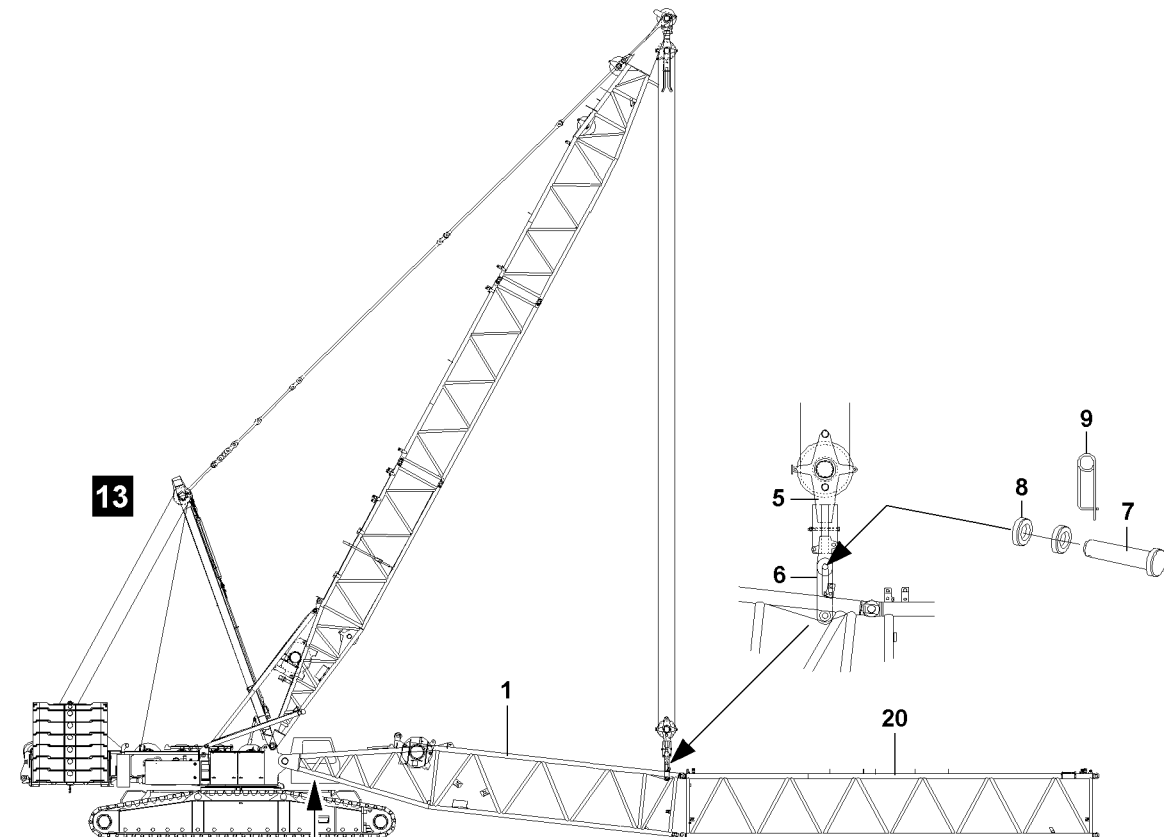

4 Disassembling the SwD-boom combination



WARNING

Risk of falling!

During assembly and disassembly, personnel must be secured with appropriate aids to prevent them from falling! If this is not observed, assembly personnel can fall and suffer life-threatening or fatal injuries!

- ▶ Any work, where there is a danger of falling must be carried out with suitable aids (for example: lifting platforms, scaffoldings, ladders, auxiliary crane)!
- ▶ If the work cannot be carried out with such aids nor from the ground, then the assembly personnel must secure themselves with approved fall arrest systems to avoid falling, see Crane operating instructions chapter 2.04!
- ▶ If railings are present on the components, then they must be brought into the corresponding position and secured for assembly / disassembly work!
- ▶ Step on aids and fall protection equipment only with clean shoes!
- ▶ Keep aids and fall protection equipment clean and free from snow and ice!
- ▶ During all assembly and disassembly work, maintenance work and inspections, travel or crane operation is prohibited!



WARNING

Falling components!

If unsecured or non-supported components are installed or removed, they can fall down!

Personnel can be severely injured or killed!

- ▶ During pinning and unpinning of the lattice sections, it is prohibited for anyone to remain **under** or **on** the components as well as within the entire danger zone!
- ▶ Support the boom and components before pinning / unpinning!
- ▶ Pin or unpin both pins laying in a horizontal, i.e. **left** and **right**!
- ▶ Secure the pins in the bearing points and in the receptacles!
- ▶ Do not disengage the auxiliary crane until each component is pinned on and secured!
- ▶ It is prohibited to lean a ladder against the component being disassembled!



WARNING

Danger of impact / crushing!

When installing / removing crane components with the auxiliary crane, crane components can start to swing back and forth!

When lifting / lowering and positioning crane components, there is an increased danger of impacts / crushing!

Personnel can be severely injured or killed!

- ▶ Make sure that personnel cannot be caught by components!
- ▶ Make sure that the crane is aligned in horizontal position to avoid the support beams from swinging by themselves!
- ▶ When working in danger zones: Use aids to protect limbs!
- ▶ Guide components with suitable aids to minimize oscillation!

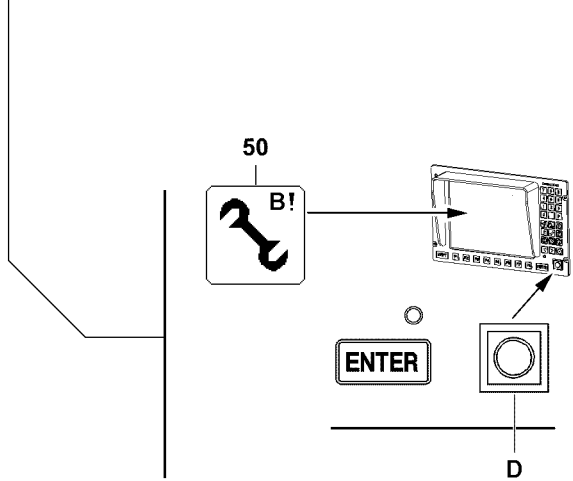
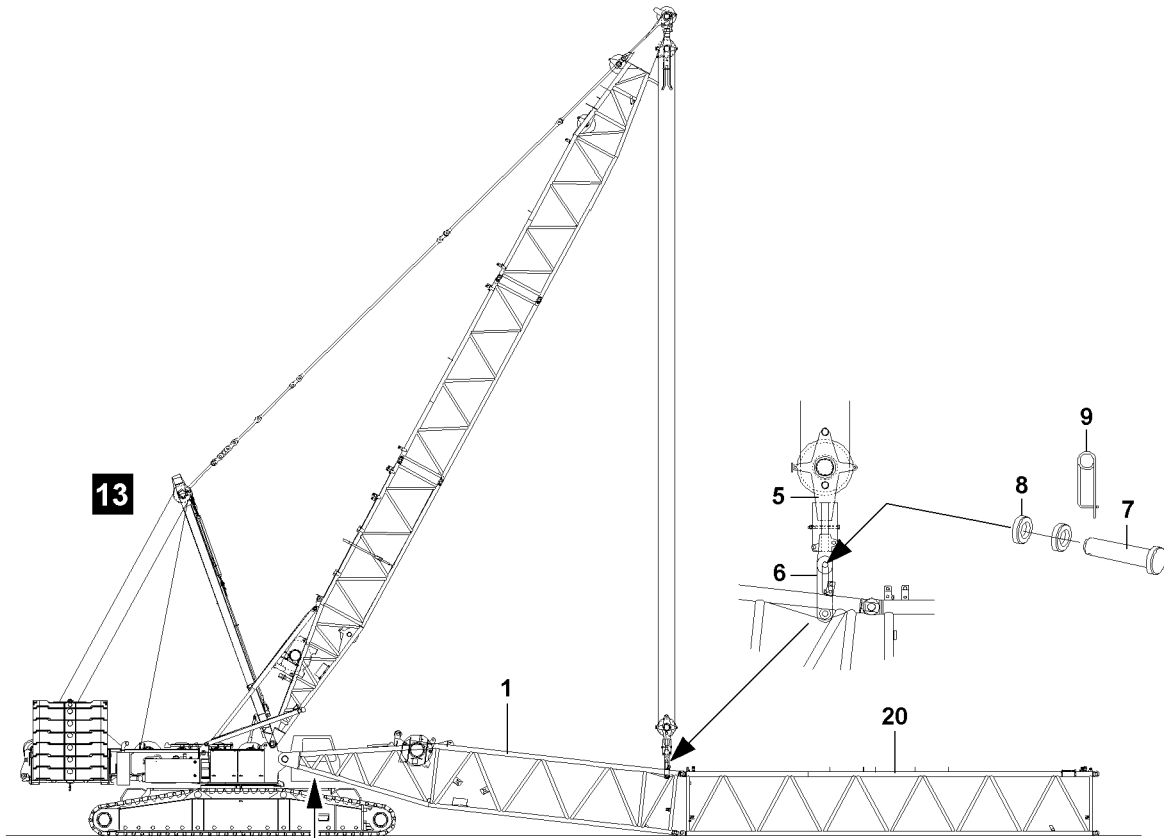

4.1 Taking the Sw-booms down



WARNING

Risk of accident!

If the following instructions are not observed, personnel can be severely injured or killed!

- ▶ The turntable may not be turned during the assembly of the Sw-boom!
- ▶ Observe the safety technical notes, see Crane operating instructions, chapter 5.01!
- ▶ Observe the data in the erection and take down charts!

NOTICE

Damage of boom components!

Taking down the boom system can lead to a collision between the hook block and the pulley head.

There is the danger that boom components may be significantly damaged!

- ▶ When taking down the boom system, always spool out the hoist winch at the same time!
- ▶ When luffing the boom system down, the derrick boom must remain in operating position until the end section is laying on the ground!

Make sure that the following prerequisites are met:

- The crane is aligned in horizontal direction.
- An auxiliary crane is available.
- An assembly scaffolding / work platform is available.
- The counterweight has been installed to the turntable according to the erection chart.
- The LICCON overload protection has been set according to the data in the load chart.
- ▶ Turn the turntable in longitudinal axle of the crawler travel gear against the travel direction or vertically to the crawler travel gear, see Erection and take down chart.



Note

- ▶ The luff down movement is turned off as soon as the lowest operating position is reached!
- ▶ When the lowest operating position of the boom is reached, the load display in the maximum load icon turns off and instead of the load display appears the display “???”!
- ▶ In the crane operating screen appear alarm functions!

- ▶ Luff the S-boom down to the “lowest” operating position.

Result:

- The luff down movement is turned off.
- The “STOP” icon appears on the LICCON monitor.
- The horn icon appears on the LICCON monitor.

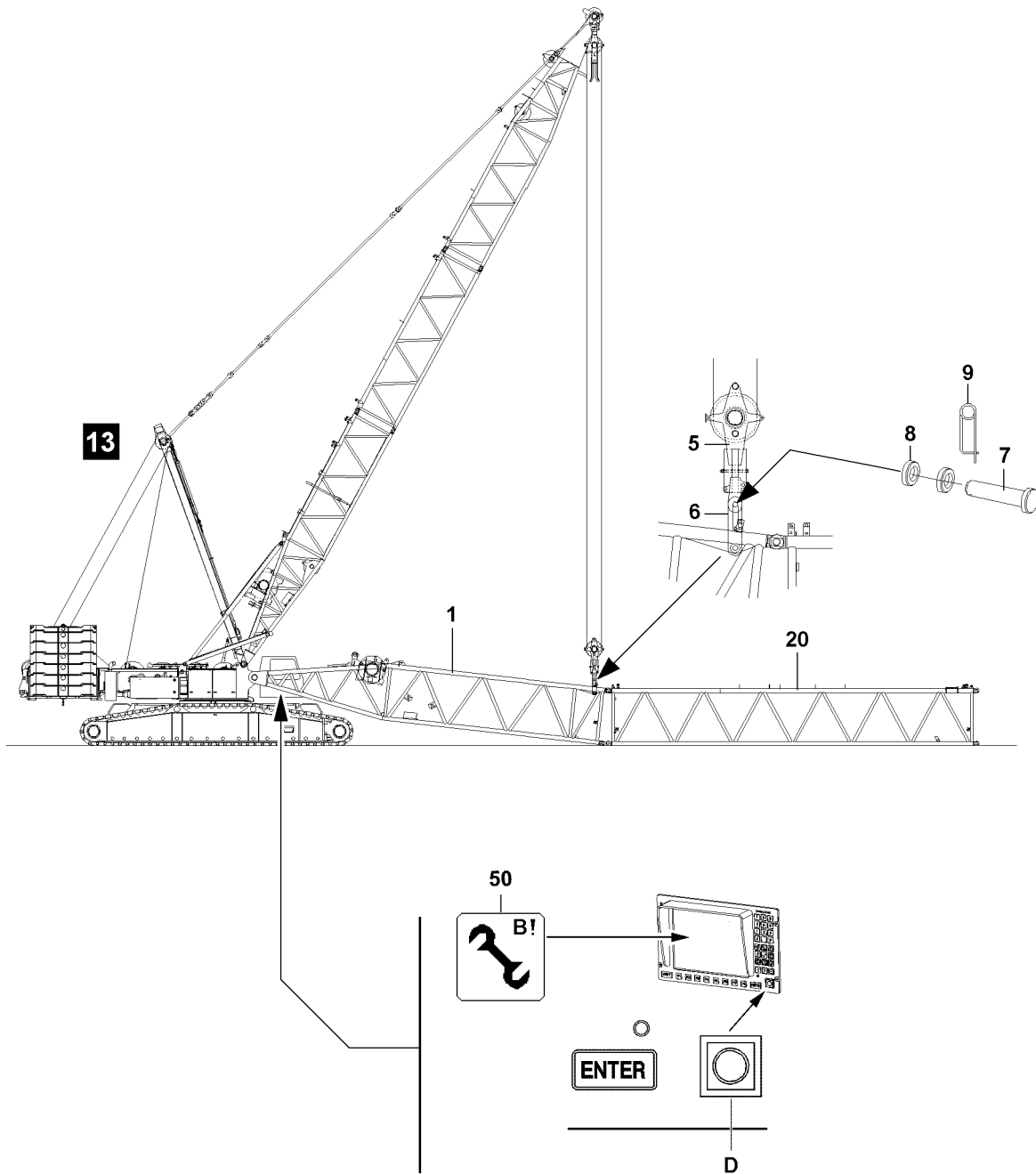

**WARNING**

Assembly with turned on set up key!

When the set up key is turned on, the LICCON overload protection is exceeded!

In the event of deliberate improper use, the crane could collapse, the boom can break off or the crane can topple over!

Personnel can be severely injured or killed!

This could result in high property damage!

- ▶ The set up key **D** may only be actuated by persons who know the effects of a bypass!
- ▶ Press the set up key **D** only when the set up status was correctly entered into the LICCON computer system!
- ▶ Observe the erection / take down charts!
- ▶ Crane operation with the set up key **D** turned on is strictly prohibited!

- ▶ When the S-boom has reached the “lowest” operating position:
Turn the set up key **D** to the right.

Result:

- The LICCON overload protection is deactivated.
- The assembly icon **50** appears on the LICCON monitor.
- ▶ At the same time, spool the hoist winch out and luff the Sw-boom down further until the hook block touches the ground.
- ▶ Remove the hoist limit switch weight and unreeve the hook block.
- ▶ Luff the boom down until the boom head is lying on the support on the ground.

NOTICE

Overspooled winch!

If the rope is pulled under the winch when spooling up, the settings of the cam limit switch are not longer correct and there is an increased danger of accidents!

As a result, extensive adjustment work on the cam limit switch is required!

- ▶ Slowly spool up the hoist rope over the rope pulleys back to the winch!
- ▶ Stop the winch in time, with sufficient rope reserve!
- ▶ Do not overspool the winch!
- ▶ Remove the hoist rope.

B195219

4.2 Disconnecting the electrical connections

Make sure that the following prerequisite is met:

- The boom has been placed down.
- ▶ Disconnect the electrical connections.

NOTICE

Damage to cable drum or cable!

If the cable of the cable drum is not properly spooled up on the cable drum after unplugging, then the cable drum or the cable can be significantly damaged!

- ▶ Spool the cable drum up after unplugging!
- ▶ Spool the cable drum up and secure it to prevent inadvertent spooling out.
- ▶ Make sure that all electrical connections on the boom have been disconnected.

4.3 Disconnecting the hydraulic connection

When releasing hydraulic lines with quick release couplings, make sure that the coupling procedure is carried out correctly.



WARNING

Pressure in the hydraulic lines!

If the pressure supply is not interrupted before connecting / releasing the hydraulic lines, the hydraulic oil can escape with high pressure!

Personnel can be severely injured or killed!

- ▶ Release the pressure in the hydraulic system before connecting / disconnecting: Interrupt the pressure supply and wait for a short time!
- ▶ Install the coupling components (sleeve and connector) with the hand-tightened nut.
- ▶ Disconnect the hydraulic connections.
- ▶ Install dust caps on the quick release couplings.

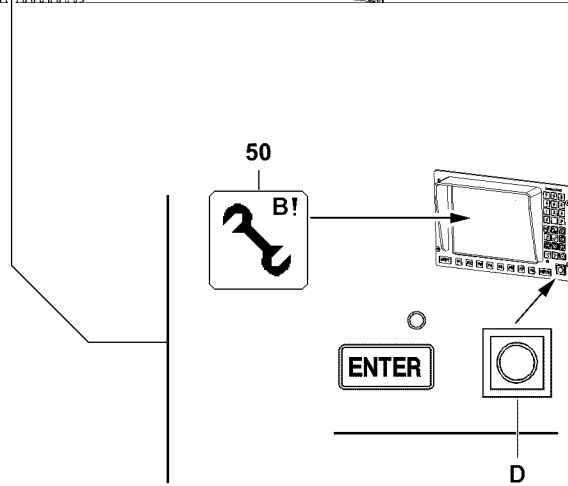
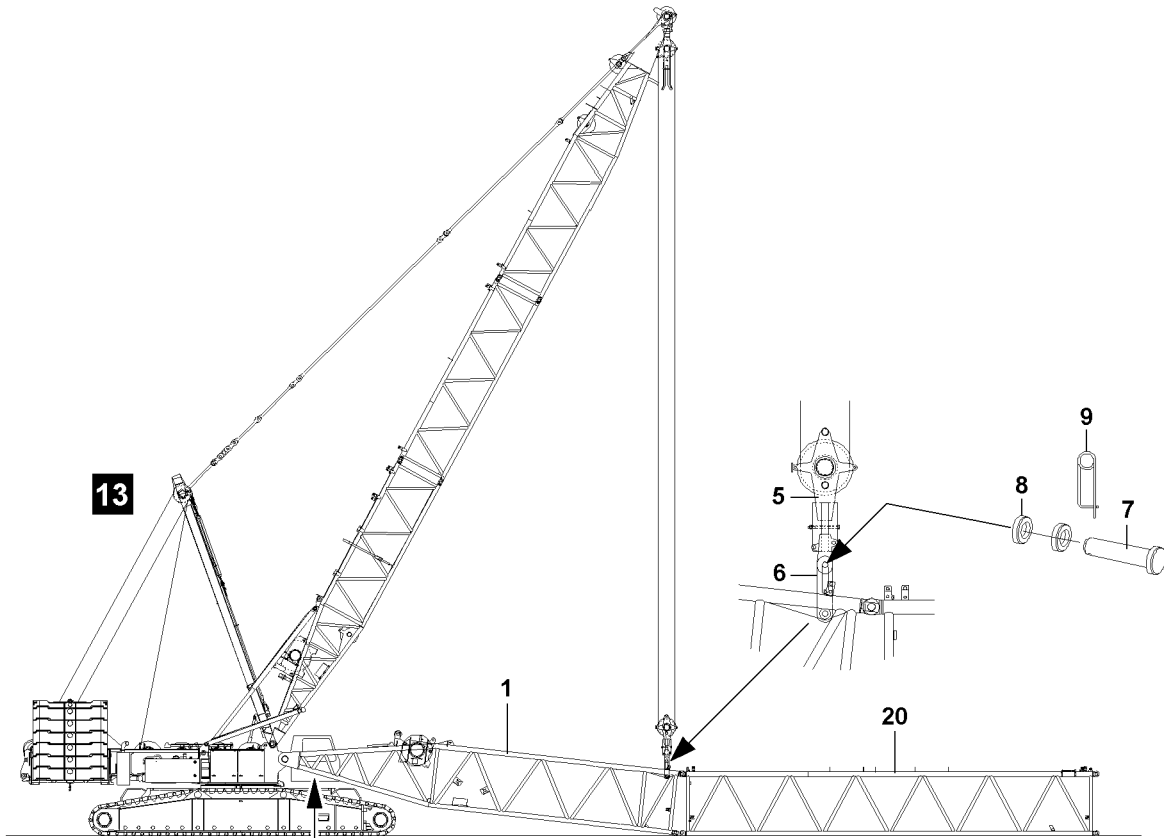

4.4 Disassembling the boom



WARNING

The Sw-boom can suddenly fold down!

If the following conditions are not met prior to dismantling the Sw-boom, the Sw-boom can fold down and fatally injure people!

- ▶ Support the Sw-boom during disassembly with suitable materials or place it on the ground!
- ▶ It is prohibited for anyone to remain under the Sw-boom or in any part of the danger zone during the boom pinning and unpinning procedure!

Make sure that the following prerequisite is met:

- All electrical and hydraulic connections are separated on the boom.
- ▶ Relieve the guying: Luff the derrick boom down to the front.
- ▶ When the guying is relieved:
Unpin the upper pulley block on the guy rods.
- ▶ Place the guy rods on the intermediate sections and secure with transport retainers.
- ▶ Erect the derrick boom.
- ▶ Lower the upper pulley block **5** until it is over the assembly brackets.
- ▶ Pin and secure the upper pulley block **5** with the assembly brackets **6**.
- ▶ Use pin **7**, washer **8** and spring retainer **9**.



WARNING

The crane can topple over!

If the following conditions are not met, the crane can topple over or be significantly damaged!

Personnel can be severely injured or killed!

- ▶ The maximum permissible total force on test point **MS1** may **not** be exceeded!
- ▶ Lifting the following boom lengths is permissible providing the maximum permissible total force at test point **MS1** is observed. Refer to the following charts!



Note

- ▶ The ACTUAL force on test point **MS1** is shown on monitor 1!
- ▶ Tension the guy rods on the SA-bracket with the same force as during the assembly!
- ▶ For this, refer the ACTUAL force at the measuring point measured and recorded during the assembly (MS1)!
- ▶ The pins can be pulled easier and the pins and lugs are therefore not damaged!

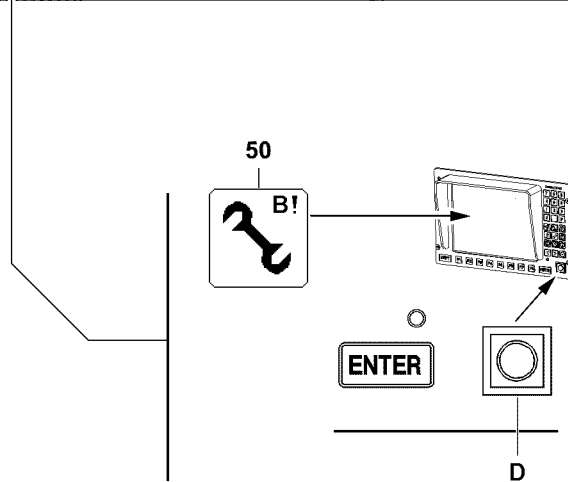
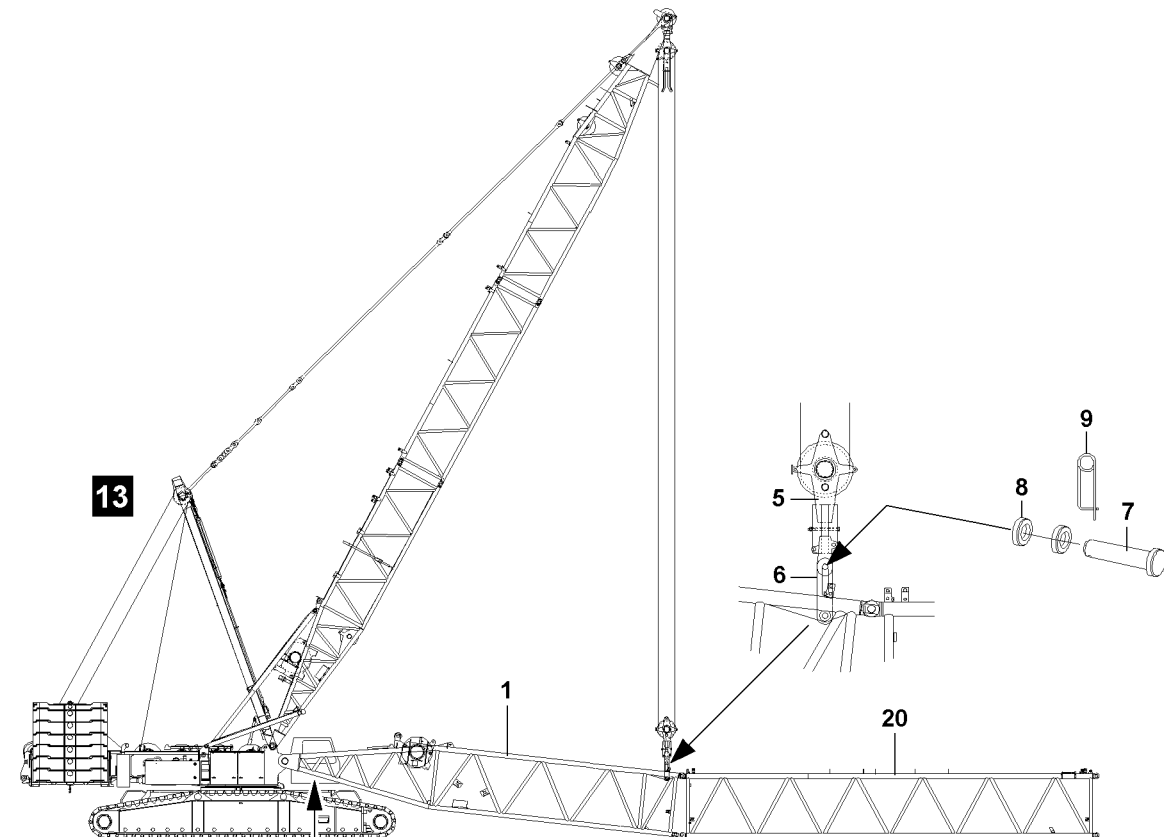

**WARNING**

The crane can topple over!

- ▶ When disassembling the boom, it must be ensured that a counterweight of at least 95 t is installed on the turntable and a central ballast of 43 t is installed on the crawler center section!

	Maximum permissible system lengths for a maximum total force MS1 110 t					
	49.0 m	48.4 m	45.5 m	45.5 m	38.5 m	45.5 m
	DB _{min} ¹⁾ 95 t / ZB _{min} ²⁾ 43 t					
S-pivot section 13.4 m	1x	1x	1x	1x	1x	1x
S-intermediate section 7.0 m	1x	1x	—	1x	—	1x
S-intermediate section 14.0 m	1x	2x	2x	1x	1x	—
SW-reducer section 4.1 m	1x	—	1x	1x	1x	1x
W-intermediate section 7.0 m	—	—	—	1x	1x	1x
W-intermediate section 14.0 m	—	—	—	—	—	1x
W-end section 10.5 m	1x	—	—	—	—	—

1) This counterweight **must** at least be installed on the turntable during "Disassembly".

2) This central ballast **must** at least be installed on the crawler center section during "Disassembly".

**Note**

- ▶ Unpin the intermediate sections with the pin pulling device, see Crane operating instructions, chapter 5.30!

NOTICE

Danger of property damage!

If the maximum permissible total force is not observed when lifting the boom system for disassembly, then the crane components can be severely damaged!

- ▶ Do not exceed the maximum permissible total force!
- ▶ Disconnect the electrical connections and store the cables carefully.
- ▶ Spool the cable drum up and secure it to prevent inadvertent spooling out.
- ▶ Lift the S-pivot section **1** with the upper pulley block **1** and unpin on both sides at point **Z**: Remove the spring retainer **9** and unpin the pin **7**.
- ▶ Lower the S-pivot section **1** to the ground.
- ▶ Relieve the guying by lowering the upper pulley block **5**.
- ▶ Unpin the upper pulley block **5** on the assembly brackets **6**: Remove the spring retainer **9** and unpin the pin **7**.
- ▶ Unpin and disassemble the intermediate sections.

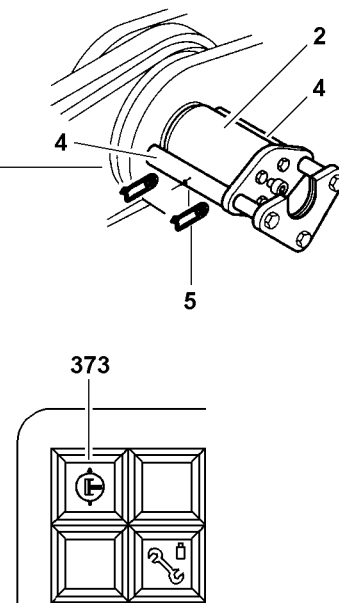
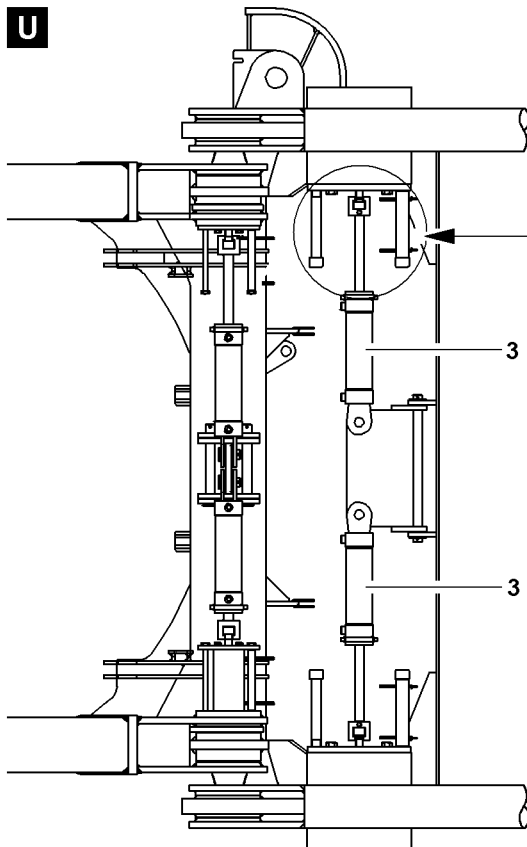
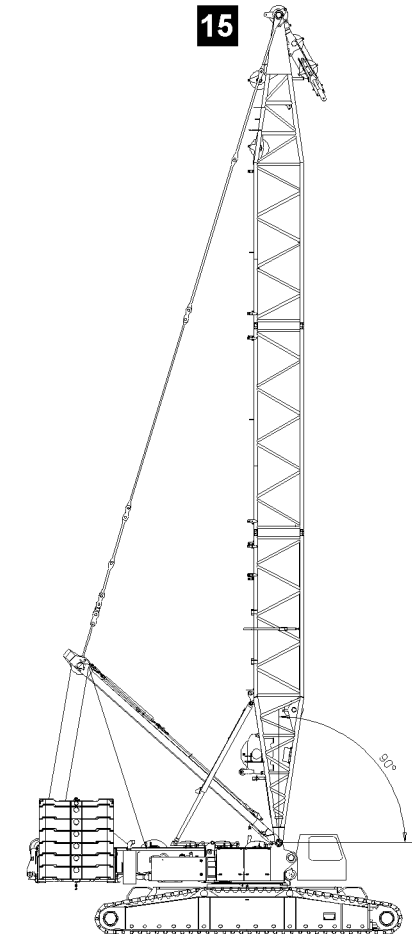
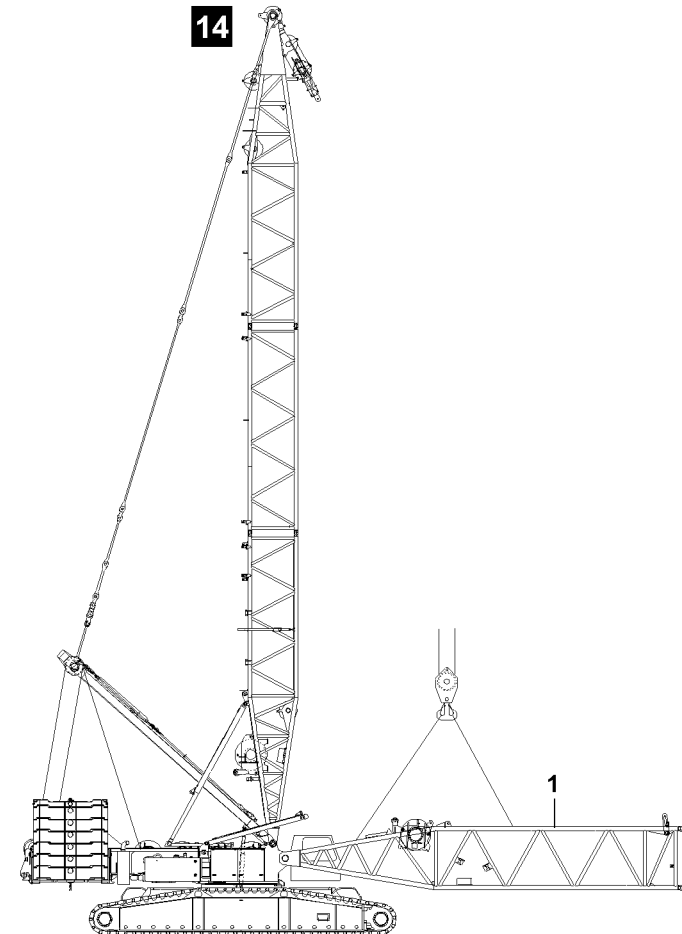

B111507

4.5 Unpinning the S-pivot section



WARNING

General danger notes!

- ▶ Insert and secure all pins after disassembly in the intended transport receptacles!

Make sure that the following prerequisite is met:

- The derrick boom is erected to the point where the S-pivot section can be disassembled without obstructions.
- ▶ Attach the S-pivot section **1** on the auxiliary crane.
- ▶ Lift the S-pivot section **1** with the auxiliary crane to the horizontal.

Establish the hydraulic connection to the pin pulling device via two quick couplers.

Release and unpin the S-pivot section **1** on the turntable.

- ▶ Establish the hydraulic connection to the pin pulling device.
- ▶ Turn the pressure change over switch **373** on.



WARNING

Falling S-pivot section!

- ▶ Make sure that the S-pivot section is safely held by the auxiliary crane before unpinning the pins **2**!
- ▶ Remove the spring retainer **5** on the retaining plate **4** on the left and right.
- ▶ Remove the retaining plate **4** left and right.
- ▶ Unpin the connector pins **2** with the hydraulic pin pulling device **3**.
- ▶ Turn the pressure change over switch **373** off.
- ▶ Disconnect the hydraulic connections to the pin pulling device.

NOTICE

Danger of property damage on the turntable and on the S-pivot section!

- ▶ Slowly swing the S-pivot section out with the auxiliary crane and at low speed on the turntable!
- ▶ Place the S-pivot section with the auxiliary crane on the support on the ground.
- ▶ Remove the pin pulling device.
- ▶ Remove the auxiliary crane.



Note

- ▶ Disassemble the derrick boom, see Crane operating instructions, chapter 5.05!

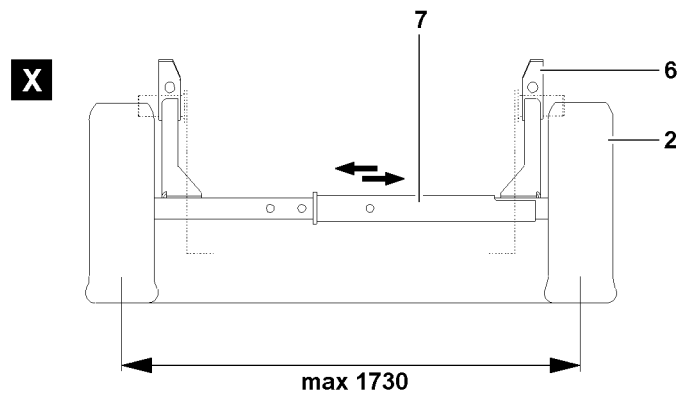
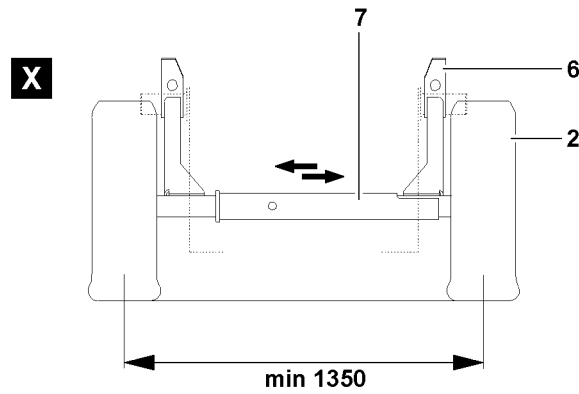
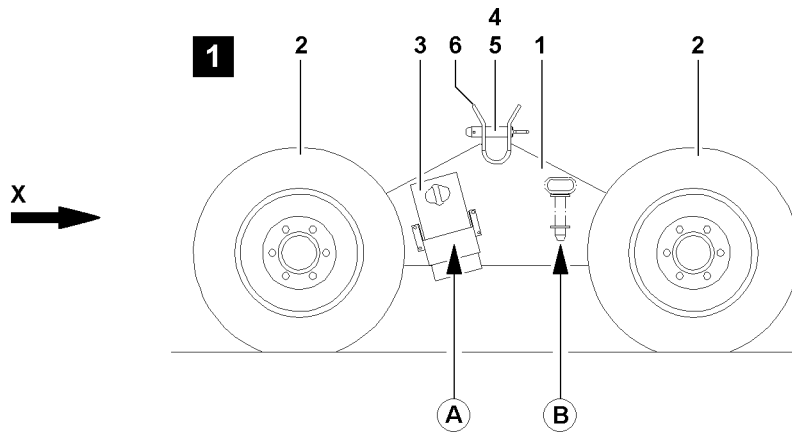

B105433

1 Components of pulley cart

Position	Description
1	Pulley cart (steel construction)
2	Tires
3	Wedge
4	Retaining pin
5	Linch pin
6	Receptacle
7	Axle (telescopeable)

1.1 Adjusting the track width on the pulley cart

The track width of the pulley cart can be telescoped out via the telescopeable axles **7** to the width of the corresponding end section and affixed in this position with set screws.

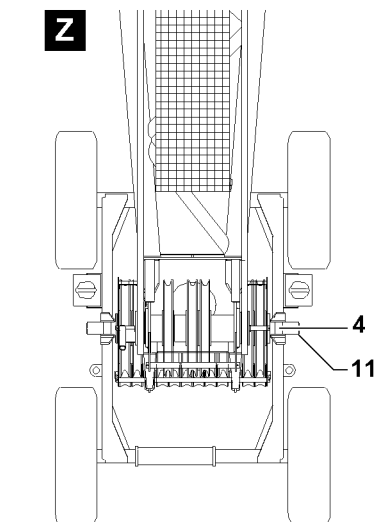
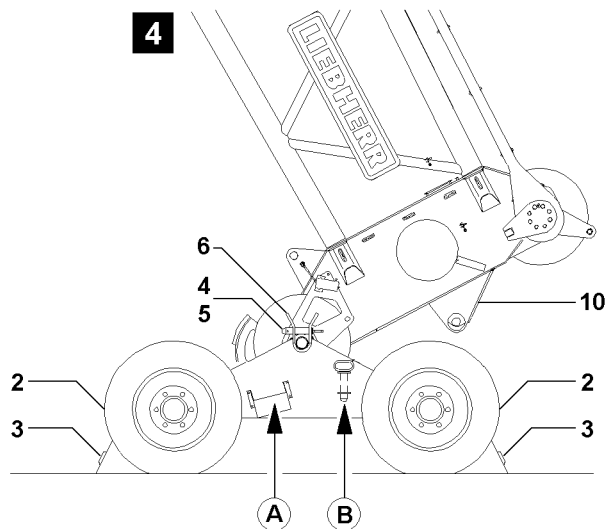
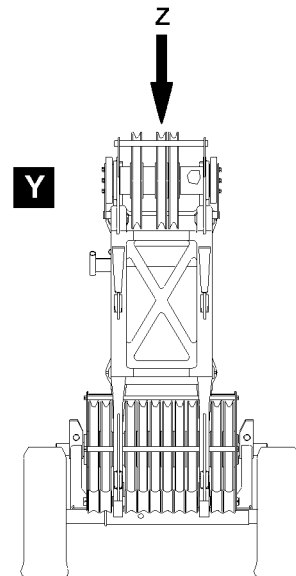
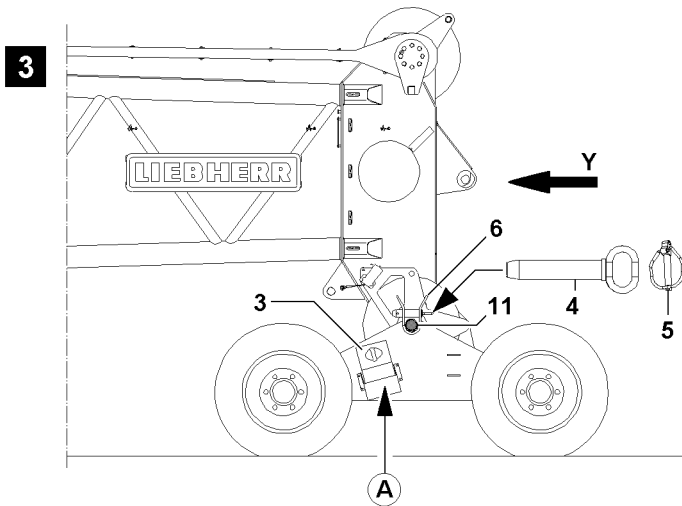
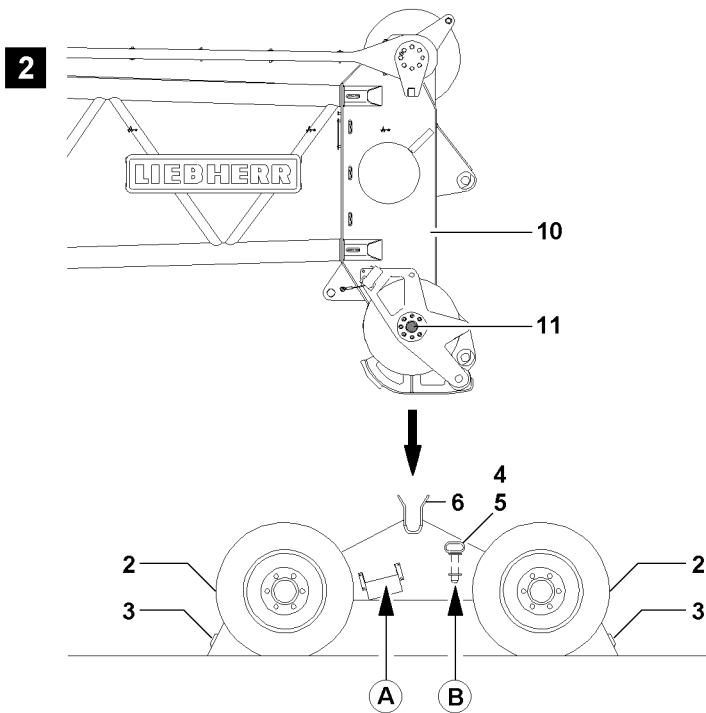

B105434

1.2 Installing the pulley cart

Place the pulley cart **1** under the W-end section and affix with wedges **3**.

- ▶ Remove the wedges **3** from the transport retainer (point **A**) on the pulley cart.
- ▶ Secure the pulley cart **1** with wedges **3** to prevent it from rolling off: Push the wedges **3** on the left and right hand side tightly under the wheels **2**, illustration **2**.
- ▶ Slowly lower the W-boom until the studs **11** of the W-end section **10** are placed in the receptacles **6** of the pulley cart, fig. **3**.

Secure the studs **11** in the receptacles **6** of the pulley cart **1**.

- ▶ Unpin the retaining pin **4** from the transport receptacle (point **B**).
- ▶ Insert the pin **4** at receptacles **6** and secure with linch pin **5**, illustration **3**.
- ▶ Remove the wedges **3** on the wheels.
- ▶ Remove the wedges **3** on the transport receptacle (point **A**) on the pulley cart.

1.3 Removing the pulley cart

When the boom system has reached a certain angle between the S-boom and the W-lattice jib, then the pulley cart is no longer required. Before luffing the boom system all the way up, remove the pulley cart on the W-end section.



WARNING

Overload of crane!

If the pulley cart is not removed before erecting the boom system all the way, the crane can be overloaded and topple over!

Personnel can be severely injured or killed!

- ▶ Remove the pulley cart before lifting the boom system from the ground!

- ▶ Remove the wedges **3** from the transport retainer (point **A**) on the pulley cart.
- ▶ Secure the pulley cart **1** with wedges **3** to prevent it from rolling off: Push the wedges **3** on the left and right hand side tightly under the wheels **2**, illustration **4**.
- ▶ Release the retaining pin **4**: Remove the linch pin **5**.
- ▶ Unpin the retaining pin **4** on the receptacle **6** and insert it into the transport receptacle (point **B**).
- ▶ Secure the retaining pin **4** in the transport receptacle (point **B**) with linch pin **5**.
- ▶ Luff the boom system up.
- ▶ When the boom system is luffed up:
 - Remove the wedges **3** on the wheels.
- ▶ Remove the wedges **3** on the transport receptacle (point **A**) on the pulley cart.
- ▶ Remove the pulley cart.

6.00 Additional equipment

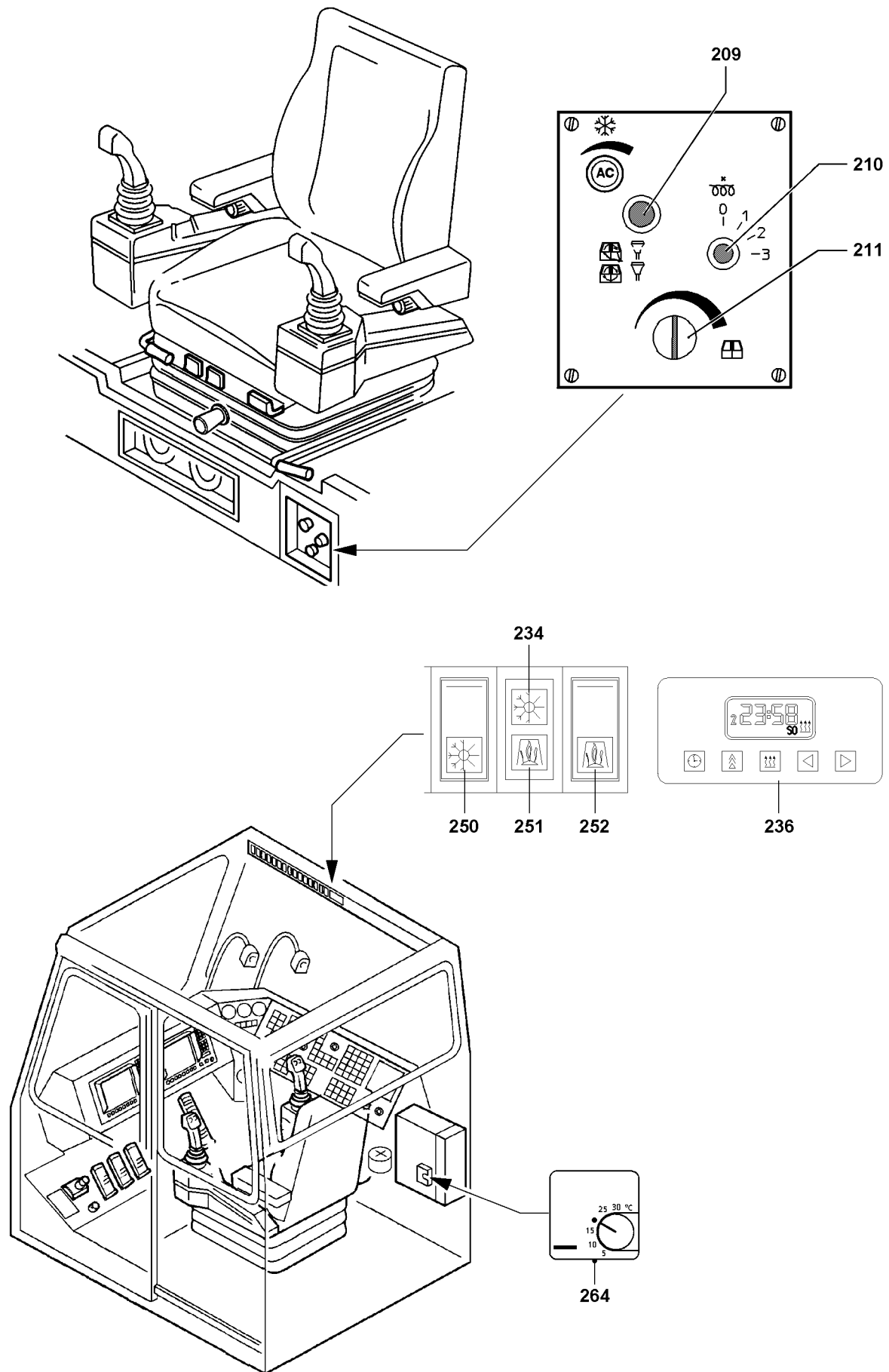

B110520

1 Heating the crane operator's cab

The cab can be heated with two heaters, which are independent of each other:

- Engine-dependent heater.
- Engine-independent auxiliary heater, for outside temperatures of up to -40 °C, WEBASTO; Thermo 90 S.*

The individual adjustment of the heater (for both engine-dependent and engine-independent auxiliary heaters*) is carried out with the control elements under the crane operator's seat as well as via switches and indicator lights on the instrument panel.

NOTICE

Risk of damage to the heater control units* when carrying out electrical welding work on the crane!

- ▶ Disconnect the negative and positive cables from the batteries and connect the positive cables to the vehicle ground.
-

1.1 Heater operation

1.1.1 Adjusting the temperature

The cab is heated with the engine coolant.

- ▶ Set the knob **211**.

1.1.2 Adjusting the ventilation

- ▶ Set the blower with the 3-stage rotary switch **210**.

Result:

- The air volume will be regulated.

1.1.3 Adjusting the recirculated air / fresh air

- ▶ Actuate the changeover switch **209**.

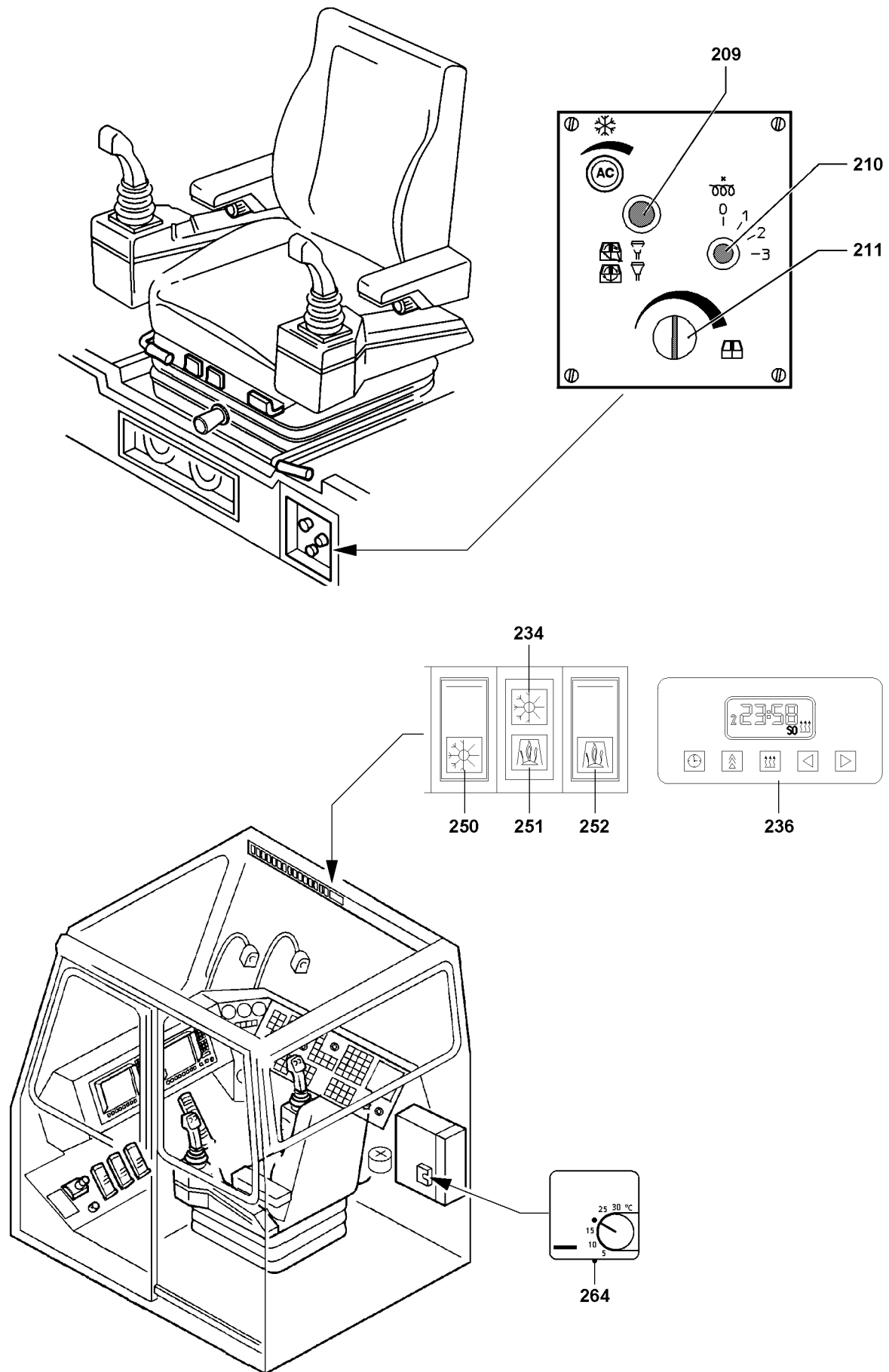

B110520

1.2 Operating the engine-independent auxiliary heater*

The engine-independent auxiliary heater is used to heat the cab when the engine is turned off and as auxiliary heater* at low ambient temperatures, if the engine-dependent heating is insufficient.

For detailed description of the auxiliary heater* refer to the enclosed manufacturer's operating instructions.

In summer run the auxiliary heater* once a month for approx. 15 to 20 minutes.

Carry out maintenance work on the auxiliary heater* as outlined in the enclosed manufacturer's operating instructions.

1.2.1 Start up

NOTICE

Risk of damage to auxiliary heater!

- ▶ Fill all units with sufficient service fluids for winter operation, as specified in the lubricant chart.
-



DANGER

Risk of poisoning and suffocation in enclosed areas!

- ▶ Operate the heater, even with a timer, only in closed areas such as garages or workshops if an exhaust suction system is present.
-



DANGER

Risk of explosion!

In areas where combustible fumes or dust could form, such as in the vicinity of storage areas for fuel, coal, wood dust or grain storage or similar and in the vicinity of filling stations or tank depots, there is a risk of explosion.

- ▶ Turn off the heater.
-

- ▶ Set the knob **211** to "warm".

- ▶ Actuate the switch **252**.

Result:

- The function control on the switch **252** lights up.
 - The indicator light **251** lights up.
-

1.2.2 Turning off

- ▶ Actuate the switch **252**.

Result:

- The function control on the switch **252** turns off.
 - Each time the auxiliary heater is turned off, it continues to run up to 150 seconds longer.
-

NOTICE

Danger of property damage!

- ▶ Only turn off the battery master switch once the heater after run is over.
-

- When the after run is over:
The indicator light **251** turns off.

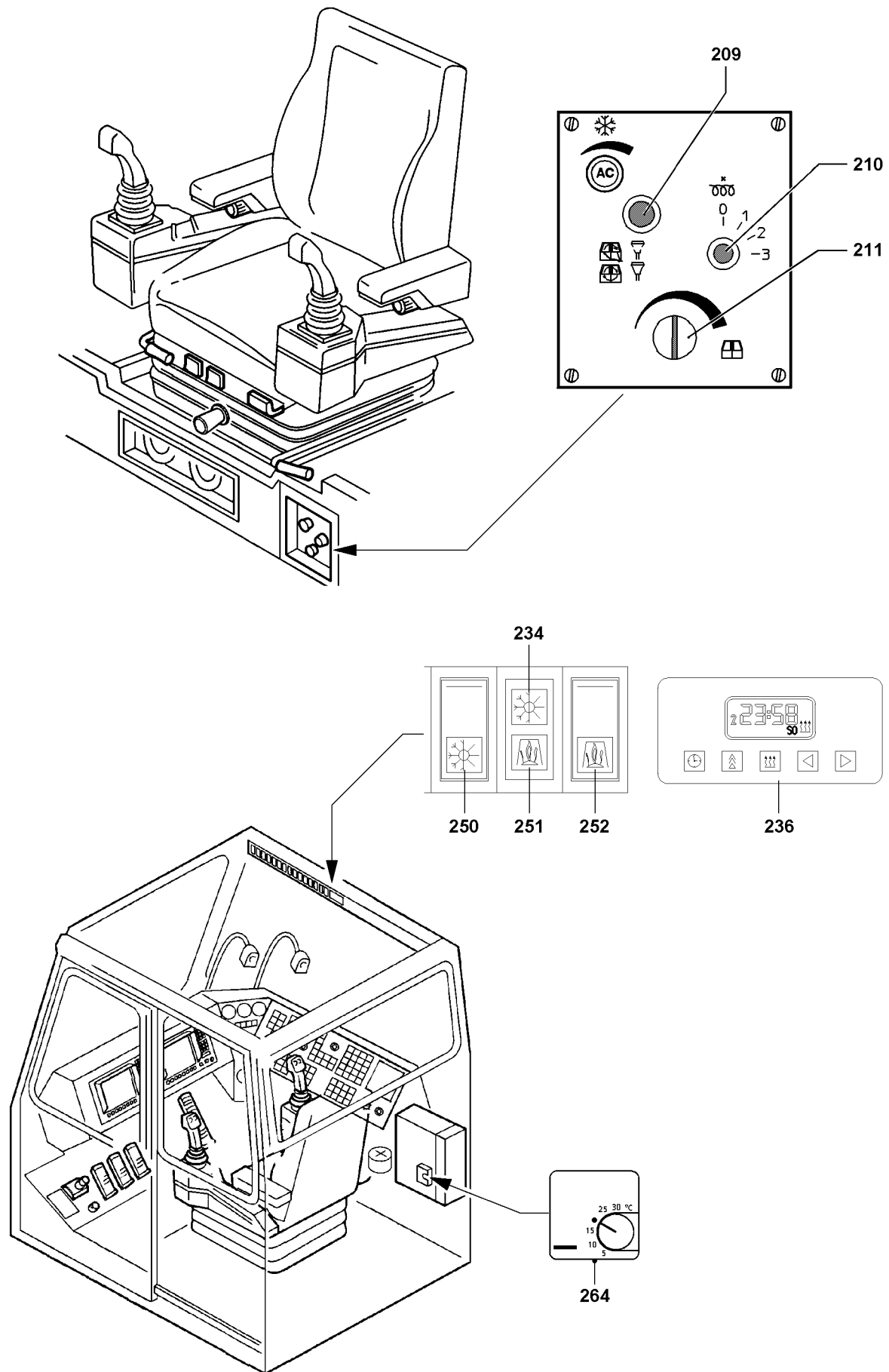

B110520

1.2.3 Operation with timer*

For a detailed description of the timer **236** refer to the enclosed manufacturer's operating instructions.

- ▶ Set the required turn-on time, temperature and duration of heater operation on the timer **236**.
- ▶ Open or close the air vents as desired.

Result:

- Upwards or downwards air distribution will be selected.

- ▶ Set the knob **211** to "warm".

1.2.4 Operating the thermostat*

Ensure that the following prerequisites are met:

- The knob **211** is set to "warm".
- ▶ Turn the thermostat **264** to the desired temperature.

1.2.5 Venting the system

When refilling, the system should be carefully vented.

- ▶ Add coolant into the expansion tank for the heater system according to the lubricant chart.
- ▶ Start the engine.
- ▶ Set the knob **211** to "warm".
- ▶ Check the expansion tank for air bubbles.

Result:

- The heating system is vented as soon as no more air bubbles rise up.

- ▶ Set the knob **211** to "cold".
- ▶ Check the expansion tank for air bubbles.

Result:

- The circuit is vented as soon as no more air bubbles rise up.

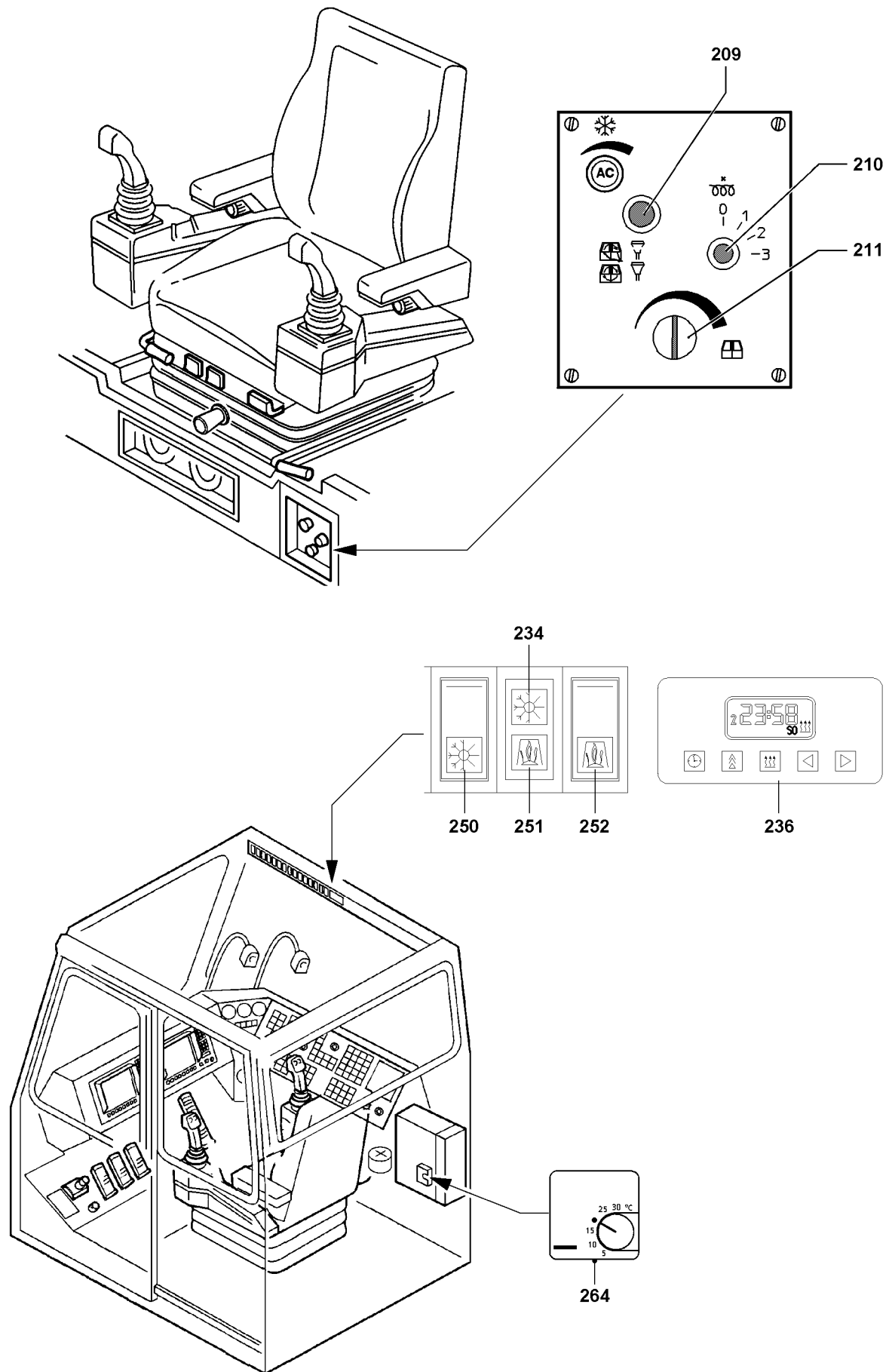

B110520

1.3 Air conditioning system* operation

For a detailed description of the air conditioning system*, refer to the enclosed manufacturer's operating instructions.

Carry out maintenance work on the air conditioning system* according to the enclosed manufacturer's operating instructions.

1.3.1 Start up

Make sure that the following prerequisites are met:

- The battery master switch is turned on.
- The engine is running.
- The air intake opening for recirculated air operation is clear.

▶ Open or close the air vents as desired.

Result:

- Upwards or downwards air distribution will be selected.

▶ Close both windows and the cab door.

▶ Set the changeover switch **209** for fresh air / recirculated air to recirculated air operation.

▶ Actuate the switch **250**.

Result:

- The indicator light **234** lights up.
- The air conditioning system* is turned on and ready to operate.

▶ Open the appropriate air vent for upward air distribution.

▶ Turn on the fan with the rotary switch **210**.

▶ Regulate the temperature with the knob **211**.

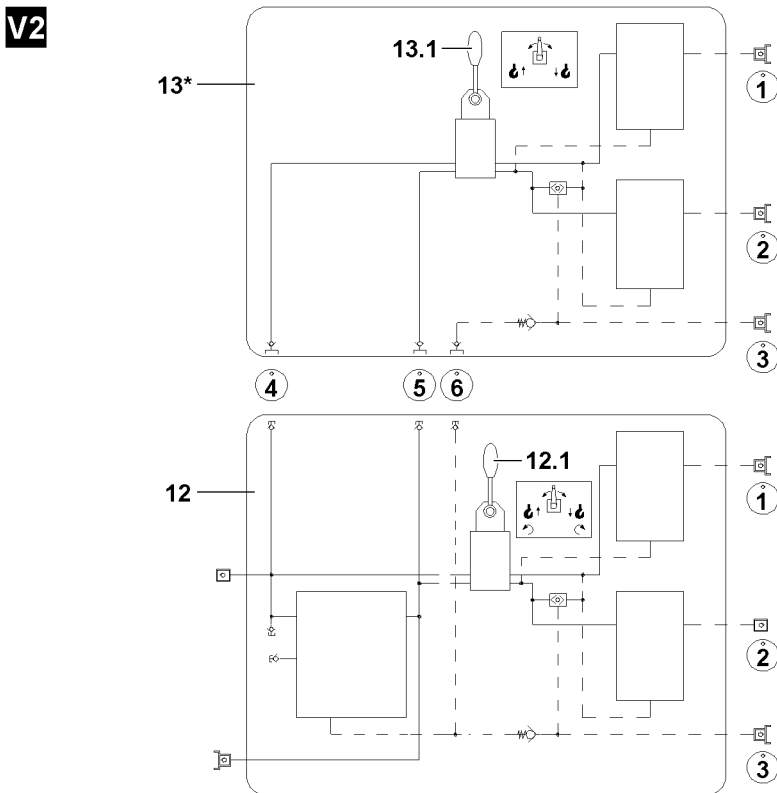
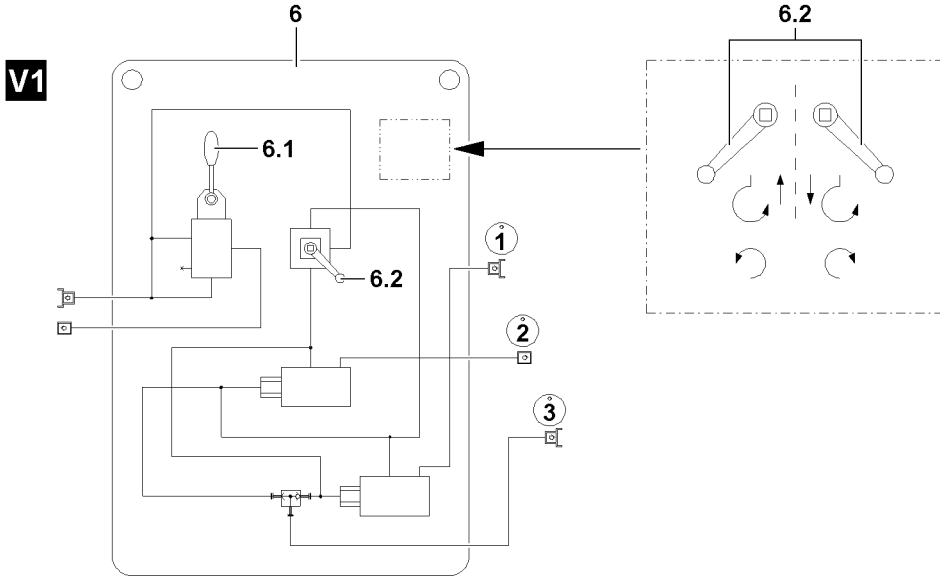

B109407

1 Emergency operation



Note

► The illustrations in this chapter are examples and may not apply exactly to your crane!



Note

► Before you start with preparations for emergency operation, check which of the following assembly plates you have available to carry out the emergency operation!

There are two **different** variations of assembly plates.

With variation 1 **V1**, all winches, which are equipped with the respective auxiliary hydraulic for emergency operation and the slewing gear can be actuated, each individually.

With variation 2 **V2**, which consists of two assembly plates, all winches, which are equipped with the respective auxiliary hydraulic for emergency operation can be actuated, each individually, **or** winch 1 **WI** and winch 2 **WII** can be actuated in parallel operation or the slewing gear can be actuated individually.



Note

► Observe the following charts!

	Variation 1 (V1) each in individual operation	Variation 2(V2) each in individual operation
Winch 1	X	X
Winch 2	X	X
Winch 1II2 ¹⁾	—	X
Winch 3	X	X
Winch 4	X	X
Winch 5	X	X
Winch 6	X	X
Slewing gear	X	X

1) Parallel operation Winch 1 and winch 2 (1II2)

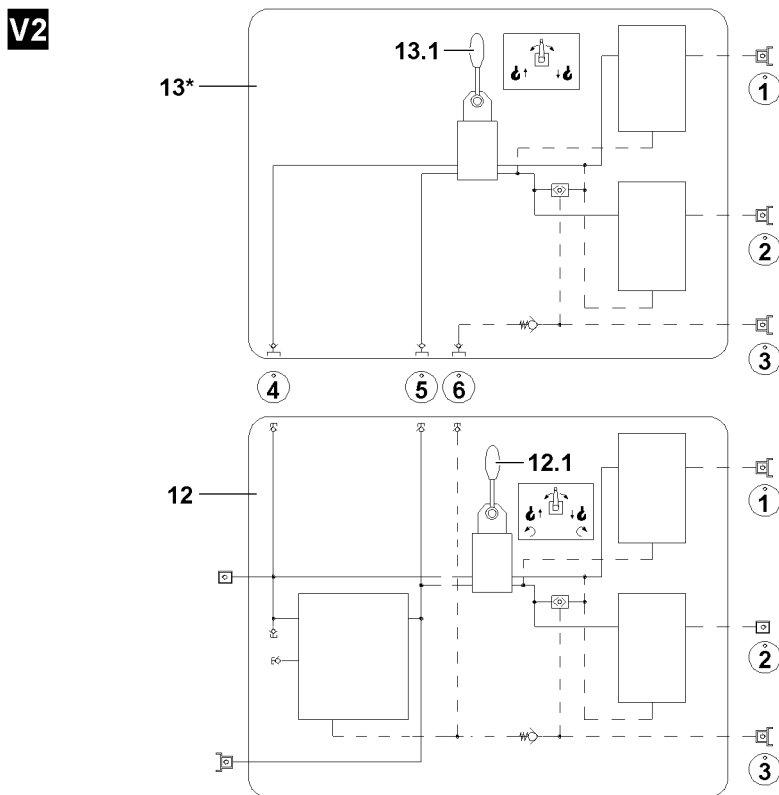
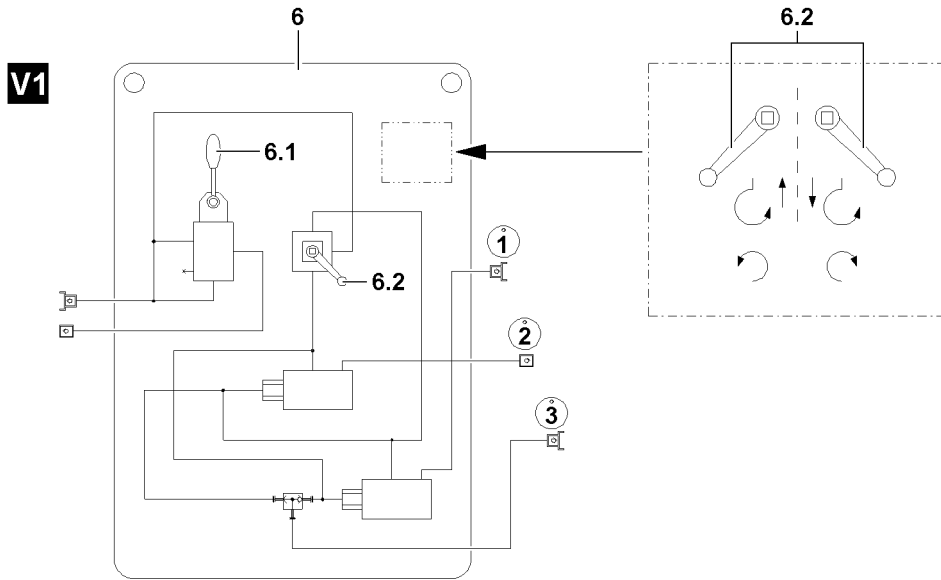

B109407

1.1 General danger notes



DANGER

Significant accident risk during emergency operation!

During an emergency operation, crane movements are no longer monitored by the LICCON computer system!

In the event of improper operation or deliberate misuse, the crane can topple over!

There is an increased risk of accident if the following danger notes are not observed!

Personnel can be severely injured or killed!

This could result in high property damage!

► All hazard warnings are to be observed and maintained!

General danger notes!

- 1.) **Emergency operation of the crane superstructure may only be carried out:**
 - To remove a dangerous situation.
 - After consultation with customer service at LIEBHERR-Werk Ehingen GmbH.
 - By authorized personnel who are knowledgeable of the hydraulic circuit diagram, the connection diagram and carrying out emergency operation.
 - By authorized personnel who are aware of the risks of emergency operation.
 - To carry out load reducing movements.
- 2.) **The danger zone must be blocked off!**
- 3.) **No persons or objects may remain in the danger zone!**
- 4.) **If a load is on the hook, then it must first be set down to relieve the boom!**
- 5.) **During emergency operation, all safety devices, with the exception of “winch spooled out” are automatically bypassed!**
- 6.) **In the event of a defect or failure of the LICCON computer system, each step must be carried out and monitored with extreme caution and care, since a visual check on the LICCON monitor is no longer possible. Visual check!**
- 7.) **All crane movements must be travelled with extreme caution and at the lowest speed!**
- 8.) **The crane operator must be in visual contact with auxiliary personnel or guides person!**



Note

Please note!

► The hydraulic supply for the crane can, to the extent that the crane has been equipped, take place through an emergency unit*. If this is not the case, the crane must be taken down by using additional auxiliary cranes!



WARNING

The crane can topple over!

- The boom may only be luffed down if the stability of the crane permits this action, observe information in the load tables and maintain them!
- When taking down the boom, the information in the erection and take down charts are to be observed and followed!

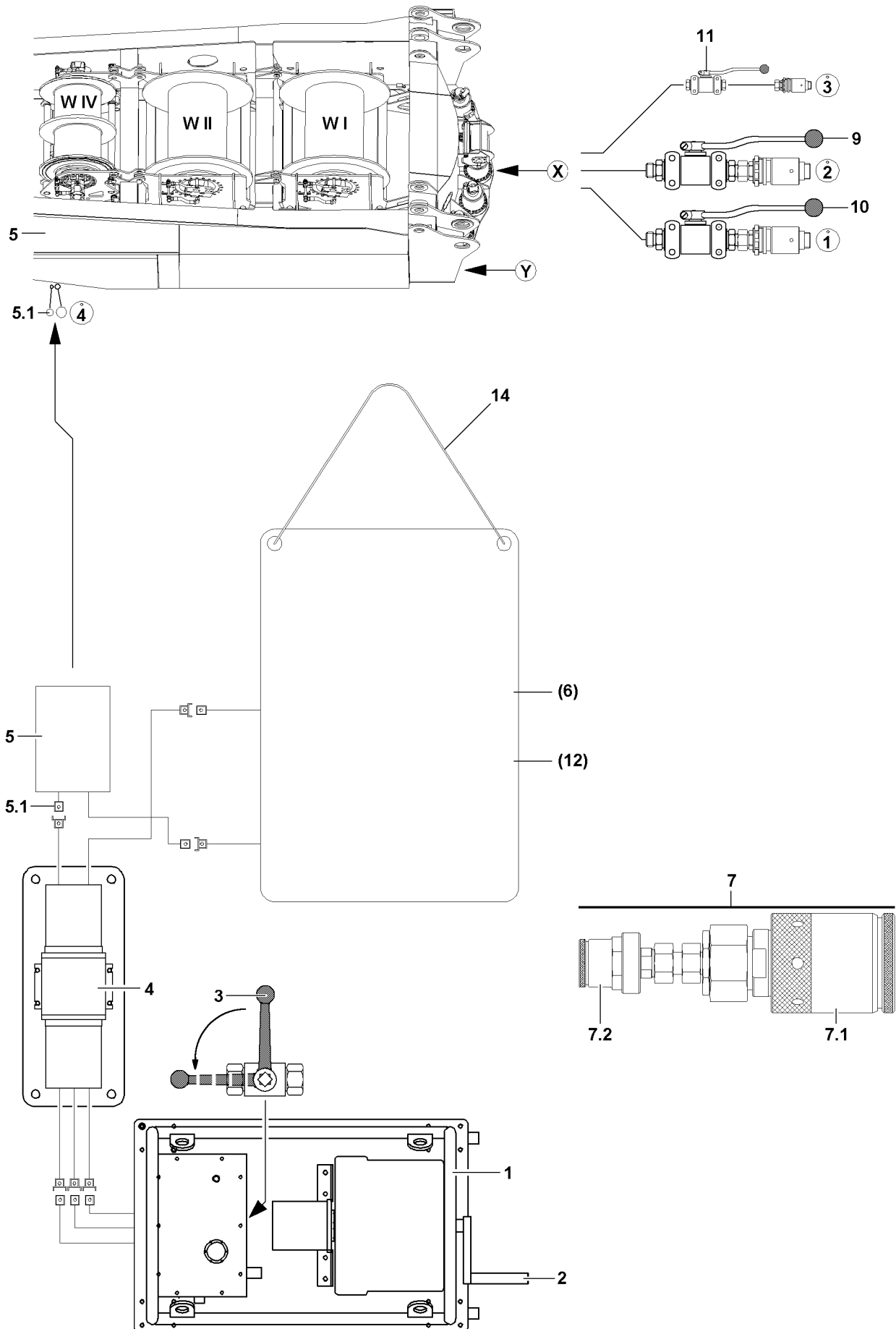

B109408

1.2 Handling of assembly plates



WARNING

Falling assembly plates!

Non-secured assembly plates can fall down when carrying out the emergency operation!

Personnel can be severely injured or killed!

- ▶ For emergency operation, secure the assembly plates with the chains **14** to prevent them from falling down!
- ▶ Do not secure the assembly plates near movable crane components!

1.3 Prerequisites for emergency operation



Note

- ▶ On the basis of different line diameters on the hydraulic lines, false couplings are prevented, additionally the hydraulic connections are identified with numbers!

Make sure that the following prerequisites are met:

- The hydraulic circuit diagram is available.
- The hydraulic system is functioning.
- An emergency operation aggregate **1** is available.
- A “Hydraulic transformer **4** ” is available.
- The assembly plate(s) are available.
- Reducer sections **7** (adapter) are available.
- The dust plugs for the hydraulic connections are removed.

1.4 Establishing the hydraulic connections



WARNING

Danger due to hydraulic pressure!

If the hydraulic lines are pressurized when releasing the connections, it can lead to severe injuries to assembly personnel!

- ▶ Relieve the pressure in the hydraulic lines before releasing!
- ▶ Establish the hydraulic connections from the emergency operation aggregate* **1** to the transformer **4**.
- ▶ Establish the hydraulic connection from the transformer **4** to the (suction line) on the turntable **5** of the crane, connection **5.1**.
- ▶ Hydraulic connection (return line, number **4**) from the turntable of the crane to the assembly plate **6** or to the assembly plate **12**.
- ▶ Establish the hydraulic connection (pressure line) from the transformer **4** to the assembly plate **6** or to the assembly plate **12**.

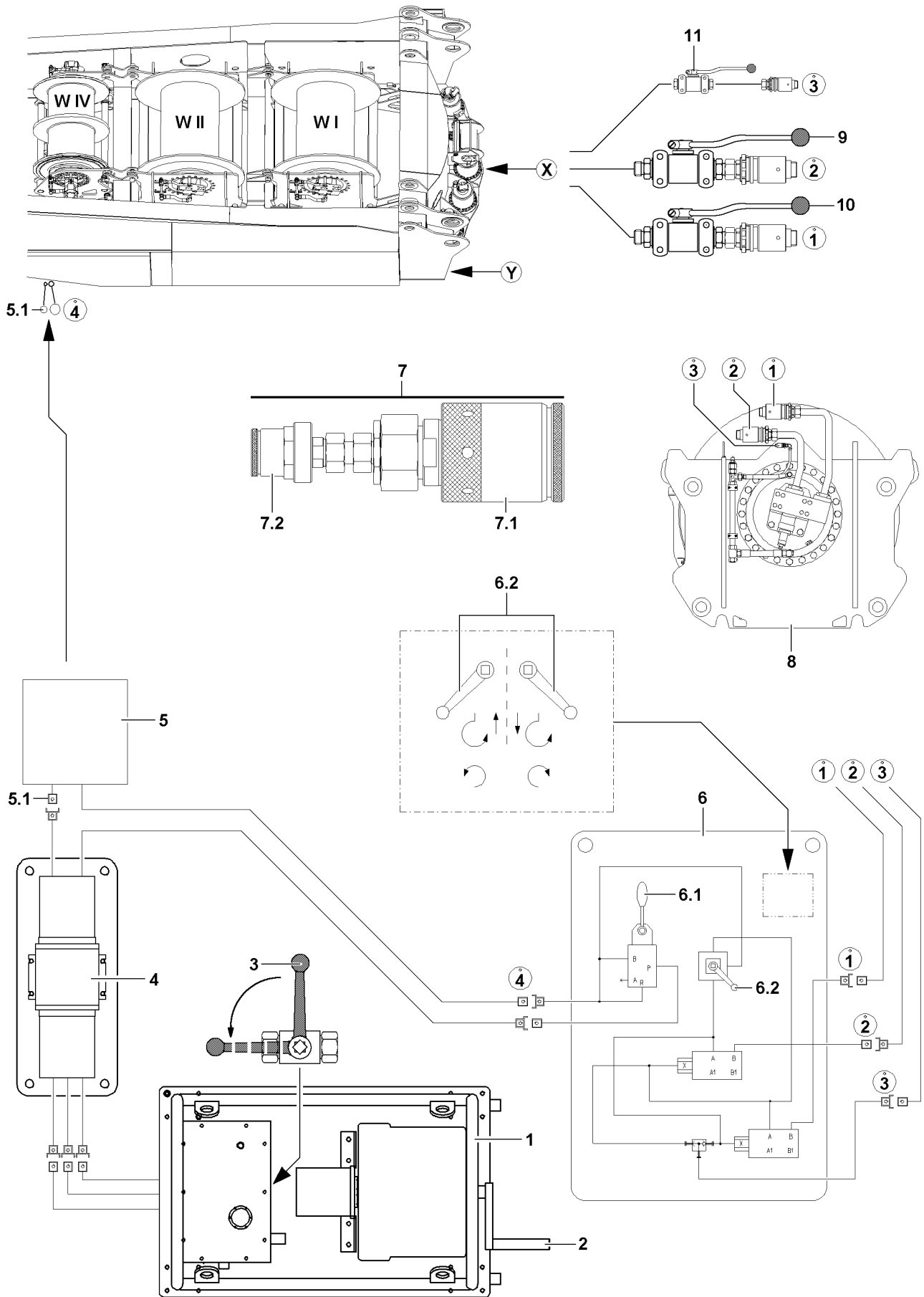

B108301

2 Emergency operation with assembly plate Variation 1 (V1)



Note

- ▶ The procedure of the emergency operation - except winch 4 on the LR1600/2 and LR1600/2-W - is identical for all winches and is described on the example of one winch!

Exception LR1600/2 and LR1600/2-W:

- ▶ Before emergency operation of winch 4 **W IV** on the LR1600/2 and LR1600/2-W, in addition to the hydraulic connections to lift, lower and for the control pressure of the brake, a control line must be connected, see section: "Emergency operation of winch 4 **W IV** on the LR1600/2 and LR1600/2-W!"

To carry out the emergency operation, use an emergency operation aggregate **1**, a hydraulic transformer **4** and the assembly plate **6**.

2.1 Functional selection on the assembly plate

With the ball valve **6.2** on the assembly plate **6** the following movements are preselected:

- Lift or lower
- Turn left or right
- ▶ Preselect crane movement: Activate ball valve **6.2** in the corresponding direction.

Moving the hand lever **6.1** determines the speed of the each crane movement.

- ▶ Operate the hand lever **6.1** and carry out the respective crane movement carefully.

2.2 Start the emergency operation aggregate

- ▶ Turn the crank **2** on the emergency operation aggregate* **1**.
- ▶ Switch the ball valve **3** to "horizontal" position.



Note

- ▶ The engine rpm on the emergency operation aggregate can be set via a separate speed regulator!

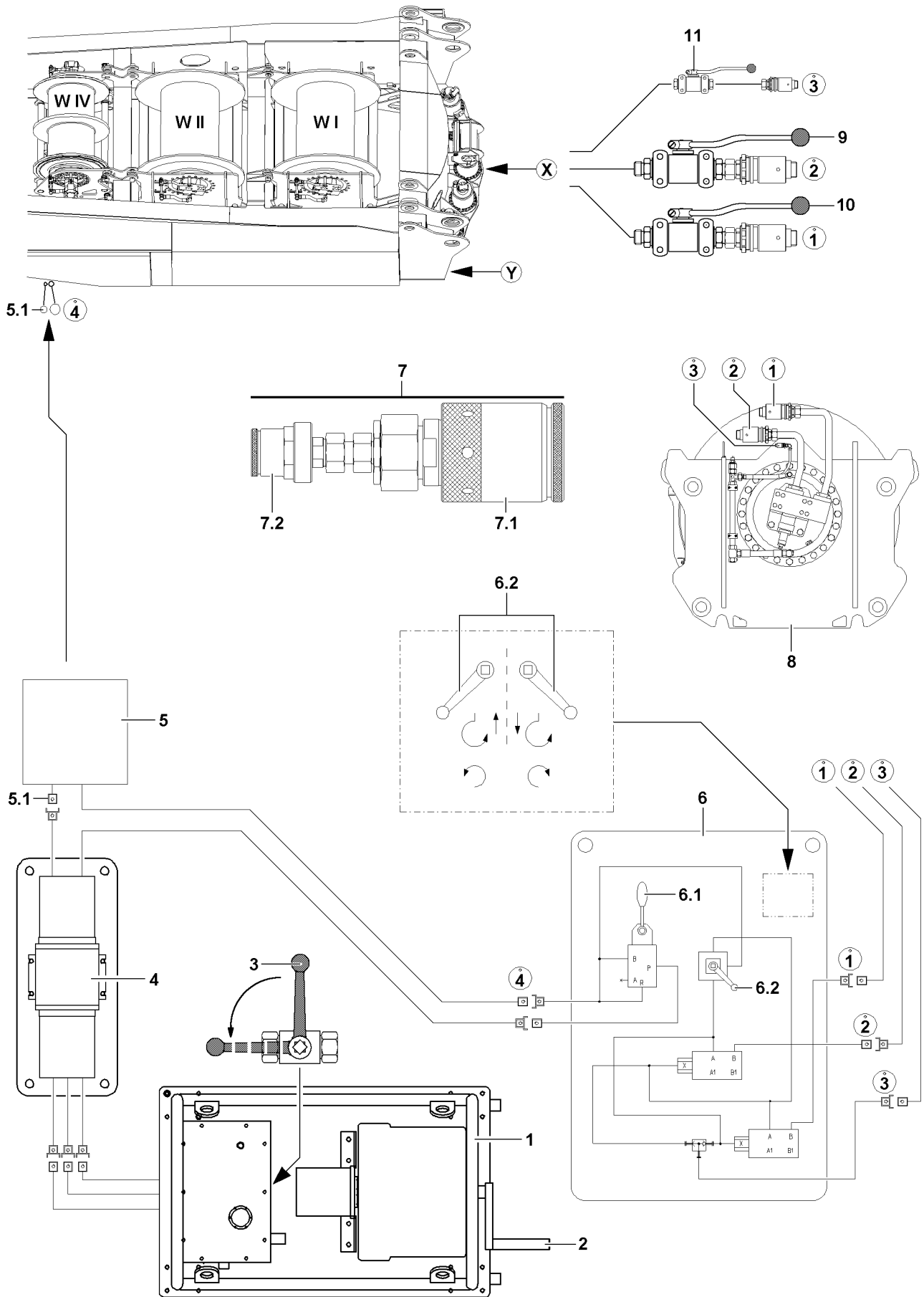

B108301

2.3 Emergency operation of winch 4 on the LR1600/2 and LR1600/2-W



WARNING

Emergency operation winch 4 **W IV!**

- ▶ Observe the section “Emergency operation of winch 4 (W IV) on the LR1600/2 and LR1600/2-W”!
-

2.4 Emergency operation winches

2.4.1 Establishing the hydraulic connections to the winch

Make sure that the following prerequisite is met:

- The pressure in the hydraulic system has been relieved.
 - ▶ Release the hydraulic connections on the corresponding winch.
 - ▶ Install the reducer sections **7** (adapter) with coupling sleeve **7.1** on the connection **1** and on the connection **2** of the winch **8**.
-



Note

- ▶ Observe the numbering of the hydraulic lines!
-
- ▶ Establish the hydraulic connections for the assembly plate **6** (connection **1**, connection **2** and brake **3**) to the winch **8**.

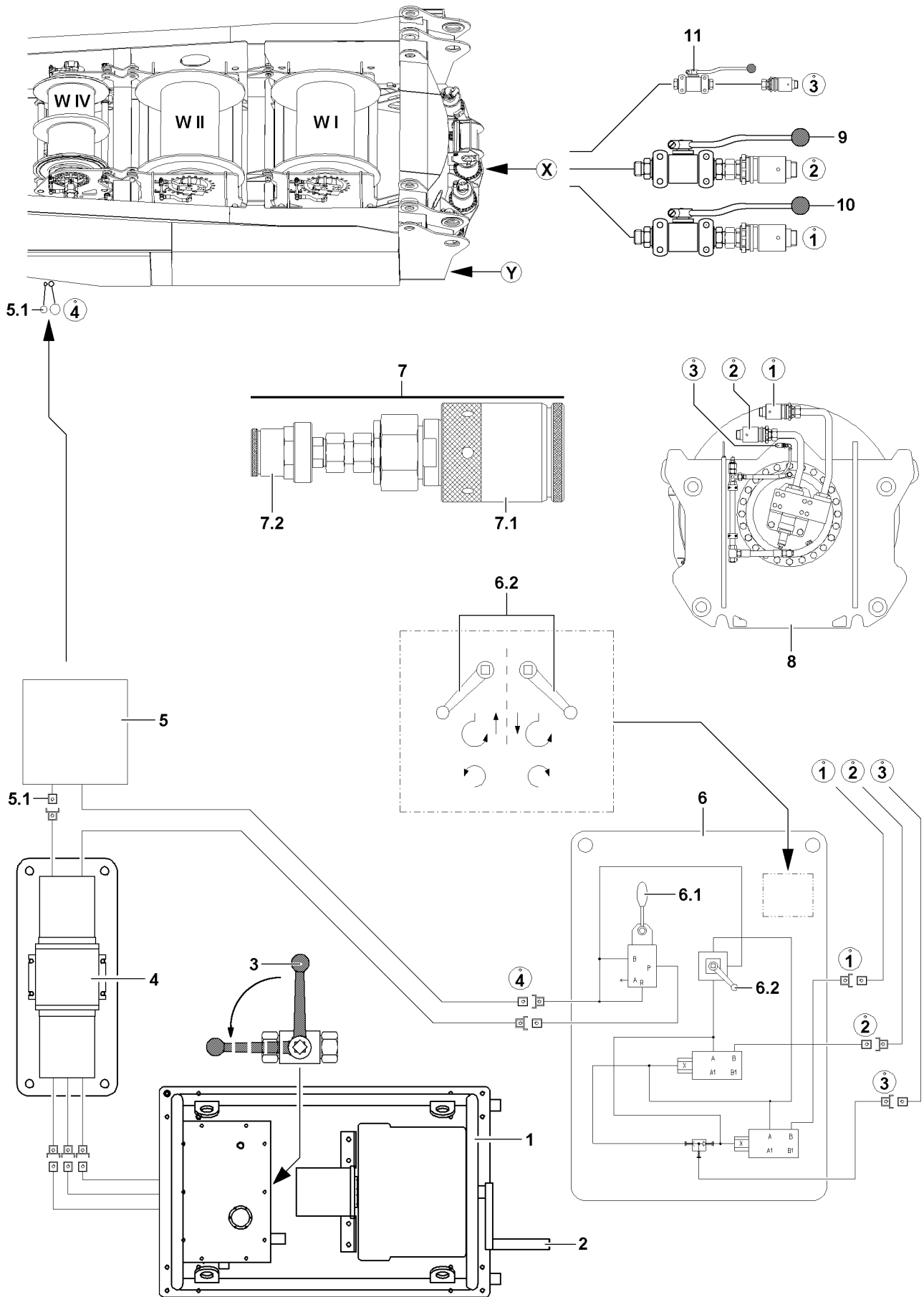

B108301

2.4.2 Spooling the winch out

- ▶ Set the ball valve **6.2** for the assembly plate **6** on “lower”.
- ▶ Move the manual lever **6.1** carefully.

Result:

- The winch spools out.

2.4.3 Spooling the winch up

- ▶ Set the ball valve **6.2** for the assembly plate **6** on “lift”.
- ▶ Move the manual lever **6.1** carefully.

Result:

- The winch spools up.

2.5 Disconnecting the hydraulic connections

Make sure that the following prerequisites are met:

- The emergency operation is completed.
- The pressure in the hydraulic system has been relieved.
- ▶ Disconnect the hydraulic connections from the winch **8** to the assembly plate **6**.
- ▶ Remove the reducer sections **7** (adapter).
- ▶ Close off the hydraulic connections of the winch **8** with dust caps.

or

- Reconnect the winch **8** onto the hydraulic system of the crane.

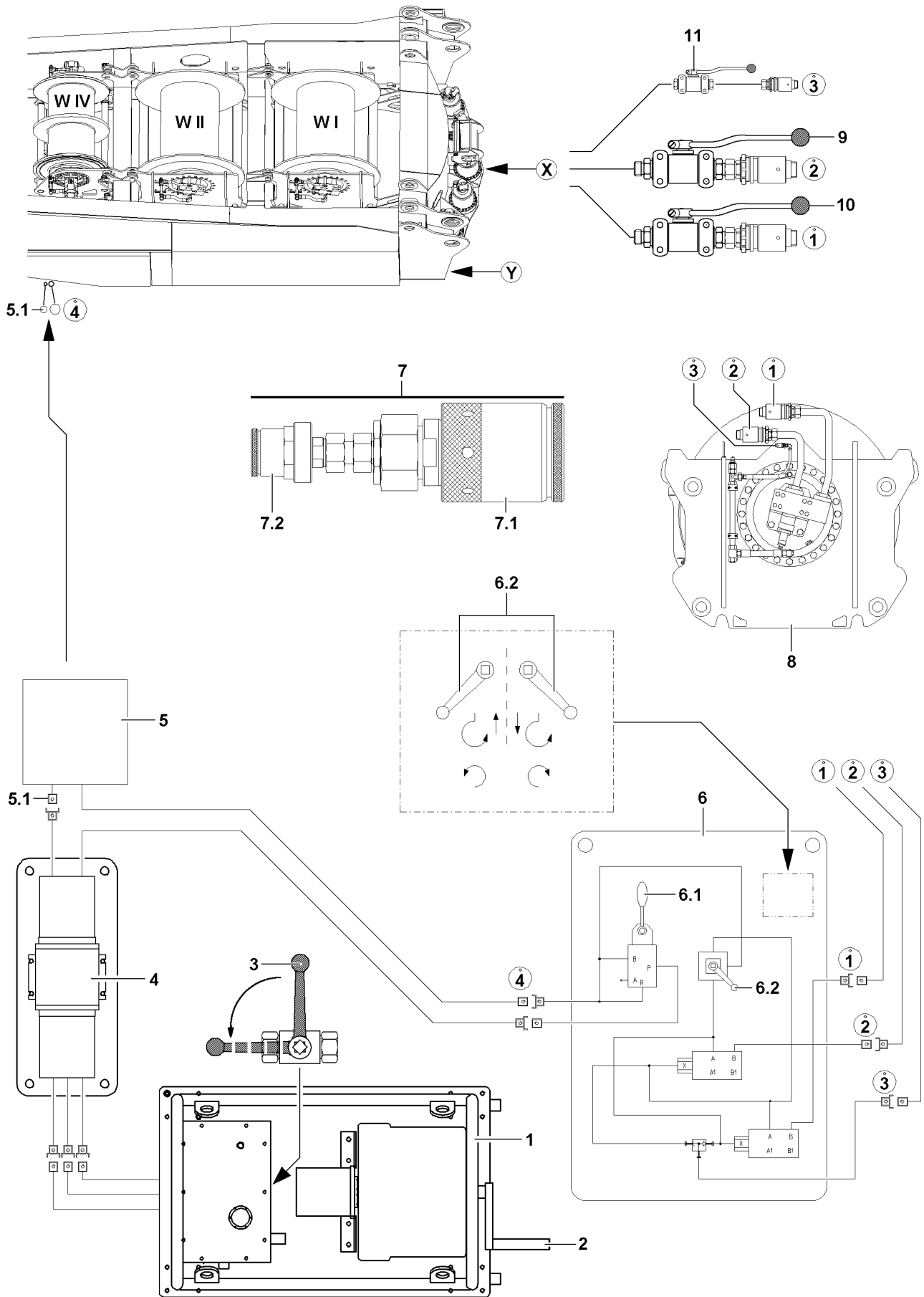

B108301

3 Emergency operation of slewing gear(s) with assembly plate Variation 1 (V1)



WARNING

Danger due to hydraulic pressure!

If the hydraulic lines are pressurized when releasing the connections, it can lead to severe injuries to assembly personnel!

- ▶ Relieve the pressure in the hydraulic lines before releasing!



Note

- ▶ For each crane type, the installation position of the ball valves for emergency operation of the slewing gear on the turntable varies!
- ▶ Possible installation positions of the ball valve: Point **X** or point **Y**!

3.1 Establishing the hydraulic connection to the slewing gears

Make sure that the following prerequisite is met:

- The pressure in the hydraulic system has been relieved.



Note

- ▶ Observe the numbering of the hydraulic lines!
- ▶ Establish the hydraulic connections of the assembly plate **6** (connection **1**, connection **2** and brake **3**) to the “Ball valves” on the turntable.

3.2 Turning the turntable to the left

- ▶ Set the ball valve **9** into emergency operation position.
- ▶ Set the ball valve **10** into emergency operation position.
- ▶ Set the ball valve **11** into emergency operation position.
- ▶ Set the ball valve **6.2** for the assembly plate **6** on “turn left”.
- ▶ Move the manual lever **6.1** carefully.

Result:

- The turntable turns to the left.

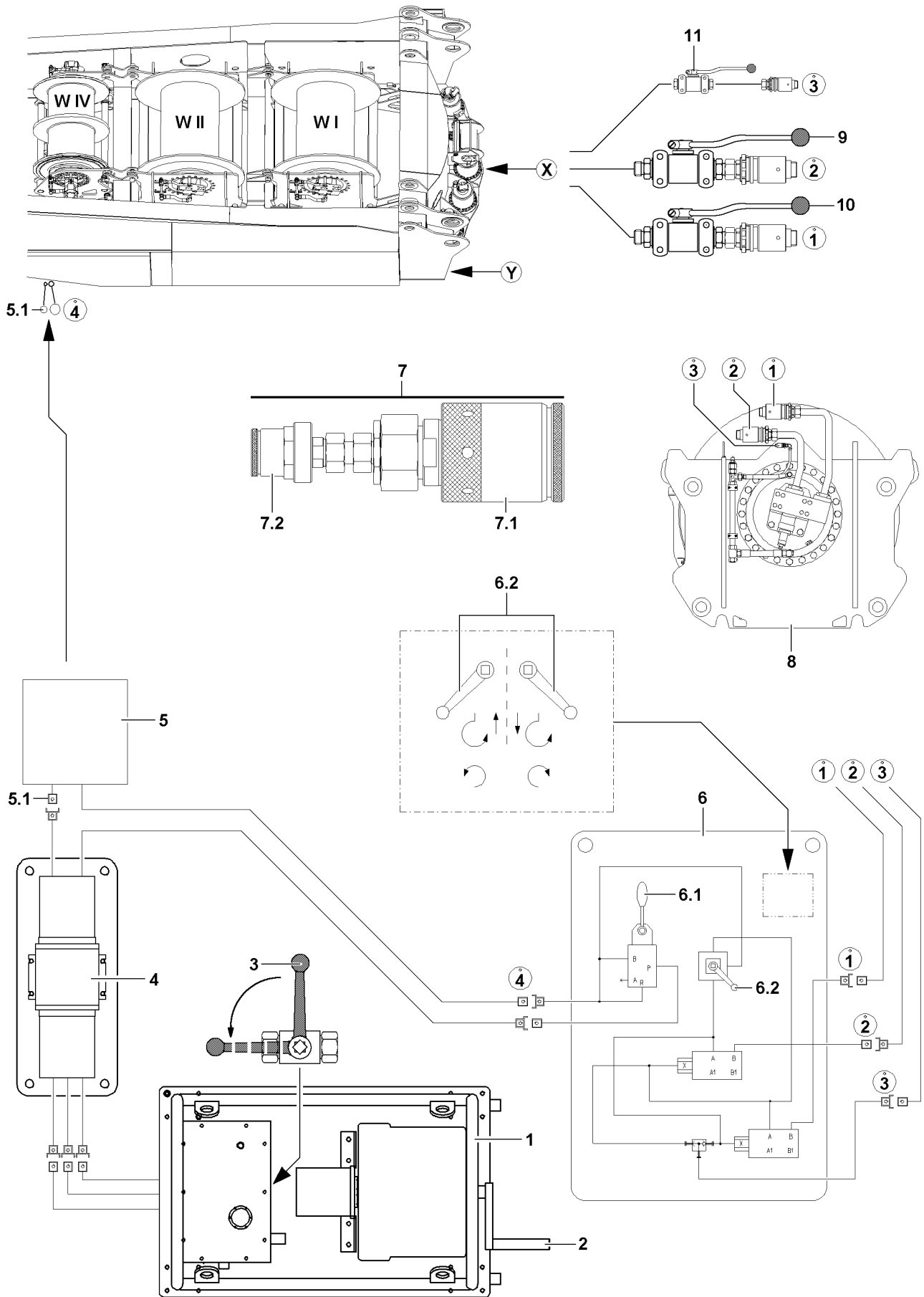

B108301

3.3 Turning the turntable to the right

- ▶ Set the ball valve **9** into emergency operation position.
- ▶ Set the ball valve **10** into emergency operation position.
- ▶ Set the ball valve **11** into emergency operation position.
- ▶ Set the ball valve **6.2** for the assembly plate **6** on “turn right”.
- ▶ Move the manual lever **6.1** carefully.

Result:

- The turntable turns to the right.

3.4 Disconnecting the hydraulic connections

Make sure that the following prerequisites are met:

- The emergency operation is completed.
- The pressure in the hydraulic system has been relieved.

Disconnect the hydraulic connections to the assembly plate **6**.

- ▶ Reposition the ball valve **9** in position for crane operation.
- ▶ Reposition the ball valve **10** in position for crane operation.
- ▶ Reposition the ball valve **11** in position for crane operation.
- ▶ When the ball valve **9**, ball valve **10** and ball valve **11** are repositioned into crane operation position:
Disconnect the hydraulic connections to the assembly plate **6**.
- ▶ Close off the hydraulic connections with dust plugs.

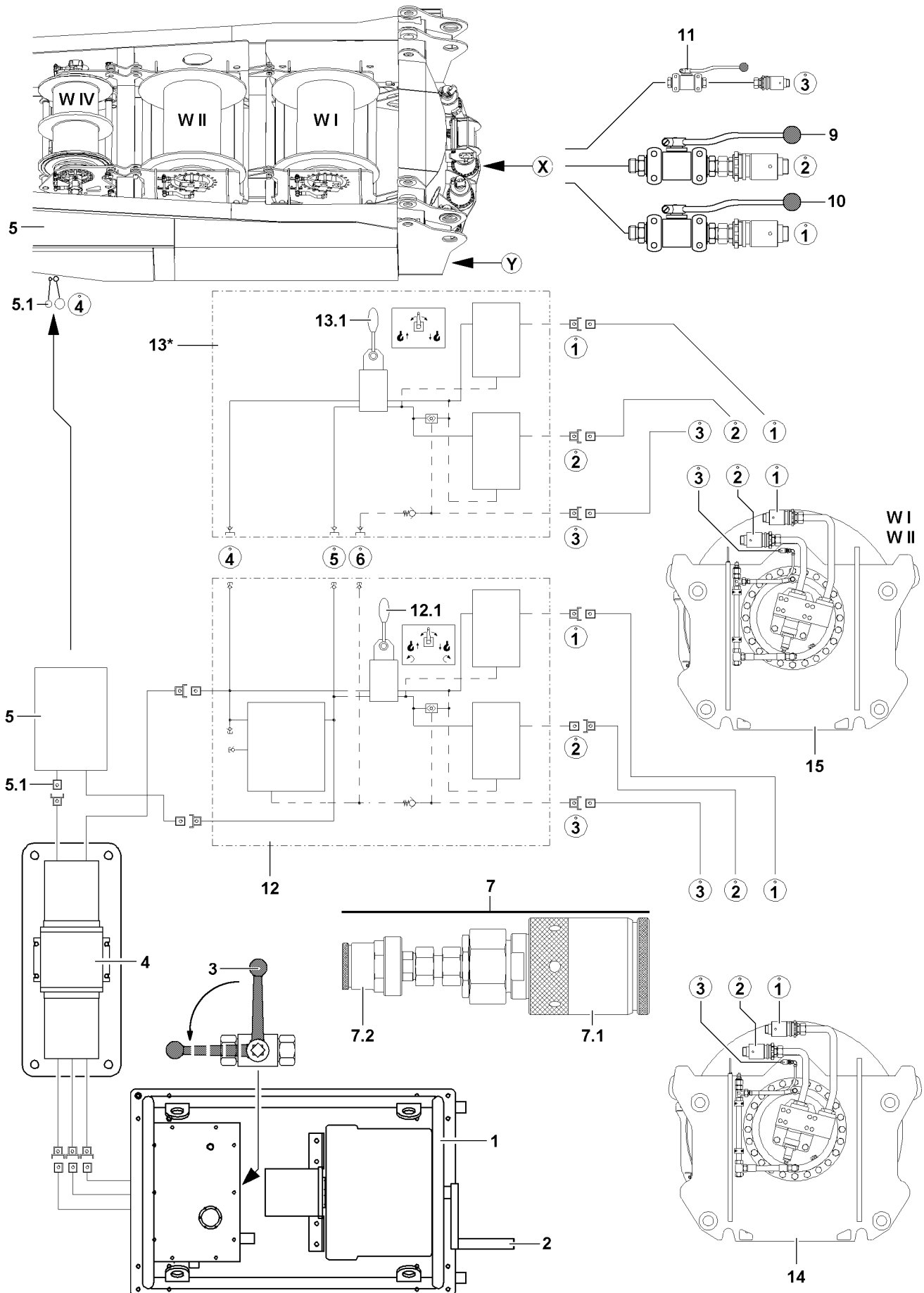

B109393

4 Emergency operation with assembly plate(s) Variation 2 (V2)



Note

- ▶ The procedure of the emergency operation - except winch 4 on the LR1600/2 and LR1600/2-W - is identical for all winches and is described on the example of one winch!

Exception LR1600/2 and LR1600/2-W:

- ▶ Before emergency operation of winch 4 **W IV** on the LR1600/2 and LR1600/2-W, in addition to the hydraulic connections to lift, lower and for the control pressure of the brake, a control line must be connected, see section: "Emergency operation of winch 4 **W IV** on the LR1600/2 and LR1600/2-W!"

To carry out the emergency operation, use an emergency operation aggregate **1**, a hydraulic transformer **4** and the assembly plate **12**. To carry out the emergency operation from winch **1 W I** and winch **2 W II** in parallel operation (1|1|2), in addition to the assembly plate **12**, the assembly plate **13** is needed. Connect the assembly plate **12** with the assembly plate **13** hydraulically on hydraulic connections 4, 5 and 6.

4.1 Start the emergency operation aggregate

- ▶ Turn the crank **2** on the emergency operation aggregate* **1**.
- ▶ Switch the ball valve **3** to "horizontal" position.



Note

- ▶ The engine rpm on the emergency operation aggregate can be set via a separate speed regulator!

4.2 Emergency operation of winch 4 on the LR1600/2 and LR1600/2-W



WARNING

Emergency operation winch 4 **W IV**!

- ▶ Observe the section "Emergency operation of winch 4 (W IV) on the LR1600/2 and LR1600/2-W"!

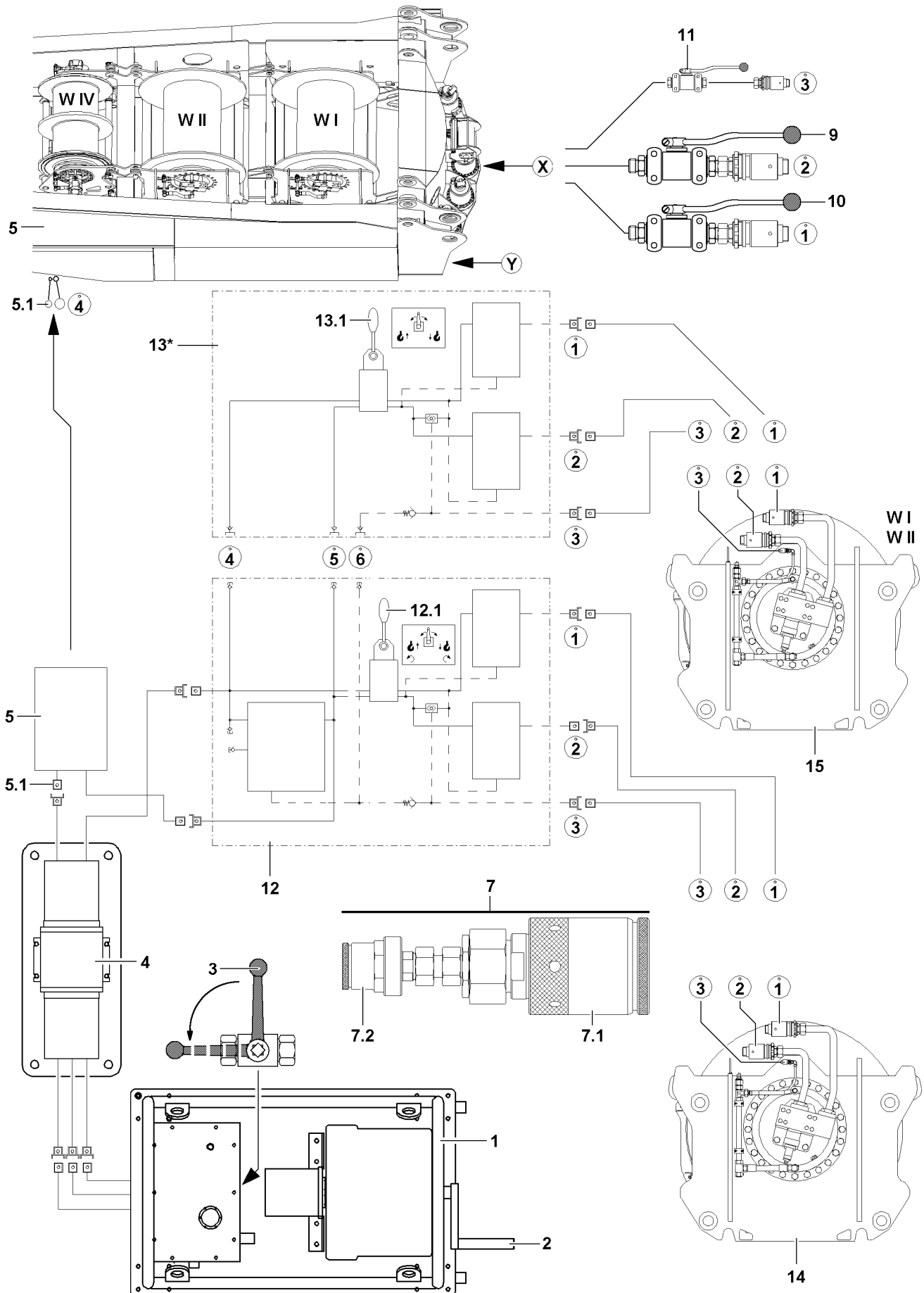

B109393

4.3 Emergency operation of winches, individual operation



Note

- ▶ The crane movements are actuated and the speed of the respective crane movement is determined via the ball valve **12.1** and ball valve **13.1**!

4.3.1 Establishing the hydraulic connections to the winch

Make sure that the following prerequisite is met:

- The pressure in the hydraulic system has been relieved.
- ▶ Release the hydraulic connections on the corresponding winch.
- ▶ Install the reducer sections **7** (adapter) with coupling sleeve **7.1** on the connection **1** and on the connection **2** of the respective winch.



Note

- ▶ Observe the numbering of the hydraulic lines!
- ▶ Establish the hydraulic connection of the assembly plate **12** (connection **1**, connection **2** and brake **3**) to the respective winch.

4.3.2 Spooling the winch out

- ▶ Set the ball valve **12.1** for the assembly plate **12** on “lower”.

Result:

- The winch spools out.

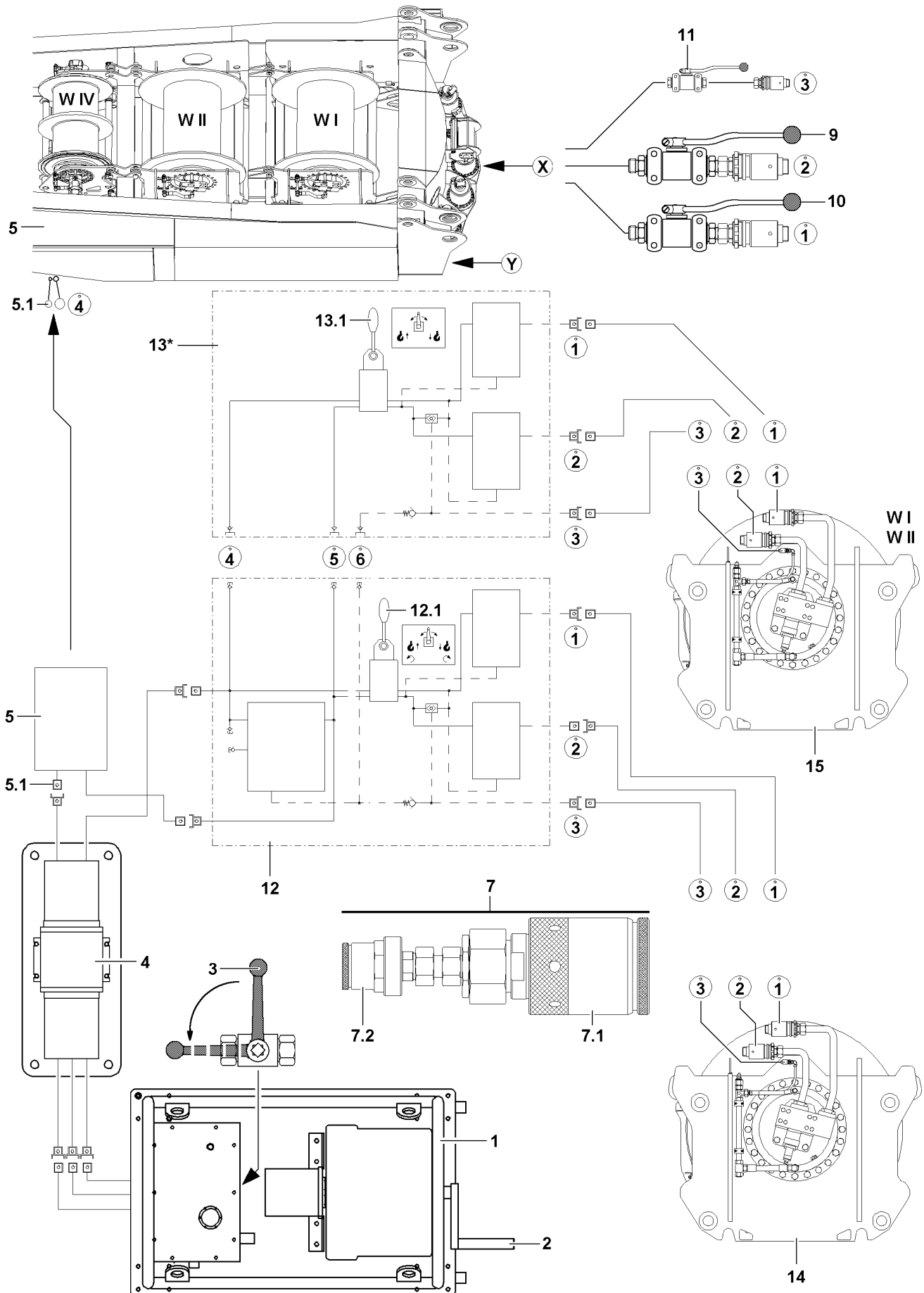

B109393

4.3.3 Spooling the winch up

- ▶ Set the ball valve **12.1** for the assembly plate **12** on "lift".

Result:

- The winch spools up.

4.3.4 Disconnecting the hydraulic connections

Make sure that the following prerequisites are met:

- The emergency operation is completed.
- The pressure in the hydraulic system has been relieved.
- ▶ Separate the hydraulic connections from the respective winch to the assembly plate **12**.
- ▶ Remove the reducer sections **7** (adapter).
- ▶ Close off the hydraulic connections of the winch with dust plugs.

or

- Reconnect the winch to the hydraulic system of the crane.

4.4 Emergency operation of winches, parallel operation winch 1|12



Note

- ▶ The crane movements are actuated and the speed of the respective crane movement is determined via the ball valve **12.1** and ball valve **13.1**!



WARNING

Risk of accident!

If the following notes are not observed, dangerous situations can arise!

Personnel can be severely injured or killed!

- ▶ If winch 1 and winch 2 are actuated in emergency operation in parallel operation, then it must be ensured that the hook blocks are horizontally aligned!
- ▶ Always actuate winch 1 and winch 2 simultaneously!

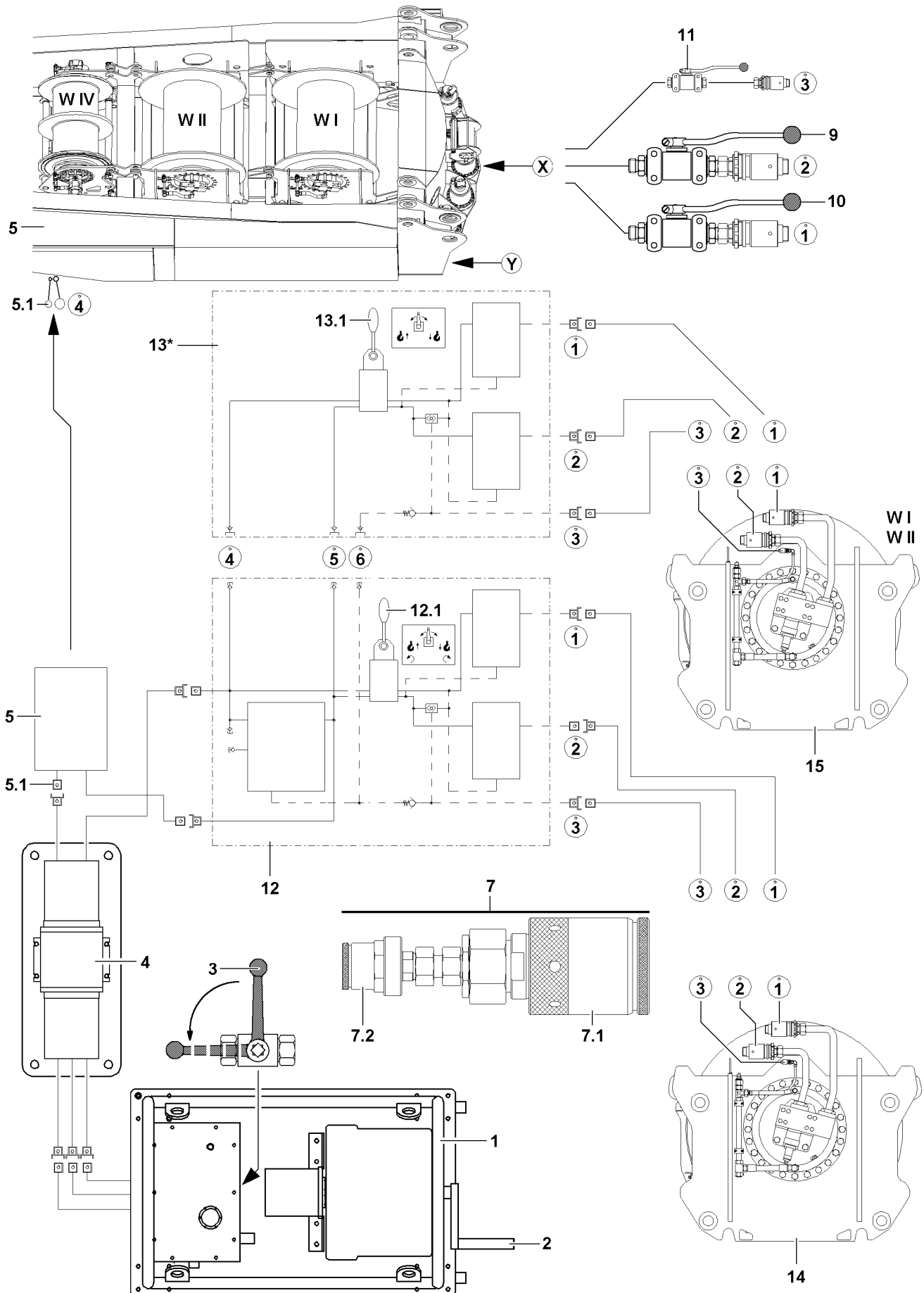

B109393

4.4.1 Establishing the hydraulic connections to the winches

Make sure that the following prerequisite is met:

- The pressure in the hydraulic system has been relieved.
- ▶ Release the hydraulic connections on winch 1 and winch 2.
- ▶ Install the reducer sections **7** (adapter) with coupling sleeve **7.1** on the connection **1** and on the connection **2** of the respective winch.



Note

- ▶ Observe the numbering of the hydraulic lines!

-
- ▶ Establish the hydraulic connections for the assembly plate **12** (connection **1**, connection **2** and brake **3**) to winch 1.

or

- Establish the hydraulic connections for the assembly plate **12** (connection **1**, connection **2** and brake **3**) to winch 2.
- ▶ Establish the hydraulic connections for the assembly plate **13** (connection **1**, connection **2** and brake **3**) to winch 1.

or

- Establish the hydraulic connections for the assembly plate **13** (connection **1**, connection **2** and brake **3**) to winch 2.

4.4.2 Spooling the winches out



Note

- ▶ Check which winch you have connected to which assembly plate!

-
- ▶ Set the ball valve **12.1** for the assembly plate **12** on “lower”.

Result:

- Winch 1 or winch 2 spools out.

- ▶ Set the ball valve **13.1** for the assembly plate **13** on “lower”.

Result:

- Winch 2 or winch 1 spools out.

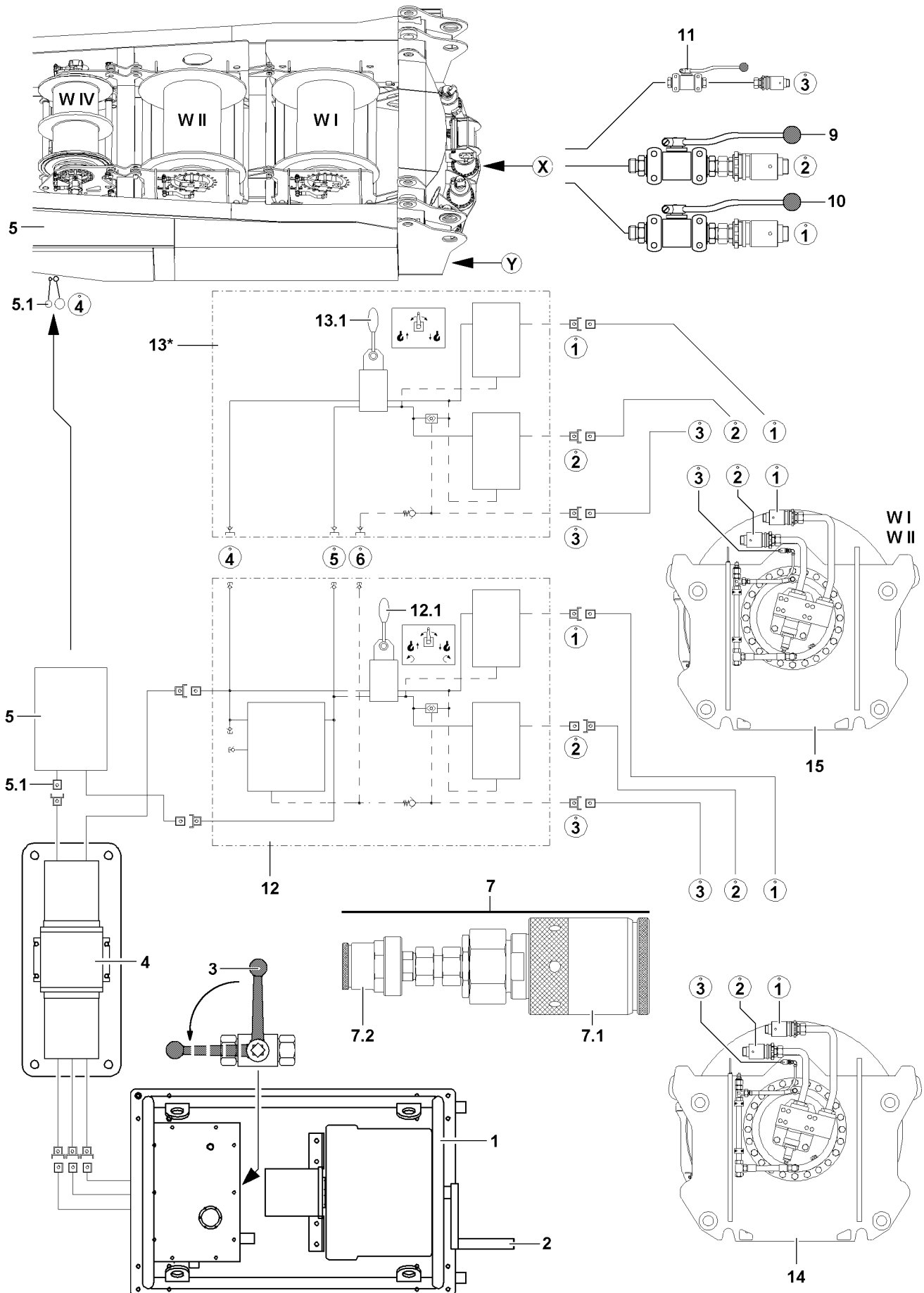

B109393

4.4.3 Spooling the winches up

- ▶ Set the ball valve **12.1** for the assembly plate **12** on "lift".

Result:

- Winch 1 **or** winch 2 spools up.

- ▶ Set the ball valve **13.1** for the assembly plate **13** on "lift".

Result:

- Winch 2 **or** winch 1 spools up.

4.4.4 Disconnecting the hydraulic connections

Make sure that the following prerequisites are met:

- The emergency operation is completed.
- The pressure in the hydraulic system has been relieved.
- ▶ Disconnect the hydraulic connections of winch 1 and winch 2 to the respective assembly plates.
- ▶ Remove the reducer sections **7** (adapter).
- ▶ Close off the hydraulic connections of the winches with dust plugs.

or

- Reconnect the winches to the hydraulic system of the crane.

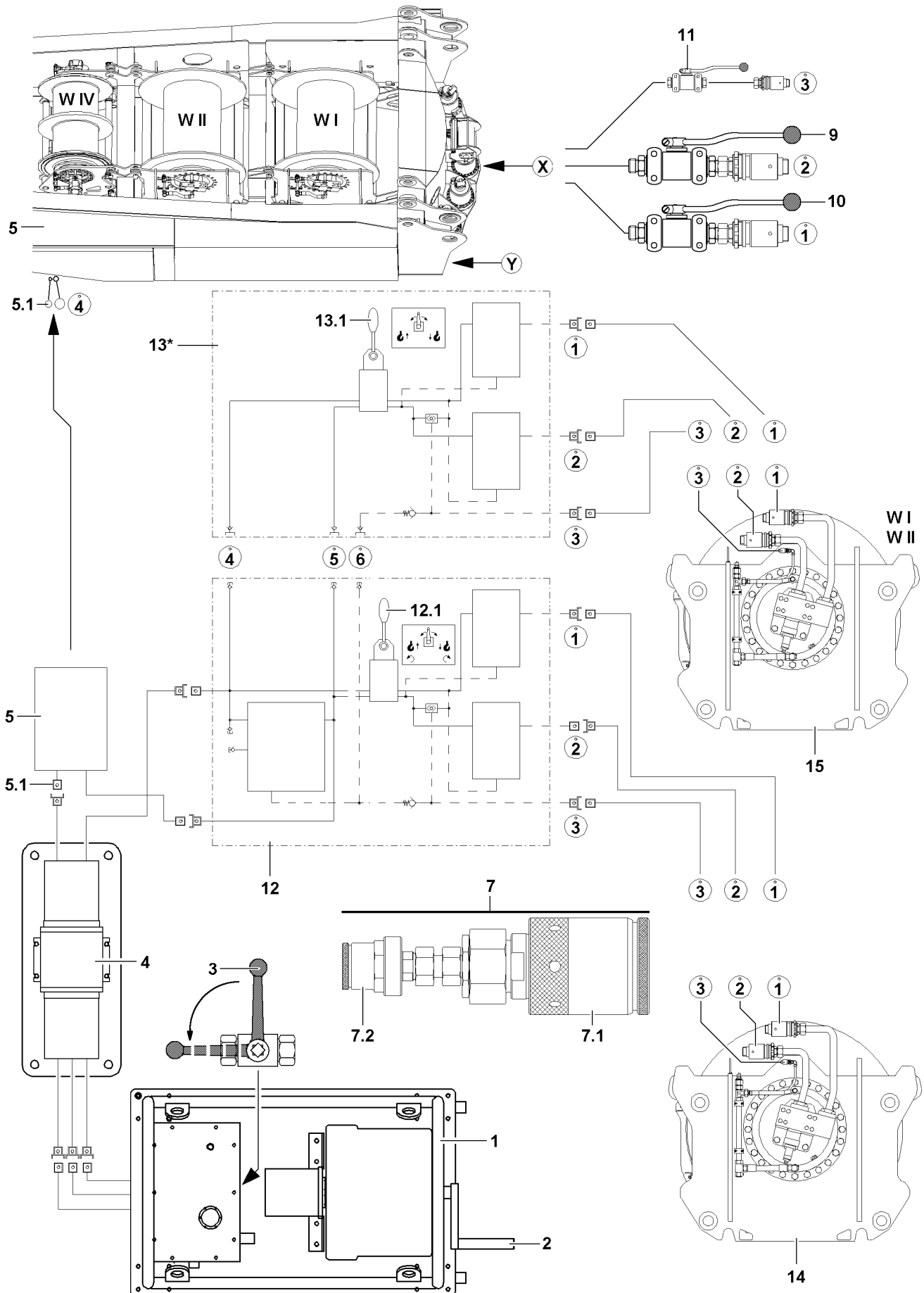

B109393

5 Emergency operation slewing gear(s) with assembly plate(s) Variation 2 (V2)



WARNING

Danger due to hydraulic pressure!

If the hydraulic lines are pressurized when releasing the connections, it can lead to severe injuries to assembly personnel!

- ▶ Relieve the pressure in the hydraulic lines before releasing!



Note

- ▶ For each crane type, the installation position of the ball valves for emergency operation of the slewing gear on the turntable varies!
- ▶ Possible installation positions of the ball valve: Point **X** or point **Y**!



Note

- ▶ The slewing movement is actuated and the speed of the slewing movement is determined via the ball valve **12.1**!

5.1 Establishing the hydraulic connection to the slewing gears

Make sure that the following prerequisite is met:

- The pressure in the hydraulic system has been relieved.



Note

- ▶ Observe the numbering of the hydraulic lines!
- ▶ Establish the hydraulic connections of the assembly plate **12** (connection **1**, connection **2** and brake **3**) to the “Ball valves” on the turntable.

5.2 Turning the turntable to the left

- ▶ Set the ball valve **9** into emergency operation position.
- ▶ Set the ball valve **10** into emergency operation position.
- ▶ Set the ball valve **11** into emergency operation position.
- ▶ Set the ball valve **12.1** for the assembly plate **12** on “turn left”.

Result:

- The turntable turns to the left.

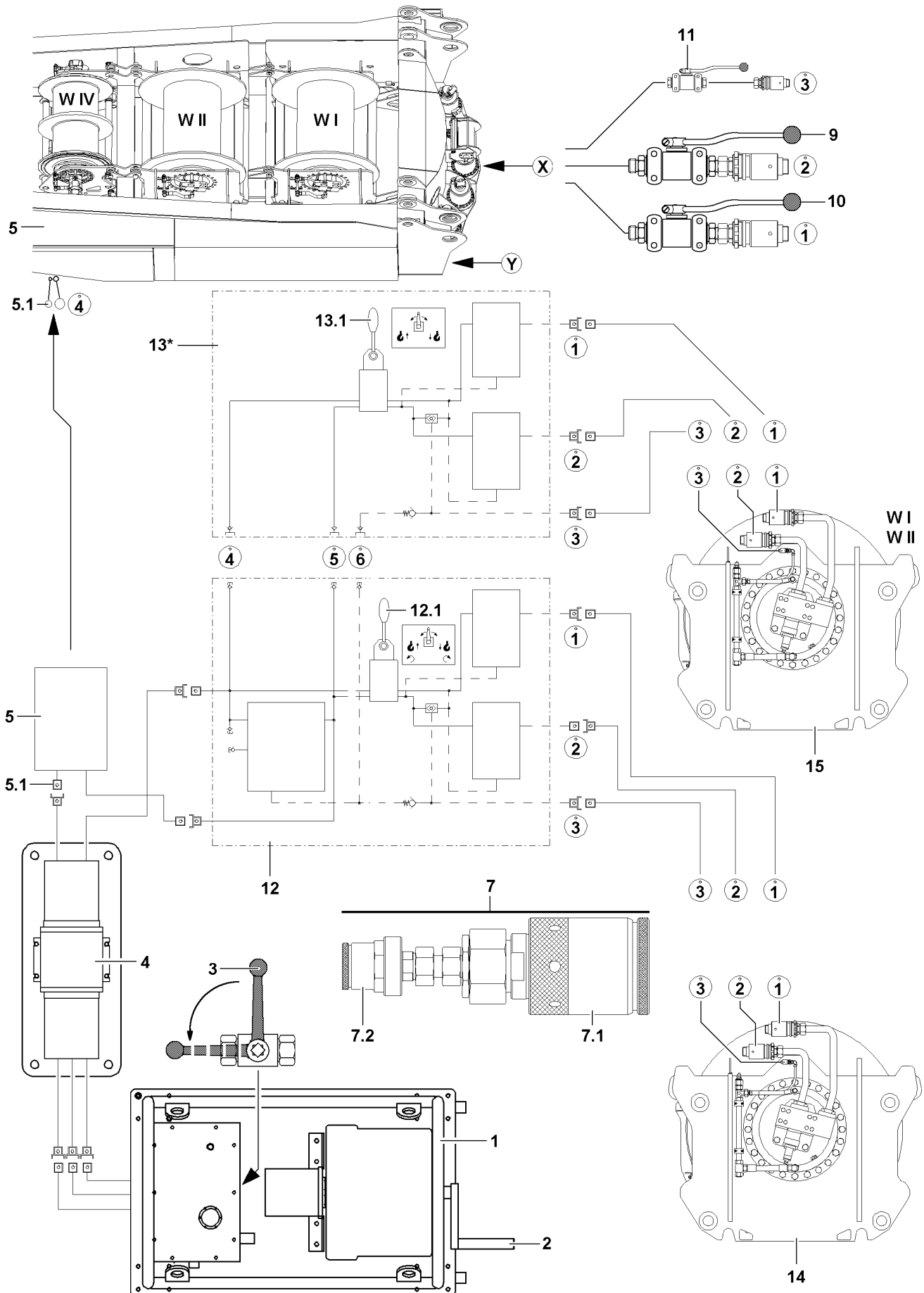

B109393

5.3 Turning the turntable to the right

- ▶ Set the ball valve **9** into emergency operation position.
- ▶ Set the ball valve **10** into emergency operation position.
- ▶ Set the ball valve **11** into emergency operation position.
- ▶ Set the ball valve **12.1** for the assembly plate **12** on “turn right”.

Result:

- The turntable turns to the right.

5.4 Disconnecting the hydraulic connections

Make sure that the following prerequisites are met:

- The emergency operation is completed.
- The pressure in the hydraulic system has been relieved.

Disconnect the hydraulic connections to the assembly plate **12**.

- ▶ Reposition the ball valve **9** in position for crane operation.
- ▶ Reposition the ball valve **10** in position for crane operation.
- ▶ Reposition the ball valve **11** in position for crane operation.
- ▶ When the ball valve **9**, ball valve **10** and ball valve **11** are repositioned into crane operation position:
 - Disconnect the hydraulic connections to the assembly plate **12**.
- ▶ Close off the hydraulic connections with dust plugs.

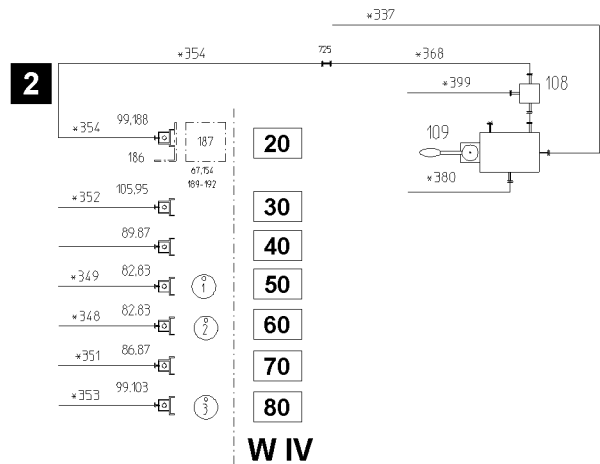
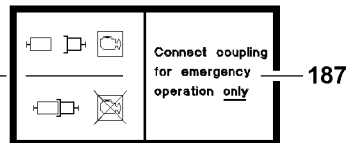
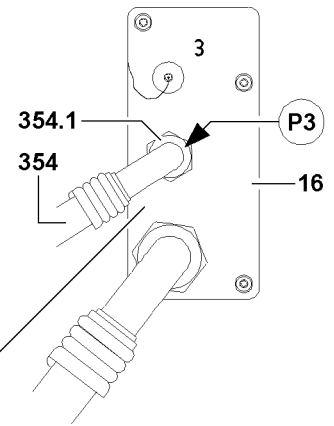
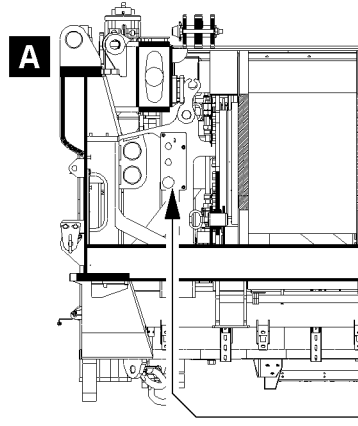
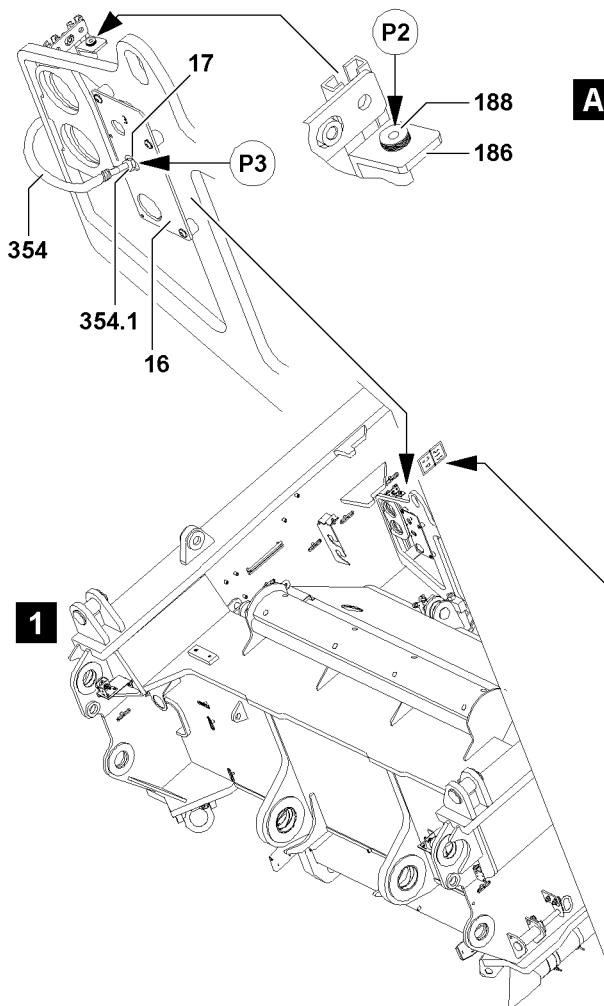
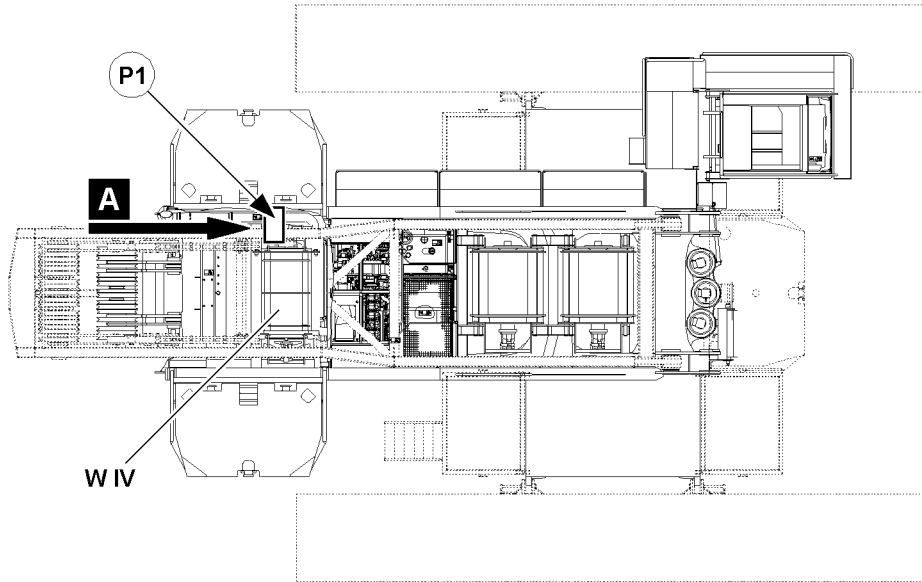

B112453

6 Emergency operation of winch 4 (W IV) on the LR1600/2 and LR1600/2-W

NOTICE

Damage of crane components!

If the hydraulic hose (control line) **354** for the emergency operation is not connected properly, then hydraulic parts or crane components can be damaged!

- ▶ Make sure, before starting the emergency operation, that the hydraulic hose **354** is properly connected!

6.1 Emergency operation winch 4 (WIV)

6.1.1 Establishing the hydraulic connections to winch 4 (WIV)



Note

- ▶ The hydraulic connections to winch 4 - connection 1, connection 2 and brake - have been established, see section "Emergency operation of winches"!
- ▶ Pay attention to the different variations of the assembly plates!

Before emergency operation of winch 4 **W IV**, in addition to the hydraulic connections for the emergency operation of the winch, the hydraulic hose **354** must be connected.

Make sure that the following prerequisites are met:

- The hydraulic connections to winch 4 are established.
- The hydraulic hose **354** is in park position, point **P2**.
- ▶ Release the hydraulic hose **354** with the fitting **354.1** on the plug **188** (park position), point **P2**.
- ▶ Guide the hydraulic hose **354** to the front to the connector plate **16**.
- ▶ Connect the hydraulic hose **354** with the fitting **354.1** on the supply line **17**, point **P3**, of the connector plate **16**.



Note

- ▶ Observe the notes in the sections "Emergency operation of winches"!

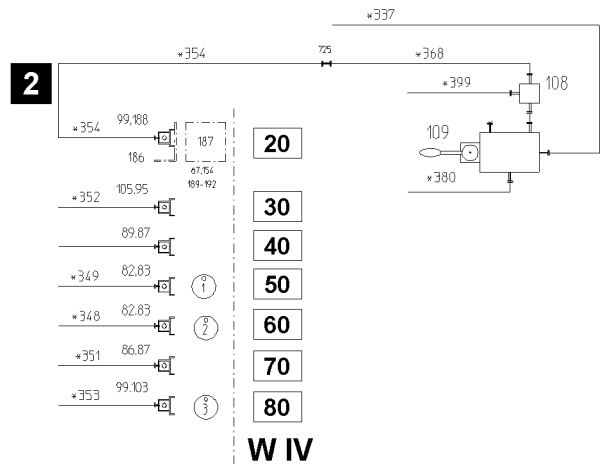
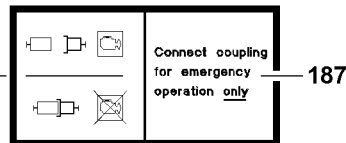
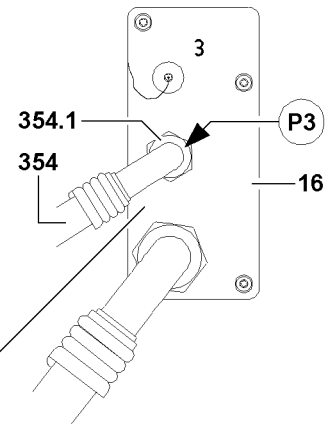
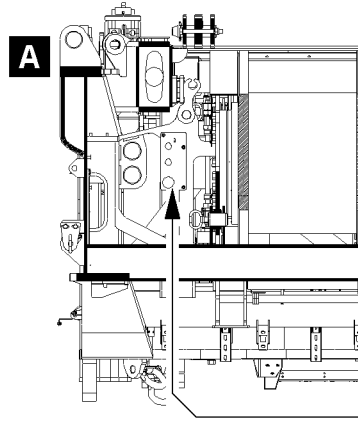
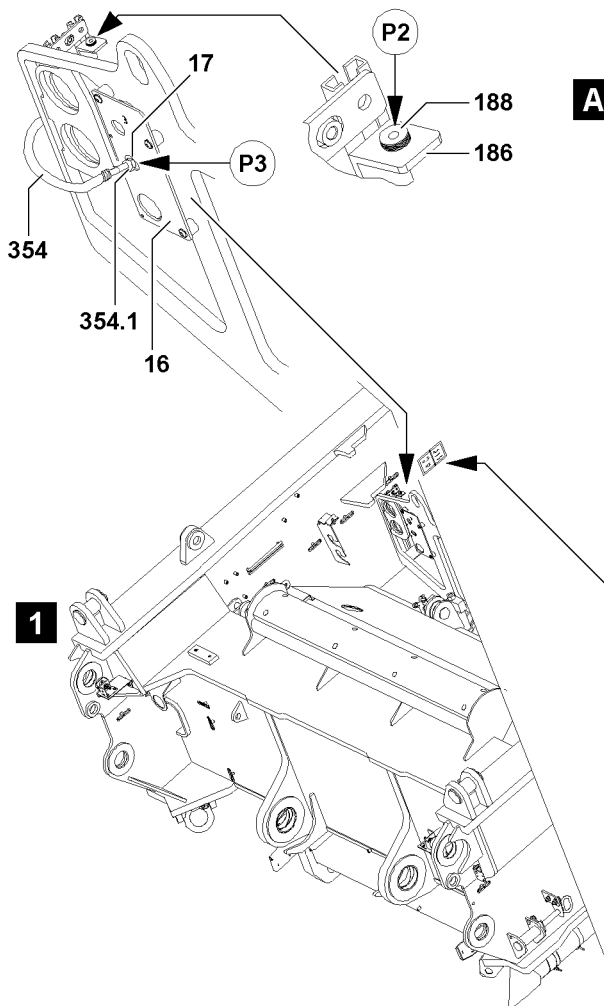
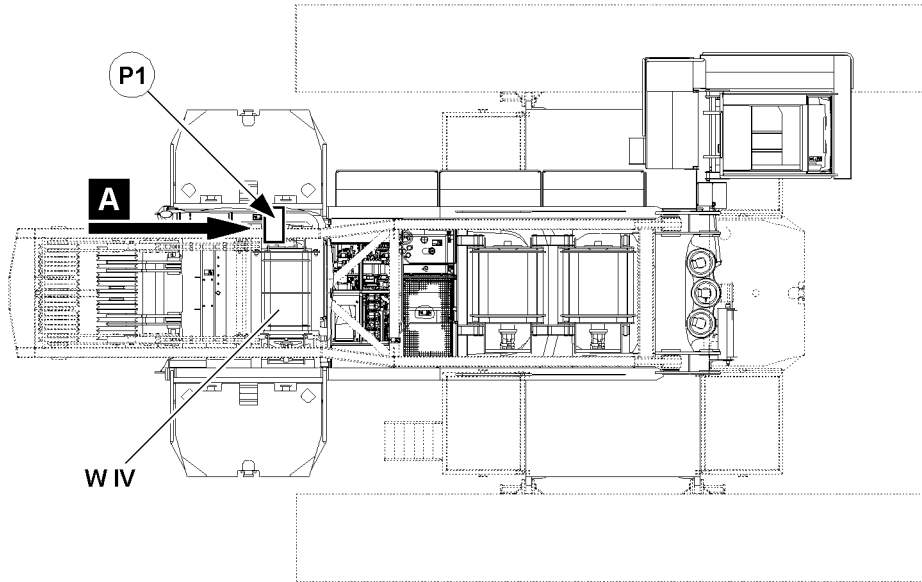

B112453

6.1.2 Spooling the winch out

- ▶ See section: "Emergency operation with assembly plate Variation 1 (V1)"
- or
- See section: "Emergency operation with assembly plate Variation 2 (V2)"

6.1.3 Spooling the winch up

- ▶ See section: "Emergency operation with assembly plate Variation 1 (V1)"
- or
- See section: "Emergency operation with assembly plate Variation 2 (V2)"

6.2 Disconnecting the hydraulic connections

Make sure that the following prerequisites are met:

- The emergency operation is completed.
- The pressure in the hydraulic system has been relieved.
- ▶ Disconnect the hydraulic connections from the winch 4 to the assembly plate.
- ▶ Remove the reducer sections (adapter).
- ▶ Close off the hydraulic connections of the winch 4 **W IV** with dust caps.
- or
- Reconnect the winch 4 **W IV** onto the hydraulic system of the crane.
- ▶ Disconnect the hydraulic hose **354** at point **P3**.
- ▶ Bring the hydraulic hose **354** in parking position: Install the fitting **354.1** onto the plug **188**.

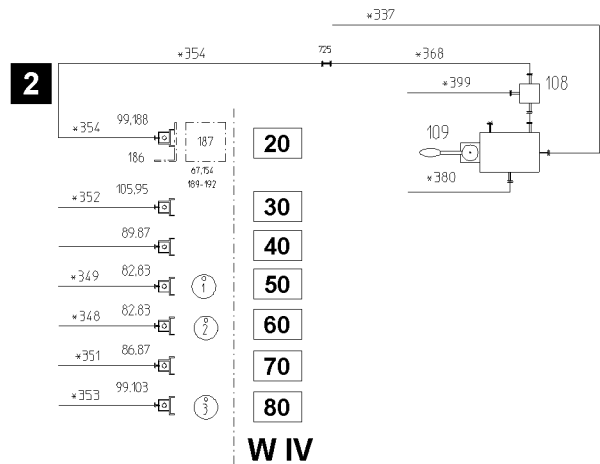
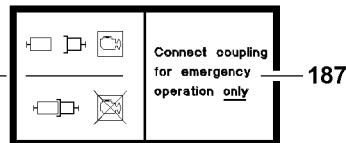
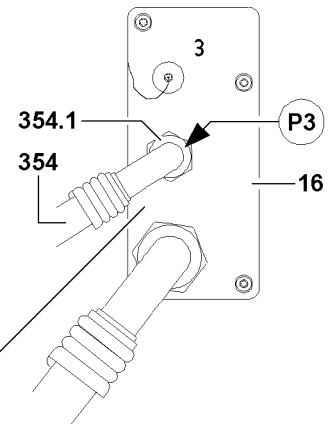
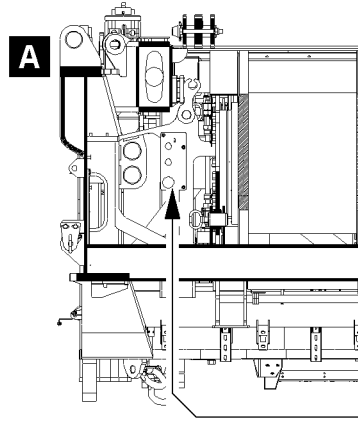
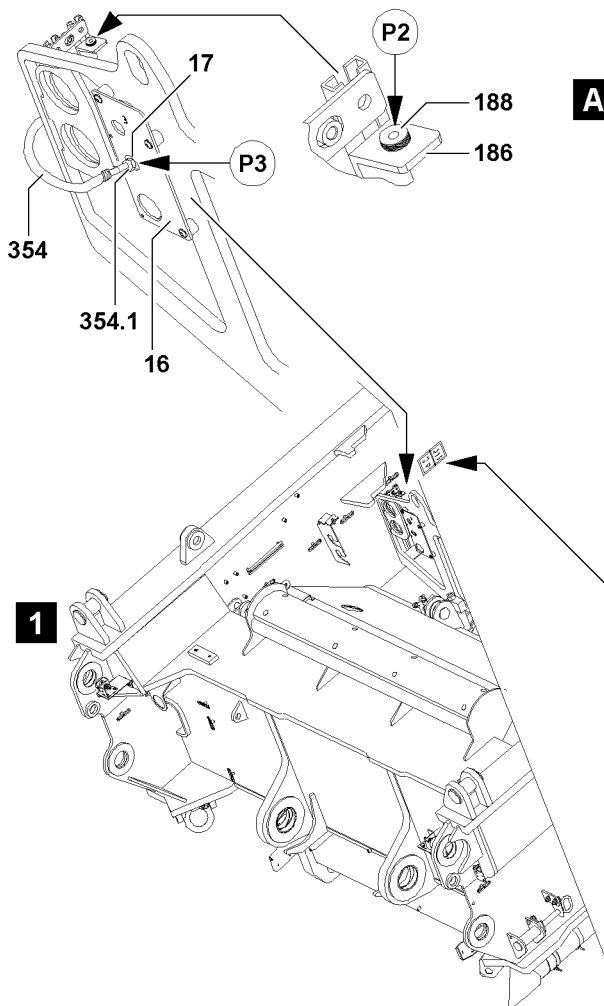
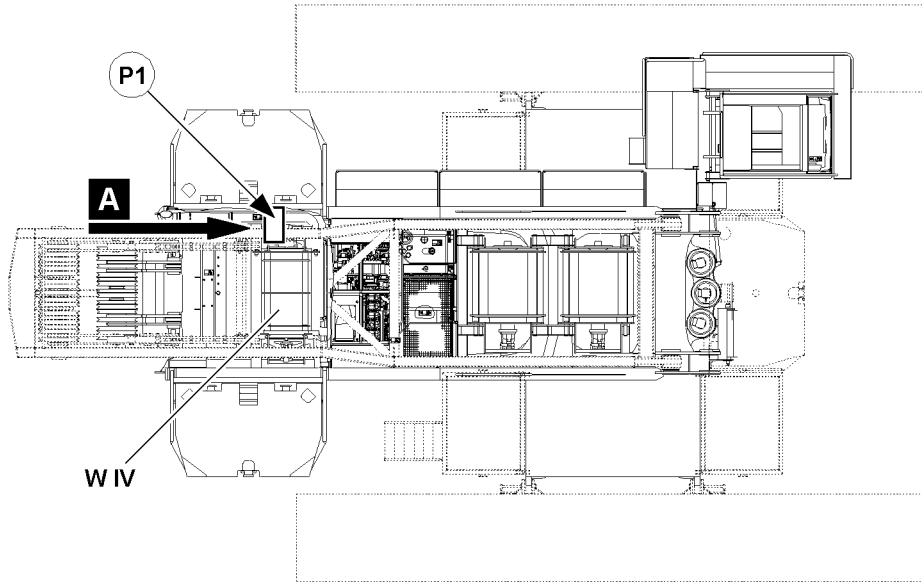

B112453

6.3 Connection schematic for emergency operation, illustration 2



Note

- ▶ See also Hydraulic schematic!

Position	Connection / description
20	Control pressure SA-frame
50	Lifting
60	Lowering
80	Replenishing pressure brake

7 Ending emergency operation

7.1 Procedure

- ▶ Turn the emergency operation aggregate* 1 off.
- ▶ Close the ball valve 3.
- ▶ Disconnect the hydraulic connections and close them off with dust plugs.

7.00 Service and maintenance

B195219

1 General



WARNING

Danger of fatal injury due to damaged crane components!

If crane components, which were damaged, for example due to maintenance errors, are not replaced immediately, personnel can be fatally injured!

- ▶ Maintain mobile crane components according to the data in the maintenance intervals, the maintenance notes and the lubrication chart!
- ▶ Replace damaged crane components immediately!

NOTICE

Damage of crane components!

If mobile crane components are not maintained according to the maintenance intervals and maintenance guidelines in the individual chapter, or if other lubricants are used than specified in the lubrication chart, the respective crane components can be damaged and/or functionally fail!

The warranty for the respective crane components are voided!

- ▶ Maintain mobile crane components according to the data in the maintenance intervals, the maintenance notes and the lubrication chart!

1.1 Liebherr Service

Liebherr mobile cranes, whether truck-mounted, mobile or crawler cranes - are technically advanced products, which prove their worth daily even under tough conditions.

The high technical standards of these cranes provide functional security, resistance to failure and ease of maintenance.

Liebherr is continuously developing the drive and control components. The combination of well proven units and modern manufacturing methods produces cranes that are safe to operate and easy to maintain.

Several hundred cranes are built every year for the international market, supported by international service.

Liebherr's "After Sales Service" plays an important role at Liebherr, in ensuring operational readiness and high crane availability.

With Liebherr, service begins when the crane is handed over. Your crane operators will be professionally trained in line with their level of knowledge, and we devote much time to this.

We also train your workshop staff in all crane-specific matters, because we know that they can deal with more than just minor repairs themselves. Often there are specialists who can quickly and reliably carry out crane repairs.

We have special service advisers available who will solve any problems you may have. This phone contact saves time and money. You should take advantage of it as soon as possible.

Our service technicians are specialists with years of experience, who can be deployed from local support points. Naturally these experts have specialized knowledge and special tools.

But before you call these specialists, it is worth making use of the facilities for getting advice mentioned above.



Note

Customers claims for warranties and refunds!

The buyer only has a claim to warranties and possible refund if only Original Liebherr replacement parts, Liebherr service items and Liebherr lubricants are used for the Liebherr crane!

- ▶ Only original Liebherr replacement parts have been tested for crane operational use, and may be used without risking safety!

**Note**

Exclusion of liability!

In the event that replacement parts are used that are **not** Original Liebherr replacement parts and **not** Original Liebherr service items and lubricants, Liebherr-Werk Ehingen GmbH disclaims all liability for system functionality as well as for the parts!

- ▶ Use only Original Liebherr spare parts!

1.2 What does “Checking” mean

The term “checking” includes all required work, such as:

- Determining a specified value
- Cleaning
- Adjusting
- Refilling
- Replacing

1.3 Checking the battery voltage

**Note**

If a crane is taken “out of service” and a user, such as the airplane warning light is turned on:

- ▶ Check the battery voltage in regular intervals. If necessary, recharge the battery.

1.4 Checking the antislip coverings

Check the antislip coverings before stepping on them regarding their antislip properties and cleanliness. If dirty, clean antislip coverings with a strong brush to retain the antislip properties. For cleaning the surfaces, use commercially available cleaners. Flush with water.

**WARNING**

Risk of falling!

If the following measures are not observed, personnel can fall down and be killed or severely injured!

- ▶ Keep antislip coverings clean and free of snow and ice!
- ▶ Only step on antislip coverings with clean shoes!
- ▶ Replace or renew missing or damaged antislip coverings!

2 Cleaning and care of the crane

2.1 Instructions for sound damping (soundproofing)

Sound damping in the area of engines and other noise sources is an integral part of construction. It is your task to limit the noise generation of vehicles and the sound level in the workplace to the legally specified values in connection with sound absorption and the design of the equipment. They are therefore an integral part for the construction permits for the machines. They may not be removed, and if damaged, they must be replaced by original Liebherr replacement parts.

From a construction point of view, they have been designed to be maintenance-free. They have been equipped with surfaces that repel dirt, oil and water. They are very flame-resistant and some of them, depending on application, are fireproof.

For these reasons, these parts need minimal care. Any small dirt deposits can be disregarded, as the acoustic effectiveness of the parts is not reduced.

NOTICE

Sound insulation (soundproofing) damage!

By using unsuitable tools or cleaning methods, sound insulation can be destroyed or damaged during cleaning!

- ▶ Remove severe contamination with suitable tools, for example with soft plastic scrapers!
- ▶ Do not use tools with sharp edges!
- ▶ Only use steam cleaners with extreme care and with a sufficient distance to the sound insulation and with low water pressure!
- ▶ Do **not** use **solvents** for cleaning!

**WARNING**

Impurities from solvents or foreign substances!

For example, if sound insulation is polluted by solvents, motor oils, gear oils, hydraulic oils or fuels, such substances can ignite and significantly detrimentally change the fire performance of the sound insulation!

- ▶ If such contamination of the sound insulation occurs, **remove immediately** and replace it immediately with **original parts**!

2.2 Care instructions for the cab and the crane operator's cab

**Note**

- ▶ The steering wheel, center console, instrument panel cover, floor covering and dirty upholstery in the driver's cab and the crane operator's cab should only be cleaned with warm water mixed with dishwashing detergent!
- ▶ Do not use any scouring agents!

3 Measures for work interruption or transport

3.1 Hydraulic cylinder

NOTICE

Corrosion danger to the hydraulic cylinders!

When using cranes under aggressive environmental conditions, for example at places with maritime climates and particularly salty air, hydraulic cylinders can corrode and thereby be destroyed or severely damaged!

Expensive and extensive repairs can result!

If the crane is taken out of operation for an extended period of time:

- ▶ Disassemble the crane!
- ▶ Fully retract all crane hydraulic cylinders! If the hydraulic cylinders can not be completely retracted, protect exposed areas of the piston rod from corrosion, for example by applying grease!
- ▶ Grease any exposed areas on the piston rods, for example on luffing cylinders and ballasting cylinders, especially carefully!

4 Maintenance work on the crane superstructure or boom



WARNING

Risk of falling!

During maintenance work on the crane superstructure or boom, personnel must be secured with appropriate safety measures to prevent them from falling! If this is not observed, working personnel can fall and be killed or severely injured!

- ▶ For all work on the crane where there is a danger of falling, take suitable safety measures!
- ▶ The crane superstructure or boom may not be accessed without suitable aids!
- ▶ Suitable aids are, for example: Lifting platforms, scaffoldings, ladders, assembly platforms, auxiliary crane.
- ▶ If railings are present on the crane superstructure, then they must be swung into operating position and secured for all work, see Crane operating instructions, chapter 2.06!
- ▶ Only step on such aids with clean shoes!
- ▶ Keep aids clean and free of snow and ice!
- ▶ If the work cannot be carried out with such aids nor from the ground, then the maintenance personnel must secure themselves with approved fall arrest systems to avoid falling, see Crane operating instructions, chapter 2.04!
- ▶ It is prohibited to step on the driver's cab or cab roof and specially marked surfaces, see Crane operating instructions, chapter 2.05!

5 Maintenance and inspection guidelines



Note

- ▶ Carry out the maintenance and inspection work on the crane chassis according to operating hours or kilometers driven!
- ▶ Carry out the maintenance and inspection work on the crane superstructure according to operating hours!

Observe the following chapters for maintenance and inspection of the crane:

- Chapter 7.02: Maintenance intervals - Crane chassis ¹
- Chapter 7.03: Maintenance intervals - Crane superstructure ¹
- Chapter 7.04: Maintenance guidelines - Crane chassis ²
- Chapter 7.05: Maintenance guidelines - Crane superstructure ²
- Chapter 7.06: Fill quantities, lubrication chart
- Chapter 7.07: Service items and lubricants

¹ These chapters contain a list of service intervals for all maintenance work. Only the relevant work is to be carried out.

² For individual components, the manufacturer's specifications must be observed.



WARNING

Danger of accidents during maintenance and inspection of crane components!

During maintenance and inspection work on crane components, there exists increased danger of accidents if maintenance and inspection guidelines are not observed!

Personnel can be severely injured or killed!

- ▶ Observe and adhere to the following listed warning notes and the generally applicable safety rules!

5.1 Warning notes

5.1.1 Preparatory work



WARNING

Fatal injury when driving or operating the crane during maintenance, inspection or repair work!
If the mobile crane is operated during maintenance, inspection or repair work, then personnel can be killed or severely injured!

This could result in high property damage!

- ▶ During maintenance, inspection or repair work, it is strictly prohibited to drive or operate crane!
 - ▶ Show clearly with signs that maintenance, inspection or repair work is being carried out on the mobile crane!
 - ▶ Use signs which show without a doubt that it is prohibited to drive and operate the crane! The national regulations regarding labeling on mobile cranes and on the signs must be observed!
 - ▶ Carry out maintenance, inspection or repair work only with authorized and trained expert personnel.
 - ▶ It is prohibited for unauthorized personnel to remain in the danger zone!
-
- ▶ Turn the engine on the crane superstructure and the crane chassis off!
 - ▶ Apply the "parking brake crane chassis".
 - ▶ If possible:
Lock the driver's cab and the crane operator's cab.
 - ▶ Hand the ignition key from the crane superstructure and the crane chassis to an authorized person.

5.1.2 Warning notes on risk of burns



WARNING

Risk of burns during maintenance or inspection work!

While carrying out maintenance or inspection work, you can get severe burns on hot surfaces of the crane components! This applies especially for the exhaust system or the travel gear!

- ▶ Let any components to be maintained or inspected cool off!
- ▶ Do not spill any service fluids over the hot components!
- ▶ Avoid short circuits in the electrical system, especially on the battery!
- ▶ Replace or change missing or defective protective insulation!

5.1.3 Warning notes for rotating parts



WARNING

Risk due to rotating parts!

If inspection work must be carried out while the engine is running, a significant danger exists due to rotating parts and the ignition system!

Personnel can be severely injured!

- ▶ Proceed especially careful!
- ▶ Never reach into rotating parts!
- ▶ Never reach into the cooler fan when the engine is warm! The cooler fan could turn on suddenly!

5.1.4 Warning notes for scalding risk



WARNING

Risk of scalding during maintenance or inspection work!

The cooling system is under pressure!

When the coolant reservoir is opened, hot coolant can escape explosively!

The most severe scalding on the entire body can result!

When the engine is warm:

- ▶ Do not open the cover of the coolant reservoir!
- ▶ To protect face, hands and arms from hot steam of hot coolant, cover the cap with a large rag when opening!

5.1.5 Warning notes on fire danger



DANGER

Danger of fire!

When working on fuel systems or on electrical systems, an increased danger of fire exists if the general safety rules are not observed!

Personnel can be severely injured or killed!

This can result in increased property damage!

- ▶ Disconnect the battery from the power supply!
- ▶ Do not smoke!
- ▶ Do not work near open flames!
- ▶ Keep a functioning fire extinguisher ready!

5.1.6 Improper maintenance

NOTICE

Damage of components!

In case of incorrect maintenance, severe functional defects and damage on the components can occur!

- ▶ Add correct and sufficient service fluids during maintenance!
- ▶ For all maintenance work, observe utmost cleanliness to prevent dirt from entering the inside of the components!
- ▶ Check components for leaks!
- ▶ Have leaking components sealed immediately and properly!

5.2 Refueling AdBlue®



WARNING

Skin irritation and eye injuries!

AdBlue® can cause skin irritation and eye injuries at contact!

- ▶ Do not allow for AdBlue® to come in contact with skin, eyes or clothing!

If persons did come in contact with AdBlue®:

- ▶ In case of eye contact, flush out the eyes immediately and consult a physician if necessary!
- ▶ Clean affected skin areas with clear water!

If AdBlue® was swallowed:

- ▶ Flush the mouth with a lot of water! Then drink a lot of water and consult a physician, if necessary!

**WARNING**

Irritation of eyes and mucous membranes!

If the AdBlue® tank cover is opened at high temperatures, ammonia vapors can emerge! If ammonia vapors are breathed in, then it can cause burning eyes, nose, throat and coughing!

- ▶ Do not breathe in ammonia vapors!

NOTICE

Danger of corrosion!

If AdBlue® is spilled during refueling, affected surfaces can corrode!

- ▶ Flush affected areas immediately with lots of water!
- ▶ Do not overfill the tank!

If possible:

- ▶ Refuel on a gas pump with nozzle!

1 Crane chassis maintenance and inspection schedule



Note

- ▶ The operating hour meter of the crawler travel gear is the deciding factor for the maintenance intervals in this chart!
- ▶ The operating hour meter "crawler travel gear" * is located in the control cabinet!

	First maintenance after	Regular maintenance, every			Minimum maintenance Annually	Checks	
		1 h	100 h	1000 h		Daily	Weekly
Travel gear							
Oil change	200 h			4000 h	Every 4 years		
Check for leaks		X					
Grease the sprocket bearing		X					
Check the mounting screws for tight seating		X			X		
Crawler carrier							
Check track rollers, carrier rollers with oil lubrication for leaks			X				
Grease track rollers, carrier rollers with grease lubrication		X					
Grease guide rails on sliding section					X		
Lubricate the consoles					X		
Track chain							
Check correct mounting			X				
Check for damage			X				
Check the chain tension, retension if necessary			X				X
Check the wear on the bores of the track pads, replace track pads if necessary			X				

	First maintenance after	Regular maintenance, every			Minimum maintenance Annually	Checks	
		1 h	100 h	1000 h		Daily	Weekly
Check the wear on the connector pins of the track pads, replace pins if necessary			X				
Assembly support							
Check the hydraulic cylinder for leaks							X
Check support beam for ease of movement, grease					X		
Lubricate the bearing points of the support beams					X		
Check sight gauge, adjust if necessary					X		
Crane support							
Check the hydraulic cylinder for leaks							X
Check support beams for ease of movement, grease					X		
Lubricate the struts					X		
Lubricate the mounting pins on the struts					X		
Lubricate the support pad bearing					X		
Rotary connection							
Lubricate				X			
Hydraulic cylinder							
Check for leaks							X
Hydraulic hose lines							
Check for leaks and damage						X	
Have safe working condition checked by expert					X		

	First maintenance after	Regular maintenance, every			Minimum maintenance Annually	Checks	
		1 h	100 h	1000 h		Daily	Weekly
Central lubrication system							
Check grease supply of central lubrication system		X					
Check for correct function			X				

2 Ballast trailer maintenance and inspection schedule

	First maintenance after	Regular maintenance, every			Minimum maintenance Annually	Checks	
		10 h	100 h	1000 h		Daily	Weekly
Tires							
Check for external damage							X
Check the tire pressure							X
Check lug nuts for tight seating, retighten if necessary		X					
Axle link							
Lubricate			250 h		X		
Hydraulic cylinder							
Check for leaks							X
Hydraulic hose lines							
Check for leaks and damage						X	
Have safe working condition checked by expert					X		
Slewing gear							
Check for leaks						X	
Check the oil level							X
Check the mounting screws for tight seating	250 h		500 h		X		
Oil change				4000 h	Every 4 years		
Central lubrication system							
Check grease supply of central lubrication system		X					
Check for correct function			X				
Emergency control							
Check for correct function					X		

1 Crane superstructure maintenance and inspection schedule

	First maintenance after	Regular maintenance, every				Minimum maintenance Annually	Checks	
		125 h	250 h	500 h	1500 h		Daily	Weekly
Safety systems								
Personal protective equipment Follow the instructions of the manufacturer						X		
Height rescue system Follow the instructions of the manufacturer						X		
Check protection points						X		
Check safety ropes						X		
Diesel engine								
Check the oil level For all other maintenance tasks, observe the instructions of the engine manufacturer							X	
Check the coolant level in the expansion tank							X	
Replace coolant						Every 2 years		
Engine independent heater								
Check the fluid level in the expansion tank							X	
Change the fluid for the heating system						Every 2 years		
Air filter								
Check monitoring device							X	

	First maintenance after	Regular maintenance, every				Minimum maintenance Annually	Checks	
		125 h	250 h	500 h	1500 h		Daily	Weekly
Clean, change the filter insert Observe the instructions of the engine manufacturer								
Slewing ring connection								
Lubricate the gears			X					
Lubricate the slewing ring connection						X ¹		
Check the mounting screws for tight seating	250 h				X	X		
Check the tilt play					X	X		
Rope winches								
Check for leaks							X	
Check the oil level								X
Check the mounting screws for tight seating	250 h			X		X		
Check condition of gear oil						X		
Change the gear oil					3000 h	Every 4 years		
Check the remaining theoretical utilization life by a technical expert						X		
Check the remaining theoretical utilization life by authorized specialist						Every 4 years		
Hoist gear brakes								
Check for leaks							X	
Check the oil level						X		
Change the oil					4000 h	Every 4 years		
Gear shafts								
Check the flange screws for tight seating		X						

	First maintenance after	Regular maintenance, every				Minimum maintenance Annually	Checks	
		125 h	250 h	500 h	1500 h		Daily	Weekly
Lubricate		X				X		
Lattice sections								
Check cracks, damage and distortion						X		
Guy rods								
Check for cracks, damage and distortion by a technical expert						X		
Check for cracks, damage and distortion by an authorized inspector						Every 4 years		
Checking the retaining elements						X		
Relapse supports								
Lubricate bearings				X		X		
Check the oscillation guard for easy movement	X ^{2,6}							
Relapse cylinder								
Check for leaks	X ^{2,6}							
Check pretension pressure (nitrogen)	X ^{2,6}			X		X		
Check the oil quantity	X ^{2,6}			X		X		
Pneumatic springs								
Check for correct function	X ^{2,5,6}			X		X		
A-bracket								
Lubricate bearing				X				
Check the lever for the limit switch on the A-frame 3 for easy movement and reset of spring						X		

	First maintenance after	Regular maintenance, every				Minimum maintenance Annually	Checks	
		125 h	250 h	500 h	1500 h		Daily	Weekly
Check the rods with guide rail on the A-frame 2 and A-frame 3 for easy movement and distortion						X		
Counterweight								
Check tightening torque of mounting screws	1,000 km			or 10,000 km		X		
Ballasting								
Lubricate bearings			X			X		
Press on pulleys of rope winches								
Grease guides			X			X		
Rope pulleys								
Check for wear, damage, cracks and easy movement					X	X		
Lubricate					X	X		
Crane ropes								
Check cracks, damage and distortion							X	
Check, grease by expert personnel						Monthly		
Check by technical expert						X		
Check by authorized inspector						Every 4 years		
Hook blocks								
Grease hook				X		X		
Check distance dimension (y)				X		X		
Crane operator's cab								
Check instruments for function							X	
Check indicator lights for function							X	

	First maintenance after	Regular maintenance, every				Minimum maintenance Annually	Checks	
		125 h	250 h	500 h	1500 h		Daily	Weekly
Replace filter insert in water heater						X		
Check fluid level in expansion tank of engine control							X	
Crane cab, extendable or inclinable								
Check for correct function				X		X		
Lubricate bearings				X		X		
Overload protection								
Check for correct function							X	
Check length sensor for function				X		X		
Check length sensor rope for damage				X		X		
Electrical system								
Check cable connections and battery acid levels						X ³		
Fuel system								
Check for leaks							X	
Check condition and mounting						X		
Drain off water and sediments						X		
Slewing gear								
Check for leaks							X	
Check the oil level								X
Check the mounting screws for tight seating	250 h			X		X		
Change the oil					4000 h	Every 4 years		
Turntable locking mechanism								
Check for correct function				X		X		
Lubricate				X		X		
Bearings								

	First maintenance after	Regular maintenance, every				Minimum maintenance Annually	Checks	
		125 h	250 h	500 h	1500 h		Daily	Weekly
Check the retaining elements						X		
Pump distributor gear								
Check for leaks							X	
Check the oil level								X
Change the gear oil	500 h				X	X		
Hydraulic hose lines								
Check for leaks and damage							X	
Check for safe condition by expert						X		
Hydraulic system								
Check the oil level							X	
Check for leaks								X
Replace the servo pressure and replenishing pressure filter inserts	250 h			X		X		
Replace return filter inserts (only for cranes with open hydraulic circuit)	250 h			X		X		
Replace bleeder filter of hydraulic tank	250 h			X		X		
Check hydraulic oil, required degree of purity: 20/18/15 Take oil sample and have it tested by oil supplier	500 h				X	X		
Hydraulic cylinder								
Check for leaks								X
Hydraulic pressure accumulator (nitrogen)								
Check pretension pressures				X ⁴		X ⁴		
Air pressure system								
Check for leaks								X
Check operating pressure								X
Check shut off pressure								X

	First maintenance after	Regular maintenance, every				Minimum maintenance Annually	Checks	
		125 h	250 h	500 h	1500 h		Daily	Weekly
Check operation of automatic drain valve								X
Replace air drier granular cartridges						X		
Clean air drier preliminary filter						X		
Central lubrication system								
Check for correct function				X				
Check the grease container fill level		X				X		
Emergency control								
Check for correct function						X		
Telescopic boom with rope mechanism								
Check telescopic boom for distortions and cracks						X		
Grease the sliding surfaces of the telescopic boom bearing		X				X		
Lubricate change over pulleys of telescoping mechanism		X				X		
Check mounting screws on change over pulleys for tight seating		X				X		
Check, adjust rope mechanism	250 h			X				
Disassemble and check the boom					20000 h	Every 10 years		
Pneumatic boom lock								
Clean air filter with compressed air		X				X		
Check locking pins				X		X		
Lubricate locking pins					X	X		

	First maintenance after	Regular maintenance, every				Minimum maintenance Annually	Checks	
		125 h	250 h	500 h	1500 h		Daily	Weekly
Telematik telescopic boom system								
Check telescopic boom system for distortion, damage and cracks						X		
Check hydraulic components for leaks and damage						X		
Check telescoping cylinder for proper condition				X		X		
Check pull knob retainer and mounting screws for tight seating						X		
Check mounting screws of push out cylinder for tight seating						X		
Check twist guard of cylinder pinning and telescopic boom pinning						X		
Check push out gripper for proper condition				X		X		
Check locking pins and locking bores for proper condition				X		X		
Check inner and outer sliding surfaces for proper condition				X		X		
Lubricate sliding surfaces						X ⁵		
Grease guide rails on telescoping cylinder						X ⁵		
Disassemble and check the boom					20000 h	Every 10 years		
Telescopic boom guying								
Check for distortions and cracks						X		

	First maintenance after	Regular maintenance, every				Minimum maintenance Annually	Checks	
		125 h	250 h	500 h	1500 h		Daily	Weekly
Lubricate grease fitting on the TA / TY-guying						Every 3 months ^{5, 6}		
Check guy winch for leaks							X	
Check the oil level on the guy winch								Every 6 months
Check the mounting screws for tight seating	250 h			X		X		
Change gear oil of guy winch						Every 4 years		
Derrick ballast								
Check frame, suspension and guide section for distortion and cracks						X		
Check wheels for condition and tight seating						X		

¹ every 3 months if the crane is not moved

² carry out a visual inspection before every start up

³ in hot climates 2x a year

⁴ note chapter 7.05, Crane superstructure maintenance instructions

⁵ and as necessary

⁶ during assembly

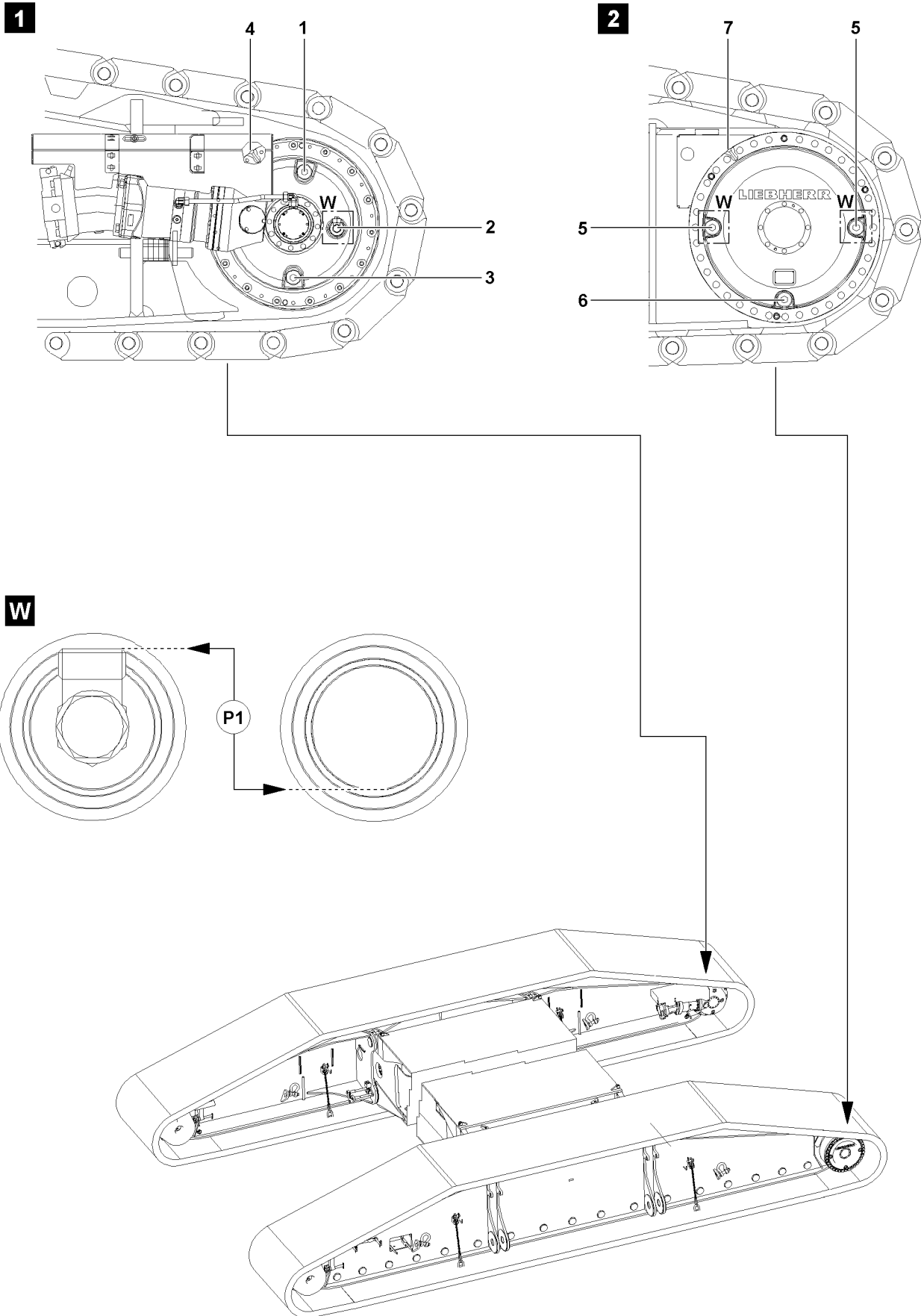

B110043

1 Servicing the travel gear



Note

- ▶ Use service items and lubricants according to the chart, see Crane operating instructions, chapter 7.07!
- ▶ Observe the maintenance intervals, see Crane operating instructions, chapter 7.02!

The travel gear consists of

- Miter gear with brake, illustration 1
- Planetary gear, illustration 2



WARNING

- Danger of burns during maintenance and inspection work!
Severe burns can result due to the travel gear and oils at operating temperatures!
- ▶ Avoid direct body contact to heated components and fluids!

NOTICE

Dirt in travel gear!

If any dirt gets into the inside of the travel gear, gear damage can occur!

- ▶ Make sure that no dirt gets into the inside of the travel gear!

The following maintenance openings are on the miter gear with brake, see illustration 1:

- 1 Oil filler plug, oil filler port
- 2 Oil level plug, oil level port
- 3 Oil drain plug, oil drain port
- 4 Grease lubrication miter gear

The following maintenance openings are on the planetary gear, see illustration 2:

- 5 Oil level plug, oil level port
- 6 Oil drain plug, oil drain port
- 7 Grease lubrication planetary gear



Note

- ▶ No separate oil filler port is located on the planetary gear, the oil level port is used for this purpose!
- ▶ Oil level ports on planetary gears and miter gears can be constructed differently!
- ▶ The planetary gear and the miter gear have separate, different sized oil chambers! The oil levels in gears must be checked independently of each other!

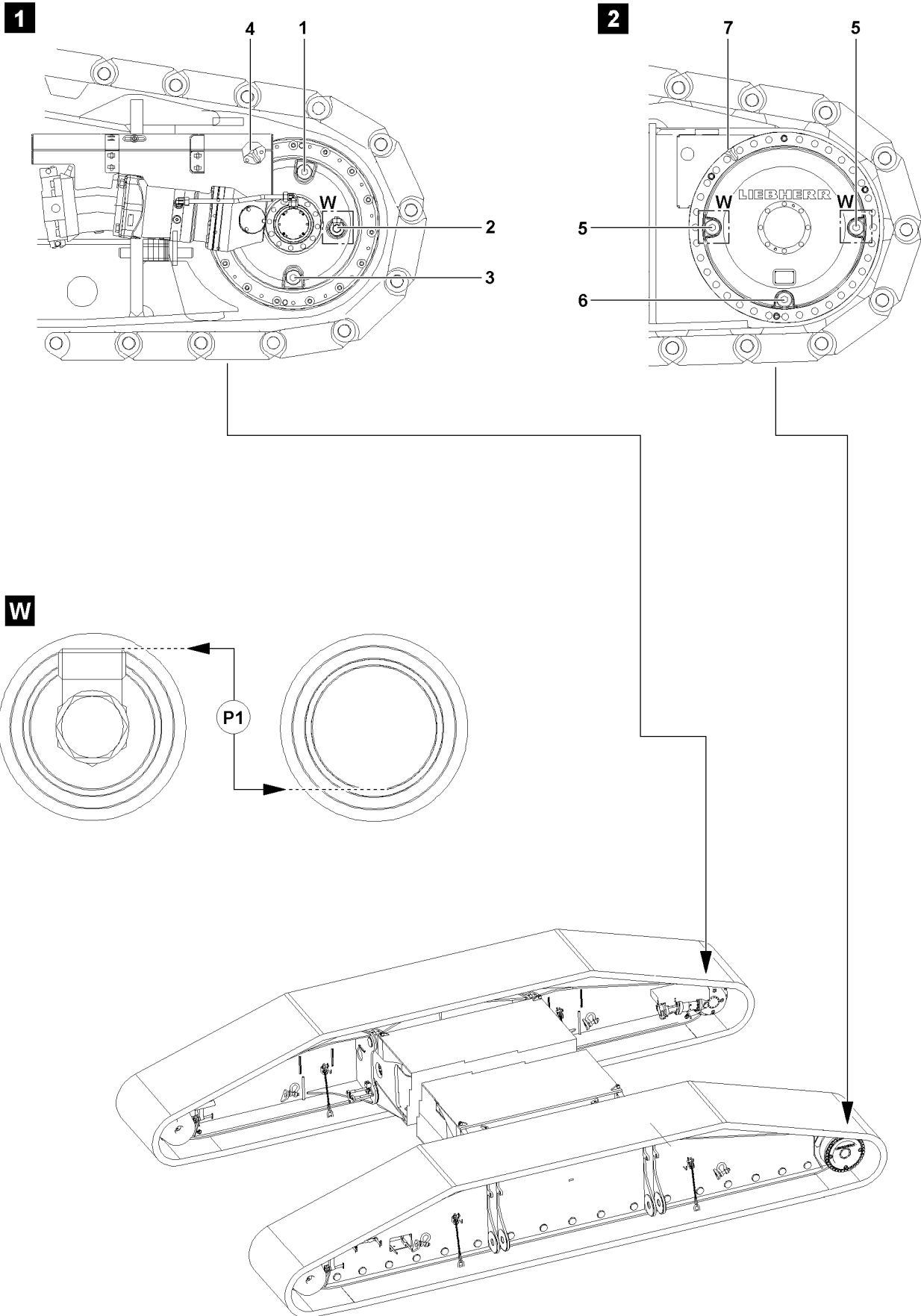

B110043

1.1 Checking for leaks

- ▶ Check visually to ensure that the travel gears do not leak.

1.2 Checking the oil level

NOTICE

Damage to the travel gear!

If seals are used repeatedly, it can result in loss of oil!

Due to loss of oil, the travel gears can wear significantly and / or be damaged!

- ▶ Use the seals on the maintenance ports only once!
-

NOTICE

Varying oil level in planetary gear!

Depending on the position of the gears in the planetary gear, the oil level can vary slightly upward!

When opening the oil level plug, oil can emerge despite correct fill quantity!

- ▶ The fill height must be at least on the height of the point **P1**!
 - ▶ If any oil emerged during the check, replace the same amount!
-

Make sure that the following prerequisites are met:

- The crane is in horizontal position.
- The travel gear is at a standstill.



Note

- ▶ To ensure a reliable oil level check, it must be ensured that the travel gears have been at a standstill for at least two minutes. This ensures that the oil has returned to the oil chamber completely!
-

- ▶ Open the oil level port carefully.
-

NOTICE

Insufficient oil fill quantity!

If the oil level drops below the fill level on point **P1**, the travel gears can be damaged!

- ▶ Add gear oil until the oil level is again on the fill level on point **P1**!
 - ▶ If gear oil must be added:
Add oil on the oil filler port.
 - ▶ If the oil level is on the fill level on point **P1**, then the oil level on the travel gear is OK.
 - ▶ Close the maintenance ports tightly.
-

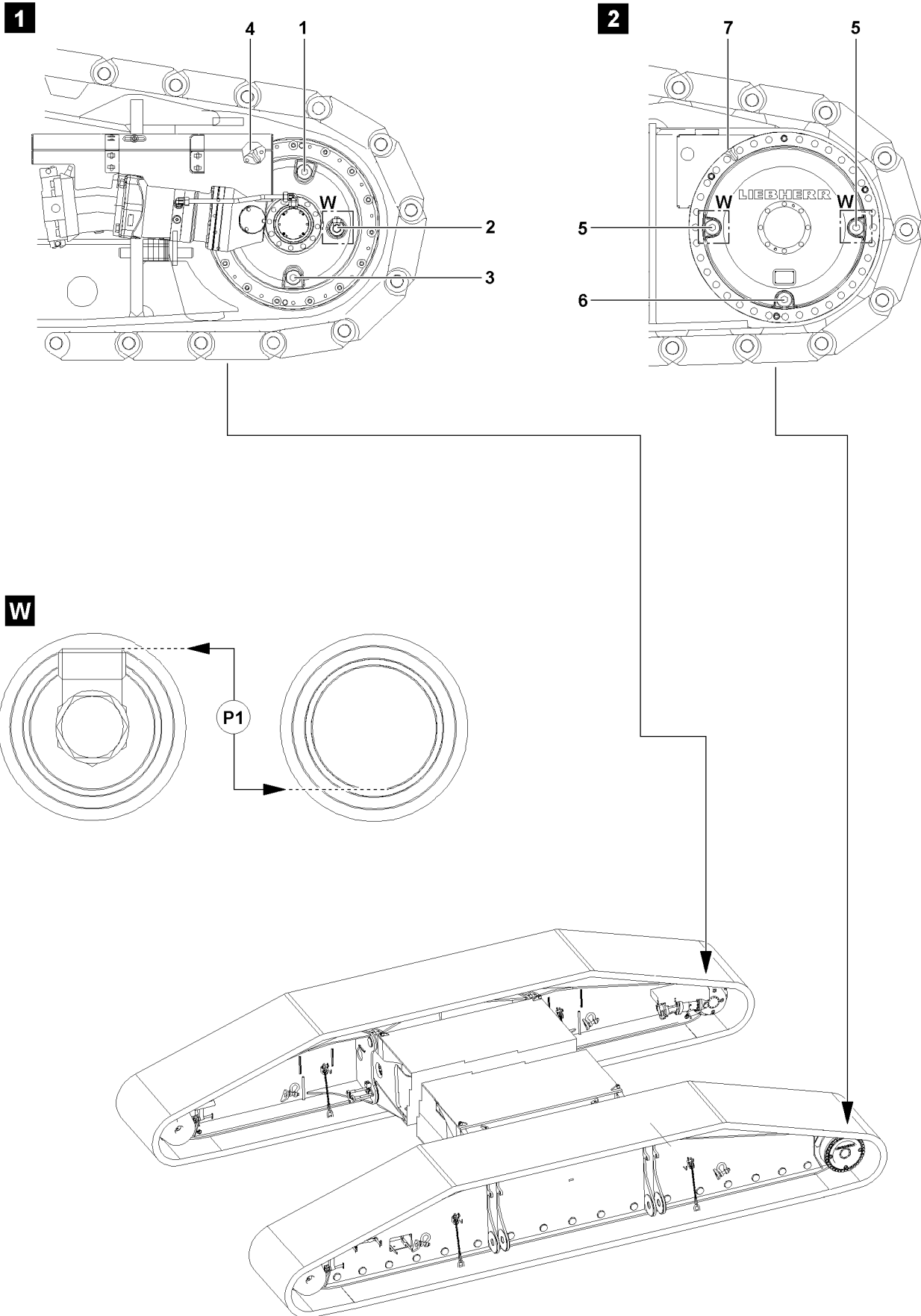

B110043

1.3 Changing the oil

NOTICE

Damage to the travel gear!

If seals are used repeatedly, it can result in loss of oil!

Due to loss of oil, the travel gears can wear significantly and / or be damaged!

- ▶ Use the seals on the maintenance ports only once!
-

1.3.1 Changing oil on the miter gear

Make sure that the following prerequisites are met:

- The crane is in horizontal position.
- The travel gear must be at a standstill.
- The travel gear is at operating temperature.
- A container to catch the used oil is available.



Note

- ▶ When selecting the container to catch the use oil, make sure that the container is sufficiently sized to be able to catch all the used oil!
 - ▶ For fill quantity of miter gear, see Crane operating instructions, chapter 7.06!
-

- ▶ Remove the oil filler plug **1**.
 - ▶ Remove the oil drain plug **3** and drain oil into a suitable container.
-



Note

- ▶ Allow the miter gear to empty completely!
- ▶ Clean the oil drain plug **3** and the sealing surface.
- ▶ Close off the oil drain port **3** tightly.
- ▶ Open the oil level port **2**.
- ▶ Add oil on the oil filler port **1** until it “stands” at the height of the fill level on point **P1** of the oil level port **2** or until it starts to run over.
- ▶ Clean the sealing surfaces.
- ▶ Close off the oil level port **2** tightly.
- ▶ Close off the oil fill port **1** tightly.

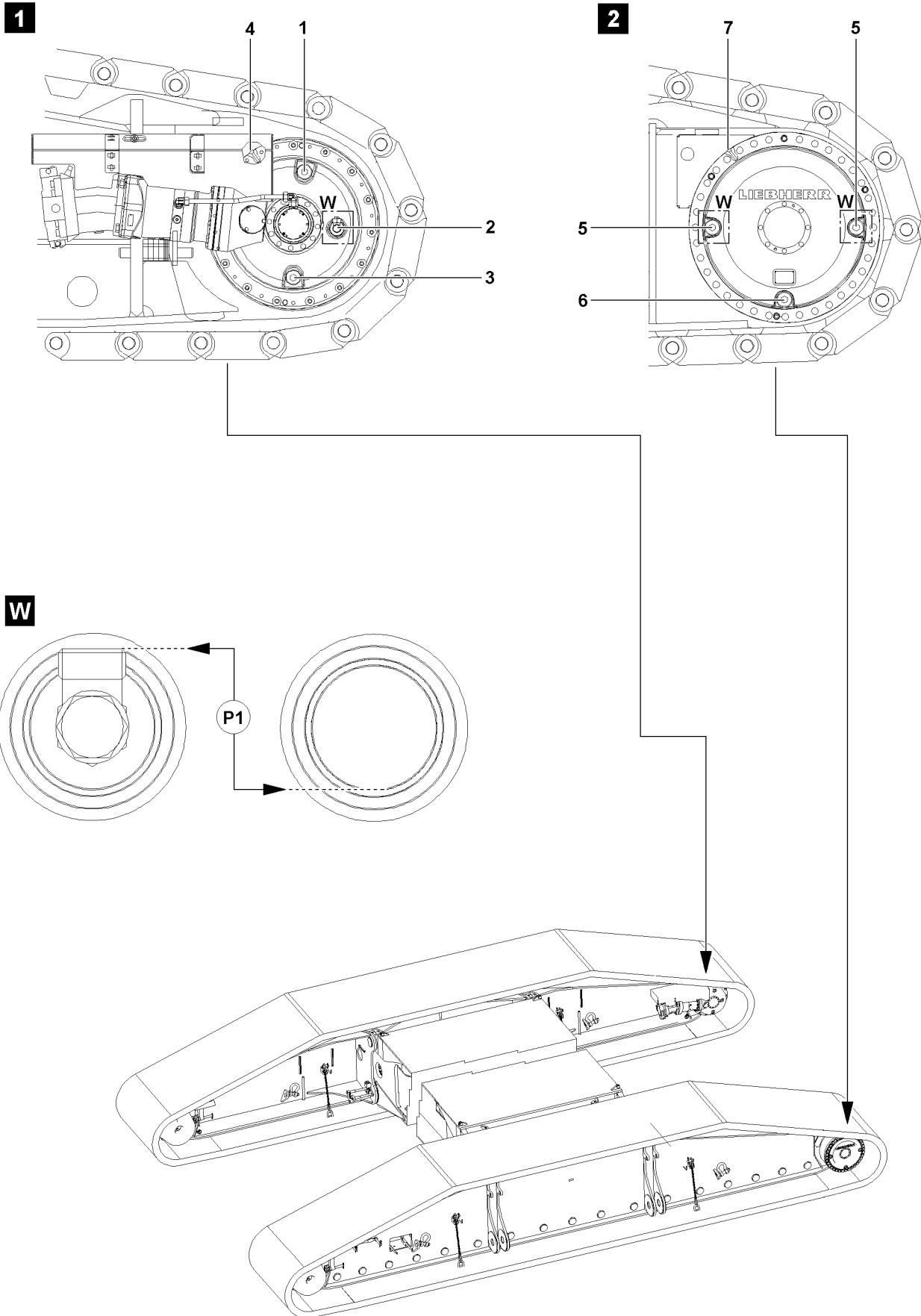

B110043

1.3.2 Changing oil on the planetary gear

Make sure that the following prerequisites are met:

- The crane is in horizontal position.
- The travel gear must be at a standstill.
- The travel gear is at operating temperature.
- A container to catch the used oil is available.

**Note**

- ▶ When selecting the container to catch the use oil, make sure that the container is sufficiently sized to be able to catch all the used oil!
- ▶ For fill quantity of planetary gear, see Crane operating instructions, chapter 7.06!

-
- ▶ Remove the oil level plugs **5**.
 - ▶ Remove the oil drain plug **6** and drain oil into a suitable container.

**Note**

- ▶ Allow the planetary gear to empty completely!
-
- ▶ Clean the oil drain plug **6** and the sealing surface.
 - ▶ Close off the oil drain port **6** tightly.
 - ▶ Add oil on the oil level port **5** until it “stands” at the height of the fill level **P1** of the oil level ports **5** or until it starts to run over.
 - ▶ Clean the sealing surfaces.
 - ▶ Close off the oil level ports **5** tightly.

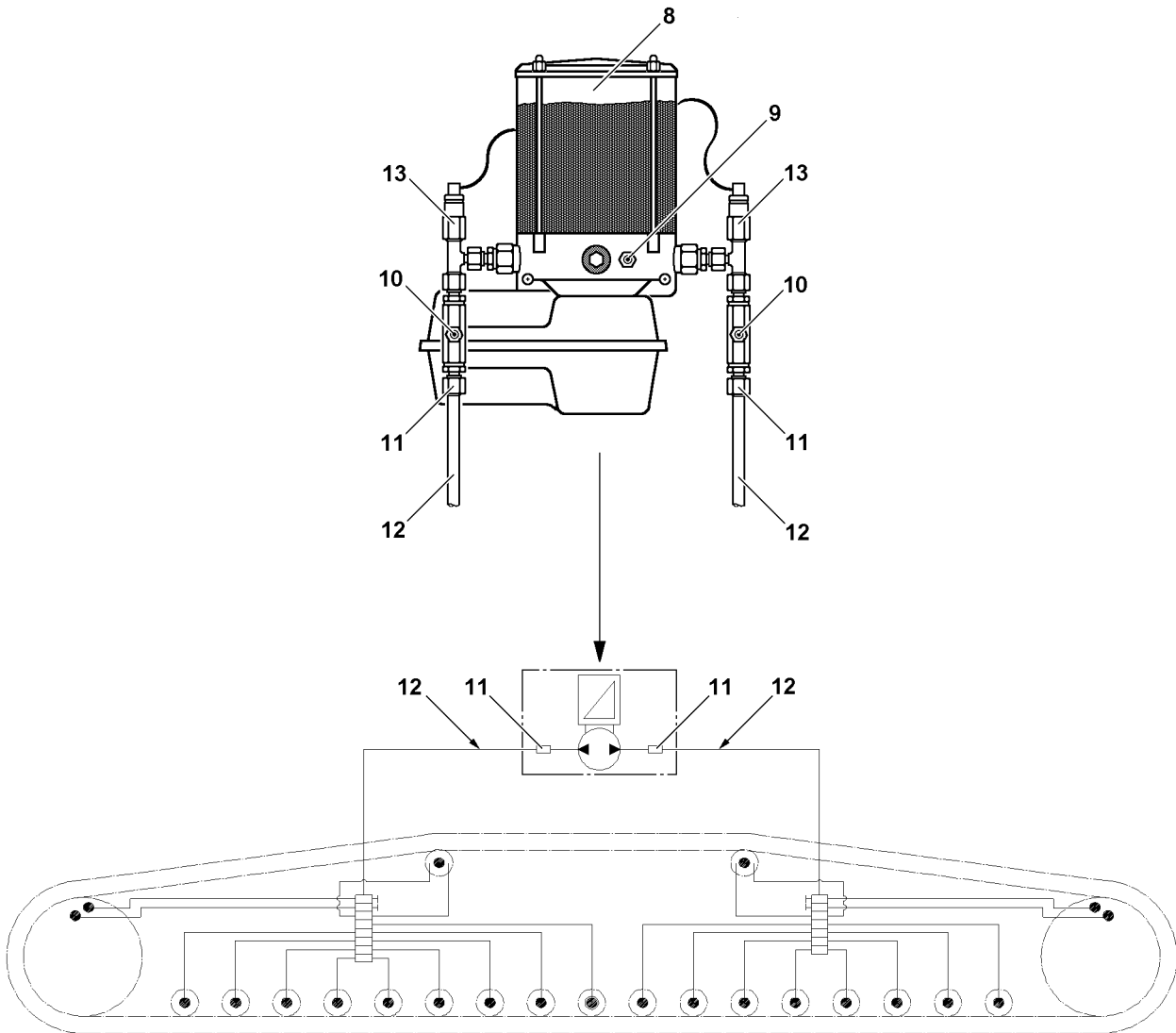

2 Servicing the central lubrication system of the crawler carrier



Note

- ▶ The illustrations in this chapter are examples and may not apply exactly to your crane!
- ▶ Use service items and lubricants according to the chart, see Crane operating instructions, chapter 7.07!
- ▶ Observe the maintenance intervals, see Crane operating instructions, chapter 7.02!

If the crane is driven via the crawler travel gear, then the central lubrication system for the crawler carrier turns on automatically and supplies all grease points with the correct amount of grease.

NOTICE

Insufficient lubrication!

The lubrication film is removed over time due to environmental influences!

Due to insufficient lubrication, the crawler carriers are exposed to significant wear and can be damaged!

- ▶ If the crawler carriers are not moved for a period of more than three months, then it must be lubricated every quarter, possibly with an external grease pump!



Note

- ▶ When putting the crane back into service after an extended downtime, check the central lubrication system for function!
- ▶ When working on the central lubrication system, observe utmost cleanliness!
- ▶ Every crawler carrier has a separate grease pump with several lubrication circuits!
- ▶ Every lubrication circuit has its own main line **12**!

On the grease pump, see illustration, there are the following maintenance relevant components:

- | | |
|---------------------------------|--------------------------------|
| 8 Grease container | |
| 9 Grease fitting | • Filling the grease container |
| 10 Grease fitting | • Filling the lube lines |
| 11 Main line connection | |
| 12 Main line | |
| 13 Pressure relief valve | |

2.1 Filling the grease container

NOTICE

Insufficient lubrication!

In case of insufficient lubrication, the grease lubrication points can run dry!

This could result in high property damage!

- ▶ Fill the grease container **8** before it is completely empty!



Note

- ▶ Do not deplete the grease container **8**!
- ▶ If the grease container **8** is empty, the central lubrication system must be bled!
- ▶ Fill the grease container **8** using an external grease pump via the grease fitting **9**.

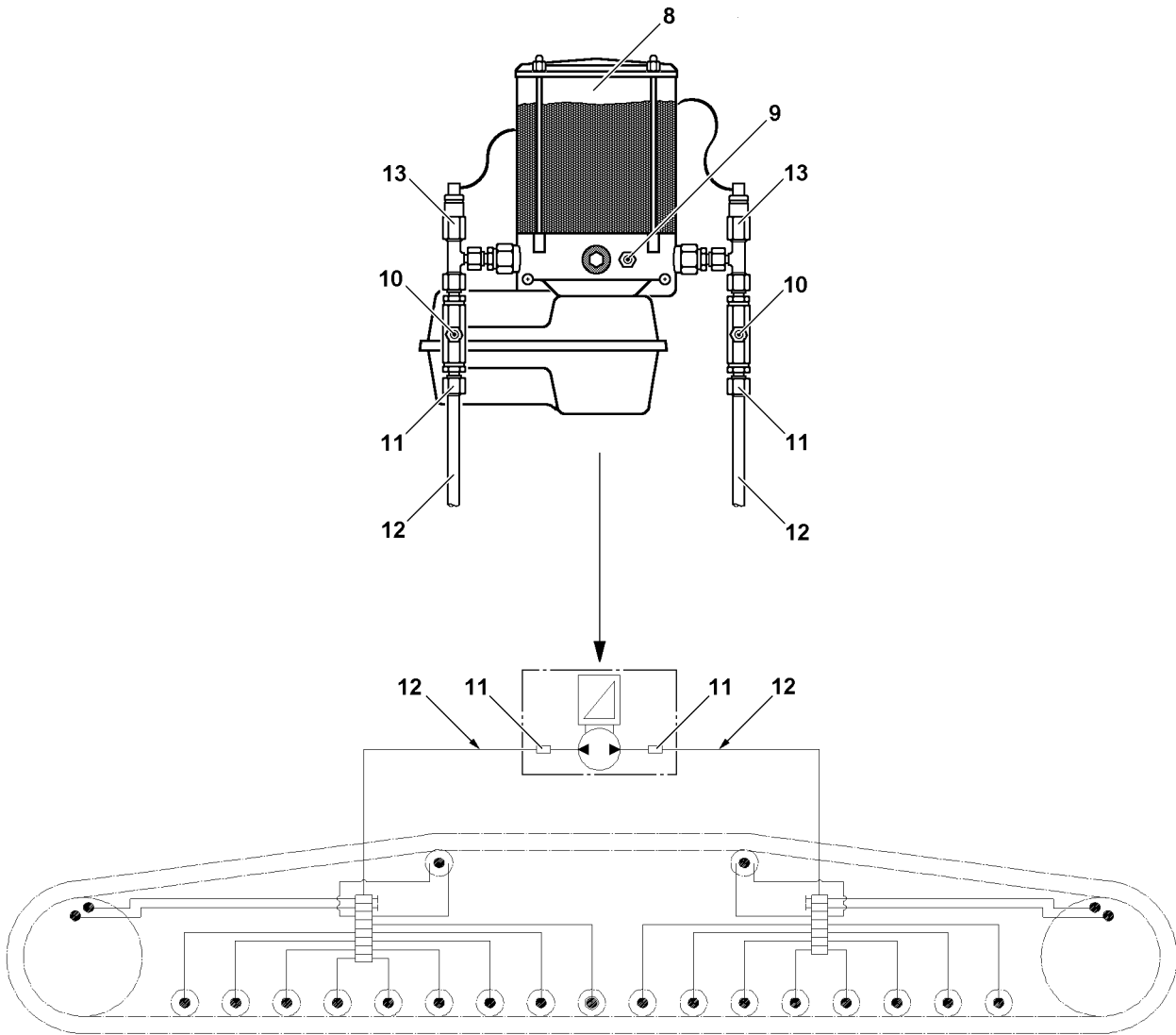

B110102

2.2 Bleeding the central lubrication system

NOTICE

Insufficient lubrication!

If there is air in the grease pump, lubrication points can run dry!

- ▶ Bleed the central lubrication system carefully!

The central lubrication system of the crawler travel gear can be bled two ways:

- By actuation of the grease pump by simulating the crawler operation
- By separate actuation of the grease pump with the aid of the electric wiring plan

2.2.1 Bleeding by simulating crawler operation



WARNING

Crane can start to drive unintentionally!

If the foot rocker in the crane operator's cab or the manual control lever on the radio remote control console* is moved too far while bleeding the grease pump, then the track chain can start to move!

The crane can start to drive and catch personnel!

Personnel can be severely injured or killed!

- ▶ Actuate the foot rocker carefully while bleeding the grease pump!
 - ▶ Watch the emergence of grease from the grease pump for a safe position!
-
- ▶ Fill the grease container **8** using an external grease pump via the grease fitting **9**.
 - ▶ Fill the main lines **12** with an external grease pump via the grease fittings **10** until grease free of air bubbles emerges on all grease points.



Note

- ▶ Carry out the bleeding procedure individually for each main line connection **11**!
 - ▶ Every crawler carrier has a separate grease pump!
-
- ▶ Unscrew the main line **12** from the main line connection **11**.
 - ▶ Start the crane engine.
 - ▶ Select crawler operation.
 - ▶ Actuate the foot rocker / manual control lever of the crawler carrier of the grease pump which is being bled only so far that the track chain does not start to move.
- Result:**
- The grease pump starts to supply.
 - The acoustic signal crawler operation sounds.
- ▶ Actuate the foot rocker / manual control lever only until grease free of air bubbles emerges on the main line connection **11**.
 - ▶ Connect the main line **12** again.
 - ▶ Actuate the foot rocker / manual control lever again until grease emerges again on at least one of the grease points in the bled lubrication circuit.

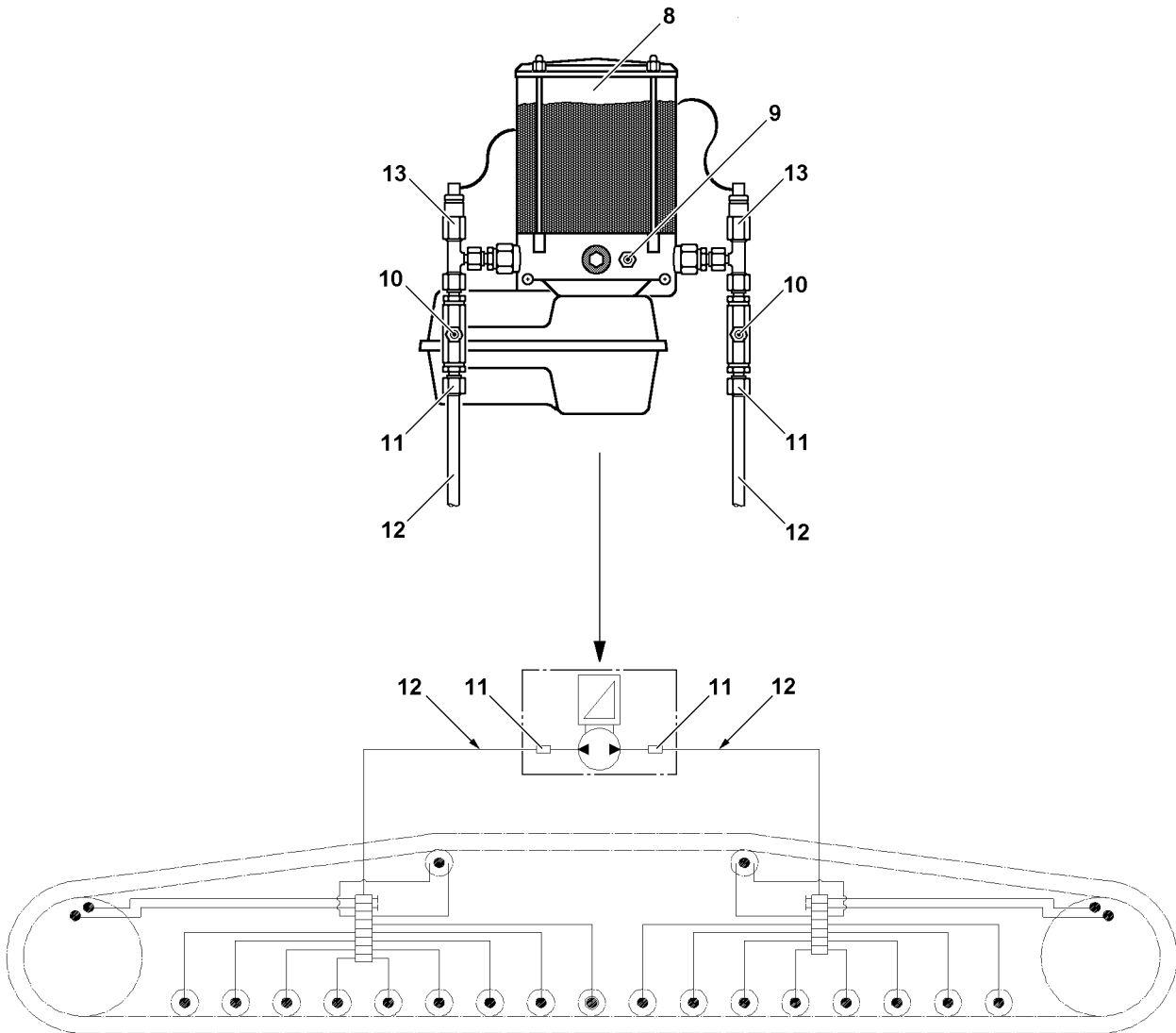

B110102

2.2.2 Bleeding by separate actuation of the grease pump



Note

- ▶ Work on the electrical system of the crane may only be carried out by authorized and trained expert personnel!

Make sure that the following prerequisite is met:

- The separate electric wiring diagram of the crane is available.
- ▶ Fill the grease container **8** using an external grease pump via the grease fitting **9**.
- ▶ Fill the main lines **12** with an external grease pump via the grease fittings **10** until grease free of air bubbles emerges on all grease points.



Note

- ▶ The bleeding procedure must be carried out individually for each main line connection **11**!
- ▶ Every crawler carrier has a separate grease pump!

- ▶ Unscrew the main line **12** from the main line connection **11**.
- ▶ Actuate the grease pump separately, see crane electric wiring plan.

Result:

- The grease pump starts to supply.
- ▶ Actuate the grease pump until grease free of air bubbles emerges on the main line connection **11**.
- ▶ Connect the main line **12** again.
- ▶ Actuate the grease pump again until grease emerges again on at least one of the grease points in the bled lubrication circuit.

2.3 Bleeding repaired lubrication lines

NOTICE

Insufficient lubrication!

If there is air in the lube lines, lubrication points can run dry!

- ▶ If the lubrication lines are repaired or replaced, make sure that they are completely filled with grease!
- ▶ Fill lubrication lines completely with grease before installation.
- ▶ Check repaired lubrication lines for function and leaks.

2.4 Intermediate lubrication of crawler carriers

- ▶ Fill the main line **12** with an external grease pump via the grease fitting **10** until grease free of air bubbles emerges on all grease points.

or

- Actuate the foot rocker / manual control lever in crawler operation until the grease pump starts to supply, but the track chain does not yet start to move. Continue actuation until grease emerges on all lube points.

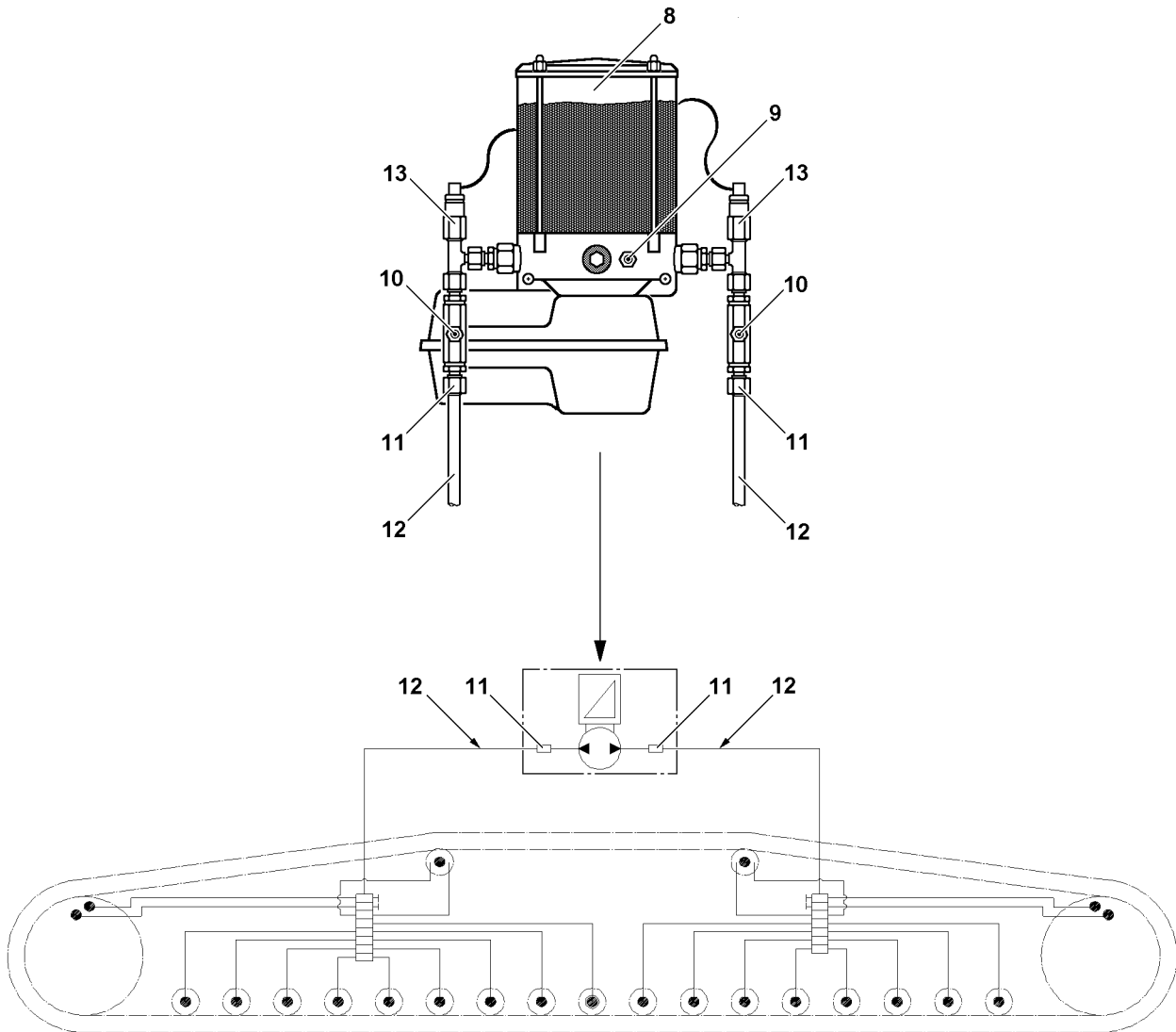

B110102

2.5 Troubleshooting on the central lubrication system

Problem	Cause	Remedy
The grease pump does not work	Electrical line interrupted, grease pump defective	Fix or replace the electrical line, replace the grease pump
Grease pump operates, but does not deliver	Air cushion in delivery piston, minimum fill level fallen below, grease pump element defective	Bleed grease pump, fill reservoir, replace grease pump element
No grease collar on all lube points	Grease pump does not work, system blocked	See "Grease pump does not work" or "Grease emerges via pressure relief valve"
No grease collar on several lube points	Supply lines to secondary distributors broken or leaking, screw connections leaking	Replace lines, tighten or replace screw connections
No grease collar on one lube point	Associated lube line broken or leaking, screw connection leaking	Replace line, tighten or replace screw fitting
Grease pump speed reduced	Higher system pressure, lower ambient temperature	Check system / bearing points, no damage: Lubricate once or twice in between if necessary ¹⁾
Grease escapes at the pressure relief valve	System pressure too high, distributor blocked, system blocked, defective valve spring on pressure relief valve	Check system, replace distributor, repair blocked / seized bearing point, replace pressure relief valve

1) See section "Intermediate lubrication of crawler carriers".

If a problem cannot be remedied, contact the Service Dept. at Liebherr-Werk Ehingen.

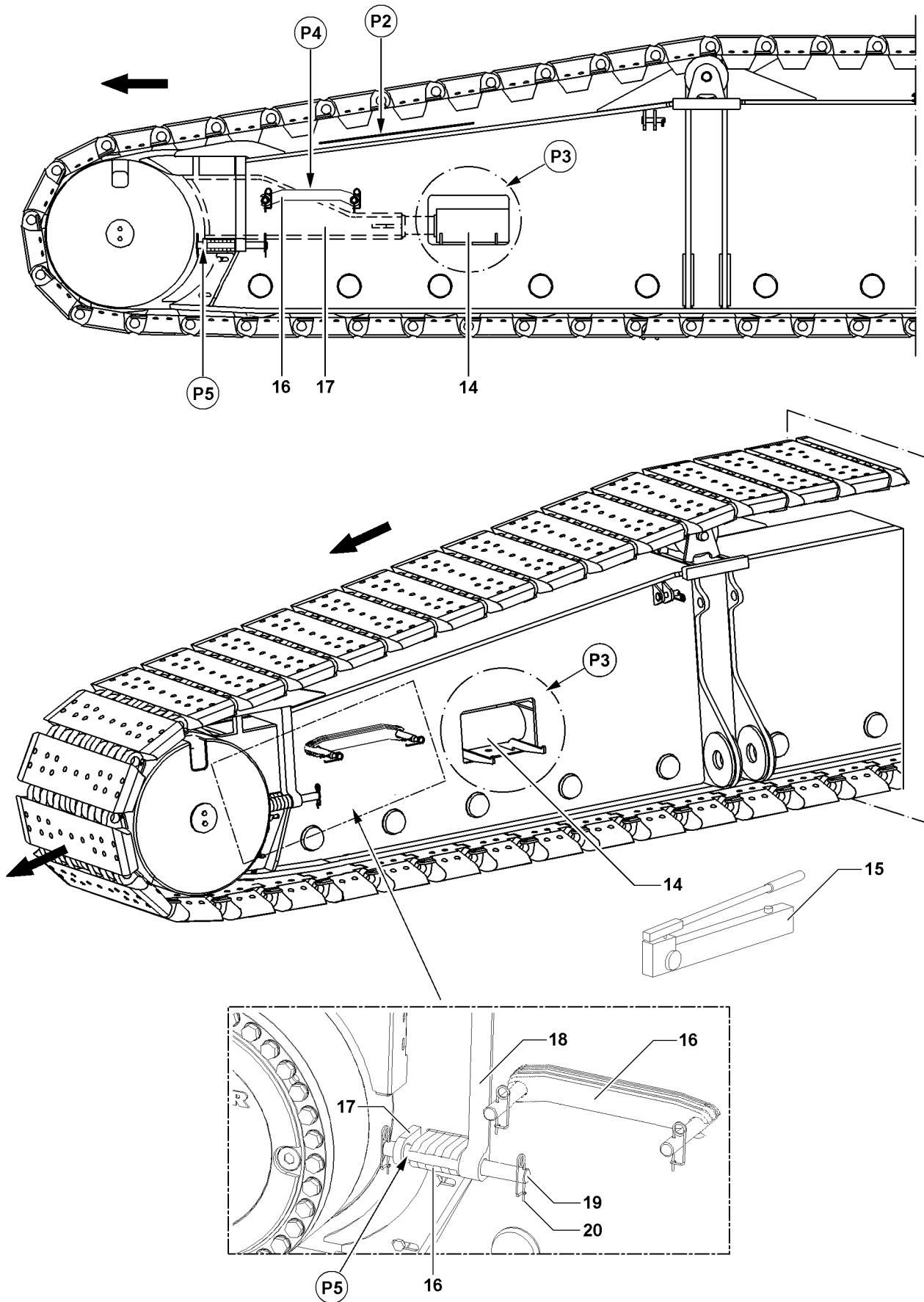

B108951

3 Servicing the track chain



Note

- ▶ The illustrations in this chapter are examples and may not apply exactly to your crane!

In crawler operation, the components of the track chain wear and must therefore be checked in specified intervals, see Crane operating instructions, chapter 7.02 and replaced with new components, if necessary.

3.1 Tensioning the track chain

NOTICE

Damage to the track chain!

If the chain tension is not checked within the specified maintenance intervals, the track chain or the steel structure of the crawler carrier can be damaged!

- ▶ Observe the maintenance intervals, see Crane operating instructions, chapter 7.02!
- ▶ If the track chain of the steel structure of the crawler carrier gets close to point **P2** or if it has already made contact with the steel structure, then the track chain must be retensioned **immediately!**



Note

- ▶ By extending the tension cylinder **14**, the sliding section **17** of the crawler carrier is moved in direction of the arrow!
- ▶ The chain tension is held by spacer plates **16!**

NOTICE

Foreign particles in track chains!

Foreign particles in the track chains and on the travel drive can cause damage!

- ▶ Before tensioning the track chains, check the track chains and the travel drives for foreign particles, such as rocks and clean them, if necessary!

Make sure that the following prerequisites are met:

- The crane is in horizontal position.
- The tension cylinder **14** is placed into the cylinder receptacle on point **P3**, see illustration.
- ▶ Extend the tension cylinder **14** with the hand pump **15** until the hand pump lever can no longer be moved.

Result:

- The track chain is tensioned.
- ▶ Remove the spacer plates **16** from the transport receptacle on point **P4**.
- ▶ On point **P5**, insert as many spacer plates **16** as fit into the gap between the sliding section **17** and the crawler carrier **18!**
- ▶ Secure the spacer plates **16** with pin **19** and spring retainer **20**.

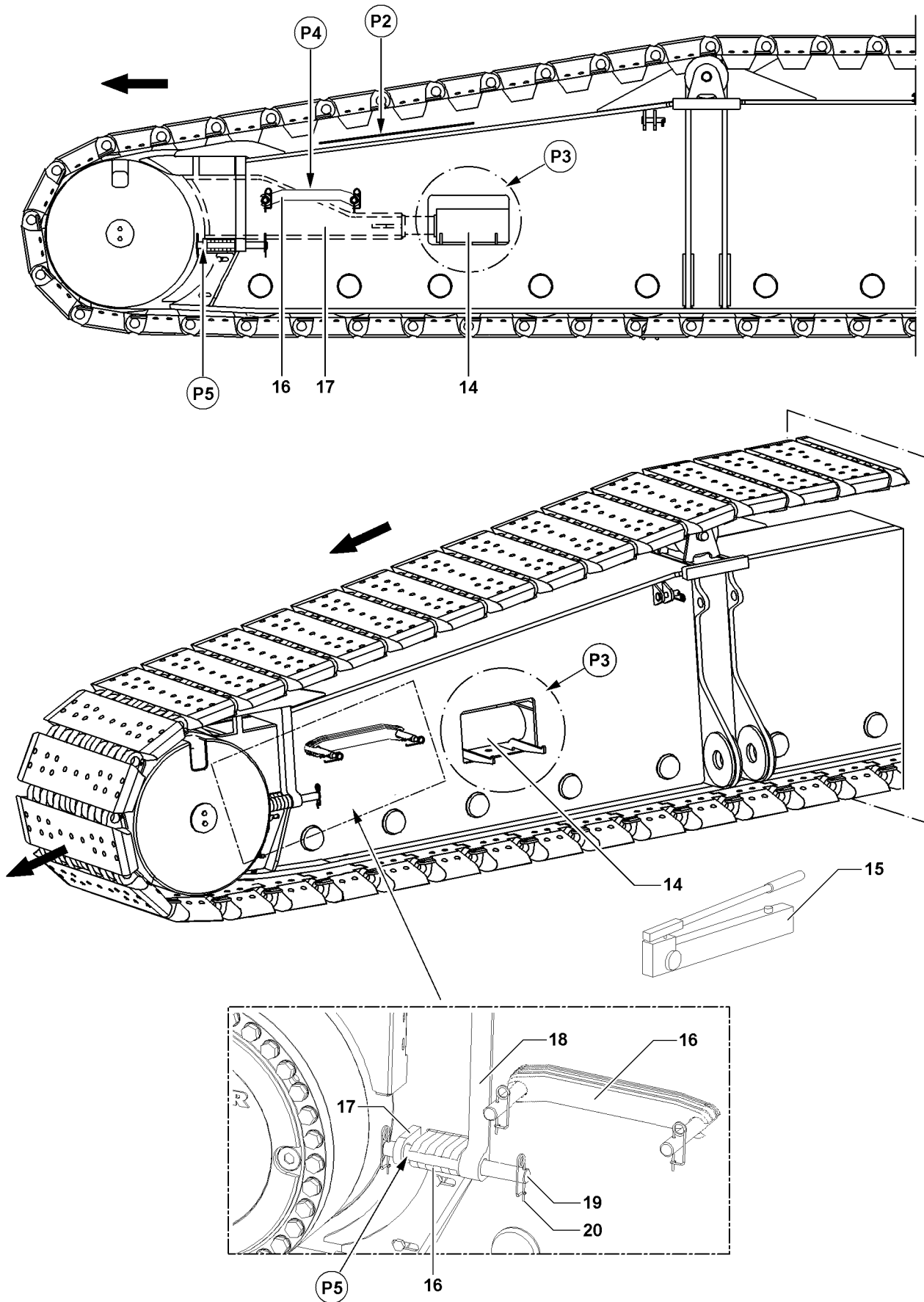

B108951

**WARNING**

Danger of crushing!

When releasing the tension cylinder **14**, body parts, such as: fingers, hands and arms can be crushed or severed!

▶ When relieving the tension cylinder **14**, nearly all work on the crawler carrier is prohibited!

▶ Relieve the tension cylinder **14** again.

▶ After the tension procedure, drive the crawler back and forth about one crawler length in operating mode "Straight forward travel".

Result:

– The tension of the track chain is reduced.

▶ Check the distance of the track chain to the steel construction of the crawler carrier again at point **P2**.

**Note**

▶ If necessary, repeat the tension procedure of the track chain and insert additional spacer plates **16**!

▶ If the lift on the tension cylinder **14** is no longer sufficient to tension the track chain, then trained expert personnel must remove one track pad!

▶ Take the relieved tension cylinder **14** from the cylinder receptacle on the crawler carrier **P3**.

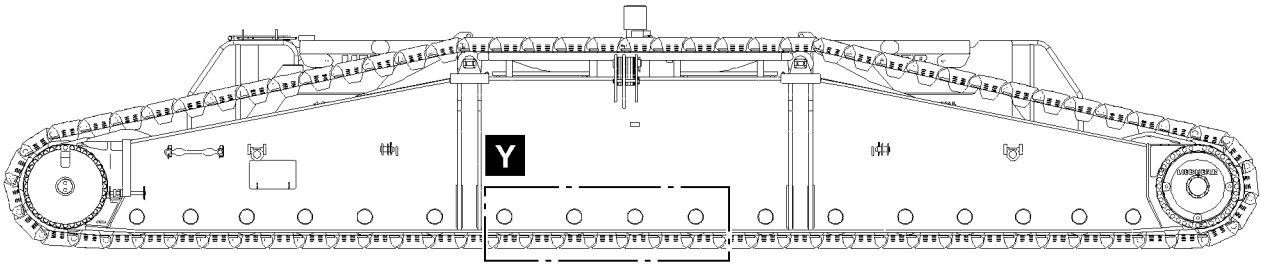

Y1

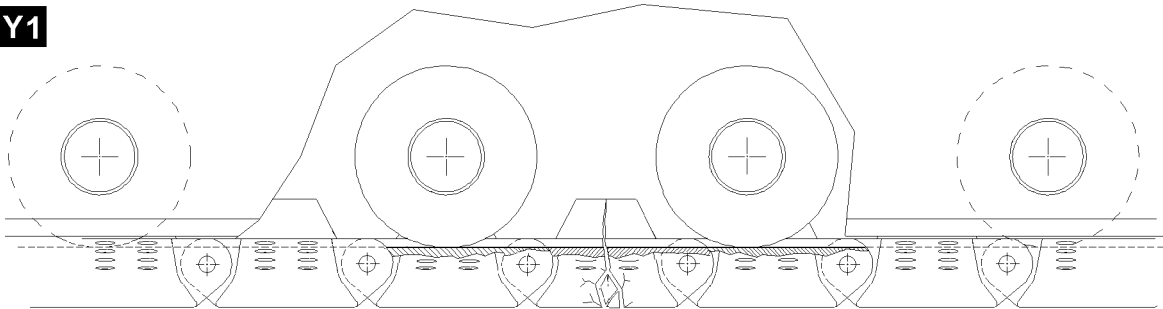

Y2

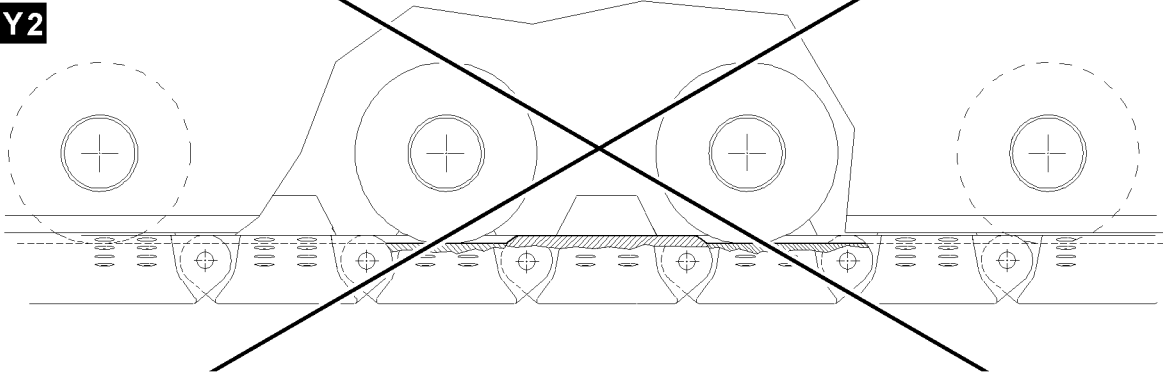

Y3

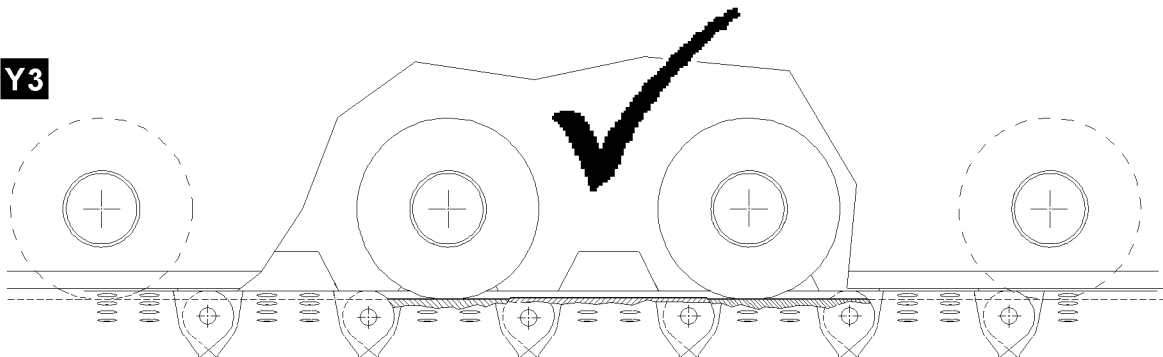

B109917

3.2 Checking wear on the track chain



WARNING

Track chain can be ripped off!

If the wear limit on the track pads **21**, bolts **22** or track rollers **23** is exceeded, then the track chain can break off during crawler operation!

The crane can topple over and personnel can be severely injured or killed!

- ▶ Random checks of the track pads **21**, bolts **22** and track rollers **23** must be carried out within the specified intervals!
- ▶ During the random inspection of the track rollers, the first and last track roller on the crawler carrier must be included in the inspection!
- ▶ If a wear limit on the component is reached, then the component must be replaced or remachined!

NOTICE

Significant wear of crawler travel gear!

If an individual track pad **21** must be replaced then it may not be replaced with a track pad **21** which shows a much lower degree of wear!

Significant height differences between the individual track pads **21**, see illustration **Y2**, lead to an increased mechanical stress on the track pads **21** and the track rollers **23** of the crawler carrier!

- ▶ Replace a defective track pad **21** with a track pad **21** which shows a similar degree of wear, see illustration **Y3**!



Note

- ▶ Due to the break-in period of the components toward each other, a larger stretch of the track chains occurs on a new crawler travel gear. For that reason, it may be necessary to remove a track pad **21** earlier to be able to tension the track chain correctly!

The wear of the track pad **21**, bolts **22** and track rollers **23** depends a various factors:

- Length of travel route
- Frequency of driving in curves
- Friction ratios track pad **21** - ground
- Evenness of the ground
- Type of ground
- Load bearing capacity of the ground / base
- Position of the total center of gravity
- Load on the hook
- Placed ballast on the crane

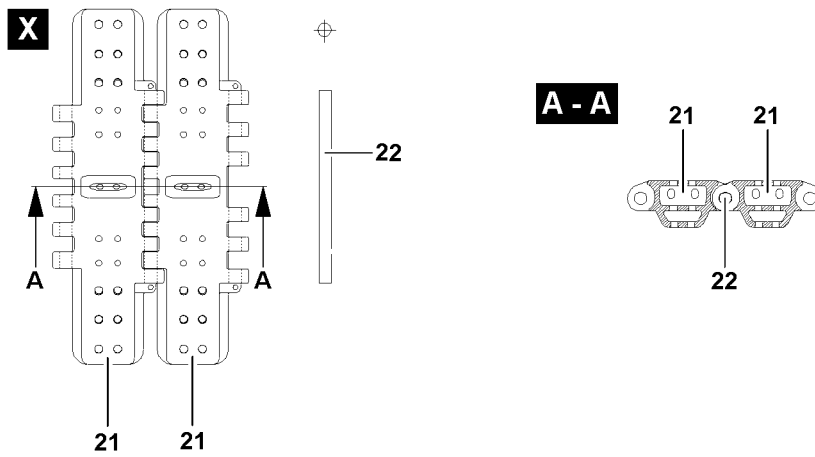
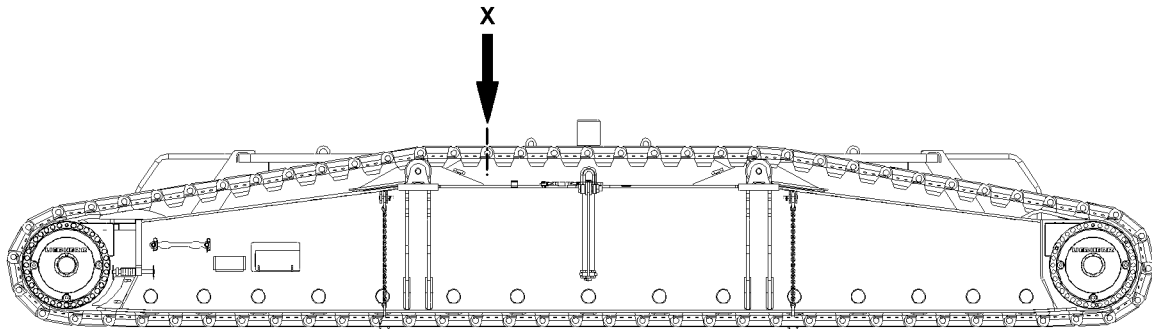

B108536

3.2.1 Checking the wear on the connections of the track pads

NOTICE

Damage to the sprocket!

If the wear limit on the connections to the track pads is achieved, it can lead to increased wear on the sprocket and on the transporting lugs of the track pads due to excessive chain stretch!

Expensive and extensive repairs can result!

- ▶ The random inspection of the bolt diameter must be made within the specified intervals!
- ▶ If one bolt **22** falls below the minimum permissible dimension, then it must be replaced with a new bolt **22**!
- ▶ The random inspection of the bore diameter must be made within the specified intervals!
- ▶ If the bore diameter exceeds the maximum permissible dimension, then the track pad **21** must be replaced!

The track pads **21** of the crawler track are connected by bolts **22**.

Wear limit bore for the track pad	
Initial diameter	48 mm
Maximum permissible upper limit	51 mm

Wear limit bolt	
Initial diameter	45 mm
Maximum permissible minimum dimension	44 mm

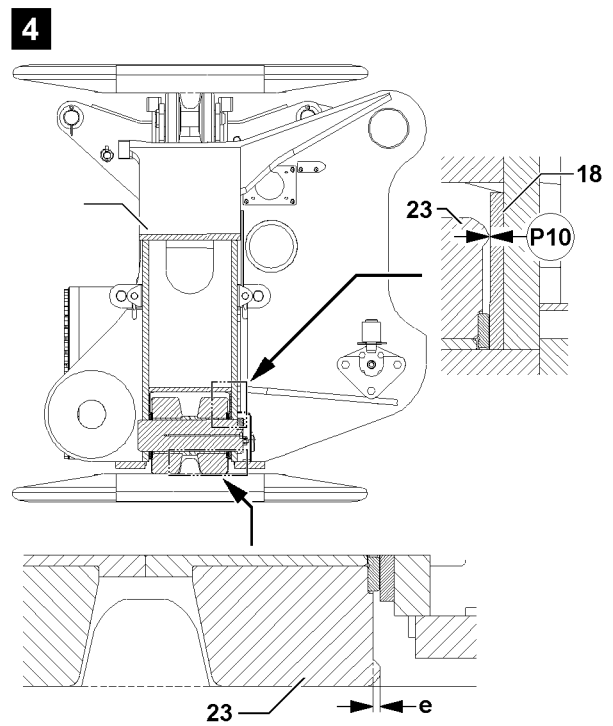
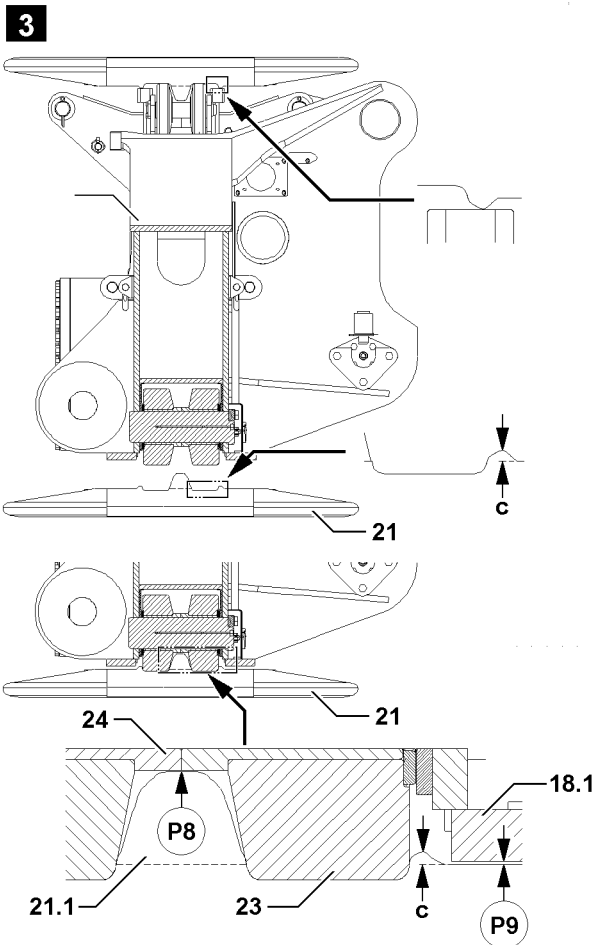
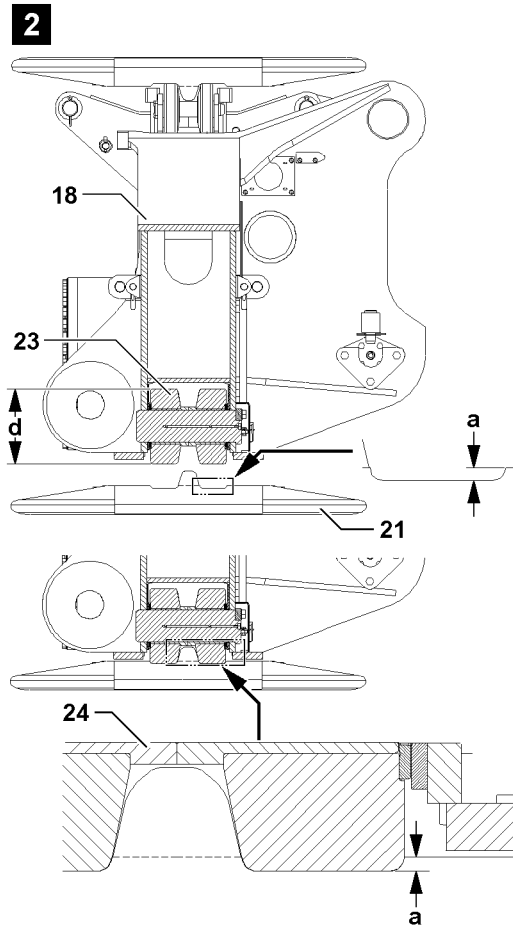
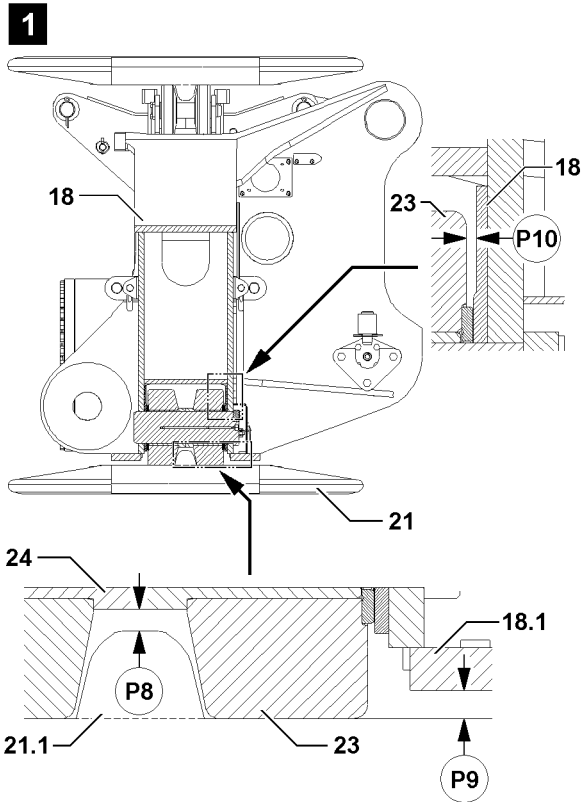

B109882

3.2.2 Checking the wear on the roll off surfaces of the track pads / track rollers

NOTICE

Destruction of track pad!

If a track pad **21** is not fixed or replaced after reaching the wear limit, then the track pad **21** will be destroyed and can cause damage to the crawler carrier **18**!

This could result in high property damage!

- ▶ Fix or replace the track pad **21** after reaching the wear limit!
-

NOTICE

Failure of track rollers!

If the track rollers **23** are not replaced after reaching the wear limit, then they can fail and cause damage to the crawler carrier **18** and track pad **21**!

This could result in high property damage!

- ▶ Replace track rollers **23** after reaching the wear limit!
-

NOTICE

Increased wear!

If the bulges on the track pads **21** and the track rollers **23** become too large, see illustration **3** and illustration **4**, then it results in increased wear on the crawler travel gear!

This could result in high property damage!

- ▶ Grind off / remove bulges in time!
-

If the wear limits are not adhered to, the minimum distances are fallen below:

- On point **P8** between the transporting lugs **21.1** and track roller body **24**
- On point **P9** between the track pad **21** and base belt **18.1**
- On point **P10** between the track rollers **23** and crawler carrier **18**

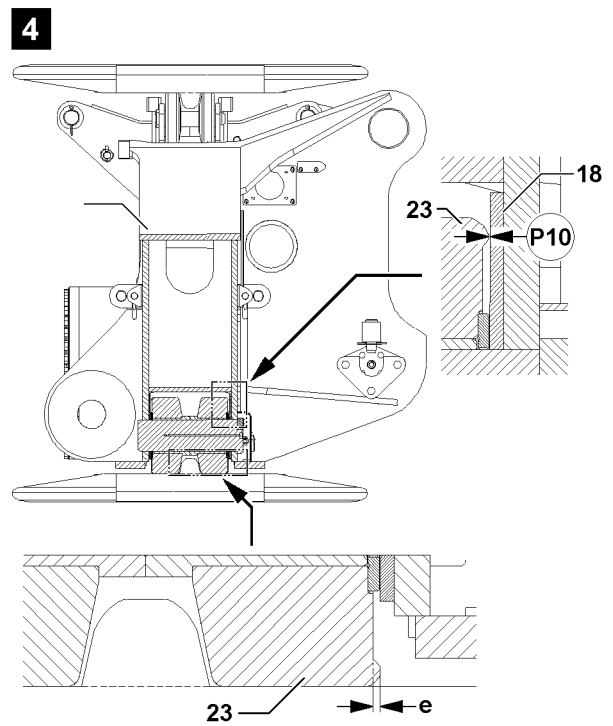
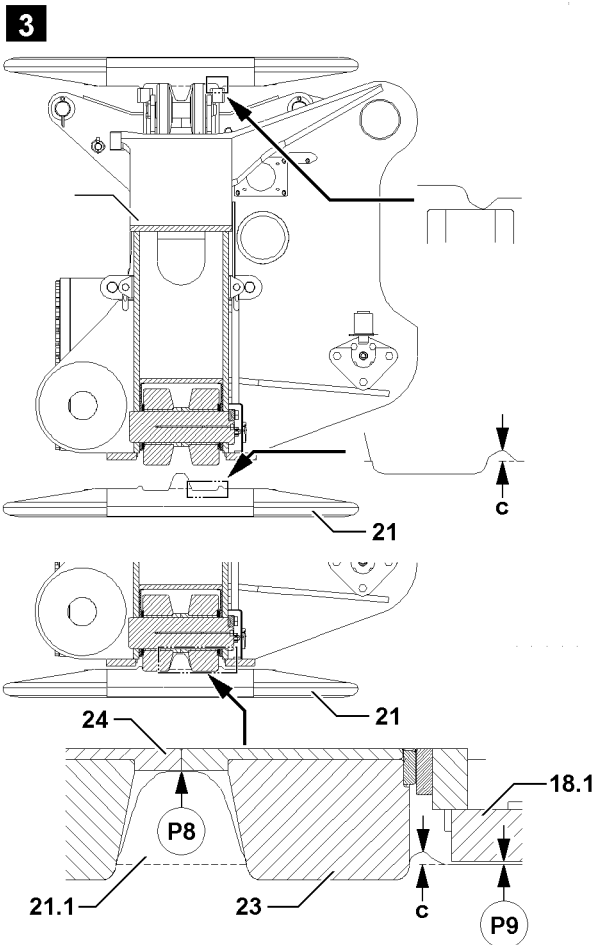
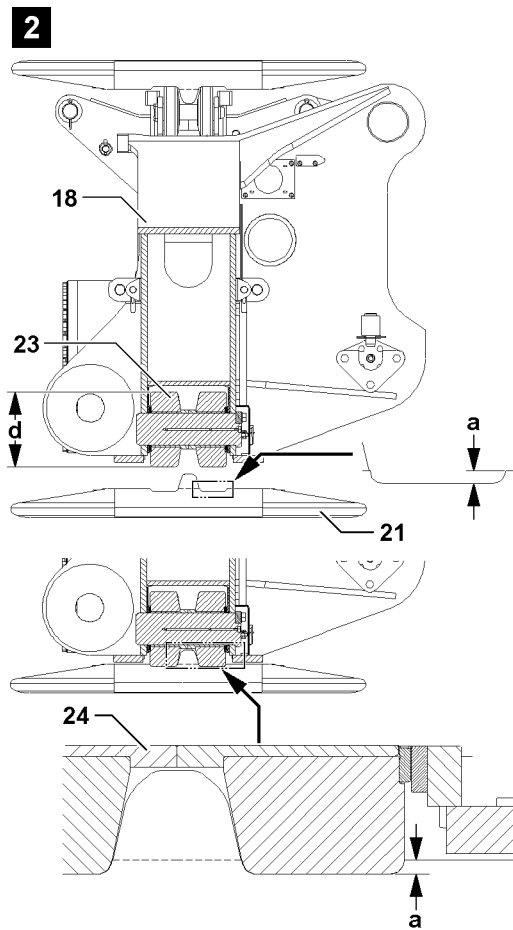
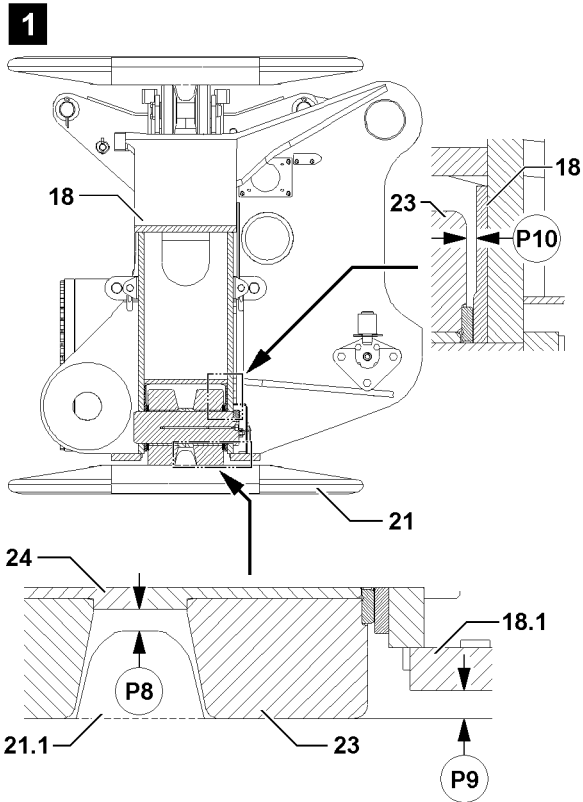

B109882

Wear limit track pad	
Maximum permissible run in depth a	10 mm
Maximum permissible bulge c	1)

Wear limit track roller	
Initial diameter	320 mm
Permissible minimum diameter d (measured in the center of the running surface)	316 mm
Maximum permissible bulge e	3 mm ²⁾

1) As soon as the bulge scrapes on the base belt of the crawler carrier, **grind bulge off!**

2) Valid for all travel gear systems: If bulge is more than 3 mm, **grind the bulge off!**



WARNING

Danger of injury due to improper procedure!

- ▶ All work on the track chains must be carried out by trained expert personnel!



Note

- ▶ Track pads, which have reached the maximum run in depth or whose running surface is heavily worn can be repaired by repair welds according to welding guideline or repair instructions of **LIEBHERR-Werk Ehingen GmbH!**
 - ▶ Damage on sprocket and track pads - caused by operational wear - can be repaired by repair welds according to welding guidelines or repair instructions of **LIEBHERR-Werk Ehingen GmbH!**
 - ▶ Please contact the Service Dept. at **LIEBHERR-Werk Ehingen GmbH!**
-
- ▶ Replace worn track rollers **23**.
 - ▶ Grind off excessive bulges, see illustration **3** and illustration **4**.

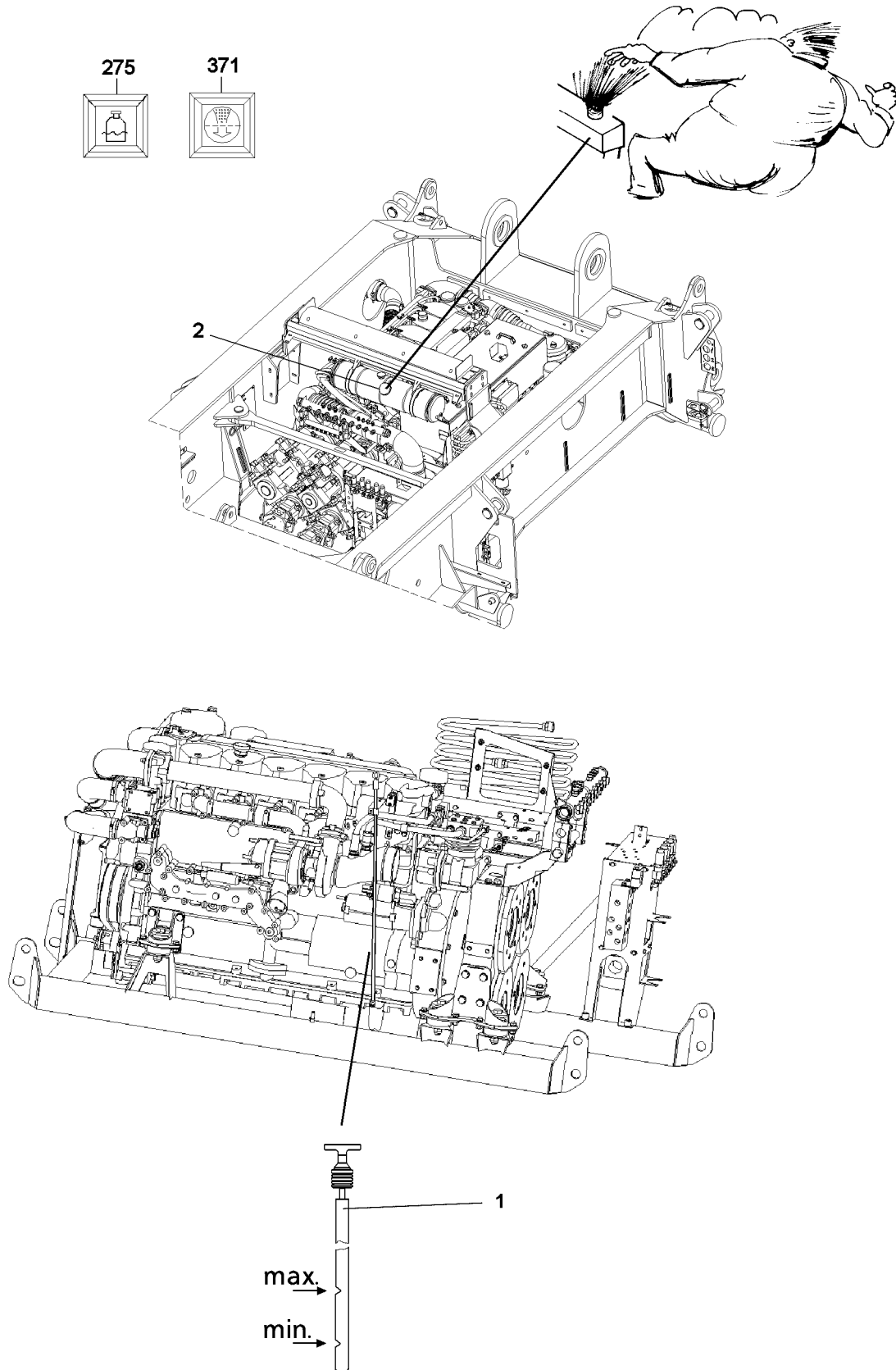

B105290

1 Diesel engine

Never step on fuel lines during maintenance or repair work in the engine area!



DANGER

Risk of fire!

- ▶ Make sure that the engine area is kept free of diesel fuel!
- ▶ Extreme cleanliness is vital, particularly during filter changes and bleeding. Wipe up any spilled fuel!
- ▶ When replacing the filter, it is recommended to put down cleaning rags before removing the filter in order to absorb fuel!

1.1 Engine oil

1.1.1 Checking the oil level

Make sure that the following prerequisites are met:

- The crane is in horizontal position.
- The engine is turned off and the oil has collected in the oil pan.
- ▶ Remove the dipstick **1** and wipe it off.
- ▶ Reinsert the dipstick **1** and pull it out again.

The oil level must be between the min. and max. marks on the dipstick **1**.

- ▶ Check the oil level.



CAUTION

Risk of damaging the engine!

If the oil level has dropped below the minimum mark, add engine oil according to the lubrication chart until the oil level is between the minimum and maximum marks!

- ▶ Add engine oil and check again!
- ▶ Reinsert the dipstick **1**.

1.1.2 Changing the oil

Refer to separate operating instructions for “Liebherr Diesel engines”.

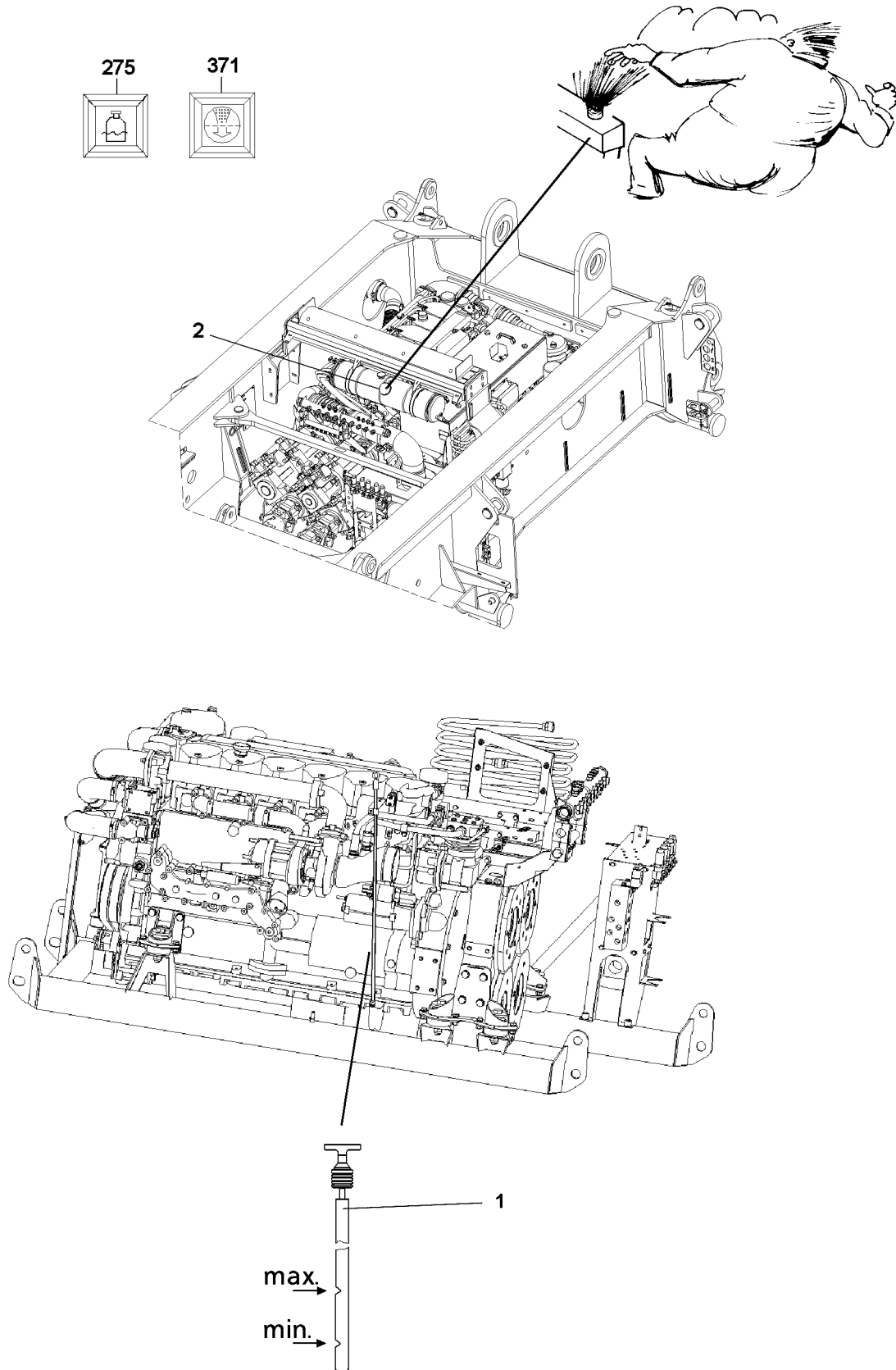

B105290

1.2 Coolant Engine cooling

The coolant level is monitored electrically. If the coolant level is too low the "Coolant level too low" **275** icon appears on the right instrument panel.



DANGER

Risk of skin burns!

▶ Check the coolant only when the engine is cold!

- ▶ Turn the cap **2** on the filler neck of the water cooler expansion tank to the 1st notch.
- ▶ Release excess pressure.
- ▶ Remove the cap **2**.
- ▶ Check the coolant level.

Add coolant as specified in the lubrication chart only on the filler neck of the water cooler expansion tank.

- ▶ Add coolant to overflow level if necessary.
- ▶ Close the cover **2** tightly.

1.3 Air filter

The air filter is monitored electrically. If the vacuum increases in the intake line due to dirty filter units, the "Air filter contaminated" **371** icon lights up on the instrument panel.

- ▶ If the "Air filter contaminated" **371** icon appears:
Clean or replace filter unit.

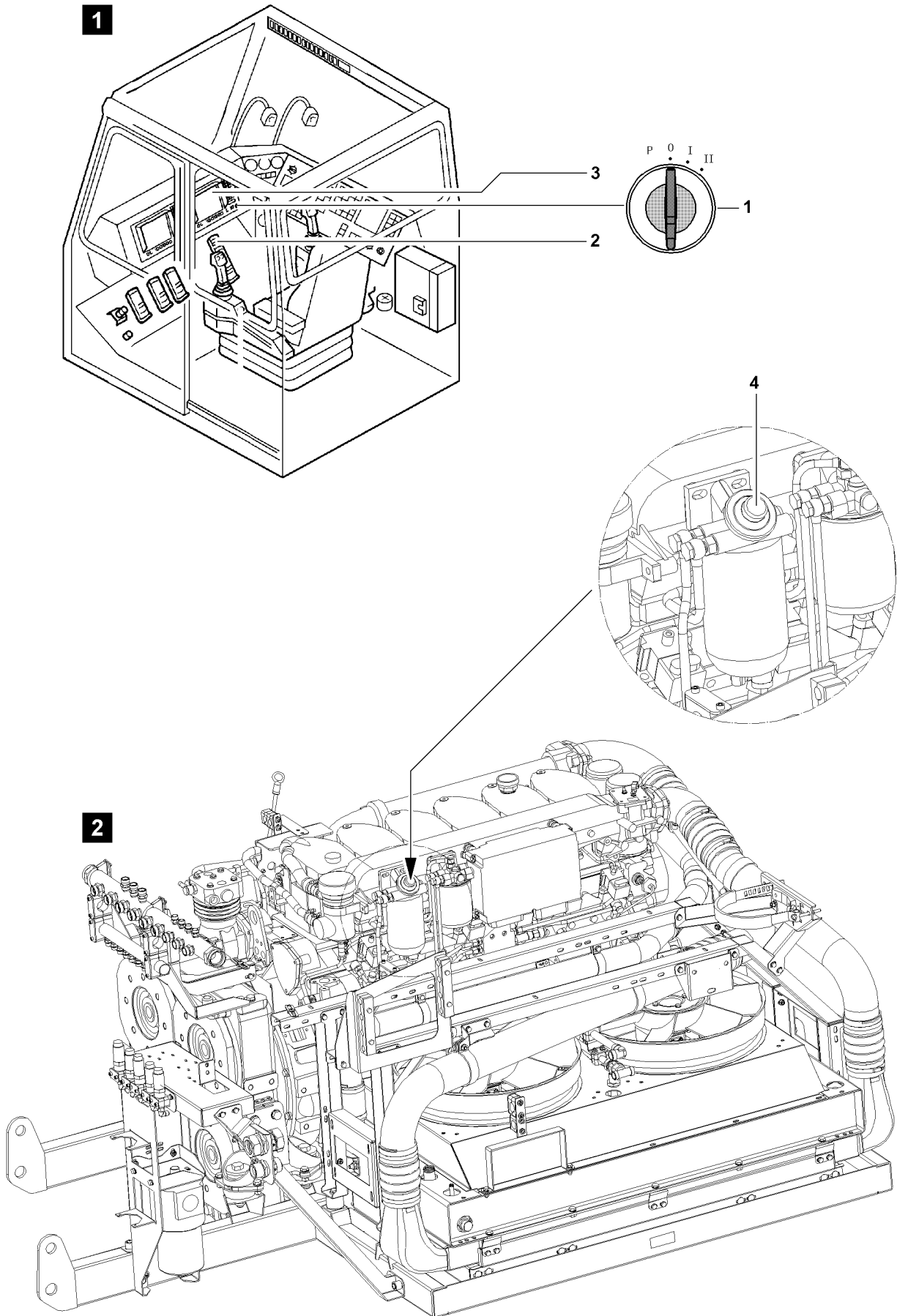

B105897

1.4 Bleeding the injection lines



Note

- ▶ Two persons are required to bleed the injection lines!

Make sure that the following prerequisites are met:

- The engine is turned off.
- The ignition switch in the crane operator's cab is in the "0 position" (OFF).
- The diesel engine is easily accessible.



DANGER

Risk of falling!

During the bleeding process of the injection lines, the assembly personnel must be protected from falling with suitable aids, depending on the turntable position!

If this is not observed, assembly personnel could fall and suffer life-threatening injuries!

- ▶ All assembly work from a height of 2 m must normally be carried out using suitable aids (scaffolding, ladders, etc.)! The height above which assembly / maintenance work must be carried out with aids depends on national regulations. The national regulations must be adhered to!

1.4.1 Activating the bleeding function

The bleeding function is activated from the crane operator's cab.

A higher injection rate is required to bleed the injection lines on the engine. It is therefore necessary to operate the manual feed pump **4** on the engine during the bleeding process.

- ▶ Turn the ignition on in the crane operator's cab: Turn the ignition switch **1** to "Position I".
- ▶ When the ignition is turned on:
Floor the engine regulation **2** within 10 s.
- ▶ Repeat this step within the next 10 s: Release the engine regulation **2** and floor it again.
- ▶ To activate the bleeding function: Repeat this procedure five times.

Result:

- The bleeding function is now activated.
- The LICCON monitor **3** displays an operating error message with the text: "Bleeding function activated".

Troubleshooting

If the LICCON monitor **3** does not display an operating error message with the text: "Bleeding function activated"?

The bleeding function has not been correctly carried out or the specified time has been exceeded.

- ▶ Turn the ignition off: Turn the ignition switch **1** to "Position 0".
- ▶ Repeat the procedure according to the description.

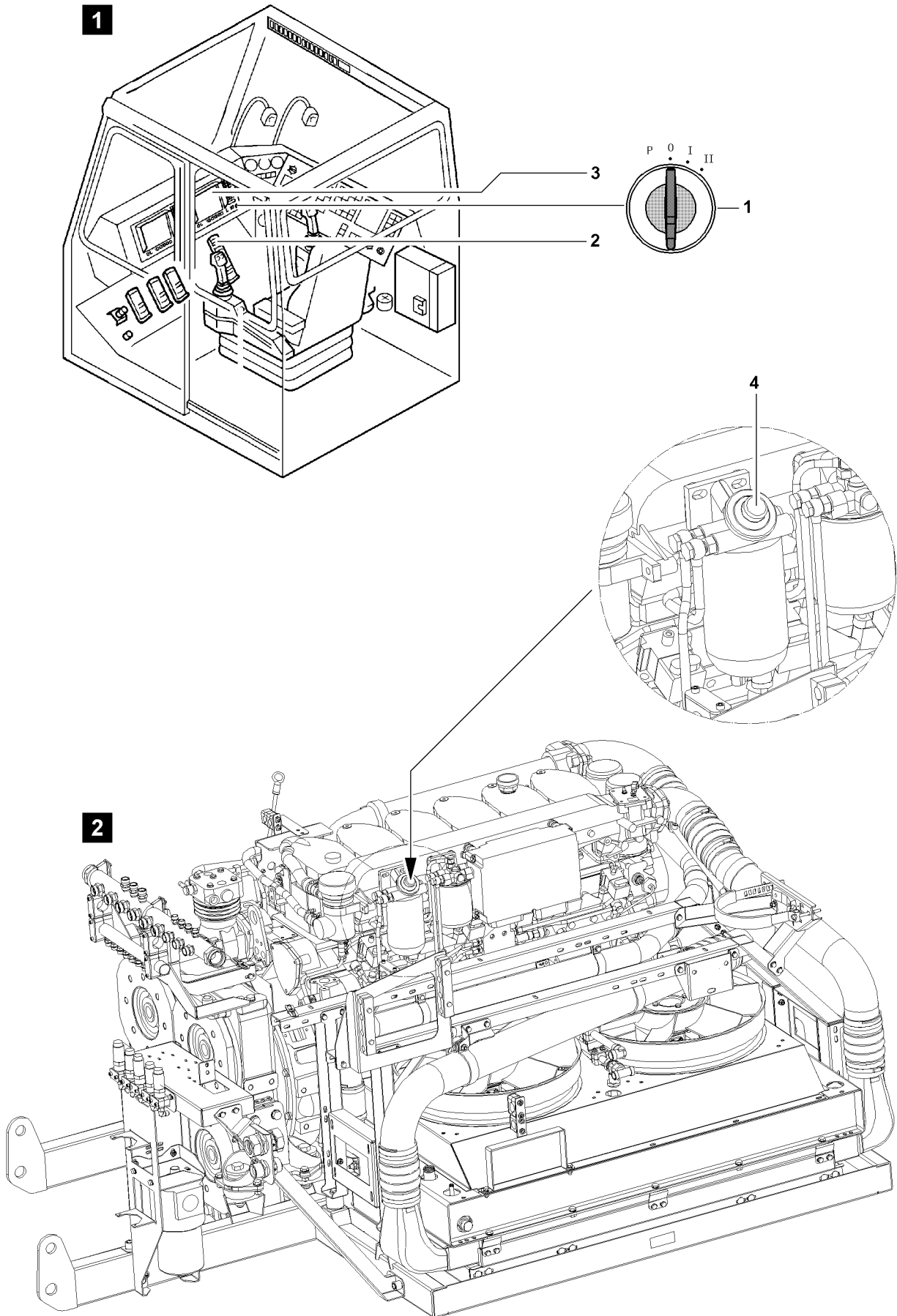

B105897

1.4.2 Carrying out the bleeding procedure



Note

- ▶ Do **not** operate the engine regulation during the bleeding procedure!

Make sure that the following prerequisites are met:

- The bleeding function is activated.
- The operating error message is displayed on the LICCON monitor.

Pump the manual feed pump **4** to operate it during the entire engine start procedure (approx. 20 s).

- ▶ Turn the ignition switch **1** in the crane operator's cab to "Position II" and hold it for approx. 20 s in "Position II".
- ▶ When the ignition switch **1** is actuated:
Immediately pump the manual feed pump **4** for approx. 20 s and at least as long as the ignition switch is being turned.

Result:

- The injection lines are bled.
- The engine starts up and runs at low idle speed after a successful bleeding procedure.
- The bleeding function will be deactivated.
- The system switches over to normal operation.

Troubleshooting

The injection lines are not bled and the engine does not run at low idle speed?

The ignition switch **1** was not operated long enough or the manual feed pump **4** was used incorrectly.

- ▶ Hold the ignition switch **1** for 20 s in "Position II".
- ▶ Continuously pump the manual feed pump **4**.



Note

- ▶ The starter block is deactivated if the bleeding function has been activated!
- ▶ Several starting attempts can be made without turning the "Ignition OFF"!

1.4.3 Deactivating the bleeding function



Note

- ▶ The bleeding function is automatically deactivated after successfully bleeding the injection lines or when the ignition is turned off!

Once the injection lines have been successfully bled, the engine is regulated by the engine electronic to low idle speed after a short period and the bleeding function is automatically deactivated.

- ▶ Turn the ignition off: Turn the ignition switch to "Position 0".

Result:

- The engine is turned off.
- The bleeding function is deactivated.

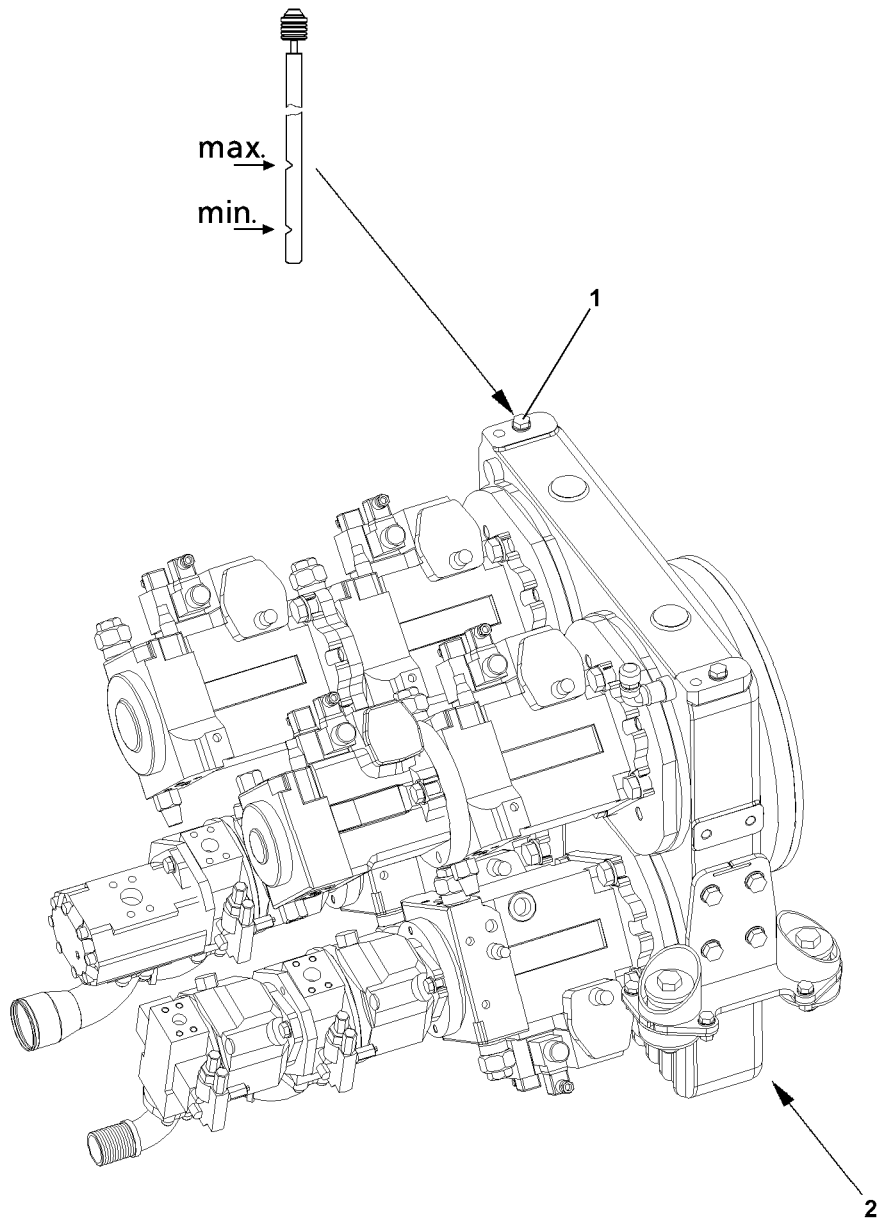

B105291

2 Pump distributor gear

Maintain utmost cleanliness during all work to prevent any dirt from entering the inside of the gear.

2.1 Checking the oil level

**Note**

▶ Make sure that the crane is in horizontal position!

- ▶ Remove the dipstick **1** and wipe it off.
- ▶ Reinsert the dipstick **1** and pull it out again.

The oil level must be between the min. and max. marks on the dipstick **1**.

- ▶ Check the oil level.

**CAUTION**

Danger of gear damage!

If the oil level has dropped below the minimum mark, add engine oil as specified in the lubrication chart until the oil level is between the minimum and maximum marks!

- ▶ Add oil and check again!

- ▶ Reinsert the dipstick **1**.

2.2 Changing the oil

Make sure that the following prerequisites are met:

- The crane is in horizontal position.
- The gear has warmed up.
- ▶ Remove the dipstick **1**.
- ▶ Remove the oil drain plug **2** and drain the oil.
- ▶ Install the oil drain plug **2** with new seal and tighten.
- ▶ Add oil as specified in the lubrication chart on the dipstick **1** until the oil level is between the min. and max. mark on the dipstick **1**.
- ▶ Install the dipstick **1** with new seal.
- ▶ Check the oil level.

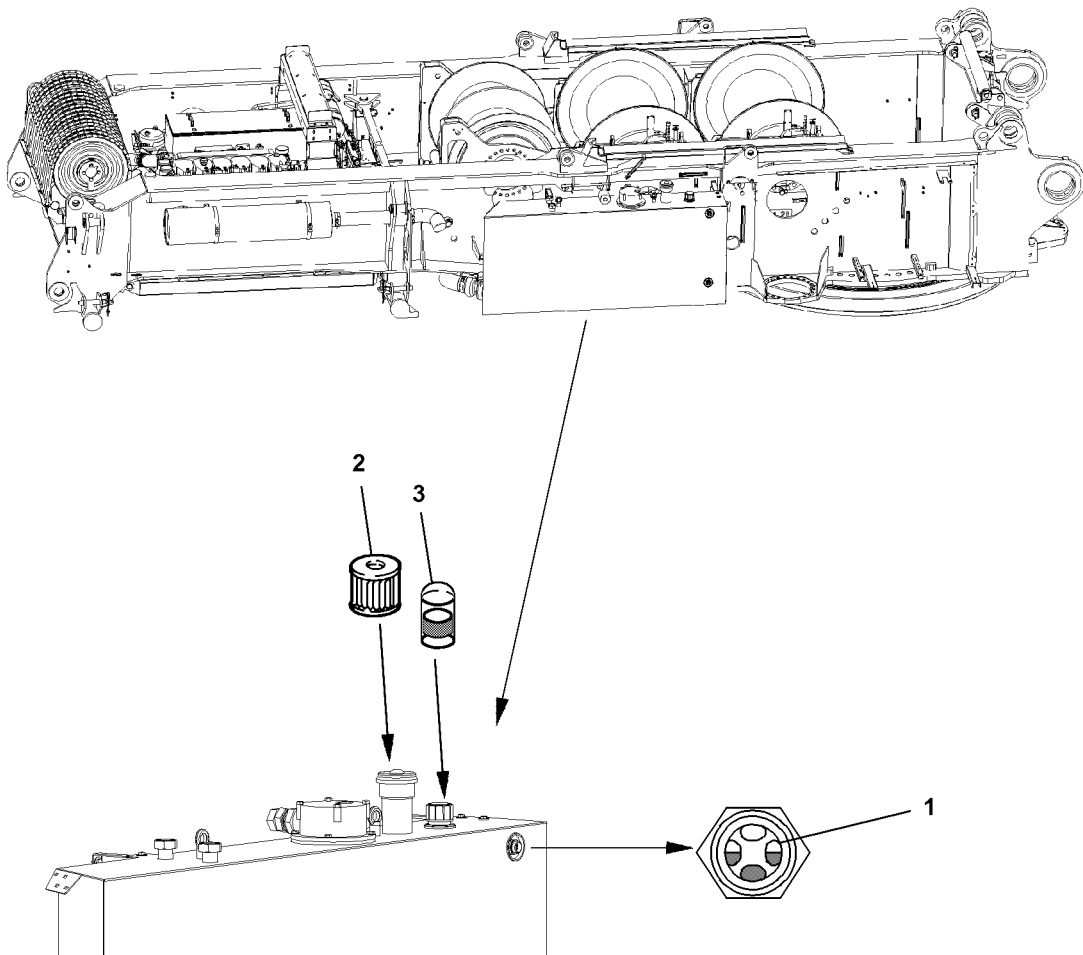

B105292

3 Hydraulic system



CAUTION

Damage to the hydraulic system!

If the hydraulic system is contaminated when working on the hydraulic system, then the hydraulic system can be damaged and fail!

- ▶ Always keep up most cleanliness when working on the hydraulic system!
- ▶ This applies especially for filter changes, refilling of hydraulic oil or changing of components!

3.1 Hydraulic tank

3.1.1 Checking the oil level

Make sure that the following prerequisites are met:

- The crane is in horizontal position.
- All hydraulic cylinders are fully retracted.

The oil level must be in the center of the oil level sight gauge **1**.

- ▶ Check the oil level on the oil level sight gauge **1** of hydraulic oil tank.

Troubleshooting

No oil is visible in the oil level sight gauge **1**?

- ▶ Add oil as specified in the lubrication chart using a fine-mesh strainer until oil level is in center of the oil level sight gauge **1**.

3.1.2 Checking the breather / vent filter

- ▶ Open the cover with turn lock.
- ▶ Check the filters **2** for impurities (visual inspection).
- ▶ In the event of heavy contamination:
Replace the filters **2**.
- ▶ Close the cover with the turn lock again.
- ▶ Start the engine.
- ▶ Slowly run through all crane movements.
- ▶ Check the oil level again and add oil if necessary.

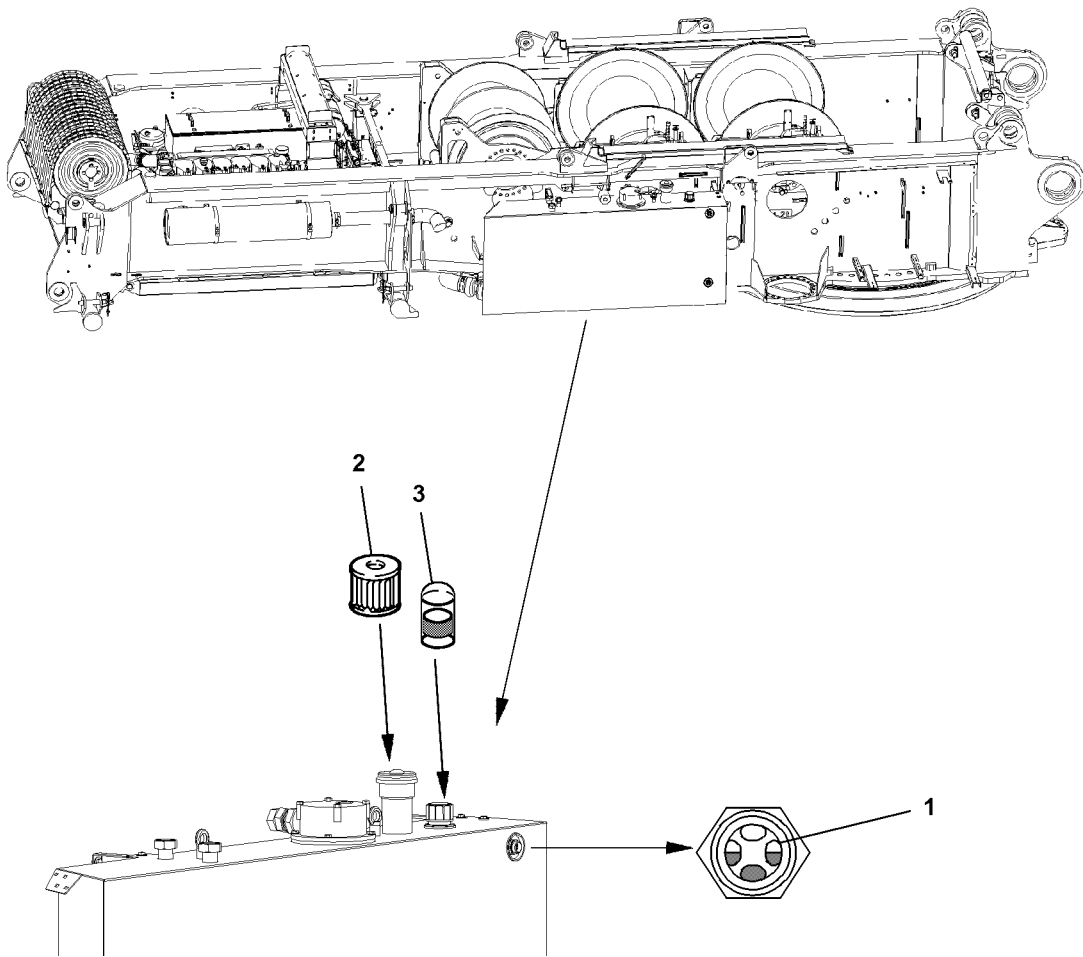

B105292

3.1.3 Return filter

The return filters **3** are equipped with a maintenance indicator. If the red mark is visible when the oil is at operating temperature, then the filter insert must be replaced.

- ▶ Unscrew and remove both filter covers.
- ▶ Remove the filter units.
- ▶ Rinse out the filter housing.
- ▶ Clean the sealing surfaces on the covers and filter housings.
- ▶ Insert new filter units.
- ▶ Lubricate the rubber seal rings in the covers with oil.
- ▶ Replace both filter covers and screw tight.
- ▶ Start the engine and check the filter for leaks.
- ▶ Check the oil level and add oil if necessary.

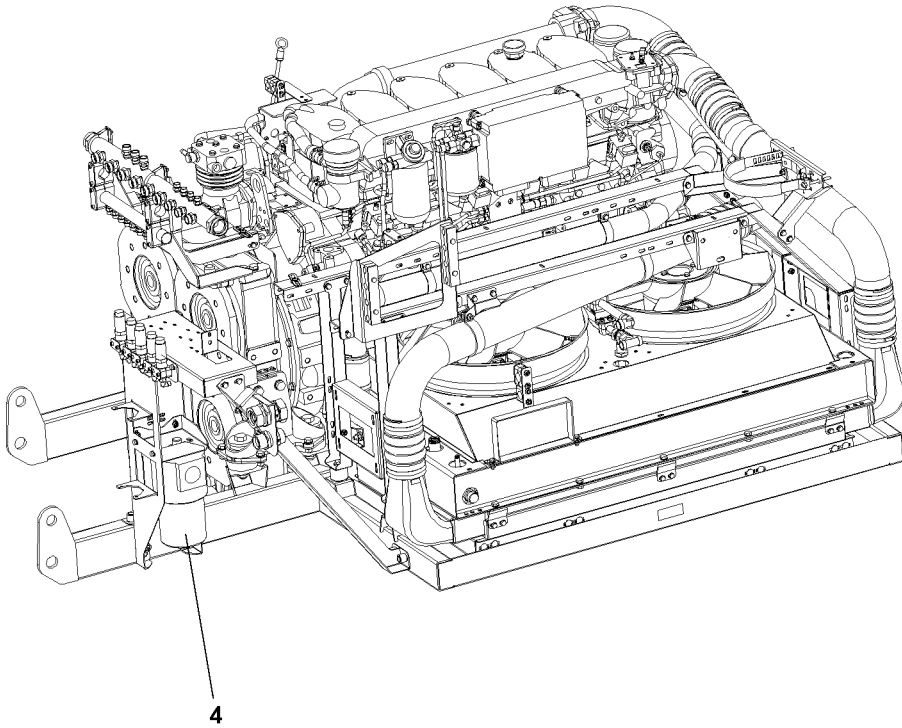

B105293

3.2 Pressure filter in the crane hydraulic

The pressure filter 4 is equipped with a maintenance indicator. If the red bar indicator is visible when the oil is at operating temperature, then the filter cartridge must be replaced.

- ▶ Turn the engine off.
- ▶ Release the filter cartridge and collect any escaping oil in a suitable container.
- ▶ Unscrew, remove and dispose of filter cartridge.
- ▶ Clean the sealing surface on the filter bracket.
- ▶ Lubricate the rubber seal ring on the new oil filter cartridge with oil.
- ▶ Screw on and tighten new filter cartridge.
- ▶ Start the engine and check for leaks.
- ▶ Slowly run through all crane movements.

Result:

- This bleeds the hydraulic system.
- ▶ Check the oil level again and add oil if necessary.

3.3 Diaphragm reservoirs

Various diaphragm reservoirs are installed in the hydraulic system. The pretension pressures are specified in the hydraulic circuit diagram as well as on the individual diaphragm reservoirs. The pretension pressure must be measured separately in each diaphragm reservoir.



CAUTION

Risk of damaging the hydraulic system!

If the ambient temperatures fluctuate considerably, for example after transfer to countries with extremely hot or cold temperatures or in countries with considerable differences between the summer and winter temperatures, the accumulator pressures may change!

- ▶ Check the accumulator pressures and correct if necessary!

Make sure that the following prerequisite is met:

- The engine is turned off.
This relieves the diaphragm reservoir at the fluid side.



DANGER

Risk of explosion!

The pressure in the nitrogen cylinder must be less than the maximum permissible operating pressure of the accumulator or the pressure gauge. Otherwise install a pressure reducer between the cylinder and the filling device!

- ▶ Do not use air or oxygen to fill the diaphragm reservoir!

The pretension pressure in the hydraulic reservoirs may only be checked by an expert with appropriate training and equipment. In addition, the national regulations for pressurized container inspections must also be observed.

- ▶ Check the pretension pressure with a testing and filling device and correct it, if necessary.

3.4 Hydraulic hose lines

The hydraulic hose lines must be checked according to ISO 9927-1 by an **experienced technician** or **expert mechanic**, as required, depending on the duration of use and the operating conditions, but at least once a year.

Experienced technicians are persons who:

- possess sufficient knowledge about cranes due to their professional background and experience,
- are familiar with the relevant settings to detect any abnormal deviations,
- have undergone special training.

Expert mechanics are mechanics, who:

- are experienced in the design, construction or maintenance of cranes,
- possess sufficient knowledge about the relevant settings and standards,
- are fully equipped to perform inspections,
- are able to assess the safety of the crane,
- can decide which action needs to be taken to ensure the crane can continue to be operated safely.



Note

► The applicable national regulations must also be complied with!

3.4.1 Checking the hydraulic hoses within area of responsibility of the German employer's liability insurance associations

At least once a year, an **expert** must check whether the hydraulic hoses are in a safe condition. The crane must be inspected by an **authorized inspector** every four years from the day it was first licensed. After the 12th year of operation, the crane must be inspected by the authorized inspector annually.

The **expert** or **authorized inspector** must document the fact that the hydraulic hoses can continue to be used in the crane!

An expert is someone:

- whose technical training and experience means that he has adequate knowledge in the field of hydraulic hoses and hose systems,
- who is familiar with the relevant occupational health and safety regulations,
- who is familiar with the relevant accident prevention guidelines,
- who is familiar with the directives and generally accepted technical regulations (e.g. DIN standards, VDE regulations, technical regulations of other EU member states or other countries that have signed the European Economic Community agreement),
- who can properly assess whether hydraulic hoses and hose systems are deemed safe in accordance with the guidelines and regulations stated above.

Authorized inspector(s) is / are :

- an authorized expert employed by the technical supervisory authorities,
- in Hamburg this is the Amt für Arbeitsschutz (office for occupational health and safety),
- in Hessen these are the technical supervisory offices,
- an authorized expert appointed by the professional associations.

3.4.2 Examples of possible defects in hose lines



WARNING

Risk of fire or accident!

If problems are discovered during inspections, then they must be remedied immediately or suitable measures are to be taken. Failure to do this can result in serious injury to persons, death or damage to property!

► Remedy problems or take suitable measures!

- Damage to the outer layer as far as the intermediate later (e.g. chafing, cuts and cracks)
- Outer layer brittleness (hose material cracking)
- Deformation that differs from the natural shape of the hose or hose system when depressurised or pressurised or when the hose is bent (e.g. layer separation, bubbling, crushing or kinking)
- Leaks
- Failure to follow installation instructions
- Damage or deformation of hose fittings that inhibit the operation and strength of the fitting or the hose / fitting connection
- Hose slipping out of fitting
- Fitting corrosion that inhibits function and strength
- Storage time or usage period exceeded

3.4.3 Maintaining hose lines

- We recommend to check all hoses, hose lines and screw fittings daily, but at least every two weeks for leaks and externally recognizable signs of damage.
- Damaged parts must be replaced immediately! Oil spray can lead to injuries and fires.
- Hydraulic lines and hoses may not be repaired.
- Hoses that have already been used in a hose system may not be reinstalled in hose systems.
- Always use original LIEBHERR spare parts when replacing hoses and hose systems.
- Always ensure that the hoses are routed free of torsion. If high pressure hoses are being used, attach screws of half clamps or full flange at both ends of hose and then tighten.
- When using high pressure hoses with a bent fitting, tighten the end with the bent fitting first when tightening the flanges, then the end with the straight fitting.
- Any mounting clamps in the hose center may be attached and tightened only thereafter.
- Route the hoses in such a way that chafing with other hoses or other structures is prevented. Maintain minimum clearance of approximately $\frac{1}{2}$ the outer diameter of the hose from other parts. The clearance should never be less than 10 mm - 15 mm.

3.4.4 Replacing the hose lines



WARNING

Risk of fire or accident!

Failure to replace hose lines at appropriate intervals can cause serious injury to persons, death or damage to property!

► Replace hose lines at appropriate intervals!

This must be documented in the crane's log book by the **expert** or the **authorized inspector**.

The service life of a hose system may not exceed six years, including a storage period of a maximum of two years (observe the manufacturing date on the hoses). The duration of use can also be defined by the **expert** or **authorized inspector** in accordance with existing test and empirical data in the individual application areas, taking the usage conditions into consideration.

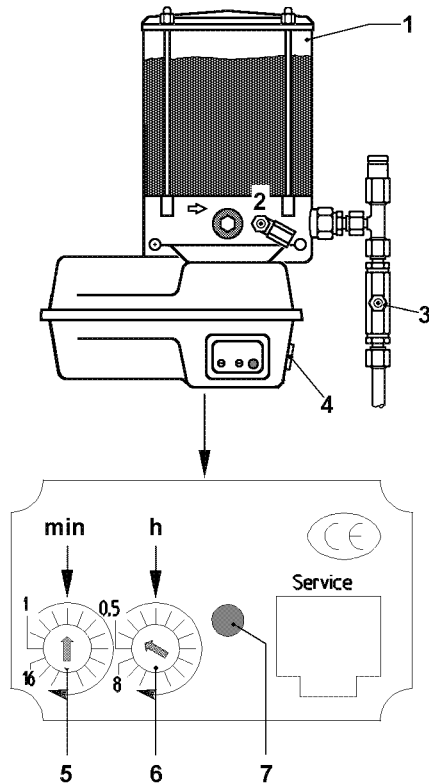
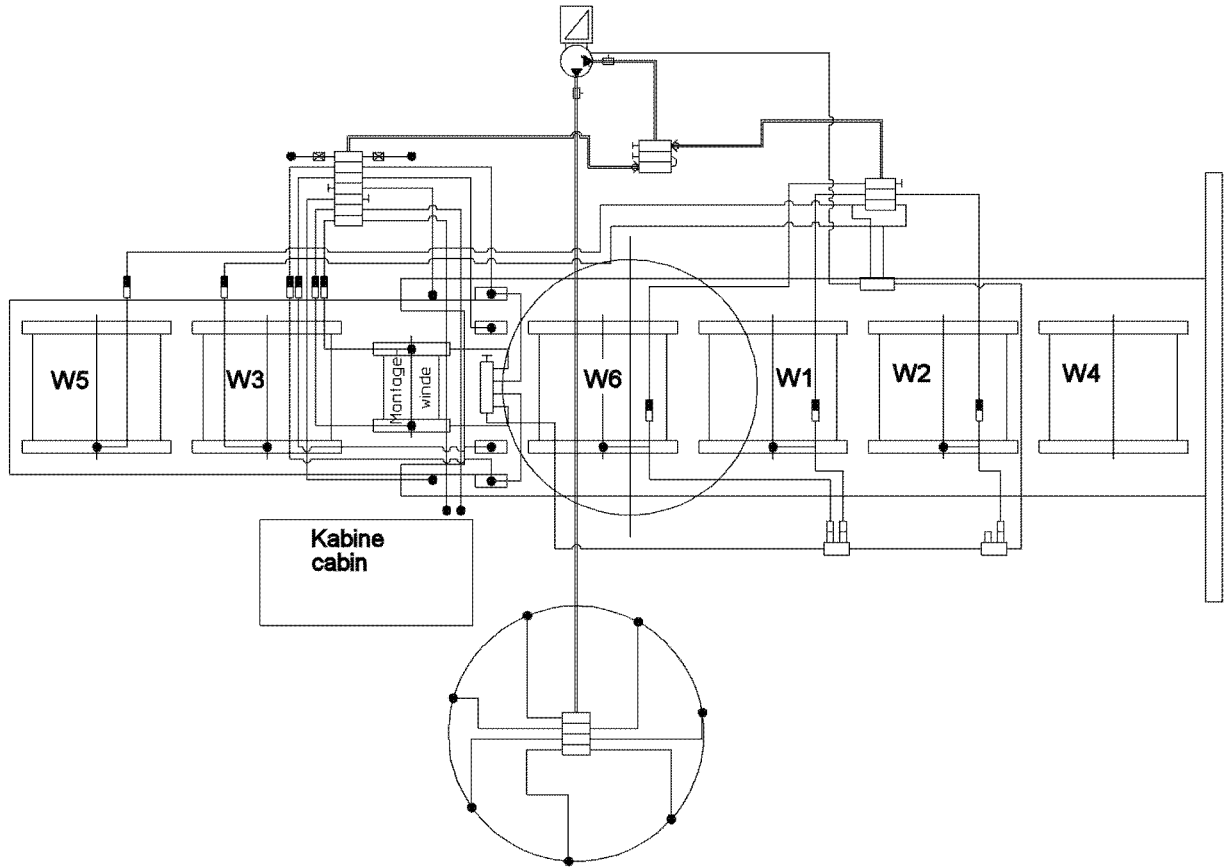

B105351

4 Central lubrication system

The turntable, the rotary connection and the winches are equipped with a central lubrication system. All grease points (see illustration on the left) are automatically provided with the correct amount of grease.

If the crane has not been moved for more than 3 months, then it must be lubricated every 3 months with an external grease pump until grease emerges from all grease points. Then the relevant crane movement must be repeated several times and the lubrication procedure must be carried out again.

4.1 Central lubricating system - turntable

Lubricating time: 5 min

Break period: 1 h

4.1.1 Components of the system

Grease container **1**

Grease fitting **2**: - Filling the central lubricating system

Grease fitting **3**: - Filling the lubrication lines

Push button **4**: - Intermediate lubrication

Latched switch **5**: - Lubricating time min

Latched switch **6**: - Break period h

LED **7** yellow

4.1.2 Setting the lubrication and break periods

The LED **7** on the engine protection housing blinks in a 0.5 second cycle during the lubrication process. The lubrication and interval time is set at the factory. The times can possibly be changed by using the latched switch **5** and latched switch **6**.

► Turn on the engine ignition.

Result:

- When turning on the ignition, the LED **7** lights up for approximately 1.5 s and displays the operational readiness.

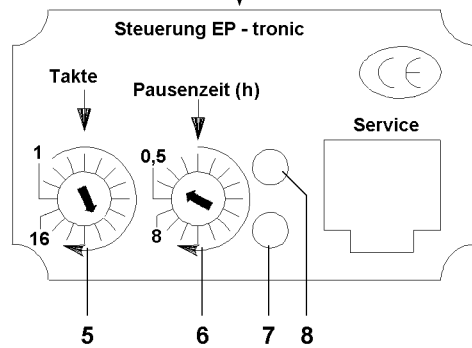
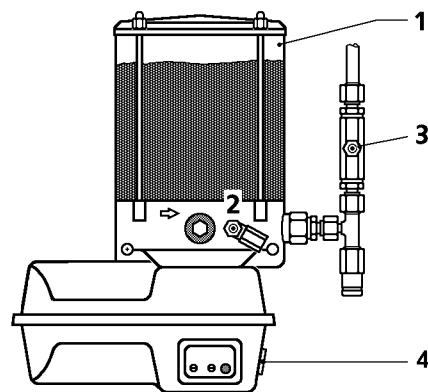
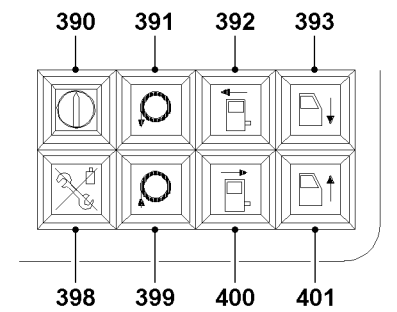
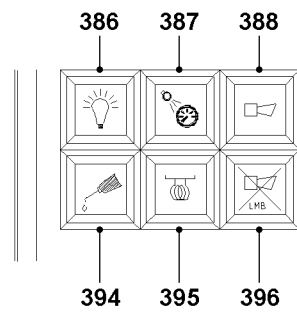
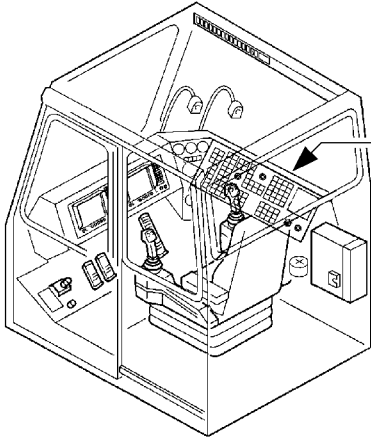

B112522

4.2 Central lubricating system - slewing ring connection

Pump operation period: 12 cycles

Cycle time: 1 h

4.2.1 Components of the system

Grease container **1**

Grease fitting **2**: - Filling the central lubricating system

Grease fitting **3**: - Filling the lubrication lines

Push button **4**: - Intermediate lubrication

Latched switch **5**: - Cycles

Latched switch **6**: - Break period h

LED **7** green

LED **8** red

4.2.2 Adjusting the lubrication and break period

The lubrication and break period is set in the factory.

▶ Adjust running time of the pump with the latched switch **5**.

▶ Adjust the break period with the latched switch **6**.

4.2.3 Cycle control

The central lubrication system is progressively monitored. This means that a proximity switch converts the piston strokes of the central lubrication system distributor into electric control signals and relays them to the control unit. If the control signals are not present or incomplete, the indicator light **394** shows a malfunction.

Blinker code - cycle control

The LED **7** performs the equivalent function of the indicator light **394**.

During operation

Ignition on, ready for operation:

Indicator light **394** lights up for 1.5 s and turns off.

Lubrication:

Indicator light **394** lights up during the lubricating period.

In case of a problem

Error in monitoring time cycle input:

The indicator light **394** lights up for 1 s and is off for 1 s etc.

Memory error, battery error:

Indicator light **394** does not light up.

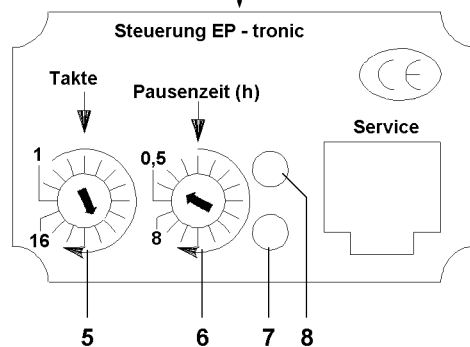
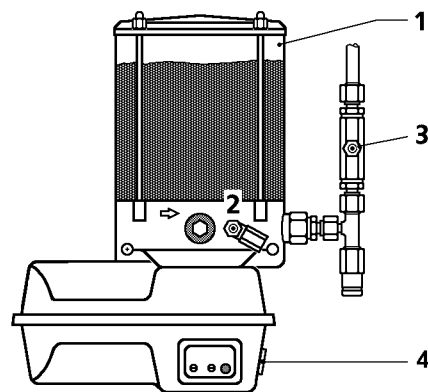
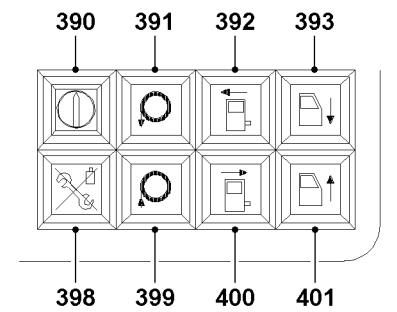
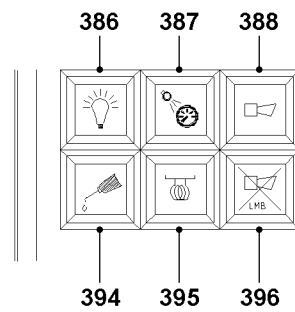
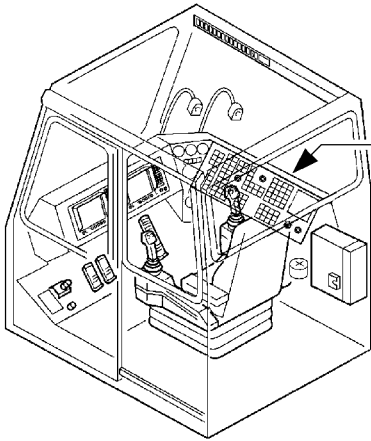

B112522

4.3 Central lubricating system in general

4.3.1 Intermediate lubrication

Intermediate lubrication can be carried out manually after washing the crane, for example.

- ▶ Press the push button 4.

Result:

- Components are greased.

4.3.2 Function check



Note

- ▶ Ensure that the ignition is turned on!

- ▶ Trigger 2 or 3 grease pulses via the push button 4.

Result:

- Grease exits from the pressure relief valve.

4.3.3 Filling the grease container



CAUTION

Risk of damage due to insufficient lubrication!

- ▶ There must always be sufficient grease in the grease container 1!
- ▶ Observe utmost cleanliness when filling the grease container 1!

- ▶ Fill grease container 1 using grease pump via the grease fitting 2.

4.3.4 Filling the lubrication lines



CAUTION

Risk of damage due to insufficient lubrication!

The lubrication lines must be refilled after any repair on components, which are lubricated with grease. If this is not observed, the component may run dry!

- ▶ Sufficient grease must be available in the grease lines after every repair on greased components!
- ▶ Observe utmost cleanliness when filling the grease lines!

- ▶ Add grease with an external grease pump via the grease fitting 3.

or

- Push the red button on the engine protection housing of the grease pump while the ignition is on.

4.3.5 Bleeding the central lubricating system

If the grease container 1 has been emptied, then it may be necessary to bleed the central lubrication system.

- ▶ Fill the grease container 1.
- ▶ Unscrew the main line from the grease pump outlet.
- ▶ Activate intermediate greasing until bubble-free grease exits from the grease pump outlet.
- ▶ Reconnect the main line.
- ▶ Trigger intermediate lubrication.

4.4 Troubleshooting on the central lubrication system

Problem	Cause	Remedy
The grease pump does not work	Integrated electronic control defective, electrical line interrupted, grease pump defective	Replace lower part of motor protection housing, replace electrical line, replace grease pump
Grease pump operates, but does not deliver	Air cushion in delivery piston, minimum fill level fallen below, grease pump element defective	Bleed grease pump, fill reservoir, replace grease pump element
No grease collar on all lube points	Grease pump not operating, interval time too high or cycle time too short, system blocked	See "Grease pump not operating", reduce interval time or increase number of cycles, refer to "Grease emerges on pressure relief valve"
No grease collar on several lube points	Supply lines to secondary distributors broken or leaking, screw connections leaking	Replace lines, tighten or replace screw connections
No grease collar on one lube point	Associated lube line broken or leaking, screw connection leaking	Replace line, tighten or replace screw fitting
Grease pump speed reduced	Higher system pressure, lower ambient temperature	Check system / bearing points, no damage: Grease intermediately once or twice, if necessary
Grease escapes at the pressure relief valve	System pressure too high, progressive distributor blocked, system blocked, defective valve spring	Check system, replace distributor, repair blocked / seized bearing point, replace pressure relief valve
The red LED blinks very fast	Error CPU / memory	Consult Liebherr Service
The red LED and the indicator light blink fast	Error in the monitoring period from cycle start	The proximity switch is defective, consult Liebherr Service

5 Slewing ring connection

5.1 Greasing the slewing ring

Before and after long breaks in operation, especially before and after a possible winter break, carry out the lubrication procedure with special care to ensure the best possible corrosion protection.

If the crane has not been moved for more than 3 months, then it must be lubricated every 3 months with an external grease pump until grease emerges from all grease points. Then the relevant crane movement must be repeated several times and the lubrication procedure must be carried out again.

- ▶ Grease exterior of slewing ring.

5.2 Tilt play of roller ring connection

The wear of the roller ring connection is determined by measuring the "Tilt play" with the ring installed.



Note

- ▶ The determination of the "Tilt play" must be carried out according to the **test instructions** of **Liebherr-Werk Ehingen GmbH!**
- ▶ Contact the Service Dept. at **Liebherr-Werk Ehingen GmbH** for **test instructions!**



DANGER

Danger of accident if tilt play of roller ring connection is too large!

If the permissible tilt play of 2.0 mm is exceeded, then safe crane operation is no longer possible.

- ▶ Replace the roller ring connection if the tilt play is larger than 2.0 mm!

1

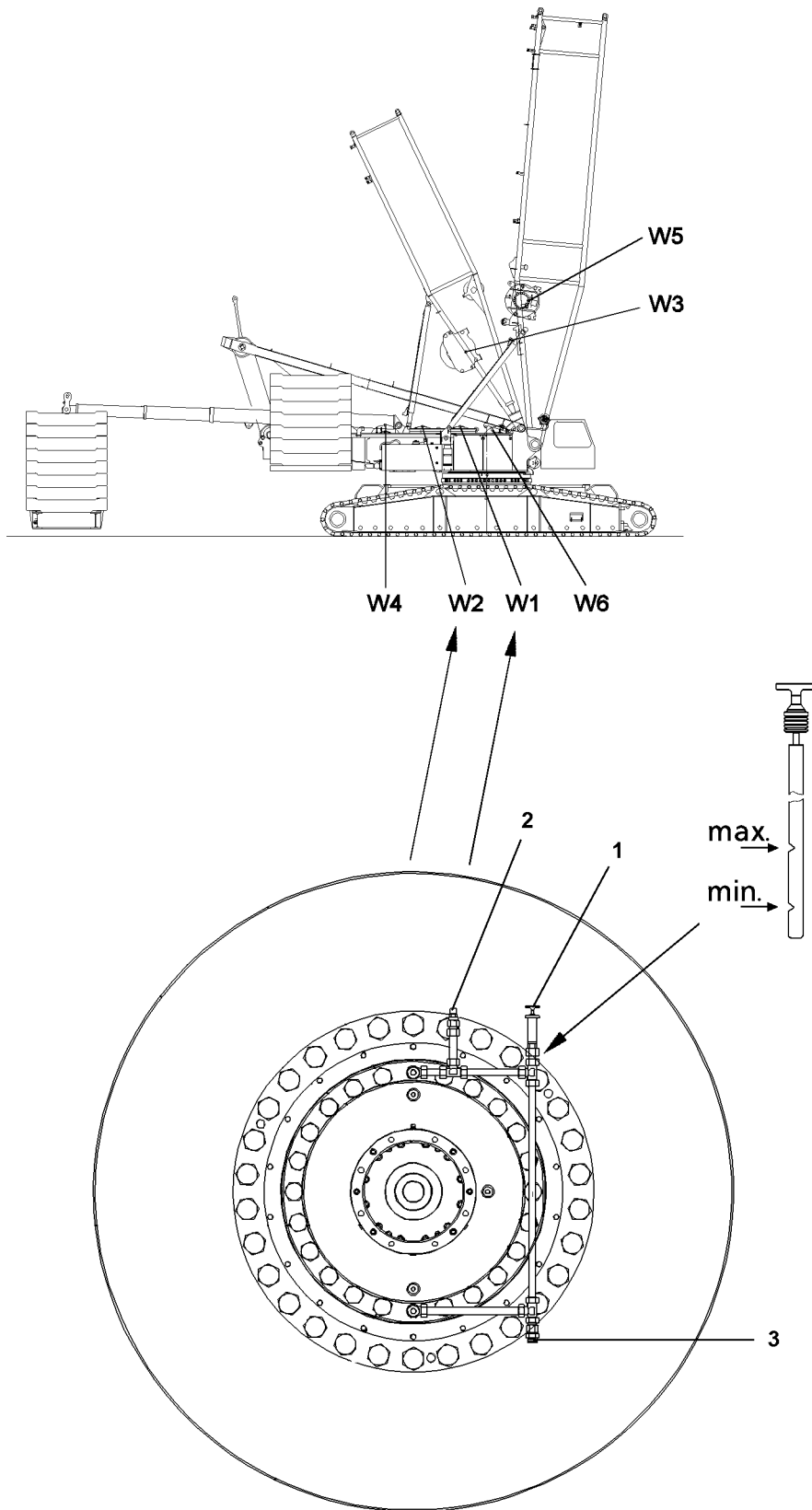

B105370

6 Winches

Maintain utmost cleanliness during all work to prevent any dirt from entering the inside of the gear.

6.1 Illustration overview - winches

Winch 1 + 2, illustration 1

Winch 3, illustration 2

Winch 4, illustration 3

Winch 5, illustration 4

Winch 6, illustration 5

6.1.1 Overflow container

When the oil heats up in the hydraulic motor of winch, the oil can enter the overflow container via a check valve, but cannot flow back into the hydraulic system after cooling off. For this reason the oil that has collected in the overflow container must be disposed of at regular intervals.

6.2 Hoist gear

Make sure that the following prerequisites are met:

- The hoist gear is inactive.
- The crane is in horizontal position.

6.2.1 Checking the oil level



CAUTION

Danger of gear damage!

If the oil level has dropped below the minimum mark, top up engine oil as shown in the lubrication chart.

▶ Add oil, recheck and reinsert the dipstick 1.

▶ Remove and wipe the dipstick 1 off.

▶ Reinsert the dipstick 1 and pull out again.

The oil level must be between the min. and max. marks on the dipstick 1.

▶ Check the oil level.

6.2.2 Changing the oil

▶ Unscrew the breather screw 2.

▶ Remove the oil drain plug 3 with seal ring and drain the oil into a suitable container.

▶ Reinstall the oil drain plug 3 with new seal ring and tighten.



Note

▶ Remove the dipstick 1 to open the oil filler port!

▶ Add oil at oil filler port according to the lubrication chart.

▶ Reinstall the breather screw 2 and tighten.

▶ Check the oil level as described above.

1

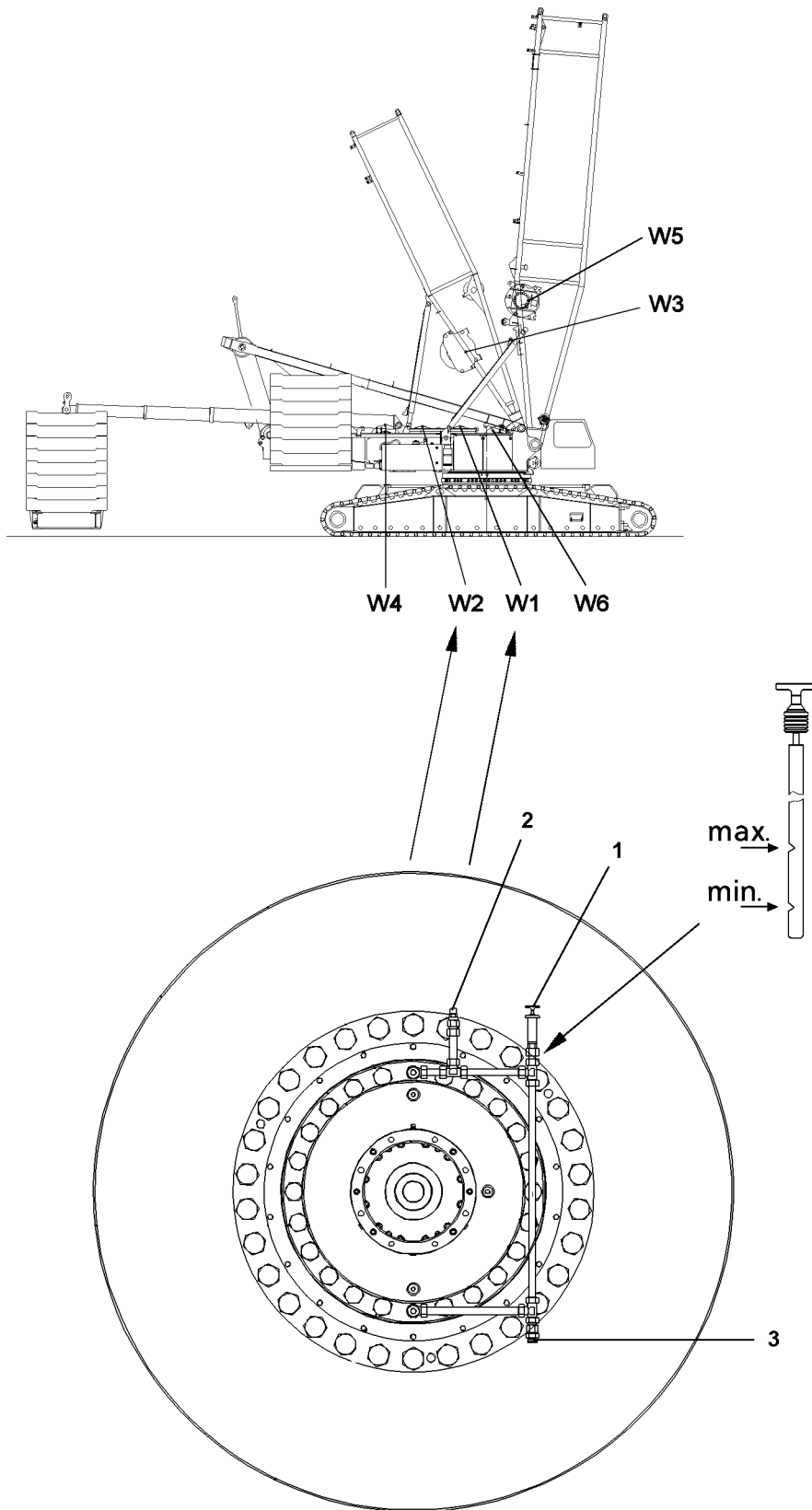

B105370

6.3 Hoist gear brake

Make sure that the following prerequisites are met:

- The hoist gear is inactive.
- The crane is in horizontal position.

6.3.1 Checking the oil level

- ▶ Remove screw **4**.

The oil level must reach the edge of the bore.

- ▶ Perform a visual inspection.



CAUTION

Danger of gear damage!

- ▶ If the oil level has dropped, add the oil as specified in the lubrication chart until it overflows on the filler port!

-
- ▶ Clean the sealing surfaces on the housing and on the plug.
 - ▶ Reinstall the screw **4** and tighten.

6.3.2 Changing the oil

- ▶ Remove the oil filler plug **5** and clean the sealing surface.
- ▶ Remove the oil drain plug **6** with seal ring and drain the oil into a suitable container.
- ▶ Clean the oil drain plug **6** and sealing surface on the housing.
- ▶ Reinstall the oil drain plug **6** with new seal ring and tighten.
- ▶ Add oil at the oil filler port as specified in the lubrication chart until the oil begins to overflow at the port **4**.
- ▶ Clean the oil filler plug **5** and reinstall it with a new seal ring and tighten.
- ▶ Check the oil level as described above.

2

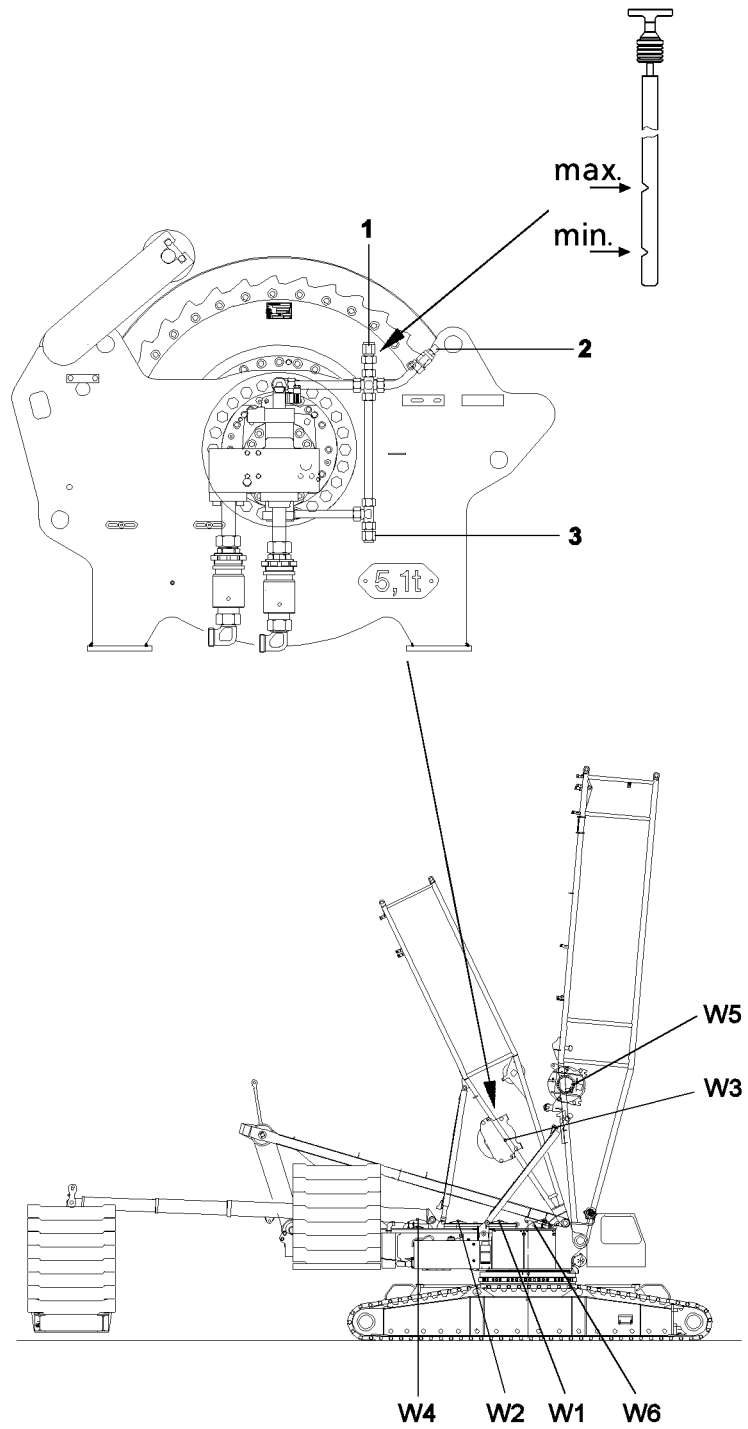

B105461

3

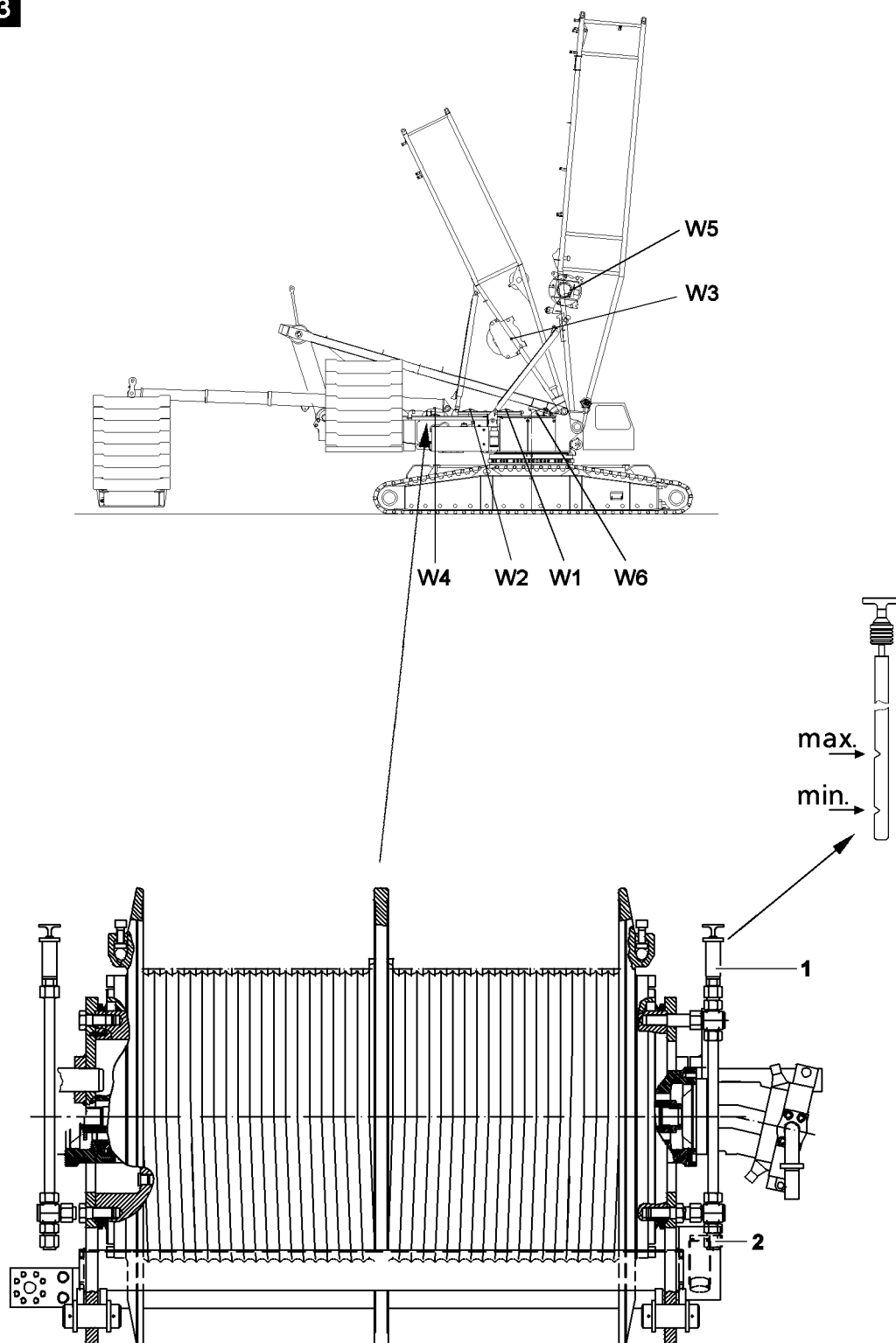

B105372

4

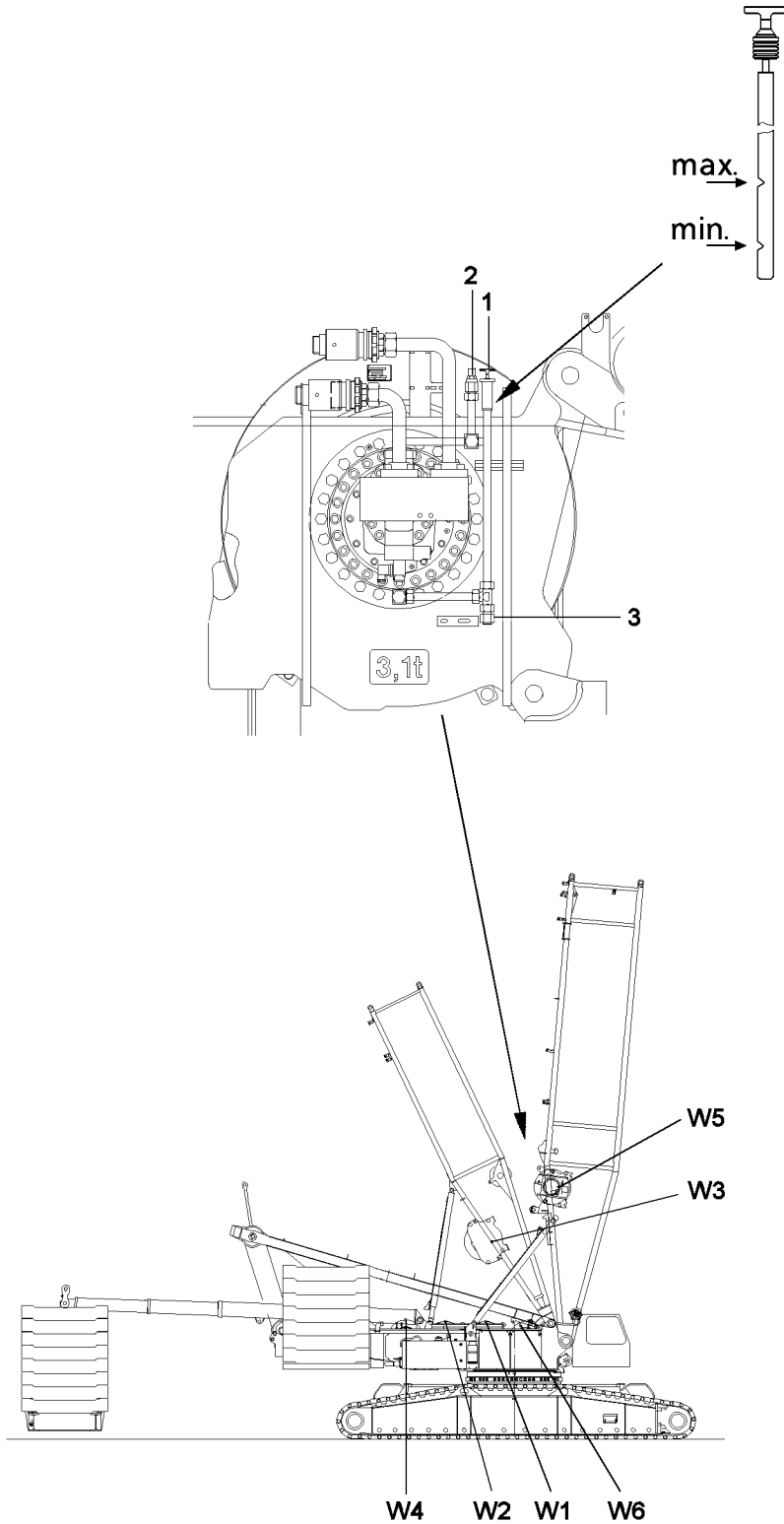

B105371

5

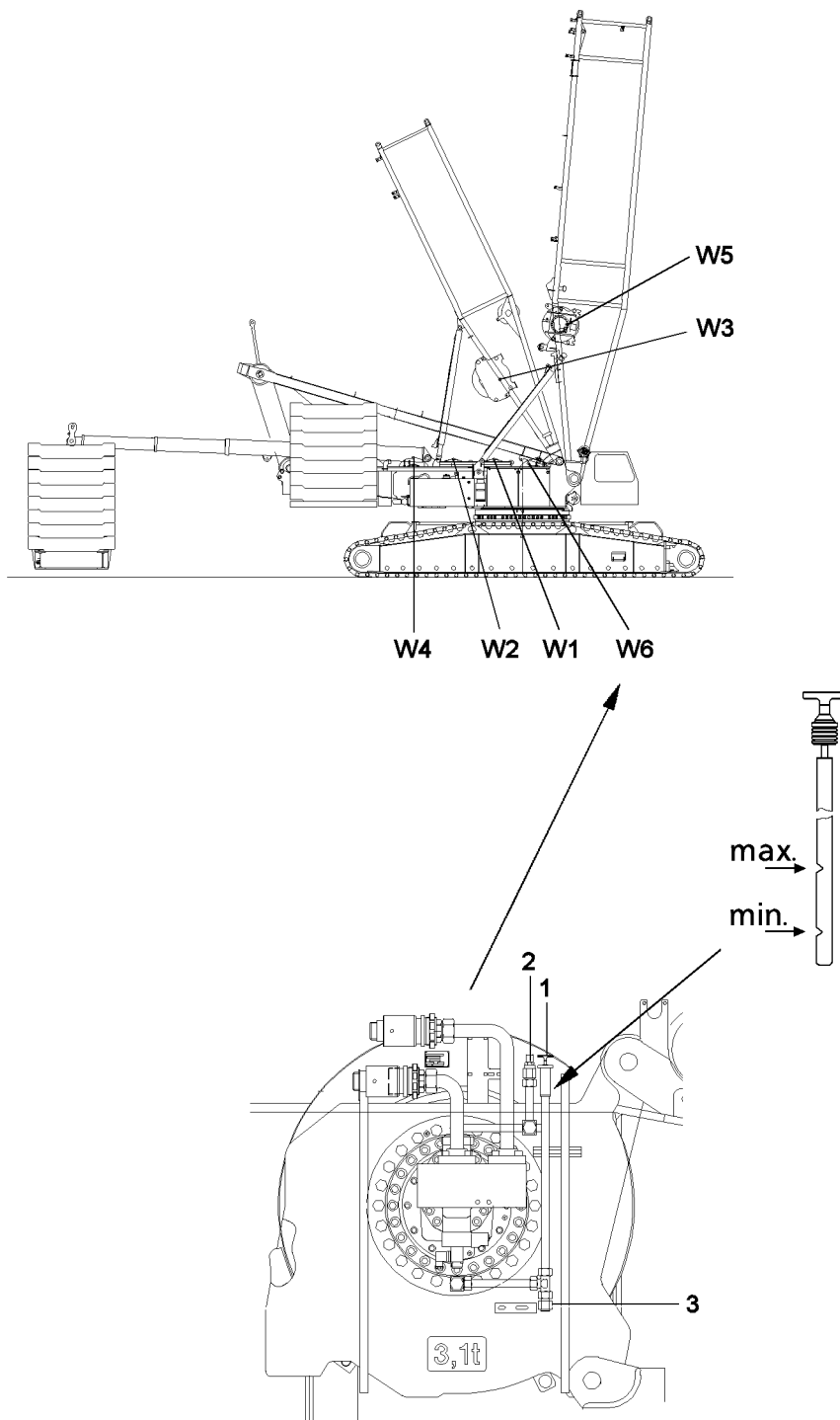

B105436

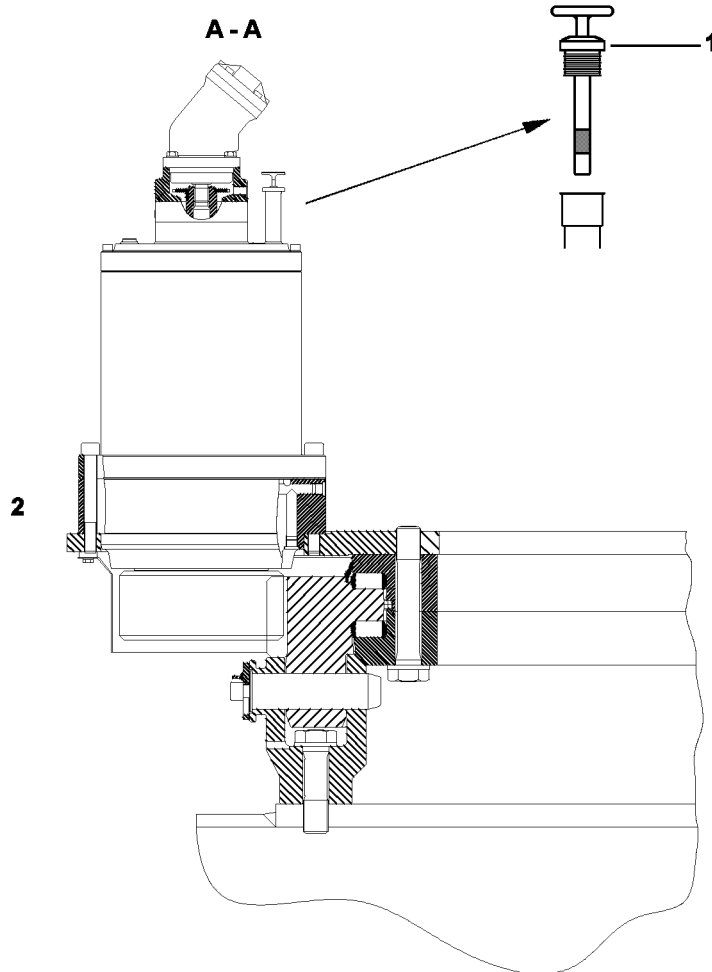
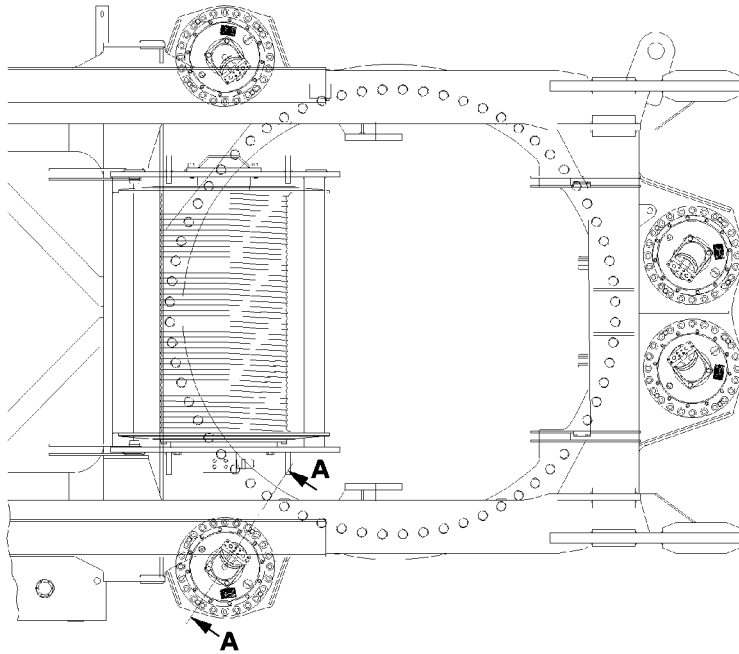

B105437

7 Slewing gear

Maintain utmost cleanliness during all work to prevent any dirt from entering the inside of the gear.

7.1 Checking the oil level

Make sure that the following prerequisites are met:

- The crane is in horizontal position.
- ▶ Remove the dipstick **1** and wipe it off.
- ▶ Reinsert the dipstick **1** and pull it out again.

The oil level must be between the two notches on the dipstick **1**.

- ▶ Check the oil level.



CAUTION

Danger of gear damage!

If the oil level has dropped below the lower notch, add oil as specified in the lubrication chart until the oil level is between the two notches!

- ▶ Add oil and check again!

-
- ▶ Reinsert the dipstick **1**.

7.2 Changing the oil

Make sure that the following prerequisites are met:

- The crane is in horizontal position.
- The gear has warmed up.
- ▶ Open the oil filler port by unscrewing the dipstick **1**.
- ▶ Remove the oil drain plug **2** with the seal ring and drain the oil.
- ▶ Clean the oil drain plug **2** and sealing surface on the housing.
- ▶ Install the oil drain plug **2** with new seal ring and tighten.
- ▶ Add oil as specified in the lubrication chart on the oil filler port until the oil level is between the two notches on the dipstick **1**.
- ▶ Close the oil filler port by screwing in the dipstick **1**.
- ▶ Check the oil level as described above.

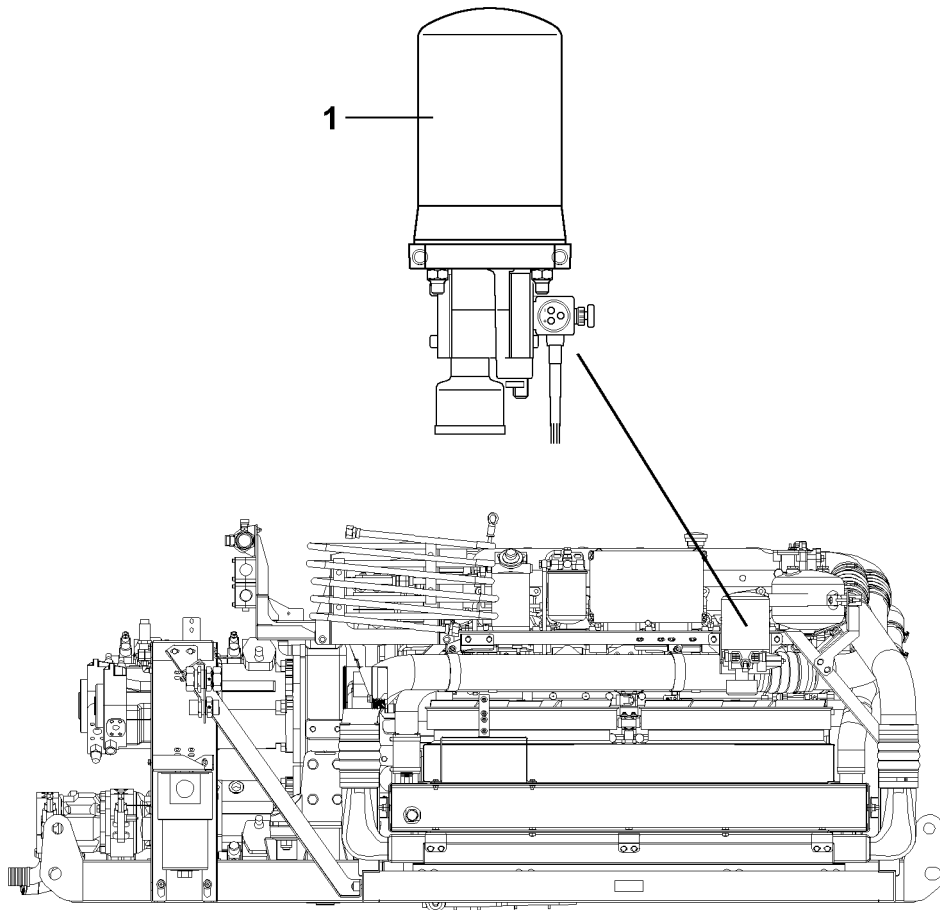

B105798

8 Air dryer of the compressed air system of the crane superstructure

8.1 Replacing the granular cartridge

**CAUTION**

Risk of accident due to pretensioned granular cartridge!

The granular cartridge 1 is under spring tension!

▶ Caution when replacing the granular cartridge!

▶ Replace the granular cartridge 1 once per year.

9 Electrical system - Lighting

The maintenance of the electrical system is essentially limited to replacing defective fuses and bulbs and maintaining the batteries.

NOTICE

Damage to electrical system!

Never short circuit defective fuses with wire or similar items!

▶ Always replace defective fuses with fuses of the same amperage!

▶ If there is a repeat problem with the same fuse, check the electrical system!

9.1 Battery maintenance

**DANGER**

Risk of fatal injury!

▶ Always disconnect the batteries from the power circuits when working on the electrical system of the crane and during all welding work!

▶ Keep batteries dry and clean.

▶ Do not bring oil, grease, fuel or solvents into contact with the battery casting compound.

▶ Release dirty terminals, clean and grease them with an acid-free and acid-resistant grease.

▶ Check the acid levels in batteries at least once a year. In summer and in hot climate zones, check it at least twice a year.

▶ On conventional batteries, check electrolyte level at regular intervals and add distilled water to the specified "Max mark", if necessary.

▶ When adding distilled water:

Measure the acid concentration only after 30 minutes. The acid temperature for measuring should be +20 °C if possible.

The following specifications must be adhered to when checking the battery charge:

Specific weight	Charge condition
1.28/1.23*	Well charged
1.20/1.16*	Semi-charged, recharge
1.12/1.08*	Discharged, recharge immediately

* in tropical countries

Reduced battery performance requires greater power requirements.

- ▶ Ensure that batteries are well charged, particularly during the colder months.

9.2 Mixing battery acid

- ▶ Ensure that work area is well ventilated.



DANGER

Risk of explosion!

- ▶ When mixing battery acid, always pour distilled water into the container first, then the concentrated sulphuric acid!
- ▶ Observe this order, otherwise explosions and spattering can occur!
- ▶ Stir the mixture with an acid-proof stick (glass or plastic).

Desired acid concentration kg/l	1.23	1.24	1.25	1.26	1.27	1.28
Volume ratio of concentrated sulphuric acid (96 % %) to distilled water	1:3.8	1:3.6	1:3.4	1:3.2	1:3.0	1:2.8

When adding the battery acid, the acid level should be 15 mm above the top edge of the battery plates and the temperature of the acid should be approximately 15 °C.

- ▶ Add battery acid to battery.

Wait approximately 20 minutes before connecting the battery. By that time, it will be balanced out.

- ▶ Connect the battery after approximately 20 minutes.

9.3 Removing and recharging the battery



WARNING

Danger of injuries!

- ▶ Do not place tools on batteries and keep open flames away!

9.3.1 Removing the battery

Make sure that the following prerequisites are met:

- The engine is turned off.
- All electrical consumers are turned off.

NOTICE

Damage to alternator!

- ▶ Do not disconnect batteries unless the engine has been turned off!
- ▶ Carry out work in well ventilated rooms and avoid sparks.
- ▶ Disconnect the negative terminal first (ground cable), then the positive terminal.

- ▶ Remove the battery.
- ▶ Avoid spark formation caused by electrostatic charge. To avoid this, touch the ground support point in the driver's cab.
- ▶ Do not tilt or shake the battery.

9.3.2 Recharging the battery

NOTICE

Damage to battery!

- ▶ Recharge only with direct current, the strength of which does not exceed 1/10 of the battery capacity!
-

Recharging example: A battery with 170 Ah should be charged with a maximum charging current of 17.0 A.

- ▶ Frozen batteries must be thawed out before charging.
- ▶ Remove all plugs before charging.
- ▶ Provide ventilation during charging (risk of oxyhydrogen gas explosion!).
- ▶ Connect the battery to a battery charger (positive to positive and negative to negative).
- ▶ Turn on the battery charger after connecting the battery.

Stop charging immediately if:

- The acid temperature exceeds 55 °C (casing more than warm to the touch).
 - The battery starts to give off gas.
 - The acid concentration or the charging voltage has not changed for 2 hours.
- ▶ Turn the battery charger off after charging, then remove the connector cables individually from battery and battery charger.

9.3.3 Installing the battery

- ▶ Reinstall the battery tightly in the vehicle.
- ▶ Avoid spark formation caused by electrostatic charge. To avoid this, touch the ground support point in the driver's cab.
- ▶ Connect the positive terminal to the battery first, then the negative terminal (ground cable).
- ▶ Check that the terminals are tightly seated (low contact resistance).
- ▶ Grease the terminals and terminal posts with acid-free and acid-resistant grease (use corrosion protection even for modern maintenance-free batteries).

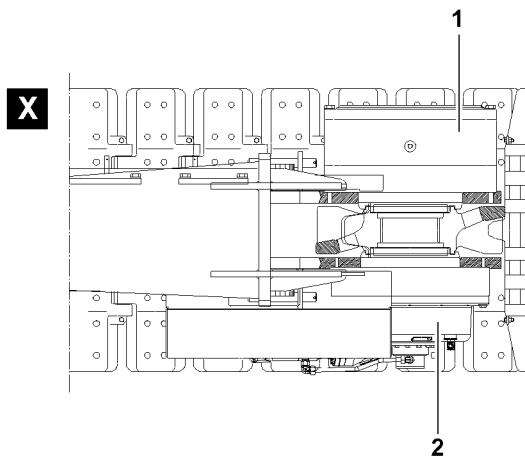
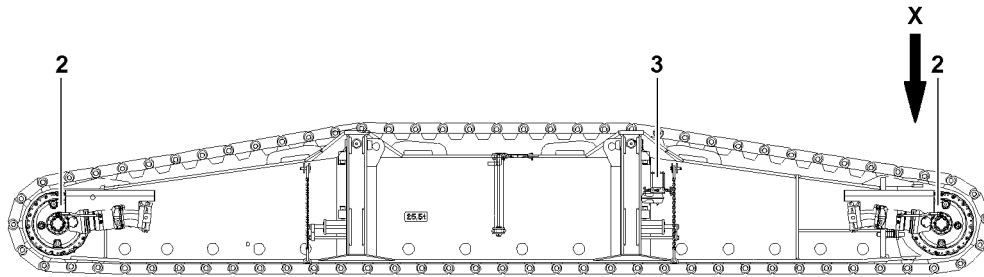
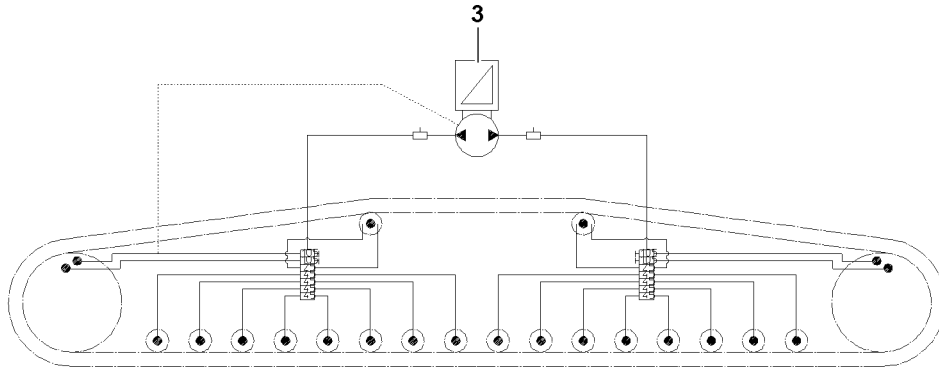

B108361

1 Fill quantities

1.1 Crawler chassis fill quantities

The specified fill quantities (change quantities) are orientation values. The marks on the dipsticks, inspection ports and sight gauges are decisive for filling.

NOTICE

Danger of property damage!

► Do not mix synthetic oils with mineral oils!

Position	Component	Fill quantity
1	Planetary gear	35.0 l
2	Miter gear with travel gear brake	10.0 l
3	Central lubrication system	2.5 kg

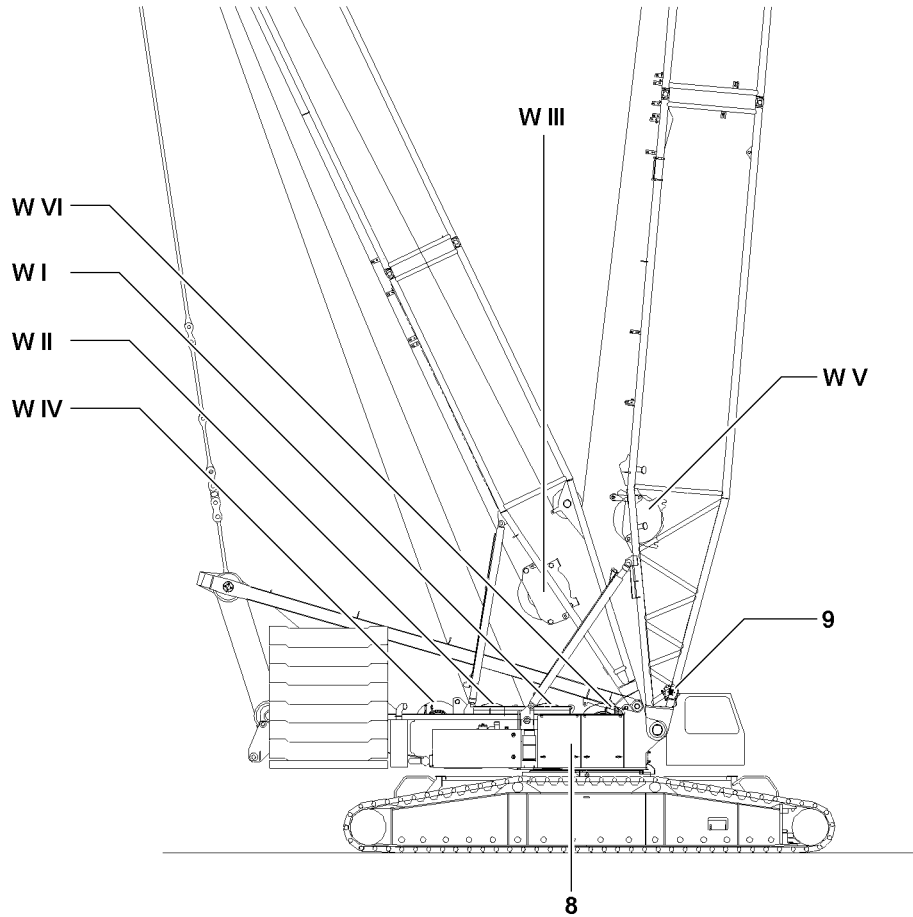
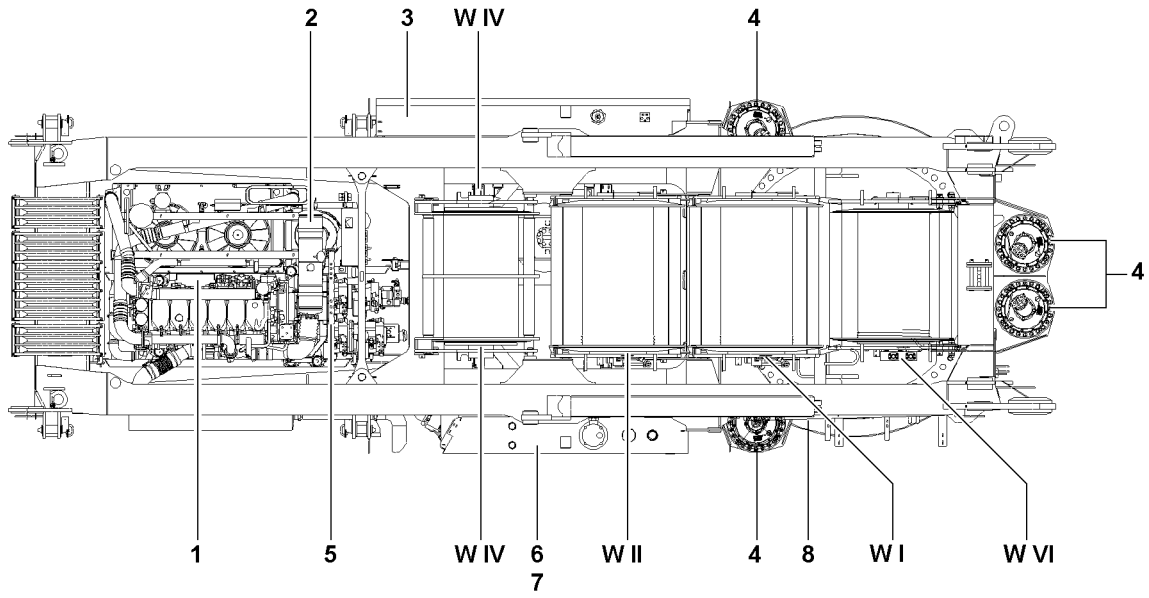

B108362

1.2 Fill quantities crane superstructure

The specified fill quantities (change quantities) are orientation values. The marks on the dipsticks, inspection ports and sight gauges are decisive for filling.

NOTICE

Danger of property damage!

- ▶ Do not mix synthetic oils with mineral oils!

Position	Component	Fill quantity
1	Diesel engine	40.0 l
2	Cooling system	60.0 l
3	Fuel tank	1000.0 l
4	Slewing gear	23.0 l
5	Pump distributor gear	9.2 l
6	Hydraulic oil tank ¹	450.0 l
7	Hydraulic oil tank ¹ with crane support	720.0 l
8	Central lubrication system	4.0 kg
9	Assembly winch	0.4 l
W I	Winch W I	9.0 l
	Winch brake winch W I	0.75 l
W II	Winch W II	9.0 l
	Winch brake winch W II	0.75 l
W III	Winch W III	6.5 l
	Winch brake W III	0.8 l
W IV	Winch W IV (double winch)	2 x 12.0 l
	Winch brake W IV	2 x 0.4 l
W V	Winch W V	6.5 l
	Winch brake winch W V	0.8 l
W VI	Winch W VI	9.0 l
	Winch brake W VI	0.75 l

¹When the oil level is checked, all hydraulic cylinders must be retracted. The oil level must be in the center of the sight gauge.

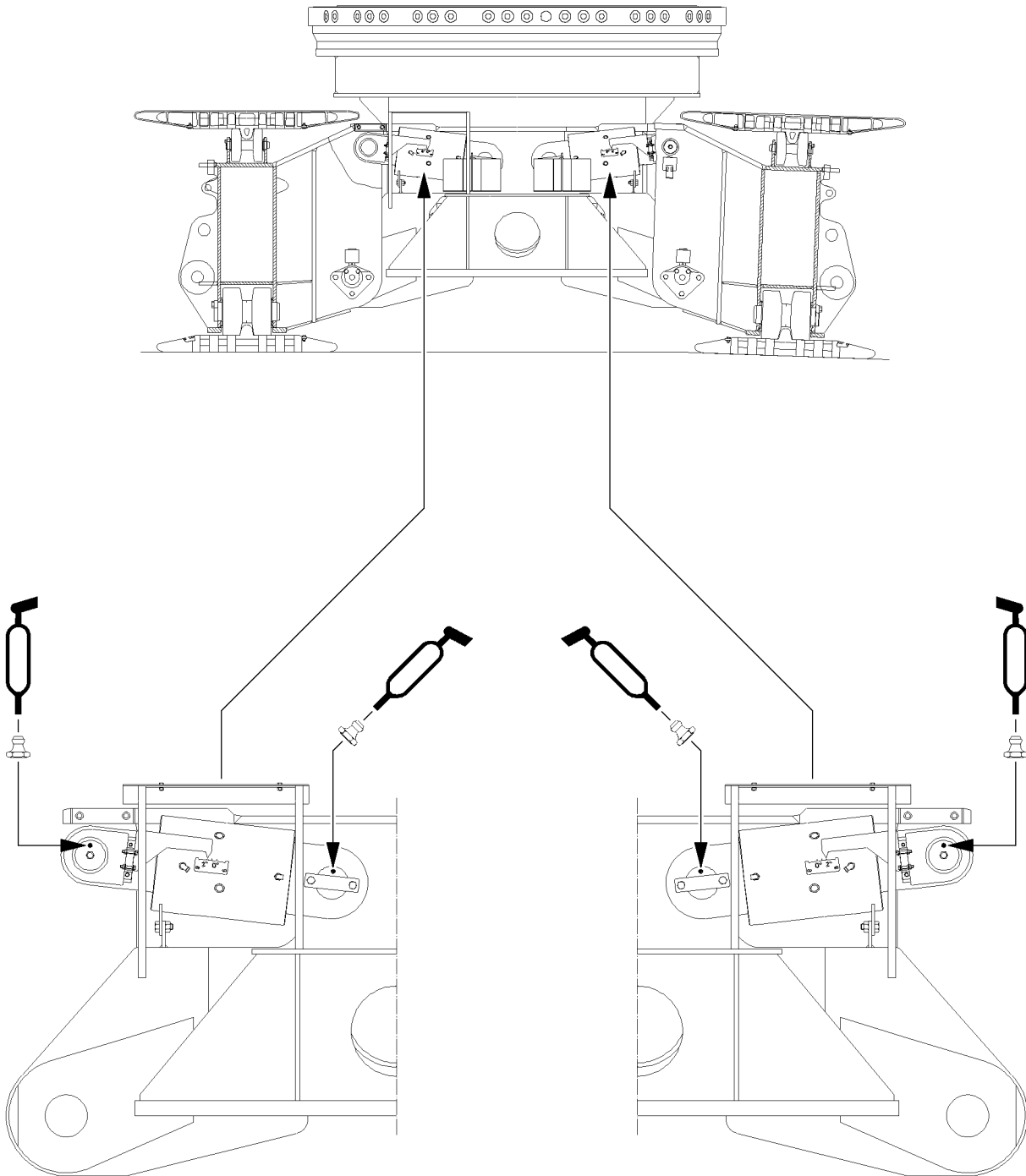

B108386

2 Lubrication schedule

2.1 Lubrication schedule - Crawler chassis

2.1.1 Narrow crawler

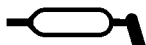

Note

▶ The lube points are marked with this icon!

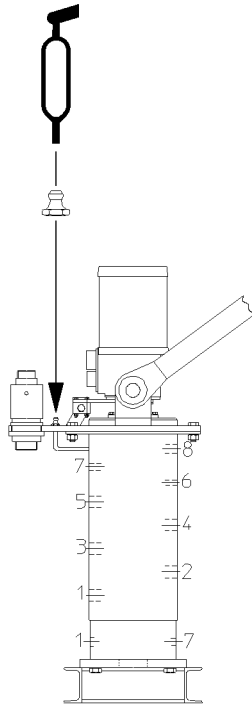

B108366

2.1.2 Rotary connection

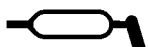

Note

▶ The lube points are marked with this icon!

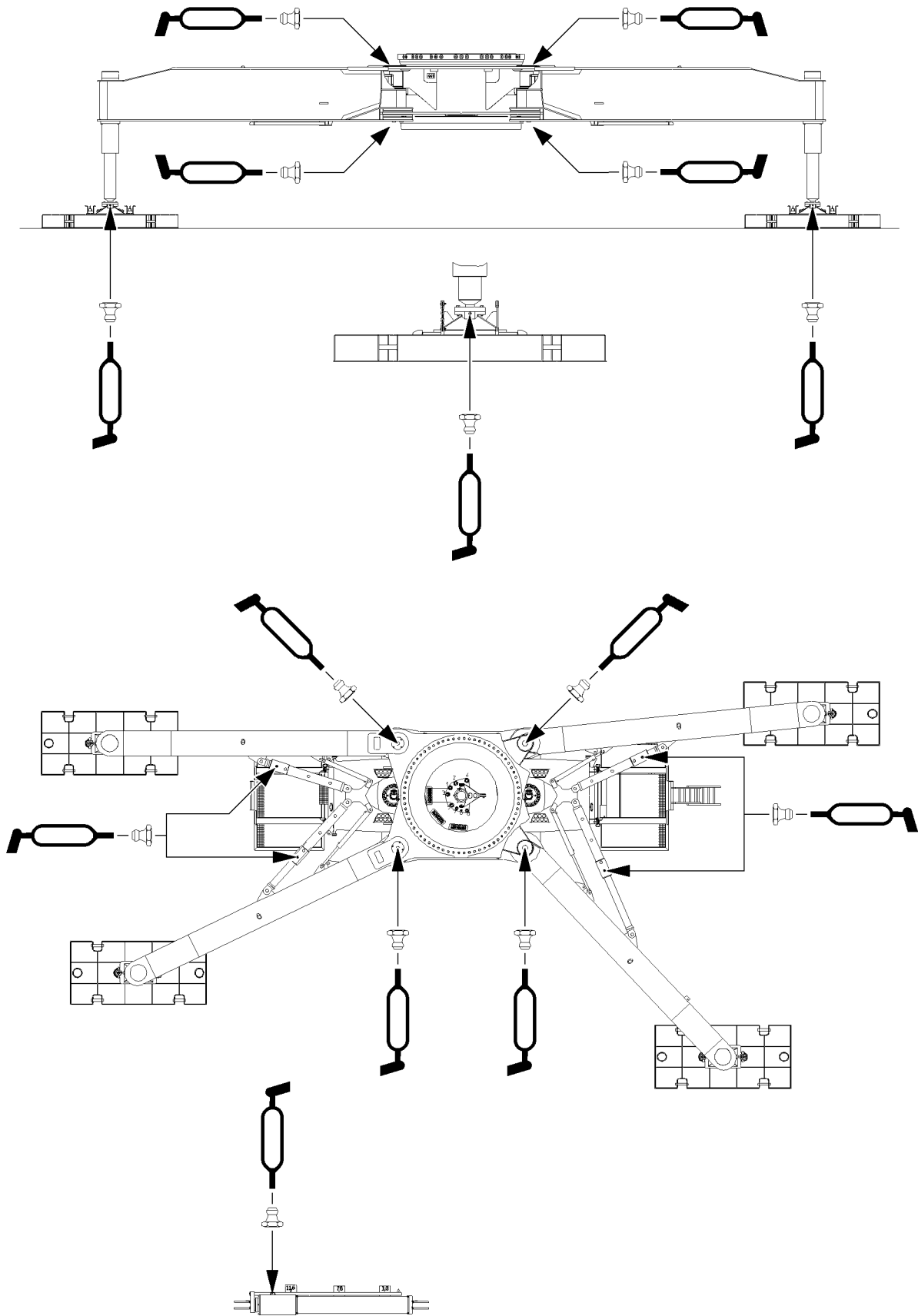

B108365

2.2 Lubrication schedule for crane support narrow crawler

2.2.1 Crane support

**Note**

- ▶ Only in connection with narrow crawler center section!
-

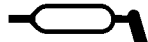
**Note**

- ▶ The lube points are marked with this icon!
-

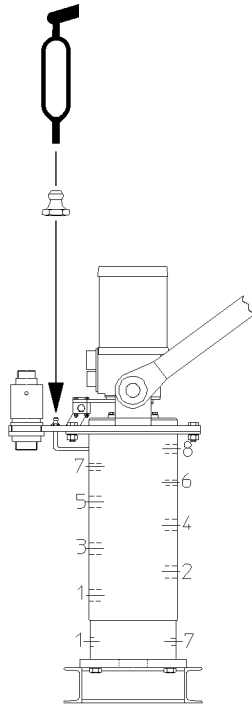

B108366

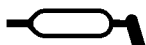
Rotary connection**Note**

▶ The lube points are marked with this icon!

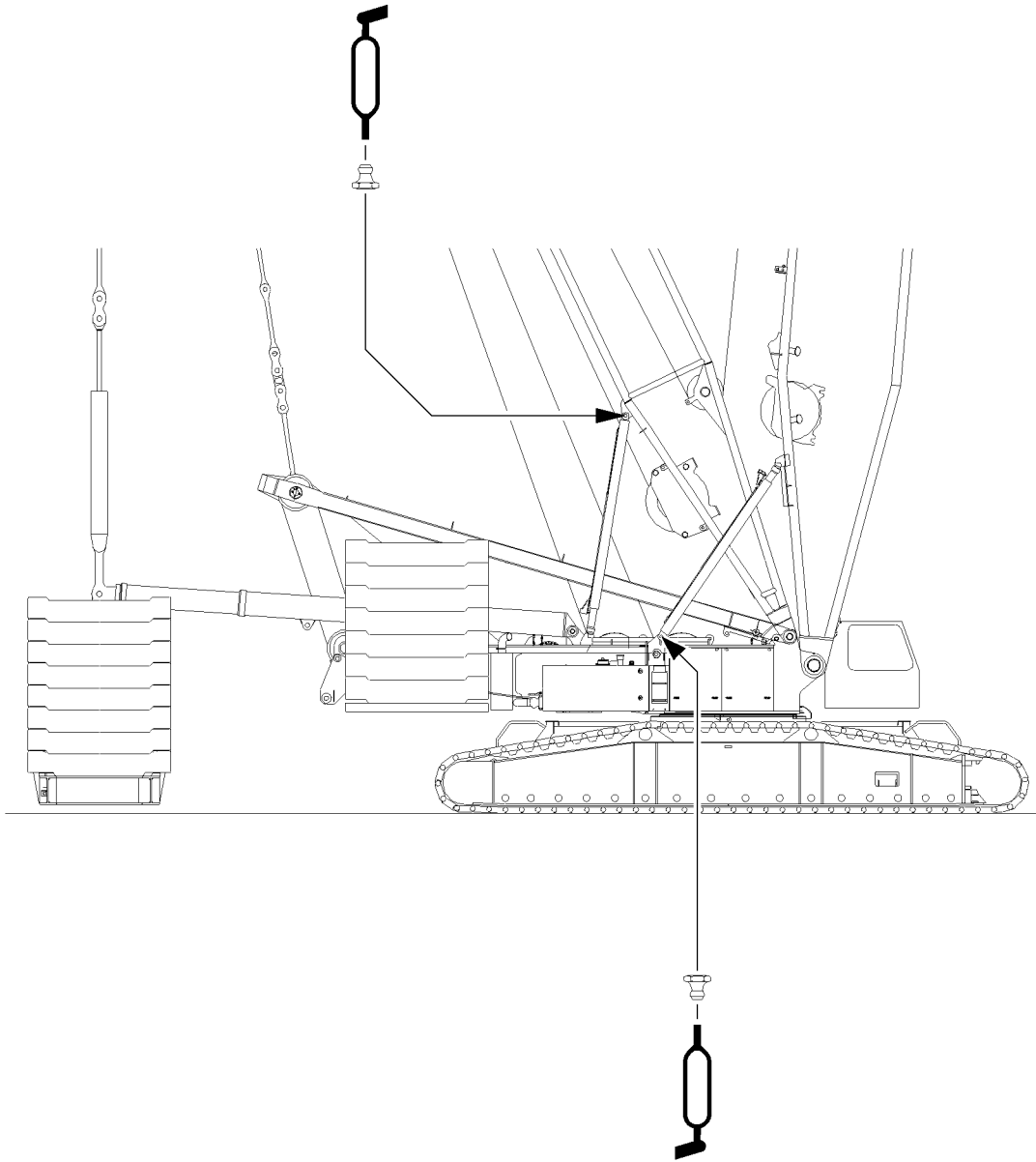

B108461

2.3 Lubrication schedule for crane superstructure

2.3.1 Relapse cylinder bearing

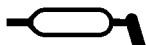

Note

► The lube points are marked with this icon!

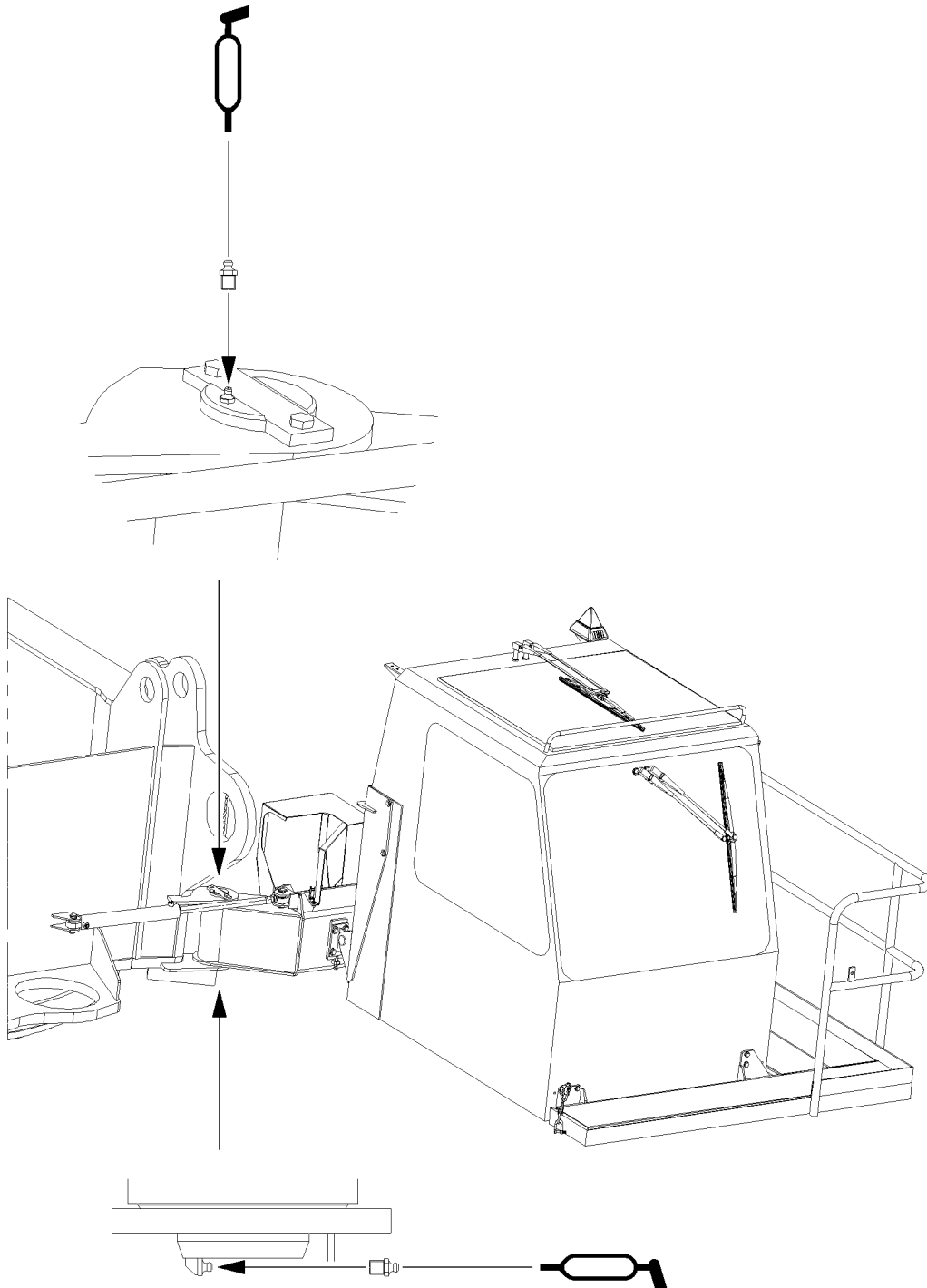

B108987

2.3.2 Swing arm crane operator's cab

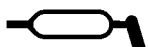

Note

▶ The lube points are marked with this icon!

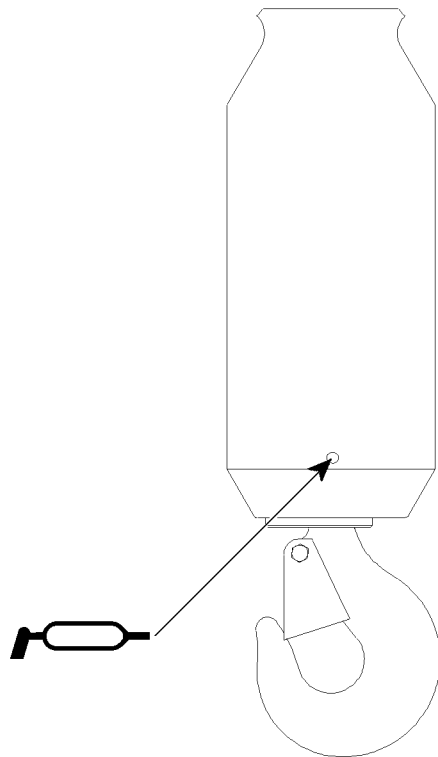
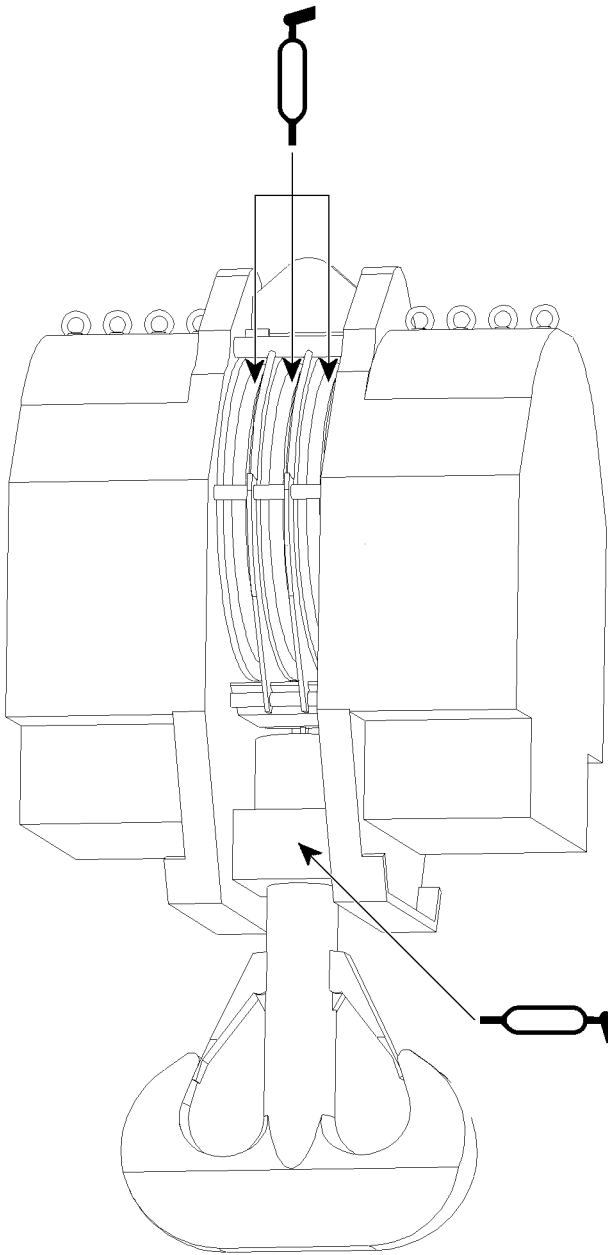

B108145

2.4 Lubrication schedule - Equipment

2.4.1 Hook block / load hook

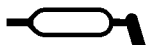

Note

► The lube points are marked with this icon!

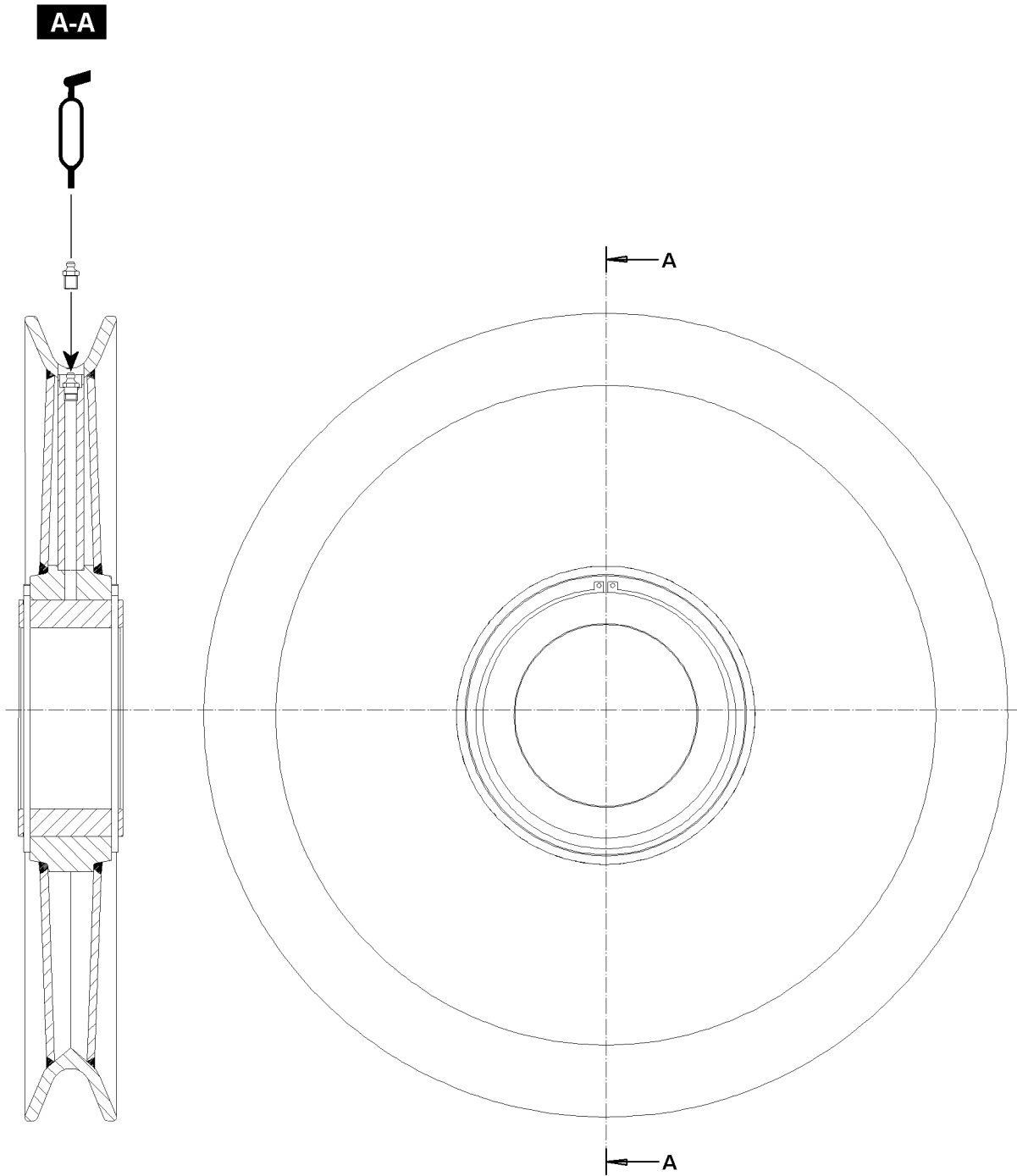

B108928

2.4.2 Cable pulley

**Note**

- ▶ The rope pulley shown in this chapter is only an example and can deviate in type and version from other rope pulleys!
-

**Note**

- ▶ The lube points are marked with this icon!
-

B195219

1 Specified service items and lubricants for Liebherr cranes

1.1 Service items and lubricants



Note

- ▶ To improve the cold start ability of the diesel engine at an ambient temperature below -10 °C, we recommend the use of the following engine oil:
- ▶ Viscosity grade SAE 5W-30 according to specification ACEA E6.
- ▶ **LWE Id. No.: 11100934!**

	Usage	Ambient temperature for driving and crane operation	
		-25 °C to +50 °C	-40 °C to +30 °C
1	Diesel engine	LWE Id. No.: 10663796 SAE 10W-40 low ash ACEA E6 Observe the instructions of the engine manufacturer. Below -20 °C with pre-heating	LWE Id. No.: 11100934 SAE 5W-30 low ash ACEA E6 Observe the instructions of the engine manufacturer. Below -20 °C with pre-heating
2	Drive axle With differential locks, Planetary gear and Installed distributor gear	LWE Id. No.: 861901008 SAE 90 API GL 5	LWE Id. No.: 10425142 SAE 75W-90 API GL 5
3	Axle drive ZF DK-7	LWE Id. No.: 861901008 ZF TE-ML 05	LWE Id. No.: 10425142 ZF TE-ML 05
4	Vehicle distributor gear KESSLER VG 1800, VG 2400, VG 2550, VG 2600, VG 3750 W 3750 ZF Passau, STEYR PUCH VG 1200, VG 1600, VG 2000, VG 3800	LWE Id. No.: 861901008 SAE 90 API GL 5 ZF TE-ML 19	LWE Id. No.: 10425142 SAE 75W-90 API GL 5 ZF TE-ML 19
5	Offset gear (drop box) ZF Passau, STEYR PUCH	LWE Id. No.: 861901008 ZF TE-ML 19	LWE Id. No.: 10425142 ZF TE-ML 19

1.2 Service items and lubricants (continuation)

	Usage	Ambient temperature for driving and crane operation	
		-25 °C to +50 °C	-40 °C to +30 °C
6.1	Pump distributor gear Filled with mineral gear oil	LWE Id. No.: 861901008 SAE 90 API GL 5	LWE Id. No.: 10425142 SAE 75W-90 API GL 5
6.2	Pump distributor gear Filled with synthetic gear oil	LWE Id. No.: 861901208 CLP PG 220, DIN 51517-3 Do not mix with mineral oils!	LWE Id. No.: 10664125 CLP PG 150, DIN 51517-3 Do not mix with mineral oils!
6.3	Pump distributor gear LTC 1055-3.1	LWE Id. No.: 10425142 SAE 75W-90 API GL 5	LWE Id. No.: 10425142 SAE 75W-90 API GL 5
6.4.1	Pump distributor gear Primary aggregate	LWE Id. No.: 861900608 ATF Dexron III	LWE Id. No.: 861900608 ATF Dexron III
6.4.2	Pump distributor gear Secondary aggregate	LWE Id. No.: 10424910 CLP HC 150, DIN 51517-3	LWE Id. No.: 10424910 CLP HC 150, DIN 51517-3
6.5	Pump distributor gear Cranes with Diesel engines of exhaust emission stage III B	LWE Id. No.: 10424910 CLP HC 150, DIN 51517-3	LWE Id. No.: 10424910 CLP HC 150, DIN 51517-3

1.3 Service items and lubricants (continuation)

	Usage	Ambient temperature for driving and crane operation	
		-25 °C to +50 °C	-40 °C to +30 °C
7.1	Powershift transmission ZF Torque converter transmission WG 120, WG 150, WG 180, WG 181, WG 200, WG 201	LWE Id. No.: 8610240 ZF TE-ML 03 Below -20 °C run until warm according to operating instructions	LWE Id. No.: 861900608 ZF TE-ML 03 Below -20 °C run until warm according to operating instructions
7.2	Powershift transmission ZF torque converter WG 251* ZF ERGOPOWER WG 210, WG 260, WG 310 * also for ambient temperatures above -10 °C	LWE Id. No.: 861900608 ZF TE-ML 03 Below -20 °C run until warm according to operating instructions	LWE Id. No.: 861900608 ZF TE-ML 03 Below -20 °C run until warm according to operating instructions
8	Powershift transmission CLARK	LWE Id. No.: 8610240 SAE 10W-40 ACEA E4 Below -20 °C run until warm according to operating instructions	LWE Id. No.: 861900608 ATF Dexron II D ALLISON C4 Below -20 °C run until warm according to operating instructions
9	Offset gear (drop box) ALLISON	LWE Id. No.: 8610240 SAE 10W-40 API CF, ACEA E4 Below -20 °C run until warm according to operating instructions	LWE Id. No.: 861900608 ATF Dexron II D ALLISON C4 Below -20 °C run until warm according to operating instructions

1.4 Service items and lubricants (continuation)

	Usage	Ambient temperature for driving and crane operation	
		-25 °C to +50 °C	-40 °C to +30 °C
10.1	Automatic transmission ALLISON CLBT 740, CLBT 750, CLBT 754, CLBT 755, HT 755, HD 4560	ATF Dexron III ALLISON C4 Below -20 °C run until warm according to operating instructions	LWE Id. No.: 861903708 CASTROL Transynd Below -20 °C run until warm according to operating instructions
10.2	Automatic transmission ZF	LWE Id. No.: 861900608 ZF TE-ML 14 Below -20 °C run until warm according to operating instructions	LWE Id. No.: 861900608 ZF TE-ML 14 Below -20 °C run until warm according to operating instructions
11	Automatic transmission ZF AS-Tronic ZF TC-Tronic (basic gear) ZF TC-Tronic HD (basic gear)	LWE Id. No.: 10218305 ZF-Ecofluid M ZF TE-ML 02	LWE Id. No.: 10218305 ZF-Ecofluid M ZF TE-ML 02 below -20 °C preheat gear according to operating instructions
12.1	Converter clutch unit ZF TC HD	LWE Id. No.: 10218305 ZF-Ecofluid M ZF TE-ML 02	LWE Id. No.: 10218305 ZF-Ecofluid M ZF TE-ML 02 below -20 °C preheat gear according to operating instructions
12.2	Converter clutch unit ZF TC 2	LWE Id. No.: 861900608 ZF TE-ML 14	LWE Id. No.: 861900608 ZF TE-ML 14
13	Gearbox ZF ECO-Split	LWE Id. No.: 10218305 ZF Ecofluid M ZF TE-ML 02	LWE Id. No.: 10218305 ZF Ecofluid M ZF TE-ML 02

1.5 Service items and lubricants (continuation)

	Usage	Ambient temperature for driving and crane operation	
		-25 °C to +50 °C	-40 °C to +30 °C
14	Rope winch	LWE Id. No.: 861901208 CLP PG 220, DIN 51517-3 Do not mix with mineral oils!	LWE Id. No.: 861901208 CLP PG 220, DIN 51517-3 Do not mix with mineral oils!
15	Slewing gear	LWE Id. No.: 861901208 CLP PG 220, DIN 51517-3 Do not mix with mineral oils!	LWE Id. No.: 861901208 CLP PG 220, DIN 51517-3 Do not mix with mineral oils!
16	Winch of Telescopic boom guying	LWE Id. No.: 861901208 CLP PG 220, DIN 51517-3 Do not mix with mineral oils!	LWE Id. No.: 861901208 CLP PG 220, DIN 51517-3 Do not mix with mineral oils!
17.1	Crane hydraulics Crane chassis and crane super- structure	LWE Id. No.: 861903508 Liebherr Hydraulic 37	LWE Id. No.: 10293807 Liebherr Hydraulic Plus Arctic
17.2	Crane hydraulics LTC 1055-3.1	LWE Id. No.: 10293807 Liebherr Hydraulic Plus Arctic	LWE Id. No.: 10293807 Liebherr Hydraulic Plus Arctic
17.3	Crane hydraulics LTM 11200-9.1 Crane chassis and crane superstructure LTR 11200 Crane superstructure	LWE Id. No.: 10293807 Liebherr Hydraulic Plus Arctic	LWE Id. No.: 10293807 Liebherr Hydraulic Plus Arctic

1.6 Service items and lubricants (continuation)

	Usage	Ambient temperature for driving and crane operation	
		-25 °C to +50 °C	-40 °C to +30 °C
18	Brake system if hydraulically actuated	LWE Id. No.: 861000108 DOT 4 SAE J 1703e	LWE Id. No.: 861000108 DOT 4 SAE J 1703e
19	Clutch actuator	LWE Id. No.: 861000108 DOT 4 SAE J 1703e	LWE Id. No.: 861000108 DOT 4 SAE J 1703e
20	King pin bearing Drive shaft if not maintenance-free	Special regulations: Liebherr LWE Id. No.: 861301308 Liebherr Special grease 9610 Plus	Special regulations: Liebherr LWE Id. No.: 10296825 Liebherr Universal grease Arc- tic
21	Slide and roller bearing roller bearing joint	Special regulations: Liebherr LWE Id. No.: 861301308 Liebherr Special grease 9610 Plus	Special regulations: Liebherr LWE Id. No.: 10296825 Liebherr Universal grease Arc- tic
22	Central lubrication system	Special regulations: Liebherr LWE Id. No.: 861301308 Liebherr Special grease 9610 Plus	Special regulations: Liebherr LWE Id. No.: 10296825 Liebherr Universal grease Arc- tic
23	Boom lock	Special regulations: Liebherr LWE Id. No.: 861301308 Liebherr Special grease 9610 Plus	Special regulations: Liebherr LWE Id. No.: 10296825 Liebherr Universal grease Arc- tic
24	Slewing ring connection Roller bearing	Special regulations: Liebherr LWE Id. No.: 861301308 Liebherr Special grease 9610 Plus	Special regulations: Liebherr LWE Id. No.: 10296825 Liebherr Universal grease Arc- tic

1.7 Service items and lubricants (continuation)

	Usage	Ambient temperature for driving and crane operation	
		-25 °C to +50 °C	-40 °C to +30 °C
25	Support pad with equalization Glide shoes of cab guide on vehicle frame LTC 1045-3.1	Special regulations: Liebherr LWE Id. No.: 861303608 Liebherr Telescope grease 9613 Plus	Special regulations: Liebherr LWE Id. No.: 861303608 Liebherr Telescope grease 9613 Plus
26	Plastic slide bearing Sliding beam	Special regulations: Liebherr LWE Id. No.: 861303608 Liebherr Telescope grease 9613 Plus	Special regulations: Liebherr LWE Id. No.: 861303608 Liebherr Telescope grease 9613 Plus
27	Plastic slide bearing Telescopic boom	Special regulations: Liebherr LWE Id. No.: 861303608 Liebherr Telescope grease 9613 Plus	Special regulations: Liebherr LWE Id. No.: 861303608 Liebherr Telescope grease 9613 Plus
28	Outer slide bearing Telescopic boom Guide rail on Telescoping cylinder	Special regulations: Liebherr LWE Id. No.: 861303308 Liebherr Special grease 1336 (Spray grease)	Special regulations: Liebherr LWE Id. No.: 861303308 Liebherr Special grease 1336 (Spray grease)
29	Inner slide bearing Telescopic boom (only during assembly)	Special regulations: Liebherr LWE Id. No.: 861303308 Liebherr Special grease 1336 (Spray grease)	Special regulations: Liebherr LWE Id. No.: 861303308 Liebherr Special grease 1336 (Spray grease)

1.8 Service items and lubricants (continuation)

	Usage	Ambient temperature for driving and crane operation	
		-25 °C to +50 °C	-40 °C to +30 °C
30	Gear ring rotary connection Slewing gear drive pinion	Special regulations: Liebherr LWE Id. No.: 861007708 Liebherr RHS-Fluid	Special regulations: Liebherr LWE Id. No.: 861007708 Liebherr RHS-Fluid
31	Running rope	LWE Id. No.: 10173371 Liebherr WR-Lube SC	LWE Id. No.: 10173371 Liebherr WR-Lube SC
32	Radiator fluid Diesel engine and heating system	Special regulations: Liebherr LWE Id. No.: 861600508 50 % anti-corrosion fluid / antifreeze 50 % water	Special regulations: Liebherr LWE Id. No.: 861600508 50 % anti-corrosion fluid / antifreeze 50 % water
33.1	Drive transmission crawler crane	see nameplate	see nameplate
33.2	Drive transmission crawler crane LTR 1100	LWE Id. No.: 861901008 SAE 90 API GL 5	LWE Id. No.: 10425142 SAE 75W-90 API GL 5
34	Recovery winch	See data tag and manufacturer's instructions	See data tag and manufacturer's instructions
35	Recovery winch rope	See manufacturer's instructions	See manufacturer's instructions
36	Steering uncoupling LTC 1045-3.1	LWE Id. No.: 10800345 Teflon Spray	LWE Id. No.: 10800345 Teflon Spray

blank page!

B197077

1 Procedure to follow in case of a problem

This chapter is supportive for the following questions:

- What to do in case of a problem?
- Which displays and component groups are relevant for error diagnostics?
- How can an error diagnostics be carried out?
- How to proceed in case of error messages of the LICCON computer system?
- Which measures are to be taken for defective components?
- Which measures are to be taken in clear problem cases?
- Which data is important for communication with Liebherr Service?



WARNING

Erroneous or insufficient repair!

If a crane is not properly or insufficiently repaired, then this can result in accidents!

Personnel can be killed or seriously injured!

This could result in property damage!

- ▶ The crane may only be repaired by authorized and trained expert personnel!



WARNING

Measures without the help of Liebherr Service!

Measures in case of a problem, which are carried out without consulting Liebherr Service can cause damage to the crane!

Personnel can be killed or seriously injured!

This could result in property damage!

- ▶ If problems remain or in case of error messages, consult Liebherr Service to determine the cause of the problem and further procedure.



WARNING

Problems with raised load!

If a crane is checked, diagnosed or repaired with a raised load, then there is a danger of accidents!

During accidents, personnel could be killed or seriously injured!

This could result in property damage!

- ▶ If possible, set the load down!
- ▶ If possible, place down the boom system!
- ▶ If the load cannot be set down and / or the boom system cannot be placed down, secure a wide-ranging danger zone!



Note

- ▶ The illustrations in this chapter are examples, they can deviate from the crane.
- ▶ In normal crane operation, an identical display may **not** appear on the LICCON monitors. The crane configuration and version of the illustrated crane can be different.

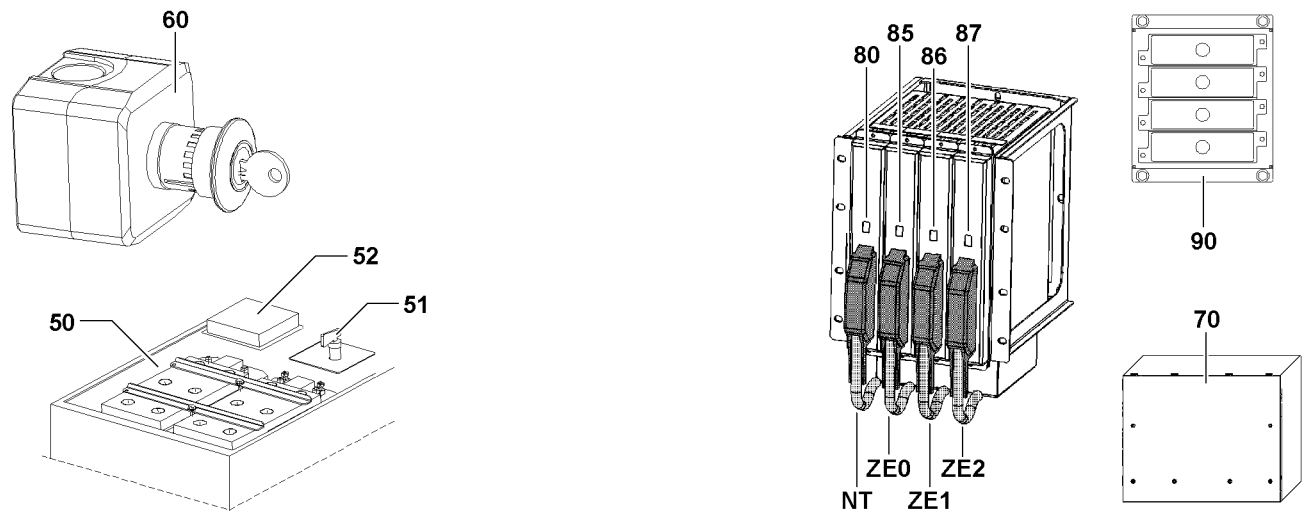
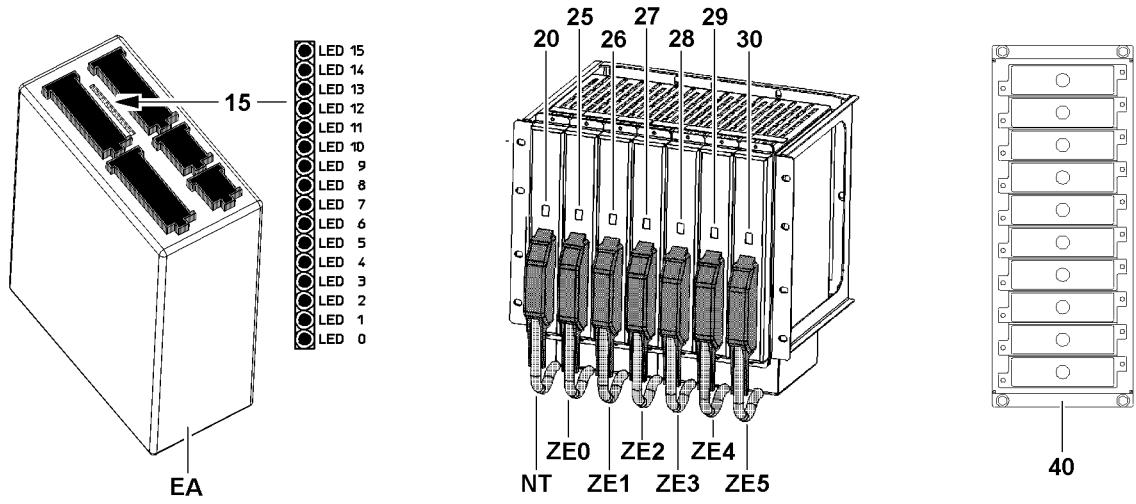
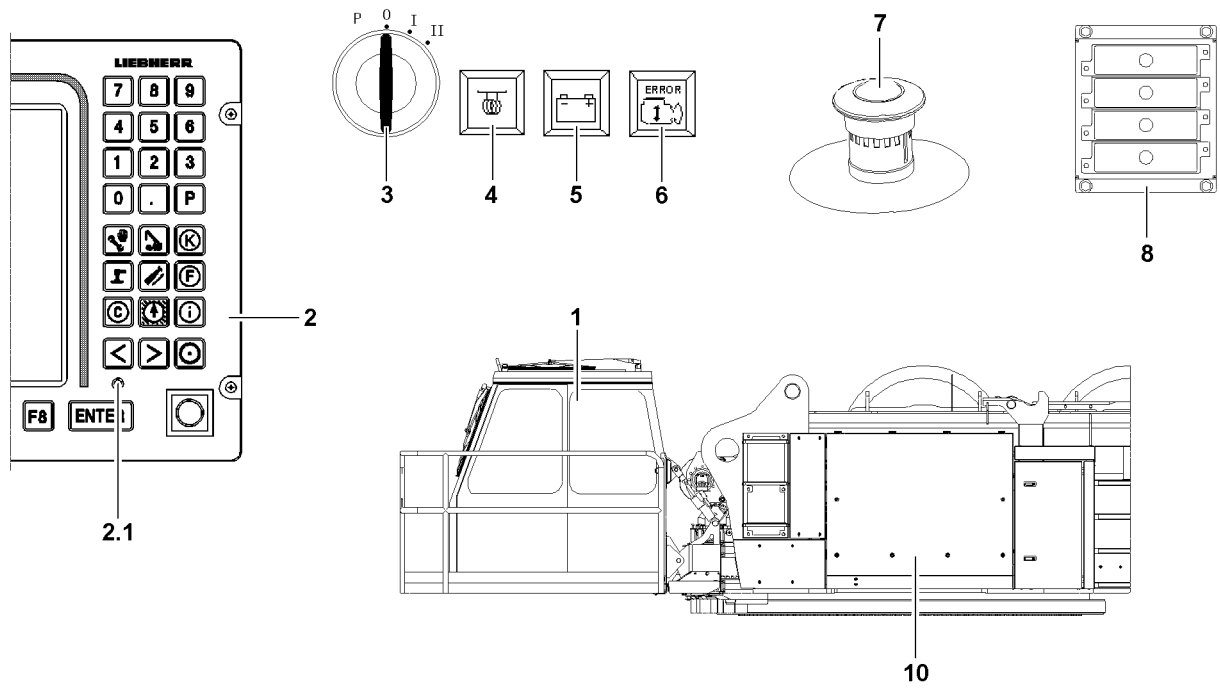

B113286

1.1 Overview of displays and component groups for error diagnostics

Various displays and component groups allow the crane driver:

- To localize errors.
- To prepare quicker and more precise communication with Liebherr Service.
- To diagnose and remedy errors with the help of the “Diagnostics operating instructions”.



Note

- ▶ If separate Operating instructions have been provided by the supplier as part of the scope of delivery for the crane, then it must be observed!

Position	Crane operator's cab 1
2	LICCON monitor
2.1	LED-display power supply LICCON monitor
3	Ignition switch
4	Indicator light Engine preheating (heat flange)
5	Warning light Charge control
6	Warning light engine error (only LR 1400/2)
7	EMERGENCY STOP switch in crane operator's cab
8	Fuses (Installation location: in the side console - illustration exemplary)

Position	Switch cabinet 10
EA	I / O module
15	LED display I / O module
NT	Power supply
CPU-5	CPU 0 to 5
20	LED display power supply
25–30	LED displays CPU0 to CPU5
40	Fuses Switch cabinet (illustration exemplary)

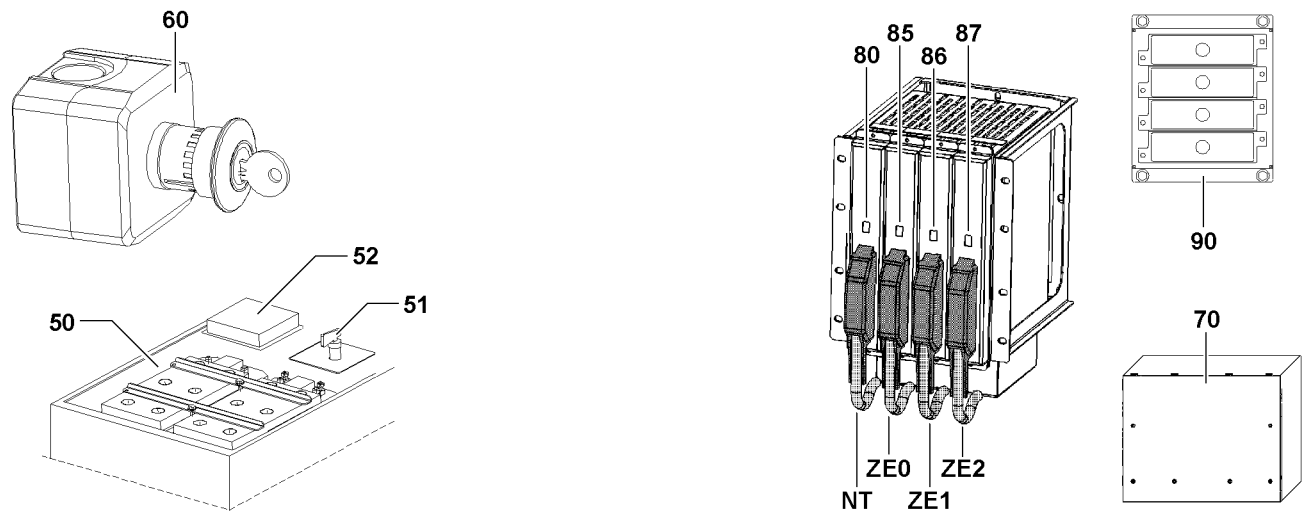
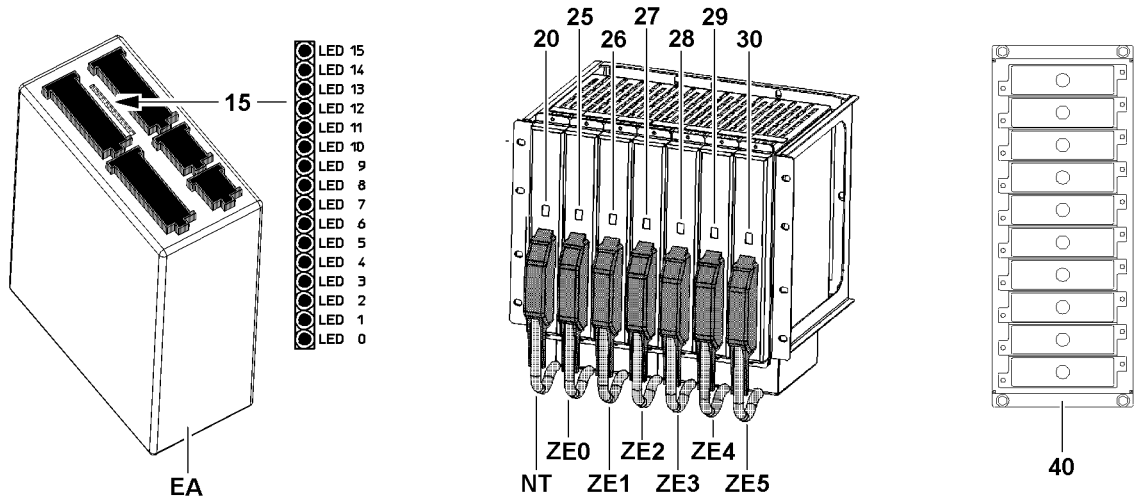
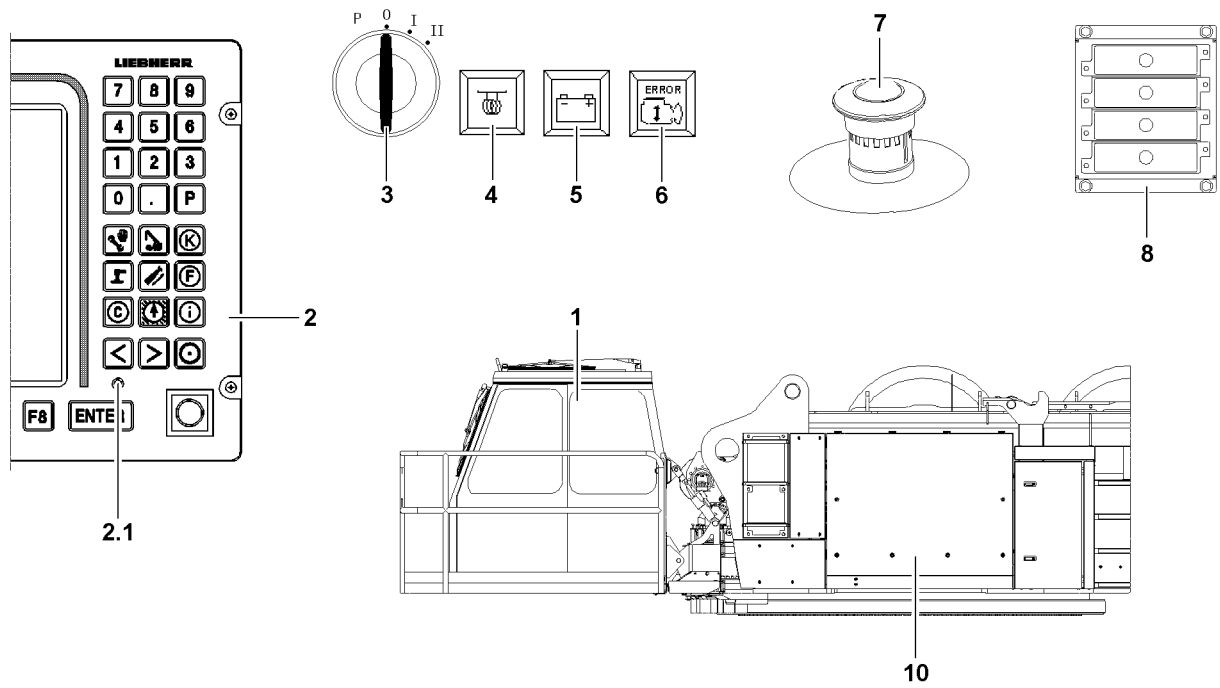

B113286

Position	Crane general
50	Battery box (illustration exemplary)
51	Mechanical battery master switch (if present - illustration exemplary)
52	Fuses Battery box (illustration exemplary)
60	EMERGENCY STOP switch* (outside the crane operator's cab - illustration exemplary)

Position	Switch cabinet Ballast trailer* / Narrow track crawler track
70	Switch cabinet Ballast trailer* or Switch cabinet narrow track crawler track (only LR 1400/2W)
NT	Power supply
CPU0	CPU 0
CPU1	CPU 1
CPU2	CPU 2 (only certain crane types)
80	LED display power supply
85–87	LED displays CPU0 to CPU2
90	Fuses Switch cabinet (illustration exemplary)

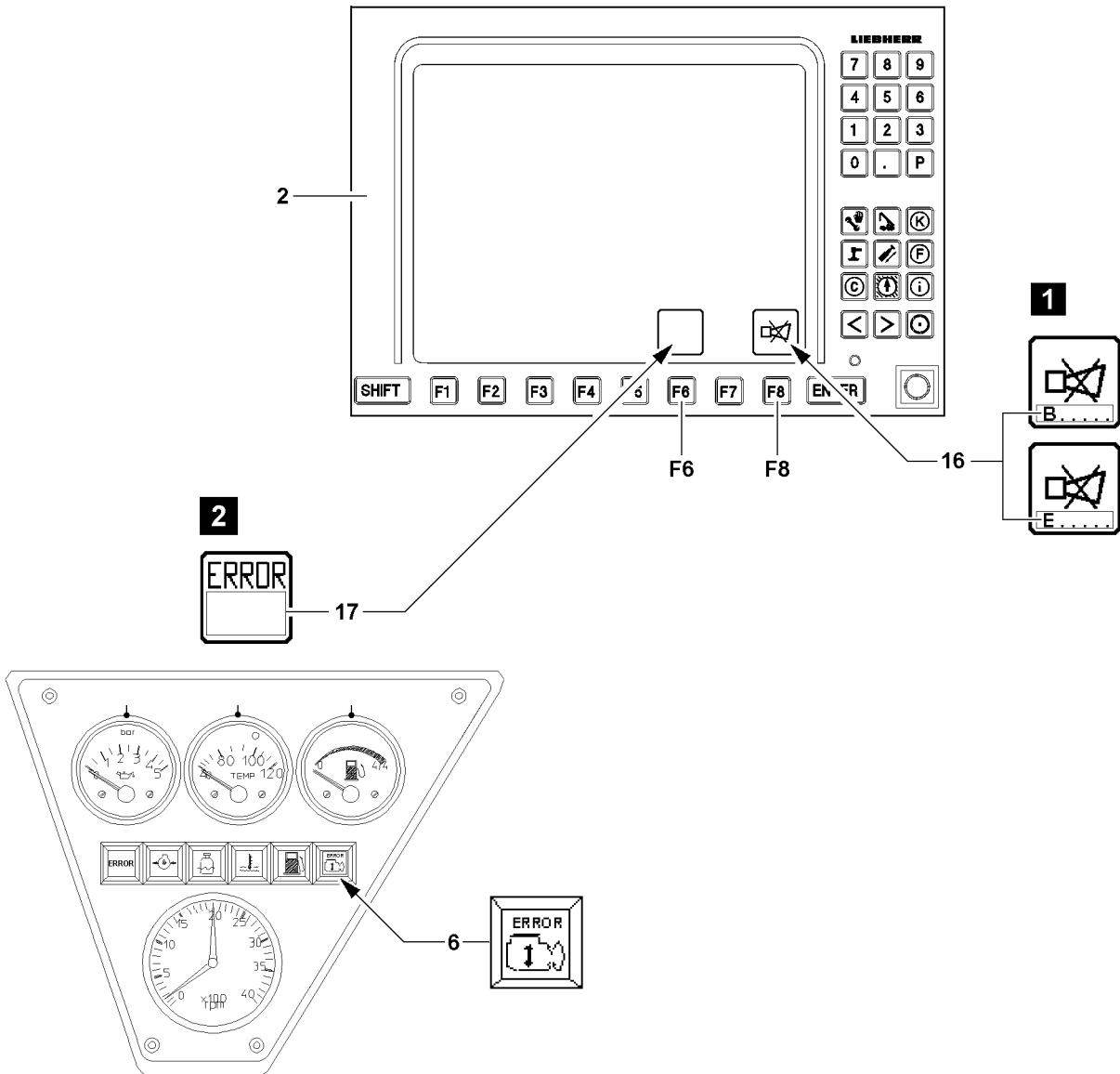

B113287

1.2 Type of problem

Problems can be assigned to various error sources:

- Operating error / system error
 - Displayed by error messages
 - to be remedied by crane operator
- Errors on mechanics / components
 - To be remedied by crane operator / Liebherr Service.
- Combination of error sources
 - To be remedied by crane operator / Liebherr Service.



Note

Evaluation of error messages

- ▶ With the aid of the "LICCON Error Code Manual" (LICCON error code list) and the Diagnostics manual, all error messages can be evaluated!

1.2.1 Error messages LICCON monitor

Two types are differentiated (all crane types except LR1400/2):

- Operating errors
 - Displayed in field **16** by error number / LEC: B.....
- System errors in LICCON computer system
 - Displayed in field **16** by error number / LEC: E.....

Only LR1400/2:

- Error messages
 - Displayed in field **17**

1.2.2 Error messages Warning light engine error (LR 1400/2)

Only LR1400/2:

- Blinker code Engine monitoring
 - Displayed by Warning light Engine error **6**

1.2.3 Error messages via LED on components

LED displays are on the following components:

- LED display I / O module
- LED display power supply
- LED display CPU

2 Carrying out error diagnostics

The crane is monitored:

- By the LICCON computer system for operating / system errors.
- By indicator lights and control displays.

If errors occur, error messages are issued and / or indicator lights light up.

Error messages appear:

- In LICCON monitor.
- On I / O module, power supply (NT) or CPU

Indicator lights are located within view:

- In the Crane operator's cab.
- On Components.
- In the switch cabinets.

**WARNING**

Risk of accident!

When carrying out the error diagnostics, there is a danger of accidents!

During accidents, personnel could be killed or seriously injured!

This could result in property damage!

- ▶ Take the crane out of service!
- ▶ In case of safety defects, secure the crane to prevent continued operation!
- ▶ The crane may only be inspected, diagnosed and repaired at a standstill and in shut down condition!
- ▶ Inspections, error diagnostics and repairs, for which the crane must be in operation are only permissible with extreme caution and constant visual and voice contact between all associated personnel!
- ▶ Inspections, error diagnostics and repairs may only be carried out by expert or trained personnel!
- ▶ For inspections, error diagnostics and repairs of electrical devices on the crane, power must be turned off and ensured to remain so for the duration of the work!
- ▶ Test operation after a repair must be made by the crane operator or in his presence!

**Note**

- ▶ Always observe error messages and illuminated indicator lights!
- ▶ For overview of indicator lights on the crane superstructure, see Crane operating instructions, chapter 4.01.
- ▶ For detailed procedure in case of error messages, see Diagnostics operating instructions.

Several possibilities exist for an error diagnostics:

- Without the help of Liebherr Service.
- With the help of Liebherr Service: Error diagnostics by phone.
- With the help of Liebherr Service: Remote diagnostics

2.1 Error diagnostics without the help of Liebherr Service

**WARNING**

Acting on your own authority!

If measures are carried out on your own authority in case of a problem, then this can result in damage to the crane!

Damage on the crane can cause erroneous functions and accidents!

Personnel can be severely injured or killed!

This could result in property damage!

- ▶ Observe and adhere to the notes and instructions in this chapter.
- ▶ Observe the Diagnostics operating instructions.
- ▶ In case of lack of clarity, contact Liebherr Service.
- ▶ If problems remain or in case of error messages, consult Liebherr Service to determine the cause of the problem and further procedure.

2.1.1 Calling up an error message

- All crane types except LR1400/2
- Error messages are always shown in the LICCON monitor **2**, which also shows the set up screen and the crane operating screen.
- ▶ After display of an error message in LICCON monitor **0 2**:
Press the function key **F8**.

Result:

- Acoustic warning is turned off.
- ▶ Press function key **F8** again.

Result:

- The error code with error text is displayed (error determination display in “test system”).
- In addition, all errors are listed in a separate error list (error text, cause, remedy).

In the error code, two different error types are differentiated:

- Operating errors - Error code starts with a “B”.
- System errors / application errors - Error code starts with an “E”.

- ▶ If an error code starts with a “B”:
Correct the operating error.
- ▶ If an error code starts with an “E”:
Call up the test system, see Diagnostics operating instructions.

or

In case of lack of clarity:

- Consult Liebherr Service.

2.1.2 Evaluating the error message

- Only LR1400/2
- Error messages are always shown in the LICCON monitor **2**, which also shows the set up screen and the crane operating screen.
- ▶ After display of an error message in LICCON monitor **0 2**:
Evaluate the error message with the aid of the “LICCON Error Code Manual” (LICCON error code list) and the Diagnostics manual.

2.1.3 Evaluating the blinker code

- Only LR1400/2
- ▶ After display of a blinker code via the Warning light Engine error **6**:
Evaluate the blinker code with the aid of the “LICCON Error Code Manual” (LICCON error code list) and the Diagnostics manual, see also chapter 4.03.

2.1.4 Calling up the test system



Note

- ▶ For calling up the test system, see Diagnostics Manual!
-

2.1.5 Problems on the mechanics / components of the crane

- ▶ Determine the damage and remedy it properly by using **original spare parts**.

2.1.6 Problems on pipes / hoses

Supply lines, return lines and control lines handle various media:

- Pneumatic pipes / hoses.
- Hydraulic pipes / hoses.
- Pipes / hoses for fluids and gases.
- ▶ Determine the damage and remedy it properly by using **original spare parts**.

2.1.7 Problems in electrical connections of the crane

- If a component / component group does no longer react, then the electrical connections may be interrupted.
- ▶ Check the error messages.
- ▶ Check the plug connections.
- ▶ Check the electrical connections visually.

Troubleshooting

The erection of the crane, for example after assembly on a new job site or with another equipment configuration, is not possible due to an error message?

- ▶ As the first step, make sure that all electrical connections have been made.
 - ▶ Check if all sensors or dummy plugs with integrated electronic have been connected properly.
-

- ▶ Determine the damage and remedy it properly by using **original spare parts**.

or

In case of lack of clarity:

- Observe the Diagnostics operating instructions.

or

- Consult Liebherr Service.

2.2 Error diagnostics with the help of Liebherr Service

2.2.1 Which data is required by Liebherr Service?

If the assistance of Liebherr Service is required, always provide the following information:

- Crane type
- Crane number
- Complete error number and any error message displayed on the LICCON monitor
- Complete blinker code (only LR1400/2)
- For certain errors: LED displays of power supply **NT** and CPUs **ZE**
- Application conditions of crane.
- Action during which the error occurs.
- Possibly frequency of error.

2.2.2 Error diagnostics by phone

If there is any lack of clarity, contact Liebherr Service to determine the cause of the problem and further procedure.

- ▶ Contact Liebherr Service.
- ▶ Observe and adhere to the notes and instructions given by Liebherr Service.

2.2.3 Remote diagnostics*

The remote diagnostics makes it possible for Liebherr Service to check Liebherr cranes from a remote location in case of problems.

Make sure that the following prerequisite is met:

- The crane is equipped with the optional Remote diagnostics*.
- ▶ Contact Liebherr service by phone.
- ▶ Follow the instructions given by Liebherr Service to set up the Remote diagnostics*.
- ▶ Keep the phone connection to Liebherr Service up during the Remote diagnostics*.

blank page!

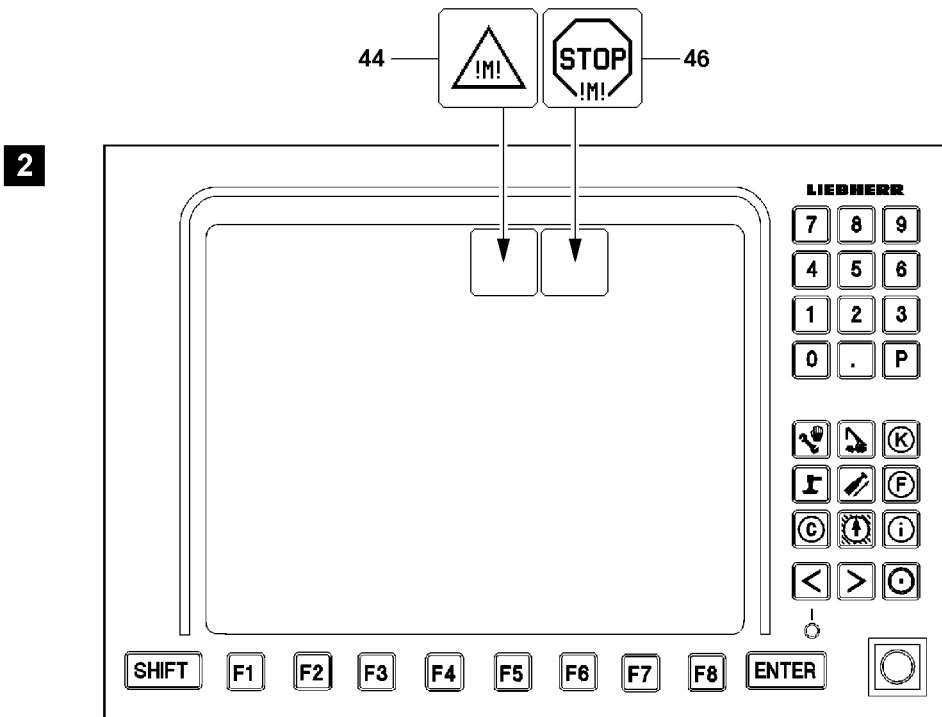
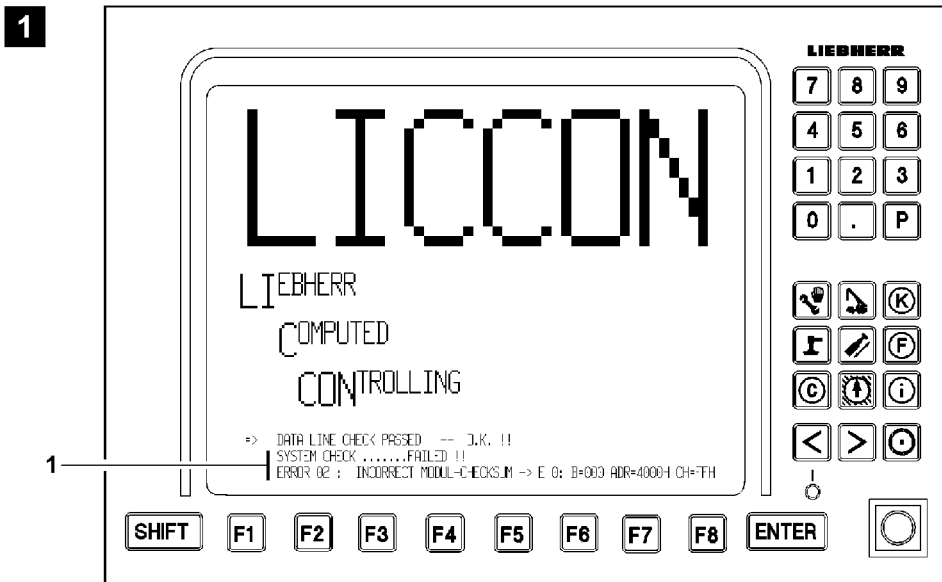

3 Measures in clear problem cases



Note

If a problem occurs, which is not described in this chapter:

- ▶ Contact Liebherr Service to determine the cause of the problem and further procedure.

3.1 Remediating temporary errors during system start



Note

- ▶ While the LICCON computer system starts, temporary error messages **1** can occur, see illustration **1**.

Errors, which occur temporarily, can have various causes, for example:

- Fluctuations in the power supply.
- Loose connection in plug connections of electrical lines.
- Error message can be a follow up error (of an already remedied error).
- ▶ Turn the LICCON computer system off and restart it after waiting for at least 5 s.
- ▶ Repeat this procedure up to three times (wait 2 min after 3 start attempts).
- ▶ If the same error image appears several times:
Call up the test system, see Diagnostics operating instructions.
- ▶ Contact Liebherr Service to determine the cause of the problem and further procedure.

3.2 Monitoring function reports a problem

- Does not apply for LR1400/2, since this crane type has separate display instruments.



Note

- ▶ For a detailed description of monitoring functions, see Crane operating instructions, chapter 4.02.

NOTICE

Danger of severe engine damage!

If the monitoring functions report a problem and / or warning occurrence, then you must react immediately and remedy the problem!

- ▶ React to problems and / or warning occurrences immediately and remedy the problem!
- ▶ If necessary, stop crane operation and turn the engine off!

The following alarm functions are indicated by blinking icons on the LICCON monitor (illustration **2**):

- Advance warning - engine **44**
- Engine stop **46**
- ▶ If an “Advance warning - engine” **44** or an “Engine stop” **46** is triggered, react immediately.
- ▶ In case of an Engine stop **46**, stop crane operation and turn the engine off.
- ▶ Find the cause and remedy it.

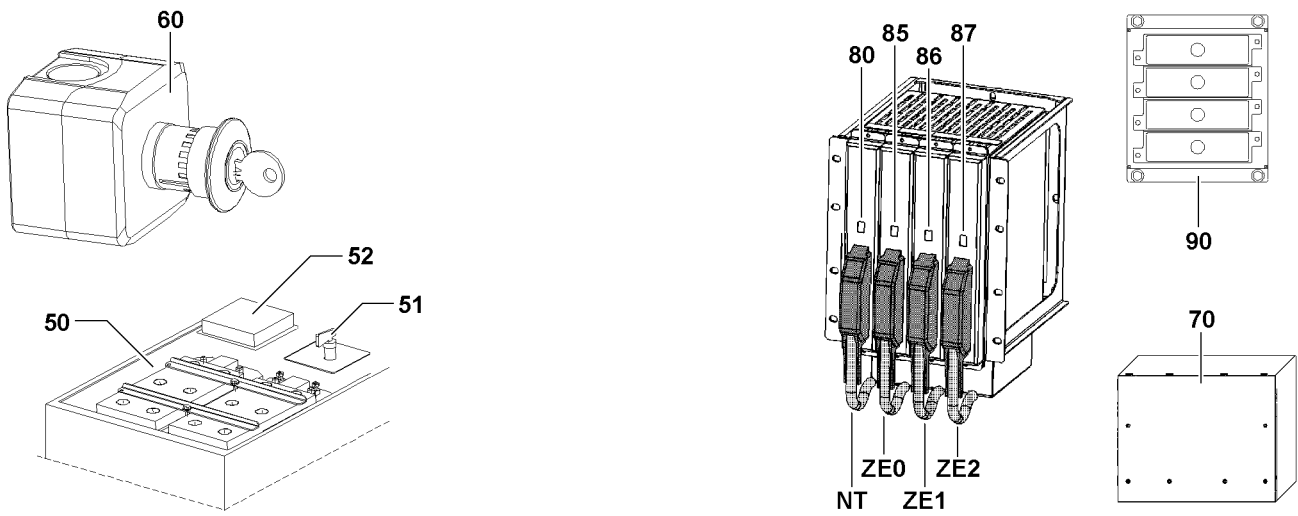
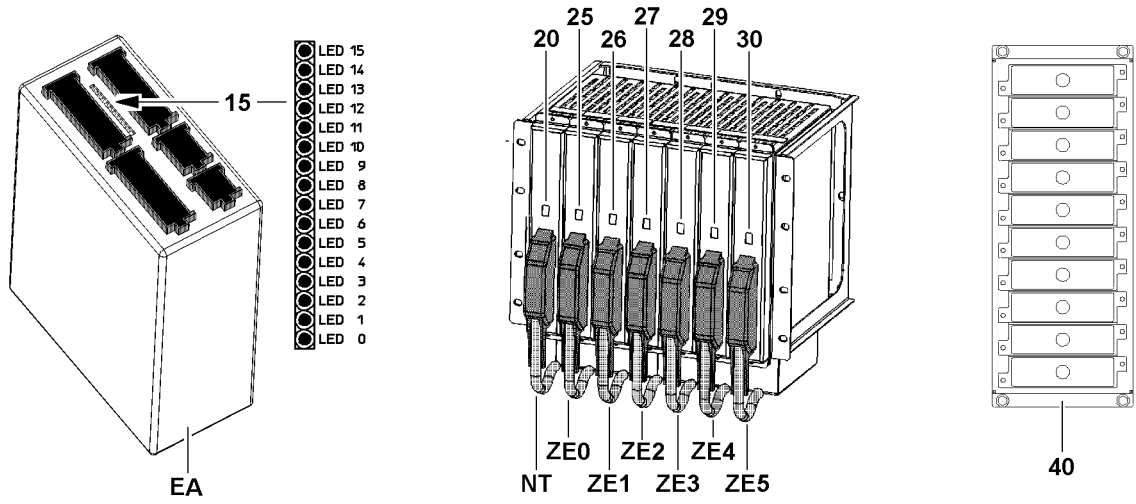
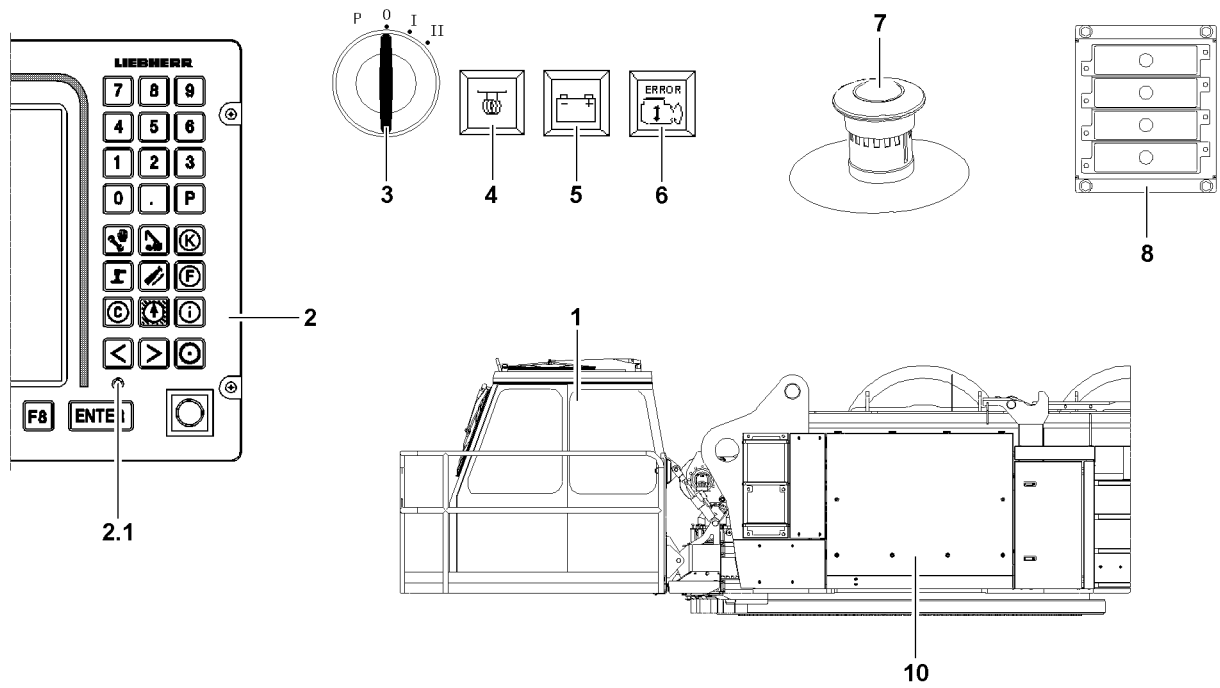

B113286

3.3 Engine does not start

Make sure that:

- There is sufficient fuel in the fuel tank.
- There is sufficient voltage in the batteries.

3.3.1 Checking the EMERGENCY STOP switch

Make sure that no EMERGENCY STOP switch is actuated:

- EMERGENCY STOP switch **7** in crane operator's cab
- EMERGENCY STOP switch **60** outside the crane operator's cab*

3.3.2 The engine does not start?

- ▶ No EMERGENCY STOP switch is actuated:
Turn the ignition off (turn ignition switch **3** to position **0**).
- ▶ Try to start the engine via the ignition switch **3**.
- ▶ If the engine still cannot be started:
Watch and evaluate the Warning light charge indicator **4** , Indicator light Preheat engine (heat flange) **5** and Warning light Engine error **6** (only LR 1400/2), see Crane operating instructions, chapter 4.03, section "Starting and stopping the engine".
- ▶ If the error cannot be remedied:
Contact Liebherr Service to determine the cause of the problem and further procedure.

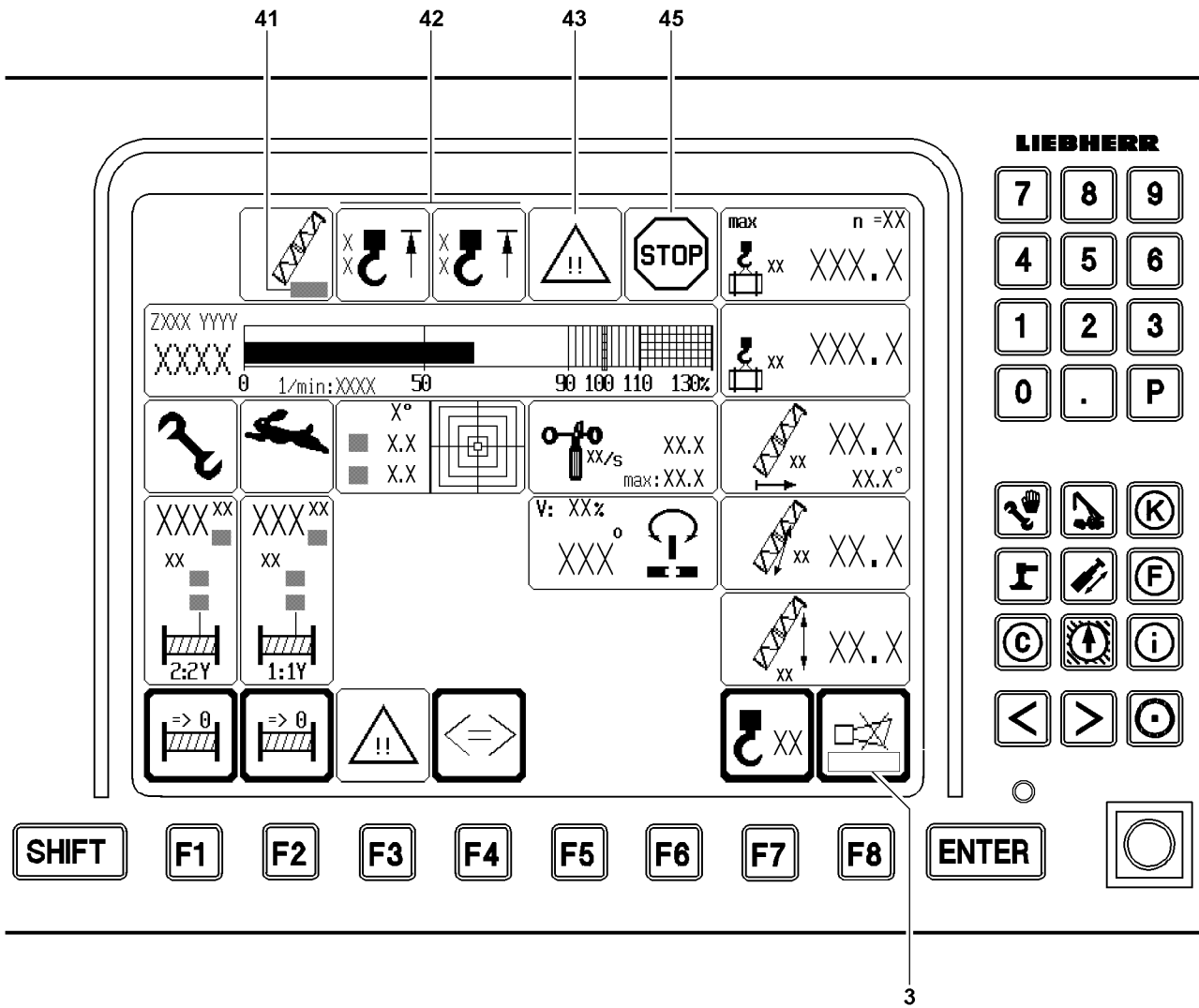

3.4 LICCON monitor

3.4.1 Operating errors: Did an alarm function occur?



Note

- ▶ For procedure of shut off of crane movement, see Crane operating instructions, chapter 4.20.
 - ▶ For a detailed description of alarm functions, see Crane operating instructions, chapter 4.02.
 - ▶ In case of an alarm function, an error message **3** with LICCON error code appears at the same time (not LR1400/2).
-

The following alarm functions are indicated by blinking icons on the LICCON monitor:

- Boom limitation **41**
- Hoist top limit switch **42**
- Advance warning **43**
- LMB Stop **45**

The limit ranges of the crane movements are monitored by:

- Hoist limit switch
- Angle sensors
- Pressure sensors
- Pull test brackets (force test boxes)
- Wind sensor
- Inductive sensors

If the limit ranges for these sensors are exceeded, the crane movements are turned off (LMB-STOP).

- ▶ Correct the operating error.

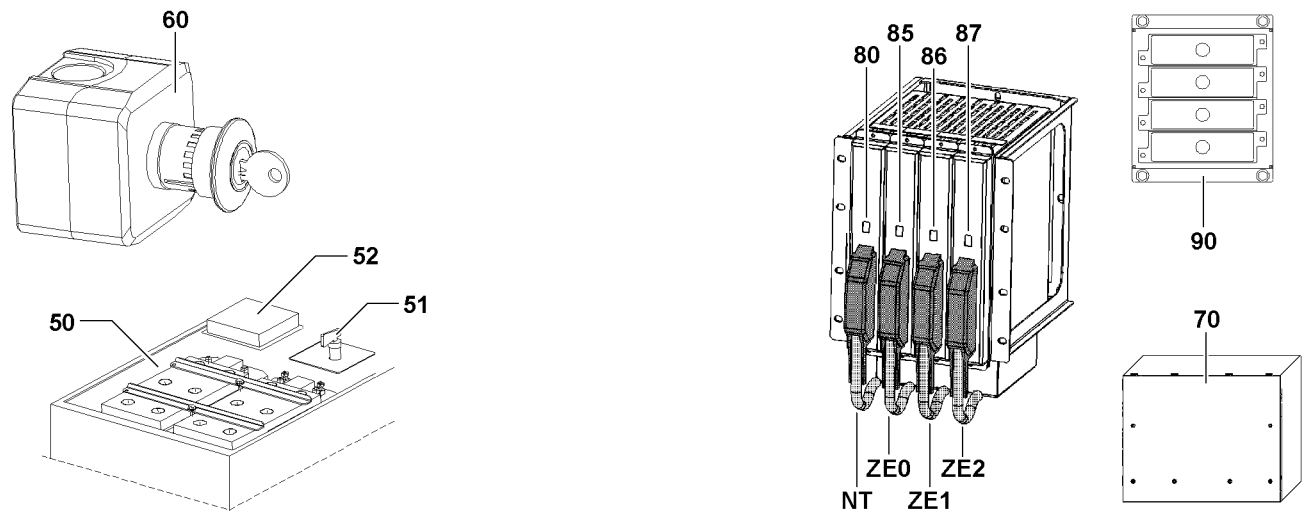
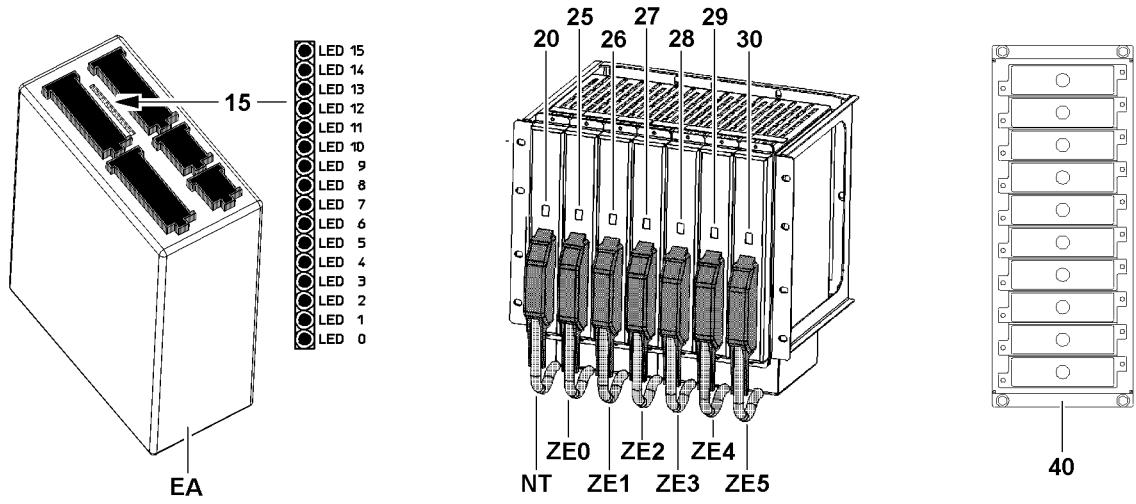
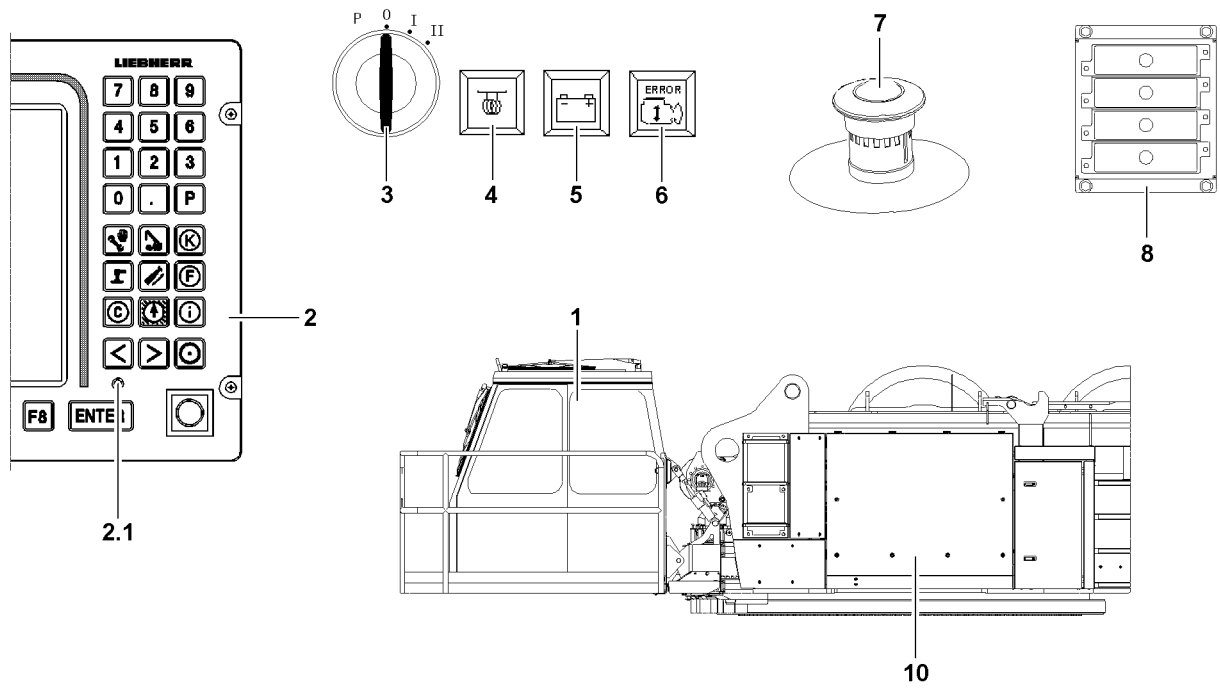

B113286

4 Measures for defective components



WARNING

Impairment of crane safety!

When using non-original spare parts, crane safety can be impaired!

Changed or manipulated components can fail!

Safety relevant components can malfunction!

The crane license as well as the manufacturer's warranty will become void!

Risk of accident!

Personnel can be severely injured or killed!

This could result in property damage!

- ▶ Use only original spare parts or spare parts approved by Liebherr Werk Ehingen!
 - ▶ Leave installed original parts unchanged!
-

Make sure that the following prerequisites are met:

- Error diagnostics has been carried out.
- Defective component has been determined.

4.1 Failure of hydraulic, electric or engine



Note

If the crane is equipped with the optional "Hydraulic emergency control*", then the crane can be taken down in case of failure of the crane hydraulic, crane electric or crane engine.

- ▶ For hydraulic emergency control, see Crane operating instructions, chapter 6.05.
-

- ▶ Take the crane down with the hydraulic emergency control* and repair it, contact Liebherr Service if necessary.

or

If the crane has no "Hydraulic emergency control*":

- Secure the crane and danger zone wide-ranging.
- ▶ Fix the crane, contact Liebherr Service if necessary.

4.2 Defective power supply (NT)

- ▶ Replace the defective power supply (NT) with a functioning power supply (NT).
-



Note

- ▶ For instruction of replacement of a defective power supply (NT), see Diagnostics operating instructions.
-

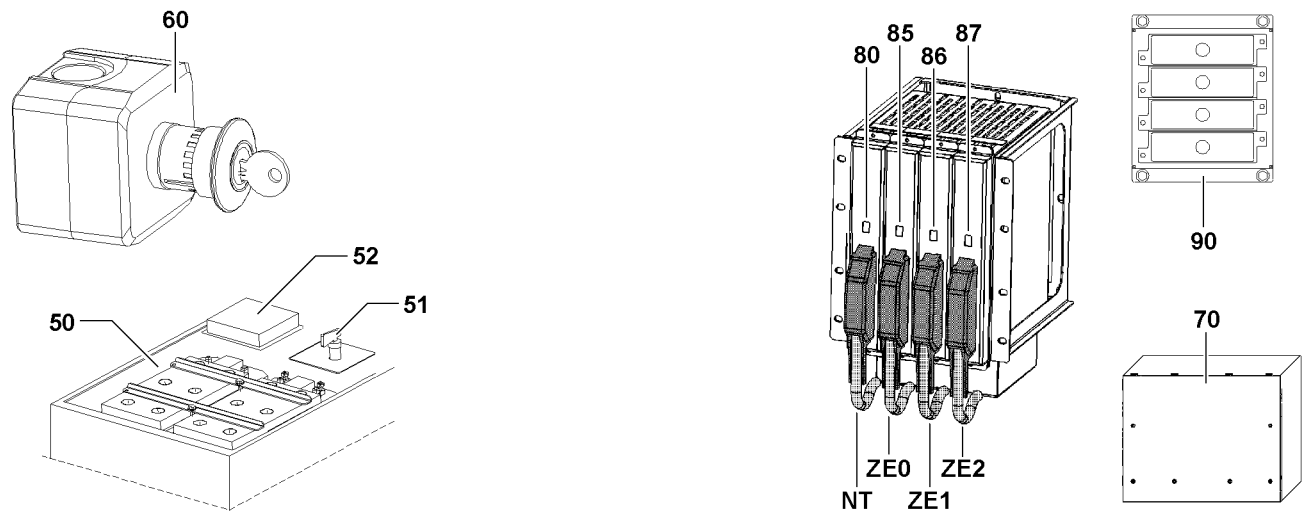
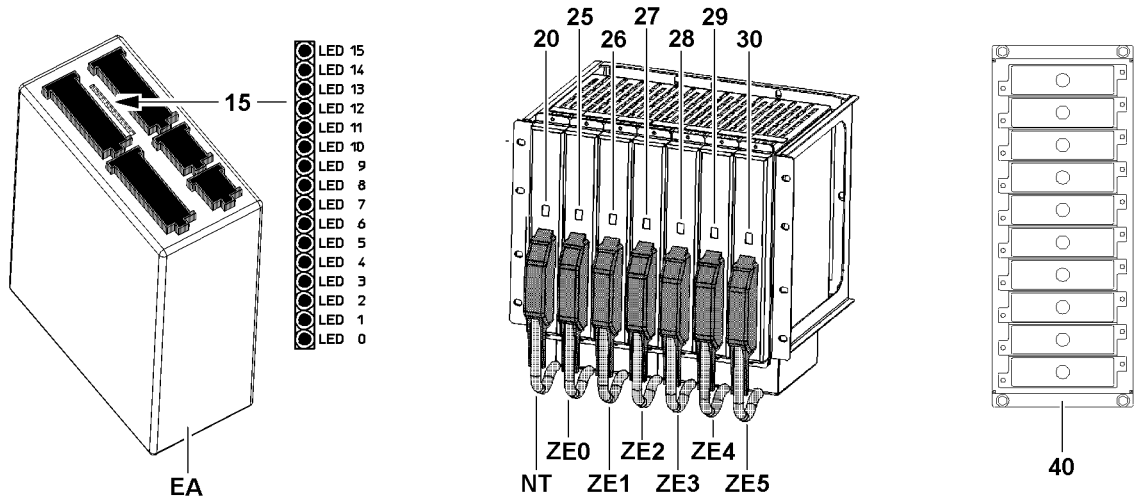
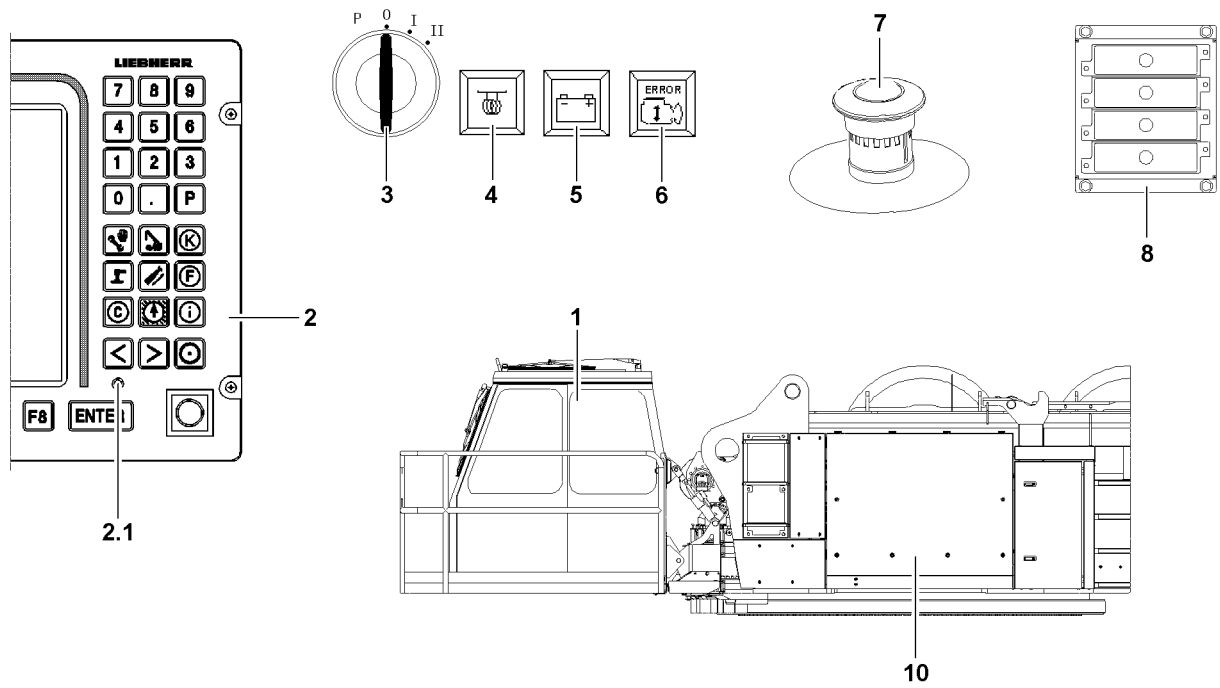

B113286

4.3 Defective Central processing unit (CPU)

- ▶ Replace a defective CPU with a functioning CPU.



Note

- ▶ For instruction of replacement of a defective CPU, see Diagnostics operating instructions.
-

4.4 Replacing a defective fuse

If a fuse is defective, then it must be replaced.

Make sure that the following prerequisites are met:

- Ignition switch **3** is in position **0**.
- Mechanical battery master switch **51** (if present) is in position **0**.
- A spare fuse of the same size and strength is available.

Fuses are located:

- In the fuse box crane operator's cab **8** (in the side console)
- In the fuse box switch cabinet. **40**
- In the battery box **50** (Fuses **52**)
- In the fuse box **90** (switch cabinet ballast trailer or narrow track crawler track)
- Directly on the individual components.

- ▶ Replace a defective fuse.
- ▶ Check the function.

Troubleshooting

The same fuse fails again?

- ▶ Continue troubleshooting, contact Liebherr Service if necessary.
 - ▶ Never bypass a defective fuse or replace it with a stronger fuse.
-

4.5 The LICCON monitor remains dark

- ▶ If the LICCON monitor **2** does not turn on after turn on:
See section Monitor errors in the Diagnostics operating instructions.
- ▶ If the problem cannot be remedied:
Contact Liebherr Service to determine the cause of the problem and further procedure.

4.6 Defective sensors

4.6.1 General

Depending on the classification of the sensor, crane operation with defective sensor:

- Can be continued without restriction.
- Can be continued with restriction.
- Can be continued only in LMB emergency operation.



WARNING

Limited warning functions!

If there is a defect on a participating sensor (LMB) and the crane is continued to be operated by bypassing the sensor other otherwise, then the warning functions and the shut offs of the LICCON overload protection are deactivated / limited!

- ▶ If there is a defect on a participating sensor (LMB), then the crane may be operated further only in emergency cases!
- ▶ Fix / replace the sensor before starting crane operation again!

Certain crane functions are also monitored with two sets of sensors.

If a defective sensor is shown:

- ▶ Replace / repair the defective sensor.

4.7 Defective limit switch

Depending on the classification of the limit switch, crane operation with defective limit switch:

- Can be continued without restriction.
- Can be continued with restriction.
- Can continued to be operated only in LMB emergency operation or with bypassed overload safety.

Certain crane functions are monitored with two sets of limit switches.



WARNING

Limited warning functions!

If one of the double version limit switches is not ok and the crane is continued to be operated, then the warning functions of the LICCON overload protection are limited!

- ▶ The crane can only be operated in an emergency after failure of a double version limit switch!

If a defective limit switch is shown:

- ▶ Replace / repair the defective limit switch.

4.8 Bypass of overload protection

To bring the crane into safe condition after failure of a component required for the overload protection, it can be necessary that the overload protection has to be bypassed.



DANGER

Bypassing the overload protection!

If the overload protection is bypassed, there is no further protection against crane overload!

In the event of deliberate improper use, the crane could collapse, the boom can break off or the crane can topple over!

Personnel can be killed or seriously injured!

This could result in property damage!

- ▶ The bypass of the overload protection is only permitted in emergency cases!
 - ▶ The bypass may only be carried out by persons who are aware of the effects of their acts regarding the bypass of the overload protection!
 - ▶ Bypassing the overload protection requires the presence of an authorized person and must be performed with utmost caution!
 - ▶ Missing values must be monitored manually and must match the load chart.
 - ▶ Crane operation with bypassed overload protection is prohibited!
-

**WARNING**

Bypassed overload protection!

If the overload protection is bypassed, crane movements are no longer monitored!

The crane can be overloaded and collapse!

Personnel can be killed or seriously injured!

This could result in property damage!

- ▶ Only carry out crane movements within the range of the load chart as well as the erection / take down charts!
-

As a rule, all specifications in the load chart must be adhered to strictly:

- The exact weight of the load, including load suspension equipment, must be known.
 - The boom status and the boom geometry must be known.
 - The boom length and boom radius must be measured manually.
 - All values must match the values in the respective load chart.
-

**Note**

- ▶ Depending on the configuration of the crane, the overload protection of the crane is bypassed various ways, see the following sections.
-

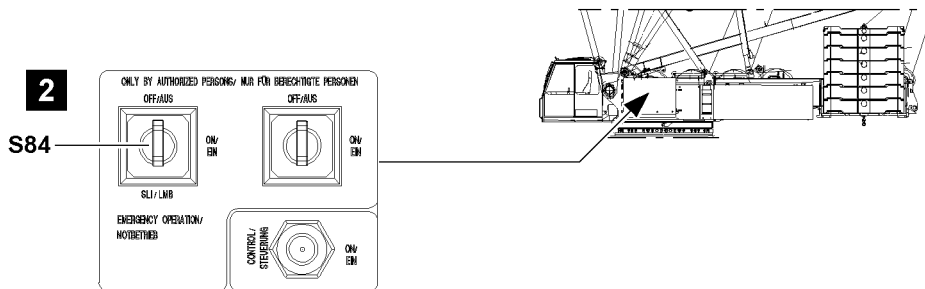
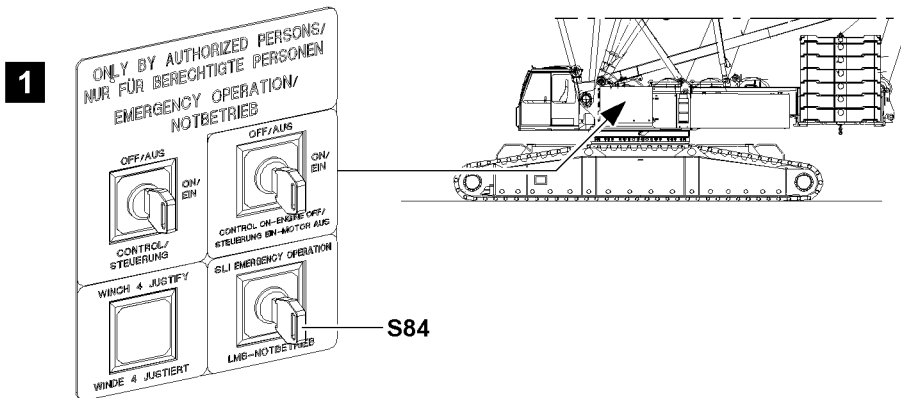
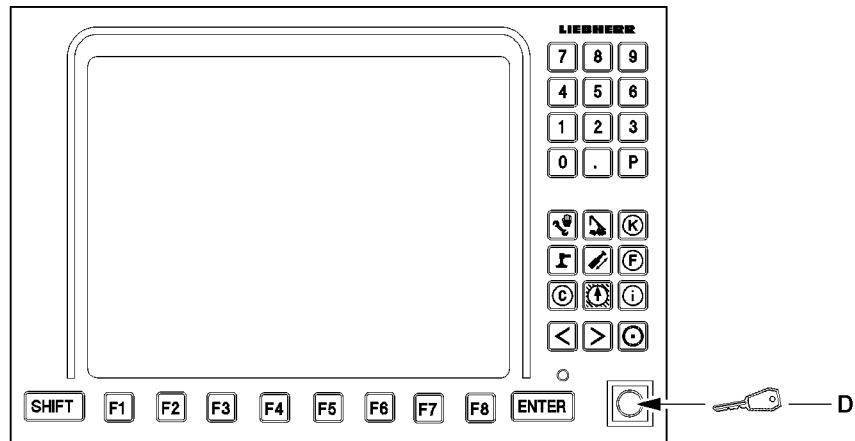

4.8.1 Bypass of overload protection: Failure of the overload protection



Note

- ▶ Does **not** apply for cranes with CE-mark and configuration according to EN 13000:2010!
- ▶ For description of set up button **D**, see Crane operating instructions, chapter 4.02!

- ▶ Press the set up button **D**:

Result:

- The overload protection is bypassed.
- The crane is in emergency operation.

To turn the bypass of overload protection off:

- ▶ Press the set up button **D** again.

Result:

- The bypass of the overload protection is turned off.

4.8.2 Bypass of overload protection: Failure of overload protection (according to EN 13000:2010)

- LR 1350/1 and LR1400/2, see illustration 1
- LR/LG 1750, see illustration 2



Note

- ▶ Applies **only** for cranes with configuration according to EN 13000:2010!
- ▶ For location and description of the bypass device outside the crane operator's cab, see Crane operating instructions, chapter 4.01 and chapter 4.02.

The bypass of the overload protection can be carried out with the restriction, that:

- The bypass is automatically reset when the engine is turned off.
- The bypass is automatically reset after no later than 30 minutes.
- The bypass of the overload protection limits the working speed to no more than maximum 15%.

- ▶ The bypass is made by actuating the key button **S84**:
Actuate the key button **S84**.

Result:

- The overload protection is bypassed.
- The crane is in emergency operation.

To turn the bypass of overload protection off:

- ▶ Actuate the key button **S84** again.

Result:

- The bypass of the overload protection is turned off.

4.9 Ending the load lift to avert emergency situations

When the crane movements must be carried out manually (for example with the optional "Hydraulic emergency control*").

**WARNING**

Crane operation without overload protection!

If the LICCON overload protection is no longer functioning properly because of one or more errors, then there is a danger of accidents if crane operation is continued!

Due to operation of the crane with failed LICCON overload protection, the crane can be overloaded and collapse!

Personnel can be killed or seriously injured!

This could result in property damage!

- ▶ Crane operation without overload protection is only permissible in emergency cases!
- ▶ Crane operation without overload protection may only be carried out by persons who know the effects of their actions regarding crane operation without overload protection!
- ▶ Crane operation without overload protection requires the presence of an authorized person and must be performed with utmost caution!
- ▶ Missing values must be monitored manually and must match the load chart.
- ▶ Do not take up regular crane operation again until the overload protection is functioning again!

Ending the load lift to avert emergency situations:

- Before continuing the load lift, contact the nearest Liebherr Service center or the Liebherr-Werk in Ehingen.

If this is not possible, then the load lift can be completed with utmost caution, as follows:

- All values that are needed for the exact determination of the equipment configuration and the associated load chart must be measured or manually determined.

As a rule, all specifications in the load chart must be adhered to strictly:

- The exact weight of the load, including load suspension equipment, must be known.
- The boom status and the boom geometry must be known.
- The boom length and boom radius must be measured manually.
- All values must match the values in the respective load chart.

8.00 Inspections of cranes

1 General

This crane was tested at the manufacturer's facilities prior to shipment in accordance with the latest ISO, FEM and DIN Standards and BGV D6 (BGG 905).

The safety level achieved during initial commissioning may not be attainable during operation. Examples of the root cause of such deviations include; e.g., wear and tear, corrosion, effects of external forces, changes in the environment and changes to the mode of operation.

The operator is responsible for taking the necessary steps to ensure that the maximum level of safety is maintained.

The crane operator is therefore obligated to have the crane inspected by an **expert**, at intervals depending on the operational conditions but at least once per year, from the first day of vehicle registration.

The crane must be inspected by an **authorized inspector** every four years after it has been licensed. The crane must be annually inspected by an **authorized inspector** after its twelfth year of operation. To ensure the high safety standard of the crane, we recommend - no later than the 12th year, in the 20th year, in the 26th year and then every 4 years - to have the crane undergo a general inspection by an **authorized inspector**. At that time, in addition to the usual scope of inspection, all load carrying parts of the crane - the complete steel structure with all welding seams as well as all components and connecting devices - are to be subjected to a complete visual inspection. The following procedural notes for repeat inspections are to be observed for that.



WARNING

There is a risk of weakening the supporting components when major changes or repairs are made to the crane!

- ▶ In this case, the operator must have the crane reinspected by an authorized inspector before putting it back into service!

Respective local regulations also apply.

Expert: Is a person whose technical training and experience means that he has adequate knowledge in the field of inspecting technical equipment. He is adequately familiar with the relevant national work safety regulations, accident prevention regulations, and standards that he is able to evaluate the operational safety of the equipment (for example cranes). Responsible employees from specialist workshops and customer service engineers may be considered as experts.



Note

- ▶ Experts are not authorized inspectors!

Authorized inspector: Is a person whose technical training and experience means that he has explicit knowledge in the field of inspecting technical equipment. He is adequately familiar with the relevant national work safety regulations, accident prevention regulations, and standards that he is able to evaluate the operational safety of the equipment (for example cranes). He is to test the technical equipment and is able to certify the equipment as safe. Authorized inspectors can be active engineers.



Note

- ▶ Authorized inspectors are legally recognized experts who have received special training!

The periodic inspection is principally a visual inspection, wherein the inspector / technical expert appraises the condition of the crane and its components.

The purpose of the inspections is to avoid accidents by detecting deficiencies in a timely fashion. Any deficiencies determined by the inspectors must be documented, remedied, and subsequently reinspected.

A number of important examples of items that are particularly important during the periodic crane inspections are listed in the following: We wish to advise that the authorized inspectors / experts take sole responsibility for the crane inspections that they carry out.

**Note**

- ▶ The inspection may not be solely limited to the following positions shown in the sample construction illustrations. Rather the **entire** crane structure must be subjected to a careful inspection!

A checklist for periodic inspections recommended for Liebherr mobile and crawler cranes is included in the appendix to assist the inspectors.

If the inspector has any questions they should be directed through our Service Department to Liebherr-Werk Ehingen GmbH's technical departments.

**WARNING**

Risk of accident!

- ▶ Adhere to the following inspection guidelines and intervals.

2 Inspection of carrying crane structures, especially steel structures

**DANGER**

Risk of fatal injury!

The crane structures, particularly steel constructions have to be checked by an expert or authorized inspector at least once a year. If this is not the case, they could fail and cause fatal injury or seriously damage the crane!

- ▶ Crane structures, particularly steel structures must be checked by an expert or an authorized inspector at least once a year!
- ▶ Shorten the inspection intervals if the crane is subjected to above-average load spectrums, for example when handling large material quantities or frequently erecting long boom systems.
- ▶ If the crane was subjected to excessive operating loads; e.g., due to an unusual impact, the crane structure, especially the steel structures must be inspected immediately!

Crane structures, especially steel structures, such as booms, turntables, chassis, support equipment (e.g., sliding beams or folding outriggers) must be carefully inspected, at the very least during the annual recommended crane inspections. Inspect welding seams especially through an intensive visual inspection.

If paint damage with corrosion (rust) is found on load carrying parts of the crane structure, especially on telescopic booms, lattice booms, lattice jibs, pull rods etc., then the rust must be removed, primed and painted.

During an electrolyte process, such as corrosion in combination with water, an atomic hydrogen is created, which causes to hydrogen induced corrosion with resulting cracks on high tensile fine grain construction steel.

If disassembly and assembly work on the crane is required to carry out the inspections, then they must be carried out by taking the manufacturer's data into account or in coordination with the crane manufacturer.

We would like to point out that the framework of mobile cranes is designed for a limited number of stress work cycles. This also determines the utilization or service life of the framework. The service life is not determined solely by the number of stress cycles. It also depends on the loads (load spectrum) applied during the time in operation.

Liebherr mobile and crawler cranes are designed for specific characteristics and movements, such as constant deployment of drive forces, only occasional operation and load conditions according to EN 13000:2010.

Liebherr mobile and crawler cranes are designed for assembly operation and - according to EN 13000:2010, chapter 4.1.2.1 - they can only take on a limited number of work cycles ($N = 32000$) when grouping them into collective class $Q_1 = \text{light}$ ($k_p = 0.125$).

Example of a load collective according to grouping in collective class $Q_1 = \text{light}$ ($k_p = 0.125$).

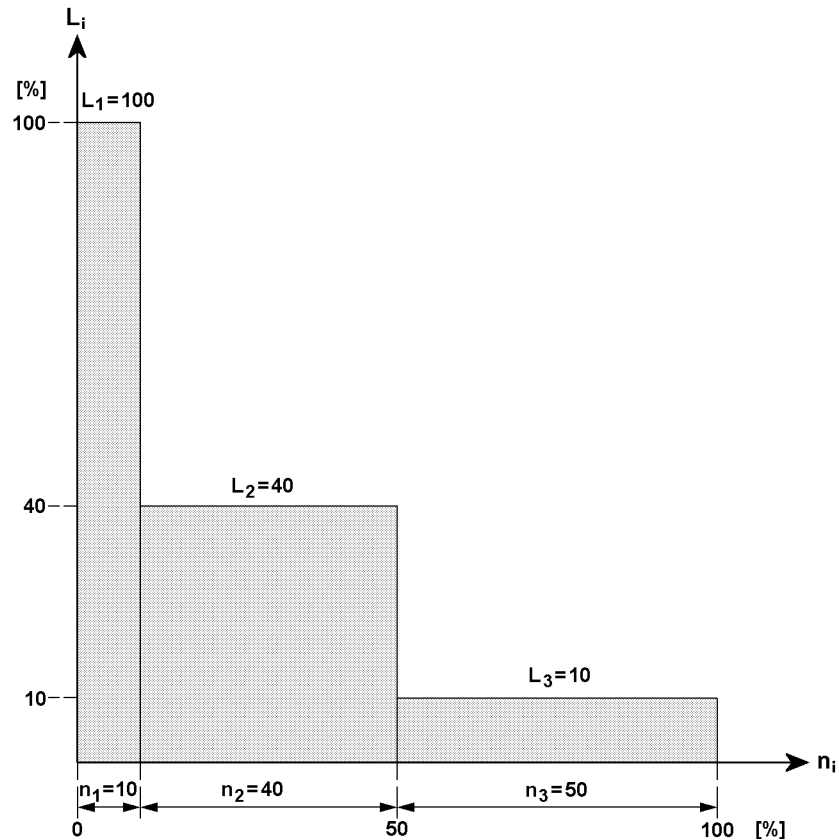

L_i : Load proportion in relation to maximum load [%]
 n_i : Load cycles in relation to maximum number [%]



Note

- ▶ The service life of Liebherr mobile and crawler cranes can be drastically reduced, for example when used in magnet, grapple or material handling applications!
- ▶ Repeated inspection of crane structure, especially the steel structure and the welding seams must then be carried out in shorter intervals than specified.

For that reason, the steel structures and the welding joints must be subjected to an visual intensive inspection by the expert during the specified periodic inspections.

If any damage (such as cracks or suspicion of cracks) are apparent on any part of the steel structure, the total extent of the damage must be determined by qualified specialists using appropriate material testing methods, such as magnetic crack detection, ultrasound or x-rays. Thereafter, the qualified personnel must determine whether or not the damaged area can be repaired by welding or by other means.

The following diagrams are samples of the load-bearing weld designs. The welding joints or seams or steel structural zones that require inspection may be present more than once and in various forms. The joints or zones must be inspected all around at the locations identified by arrows.



Note

- ▶ The scope and extent of all inspections remain the sole responsibility of the inspectors!
- ▶ The scope and results of tests should be documented to permit reproducibility. This documentation forms part of the crane records and should be safely stored during the entire service life of the crane!
- ▶ The following diagrams are provided to assist the inspector. The sketches are only examples and are not necessarily 100 % complete!

2.1 Repair welds

If defects such as cracks or permanent deformation are detected on load-bearing steel components, they should be immediately reported to **Liebherr-Werk Ehingen GmbH** (hereinafter called **LWE**), **Customer Service Department**.

Furthermore, the defect must immediately be appraised by an authorized inspector in accordance with standard welding practice rules. The inspector must immediately ascertain whether or not the crane can continue to be safely operated until the time of the repair.

The following items apply to the repair weld:

- Repair welds may only be carried out by **LWE** personnel, or third party personnel contracted by **LWE**, with appropriate welding qualifications according to EN 287-1 for the subject material and welding method!
- The repair weld must be carried out in accordance with the latest revision of **LWE's** internal welding guideline ISR B 010!
- The repaired structural component must subsequently be subjected to a load test. The required test loads and boom configurations are to be determined by **LWE Service!** Successful test results are to be documented in the crane inspection log!
- We also refer to observing the accident prevention regulations "Principles for testing cranes by authorized inspectors or experts in accordance with UVV **Cranes** BGV D6 and BGG 905"!



WARNING

Danger of accidents in case of defective repair welds!

Due to defective repair welds, severe personnel and property damage can result!

- ▶ Observe and adhere to the instructions and welding regulations!



Note

Exclusion of liability!

For repair welds, which are not made by **LWE** personnel or by personnel authorized by **LWE**, Liebherr-Werk Ehingen GmbH excludes liability for the system functionality as well as for the parts!

- ▶ Have repair welds only made by **LWE** personnel or by personnel authorized by **LWE!**

blank page!

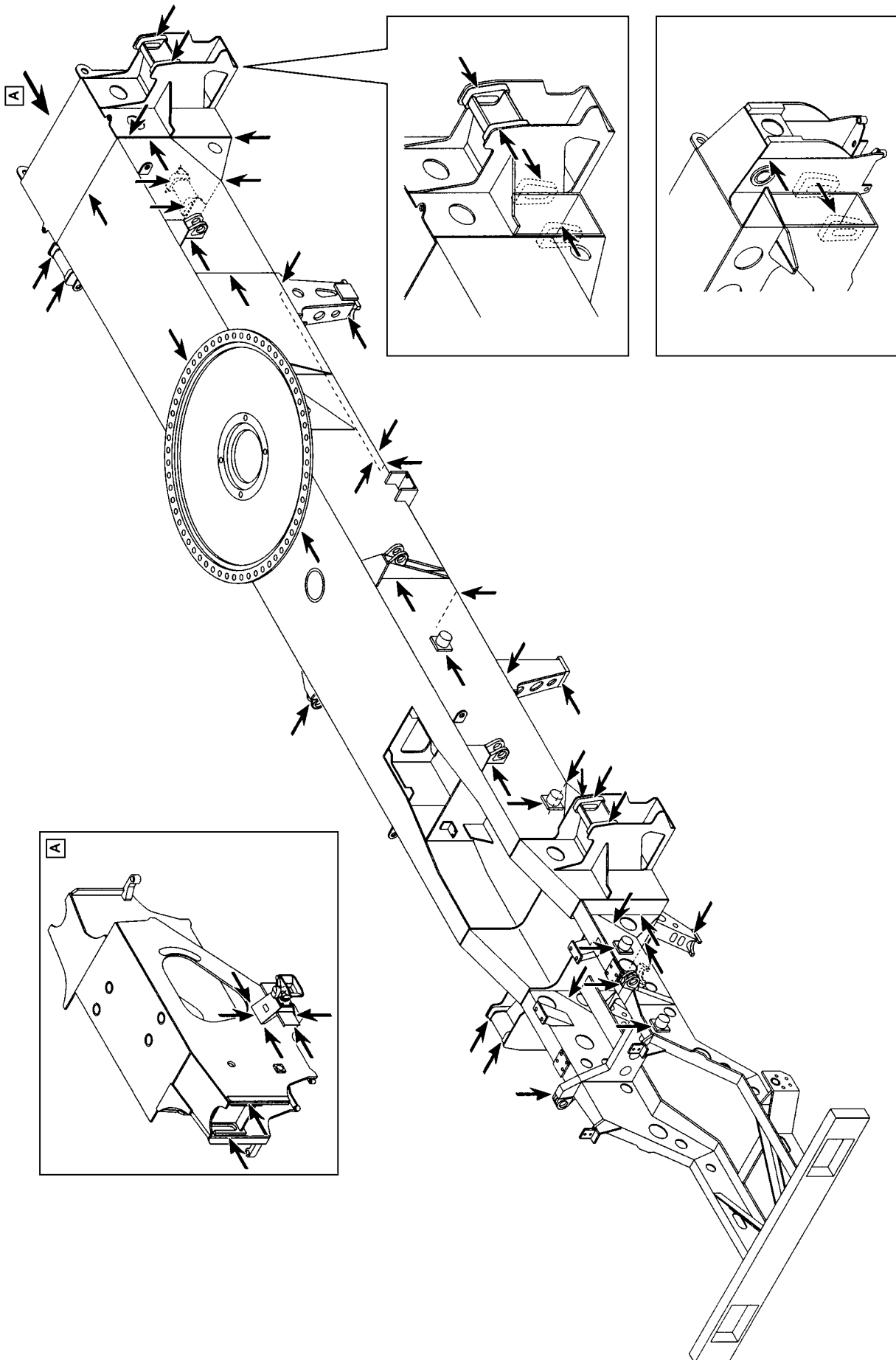

Example for vehicle frame

B185046

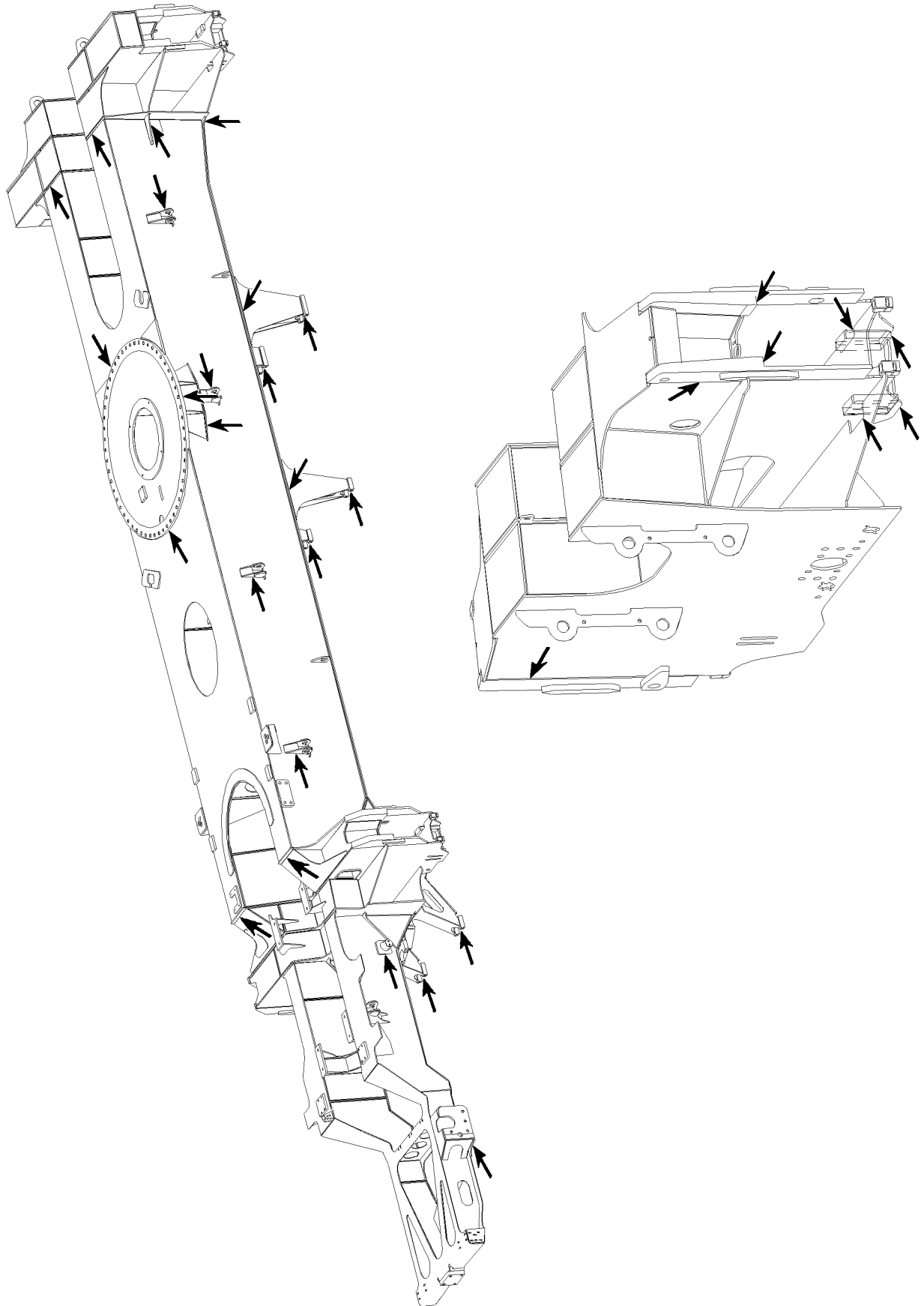

B105702

Example for vehicle frame

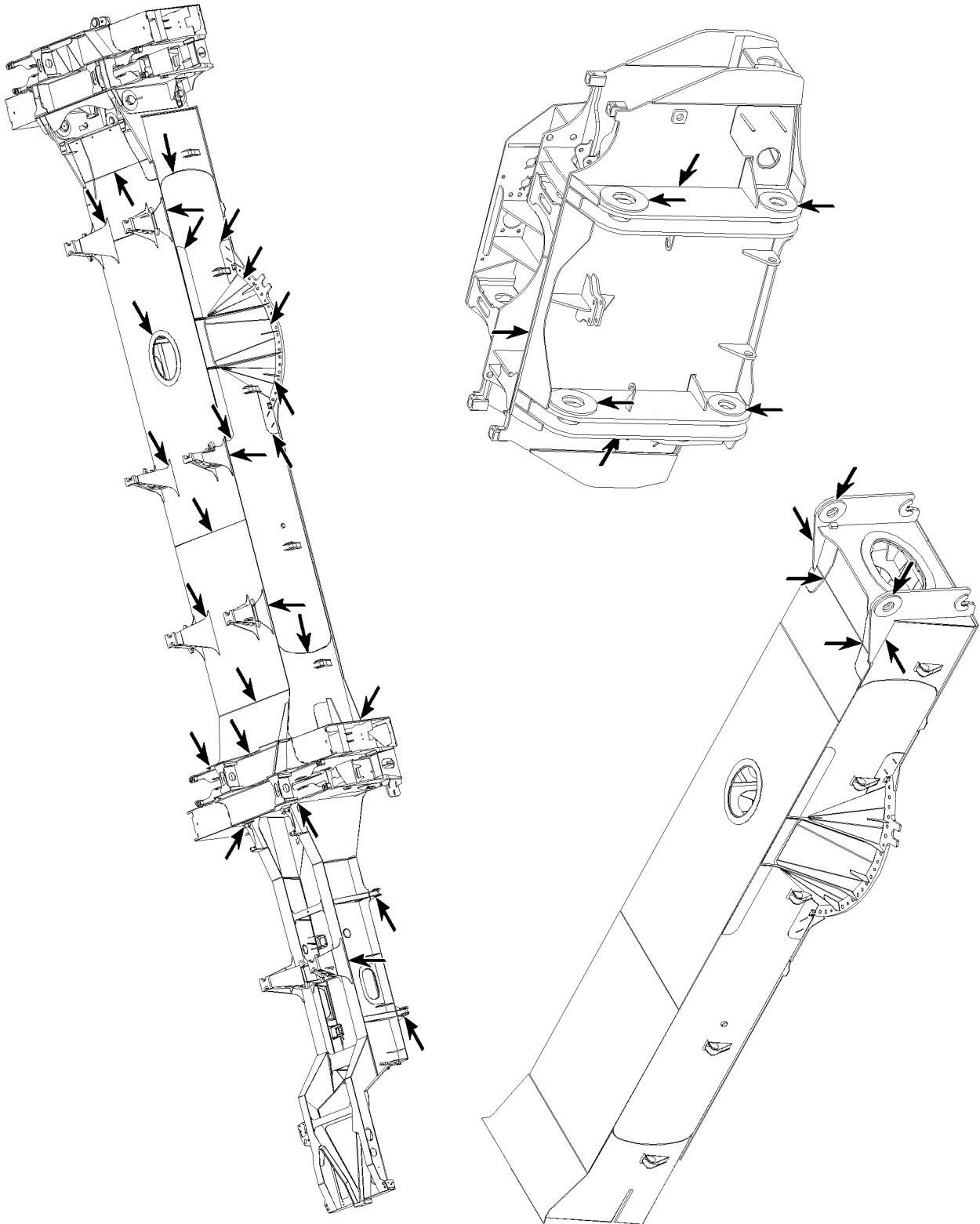

B105719

Example for vehicle frame

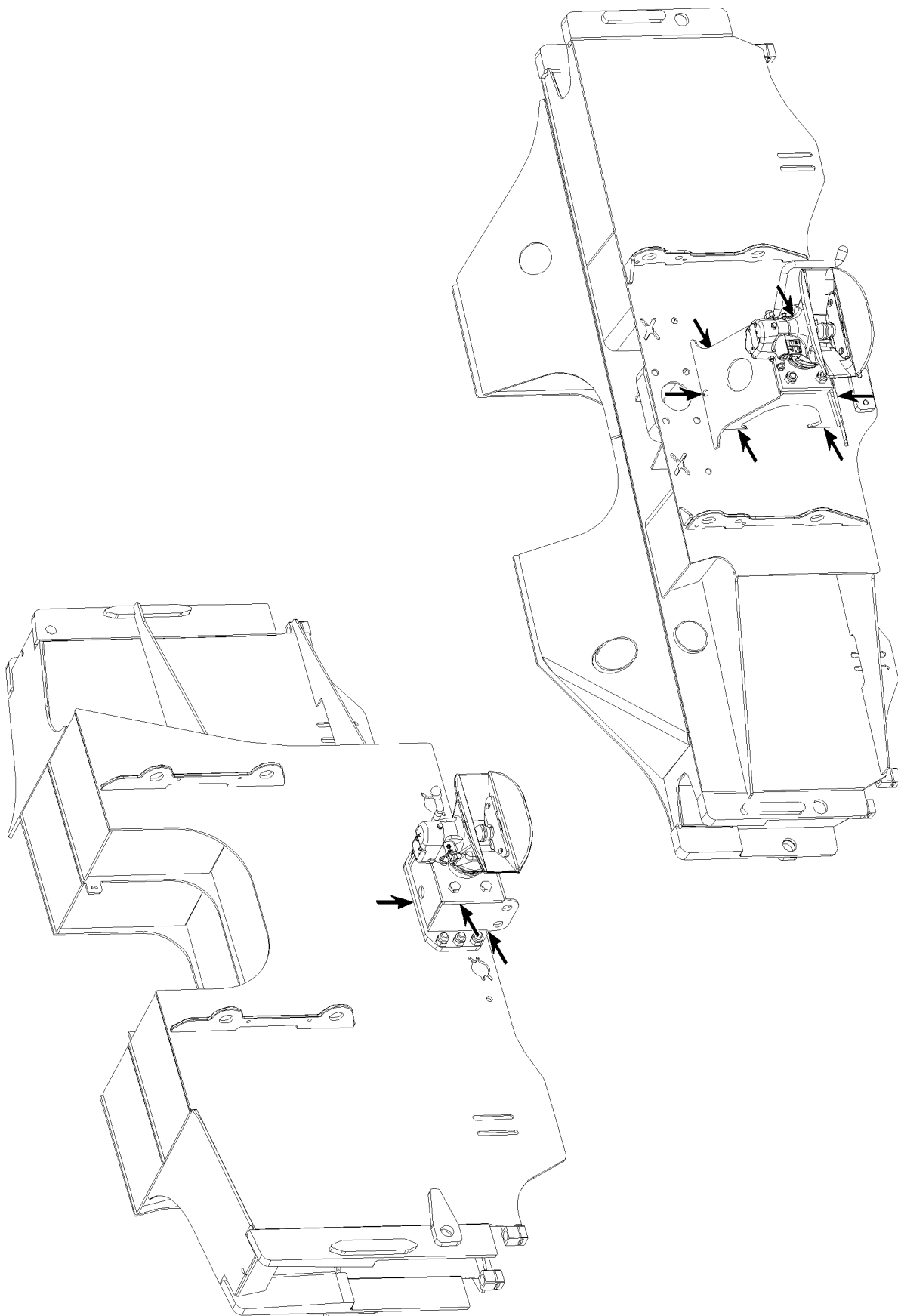

B105687

Example for tow coupling

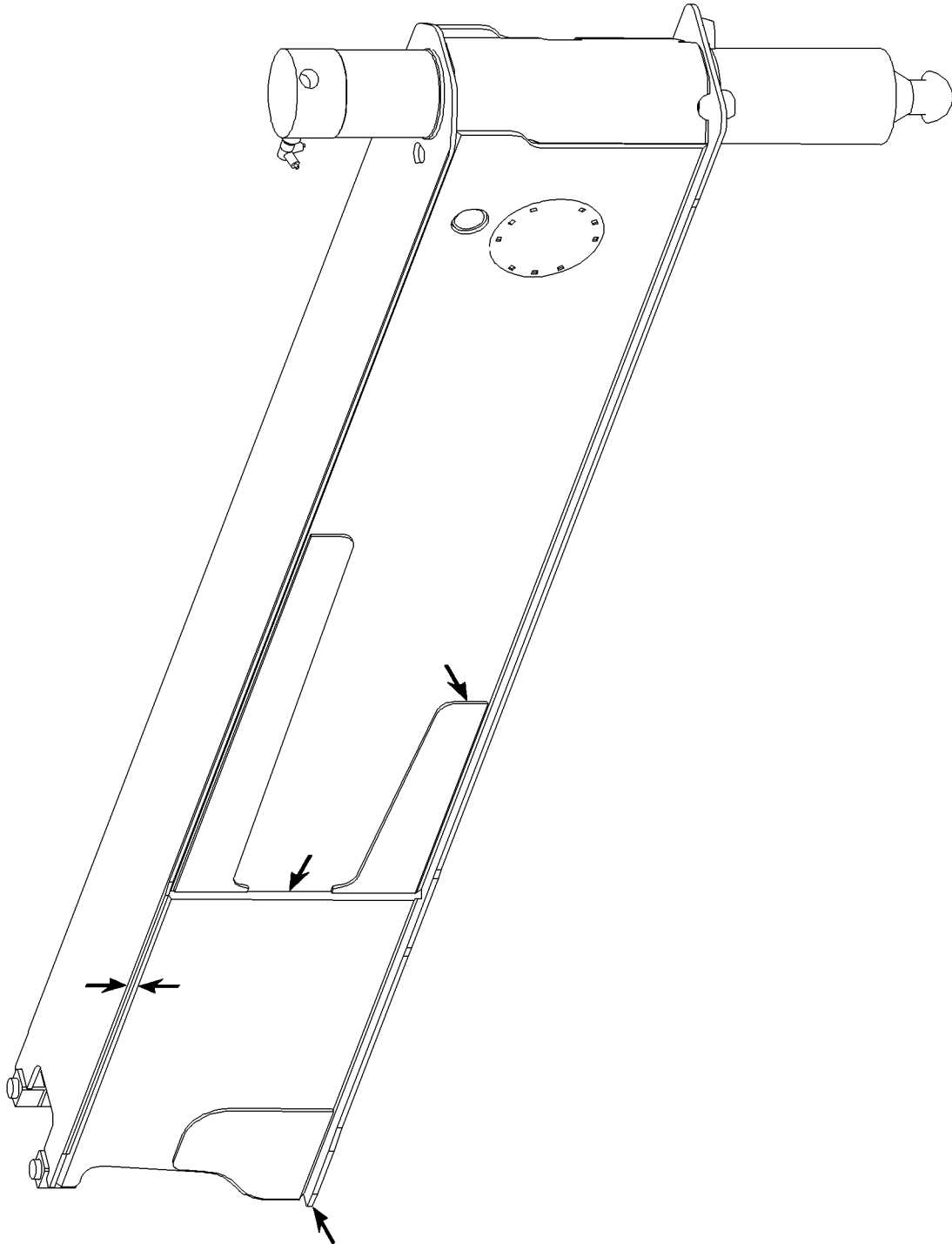

B105698

Example for sliding beam

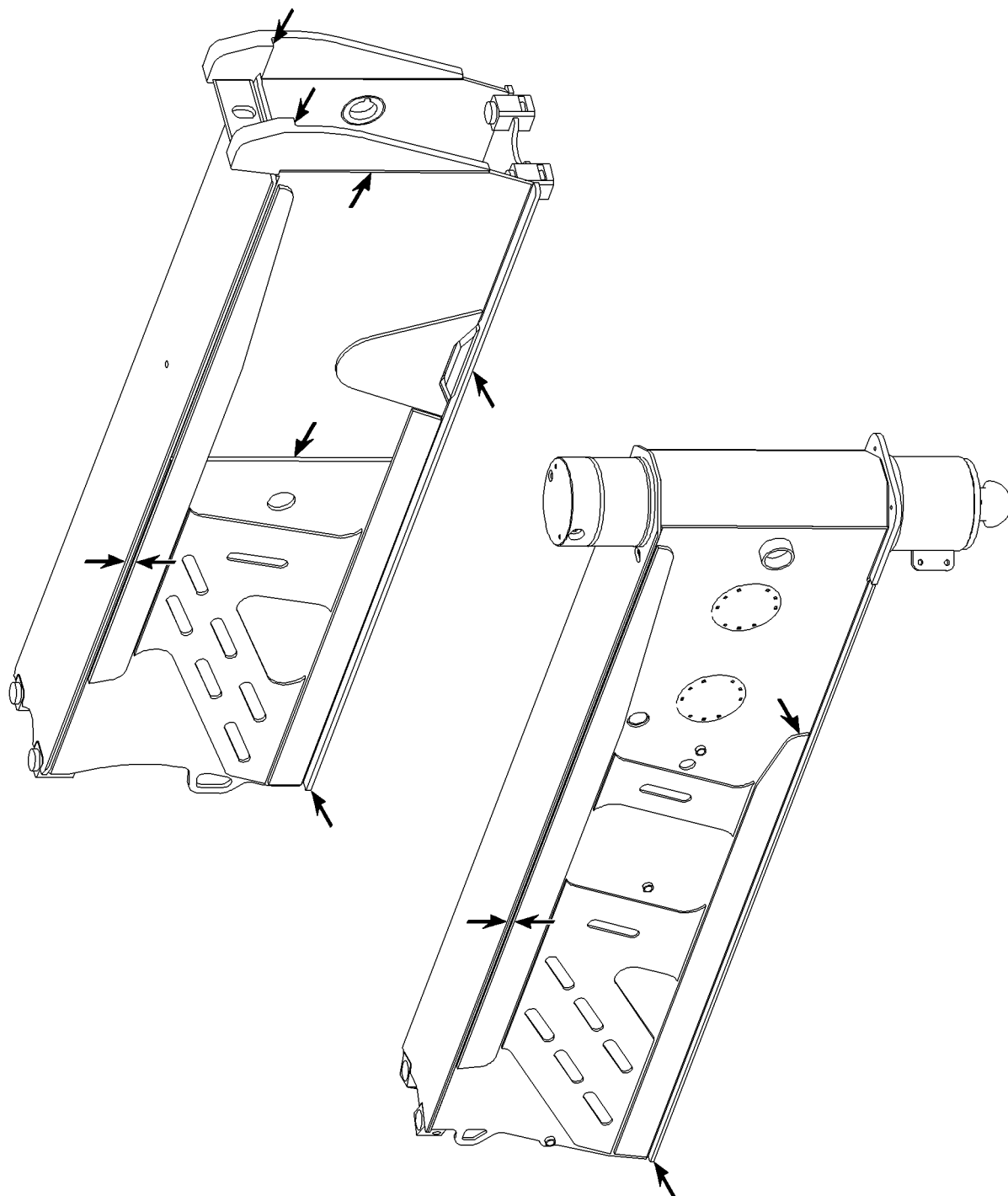

B105717

Example for sliding beam

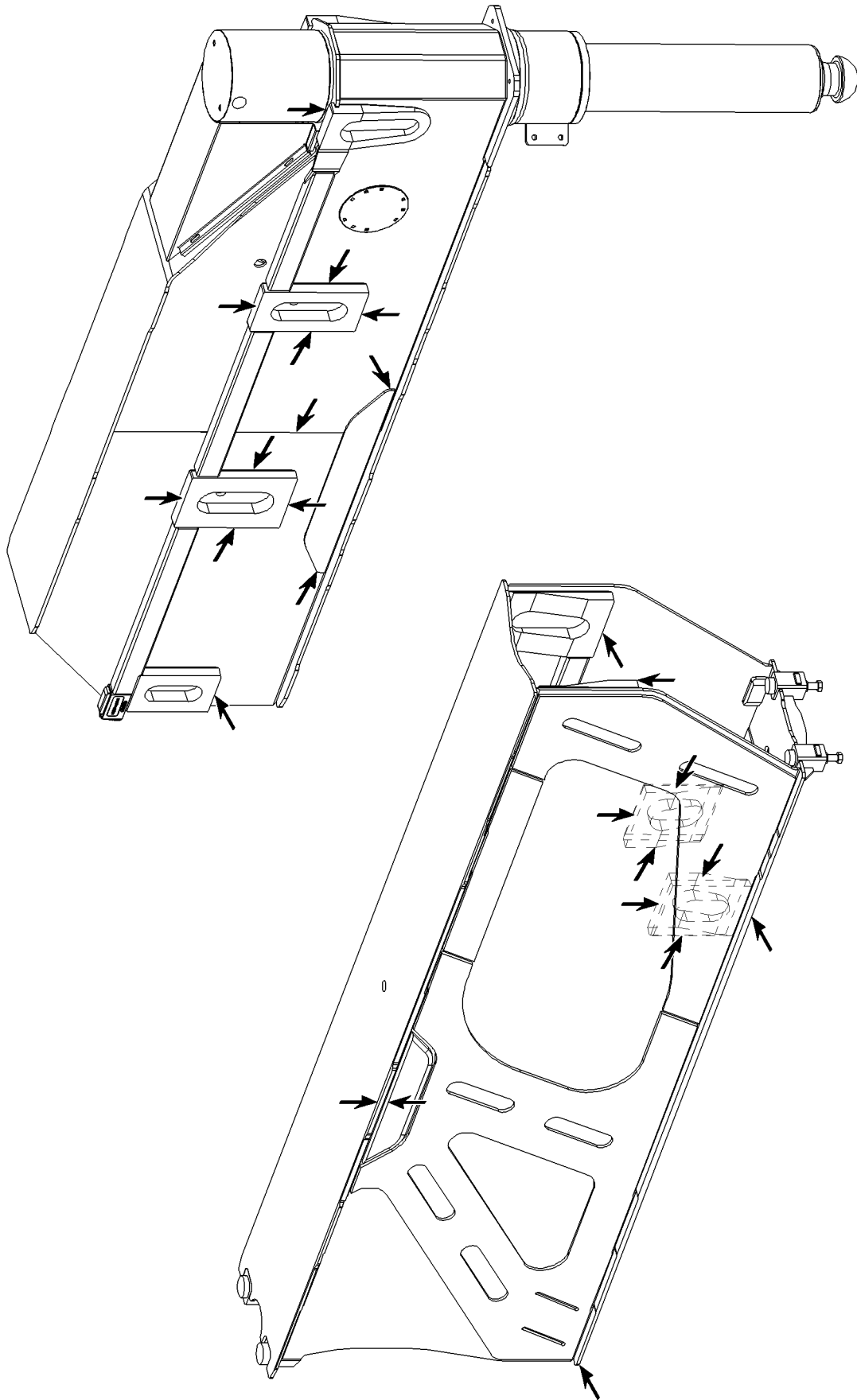

Example for sliding beam

B105718

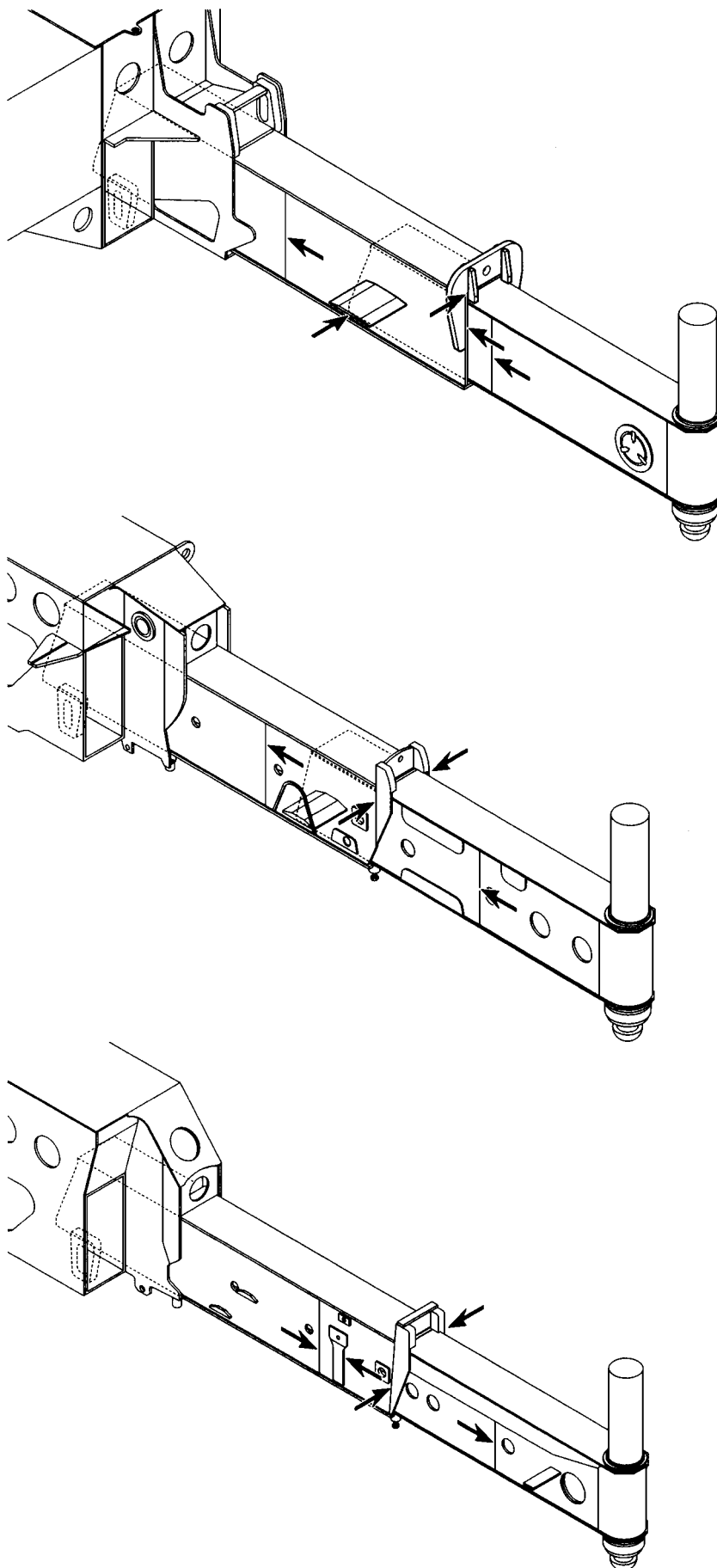

B185047

Example for sliding beam

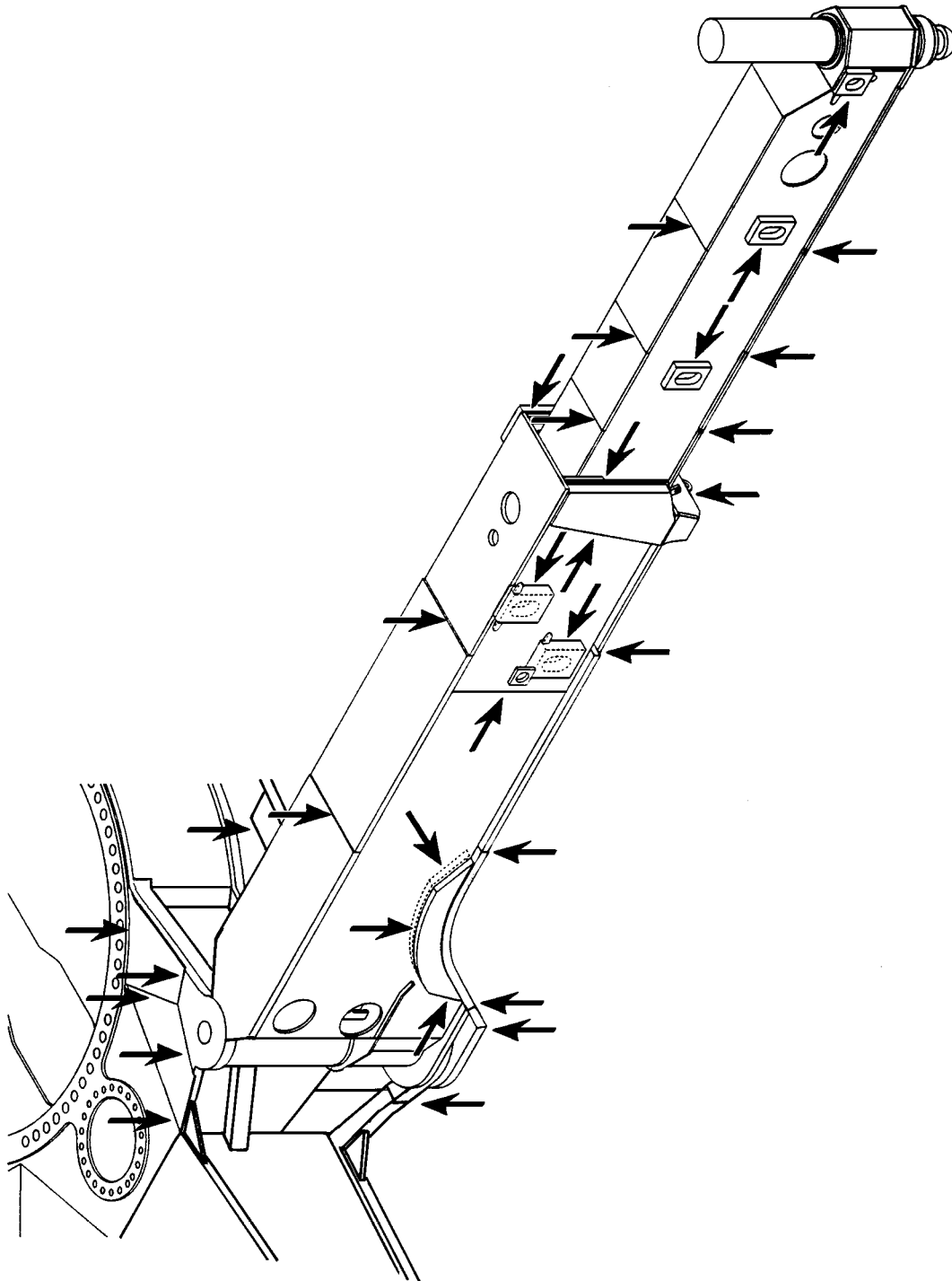

B185060

Example for slewing sliding beam

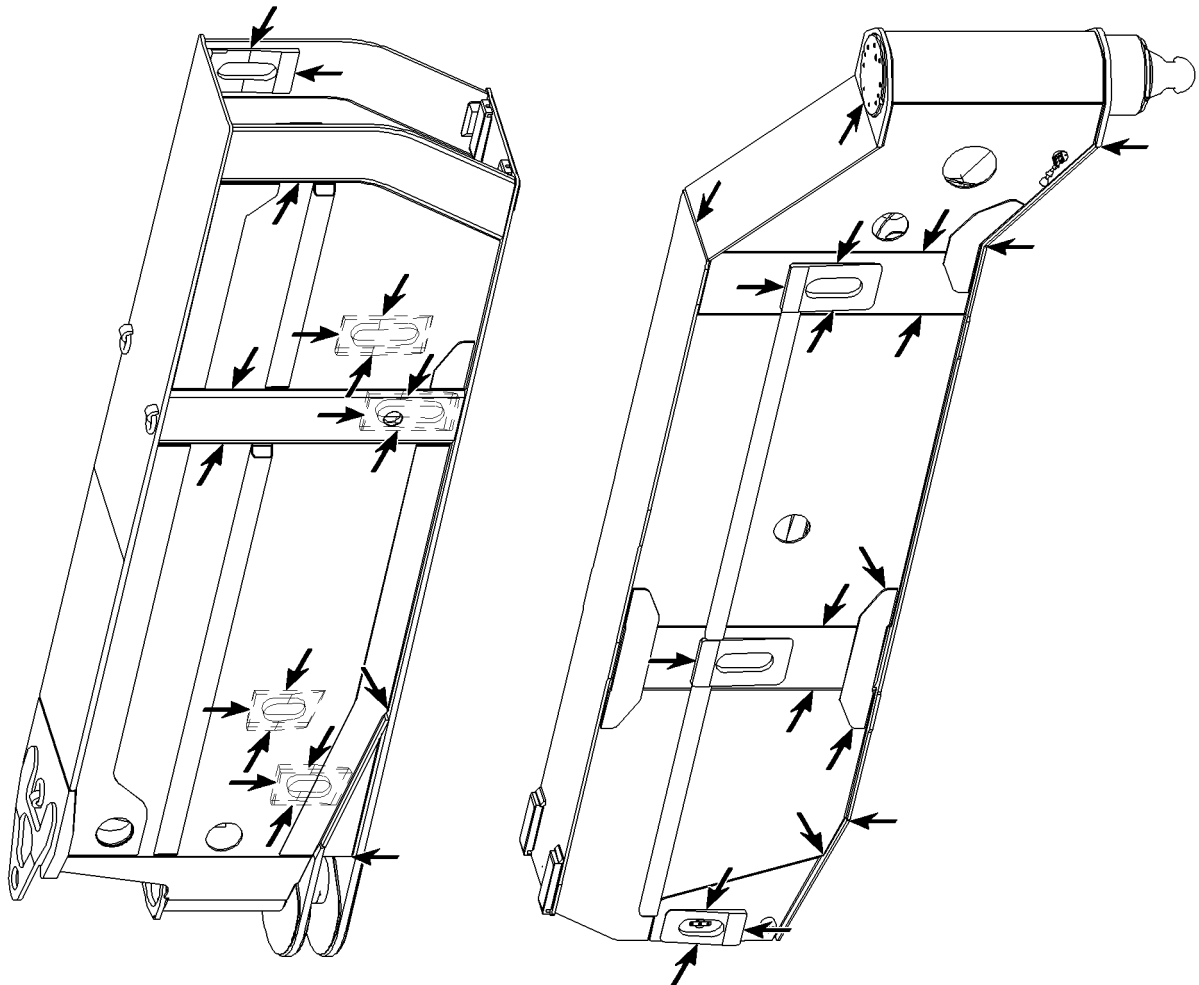

B105690

Example for slewing sliding beam

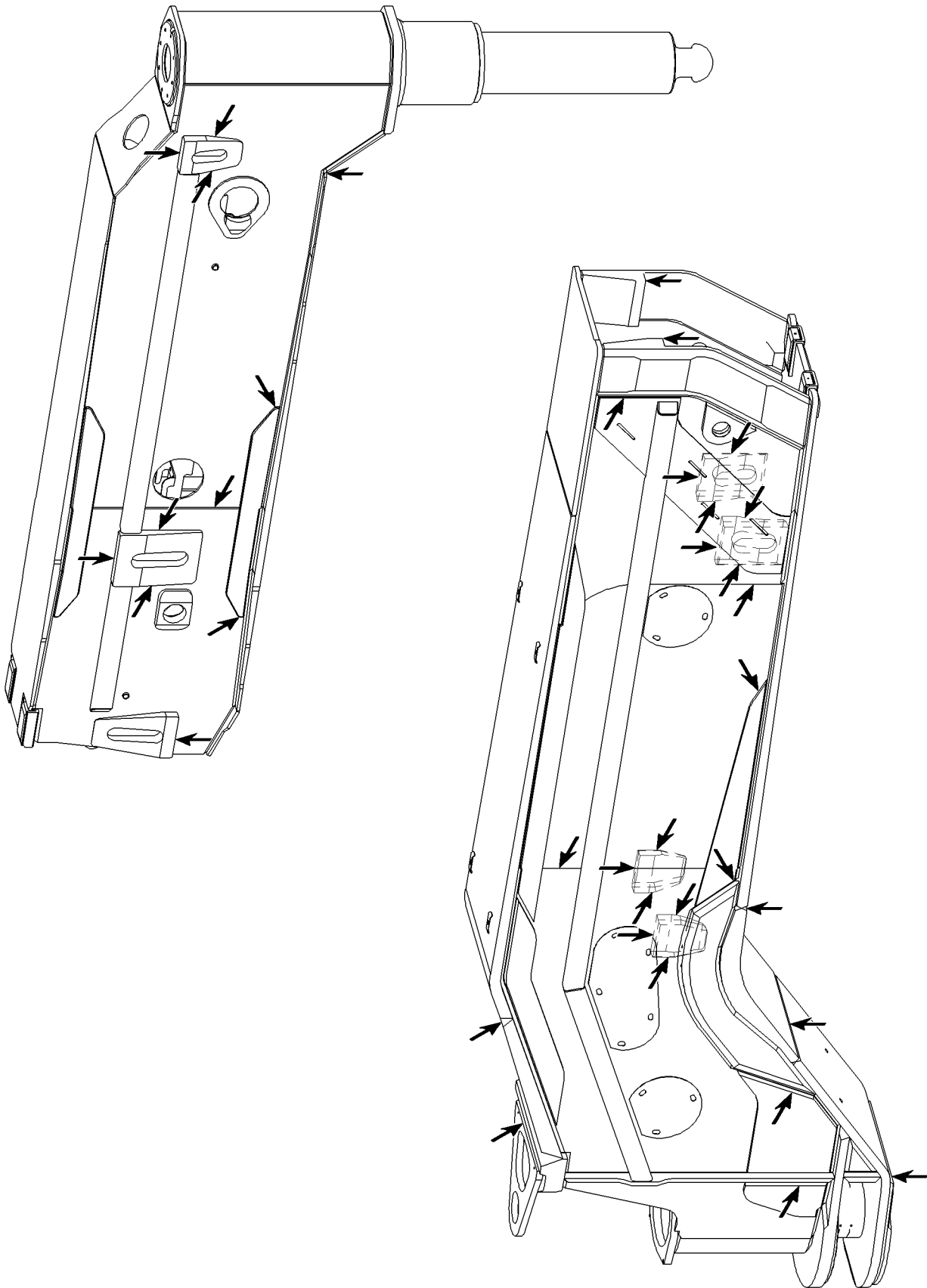

B105704

Example for slewing sliding beam

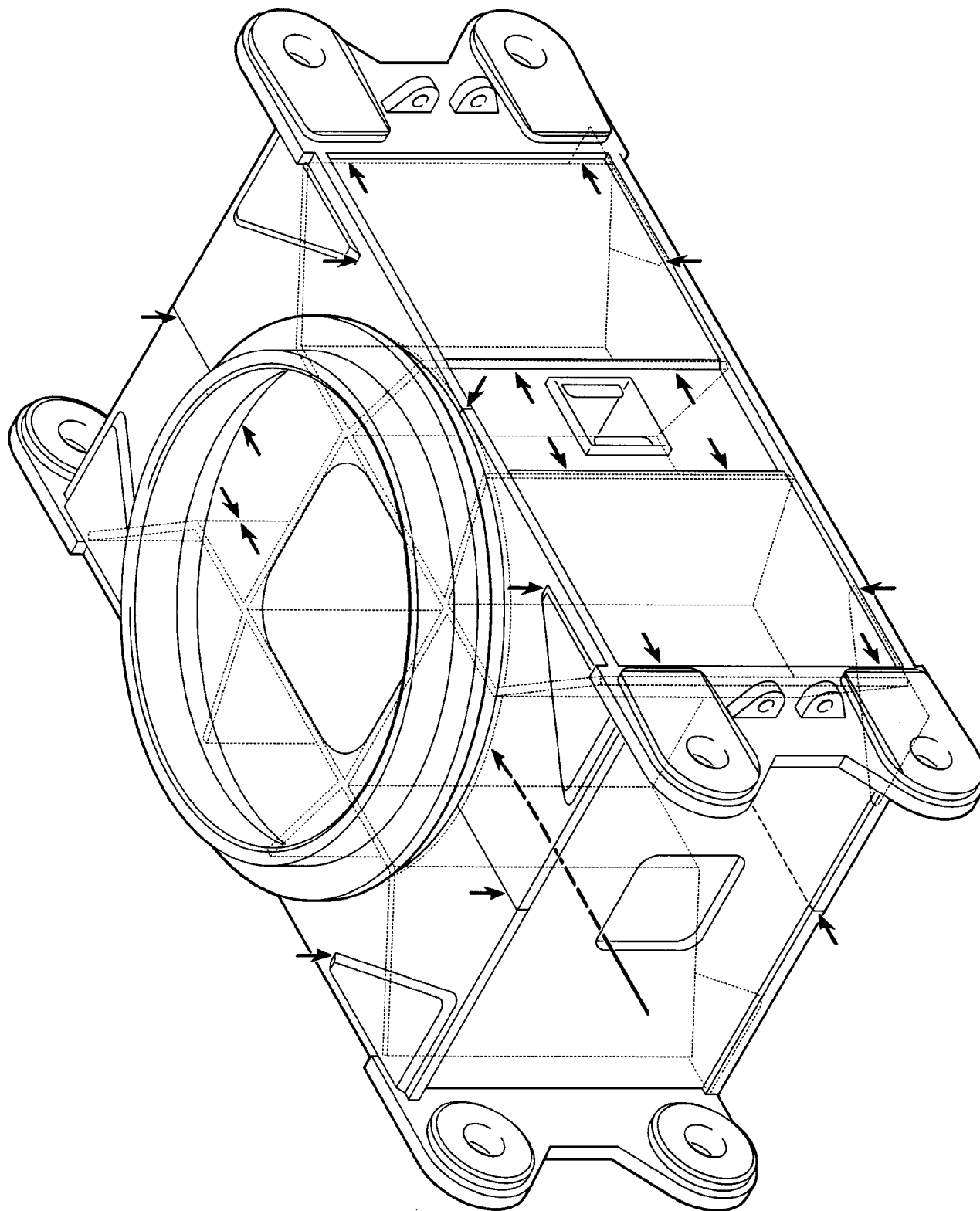

B187347

Example for crawler center section

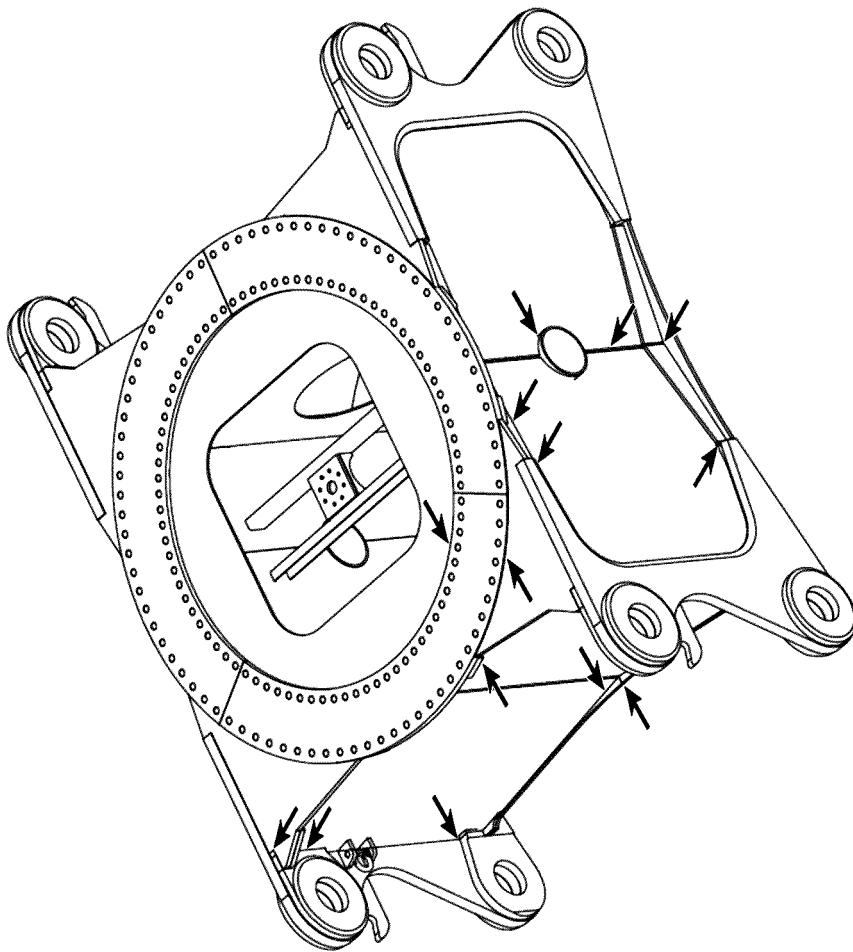

B105725

Example for crawler center section

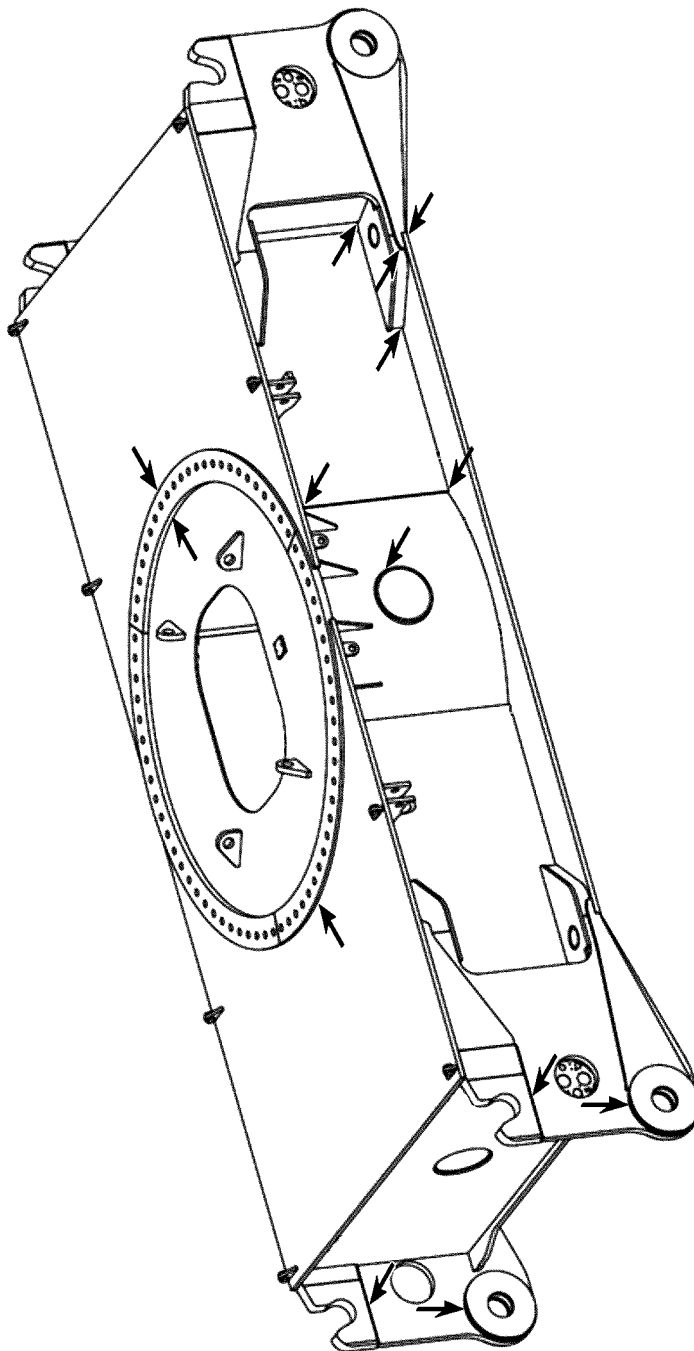

B105726

Example for crawler center section

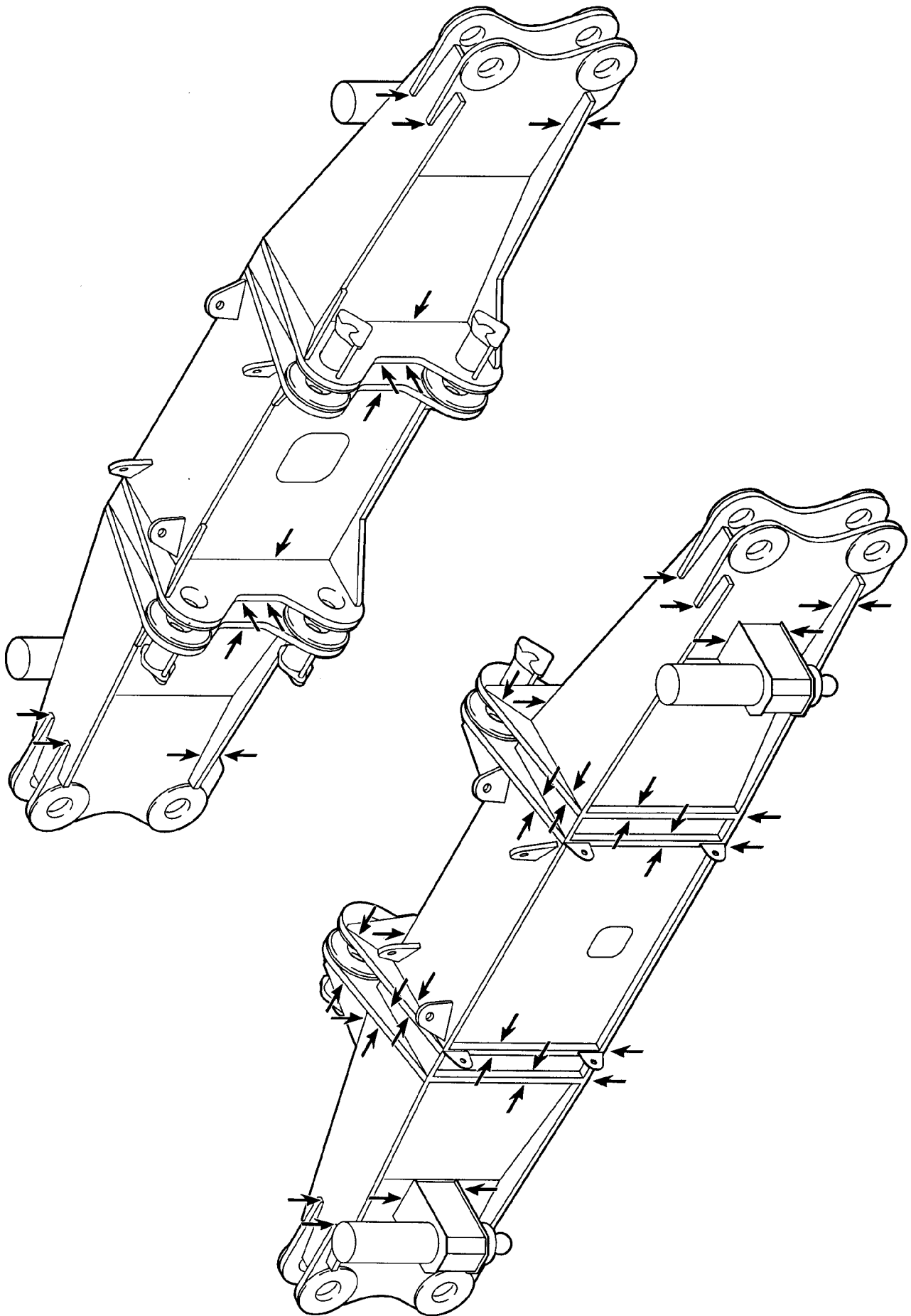

Example for cross carrier

B187348

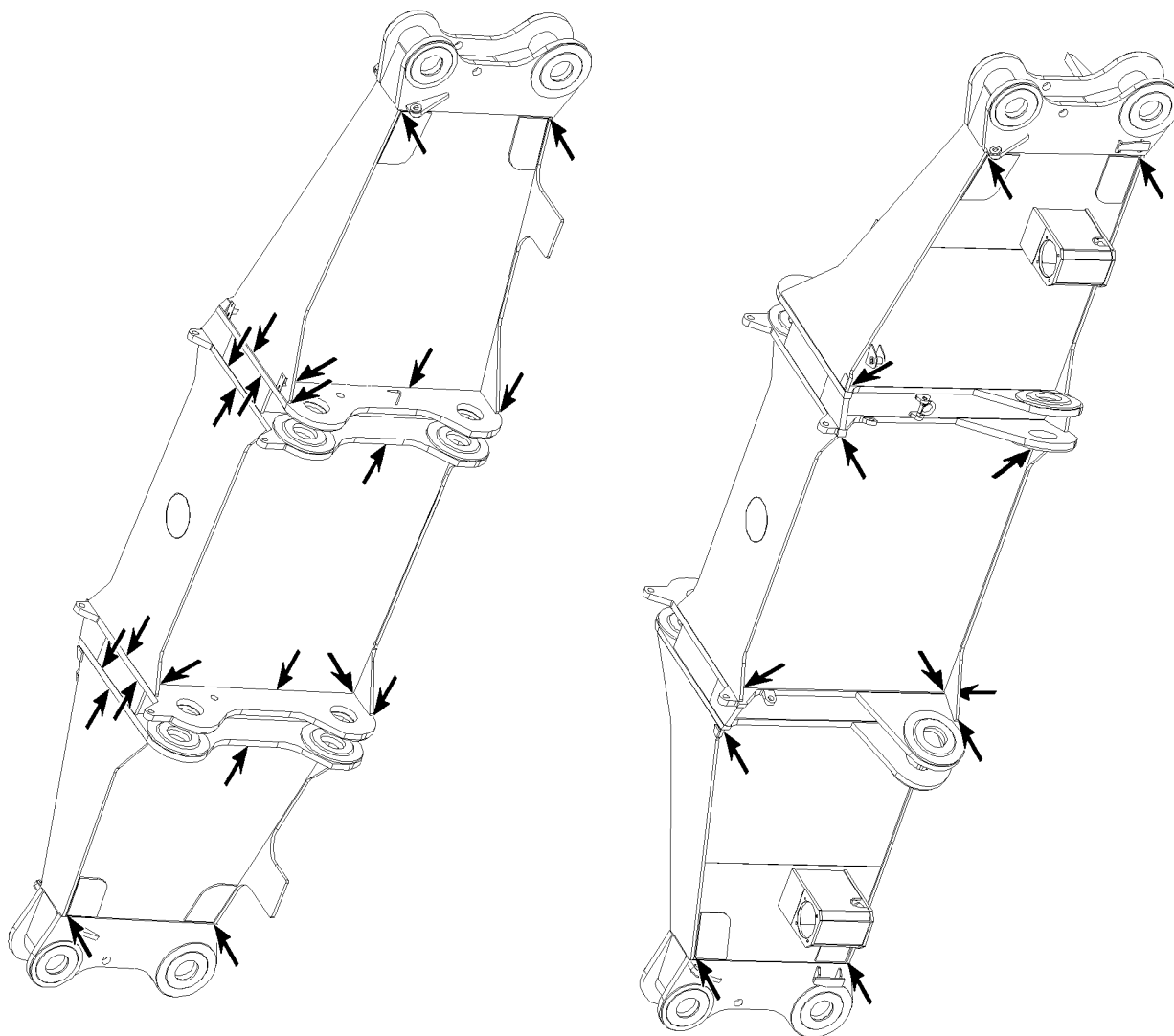

B105727

Example for cross carrier

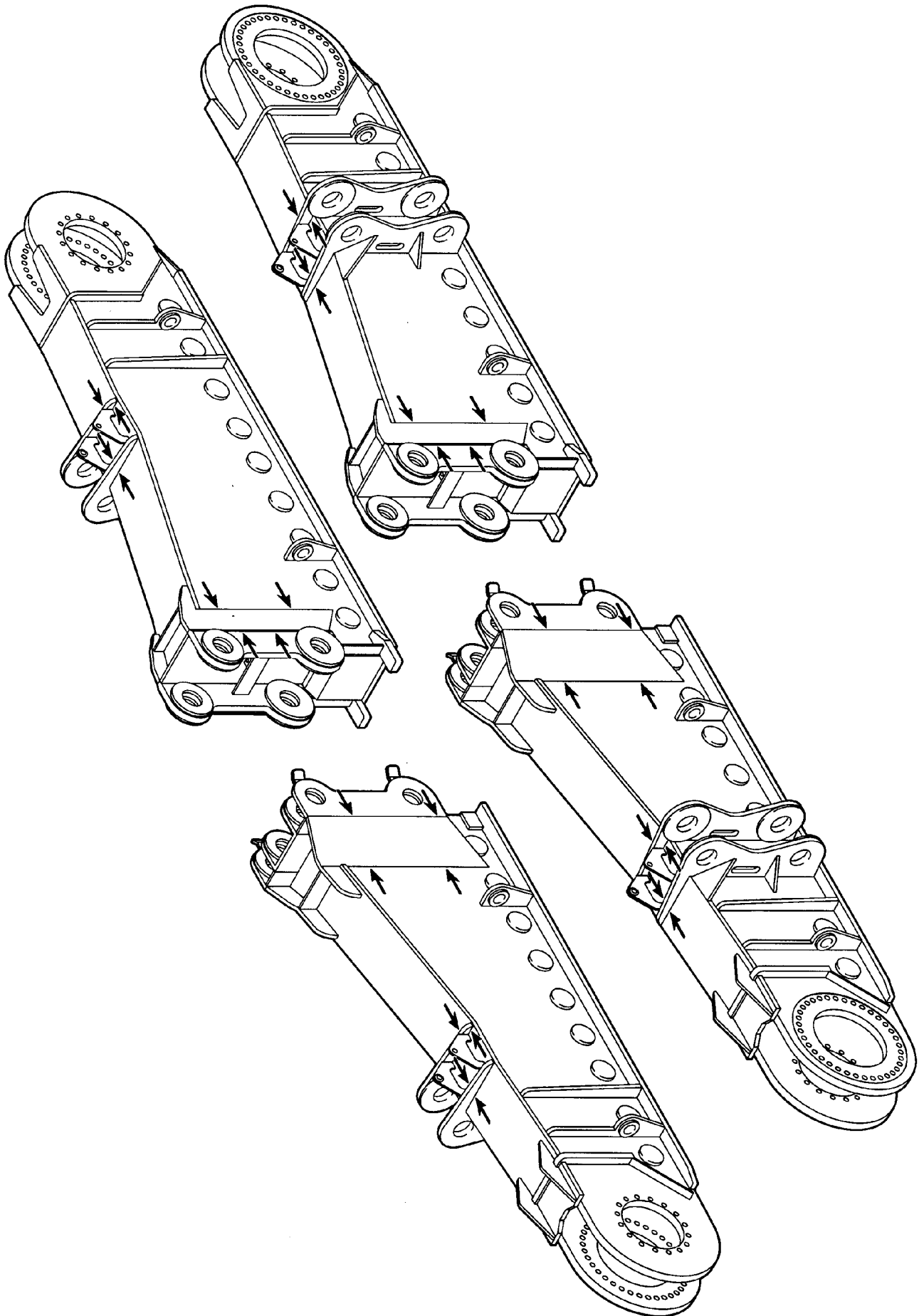

Example for crawler carrier

B187349

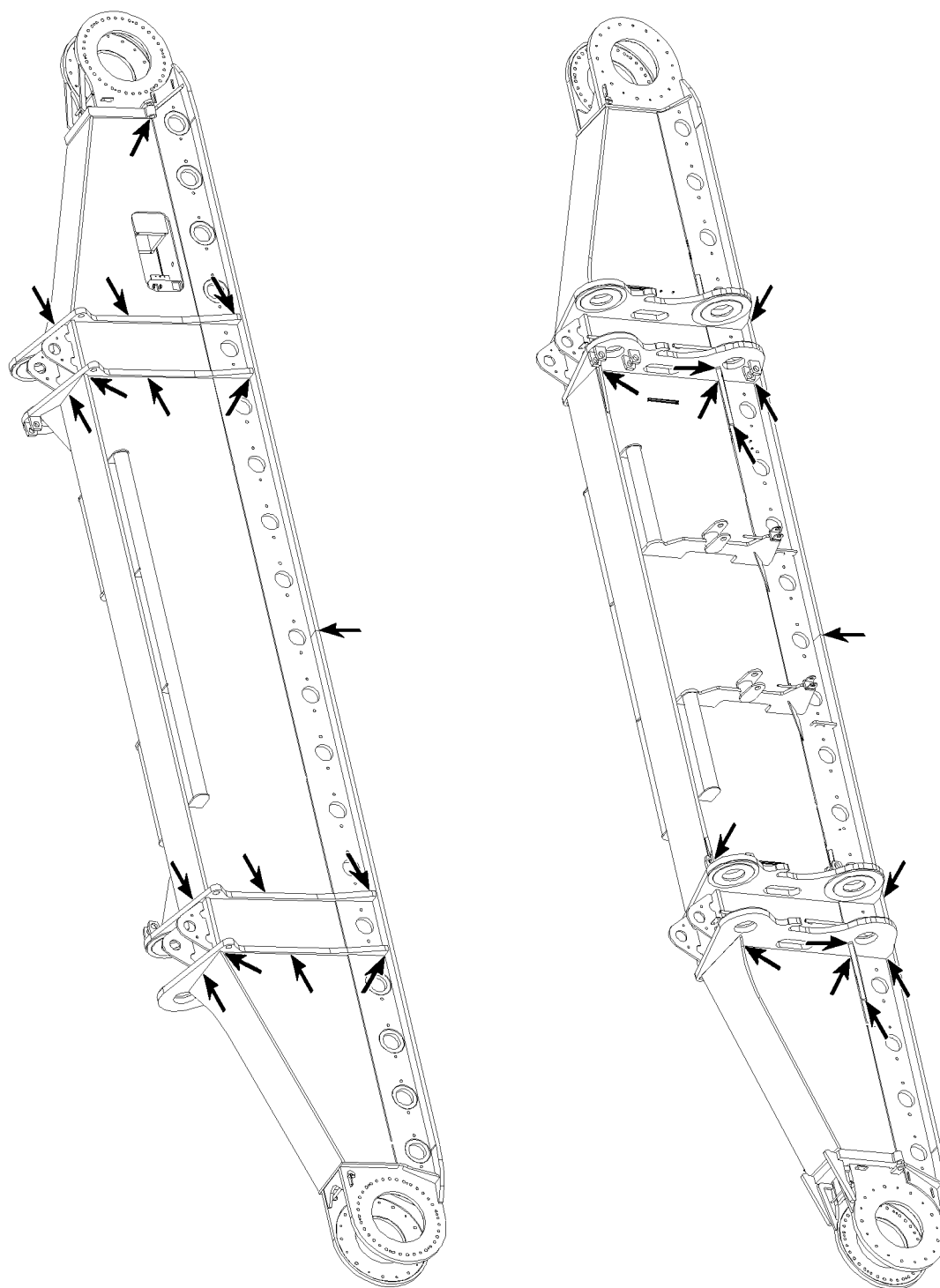

B105728

Example for crawler carrier

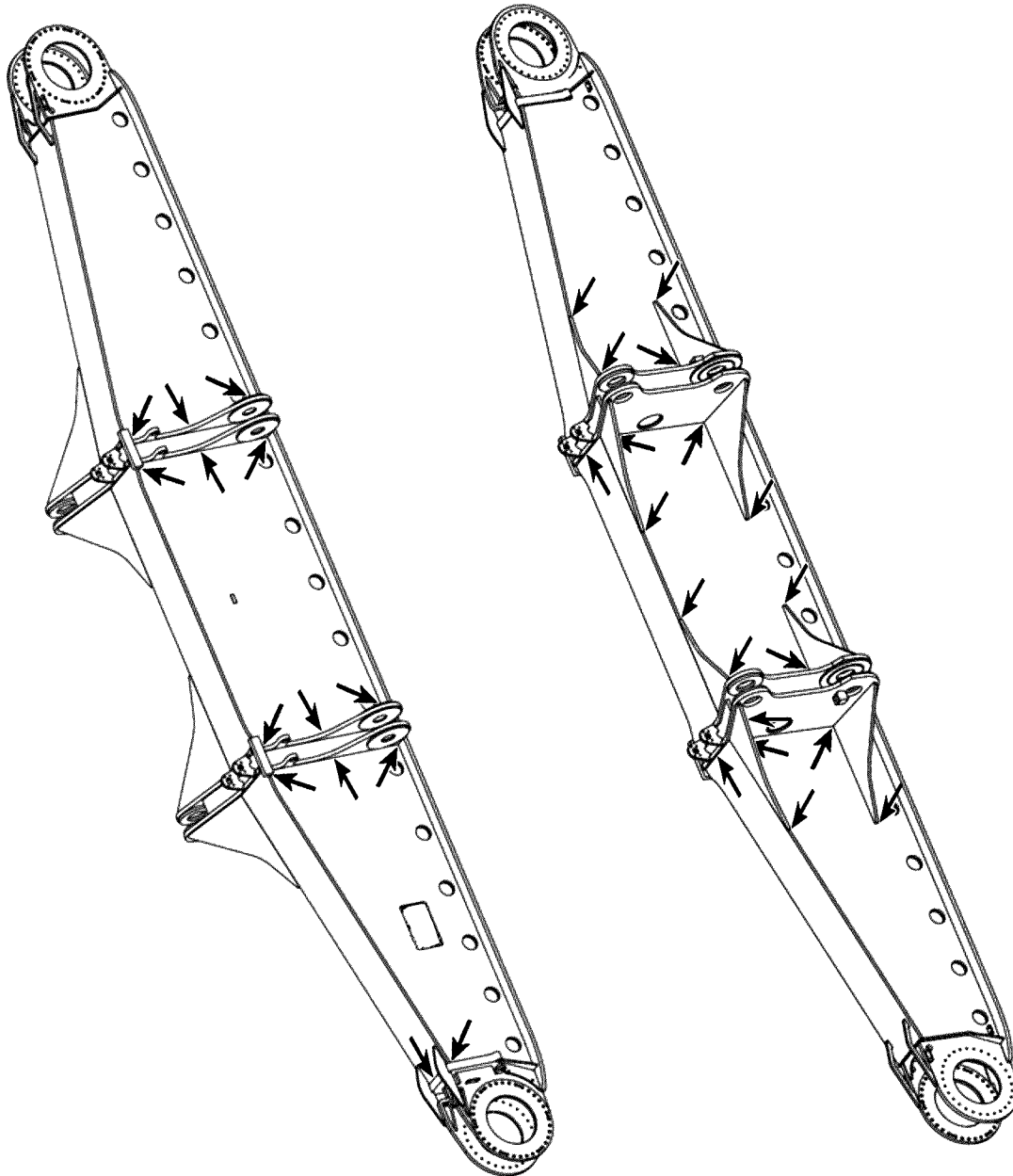

B105729

Example for crawler carrier

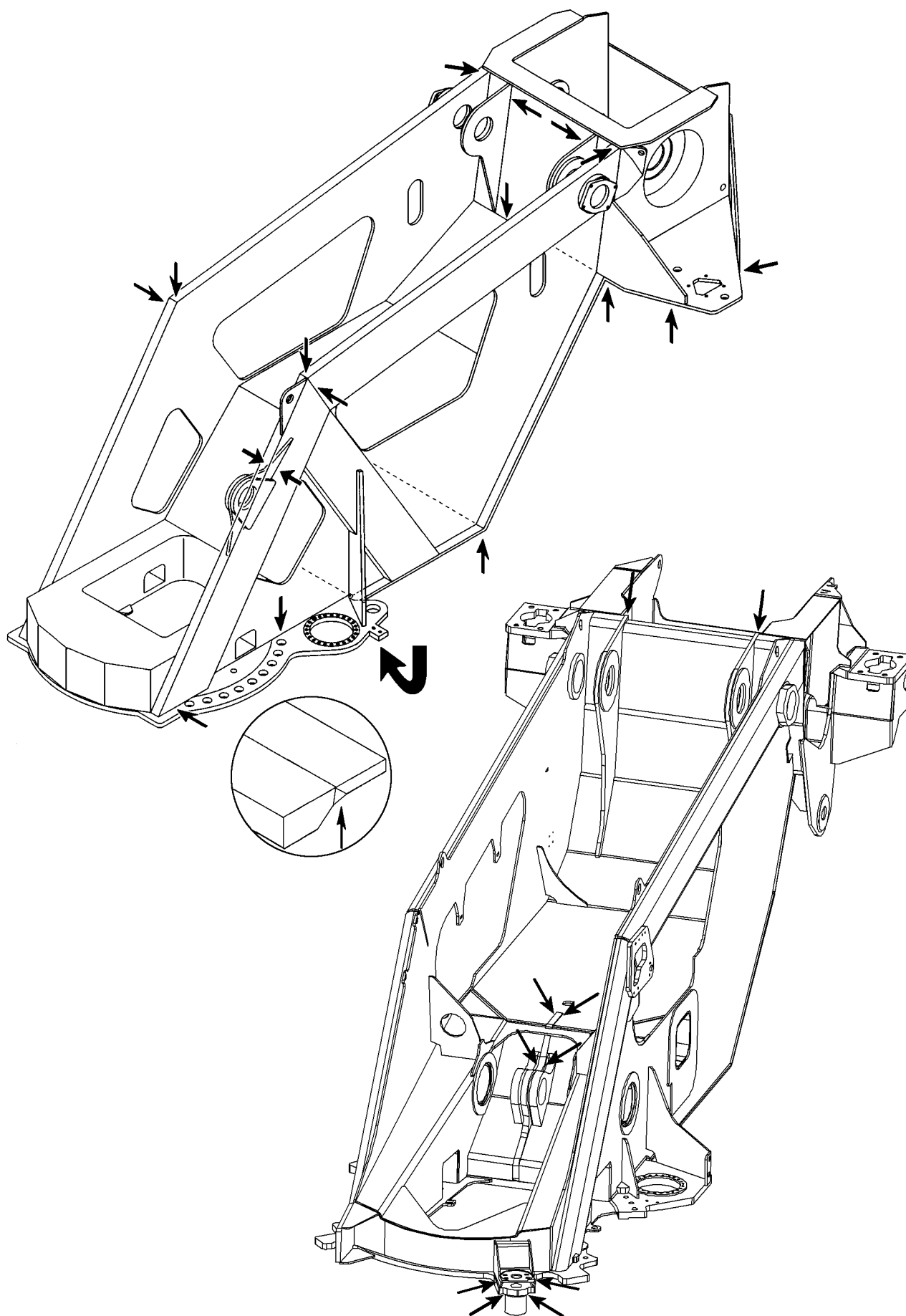

B185048

Example for turntable frame

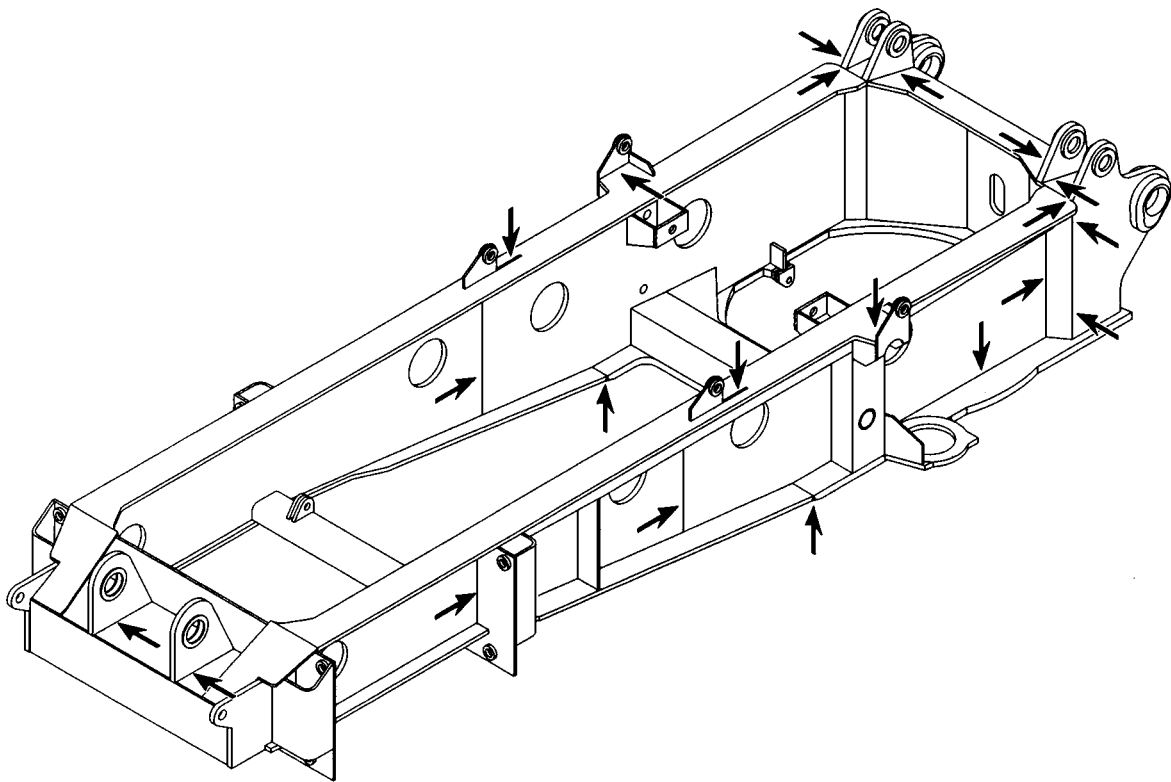

B185049

Example for turntable frame

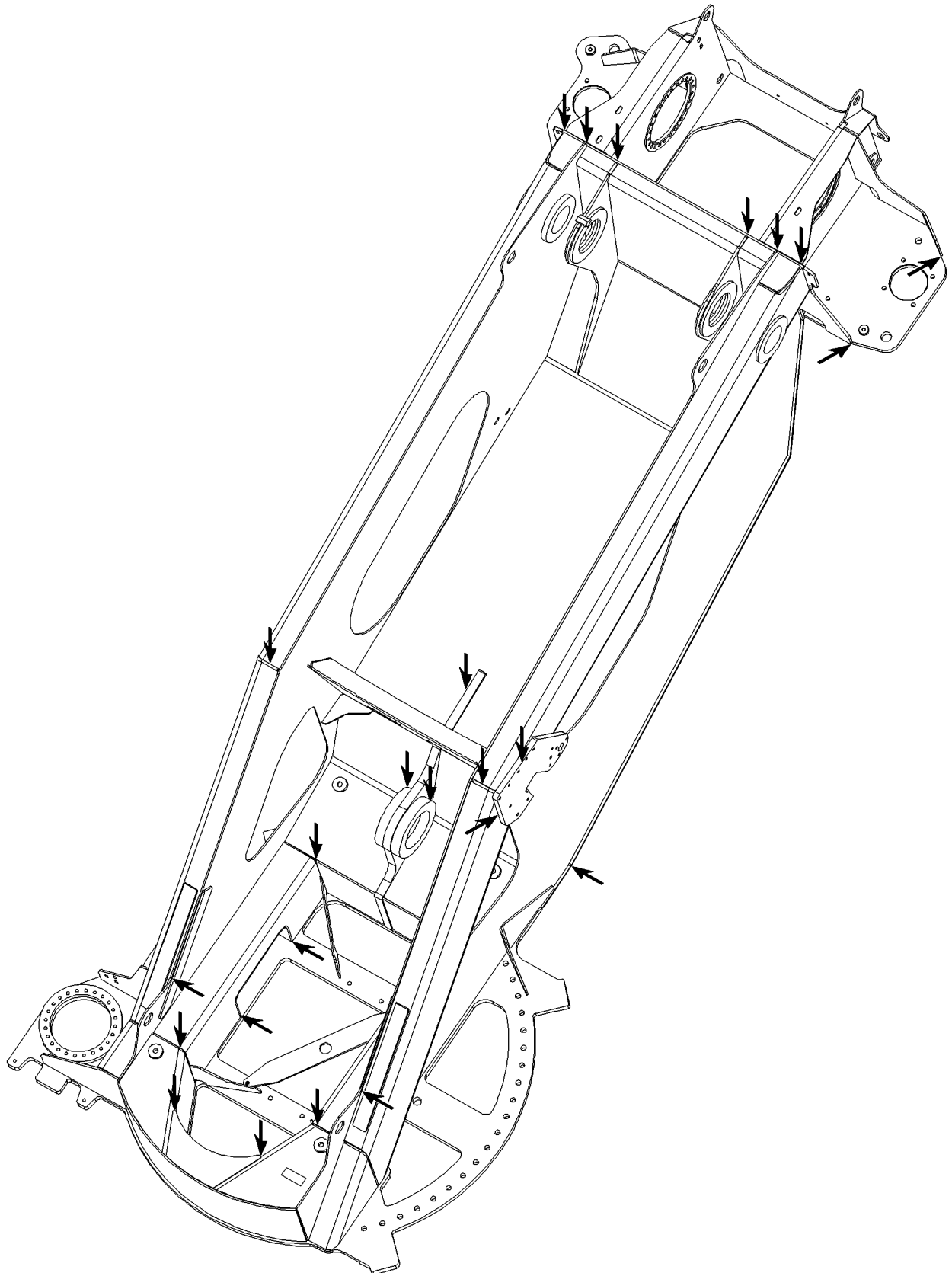

B105700

Example for turntable frame

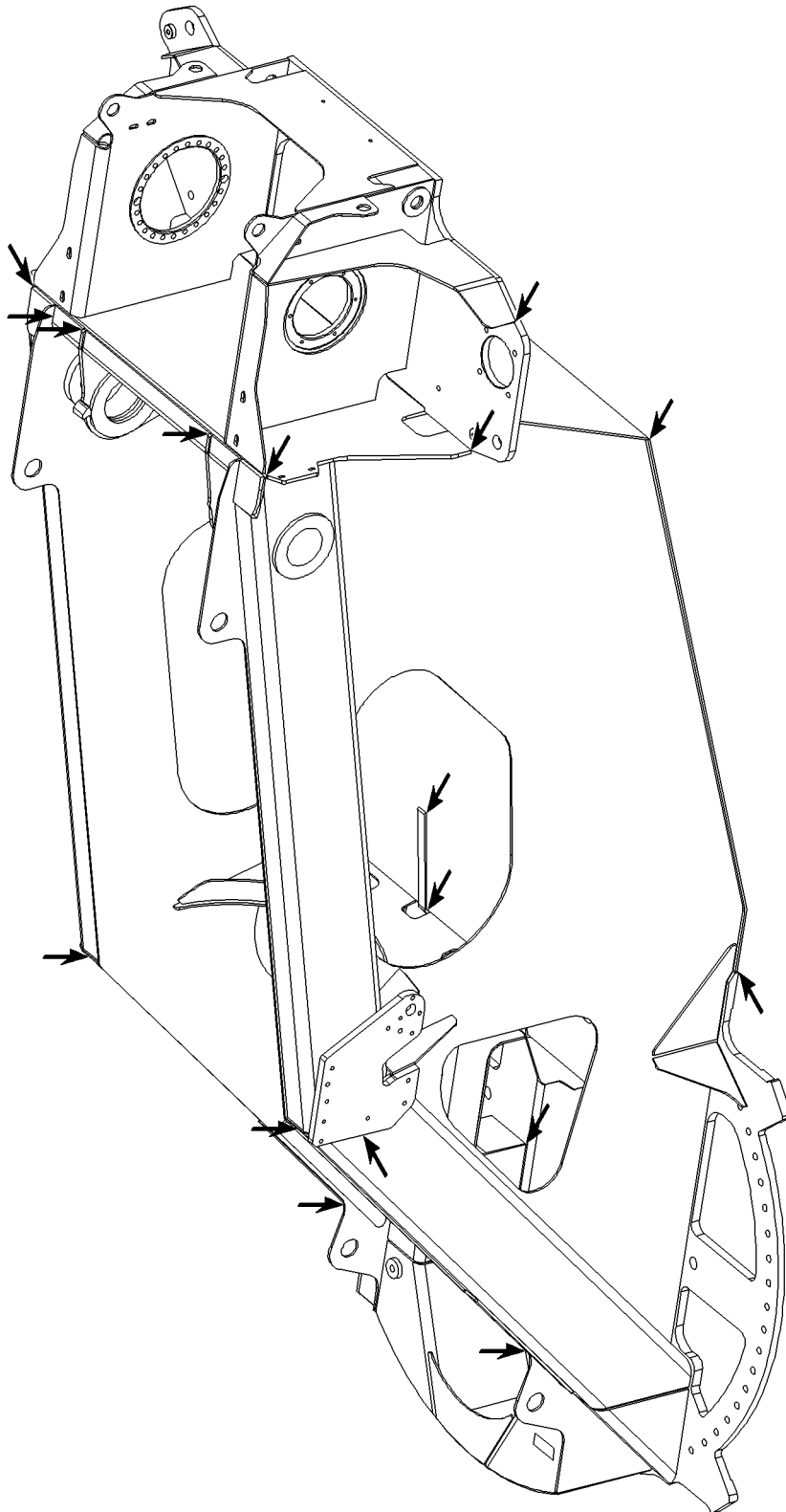

B105701

Example for turntable frame

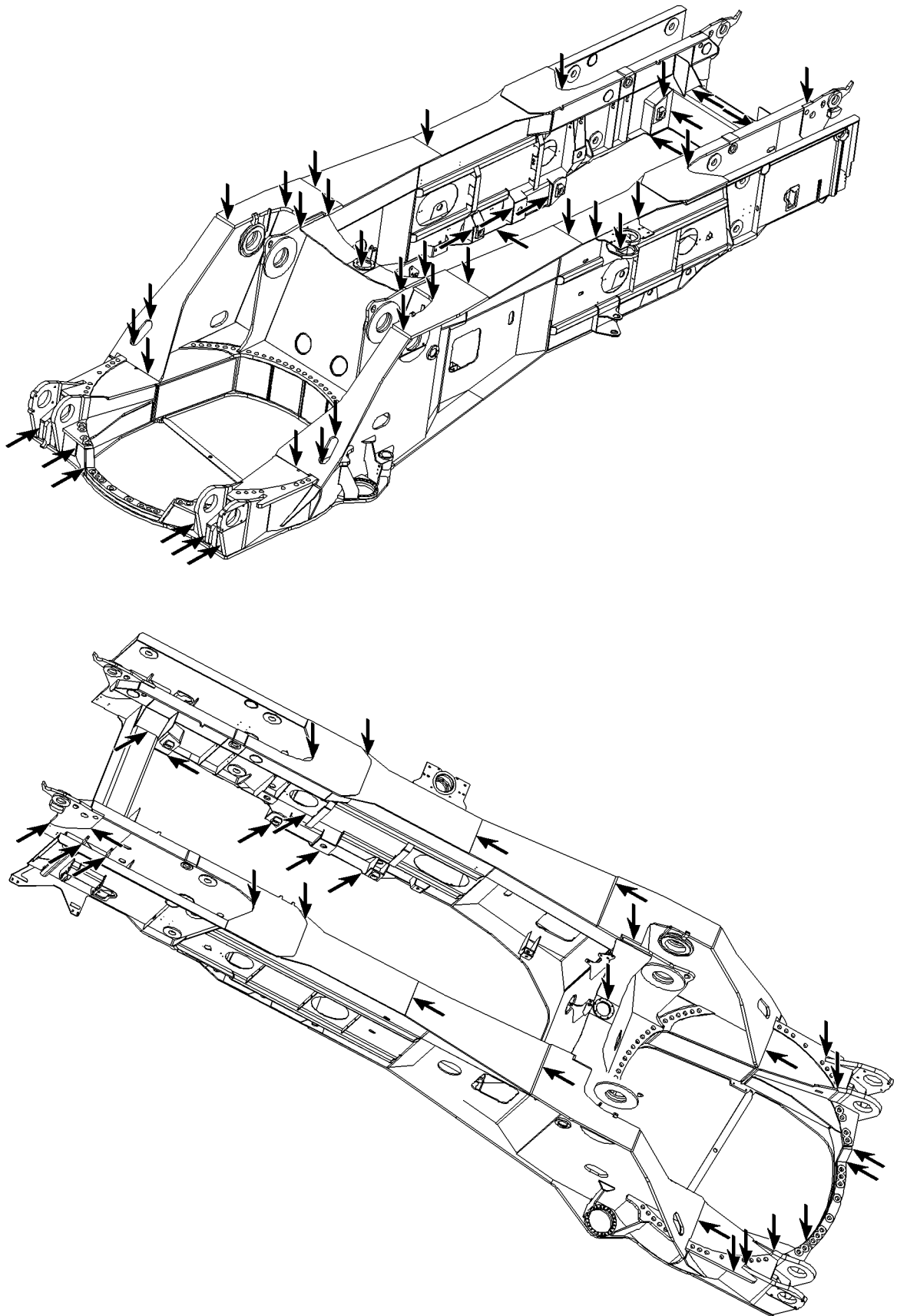

B105706

Example for turntable frame

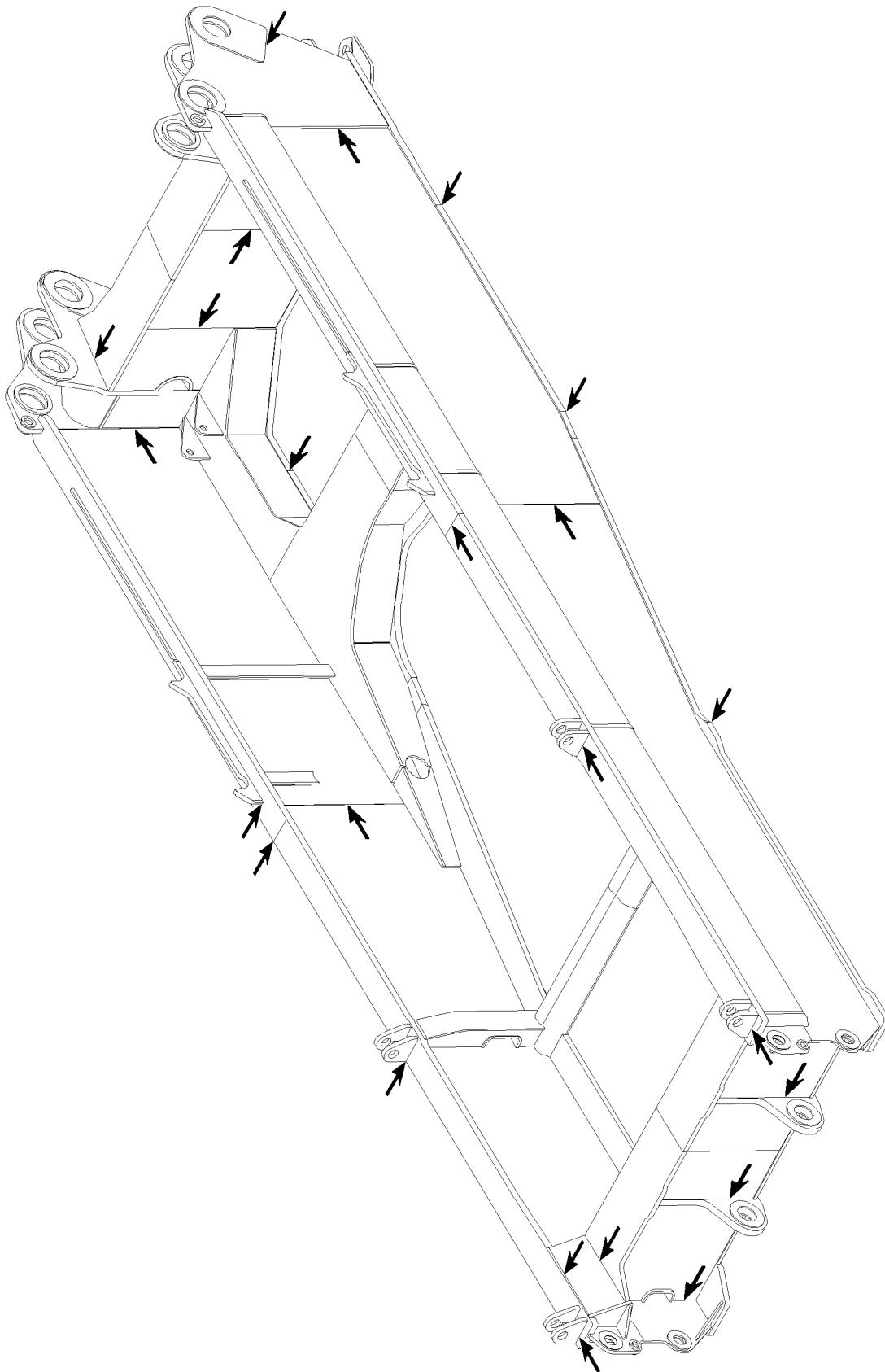

B105694

Example for turntable frame

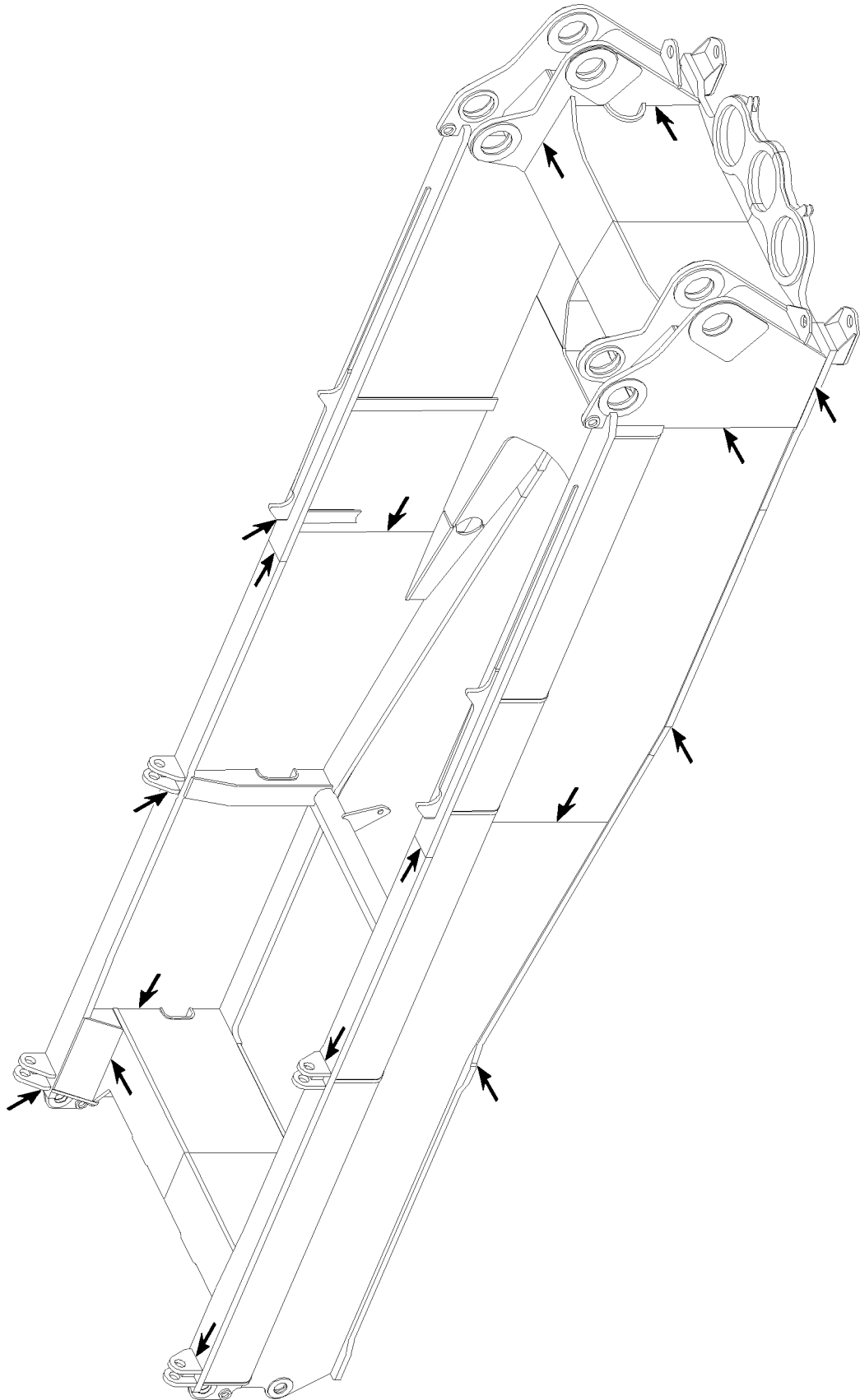

B105695

Example for turntable frame

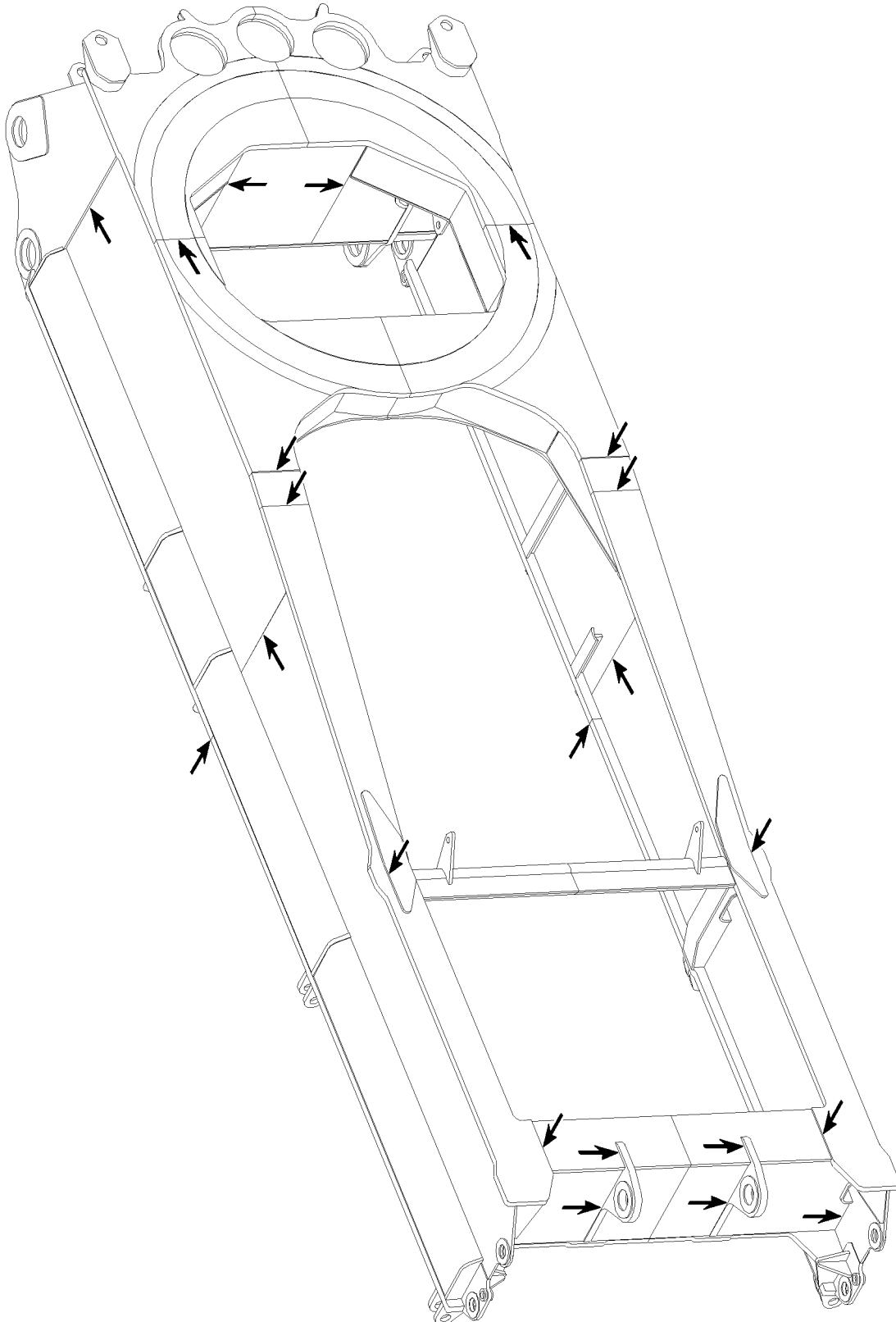

B105696

Example for turntable frame

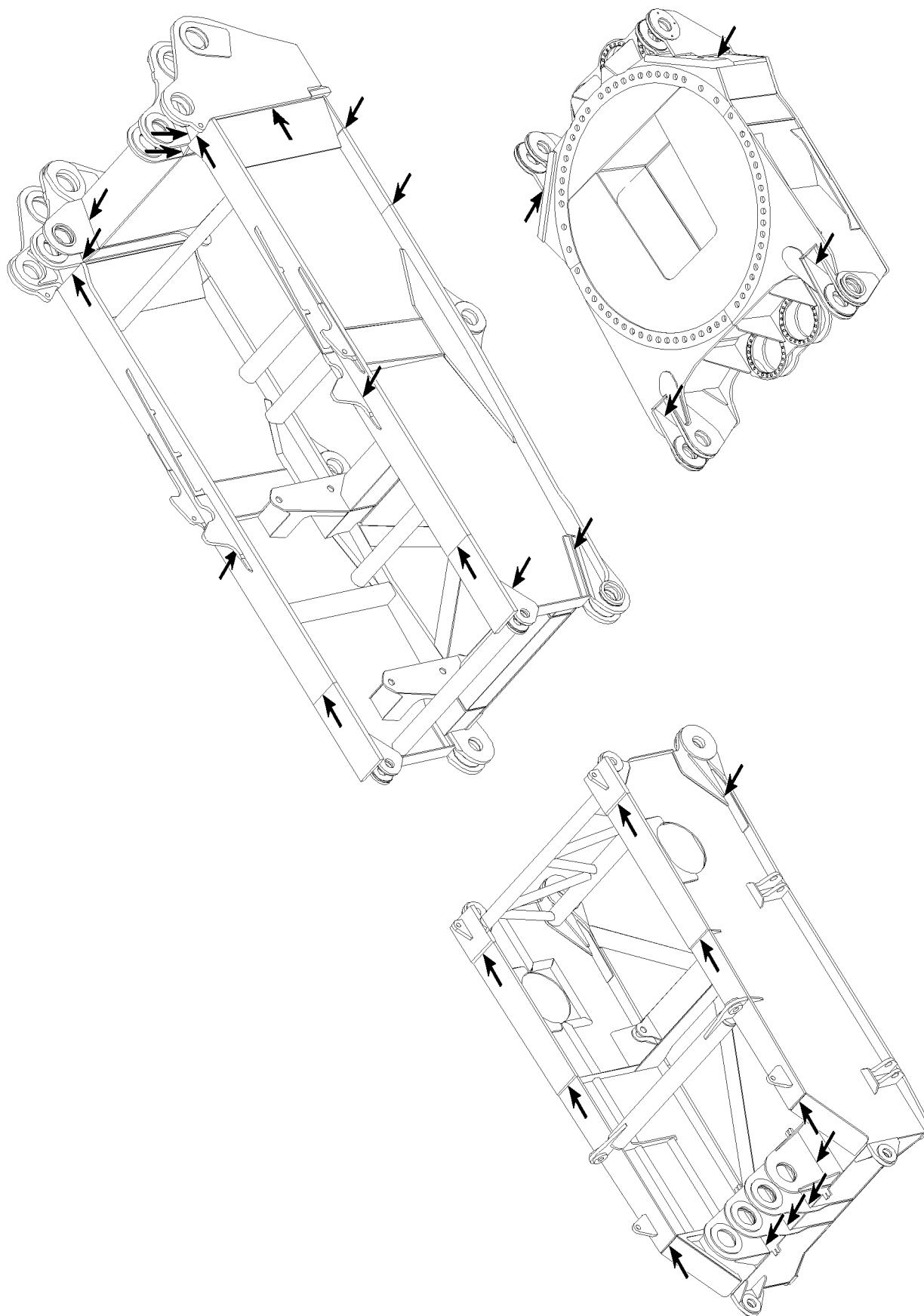

B105691

Example for turntable frame

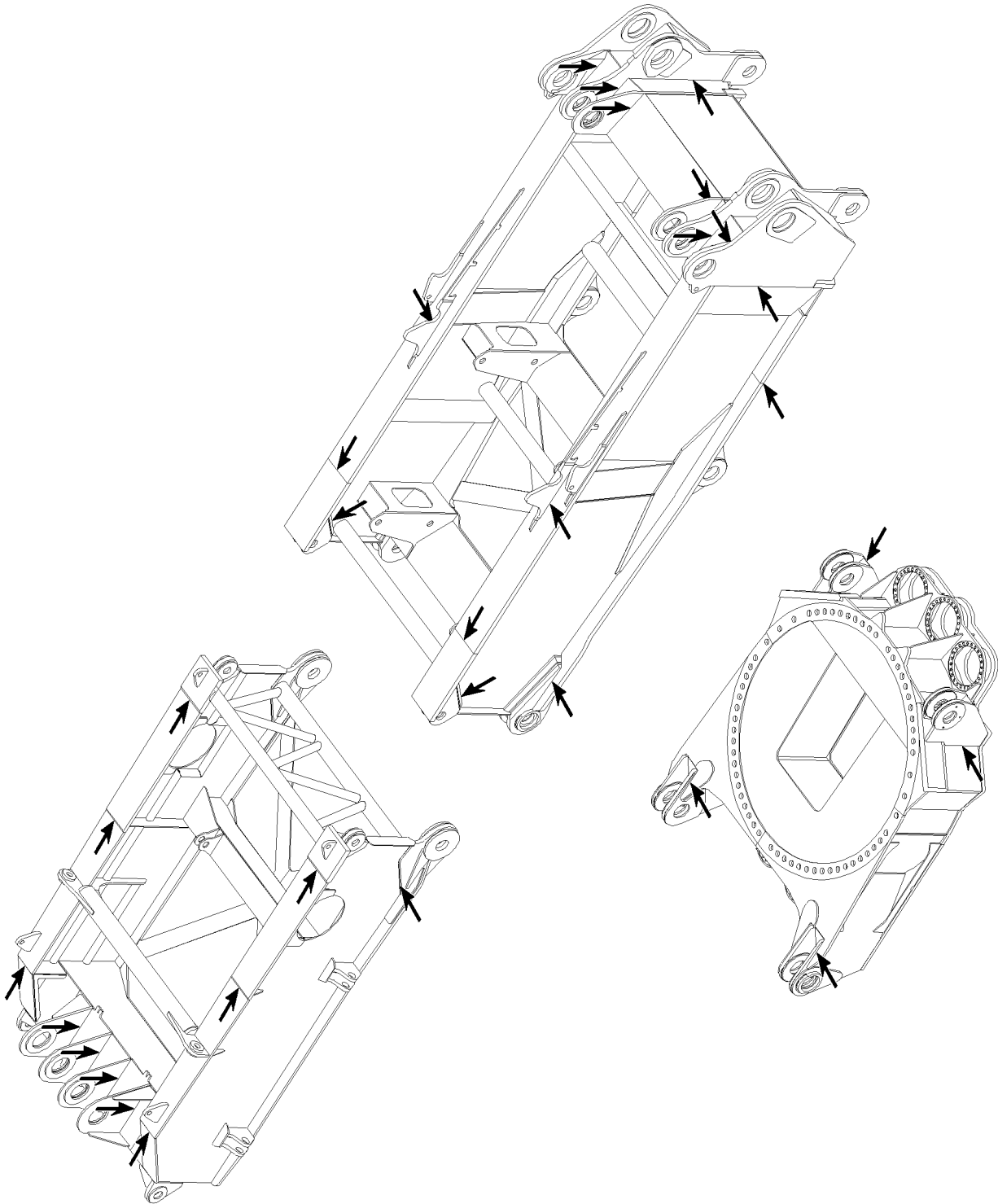

B105692

Example for turntable frame

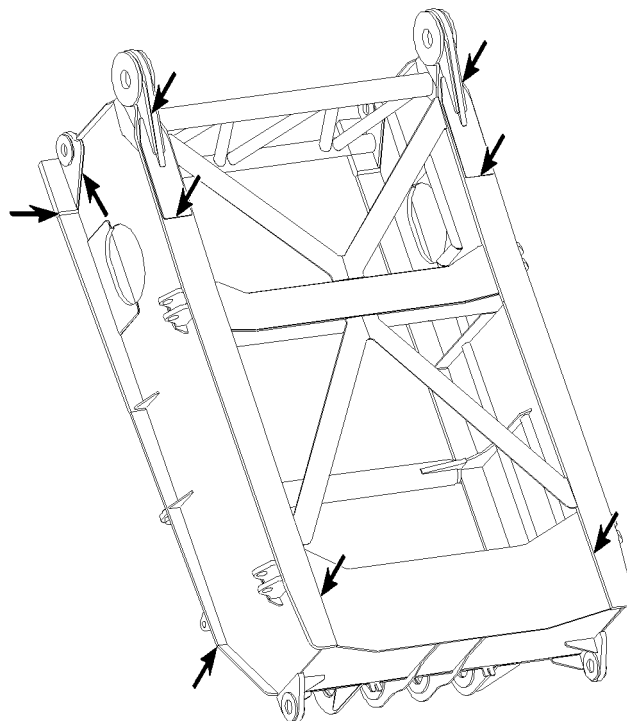
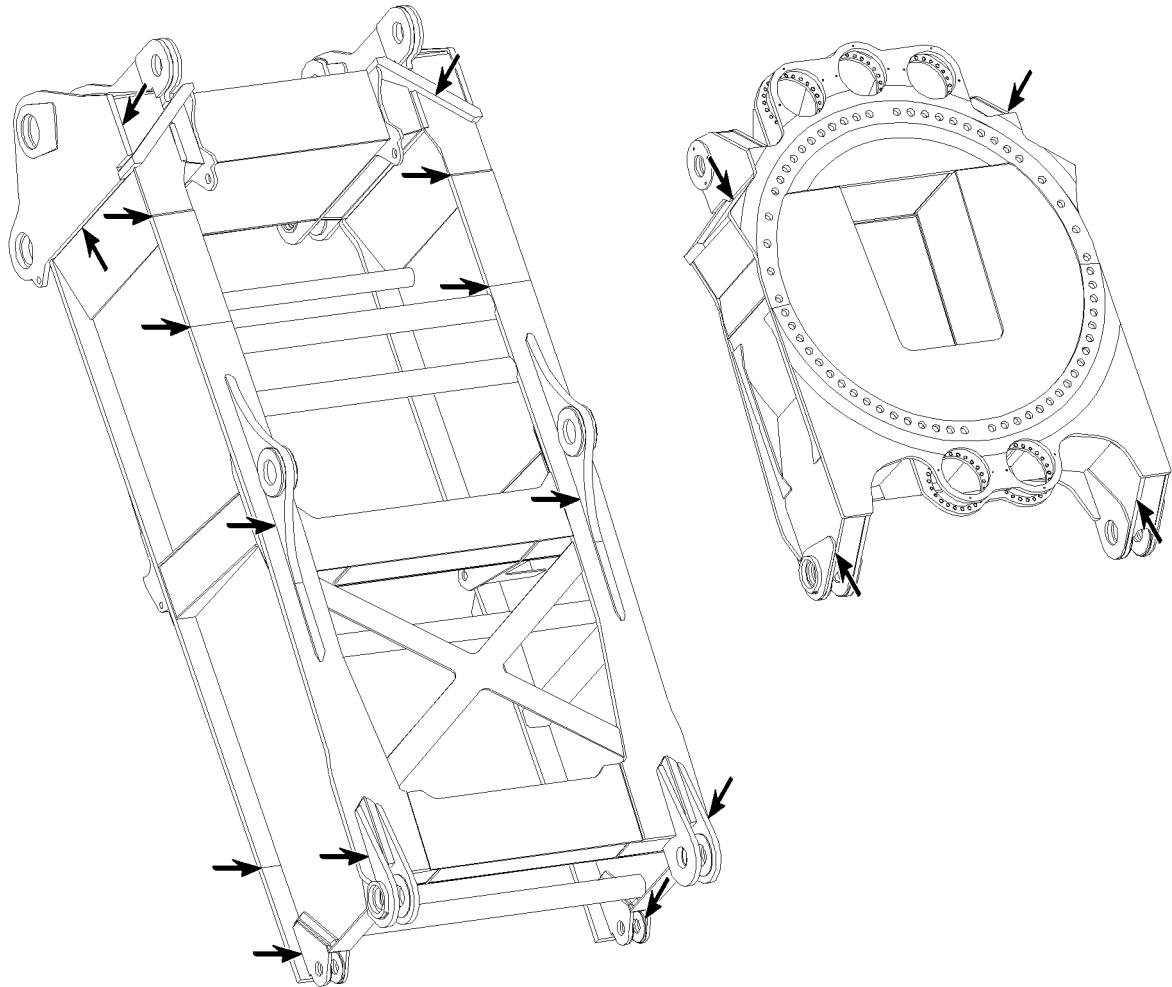

B105693

Example for turntable frame

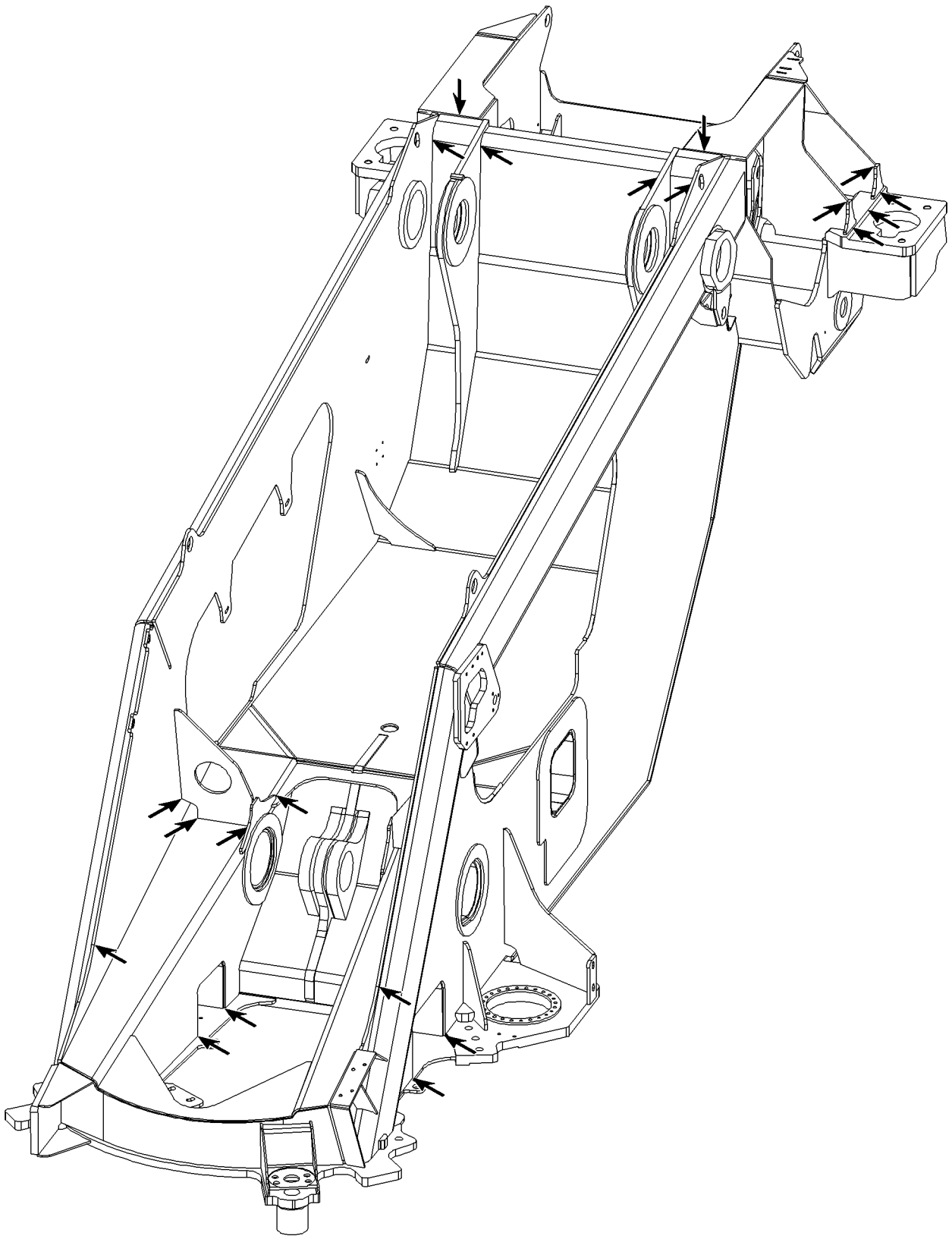

B105722

Example for turntable frame

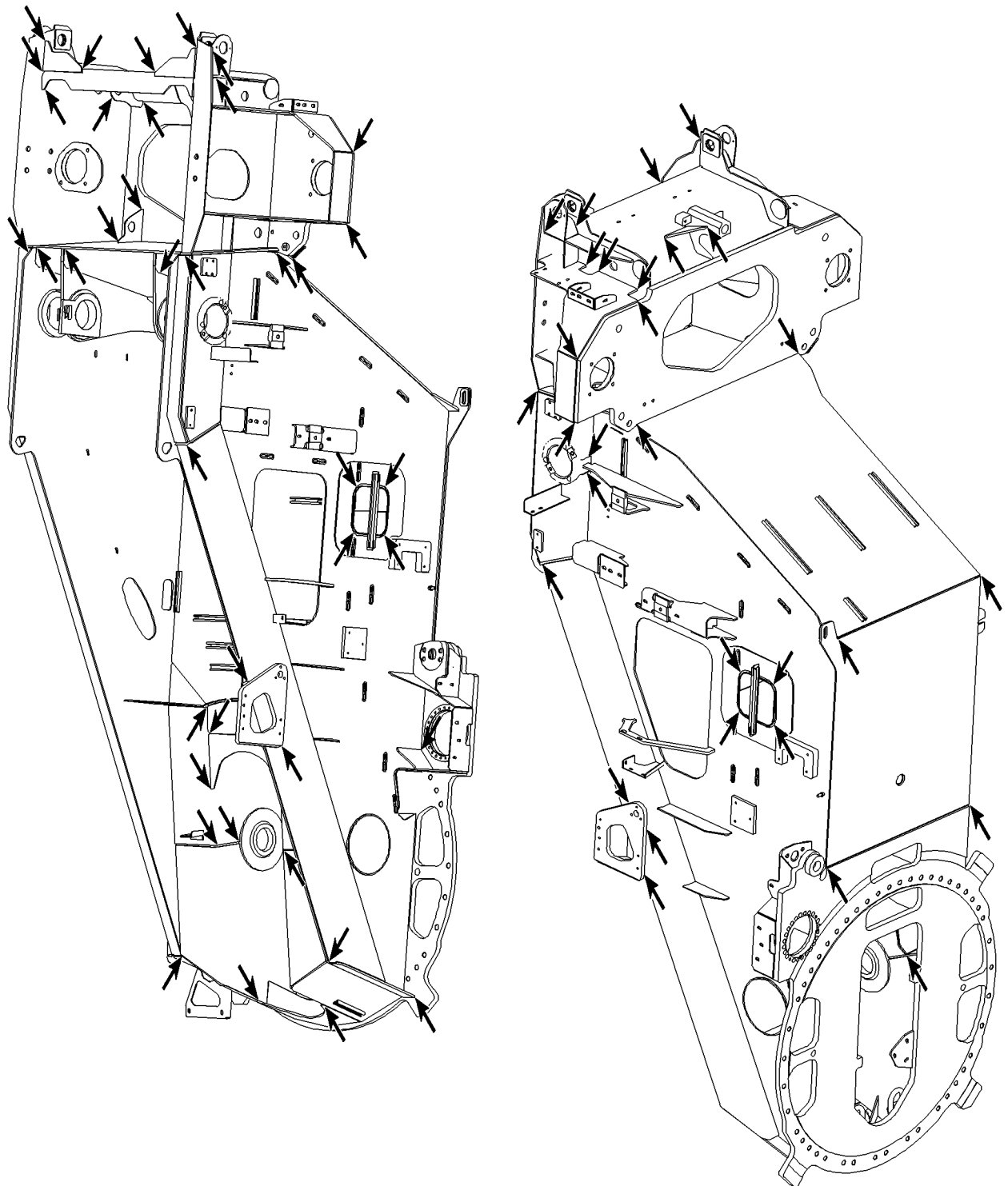

B105932

Example for turntable frame

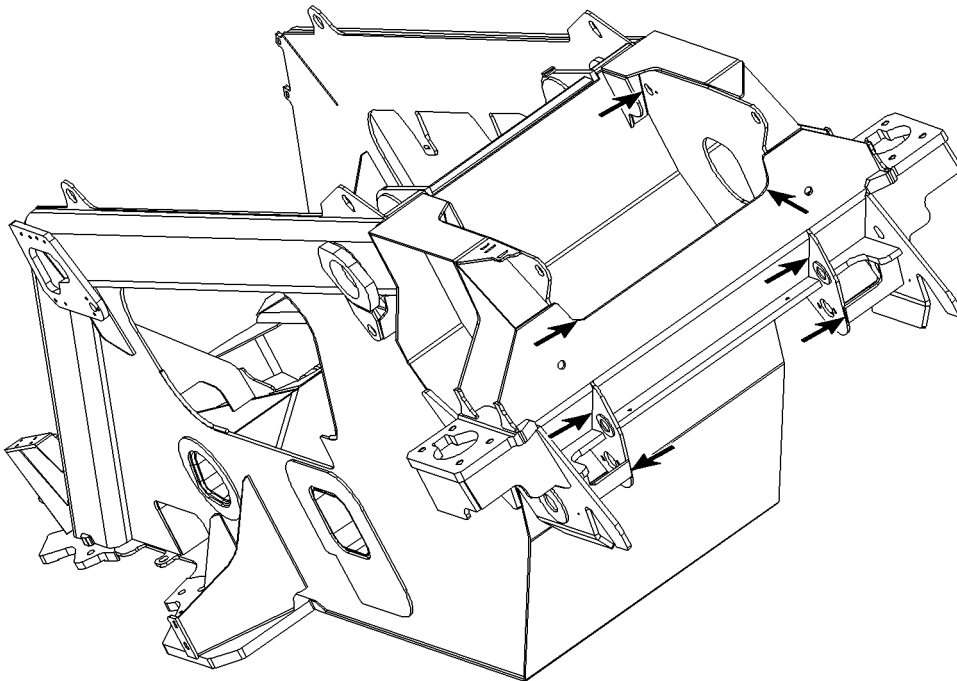
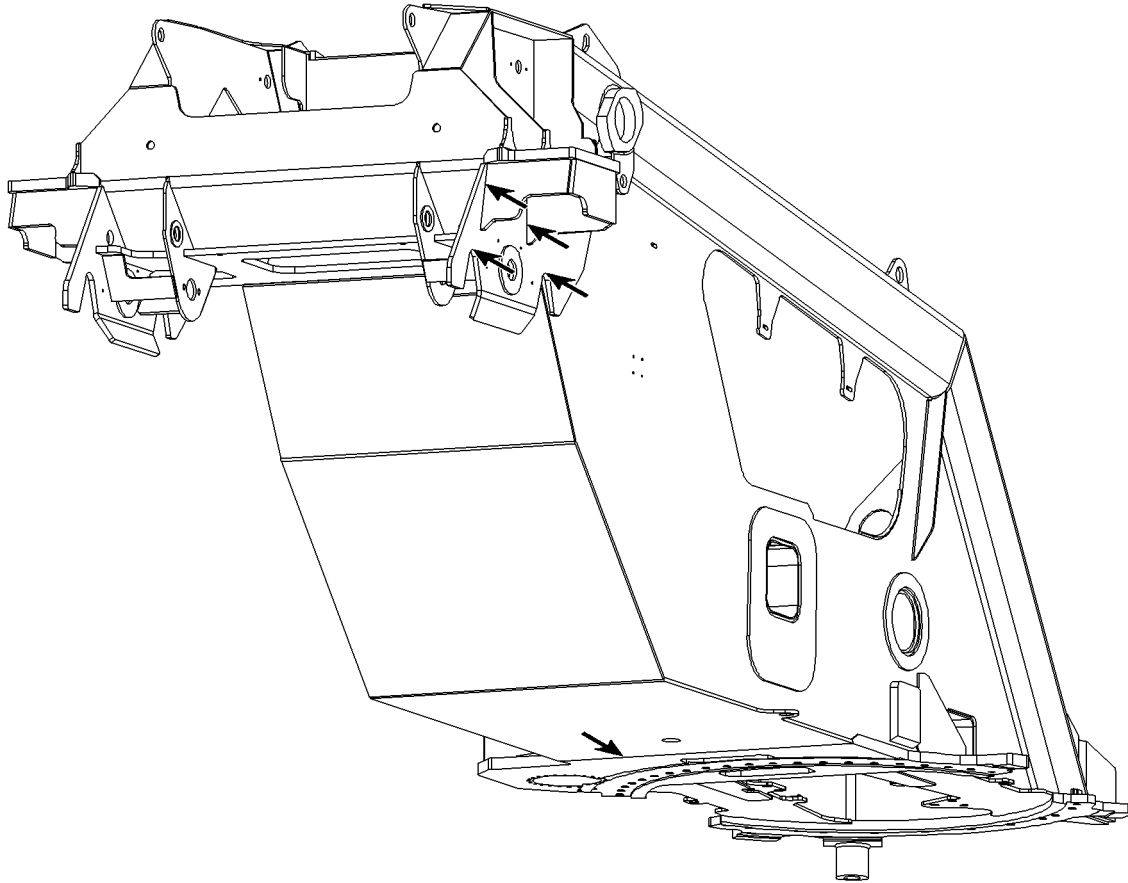

B105723

Example for turntable frame

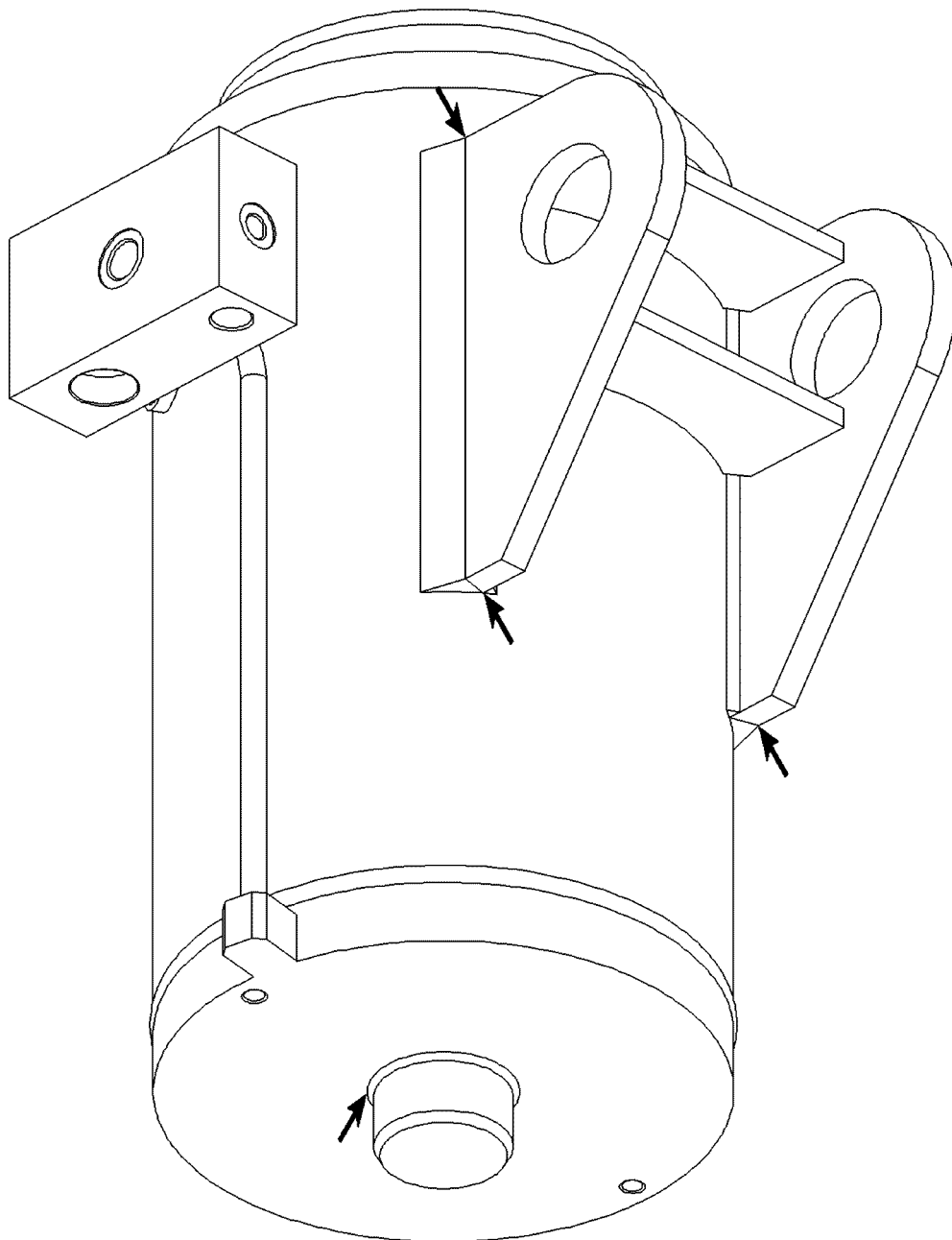

B105801

Example for ballasting cylinder

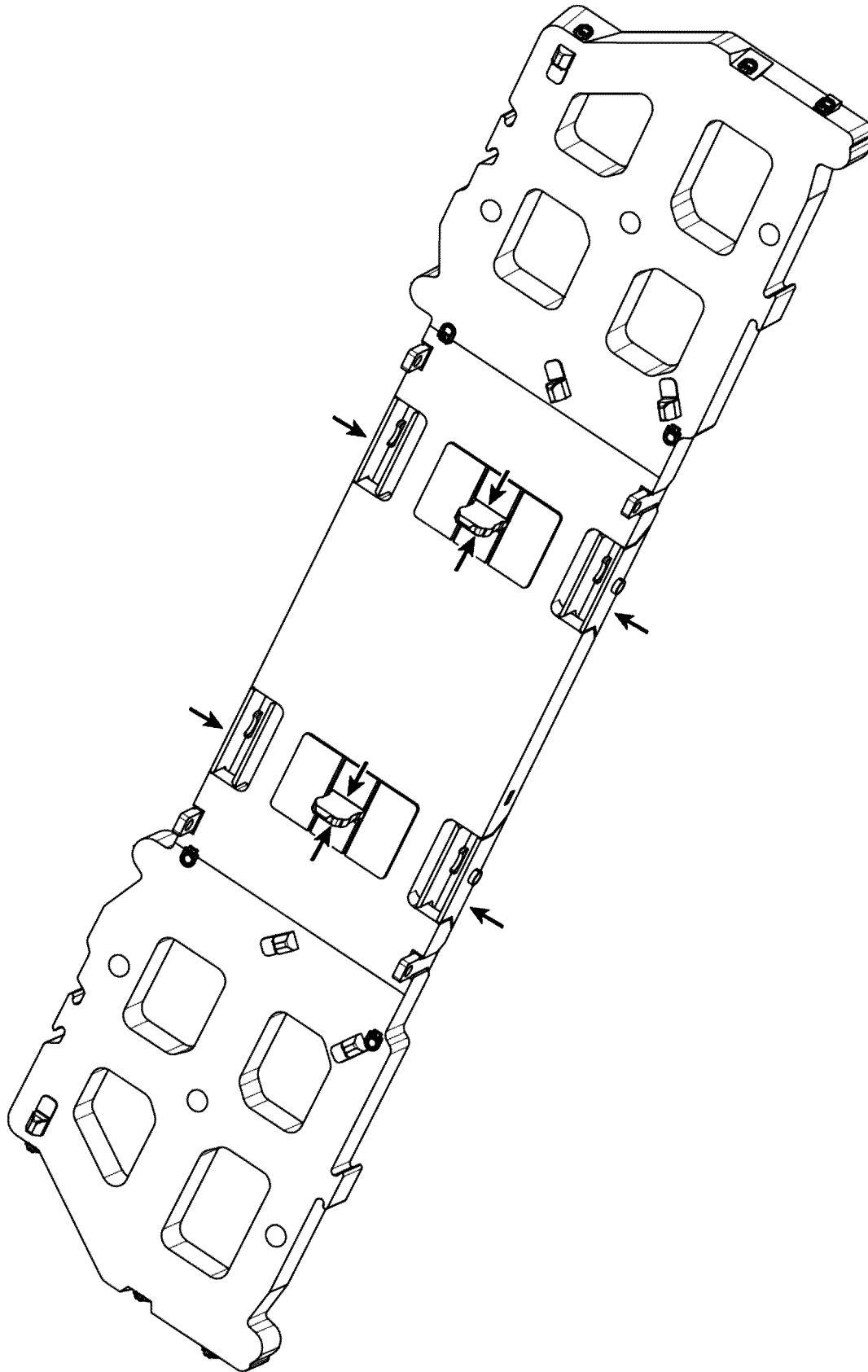

B105705

Example for mounting plate

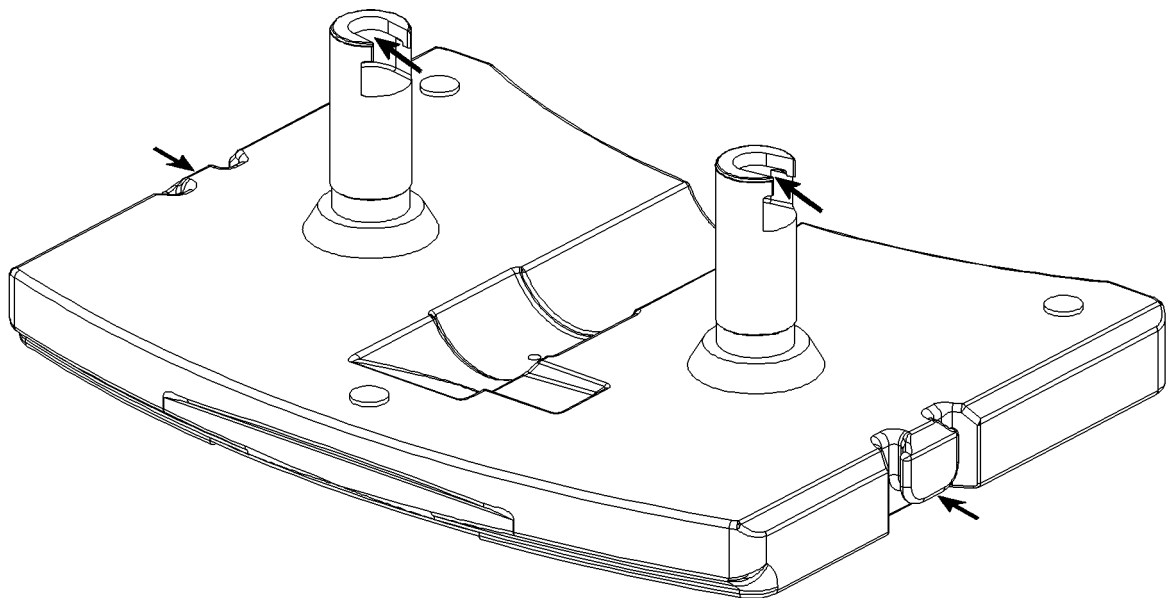
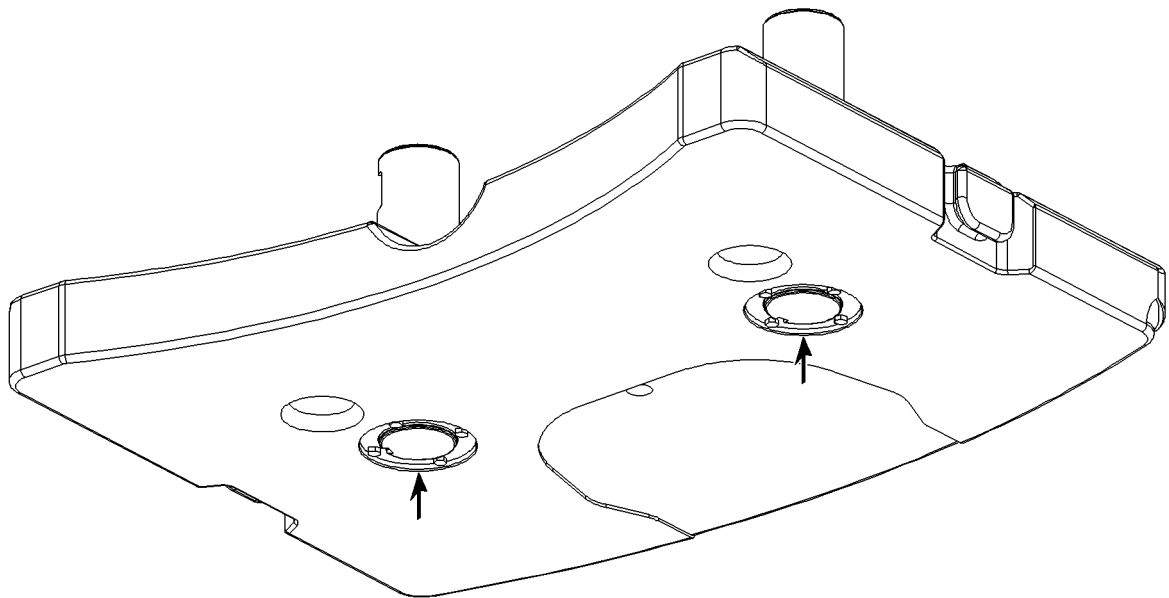

B105807

Example for base plate

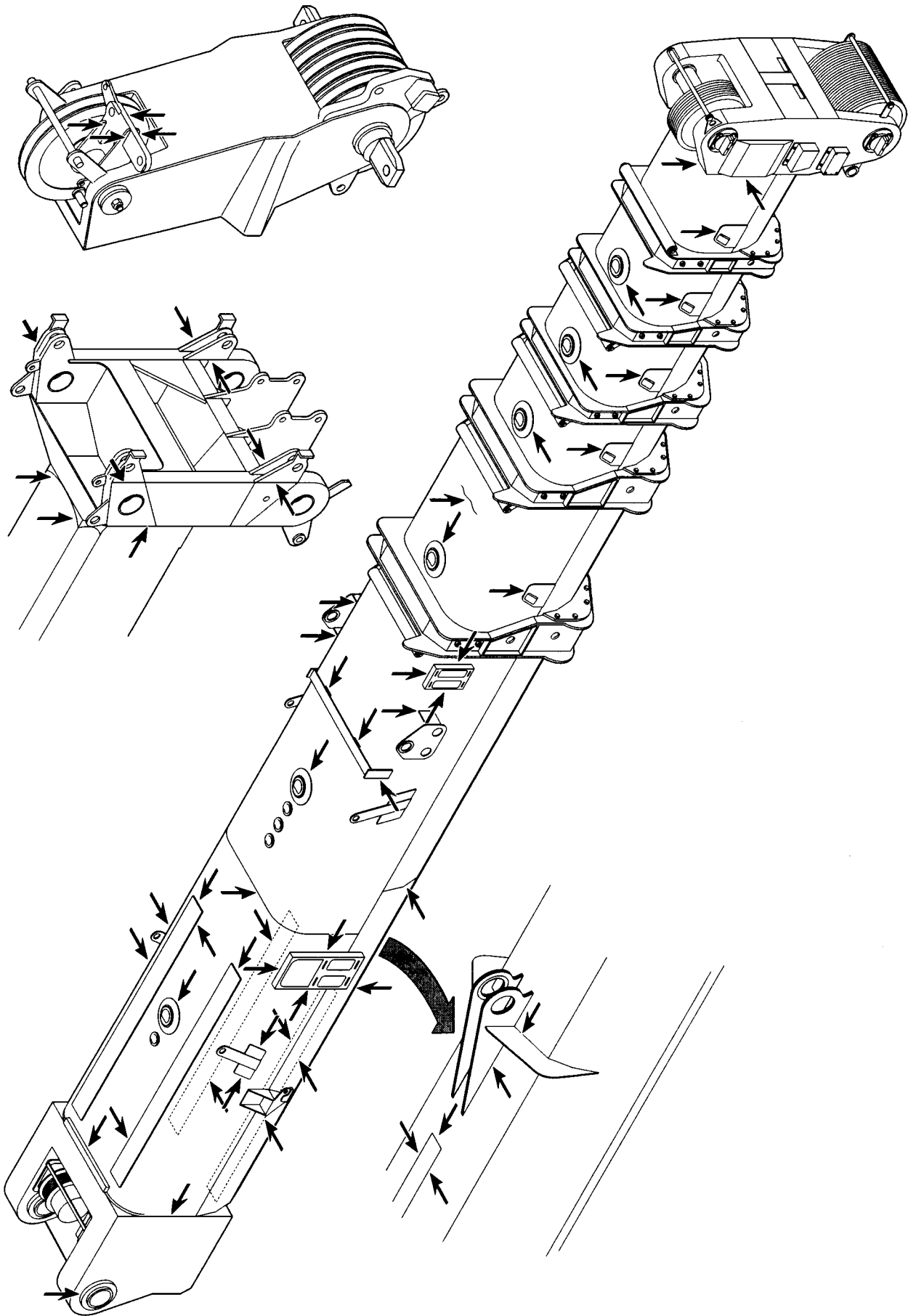

B185050

Example for telescopic boom

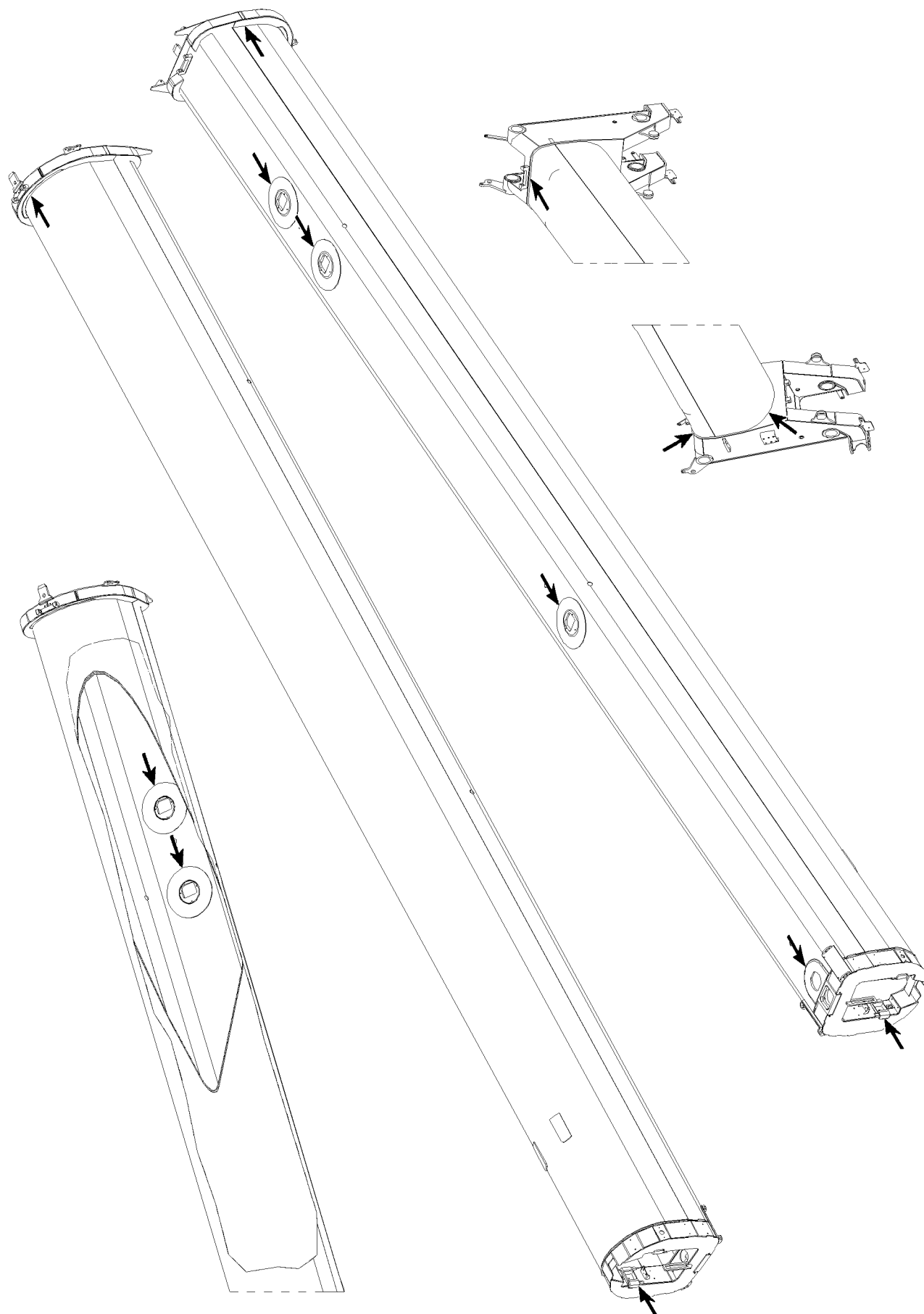

B105710

Example for telescopic boom

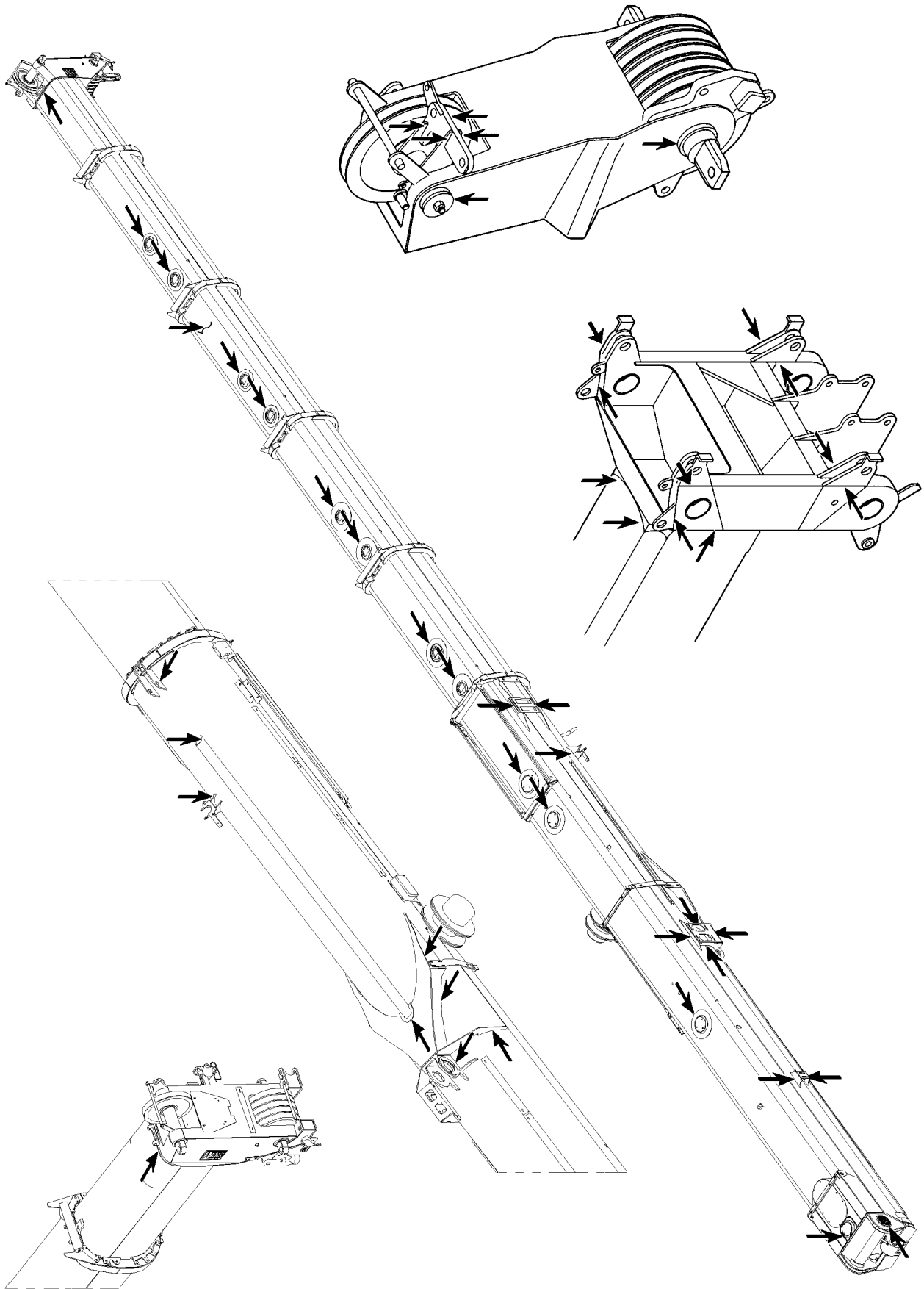

B105711

Example for telescopic boom

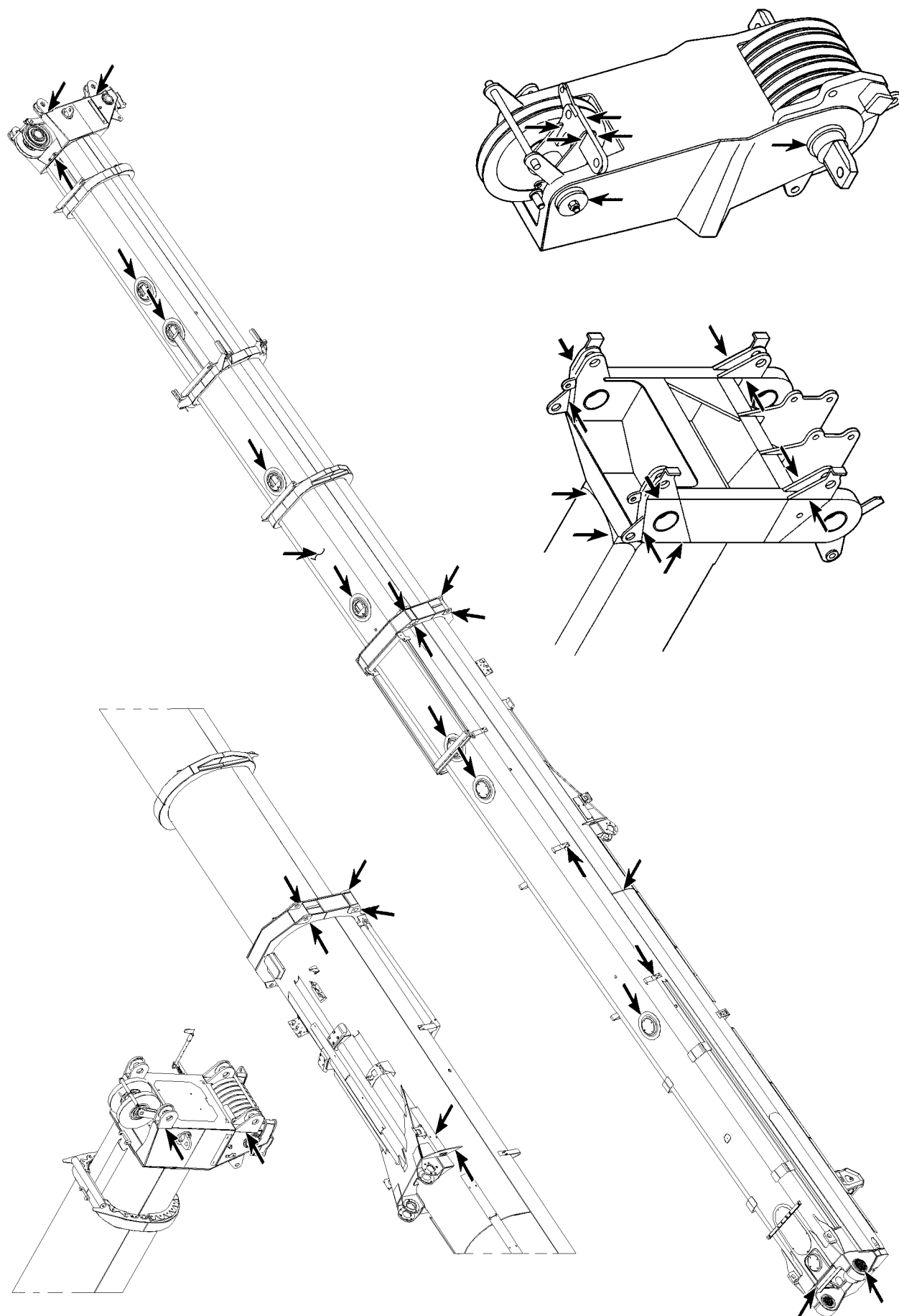

B105720

Example for telescopic boom

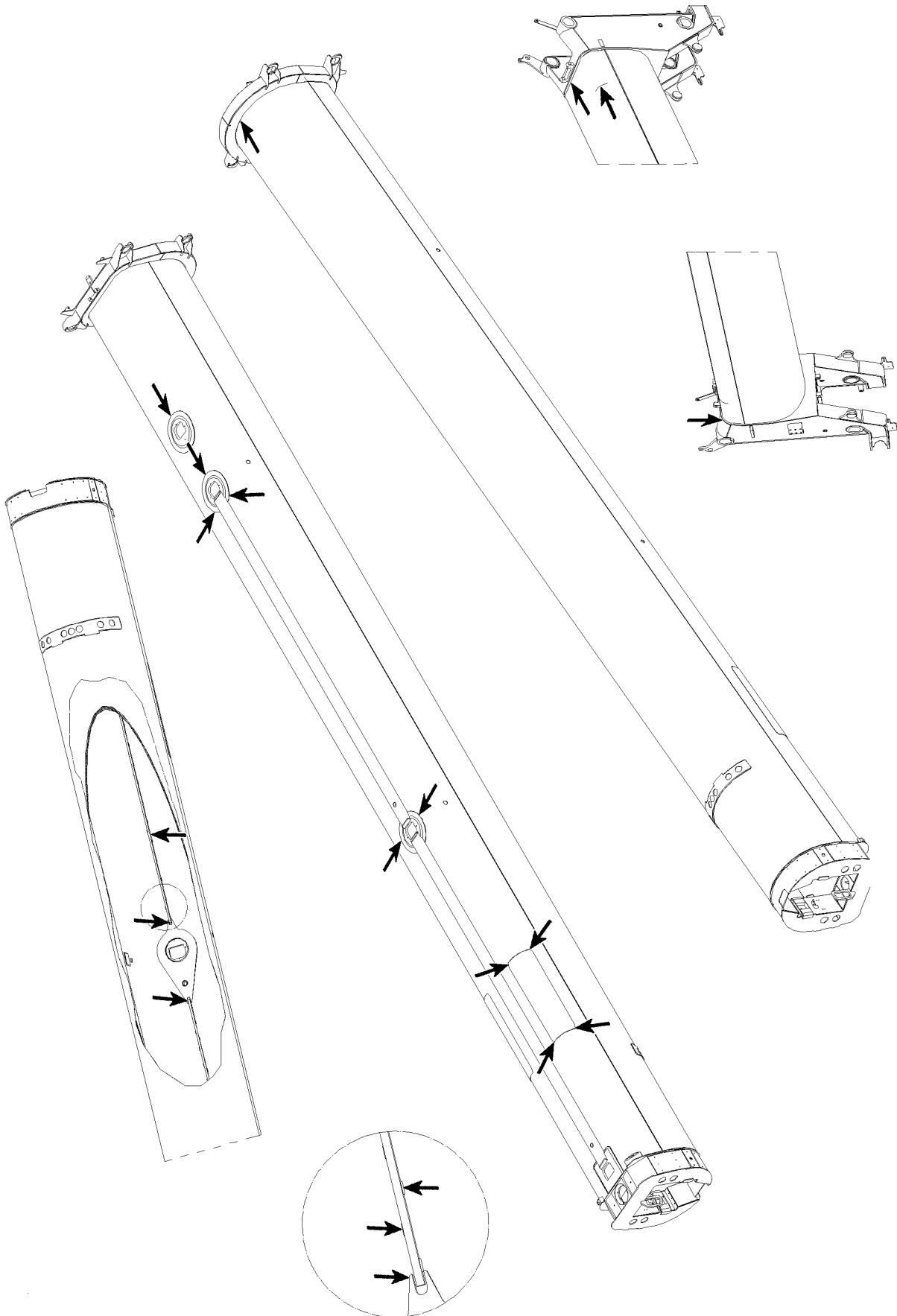

B105721

Example for telescopic boom

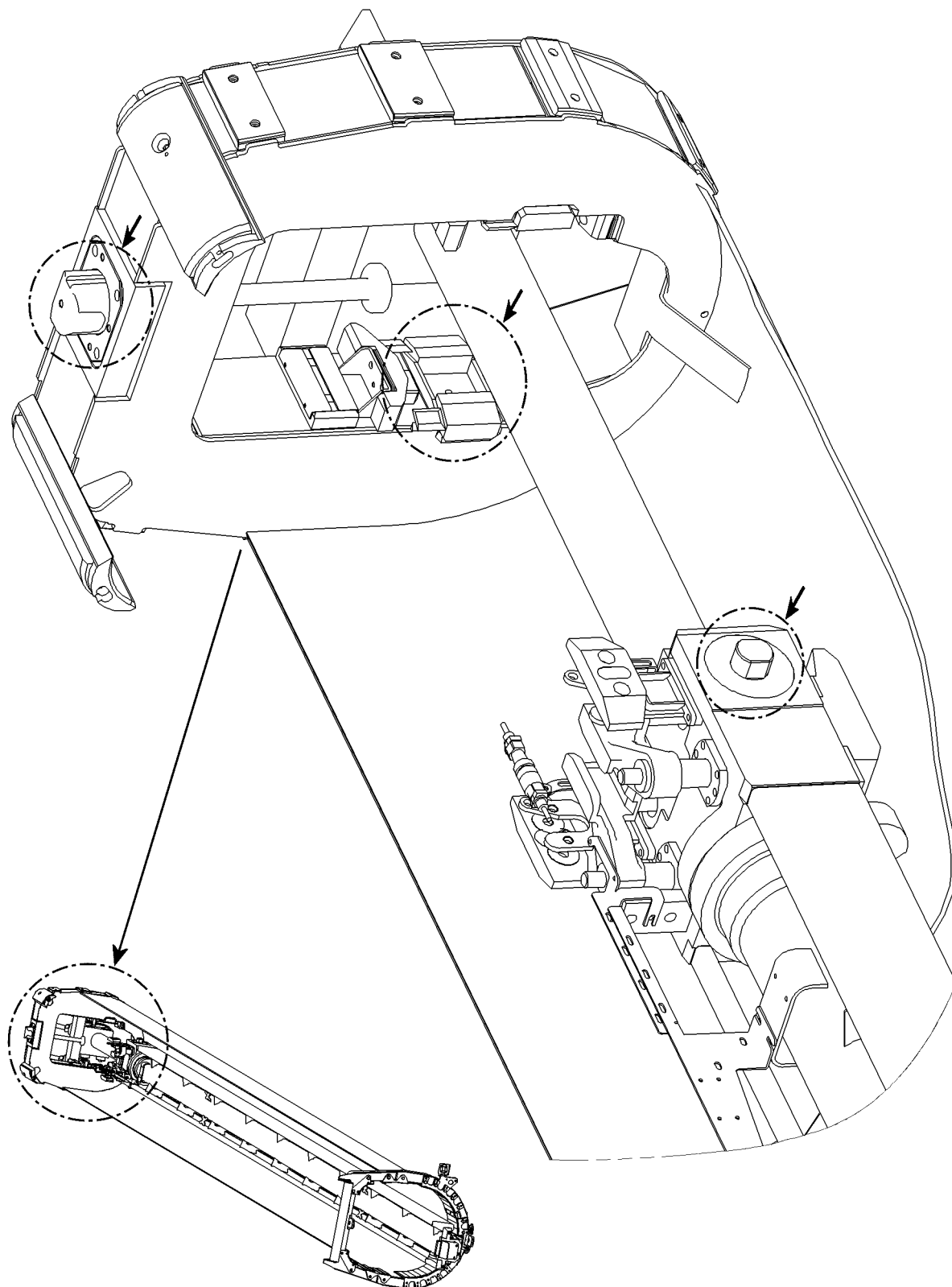

B105891

Example for push out mechanics telescopic boom

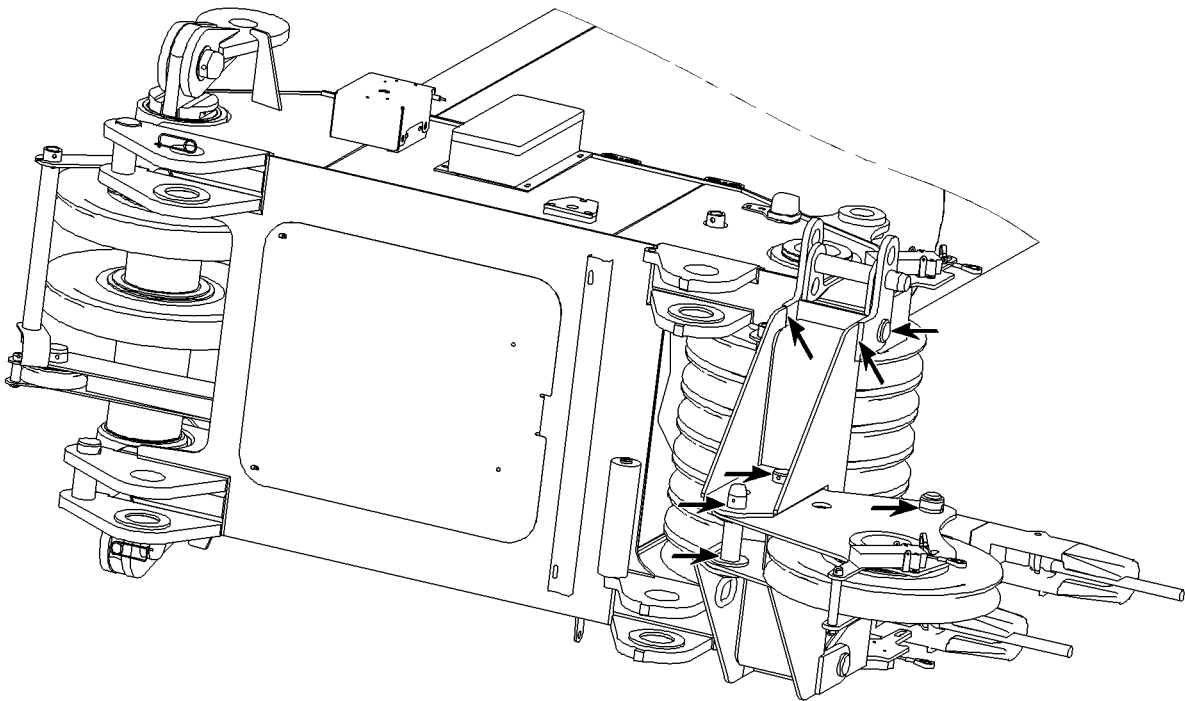
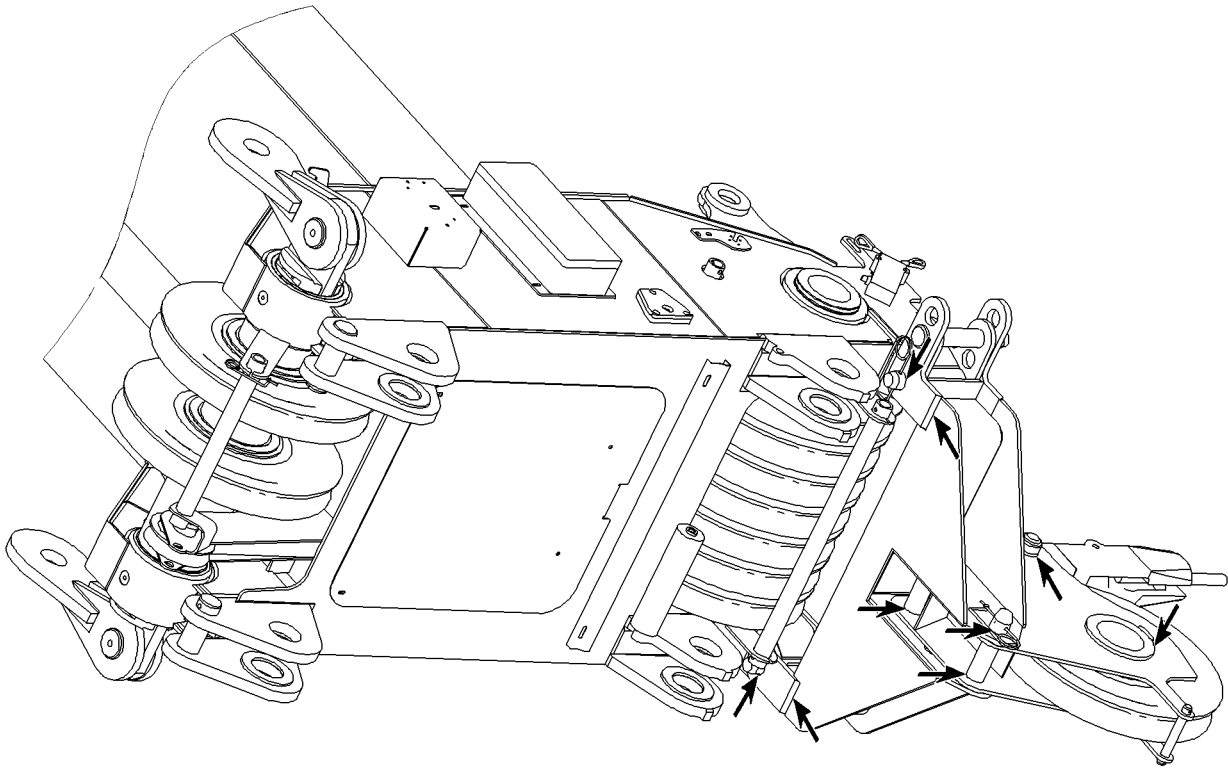

B105892

Example for boom nose

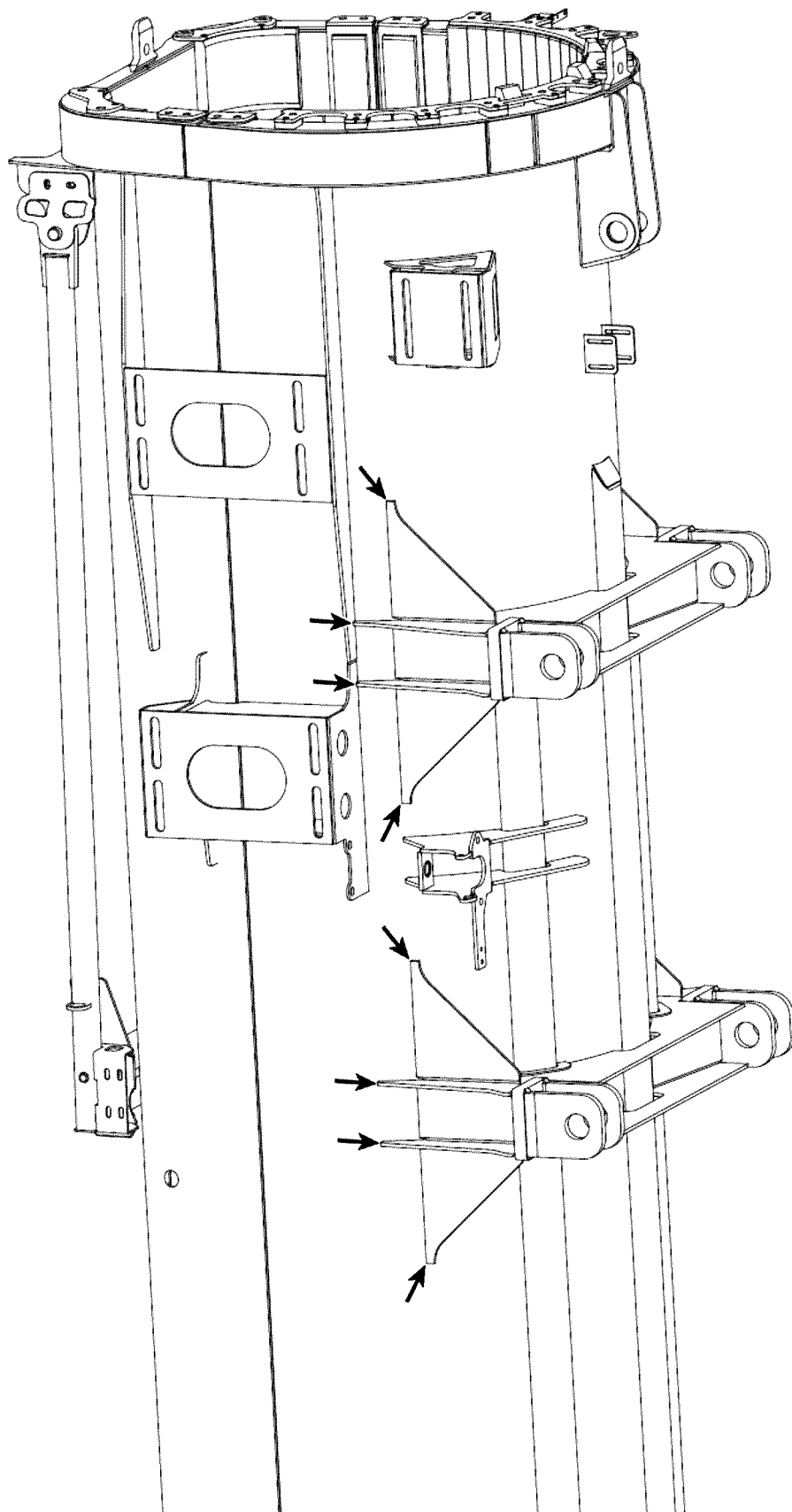

B105689

Example for dolly console

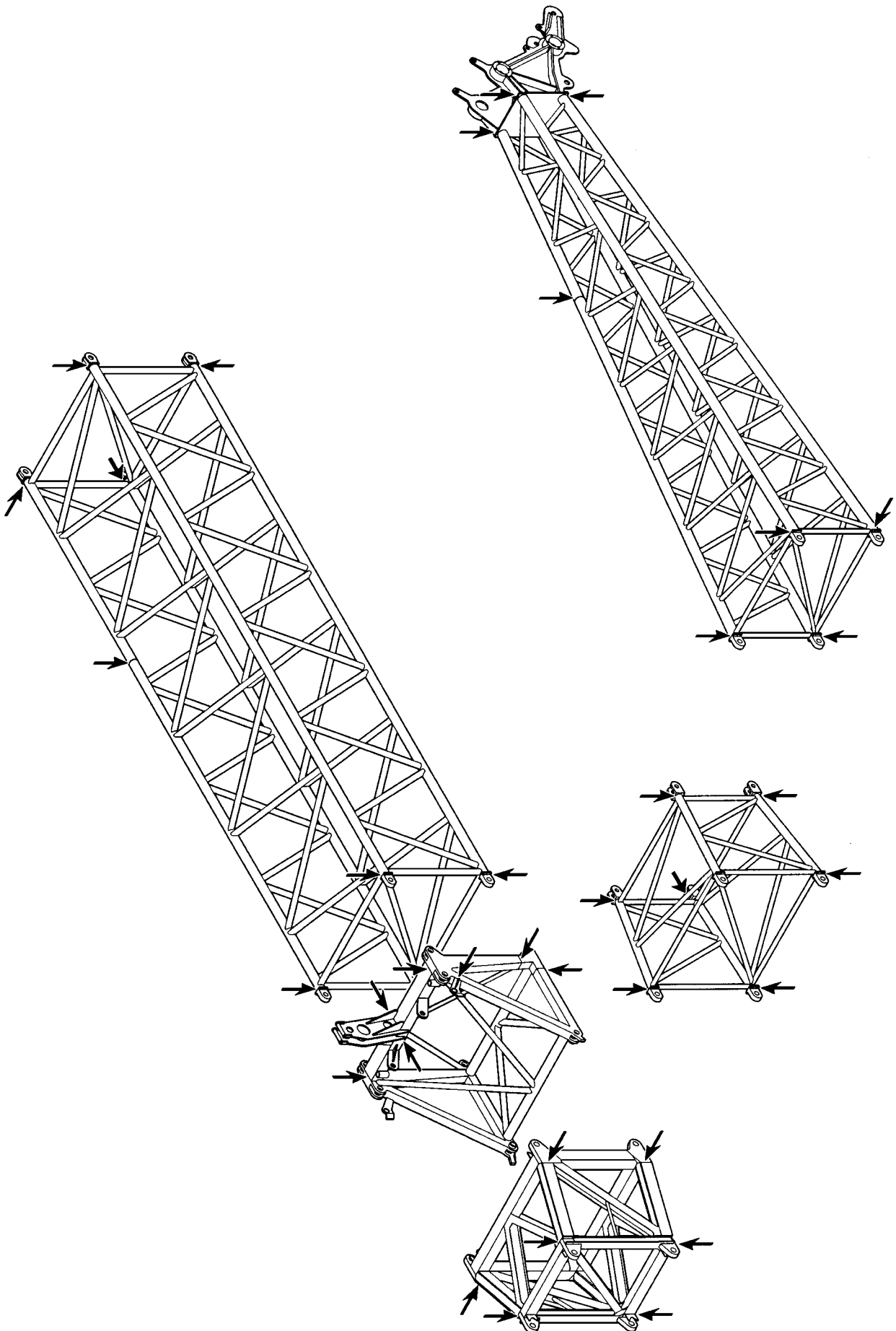

Example for lattice jib

B185051

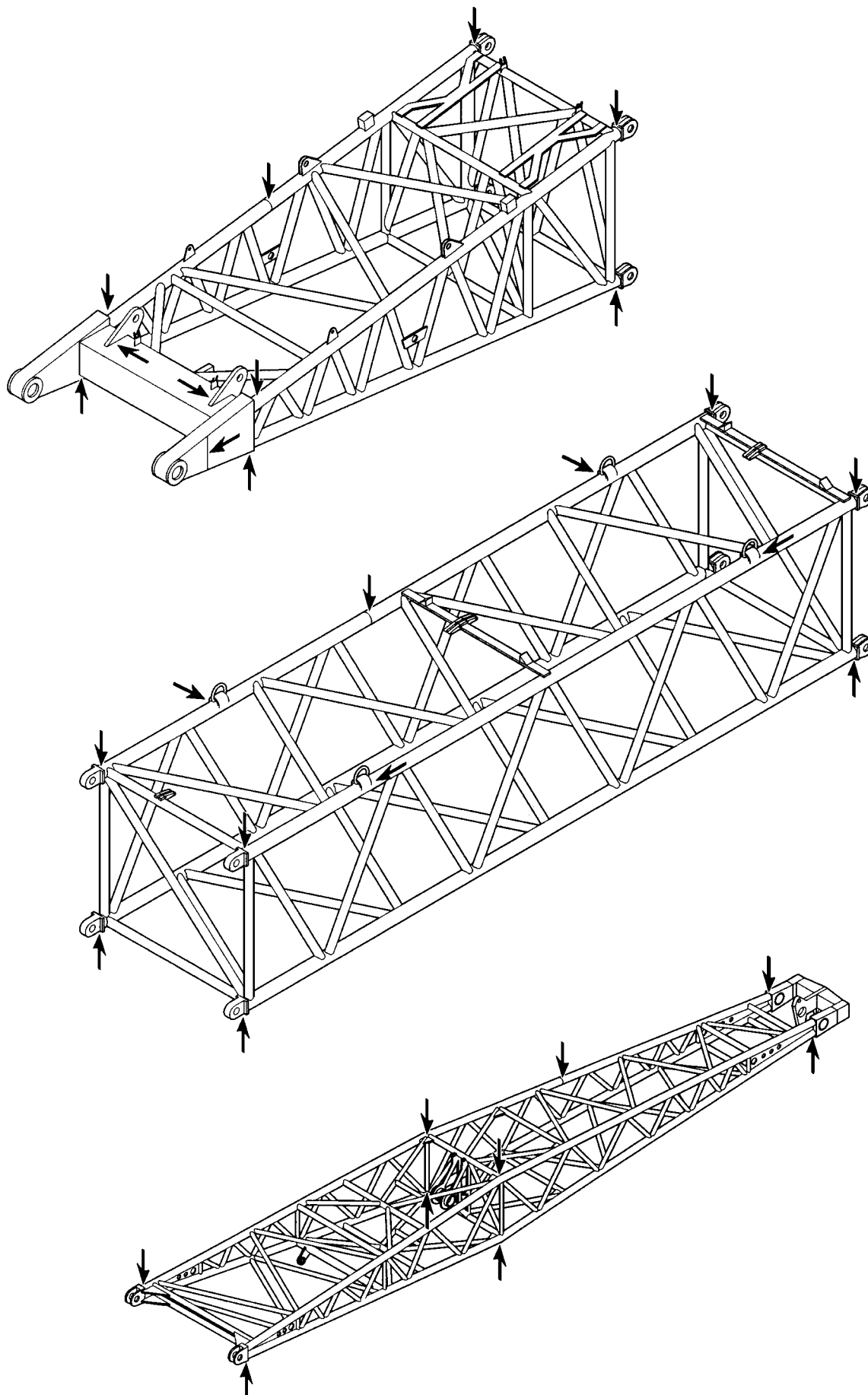

B185052

Example for NA / WA frame

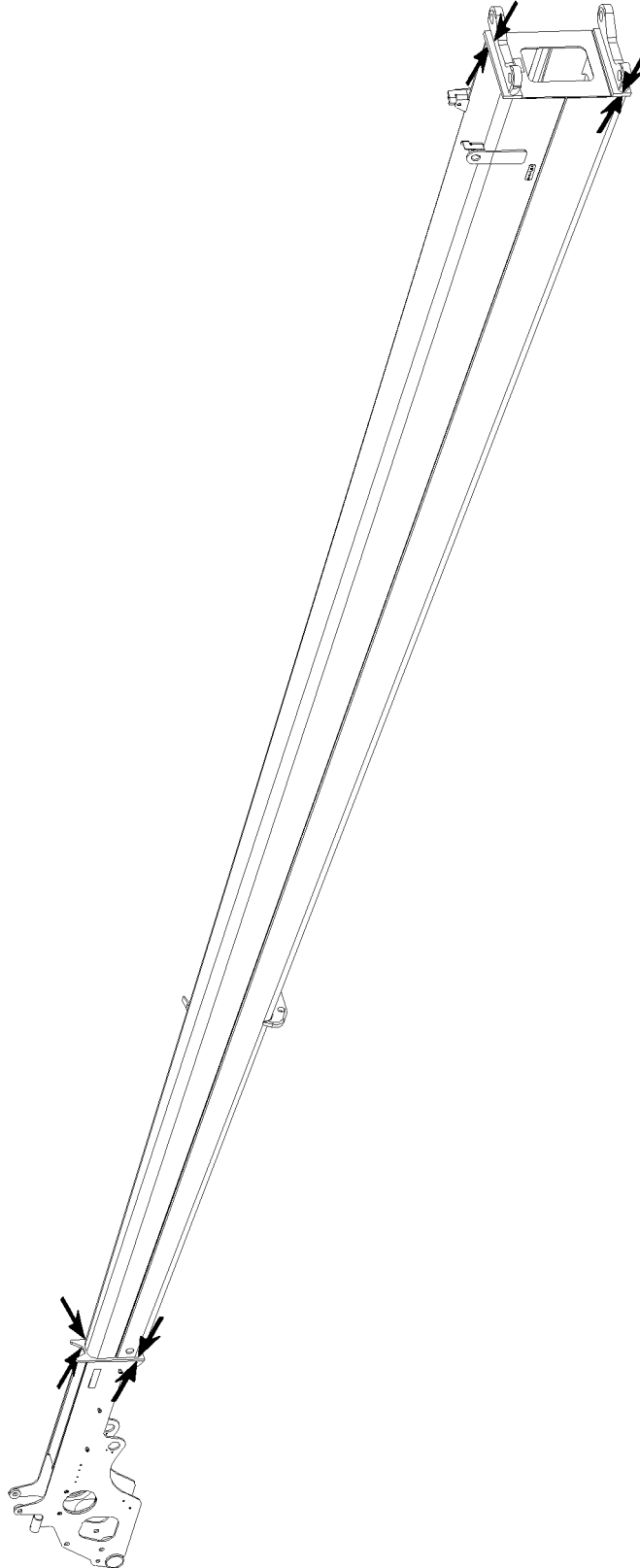

B105713

Example for end section

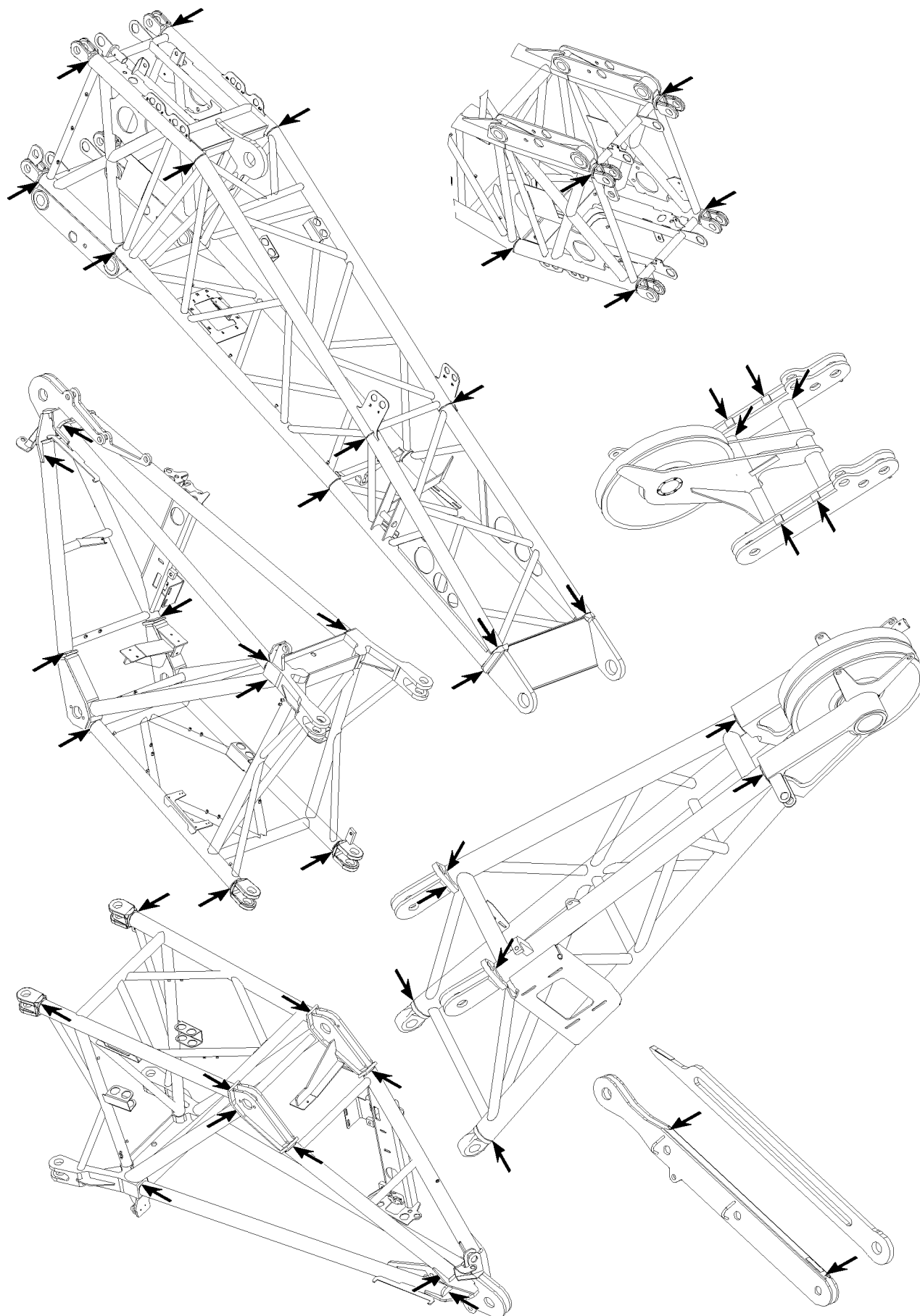

B105836

Example for pivot section, adapter and boom nose

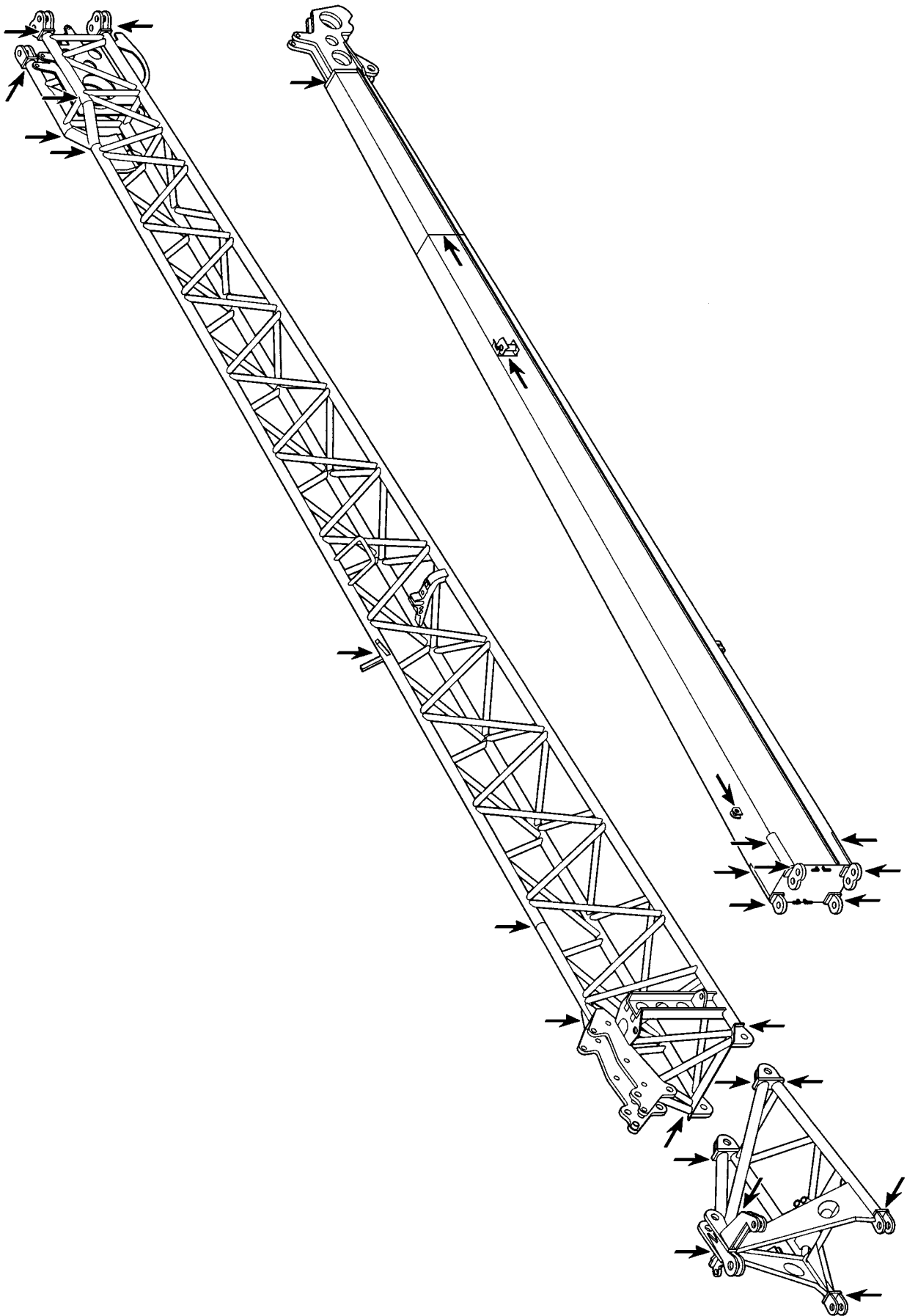

B185058

Example for folding jib

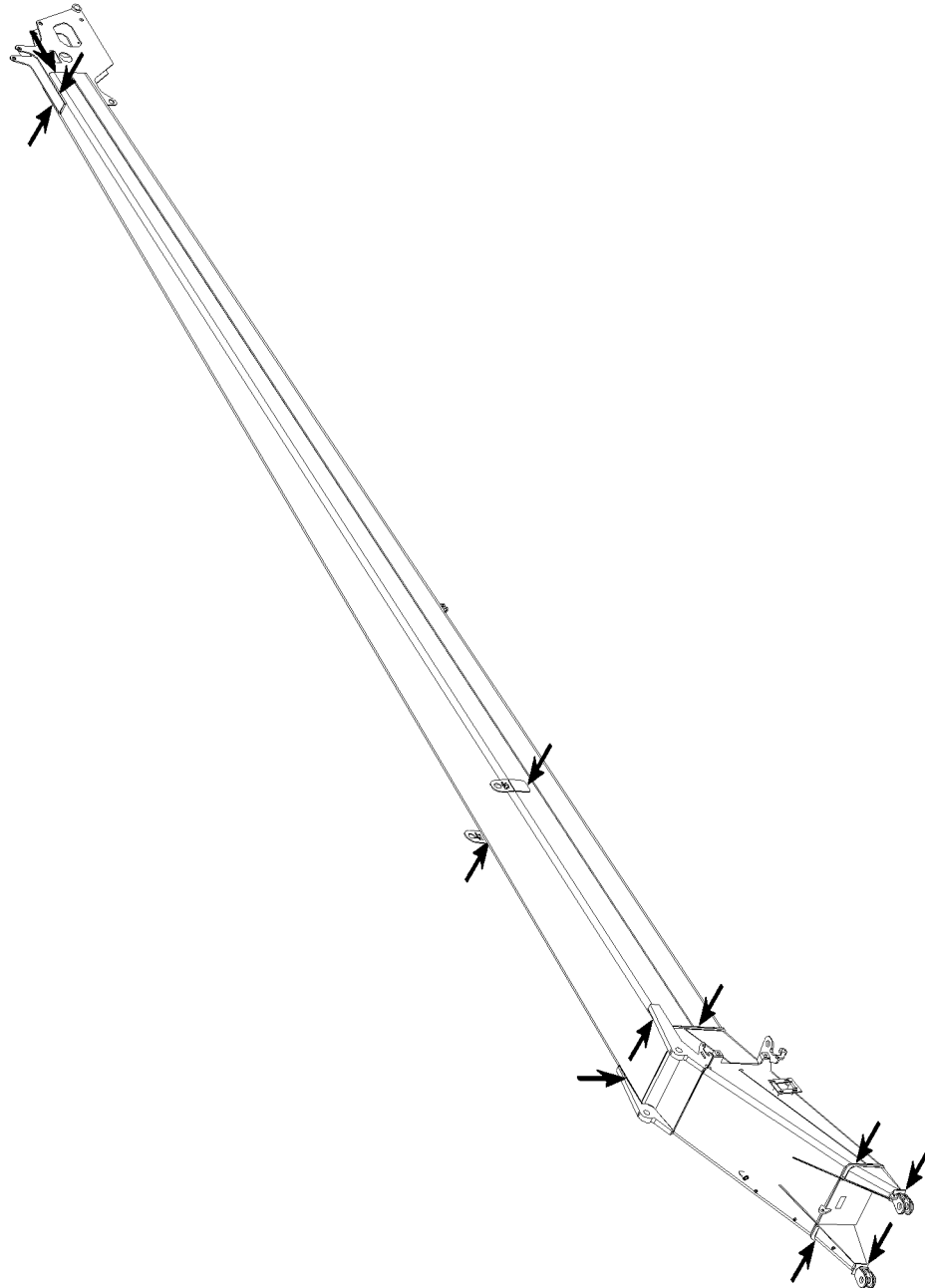

B105697

Example for folding jib

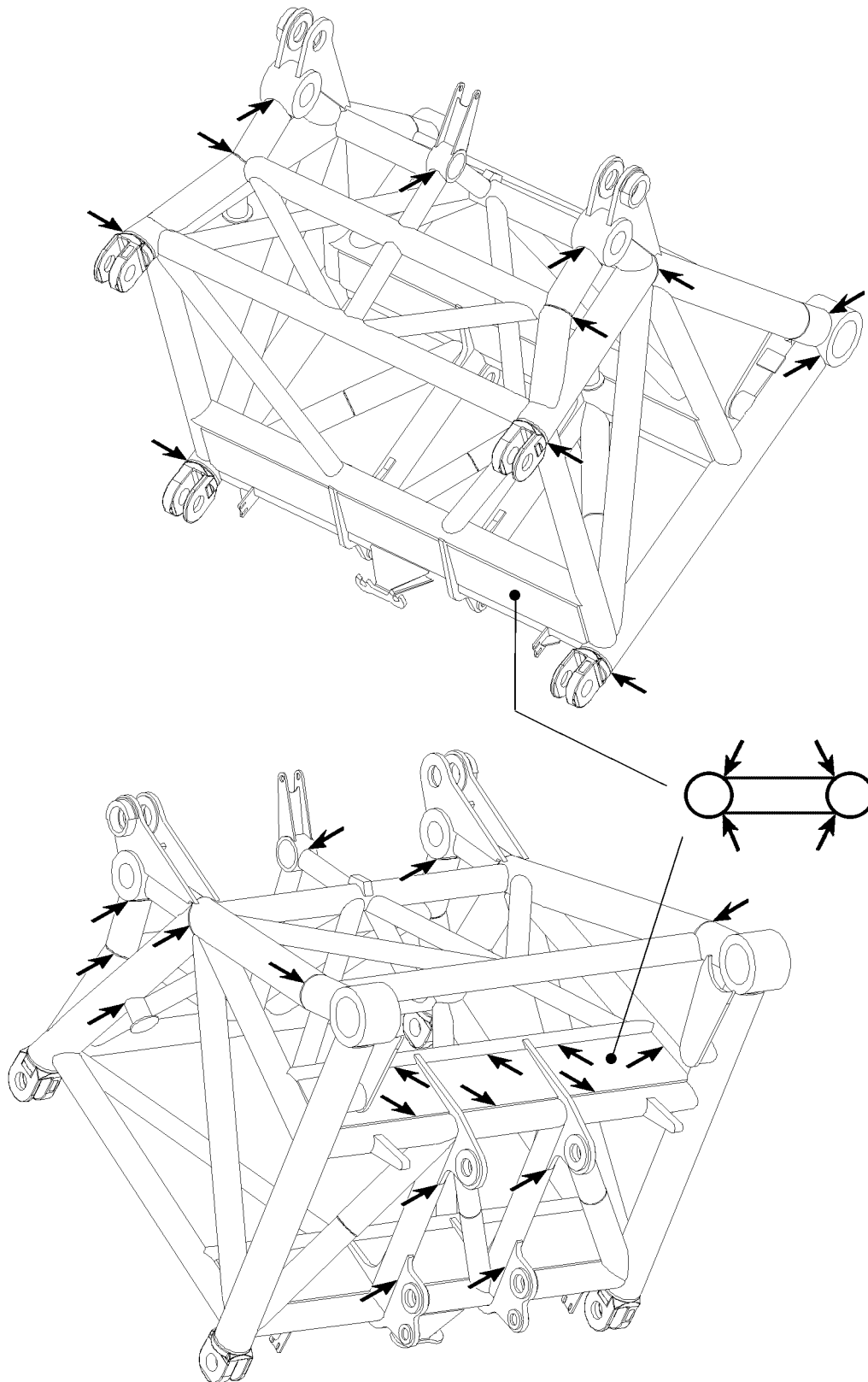

B105732

Example for W-connector head

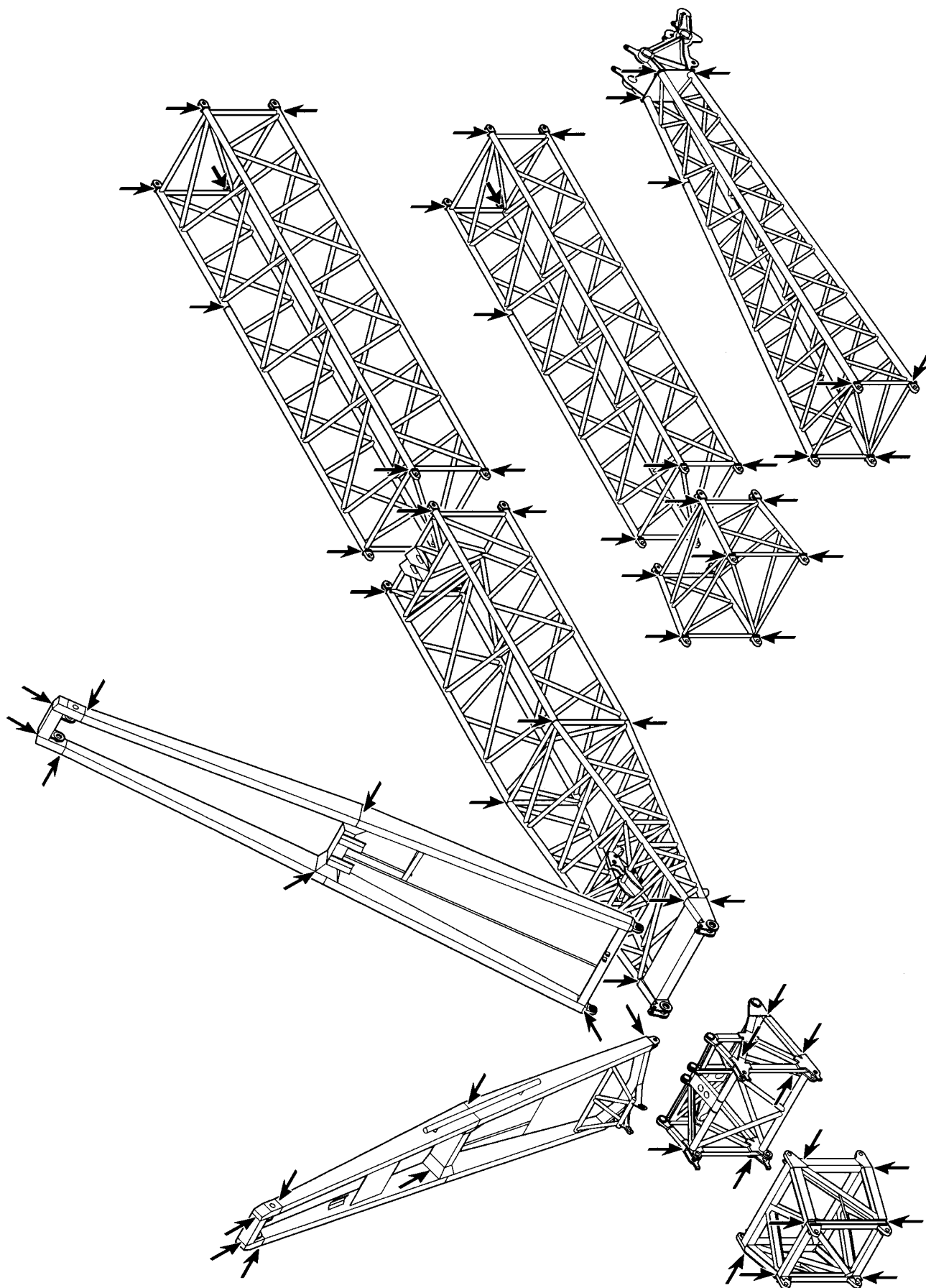

B185053

Example for assembly unit with lattice jib

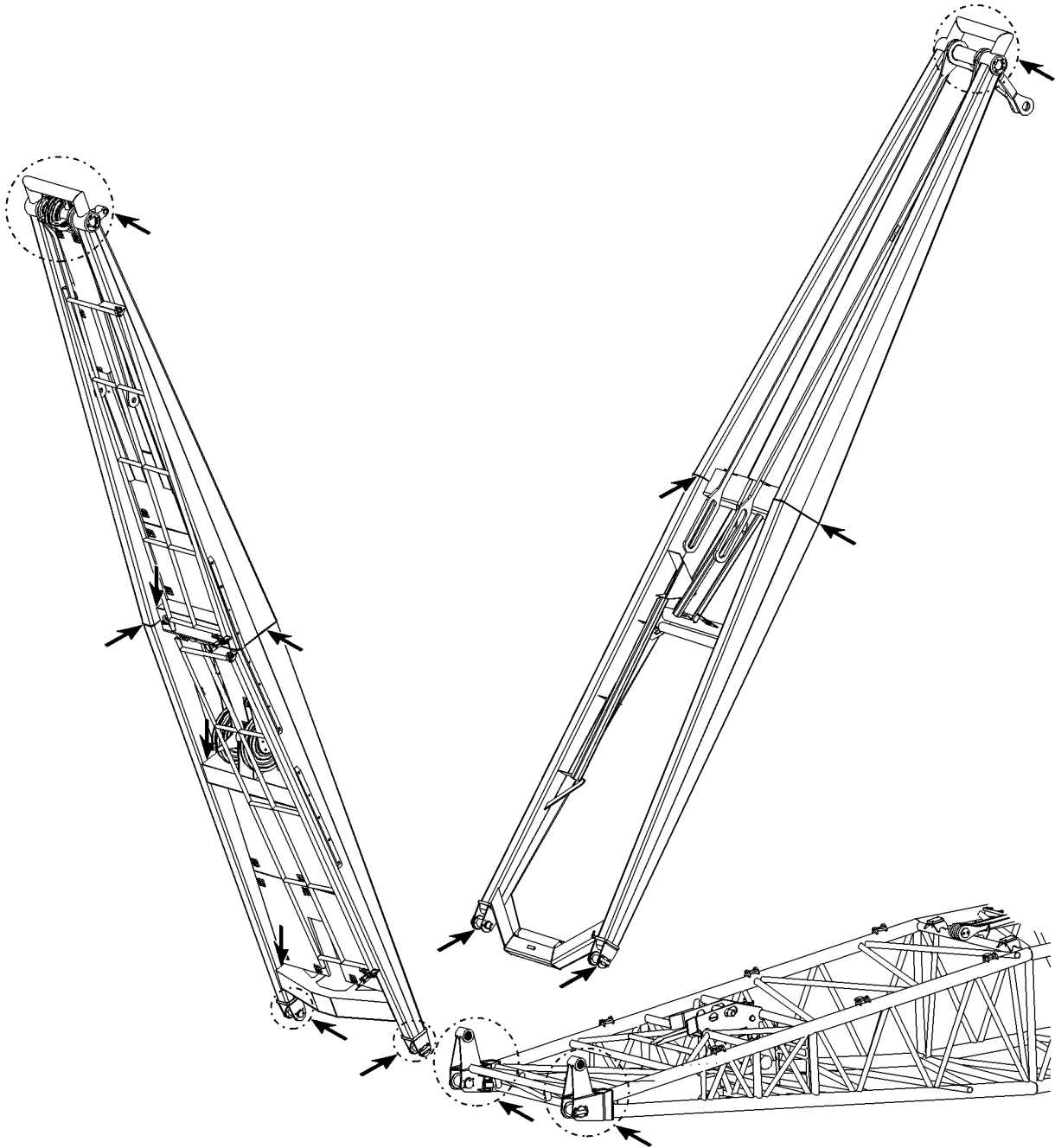

B105838

Example for NA frames

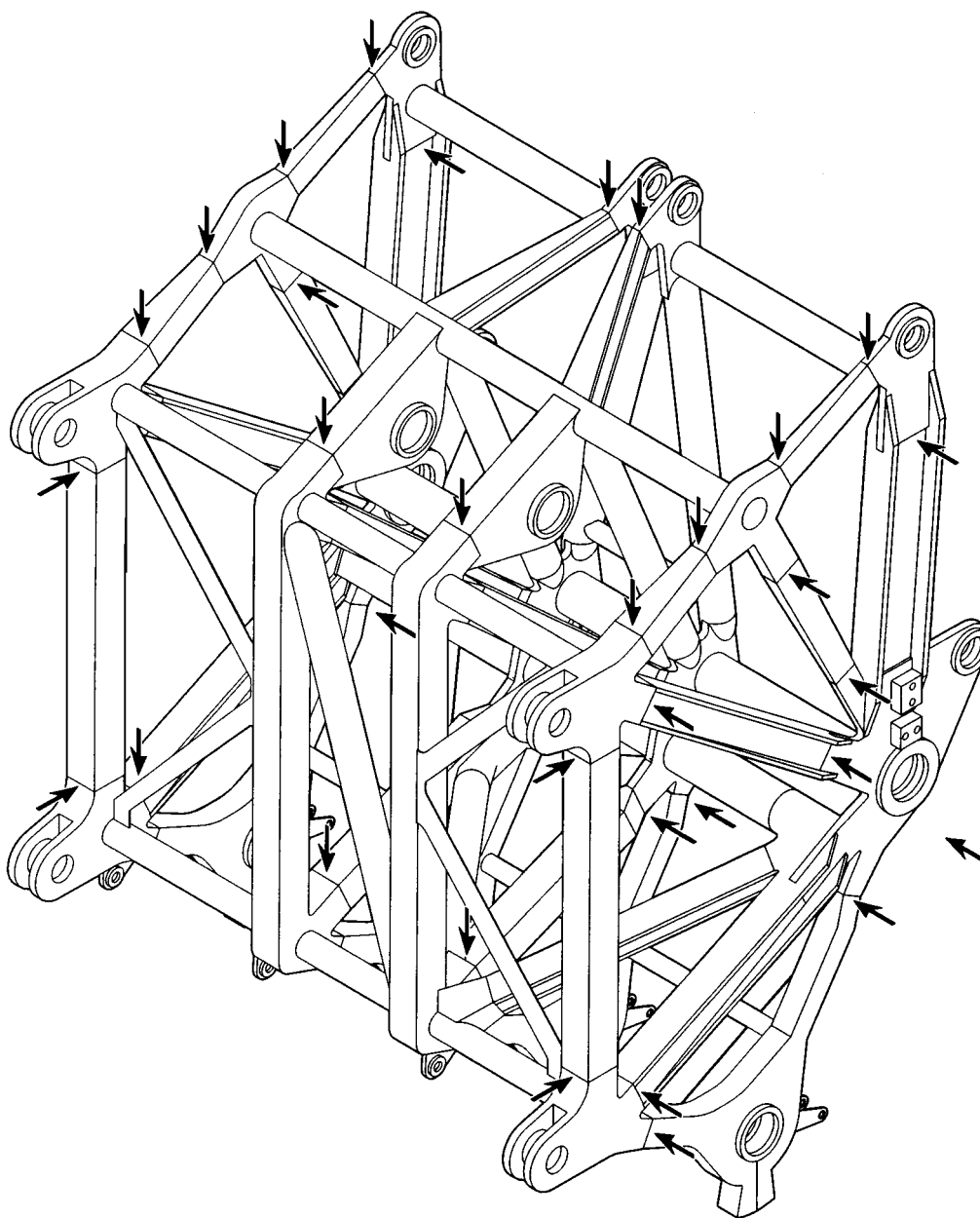

B185054

Example for pulley head

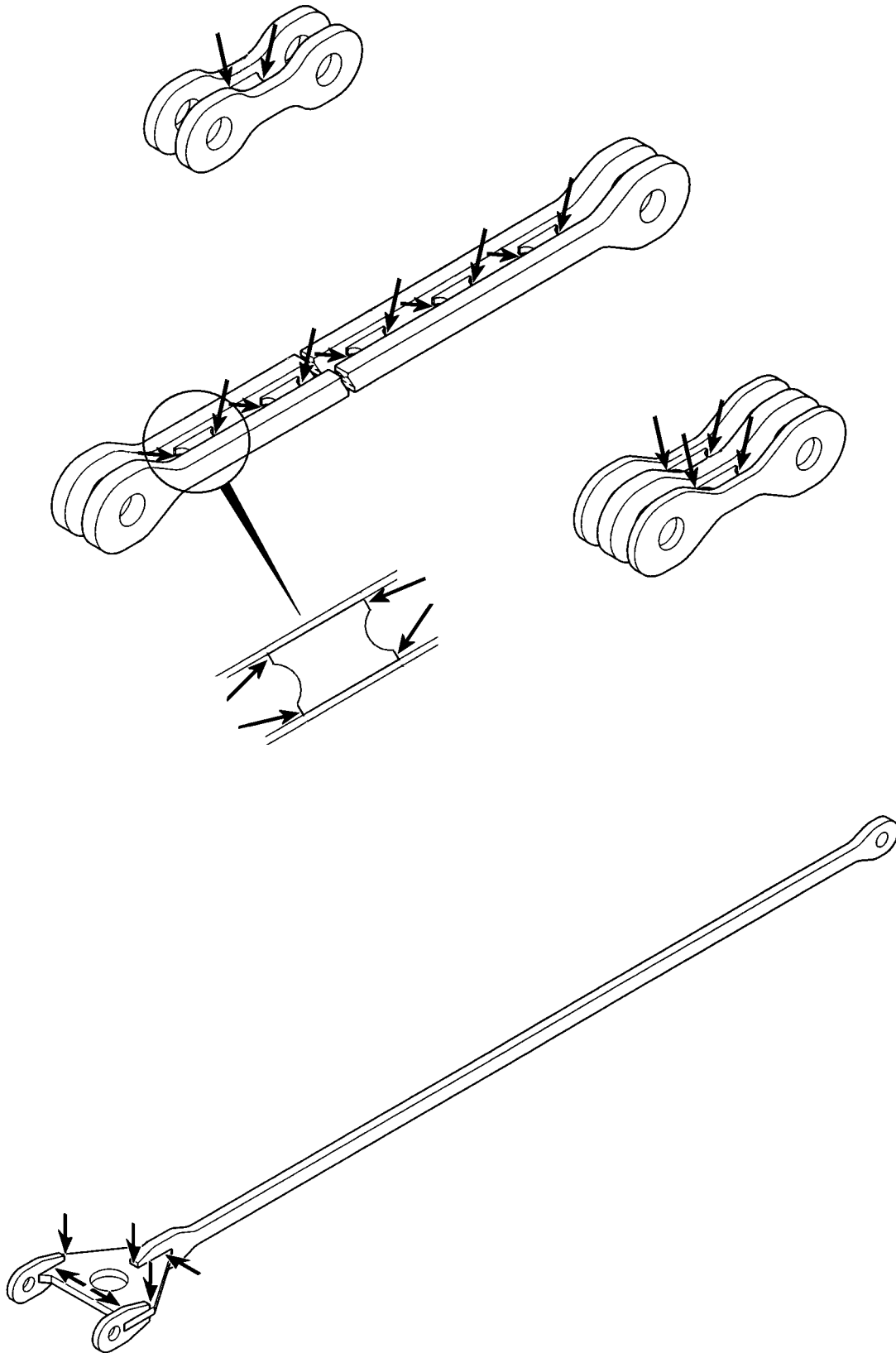

Example for guy rod

B185055

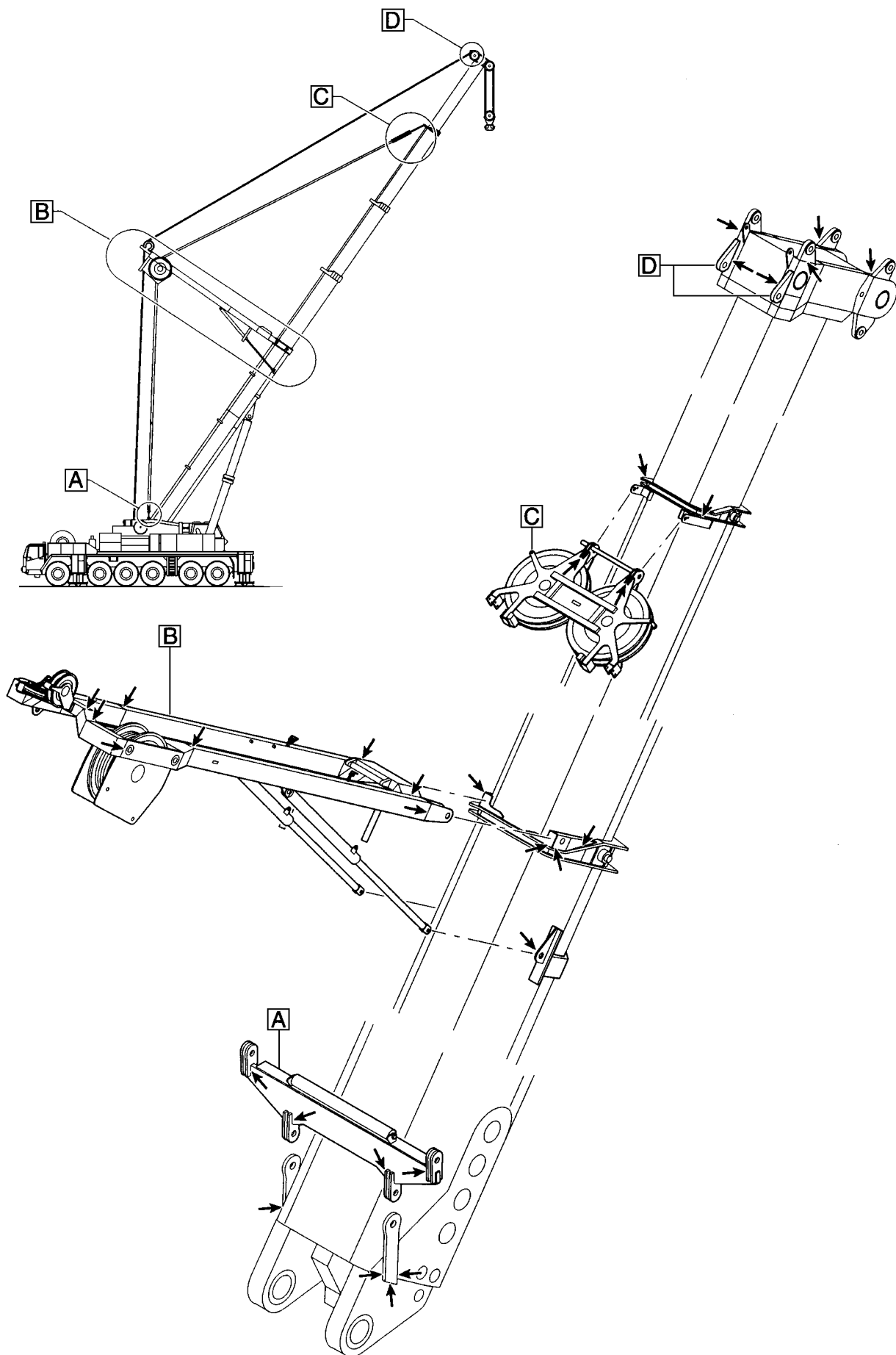

B185059

Example for TA-guying

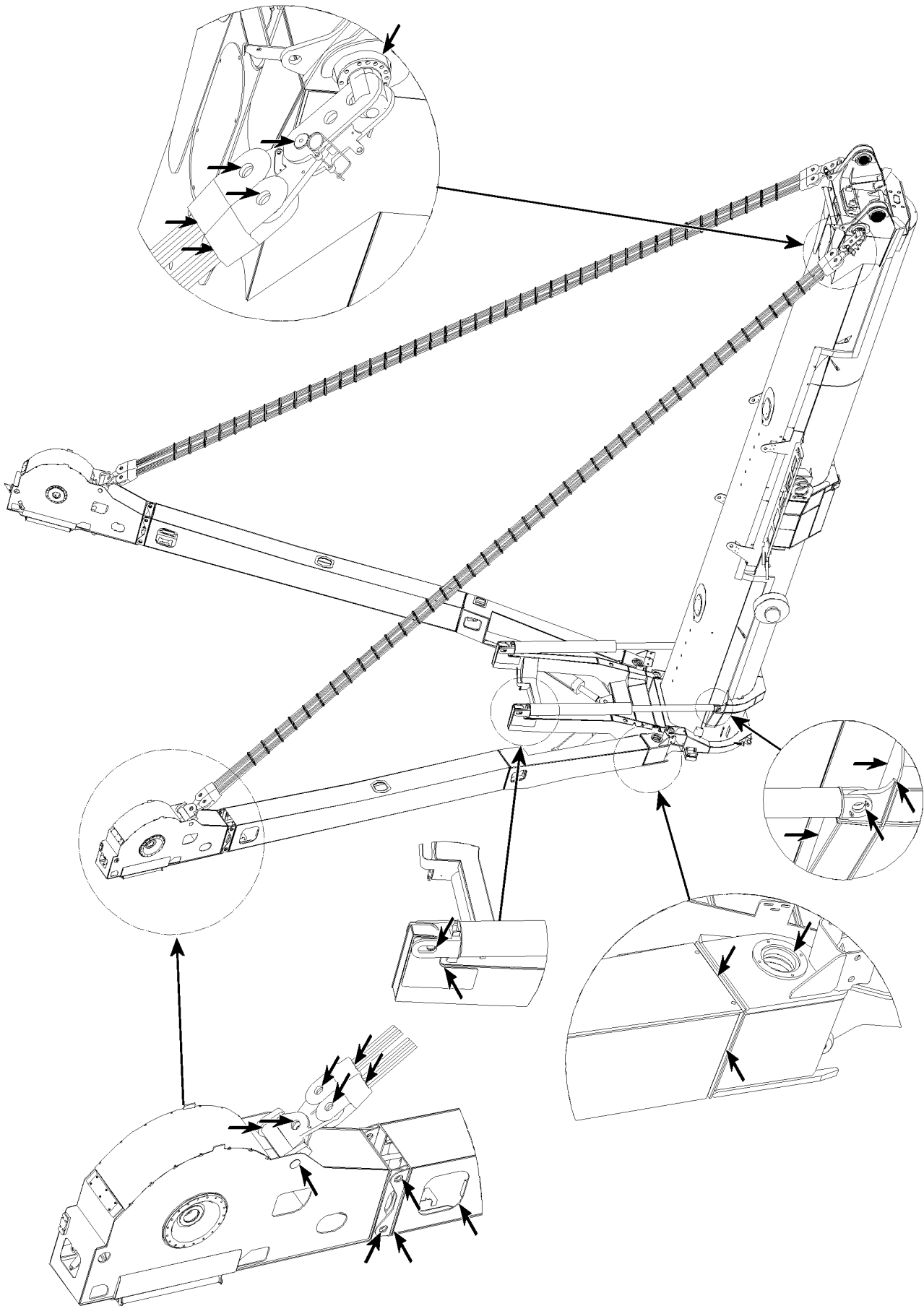

B105707

Example for TY-guying

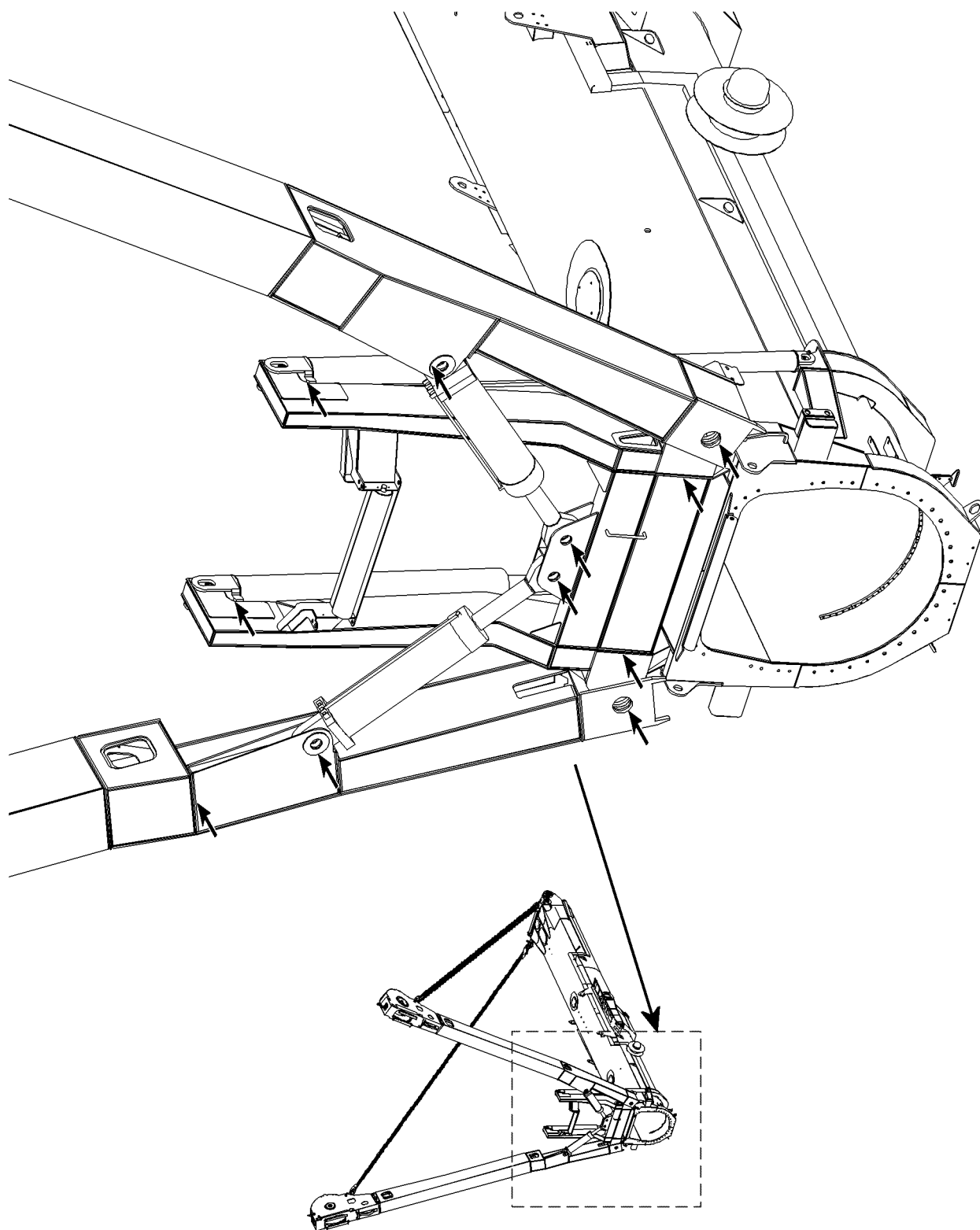

B105708

Example for TY-guying

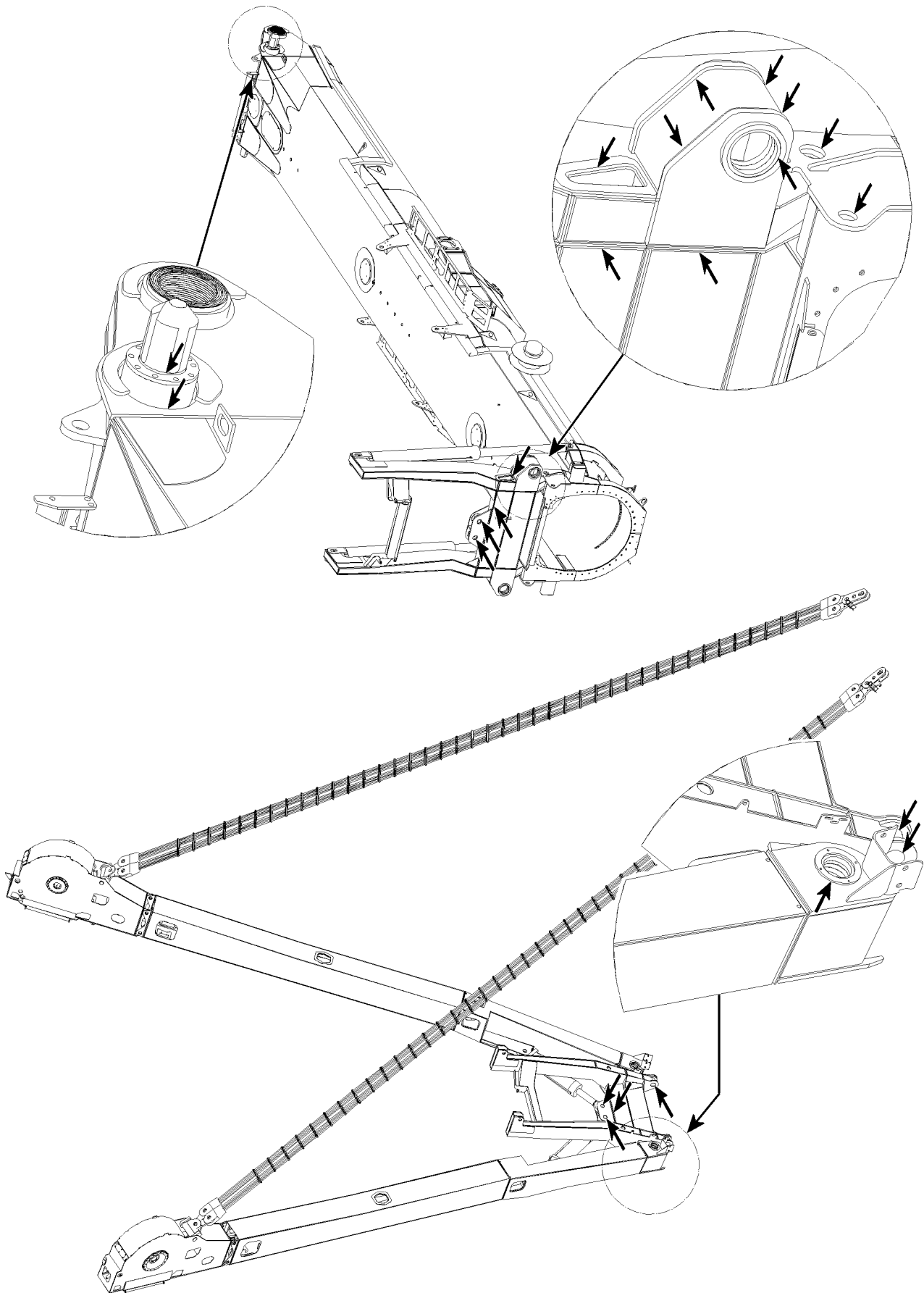

B105709

Example for TY-guying

2.2 Inspection of lattice sections



Note

- ▶ The illustration is only an example and is valid for all lattice sections!
- ▶ Check all diagonal and frame pipe connections!

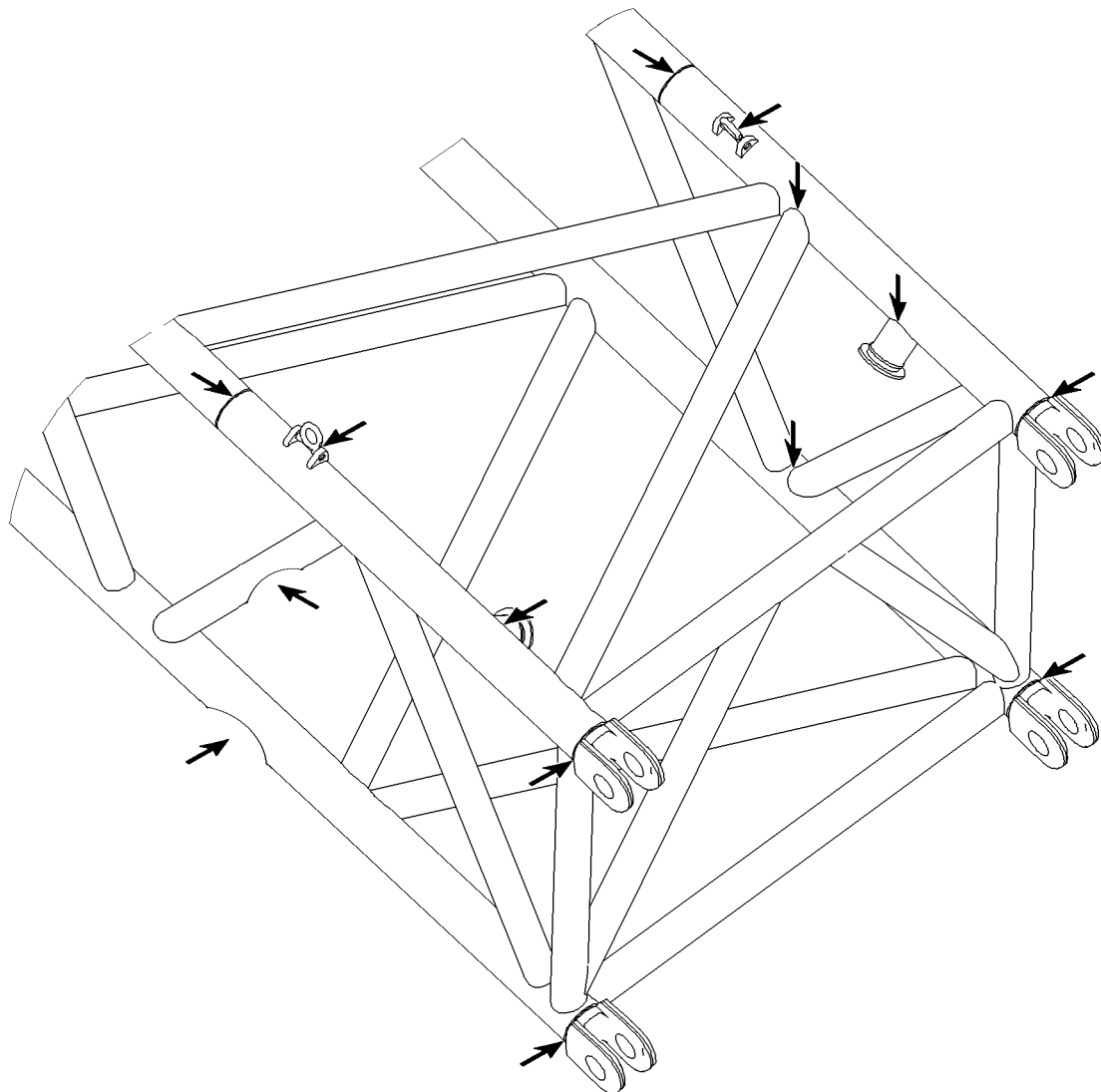

Example for lattice sections

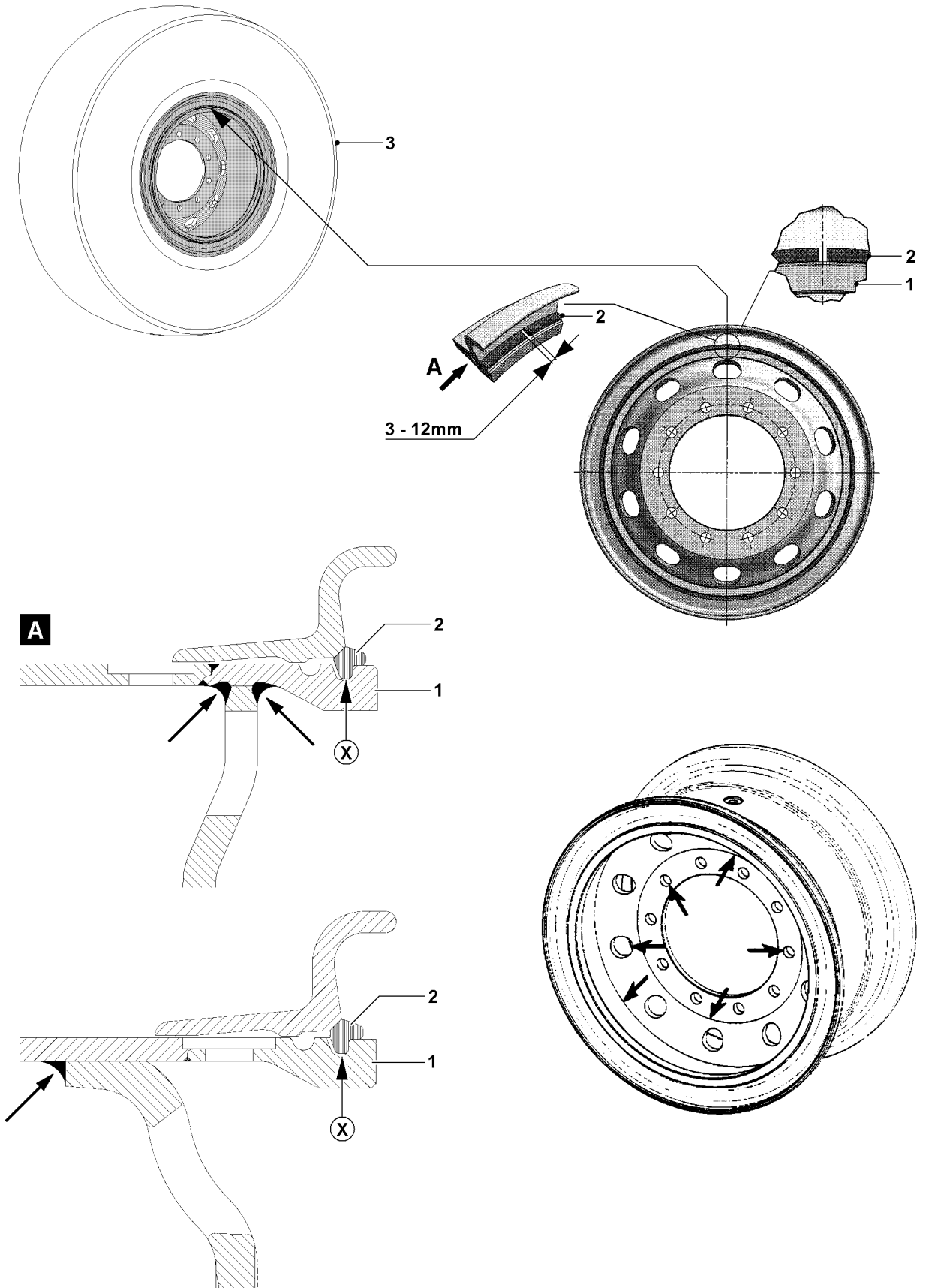

B107378

3 Inspection of tires and disk wheels

3.1 Inspection of tires



WARNING

Risk of accident if incorrect tires are used!

The use of improper tires and tires which do **not** meet the license permits may result in serious accidents with fatal injuries!

- ▶ Only tire types and sizes approved for this crane may be assembled on the crane.
- ▶ Regularly check the tires for damage, tread depth, foreign particles and tire pressures!
- ▶ Carefully remove any foreign particles stuck or wedged in the tire tread before starting to travel (for example: rocks or gravel)!

The tread depth of the tire may not fall below the legally specified minimum value.

- Check the tread depth.
- Check the tires for damage.
- Make sure that the tire **3** is correctly seated on the disk wheel **1**. The tire bead must touch the inside and outside of the disk wheel evenly.



WARNING

Risk of fatal injury if the lock ring **2** is not properly seated!

Personnel can be severely injured or killed due to an incorrectly assembled lock ring **2**!

- ▶ Check to ensure that the lock ring is correctly seated!
- ▶ Consult with authorized and trained specialists if there is any doubt whether a lock ring **2** has been correctly assembled!

Indications of an incorrectly installed lock ring are present if:

- The lock ring **2** is not completely seated with its entire circumference in the groove (point **X**) of the disk wheel, see illustration **A**.
- The gap of the installed lock ring **2** is outside the permissible tolerance range of 3 mm to 12 mm.

3.2 Inspection of tire pressure

Make sure that the following prerequisites are met:

- The tire **3** is correctly seated on the disk wheel.
- The lock ring **2** correctly sits in the groove (point **X**) on the disk wheel, see illustration **A**.
- The gap on the lock ring **2** is between 3 mm and 12 mm.



WARNING

Risk of fatal injury!

When checking the tire inflation pressure on the vehicle or after assembling tires, make sure that the lock ring **2** is correctly installed on the disk wheel.

If the tire pressure has dropped below 3 bar and the tires are improperly inflated, there is a risk of fatal injury if the lock ring **2** jumps off explosively.

- ▶ If the tire pressure is below 3 bar, the tire may only be inflated by authorized and trained specialists!
- ▶ If the lock ring **2** is not correctly seated on the disk wheel, it is essential that authorized and trained personnel are called in. Do **not** attempt to change the tire pressure yourself!
- ▶ Adhere to the specified tire pressure!

The tire pressure may not exceed or fall below the permitted range, otherwise the body of the tire could be damaged and tire failure may occur.

**Note**

- ▶ Always check the tire pressure when the tires are cold!
- ▶ The specified tire pressure must be within the tolerance range of ± 0.2 bar!

Observe the tire pressure, which is approved for the tire assembled on the crane. See Crane operating instructions, chapter 1.03.

- Check the tire pressure.

3.3 Inspection of disk wheels

The disk wheel is one of the most important safety relevant components on the vehicle.

The disk wheel is a welded steel structure and must be inspected according to section 2.

In addition, at least during the annual specified inspection of cranes, the outside and the inside of the disk wheel must be visually inspected, taken the below listed points into account.

If cracks on the outside in the paint of the disk wheel can be seen, also recognizable by rust lines in the paint, then the disk wheel must be inspected closely for cracks. The “color penetration procedure” is recommended for this crack inspection.

In particular, the disk wheels must be inspected for cracks that are developing in the base material, as well as at the locations indicated by the arrows.

Any disk wheels that show evidence of cracks or crack formation must be replaced immediately.

After a mileage of maximum 40,000 km, the operator must routinely inspect the disk wheel regardless of the actual load spectrum.

The following safety and maintenance guidelines are the manufacturer's recommendations for avoiding safety risks caused by damaged disk wheels. In addition, the manufacturer can only provide a warranty in case of a claim if these guidelines have been observed.

**Note**

- ▶ Tires may only be changed by authorized and trained specialists!
- ▶ This applies both to dismounting and mounting of the tire on the disk wheel 1!

Workshop personnel or authorized and trained specialists should check the wheels at the rim and the disk wheel for the following when changing the tires:

- Excessive rust or corrosion.
- Bent rim flanges.
- Cracks in the disk wheel.
- Cracks in the brake drum fastening on the inside or outside of the disk wheel.
- Weld seam connection on inside or outside of disk wheel.
- Damage to side and locking rings.
- Damaged wheel bolts or nuts.
- Worn out pin holes.
- Matching disk wheel parts.

**WARNING**

Risk of overload breakage!

Disk wheels with worn bolt holes must be scrapped immediately. Repairing these highly-stressed disk wheel components causes structural changes in the material, which can lead to premature overload breakage!

- ▶ No welding work is permitted on rims and disk wheels, particularly repairs to worn bolt bores!

- If damaged disk wheel parts are discovered during the inspection:
Remove and replace any damaged disk wheel components.
- If paint damage or minor rust formation is found:
Recondition the wheels with commercially available paint after removing the rust. Pay special attention to a perfect surface on the tire seating surfaces.

4 Inspecting the hoist and luffing winches

The hoist and luffing winches are designed in sealed planetary gear version. These gears are sized for long service life and the drive shafts and gears are rated for endurance.

Even though the hoist and luffing winches are designed for long life, an external visual inspection is not adequate, since their life can be significantly affected by bad maintenance (insufficient oil), using oil that does not meet specification requirements, defective seals, improper operation or overloading. The annual inspection must therefore be carried out by an **expert** in accordance with the following requirements.

The winches must be inspected by an **authorized inspector** every four years after the initial license. Within the territorial validity of the BGV D6, after the 10th year in operation, counted from the first day of initial license, if the theoretical utilization time is not over, the winches must be checked annually by an **authorized inspector**.

4.1 Inspections

4.1.1 Inspection intervals

At least once a year, see Crane operating instructions, chapter 7.03.

4.1.2 Inspecting oil level

Re-check oil level using the dipstick.

For hoist and intake winches **without** a dipstick, we recommend that the oil is drained and the amount compared to the specified oil quantity.

4.1.3 Evaluating oil color

Assume that the oil has been overheated if it is black and/or a burnt oil smell is detected. Change the oil.

4.1.4 Checking for foreign substances

The used oil is to be dribbled on special filter fleece. Visual inspection with a magnifying glass may reveal coarse particles. If particles are detected, all the oil's properties must be examined by a qualified laboratory.



Note

- ▶ The evaluation of the foreign particles found in the oil must be made by a qualified laboratory!
- ▶ The maximum permissible quantity of foreign material measured by weight is 0.15 % of total oil weight!
- ▶ Maximum permissible foreign particle size from fine abrasion is 0.25 microns!
- ▶ If the above value have been exceeded, remove the gear and search for the cause of the increased abrasion!
- ▶ Damaged components must be replaced and the gear refilled with fresh oil!

NOTICE

Risk of property damages!

- ▶ Repairs may only be carried out by specialists with appropriate technical knowledge!

4.1.5 Visual inspection for leaks

The gears must be checked for leaks, since loss of oil, in addition to polluting the environment, can lead to gear failure.

4.1.6 Inspecting the gear brakes

Check the brakes each time the gears are inspected.

Proceed as follows:

- Attach a load, which creates the maximum rope pull in the uppermost layer of the coil and raise it just off the ground.
- Remove the plug on the brake vent magnet.
This causes the brake to remain engaged when operated.
- Operate the winch to lower it.



Note

- ▶ The brake should not slip, i.e. the winch should not turn. If the brake slips, contact the Service department at Liebherr-Werk Ehingen GmbH!
- ▶ Only operate the crane after it has been checked and approved for use by the Service department at Liebherr Werk Ehingen GmbH!

NOTICE

Risk of property damages!

- ▶ Only qualified personnel with specialized knowledge may be used to evaluate gears and brakes!

4.1.7 Documenting the completed inspection and tests

The results of the annual inspections and maintenance work, including the steps taken, must be documented by the competent or authorized inspector, including attachments from the inspection labs and qualified service companies if applicable.

This documentation must be filed in the crane inspection log under the heading "Periodic inspections".

4.2 Requirements for monitoring the winches

4.2.1 Theoretical service life

The designer of your crane used a theoretical total operating time when designing and sizing the winches. This resulted in the theoretical service life of the equipment.

The winches of your crane are classified according to ISO 4301/1 as follows:

Winches	Classification
Power train group:	M3
Load spectrum:	L1
Load spectrum factor Km:	0,125
Theoretical service life D:	3200 h

**Note**

► The “theoretic service life” is not equal to the real (true) service life of a winch!

The true service life of the winch is affected by many additional outside factors; for example:

- Overloads caused by unapproved use of the crane.
- Inadequate maintenance: Oil is not changed in a timely manner.
- Improper operation:
 - Extreme acceleration or deceleration of the load.
 - Load falling into the ropes.
- Improper maintenance:
 - Using the wrong type of oil.
 - Too much or too little oil.
 - Contamination during oil change.
- Assembly errors during repair and maintenance.
- Undetected leakage.
- Incorrectly set safety devices.
- Hidden damage from accidents.
- Extreme environmental conditions:
 - Extreme low or high temperatures.
 - Corrosive atmosphere.
 - Dust and dirt.

4.2.2 Actually used part of the Service life

The crane operator is obligated to carry out an inspection of the crane at least once a year.

At this time, the actually used part of the theoretical service life must also be calculated. If necessary, the crane operator must contract an authorized inspector.

For the determination of the used part of the theoretical service life, the actual operating conditions (load spectrum) and the hoist gear operating hours for each inspection interval are to be determined. The operator is responsible for the documentation in the crane inspection log.

Determining the operating conditions (load spectrum)

The load spectrum of the crane is divided into groups, please refer to ISO 4301/1.

Select one of the following load spectrums and record it in the crane inspection log for the respective inspection interval based on the actual operating conditions. A more precise determination of the load spectrum is permissible.

Load spectrum class: Light L1

Definition:

Power train or parts thereof are subjected to maximum stress only in exceptional cases, but normally only operate at very light loads.

Operating time rates:

10 % of the time at maximum load (dead load and 1/1 working load)

40 % of the time with dead load and 1/3 working load

50 % of the operating time, with dead load only

Factor of load spectrum:

$K_m = 0.125$

Graphic view:

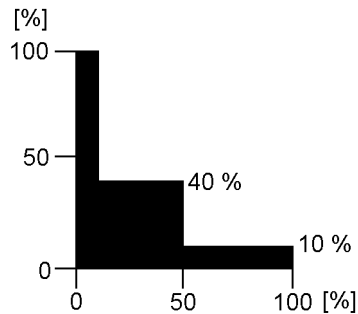

Note

- Load spectrum L1 with load spectrum factor $K_m = 0.125$ is normally applied to cranes used for assembly operations!

Load spectrum class: Medium L2

Definition:

Power train or parts thereof are subjected to maximum load relatively often, but normally only operate at light load.

Operating time rates:

1/6 of the time at maximum load (dead load and 1/1 working load).

1/6 of the time with dead load and 2/3 working load.

1/6 of the time with dead load and 1/3 working load.

50 % of the operating time, with dead load only

Factor of load spectrum:

$K_m = 0.25$

Graphic view:

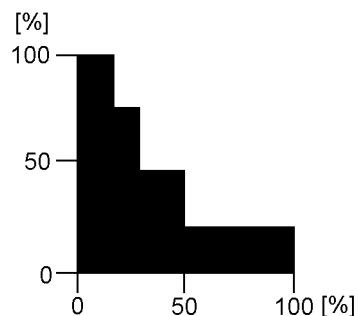

Load spectrum class: Heavy L3

Definition:

Power train or parts thereof are frequently subjected to maximum load and normally operate at medium load.

Operating time rates:

50 % of the time at maximum load (dead load and 1/1 working load)

50 % of the operating time, with dead load only

Factor of load spectrum:

$K_m = 0.5$

Graphic view:

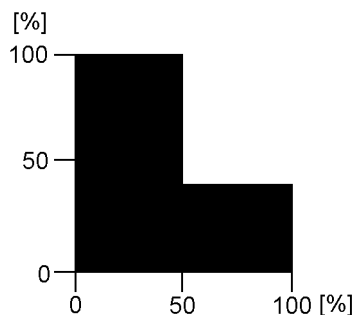
**Load spectrum class: Very heavy L4****Definition:**

Power train or parts thereof are regularly subjected to near maximum load.

Operating time rates:

90 % of the time at maximum load (dead load and 1/1 working load)

10 % of the operating time, with dead load only

Factor of load spectrum:

$K_m = 1$

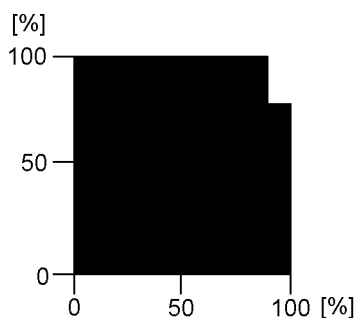
Graphic view:

Determining the effective operating hours T_i

The effective operating hours calculated as follows must be entered into the crane inspection log for the respective inspection interval.

There are four different scenarios:

- 1.) Operating hour meter installed on every winch.
If an operating hour meter is installed on every winch, the effective operating hours T_i can be read directly during each inspection.
- 2.) Operating hour meter installed for the overall crane drive.
The winch proportion of the total superstructure operating hours must be estimated.
For cranes used in assembly operations, the operating time for the hoist winches can be estimated at 20 % in relation to the total operating hours of the superstructure.
- 3.) One operating hour meter is used for both the crane engine and the crane drive.
The winch proportion of the total crane operating hours must be estimated.
For cranes used in assembly operations, the operating time for the superstructure can be estimated at 60 % of the total operating hours of the crane. If the hoist winch proportion is estimated at 20 % of the superstructure operating hours (see previous item), then the result in relation to the **total** operating hours of the crane is: 12 %.
- 4.) No operating hour meter installed.
In this case the operator must estimate and document the actual operating hours of the winch.
The approximate percentages stated above normally apply to main hoist winches. For auxiliary hoist winches or boom control winches, the proportion of the total operating hours can be significantly less and should therefore be estimated by the operator.

Determining the used proportion of the theoretical service life

For an inspection interval i (max. 1 year), the actually used proportion S_i of the theoretical Service life is derived from the formula:

$$S_i = \frac{K_{m_i}}{K_m} \times T_i$$

Abbreviation	Explanation
S_i	Used proportion of the theoretical service life.
K_m	Load spectrum factor that was used to calculate the winch rates. This factor is provided in the Operating instructions.
K_{m_i}	Load spectrum factor for inspection interval i according to section "Determining the operating conditions" .
T_i	Effective operating hours for inspection interval i according to section "Determining the effective operating hours T_i " .

The actually used proportion is subtracted from the remaining theoretical service life D_i after each inspection interval (see example).

If the remaining theoretical service life is not long enough to cover the next projected operating period, a general overhaul of the winch is required.

If the theoretical service life D has been reached (see chapter on “Theoretical service life”), then the winch may only be operated after conducting a general overhaul.

A general overhaul of the winch is required not later than 10 years after commissioning.

The general overhaul shall be arranged by the operator and carried out by the manufacturer or the manufacturer's authorized representatives and must be documented in the inspection log. After the general overhaul, the manufacturer or the manufacturer's authorized representative will define a new theoretical service life D .

If the theoretical service life has not been reached after 10 years, continued operation of the winch without a general overhaul is acceptable, provided that the crane's authorized inspector has confirmed the accuracy of the actual usage calculation by signing the crane inspection log at each authorized inspection interval.

In such a case, the crane authorized inspector must thoroughly inspect the winch. This comprises at least:

- External visual inspection (leakage, damage, deformation, etc.).
- Oil check, especially for metal residues.
- Load test at minimum and maximum rope tension and at maximum possible speed in both cases. At least one layer must be spooled up. Pay particular attention to any unusual noises during this load test.

The crane's authorized inspector must confirm this inspection in the crane inspection log and must make a statement regarding suitability of the winch for continued operation. The next inspection must take place at the end of the 12th operating year and annually thereafter.

4.2.3 Example

According to the manufacturer's operating manual, a mobile crane with a separate operating hour meter for the crane engine and the crane drives classified as follows:

- Power train group: M3
- Load spectrum: Light L1
- Factor of load spectrum: $K_m = 0.125$
- Theoretical service life: $D = 3200$ h

Actual usage proportion S of the theoretical service life is calculated using the individual inspection intervals as follows:

First inspection (first year)

The crane was used for assembly work during the elapsed year:

Load spectrum L1, in other words $K_{m1} = 0.125$.

The superstructure hour meter indicates 800 h. The winch was operated about 20 % of the time; i.e.

$T_1 = 160$ h.

The actual usage proportion S of the theoretical service life at the time of the first inspection is therefore:

$$S_1 = \frac{0,125}{0,125} \times 160 \text{ h} = 160 \text{ h}$$

Remaining theoretical service life:

$D_1 = 3200 \text{ h} - 160 \text{ h} = 3040 \text{ h}$

The above values are recorded in the crane inspection log.

Second inspection (second year)

The crane was used at a harbor for unloading work:

Load spectrum L3, in other words $K_{m2} = 0.5$.

The superstructure hour meter indicates 2000 h; i.e., during this period:

$2000 \text{ h} - 800 \text{ h} = 1200 \text{ h}$ (800 h were used in the first year of operation)

The winch was operated about 40 % of the time; i.e. $T_2 = 480$ h.

The actual usage proportion S_2 of the theoretical service life at the time of the second inspection is therefore:

$$S_2 = \frac{0,5}{0,125} \times 480 \text{ h} = 1920 \text{ h}$$

Remaining theoretical service life:

$$D_2 = 3040 \text{ h} - 1920 \text{ h} = 1120 \text{ h}$$

Third inspection (third year)

The crane was used for assembly work and occasionally at a harbor for unloading work:

Load spectrum L2, in other words $Km_3 = 0.25$.

The superstructure hour meter indicates 3000 h; i.e., during this period:

$3000 \text{ h} - 2000 \text{ h} = 1000 \text{ h}$ (2000 h were used in the first two years of operation)

The winch was operated about 30 % of the time; i.e. $T_3 = 300 \text{ h}$.

The actual usage proportion S_3 of the theoretical service life at the time of the third inspection is therefore:

$$S_3 = \frac{0,25}{0,125} \times 300 \text{ h} = 600 \text{ h}$$

Remaining theoretical service life:

$$D_3 = 1120 \text{ h} - 600 \text{ h} = 520 \text{ h}$$

4.2.4 Table for theoretically determining the remaining service life

Table 1 includes an example.

The theoretical remaining service life should be documented in table 2.

blank page!

Chart to determine the remaining theoretical service life of winch No. 1 (Main hoist winch)

Crane type: LTM 1050
 Fabrication No.: 0010 540 08
 Put in service: 12345
 Serial number of winch according to data tag: 0815
 Last general overhaul performed on:
 Configuration data of winch (see Operating Manual):
 Drive gear group: M 3
 Load collective: Q 1 (L1)
 Factor of load collective Km: 0.125
 Theoretical service life D: 3200 hrs.

S_i = Used part of theoretical service life since last inspection
 D_i = Remaining theoretical service life
 D_{i-1} = Remaining theoretical service life after previous inspection
 Km = Factor of load collective, which was taken for calculation of winch.
 This factor is to be taken from the Operating Manual
 Km_i = Factor of load collective in inspection interval i
 T_i = Effective operating hours in inspection interval i

(*) In the following pages, carry over the last line from the previous page.

Inspection interval No. (max. annually)	Date of initial service data of inspection	Operating conditions since last inspection (load collective)	Factor of load collective	Total crane operating hours	Operating hours of super-structure since last inspection	Operating hours of winch	Operating hours of winch since last inspection T_i	Used part of theoretical service life $D: S_i = \frac{Km_i}{Km} \times T_i$	Remaining theoretical service life $D_i = D_{i-1} - S_i$	Name of inspector	Signature	Remarks	Name of expert	Signature
i			Km_i	[h]	[h]	[h]	[h]	[h]	[h]					
(*) 0	10.06.90	-	-	-	0	-	-	0	3200					
1	05.06.91	L1	0,125	-	800	-	160 (20 % of 800)	160	3040	Müller				
2	20.05.92	L3	0,5	-	2000	-	480 (40 % of 1200)	1920	1120	Huber				
3	18.05.93	L2	0,25	-	3000	-	300 (30 % of 1000)	600	520	Maier				
4														

CAUTION: Perform general overhaul at least once every 10 years. In case of deviation, see guidelines in this chapter.

General overhaul last performed on :

Chart to determine the remaining theoretical service life of winch No.

Crane type:
 Fabrication No.:
 Put in service:
 Serial number of winch according to data tag:
 Last general overhaul performed on:
 Configuration data of winch (see Operating Manual):
 Drive gear group: M.....
 Load collective: Q.....(L.....)
 Factor of load collective Km:
 Theoretical service life D:
 S_i = Used part of theoretical service life since last inspection
 D_i = Remaining theoretical service life
 D_{i-1} = Remaining theoretical service life after previous inspection
 Km = Factor of load collective, which was taken for calculation of winch.
 This factor is to be taken from the Operating Manual
 Km_i = Factor of load collective in inspection interval i
 T_i = Effective operating hours in inspection interval i
 *) In the following pages, carry over the last line from the previous page.

Inspection interval No. (max. annually)	Date of initial service data of inspection	Operating conditions since last inspection (load collective)	Factor of load collective	Total operating hours	Operating hours of super-structure	Operating hours of super-structure since last inspection	Operating hours of winch	Operating hours of winch since last inspection T _i	Used part of theoretical service life D _i = $\frac{Km_i}{Km} \times T_i$ [h]	Remaining theoretical service life D _i = D _{i-1} - S _i [h]	Name of inspector	Signature	Remarks	Name of expert	Signature	
i			Km _i	[h]	[h]	[h]	[h]	[h]	[h]	[h]						
(*)																

CAUTION: Perform general overhaul at least once every 10 years. In case of deviation, see guidelines in this chapter.

General overhaul last performed on :

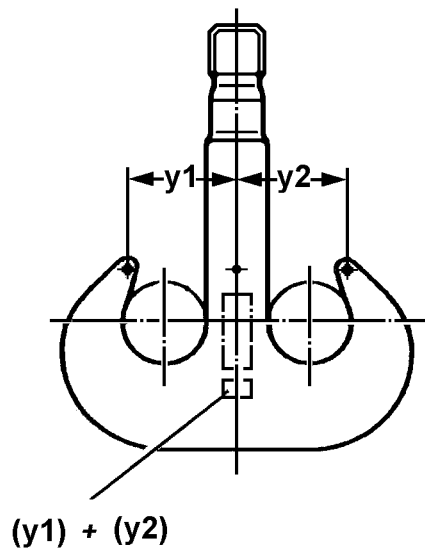
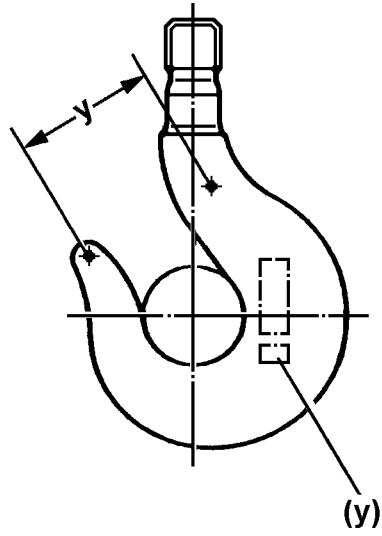

5 Inspecting load hooks

The load hooks must be visually inspected annually by a competent inspector.

This inspection must be carried out by an authorized expert every 4 years.

The purpose of the inspections is to avoid accidents by detecting deficiencies in a timely fashion.

Any deficiencies determined by the inspector must be documented, corrected, and subsequently reinspected.

5.1 Inspection and monitoring procedure

5.1.1 Deformation

The hook should be inspected for distortion as required, but at least once a year; e.g., at the hook jaw.

The original dimensions, (y) or (y1) and (y2), are given on the load hook itself.

Measure between the punch marks.



DANGER

Risk of accident!

Hook jaw expansion may not exceed 10 % of the original dimensions (y) or (y1) and (y2)!

- ▶ Do not use a load hook that exhibits greater expansion!
- ▶ Contact the Service department at Liebherr-Werk Ehingen GmbH!

5.1.2 Corrosion



DANGER

Risk of accidents caused by thread corrosion / wear and tear!

- ▶ Stop using the load hook!
- ▶ Contact the Service department at Liebherr-Werk Ehingen GmbH!

Unscrew the nut from the hook shank every 4 years so that the threads can be inspected for corrosion and wear by the inspection through an authorized expert.

6 Inspecting the rope feed mechanics in the telescopic boom

- For inspection of rope end mounts, see Crane operating instructions, chapter 7.05.
- For inspection of the pre-tension on the intake ropes, see Crane operating instructions, chapter 7.05.
- For inspection of ropes for damage according to DIN 15020 or ISO 4309, see Crane operating instructions, chapter 8.04.

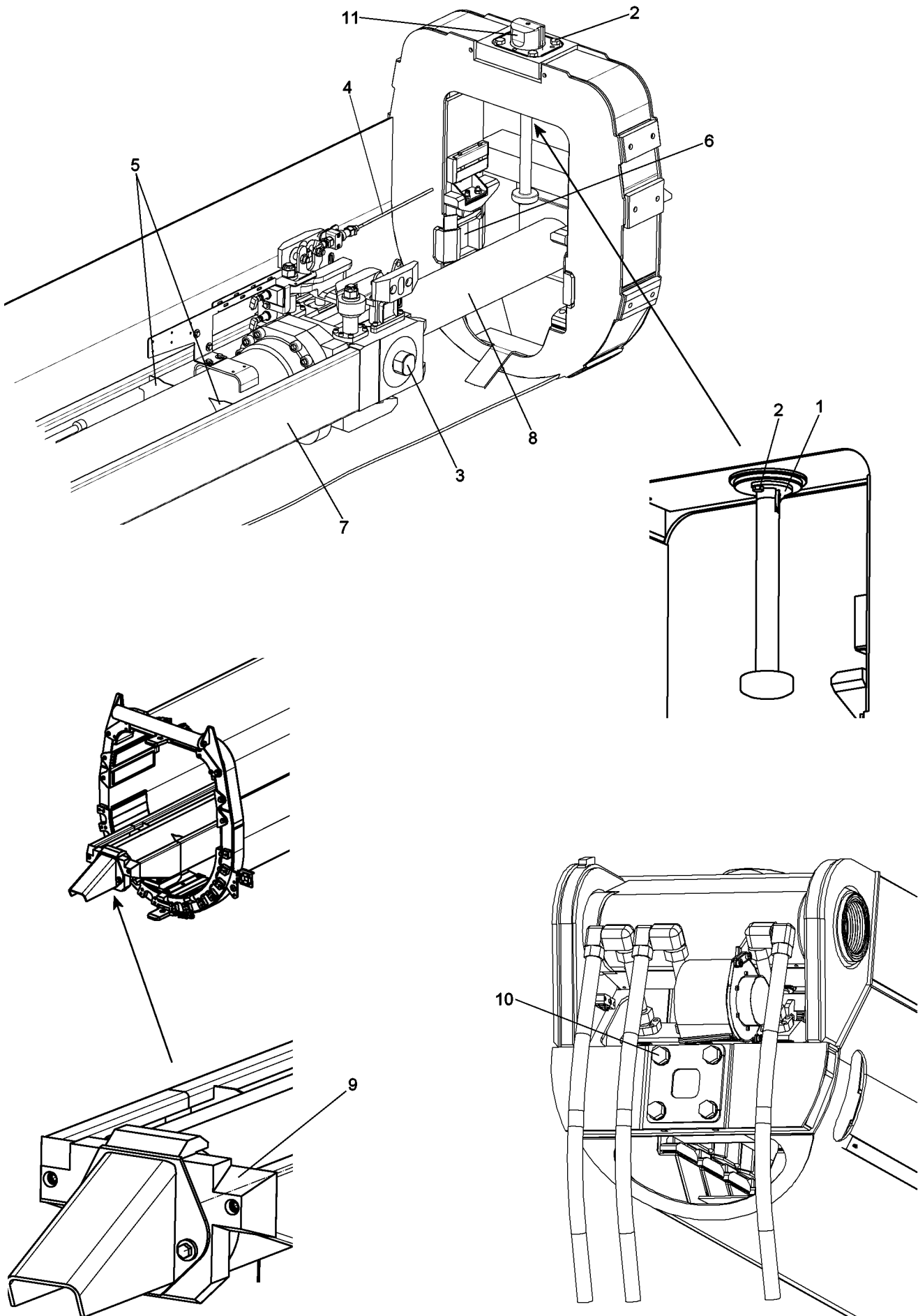

B109286

7 Inspection of locking system of telescopic boom

7.1 For cranes with pneumatic boom locking system

- For inspection of function, see Crane operating instructions, chapter 8.11.
- For inspection of pin wear pattern, see Crane operating instructions, chapter 8.11.
- For inspection of wear, see Crane operating instructions, chapter 8.11.
- For inspection of safety control, see Crane operating instructions, chapter 8.11.

7.2 For cranes with telescopic boom system Telematik

- Inspection of the pull knob safety **1** and all mounting screws **2** for tight seating
- Inspection of twist guards of cylinder pinning **3** and the telescopic boom pinning **11**
- Inspection of the length sensor rope **4** for damage
- Inspection of the cylinder barrel in the area of all welding seams **5** for crack formation
- Inspection of the locking pockets **6** for damage
- Grease the guide rail **7**
- In case of leakage: Inspection of the piston rod **8** for grooves
- Inspection of the wear pattern on the cylinder pinning **3** and the telescopic boom pinning **11**
- Inspection of guide rail **7** for distortion of contour
- Inspection of plastic guide **9** on cylinder bottom for damage
- Inspection of all mounting screws **10** on the push out cylinder for tight seating

8 Inspection of membrane accumulator



Note

- ▶ The national regulations for pressurized container inspection must be observed!

The inspection of the membrane accumulators for specified gas pressure must be carried out by authorized and trained expert personnel, see Crane operating instructions, chapter 7.04, 7.05.

9 Inspection of relapse cylinders

9.1 Check the relapse cylinders for visible defects



WARNING

Defective relapse cylinders!

The relapse cylinders can be damaged due to loss of oil or corrosion and a safe crane operation can no longer be ensured! This could result in serious accidents!

Personnel can be severely injured or killed!

- ▶ Before any operation, visually check the relapse cylinders for leaks, damage and corrosion!
- ▶ If any defects are found, the relapse cylinders must be inspected by the cylinder manufacturer!

9.2 Checking the gas pressure and oil fill

9.2.1 Checking the gas pressure



Note

- ▶ The gas pressure may only be checked by an expert for pressurized containers!

9.2.2 Check the oil quantity



Note

► The oil fill may only be checked by an expert for pressurized containers!

10 Inspection of the safety controls on the relapse cylinders

For inspection of the safety control or limit switches on the relapse cylinders and the boom A-frames, see Crane operating instructions, chapter 8.12.

11 Inspecting the cable pulleys



DANGER

Risk of accident when damaged or cracked!

► Replace rope pulley immediately!

Inspect the rope pulleys all around once a year for damage and cracks.

If rope pulleys are subjected to any impacts (e.g., with buildings) or are otherwise overloaded, they must be immediately visually inspected for damage or cracks.

Also check for wear in the rope groove. Replace the pulley if the bottom of the rope groove has been run down up to 1/4 of the rope diameter.

12 Inspecting the function of the overload protection

Position the longest boom at minimum and maximum radius: Check the load indicator, using the hook block as a test load.

The indicator reading shall not deviate more than 10 % off the true load value at these two extreme positions.

Measure the indicated radius for the longest boom at its minimum radius and at a boom angle of 45°. The indicator reading may not deviate more than 10 % off the measured projection.

13 Inspecting the roller ring connection

For tilt play dimension, see Crane operating instructions, chapter 7.05.

14 Inspecting the mounting of the load bearing equipment

Check that the mounting bolts for the roller ring connection, winches, slewing gears and towing hitch are properly seated.

Slewing ring connection mounting bolts are pre-stressed at the factory, so that no loosening of the bolted connections will occur during normal crane operation.

However, the bolted connection may become overloaded and the bolts may be permanently stretched if the crane is overloaded or if the load is pulled free. It is therefore important to check these screws for tight seating during the annual crane inspection or after an overload.

Completely remove loose screws, plus the two adjacent ones on the left and right hand side and check them immediately for damage. Inspect the screws, particularly for cracks or permanent distortion. If a screw has been stretched by more than 0.2 % (in relation to its original length) or if cracks or other damage are detected, then the damaged screws must be replaced. If the screws have been stretched or there is other damage, then the adjacent screws must also be replaced.

blank page!

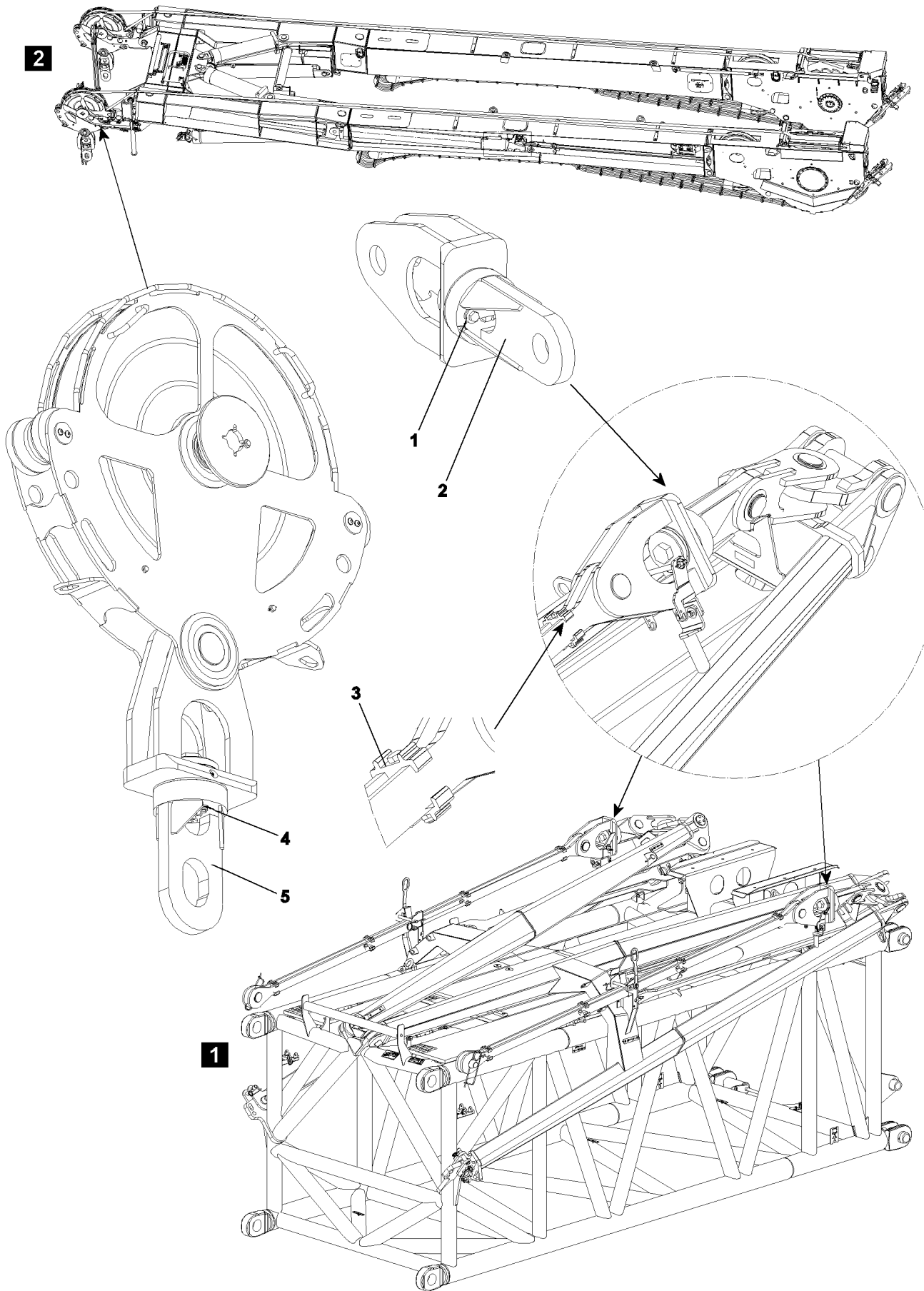

B109096

15 Inspection of the tele extension with eccentric, illustration 1

- Inspection of twist guard **1** for damage and loose screw connection
- Inspection of rotator **2** for easy turnability
- Inspection of all clamps **3** for damage and function

16 Inspection of change over pulleys, illustration 2

- Inspection of twist guard **4** for damage and loose screw connection
- Inspection of rotator **5** for easy turnability

17 Inspecting the oil and fuel reservoirs

Visually check the oil and fuel tanks at least once a year for leaks and safe mounting.

Repairs shall only be carried out by trained and knowledgeable specialists.

Improper repairs; e.g., welding, hard or soft soldering is not permitted, particularly if the Service department at Liebherr-Werk Ehingen GmbH has not been consulted!

18 Inspection of the auxiliary reeving winch, towing winch and spare wheel winch

Determine the service life of the auxiliary reeving winch, recovery winch and spare wheel winches from their respective original manufacturer.

19 Appendix

The following is a checklist to assist the inspector during the periodic inspections of Liebherr mobile and crawler cranes.

19.1 Inspection recommendations for periodic inspections of Liebherr mobile and crawler cranes

Company:	Inspector:
Crane manufacturer: LIEBHERR	Crane type:
Serial number:	Stock number:
Construction year:	Date:
Inspector's signature for No. 1 to 22:	

1. Inspection category: Crane document						
Component inspected	A	B	C	D	E	Comments
Crane inspection log						
Operating and installation instructions						
Crane control log						
Load chart manual						
Job planner						

2. Inspection category: Signs / identification						
Component inspected	A	B	C	D	E	Comments
Factory tag						
Load data						
Operating specifications label						
Prohibition and command signs						
Other safety signs						

3. Inspection category: Travel gear ¹						
Component inspected	A	B	C	D	E	Comments
Frame ²						
Supports ³						
Axles						
Wheels						

3. Inspection category: Travel gear¹						
Component inspected	A	B	C	D	E	Comments
Tires						
Bearings						
Gear						
Universal drive shaft						
Flat springs / springs						
Shock absorbers						
Steering						
Brakes						
Hydraulic axle suspension						

4. Inspection category: Chassis¹						
Component inspected	A	B	C	D	E	Comments
Coverings						
Treads						
Counterweight holders ²						
Suspension equipment						
Ladders						
Hook block mounting ²						
Boom support ²						

5. Inspection category: Chassis - driver's cab¹						
Component inspected	A	B	C	D	E	Comments
Doors						
Windows / windshields						
Windshield wipers						
Mirrors						
Seat						
Heater						
Ventilation						
Sound-proofing						
Trip recorder						
First aid kit						

5. Inspection category: Chassis - driver's cab¹

Component inspected	A	B	C	D	E	Comments
Spare bulbs						
Hazard warning triangle						
Safety vest						

6. Inspection category: Chassis - drive¹

Component inspected	A	B	C	D	E	Comments
Combustion engine						
Exhaust system						
Fuel tank						
Filters						
Sound-proofing						
Engine mount						
Oil levels						
Fuel lines						

7. Inspection category: Chassis - hydraulics¹

Component inspected	A	B	C	D	E	Comments
Oil reservoir						
Filters						
Pumps						
Motors						
Valves						
Lines						
Hoses						
Cylinder						
Pressure limiting valves						

8. Inspection category: Chassis - pressurized air system¹

Component inspected	A	B	C	D	E	Comments
Compressor						
Filters						
Air tanks						
Valves						

8. Inspection category: Chassis - pressurized air system ¹						
Component inspected	A	B	C	D	E	Comments
Lines						
Hoses						
Cylinder						

9. Inspection category: Chassis - electrical system ¹						
Component inspected	A	B	C	D	E	Comments
Motors						
Generators						
Battery						
Switch						
Lines						
Fuses						
Resistors						
Lighting						
Brake lights						
Indicator lights						
Tail lights						
Working lights						
Signaling systems						
Indicator lights						
Battery switch						
Limit switches: Transmission, steering, drive train						
Support pressure indicator ²						

10. Inspection category: Chassis - control devices ¹						
Component inspected	A	B	C	D	E	Comments
Engine regulation						
Gear						
Couplings						
Circuits						
Brakes						
Steering						
Indicator displays						
Engine shut off line						

10. Inspection category: Chassis - control devices¹						
Component inspected	A	B	C	D	E	Comments
Control of supports ²						
Axle suspension						
Crane leveling						
Rear axle steering						

11. Inspection category: Superstructure						
Component inspected	A	B	C	D	E	Comments
Frame						
Coverings						
Treads						
Bearings						
Counterweights						
Relapse retainer						
Rotary connection: Tilt play						
Rotary connection: Mounting screws						
Rotary connection: Gearing						
Slewing gear: Mounting screws						
Slewing gear: Gearing						

12. Inspection category: Superstructure - crane operator's cab						
Component inspected	A	B	C	D	E	Comments
Doors						
Windows / windshields						
Windshield wipers						
Mirrors						
Seat						
Heater						
Ventilation						
Sound absorber						
Joystick for working functions						
Gear shifts						
Safety: Crushing / shear locations						

13. Inspection category: Superstructure - Retaining and protection devices						
Component inspected	A	B	C	D	E	Comments
Grab handles and accesses						To the cab and to the power train
Coverings						
Covers						
Hatches						

14. Inspection category: Superstructure - drive train						
Component inspected	A	B	C	D	E	Comments
Combustion engine						
Exhaust system						
Fuel tank						
Filters						
Sound-proofing						
Engine mount						
Fuel lines						

15. Inspection category: Superstructure - hydraulic system						
Component inspected	A	B	C	D	E	Comments
Oil reservoir						
Filters						
Pumps						
Motors						
Valves						
Lines						
Hoses						
Cylinder						
Pressure limiting valves						
Lowering brake valves						
Brake control: Hoist gear						
Brake control: Slewing gear						

16. Inspection category: Superstructure - electrical system						
Component inspected	A	B	C	D	E	Comments
Motors						
Generators						
Batteries						
Switch						
Lines						
Fuses						
Resistors						
Lighting						

17. Inspection category: Superstructure - control systems						
Component inspected	A	B	C	D	E	Comments
Engine regulation						
Gear						
Flexible couplings						
Circuits						
Engine shut off line						
Monitoring indicators						

18. Inspection category: Superstructure - rope drives						
Component inspected	A	B	C	D	E	Comments
Winch 1 ³						
Winch 2 ³						
Winch 3 ³						
Winch 4 ³						
Rope pulleys						
Rope end connection						
Rope for winch 1						
Rope for winch 2						
Rope for winch 3						
Rope for winch 4						
Guy ropes						

19. Inspection category: Superstructure - load hook						
Component inspected	A	B	C	D	E	Comments
Pulleys						
Rope guards on pulleys						
Axle support						
Load hook						
Load hook mounting						
Hook retention						

20. Inspection category: Superstructure - safety and switch systems						
Component inspected	A	B	C	D	E	Comments
Hoist emergency limit switch I						
Hoist emergency limit switch II						
Lowering emergency limit switch I						
Lowering emergency limit switch II						
Boom emergency limit switch I						
Boom emergency limit switch II						
Luffing jib: Boom limit switch I						
Luffing jib: Boom limit switch II						
Load moment limiter						
Angle display: Boom						
Angle display: Luffing jib						
Angle display: Slewing gear						
Safety devices: Control						
Operating range limiter						
Pressure sensors						
Speed sensor						
Wind sensor						
Sliding beam monitoring						
Support pressure indicator						
Incline display						
Length indicator: Radius, boom length						
Emergency off system						
Engine stop						

21. Inspection category: Boom						
Component inspected	A	B	C	D	E	Comments
Weld structure						
Rope pulleys						
Luffing cylinder						
Telescoping cylinder						
Boom extension ropes						
Boom retraction ropes						
Boom bearings						
Boom pinning						
Guy rods						
Relapse cylinders						

22. Inspection category: Equipment						
Component inspected	A	B	C	D	E	Comments
Weld structure						
Rope pulleys						
Relapse cylinder						
Relapse support						
Oscillation guard						
A-frame bearings						
Pinning of components						
Guy rods with pinning						
Rods with guide rail on A-frame 2 and A-frame 3						
All limit switches with switch mechanism						

Inspection criteria:

- A = Present / complete
- B = Condition / maintenance
- C = Function
- D = Repair / replace
- E = Reinspection required

Evaluation:

Satisfactory = x

Unsatisfactory = -

Not required = 0

Comments:

¹ Inspection of the crane carrier vehicle road worthiness is also fulfilled if it has already been certified by the road traffic department certification authority. For cranes that are not certified for use on public roads, an expert or authorized inspector must conduct the required tests to validate the vehicle's road worthiness.

² These inspections must be carried out by an authorized inspector even if it has passed the road traffic department test and is certified.

³ Inspection of the winches regarding the used portion of the theoretical service life.

1 Introduction



DANGER

Danger of fatal injury due to defective crane ropes!

► Please observe the following criteria.

The rope should be considered to be a wear part, which must be replaced if the inspection shows that its strength has reduced to such an extent that continued use may be dangerous.

Regular inspection of the rope is required in order to safely carry loads with correctly deployed equipment, meaning that the rope must be taken out of service at an appropriate point in time.

The take-down criteria with regard to wire breaks, wear, corrosion and deformation can be applied immediately under all application conditions. The different factors are dealt with in ISO 4309, which is intended to serve as a guideline to competent experts who are involved in the maintenance and inspection of cranes.

We recommend to carry out an annual inspection by an **expert** according to the following standard (ISO 4309).

The ropes should be inspected every 4 years by an **authorized inspector**.

The scope of the inspection and the inspection results must be traceably documented, see addendum 2. This documentation must be retained as part of the crane records!

The criteria that are covered here are intended to provide an appropriate safety margin for movement of loads with cranes until the rope is taken down.

2 Wire rope

2.1 Condition before installing

The rope is usually replaced with a rope that is of the same type as the original. If the spare rope is of another type, then the user must ensure that the rope characteristics are at least as good as those of the rope that was taken down.

Before installing a new wire rope, the grooves of the rope drums and pulleys must be checked in order to ensure that the spare ropes is placed correctly in the rope grooves (see section entitled "Inspection").

2.2 Installation

When the rope is removed from the spool or unwound from a reel, it must be ensured that the rope is not twisted, otherwise loops, reverse bends or kinks could originate in the rope.

If the rope is looped over any part of the system when it is not under strain, these areas must be protected accordingly.

Before starting to use the rope on the system, the user must ensure that all components that are functionally associated with the wire rope in connection with the standing components have been set up in such a way that they will operate correctly.

To stabilize the wire rope, a few lifting procedures should be carried out at approximately 10 % of the normal load.

2.3 Maintenance

The maintenance of the wire ropes depends on the type of lifting device, its application, the environment as well as the type of rope that is used. Unless other instructions from the crane or rope manufacturer are provided, the wire rope should be cleaned, if possible, and lubricated with grease or oil, particularly in areas in which the rope is subjected to bending when it runs over pulleys.

The kind of grease that is used must be suitable for steel ropes.

Lack of maintenance will reduce the service life of the rope, particularly if the crane is used in a corrosive environment and if re-lubricating is not possible because of the nature of the respective crane application.

2.4 Inspection according to ISO 4309

2.4.1 Frequency

Daily inspection

If possible, all visible parts of the ropes must be checked for general wear and distortion every working day. Special attention must be paid to the rope end connections. Any suspected changes in the condition of the rope must be reported and the rope must be inspected by a trained expert inspector in accordance with the section "Points to check on the rope".

In the event that the lower rope layers on the drum are used infrequently or not at all, periodically unwind and rewind the entire drum under pretension. A rope is most cost-effective if it is used over its entire length. For that reason, it is recommended to use an appropriate rope length when operating the crane over longer periods.



Note

- ▶ If a rope is newly placed, then it must be pretensioned and placed with a pretension of at least 10 % of the maximum rope pull.

Special inspection as described in section "Points to check on the rope"

The rope must be checked after any events that may have led to damage to the rope and / or the rope ends and whenever the rope is taken back into service after being taken down and then re-installed.

2.4.2 Checking the spooling behavior of the rope on the cable drum

To avoid spooling errors and associated rope damage, it is necessary to check the spooling behavior daily. If spooling errors are determined, the rope must be reeled off until there are only 3 rope coils on the winch. Thereafter, the rope is to be tensioned with a pretension of at least 10 % of the maximal rope pull and then placed again.

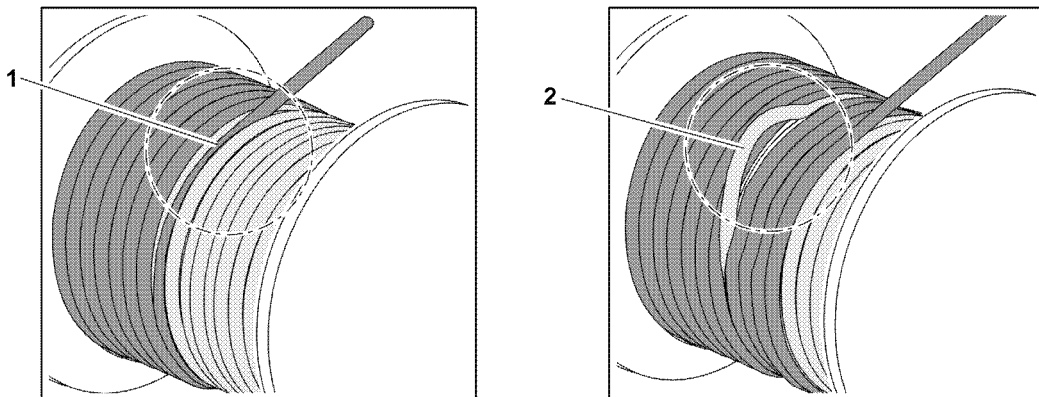

Possible spooling errors:

- Cutting into the lower rope layers 1
- Loop formation in the lower rope layers 2

2.4.3 Points to check on the rope

General

Although the entire length of the rope must be checked, particular attention must be paid to checking the following areas:

- At the rope end points on both sides, for movable as well as fixed ropes.
- The part of the rope that runs through the block or over rope pulleys; particular attention must be paid to parts of the rope that are on rope pulleys when under load (see appendix 1) in systems that carry out repeated movements.
- Parts of the rope that run over a compensation pulley.
- All parts of the rope that can be subjected to wear caused by external elements (e.g. protruding hatch surrounds).
- All parts of the rope that are subjected to the effects of heat.
- On the contact positions of the ropes when spooling up.
- Check the inside of the rope for corrosion and material fatigue.

The results of the inspection must be entered in the inspection log for the system (for typical example see section entitled “Rope inspection log” and appendix 2).

Checking the rope in the uphill pitch zones of the rope coil for flat sections

In the cross area of the coiled up rope layers, the rope is under more strain and can therefore be flattened. To void flat sections, the rope can be shortened on the rope drum fixed point.

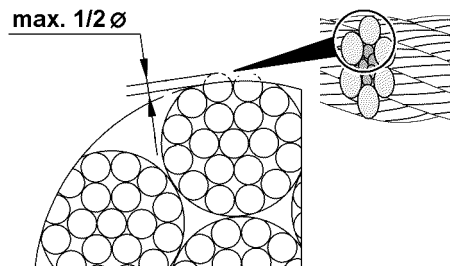

If the wires in the outer braids are flattened to no more than maximum half the wire diameter:

- Shorten the rope by a length of 1/3 of the rope drum circumference and reset.



DANGER

Rope breakage!

If the following measures are not observed, the rope can break, the load can fall down and fatally injure personnel!

- ▶ Take the rope down when the take down criteria is reached, as described in section “Take down criteria”!
- ▶ Take the rope down when the wires in the outer braids are flattened by more than half the wire diameter!

Rope suspension and connection systems - except loops

The rope must be examined at the exits of the rope suspension and connection system, since this area is particularly susceptible to initial signs of material fatigue (wire breaks) and corrosion. The rope suspension and connection systems must also be examined for signs of deformation or wear.

Rope suspension and connection systems with pressure sleeves must undergo the same checking, and the sleeve must be checked for cracks in the sleeve material and possible slippage of the rope in the sleeve.

Detachable rope suspension systems (cotters, rope clamps) must be checked for wire breaks inside and beneath the mount or fastening; it must also be examined whether the cotters and screwed-on rope clamps are firmly connected to the rope. This check should also ensure that the requirements of the rope suspension and connection systems standards and procedural guidelines are complied with.

2.5 Take-down criteria

The safe use of the rope is assessed in accordance with the following criteria:

- 1.) Number of wire breaks
- 2.) Broken wire nests
- 3.) Wire break increase rate
- 4.) Strand breaks
- 5.) Rope diameter reduction, including the reduction caused by damage to the rope core
- 6.) External and internal wear
- 7.) External and internal corrosion
- 8.) Deformation
- 9.) Damage caused by the effects of heat or arc welders

These individual factors must be taken into consideration in accordance with the relevant criteria during all examinations. However, rope quality deterioration frequently results from a combination of the individual factors, meaning that a worsening effect occurs that can be detected by an expert and that influences the decision as to whether the rope has reached its rope removal limit and whether it can continue to be used.

The checker must investigate whether the deterioration has been caused by a fault in the system; if this is the case remedial action should be recommended before fitting a new rope.

2.5.1 Number of wire breaks

The number of wire breaks must be determined by visually inspecting the entire length of the rope. If a wire break is found, sections that are $30 \times d$ (d = nominal rope diameter) in length are marked at both sides of this point. These sections must be examined extremely carefully. All wire breaks are now carefully counted in each section. Please compare the number of visible wire breaks with appendix 4. If the number of visible wire breaks is less than the number specified in the table, the area in which the most broken wires are found is marked to a length of $6 \times d$. Count the number of visible wire breaks again and compare the result with appendix 4. If the number of visible wire breaks is less than the number specified in the table, the rope does not have to be taken down yet.



Note

Defining the interval until the next inspection

- ▶ The interval until the next inspection is set depending on the number of visible wire breaks.

2.5.2 Broken wire nests

If the wire breaks are extremely close together and form wire nests, the rope must be taken down. If the frequency of such wire breaks occurs over a rope length of less than $6d$ or is concentrated on one strand, taking the rope down is recommended, even if the number of wire breaks is less than the maximum number specified in the tables.

2.5.3 Wire break increase rate

For applications in which the main reason for damage to the rope is material fatigue, the first wire breaks will not occur until a certain time has elapsed, but the number of wire breaks will increase rapidly at ever-decreasing intervals.

Careful checking and logging of the increased number of wire breaks over time is recommended in these cases.

2.5.4 Strand breaks

If an entire strand breaks, the rope must be taken down.

2.5.5 Reduction in rope diameter caused by damage to core rope

The rope diameter can be reduced as a result to damage to the core because of:

- 1.) Internal wear and notching
- 2.) Internal wear due to friction between individual strands and wires in the rope, particularly if it is subjected to bending
- 3.) Steel core breakage
- 4.) Break in internal layers of multi-strand ropes

If the rope diameter (average of two diameter measurements) is reduced by 3 % of the nominal diameter (rotation resistant ropes) or 10 % of the nominal diameter of other ropes due to these factors, the ropes must be taken down, even if no wire breaks are visible.



Note

Diameter of new ropes

- ▶ New ropes can have an actual diameter that is greater than the nominal diameter, meaning that proportionally greater wear is possible.
-

2.5.6 External wear

Abrasion of outer wires of outer rope strands as a result of rubbing contact under pressure with the grooves in the rope reels and drums. This condition is particularly evident in moving ropes in the areas in which they come into contact with rope pulleys when the load is being moved and braked, and manifest themselves as flattened surfaces on the outer wires. Abrasion is exacerbated by a lack of or incorrect lubrication as well as the effects of dust.

Wear reduces the breaking strain of steel ropes because the cross section of the steel is reduced. The rope must be taken down if the actual rope diameter has reduced by 7 % or more because of outer wear, even if no wire breaks are visible.

2.5.7 External and internal corrosion

Corrosion is a particular problem in maritime climates and atmospheres that are polluted by industrial emissions, reducing breaking strain and accelerating material fatigue because of the reduction in the rope material cross section, leading to irregular surfaces that are the starting point for stress cracks. Extreme corrosion can reduce the elasticity of the rope.

- 1.) External corrosion
Corrosion of the outer rope wires can be determined by visual inspection.
- 2.) Internal corrosion
This condition is more difficult to detect than external corrosion.



Note

Internal corrosion

- ▶ If there are any signs of internal corrosion the rope must be checked by a competent expert.
-



DANGER

Occurrence of internal corrosion!

- ▶ If the suspicion of extreme internal corrosion is confirmed, the rope must be taken down immediately.
-

2.5.8 Rope deformation

A visible change to the rope structure is referred to as "rope deformation" and can cause a change at the deformation point that results in irregular rope tension.

A distinction is made between the following important types of rope deformation on the basis of the rope appearance (see following sections):

- 1.) Corkscrew-like deformation
- 2.) Basket formation
- 3.) Strands protruding from the rope
- 4.) Wire loop formation
- 5.) Flattening
- 6.) Reverse bends or knots
- 7.) Kinks

Corkscrew-like deformation (see appendix 3, table 1)

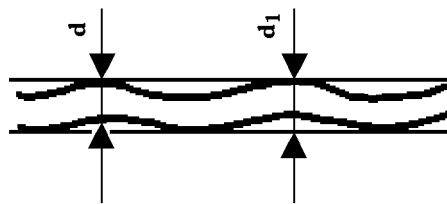

Corkscrew-like deformation

If there is any corkscrew-like deformation the rope must be taken down if the following condition is met:

$$d_1 > \frac{4d}{3}$$

d = nominal diameter of rope

d₁ = rope sheath diameter of the distorted rope

Basket formation (see appendix 3, table 2)

If there are kinks in the rope, it must be replaced immediately.

Strands protruding from the rope (see appendix 3, table 3)

The rope must be replaced immediately if this kind of deformation occurs.

Wire loop formation (see appendix 3, tables 4 and 5)

In this case, certain wires or groups of wires protrude from the rope at the side facing the rope pulley in the form of loops - this is normally the result of sudden strain. If serious deformation occurs, the rope must be taken down.

Flattening (see appendix 3, tables 8 and 9)

Flattening is the result of mechanical damage; if it is pronounced the rope must be replaced.

Reverse bends or knots (see appendix 3, tables 6 and 7)

If the rope has any reverse loops or knots it must be taken down immediately.

Kinks (see appendix 3, table 10)

Kinks are angled deformations in the rope caused by external influences. If there are kinks in the rope, it must be replaced immediately.

2.5.9 Damage caused by the effects of heat or arc welders

Steel ropes that have been subjected to extremely high temperatures, which can be detected externally because of the colouring that it causes, must be taken down.

3 Operating behavior of steel ropes

Exact logging of information by the checker can be useful for predicting the behaviour of a certain type of steel rope on a crane. This information is useful for planning and adapting maintenance instructions and controlling the stocking of spare ropes. The use of such a prediction system should not cause the examinations to be less strict or the rope usage time to be extended beyond the criteria that are specified in the previous sections of this guideline for monitoring and taking down of crane ropes.

4 Condition of equipment that is functionally associated with the rope



Note

Groove radius

- ▶ The radius must not be smaller than the actual diameter of the rope.

Rope drums and pulleys must be checked at regular intervals in order to ensure that all these components rotate correctly in their bearings. Stiff or blocked rope pulleys wear rapidly and unevenly and cause serious rope abrasion. Ineffective compensation pulleys can lead to irregular rope tension. The radius at the bottom of the rope grooves of all rope pulleys and the drum must be suitable for the nominal diameter of the rope. If the radius has become too big or too small the rope groove must be reworked or the rope pulley replaced.

5 Rope inspection log

The user must provide a log for each of the regular inspections in which all rope inspection information is recorded. Typical example of a log - see appendix 2.

6 Rope storage and marking

Clean, dry rope storage facilities must be provided in order to prevent damage to ropes that are not in use; it must also be ensured that the ropes can be clearly and unambiguously assigned to their checking logs.

7 Wire ropes and rope end connections



DANGER

Risk of accident!

- ▶ Correct choice and use of the wire rope and the rope end connections are a decisive precondition for proper and accident-free crane operation.

The wire ropes and rope end connections selected in accordance with their usage. It must be determined whether a rotation-resistant or non-rotation free rope is required. The type of rope that is selected then determines the type of rope end connections that are used.

7.1 Rotation-resistant ropes and their rope end connections

Rotation-resistant ropes are special ropes that produce extremely little torque and twisting at the rope end connection when they are under strain.



Note

- ▶ Rotation-resistant ropes are used as **hoist ropes**.

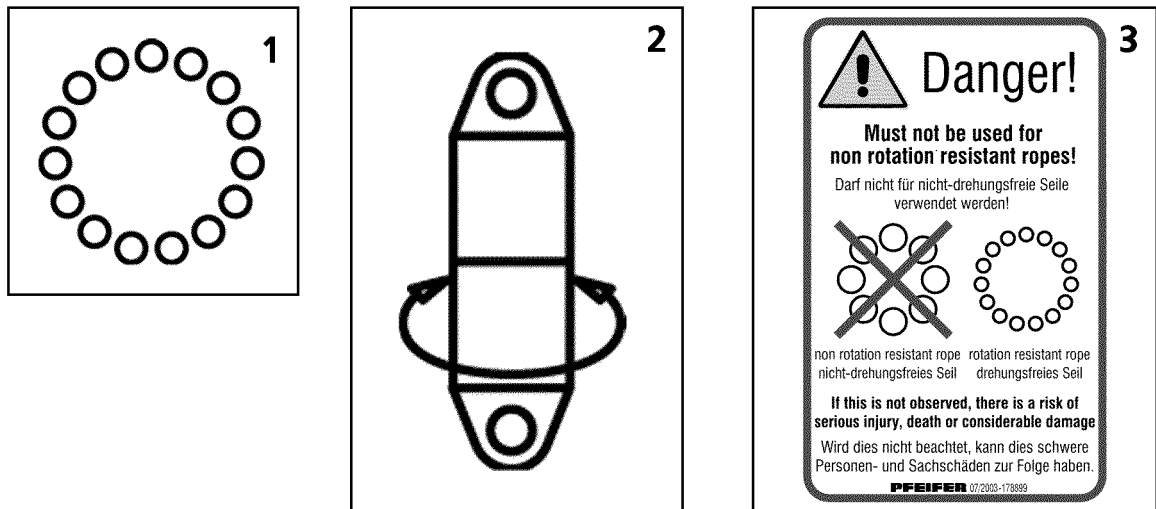

Typical rotation-resistant wire rope structures are ropes with 15 to 18 outer strands. Rotation-resistant ropes are symbolically depicted with 15 outer strands (circles) (see table 1).

Rotation-resistant ropes can be optionally used with the following rope end connections:

- Rope end connection **rotating** in the form of a PFEIFER link **with** swivel or spin stabiliser / swivel.
- Rope end connection **non-rotating** in the form of a PFEIFER link **without** swivel or gib and cotter.

If possible, preference should be given to the use of a twisting rope end connection to reduce torsional stress with **rotation-resistant ropes** (see table 2).



DANGER

Danger of serious personnel injury and equipment damage!

- ▶ **Never** use rotating rope end connections with non-rotation free ropes!



Note

Usage warning notes

- ▶ The usage warning notes on the rotating PFEIFER link with pulley indicates that this rope end connection may **not** be used for non-rotation free ropes (see table 3)!

7.2 Non-rotation free ropes and their rope end connections

Non-rotation free ropes generate high torque levels at the rope end connection when they are under load. For this reason, the rope ends must be protected from twisting using an appropriate rope end connection to prevent the rope from unscrewing under strain!



Note

- ▶ Non-rotation free ropes are used as **guy ropes** or **control ropes**.

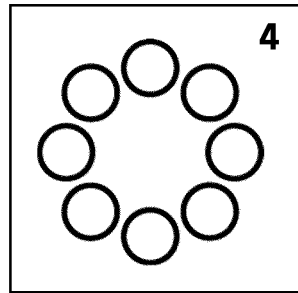

Typical non-rotation free wire rope structures are ropes with 8 to 10 outer strands. Twisting ropes are symbolically depicted with 8 outer strands (circles) (see table 4).

Non-rotation free ropes can only be used with the following rope end connections:

- Rope end connection **non-rotating** in the form of a PFEIFER link **without** swivel or gib and cotter. A non-rotating rope end connection is also the mount of the rope on the fixed point of the winch drum.



DANGER

Danger of serious personnel injury and equipment damage!

- ▶ **Never** use rotating rope end connections with non-rotation free ropes!
- ▶ Never install a twist compensator / swivel!



Note

Usage warning notes

- ▶ The usage warning note on PFEIFER links without swivel and cotter indicates that this rope end connection may **not** be used for non-twist free ropes **in combination** with a twist compensator / swivel (see table 5)!

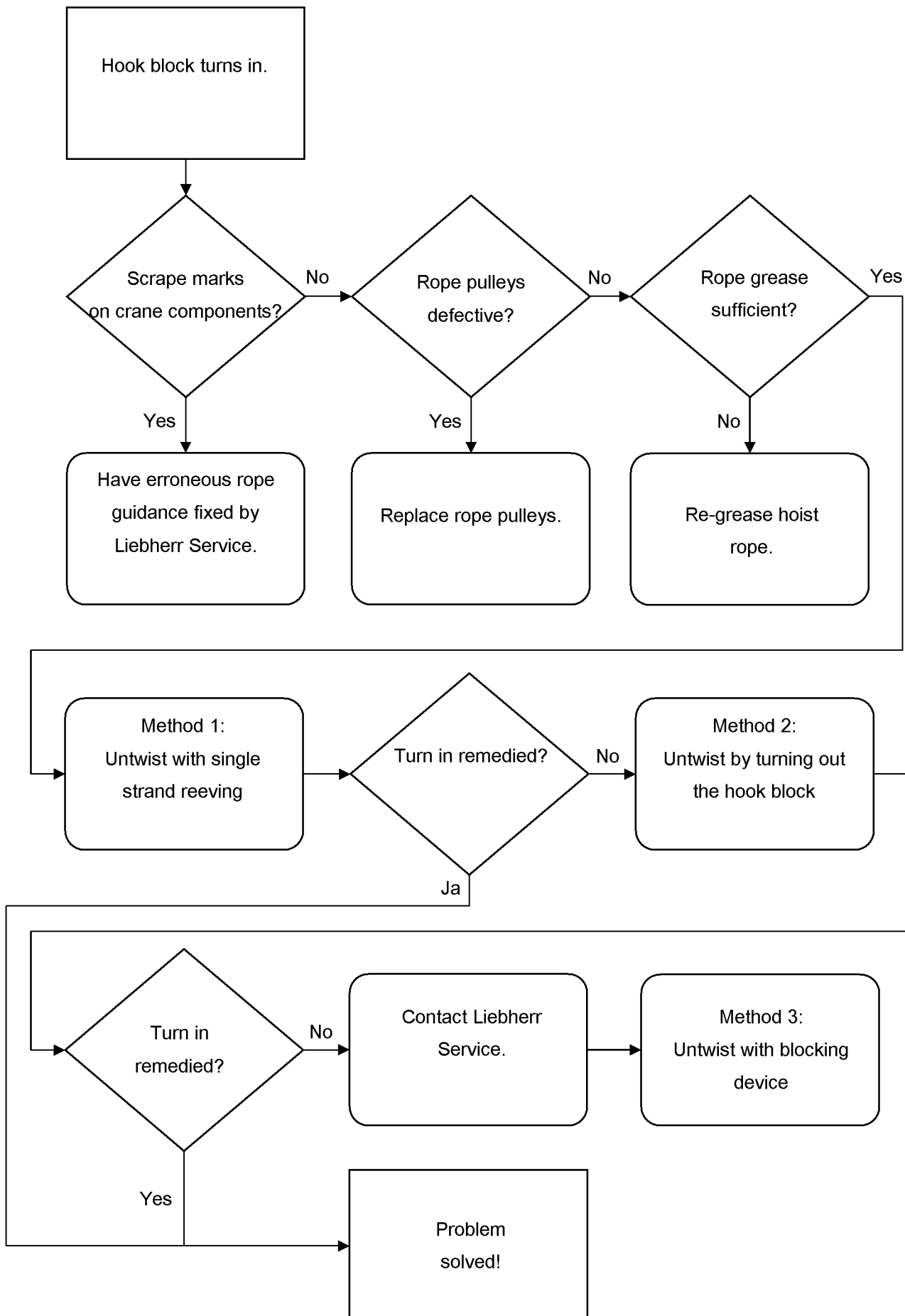

B106181

8 Twisting caused by stretching in rotation-resistant ropes and its remedy

For procedure, see illustration opposite.



WARNING

Damage to the rope!

- ▶ Please proceed with extreme caution when performing the following actions.
- ▶ Please heed the following instructions to the letter.

8.1 General

The cause for the turn-in of the hook block can have various reasons. For that reason, check the crane first for the following features.

- Scrub marks: Are hoist rope scrub marks present on the crane components? If scrub marks are present, check the hoist rope pathway and rectify.
- Rope pulleys: Has the groove diameter become too small, or do the rope pulleys exhibit a negative profile?
 - Groove diameter dimensional stability must be present.
 - The rope groove must be uniformly smooth without a hoist rope negative profile.
 - If this is not the case, the rope pulley must be exchanged.
- Rope greasing: Has the hoist rope been sufficiently greased? If the rope surface is dry, the hoist rope must be re-greased.

If the crane does not display other features, the hoist rope must be spun out. Following, two methods are described by which the hoist rope can be spun out. The methods must be applied in the described sequence.

8.2 Turning out extremely rotation-resistant hoist ropes

8.2.1 Method 1: Spinning out with one strand reeve

- 1.) Reeve in the one strand hoist rope.
- 2.) Extend the boom to the maximal boom length and hook height.
- 3.) Lower hooks to approximately 1 m above the ground and allow the hoist rope to spin out.
- 4.) With an empty hook block, carry out one complete hoist cycle.
- 5.) Lower the hook again to approximately 1 m above the ground and allow the hoist rope to spin out again.
- 6.) Reeve the number of strands of hoist rope carefully and spin free where the twisting of the hook block is largest.
- 7.) Carry out at least two complete hoist cycles at maximum boom length and hook height, in order to divide the spin out onto the entire rope length.

If the hook block turns in further, method 2 must be used.

8.2.2 Method 2: Spin out by turning out the hook block

- 1.) The hook block is reeved with the largest number of strands are twisted.
- 2.) Extend the boom completely and lower the hook block.
- 3.) Attach a load of approximately 10 % of the nominal rope pull on the hook block.
- 4.) Before lifting the load, an assistant must carry out the following measures: Rotate the twisted hook block to a straight position by hand until the rope strands no longer touch each other.
- 5.) Rotate the hook block further by a complete revolution, the rope strands touch each other again.
- 6.) Hold the hook block in the prescribed position until the load lifts off the ground.

- **NOTICE:**

When the hook block comes under load, it will attempt to rotate back to a straight position.
Release the hook block.

- 7.) Move the load until approximately 15 m before the uppermost hook position of the completely extended boom.
- 8.) Lower load and set it down. The twisting should now be remedied.

If the hook block turns in further, then the process must be repeated. If the problem is not remedied by this, contact Liebherr Service.

blank page!

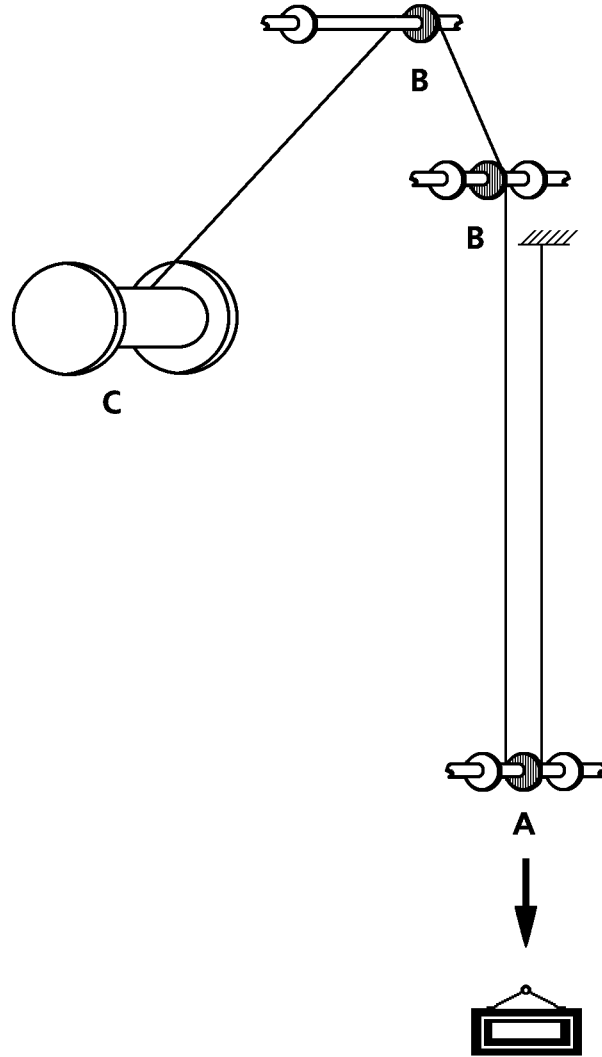

Fig. 1

B193940

A Hook block

B Cable pulley

C Rope drum

9 Appendix 1

Diagram of possible defects, with reference to different areas that must be considered during inspection:

- 1.) Check rope end connection at rope drum
- 2.) Examine for incorrect spooling up, which causes deformation (crushing) and wear, which can have serious consequences at rope crossing points
- 3.) Examine for wire breaks
- 4.) Examine for corrosion
- 5.) Look for deformation as a result of hook block loading
- 6.) Inspect parts of rope that run over rope pulleys for wire breaks and wear
 - Rope suspension and rope mountings:
 - Check for wire breaks and corrosion
 - Also inspect parts of rope that run on or next to compensating pulleys
- 7.) Look for deformation
- 8.) Check rope diameter
- 9.) Carefully check length of rope that runs through the hook block, particularly the part that rests on the rope pulley under load
- 10.) Check for wire breaks and surface wear
- 11.) Check for corrosion

Datasheet for ropes		Machine: Application:					
Construction: Direction of rope lay: RH / LH ¹⁾ Type of lay: Ordinary / Langs ¹⁾ Nominal diameter: Tensile grade: Quality: ungalvanized / galvanized ¹⁾ Type of core: steel / natural or synthetic textile / mixed ¹⁾ Preformation: Length of rope: Type of termination:		Date fitted: Date discarded: <hr/> Minimum breaking load: Working load: <hr/> Diameter measured: under a load of:					
Visible broken wires		Abrasion of outer wires	Corrosion	Reduction of rope diameter	Positions measured	Overall assessment	Damage and deformations
Number in length of 6 d	Number in length of 30 d	Degree of deterioration ²⁾	Degree of deterioration ²⁾	%		Degree of deterioration ²⁾	Nature
Date:					Signature:		
Rope supplier:				Number of working hours:			
Other observations:				Reasons for discard:			

1) Delete as applirope
 2) In these columns, describe the latter as: slight, medium, high, very high, discard.

10 Appendix 2

Typical example for an inspection log

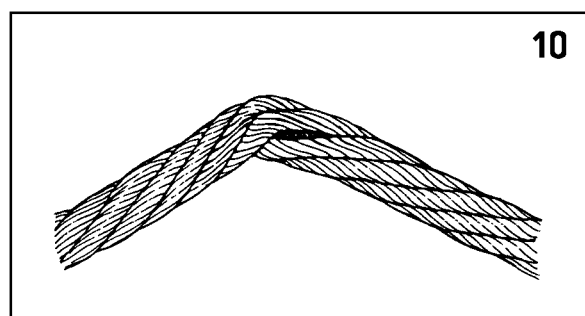
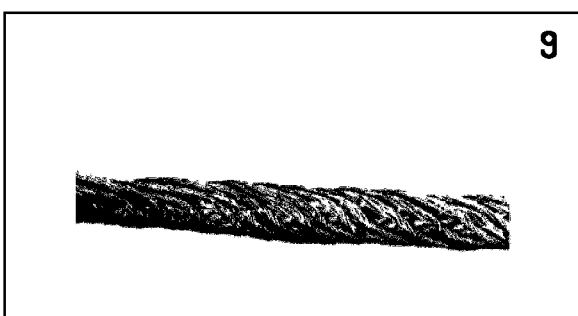
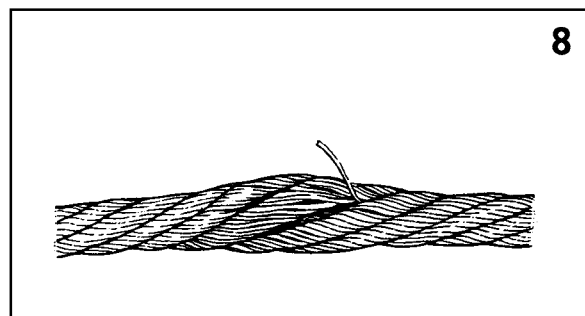
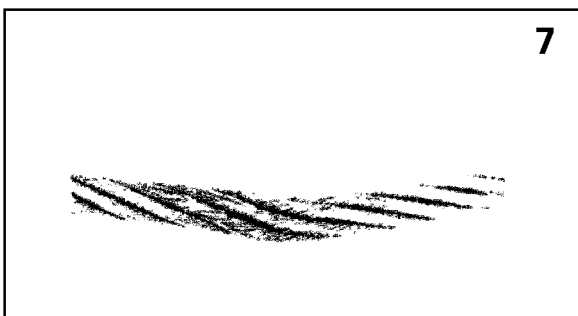
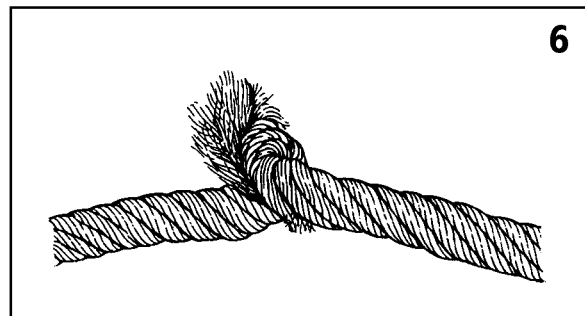
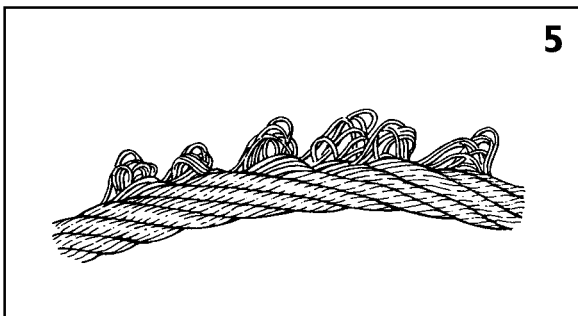
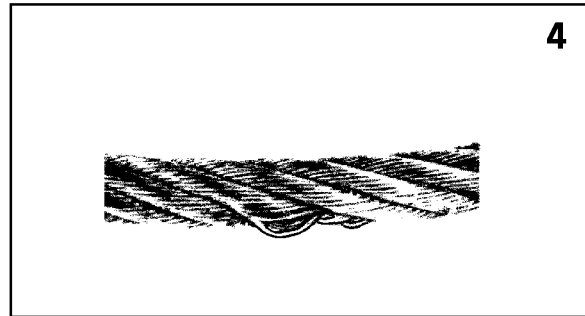
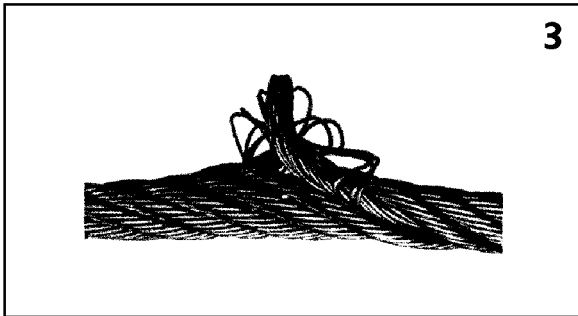
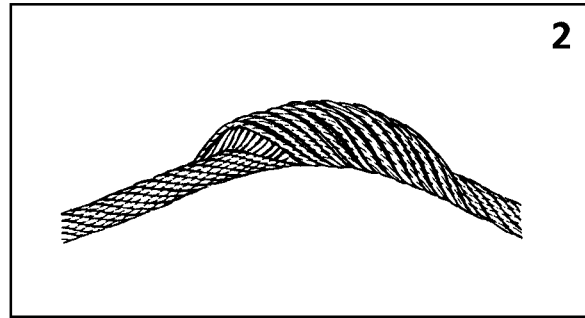
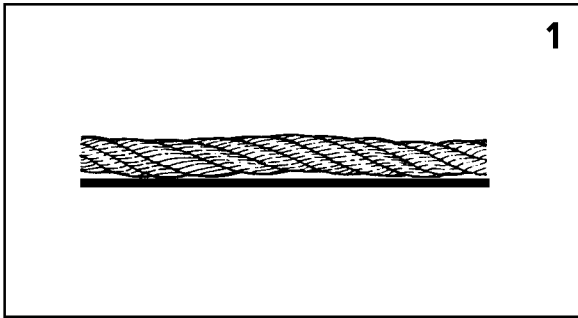

11 Appendix 3



Note

Depiction of deformation

The deformation that is depicted on many pictures is exaggerated in order to show it more clearly.

► The ropes that are shown would have had to be taken down long before they reached this stage.

Typical examples of damage that can occur to wire ropes:

- Picture 1:
Corkscrew-like deformation: deformation where rope is in the form of a spiral along its longitudinal axis.
The rope must be taken down if the deformation exceeds the value that is mentioned in chapter “Take-down criteria”, section entitled “Corkscrew-like deformation”.
- Picture 2:
Basket formation on a multi-strand rope.
Reason for immediate rope take-down.
- Picture 3:
Steel core rope exit, generally in combination with basket formation in the immediate vicinity.
Reason for immediate rope take-down.
- Picture 4:
Only one strand is affected by loop formation, although the examination of a longer section of rope shows that the deformation is visible at regular intervals; normally deformation along the length of a lay.
Reason for immediate rope take-down.
- Picture 5:
Serious worsening of the previous problem (see picture 4) (typical of hoist rope in a ram system).
Reason for immediate rope take-down.
- Picture 6:
A serious reverse bend or knot.
Note the destroyed lay that leads to the exit of the fibre layer.
Reason for immediate rope take-down.
- Picture 7:
A wire rope that has been kinked during installation but still taken into operation, and now suffers from localised wear and substandard rope tension.
Reason for rope take-down.
- Picture 8:
Crushing as a result of local mechanical damage causing imbalance beneath the strands, resulting in wire breaks.
Reason for rope take-down.
- Picture 9:
Crushing of a multi-strand rope caused by incorrect spooling up on the rope drum.
Note increase in length of outer strands of lay. Here too, imbalance would occur under load.
Reason for rope take-down.
- Picture 10:
Example of serious kinking.
Reason for rope take-down.

12 Appendix 4

Guideline for number of wire breaks in accordance with ISO 4309 for power train classification groups M1, M2, M3 and M4

12.1 Wire ropes

12.1.1 Hoist ropes

Rope diameter	Number of visible broken wires requiring rope removal, over a length of	
	6 x rope diameter	30 x rope diameter
See chapter 1.03	2	4



Note

- ▶ If a rotation resistant hoist rope is placed on winch 5, then it can be used for the jib adjustment or as a hoist rope for the boom nose!



WARNING

Use the hoist rope as control rope!

Frequent jib adjustment movements with a rotation resistant hoist rope lead to significant wear and require premature take down of the hoist rope!

If it is not recognized in time that the rope needs to be taken down, the hoist rope can rip!

The crane can topple over and personnel can be severely injured or killed!

- ▶ In case of frequent jib adjustment movements, a non-rotation free control rope must be placed!
- ▶ Make sure that no spin stabiliser / swivels are used as rope end connections when using a non-rotation free control rope!
- ▶ Remove spin stabiliser or swivels!

12.1.2 Assembly ropes

Rope diameter	Number of visible broken wires requiring rope removal, over a length of	
	6 x rope diameter	30 x rope diameter
See chapter 1.03	2	4

12.1.3 Guy ropes, control ropes

Rope diameter	Number of visible broken wires requiring rope removal, over a length of	
	6 x rope diameter	30 x rope diameter
See chapter 1.03	6	13

**WARNING**

Non-rotation free control ropes can rip off!

If a non-rotation free control rope is used in connection with a rotating rope end connection, the rope damage can occur or the control rope can rip off!

The crane can topple over and personnel can be severely injured or killed!

- ▶ Make sure that no spin stabiliser / swivels are used as rope end connections when using a non-rotation free control rope!
- ▶ Remove spin stabiliser or swivels!

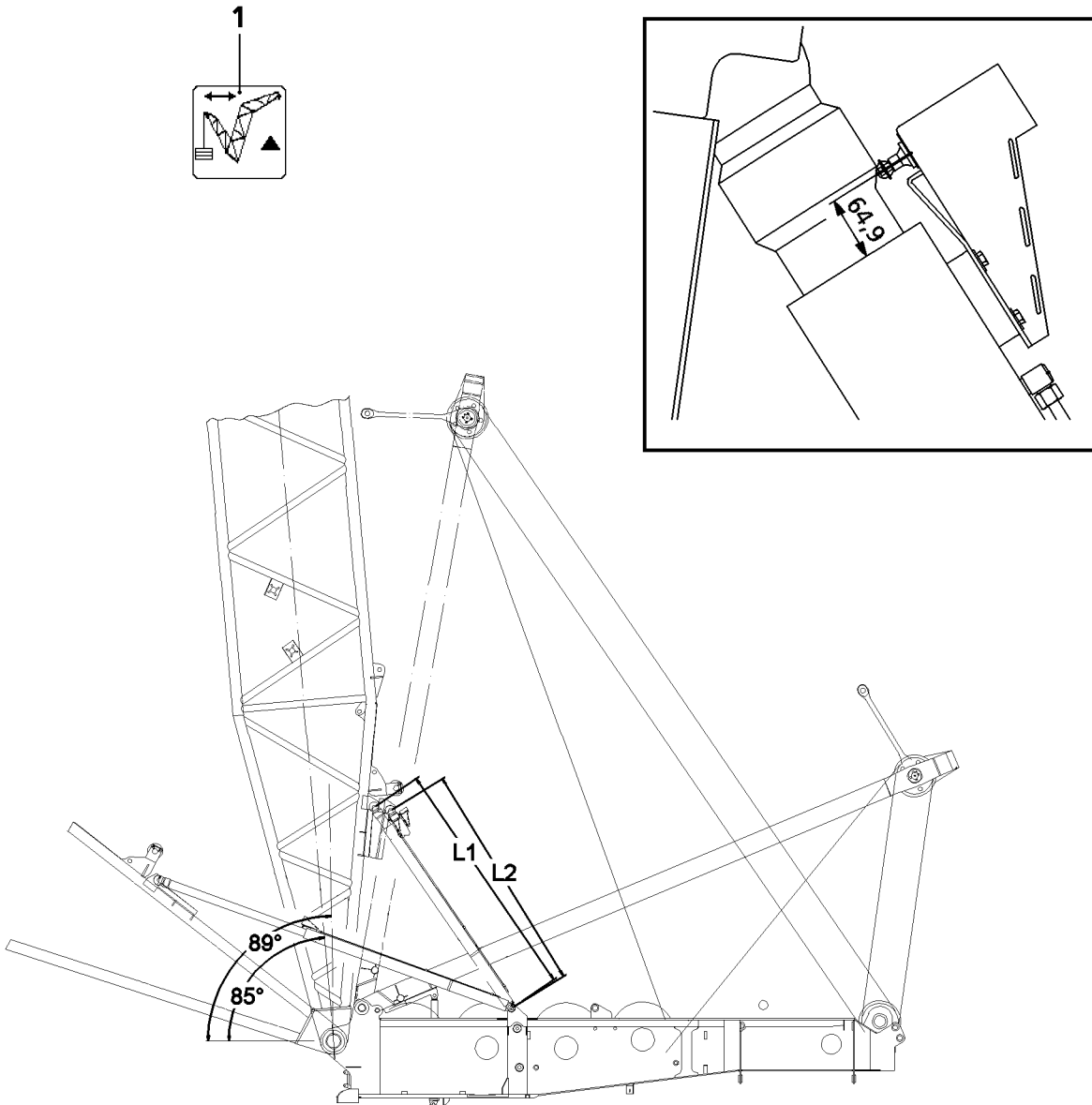

B105795

1 Boom relapse retainer

Two hydraulic cylinders prevent the boom from falling backward.

They are controlled on high or low pressure, depending on the operating mode or boom length.

In steepest boom position, the luffing up movement is turned off by the actuated limit switches in the cylinders.

1.1 Checking the limit switch initiators for function

Cover limit switch initiators on the relapse cylinder individually with a metal plate.

- The boom “luffing up” movement must turn off.
- The icon **1** must appear on the LICCON monitor.

	L-operation S-operation SL-operation	LL-operation	LN-operation SW-operation SLN-operation	LD-operation SD-operation SLD-operation	SDW-operation
Operating position	85°	83°	87°	85°	87°
Cylinder length L1	3655 mm	3741 mm	3568 mm	3655 mm	3568 mm
Electric switch position	88°	88°	88°	88°	88°
Cylinder length	3524 mm	3524 mm	3524 mm	3524 mm	3524 mm
Block position	89°	89°	89°	89°	89°
Cylinder length L2	3480 mm	3480 mm	3480 mm	3480 mm	3480 mm

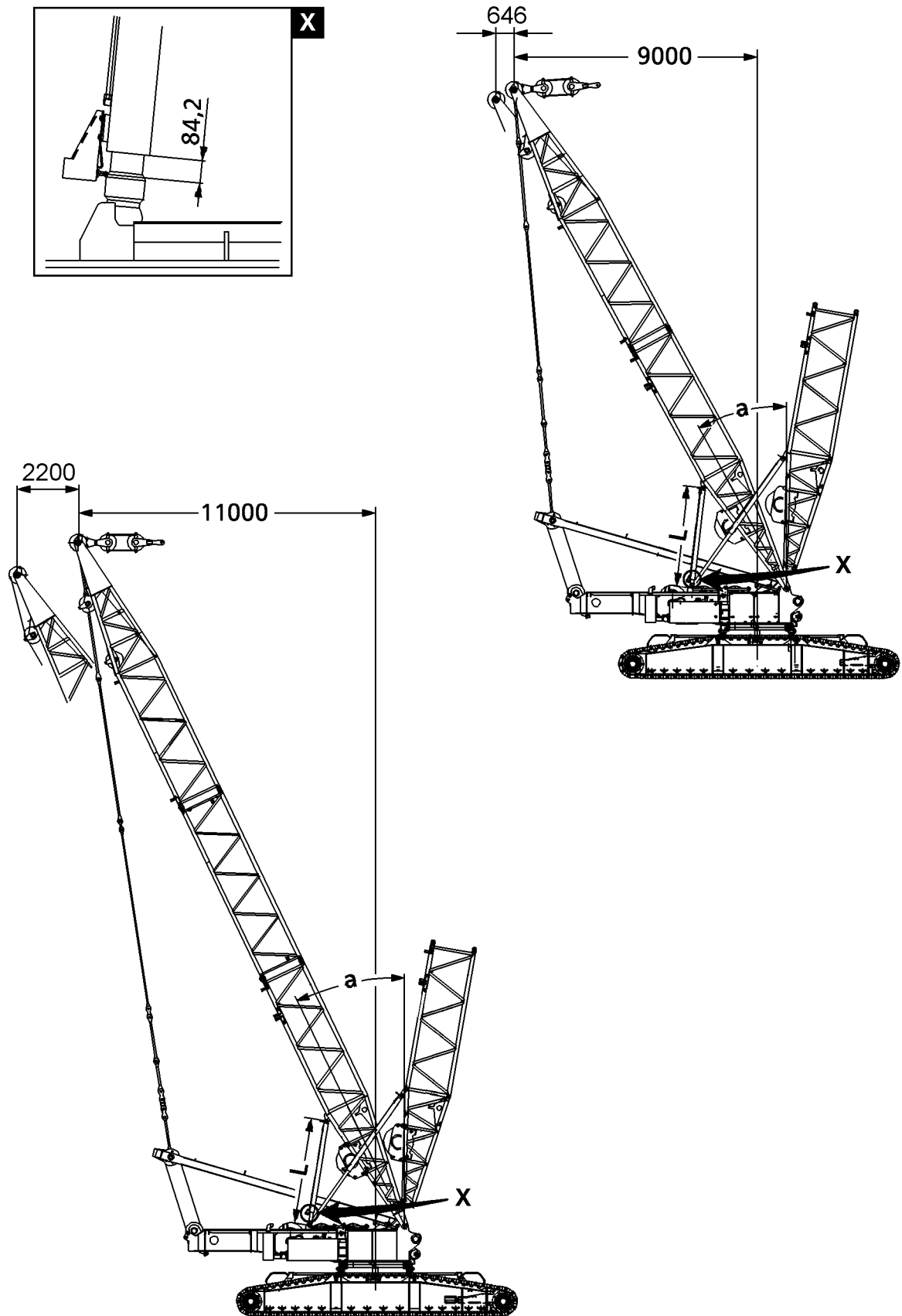

B198562

2 Derrick relapse retainer

Two hydraulic cylinders prevent the derrick from falling backward.

- If the limit switches on the cylinders are actuated, the winch 4 “spool up” movement is turned off.

2.1 Checking the limit switch initiators for function

Cover limit switch initiators on the D-relapse cylinder individually with a metal plate.

- The D-boom “luffing up” movement must turn off.

	D-21/9m	D-28/9m	D-28/11m
Distance center of rotation - derrick head	9000 mm	9000 mm	11000 mm
Theoretical operating position (a)	28,7°	21,1°	25,5°
Cylinder length	3726 mm	4182 mm	3915 mm
Distance center of rotation - derrick head	9330 mm	12798 mm	12798 mm
Electric switch position	29,7°	29,7°	29,7°
Cylinder length	3665 mm	3665 mm	3665 mm
Distance center of rotation - derrick head	9646 mm	13220 mm	13220 mm
Block position	30,7°	30,7°	30,7°
Cylinder length	3600 mm	3600 mm	3600 mm

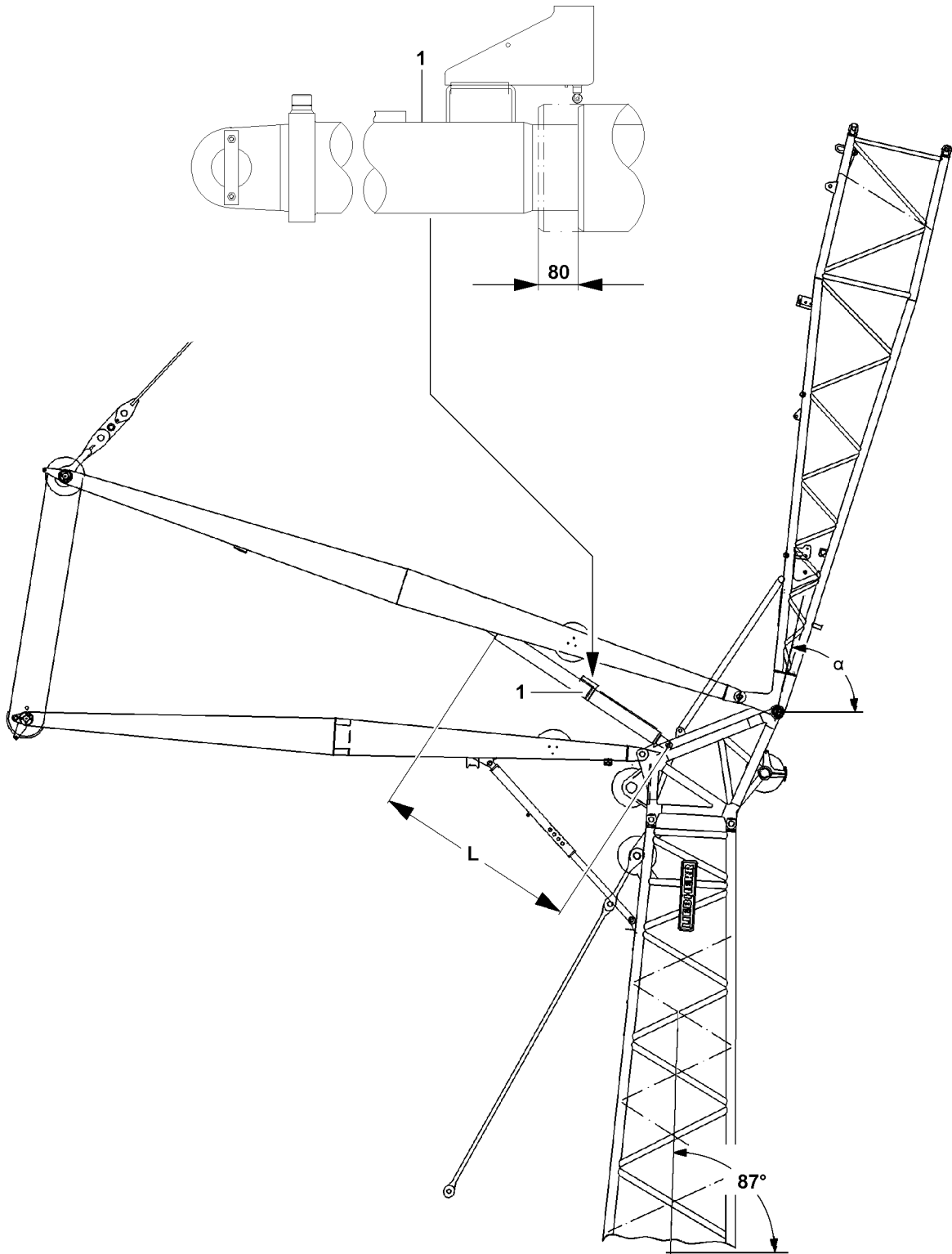

B109331

3 N-lattice jib

3.1 Checking the limit switch initiators for function

Cover limit switch initiators on the N-relapse cylinder 1 individually with a metal plate.

- The N-control winch movement “spooling up” must turn off.

After successful test, reset the A-frames to set up condition.

	Lattice jib angle α	Cylinder length L	Stroke	Pressure at			
				-20 °C	0 °C	+20 °C	+40 °C
Flattest operating position	25°	–	–	–	–	–	–
Steepest operating position	80°	4920 mm	1380 mm	273.0 bar	294.0 bar	315.5 bar	336.5 bar
Mechanical block position through relapse support	83°	–	–	–	–	–	–

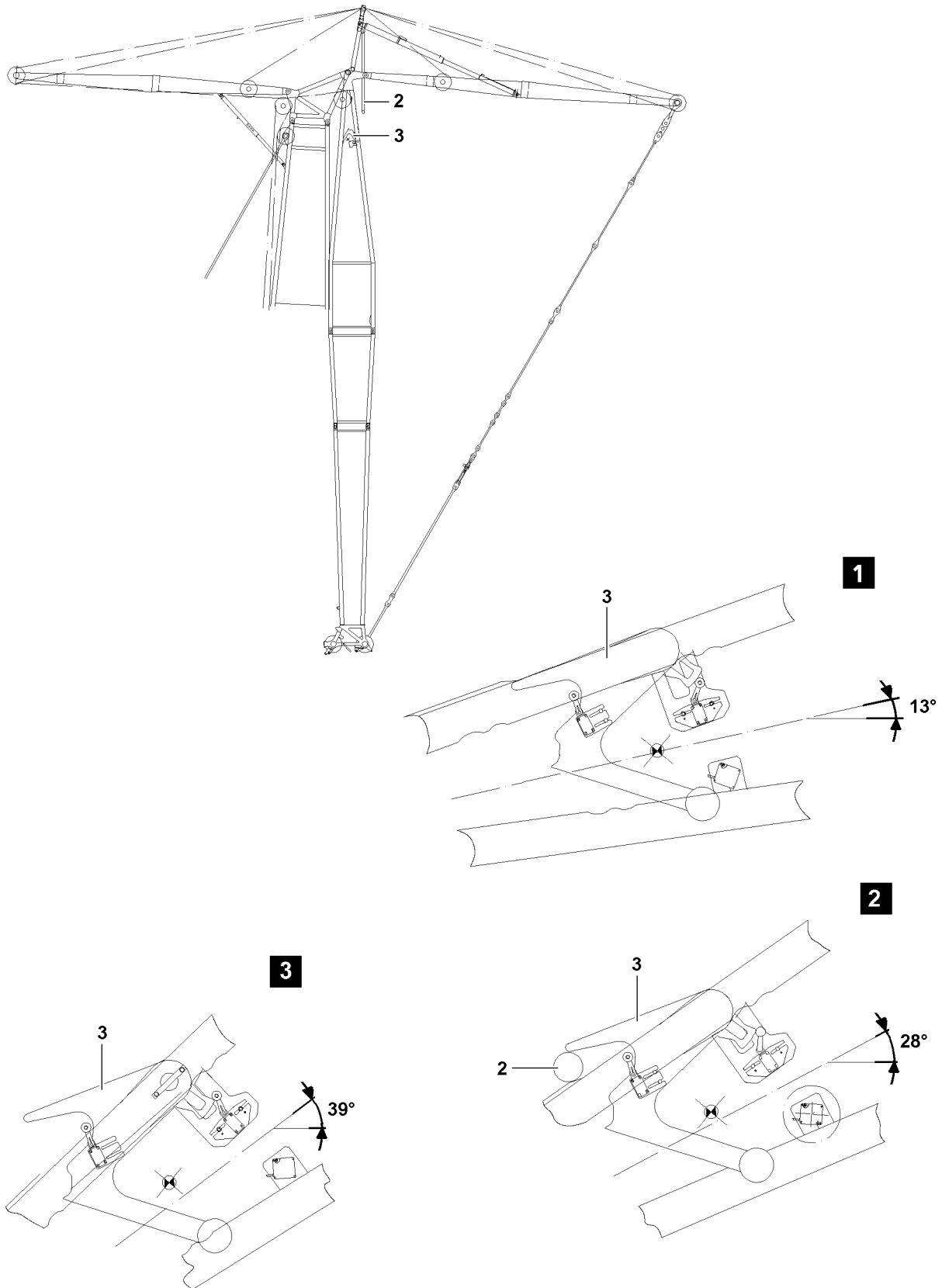

B109334

3.2 Checking the limit switch initiators for the mechanical relapse retainer for function

Mechanical relapse support **2**.

Oscillating safety **3** for mechanical relapse support.

In addition to the relapse cylinders, the lattice jib is also secured by a mechanical relapse support **2**, which engages in steepest lattice jib position into the flap of the oscillating safety **3**. The luffing up movement is turned off by the actuated limit switches on the oscillation guard.



WARNING

Danger of tipping over if the oscillation guard is hard to move!

If the oscillation guard **3** is hard to move, the mechanical relapse retainer will no longer function. The W-lattice jib can tip backwards uncontrolled and cause the crane to topple over!

- ▶ Crane operation with hard to move oscillation safety **3** is prohibited!
 - ▶ Before erection, the pendulum of the mechanical relapse retainer must be checked for easy movement over the complete swing range of the pendulum!
-

Depending on the lattice jib position (boom position = 87 °), the flap on the oscillation safety is swung out by the weight of the pendulum:

- 13 ° the flap is swung in, see illustration **1**.
- 28 ° the flap can be pushed up, see illustration **2**.
- 39 ° the flap is swung out, see illustration **3**.

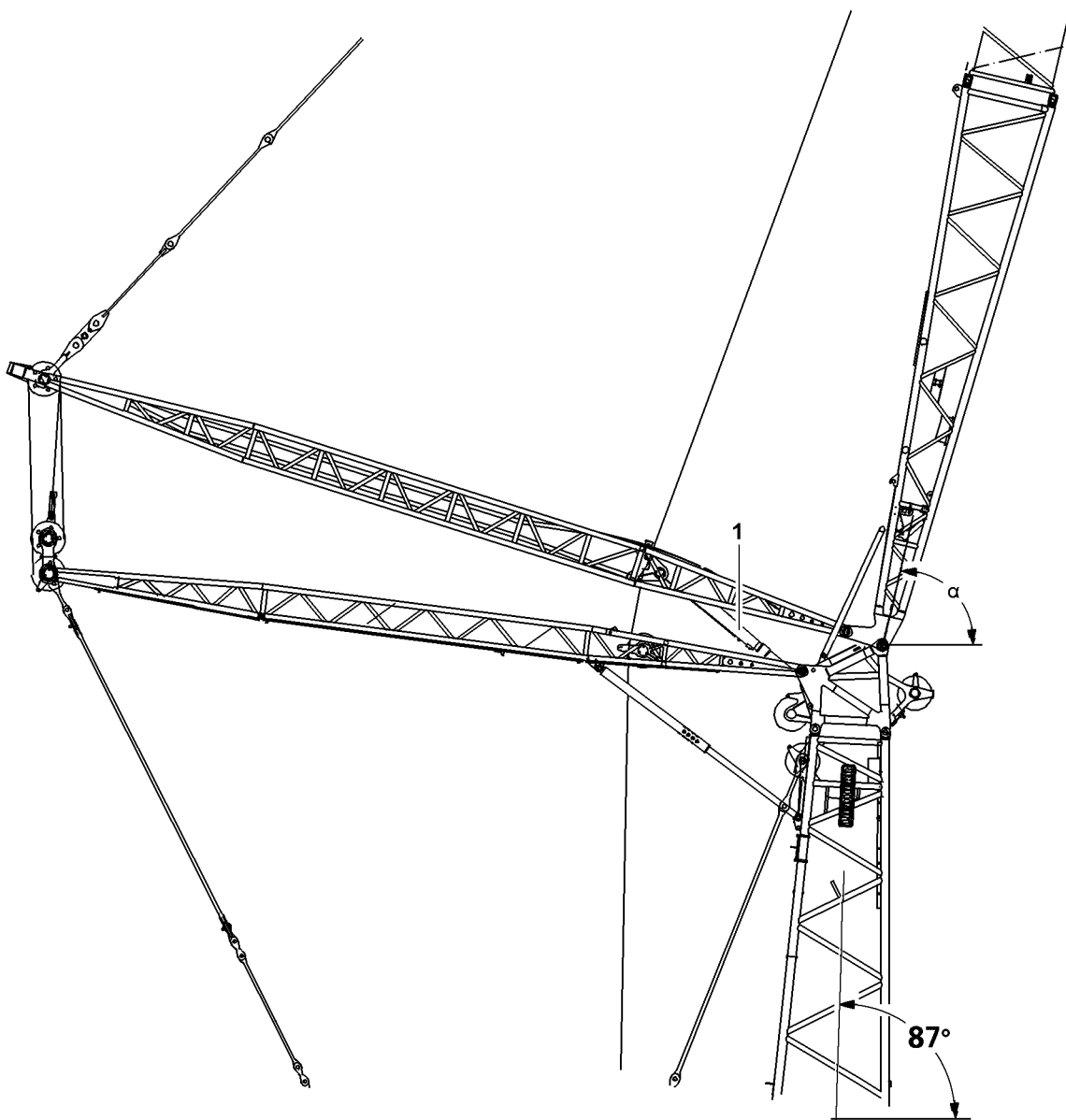

B109332

4 W-lattice jib

4.1 Checking the limit switch initiators for function

Cover the limit switch initiators on the W-relapse cylinder 1 individually with a metal plate.

- The W-control winch “spool up” movement must turn off.
- Limit switch initiators, see adjacent illustration.

	Lattice jib angle α	Cylinder length L	Stroke	Pressure at			
				-20 °C	0 °C	+20 °C	+40 °C
Flattest operating position	25°	maximum	–	–	–	–	–
Steepest operating position	80°	3735 mm	85 mm	280.0 bar	303.0 bar	326.0 bar	347.0 bar
Mechanical block position through retention support	83°	3659 mm	–	–	–	–	–

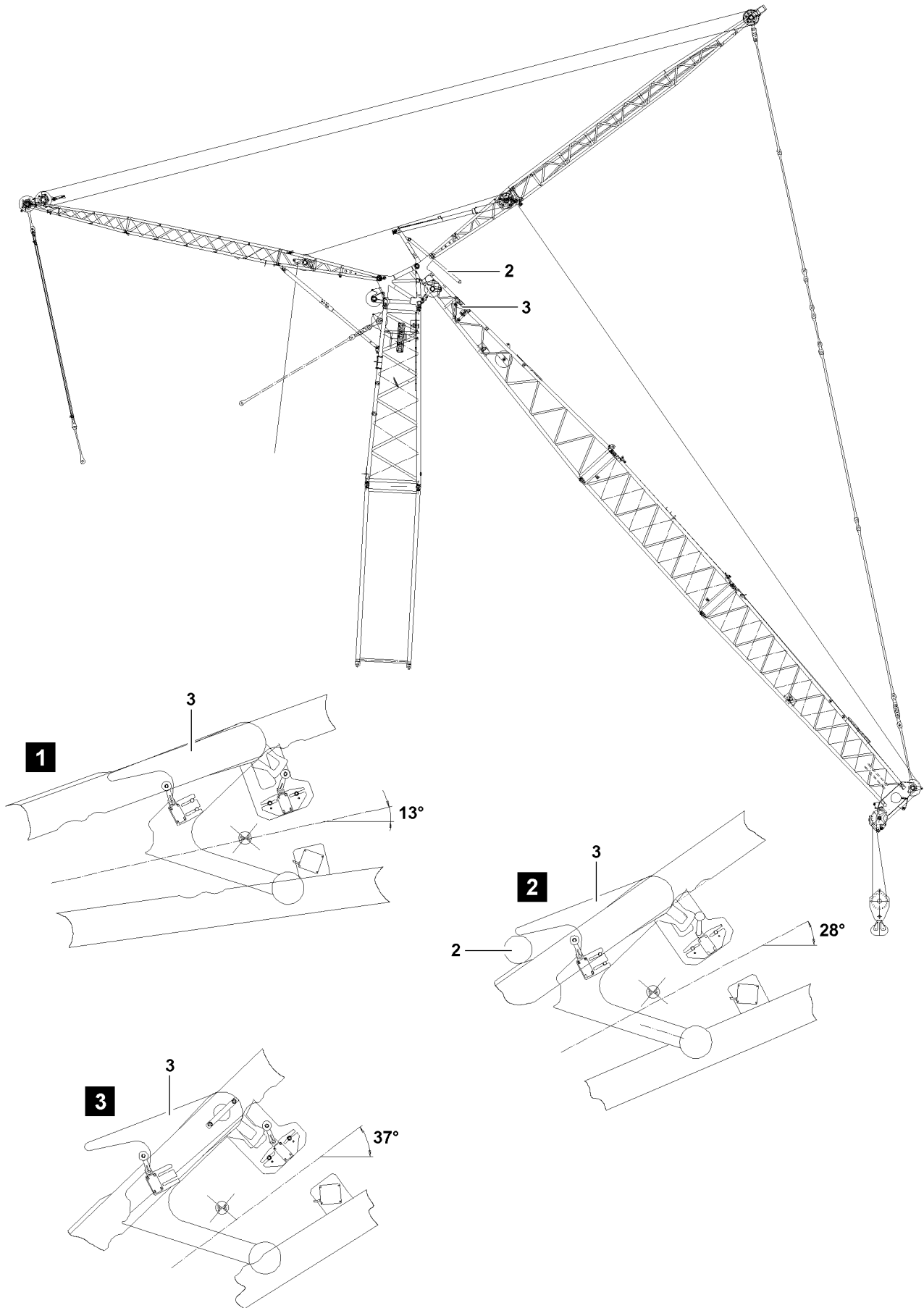

B109333

4.2 Checking the limit switch initiators for the mechanical relapse retainer for function

Mechanical relapse support **2**.

Oscillating safety **3** for mechanical relapse support.

In addition to the relapse cylinders, the lattice jib is also secured by a mechanical relapse support **2**, which engages in steepest lattice jib position into the flap of the oscillating safety **3**. The luffing up movement is turned off by the actuated limit switches on the oscillation guard.



WARNING

Danger of tipping over if the oscillation guard is hard to move!

If the oscillation guard **3** is hard to move, the mechanical relapse retainer will no longer function. The W-lattice jib can tip backwards uncontrolled and cause the crane to topple over!

- ▶ Crane operation with hard to move oscillation safety **3** is prohibited!
 - ▶ Before erection, the pendulum of the mechanical relapse retainer must be checked for easy movement over the complete swing range of the pendulum!
-

Depending on the lattice jib position (boom position = 87 °), the flap on the oscillation safety is swung out by the weight of the pendulum:

- 13 ° the flap is swung in, see illustration **1**.
- 28 ° the flap can be pushed up, see illustration **2**.
- 37 ° the flap is swung out, see illustration **3**.

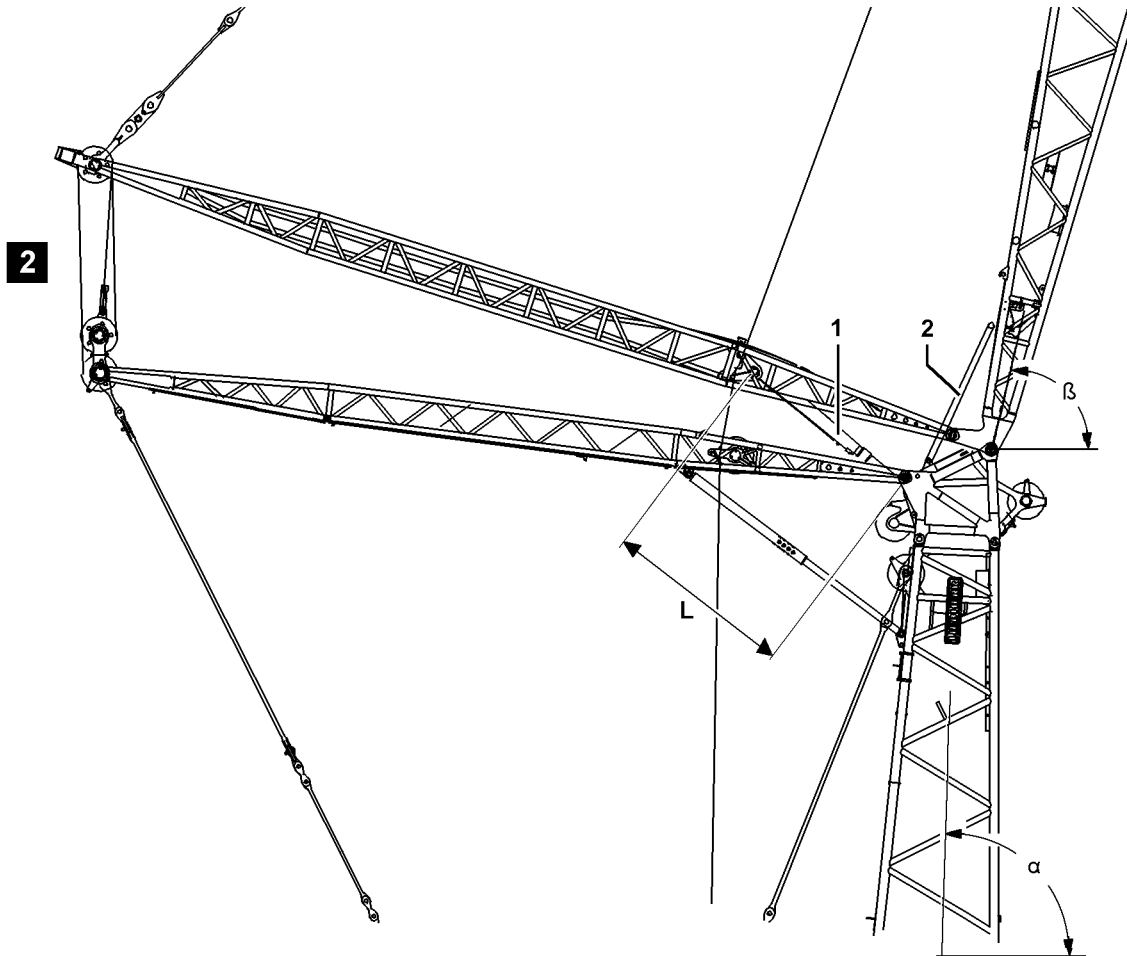
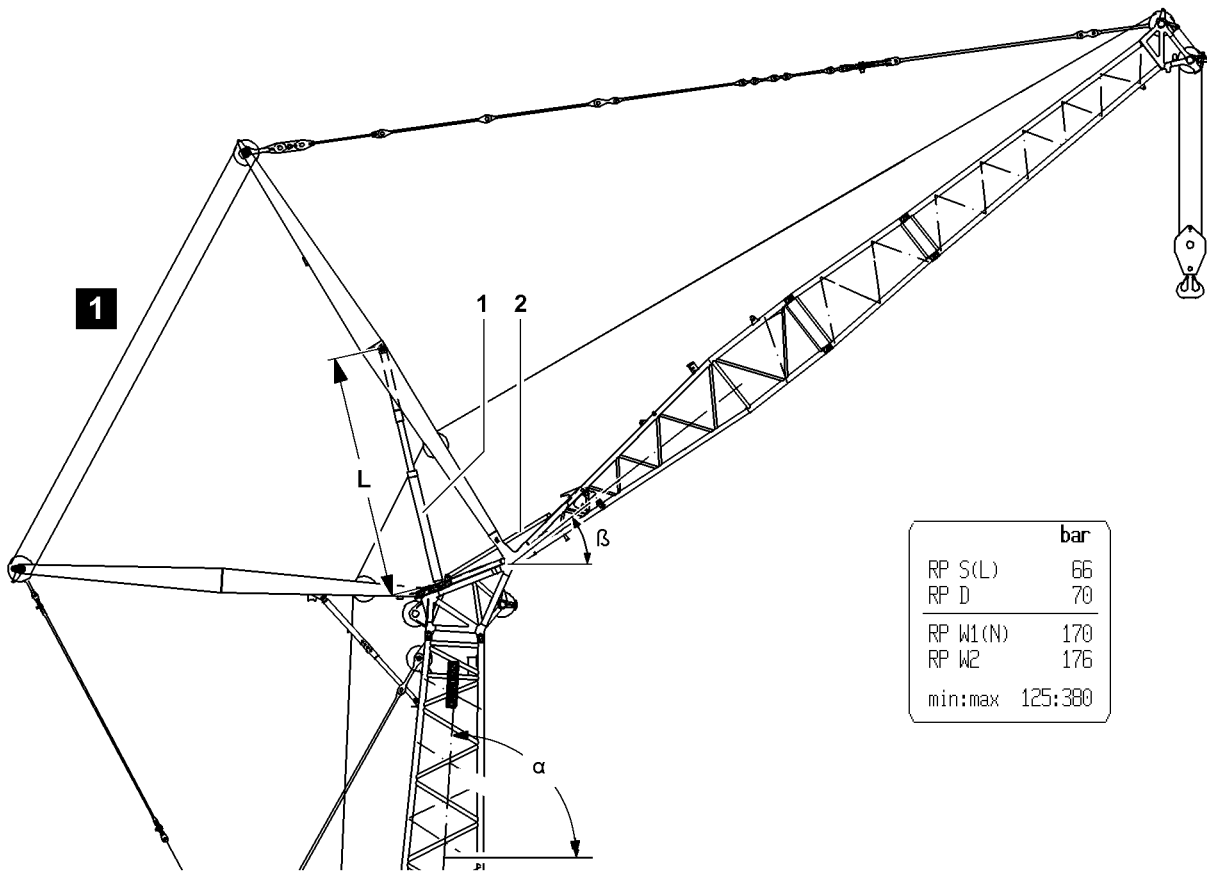

B109288

1 Checking the accumulator pressure in the relapse cylinders

The accumulator pressure in the relapse cylinders must be checked before and during crane operation via the LICCON crane operating screen, see Diagnostics manual.

The actual pressure shown in the LICCON crane operating screen must match the nominal pressure in the respective chart.



Note

- ▶ The specified nominal pressure depends on the ambient temperature!
- ▶ The maximum permissible difference between the actual and the nominal pressure is ± 10 bar!

2 N-lattice jib

Illustration 1



Note

- ▶ Set the main boom and the lattice jib to the angles specified in the charts!
- ▶ Compare the nominal pressure in the chart with the actual pressure in the LICCON crane operating screen!

2.1 Checking the accumulator pressure with the “relapse cylinder in test position”

Boom an- gle α	Lattice jib an- gle β	Cylinder length	Stro- ke	Nominal pressure at			
				-20 °C	0 °C	20 °C	40 °C
87°	38° + 2°	6100 mm	200 mm	64.5 bar	69.5 bar	74.5 bar	79.5 bar

2.2 Checking the accumulator pressure with “relapse cylinder fully extended”

Boom an- gle α	Lattice jib an- gle β	Cylinder length	Stro- ke	Nominal pressure at			
				-20 °C	0 °C	20 °C	40 °C
87°	32°	6300 mm	0 mm	57.5 bar	62.0 bar	66.5 bar	71.0 bar

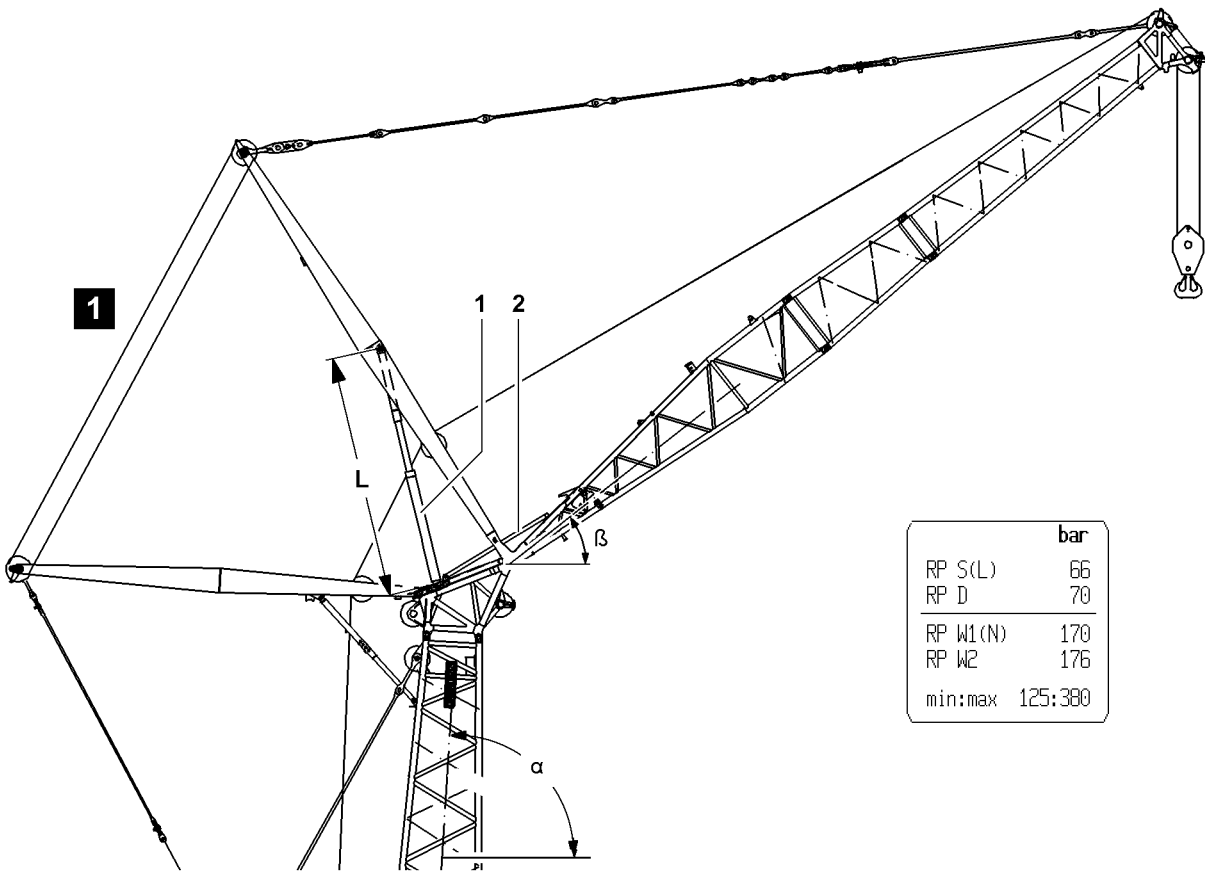

	bar
RP S(L)	66
RP D	70
RP W1(N)	170
RP W2	176
min:max	125:380

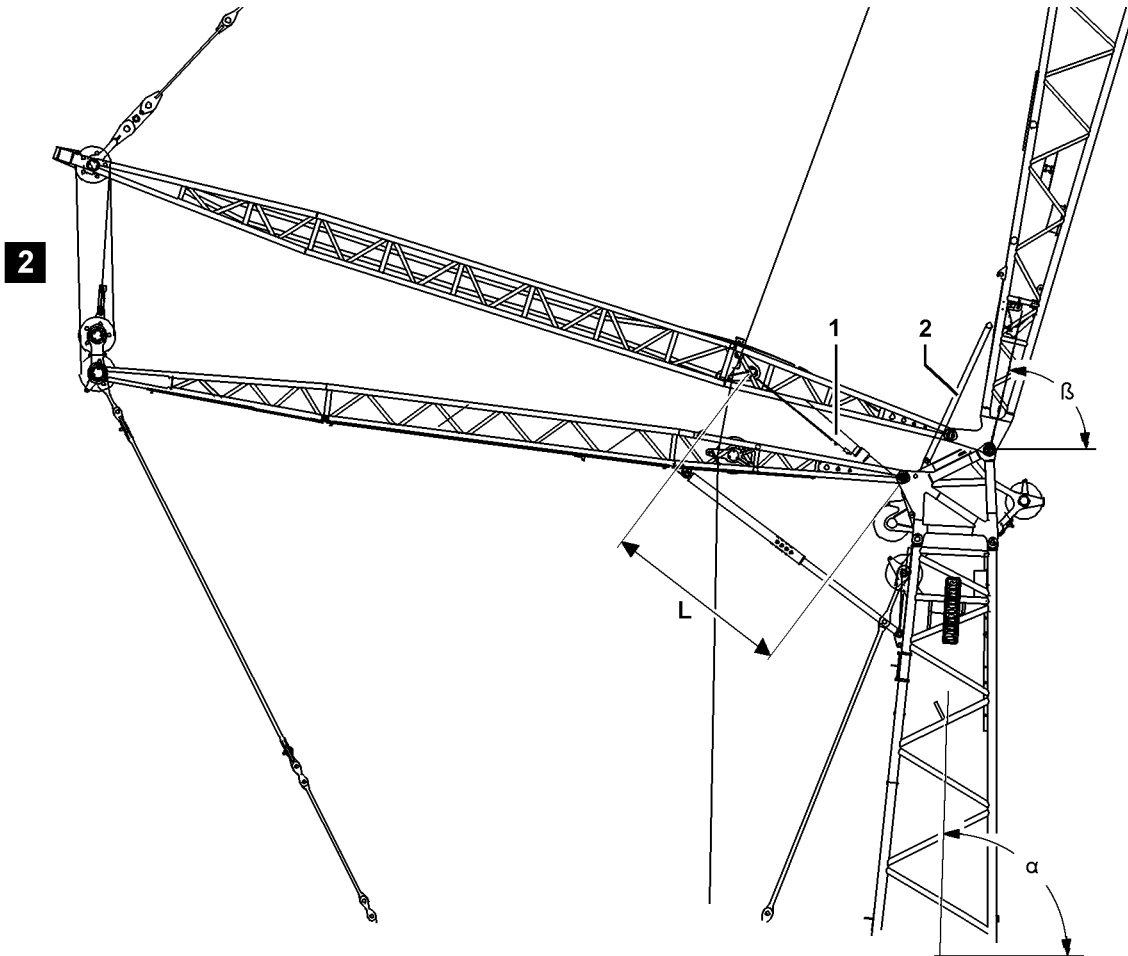

B109288

3 W-lattice jib

Illustration 2



Note

- ▶ Set the main boom and the lattice jib to the angles specified in the charts!
- ▶ Compare the nominal pressure in the chart with the actual pressure in the LICCON crane operating screen!

3.1 Checking the accumulator pressure with the “relapse cylinder in test position”

Boom an- gle α	Lattice jib an- gle β	Cylinder length	Stro- ke	Nominal pressure at			
				-20 °C	0 °C	20 °C	40 °C
87°	38° + 2°	4801 mm	1151 mm	95.9 bar	103.6 bar	111.3 bar	118.5 bar

3.2 Checking the accumulator pressure with “relapse cylinder fully extended”

Boom an- gle α	Lattice jib an- gle β	Cylinder length	Stro- ke	Nominal pressure at			
				-20 °C	0 °C	20 °C	40 °C
87°	36,2°	4850 mm	1200 mm	93.0 bar	100.5 bar	108.0 bar	115.0 bar

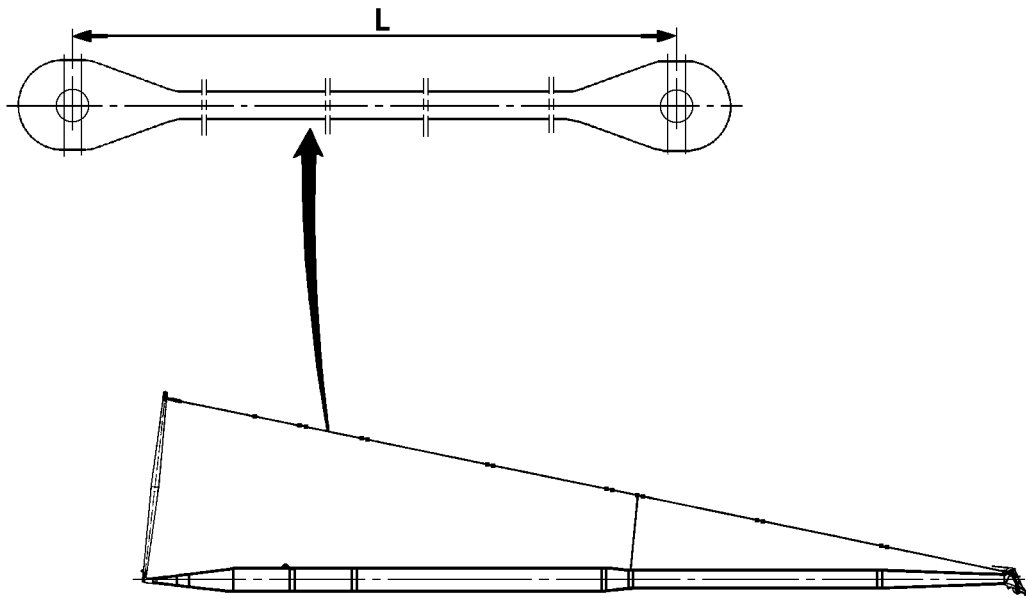

1 General

Always check the entire length of the guy rods before every assembly.
Also check the concealed bearing surfaces and bores.

2 Repeat inspection of guy rods

The guy rods must be checked at least once a year by an expert according to VGB D6.
The inspection must be carried out by an authorized expert every 4 years.
If a load was dropped or if the crane was overloaded, an additional inspection by an expert is required.
The inspections must be documented.



DANGER

Risk of accident in case of guy rod failure!

- ▶ If the following damage is found, the guy rods may no longer be used and must be replaced immediately!

2.1 Cracks and dents

The guy rods must be thoroughly inspected visually for cracks and dents.
If cracks are present, the guy rods must be replaced. Repairs are not permitted.



Note

- ▶ In case of doubt, the relevant areas must be carefully examined, for example with magnetic crack detection!

2.2 Stretching

Check for guy rod stretching by measuring the guy rods.
The stretch may be no more than max. 0.2 %, for example 14 mm, for an initial dimension (L) of 7000 mm.



Note

- ▶ The initial dimension (L) of the guy rods is noted in the separate rod diagram!

2.3 Wear

Check the bores, pins and pin retainers for signs of wear.

2.4 Damaged paint

Check the paint on the guy rods at regular intervals (signs of corrosion).
Repair damaged paint.



Note

- ▶ The guy rods may not be stored in aggressive media, such as salt water!

2.5 Ductile distortion

After a ductile distortion, such as bending, the guy rods must be replaced.

9.00 General notes

B195219

1 Checks before start up

We recommend to carry out the following visual inspections in the engine compartment before start up:

- Check if all oil and fuel lines are leak-free and dry.
- Check if the injection pump, fuel and oil filters are leak-free.
- Check if the hydraulic units, the hydraulic motors for the fan drives and their supply lines are leak-free.
- Check if the exhaust system and exhaust flange are leak-free.
- Check if the exhaust flap retention flap is moveable.

The return springs that open the exhaust flaps must function properly, because seized (therefore closed) exhaust flaps during engine operation will result in considerable overheating.

- Inspect electrical wiring and ensure that there is sufficient clearance to hot exhaust system piping and that it is properly fastened and that there is no insulation damage.
- Inspect the soundproofing mats for soiling from solutions and large quantities of oil or fuel, as well as other damage.

Immediately remove any soundproofing mats that are excessively damaged or soiled and replace them with original parts.

When cleaning the engine and gear compartments, observe the care instructions for the sound insulation, see Crane operating instructions, chapter 7.01.

2 Repair and maintenance tasks



Note

- ▶ Repair and maintenance tasks are to be carried out carefully!

Take particular precautions regarding cleanliness when replacing diesel and oil filters. Remove any diesel fuel or oil that has leaked. Perform a test run on the systems to ensure that there are no leaks. The diesel engine V-room must be inspected regularly, and any oil or diesel fuel must be cleaned up, particularly after repairs and servicing. Any fuel that has collected in V-room can spread throughout the engine room while the crane is travelling on the road and can ignite if it comes into contact with hot surfaces.

We stress that all electrical wiring must be installed according to the regulations and must be properly fastened. Immediately repair any wiring insulation that exhibits signs of chafing or brittleness as a result of operational activities. Any wiring that is not in perfect condition is to be immediately and professionally replaced.

We would like to particularly emphasise that over time fuel and oil lines can become brittle or porous as they age. Any hoses that appear to be excessively porous should be replaced immediately, see crane maintenance chapter.

3 Important servicing

The following service tasks are to be carried out regularly:

- Check gearbox and engine oil levels regularly.
Add oil as required during normal operation. If oil consumption or loss is unusually high, determine the cause and correct.

4 Maintenance notes for replacement parts

The following is to be considered when replacing drive components such as engine, gearbox or axles:

- Before start up, be sure to refill with the correct type of oil to the center of the min. - max. marks.
For type of oil, refer to the data tag and service items and lubricants.
- Conduct initial maintenance according to chapter “Maintenance intervals”; thereafter, maintain in accordance with the specified periodic maintenance intervals.
- Maintain break-in instructions, see Crane operating instructions, chapter 2.02.

5 Recommendations for travel operation

NOTICE

Risk of engine damage!

If the permissible engine speed is exceeded, the engine can be seriously damaged!

- ▶ Do not exceed the permissible engine rpm!
-

6 Disposal of fuels and greases



Note

Engine, gearbox and hydraulic oils, brake fluids, grease and fuels are dangerous waste materials!

- ▶ These materials must be disposed of separately!
 - ▶ These materials may not be disposed of in the ground or in any bodies of waters: wastewater systems, sewers or groundwater!
 - ▶ Comply with the regulations specified by local authorities before disposing of any of these items or substances!
-



Note

Radiator fluid for diesel motors and heating systems are dangerous waste materials!

- ▶ Undiluted antifreeze / corrosion inhibitor must be handled as dangerous waste materials!
 - ▶ Follow the regulations of the local authorities when disposing of used cooling fluids (mixture of antifreeze / corrosion inhibitor and tap water).
-

90.00 Appendix

1 Preface

This crane may only be used in flawless technical condition and according to its mission as well as with constant awareness of safety and dangers. Any problems, which could affect safety must be fixed immediately.



Note

- Modifications on the crane may only be made with written approval by Liebherr-Werk Eching GmbH.

1.1 Changes and updates for Operating instructions

Changes and updates for Operating instructions, which you receive in the circular as Customer information, must be filed in the Operating instructions for the respective crane under chapter 90.10.



Note

Procedure after receiving customer information!

- File changes and updates in the Operating instructions under chapter 90.10 and fill out the update confirmation in chapter 90.05.
- Attach the decals **1**, which are enclosed in the customer information to the footer of the respective chapter. See following example.



Example:

A change or update affects the Crane operating instructions, chapter 2.04 on page 108.

- Attach the decal **1** in the footer of chapter 2.04 on page 108.

Index

A

Abbreviations **27, 29, 31, 33**
Access to lattice sections or booms **84**
Acoustic and optical warning devices **431**
Acoustic warning on monitor 1 **375**
Activating crawler operation **559**
Adding the slewing gear brake (block) **469**
Air conditioning system* operation **1513**
Air filter **1607**
Air dryer of the compressed air system of the crane superstructure **1641**
Additional equipment **1505**
Adjusting the crane operator's seat **387**
Adjusting the track width on the pulley cart **1501**
Alarm functions **293, 361**
Angle sensors **441**
Angular pulling **537**
Appendix 1 **1815**
Appendix 2 **1817**
Appendix 3 **1819**
Appendix 4 **1819**
Appendix **1845**
Appendix **1790**
Arrangement of intermediate sections **733**
Arrangement of intermediate sections on the boom **731**
Assembling F-lattice jib **941**
Assembling F-lattice jib **945**
Assembling / disassembling the wedge lock **491**
Assembling / disassembly of hydraulic lines **717**
Assembling the ballast guy rods **1041**
Assembling the ballast trailer **1029**
Assembling the boom nose 36 t (H) **883**
Assembling the boom nose 48 t (H2) **899**
Assembling the boom nose 60 t (H) **913**
Assembling the boom nose 72 t (H) **925**
Assembling the crawler travel gear with SA-bracket **155**
Assembling the D-boom **743**
Assembling the D-guy rods **753**
Assembling the FA-bracket **945**
Assembling the F-pivot section **945**
Assembling the guy rods between the NA-bracket II and th **793**
Assembling the guy rods between the WA-bracket II and th **841**
Assembling the guy rods **947, 1471**
Assembling the LD/SLD/SD-boom **1335**
Assembling the L-lattice sections **1223**
Assembling the L/LL-boom **1215**
Assembling the N-lattice jib **797**
Assembling the pulley block **757**
Assembling the S-guy rods **1295, 1357**
Assembling the S-lattice sections **1281, 1341**
Assembling the S-pivot section on the turntable **1279, 1339**
Assembling the S/SL boom **1273**

Assembling the Sw-boom **1401**
Assembling the SwD-boom combination **1453**
Assembling the SwD-boom combination with support **1469**
Assembling the wedge lock **491**
Assembling the W-lattice jib **845**
Assembly **219, 741, 785, 833**
Assembly **1141**
Assembly / disassembly **689**
Assembly / disassembly of booms **691**
Assembly of central ballast **205**
Assembly of crawler carrier with SA-bracket **167**
Assembly of lattice sections for lattice mast cranes **705**
Assembly of lattice sections for telescopic cranes **693**
Assembly of turntable with Quick Connection* **197**
Assembly procedure **219**
Assembly ropes **63**
Attaching / removing the hoist limit switch weight **487**
Attaching the hoist limit switch weight **487**
Attaching the load **535**
Attaching the W-assembly unit to the S-boom **835**
Auxiliary guying **735**

B

Ballast frame for central ballast **45**
Ballasting the ballast trailer **1043**
Ballast trailer **59**
Ballast trailer guide **59**
Ballast trailer maintenance and inspection schedule **1565**
Ballast trailer tires **1129**
Battery maintenance **1641**
Bleeding repaired lubrication lines **1589**
Bleeding the central lubrication system **1587**
Bleeding the injection lines **1609**
Block position of relapse cylinders when setting down a **682**
Boom components **731**
Boom **23, 25**
Boom nose 36 t (H) **881**
Boom nose 48 t (H2) **899**
Boom nose 60 t (H) **913**
Boom nose 72 t (H) **925**
Boom nose **57**
Boom nose lattice boom **878**
Boom relapse retainer **1823**
Boom systems **730**
Boom systems **27**
Breaking away fixed loads **539**
Bypassing during crawler assembly **717**
Bypass of overload protection **425, 1696**
Bypass of the hoist top shut off **615, 663**

C

- Calculating the minimum required hook block weight **977**
- Calculation example counterweight combination **495**
- Calculation examples **980**
- Camera monitoring **237**
- Care instructions for the cab and the crane operator's c **1555**
- Carrying out error diagnostics **1681**
- Central ballast 1 **45**
- Central ballast 2 **45**
- Central ballast **204**
- Central lubricating system in general **1627**
- Central lubricating system - slewing ring connection **1625**
- Central lubricating system - turntable **1623**
- Central lubrication system **1623**
- Central lubrication system **1131**
- Changes and updates for Operating instructions **1847**
- Changing the maximum rotation speed of slewing gear **381**
- Changing the oil **1581, 1613, 1639**
- Changing the wheel sets **1059**
- Checking for leaks **1579**
- Checking the accumulator pressure in the relapse cylinders **1835**
- Checking the accumulator pressure with "relapse cylinder" **1835, 1837**
- Checking the accumulator pressure with the "relapse cyli" **1835, 1837**
- Checking the antislip coverings **1554**
- Checking the battery voltage **385, 1554**
- Checking the central lubrication system **387**
- Checking the coolant level **385**
- Checking the fuel level **385**
- Checking the function of the safety devices **953, 1237, 1301, 1363**
- Checking the gas pressure and oil fill **1785**
- Checking the general condition of the crane **387**
- Checking the horn **393**
- Checking the instruments after starting the engine **399**
- Checking the length sensor value on the ballast trailer **1101**
- Checking the limit switch initiators for function **1823, 1825, 1827, 1831**
- Checking the limit switch initiators for the mechanical **1829, 1833**
- Checking the limit switch relapse cylinder **795**
- Checking the oil level and filters **385**
- Checking the oil level **1579, 1613, 1639**
- Checking the prerequisites **719**
- Checking the retaining elements **679**
- Checking the rigging and fastening points **77**
- Checking the ropes **679**
- Checking the safety measures **100**
- Checking the settings **809, 861, 963**
- Checking wear on the track chain **1597**
- Checks before starting to work with the crane **532**
- Checks before start up **385, 1843**
- Check the relapse cylinders for visible defects **1785**
- Circular driving **1061**
- Cleaning and care of the crane **1554**
- Command and prohibition signs **141**
- Component description and general notes **1021**
- Component overview boom nose **881, 899, 913, 925**
- Component overview D-boom **739**
- Component overview - Derrick ballast **1135**
- Component overview **23, 937**
- Component overview LD/SLD/SD boom **1333**
- Component overview L-/LL-boom **1213**
- Component overview "narrow crawler" **25**
- Component overview of assembly unit **783**
- Component overview of assembly unit **829**
- Component overview S-pivot section **1397**
- Component overview S-/SL-boom **1271**
- Components **493**
- Components of pulley cart **1501**
- Components, weights **1021**
- Condition before installing **1801**
- Condition of equipment that is functionally associated with the rope **1807**
- Connection schematic for emergency operation, illustrati **1549**
- Consideration of wind conditions **101**
- Console **45**
- Control elements on the control panels **1025, 1137**
- Control elements Roof console **225**
- Control measures - crawler cranes **682**
- Control measures - mobile cranes **681**
- Control release **439**
- Control ropes **63**
- Conversion chart for wind force **105**
- Conversion chart for wind velocity and dynamic pressure **105**
- Coolant Engine cooling **1607**
- Counterweight combinations counterweight plates **495**
- Counterweight combinations **495**
- Counterweight **492**
- Counterweight **36, 119**
- Counterweight plates **493**
- Counterweights for turntable / suspended ballast / ba **45**
- Cracks and dents **1839**
- Crane alignment **100**
- Crane assembly **151**
- Crane chassis maintenance and inspection schedule **1561**
- Crane control **35**
- Crane engine **35**
- Crane engine running **449**
- Crane geometry and load information **279**
- Crane movement - Telescoping **533**

Crane operation **442**
Crane operation **539, 809, 861, 1249, 1311, 1431**
Crane operation **121, 891, 907, 919, 931**
Crane operation in case of thunderstorms **123**
Crane operation planning **67**
Crane operation with a load **119**
Crane operation with derrick ballast **1087**
Crane operation with derrick boom combination **1375, 1485**
Crane operation with winch 6* on the boom nose **421**
Crane operator's cab **387**
Crane operator's cab **36**
Crane operator's cab with incline adjustment **73**
Crane operator's cab with retractable / extendable step **73**
Crane drive **35**
Crane speeds **62**
Crane start up and taking the crane out of service **384**
Crane superstructure **35**
Crane superstructure maintenance and inspection schedule **1567**
Crane support **25, 61**
Crawler carrier assembly **152**
Crawler carrier **41, 153**
Crawler center section **41**
Crawler chassis fill quantities **1645**
Crawler track **23, 25**
Crawler travel gear **35**

D

Damaged paint **1839**
Danger of being crushed! **539**
Danger of crushing when closing the windows **69**
Dangerous conditions without shut off **682**
Dangers when working together with several cranes **111**
Danger zone of crane **69**
D-boom **738**
Defective Central processing unit (CPU) **1695**
Defective limit switch **1696**
Defective power supply (NT) **1693**
Defective sensors **1696**
Defined ballast trailer operation **1085**
D-end section 10.5 m **53**
Derrick ballast - Ballast trailer **1018**
Derrick ballast - Suspended ballast **1134**
Derrick ballast, weight and utilization **349**
Derrick boom angle **347**
Derrick boom radii **1139**
Derrick relapse retainer **1825**
Descending from lattice sections or booms **84**
Description **1135**
Description of crane **21**
Determination of forces in operating mode with derrick b **1093**
Determining the factor for reeving **978**
Determining the rope weight for the rope

diameter **978**
Diaphragm reservoirs **1619**
Diesel engine **1605**
Difference force monitoring of ballast guying **1103**
Dimensions and weights **39**
Dimensions **1021**
Dimensions, weights and centers of gravity **153**
D-intermediate section 7.0 m **53**
Disassembling the ballast guy rods **1115**
Disassembling the ballast trailer **1105**
Disassembling the boom **1495**
Disassembling the boom nose 36 t (H) **893**
Disassembling the boom nose 48 t (H2) **909**
Disassembling the boom nose 60 t (H) **921**
Disassembling the boom nose 72 t (H) **933**
Disassembling the crawler travel gear with SA-bracket **179**
Disassembling the D-boom **769**
Disassembling the FA-bracket **975**
Disassembling the F-lattice jib **965**
Disassembling the F-lattice jib **975**
Disassembling the F-pivot section **975**
Disassembling the guide from the ballast frame **1121**
Disassembling the guy rods **819, 871, 973**
Disassembling the LD/SLD/SD-boom **1377**
Disassembling the L-lattice sections **1261**
Disassembling the L/LL-boom **1251**
Disassembling the L-pivot section **1269**
Disassembling the N-lattice section **821**
Disassembling the S-lattice sections **1323, 1387**
Disassembling the S-pivot section **1331**
Disassembling the S/SL boom **1313**
Disassembling the SwD-boom combination **1487**
Disassembling the wedge lock **491**
Disassembly **767, 811, 863**
Disassembly **1189**
Disassembly of crawler carrier with SA-bracket **183**
Disassembly of the turntable with Quick Connection* **203**
Disconnecting the electrical connections **971, 1439, 1493**
Disconnecting the electrical connections on the D-boom **869**
Disconnecting the electrical connections on the N-lattice **819**
Disconnecting the electrical connections to the L-boom **1259**
Disconnecting the electrical connections to the N-lattice **825**
Disconnecting the electrical connections to the S-boom **1321, 1385**
Disconnecting the hydraulic connection **1439, 1493**
Disconnecting the hydraulic connection on the L-boom **1259**
Disconnecting the hydraulic connections **1525, 1529, 1543, 1547**
Disconnecting the hydraulic connections to the S-boom **1321, 1385**

Disconnecting the hydraulic connection to the crawler tr **181**
 Dismantling the Sw-booms **1441**
 Disposal of fuels and greases **1844**
 Documentation **85**
 D-pivot section 10.5 m **53**
 Drive **35**
 Driving from the crane operator's cab **541**
 Driving the crane with the ballast trailer **1075**
 Driving the crawler crane **557**
 Driving the crawler **561**
 Ductile distortion **1839**

E

Electrical system **36**
 Electrical system - Lighting **1641**
 Emergency exit - crane operator's cab **75**
 Emergency exit **75**
 Emergency exit - driver's cab **75**
 Emergency operation **1123, 1515**
 Emergency operation of ballast trailer **1123**
 Emergency operation of slewing gear(s) with assembly plate Variation 1 (V1) **1527**
 Emergency operation of the ballast trailer - Circular dr **1127**
 Emergency operation of the ballast trailer - Towing **1125**
 Emergency operation of winch 4 on the LR1600/2 and LR16 **1523, 1531**
 Emergency operation of winch 4 (W IV) on the LR1600/2 and LR1600/2-W **1545**
 Emergency operation of winches, individual operation **1533**
 Emergency operation of winches, parallel operation winch **1535**
 Emergency operation slewing gear(s) with assembly plate(s) Variation 2 (V2) **1541**
 Emergency operation winch 4 (WIV) **1545**
 Emergency operation winches **1523**
 Emergency operation with assembly plate(s) Variation 2 (V2) **1531**
 Emergency operation with assembly plate Variation 1 (V1) **1521**
 EMERGENCY STOP switch / EMERGENCY OFF switch **437**
 Emergency take-down **1514**
 Endangering air traffic **100**
 Engine monitoring **401**
 Engine does not start **1689**
 Engine oil **1605**
 Engine RPM **447**
 Ending crane operation **126**
 Ending crane operation **126**
 Ending emergency operation **1549**
 Ending the load lift to avert emergency situations **1699**
 Equipment **677**
 Erecting the boom **803, 855, 1425, 1479**
 Erecting the D-boom **763**
 Erecting the L - boom **1241**
 Erecting the L - boom **1245**
 Erecting the NA-bracket II **795**
 Erecting the SA-bracket **159, 723**
 Erecting the SA-frame **405**
 Erecting the S-boom **1305, 1367**
 Erecting the S-boom **1309, 1371**
 Erecting the SF-boom **957**
 Erection cart **57**
 Erection / take down for crawler cranes **719**
 Erection / take down for mobile cranes **718**
 Erection / take down **718**
 Erect the WA-bracket II **843**
 Error diagnostics without the help of Liebherr Service **1682**
 Error diagnostics with the help of Liebherr Service **1684**
 Error messages by the LICCON computer system **431**
 Error messages **243**
 Establishing the electrical connections **799, 851, 953, 1235, 1299, 1421, 1473**
 Establishing the electrical connections to the boom **1361**
 Establishing the electrical connections to the D-boom **759**
 Establishing the electrical connections to winch 6* **417**
 Establishing the hydraulic connections **1421, 1473, 1519**
 Establishing the hydraulic connections to the boom **1361**
 Establishing the hydraulic connections to the D-boom **759**
 Establishing the hydraulic connections to the L-boom **1235**
 Establishing the hydraulic connections to the S-boom **1299**
 Establishing the hydraulic connection to the crawler tra **175**
 Establishing the hydraulic connection to the slewing gea **1527, 1541**
 Establish the hydraulic connections to winch 6* **419**
 Exceeding the LICCON overload protection for assembly **1219, 1277, 1453**
 Exceeding the overload protection **687**
 Exceeding the shut off limits of the LICCON overload pro **619, 667**
 Exhaust systems and other crane components with high tem **69**
 Extending the L-relapse cylinder **1243**
 Extending the S-relapse cylinder **1307, 1369**

F

FA-bracket **937**
 FA-frame 7.0 m **51**
 Failure of hydraulic, electric or engine **1693**
 Fastening points D-components **739**
 Fastening points **937**

Fastening points LD/SLD/SD-components **1333**
 Fastening points L-/LL-components **1213**
 Fastening points S/SL-components **1271**
 F-end section 8.0 m **51**
 F-end section **937**
 Filling the grease container **1585**
 Fill quantities crane superstructure **1647**
 Fill quantities **1645**
 Fill quantities, lubrication chart **1644**
 First aid measures after rescue **85**
 Fitting the S-intermediate sections, SW-reducer section **1407, 1459**
 Flying assembly of the D-boom **751**
 Flying assembly of the intermediate sections **1413**
 Footbridge **61**
 For cranes with pneumatic boom locking system **1785**
 For cranes with telescopic boom system Telematik **1785**
 Foreword to appendix **1846**
 F-pivot section 2.5 m **51**
 F-pivot section **937**
 Frame **35**
 Functional selection on the assembly plate **1521**
 Function check **761, 801, 851, 1423, 1475**
 Function key line **369**

“

“Flying” assembly of the SwD-boom **1463**
 “Narrow” crawler center section **61**

G

General **69, 205, 219, 241, 423, 443, 569, 577, 829, 1553, 1703, 1839**
 General **85, 129, 539, 1811**
 General hand signals **112**
 Generally valid instructions: **122**
 General notes **1841**
 General notes **443**
 General prerequisites for driving of crawler cranes **543**
 General safety technical guidelines **68**
 General safety technical notes for operation with ballast trailer **146**
 Gravity actuated relapse retainer **439**
 Greasing the slewing ring **1628**
 Grounding **101**
 Grounding the crane **101**
 Grounding the load **101**
 Ground pressure **62**
 Guiding the load **539**
 Guy ropes **63**
 Guy rods **684**
 General danger notes **1517**

H

Handling of hook blocks **983**
 Hand signals for guidance **112**

Heater / engine pre-heating **1506**
 Heater operation **1507**
 Heating the crane operator's cab **1507**
 Hoist gear brake **1633**
 Hoist gear **1631**
 Hoist gear, hoist rope **120**
 Hoist limit switch “Hoist top” **431**
 Hoist ropes **63**
 Hook block overview **983**
 Hook blocks **976**
 Horizontal movements **115**
 Hydraulic cylinder **1555**
 Hydraulic hose lines **1129, 1620**
 Hydraulic safety valves **439**
 Hydraulic system **1615**
 Hydraulic tank **1615**
 Handling of assembly plates **1519**

I

Illustration overview - winches **1631**
 Important servicing **1843**
 In addition, the following applies for Germany: **123**
 Index **1851**
 Indicator light instrument panel, right front **229**
 Input window hook block weight **273**
 Inspecting load hooks **1783**
 Inspecting the cable pulleys **1786**
 Inspecting the function of the overload protection **1786**
 Inspecting the hoist and luffing winches **1771**
 Inspecting the mounting of the load bearing equipment **1786**
 Inspecting the oil and fuel reservoirs **1789**
 Inspecting the roller ring connection **1786**
 Inspecting the rope feed mechanics in the telescopic boom **1783**
 Inspection according to ISO 4309 **1802**
 Inspection and maintenance of guy rods **1838**
 Inspection and monitoring procedure **1783**
 Inspection of accumulator pressure in relapse cylinder **1834**
 Inspection of carrying crane structures, especially steel structures **1704**
 Inspection of change over pulleys, illustration 2 **1789**
 Inspection of crane wire ropes **1800**
 Inspection of disk wheels **1770**
 Inspection of lattice sections **1767**
 Inspection of locking system of telescopic boom **1785**
 Inspection of membrane accumulator **1785**
 Inspection of relapse cylinders **1785**
 Inspection of safety switching on the relapse supports **1822**
 Inspection of the auxiliary reeving winch, towing winch and spare wheel winch **1789**
 Inspection of the safety controls on the relapse cylinders **1786**
 Inspection of the tele extension with eccentric,

illustration 1 **1789**
 Inspection of tire pressure **1769**
 Inspection of tires and disk wheels **148, 1769**
 Inspection of tires **1769**
 Inspection procedures **680**
 Inspection recommendations for periodic inspections of **1790**
 Inspections **1771**
 Inspections of cranes **1701**
 Installation **1801**
 Installing a double hook block for parallel operation **995**
 Installing a double hook block for single operation **985**
 Installing the access ladder **215**
 Installing the auxiliary guying **735**
 Installing the ballast frame **207**
 Installing the bracket **501**
 Installing the central ballast 11 t **213**
 Installing the central ballast 43 t **207**
 Installing the counterweight **499**
 Installing the counterweight plate **211, 215**
 Installing the guide on the ballast frame **1031**
 Installing the hook block **985, 995**
 Installing the N-assembly unit on the L-/SL-boom **789**
 Installing the pulley cart **1503**
 Installing the single blocks **1007**
 Installing the turntable **197**
 Installing the turntable **199**
 Instructions for resuming crane movements for cranes with CE mark **581**
 Instructions for resuming crane movements for cranes without CE mark **629**
 Instructions for sound damping (soundproofing) **1554**
 Intermediate lubrication of crawler carriers **1589**
 Interrupting crane operation **125**
 Interruption of crane operation **125**
 Introduction **1801**
 Identification **85**

J

Joint lifting of a load with two cranes **111**
 Job planning **66**

K

Key button "Ballast trailer lifted off" **1083**

L

LD/SLD/SD-boom combination **1332**
 L-end section 350 t **57**
 L-end section **57**
 Leveling instruments **429**
 LICCON computer system after engine start **409**
 LICCON computer system boot up **245**
 LICCON computer system **240**
 LICCON computer system **424, 449**

LICCON monitor **1691**
 LICCON overload protection **424, 1091**
 Liebherr Service **1553**
 Lifting and lowering the ballast trailer at installation **1053**
 Lifting and lowering the ballast trailer in crane operation **1053**
 Lifting equipment **62**
 Lifting / lowering **451**
 Lifting of personnel **122**
 Lifting the load **537**
 Lifting the turntable and the crawler center section with **163**
 Lift the turntable from transport vehicle **197**
 Limit switch Boom system **441**
 Limit switch winch spooled out **433**
 L-intermediate section 14.0 m, 2620.10 **49**
 L-intermediate section 7.0 m, 2620.10 **49**
 L/LL-boom **1212**
 LN/SLN-boom **782**
 Lowering the hook block if slack rope forms **980**
 Lowering the SA-bracket to the front **165**
 Lubrication and fill quantities **1131**
 Lubrication chart **1133**
 Lubrication schedule - Crawler chassis **1649**
 Lubrication schedule - Equipment **1661**
 Lubrication schedule for crane superstructure **1657**
 Lubrication schedule for crane support narrow crawler **1653**
 Lubrication schedule **1649**
 Luffing **463**
 Luffing the derrick, for all D operating modes **465**
 Luffing the lattice jib in SW/SDW(B,BW) operation **465**
 Luffing the main boom at S/SL/SD/SLD/SDWV(B,BW) operation **463**
 Luffing the main boom in SW/SDW(B,BW)-operation **463**
 Luffing the S-boom down **1317**
 L-adapter 7.0 m **49**

M

Maintenance intervals - Crane superstructure **1566**
 Maintenance and inspection guidelines **1556**
 Maintenance and service - General **1552**
 Maintenance **1129**
 Maintenance **129, 1801**
 Maintenance guidelines - Crane chassis **1576**
 Maintenance guidelines - Crane superstructure **1604**
 Maintenance intervals Crawler chassis, ballast trailer **1560**
 Maintenance intervals for the ballast trailer **1127**
 Maintenance notes for replacement parts **1844**
 Maintenance work on the crane superstructure or boom **1556**
 Manual corrective steering **1071**
 Manual operation for assembly **1073**
 Manual rope winches for assembly support of

components **683**
Maximum permitted level difference **1079**
Measures for defective components **1693**
Measures for work interruption or transport **1555**
Measures in clear problem cases **1687**
Mechanical auxiliary support **218**
Mechanical auxiliary support **41**
Minimum required hook block weight **977**
Mixing battery acid **1642**
Monitored auxiliary functions for crane operation **311**
Monitoring function reports a problem **1687**
Monitoring of crane movement **591, 639**
Movement on the crane **69**
Moving the support cylinders out **1117**
Machine related movements **116**

N

NA-intermediate section 14.0 m **49**
NA-intermediate section 7.0 m **49**
NI-intermediate section 14.0 m **51**
NI-intermediate section 14 m **939**
NI-intermediate section 7.0 m **51**
NI-intermediate section 7 m **939**
NI-reducer section 3.5 m **49**
N-lattice jib **1827, 1835**
Non-defined ballast trailer operation **1085**
Non-rotation free ropes and their rope end connections **1808**
Notes to change the wheel sets **1059**
Notice sign for refueling (position 49) **145**
Notice signs **143**

O

Obligations of the crane operator **87**
Observe the warning lights **445**
Opening the front window **393**
Operating and control instruments **225**
Operating and monitoring instruments on the crane superstructure **224**
Operating behavior of steel ropes **1807**
Operating elements - Crane operator's seat / air conditi **225**
Operating elements, General **227**
Operating elements - Instrument panel right **231**
Operating elements of the LICCON computer system on monitor 0 **249**
Operating elements of the LICCON computer system on monitor 1 **333**
Operating elements on control panel **229**
Operating elements switch cabinet **239**
Operating instructions for cranes (position 13) **143**
Operating mode preselection on the LICCON computer syste **245**
Operating the crane **963**
Operating the engine-independent auxiliary heater* **1509**
Operating the windshield wiper / windshield washer

syste **391**
Operating winch 6* with the supply lines of winch 5 (actuation with master switch MS2y) **415**
Operation of crane superstructure **223**
Operations with a boom extension (folding jib, auxiliary **573**
Operations with a boom nose* on the lattice jib **571**
Operations with a boom nose* on the telescopic boom **569**
Other operating elements **329**
Overload monitoring in operating mode with derrick balla **1097**
Overload protection (LMB) **243**
Overview load chart for cranes with CE mark **581**
Overview load chart for cranes without CE mark **629**
Overview of acoustic / visual warnings for cranes with C **583**
Overview of acoustic / visual warnings for cranes withou **631**
Overview of displays and component groups for error diag **1677**

P

Parallel operation **457**
Parallel driving **1067**
Parking the vehicle **126**
Periodic crane inspections **1702**
Permissible ballast assemblies **1027**
Permissible counterweight assemblies **497**
Permissible ground pressures **94**
Permitted ground pressure for crawler cranes **95**
Permitted ground pressure for mobile cranes **95**
Personal protective equipment **79**
Pinning and unpinning pins on the cross carriers or the **1017**
Pinning and unpinning the pins on the boom lattice secti **1017**
Pinning and unpinning with pin pulling device **1015**
Pinning the guide on the turntable **1033**
Pinning the L-pivot section on the turntable **1221**
Pinning the S-pivot section on the turntable **1405, 1455**
Pinning the upper pulley block on the S-pivot section **1457**
Pin pulling device **1014**
Place the ballast plates on the ballast frame **209**
Placing the boom down **813, 865**
Placing the counterweight **503**
Placing the hoist rope **679**
Placing the L-boom down **1253**
Placing the NA-brackets down **823**
Placing the SA-bracket onto the turntable **727**
Placing the WA-bracket II down **875**
Pneumatic springs for assembly support of components **683**
Preface **1847**
Preparatory work **1015**
Preparing for crane operation **963, 1249, 1311,**

1375, 1431, 1485

Prerequisites for crawler operation **543**

Prerequisites for emergency operation **1519**

Prerequisites for driving on uphill slopes **550**

Prerequisites for driving with a load and / or derrick
b **548**

Prerequisites for driving without a load and without
der **549**

Pressure filter in the crane hydraulic **1619**

Pressure monitoring in the relapse cylinders **435**

Procedure for shut off of crane movements **576**

Procedure **1549**

Procedure in case of problems **1673**

Procedure in case of slack rope **980**

Procedure to follow in case of a problem **1675**

Prohibition signs **141**

Product description **34**

Pulley cart **1500**

Pump distributor gear **1613**

Q

Quick test Crane geometry **423**

Quick test Overload protection **423**

R

Ram work or pulling sheet piles **540**

Recommendations for travel operation **1844**

Reeving in the hook block **475, 1243, 1307, 1369**

Reeving in the N-control rope between the
NA-bracket I a **791**

Reeving in the W-control rope between the
WA-bracket I a **839**

Reeving plans **574**

Reeving plans **575**

Reeving the hook block in and out **475**

Refueling AdBlue® **1558**

Releasing the counterweight **517**

Remedying temporary errors during system
start **1687**

Removing and recharging the battery **1642**

Removing the bracket **529**

Removing the central ballast **217**

Removing the central ballast **217**

Removing the counterweight **515**

Removing the counterweight **519**

Removing the hoist limit switch weight **489**

Removing the hook block **991, 1001**

Removing the load hook* **485**

Removing the pulley cart **1503**

Removing the single blocks **1011**

Removing the turntable **203**

Repair and maintenance tasks **1843**

Repair welds **1706**

Repeat inspection of guy rods **1839**

Replacing a defective fuse **1695**

Replacing the granular cartridge **1641**

Requirements for monitoring the winches **1772**

Requirements for the crane operator **85**

Rescuing the assembly personnel **85**

Resuming crane operation **125**

Resuming crane operation **125**

Retracting the support cylinder **1039**

Rope end connections **473**

Rope inspection log **1807**

Rope pulleys **679**

Rope reeving **472**

Rope reeving **491**

Ropes **63**

Rope storage and marking **1807**

Rotation-resistant ropes and their rope end connec-
tions **1807**

S

S-adapter 7.0 m **47**

SA-bracket **720**

SA-bracket **721**

SA-bracket in assembly operation **727**

Safety equipment **422**

Safety devices on the crane **429**

Safety **65**

Safety guidelines for ladders **129**

Safety guidelines for travel operation **1075**

Safety guidelines **147, 879**

Safety guidelines **1087**

Safety instructions for external power supply (230 V
AC) **124**

Safety signs on the ladders **131**

Safety systems **36**

Safety technical guidelines for assembly and
disassembly **678**

Securing and removing the load hook* **483**

Securing the assembly personnel against falling **83**

Securing the counterweight **513**

Securing the load hook* **483**

Selecting the location, illustrations 1 to 3 **91**

Selecting the travel speed **559**

S-end section 400 t **57**

Service and maintenance **1551**

Service fluids and lubricants **1664**

Service items and lubricants (continuation) **1666,**
1667, 1668, 1669, 1670, 1671, 1672

Service items and lubricants **1665**

Servicing the central lubrication system of the
crawler carrier **1585**

Servicing the track chain **1593**

Servicing the travel gear **1577**

Servo oil pressure monitoring in the winches **435**

Setting a new set up configuration and new hoist
rope re **411**

Setting the ballast trailer radii **1055**

Setting the boom to 67°/77° **809**

Setting the boom to 67 °/77 ° **861**

Setting the control parameters **413**

Setting the derrick ballast **413**

Setting the operating mode and set up
configuration **253**

Setting the turntable and the crawler center section

- ont **157**
 - Set up program areas **255**
 - SF-boom combination **936**
 - Short description of assembly procedure **155**
 - Short description of disassembly procedure **181**
 - Shut off of crane movement: LMB STOP by LICCON overload **601, 649**
 - Shut offs in SA-assembly operation **727**
 - Signs on the crane **135**
 - Single hook blocks **1007**
 - S-intermediate section 14.0 m, 2620.20 **47**
 - S-intermediate section 14.0 m for flying assembly, 26 **47**
 - S-intermediate section 7.0 m, 2620.20 **47**
 - Slewing gear **1639**
 - Slewing gear **36, 1129**
 - Slewing gear, general **467**
 - Slewing range (position 41) **139**
 - Slewing ring connection **1628**
 - Slopes and excavations, illustrations 4 and 5 **94**
 - Special functions **305**
 - Specified service items and lubricants for Liebherr cranes **1665**
 - S-pivot section 13.4 m **47**
 - Spooling the hoist rope up **1319**
 - S/SL-boom **1270**
 - Stability and tipping safety in case of non-installed ba **1023**
 - Starting and stopping the engine **395**
 - Starting the engine **395**
 - Starting the engine with heat flange control **397**
 - Starting the program **377**
 - Start the emergency operation aggregate **1521, 1531**
 - Steering programs **1057**
 - Stretching **1839**
 - Supplementary service work **1842**
 - Supplied fall arrest system (safety harness and heights) **81**
 - Supporting **99**
 - Support plate **61**
 - Suspended ballast **1135**
 - Suspended ballast with guide **59**
 - Sw-assembly **1399**
 - Sw-boom **1396**
 - SwD-assembly **1451**
 - SwD-boom combination **1448**
 - SwD-boom combination **1449**
 - Swinging the crane operator's cab in into transport position **405**
 - Swinging the crane operator's cab into operating / transport position **405**
 - Swinging the crane operator's cab out into operating position **405**
 - Swinging the hydraulic support out **157**
 - Sw-disassembly **1433**
 - Switching back to the crane operation program **383**
 - Switching the slewing gear to coasting **469**
 - Sw-reducer section **57**
 - SW/SDW boom combination **828**
- ## T
- Take-down criteria **1804**
 - Taking on a load **535**
 - Taking over the previously selected set up configuration **409**
 - Taking the ballast trailer down **1107**
 - Taking the S-boom down **1315, 1379**
 - Taking the SF-boom down **967**
 - Taking the Sw-booms down **1435, 1489**
 - Technical data **37**
 - Technical safety instructions for working with a load **531**
 - Telescopic boom distortion because of sunshine on one side **532**
 - Telescoping the guide out and in **1055**
 - Tensioning the track chain **1593**
 - Terminology **22**
 - Test brackets (KMD = force test box) **441**
 - Test point 1 = F1 **335**
 - Test point 2 = F2 and test point 3 = F3 **345**
 - The Control parameter program **377**
 - The Crane operation program on monitor 0 **279**
 - The Crane operation program on monitor 1 **335**
 - The function key line in the crane operation program **325**
 - The LICCON monitor remains dark **1695**
 - The set up program **253**
 - The S-relapse cylinders retract or extend **177**
 - Tilting the crane operator's cab **389**
 - Tilt play of roller ring connection **1629**
 - Tires foamed with special foam **149**
 - Tires with air inflation **149**
 - Towing **1063**
 - Tracks **35**
 - Transporting components **682**
 - Transporting lattice sections **683**
 - Transport weights and centers of gravity of the turntable **197**
 - Transport weights **39**
 - Transport weights of components (Position 36) **143**
 - Transport weights of components (Position 38) **143**
 - Travel power **35**
 - Troubleshooting on the central lubrication system **1591, 1627**
 - Turning **467**
 - Turning out extremely rotation-resistant hoist ropes **1811**
 - Turning / driving in reverse **126**
 - Turning the crane superstructure **467**
 - Turning the engine off **403**
 - Turning the heater / ventilation on **389**
 - Turning the instrument panel illumination on / off **393**
 - Turning the turntable into assembly position **1217, 1275**
 - Turning the turntable into disassembly

position **1315**

Turning the turntable to the left **1527, 1541**

Turning the turntable to the right **1529, 1543**

Turntable and crawler center section **41, 153**

Turntable assembly **196**

Turntable **23, 25, 41, 153**

Turn the seat heater* on **389**

Twisting caused by stretching in rotation-resistant ropes and its remedy **1811**

Two hook operation **568**

Type of problem **1681**

U

Unpinning the assembly unit on the L-/SL-boom **827**

Unpinning the assembly unit on the S-boom **877**

Unpinning the guide from the turntable **1117**

Unpinning the S-pivot section **1395, 1447, 1499**

Unreeving the hook block **481, 1319**

Update confirmation **1848**

Update confirmation **1849**

Use of double-stranded height safety equipment, illustration 2 **83**

Use of single-stranded height safety equipment, illustration 1 **83**

User interface **379**

V

Vertical movements **113**

Vibrations **62**

Visual check for damage **532**

W

Waiting for the boot up phase **409**

Walking on lattice sections or booms **84**

Walking on the telescopic boom **84**

Warning notes **1557**

Warning of high voltage (position 40) **137**

Warning of suspended load (position 11) **137**

Warning signs **137**

Warranted maximum sound output level (position

79) **145**

W-assembly unit **53**

Wear **1839**

Weights **684**

Welding work on the load **124**

W-end section 10.5 m **55**

What does "Checking" mean **1554**

Winch 1 **43**

Winch 1 - hoist winch **451**

Winch 2 **43**

Winch 2 - hoist winch **451**

Winch 5 **453**

Winch 6 hoist winch boom nose **455**

Winch and master switch assignment to operating modes **449**

Winches **1631**

Winches **35, 381**

Winch display **321**

Winch displays **363**

Wind influences in crane operation **106**

Wind influences during erection and take down **106**

Wind influences when the "Crane is not in service" **107**

Wind speed sensor **433**

W-intermediate section 14.0 m, 2116.20 **55**

W-intermediate section 7.0 m, 2116.20 **55**

Wire rope **1801**

Wire ropes and rope end connections **473, 1807**

Wire ropes **473, 1820**

W-lattice jib **1831, 1837**

Working in the vicinity of electricity transmission line **540**

Working in the vicinity of transmitters **109**

Working on lattice sections or booms **84**

Working on the auxiliary boom **83**

Working on the crane superstructure or boom **86**

Working on the telescopic boom head **83**

Working ranges of several cranes overlap **111**

Working with a load **530**

Workplace-related emission value **62**