

LIEBHERR
LATTICE BOOM CRAWLER TRACK CRANE

LR 1750

LR 1750-000

Operating instructions

BAL-No. 12812-11-02

pages : 1 up to 1147

Crane number	
Date	

The operating instructions are part of the crane !

Always keep on hand !

Comply with road travel and crane operating regulations !

LIEBHERR-WERK EHINGEN GmbH, Postfach 1361, D-89582 Ehingen / Donau

Telefon (07391) 5 02-0, Telefax (07391) 5 02-33 99

www.lwe.liebherr.de, E-mail: info@lwe.liebherr.com

General

This crane has been built according to the present level of technology and recognized safety technical regulations. Despite that, dangers to body and life for the user and/or third persons or damage to the crane and /or other material assets can occur.

This crane may only be used in flawless technical condition and according to its mission as well as with constant awareness of safety and dangers.

Any problems, which could affect safety must be fixed immediately.

Modifications on the crane may only be made with written approval by Liebherr-Werk Ehingen GmbH .

Operating instructions

These operating instructions should enable you to operate the crane safely and utilize its capabilities to the fullest extent possible. They also provide notes on how important sub-assemblies and systems function.

Certain terms are used in these operating instructions, and in order to avoid misunderstandings while operating, these terms should be used consistently.

These operating instructions have been translated according to best of one's knowledge. Liebherr-Werk Ehingen GmbH assumes no liability for translation errors. The German operating instructions are solely decisive for factual accuracy. If you find any errors when reading these operating instructions or if there is any confusion, please contact Liebherr-Werk Ehingen GmbH immediately.

D A N G E R : **Only qualified and trained expert personnel may work on this crane.
If this is not observed, there is a danger of accidents!**

All regulations and guidelines applicable to the job site, such as accident prevention regulations and all guidelines and regulations stated in these operating instructions must be strictly adhered to.

Using these operating instructions

- **makes it easier** to become familiar with the crane
- **avoids** malfunctions due to improper operation

Observing these operating instructions

- **increases** reliability in operations
- **increases** the operating life of the crane
- **reduces** repair costs and down-time

Always keep these operating instructions handy in the driver's and crane cab - they are an integral part of the crane!

Operate this crane only with a thorough knowledge of its capabilities and limitations and in strict observance of these operating instructions.

If you receive further information on the crane from us, e.g. in the form of technical information letters, this must be observed and filed with the operating instructions.

If there are parts of these instructions or individual chapters that you do not understand, please do not hesitate to ask us before you begin operation - we are glad to answer any inquiries you may have.

No part of these operating instructions may be circulated, nor may they be used for the purposes of competition. All rights expressly reserved according to copyright law.

All accident prevention guidelines, operating instructions, etc. are based on destined use of the crane.

Destined use

The destined use of the crane consists solely in vertical lifting and lowering of free and non-adhered loads, whose weight and center of gravity are known.

To do so, a hook or hookblock approved by Liebherr must be reeved on the hoist cable and it may only be operated in the permissible equipment configurations.

Driving with the crane, with or without an attached load is only permissible if a corresponding driving or load chart is available. The equipment configurations intended for it and the safety conditions must be observed according to the corresponding operating instructions.

Any other use or any other exceeding utilization is **not** destined use .

Part of destined use is also adherence of required safety regulations , conditions, prerequisites, equipment configurations and working steps as noted in the crane documentation (Operating manual, load chart, job planer) .

The manufacturer is not liable for damages, which are caused by non-destined use or improper usage of the crane. Any associated risk it is carried solely by the owner, the operator and the user of the crane.

Non-destined use is:

- Working outside the permissible equipment configurations according to the load chart
- Working outside the permissible radii and turning ranges according to the load chart
- Selecting load values, which do not correspond to the actual equipment configuration
- Selecting LMB-Codes, which do not match the actual equipment configuration
- Working with bypassed load moment limiter or bypassed hoist limit switch
- Increasing the overhang radius of the lifted load after a LMB shut off, for example by diagonally pulling the load
- Using the support pressure indicator as safety function against tipping over
- Using equipment or attachment parts which are not approved for the crane
- Usage at sports and recreational events, especially for 'Bungee' jumps
- Driving on a public road in non-permissible travel condition (axle load, dimension)
- Driving the equipped crane in a non-permissible travel condition
- Pushing, pulling or lifting loads with the leveling regulation, the sliding arms or the support cylinders
- Pushing, pulling or lifting loads by actuating the slewing gear, the luffing gear or the telescoping gear
- Ripping stuck objects loose with the crane
- Utilizing the crane for a longer period of time for material handling tasks
- Releasing the crane suddenly (grapple or dumping operation)
- to utilize the crane if the weight of the load, which is suspended on the crane, has been changed, for example by filling a container which is suspended on the load hook.

The crane may **not** be used for :

- to attach a stuck load, for which the weight and the center of gravity are unknown and to release it first, for example by flame cutting.
- letting persons drive along outside the driver's cab
- transporting personnel in the crane cab while driving
- transporting personnel with the load tackle and on the load
- transporting personnel with containers, such as cherry pickers, if no written approval of the corresponding job safety board has been issued
- transporting loads on the chassis
- two hook operation without auxiliary equipment
- extended material handling operation

These operating instructions are to be read and the information in them is to be observed by all persons operating, maintaining, or otherwise working in any capacity on this crane.

Notes

Throughout these instructions, the terms "**Note**", "**C A U T I O N**" and "**D A N G E R**" occur - these refer any persons working with the crane to **IMPORTANT OPERATING METHODS** that must be observed.

Note: The term "**Note**" is used whenever the observance of certain instructions or notes is economically meaningful to the utilization of the crane.

C A U T I O N: The term "**C A U T I O N**" is used whenever damage to the crane can occur if the operating instruction(s) is not observed and adhered to.

D A N G E R: The term "**D A N G E R**" is used whenever the nonobservance of the warning given may injure or lead to the death of persons and damage to the crane.

Safety devices

The safety devices integrated into the crane system deserve your special attention. They must always be checked to see that they are functioning properly. If they do not function or function incorrectly, the crane may not be operated. Your motto should always be:

" S A F E T Y F I R S T "

Attachment and spare parts

This crane has been designed for both crane operation and travel operation, in accordance with valid guidelines, and has been inspected and approved by the respective authorities

D A N G E R: **Danger if original attachment parts are not used!**
If the crane is not operated with original attachment parts, then the crane can fail and cause fatal accidents!
Crane components can be damaged!
 - Operate the crane only with original attachment parts!
 - Crane operation with attachment parts which do not belong to the crane is prohibited!

D A N G E R: **Should modifications, manipulations or replacement of originally installed components (e.g. dismantling of components, installation of components other than original parts) be carried out by unauthorised personnel, authorisation of crane operation, as well as manufacturer warranty are rendered immediatly invalid.**

Definition der Richtungsangaben

Vorwärts fahren bedeutet fahren mit dem Fahrerhaus voran.

Rückwärts fahren bedeutet fahren mit den Rücklichtern des Unterwagens voran.

Vorn, hinten, rechts, links beziehen sich beim **Kran** auf den Zustand, dass Fahrerhaus und Ausleger in die gleiche Richtung zeigen. Vorn ist immer in Richtung des Fahrerhauses.

Vorn, hinten, rechts, links beziehen sich im **Fahrerhaus** auf den Kranunterwagen. Das Fahrerhaus ist immer vorn.

Vorn, hinten, rechts, links beziehen sich in der **Krankabine** auf den Kranoberwagen. Vor ist immer in Richtung des Auslegers.

CONTENTS

1.00	DESCRIPTION OF THE CRANE	12
1.01	TERMINOLOGY	14
1.02	PRODUCTDESCRIPTION	28
1.03	TECHNICAL DATA	30
	1. The load tackle	31
	2. Workplace related emission values	31
	3. Speeds	31
	4. Transport weights and center of gravity	33
	5. Transport weights and center of gravity	35
2.00	SAFETY	54
2.03	OPERATIONAL PLANNING	56
2.04	SAFETY-TECHNICAL NOTES	58
	1. Requirements of the crane operator	59
	2. Selecting an operating site	63
	3. Slopes and trenches	65
	4. Permissible ground-bearing load	66
	5. Checking safety measures	68
	6. Crane operation with a load	69
	7. Grounding	71
	7.1. Grounding the crane	71
	7.2. Grounding the load	72
	8. Crane operation in case of thunderstorms	73
	9. Welding work on the load	73
	10. Safety guidelines for auxiliary power supply (230 V AC)	75
	11. Working near transmitters/ transformers	75
	12. Endangering the air traffic	79
	13. Hand signals for guides	81
	14. Consideration of wind conditions	82
	15. Interruption of crane work	84
	16. Parking the crane	85
3.00	CRANE ASSEMBLY	86
3.01	INSTALLATION CRAWLER GEAR	88
	1. Transport weights and dimensions	89
	2. Installation of crawler carrier	91
	2.1. Swing out the hydraulic support, lock and pin (fig. 5)	91
	2.2. Lift the slewing platform and crawler center section (fig.6) from the flatbed trailer with the support	93
	2.3. Erect the A-bracket	93
	2.4. Installation of the crawler carrier with the A-bracket	95
	2.5. Establish the hydraulic connection to the two crawler travel gears	99
3.02	INSTALLATION OF SLEWING PLATFORM WITH QUICK CONNECTION (QC)	100
	1. Transport weights and center of gravity of slewing platform	101
	2. Montage der slewing platform	101
	3. Removal of the slewing platform	107

CONTENTS

3.03	CENTRAL BALLAST	108
	1. Installation of central ballast 20t / 45t / 95t, at crane mode on crawlers	109
	2. Installation of central ballast at crane mode on hydraulic supports	115
3.05	CRANE SUPPORT	122
	1. Support components overview	123
	2. Hydraulic crane support	125
	3. Install support	127
	4. Control elements, support control unit left / right	129
	5. Support the crane via the support control unit	131
	6. Crane support from the crane cab	139
3.06	INSTALLATION CONDITIONS	148
	1. Installation conditions	149
	2. Erection / take down of main boom systems in operation on supports	151
4.00	OPERATION OF THE SUPERSTRUCTURE	152
4.01	CONTROLS AND INDICATORS	154
4.02	LICCON COMPUTER SYSTEM	166
	1. General	167
	2. LICCON programs for crane operation	169
	3. Booting up the LICCON computer system after turning it on	177
	10. The control elements of the LICCON computer system on monitor 0	181
	11. The "Set up" program	183
	12. The "Operation" program	205
	13. The "ControlParameter" program	259
	14. The "Support" * program	263
	16. Engine monitor	273
	20. The control elements of the LICCON computer systems on monitor 1	277
	21. The "Operation am Monitor 1" program	279
4.03	STARTING UP THE CRANE	306
	1. General crane condition	307
	2. Crane operator's cab adjustment	307
	3. Checks before start up	307
	4. Crane operator's cab	309
	5. Start and turn the crane engine off	313
	6. LICCON computer system after engine start	321
	7. Set the control parameters	331
	8. Setting the derrickballast	333
	9. Adjust winches	334
	10. Load weighing and load indication	336
4.04	SAFETY DEVICES	338
	1. General	339
	2. LICCON Computer system	339
	3. EMERGENCY "OFF" button	341
	4. Control release	341
	5. Button "Luffing up at overload" (73)	341
	6. Bypass keyed button	343
	7. Wind warning device	343
	8. Hoist limit switch " Hoist top"	343
	9. Limit switch winch spooled up or out	343
	10. Limit switch initiators	344
	11. Indication of winch turning direction and hook path 1)	345
	12. Servo oil pressure monitor in winches I, II, III, IV, V, VI	345

CONTENTS

4.05	CRANE OPERATION	348
1.	Crane operation	349
2.	LICCON Computer system	349
3.	Release of crane control	351
4.	Engine monitoring	351
5.	Winch operation	351
6.	Winches, pumps and master switch (MS) assignment to operating modes	353
7.	Control of crane movements	355
10.	Winch 6 and 5	365
4.06	CABLE REEVING	366
4.07	SLEWING PLATFORM BALLAST	454
1.	Slewing platform ballast installed on slewing platform	455
2.	Slewing platform ballast installed on extension of slewing platform	461
4.08	WORKING WITH A LOAD	470
1.	Safety technical notes for working with a load	470
2.	Checking before starting to work with the crane	471
3.	Taking on a load	475
4.	Crane operation	477
4.12	TWO-HOOK OPERATIONS	480
5.00	EQUIPMENT	486
5.01	SAFETY TECHNICAL NOTES	488
1.	Check the safety elements	488
2.	Check the cables	488
3.	Control measures	489
4.	Danger conditions without shut off	490
5.	Transporting components	490
6.	Pneumatic springs to support installation of components	490
7.	Weights	491
8.	Reduction of load carrying capacity with placed guy rods	491
9.	By pass button LICCON	493
10.	Assembly / disassembly	497
11.	Erection / take down	513
5.02	SA - BRACKET	514
1.	Erect the A- Bracket	515
2.	Installation equipment configuration on crawler 9.10m×8.80m×1.50m	515
3.	Erection	517
4.	Place the A- bracket onto the slewing platform	519
5.03	ATTACHMENT LATTICE MAST SYSTEMS	520
5.04	S/SL - BOOM COMBINATION	616
1.	Installation	617
2.	Install the S- pivot section	619
3.	Installation of the guy rods	629
4.	Electrical connections	631
5.	Function check	631
6.	Erection / take down procedure	633
7.	Place down the S - boom	637

CONTENTS

5.05	SD - BOOM COMBINATION	640
	1. Installation	641
	2. Install S- pivot section	643
	3. Electrical connections	651
	4. Function check for limit switches	651
	5. D- relapse cylinder	651
	6. Erect the derrick	653
	7. Install the S-pivot section	653
	8. Establish the electrical connections	669
	9. Function check	669
	10. Installation of guy rods	671
	11. Erection / take down procedure	673
	12. Crane operation with D - boom combination	677
	13. Place down the S - boom	679
	14. Place down and remove the derrick	683
5.06	SDW BOOM COMBINATION	684
	1. W- installation unit	685
	2. Installation	687
	3. Reeve the W - control cable between WA-bracket I and II	689
	4. Installation procedure	691
	5. Erect the WA-bracket II	693
	6. Install the W- lattice jib	699
	7. Electrical connections	707
	8. Erection / take down procedure	711
	9. Crane operation with SW/SDW/SDWBW - boom system	717
	10. Take down procedure	719
	11. Removal	725
5.06	SDW-BOOM COMBINATION, NA-BRACKET II WITH CYLINDER	726
	1. W- Installation unit	727
	2. Installation	729
	3. Reeve the W - control cables between the WA-bracket I and II	731
	4. Pull the erection support (1) into installation position - Fig. 1	733
	5. Erect the WA-bracket II	735
	6. Install the W- lattice jib	739
	7. Electrical connections	747
	8. Erection / take down procedure	751
	9. Crane operation with SW/SDW/SDWBW - boom system	757
	10. Take down procedure	759
	11. W-Remove the W-lattice jib	761
	12. Take down procedure, WA-bracket I + II	763
	13. Removal work	765
5.07	WV - ATTACHMENT	766
	1. Description SDWV	767
	2. Description S6D2WV (for LG 1750 only)	777
5.08	RADIO REMOTE CONTROL	778
	1. Radio transmitter	779
	2. Remote control	779
	3. Pin points	781
	4. Prerequisite	783
	5. Control	783
5.10	BOOM NOSE 60 t	784
5.11	BALLAST TRAILER	792

CONTENTS

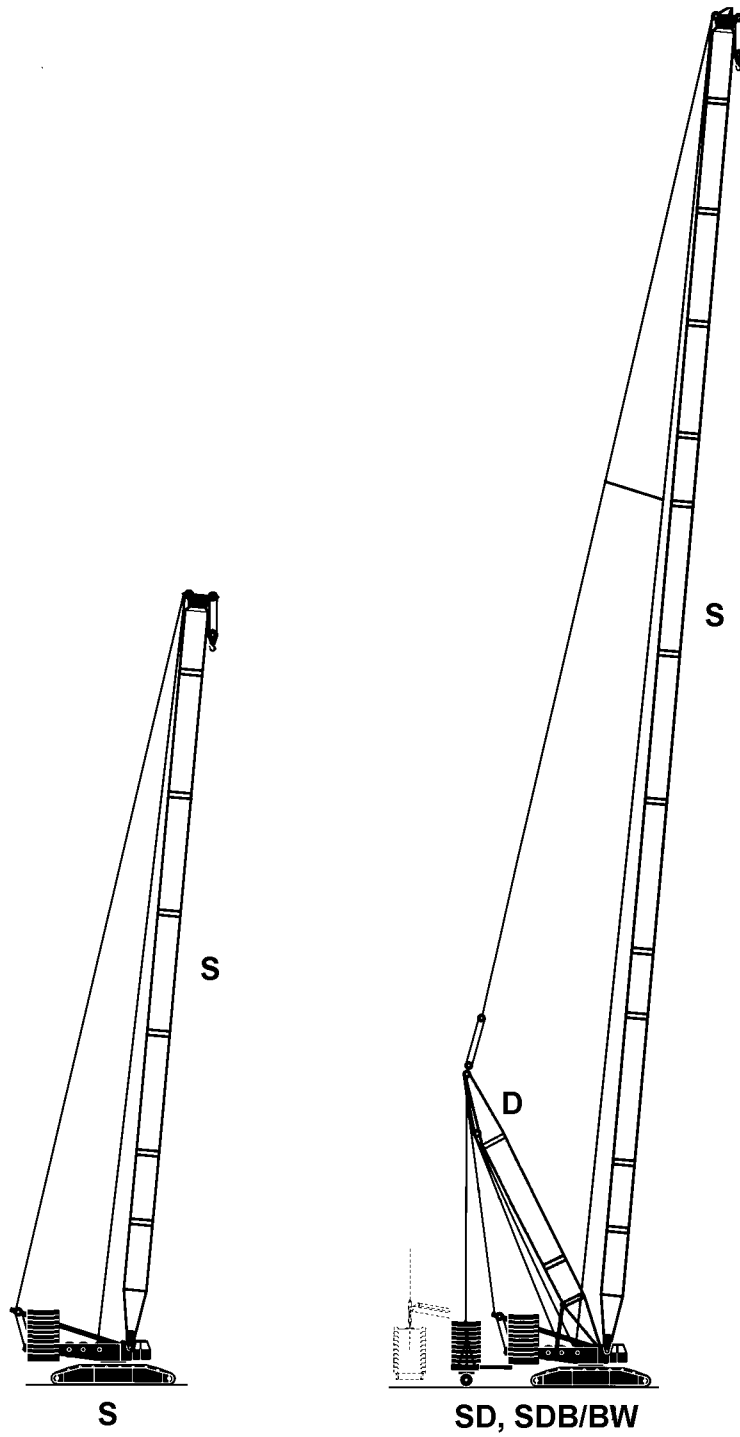
5.12	SUSPENDED BALLAST	884
1.	Suspended ballast B	885
2.	Components	887
3.	Installation of the suspended ballast	889
3.1.	Preassemble the guide (1)	889
3.2.	Pin the guide (1) on the slewing platform	889
3.3.	Installation of the ballast pallet	891
3.4.	Disassembly	891
3.5.	Ballasting the ballast trailer	893
3.6.	Lifting and lowering the suspended ballast with cylinders	895
3.7.	Telescoping the suspended ballast in or out	897
8.	LICCON Overload safety system	899
5.13	AUXILIARY JIB HS - SL2 / SL3HS / SL4HS / SL8HS / SL7DHS	914
1.	Operating mode overview for SL - operating modes with installed auxiliary jib HS	915
2.	Installation of the auxiliary jib HS	917
3.	Electrical connections SL2	921
4.	Electrical connections SL3HS / SL4HS / SL8HS / SL7DHS	923
5.	Function check	925
6.	Erect / take down the boom	927
7.	Crane operation	929
8.	Two hook operation for SL3HS / SL4HS / SL8HS / SL7DHS	931
9.	Removal of auxiliary jib HS	933
5.14	INSTALLATION BOOM - S3	934
1.	Installation boom - S3 with installation head 47t	935
5.15	SLK-BOOM	938
1.	Description	939
1.1.	Components SLK	939
2.	Combination of equipment	941
3.	Assembly	949
6.	Relapse retainer	959
7.	Electrical connections	963
8.	Erection/ take down	966
9.	Crane operation	971
10.	Take down	973
11.	Disassembly	975
5.30	PIN PULLING DEVICE	980
6.00	ADDITIONAL EQUIPMENT	984
6.01	HEATING	986
6.02	EMERGENCY CONTROL	990
7.00	SERVICE AND MAINTENANCE	1006
7.01	SERVICING AND MAINTENANCE	1008
1.	Liebherr Service for you	1008
2.	Cleaning and care of the crane	1010
3.	Putting the crane out of service for downtime	1010
4.	Maintenance instructions	1011

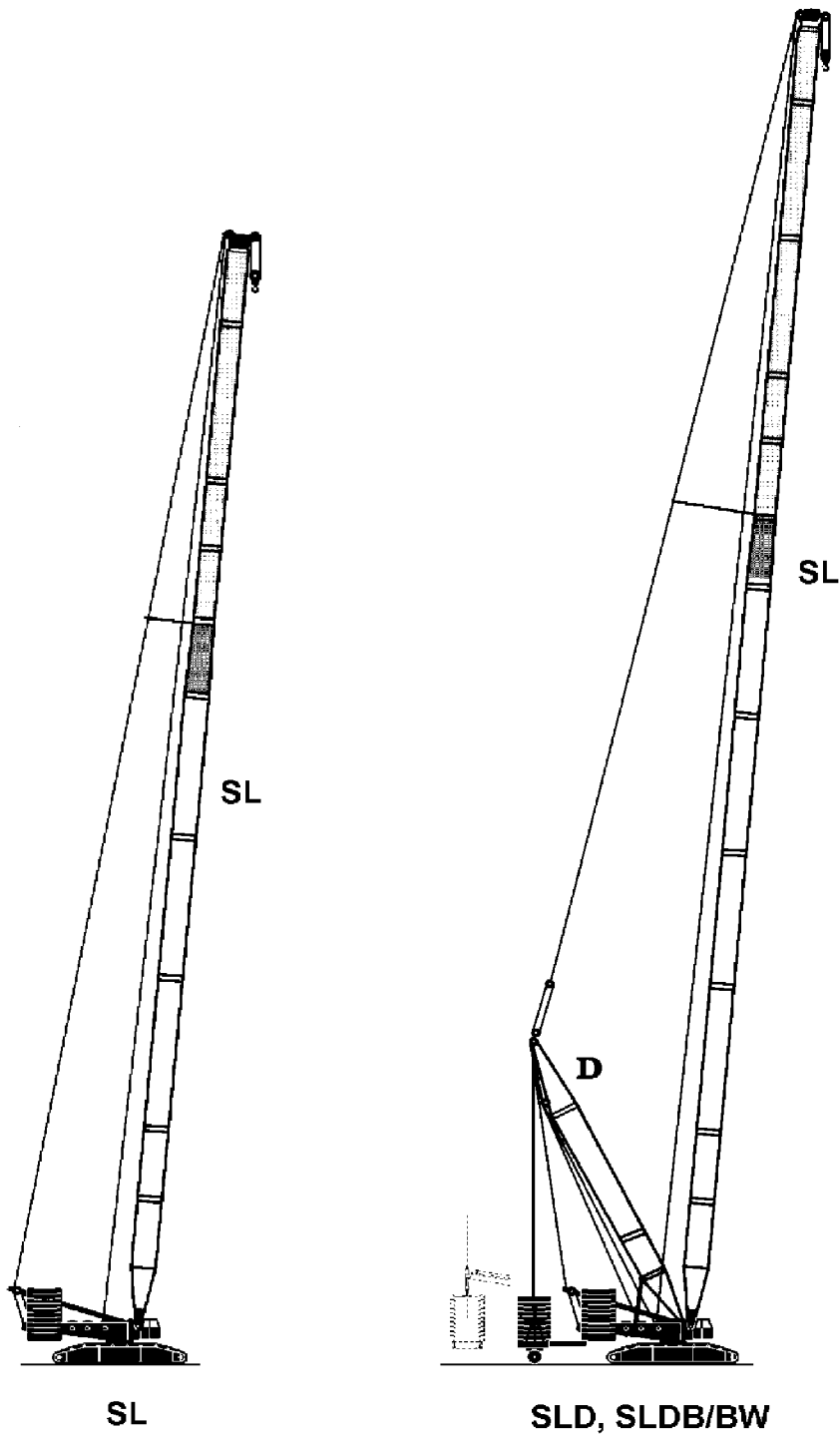
CONTENTS

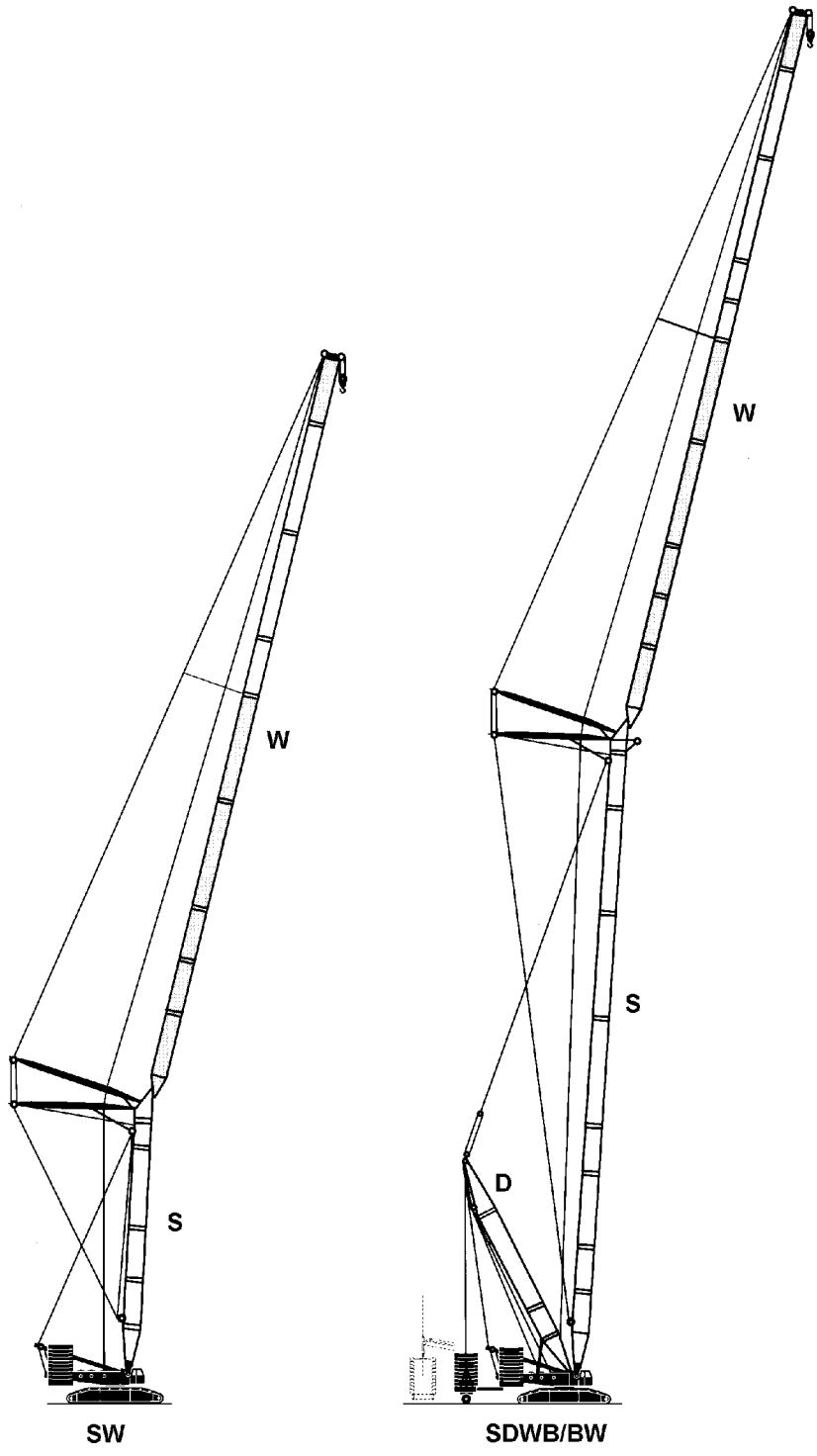
7.02	MAINTENANCE INTERVALS ON CRANE CHASSIS	1012
7.03	MAINTENANCE INTERVALS ON CRANE SUPERSTRUCTURE	1022
7.04	MAINTENANCE INSTRUCTIONS - CHASSIS	1028
	1. Oil level in travel and angular gear	1029
	2. Central lubrication system for crawler	1031
	3. Tension the track chain	1033
7.05	MAINTENANCE GUIDELINES FOR CRANE SUPERSTRUCTURE	1034
	1. Crane engine	1035
	2. Oil level - hydraulic fluid reservoir	1039
	3. Rope winches Fig. 4	1041
	4. Slewing gear Fig 6	1043
	5. Pump transfer case Fig. 7	1045
	6. Slewing ring connection	1047
	7. Diaphragm reservoir in the hydraulic system	1049
	8. Central lubrication system	1051
7.06	LUBRICATION CHART, FILLING CAPACITIES	1056
	1. Filling capacities (Crane chassis)	1057
	2. Filling capacities (crane superstructure)	1059
7.07	SCHMIERSTOFFTABELLE	1060
8.00	CRANE INSPECTIONS	1068
8.01	REPEAT CRANE INSPECTIONS	1070
8.04	CODE OF PRACTICE FOR EXAMINATION AND DISCARD OF CRANE WIRE ROPES	1110
	1. Introduction	1110
	2. Wire rope	1110
	3. Operating performance of wire rope	1116
	4. Condition of equipment related to rope	1116
	5. Rope examination record	1116
	6. Rope storage and identification	1116
	7. Wire ropes and rope end connections	1117
	8. Extension torsion in rotation resistant ropes and how to solve the problem	1119
8.12	TESTING OF SAFETY CONTROLS ON RELAPSE SUPPORTS	1128
	1. Relapse retainers	1129
8.14	CHECKING THE RELAPSE ACCUMULATOR CYLINDERS WITH PRESSURE MONITOR	1138
8.15	INSPECTION AND MAINTERNANCE OF THE TENSION COLUMNS	1140
9.00	GENERAL NOTES	1142
9.02	GUIDELINES TO PREVENT FIRES IN THE ENGINE AREA AND IMPORTANT SERVICE WORK TO BE PERFORMED	1144

Chapter 1

Description of the Crane





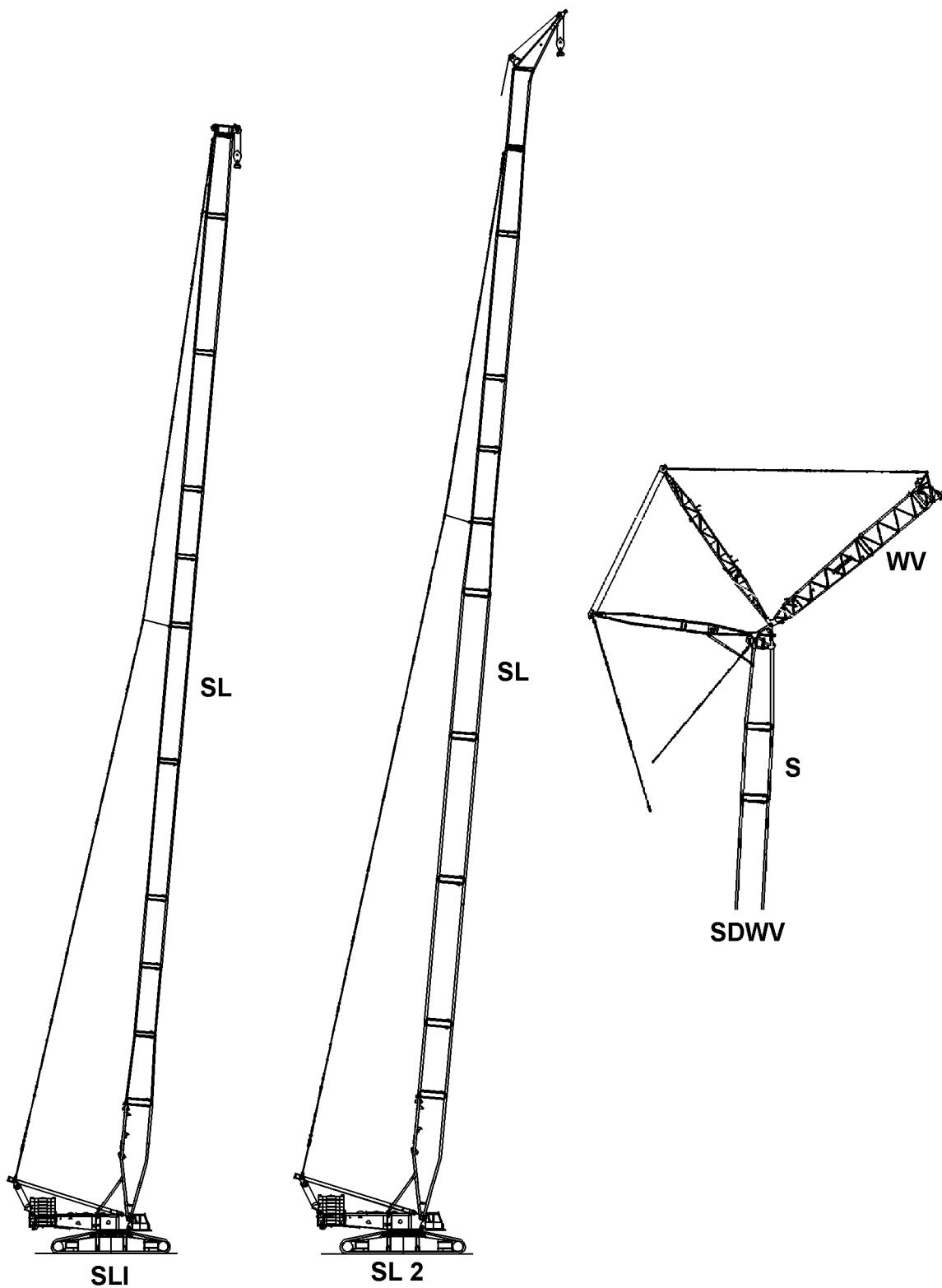


Short description of boom systems

S	-	Main boom
W	-	Luffing lattice jib
D	-	Derrick boom
B	-	Suspended ballast
BW	-	Ballast trailer

Boom combination

SW	-	Boom combination	S	=	35,0 m	-	63,0 m
			W	=	28,0 m	-	105,0 m
SDWB/BW	-	Boom combination	S	=	35,0 m	-	91,0 m
			W	=	28,0 m	-	105,0 m
			D	=	31,5 m		

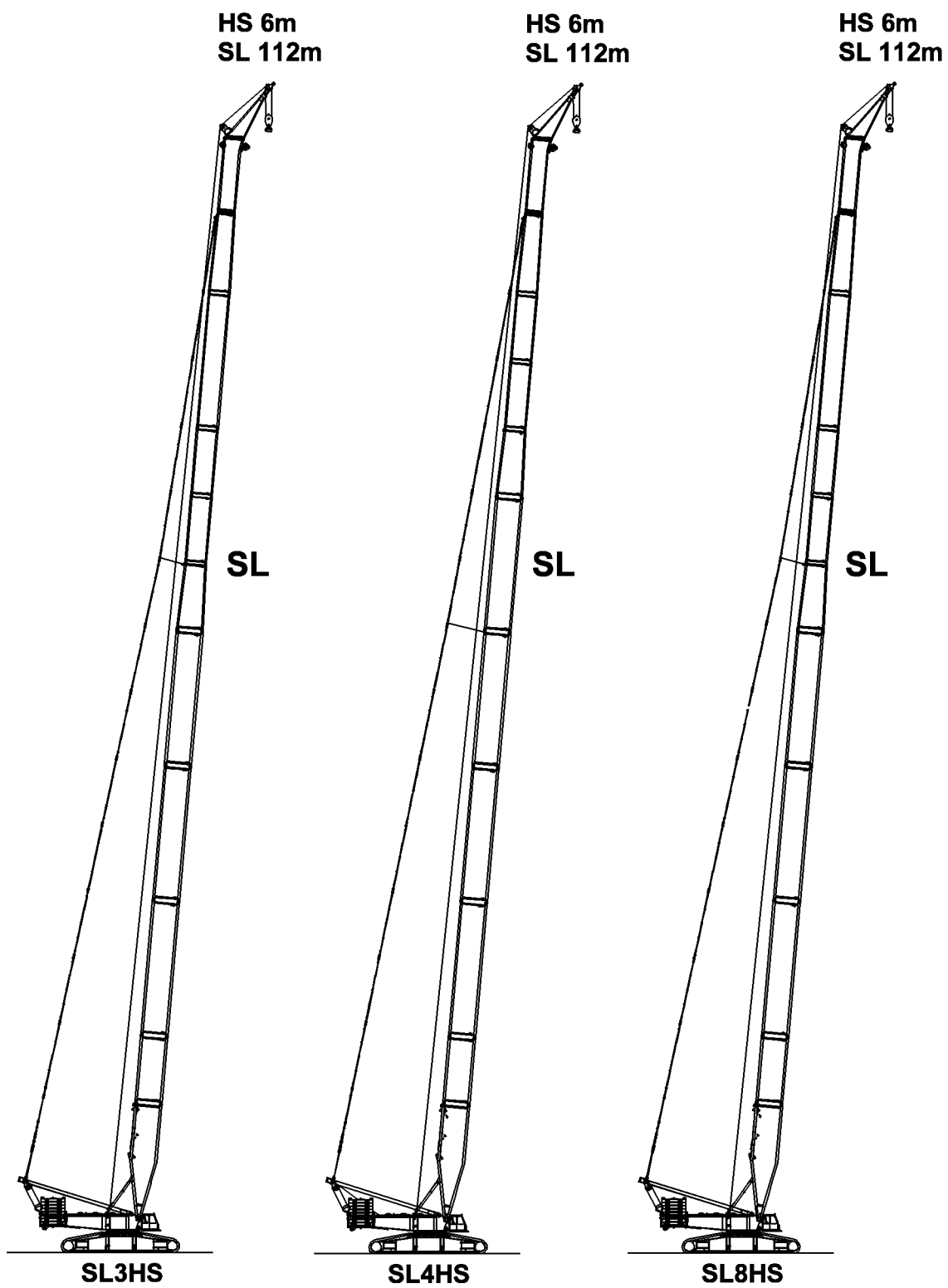


Short description of boom systems

SLI	-	Main boom
SL2	-	Main boom
S	-	Main boom
D	-	Derrick boom
WV	-	Lattice jib
B	-	Suspended ballast
BW	-	Ballast trailer

Boom combination

SLI	-	Boom combination	SL	=	28,0 m	-	112,0 m
SL 2	-	Boom combination	SL	=	76,0 m	-	118,0 m
SDWVB/BW	-	Boom combination	S	=	35,0 m	-	91,0 m
			WV	=	14,0 m	-	21,0 m
			D	=	31,5 m		



Short description of boom systems

SL3 - Main boom

HS - Auxiliary jib (100t)

SL4 - Main boom

HS - Auxiliary jib (120t)

SL8 - Main boom

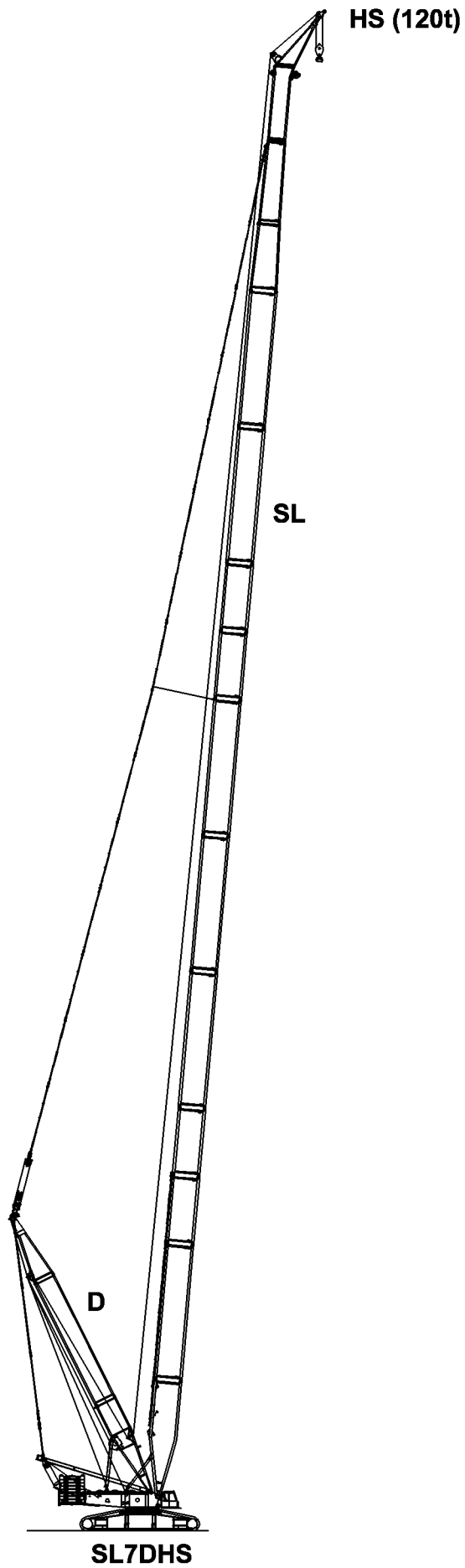
HS - Auxiliary jib (120t)

Boom combination

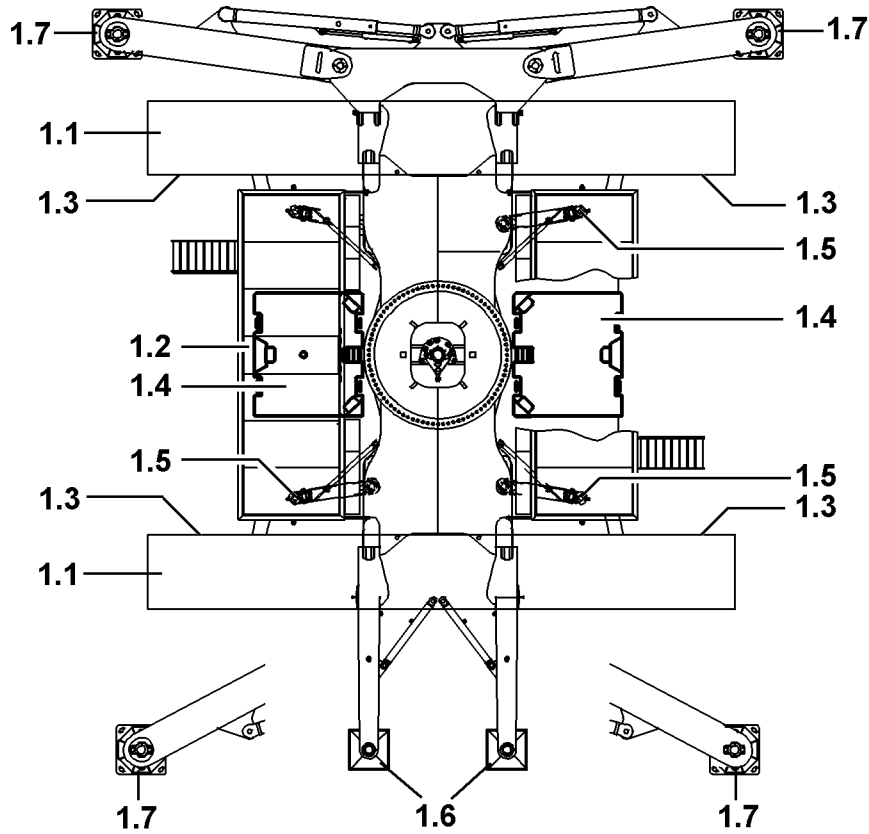
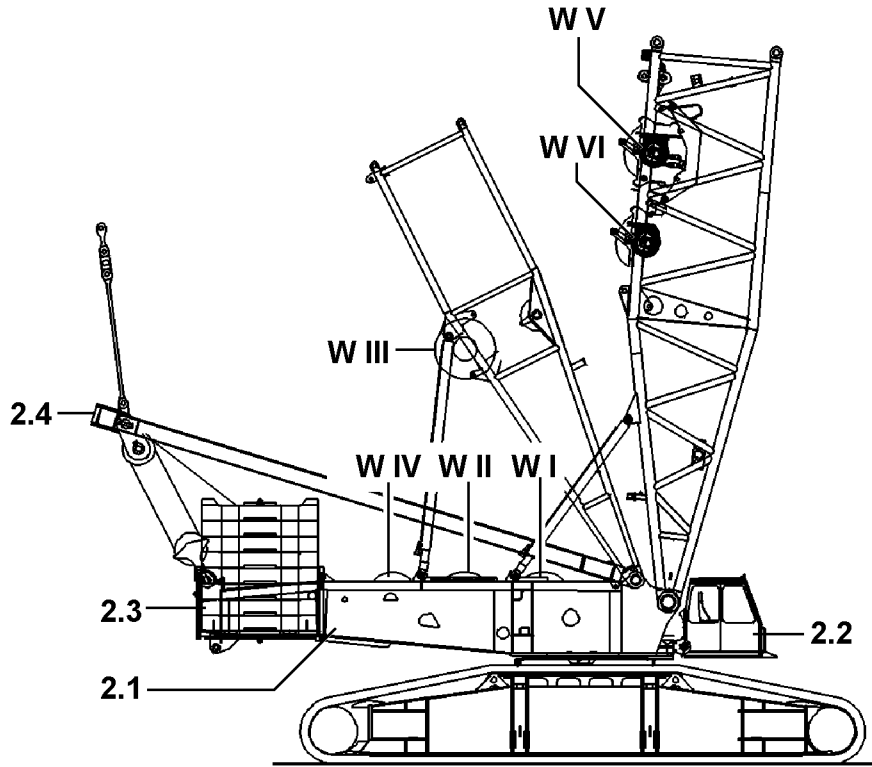
SL3HS	- Boom combination	SL	=	70,0 m	-	112,0 m
		HS	=	6,0 m		

SL4HS	- Boom combination	SL	=	70,0 m	-	112,0 m
		HS	=	6,0 m		

SL8HS	- Boom combination	SL	=	70,0 m	-	112,0 m
		HS	=	6,0 m		



Short description of boom systems**SL7** - Main boom**HS** - Auxiliary jib (120t)**D** - Derrick boom**Boom combination****SL7DHS** - Boom combination**SL** = 105,0 m - 147,0 m**D** = 31,5 m**HS** = 6,0 m



Component overview**1 Crane chassis**

- 1.1 Crawler carrier
- 1.2 Crawler center section
- 1.3 Travel gear
- 1.4 Central ballast
- 1.5 Hydraulic installation supports
- 1.6 Mechanical added supports
- 1.7* Crane support

2 Slewing platform

- I Winch I
 - II Winch II
 - III Winch III
 - IV Winch IV
 - V Winch V
 - VI Winch VI
-
- 2.1 Diesel engine
 - 2.2 Crane operator's cab
 - 2.3 Counterweight
 - 2.4 LA - Bracket

3 Boom / jib combinations

See chapter 5.03 Attachment lattice mast systems

* = If installed

Crawler track chassis.

Frame:	Self-manufactured, torsion resistant, welded construction of high-tensile steel. The crawler carriers are removable and can be re-installed by the crane itself.
Travelling gear:	Maintenance-free, tracklaying gear with flat track pads. Pad width: 1,5 m (optional 2 m), track gauge: 8,8 m.
Drive:	Per crawler carrier, 1 (optional 2) hydraulic travelling drive with planetary gear. The crawler chains can be controlled independently and opposed, i.e. there is no preferential travelling direction.
Driving performance:	Infinitely variable speed from 0 to 1,75 km/h.

Crane superstructure.

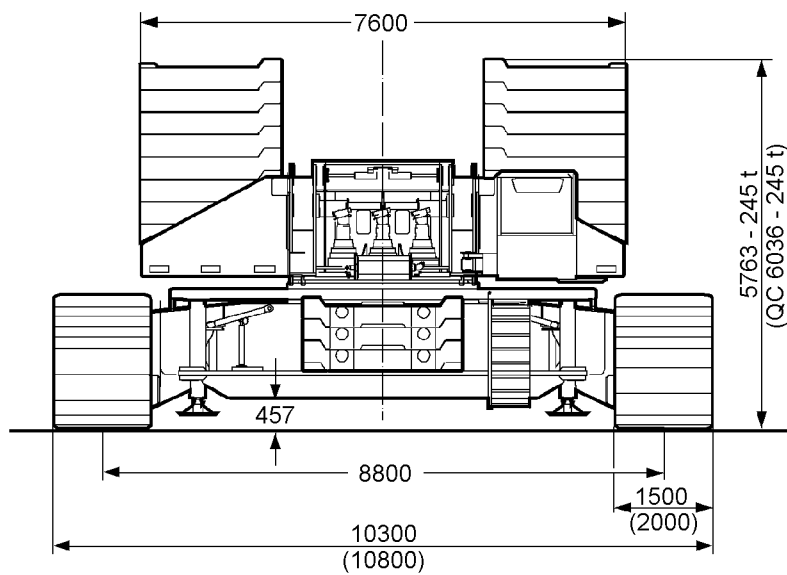
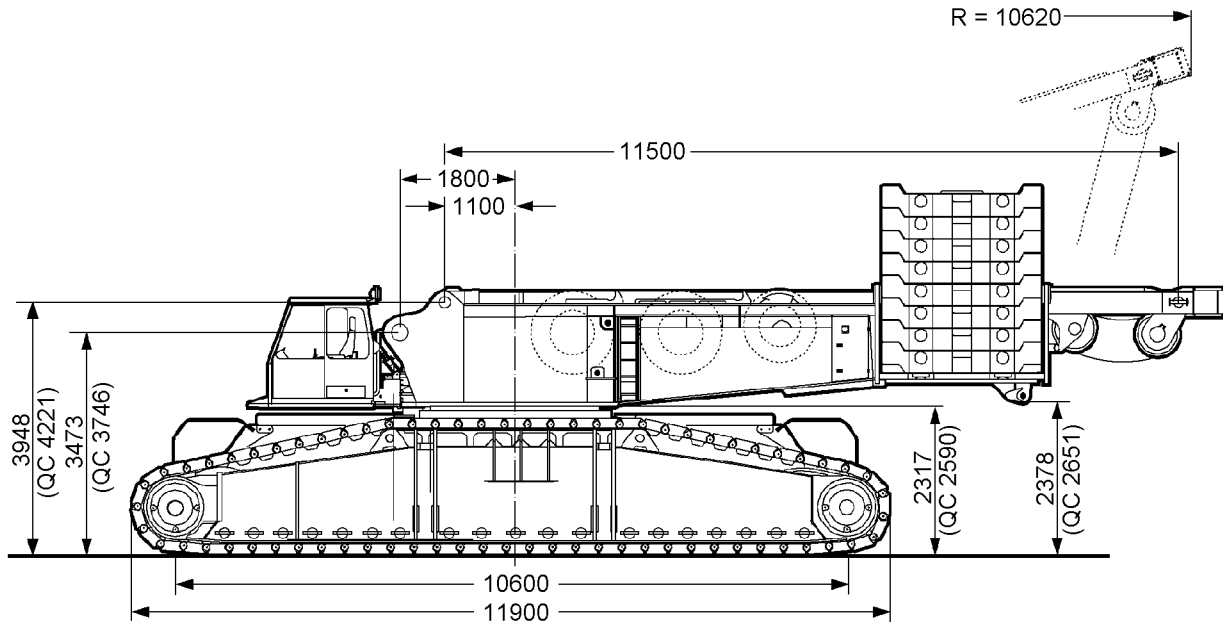
Frame:	Self-manufactured, torsion resistant, welded construction of high-tensile steel. Connected to chassis by a 3-row roller slewing ring, 360° slewing range.
Engine:	8 cylinder Liebherr Turbo Diesel, type D 9408 TI-E A4, water cooled, output acc. to DIN 400 kW (544 HP) at 1800 min-1, max. torque 2425 Nm at 1000min-1. Fuel tank capacity: 850 litres.
Crane drive:	Hydraulically by pump transfer case and 4 axial piston variable displacement pumps with capacity control, closed hydraulic circuits.
Crane control:	Servo control with electronic synchronizing device on hoisting winches. Energy recycling during lowering of load. All motions controlled independently by joystick selectors.
Winches 1, 2 and 4:	Winches 1 and 2 as hoist gears and winch 4 as luffing gear, hydraulically controlled by axial piston variable displacement pumps and planetary gears. Spring-load multi-disc brake with hydraulic release.
Slewing gear:	Hydraulically controlled by axial piston pump and planetary gear, spring-loaded multi-disc brake with hydraulic release. Infinitely variable slewing speed 0 – 0,8 min-1.
Counterweight:	245 t, consisting of: 2 base slabs of 10 t each, 18 slabs of 12,5 t each.
Operator's cab:	Sheet steel design with safety glazing, movable sideways and inclinable to the rear, including operating equipment and check instruments, warm water heating.
Safety devices:	LICCON safe load indicator, hoist limit switch, electronic display of inclination (inclinometer), safety valves to protect hydraulic system against pipe and hose fracture.
Electrical system:	24 V DC – 2 batteries, 143 Ah each.

Boom configurations and optional features.

Winches 3, 5 and 6:	Winch 3 for luffing motion S or SL at derrick mode. Winch 5 for luffing motion of jib. Winch 6 as winch for boom nose.
Supporting devices:	4 hydraulic supporting rams, at the crawler center section for the self-erection of the crane.
Quick Connection:	For separating the crane superstructure from the crawler.

Dimensions

QC = with Quick Connection



1. The load tackle

Load carrying capacity	Rollers	Sheaves	Weight in t
600	2 × 11	2 × 22	*
400	2 × 7	2 × 14	*
312	11	23	*
215	7	15	*
160	5	11	*
107	3	7	*
47	1	3	*
16	--	1	*

* = see chapter 4.06

2. Workplace related emission values

Workplace		Emission value [dB]
Crane operator's cab	L_{pA}	72
Sound output level	LWA _{warranted}	113

3. Speeds

The crane speeds at an engine RPM of 1900 min⁻¹

Drives	stepless	Cable diameter Ø
Winch I, II	0 - 130 m / min for single strand	28 mm
Winch III	0 - 130 m / min for single strand	28 mm
Winch V	0 - 130 m / min for single strand	28 mm
Winch VI	0 - 130 m / min for single strand	28 mm
Winch IV	2 × 70 m / min for single strand	28 mm
Slewing gear	0 - 0,8 min ⁻¹	

4. Transport weights and center of gravity

Fig. 1	A-bracket with winch IV and cable	width 2,3m
Fig. 2	Slewing platform	width 3,0m
Fig. 3	center section (light)	width 3,0m
Fig. 4	center section (for crane supports)	width 3,0m

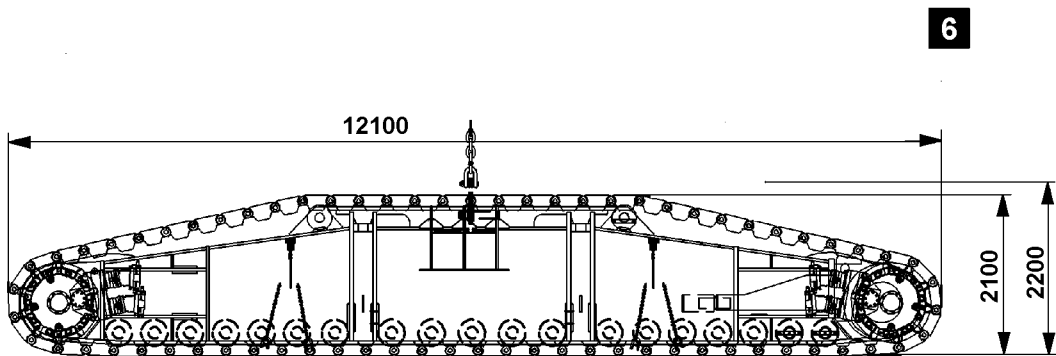
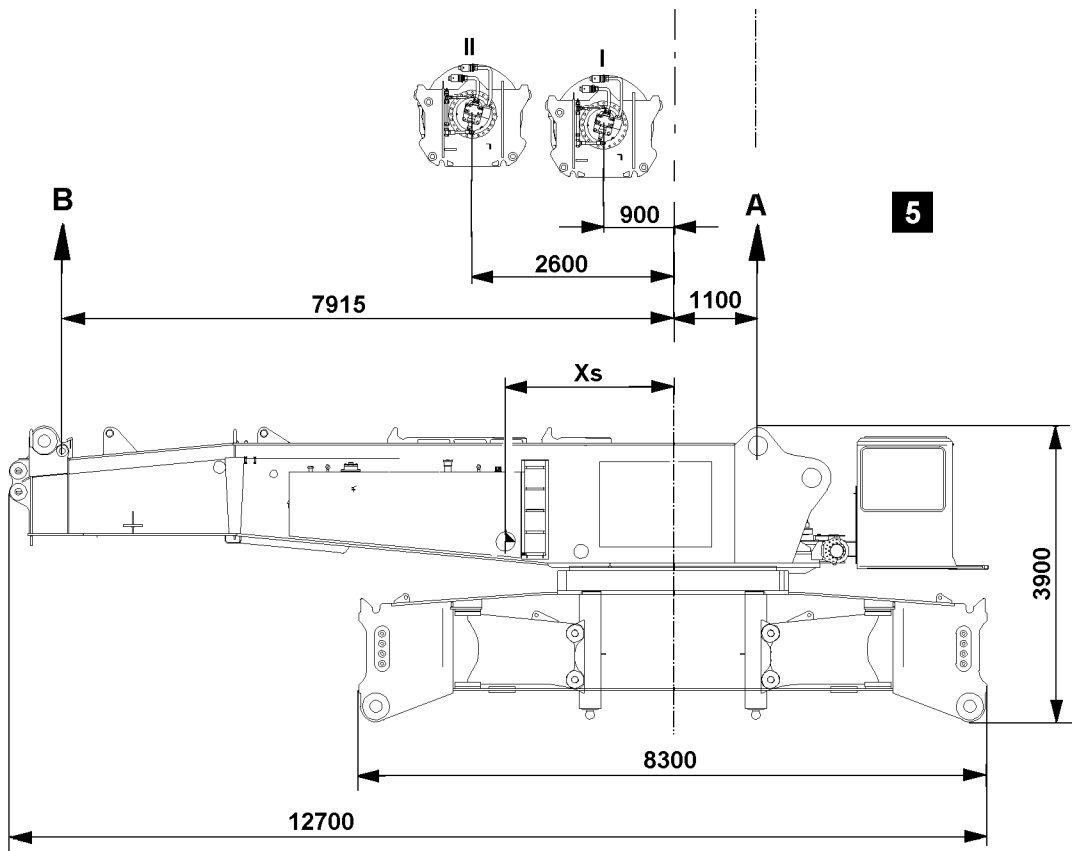
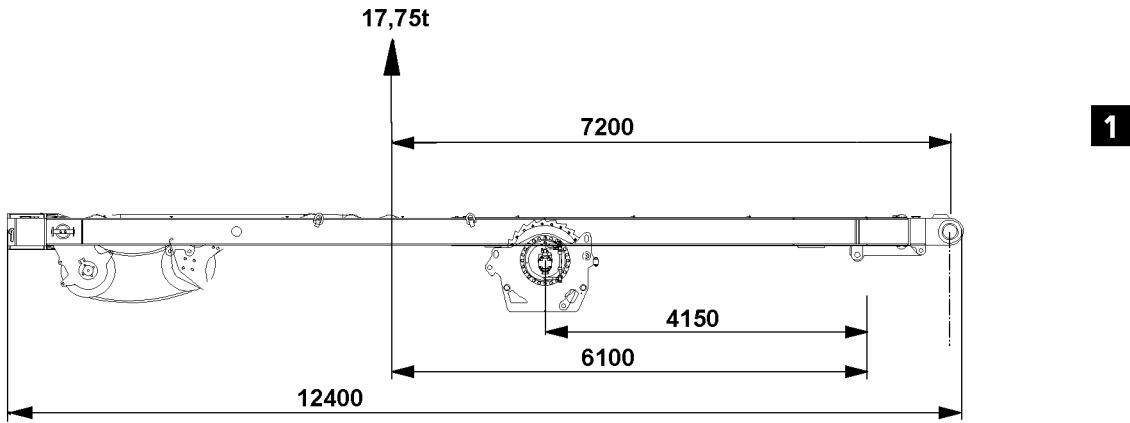
Components

- Full hydr. tank
- Fuel tank ca. 66%
- 2 slewing gears
- cab in operating position

4.1 Dimensions and weights - slewing platform:

Condition with Q.C

	weight (t)	A (t)	B (t)	Center of gravity (mm) Xs
slewing platform (2 slewing gears)	35940	24,52	11,42	1765
1 slewing gear	820	+0,97	-0,15	
winch I with 1250m cable	8700	+6,77	+1,93	
winch II with 1250m cable	8700	+5,13	+3,57	
SA-bracket with winch IV and cable	17750	+3,55	+14,20	
additinal hydr. tank for crane supports	350	+0,10	+0,25	
supports for transportation	2830	+1,46	+1,38	
center section (light)	30800	+27,04	+3,76	
center section (for crane supports)	42500	+37,32	+5,18	



5. Transport weights and center of gravity

- Fig. 1 A-bracket with winch IV and cable width 2,3m
 Fig. 5 Slewing platform and center section width 3,0m
 Fig. 6 Crawler carrier

5.1 Dimensions, weights and center of gravity:

Condition without Q.C

Chart 1

	Weight (t)	A (t)	B (t)	Center of gravity (mm) Xs
slewing platform (2 slewing gears)	35940	23,52	11,42	1765
slewing platform with center section (2DW)	65200	48,64	16,42	1190
1 slewing gear	820	+0,97	-0,15	
winch I with 1250m cable	8700	+6,40	+1,82	
winch II with 1250m cable	8700	+4,85	+3,37	
SA-bracket with winch IV and cable	17750	+3,55	+14,20	
additinal hydr. tank for crane supports	350	+0,10	+0,25	

Chart 2

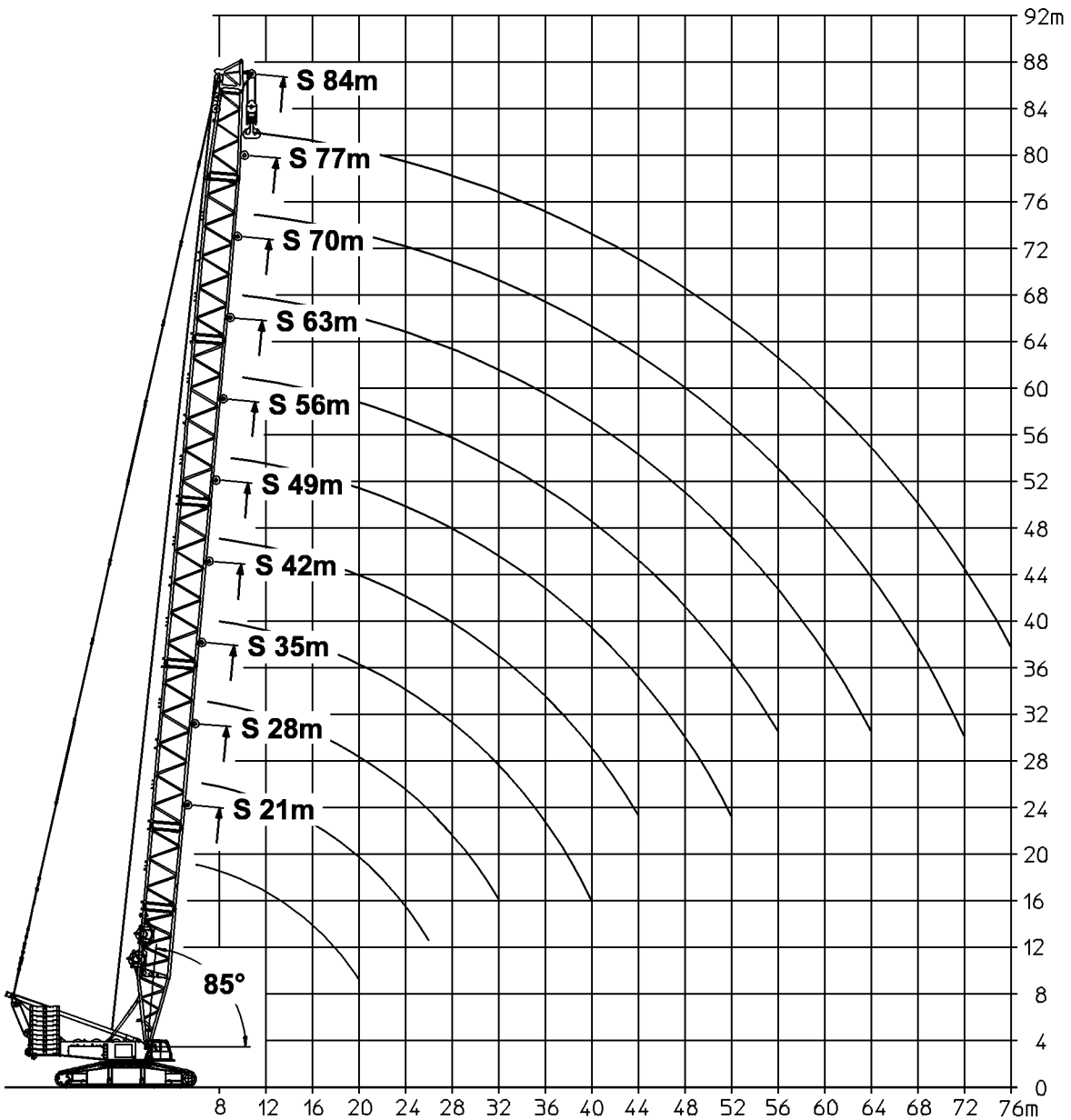
Condition	Weight (t)	Center of gravity (mm) Xs
slewing platform + center section + winch II with cable	73,9	1360
slewing platform + center section + SA-bracket with winch IV and cable	83,0	2240
slewing platform + center section + SA-bracket with winch IV and cable + winch II and cable	91,7	2270

Crawler carrier

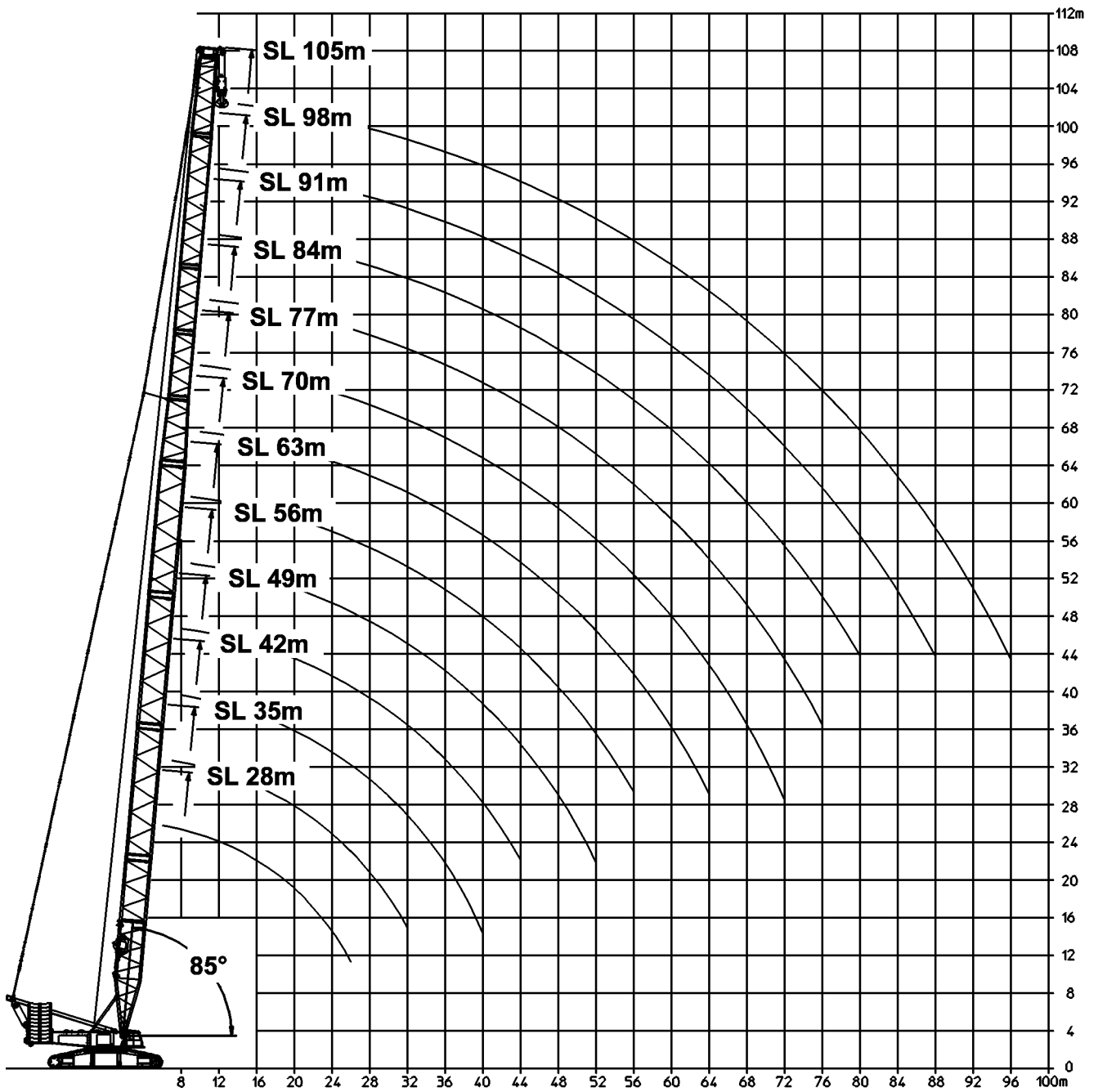
Crawler carrier	Track pad width (mm)		Number of travel drives	
	1500	2000	1	2
Weight (t) 43,6	X		X	
Weight (t) 45,8	X			X
Weight (t) 52,8		X	X	
Weight (t) 55,0		X		X

- At a track pad width of 1500 mm, the crawler carrier height is 2100 mm.
- At a track pad width of 2000 mm, the crawler carrier height is 2200 mm.

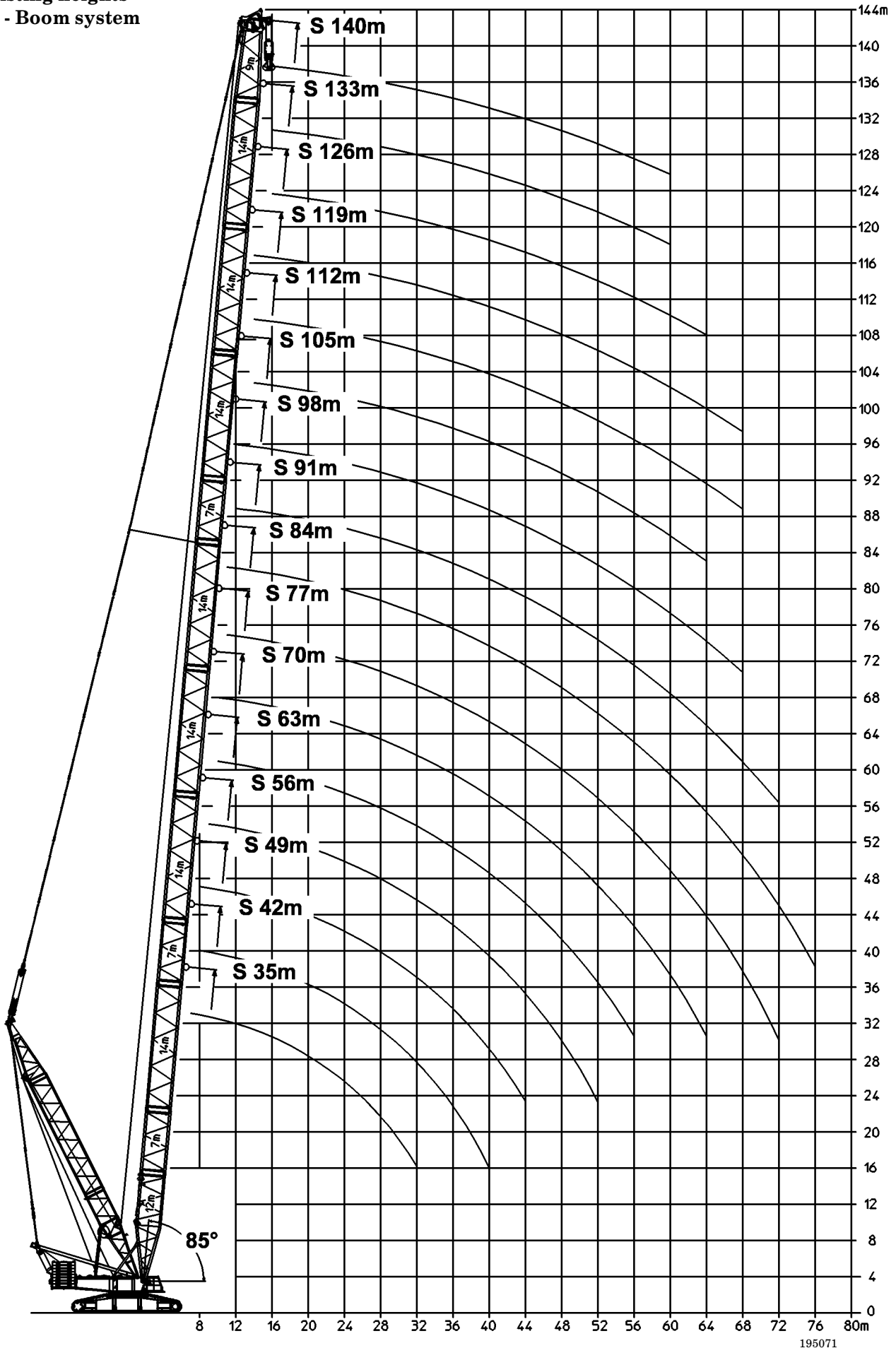
Hoisting heights
S - Boom system



Hoisting heights
SL - Boom system

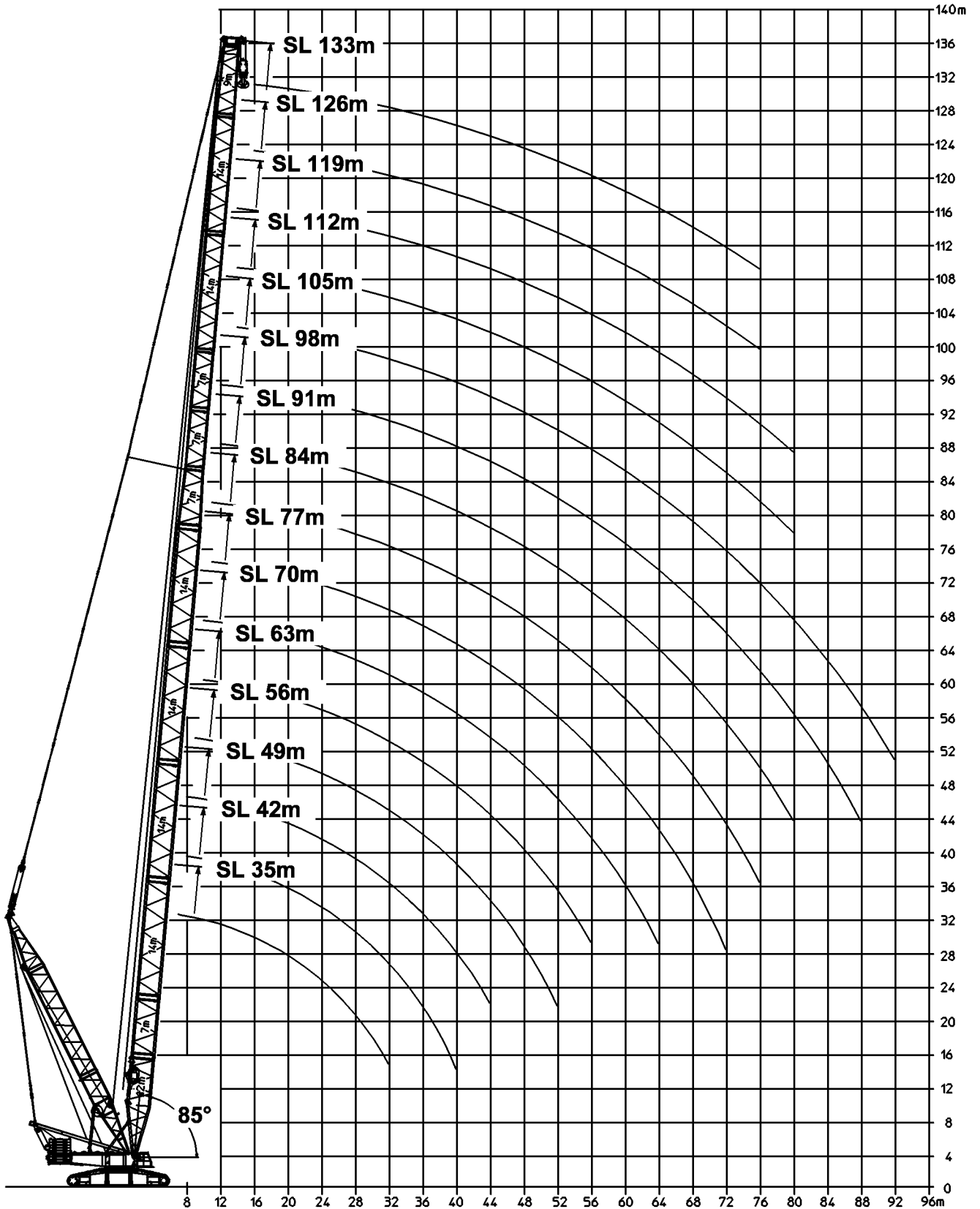


Hoisting heights
SD - Boom system

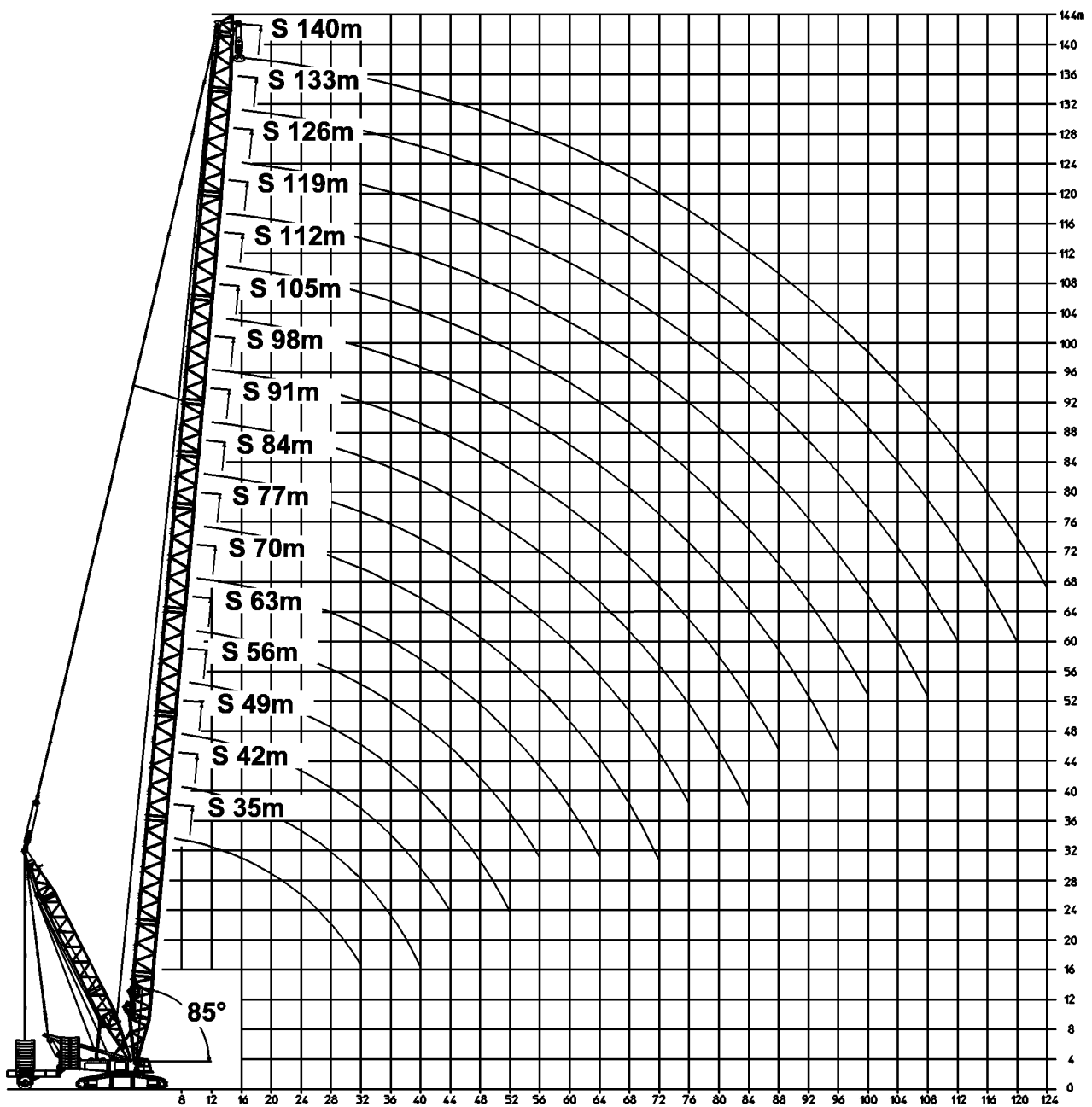


195071

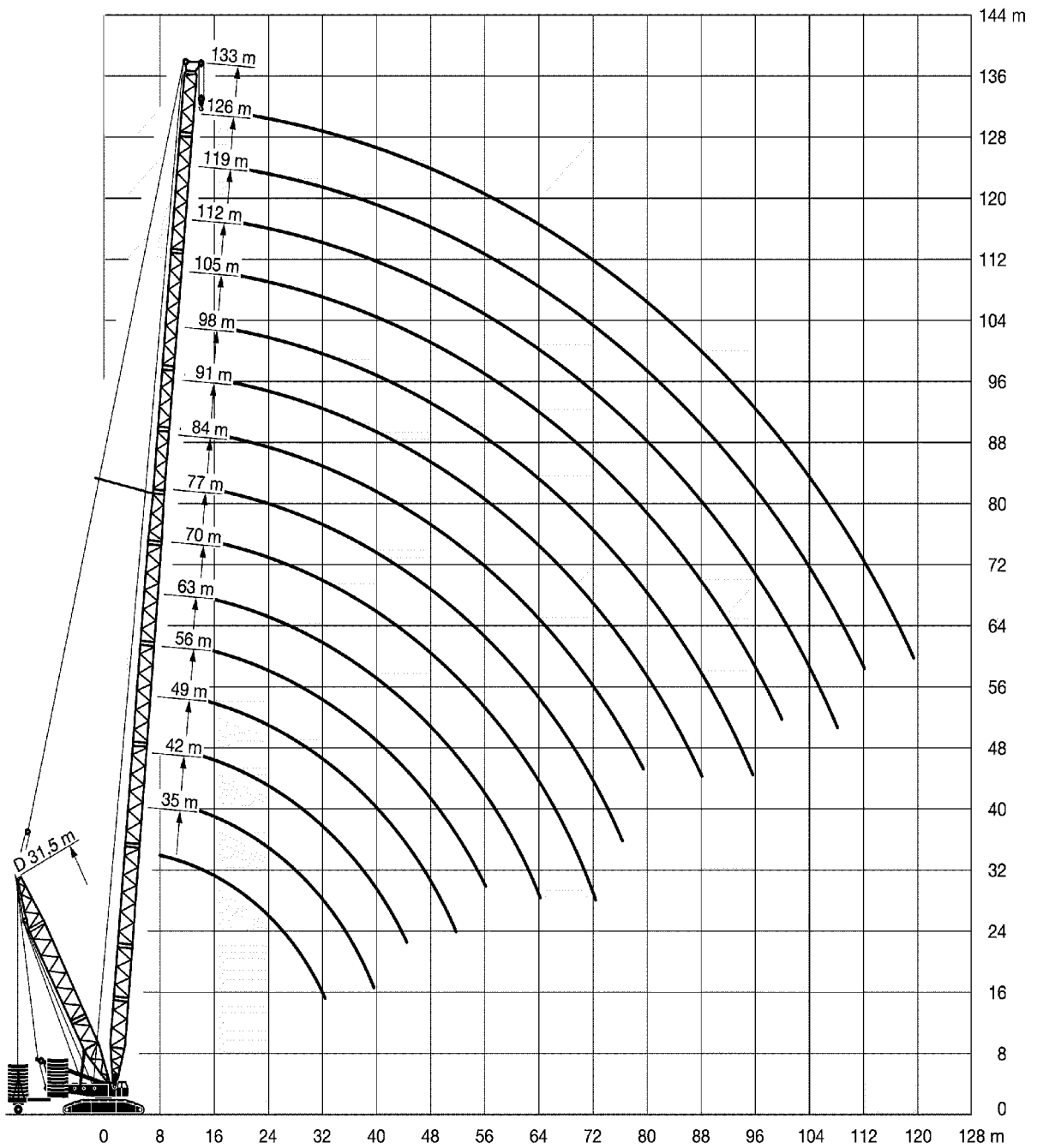
Hoisting heights
SLD - Boom system



Hoisting heights
SDB / BW - Boom

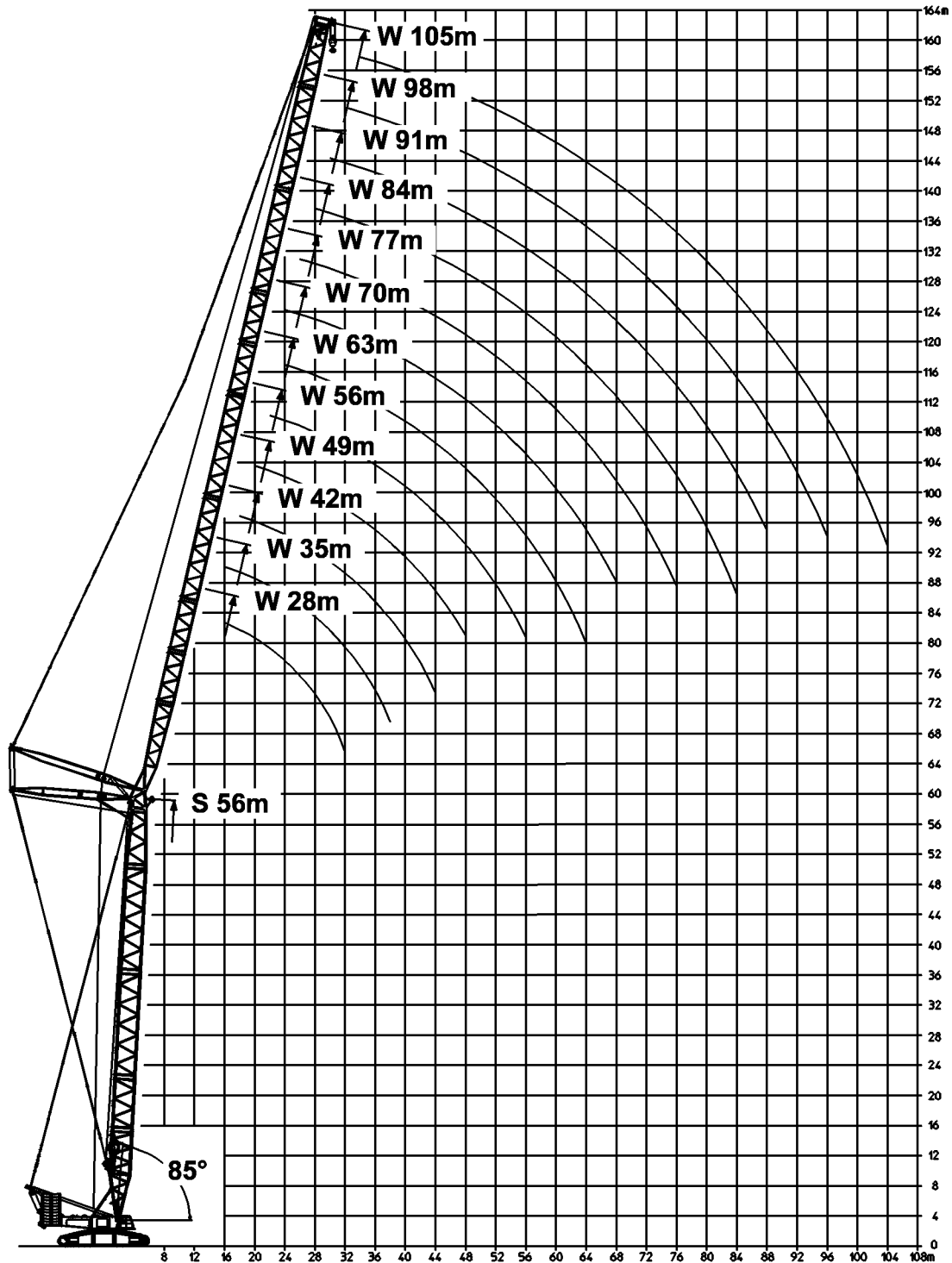


Hoisting heights
SLDB / BW - Boom system



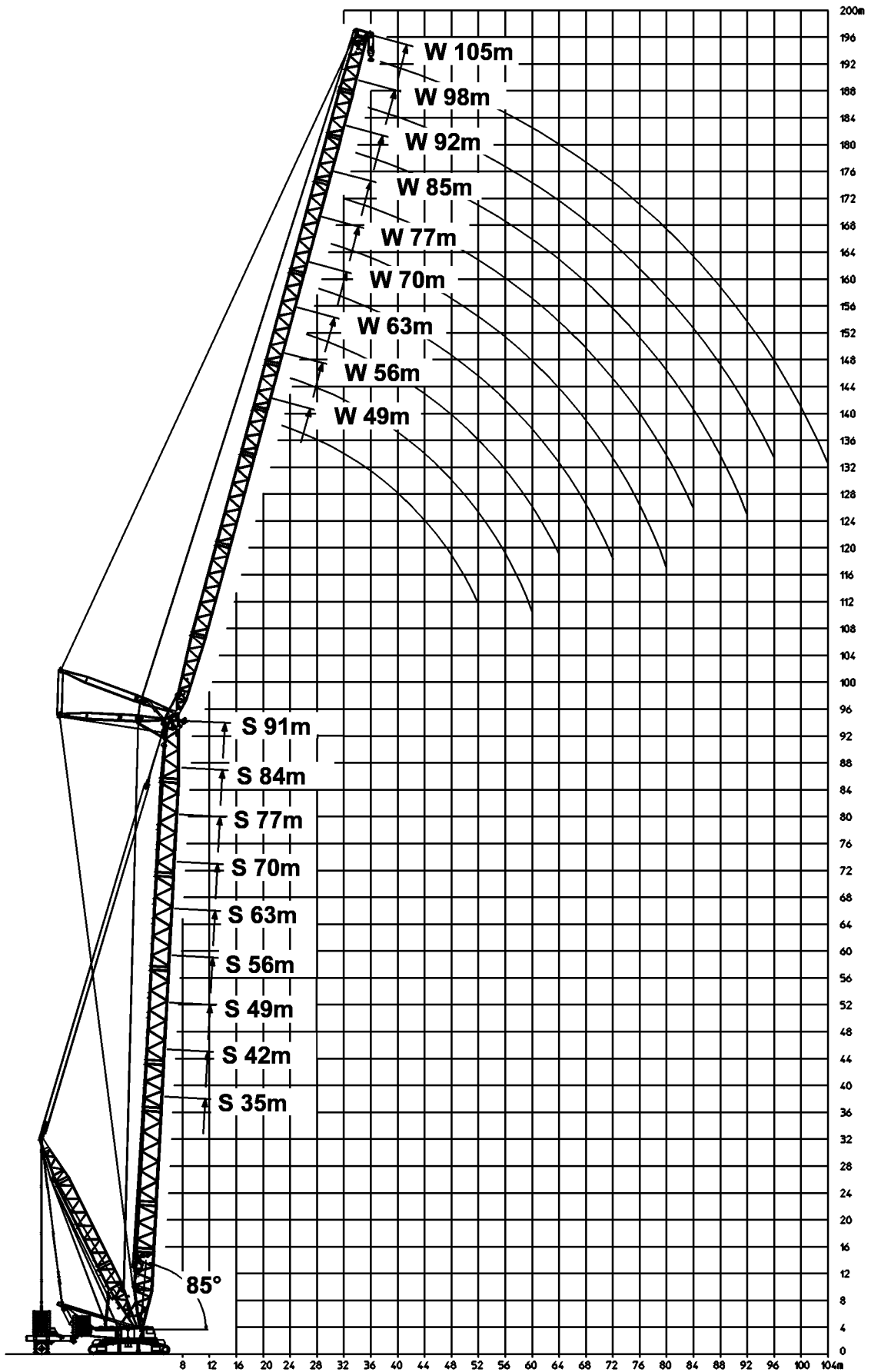
Hoisting heights

SW - Boom system; S = 85°



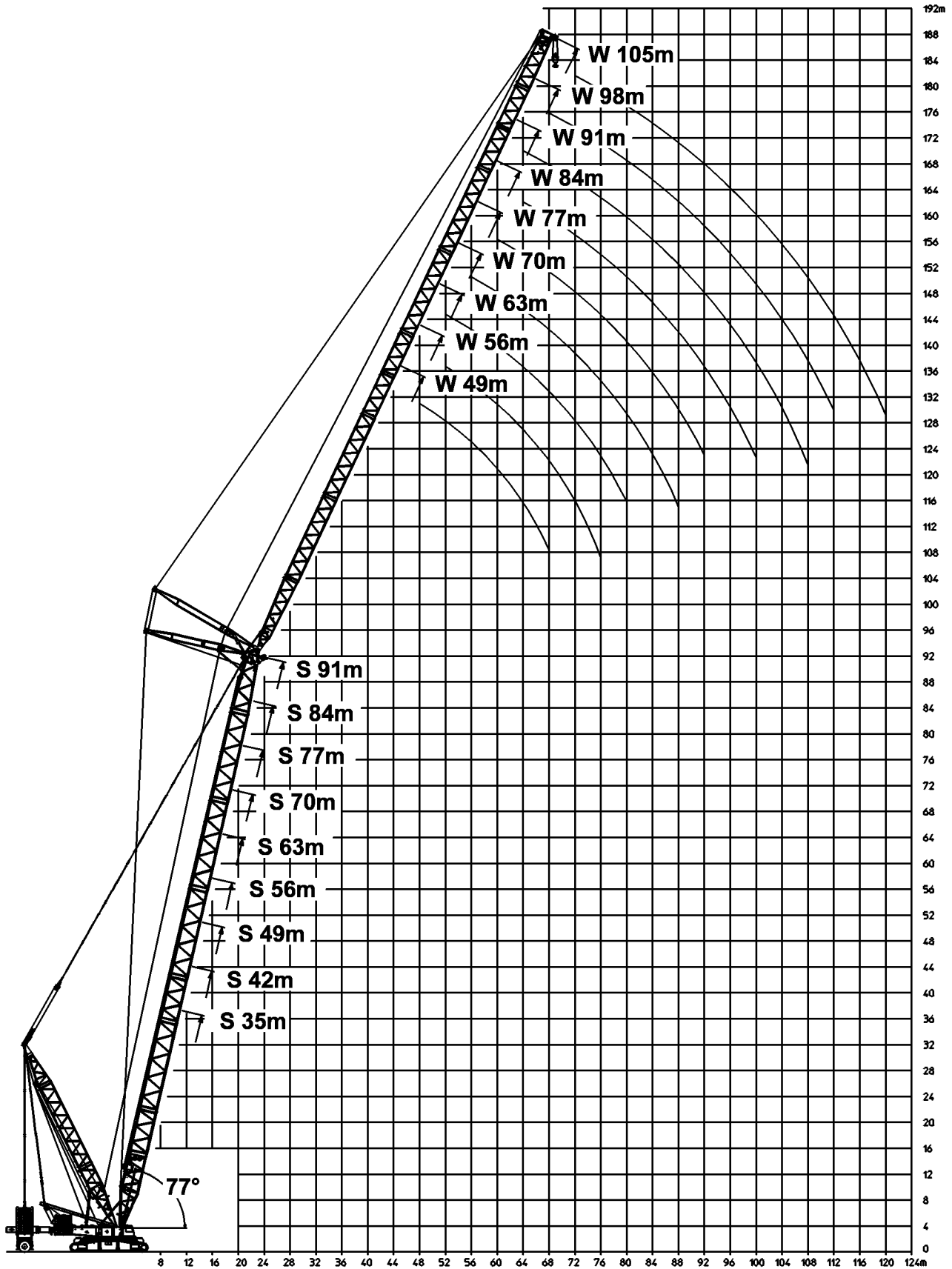
Hoisting heights

SDWB / BW - Boom system, S = 85°



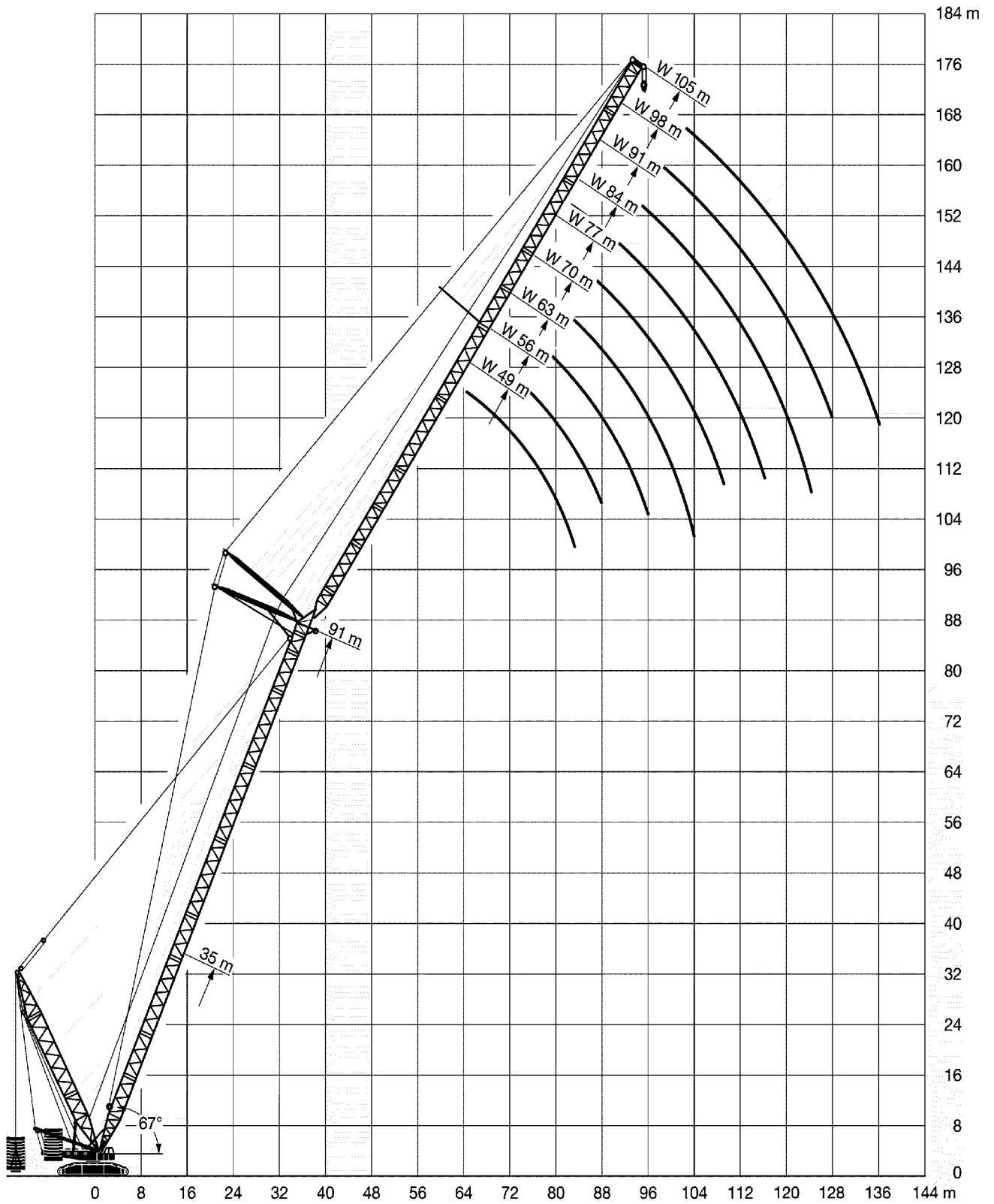
Hoisting heights

SDWB / BW - Boom system, S = 77°



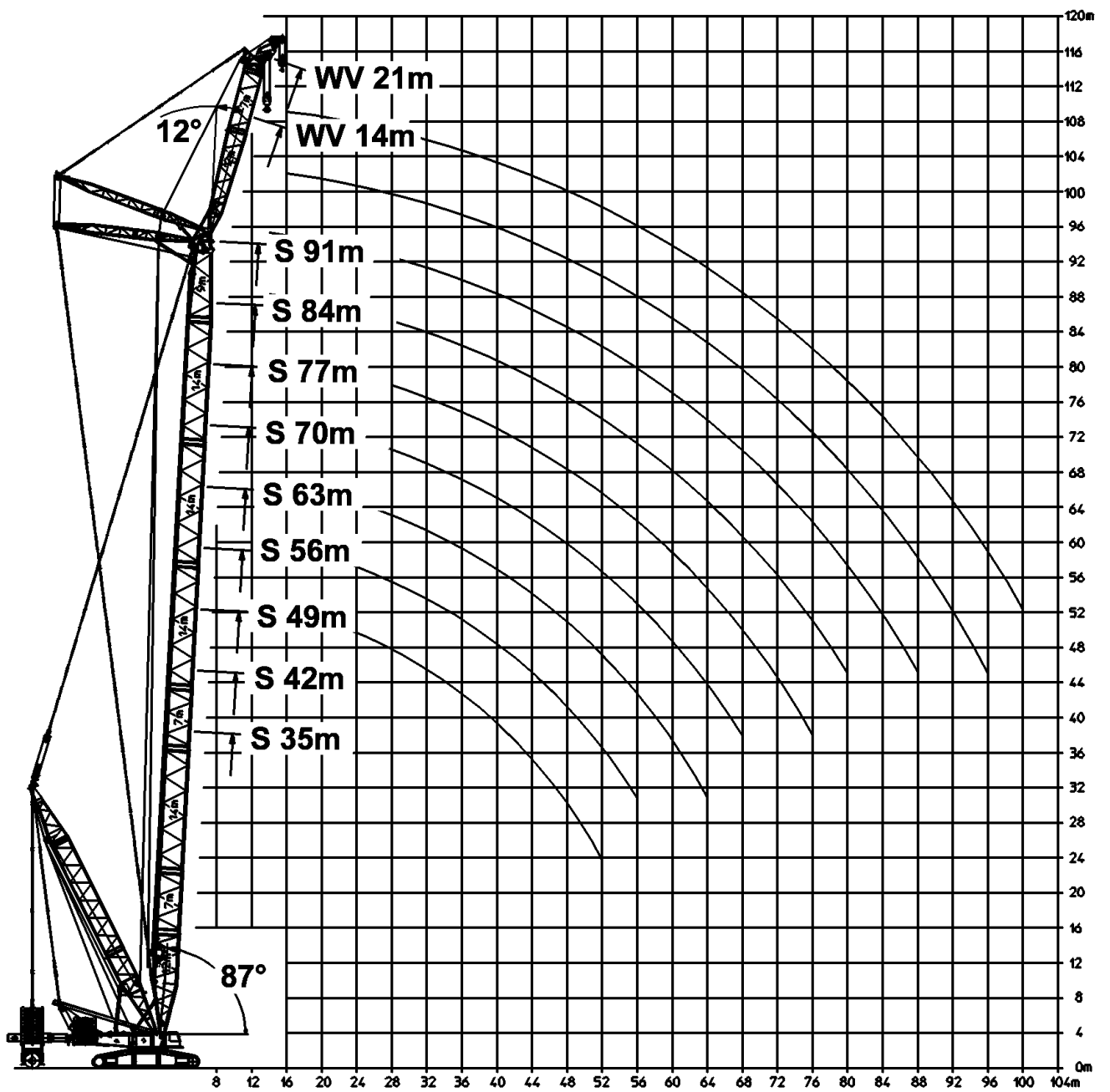
Hoisting heights

SDWB / BW - Boom system, S = 67°



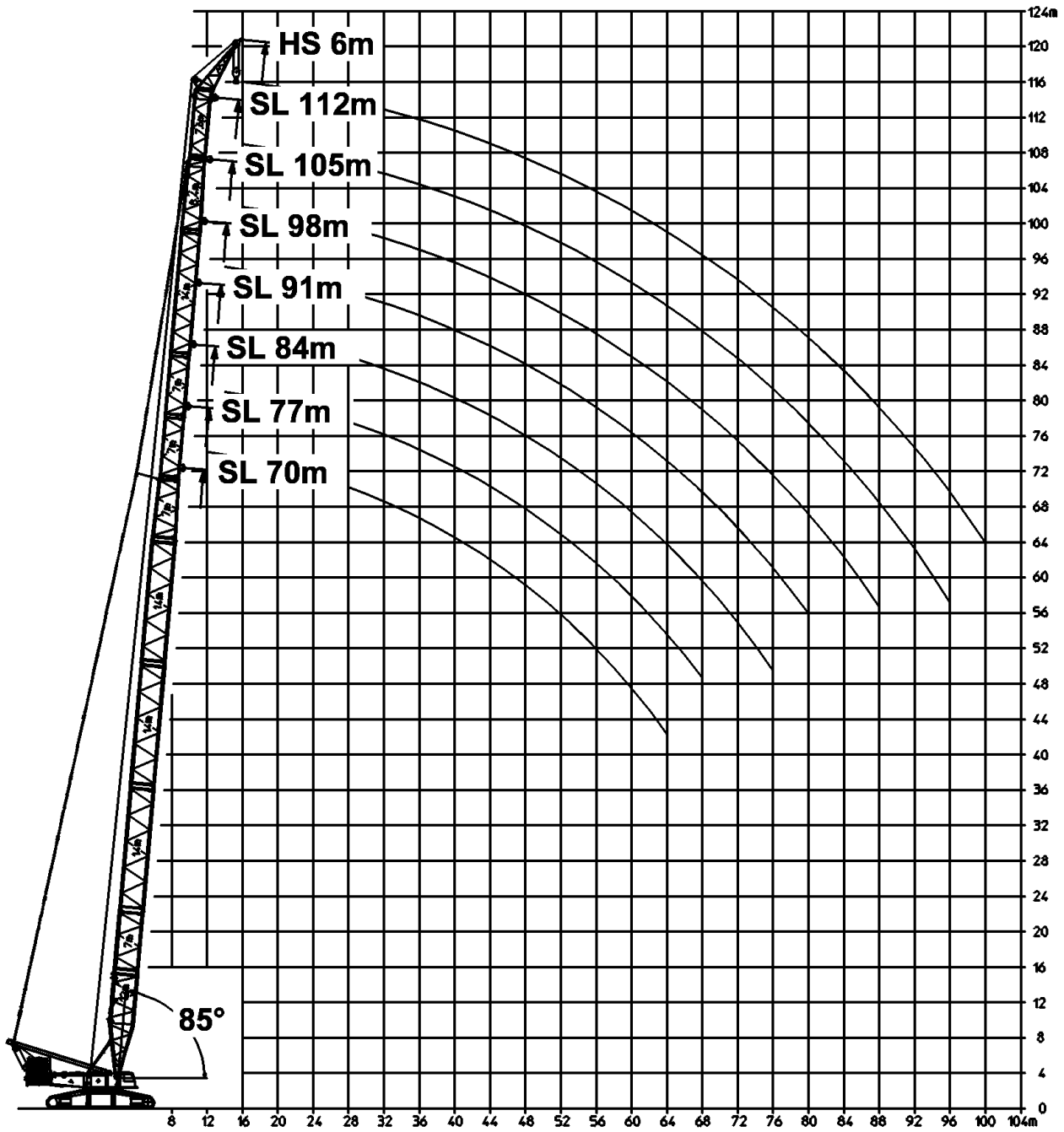
Hoisting heights

SDWVB / BW - Boom system, WV = 12°



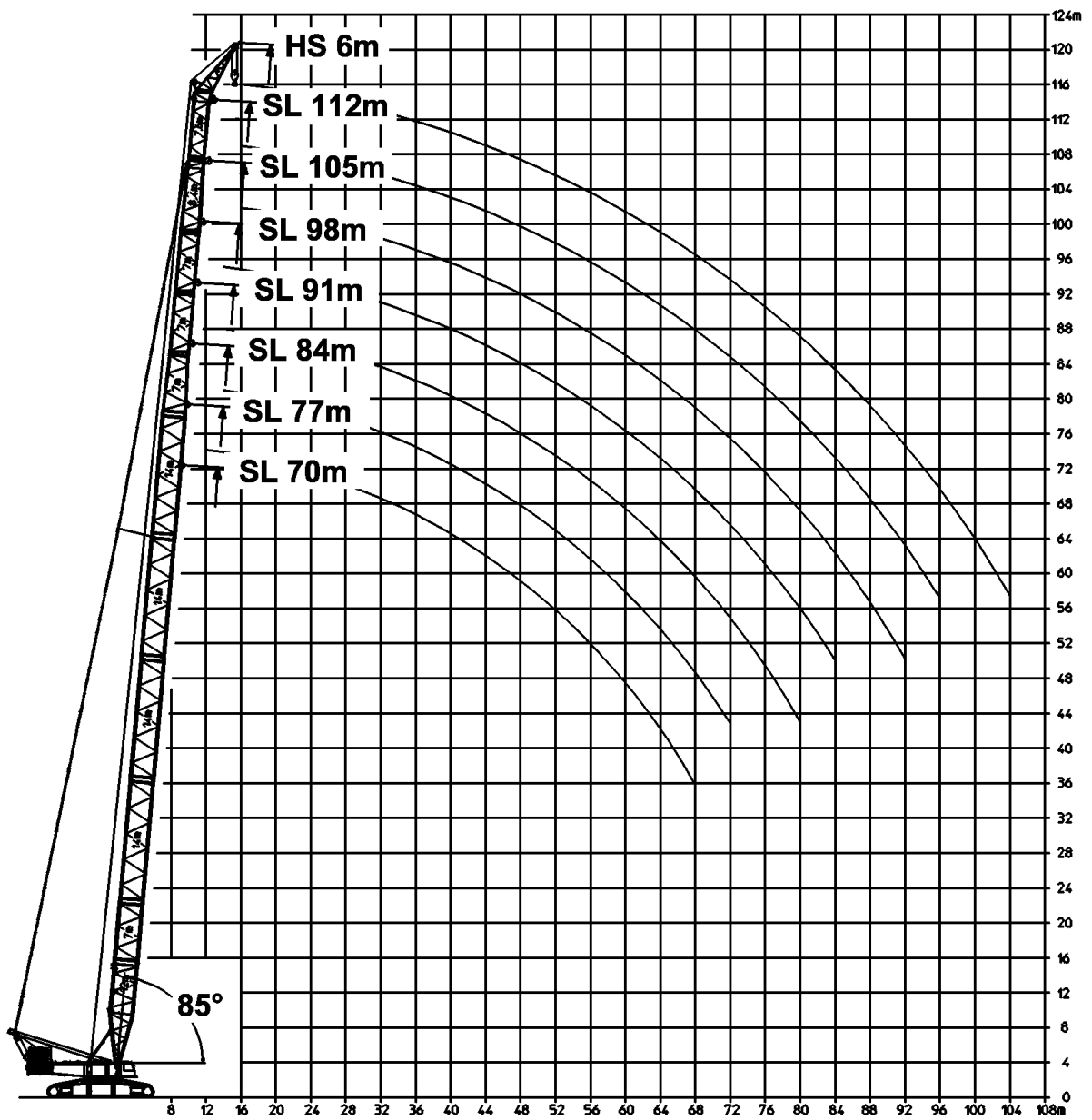
Hoisting heights

SL3HS - Boom system, SL = 85°



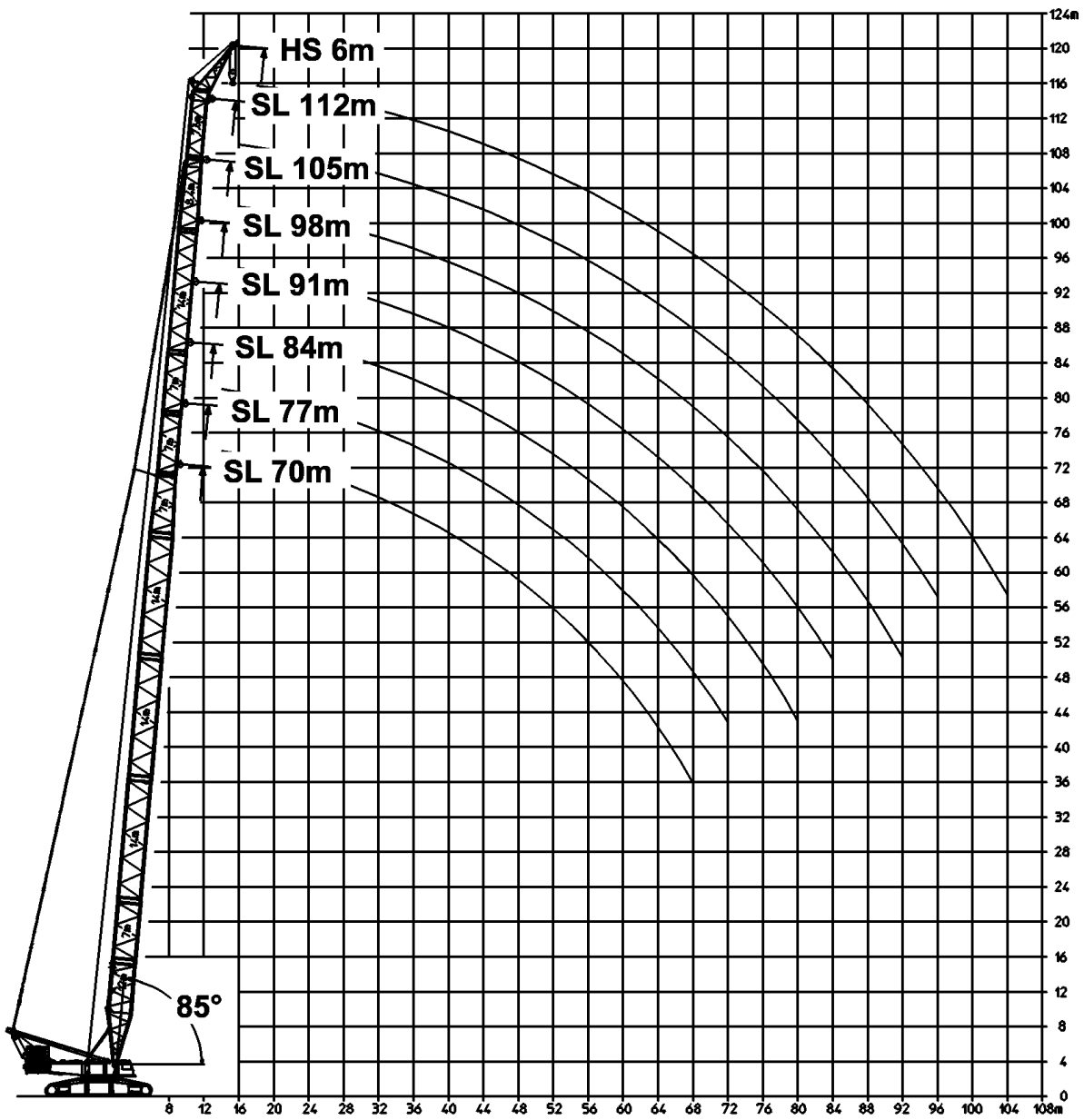
Hoisting heights

SL4HS - Boom system, SL = 85°



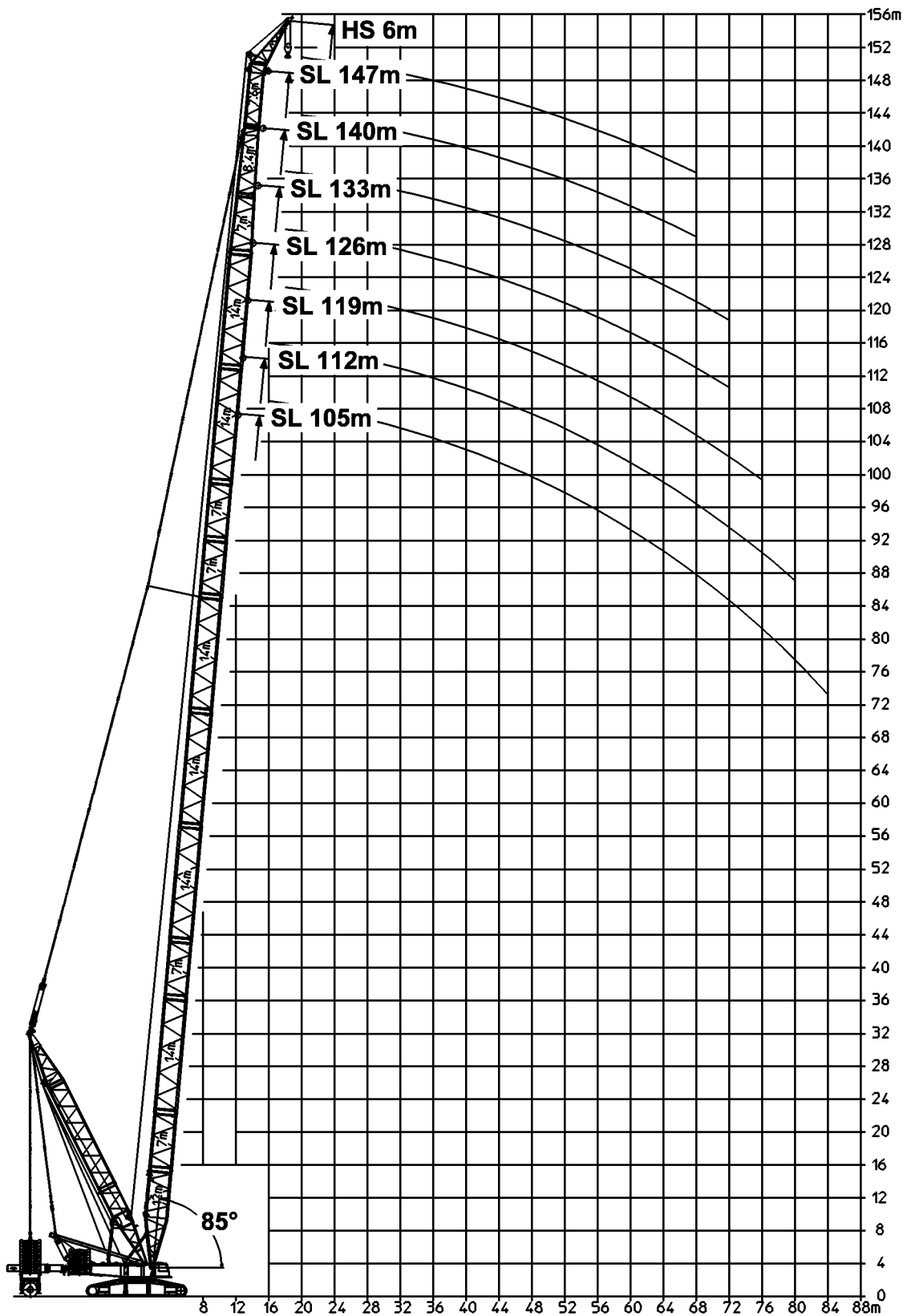
Hoisting heights

SL8HS - Boom system, SL = 85°



Hoisting heights

SL7DHS - Boom system, SL = 85°



Chapter 2

Safety

Operational planning

As well as a fully functioning crane and well-qualified personnel, **operational planning** is an important precondition for safe and reliable crane operation.

The crane operator must be in possession of or procure all the necessary information before starting the crane operation, especially:

- Nature of work
- Height and side clearances
- Electrical overhead wires (complete with voltage data)
- Space requirements at the operating sites
- Movement restrictions due to surrounding structures
- Weight and dimensions of load(s) to be lifted
- Required lifting height and radius
- Load-bearing capacity of soil or surface to be operated upon

The crane operator can then use this information to decide on the correct crane operating equipment:

- Hook blocks/load blocks
- Auxiliary telescopic boom
- Lifting / slinging tackle
- Counterweight

DANGER: If the crane operator does not possess all necessary and required information, it may prove impossible to carry out the intended work, or he may be tempted to improvise - and accidents may be the result!

1. Requirements of the crane operator

1.1 General

The most important requirement of the crane operator is to control, operate and adjust the crane so that there is no danger to the crane crew and/or third parties.

In order to fulfill this requirement, we would like to give you the following important safety notes.

Many problems and damages with mobile cranes are caused by improper crane operation.

Improper operating procedures most often carried out are:

Not paying careful attention while working in the case of, for example:

- slewing too quickly,
- quick braking of the load,
- cross pulling,
- loose cable formations

Overloading

Driving too fast with a load, or setting up and loading on an uneven surface.

Improperly slinging a load.

Operating in unsuitable conditions, especially pulling at an angle or fixed loads coming loose.

Wind on suspended load.

Collision with bridges, ceilings, high-voltage wires due to insufficient vertical clearance.

Improper assembly / disassembly of telescopic booms.

Many of accidents involving cranes are due to improper maintenance:

- Lack of oil, grease or antifreeze
- Accumulation of too much dirt
- Broken cable wires, defective crawler plates, worn parts
- Emergency limit switch or load moment limiter not operational
- Brake and / or transmission failure
- Defects in the hydraulic systems; for example, tears in hoses
- Loose screws

D A N G E R : **In your interest and in the interest of others, please learn to command your crane thoroughly and familiarize yourself with all the dangers associated with the work to be carried out.**

1.2 Personal protective devices

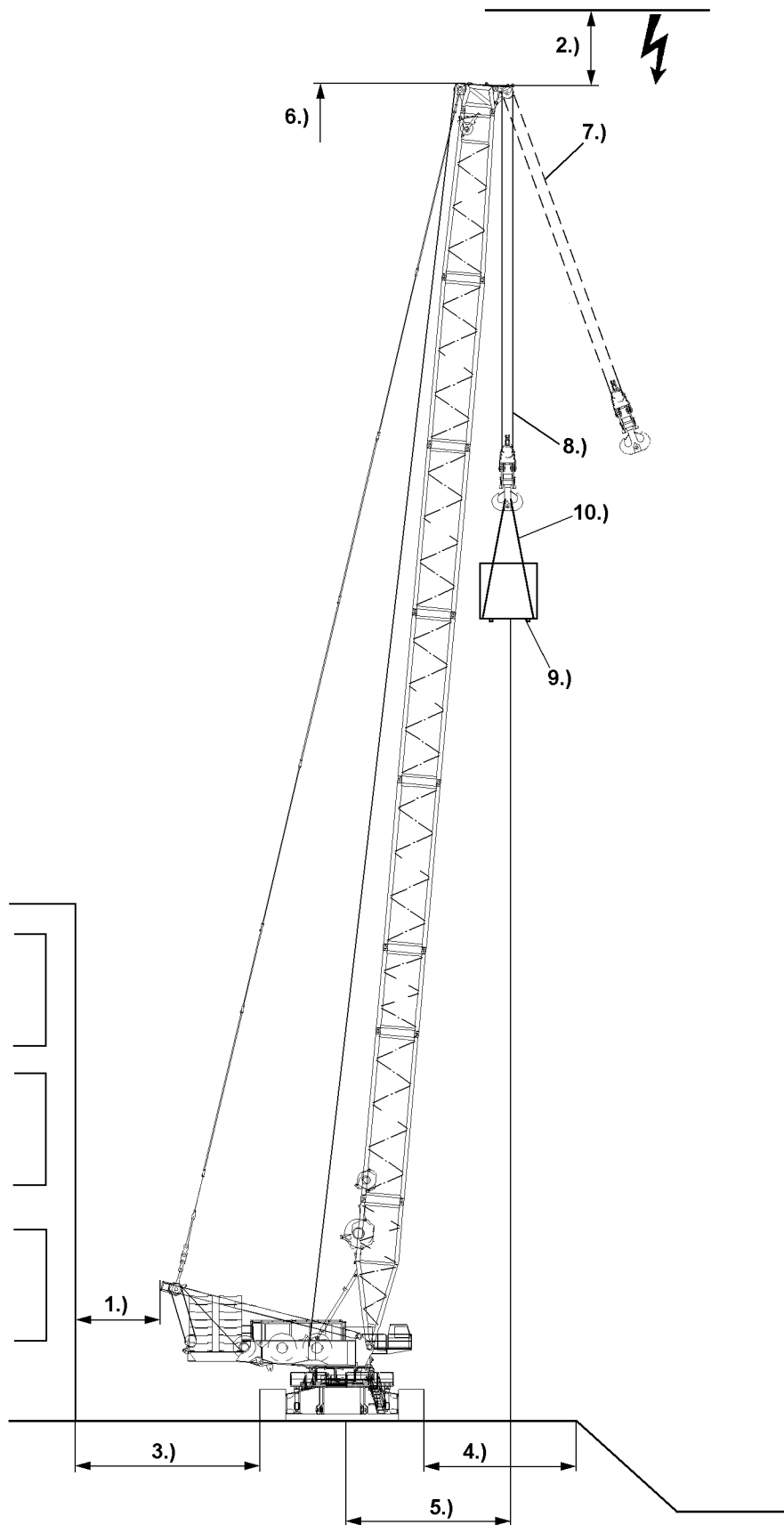
DANGER: **Increased danger of accidents!**
If protective devices are not worn, the crane operator or the auxiliary personnel can be killed or severely injured!
The crane operator and auxiliary personnel are obligated to carry personal protective devices along and to wear them!
Use personal protective devices according to relevant standards!

Personal protective devices include the following equipment:

- Hard hat
- Protective gloves
- Catch belt to prevent falling
- Safety shoes
- Warning apparel

1.3 Obligations of the crane operator

- 1.) Before starting to work, the crane operator must check the brake function and the emergency shut off devices. He must monitor the condition of the crane for obvious defects. On wireless controlled cranes, he must check the assignment of control unit and crane.
- 2.) The crane operator must cease crane operation in case of defects, which would endanger the safety .
- 3.) The crane operator must report all defects on the crane to the appropriate supervisor, also to his replacement in case of crane change. For mobile cranes, which are set up and taken down at their corresponding jobsite, he must enter any defects in the crane log book.
- 4.) The crane operator must make sure that:
 - all control devices are set to neutral or idle position before release of the energy supply to the drive components ,
 - the control devices are set to neutral or idle position and the energy supply is shut off before leaving the control platform,
 - when taking down the control unit for wireless control, it is secured to prevent unauthorized operation.
- 5.) The crane operator must ensure that cranes subjected to wind are not operated past the limits which were set by the crane manufacturer, and that the boom is taken down at least when the critical wind speeds for the crane are reached and at the end of the work.
- 6.) The crane operator must monitor the load at all crane movements or the load tackle devices when moving the crane without a load, if they could cause a dangerous situation. If observation is not possible, then the crane operator may move the crane only with the aid of a guide.
- 7.) The crane operator must give warning signs when necessary.
- 8.) The crane operator may not move loads over personnel.
- 9.) Any loads attached by hand may only be moved by the crane operator after he received a clear sign from the person who attached the load, the guide or any other responsible party which was assigned to that task by the contractor. If signals must be used to communicate with the crane operator, then they must be agreed upon before use between the responsible party and the crane operator. If the crane operator determines that the loads are not properly attached, then he may not move them.
- 10.) As long as a load is suspended on the crane, the crane operator must keep the control devices within reach. This does not apply for towing of vehicles with towing cranes.
- 11.) The crane operator may not run up to end positions operationally, if they are limited by the emergency limit switches.
- 12.) After a load moment limiter was triggered, the crane operator may not take on an overload by pulling in / raising the boom.
- 13.) The crane operator may not bypass the overload safety to increase the hoisting power of the crane.



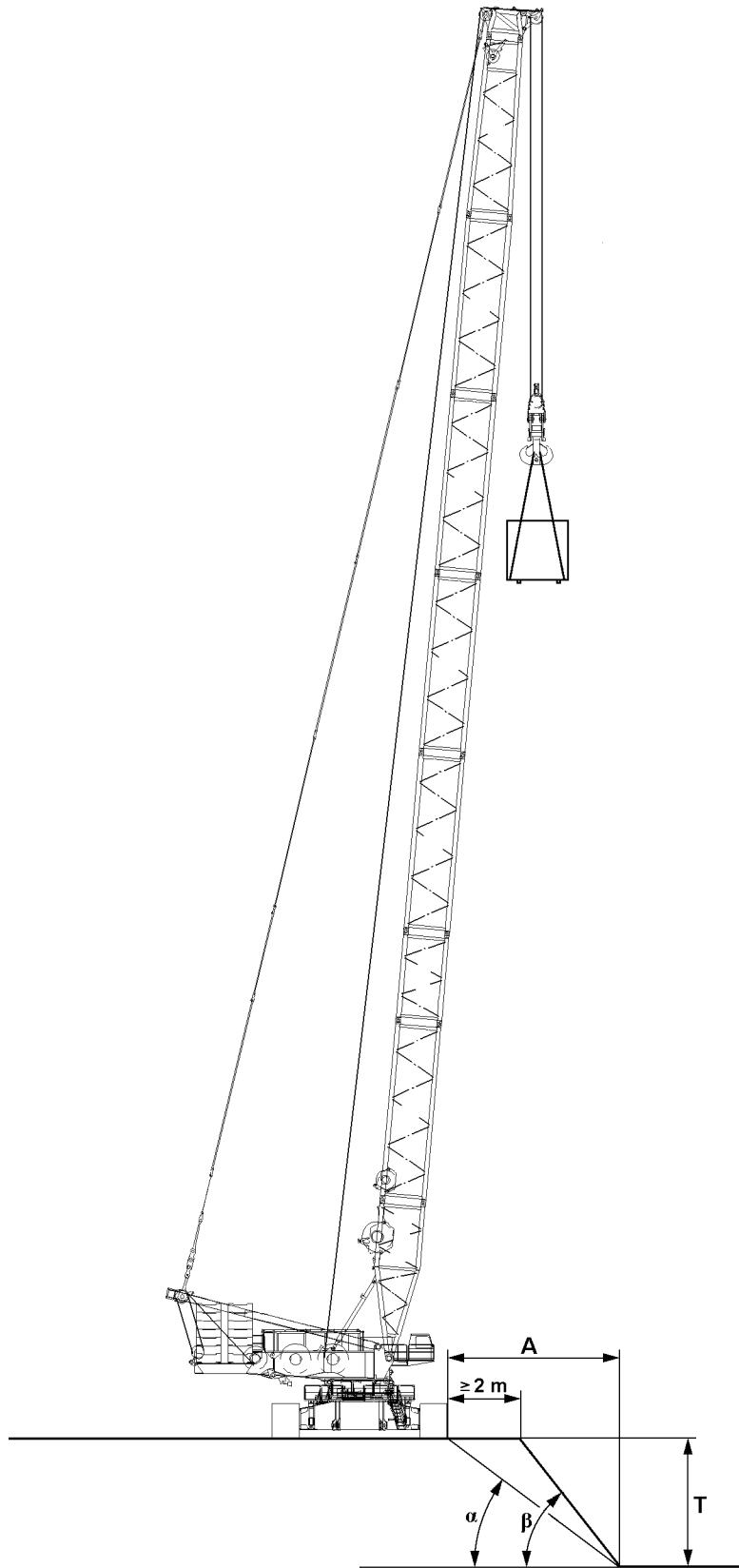
2. Selecting an operating site

To avoid accidents from the outset, the correct selection of an **operating site** is extremely important.

D A N G E R : **Risk of accidents due to ground with insufficient load bearing capacity!**
If the crane is supported on ground with insufficient load bearing capacity, then it can topple over and kill personnel!
Support the crane only on ground with sufficient load bearing capacity!
Note the following points!

When selecting the placement location of the crane, observe the following:

- 1.) Select the placement location in such a way that crane movements can be carried out without collision, and that the outrigger supports can be extended to the support base stipulated in the load charts. Make sure that no personnel is injured or killed! Always keep a safety distance of 0.5 m. If this is not possible, secure the danger zone.
- 2.) Support the crane correctly and support the support pads according to the load bearing capacity of the ground on the placement location.
- 3.) Keep a safety distance to basements or similar.
- 4.) Keep a safety distance to slopes or embankments or similar.
- 5.) Keep the radius to a minimum. Never utilize the crane 100%.
- 6.) Select the correct boom length to the load case.
- 7.) Diagonal pull is not permitted!
- 8.) Select the correct reeving of the hoist rope to the load case.
- 9.) Bear in mind the weight and the wind exposure surface of the load.
- 10.) Select tackle according to the weight of the load, the type of attachment and the incline angle.
- 11.) Keep sufficient distance to electrical overhead.



102730

3. Slopes and trenches

The crane must not be set up too close to slopes or trenches and depending on the type of soil, a safe distance must always be kept from them.

D A N G E R : Crane can topple over!

The edge of the slope or ditch can break in if the safety distance A or slope angle of β is not observed. If the edge of the slope or ditch breaks in, the crane can topple over and kill personnel!

Support the sides of the slope or ditch!

Keep a safety distance!

Observe the slope angle!

Term	Abbreviation
Distance to bottom of ditch	A
Depth of ditch	T
Load entry angle	α
Slope angle	β

Note: Without calculated proof of safe placement, the slope angles of β given in the chart may not be exceeded!

Ground	Slope angle
for non-cohesive and soft cohesive ground	$\beta = 45^\circ$
for stiff or semi-solid cohesive ground	$\beta = 60^\circ$
for rock	$\beta = 80^\circ$

Calculating safety distance A		
Soil type	required load entry angle α	Formula
soft ground	$\alpha \leq 30^\circ$	$A = 2 \times T$
solid ground	$\alpha \leq 45^\circ$	$A = 1 \times T$

4. Permissible ground-bearing load

During crane operation, significant forces are transferred into the ground. It is imperative that the ground can withstand the pressure. If the surface of the crawlers is not sufficient, then they must be supported from below, depending on the load bearing capacity of the ground .

D A N G E R : **Danger of tipping over due to improper support!**
The support must be large enough, depending on the ground conditions, and be made of strong materials such as wood, steel or concrete plates!

Permissible ground-bearing load

Type of Soil	[N / cm ²]
1.) Organic ground: peat, sludge, muck	0
2.) Uncompacted fill: construction debris	0 to 10
3.) Non-cohesive ground: sand, gravel, rocks and mix	20
4.) Cohesive soil:	
a) clayed silt, mixed with topsoil	12
b) silt, consisting of poor clay and coarse clay	13
c) plastic clay, consisting of potter's clay and fill	
stiff	9
semi-solid	14
solid	20
d) mixed granular ground, clay to sand, gravel and rocky areas	
stiff	
semi-solid	15
solid	22
	33
5.) Rock in evenly solid condition:	
a) brittle, with traces of decomposition	150
b) not brittle	400

If there is any doubt as to the load-bearing capacity of the ground at the operating site, the ground must be investigated; for example, with a dynamic sounding rod.

5. Checking safety measures

Crane supported

- Has the operating site been selected so that the crane may operate within the smallest possible boom radius?
- Is the load-bearing capacity of the ground sufficient?
- Is there a sufficiently safe distance from slopes and trenches?
- Has it been established that the crane is not in the vicinity of electrical overhead wires?
- Are there any obstacles in the area that will hinder necessary crane movements?
- Is axle suspension blocked?
- Are all 4 sliding arms and support jacks extended to the support base as given in the load-capacity tables?
- Are the sliding arms secured with pins?
- Are the support pads secured?
- Is the crane horizontally aligned?
- Have the axles been relieved of loads, i.e., is there no longer contact between the ground and the tires?

6. Crane operation with a load

Before beginning any work, the crane operator must be convinced that the crane is in safe operating condition. The safety devices, such as load moment limiter, hoist limit switch, brakes, and so forth, must all be operational.

- The load torque limiter must be set to the current operating status of the crane.
- The load capacities as given in the load capacity tables must be adhered to.
- The crane must never be operated with a load exceeding the permissible load capacities.
- Before beginning any operations, the crane operator must know the weight, the center of gravity and dimensions of the load.
- All hoisting and slinging tackle must meet the requirements of the work to be carried out.
- It must be ensured that the weights of the hoisting, slinging and staying tackle are deducted from the load capacity.

Example:

Highest permissible load capacity according to table		30.000 t
Weight of the hook block	350 kg	- 0.350 t
Weight of the slinging rope	50 kg	- 0.050 t
Actual useful load of the crane		= 29.600 t

In this case, the load to be lifted may not exceed **29.6 t**.

Counterweight

The required ballast is dependent on the load to be lifted and necessary boom radius for operating with that load. Data in the corresponding load capacity table is decisive in selecting ballast.

D A N G E R : **If ballast is not mounted according to the load capacity table, there is danger of the crane toppling over.**

Hoisting gear, hoisting cable

The lifting capacity of the crane depends on the tensile force, or pull, of the hoisting cable and the number of possible hoist reeving cables. When working with a single cable, the crane can only lift as much as the hoisting gear pulls.

If the load to be lifted is greater than the pull of the hoisting gear, the hoisting cable must be reeved between the pulley head on the boom and the hook block as many times as necessary according to the principle of a block and pulley.

When reeving, ensure that the data given in the load capacity table book and operating instructions are observed and adhered to.

D A N G E R : **If the maximum tensile force is exceeded, there is the danger that the cable(s) may snap or that the hoisting gear and/or drive motor may be damaged.**

Crane operation**D A N G E R exists if:**

1. The load torque limiter is not set to the actual equipment status of the crane, and as a result, cannot fulfill its function as a safety device.
2. The load torque limiter is defective or put out of operation.
3. The limit switches are defective or put out of operation.
4. The angle indicators and the strain gauges are not in function.
5. The support pads are not supported with stable base material sufficiently large for the soil conditions.
6. If the load is pulled at an angle.
It is particularly dangerous when pulling to the side since the telescopic boom has a lower torque resistance to the side. **The load may not be pulled at an angle.**
7. An excessive load is attached to the hook during dismantling work, which then hangs freely on the crane when it is detached.
8. If loads which have become stuck are pulled free with the hook block. Even if the weight of the load which is stuck is no greater than the permissible lifting load, the crane may topple over backwards if the load is suddenly freed since the tension created in the boom can cause it to jerk back violently.
9. Work is carried out in strong winds. Refer to the data given in the load capacity table.
10. The crane is not aligned horizontally and the load is slewed toward the slope.
11. The hook load begins swinging because the crane operator has not properly controlled the movements.
12. The loads and radii contained in the load capacity tables are exceeded.
13. When working in the vicinity of power cables, these are not isolated by electricity engineers or if the hazardous area is not covered or fenced off. If it is not possible to take such measures, a sufficient safety clearance must be maintained:

Rated Voltage	Minimum distance	
	[m]	[ft]
up to 1 kV (1000 V)	1	3
above 1 kV up to 110 kV	3	9
above 110 kV up to 220 kV	4	13
above 220 kV up to 380 kV	5	16
if rated voltage is unknown	5	16

- Note:** If, despite all precautions having been taken, a flashover occurs, carry out the following procedure:
- Keep calm.
 - Do not leave the crane cab.
 - Warn those around the crane not to move and not to touch the crane.
 - Move the crane away from the danger area.

D A N G E R: Not observing the above points can lead to (fatal) accidents and damage!

7. Grounding

7.1 Grounding the crane

DANGER: Danger of accidents due to electrical shock!

The crane must be grounded before operation:

- near transmitters (radio and TV transmitters, radio stations, etc.)
- near high frequency switching systems
- in case of severe possibility of thunderstorms or potential thunderstorms

The crane can become electrostatically charged especially if the crane is equipped with synthetic outrigger support pads or if the support pads are placed on insulating materials (such as wooden planks).

DANGER: Danger of accidents due to electrical shock!

To prevent the crane from electrostatic charge, the following is required :

- an electrically conductive grounding rod, approx. 2 m long, which is inserted into the ground
- an electrically conductive cable with a diameter of at least 16 mm²
- a screw clamp as is used for welding work.

The following applies :

- Always use a cross grounding rod as grounding rod.
- The grounding resistance must be less than 0,5 Ohm.
- The connection between the crane and the ground must always be a proper electrically conductive connection.

Connect one end of the grounding cable with a diameter of at least 16mm² with the grounding rod, which is inserted into the ground.

Insert the grounding rod at least 1,5 m into the ground.

Moisten the soil around the metal rod for better conductivity.

CAUTION: The grounding resistance depends on the make up of the ground material and on the active contact surfaces of the grounding rod.

Connect the other end of the grounding cable with a diameter of at least 16 mm² with the grounding pin on the crane.

CAUTION: The connection between the crane and the ground must be a proper electrically conductive connection .

If there is a possibility to connect a foundation or band ground with correspondingly smaller grounding resistance, then this grounding method should always be preferred.

**DANGER: Danger of accidents due to electrical shock!
There is a risk of electrical shock, if the crane is not properly grounded.
Make sure that the connection between the crane and the ground is a proper electrically conductive connection .**

7.2 Grounding the load

DANGER: Danger of accidents due to electrical shock !

The load should be grounded before operation :

- near transmitters (radio and TV transmitters, radio stations, etc.)
- near high frequency switching systems
- in case of severe possibility of thunderstorms or potential thunderstorms

The load can become electrostatically charged, even if the crane is grounded. This applies in particular if a hook block with pulleys made of synthetic material and non-conductive tackle (for example plastic or manila ropes).

To prevent the load from becoming electrostatically charged, the following is required:

- an electrically conductive grounding rod, approx. 2 m long, which is inserted into the ground
- an electrically conductive cable with a diameter of at least 16 mm²
- an electrically conductive metal rod with insulated handle to touch the load.

DANGER: Danger of accidents due to electrical shock !

CAUTION: The connection between the load and the ground must be a proper electrically conductive connection .

Connect one end of the grounding cable with a diameter of at least 16 mm² with the grounding rod which is inserted into the ground.

Insert the grounding rod at least 1.5 m into the ground.

Moisten the soil around the metal rod for better conductivity.

CAUTION: The grounding resistance depends on the make up of the ground material and on the active contact surfaces of the grounding rod.

Connect the other end of the grounding cable with a diameter of at least 16 mm² with the metal rod with insulated handle.

DANGER: Danger of accidents due to electrical shock !
The metal rod may only be held on the insulated handle !

Hold the metal rods on the insulated handle.

Touch the load with the metal rod before touching it with the hands.

8. Crane operation in case of thunderstorms

In weather conditions, which can include lightning :

- Stop work on the crane immediately.
- Always place down the load.
- If possible, take the boom down and bring it into a safe condition.
- Turn the crane engine off.

D A N G E R : **Danger of accidents due to lightning!**

Make sure that there are no persons near the immediate area of the crane .

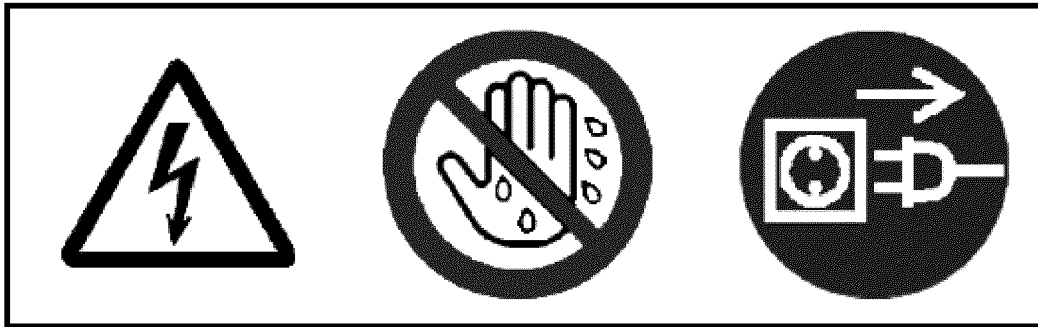
9. Welding work on the load

C A U T I O N : **The load must also be grounded.**

In case of welding work on the load, the screw clamp of the welding unit must be attached on the welding piece to avoid current flow via hoist cable, crane superstructure or crane chassis .

C A U T I O N : **Danger of damage to the heater control units .**

Disconnect the negative and positive cable from the batteries and place the positive cable onto the vehicle ground.



⚠ DANGER
Electrical hazard.
Contact with water will
cause electric shock.
Do NOT touch with wet
hands. Always unplug
when not in use.

10. Safety guidelines for auxiliary power supply (230 V AC)

If the crane is supplied by an auxiliary power supply from a low voltage power supply distribution network (230V AC), then it poses a potential danger.

Electrical power is especially dangerous if there is an interruption in the protective conductor, (due to mechanical wear of the flexible supply line or the house installation), in case of loose terminal connections, high line and transfer resistance, interchanged conductors, defective or non-existing protective measures in connection with an insulation fault on the crane.

DANGER: **Moisture infiltration and / or defective machines can cause voltage displacement due to an insulation fault.**
The person touching the unit will be exposed to a dangerous voltage surge.
There is a DANGER OF LIFE AND DEATH!

For that reason, it must be assured that the flexible auxiliary supply line is fully functioning and in proper order.

If necessary, we recommend to connect a power isolating transformer.

CAUTION: **To check the protective measures and to decide if the crane can be supplied with power from the general power supply distribution network, a competent trained electrician must be called in with the appropriate test instruments according to VDE (Association of German Electrotechnical Engineers).**

11. Working near transmitters/ transformers

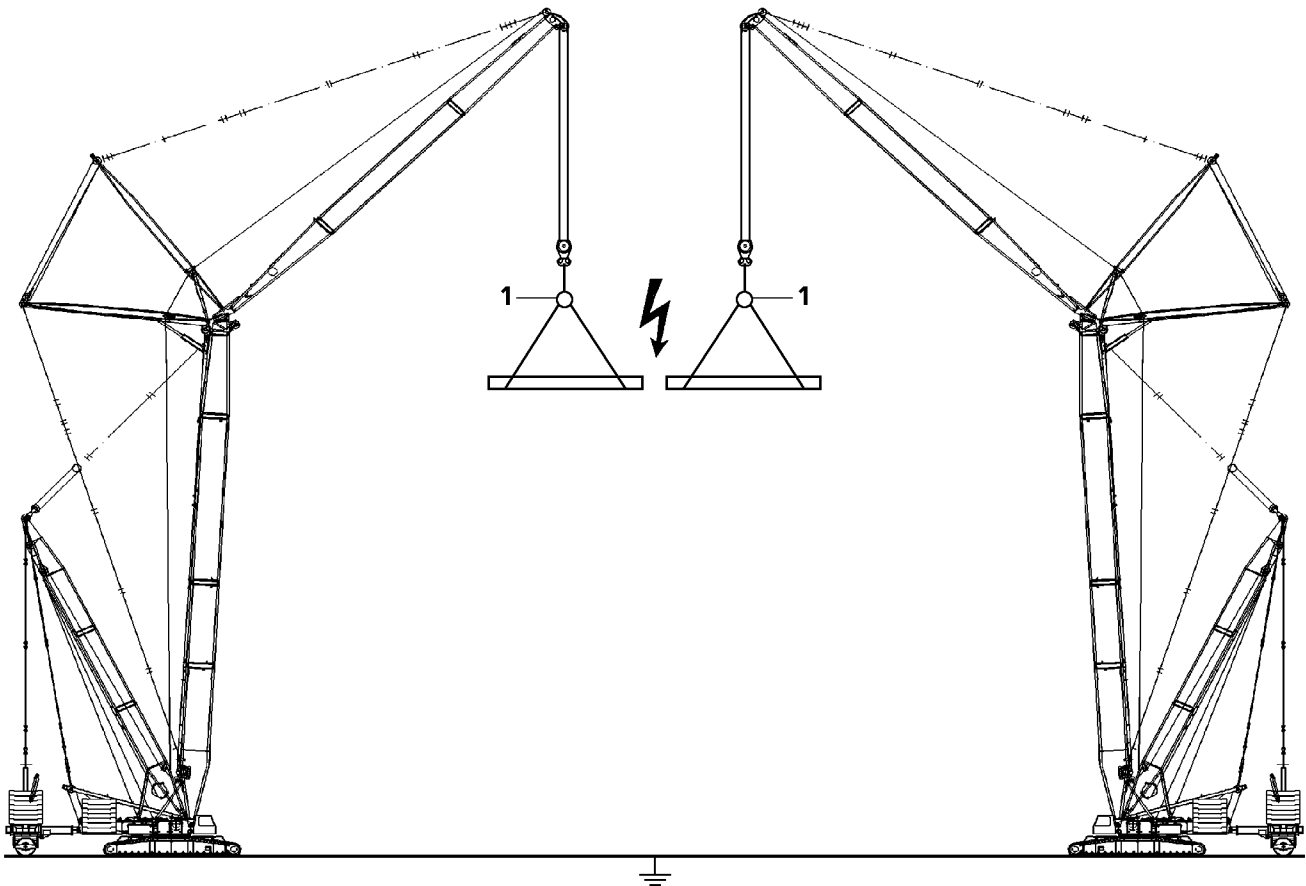
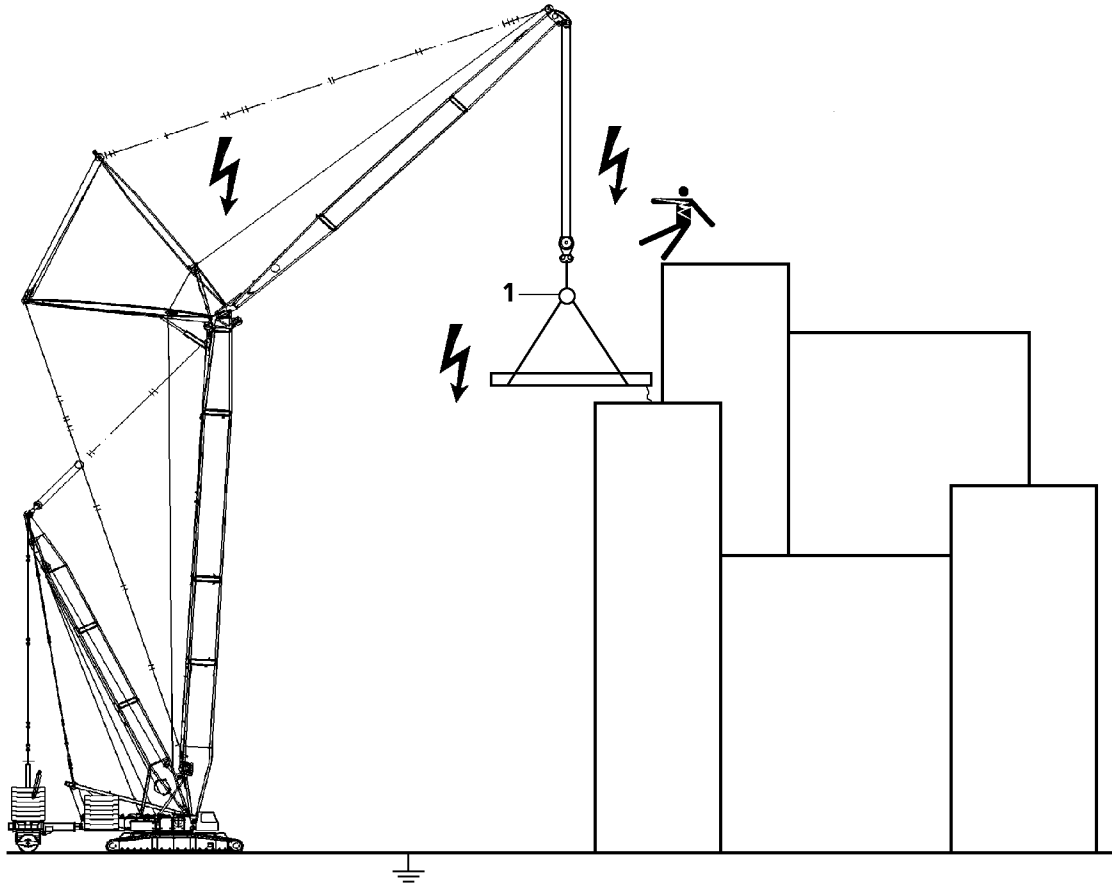
If there is a transmitter / transformer near the job site, strong electro-magnetic fields may exist.

DANGER: **These electro-magnetic fields can pose direct or indirect danger to persons or objects, for example:**

- **Effect on human organs due to temperature increase**
- **Danger of burns or inflammation due to temperature increase**
- **Spark or electric arc formation**

In any case, before working with the crane near transmitters / transformers, contact your LIEBHERR representative .

In addition, consult a high frequency specialist.



189694

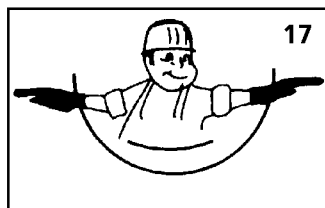
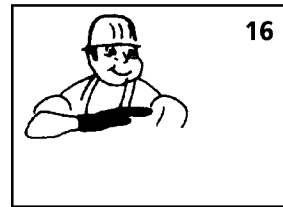
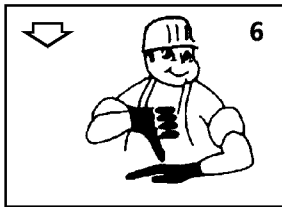
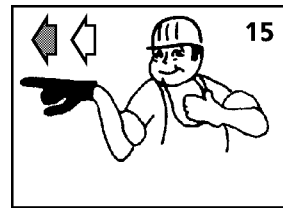
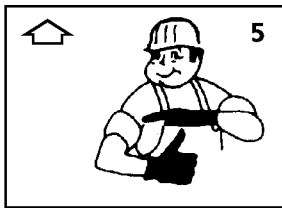
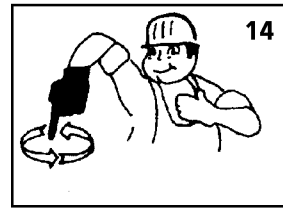
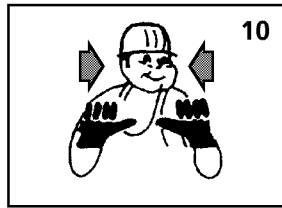
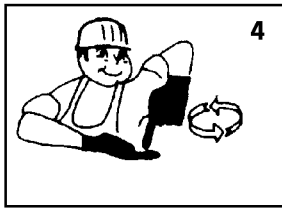
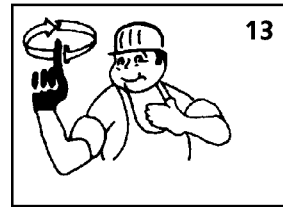
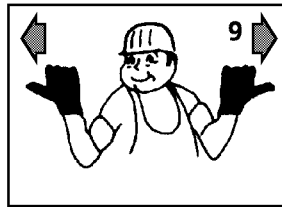
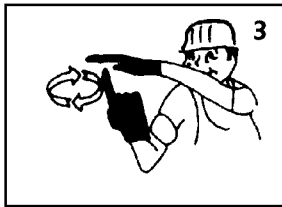
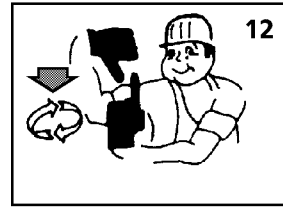
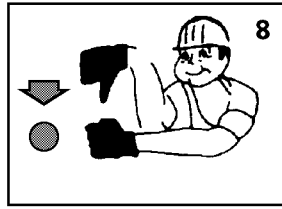
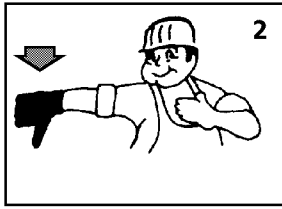
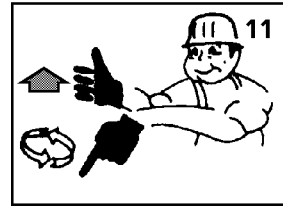
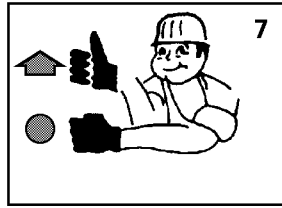
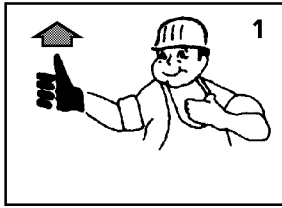
The high frequency (HF-) rays from a transmitter require an increased working protection and special UVV-guidelines (Accident Control Regulations) for crane operator and crane personnel

1. Every crane must be "totally" grounded. Check visually or with a simple tester to ensure that ladder, cab and cable pulleys are grounded.
2. All persons working on the crane or on larger metal parts must carry special protective gloves without metal connectors and suitable protective suits to protect them from burns while working.
3. If one should feel an increase in temperature, there is no need for panic. Simply act as if the affected tool, component or carrier is "hot".
4. The temperature of the tools affected by high frequency depends on their "size". Cranes, carriers and coverings, for example, are "hotter".
5. When moving the crane, do not allow it to touch other crane loads (light arcs).
Since burn nicks reduce the load carrying capacity of the cables significantly, contact your supervisor (master) any time such a contact has occurred, so that the cables can be checked and inspected.
6. An insulator (1) must always be between the load hook of the crane and the tackle. This insulator (1) may not be removed. This is strictly prohibited.
7. The cable may not be touched above the insulator (1). This is strictly prohibited!
8. Never touch the crane with attached loads with unprotected body parts after lift off or after set down.
9. Never work with exposed, unclothed upper body or short pants, this is strictly prohibited!
10. If possible, transport larger loads in horizontal direction, to reduce high frequency absorption!
11. Before carrying out any necessary manual work, ground the loads first or insulate them (place a rubber cloth between the tool and the glove).
12. The temperature of the tool can be checked with a suitable tester.
If, for example 500 V can be measured on a tool at a distance of 1 to 2 cm, then the tool may not be touched with bare hands.
The larger the distance, the higher the voltage is on the tool:
at a distance of 10 cm, the voltage is approx. 600 V, at a distance of 30 cm, the voltage is approx. 2000 V.
13. To prevent accidents, work on components located higher up, may only be carried out with a safety belt.
14. Handling explosive matter (such as refueling) may only be done at least 6 m away from the place where sparks could form due to handling of larger metal parts.
To refuel, use only appropriate and approved rubber hoses .
15. All accidents or special occurrences must be reported immediately to the local construction supervisor and the safety engineer.

12. Endangering the air traffic

When working with cranes, heights are reached which could endanger air traffic. This applies especially to areas near airports.

D A N G E R : **Endangering air traffic!**
If no protective measures are taken, this can result in endangerment to air traffic!
Get the approval from the agency responsible for air traffic! Install the airplane
warning light on the boom head and turn it on!



13. Hand signals for guides

When performing any movement, the crane operator must always keep his eye on the load, and when moving the crane without a load, he should observe the crane hook or the lifting tackle.

D A N G E R : **A suspended load is always a risk!**
 Constantly keep loads in sight!
 Do not remain under a suspended load!

If this is not possible, he must only operate the crane according to instructions given to him by a signaler. These instructions may be given in the form of hand signals or over a two-way radio. Whatever method is used, precautions must be taken to eliminate the risk of misunderstandings.

C A U T I O N : **Hand signals must first be discussed and agreed upon and then clearly given.**
 Misunderstandings can lead to serious accidents.

The hand signals illustrated on the opposite page are given as recommendations for safe working.

When operating in foreign countries, always observe NATIONAL TRAFFIC REGULATIONS.

Explanation of hand signals

- 1 = Raise boom
- 2 = Lower boom
- 3 = Lift load slowly
- 4 = Lower load slowly
- 5 = Raise boom slowly
- 6 = Lower boom slowly
- 7 = Raise boom and hold load
- 8 = Lower boom and hold load
- 9 = Extend boom
- 10 = Retract boom
- 11 = Raise boom and lower load
- 12 = Lower boom and raise load
- 13 = Raise load
- 14 = Lower load
- 15 = Slew load this way
- 16 = Shut down all systems
- 17 = Stop!

14. Consideration of wind conditions

It is imperative to observe the permissible wind speed data given in the load charts:

- for the equipped crane
- for crane operation.

If the wind speed is larger than the maximum permissible wind speed, then crane operation must cease. The boom and the attachments must be taken down. The crane operator must check with the appropriate weather bureau about the expected wind speeds, at :

- 1.) the start of crane operation
- 2.) interruption of crane operation
- 3.) when resuming crane operation.

D A N G E R : **If the crane is operated at wind speeds which are larger than the maximum permissible wind speeds according to the load charts, then it can topple over and kill personnel!**
If wind speeds are expected which are larger than the maximum permissible wind speeds for the equipped crane, then the attachments and the boom must be taken down! If wind speeds are expected which are larger than the maximum permissible winds speeds for the crane operation, then it is prohibited to lift a load!

Wind Force		Wind Speed		Effects of Wind in the inland
Beaufort degree	Description	[m/s]	[km/h]	
0	Calm	0 - 0,2	1	No wind, smoke rises straight up
1	Slight air (draft)	0,3 - 1,5	1 - 5	Wind direction is shown only by observing the trail of smoke, not by the wind sock
2	Light breeze	1,6 - 3,3	6 - 11	Wind can be felt on the face, the leaves rustle, wind sock moves slightly
3	Gentle breeze	3,4 - 5,4	12 - 19	Leaves and thin twigs move Wind extends a small breeze flag
4	Moderate breeze	5,5 - 7,9	20 - 28	Swirls up dust and loose paper, moves twigs and thin branches
5	Fresh breeze	8 - 10,7	29 - 38	Small deciduous trees begin to sway, foam forms at sea
6	Strong wind	10,8 - 13,8	39 - 49	Thicker branches move Telephone lines begin to whistle, umbrellas are difficult to use
7	Stiff wind	13,9 - 17,1	50 - 61	Entire trees swaying; difficult to walk into wind
8	Gale force wind	17,2 - 20,7	62 - 74	Breaks twigs off trees, walking becomes difficult
9	Gale	20,8 - 24,4	75 - 88	Minor damage to property (chimney tops and roofing tile are blown off)
10	Severe gale	24,5 - 28,4	89 - 102	Trees are uprooted, significant damage to property
11	Violent storm	28,5 - 32,6	103 - 117	Extensive, widespread storm damage
12	Hurricane	32,7 and more	118 and more	Major destruction

15. Interruption of crane work

15.1 Interruption of crane work

If the crane operator leaves the equipped crane during crane operation, then it must be ensured that no danger to crane or surrounding area can occur in case of an unforeseen event.

D A N G E R : **If the crane is not guarded, events can occur which could bring the crane to an unsafe condition.
This can cause the crane to topple over and as a result, severe personal injury or property damage can occur.
For that reason, always keep the crane under control!**

Events are, for example:

- The ground giving way due to severe rain
- Melting ice under the supports
- Storms, thunderstorms
- Land slide
- Wash outs
- Support cylinder giving way
- Luffing cylinder giving way
- Vandalism

Make sure that the following prerequisites are met:

- There is no load on the hook
- The crane poses no traffic obstacle.

Note: If crane work must be interrupted if the crane is equipped, then it must be ensured that measures are initiated in time by trained, qualified personnel, to bring the crane into a safe condition in case something happens.

D A N G E R : **If it is not possible to keep the equipped crane constantly under guard, then the attachments and the boom must be taken down.
There is a danger of accidents!**

15.2 Taking up crane operation again

If the crane operation is taken up again, then the crane operator is obligated to check the crane condition and the safety devices.

D A N G E R : **If the crane operator leaves the crane operator's cab, even if only for a short time, then he is obligated before starting to work again with the crane, to check the operating mode settings and to reset them, if necessary.
There is a danger of accidents!**

15.3 Ending crane operation

Before the crane operator may leave the crane, the following prerequisites must be met:

- Remove the load on the crane hook or place it on the ground.
- Telescope the telescopic boom all the way in and place the boom down.
- Bring the control lever (master switch) to 0-position.
- Turn the heater off.
- Apply the parking brake on the crane chassis.
- Turn the engine off and pull the ignition key.
- Secure the mobile crane to prevent unauthorized use. close all control platforms with a lock, if they are not used at the time or if they are not occupied.
- Secure the mobile crane to prevent it from rolling off. See paragraph „Parking the vehicle“.

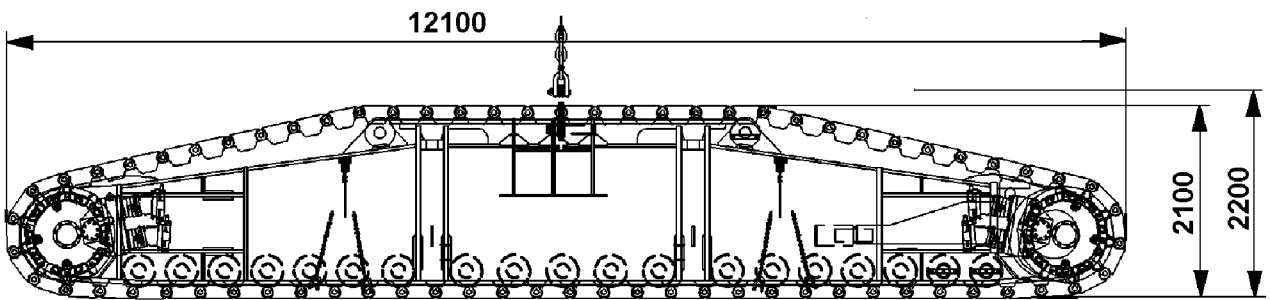
16. Parking the crane

DANGER: **Danger of accidents due to uncontrolled slipping or movement of the crane! If the following points are not observed by the crane operator, then personnel can be fatally injured.**

- **Do not park the crane on a downhill or on an unhill slope!**
- **Park the crane only on level ground with sufficient load bearing capacity!**

Chapter 3

Crane assembly



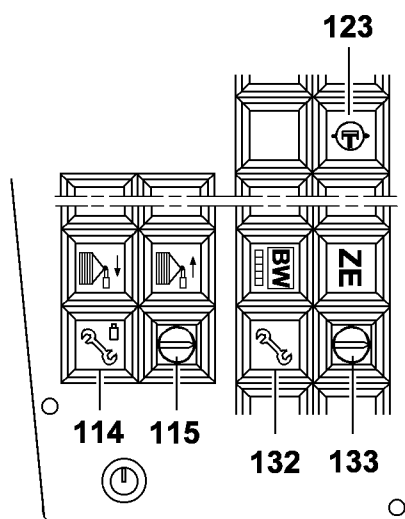
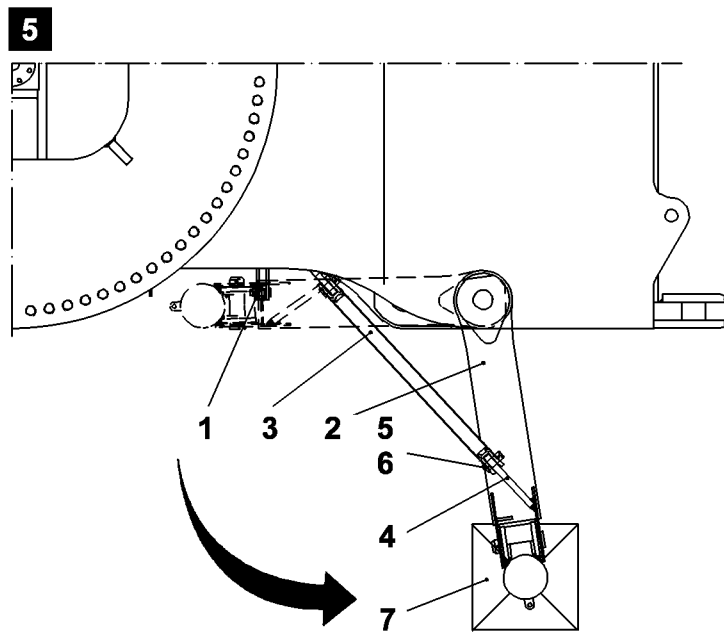
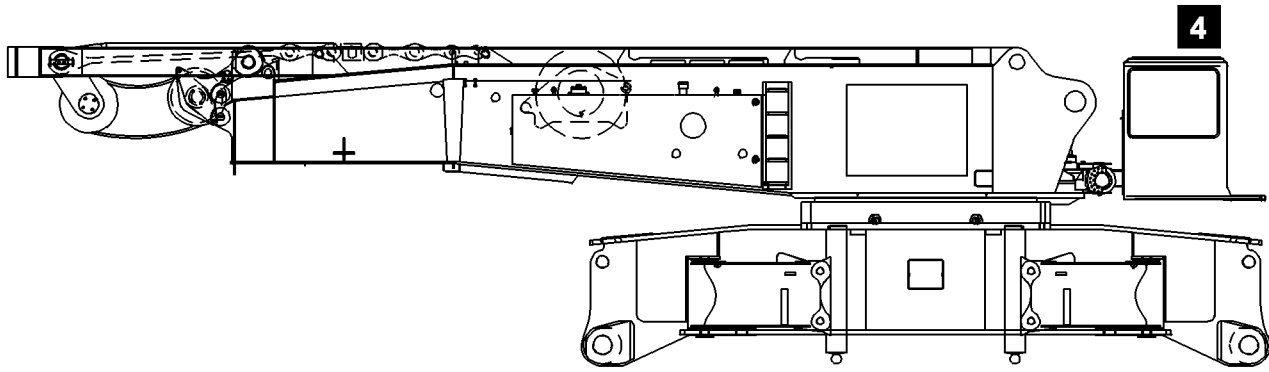
1. Transport weights and dimensions

Fig. 1

Crawler carrier

Crawler carrier	Track pad width (mm)		Number of travel drives	
	1500	2000	1	2
Weight (t) 43,6	X		X	
Weight (t) 45,8	X			X
Weight (t) 52,8		X	X	
Weight (t) 55,0		X		X

- At a track pad width of **1500 mm**, the crawler carrier height is **2100 mm**.
- At a track pad width of **2000 mm**, the crawler carrier height is **2200 mm**.



2. Installation of crawler carrier

Prerequisites:

- The crane engine is running - see chapter 4.03
- Press installation keyed button (133) and keyed button "Crawler installation" (115) betätigen. Die The indicator lights "Installation" (132) and "crawler installation" (114) light up.
- Set the operating mode, which is being installed, on the LICCON.
- The pressure supply change over switch to the auxiliary users (123) must be turned on in the cab.

Installation procedure:

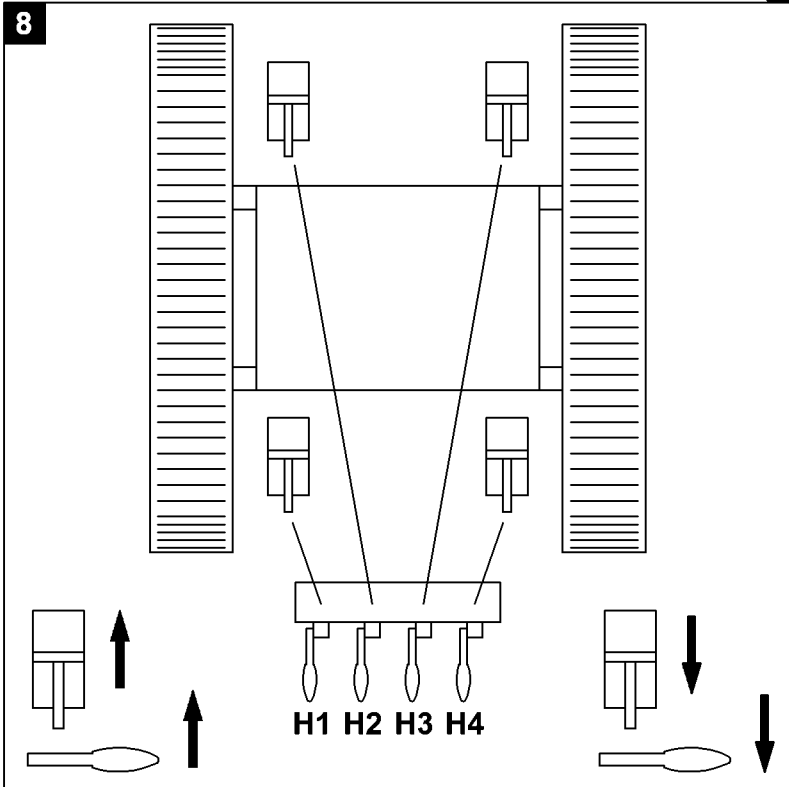
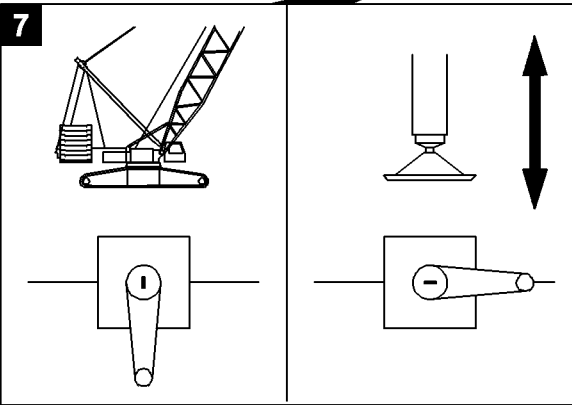
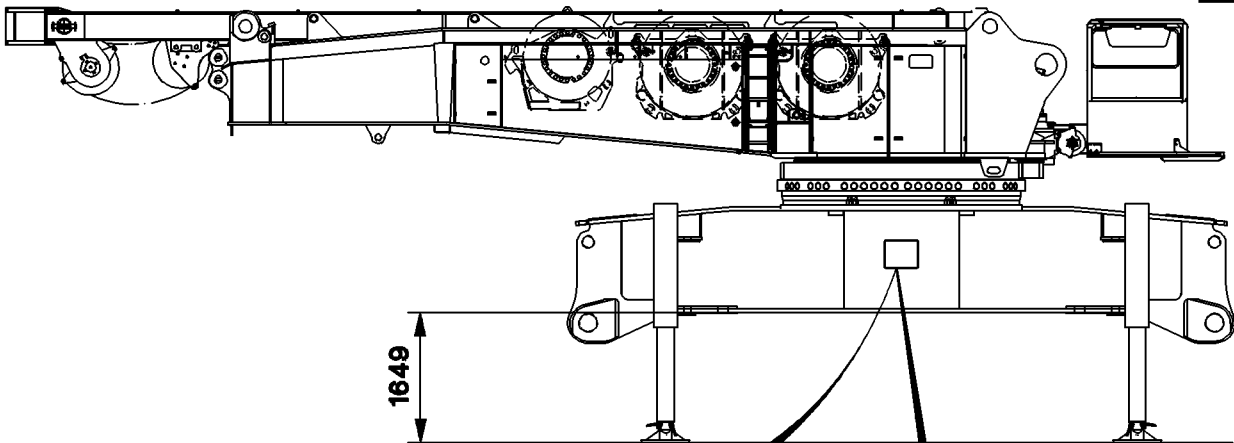
- 2.1 Swing out the hydraulic support, lock and pin
- 2.2 Lift the slewing platform and crawler center section (fig. 4) from the flatbed truck with the support.
- 2.3 Erect the A-bracket - see chapter 5.02
- 2.4 Installation of crawler carrier with the A-bracket
 - 2.4.1 Installation of the first crawler carrier
 - 2.4.2 Installation of the second crawler carrier
- 2.5 Hydraulic connections for quick couplings

2.1 Swing out the hydraulic support, lock and pin (fig. 5)

- Release the transport retainer (1) .
- Swing out the support (2) .
- Lock the support pipe (3) on bracket (4) .
- Insert pin (5) and secure with spring retainer (6) .

D A N G E R: **Make sure that there are no persons or objects within the swing range of the support .**
 There is a great danger of accidents!

6



2.2 Lift the slewing platform and crawler center section (fig.6) from the flatbed trailer with the support

Prerequisite:

- No central ballast and no slewing platform ballast may be installed on the crane.
- The hydraulic support must be swung out, locked and pinned.
- The ball cock (fig. 7) must be open .
- The support cylinders are actuated with the manual control levers H1, H2, H3, H4 (fig. 8).
 - H 1 = Manual control lever for support cylinder, left front
 - H 2 = Manual control lever for support cylinder, left rear
 - H 3 = Manual control lever for support cylinder, right rear
 - H 4 = Manual control lever for support cylinder, right front

Support

The support plates (7) (fig. 5) must be supported from below with suitable, stable materials, such as wood, steel or concrete plates, depending on the ground conditions.

Note: Note the safety guidelines and permissible ground pressures (Chapter 2.04) !

D A N G E R : Only suitable materials may be used for the ground support.
The support must be placed in the center underneath the support plates.
If this is not observed, there is a danger of accidents!

Actuate the manual lever "push" and lift the slewing platform and crawler center section with the hydraulic support cylinders to approx. 1649 mm (fig. 6). The slewing platform and the crawler center section must be aligned in horizontal direction !

D A N G E R : Before lifting the crane, make sure that all transport retainers have been removed between the flatbed trailer and the crane.
During the lifting procedure, make sure that the crane always remains in horizontal position. After lifting and alignment, close the ball cock (fig. 7) .

Remove the flatbed trailer from the installation area of the crane.

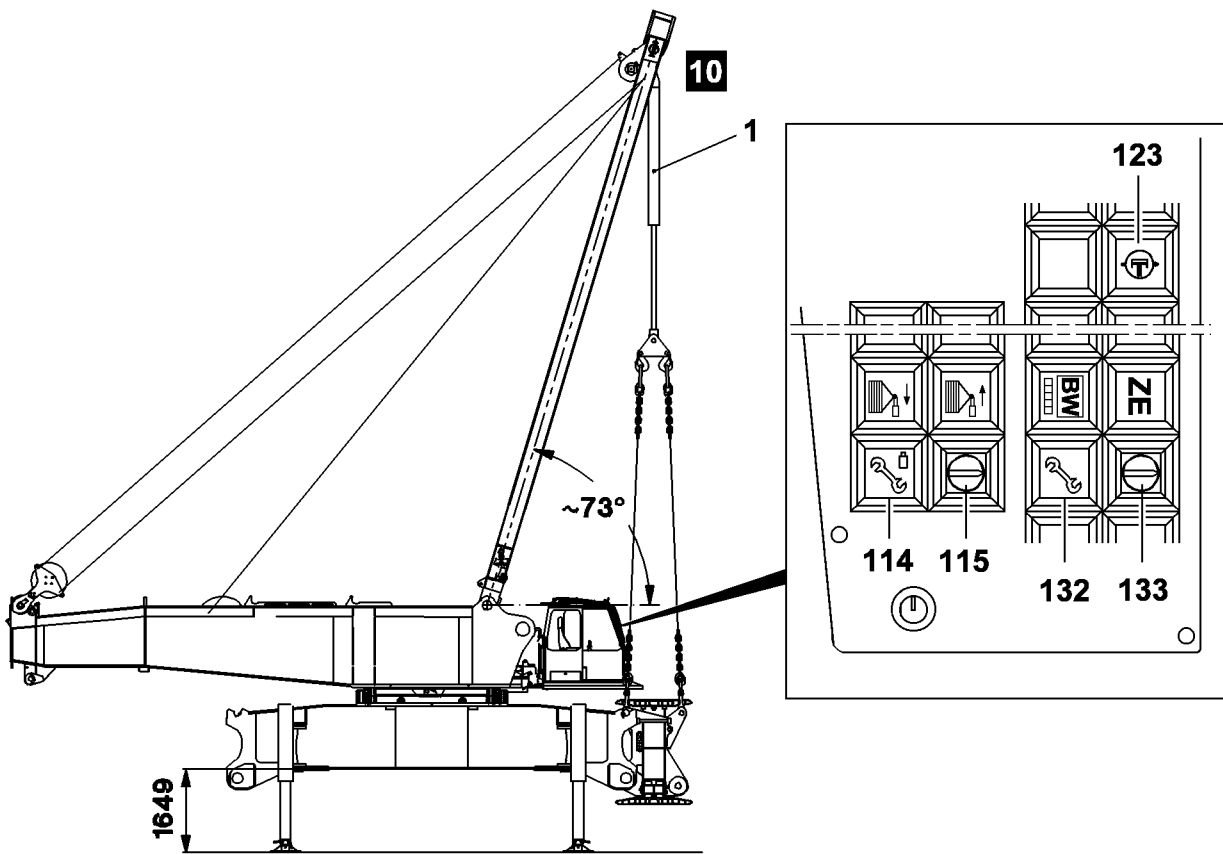
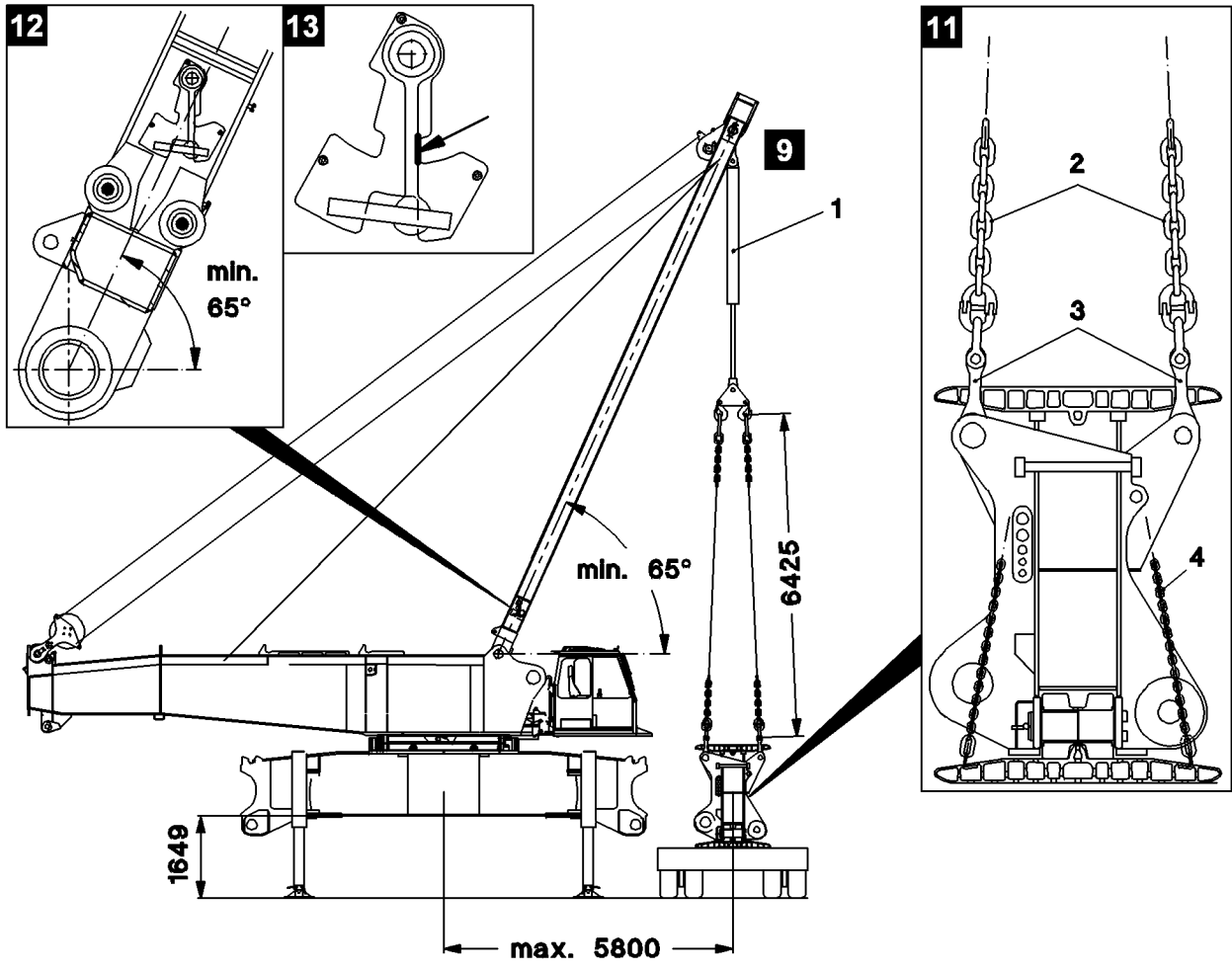
2.3 Erect the A-bracket

For procedure to erect the A-bracket, see chapter 5.02 / 3. - Erection

With supported and aligned crane :

- the A-bracket can be moved between 0° and 163° .
- the slewing platform can be turned by 360° .

D A N G E R : On the supported crane, no central ballast and no slewing platform ballast may already be installed or maybe installed later!
There is a danger of tipping over!



2.4 Installation of the crawler carrier with the A-bracket

Prerequisite:

- The crane must be horizontally aligned.
- Drive the transport vehicle with the crawler carrier as close as possible to the crane. The maximum permissible distance of the crawler carrier to the slewing platform center point **may not exceed 5800 mm** (fig. 9).

CAUTION: Make sure the crane is horizontally aligned!
The distance of 5800 mm max not be exceeded!

2.4.1 Installation of the first crawler carrier

Attach the crawler carrier (fig. 9 / fig. 11))

- Lower the A-bracket to the front.
- Do not fall below 65° on the A-bracket (fig. 12)
- 65° on the A-bracket are reached if the pendulum (fig. 13) remains in the drawn position.
- Extend the installation cylinder (1) and attach the tackle (2) on the installation brackets (3). To do so, the installation brackets must be folded upward (fig. 11).

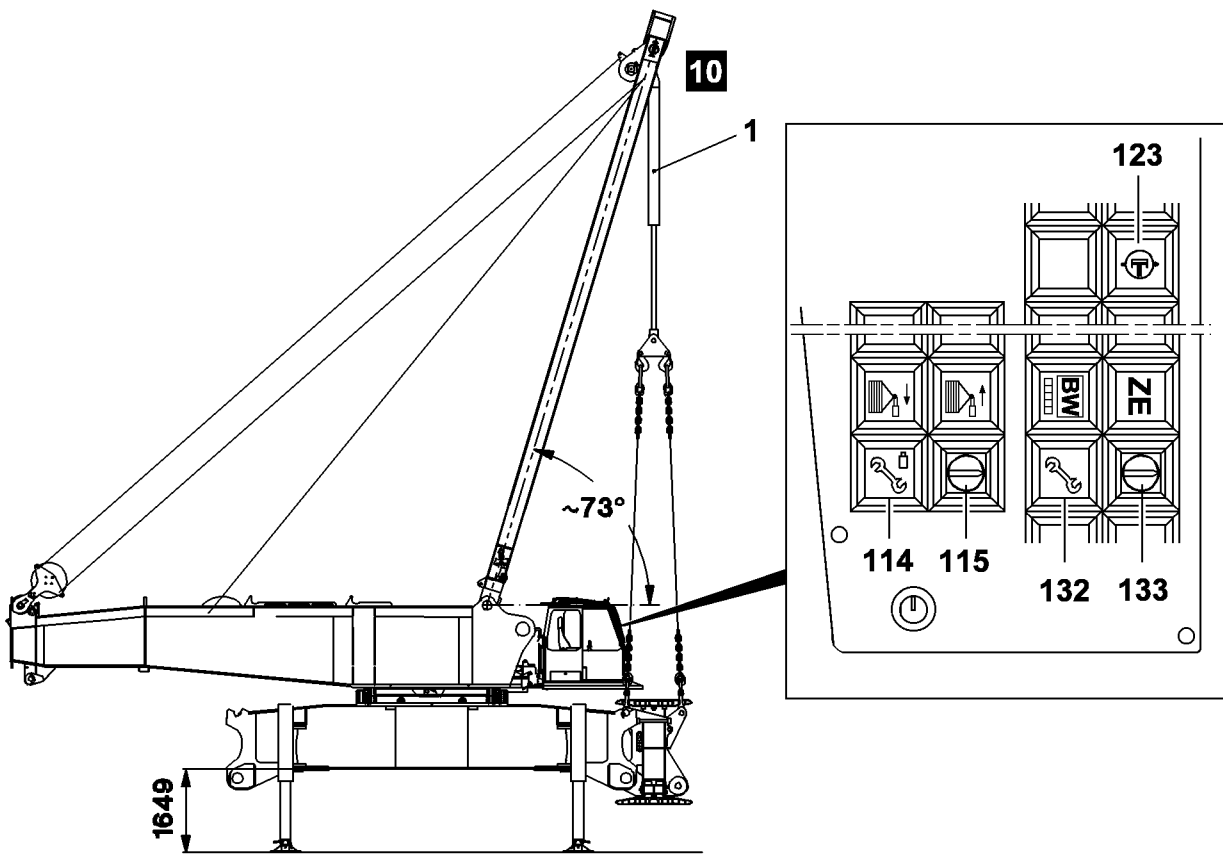
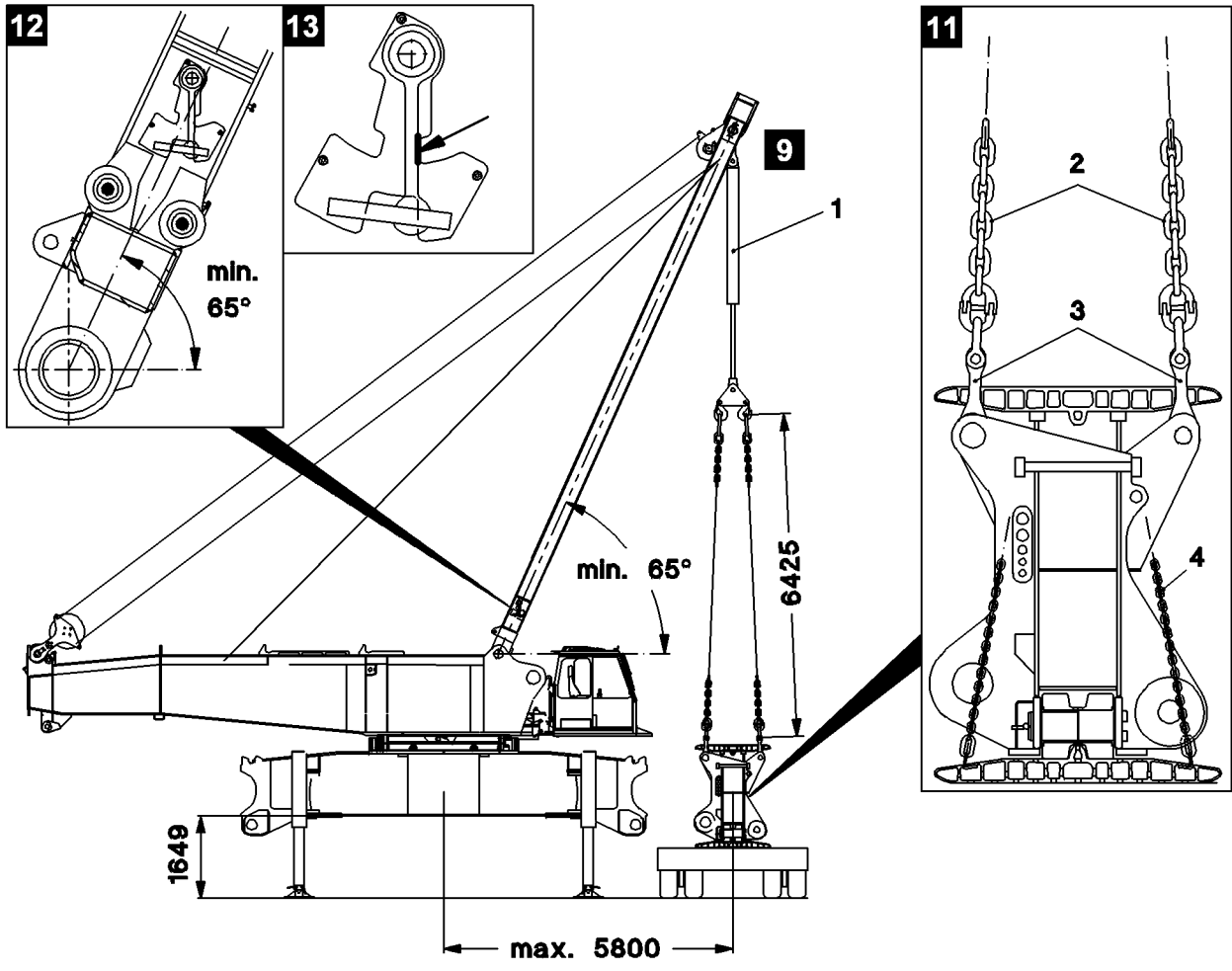
DANGER: The crawler plates of the crawler carrier must be secured with the transport retainers (4) (fig. 11) to prevent them from hanging through.
Otherwise there is a danger of accidents!

Lift the crawler carrier with the installation cylinder from the transport vehicle.

Note: The weight of the crawler carrier, depending on the equipment configuration, is max. 55 t - see chart in chapter 3.01 / 1.Crawler carrier.
Pay attention to the mark on the crawler carrier and on the receptacle.

DANGER: The max. distance of 5800 mm (fig. 9) may not be exceeded when lifting off the crawler carrier, since there is no overload shut off for the SA-bracket .
Indication via pendulum on the SA-bracket (fig. 13).
There is a danger of tipping over!

In operating mode, keyed button " crawler installation" (115) turned on - there is no overload shut off for the installation cylinder as well as for the crane.
There is a danger of accidents!



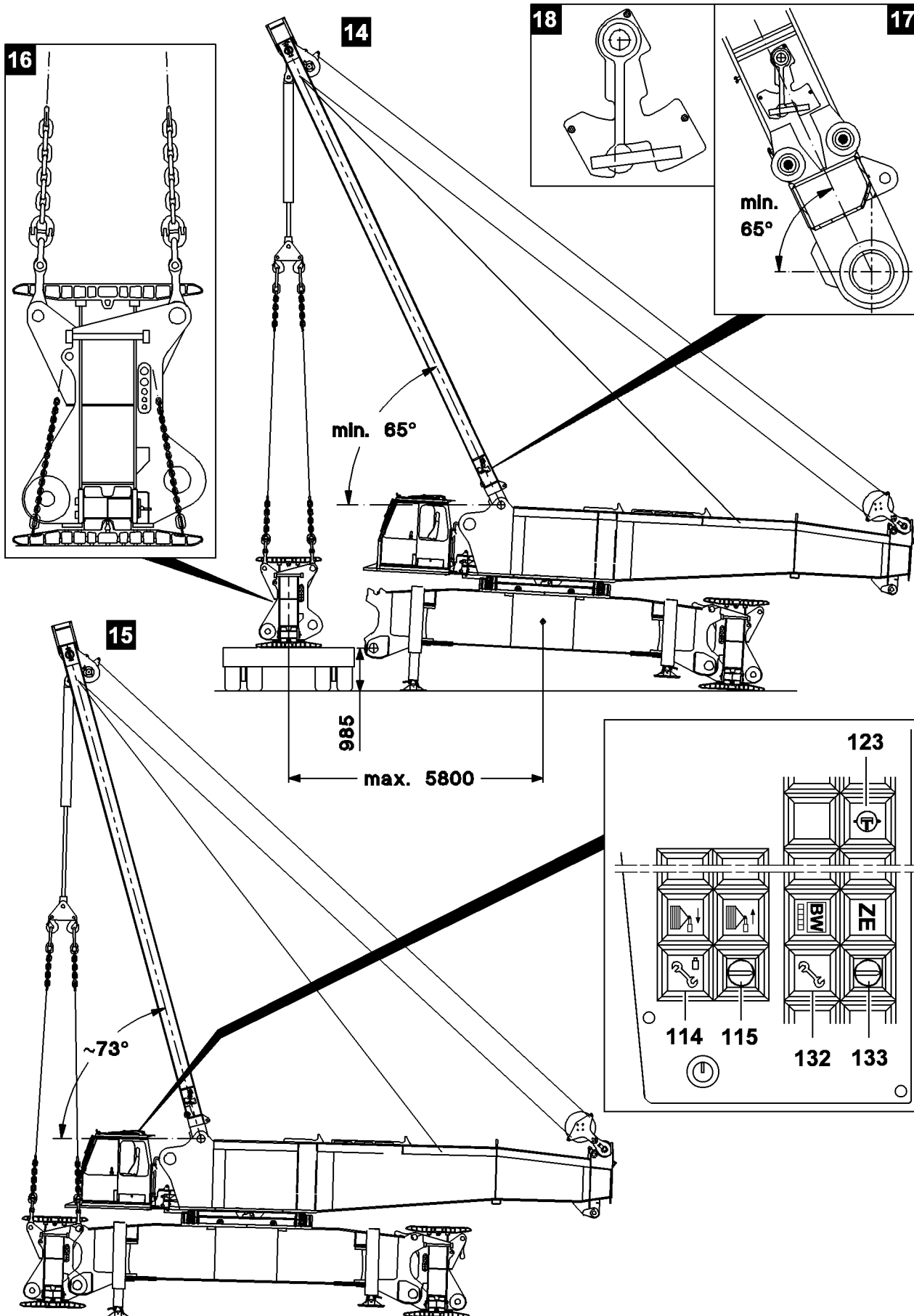
Installation of the first crawler carrier (fig. 10)

- Swing the crawler carrier, with the A-bracket to the receptacle on the crawler center section.
- Carefully retract the crawler carrier and pin and secure on the receptacles on the crawler center section.
- Release the tackle (2) from the installation brackets (3) and remove. Fold down the installation brackets.
- Lower all supports from 1649 mm to 985 mm .

C A U T I O N: **Make sure the crane is aligned in horizontal position!**

- Set down the first crawler carrier onto the ground by retracting the two support cylinders **on the crawler side**. Fully retract the support cylinder on the side of the pinned on crawler carrier .

D A N G E R: **Before turning the slewing platform, the first crawler carrier must be positioned on the ground.**
Otherwise there is a danger of tipping over!



2.4.2 Installation of the second crawler carrier

Turn the slewing platform .

C A U T I O N : Before turning the slewing platform, the installed first crawler carrier must be on the ground and the support cylinders on the crawler center section must be fully retracted (fig. 14).
There is a danger of tipping over!

D A N G E R : The max. distance of 5800 mm (fig. 14) may not be exceeded when lifting the crawler carrier, since there is no overload shut off for the SA-bracket .
Indication via pendulum on the SA-bracket (fig. 18).
There is a danger of tipping over!

In operating mode, keyed button " crawler installation" (115) turned on - there is no overload shut off for the installation cylinder as well as for the crane.
There is a danger of accidents!

The installation of the second crawler carrier must be carried out according to the description for the installation of the first crawler carrier.

After the installation of the second crawler carrier, lower it by retracting the support cylinders to the ground.

- Fully retract the support cylinder.
- However, the support remains swung out.
- Release and remove the tackle from the installation brackets, fold the installation brackets down.
- Close the ball cock (fig. 7) .
- Turn the pressure change over in the cab off.
- Fully retract the installation cylinder and turn the crawler installation off.

2.5 Establish the hydraulic connection to the two crawler travel gears

The hydraulic connection to the crawler travel gears is established with quick couplings.

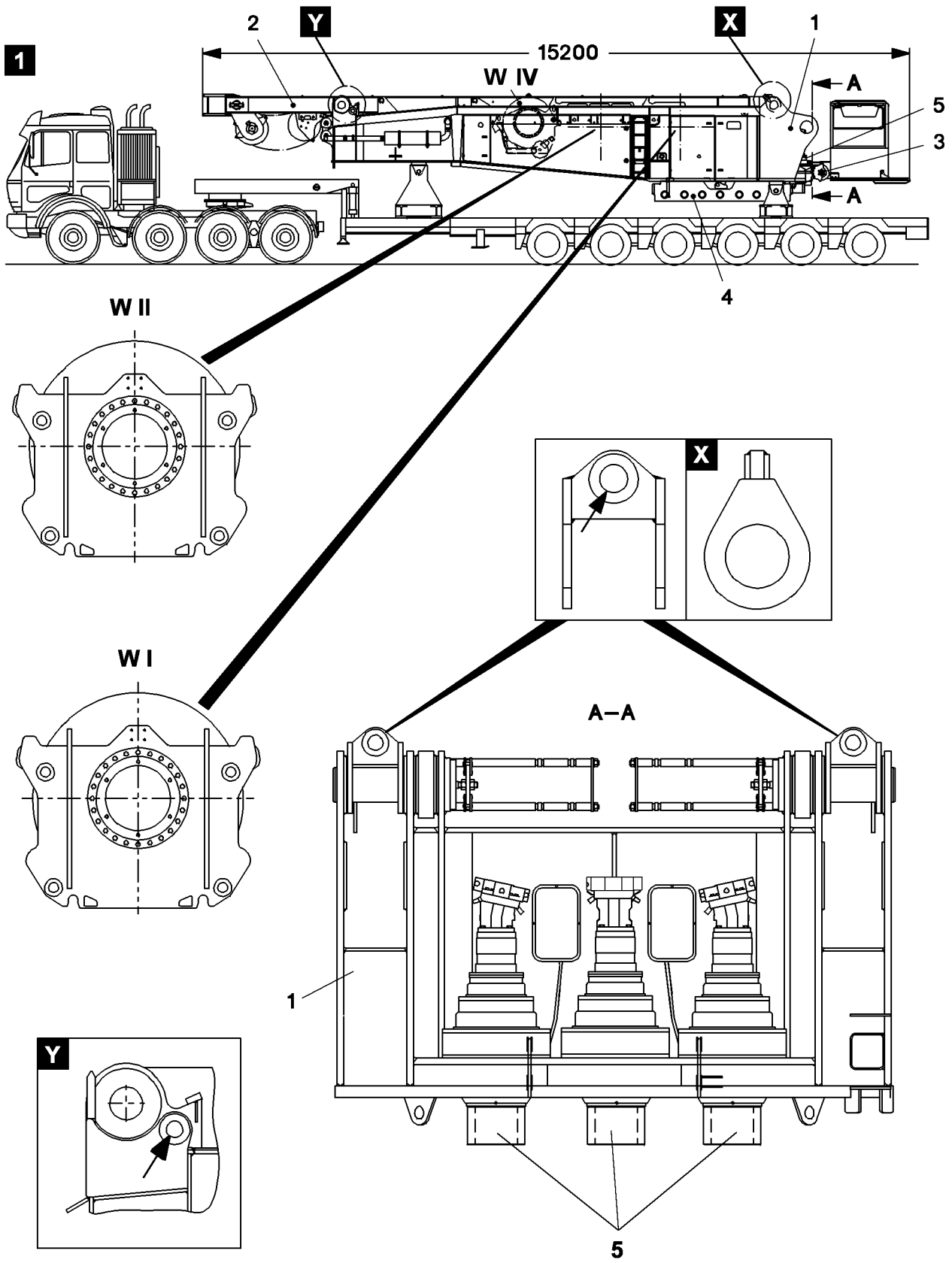
Note: The corresponding quick couplings are marked.

Connect or release the hydraulic lines with quick couplings

D A N G E R : When connecting or releasing hydraulic lines via quick couplings it must be ensured that the coupling procedure is carried out correctly.

- Prerequisite for a correct coupling connection is
- The pressure in the hydraulic system must be released before connecting or releasing the couplings (the engine must be at a standstill - wait for 5 minutes).
- Push the coupling sections (sleeve and plug) into each other and screw together with hand nut.
- Turn the nut past the O-ring until you can feel a noticeable, fixed stop.
- The couplings may only be tightened by hand - without tools (this could damage the couplings).

Improperly connected couplings can cause loss of pressure or sudden leakages, which in turn can cause serious accidents.



1. Transport weights and center of gravity of slewing platform

Slewing platform (1) on flatbed trailer (fig. 1) installed are:

- Winch IV incl. cable
- A-bracket incl. pulleys (2)
- Installation winch incl. cable (3)
- Upper section of roller slewing connection (ROD) with Quick Connection(4)
- 1-3 slewing gears (5) depending on equipment (slewing gear 2 or 3, as option)

Weights of slewing platform:

Slewing platform	Winch I incl. cable (8,7 t)	Winch II incl. cable (8,7 t)
Weight (t) 56,2	---	---
Weight (t) 64,9	---	X
Weight (t) 73,6	X	X

Center of gravity of slewing platform:

(Chapter 3.01 / 1. Transport weights and center of gravity)

2. Montage der slewing platform

Prerequisite:

- Brackets (X) are pinned on receptacle points for pivot section (A-A).

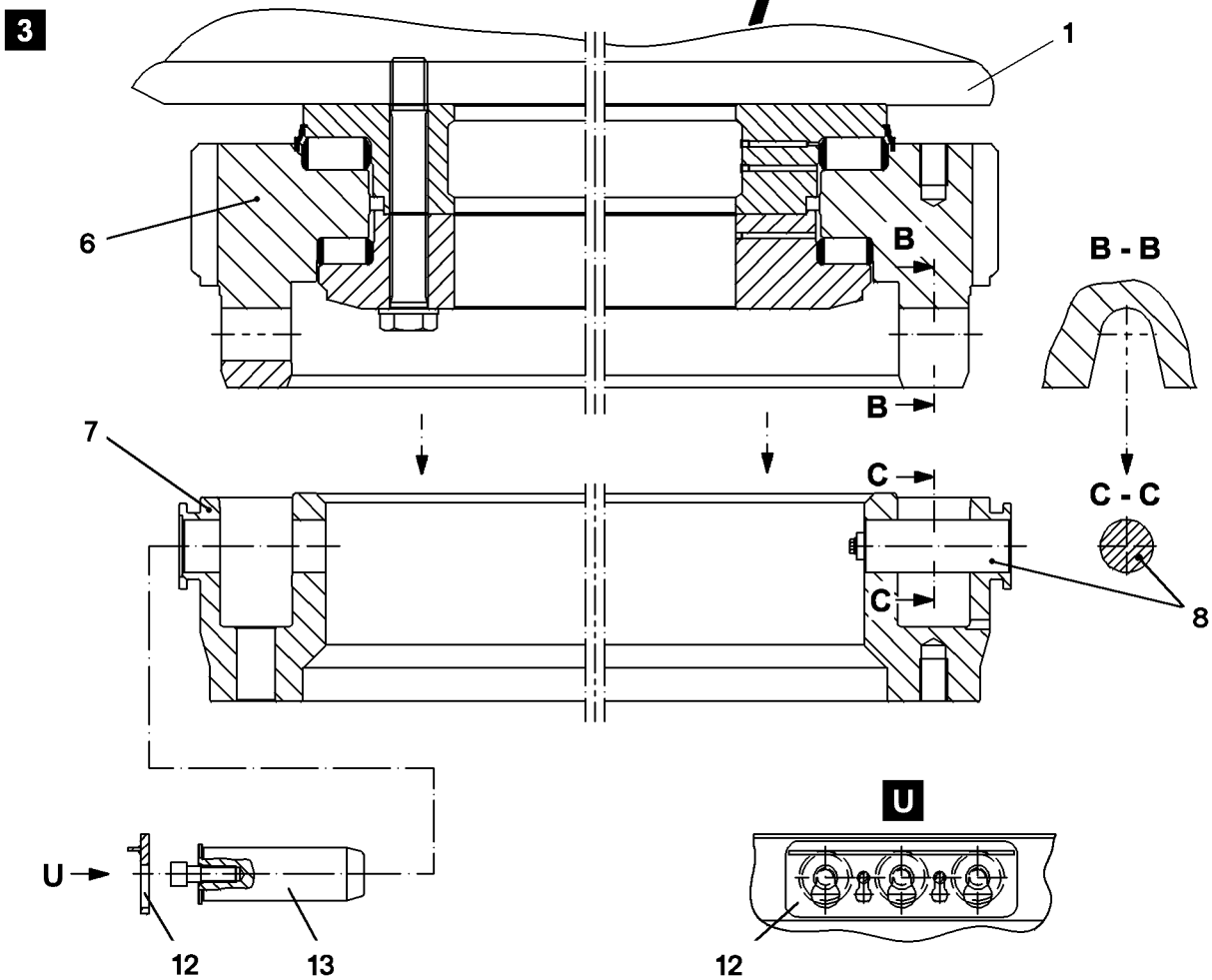
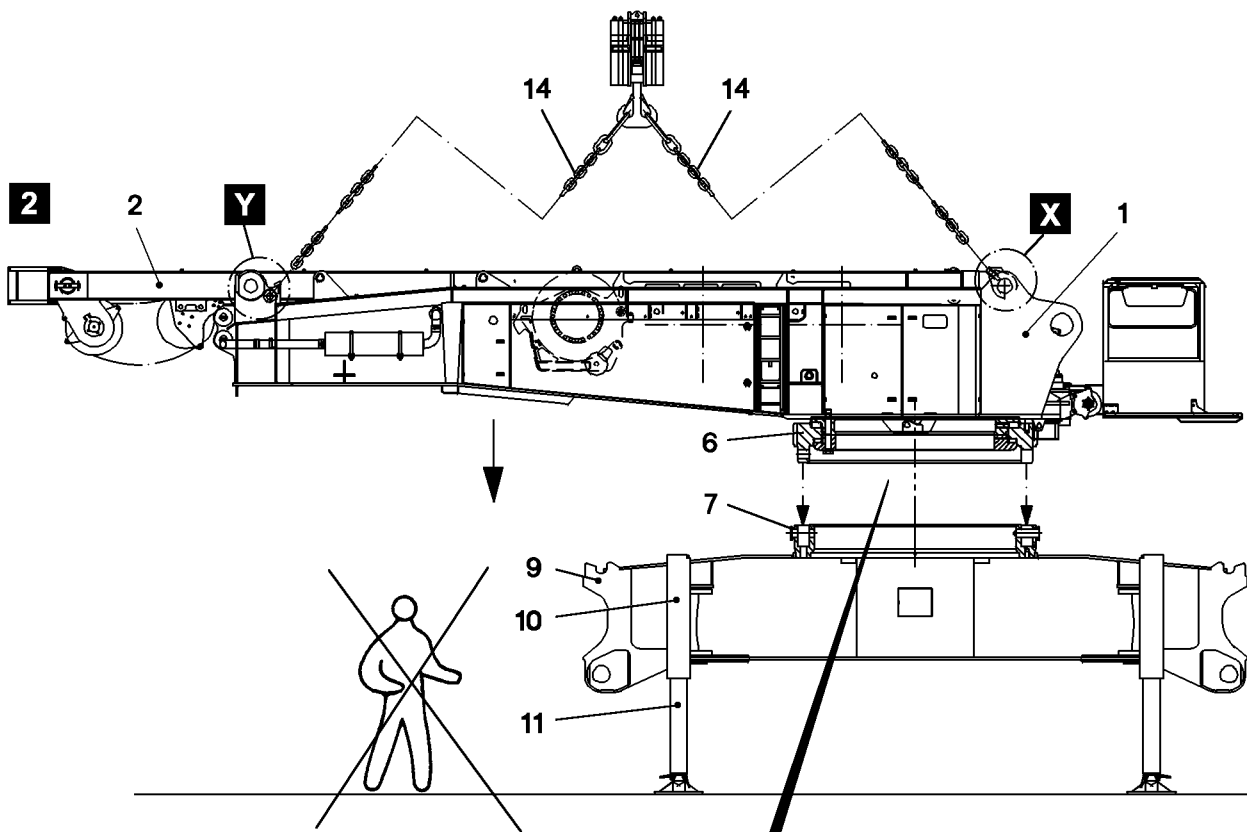
D A N G E R: It must be ensured that the brackets (X) are pinned correctly.
If this is not observed, there is a danger of accidents!

- The tackle devices are attached on the receptacle points (X / Y) (arrow).
- Bring the tackle device to "Tension" .
- Release and remove the transport retainers of the slewing platform.
- Lift the slewing platform with the auxiliary crane from the flatbed trailer

D A N G E R: Attach the tackle devices only on the intended receptacle points (X / Y) (fig. 1 // fig. 2)
It must be ensured that the tackle are attached correctly and secured sufficiently to prevent them from loosening up.
If this is not observed, there is a danger of accidents!

Installation procedure:

- 2.1 Clean the receptacle and contact surfaces of the roller slewing connection .
- 2.2 Set the slewing platform with the auxiliary crane onto the crawler center section.
- 2.3 Pin the slewing platform with crawler center section.
- 2.4 Establish the hydraulic connection to the slewing platform.



2.1 Clean the receptacle or contact surfaces of the roller slewing connection (ROD)

- The receptacle or contact surfaces on the upper (6) and lower section (7) of the roller slewing connection (ROD) must be cleaned before installation.
- Clean the pin bores on the upper and lower section of the roller slewing connection .

2.2 Set the slewing platform with the auxiliary crane onto the crawler center section

Prerequisite:

- The hydraulic support (10) on the crawler center section (9) is swung out, locked and pinned.
- The support cylinders (11) are extended.
- The crawler center section (9) is horizontally aligned.
- The upper (6) and lower section (7) of the ROD have been cleaned.
- The two centering pins (8) on the lower section of the ROD are installed and secured.
- The centering pins (8) have been greased with waterproof grease.

Installation procedure:

- The tackle devices (14) are attached on the receptacle points of the slewing platform (X / Y) (fig. 2).

D A N G E R : It must be ensured that the tackle devices are correctly attached on the receptacle points (X / Y) and sufficiently secured to prevent them from loosening up.
There is a danger of accidents!

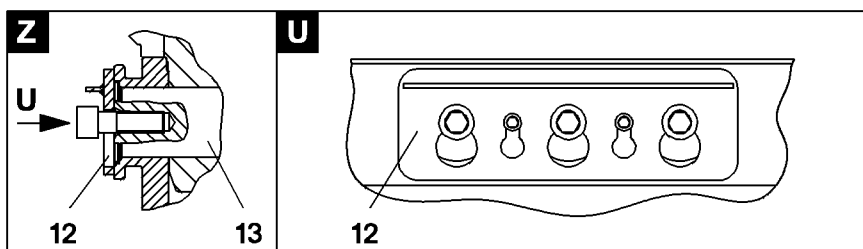
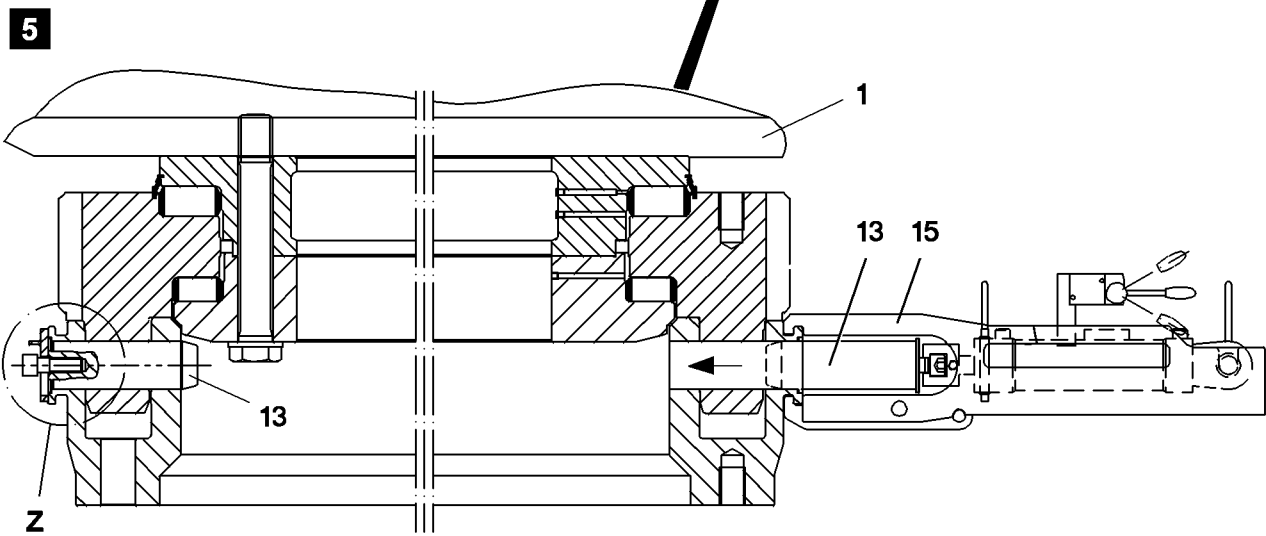
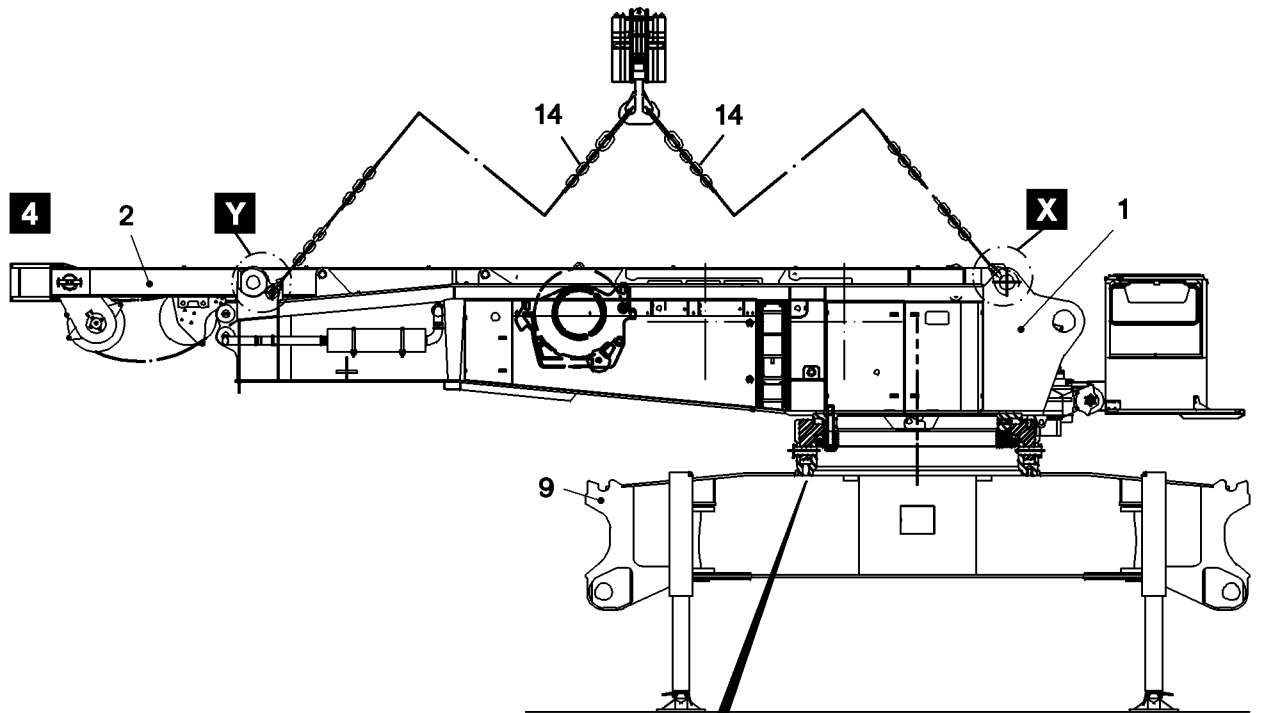
- With the auxiliary crane, slowly swing in the slewing platform (1) over the supported and horizontally aligned crawler center section.
- Lower the slewing platform slowly.

Note: Before lowering, bring the slewing platform in position so that the centering pin (8) (C - C) on the lower section (7) and the receptacles (B - B) on the upper section (6) can be "paired up" .
It is not possible to "incorrectly " set the slewing platform onto the lower section (7) due to the design of the location of the centering pins.

C A U T I O N: However, the slewing platform or the receptacles to the centering pins must be aligned correctly.

D A N G E R : It is not permitted for anyone to remain in the swing range of the auxiliary crane and under the slewing platform when swinging the slewing platform in or lowering it.
There is a danger of accidents!

- Carefully set the slewing platform on the crawler center section.
- The slewing platform must be lowered with the upper section to the stop on the lower section.



2.3 Pin the slewing platform with the Quick Connection

Prerequisite:

- slewing platform (1) sitzt auf crawler center sectionl (9).
- the tackle devices (14) between the slewing platform and the auxiliary crane are **"tensioned"**
- the pin bores on the circumference of the roller slewing connection are clear.

Installation procedure:

- All 64 connector pins (13) have been greased with waterproof grease.
- Insert all 64 connector pins (13) by hand to the stop in the pin bores (Z) and pin the slewing platform with the crawler center section. (fig. 5)
- If it is too hard, use a pin pulling device (15) for pinning.
- Attach the retaining bar (12) and secure the connector pins (13) (U).

**D A N G E R . The connector pins must be secured immediately after pinning the slewing platform with the crawler center section.
If this is not observed, there is a danger of accidents!**

- After the roller slewing connection is pinned and secured, remove the tackle devices .

2.4 Establish the hydraulic connection to the slewing platform.

The hydraulic connection from the rotary connection in the crawler center section to the slewing platform is established with quick couplings.

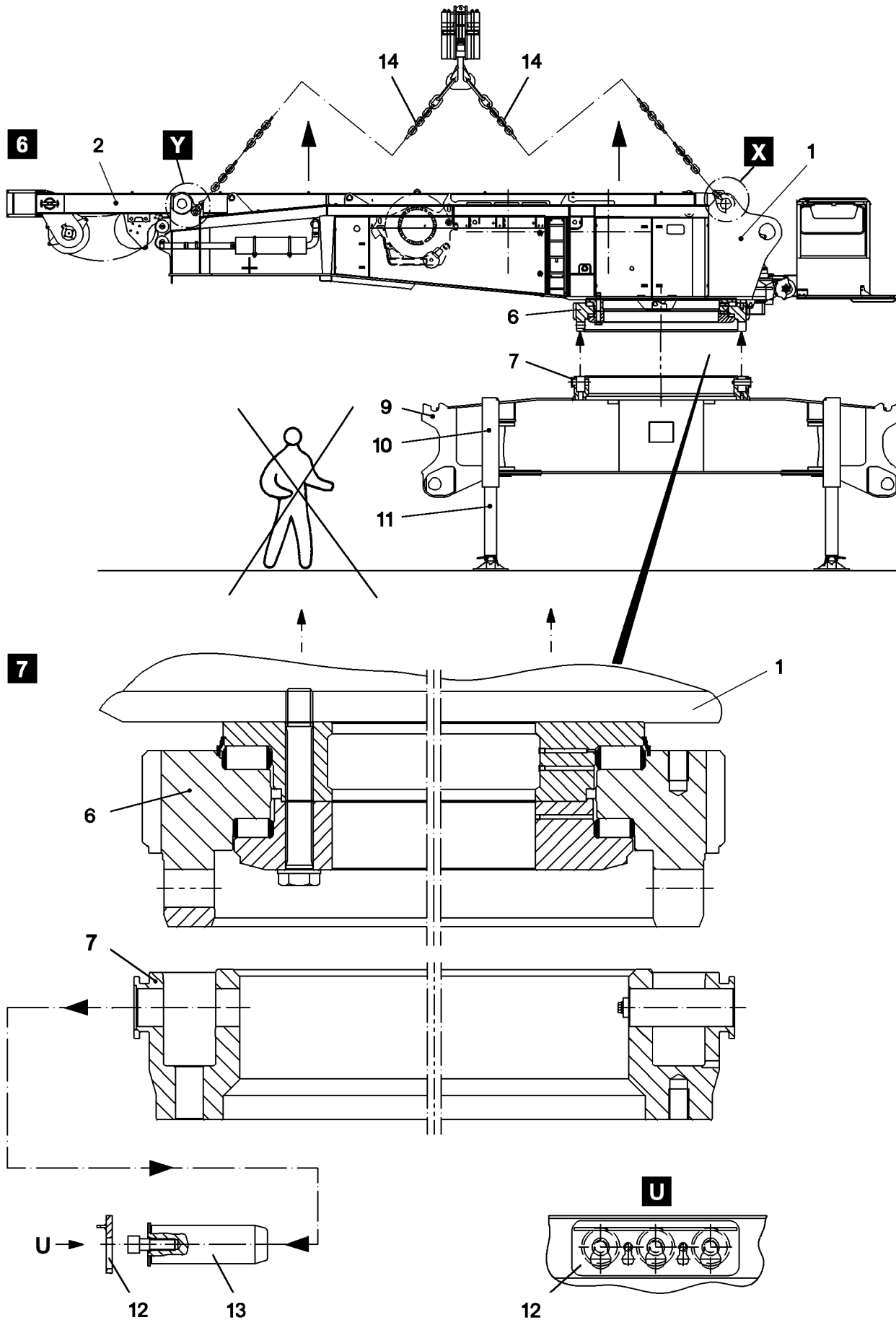
Note: The quick couplings which belong together are marked.

To connect or release the hydraulic lines with quick couplings

D A N G E R : **When connecting or releasing the hydraulic lines with quick couplings, it must be ensured that the coupling procedure is carried out correctly.**

Prerequisites for a correct coupling connections:

- **The pressure in the hydraulic system must be released before connecting or releasing the couplings (the engine must be at a standstill - wait 5 minutes).**
- **Push the coupling sections (sleeve and plug) into each other and screw together with the hand nut.**
- **Turn the hand nut past the O-ring until you feel a noticeable, fixed stop.**
- **The couplings may only be tightened by hand - without tools - (they could damage the couplings).**
- **Improperly connected couplings could cause loss of pressure or sudden leakage and could cause accidents.**



3. Removal of the slewing platform

Remove the slewing platform with the auxiliary crane after crane operation.

Prerequisite:

- The slewing platform ballast and the boom systems have been removed.
- The crawler carriers are removed.
- The hydraulic support (10) on the crawler center section (9) is swung out, pinned and secured.
- The support cylinders (11) are extended.
- The crawler center section is horizontally aligned.
- The A-bracket (2) is placed on the slewing platform (1).
- The hydraulic connections on the rotary connections to the slewing platform have been disconnected.
- The brackets (X) are installed and pinned (fig. 1).
- The tackle devices are attached on the receptacle points (X / Y) on the slewing platform (fig. 6).

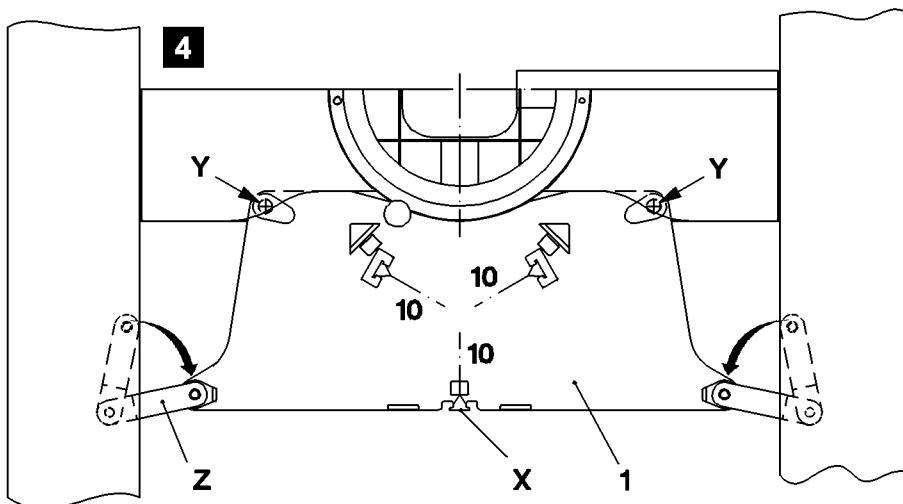
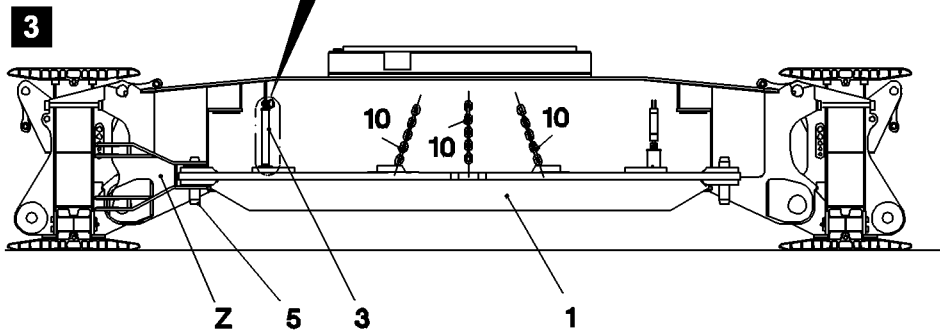
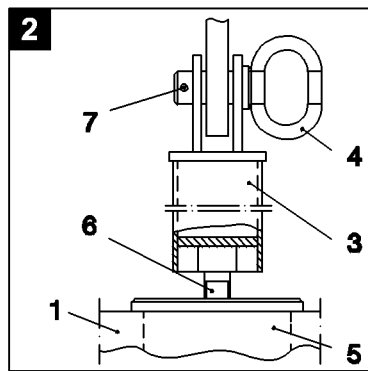
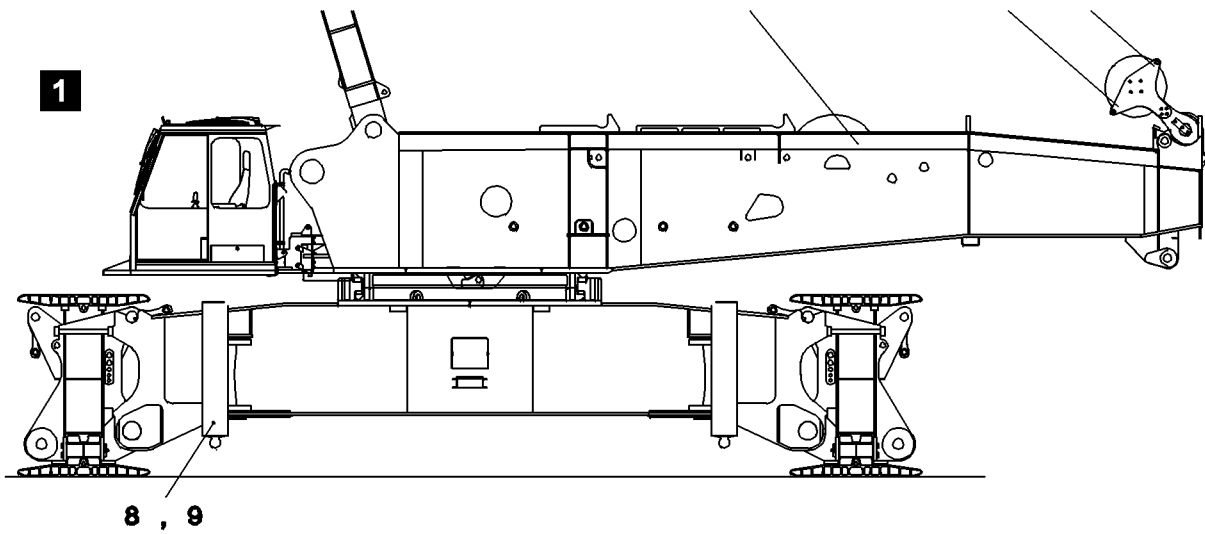
CAUTION: It must be ensured that all hydraulic connections between the rotary connection and the slewing platform are disconnected.

Removal procedure

- Bring the tackle devices (14) with the auxiliary crane to "tension".
- Release and remove the retaining bar (12) (U).
- Unpin all connector pins (13) by using the pin pulling device.
- When all connector pins have been removed, carefully lift the slewing platform with the auxiliary crane.

CAUTION: Before lifting the slewing platform with the auxiliary crane, make sure that ALL connector pins for the Quick Connection have been removed.

DANGER: It is strictly prohibited for anyone to remain in the danger zone of the slewing platform while lifting and swinging the slewing platform (fig. 6).
It is prohibited to remain in the swing range of the auxiliary crane.
There is a danger of accidents!



1. Installation of central ballast 20t / 45t / 95t , at crane mode on crawlers

Prerequisites:

- The installation of the crawler carrier (chapter 3.01) is completed.
- All connections between crawler carrier center carrier and crawler carrier are pinned and secured.
- The hydraulic support (8) **must** be swung out, locked and pinned.
- The hydraulic support cylinders (9) are fully retracted.
- Both crawler carriers are standing on the ground.
- The slewing platform is positioned 90° to the crawler carriers (fig. 1)
- Install the central ballast only according to the load charts .

CAUTION. When driving the crane, the base plates must always be installed! The base plates have the task to take on the resulting steering forces on the crawler carriers.

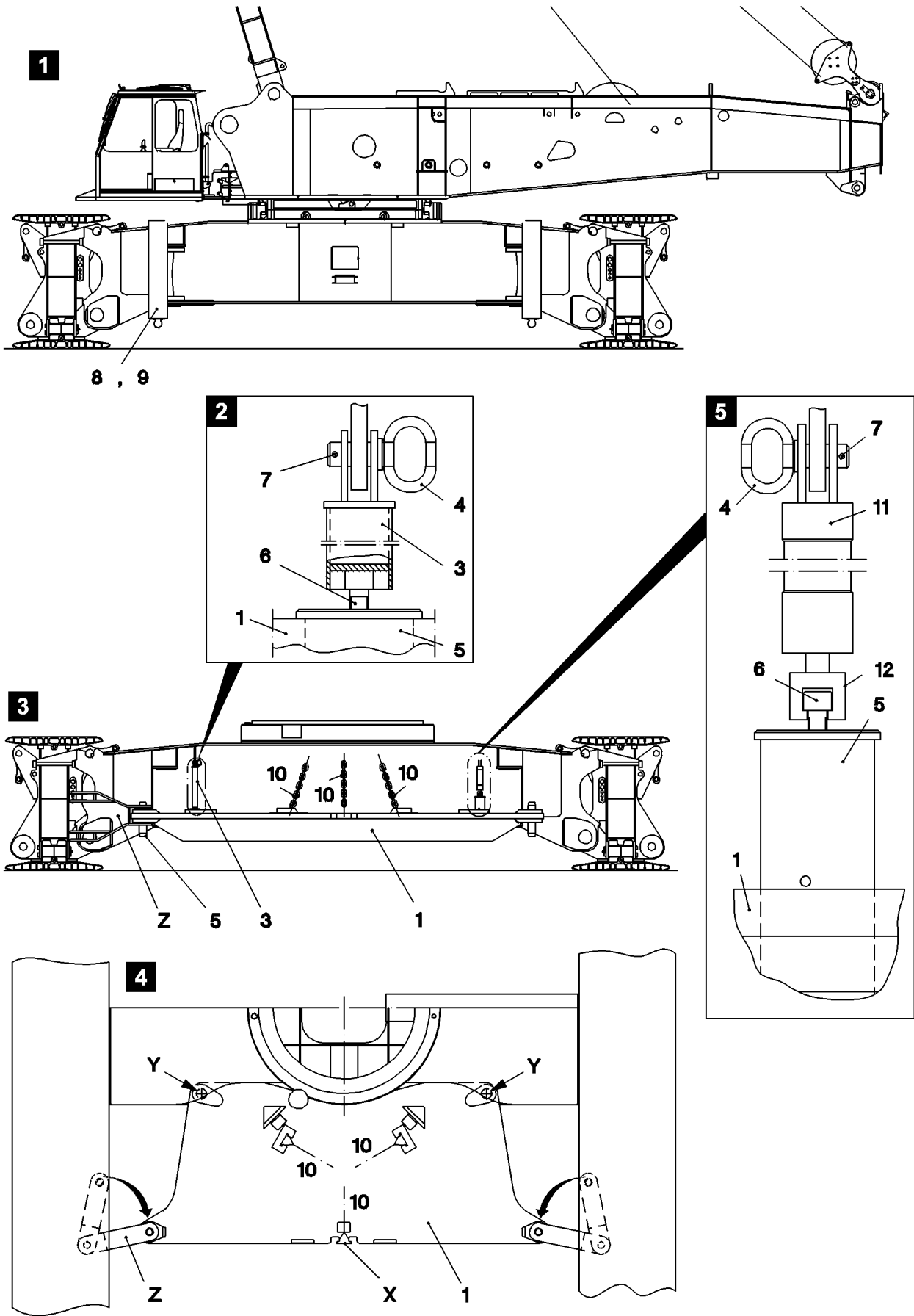
DANGER: The central ballast may only be installed according to the load charts!
When driving the crane, the base plates must always be installed! If this is not observed, there is a danger of accidents !

1.1 Components for installation of central ballast (ZB / CB) :

Pos.	Description	Quantity
1	Base plate approx 10 t	2
2	Counterweight 12,5 t	6
3	Pipe	4
4	Pin	4
5	Pin Ø 145 x 405 mm	4
6	Screw M 24 x 60 DIN912 10.9	4
7	Spring retainer 6	4

1.2 Assembly of central ballast (ZB / CB)

ZB 20 t:	2	x	Base plate approx	10,0 t	Pos. 1
ZB 45 t:	2	x	Base plate approx.	10,0 t	Pos. 1
	2	x	Counterweight	12,5 t	Pos. 2
ZB 95 t:	2	x	Base plate approx.	10,0 t	Pos. 1
	6	x	Counterweight	12,5 t	Pos. 2



1.3 Installation Base plate

Install the base plate (1) with the auxiliary crane, attach tackle (10) to holders (X).

Lift the base plate with auxiliary crane and run it in to the stop on the crawler center section. First pin and secure the base plate on the pin points (Y) (fig. 4) on the crawler center section with pins (5) and secure. Swing out the brackets (Z) (fig. 4), pin and secure them with pin on the base plate.

D A N G E R : It must be ensured that the tackle is correctly attached on the holders and secured sufficiently to prevent it from loosening up.
There is a danger of accident as the base plate can tip over or fall down!

1.3.1 Installation procedure :

- Pins (5) are seated in the pin bores (Y) of the base plate .
- Lift the base plate with the auxiliary crane and run it in to the stop on the crawler center section .

Note: Weight of base plate is approx. 10 t

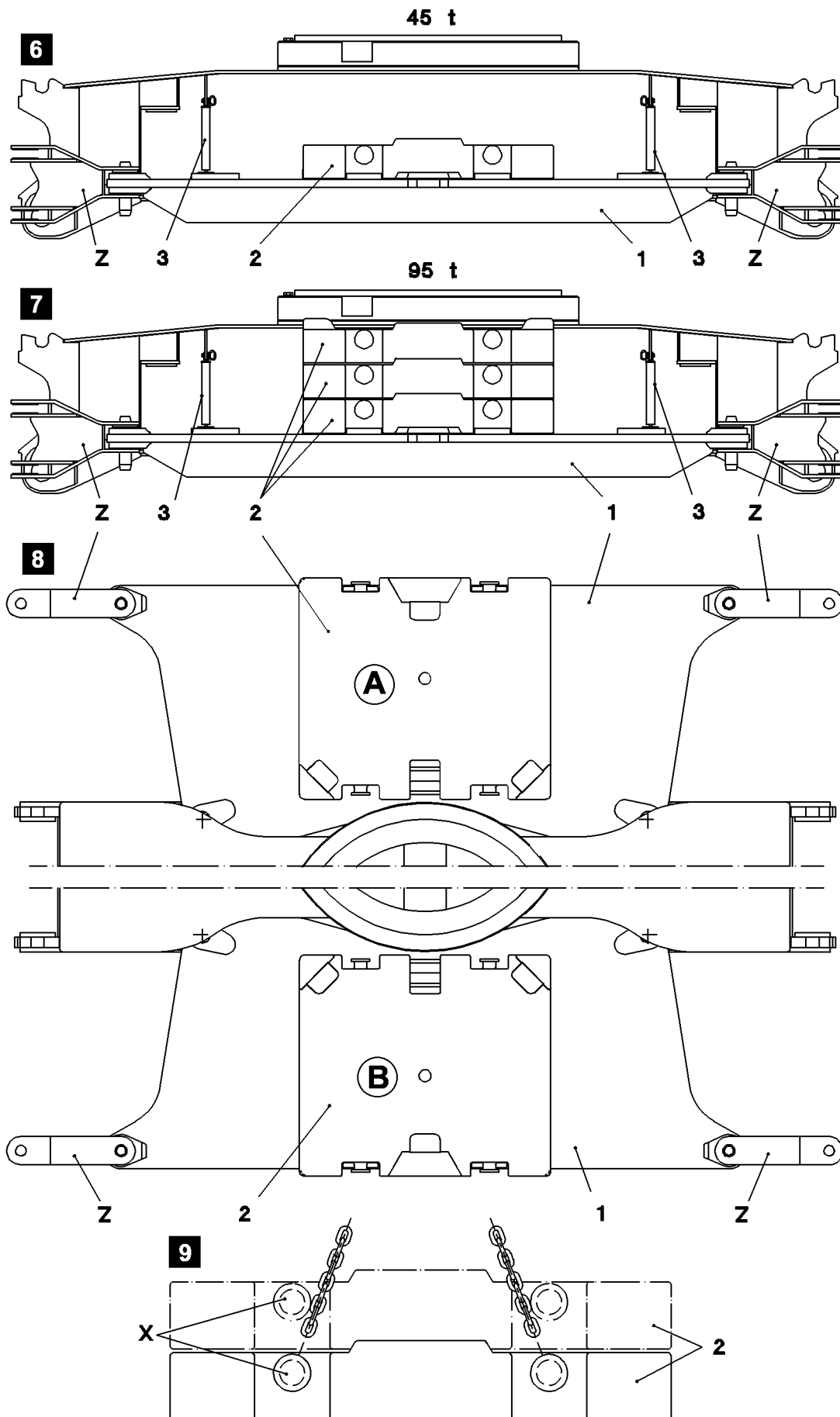
D A N G E R : Make sure that no one is between the base plate and the crawler center section or the crawler carriers while the base plate is run in! This is strictly prohibited!
There is an increased danger of accidents due to crushing !

- Carefully lower the base plate and align it until the bores of the base plate and the crawler center section align and the pins (5) slip into the bore due to their own weight. If necessary, help it along.
- If the pins (5) do not move easily, use a pin pulling device (fig. 5). To do so, push the pin pulling device (11) with the fork head (12) over the screw head, pin with pins (4) on the pin pulling device and secure with the spring retainer (7) . Push the pin (5) into the bore hole.
- Remove the pin pulling device.

D A N G E R : Before pinning, make sure that the pin bore holes are clear.
After pinning, secure the pin immediately!

- Secure the pin (5) with pipe (3) to prevent it from loosening up (fig. 2)
- Push the pipe (3) over the screw head (6), pin with pin (4) and secure with spring retainer (7) .
- Swing out the brackets (Z) of the crawler carriers (fig. 4), pin and secure with the base plate, using pins.
- When all pin points on the base plate are pinned and secured, remove the tackle (10) .

D A N G E R : Make sure that there are no persons within the swing range of the brackets.
There is a danger of accidents !



192723

1.4 Installation of counterweight plates

Prerequisite:

- The slewing platform is turned by 90° to the crawler carriers (fig. 1)
- The base plate is pinned and secured .
- The central ballast may only be installed according to the load charts.

D A N G E R : **The central ballast may only be installed according to the load charts!
At A and B (fig. 8) always place the same counterweight!
If this is not observed, there is a danger of accidents!**

1.4.1 Installation procedure:

- Place the counterweight plates (2) with the auxiliary crane onto the base plate (1) (fig. 6 / 7).
- Attach the tackle to the holders (X) of the counterweight plates (fig. 9).

D A N G E R : **It must be ensured that the tackle is correctly attached on the holders and secured sufficiently to prevent it from loosing up.
There is a danger of accident !**

- Do not attach more than **max. two** counterweight plates at the same time (fig. 9)
- Place the counterweight plate (s) with the auxiliary crane onto the base plate (1) .
- The counterweight plates must be placed on the base plate in such a way that they are laying on it with the complete surface and centered in the receptacles .
- Always place the same counterweight on sides **A** and **B**, (fig. 8) .

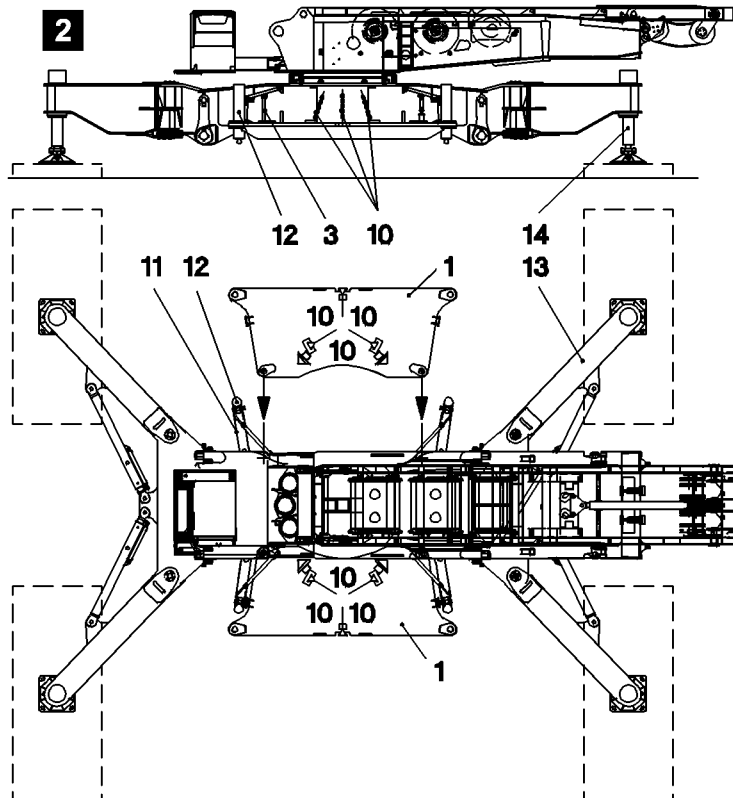
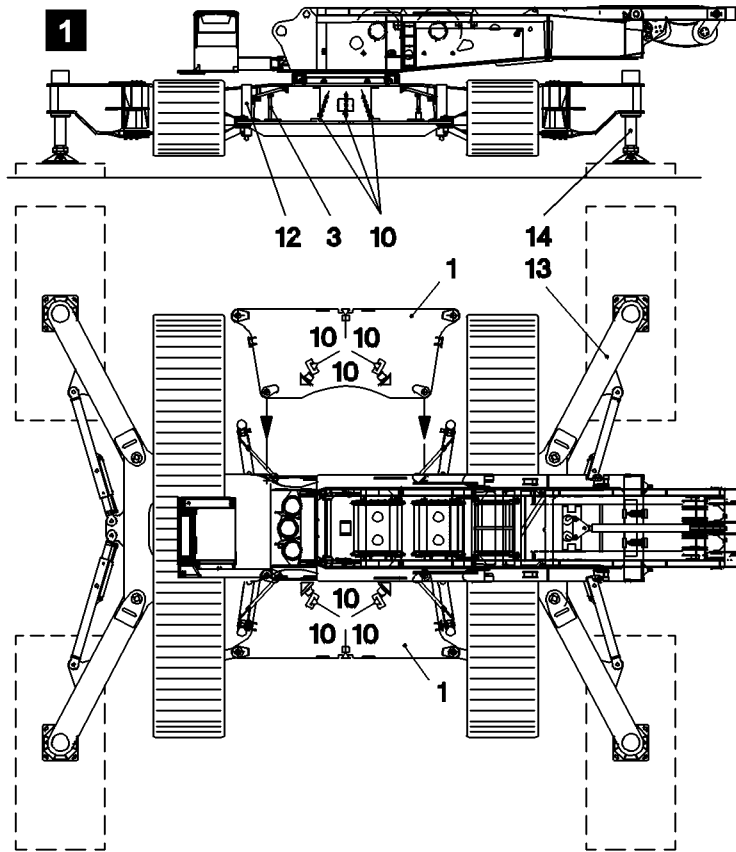
D A N G E R : **Make sure that no one is between the base plate and the crawler carriers during the run in of the counterweight plates! This is strictly prohibited.
There is a danger of accident!**

**Do not place more than max. two counterweight plates at the same time.
If this is not observed, there is a danger of accidents!**

1.5 Removal of counterweights and base plates

- Lift the counterweights with the auxiliary crane from the base plates.
- Attach the tackle to the holders (X) of the base plate (1) (fig. 3) .
- With the auxiliary crane, bring the tackle (10) to "tension" (fig. 3) .
- Release the pins on the brackets (Z) .
- Loosen and remove the pins on the brackets (Z) .
- Swing in the brackets .
- Remove the pin retainer, pipe (3).
- Loosen and remove the pin (5) on the crawler center section. If it does not move easily, use the pin pulling device.
- Lift the base plate with the auxiliary crane and run it out.

D A N G E R : **Make sure that no one is between the base plate and the crawler carriers during the run out of the counterweight plates! This is strictly prohibited.
There is a danger of accident !**



2. Installation of central ballast at cran mode on hydraulic supports

Prerequisites:

- Installation of crane support on crawler carrier (fig. 1) or installation of crane support on crawler center section (fig. 2) is completed.(Chapter 3.05 / 3. Install support)
- All pin connections between crawler center section, crawler carriers and crane support (fig. 1) or between crawler center section and crane support (fig. 2) are pinned and secured.
- The hydraulic support (11) **must** be swung out, locked and pinned.
- The hydraulic support cylinders (12) are fully retracted.
- The support arms (13) for the crane support are folded out.
- The support cylinders (14) for the crane support are extended.
- The crane is properly supported and horizontally aligned.
- Turn the slewing platform into a position so that it is possible to install the base plates and the counterweights without restriction (fig. 1 / fig. 2)
- The central ballast may only be installed according to the load charts.

D A N G E R : **The central ballast may only be installed according to the load charts!**
If this is not observed, there is a danger of accidents!

2.1 Components for installation of central ballast (ZB/ CB) :

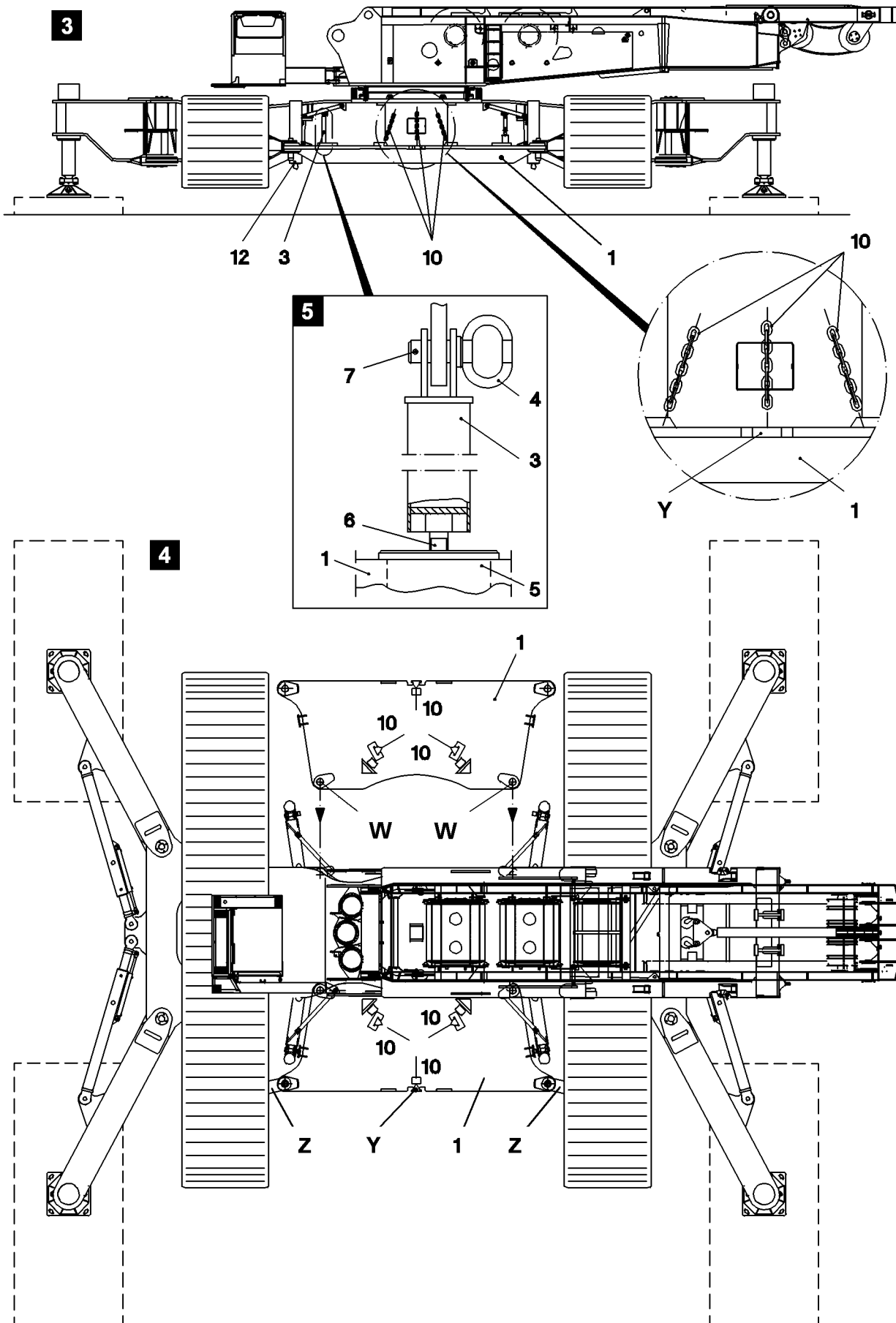
Pos.	Description	Quantity
1	Base plate approx. 10,00 t	2
2	Counterweight 12,50 t	2
3	Pipe	4
4	Pin	4
5	Pin Ø 145 x 405 mm	4
6	Screw M 24 x 60 DIN912 10.9	4
7	Spring retainer	4
8	Counterweight 25,00 t	2
9	Counterweight 3,75 t	4

2.2 Assembly of 110 t Central ballast (ZB / CB)

ZB 20 t:	2	x	Base plate approx	10,00 t	Pos. 1
ZB 110 t:	2	x	Base plate approx	10,00 t	Pos. 1
	2	x	Counterweight	12.50 t	Pos. 2
	2	x	Counterweight	25,00 t	Pos. 8
	4	x	Counterweight	3,75 t	Pos. 9

CAUTION: **ZB 20 t:** **at cran mode on supports, crawlers installed**

ZB 110 t: **only permissible at cran mode on hydraulic supports**
(crawlers NOT installed)



2.3 Installation base plate / crawler carrier installed

Install the base plate (1) with the auxiliary crane, attach tackle (10) to holders (Y).
Lift the base plate with auxiliary crane and run it in to the stop on the crawler center section. Pin and secure the base plate on the pin points on the crawler center section with pins (5). Swing out the brackets (Z) (fig. 4) and pin and secure with pin on base plate.

D A N G E R : It must be ensured that the tackle is correctly attached on the holders and secured sufficiently to prevent it from loosening up.
There is a danger of accident as the base plate can tip over or fall down!

2.3.1 Installation procedure :

- Pins (5) are seated in the pin bores (W) of the base plate (1).
- Lift the base plate with the auxiliary crane and run it in to the stop on the crawler center section (fig. 4).

Note: Weight of base plate is approx. 10 t

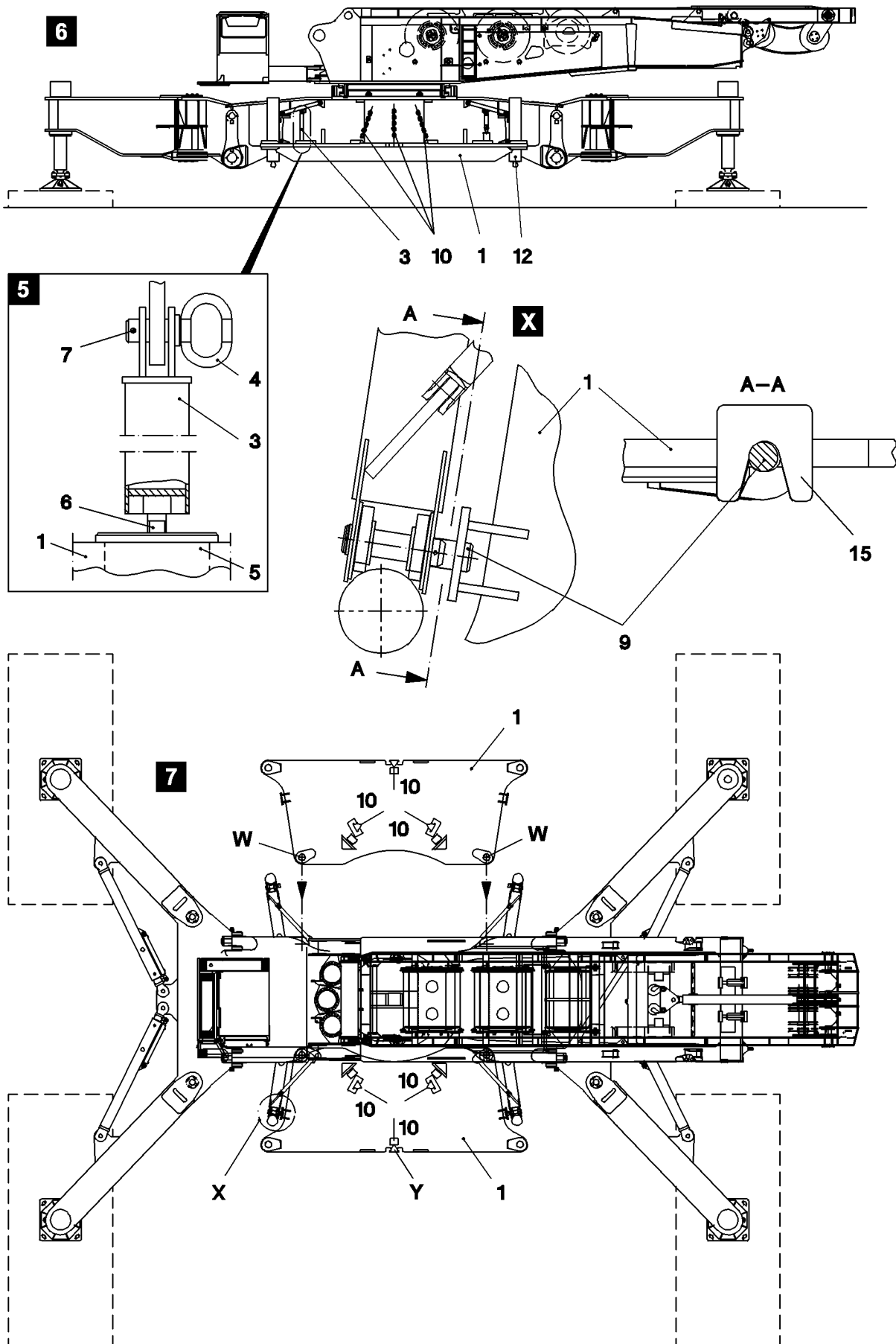
D A N G E R : Make sure that no one is between the base plate and the crawler center section or the crawler carriers while the base plate is run in! This is strictly prohibited!
There is an increased danger of accidents due to crushing !

- Carefully lower the base plate and align it until the bores of the base plate and the crawler center section align and the pins (5) (fig. 5) slip into the bore due to their own weight. If necessary, help it along.
- If the pins (5) do not move easily, use a pin pulling device. To do so, pin the pin pulling device with the pin (4) on bracket (fig. 5) and secure with the spring retainer (7).
Push the pin (5) into the bore hole.
- Remove the pin pulling device.

D A N G E R : Before pinning, make sure that the pin bore holes are clear.
After pinning, secure the pin immediately!

- Secure the pin (5) with pipe (3) to prevent it from loosening up (fig. 5)
- Push the pipe (3) over the screw (6), pin with pin (4) and secure with spring retainer (7).
- Swing out the brackets (Z) of the crawler carriers (fig. 4), pin and secure with the base plate.
- When all pin points on the base plate are pinned and secured, remove the tackle (10).

D A N G E R : Make sure that there are no persons within the swing range of the brackets.
There is a danger of accidents !



2.4 Installation of base plate / crawler carrier not installed

Install the base plate (1) with the auxiliary crane. Attach the tackle (10) to the handles (Y). Lift the base plate with the auxiliary crane to the stop on the crawler center section. Lower the base plate, until the receptacles (15) of the base plate are centered on the extended pins (9) of the cylinder mount and are touching (A-A). Pin and secure the base plate on the pin points with pins (5) and secure. The base plate is laying loosely at X, without being secured .

D A N G E R : It must be ensured that the tackle is correctly attached on the holders and secured sufficiently to prevent it from loosening up.
There is a danger of accident as the base plate can tip over or fall down!

2.4.1 Installation procedure:

- The pins (5) sit in the pin bores (W) of the base plate (fig. 7).
- Lift the base plate with the auxiliary crane and run it in to the stop on the crawler center section.

Note: The weight of the base plate is approx. 10 t

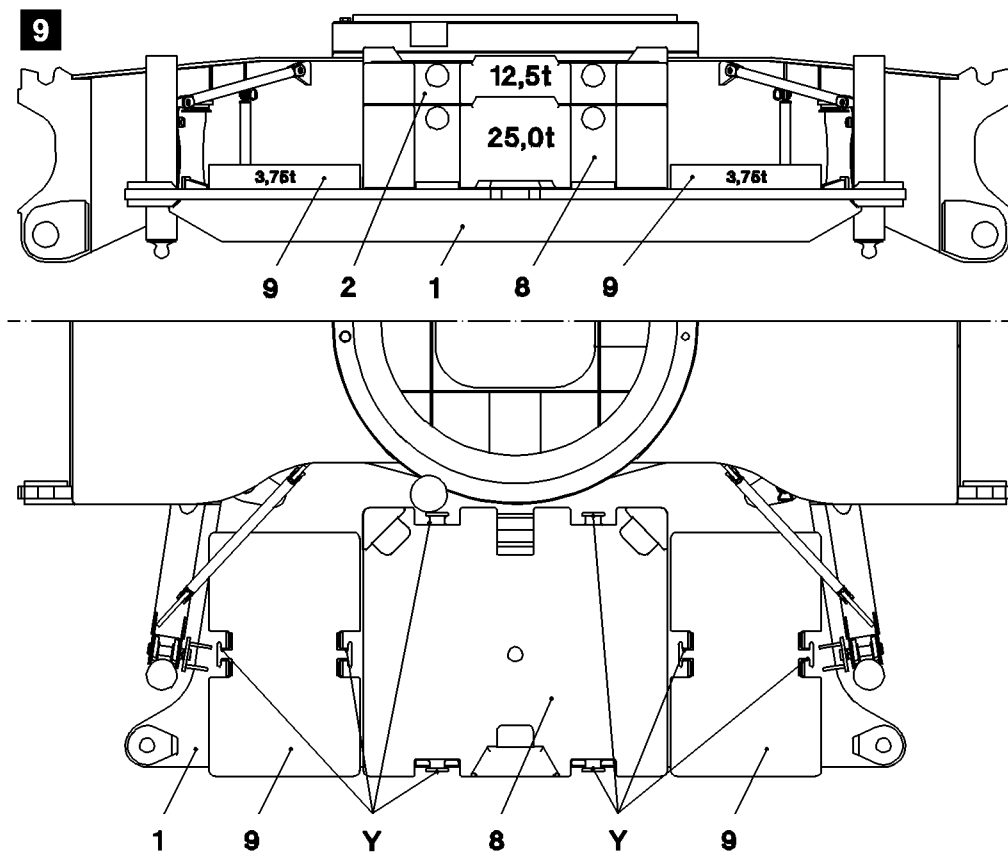
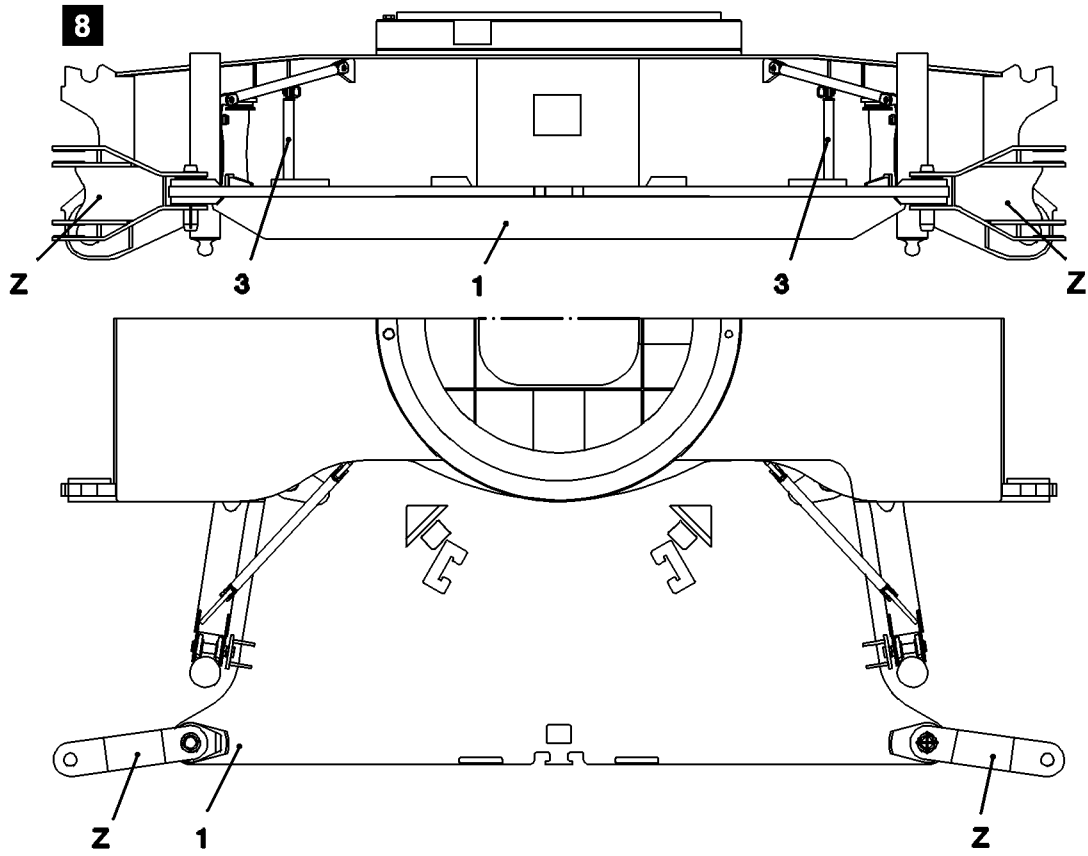
D A N G E R : Make sure that no one is between the base plate and the crawler center section or the crawler carriers while the base plate is run in! This is strictly prohibited!
There is an increased danger of accidents due to crushing !

- Carefully lower the base plate and align it until the bores of the base plate and the crawler center section align and the pins (5) (fig. 5) slip into the bore due to their own weight. If necessary, help it along.
- If the pins (5) do not move easily, use a pin pulling device. To do so, pin the pin pulling device with the pin (4) on bracket (fig. 5) and secure with the spring retainer (7) .
Push the pin (5) into the bore hole.
- Remove the pin pulling device.

D A N G E R : Before pinning, make sure that the pin bore holes are clear.
After pinning, secure the pin immediately!

- Attach the base plate (1) with receptacles (15) on the extended pins (9) of the cylinder mount (X) .
- Secure the pin (5) with pipe (3) to prevent it from loosening up (fig. 5)
- Push the pipe (3) over the screw (6), pin with pin (4) and secure with spring retainer (7) .
- Only when the base plate is pinned to the crawler center section and the receptacles (15) of the base plate are laying on the extended pins (9), remove the tackle (10) .

D A N G E R : It must be ensured that all pins (5) are secured and the receptacles (15) are laying on the extended pins (9) (A-A).
If this is not observed, there is a danger of accidents!



2.5 Installation of counterweight plates

Prerequisite:

- Turn the slewing platform into position that access to install the counterweights is unrestricted (fig. 6).
- The base plate is pinned and secured.
- The crane is aligned in horizontal direction.
- The central ballast may only be installed according to the load charts.

D A N G E R : **The central ballast may only be installed according to the load charts!
If this is not observed, there is a danger of accidents!**

2.5.1 Installation procedure:

- Place the counterweight plate (8) with the auxiliary crane onto the base plate (1) (fig. 9).
- Place the counterweight plate (2) with the auxiliary crane onto the counterweight (8) (fig. 9)
- Place the counterweight plate (9) with the auxiliary crane onto the base plate (1) (fig. 9)
- Attach the tackle to the holders (Y) of the counterweight plates.

D A N G E R : **It must be ensured that the tackle is correctly attached on the holders and secured sufficiently to prevent it from loosing up.
There is a danger of accident !**

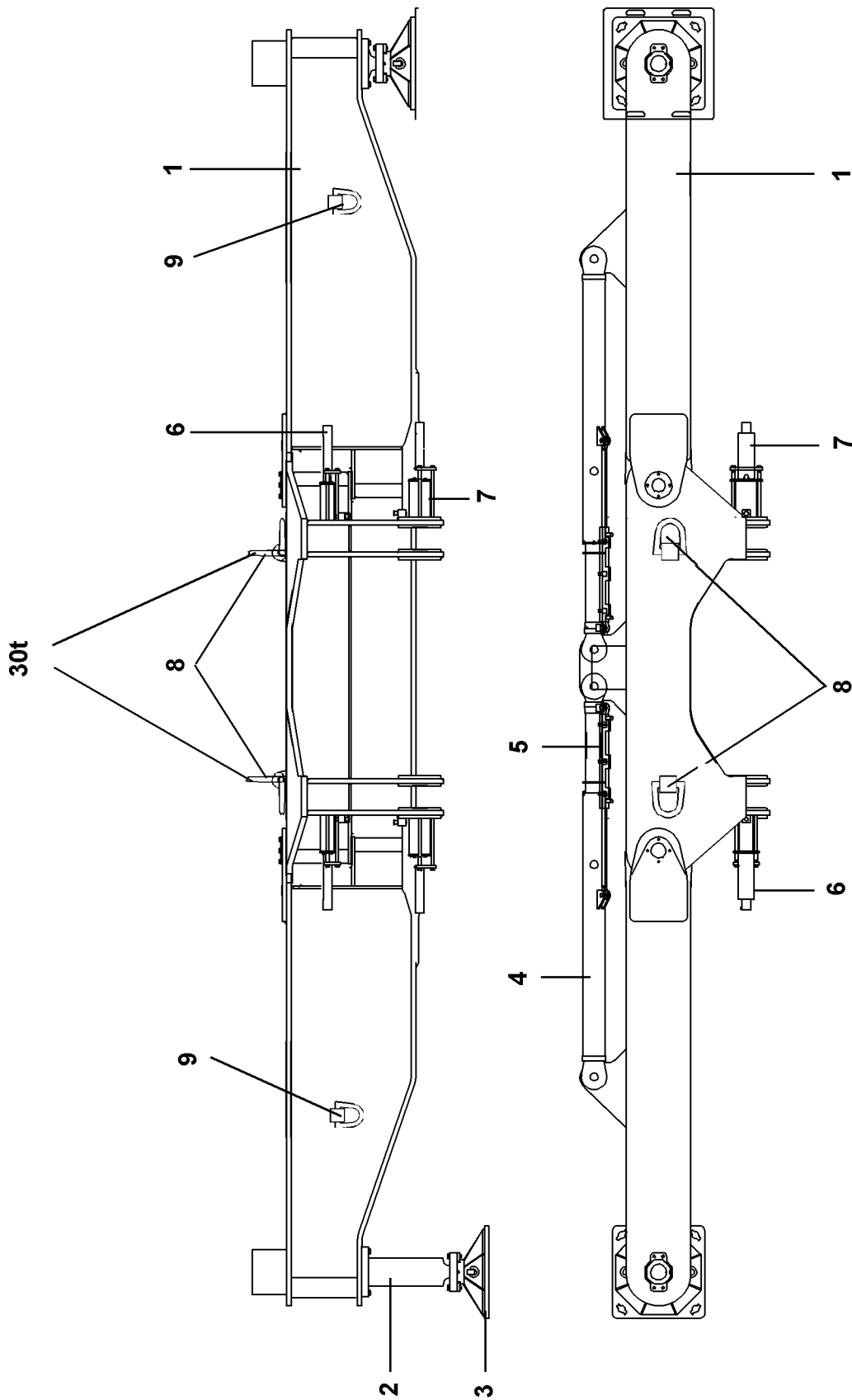
- Place and add the counterweight plates individually with the auxiliary crane .
- Always place the same counterweight on both base plates.

D A N G E R : **Make sure that no one is between the base plate and the crawler carriers or the base plate and the crane supports during the run in of the counterweight plates! This is strictly prohibited.
Always place the same counterweight on both base plates.
There is a danger of accident !**

2.6 Removal of counterweights and base plates

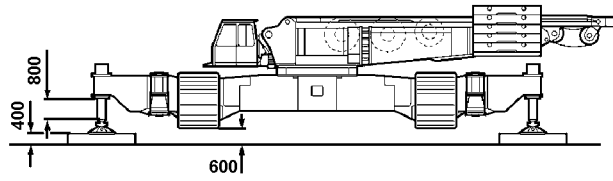
- Lift the counterweights with the auxiliary crane from the base plates.
- Attach the tackle to the holders (Y) of the base plate (1) .
- With the auxiliary crane, bring the tackle to "tension" .
- Release the pins on the brackets (Z) .
- Loosen and remove the pins on the brackets (Z) .
- Swing in the brackets .
- Remove the pin retainer, pipe (3) .
- Loosen and remove the pin (5) on the crawler center section. If it does not move easily, use the pin pulling device.
- Lift the base plate with the auxiliary crane and run it out.

D A N G E R : **Make sure that no one is between the base plate and the crawler carriers or the base plate and the crane supports during the run out of the counterweight plates! This is strictly prohibited.
There is a danger of accident !**

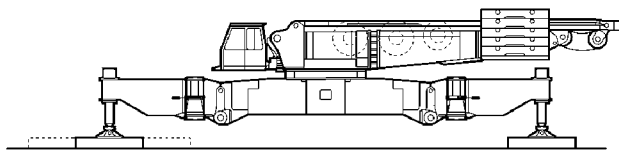
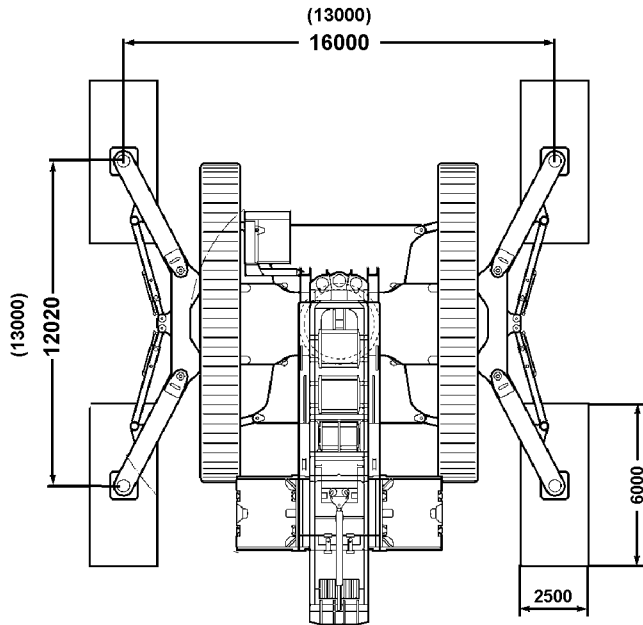


1. Support components overview

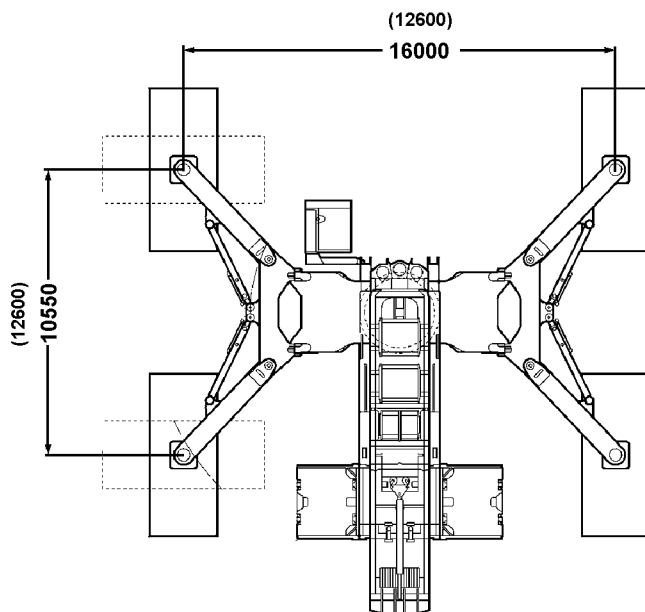
- 1 Support arms
- 2 Support cylinder
- 3 Support plates
- 4 Swing cylinder
- 5 Scale for support base
- 6 Pinning, top
- 7 Pinning, bottom
- 8 Eye hooks
- 9 Rigging hooks for transport



1



2



2. Hydraulic crane support

The hydraulic crane support consists of :

- Center section with support control unit and pinning device
- 4 support arms which can be folded out, with hydraulic cylinders

2.1 Support base

Fig. 1

Support base for installation on crawler carrier

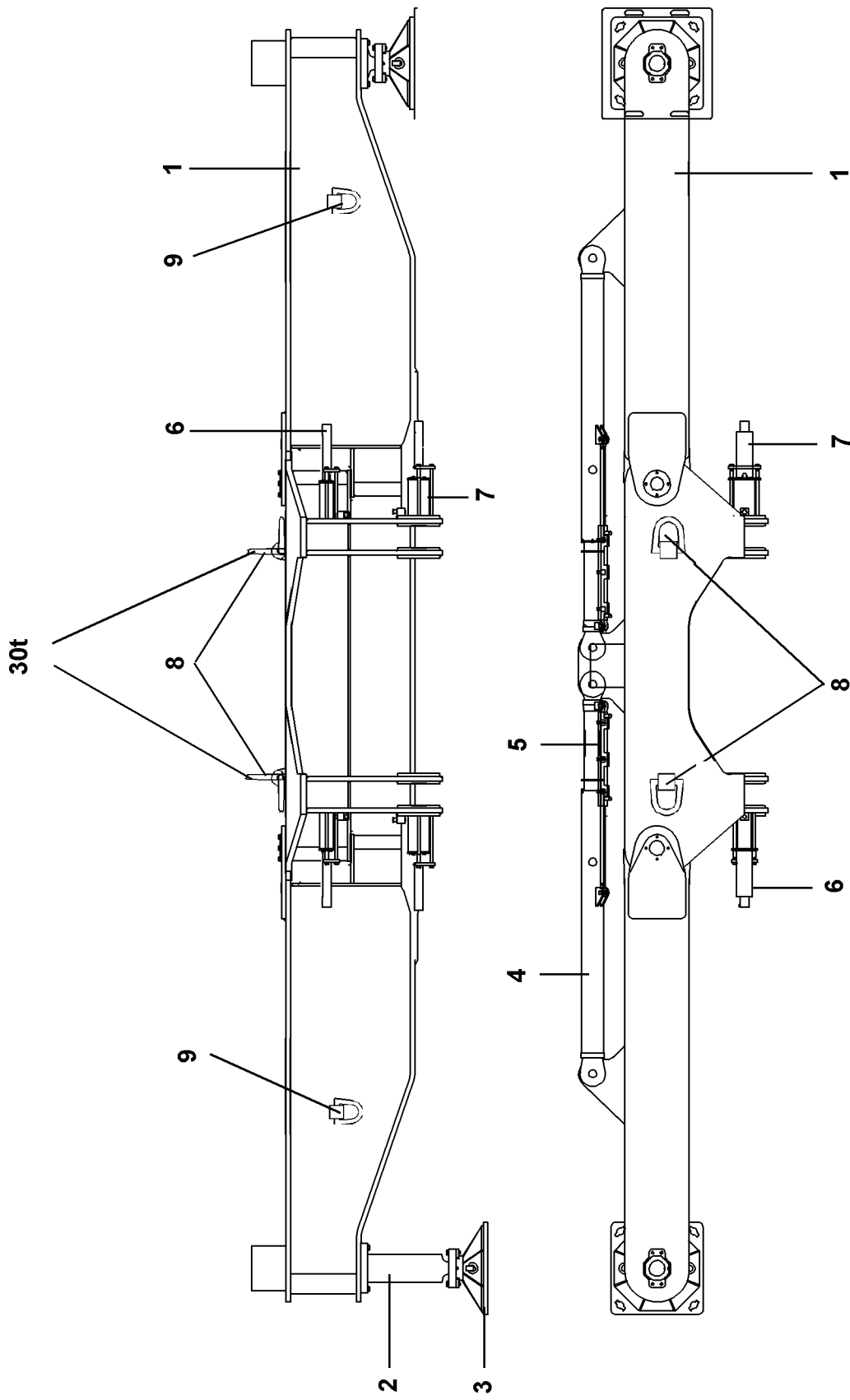
- square $13\text{m} \times 13\text{m}$
- rectangular $16\text{m} \times 12\text{m}$

Fig. 2

Support base, for installation directly on crawler center section

- square $12,6\text{m} \times 12,6\text{m}$
- rectangular $16\text{m} \times 12\text{m}$

-



3. Install support

Take on the complete support on the eye hooks and swing in to the pin points on the crawler carrier or on the center section.

Note: Weight, approx.30t

D A N G E R: **Make sure that there are no persons or obstacles between the support and the crawler carrier or the center section when swinging the support in. This is strictly prohibited.**
There is a danger of accidents!

Establish the hydraulic connections, 4× quick couplings

Establish the electrical connection

Turn the ignition on

Start the engine .

Pin the support on the crawler carrier or on the center section .

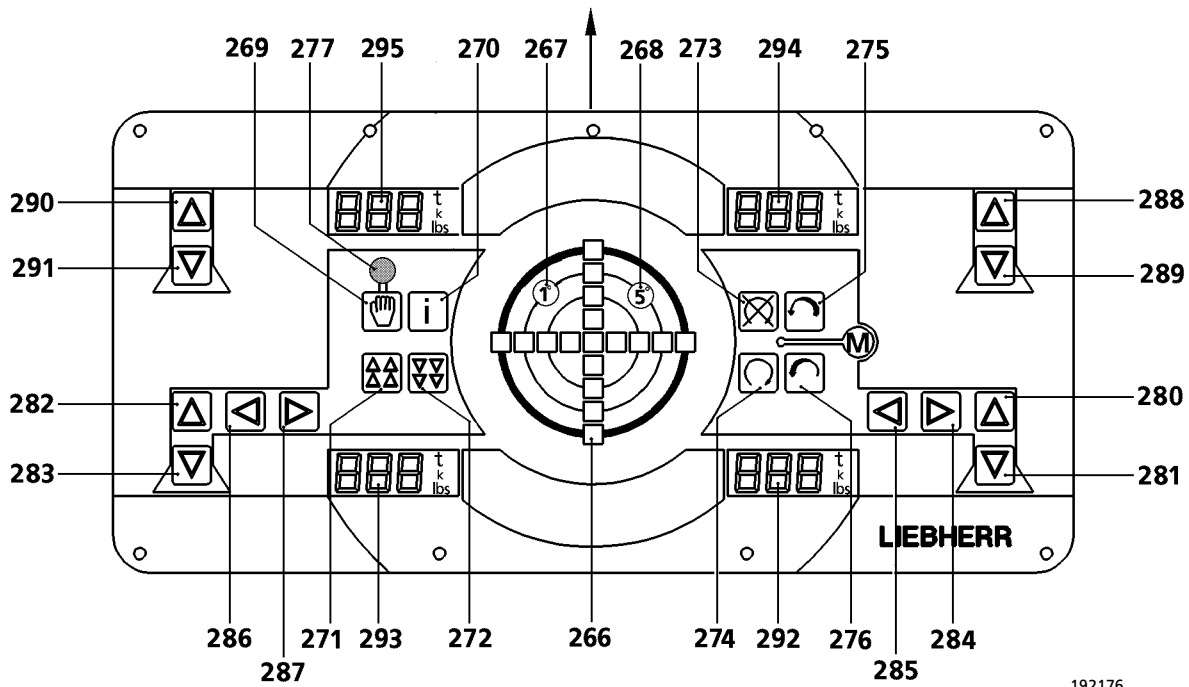
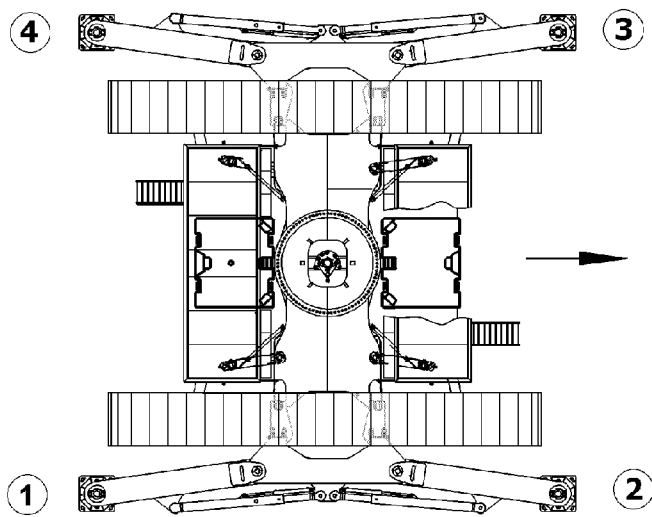
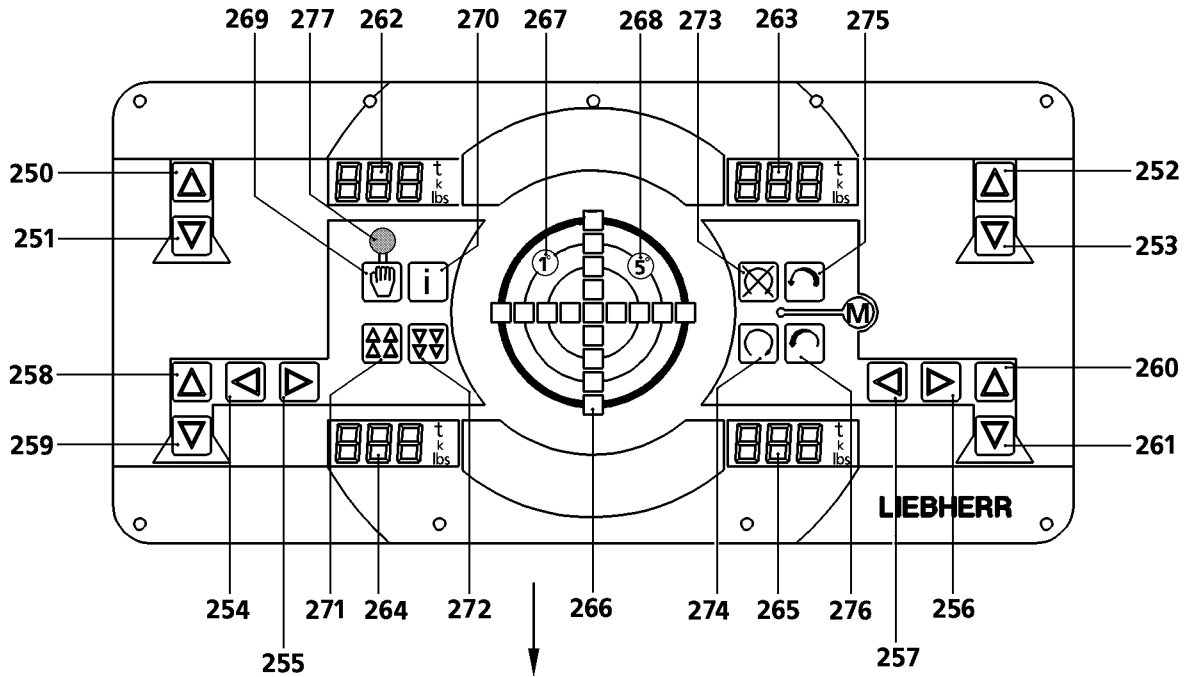
Actuate the radio remote control and pin and secure the support on the crawler carrier or on the center section with pins on top and bottom .

Note: For control of radio remote control, see chapter 5.08, Radio remote control.

D A N G E R: **Before pinning, it must be ensured that the pin bore is clear. The pin must be secured immediately after pinning.**

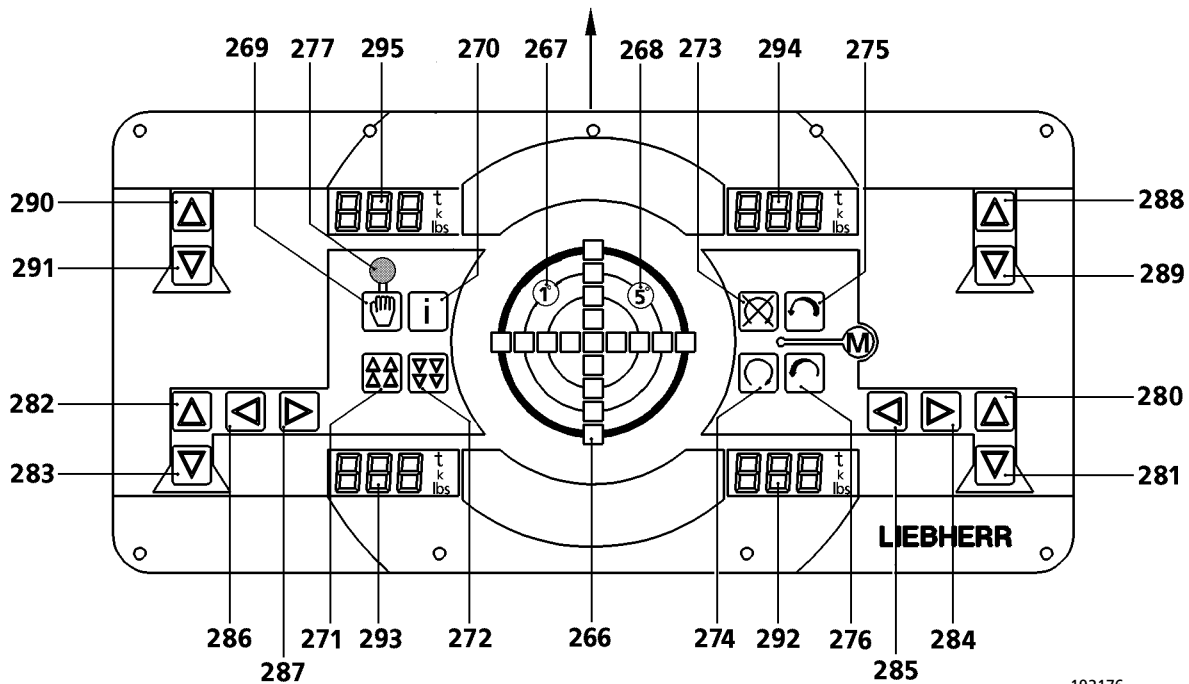
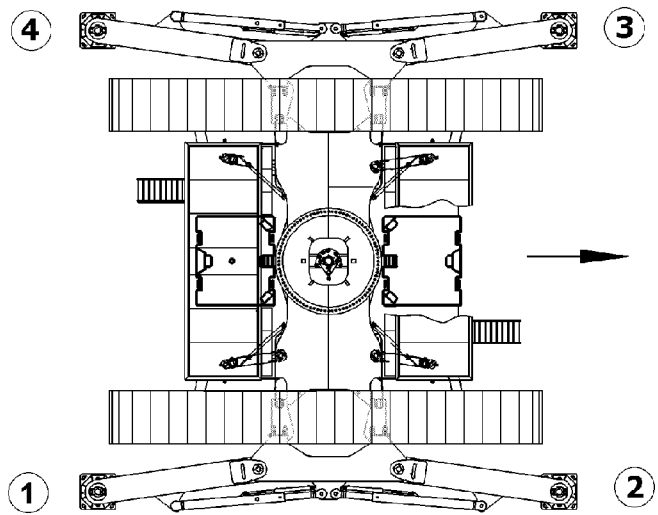
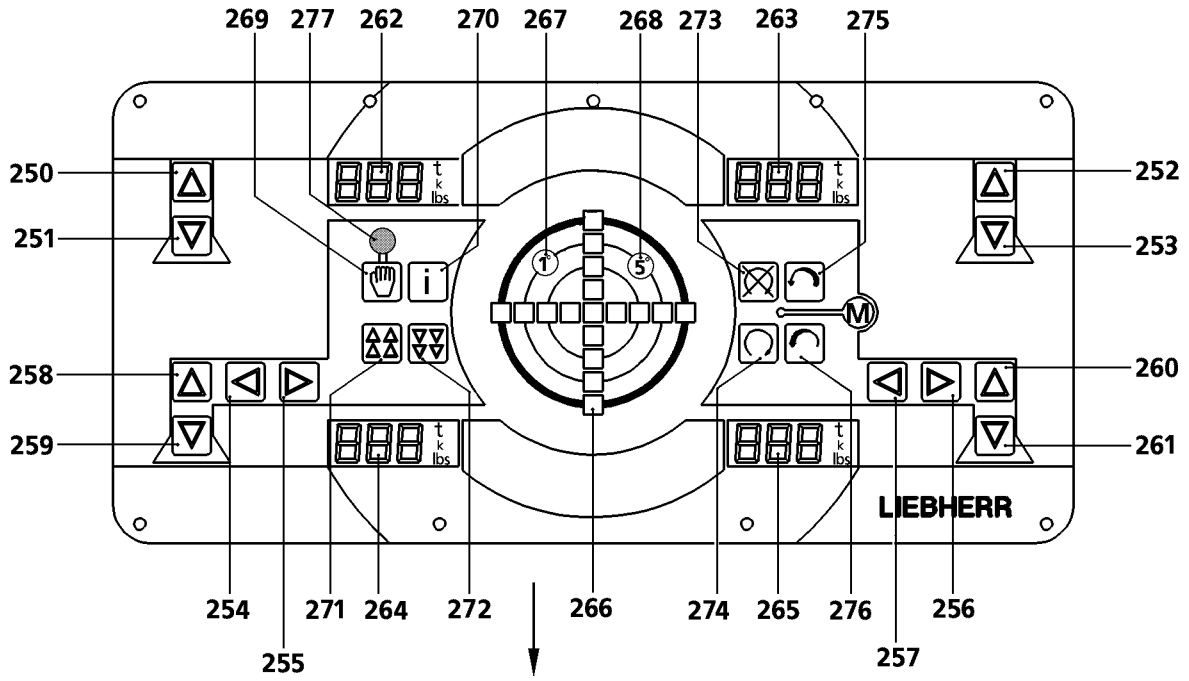
Before unpinning, the retainer on the pin which is to be unpinned must be removed. All other pins must remain secured.

If this is not observed, there is a danger of accidents!



4. Control elements, support control unit left / right

	Support control unit left	Support control unit right	
250	Support cylinder - right front in	Support cylinder - right front in	280
251	Support cylinder - right front out	Support cylinder - right front out	281
252	Support cylinder - right rear in	Support cylinder - right rear in	282
253	Support cylinder - right rear out	Support cylinder - right rear out	283
254	Support arm - left front out	Support arm - right front out	284
255	Support arm - left front in	Support arm - right front in	285
256	Support arm - left rear out	Support arm - right rear out	286
257	Support arm - left rear in	Support arm - right rear in	287
258	Support cylinder - left front in	Support cylinder - left front in	288
259	Support cylinder - left front out	Support cylinder - left front out	289
260	Support cylinder - left rear in	Support cylinder - left rear in	290
261	Support cylinder - left rear out	Support cylinder - left rear out	291
262	Support force indicator - right front	Support force indicator - right front	292
263	Support force indicator - right rear	Support force indicator - right rear	293
264	Support force indicator - left front	Support force indicator - left front	294
265	Support force indicator - left rear	Support force indicator - left rear	295
266	Incline indicator	Incline indicator	266
267	LED 1°	LED 1°	267
268	LED 5°	LED 5°	268
269	Release support control unit	Release support control unit	269
270	not used	not used	270
271	Retract all support cylinders and align horizontally	Retract all support cylinders and align horizontally	271
272	Extend all support cylinders and align horizontally	Extend all support cylinders and align horizontally	272
273	Engine OFF	Engine OFF	273
274	Engine ON	Engine ON	274
275	RPM lower	RPM lower	275
276	RPM higher	RPM higher	276
277	LED Release support control unit	LED Release support control unit	277



5. Support the crane via the support control unit

The crane can be supported via the support control units on the support as well as from the crane cab. A support control unit to control the support system is installed on both sides.

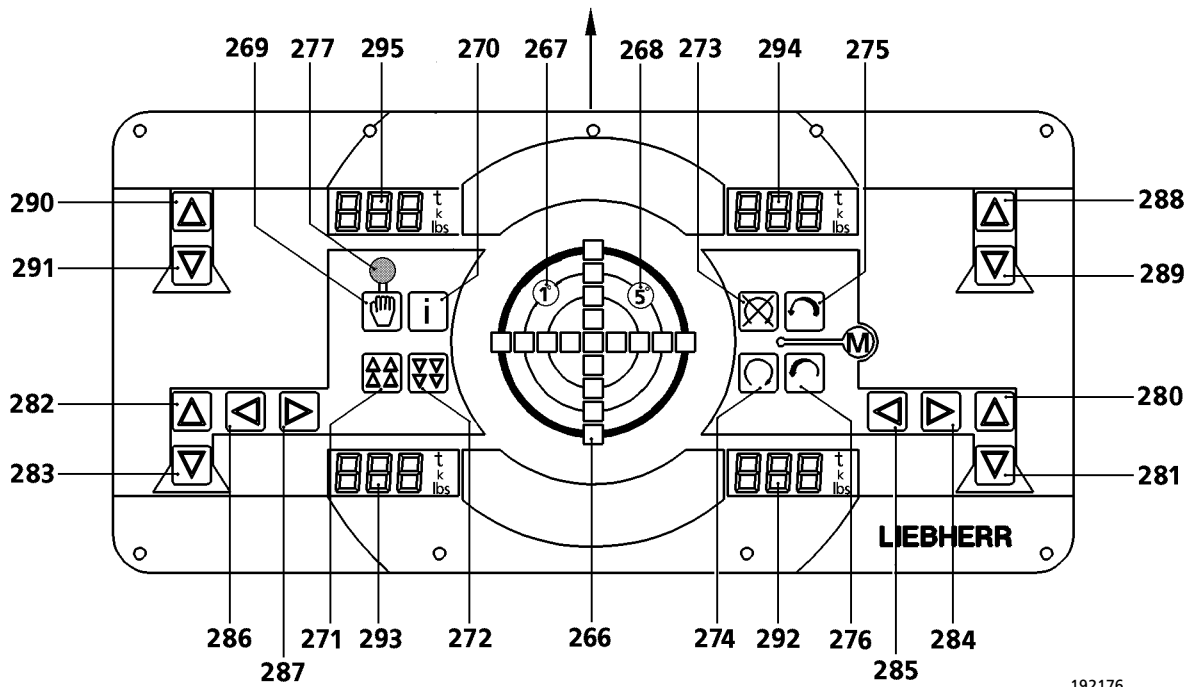
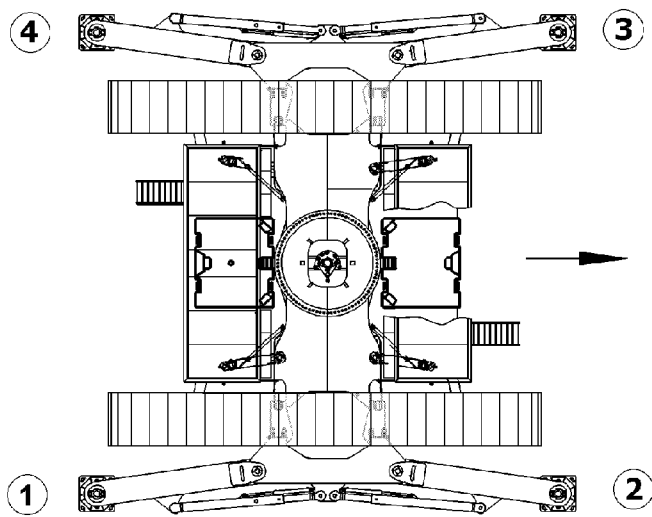
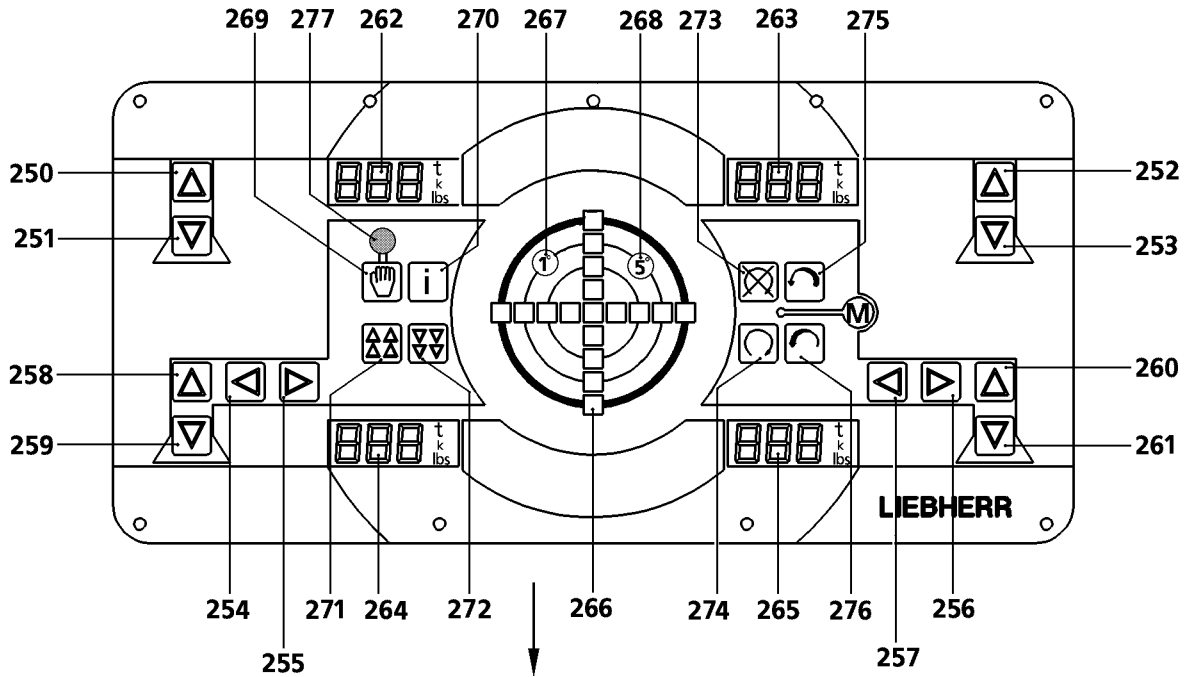
- Turn the ignition on.

The engine can be started with button (274) or turned off with button (273) .

The engine RPM can be changed during the support procedure with buttons (276) and (275) .

Note: Before the support cylinder or the support arms can be moved, the **release support control unit** (269) must be actuated.
The button and the green LED (277) "Release support control unit" lights up if the support control unit is actuated.
The release turns off if no other button is actuated within 120 seconds or if the button (269) is pressed again.
If the support control unit is deactivated, the button blef and the green LED (277) turns off.

D A N G E R: **The crane operator is obligated the set the correct load chart in the LICCON overload safety system which corresponds to the current support width .
The support cylinders must be supported properly from below.**



5.1 Extend the support arms with the support control unit

Note: The support arms on the left side of the crawler can only be actuated from the support control unit installed on that side.
The support arms installed on the right side of the crawler can only be actuated from the support control unit installed on that side.

- Unpin the retaining pins (B) on the four swing cylinders.
- Open the switch box for the left or right support control unit.

DANGER: **The operator must monitor the extension / retraction of the support arms .
When extending or retracting the support arms, it must be ensured that there are no persons or objects within the danger zone.**

- Extend the support arms to the support base given in the load chart.
Support control unit left: button (254 and 256).
Support control unit right: button (284 and 286)
- Pin and secure all 4 swing cylinders.

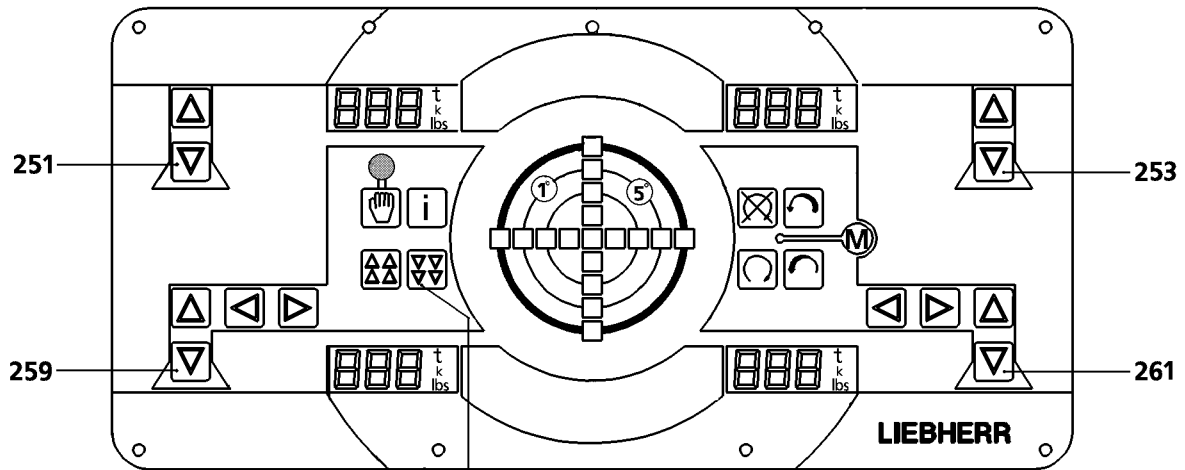
DANGER: **The support arms must be pinned to prevent the support surfaces from shifting, otherwise there is a danger of accidents!
All retaining pins must be pinned and secured.
The crane may not be supported in intermediate positions!**

5.2 Extend the support cylinder with the support control unit

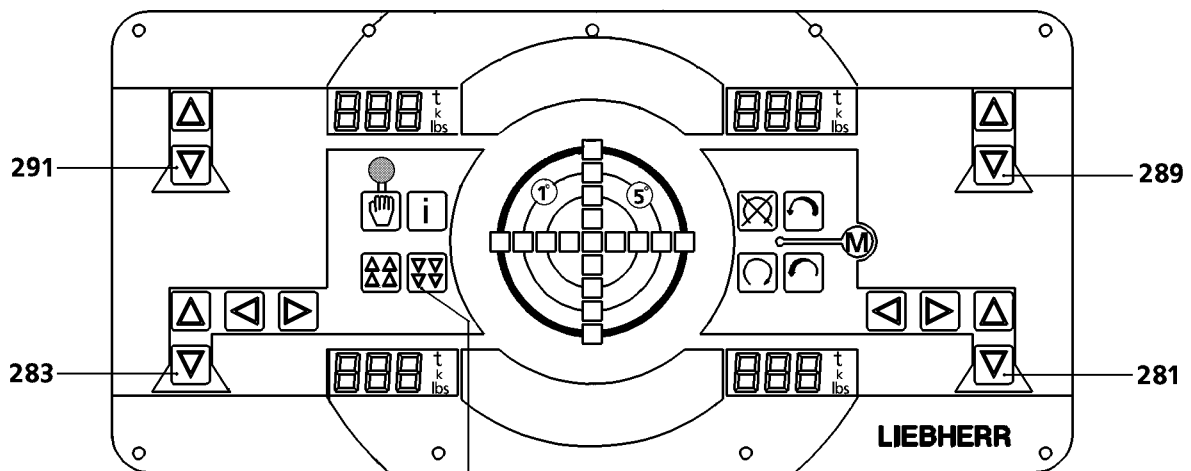
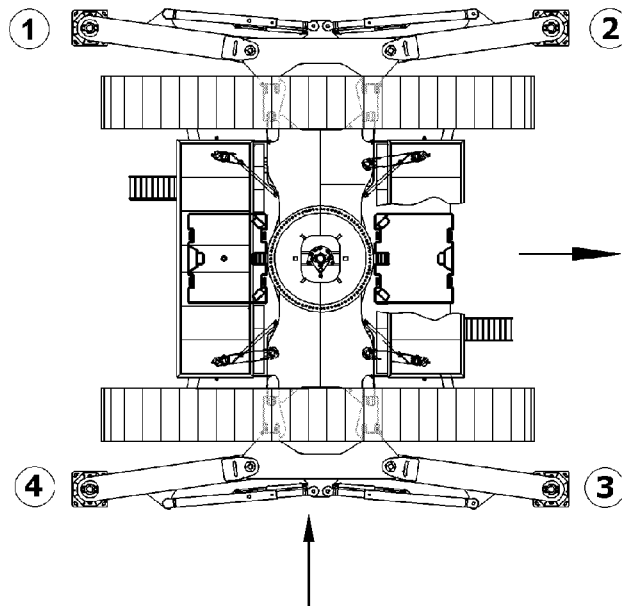
All support cylinders can be actuated from both support units on the left and right hand side of the crawler.

CAUTION: **For crane supports with installed crawler carrier, the crane must be raised until the crawler has no more contact with the ground. Otherwise there is a danger of tipping over due reduced stability momentum. For safety reasons, the support cylinders may not be extended all the way (to the stop) in crane operation.
If the support cylinders are fully extended, then all support cylinders must be retracted by at least 10 mm .**

DANGER: **When extending or retracting the support cylinder, it must be ensured that there are no persons or objects within the danger zone**



272



272

5.2.1 Manual supporting

- Evenly extend the individual support cylinders by actuating the corresponding button and support the crane.

Support control unit left: button (251, 253, 259, and 261).

Support control unit right: button (281, 283, 289, and 291)

5.2.2.1 Align the crane horizontally

- Align the crane in horizontal direction by extending and retracting the individual support cylinders. The crane is aligned in horizontal direction when the innermost LEDlights up.

Note: The maximum permissible deviation from the horizontal crane position is $\pm 0.5\%$ ($\pm 0.3^\circ$).

D A N G E R : If the crane is not horizontally aligned, there is a danger of accidents.

5.2.3 Automatic supporting and horizontal alignment

- By pressing the button (272), all support cylinders are extended and the crane is horizontally aligned.

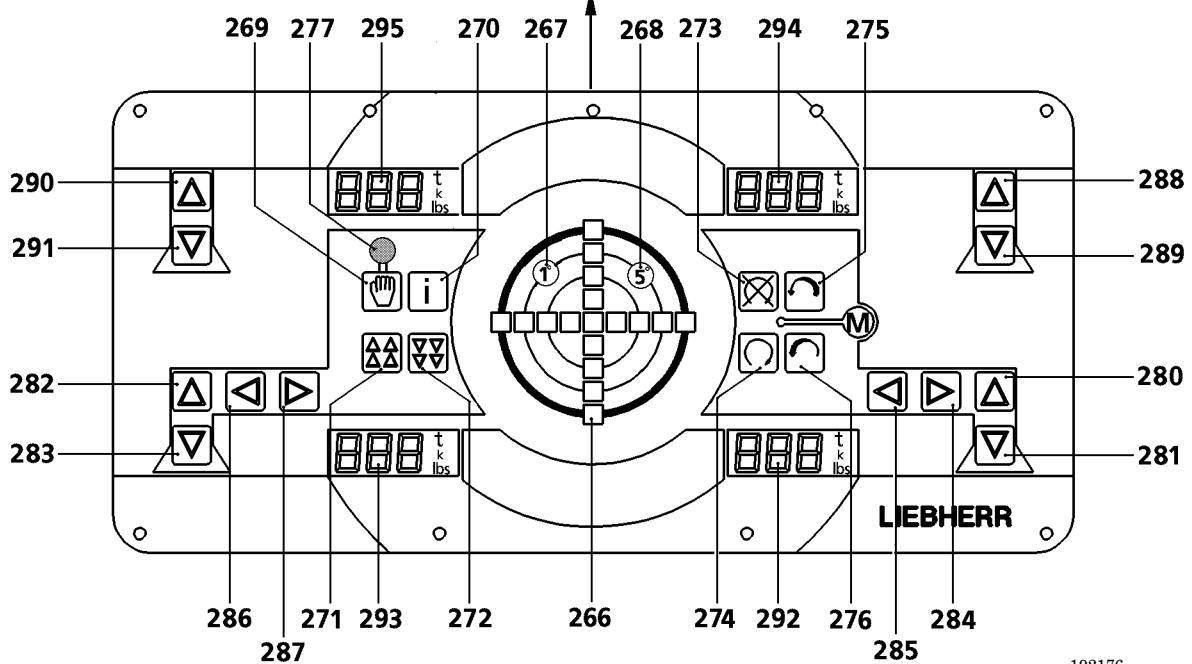
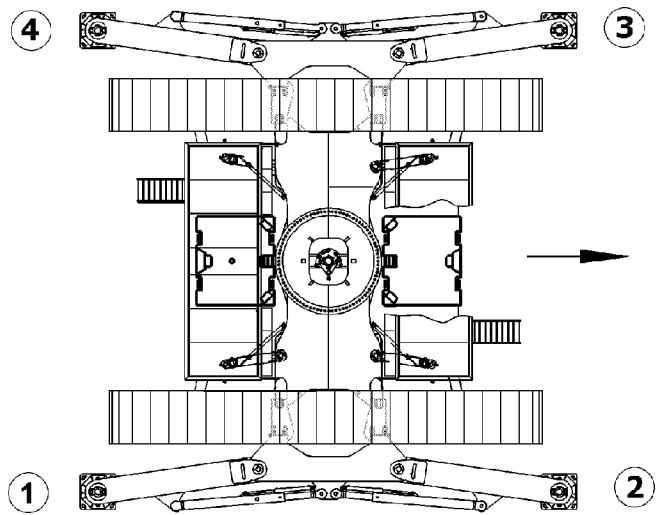
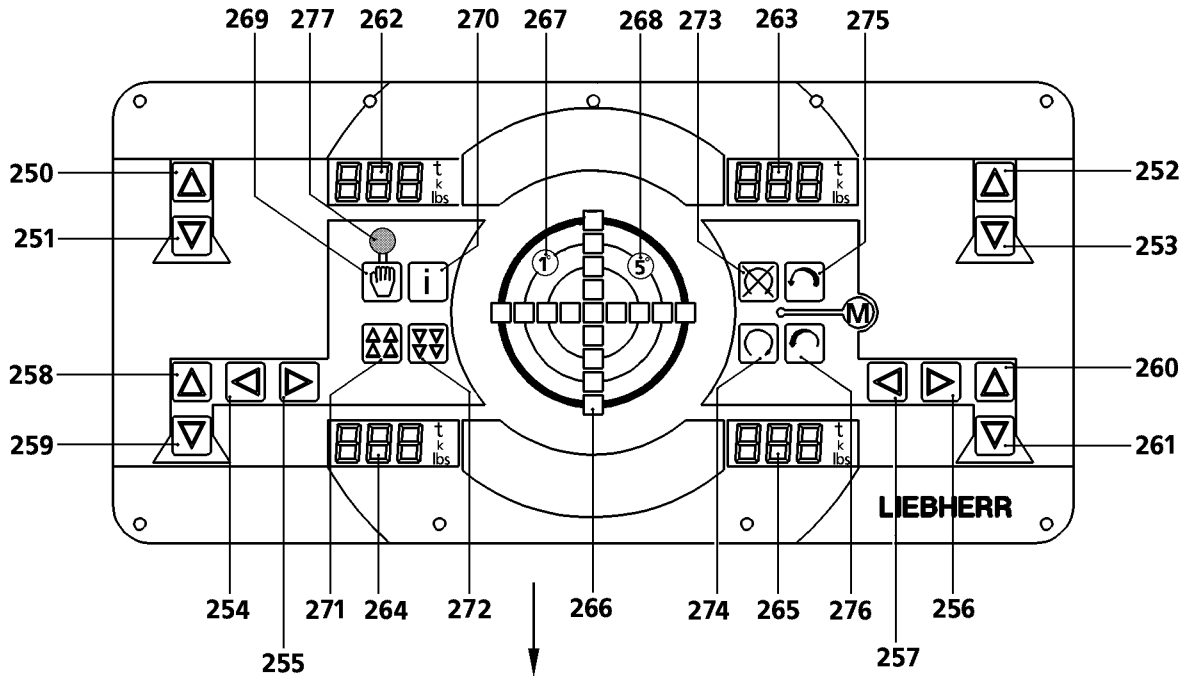
D A N G E R : The crane is automatically aligned in horizontal direction via the automatic support. However, the operator must still check if the alignment is within the permissible tolerance and if all four support plates are in contact with the ground. If this is not the case, there is a danger of accidents.

5.2.4 Check the supports

D A N G E R : It must be checked again, if the support base and the following safety regulations have been adhered to.

All 4 support arms of the support system must be extended, even those on the opposite side of the load. If only the support arms on the side of the load are extended, then this could have serious consequences.

1. Due to the load hanging on the hook, the hoist cable and the boom (when in use, also the auxiliary boom and the guy ropes) are tensioned and distorted. If in this situation the load should fall from the tackle cables or the tackle or hoist cable breaks, then a sudden relief will occur. The boom will snap backward which can cause the crane to topple over.
2. Despite previous assumption, it might become necessary to swing the load to the opposite side. This can cause the crane to topple over.
3. When turning from crawler lengthwise direction, the crane can topple over due to the boom or counterweight momentum.



192176

5.3 Retract the support cylinder

- Open the switch box for the left or right side of the vehicle.
- Start the engine.
- Retract the support cylinders individually by pressing the corresponding buttons until the wheels are in contact with the ground.
Support control unit left: button (250, 252, 258, and 260).
Support control unit right: button (280, 282, 288, and 290)
or
retract all support cylinders by pressing button (271) .
- Fully retract all four support cylinders.

D A N G E R : **The operator must monitor the extension / retraction of the support cylinders .**
When extending or retracting the support arms, it must be ensured that there are no persons or objects within the danger zone.

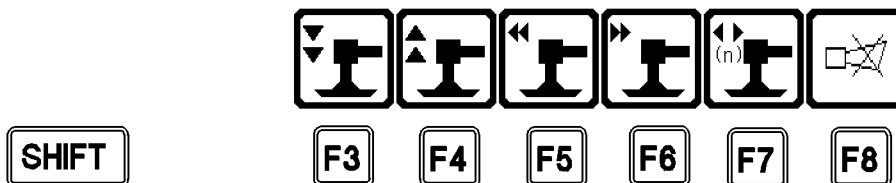
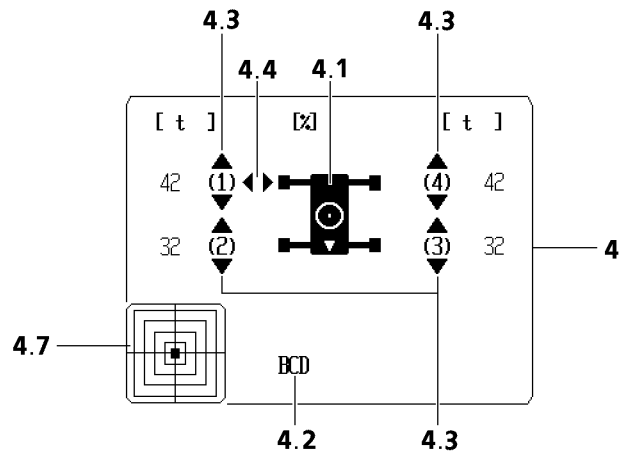
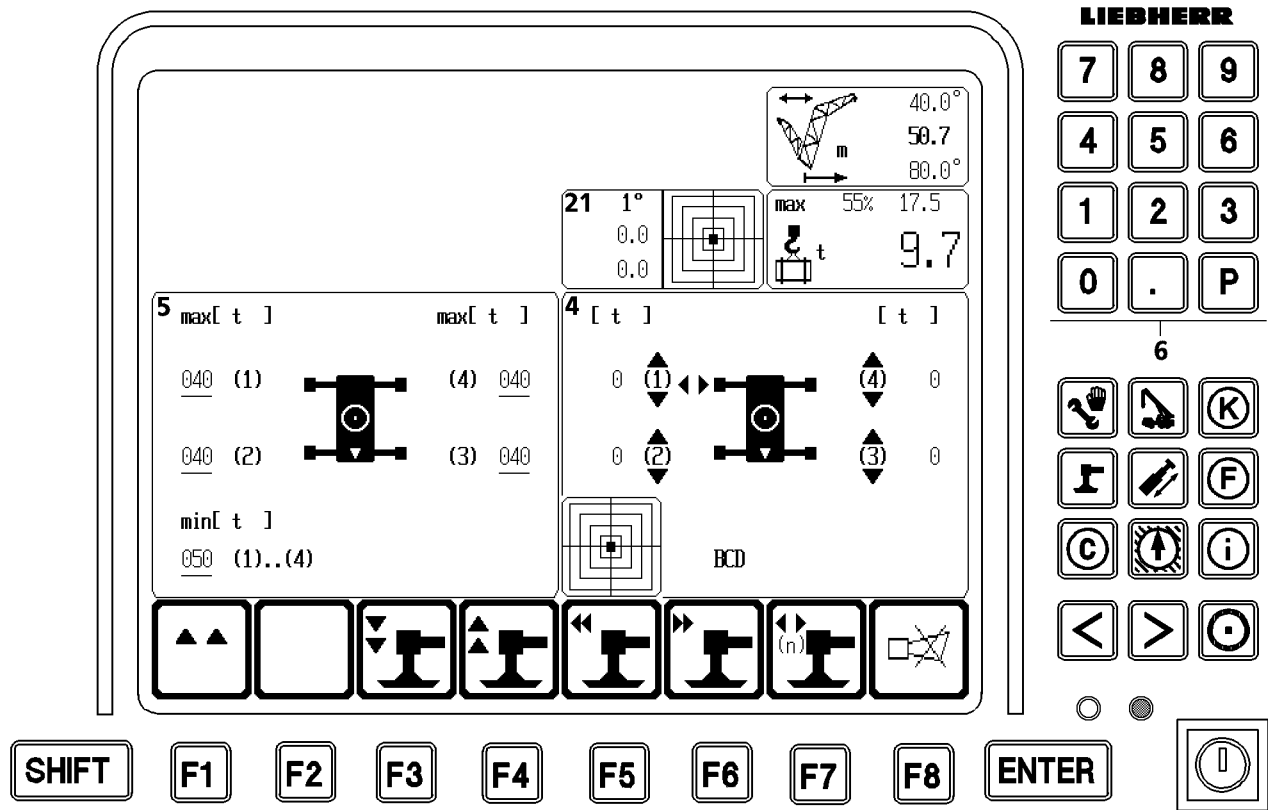
5.4 Retract the support arms

Note: The support arms on the left side of the crawler can only be actuated from the support control unit installed on that side.
The support arms installed on the right side of the crawler can only be actuated from the support control unit installed on that side.

- Unpin the retaining pins on the swing cylinder.
- Retract the support arms individually and pin and secure with the retaining pins in transport position.
Support control unit left: button (255 and 257).
Support control unit right: button (285 and 287)

D A N G E R : **Only those support arms may be actuated which can be seen from the operator.**
When extending and retracting the support arms, it must be ensured that there are no persons or objects within the danger zone.

- If necessary, reduce the engine RPMs to low idle speed.
- Turn the engine off.



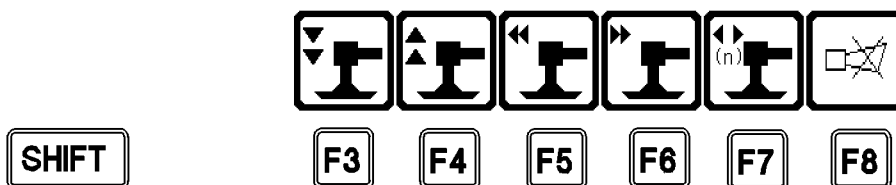
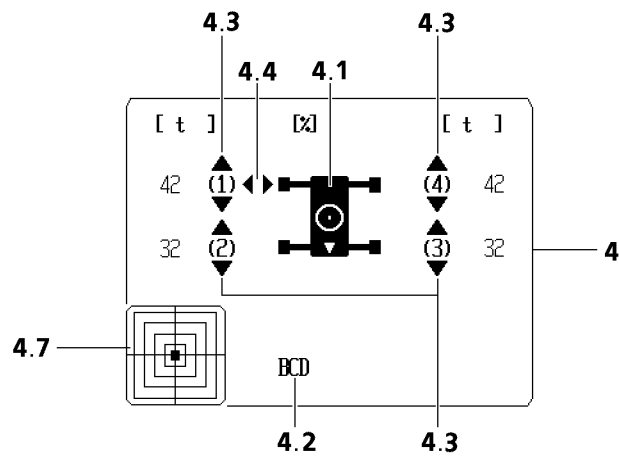
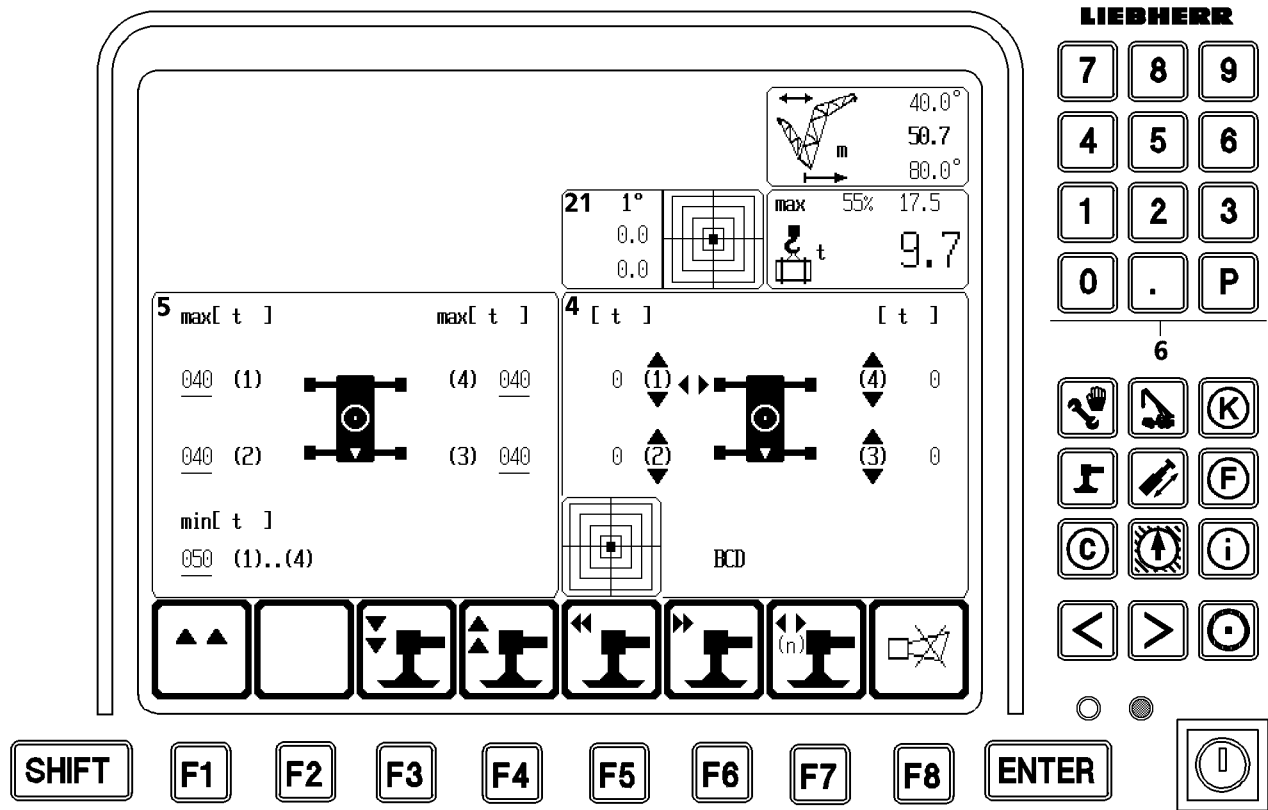
6. Crane support from the crane cab

The support system can also be operated from the crane cab, via a process visualization on the LICCON monitor.

Note: See also **Chapter 4.02 "LICCON COMPUTER SYSTEM"**, paragraph "The support program"

The crane can also be operated and driven in the "Support" program. If support procedures have to be repeated within short intervals, then the operator does not need to switch back to the "Operation" program.

D A N G E R : **The operator must monitor the extension / retraction of the support arms**
When extending or retracting the support arms without visual contact with the corresponding support cylinder or support arm, a guide must be available.
When extending or retracting the support arms, it must be ensured that there are no persons or objects within the danger zone.
If the crane is not horizontally aligned, there is a DANGER OF ACCIDENTS!
All 4 support arms and support cylinders must be extended, even those on the opposite side of the load.
Observe all regulations and danger notes in paragraph 2 "Crane support with support control unit" !

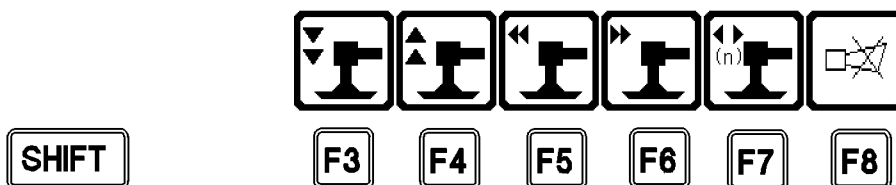
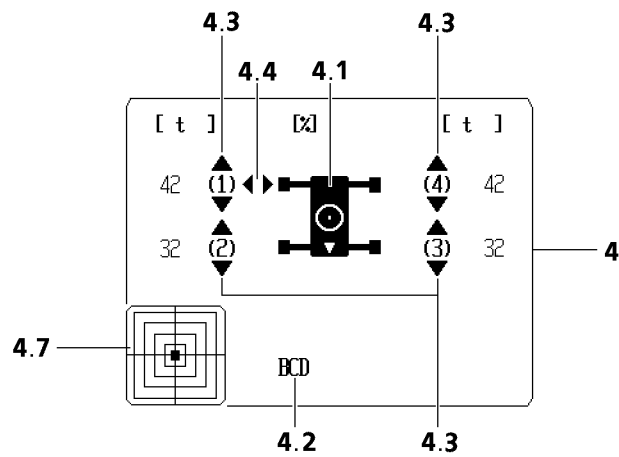
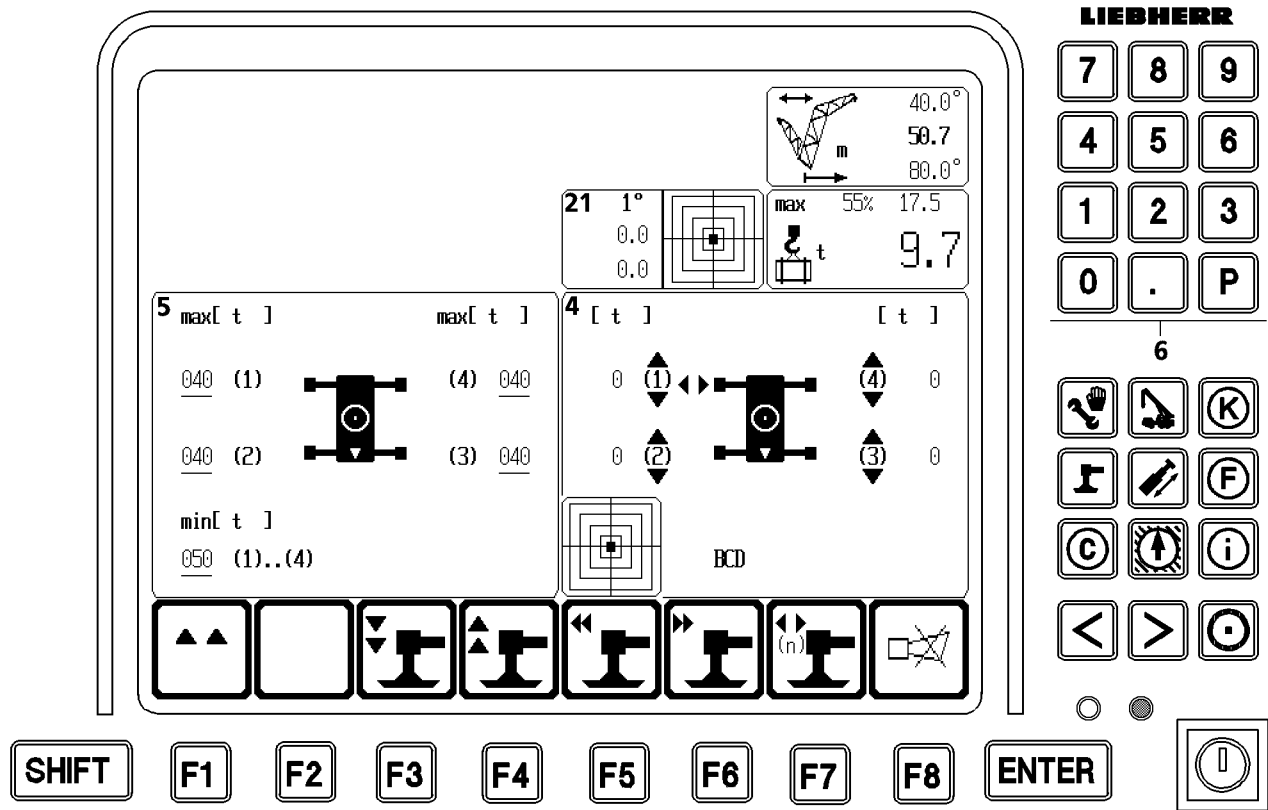


6.1 Control elements for supporting from the crane cab

The following elements are important for supporting from the crane cab.

- P₃** Start the "Support" program
- P₁** End the "Support" program and switch back into the operating view
- 4** Monitoring and control field
 - 4.1 Crane symbol
 - 4.2 Dimension of maximum support in given unit [m/ft]
 - 4.3 Function selectors to control the support cylinders
 - 4.4 Function selectors to control the support arms
- 10** Symbol element
"Radius and main boom angle"
- 20** Symbol element
Current load, maximum load carrying capacity and dynamic utilization in %
- 21** Symbol "Crane incline "
In this symbol, the incline of the crane is shown. The indication is graphic as well as numeric.
 - 21.1 Graphic section**
The graphic view is in the form of a sight gauge, in which a moveable dot (small square) depicts the air bubble. The center of the point shows the exact incline value.
 - 21.2 Numeric section**
 - 21.2.1 Incline range 1° or 5°
This value shows the resolution of the graphic view, the distance of 2 lines (lengthwise and crosswise) of the sight gauge. It is shown in the units of [°] = [degrees] and can take on the two values "1" or "5".
If the crane incline is in crosswise **and** in lengthwise direction < 1°, then the gauge is in the 1° - range. If at least one value exceeds the 1° limit, then it shifts into the 5° range.

Note: The range shift occurs automatically.
 - 21.2.2 Incline of crane in [°] in crosswise direction
The double arrow shows the direction of the incline:
Double arrow left = the crane slopes to the left
Double arrow right = the crane slopes to the right
 - 21.2.3 Incline of crane in [°] in lengthwise direction.
The arrow shows the direction of the incline:
Arrow up = The crane slopes to the front
Arrow down = The crane slopes to the rear



6.1 Control elements for supporting the crane from the crane cab, continuation

- 5 Function keyboard in the monitoring mode and control mode (program start)
The function keys should always be viewed with the function key symbol bar shown above it on the monitor.

"F3" Extend the preselected support cylinder

"SHIFT" + "F3"

Press key combination "SHIFT" + "F3" to extend all support cylinders and to align the crane in horizontal direction.

"F4" Retract the preselected support cylinder

"SHIFT" + "F4"

Press the key combination "SHIFT" + "F4" to retract all support cylinders and to align the crane in horizontal direction.

"F5" Extend the preselected support arm

"F6" Retract the preselected support arm

"F7" Select the support arm

"F8" Turn off horn / error diagnostics

Note: Functions "F3" and "F4" (extend / retract support cylinder) only make sense if at least one support cylinder has been preselected. If no support cylinder has been preselected, then the horn will sound.

CAUTION: For safety reasons, functions for "F3" to "F6" are active only as long as the corresponding button is pressed. For that time period, a rhythmic sound of the horn can be heard as an acoustical confirmation.

- 6 Keyboard

With keys 1 - 4, select or deselect the corresponding support.

6.2 Extend the support arms from the crane cab

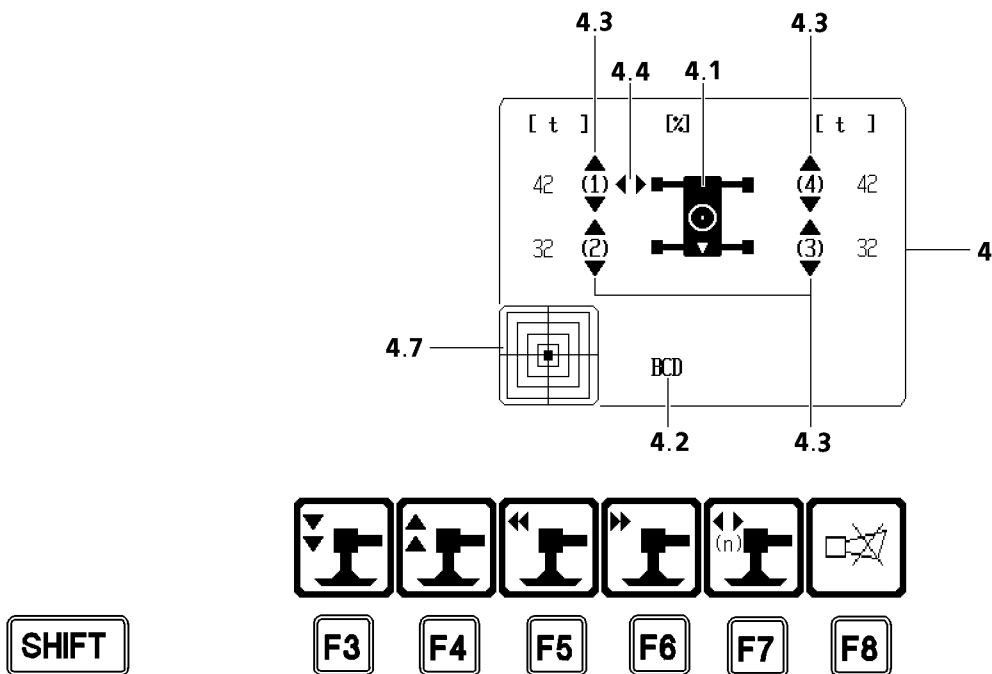
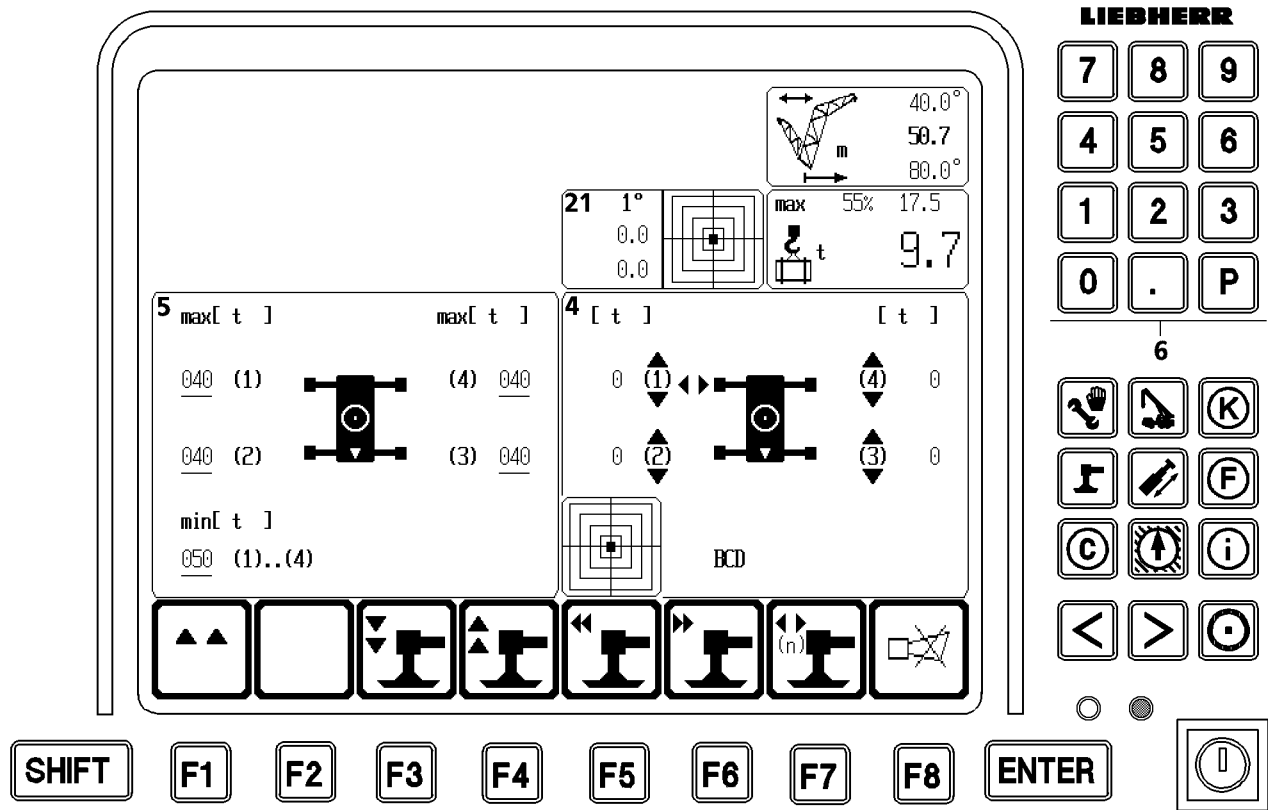
DANGER: All 4 support arms must be extended, even those on the opposite side of the load.

Note: Only one support arm can be extended at the same time.

- With selector **F7**, select the desired support arm, a double arrow appears on the selected support arm
- with function key **F5**, extend the selected support arm to the support base given on the corresponding load chart.

- Pin and secure all 4 swing cylinders.

DANGER: The support arms must be pinned to prevent the support surfaces from shifting, otherwise there is a danger of accidents!
All retaining pins must be pinned and secured.
The crane may not be supported in intermediate positions!



6.3 Extend the support cylinder from the crane cab

D A N G E R : **The crane must be raised until the crawler has no more contact with the ground. Otherwise there is a danger of tipping over due reduced stability momentum. For safety reasons, the support cylinders may not be extended all the way (to the stop) in crane operation. If the support cylinders are fully extended, then all support cylinders must be retracted by at least 10 mm .**

6.3.1 Manual supporting

- With the numeric keyboard (1 - 4) on the LICCON monitor, select or deselect the corresponding support or support combinations, the selector (s) appear or disappear on the selected support or support combination.

Note: Support cylinders can be moved at the same time.

- Extend the preselected support or support combination with function key **F3** .

6.3.1.1 Align the crane in horizontal direction

- Align the individual support cylinders in horizontal direction by extending or retracting the individual support cylinders.

This point is reached when the dot (small square) is in the center of the graphic sight gauge. The maximum permissible deviation from the horizontal crane position is $\pm 0.5\%$ ($\pm 0.3^\circ$).

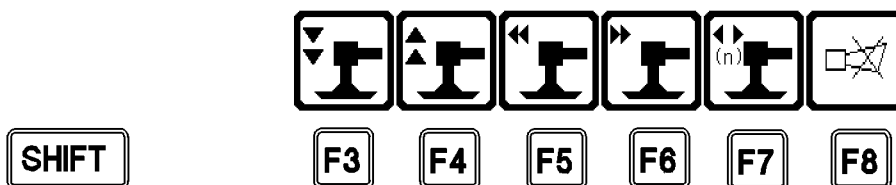
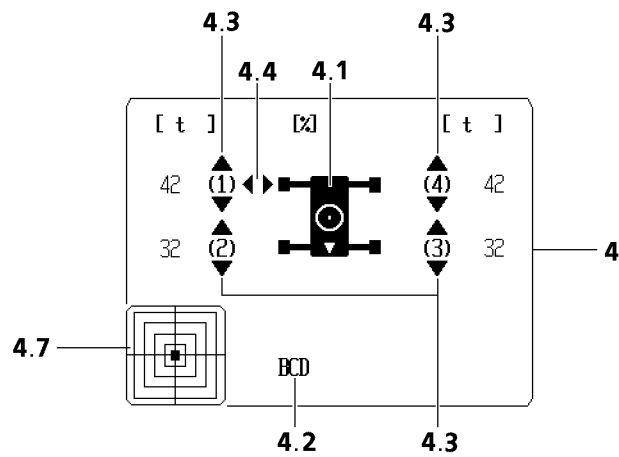
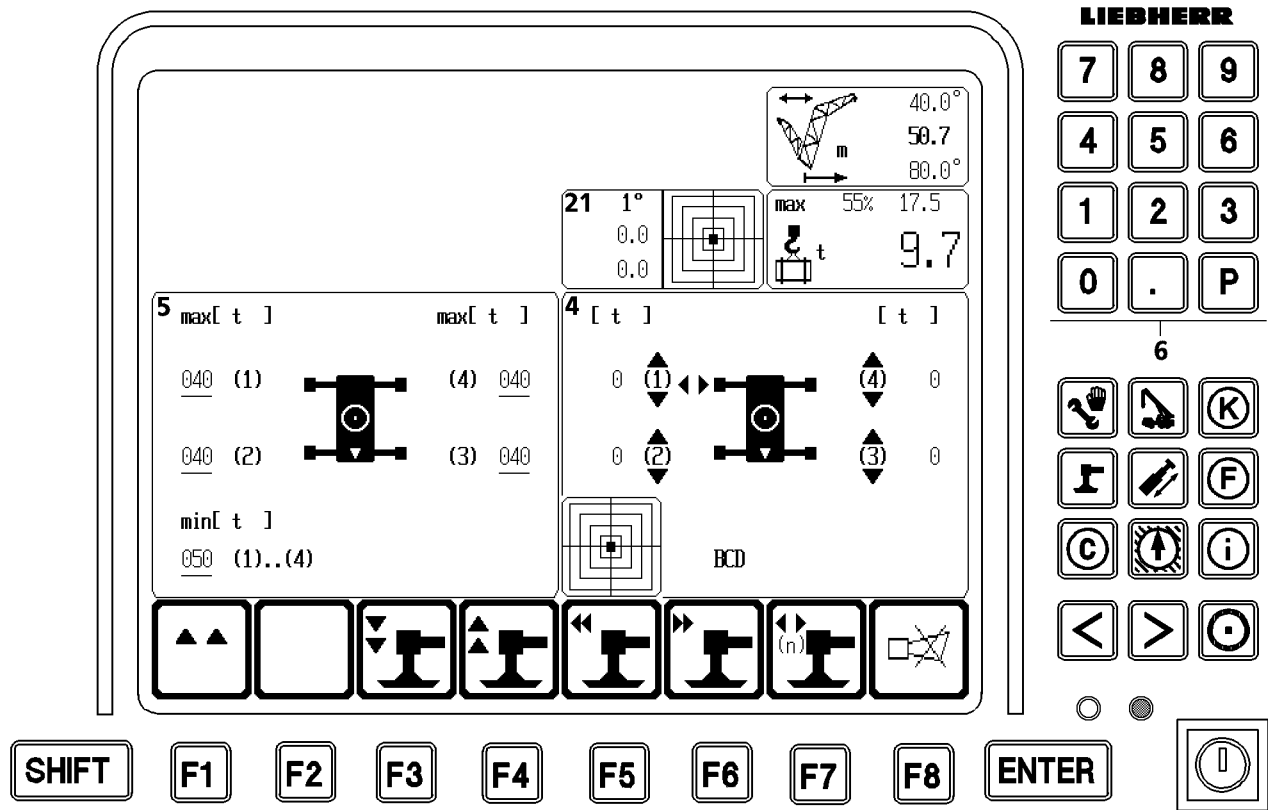
D A N G E R : **If the crane is not horizontally aligned, there is a DANGER OF ACCIDENTS!**

6.3.2 Automatic supporting and horizontal alignment

"SHIFT" + "F3"

By pressing the key combination "SHIFT" + "F3" , all support cylinders are extended and the crane is horizontally aligned.

D A N G E R : **The crane is automatically aligned in horizontal direction via the automatic support. However, the operator must still check if the alignment is within the permissible tolerance and if all four support plates are in contact with the ground. If this is not the case, there is a danger of accidents.**



6.4 Retract the support cylinders from the crane cab

Note: Support cylinders can be moved at the same time.

- With the numeric keyboard (1 - 4) on the LICCON monitor, select or deselect the corresponding support or support combinations, the selector (s) appear or disappear on the selected support or support combination.
- Retract the preselected support or support combination with function key **F4** .
or
- Press the key combination "SHIFT" + "F4" to retract all support cylinders.

- Retract all four support cylinders all the way.

6.5 Retract teh support arms from the crane cab

Note: Only one support arm can be retracted at the time.

- Unpin the retaining pins on the swing cylinder .
- With the support arm selector **F7** .select the desired support arm , the selector (double arrow) appears on the selected sliding arm
- with function key **F6** , retract teh selected support arm .
- Retract the support arms individually and secure and lock with the retaining pin in transport position.

D A N G E R : **Only those support arms may be actuated which can be seen from the operator.**
When extending and retracting the support arms, it must be ensured that there are no persons or objects within the danger zone.

- If necessary, reduce the engine RPM to low idle speed.
- Turn the engine off.

1. Installation conditions

- 1 = with placed down SA bracket (with and without cable on winch IV)
- 2 = 90° SA bracket (with and without cable on winch IV)
- 3 = with placed down SA bracket, winch I and IV mit Seil
- 4 = 90° SA- bracket, winch I and IV with cable
- 5 = 90° SA- bracket, winch I and IV with cable, S- pivot section installed

Chart 1: Max. permissible slewing platform ballast for the following installation conditions in operation on crawlers

Installation condition	A 360° on crawler 9,1 m x 8,8 m Central ballast				B 360° on crawler 9,1 m x 8,8 m Supports installed incl. central ballast 20 t
	95 t	70 t	45 t	20 t	
1	170	170	120	70	170
2 Max. permissible	220	170	170	70	220
3 slewing platform	170	170	120	70	170
4 ballast	220	170	170	70	220
5	245	170	170	70	245
1 Max. permissible	---	---	---	---	---
2 slewing platform	---	---	---	---	---
3 ballast on	---	---	---	---	---
4 slewing platform	---	---	---	---	---
5 extension	---	---	---	---	---

Chart 2: Max. permissible slewing platform ballast for the following installation conditions in operation on supports

Installation condition	C 360° on supports 12,6 m x 12,6 m	D* 360° on supports 12,6 m x 12,6 m central ballast 110 t	E to the side on supports 16,0 m x 10,5 m	F 360° on supports 16,0 m x 10,5 m
	1 Max.	245	245	245
2 permissible	245	245	245	170
3 slewing	245	245	245	170
4 platform	245	245	245	195
5 ballast	245	245	245	195
1 Max.				
2 permissible	125	250	225	75
3 slewing	125	250	250	75
4 platform	125	250	250	75
5 ballast on	150	250	250	100
slewing	150	250	250	100
platform				
extension				

* = Special central ballast

Chart 3: Max. permissible slewing platform ballast for the following installation conditions in operation on supports with installed crawler

Installation condition		D 360° on supports 13,0 m x 13,0 m crawler installed incl. central ballast 20 t	G to the side on supports 16,30 m x 12,0 m crawler installed incl. central ballast 20 t	H 360° on supports 16,0 m x 12,0 m crawler installed incl. central ballast 20 t
1	Max. permissible slewing platform ballast	245	245	245
2		245	245	245
3		245	245	245
4		245	245	245
5		245	245	245
1	Max. permissible slewing platform ballast on slewing platform extension	250	200	250
2		250	200	250
3		250	200	250
4		250	225	250
5		250	225	250

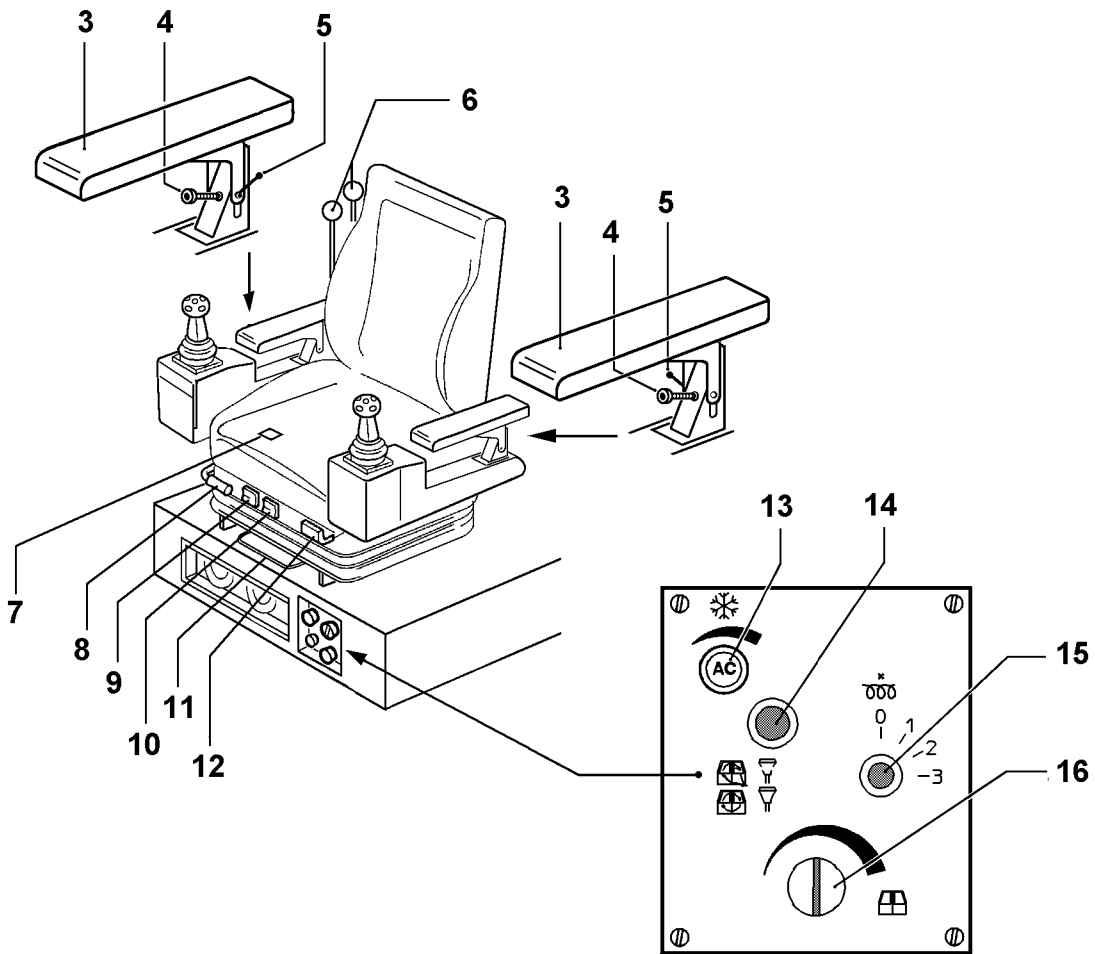
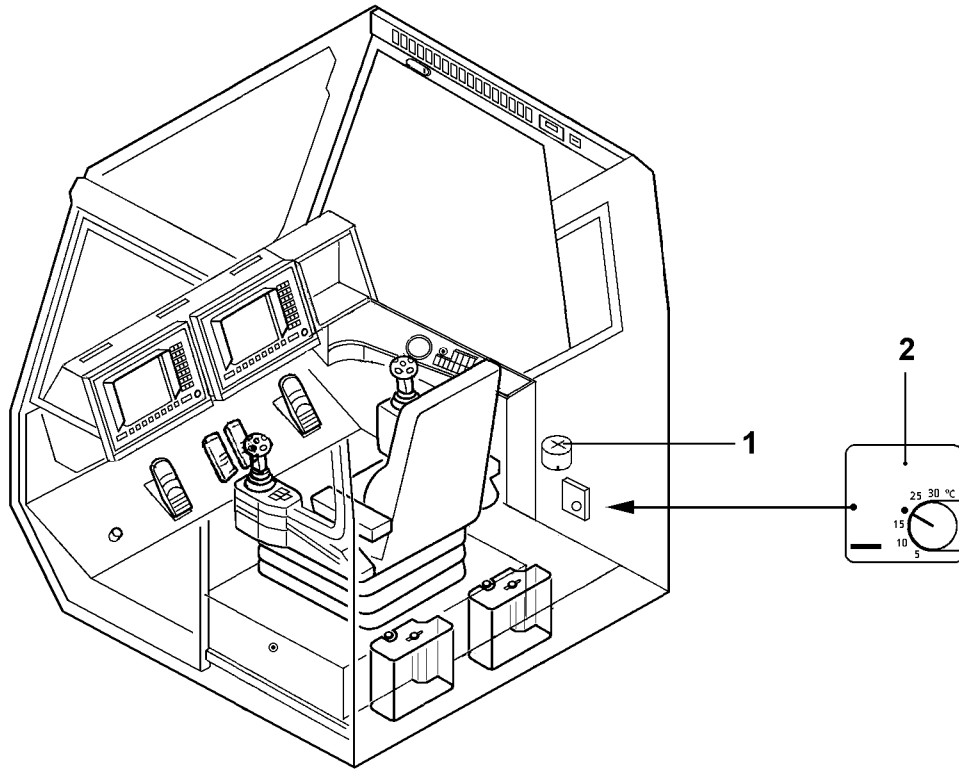
2. Erection / take down of main boom systems in operation on supports

CAUTION: The determining factors are the corresponding erection charts and taking into account charts (1 - 3)

<p style="text-align: center;">Erection</p> <p>Required slewing platform ballast according to erection chart \leq max. permissible slewing platform ballast according to chart 1-3</p> <p>Procedure as for erection in operation on crawlers.</p>	<p style="text-align: center;">Erection</p> <p>Required slewing platform ballast according to erection chart $>$ max. permissible slewing platform ballast according to chart 1-3</p> <ol style="list-style-type: none"> 1. Before installation of the boom, only the max. permissible slewing platform ballast according to chart 1-3 may be placed. 2. Before pulling the main boom guying, the max. permissible slewing platform ballast according to chart 1-3 must be placed. 3. The main boom guying must be tensioned. The relieved supports may not lift off. Check figure data via max. permissible guy force / slewing ring overload 4. The required slewing platform ballast according to the erection charts must be placed. 5. The boom can be pulled up.
<p style="text-align: center;">Take down</p> <p>Required slewing platform ballast according to erection chart \leq max. permissible slewing platform ballast according to chart 1-3</p> <p>Procedure as for take down in operation on crawlers .</p>	<p style="text-align: center;">Take down</p> <p>Required slewing platform ballast according to erection chart $>$ max. permissible slewing platform ballast according to chart 1 - 3</p> <ol style="list-style-type: none"> 1. Place down the boom; the main boom guying must remained tensioned 2. Remove the slewing platform ballast until only the max. permissible slewing platform ballast according to chart 1-3 is placed. 3. The main boom guying can be relieved. 4. The main boom can be removed.

Chapter 4

Operation of the Superstructure



Pos.:

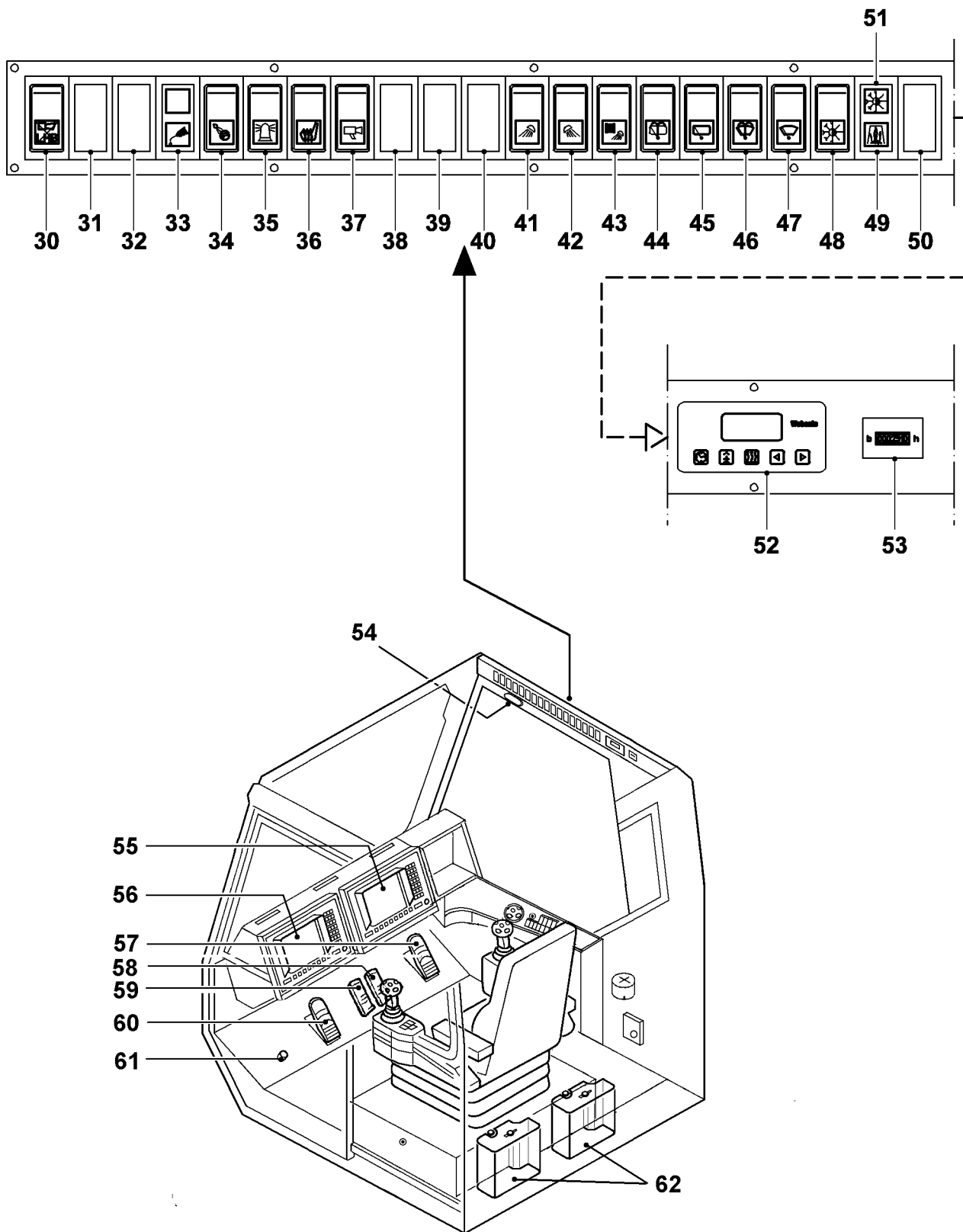
- | | | |
|---|----------------------|---|
| 1 | Pressure gauge | - Erection cylinder A- bracket |
| 2 | Thermostat | - Auxiliary heater |
| 3 | Arm rest | |
| 4 | Set screw | - Adjustment for arm rest incline |
| 5 | Lock lever | - Adjustment for arm rest height |
| 6 | Manual control lever | - Crawler travel gear, left
- Crawler travel gear, right |

Note: The crawler travel gear can also be run via the manual control lever. - To do so, they must be inserted into the foot pedals (58, 59) .

- | | | |
|-----|---------------------|--|
| 7 | Seat contact switch | |
| 8 | Manual lever | - Seat surface incline adjustment |
| 9 | Button | - Back support in lower area of backrest |
| 10 | Button | - Back support in upper area of backrest |
| 11 | Manual lever | - Lock for horizontal seat adjustment |
| 12 | Manual lever | - Seat backrest incline adjustment |
| 13* | Knob | - Air conditioning system |
| 14 | Change over switch | - Change between air circulation / fresh air, air quantity |
| 15 | Rotary switch | - Fan, 3-stage |
| 16 | Knob | - Temperature cab heater |

17 - 29 not used

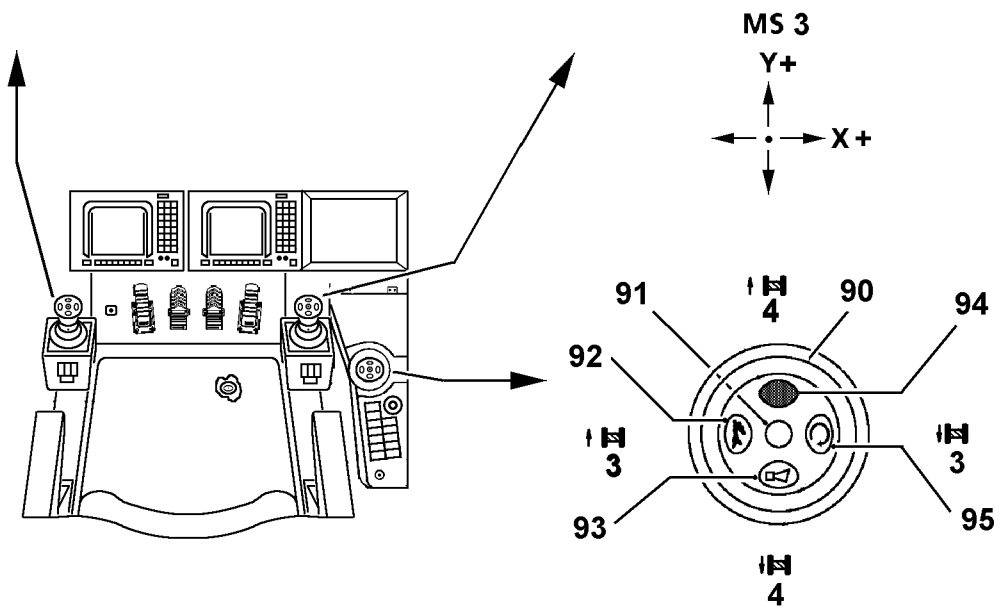
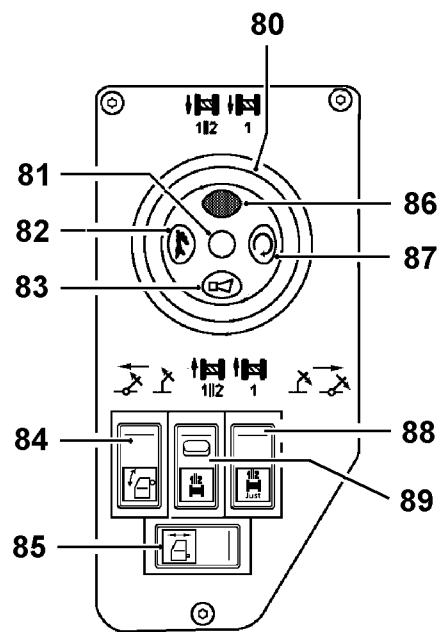
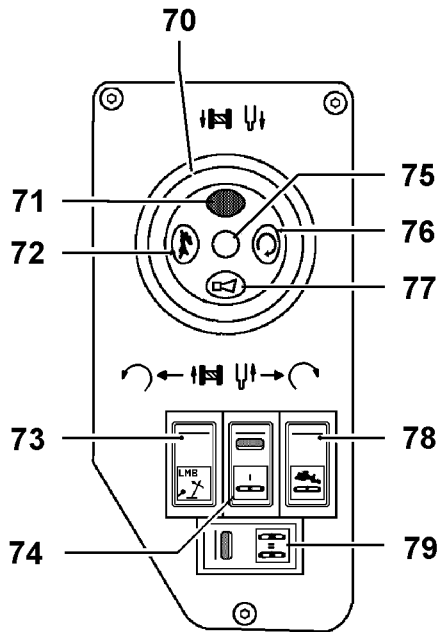
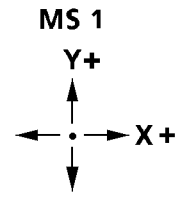
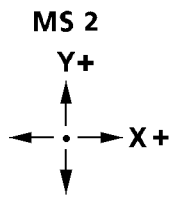
* Optional



Pos.:

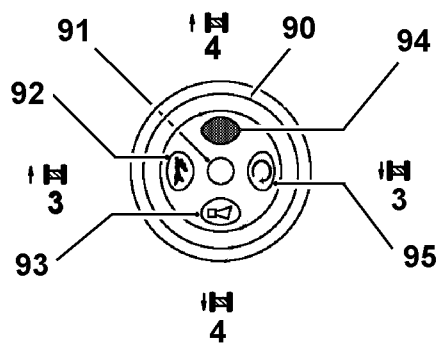
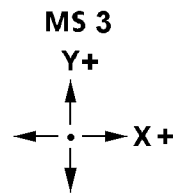
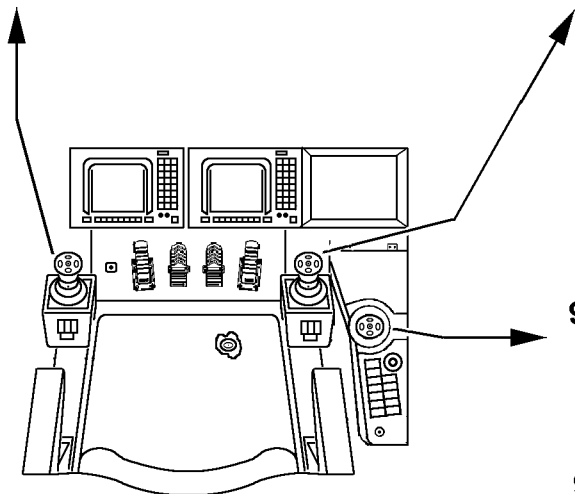
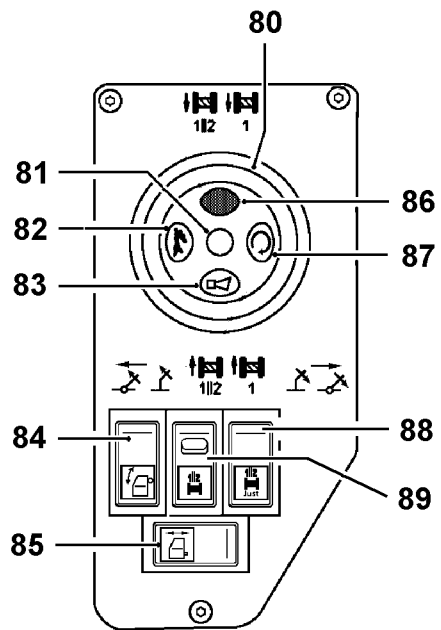
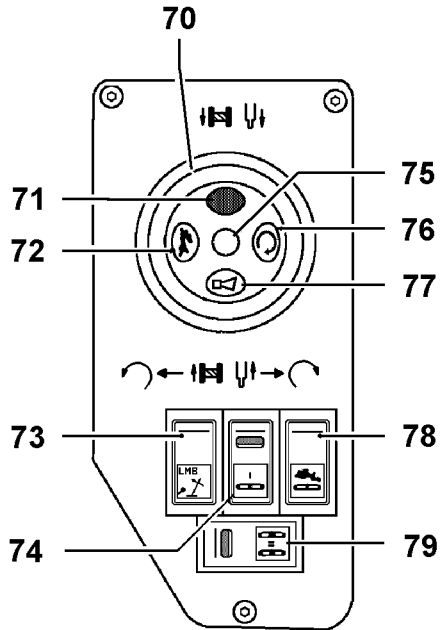
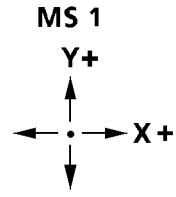
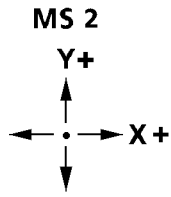
30*	Button	- Shut off LML bell
31	not used	
32	not used	
33	Indicator light	- Central lubrication system in lubrication mode or error code indication
34	Switch	- Instrument illumination
35	Button	- Airplane warning light / beacon
36	Switch	- Seat heater
37	Switch	- Lightning cameras for winches 1, 2 and 4, 3, 5 and 6
38-40	not used	
41	Switch	- Working floodlight - cab base
42	Switch	- Working floodlight - cab roof, rear
43	Switch	- Working floodlight, winch illumination / mirror heater
44	Button	- Windshield wiper / washer, front window
45	Switch	- Windshield wiper, front window, 2 stage
46	Button	- Windshield wiper / washer, roof window
47	Switch	- Windshield wiper, roof window, 2 stage
48	Switch	- Air conditioner
49	Indicator light	- Auxiliary heater turned on
50	not used	
51	Indicator light	- Air conditioner turned on
52	Digital clock	- with the following indicators: Time of day and day of the week Problem in auxiliary heater Air temperature Preselection of auxiliary heater operation with 3 preselection times (each preselection time can be preprogrammed up to 7 days in advance.)
53	Hour meter	
54	Cab illumination	
55	LICCON Monitor 0	
56	LICCON Monitor 1	
57	Pedal	- Engine regulation / gas pedal
58	Foot pedal	- Crawler, right
59	Foot pedal	- Crawler, left
60	Pedal	- Foot brake, slewing gear
61	Foot button	- Coasting of slewing gear
62	Reservoir	- Windshield cleaning fluid

* Optional



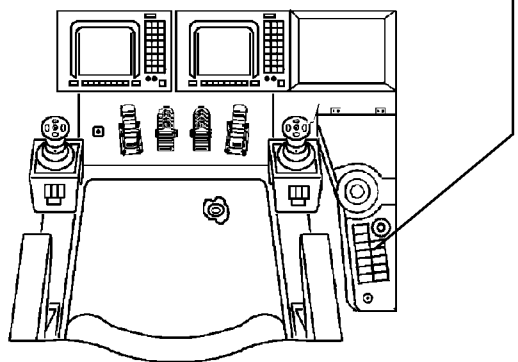
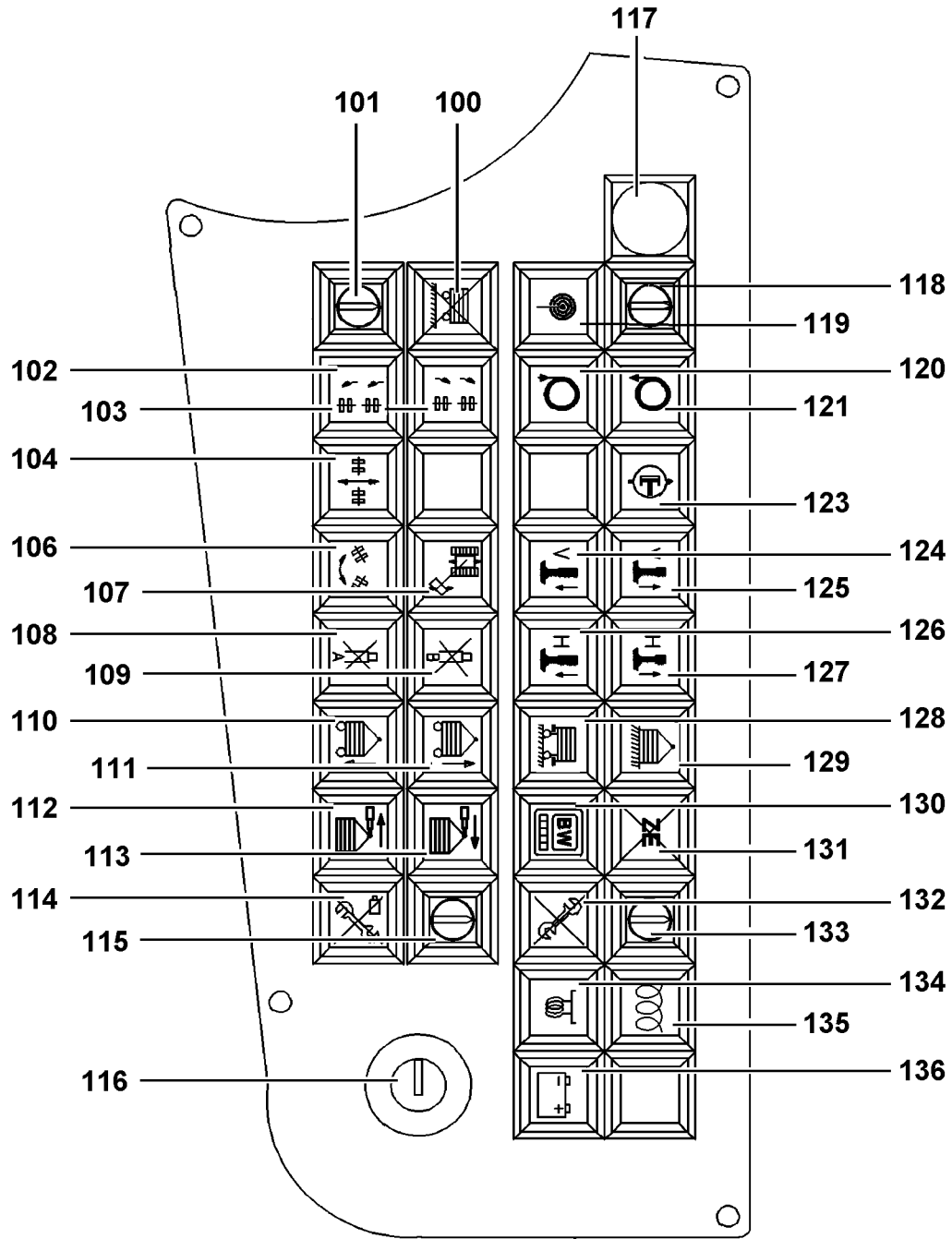
Pos.:

- | | | |
|----|----------------------|--|
| 70 | Master switch (MS 2) | |
| | Note: | For assignment of master switch to operating modes, see chart, chapter 4.05 |
| 71 | Button | - Bypass seat contact switch
or,
if the seat contact switch is actuated ,
turn vibration sensor (75) on / off |
| 72 | Button | - Turn "POWER PLUS" on / off |
| 73 | Button | - Bypass overload safety device to luff up at overload |
| | D A N G E R : | The bypass may only be made if the overload was caused by luffing down with suspended load and the crane operator is absolutely sure that he can leave the overload range by luffing up. |
| 74 | Switch | Crawler "ON", unlock switch (74) and press switch on front.
Crawler "OFF", press switch (74) into 0-position. |
| | Note: | After completion of the crawler operation, the crane must be shifted back to crane operation. Crawler "OFF", press switch (74) into 0-position |
| | D A N G E R : | When working with the crane support, for safety reasons, the crawler gear must always be turned off , because the support system could be severely damaged in case the pedals for the crawler gear left / right are inadvertently pressed down! |
| 75 | Vibration sensor | - Turn sensor for slewing gear or for winches 2, 5, 6 (depends to operating mode) |
| 76 | Button | - Lock in the constant engine RPM |
| | Note: | By actuating it, the engine RPM is locked in the current position . |
| 77 | Button | - Horn |
| 78 | Switch | - Crawler rapid gear |
| 79 | Switch | - Crawler parallel travel, left and right crawler same speed |



Pos.:

80	Master switch (MS 1)	
	Note:	Assignment of master switch to operating modes, see chart, chapter 4.05
81	Vibration sensor	- Winch rotation sensor or for winches 1, 2, 3, 4, 5 (depends on operating mode)
82	Button	- Turn "POWER PLUS" on / off
83	Button	- Horn
84	Button	- Tilt cab Position II (front) Tilt cab up Position 0 (center) OFF Position 1 (rear) Tilt cab down
85	Button	- Swing cab Position I (left) Swing cab out Position 0 (center) OFF Position II (right) Swing cab in
86	Button	- Bypass seat contact switch or, if seat contact switch is actuated, Turn vibration sensor (81) on / off
87	Button	- Lock in the constant engine RPM
	Note:	By actuating it, the engine RPM is locked in the current position.
88	Button	- Adjust the parallel control of winch 1 II 2
	Note:	Adjustment can only be made when the hook blocks are parallel.
89	Switch	- Parallel operation of winch 1 II 2
90	Master switch (MS 3)	
	Note:	Assignment of master switch to operating modes, see chart, chapter 4.05
91	Vibrationsensor	- Winch rotation sensor or for winches 3, 4, 5 (depends on operating mode)
92	Button	- Turn "POWER PLUS" on / off
93	Button	- Horn
94	Button	- Bypass seat contact switch or, if seat contact switch is actuated, Turn vibration sensor (91) on / off
95	Button	- Lock in the constant engine RPM
	Note:	By actuating it, the engine RPM is locked in the current position.



Pos.:

100 Button with warning light

- If "Derrickballast raised" is turned on with the keyed button (101), then this is shown by the blinking warning light (100).
Press the button (100) to turn off "Derrickballast raised". The warning light in the button (100) turns off.
The LICCON monitor shows the derrick ballast symbol on the ground.

101 Keyed button **"Derrickballast lifted off"**

By actuating the keyed button momentarily, the operating mode **"Derrickballast lifted off"** is turned on (self retaining).

The **"Derrickballast lifted off"** is turned on when the blinking warning light (100) is on. In addition, the ballast trailer symbol is shown on monitor 1 in suspended condition.

Note: Derrickballast = Ballasttrailer or suspended ballast

D A N G E R: **"Derrickballast lifted off" must be turned on if the ballast trailer lifts off during towing and the wheels are no longer in contact with the ground. Keep constant visual check .**

- see also chapter 5.11 Ballast trailer .

102 Button

- Operating mode **"manual steering adjustment"** on - Indicator light is on
Ballast trailer wheels turn to the left, to drive on tight job and construction sites

103 Button

- Operating mode **"manual steering adjustment"** on - Indicator light is on
Ballast trailer wheels turn to the right to drive on tight job and construction sites

104 Button

- Set ballast trailer wheels into driving position - the indicator light blinks, wheels in driving position - indicator light lights up

106 Button

- Turn ballast trailer wheels in turn position - indicator light blinks;
wheels in turn position - indicator light lights up constantly.

107 Button

- Turn ballast trailer wheels to parallel drive position (crab walk) - indicator light blinks; wheels in parallel drive position - indicator light lights up constantly

102-107

- see also chapter 5.11 Ballast trailer .

108 Button

- Block cylinder (A) on derrick ballast

109 Button

- Block cylinder (B) on derrick ballast

110 Button

- Derrick ballast "DOWN"

111 Button

- Derrick ballast "UP"

112 Button

- Telescope derrick ballast in

113 Button

- Telescope derrick ballast out

114 Button

- Turn off self retention of keyed button (115)

115 Keyed button

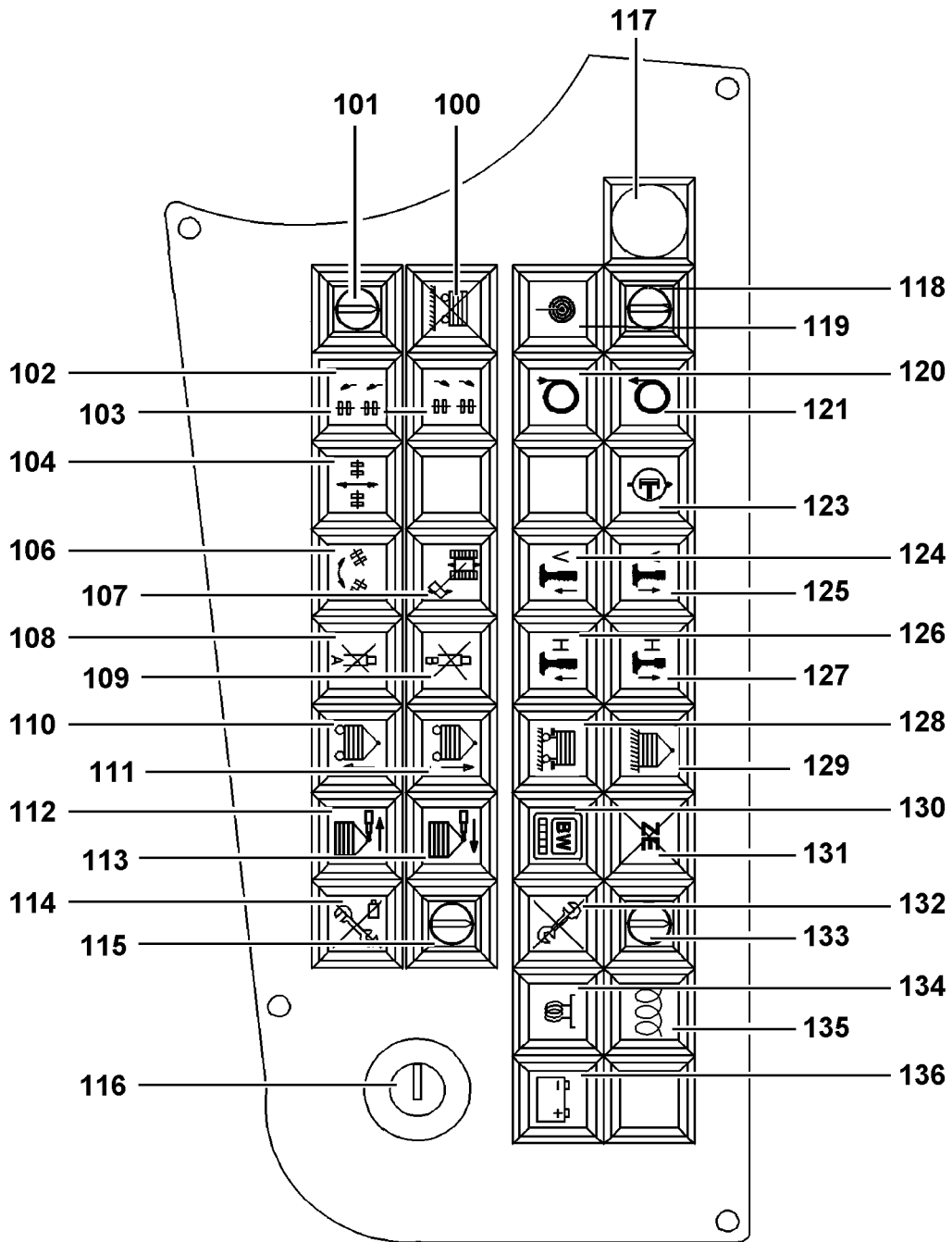
By pressing the keyed button for a short time, the crawler installation with hydraulic cylinder is preselected (self retention)

Prerequisite: Operating mode "Installation" on - indicator light on button lights up

The fact that the keyed button is turned on is shown by the indicator light in button (114), as well as a red beacon, which is installed on the crane operator's cab.

D A N G E R: **If operating mode "crawler installation"- keyed button (115) is turned on, no overload shut off will be made for the installation cylinder as well as for the crane. This is a dangerous situation, which can lead to accidents!**

116 Ignition starter keyed switch



102

103

104

106

107

108

109

110

111

112

113

114

115

116

101

100

117

118

119

120

121

123

124

125

126

127

128

129

130

131

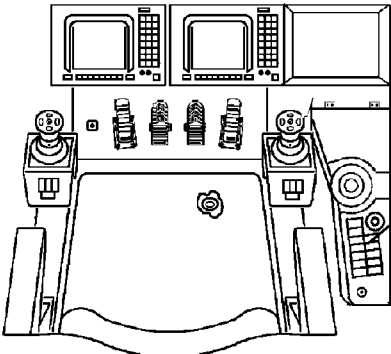
132

133

134

135

136



Pos.:

117	Button	- EMERGENCY "OFF" button
118	Keyed switch	- Position "0" (horizontal), Radio remote control Locking "ON" - Position "1" (vertical), Radio remote control Locking "ON"
118	Button	- Radio remote control
119	Indicator light	- Radio remote control ON
120	Button	- Spool up installation winch
121	Button	- Spool out installation winch
123	Button	- Pressure supplz change over to auxiliary users: - SA-Bracket erection cylinder - Installation support cylinder
	Note:	For all functions, which must be controlled with the hydraulic manual control lever, the pressure supply must be turned on .
124	Button	- Support cylinder Ballast trailer front down
125	Button	- Support cylinder Ballast trailer front up
126	Button	- Support cylinder Ballast trailer rear down
127	Button	- Support cylinder Ballast trailer rear up
128	Warning light	- Ballast trailer support retracted
129	Warning light	- Suspendedballast on the ground
130	Switch	- Change over from monitor "1" to test system ballasttrailer control
	Note:	Can only be changed over if "engine off".
131	Warning light	- Central unit ballast trailer does not "boot up" resp. pressure sensor or length sensor are defekt or missing. - see also chapter 5.11 Ballast trailer.
132	Button	- Turn off self retention of keyed button (133)
133	Installation keyed button	By pressing the keyed button for a short time, the operating mode Installation is preselected (self retention). Observe safety instructions, see chapter 4.04 !
	D A N G E R:	The LICCON overload safety device is no longer effective. If the operating mode Installation is turned on, it is shown by the indicator light in button (132), the symbol on the monitor as well as by the red beacon which is installed on the crane operator´s cab.
134	Indicator light	- Preheat engine, flame start system
135	Switch	- Fuel preheating
136	Change indicator light	

Contents

1. General
2. Overview of LICCON programs
3. Booting up the LICCON computer system

10. Control elements of the LICCON computer system, monitor 0
11. The "Set up" program
12. The "Operation" program
13. The "Control Parameter" program
14. The "Support" program
16. The "Engine monitoring" program

20. Control elements of the LICCON computer system, monitor 1
21. The "Operation on monitor 1" program

40. Slewing range change over

Note: The monitor illustrations in this chapter are only examples. The number values in the individual symbol elements and charts might not match the crane. In addition, some illustrations show the maximum assignment of the LICCON monitor with symbol elements. In normal crane operation, an identical view might not appear on the LICCON monitor .

1. General

The LICCON computer system is a computer system to control and monitor mobile cranes. In addition to overload safety (Loadmomentbegrenzung ⇒ LMB / **Load Moment Limiter** ⇒ LML) there are a number of other application programs used to control and monitor the crane movements. At this time, the LICCON computer system includes the following application programs:

Application programs

- The "Set up" program
- The "Operation" program
- The "Support" program (optional)
- The "Control Parameter" program
- The "Engine monitoring" program
- The "Operation on monitor 1" program (optional)

Overload safety device system (LML)

The overload safety is carried out on the micro processor unit 0 for basic component group 0. The LICCON Computer system operates according to the principle of comparison between the actual load and the maximum permissible load according to the load capacity chart and reeving.

Actual load

The actual load is determined by obtaining changing values:

The load of the crane is a combination of load momentum and boom momentum. It affects a force in the boom luffing cylinder, which is measured by pressure sensors.

The boom momentum is calculated from the angle sensor information (boom angle), the length sensor information (boom length) and the crane data (boom weights) for the adjusted operating mode.

The radius is determined on hand of the angle sensor information (boom angle), the length sensor information (boom length), and the geometric data of the adjusted operating mode. The boom flexation due to its own weight and the weight of the load is taken into account.

The actual load is calculated from the total load, the boom momentum and the radius .

Maximum load according to load capacity chart and reeving

The crane data as well as load capacity charts, boom weights and geometric data are stored in the central data bank of the LICCON Computer system.

From the load capacity charts , the "maximum load according to the load capacity chart and reeving" is constantly being determined for the entered equipment configuration, the entered reeving and the calculated radius.

Comparison

The actual load and the "maximum load according to the load capacity chart and reeving" is compared. When the value gets close to the given limit, a prewarning is given. If this limit is reached or exceeded, the overload warning device (STOP) is triggered and the load moment increasing crane movements are turned off.

The integration of electric and electronic components in the chassis and the crane superstructure is handled via data bus transfer technology (Liebherr-System-Bus ⇒ LSB).

LIEBHERR

		m > < t	CODE >XXXX< BXXX YYZZ.1(2)					
	35,0	35,0	35,0	35,0	35,0	35,0	35,0	
12,0								
14,0	380,0	380,0	380,0	380,0				
16,0	372,0	372,0	372,0	372,0				
18,0	363,0	363,0	363,0	363,0				
20,0	350,0	350,0	349,0	349,0				
22,0	336,0	337,0	337,0	337,0				
24,0	305,0	313,0	312,0	312,0	307,0	319,0	328,0	
26,0	278,0	283,0	283,0	283,0	284,0	301,0	310,0	
* n *	* 29 *	* 29 *	* 29 *	* 29 *	* 23 *	* 24 *	* 25 *	
xx	87,0	87,0	87,0	87,0	77,0	77,0	77,0	
yy	13,0	15,0	18,0	20,0	13,0	15,0	18,0	
							>>	

xx° SDB
35m

W
28m

12.0 x
12.0 t

O.K.

SHIFT

F1

F2

F3

F4

F5

F6

F7

F8

ENTER

LIEBHERR

BXXX YYZZ
XXXX

max n = 10
t 156.0

0 1/min:1634 50 90 100 110 130%

t 28.3

1°
0.0
0.0

0.0
0.0
max: 12.8

m/s
23.8
80.0°

191.99 m
2:1Y

191.99 m
1:1Y

1 4 t
0 0
2 3
XXXXXX

V: 40%
0°

m
28.0
35.0
60.0°
62.6

SHIFT

F1

F2

F3

F4

F5

F6

F7

F8

ENTER

2. LICCON programs for crane operation**The "Set up" program****(Monitor 0)**

The crane operator enters the data for the selected equipment configuration in the LICCON set up program and receives the corresponding load capacity charts on the monitor. The equipment configuration is entered via dialog functions or short code.

The "Operation" program**(Monitor 0)**

In the "Operation" program , symbol elements constantly inform the operator about all important crane data. All critical indications are also signaled via an acoustical signal. Depending on the configuration, a number of additional indicators can be added by the crane operator as auxiliary indicators, or will be added automatically in case of a problem.

LIEBHERR-WERK EHINGEN LX
LIEBHERR

V_{max}
↻
40 %

(1)

100%

(5)

100%

(2)

100%

(6)

100%

=> (3)

100%

(4)

100%

5 %
10 %
20 %
40 %
70 %
=> 100 %

▼

◀▶

▼

▼▼

SHIFT

F1

F2

F3

F4

F5

F6

F7

F8

ENTER

LIEBHERR

max[t]
max[t]

(1)

(4)

(2)

(3)

60.0
23.8
80.0°
1°
0.0
0.0
max 18% 156.0
t 28.3
XXXXXX

▲▲

▼▼

▲▼

▼▲

◀

▶

(n)

✖

SHIFT

F1

F2

F3

F4

F5

F6

F7

F8

ENTER

The "Control" program**(Monitor 0)**

With the "Control Parameter" program, maximum speeds for slewing and hoist gear can be preselected in stages. In addition, winches can be deactivated.

The "Support" program ***(Monitor 0)**

The control of functions is made via a process visualization on the LICCON monitor, which is linked into the support force monitoring platform.

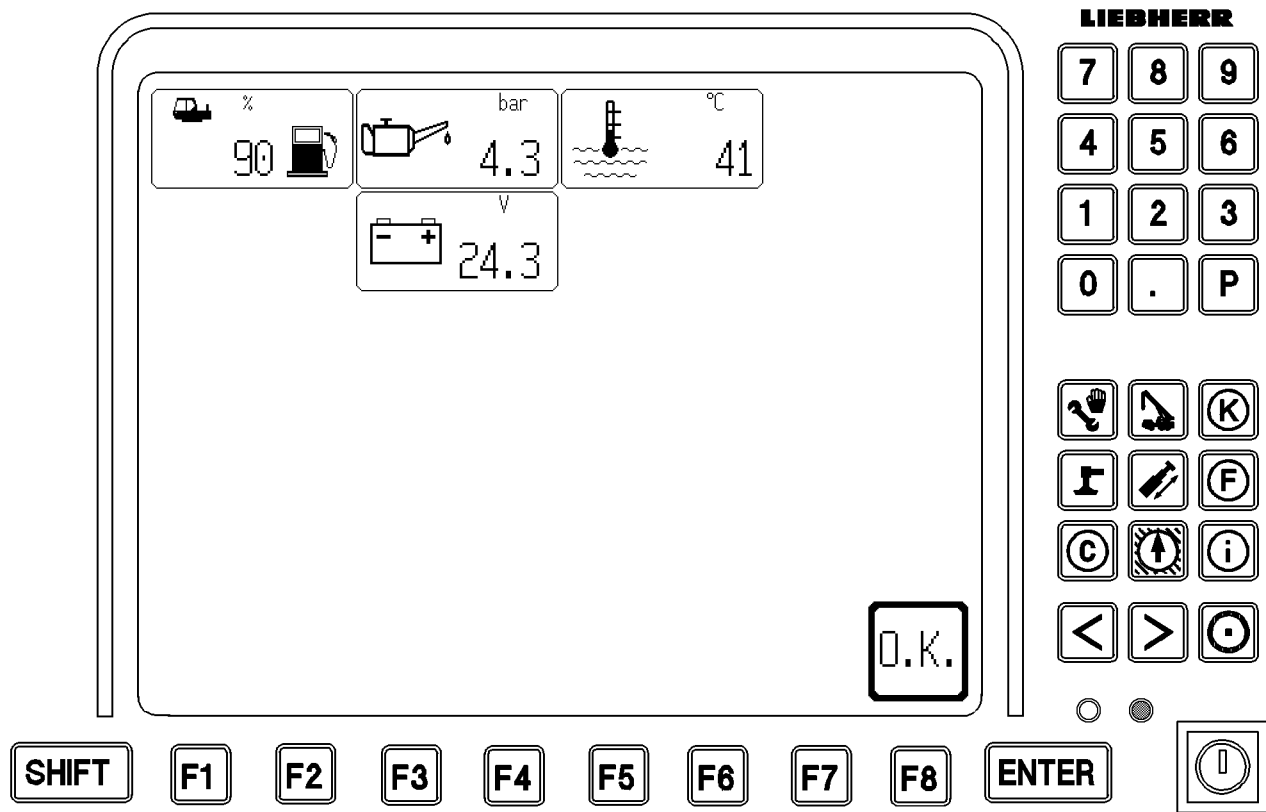
1) Support

The folding arms as well as the support cylinders can be retracted or extended via the support function, and the crane can be horizontally aligned.

2) Support force monitoring

The support force monitoring system constantly determines the current pressure on all 4 support cylinders via pressure sensors, and shows it as support force for each support. Due to the variable programming capability of the limit values, the support force monitoring system can also be utilized as a prewarning system.

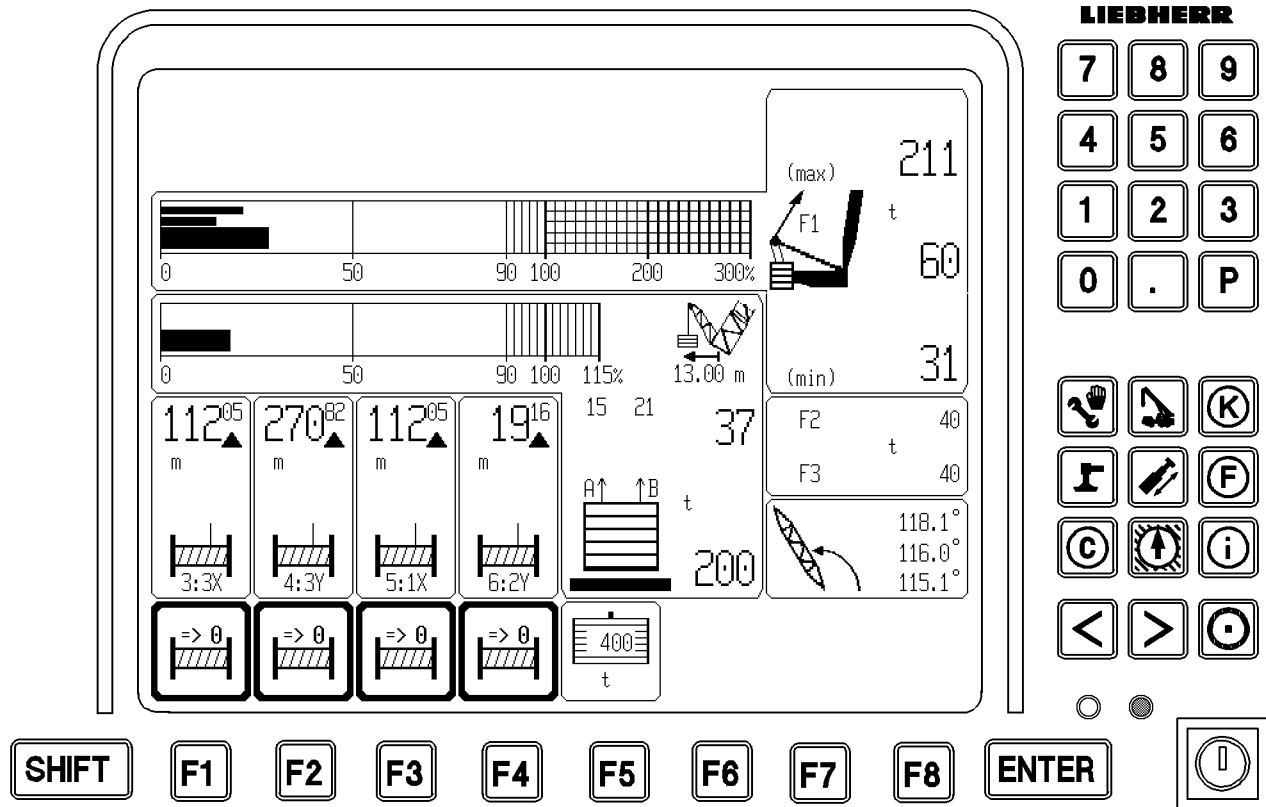
* Optional



The "Engine monitoring " program

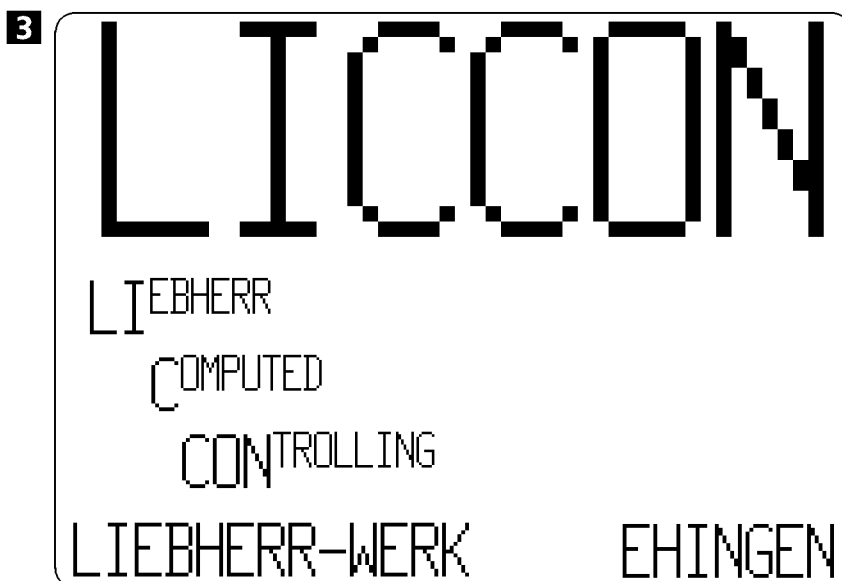
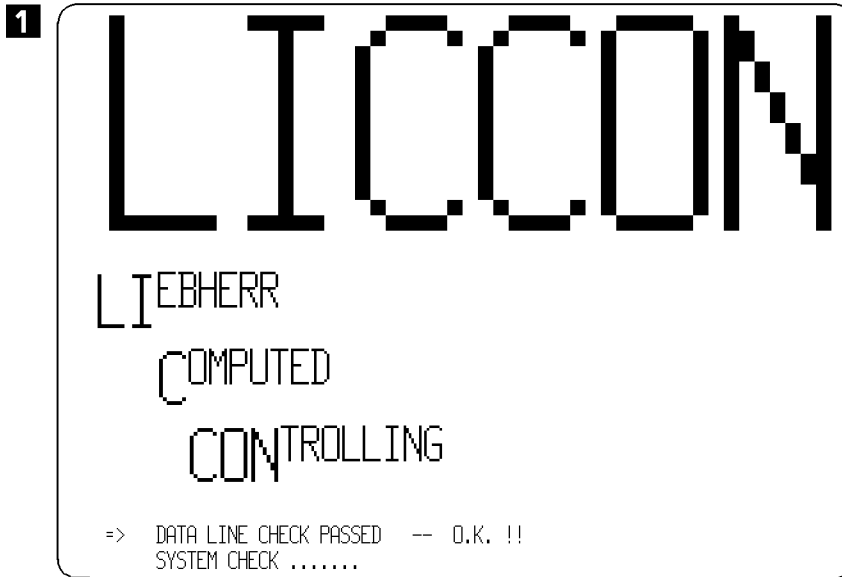
(Monitor 0)

In the engine monitoring view, all relevant data for the engine are shown, such as engine oil pressure, coolant temperature, etc. In case of a problem, the change from the "Operation", "Support" programs occurs automatically.



The "Operation on monitor 1" program

(Monitor 1)



3. Booting up the LICCON computer system after turning it on

After the LICCON computer system is turned on, it runs through a self test.

The connections from the micro processor central units (CPUs) to the monitor are checked first. If no error was found, the following is shown on the monitor:

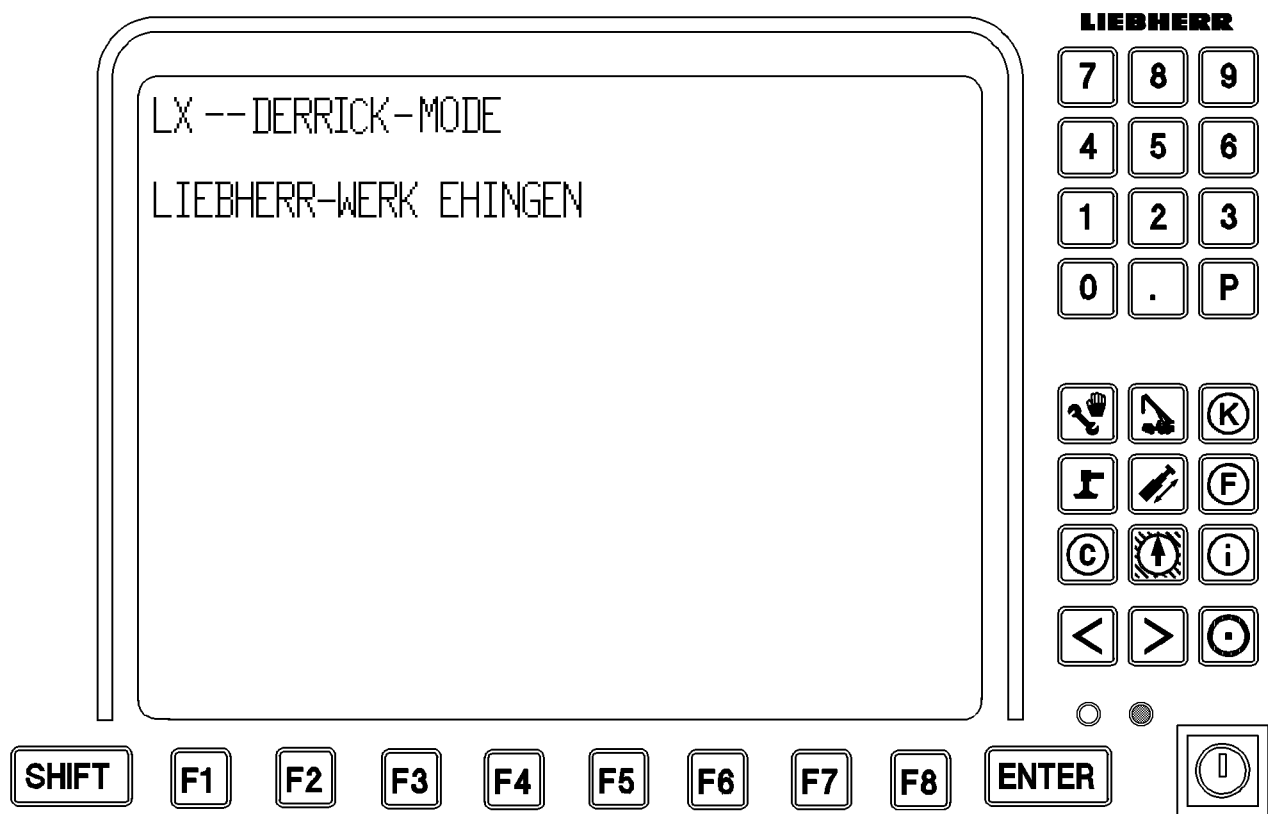
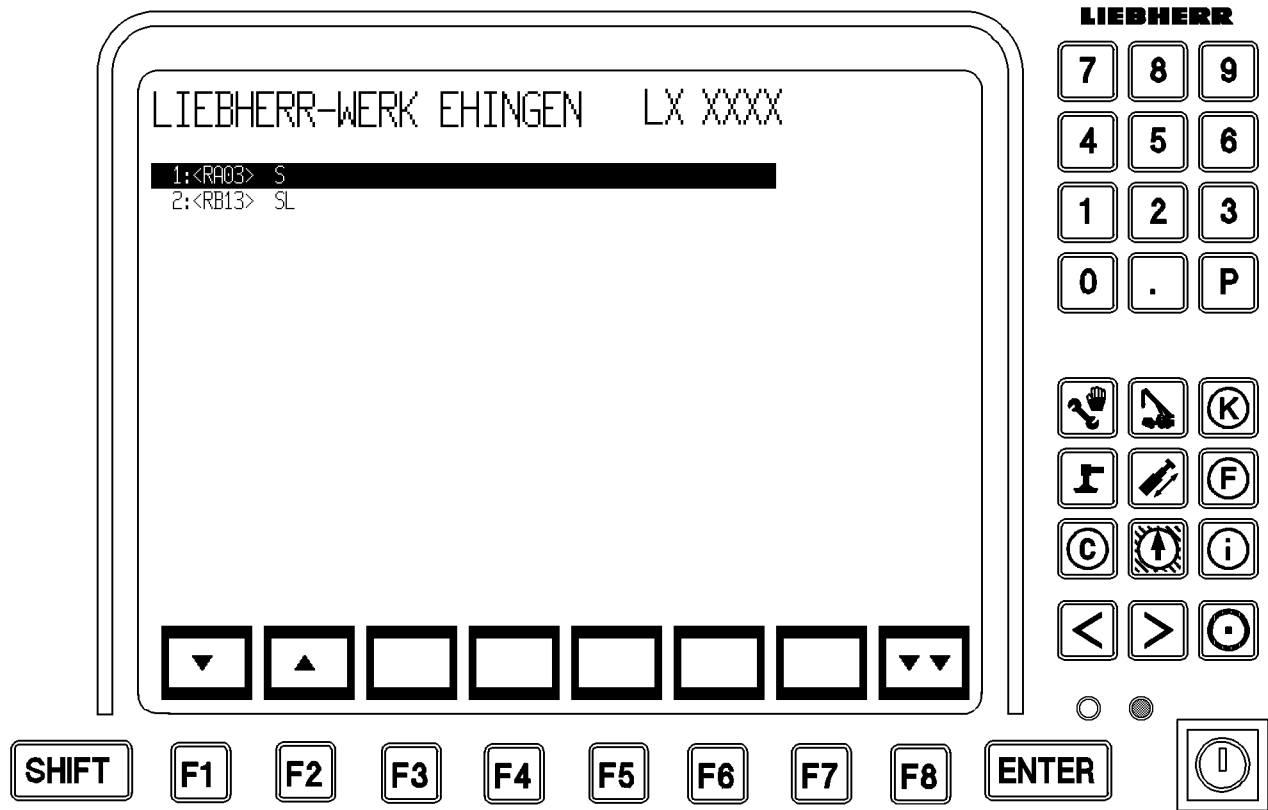
```
⇒ DATA LINE CHECK PASSED  --  O.K. !!           (fig. 1)
   SYSTEM CHECK . . . . .
```

If no problems were found on the connections, a system test is carried out on all micro processor central units (CPUs). The step by step run of the self test can be viewed on the 7segment indicators of the CPUs. If no error was found during the system test, the following is shown on the monitor :

```
⇒ DATA LINE CHECK PASSED  --  O.K. !!           (fig. 2)
   SYSTEM CHECK . . . . . PASSED  --  O.K. !!
```

Then the general initialization view appears on the monitor for a short time:

```
LIEBHERR-WERK      EHINGEN                               (fig. 3)
```



Booting up the LICCON computer system (continuation)

If the starting procedure is completed successfully and the LICCON computer system has run through the self test , the following appears :

Monitor 0 The program to preselect the operating modes.

Note: Normally, the last used operating mode group is shown , which was used before the LICCON computer system was turned off. Only in case of a data loss, for example due to a cold boot (after a change of the battery or one of the CPUs, etc.) appears the 1st valid equipment configuration with the 1st valid operating mode.

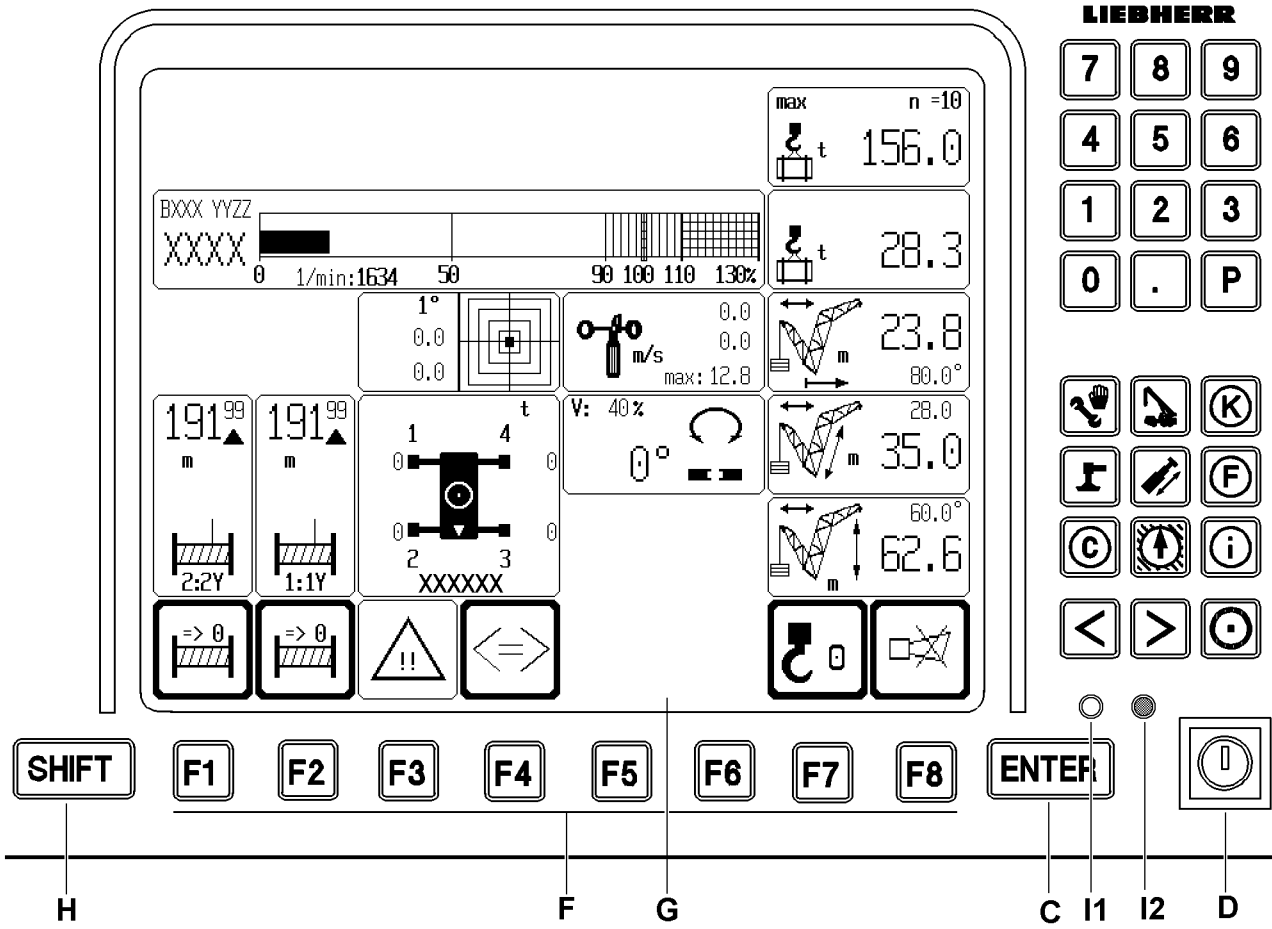
- Move the cursor up or down with function key "F1" or "F2" to preselect the desired operating mode preselection group.

- Confirm the preselection with the "F8" key or "ENTER" .

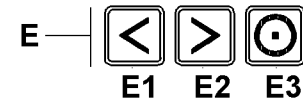
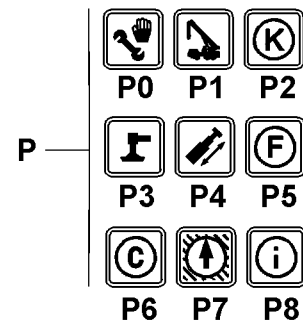
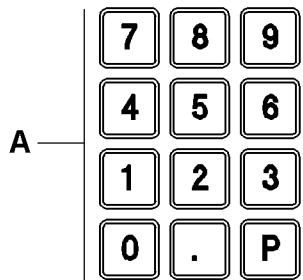
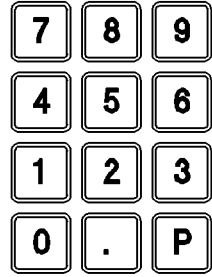
The "Set up / equipment configuration" program appears.

Note: If no new operating mode group is selected within 3 seconds, then the former operating mode group remains and the system changes into the "Set up" program. This means that if the previously set operating mode group is to remain, no entry is necessary.

Monitor 1 The monitor 1 title view (Derrick mode).



LIEBHERR



10. The control elements of the LICCON computer system on monitor 0**A Alpha numeric keyboard****P Program keys**

To start the individual LICCON programs

P0: Set up /Equipment configuration program

P1: Operating program

P2: Crane delivery program (Correction coefficients)

P3: Support program *

P4: not used

P5: not used

P6: Control Parameter

P7: not used

P8: LICCON test system

C Input key "ENTER"

To confirm changes.

D Keyed switch

- Position to the right (touching) ⇒ Hoist limit switch and shut off of LML bypassed

- Center position (self retaining) ⇒ Normal operation

E Special function keys**Brightness adjustment of monitor**

The brightness level of the monitor can be adjusted with this key.

- "E1" background illumination ON /OFF

- "E2" brightness adjustment in three stages

Note: Additional functions of special function keys depend on the program and will be explained in detail in the description of the individual LICCON programs.

F Function keys (F1 to F8)

The function keys must always be viewed together with the function key symbol line shown on the monitor above.

G Monitor

Shows individual program views (example : Operating view).

H SHIFT key

Key assignment on 2nd level, "Supervisory function".


I LED indicators


I1: (LED red) Monitor error

I2: (LED yellow) Power supply for monitor available.

Note: The function of the individual monitor control elements depends on the program, which means it might differ depending on the currently executed LICCON program. It will be explained in detail in the description of the individual LICCON programs..

*Optional






$m > < t$


CODE >XXXX< BXXX YYZZ.1(2)

12,0	35,0	35,0	35,0	35,0	35,0	35,0	35,0
14,0	380,0	380,0	380,0	380,0			
16,0	372,0	372,0	372,0	372,0			
18,0	363,0	363,0	363,0	363,0			
20,0	350,0	350,0	349,0	349,0			
22,0	336,0	337,0	337,0	337,0			
24,0	305,0	313,0	312,0	312,0	307,0	319,0	328,0
26,0	278,0	283,0	283,0	283,0	284,0	301,0	310,0
* n *	* 29 *	* 29 *	* 29 *	* 29 *	* 23 *	* 24 *	* 25 *
xx	87,0	87,0	87,0	87,0	77,0	77,0	77,0
yy	13,0	15,0	18,0	20,0	13,0	15,0	18,0
							>>




xx° SDB
35m

W
28m




t

12.0 x
12.0 t



yy m



n
10 x

O.K.

95
t

SHIFT

F1

F2

F3

F4


F5

F6

F7

F8

ENTER



LIEBHERR

7

8

9

4

5

6

1


2


3


0


.


P
































11. The "Set up" program

After turning it on, and after the LICCON computer system is booted up and the operating mode group is preselected, the system changes automatically into the "Set up" program.

Note: If an equipment configuration from the same operating mode group was set before the LICCON computer system was turned off, then this last used equipment configuration and the reeving used at that time is automatically reset and shown.
If another operating mode group was selected before the LICCON computer system was shut off, or if the LICCON computer system is turned on for the first time, or in case of data loss (memory loss due to cold boot), then, after this operating mode is confirmed, the first valid equipment configuration of the first valid operating mode appears in the equipment configuration view.

C A U T I O N : In case of cold boot, the setting for the hoist cable reeving is set to "0" !

Note: All entries and settings, which are made in the "Set up" program can only be made on monitor 0.

Setting the operating mode and the equipment configuration

The operating mode and the equipment configuration can be set two ways:

1. With function keys :
 - "F2" Setting the main geometric condition
 - "F3" Setting the auxiliary equipment
 - "F4" Setting the slewing platform weight
 - "F5" Setting the central ballast (at LR1750 only) or support
 - "F6" Setting the slewing range in operating modes with various slewing ranges
 - Confirm settings with the "ENTER" key.
2. With the short code:
 - Enter the 4-digit short code with the alpha-numeric key on monitor 0.
 - Confirm settings with the "ENTER" key.

After entry, the data for the selected load capacity chart can be viewed.

Setting the hoist cable reeving

Press "F7" to set the "Hoist cable reeving"

Press "F8" to end the "set up" program and take over the entered parameters into the "Operation" program .

Note: If an equipment configuration has been confirmed at least once with the "O.K." key, than the "set up" program can also be ended by pressing one of the program keys ("P1" - "P8"). In that case, the LICCON computer system drops all setting made in the "set up" program and uses the previous operating condition, which had last been confirmed with "O.K."

5.4

LIEBHERR

		$m > < t$		CODE >XXXX< BXXX YYZZ.1(2)			
		35,0	35,0	35,0	35,0	35,0	35,0
12,0							
14,0	380,0	380,0	380,0	380,0			
16,0	372,0	372,0	372,0	372,0			
18,0	363,0	363,0	363,0	363,0			
20,0	350,0	350,0	349,0	349,0			
22,0	336,0	337,0	337,0	337,0			
24,0	305,0	313,0	312,0	312,0	307,0	319,0	328,0
26,0	278,0	283,0	283,0	283,0	284,0	301,0	310,0
* n *	* 29 *	* 29 *	* 29 *	* 29 *	* 23 *	* 24 *	* 25 *
xx	87,0	87,0	87,0	87,0	77,0	77,0	77,0
yy	13,0	15,0	18,0	20,0	13,0	15,0	18,0
							>>

5.1

$m > < t$ CODE >XXXX< BXXX YYZZ.1(2) — 5.1

		$m > < t$		CODE >XXXX< BXXX YYZZ.1(2)			
		35,0	35,0	35,0	35,0	35,0	35,0
12,0							
14,0	380,0	380,0	380,0	380,0			
16,0	372,0	372,0	372,0	372,0			
18,0	363,0	363,0	363,0	363,0			
20,0	350,0	350,0	349,0	349,0			
22,0	336,0	337,0	337,0	337,0			
24,0	305,0	313,0	312,0	312,0	307,0	319,0	328,0
26,0	278,0	283,0	283,0	283,0	284,0	301,0	310,0
* n *	* 29 *	* 29 *	* 29 *	* 29 *	* 23 *	* 24 *	* 25 *
xx	87,0	87,0	87,0	87,0	77,0	77,0	77,0
yy	13,0	15,0	18,0	20,0	13,0	15,0	18,0
							>>

5.2

5.3

The monitor in the equipment configuration view is divided into three areas :

- 11.1 General information line
- 11.2 Indicator area for the values of the load capacity chart
- 11.3 Function key bar
- 11.4 Other control elements

Note: The monitor illustrations in this chapter are only examples. The numeric values in the individual symbol elements and charts might not match this particular crane. The programmed load capacity charts for the crane apply.

In addition, some views on the monitor show the maximum possible assignment of the LICCON monitor with symbol elements. In normal crane operation, such an identical view would not appear on the LICCON monitor .

		CODE >XXXX< BXXX YYZZ.1(2)					
		m>	<t				
		35,0	35,0	35,0	35,0	35,0	35,0
12,0							
14,0	380,0	380,0	380,0	380,0			
16,0	372,0	372,0	372,0	372,0			
18,0	363,0	363,0	363,0	363,0			
20,0	350,0	350,0	349,0	349,0			
22,0	336,0	337,0	337,0	337,0			
24,0	305,0	313,0	312,0	312,0	307,0	319,0	328,0
26,0	278,0	283,0	283,0	283,0	284,0	301,0	310,0
* n *	* 29 *	* 29 *	* 29 *	* 29 *	* 23 *	* 24 *	* 25 *
xx	87,0	87,0	87,0	87,0	77,0	77,0	77,0
yy	13,0	15,0	18,0	20,0	13,0	15,0	18,0
							>>

xx° SDB
35m

W
28m

t

12.0 x
12.0 I

yy m

n
10 x

O.K.

LIEBHERR

7

8

9

4

5

6

1

2

3

0

.

P

K

F

C

i

<

>

95
t

SHIFT

F1

F2

F3

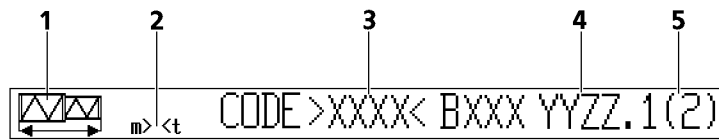
F4

F6

F7

F8

ENTER



11.1 General information line

- 1) The symbol "Main boom length" (the same for all operating modes)
- 2) Abbreviations for programmed length units (LE) and weight units (GE). Possible length units are meters [m] and feet [ft]. Possible weight units are tons [t] and pounds [lbs].
- 3) Next to the word "CODE" is a 4 digit short code (XXXX) in parenthesis (> <). Each short code describes an equipment configuration for the crane. The valid equipment configurations for the crane and the corresponding short code numbers are listed in the load capacity chart manual for the crane.
- 4) 8-digit organization number, which depends on the operating mode (BXXX YYZZ) for the entered load capacity chart. The letter at the 1st digit defines the calculation base for the load chart by country and the measuring unit in use.

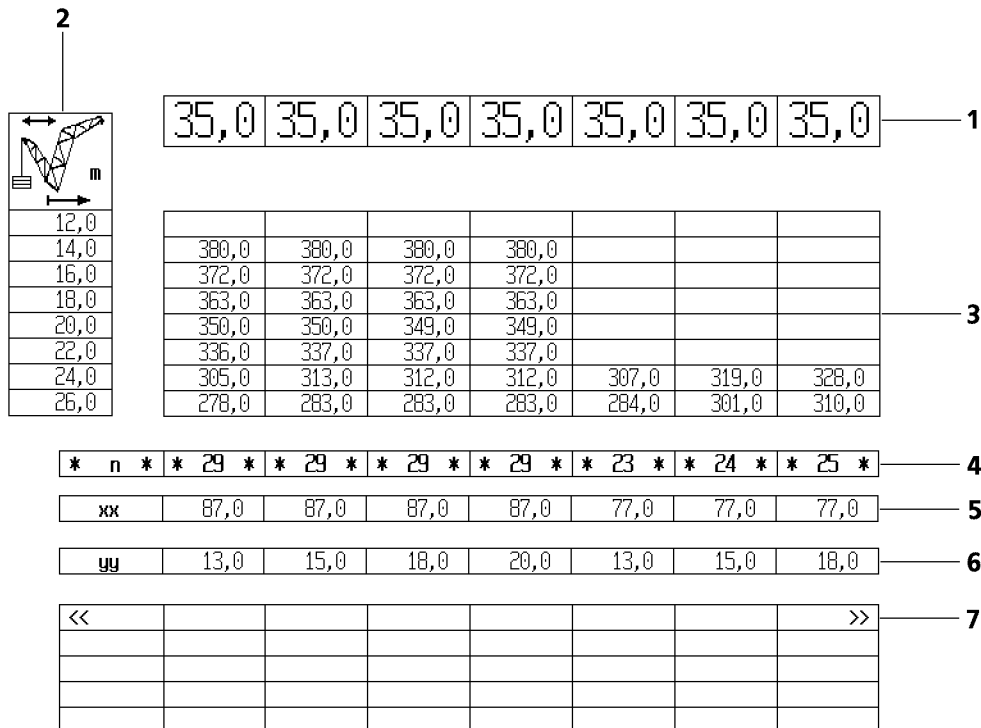
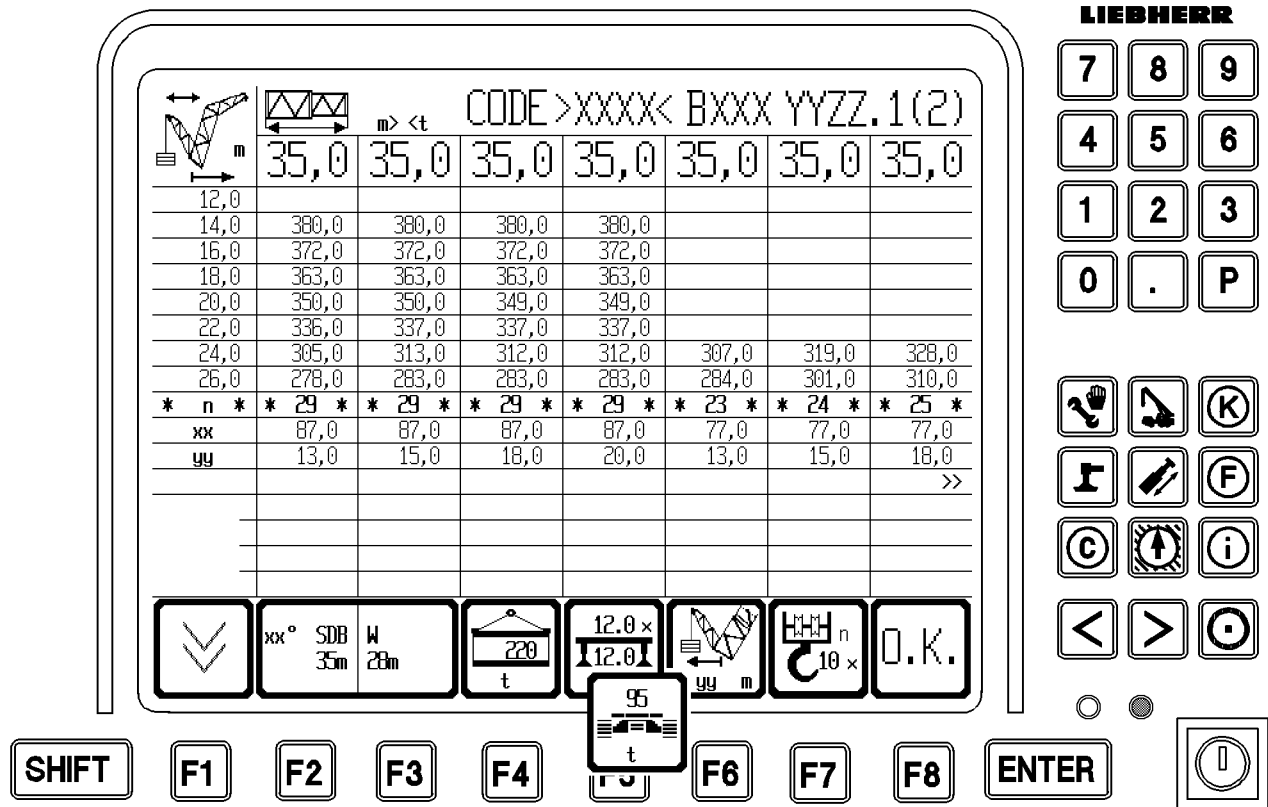
The following number combination (xxx) describes the crane type.

The 4-digit number block (yyzz) defines the entered operating mode.

YY defines the main geometry condition,

ZZ defines the auxiliary equipment geometry condition

- 5) The page number of the currently shown section of the load capacity chart is separated by a point "." from the organization number, the total number of pages of this chart is shown in parenthesis ().



11.2 Indicator range for load capacity chart values

- 1) Main boom lengths in length units (LU) of meters ([m] or feet [ft]) in max. 7 columns per page. They form the horizontal axle of the load capacity value field.
- 2) The operational mode dependent symbol element "radius" in length units (LU) of meters ([m] or feet [ft]), below maximum 10 lines of radius values. They form the vertical axle of the load capacity value field.
- 3) Load capacity value field
In columns below the main boom lengths and in lines to the right of the radius values are the **load capacity values**, depending on the boom length and the radius.
- 4) Line * **n** * = Hoist cable reeving
The numbers in this line show how often the hoist cable must be reeved between the boom head and the hook block (n), to be able to lift the maximum load according to the load chart column.

Note: If the load capacity value in the column exceeds the load which can be lifted with the maximum possible reeving, then an exclamation mark ("!") is next to the reeving number, to show that special equipment is necessary to lift this load.

Note: For parallel operation of hoist winches, an even reeving number must be used and entered. If the minimum value happens to be uneven, then the next higher reeving number must be used for parallel operation of the hoist winches.

		$m > < t$	CODE >XXXX< BXXX YYZZ.1(2)				
	35,0	35,0	35,0	35,0	35,0	35,0	35,0
12,0							
14,0	380,0	380,0	380,0	380,0			
16,0	372,0	372,0	372,0	372,0			
18,0	363,0	363,0	363,0	363,0			
20,0	350,0	350,0	349,0	349,0			
22,0	336,0	337,0	337,0	337,0			
24,0	305,0	313,0	312,0	312,0	307,0	319,0	328,0
26,0	278,0	283,0	283,0	283,0	284,0	301,0	310,0
* n *	* 29 *	* 29 *	* 29 *	* 29 *	* 23 *	* 24 *	* 25 *
xx	87,0	87,0	87,0	87,0	77,0	77,0	77,0
yy	13,0	15,0	18,0	20,0	13,0	15,0	18,0
							>>

LIEBHERR

7	8	9
4	5	6
1	2	3
0	.	P

xx° SDB
35m

W
28m

12.0 x
12.0 t

O.K.

SHIFT

F1

F2

F3

F4

F5

F6

F7

F8

ENTER

2

35,0 35,0 35,0 35,0 35,0 35,0 35,0

1

12,0							
14,0	380,0	380,0	380,0	380,0			
16,0	372,0	372,0	372,0	372,0			
18,0	363,0	363,0	363,0	363,0			
20,0	350,0	350,0	349,0	349,0			
22,0	336,0	337,0	337,0	337,0			
24,0	305,0	313,0	312,0	312,0	307,0	319,0	328,0
26,0	278,0	283,0	283,0	283,0	284,0	301,0	310,0

* n *	* 29 *	* 29 *	* 29 *	* 29 *	* 23 *	* 24 *	* 25 *
xx	87,0	87,0	87,0	87,0	77,0	77,0	77,0
yy	13,0	15,0	18,0	20,0	13,0	15,0	18,0

3

4

5

6

7

<<							>>

- 5) Line **xx** = Main boom angle in [°]
Appears only in operating modes with luffing lattice jib.
- a) If "xx°" appears in the symbol element main geometry (for example **xx° SDBW**), then **xx°** = main boom angle in [°]. The main boom angles, which must be set to be able to lift the load values according to the corresponding load chart column are shown in columns next to each other.

Note: See also paragraph 30.3.1 Main boom angle interpolation and paragraph 30.3.4 Combination of main boom angle and derrick ballast radius interpolation.

- b) If "xx°" appears in symbol element auxiliary geometry (for example **WV xx°**), then **xx°** = jib relative angle in [°]. This means the jib angle in relation to the main boom angle (main boom angle on pulley head jib angle bottom).

The jib relative angles, which must be set to be able to lift the load values according to the corresponding load chart column are shown in columns next to each other.

Note: See also paragraph 30.3.2 Jib relative angle interpolation and paragraph 30.3.5 Combination of jib relative angle interpolation and derrick ballast radius interpolation.

- 6) Line **yy** = Derrick ballast radius in [m]
Appears only in operating modes with derrick ballast.
The columns show the derrick ballast distances, which must be set to be able to lift the load values shown on the corresponding load chart column .

Note: See also paragraph 30.3.3 Derrick ballast radius interpolation, paragraph 30.3.4 Combination of main boom angle and derrick ballast radius interpolation and 30.3.5 Combination of jib relative angle interpolation and derrick ballast radius interpolation.

- 7) Line for special indicators
If a load capacity chart consists of more than 7 columns, then it cannot be shown completely due to the size of the monitor. In this case, arrows in the 1st field (<<) or in the 7th field (>>) in this line show that there are additional columns to the left or right, which can be viewed by pressing the arrow keys "<" or ">".

Note: Page to the left or right by 7 load chart columns (1 page) by using key combination "SHIFT" + "<" or "SHIFT" + ">".

		m > < t		CODE >XXXX< BXXX YYZZ.1(2)			
	12,0	35,0	35,0	35,0	35,0	35,0	35,0
	14,0	380,0	380,0	380,0	380,0		
	16,0	372,0	372,0	372,0	372,0		
	18,0	363,0	363,0	363,0	363,0		
	20,0	350,0	350,0	349,0	349,0		
	22,0	336,0	337,0	337,0	337,0		
	24,0	305,0	313,0	312,0	312,0	307,0	319,0
	26,0	278,0	283,0	283,0	283,0	284,0	301,0
* n *	* 29 *	* 29 *	* 29 *	* 29 *	* 23 *	* 24 *	* 25 *
xx	87,0	87,0	87,0	87,0	77,0	77,0	77,0
yy	13,0	15,0	18,0	20,0	13,0	15,0	18,0
							>>

LIEBHERR

7	8	9
4	5	6
1	2	3
0	.	P

SHIFT

F1

F2

F3

F4

F5

F6

F7

F8

ENTER

±30°

360°

HHH
n
4x
32x

xx° SDB
35m

W
28m

220
t

12.0 x
12.0

HHH
n
10x

O.K.

F1

F2

F3

F4

F5

F6

F7

F8

11.3 The function keybar

The function key bar contains 8 symbol elements, which correspond to the function keys underneath, which means they either depict a function, which can be triggered with the function keys ("F1" to "F8") or they change their image or their text contents and show a change of operating mode or equipment configuration.

"F1" Vertical paging

Due to the size of the monitor, maximum 10 load chart lines can be shown at the same time. If the chart consists of more than 10 lines, then the view is split to several pages. By pressing the key, the next page of the load capacity chart is shown, and the number of the current page in the "General information line " is increased by 1. When the last page is reached, and "F1" is pressed again, page 1 reappears.

"F2" Setting the operating mode "Main geometry condition)

The various main boom operating modes and main boom lengths can be set here. The types are described in the symbol by abbreviation and length data.

For example xx° SDBW, 35 m

"SHIFT" + "F2" Previous main geometry condition

"F3" Setting the operating mode "Auxiliary equipment"

The crane operator can select the various types of auxiliary crane equipment, if available. The types are described in the symbol by abbreviation and angle and length data, for example W 28 m = luffing lattice jib 28 m

"SHIFT" + "F3" Previous auxiliary equipment condition .

Note: If function keys "F2" and / or "F3" are pressed, all operating mode and equipment configuration dependent data is deleted from the monitor and sets the short code in the "General information line " to "CODE >????<".

Operating mode dependent data are:

- Boom length symbol in the General information line
- Length units and weight units
- Organization number of load capacity chart
- Radius symbol
- Boom length data

Equipment configuration dependent data are:

- Numbering for current page number and total page number of load capacity chart
- Radius values in length units
- Load chart values in weight units .

		m > < t		CODE >XXXX< BXXX YYZZ.1(2)			
		35,0	35,0	35,0	35,0	35,0	35,0
12,0							
14,0	380,0	380,0	380,0	380,0			
16,0	372,0	372,0	372,0	372,0			
18,0	363,0	363,0	363,0	363,0			
20,0	350,0	350,0	349,0	349,0			
22,0	336,0	337,0	337,0	337,0			
24,0	305,0	313,0	312,0	312,0	307,0	319,0	328,0
26,0	278,0	283,0	283,0	283,0	284,0	301,0	310,0
* n *	* 29 *	* 29 *	* 29 *	* 29 *	* 23 *	* 24 *	* 25 *
xx	87,0	87,0	87,0	87,0	77,0	77,0	77,0
yy	13,0	15,0	18,0	20,0	13,0	15,0	18,0
							>>

xx° SDB
35m

W
28m

12.0 x
12.0 t

HHH n
10 x

O.K.

LIEBHERR

7	8	9
4	5	6
1	2	3
0	.	P

SHIFT

F1

F2

F3

F4

F5

F6

F7

F8

ENTER

±30°

360°

HHH n
4 x
32 x

xx° SDB
35m

W
28m

12.0 x
12.0 t

HHH n
10 x

O.K.

F1

F2

F3

F4

F5

F6

F7

F8

"F4" Setting the equipment configuration "Counterweight" (slewing platform)
By pressing this key, the LICCON computer system is set to the current counterweight on the slewing platform. By pressing the key, the symbol with text is shown in the counterweight symbol.

"F5" Setting the equipment configuration "Chassis" (crawler, support, central ballast)
In operating modes, which have various chassis versions, such as ballast on chassis, variable support), the configuration can be set with the F5 key.

"F6" Setting the equipment configuration "slewing range of the crane superstructure"
In operating modes with various slewing ranges.

- 1) 360° working range
Unlimited turning of crane superstructure possible, the same load carrying value is valid for the complete 360° working range.
- 2) $\pm 30^\circ$ working range*
For the limit slewing angle range ($\pm 30^\circ$ to the side), there are increased load charts. If the crane turns past this angle range, the Load Moment Limiter (LML) automatically shifts to the lower 360° load chart.

Note: If the current load can only be lifted in limited slewing angle range ($\pm 30^\circ$ to the side), then the slewing speed is reduced to the limit of the slewing range, until "Zero" (slewing range shut off). This eliminates overloading the crane due to slewing.
See paragraph 40, Automatic slewing range change over.

Setting the equipment configuration "Derrick ballast radius"
In operating modes with derrick ballast.

Note: When pressing "F4", "F5" or "F6", all operating mode dependent data is shown (if they were first deleted and the selected operating mode exists). The short code is then always Code>????<.

* Optional

		m > < t		CODE >XXXX< BXXX YYZZ.1(2)			
	12,0	35,0	35,0	35,0	35,0	35,0	35,0
	14,0	380,0	380,0	380,0	380,0		
	16,0	372,0	372,0	372,0	372,0		
	18,0	363,0	363,0	363,0	363,0		
	20,0	350,0	350,0	349,0	349,0		
	22,0	336,0	337,0	337,0	337,0		
	24,0	305,0	313,0	312,0	312,0	307,0	319,0
	26,0	278,0	283,0	283,0	283,0	284,0	301,0
* n *	* 29 *	* 29 *	* 29 *	* 29 *	* 23 *	* 24 *	* 25 *
xx	87,0	87,0	87,0	87,0	77,0	77,0	77,0
yy	13,0	15,0	18,0	20,0	13,0	15,0	18,0
							>>

xx° SDB
35m

W
28m

220
t

12.0 x
12.0 t

yy m

n
10 x

O.K.

LIEBHERR

7

8

9

4

5

6

1

2

3

0

.

P

K

F

C

i

<

>

E3

SHIFT

F1

F2

F3

F4

F5

F6

F7

F8

ENTER

±30°

360°

n
4 x
32 x

xx° SDB
35m

W
28m

220
t

12.0 x
12.0 t

yy m

n
10 x

O.K.

F1

F2

F3

F4

F5

F6

F7

F8

- "F7" Setting the "Hoist cable reeving"
Press the "F7" key to set the number of hoist cable strands, which is reeved on the corresponding pulley head (boom, boom nose).
- Note:** The reeving for the boom nose (upper number) is only shown if the boom nose is installed. If the boom nose is installed while the operation program is running, then the reeving of the boom nose must be entered correctly in the "Set up" program.
- "F7" The number of the **hoist cable reeving of the boom** shown in the symbol can be increased by 1 by pressing the key, to the maximum value for the corresponding operating mode; then the counter starts again at the minimum value for this operating mode.
- Note:** For parallel operation of hoist winches (1||2), at hoist rope reeving, enter the total reeving of winch 1 and winch 2 on the LICCON computer system (Example: Winch 1 and winch 2 are each reeved 7-ways, the total reeving is therefore $n = 14$).
The total reeving **must** always show an even number value in parallel operation!
- "SHIFT" + "F7" The number of the **hoist cable reeving of the boom** shown in the symbol can be decreased by 1 by pressing the key, to the maximum value for the corresponding operating mode; then the counter starts again at the minimum value for this operating mode.
- "E3" + "F7" The input value (upper number) for the **hoist cable reeving of the boom nose** can be increased by 1 by pressing the key.
(See "F7")
- "SHIFT" + "E3" + "F7" The input value (upper number) for the **hoist cable reeving of the boom nose** can be decreased by 1 by pressing the key.
(See "SHIFT" + "F7")
- Note:** If the set value is within this range (minimum value \leq actual value \leq maximum value), when changing over, then it retains its validity. Otherwise the input value is set to the minimum value of the new operating mode.
- CAUTION:** For parallel operation of hoist winches an even reeving must always be used and entered. If the minimum value is uneven, then the next higher reeving number must be set for parallel operation of hoist winches.
- Note:** After a "cold start" (for example data loss in memory bank), the indication of hoist cable reeving is on "0".

* Optional

		m><t		CODE >XXXX< BXXX YYZZ.1(2)			
		35,0	35,0	35,0	35,0	35,0	35,0
12,0							
14,0	380,0	380,0	380,0	380,0			
16,0	372,0	372,0	372,0	372,0			
18,0	363,0	363,0	363,0	363,0			
20,0	350,0	350,0	349,0	349,0			
22,0	336,0	337,0	337,0	337,0			
24,0	305,0	313,0	312,0	312,0	307,0	319,0	328,0
26,0	278,0	283,0	283,0	283,0	284,0	301,0	310,0
* n *	* 29 *	* 29 *	* 29 *	* 29 *	* 23 *	* 24 *	* 25 *
xx	87,0	87,0	87,0	87,0	77,0	77,0	77,0
yy	13,0	15,0	18,0	20,0	13,0	15,0	18,0
							>>

xx° SDB
35m

W
28m

t

12.0 x
12.0

yy m

n
10 x

O.K.

LIEBHERR

7	8	9
4	5	6
1	2	3
0	.	P

SHIFT

F1

F2

F3

F4

F5

F6

F7

F8

ENTER

±30°

360°

n
4 x
32

xx° SDB
35m

W
28m

t

12.0 x
12.0

yy m

n
10 x

O.K.

F1

F2

F3

F4

F5

F6

F7

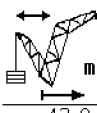
F8


- "F8" 1) Confirmation of entered equipment configuration
By pressing the ""F8 / O.K." key, the selected equipment configuration and the selected reeving is confirmed and the parameters are transferred to the "Operation" program. The following must be observed:
- The setting of the equipment configuration must be completed, which means a valid short code is shown and in the chart field are load capacity values.
 - The external conditions for this equipment configuration, if stipulated, must also be met (for example: slewing platform lock).
 - The crane may not be utilized by more than 20%, or the load hanging on the hook may not be heavier than 0.5 t .
- Otherwise, change over to the "Operation" program can only be made via the program key "P1". In this case, the new settings for the equipment configuration are not taken over.

Note: It must be ensured that the selected equipment configuration (short code) and the hoist cable reeving (s) have been accepted after shifting into the operation view .

- 2) Indication of operating errors, which were caused in the "Set up" program.
Operating error, which were created in the "Set up" program are shown for approx. 5 seconds in the symbol element above the "F8" key. If the "F8" key is pressed within 5 seconds, then the system changes automatically to the error determination view in the test system, where the error is documented. Operating errors are not stored.

Note: Operating errors are always on top of the error stack.
See also Diagnostics Manual.






$m > < t$


CODE >XXXX< BXXX YYZZ.1(2)

12,0	35,0	35,0	35,0	35,0	35,0	35,0	35,0
14,0	380,0	380,0	380,0	380,0			
16,0	372,0	372,0	372,0	372,0			
18,0	363,0	363,0	363,0	363,0			
20,0	350,0	350,0	349,0	349,0			
22,0	336,0	337,0	337,0	337,0			
24,0	305,0	313,0	312,0	312,0	307,0	319,0	328,0
26,0	278,0	283,0	283,0	283,0	284,0	301,0	310,0
* n *	* 29 *	* 29 *	* 29 *	* 29 *	* 23 *	* 24 *	* 25 *
xx	87,0	87,0	87,0	87,0	77,0	77,0	77,0
yy	13,0	15,0	18,0	20,0	13,0	15,0	18,0
							>>




xx° SDB
35m

W
28m




t

12.0 x
12.0 I



yy m



n
10 x

O.K.

95
t

SHIFT

F1

F2

F3

F4

F5

F6

F7

F8

ENTER

H
C
D

LIEBHERR

7

8

9

4

5

6

1


2


3

0


.


P






K





F

C



i

<

>

E

E₁
○

E₂
●

11.4 Other control elements

The other control elements on the LICCON indicator and control unit, which are located in the "set up" program have the following functions :

A Alpha numeric keyboard

With the keys "1" to "9" of the alpha-numeric key block, direct access is provided to the short code field in the General information line and the short code is entered.

Note: Using the alpha-numeric keys deletes all operating mode and equipment configuration dependent data from the monitor.

The keys "P" and "." have no function in the "set up " program.

P Program keys

With the program keys you can select between the various programs. The settings entered in the equipment configuration program are thrown out and the system continues to use the equipment configuration and the reeving which had been confirmed last with "O.K."

Note: The currently running program **cannot be recalled** by pressing its program key.

C Input key "ENTER"

- "ENTER" is the input confirmation when entering the short code as well as when changing the equipment configuration via the function keys.
- "ENTER" after short code input searches the short code in all stored load capacity charts. If the corresponding load capacity chart has been programmed into the system, then it is shown completely (including the lettering on the symbols in the function key bar), otherwise there is an error message in the form of question marks "???" in the 2nd part of the organization number (see General information line) and the horn can be heard.
- "ENTER" after changing the operating mode via the function keys searches for this operating mode, in case of success it sets the 1st equipment configuration and shows the corresponding load capacity chart and its short code. In case of an error, the short code indication remains on CODE >???, "B xx???" is shown as the organization number and the horn can be heard.
- "ENTER" after changing the equipment configuration with function keys "F4", "F5", "F6" shows that load capacity chart, if available, with short code on the monitor. In case of an error, the short code remains on CODE >???, and the horn can be heard.

D Keyed switch

Bypass of overload safety and hoist top shut off, see paragraph 6.7.

		m > t		CODE >XXXX< BXXX YYZZ.1(2)			
12,0		35,0	35,0	35,0	35,0	35,0	35,0
14,0	380,0	380,0	380,0	380,0			
16,0	372,0	372,0	372,0	372,0			
18,0	363,0	363,0	363,0	363,0			
20,0	350,0	350,0	349,0	349,0			
22,0	336,0	337,0	337,0	337,0			
24,0	305,0	313,0	312,0	312,0	307,0	319,0	328,0
26,0	278,0	283,0	283,0	283,0	284,0	301,0	310,0
* n *	* 29 *	* 29 *	* 29 *	* 29 *	* 23 *	* 24 *	* 25 *
xx	87,0	87,0	87,0	87,0	77,0	77,0	77,0
yy	13,0	15,0	18,0	20,0	13,0	15,0	18,0
							>>

LIEBHERR

7

8

9

4

5

6

1

2

3

0

.

P

K

F

C

i

<

>

E

E₁

E₂

SHIFT

F1

F2

F3

F4

F5

F6

F7

F8

ENTER

H

C

D

E Horizontal paging "E1" and "E2"

If a load capacity chart consists of more than 7 columns, then columns 1 to 7 are always shown during the first display of the equipment configuration.

A double arrow on the rear / front edge of the line shows that there are still additional columns in this direction.

Press "E2" , the next column to the right is shown.

Press "E1" , the next column to the left is shown .

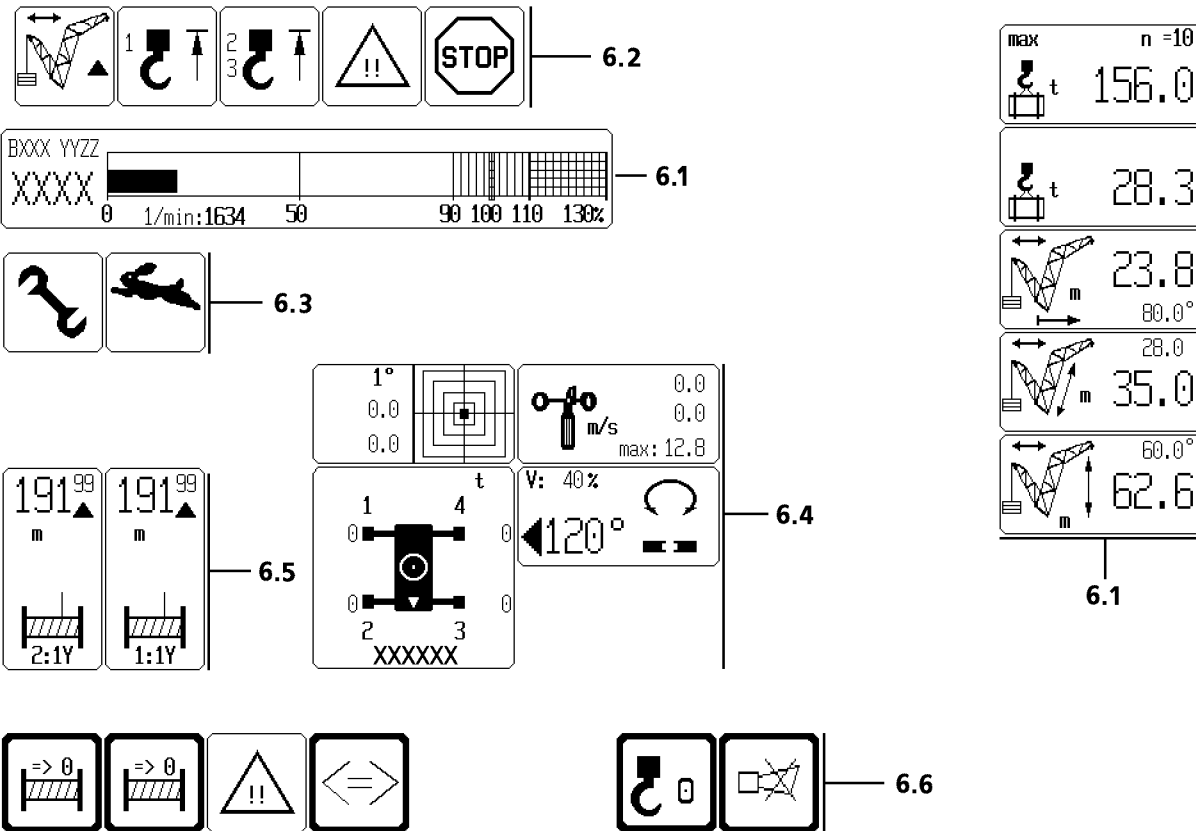
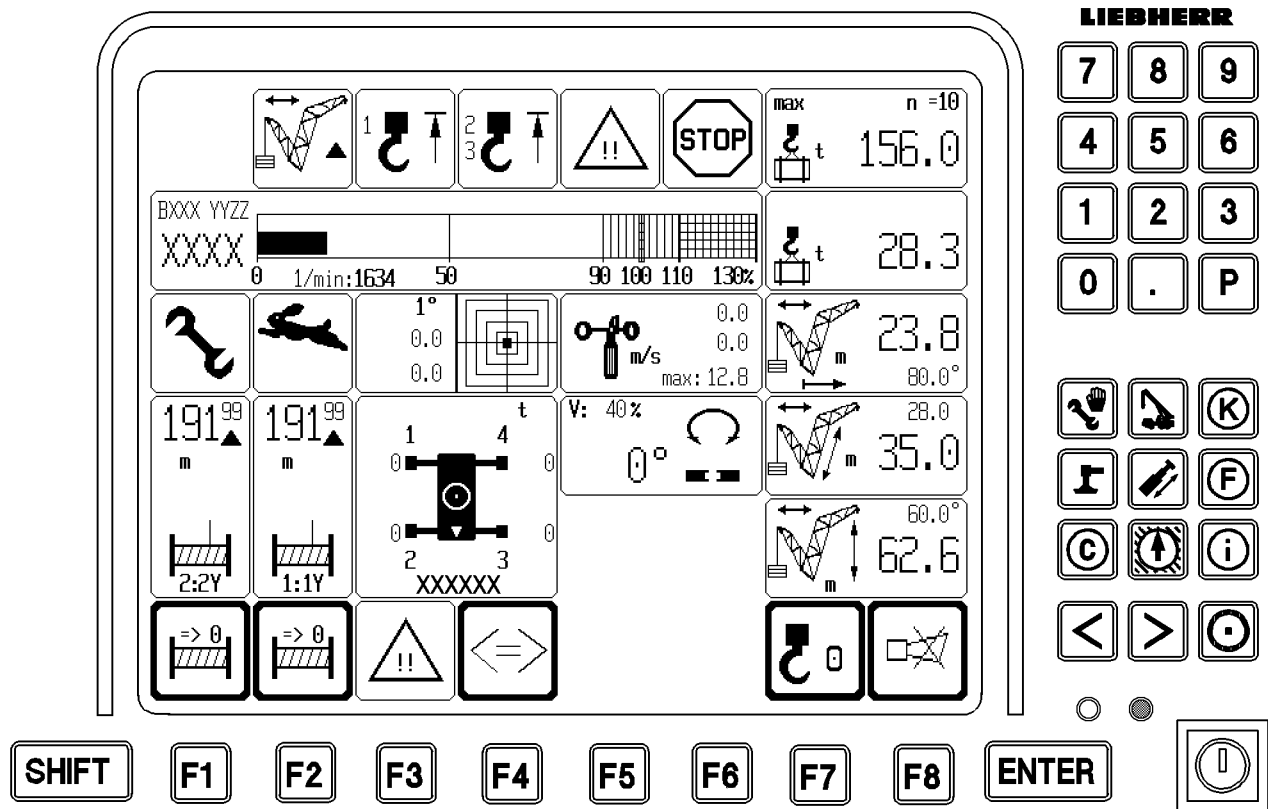
Note: The keys "E1" and "E2" are only functioning if it is noted in the "line for special indications".

Brightness adjustment of monitor

See paragraph 4.2.4

H SHIFT key

By pressing the "SHIFT" key and a function key at the same time, the previous main geometry condition, auxiliary equipment geometry condition and the previous reeving number are reset. See paragraph 5.3 The function keybar .



12. The "Operation" program**Monitor 0**

The LICCON "Operation" program supports the crane operator by displaying relevant data for crane operation on monitor 0, in a clear view. In addition, the crane operator is alerted about upcoming overload conditions. In case of an overload and a number of error conditions, which could endanger crane operation, the crane is shut down.

The monitor is divided into six areas in the "Operation" program:

12.1 Information about crane geometry and load

12.2 Alarm functions

12.3 Special functions

12.4 Monitored added functions

12.5 Winch indication Winch 1 and 2

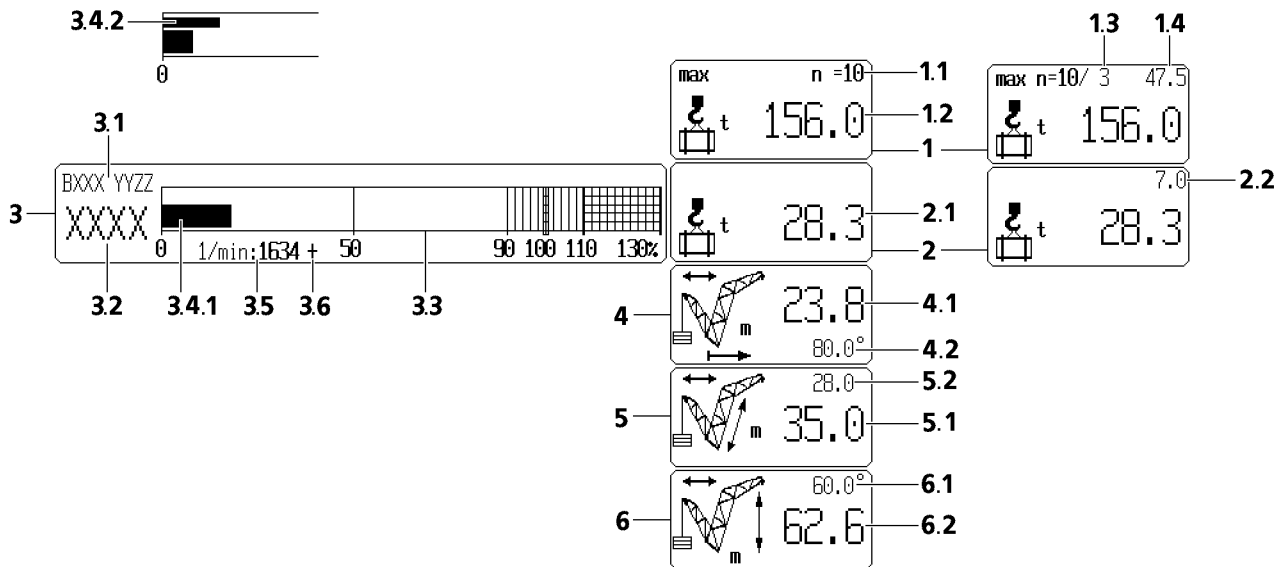
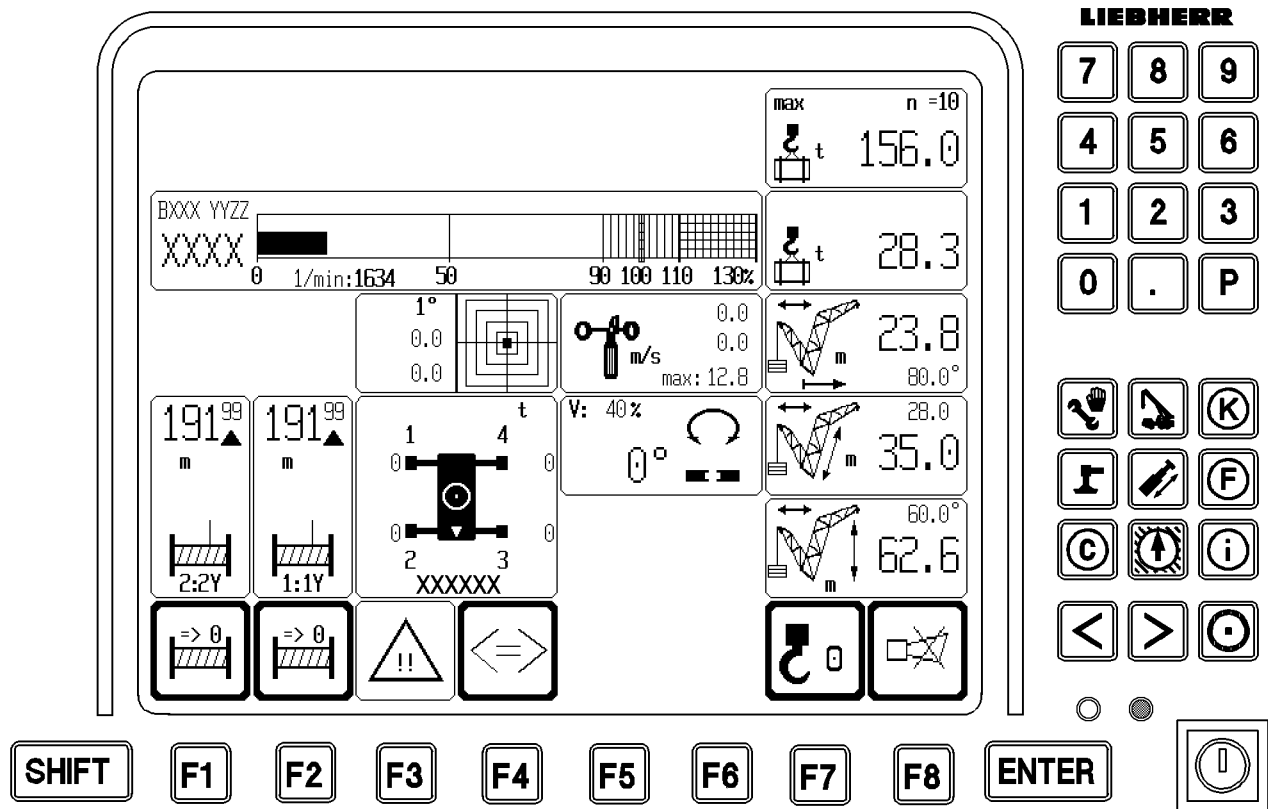
12.6 Function keybar symbol line

12.7 Other control elements

Note:

The monitor illustrations in this chapter **are only examples**. The numeric values in the individual symbol elements and charts might not match this particular crane. The configuration of the LICCON monitor with the symbol elements is only used to describe the system.

In addition, some illustrations of the monitor show the maximum possible assignment of the LICCON monitor with symbol elements. In normal crane operation, an identical display would not appear on the LICCON monitor.



12.1 Information about crane geometry and load

1) Symbol elements "Maximum load capacity" in weight unit in tons (t) or pounds [lbs]

1.1 The reeving number of the hoist cable which is reeved for the pulley head, which has been selected via the load chart .

1.2 Maximum load in [t] or [lbs], which can be carried on the selected pulley head of the boom, according to load capacity chart and reeving is shown in the indicated weight unit of tons [t] or pounds [lbs].

The "maximum load which can be carried according to the load capacity chart and reeving" depends:

- on the selected operating mode
- on the selected equipment configuration (→ Load capacity chart)
- on the radius
- on the main boom angle or jib relative angle*
- on the derrick ballast radius *
- on the reeving of the hoist cable

Note: The "maximum load carrying capacity according to the load chart and reeving" is independent of the size of the derrick ballast.

In operating modes with derrick ballast, the "maximum load carrying capacity according to the load chart " is the load, which the crane can lift in the current operating condition **with** the optimum (large) derrick ballast . The calculation of the optimum derrick ballast is described in the load chart manual. If the derrick ballast is smaller than the optimum ballast, then the load shown in 1.2 cannot be lifted. The system shuts off before via test point 1 - Operation maximum force.

Note: "?? . ?" is shown if no load capacity chart value is available, for example if the crane is not within the range of the load capacity chart or one or more sensor errors or defects occurred, and the radius cannot be calculated.

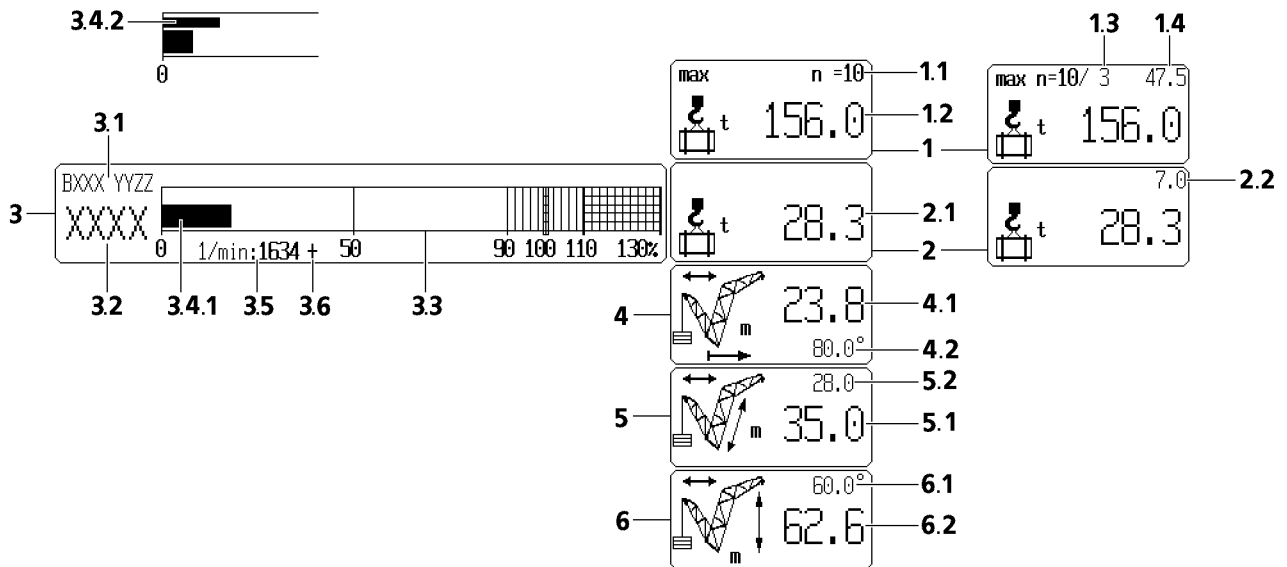
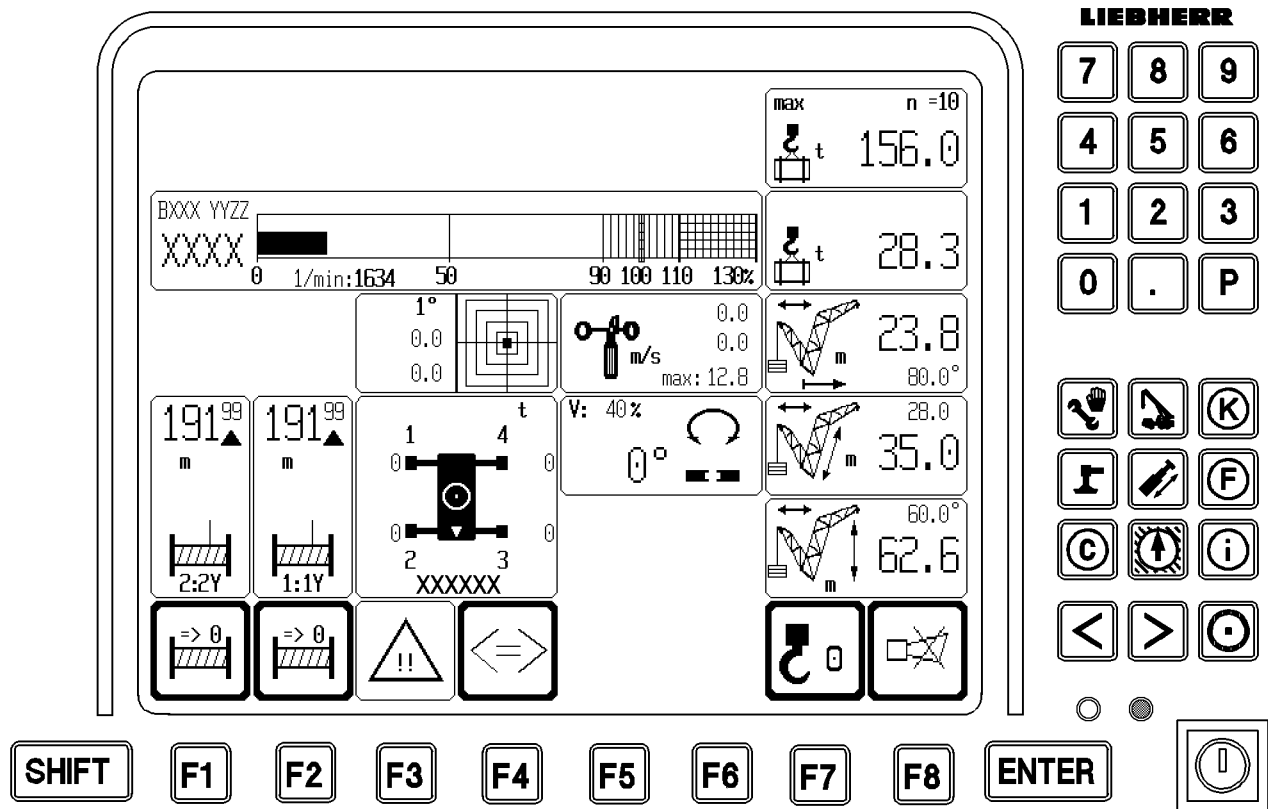
1.3* Reeving number of the hoist cable, which is reeved on the pulley head fo the boom nose * selected via the load chart.

1.4* Maximum load on the installed boom nose *

Note: The maximum load carrying capacity on the boom nose depends only on the set reeving of the boom nose.

CAUTION: Both load carrying capacities (as described in paragraph 1.2 and 1.4) are monitored at the same time. If the load carrying capacity of the boom is being exceeded, then the LML stop is triggered. The hoist gear up function is shut off in all hoist gears. The luff down function is shut off on all booms.

* Optional



2) Symbol elements "current load" in weight unit in tons [t] or pounds [lbs]

2.1 Current load (actual load indication) on the boom

= Load (in weight unit in tons [t] or pounds [lbs], which is currently suspended from the crane hook.

The calculated total load on the boom is shown, including hook block and tackle, but without the nominal weight of the hoist cable.

Note: Nominal weight of hoist cable = Reeving \times pulley head height
 \times specific hoist cable weight

See chapter 4.03, Weighing the load.

If the function key "Tara" is pressed (see description "F7" in paragraph 6.6), then the indication can be changed over to net load indication. In this case, the word "net" appears in the symbol, and the description of the weight unit is next to the load symbol.

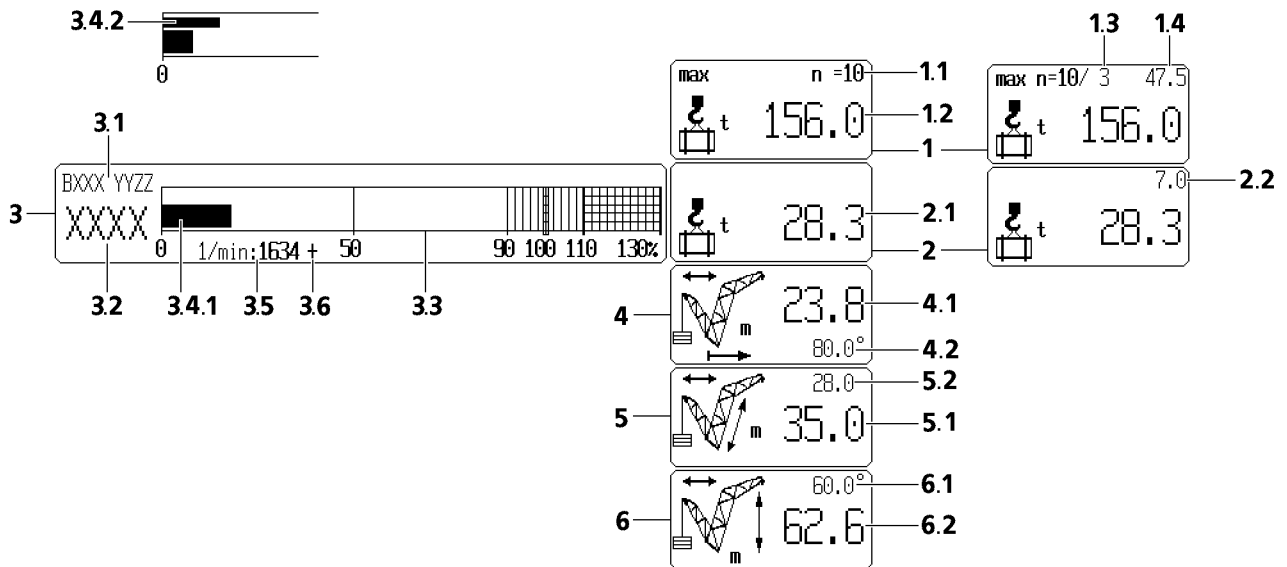
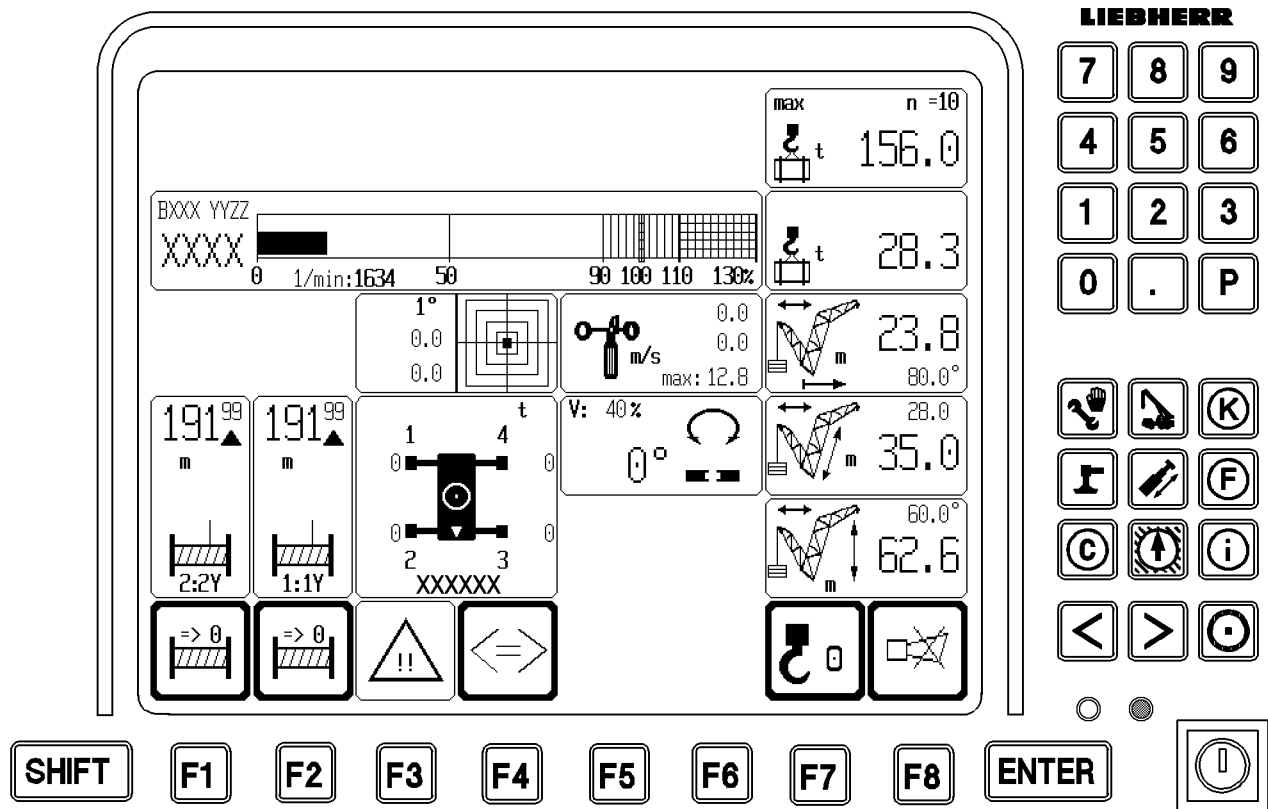
Note: "???.?" is shown if one or more sensors are missing or are defective, so that the current load cannot be calculated.

2.2 Current load (actual load indication) on the boom nose *

The calculated total load on the boom nose is shown, including the weight of the hoist cable, hook block and tackle.

If the function key "Tara" is pressed (see description "F7" in paragraph 6.6), then the indication can be changed over to net load indication. In this case, the word "net" appears in the symbol, and the description of the weight unit is next to the load symbol.

Note: "???.?" is shown if one or more sensors are missing or are defective, so that the current load cannot be calculated.



3) Symbol element "Utilization" [%]

3.1 8- digit organization number

shows the type of selected load capacity chart and the operating mode, see paragraph 5.

3.2 Short code (CODE >Zahl<) of the set equipment configuration , see paragraph 5.

3.3 Utilization scale

The utilization scale is marked on important points by percentages.

- Prewarning from 90 % utilization
- STOPshut off at 100 %utilization

3.4 Utilization bar

3.4.1 Utilization bar of the crane according to load chart and reeving

$$\text{Utilization of the crane according to load chart and reeving} = \frac{\text{Current load on the boom head}}{\text{maximum load according to load chart and reeving}}$$

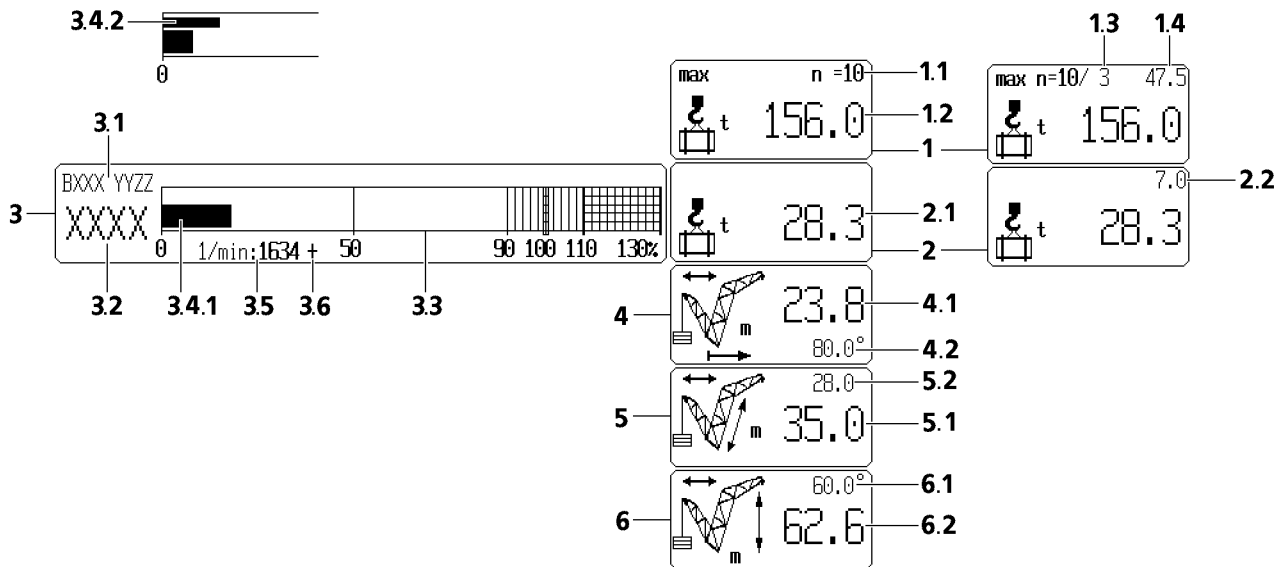
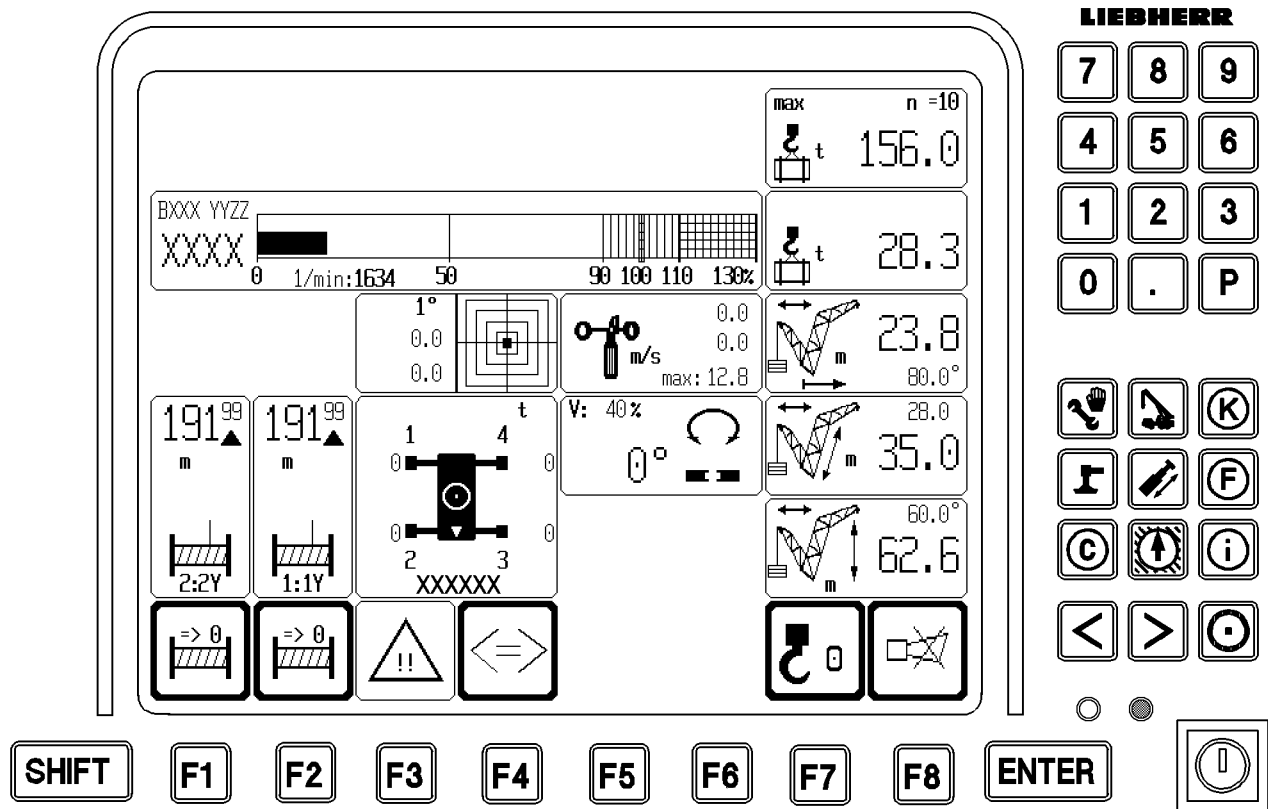
Note: In operating modes with derrick ballast, the utilization bar shows the utilization of the crane with optimum ballast. With partial derrick ballast, there is still another measurement of the utilization of the crane on test point 1 (see paragraph 21.4).

CAUTION: In operating modes without derrick ballast, this utilization bar is the only measurement for the utilization of the crane.

3.4.2 Utilization bar of the boom nose *

$$\text{Utilization of the boom nose} = \frac{\text{Current load on the boom nose}}{\text{maximum load on the boom nose}}$$

Note: The current load carrying capacity on the boom nose is the capacity, which the boom nose is able to lift alone, at sufficiently high maximum load carrying capacity on the boom head and in operating modes with derrick ballast at sufficiently high F1-operating max-limit.

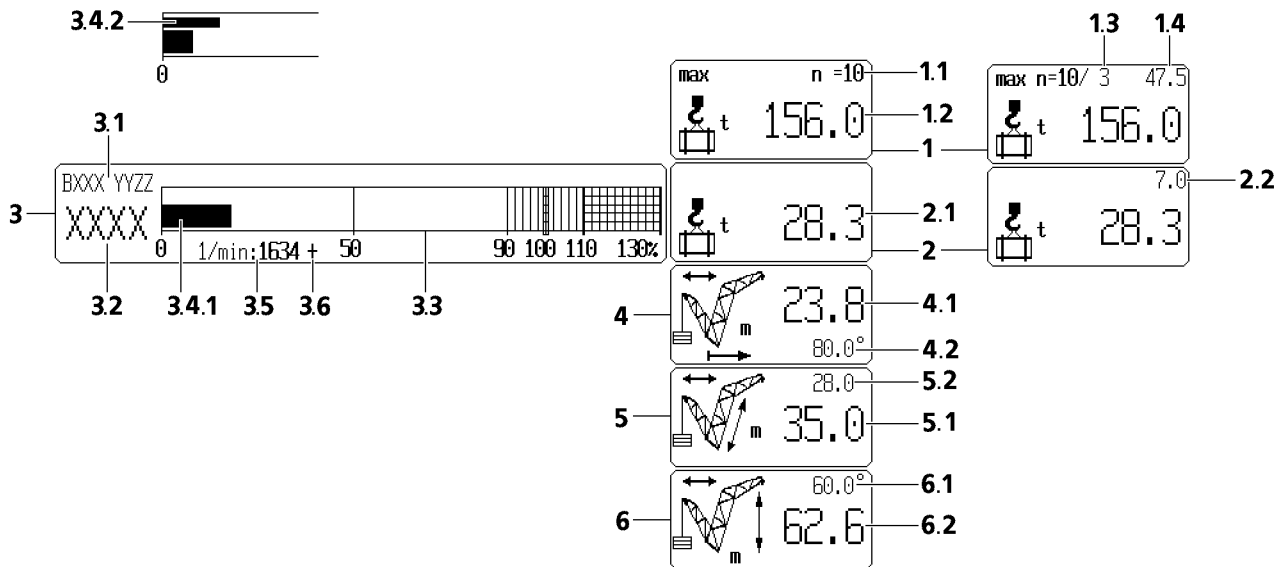
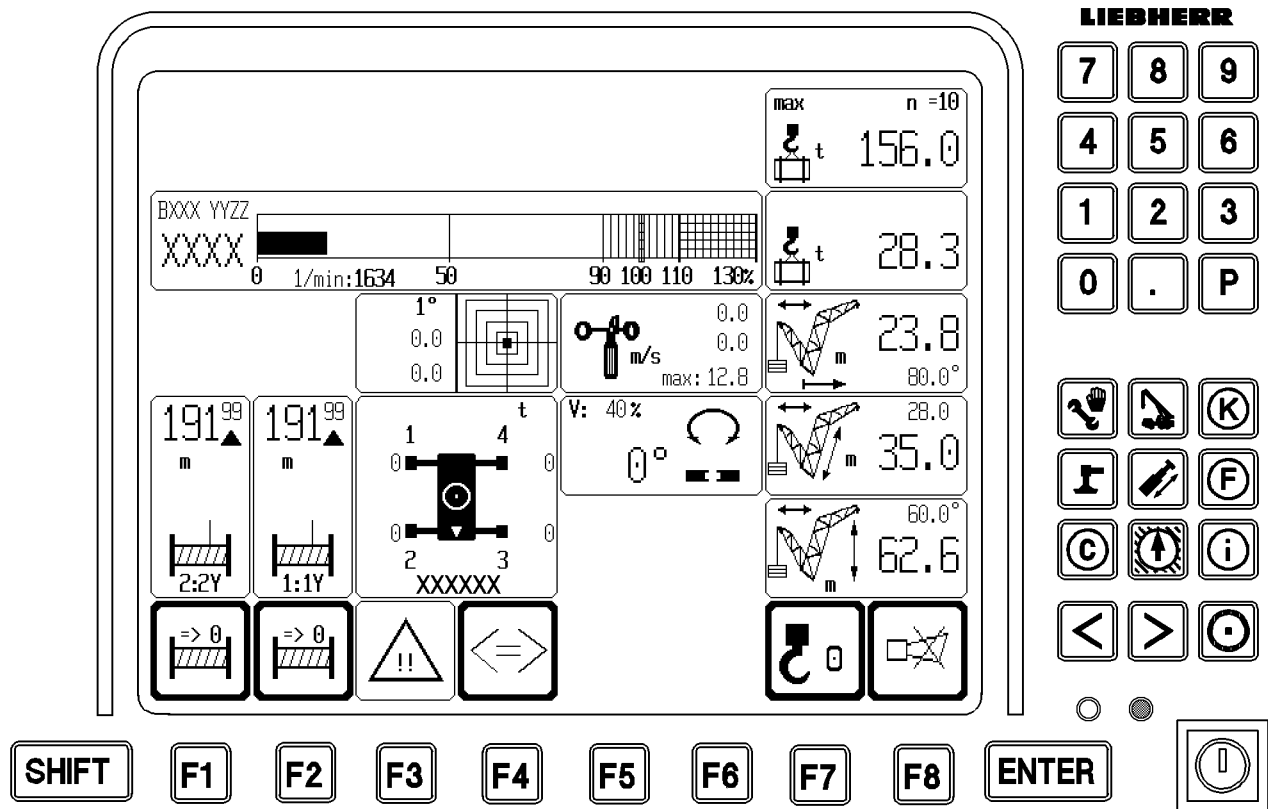


3.5 Current engine RPM in [1/min]

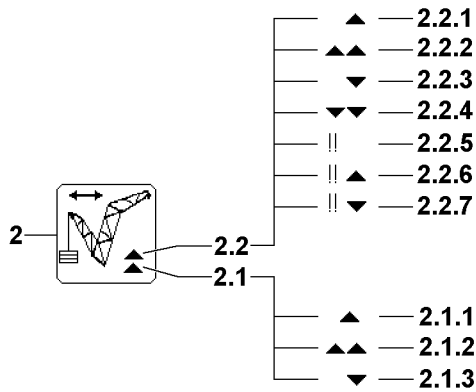
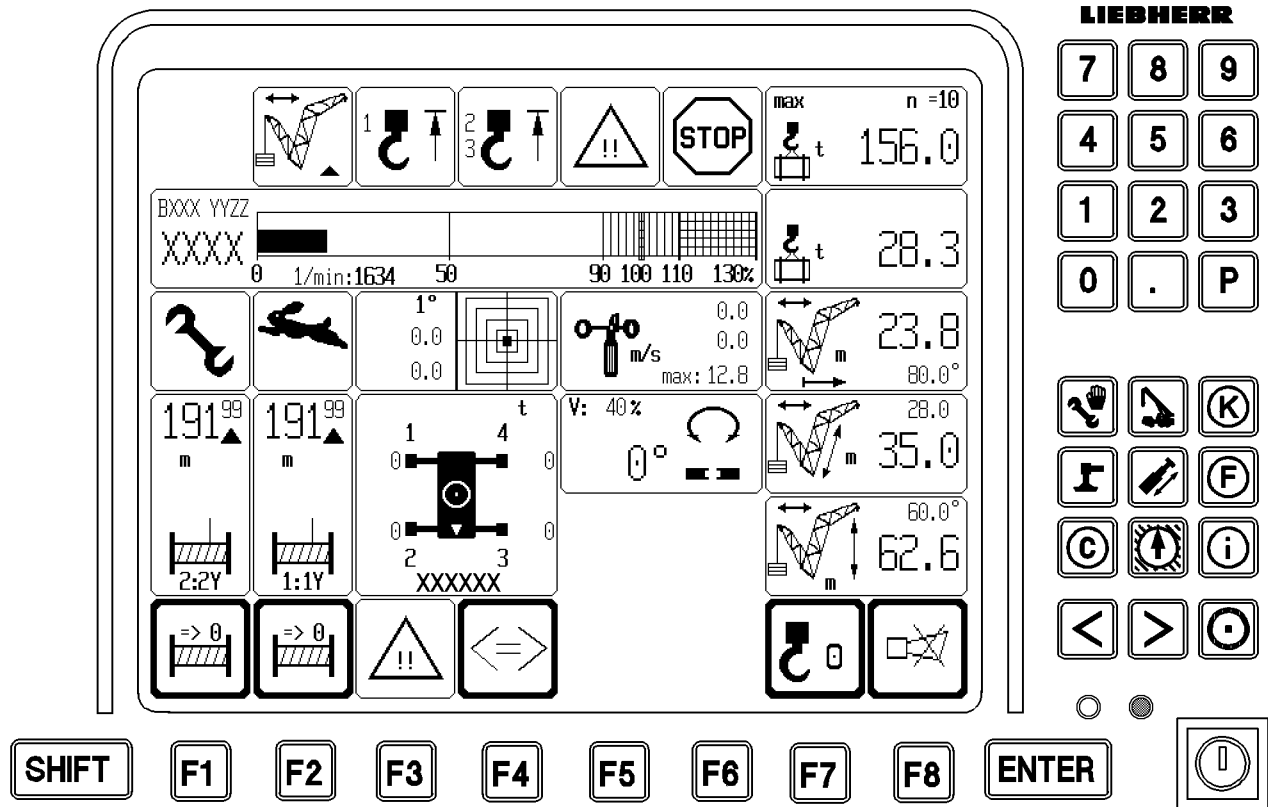
Note: "???" is shown in case of an invalid RPM value (for approx. 10 seconds). If there is a problem, the system changes to fixed RPM. The indicator blinks, in addition, an error message is issued.

3.6 Lock the engine RPM

The engine RPM can be locked / retained with the button on the master switch. In case of a locked engine RPM, the symbol " + " appears after the RPM data.



- 4) Symbol element "Radius" with length unit in meters [m] or feet [ft]
- 4.1 Radius in [m] or [ft]
= horizontal distance of load on the load hook for the operating mode from the turning axle of the crane superstructure, measured on the ground. The boom flexation due to its own weight and the suspended load has been taken into consideration.
- Note:** "???" is shown if the geometric data or sensor values are missing , so that the current radius cannot be calculated.
- 4.2 Main boom angle to the horizontal in degrees [°]
The value of the angle sensor in the main boom pivot section is shown. If this angle sensor value is invalid, then the value for the angle sensor on the main boom pulley head is shown.
- Note:** "???" is shown if both angle sensor values are invalid or if the difference of the two angle sensor is unbelievably large.
- 5) Symbol element "Main boom length " in length unit of meters [m] or feet [ft]
- 5.1 Length of main boom in [m] or [ft]
- 5.2 Length of auxiliary equipment, such as lattice jib in [m] or [ft]
- 6) Symbol element "Pulley head height" in length unit of meters [m] or feet [ft]
- 6.1 Angle of lattice jib to the horizontale in [°]
Shown is the value of the angle sensor in the pivot section of the lattice jib (bottom). If his angle sensor value is invalid, then the value for the angle sensor on the pulley head of the latic jib is shown.
- Note:** "???" is shown if both angle sensor values are invalid or if the difference of the two angle sensor is unbelievably large.
- or
- Relative angle between main boom angle (α) and jib angle (β)
($=\alpha - \beta$) in [°]
- Note:** Indication of relative angle always in operating modes with load chart for fixed defined jib relative angle (for example WV)
- Note:** "???" is shown if the relative angle cannot be calculated.
- 6.2 Pulley head height in [m] or [ft]
= vertical distance from ground surface of the crane to the selected pulley head axle, which is valid for the indicated maximum load capacity.
- Note:** "???" is shown if geometric data or sensor values are missing, so that the pulley head height cannot be calculated .



12.2 Alarm functions

The crane movements are monitored in their limit ranges. When these limits are reached, the crane operator is alerted to that fact by blinking symbol elements:

2) Symbol element "Boom limitation "

The luffing range of the boom is limited upward as well as downward. If the end position, which is assigned by the selected load capacity chart, is reached, the operating mode dependent symbol element "Boom limitation " appears .

2.1 Limitation signs for main boom

- 2.1.1 An arrow pointing upward shows that the shut off of the crane movement "luff up main boom " has been made:
- by triggering the upper load chart limit or
 - by utilization >95% and lowered load carrying capacity when luffing up the boom

Note: The crane movement "luff down main boom" remains possible.

D A N G E R: The shut off of the crane movement "luff up main boom " can only be bypassed with the turned on installation keyed switch.

- 2.1.2 Two arrows pointing upward show that the shut off of the crane movement "luff up main boom " has been made: :
- by triggering a block limit switch on the main boom
Relapse cylinders left / right or
 - by an error in a block limit switch relapse cylinders.

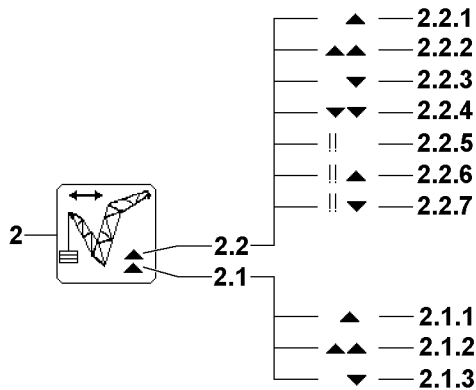
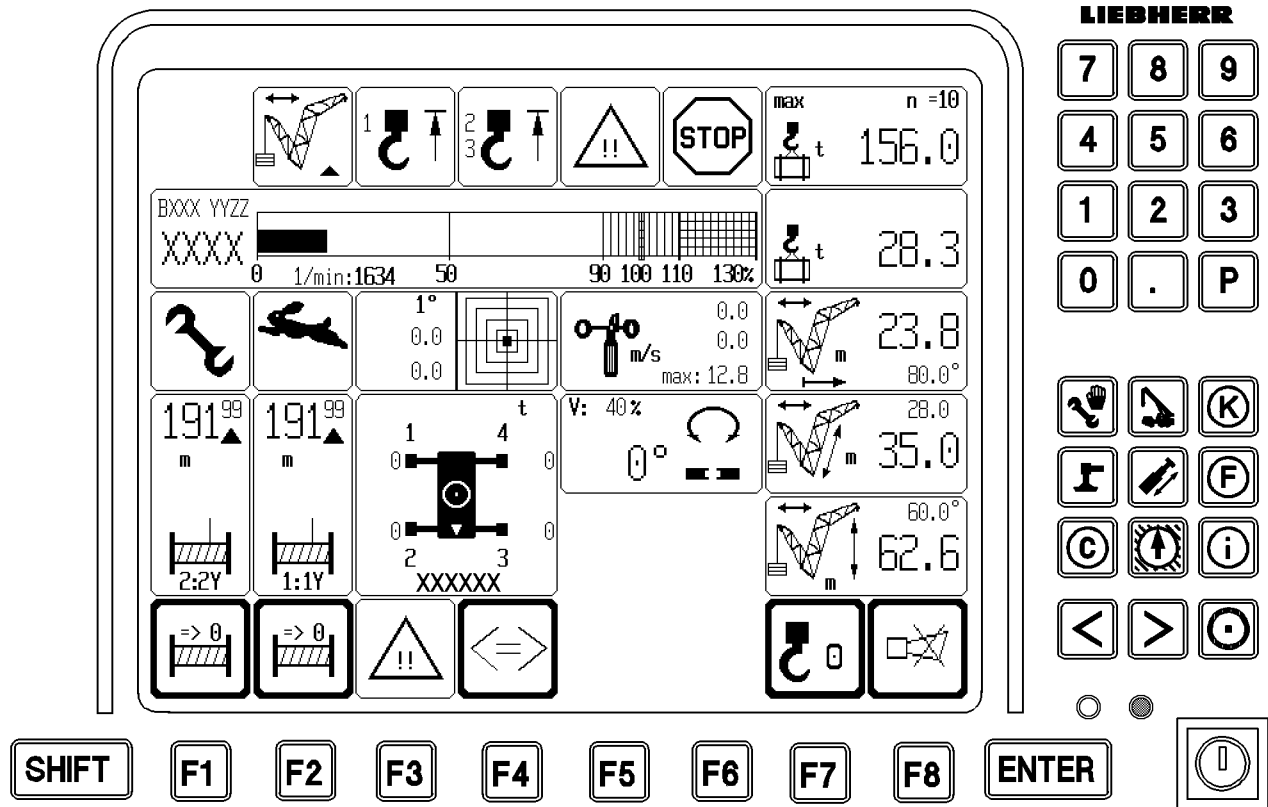
Note: The crane movement "luff down main boom " remains possible, the crane movement "luff up main boom " is shut off and **cannot be bypassed**.

- 2.1.3 An arrow pointing downward shows that the shut off of the crane movement "luff down main boom " has been made by reaching the lower load chart limit.

Note: The crane movement "luff up main boom " remains possible.

D A N G E R: The shut off of the crane movement "luff down main boom " can only be bypassed with the turned on installation keyed switch.

* Optional



2.2 Limit signs for attachment (luffing jib*, fixed jib*)

- 2.2.1 An arrow pointing upward shows that the shut off of the crane movement "luff up attachment" has been made by reaching the upper load chart limit.

Note: The crane movement "luff down attachment" remains possible.

D A N G E R: The shut off of the crane movement "luff up attachment " can only be bypassed with the turned on installation keyed switch.

- 2.2.2 Two arrows pointing upward show that the shut off of the crane movement "luff up attachment" has been made by :
- triggering a block limit switch on the relapse cylinder luffing jib, the relapse flap or
 - by an error on this limit switch .

Note: The crane movement "luff down attachment" remains possible, the crane movement "luff up attachment " is shut off and **cannot be bypassed**.

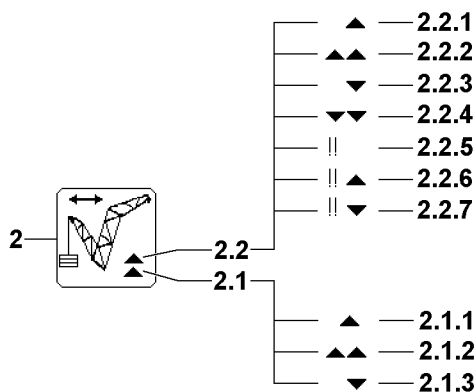
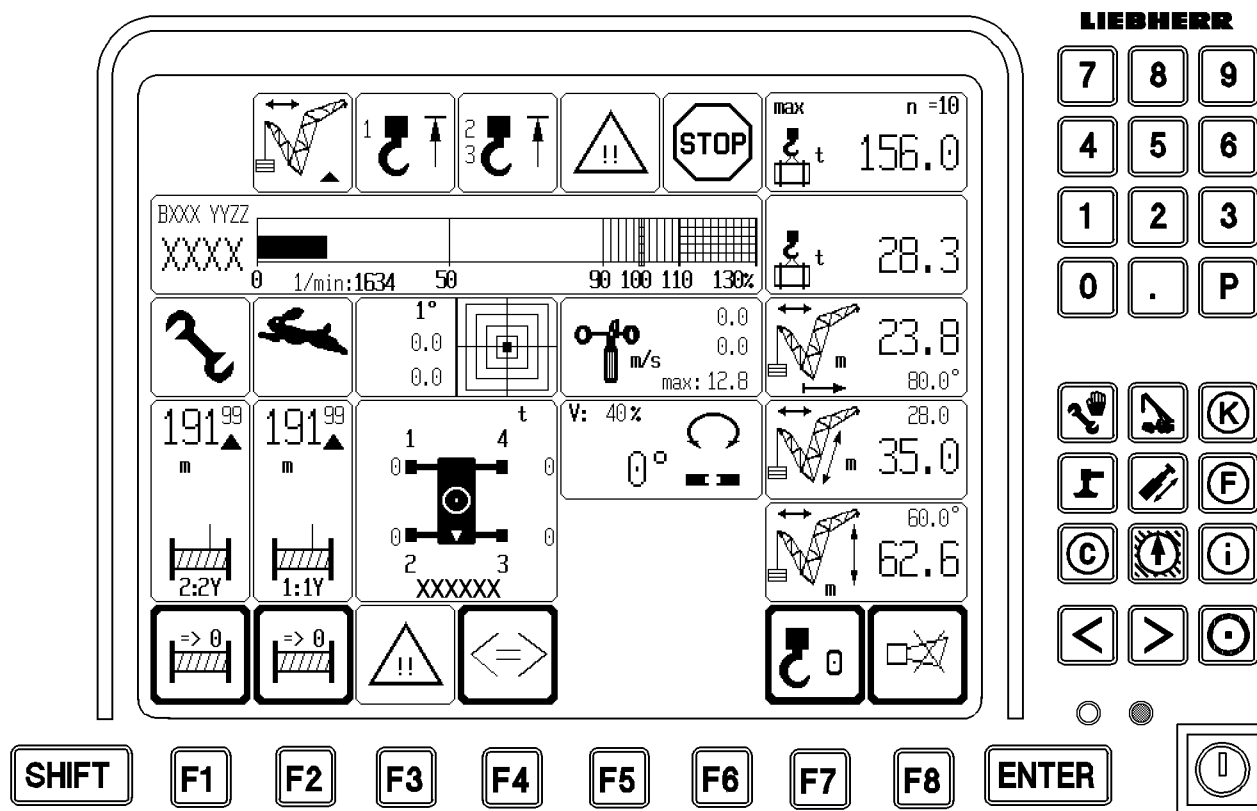
- 2.2.3 An arrow pointing downward shows that the shut off of the crane movement "luff down attachment" has been made by reaching the lower load chart limit.

Note: The crane movement "Ausrüstung aufwippen" remains possible.

D A N G E R: The shut off of the crane movement "luff down attachment " can only be bypassed with the turned on installation keyed switch.

- 2.2.4 Two arrows pointing downward show that the shut off of the crane movement "luff down attachment" has been made by :
- triggering a block limit switch for the monitor "Attachment lower left / right"
 - an error on this limit switch.

Note: The crane movement "luff up attachment" remains possible, the crane movement "luff down attachment " is shut off and **cannot be bypassed**.



2.2.5 Two exclamation marks show that one or both limit switches or angle sensors of the attachment do no longer report on the LSB (LICCON-System-Bus) or are defective.

Note: If both limit switches are defective or are missing on the LSB, then the corresponding luffing movement is shut off and **cannot be bypassed**. When deflecting the master switch, a control error message is given, which shows which limit switches are missing on the LSB or are defective.

C A U T I O N: **If only one limit switch or angle sensor is not working properly, then the crane can still continue to be operated with "normal functions". However, the crane must be operated with utmost care, because only one of the double limit switches is functioning. The error must be fixed immediately. At the same time, a system error message will be issued.**

2.2.6 Two exclamation marks and one arrow pointing upward show that the shut off of the crane movement "luff up attachment" was made by:

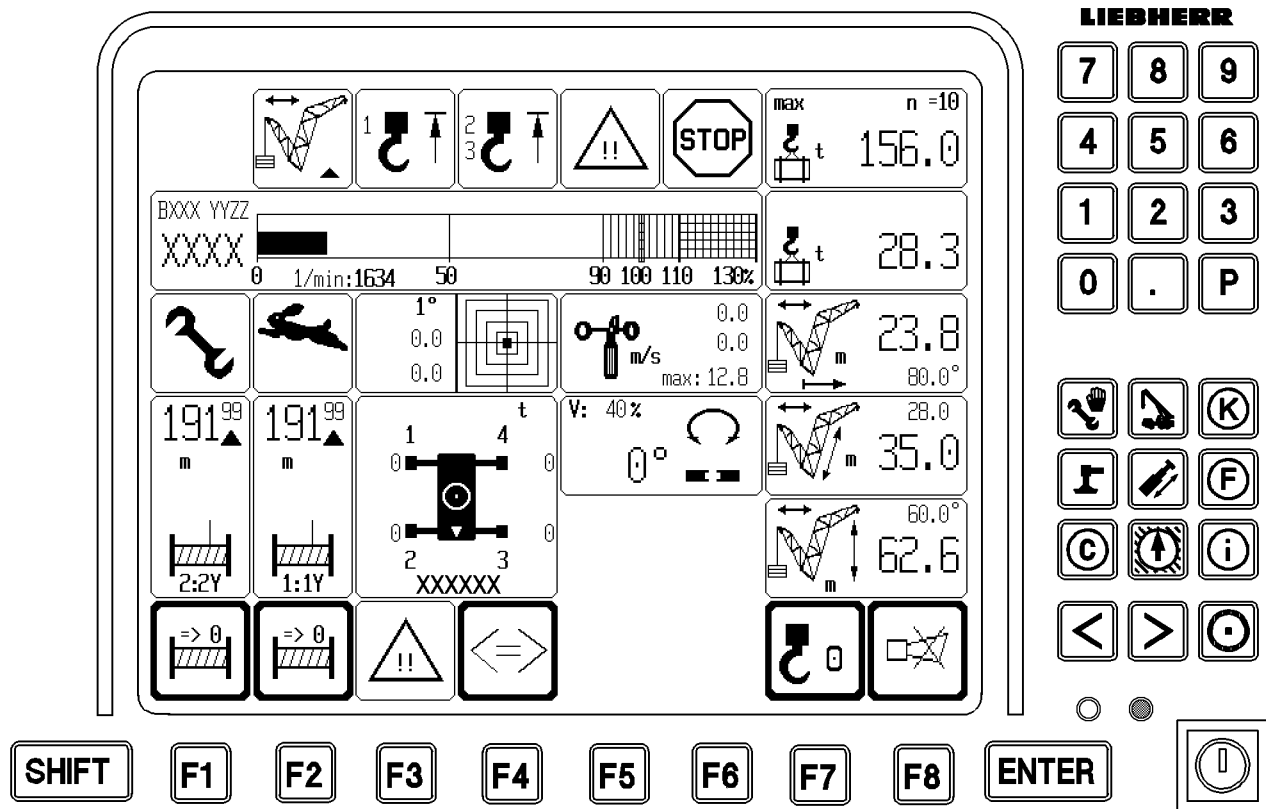
- triggering the upper load chart limit
- triggering a block limit switch of the relapse cylinder luffing jib or relapse flap.

In addition, one or both limit switches or angle sensors of the attachment do not report to the LSB or are defective.

Note: The crane function "luff down attachment" remains possible.

D A N G E R: **If the shut off was not created by several block limit switches, then the crane movement "luff up attachment" can be bypassed with the installation keyed switch.**

C A U T I O N: **If only one limit switch or angle sensor is not working properly, then the crane can still continue to be operated with "normal functions". However, the crane must be operated with utmost care, because only one of the double limit switches is functioning. The error must be fixed immediately. At the same time, a system error message will be issued.**



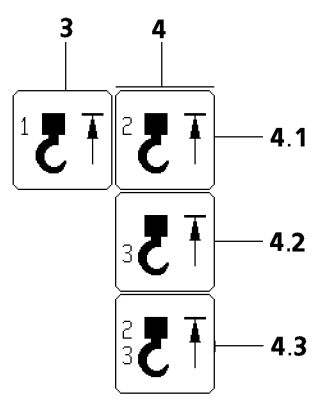
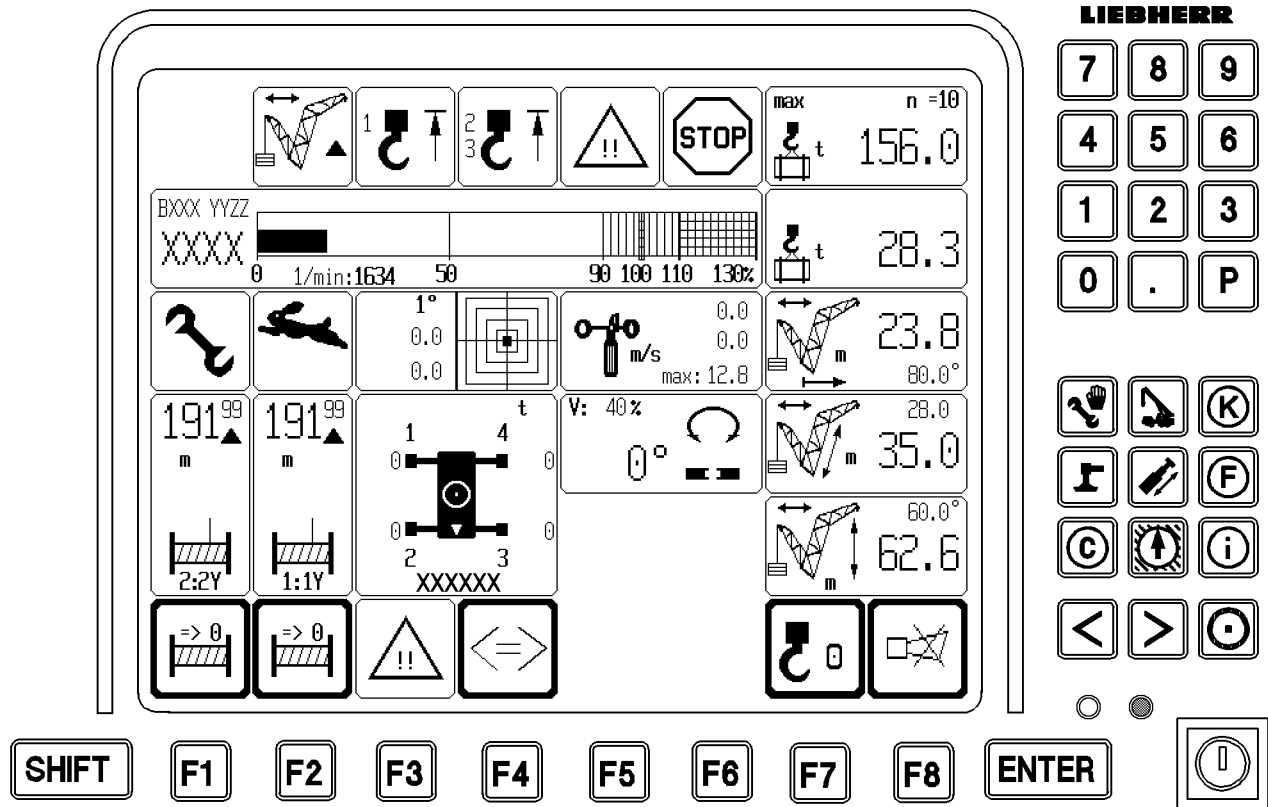
- 2.2.7 Two exclamation marks and an arrow pointing downward show that the shut off of the crane movement "luff down attachment" was made by
- triggering the lower load chart limit
 - triggering a block limit switch of the monitor "Attachment lower left or right. "
- In addition, one or both limit switches or angle sensors of the attachment do not report to the LSB or are defective.

Note: The crane function "luff up attachment" remains possible.

D A N G E R: If the shut off was not created by several block limit switches, then the crane movement "luff down attachment" can be bypassed with the installation keyed switch.

C A U T I O N: If only one limit switch or angle sensor is not working properly, then the crane can still continue to be operated with "normal functions" . However, the crane must be operated with utmost care, because only one of the double limit switches is functioning. The error must be fixed immediately. At the same time, a system error message will be issued .

* Optional



- 3) or 4) Symbol elements "Hoist top on main boom " or "Hoist top on auxiliary boom"

General

To prevent that the crane is operated without hoist top limit switch (HES), a minimum hoist top limit switch configuration is constantly being monitored to ensure it is present. If a required limit switch for a certain operating mode is not plugged in, which means it is also not active on the LSB-Bus System, then an LMB-STOP is triggered, in addition to an operating error message.

Possible hoist limit switches:

HES 1A / HES 1B	Main boom End section S	-S931 / -S932	Bus address "27" / "28"
	Main boom End section L	-S971 / -S972	Bus address "27" / "28"
HES 2A / HES 2B	Luffing jib	-S961 / -S962	Bus address "27" / "28"
	Luffing jib	-S971 / -S972	Bus address "27" / "28"
HES 3	Boom nose 2 t End section S	-S981	Bus address "25"
	Boom nose 1 t End section L	-S991	Bus address "24"

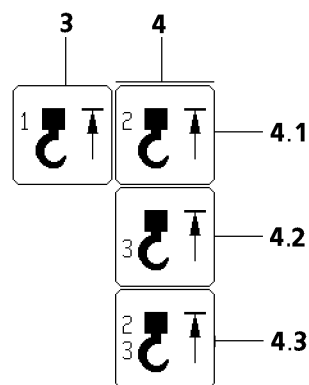
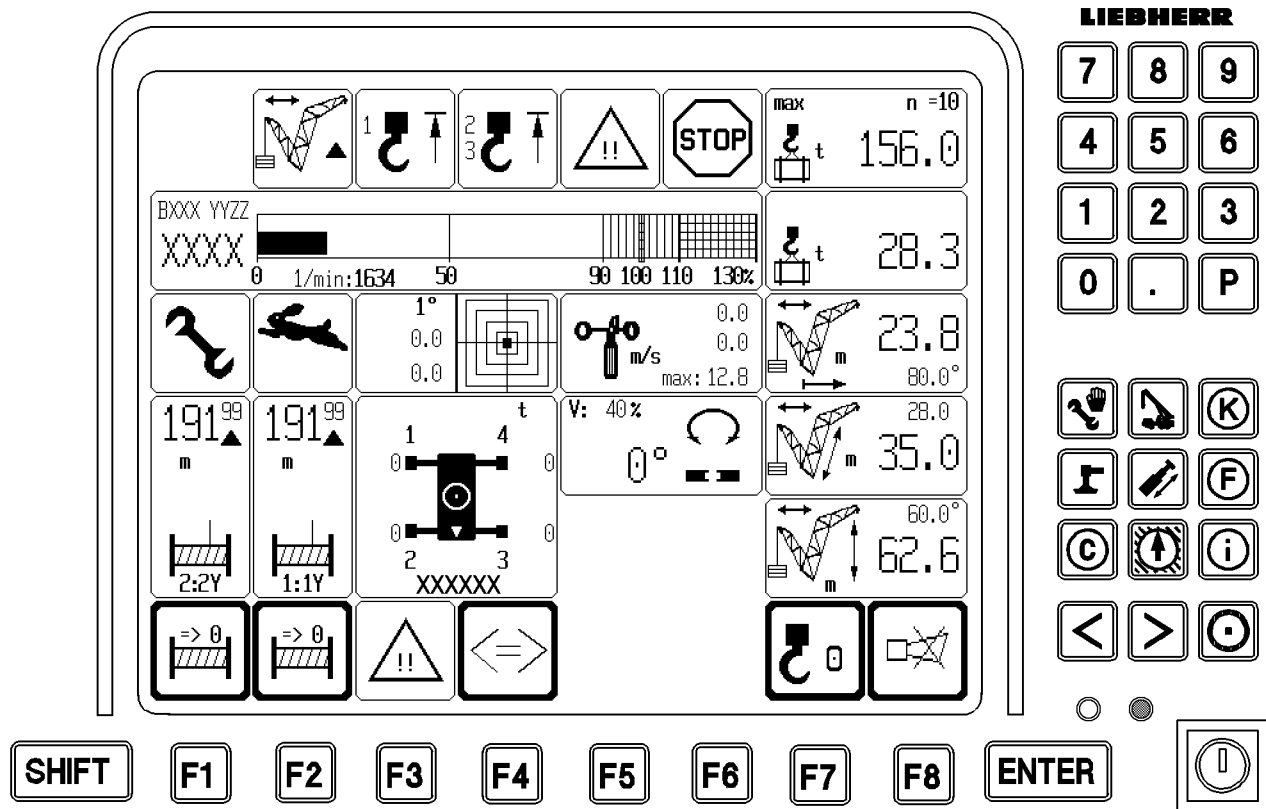
- 3) Symbol element "Hoist top on main boom"; HES 1 (1A /1B)
Main boom End section L, S

The symbol element appears if :

- The hookblock runs against the HES 1A and / or 1B on the end section main boom ,
- HES 1A and / or 1B not active, even though its presence is required ,
- HES 1A and / or 1B have an internal error.

The crane movements spool up hoist winches and luff down main boom as well as luff down derrick are shut off .

Note: In all operating modes with installed main boom, the HES1 must also be plugged in and turns off the same functions are the required hoist limit switch, which must be present.



4) Symbol element "Hoist top on auxiliary boom"

4.1 Symbol element HES 2 (2A / 2B)
Luffing jib

The symbol element appears if:

- the hookblock runs against the HES 2A and / or HES 2B on the end section of the luffing jib,
- HES 2A and / or 2B not active, even though its presence is required ,
- HES 2A and / or 2B have an internal error.

The crane movements spool up hoist winches, luff down main boom and luffing jib as well as derrick are turned off.

Note: The HES 2A/B must be plugged in in all luffing jib operating modes. If this is not the case, an "LMB-STOP" (paragraph 6.1) is triggered and in addition, the control error message "ZE (CPU) 0: LMB STOP: HES2 A/B not connected" is issued.

4.2 Symbol element HES 3
Boom nose

The symbol element appears if:

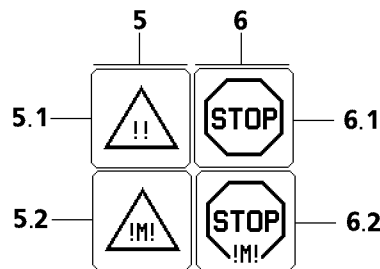
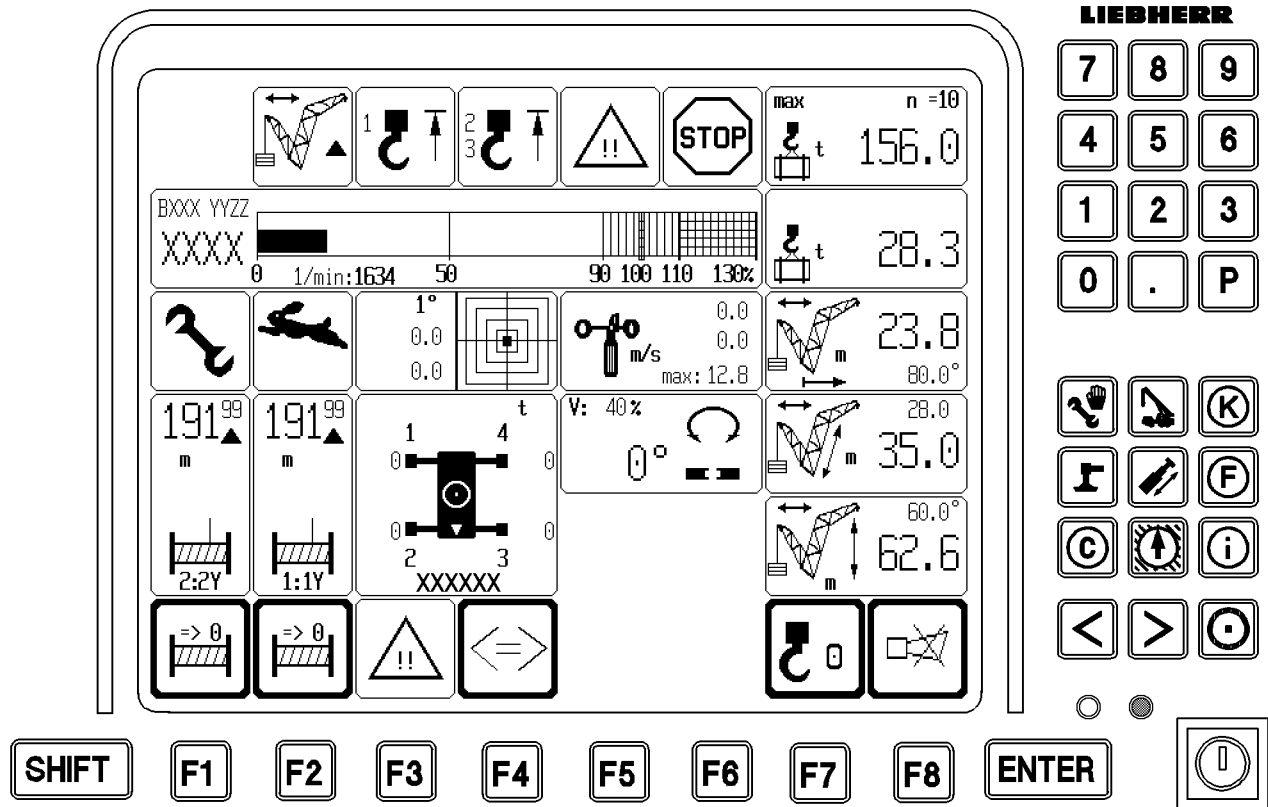
- the hookblock runs against the HES 3 on the boom nose ,
- HES 3 not active, even though its presence is required,
- HES 3 have an internal error.

The crane movements spool up hoist winches, luff down main boom, luffing jib and derrick are turned off.

Note: The HE3 must be plugged in if the boom nose is installed. If this is not the case, an "LMB-STOP" (paragraph 6.1) is triggered and in addition, the control error message "ZE (CPU) 0: LMB-STOP: HES not connected" is issued.

4.3 Symbol element HES 2 and HES 3

The symbol element HES 2 and HES 3 appears if the symbol elements HES 2 (see 4.1) and HES 3 (see 4.2) appear at the same time.



5) Symbol element "Pre-warning"

5.1 Load carrying capacity utilization

The symbol element appears:

- if the current utilization of the crane according to load chart and reeving has exceeded the programmed limit for a prewarning (for example 90 %), or
- if the current utilization of the boom nose * has exceeded the programmed limit for prewarning (for example 90 %).

5.2 Engine monitoring

If a warn occurrence happens in the engine monitoring system, then the symbol element "Prewarning - engine monitoring" appears on the LICCON monitor.

(See paragraph 12, Engine monitoring)

6) Symbol element "STOP"

6.1 Load carrying capacity exceeded

The symbol element "STOP" appears:

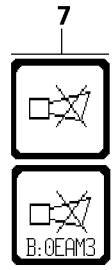
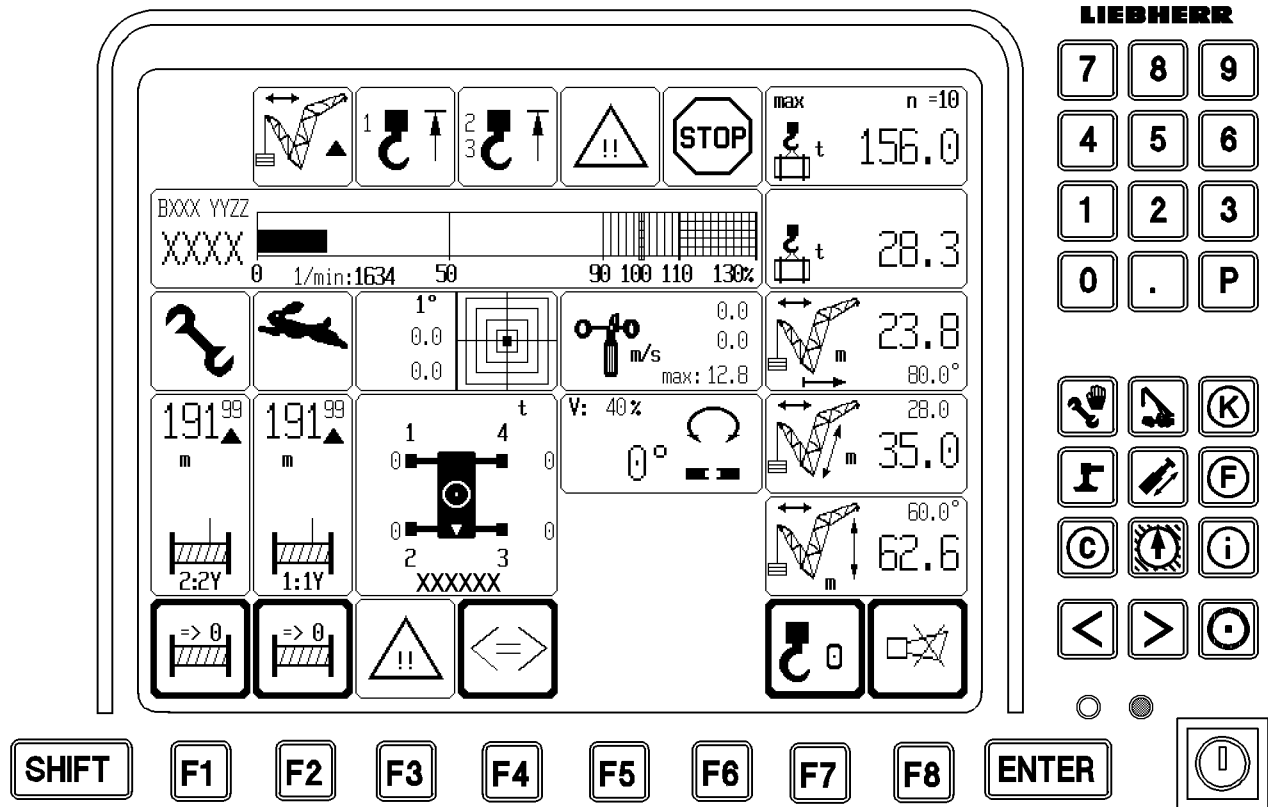
- if the current load carrying capacity on the boom head has exceeded the maximum load carrying capacity and reeving according to the load chart (100%), or
- if the current load carrying capacity on the boom nose has exceeded the maximum load carrying capacity of the boom nose .

Note: All load moment increasing crane movements are shut off.

6.2 Engine monitoring

If a STOP occurrence happens in engine monitoring, the system switches over automatically from operating view to engine monitoring view.

(See paragraph 12, Engine monitoring)



7) Symbol element "Horn" (acoustical signal)

Any operational errors on monitor 0, which cause the shut down of a movement and application errors with an error number (such as sensor errors, which occurred due to insufficient sensor signals or defective sensors) are shown optically and are also reported by an acoustical signal "HORN" on the monitor 0. "HORN" is a 0.5 second long sound, which is repeated in one second intervals.

Operational errors shown on monitor 0 are:

- overload
- Boom outside the angle range of the load chart
- Boom outside the radius range of the load chart

Monitored sensor are:

- Hoist limit switch
- Length sensor
- Angle sensor
- Pressure sensor
- wind sensor
- pull test brackets
- Battery voltage
- Inductive sensors

"Short horn"

Error messages, which have no error number and which do not cause a crane movements shut down by the LICCON system are also reported by an an acoustical signal "SHORT HORN" , in addition to the optical indication. "SHORT HORN" is a 0.1 second long sound, which is repeated in two second intervals.

Monitored errors:

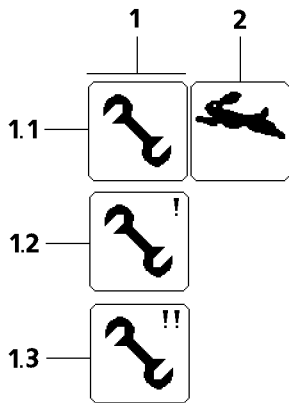
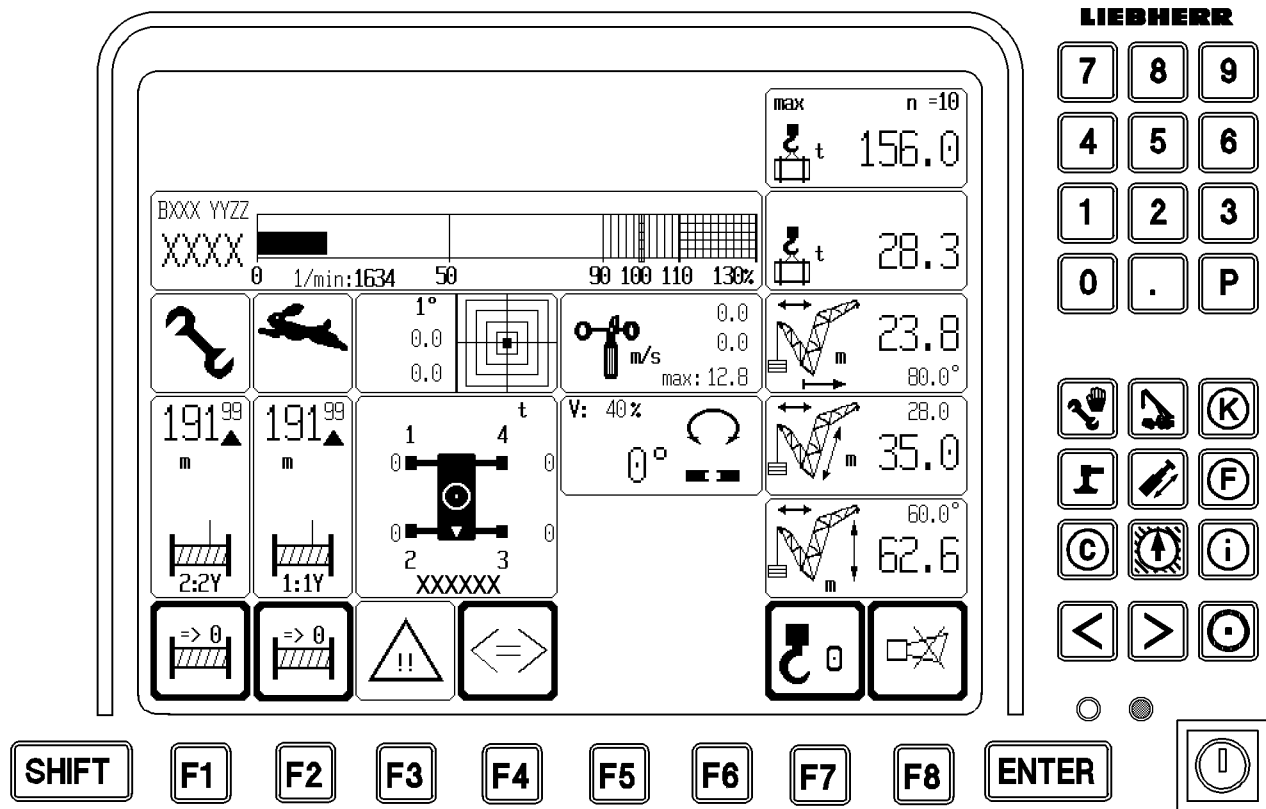
- maximum permissible wind velocity speed has been exceeded
(only if wind velocity sensor is activated)
- maximum support force has been exceeded or fallen below minimum support force
(only if support force monitor * is activated)
- prewarning threshold for crane utilization is reached.
"CAUTION" at 90%

Priority and "Horn off"

The alarm "Horn" has a higher priority than the alarm "SHORT HORN", which means "Horn" surpasses "SHORT HORN".

- "Horn" as well as "SHORT HORN" can be turned off by the monitor via the function key "F8" .
- By pressing the function key "F8" again, the system automatically changes to the error determination view in the test system. The error is documented in the error determination view.

Note: "HORN" as well as "SHORT HORN" become active again if a new error occurs.



12.3 Special functions

1) Symbol element "Installation Operation"

1.1 Installation

The symbol element blinks if the crane control is set to "Installation" via the installation keyed switch. Then the operating view is locked, which means no other program can be turned on via the program keys.

1.2 Emergency operation without installation

The symbol element blinks in emergency operation, if "Installation" is not selected via the installation keyed switch.

Note: In this case, the operating view is not locked.

1.3 Emergency operation and installation

The symbol element blinks in emergency operation, if "Installation" is selected via the installation keyed switch.

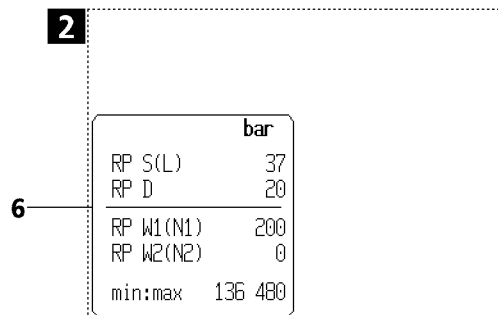
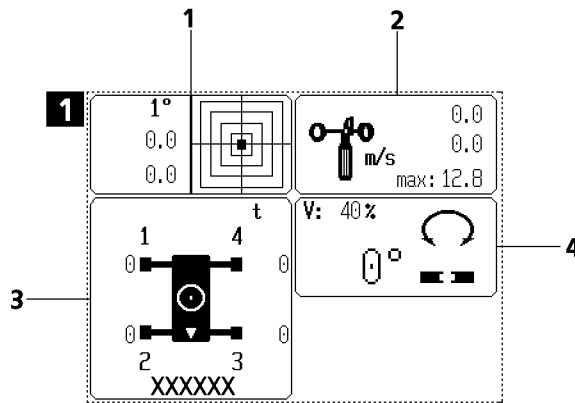
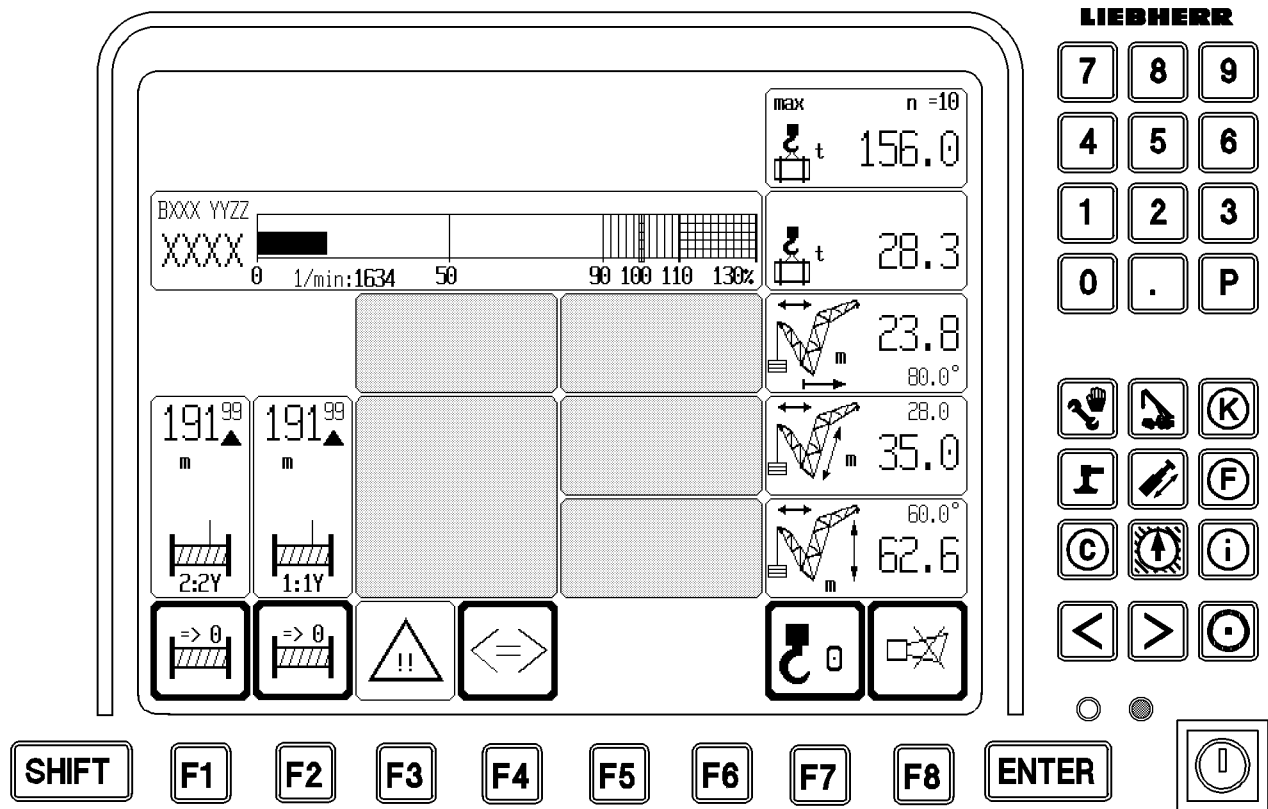
2) Symbol element "Rapid gear " (Power Plus)

The speed increase can be added for various crane movements via master switches MS1, MS2 or MS3 . The symbol element "rapid gear" appears in the operating view.

Note: If a crane movement has reached its maximum speed due to its current utilization, then no speed increase is possible by adding the rapid gear.

If the total power of all actuated crane movements is higher than the available power, then the speed for the crane movement which requires the highest power is reduced.

CAUTION: If another crane movement is added to one or more actuated crane movements, then it influences the other movements. For that reason, in situations where the individual crane movements are influenced, we recommend not to add the rapid gear (Power Plus) or to turn the rapid gear (Power Plus) off .



12.4 Monitored added functions

Via function key "F3", additional monitored added functions can be turned on. The symbol elements of the monitored added function are assigned to a fixed place on the LICCON monitor. Since not all symbol elements can be shown on one page, they are split to two pages. The symbol elements on page 2 can be viewed via the function key "F4".

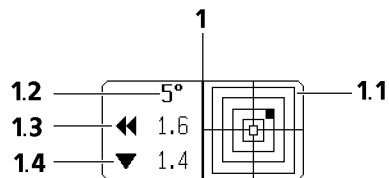
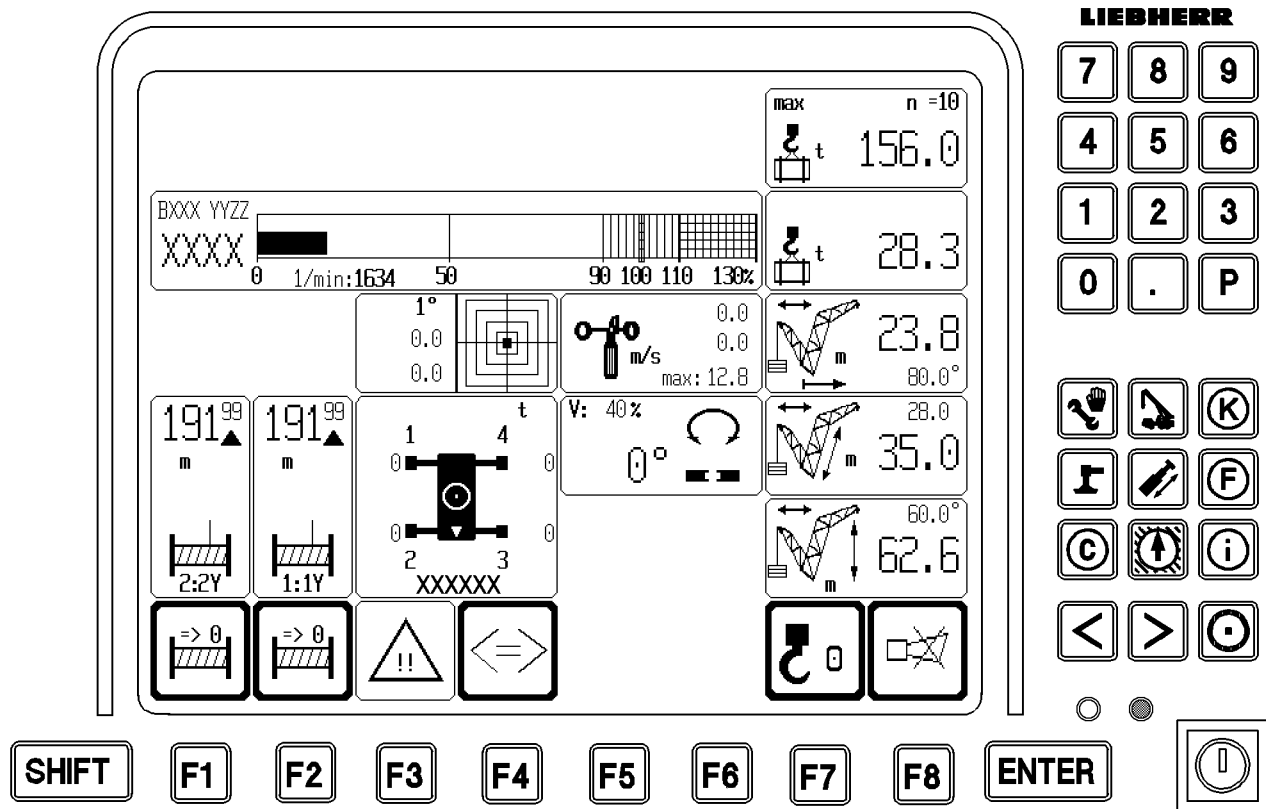
Page 1	1	Crane incline	(Fig. 1)
	2	Wind speed	
	3	Support force indicator *	
	4	Slewing range	

Page 2	6	Relapse cylinder monitor	(Fig. 2)
---------------	---	--------------------------	----------

If an error occurs in one or more of these monitored functions, then this is shown in the crane operating view as follows:

- a) Monitored added functions turned off "F3"
- Error of one function on page 1 ⇒ Symbol element shown on page 1
 - Error of one function on page 2 ⇒ Symbol element shown on page 2
 - Error of one function on page 1 and 2 ⇒ Symbol element shown on page 1 and symbol element above "F4" blinks
= Note error on page 2
- b) Monitored added functions turned on "F3"
- No error ⇒ the optional symbol elements (Optional) are shown, if there are some on page 2, then the symbol element "change page" of key "F4" is actuated = to show change over possibility.
 - Error of one function on page 1 ⇒ Symbol element is already shown
 - Error of one function on page 2 ⇒ Symbol element "change page" blinks = Note error on other page
 - Error of one function on page 1 and 2 ⇒ Symbol element shown on page 1. Symbol element "change page" blinks
= Note error on other page

* Optional



12.4.1 Added function "crane incline"**Page 1**

In this symbol element, the incline of the crane superstructure to the horizontal is shown in lengthwise and crosswise direction. The indication is graphic as well as numeric.

Note: The incline of the crane superstructure is determined with the aid of the incline sensor crane chassis and slewing sensor.

?? is shown if the value of the slewing sensor is not correct.

Graphic section

1.1 The graphic view has the shape of a sight gauge, in which a dot (small square), which depicts the air bubble, moves. The center of the dot shows the exact incline value.

Numeric section

1.2 Incline range 1° or 5°

This value [°] depicts the graphic view, and can take on only the two values "1" or "5". If the crane slopes in crosswise direction and in lengthwise direction is more than $< 1^\circ$, then the gauge is in the 1° range. If at least one value exceeds the 1° range, then it shifts into the 5° range.

Note: The range shift occurs automatically.

1.3 Incline of crane in degrees [°] in crosswise direction

The double arrows shows the direction of incline:

Double arrow left = Crane is sloped to the left

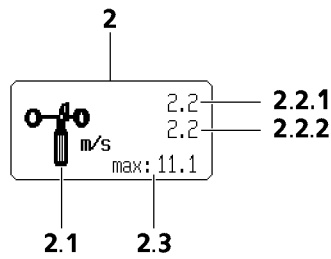
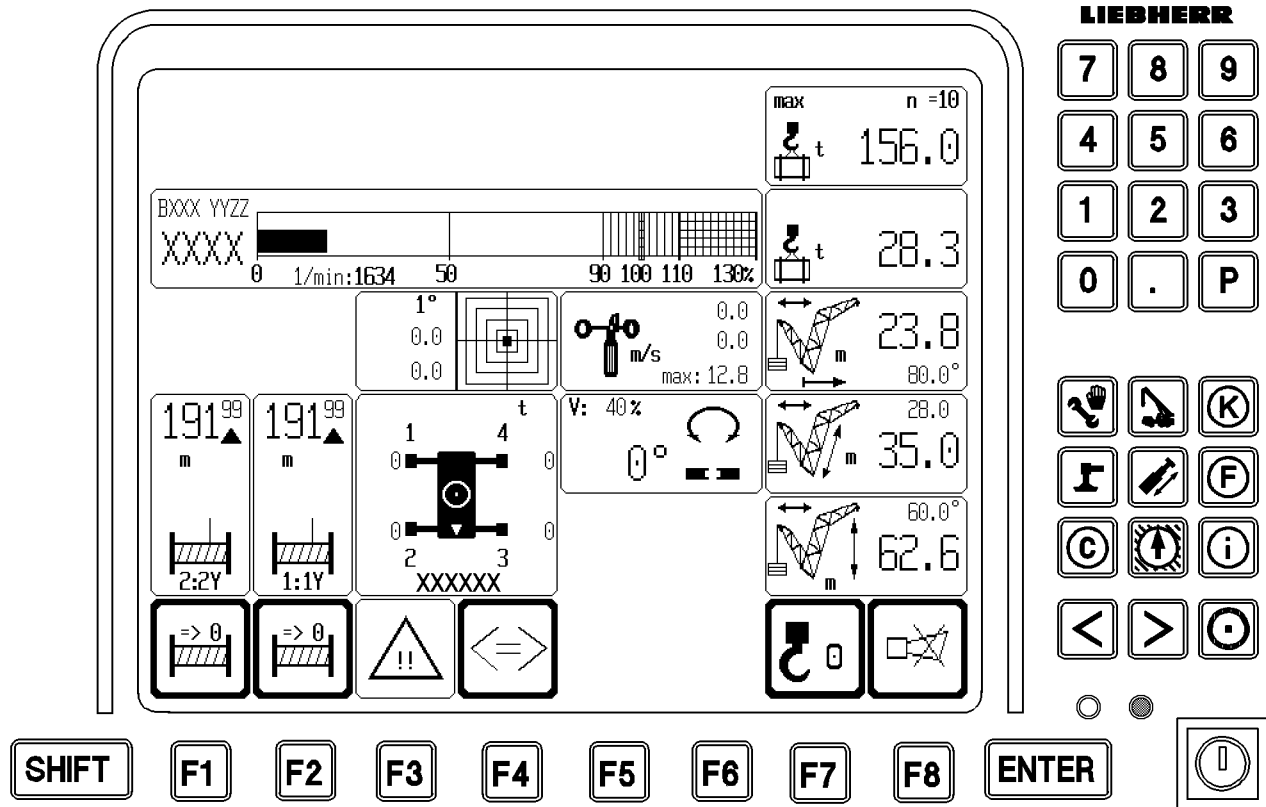
Double arrow right = Crane is sloped to the right

1.4 Incline of crane in degrees [°] in lengthwise direction

The arrows shows the direction of incline:

Arrow points up = Crane is sloped to the front

Arrow points down = Crane is sloped to the rear



12.4.2 Added function "Wind velocity"

The wind speeds are shown depending on the unit used in the load capacity chart, in meters per second [m/s] or feet per second [ft/s] .

2.1 Symbol "Wind velocity " in meters per second [m/s] or feet per second [ft/s]

2.2 Current wind speed

2.2.1 Wind sensor 2 Wind sensor - auxiliary equipment (luffing jib)

2.2.2 Wind sensor 1 Wind sensor - main boom

Note: No wind sensor can be installed on the boom nose *.

	Main boom	Auxiliary equipment
Wind sensor 1 available	Current wind speed is shown by wind sensor 1	Current wind speed is shown by wind sensor 1
Wind sensor 1 not available	"???" is shown at wind sensor 1 (static)	"???" is shown at wind sensor 1 (static)
Wind sensor 2 available	no indication	Current wind speed is shown by wind sensor 2
Wind sensor 2 not available	no indication	"???" is shown (static)

2.3 Maximum permissible wind speed with symbol text "max:"

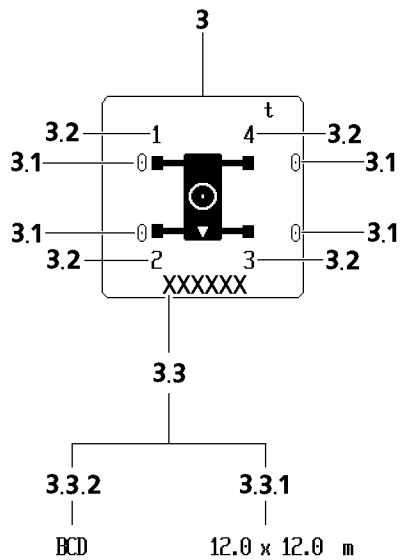
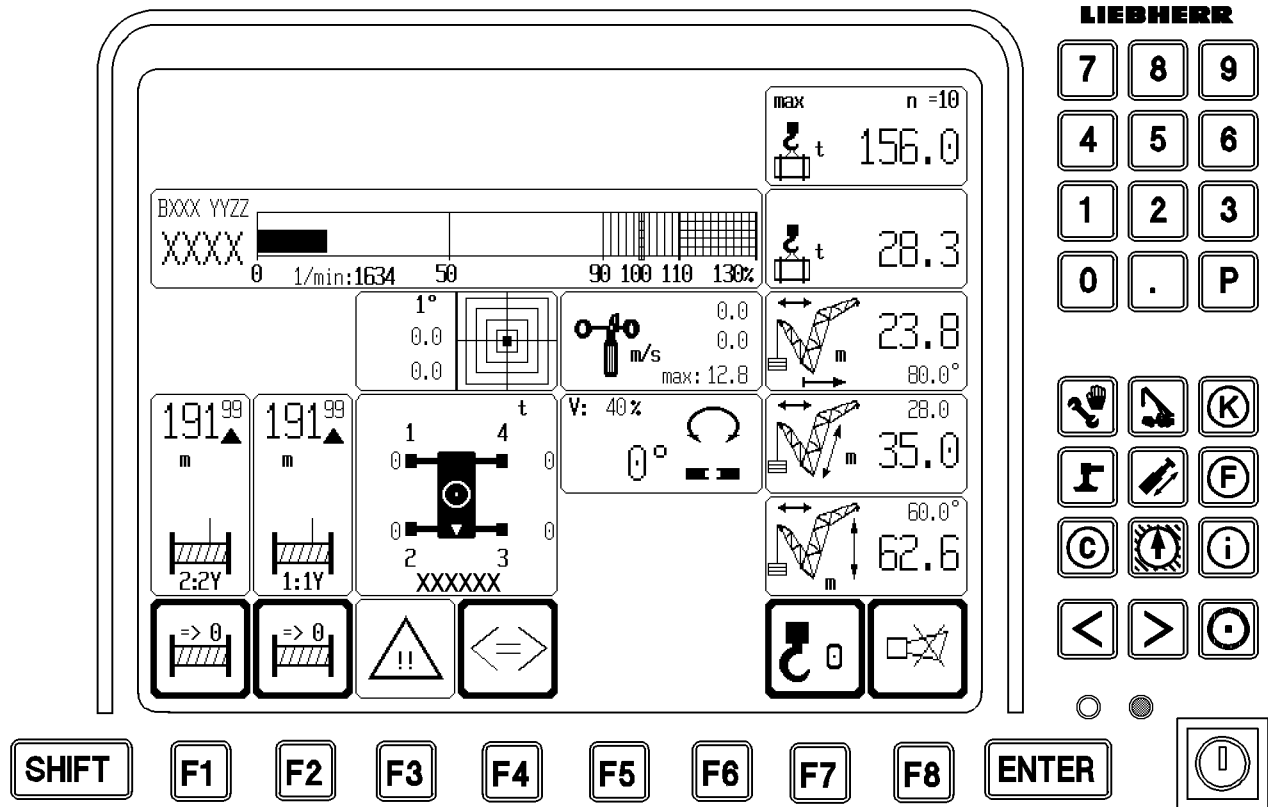
The value depends on the operating mode and the set up condition / equipment configuration.

Note: If access to a load chart is no longer possible, the maximum value blinks as invalid value (???) and an acoustical alarm "SHORT HORN" can be heard.

If a current value of the wind speed exceeds the indicated maximum value (Wind sensor 1 or 2 > maximum value), then the maximum value blinks as invalid value (???) and an acoustical alarm "SHORT HORN" can be heard .

CAUTION: The crane movements are not shut off!

* Optional



12.4.3 Added function "Support force indication" ***Page 1**

During crane operation, the LICCON support force monitoring system constantly checks the current hydraulic pressure in all 4 outrigger support cylinders and calculates it into a support force value [t] for each support.

Via function key "F3", the symbol element "Support force monitor" is shown, or the symbol appears automatically with the alarm signal "Short horn", when a support has either reached or exceeded the maximum force or if the minimum force has been reached or fallen below. The value(s) which triggered the warning are blinking.

Independent of the programmed minimum / maximum values, the system constantly monitors if the sum of the support forces of the two rear supports (the supports farthest away from the boom head) is less than 15% of the total support forces. If this limit is fallen below, then the two supports with the least forces are displayed blinking.

CAUTION: **When the minimum / maximum support forces are reached, no crane movements are shut off!**

Note: The maximum and minimum support forces are programmed in the "Support" program, see chapter 10.

3.1 Indication of current support force [t]
The support force is shown for each support.

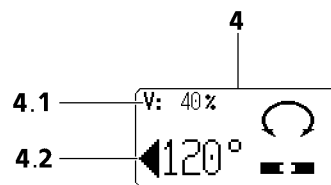
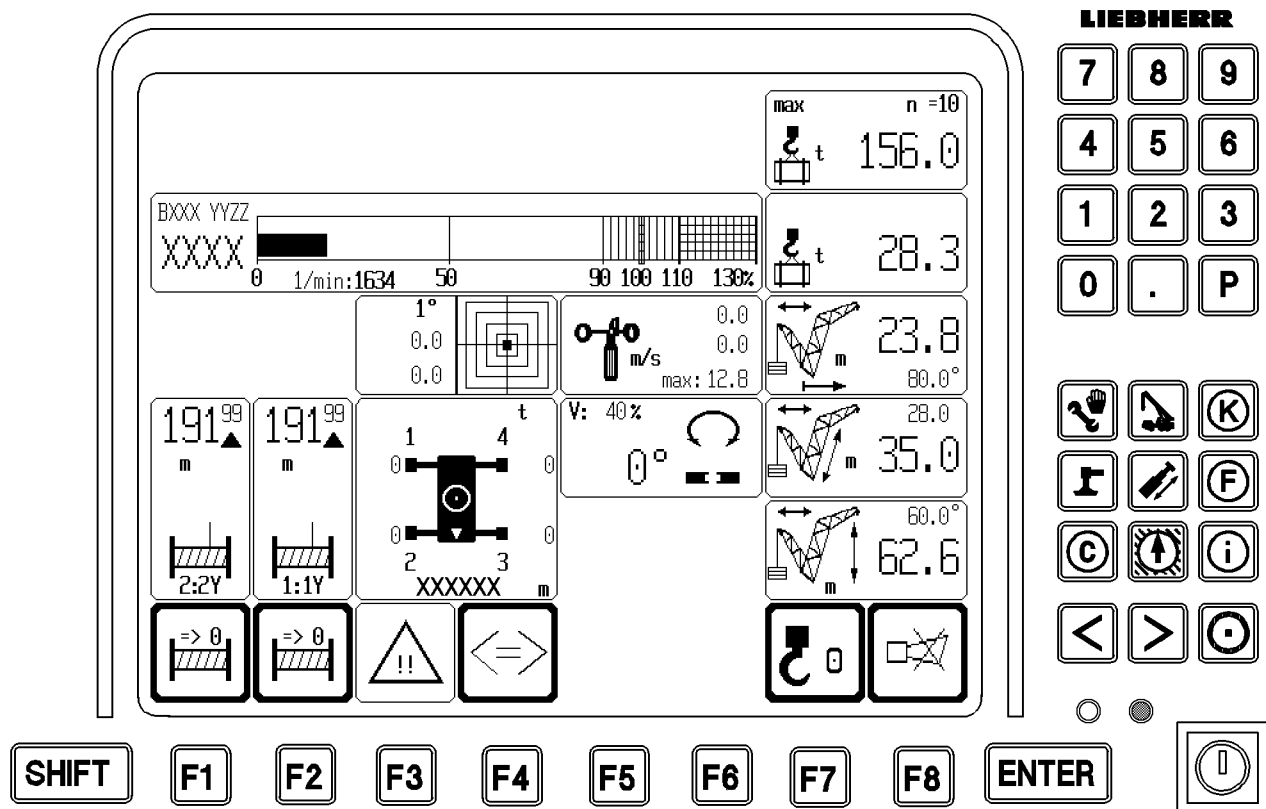
DANGER: **The support force indicator is incorrect if the support cylinders are fully extended or retracted.**
If the support cylinders are fully extended, the maximum force can be shown .
If the support cylinders are fully retracted, "0" value can be shown .

3.2 Indication of support numbers
The 4 supports are marked numerically on the crane and in the symbol element .

3.3 Indication of support base LG1750/LR1750

3.3.1 **LG1750:** 12m x 12m
 16m x 16m

3.3.2 **LR1750:**
The various support bases are shown with letters (combinations):
for example: A, B, C, D, E, F, G, H



12.4.4 Added function "Slewing range"**Page 1****4.1 Maximum slewing speed V: [%]**

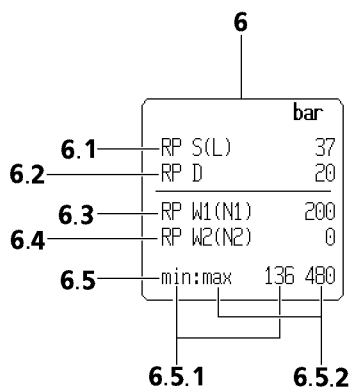
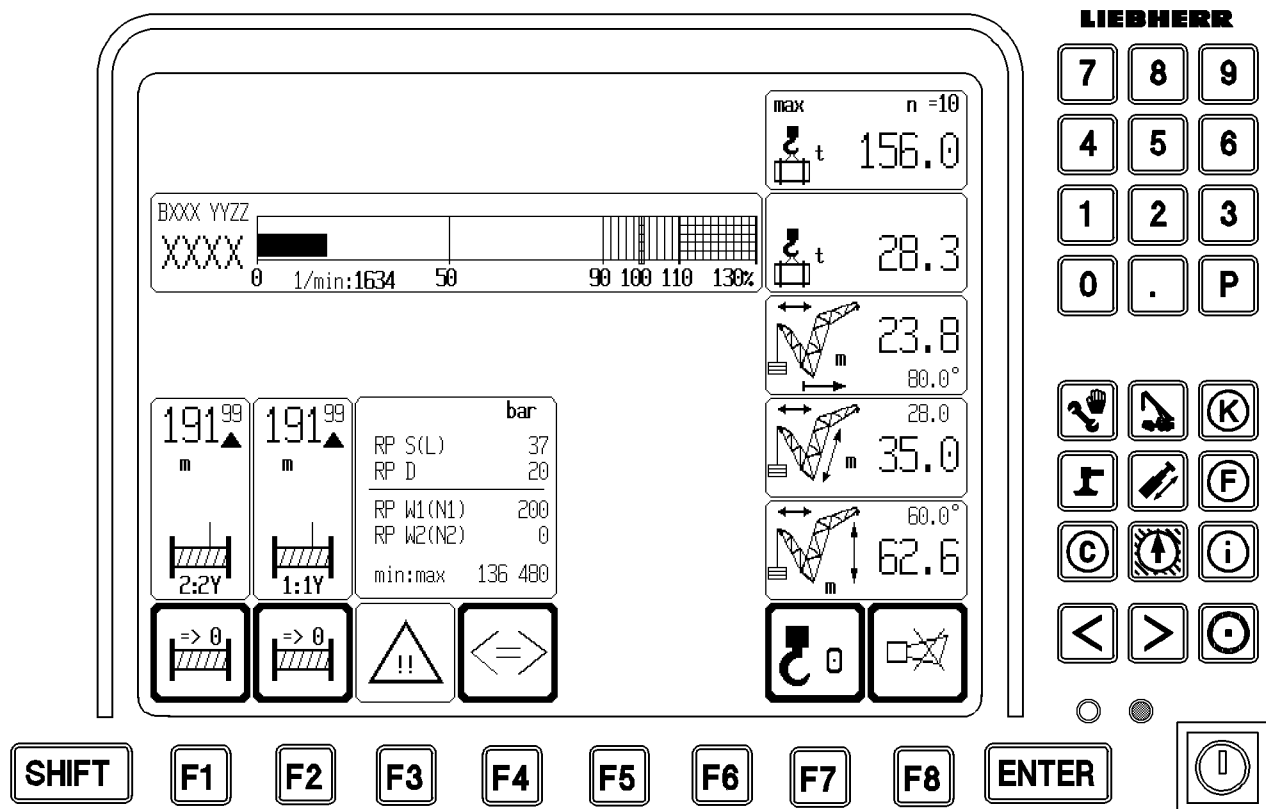
= current (selected) "maximum slewing speed" of the slewing gear at fully deflected manual control lever, in relation to the maximum obtainable slewing speed of the slewing gear at 100% speed preselection .

In the LICCON program "Control Parameter" (see paragraph 8), this value can be preselected in fixed percentage stages.

D A N G E R : The preselection must be carried out according to the data given in the load chart manual. If the slewing speed is too high, there is an increased risk of having a serious ACCIDENT!

4.2* Current position of the crane superstructure in relation to the direction to the front (chain tension side). The arrow in front of the value shows the direction of deviation. The value increases up to a value of 180° .

0°	Position exactly to the front
> 179°	Turn to the right
< 179°	Turn to the left
180°	Position exactly to the rear

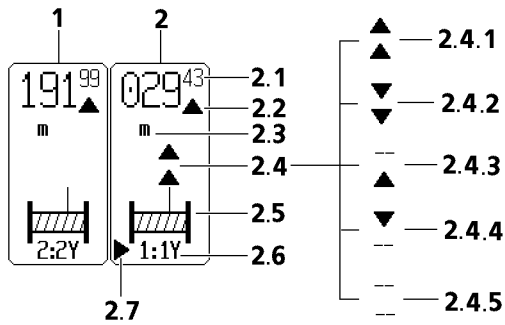
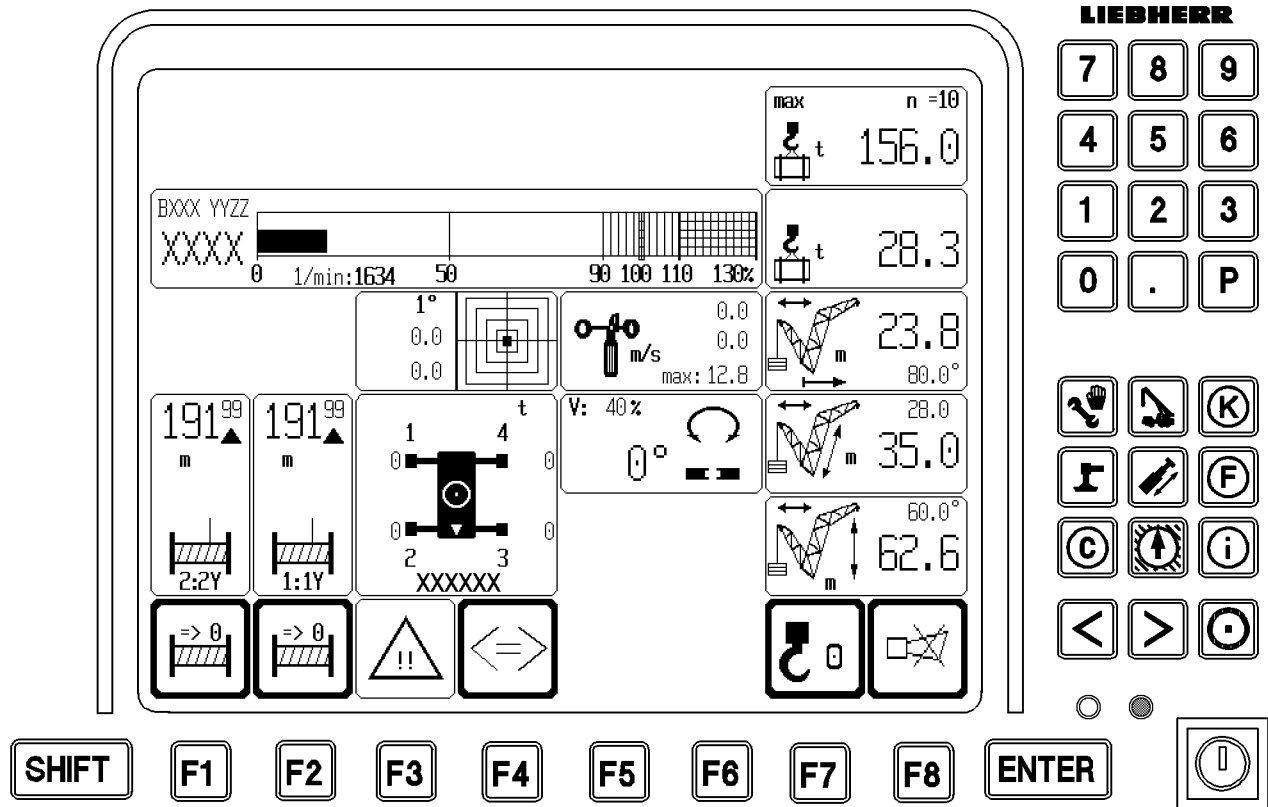


12.4.6 Added function „Relapse cylinder monitor“**Page 2**

- 6.1 Pressure [bar] in S or L boom relapse cylinders
- 6.2 Pressure [bar] in Derrick relapse cylinders
- 6.3 Pressure [bar] in W1 lattice jib relapse cylinder (=RPW1) in W operation or
Pressure [bar] in N1 lattice jib relapse cylinder (=RPN1) in N operation
- 6.4 Pressure [bar] in W2 lattice jib relapse cylinder (=RPW2) only in W operation, if available.
Pressure [bar] in N2 lattice jib relapse cylinder (=RPN2) only in W operation, if available.
- 6.5 Monitored relapse cylinder (RP) - pressure limits in jib - RP (W/N)
Minimum / maximum pressure for RPW1 (N1) and RPW2 (N2)
 - 6.5.1 Minimum pressure [bar] for jib - RP (W/N).
This monitored minimum pressure is calculated from the angle of the main boom and the jib. If one of the angles is invalid and the indication is shown with "???", then there can also be no monitoring for minimum pressure.
 - 6.5.2 Maximum pressure for jib - RP (W/N).
If a pressure limit value is exceeded, then it is shown with a blinking actual pressure value and also as an error message .

Note: Pressure indication = 0, if this relapse cylinder (s) is (are) not available for the set operating mode.

Pressure indication = ???, if the pressure sensor is not correct , (broken wire or short circuit). An error indication is issued with error number .



12.5 Symbol element "Winch indication winch 1 and 2"

1. Symbol element "Winch 2"
The meaning of the individual symbols for winch 1 and winch 2 is identical and is explained on symbol element "Winch 1".
2. Symbol element "Winch 1"
 - 2.1 If the winches operate individually with the reeving set in the equipment configuration view, or if the winch is operated in parallel operation, then the indicated value is the completed hook path (for parallel operation: path of the pulleyblock) from a predetermined zero point in the indicated length unit of meters ([m] or feet [ft]).
The numbers in front of the comma (point) are shown with maximum 3 large numbers.
The numbers after the comma (point) are shown with small numbers. (See also chapter 6.6, description of function keys "F1" and "F2").

As a prerequisite for correct indication, the entered value must match the actual number of cable reevings between boom head and hook block.

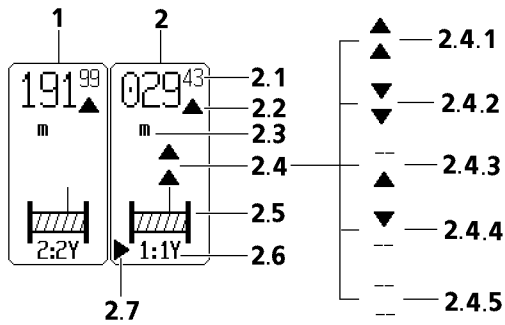
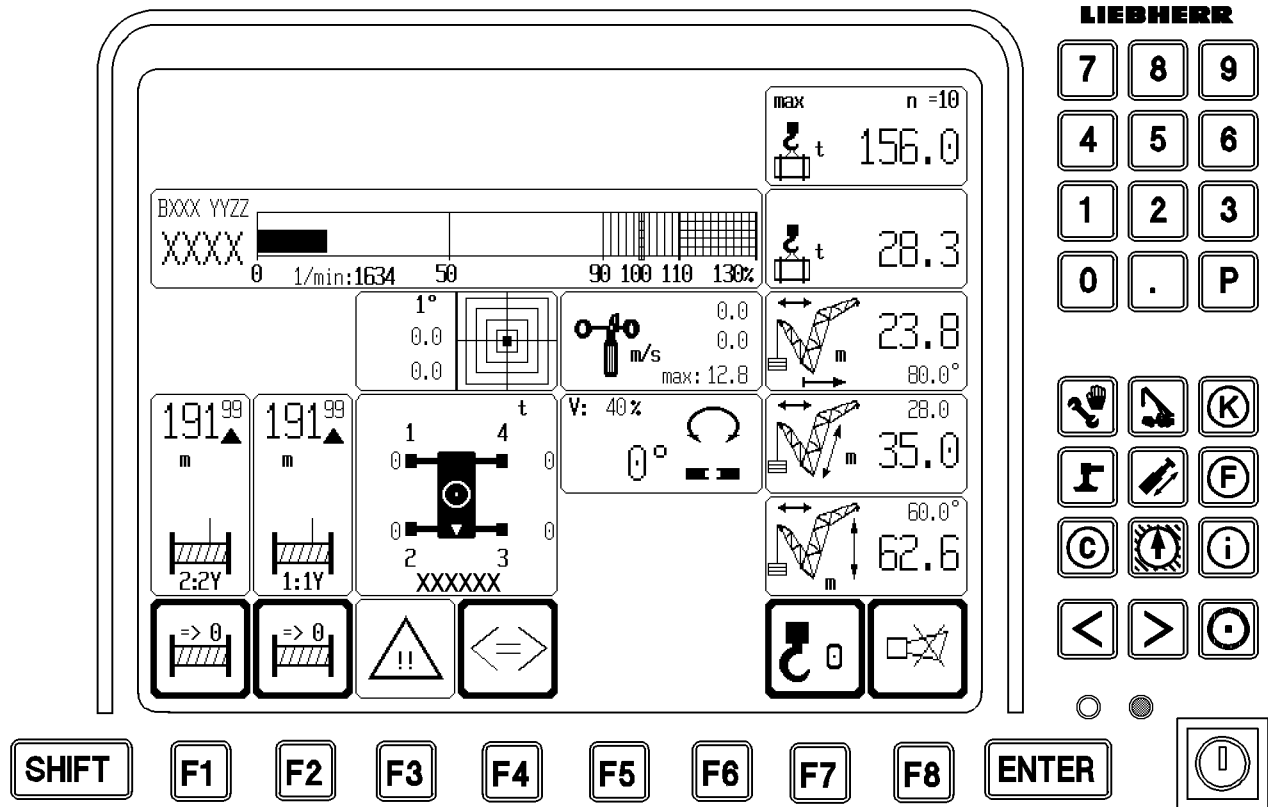
If the adjusted reeving does not match the reeving of the corresponding winch, then the correct hook path can be calculated from the indicated hook path as follows:

$$\text{correct hook path} = \frac{\text{indicated hook path} \times \text{adjusted reeving}}{\text{actual reeving}}$$

The hook path calculation works only if the load is suspended freely, and if the boom is not luffed up or down during the hoisting procedure. Boom flexation and cable stretch are not taken into account.

C A U T I O N: The length indication (hook path indication) is only correct and the coil jump is only taken into account correctly if the winch has been adjusted and if there was no CPU power interruption since then ("Cold start"). The adjustment of the hook path indication is done by spooling the cable on / off until the adjusting switch is triggered.

- 2.2 The arrows on the length value show the direction of the hook movement in relation to the zero point :
Arrow up = Hook has moved upward from zero point.
Arrow down = Hook has moved downward from zero point.
- 2.3 Length unit for hook path indication : [m] or [ft]



Symbol element "Winch indication winch 1 and 2" (continuation)

2.4 Winch status indication

The following winch status symbols are available (all blinking) :

2.4.1 Spool out

2.4.2 Spool up

2.4.3 Spooled out → spool out is locked

2.4.4 Spooled up → spool up is locked

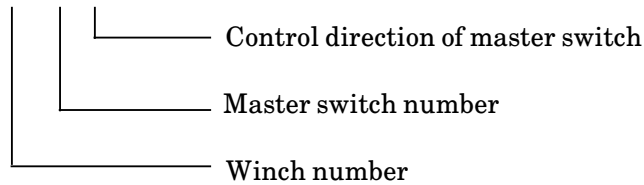
2.4.5 Winch is deactivated → spool up and spool out is locked (via the "Control Parameter" program)

Note: If no winch status symbol appears then the active winch is at a standstill and is neither spooled up nor out.

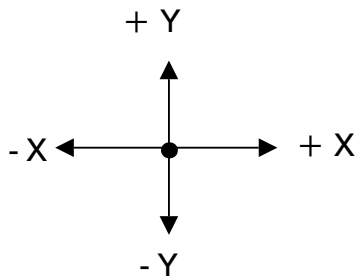
2.5 Winch symbol (with cable end for winch status symbol)

2.6 Assignment of master switch and winch

Example: **1 : 1 Y**



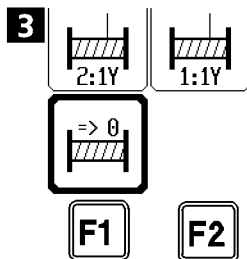
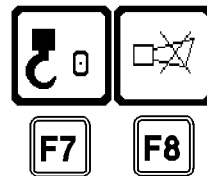
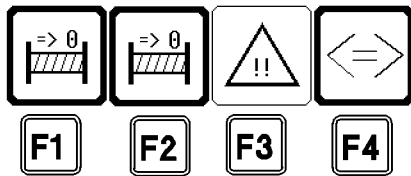
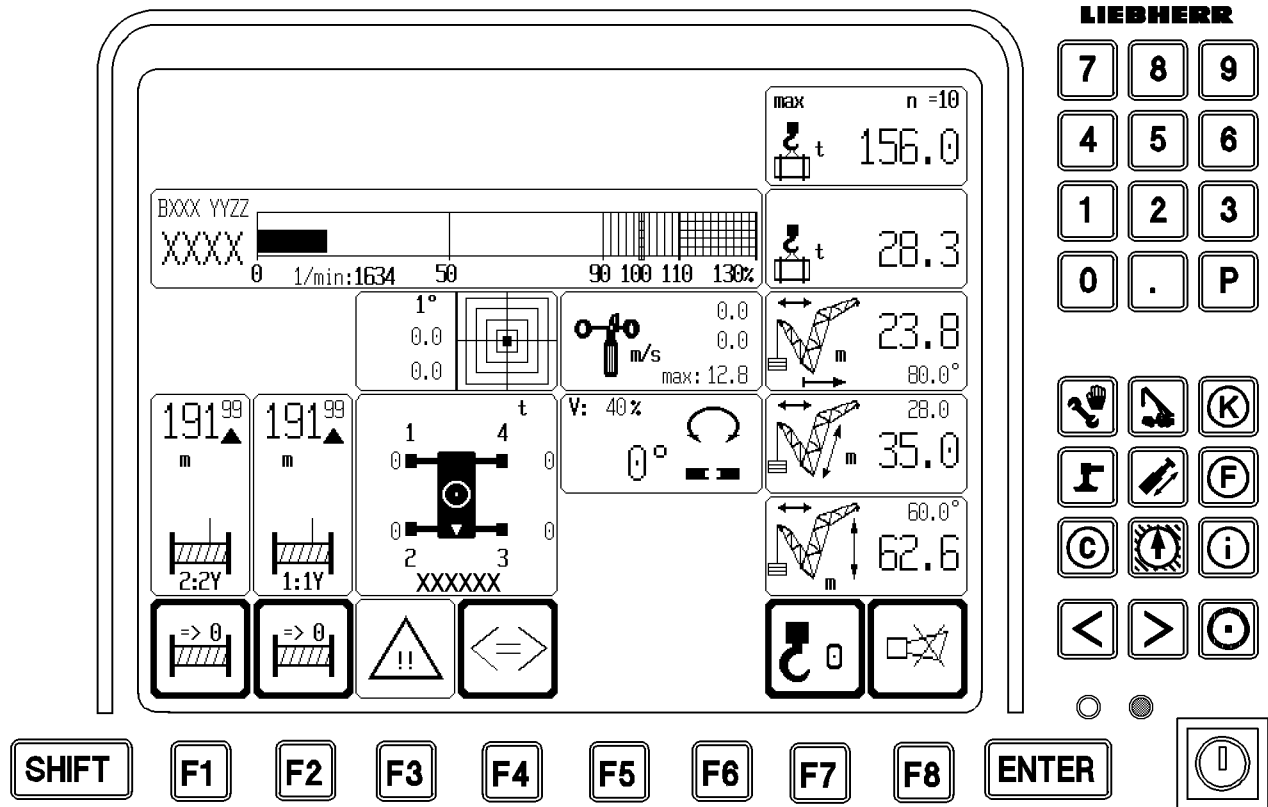
1: - - Due to incorrect settings , an assignment of master switch and winch is not possible!



2.7 Vibration sensor

If the vibration sensor for a winch is added on the master switch, then the symbol " ▶ " (2.7) appears in the winch symbol element for the added vibration sensor.

Note: The vibration sensor is added at the first actuated crane function.



12.6 Function keybar symbol line

The function keybar symbol line contains up to 8 symbol elements, which correspond to the function keys "F1" to "F8" below, which means they either describe a function, which can be triggered with the corresponding key and / or change their view and their meaning when the key is pressed.

"F1" Zero point for hook path indication of winch 2

Press key "F1" to show the symbol "Set winch indication to zero", which means if the key is pressed, the hook path indication of winch 2 is set in the winch symbol above to "000,00" and the path is measured from this point on.

"F2" Zero point for hook path indication of winch 1

As described for "F1" for winch 1.

Note: If winch 1 and winch 2 work in **parallel operation**, then the length indications of winch 1 and 2 can only be set together with the "F1" key to 000,00. The function key "F2" has then no function and the corresponding symbol element is blended out (Fig.3).

"F3" Turn monitoring symbol element on or off

With function key "F3", all symbol elements of the monitored added functions can be turned on and off. The symbol element changes accordingly:

Thick frame = Added function symbols turned off

Thin frame = Added function symbols turned on

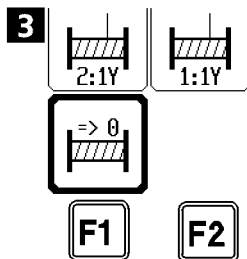
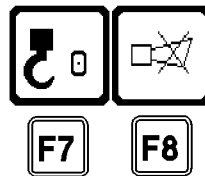
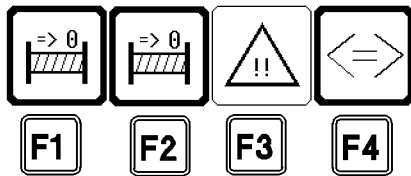
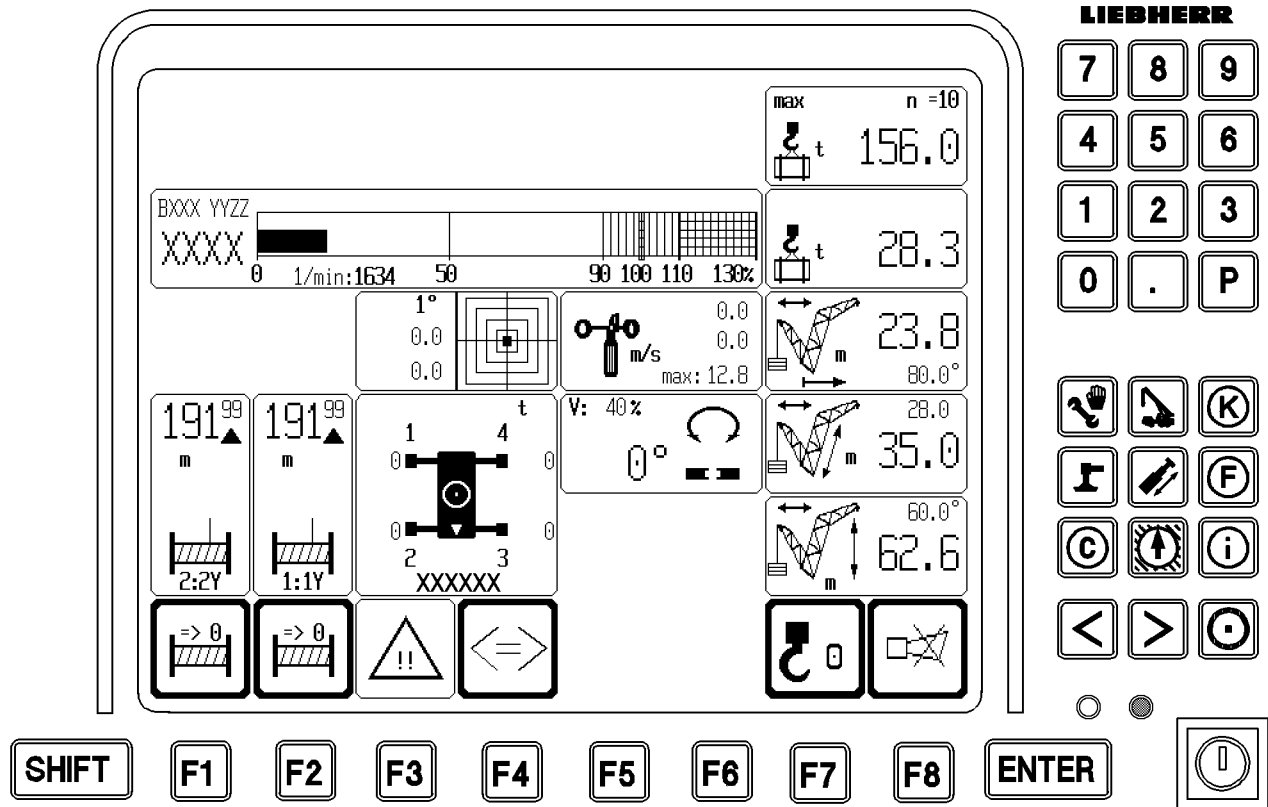
Note: The added function monitor function is always turned on; only the symbol elements can be turned off. In case a monitored limit is being exceeded, an acoustical warning can be heard (horn) and the corresponding symbol element is shown, even if the monitoring symbols had been turned off. (See also paragraph 6.4, "Monitored added functions.")

"F4" Switch over to monitoring page, if available.

(See also paragraph 6.4, "Monitored added functions.")

"F5" not used

"F6" not used



"F7" Tara

If the function key "F7" is pressed, the actual load indication is set to "Zero". At the same time, the word "net" appears in the symbol element of the actual load indication. This function makes it possible to eliminate the weights of hoist cable, load carrying components, load receptacles and tackle and to show only the weight of the load to be lifted (net load). This tare function can be stopped 3 ways:

1. press the "F7" key again,
2. Luff by more than $\pm 4^\circ$

The word "net" disappears from the symbol element for actual load indication and the gross load value is shown again.

Note: The "F7" key is effective with installed boom nose as well as actual load indication of the boom nose.

"F8" Horn OFF / Error diagnostics

- 1) Turn off the acoustical warning

The acoustical warning signals "Horn" and "SHORT HORN" can be turned off by pressing the "F8" key.

Note: A new error will turn the acoustical warning system on again.

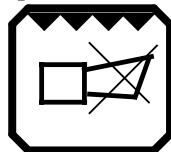
- 2) Error messages in the symbol element "Horn"



If a system application or operating error occurs, an error message appears in the symbol element "Horn", such as E:0EAM1

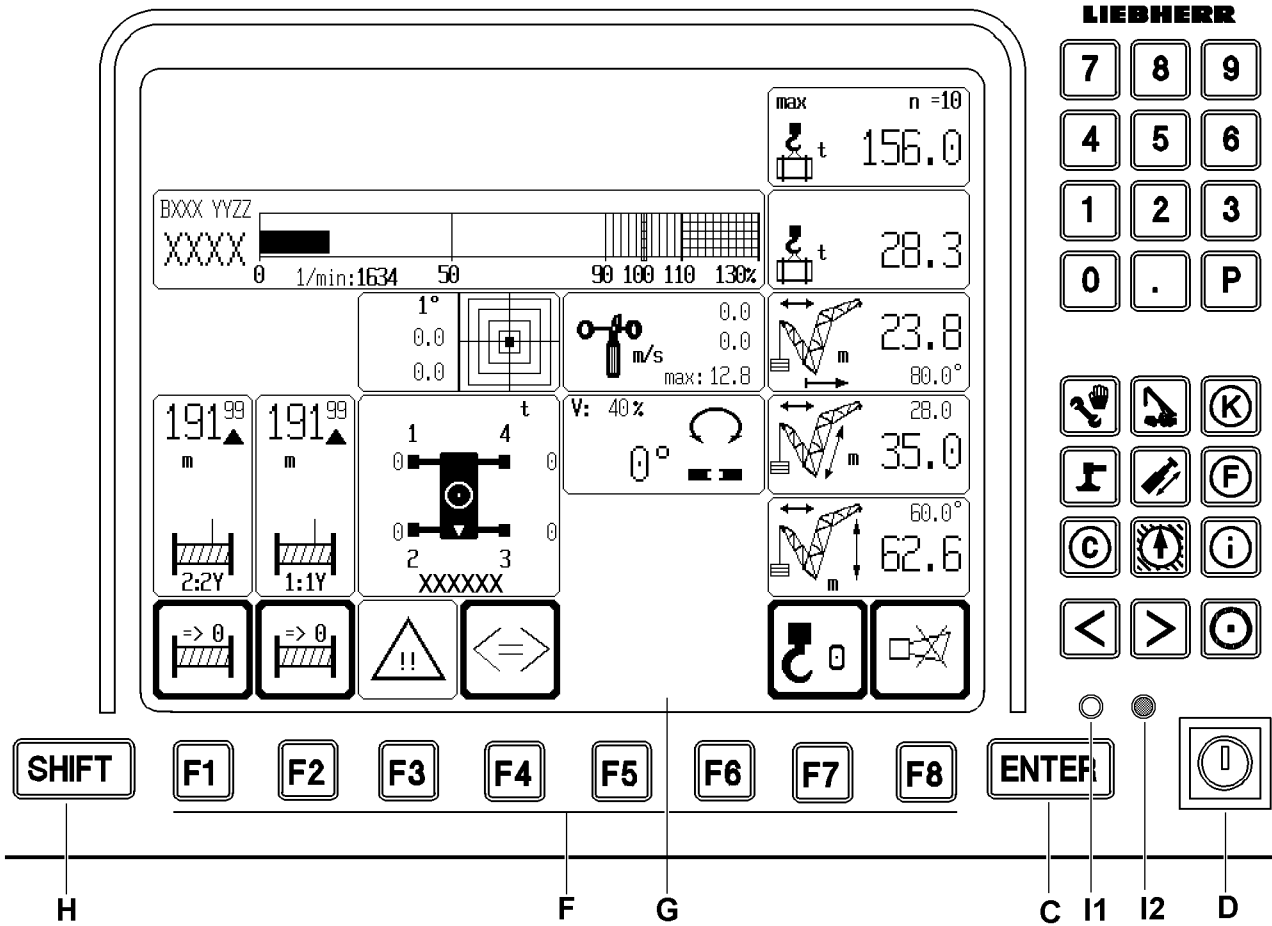
By pressing the "F8" key twice, the acoustical warning is turned off and changes to the "Test system", program, error determination view, where the error is documented (see Diagnostics Manual)

- 3) Special function Symbol element "Horn"

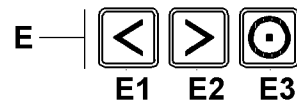
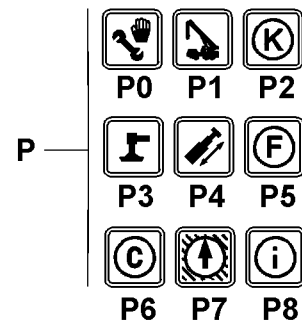
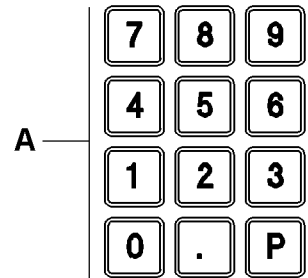
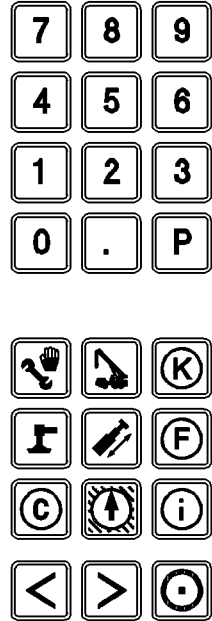


For crane delivery, a special program is available in the LICCON computer system. After the crane has been delivered to the new owner, this program is locked. If an additional mark (claw) appears in the symbol element Horn, then this means that the delivery program has not yet been locked. In this case, contact LIEBHERR Service immediately.

CAUTION: To prevent error functions, access to the special program is only given to trained LIEBHERR personnel.



LIEBHERR



12.7 Other control elements

The other control elements on the indicator and control unit of the LICCON computer system are assigned the following functions in the "Operation" program:

A Alpha numeric keyboard

- Keys "0" to "9", "P"
have no function in the "Operation" program.

- Keys "SHIFT" + "."
With the key "." the so-called test view functions are turned on / off, which means all existing symbol elements appear with an erroneous indicator value on the monitor.

Note: However, the monitored added functions must be shown on the desired page, if they are to appear in the test view. After 10 seconds or after pressing the "." key again, the normal operating view will reappear.

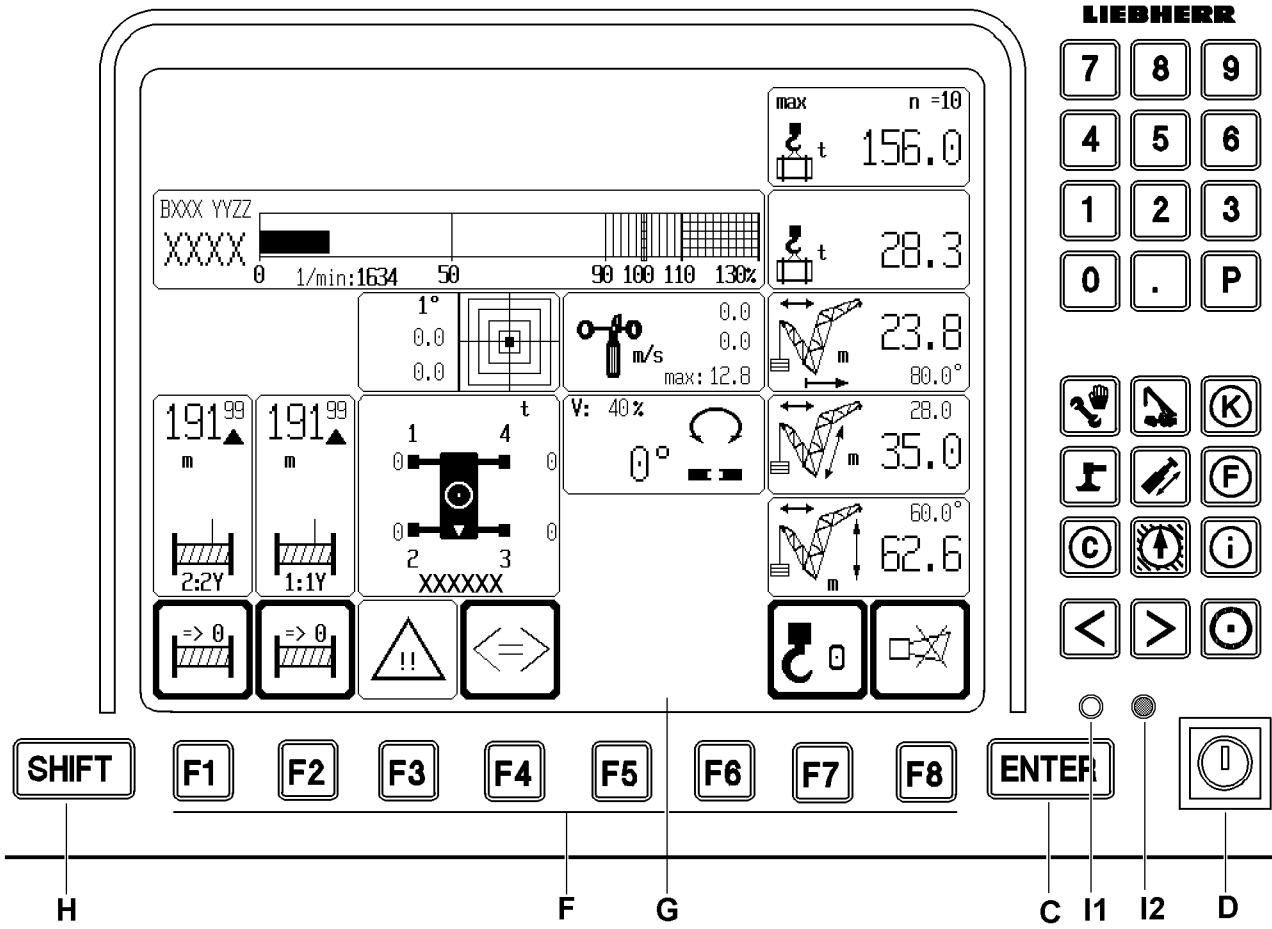
P Program keys

Use the program keys to select between the individual programs. However, the program specific peculiarities must be noted, such as shifting from "SET UP" to "Operation" by pressing 1 × O.K. .

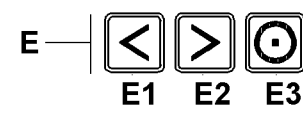
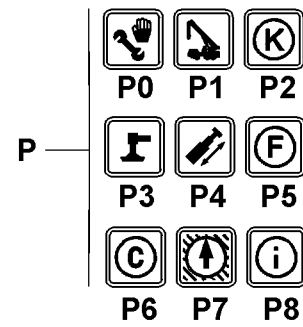
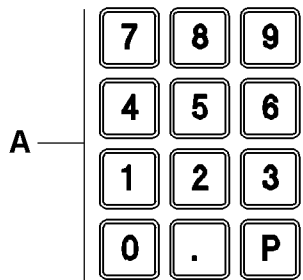
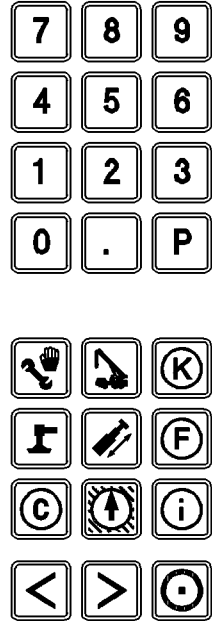
Note: The currently running program **cannot** be called up again via its program key. The programs can only be called up with their programs keys if the keyed "Installation" switch is not in "Installation" position.

C "ENTER" key

This key has no function in the "Operation" program .



LIEBHERR



D Keyed switch (see also chapter 4.04)

The keyed switch has two positions :

- Position to the right (touching) ⇒ Hoist limit switch and shut off of LML bypassed
- Center position (self retaining) ⇒ Normal operation

a) Bypass the overload safety device

If the maximum permissible load momentum is being exceeded, the LICCON overload safety device turns off all load moment increasing crane movements. This shut off can be bypassed with the keyed switch in position "to the right" .

C A U T I O N : **The overload safety device may only be bypassed if a supervisor is present, and under utmost care. All indicators of the LICCON overload safety device remain functioning.**

D A N G E R : **If the overload safety device is bypassed, there is no protection against overloading the crane. This increases the risk of ACCIDENTS !**

b) Bypassing the upper hoist shut off

If the hook block touches the hoist limit switch weight during an upward movement, the hoist limit switch is triggered. The crane movements 'spool up winch' is turned off. This shut off can be bypassed by turning the keyed switch to "right" .

C A U T I O N : **The hoist limit shut off function may only be bypassed if a supervisor is present, and if a "guide" is available. The guide must be in direct contact with the crane operator, and must monitor the distance between the hook block and the boom head at all times. All crane movements must be carried out with utmost care, at the least possible speed.**

D A N G E R : **If the upper hoist limit is bypassed, there is no protection against overloading the cable or the crane. This increases the risk of ACCIDENTS !**

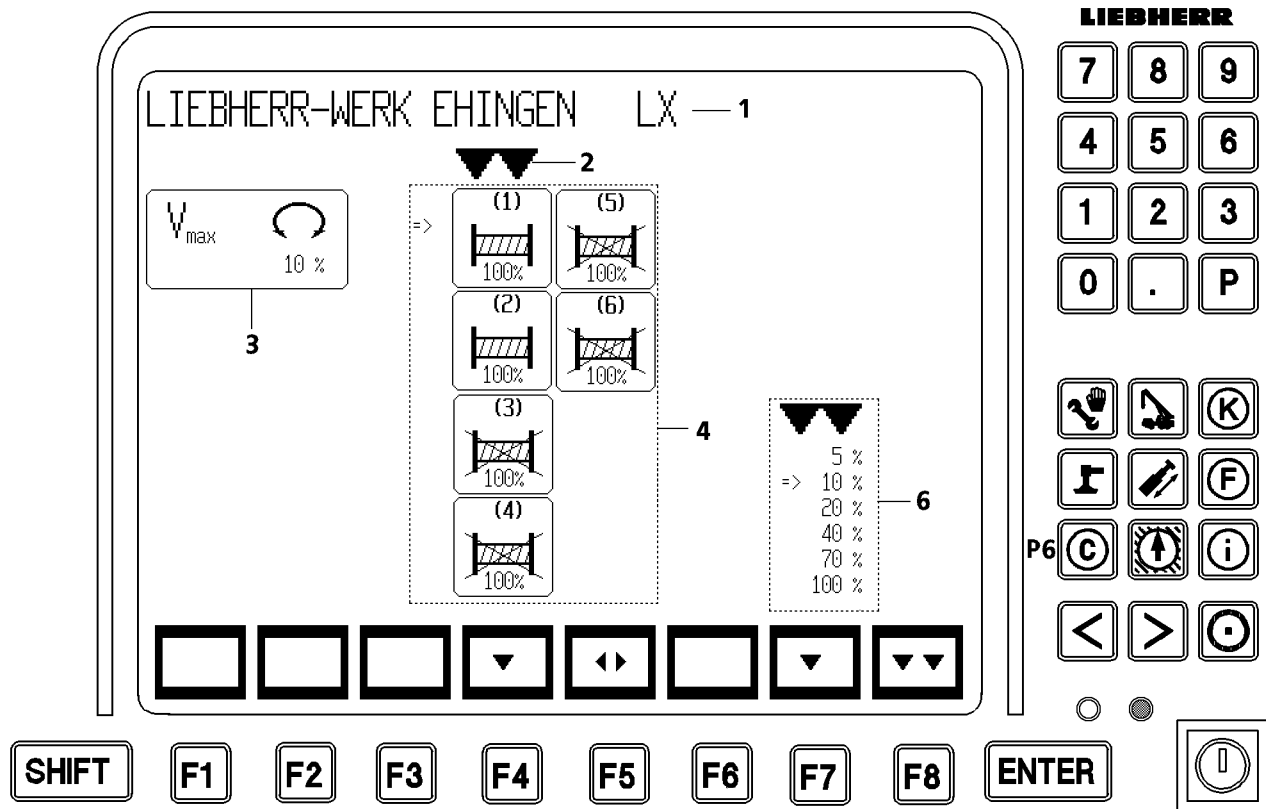
E Special function keys**Brightness adjustment of the monitors**

See paragraph 4.2.4

H "SHIFT" key

- Key assignment 2nd level .

Program call up engine monitoring with "SHIFT" + "P0"



13. The "ControlParameter" program

The "Control-Parameter" program offers the possibility to:

- preselect the maximum slewing speed of the slewing gear
- preselect the maximum slewing speed of the winches as well as to activate or deactivate the individual winches.

Note: During the "Control-Parameter" program, the installation and bypass switches are monitored. If one of these switches is actuated during the program, then the system shifts back immediately into the "Operation" program.

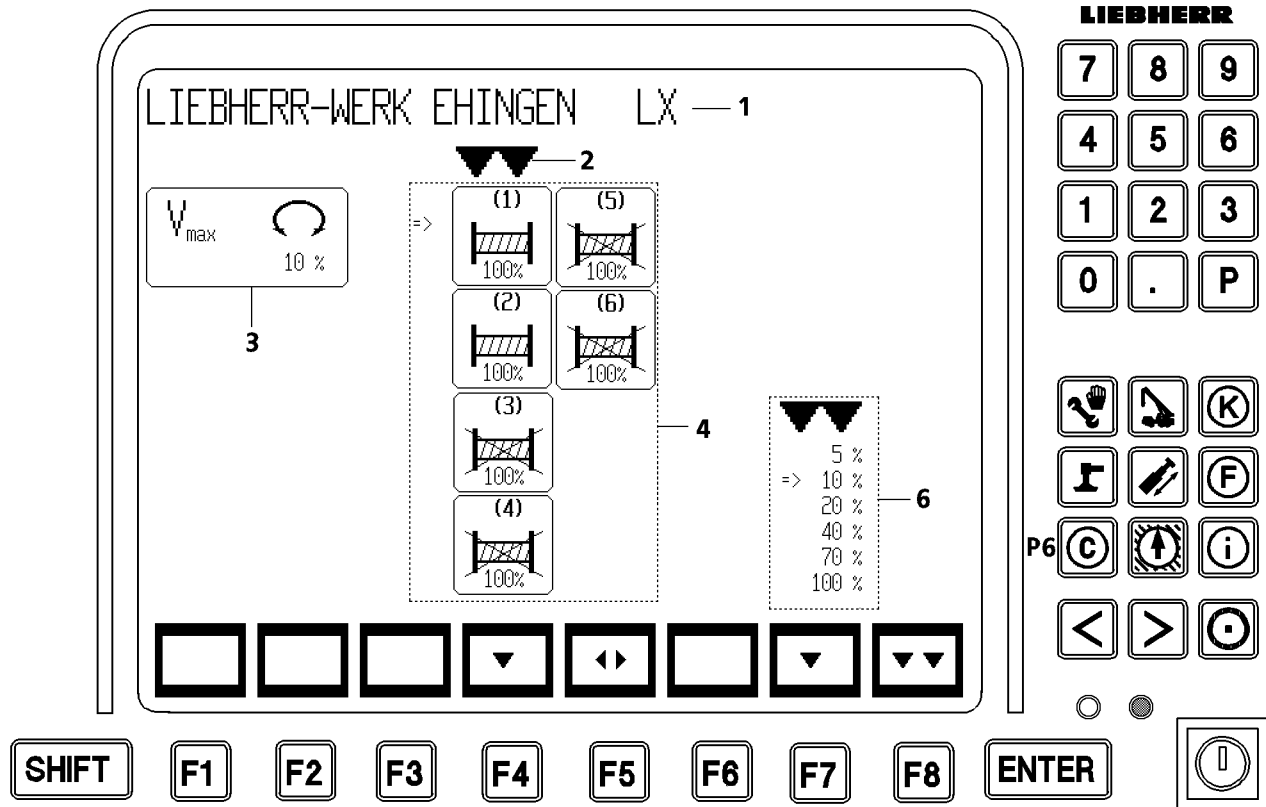
CAUTION: A change of maximum speed as well as activation / deactivation of the winches may not be made during a control of a crane movement.

13.1 Starting the program

- start with program key "P6"

13.2 Control surface of "Control Parameter" program

- 1) Crane type
- 2) Selector (double arrow) to select the symbol elements
- 3) Symbol element max. slewing speed : V_{\max}
- 4) Symbol element groups cable winches
with selector ($= >$) for the individual winches
- 6) Value field with selector ($= >$)
The percentage values describe the speed at maximum deflection of manual control lever. Always refers to maximum obtainable speed of drive, at a speed preselection of 100%. 6 stages can be preselected .
- 7) Function keybar
 - "F1" not used
 - "F2" not used
 - "F3" not used
 - "F4" Selection of winches
 - "F5" Deactivate or activate the selected cable winches.
 - "F6" not used
 - "F7" Selection of percentage value for corresponding speed in value field
 - "F8" Shift back to "Operation" program and take over parameters
- 8) ENTER key
Take over selected speed setting for preset functions.
- 9) Special function keys
 - "E1" moves the selector (2) to select symbol elements to the left
 - "E2" moves the selector (2) to select symbol elements to the right



13.3 Change maximum slewing speed - slewing gear

- Select symbol element "max. slewing speed (3)" with keys "E1" or "E2".
Selector (2) appears above the symbol element group.
- Select maximum slewing speed in [%] with key "F7",
Selector (= >) points to the selected maximum slewing speed in percentages.
- Confirm the selected maximum slewing speed with the "ENTER" key.
- Take over setting

D A N G E R : **The maximum slewing speeds (according to load capacity charts) which depend on the boom length and the operating mode, may NOT be exceeded during crane operation with a load !**

The larger the boom length, the heavier the attachment and the larger the load the smaller the adjusted "maximum slewing speed" must be.

With maximum load, the manual control lever for the slewing gear may not be deflected all the way to the stop.

13.4 Change the maximum slewing speed - winches

- Select symbol element "Winches" (4) with keys "E1" or "E2".
Selector (2) appears above the symbol element group.
- Select symbol element for winch 1, 2, 3, 4, 5 or 6 with key "F4",
Selector (= >) points to the selected winch.
- Select maximum slewing speed in [%] with key "F7",
Selector (= >) points on selected percentage value.
- Confirm the selected maximum slewing speed with the "ENTER" key.
- Take over setting.

13.4.1 Activate / deactivate the individual winches

To prevent inadvertent movement of a winch, which is currently not required, the individual winches can be deactivated.

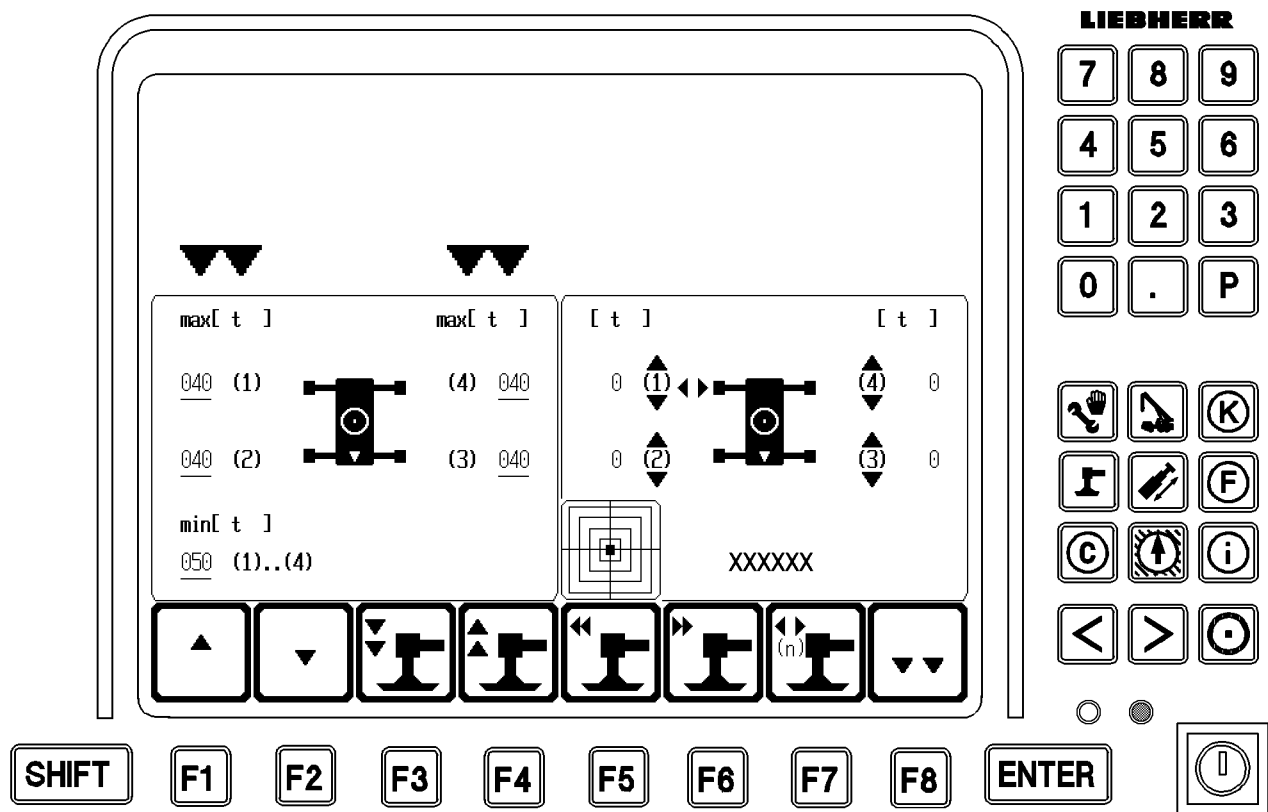
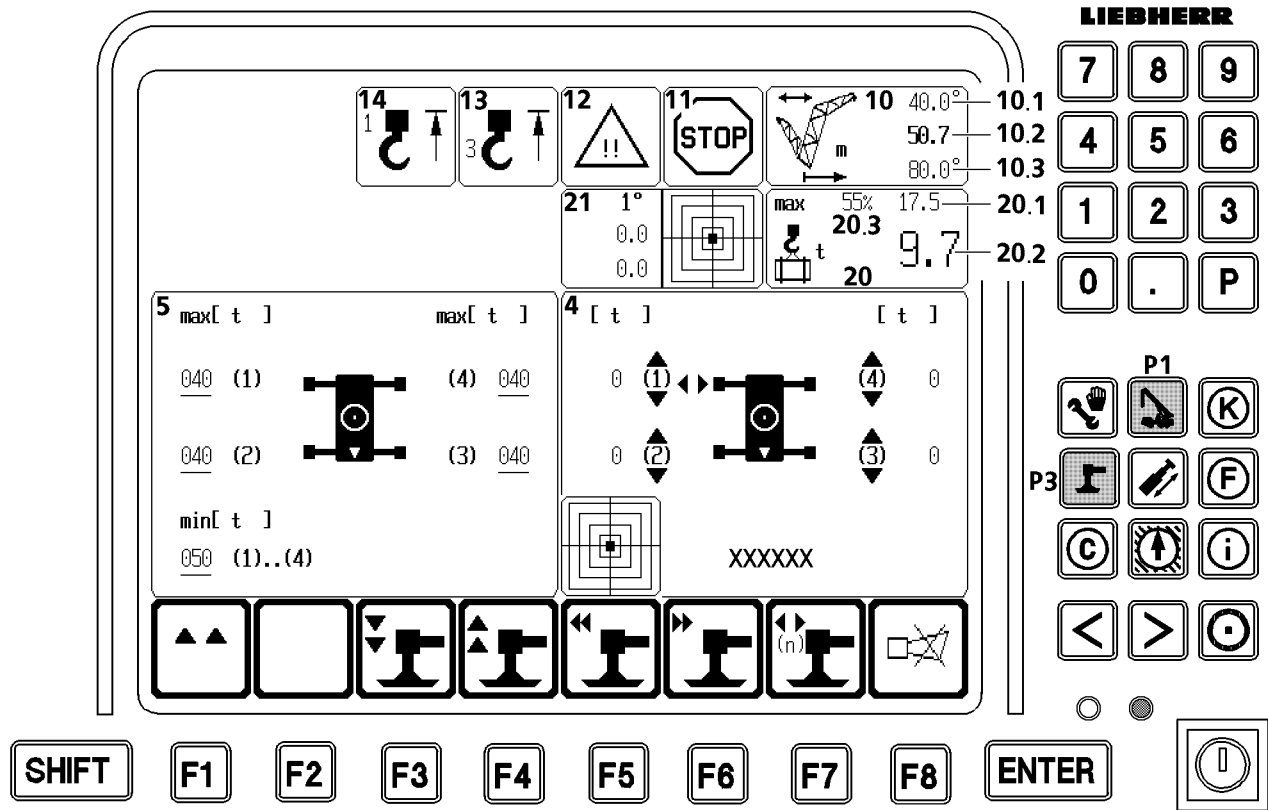
- Select symbol element group "Winches" with keys "E1" or "E2".
Selector (2) appears above the symbol element group.
- Select symbol element for winch 1, 2, 3, 4, 5 or 6 with key "F4",
Selector (= >) points to selected winch.
- Activate or deactivate the selected winch with key "F5".

The winch symbol in the symbol element changes as follows:

Winch symbol crossed out	=	Winch deactivated
Winch symbol not crossed out	=	Winch active

13.5 Shift back into the crane operating view

- with function key "F8"
The parameters previously confirmed with "ENTER" are taken over.



14. The "Support" * program

Note: The monitor view shows the complete configuration of the "Support" program. Depending on the options, the individual parts of the program are inactive and not visible on the LICCON monitor. The number values in the symbol elements are only examples and might not match this particular crane.

14.1 Start / end the program

14.1.1 Start the program

- with program key "P3"

14.1.2 End the program and shift back to the "Operation" program

- with program key "P1"

14.1.3 Crane operation in "support" program

Note: This function is only released for the option "Crane support*".

C A U T I O N: The utilization of the boom nose and the wind speed are not shown.

D A N G E R: During unclear wind conditions, it is prohibited to work with the boom nose and working with a load in the support program.

- 10) Symbol element "Radius and main boom angle"
 - 10.1 Auxiliary equipment angle [°]
 - 10.2 Radius of load on boom [m] or [ft]
 - 10.3 Main boom angle [°]
- 11) Symbol element "STOP"
- 12) Symbol element "Prewarning"
- 13) Symbol element "Hoist top on auxiliary boom" or "Hoist top on boom nose"
- 14) Symbol element "Hoist top on main boom"
- 20) Symbol element "Load carrying capacity "
 - 20.1 Maximum load on boom [t] or [lbs]
 - 20.2 Current load on boom [t] or [lbs]
 - 20.3 Dynamic utilization on boom in [%]
- 21) Symbol element "Incline superstructure"

Note: For detailed description of symbol elements, see paragraph 6.1, Information about crane geometry and load as well as paragraph 6.2, Alarm function.

- Change over into the adjustment field for support limit forces (5) with function key "F1".

Note: However, LMB-STOP is triggered immediately. All hoist and luffing movements are stopped and the symbol elements for crane operation disappear.

- End the adjustment mode with function key "F8".

All symbol elements for crane operation will reappear and all crane movements are released.

14.2 Configuration of program

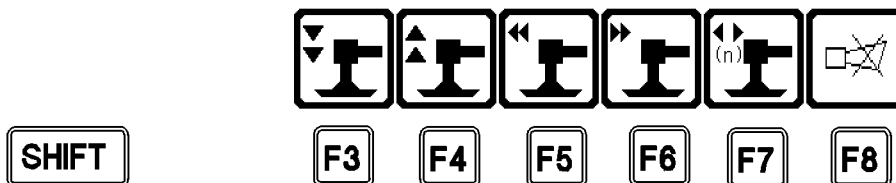
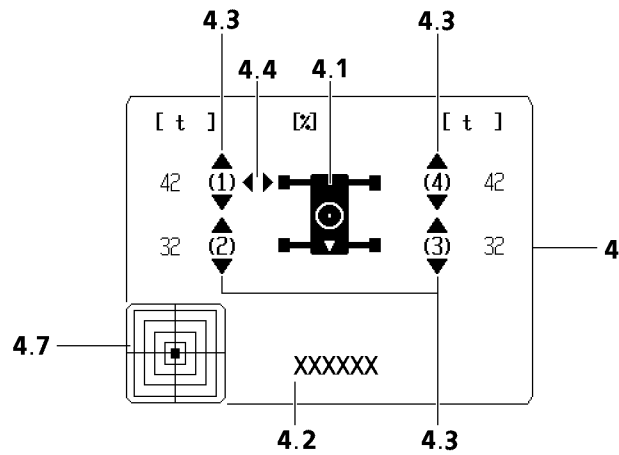
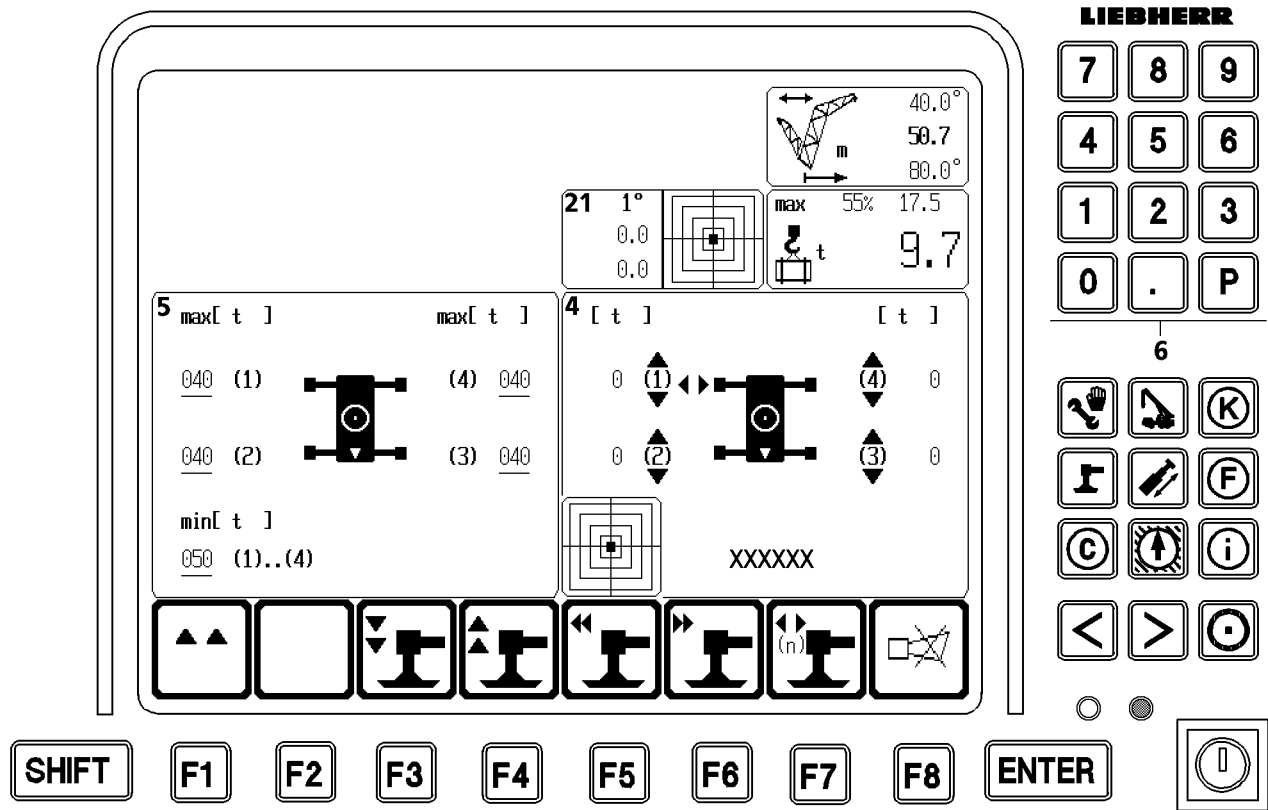
14.2.1 Support

14.2.1.1 Manual support

14.2.1.2 Automatic support and horizontal alignment

14.2.2 Support force monitor *

* Optional



14.2.1 Support

14.2.1.1 Manual support

see also Crane operating instructions, chapter 3.05.

4) Monitoring and control field

- 4.1 Crane symbol with numbers of support cylinders
- 4.2 Support base
- 4.3 Function selectors to select support cylinder
- 4.4 Function selectors to select folding arms
- 4.7 Symbol "Incline chassis"
(see paragraph 6.4.1 Added function "Crane incline ", graphic section)

Function keybar in monitoring / control mode (at program start)

- "F3" Extend preselected support cylinder
- "F4" Retract preselected support cylinder
- "F5" Extend preselected folding arms
- "F6" Retract preselected folding arms
- "F7" Select folding arm
- "F8" Turn horn off / error diagnostics

Note: For safety reasons, only one folding arm can be selected via the function key "F7".

The functions "F3" and "F4" are only of value if at least one support cylinder is preselected. If no support cylinder is preselected, then a sound can be heard.

CAUTION: For safety reasons, the functions behind "F3" to "F6" are only active as long as the corresponding button is actuated. An acoustical message, a "rhythmic horn sound" can be heard for the duration of the function.

6) Keyfield

With buttons 1 to 4, select or deselect the corresponding support cylinder.

14.2.1.2 Align the support and crane automatically in horizontal direction

"SHIFT" + "F3" By actuating the key combination "SHIFT" + "F3", all support cylinders are extended and the crane is aligned in horizontal direction.

"SHIFT" + "F4" By actuating the key combination "SHIFT" + "F4", all support cylinder are retracted and the crane is aligned in horizontal direction.

Note: By taking the incline values sent by the incline sensor into account, the supports are moved independent of the selection into the preselected direction so that the crane moves into a horizontal position.

DANGER: However, it must be checked that all four support plates are in contact with the ground. If this is not the case, there is a danger of accidents!

The support force indication is incorrect if the support cylinders are extended or retracted all the way. There is a danger of accidents!

The main control panel features a central display area with several sections:

- Top Right:** A diagram of a crane boom with angles 40.0°, 50.7, and 80.0°.
- Top Center:** A target icon with a 1° angle and values 0.0, 0.0.
- Top Right (below target):** A crane hook icon with 'max 55%' and '17.5'.
- Bottom Right (below hook):** A value of '9.7'.
- Left Side:** Two columns of 'max[t]' and 'min[t]' settings. The 'max' settings are '040 (1)' and '040 (2)' on the left, and '(4) 040' and '(3) 040' on the right. The 'min' setting is '050 (1)..(4)'.
- Center:** A crane hook diagram with dimensions: '4 [t]' and '4.6 [t]' at the top, '4.5' on the left, and '4.1' on the right. Below it is a target icon and 'XXXXXX — 4.2'.
- Bottom Row:** A series of icons for crane functions: two upward arrows, a crane hook, two downward arrows, two crane hooks, two crane hooks with arrows, a crane hook with '(n)', and a crane hook with a slash.

LIEBHERR

7	8	9
4	5	6
1	2	3
0	.	P

<	>	

SHIFT	F1	F2	F3	F4	F5	F6	F7	F8
-------	----	----	----	----	----	----	----	----

ENTER		

The main control panel features a central display area with several sections:

- Top:** A diagram of a crane hook with a dimension of '5.5'.
- Left Side:** Two columns of 'max[t]' and 'min[t]' settings. The 'max' settings are '5 max[t]' and '5.1 max[t]' on the left, and '(4) 040' and '(3) 040' on the right. The 'min' setting is '5.3 min[t]' and '050 (1)..(4)'. A dimension of '5.4' is also shown.
- Center:** A crane hook diagram with dimensions: '5.1' on the left, '5.2' in the middle, and '5.3' on the right. Below it is a target icon and 'XXXXXX'.
- Bottom Row:** A series of icons for crane functions: an upward arrow, a downward arrow, two crane hooks, two crane hooks, two crane hooks with arrows, a crane hook with '(n)', and two downward arrows.

LIEBHERR

7	8	9
4	5	6
1	2	3
0	.	P

<	>	

SHIFT	F1	F2	F3	F4	F5	F6	F7	F8
-------	----	----	----	----	----	----	----	----

ENTER		

14.2.2 Support force monitoring *

D A N G E R: **The LICCON support force monitor is only a tool to aid in the monitoring function. A possible overload of the crane is not prevented. The support force monitor may not be used to utilize the crane to its tipping limit!**

4) Monitoring and control field

4.1 Crane symbol with numbers of support cylinder

4.2 Support base

4.5 Support force values in [t] or [kibs]

4.6 Unit of indicated support force values in [t] or [kibs]

Function keybar in monitoring / control mode (at program start)

"F1" Change over to set up field for support force monitors

"F8" Turn horn off / error diagnostics

5) Set up / adjustment field for support limit forces

5.1 Unit of maximum support limit force values [t] or [kibs]

5.2 Crane symbol with support numbers

5.3 Maximum support limit force values **max** in [t] or [kibs]

5.4 Minimum support limit force values **min** in [t] or [kibs]

Note: Valid for all four supports.

5.5 Selector arrows

Point to the set up field, if it is active.

Function keybar in set up / adjustment mode

"F1" Move cursor to next support limit force value.

"F2" Move cursor to previous support limit force value.

"F8" Shift back to monitoring and control field (4).

BXXX YYZZ
XXXX

1/min:1634 50 90 100 110 130%

max n =10
t 156.0

191⁹⁹▲
m
2:2Y

191⁹⁹▲
m
1:1Y

1°
0.0
0.0

m/s
0.0
max: 12.8

t
28.3

23.8
80.0°

0 1 2 3
XXXXXX

V: 40%

28.0

35.0

60.0°

62.6

=> 0

=> 0

!!

<=>

t

t

LIEBHERR

7	8	9
4	5	6
1	2	3
0	.	P
<	>	⊙

SHIFT

F1

F2

F3

F4

F5

F6

F7

F8

ENTER

⊙

max[t]

max[t]

40.0°
50.7
80.0°

040 (1)

(4) 040

1°
0.0
0.0

max 55% 17.5
t 9.7

040 (2)

(3) 040

[t]

[t]

min[t]

XXXXXX

050 (1)..(4)

XXXXXX

▲

▼

LIEBHERR

7	8	9
4	5	6
1	2	3
0	.	P
<	>	⊙

SHIFT

F1

F2

F3

F4

F5

F6

F7

F8

ENTER

⊙

14.2.2.1 Indication of current support forces

During crane operation, the support force monitor determines the current pressure on 4 support cylinders via pressure sensors and shows it as support force [t] or [kibs] for each support.

The support forces are shown in the equipment configuration "supported", either as required via the function key "F3" or if a critical situation occurs in the "Operation" program. The symbol element appears together with the acoustical warning signal if the maximum force is exceeded at least on one support or if the minimum force is reached or fallen below. In these conditions, the support limit force value which is too high or too low is shown blinking.

D A N G E R: **The crane movements are not shut off when the minimum and maximum support forces are reached.**

Note: At the factory, the maximum and minimum support values, depending on the crane type, have been programmed into the system. With the " support force monitor", the crane operator can change these values, depending on the situation (see paragraph 10.2.2.3).

14.2.2.2 Notes

Due to the possibility to determine the limit values himself, the LICCON support force monitor can also be utilized as a prewarning device.

Note: Possible inaccuracy of the indication must be taken into account.

C A U T I O N: **To ensure that the LICCON support force monitor works properly, the support cylinders may not be moved to "Block bottom" nor to "Block top". Otherwise, the support forces are incorrect!**

Due to friction in the support cylinders, the indicated support forces can be incorrect up to 40 t, especially in case of

- large support forces
- far extended support cylinders
- during extension of support cylinder (up to 15 minutes later).

D A N G E R: **The LICCON support force monitor is only a tool to aid in the monitoring function. A possible overload of the crane is not prevented. The support force monitor may not be used to utilize the crane to its tipping limit!**

The main control panel features a central display area with several sections:

- Top Right:** A diagram of a crane boom with angles 40.0°, 50.7, and 80.0°.
- Top Center:** A 1° angle indicator and a target symbol.
- Top Right (Text):** max 55% 17.5, 9.7.
- Left Side:** max [t] and min [t] labels with sub-labels 040 (1) through (4) and 050 (1)..(4).
- Center:** A crane diagram with dimensions 4.5, 4.6, and 4.1. It includes numbered callouts (1) through (4) and a target symbol.
- Bottom Right:** A target symbol and the text XXXXXX — 4.2.

Below the display is a row of eight function buttons with icons for crane movements and settings.

LIEBHERR

7	8	9
4	5	6
1	2	3
0	.	P

<	>	

SHIFT F1 F2 F3 F4 F5 F6 F7 F8

ENTER

The main control panel features a central display area with several sections:

- Top:** A diagram showing a width of 5.5.
- Top Left:** 5 max [t] — 5.1 — max [t]
- Left Side:** min [t] label with sub-labels 040 (1) through (4) and 050 (1)..(4). Dimensions 5.2, 5.3, and 5.4 are shown.
- Center:** A crane diagram with callouts (1) through (4) and a target symbol.
- Bottom Right:** A target symbol and the text XXXXXX.

Below the display is a row of eight function buttons with icons for crane movements and settings.

LIEBHERR

7	8	9
4	5	6
1	2	3
0	.	P

<	>	

SHIFT F1 F2 F3 F4 F5 F6 F7 F8

ENTER

14.2.2.3 Change the minimum and maximum support forces

Prerequisites:

The crane must be supported during operation.
The installation switch may not be actuated.

Note: As additional safety measure, this program monitors the installation switch. In case of attempted operation in installation, the system shifts back to the "Operation" program.

In the monitoring and control field (4) , the current support force values are shown.

Note: If one or more values are below the set minimum or above the set maximum values, then the depicted values will blink.

In the set up / adjustment field (5) , the programmed maximum / minimum values are shown.

The program runs first in the monitoring mode. All relevant symbol elements for crane operation are shown.

- Press function keybar "F1" .

Two double arrows now point to the set up field for support limit forces (5), the cursor appears on the maximum value of support 1.

Note: However, LML STOP is triggered immediately. All hoisting and luffing movements are stopped and the symbol elements for crane operation disappear.

- With function keys "F1" or "F2", continue the cursor to the next or previous maximum support limit force value or the minimum support limit force value (valid for all four support cylinders).

- Change the value via the alpha numeric keys.

- Close the input function with the "ENTER" key.


Note: Each new entered value is checked for its validity and then is taken over directly or returned as an error (too large / too small) ⇒ for example ERROR : X >> 600


- Return to the monitoring and control field (4) with "F8".

- Return to the "Operation" program with "P1".

* Optional

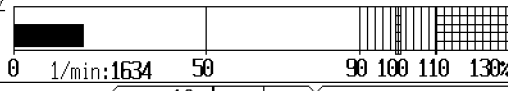
5.2
6.2






max n = 10
t 156.0

BXXX YYZZ
XXXX



t 28.3


1°
0.0
0.0




m/s
0.0
0.0
max: 12.8

23.8
80.0°

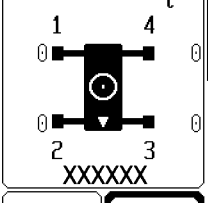
191⁹⁹
m



191⁹⁹
m




t





XXXXXX


V: 40%





28.0
35.0
60.0°
62.6























LIEBHERR

7	8	9
4	5	6
1	2	3
0	.	P
		
		
		
<	>	


SHIFT	F1	F2	F3	F4	F5	F6	F7	F8	ENTER
-------	----	----	----	----	----	----	----	----	-------




%
90




bar
4.3




°C
41



13
14













V
24.3




O.K.

LIEBHERR

7	8	9
4	5	6
1	2	3
0	.	P
		
		
		
<	>	

SHIFT	F1	F2	F3	F4	F5	F6	F7	F8	ENTER
-------	----	----	----	----	----	----	----	----	-------



16. Engine monitor

16.1 Start the program

On request :

- with key combination "SHIFT" + "P0"

automatic:

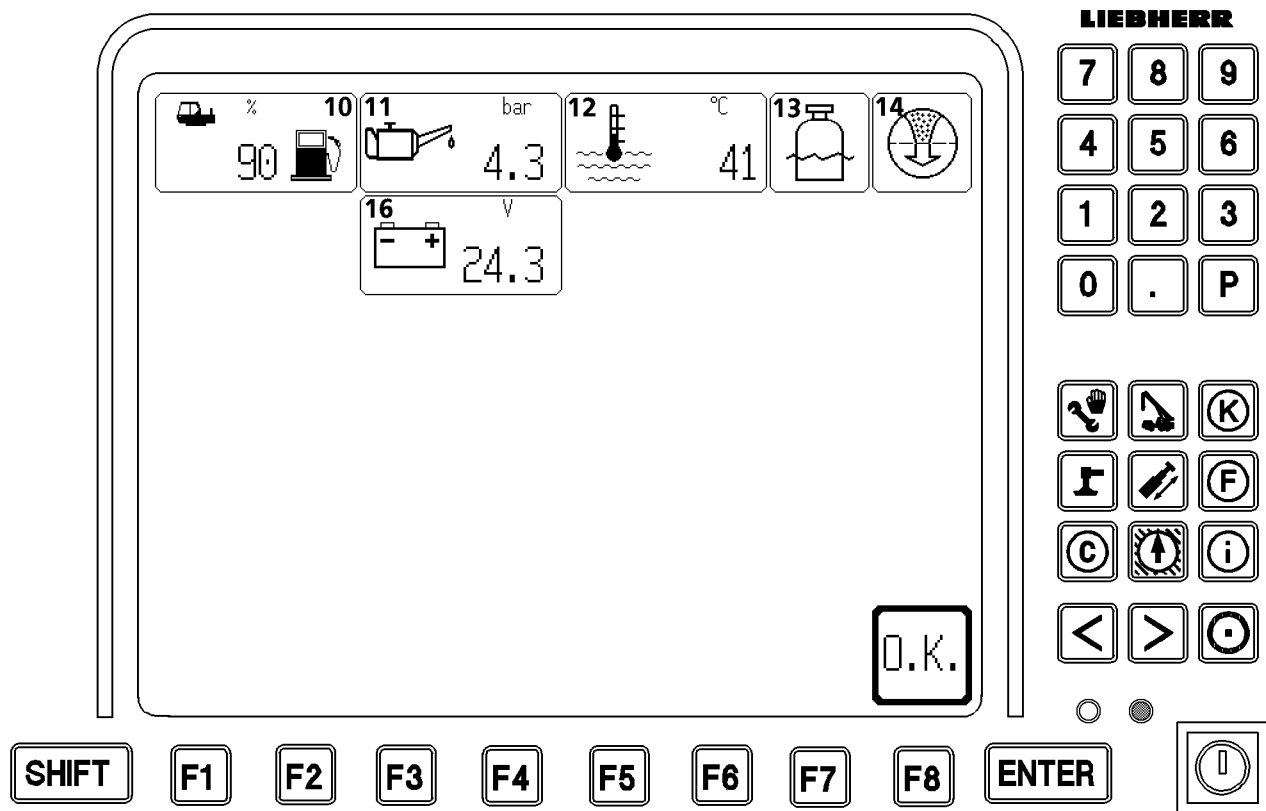
- **Once**, if a STOP occurrence happens
- In case of a prewarning, warning or STOP occurrence while the LICCON computer system boots up

16.2 Possible prewarning, warning, STOP occurrences of engine monitor

Occurrences	Prewarning at engine start	Warning (5.2)	STOP (6.2)
Engine oil pressure (Indicator value) is missing		x	
Engine oil pressure (Indicator value) erroneous		x	
Engine oil pressure Warning active			x
Coolant temperature (Indicator value) missing		x	
Coolant temperature (Indicator value) erroneous		x	
Coolant temperature Warnung active			x
Coolant level Warning active			x
Air filter check		x	
Battery voltage (Indicator value) is missing	x		
Battery voltage (Indicator value) erroneous	x		
Battery voltage $\leq 16\text{ V}$ or $\geq 36\text{ V}$	x		
Fuel reserves (Indicator value) is missing	x		
Fuel reserves (Indicator value) erroneous	x		
Fuel reserves (Indicator value) $\leq 10\%$	x		
Fuel reserves (Indicator value) $\leq 6\%$		x	
Fuel reserves (Indicator value) 1%			x

Note: The automatic change over into the "engine monitoring" program is only made from "Operation" or "Support " programs. The change over is made for approx. 5 seconds, the crane functions are not stopped.
 If a monitoring occurrence is confirmed in the "Engine monitoring" program with "F8", then, if the same occurrence happens again, the system **will not** shift again automatically into the "Engine monitoring" program.
 When shifting back into the "Operation" program, the STOP symbol element (6.2) or the warning symbol element (5.2) appears.
 Prewarnings are not noted in the "Operation" program.

CAUTION: If you work for a longer period of time in other programs, for example "Set up", "Test system", then it must be ensured, by occasionally changing back into the "Engine monitoring" program, that no engine monitoring occurrences have happened, which could damage the engine.
The engine or crane functions are not shut off! For that reason, do not ignore a STOP occurrence, as this could severely damage the engine!



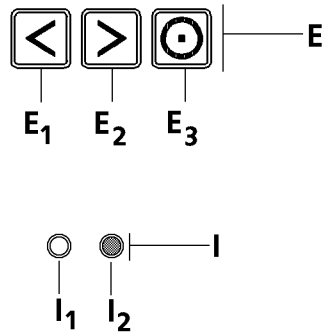
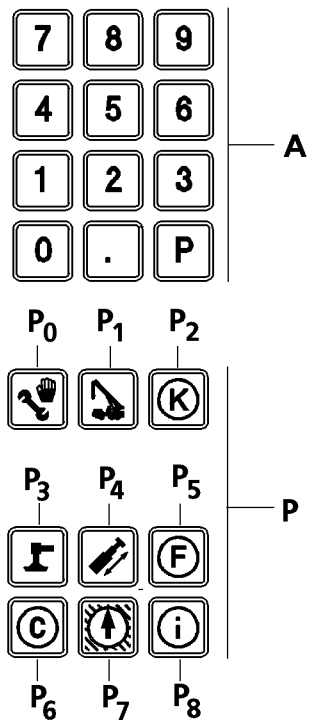
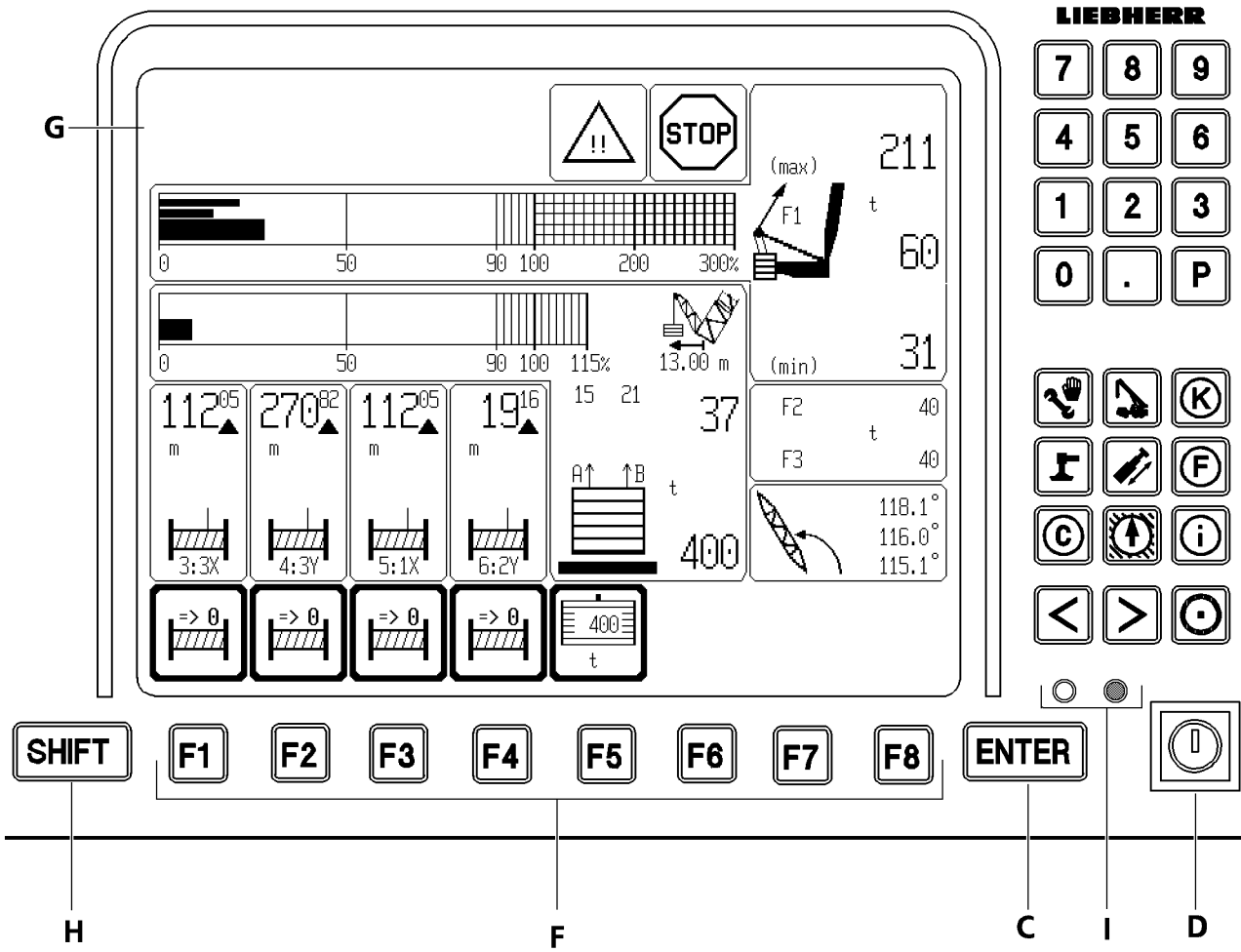
16.3 Symbol elements for engine monitoring

- 10) Tank contents in [%]
Symbol element blinks if the fuel reserves is < 5% .
- 11) Oil pressure in [bar]
Number indicator in the symbol element blinks if the engine oil pressure is too low.
- 12) Coolant temperature in [°C]
Number indicator in the symbol element blinks if the coolant temperature is too high.
- 13) Coolant level too low
Symbol element appears if the coolant level is too low.
- 14) Air filter contaminated
Symbol element appears if the air filter is contaminated
- 16) Added function battery voltage in [V]
Number indicator in symbol element blinks if the operating voltage is < 16 Volt or > 36 Volt .

16.4 Function keys

"F1" bis "F7" not used

"F8" Back to the Operating view.



20. The control elements of the LICCON computer systems on monitor 1**A Alpha numeric keyboard**

To edit the derrickballast input values

P Program keys

No function

C Input key "ENTER"

To confirm changes.

D Keyed switch

No function.

Note: The keyed switch / button may not be positioned in shift position "left" .

E Brightness adjustment

see brightness adjustment on monitor 0

F Function keys

The function keys must always be viewed together with the function key symbol line shown on the monitor above.

G Monitor

Monitor 1 normally shows the operating view of Monitors 1.

Note: For diagnostics purposes, monitor 1 can be assigned for ballast trailer control.

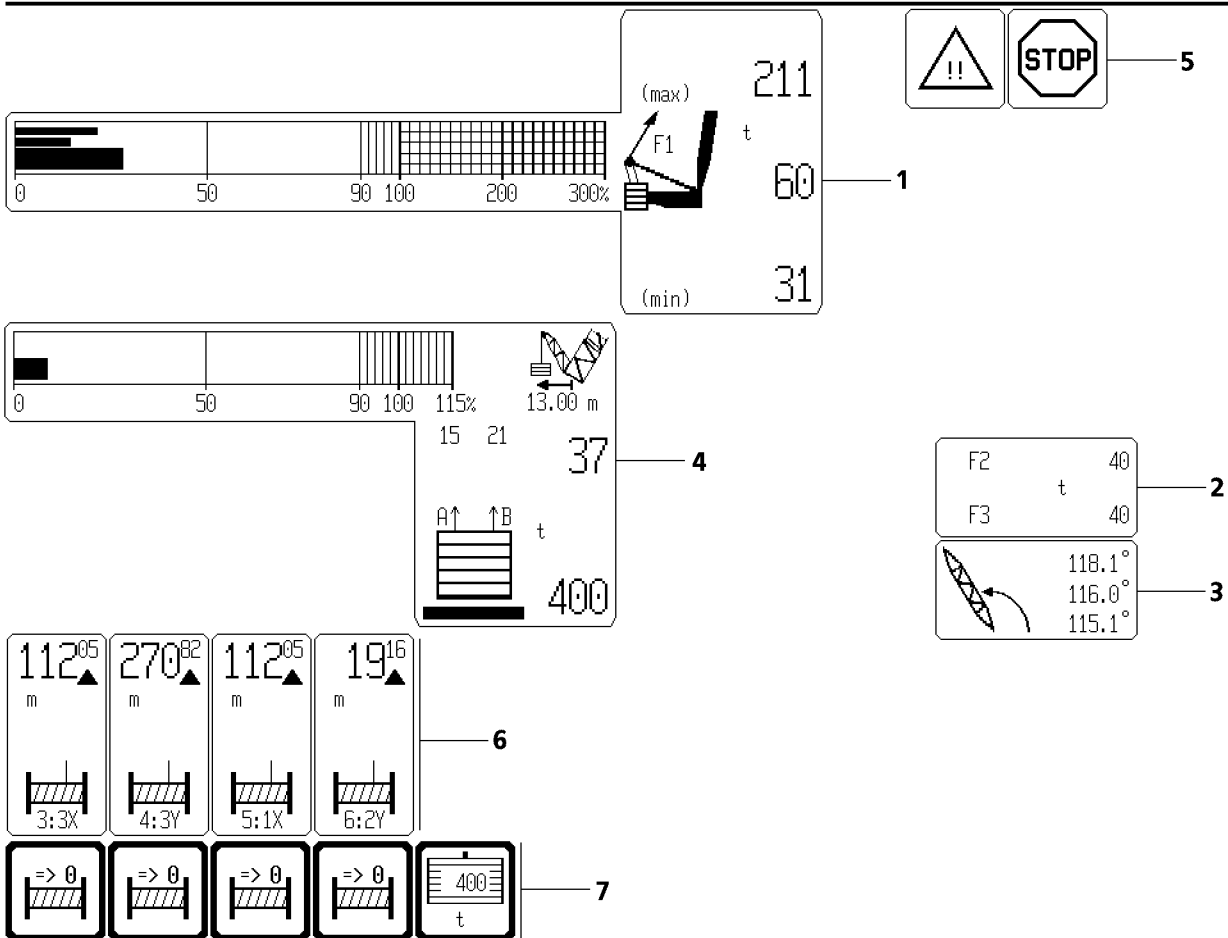
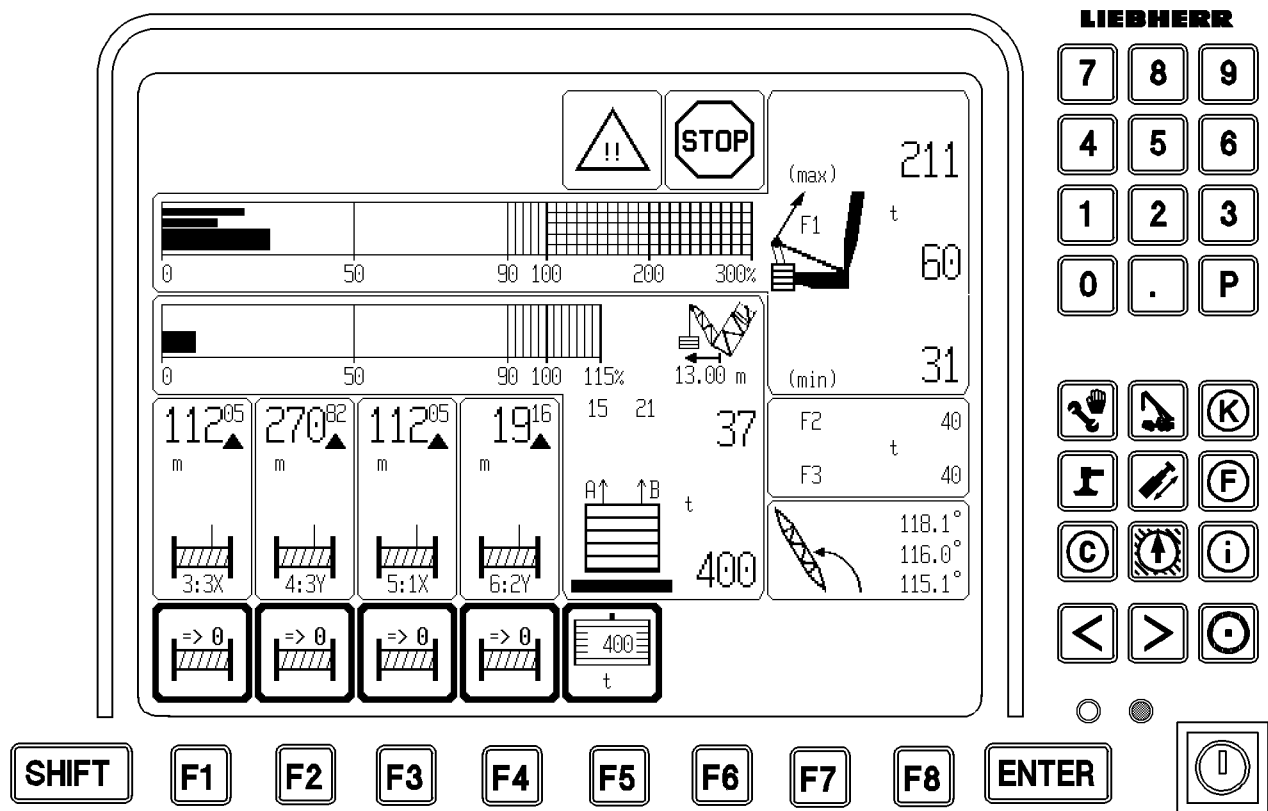
H SHIFT key

No function

I LED indication

I1: (LED red) Monitor error

I2: (LED yellow) Supply voltage for monitor available.



198892

21. The "Operation am Monitor 1" program

On cranes with derrick ballast *, the required maximum and minimum load for crane balance can be increased or reduced even during operation and under load by increasing or recuing the derrick ballast.

Note: **Ballast** is the derrick ballast, which means the suspended ballast or the ballast trailer.
Counterweight is the fixed compensation weight installed on the slewing platform.

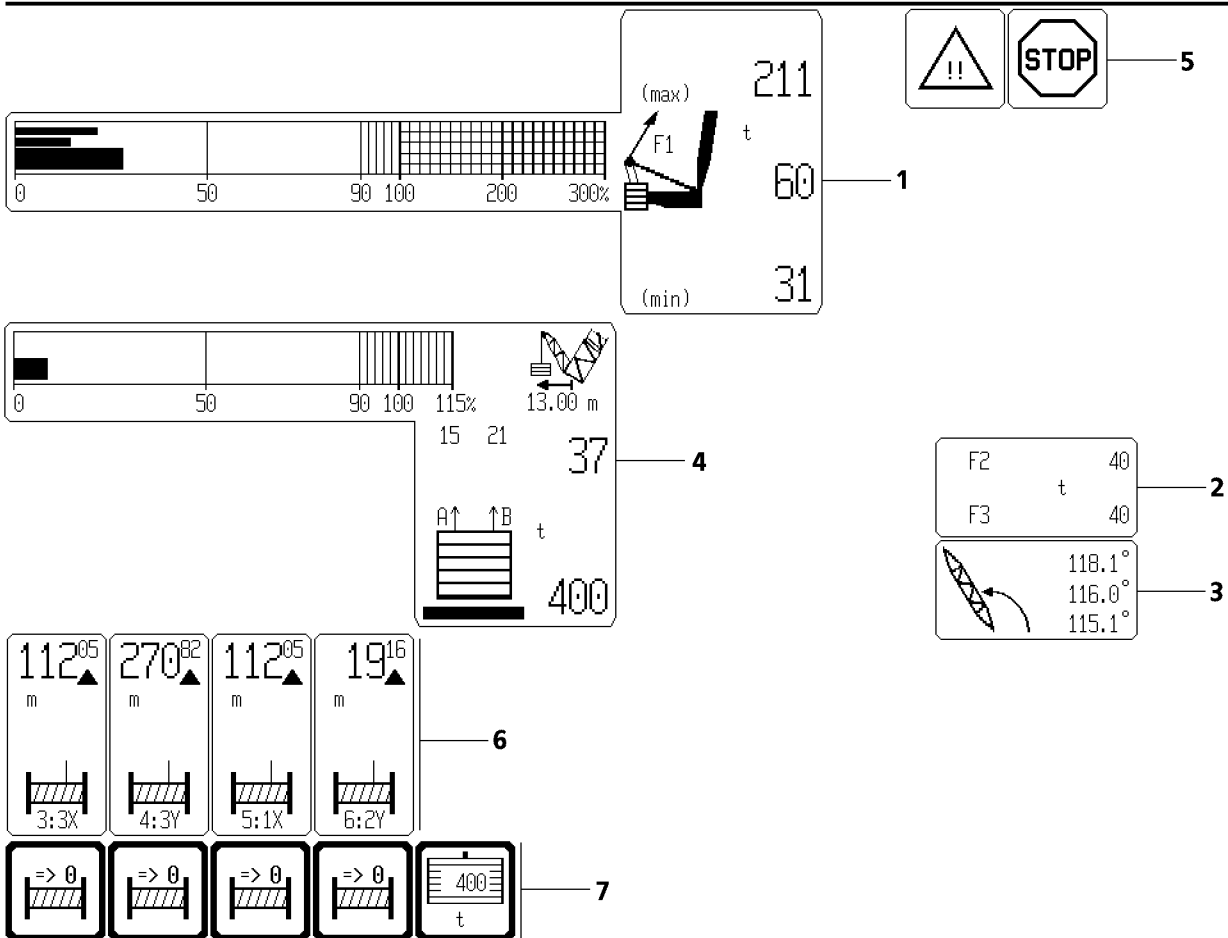
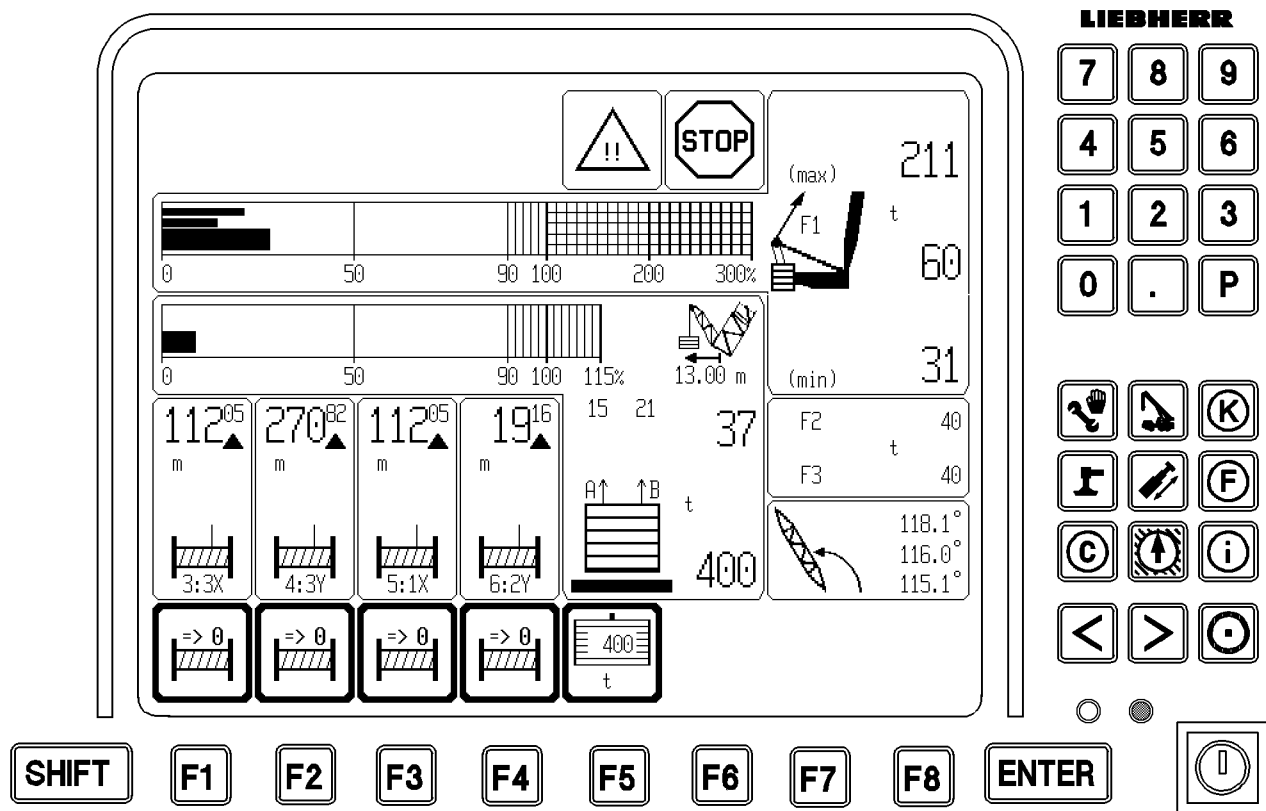
If only a partial load is lifted, then, most of the time, only a partial derrick ballast is used. In this case, the maximum load shut off is made by the derrick overload safety device on CPU1, with the aid of value $F1_{\text{max-Operation}}$. The corresponding values are shown on monitor 1, see illustration on the left.

The monitor 1 in the "Operation am Monitor 1" program is split into 7 areas :

- 1 Test point 1 = F1 Pull test brackets Test point 1A and 1B in A - Bracket guying
- 2 Test point 2 = F2 Pull test brackets Test point 2A and 2B in N/W guying
- Test point 3 = F3 Pull test brackets Test point 3A and 3B in S- guying in derrick operation
- 3 Derrick boom angle
- 4 Derrick ballast, weight and utilization
- 5 Alarm functions
- 6 Winch indication winch 3*, 4, 5* and 6*
- 7 Function keybar symbol line

Note: The monitor illustrations in this chapter are only examples. The number values in the individual symbol elements might not match your particular crane.

In addition, some illustrations show the maximum possible assignment of the LICCON monitor with symbol elements. In normal crane operation, an identical view would not appear on the LICCON monitor .



198892

21.1 Test point 1 = F1

Installation maximum force values

The monitoring function of test point 1 carried out by the LICCON computer system provides an additional safety function. Due to the complexity of the installation procedure, the installation limits are not always valued or exact.

D A N G E R : **This means that the crane cannot be utilized to this installation limit without danger. The crane may always only be erected without a load, as noted in the Operation Manual.**

F1- installation maximum force values in operating modes without derrick

In operating modes without derrick, there are 2 different F1- installation maximum force values.

1. F1- installation maximum force value outside the operating range
For erection and installation of the crane.
2. F1- installation maximum force value inside the operating range
Within the boom angle range with load chart and a few angle degrees next to it.
Maximum not bypassable F1-max limit in operating range.

Note: For statistical reasons, the F1- installation maximum force value can be higher in operating range with load chart (and a few angle degrees next to it) than outside the operating range, for example when lifting off the main boom jib or fly jib from the ground.

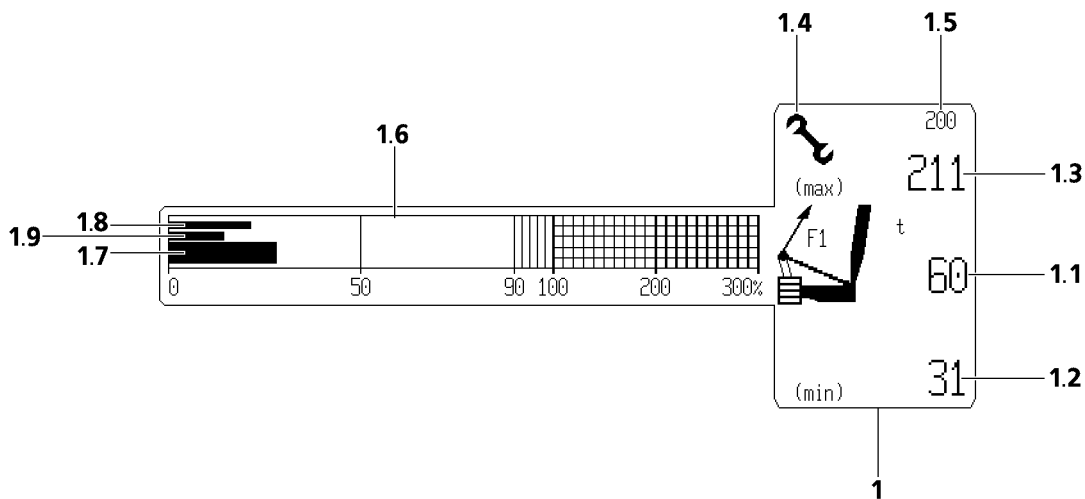
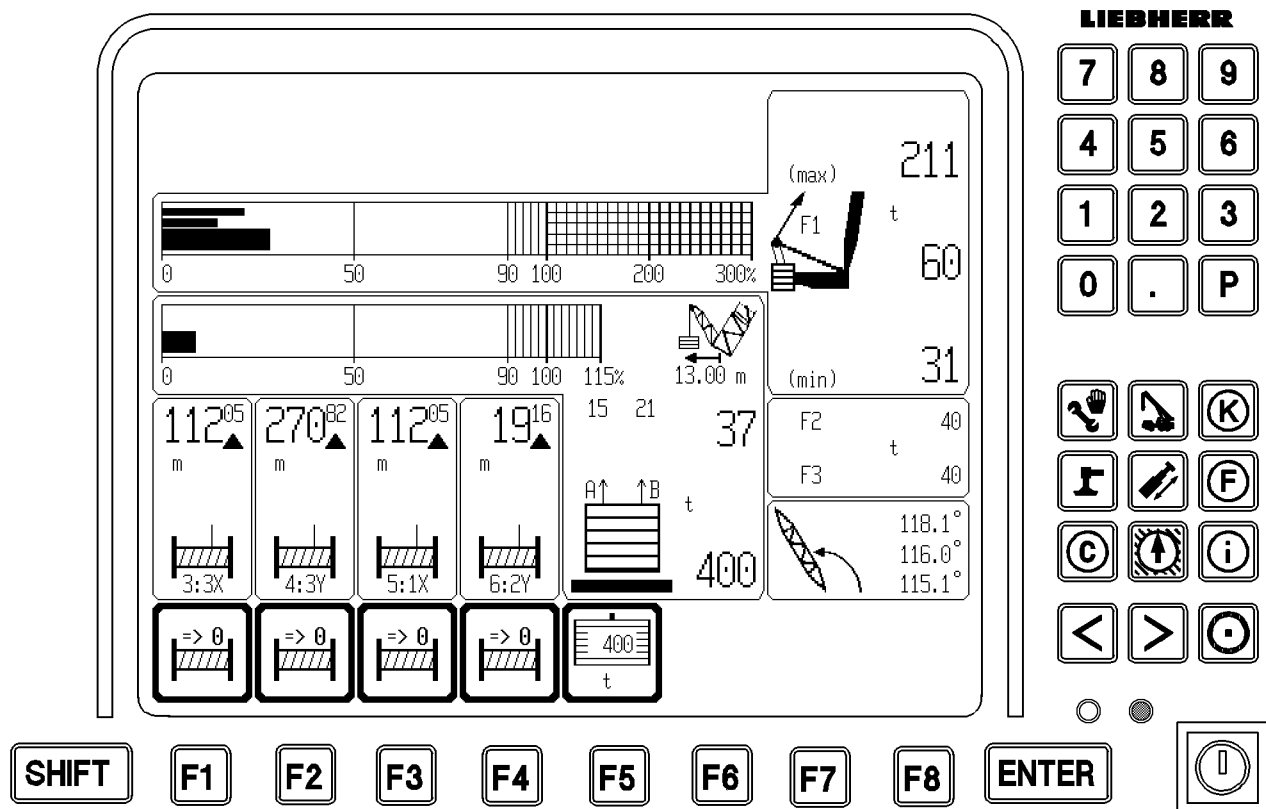
C A U T I O N : **The selection of the F1- installation maximum force values for inside or outside the operating range is made on the basis of values of angle sensor main boom and angle sensor fly jib.**
In operating range, the current F1- force may be above the F1- installation maximum force outside the operating range.

If both angle sensor on the main boom for the LML are erroneous or are missing or both angle sensors on the fly jib are erroneous or are missing, then the LML cannot determine if the boom is within the operating range or not.
So that in this case the F1- installation maximum force shut off is not shut off and cannot be bypassed, the F1- installation maximum force value of the operating range is used for the shut off.

D A N G E R : **If both angle sensors on the main boom for the LML are erroneous or are missing or both angle sensors on the fly jib are erroneous or are missing, then the LML will use the higher F1- installation maximum force value inside the operating range for the non-bypassable F1- installation force shut off.**

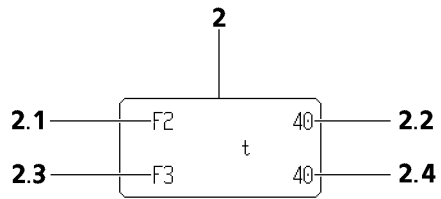
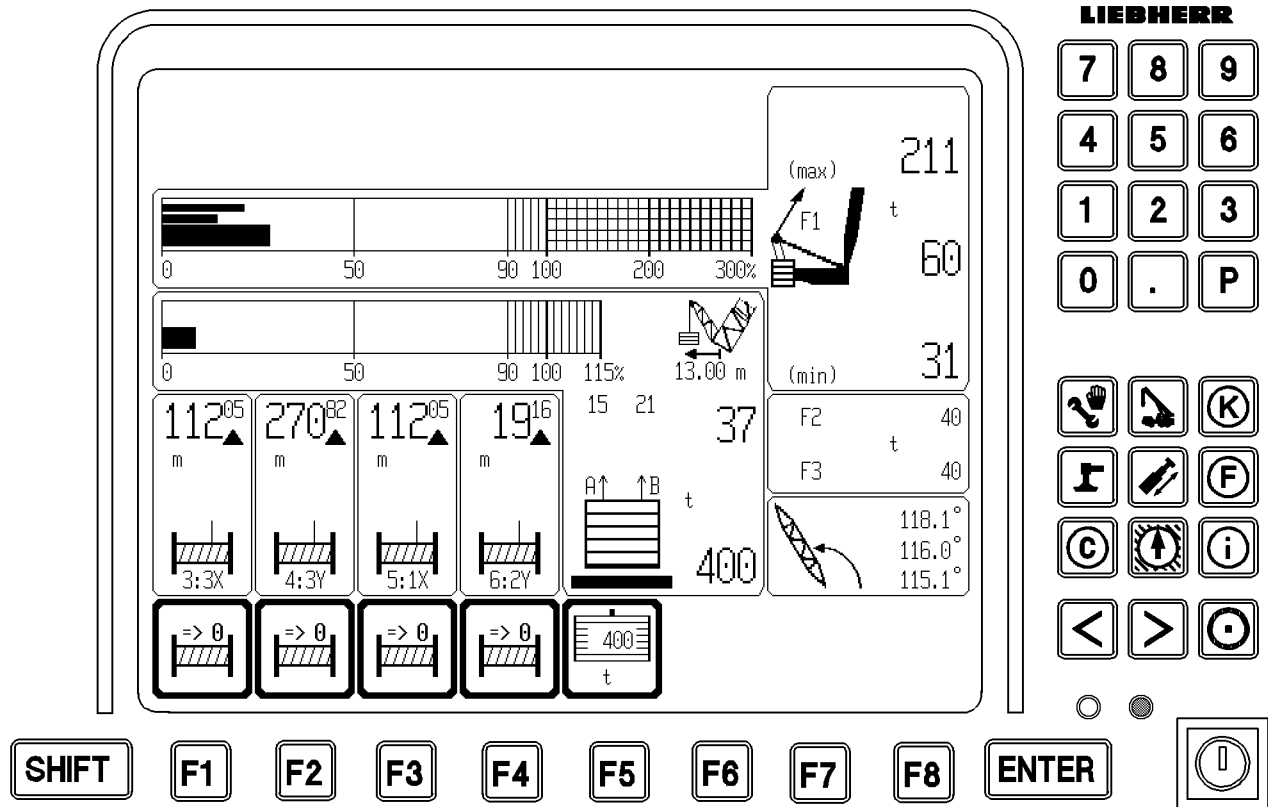
This ensures that the crane can be set up and taken down even in case of erroneous or missing sensors. However, the F1- installation maximum force value outside the operating range (F1max limit) for the erection is no longer shown and monitored. If the crane is not taken down exactly as noted in the Operating Manual, then it can be overloaded. In this case, there is an increased chance of having a serious accident!

* Optional



21.1 Test point 1 = F1 (continuation)
 Pull test brackets Test point 1A and 1B in the A- bracket guying

Pos.	Symbols / Indicator values	Type of indication	is shown
1	Symbol element "Test point 1" = F1 in units [t] or [kips]	static	always
1.1	Actual force = $F1 = F1_{ist}$ $F1 = F1A + F1B$ F1A = force Test point 1A (A-bracket left) F1B = force Test point 1B (A-bracket right)	static	for valid value
		??? blinking	for invalid value
1.2	Minimum force = $F1_{min}$	static	always Note: A shut off by $F1_{min}$ is only made in operating modes with suspended ballast / ballast trailer , in all other operating modes $F1_{min} = 0$, for these operating modes, the condition $F1 = F1_{min}$ cannot be reached during operation.
1.3	Maximum operating force = $F1_{max-Operation}$	static	in operating modes with suspended ballast / ballast trailer
1.4	Installation symbol	static	For "Installation"
1.5	Maximum installation force = $F1_{max-installation}$	static	For "Installation" and $F1 < F1_{max-installation}$
		blinking	For "Installation" and $F1 \geq F1_{max-installation}$
1.6	F1 - Utilization scale in [%]	static	always
1.7	F1 - Utilization bar indicator = $F1 / F1_{max-Operation}$ 0% for: $F1_{max-Operation} = 0$ or F1 = invalid.	dynamic	in operating modes with suspended ballast / ballast trailer
1.8	F1-Min-Warning bar = $F1_{min-warning-value} / F1_{max-operation}$ ($F1_{min-warning-value} = F1_{min} + 15 t$). 0 % for: $F1_{max-Operation} = 0$ or $F1_{max-Operation} = invalid$	dynamic	in operating modes with suspended ballast / ballast trailer
1.9	F1-Min-Stop bar = $F1_{min} / F1_{max-Operation}$ 0% for: $F1_{max-Operation} = 0$ or $F1_{max-Operation} = invalid$	dynamic	in operating modes with suspended ballast / ballast trailer

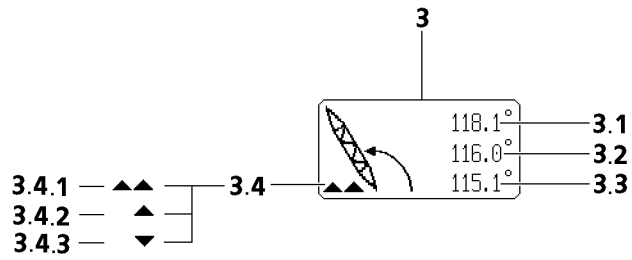
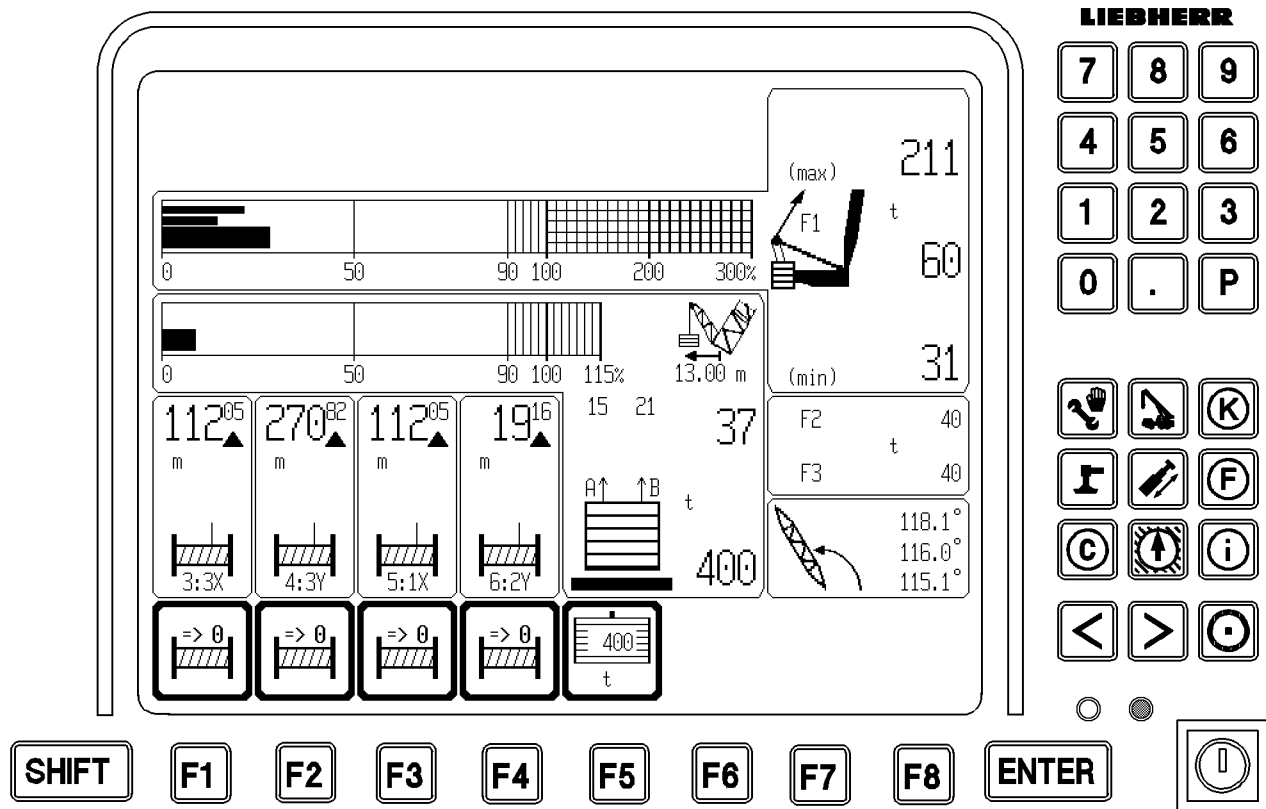


21.2 Test point 2 = F2 / Test point 3 = F3

Pull test brackets Test point 2A and 2B in N/W guying /Pull test brackets Test point 3A and 3B in S-guying for derrick operation

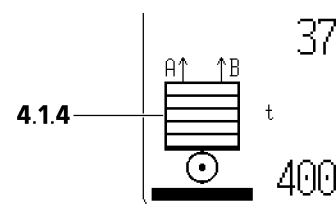
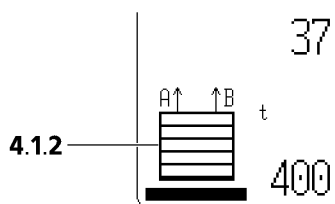
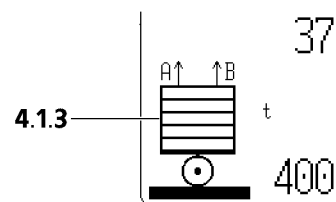
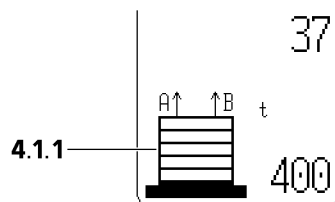
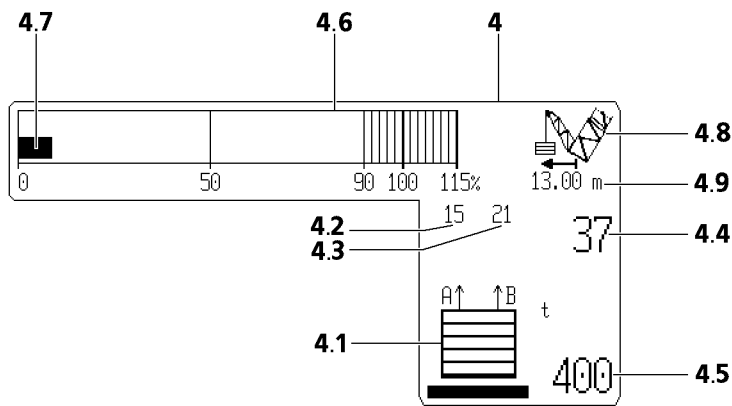
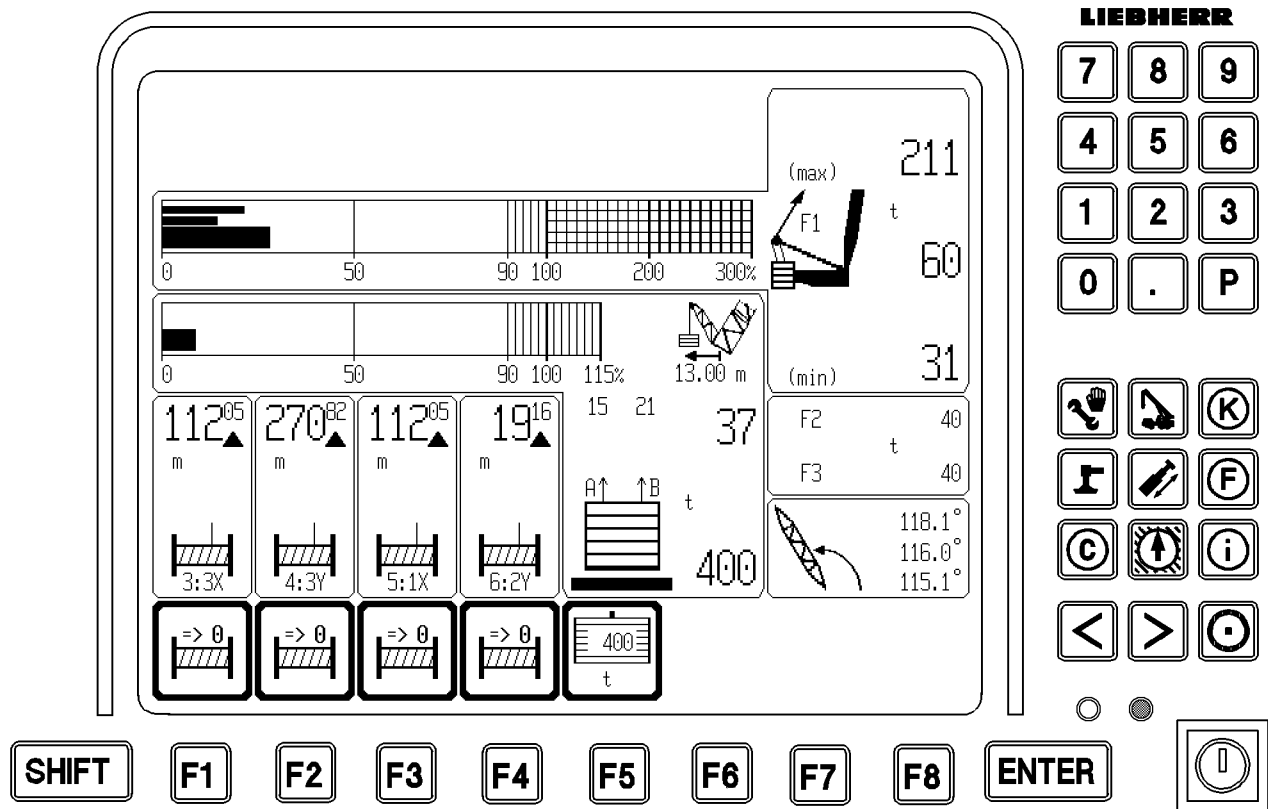
Pos.	Symbols / Indicator values	Type of indication	is shown
2	Symbol element for N/W guy force and main boom S-guy force for derrick operation in measuring unit [t] or [kips]	static	in operating modes with lattice jib or with derrick
2.1	Symbol F2 for N/W Guy force Test point 2	static	in operating modes with lattice jib
2.2	F2-actual value F2 = F2A + F2B Test point 2A/B is in jib guying on jib head Test point 2 A = left Test point 2 B = right	static	in operating modes with lattice jib and valid F2-value
		??? blinking	in operating modes with lattice jib and invalid F2-value
2.3 *	Symbol F3 for main boom S-guy force Test point 3	static	in operating modes with derrick
2.4 *	F3- actual value F3 = F3A + F3B Test point 3A/B is in the derrick main boom guying on the main boom head Test point 3 A = left Test point 3 B = right	static	in operating modes with derrick and valid F3-value
		??? blinking	in operating modes with derrick and invalid F3-value

* in operating modes with derrick and main boom



21.3 Derrick boom angle

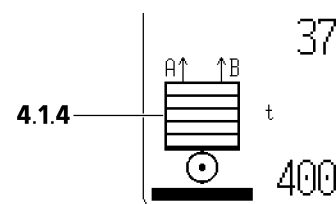
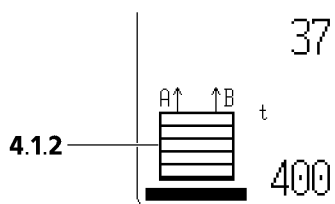
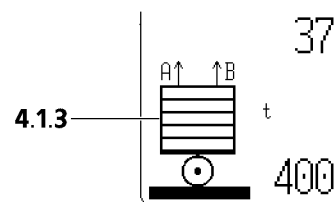
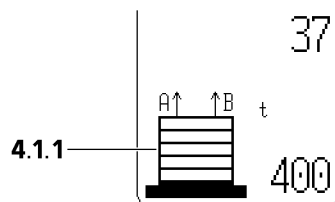
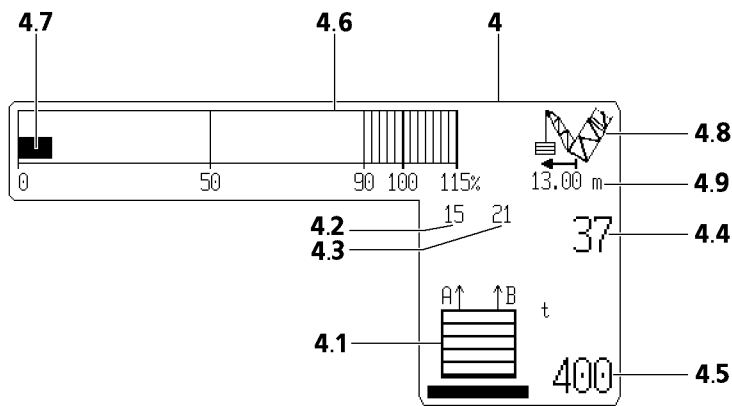
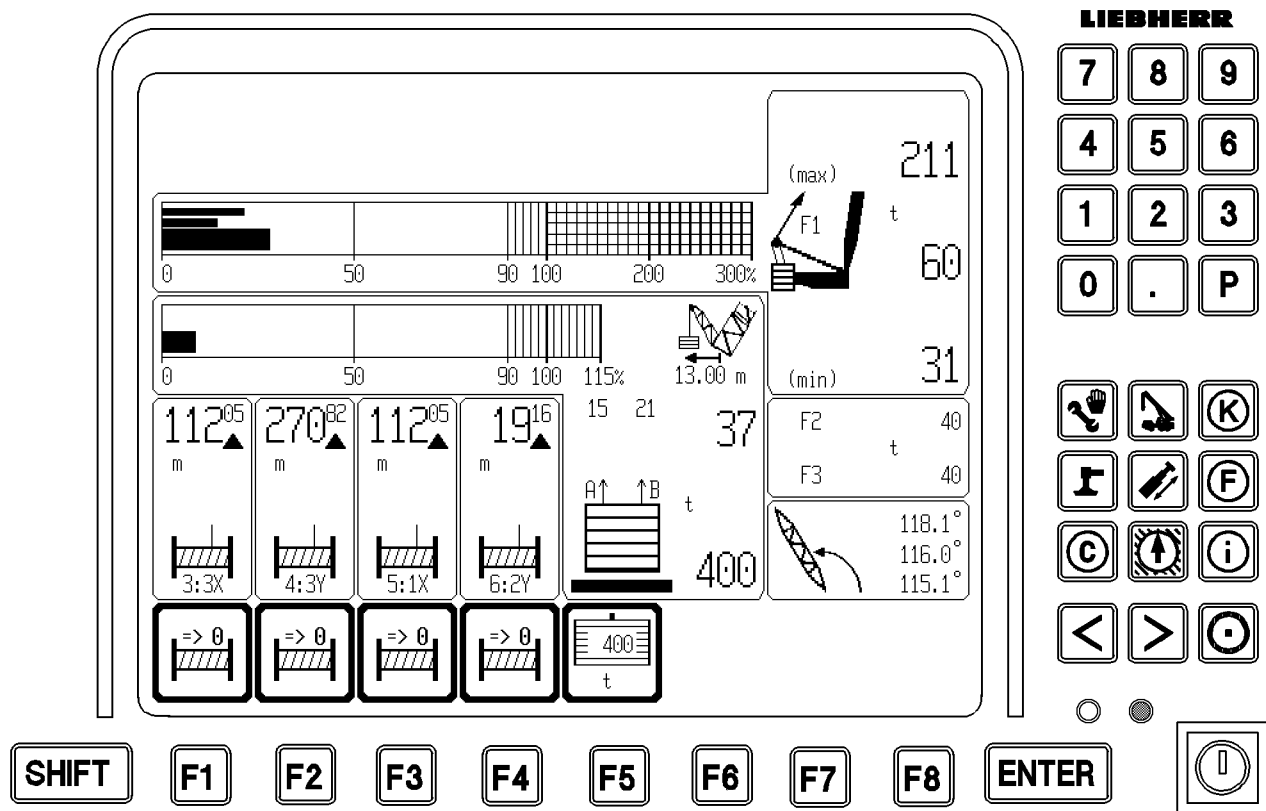
Pos	Symbole / Indicator values	Type of indication	is shown
3	Symbol element "Derrick boom angle"	static	in operating modes with derrick
3.1	Maximum derrickwinkel in operation (\angle_{Dmax}) in [°]	static	in operating modes with derrick and $\angle_{Dakt} \leq \angle_{Dmax}$
		blinking	in operating modes with derrick and $\angle_{Dakt} > \angle_{Dmax}$
3.2	Current derrick angle (\angle_{Dakt}) in [°]	static	in operating modes with derrick and valid value
		??? blinking	in operating modes with derrick and invalid value
3.3	Minnimum derrick angle in operation (\angle_{Dmin}) in [°]	stastic	in operating modes with derrick und $\angle_{Dakt} \geq \angle_{Dmin}$
		blinking	in operating modes with derrick und $\angle_{Dakt} < \angle_{Dmin}$
3.4	Limitation of relapse cylinder derrick boom condition symbols		
3.4.1	2 arrows upward	static	Relapse cylinder on block one limit switch actuated or erroneous
3.4.2	Arrow up	static	at $\angle_{Dakt} > \angle_{Dmax}$
3.4.3	Arrow down	static	at $\angle_{Dakt} < \angle_{Dmin}$



198896

21.4 Derrick ballast, weight and utilization

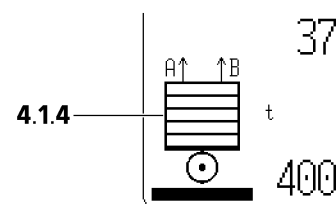
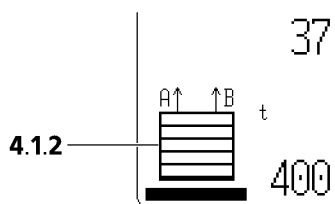
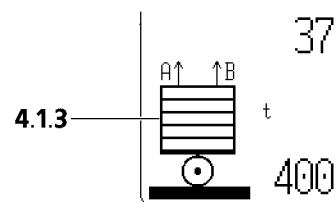
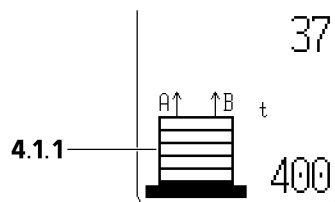
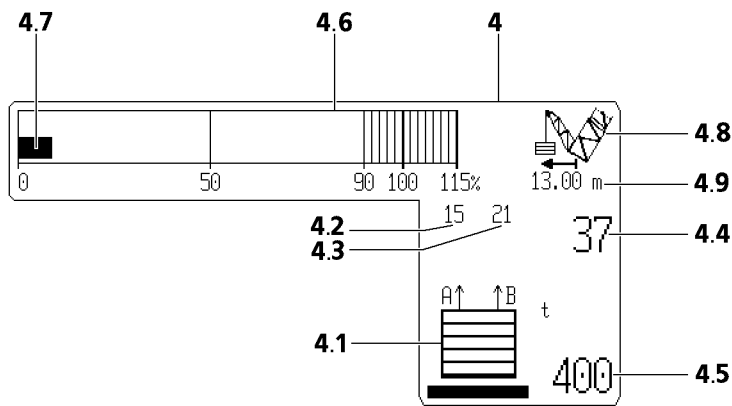
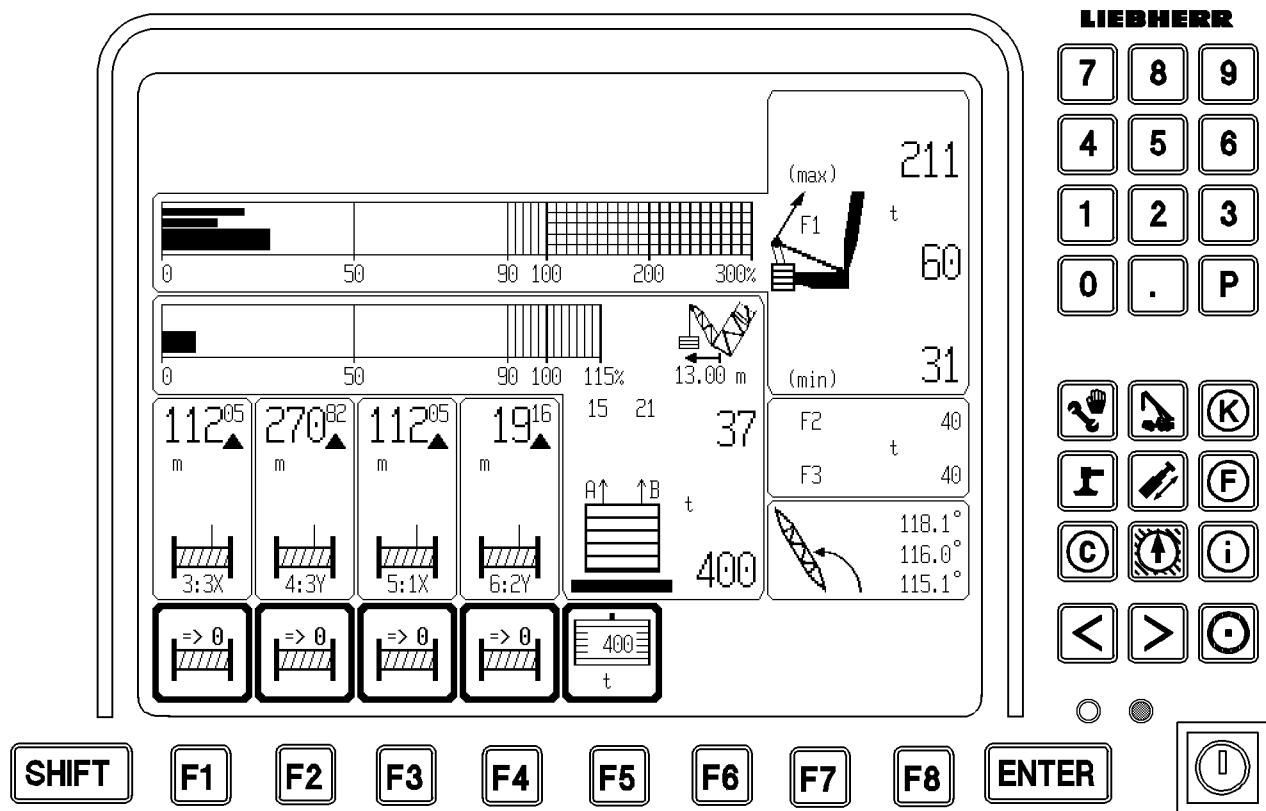
Pos.	Symbols / Indicator values	Type of indication	is shown
4	Symbol element "Derrick ballast, weight and utilization "	static	always
4.1	Symbol "Derrick ballast" in unit [t] or [kibs]. Note: This force unit is valid for all values shown in the frame.	static	in operating modes with suspended ballast / ballast trailer depending on type and condition of derrick ballast (see 4.1.1 - 4.1.4).
4.1.1	Symbol "Suspended ballast on ground"	static	in operating modes with suspended ballast and suspended ballast not suspended according to limit switch
4.1.2	Symbol "Suspended ballast suspended"	static	in operating modes with suspended ballast and suspended ballast suspended according to limit switch
4.1.3	Symbol "Ballast trailer on ground" Note: its shown at LR1750 only	static	in operating modes with ballast trailer and ballast trailer not suspended according to keyed switch
4.1.4	Symbol "Ballast trailer suspended" Note: its shown at LR1750 only	static	in operating modes with ballast trailer and ballast trailer suspended according to keyed switch
4.2	Force in derrick ballast guying A (left) = F4A5 = F4A - F5 Test point 4A = Pressure sensor ring surface left, Test point 5 = Pressure sensor piston surface right and left, if test point 5 is invalid , when F5=0 is used F4A = Force 4A on ring surface left F4B = Force 4B on ring surface right F5 = Force F5 on piston surface	static	in operating modes with suspended ballast / ballast trailer and F4A valid
		blinking	in operating modes with suspended ballast / ballast trailer and F4A and F4B valid and the difference between the guy force A and B is larger than permissible (45t)
		??? blinking	in operating modes with suspended ballast / ballast trailer and F4A invalid
4.3	Force in derrick ballast guying B (right) = F4B5 = F4B - F5 Test point 4B = Pressure sensor ring surface right, Test point 5 = Pressure sensor piston surface right and left, if test point 5 is invalid , then F5=0 is used	static	in operating modes with suspended ballast / ballast trailer and F4A valid
		blinking	in operating modes with suspended ballast / ballast trailer and F4A and F4B valid and difference between guy force A and B is larger than permissible (45t)
		??? blinking	in operating modes with suspended ballast / ballast trailer and F4B invalid



198896

Derrick ballast, weight and utilization (continuation)

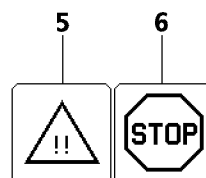
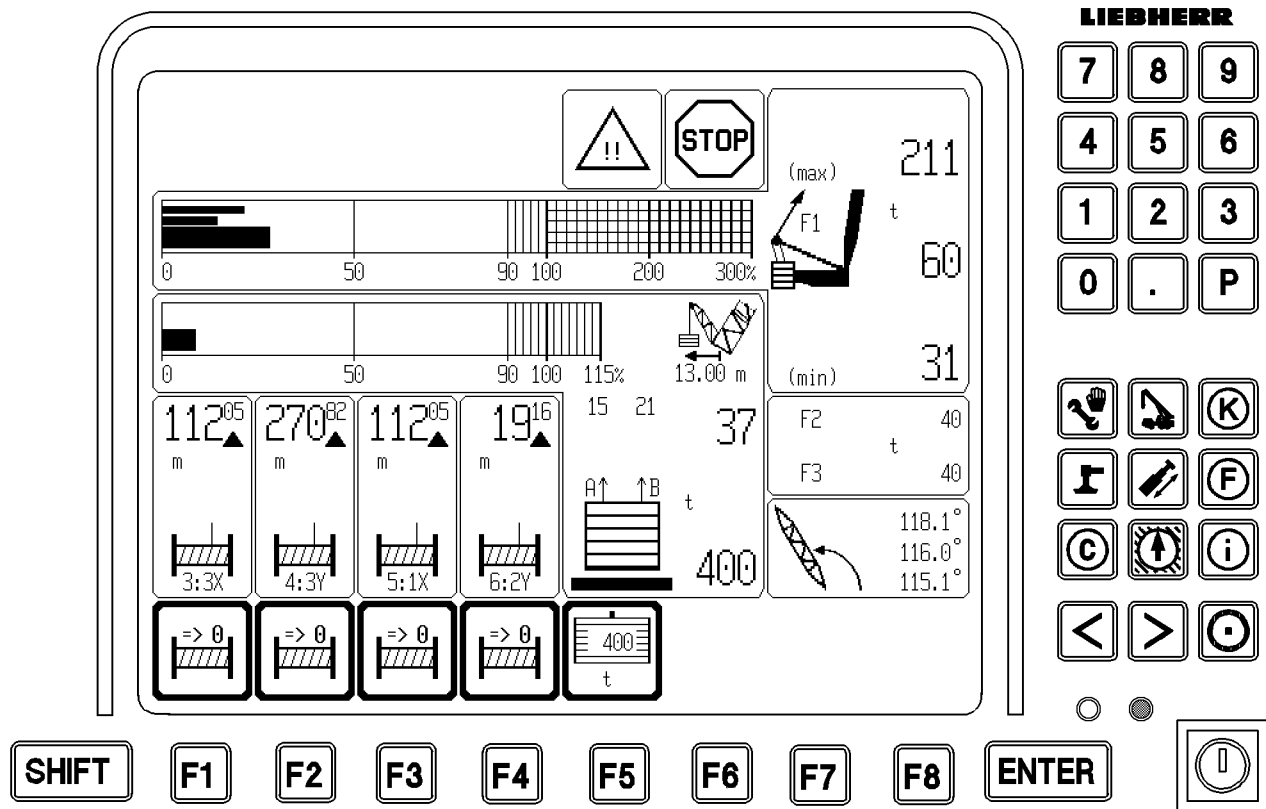
Pos.	Symbols / Indicator values	indication	is shown
4.4	Pulled derrick ballast = BA_{pulled} = vertical force components of force in derrick ballast guying (= $F_{4A5} + F_{4B5}$) calculated from test points 4A, 4B and 5. Note: The sum of forces F_{4A5} and F_{4B5} is larger or the same as the pulled derrick ballast = BA_{pulled}	static	in operating modes with suspended ballast / ballast trailer, if valid
		??? blinking	in operating modes with suspended ballast / ballast trailer, if value is invalid, or M4A or M4B defective or derrick ballast radius invalid Note: in case of M5 defect, the pressure is calculated as $M5 = 0$ → Indication remains static
4.5	Placed derrickballast = BA_{placed} Note: This value has been entered by hand and confirmed with the "ENTER" key. The value is stored when the system is turned off and is valid again after turning it on again, until it is changed with the "F5" function key.	static	in operating modes with suspended ballast / ballast trailer, if value for BA_{placed} is not permissible
		blinking	in operating modes with suspended ballast / ballast trailer, if value for BA_{placed} is questionable,
		??? blinking	in operating modes with suspended ballast / ballast trailer, if value for $BA_{placed} < 0$ or > 9999
4.6	Ballast utilization scale	static	in operating modes with suspended ballast / ballast trailer
4.7	Derrick ballast utilization bar indication = $BA_{pulled} / BA_{placed}$ in percentages (%), The bar is "0" when: $BA_{placed} < 5\text{ t}$ or $BA_{pulled} = \text{invalid}$ The bar can show maximum 115 % .	dynamic	in operating modes with suspended ballast / ballast trailer



198896

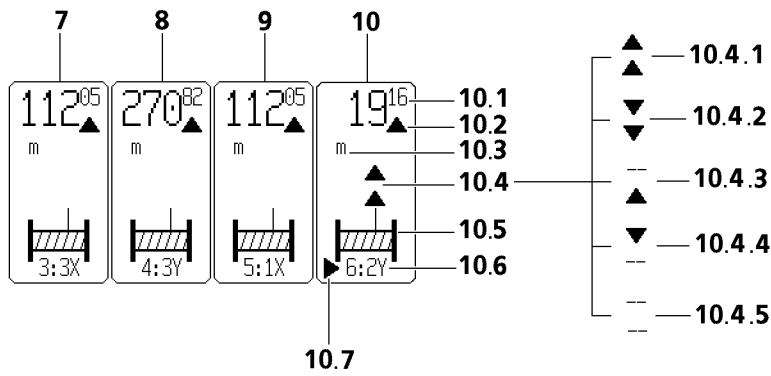
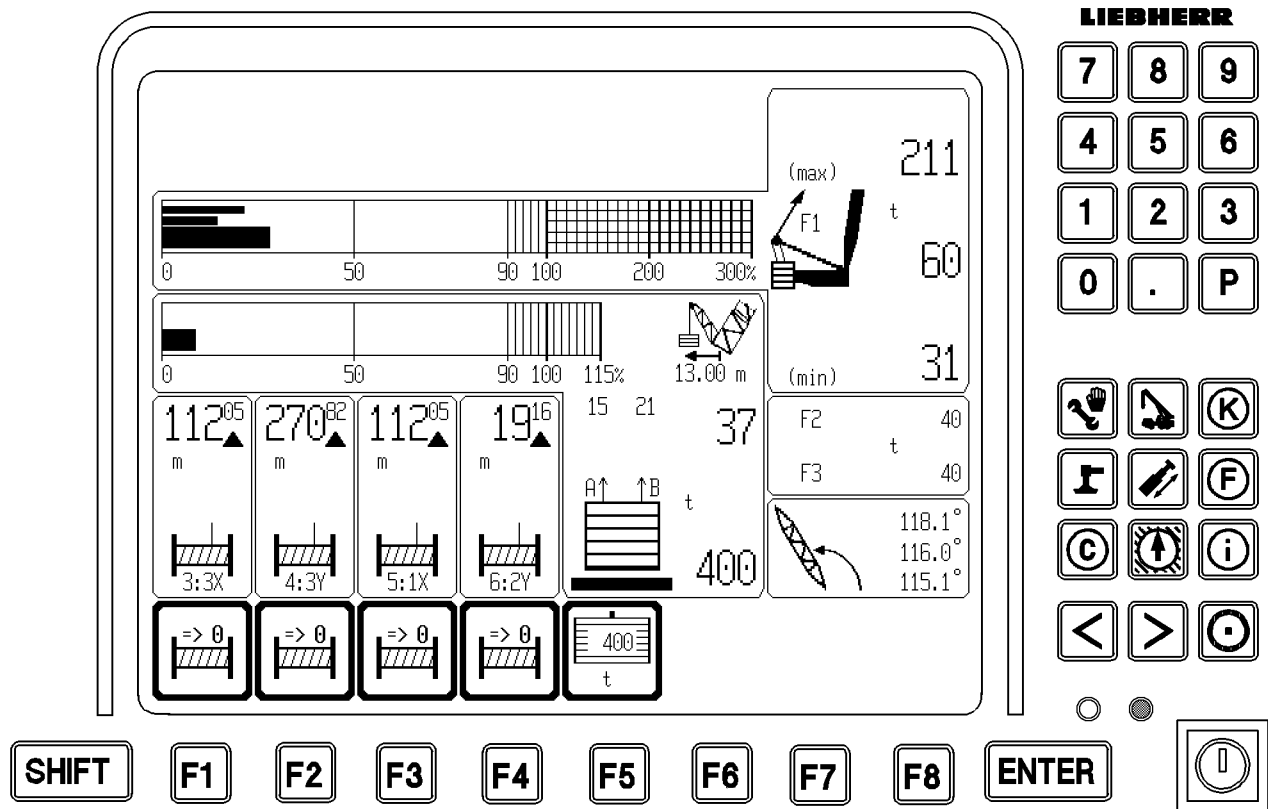
Derrick ballast, weight and utilization (continuation)

Pos.	Symbols / Indicator values	Type of indication	is shown
4.8	Symbol "Derrick ballast radius symbol"	static	in operating modes with suspended ballast / ballast trailer with variable derrick ballast radius
4.9	Indication "Derrick ballast radius" [m] or [ft]	static	in operating modes with suspended ballast / ballast trailer with variable derrick ballast radius and derrick ballast radius value valid
		blinking	in operating modes with suspended ballast / ballast trailer with variable derrick ballast radius and derrick ballast radius value invalid



21.5 Alarm functions

Pos.	Symbols / Indicator values	Type of indication	is shown
5	Symbol element "CAUTION"	blinking	<p>for $F1_{\text{min}}$-prewarning ($F1_{\text{ist}} < F1_{\text{min-warning value}}$)</p> <p>or</p> <p>for $F1_{\text{max-Operation-Prewarning (90%)}}$ ($F1 \geq F1_{\text{max-Operation warning value}}$)</p> <p>or</p> <p>for $F1_{\text{min-Stop-afterrun}}$</p> <p>or</p> <p>for $F1_{\text{max-Operation-Stop-afterrun}}$</p>
6	Symbol element "STOP"	blinking	<p>bei $F1_{\text{min-Stop}}$ ($F1_{\text{ist}} < F1_{\text{min}}$, with afterrun 3 sec.)</p> <p>or</p> <p>$F1_{\text{max-Operation-Stop}}$ ($F1 \geq F1_{\text{max-Operation}}$) with afterrun 3 sec.)</p> <p>or</p> <p>$F1_{\text{max-installation-Stop}}$ ($F1_{\text{ist}} \geq F1_{\text{max-installation}}$) with afterrun 3 sec.)</p>



21.6 Winch indication

The symbol elements for winches 3* 6* are shown only on monitor 1 if the crane is equipped with these winches.

The indication of winch 3* to 6* functions the same way as indication for winch 1 and 2 on monitor 0.

In addition, the following applies:

If winch 5* or winch 6* is used as hoist winch, then the **hook path** is shown in the winch symbol. The value calculated by the corresponding function key is shown even after turning the system on or off or after an operating mode change.

If one of the winches is used as a control winch, then the **current cable length on the winch drum** is shown, not the path of the hookblock. Tare can be calculated, but after turning the system on or off and after an operating mode change, the original value "Cable length on the cable drum" is shown again.

CAUTION: The indication only has 3 digits in front of the comma, digits further in front are cut off. For that reason, it must be estimated if 200 m or 1200 m cable are on the winch. The indication is in both cases "200⁰⁰".
The length indication is only exact if the winch has been adjusted and no data loss has occurred since then.

Pos.	Symbols / Indicator values	Type of indication	is shown
7	Winch indication Winch 3*	static	if winch 3 is installed
8	Winch indication Winch 4 *	static	if winch 4 is installed
9	Winch indication Winch 5*	static	if winch 5 is installed
10	Winch indication Winch 6*	static	if winch 6 is installed
10.1	Hook path = Cable length on winch / Hoist cable reeving according to entry by hand or = Cable length on winch drum (for intake gear, the cable length is even for the left and the right half of the cable drum)	static	if winch is calculated as hoist winch
		static	if winch is calculated as control winch
		??? blinking	in case of error in winch path measurement → adjust winch again

Winch 3 and 4 are always calculated as control winch.

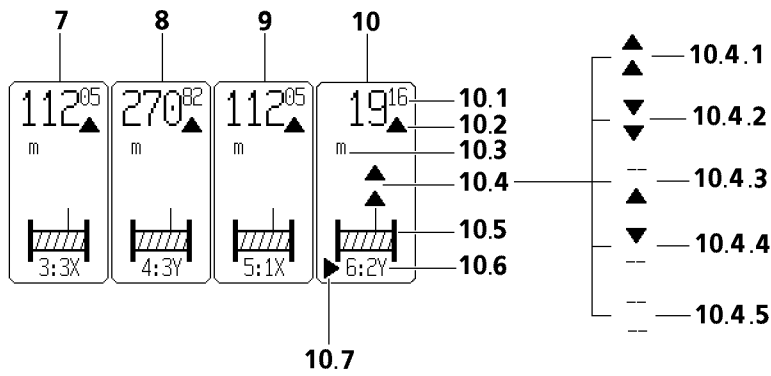
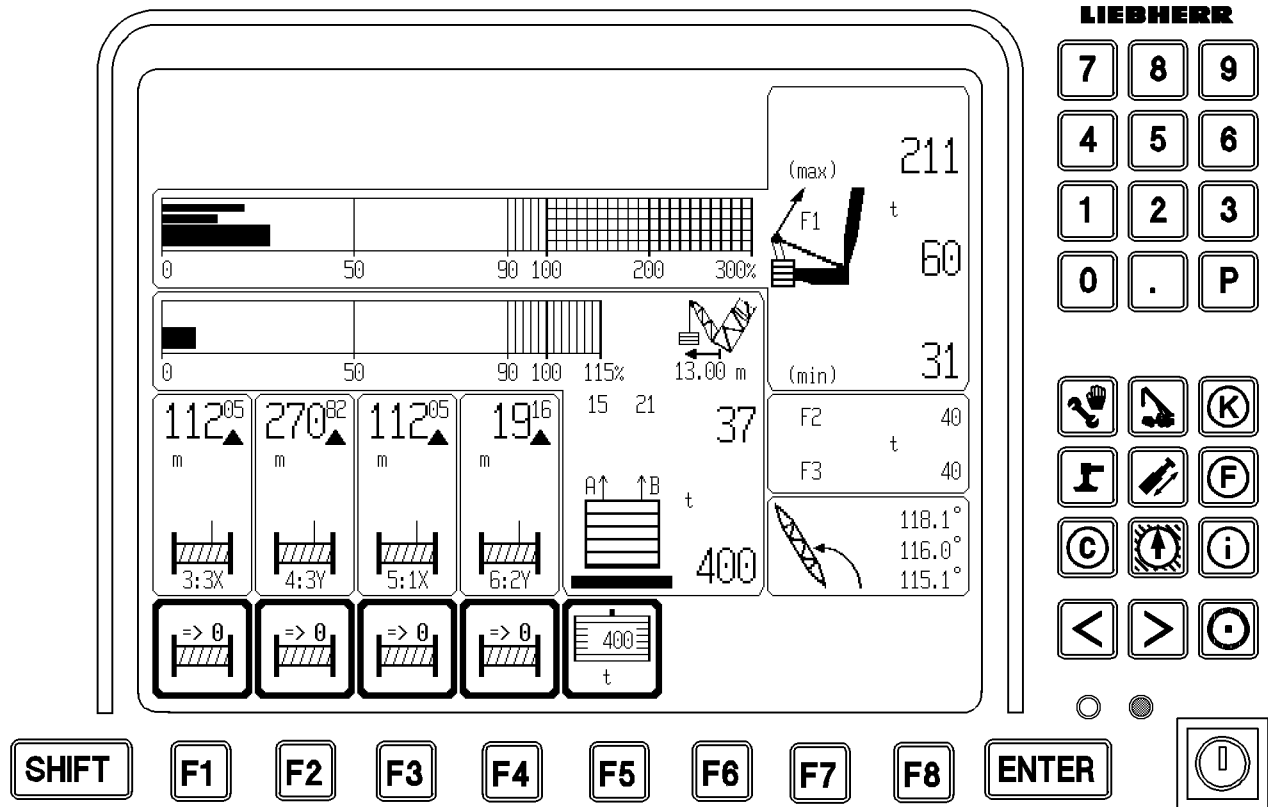
Winch 5 is calculated as control winch, in operating system with jib / luffing jib .

Winch 5 is calculated as hoist winch, in operating system without jib / luffing jib .

Winch 6 is always calculated as hoist winch .

Note: If winch 5 or winch 6 is calculated as hoist winch, and no boom nose is installed, then the hook path calculation is made with the reeving of the boom. If the boom nose is installed, the hook path calculation is made with the reeving of the boom nose.

* if installed



Symbol element "Winch indication"

10.2 The arrows on the length value show the direction of the hook movement in relation to the zero point :

- Arrow upward = Hook has moved upward from the zero point,
- Arrow downward = Hook has moved downward from the zero point.

10.3 Length unit for hook path indication : [m] or [ft]

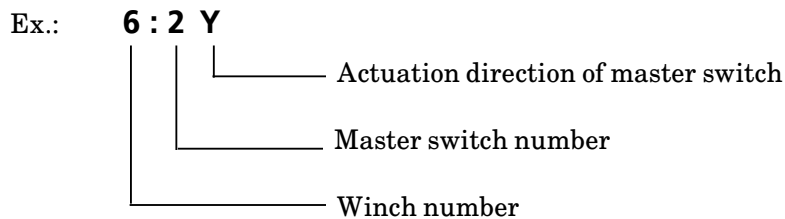
10.4 Winch status indication
The following winch status symbols are shown (all blinking) :

- 10.4.1 Spool out
- 10.4.2 Spool up
- 10.4.3 Spooled out → Spool out function is locked
- 10.4.4 Spooled up → Spool up function is locked
- 10.4.5 Winch is deactivated or unplugged → Spool up and out is locked
or
Winch is spooled up and out
at the same time, according to the sensor
(via "Control parameter program")

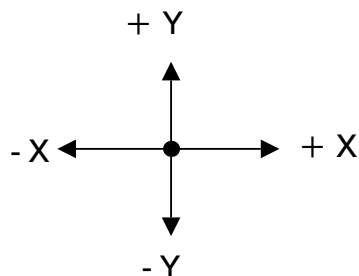
Note: If no winch status symbol appears, then the activated winch is standing still and is neither spooled up nor out.

10.5 Winch symbol (with cable end for winch status symbol)

10.6 Assignment of master switch and winch

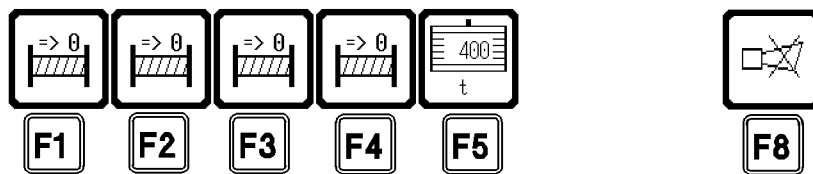
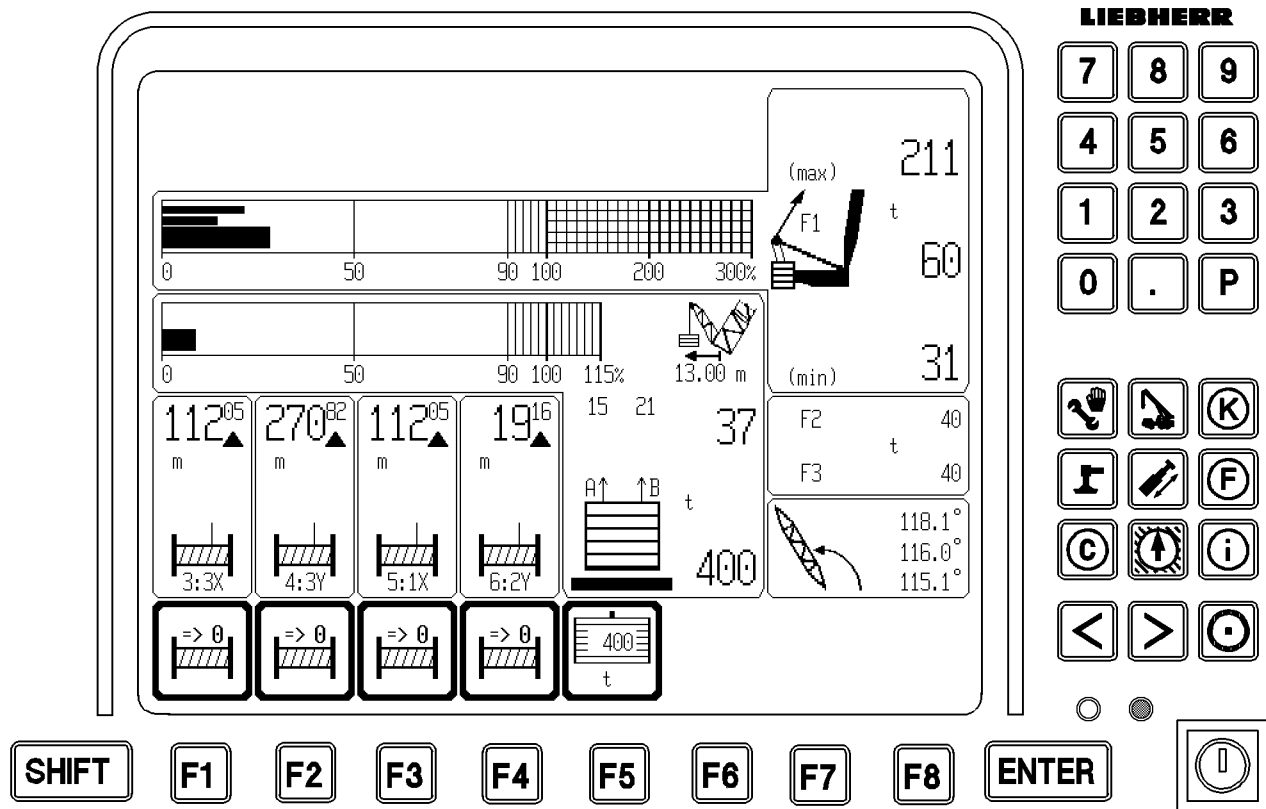


6 : - - Due to incorrect setting, an assignment of the master switch and winch is not possible!



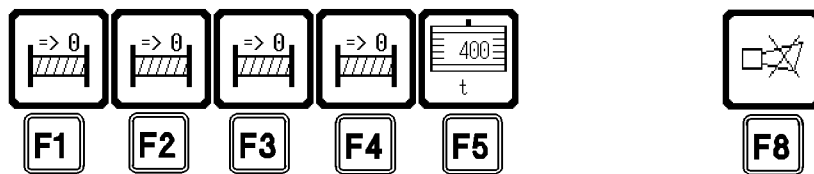
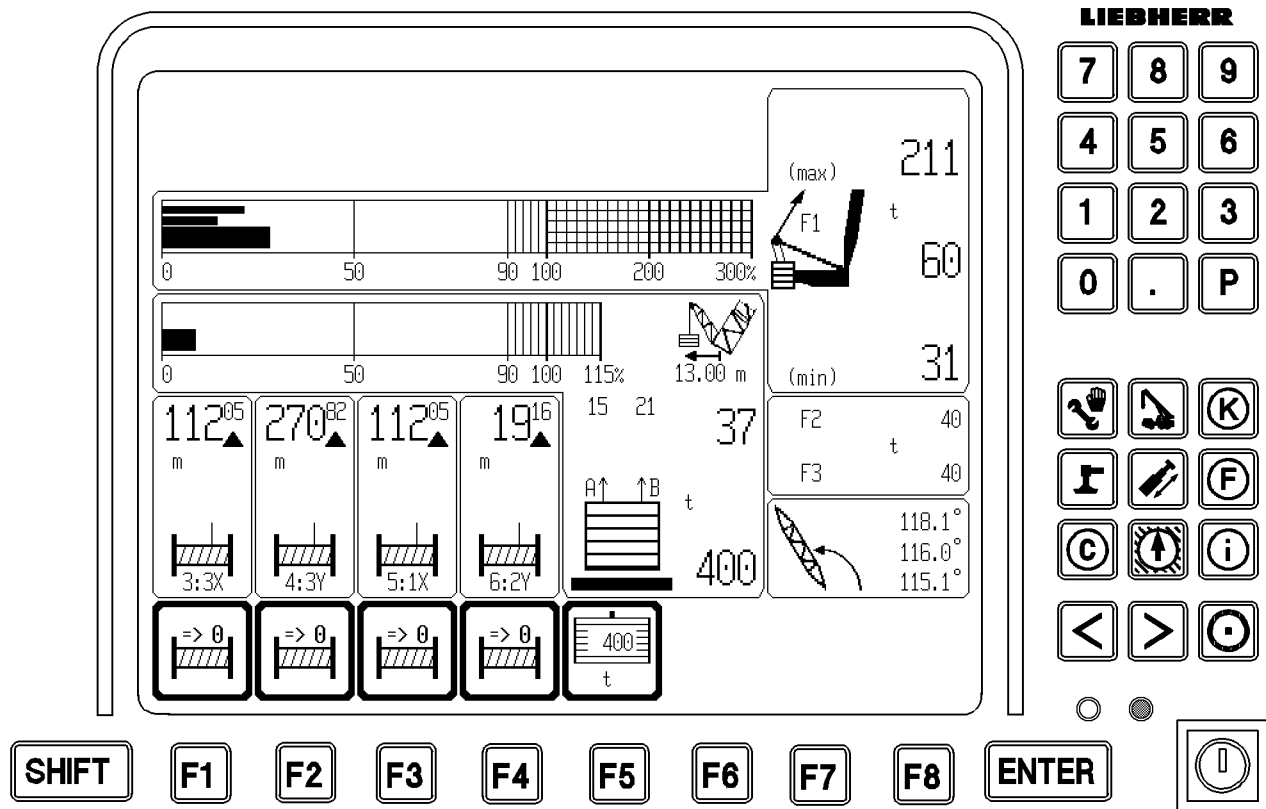
10.7 Vibration sensor
If the vibration sensor for a winch is added on the master switch, then the symbol " ▶ " (10.7) for the added vibration sensor appears in this winch symbol element.

Note: The vibration sensor is added for the first actuated crane function .



21.7 Function keybar symbol line

Pos.	Function, function keybar symbol line	Type of indication	is shown
F1	Tare the length indication of winch 3 * Note: Tare = Length indication is set to 0 ⁰⁰	static	if winch indication for winch 3 is shown
F2	Tare the length indication of winch 4	static	if winch indication for winch 4 is shown
F3	Tare the length indication of winch 5*	static	if winch indication for winch 5 is shown
F4	Tare the length indication of winch 6*	static	if winch indication for winch 6 is shown
F5	<p>* Ballast editing key</p> <p>When pressing the "F5" key, the thick symbol frame changes into a thin symbol frame. A blinking cursor appears in the ballast editing field. The value for the placed ballast can now be entered in the given weight unit [t] or [kips] via the numeric keybar A on monitor 1 .</p> <p>The ballast editing can be completed :</p> <ul style="list-style-type: none"> - by pressing the "ENTER" key = take over value. The entered value now appears as value for the placed ballast (BA_{placed}) in the ballast symbol or - by pressing the "F5" key = brake off editing. The change is dumped. The old value of BA_{placed} remains in the ballast symbol . <p>CAUTION: When editing the ballast, the notes in chapter . 4.03 , paragraph 8 must be observed.</p>	static	in operating modes with suspended ballast / ballast trailer
F5	Ballast input value (BA _{edit}) * = edited ballast value in function key symbol of "F5"	static	for valid ballast input value
		blinking (???)	for invalid ballast input value
F6-F7	not used		
F8	<p>Symbol element "Horn"</p> <ul style="list-style-type: none"> - Turn off the acoustical signal "Horn" on monitor 1 by pressing the "F8" key 	blinking	if acoustical signal "Horn" sounds on monitor 1 (see paragraph 21.8)



21.8 Acoustical warning on monitor 1**"HORN"**

For some of the operational errors found on CPU 1, which possibly lead to shut down of a movement, it is important to look at the Operating view on monitor 1. In addition to the optical view, these errors are also reported acoustically via the "HORN".

Note: "HORN" is a sound which lasts approx. 0.5 seconds, and is repeated in one second intervals.

Operational errors with "HORN" on monitor 1 without LEC error are :

- Exceeding of test point 1 - Installation - maximum threshold (only lattice jib)
- Exceeding of test point 1 - Operational maximum threshold
- Falling below test point 1 - Minimum threshold
- Exceeding of maximum derrick angle
- Falling below maximum derrick angle

Additional errors with "HORN" on monitor 1 and LEC errors are :

- Derrick ballast input error
- Derrick ballast guy force: Difference between right (A) and left (B) is too large

Note: The sensors (pull test bracket, pressure sensor, angle sensor) which are monitored by the CPU 1 are shown in case of an error via a LEC error on monitor 0. No acoustical signal "HORN" is issued on monitor 1.

"SHORT HORN" on monitor 1

Error without LEC (LICCON Error Code), which do not immediately lead to shut off of crane movement by the LICCON overload safety are also reported by the acoustical signal "SHORT HORN" in addition to the optical indication.

Note: "SHORT HORN" is a sound which lasts approx. 0.1 seconds, and is repeated in two second intervals.

Monitored errors are :

- Prewarning threshold of test point 1 - Operational maximum force is reached ("CAUTION" at 90%)
- Prewarning threshold of test point 1 - Minimum force is reached ("CAUTION" at approx. 15 t over $F_{1_{min}}$)

Priority of acoustical warnings

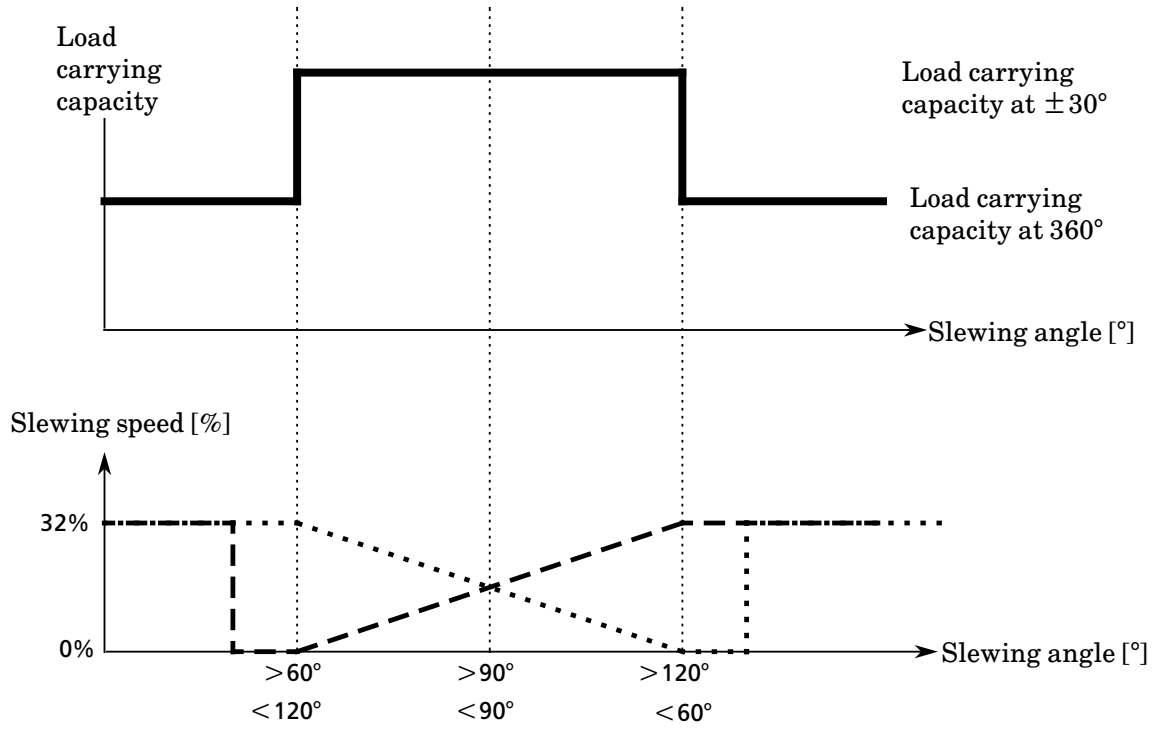
The alarm "HORN" has a higher priority than the alarm "SHORT HORN".

Turn acoustical warnings off

- "HORN" as well as "SHORT HORN" can be turned off via the function key "F8". If an error occurs again, then the acoustical warning "HORN" or "SHORT HORN" becomes active again.

Note: Errors with LEC are indicated on monitor 0 in operating view, above the "F8" key.

- Load carrying capacity
- Slewing speed - turn right (at current load > load carrying capacity 360°)
- Slewing speed - turn left (at current load > load carrying capacity 360°)



40. Automatic slewing range change over

40.1 General

There are set up conditions, which have different load carrying capacities for different angle positions of the slewing platform.

For example: Crane with outrigger support, support base: 16×12 m

There is a stronger load chart for the large support base, in an angle range of $\pm 30^\circ$ to the side. This load chart for the limited slewing angle range is called the $\pm 30^\circ$ - load chart. There are also load charts for the remaining angle range (360° load chart).

40.2 Setting the load chart

In the "Set up" program, each load chart can be selected with the function keys or the short code and "ENTER". The selected load chart is shown.

Note: If the 360° chart is selected, then there is no slewing range change over. Only the load shown in the 360° chart can be lifted in the complete 360° slewing range.

If the $\pm 30^\circ$ chart is selected and confirmed with "F8" (OK), the slewing range change over becomes active.

C A U T I O N : Before selecting the $\pm 30^\circ$ chart, the $\pm 30^\circ$ chart and the corresponding 360° chart must be checked to see which load the crane can lift in which slewing range.

If the crane is in the $\pm 30^\circ$ range with selected slewing range change over, then the load carrying capacity in the $\pm 30^\circ$ chart applies, otherwise the load carrying capacity listed in the 360° chart applies.

After changing over from the "Operation" program to the "set up" program, always that chart is shown, which was previously confirmed with "OK".

Note: To be able to check in the "Set up" program, which load can be lifted in the current angle position, the current slewing angle must be read in the "Operation" program and the corresponding load chart (360° or $\pm 30^\circ$) must be selected in the "Set up" program.

40.3 Slewing gear control

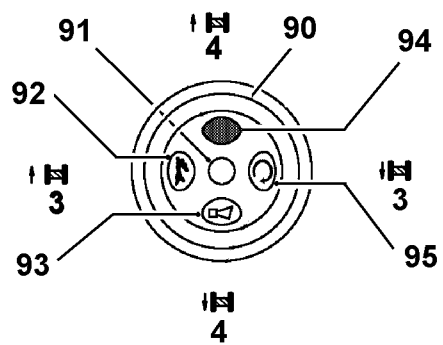
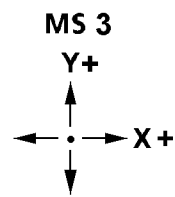
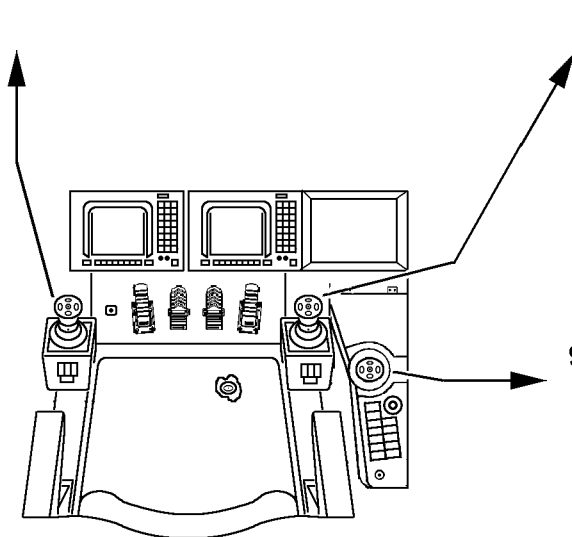
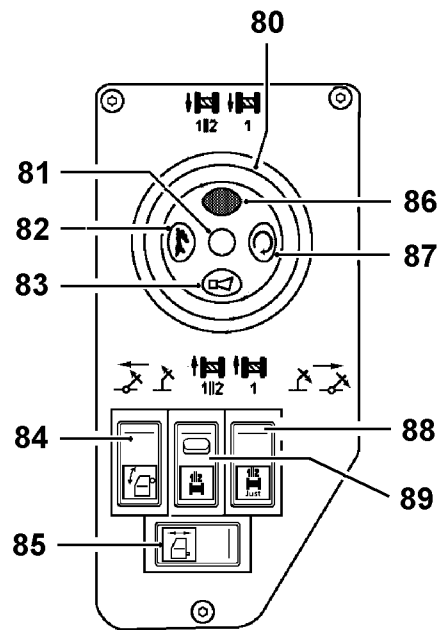
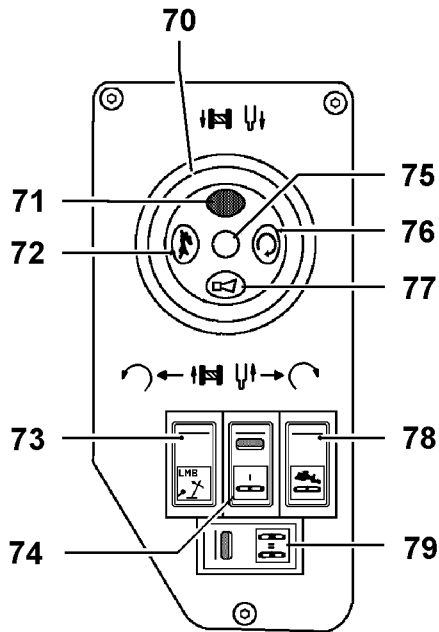
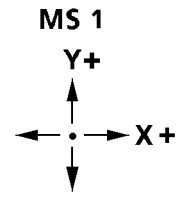
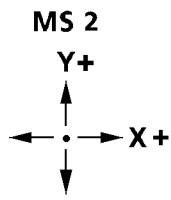
If the slewing range change over is set and a load is lifted in the $\pm 30^\circ$ range which is in the **> 360° load chart**, then - depending on the current slewing angle - the maximum slewing speed for "Turning left / right" is calculated, as shown on the illustration on the left, and the slewing movement to the edge of the $\pm 30^\circ$ range is reduced more and more until the shut off.

Note: A slewing speed reduced by the LML can only be lifted after removing the overload in the 360° slewing angle range if the crane movement "slewing" is not actuated.

40.4 Coasting the slewing gear

At a set slewing range change over and $> 360^\circ$ load carrying capacity, coasting the "slewing gear" by pressing the foot button is not possible.

Note: If the slewing range change over is set and the coasting slewing gear is actuated, then the load carrying capacity from the 360° chart is valid.



1. General crane condition

Before starting up the crane, the operator must ensure that the following conditions are met:

- The crane is horizontally aligned
- The gear on the slewing ring must be clean and greased.
- The air intake for oil coolant and radiator is "clear / unobstructed".
- The side covers are closed and locked.
- There are no persons or objects within the danger zone of the crane.
- The cable and rope drums as well as the limit switches are free of ice and snow.
- There are no loose parts on the slewing platform and the boom.

D A N G E R : Before the boom is erected, the operator must ensure that there are no loose parts on the boom, such as pins, spring retainers or ice. If this is not observed, there is a DANGER OF ACCIDENTS due to falling items.

2. Crane operator's cab adjustment**From transport to operating position**

The cab is swung in front of the slewing platform during transport.

Press button (85) and swing out the cab into operating position.

Press button (84) and incline the cab to the desired operating position.

From operating position to transport position

Press button (84) and move the cab into horizontal position.

Press button (85) and swing the cab all the way in.

D A N G E R : Make sure that no one remains in the swing range. There is a danger of crushing!

3. Checks before start up

Before start up, the following checks must be made :

Note: For detailed description of the below listed check, see chapter 7.05, "MAINTENANCE GUIDELINES"

Check the oil level and filters

- Check the oil level on the crane engine
- Check the oil level on the hydraulic tank for crane hydraulic
- Check the filter on the hydraulic tank

Fuel level

On the LICCON monitor, the tank contents is given in percentages [%] in numerical form.

C A U T I O N : Do not wait until the fuel tank is empty before refueling, otherwise the fuel system must be cleaned and bled.

Coolant level

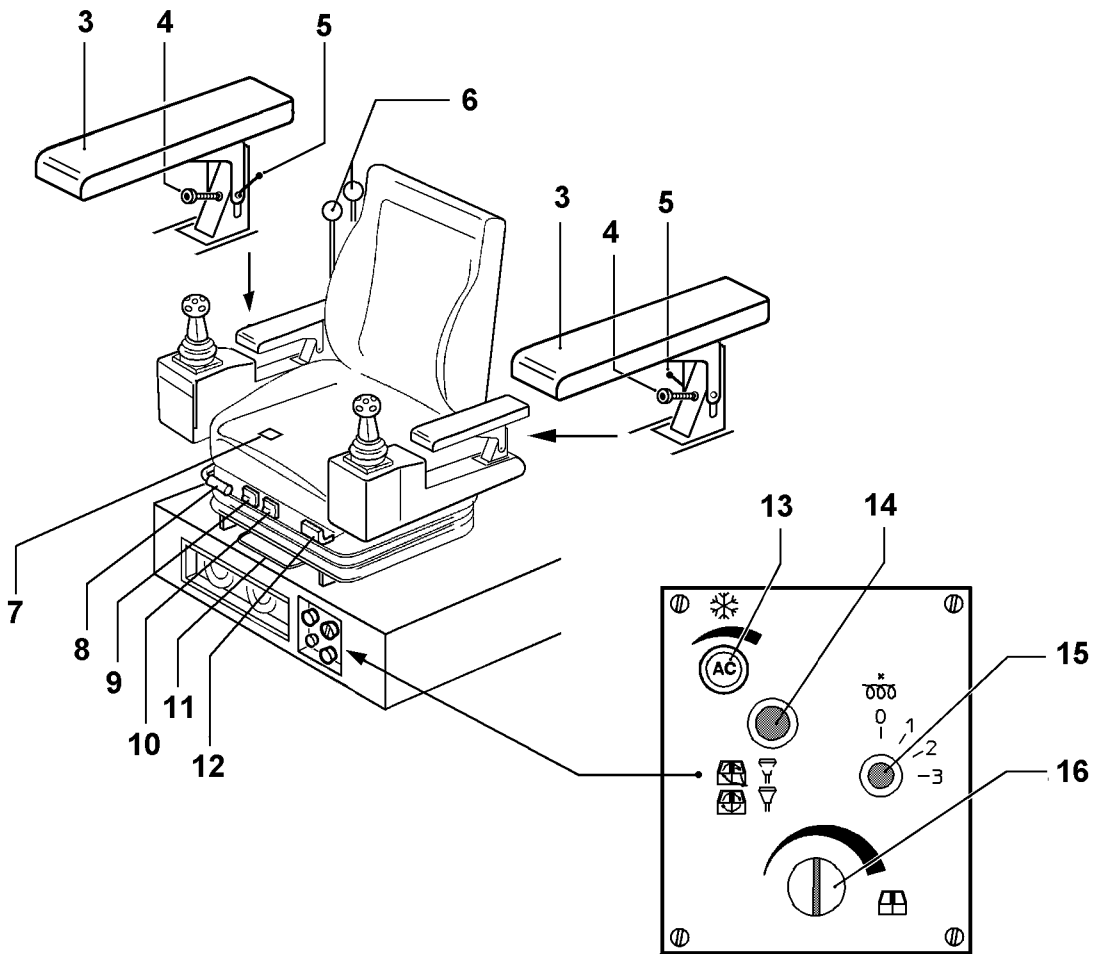
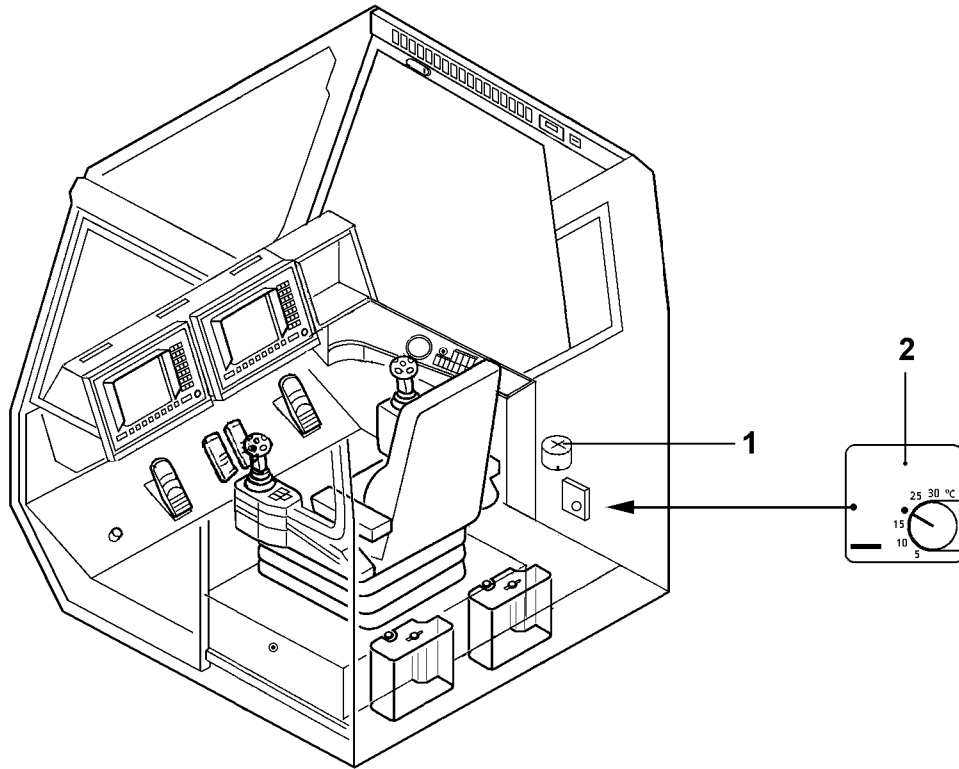
The coolant reservoir must be filled until the coolant runs over on the filler neck.

D A N G E R : Check and add coolant only when the engine is cold There is a DANGER OF SERIOUS SKIN BURNS AND SCALDING!!

Central lubrication system

It must be assured that the grease container is always filled with grease, according to the lubrication chart.

Note: See also chapter 7.05 "MAINTENANCE GUIDELINES, CRANE SUPERSTRUCTURE"



4. Crane operator's cab

4.1 Adjust the seat

The suspended crane operator's seat can be adjusted to any body size.

- Adjustment of arm rest incline (5)
- Adjustment of seat surface incline (8)
- Adjustment of backrest incline (12)
- Release for horizontal seat adjustment (11)
- Adjustment of back support in the upper area of the backrest (10)
- Adjustment of back support in the lower area of the backrest (9)

4.2 Heater / ventilation

The crane operator's cab can be heated or ventilated, depending on the desired temperature.

The control elements for the heater / ventilation are below the crane operator's seat .

For detailed description, refer to chapter 6.01, HEATER .

Heat

- Switch change over switch (14) to air circulation.
- Turn on the blower with the knob (15) .
- Regulate the temperature with the knob (16) .

Ventilation

- Switch change over switch (14) to fresh air.
- Turn on the blower with the knob (15) .

4.3 Seat heater *

- The crane operator's cab can be heated by turning on the switch (36) .

4.4 Adjust the crane operator's cab

The crane operator's cab can be "tilted upward" hydraulically by approx. 15° to increase the field of visibility for the operator.

D A N G E R : **When the crane operator's cab is tilted, nobody may step on the step in front or next to the cab! This is strictly prohibited!**
After completion of crane operation, the cab must be returned to horizontal position, otherwise the operator cannot leave the cab safely.

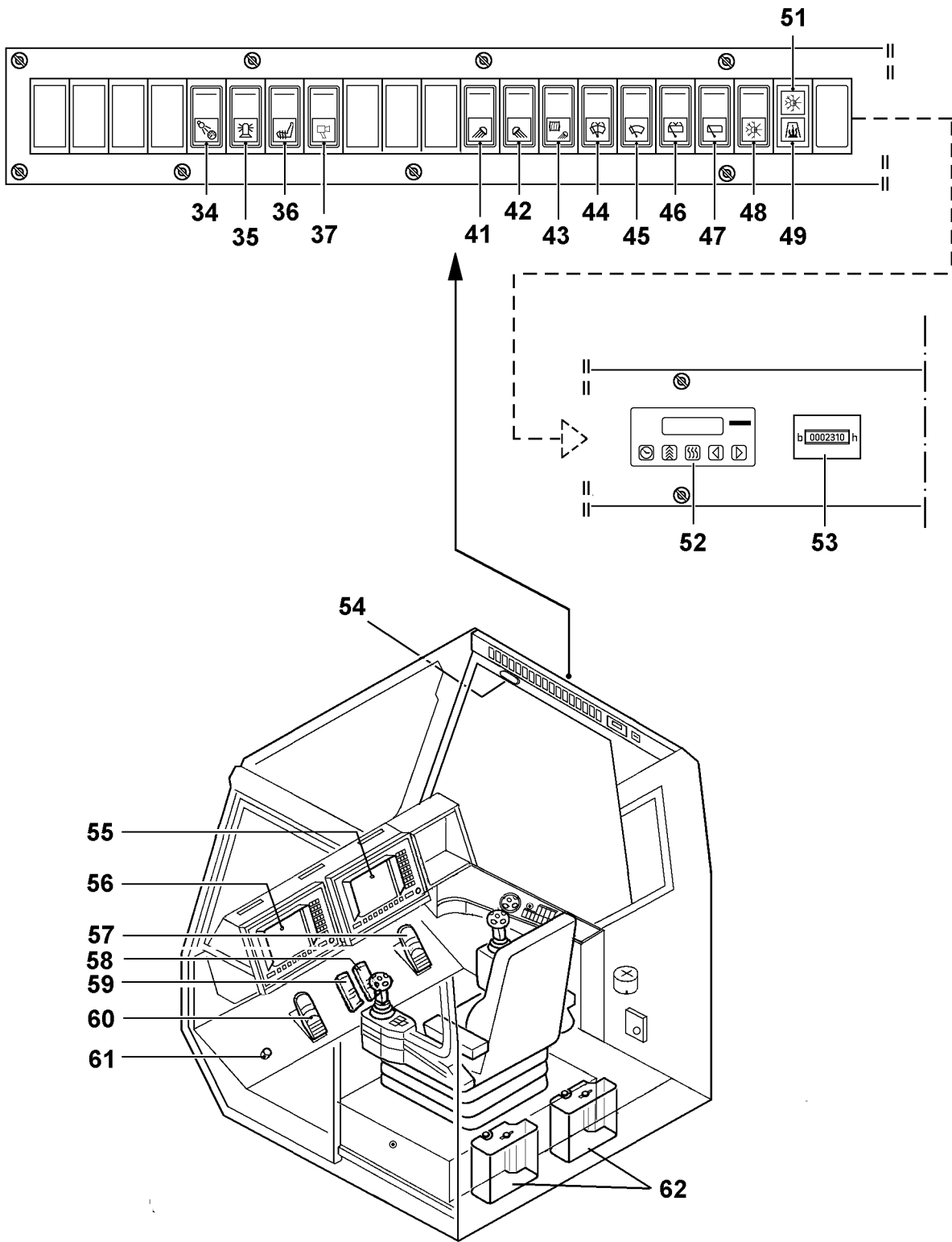
Tilt the crane operator's cab "upward"

- Press the button (84) "on the bottom" and hold it until the desired field of visibility is reached.

C A U T I O N : **When the crane operator's cab is tilted and the cab door is opened, it will run back quickly at an increased speed due to its own weight. For that reason, hold the door by the handle and open it slowly.**

Set the crane operator's cab to horizontal position

- Press the button (84) "on the top" and hold it until the horizontal position is reached.



4.5 Windshield wiper / windshield washer system**4.5.1 Windshield wiper**

The windshield wipers on the front window as well as on the roof window can be actuated with the 2 stage switch

(1. Stage - Intermittent, 2. Stage - wipe).

- Windshield wiper on front window - switch (45)
- Windshield wiper on roof window - s witch (47).

4.5.2 Windshield wiper / windshield washer system

The windshield wipers on the front window as well as on the roof window can be enhanced with a windshield washer system .

Note: Before begin of the cold season, the reservoir for the windshield cleaning fluid must be filled with commercially available antifreeze fluid.

- Windshield wiper / washer on front window - button (44)
- Windshield wiper / washer on roof window - button (46).

4.6 Front window

The front window can be opened by simply pushing against it from the inside, a pair of nitrogen cylinders aids in the hoist movement.

If the window is to be opened only partially, then it can be held at any angle by holding it with the installed perforated belt.

D A N G E R : Be careful with your hands when closing the front window to prevent injury .

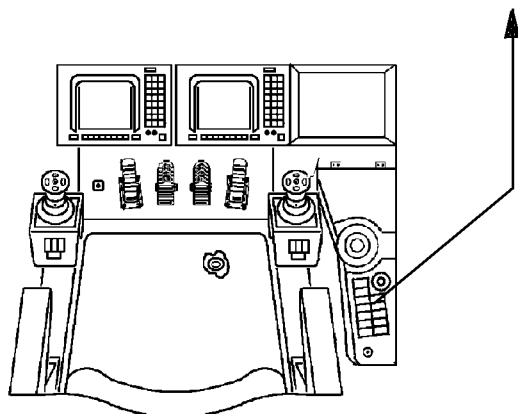
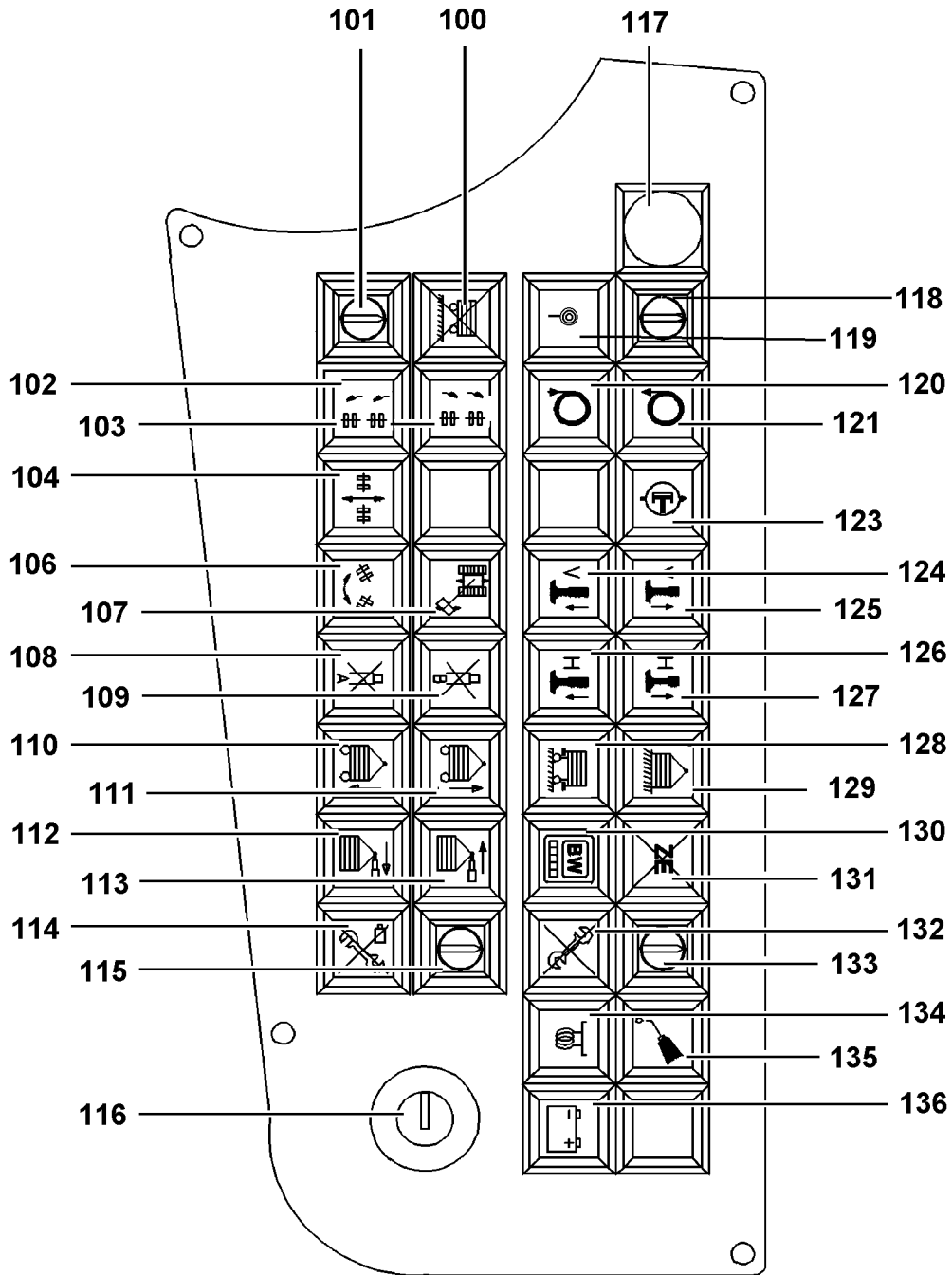
4.7 Horn

Before starting to work, check the horn for proper function .

D A N G E R : The horn may only be used in danger situations, to retain its warning effectiveness!

4.8 Turn the lights on / off

34	Switch	Instrument panel illumination
35	Switch	Airplane warning light
41	Switch	Working floodlight, on cab base
42	Switch	Working floodlight , front and rear of cab roof
43	Switch	Working floodlight for hoist winch and mirror heater



5. Start and turn the crane engine off

5.1 Start the crane engine

- Turn the ignition starter switch (116) to position "1".
The indicator light (134) blinks, the engine is ready to start.
- Turn the ignition starter switch to position "2" and start the engine.

CAUTION: The engine may only be started if:

- the charge indicator light (136) lights up.
- the indicator light for the flame start system (134) blinks.

If the engine does not start after max. 10 seconds, wait for 1 minute.

Do not crank the starter more than 3 times per starting procedure, with a one minute break between each attempt.

If the engine starts but stops again after 4 seconds, then there is a sensor defect in the engine control.

To prevent the engine from "turning off", turn the ignition starter switch to position "0". Then preglow the engine for **approx. 10 seconds**, then start. The engine control now runs with default values. However, the error message must be observed.

5.1.1 Start the crane engine with the flame start system

The engine is equipped with a flame start system to improve the cold start procedure and the warm up phase. It automatically turns on at a coolant temperature of $\leq 15^{\circ}\text{C}$ and remains in operation until the coolant temperature reaches 25°C .

The flame start system does not turn on at a coolant temperature above 15°C .

- Turn the ignition starter switch (116) to position "1" drehen.
The indicator light (134) lights up and starts to blink after 5 to 35 seconds, the engine is ready to start.
- Turn the ignition starter switch to position "2" and start the engine.

The flame start system turns off automatically if:

- the engine is not started during the starting readiness period,
- the engine is started while the indicator light (134) lights up,
- the coolant temperature reaches 25°C with the engine running.

Error recognition

The flame start control unit recognizes errors on the flame start system and shows that there is an error by **rapidly** blinking the indicator light (134).

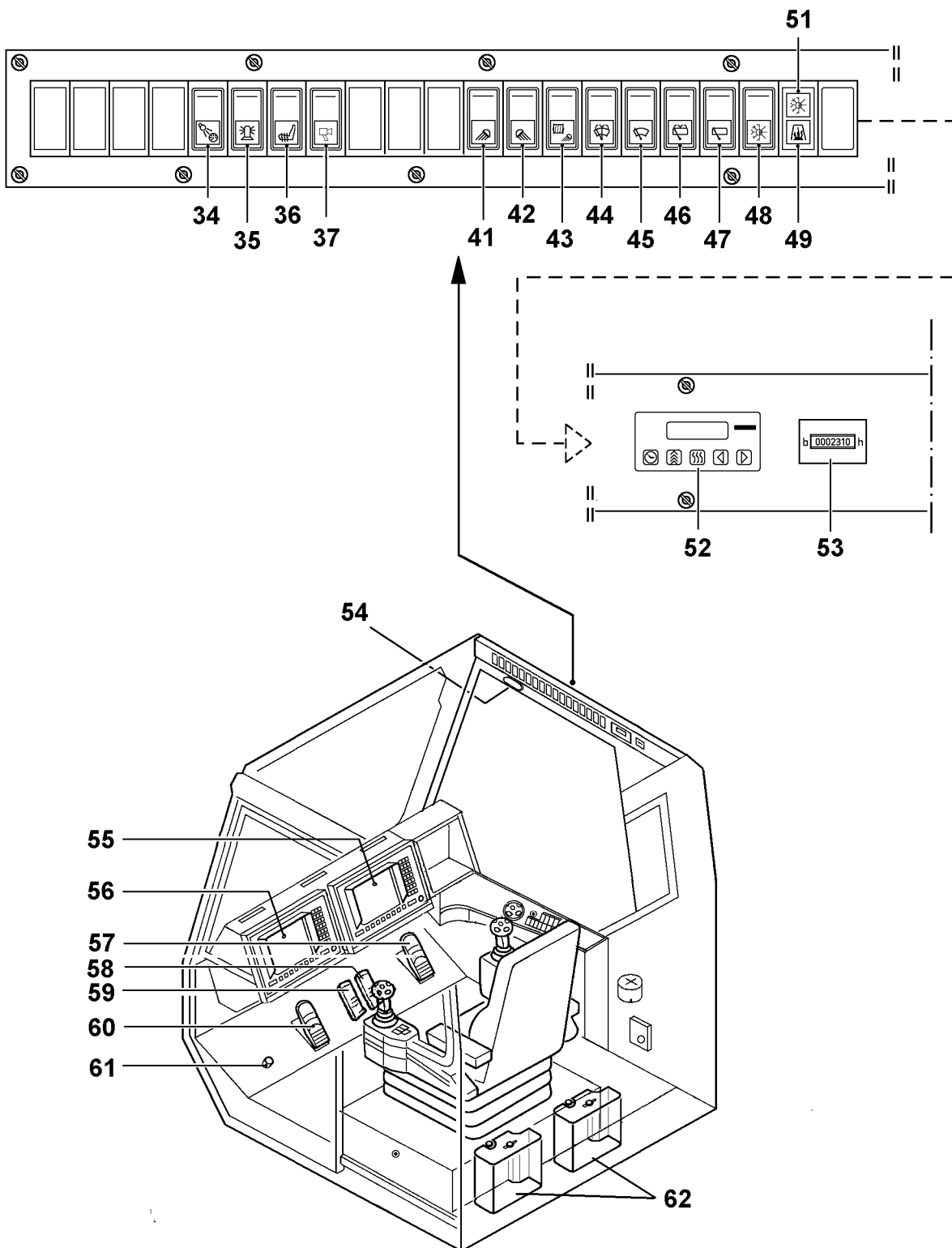
Recognized errors are:

- interruption of flame glow plug heater coils.
- missing power supply on terminal 30.
- Defective fuse for flame start control unit.

Note:

Pay special attention to the batteries during the cold season.

The starting capacity is greatly reduced in cold temperatures; for example, at -10°C it is only 66% of its normal capacity. For that reason, after the engine is turned off, the batteries should be stored in a heated room.



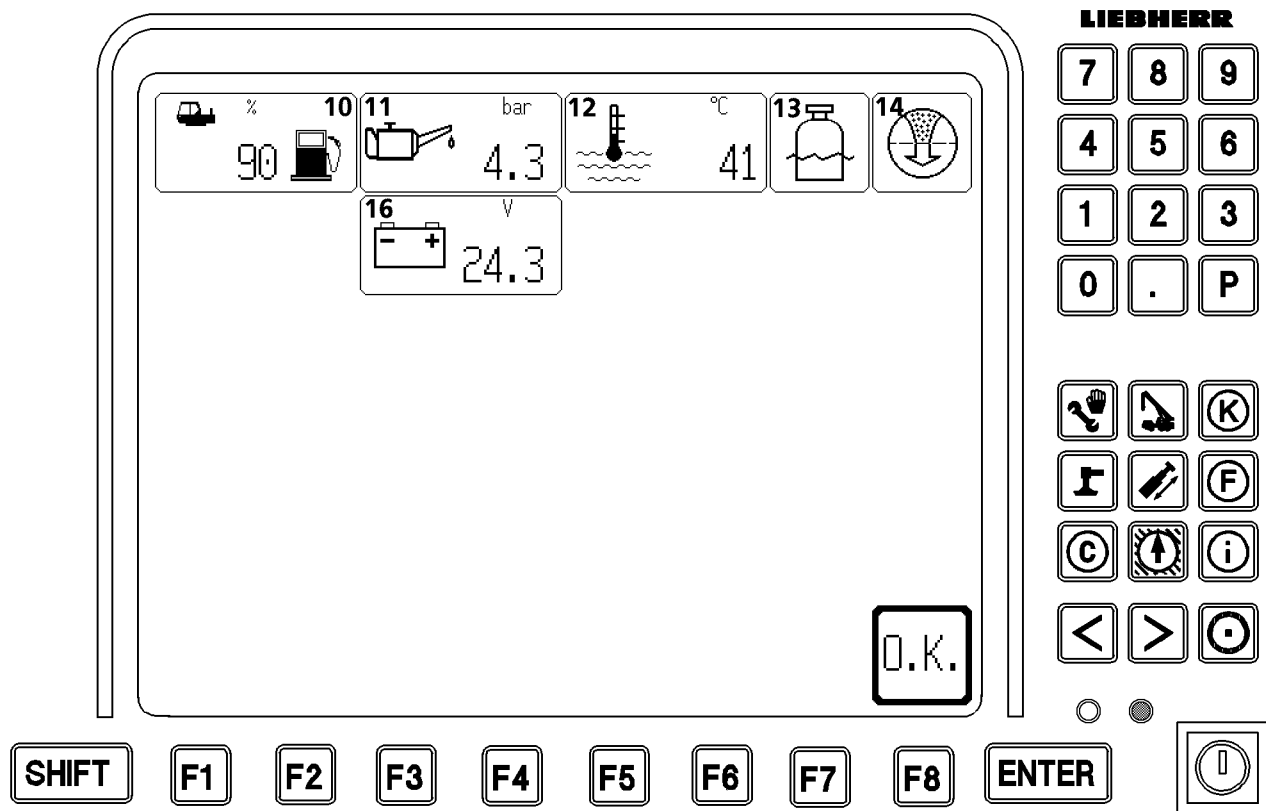
5.1.2 Engine preheating with timer

Note: See separately issued WEBASTO operating manual, Operation with timer *.

- Turn on the battery master switch .
- Depending on the ambient temperature, turn the auxiliary heater on with the timer (52) up to approx. 75 minutes before starting the engine, the indicator light (49) lights up.
- 10 to 25 seconds after turning it on (prerun), the auxiliary heater starts , the auxiliary heater runs in automatic regulation.

Turn the auxiliary heater off after completion of the preheat time

- Turn the auxiliary heater off on the timer (52) .
The auxiliary heater continues to run for up to 150 seconds.



5.2 Check the instruments after the start

5.2.1 The engine is running

As soon as a stable voltage is available, the electric crane control and the LICCON Computer system turns on automatically. The micro processor system runs through a self test; after a few seconds, the equipment configuration view appears on the monitor (see chapter 4.02).

Note: If no prewarning or STOP occurrence of the engine monitoring system is present, then the system does not switch to the engine monitoring view, but directly into the equipment configuration view.

5.2.2 Check the instruments

Note: To check the instrument, switch into the engine monitoring view by pressing key combination "SHIFT" + "Po".

When the engine is running, the battery charge indicator light (136) must run off:
The number indicator for engine oil pressure in symbol element "Engine oil pressure" (11) on the LICCON Monitor may not blink.

The following symbol elements on the **monitor** must be checked when the crane engine is running:

- Tank contents (10)
- Coolant temperature (12)
- Coolant level (13)
- Air filter (14)
- Battery voltage (16)

CAUTION: If the number indicator for engine oil pressure in the symbol element "Engine oil pressure" still blinks after approx. 10 seconds, or if the indicator starts to blink during crane operation, then the engine oil pressure is too low. Turn the engine off immediately and find the cause! If this is not observed, the engine can be damaged due to insufficient oil pressure.

If the number indicator for the coolant temperatures in the symbol element "coolant temperature" blinks during operation, then it is too high. Turn the engine off immediately, increased coolant temperature can damage the engine.

Do not put a full engine load on the engine until it is at operating temperature!

5.3 Engine monitoring

5.3.1 General

Start the program

on request:

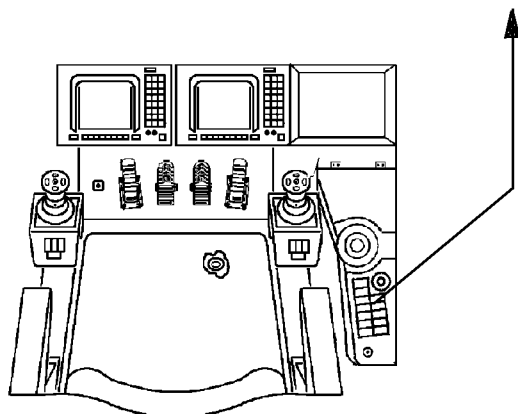
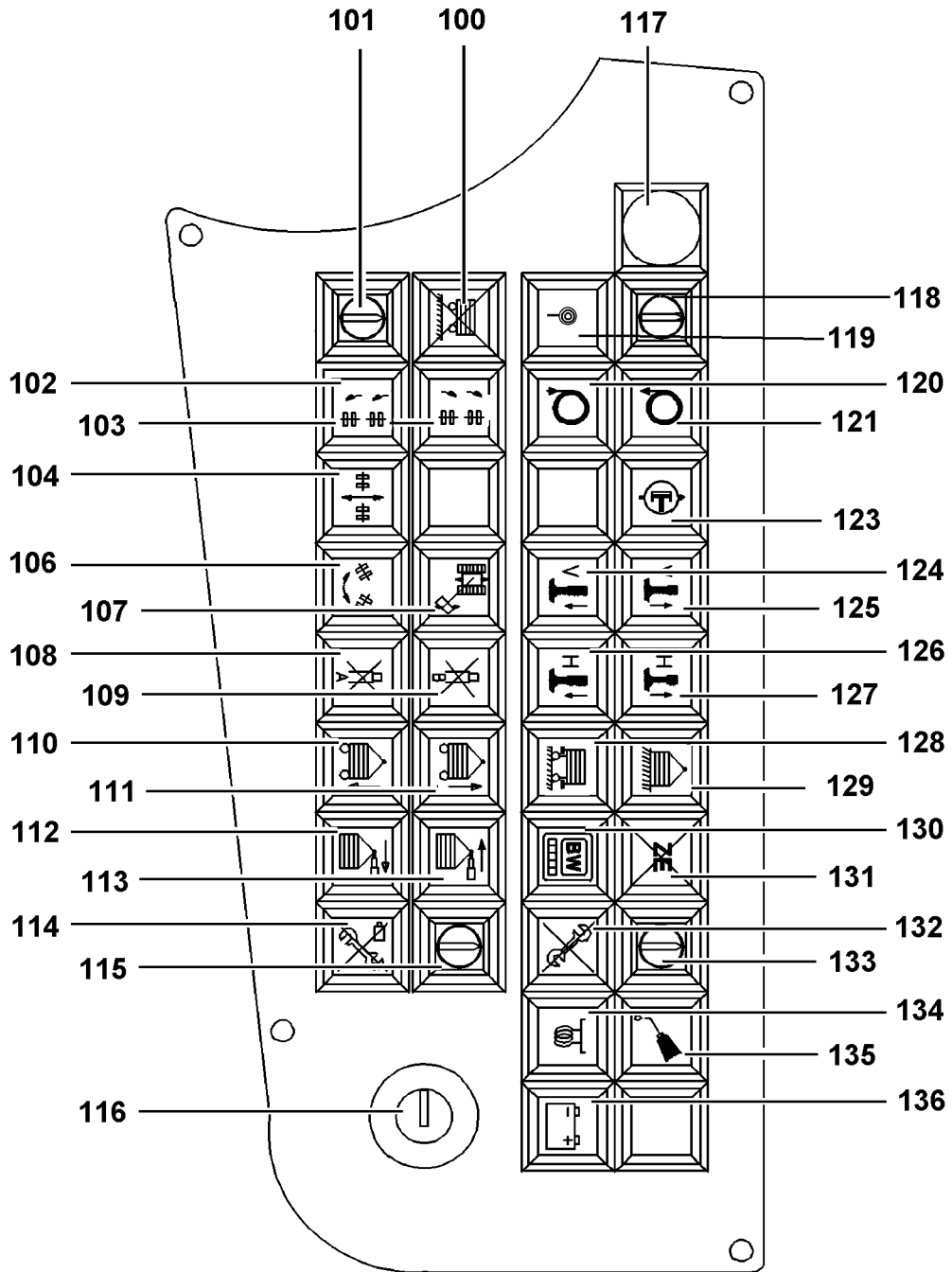
- with key combination "SHIFT" + "P"

automatic:

- if a STOP occurrence happens

or

- if a prewarning, warning or STOP occurrence happens during the boot up phase of the LICCON computer system



5.4 Turn the crane engine off

- Turn the ignition starter switch (116) back to the stop,
- pull the ignition starter switch (116) and store it.

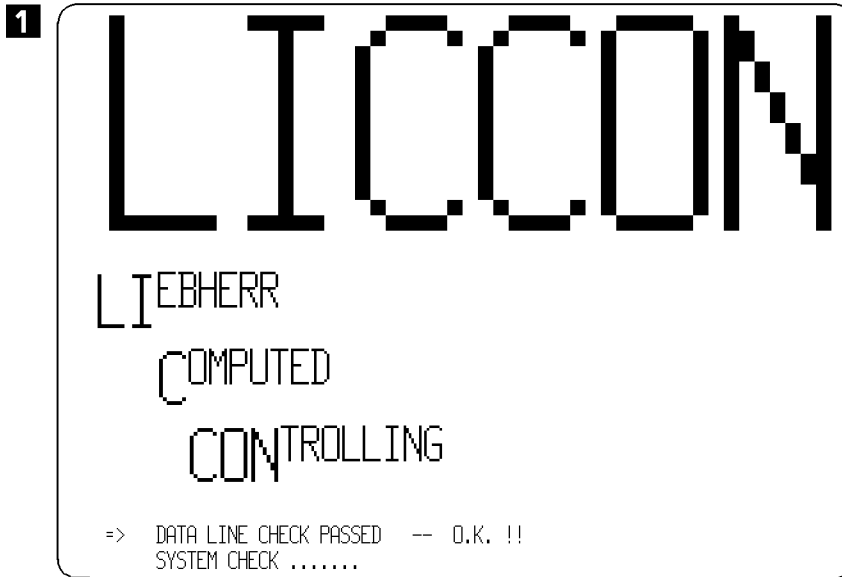
Note: After operation with full engine power or in case of increased coolant temperature over 95°C, let the engine run for 1-2 minutes without load in low idle speed.

5.5 Turn the engine off in case of danger

In case of danger, turn the engine off by pressing the EMERGENCY "OFF" button (117) .

- Push the button (117), the crane is turned off immediately.

CAUTION: The emergency "OFF" button (117) may only be used in true emergency situations. The emergency OFF button may not be used to turn the engine off during normal operation, this is strictly prohibited!



6. LICCON computer system after engine start

6.1 Boot up phase

After the LICCON computer system is turned on, it runs through a self test .

Note: See chapter 4.02, LICCON COMPUTER SYSTEM.

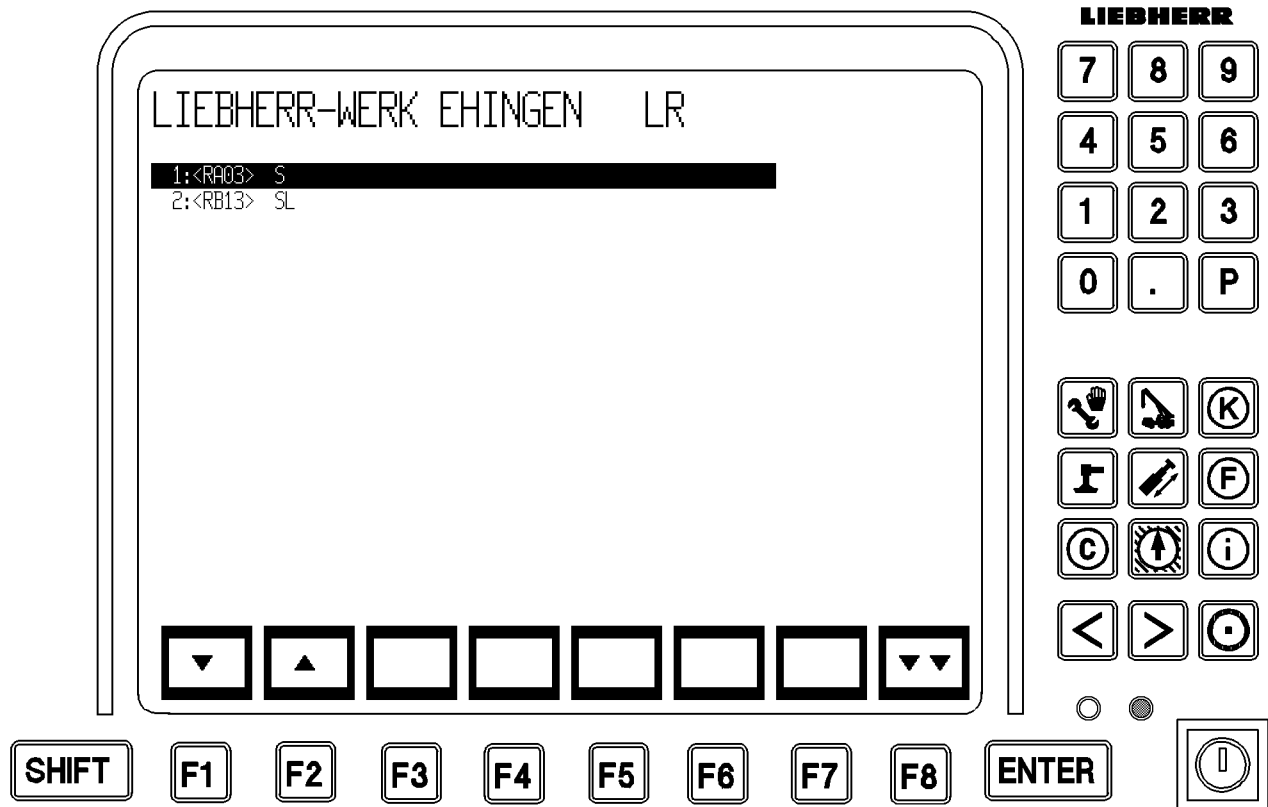
If the starting procedure is completed successfully, then the view to preselect the operating mode (operating mode preselection view, see next page) appears for a short time on the **Monitor** .

Note: In normal cases, the operating mode preselection group is set on the operating mode preselection view which had been chosen before the LICCON computer system had been turned off. Only if there was a loss of data in the memory, for example due to a cold boot (change of battery or CPU, etc.) then the first operating mode preselection group is placed.

- Select the desired operating mode preselection group with the function key "F1" (move cursor down) or "F2" (move cursor up) .
- With "F8" or "ENTER", confirm the preselection .
The equipment configuration view appears .

Note: If no operating mode preselection group is selected within 3 seconds, the previous operating mode preselection group remains, and the equipment configuration view is shown without having to enter anything. This means, if the previous operating mode preselection group is to remain, no entry is necessary.

Note: If during the boot up phase of the computer system a master switch (manual control lever) is moved from the zero position, then the boot up phase is interrupted.



6.2 Set the operating condition with the crane engine at a standstill**Initial condition :**

Crane engine is off

6.2.1 Start the crane engine

- Turn the ignition starter switch to stage 2.

Note: After turning it on, the LICCON computer system runs through a self test. If the starting procedure is completed successfully, then the view to preselect the operating mode (operating mode preselection view) appears for a short time on the **Monitor** . (For detailed description of the boot up function, see paragraph 6.1)

6.2.2 Make the operating mode preselection

- Select the desired operating mode preselection group with the function key "F1" (move cursor down) or "F2" (move cursor up) , which corresponds to the actual crane set up.

- With "F8" or "ENTER", confirm the preselection .
The equipment configuration view appears with the selected operating mode preselection group.

Note: If an equipment configuration from the same operating mode preselection group had been set before the LICCON was turned off, then this equipment configuration view appears again, i.e. the previous equipment configuration and the previous reeving will be automatically reset.

6.2.3 Set the operating mode and the equipment configuration

If the previously set and shown operating mode or the previous equipment configuration is to be changed, it can be done two ways:

1. with function keys:

- "F2" Adjust operating mode main geometry condition
- "F3" Adjust operating for selected mode equipment condition,
- "F4" Adjust equipment configuration slewing platform counterweight
- "F5" Adjust equipment configuration undercarriage (crawler,/supports, central ballast)
- "F6" Adjust slewing range of slewing platform
- Confirm settings by pressing the "ENTER" key

2. with short code:

- Enter the 4 digit short code with numeric keys on monitor 0.
- Confirm settings by pressing the "Enter" key.

- Check the selected load capacity chart.
- Check the adjusted reeving,

m > < t
CODE >XXXX< BXXX YYZZ.1(2)

	35,0	35,0	35,0	35,0	35,0	35,0	35,0
12,0							
14,0	380,0	380,0	380,0	380,0			
16,0	372,0	372,0	372,0	372,0			
18,0	363,0	363,0	363,0	363,0			
20,0	350,0	350,0	349,0	349,0			
22,0	336,0	337,0	337,0	337,0			
24,0	305,0	313,0	312,0	312,0	307,0	319,0	328,0
26,0	278,0	283,0	283,0	283,0	284,0	301,0	310,0
* n *	* 29 *	* 29 *	* 29 *	* 29 *	* 23 *	* 24 *	* 25 *
xx	87,0	87,0	87,0	87,0	77,0	77,0	77,0
yy	13,0	15,0	18,0	20,0	13,0	15,0	18,0
							>>

xx° SDBW
35m

W
28m

220
t

95
t

yy m

n
10 x

O.K.

LIEBHERR

7

8

9

4

5

6

1

2

3

0

.

P

K

F

C

i

<

>

SHIFT

F1

F2

F3

F4

F5

F6

F7

F8

ENTER

6.2.4 Set the hoist cable reeving number

"F7" Push the function key "F7" until the current reeving on the current pulley head is set.


6.2.5 Take over setting and check


- Push the function key "F8" (OK), if the set equipment configuration and the reeving have been checked.

The "SET UP" program is completed and the adjusted parameters are taken over into the re-started "OPERATION" program.

- Check that the short code and the reeving that has been set in the operating view as intended by the crane operator.

Note: For detailed description of the "SET UP" program, see chapter 4.02, LICCON COMPUTER SYSTEM.






$m > < t$


CODE >XXXX< BXXX YYZZ.1(2)

	35,0	35,0	35,0	35,0	35,0	35,0	35,0
12,0							
14,0	380,0	380,0	380,0	380,0			
16,0	372,0	372,0	372,0	372,0			
18,0	363,0	363,0	363,0	363,0			
20,0	350,0	350,0	349,0	349,0			
22,0	336,0	337,0	337,0	337,0			
24,0	305,0	313,0	312,0	312,0	307,0	319,0	328,0
26,0	278,0	283,0	283,0	283,0	284,0	301,0	310,0
* n *	* 29 *	* 29 *	* 29 *	* 29 *	* 23 *	* 24 *	* 25 *
xx	87,0	87,0	87,0	87,0	77,0	77,0	77,0
yy	13,0	15,0	18,0	20,0	13,0	15,0	18,0
							>>





xx° SDBW
35m

W
28m



95
t





O.K.

SHIFT

F1

F2

F3

F4


F5

F6

F7

F8

ENTER



LIEBHERR

7

8

9

4

5

6

1


2


3

0


.


P
































6.3 Set the new operating condition, when the engine is running**Initial condition:**

The crane engine is running.

The LICCON computer system is in the Operating View.

The new operating conditions is part of the selected operating mode preselection group, but the operating mode, equipment configuration or reeving must be changed.

Note: If the new operating condition is part of another operating mode preselection group, then the engine must be turned off for selection, and the LICCON computer system must be rebooted.

6.3.1 Change the operating mode and the equipment configuration

- Press the program key "P0" to start the "Set up" program .
- Set the operating mode and equipment configuration with function keys or with short code.
- Press the "ENTER" key.
Then the data in the selected load capacity chart can be viewed.
- Check the selected load capacity chart.


6.3.2 Change the reeving


- Set the reeving number of the hoist cable by pressing the function key "F7" until the desired reeving is selected.

6.3.3 Take over the setting and check

- Push the function key "F8" = "O.K.", when the selected equipment configuration and the reeving has been checked.
The "Set up" program is completed and the selected parameters are taken over into the restarted "OPERATION" program.
- Check that the correct short code and the correct reeving has been set in the Operation view.

Note: For detailed description of the "Set up" program, see chapter 4.02, LICCON Computer system.






$m > < t$


CODE >XXXX< BXXX YYZZ.1(2)

	35,0	35,0	35,0	35,0	35,0	35,0	35,0
12,0							
14,0	380,0	380,0	380,0	380,0			
16,0	372,0	372,0	372,0	372,0			
18,0	363,0	363,0	363,0	363,0			
20,0	350,0	350,0	349,0	349,0			
22,0	336,0	337,0	337,0	337,0			
24,0	305,0	313,0	312,0	312,0	307,0	319,0	328,0
26,0	278,0	283,0	283,0	283,0	284,0	301,0	310,0
* n *	* 29 *	* 29 *	* 29 *	* 29 *	* 23 *	* 24 *	* 25 *
xx	87,0	87,0	87,0	87,0	77,0	77,0	77,0
yy	13,0	15,0	18,0	20,0	13,0	15,0	18,0
							>>





xx° SDBW
35m

W
28m



95
t





O.K.

SHIFT

F1

F2

F3

F4


F5

F6

F7

F8

ENTER



LIEBHERR

7

8

9

4

5

6

1

2

3

0

.

P





K

F



F

C



i

<

>





6.4 Set the previous operating condition, the engine is not running**Initial condition :**

The crane engine is not running.

6.4.1 Start the crane engine

- Turn the ignition starter switch to stage 2.

Note: After turning it on, the LICCON computer system runs through a self test. When the starting procedure has been completed successfully, then the operating mode preselection view appears for a short time on the **monitor**. The last used equipment configuration and the last used reeving are selected. (For detailed description of the boot procedure, see paragraph 4.1)

6.4.2 Make operating mode preselection

- Check the selected operating mode preselection group.

Note: If not operating mode preselection group is selected within 3 seconds, then the previous operating mode preselection group remains, and the equipment configuration view is shown without entry.

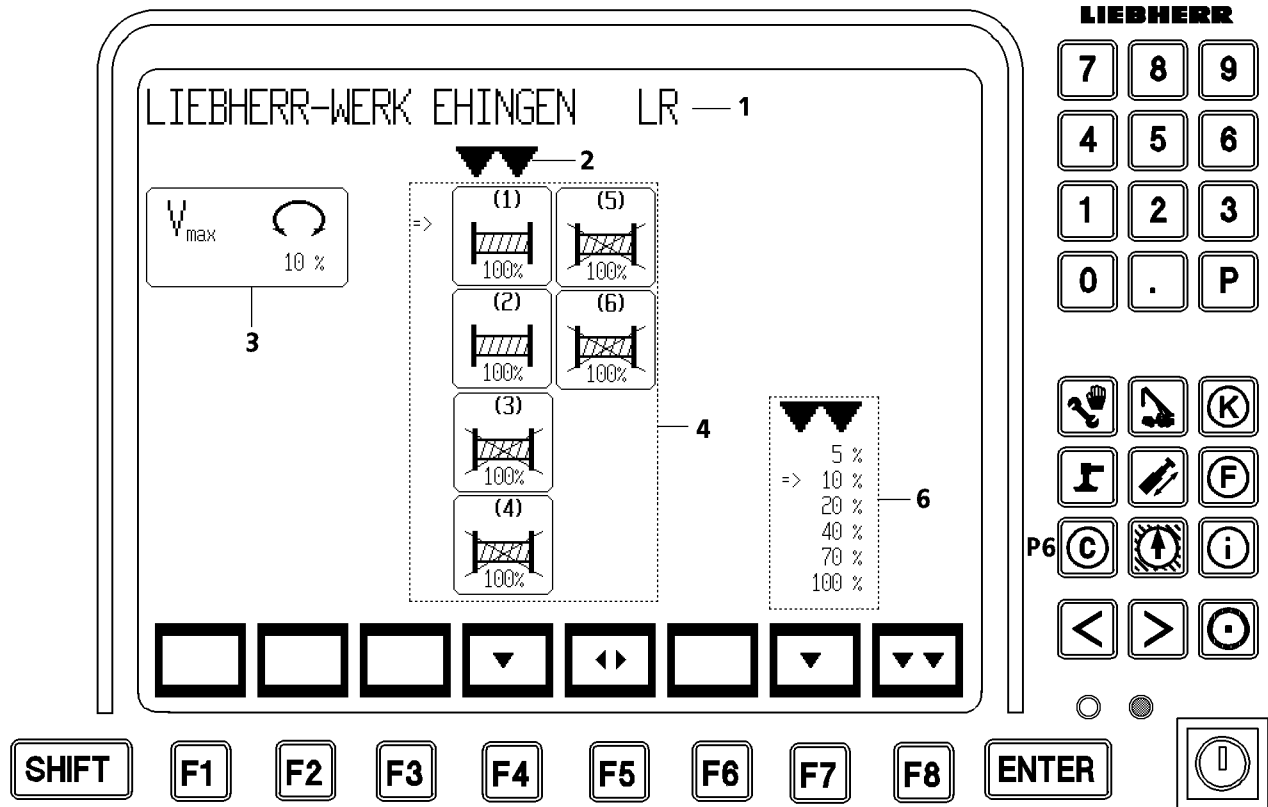
6.4.3 Set the operating mode and the equipment configuration view

- Check the selected load capacity chart.
- Check the adjusted reeving,

6.3.4 Take over the setting and check

- Push the function key "F8" = "O.K.". The "Set up" program is completed and the selected parameters are taken over into the restarted "OPERATION" program.
- Check that the correct short code and the correct reeving has been set in the Operation view.

Note: For detailed description of the "Set up" program, see chapter 4.02, LICCON Computer system.



7. Set the control parameters

The crane operator must:

- preselect and check the maximum slewing speed of the slewing gear
- preselect and check the maximum slewing speed of the winches
- as well as to activate or deactivate the individual winches.

Note: During the "Control-Parameter" program, the installation and bypass switches are monitored. If one of these switches is actuated during the program, then the system shifts back immediately into the "Operation" program.

Symbol elements

- 1) Header line, crane type
- 2) Selector to select the symbol elements
- 3) Symbol element max. slewing speed
- 4) Symbol element group, cable winches
- 6) Value field with selector

Function keys

- "F4" Select the winches
- "F5" deactivate or activate the cable winches
- "F7" Select the percentage values of the corresponding speed
- "F8" Shift back to the Operation program

"ENTER" Take over the selected speed setting

Special function keys

" < ", " > " Move selector to the left or right

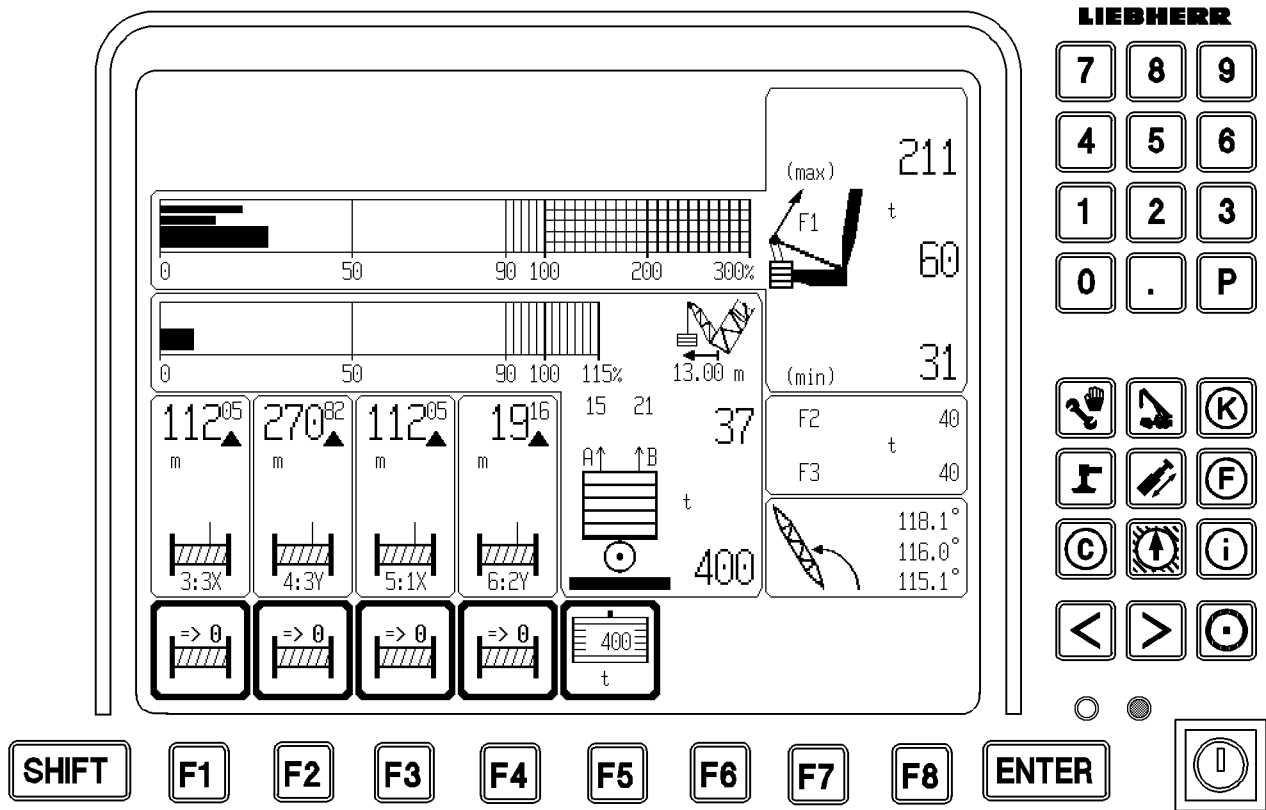
D A N G E R : **The maximum slewing speeds (according to load capacity charts) which depend on the boom length and the operating mode, may NOT be exceeded during crane operation with a load !**

The larger the boom length, the heavier the attachment and the larger the load the smaller the adjusted "maximum slewing speed" must be.

With maximum load, the manual control lever for the slewing gear may not be deflected all the way to the stop.

A change of the maximum speeds as well as activation / deactivation of winches may not be made while a crane movement is carried out.

Note: For a detailed description to set the control parameters, see **chapter 4.02, LICCON COMPUTER SYSTEM.**



8. Setting the derrickballast

When operating the crane with derrickballast, the current size of the derrick ballast **must** always be set. The corresponding weight of the empty ballast palette (or the empty ballast trailer) and the weight of the derrick ballast plates .

Control:

- **Press the F5 key** → on symbol above F5, the thick symbol frame is exchanged against the thin symbol frame and a blinking cursor appears in the ballast editing field.
- **Enter the value for the placed ballast** with the numeric keys on the monitor in the given weight unit ([t] or [kips])
- **Press "ENTER" = to take over the value** → The entered value now appears as the value for the placed ballast (=BA_AUF) in the ballast symbol

(**Press the F5 key = to discontinue editing** → The change is dumped. The old value of the placed ballast (BA_AUF) remains in the ballast symbol .)

D A N G E R: During ballast editing, the remaining indications on the monitor cannot be shown. The operating view on the monitor is frozen and can therefore show incorrect data.

For that reason, complete the ballast editing function quickly.

(If a manual control lever is actuated during ballast editing, then ballast editing is automatically interrupted. The old value of the placed ballast (BA_AUF) remains in the ballast symbol).

The set derrick ballast value must match the actually installed derrick ballast weight.

If a derrick ballast weight is set, which is too low, then the derrick ballast utilization indicator is too large, then the 90% warning occurs too soon.

If a derrick ballast weight is set, which is too large, then the derrick ballast utilization indicator is too small and the ballast utilization dependent safety shut offs of test point 1 (F1min) are ineffective .

There is a danger!

9. Adjust winches

General

All cable winches are equipped with an increment counter to measure the relative path (measurement of the relative turning angle). So that the LICCON can calculate the absolute path or the cable length in length units, the system must know the cable length in a certain winch position (adjusting position). The data belonging to this winch position (cable length and current angle radius) are stored with the remaining geometric data on the program memory cards of CPUs 0 and 1.

An adjusting switch (cam limit switch) of winch 1 - 6 recognizes when the winch is in this adjusting position.

Note: Winch 4 has no cam limit switch.

The adjusting switch of the winches is set in such a way that it shifts in this adjusting position from 0 to 1 when the cable spools out.

9.1 When do the winches need to be adjusted:

The winches must be adjusted when the hook path indicator / cable length indicator is to be correct. The winches must always be adjusted when the absolute path information of the incremental sensor in the memory is lost, for whatever reason.

This is the case,

- if the LICCON is separated from the power supply (when disconnecting the LICCON from the battery), → all winches must be readjusted
- if the power for LICCON basic component group 0 is pulled → all winches must be readjusted
- if one of the following CPUs is pulled:

CPU 1 pulled: → adjust winch 1 and 2 again

CPU 3 pulled: → adjust winch 3 and 4 again

CPU 4 pulled: → adjust winch 5 and 6 again

- if an error in the winch calculation or on the incremental sensor occurred, then the winch might have to be readjusted, description is shown in description of error remedy in chapter 4.14.

If the winch is not adjusted, then no absolute path calculation can be made. In that case, a relative path calculation is shown, which can be very incorrect and not exact, because the current angle radius is not known.

The winches must always be adjusted correctly, so that the control can calculate the current winch angle radius and thereby the winch momentum. If the winch is adjusted incorrectly or not at all, then it can happen that the control uses a slightly incorrect winch momentum, which can cause the winch to start out with a slight jerk, because the brake of the winch opened too early or too late.

Note: The adjusting positions have been set in such a way that they can be actuated in crane operation, see chart on the next page.

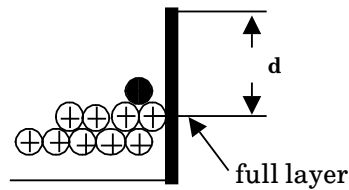
9.2 Carry out adjustment of winch 1, 2, 3, 5, 6

- Spool the winch up / out until the adjusting position (condition layer No. X full, see chart)
- run over the adjusting point by some turns, if winch is being spooled up
- then run over the adjusting switch when **spooling out**
- check the winch indicator.

Carry out adjustment of winch 4

- Spool the winch up / out until the adjusting position (condition layer No. X full, see chart)
- Push the adjusting button in the control box 1× by hand.
- check the winch indicator.

Adjusting positions:



Winch	Adjusting position at	Distance d (full layer until disk edge)	full layer has: (for intake gear, the left drum half applies)
Winch 1, 2, 3	Layer 8 full (approx. 960 m)	116 mm	Right sided winding
Winch 5	Layer 9 full (approx. 1112 m)	91 mm	Left sided winding
Winch 4	Layer 5 full (approx. 560 m)	80 mm	Left sided winding
Winch 6	Layer 3 full (approx. 306 m)	244 mm	Left sided winding

Explanation: A cable layer is full if the cable diameter is for the first time in the layer over a full layer .

CAUTION: When changing the cable, the cable may not be pulled from a standing winch nor may the empty winch be turned. This is especially dangerous for limit switches "Winch spooled up" and "Winch spooled out". Otherwise the cam limit switch of the winch must be reset again.

Before the winch is taken into operation, the crane operator must check if the hook path indication is exact, before he uses it.

* Optional

10. Load weighing and load indication

DANGER: The crane operator must know the weight of the load, before he can lift it.
The crane operator must check, before lifting the load, if he may even lift the load.

10.1 Weighing the load

Prerequisites for exact load indication:

DANGER: If the load is not weighed exactly, then there is a danger! The crane can be overloaded, because the exact weight is not known!

- The boom positions, where the relapse cylinders (RFP) are actuated must be recognized exactly by the LICCON via the sensors, because the relapse cylinders (RFP) would otherwise have too much effect onto the load (weighing error to 10 t)

In addition, the angle sensor in the main boom pivot section and the incline sensor length and crosswise in the chassis and the angle sensor in the slewing platform must be functioning.

If only one of these sensor is not functioning, then the load and especially there where the main boom relapse cylinder enter are not exact.

- Both angle sensors on the main boom must be functioning.

If only one angle sensor on the boom is not functioning properly, the LEC error is shown, but the calculation is made anyway, and the result will not be correct.

Note: If the load has been raised far above the ground level, then the weight of the hoist cable from the load to the ground is not reflected in the load indication, which is then too low.

- The number of reevings must be correctly set on the LICCON, but the reeving may not be more than the nominal reeving, otherwise the hoist cables reeved over the nominal reeving count to the load.

Note: The nominal reeving determines, for which maximum reeving the load carrying capacities of a load chart are valid.

- For the calculation of the indicated load, the weight of the hoist cable from the pulley head to the ground is deduced from the total load, which is suspended on the pulley head.

The number of reevings (set on the LICCON) is taken into account, however, the maximum number is the nominal reeving.

Exception: If the crane is in a position outside the load chart, then the hoist cable is added to the load, because no nominal reeving is known outside the load chart.

- As a result :

Lifting overhead

If the load is lifted above the crane level (for example a **skyscraper or high building**), then the hoist cable to the ground is always deducted, this causes the load to be lighter than on the ground, when it is lifted. For that reason, in high heights, a somewhat larger load can be **lifted** than on the ground, without triggering the LML overload shut off device at 100% .

This is not dangerous because the load for the crane is the same, when, for example, 200 t load on the bottom and 2t cable or 202t load on top and 0t cable hang on the pulley head.

Lifting below ground

If the load is lowered under the crane level (for example in a ditch) , then the hoist cable **underneath the crane level** is calculated and shown .

D A N G E R: It must be ensured that the load indication is right when lifting below ground, the overload of the crane is also shown in the utilization bar, but there is no shut off of the lowering movement!

The values of the load chart cannot be reached underneath the crane level.

D A N G E R: At LML overload, all crane movements, which would increase the overload, are shut off, however, the load down function remains at 100%-LML shut off, because it is assumed that the overload was caused by lifting the load. Especially with high reevings with large hoist cable weight on the pulley head, the crane is also overloaded when the load is lowered. The crane operator must know this, so that he can relieve the crane by carefully lifting the load in this certain case, even though the lifting action automatically causes a shut off again and not the lowering action .

10.2 Possible weighing errors

For exact load weighing, exact signals from the pull test brackets, angle sensors and pressure sensors are required.

Since all sensor values are always within a certain tolerance, a weighing error can occur.

The weighing error becomes increasing larger, if :

- the hoist winch sits in the slewing platform instead in the main boom
- the reeving is small
- the hoist winch sits far behind the slewing platform
- several hoist winches are used (parallel operation)
- the boom, on which the load is suspended, is short
- the boom, on which the load is suspended, is in a steep position.

D A N G E R: If prerequisites for small weighing errors are not given, use special care!

10.3 Load indication

Note: In the LMB calculation, winch 2 is not used, but always the hoist cable lever arm of winch 1.

For that reason, to lift the load on the main boom and on the fixed attachment (such as the fixed jib), winch 1 must be used to receive an exact load weight.

C A U T I O N: When winch 2 is used for lifting the load on the fixed attachment (such as the fixed jib). because the cables of winch 1 and winch 2 would cross, then one must be aware that the load indication is too small, especially in small reevings. For that reason, especially for small radii, a large reeving must be selected for winch 2!

Select at least the reeving which is required for the maximum load carrying capacity in this working radius .

D A N G E R: If the load cannot be weighed exactly, there is the danger of overloading the crane without recognizing it !

1. General

The crane operator is obligated to check the function of the safety devices before every crane operation .

D A N G E R: **Crane operation without functioning warning and safety devices can cause ACCIDENTS!**

2. LICCON Computer system

The LICCON computer system is a system to control and monitor cranes .

In addition to the overload safety device (Lastmomentbegrenzung ⇒ **LMB** / **load moment limiter** ⇒ **LML**) there are a number of application programs to control and monitor the crane movements.

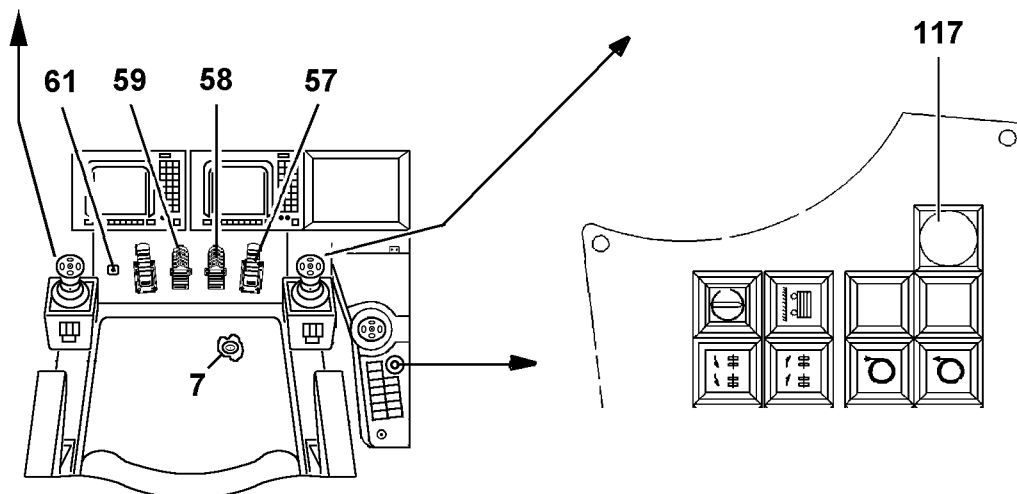
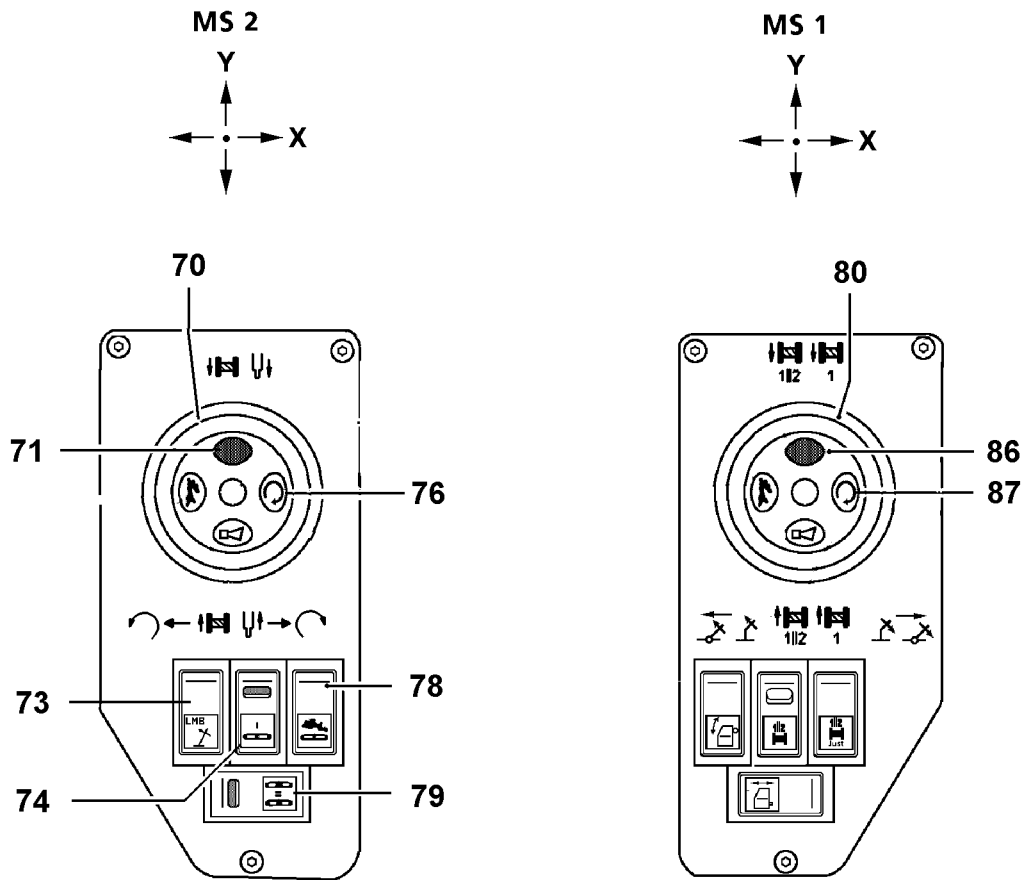
See chapter 4.02, LICCON COMPUTER SYSTEM.

2.1 Overload safety device

The electronic overload safety device turns the **load moment increasing** crane movements off if the permissible load moment has been exceeded. Only **load moment reducing** movements can be carried out.

C A U T I O N: **The presence of an overload safety device does not relieve the crane operator from his obligation to take all possible safety measurements. For example, he must know the weight of a load and the radius before lifting it and must decide, by consulting the load chart, if the crane is even able to carry out this task.**

D A N G E R: **The overload safety device is a safety device, it may not be used as an operational shut off device during lifting a load or luffing down with a load. The overload safety device must be set before crane operation to reflect the current equipment configuration of the crane, to match the load chart. Only then can it fulfill its protective function .**
If the crane operator does not use utmost care, then the crane can topple over or be severely damaged despite a functioning overload safety device .
The overload safety device cannot handle all possible operating conditions, such as counterweight, boom length, etc.
The overload safety device
 - registers, but does not monitor , for example the incline.
 - registers, but does not turn off, for example the wind speed.



3. EMERGENCY "OFF" button

If the EMERGENCY "OFF" button (117) is pressed, the engine and the electric crane control are turned off.

Any movement can be stopped immediately.

D A N G E R : **The EMERGENCY "OFF" button may only be used in absolute emergency situations.**

Operational use of the EMERGENCY "OFF" button is prohibited!

By suddenly stopping crane movements, such as turning with a load - load swing, a serious accident can occur!

4. Control release

When working in a seated position, the control release for crane operation is given by the active seat contact switch (7).

If the crane operator must work in standing position,, then the two buttons (71, 86) must be held down. When working in a seated position, the two buttons are bypassed by the seat contact switch (7).

Note: This safety control is installed to prevent inadvertent crane movements when entering or leaving the cab, due to unintentional movement of the master switch.

5. Button "Luffing up at overload" (73)

In case of overload, the "luff up" crane movement is turned off, even though this is a load moment reducing crane movement, **with freely suspended load.**

If the button (73) is held down and the manual control lever is deflected in "luff up " direction, then this crane movement can be carried out anyway.

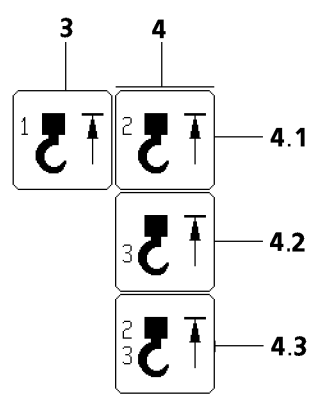
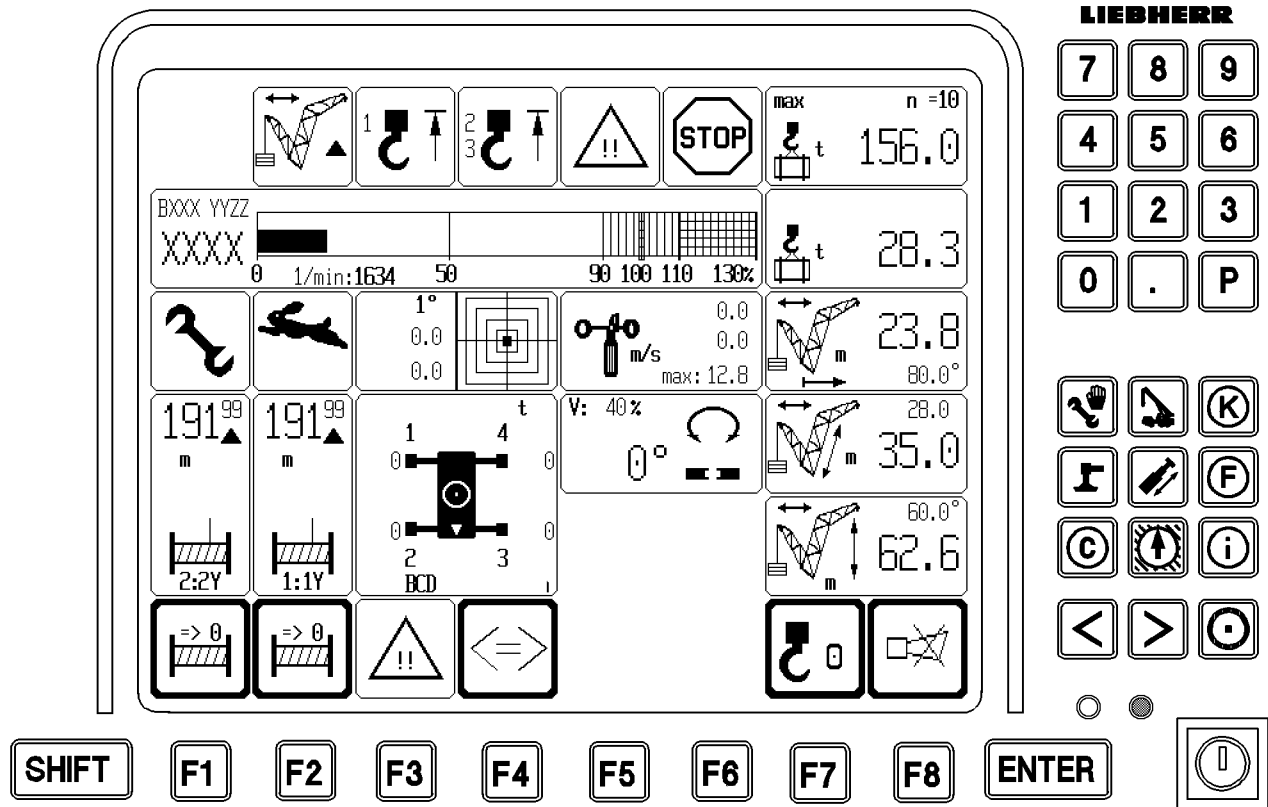
D A N G E R : **It is prohibited to lift a load from the ground via the hoist gear, if it has triggered the overload safety device and caused shut off, by luffing up the boom.**

This causes overload and can cause the crane to tip over .

In rare cases, there are load charts, which show smaller load chart values at smaller radii.

For that reason, it is only permitted , to luff up a freely suspended load with the button "Luffing up at overload" if the overload has been caused before by luffing down the boom section, or if the crane operator can clearly demonstrate according to the load chart, that the desired luffing up movement causes an increase of the maximum load carrying capacity.

If the load is luffed up with a boom section, even though this leads to a smaller load carrying capacity, then there is the danger that the crane is still subjected to mechanical overload or tips to the rear.



6. Bypass keyed button

The bypass keyed button (D) on the LICCON monitor has two positions:

- center engaged ⇒ Normal operation
- right touching ⇒ Hoist limit switch and shut off of LICCON overload bypassed

7. Wind warning device

The wind warning is given via the LICCON computer system. If the current wind speed value increases above the indicated maximum value, then the "wind warning" symbol starts to blink and the acoustical alarm »SHORT HORN« can be heard, but the crane movements are **NOT** shut off.

D A N G E R : **The crane movements are NOT shut off if the permissible wind speed is exceeded.**
Crane operation must cease and the boom must be laid down.
If this is not observed, there is a great DANGER OF ACCIDENTS !

8. Hoist limit switch " Hoist top"

The hoist limit switch is installed to prevent the hook block from running against the boom head. The hoist limit switch must be checked for proper function before every crane operation by running the hook block against the switch weight. When the hoist limit switch is triggered, the symbol element appears in the operating view. The crane movements »lift« and »luff down« are shut off.

D A N G E R : **The hoist limit switch may only be bypassed with the keyed switch during crane operation if a guide is available to monitor the distance between the hook block and the boom head.**
The guide must be in direct contact with the crane operator.
The hoist movements must be carried out with utmost care and the least possible speed.
Bypassing the hoist limit switch is only permitted in emergency situations, and only by authorized personnel! The hoist limit switch may not be used as an operational shut off. If this is not observed, crane components can be destroyed in case of an erroneous function, or the crane can topple over!

9. Limit switch winch spooled up or out

The cam limit switch installed in the winch turns the crane movement "down" off if at least 3 safety coils are on the cable drum.

D A N G E R : **If the hoist cable is spooled up during installation, it must be ensured that the end of the cable is still in front of the winch and is not spooled up over the winch. If the cable end is pulled another turn over the winch, then the shut off at 3 safety coils is no longer ensured.**
The cam limit switch must be reset. In addition, if a new hoist cable is placed, the cam limit switch must be reset, so that it shuts off when the last 3 cable coils are on the drum.
If this is not observed, the cable mounting can be pulled out, which would cause the load to drop!

10. Limit switch initiators

Hoist "top"	- on the boom, lattice jib and boom nose
Boom "top"	- steepest position, relapse cylinders
Lattice jib "top"	- steepest position, relapse cylinders
	- steepest position, mechanical flap
Lattice jib "bottom"	- lowest position
Derrick	- D-Relapse cylinders
A-Bracket 25° to the front	

D A N G E R : The limit switches may not be used as operational shut off device. If this is not observed, crane components may be destroyed in case of an erroneous function or the crane can topple over.

10.1 Angle sensor (WG)

Each one angle sensor are installed on the main boom pivot section and on the end section.

Each one angle sensor are installed on the lattice jib pivot section and on the end section.

Two angle sensors are installed on the derrick, on the bottom.

The radius is determined by measuring the boom angle to the horizontal.

10.2 Pull test bracket (KMD = Force test box)

The utilization of the crane, which is combined of load momentum and the boom momentum affects a force in the boom guying, which is measured by the pull test brackets.

The pull test brackets are:

KMD 1,A/B in the boom guying ; force between A-bracket and boom in all operating modes **without** derrick.

KMD 1 in D- guying; force between A-bracket and derrick in all operating modes **with** derrick.

KMD 2 in lattice jib guying; force between A-bracket I and lattice jib end section in all operating modes with lattice jib.

KMD 3 in boom guying: force between derrick and boom in all D - operating modes.

10.3 Pressure monitoring on relapse cylinders ¹⁾

A pressure sensor is installed in the hydraulic section of the cylinder.

The signal corresponding to the hydraulic pressure is shown in the operating view on monitor "0" in the crane cab.

During crane operation, the pressure in the relapse cylinders **must** be constantly monitored.

¹⁾ For detailed description, see chapter 4.02 paragraph "Auxiliary functions"

11. Indication of winch turning direction and hook path ¹⁾

Is integrated into the "LICCON" system

This symbol shows in the crane operating view of the "LICCON" that the winch is turning and spools up or out, even if no hook movement can be seen, due to multiple reeving or slow speed.

C A U T I O N: When spooling the cable up / out, it must be ensured that no slack cable forms on the winch (check winch visually).
Slack cable can cause cable damage.

11.1 Incline indicator ¹⁾

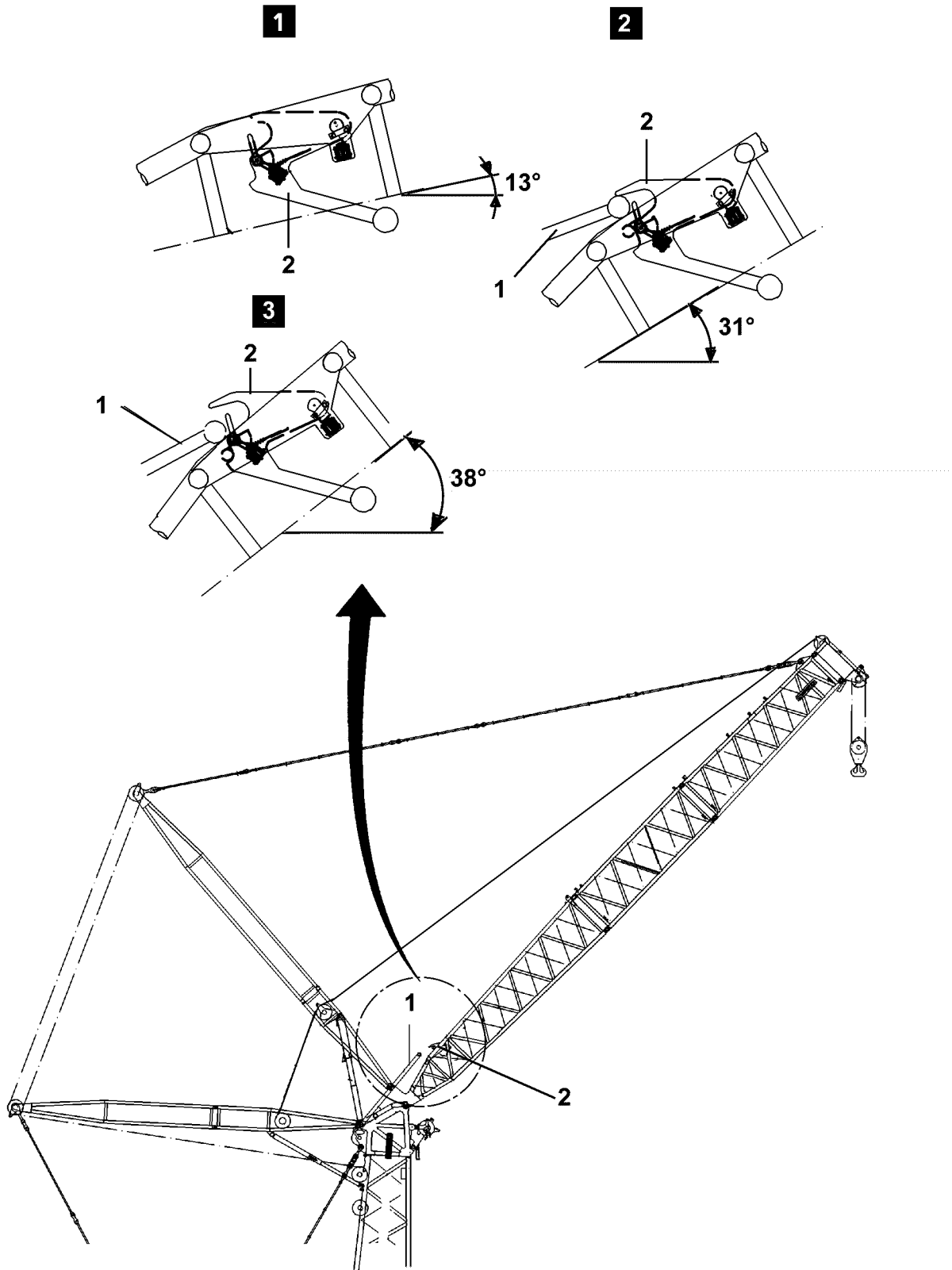
On this indicator, the position of the crane is shown graphically as well as numerically. The incline indicator has 2 test ranges, "0,2" or "1" degree range.

D A N G E R: If the permissible crane incline is exceeded, no shut off occurs!

¹⁾ for detailed description, see **chapter 4.02 paragraph "Auxiliary functions"**

12. Servo oil pressure monitor in winches I, II, III, IV, V, VI

If the servo oil pressure is not available and the master switch is deflected, then a corresponding error message will be issued.



Shut off due to collision between jib relapse support and jib flap

If there is the danger that the jib relapse support will push against the half extended flap and that it will therefore damage it, then the LIEBHERR ERROR CODE error (LEC) is shown and the luff up the jib movement will be turned off:

In detail:

In operating mode with jib

and main boom angle on pulley head Ok

and jib angle bottom Ok

and jib angle bottom $\geq 10^\circ$

and jib angle bottom $\leq 34^\circ$

and jib relative angle (= main boom angle on pulley head - jib angle bottom) so that:

jib relative angle $\geq 10^\circ$

and jib relative angle $\leq 26^\circ$

then there is a danger : collision between jib relapse support and jib flap

Shut off luff up jib (cannot be bypassed even in installation mode)

Operation view indication: Boom limit symbol (left next to upper hoist limit switch 1-Symbol) is shown with two arrows upward in the upper row for shut off luff up jib

otherwise no danger

no shut off

no symbol indication

For this shut off, 2 LEC errors apply, which are shown only if the master switch for luffing up the jib is deflected:

1. "Upper limit angle jib not clear" = Summation error from control
(Shut off occurrence in shut off diagram says "Upper limit angle jib not clear")
2. "Jib, flap and relapse support in danger of collision" = exact error text from LMB

Note:

If the main boom angle on the pulley head is not Ok

and main boom angle bottom

then the main boom angle bottom

is used instead the main boom angle on the pulley head.

Also:

If the jib angle bottom is not Ok

and jib angle top is Ok

then the jib angle top

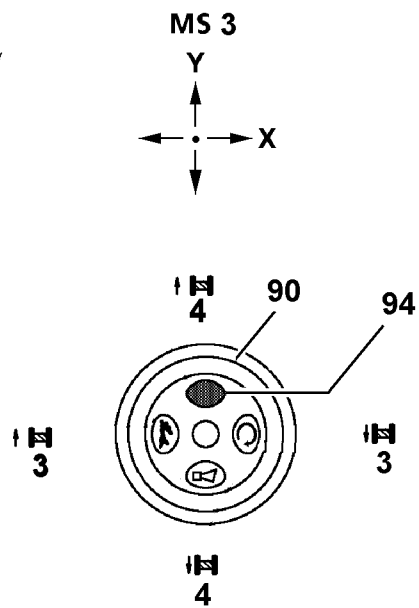
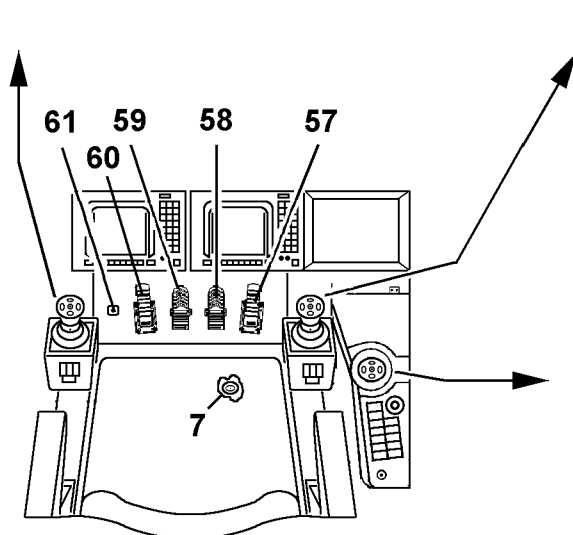
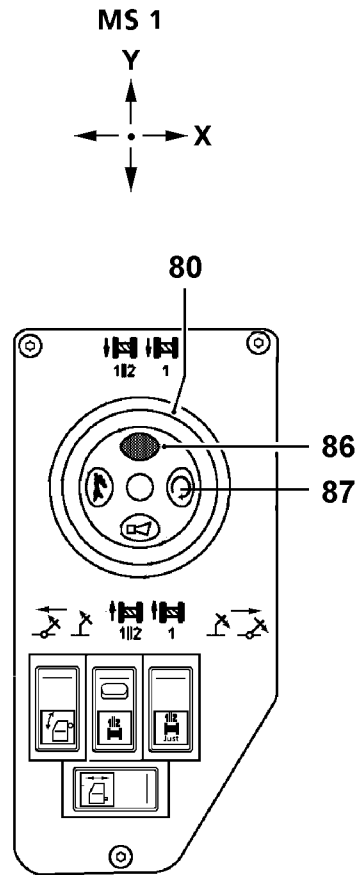
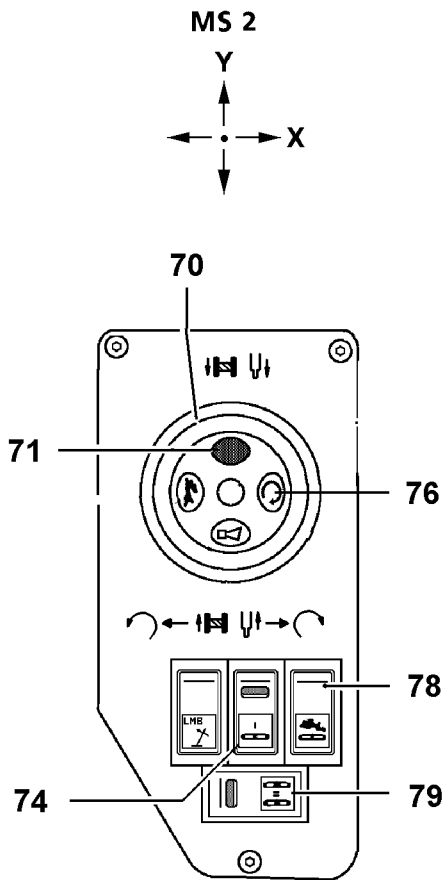
is used instead the jib angle bottom.

It is assumed that the boom flexation is smaller than the safety reserve.

CAUTION: If an angle sensor, required for collision monitoring, is defective or missing on a boom, then the crane operator must be more alert and observant, to ensure that there will be no collision !

If on one boom both angle sensor are defective or missing, then no monitoring and no shut off can occur. The crane operator must monitor himself to ensure that there will be no collision.

CAUTION: The crane operator may not depend on the fact that the shut off will function, he must know the dangerous angle positions and avoid them!



1. Crane operation

Prerequisites

- The crane is horizontally aligned.
- The counterweight is installed and secured, as noted on the load charts.
- The Diesel engine is running.
- The hook block is reeved, according to the reeving plan.
- All safety devices have been set according to the data in the load charts.
- All equipment configuration data and reeving have been set on the LICCON and have been confirmed, see chapter 4.03. Monitor 0 and Monitor 1 show the operating view.
- There are no persons or objects within the danger zone.
- Crawler "OFF", press switch (74) into 0-position.

CAUTION: Always operate the master switch slowly and sensitively.
This action spares the crane and reduces the possibility of accidents.

DANGER: Before any crane movements, make sure that no obstacles are within the working range of the crane and that there are no persons in the danger zone.
Give a warning signal (horn) before initiating a crane movement!

2. LICCON Computer system

Prerequisite

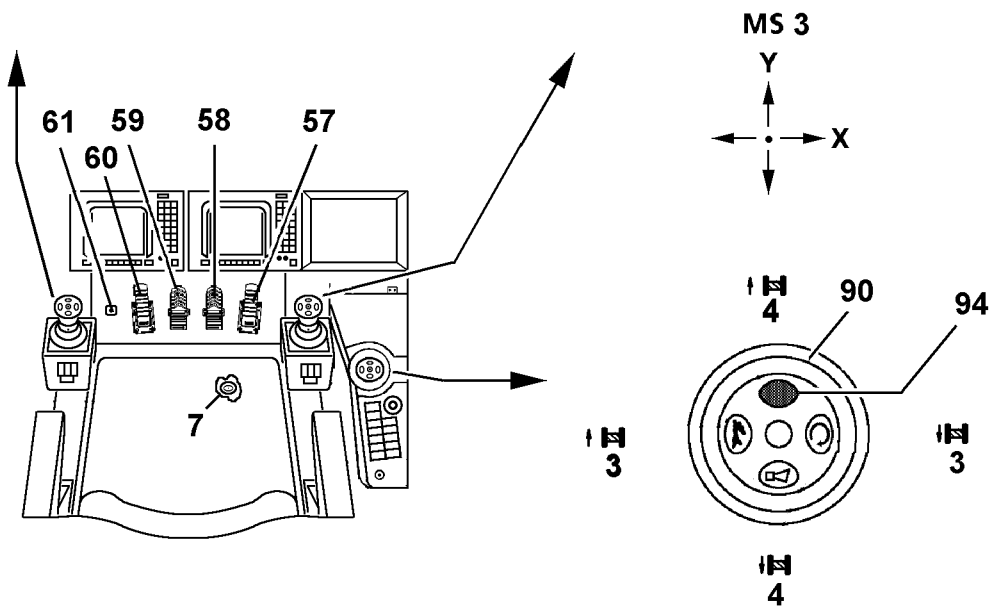
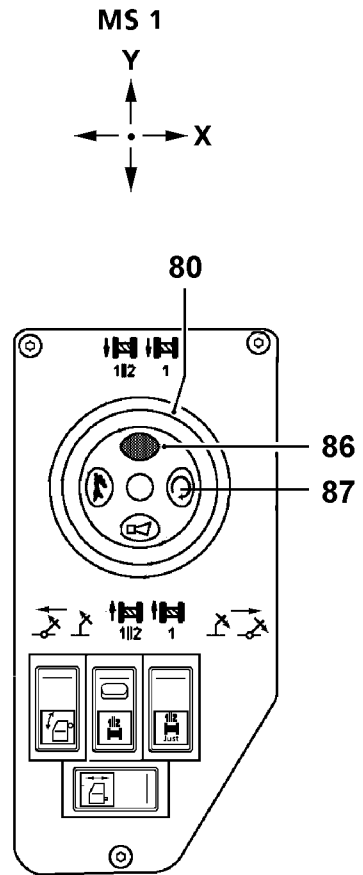
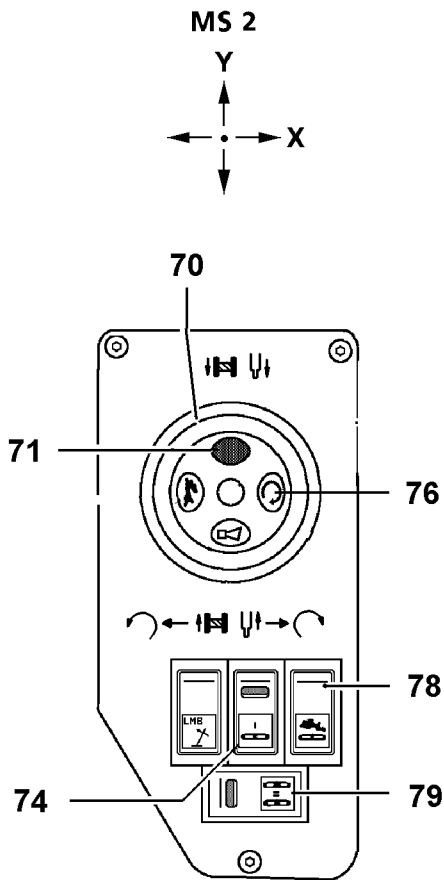
- The crane engine is running.

During operation, the indicators on the LICCON monitor must be observed. When carrying out a crane movement, the changing utilization condition and the changes in force should be seen. The overload condition should be recognized early and the crane movements should be slowed down accordingly.

The indicators must be monitored especially during a "turn slewing platform" und "drive crawler" movement, because these movements have no automatic shut off at overload.

The crane operator must constantly estimate if the data shown in the operating view can even be right. The crane operator may not blindly trust the system, he must think for himself and recognize a possible error.

DANGER: When bypassing the safety devices, there is a danger of accidents!



3. Release of crane control

In order to prevent inadvertent crane movements when entering and leaving the cab by inadvertently actuating the master switch, the crane control is shut off by a seat contact switch (7) as soon as the crane operator gets up from his seat.

Note: If the crane operator must work while standing, then the seat contact switch can be bypassed with two buttons (71, 86 or 94) on the corresponding master switch (70, 80 or 90) .

4. Engine monitoring

- see **Engine monitoring program, chapter 4.02, paragraph 12**

During crane operation, monitor the engine monitoring view by changing to it occasionally:

- Engine oil pressure
- Coolant temperature, coolant level
- Fuel level
- Air filter, battery voltage

4.1 Engine RPM

A constant engine RPM can be set. This relieves the crane operator if the crane is operated for a longer period of time.

- Press the pedal for engine regulation (57) until the desired engine RPMs are reached.
- Press the button (76 or 87,97) on master switch (70 or 80,90) , this sets a constant engine RPM, even though the pedal (57) is released.

By pushing the buttons (76,87,97) the current engine RPM, which was preselected via the foot pedal (57) is saved and held by the control until a new selection is made.

If a higher engine RPM is selected via the foot pedal (57) then the currently stored engine RPM, then the engine RPM will be increased according to the foot pedal pressure.



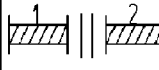












If the foot pedal is released again, the previously set engine RPM will be reset.
















Release the engine RPM lock

- Press the pedal for engine regulation (57) again, the engine RPM lock is released.

5. Winch operation

With long booms and lattice jibs, with empty hook operation and when spooling it up or out, it must be checked that no slack cable forms on the winch .

		 1			 2						 3			 4		
				F			F			F			F			F
NOT	(W1+W2)	1	1y	H1	2	2y	H2	◇ *7			3	1x	SV	4	3x	EZW
NOT	(W1 W2)	1	1y	H1	2	2y	H2	◇ *7			3	1x	SV	--	--	--
R		◇ *4			◇ *4			◇ *4			--	--	--	--	--	--
R	RA	--	--	--	--	--	--	--	--	--	--	--	--	4	1x	EZW
S	SL,L,LL,SF,SV,SLF LF,SNZF,SLNZF	1	1y	H1	2	2y	H2	1/2	1y	H1 H2	--	--	--	4	1x	SV
SW	SN,SLN,LN	1	1y	H1	2	2y	H2	1/2	1y	H1 H2	--	--	--	4	3y	SV
SNF	SWV,SLNF,LNF	1	1y	H1	2	2y	H2	1/2	1y	H1 H2	--	--	--	4	1x	SV
SD	SLD,LD,SDF SLDF,SDNZF	1	1y	H1	2	2y	H2	1/2	1y	H1 H2	3	1x	SV	4	3y	EZW
SDW	SDWN,SDN	1	1y	H1	2	2y	H2	1/2	1y	H1 H2	3	3x	SV	4	3y	EZW
SDNF	SDWV	1	1y	H1	2	2y	H2	1/2	1y	H1 H2	3	1x	SV	4	3y	EZW
SDNB(W)	SLDFB(W),SDNF(W),SDFB(W) SLDFB(W),SDNZFB(W)	1	1y	H1	2	2y	H2	1/2	1y	H1 H2	3	1x	SV	4	3y	EZW
SDWB(W)	SDNB(W)	1	1y	H1	2	2y	H2	1/2	1y	H1 H2	3	3x	SV	4	3y	EZW
SDNFB(W)	SDWVB(W)	1	1y	H1	2	2y	H2	1/2	1y	H1 H2	3	1x	SV	4	3y	EZW

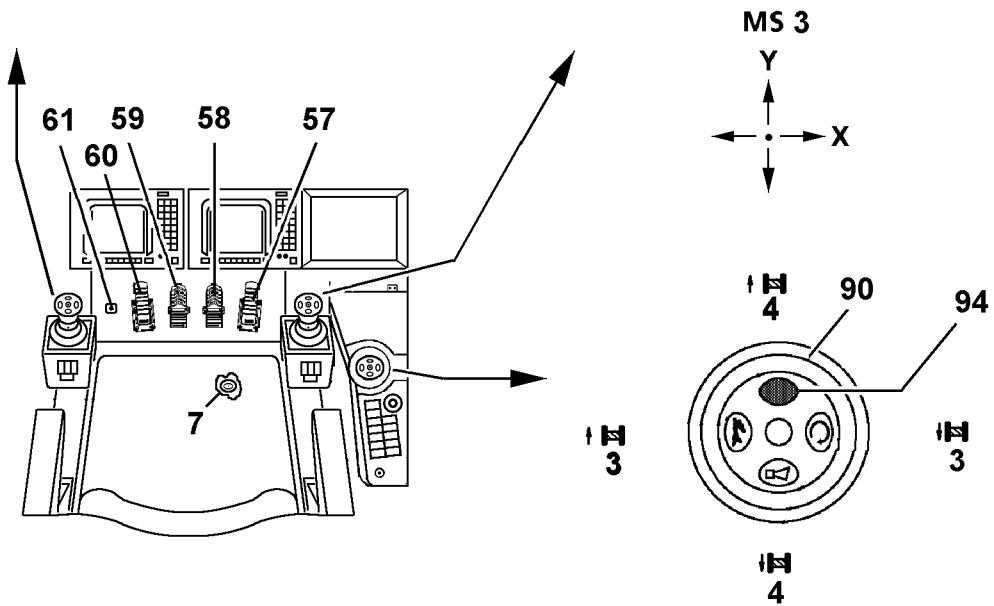
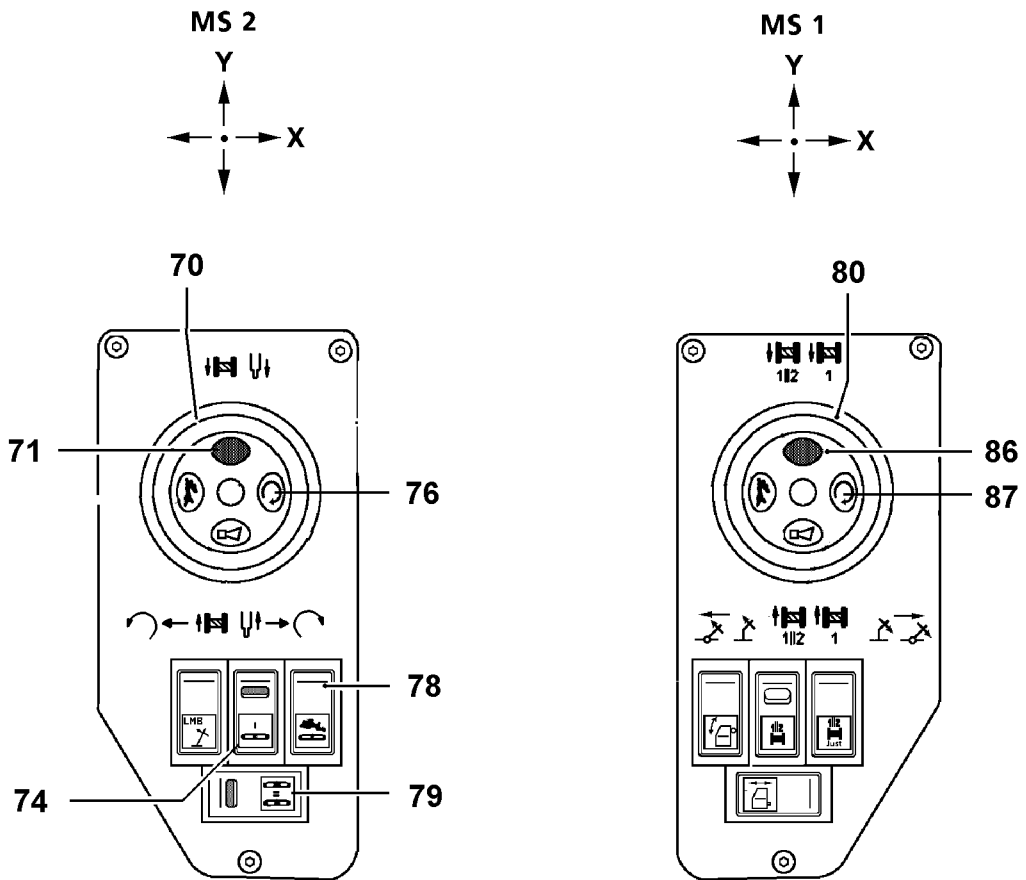
 5		 6		D				 L		 R					
		F			F			F			F			F	
5	3y	H2	NV	--	--	6	2x	D	◇ *5		◇ *6		◇ *6		
5	3y	H2	NV	4	3x	H2	6	2x	D	◇ *5		◇ *6		◇ *6	
◇ *4		--	--	--	6	2x	D	◇ *5		3	4y	R	4	5y	R
--	--	--	--	--	6	2x	D	2	2y	Z	◇ *6		◇ *6		
5	2y*1	H2	--	--	6	2x	D	--	--	--	◇ *6		◇ *6		
5	1x	NV	4	2y*3	H2	6	2x	D	--	--	--	◇ *6		◇ *6	
5	3x	NV	4	2y*3	H2	6	2x	D	--	--	--	◇ *6		◇ *6	
5	2y*1	H2	--	--	6	2x	D	--	--	--	◇ *6		◇ *6		
5	1x	NV	4	2y*3	H2	6	2x	D	--	--	--	◇ *6		◇ *6	
5	3x	NV	4	2y*3	H2	6	2x	D	--	--	--	◇ *6		◇ *6	
5	2y*1	H2	--	--	6	2x	D	--	--	--	◇ *6		◇ *6		
5	1x	NV	4	2y*3	H2	6	2x	D	--	--	--	◇ *6		◇ *6	
5	3x	NV	4	2y*3	H2	6	2x	D	--	--	--	◇ *6		◇ *6	

6. Winches, pumps and master switch (MS) assignment to operating modes

Slewing gear pump 6, Master switch 2x

- * 1 Only in switch position H1 //H2
- * 3 Only in switch position H1 //H2 and not winch 4
- * 4 see above or below
- * 5 see above or below
- * 6 see above or below
- * 7 see H1 + H2
- - locked
- ↓ ↑ see above or below
- ⇐⇒ see left or right

H1	Hoist gear 1
H2	Hoist gear 2
P	Pump
D	Slewing gear
NV	Jib control
R	Crawler
F	Function
MS	Master switch
MN	Boom nose
SV	Main boom control
EZW	Derrick control
NOT	Emergency mode
R ^{RA}	Crawler assembly
Z	Installation cylinder



7. Control of crane movements

CAUTION: When spooling the hoist cable up / out, it must be checked that no slack cable forms on the winch (check winch visually).
Slack cable can lead to cable damage.

7.1 Crane movement "main boom control" in operating modes: S, SL

The boom control is made via master switch (80) , MS1x in these operating modes.

Deflect master switch (80) to the left	=	Luff up boom
Deflect master switch (80) to the right	=	Luff down boom

Crane movement "main boom control" in operating modes: SW

The boom control is made via master switch (90) , MS3y in these operating modes.

Deflect master switch (90) to the rear	=	Luff up boom
Deflect master switch (90) to the front	=	Luff down boom

Crane movement "lattice jib control" in operating modes : SDW

The lattice jib control is made via master switch (80) , MS1x in these operating modes.

Master switch (80) deflect to the left	=	Luff up lattice jib
Master switch (80) deflect to the right	=	Luff down lattice jib

Crane movement "Derrick control" in all derrick operating modes

The boom control is made via master switch (90) , MS3y in these operating modes.

Deflect master switch (90) to the rear	=	Luff up derrick
Deflect master switch (90) to the front	=	Luff down derrick

7.2 Crane movement "Lift / lower" hoist gear 1 - Winch 1 or 1//2

Deflect master switch (80), MS1y, to the front	=	Hoist down
Deflect master switch (80) , MS1y, to the rear	=	Hoist up

Crane movement "Lift / lower" hoist gear 2 - Winch 2 or 5 or 6

Deflect master switch (70), MS2y, to the front	=	Hoist down
Deflect master switch (70), MS2y, to the rear	=	Hoist up

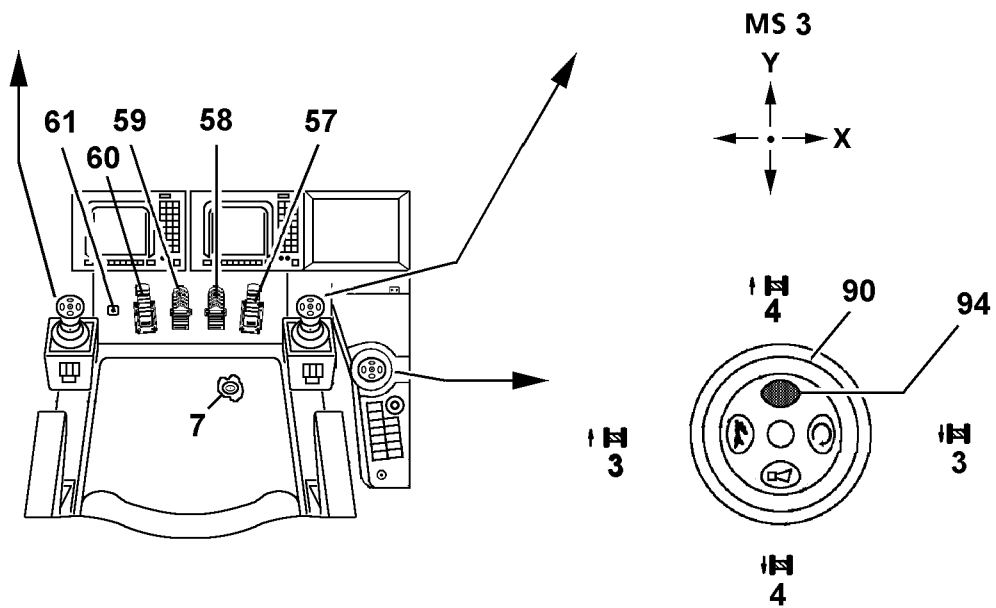
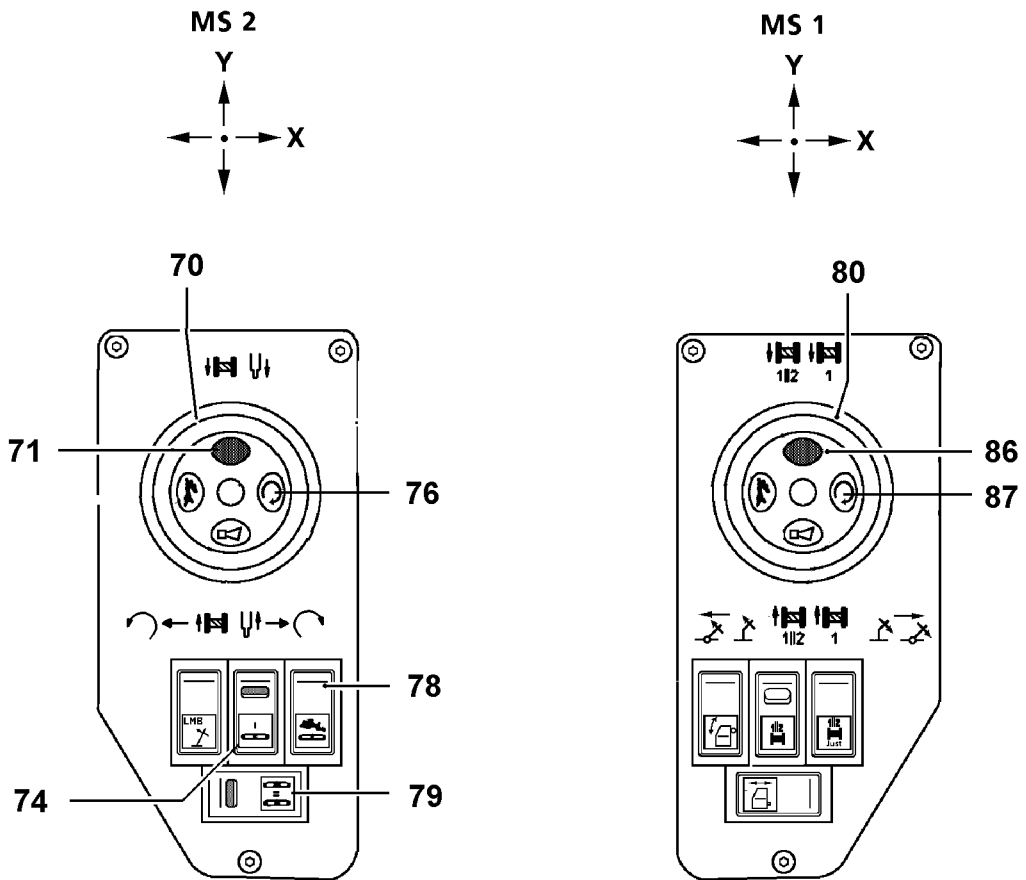
Note: The speed of the crane movement is regulated via the deflection of the manual control lever and the engine regulation.
The winch symbol on the LICCON monitor as well as a vibration sensor in the master switch show, that the winch turns, even if no hook movement can be seen due to multiple reeving and slow speed.

7.3 Preselection of maximum slewing speed of winches as well as deactivation / activation of the individual winches

In the "Control-Parameter" program it is possible to preselect the maximum turning speed of the individual winches or to deactivate / activate the individual winches.

Note: See chapter 4.02, LICCON COMPUTER SYSTEM; paragraph 8. "Control Parameter" program.

CAUTION: The maximum turning speed as well as deactivation or activation of the winches may not be made as long as a crane movement is carried out.



7.4 Crane movement "slewing"

The slewing speed range must be preselected on the LICCON monitor in percentages (%) according to the data in the load chart manual - see LICCON, chapter 4.02.

DANGER: Before initiating the crane movement "slewing", the crane operator must make sure that there are no persons or obstacles within the slewing range. Before initiating the crane movement, the crane operator must make sure that there are no persons or obstacles within the slewing range. In addition, he must sound the warning signal (horn).
If this is not observed, there is a DANGER OF ACCIDENTS!

Deflect the master switch (70), MS2x, to the right = to turn to the right
 Deflect the master switch (70), MS2x, to the left = to turn to the left

Note: The speed of the crane movement is controlled via the deflection of the manual control lever and the engine regulation.

DANGER: When turning with a load, the slewing movement or braking movement must be initiated extremely sensitively.
If a slewing movement or braking movement is initiated too suddenly or jerkily, the load can start to swing back and forth. A swinging load can cause the boom to brake or the crane to topple over.

7.4.1 Preselection of slewing speed

In the load chart manual, the maximum slewing speeds are given in percentages.

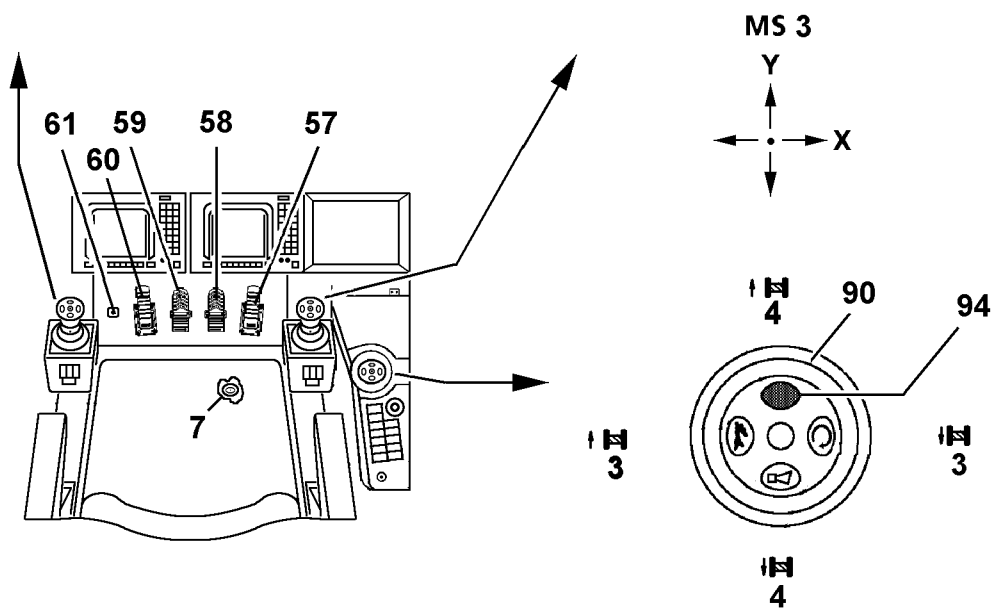
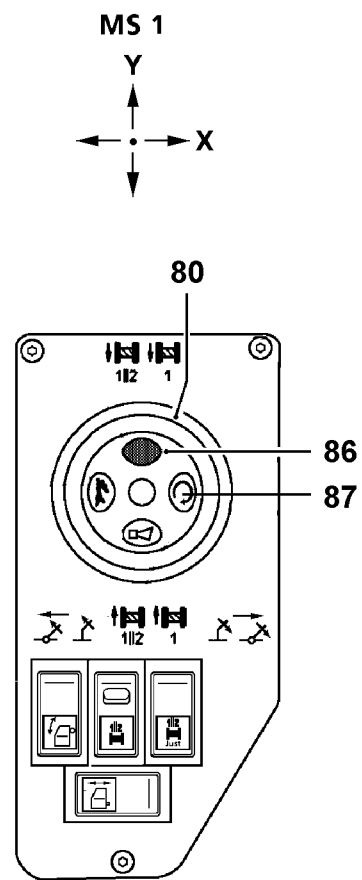
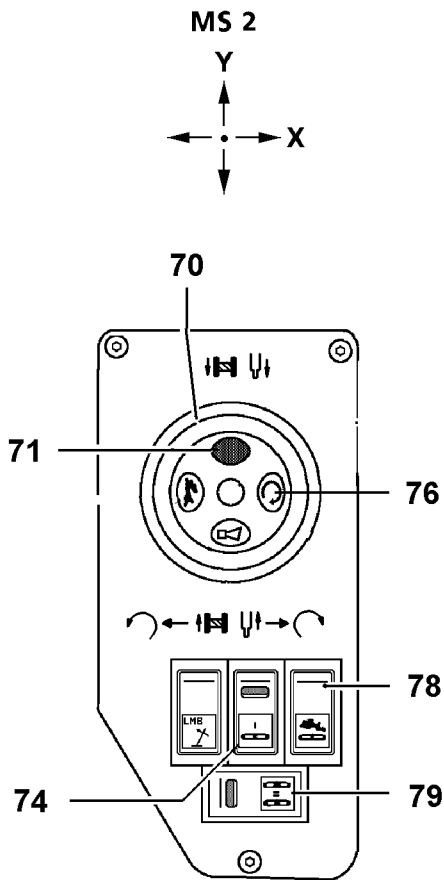
CAUTION: These values depend on the boomlength and the operating mode and may not be exceeded during crane operation with a load.

Note: The maximum slewing speeds can be set and adjusted in the "Control Parameter" program. See chapter 4.02, LICCON COMPUTER SYSTEM; paragraph 8, "Control Parameter" program.

CAUTION: The maximum slewing speed may not be changed as long as a crane movement is actuated.

The following applies:

Longer boom	}	slower speed
Larger load		



7.4.2 Coasting of slewing gear

Press the foot button (61) to switch the swing gear to coasting. This makes it easier to position the boom above the load to be lifted. The master switch 2 (70) may not be deflected.

D A N G E R : **If the crane superstructure turns inadvertently (for example due to wind), then proceed as follows:**

- **Do not release the foot button (61)!**
If the foot button is released immediately, the crane superstructure stops suddenly. This can cause the load to swing to the "rear" and can damage the crane.
- **Deflect the master switch 2 (70) in turning direction, then release the foot button. Now the turning movement can be slowed down by slowly moving the master switch.**

Note: The slewing gear cannot be switched to coasting if:
 - the slewing gear is shut off by the LML,
 - the working range limitation is activated .

7.4.3 Slewing gear block

An additional pedal (60) to block the slewing gear is installed in the crane. If the crane is turned while strong side winds are blowing and with long boom system against the wind, then the crane superstructure turns into the opposite direction, due to leakage in the hydraulic motor. This can be prevented by actuating the pedal to block the slewing gear (60) and by deflecting the master switch (70) into the desired turning direction. By slowly releasing the pedal (60) , the superstructure turns into the desired direction.

The slewing gear block may only be used at minimum slewing speed, i. e. with the master switch (70) almost in zero position and for the following applications:

1. Starting to drive with strong side wind
Actuate the pedal for slewing gear block (60) and deflect the master switch (70) into the desired turning direction. Slowly release the pedal (60) until the crane superstructure turns into the desired direction.
2. Stopping the slewing movement with strong side wind
With the master switch (70) , slow down the crane to the minimum speed. Carefully actuate the pedal (60) for the slewing gear block, until the crane comes to a standstill at the desired point.

C A U T I O N : **The slewing gear block may never be used as an additional slewing gear brake.**
If this is not observed, the slewing gear brake can be destroyed. This in turn can damage the slewing gear or the rotary connection .

D A N G E R : **If the swing movement of the crane is slowed down by swinging back into the zero position with the master switch, then this causes crane overload. Danger of accident!**

8. Crane operation

Observe the general notes in this chapter!

Prerequisites:

- The LICCON overload safety system is set according to the data given in the load chart.
- The installation keyed button is turned off.
- The installation symbol on the LICCON indicator turns off.

D A N G E R : **Check the horizontal position of the crane before and during operation. Even if the crane operator leaves the cab for only a short time, then he is obligated, before starting to work again, to check the operating mode setting and to reset them, if necessary.**

8.1 Adjustments / checks

Check the function of the overload safety system, by actuating the operating positions "top" and "bottom".
 Check the function of the hoist limit switch "on top" by actuating the hoist limit switch.
 Check the function of the limit switch "Boom steep" by actuating the relapse cylinders.
 Check the function of the limit switch "Derrick" by actuating the relapse cylinders.
 Check the function of the limit switch "lattice jib steep" by actuating the relapse cylinders.
 Check the function of the limit switch on the flap (pendulum).
 Check the retraction of the mechanical relapse support into the flap.

D A N G E R : **Before erection, the easy movement of the pendulum of the mechanical relapse support must be checked over its complete swing range. If this is not observed, the mechanical relapse support does not engage in stepp lattice jib position. There is a danger of accidents because the lattice jib may tip backward!**

8.2 Guy rods on lattice sections in crane operation

If the guy rods are not needed for the present boom combination, then they can remain on the lattice sections. However, the following must be observed:

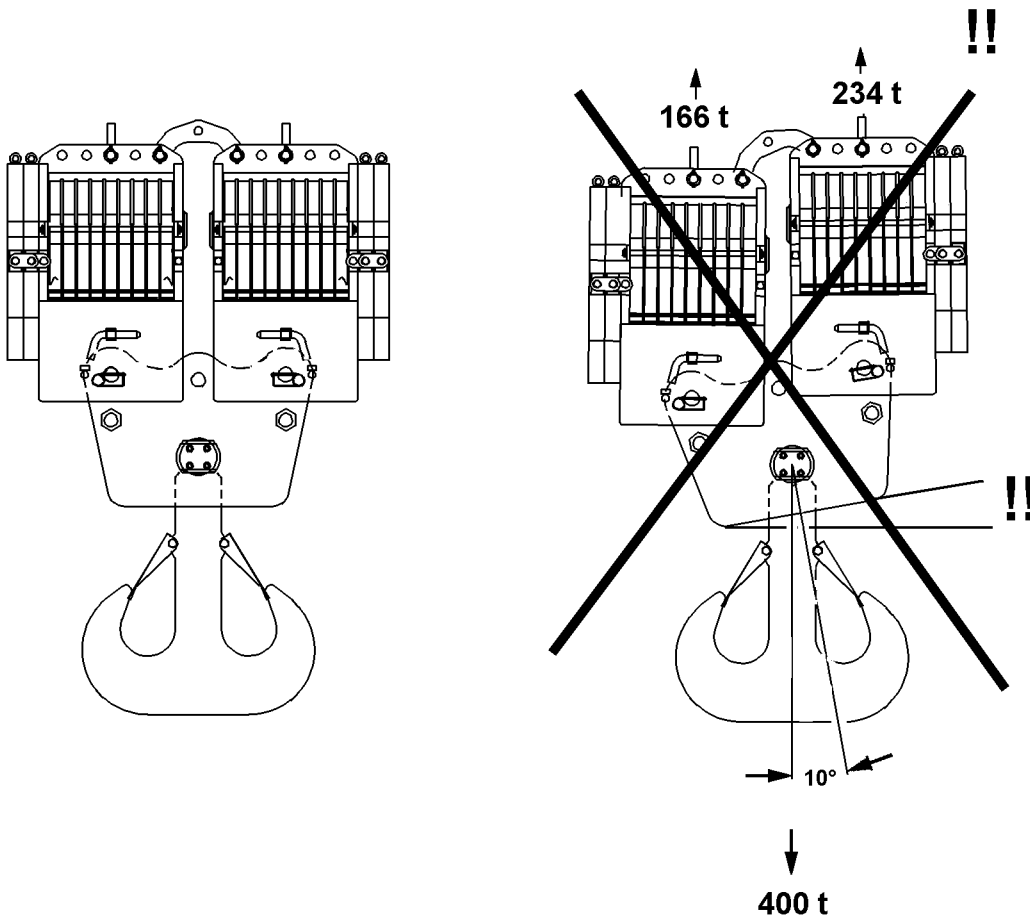
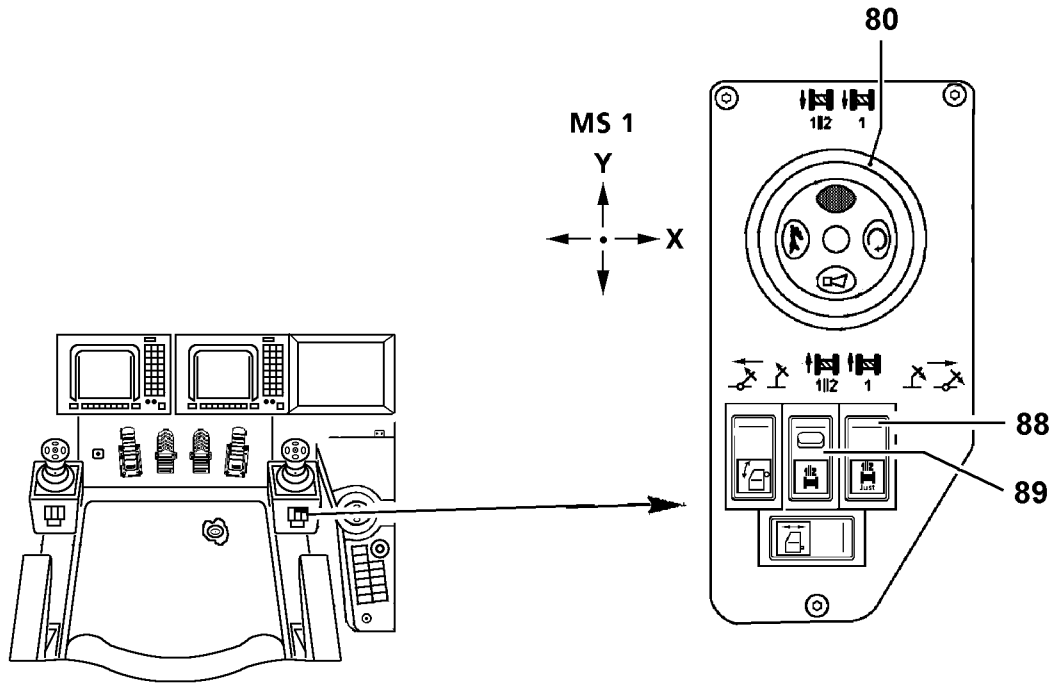
Note: If the guy rods are not removed, then the load capacity values given in the load chart must be reduced accordingly.

8.3 Danger conditions without shut off

Block position relapse cylinder - Lower load

D A N G E R : **If the crane actuates the block position of the relapse cylinders with the boom or derrick, with attached and freely suspended load, then there is danger that the boom or relapse cylinder will be damaged when setting down the load on the ground. By setting down the load, the boom is relieved, which causes the boom system to move backward.**

There is no shut off of the hoist gear down function. For that reason, the opposite direction of the movement, which caused the block position, must be actuated to release the block position again.



9. Parallel operation (winch 1 // 2) - Crane operation with double pulley blocks

The cables of winch 1 and 2 are used for this operation.

Note: Installation of hook block for double pulley block operation - see chapter 4.06.
Enter the total reeving into the LICCON.

C A U T I O N: Before horizontal alignment of the hook block and before crane operation, the transport pins on the hook blocks must be pulled.

Operation

Before a load is attached, the hook block must be aligned as follows - check visually:

- Actuate the master switch (80) - winch 1 or master switch (70) - winch 2 and spool the winches up or out until the hook blocks are aligned in horizontal direction - check visually.

- Then the parallel control of winches 1 // 2 must be adjusted with button (88) .

- Turn on the switch (89) winch 1//2, parallel operation.

Note: In parallel operation, the control for winch 1 and 2 is made only with master switch MS 1y (80).

Set the zero point for hook path indication.

Note: See chapter 4.02, LICCON COMPUTER SYSTEM

If in crane operation the difference range in the parallel control is exceeded, the winch movement is shut off.

The winches must again be set to parallel operation, as described above.

C A U T I O N: The electronic parallel control only monitors the same RPM of the two winches, it does not take the following errors into account:

1. uneven cable length
2. different winding properties
3. uneven reeving of both hook blocks (not permitted!)

The crane operator still remains responsible that the hook blocks always remain on the same level, despite electronic monitoring.

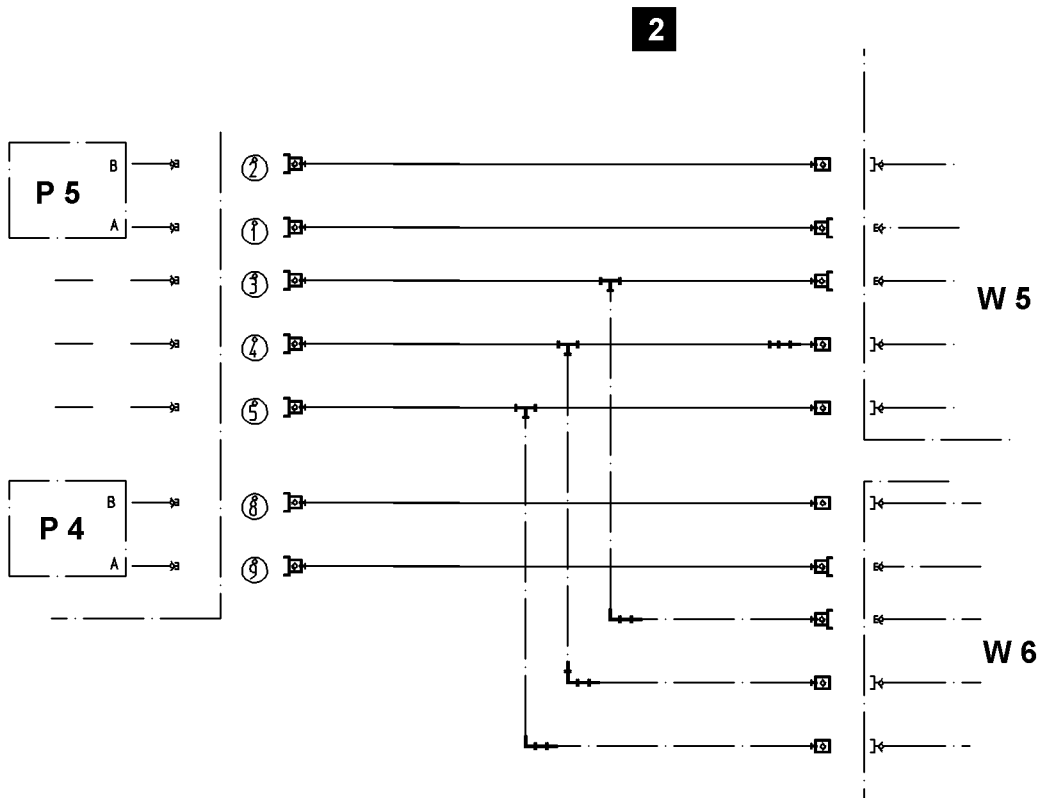
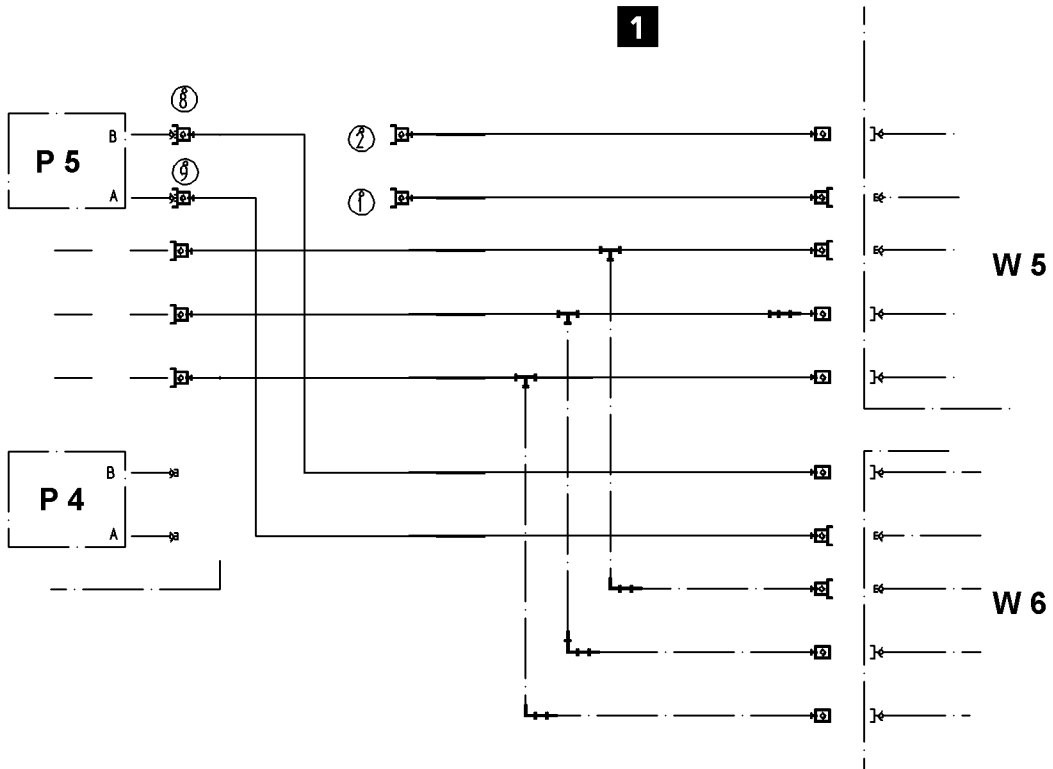
D A N G E R: In parallel operation, the crane operator must make sure that the equalization crossbar on the double hook blocks always remains in horizontal position

- Check visually!

If this is not observed, an overload of hook block, boom or cable can occur, which can cause property damage and personal injuries.

If it is not ensured that the equalization crossbar on the hook blocks always remains in horizontal position, accidents can occur!

Example : Load changes on the individual hook blocks if the equalization crossbar inclines and is positioned horizontally - see illustration!



10. Winch 6 and 5

10.1 Winch 5 and 6 are installed in the S-pivot section.

To use winch 6 in any other than the SDW system, the winch must be connected to the hydraulic and electric connections of winch 5, as winch 6 and 4 are supplied by the same pump.

These winches cannot be operated simultaneously if they are connected to the same pump.

By connecting hydraulic hoses from winch 6 to the pump 4 of winch 5, winch 6 and winch 4 can be operated separately.

Note: When winch 6 is operated with the hydraulic and electrical connections of winch 5 as hoist winch, then winch 6 is operates as winch 5.
In the LICCON operating view, winch 5 is shown instead of winch 6.
In this case, the hook path indication is not correct for winch 6!
If winch 6 (connections on pump of winch 5) is operated and then again winch 5, the hook path indication is wrong until the winch 5 is calibrated again.

10.2 If winch 6 is not installed, a hoist cable is placed on the N/W control winch, which may only be operated for no more than a maximum of 2 months of operation.

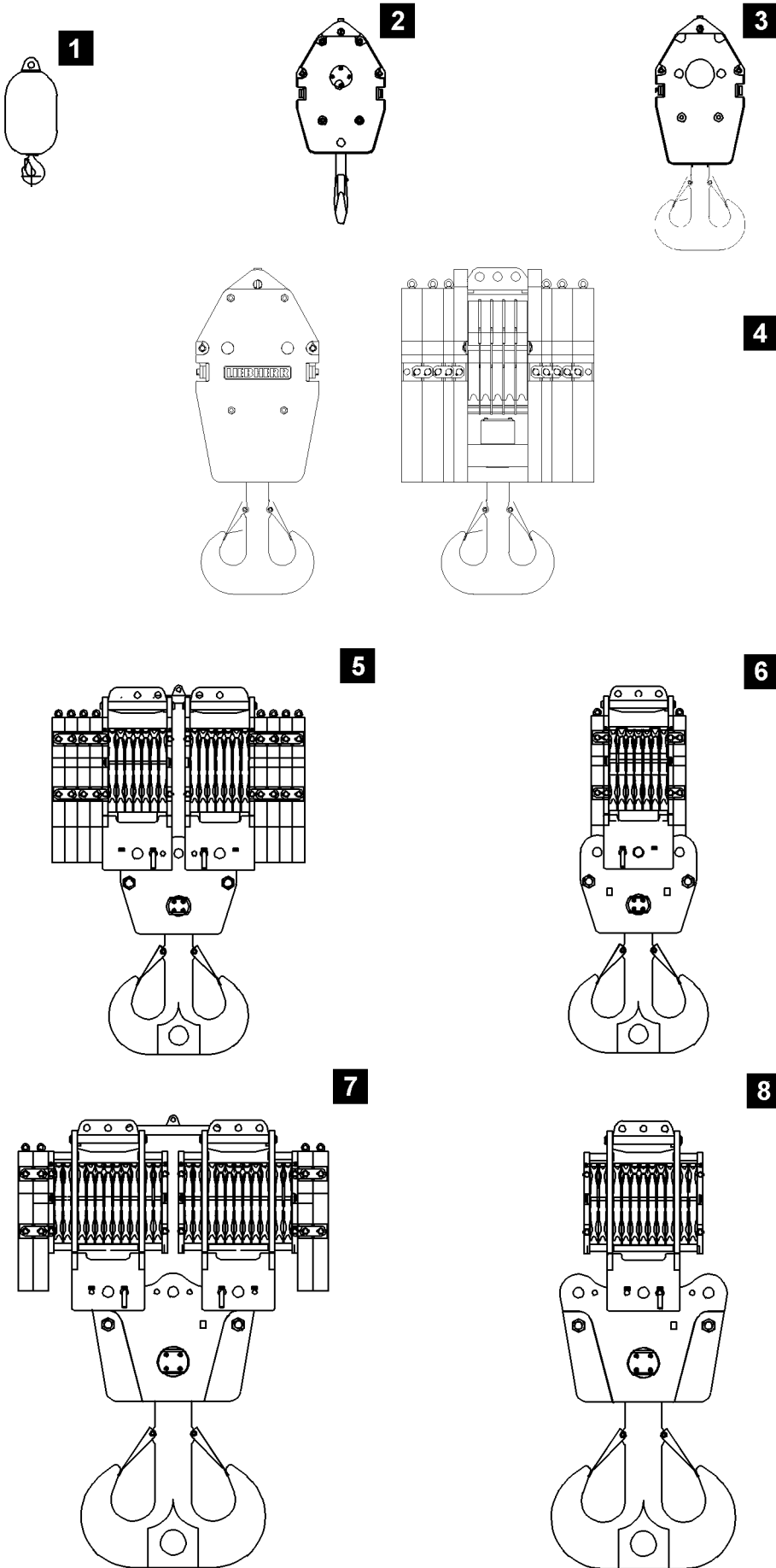
After this operating period, the cable must be unreeved, inspected and reeved again. If this is not observed, the cable can be damaged.

Note: See chapter 8.04 for important inspection and maintenance instructions for cables.

CAUTION: If the operating period is longer than 2 - 3 months, then it is necessary to place a torsionfree control cable on the control winch (winch 5) . Otherwise the cable will be damaged.

If any damage is found, the cable must be taken down immediately!

If winch 6 is purchased, a control cable is generally placed on winch 5.



Hook blocks

By bolting on additional plates the weight of the hook blocks can be raised.

Load hook 16 t (fig. 1)

Weight = 1,1 t

Hook block 47 t - 1 Pulley (Fig 2)

Single hook block with single hook

- 47 t load

Weight without additional plates: = 1,0 t

Weight with 2 additional plates: = 2,0 t

Weight with 4 additional plates: = 3,0 t

Hook block 107 t - 3 Pulleys (Fig 3)

- Single hook block with double hook

- 107 t load

Weight without additional plates : = 2,5 t

Weight with 2 additional plates, 80mm: = 3,5 t

Weight with 2 additional plates , 150mm: = 4,5 t

Weight with 4 additional plates: = 5,5 t

Hook block 160 t - 5 Pulleys (Fig 4)

- Single hook block with double hook

- 160 t load

Weight without additional plates : = 2,0 t

Weight with 2 small additional plates: = 3,0 t

Weight with 2 big additional plates: = 4,0 t

Weight with 2 small + 2 big additional plates: = 5,0 t

Weight with 4 big additional plates: = 6,0 t

Weight with 2 small + 4 big additional plates: = 7,0 t

Hook block 400 t / 215 t - 2 × 7 Pulleys (Fig 5)

- Double hook block with crossbeam consisting of a double hook with 400 t load

- crossbeam and 2 pulley sets each 7 pulleys

The double hook block can be remounted to a single hook block with load of 215 t

Weight without additional plates: = 7,0 t

Weight with 2 additional plates: = 9,0 t

Weight with 4 additional plates: = 11,0 t

Weight with 6 additional plates: = 13,0 t

Weight with 8 additional plates: = 15,0 t

Single hook block 215 t - 7 Pulleys (Fig 6)

Weight single hook block: = 5,5 / 7,5 t

Hook block 600 t / 312 t - 2 × 11 Pulleys (Fig. 7)

- Double hook block with crossbeam consisting of a double hook with 600 t load

- crossbeam and 2 pulley sets each 11 pulleys

The double hook block can be remounted to a single hook block with load of 312 t

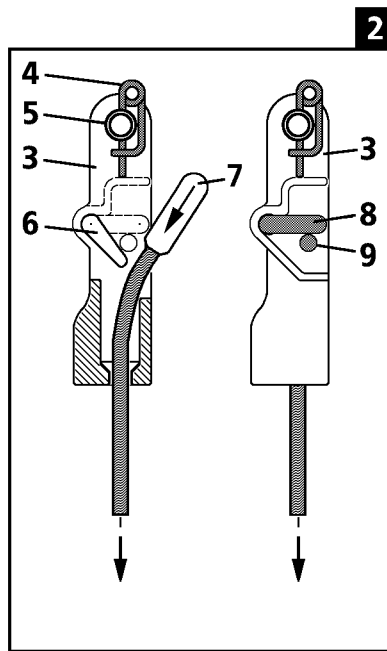
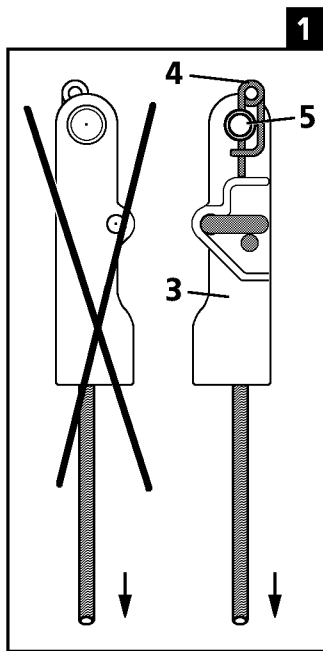
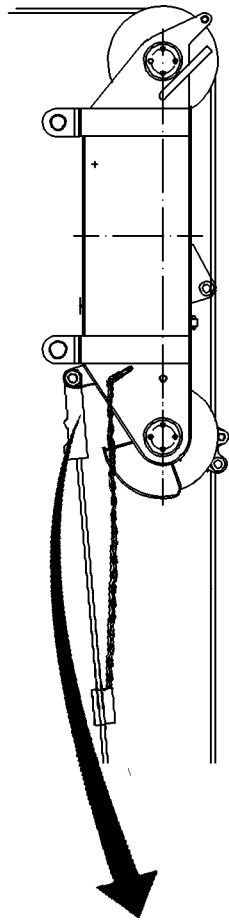
Weight without additional plates: = 11,0 t

Weight with 2 additional plates: = 13,0 t

Weight with 4 additional plates: = 16,0 t

Single hook block 312 t - 11 Pulleys (Fig 8)

Weight single hook block: = 8,4 t



Reeving the hook block

Prerequisite:

- The crane is horizontally aligned.
- An assistant is present to guide the cable .

Installation procedure:

- Loosen the spring retainer and pull out the cable retaining bars (1) on the pulley head (2).
- Place the required hook block under the pulley head of the boom.
- On the hook block, remove the spring retainers and pull out cable retaining bars.
- Start the crane engine.

Note: While the assistant guides the hoist cable to the pulley head, the crane operator must operate the winch. This procedure must be done in such a manner, that the cable does not slacken up on the cable drum.

DANGER: **This work should be completed while standing on a secure base. If it is unavoidable that the cable must be hand-guided on the boom to the pulley head, use utmost caution when walking on the boom. There is a great danger of causing a serious accident if the crane function is not operated properly and the person guiding the cable slips on the boom.**

- Lay the hoist cable over the top cable pulley and reeve the hoist cable between the pulley head and the hook block as shown on the reeving plan for the appropriate load capacity chart.
- Reinsert the cable retaining bars and secure them with spring retainers.

Note: Reeving may be done manually or with the aid of a reeving winch .
If the reeving winch is used, the auxiliary cable must first be reeved in reverse direction between the hook block and the pulley head and then connected with the hoist cable.
During the reeving procedure, the crane operator must spool out the hoist cable from hoist winch and at the same time, spool up the auxiliary cable with the auxiliary winch .

Insert the hoist cable

Fig.: 1

- Depending on the reeving, bolt the cable lock (3) either to the pulley head or to the hook block and secure with the spring retainer (4).

DANGER: **The pin (5) must always be placed from the inside to the outside and secured from the outside, to prevent the hoist cable from rubbing against the pin (5) or the spring retainer (4).**

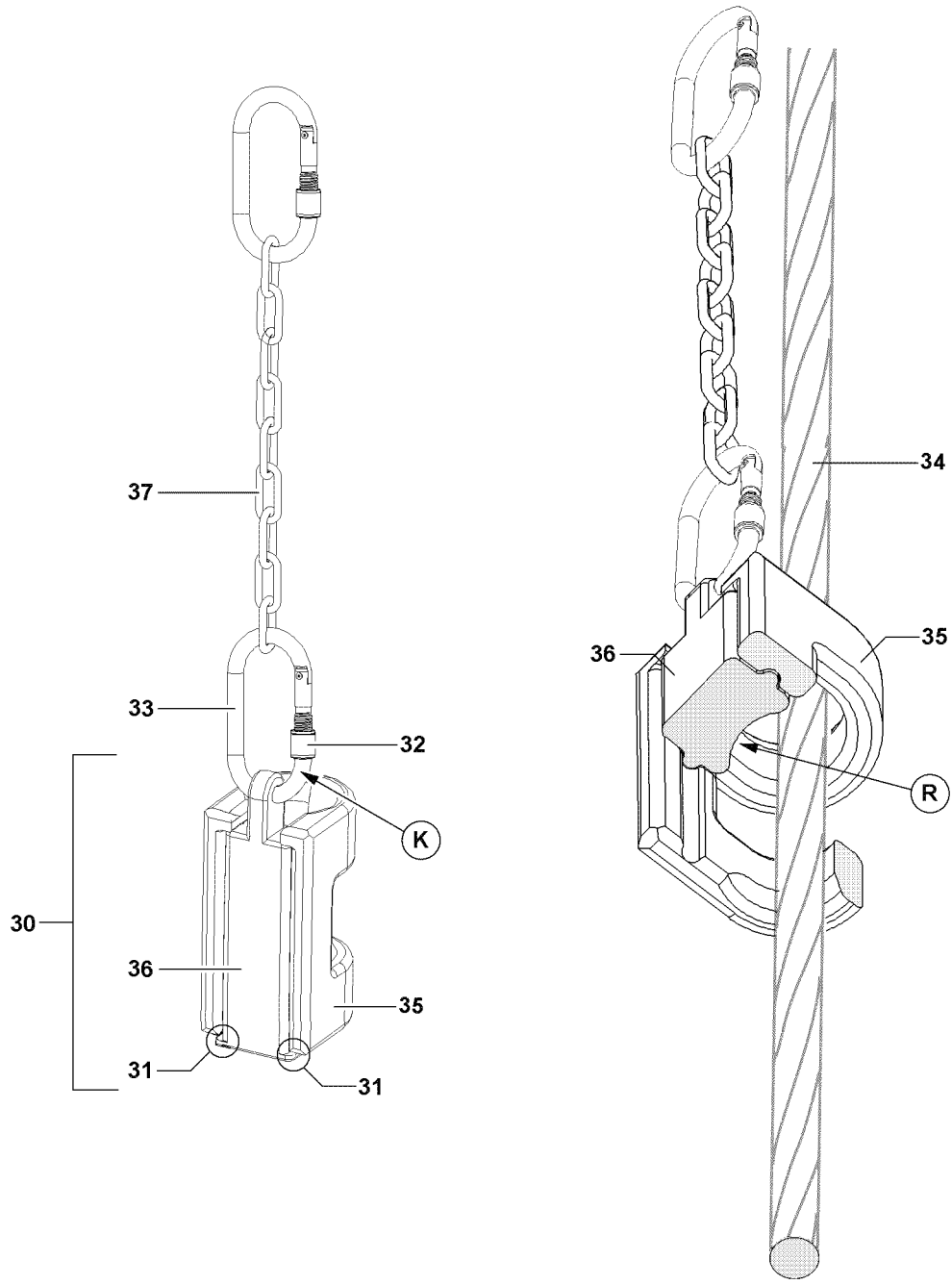
Fig.: 2

- On the cable lock (3), push in the retainer pin (9), with the lever (6) downward and hold it in this position.

Note: This causes the locking lever (8) to swing downward.

- Insert the end of the cable with the cable fitting (7) into the cable lock (3) and strongly pull it "downward" .

CAUTION: **The cable fitting (7) must touch the taper in the cable lock (3) , the lever (6) must be locked with the lock pin (9). The locking mechanism (6,8 and 9) on the cable lock must be freely movable.**



Attaching the hoist limit switch weight

The hoist limit switch weight (30) consists of 2 parts, which are pushed into each other:

- the weight (35)
- the carrier section (36)

Loosen and open the screw retainer (32).

DANGER: **The hoist limit switch can fall down!**
If the hoist limit switch weight is incorrectly installed, components can fall down!
Personnel can be severely injured or killed!

- Do not replace the snap hook (33) with other parts, such as a shackle or similar!
- When attaching or detaching the hoist limit switch weight (30) make sure that the weight (35) and the carrier section (36) do not fall down!
- Make sure that the curvature (R) of the carrier section (36) points to the hoist rope (34)!
- Make sure that the stubs (31) of the carrier section (36) touch on the weight (35)!
- Make sure that the screw retainer (32) may be turned downward, point (K)!

The attachment of the hoist limit switch weight (30) depends on the position of the rope fixed point.

Rope fixed point on the pulley head:

- In the event of multiple hoist rope reeving, the hoist limit switch weight (30) must always be laid around the “stationary rope strand”, in other words around the rope strand that leads directly to the cable lock.

Rope fixed point on hook block:

- The hoist limit switch weight (30) is laid around the outer strand which shows the least diagonal pull, i.e. the one with the smallest angle between the hanging hoist limit switch weight and the hoist rope.

Note: The chain (37) must be attached in full length during crane operation and may not be shortened.

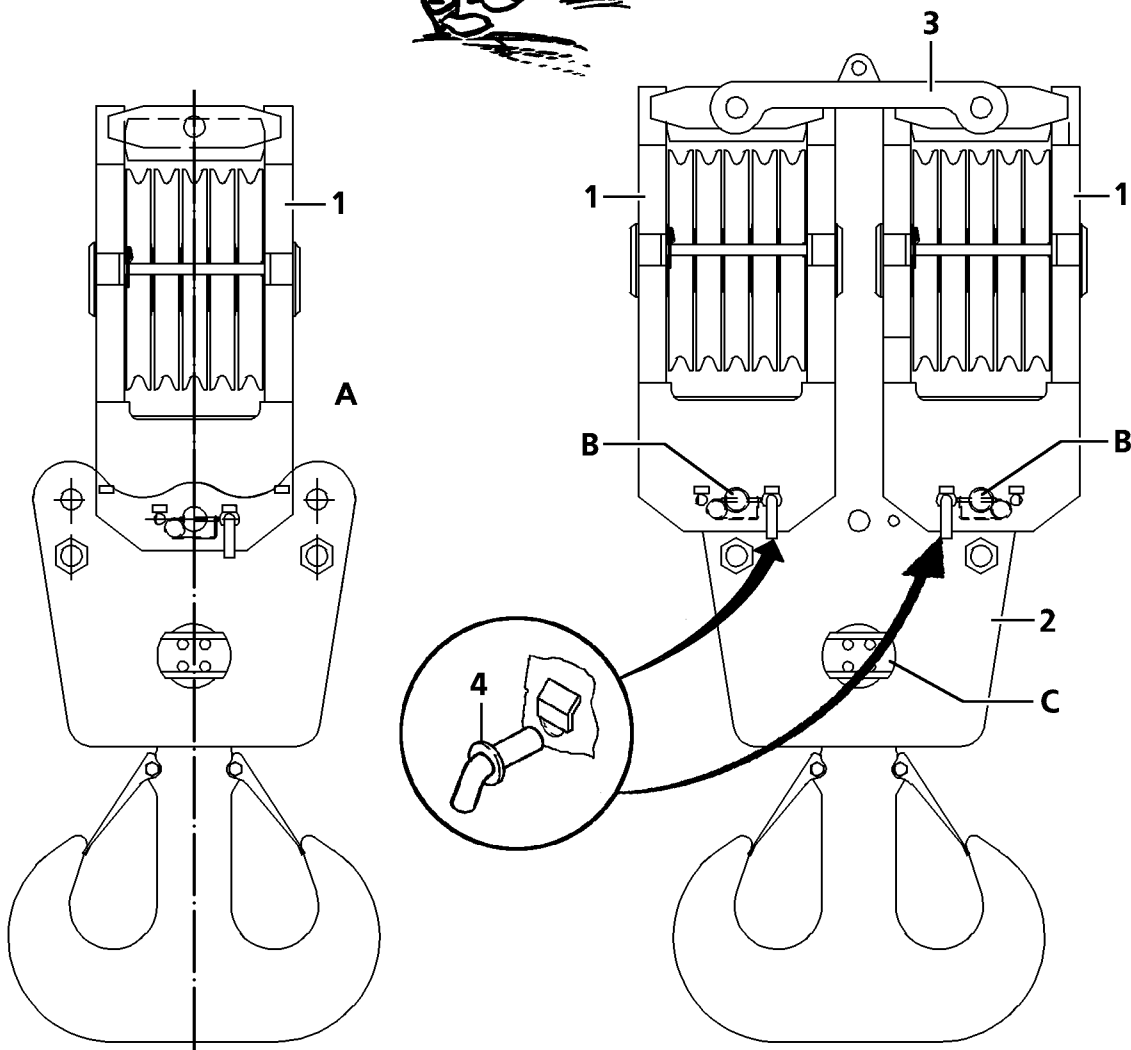
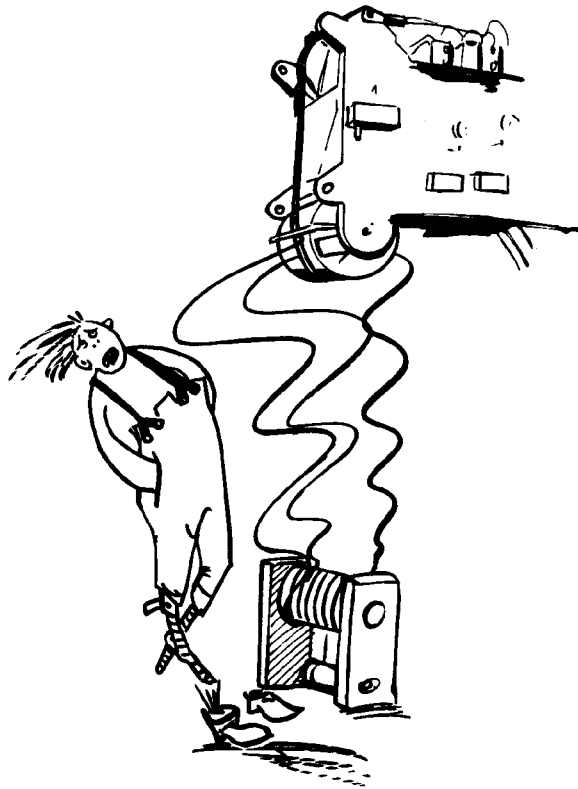
- Push the weight (35) with one hand on the hoist rope (34) and hold.
- With the other hand, guide the carrier part (36) behind the hoist rope (34) and under the weight (35). The curvature (R) of the carrier section (36) must point to the hoist rope (34).
- Push the weight (35) on the carrier section (36).
- Hang the hoist limit switch weight (30) with the carrier section (36) in the snap hook (33).

The snap hook (33) must be secured with the screw retainer (32).

- Close the screw retainer (32) on the snap hook (33).

Enter the number of reeves into the ”LICCON” safe load moment indicator or recheck it.

DANGER: **The crane operator must make sure that the reeving process has been done properly and that the safe load indicator has been set correctly.**
Incorrect reeving or entering an incorrect number of reeves can lead to serious accidents.



Unreeving the hook block**Assembly sequence:**

- Lower the hook block to the ground and check to make sure it is standing in a stable position.
- Unhook cable end on the cable joint
- Slowly rewind the hoisting cable.

DANGER: There must be no persons in the area around the hook block. During rewinding, the cable can lash out like a whip. It must be ensured that there is no loose cable on the winch.

- Attach the hoisting cable with the cable joint onto the pulley head, or rewind the complete hoisting cable onto the winch.

CAUTION: Always rewind the hoisting cable so that there is at least 2 m remaining - never rewind the cable end onto the winch!

Assembly of the hookblocks for operation with two hookblocks

Unpin the double hook from the hookblocks (A)

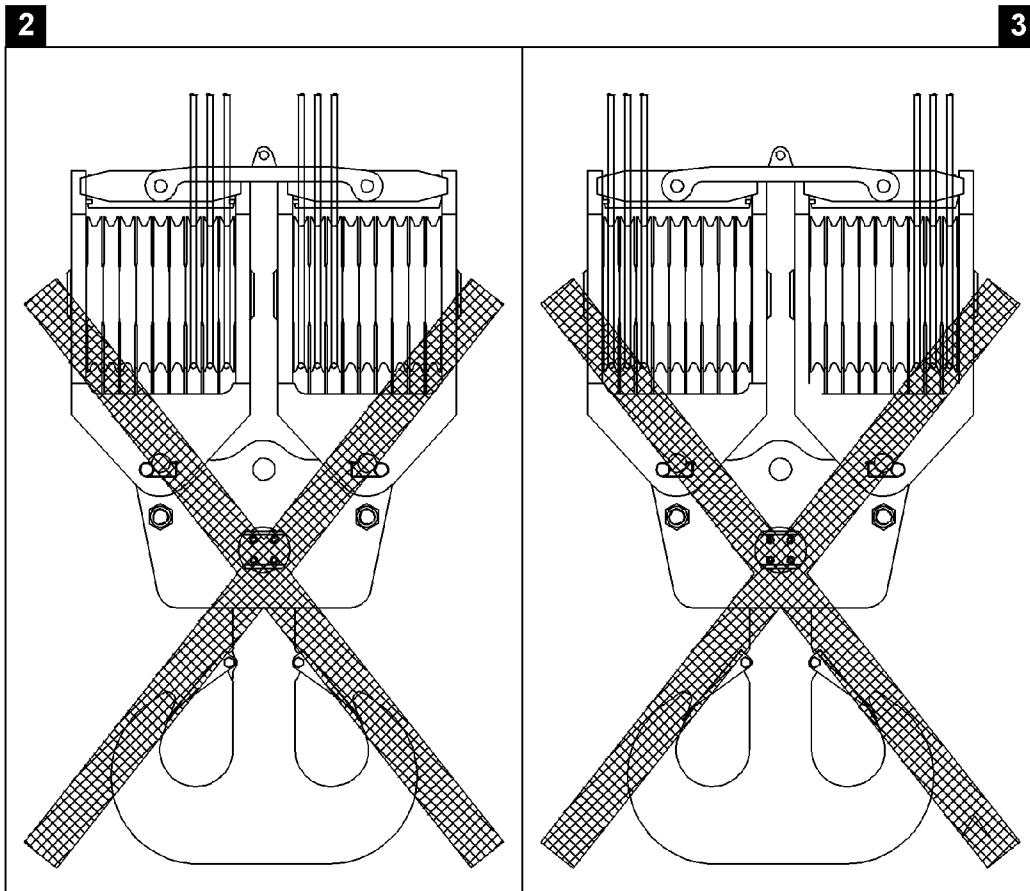
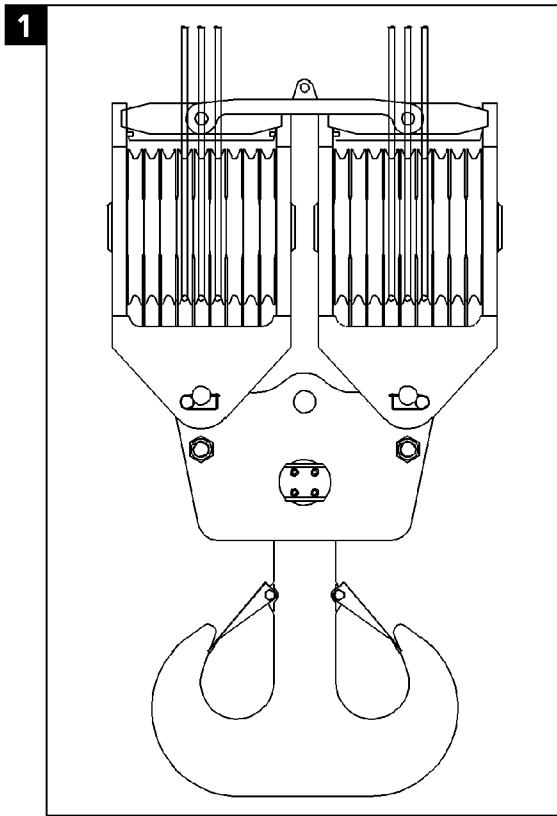
Pin the hookblocks (1) to the rocker (2) and connect with cross-strut (3).

At assembly and rope reeving the hook blocks must be pinned with pin (4) to prevent topple over.

Note: Turn handle down to secure.

CAUTION: Before starting crane operation the hook blocks must be unpinned again.

Pin (C) the double hook on the rocker (2).



Asymmetric reeving

Only the hook blocks shown in the chart are suitable for **asymmetric** reeving of the individual blocks in parallel operation.

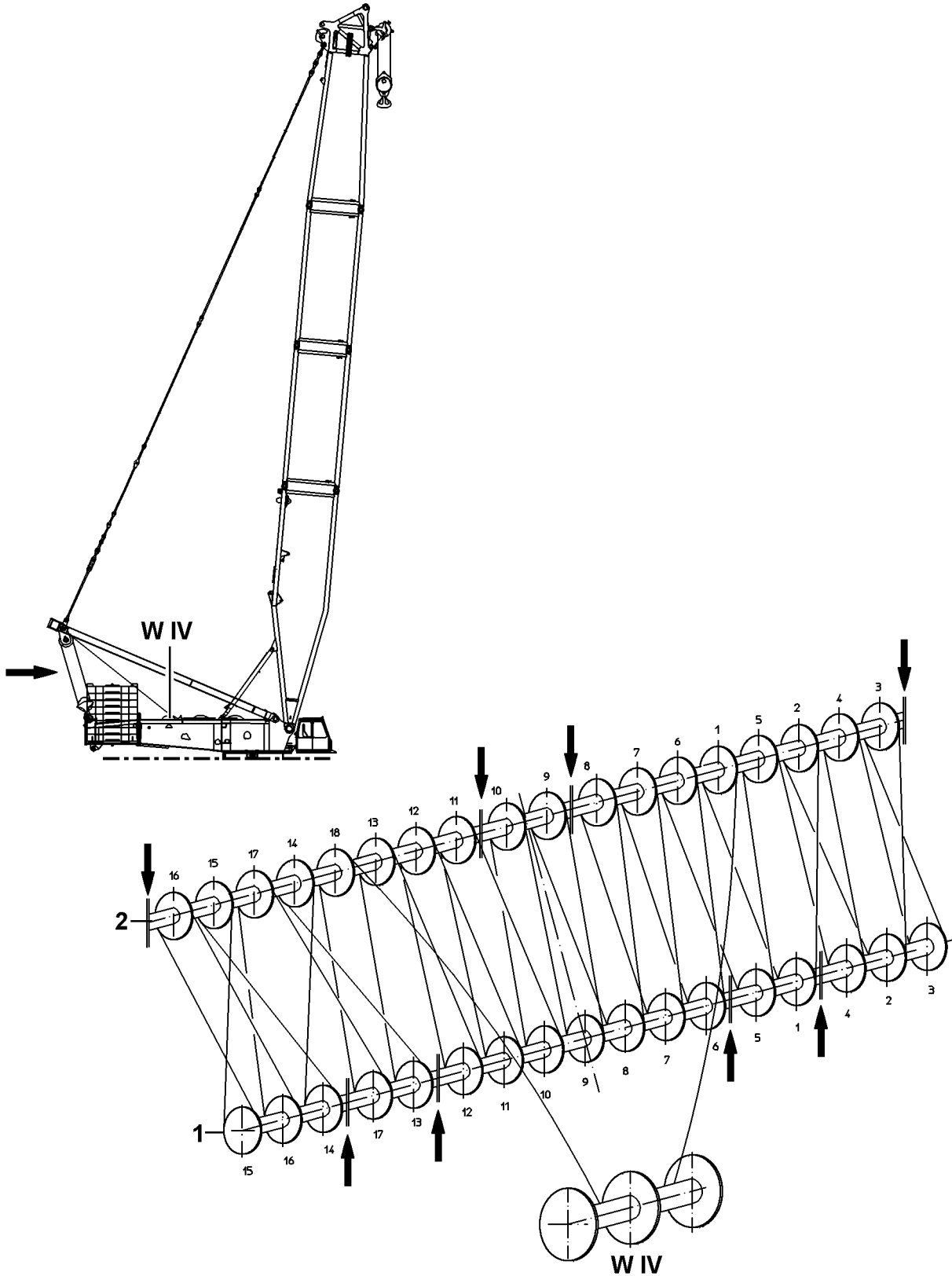
Description	Id. No. of hook block	Cable diameter [mm]	Number of pulleys
Double hook block 200/400 t	914457908	28	7/14
Double hook block 300/600 t	910464908	28	11/22
Double hook block 300/600 t	914469108	28	11/22

- Fig. 1 In parallel operation, the individual blocks **must be reeved symmetrically to the center pulley** (centered).
- Fig. 2 + 3 In parallel operation, an **asymmetric** reeving of the individual blocks (from inside to outside) **is not permissible**.

DANGER: **If this is not observed, there is a danger of accidents!**

Reeving between pulleys on the slewing platform and A - bracket

Note: Reeving (36 times) for all operating modes
 1 = pulley block on the slewing platform 2 = pulley block on the A - bracket
 IV = winch IV



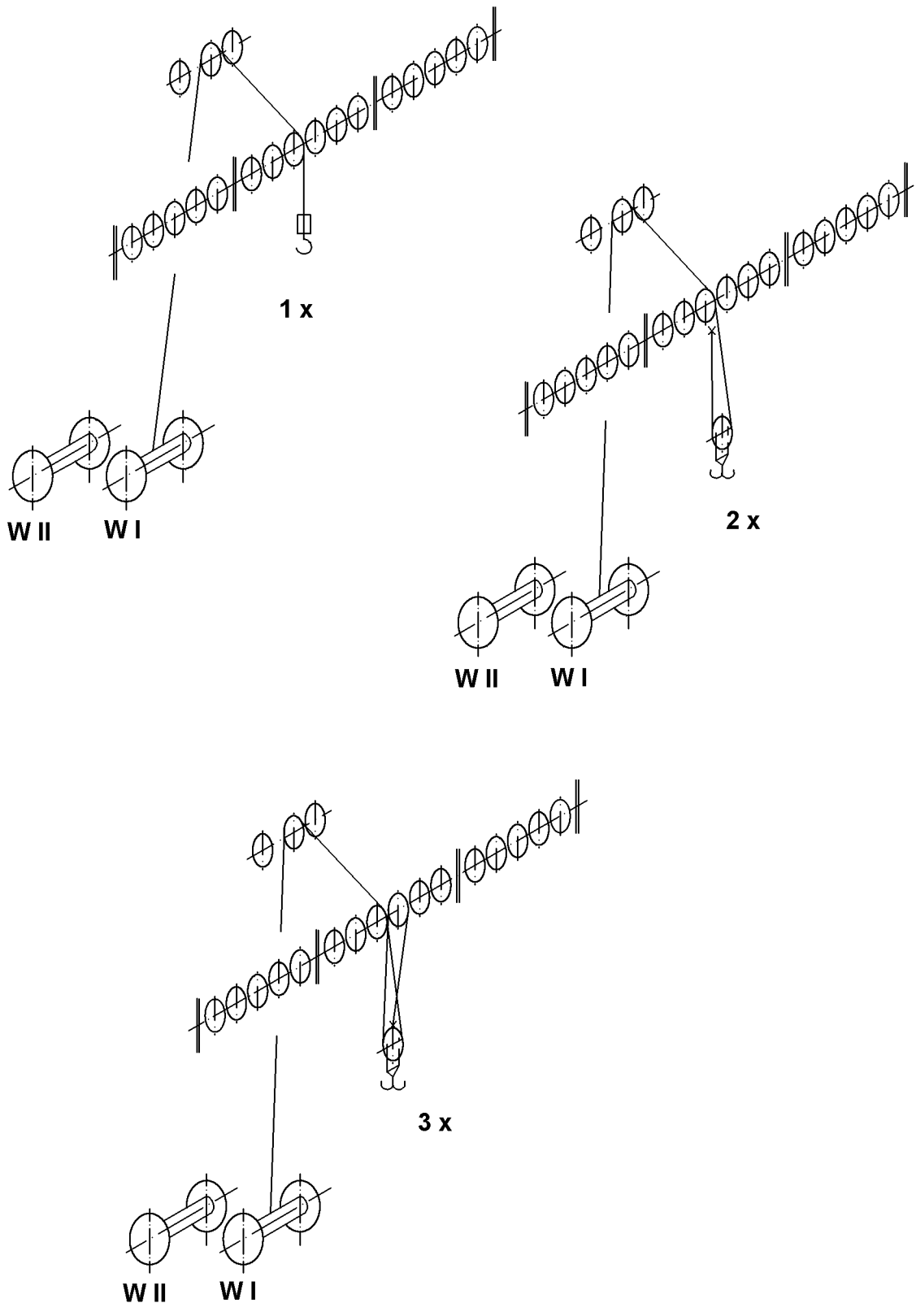
198508

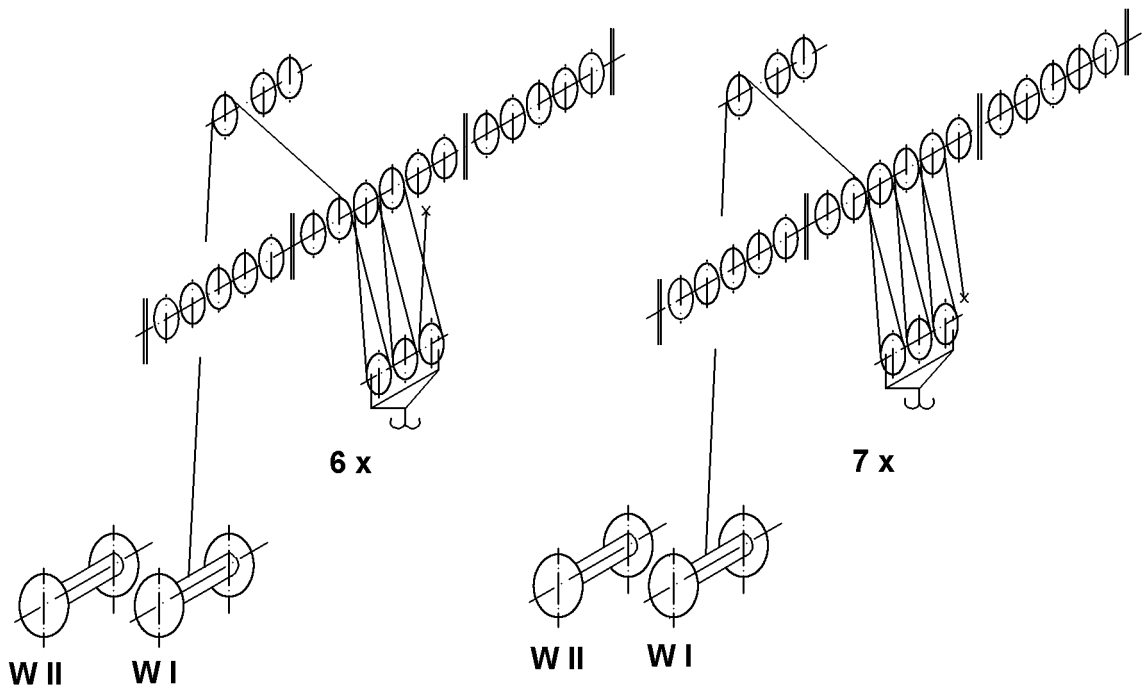
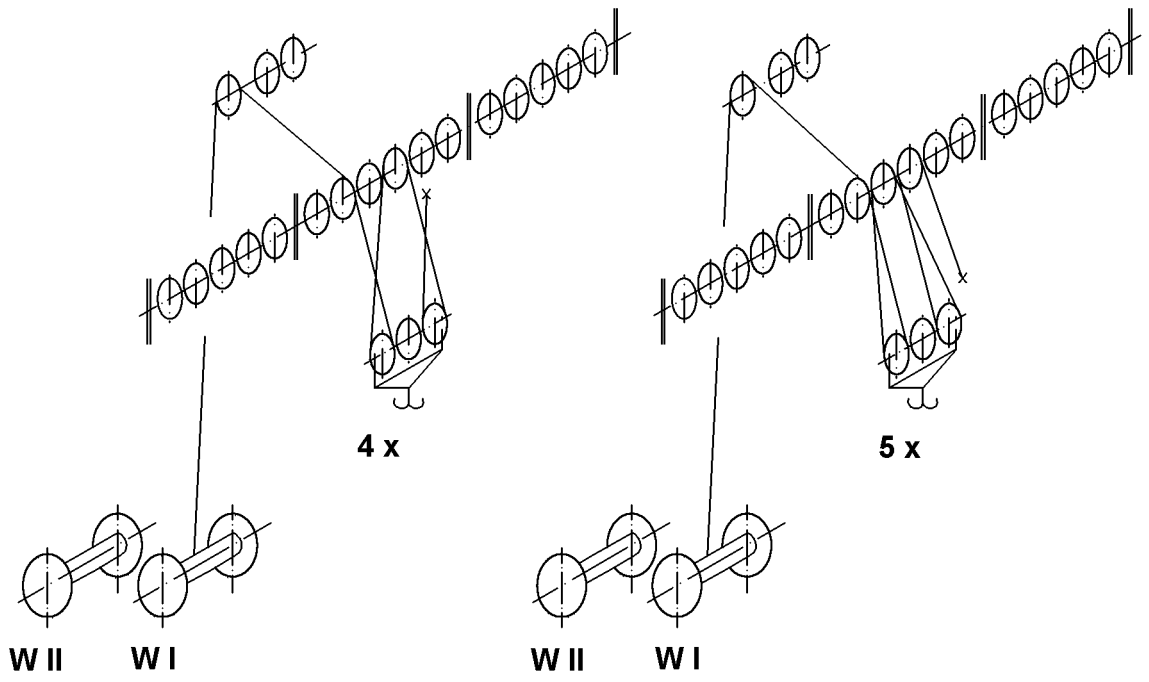
REEVING PLANS

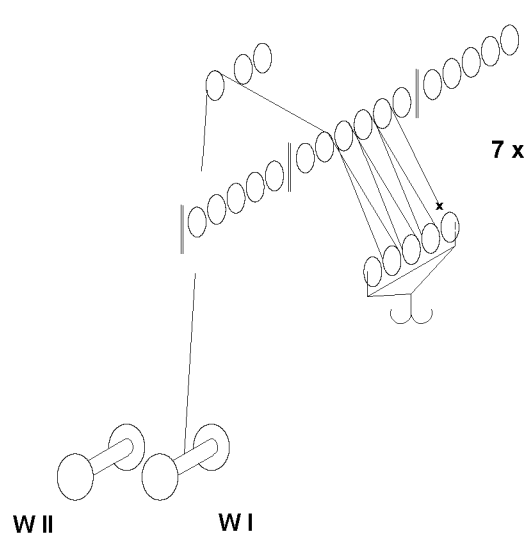
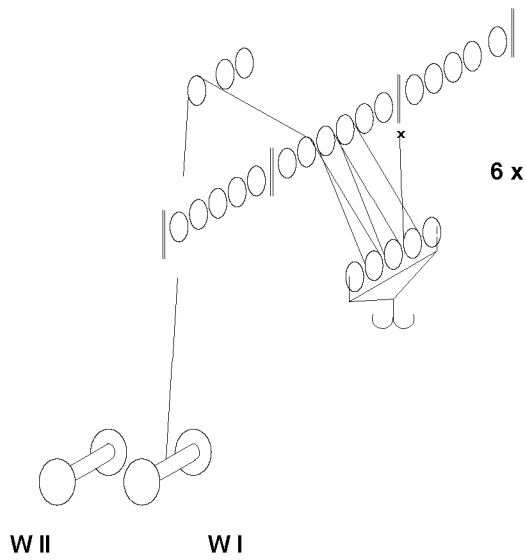
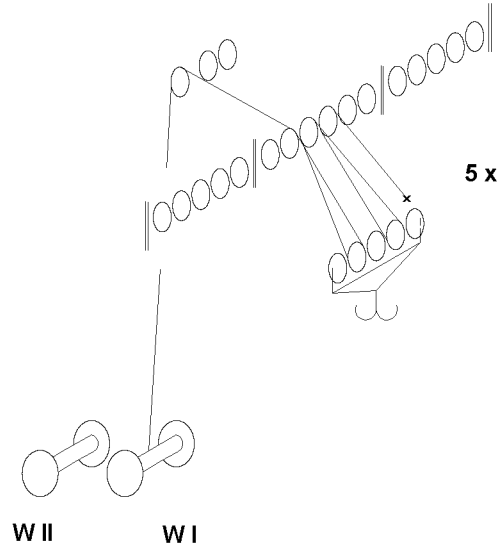
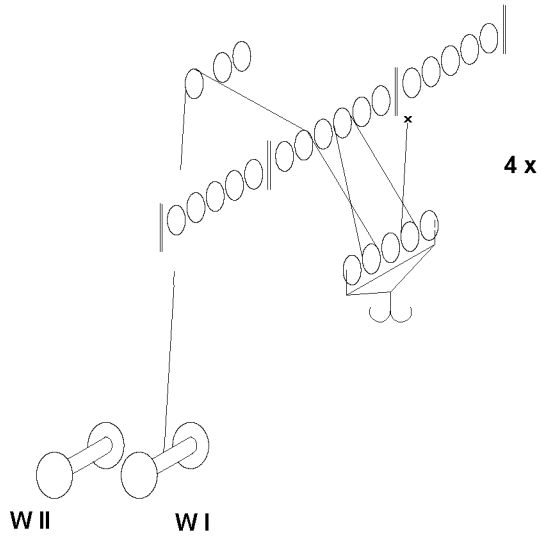
L - Head section (400 t)

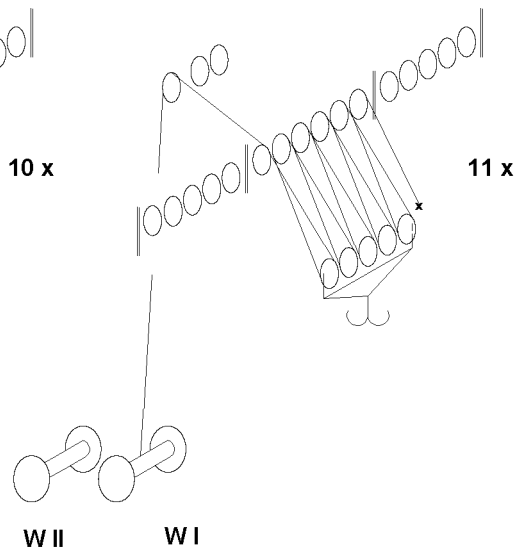
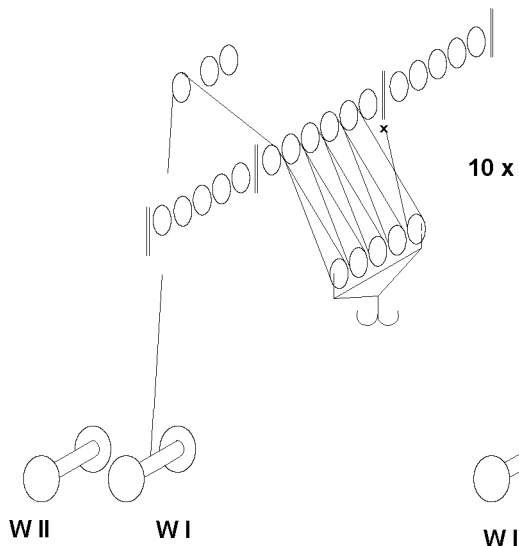
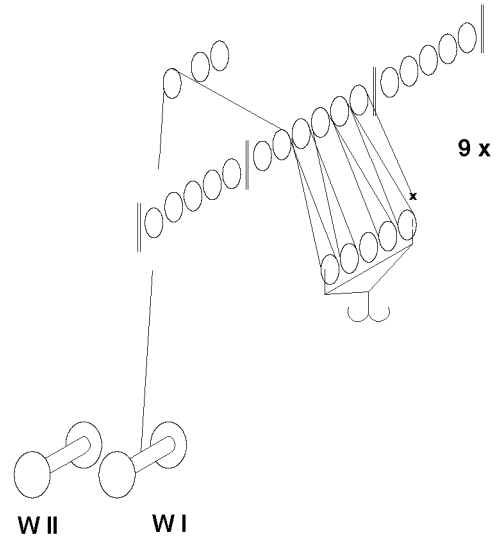
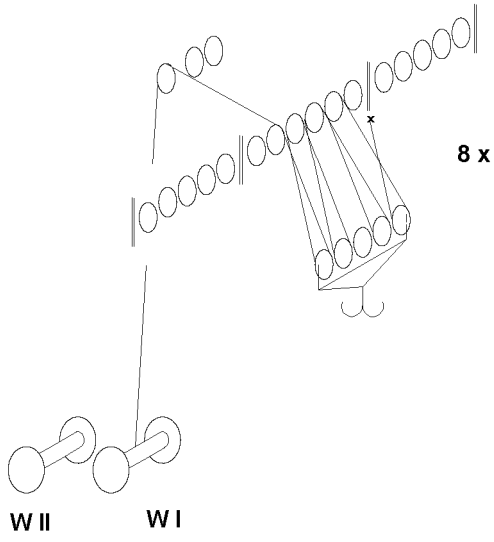
Head section - 16 pulley

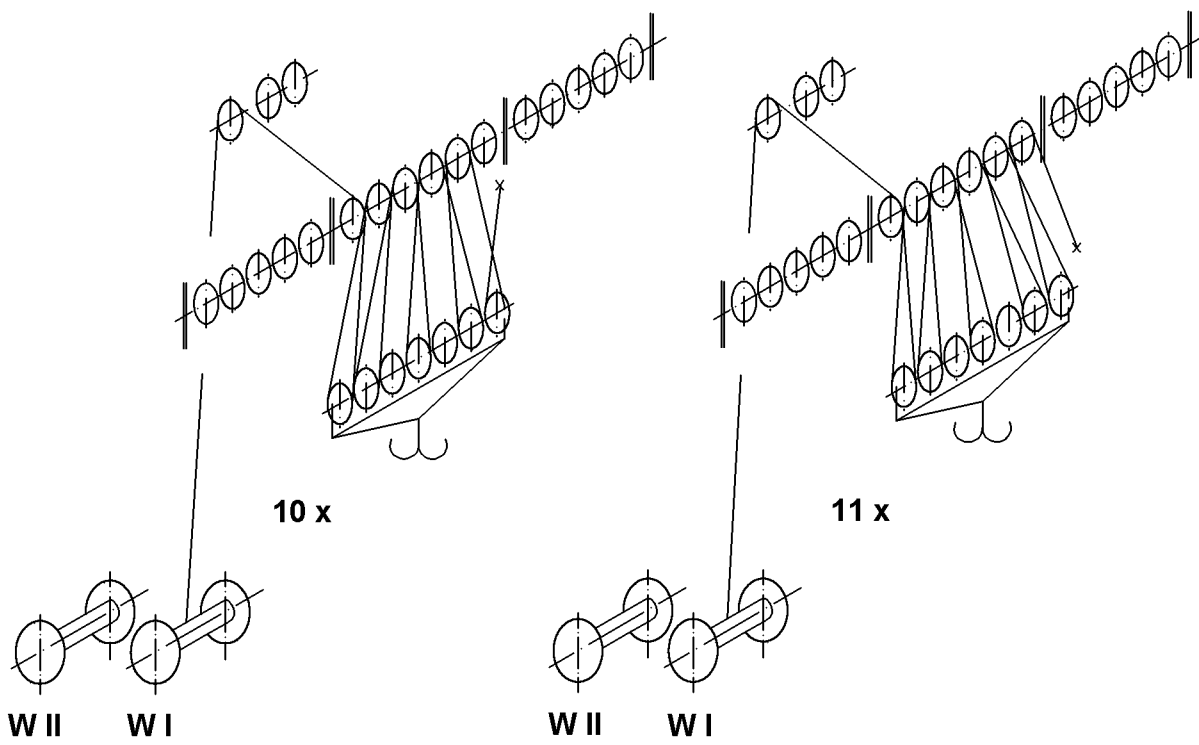
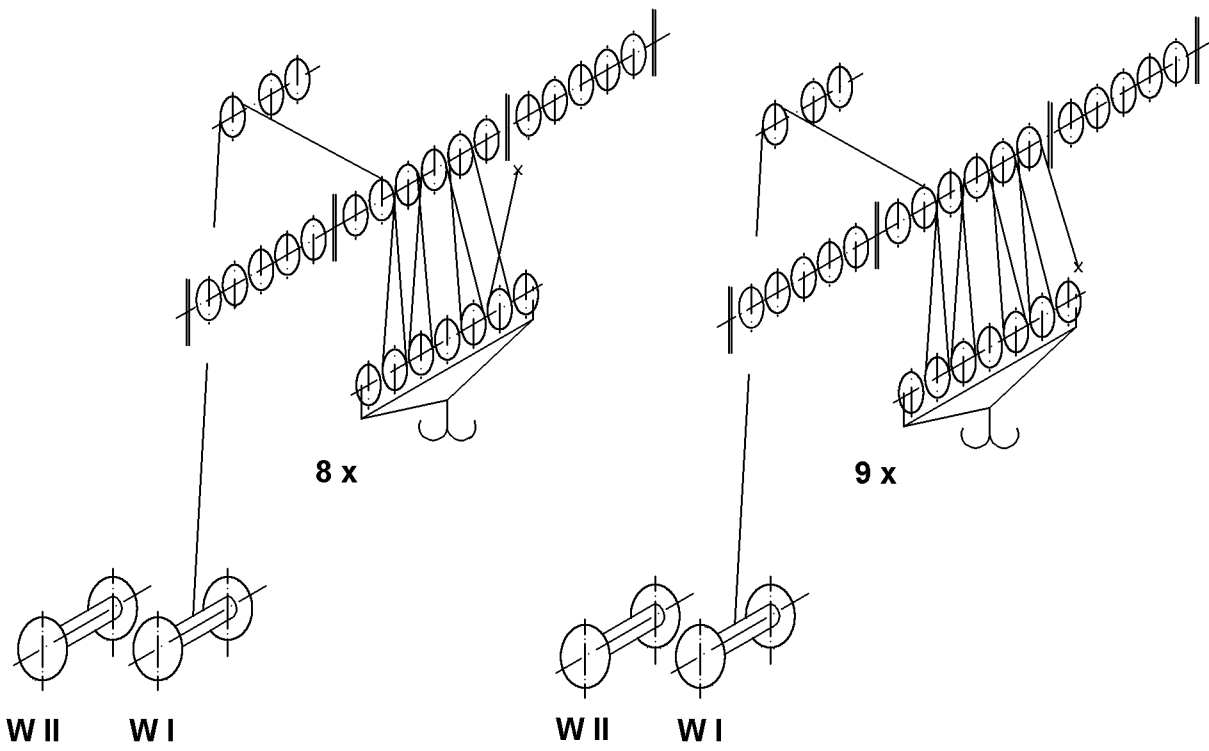
Load hook	16 t	
1 - pulley hook block,		50 t hook block
3 - pulley hook block,		125 t hook block
5 - pulley hook block,		160 t hook block
7 - pulley hook block,		215 t hook block
11 - pulley hook block,		312 t hook block

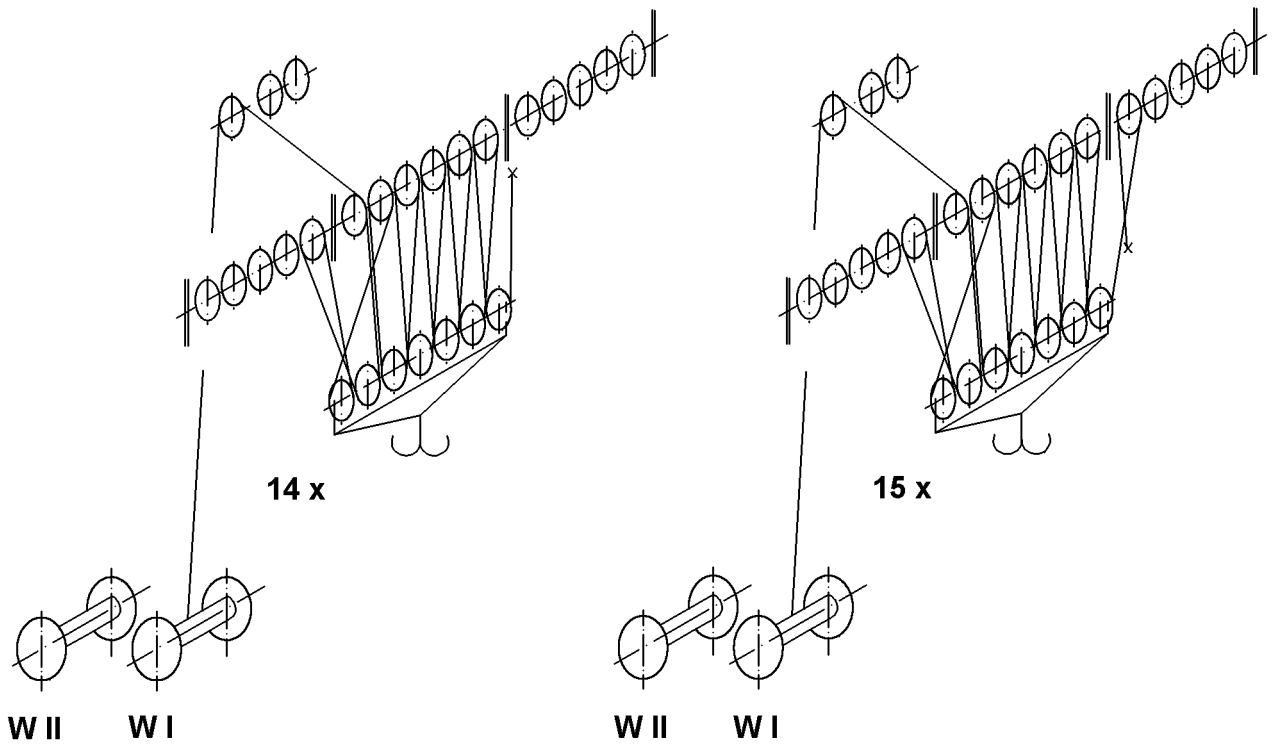
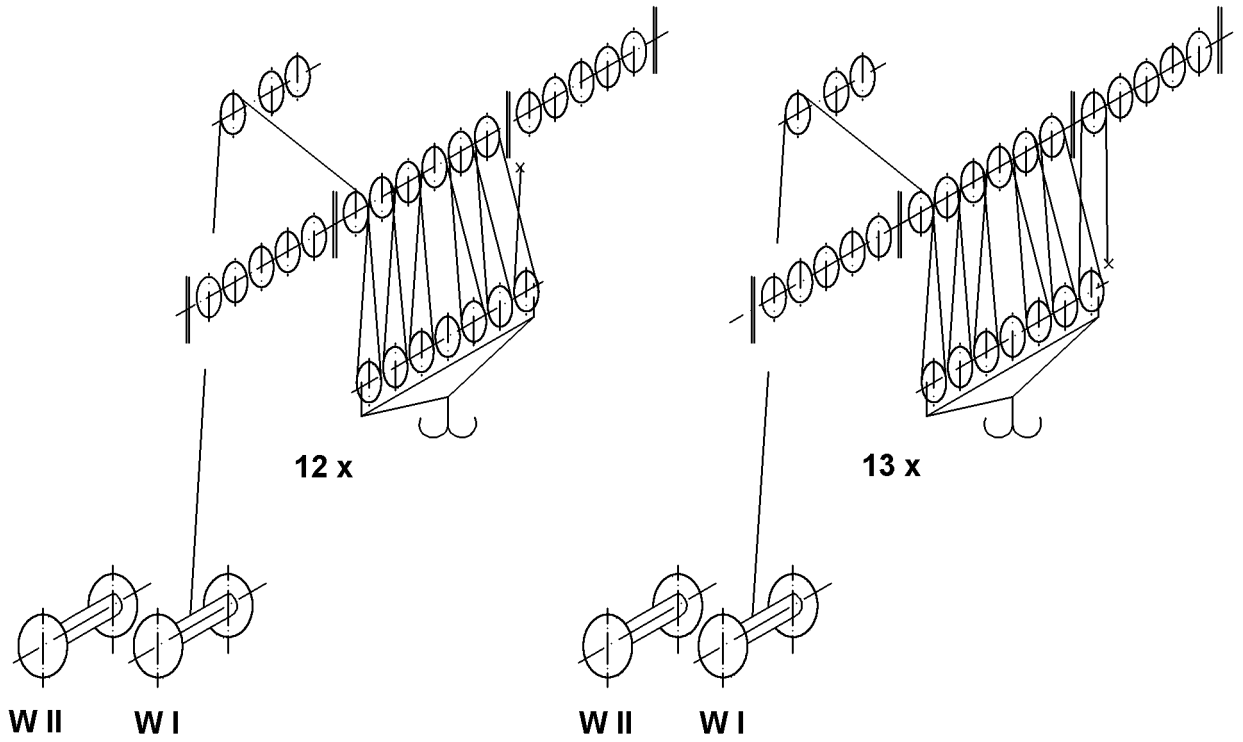


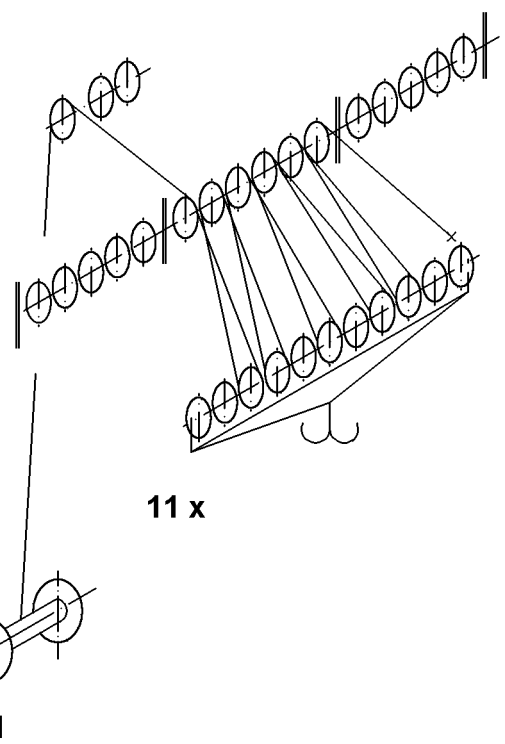
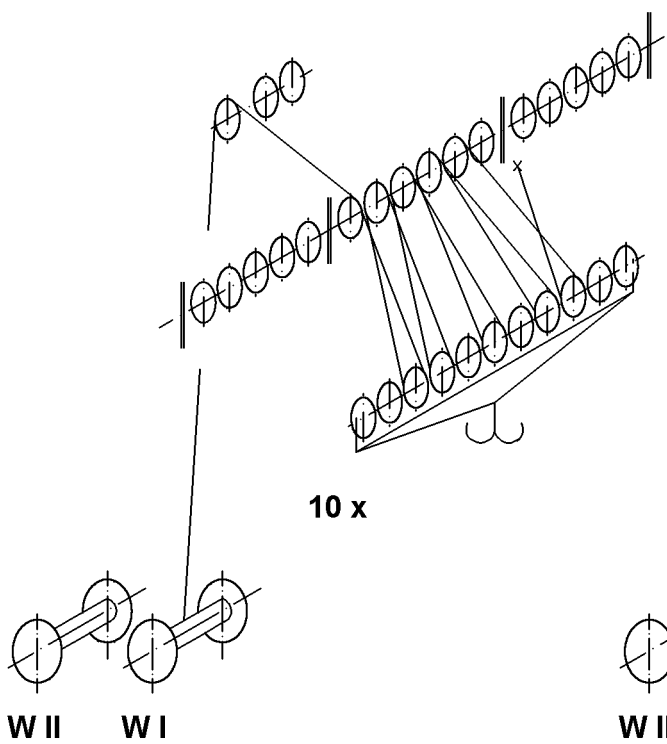
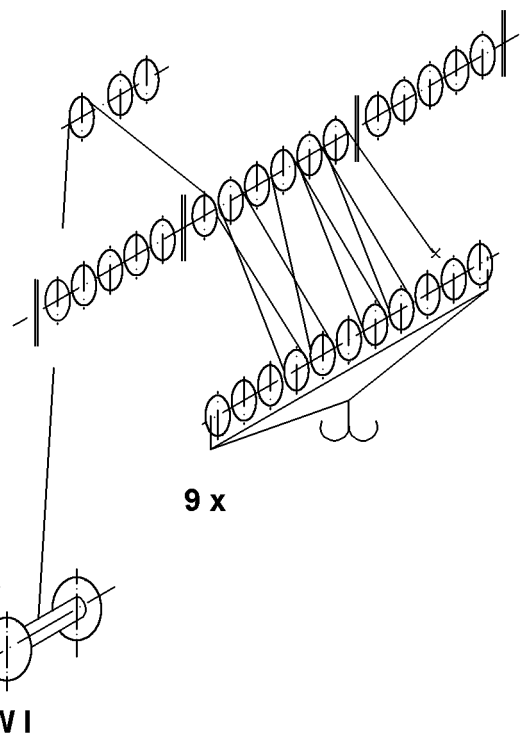
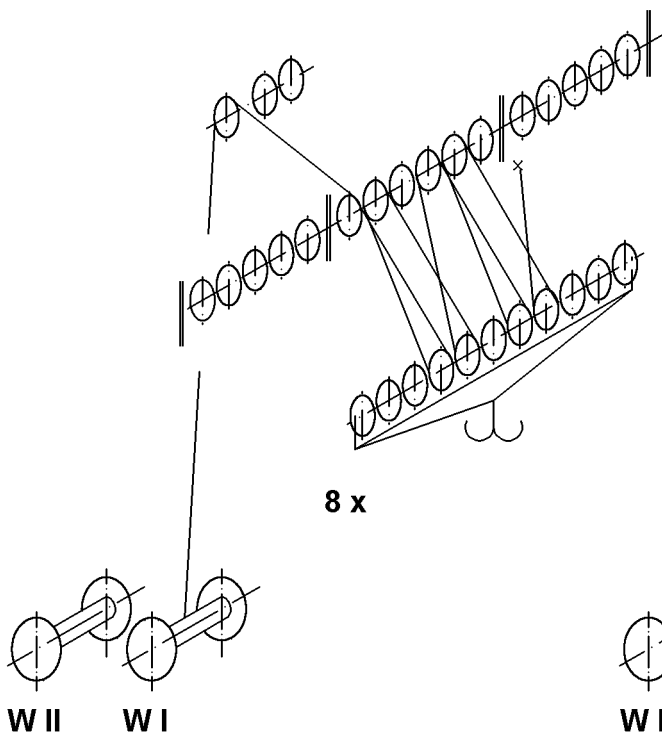


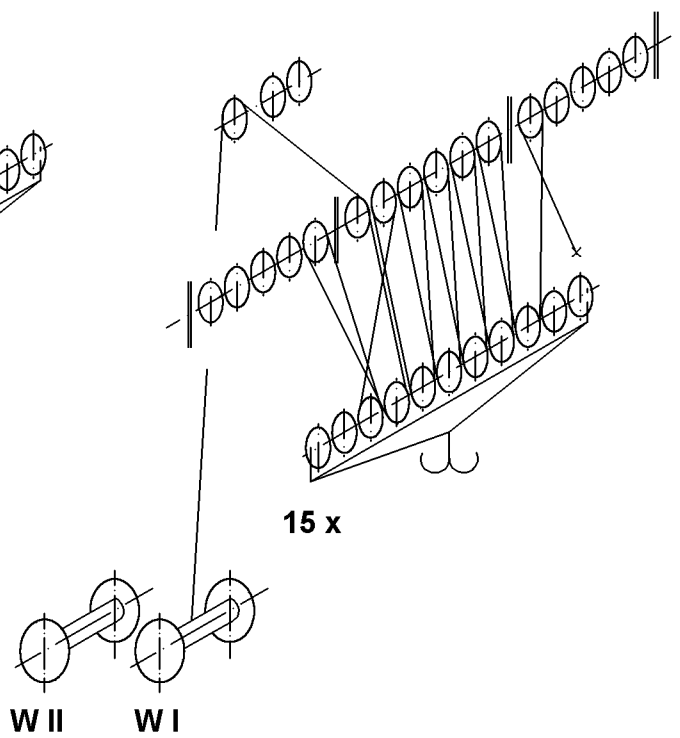
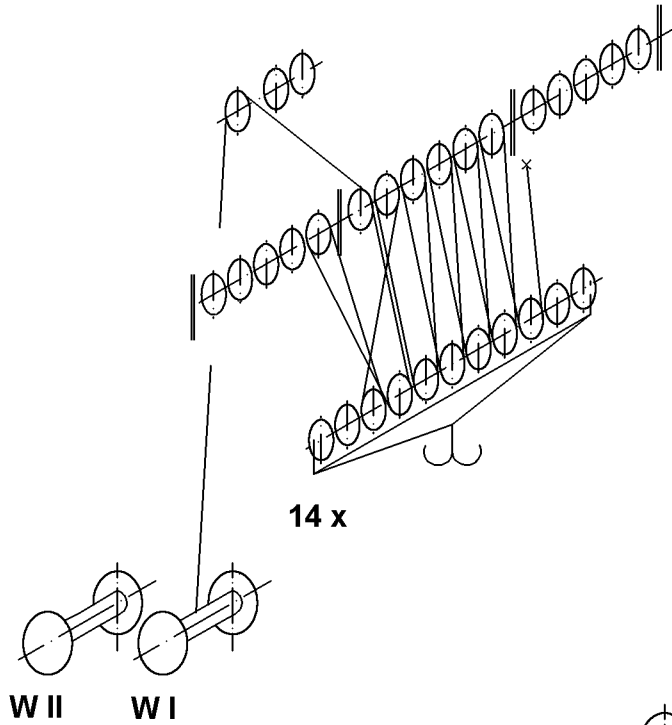
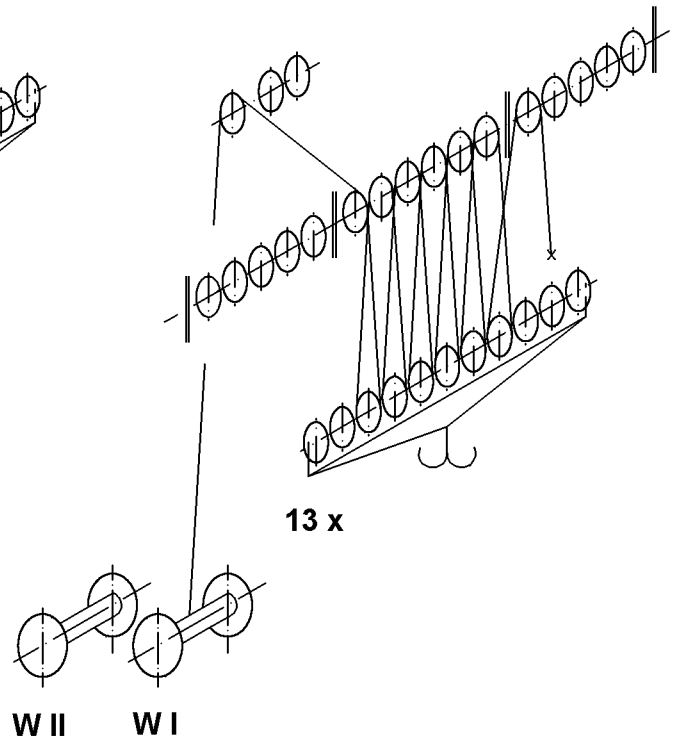
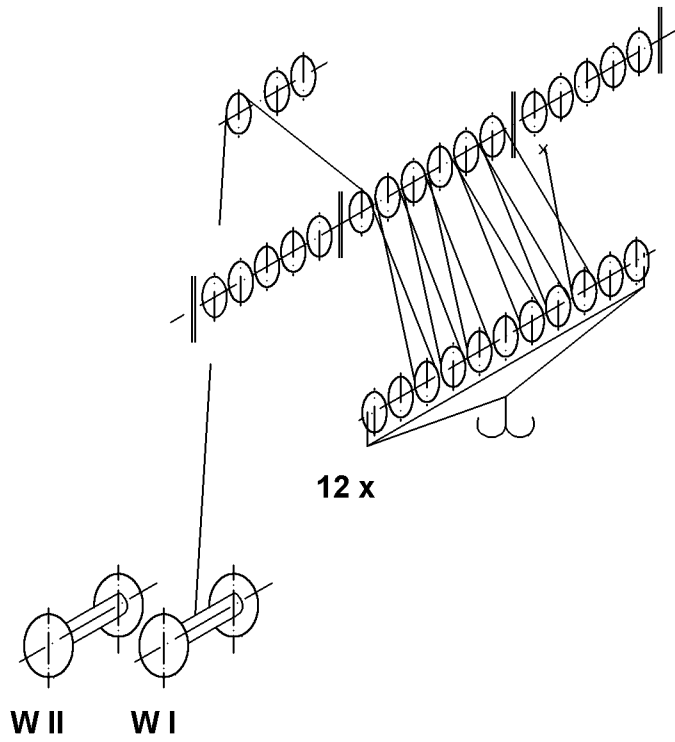


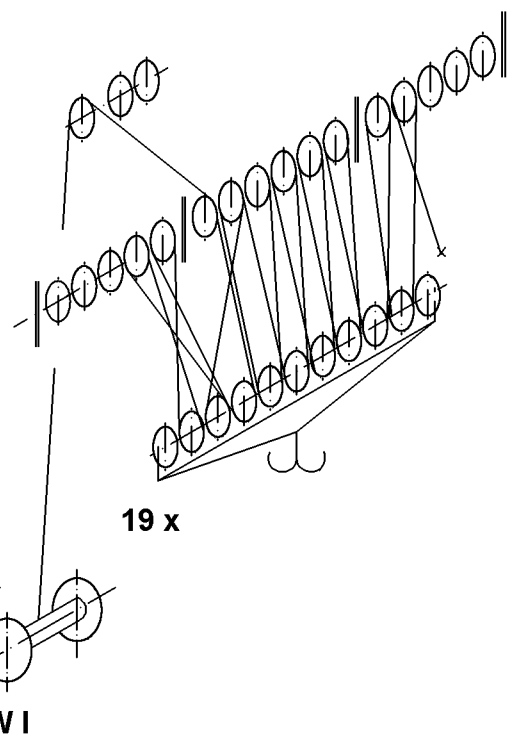
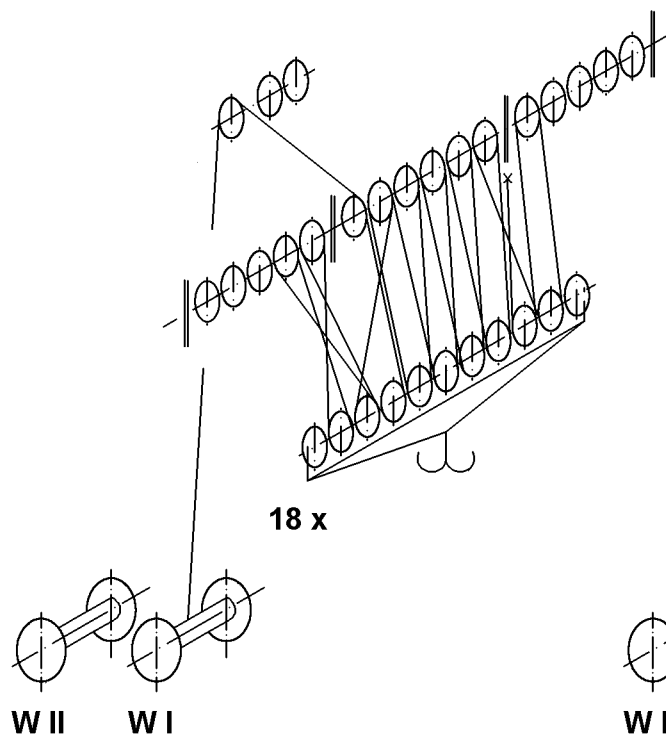
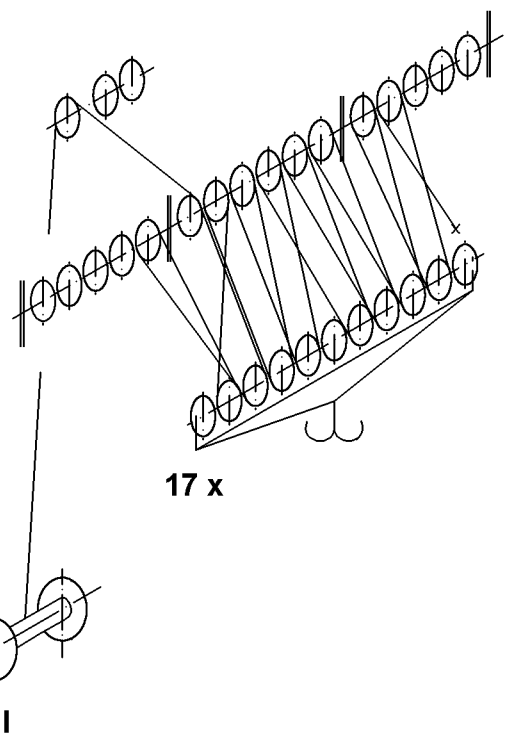
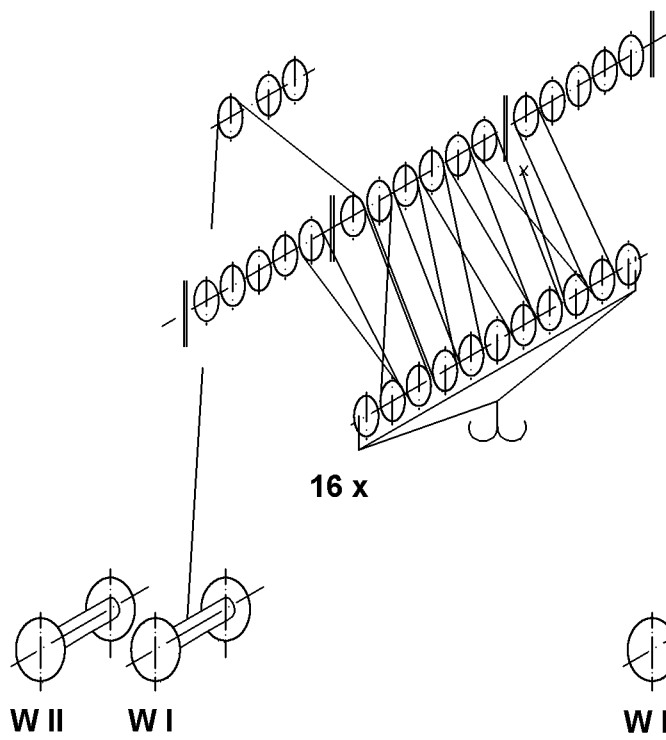


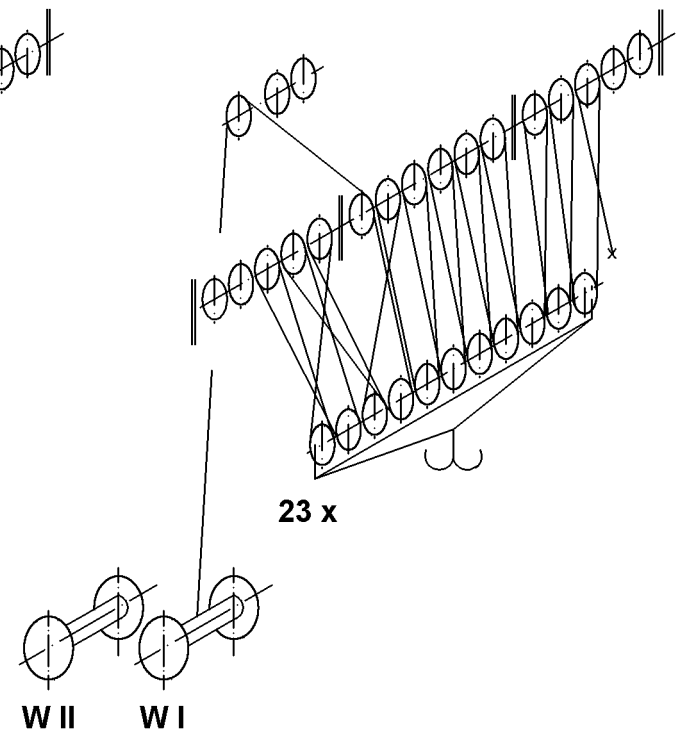
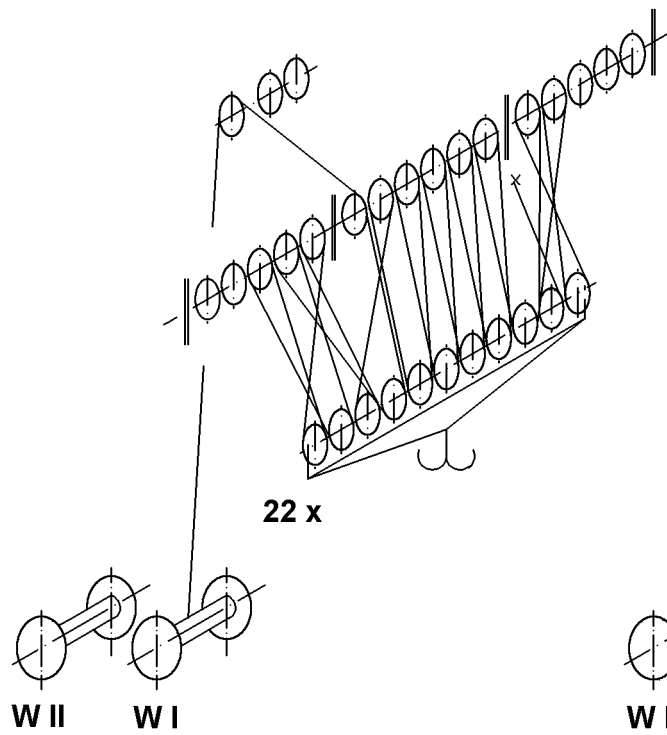
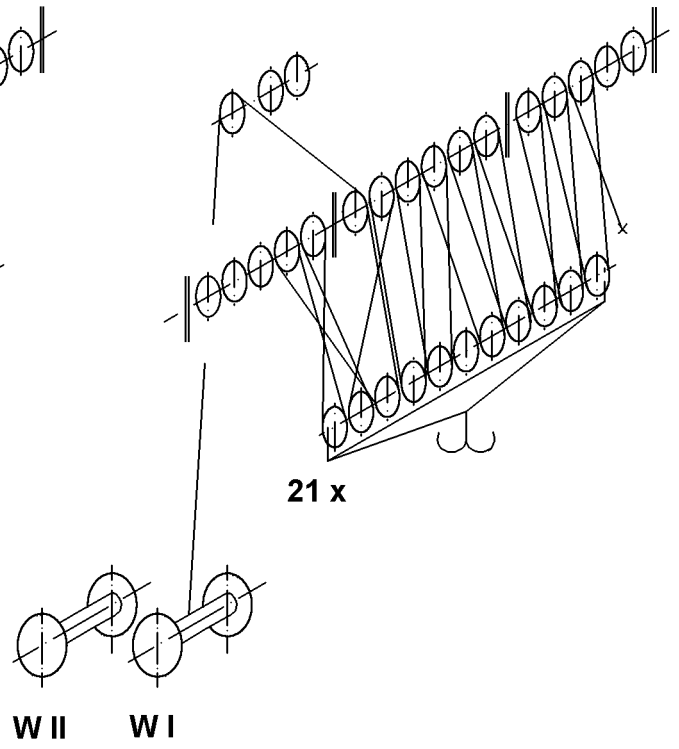
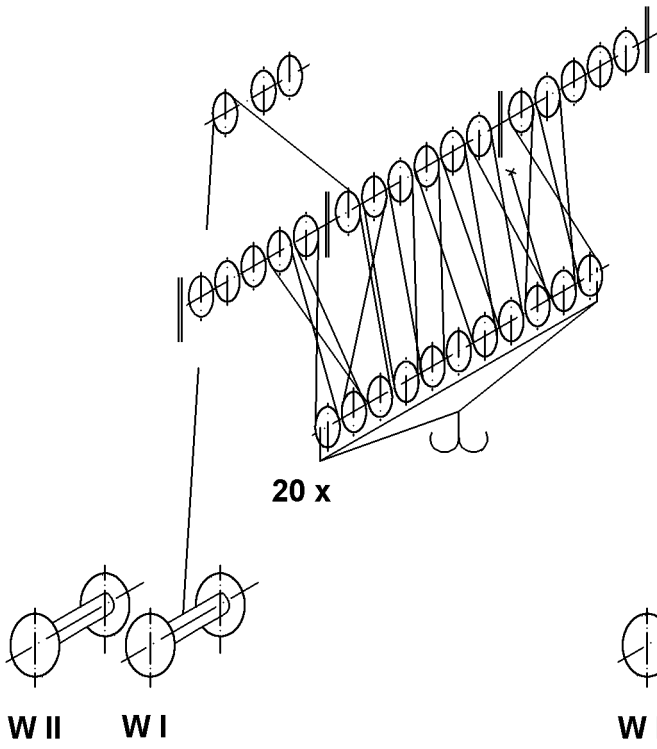












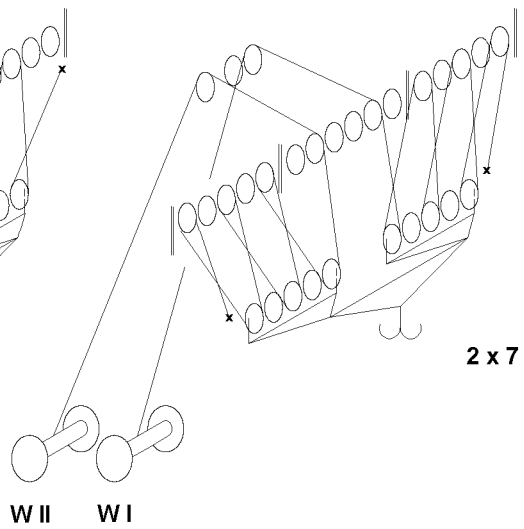
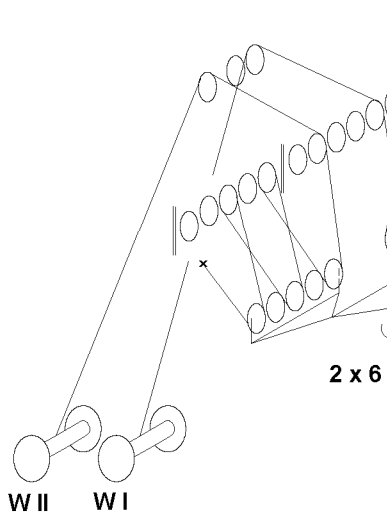
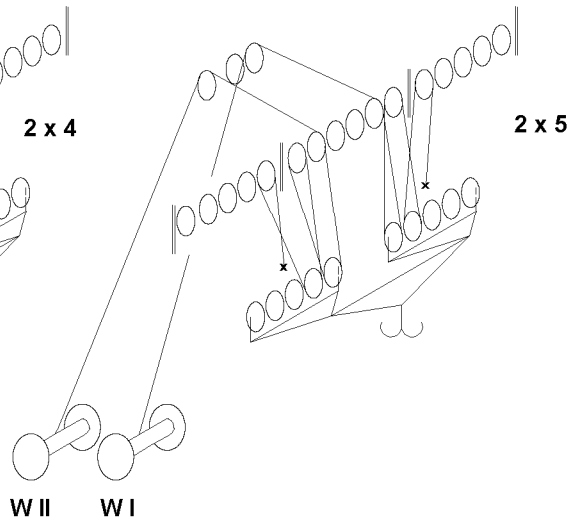
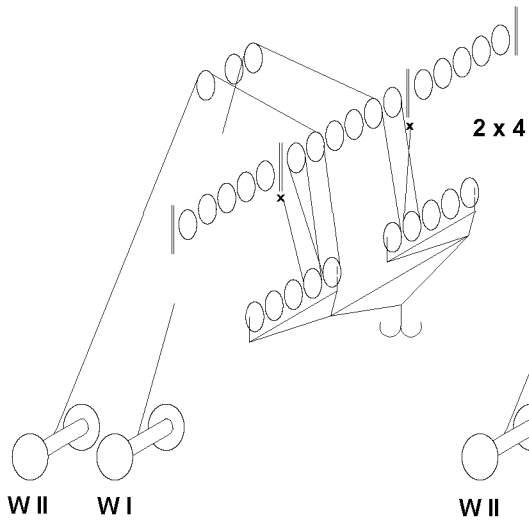
REEVING PLANS

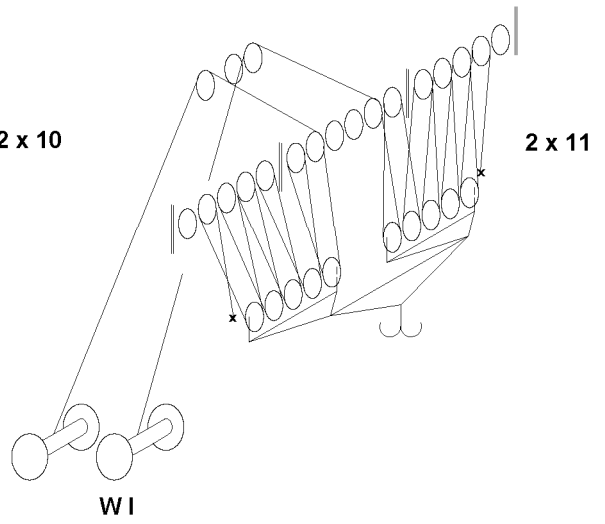
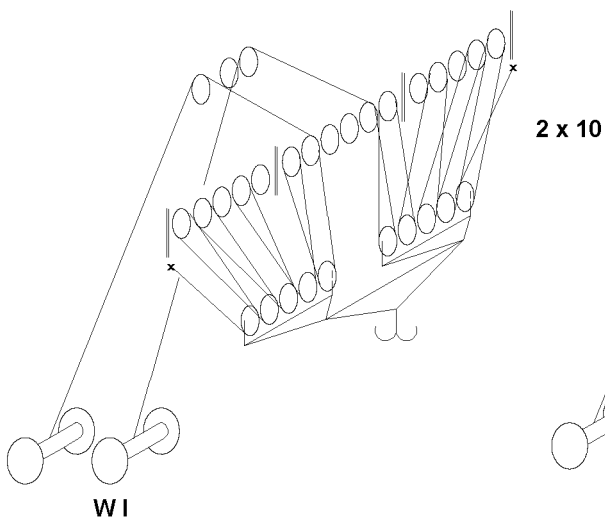
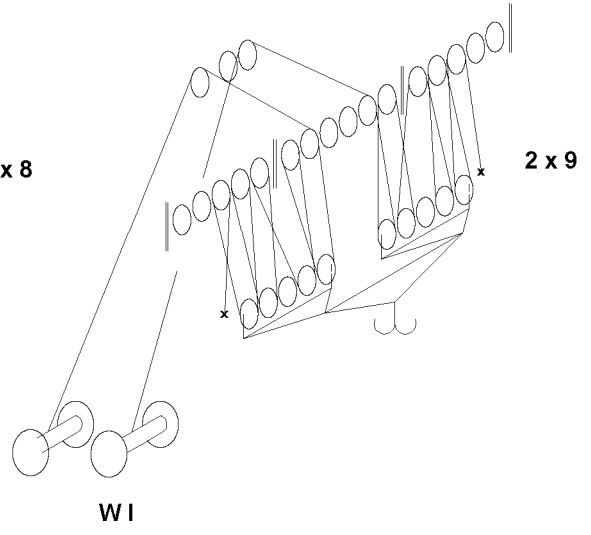
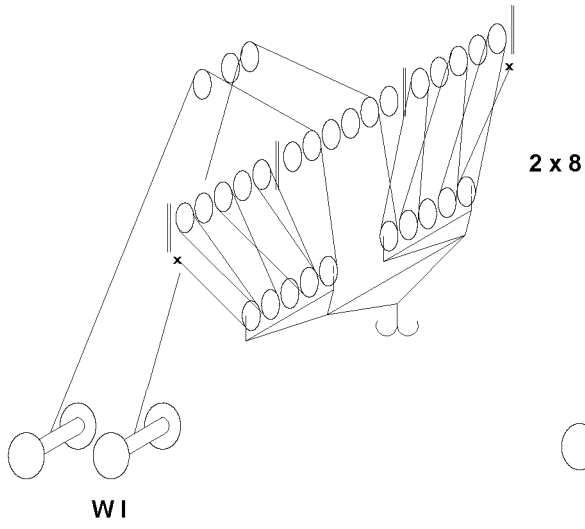
L - Head section (400 t)

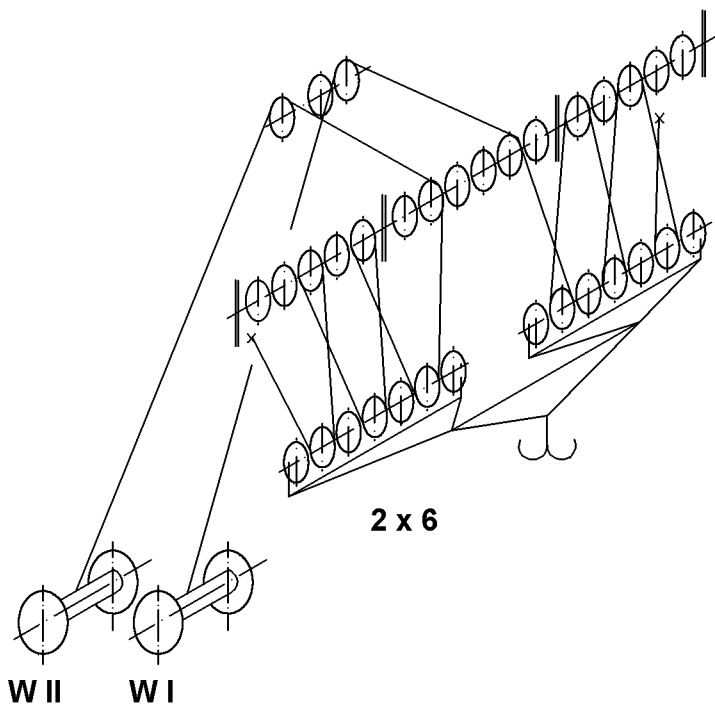
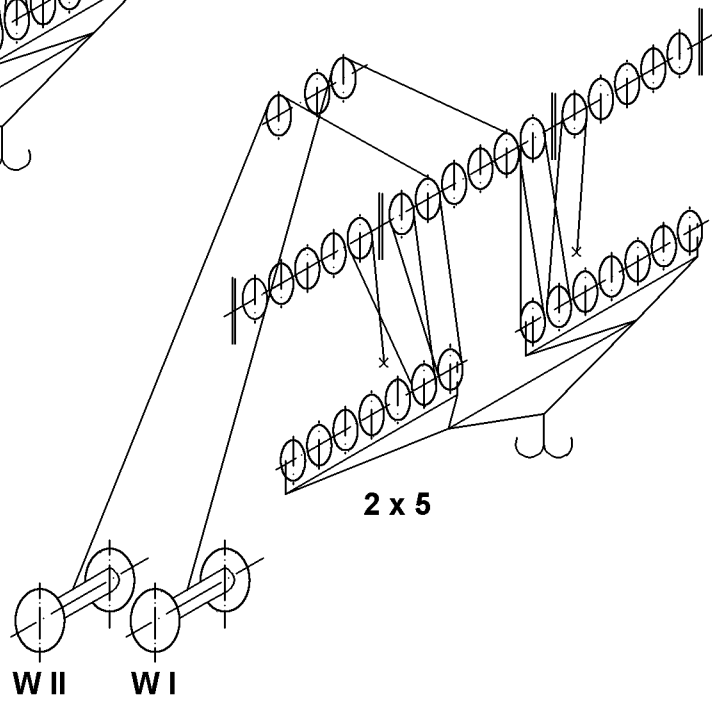
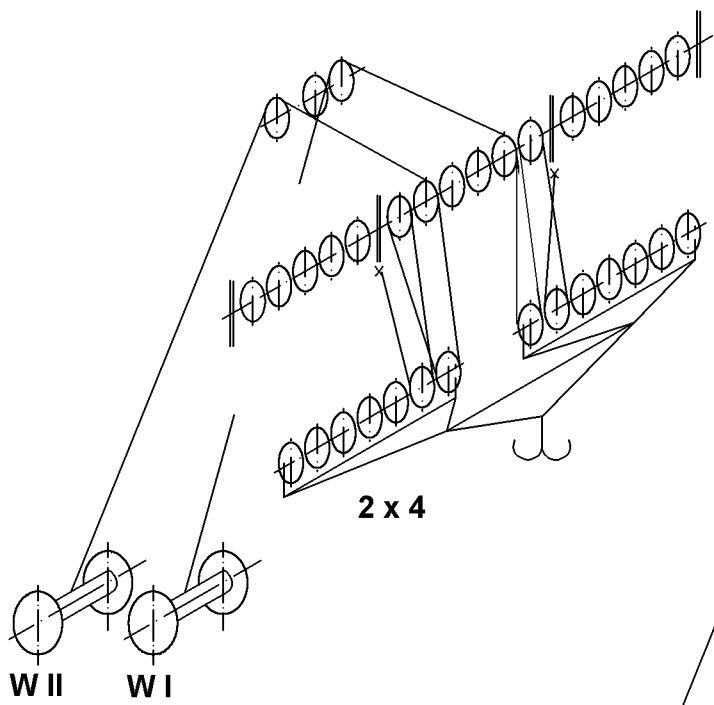
400 t - head section - 16 pulley

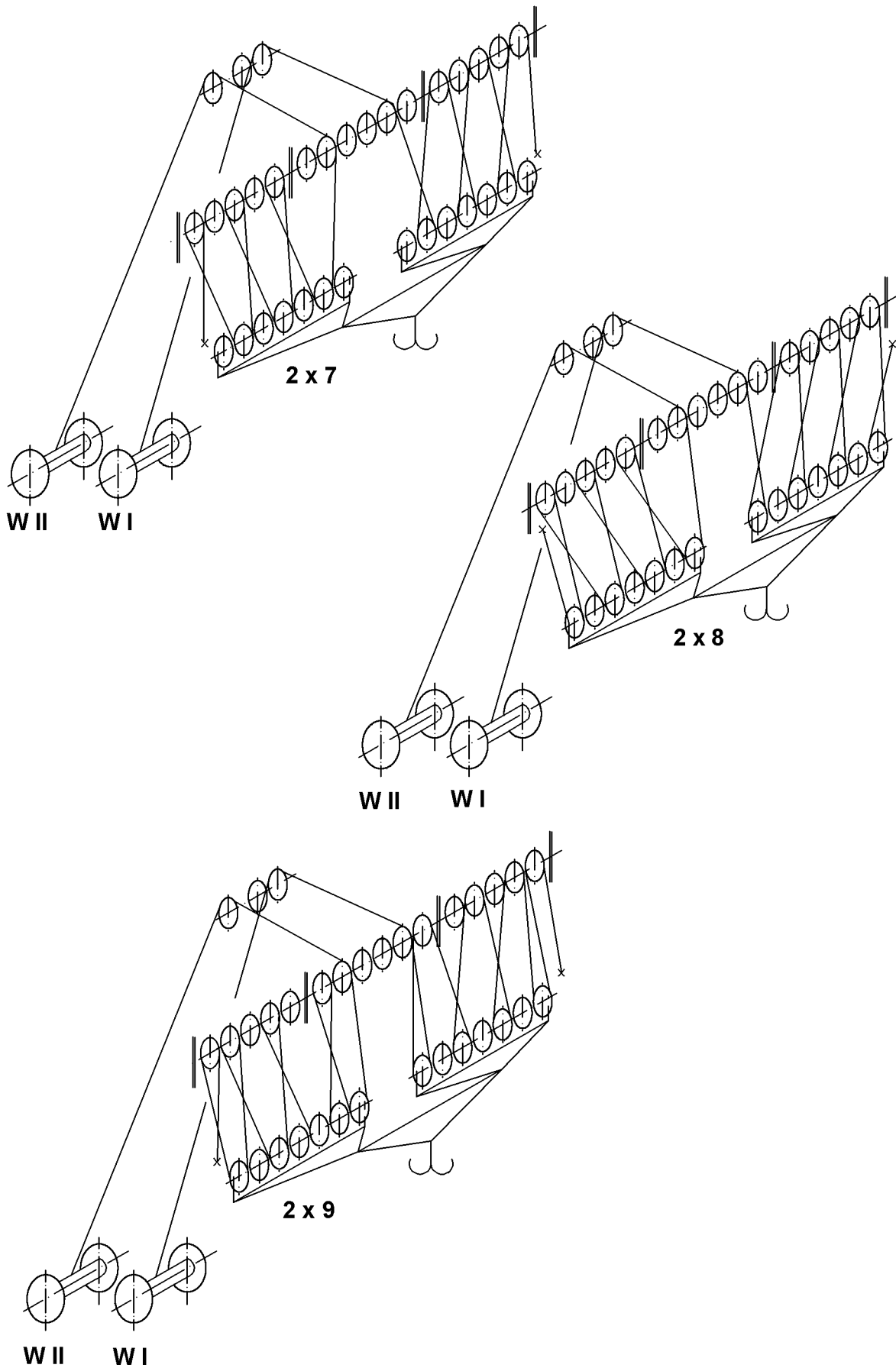
2×5 - pulley hook block (320 t hook block)

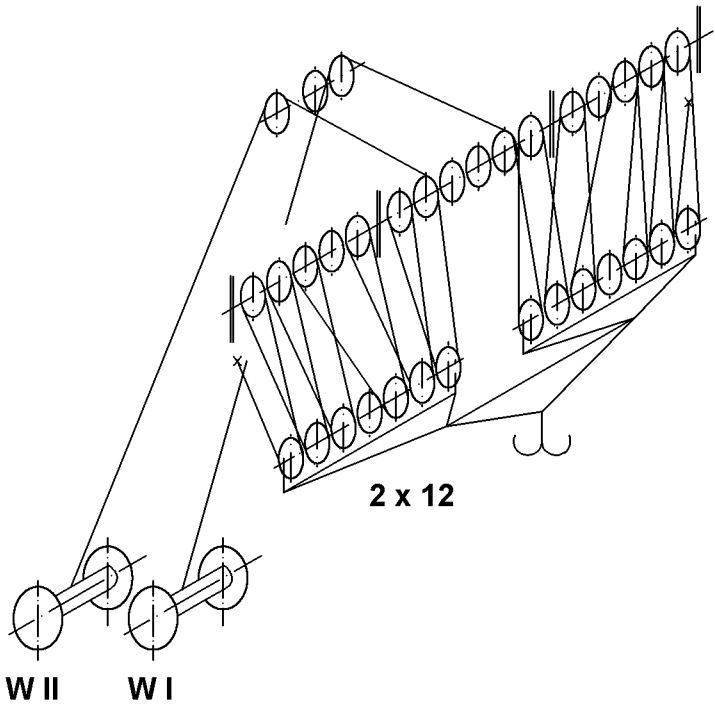
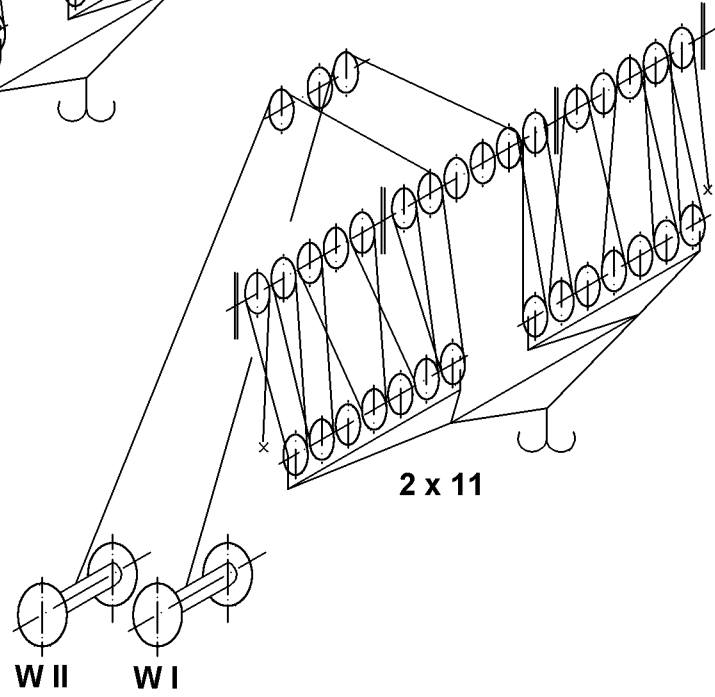
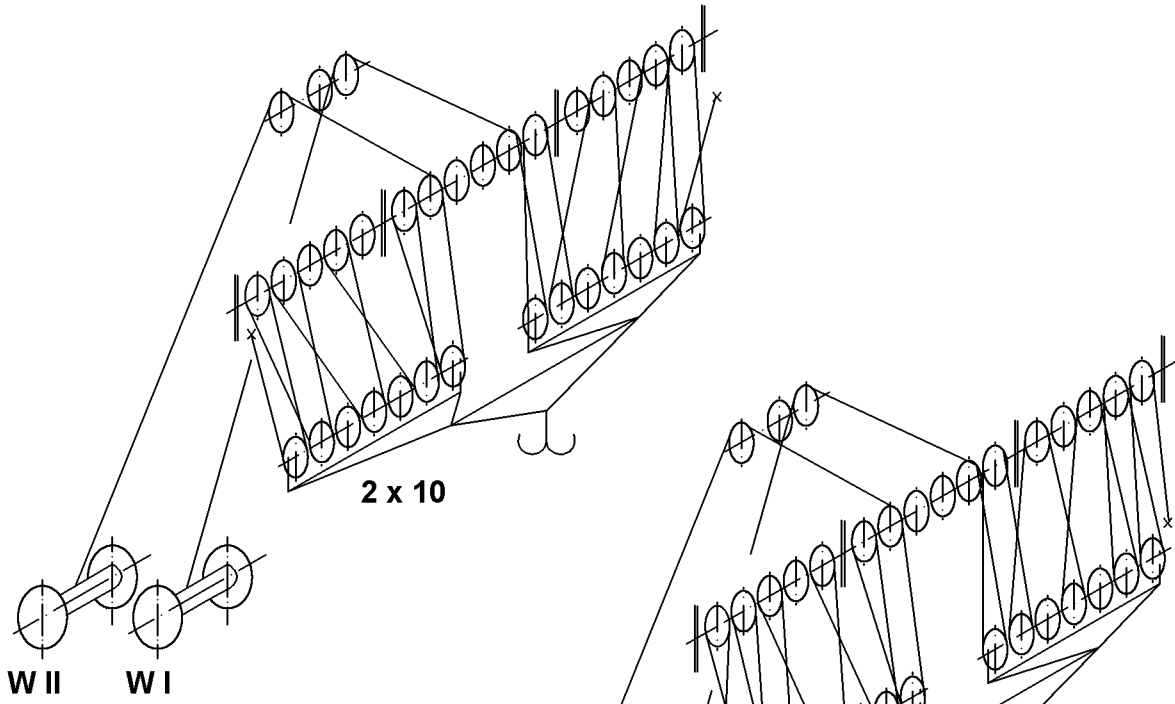
2×7 - pulley hook block (400 t hook block)

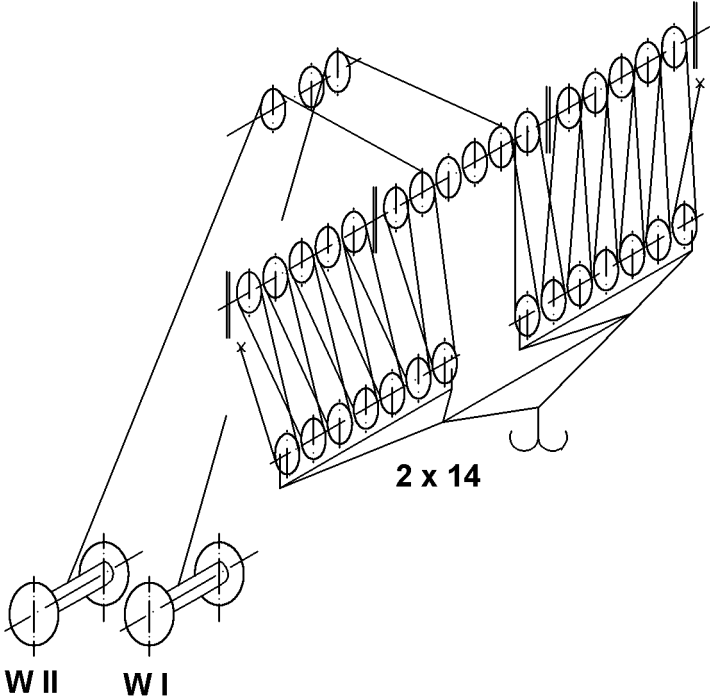
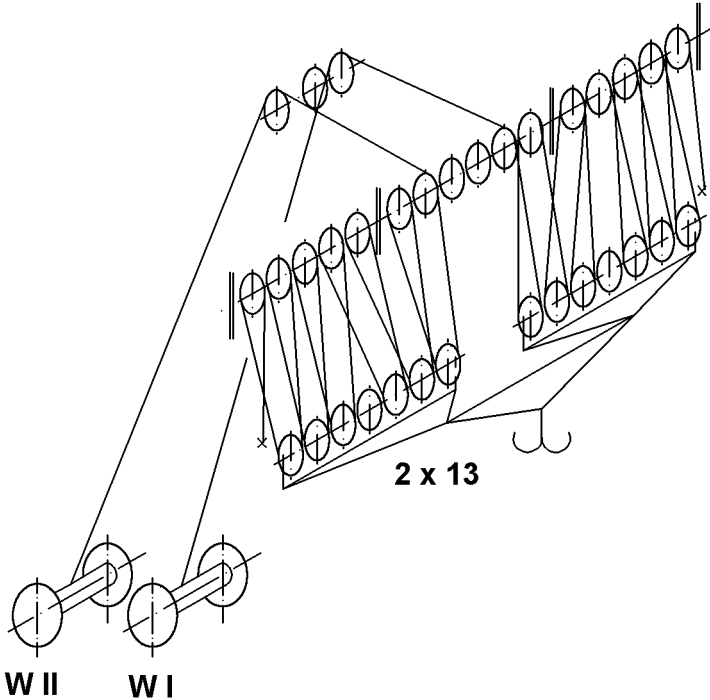










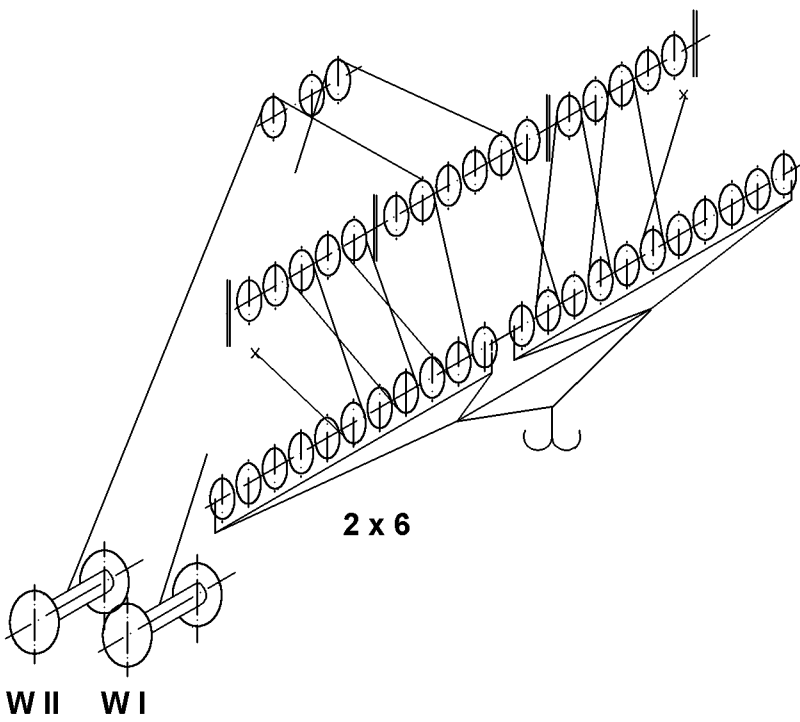
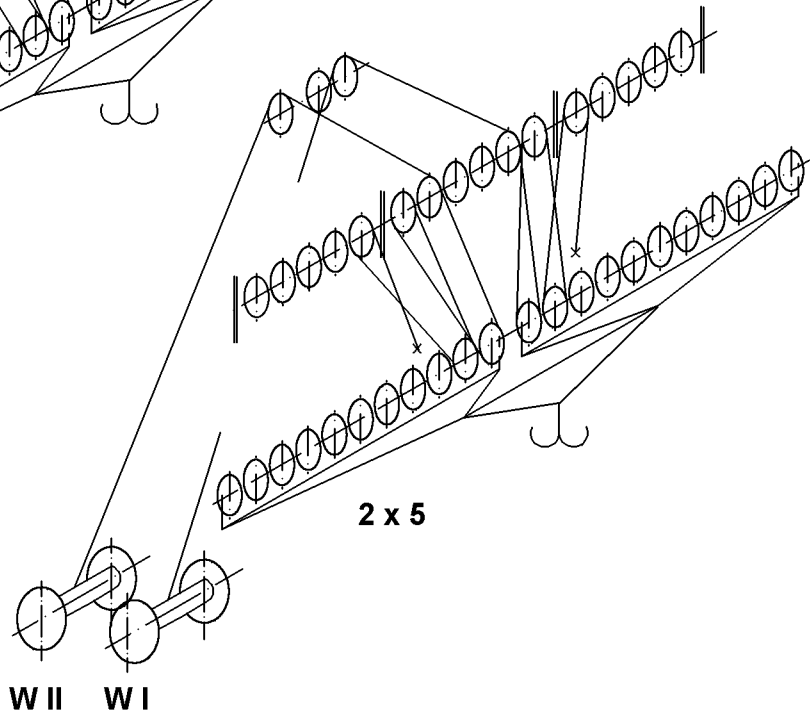
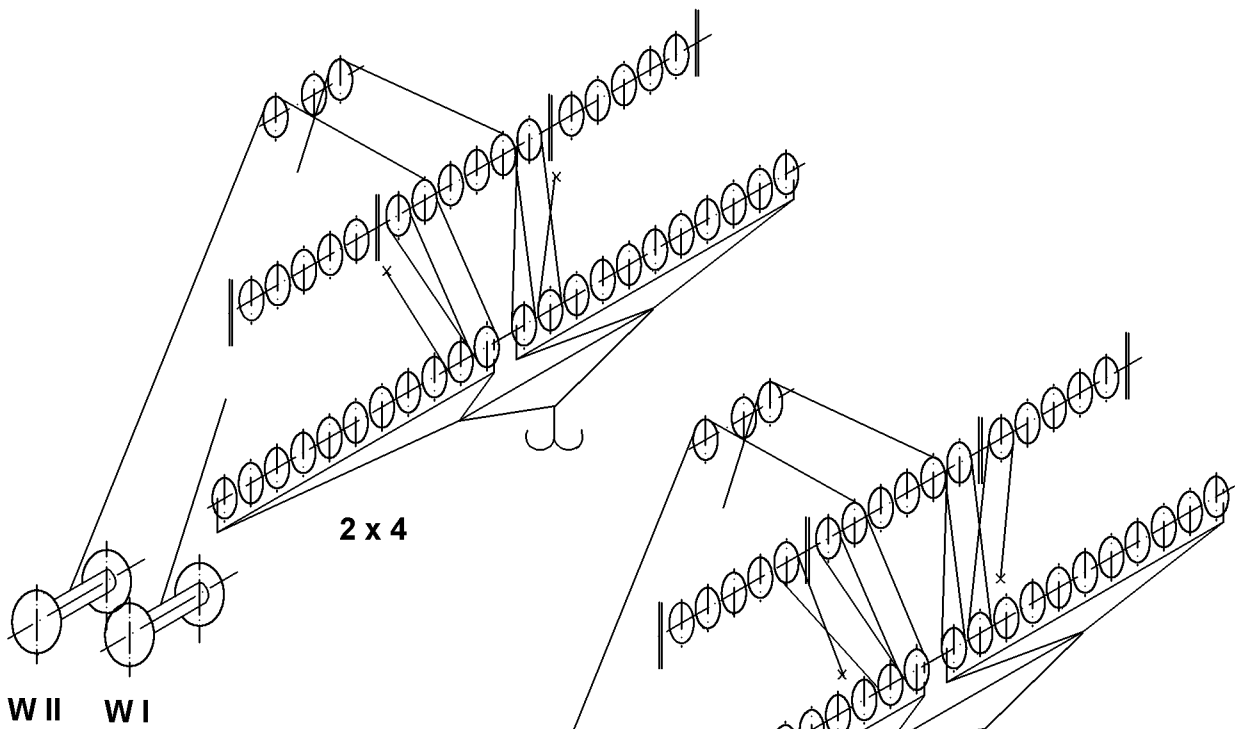


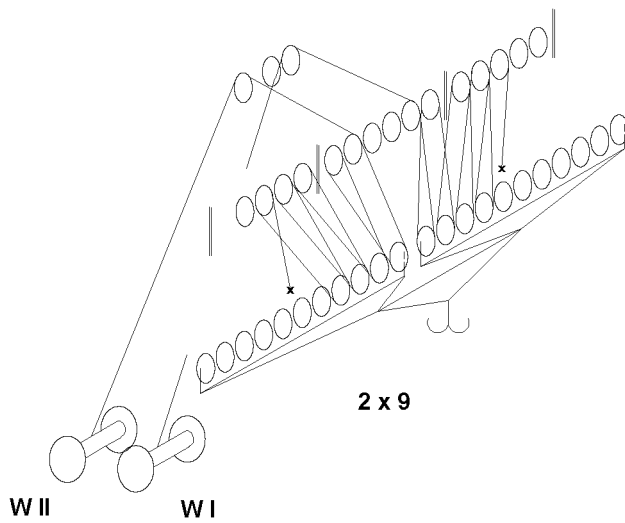
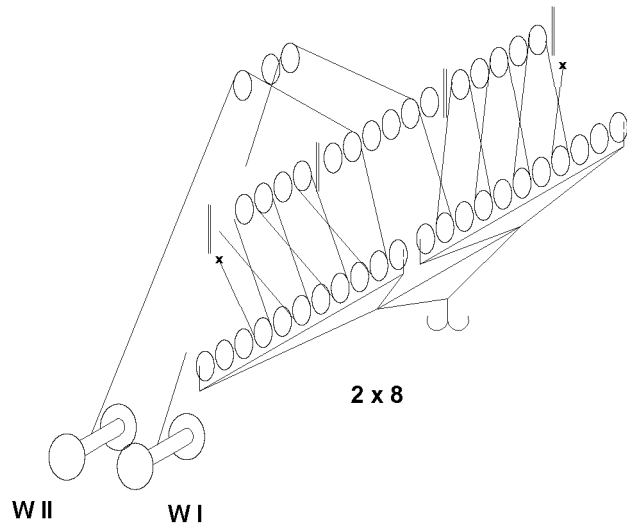
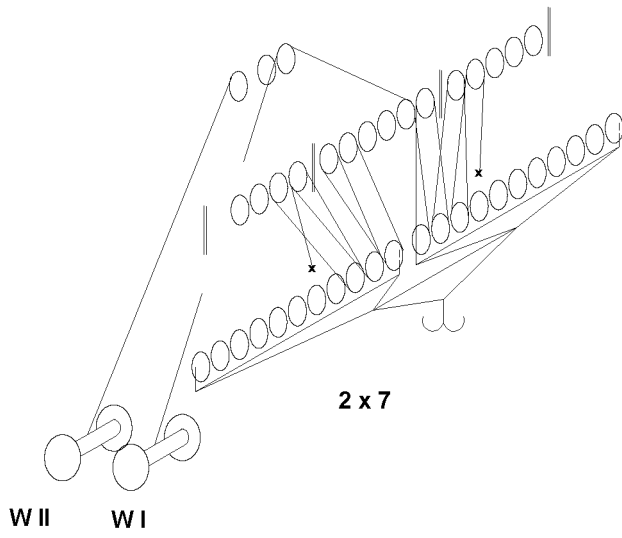
REEVING PLANS

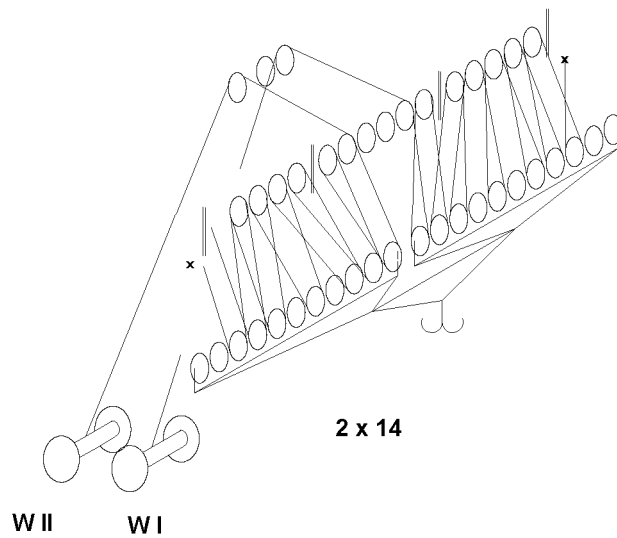
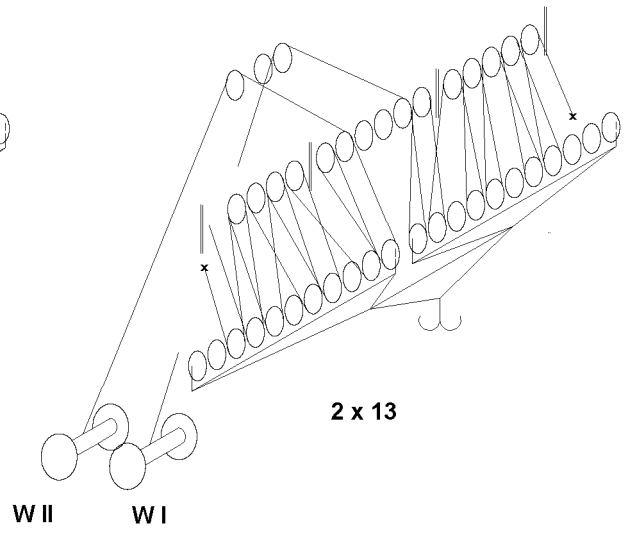
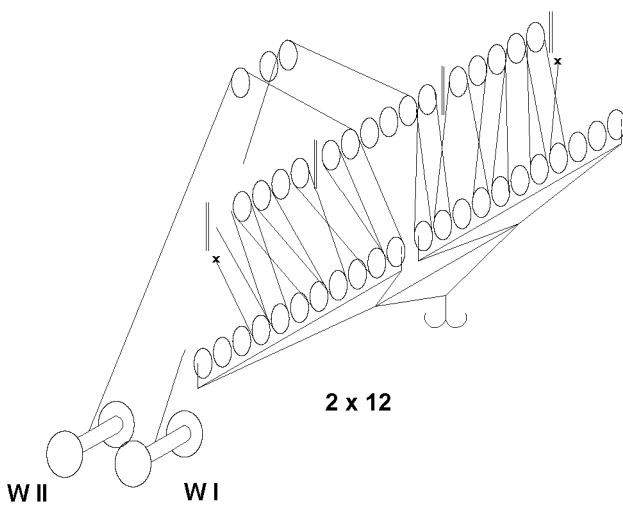
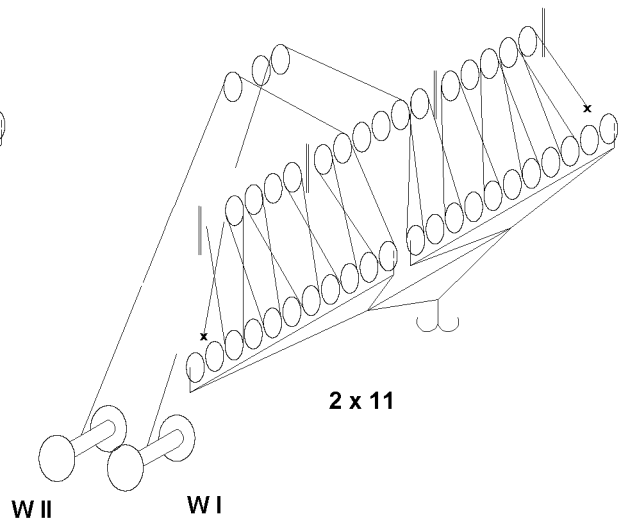
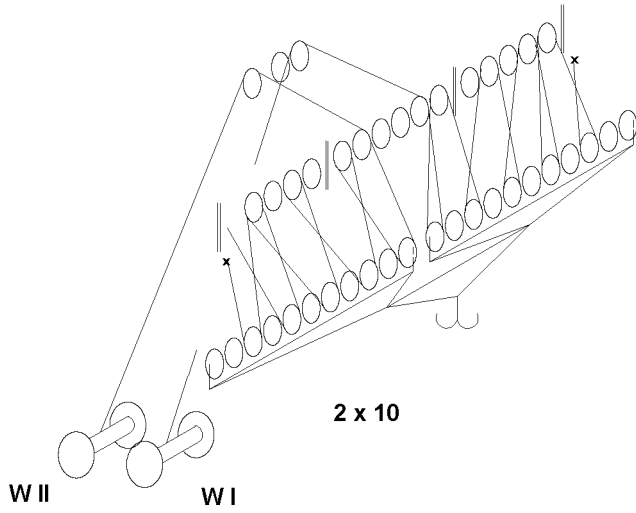
L - Head section (400 t)

400 t - head section - 16 pulley

2×11 - pulley hook block (600 t hook block)





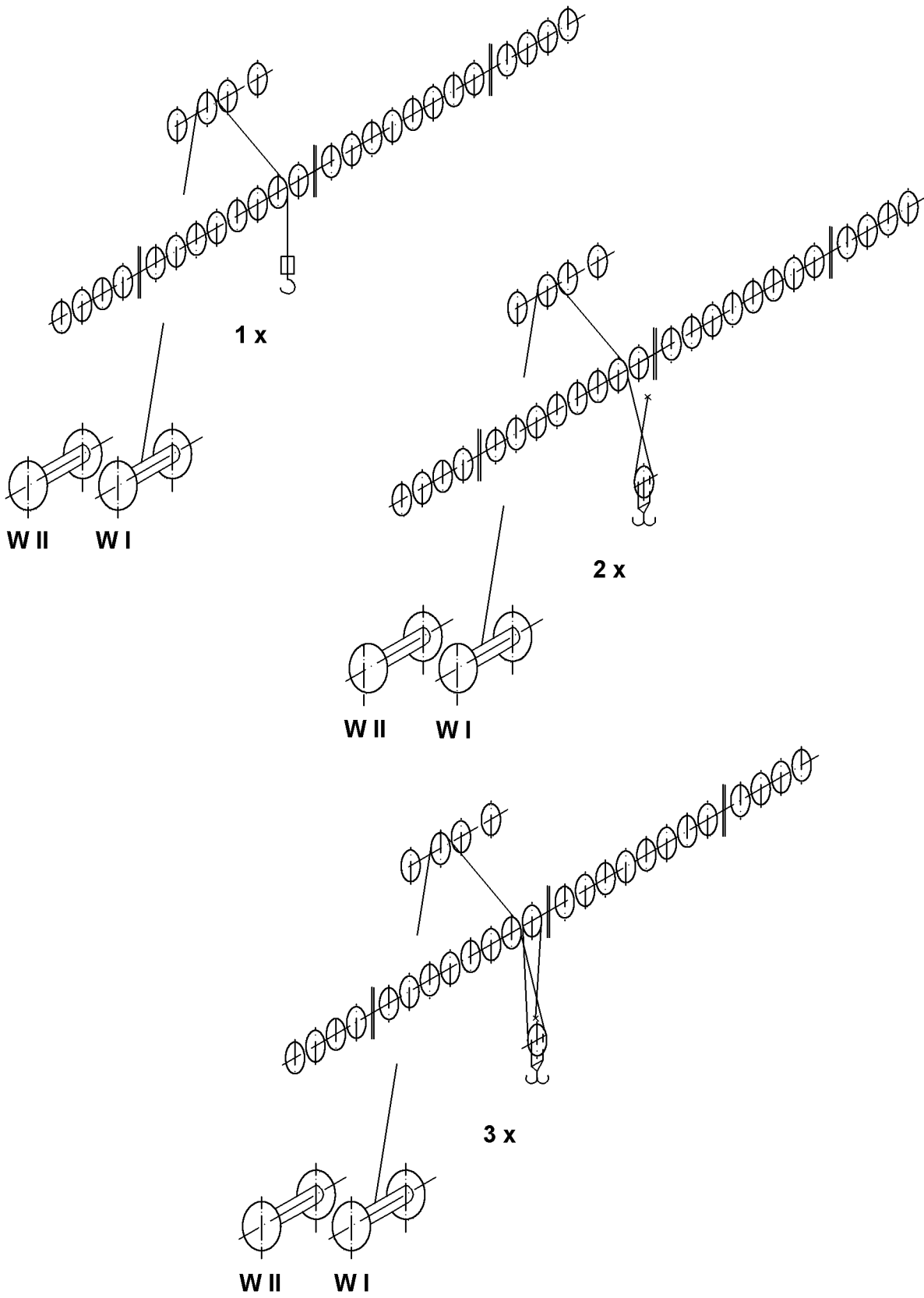


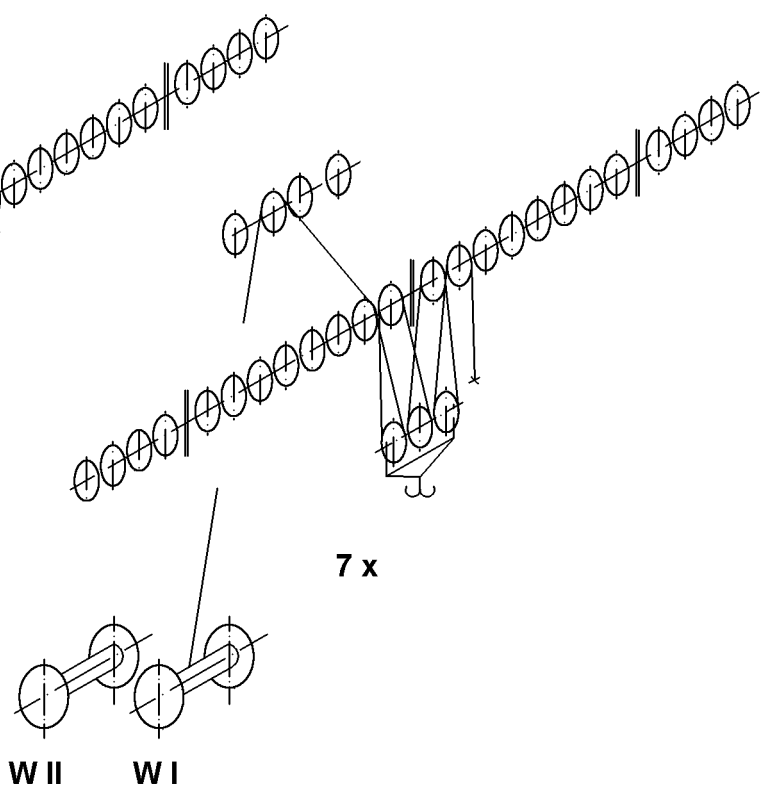
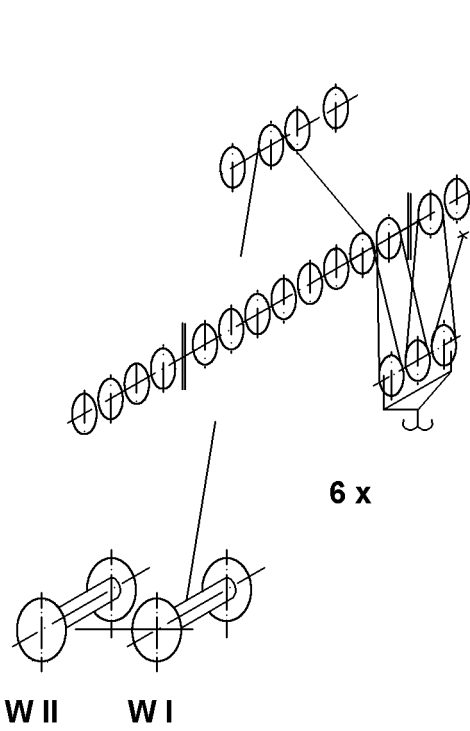
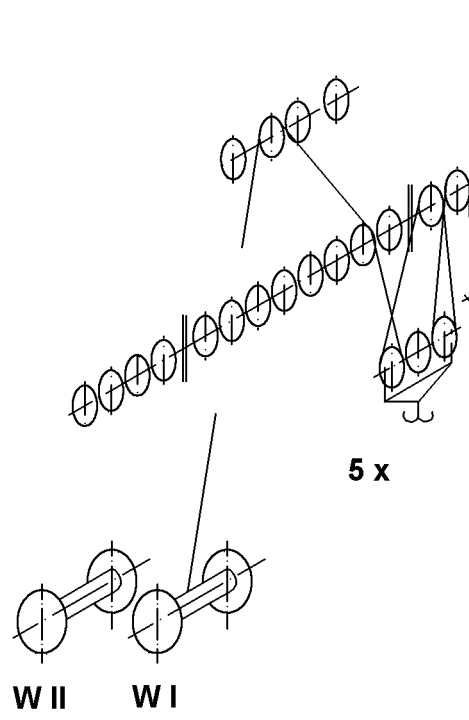
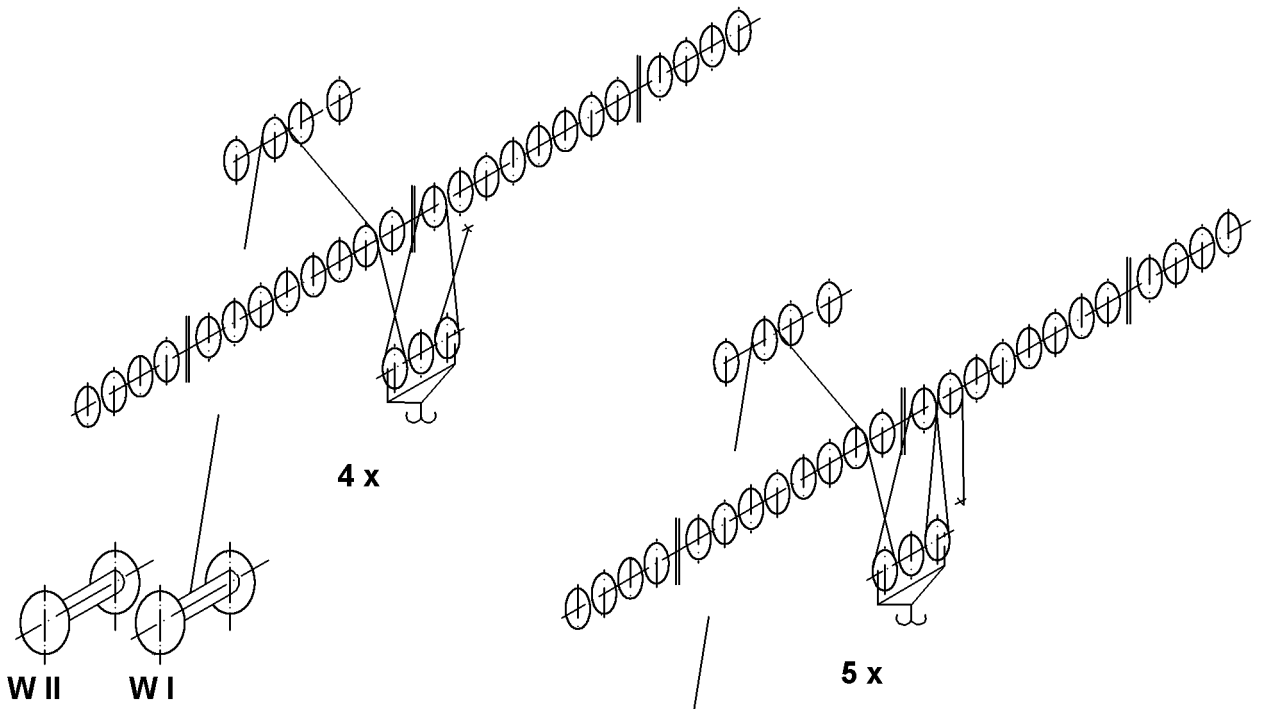
REEVING PLANS

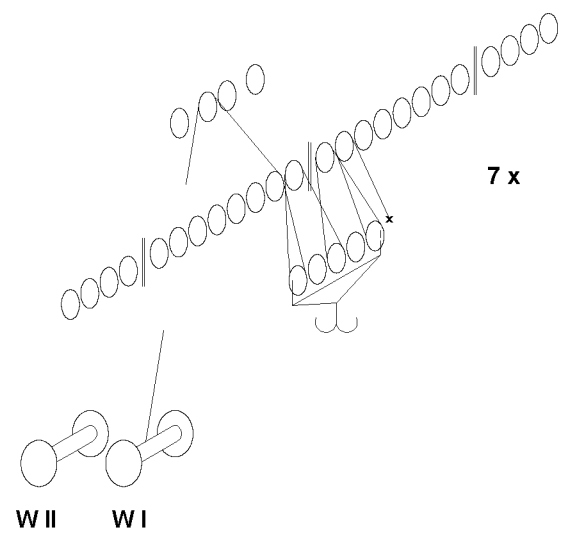
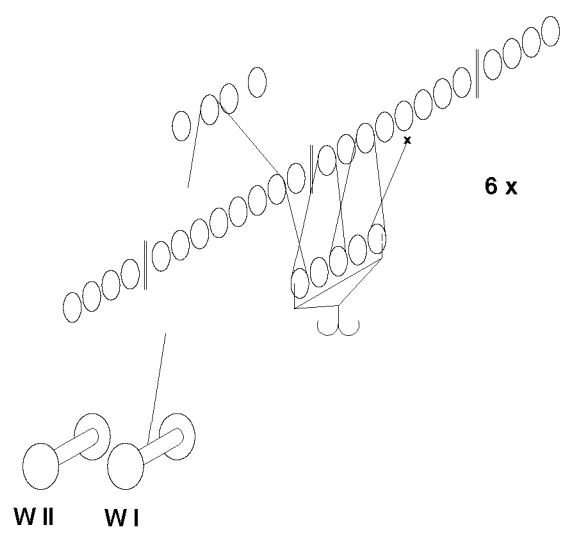
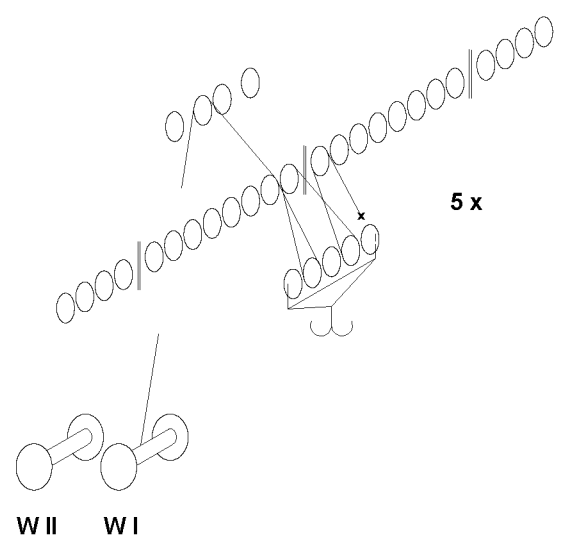
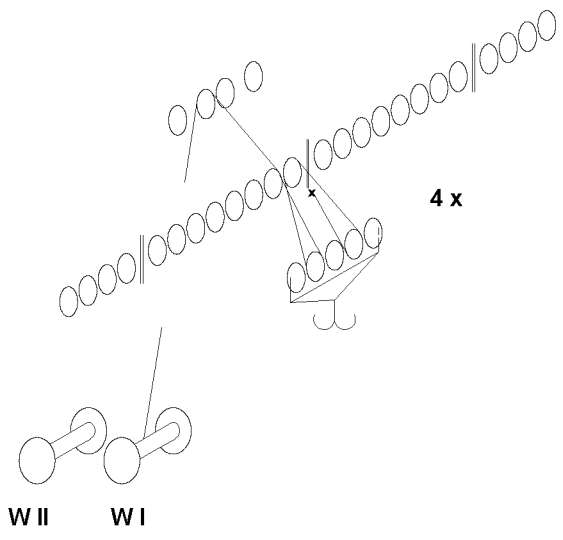
S - Head section (400 / 600 t)

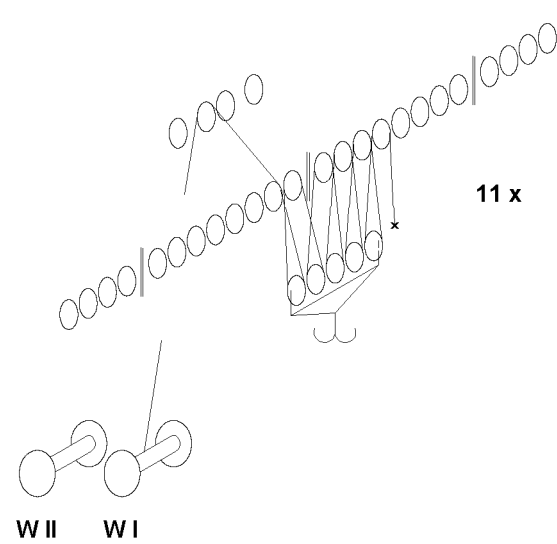
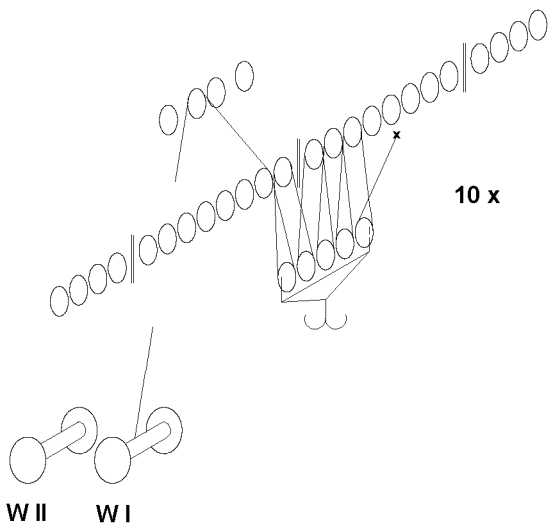
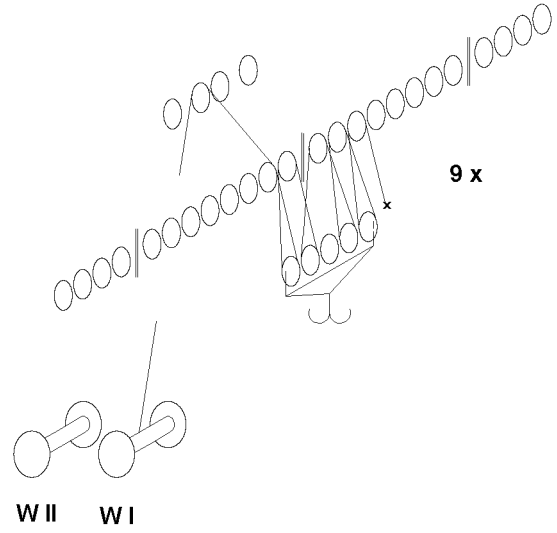
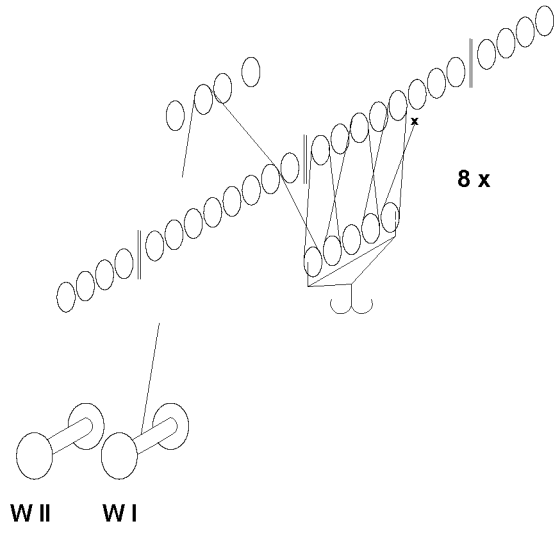
Head section - 24 pulley

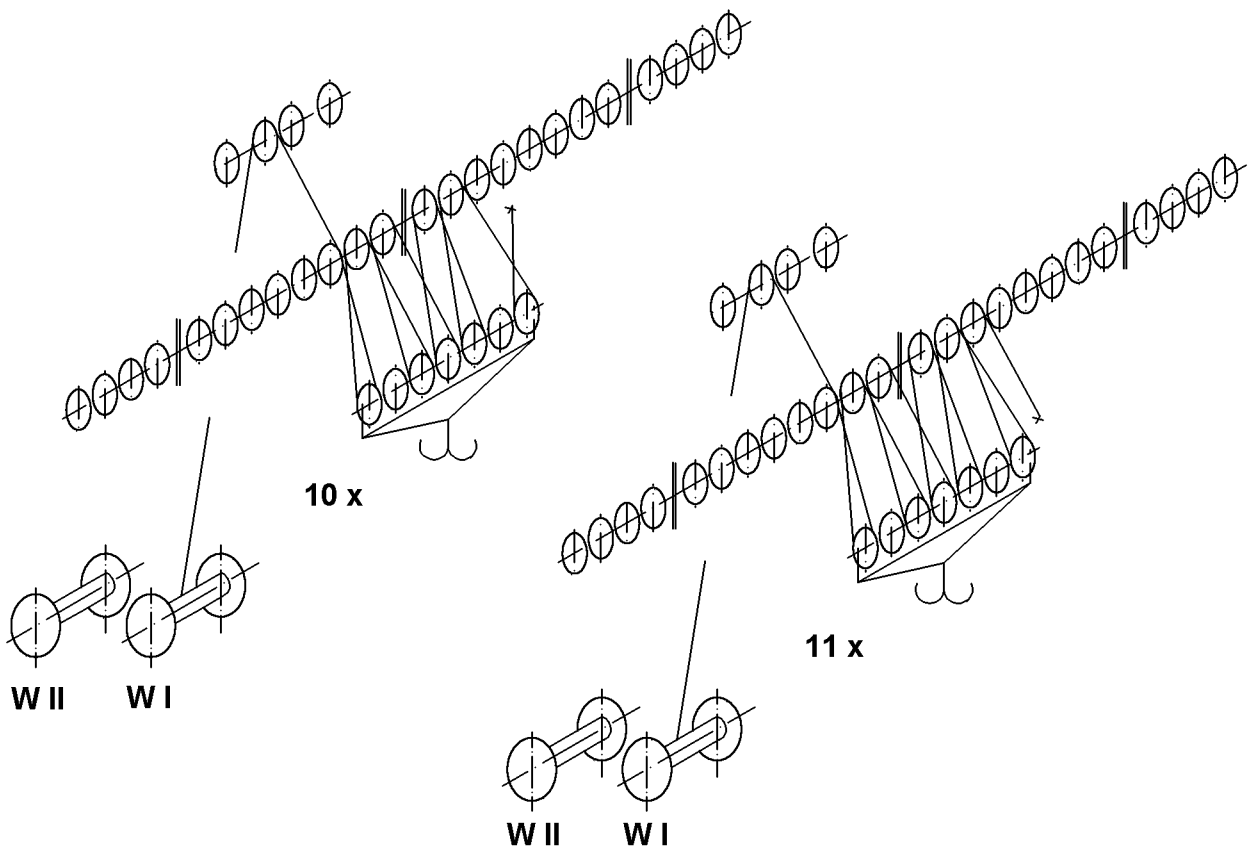
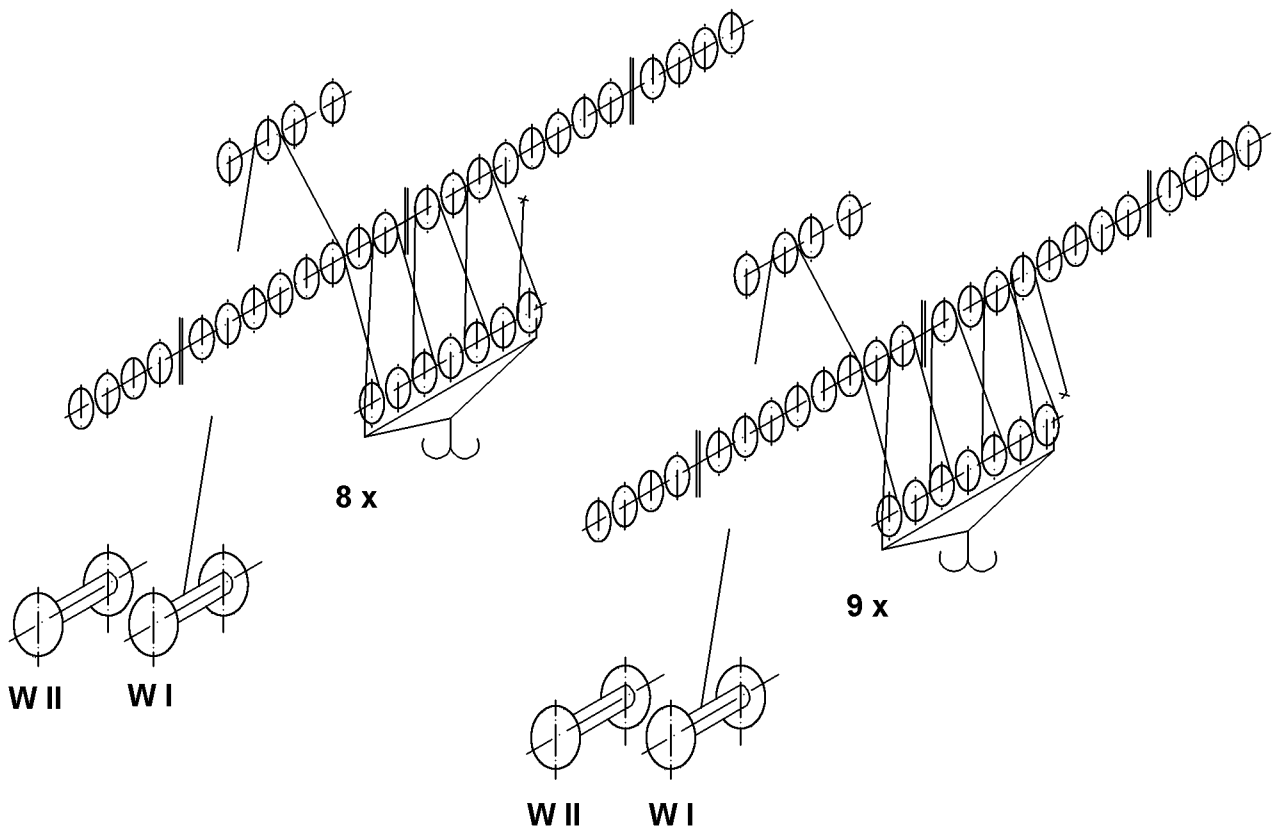
Load hook	16 t	
1 - pulley hook block,		50 t hook block
3 - pulley hook block,		125 t hook block
5 - pulley hook block,		160 t hook block
7 - pulley hook block,		215 t hook block

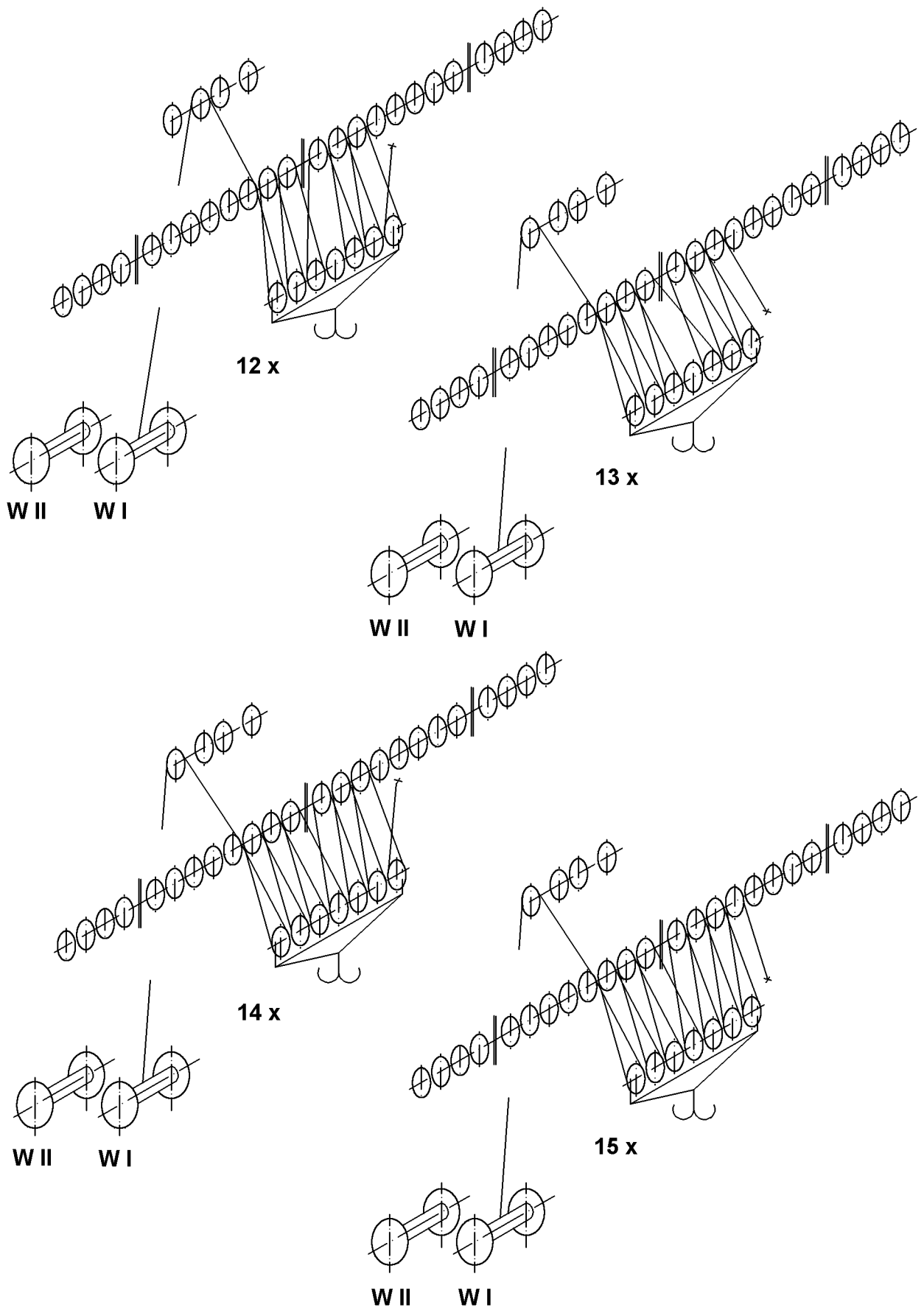










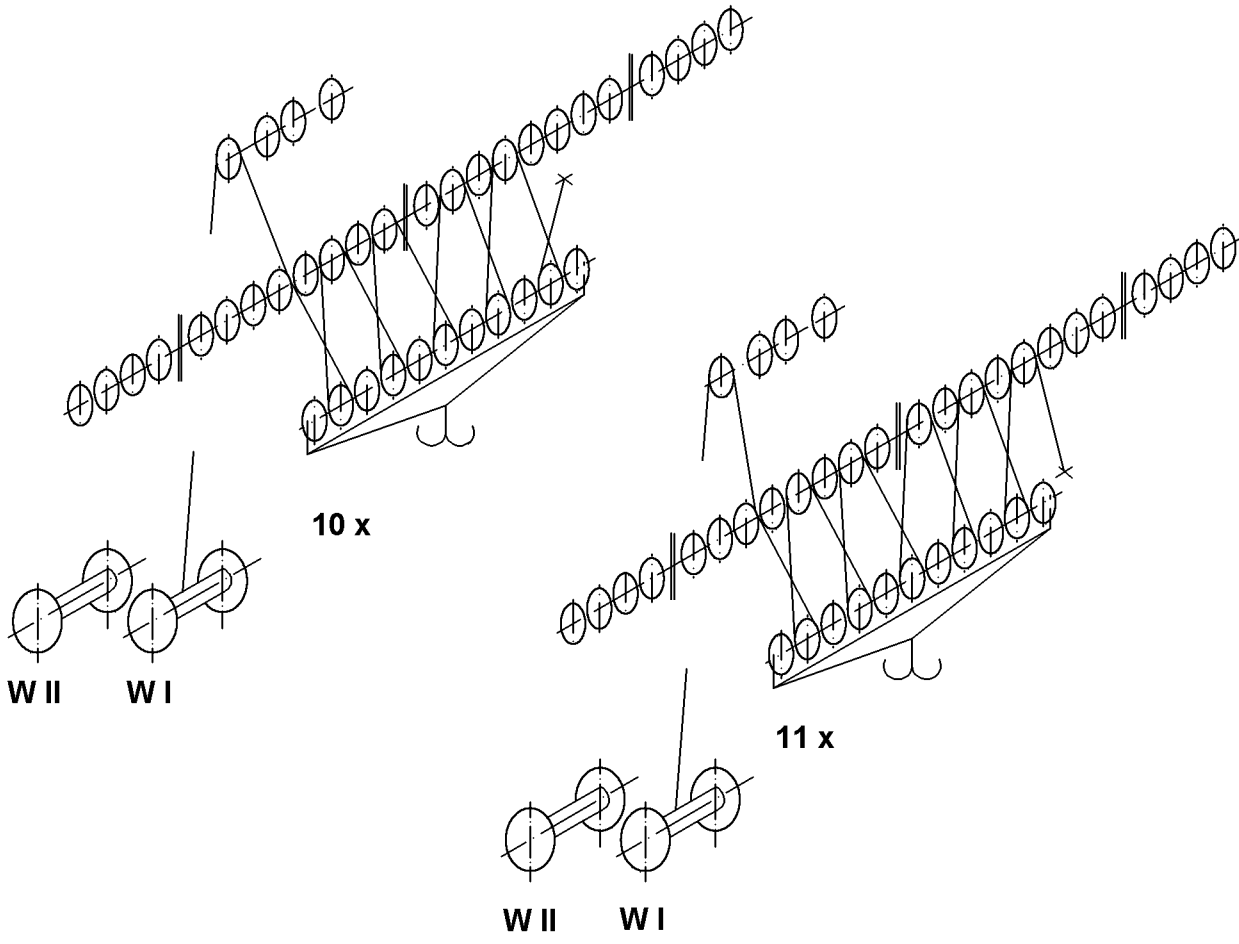
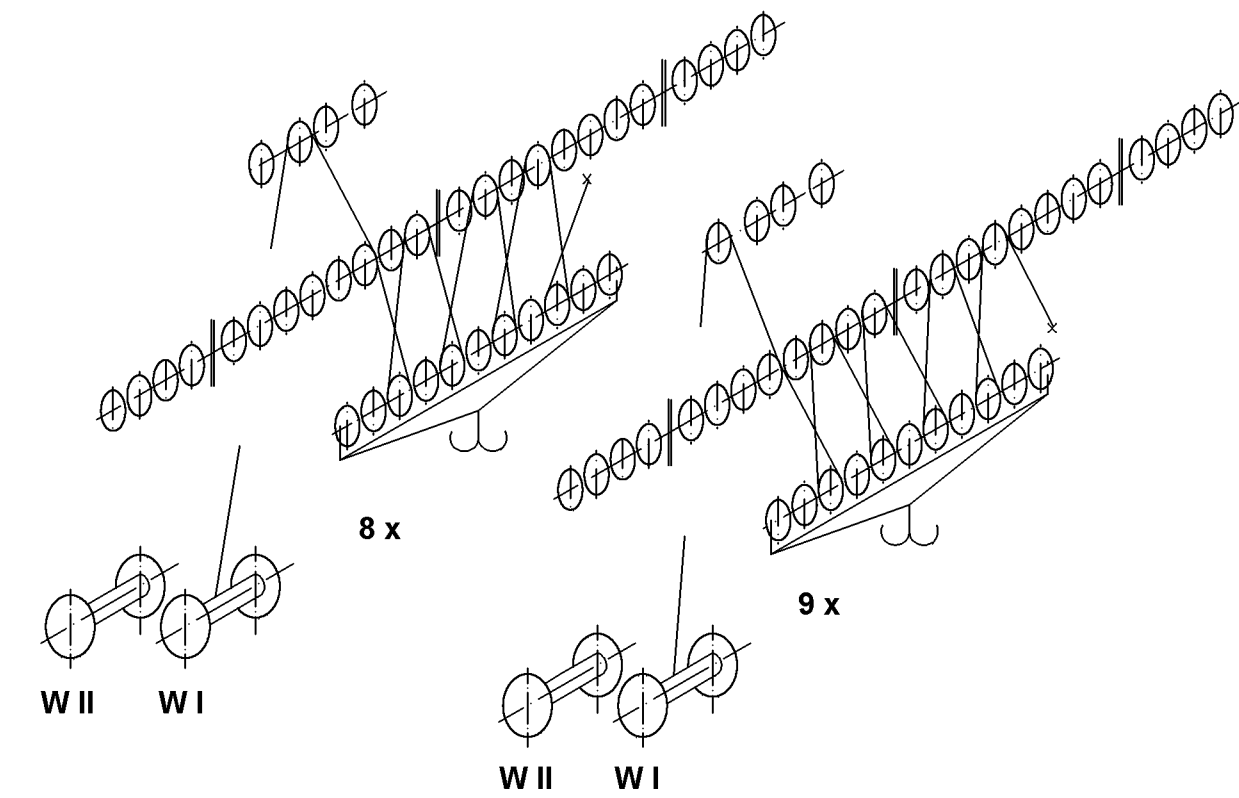


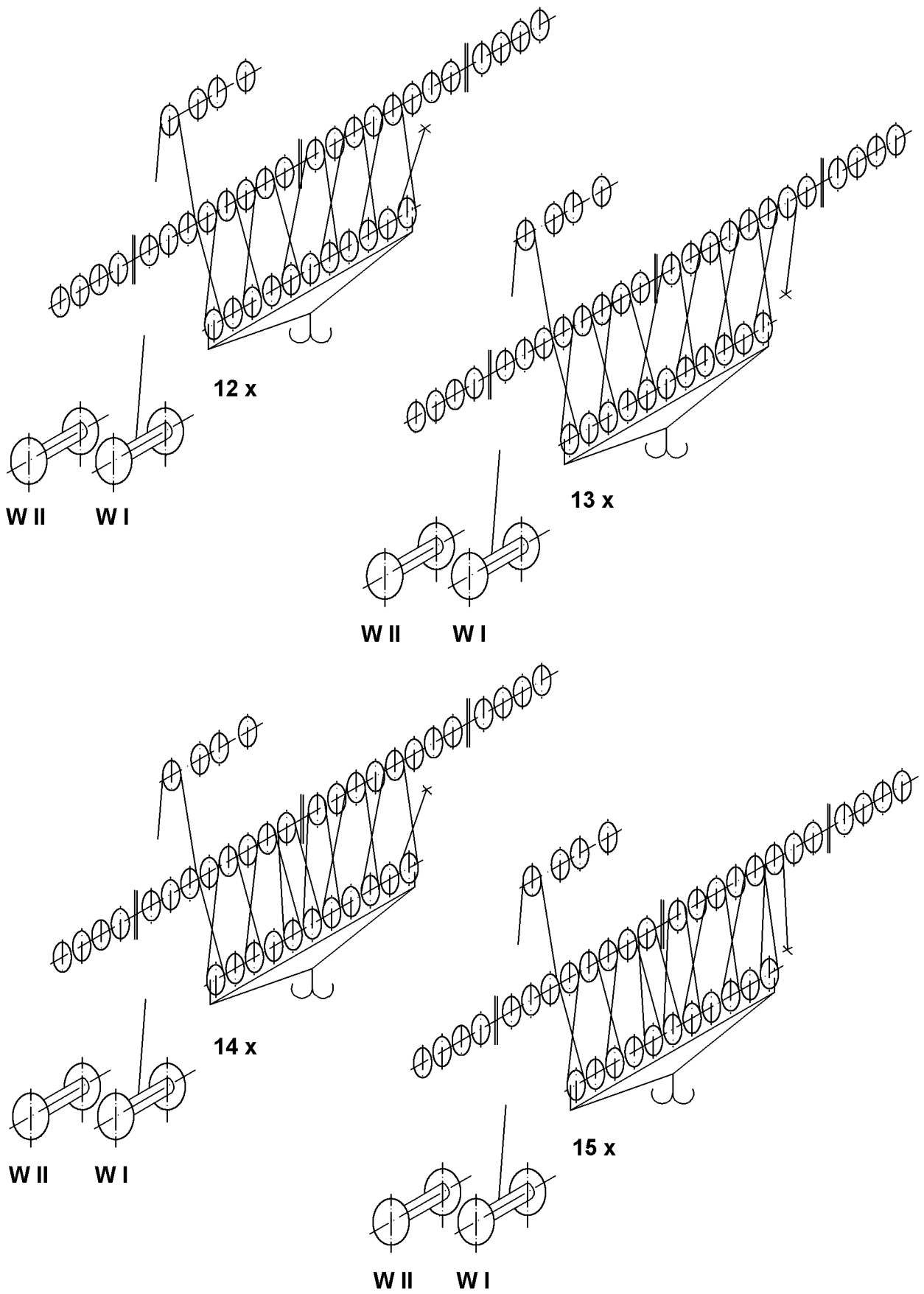
REEVING PLANS

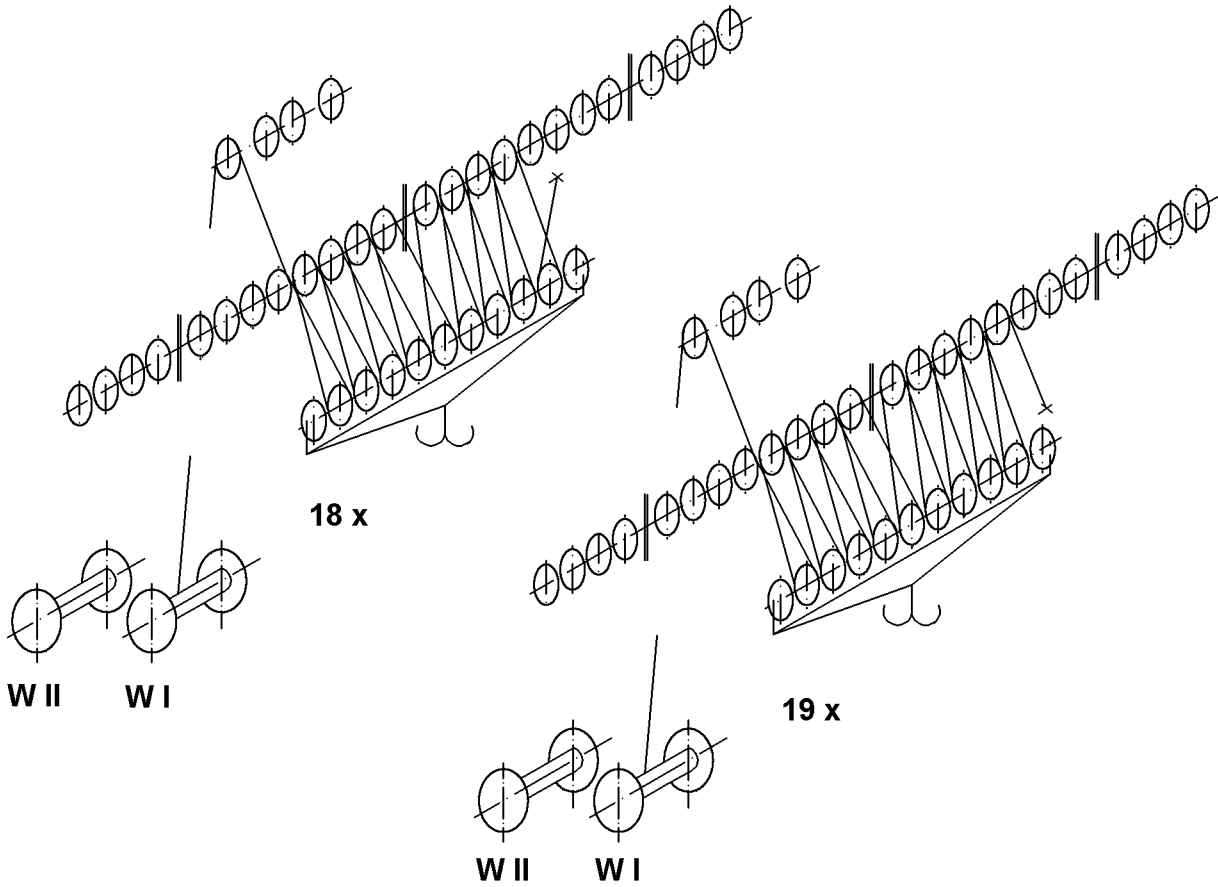
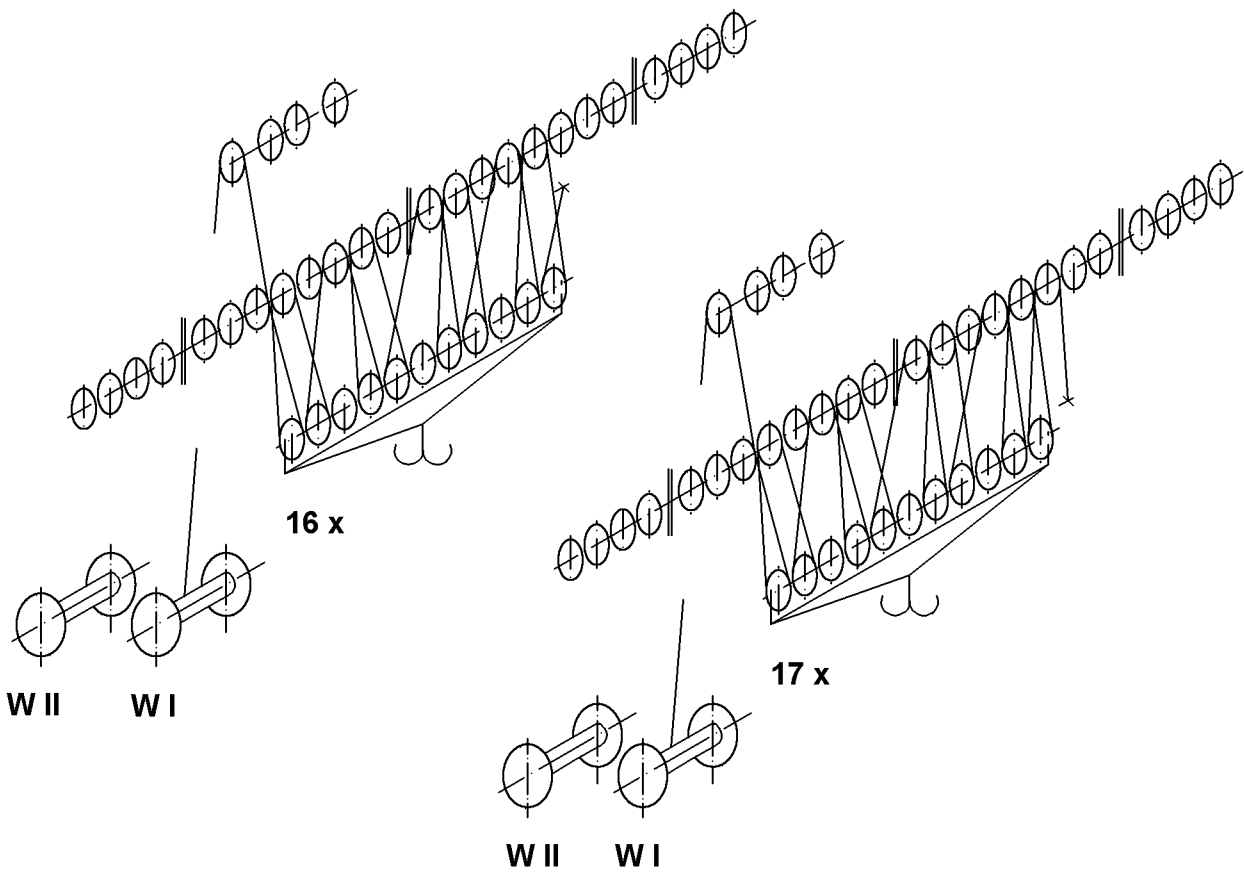
S - Head section (400 / 600 t)

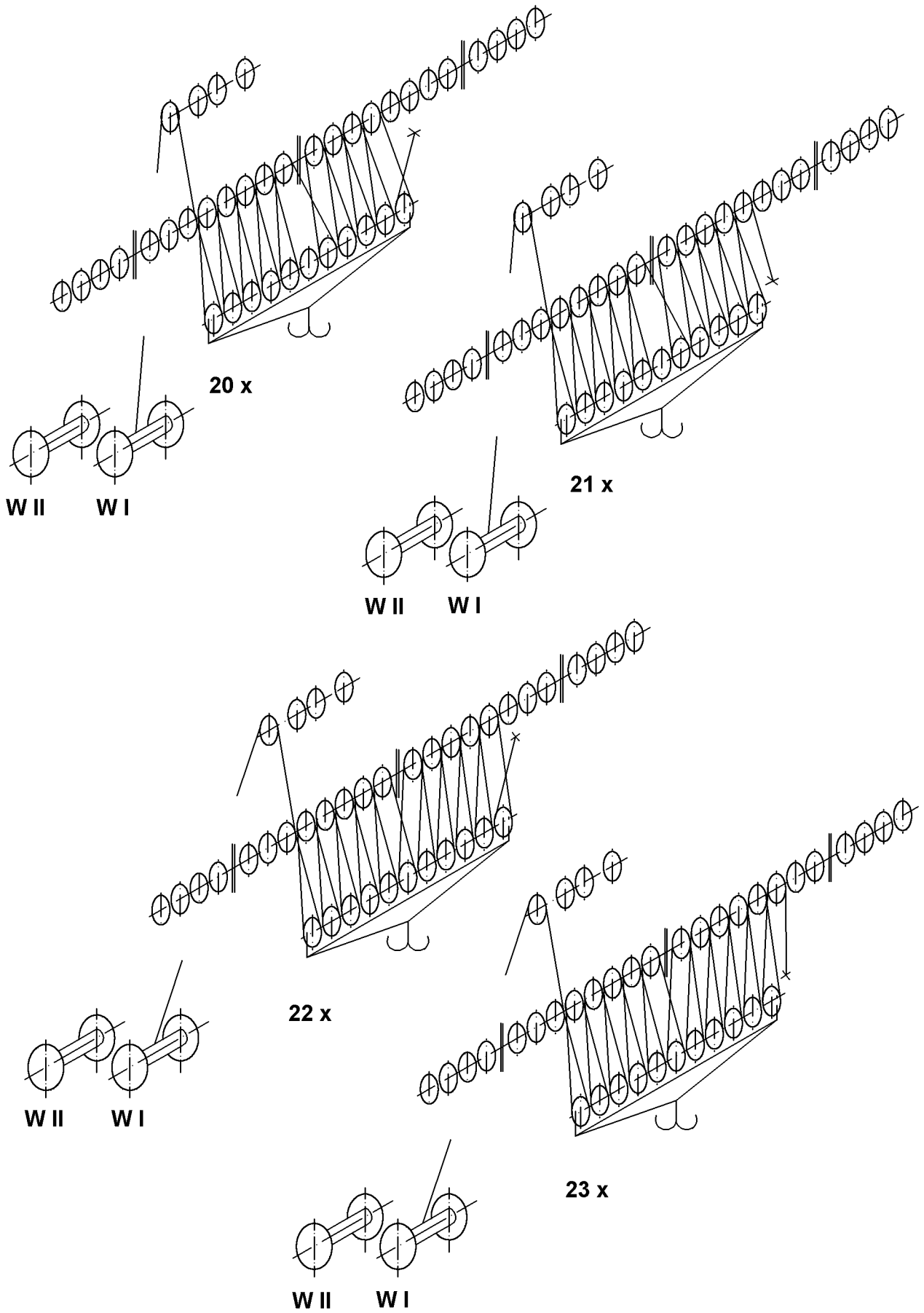
Head section - 24 pulley

11 - pulley hook block, 312 t hook block









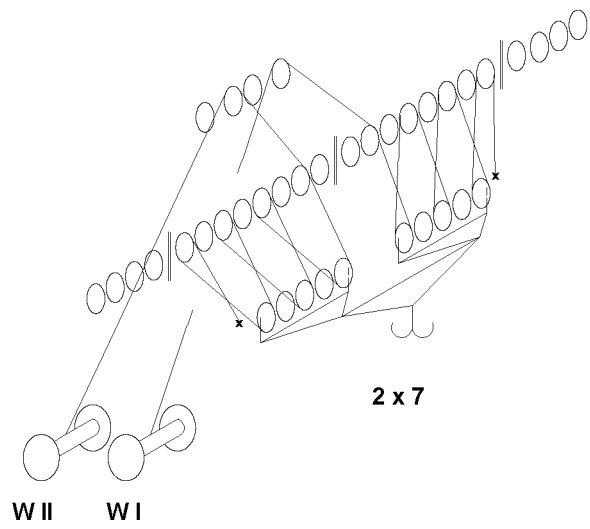
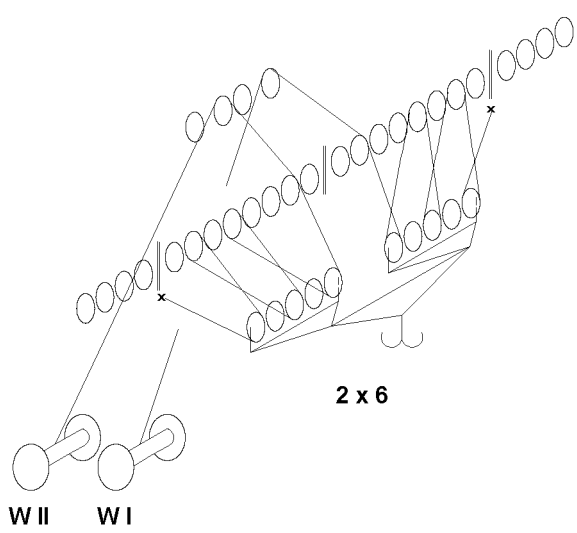
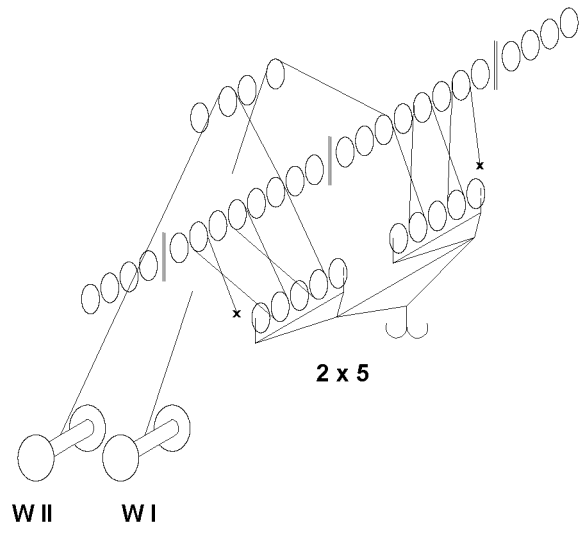
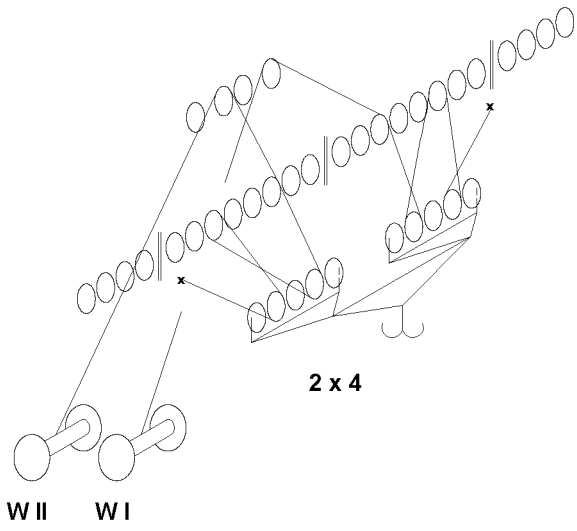
REEVING PLANS

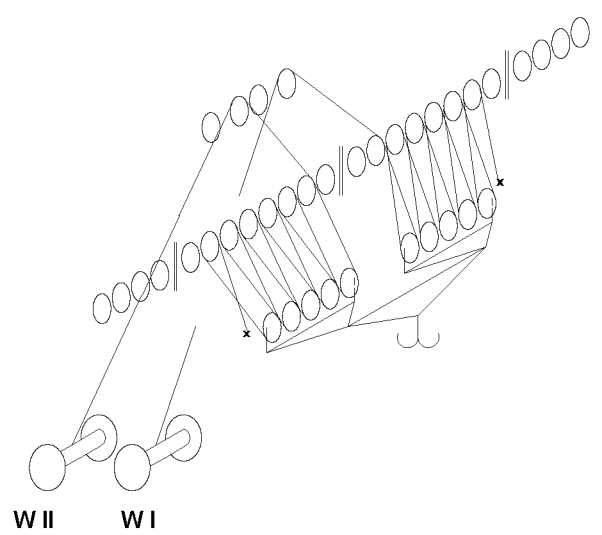
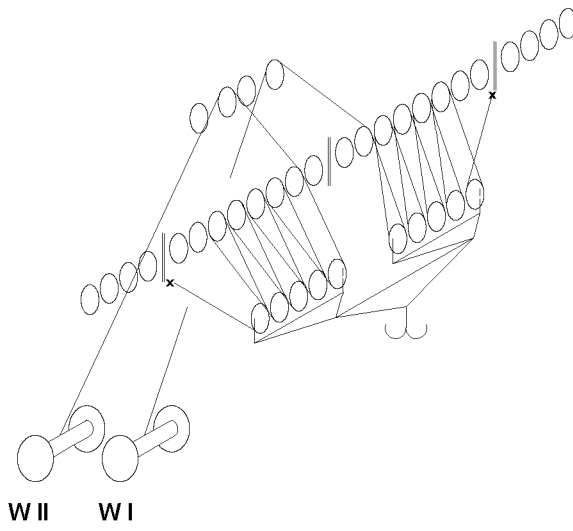
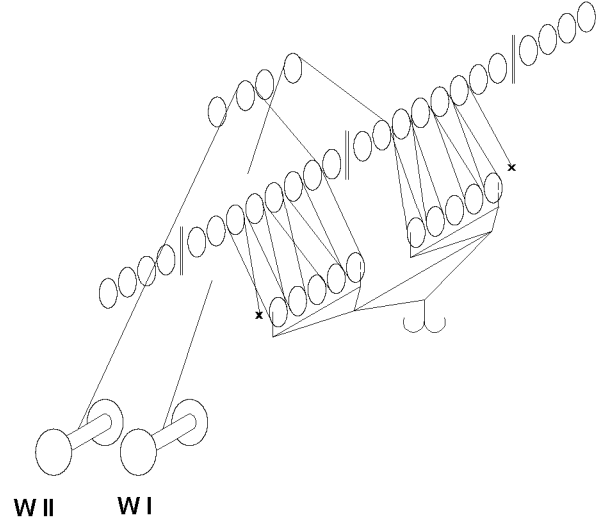
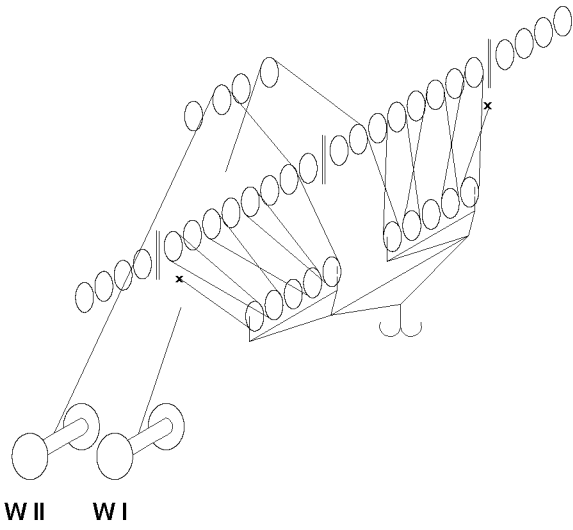
S - Head section (400 / 600 t)

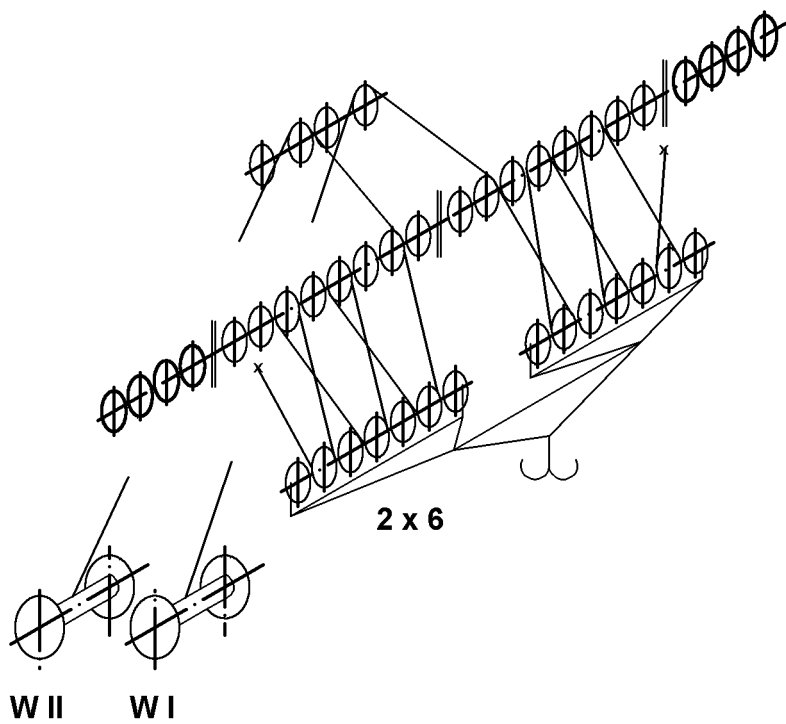
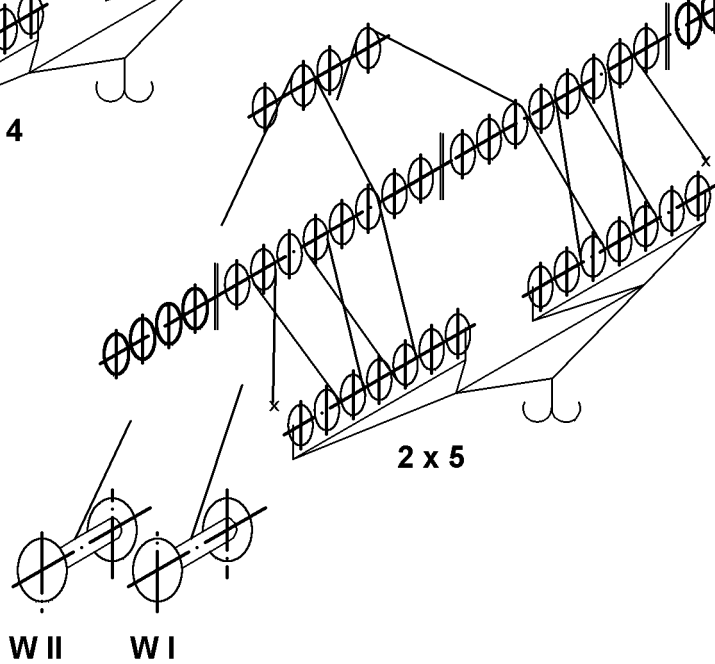
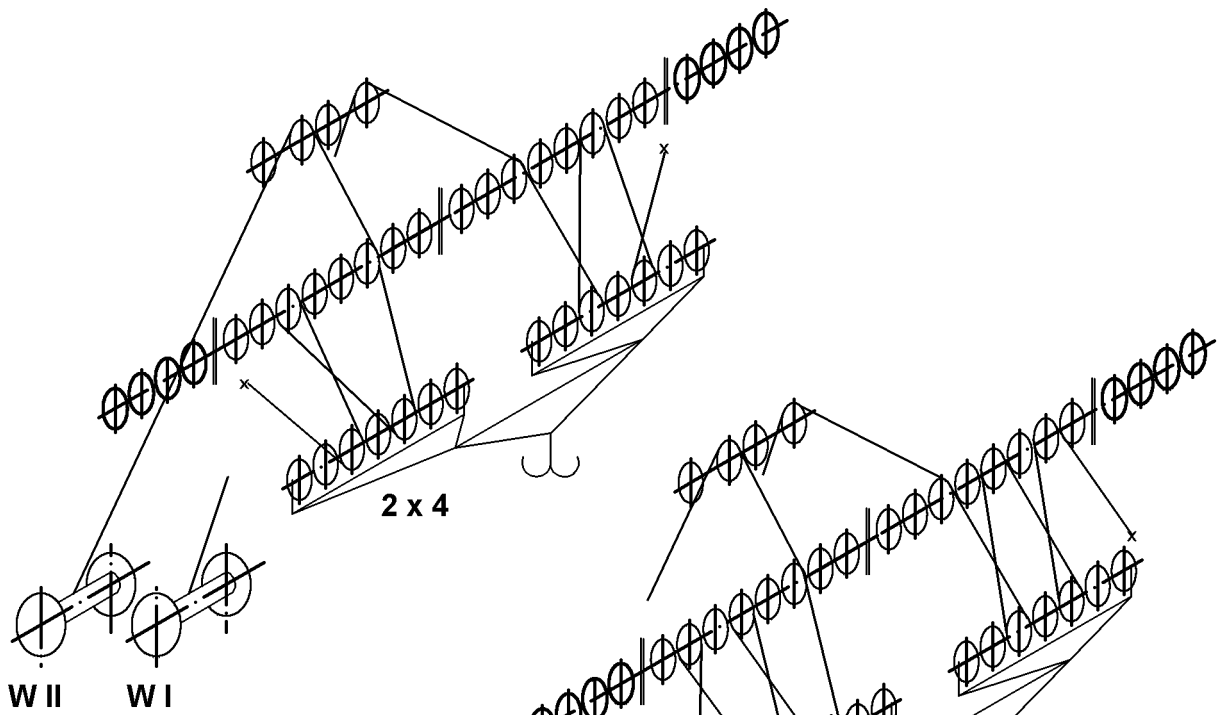
Head section - 24 pulley

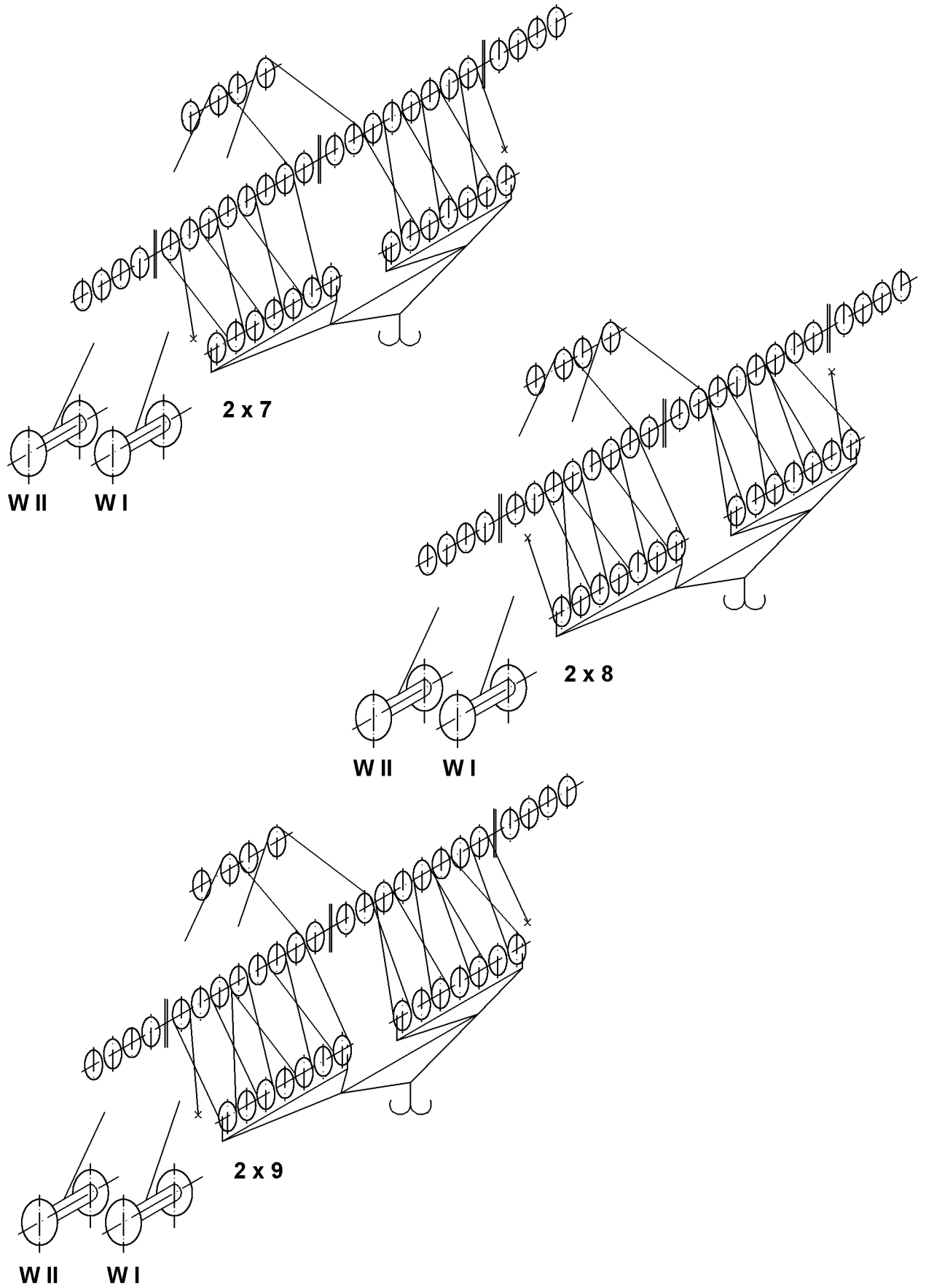
2×5 - pulley hook block (320 t hook block)

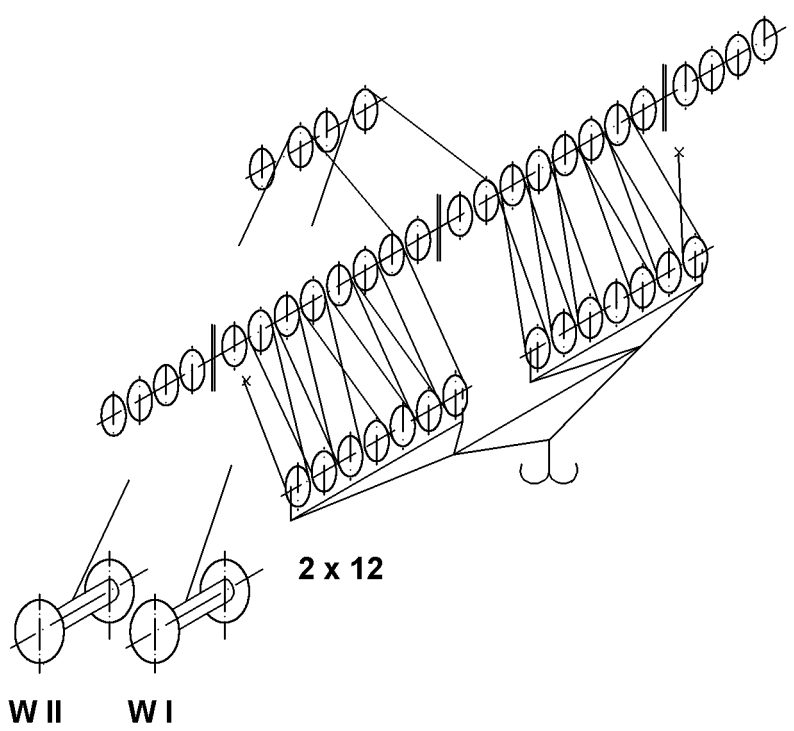
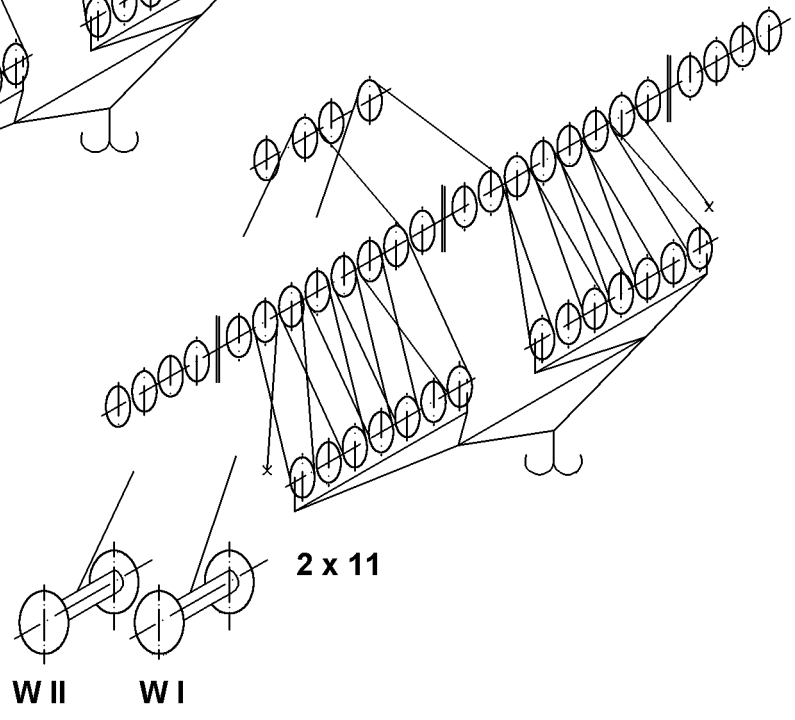
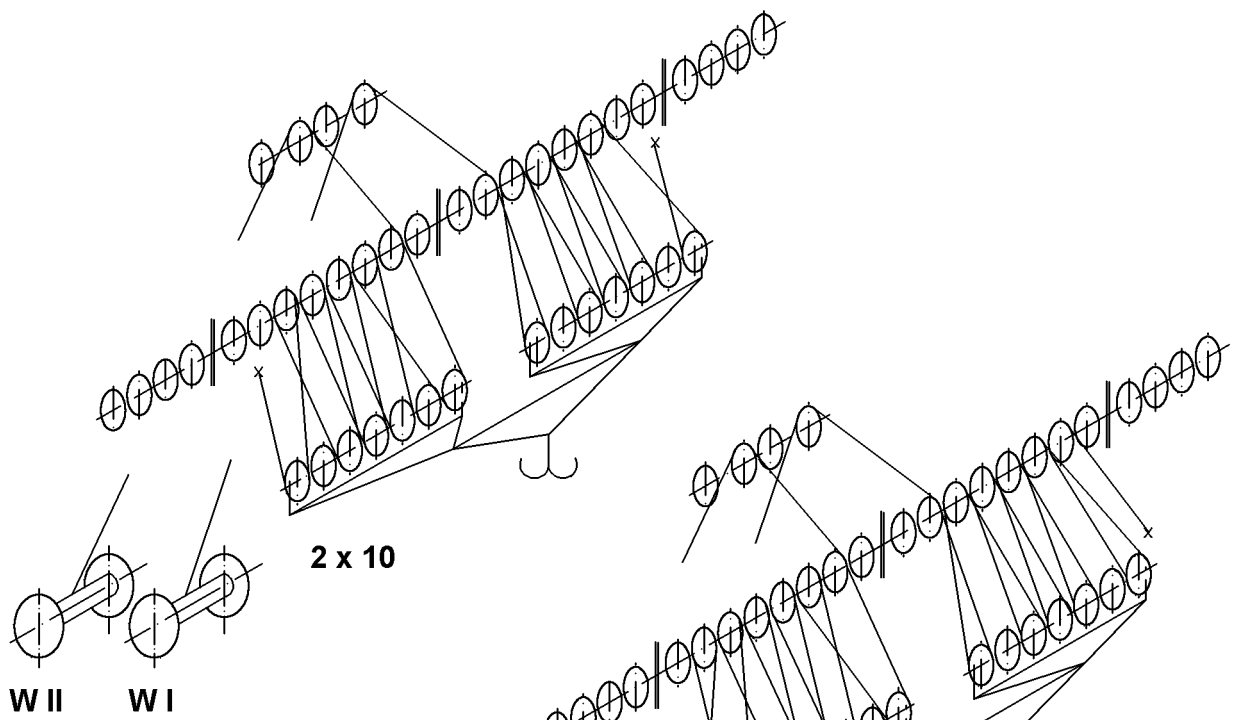
2×7 - pulley hook block (400 t hook block)

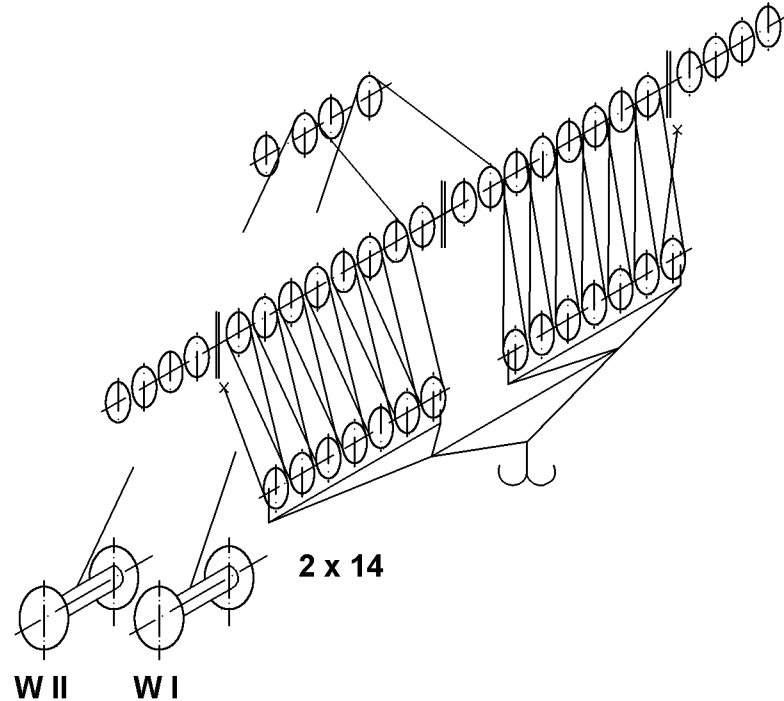
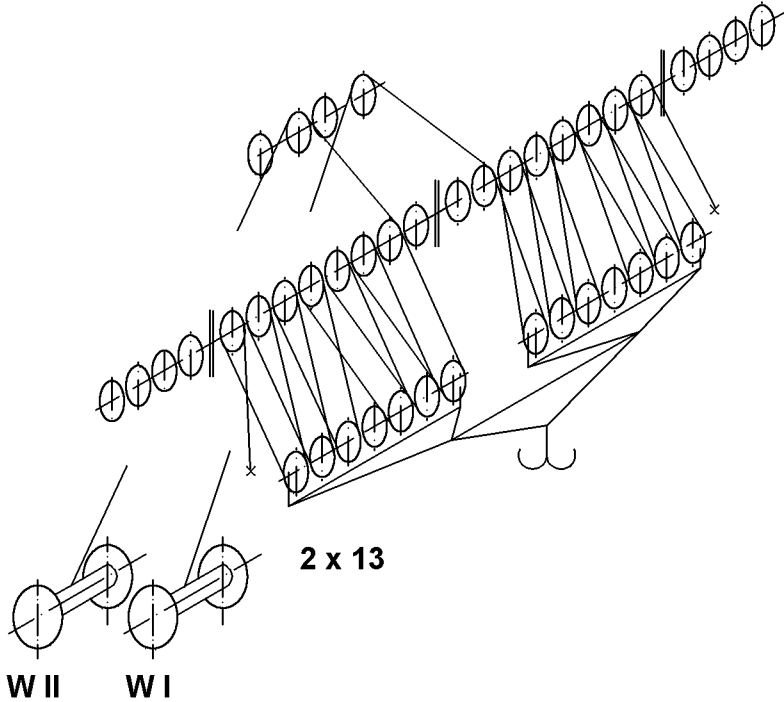










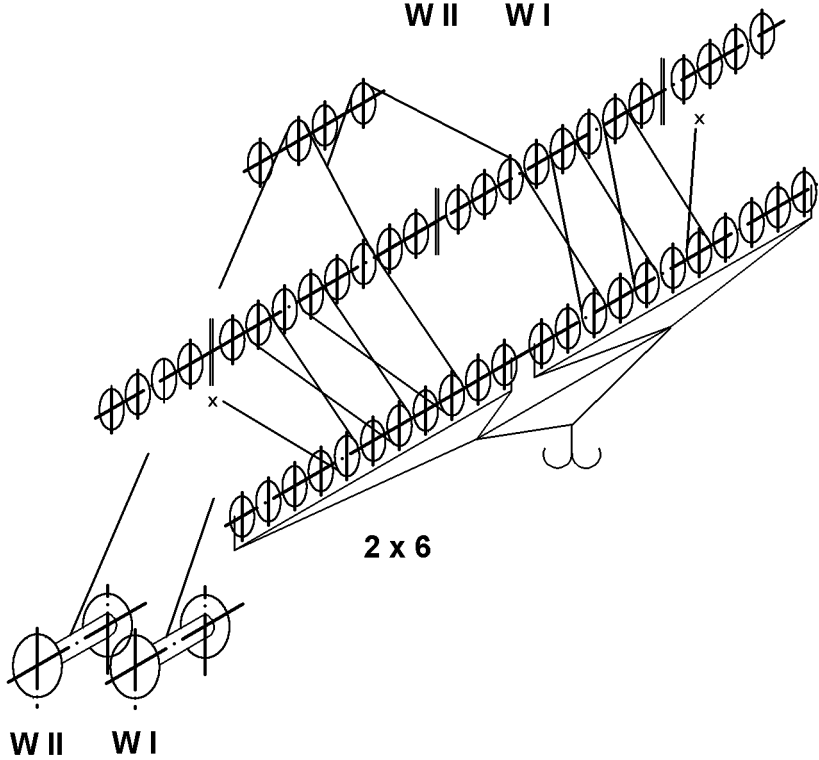
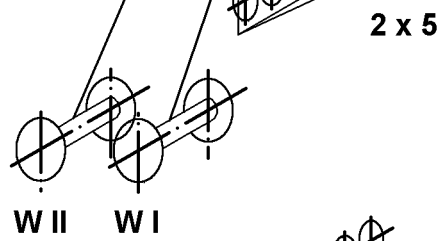
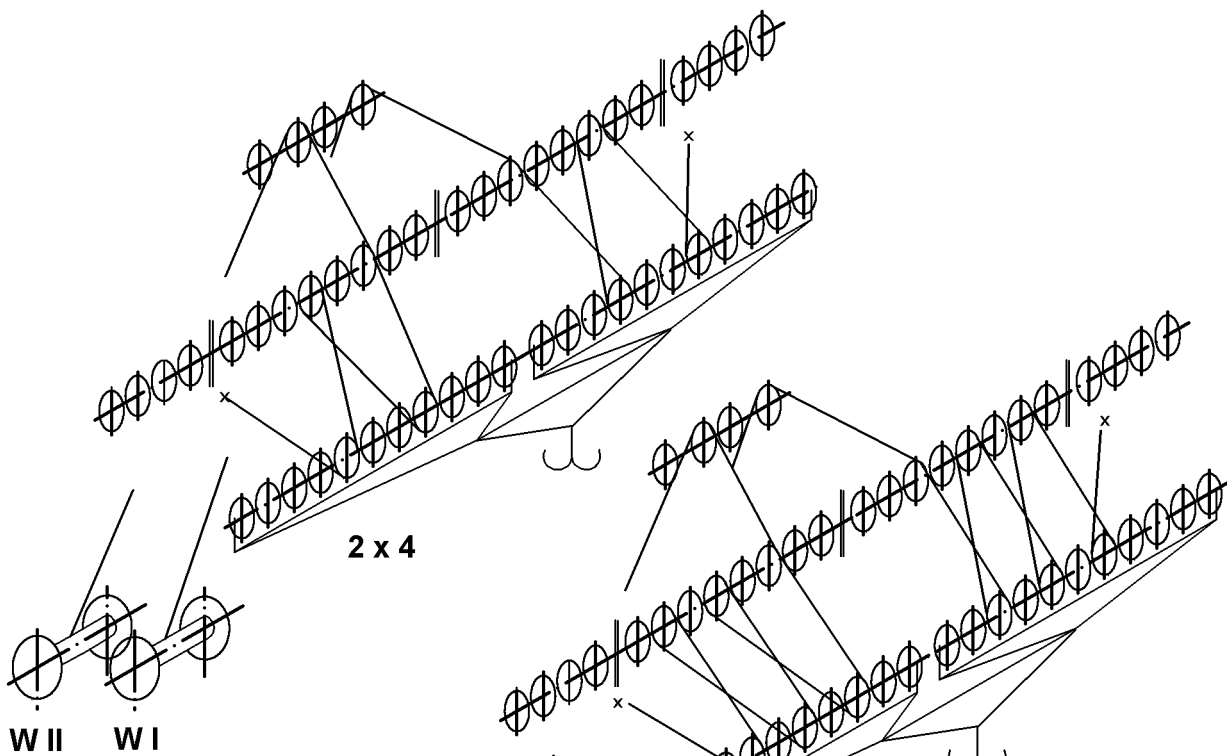


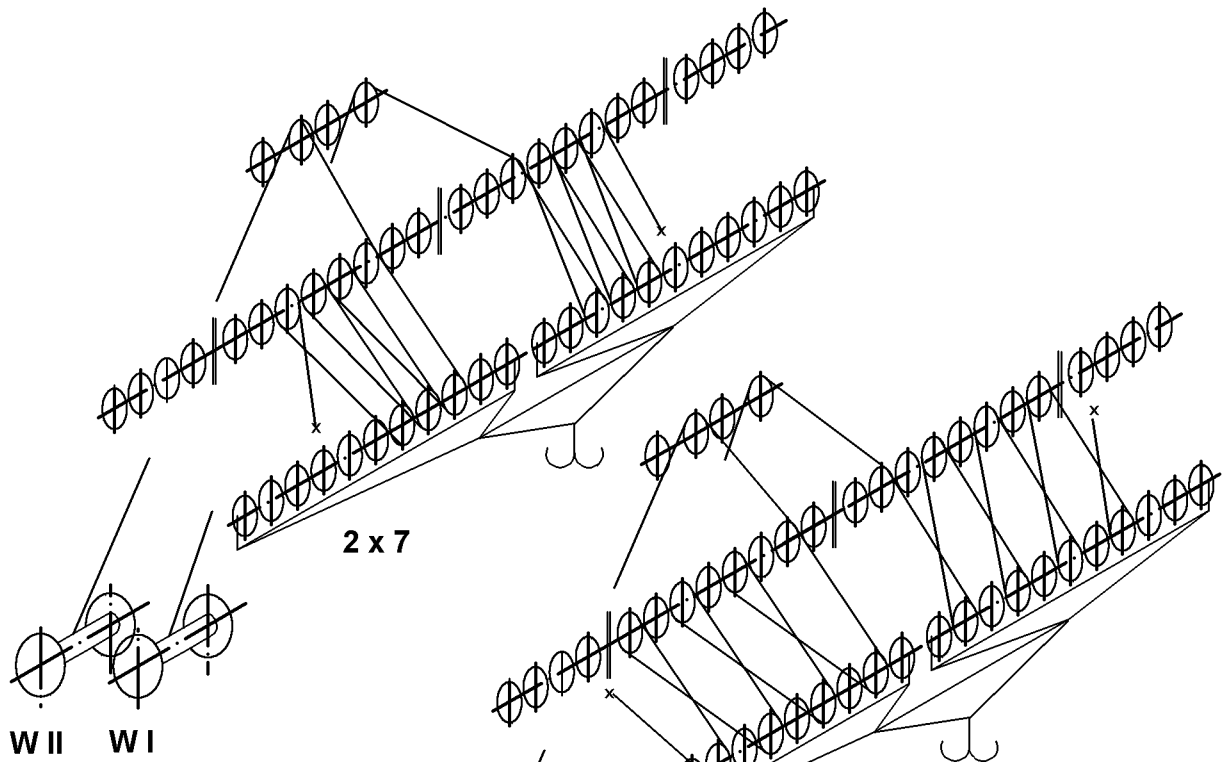
REEVING PLANS

S - Head section (400 / 600 t)

Head section - 24 pulley

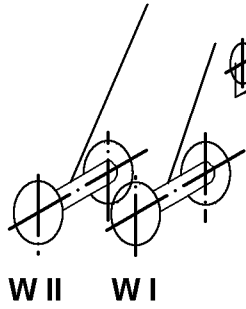
2×11 - pulley hook block (600 t hook block)





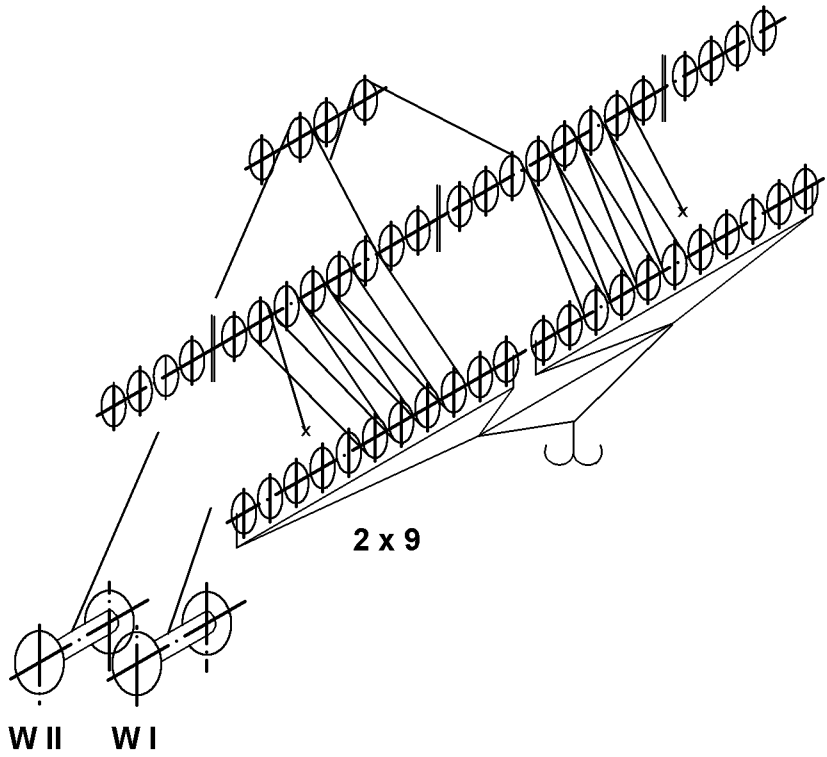
2 x 7

W II W I



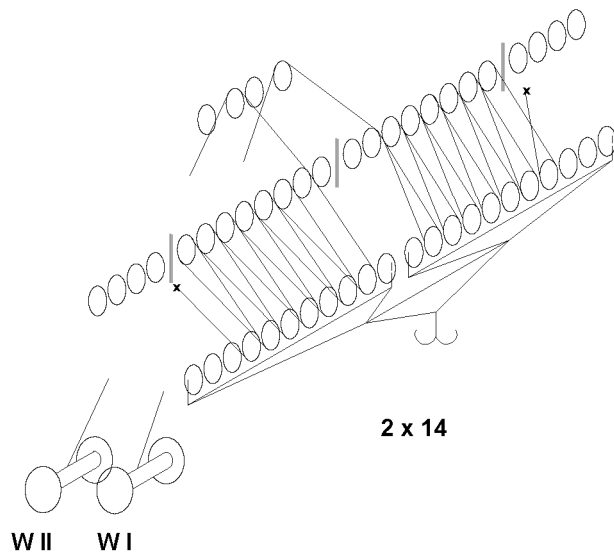
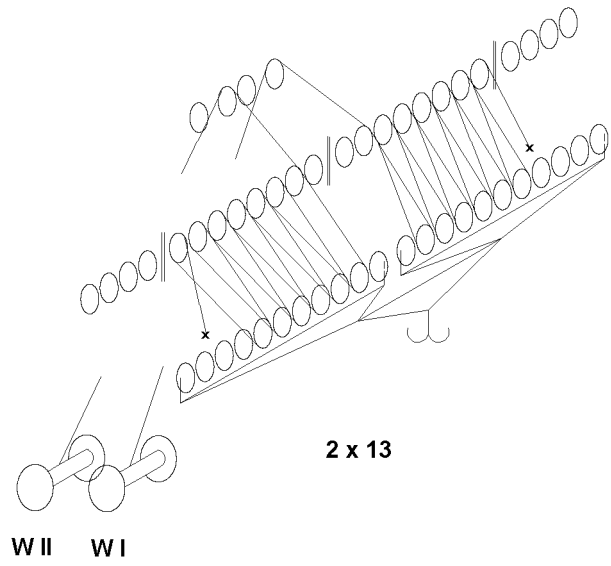
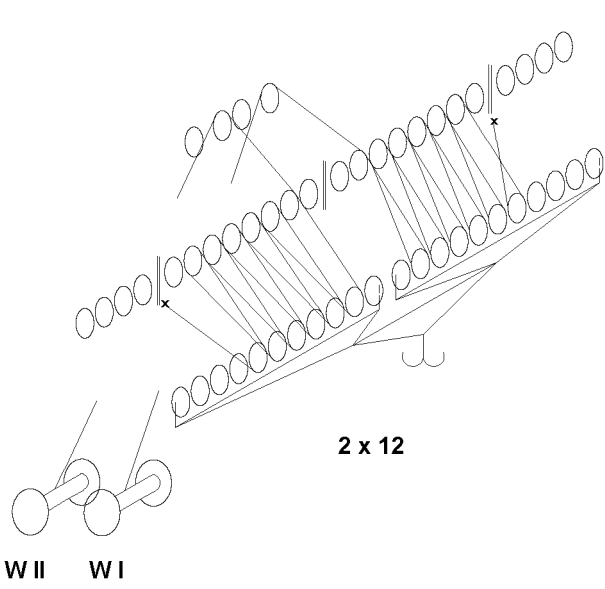
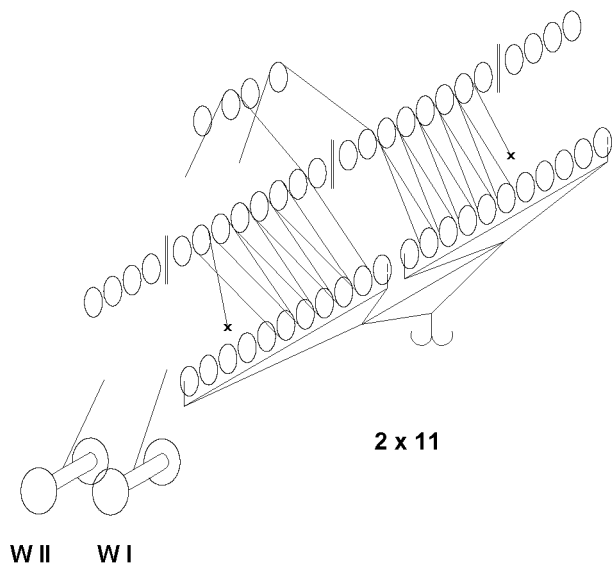
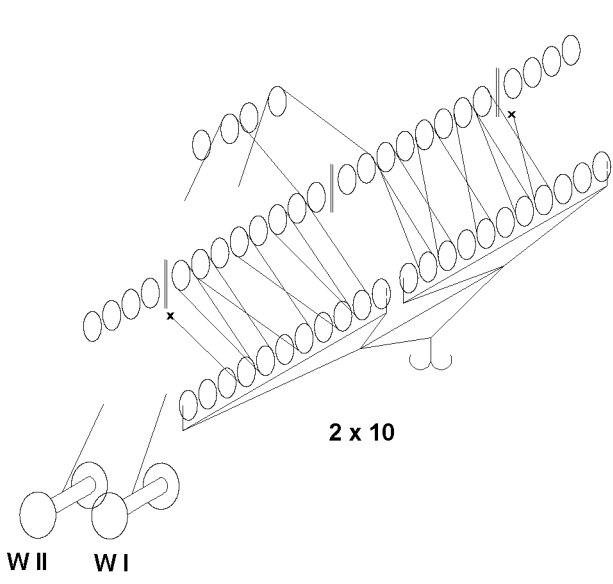
2 x 8

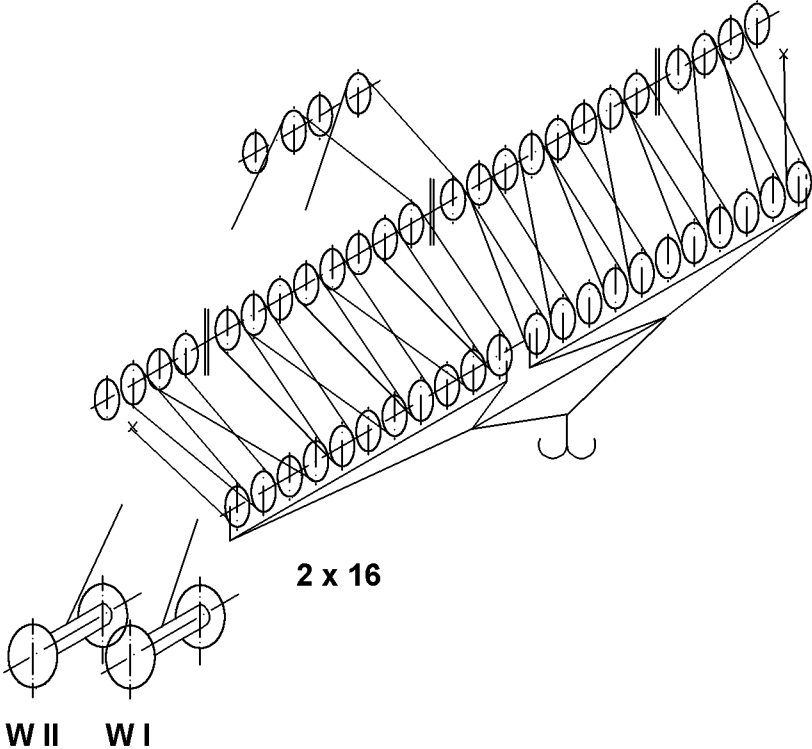
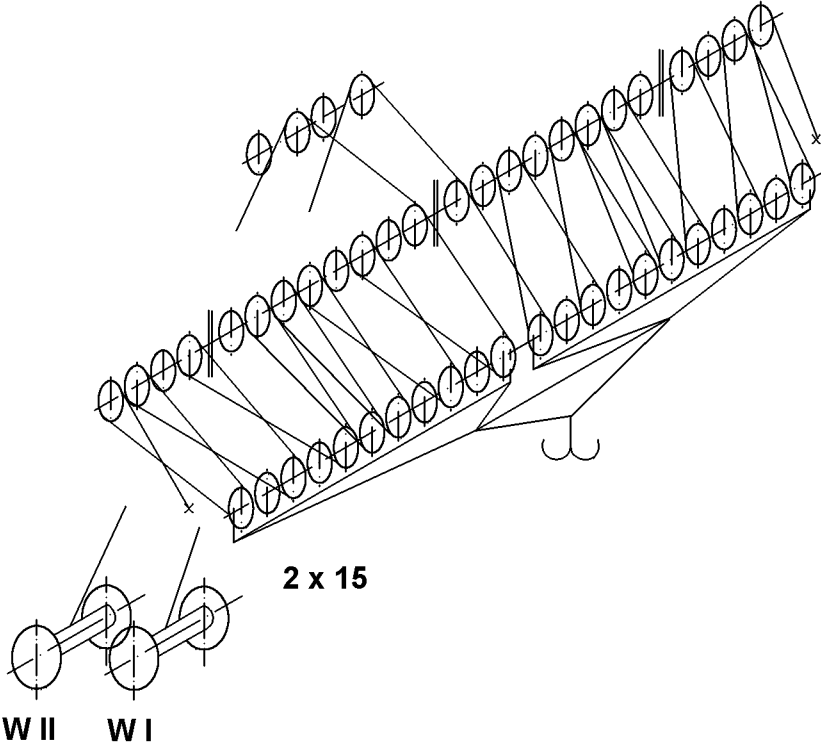
W II W I

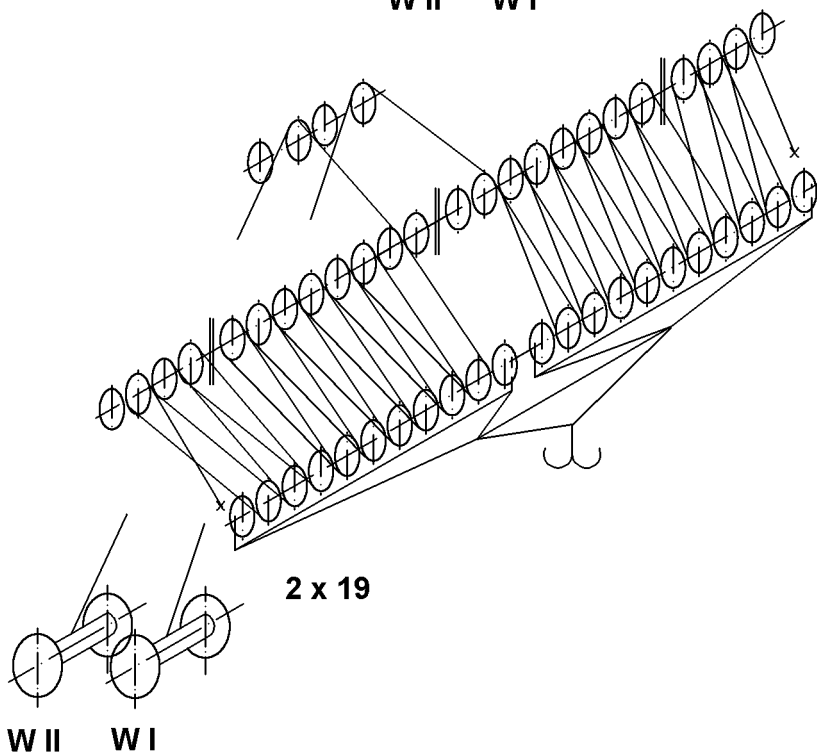
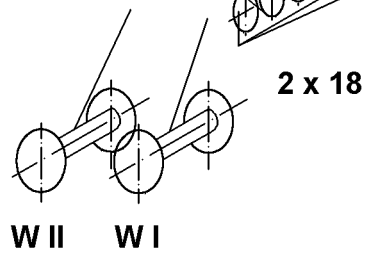
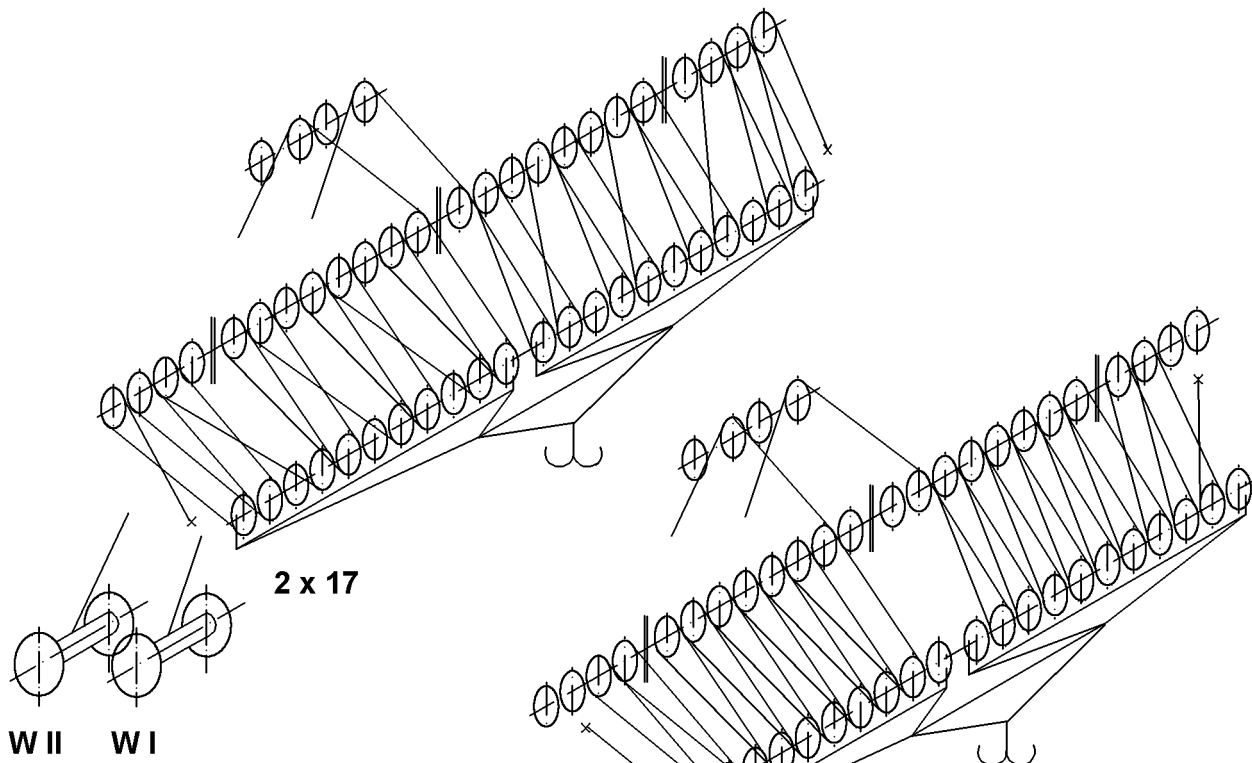


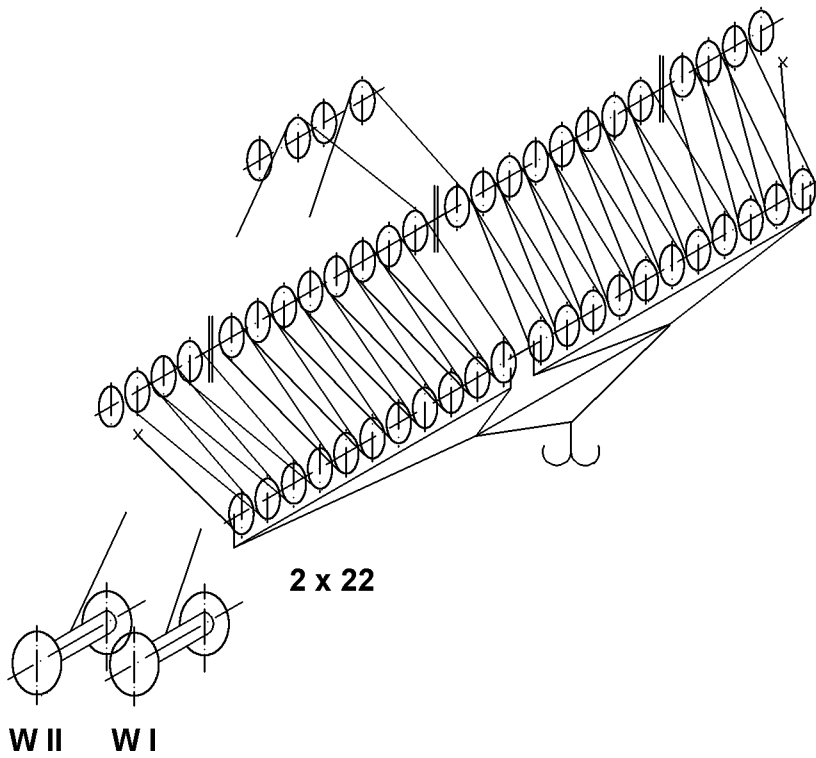
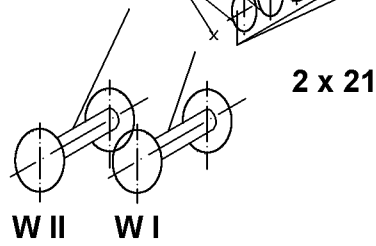
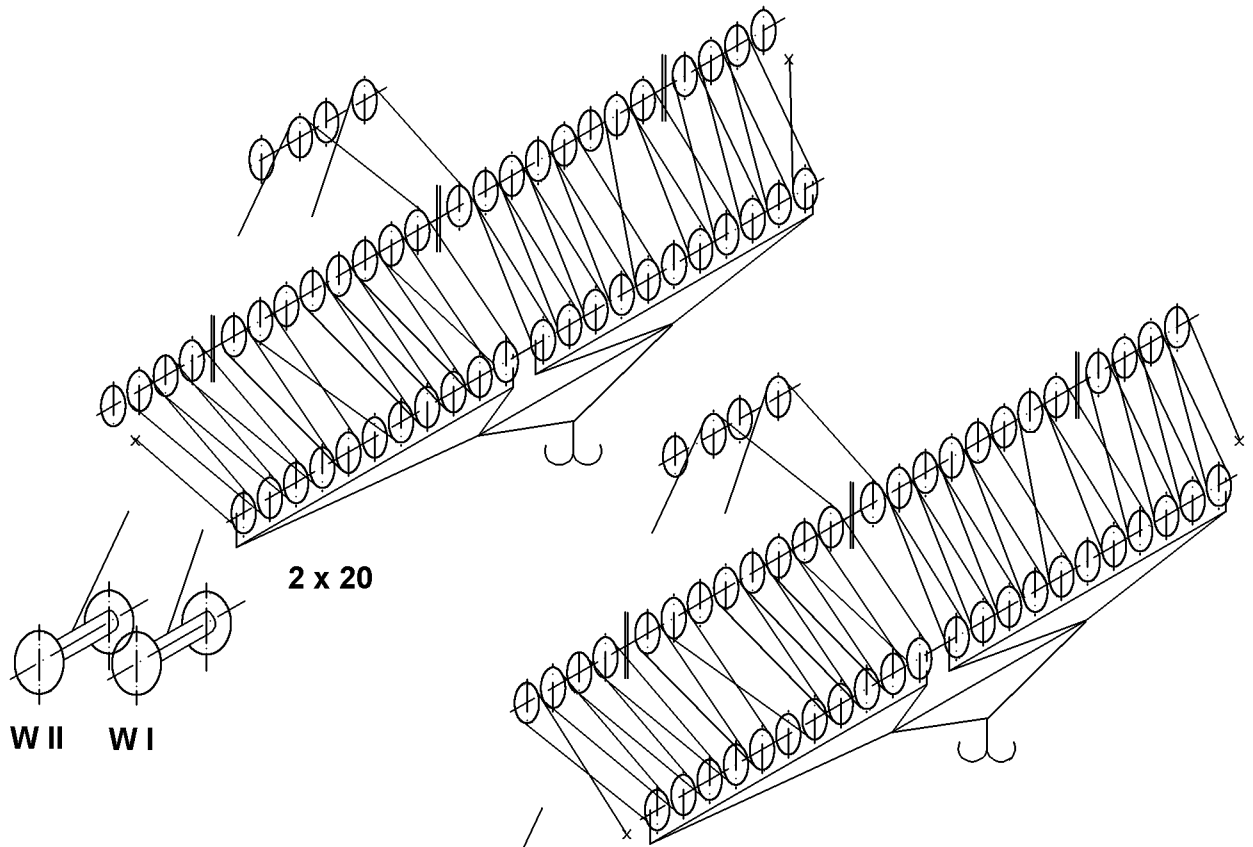
2 x 9

W II W I







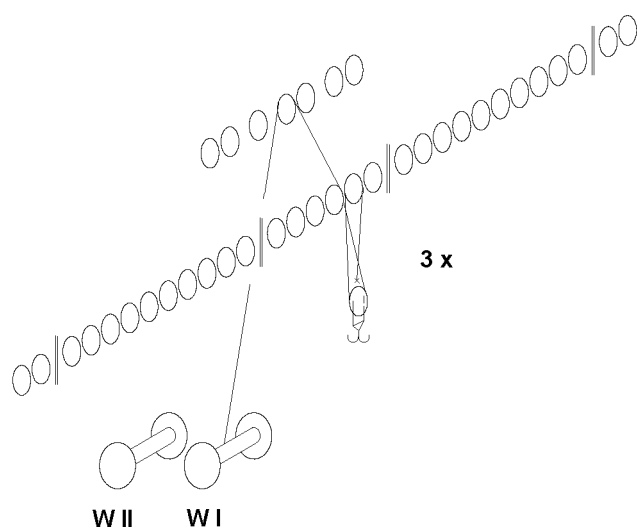
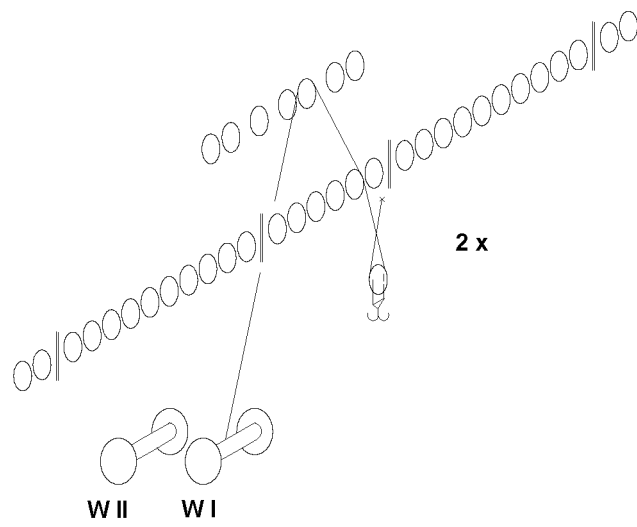
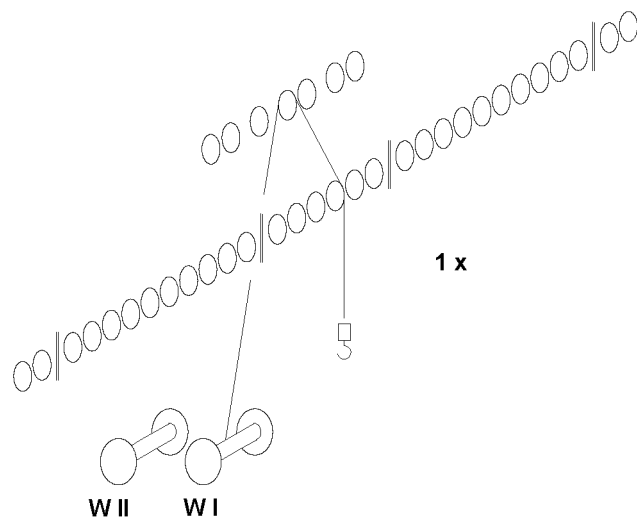


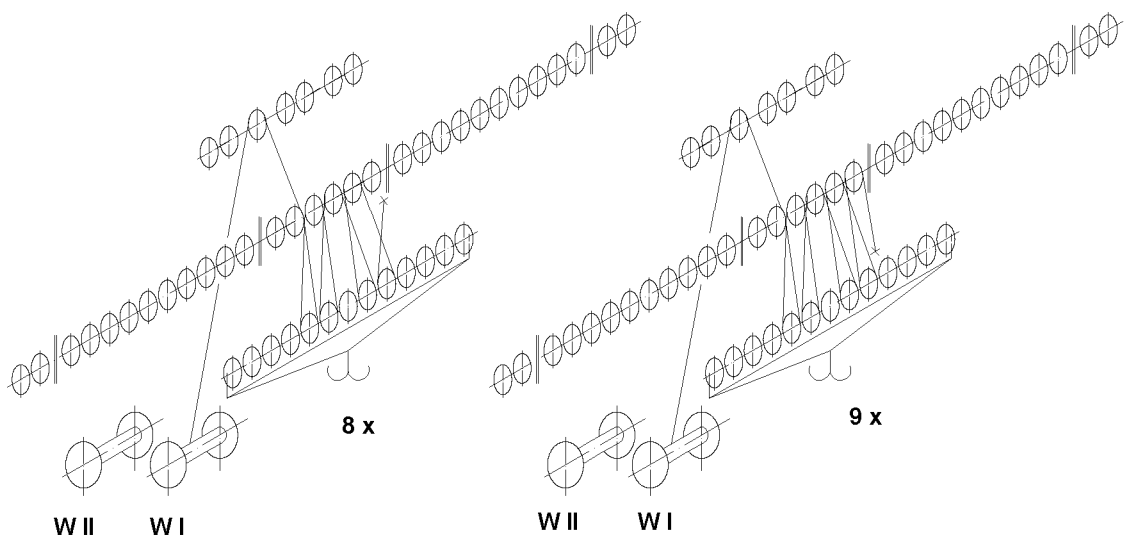
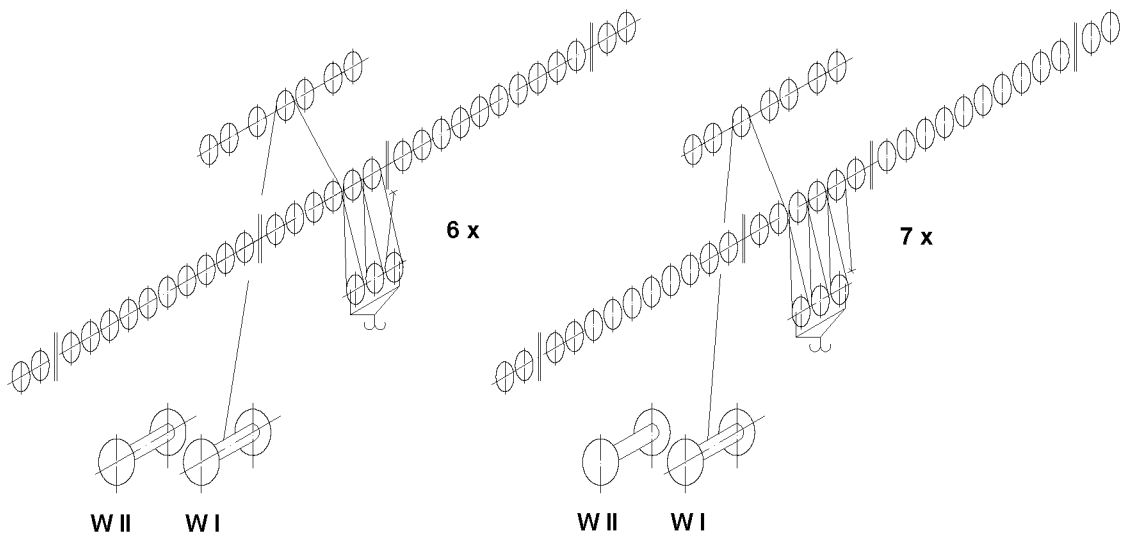
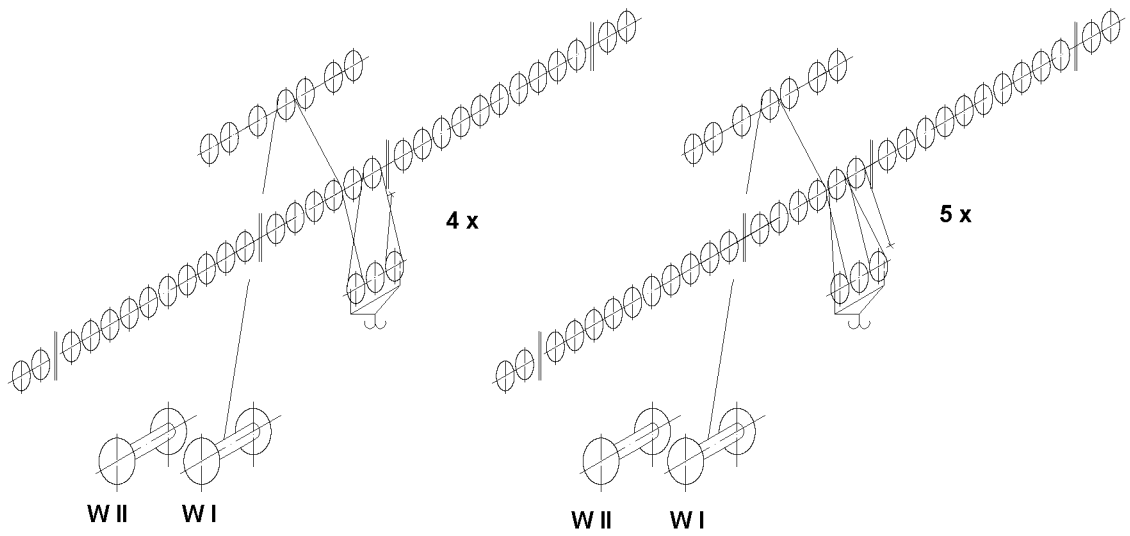
REEVING PLANS

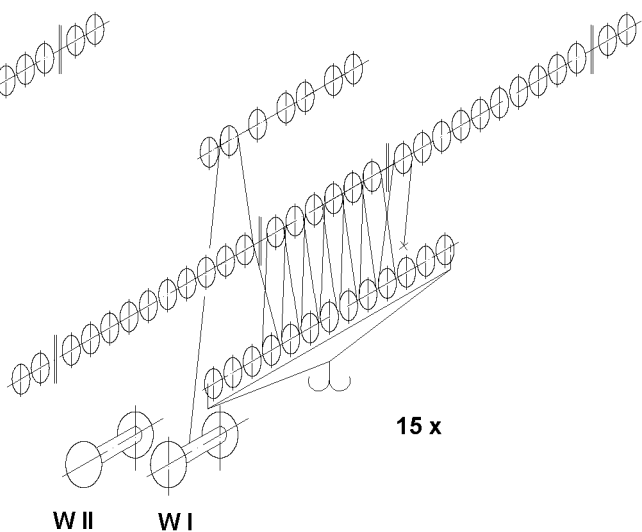
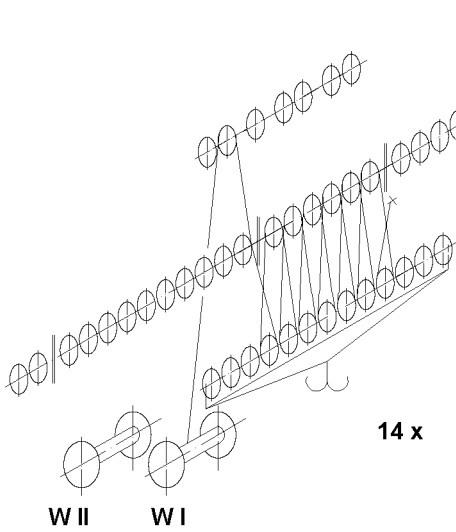
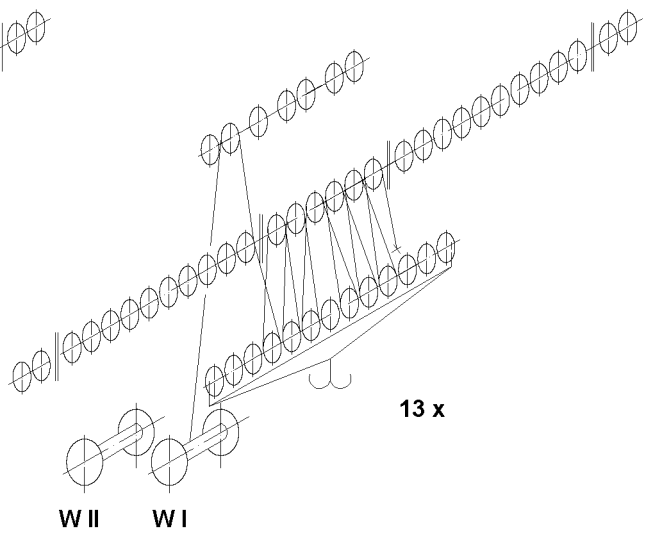
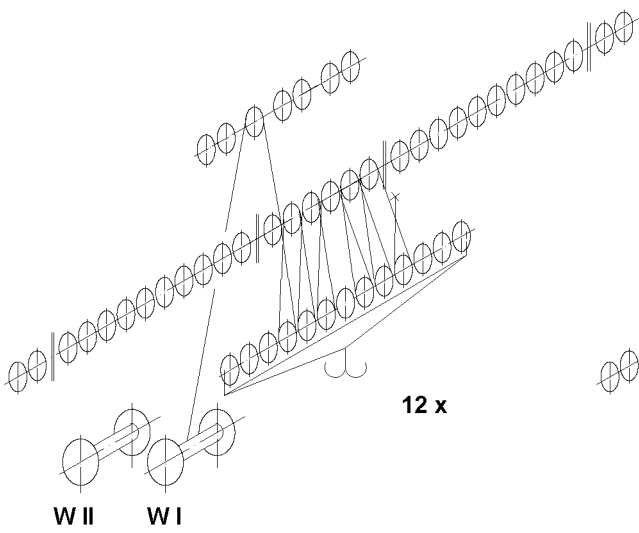
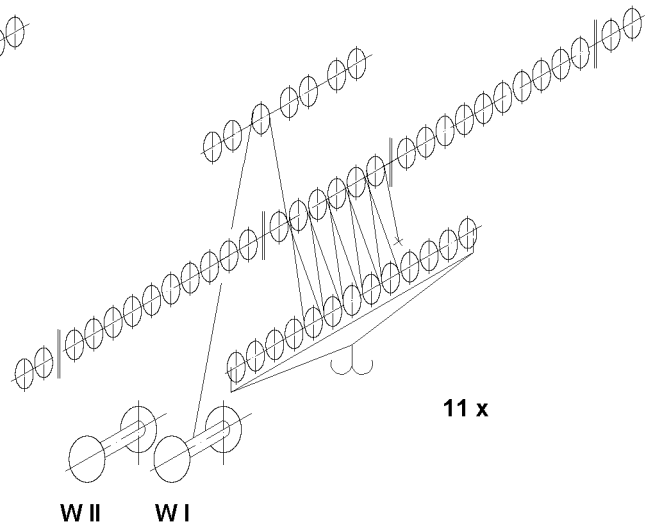
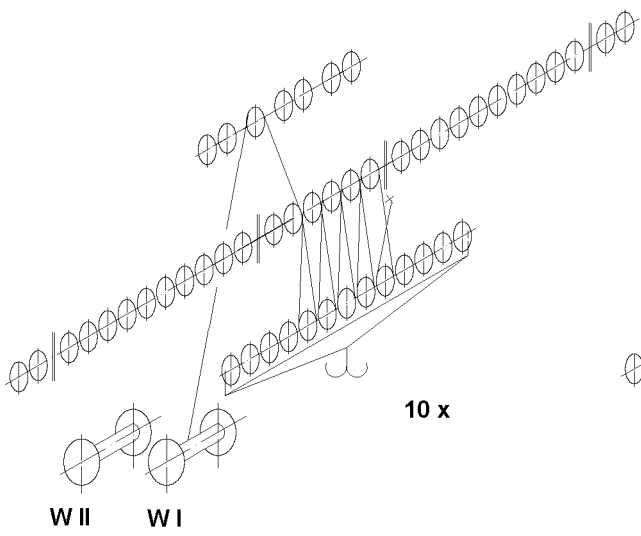
S - Head section (750 t)

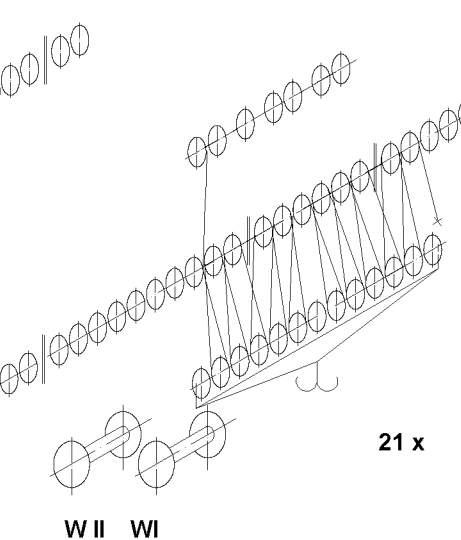
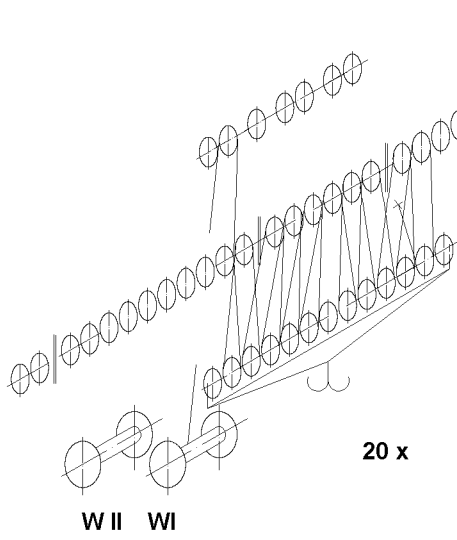
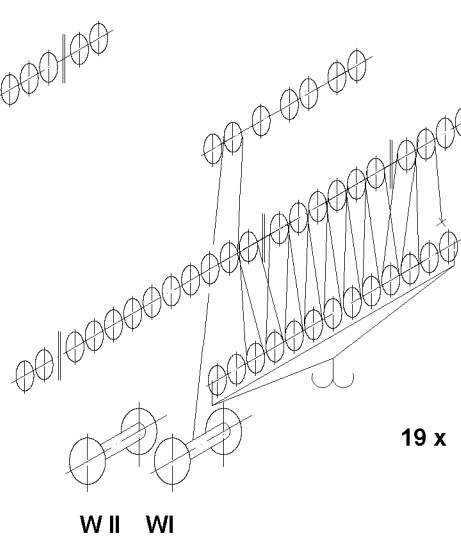
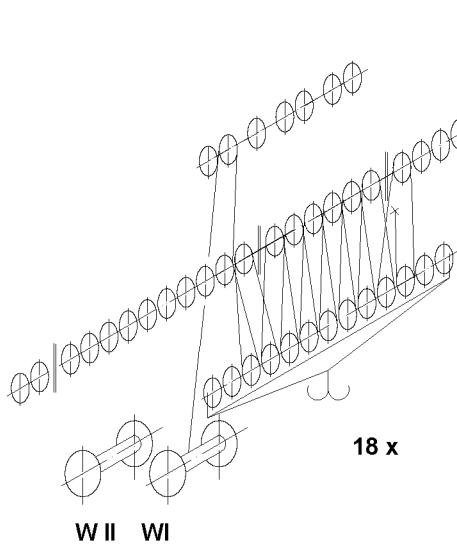
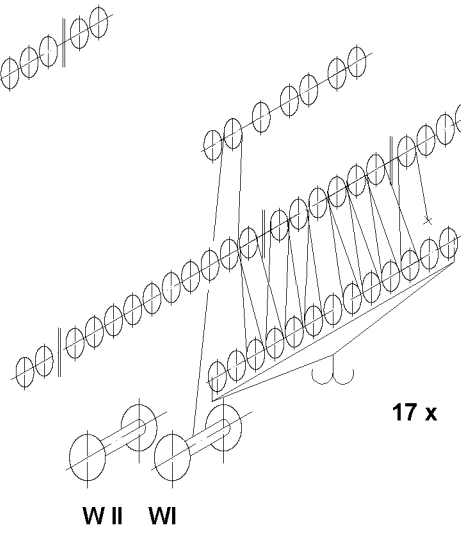
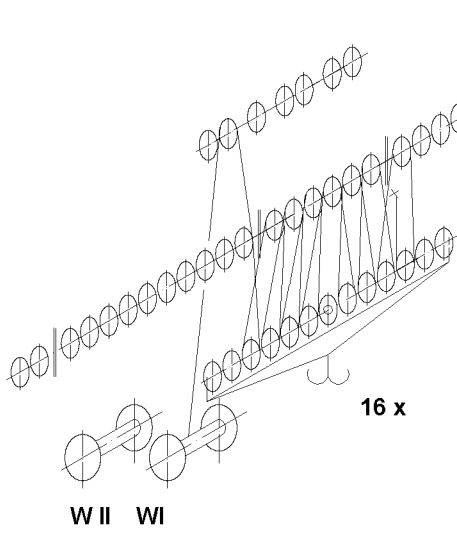
Head section - 30 pulley

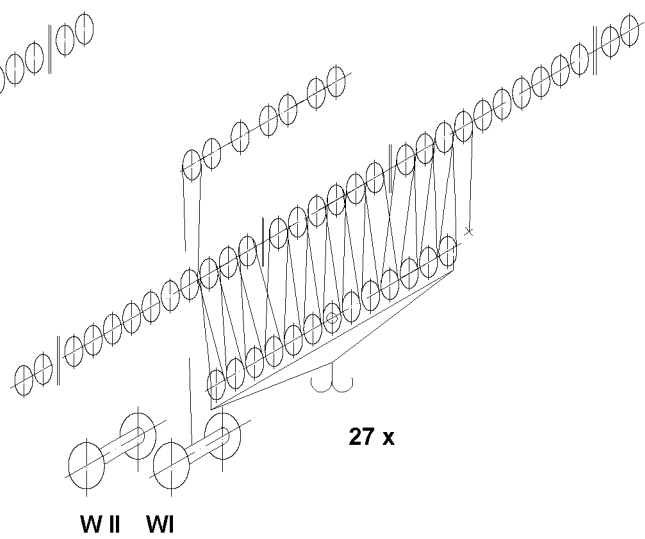
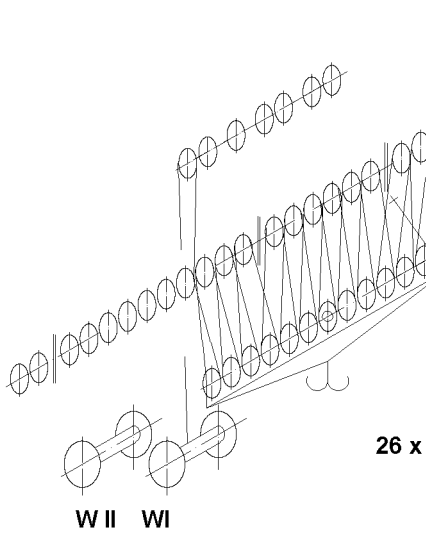
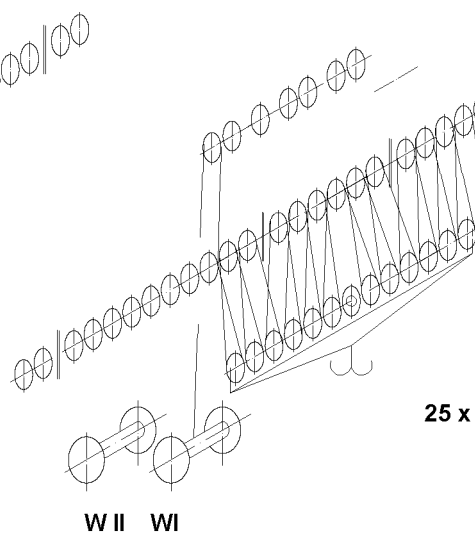
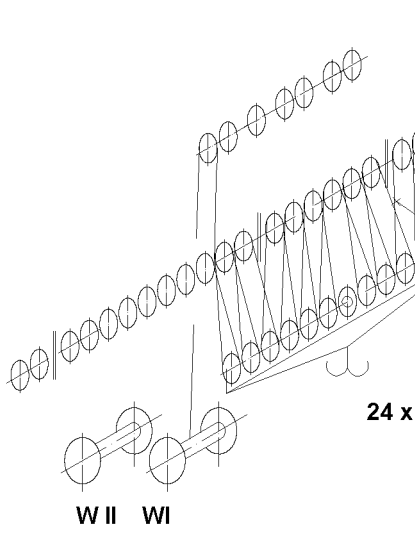
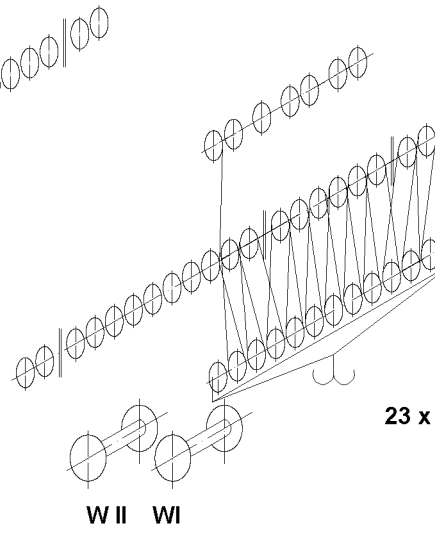
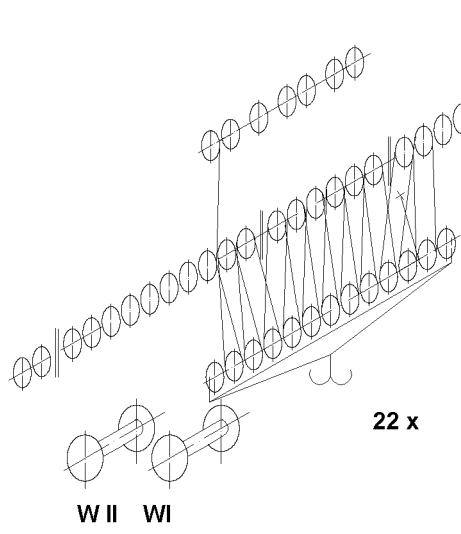
Load hook	16 t
1 - pulley hook block,	50 t hook block
3 - pulley hook block,	125 t hook block
13 - pulley hook block,	375 t hook block

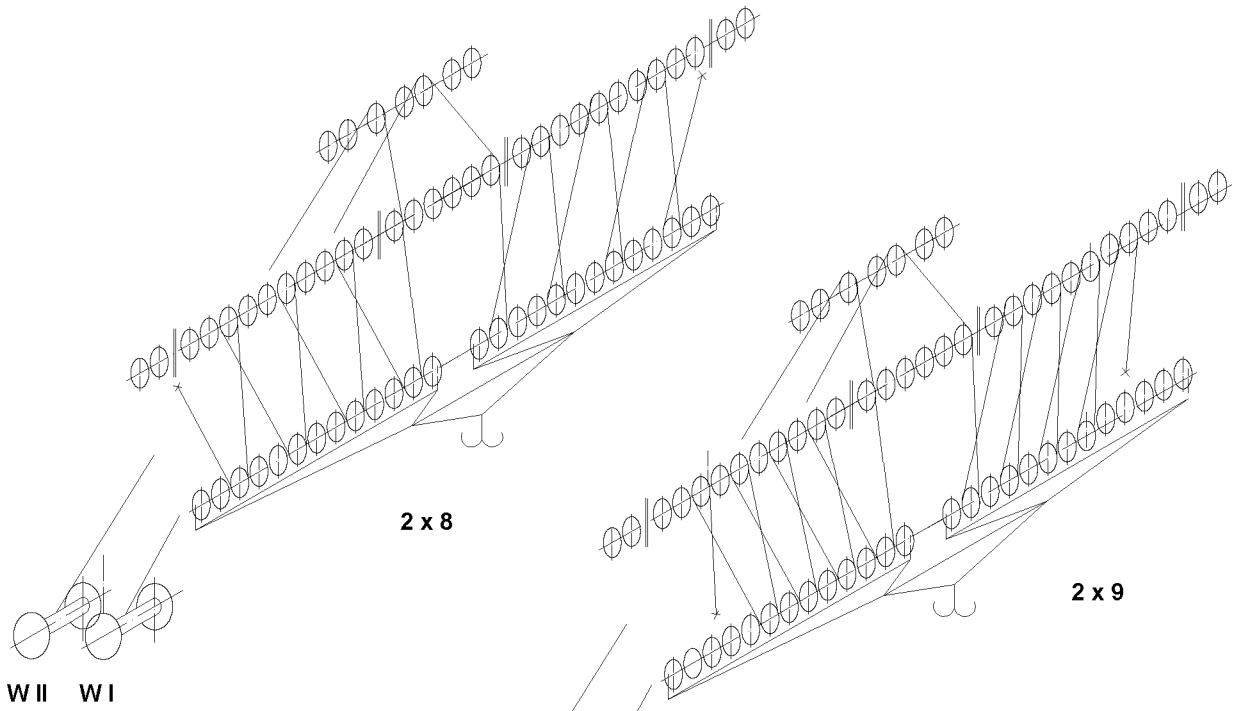










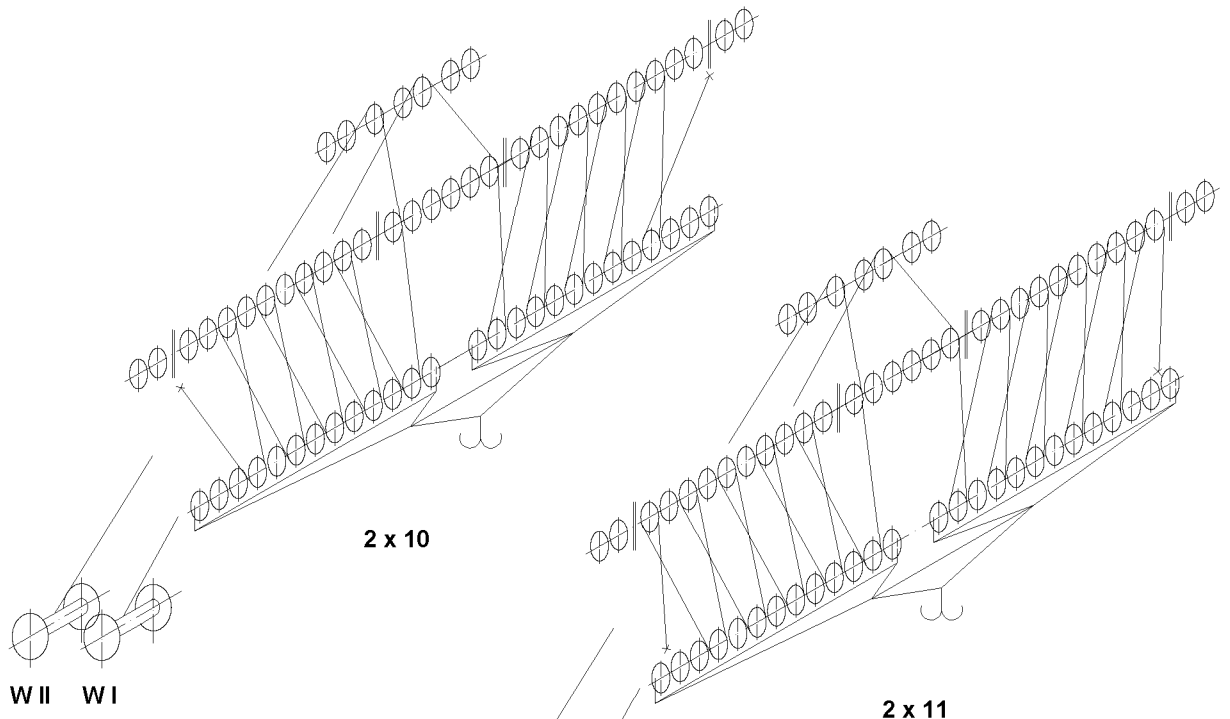


2 x 8

2 x 9

WII WI

WII WI

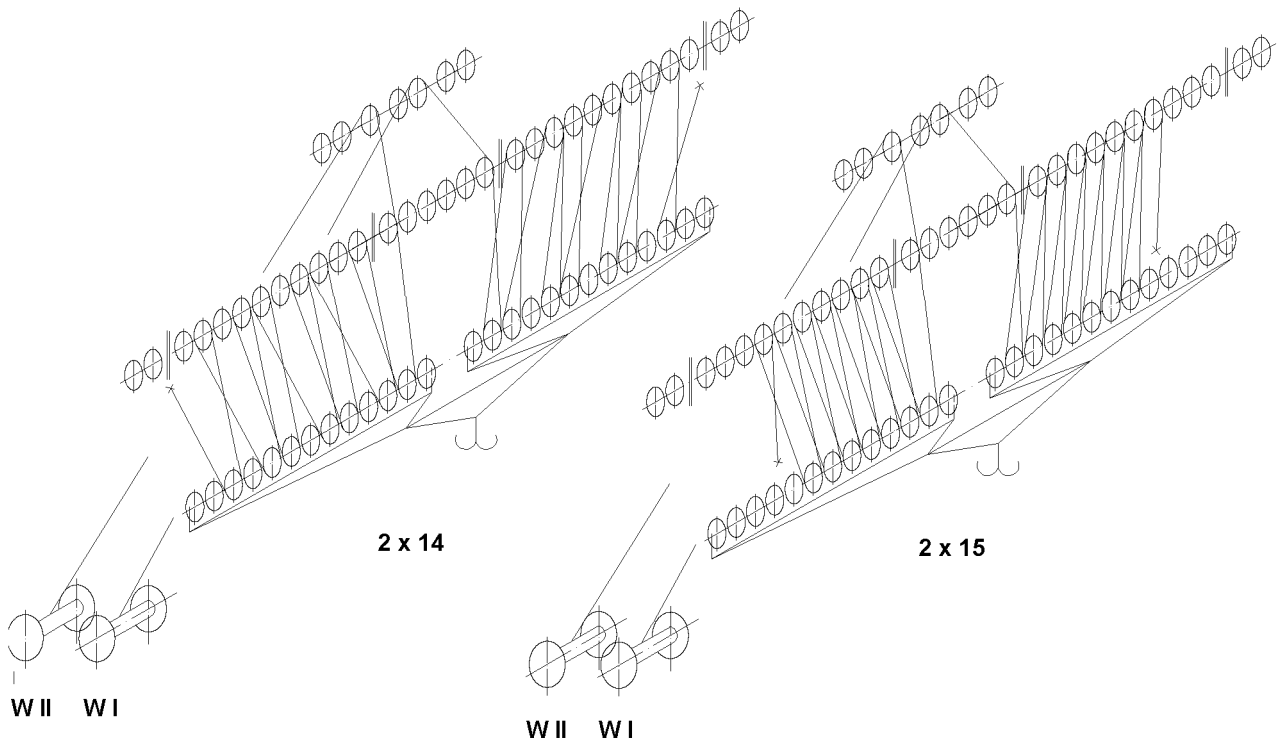
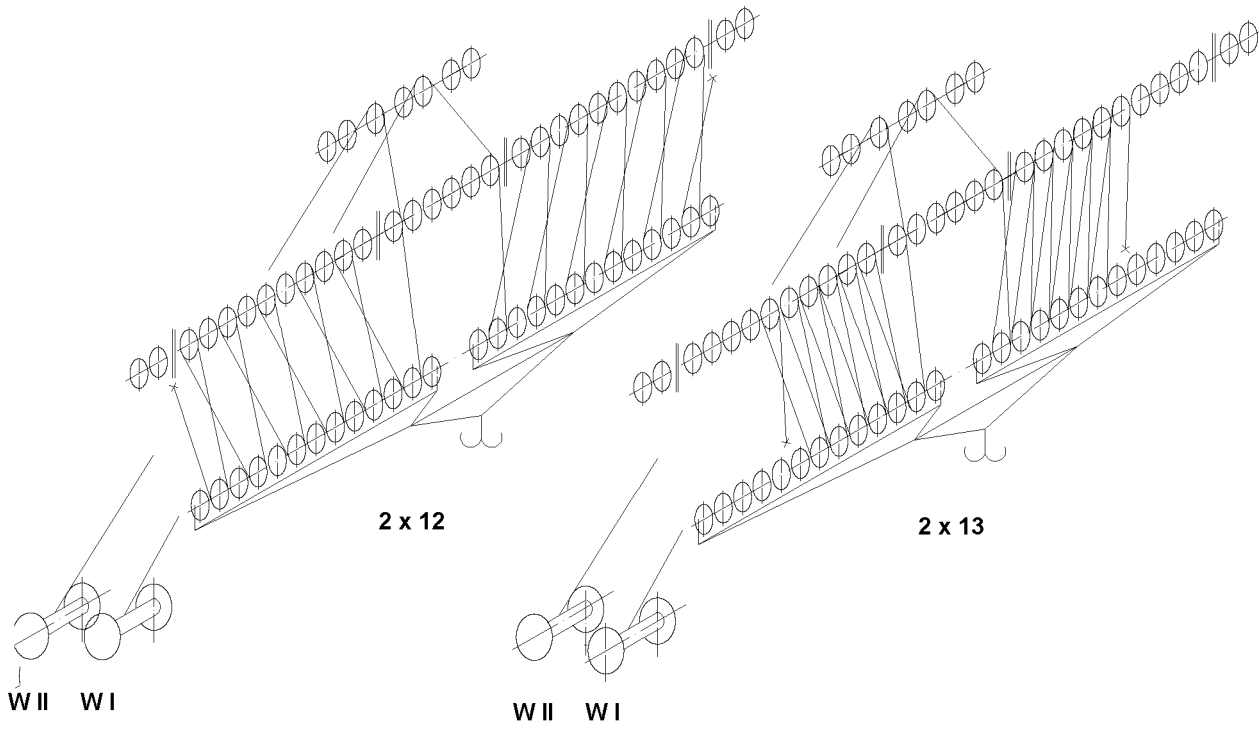


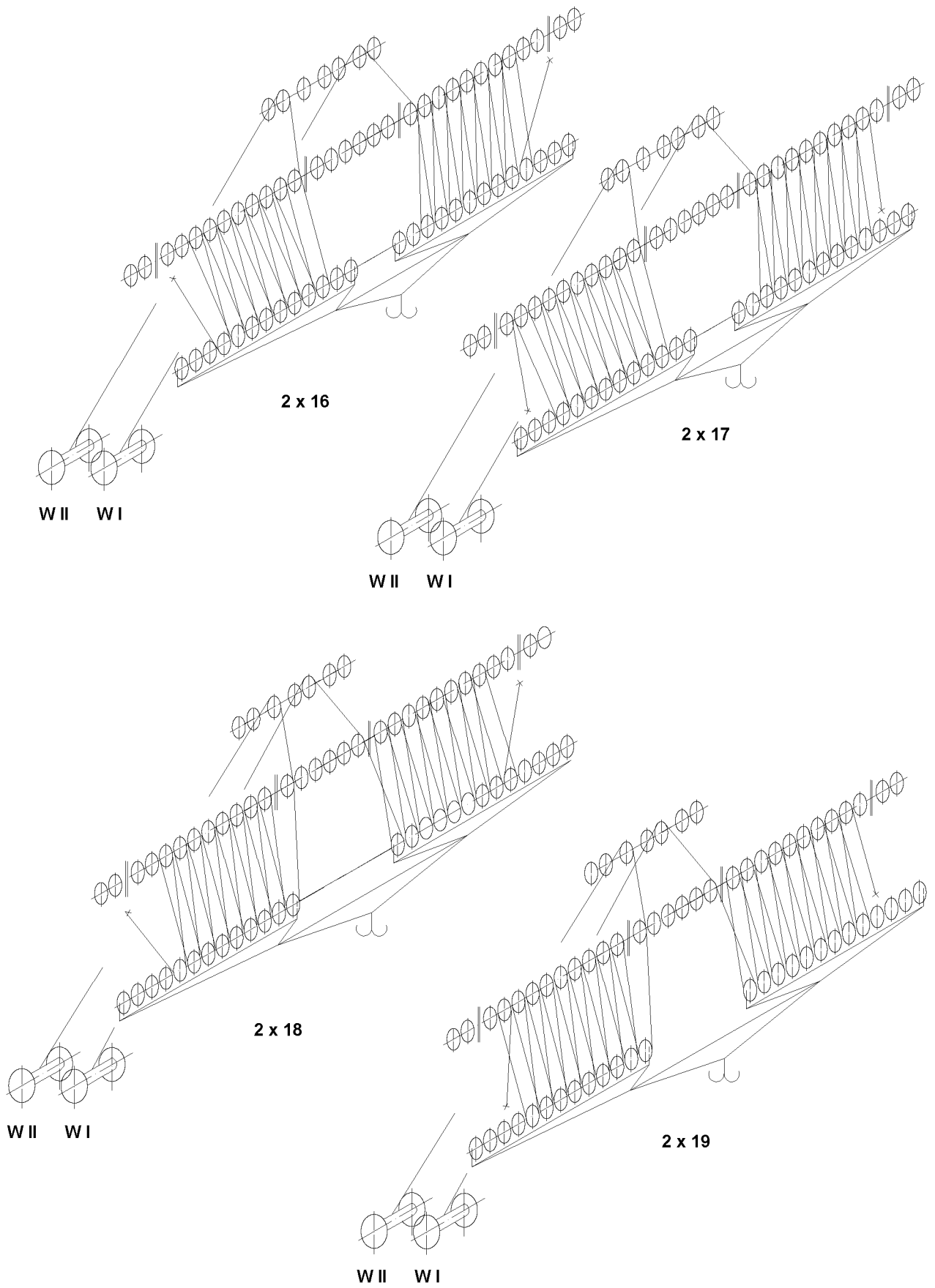
2 x 10

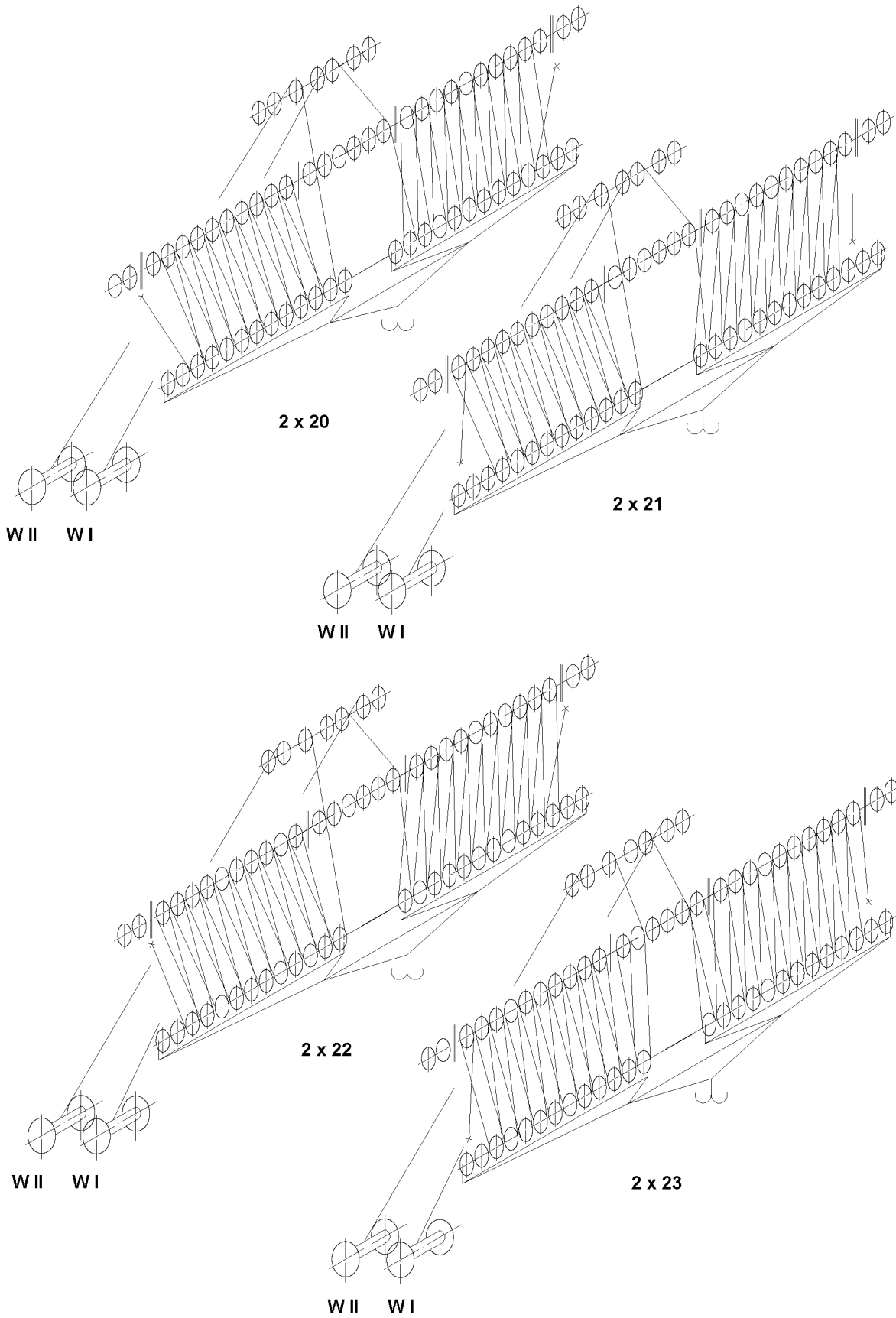
2 x 11

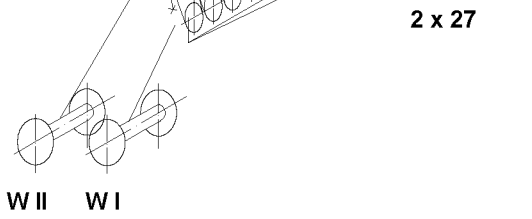
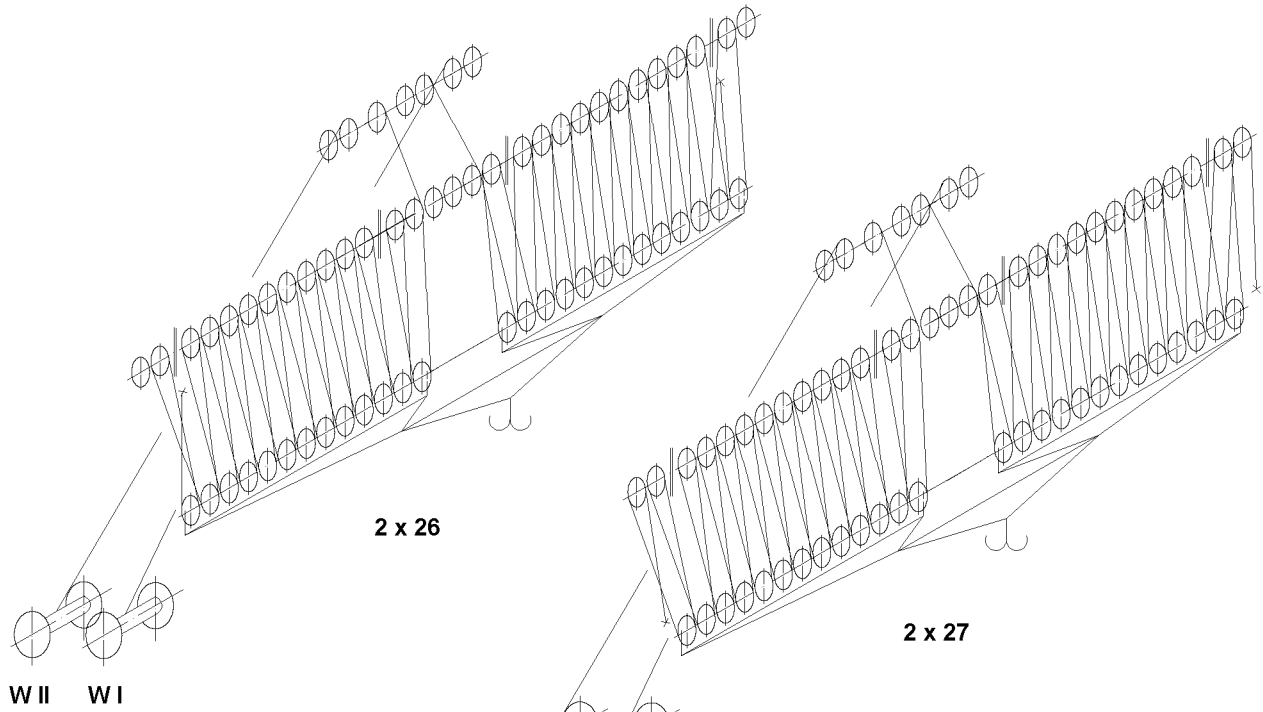
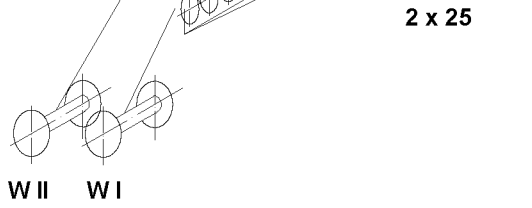
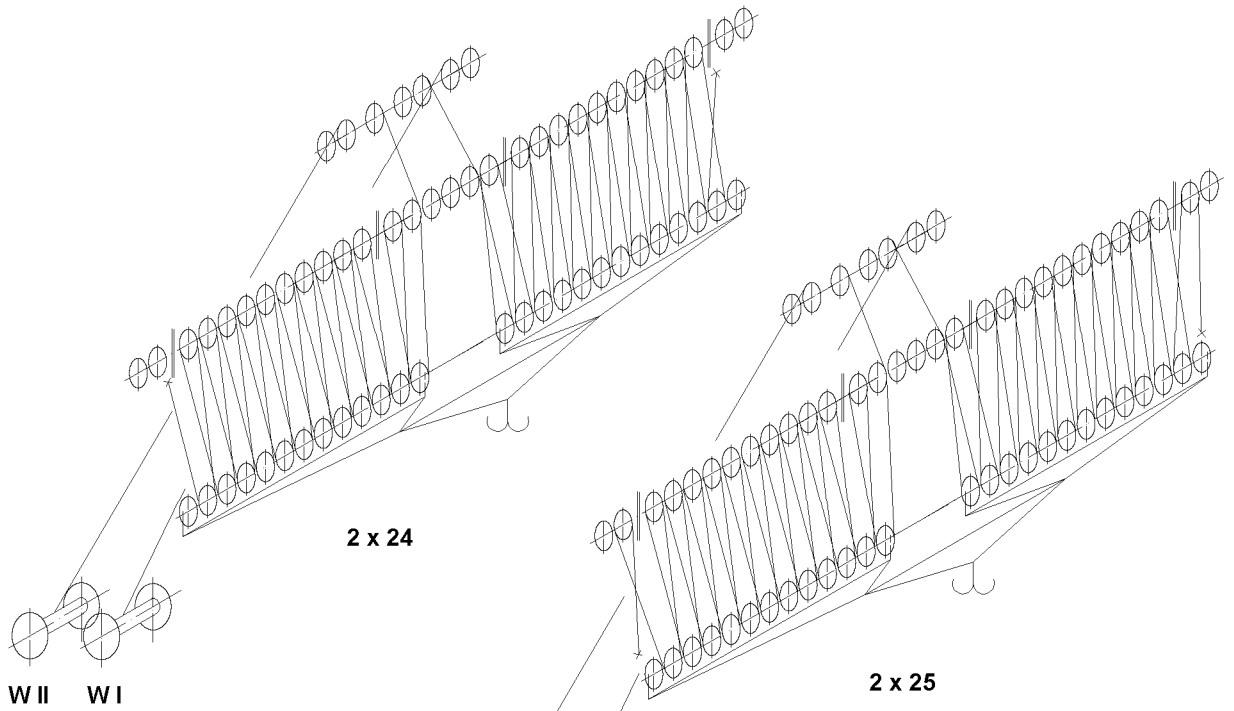
WII WI

WII WI





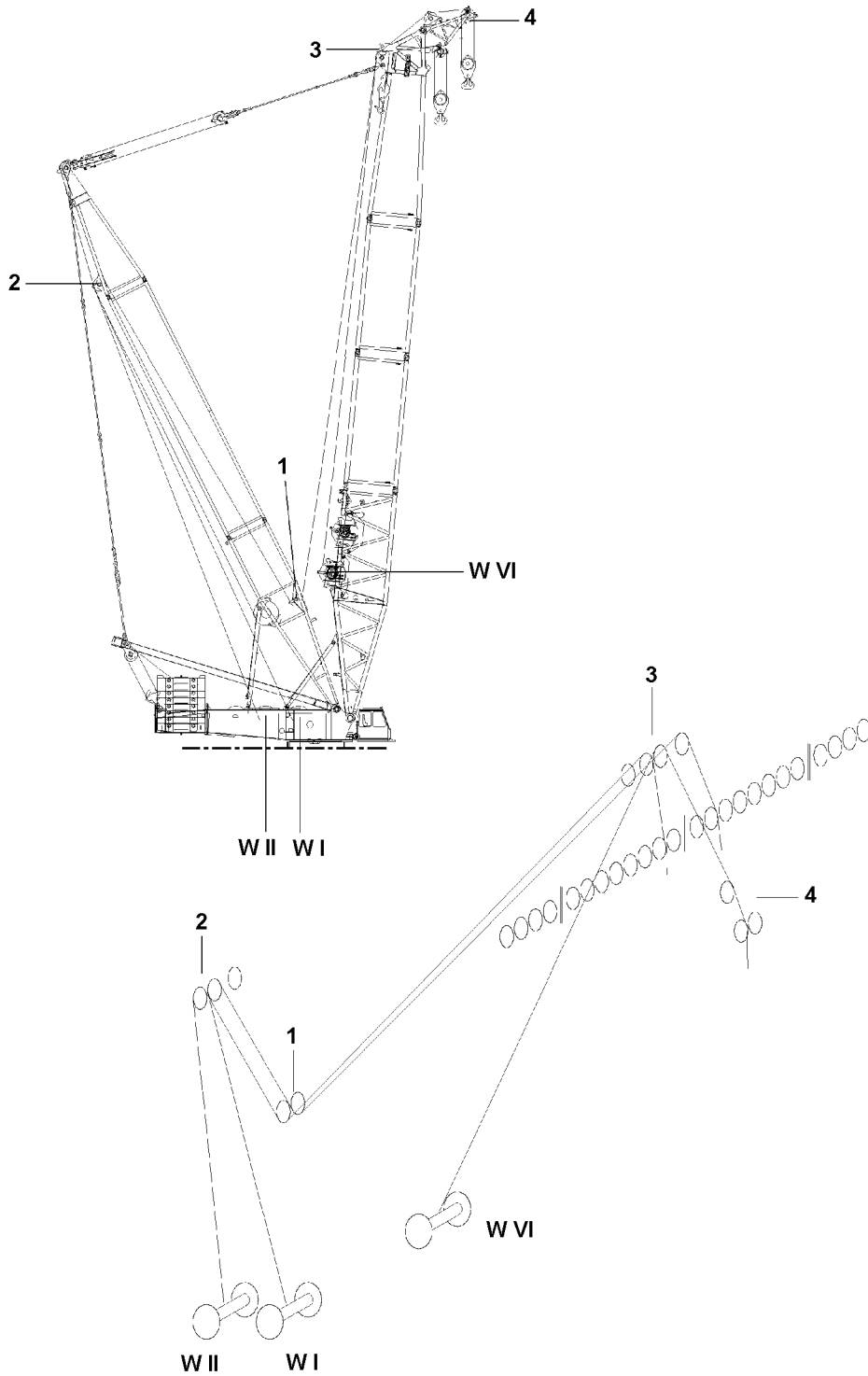




Hoisting rope guidance for Derrick

- 1 = Pulley D - head
- 2 = Pulley D - pivot section

- 3 = Pulley 600 t S-head
- 4 = Boom nose 60 t

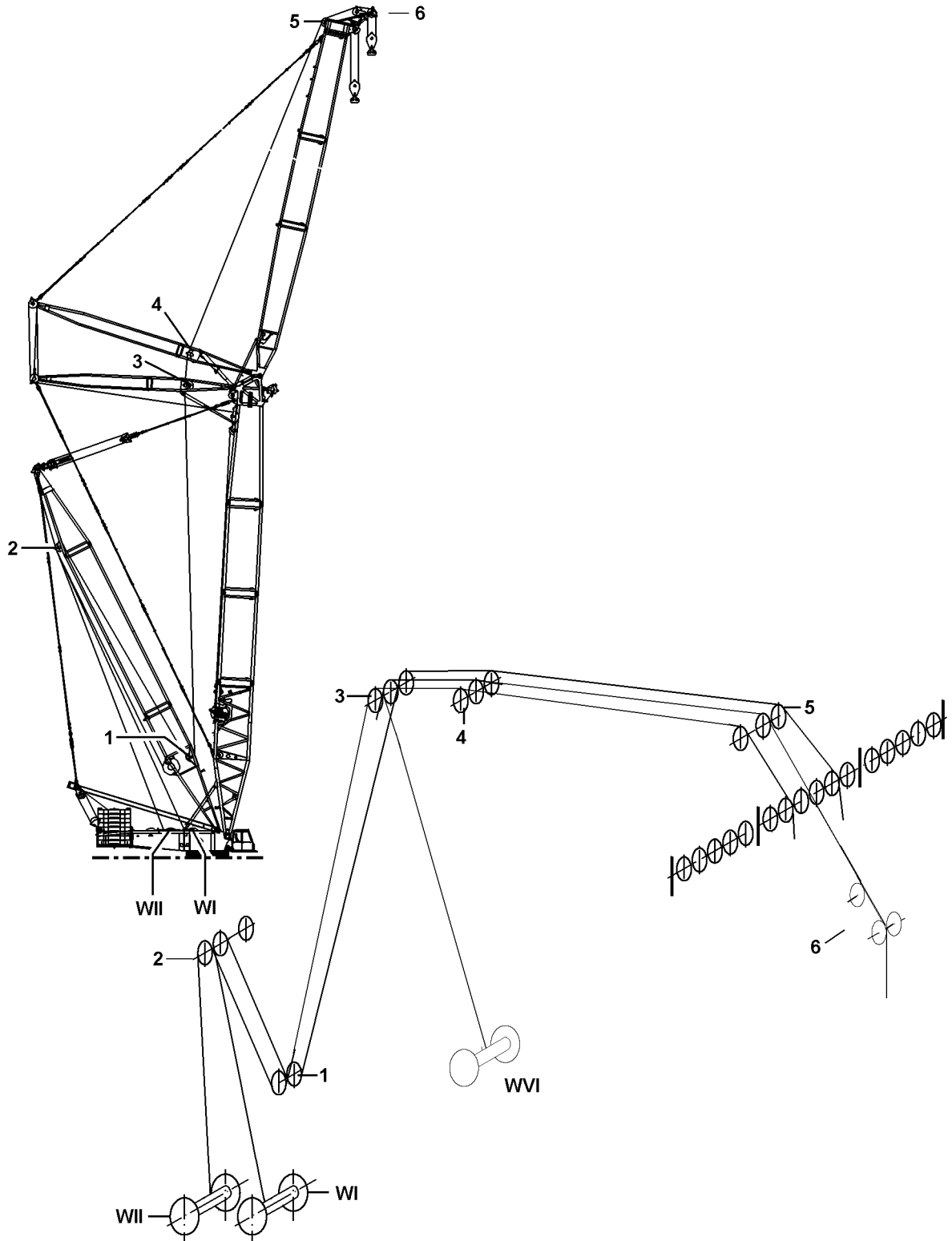


Hoisting rope guidanced for Derrick at W-mode

1 = Pulley D - pivot section
 2 = Pulley D - head

3 = Pulley WA - bracket II
 4 = Pulley WA - bracket I

5 = L - head section
 6 = Boom nose



198509

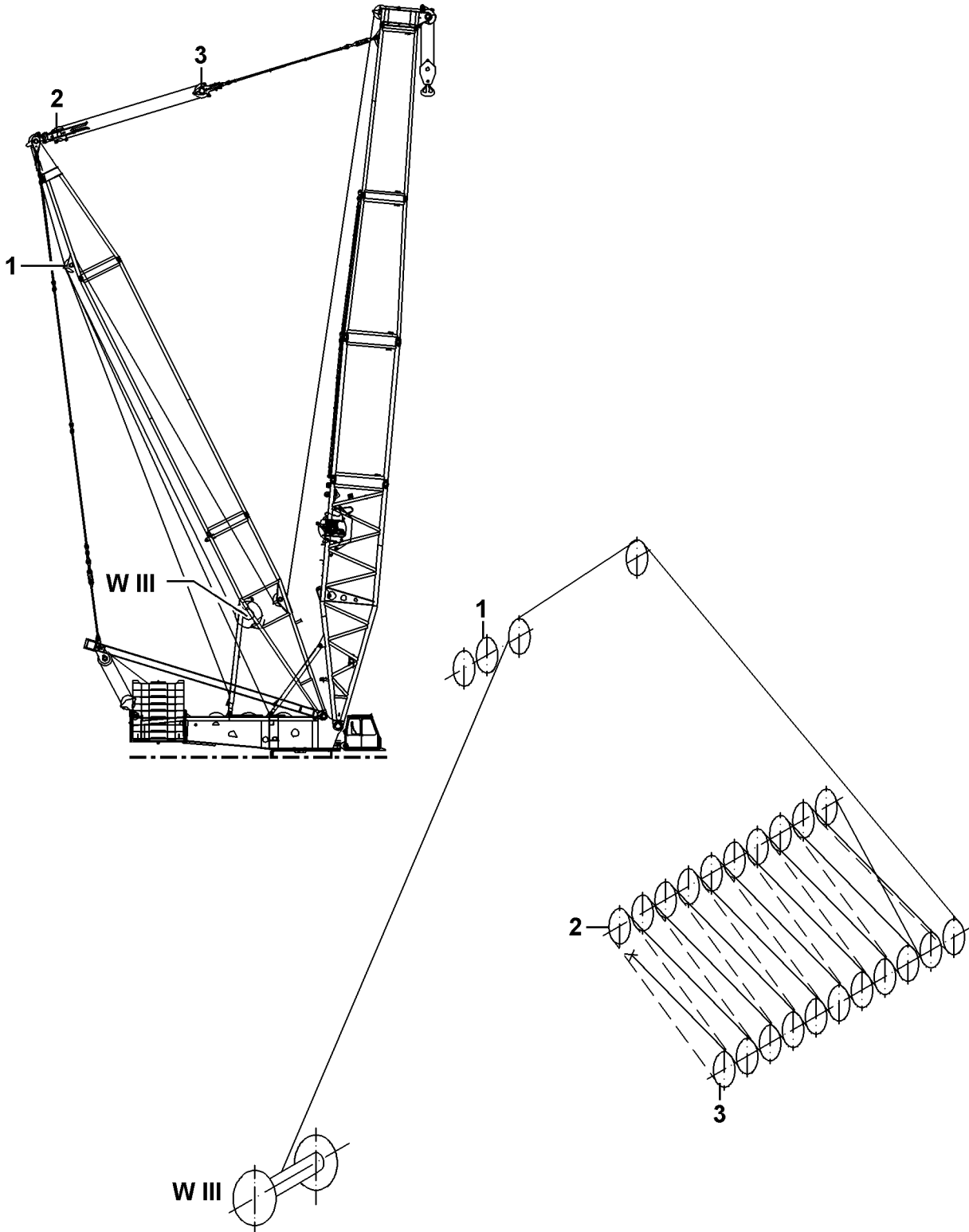
Reeving S - adjusting

1 = Pulley D - head

2 = Pulley lower adjusting block

W III = winch III

3 = Pulley upper adjusting block

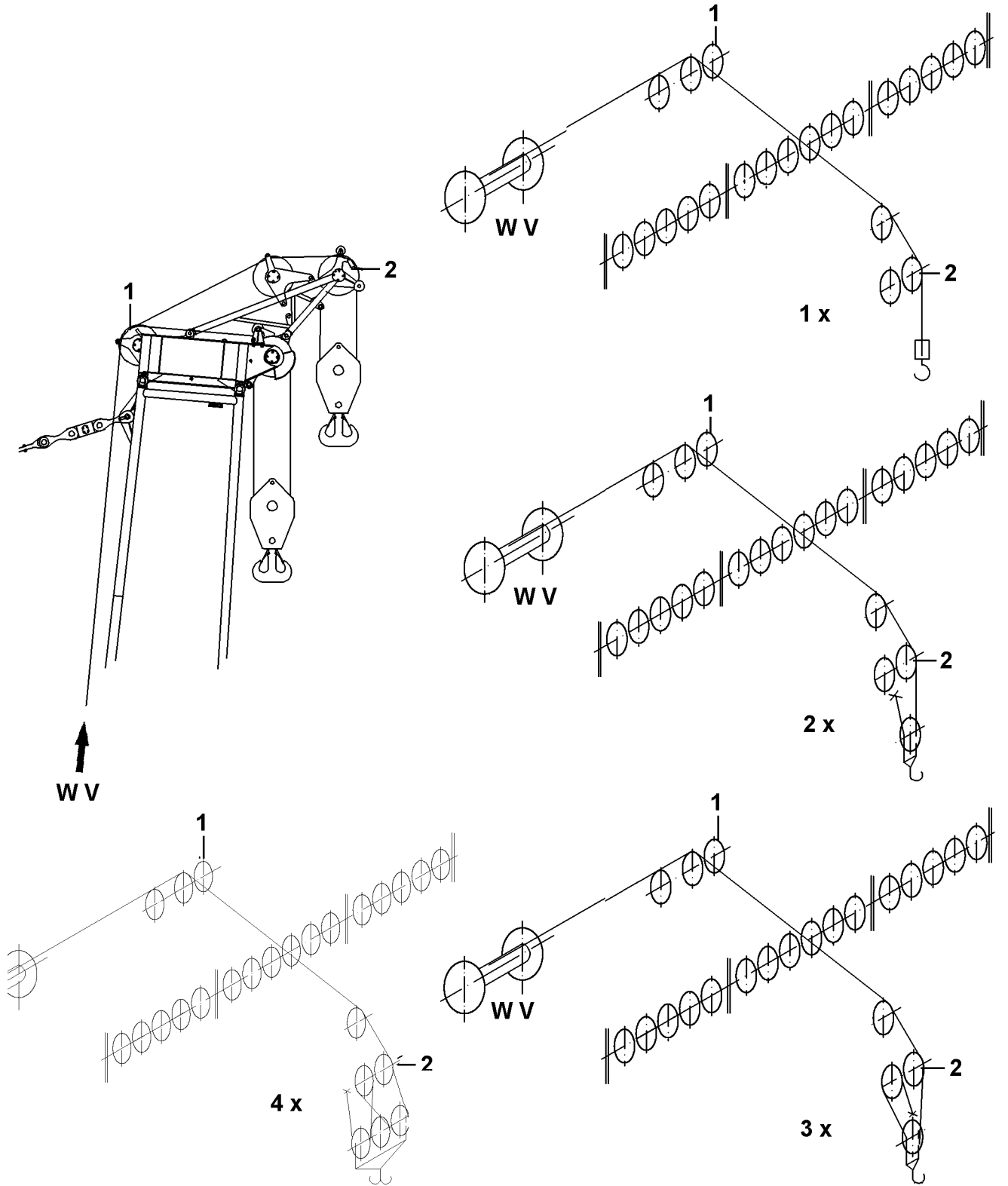


Hoisting rope guidance for 60 t boom nose at L-head section

1 = Pulley head section

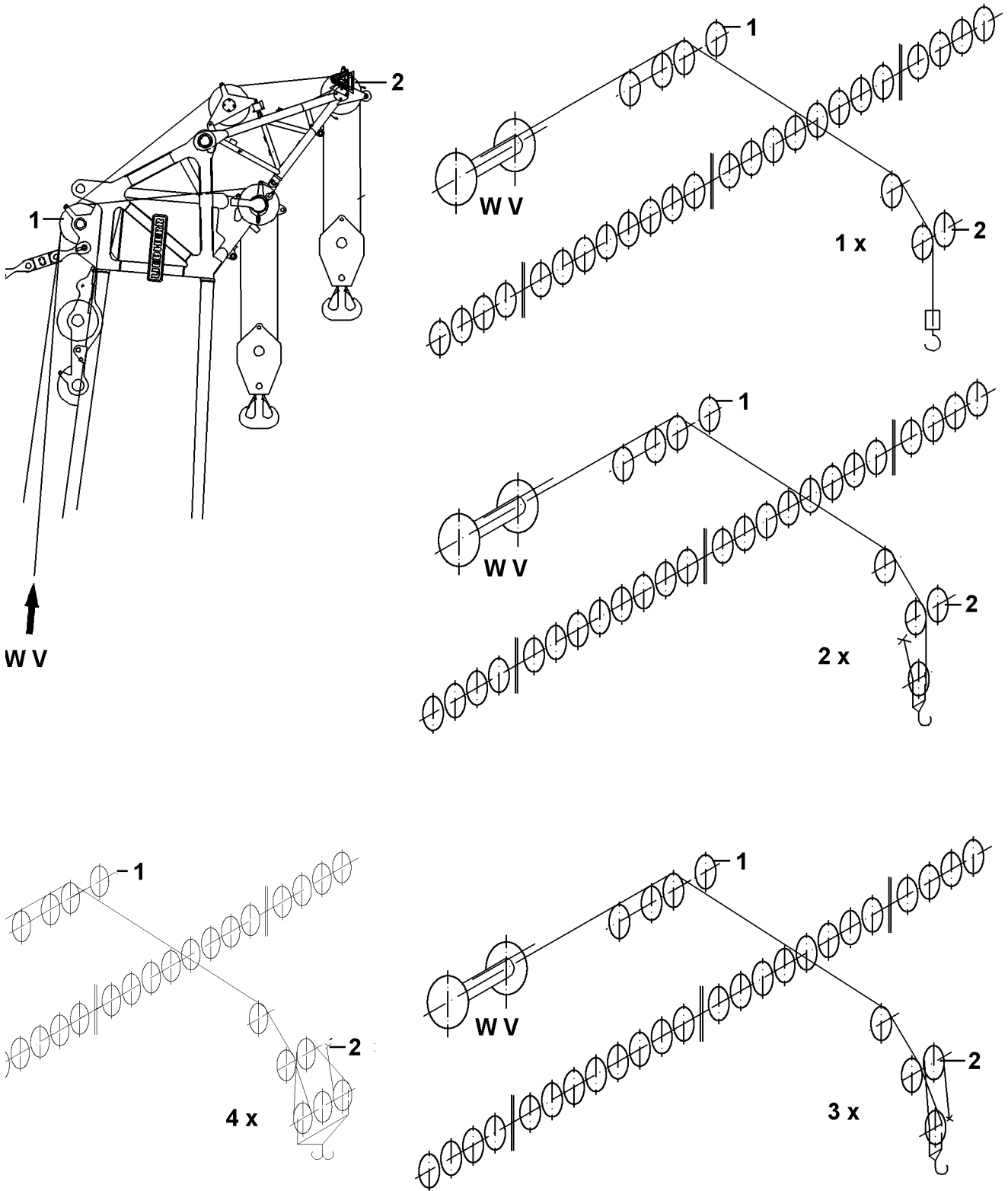
W V = Winch V

2 = Pulley boom nose



Hoisting rope guidance for 60 t boom nose at S-head section

1 = Pulley head section W V = Winch V
 2 = Pulley boom nose

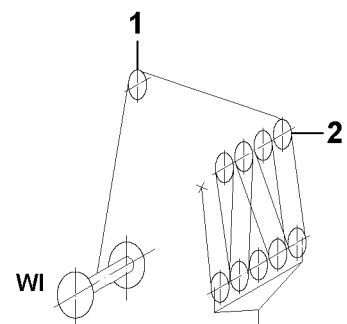
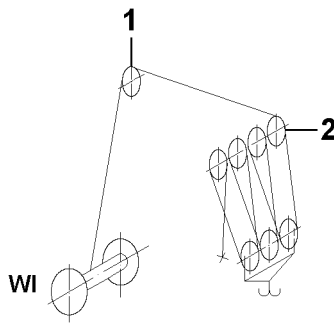
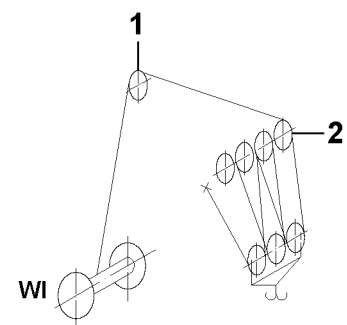
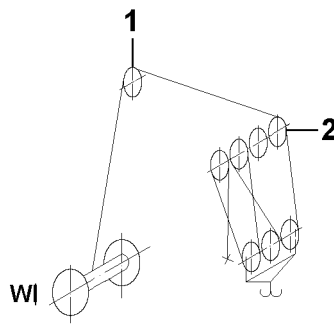
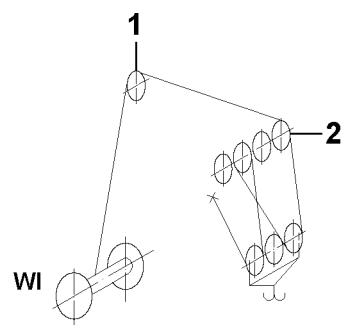
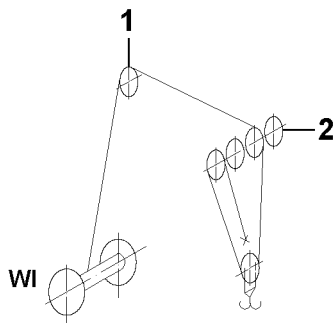
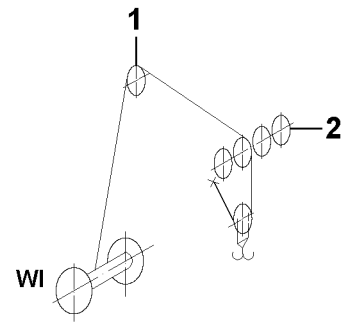
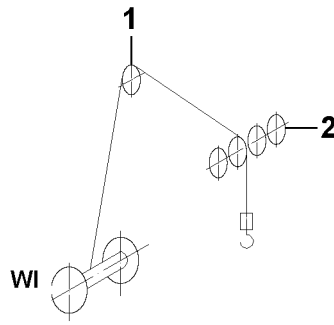
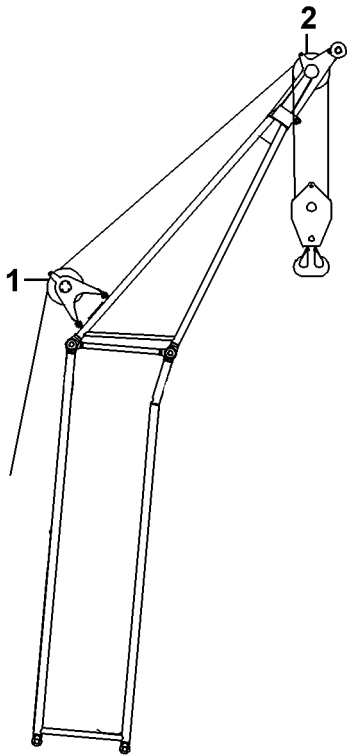


197809

Hoisting rope guidedance for 120 t auxilliary jib

1 = Pulley

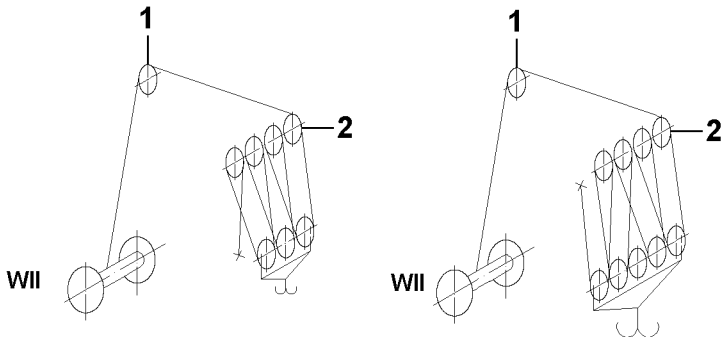
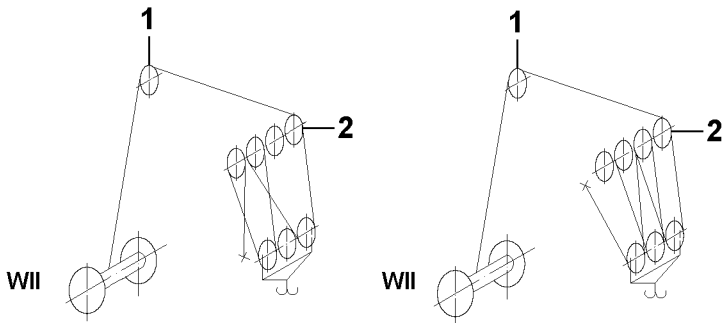
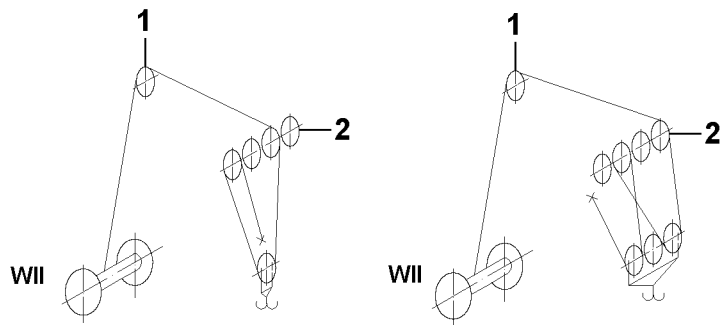
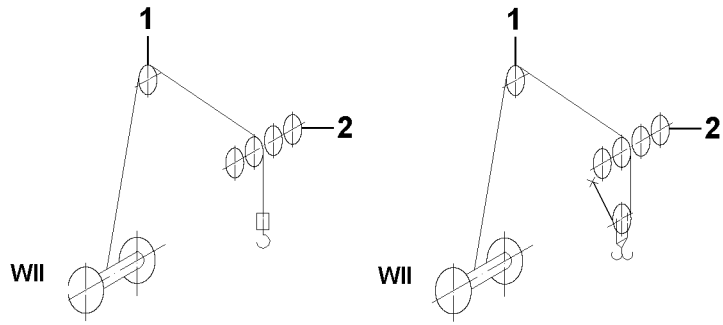
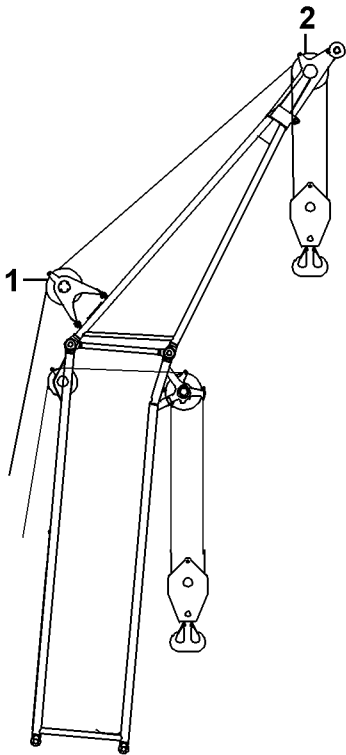
2 = Pulley auxilliary jib



Hoisting rope guidance for 120 t auxilliary jib, two hook operation

1 = Pulley

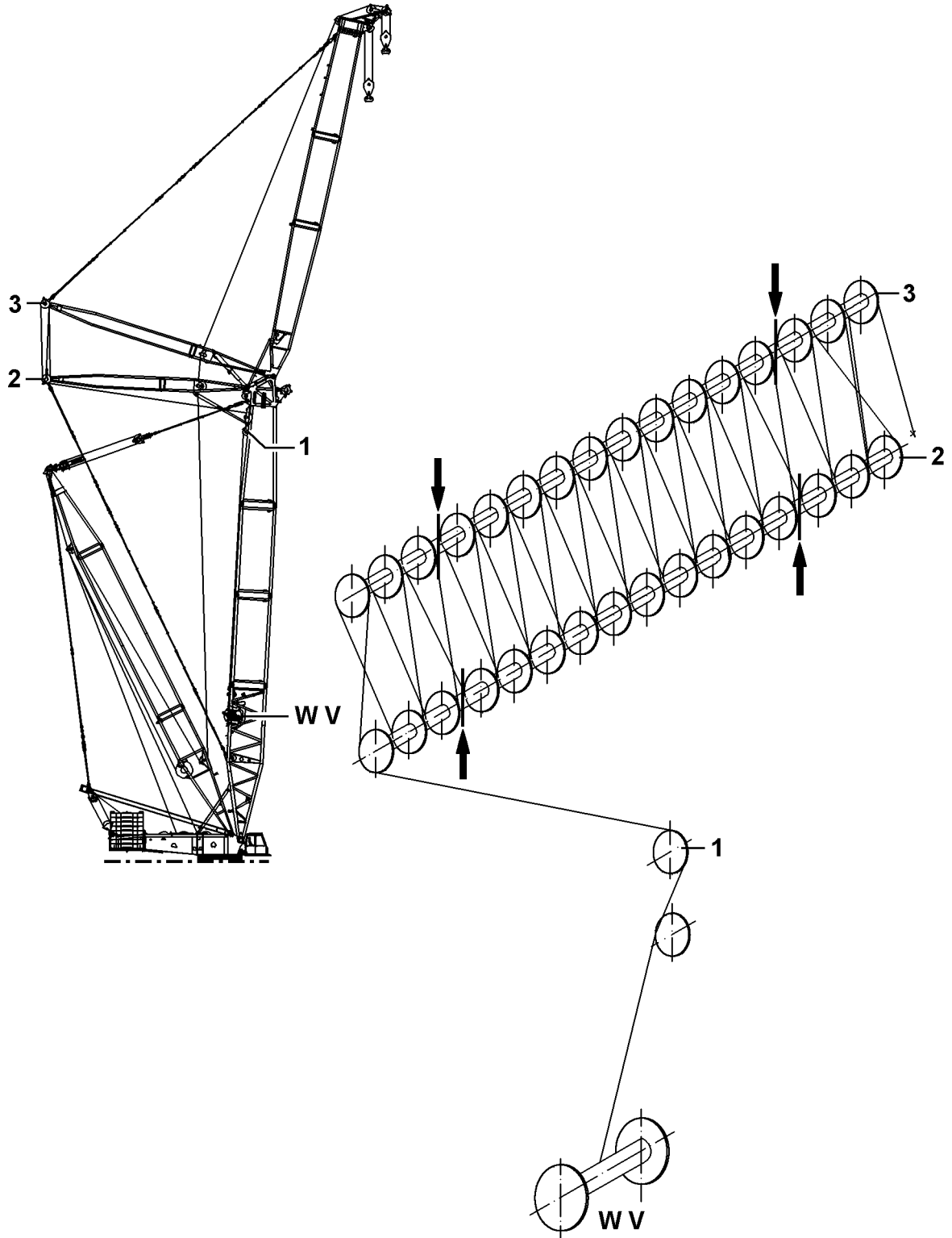
2 = Pulley uxilliary jib



Reeving plan W-fly jib adjusting

- 1 = S - head section
- 2 = WA - bracket II

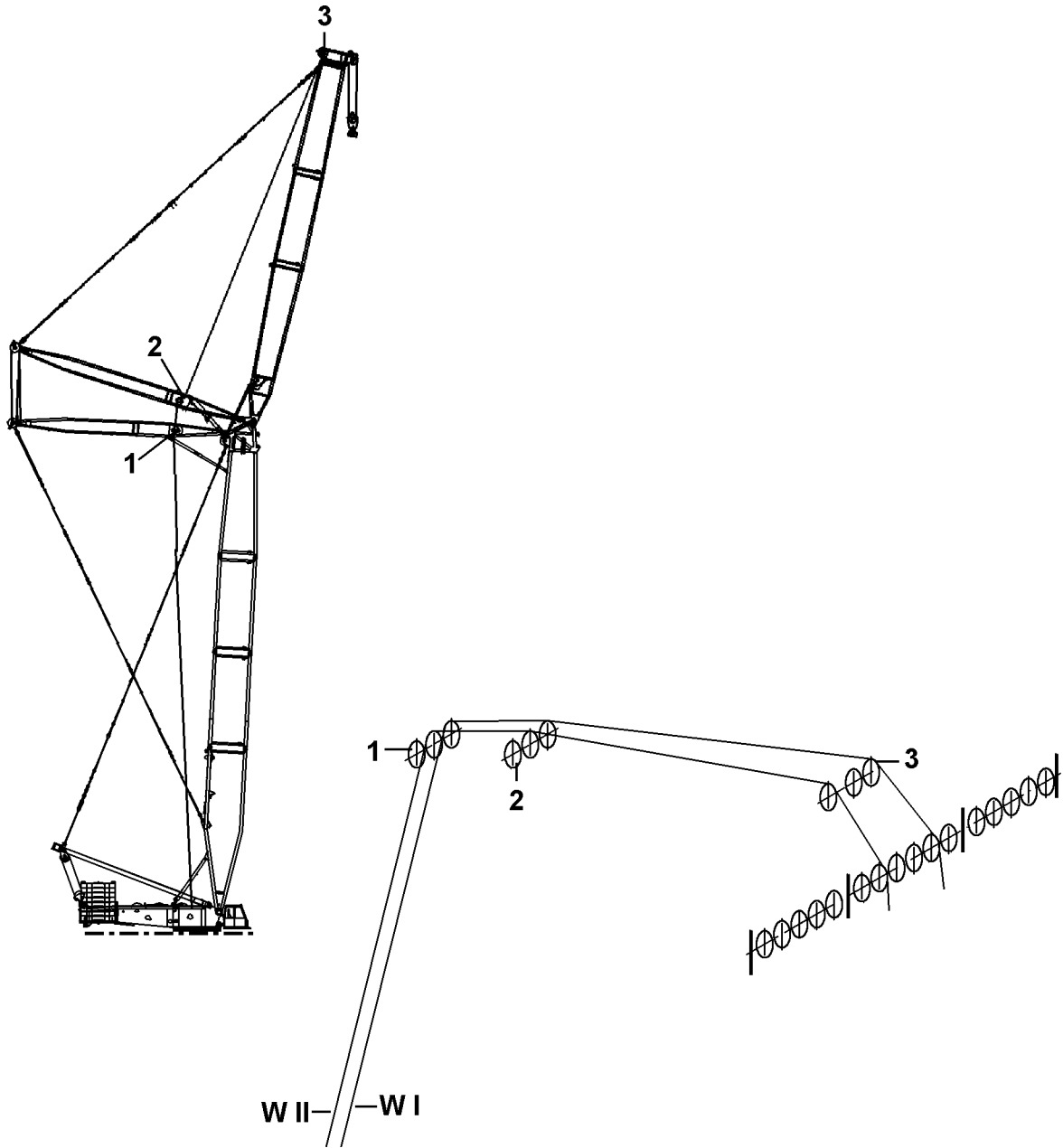
- 3 = WA - bracket I
- WV = Winch V



Hoisting rope guidance at W - operation

- 1 = Pulley WA - bracket II
- 2 = Pulley WA - bracket I

- 3 = W - head section
- W I (II) = Winch I (II)

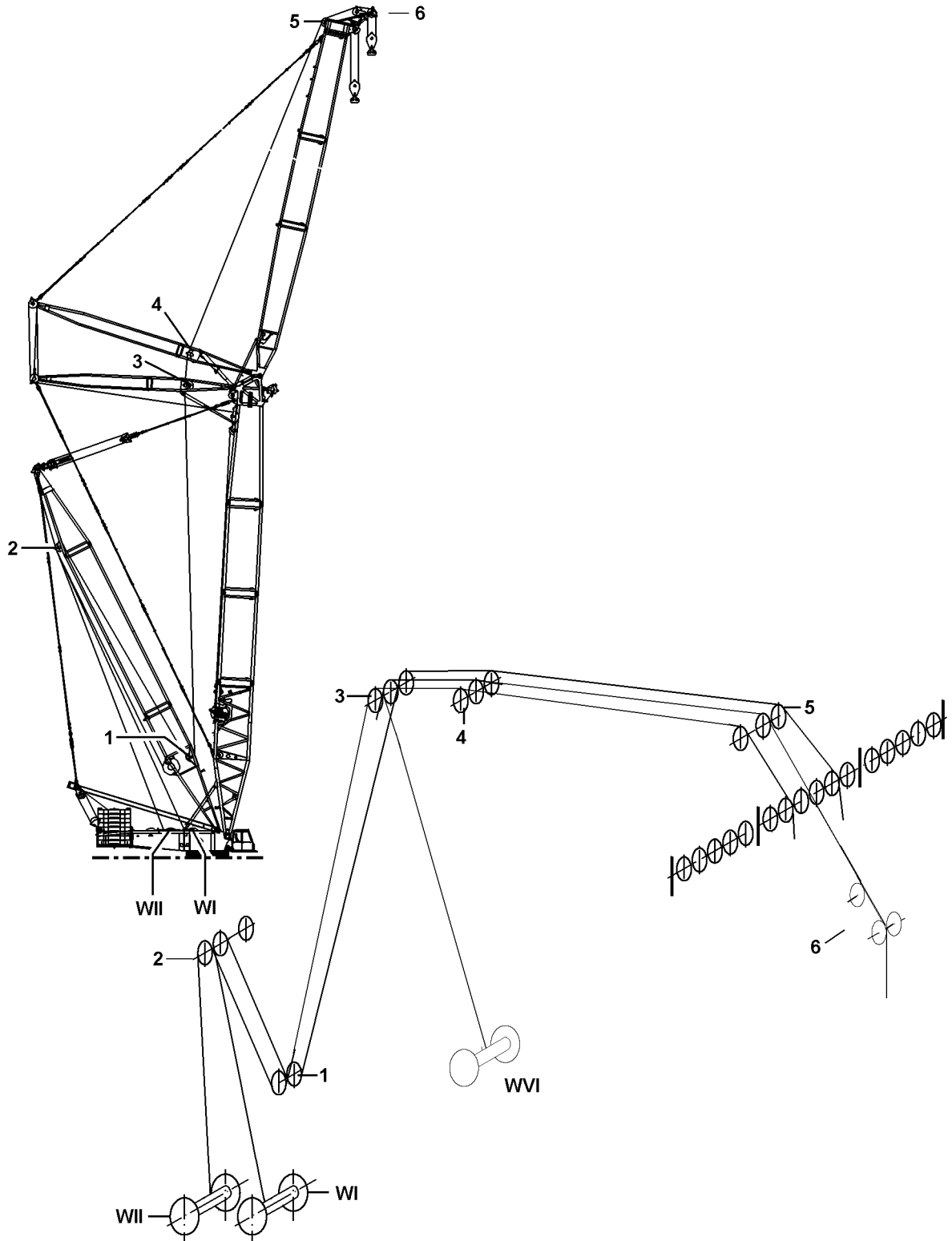


Hoisting rope guidanced for Derrick at WV-mode

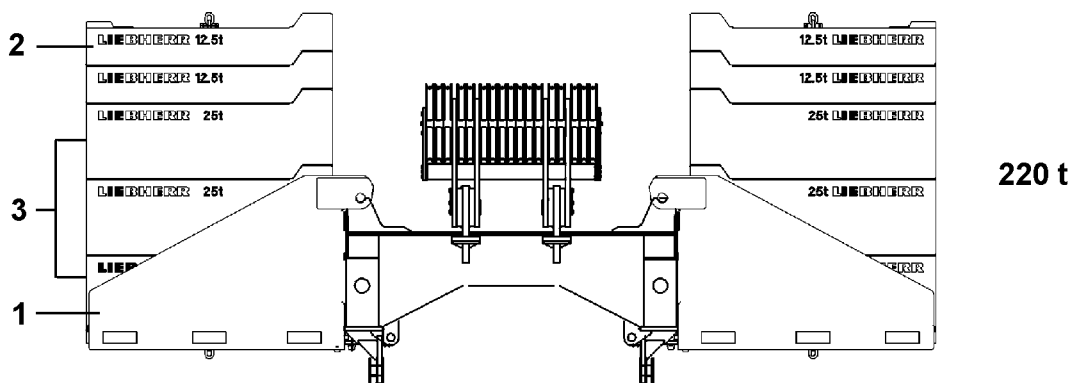
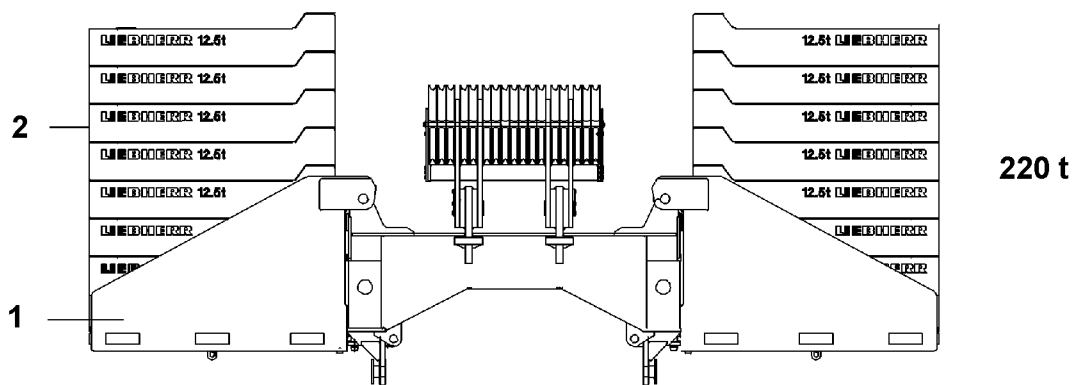
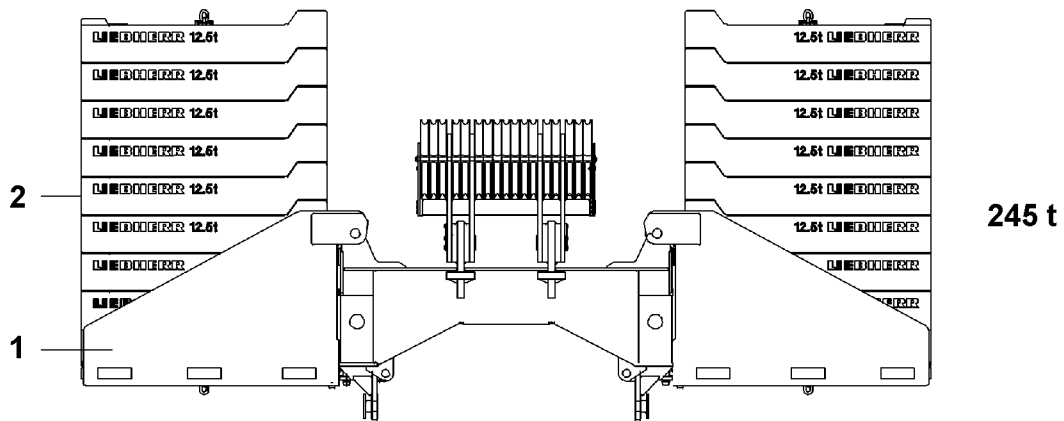
1 = Pulley D - pivot section
 2 = Pulley D - head

3 = Pulley WA - bracket II
 4 = Pulley WA - bracket I

5 = W-adapter 600t
 6 = Boom nose 60 t



198509



1. Slewing platform ballast installed on slewing platform

1.1 Ballast plates

The ballast plates are marked with their own weight.

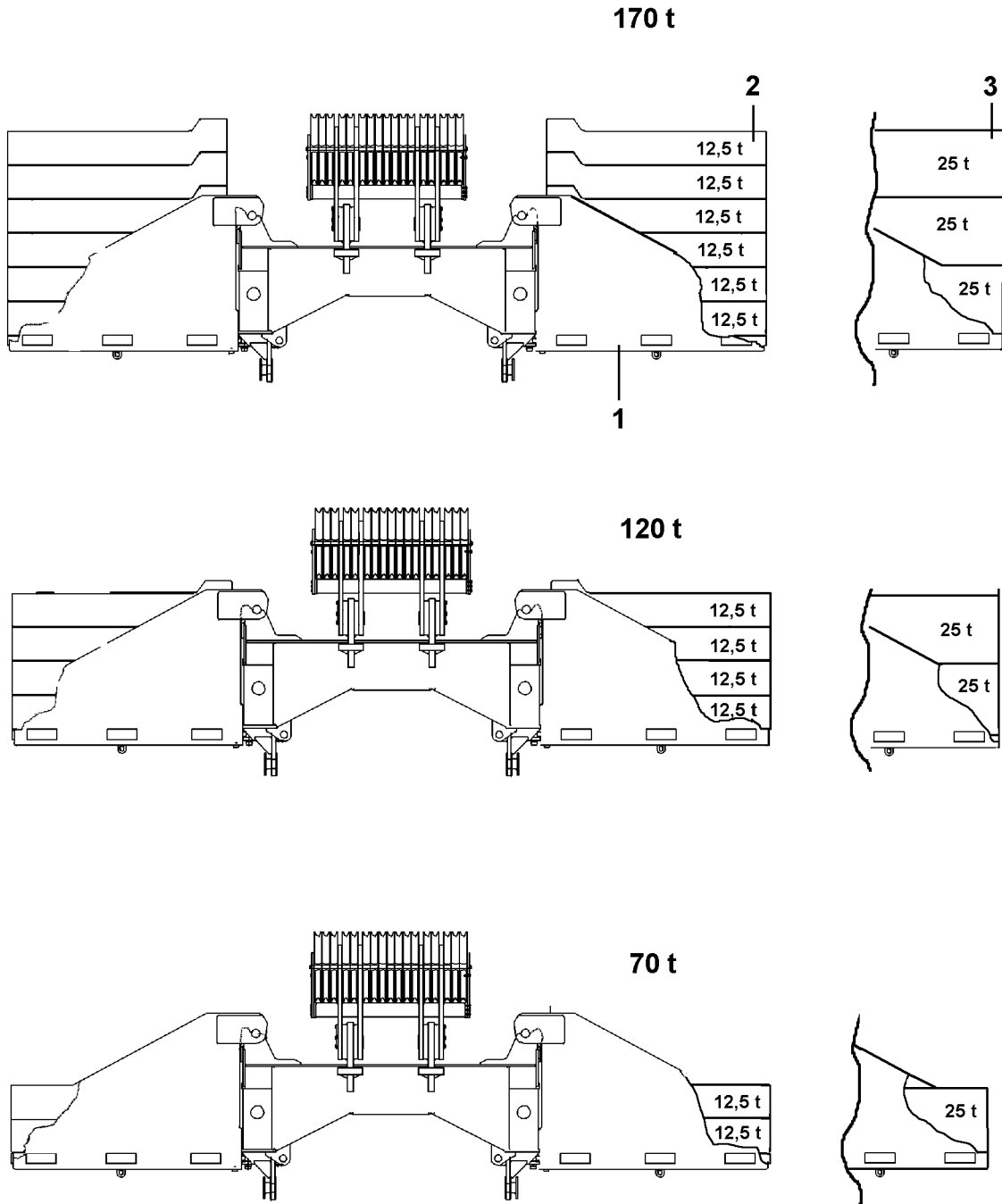
1	bracket	=	10.0 t
2	plate	=	12.5 t
* 3	plate	=	25.0 t

D A N G E R: The installed slewing platform ballast must correspond to the data in the erection and take down charts and the data in the load charts. Otherwise there is a danger of accidents!

The following combinations are possible:

Ballast	Combination			
245 t	18	×	plate	2
	2	×	bracket	1
220 t	16	×	plate	2
	2	×	bracket	1
* 220 t	4	×	plate	2
	6	×	plate	3
	2	×	bracket	1

* Optional



Ballast plates

The ballast plates are marked with their own weight.

1	bracket	=	10.0 t
2	plate	=	12,5 t
* 3	plate	=	25.0 t

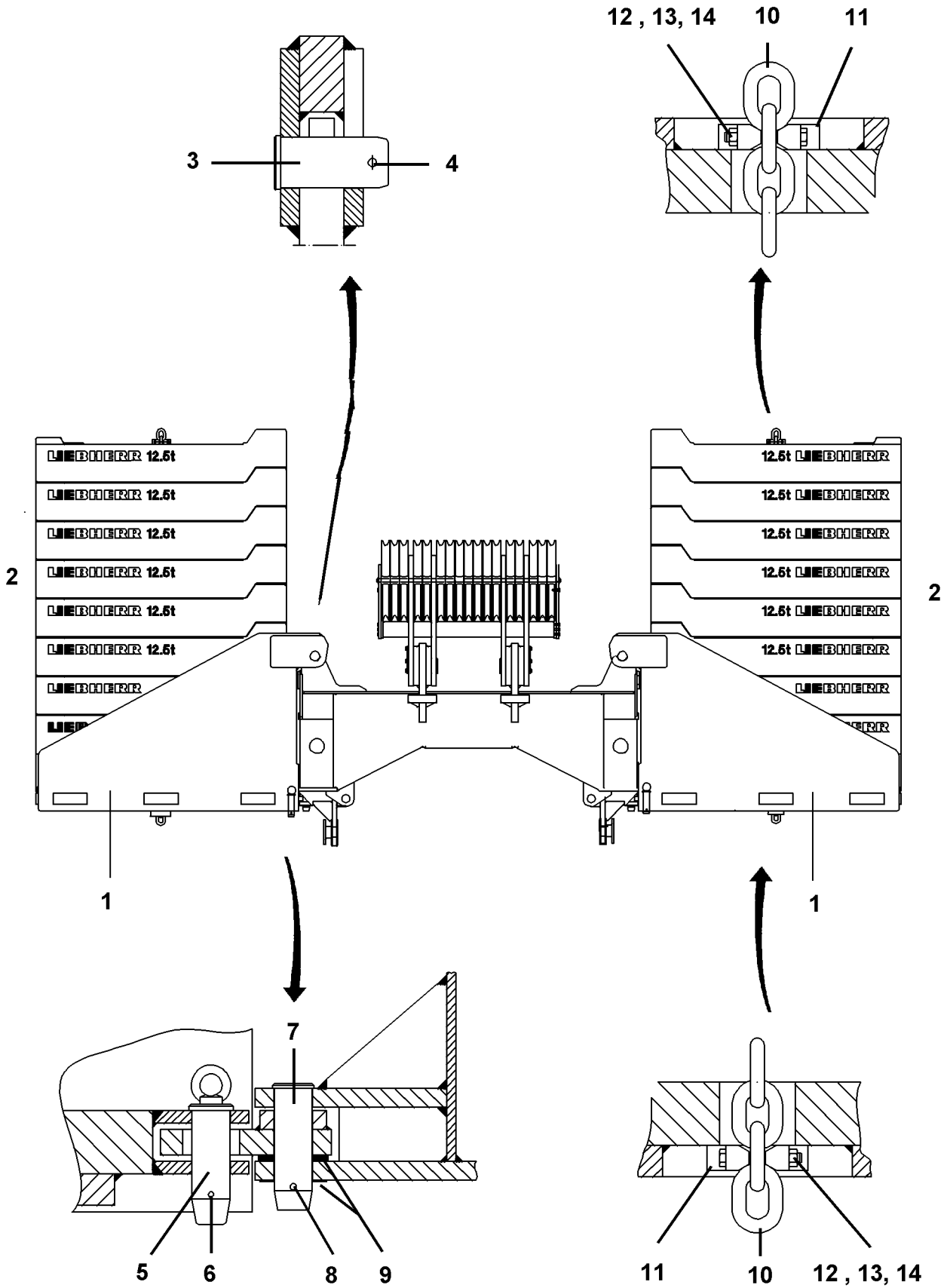
D A N G E R: The installed slewing platform ballast must correspond to the data in the erection and take down charts and the data in the load charts. Otherwise there is a danger of accidents!

The following combinations are possible:

Ballast	Combination			
170 t	12	×	plate	2
	2	×	bracket	1
120 t	8	×	plate	2
	2	×	bracket	1
70 t	4	×	plate	2
	2	×	bracket	1

* Ballast	Combination			
170 t	6	×	plate	3
	2	×	bracket	1
120 t	4	×	plate	3
	2	×	bracket	1
70 t	2	×	plate	3
	2	×	bracket	1

* Optional



1.2 Installation of slewing platform ballast

Prerequisite:

- the crane must be horizontally aligned.
- the boom is not yet installed.

D A N G E R: Before ballasting, the maximum permissible ballast variations for installation in chapter 3.06, Installation conditions, must be observed!
If this is not observed, there is a danger of tipping over!

1.3 Installation

Components:

- | | |
|----|--------------------|
| 1 | bracket |
| 2 | ballast plates |
| 3 | pin Ø 80 mm |
| 4 | cotter pin Ø 13 mm |
| 5 | pin Ø 60 mm |
| 6 | spring retainer 6 |
| 7 | pin Ø 60 mm |
| 8 | cotter pin Ø 10 mm |
| 9 | washer |
| 10 | retaining chain |
| 11 | plate |
| 12 | screw M 16 |
| 13 | nut M 16 |
| 14 | washer |

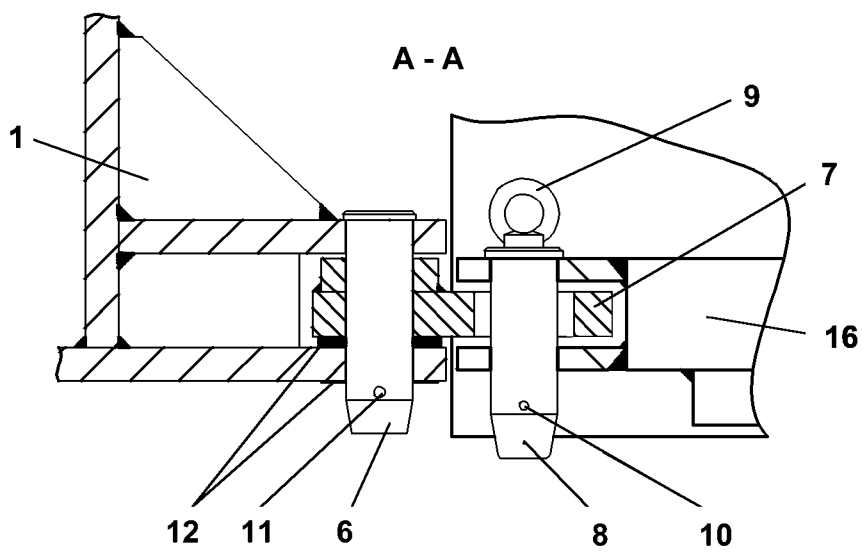
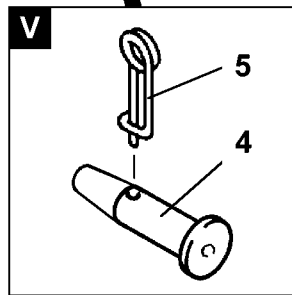
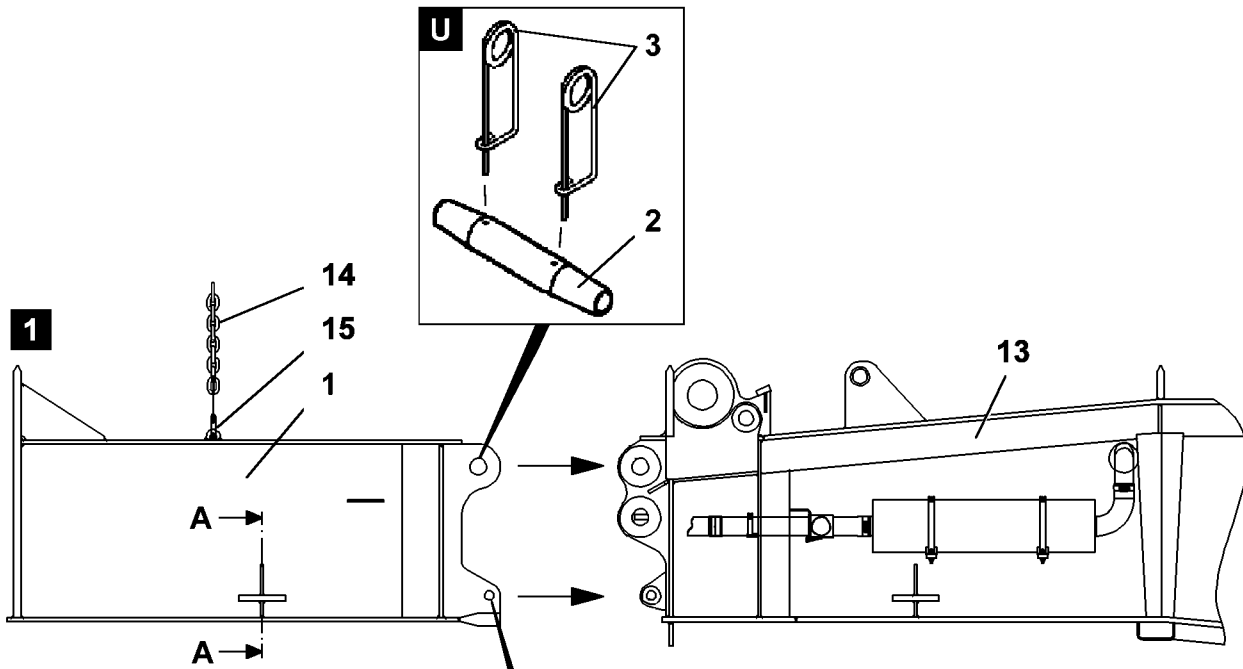
Attach the brackets (1) with an auxiliary crane to the slewing platform .

Pin brackets (1) on the bottom to brackets with pins (5) and secure with spring retainers (6) .

Stack the maximum permissible ballast plates (2) on brackets (1) .

D A N G E R: The ballast plates must be placed individually, alternately on the left and right side.
If this is not observed, there is a danger of tipping over!

Push the retaining chain (10) through on both sides, push plate (11) in on top and bottom and secure with screw (12), washer (14) and nut (13).



2. Slewing platform ballast installed on extension of slewing platform

By installing the ballast frame to the slewing platform, the slewing platform can be extended by approx. 2,5 m. This means, the slewing platform ballast is set back by approx. 2,5 m.

By using the slewing platform extension, higher load carrying capacities can be obtained in operation **WITHOUT** derrick ballast .

2.1 Installation of slewing platform extension

Prerequisite:

- The slewing platform (13) is installed on the crawler center section (chapter 3.02).
- The crane support is installed on the crawler center section of the crawler carriers (chapter 3.05).
- The crane support is swung out, pinned and secured.
- The crane is supported and horizontally aligned.
- The A-bracket is erected (chapter 5.02).

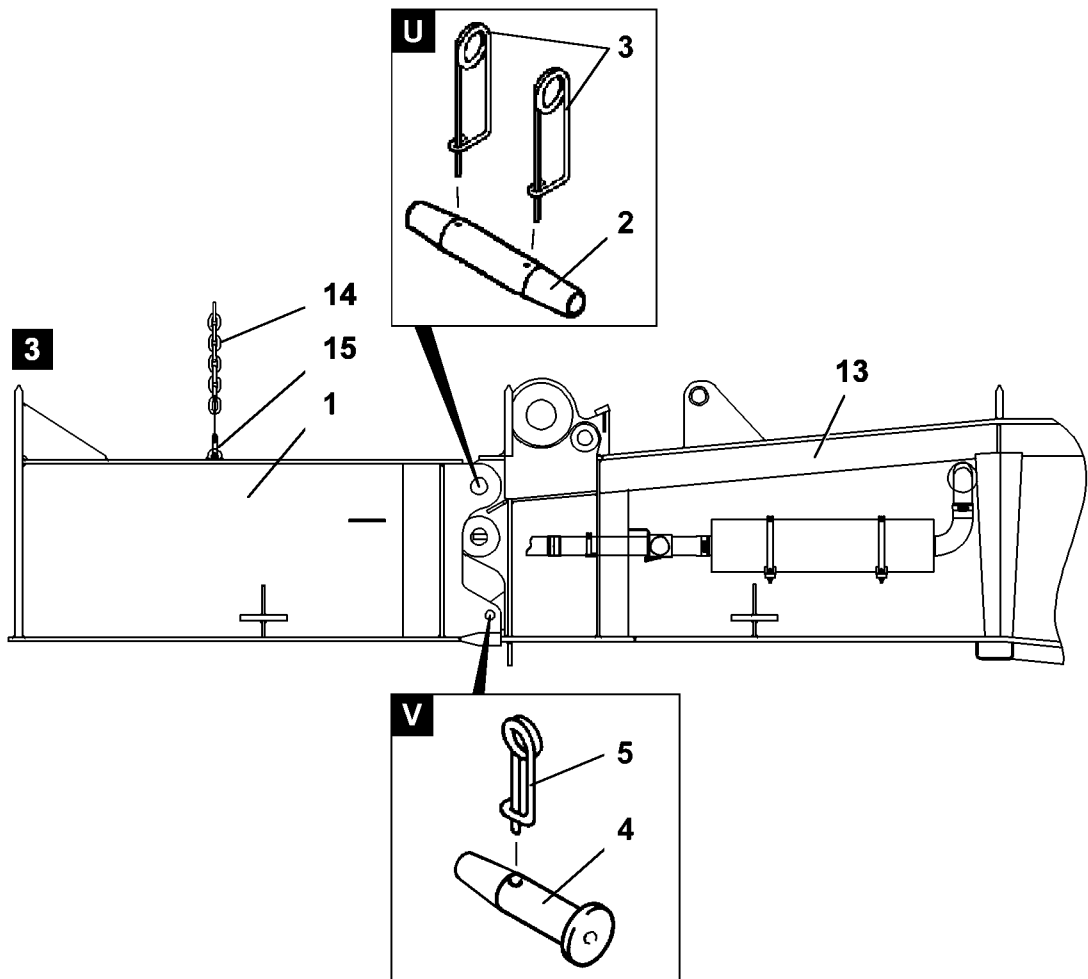
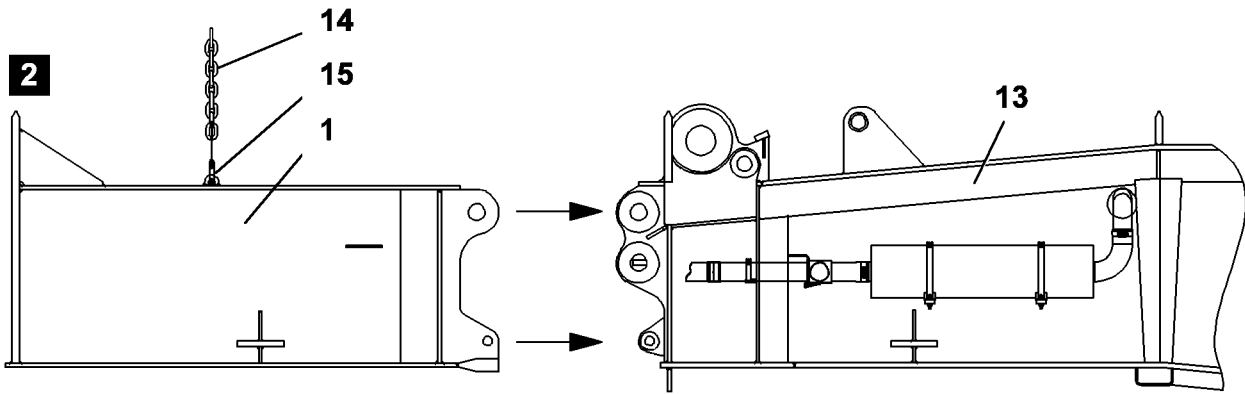
D A N G E R: - **The ballast frame may only be installed if the crane is properly supported with the crane support.**

- **Before ballasting, the maximum permissible ballast variations at installation must be observed, see chapter 3.06, Installation conditions!**

Otherwise there is a danger of tipping over!

2.2 Components for installation ballast frame

Pos.	Description	Qty.
1	ballast frame	1
2	pins \varnothing 90x 520 mm	2
3	spring retainer 8	4
4	pins \varnothing 50 x 255 mm	2
5	spring retainer 6	4
6	pins \varnothing 65 x 200 mm	2
7	bracket	2
8	pins \varnothing 60 x 180 mm	2
9	ring screw M16 DIN 580	2
10	spring retainer 6	2
11	cotter pin 10 x 80 DIN 94	2
12	washer 110 x 2	12



2.3 Installation of ballast frame

Prerequisites:

- The crane is supported via the crane support.
- The crane must be horizontally aligned.
- The A-bracket must be erected (chapter 5.02).

Note: The weight of the ballast frame = 5.0 t

Description of installation procedure:

Install the ballast frame with an auxiliary crane. Attach the tackle (14) to the eyehooks (15), lift the ballast frame and swing in to the stop on the rear of the slewing platform. Pin the ballast frame on the rear of the slewing platform and then secure the pins.

DANGER : It must be ensured that the tackle is correctly attached to the eyehooks and secured sufficiently to make sure it does not loosen up. If this is not observed, there is a danger of accidents!

Installation :

- Attach the tackle (14) to the eyehooks (15).
- Lift the ballast frame (1) with the auxiliary crane and swing to the rear of the slewing platform (fig. 1)

DANGER : It must be ensured that there are no persons within the swing range of the auxiliary crane and under the suspended load. There is a danger of accidents!

- Run the ballast frame in to the stop on the rear of the slewing platform.

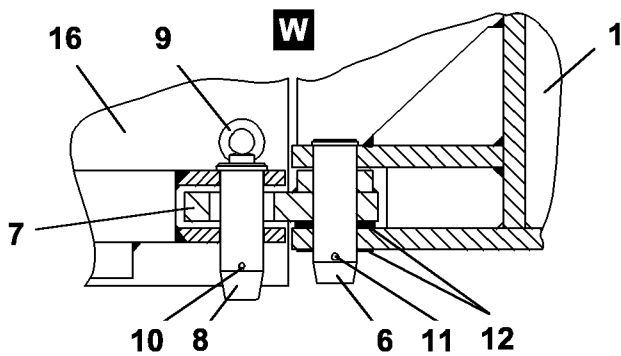
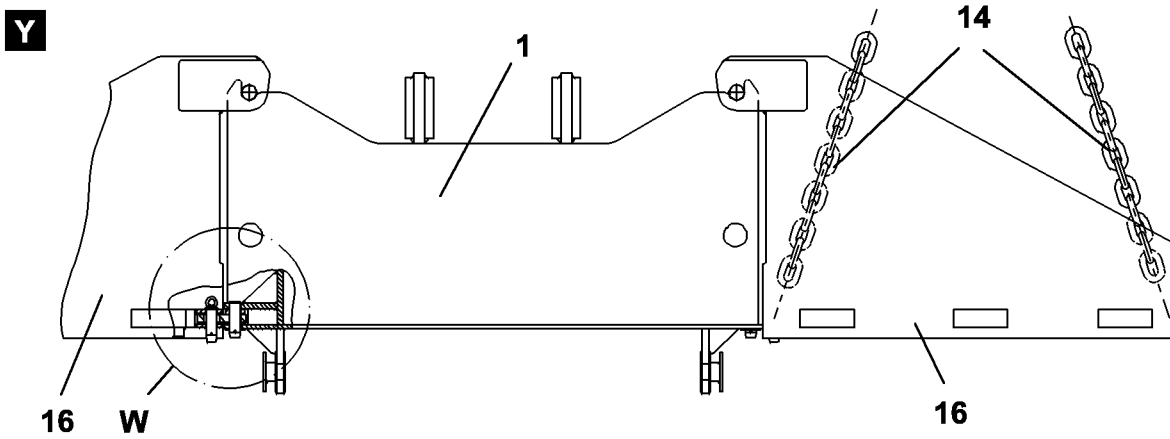
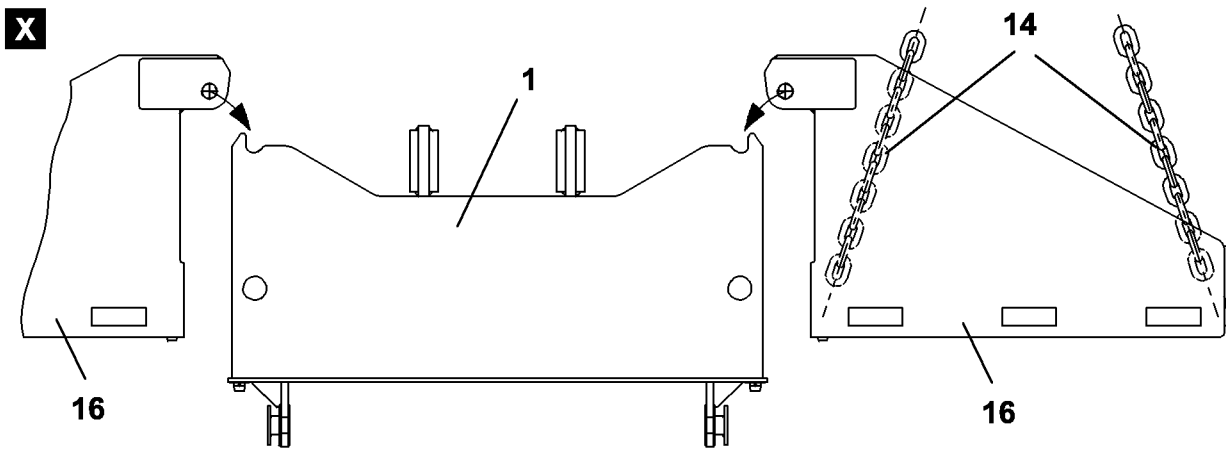
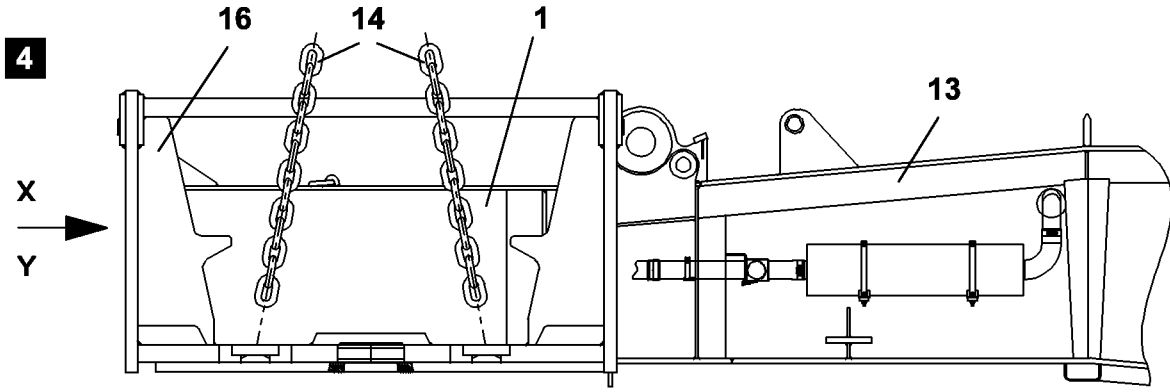
DANGER : No one may remain between the ballast frame and the slewing platform during the swing in procedure or run in of the ballast frame. This is strictly prohibited! There is an increased danger of accidents due to crushing!

- The ballast frame is pinned on the slewing platform (13) (fig. 3).
- Pin the "upper" pin bores (U) with pins (2) and then secure immediately with spring retainers (3).
- Pin the "lower" pin bores (V) with pins (4) and then secure immediately with spring retainers (5).

DANGER : Before pinning it must be ensured that all pin bores are clear. After pinning, secure the pins immediately!

- Loosen and remove all tackle (14).

DANGER: Before releasing the tackle, make sure that all pin points are correctly pinned and secured. There is a danger of accidents!



2.4 Installation of brackets

Prerequisites:

- The crane is supported with the crane support.
- The crane must be horizontally aligned.
- The ballast frame must be installed, pinned and secured on the slewing platform .

Note: The weight of one bracket = 10.0 t

Description of installation procedure:

Install the brackets (16) with the auxiliary crane to the ballast frame (1) .

Attach the tackle (14) on the studs of the brackets, lift the brackets with the auxiliary crane and swing to the side to the rear of the slewing platform. Attach the brackets on the brackets (fig. X) of the slewing platform .

D A N G E R : It must be ensured that there are no persons within the swing range of the auxiliary crane and under the suspended load.

It must be ensured that the tackle are correctly attached on the eyehooks and that it is secured sufficiently to prevent it from loosening up.

If this is not observed, there is a danger of accidents!

Installation:

- Lift the brackets (16) with the auxiliary crane and attach on the brackets (fig. X) of the slewing platform and the ballast frame.
- Pin the ballast frame (1) with the brackets (16) by using bracket (7) and pins (6 / 8) and secure with spring retainer (10) or cotter pin (11) (fig. Y // W).

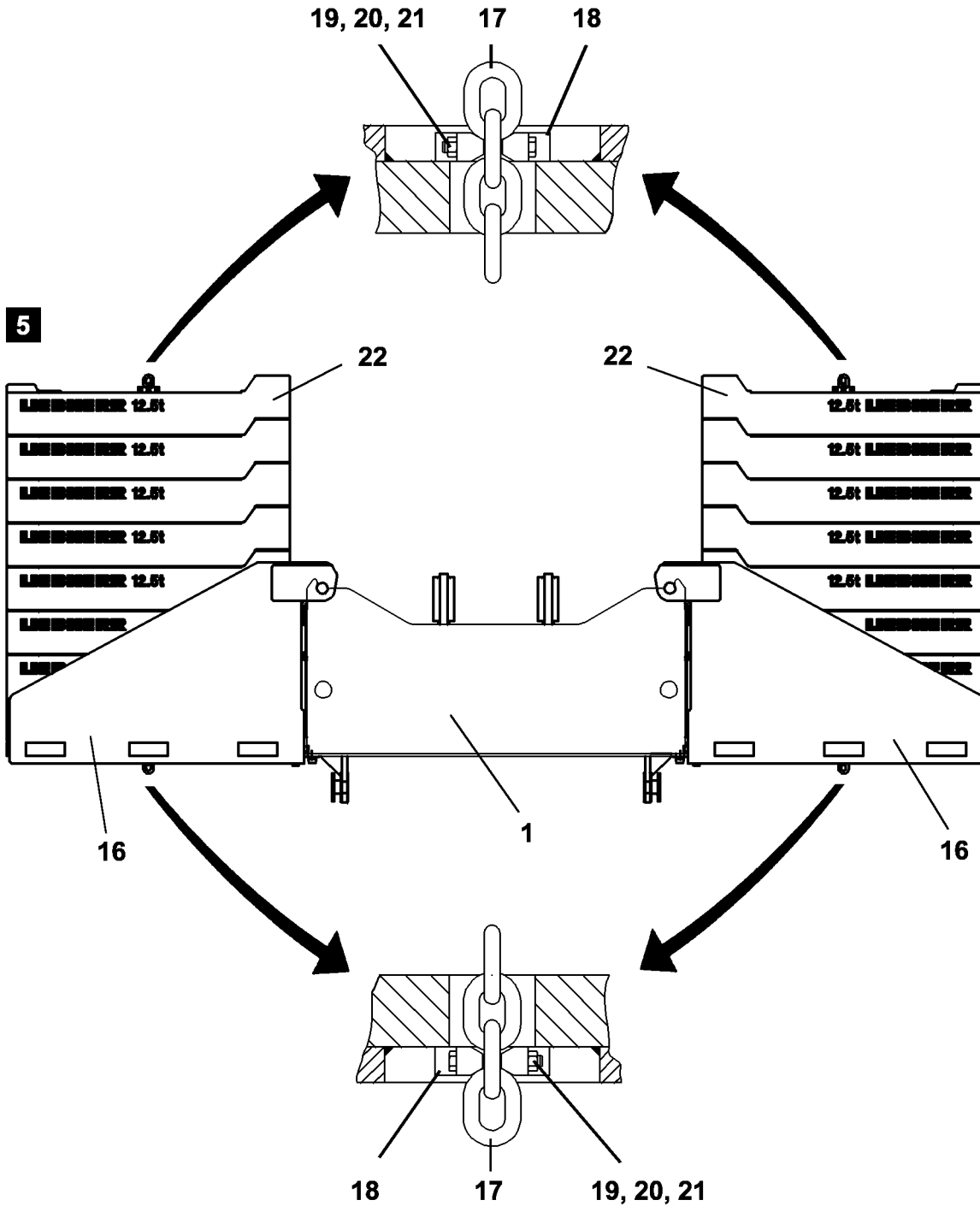
D A N G E R : It must be ensured that there is no one between the brackets and the slewing platform when swinging in the brackets with the auxiliary crane .

There is a danger of accidents!

- Remove the tackle.

D A N G E R : Before removing the tackle, the crane operator must make sure that the brackets are correctly installed on the ballast frame, that they are pinned and secured.

If this is not observed, there is a danger of accidents!



2.5 Installation of slewing platform ballast

Prerequisites:

- The crane is supported with the crane support.
- The crane must be horizontally aligned.
- The ballast frame must be installed on the slewing platform, pinned and secured.
- The brackets must be installed, pinned and secured.
- The installation conditions (chapter 3.06) must be observed.

Note: The weight of one ballast plate = 12.5 t

D A N G E R : **The installation conditions (chapter 3.06) must be observed. Otherwise there is a danger of tipping over!**

Installation procedure:

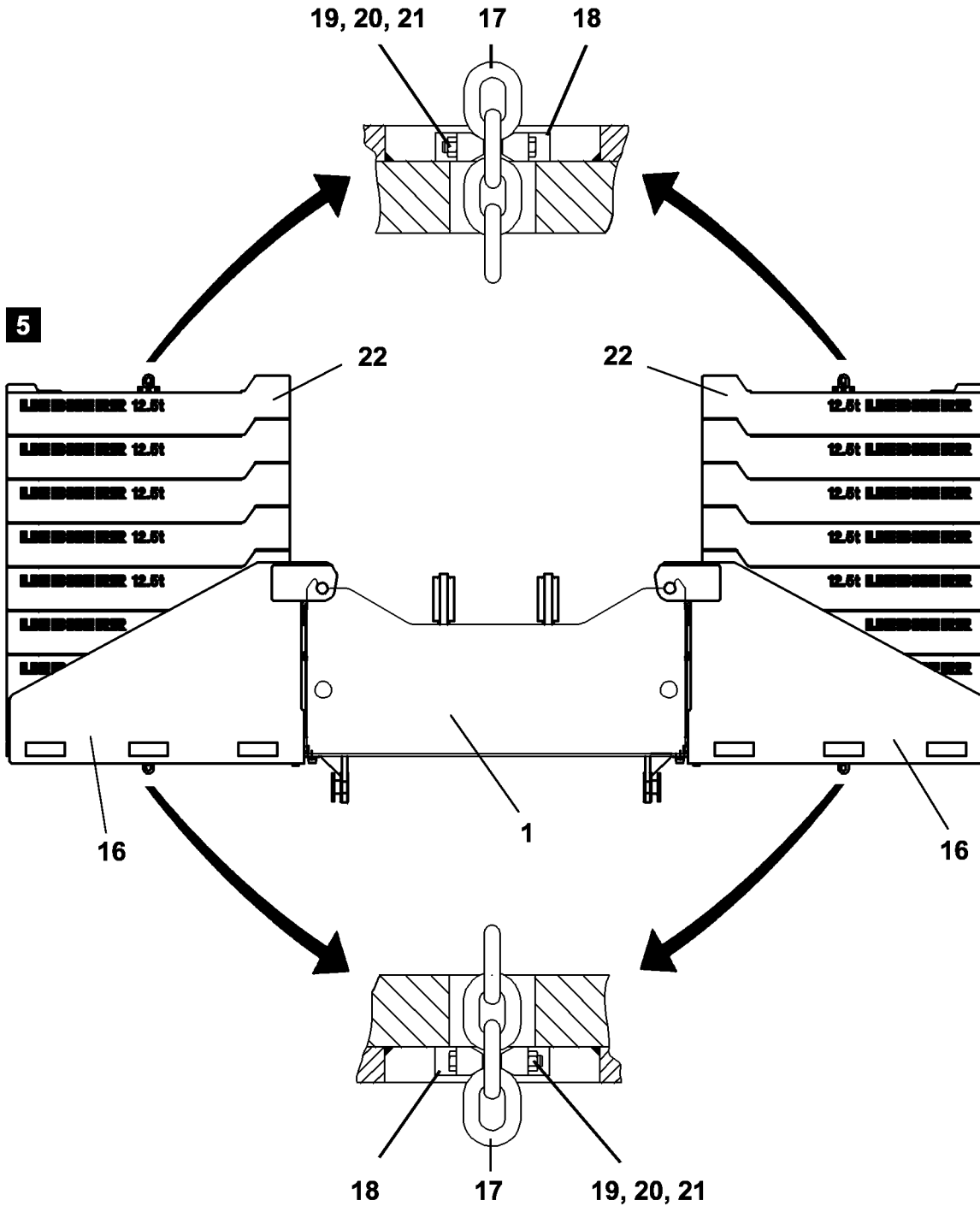
- Stack the ballast plates (22) with the auxiliary crane on brackets (16) (fig. 5).
- Attach the tackle on the studs of the ballast plates.

D A N G E R : **It must be ensured that the tackle is correctly attached on the studs on the ballast plates and that it is sufficiently secured to prevent it from loosening up. There is a danger of accidents !**

- Always attach the counterweight plates individually.
- Always stack the counterweight plates **individually** with the auxiliary crane on the brackets.
- Install the counterweight only according to the load charts.

D A N G E R : **- The ballast plates must be placed individually, alternately on the left and the right side. Otherwise there is a danger of tipping over!**

Guide the retaining chain (17) from above through the port in the middle of the ballast plates (22). Push the plate (18) in, on top and bottom and secure chain (17) with screw (19), washer (20) and nut (21).



2.6 Combination of permissible slewing platform ballast combinations

The ballast plates are marked with their own weight.

plate	12.5 t
bracket	10.0 t
ballast frame	5.0 t

D A N G E R: The installed slewing platform ballast must correspond to the data in the erection and take down charts and the data in the load charts. Otherwise there is a danger of accidents!

The following combinations are possible for the extended slewing platform :

Ballast	Combination		
250 t	18	x	plate
	2	x	bracket
	1	x	ballast frame
225 t	16	x	plate
	2	x	bracket
	1	x	ballast frame
200 t	14	x	plate
	2	x	bracket
	1	x	ballast frame
150 t	10	x	plate
	2	x	bracket
	1	x	ballast frame
125 t	8	x	plate
	2	x	bracket
	1	x	ballast frame
100 t	6	x	plate
	2	x	bracket
	1	x	ballast frame
75 t	4	x	plate
	2	x	bracket
	1	x	ballast frame

1. Safety technical notes for working with a load

Note: Observe the SAFETY TECHNICAL NOTES in chapter 2.04 !

- Always maintain the maximum load as specified in the load capacity chart!
- Always maintain the given radii as specified in the load capacity chart !

D A N G E R : **When the boom is in a steep position, for which there is no load capacity in the load charts, there is the danger of tipping "to the rear", i.e. the counterweight side, when the slewing platform is turned.**

This danger is especially acute :

- at reduced support base
- supported, but with retracted sliding arms.

**It is strictly prohibited to work at a smaller radius than given in the load chart! This also applies if there is no load on the hook.
There is a danger of accidents!**

- Always maintain the reeving numbers as noted in the load chart, corresponding to the maximum load carrying capacity!

D A N G E R : **If this is not observed, the cable could snap!
There is a great danger of accidents!**

- Always initiate all crane movements carefully, apply the brakes very carefully to prevent the load from swinging.
- When the lowest layer on the winch drum is reached, have a guide check that at least three coils remain on the winch drum.

D A N G E R : **If this is not observed, it can cause serious accidents!**

- Never reeve in a larger hook block than is required to lift the maximum load.

2. Checking before starting to work with the crane

The crane operator must make a walk-around inspection before starting to work to assure that the crane is safe to operate.

- Check that the crane is properly supported and level.
- Check that all values in the load chart that apply to the current equipment configuration have been entered and met.
- Ensure that there are no people or objects in the crane danger zone.

D A N G E R: Before initiating a slewing movement, the crane operator:

- **must give a warning signal (horn),**
- **must make sure before turning the superstructure, especially in tight job sites, there are no persons or objects within the danger zone, incl. in the rear of the counterweight to the chassis. There is a danger of accidents!**
- **Make sure that there are no personnel or objects within the danger zone of the crane .**

2.1 Visual inspection for damage

The crane operator must report all problems on the crane to the supervisory personnel at the job site, and also to the operator who relieves him at a shift change.

D A N G E R: If there are any problems which would endanger the operational safety of the crane, the crane operator must cease crane operation immediately, especially in any of the following cases:

- **Damage to load -bearing parts of the crane, such as boom, supports, etc.**
- **If the load slips due to failure of the hoist brake.**
- **In case of functional errors of the crane control.**
- **In case of non-functioning indicator and warning lights.**
- **In case of damage of the hoist cables.**
- **In case of damage of the stay ropes and guy posts.**
- **In case of non-functioning safety devices.**
- **In cases of leakage on the crane hydraulic.**

2.2 Telescopic boom distortion because of sunshine on one side

A temperature difference occurs between the side facing the sun and the side facing away from the sun in cranes with telescopic booms. This causes telescopic boom side distortion, which can reduce the load-bearing capacity of the telescopic boom. For example, a length difference of approximately 22 mm results between both sides of the telescopic boom at a temperature difference of 30 °C between the two sides of the boom and a boom length of 60 m.

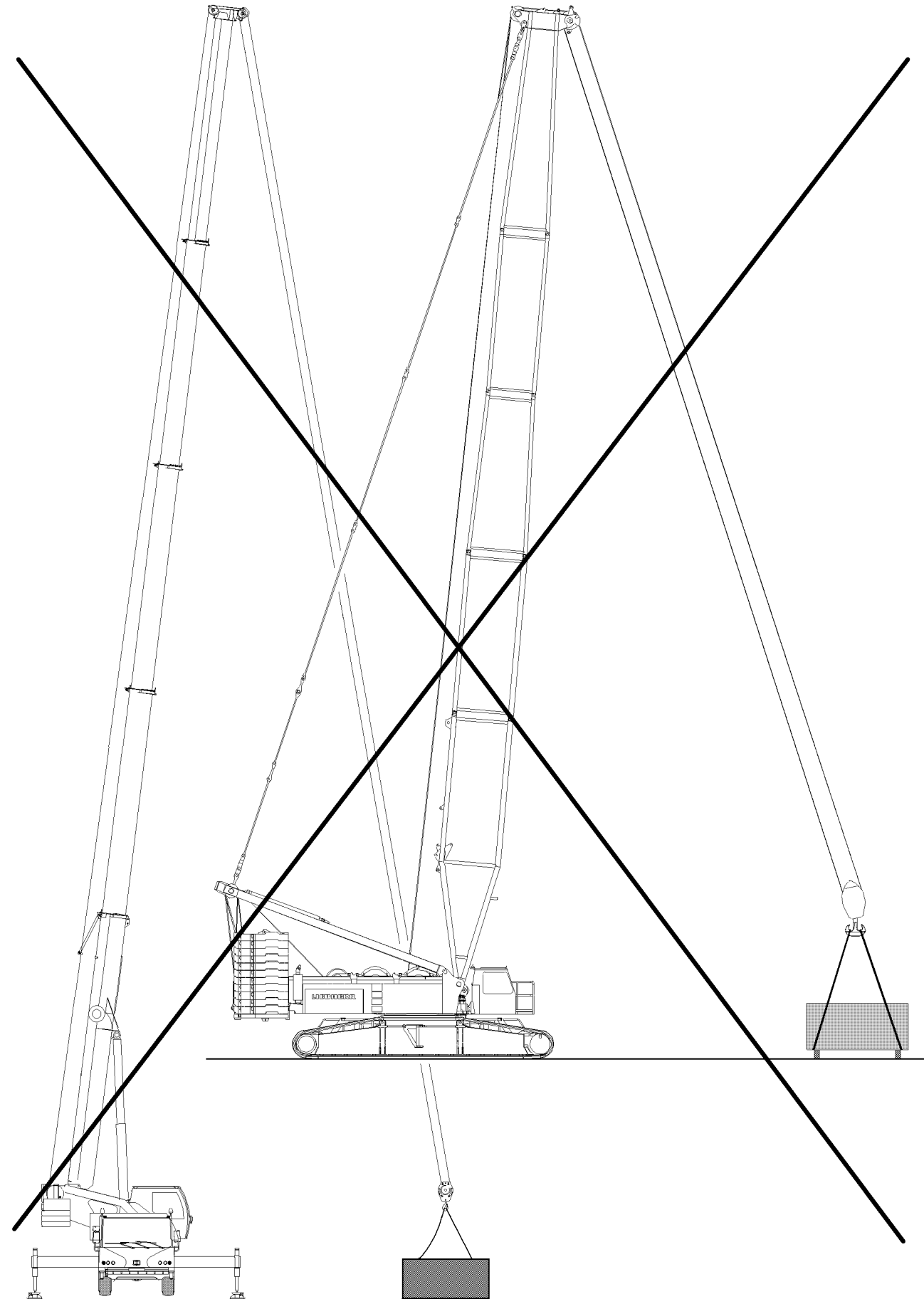
Particularly with narrow boom parts, this causes the profiles to bend sideways!

If the maximum load is being fully utilised, particularly when a telescopic boom extension such as a lattice jib, luffing lattice jib or folding jib is being used, the equipment must be visually inspected before picking up the load in order to ensure that the boom is not showing signs of side deformation because the sun shining on one side.

D A N G E R : Danger of accident because of component overloading!

If the telescopic boom has become distorted because of one-sided sunlight, this can cause component overloading and therefore accidents.

Turn the crane so that both sides of the boom are brought to about the same temperature, therefore preventing side deformation!



3. Taking on a load

The crane must always be operated in such a way, that its load bearing parts are not damaged and the safety of the crane is never compromised.

3.1 Lift a load

When lifting a load, utmost care must be taken! There is a danger of crushing any persons, which is in immediate vicinity of the crane and the load to be lifted. If the tackle cable has to be attached by a person to the load to be lifted, then the crane operator must ensure :

- that the hands of the person placing the tackle are not crushed by the tight cables between the load and the tackle cable.
- that body parts (hands, legs, etc.) are not crushed by a swinging load, when the load is raised.

D A N G E R : If there are any persons within the area of the load, there is a danger of crushing and serious injury.

It is strictly prohibited to lift a load by luffing up the boom, if it has triggered the LICCON system when attempting to lift the load via the hoist gear. This causes overload or can topple the crane over.

Note: Use the auxiliary winch (installation and reeving winch) only for installation, not to lift loads.
Lifting of loads with the auxiliary winch is prohibited!

3.2 Pulling a load at an angle

The crane is built to lift load vertically. In angular pulling, regardless of whether this is done in the same direction as the boom or diagonally, horizontal forces are generated in addition to the vertical ones, for which the boom is not designed.

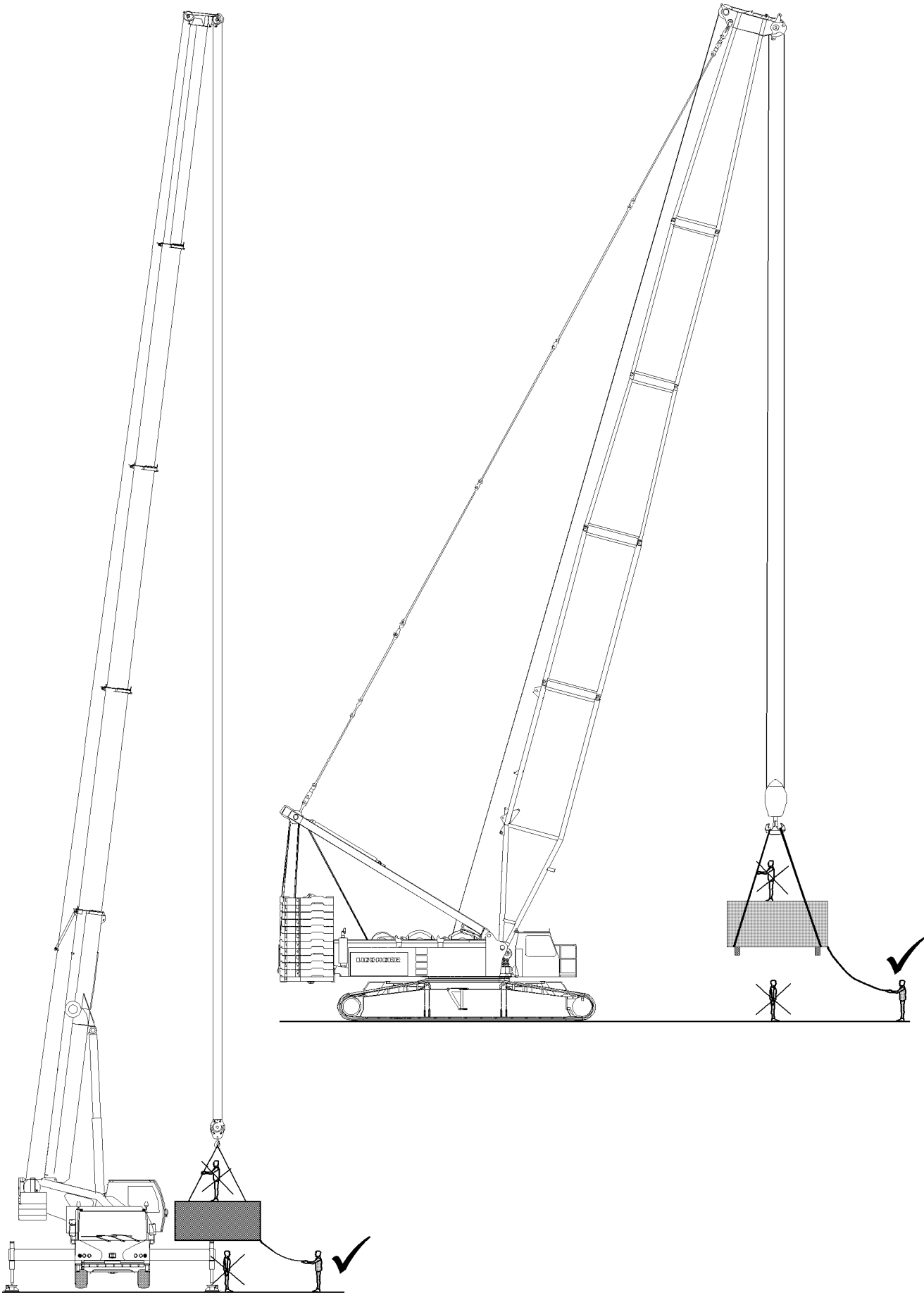
D A N G E R : Diagonal pull can destroy the crane or cause it to topple over!
Diagonal pull is p r o h i b i t e d!
The hook block must be attached (hung) vertically over the center of gravity of the load to be lifted !

3.3 Breaking away fixed loads

It is strictly **prohibited** to pull stuck or jammed loads free with the crane.

D A N G E R : It is strictly prohibited to pull stuck or jammed loads free with the crane !
This can cause the crane to topple over.

C A U T I O N : When taking down the hook blocks, booms, folding jibs, auxiliary booms and boom noses, it must be ensured that the cable pulleys do not touch or lay in the ground. If this is not observed, the cable pulleys can be damaged.



102717

4. Crane operation

The maximum load-bearing capacity is not just limited by stability, but in many cases a load-bearing component breaks when the crane is overloaded **before** the crane topples over. Particularly components that are susceptible to buckling such as the telescopic boom may fail suddenly **without showing signs of distortion** beforehand if the crane is overloaded.

4.1 In General

A suspended load must always be kept under control. A safe, sensitive actuation of crane functions is the basic requirement.

D A N G E R: A swinging load can damage the crane or cause it to topple over. There is an increased danger of accidents!

- All crane movements must be executed slowly and delicately.
- Initiate all crane movements slowly.
- Apply the brakes slowly in all crane movements.

C A U T I O N: Danger of damage to the rope pulleys!
When taking down the hook blocks, booms, folding jibs, auxiliary booms and boom noses, it must be ensured that the cable pulleys do not touch or lay in the ground. If this is not observed, the cable pulleys can be damaged.

4.2 Tag lines

To aid the crane operator in accurately guiding the load, we recommend the use of tag lines to prevent any unintentional movement of the load and subsequent damage.

4.3 Transporting persons

This crane is not designed to move persons. It is strictly prohibited, to allow any person to be carried on the raised load.

D A N G E R: Transporting persons along with the load or the load tackle is strictly prohibited. There is a great danger of accidents!

4.4 Danger of crushing

When lowering the load, utmost care must be taken. There is a great danger of crushing any person, which is in the immediate vicinity of the load to be lowered.

D A N G E R: When lowering a load, make sure that no persons or objects are within the danger zone. In general, it is never permitted for any person to be under the load. There is a great danger of accidents!

4.5 Working near overhead electrical wires and lines

If there are any electrical lines / overhead wires in the immediate vicinity of the job site, they must be disconnected by trained electricians. If this is not possible, then the danger zone must be covered or blocked off. If even these measures are not possible, then the following safe distances must be kept between the crane and the wires at all times:

Rated voltage	Min. distance in meters
to 1 kV	1
above 1 kV to 110 kV	3
above 110 kV to 220 kV	4
above 220 kV to 380 kV	5
if the rated voltage is unknown	5

Note: If, despite all precautionary measures, a flashover occurs, observe the following:

- Keep calm.
- Do not leave the crane operator's cab.
- Warn all those around the crane to remain standing where they are and not to touch the crane!
- Move the crane from the danger zone.

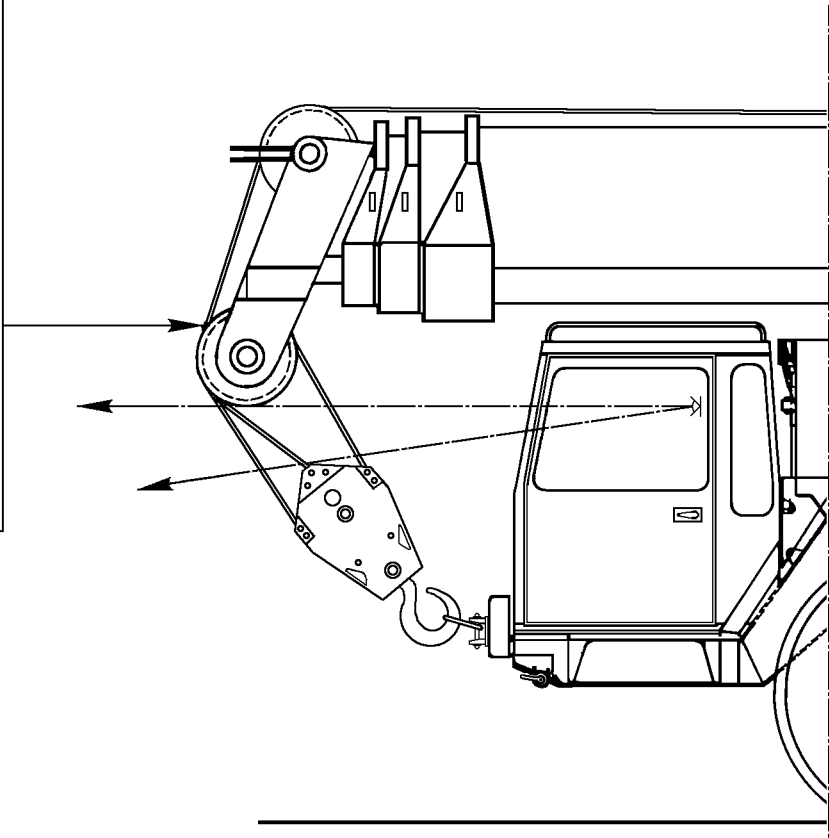
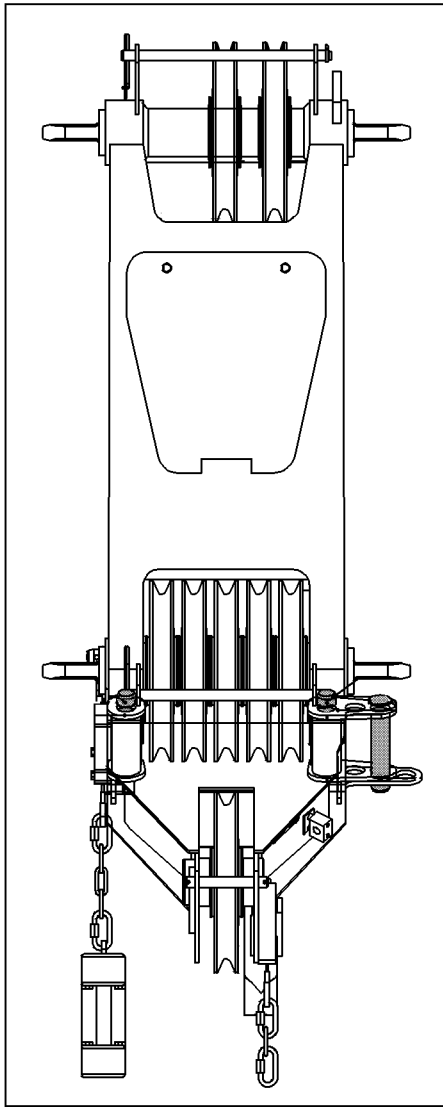
D A N G E R: If this is not observed, serious damage, injury or death can occur!

4.6 Ram work or pulling sheet piles

Vibration can be transmitted to the supporting steel structure of the crane during ram work or when pulling sheet piles with the crane. This vibration can cause premature fatigue of the material and therefore cracks in the supporting steel structure.

D A N G E R: Important instructions when carrying out ram work or pulling sheet piles! If the crane is used for ram work or pulling sheet piles the following instructions must be followed. Failure to follow the instructions can result in damage to the crane.

- The ramming equipment must not introduce vibration into the boom head!
- When pulling sheet piles the maximum lifting power of the crane is limited as per the load chart! Restricting the maximum lifting power via the crane overload protection only is forbidden. The lifting force restriction can be achieved by suspending a crane scale between the load hook and the pulling equipment.



Description

In two-hook operations, a distinction must be made between:

1. Operation with boom nose on telescopic boom
2. Operation with boom nose on lattice jib
3. Operation with boom extension (auxiliary boom, folding jib, luffing jib).

1. Operation with boom nose * on telescopic boom

This possibility is available for quick lifts via the boom nose, whereby the hookblock reeved in on the telescopic boom can remain fully reeved.

For the operation with boom nose, no extra load charts are available. The boom nose is generally run with the operating mode of the telescopic boom.

D A N G E R: **The overload safety device is only effective if the reeving on the telescopic boom is the same or larger than the reeving on the boom nose. If this is not assured, the hoist gear 1 or the hoist cable can be overloaded. The safe load indicator system must be set to the smaller reeving of both hooks.**

- Set the operating mode of telescopic boom on the safe load indicator system,
- Enter the cable reeving to reflect the actual reeving on the boom nose.

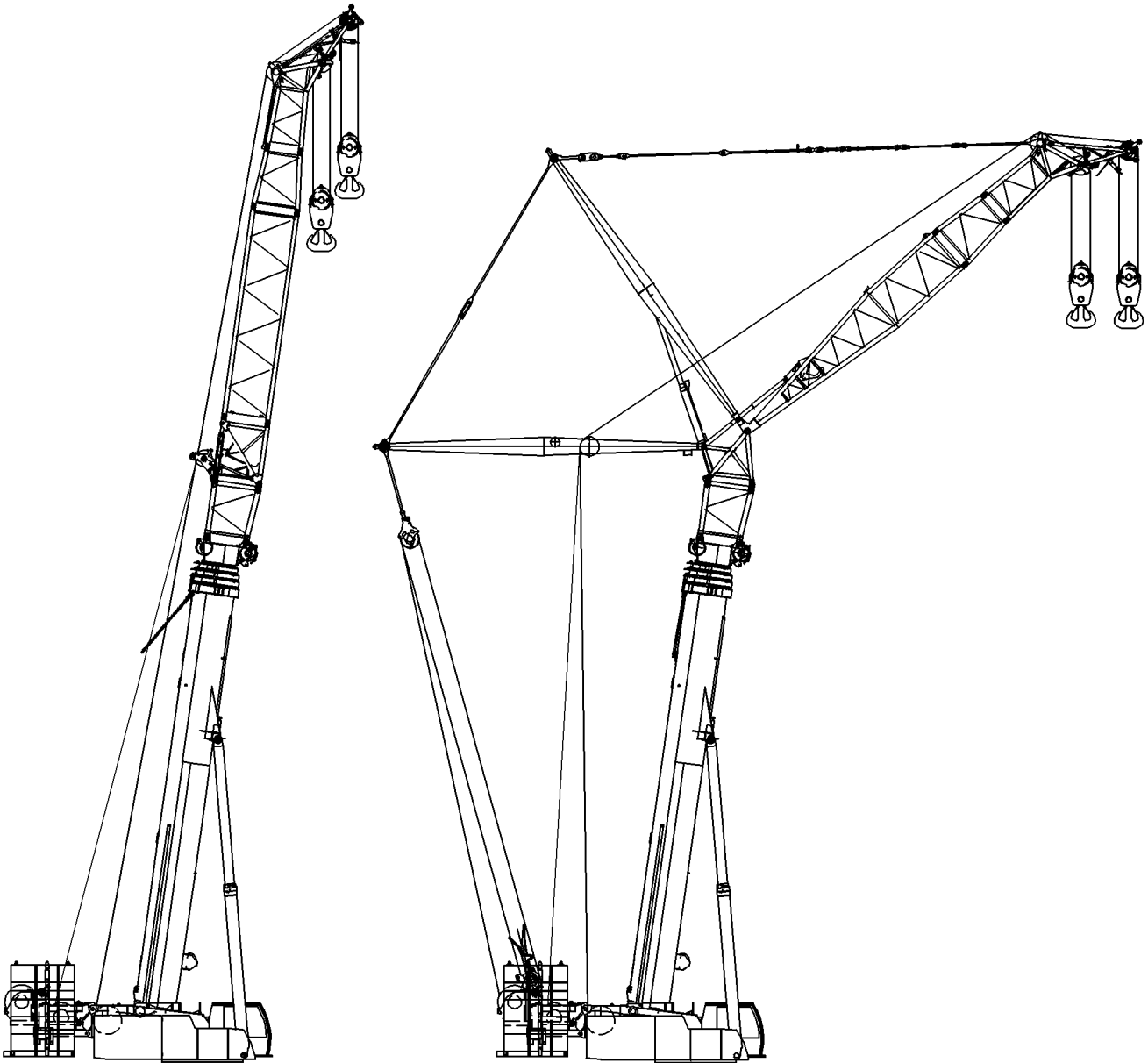
C A U T I O N: **For crane operation with boom nose, be aware that the radius and load indicator of the safe load indicator system is not exact, because the boom nose is not considered in the boom geometry.**

The safe load indicator system must be set to the actual reeving on the boom nose and the corresponding CODE No. for the appropriate boom length must be entered.

In addition, the counterweight, the support base, etc. must also be considered.

By setting the smaller reeving number of the two hooks, it is assured that the crane is not overloaded. Add the weight of the hook block (load hook), the boom nose and the tackle to the weight of the load, which is to be lifted.

* Optional



2. Operation with boom nose * on lattice jib

This possibility is available for quick lifts via the boom nose, whereby the hookblock reeved in on the lattice jib can remain be fully reeved.

For the operation with boom nose, no extra load charts are available. The boom nose is generally run with the operating mode of the lattice jib.

D A N G E R : **Protection via the safe load indicator system is only available when the reeving on the lattice jib is the same or higher than the reeving on the boom nose. If this is not observed, the hoist gear or the hoist cable can be overloaded. The safe load indicator system must be set to the smaller reeving of the two hooks.**

- Set the operating mode of the lattice jib on the safe load indicator system.
- Enter the cable reeving according to the actual reeving on the boom nose.

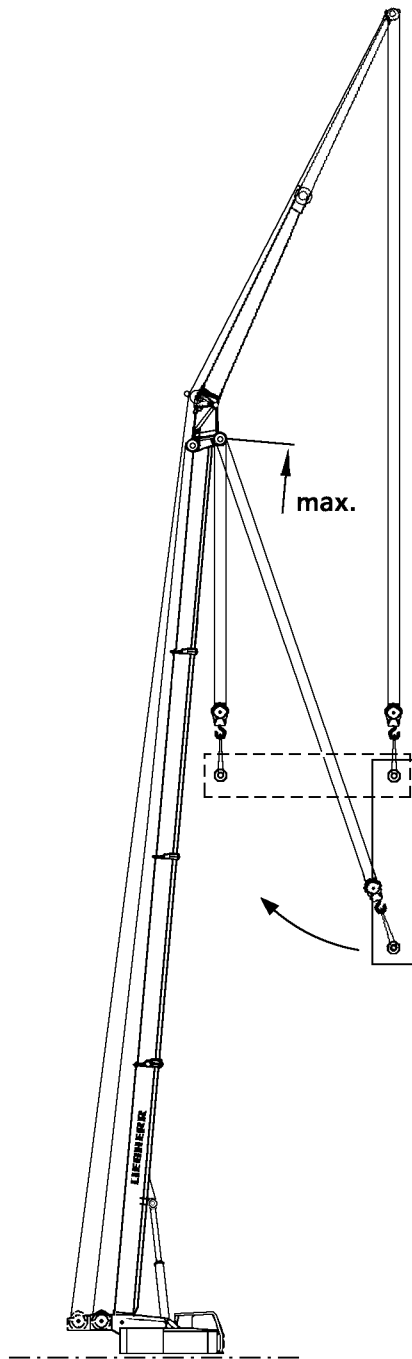
C A U T I O N : **In operation with boom nose, the radius and load indicator of the safe load indicator system is not exact, because the boom nose is not taken into account in the boom geometry.**

The safe load indicator system must be set to the actual reeving of the boom nose and the corresponding CODE No. of the corresponding boom length must be entered.

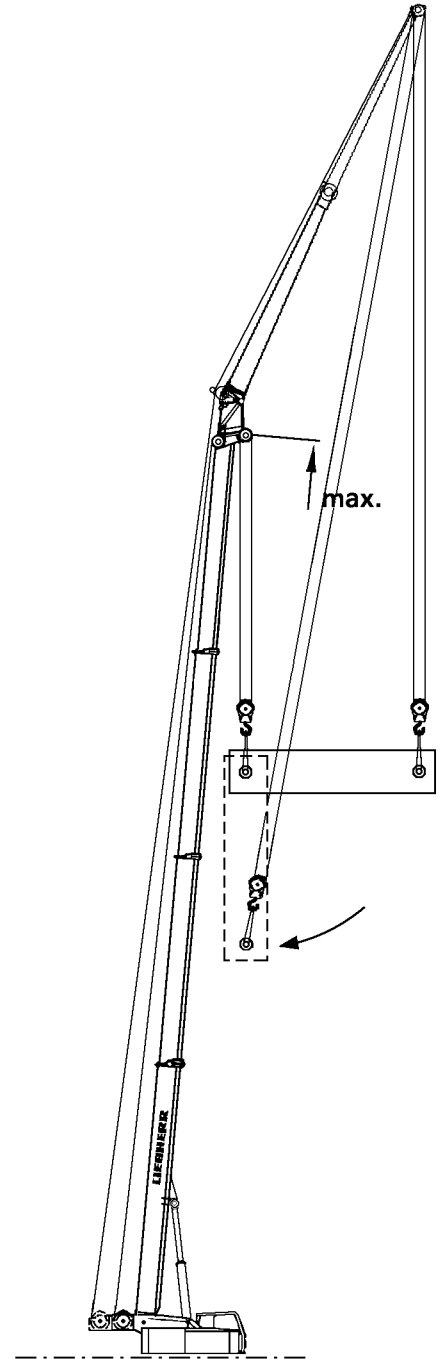
In addition, the ballast, the support base, etc. must be taken into account.

By setting the smaller reeving number of the two hooks, it is assured that the crane is not overloaded. Add the weight of the hook block (load hook), the boom nose and the tackle to the weight of the load, which is to be lifted.

* Optional



Va. 1



Va. 2

3. Operations with the folding fly jib or with the auxiliary boom *

This capability is provided for turning the load while simultaneously operating both hoisting gears.

DANGER: The load must always be raised or lowered to 100% with the weakest component (fly jib or auxiliary boom*).

- Enter the reeving in the safe load indicator in accordance with the reeving present on the folding fly jib or auxiliary boom*.

DANGER: The reeving on the main hook (telescopic boom) must be equal to or larger than the reeving on the jib (folding fly jib or auxiliary boom *).
If this is not observed, hoisting gear 1 or the hoisting cable could be overloaded.

- For operations with the **folding fly jib or the auxiliary boom ***, the safe load indicator must be set to the operating mode "**Folding fly jib**".
- Enter the cable reeving in the equipment mode diagram of the safe load indicator in accordance with the reeving present on the jib.

In this case the maximum total load corresponds to the maximum permissible load on the folding fly jib given in the corresponding load capacity table for jib operations.

The weight of the hook block and the slinging tackle must be added to the loads to be hoisted.

CAUTION: The radius display is given corresponding to the entered folding fly jib.

The individual loading capacity per hook during two-hook operations corresponds to the permissible load given in the appropriate load capacity table for operations with folding fly jib.

The sum loading capacity corresponds during two-hook operations to the permissible load given in the appropriated load capacity table for operations with folding fly jib.

DANGER: Hoisting a load with 2 hooks is only permissible in accordance with diagrams Va.1 and Va.2.

If this is not observed, there is a danger of accidents due to the overloading of the individual crane components.

Protection via the overload safety device is then no longer provided.

If a load is hoisted in accordance with Va.1, the load must first be completely hoisted to 100% with the most outer hook.

Note: As soon as the inner hook begins to take the weight of the load, the load display in the overload safety device is incorrect!.

DANGER: If both hooks are loaded, luffing the boom is prohibited!
Protection via the overload safety device is then no longer provided.
For this reason, the load must always be taken up at the maximum radius.

* Optional

Chapter 5

Equipment

1. Check the safety elements

To retain the pins in the lattice sections, safety elements are used. Due to mechanical damage or distortion, the spring force of the safety elements can be reduced significantly. If the spring force is not sufficient, the safety elements may no longer be used. The pin retention must be made with a **functioning** safety element.

D A N G E R : **Danger of accident in case of insufficient spring force of the safety element!
If the spring force of the safety element is not sufficient, the correct retention
of the pin is no longer ensured.**
- Always use safety elements with sufficient spring force!

2. Check the cables

An expert cable inspection must be made before assembly and in regular intervals, to recognize any cable damage or wear in time, see chapter 8.04.

The cables must be taken down immediately if one of the following damages is found:

- Broken strand
- Broken wires
- Wire nests
- Reduction of cable diameter as compared to nominal dimension by 10% or more
- Cable distortion

2.1. Place a new hoist cable

To ensure the safety and running properties, use only Liebherr Original spare parts.

If the cable pulleys are run in, then they have to be turned out or replaced before placing a new hoist cable. If this is not observed, it can cause damage to the newly placed hoist cable.

2.1.1 Cranes with cam limit switch

The cam limit switch is adjusted at the factory, so that it turns off if only 3 cable coils are on the winch.

D A N G E R : **Danger of accident due to falling load!
If the following notes are not observed, the hoist cable end mounting can be
ripped out and the load can fall down.**
- If a new hoist cable is placed, then the cam limit switch must be readjusted!
- The cam limit switch must be set in such a way that it turns off when only 3
hoist cable coils are on the winch!
- If the hoist cable is spooled up at assembly, then the hoist cable end must
remain in front of the winch and may not be pulled over the winch, otherwise
the cam limit switch must be readjusted!

3. Control measures

Note: If the crane operator leaves the crane cab, even if only for a short time, then he is obligated, before starting to work again, to check the operating mode settings and to reset them, if necessary.

Before crane operation, carry out the following checks:

- Check if the load carrying capacity of the ground is sufficient.
- Check if the safety distance to ditches and overhangs is sufficient.
- Check to ensure that there are no live power lines in the working range of the crane.
- Make sure that the crane operation can be carried out at the least possible radius.
- Check if there are any obstacles, which would hinder the required crane movements.
- Check if the crane is horizontally aligned.
- Check if the LICCON overload safety is set according to the data in the load chart.
- Check if the bypass keyed button on the monitor, the installation keyed button and the crawler installation keyed button are turned off .
- Check the shut off of the overload safety by triggering the operating position “top” and “bottom”.
- Check the shut off of the overload safety by running against the hoist limit switch.
- Check the easy movement and function of the wind speed sensor.
- Check the shut off of the limit switch - boom “steepest position”. See chapter 8.12.
- Check the shut off of the limit switch -Derrick. See chapter 8.12.
- Check the shut off of the limit switch -lattice jib “steepest position”. See chapter 8.12.
- Check the shut off of the limit switch - lattice jib “lowest position”. See chapter 8.12.
- Check the shut off of the limit switch - flap in position lattice jib “steepest position .” See chapter 8.12.
- Check the easy movement of the pendulum of the mechanical relapse retainer over the complete swing range of the pendulum .

D A N G E R : **The crane can topple over!**

If the control measures are not carried out before crane operation, then the crane can topple over and be damaged !

Persons can be killed or injured!

- **Crane operation with safety devices which are not functioning correctly is strictly prohibited !**
- **Start crane operation only after all safety devices have been checked and they are functioning correctly!**
- **Start crane operation only when the LICCON overload safety has been set according to the data in the load chart!**
- **Start crane operation only if the crane is properly supported and horizontally aligned !**

4. Danger conditions without shut off**4.1 Block position of the relapse cylinder when setting down the load****D A N G E R : Damage of boom or relapse cylinder!**

If the block position of the relapse cylinders is touched by the boom or the derrick with attached, freely suspended load, then there is a danger of damaging the boom or relapse cylinder when the load is set down on the ground! By setting down the load, the crane is relieved, which causes the boom system to move backward.

There is no shut off of the function hoist gear down!

- Do not use components with defective pneumatic springs! Replace defective pneumatic springs!

5. Transporting components

If components are transported on an auxiliary vehicle, then they must be secured properly. If necessary, the components must be supported from below or transported with a special transport device.

5.1 Transporting lattice section

If the lattice sections are pushed into each other for transport, then they must be secured with 2 chains each.

6. Pneumatic springs to support installation of components

On various components, pneumatic springs are installed to facilitate the installation of these components.

D A N G E R : Danger of crushing!

If the pneumatic springs are defective, then the supporting action on the moveable components is no longer ensured!

Personnel can be killed or severely injured due to falling components !

There is an increased danger of accidents!

- Do not use components with defective pneumatic springs! Replace defective pneumatic springs!

- Check the pneumatic springs for external damage every time before actuating the corresponding component!

- It is strictly prohibited for personnel or objects, which are in the movement range of the components, which is supported by the pneumatic spring, to remain within that range !

- It is prohibited for personnel or objects to remain within the complete danger zone of the moveable components!

7. Weights

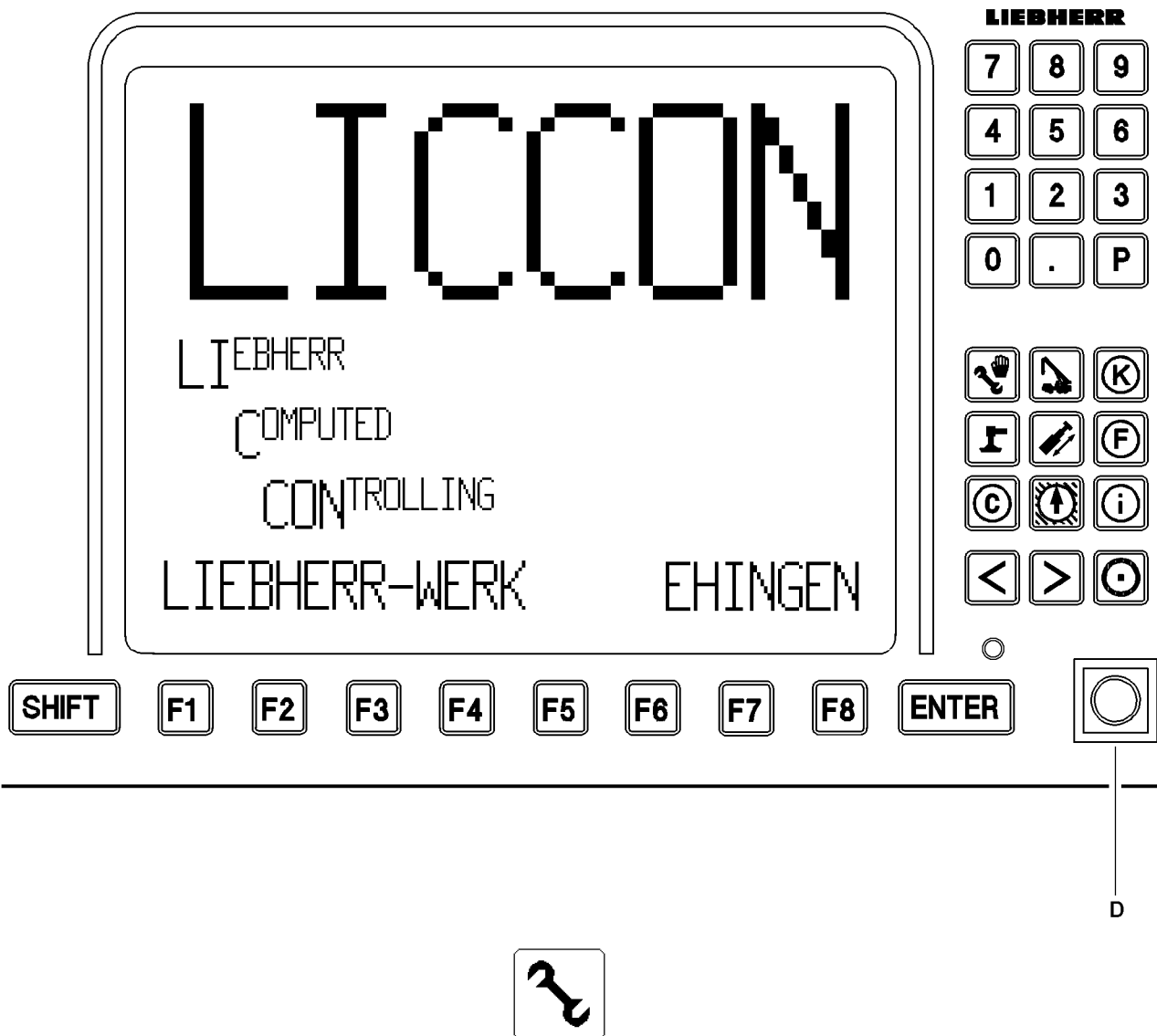
Note:**Please observe:**

- The weight of the corresponding components is noted in the corresponding chapter or on the decal on the corresponding component!
- If the weight of the corresponding components is not noted on the decal or in the operating instructions, then you must contact the Service Dept. at Liebherr Werk Ehingen to obtain the weight.
- If components are pushed into each other (such as intermediate sections) or if components are folded together (such as folding jib) , then the total weight results from the sum of the weights of the individual components.
- Use an auxiliary crane with sufficient load carrying capacity!

8. Reduction of load carrying capacity with placed guy rods

Note:

- The loads noted in the load charts do not include placed guy rods!
- When guy rods are placed, then the possible load values are reduced!
- The reduction of the load carrying capacity depends on the boom angle and the boom length. The longer the main boom and the wider the main boom is inclined to the horizontal, the larger the reduction of the load carrying capacity.



9. By pass button LICCON

The bypass keyed button on the LICCON monitor has two positions:

- Operating position (self retaining): Crane is in normal operation
- Position to the right (touching): Hoist limit switch and shut off of LMB are bypassed.

9.1 Bypass of overload safety

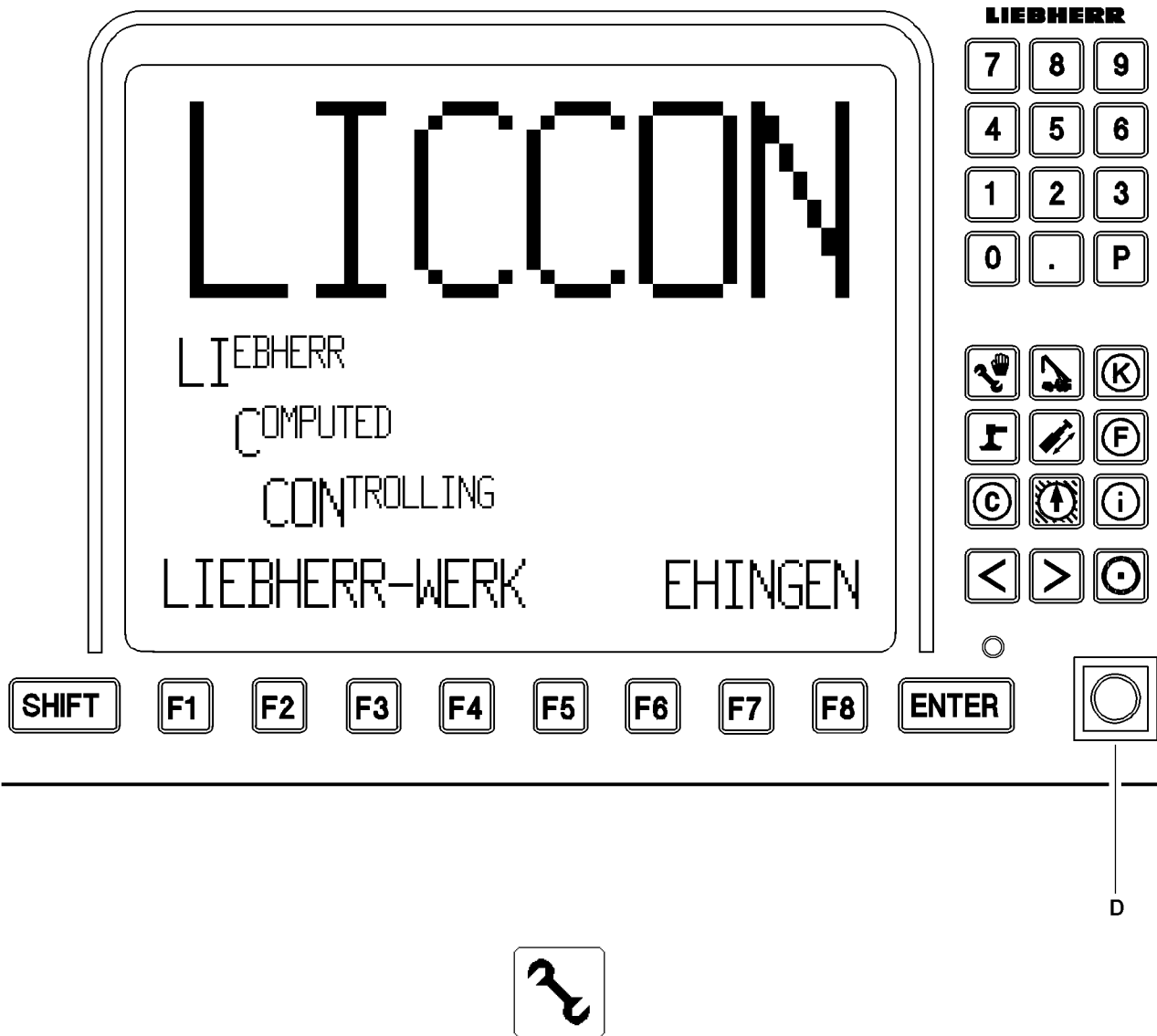
If the maximum permissible load moment is exceeded, the LICCON overload safety turns off all load moment increasing crane movements. This shut off can be bypassed by the bypass keyed button in position "right touching".

- D A N G E R :** **Increased danger of accidents due to bypass of overload safety!**
When the overload safety is bypassed, there is no additional protection against crane overload!
Due to incorrect operation, the boom can break off or the crane can topple over!
Persons can be killed!
All displays of the LICCON overload safety remain functioning.
- **The bypass of the overload safety is only permitted for assembly purposes or in emergency situations.**
 - **The bypass keyed button may only be actuated by persons, who know the effects of the actuation regarding the bypass of the overload safety system!**
 - **The bypass of the load safety may only be carried out in the presence of crane supervisory personnel, and only with extreme caution and care!**
 - **Crane operation with bypassed overload safety is prohibited!**

9.2 Bypass of hoist-top shut off

If the hook block touches the hoist limit switch weight at an upward movement, the hoist limit switch is triggered. The crane movements "Spool up winches", "Luff down the telescopic boom" and "telescoping out" are shut off. The shut off can be bypassed with the bypass keyed button in position "right touching".

- D A N G E R :** **Increased danger of accidents due to bypass of overload safety!**
When the hoist-top shut off is bypassed, there is a danger that the hook block is pulled against the pulley head at continued lift or when luffing down the boom. This can damage the pulleys and cause the load to fall down!
- **The bypass of the hoist-top shut off may only be used in the presence of crane supervisory personnel and with a guide. The guide must be in direct contact with the crane operator and must constantly monitor the distance between the hook block and the pulley head.**
 - **All crane movements must be carried out with utmost caution and at the least possible speed.**



9.3 Actuate the bypass button LICCON

- Turn the bypass keyed button to the right and hold.

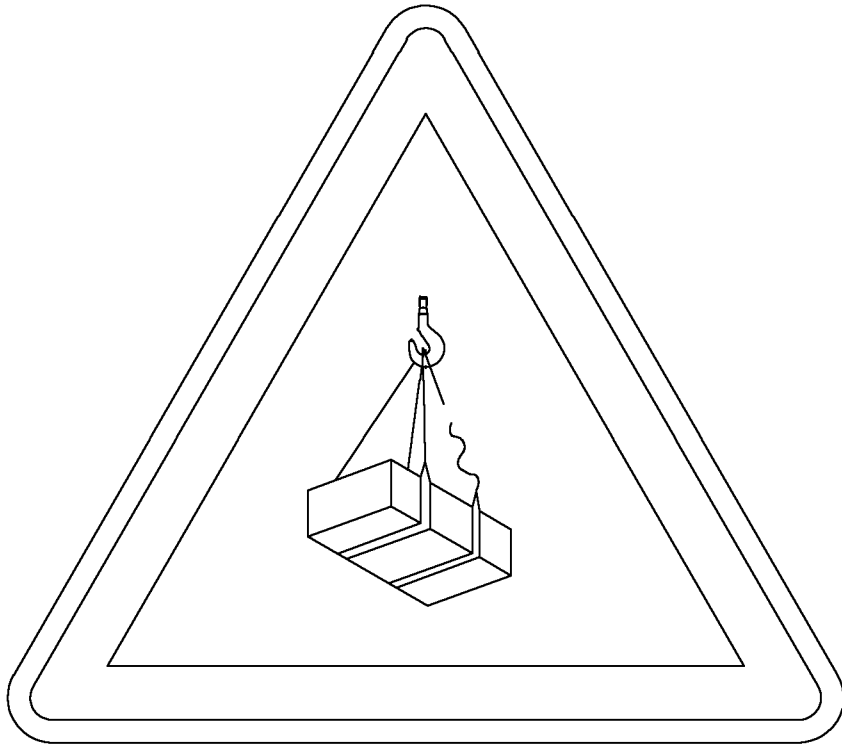
Result:

- The LICCON overload safety is inactive.
- The assembly symbol in the LICCON monitor blinks.
- An acoustical signal sounds.
- The red beacon on the crane cab lights up

- If the bypass keyed button is to be turned off, do not actuate the bypass keyed button any longer.

Result:

- The LICCON overload safety is active.
- The assembly symbol in the LICCON monitor turns off .
- The acoustical signal is off.
- The red beacon on the crane cab turns off.



10. Assembly / disassembly

10.1 General

DANGER: **Mortal danger due to erroneous assembly or disassembly!**
The assembly/disassembly of components may never be carried out by untrained personnel. Incorrect assembly / disassembly can cause death or severe injuries.
- The assembly and disassembly may only be carried out by authorized and trained expert personnel!

Note:

- During assembly/disassembly of the individual components, also observed the chapters relating to the components!
- The auxiliary winch (assembly or reeving winch) may only be used for assembly, and not to lift loads!
- Lifting loads with the auxiliary winch is prohibited!

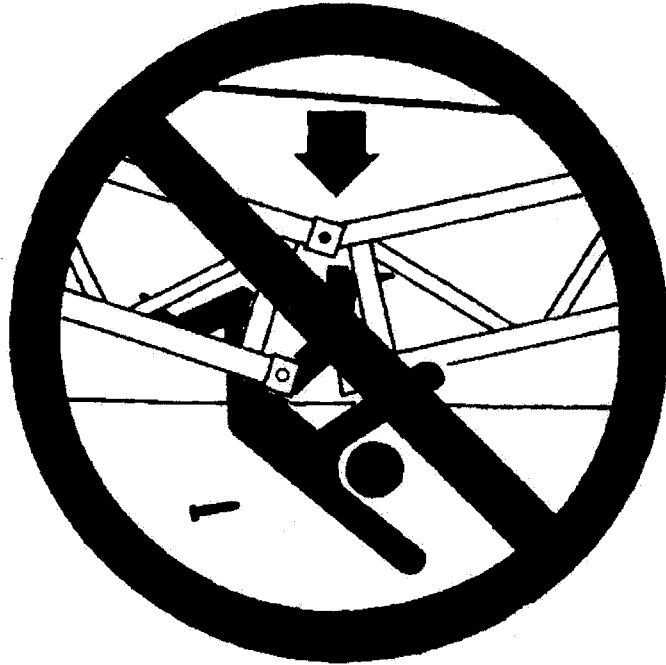
The normal assembly/disassembly procedure stipulates that all components which are transported separately must be transported with suitable auxiliary cranes and tackle near the ground level and must be connected safely (properly) with the crane.

Before assembly personnel may get near suspended loads, such as counterweights, lattice sections and boom, etc., these loads must be lowered to the ground, on supports or other items of sufficient load carrying capacity.

DANGER: **Danger of hitting or crushing!**
Staying near suspended loads will result in danger of hitting or crushing in case of side movement of loads.
During assembly / disassembly, no one may remain in the dangerous range of the suspended load or under the suspended load, before the intended mounting procedure is completed.

DANGER: **Danger of falling !**
At assembly and disassembly, the assembly personnel must be secured with suitable aids to prevent falling. If this is not observed, the assembly personnel can fall down and sustain mortal injuries.

- Normally, all assembly work must be carried out from a height of 2 m with suitable aids (such as lifting platforms, scaffolding, ladders, auxiliary crane, etc.)! The height where assembly/disassembly must be carried out with aids depends on the national regulations. The national regulations must be strictly observed!
- If such work can be carried out either with such aids or from the ground, then the assembly personnel must secure itself with personal protective devices (for example catch belts) to prevent falling!
- If antifall guards (railings) are installed on the crane superstructure, then they must be brought into position for assembly/disassembly and secured.



10.2 Assembly/disassembly of boom

If the lattice sections are not lying on the ground during assembly/disassembly, then they must be supported with suitable materials. The height of the support must be selected in such a way that the lattice sections are no longer in contact with the ground. Make sure that is the case, especially if the lattice sections have cable pulleys. Otherwise the cable pulleys can be damaged.

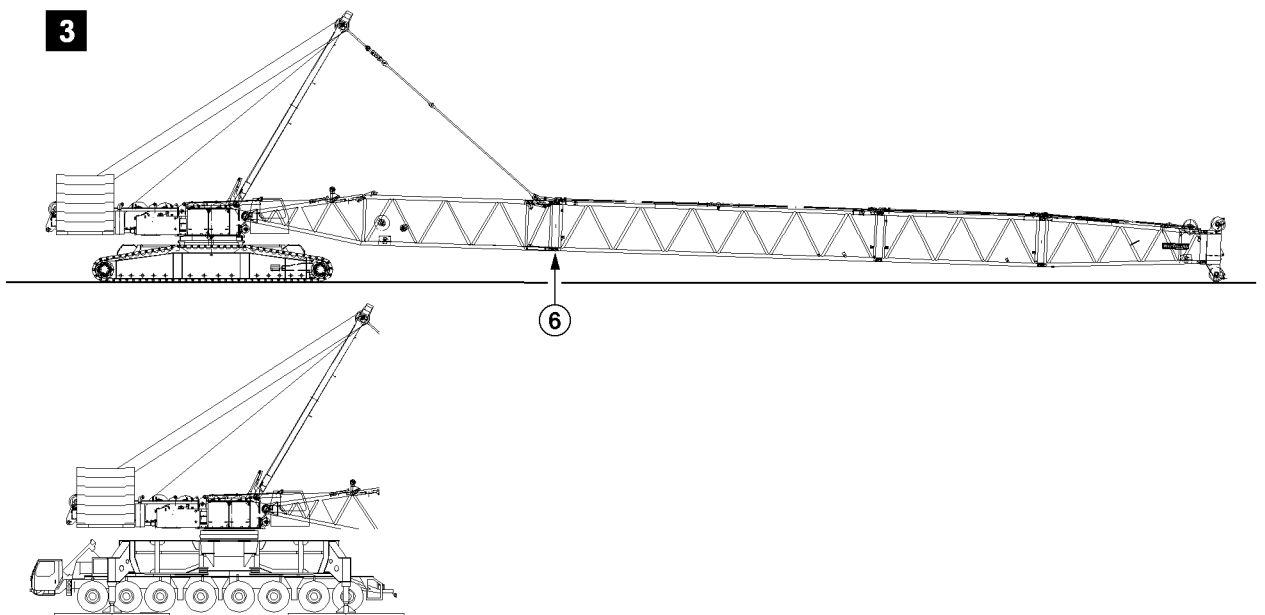
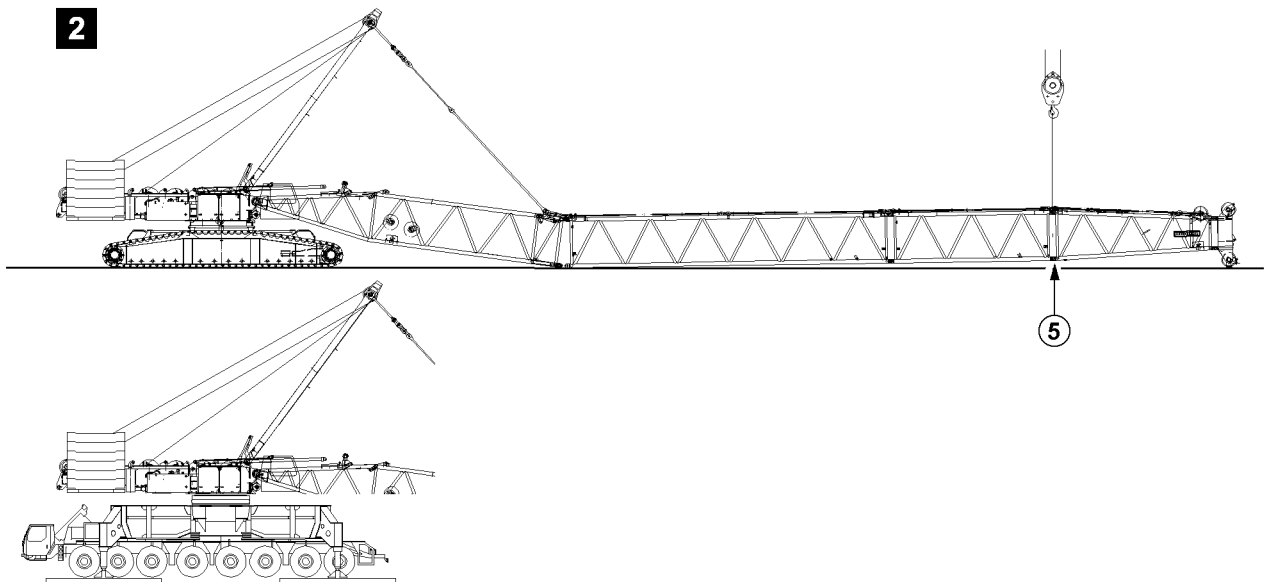
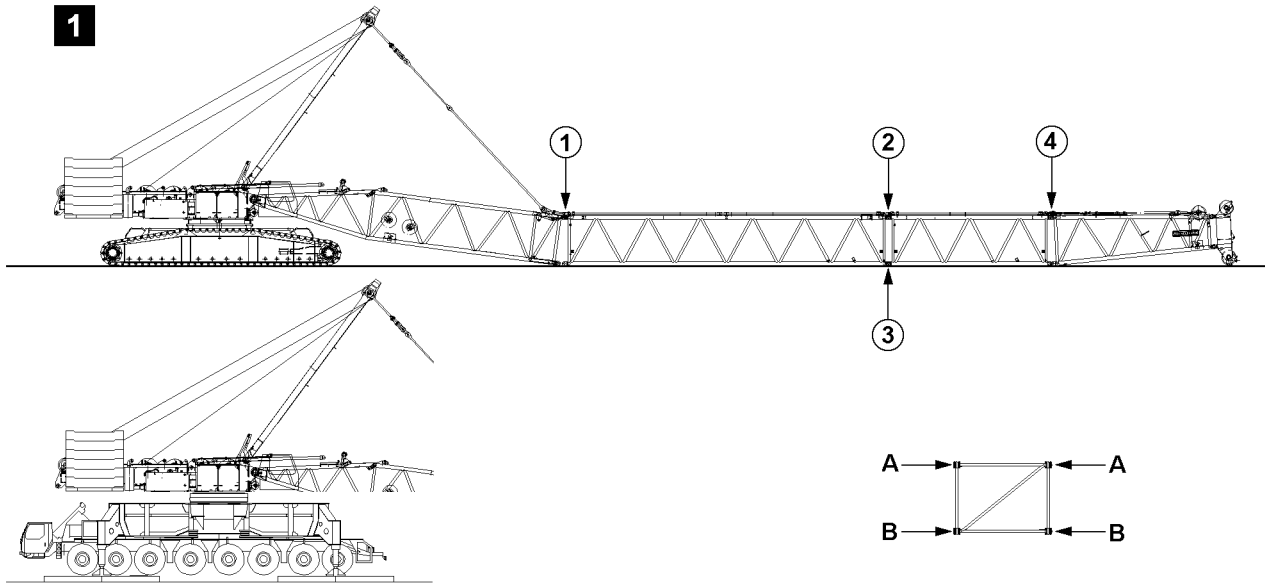
At disassembly it must be ensured that the auxiliary crane pulls the load up vertically. The crane operator must ensure that the load carrying capacity of the auxiliary crane is sufficient to safely hold the part to be removed at the corresponding radius. The auxiliary crane must be attached in such a way that the hook of the auxiliary crane is over the center of gravity of the part to be removed and that the tackle ropes are attached on the load.

DANGER: **Danger of accident if the crane topples over!**
Diagonal pull can destroy the crane or cause it to topple over.
 - **The hook block must always be attached (hung) vertically over the center of gravity of the load to be lifted!**
 - **Diagonal pull is prohibited!**

DANGER: **Danger of accidents at assembly/disassembly of booms!**
When you remove unsecured or not supported booms, then you can be killed or severely injured.
 - **Never unpin the pins under unsecured or not supported booms!**
 - **Never unpin connector pins of unsecured or not supported booms!**
 - **Remaining under booms as well as in the complete danger zone is prohibited during the pinning and unpinning procedure of the boom!**
 - **Secure the pins in the mounting points as well as in the receptacles!**
 - **It is not permitted to lean the auxiliary ladder on a component which is to be removed!**

DANGER: **Danger of accident if pins are twisted!**
The pins can twist due to diagonal pull, increased or low hoist force of the auxiliary crane. Twisted parts can loosen suddenly during unpinning of the pins and severely or mortally injure the assembly personnel.
 - **When unpinning the pins, the hoist force of the auxiliary crane must be matched to the weight of the part to be lifted!**
 - **Do not unpin seized pins by force!**
 - **Remove the reason for the twisting!**

Note: Notes for pinning and unpinning:
 - Pin or unpin both pins, which are on one horizontal level, i.e. **left and right!**
 - Pin the lower pin **from the inside to the outside** and unpin from the **outside to the inside!**
 - Pin and unpin horizontally installable double tapered pins **from the outside to the inside!**
 - Pin and unpin vertically installable double tapered pins **from top to bottom!**



10.2.1 Assembly of lattice sections

The illustrations should be viewed as examples. The illustrations might not exactly match the crane.

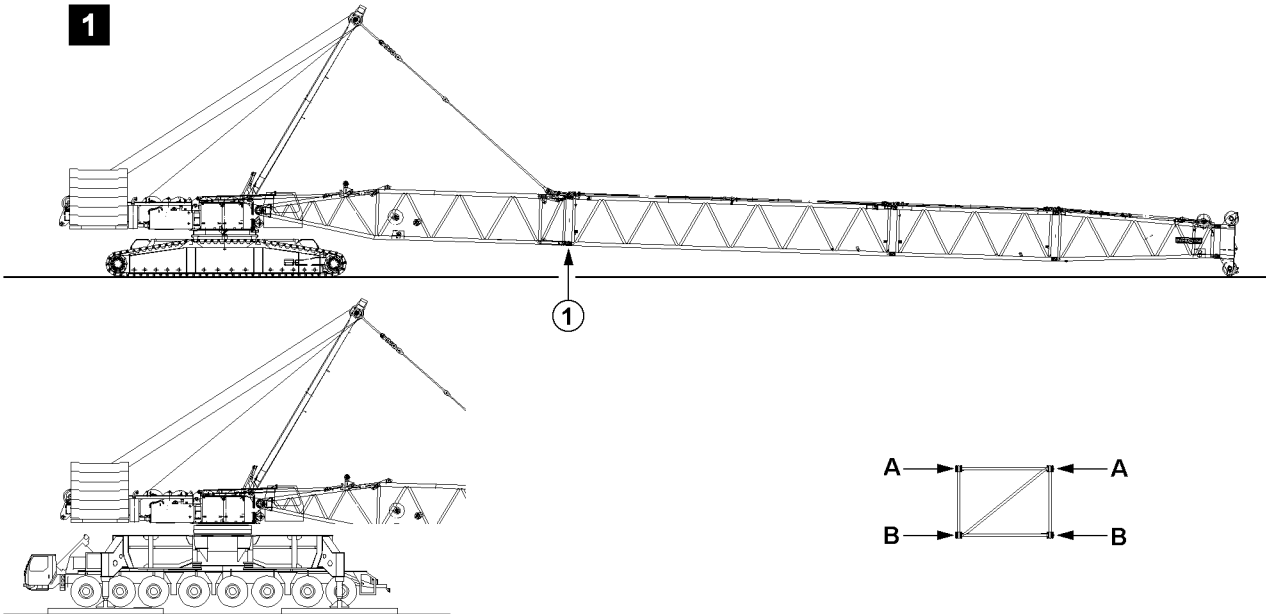
D A N G E R : Mortal danger at assembly of booms!

If the pins are not pinned in the stated sequence, the lattice sections can fold down uncontrollably and even fall down. This can cause deadly injuries to personnel.

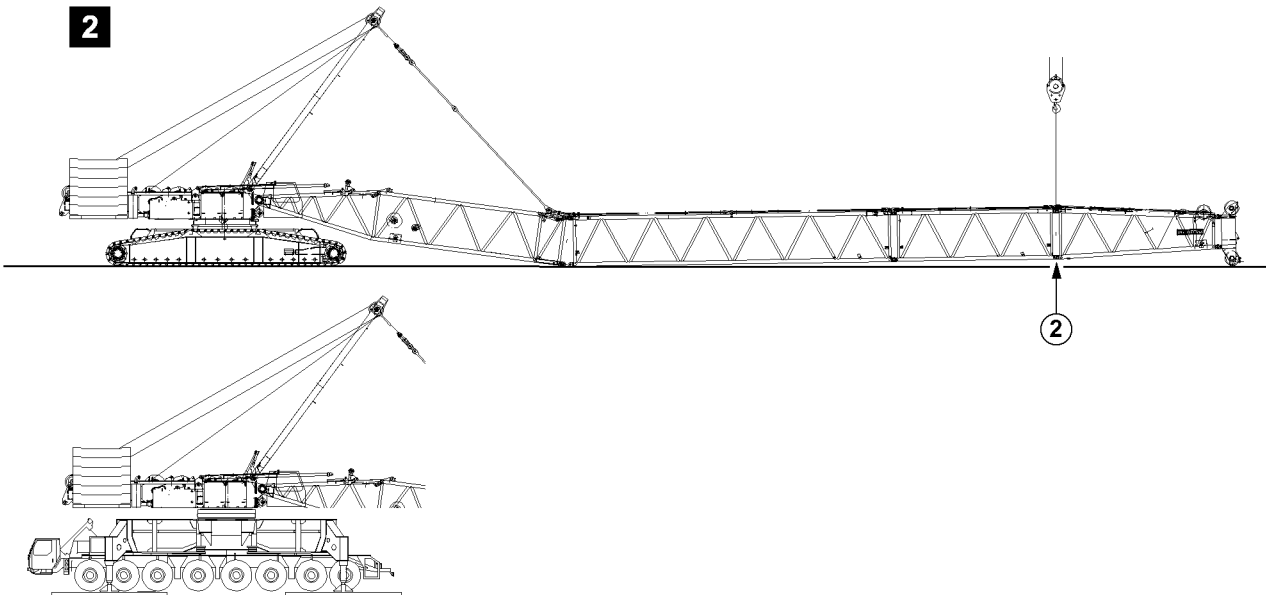
- Pin the pins in the stated sequence!

- Pin and secure the pins on both sides (level **A**) on point **1** , fig. 1.
- Pin and secure the pins on both sides (level **A**) on point **2**, fig. 1.
- Pin and secure the pins on both sides (level **B**) on point **3** , fig. 1.
- Pin and secure the pins on both sides (level **A**) on point **4** , fig. 1.
- Lift the end section with the auxiliary crane , fig. 2.
- Pin and secure the pins on both sides (level **B**) on point **5** , fig. 2.
- Lift the lattice sections, fig. 3.
- Pin and secure the pins on both sides (level **B**) on point **6** , fig. 3.

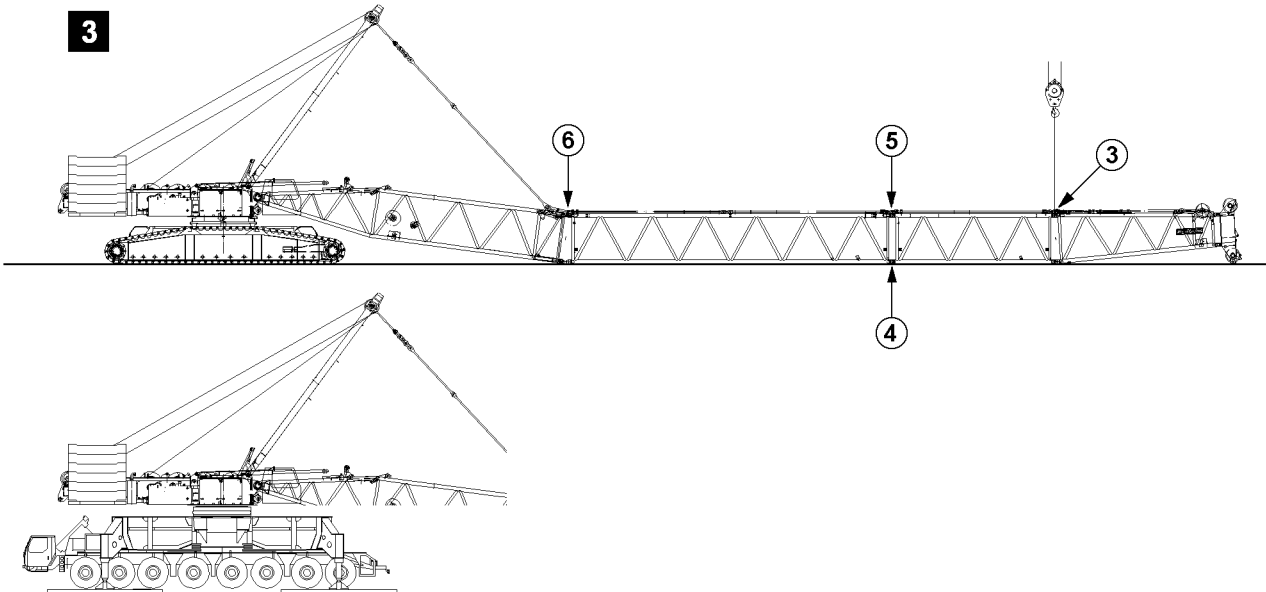
1



2



3



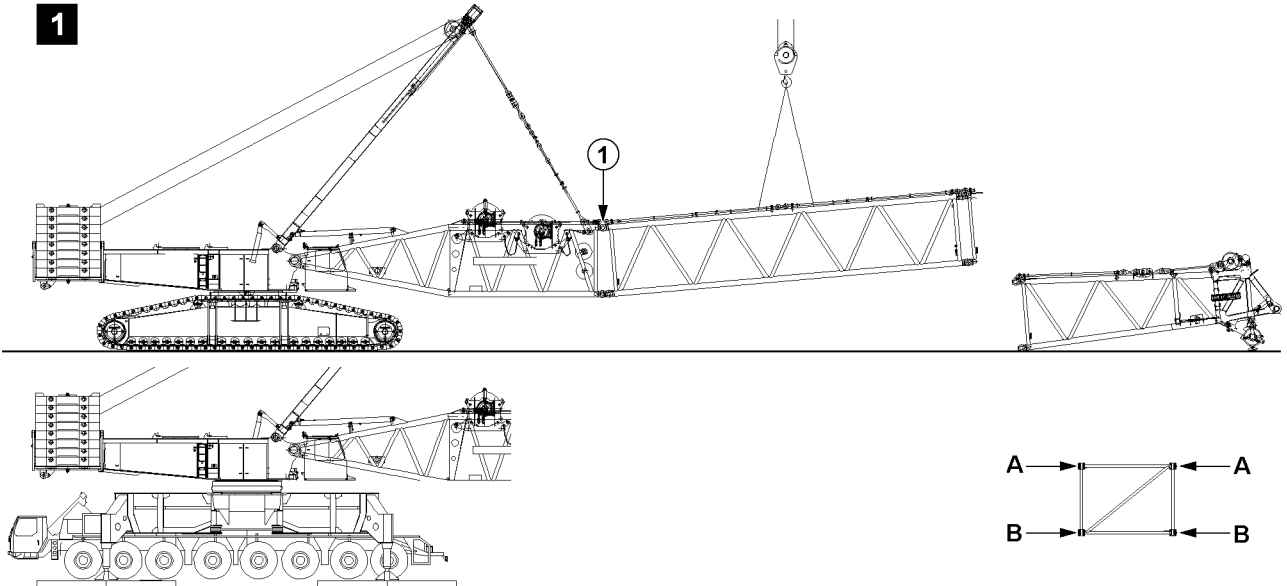
10.2.2 Disassembly of lattice sections

The illustrations should be viewed as examples. The illustrations might not exactly match the crane.

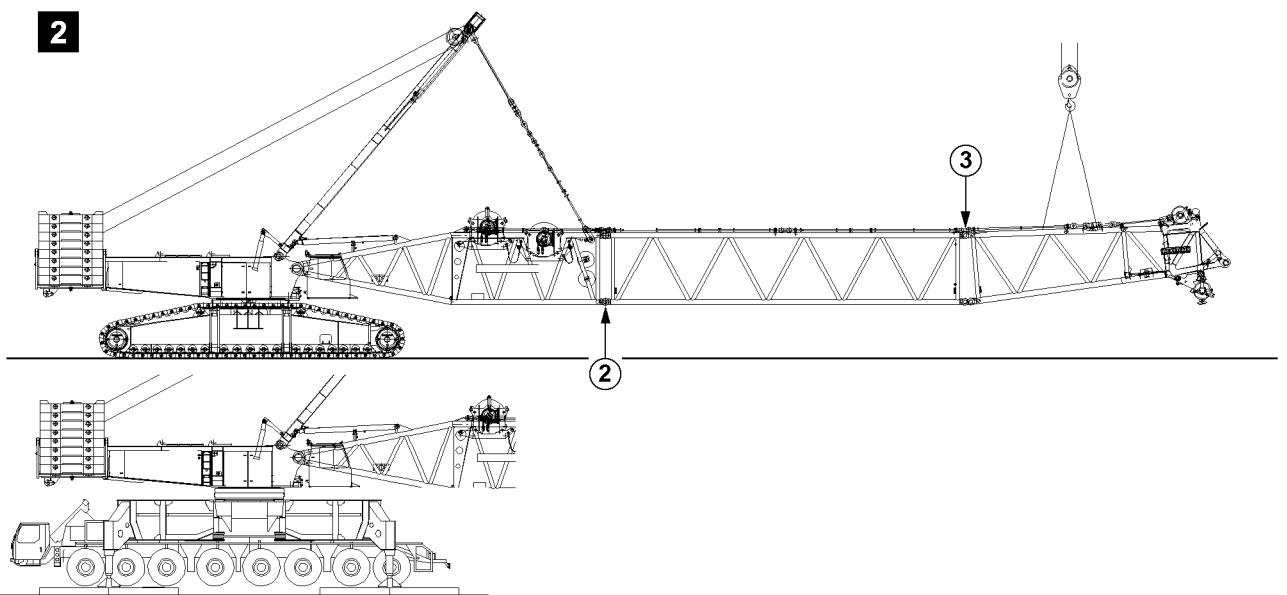
D A N G E R : Mortal danger at disassembly of booms!
If the pins are not unpinned in the stated sequence, the lattice sections can fold down uncontrollably and even fall down. This can cause deadly injuries to personnel.
- Unpin the pins in the stated sequence!

- Luff the boom down until the end section touches the ground slightly, fig. 1.
- Release and unpin the pins on both sides (level **B**) on point **1** , fig. 1.
- Place the lattice sections all the way down, fig. 2
- Lift the end section with the auxiliary crane , fig. 2.
- Release and unpin the pins on both sides (level **B**) on point **2**, fig. 2
- Release and unpin the pins on both sides (level **A**) on point **3** , fig. 3.
- Release and unpin the pins on both sides (level **B**) on point **4** , fig. 3.
- Release and unpin the pins on both sides (level **A**) on point **5** , fig. 3.
- Release and unpin the pins on both sides (level **A**) on point **6**, fig. 3.

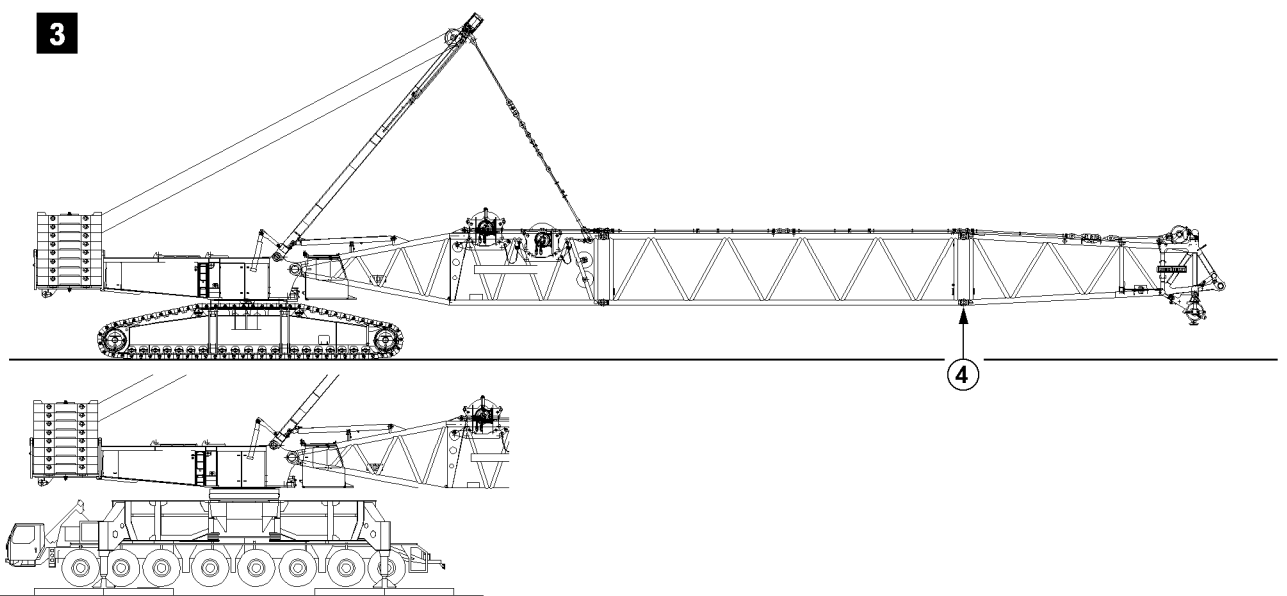
1



2



3



10.2.3 Flying assembly of lattice sections

The illustrations should be viewed as examples. The illustrations might not exactly match the crane.

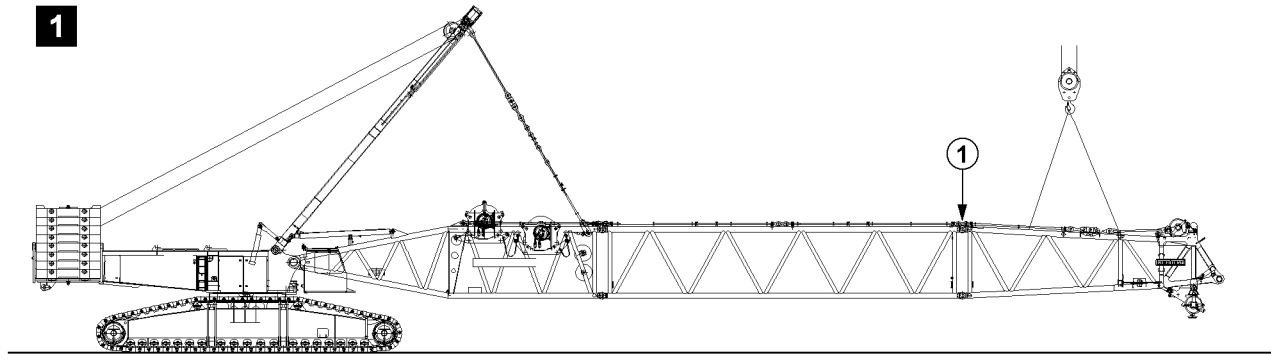
D A N G E R: Mortal danger at assembly of booms!

If the pins are not pinned in the stated sequence, the lattice sections can fold down uncontrollably and even fall down. This can cause deadly injuries to personnel.

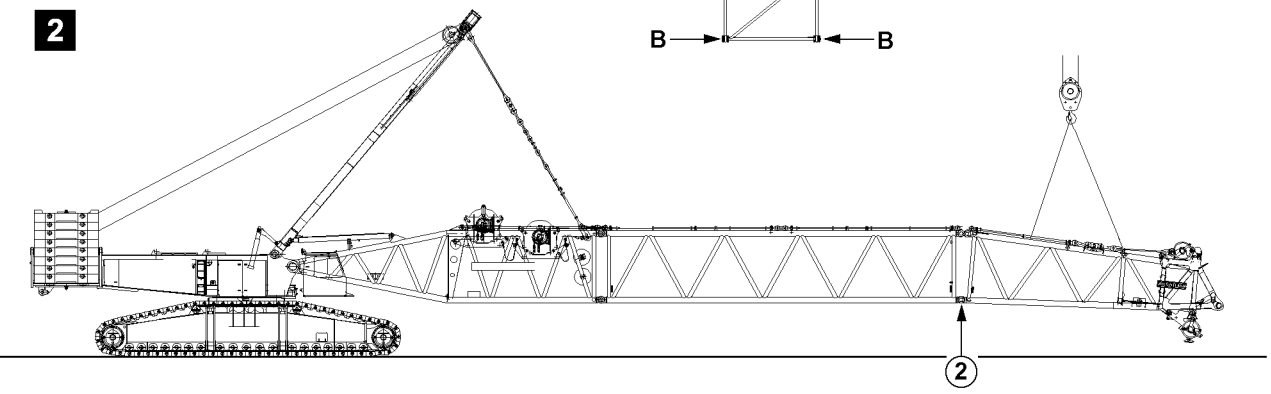
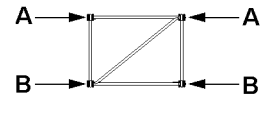
- Pin the pins in the stated sequence!

- Pin and secure the pins on both sides (level **A**) on point **1**, fig. 1.
- Pin and secure the pins on both sides (level **B**) on point **2**, fig. 2.
- Pin and secure the pins on both sides (level **A**) on point **3**, fig. 2.
- Pin and secure the pins on both sides (level **B**) on point **4**, fig. 3.

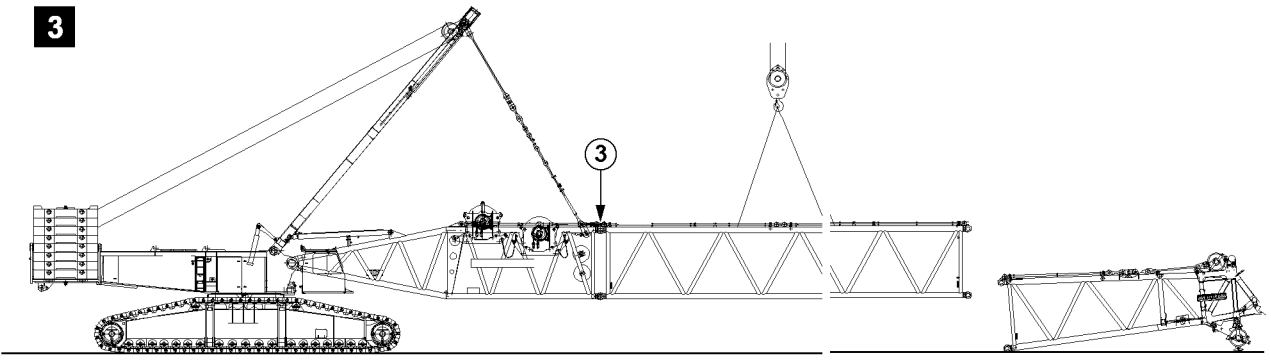
1



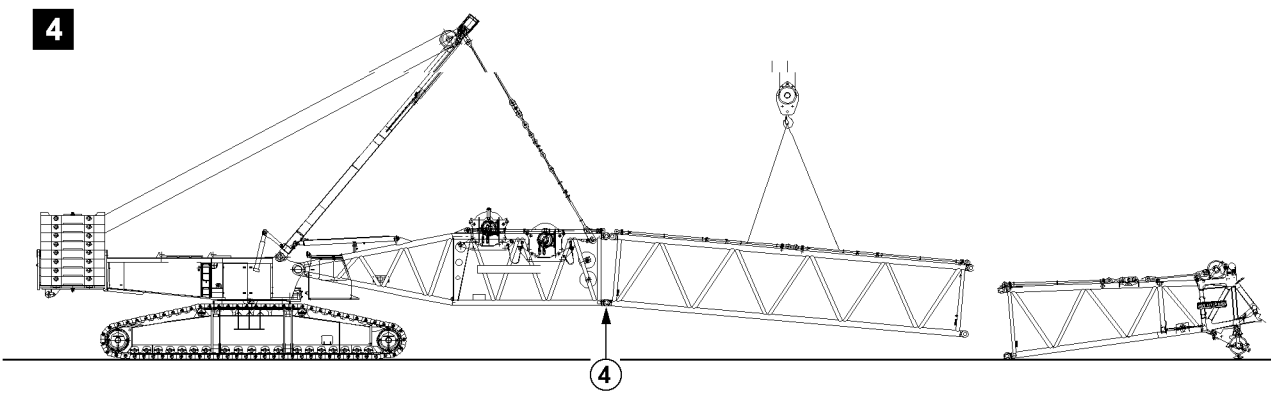
2



3



4



10.2.4 Flying disassembly of lattice sections

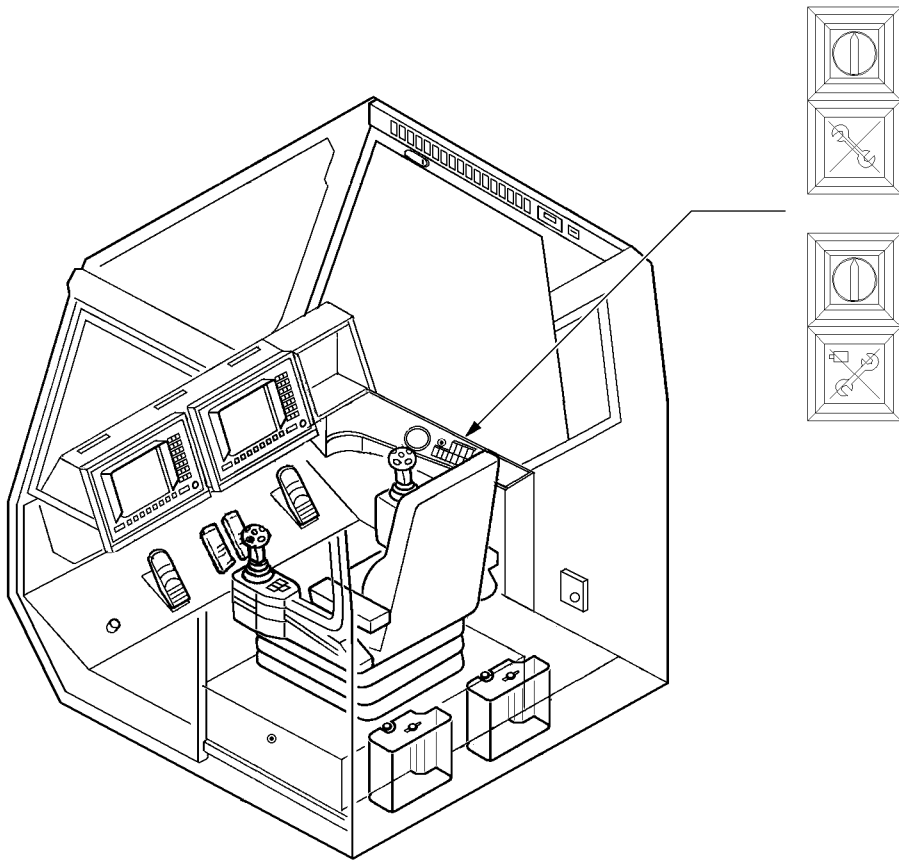
The illustrations should be viewed as examples. The illustrations might not exactly match the crane.

D A N G E R: Mortal danger at disassembly of booms!

If the pins are not unpinned in the stated sequence, the lattice sections can fold down uncontrollably and even fall down. This can cause deadly injuries to personnel.

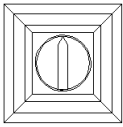
- Unpin the pins in the stated sequence!

- Release and unpin the pins on both sides (level **A**) on point **1** , fig. 1.
- Release and unpin the pins on both sides (level **B**) on point **2** , fig. 2.
- Release and unpin the pins on both sides (level **A**) on point **3** , fig. 3.
- Release and unpin the pins on both sides (level **B**) on point **4** , fig. 4.



10.3 Bypass button assembly

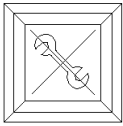
- D A N G E R :** **Mortal danger at crane operation with turned on assembly keyed button.**
- **The bypass of the overload safety is only permitted for assembly purposes.**
 - **The assembly keyed button may only be actuated by persons, which are aware of the effects of a bypass!**
 - **If the assembly keyed button is turned on, the hoist limit switch and the LICCON overload safety are bypassed!**
 - **Crane operation with turned on assembly keyed button is strictly prohibited!**
 - **The assembly keyed button must be pulled immediately after assembly work is completed and handed to an authorized person!**



- Actuate the assembly keyed button.

Result:

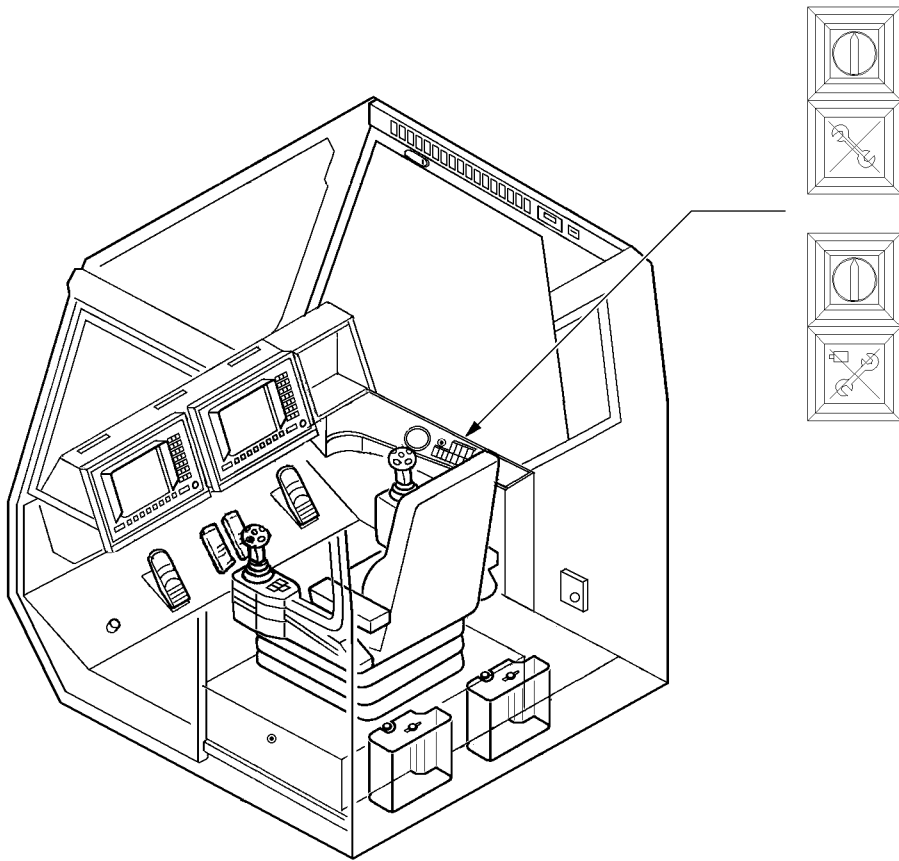
- The LICCON overload safety is inactive.
- The indicator light in the button lights up.
- The assembly symbol in the LICCON monitor blinks.
- An acoustical signal sounds.
- The red beacon on the crane cab lights up.



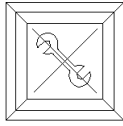
- If the assembly keyed button is to be turned off:
Turn the assembly keyed button off by actuating the button.

Result:

- The LICCON overload safety is active.
- The indicator light in the button turns off.
- The assembly symbol in the LICCON monitor turns off .
- The acoustical signal is off.
- The red beacon on the crane cab turns off.



10.4 Bypass button crawler assembly

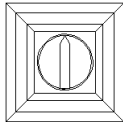
**Prerequisite:**

- The assembly keyed button is actuated
- The indicator light in the button lights up

D A N G E R : Mortal danger in crane operation with turned on crawler assembly keyed button.

If the crawler assembly keyed button is turned on, there is no overload shut off in operation with assembly cylinder and crane.

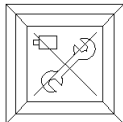
- The actuation of the crawler assembly keyed button is only permitted for assembly purposes !
- Crane operation with turned on crawler assembly keyed button is prohibited !



- Actuate the crawler assembly keyed button .

Result:

- The LICCON overload safety device is inactive.
- The indicator light in the button lights up.



- If the crawler assembly keyed button is to be turned off:
Turn the crawler assembly keyed button * off by pressing the button * .

Result:

- The indicator light in the button turns off .

10.5 Installation / removal of hydraulic lines

When connecting or releasing hydraulic lines with quick couplings, it must be ensured that the coupling procedure is carried out correctly.

D A N G E R : **Danger of accidents due to loss of pressure or leakage!**

Not completely connected quick couplings (especially return lines) as well as quick couplings loosening up by themselves can cause serious accidents due to failure of components!

- Before starting to work with the crane, check the quick couplings to ensure they are correctly connected.

- Release the pressure in the hydraulic system before connecting or releasing them. Turn the engine off and wait for a short time.
- Connect the coupling sections (sleeve and plug) and screw together with the hand nut.
- Tighten the hydraulic couplings by hand. Turn the hand nut until you feel a noticeable, strong stop.

11. Erection / take down

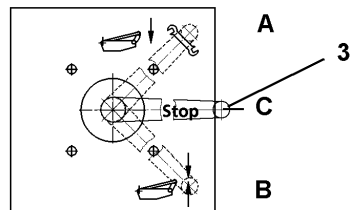
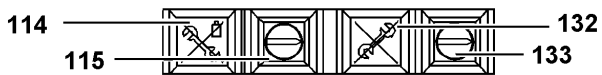
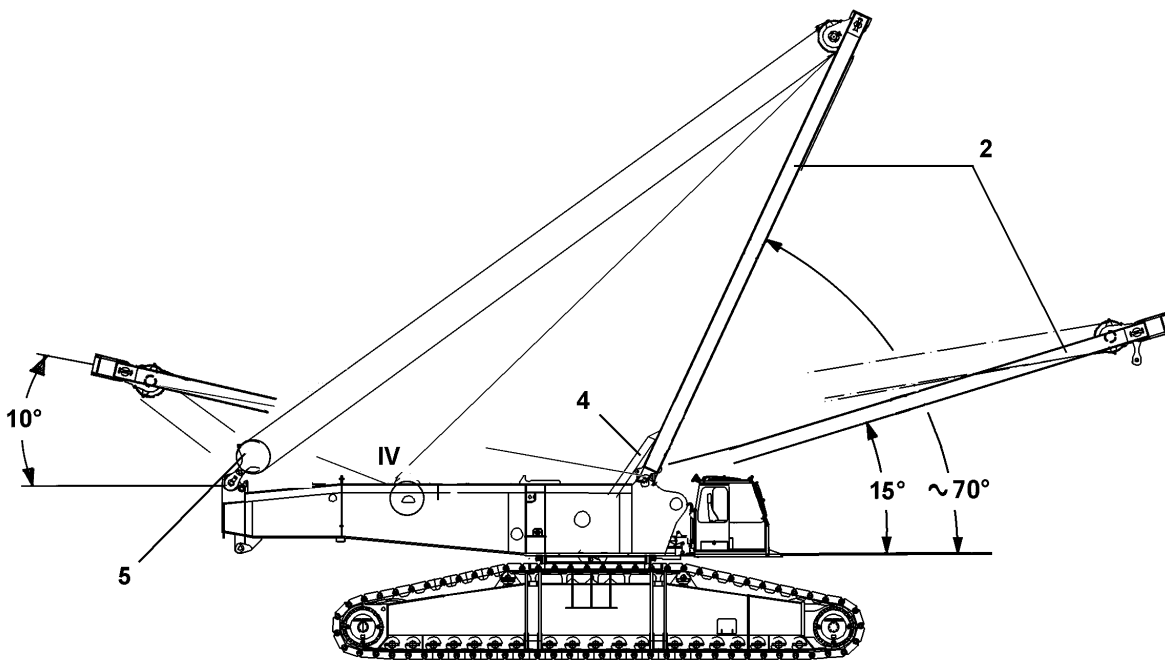
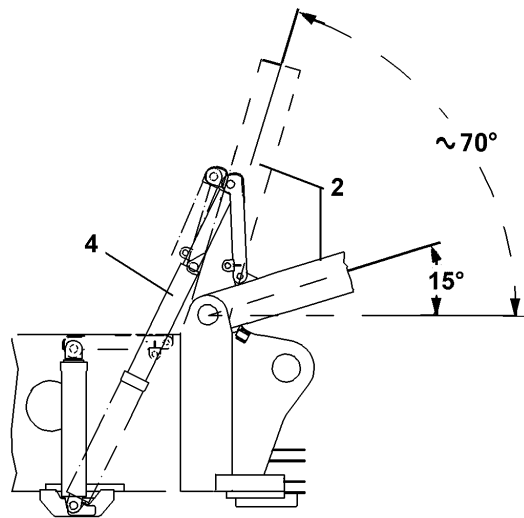
Make sure that the following prerequisites are met:

- The crane is horizontally aligned.
- The counterweight is installed on the slewing platform, according to the load chart.
- The boom is installed according to the load chart and the operating manual.
- All limit switches are correctly installed and fully functioning.
- All pin connections are secured.
- The hoist cable is correctly placed in the cable pulleys and is secured with the cable retaining pin to prevent it from jumping out .
- There are no persons within the danger zone.
- There are no loose parts on the boom.
- In winter, the boom and its components (limit switch, cable drum, beacon, wind speed sensor etc.) are free of ice and snow.

D A N G E R : Incorrectly installed or non-functioning limit switches as well as falling parts (pins, spring retainers, ice, etc.) can cause accidents!

11.1 Check the prerequisites

- Check if all prerequisites are met.



1. Erect the A- Bracket**Prerequisites:**

- The cable of winch IV - boom control - is reeved .
- The engine is running - see chapter 4.03.
- Actuate the installation keyed button (133) and keyed button (115) "crawler and boom installation", the indicator lights "Installation" (132) and "crawler and boom installation" (114) light up.
- Set the operating mode on the LICCON, which will be installed.

Note: For master switch assignment with turned on keyed buttons - see chapter 4.05

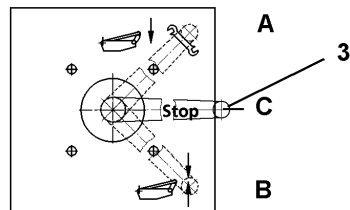
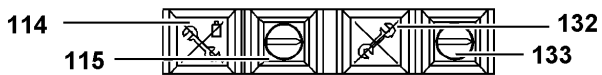
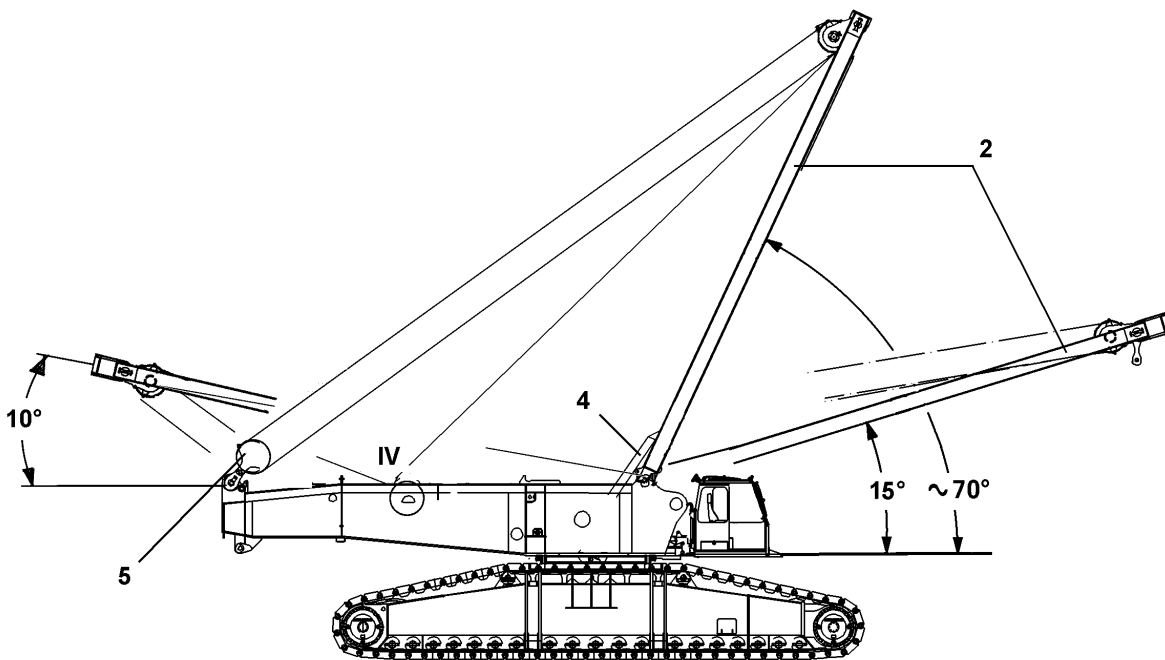
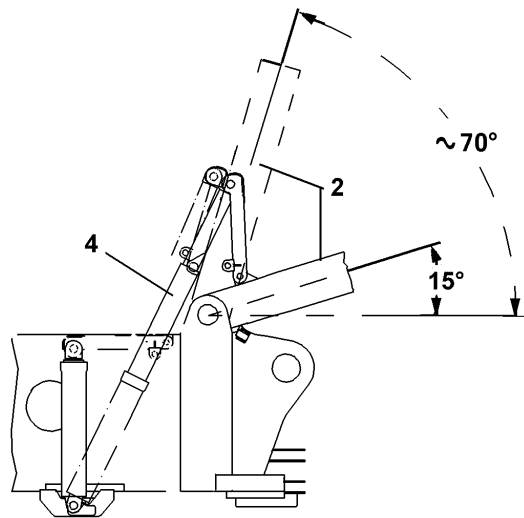
2. Installation equipment configuration on crawler 9.10m × 8.80m × 1.50m

- 1 with placed down SA-bracket (with and without cable on winch IV).
- 2 90° SA-bracket (with and without cable on winch IV).
- 3 bei abgelegtem SA-bracket, winch I and IVwith cable,
- 4 90° SA-bracket, winch I and IVwith cable,
- 5 90° SA-bracket, winch I and IVwith cable, S- pivot section installed.

D A N G E R : Before turning the slewing platform without derrick or boom, the following must be observed:

- the crawler travel gear with installed slewing platform is in horizontal position.
- the installation conditions (chapter 3.06) must be observed.

If this is not observed, there is a danger of tipping the crane over!



3. Erection

Set the ball cock (3) to **"bottom"** position (B) . The A-bracket is pushed upward by the erection cylinder (4) until the cables are tensioned between the A- bracket (2) and the slewing platform pulley bracket (5) .

Positions of ball cock (3):

- A** Position "up" - to lower the A- bracket onto the slewing platform, transport position
- C** Position "horizontal" - STOP, extension and retraction of erection cylinder is blocked
- B** Position "down" - to extend the erection cylinder, installation and operating position

C A U T I O N : **Check visually, the cables must lay correctly in the corresponding cable pulleys!**
Ball cock remains in position "B".

Actuate the master switch (MS 1, 80) and spool out winch IV .The A- bracket (2) is pushed by the erection cylinder (4) upward and up to approx. 70° forward (ca. 70° = erection cylinder fully extended).

Then it lowered to the front, due to its own weight and spooling out of winch IV.

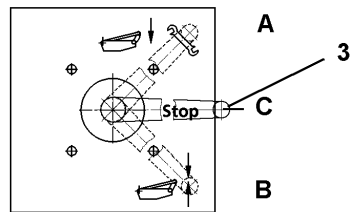
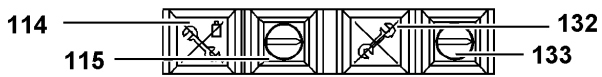
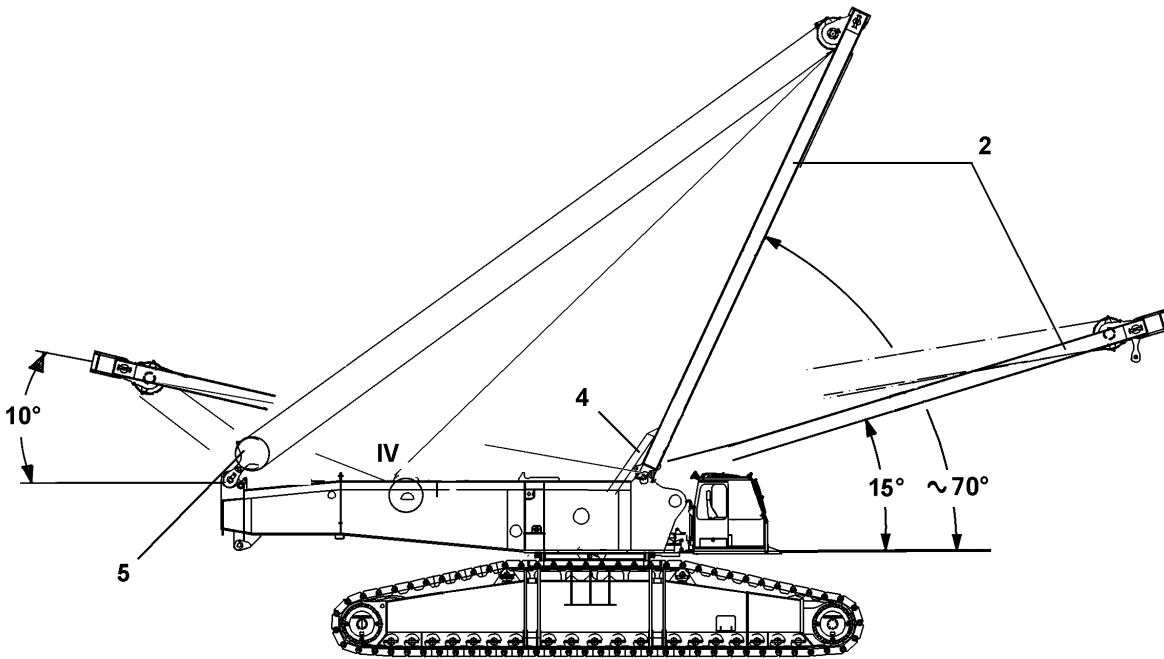
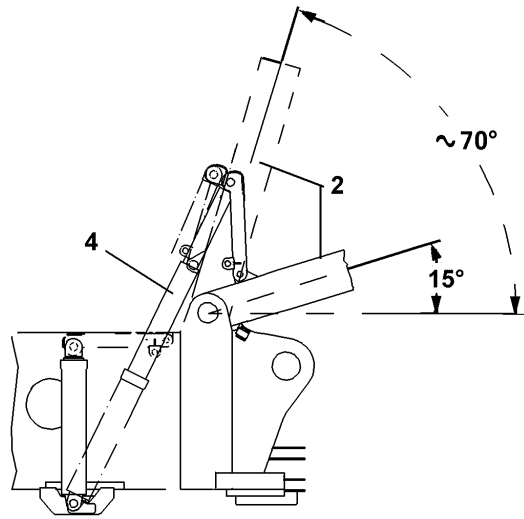
For A- bracket angle smaller than 15°, winch IV "spool out" is shut off. A control error is shown.

Shut off of winch IV "spool up / out" occurs if the minimum pressure of 30 bar in the erection cylinder is fallen below. A control error is shown.

D A N G E R : **During installation and crane operation, the ball cock (3) must be in position (B) "down" .**
The ball cock position (C) "STOP" (horizontal) and (A) "up" are only permissible when lowering the SA- bracket onto the slewing platform (transport position) !

To prevent a change, the ball cock (3) must be secured with a lock
- i m m e d i a t e l y after installation
- during crane operation.

When spooling out winch IV, make sure there is no slack cable!



4. Place the A- bracket onto the slewing platform

During installation, the ball cock (3) must be in position (B) "down" .

Actuate the master switch (MS 1, 80) and pull the A-bracket up to approx. 10° to the rear by spooling up the winch IV.

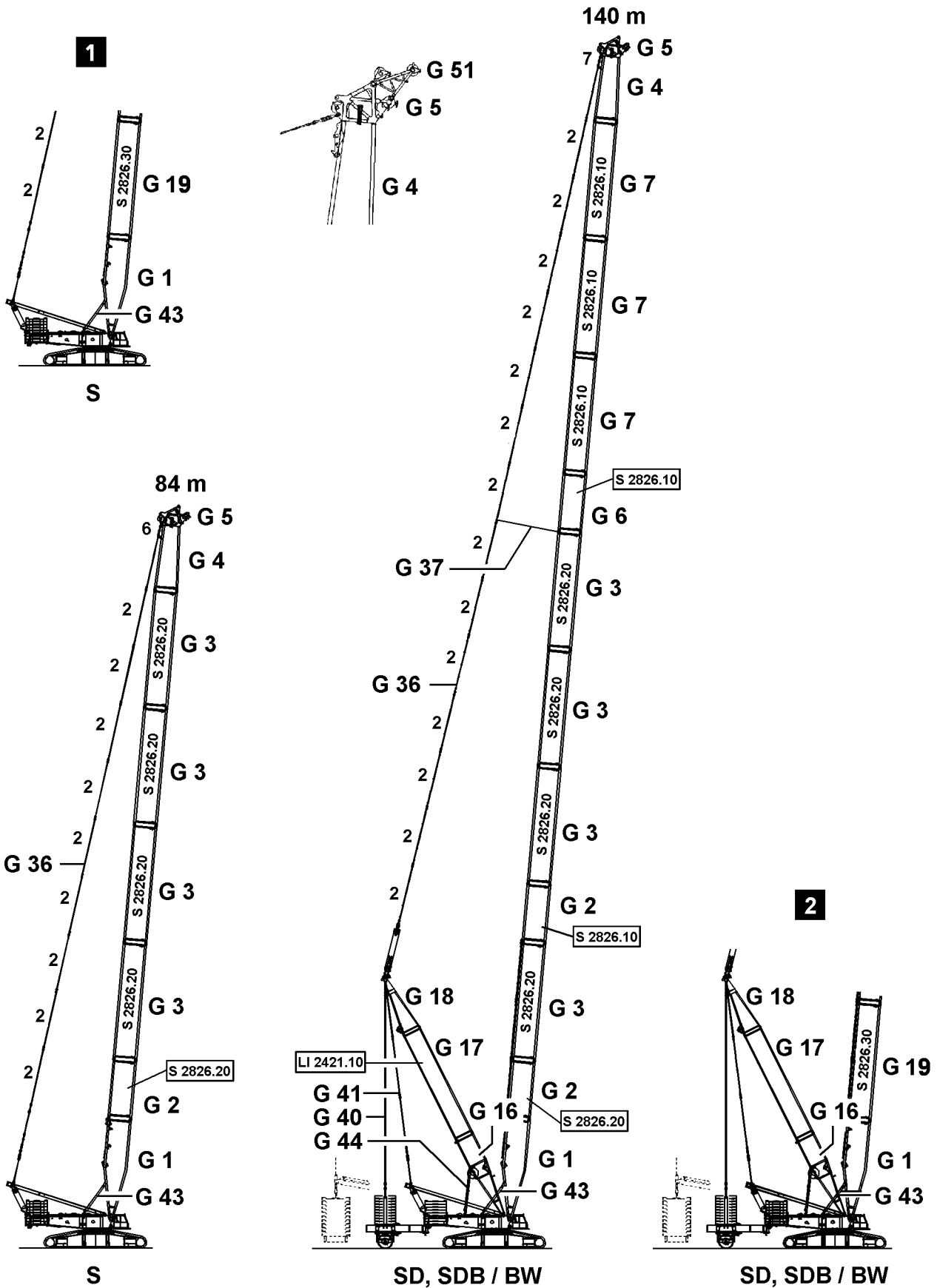
The A- bracket is pulled to the rear against the pressure of the erection cylinder .

D A N G E R: **The ball cock (3) must be in position (B) "down".**
Before lowering the A- bracket, the crane operator must make sure that there are no persons or objects within the danger zone.
Danger of crushing!

After reaching the A- bracket position of approx. 10°, the ball cock (3) must be switched to position (A) "up" . The A- bracket is slowly lowered by the erection cylinders onto the slewing platform, the hydraulic oil flows through a restrictor into the tank.

D A N G E R: **The ball cock position (C) "STOP" (horizontal) and (A) "up" are only permitted when lowering the A- bracket from 10° - 0° onto the slewing platform (transport position) !**

C A U T I O N: **At the same time, carefully spool up the intake cable - winch IV, watch for slack cable formation!**
Check visually !



S - and SD, SDB / BW - attachment

Fig. 1

S - attachment

For a S-intermediate section 14m, 2826.20, a S-intermediate section 14m, 2826.30 can be installed.

D A N G E R: The S-intermediate section 14m, 2826.30, must be installed after the S-pivot section!

Fig. 2

SD, SDB / BW - attachment

For a S-intermediate section 14m, 2826.20, a S-intermediate section 14m, 2826.30 can be installed.

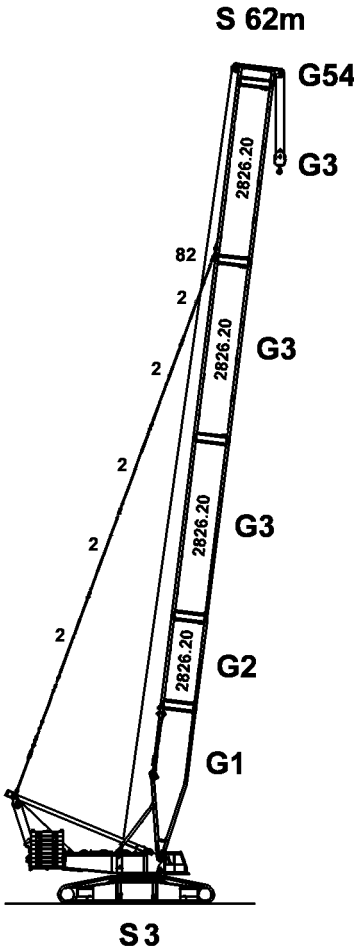
D A N G E R: The S-intermediate section 14m, 2826.30, must be installed after the S-pivot section!

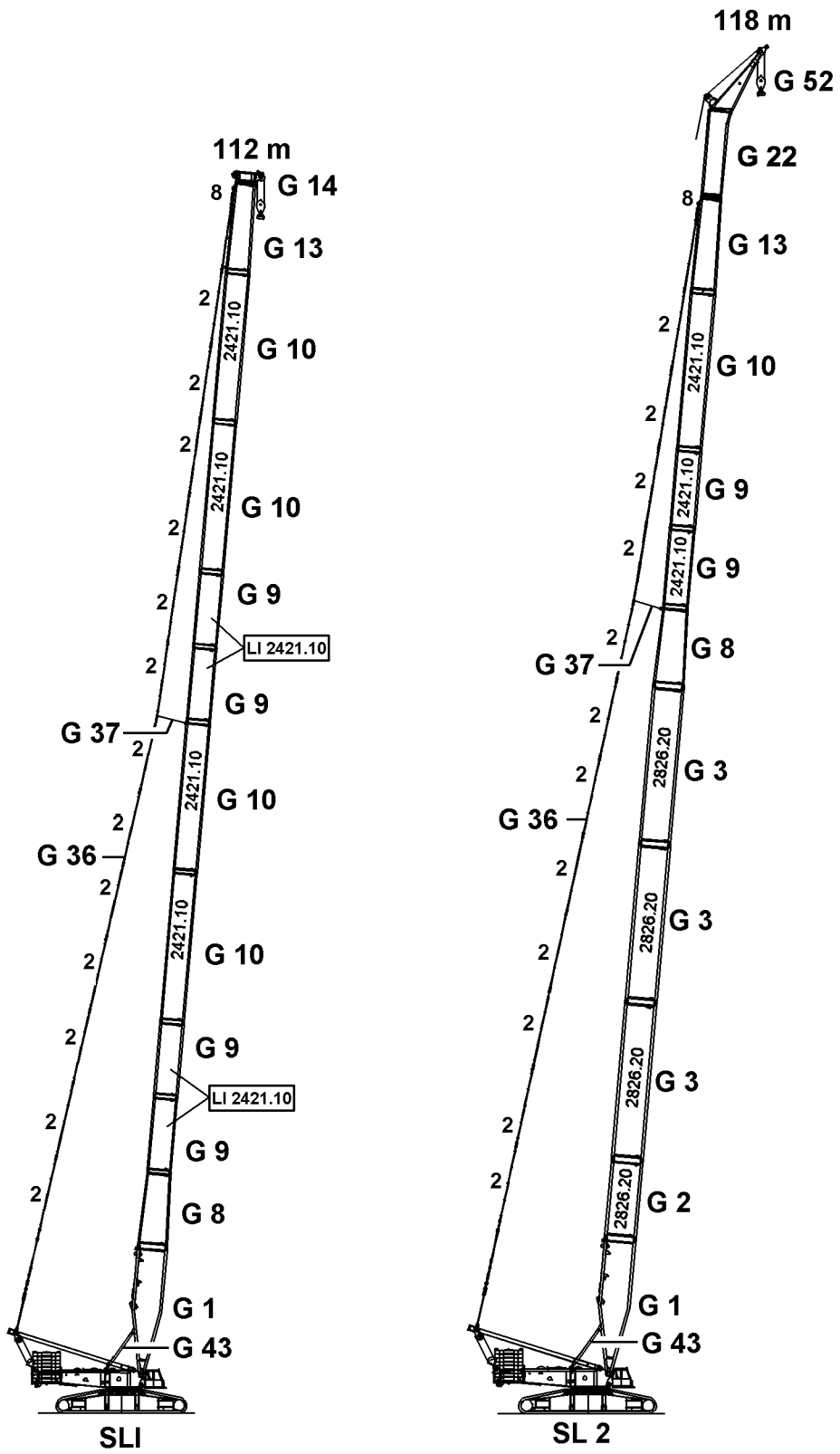
Fig. 3

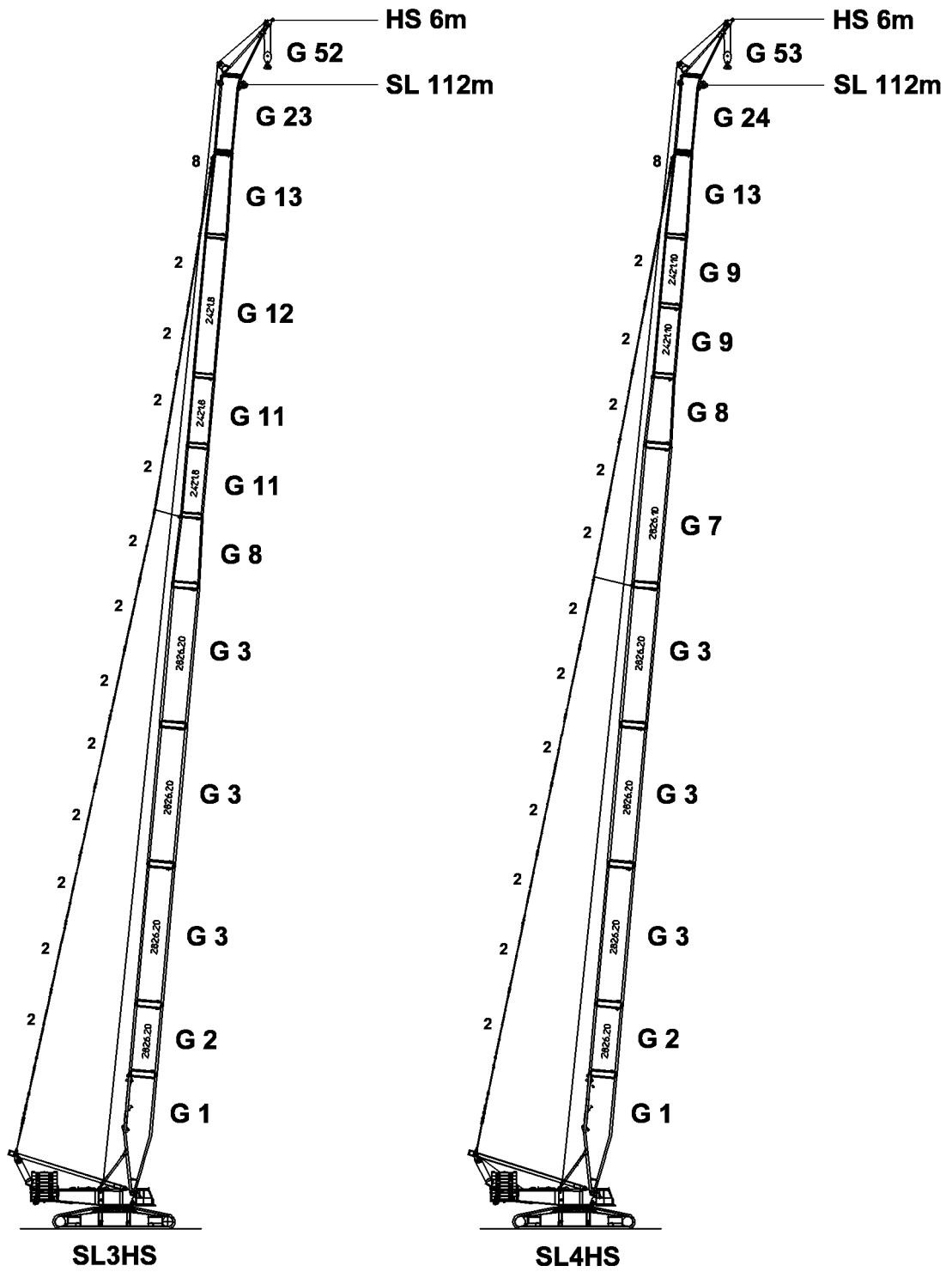
SLDB / BW - attachment

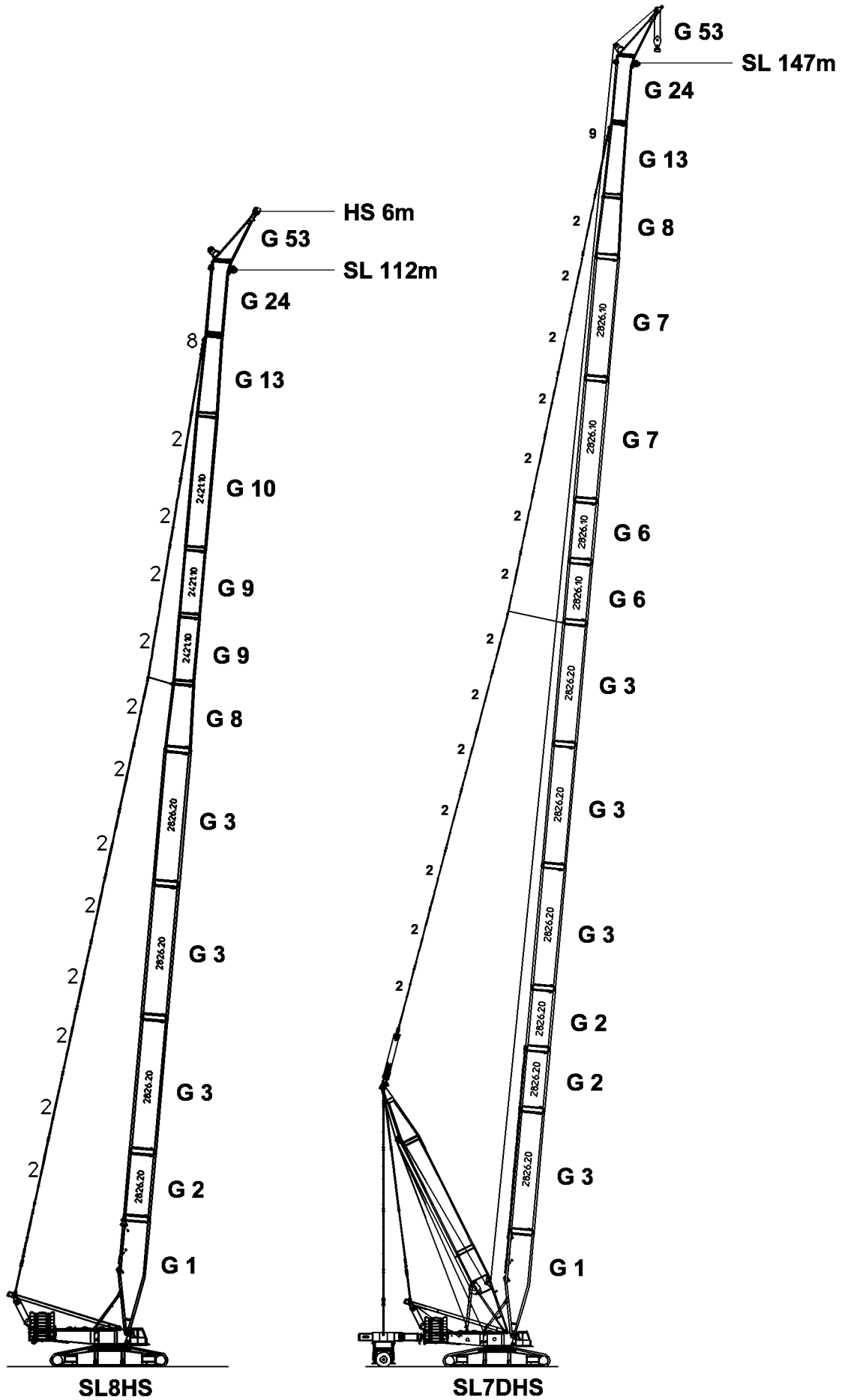
For a S-intermediate section 14m, 2826.20, a S-intermediate section 14m, 2826.30 can be installed.

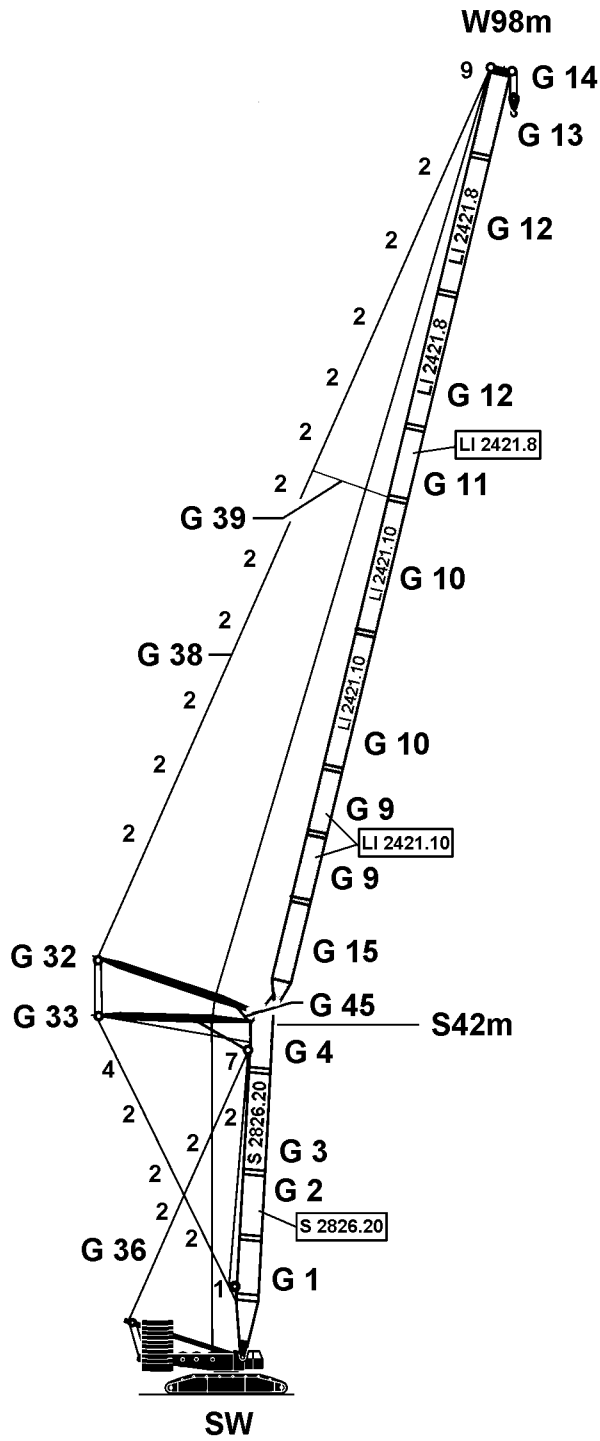
D A N G E R: The S-intermediate section 14m, 2826.30, must be installed after the S-pivot section!

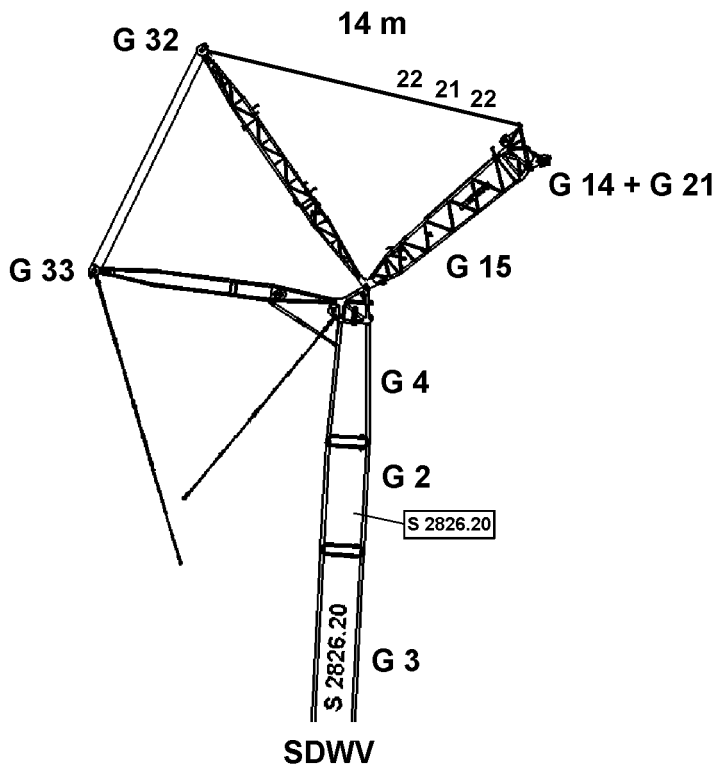
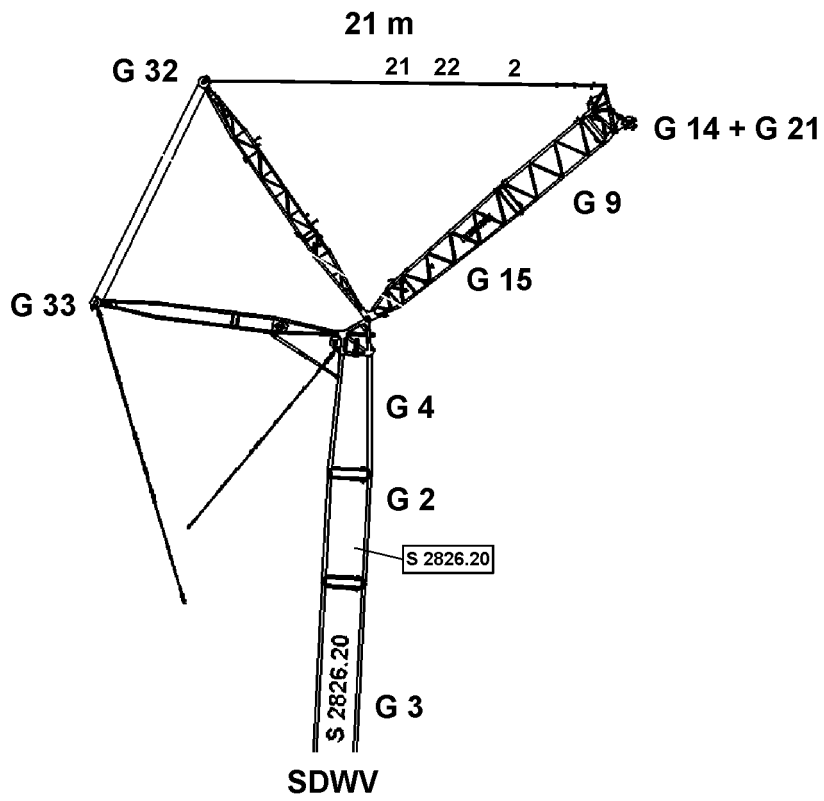












Combination of maximum possible attachment

	Description	System	Length (m)	Weight (t)
G 1	S -Pivot section with S + W-rods + retaining cylinder	2826.30	12,0	18,0
	S -Pivot section with winch V	2826.30	12,0	28,0
	S -Pivot section with winch VI	2826.30	12,0	34,0
G 2	S -Intermediate section	2826.20	7,0	6,2
G 3	S -Intermediate section	2826.20	14,0	11,3
G 4	S-End section		9,0	11,9
G 5	Pulley set 600 / 400 t for S-End section		1,7	2,7
G 6	LA -Intermediate section	2826.10	7,0	4,5
G 7	LA -Intermediate section	2826.10	14,0	8,1
G 8	SL - Reducer section		7,0	4,3
G 9	LI -Intermediate section	2421.10	7,0	3,8
G 10	LI -Intermediate section	2421.10	14,0	7,0
G 11	LI -Intermediate section	2421.8	7,0	3,1
G 12	LI -Intermediate section	2421.8	14,0	5,8
G 13	L - Adapter		8,4	6,0
G 14	L -End section (400 t)		0,6	3,6
G 15	W -Pivot section		12,0	10,6
G 16	D -Pivot sectionwith rods and pulley block	2421.10	10,5	12,7
	D -Pivot section with winch III	2421.10	10,5	15,4
G 17	D -Intermediate section	2421.10	14,0	8,6
G 18	D -End section	2421.10	7,0	11,2
G 19	S - Zwischenstück	2826.30	14,0	11,3
G 20	S - Zwischenstück	2826.30	3,5	4,2
G 21	WV- Adapter f. pulley set 600 / 400 t			5,1
G 22	Adapter f. HS without pully set (100 t)		7,6	2,7
G 23	Adapter f. HS with pully set (100 t)		7,6	3,5
G 24	Adapter f. HS with pully set (120 t)		7,6	3,1

Note: For example : 2826.20 = .20 (welded on plate on Intermediate section)
For two 7 m long Intermediate sections, one 14 m long intermediate section can be installed.

D A N G E R: Another assembly of the lattice sections and guy rods than noted in the operating manual or in the installation drawing is prohibited!
There is a danger that the intermediate sections, which are of different dimensions and do NOT look differently externally might be mixed up!
Externally, they only differ by welded on plates (.8, .10, .20, .30)
During the installation of the boom it is extremely important that the intermediate sections are installed according to their description. If this is not observed, there is a great danger of accidents!

Combination of maximum possible attachment

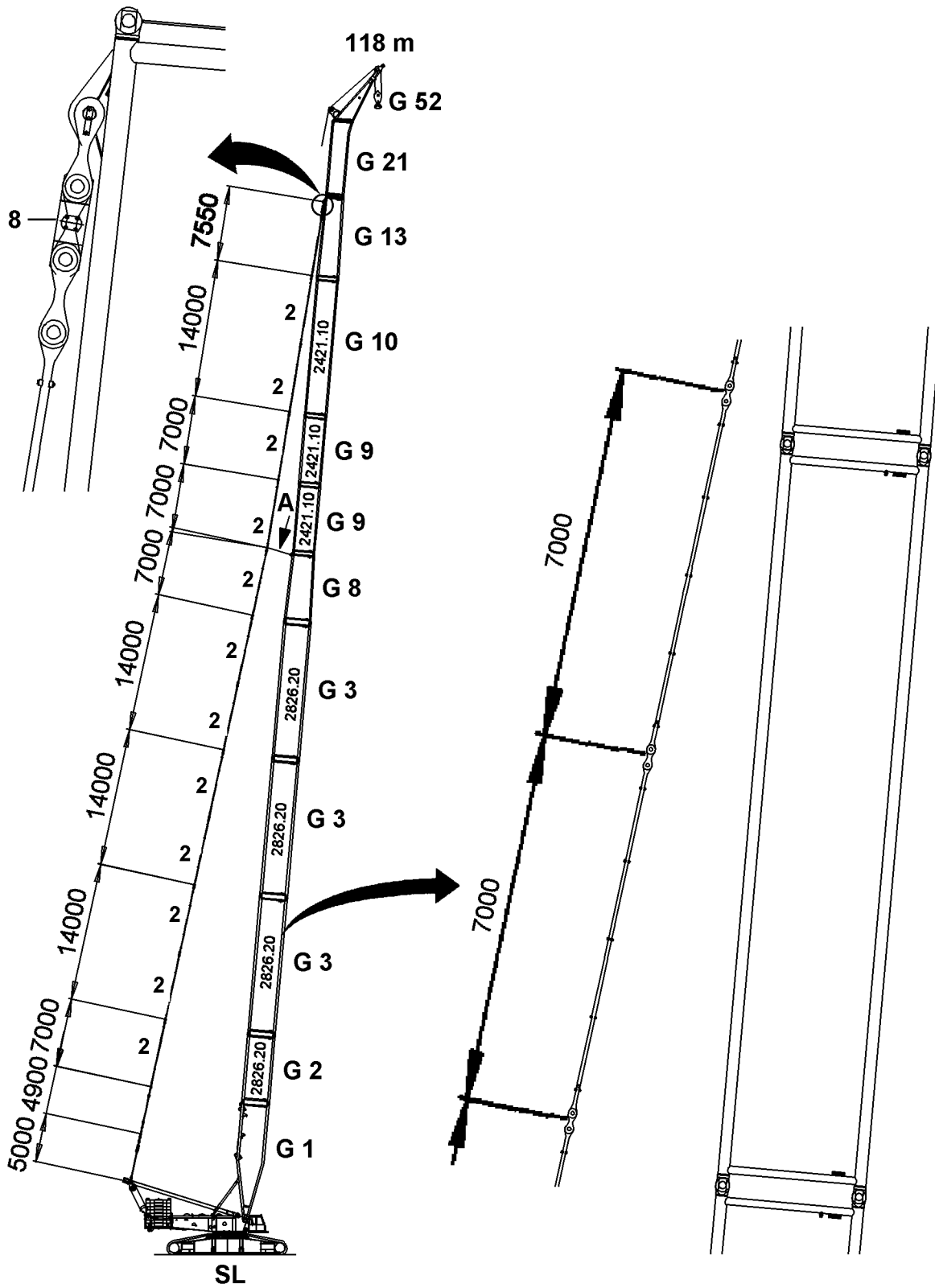
	Description	System	Length (m)	Weight (t)
G 31	W- Installation unit		13,40	10,6
G 32	WA- bracket I		17,50	5,6
G 33	WA- bracket II with rods and cylinder		15,50	11,2
G 34	L- guying			
G 35	L- added guying			
G 36	S- guying			
G 37	S- added guying			
G 38	W- guying			
G 39	W- added guying			
G 40	B or BW- guying			
G 41	D- guying			
G 43	S- retainer			
G 44	D- retainer			
G 45	W- retainer			
G 50	Boom nose (L-End section)		3,1	0,8
G 51	Boom nose (S-End section)		2,8	1,0
G 52	Auxiliary jib (100t) for SL2 - / SL3HS - boom		6,0	2,6
G 53	Auxiliary jib (120t) for SL4HS - / SL8HS- / SL7DHS - boom		6,0	2,6
G 54	Installation head (47t)		1,0	2,3

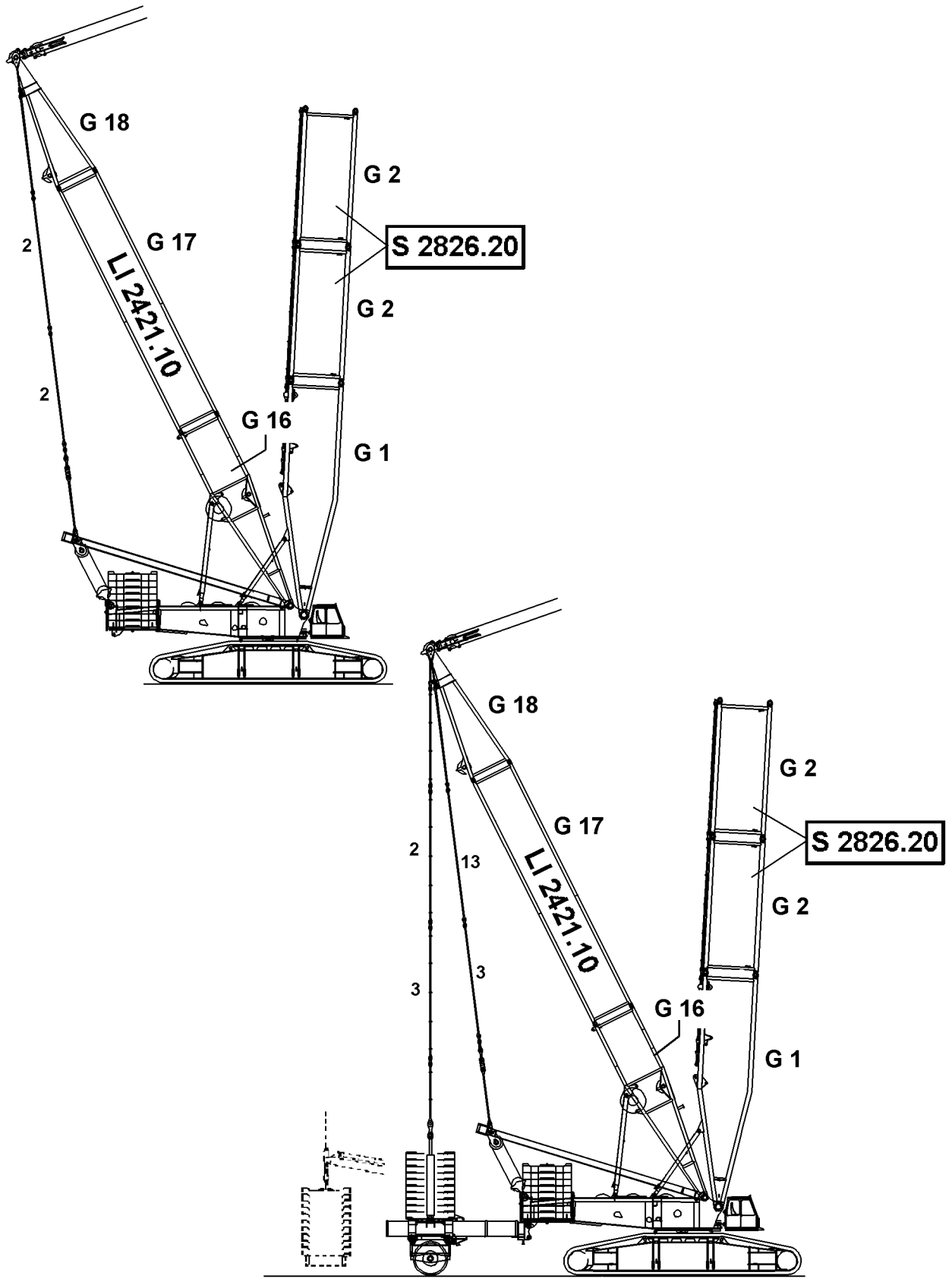
Note: For example : 2826.**.20** = **.20**(welded on plate on Intermediate section)
For two 7 m long Intermediate sections, one 14 m long intermediate section can be installed.

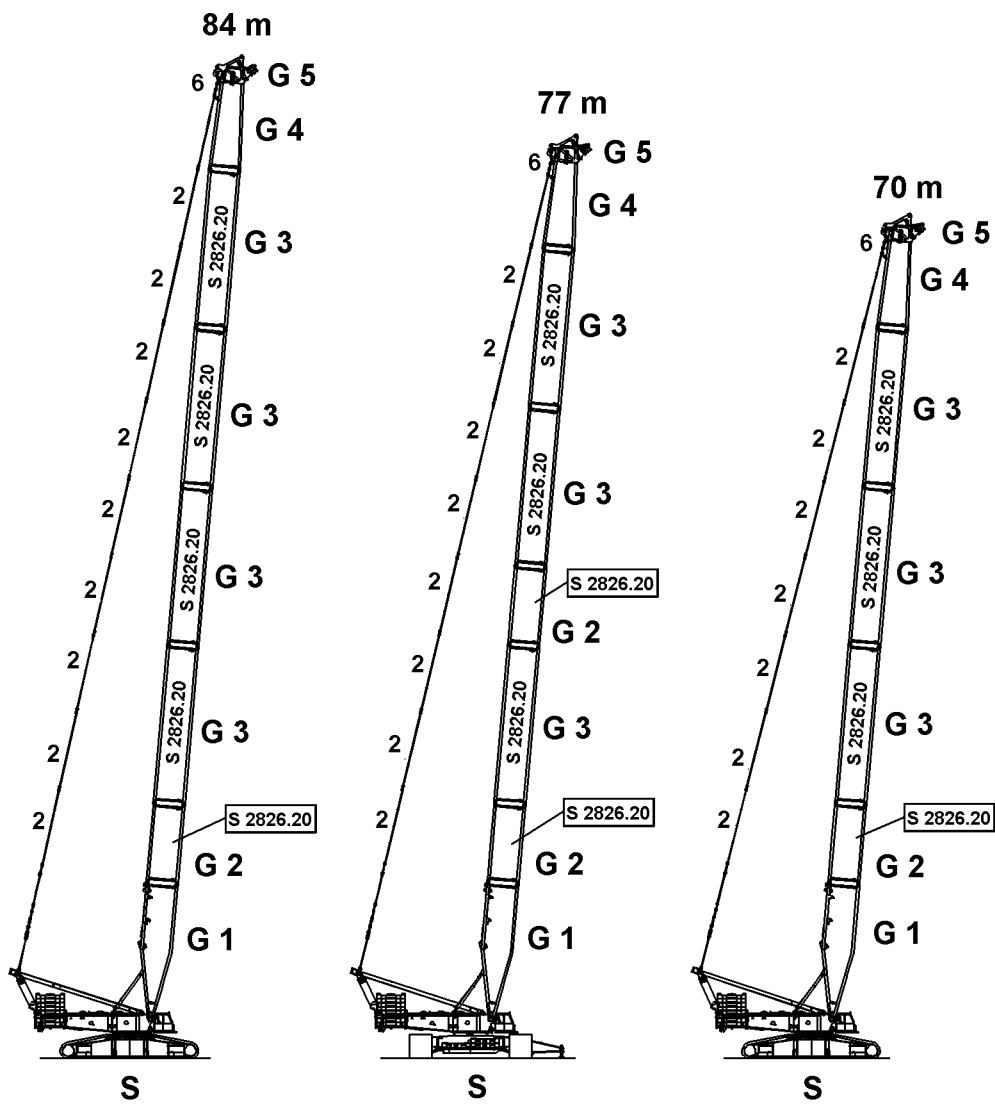
D A N G E R: **Another assembly of the lattice sections and guy rods than noted in the operating manual or in the installation drawing is prohibited!**
There is a danger that the intermediate sections, which are of different dimensions and do NOT look differently externally might be mixed up!
Externally, they only differ by welded on plates (.8, .10, .20, .30)
During the installation of the boom it is extremely important that the intermediate sections are installed according to their description. If this is not observed, there is a great danger of accidents!

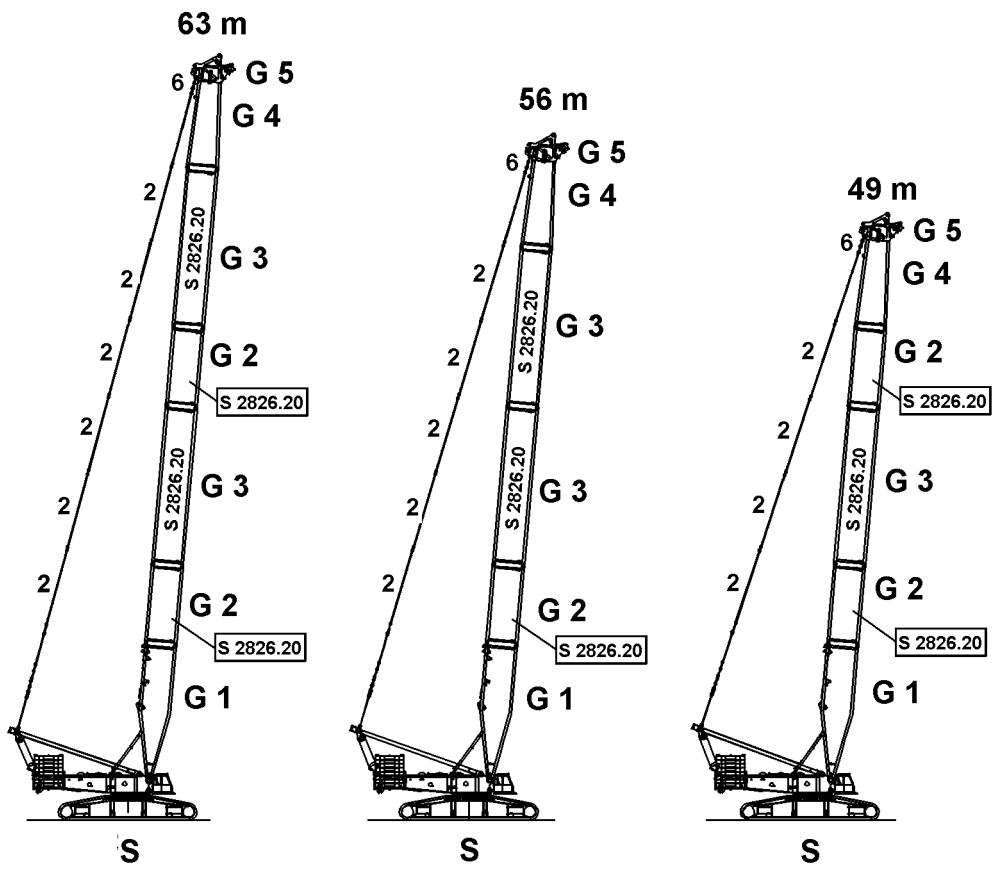
Component overview

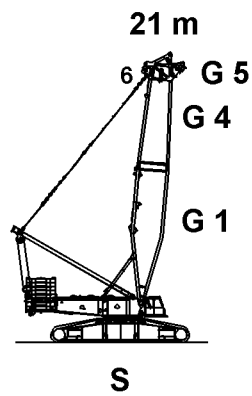
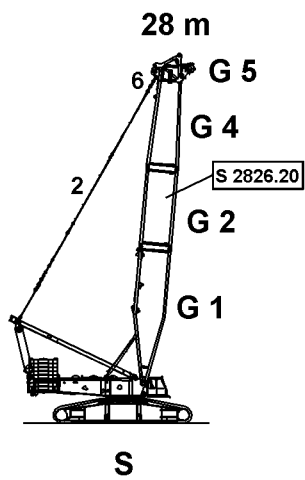
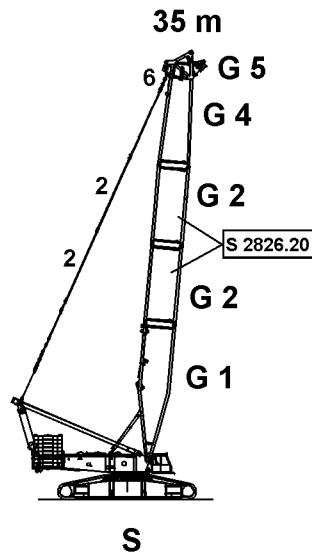
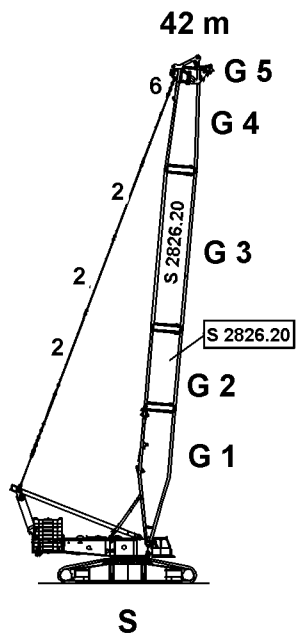
Pos.:	Description	Length
1	Guy rod, complete	5,55 m
2	Guy rod	7,00 m
3	Guy rod	7,00 m
4	Guy rod, complete	1,50 m
5	Guy rod, complete	2,40 m
6	Brackets for S - head	
7	Pull test brackets for SLD / SD / SDW	
8	Brackets for L - Adapter	
9	Pull test brackets for L - Adapter	
10	Brackets for added guying	
11	Guy rod, complete	2,33 m
12	Guy rod, complete	2,20 m
13	Guy rod, complete	5,72 m
14	Cable Ø 32 mm	4,72 m
15	Pin Ø 60 x 140 mm	
16	Spring retainer Ø 5 mm	
17	Cable Ø 32 mm	6,05 m
18	Cable Ø 32 mm	7,01 m
19	Chain	
20	Pin Ø 65 x 255 mm	
21	Spring retainer Ø 6 mm	
22	Bracket	
23	Cable Ø 32 mm	2,27 m
24	Cable Ø 32 mm	7,31 m
25	Cable Ø 32 mm	6,50 m
26	Pin Ø 70 x 140 mm	
27	Cable Ø 32 mm	6,39 m
28	Bracket	
29	Pin Ø 70 x 171 mm	
30	Nut M 48 x 1,5 mm	
31	Washer Ø 90 x 25 mm	
32	Cable Ø 32 mm	3,55 m
82	Guy rod, complete	0,71 m

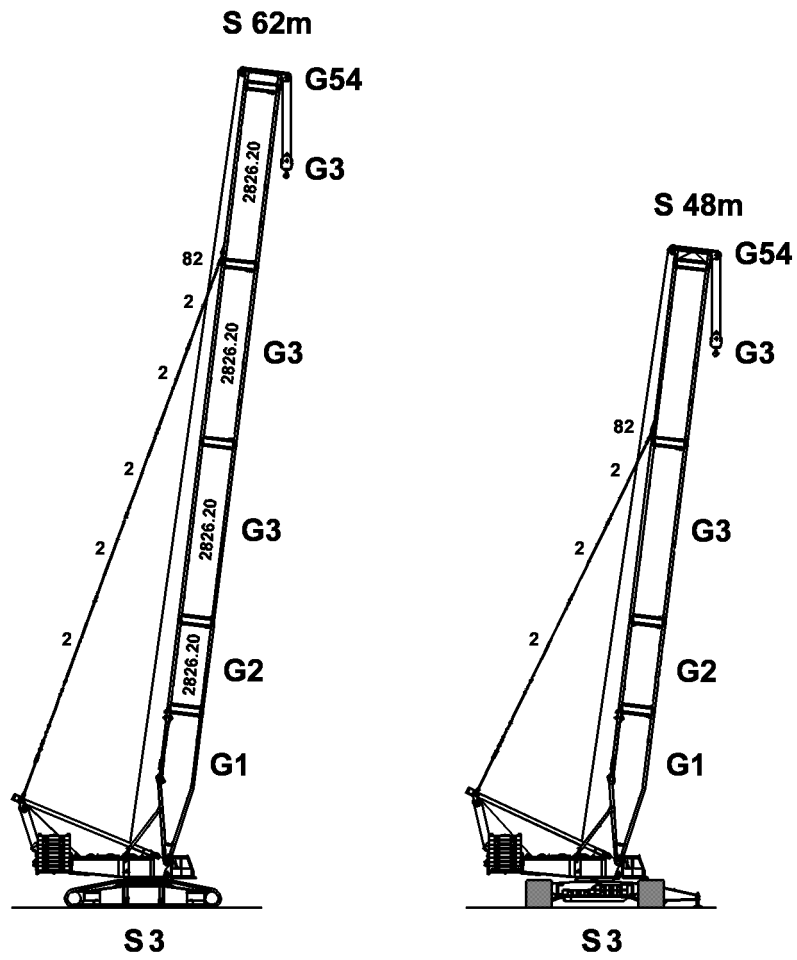


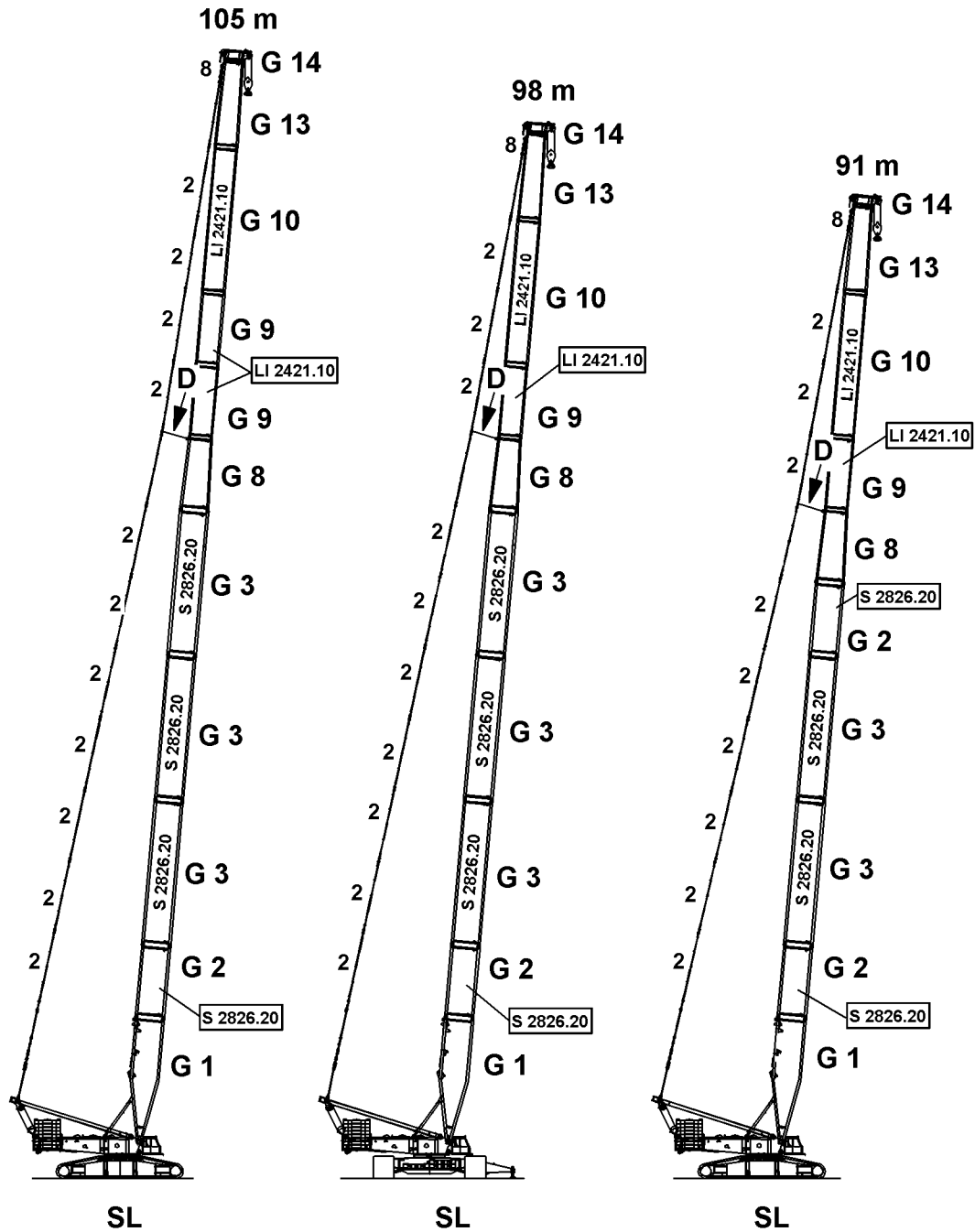


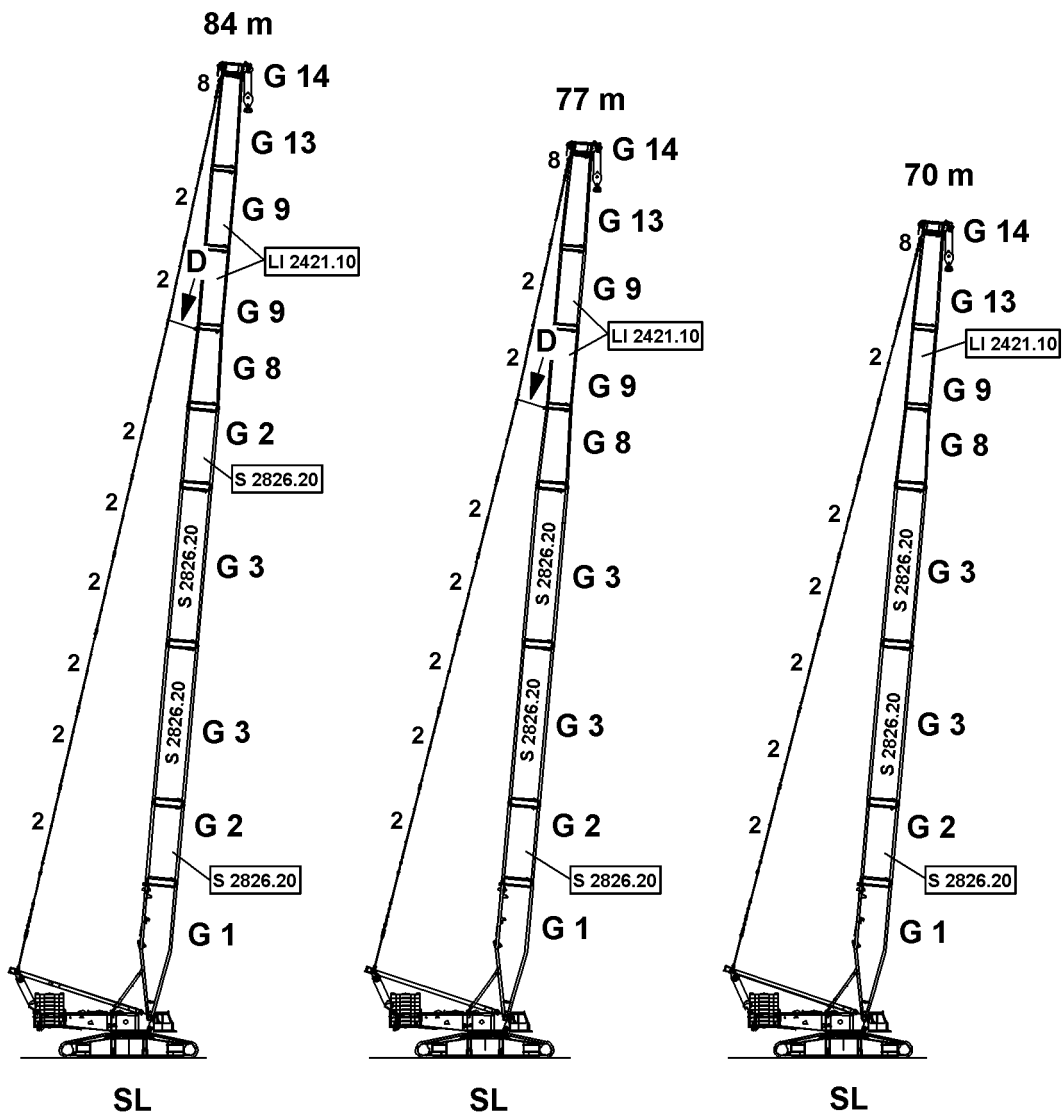


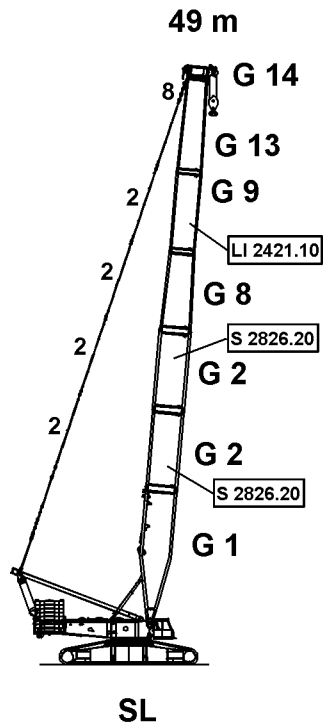
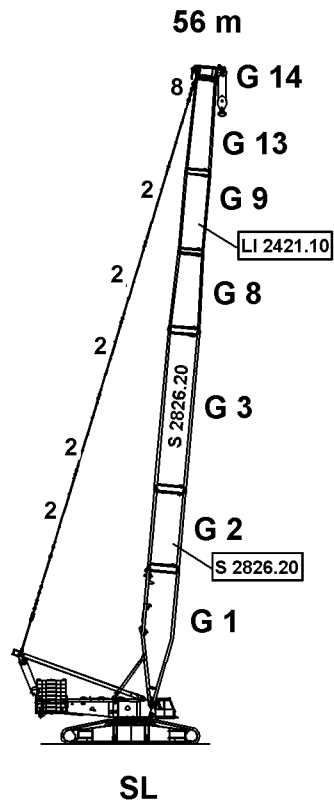
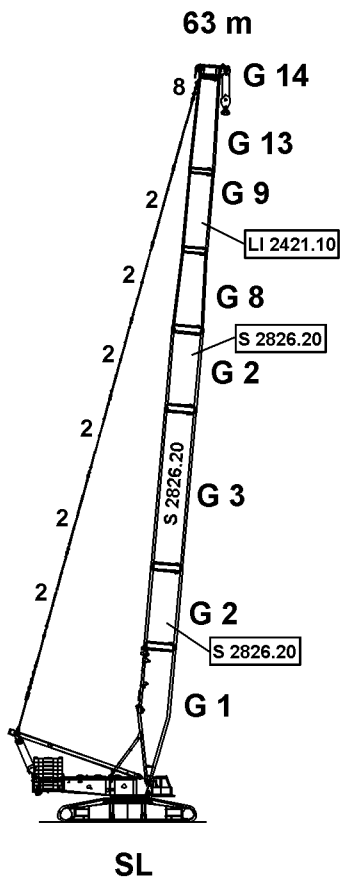


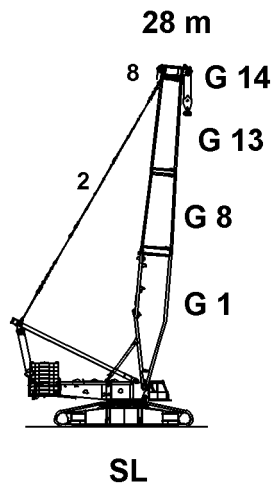
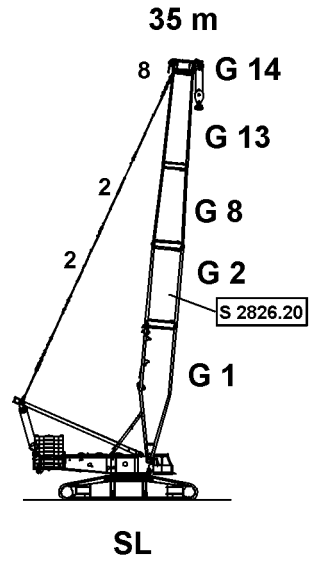
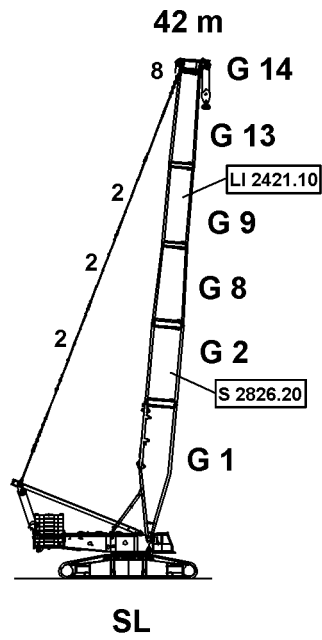


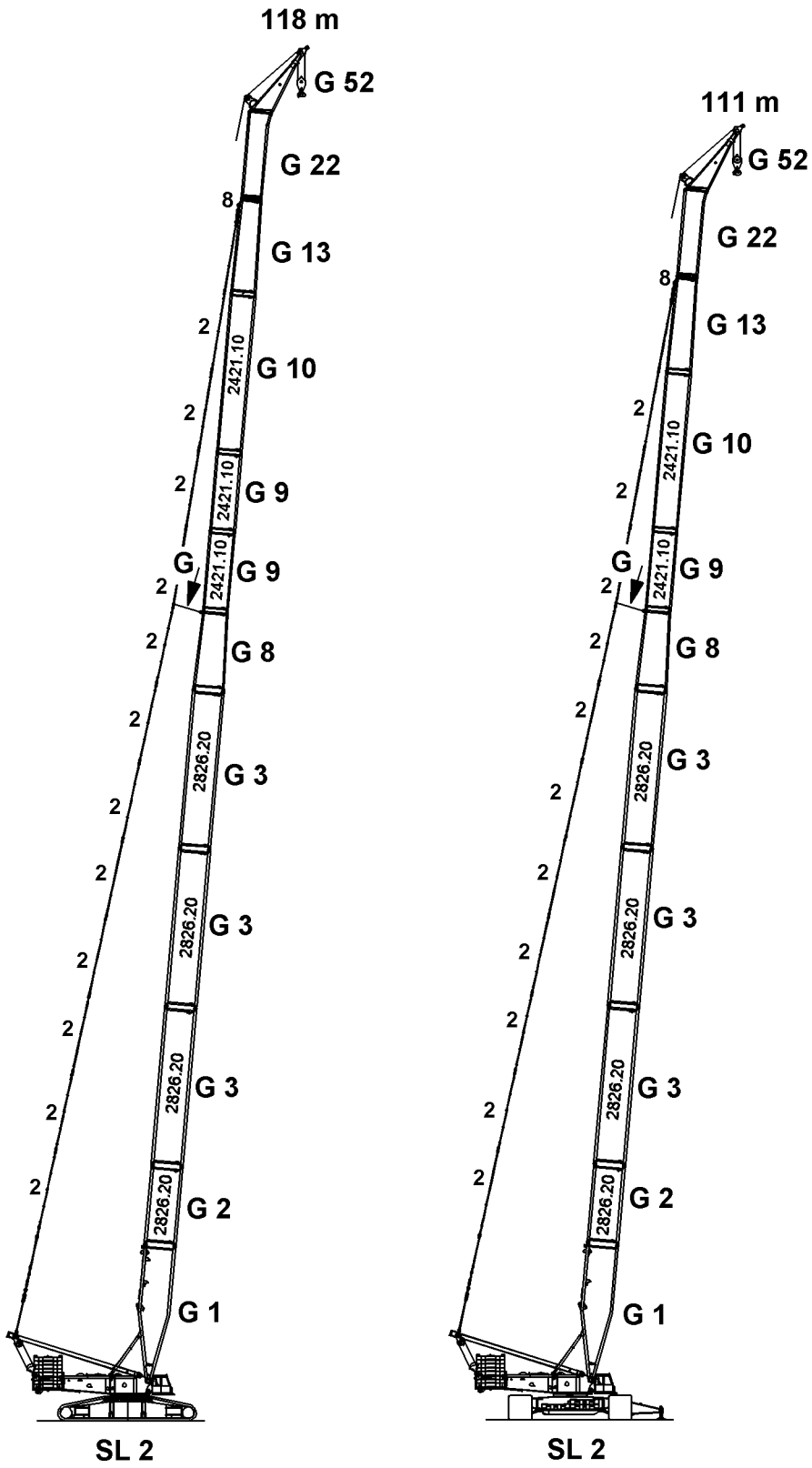


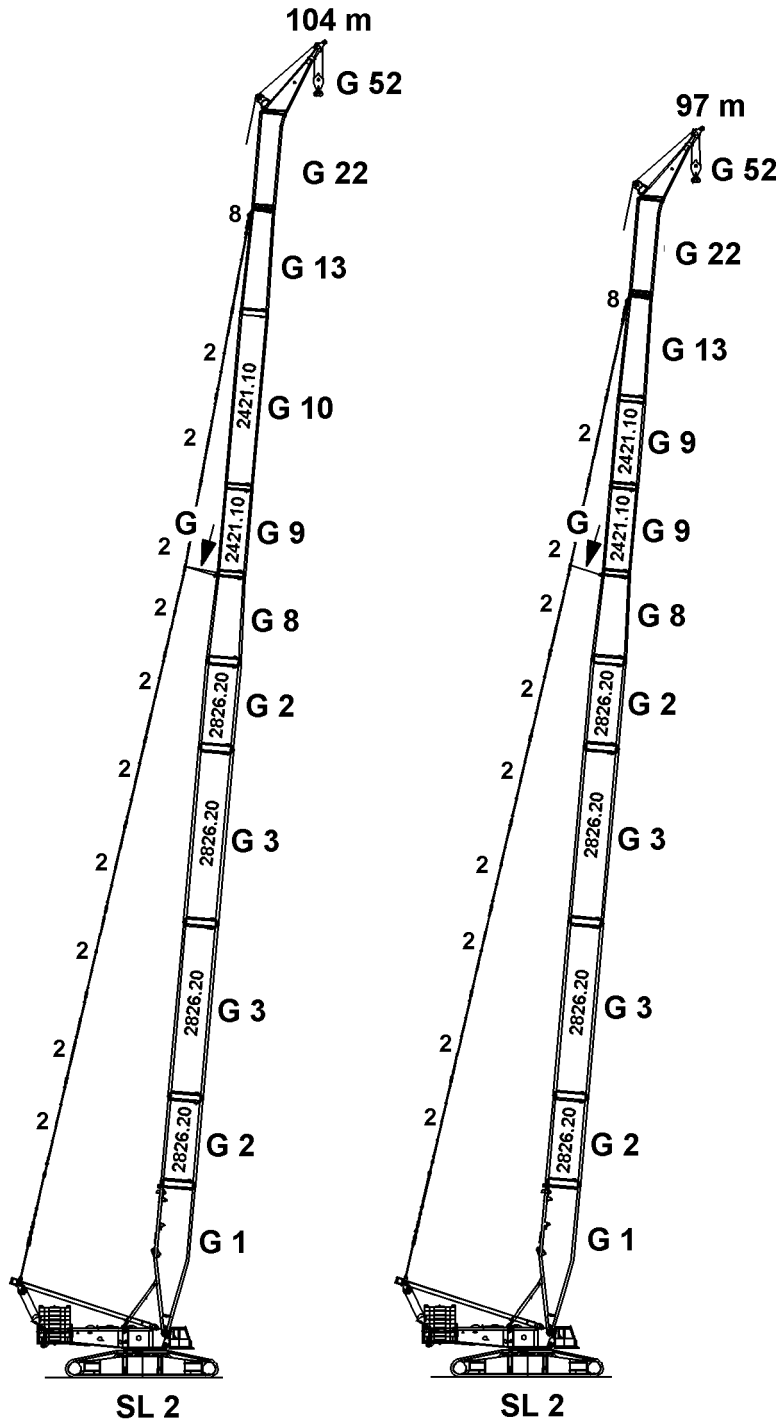


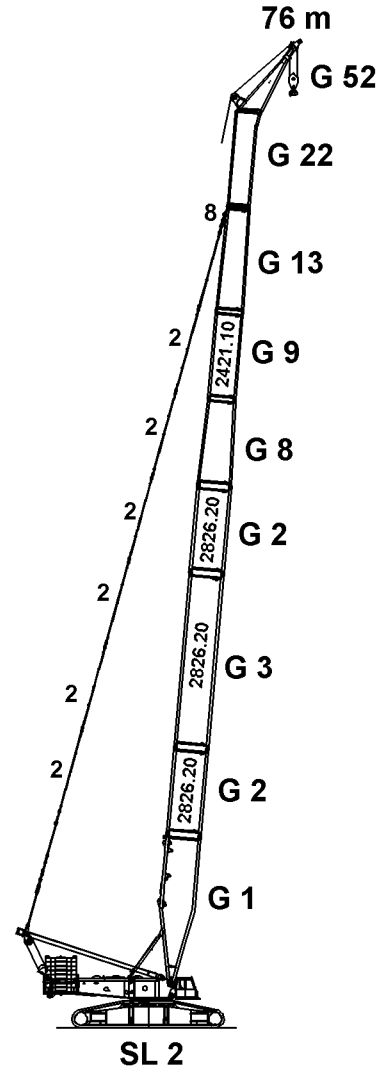
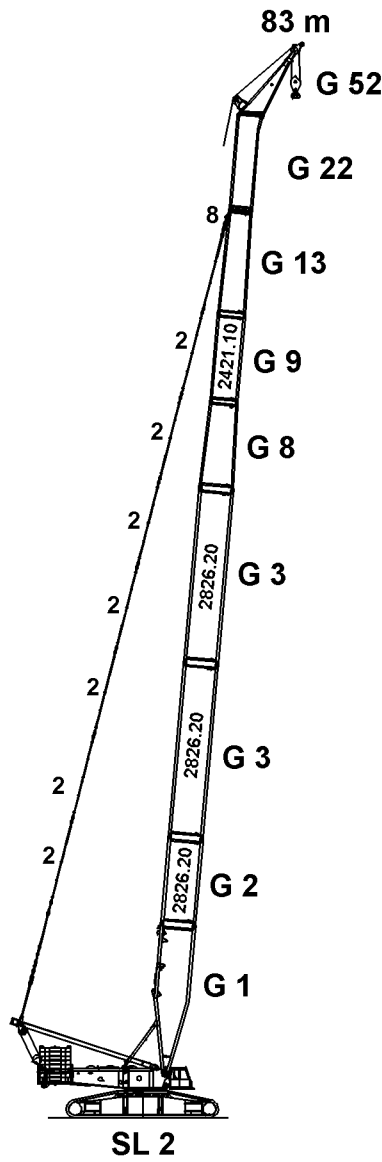
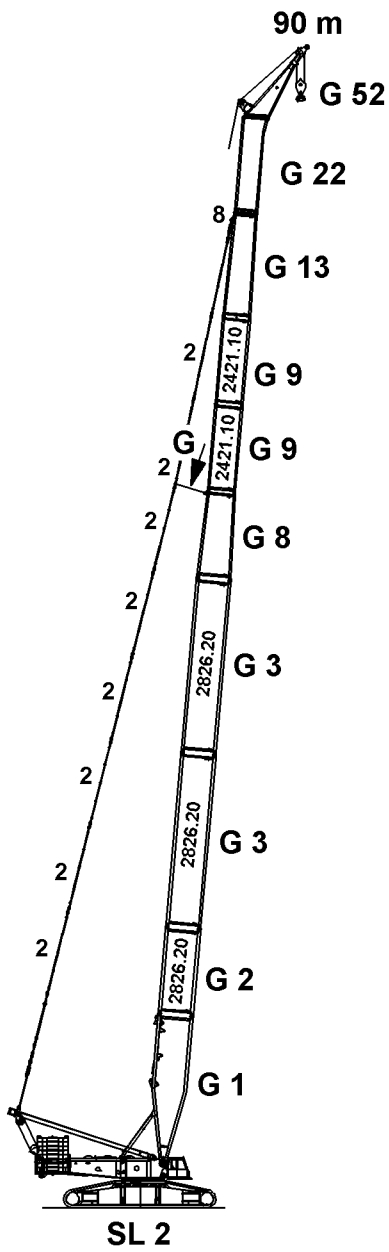


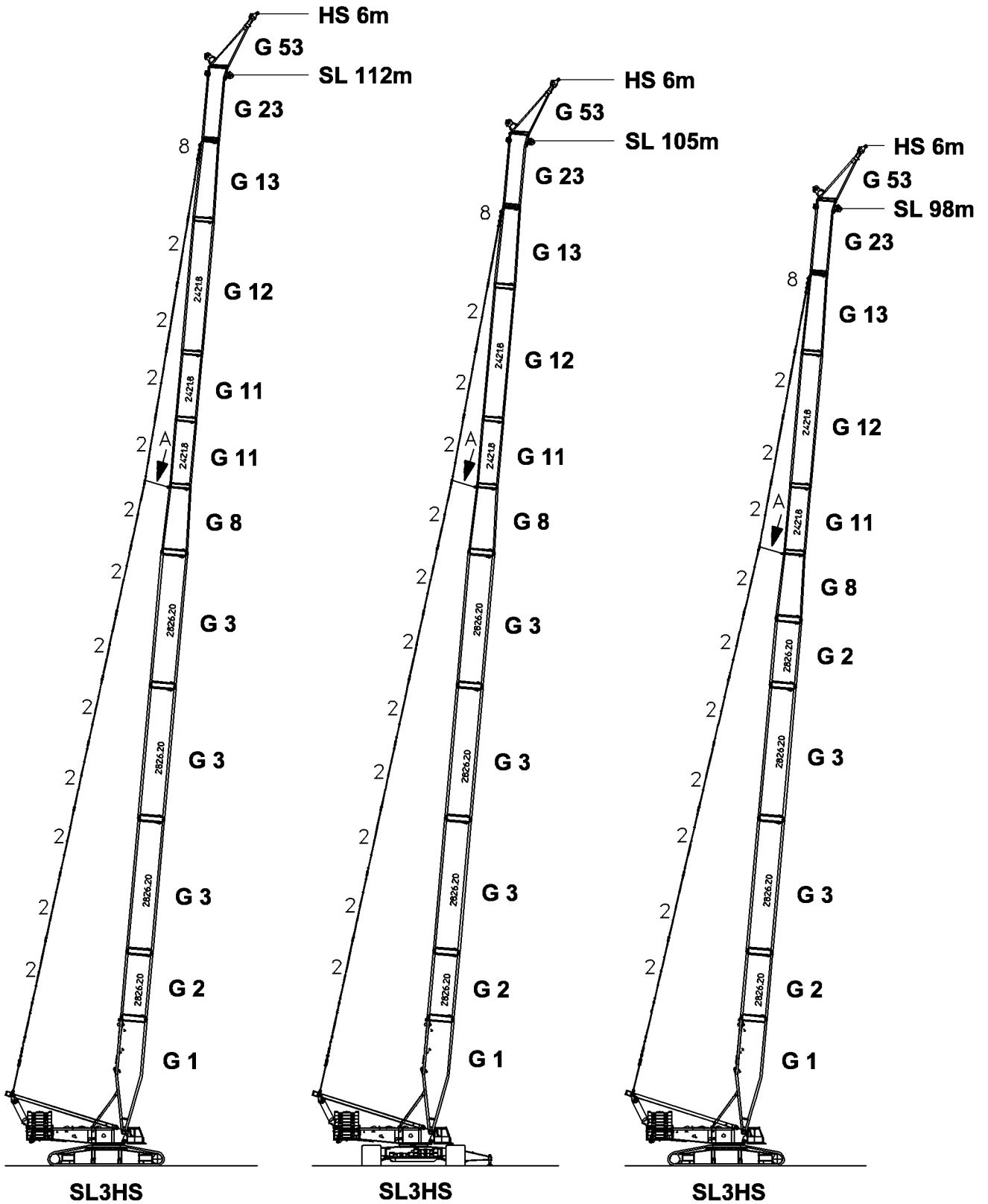


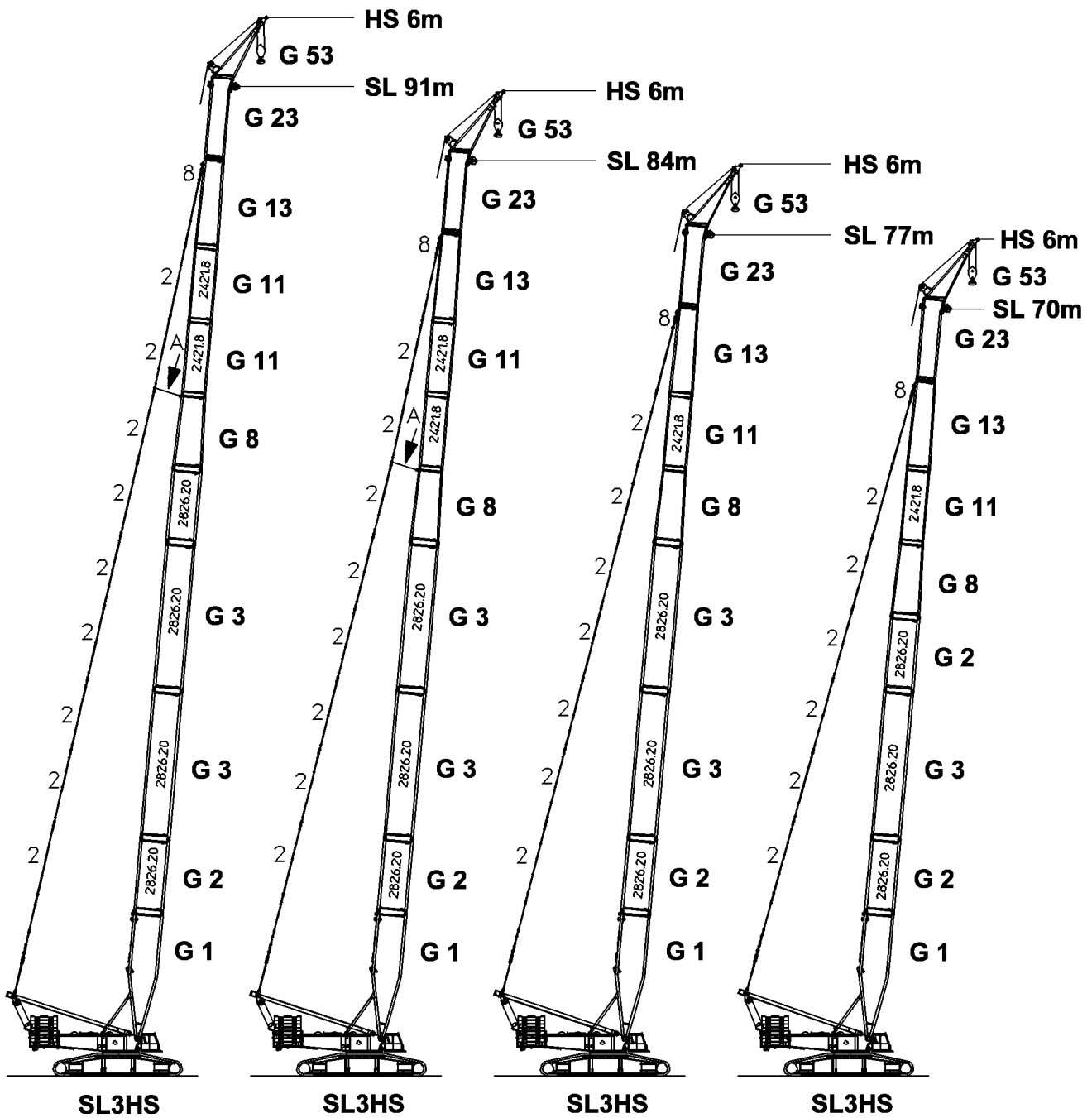


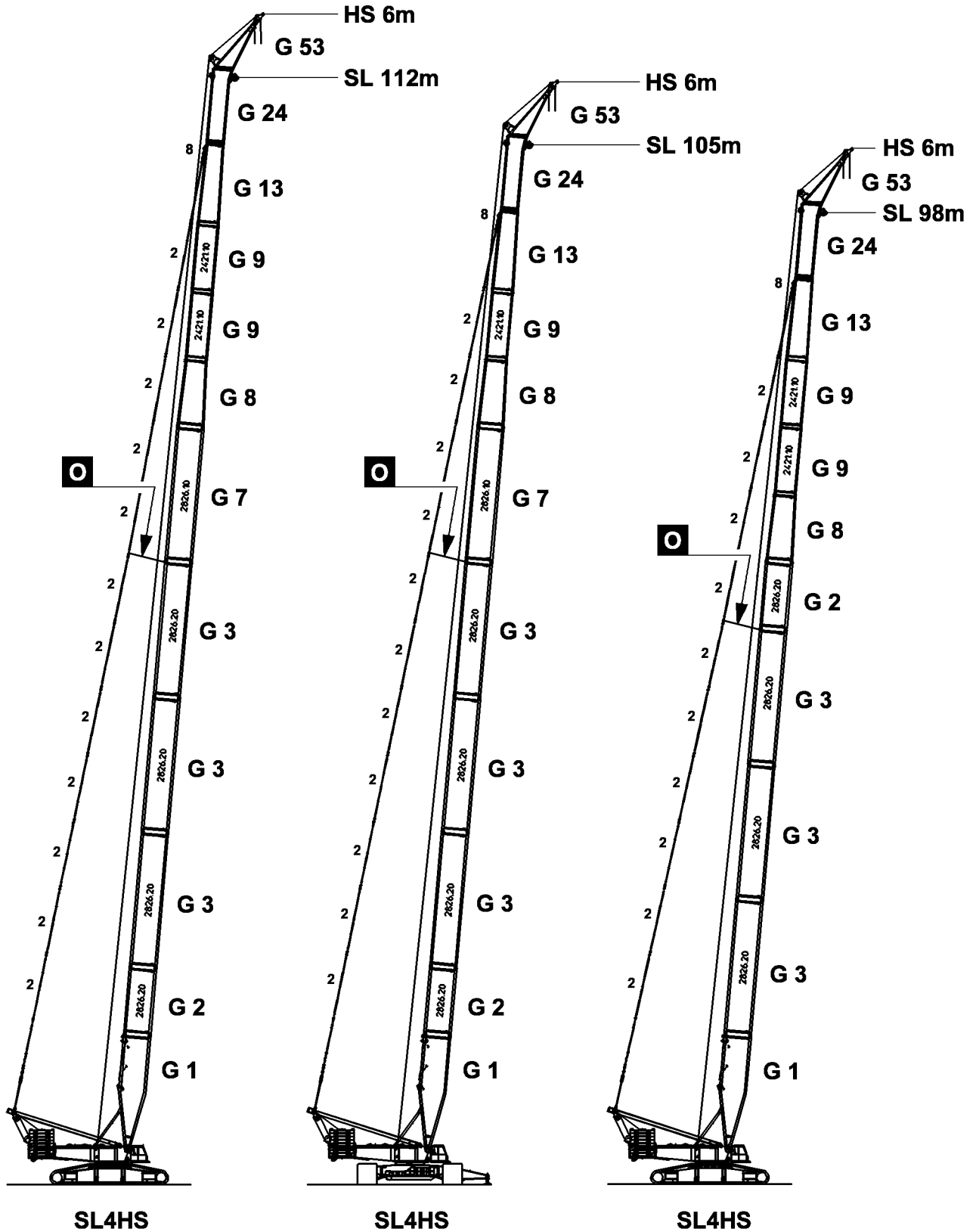


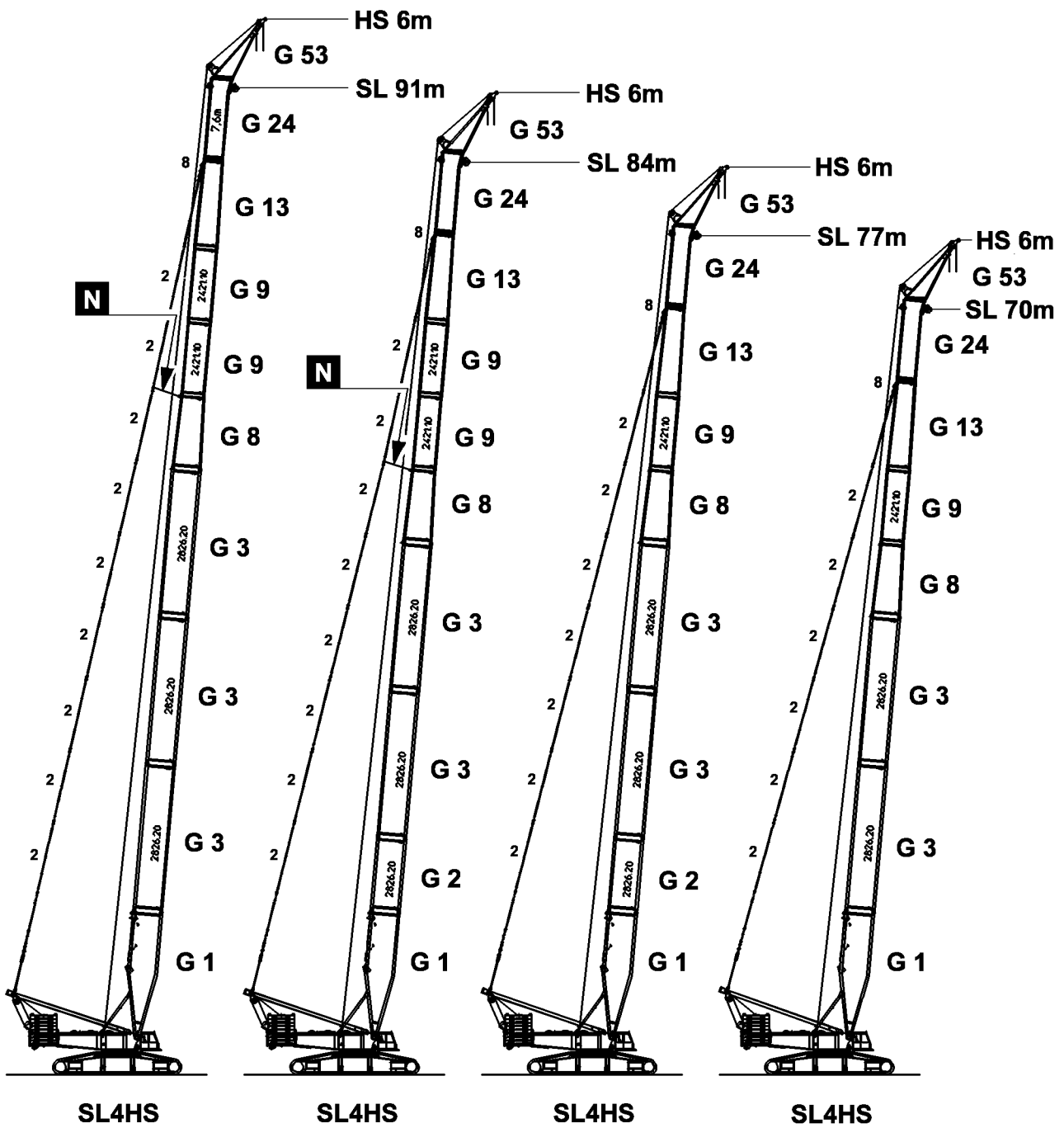


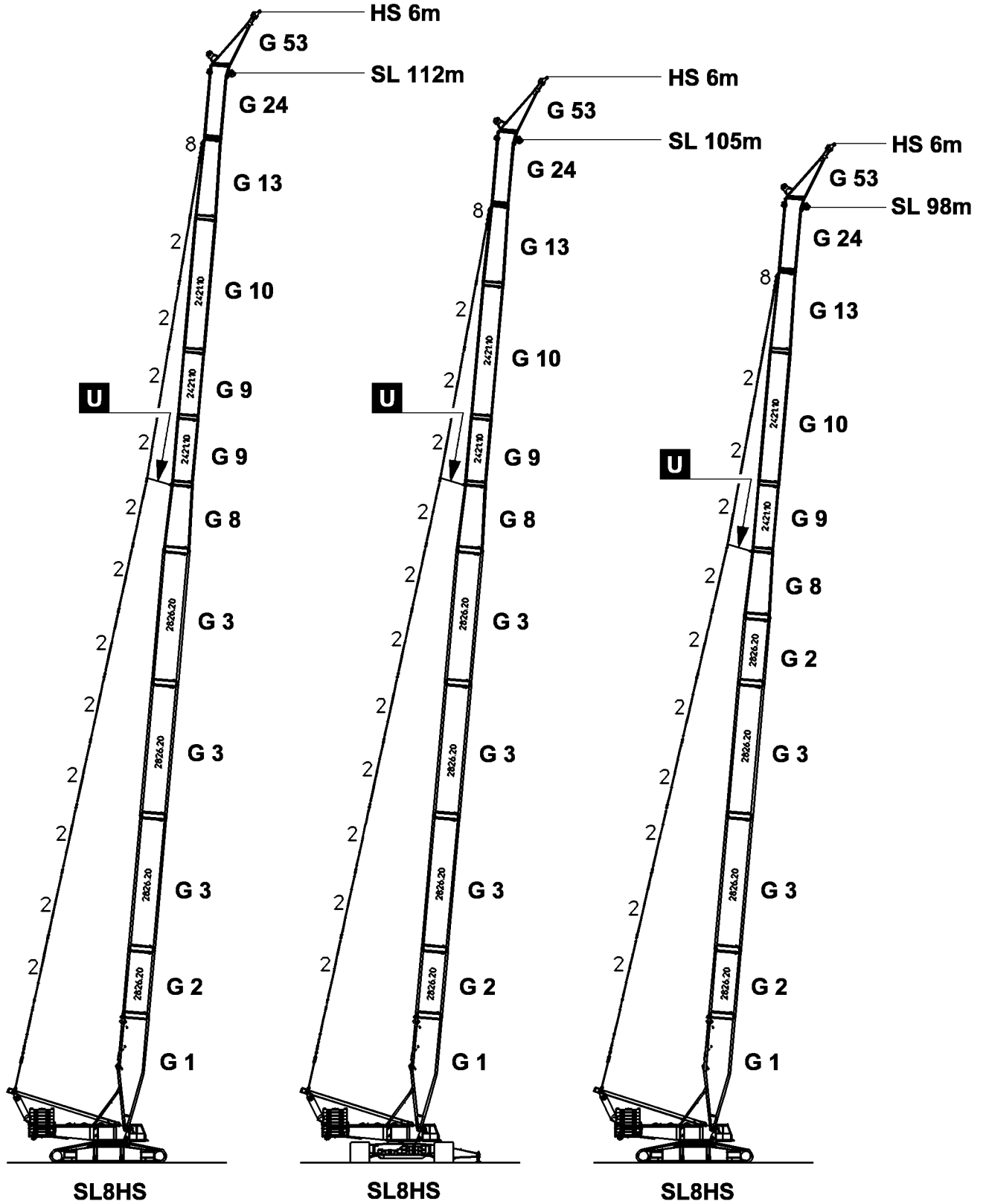


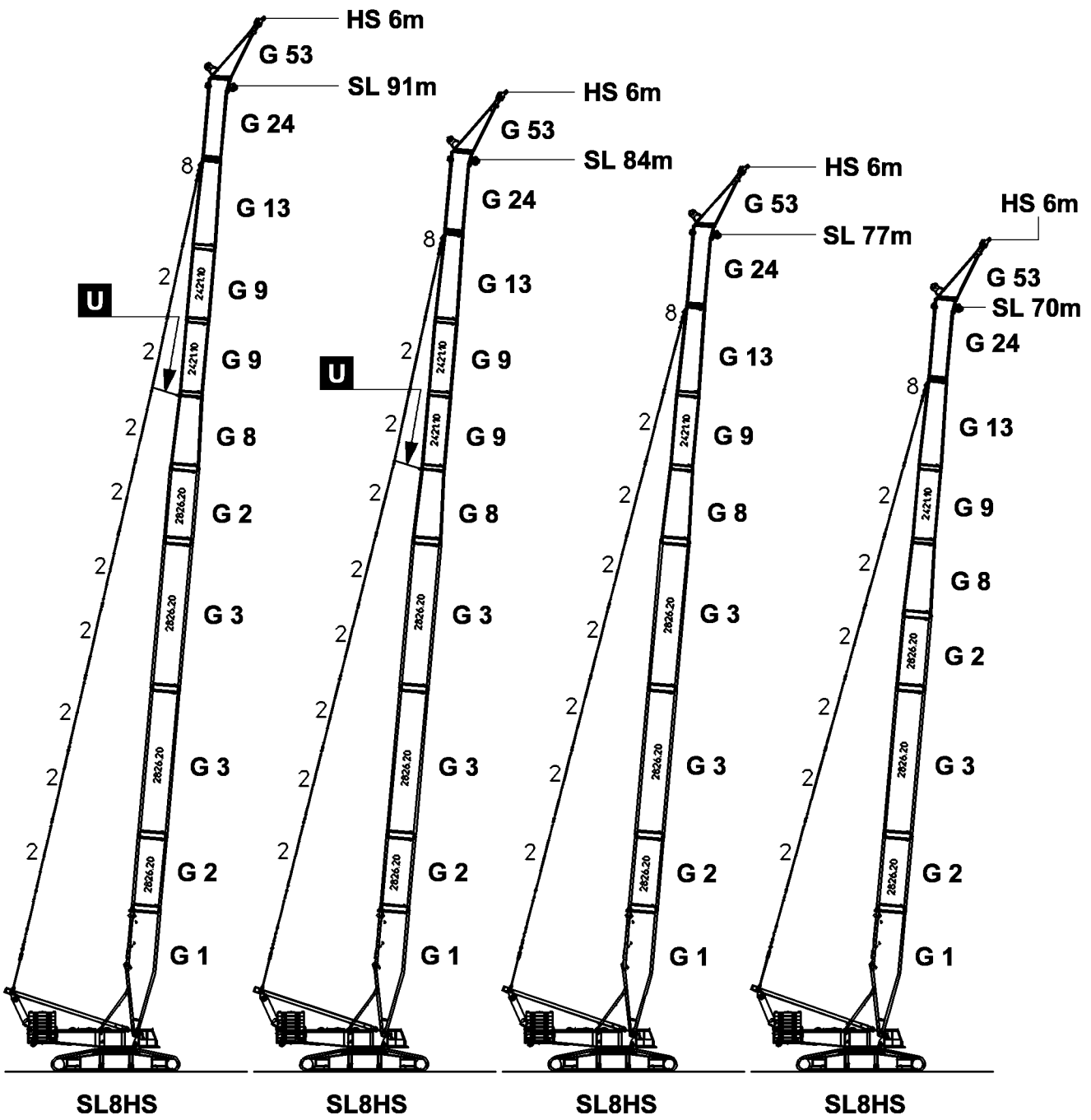


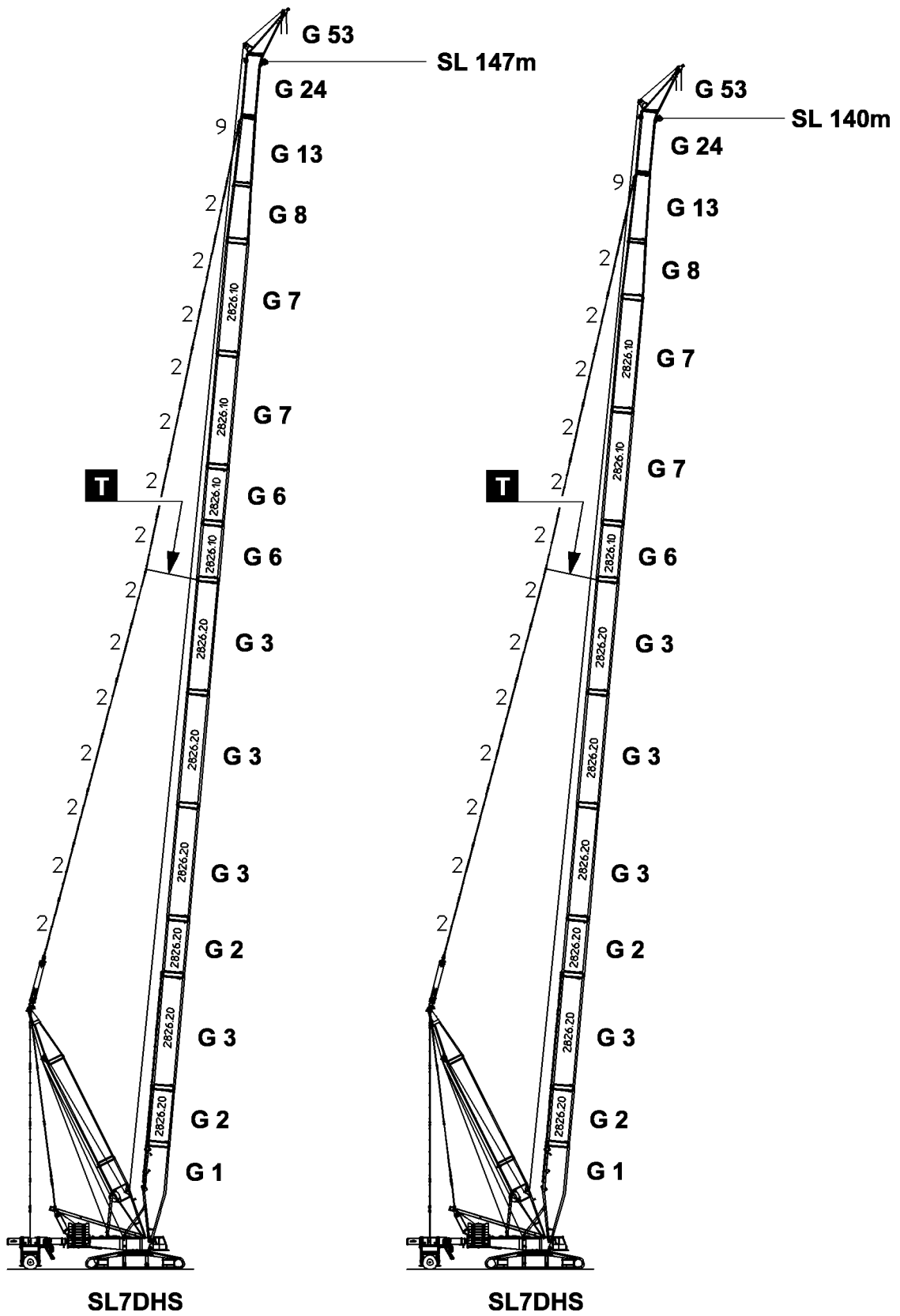


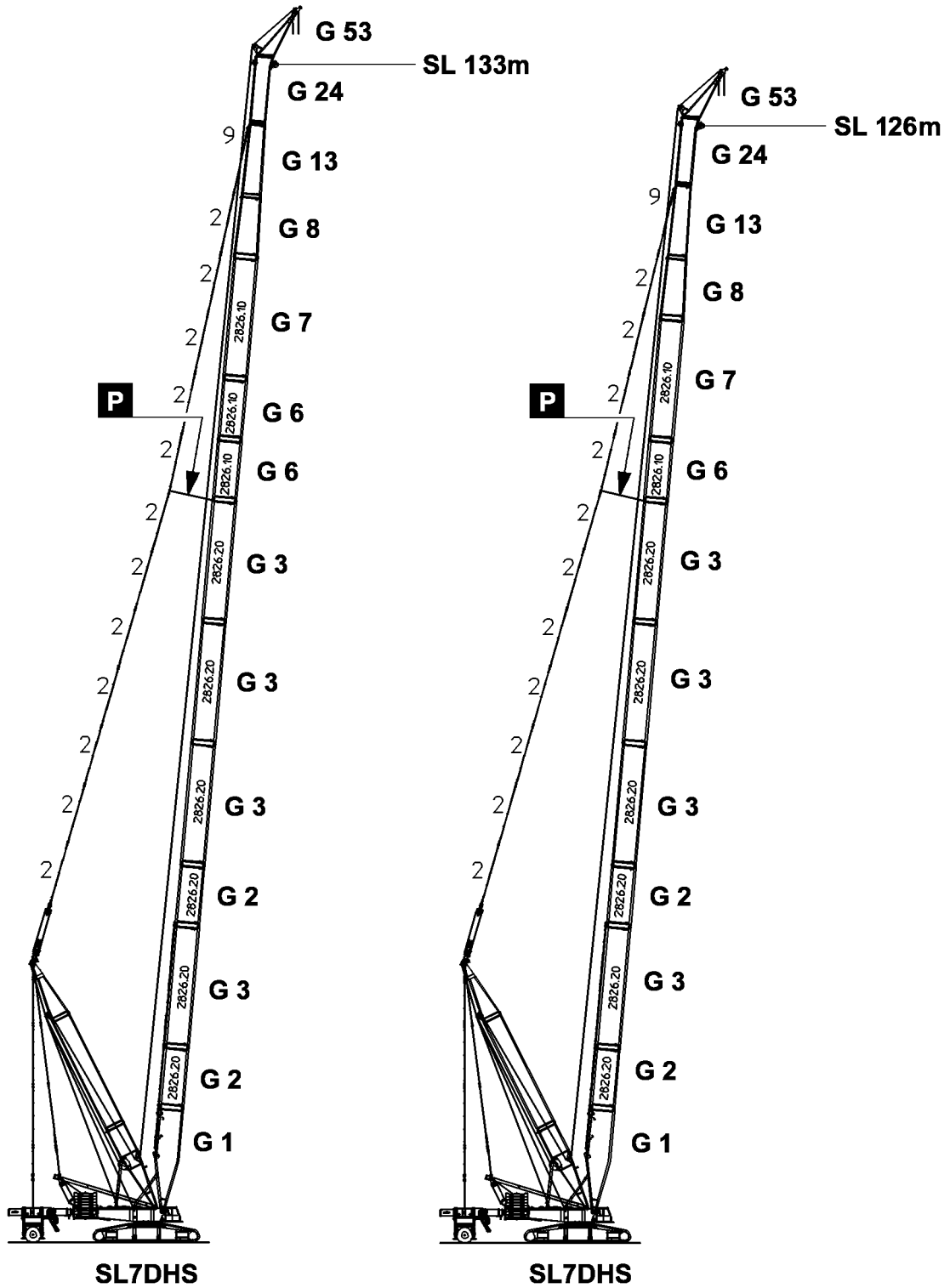












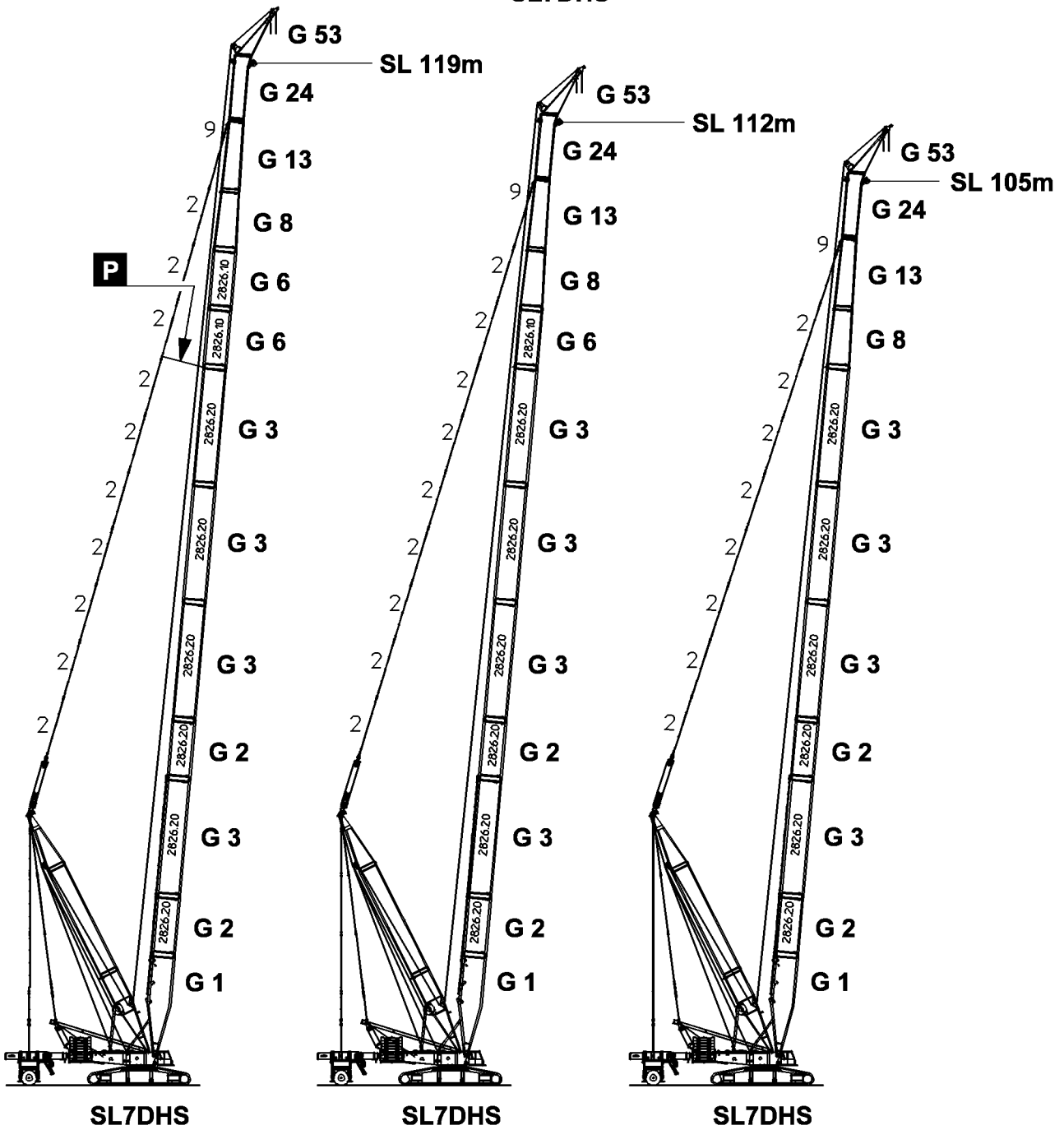
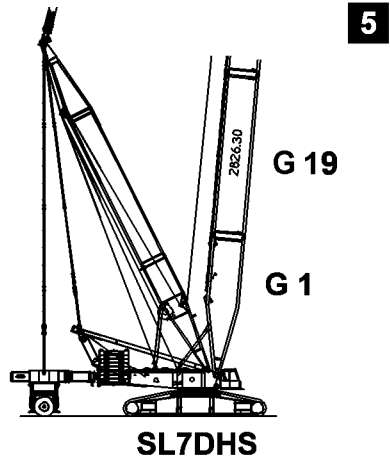
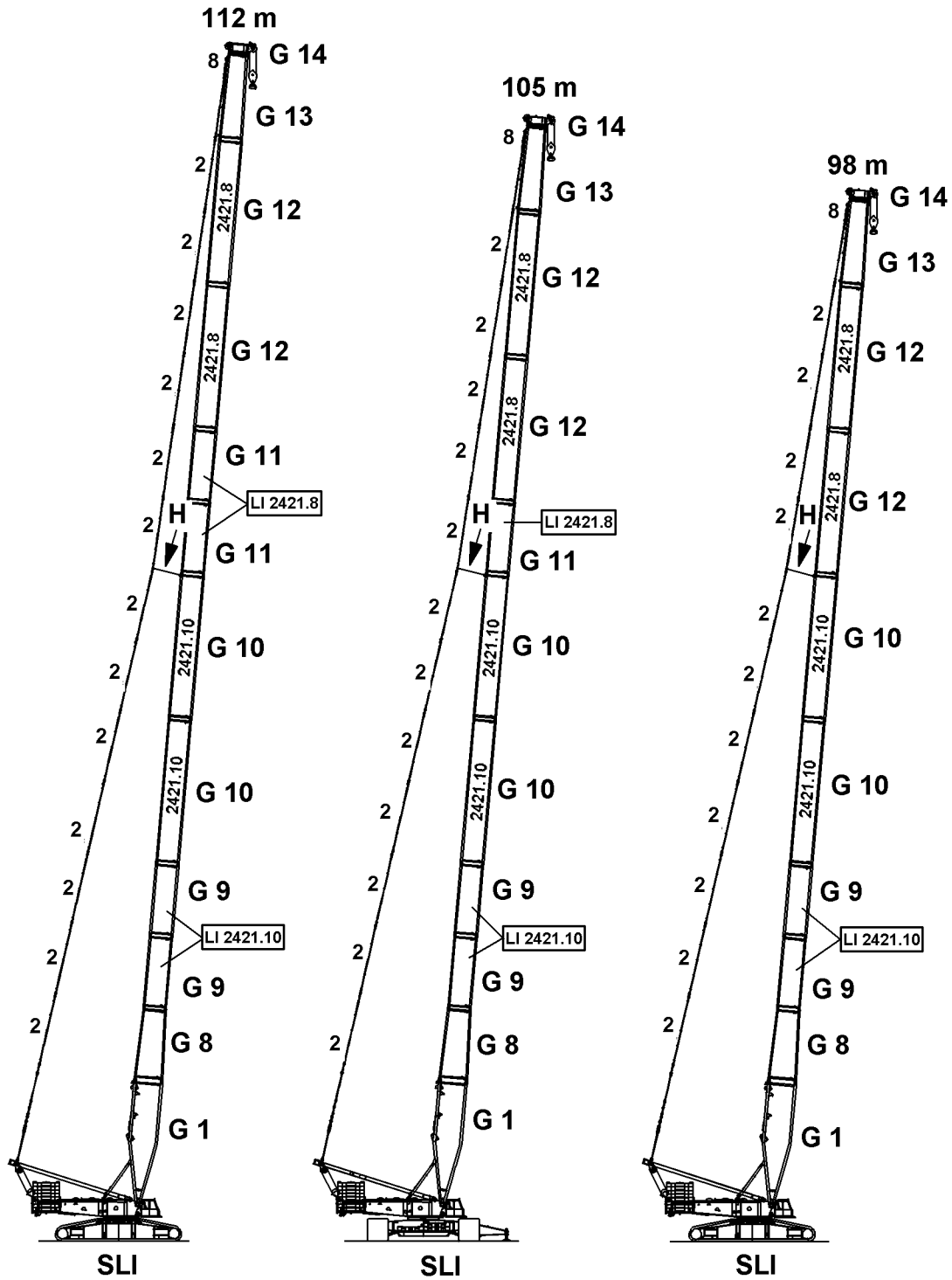


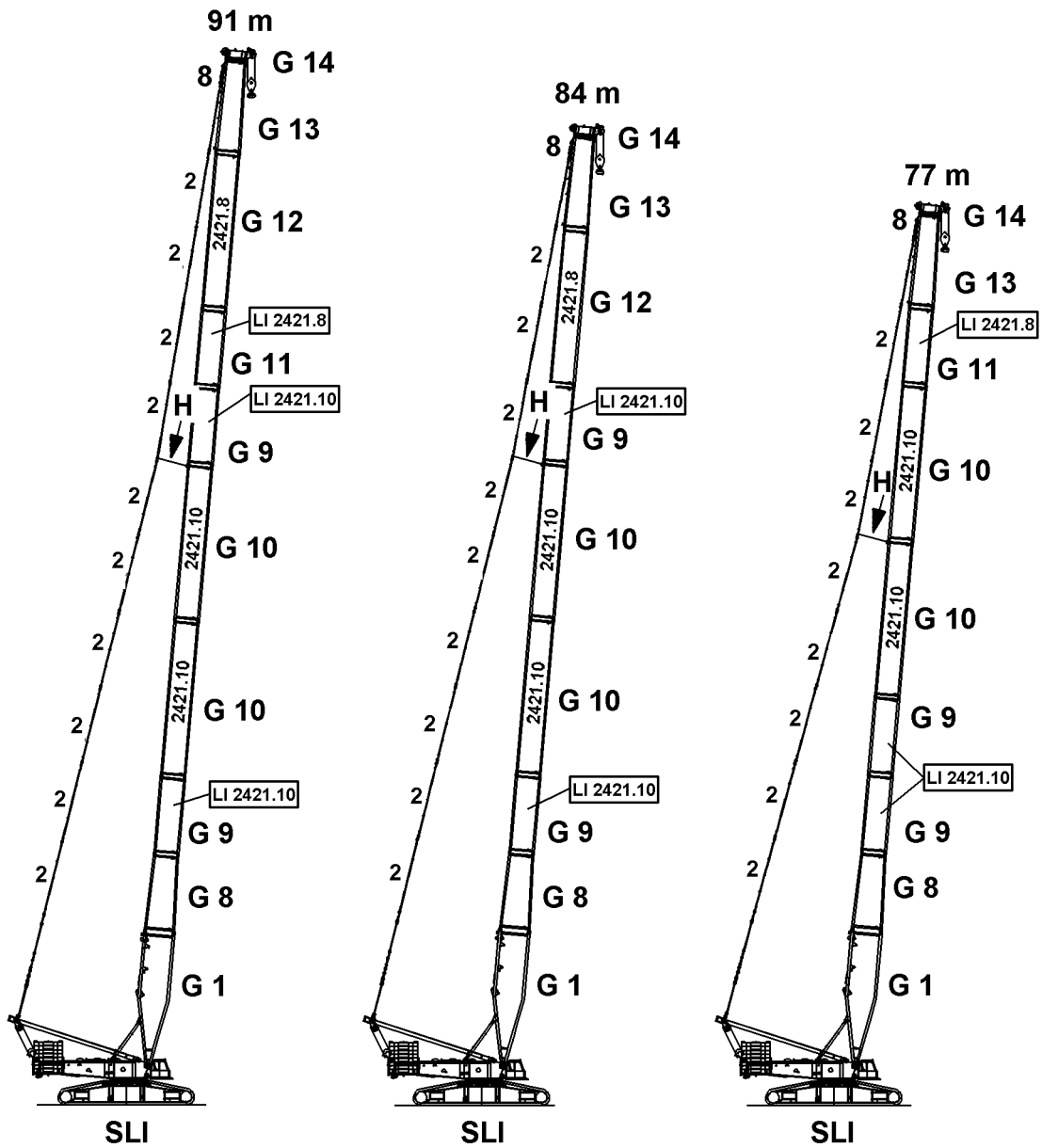
Fig. 5

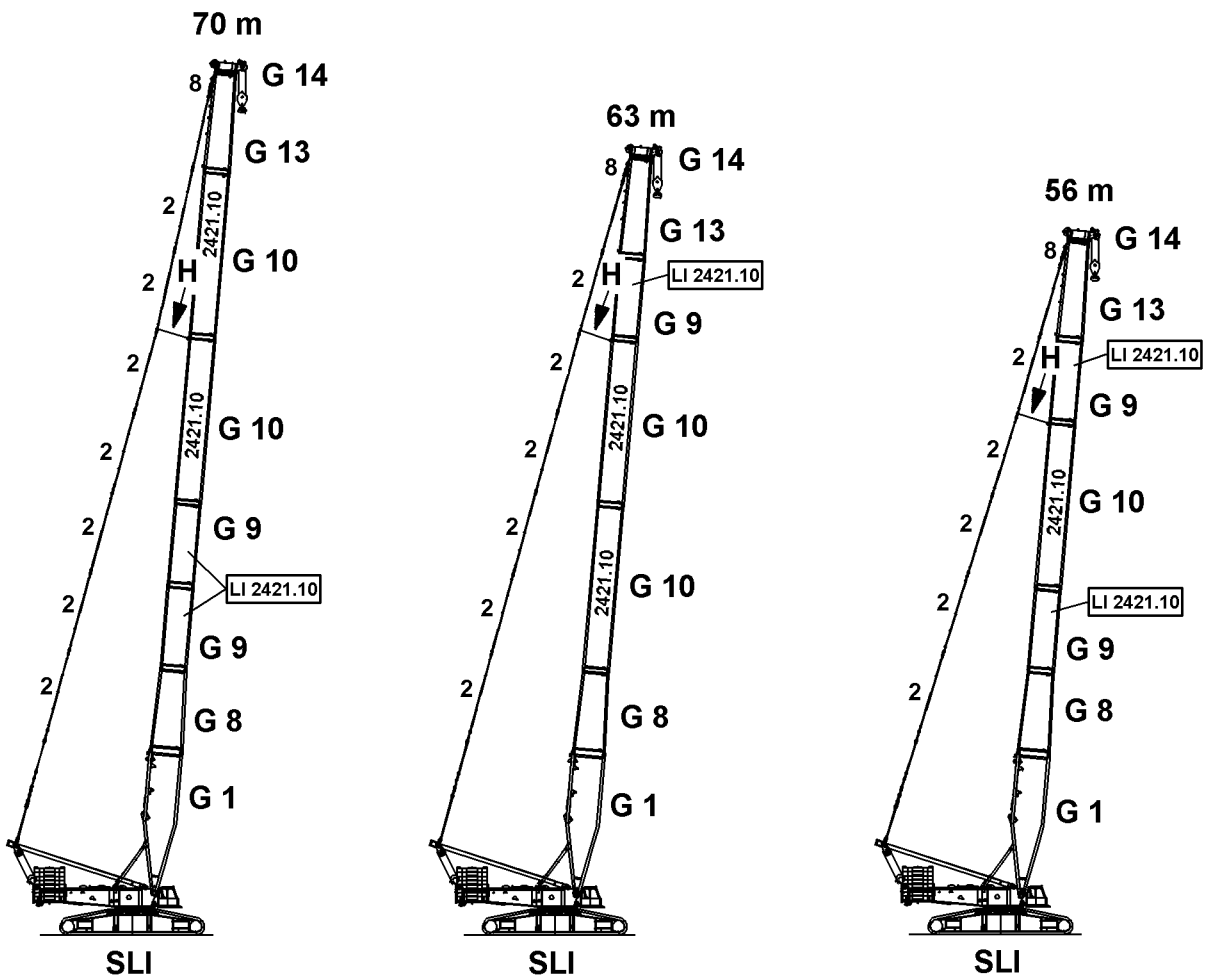
SL7DHS - attachment

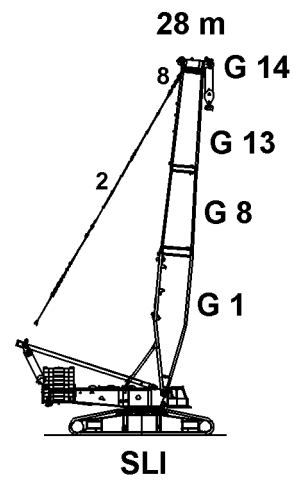
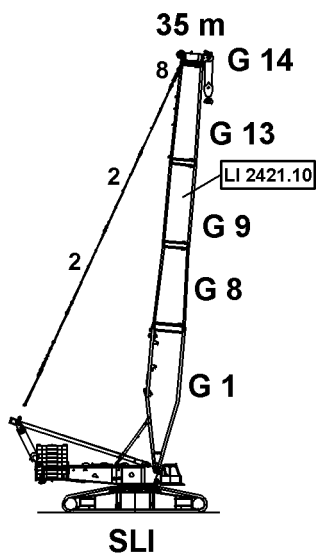
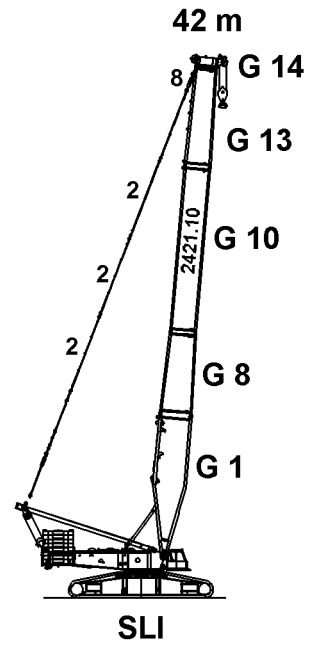
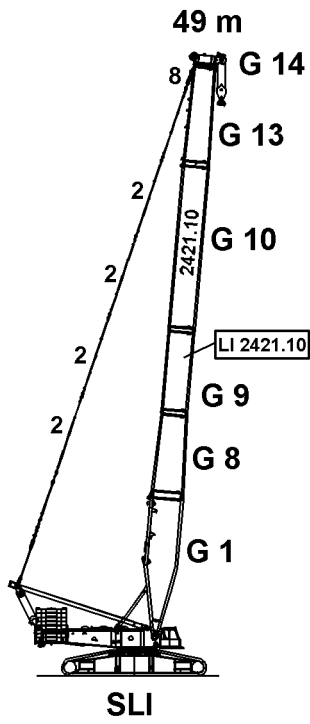
For a S-intermediate section 14m, 2826.20, a S-intermediate section 14m, 2826.30 can be installed.

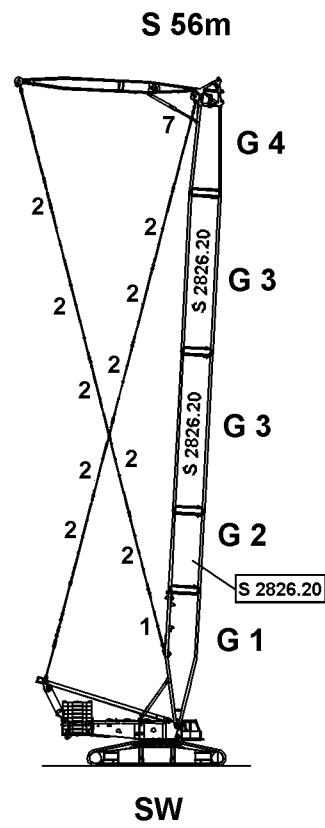
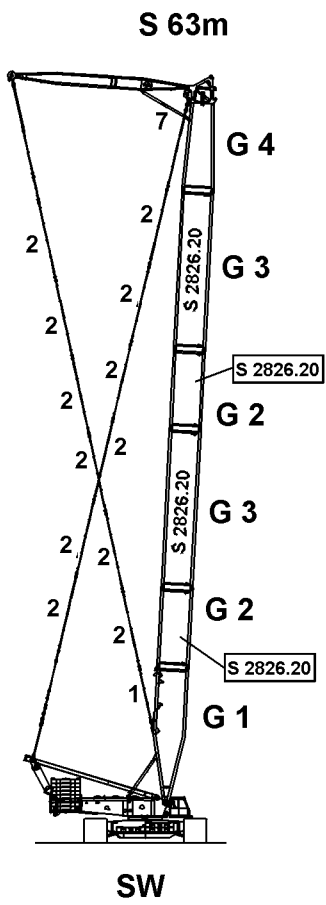
D A N G E R: The S-intermediate section 14m, 2826.30, must be installed after the S-pivot section!

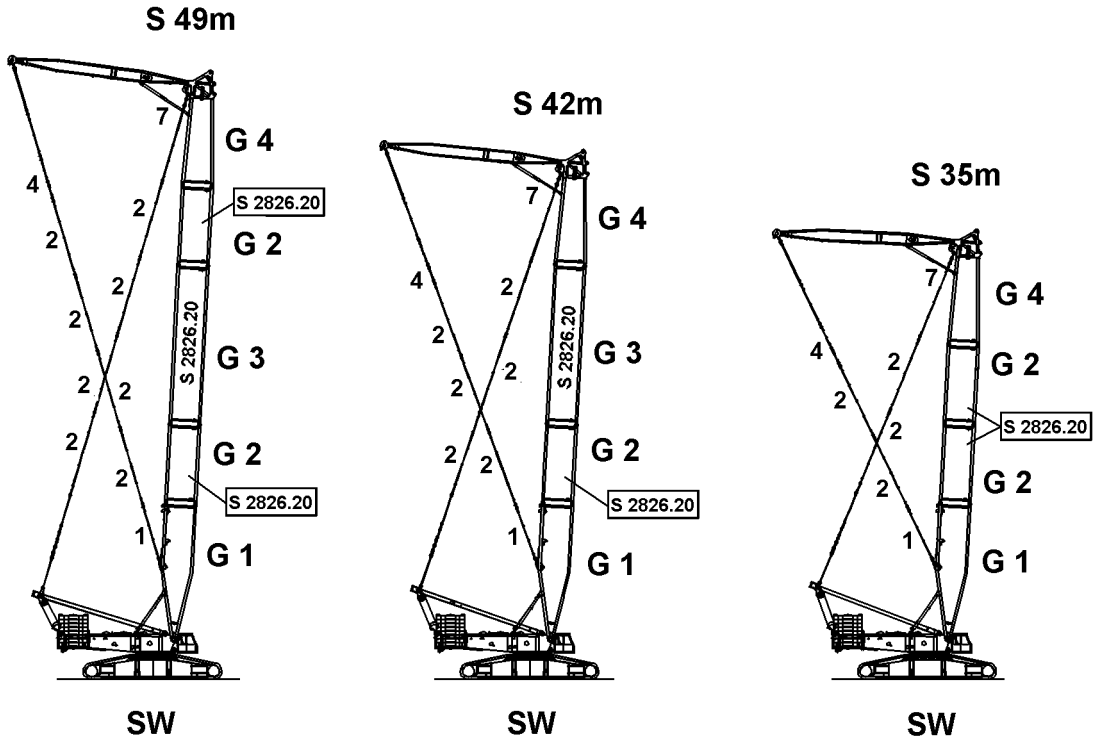


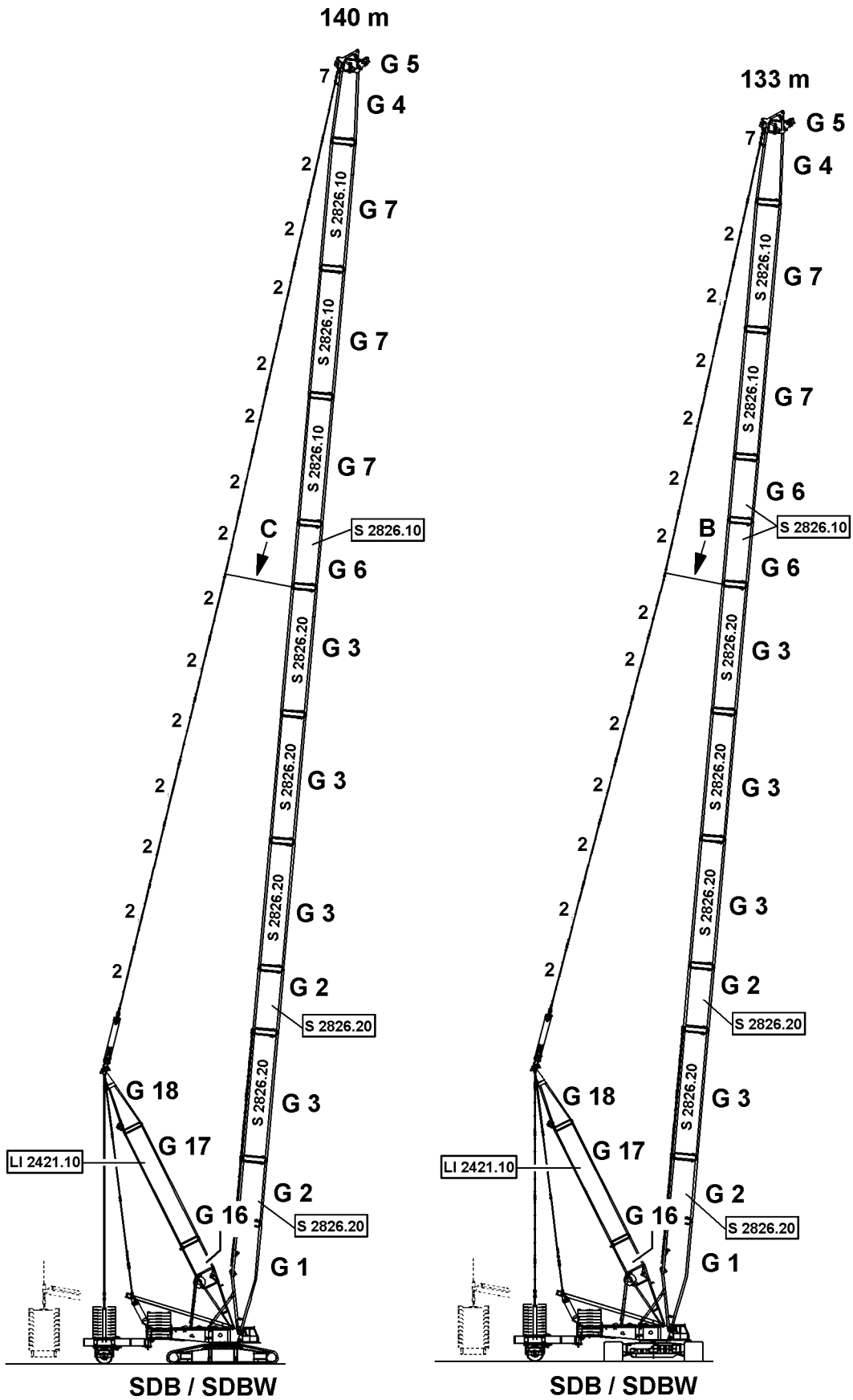


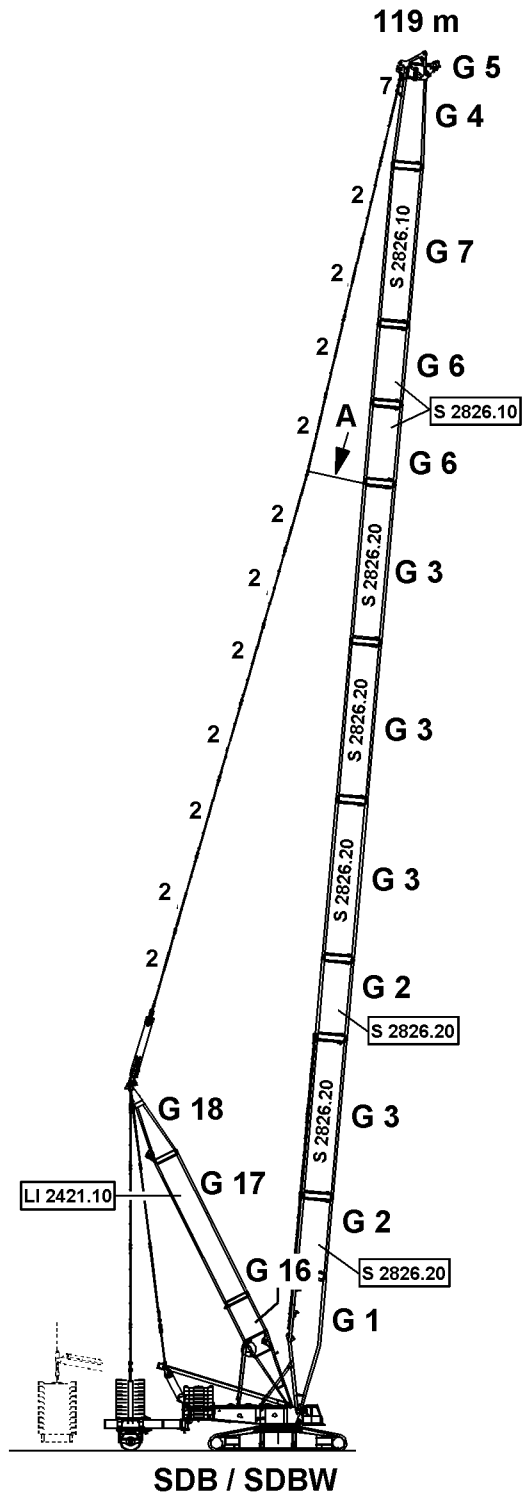
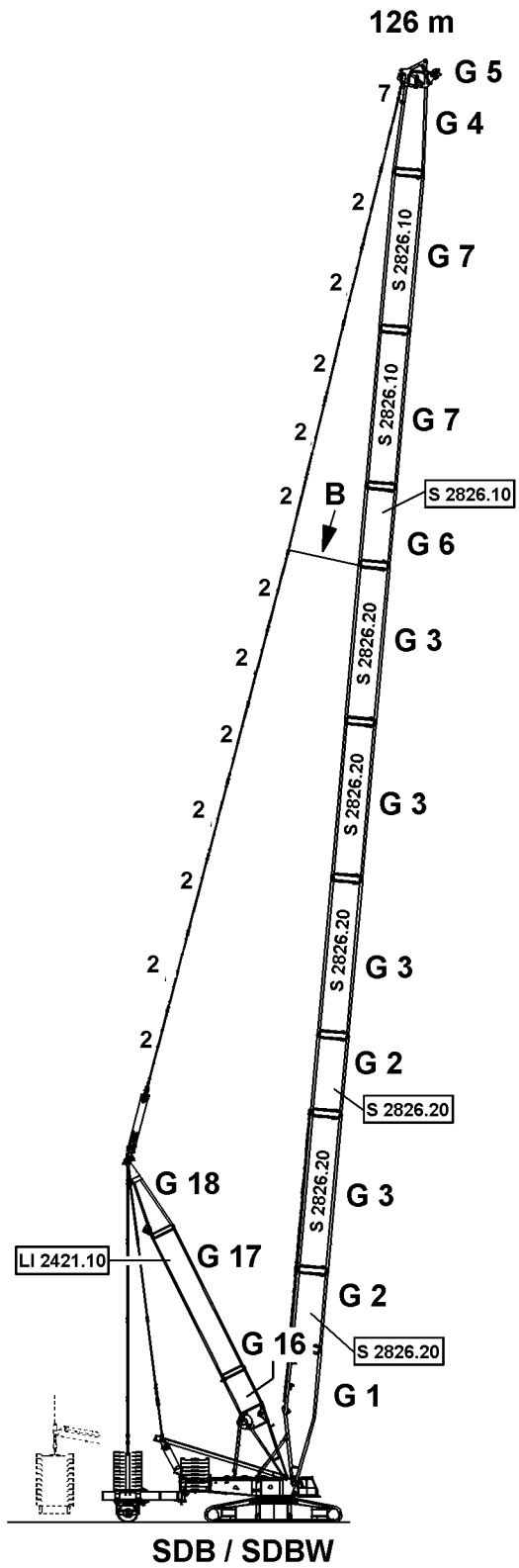


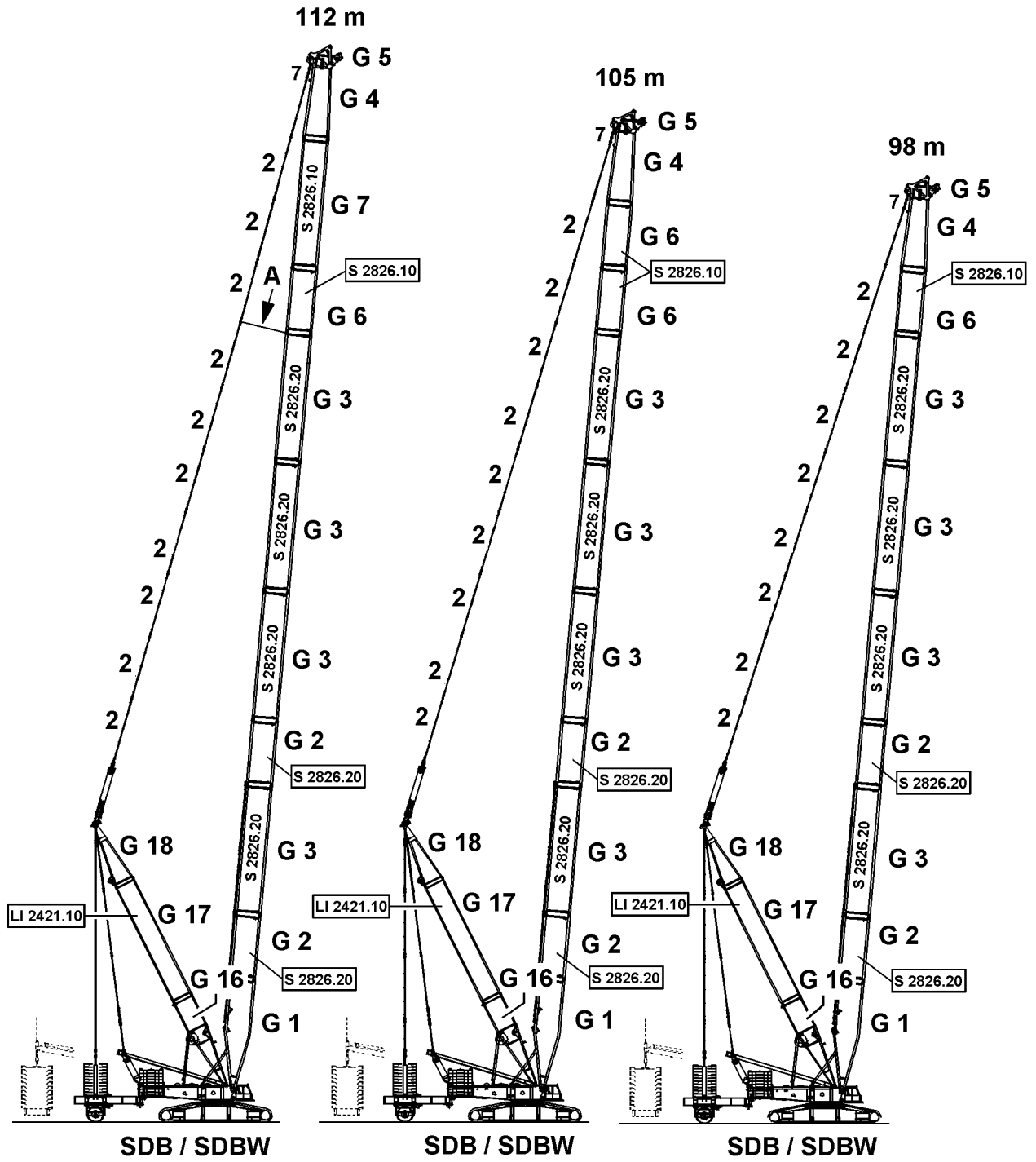


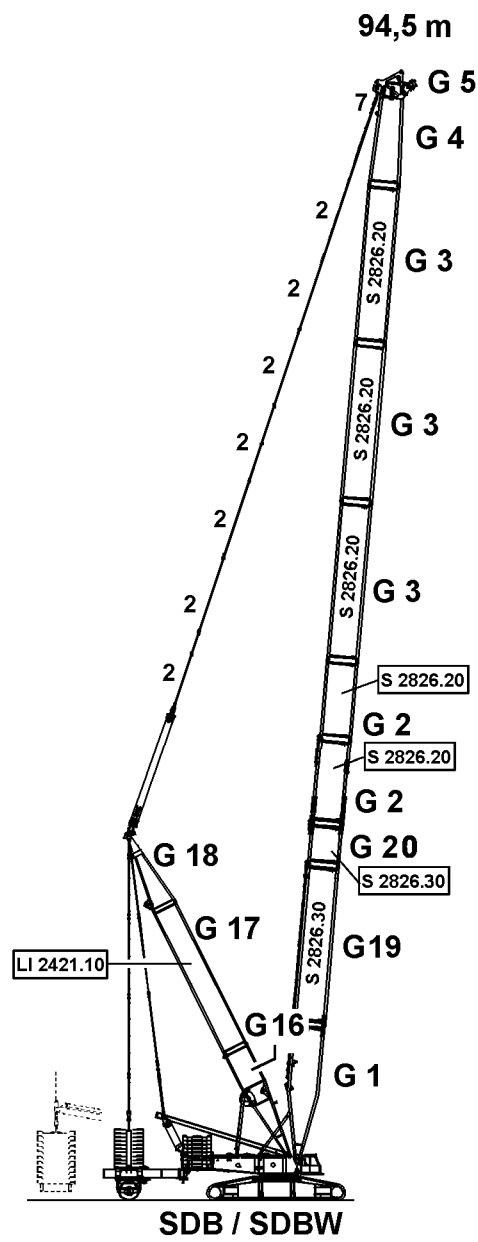
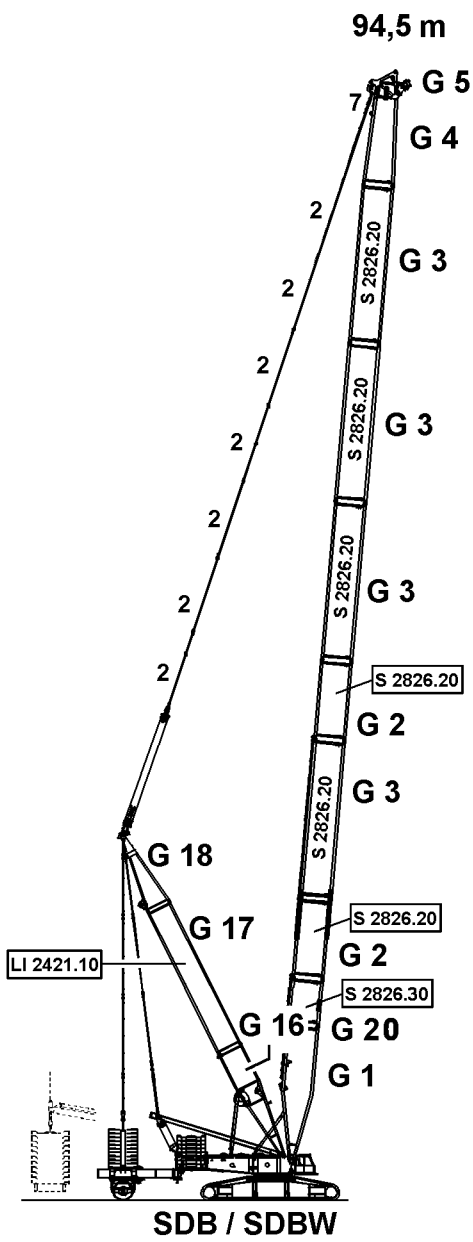












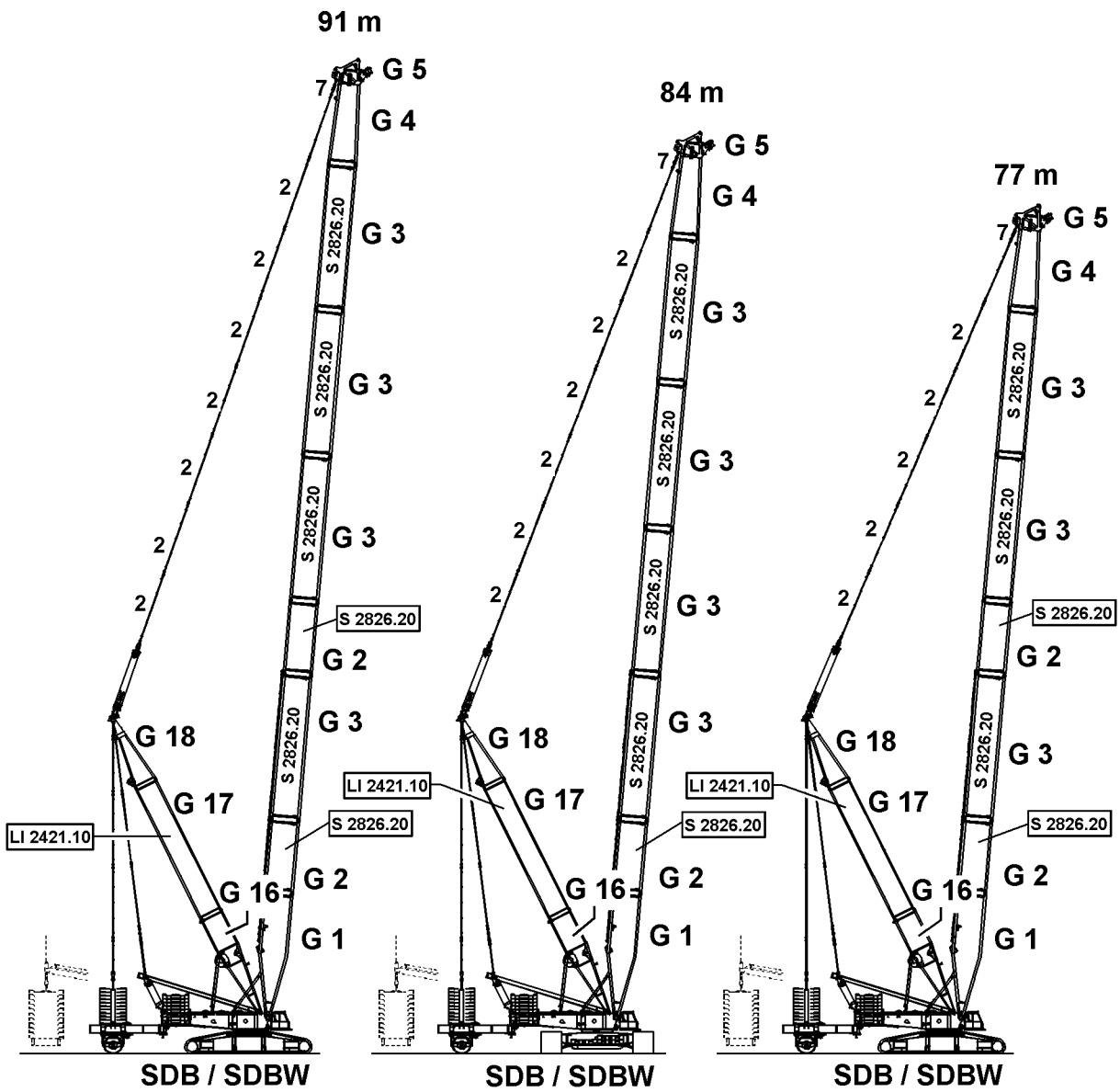
6

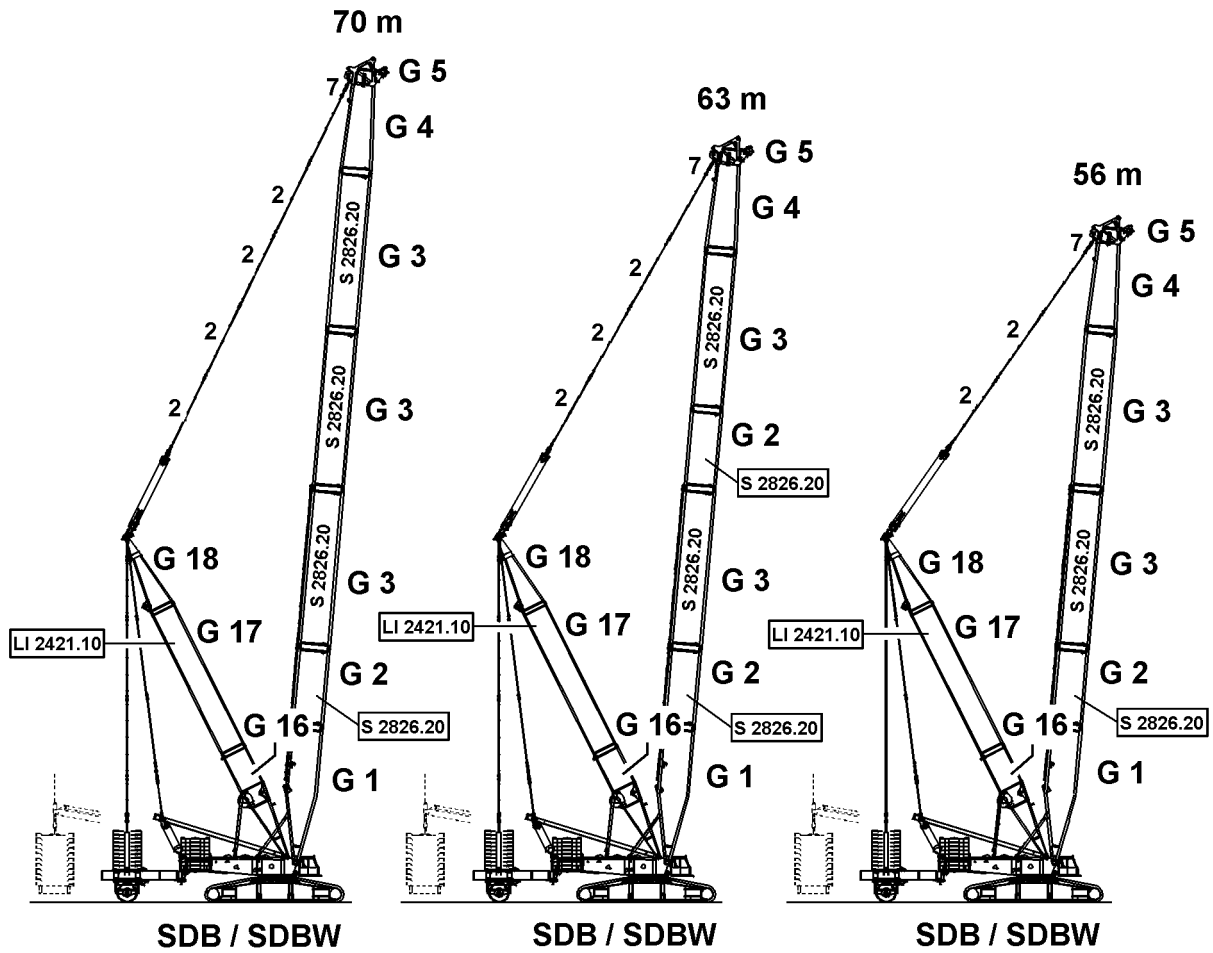
Fig. 6**SDB / SDBW- attachment**

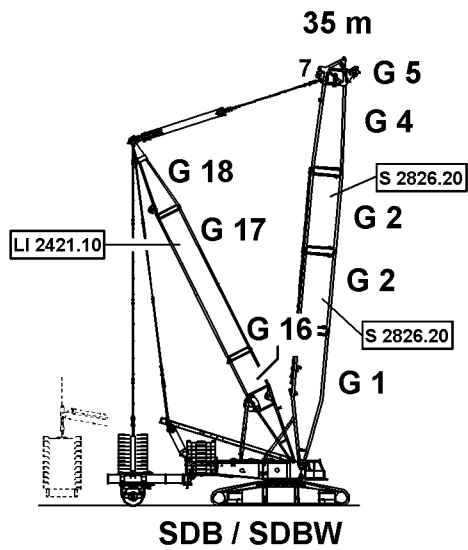
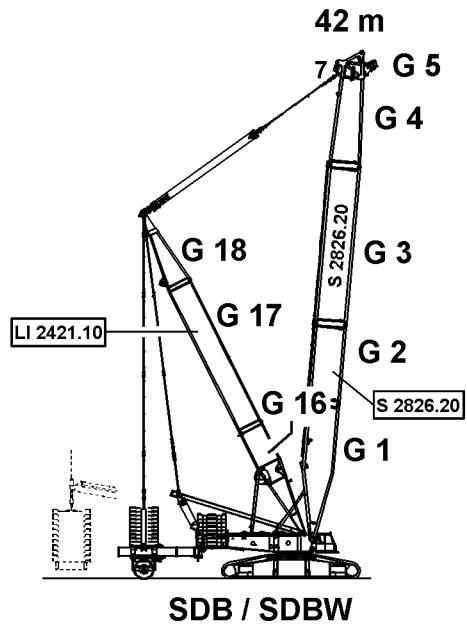
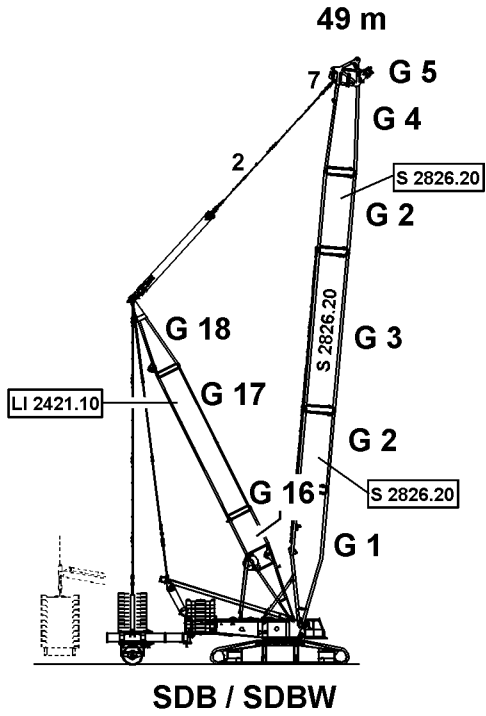
For a S-intermediate section 14m, 2826.20, a S-intermediate section 14m, 2826.30 can be installed.

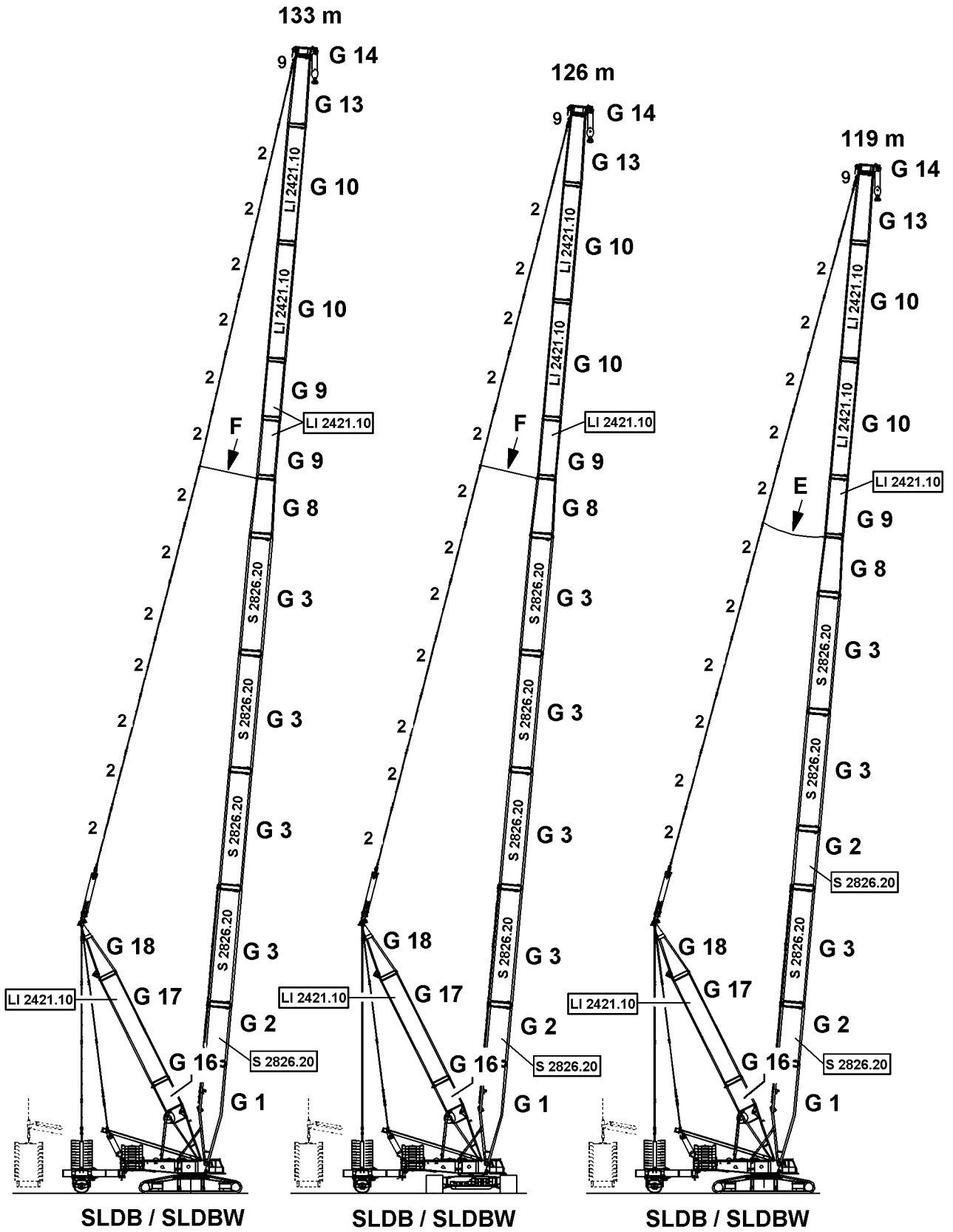
D A N G E R: The S-intermediate section 14m, 2826.30, must be installed after the S-pivot section!

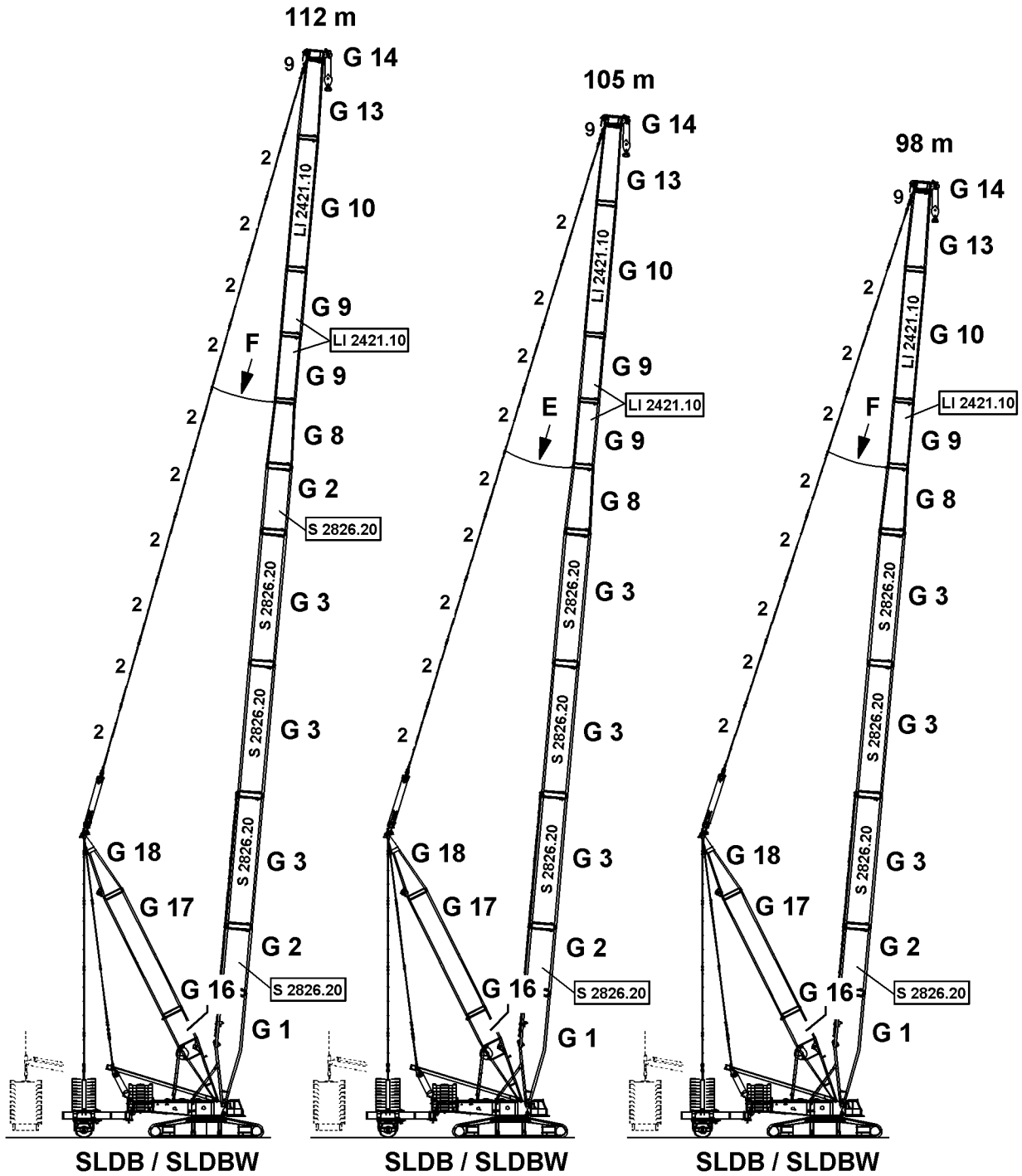
If the S-intermediate section 14m, 2826.30 is installed on the S 94,5m boom, the S-intermediate section 14m, 2826.30 and then the S -intermediate section 3,5m, 2826.30 must first be installed after the S-pivot section!

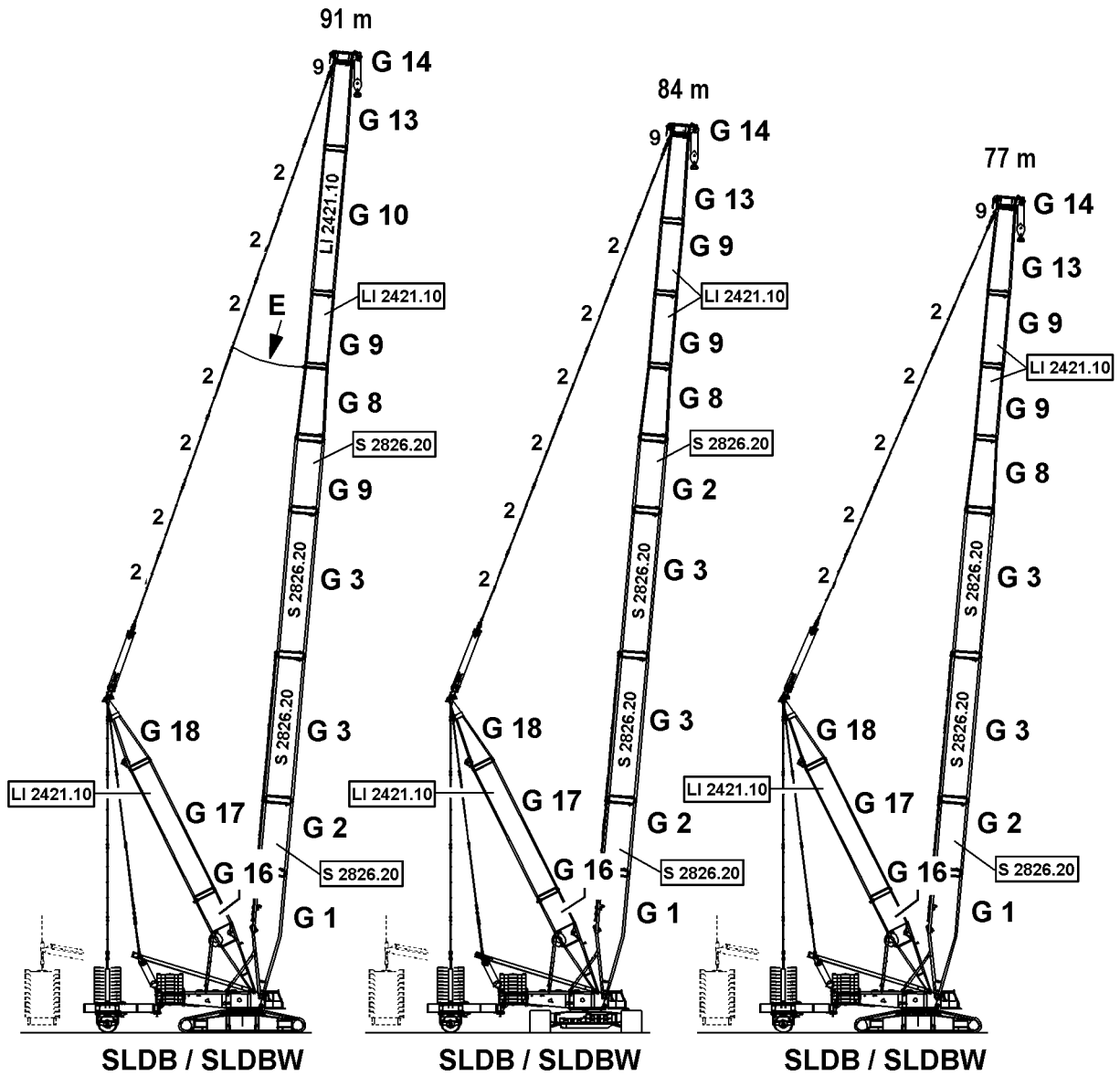


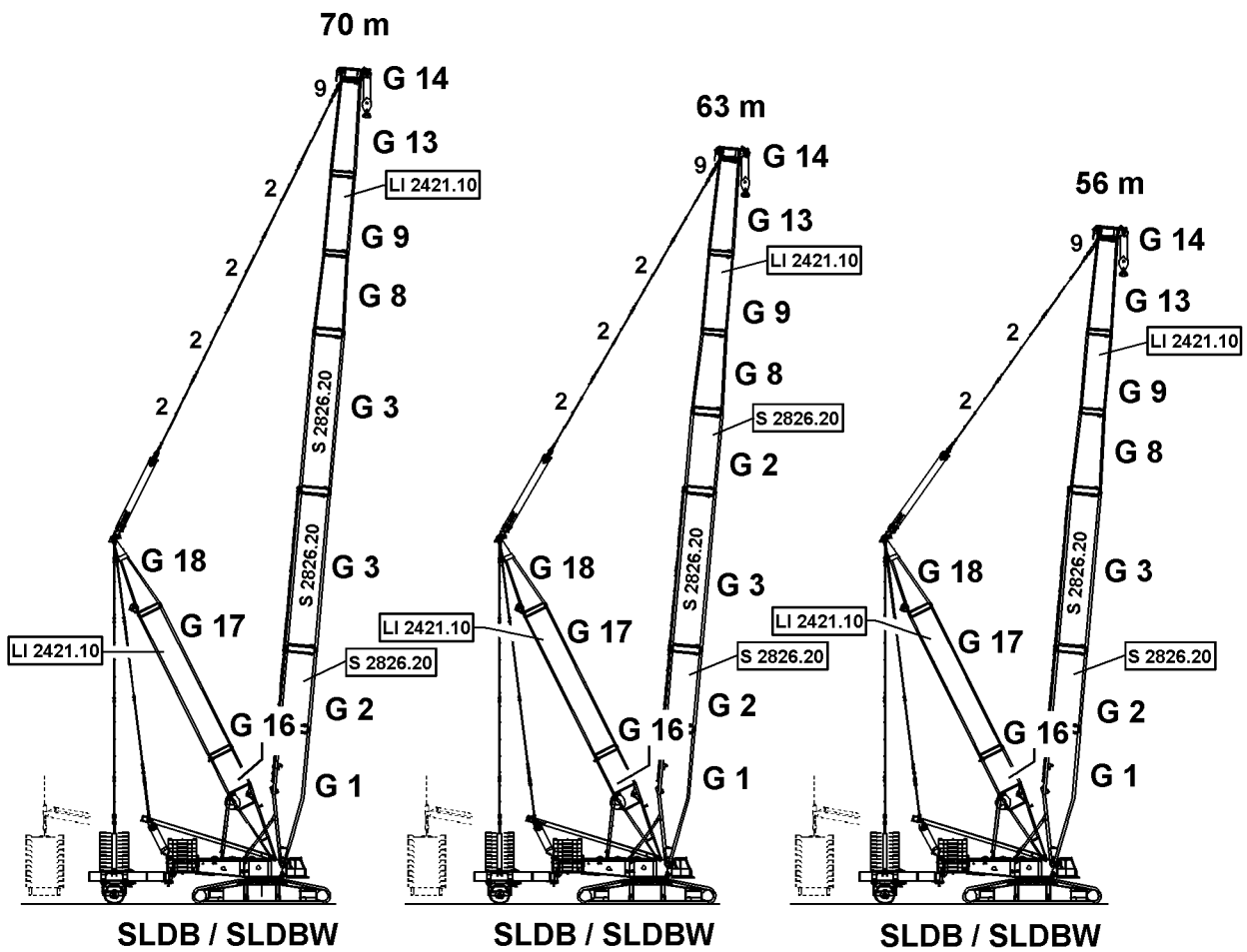


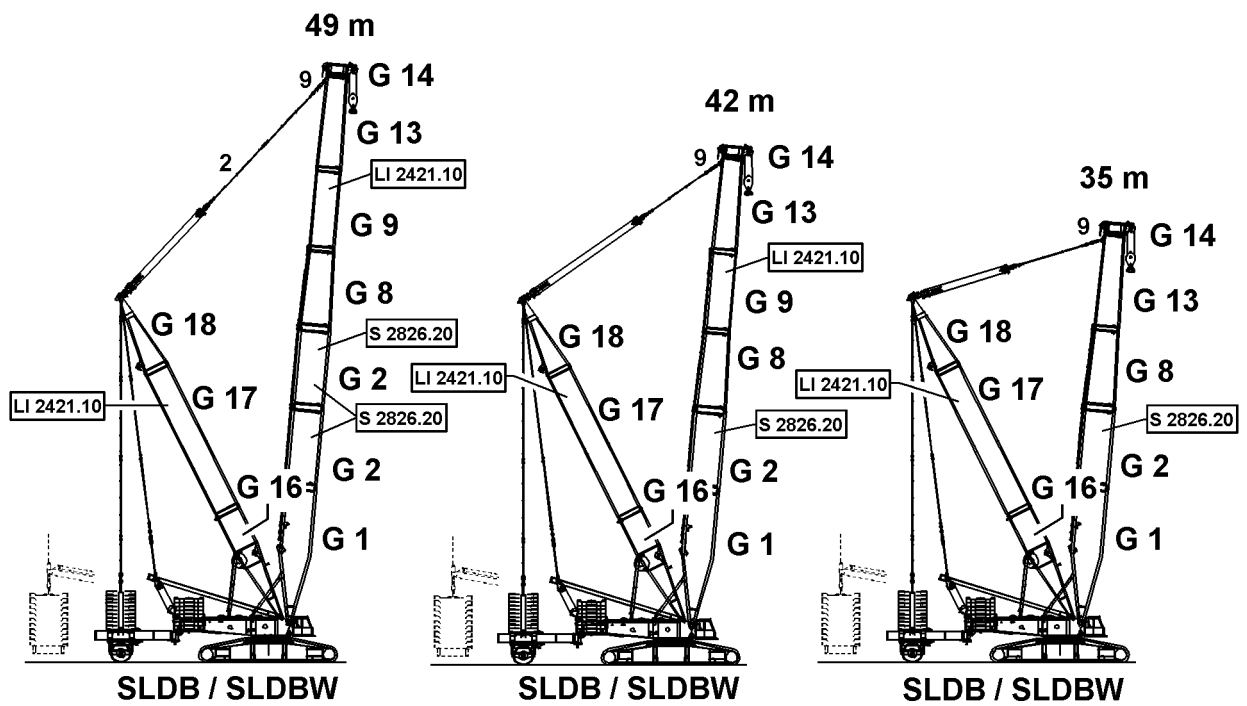


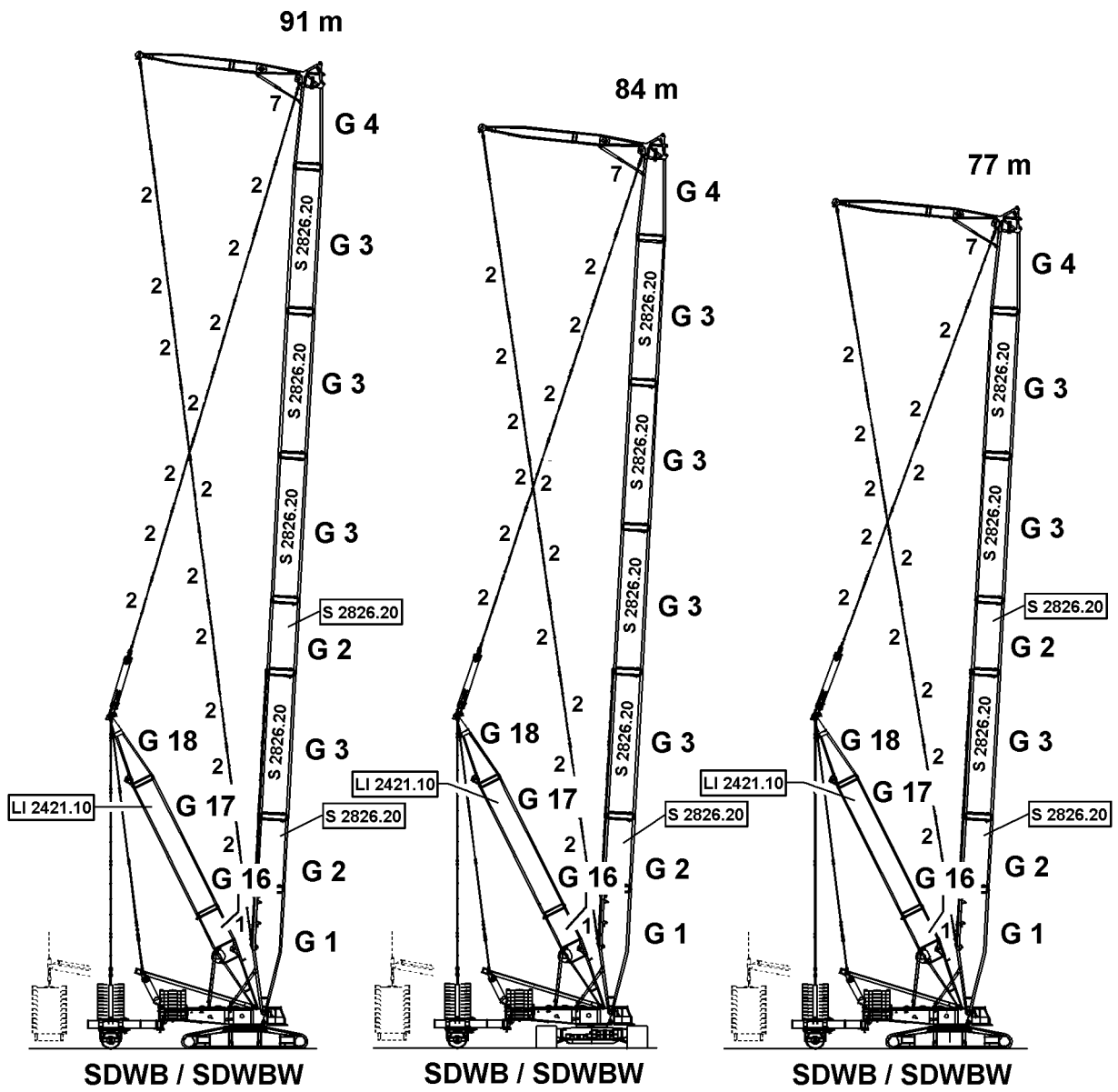


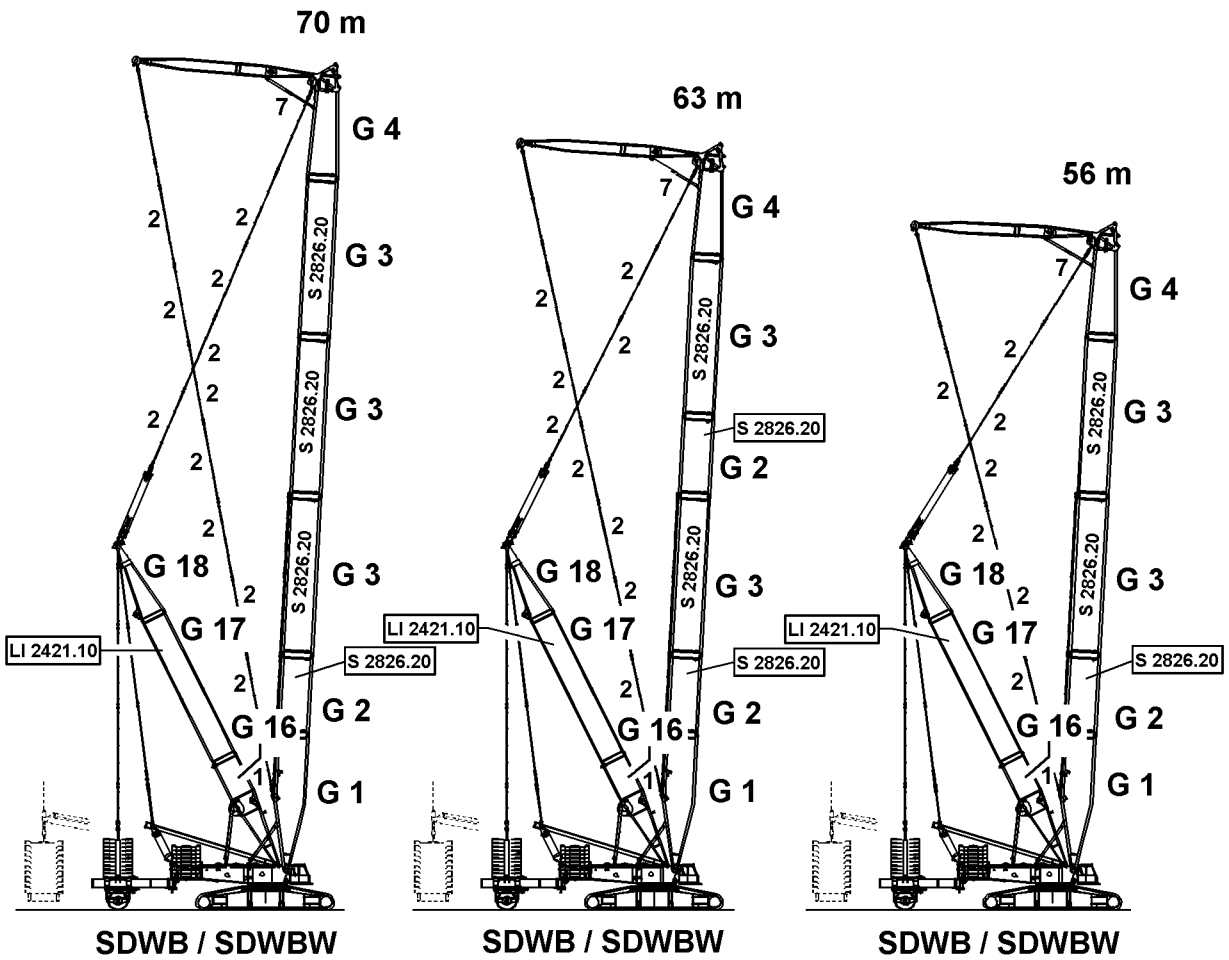


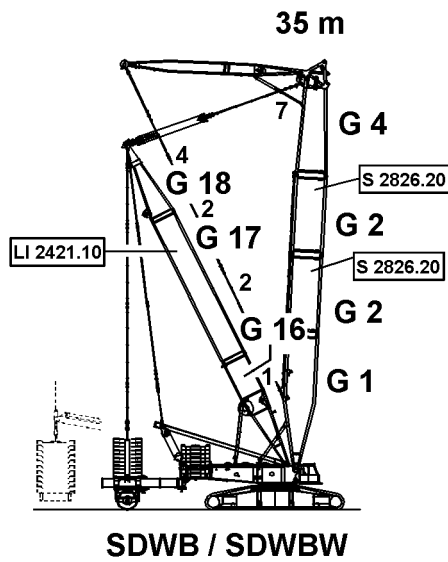
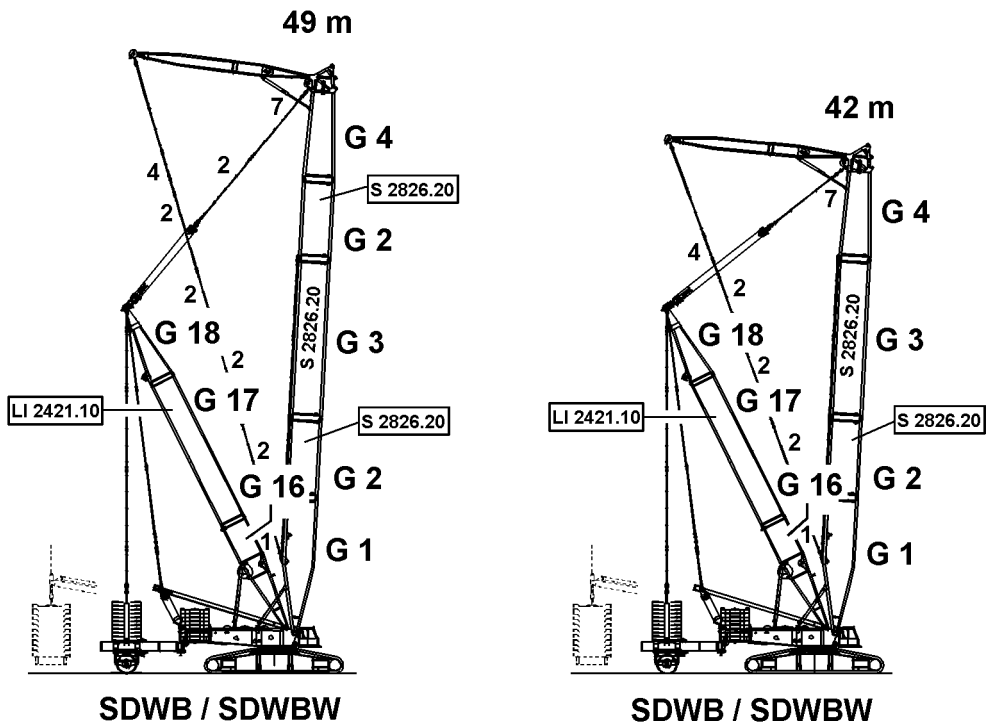






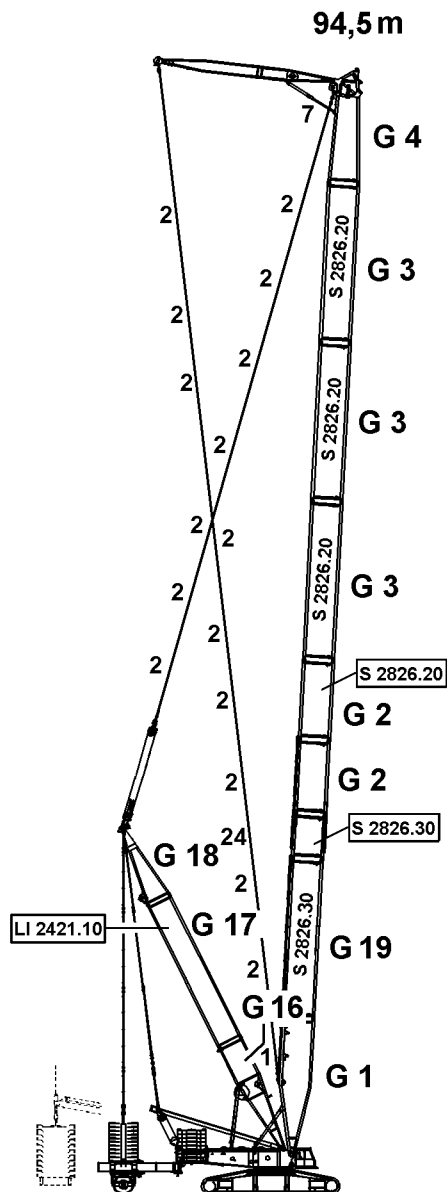


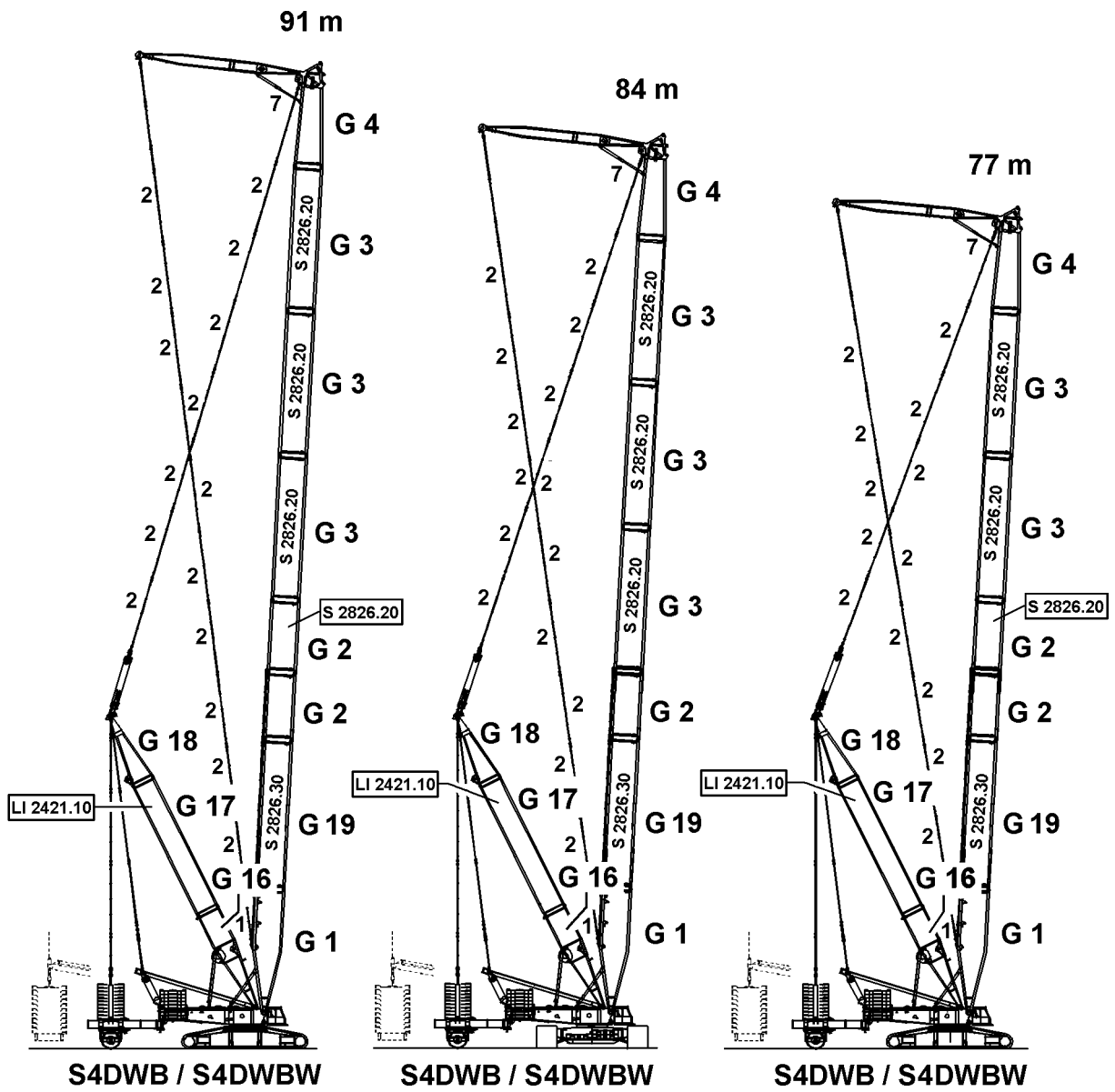




BOOM SYSTEM 94,5m

D A N G E R: S 94,5m is only possible in WV - operation!





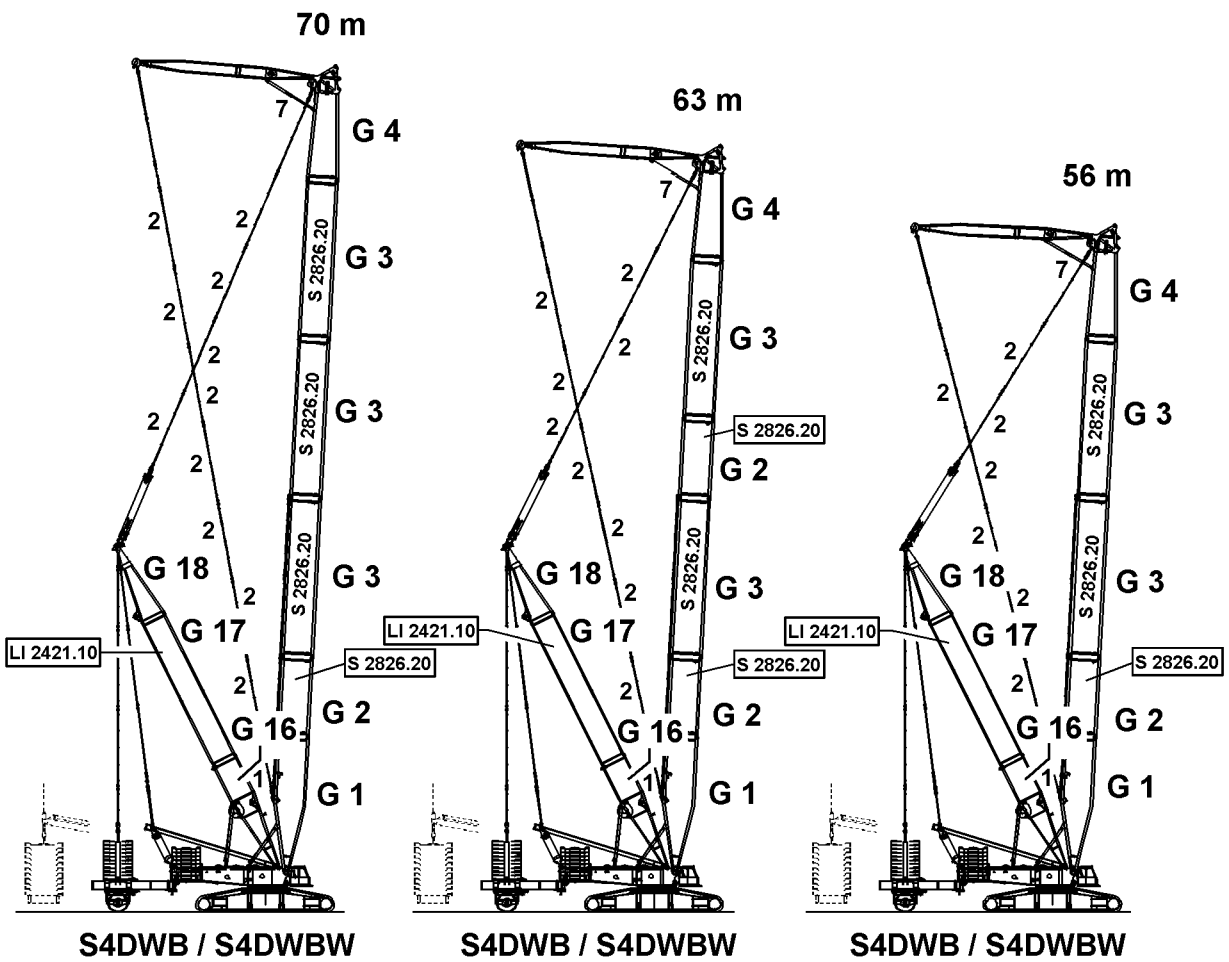
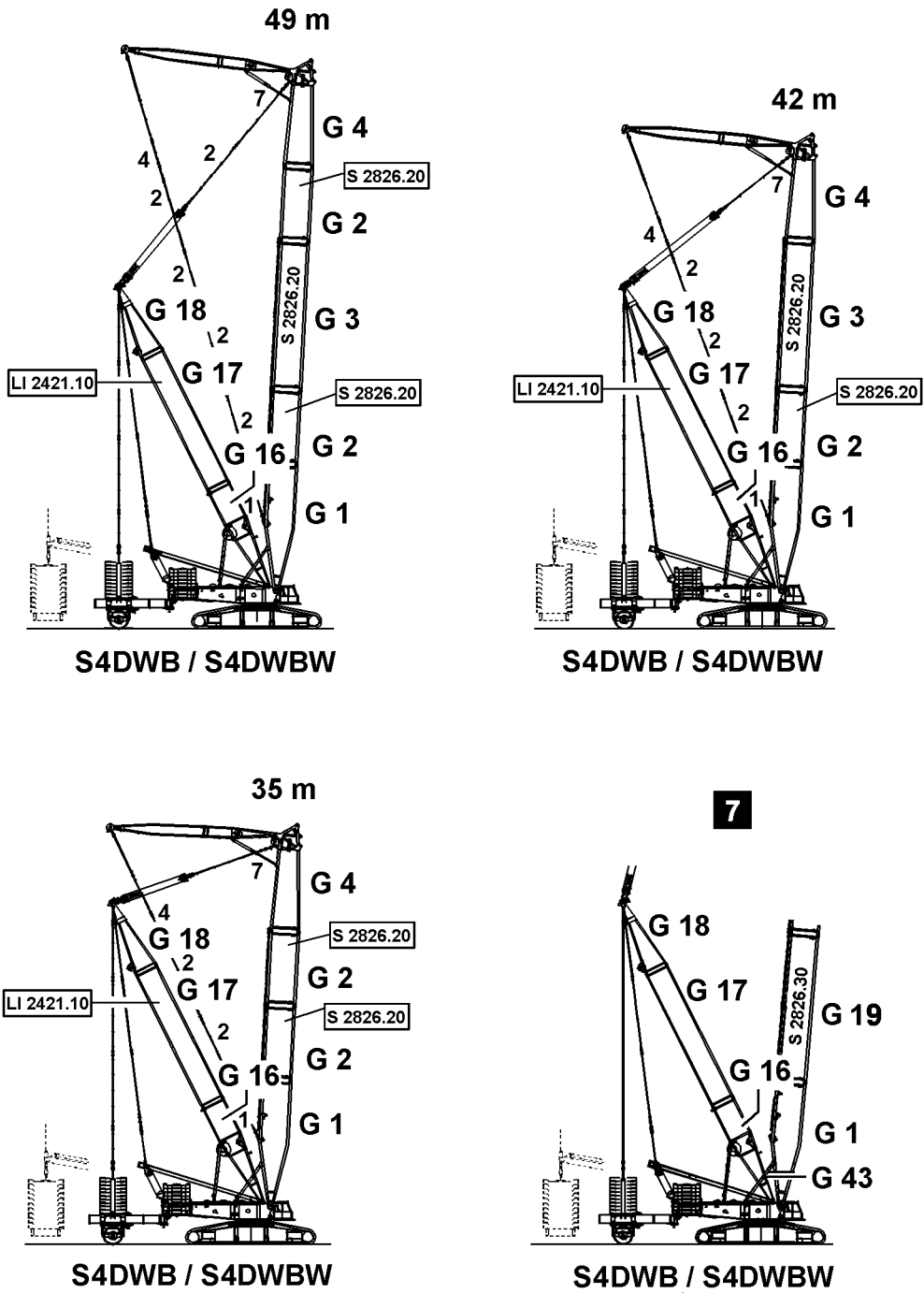


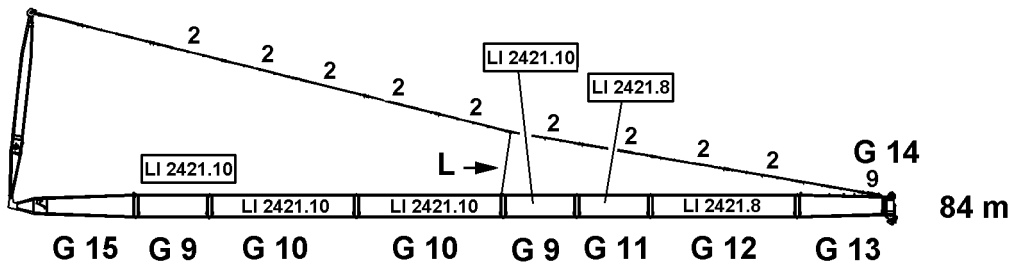
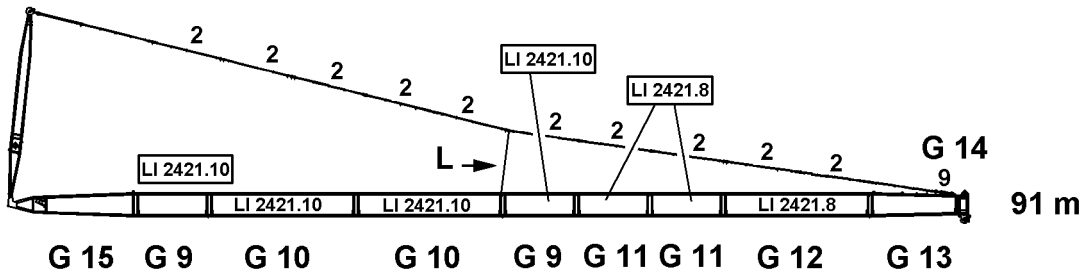
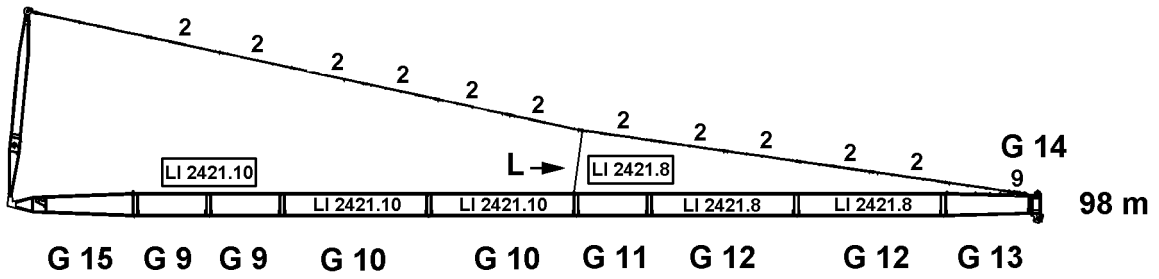
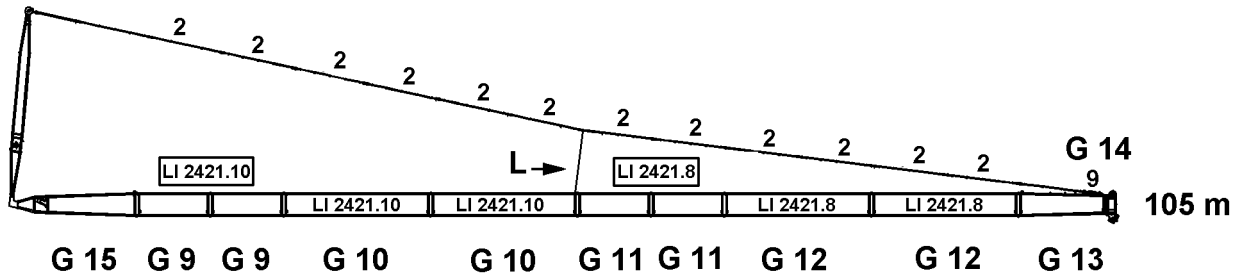
Fig. 7

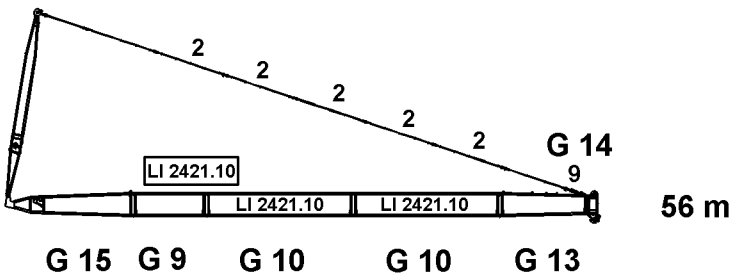
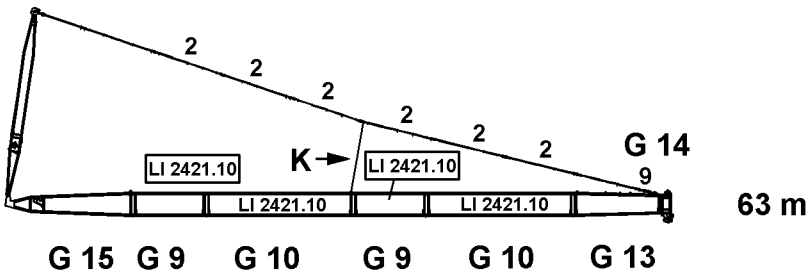
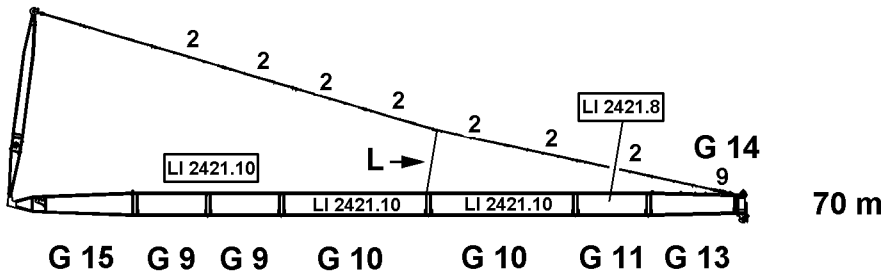
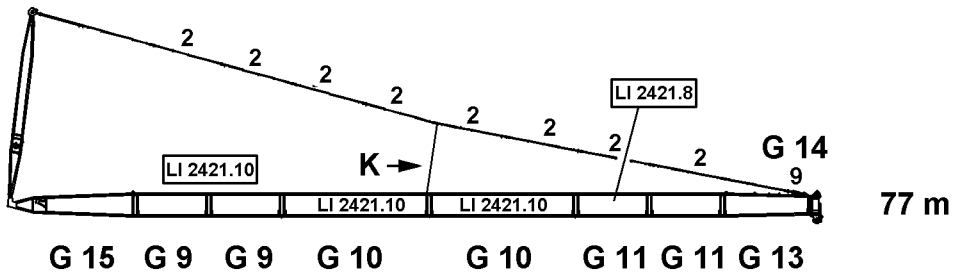
S4DWB / S4DWBW - attachment

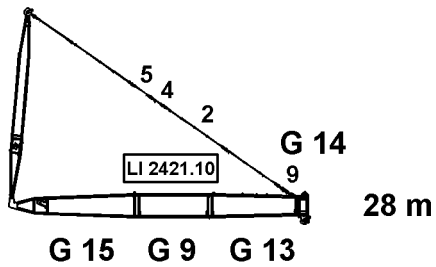
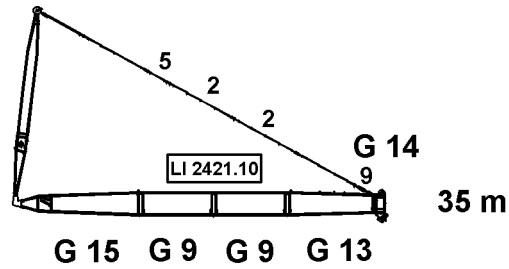
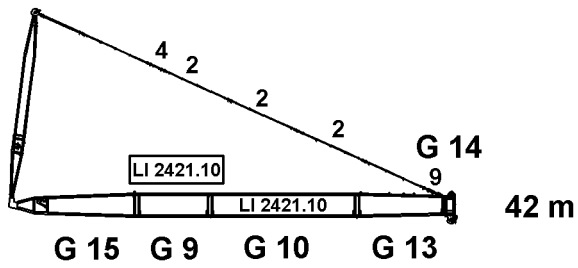
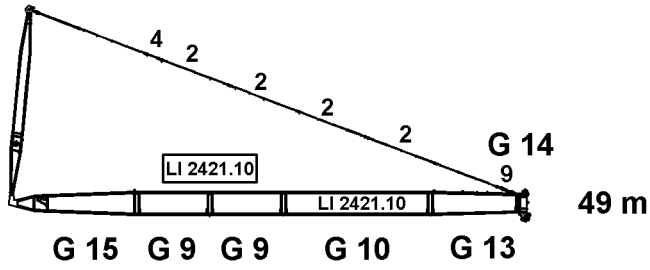
For a S-intermediate section 14m, 2826.20, a S-intermediate section 14m, 2826.30 can be installed.

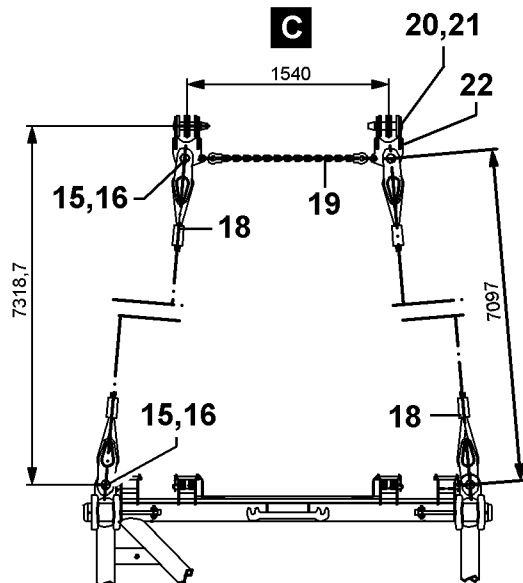
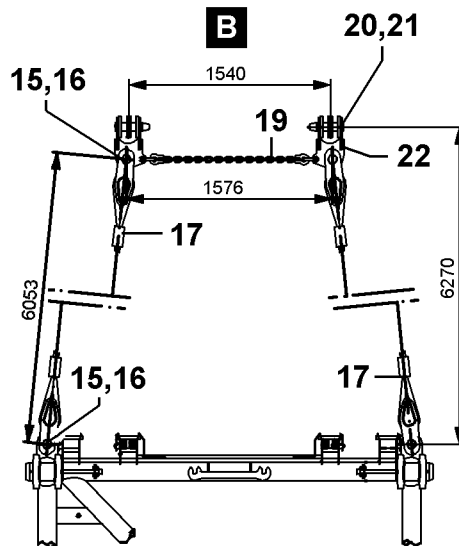
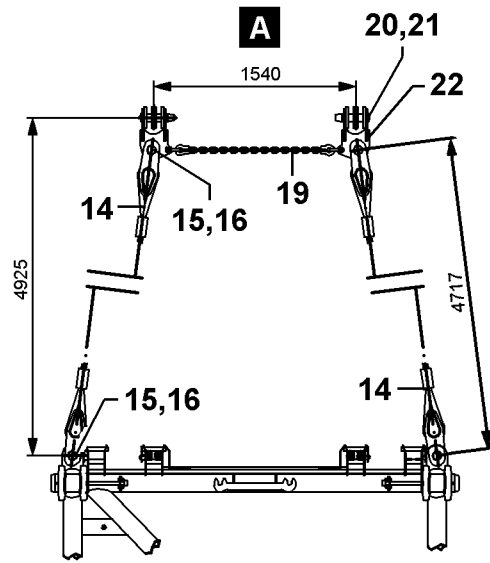
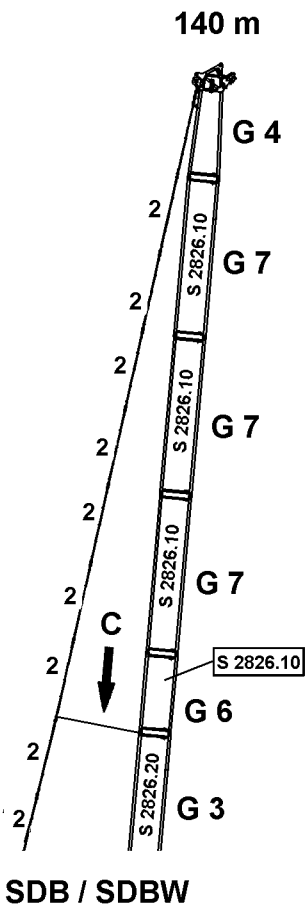
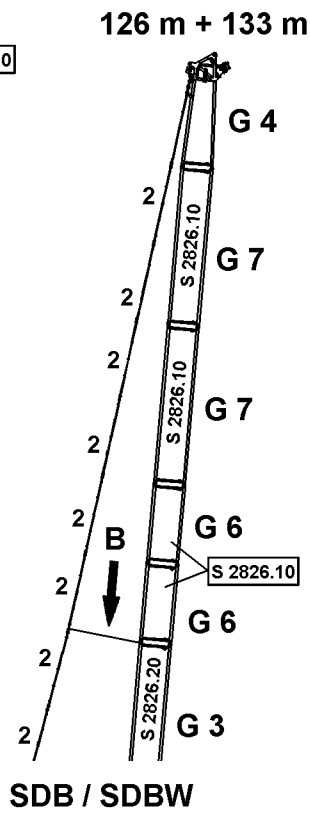
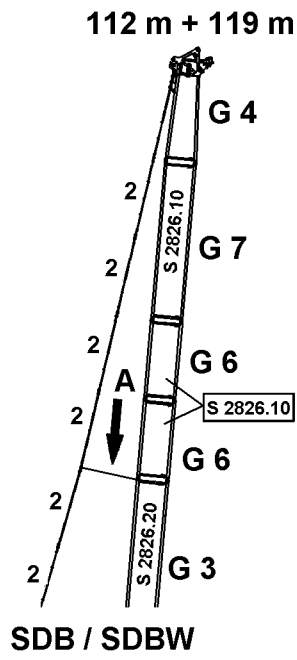
D A N G E R: The S-intermediate section 14m, 2826.30, must be installed after the S-pivot section!











Added guying SD - Boom

For a SD- boom length of 112m and 119 m, added guying (fig. A) is required between the guy rods and the boom.

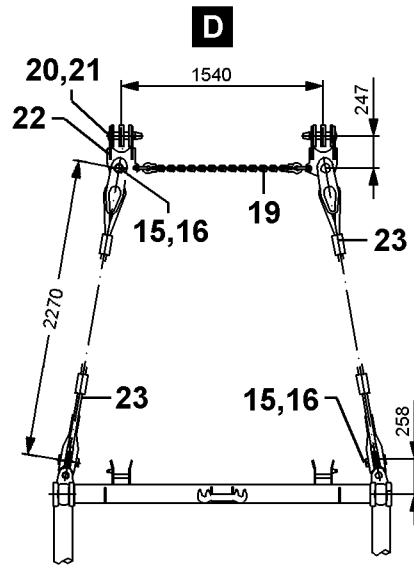
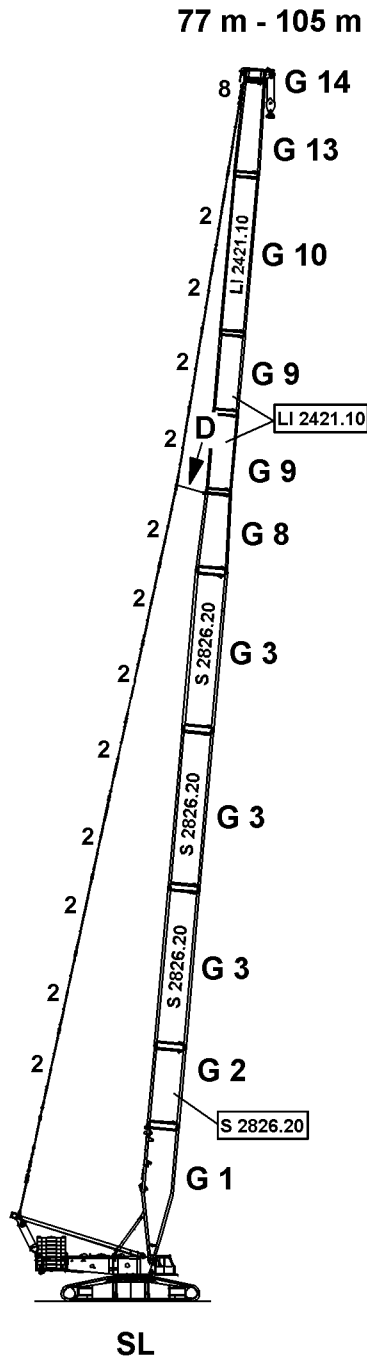
For a SD- boom length of 125 m and 133 m, added guying (fig. B) is required between guy rods and boom.

For a SD- boom length of 140 m, added guying (fig. C) is required between guy rods and boom.

The added guying consists of two each guy ropes (14,17 or 18) and two brackets (22).

The guy ropes (14,17 or 18) are pinned on the brackets (22) with pin (15) and secured with spring retainer (16) .

D A N G E R: The added guying must be installed according to the installation drawing.



Added guying SL - boom

For a SL - boom length of 77 m - 105 m, added guying (fig. D) is required between the guy rods and the boom.

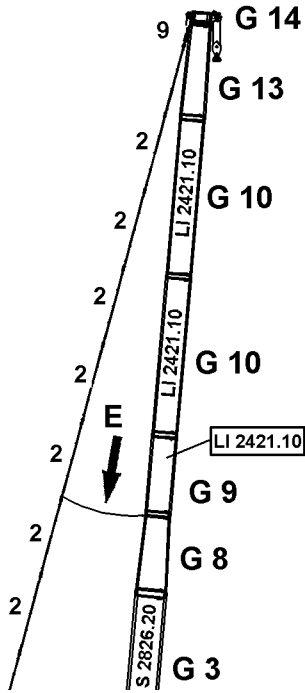
The added guying consists of two guy ropes (23), as well as two brackets (22).

The brackets (22) are pinned to the guy rods with pin (24) and secured with spring retainer (16) .

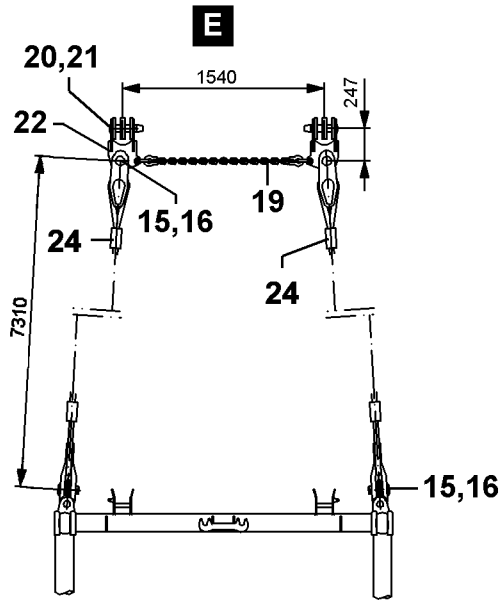
The guy ropes (23) are pinned on the connector points on the lattice jib with pin (15) and secured with spring retainer (16) .

D A N G E R: **The added guying must be installed according to the installation drawing.**

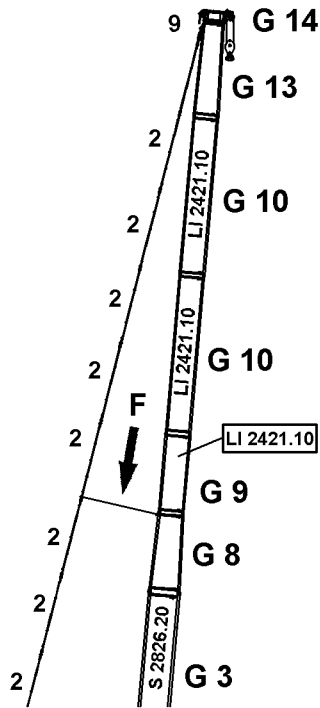
91 m, 105 m, 119 m



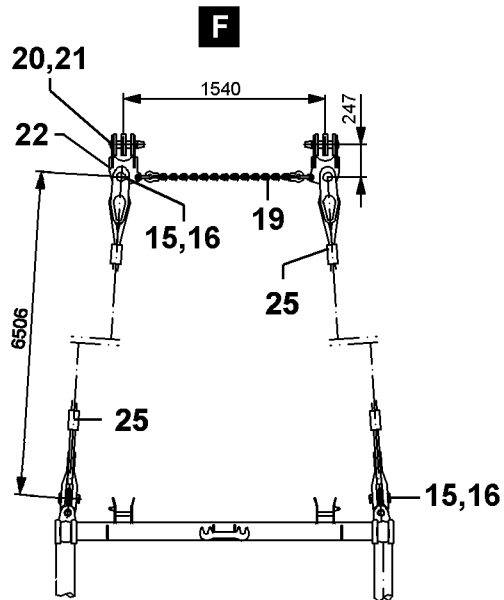
SLDB / SLDBW



98 m, 112 m, 126 m, 133 m



SLDB / SLDBW



Added guying SLD - boom

For a SLD- boom length of 91m, 115 m and 119 m, added guying (fig. E) is required between the guy rods and the boom.

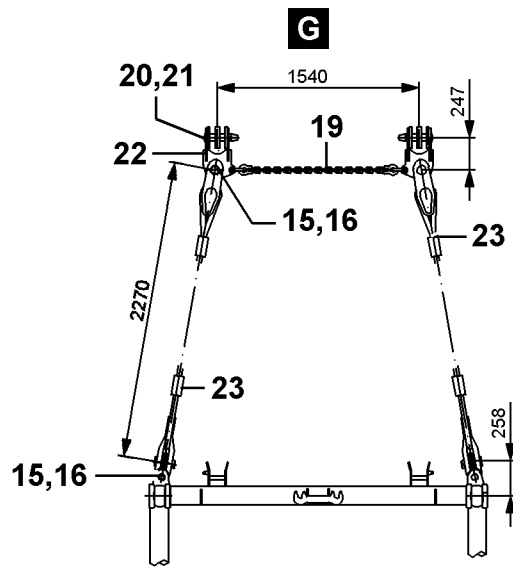
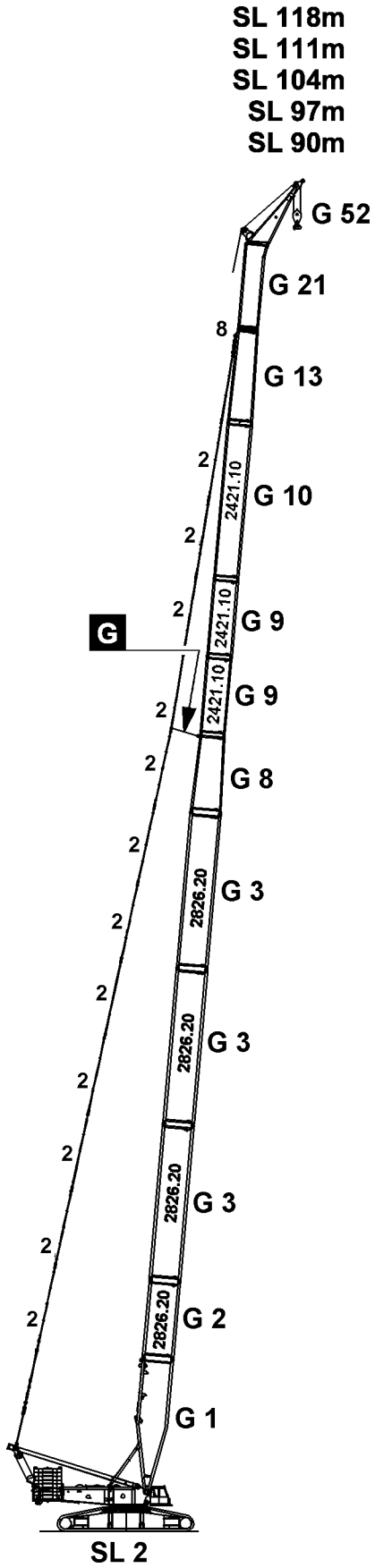
For a SLD- boom length of 98 m, 112 m, 126 m and 133 m , added guying (fig. F) is required between the guy rods and the boom.

The added guying consists of two guy ropes (25 or 26) and two brackets (22).

The guy ropes (25 or 26) are pinned and secured to brackets (22) .

The guy ropes (25 or 26) are pinned on the connector points on the lattice jib with pin (15) and secured with spring retainer (16) .

D A N G E R: The added guying must be installed according to the installation drawing.



Added guying SL2 - boom

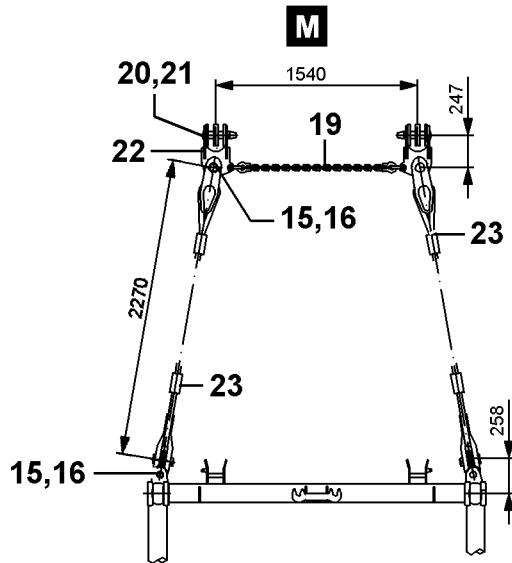
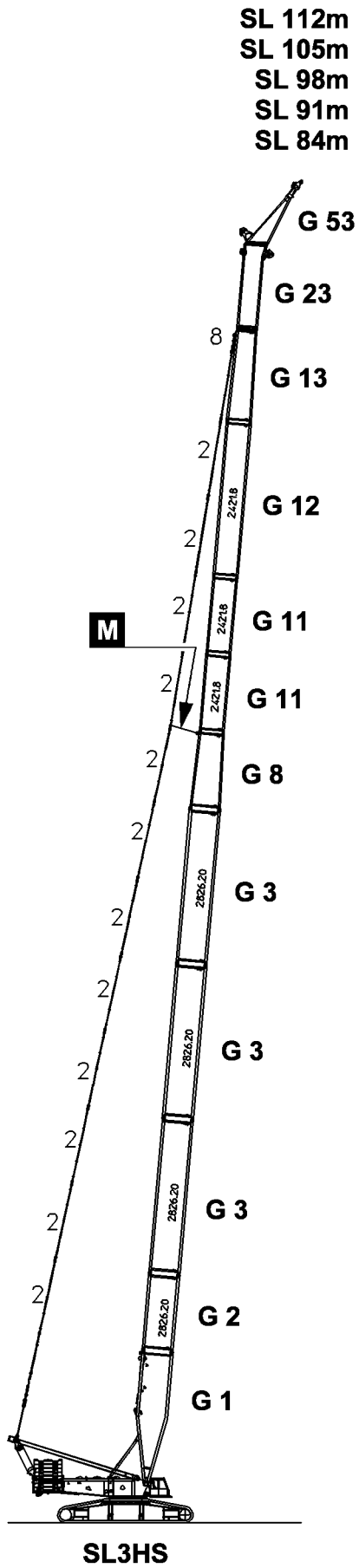
For a SL2 - boom length of 90 m - 118 m, added guying (fig. G) is required between the guy rods and the boom.

The added guying consists of two guy ropes (23), as well as two brackets (22).

The brackets (22) are pinned to the guy rods with pin (20) and secured with spring retainer (21) .

The guy ropes (23) are pinned on the connector points on the lattice jib with pin (15) and secured with spring retainer (16) .

D A N G E R: **The added guying must be installed according to the installation drawing.**



Added guying SL3HS - boom

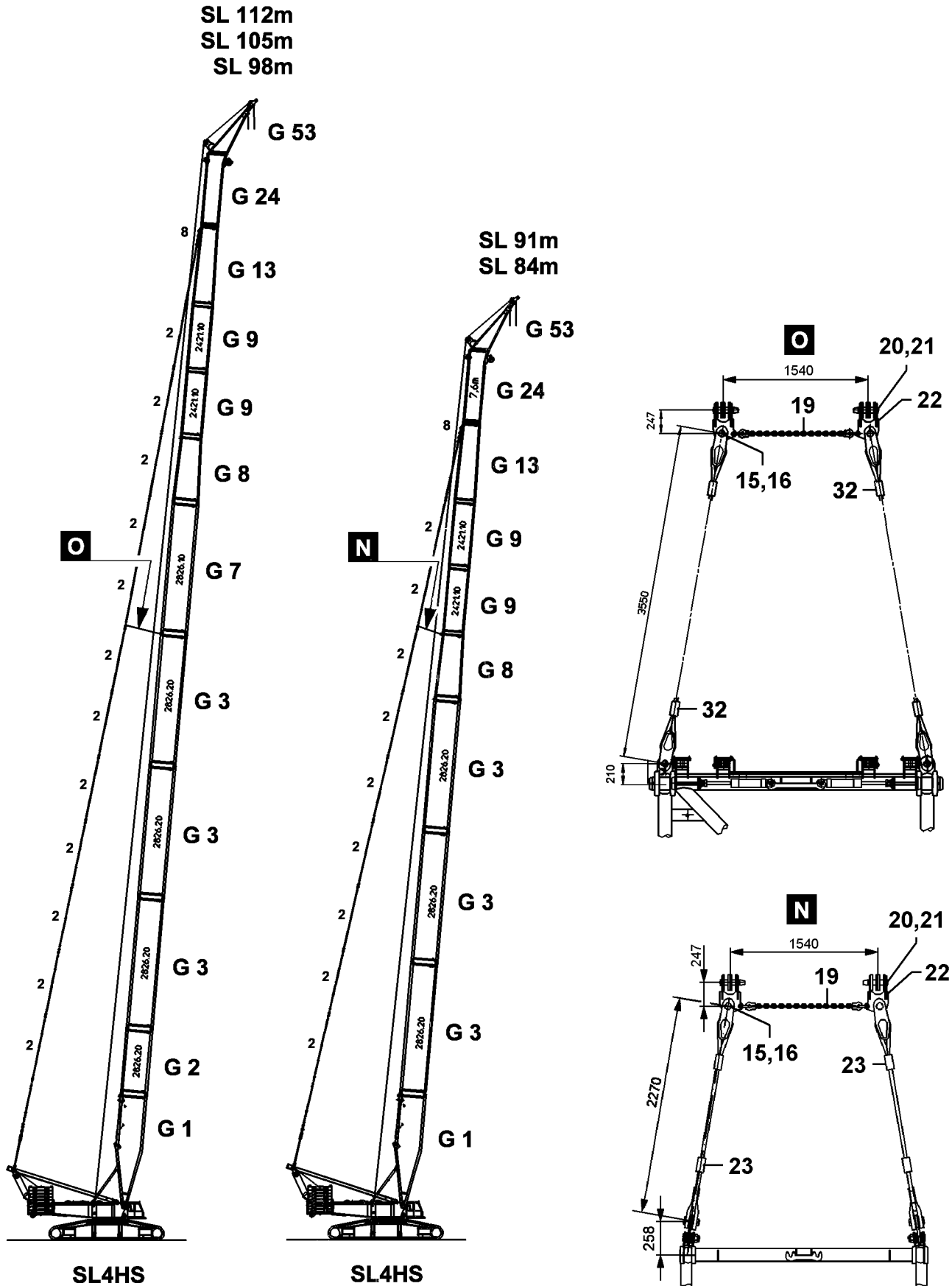
For a SL3HS - boom length of 84 m - 112 m, added guying (fig. M) is required between the guy rods and the boom.

The added guying consists of two guy ropes (23) as well as two brackets (22).

The brackets (22) are pinned to the guy rods with pin (20) and secured with spring retainer (21) .

The guy ropes (23) are pinned on the connector points on the lattice jib with pin (15) and secured with spring retainer (16) .

D A N G E R: **The added guying must be installed according to the installation drawing.**



194654

Added guying SL4HS - boom

For a SL4HS - boom length of 84m or 91 m, added guying (fig. N) is required between the guy rods and the boom.

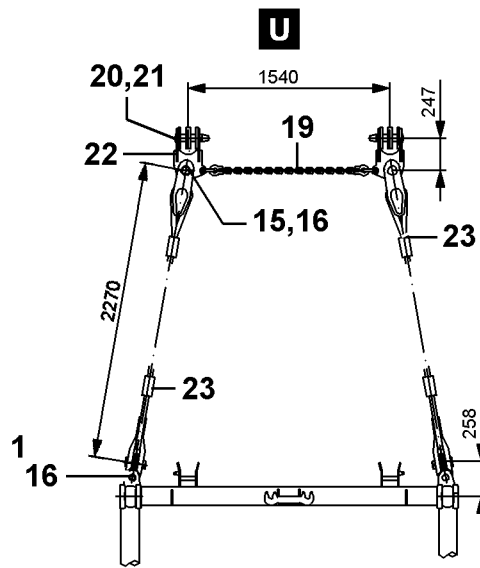
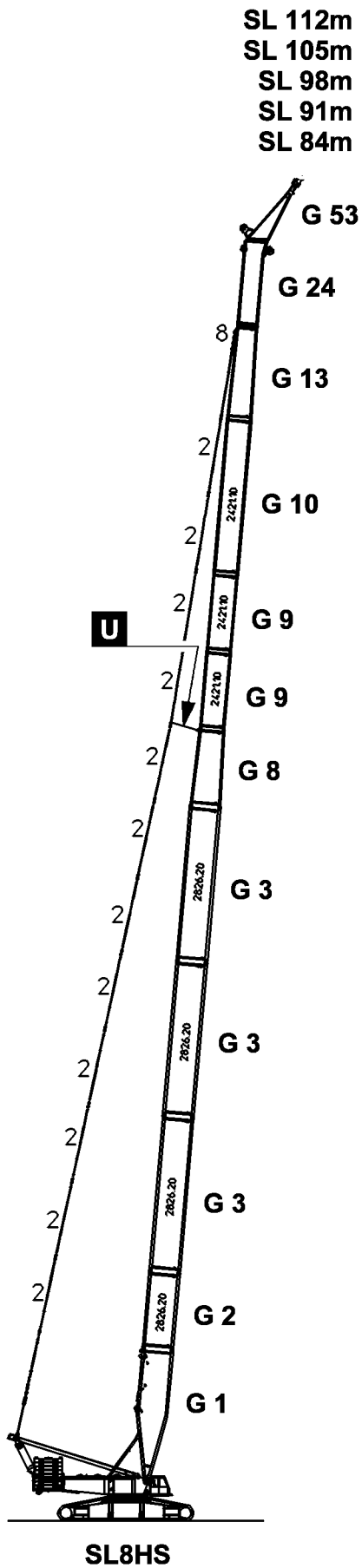
For a SL4HS - boom length of 98 m - 112 m, added guying (fig. O) is required between the guy rods and the boom.

The added guying consists of two guy ropes (23 or 32) and two brackets (22).

The brackets (22) are pinned to the guy rods with pin (20) and secured with spring retainer (21).

The guy ropes (23 or 32) are pinned on the connector points on the lattice jib with pin (15) and secured with spring retainer (16).

D A N G E R: **The added guying must be installed according to the installation drawing.**



Added guying SL8HS - boom

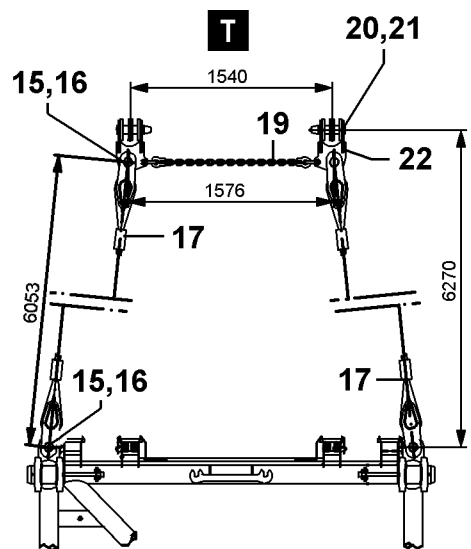
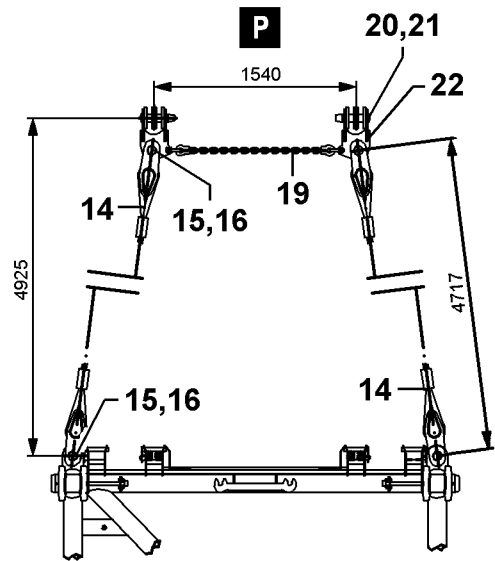
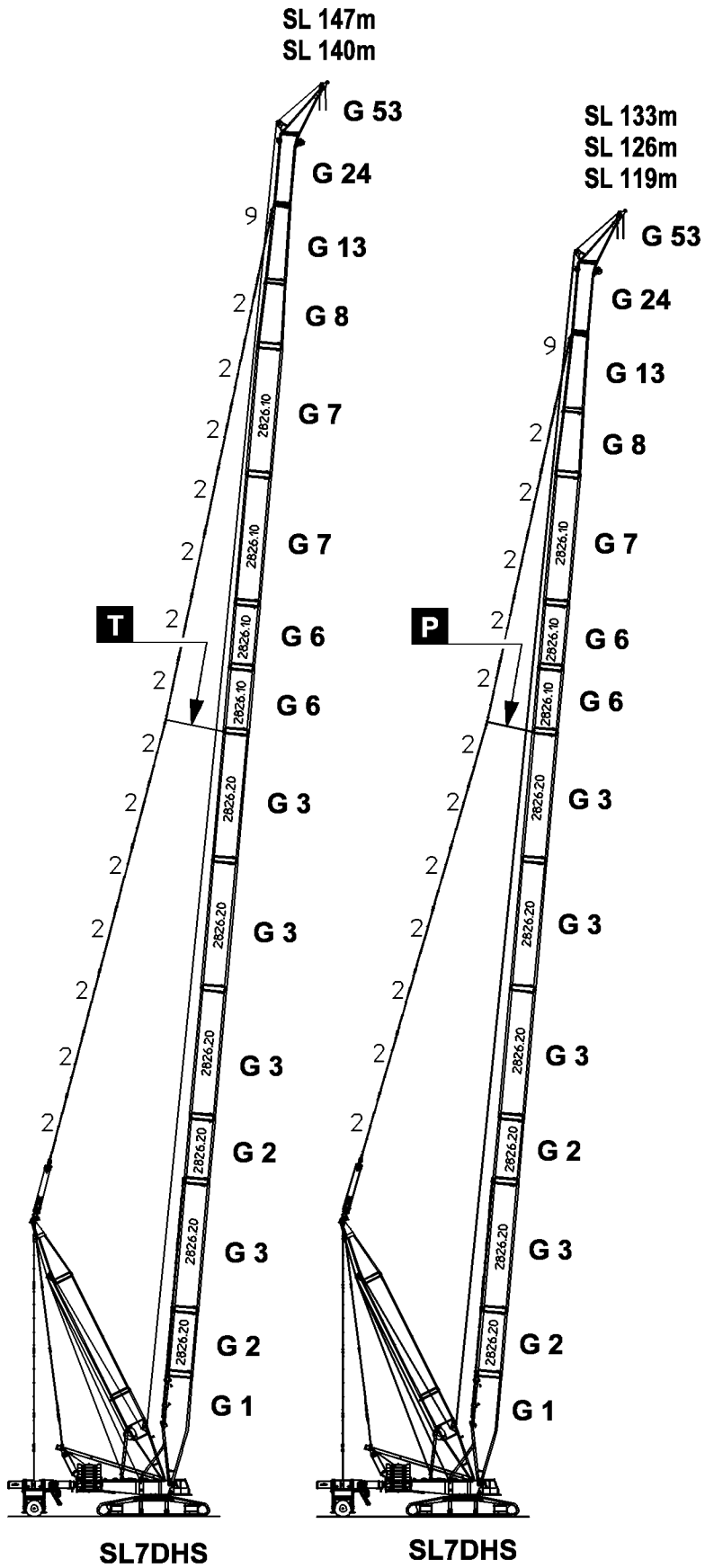
For a SL8HS - boom length of 84 m - 112 m, added guying (fig. U) is required between the guy rods and the boom.

The added guying consists of two guy ropes (23) as well as two brackets (22).

The brackets (22) are pinned to the guy rods with pin (20) and secured with spring retainer (21) .

The guy ropes (23) are pinned on the connector points on the lattice jib with pin (15) and secured with spring retainer (16) .

D A N G E R: **The added guying must be installed according to the installation drawing.**



Added guying SL7DHS - boom

For a SL7DHS - boom length of 119 m - 133 m, added guying (fig. P) is required between the guy rods and the boom.

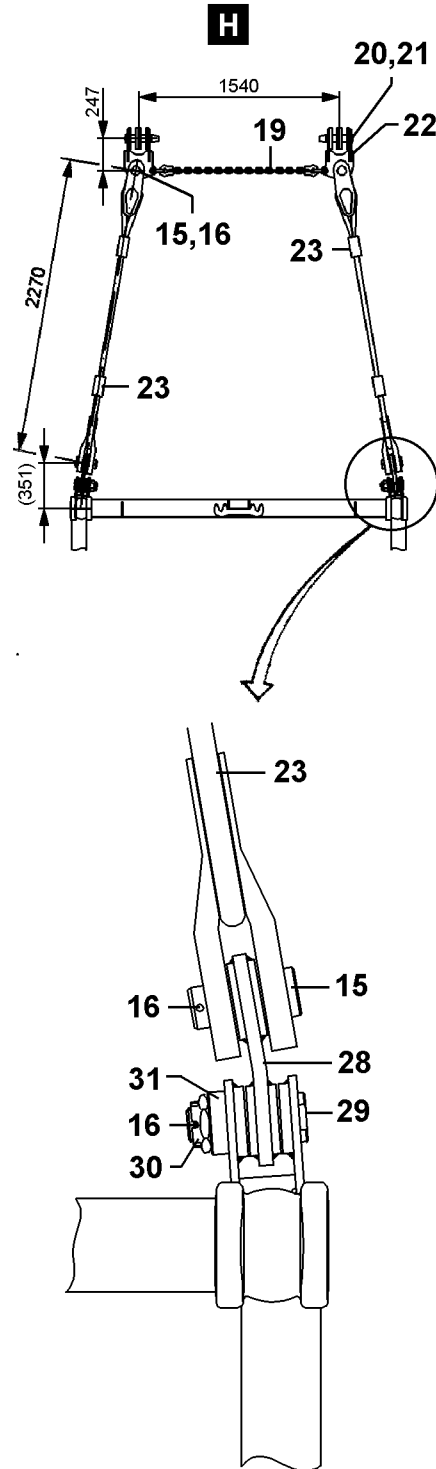
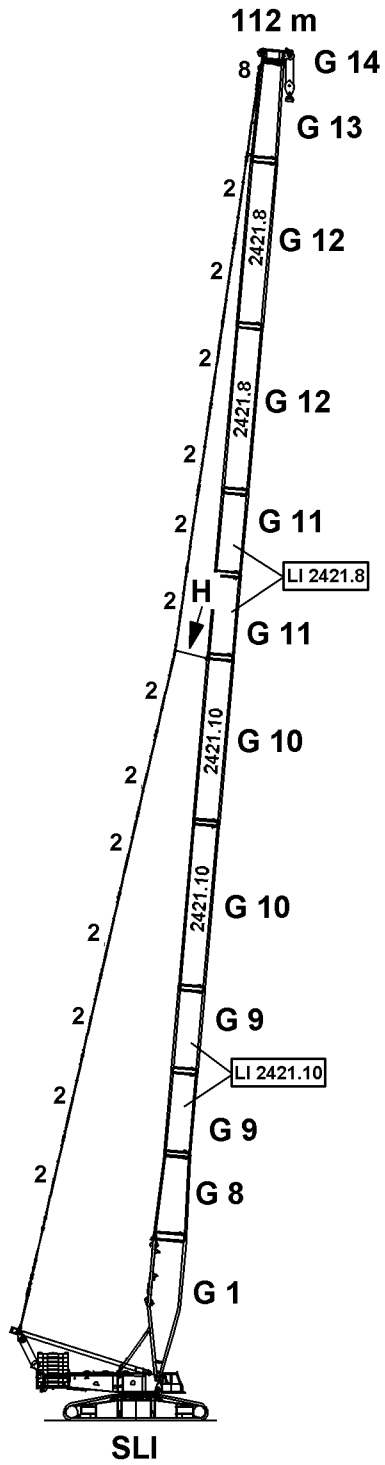
For a SL7DHS - boom length of 140 m and 147 m, added guying (fig. T) is required between the guy rods and the boom.

The added guying consists of two guy ropes (14 or 17) and two brackets (22).

The brackets (22) are pinned to the guy rods with pin (20) and secured with spring retainer (21).

The guy ropes (14 or 17) are pinned on the connector points on the lattice jib with pin (15) and secured with spring retainer (16).

D A N G E R: **The added guying must be installed according to the installation drawing.**



Added guying SLI - boom

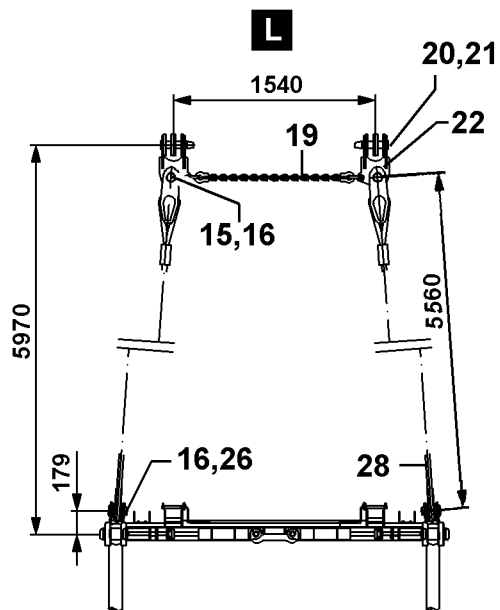
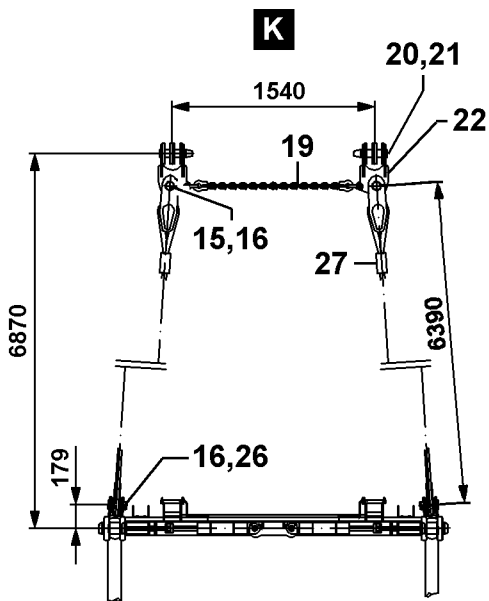
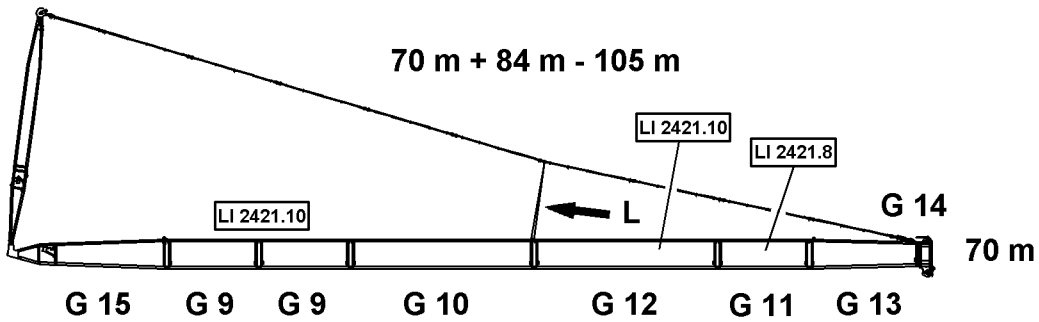
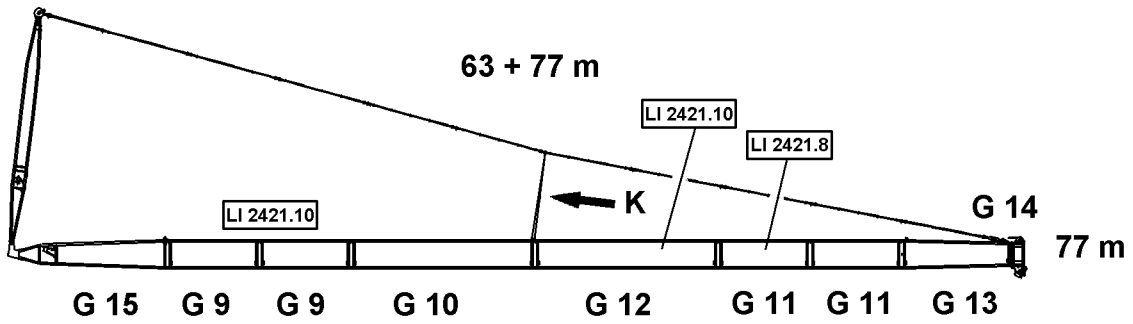
For a SLI - boom length of 56 m - 112 m, added guying (fig. H) is required between the guy rods and the boom.

The added guying consists of two guy ropes (23) as well as two brackets (22).

The guy ropes (23) are pinned on brackets (22) as well as on brackets (28) on the boom with pin (15) and secured with spring retainer (16).

The brackets (28) are pinned on the connector pins on the boom with pin (29) and secured with washer (31), nut (30) and spring retainer (16) .

D A N G E R: **The added guying must be installed according to the installation drawing.**



Added guying W- lattice jib

For a W- lattice jib length of 63 m and 77m, added guying (fig. K) is required between the guy rods and lattice jib.

For a W- lattice jib length of 70 m, as well as 84 m - 105 m, added guying (fig. L) is required between the guy rods and lattice jib.

The added guying consists of two guy ropes (27 or 28), two brackets (22) and the chain (19).

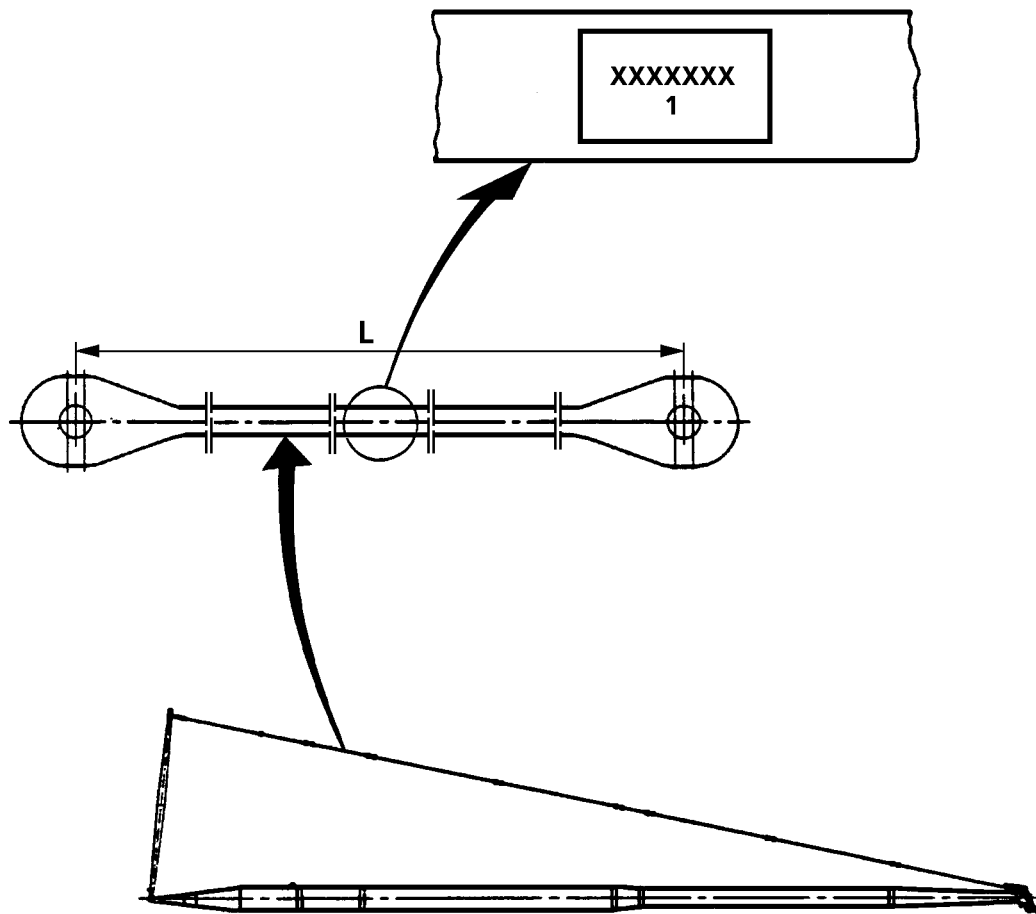
The guy ropes (27 or 28) are pinned on brackets (22) with pin (15) and secured with spring retainer (16).

The brackets (22) are pinned on the guy rods with pin (20) and secured with spring retainer (21).

The guy ropes (27 and 28) are pinned on the connector points on the boom with pin (16) and secured with spring retainer (26).

C A U T I O N: The chain (19) must be installed in any case, otherwise the guy rods will be pulled apart.

D A N G E R: The added guying must be installed according to the installation drawing.



Guy rods

The guy rods must be placed and secured on the lattice section for transport .

Note: If the guy rods were removed, then they must be placed again on the lattice sections for installation according to the installation drawing.
The numbering on the installation drawing must be compared with the numbering (1) on the guy rods.

D A N G E R: **The guy rods must be installed according to the installation drawing. The guy rods must be checked regularly, see chapter "Inspection and maintenance of guy rods".**

1. Installation

- D A N G E R :** For the installation and removal work
- a safe installation scaffolding / working platform must be used. There is a danger of accidents due to falling.
 - Improvisations are prohibited.
 - The lattice sections must be supported from below with suitable, stable materials.
 - No one may remain under the lattice jib during pinning and unpinning procedure of the lattice sections. This is strictly prohibited!

Prerequisites:

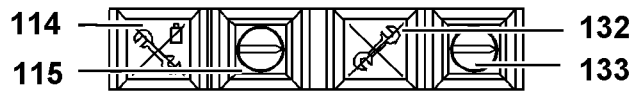
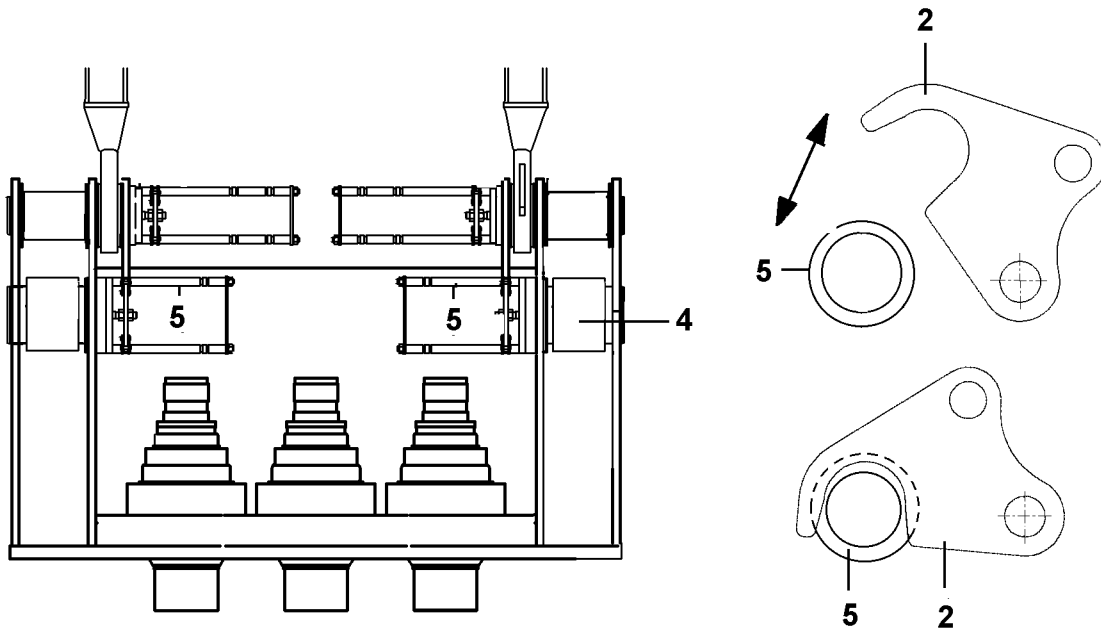
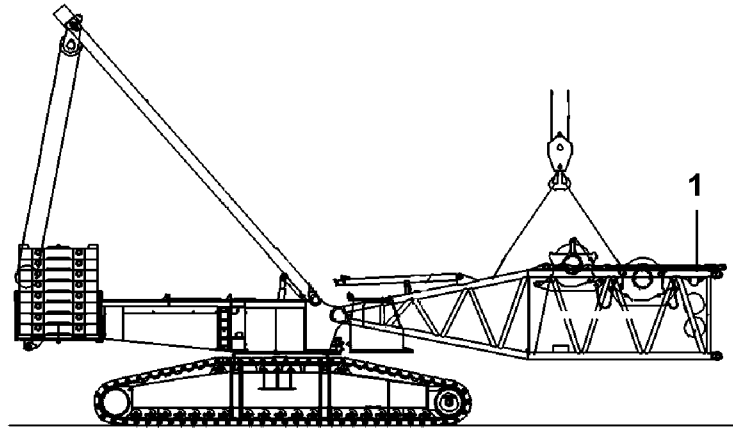
- The crane is horizontally aligned.
- An auxiliary crane as well as an installation scaffolding / working platform is available.
- The LICCON system is set according to the data given in the load charts.
- Actuate the installation keyed button (133) , the indicator light "Installation" lights up (132).
- The installation symbol on the LICCON indicator blinks.

1.1 Installation - boom

Turn the slewing platform until it is positioned in length axle of the crawler gear or to the side.

Note: Observe the data given in the erection and take down charts.

- D A N G E R :** Before turning the slewing platform without derrick or boom, the following must be observed:
- the crawler gear with installed slewing platform is horizontal.
 - the maximum permissible ballast variations in chapter 3.06, Installation conditions.
- If this is not observed, there is a danger of tipping over!



2. Install the S- pivot section

Lift the S- pivot section (1) with the auxiliary crane and swing it in to the pin points on the slewing platform.

Weights:

Component	Weight
S- pivot section	14350 kg
Relapse cylinder - 2×	1300 kg
S - guy rods	665 kg
W - guy rods	652 kg
Winch V	9500 kg
Winch VI	6390 kg

Fold both retaining hooks (2) from the guides (5) .

Retract the S- pivot section (1) on the slewing platform.

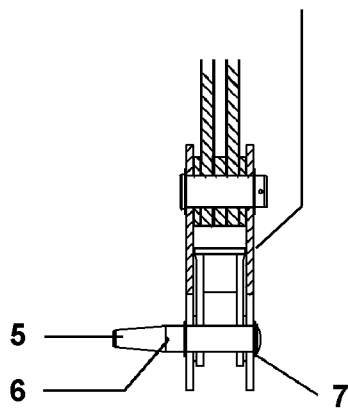
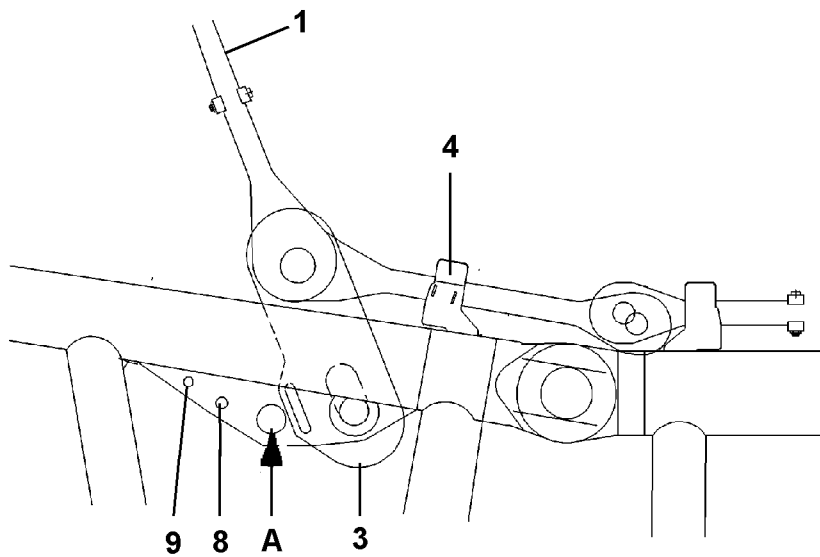
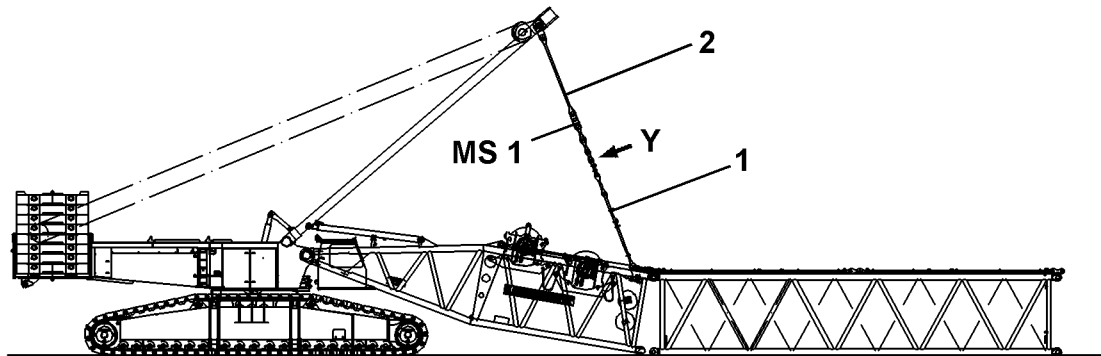
Fold the retaining hook (2) up, actuate the remote control and pin the connector pins (4) .

Secure the connector pins (4) by folding the retaining hooks (2) into the guides (5).

D A N G E R: To prevent inadvertent unpinning, the connector pins (4) must be secured with the retaining hooks (2) .

Note: For operation of remote control, see chapter 5.08.

Place the S-pivot section on the base support on the ground and remove the auxiliary crane.



2.1 Install the boom

Lower the SA - bracket to the front, see chapter 5.02 "SA-Bracket".

Pin the guy rods (2) from the SA -bracket with the guy rods (1) from the S- pivot section (G1) and secure (Y).

Release the transport retainer (4) of the guy rods.

Pin and secure the installation bracket (3) on the S - pivot section and secure. Use pins (5), washers (7) and spring retainers (6) .

C A U T I O N : **The transport retaining pins (8) must be unpinned during installation and operation.**
Insert the pins in park position (9) .

Note: A = Pin point for flying installation with derrick.

Assemble the boom and the corresponding guy rods to the required length, pin and secure.

Pin the first intermediate section on the pivot section (G1) "on top".

Pull up the S- pivot section with the SA-bracket (winch 4) until it can be pinned "on the bottom" .

Note: Note the test point 1 - "IST" (Actual) force of monitor 1 in this position, so one knows when removing the boom, which force must be used to secure when unpinning.

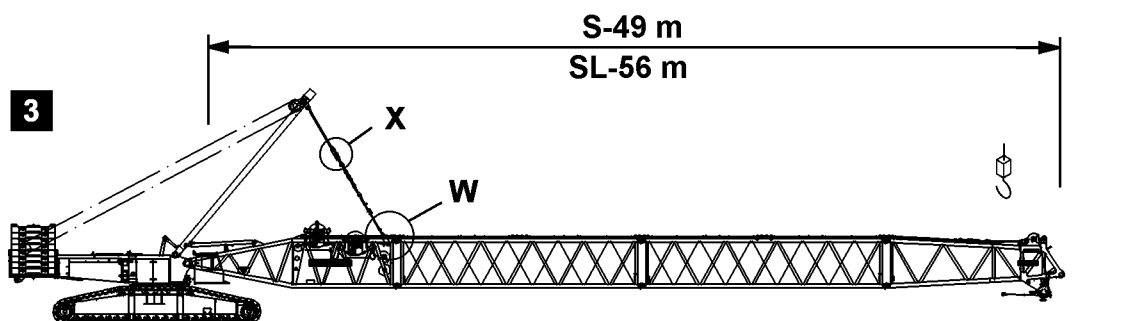
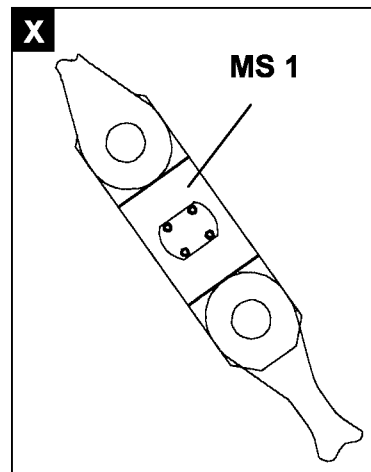
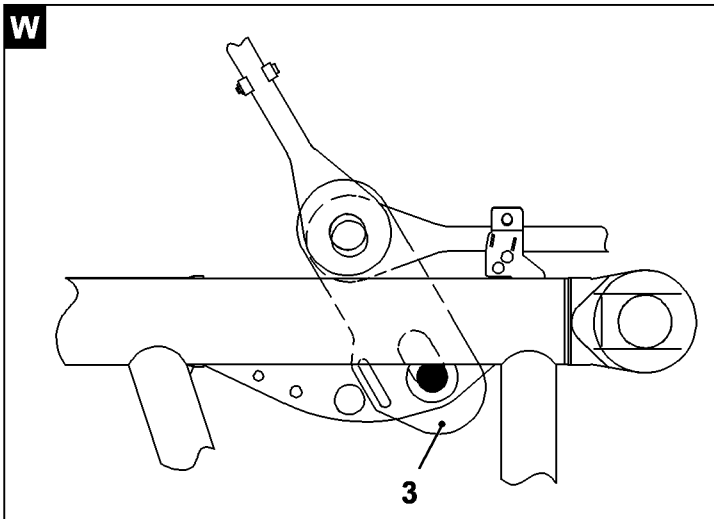
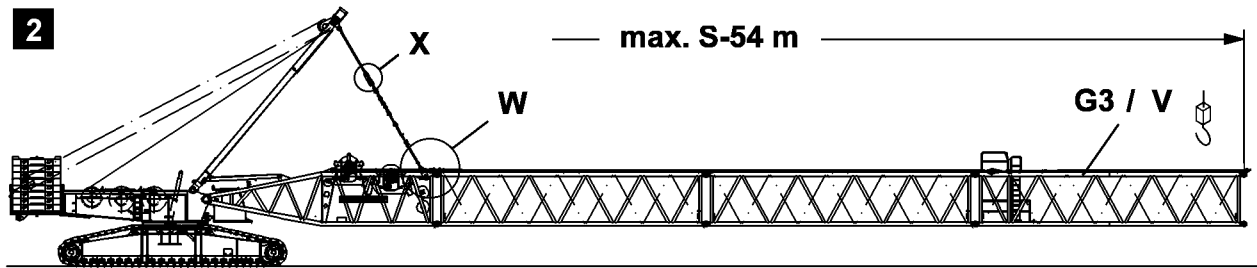
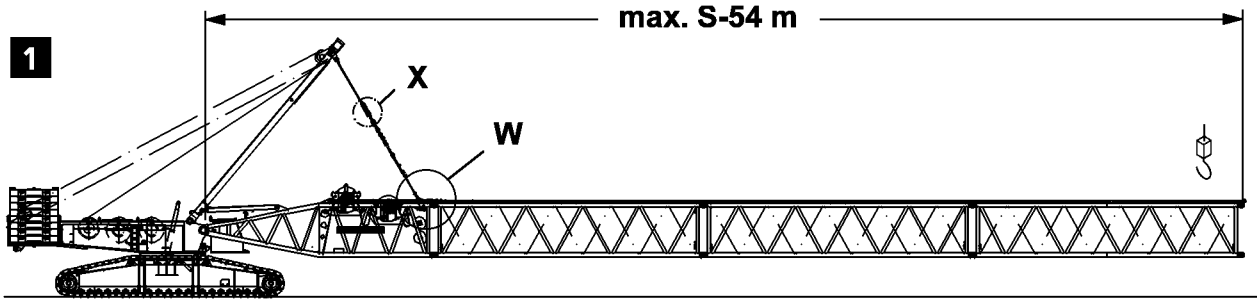
D A N G E R : **The maximum permissible total force on test point 1 = $F \leq 160$ t.**
With the SA-bracket, the following maximum boom lengths can be lifted:
 - S 84 m with installed S - and WA-bracket II guy rods
 - SL 98 m, only with installed S- guy rods
The end section may not be raised, it must lay on the ground.
If this is not observed, severe damage can occur!

Pin and secure the pivot section (G1) "on the bottom" .

Relieve the guy rods by lowering the SA- bracket .

Unpin the installation brackets (3) on the S- pivot section .

D A N G E R : **Before unpinning the guy rods on the installation brackets (3) on the S- pivot section, the boom must be pinned "on the bottom" .**
Otherwise there is a danger of accidents, as the boom might suddenly fold down!
The lattice sections must be supported from below with suitable, stable materials.
No one may remain under the lattice jib during pinning and unpinning procedure of the lattice sections. This is strictly prohibited!
There is a danger of accidents!



2.2 Flying installation of the SL / S - boom

Installation

If space is severely limited at the job site for the installation of the boom or is restricted due to nearby buildings, etc. then it is possible to install the boom up to a **max. length** in flying mode:

Fig. 1 / 2 - max. S 54 m - **without end section, without hook block**
 - with S - and WA-bracket II guy rods
 - min. slewing platform ballast 120t
 - min. central ballast 45t
 - max. permissible total force 160 t on test point MS 1 (Fig-. X)

Fig. 3 - max. S 49 m - **with end section, without hook block**
 - with S - and WA-Bock II guy rods
 - max. SL 56m - **with L - end section, without hook block**
 - with S - guy rods
 - min. slewing platform ballast 120t
 - min. central ballast 45t
 - max. permissible total force 160 t on test point MS 1 (Fig-. X)

Prerequisites:

- The pivot section is pinned and secured on the guy rods of the SA - bracket and the installation brackets (3) (Fig. W) and pulled up to horizontal position.

Installation

For a flying installation , the intermediate sections can be pinned and secured piece by piece with the auxiliary crane or the completely assembled boom can be pinned and secured on the pivot section . Pin and secure the pin "on top" and "on the bottom" .

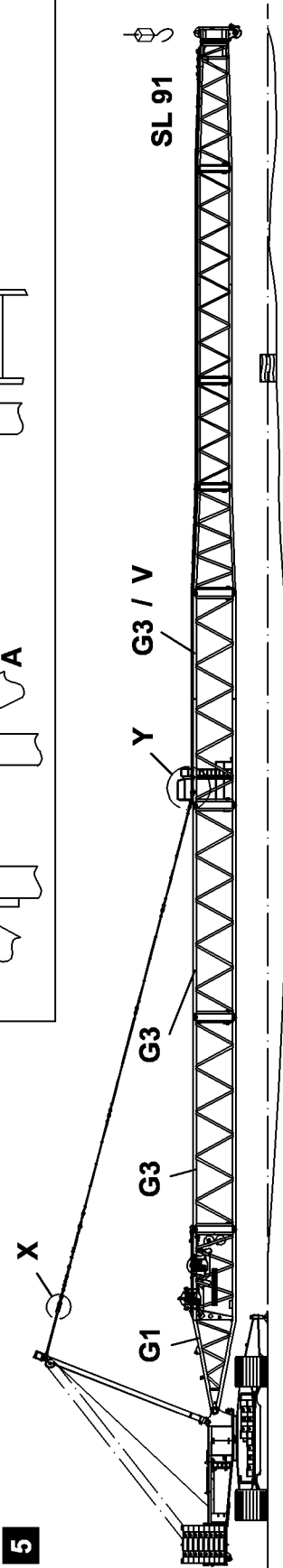
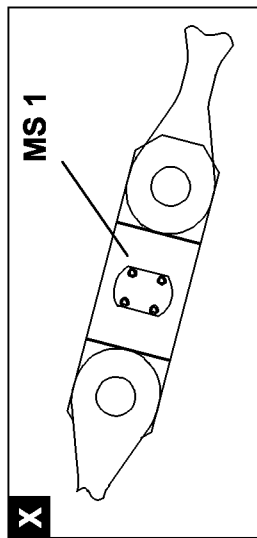
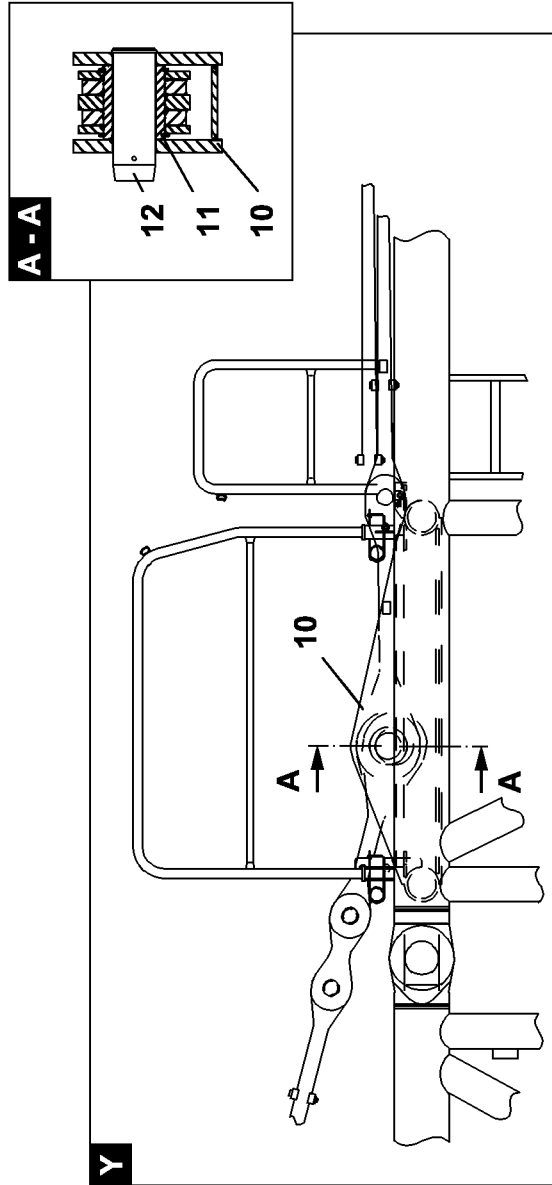
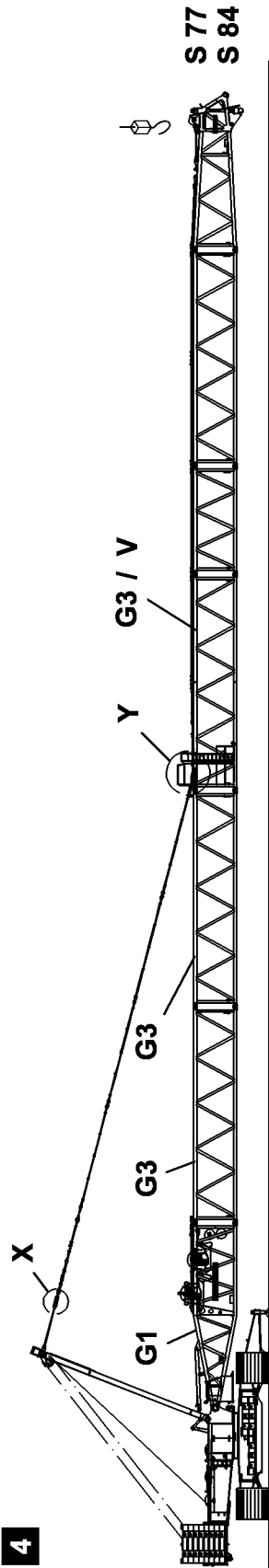
Note: For weight of the lattice sections with placed guy rods, see chapter 5.03.

D A N G E R: **Note the maximum permissible boom lengths for flying installation . If this is not observed, there is danger of accidents!**

Attach the boom on the front on the auxiliary crane (A) or support it from below with stable materials. Lower the guy rods (1, 2) to relieve the SA- bracket. Unpin the installation brackets (3) on the S- pivot section .

Note: The **reinforced** 14 m S- intermediate section (G3 / V) weighs approx. 1.6 t more than the "normal" 14 m S- intermediate sections. This addition of weight of 1.6 t has not been considered in the load charts and therefore counts **as load**, i. e. depending on the boom length, the load indicator on the main boom head is larger by approx. 800 kg due to this intermediate section.

D A N G E R: **The boom must be held with an auxiliary crane (A) or supported from below, before the installation bracket (3) on the S- pivot section is unpinned. Otherwise there is a danger of accidents, as the boom might suddenly fold down!**
The lattice sections must be supported from below with suitable, stable materials.
No one may remain under the lattice jib during pinning and unpinning procedure of the lattice sections. This is strictly prohibited!
There is a danger of accidents!



2.3 Flying installation of the SL / S - boom

Installation

If space is severely limited at the job site for the installation of the boom or is restricted due to nearby buildings, etc. then it is possible to install the boom up to a **max. length** in flying mode:

Fig. 4

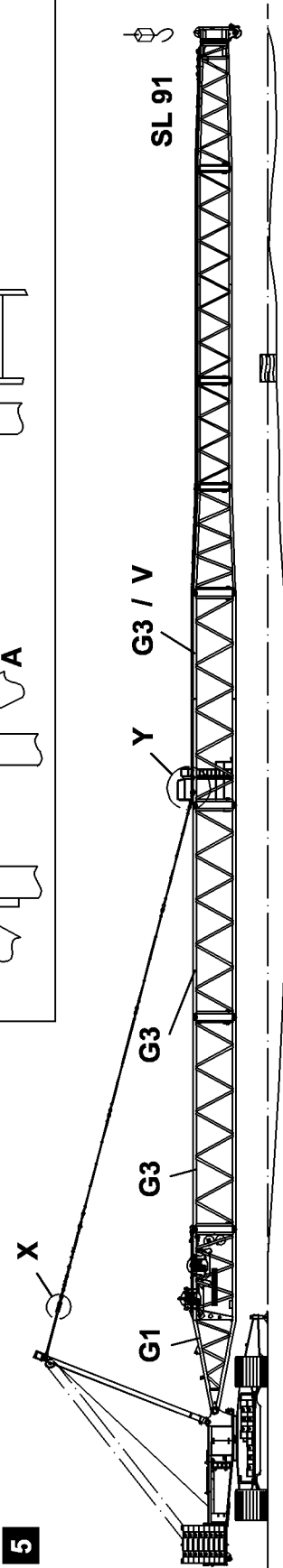
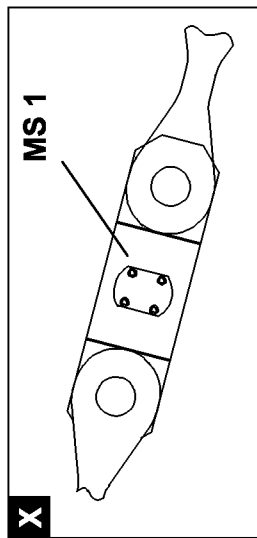
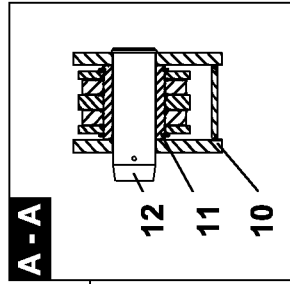
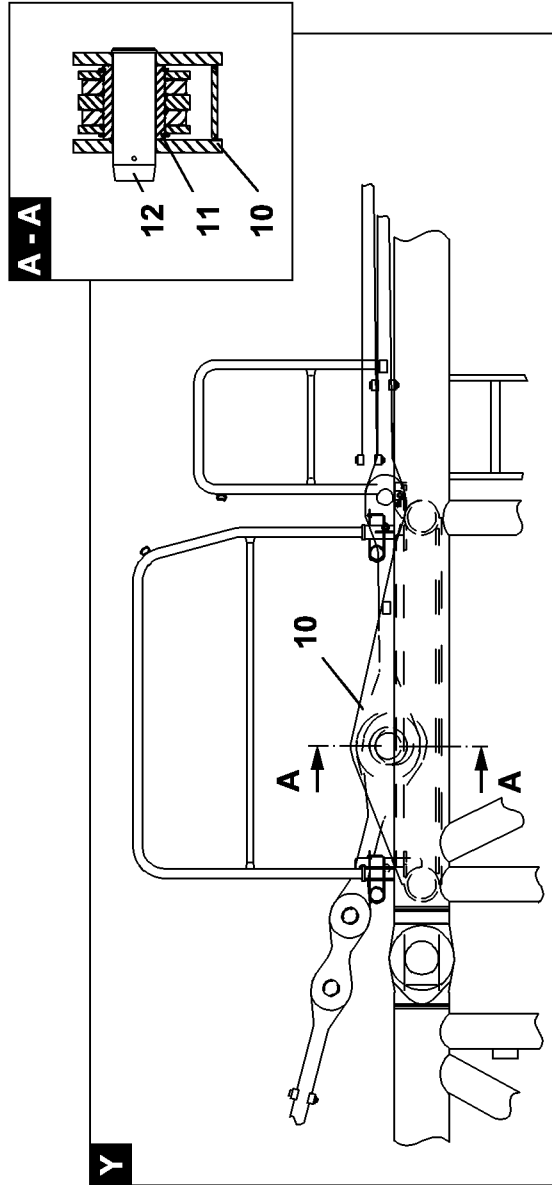
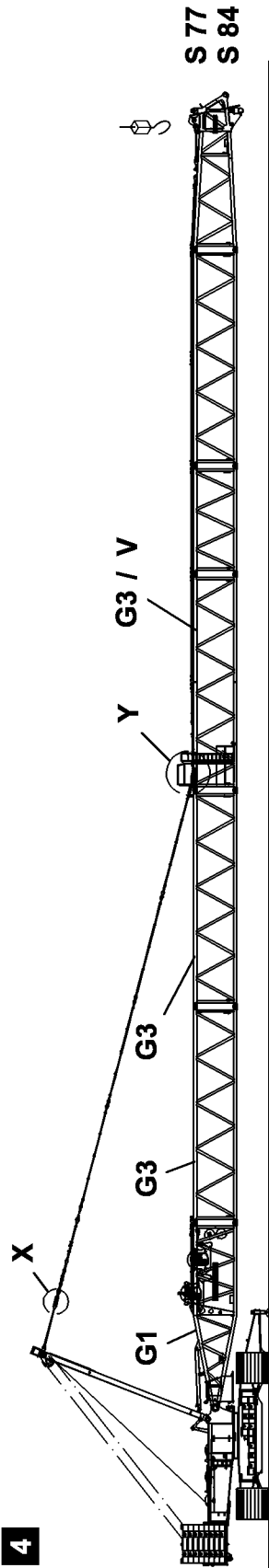
- max. S 77 m - with S - end section, without hook block
- with S - and WA-bracket II guy rods
- max. S 84 m - with S - end section, without hook block
- with S - guy rods
- min. slewing platform ballast 170t
- min. central ballast 45t
- max. permissible total force 325 t on test point MS 1 (Fig. X)

Fig. 5

- max. SL 91 m - with L - end section, without hook block
- with S - guy rods
- min. slewing platform ballast 120t
- min. central ballast 45t
- max. permissible total force 290 t on test point MS 1 (Fig. X)

Installation description :

- The S - pivot section (G1) and the S - intermediate sections (G3) must be preassembled or fully assembled at a suitable site . It must be observed that the **reinforced** intermediate section (G3 / V) is installed at the "end" of the preassembled S -boom combination (fig. 4 // 5) .
- Swing the preassembled S - boom combination (G1 + G3 + G3 + G3 / V) with the auxiliary crane to the slewing platform. (G3 / V = S - intermediate section 14m **reinforced**)
- Pin and secure the S - boom combination with the S - pivot section (G1) on the slewing platform.
- Pin the guy rods on the brackets (10) of the **reinforced** S - intermediate section (fig. Y). The guy rods are connected on the brackets (10) with a hollow axle (11) and must be pinned on the pin point of the brackets (10) with pins (12) (fig. A-A).
Secure the pins (12) .
- Erect the A - bracket until the guy rods are "tensioned", the boom combination must remain in horizontal position.
- After the boom combination is pinned, secured and tensioned, remove the auxiliary crane.
- Install the additional S - intermediate sections and the end section, individually or fully assembled with the auxiliary crane on the **reinforced** S - intermediate section (G3 / V) , pin and secure.
- Pin the guy rods of the lattice sections together, then secure.
- Attach the boom on the front on the end section with the auxiliary crane or support with stable materials .
- Lower the A-bracket to the front until the guy rods are relieved between the A-bracket and the **reinforced** S - end section (G3 / V) .
- Unpin the pins (12) on the brackets (10) .
- Erect the A-bracket until the guy rods are relieved between the A-bracket and the end section.

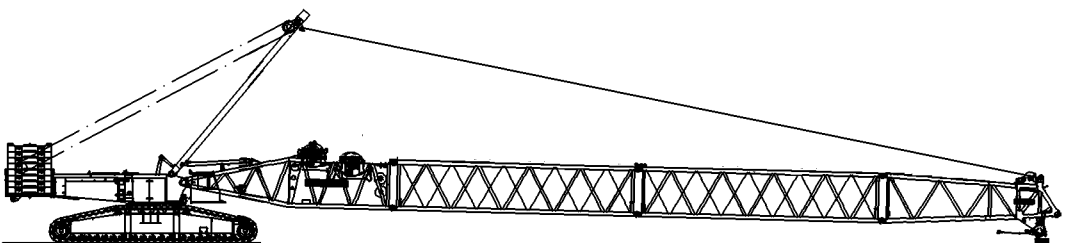
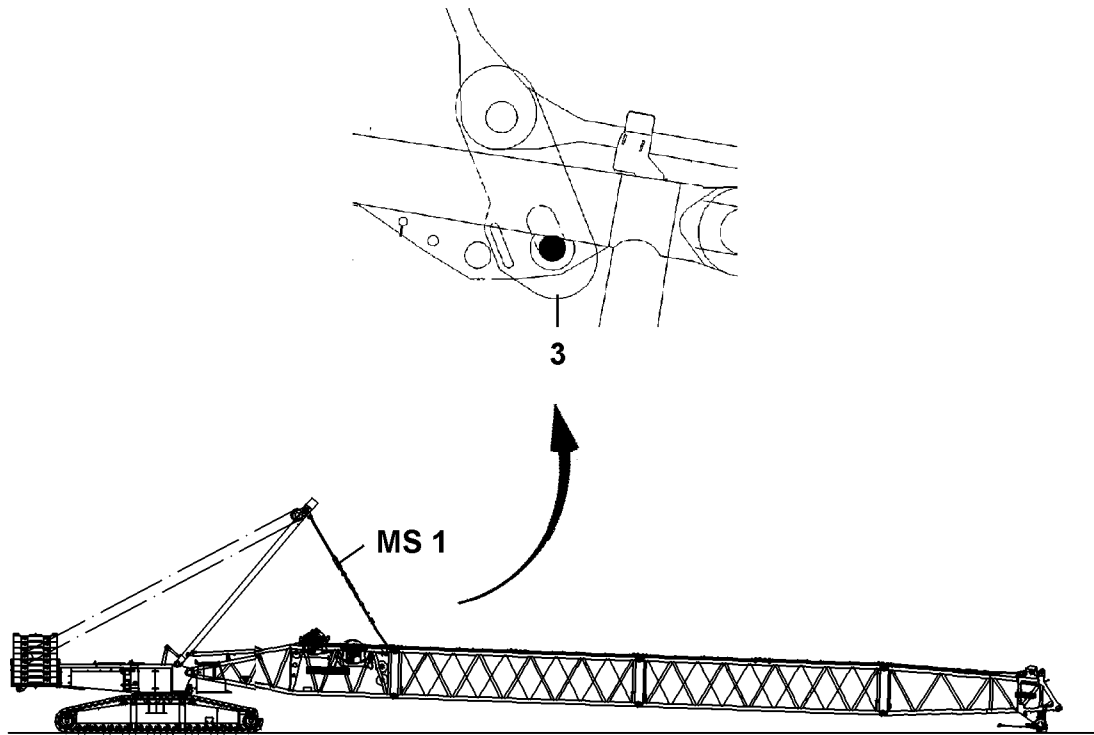


Note: For weight of the lattice sections with placed guy rods, see chapter 5.03.

D A N G E R : **Note the maximum permissible boom lengths for flying installation .
If this is not observed, there is danger of accidents!**

Note: The **reinforced** 14 m S- intermediate section (G3 / V) weighs approx. 1.6 t more than the "normal" 14 m S- intermediate sections. This addition of weight of 1.6 t has not been considered in the load charts and therefore counts **as load**, i..e. depending on the boom length, the load indicator on the main boom head is larger by approx. 800 kg due to this intermediate section.

D A N G E R : **The completely installed boom must be held with an auxiliary crane or must be supported from below, only then may the pin (12) be removed on the brackets (10) .
It is not permitted for anyone to remain under the lattice sections during the pinning or unpinning procedures.
There is a danger of accidents, the boom could suddenly fold down. When removing or installing the lattice sections, they must be supported from below with suitable, stable materials.
There is a danger of accidents!**



3. Installation of the guy rods

The guy rods must be installed and secured according to the installation drawings in **chapter 5.03**. Make sure to compare the numbers in the installation drawing with the numbers on the guy rod.

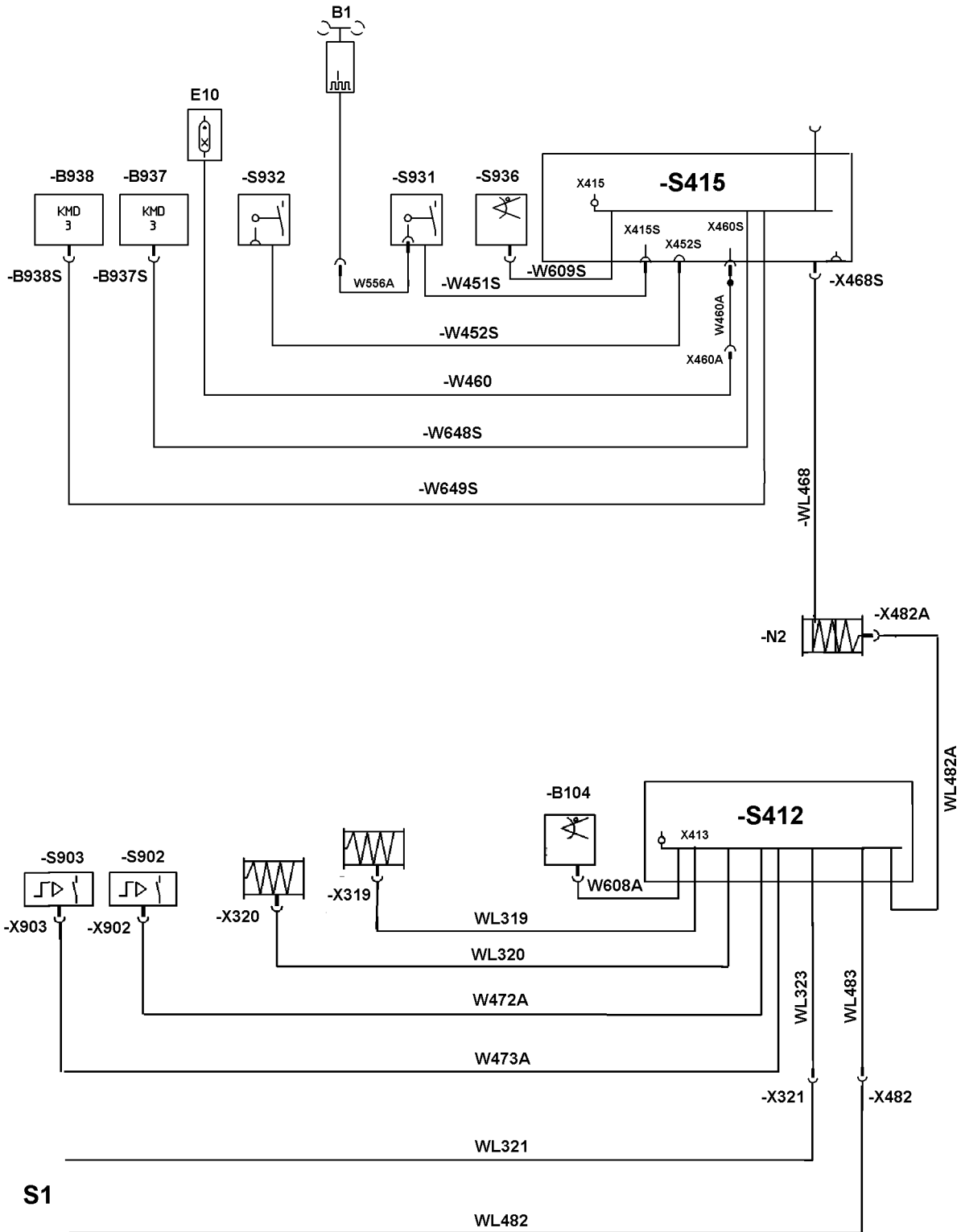
D A N G E R: **The pins of the guy rods must be inserted from the inside to the outside. If this is not observed, the hoist cable will scrape on the pins.
The guy rods must be checked regularly, see chapter " Inspection and maintenance of guy rods".**

Actuate the winch IV and tension the guy rods between the SA-bracket and the end section .

Remove the auxiliary crane on the boom head.

D A N G E R: **Do not remove the auxiliary crane until the guying between the SA- bracket and the boom head is tensioned and the boom is held by the guy rods.**

Guide the hoist cable over the cable pulley on the end section.



4. Electrical connections

Establish the electrical connection from the control box (S1) on the slewing platform to the connector box (-S412).

Connect the cable plug (WL482) with (WL483) and (WL321) with (WL323) .

Establish the electrical connection from the cable drum (N2) to the connector box (-S415) .

Plug the cable plug (WL482A) into the cable drum (N2) .

Establish the electrical connection from the connector box (-S412) to the cable drum (N2) .

Plug the cable plug (WL468A) into the connector box (-S415) .

Establish the electrical connection from the connector box (-S412) to the winches (W5 and W6) . Plug the cable plug (WL319 into W5 and WL320 in W6) .

Establish the electrical connection from the connector box (-S412) to the relapse cylinders limit switches (S902 and S903) . Plug the cable plug (W472A in X902 and W473A in X903) .

Establish the electrical connection to the angle sensor. Plug in the cable plug (WL608A) .

Install the airplane warning light and the wind speed sensor on the S- end section.

Plug in the cable plug (W460) for the airplane warning light on connector box (-S415) .

Plug in the cable plug (W451S) for the hoist limit switch (S931) and cable plug (W452S) for the hoist limit switch (S932) on connector box (-S415) .

Establish the electrical connection from the connector box (-S415) to the connector box (S416) for the boom nose.

4.1 Hydraulic connections

Establish the hydraulic connection (2× quick couplings) to the S- relapse cylinders.

5. Function check

Prerequisites:

- All electrical connections are established.
- The engine is running.

Airplane warning light

Turn on the airplane warning light , check function visually.

Wind speed sensor

Check the movement and function of the wind speed sensor.

Limit switch

CAUTION: The limit switch functions must be checked individually before crane operation.

The manual procedure is described below.

The function of the individual limit switch initiators must be determined in the test system - see Diagnostics Manual.

Hoist limit switch

Actuate the hoist limit switch manually.

The hoist winch must turn off when lifting.

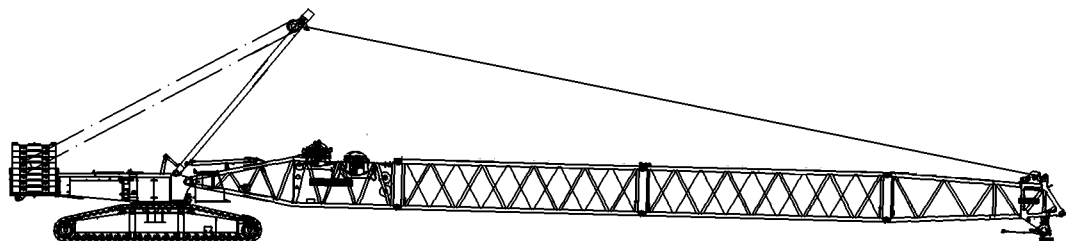
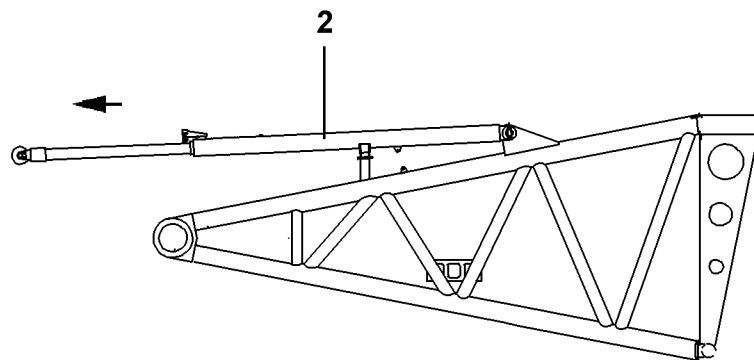
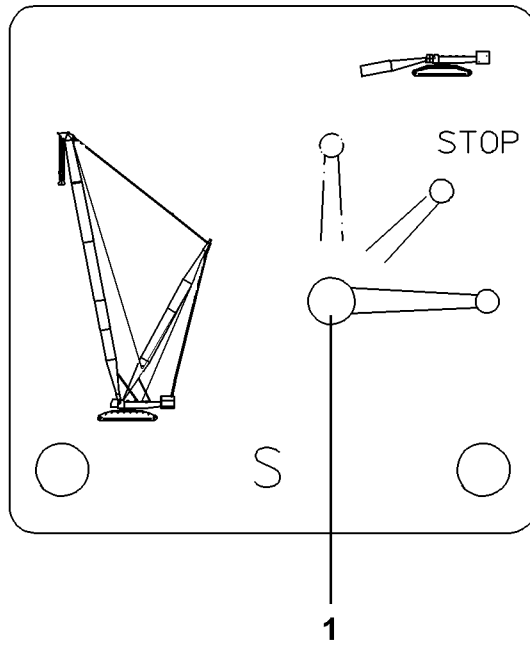
The hoist "top" symbol on the LICCON indicator must blink.

S - relapse cylinder

Cover the limit initiators individually on the S - relapse cylinders with a metal plate.

The S - control winch movement (W III) "spool up" must turn off.

The symbol must appear on the LICCON monitor.



6. Erection / take down procedure

The boom combinations must be erected or taken down according to the **Erection and take down charts**.

D A N G E R: **The erection and take down procedure must be made according to the data in the erection and take down chart.
If this is not observed, the crane can be overloaded or topple over.**

Prerequisites:

- The crane is horizontally aligned.
- The counterweight is installed on the slewing platform according to the load chart .
- The boom is installed according to the load chart and the operating manual .
- All limit switches are installed correctly and fully functioning.
- All pin connections are secured.
- The hoist cable is placed correctly into the cable pulleys and secured with cable retaining pins to prevent them from jumping out.
- There are no persons within the danger zone.
- There are no loose parts on the boom and the lattice jib.
- In the cold season: Is the boom and the lattice jib and their components (limit switch, cable drum, airplane warning light, wind speed sensor, etc.) free of snow and ice.

D A N G E R: **Incorrectly installed and non-functioning limit switches as well as falling parts (pins, spring retainers, ice, etc.) can cause accidents!**

6.1 Extend the S- relapse cylinder (2]

Establish the hydraulic connection from the slewing platform to the S - relapse cylinders.

Move the ball cock lever (1) into horizontal position and extend the piston rod of the S - relapse cylinder.

Lever positions:

Lever horizontal = Crane operation, extend piston rod

Lever vertical = Installation, retract piston rod

Lever 45° = Piston rod cannot be extended or retracted

D A N G E R: **The relapse cylinders must be extended before erection.
The ball cock lever must be in horizontal direction, and must be secured to prevent it from inadvertent actuation during crane operation.**

		m > < t		CODE >XXXX< BXXX YYZZ.1(2)			
		35,0	35,0	35,0	35,0	35,0	35,0
12,0							
14,0	380,0	380,0	380,0	380,0			
16,0	372,0	372,0	372,0	372,0			
18,0	363,0	363,0	363,0	363,0			
20,0	350,0	350,0	349,0	349,0			
22,0	336,0	337,0	337,0	337,0			
24,0	305,0	313,0	312,0	312,0	307,0	319,0	328,0
26,0	278,0	283,0	283,0	283,0	284,0	301,0	310,0
* n *	* 29 *	* 29 *	* 29 *	* 29 *	* 23 *	* 24 *	* 25 *
xx	87,0	87,0	87,0	87,0	77,0	77,0	77,0
yy	13,0	15,0	18,0	20,0	13,0	15,0	18,0
							>>

xx° SDBW
35m

W
28m

220
t

95
t

yy m

n
10 x

O.K.

LIEBHERR

7

8

9

4

5

6

1

2

3

0

.

P

SHIFT

F1

F2

F3

F4

F5

F6

F7

F8

ENTER

BXXX YYZZ

XXXX

0 1/min:1634 50 90 100 110 130%

max n = 10

t 156.0

t 28.3

m 23.8

m 28.0

m 35.0

m 62.6

1°
0.0
0.0

0.0
0.0
max: 12.8

80.0°

191.99
m

191.99
m

t

V: 40%

28.0

60.0°

2:1Y

1:1Y

LIEBHERR

7

8

9

4

5

6

1

2

3

0

.

P

SHIFT

F1

F2

F3

F4

F5

F6

F7

F8

ENTER

6.2 Erection procedure

Prerequisite:

- The LICCON overload safety device is set according to the data in the load chart and the equipment configuration.
- Actuate the installation keyed button . The indicator light "Installation" lights up.
- The installation symbol on the LICCON indicator blinks.

Adjustment on EQUIPMENT CONFIGURATION VIEW on the LICCON (see chapter 4.02)

Enter the 4-digit code number according to the required load chart and confirm with ENTER .

Enter the actual reeving.

Check the current equipment configuratoin with the entered data to make sure they match.

Press the function key -F8- "o.k.", the OPERATING VIEW will appear.

D A N G E R : **Compare the LICCON settings with the actual equipment configuration.**
If this is not observed, there is a danger of overloading the crane or tipping the crane over!

Erection

Luff up the boom until the end section lifts off the ground.

Reeve the hoist cable between the pulley head on the end section and the hook block and secure on the fixed point - see **chapter 4.06, Reeving plans.**

Attach the hoist limit switch weight.

Luff up the boom to the **lowest** operating position.

D A N G E R : **When erecting long booms, the hook block must remain on the ground in a certain boom angle range to the horizontal, otherwise the crane will be overloaded!**
Boom angle range - see Erection and take down charts.

Indications in the OPERATING VIEW during the erection procedure

The following alarm functions are activated (blink) during the erection, until the operating position is reached:

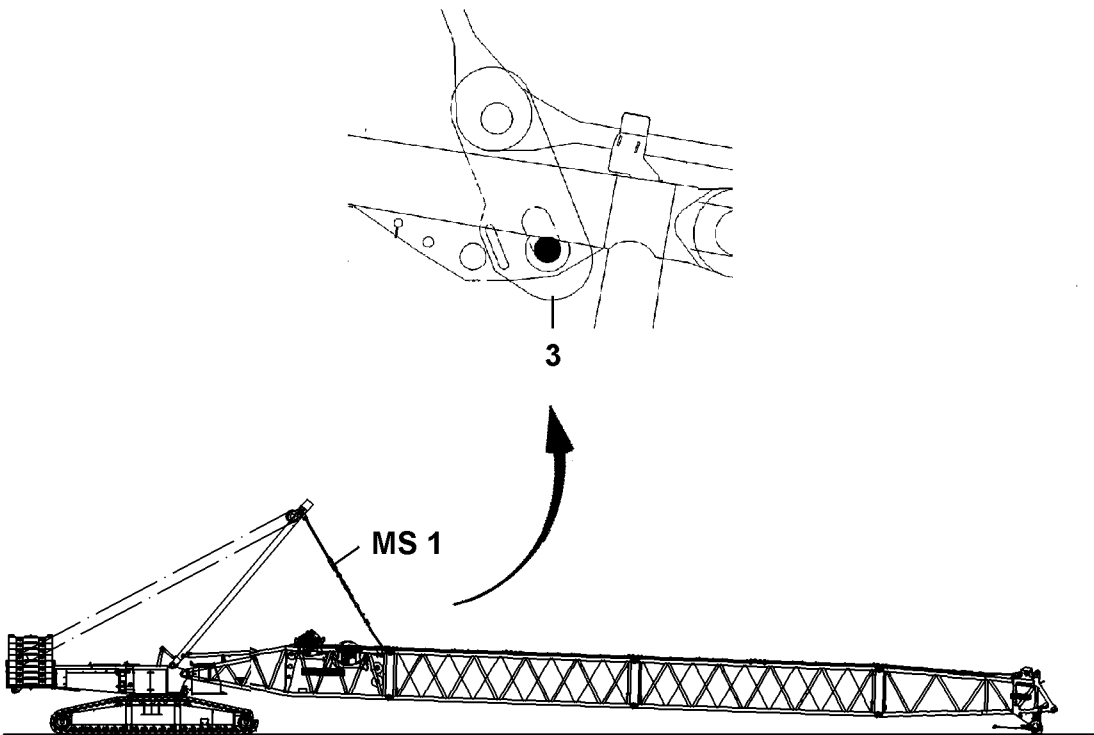
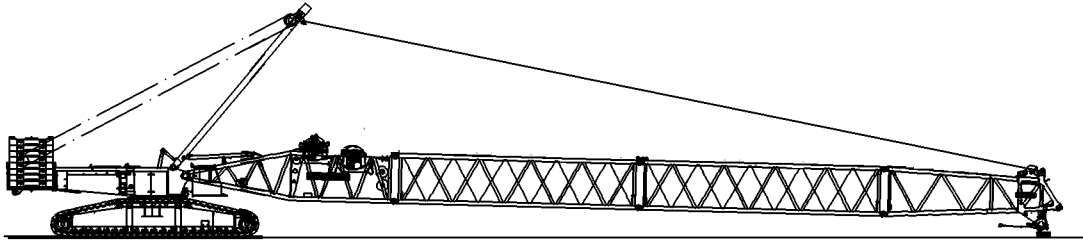
- "STOP"
- "HORN" + Acoustical signal

Note: The **lowest** operating position is reached if the indicators turn off and a load value in tons - t - appears in the symbol "MAX. LOAD" instead of the question marks ("? ? ?").

Turn off the installation keyed button by pressing the button.

The installation symbol on the LICCON indicator turns off.

D A N G E R : **The installation keyed button must be turned off immediately after reaching the lowest operating position.**
The installation keyed button bypasses the safety devices!
The radii given in the load chart may not be exceeded nor fallen below, even without a load on the hook!
If this is not observed, the crane can topple over!



7. Place down the S - boom

Luff the S- boom down until just before the lowest operating position.

Note: When the **lowest** operating position is reached, the luffing movement shuts off. At the same time, the following alarm functions are activated (blink) in the OPERATING VIEW:
 - "STOP"
 - "HORN" + Acoustical signal

Actuate the installation keyed button, the indicator light "Installation" lights up. The installation symbol on the LICCON indicator blinks.

D A N G E R: The overload safety system is no longer effective.
 The limit switch hoist "top" is bypassed.

C A U T I O N: When luffing down, the hoist winch must be spooled out at the same time to prevent the hook block from colliding with the pulley head.

Actuate the manual control lever and continue to luff down the boom until the hook block touches the ground.

D A N G E R: When taking down long booms, the hook block must be lowered to the ground in a certain boom angle range to the horizontal, otherwise the crane is overloaded!
 Boom angle range - see Erection and take down charts.

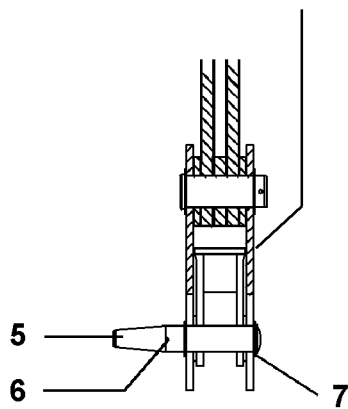
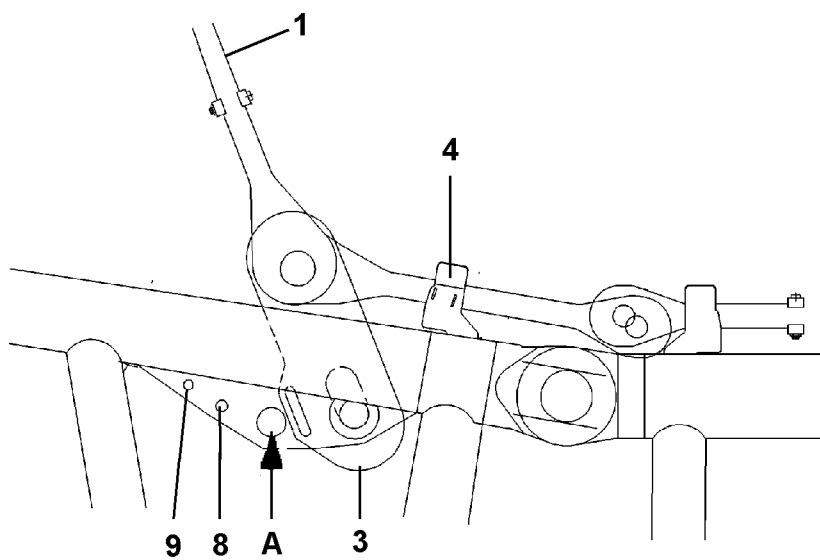
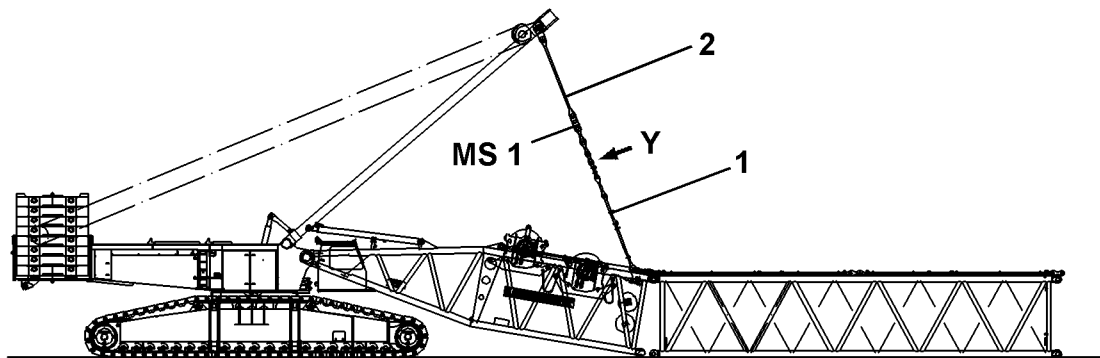
Remove the hoist limit switch weight. Unreeve the hook block.

D A N G E R: When unreeving the hoist cable, no persons may be within the danger zone.

Spool the hoist cable back to the winch .

D A N G E R: Do not overspool the winch! If the cable is pulled under the winch when spooling it up, the setting of the cam limit switch, which is to ensure that a minimum of 3 coils remains on the drum, is no longer correct. The cam limit switch must be readjusted after any work on the cable or on the winch .

Continue to luff down the S- boom until the end section lays on the ground .



Removal of the S - boom

Lower the SA - bracket to the front, see chapter 5.02 "SA-Bracket".

Pin and secure the installation bracket (3) on the S- pivot section. Use pins (5), washers (7) and spring retainers (6) .

D A N G E R : **The maximum permissible total force on test point 1 = $F \leq 160$ t.**
With the SA-bracket, the following maximum boom lengths can be lifted:
 - S 84 m with installed S - and WA-bracket II guy rods
 - SL 98 m, only with installed S- guy rods
The end section may not be raised, it must lay on the ground.
If this is not observed, severe damage can occur!

Note: With the intake gear, pull until the same F1 - actual force is set as was noted during installation.
 The pins can be pulled easier. Otherwise the pins and eyes on the lattice sections will be worn or the pin sticks.

Unpin the pivot section "**on the bottom**" and lower it all the way.

D A N G E R : **Before unpinning the S- pivot section, the installation bracket (3) on the S- pivot section must be pinned and secured .**
Otherwise there is a danger of accidents, as the boom might suddenly fold down!
During the removal and installation, the lattice sections must be supported from below with suitable, stable materials.
No one may remain under the lattice jib during pinning and unpinning procedure of the lattice sections. This is strictly prohibited!
There is a danger of accidents!

Unpin the S- pivot section and the intermediate section "**on top**" .

Relieve the guy rods (1, 2) by lowering the SA - bracket.

Unpin the installation brackets (3) on the S- pivot section and pin in bore (A) .
 Pin the transport retaining pin (8) .

Unpin the guy rods (2) from the SA- bracket from the guy rods (1) from the S- pivot section (Y).
 Place down the guy rods (1, 2) on the S- pivot section and the intermediate section and secure.

Unpin the lattice sections and remove.
 Remove the S- pivot section (G1) with the auxiliary crane on the slewing platform.

1. Installation

D A N G E R: For installation and removal work:

- A safe installation scaffolding / working platform must be used. There is a danger of accidents due to falling.
- Improvisations are prohibited.
- The lattice sections must be supported underneath with suitable, stable materials.
- Nobody may remain under the lattice jib during the pinning and unpinning procedure of the lattice sections.

Prerequisites:

- The crane is horizontally aligned.
- An auxiliary crane as well as an installation scaffolding / working platform are available.
- The LICCON - overload safety system is set according to the data given in the load charts.
- The keyed button "installation" (133) is actuated, the indicator light "installation" (132) lights up.
- The installation symbol on the LICCON - indicator blinks.
- The boom is not installed.

1.1 Installation D - Derrick

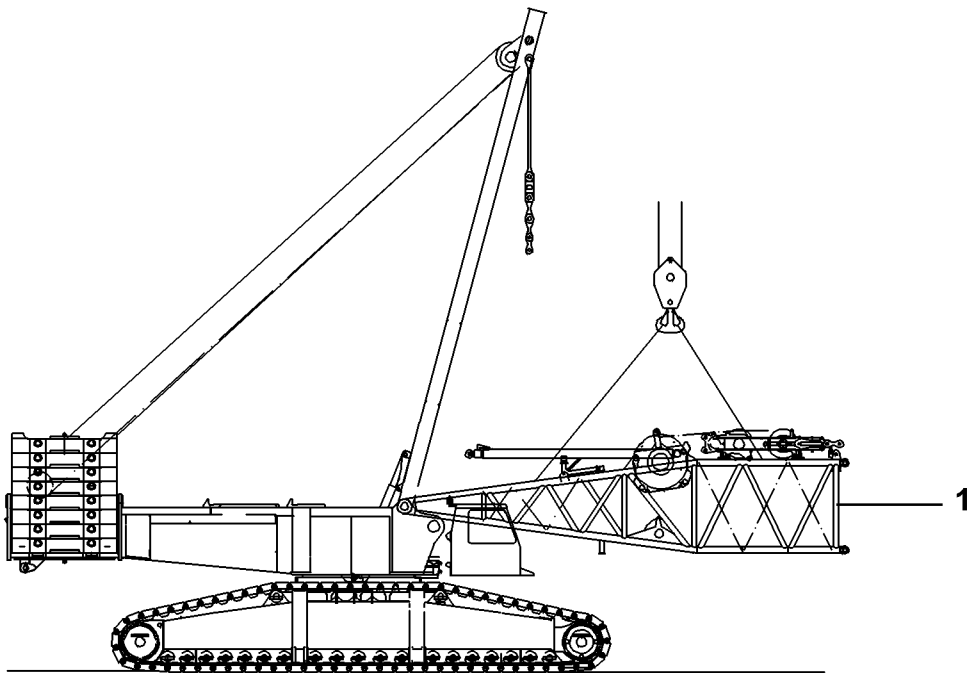
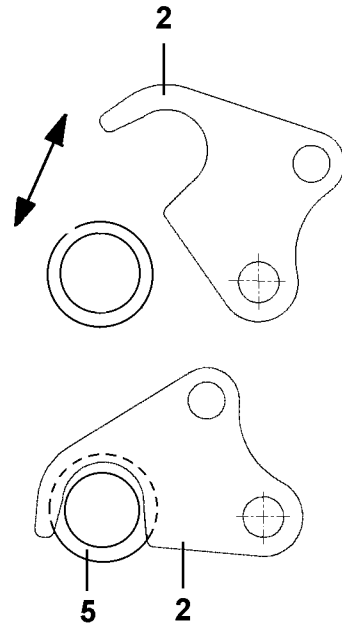
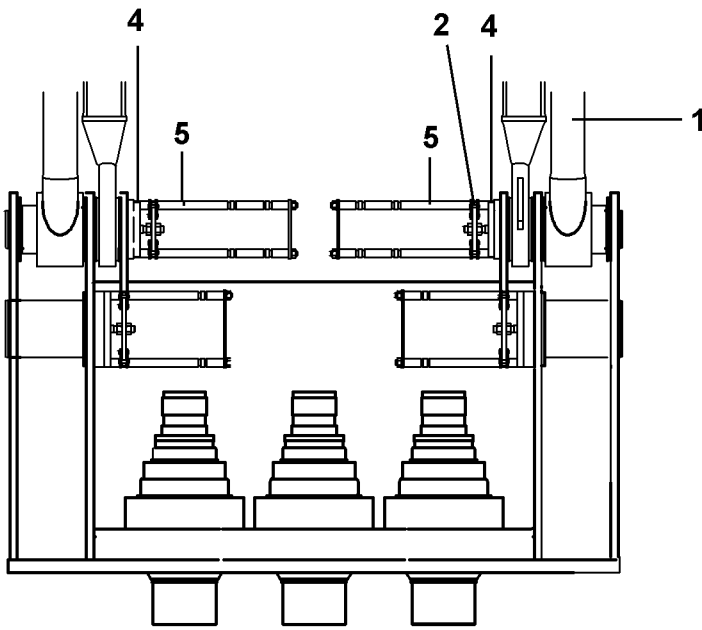
Turn the slewing platform until it is in lengthwise direction or to the side.

Note: Observe the data given in the erection and take down charts.

C A U T I O N: Before turning the slewing platform without the derrick or boom, the following must be observed:

- the crawler gear with installed slewing platform is in horizontal position.
- the maximum permissible ballast variations in chapter 3.06, Installation conditions.

If this is not observed, there is a danger of tipping the crane over!



2. Install S- pivot section

Lift the D- pivot section (1) with the auxiliary crane and swing it in to the pin points on the slewing platform.

Weights:

Component	Weight
D-Pivot section	6600 kg
Relapse cylinder - 2×	1316 kg
Rods for suspended ballast	612 kg
Rods for ballast trailer	630 kg
Winch III mit Seil 1250 m	8750 kg
Pulley blocks	3480 kg
D-Pivot section, complete	21400 kg

Fold both retaining hooks (2) from the guides (5) .

Retract the D- pivot section (1) on the slewing platform.

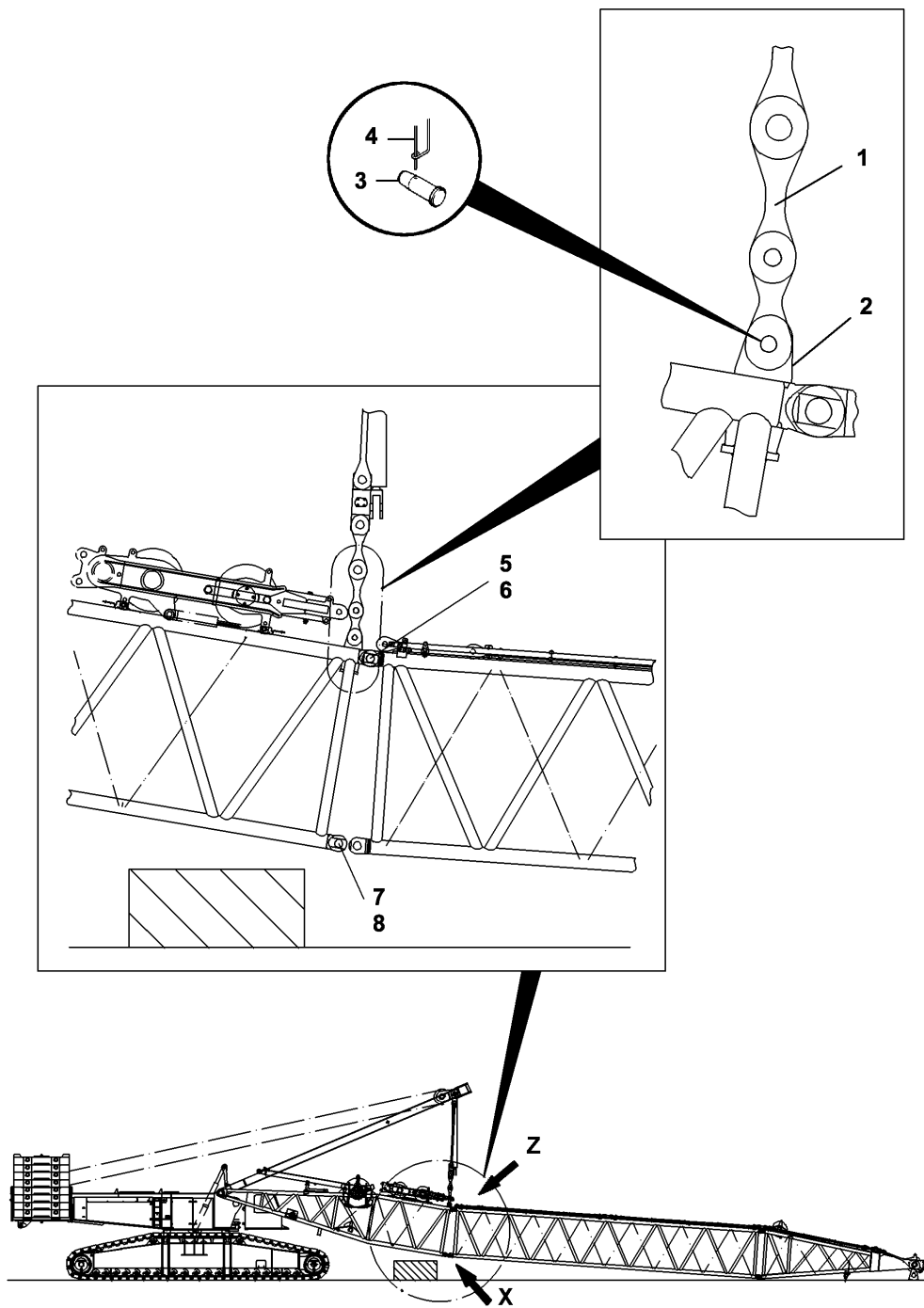
Fold the retaining hook (2) up, actuate the remote control and pin the connector pins (4) .

Secure the connector pins (4) by folding the retaining hooks (2) into the guides (5).

Note: For operation of remote control, see chapter 5.08.

D A N G E R: To prevent inadvertent unpinning, the connector pins (4) must be secured with the retaining hooks (2) .

Place the D-pivot section on the support base on the ground and remove the auxiliary crane .



2.1 Install the derrick and the guyrods

Lower the SA - bracket to the front, see chapter 5.02 "SA-Bracket".

Pin the guy rods (1) from the SA-bracket on the installation bracket (2) on the D-pivot section and secure.

Use pins (3) and spring retainers (4) .

Assemble the derrick and the corresponding guy rods to the required length, pin and secure.

Pin the D - intermediate section on the D-pivot section (Z) "**on top**".

Pin pins (5) with the pin pulling device and secure with spring retainers (6).

Pull up the D-pivot section with the SA-bracket (winch IV) until it can be pinned on the D-pivot section "**on the bottom**" (X) .

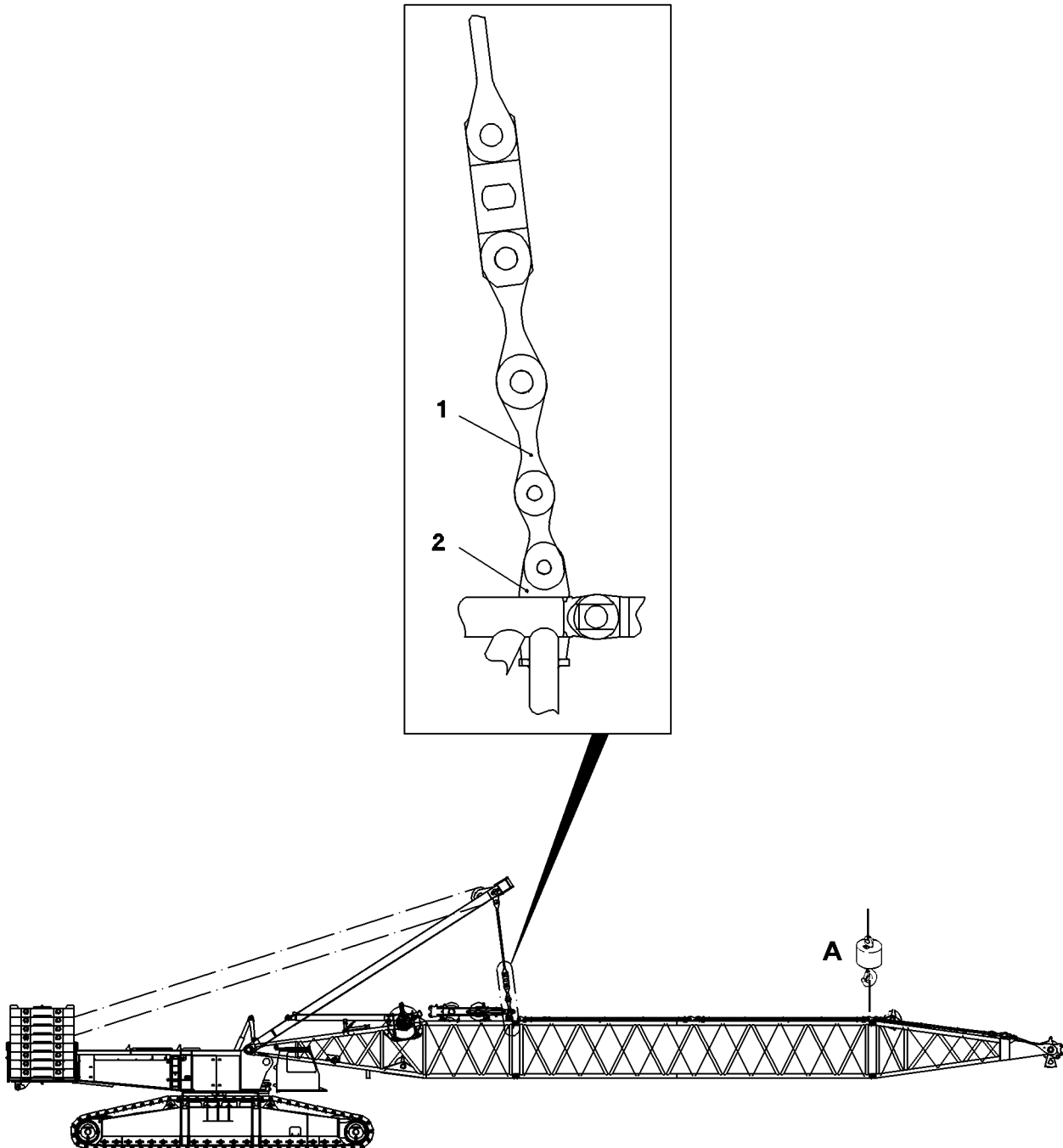
Note: Note the test point 1 - "IST" (Actual) force of monitor 1 in this position, so one knows when removing the boom, which force must be used to secure when unpinning.

Pin and secure on the D-pivot section "**on the bottom**" (X) .

Pin pins (7) with the pin pulling device and secure with spring retainers (8).

Luff down the SA-bracket and unpin guy rods (1) on the installation bracket (2) on the D-pivot section .

D A N G E R : **Before unpinning the guy rods on the installation brackets (2) on the D-pivot section, the derrick must be pinned "on the bottom" .**
Nobody may remain under the lattice jib during the unpinning procedure of the lattice sections.
There is a danger of accidents, as the derrick might suddenly fold down!



2.2 Flying installation of the derricks

Installation

If space is severely limited at the job site for the installation of the derrick, or is restricted due to nearby buildings, etc. then it is possible to install the derrick in flying mode:

Prerequisites:

- The D-pivot section hangs on the guy rods (1).
The guy rods are pinned and secured on the installation bracket (2) on the D-pivot section .

Installation

For a flying installation , the D- intermediate sections can be pinned and secured individually or the D- intermediate section and D-end section can be pinned and secured completely assembled .

Pin and secure the pin "on top" and "on the bottom" .

Note: For the weight of the lattice sections with placed guy rods, see chapter 5.03

Attach the D- end section on the auxiliary crane (A) or support it with stable materials.

Luff down the SA-bracket to relieve the guy rods (1) .

Unpin the guy rods (1) .

D A N G E R : **The derrick must be held with an auxiliary crane (A) or supported from below, only then may the guy rods (1) on the installation brackets (2) on the D-pivot section be unpinned.**
Nobody may remain under the lattice jib during the unpinning procedure.
This is strictly prohibited.
There is a danger of accidents, as the derrick might suddenly fold down!

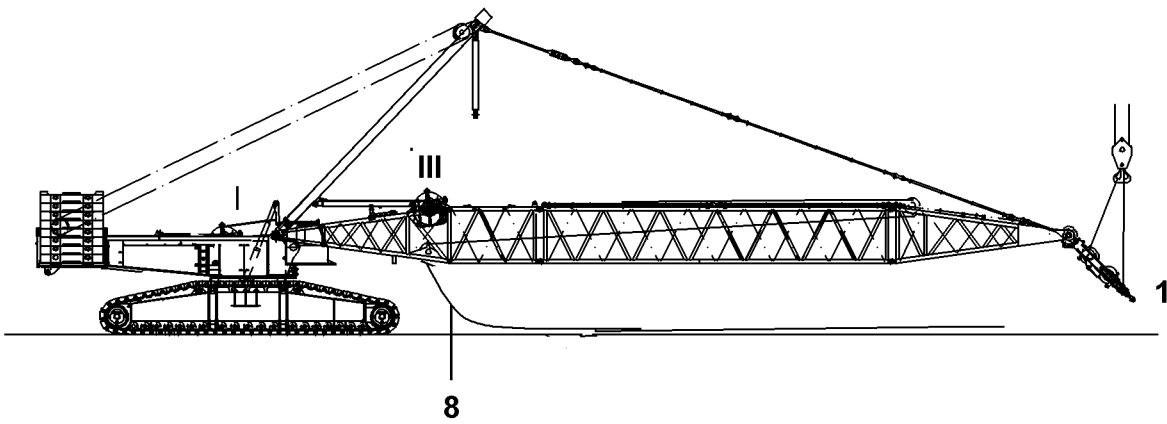
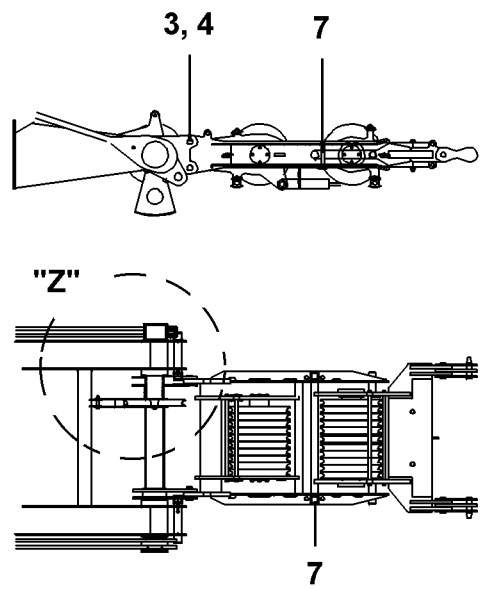
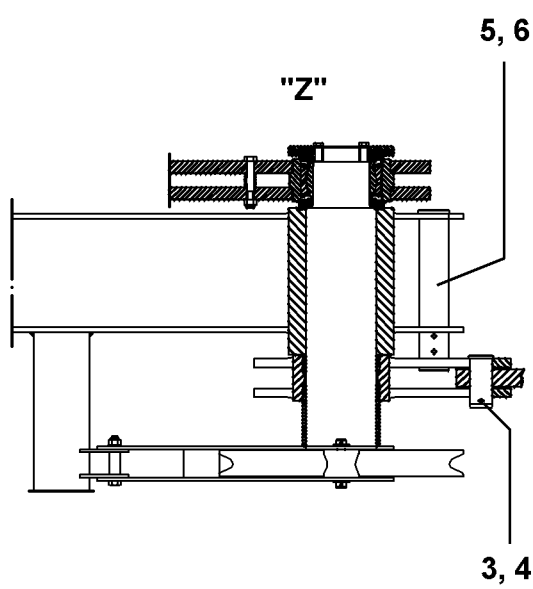
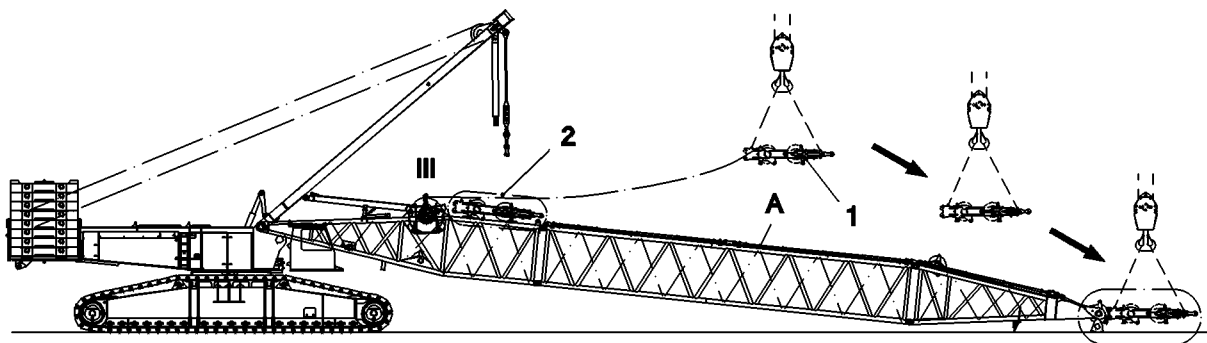
Lower the SA - bracket to the front, see chapter 5.02 " SA-bracket".

Pin and secure the guy rods from the D-end section with the guy rods from the SA-bracket .

Actuate the winch IV and tension the guy rods between the SA-bracket and the D-end section .

Remove the auxiliary crane.

D A N G E R : **Do not remove the auxiliary crane until the derrick is held by the guy rods .**
There is a danger of accidents, as the derrick might suddenly fold down!



2.3 Installation of the guy rods

Attach the S- pulley blocks (1) to the auxiliary crane and unpin on receptacle (2) on the D-pivot section.

Note: The weight of the S-pulley block is approx. 3200 kg.

Unpin the S-pulley blocks, while simultaneously spooling out the winch III, pull to the D-End section , pin with pin (3) and secure with spring retainer (4) .
Lock the S-pulley block horizontally with pin (5) and secure with spring retainer (6) on both sides.

Pin and secure guy rods (A) from the D- end section with the guy rods from the SA-bracket .
The guy rods must be installed and secured according to the installation drawings in chapter 5.03. the
Make sure to compare the numbers in the installation drawing with the numbers on the guy rod.

D A N G E R : **The pins of the derrick guy rods must be inserted from the outside to the inside.**
The guy rods must be checked regularly, see chapter " Inspection and maintenance of guy rods".

Actuate the winch IV and tension the guy rods between the SA-bracket and the D- end section and pull the derrick up to the horizontal.

Unpin the locking pin (5) on both sides.

D A N G E R : **Before unpinning, the S-pulley blocks (1) must hang on the auxiliary crane!**

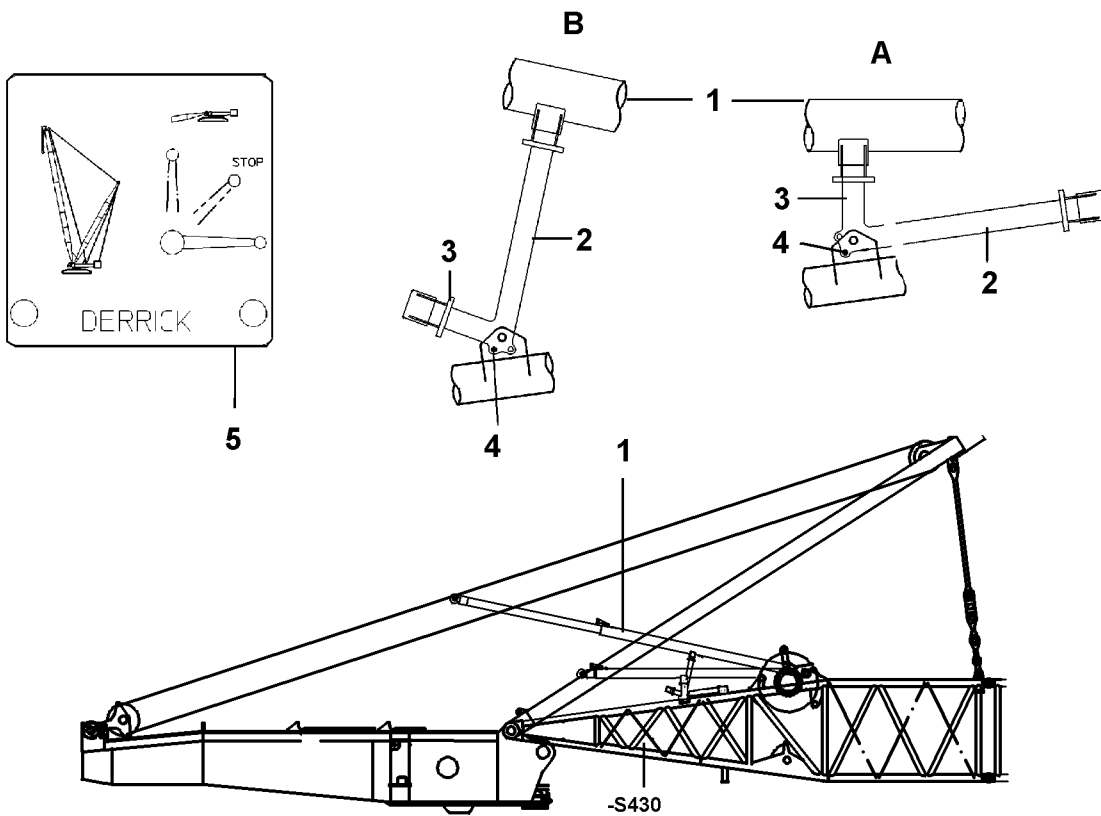
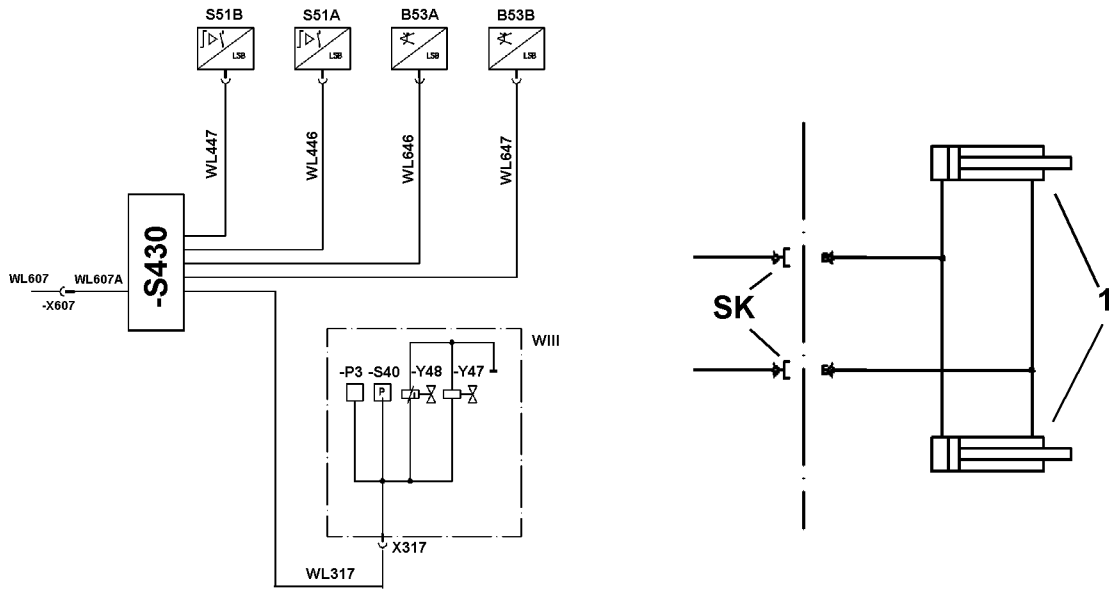
Lower the S-pulley blocks (1) with the auxiliary crane to the ground and unpin the transport pin (7) .

C A U T I O N : **The "lower" and "upper " pulley blocks must be interconnected by the transport pin (7) . In crane operation, they must be unpinned.**

Disengage the auxiliary crane.
Pull the hoist cable (8) with the auxiliary winch over the cable pulleys in the D - end section and D - pivot section .

Note: For cable routing, see chapter 4.06, Reeving

D A N G E R : **Sufficient hoist cable must be routed over the cable pulleys so that the hoist cable is not pulled backward due to its own weight when the derrick is erected.**
Otherwise there is a danger of accidents!



3. Electrical connections

Establish the electrical (W607A) from the slewing platform to the connector box (-S430).
 Establish the electrical connection to the D - relapse cylinders limit switches. Plug in the cable plug (WL446 in -S51A and WL447 in -S51B).
 Plug in the cable plug (WL317 in -X317) for replenishing pressure switch winch III.
 Establish the electrical connection to the angle sensor. Plug in the cable plug (WL646 in B53A) in (WL647 in B53B).

Hydraulic connections

Establish the hydraulic connection (2× Quick couplings) to the D-relapse cylinders.

4. Function check for limit switches**Prerequisites:**

- All electrical connections are established.
- The engine is running.

Function check

Cover the limit switch initiators individually on the D - relapse cylinders with a metal plate.
 The D- control winch movement (W IV) "**spooling up**" must turn off.
 The symbol must appear on the LICCON monitor .

C A U T I O N : **The individual limit switches must be checked for proper function before crane operation.**
Manual testing procedure is described below.
In the test system, the function of the individual limit switch initiators must be determined - see Diagnostics Manual.

5. D- relapse cylinder

A = Transport condition

B = Installation condition

For installation of long parts (2), swing the mechanical support upward and lock with pin (4) .

5.1 Extend D - relapse cylinder

Extend the piston rod of the relapse cylinders into horizontal position by actuating the ball cock lever(1).

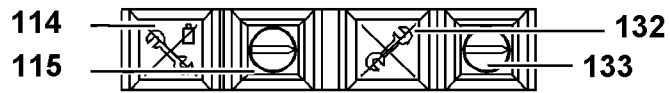
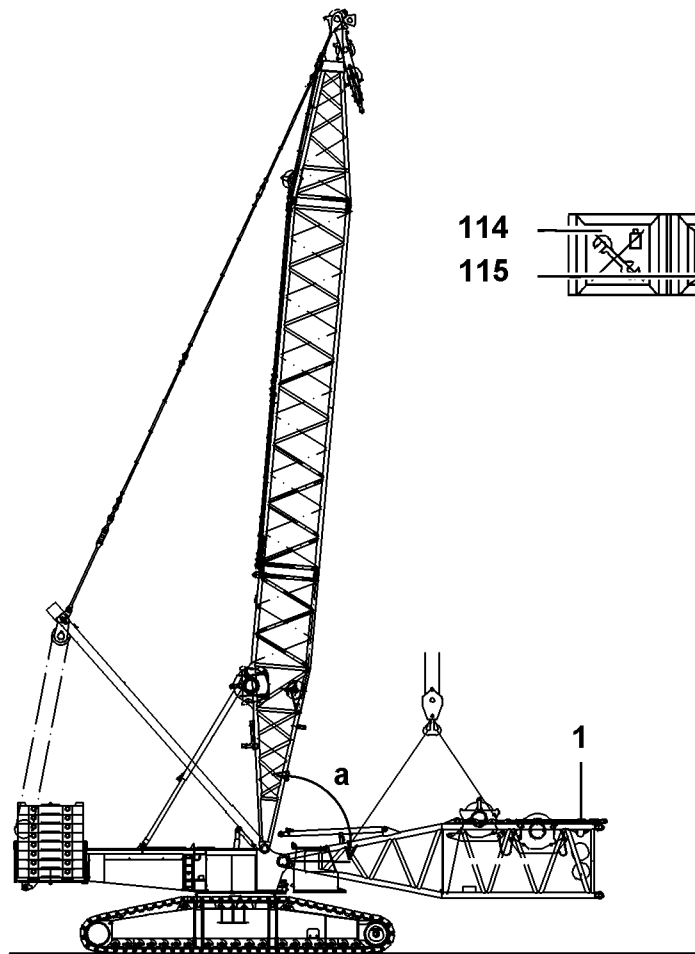
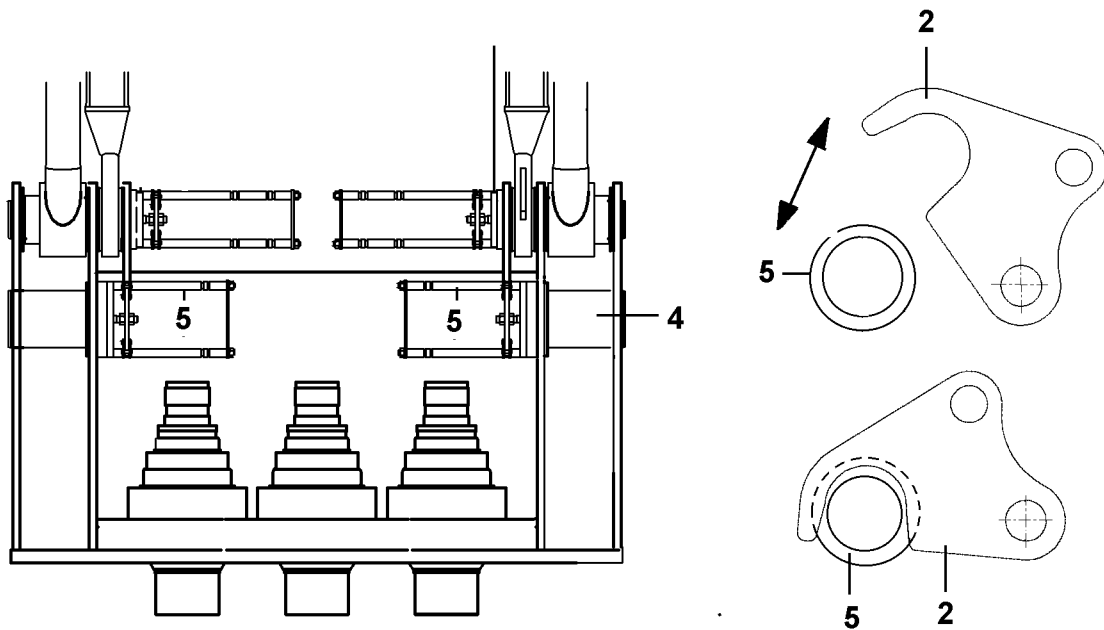
Lever positions:

Lever horizontal = Crane operation, extend piston rod

Lever vertical = Installation, retract piston rod

Lever 45° = Piston rod cannot be extended or retracted

D A N G E R : **The relapse cylinders must be extended before erection.**
The ball cock lever must be in horizontal direction, and must be secured to prevent it from inadvertent actuation during crane operation.



6. Erect the derrick

Erect the derrick to the point where the boom can be installed without restriction (approx. 75° to max. 85°).

D A N G E R: **The derrick may not be erected to the horizontal by more than 85 °. Otherwise there is a danger of tipping the crane over!**

7. Install the S-pivot section

Raise the S-pivot section (1) with the auxiliary crane and swing in to the pin points on the slewing platform.

Weights:

Component	Weight
S- pivot section	14350 kg
Relapse cylinder - 2×	1300 kg
S - guy rods	665 kg
W - guy rods	652 kg
Winch V	9500 kg
Winch VI	6390 kg

Fold both retaining hooks (2) from the guides (5) .

Retract the S- pivot section (1) on the slewing platform.

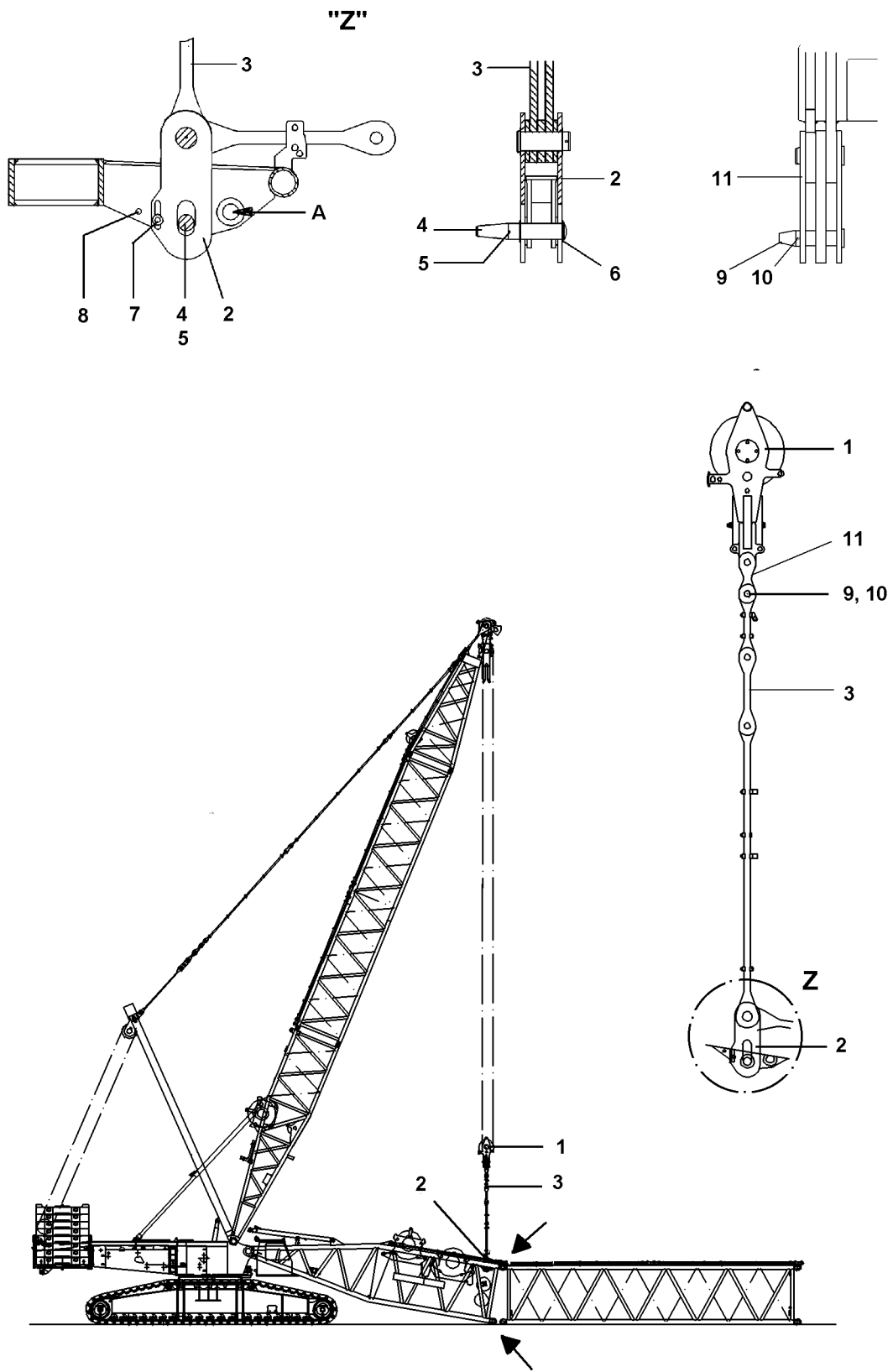
Fold the retaining hook (2) up, actuate the remote control and pin the connector pins (4) .

Secure the connector pins (4) by folding the retaining hooks (2) into the guides (5).

Note: For control of remote control, see chapter 5.08

D A N G E R: **To prevent inadvertent unpinning, the connector pins (4) must be secured with the retaining hooks (2) .**

Place the S- pivot section on the support base (U) on the ground and remove the auxiliary crane.



7.1 Install the boom

The installation brackets (2) on the S-pivot section are pinned and secured.
Use pins (4), washers (6) and spring retainers (5).
Unpin the transport retaining pin (7) and insert in parking position (8).

C A U T I O N: **The transport retaining pins (7) must be unpinned during installation and operation.**
Insert pins in parking position (8).

Note: A = Pin point for flying installation with SA-bracket .

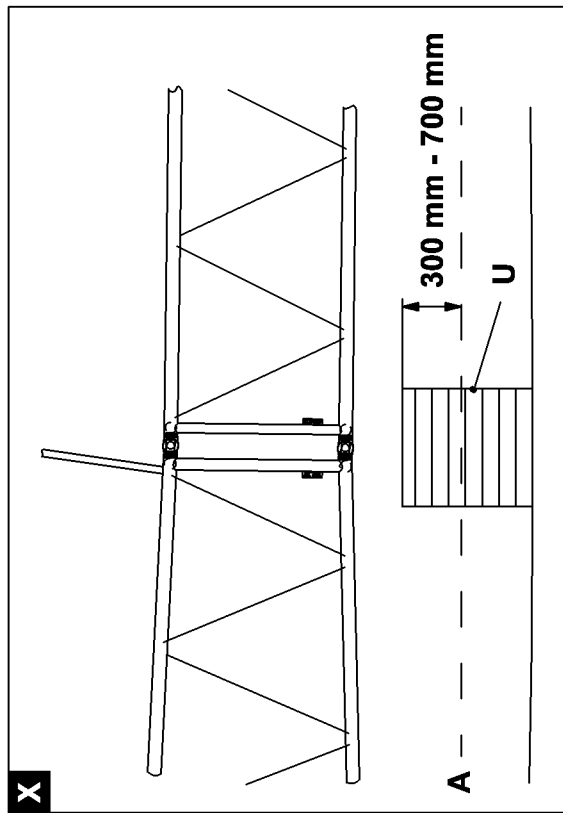
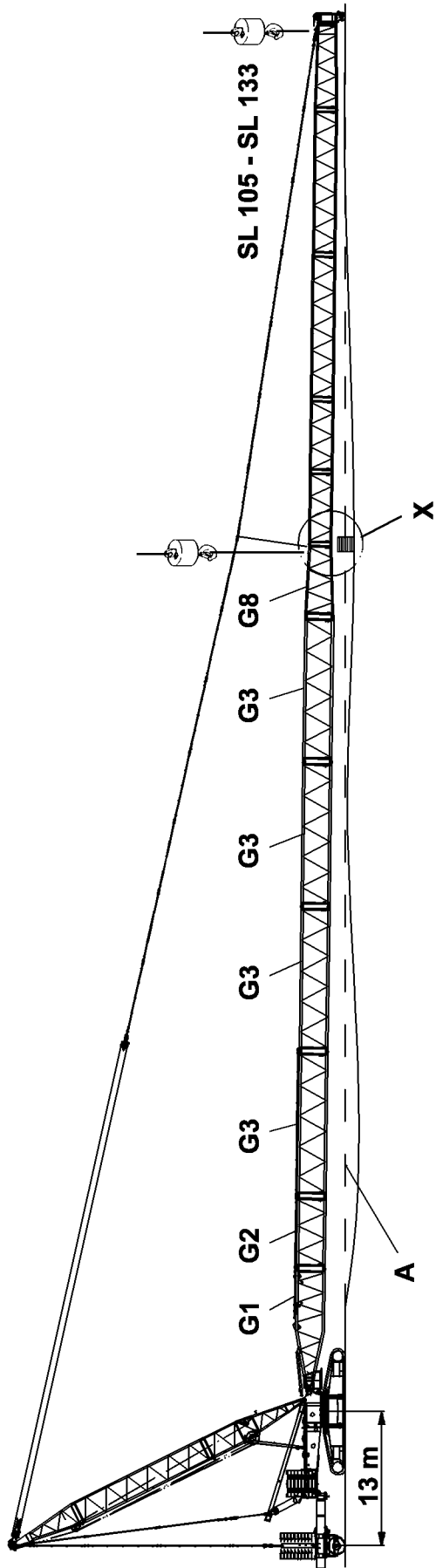
Lower the Derrick to the front and lower the bottom S- pulley block (1) .
Pin and secure the guy rods (3) on the brackets (11) .
Use pins (9) and spring retainers (10) .

Assemble the boom and the corresponding guy rods to the required length, pin and secure.
Pin and secure the first intermediate section on the S-pivot section (G1) **"on top"** .
Pull up the S-pivot section with the S- pulley block and pin and secure **"on the bottom"** .

D A N G E R: **Pins on the lattice section must be secured with spring retainers .**
With the SA-bracket, the following maximum boom lengths can be lifted:
- S140 m und SL 98 m, only with S- guy rods
- S 91 with S - and WA-bracket II guy rods
The end section may not be lifted, it must remain on the ground.
If this is not observed, severe damage can occur!

Place and secure the guy rods (3) on the S-pivot section by lowering the S-pulley block (1) .
Unpin the pulley block (1) on the guy rods (3) . Remove the spring retainer (10) and unpin the pin (9) .

D A N G E R: **Before unpinning the guy rods , the boom must be pinned "on the bottom" .**
Otherwise there is a danger of accidents, as the boom might suddenly fold down!
For removal and installation of the lattice sections, they must be supported with suitable, stable materials.
Nobody may remain under the lattice jib during the pinning and unpinning procedure of the lattice sections. This is strictly prohibited! Danger of accidents!



7.1.1 Install SL - 105 to SL - 133 boom on uneven ground**Installation**

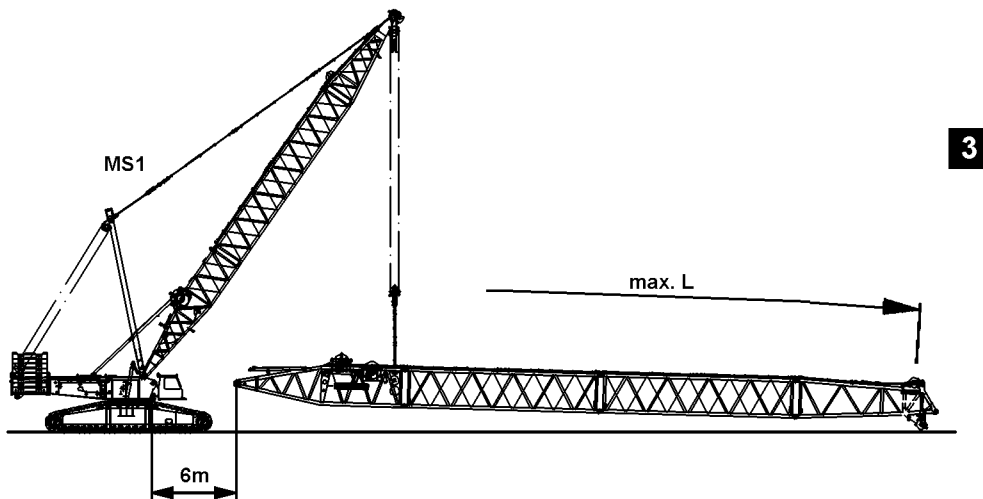
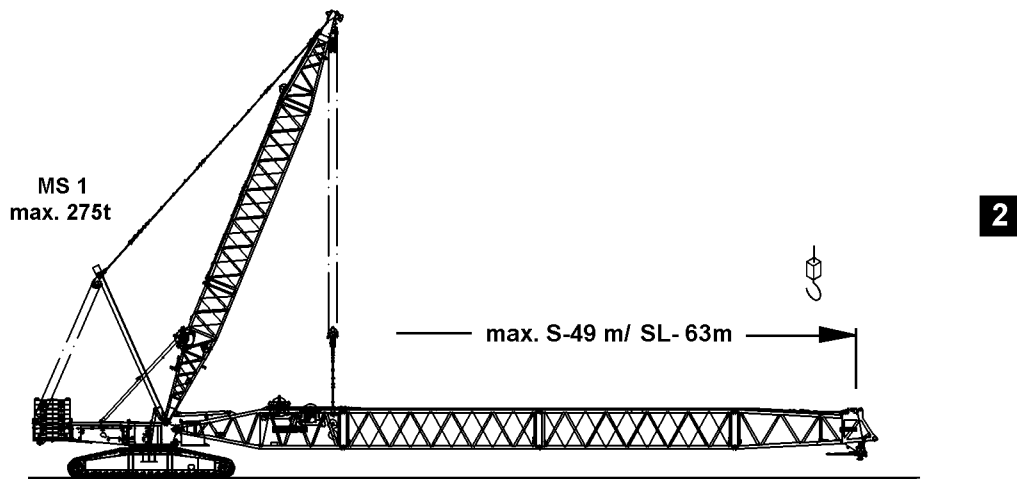
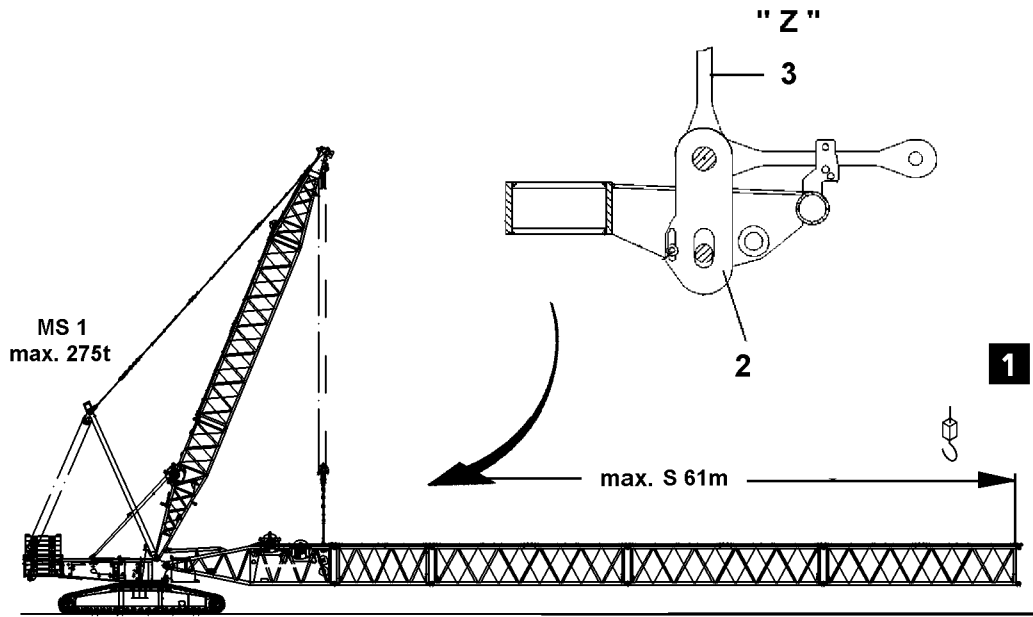
- The derrick must be raised (approx. 75° to max. 85°), so that the boom can be installed without restriction.

D A N G E R: **The derrick may not be raised further than max. 85° to the horizontal. Otherwise there is a danger of tipping over!**

- Swing in the pre-mounted S - boom combination (G1 + G2 + (4 x G3) + G8) with the auxiliary crane to the slewing platform.
- Pin and secure the S - boom combination with the S - pivot section (G1) on the slewing platform and secure .
- Place down the pre-mounted S - boom combination on the support (U) (fig. X) or hang onto the auxiliary boom.

Note: The upper edge of the support (U) (fig. X) must be 300 mm to 700 mm over the alignment level (A) (fig. X) .

- Install the remaining L - intermediate sections and the end section individually or fully assembled with the auxiliary crane to the SL - reducer section, pin and secure.



7.2 Flying installation of the SL / S -boom

Installation

If space is severely limited at the job site for the installation of the derrick, or is restricted due to nearby buildings, etc. then it is possible to install the boom up to a **max. length** in flying mode:

- | | | |
|---------------|---|---|
| Fig. 1 | - max. S 61 m | <ul style="list-style-type: none"> - without end section, without hook block - with S - and WA-bracket II guy rods - slewing platform ballast 120t - min. central ballast 45t - max. permissible total force 275t on test point MS 1 |
| Fig. 2 | <ul style="list-style-type: none"> - max. S 49 m - max. SL 63m | <ul style="list-style-type: none"> - with end section, without hook block - with S - and WA-bracket II guy rods - with S - guy rods - slewing platform ballast 120t - min. central ballast 45t - max. permissible total force 275t on test point MS 1 |
| Fig. 3 | <ul style="list-style-type: none"> - max. S 91 m - max. S 140m - max. SL 98m | <ul style="list-style-type: none"> - with end section, without hook block - with S - and WA- bracket II guy rods - with S - guy rods - with S - guy rods - max. permissible total force 245 t on test point MS 1 with slewing platform ballast 120 t and central ballast 45 t - max. permissible total force 175 t on test point MS 1 with slewing platform ballast 70 t and central ballast 20 t |

Prerequisites:

- The pivot section is pinned on the guy rods of the pulley block and the installation brackets (2) , secured and pulled up into horizontal position.

Installation

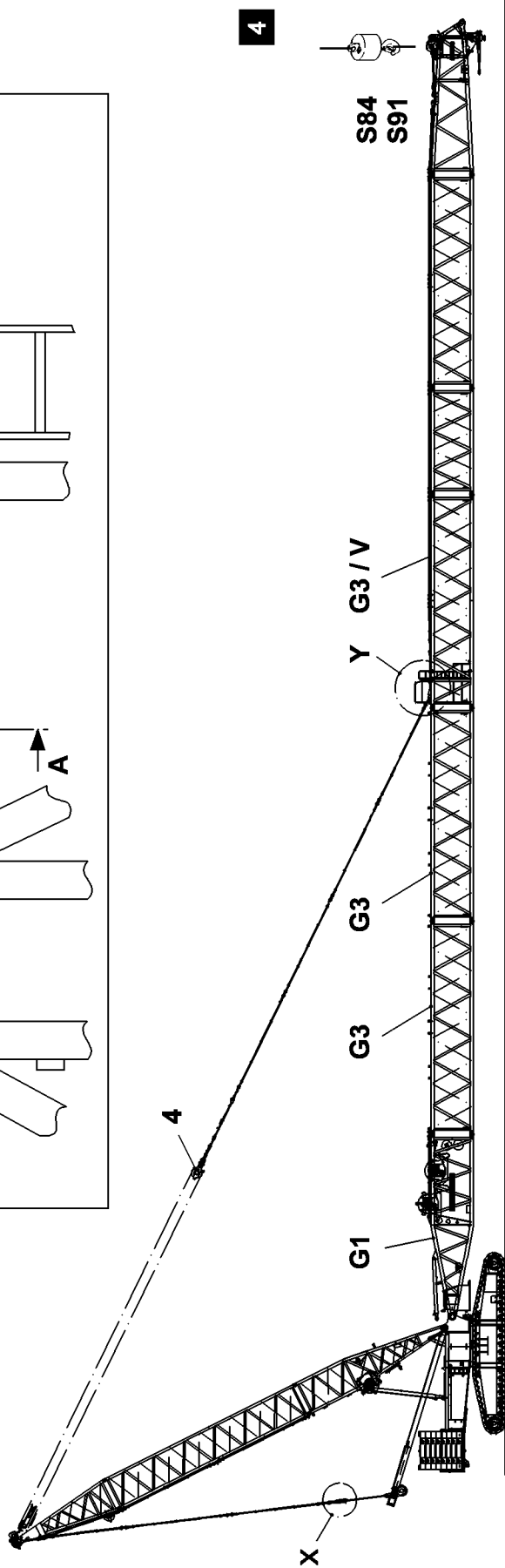
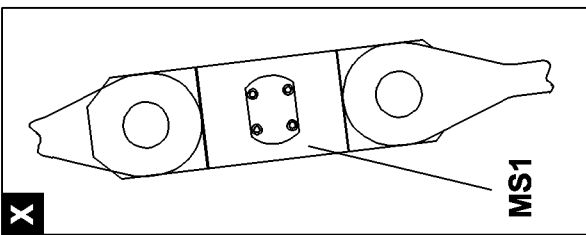
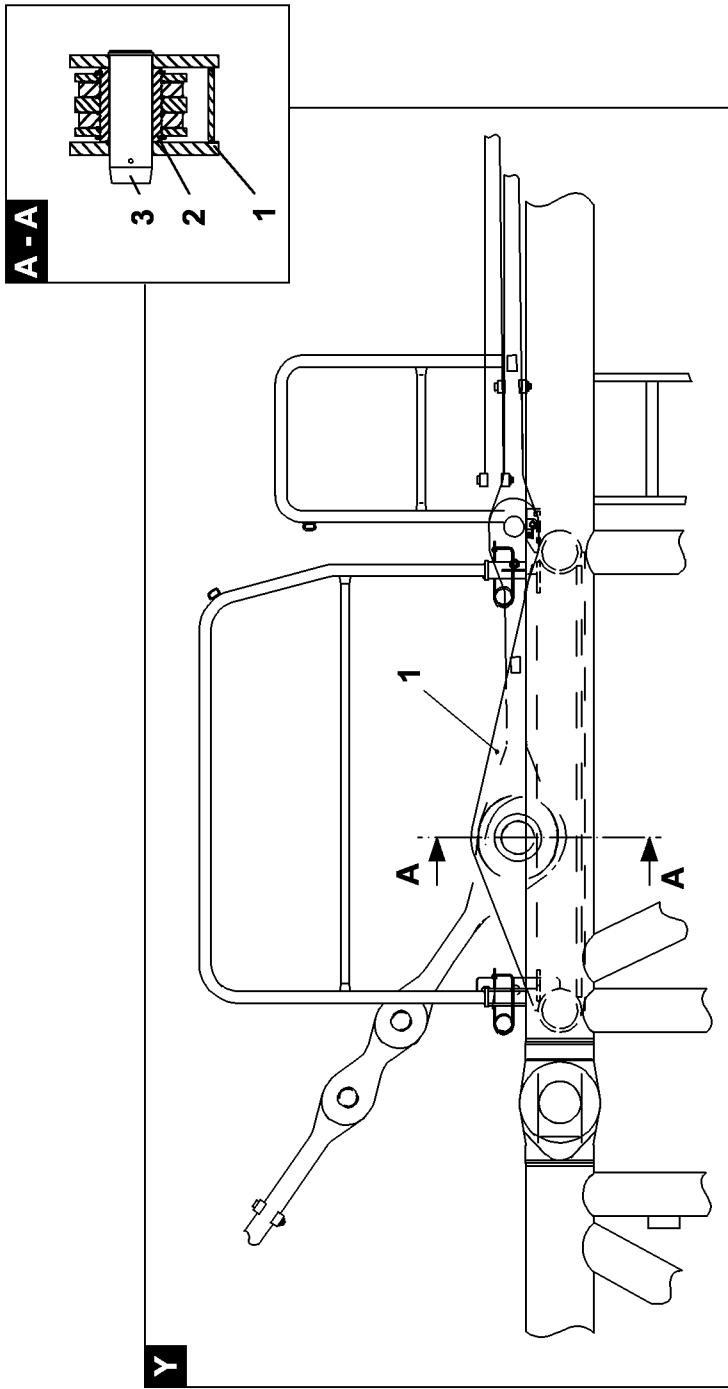
For a flying installation , the intermediate sections can be pinned and secured piece by piece with the auxiliary crane or the completely assembled boom can be pinned and secured on the pivot section . Pin and secure the pin "on top" and "on the bottom" .

Note: For the weight of the lattice sections with placed guy rods, see chapter 5.03

D A N G E R: Note the maximum permissible boom lengths for flying installation .
If this is not observed, there is danger of accidents!

Attach the boom on the front on the auxiliary crane or support it from below with stable materials. Relieve the pulley block by lowering it, unpin the guy rods on the pivot section and pin and secure with the guy rods from the end section .

D A N G E R: The boom must be held with an auxiliary crane (A) or supported from below, only then may the pulley block on the installation bracket (2) on the pivot section be unpinned.
Nobody may remain under the lattice jib during the unpinning procedure of the lattice sections. This is strictly prohibited!
There is a danger of accidents, as the derrick might suddenly fold down!



193066

7.3 Flying installation of the SL / S - boom

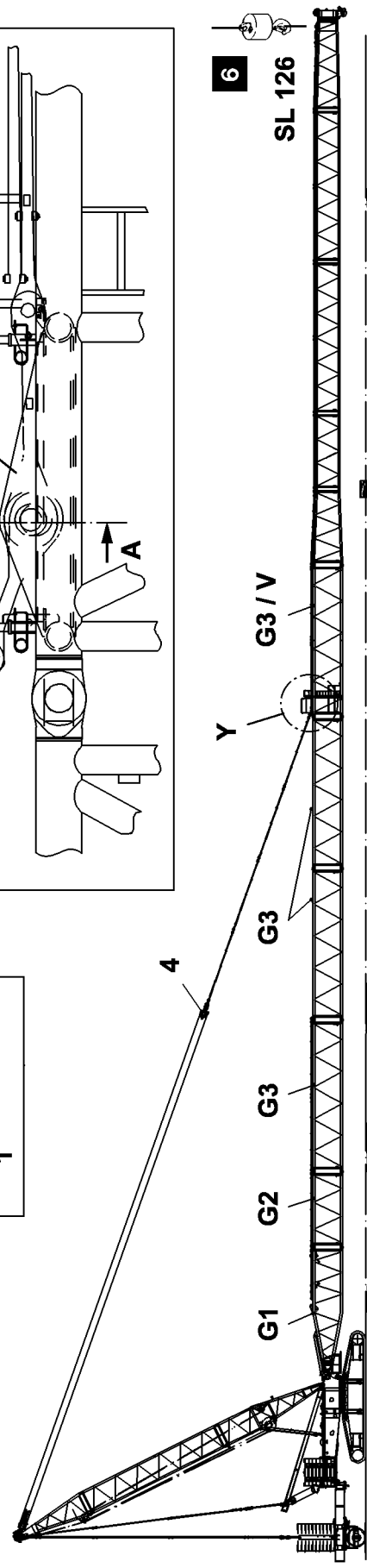
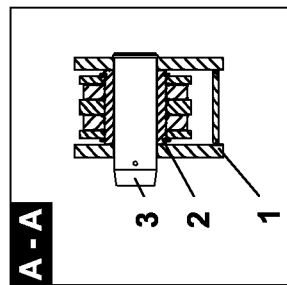
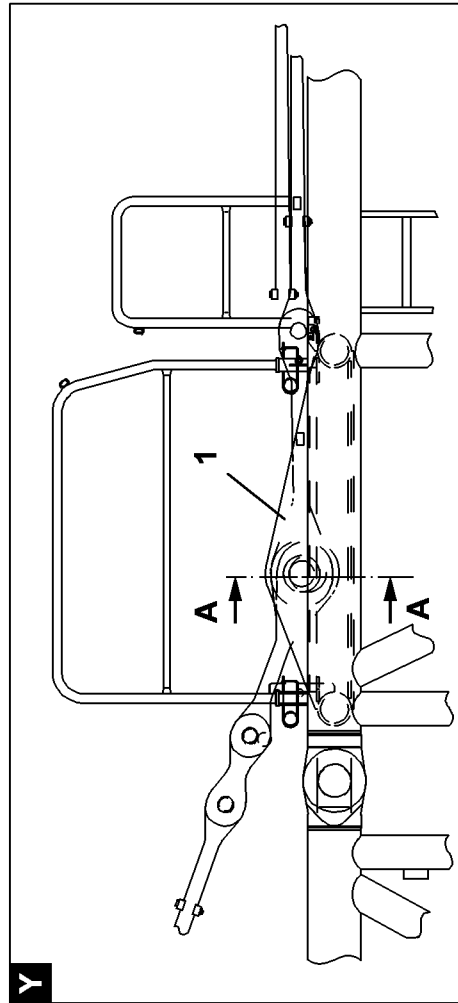
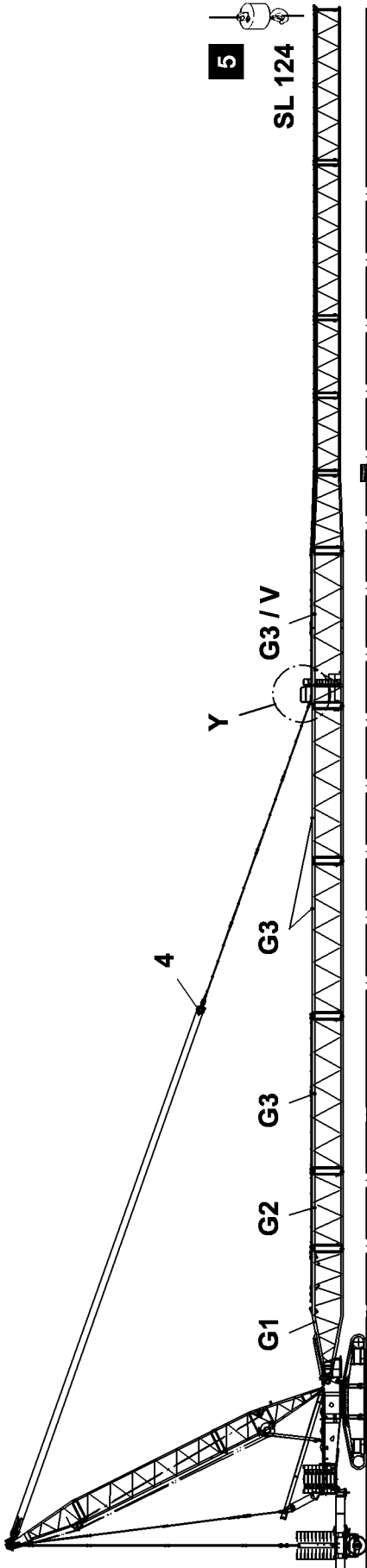
Installation

If space is severely limited at the job site for the installation of the derrick, or is restricted due to nearby buildings, etc. then it is possible to install the boom up to a **max. length** in flying mode:

- Fig. 4**
- max. S 84 m
 - with end section, without hook block
 - with S - and WA-bracket II guy rods
 - min. slewing platform ballast 245 t
 - min. central ballast 95 t
 - max. permissible total force 410 t on test point MS 1 (Fig. X)

 - max. S 91 m
 - with end section, without hook block
 - with S - and WA-bracket II guy rods
 - min. slewing platform ballast 220 t
 - min. central ballast 95 t
 - min. derrickballast 100 t at 13 m radius

Installation description : see 7.4



7.4 Flying installation of the SL / S - boom

Installation

If space is severely limited at the job site for the installation of the derrick, or is restricted due to nearby buildings, etc. then it is possible to install the boom up to a **max. length** in flying mode:

Fig. 5 - max. S 124 m - **without end section, without hook block**
- with S - guy rods
- **min. slewing platform ballast 170 t**
- **min. central ballast 45t**
- **min. derrickballast 200 t at 13 m radius**

Fig. 6 - max. S 126 m - **with end section, without hook block**
- with S -guy rods
- **min. slewing platform ballast 170 t**
- **min. central ballast 45 t**
- **min. derrickballast 200 t at 13 m radius**

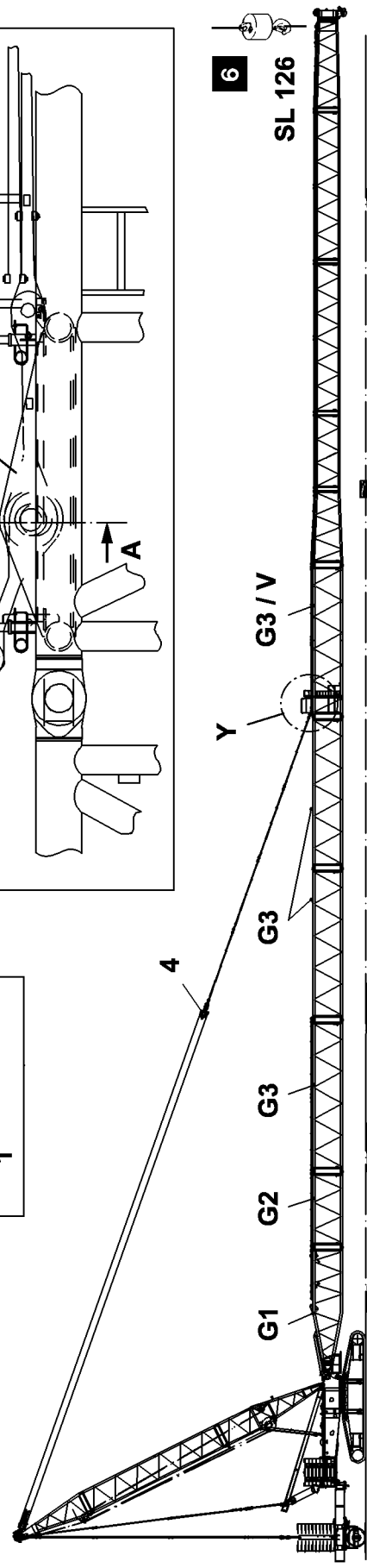
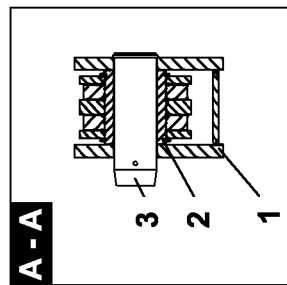
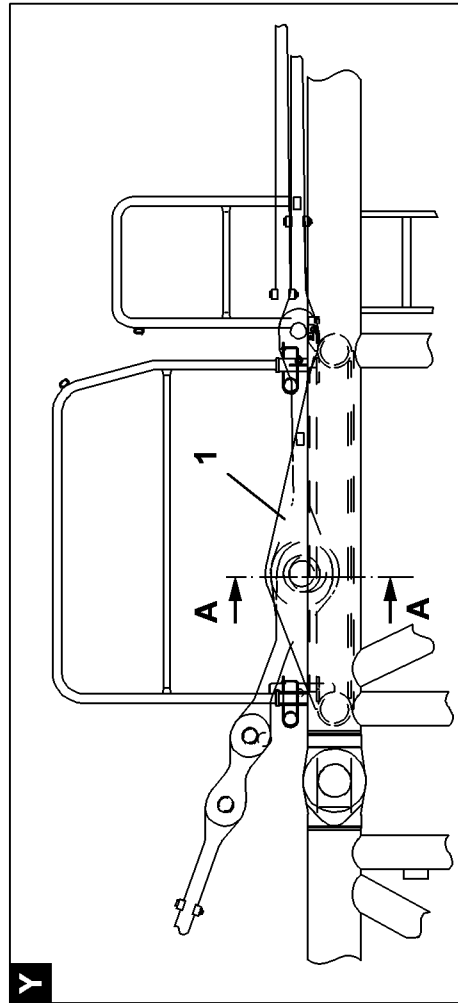
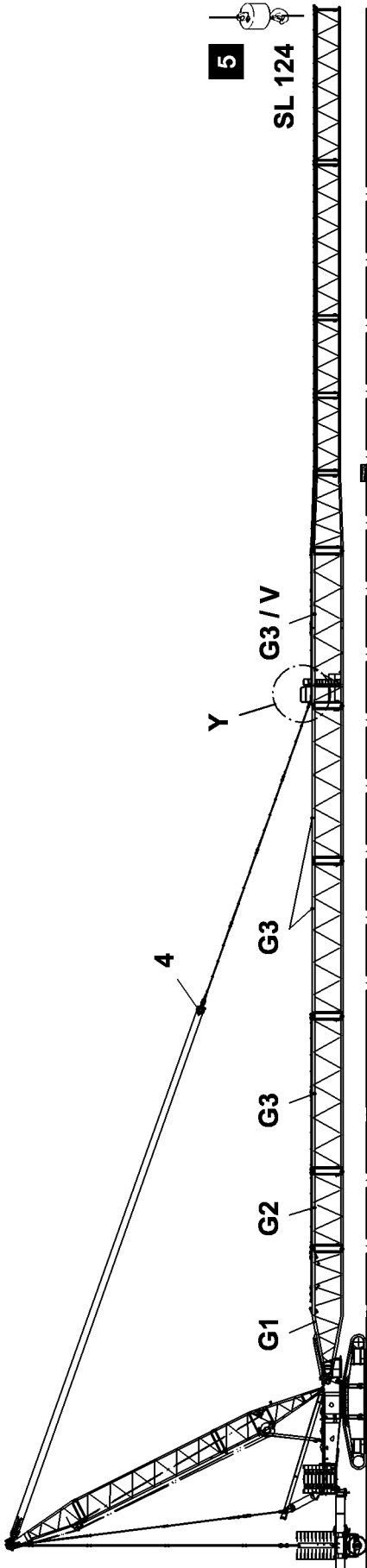
Installation description :

- The S - pivot section (G1) and the S - intermediate sections (G3) must be preassembled or fully assembled at a suitable site . It must be observed that the **reinforced** intermediate section (G3 / V) is installed at the "end" of the preassembled S -boom combination (fig. 4 // 5 // 6) .
- The derrick must be raised (approx. 75° bis max. 85°), so that the boom can be installed without restriction.

D A N G E R : **The derrick may not be raised further than max. 85° to the horizontal.
Otherwise there is a danger of tipping over!**

- Swing the preassembled S - boom combination (G1 + G3 + G3 + G3 / V) with the auxiliary crane to the slewing platform . (G3 / V = S - intermediate section 14m **reinforced**)
- Pin and secure the S - boom combination with the S - pivot section (G1) on the slewing platform.
- Lower the pulley block (4) to the pivot section or the boom.
- Pin the guy rods on the S - pulley block (4) and on the brackets (1) (fig. Y) of the **reinforced** S - intermediate section (fig. 4 // fig. 5 // fig. 6). The guy rods are connected on the brackets (1) with a hollow axle (2) and must be pinned on the pin point of the brackets (1) with pins (3) (fig. Y // fig. A - A). Secure pin (3) .
- Luff the derrick into operating position ($X = 115.1^\circ$ to 118.1°) (fig. 4 // fig. 5 // fig. 6)

D A N G E R : **It must be ensured when luffing the derrick into operating position, that the
guy rods or the cable of control winch W III are not tensioned.
This could overload the crane!**



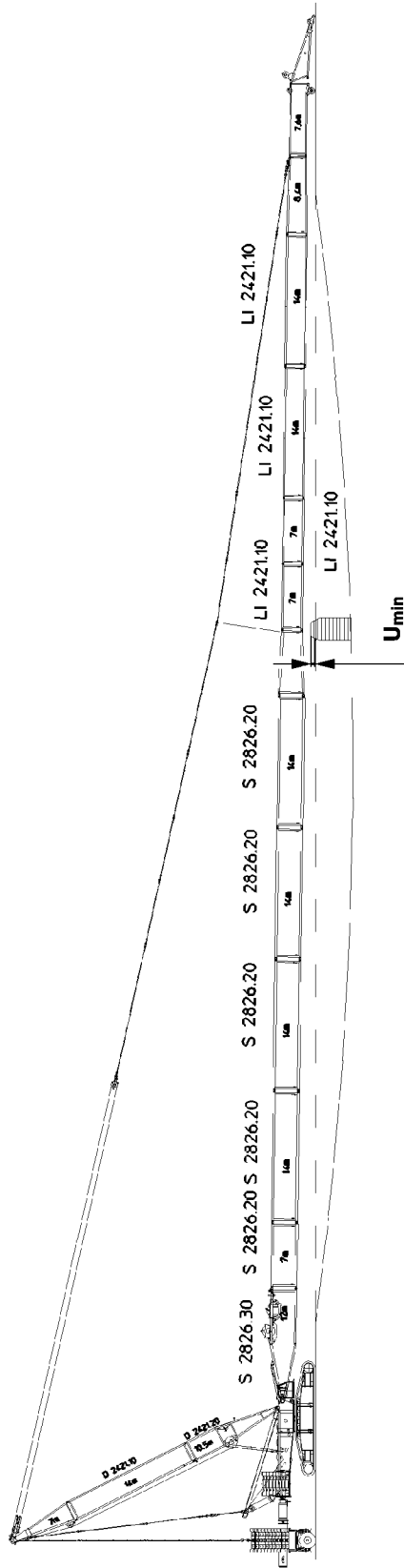
- By spooling up the control winch WIII, bring the guy rods to "tension", until the auxiliary crane is relieved. The boom combination must remain in horizontal position.
- After the boom combination is pinned, secured and tensioned, remove the auxiliary crane.
- Install the remaining S - or L - intermediate sections and the end section individually or fully assembled with the auxiliary crane on the **reinforced** S - intermediate section (G3 / V) , pin and secure .
- The guy rods of the lattice sections must be pinned together, then secured.
- Hand the boom on the front with the auxiliary crane or support with stable materials (fig. 4 //fig. 5 // fig. 6)
- Spool out the cable of the control winch WIII until the guy rods are relieved between the S - pulley block and the **reinforced** S - intermediate section (G3 / V) .
- Unpin the pins (3) on the brackets (1) .

Note: For weight of the lattice sections with placed guy rods, see chapter 5.03.

D A N G E R : **Note the maximum permissible boom lengths for flying installation .
If this is not observed, there is danger of accidents!**

Note: The **reinforced** 14 m S- intermediate section (G3 / V) weighs approx. 1.6 t more than the "normal" 14 m S- intermediate sections. This addition of weight of 1.6 t has not been considered in the load charts and therefore counts **as load**, i.e. depending on the boom length, the load indicator on the main boom head is larger by approx. 800 kg due to this intermediate section.

D A N G E R : **The completely assembled boom must be held with an auxiliary crane or supported from below before the pin (3) on the brackets (1) may be unpinned. Make sure that no one is underneath the lattice sections during the pinning or unpinning procedure! This is strictly prohibited. There is a danger of accidents, as the boom may suddenly fold down. For removal or installation of the lattice sections, they must be supported from below with suitable, stable materials. There is a danger of accidents!**



7.5 Erection / closing of SL8D- 105 m to SL8D- 140 m

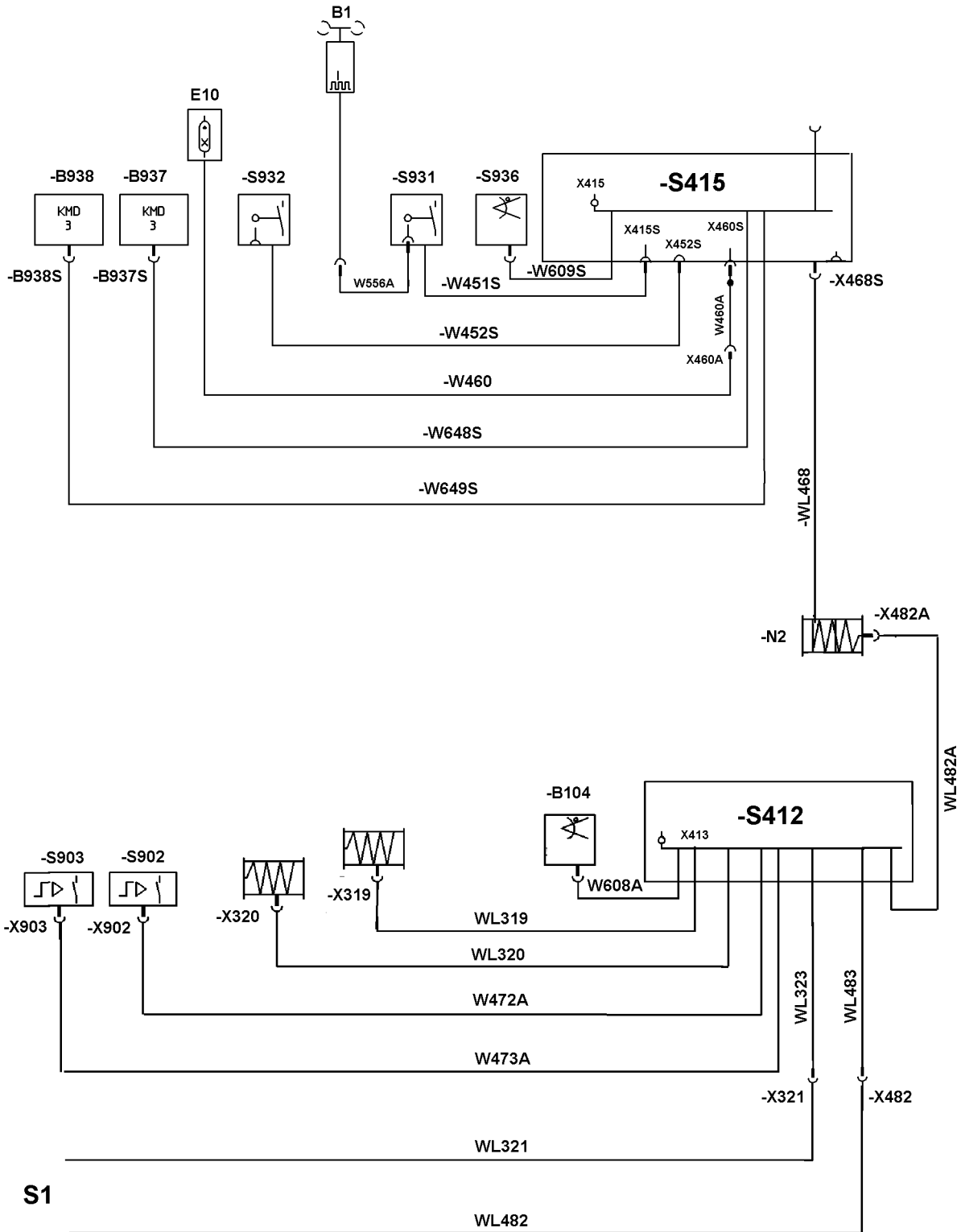
The boom combinations must be erected or taken down according to the **Erection and take down charts**.

D A N G E R: It must be erected or taken down according to the data given in the erection and take down charts.
If this is not observed, the crane will be overloaded or tip over!

Note: Up to a boom length of SLD- 119m, the L- end section may not lift off the ground when the boom is closed.

D A N G E R: When closing the boom SL8D- 126 m, the L-end section may not lift off the ground.
If this is not observed, property damage may occur or the crane may topple over.

Boom	Support (Umin)
SLD- 105m	> 1,10m
SLD- 112m	> 1,0m
SLD- 119m	> 0,90m
SLD- 126m	> 0,80m
SLD- 133m	> 0,70m
SLD- 140m	> 0,60m



8. Establish the electrical connections

Establish the electrical connection from the control box (S1) on the slewing platform to the connector box (-S412).

Connect the cable plug (WL482) with (WL483) and (WL321) with (WL323) .

Establish the electrical connection from the cable drum (N2) to the connector box (-S415) .

Plug the cable plug (WL468) into the connector box (-S415) .

Establish the electrical connection from the connector box (-S412) to the cable drum (N2) .

Plug the cable plug (WL482A) into the cable drum (N2) .

Install the airplane warning light and wind speed sensor on the S- end section .

Plug in the cable plug (W460) for the airplane warning light on the connector box (-S415) .

8.1 Hydraulic connections

Establish the hydraulic connection (2× Quick couplings) to the S-relapse cylinders.

9. Function check**Prerequisites:**

- All electrical connections are established.
- The engine is running.
- The SD - operating mode is set.

Airplane warning light

Turn on the airplane warning light, check function visually.

Wind speed sensor

Check the movement and function of the wind speed sensor.

Limit switch

CAUTION: The individual limit switches must be checked for proper function before crane operation.

Manual testing procedure is described below.

In the test system, the function of the individual limit switch initiators must be determined - see Diagnostics Manual.

Hoist limit switch

Actuate the hoist limit switch manually.

The hoist winch must turn off when lifting.

The hoist "top" symbol on the LICCON - indicator must blink.

Note:

When replacing or changing a hoist limit switch (HES) , the HES must have the correct bus address as well as the correct software version to be recognized again by the bus system (LSB).

S - relapse cylinder

Cover the limit switch initiators individually on the S - relapse cylinders with a metal plate.

The S - control winch movement (W III) "spool up" must turn off.

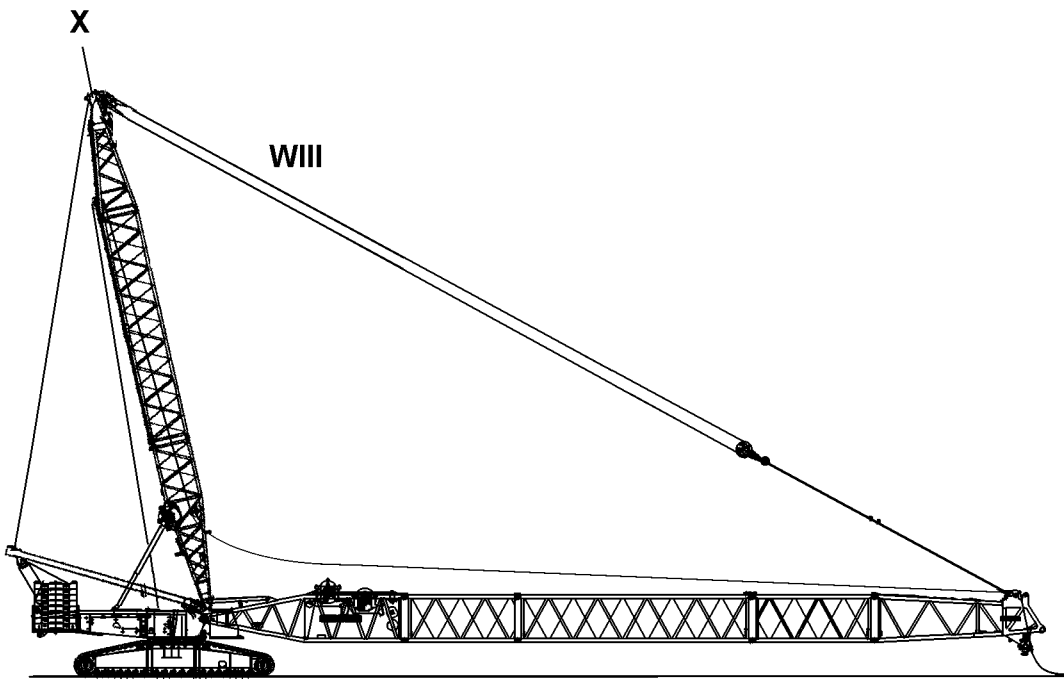
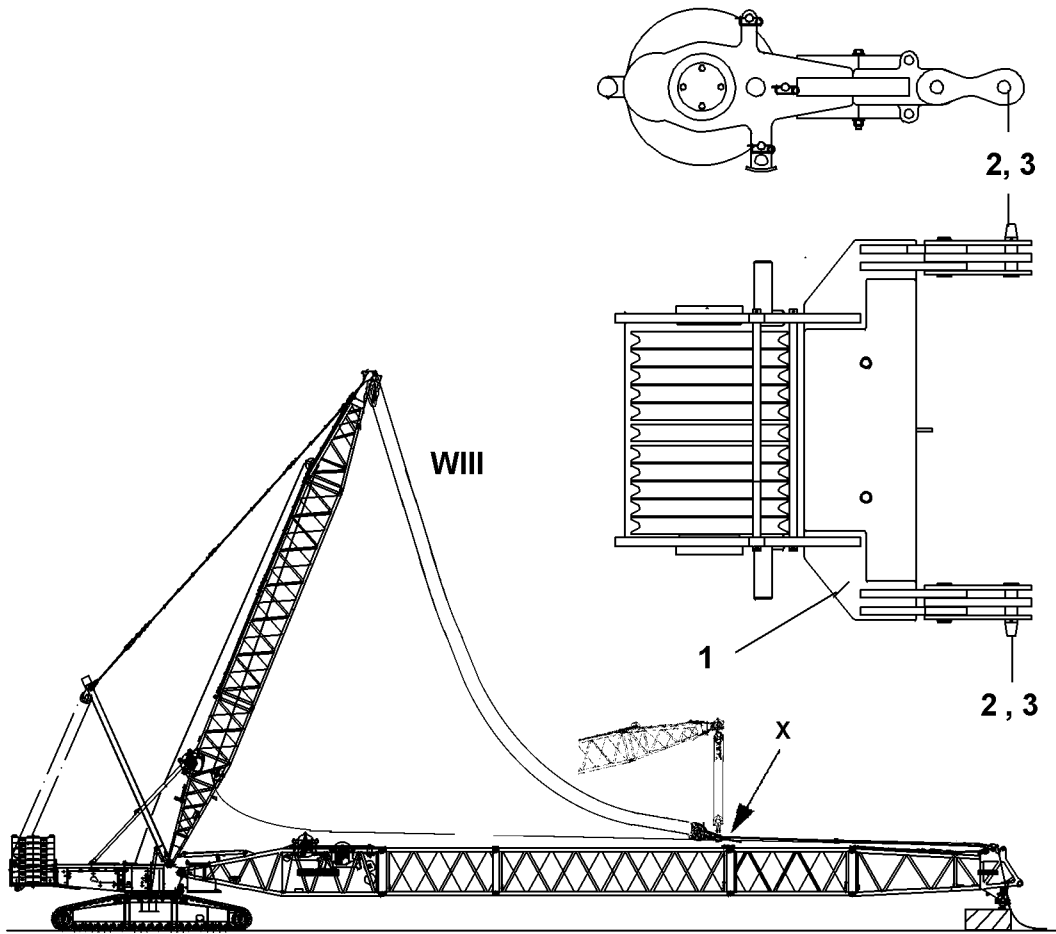
The symbol must appear on the LICCON monitor .

D - relapse cylinder

Cover the limit switch initiators individually on the D - relapse cylinders with a metal plate.

The D - control winch movement (W IV) "spool up" must turn off.

The symbol must appear on the LICCON monitor .



10. Installation of guy rods

If the boom is installed, lower the derrick to the front.

Lower the S- pulley block (1) to the boom by spooling out winch III and pin and secure with the guy rods. Use pin (2) and spring retainer (3) .

The guy rods must be installed and secured according to the installation drawings in **Chapter 5.03**. Make sure to compare the numbers in the installation drawing with the numbers on the guy rod.

D A N G E R : **The pins of the guy rods must be inserted from the inside to the outside. If this is not observed, the hoist cable will scrape on the pins. The guy rods must be checked regularly, see chapter " Inspection and maintenance of guy rods".**

Erect the derrick to the corresponding operating position ($X = 115,1^\circ - 118,1^\circ$, indicator on monitor 1), while spooling out winch III (S- boom control) at the same time, so that the boom is not pulled up with it.

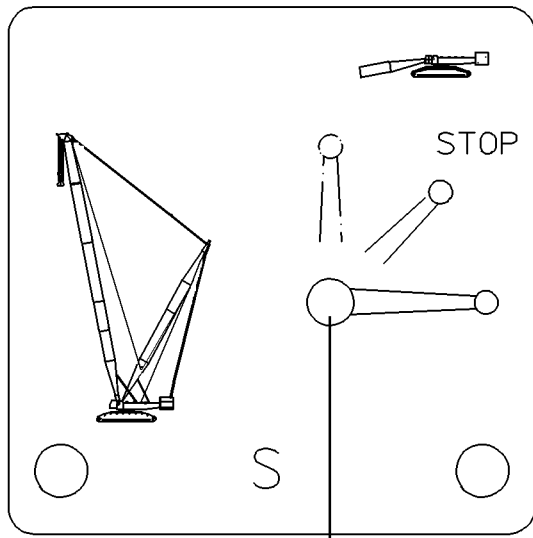
When the derrick is in operation position, the guying between the derrick and the boom head must be tensioned.

Note: At flying installation tension the guying until the auxiliary crane is relieved.

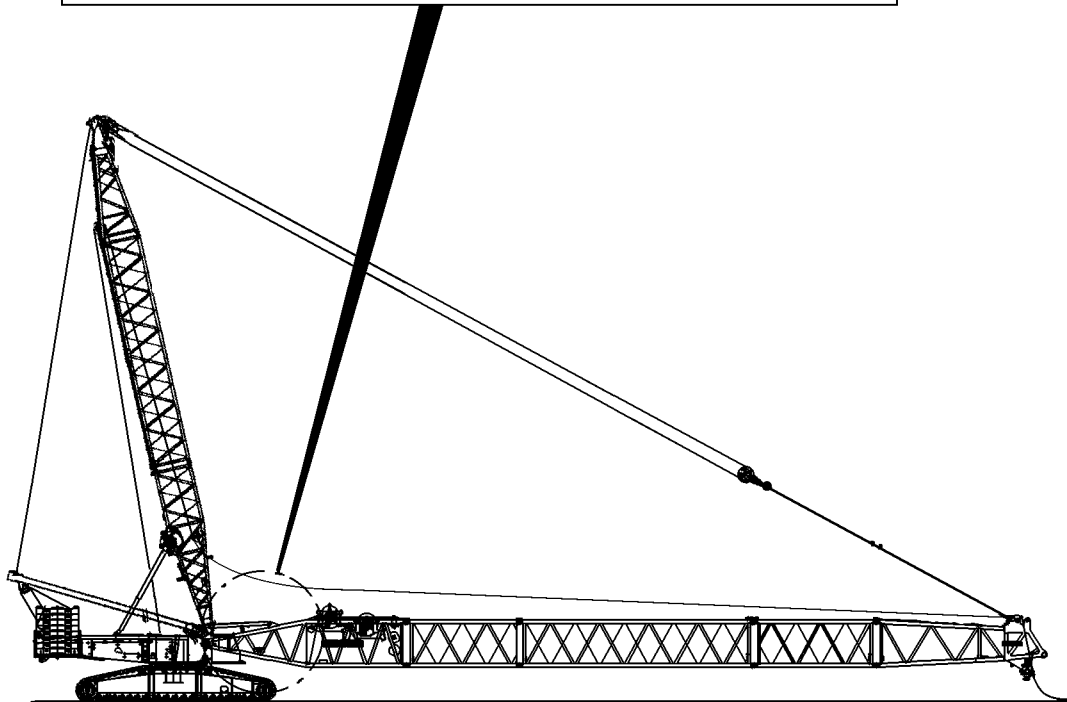
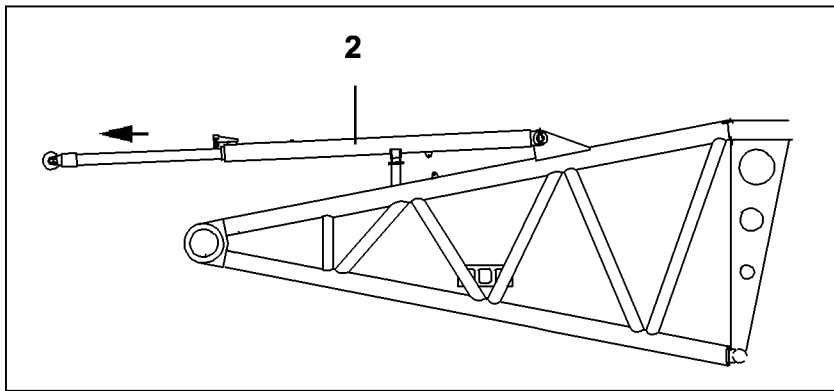
Remove the auxiliary crane on the boom head.

D A N G E R : **Do not remove the auxiliary crane until the guying is tensioned between the derrick and the boom head and the boom is held by the guy rods.**

Guide the hoist cable over the cable pulley on the end section .



1



11. Erection / take down procedure

The boom combinations must be erected or taken down according to the **Erection and take down charts**.

D A N G E R : **The erection and take down procedure must be made according to the data in the erection and take down chart. If this is not observed, the crane can be overloaded or topple over.**

Prerequisites:

- The crane is horizontally aligned.
- The counterweight is installed on the slewing platform according to the load chart .
- The boom is installed according to the load chart and the operating manual .
- All limit switches are installed correctly and fully functioning.
- All pin connections are secured.
- The hoist cable is placed correctly into the cable pulleys and secured with cable retaining pins to prevent it from jumping out.
- There are no persons within the danger zone.
- There are no loose parts on the boom and the lattice jib.
- In the cold season: Is the boom and the lattice jib and their components (limit switch, cable drum, airplane warning light, wind speed sensor, etc.) free of snow and ice.

D A N G E R : **Incorrectly installed and non-functioning limit switches as well as falling parts (pins, spring retainers, ice, etc.) can cause accidents ! The derrick must be in operating position (X = 115,1° - 118,1°, indication on monitor 1) and the S - the relapse cylinder (2) must be extended, only then may the boom be raised. During the erection procedure, it must be ensured that the hoist cable is not pulled up and falls down backward.**

11.1 Extend the S - relapse cylinder (2)

Establish the hydraulic connection from the slewing platform to the S - relapse cylinders.

Move the ball cock lever (1) into horizontal position and extend the piston rod on the S - relapse cylinder.

Lever positions:

Lever horizontal = Crane operation, extend piston rod

Lever vertical = Installation, retract piston rod

Lever 45° = Piston rod cannot be extended or retracted

C A U T I O N : **The relapse cylinders may only be extended if the derrick is fully raised. If this is not observed, they can collide with the D - relapse cylinders.**

D A N G E R : **The relapse cylinders must be extended before erection. The ball cock lever must be in horizontal direction, and must be secured to prevent it from inadvertent actuation during crane operation.**

		m > < t		CODE >XXXX< BXXX YYZZ.1(2)			
		35,0	35,0	35,0	35,0	35,0	35,0
12,0							
14,0	380,0	380,0	380,0	380,0			
16,0	372,0	372,0	372,0	372,0			
18,0	363,0	363,0	363,0	363,0			
20,0	350,0	350,0	349,0	349,0			
22,0	336,0	337,0	337,0	337,0			
24,0	305,0	313,0	312,0	312,0	307,0	319,0	328,0
26,0	278,0	283,0	283,0	283,0	284,0	301,0	310,0
* n *	* 29 *	* 29 *	* 29 *	* 29 *	* 23 *	* 24 *	* 25 *
xx	87,0	87,0	87,0	87,0	77,0	77,0	77,0
yy	13,0	15,0	18,0	20,0	13,0	15,0	18,0
							>>

>>

xx° SDBW
35m

W
28m

220
t

95
t

yy m

n
10 x

O.K.

LIEBHERR

7

8

9

4

5

6

1

2

3

0

.

P

K

F

C

i

<

>

O

SHIFT

F1

F2

F3

F4

F5

F6

F7

F8

ENTER

BXXX YYZZ

XXXX

0 1/min:1634 50 90 100 110 130%

max n = 10

t 156.0

t 28.3

m 23.8

80.0°

m 28.0

m 35.0

60.0°

m 62.6

191.99
m

191.99
m

1
0 4
0 0
2 3
BCD

V: 40%
max: 12.8

LIEBHERR

7

8

9

4

5

6

1

2

3

0

.

P

K

F

C

i

<

>

O

SHIFT

F1

F2

F3

F4

F5

F6

F7

F8

ENTER

11.2 Erection procedure

Prerequisites:

- Set the LICCON system according to the data in the load chart and the equipment configuration (see chapter 4.02, 4.03).
- Actuate the installation keyed button, the indicator light "Installation" lights up.
- The installation symbol on the LICCON - indicator blinks.

Adjustments on EQUIPMENT CONFIGURATION VIEW of LICCON (see chapter 4.02)

Enter the 4-digit code number according to the required load chart and confirm with ENTER .

Enter the actual reeving.

Check the actual equipment configuration of the crane with the entered data to ensure they match.

Press the function key -F8- "o.k.", the OPERATING VIEW will appear.

D A N G E R : **Compare and check the LICCON settings with the actual equipment configuration.**

If this is not observed, the crane can be overloaded or topple over.

Erection

Luff up the boom until the end section lifts off the ground.

Reeve the hoist cable between the pulley head on the end section and the hook block and secure on the fixed point - see **Chapter 4.06, Reeving plans.**

Attach the hoist limit switch weight.

Luff up the boom to the **lowest** operating position.

Indications in the OPERATING VIEW during the erection procedure

The following alarm functions are activated (blink) during the erection, until the operating position is reached:

- "STOP"
- "HORN" + acoustical signal

Note: The **lowest** operating position is reached if the indicators turn off and a load value in tons - t - appears in the symbol "MAX. LOAD" instead of the question marks ("????")

Turn off the installation keyed button by pressing the button.

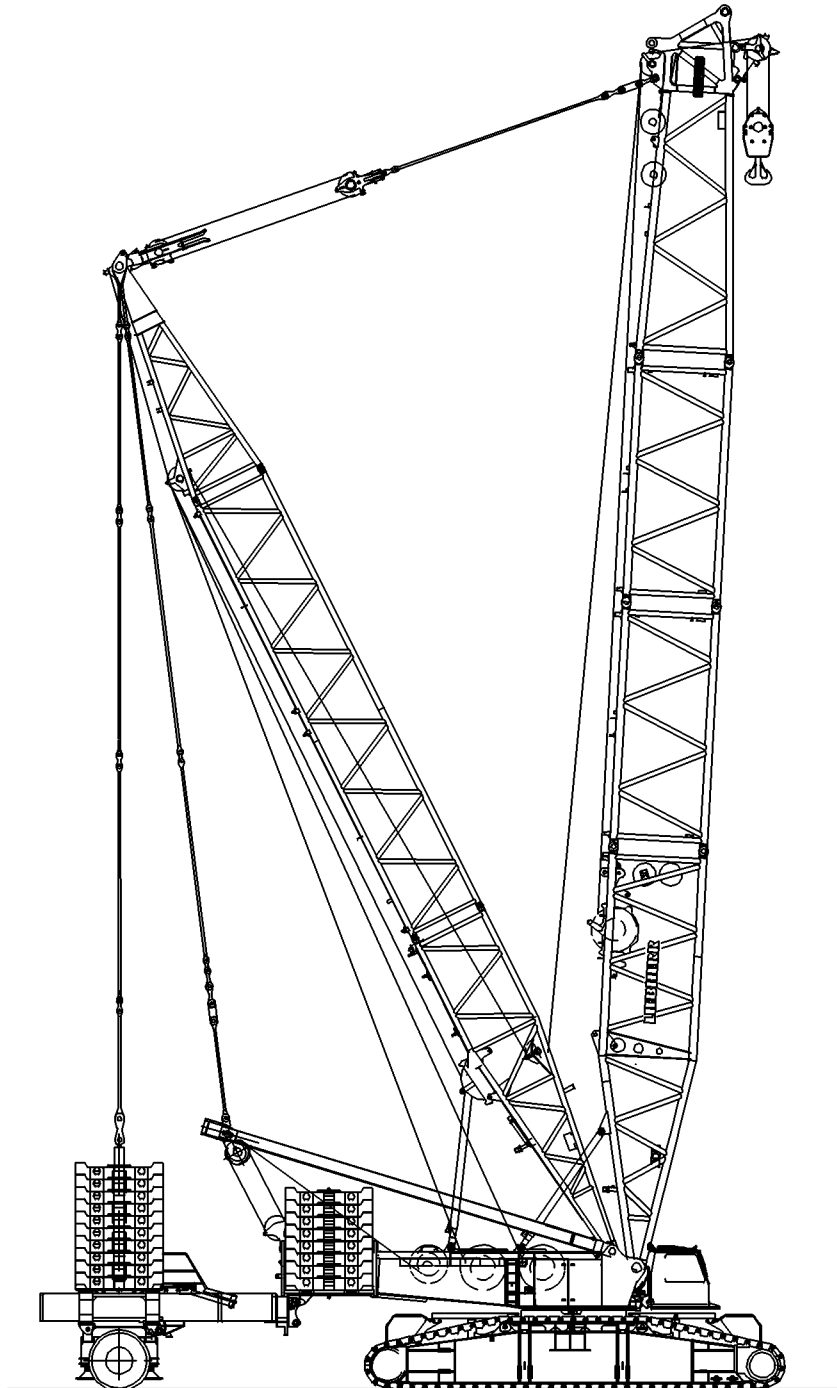
The installation symbol on the LICCON - indicator turns off.

D A N G E R : **The installation keyed button must be turned off immediately after reaching the lowest operating position.**

The installation keyed button bypasses the safety devices!

The radii given in the load chart may not be exceeded nor fallen below, even without a load on the hook!

If this is not observed, the crane can topple over!



12. Crane operation with D - boom combination

D A N G E R : The notes in chapter 4.02 "LICCON overload safety system, chapter 4.05 "CRANE OPERATION " and chapter 4.08 "WORKING WITH A LOAD " must be observed.

Prerequisites :

- Set the LICCON system according to the data in the load chart and the equipment configuration (see chapter 4.02, 4.03).
- The installation keyed button is turned off.
- The installation symbol on the LICCON indicator turns off.

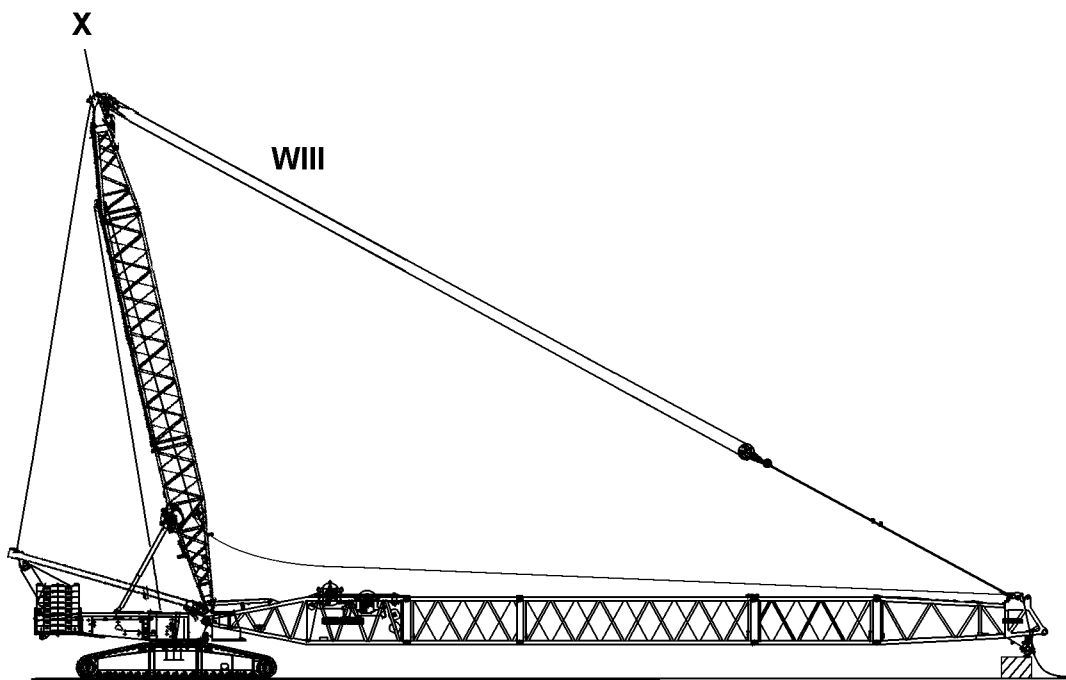
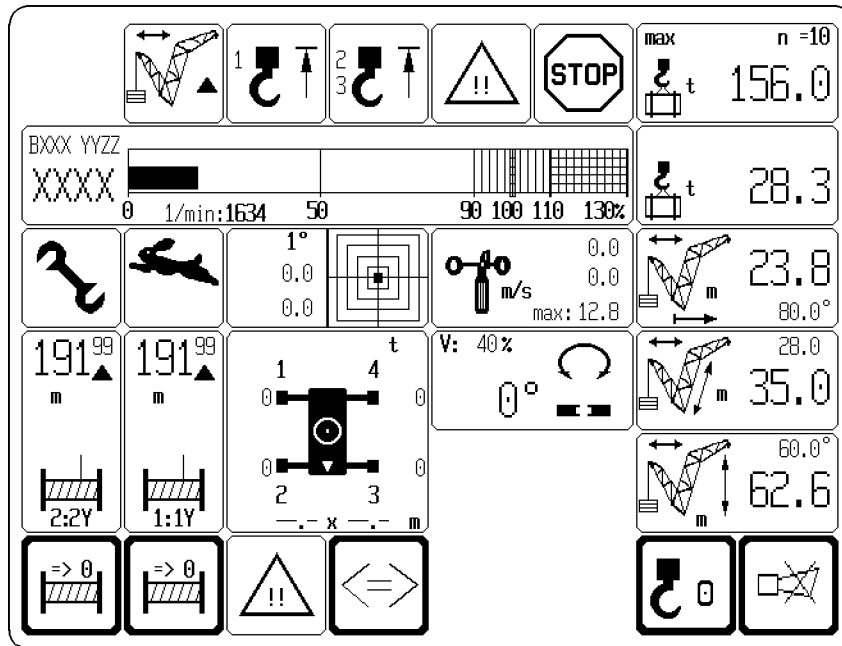
D A N G E R : Check the horizontal position of the crane before and during operation. If the crane operator leaves the cab, even if only for a short time, then he is obligated, before starting to work again, to check the operating mode settings and to readjust them, if necessary.

Adjustments / checks

Check the function of the overload safety system by actuating the operating positions "top" and "bottom" .

Check the function of the hoist limit switch "top" by running against the hoist limit switch weight.

Check the function of the limit switch "boom steep" by running against the relapse cylinders.



13. Place down the S - boom

Luff the S- boom down until just before the lowest operating position.

Note: When reaching the **lowest** operation position, the luffing down movement is shut off. At the same time, the following alarm functions are activated (blink) in the OPERATING VIEW:
 - "STOP"
 - "HORN" + acoustical signal

Actuate the installation keyed button, the indicator light "Installation" lights up. The installation symbol on the LICCON - indicator blinks.

D A N G E R: **The overload safety system is no longer effective.
 The limit switch hoist "top" is bypassed.**

C A U T I O N: **When luffing down, the hoist winch must be spooled out at the same time to prevent the hook block from colliding with the pulley head.**

Actuate the manual control lever and continue to luff down the boom until the hook block touches the ground.

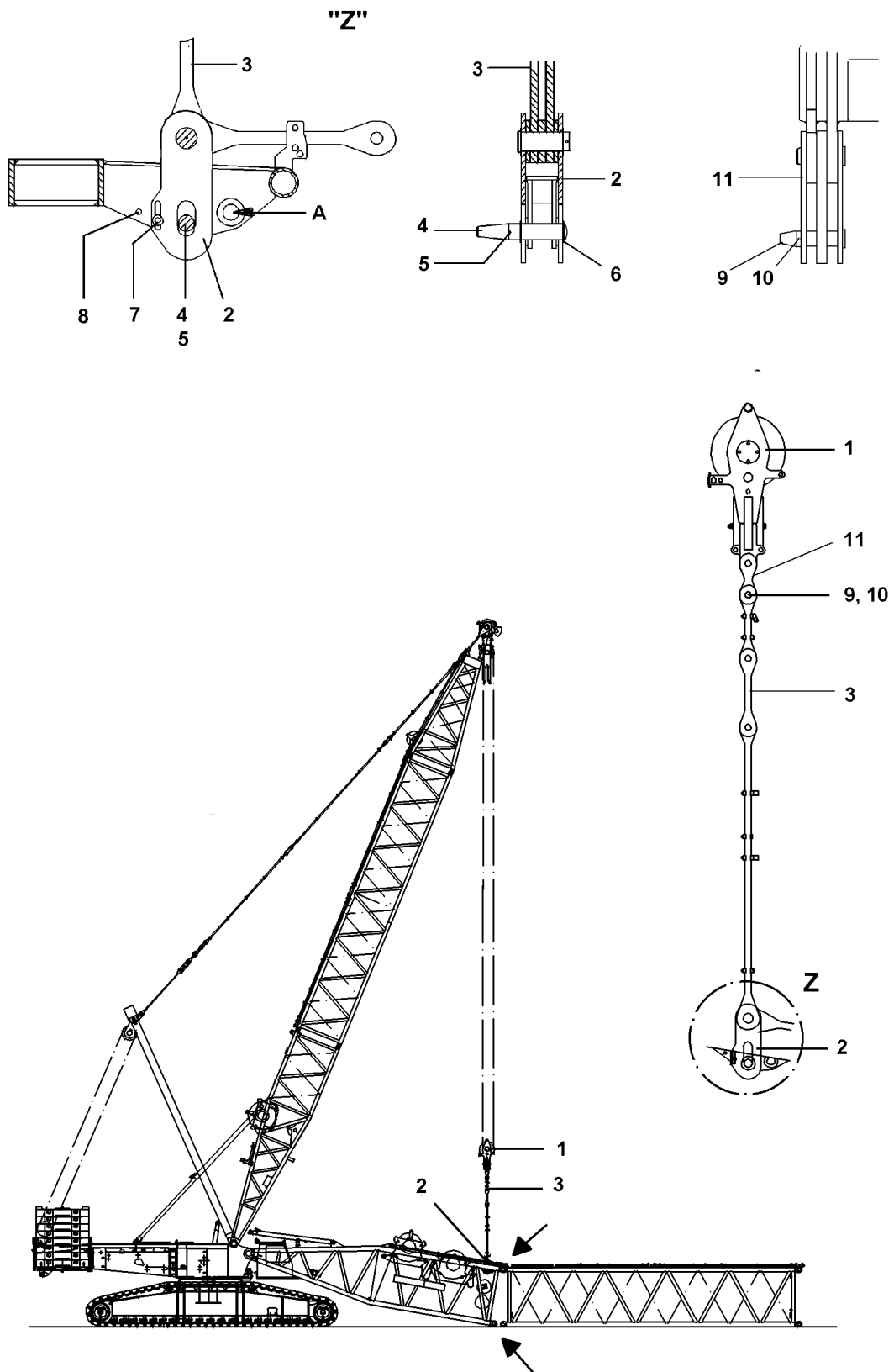
D A N G E R: **When taking down long booms, the hook block must be lowered to the ground in a certain boom angle range to the horizontal, otherwise the crane is overloaded!
 Boom angle range - see Erection and take down charts.**

Remove the hoist limit switch weight. Unreeve the hook block.

D A N G E R: **When unreeving the hoist cable, no persons may be within the danger zone.**

Continue to luff down the S- boom until the end section lays on the ground.

C A U T I O N: **The derrick must remain in operating position until the end section lays on the ground .**



13.1 Luff down the derrick

Unpin the guy rods and place on the corresponding lattice sections for transport and secure.
 Erect the derrick again and lower the S- pulley block (1) until the installation brackets (2) align with the pin hole.
 Pin and secure the installation brackets (2) . Use pins (4), washers (6) and spring retainers (5) .

C A U T I O N : **The transport retaining pin (7) must be uninned for installation and during operation.**
Pin in park position (8) .

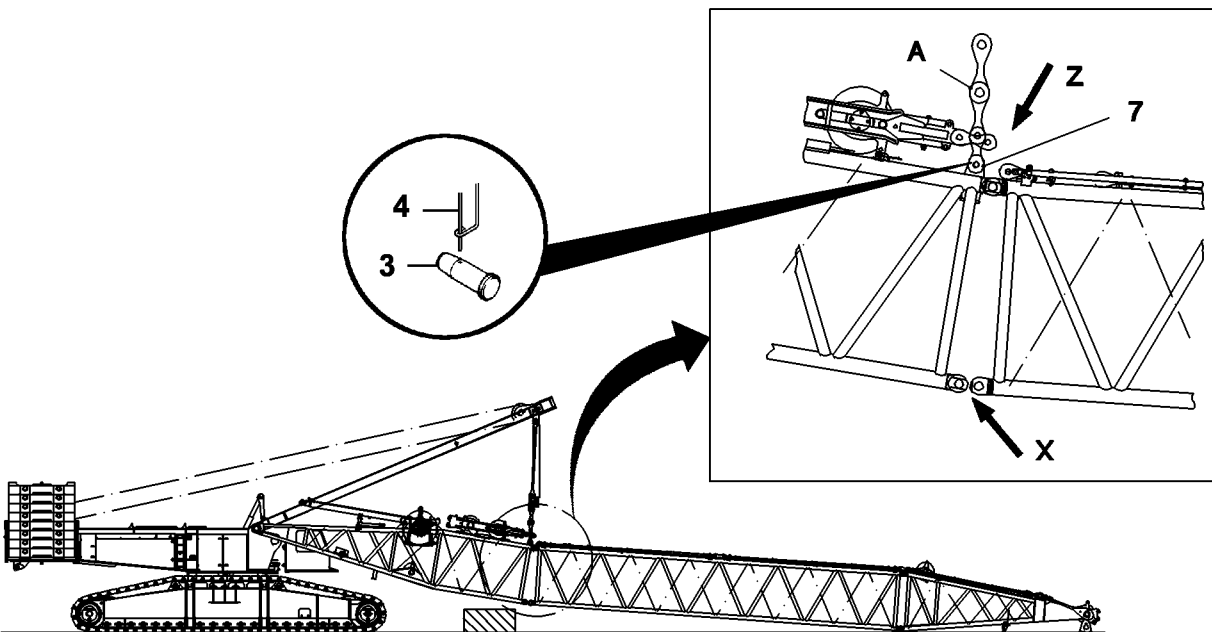
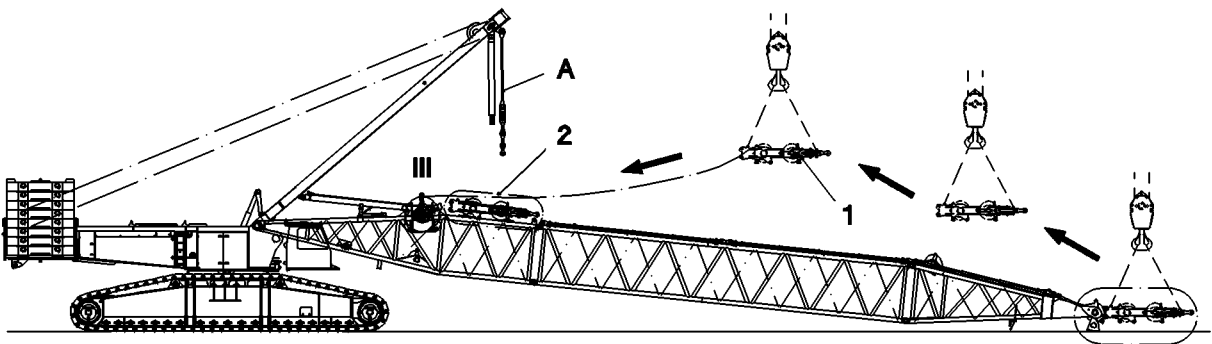
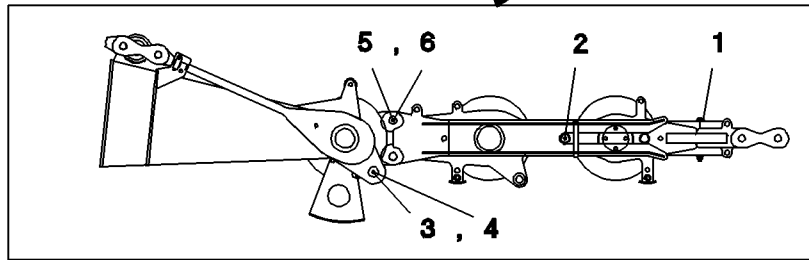
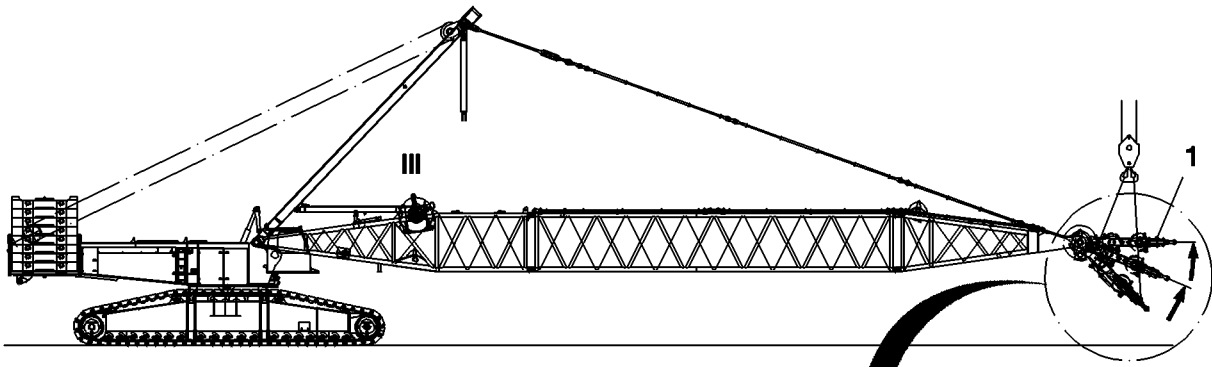
Hold the S- pivot section (G1) with the S-pulley block (1) and unpin the pivot section (G1) **"on the bottom"** .

Note: With the intake gear, pull until the same F1 - actual force is set as was noted during installation.
 The pins can be pulled easier. Otherwise the pins and eyes on the lattice sections will be worn or the pin sticks.

D A N G E R : **Before unpinning, the boom must hang on the pulley block.**
Otherwise there is a danger of accidents, as the boom might suddenly fold down!
Nobody may remain under the lattice jib during the pinning and unpinning procedure of the lattice sections. This is strictly prohibited!
With the S - pulley block, the following maximum boom lengths can be lowered :
 - S 140m and SL 98m, with S- guy rods
 - S 91 with S - and WA-Bracket II guy rods
Danger of accidents!

Set the S-pivot section on the ground support.
 Place and secure the guy rods (3) on the S-pivot section by lowering the S-pulley block (1) .
 Unpin the pulley block (1) on the guy rods (3) . Remove the spring retainer (10) and unpin the pin (9) .
 Hang the intermediate section on the auxiliary crane and unpin on the S-pivot section **"on top"** .
 Unpin the lattice sections and disassemble.

Erect the derrick to the point where the S- pivot section can be disassembled without restriction (approx. 75° to max. 90°) .
 Remove the S-pivot section (G1) with the auxiliary crane on the slewing platform.



14. Place down and remove the derrick

Lower the derrick to the horizontal and pull the S- pulley block (1) to the D- end section, by spooling up winch III.

C A U T I O N : **A guide must watch and monitor the spooling up of winch III .
When spooling up winch III , there is a danger of collision between the
S - pulley block and the D - end section!**

Connect the "lower" and "upper " pulley block with the transport pin (2) .

Lift the S - pulley block (1) with the auxiliary crane, bring it into horizontal position and lock with pin (3) and secure with spring retainers (4) .

Attach the S-pulley blocks (1) to the auxiliary crane and unpin on the D- end section. Loosen the spring retainer (6) and unpin the pin (5) .

Note: The weight of the S- pulley blocks is approx. 3200 kg.

Pull the S-pulley block to the D- pivot section while spooling up the winch III at the same time, and pin and secure on the receptacle.

Continue to luff down the derrick until the end section is on the ground or on the support.

Remove the guy rods .

Lower the SA - bracket to the front, **see chapter 5.02 " SA- bracket"**.

Pin and secure the guy rods (A) from the SA - bracket on the installation bracket (7) on the D- pivot section .

Use pin (8) and spring retainer (9) .

Luff up the SA-bracket and tension guy rods (A) .

Note: With the intake gear, pull until the same F1 - actual force is set as was noted during installation.
The pins can be pulled easier. Otherwise the pins and eyes on the lattice sections will be worn or the pin sticks.

Unpin and secure the D-pivot section **"on the bottom" (X)** .

D A N G E R : **Before unpinning the D-pivot sections "on the bottom", the guy rods (A) on the installation bracket (7) must be pinned and tensioned.
Nobody may remain under the lattice jib during the pinning and unpinning procedure of the lattice sections.
This is strictly prohibited.
There is a danger of accidents, as the boom might suddenly fold down!**

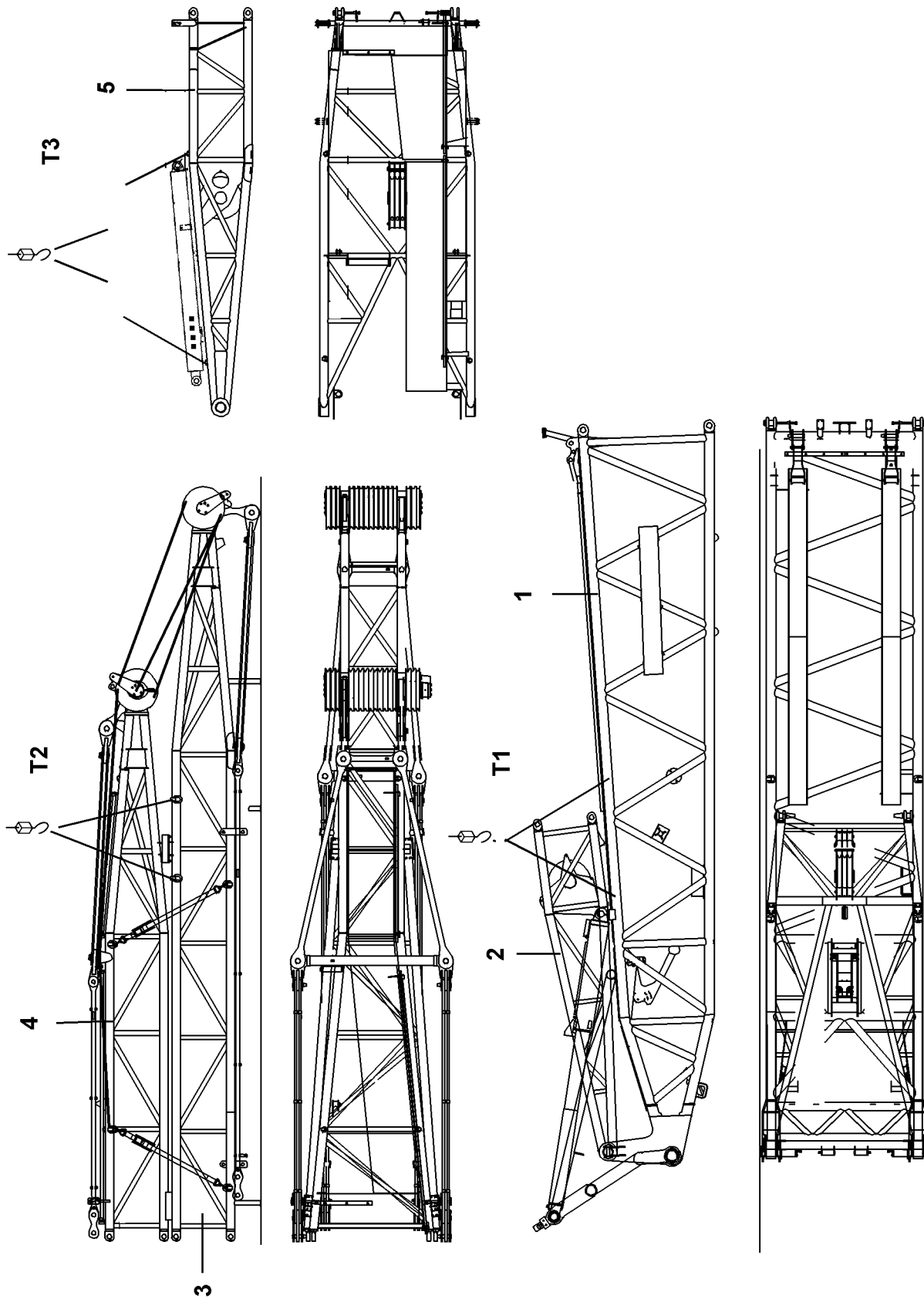
Place the D-pivot section on the support on the ground and remove the auxiliary crane.

C A U T I O N : **The pivot section must be supported, so that it does not lay on the slewing platform and is damaged!**

Remove the D - end section and LI/D - intermediate section.

Note: The removal of the lattice sections is in reverse order as for installation.

C A U T I O N : **The warning and danger notes for installation must also be observed for removal!**



1. W- installation unit

- 1 W-Pivot section
- 2 WA-Bracket I Pivot section
- 3 WA-Bracket I End section
- 4 WA-Bracket II End section
- 5 WA-Bracket II Pivot section

1.1 Transport units**Transport unit 1 (T 1)**

consisting of:

- W-Pivot section
- WA-Bracket I Pivot section

Weight = 10600kg

Transport unit 2 (T 2)

consisting of:

- WA-Bracket I End section
- WA-Bracket II End section

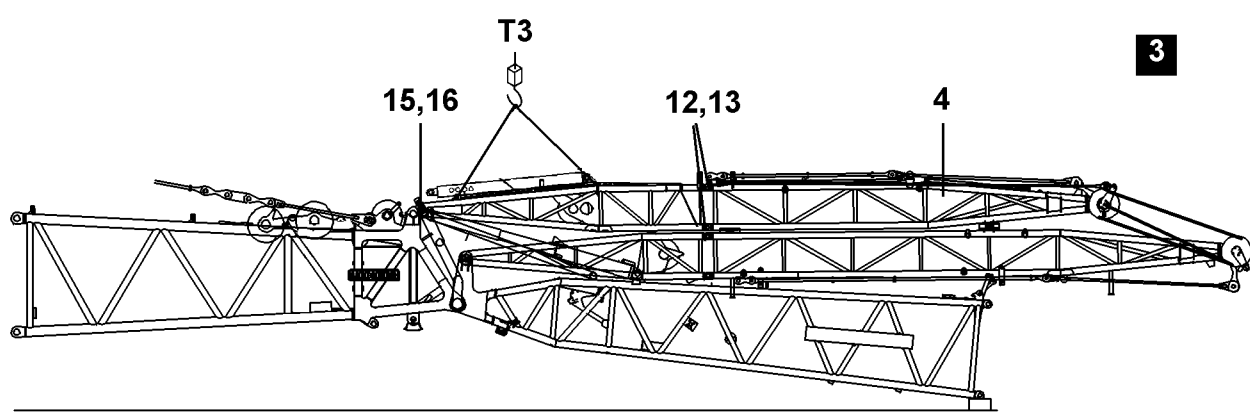
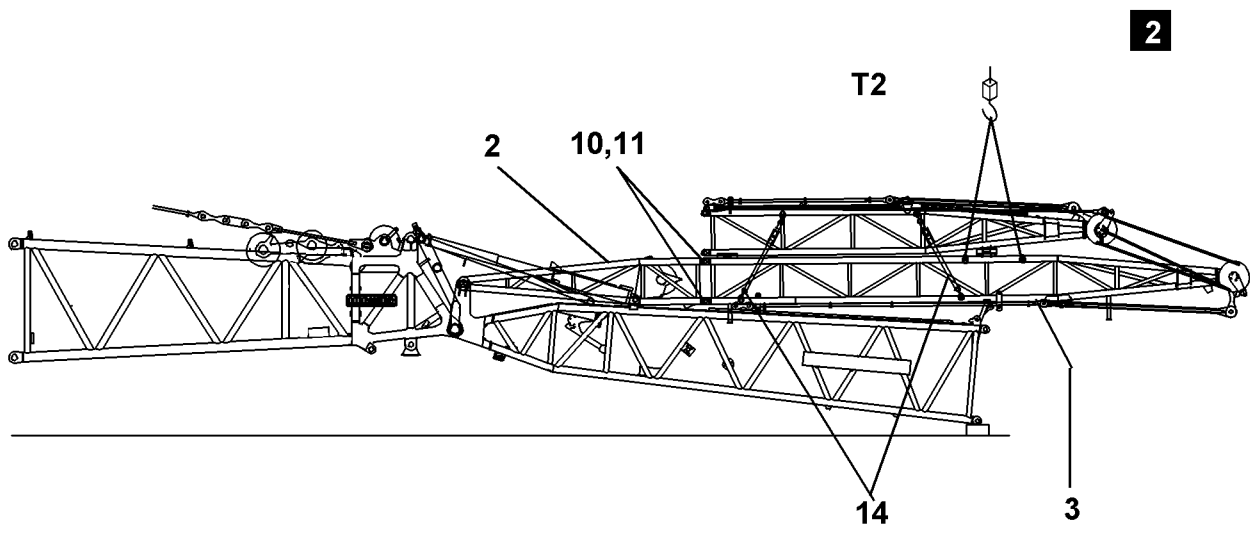
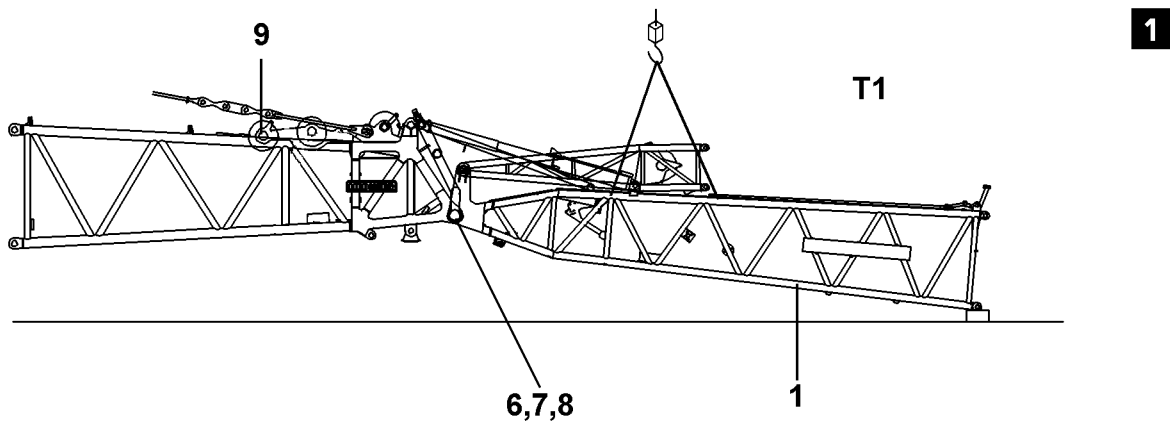
Weight = 9600kg

Transport unit 3 (T 3)

consisting of:

- WA-Bracket II Pivot section

Weight = 3500kg



2. Installation

- D A N G E R:** For installation and removal work:
- A safe installation scaffolding / working platform must be used. There is a danger of accidents due to falling.
 - Improvisations are prohibited.
 - The lattice sections must be supported underneath with suitable, stable materials.
 - Nobody may remain under the lattice jib during the pinning and unpinning procedure of the lattice sections.

Prerequisites:

- The S-boom is installed and set in horizontal position.
- The crane is horizontally aligned.
- An auxiliary crane as well as an installation scaffolding / working platform is available.
- The LICCON overload safety system is set according to the data given in the load charts.
- The keyed button "installation" is actuated, the indicator light "installation" lights up.
- The installation symbol on the LICCON indicator blef.

2.1 Fig. 1 Installation Transport unit 1 (T 1)

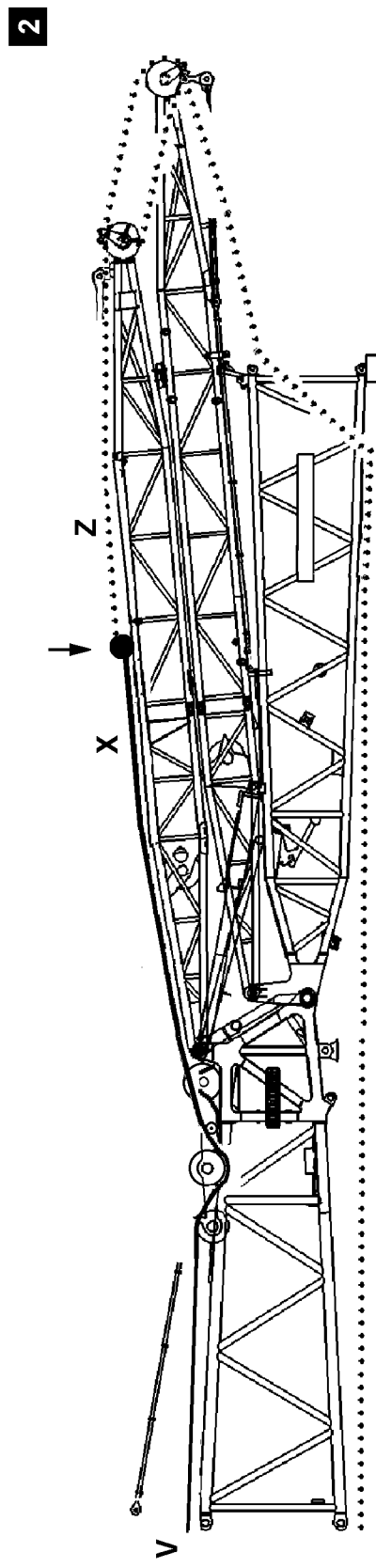
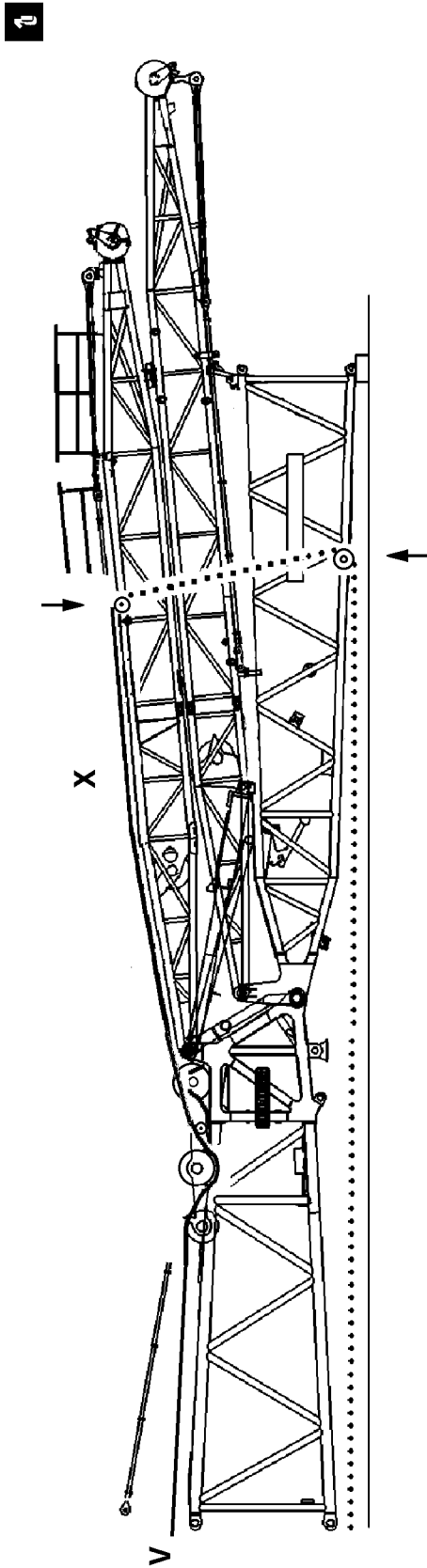
Take on the transport unit 1 (T 1) with the auxiliary crane on the tackle points on the W-pivot section (1)
 Pin the transport unit 1 - hanging down on the front - on the S-end section (Z).
 Pin the connector pins (6) with the hydraulic pin pulling device, place the retaining plate (7) and secure with spring retainer (8).
 Support the W - pivot section (1) from below.
 Lower the transport unit with the auxiliary crane until it rests on the ground.
 Pin on the pulley assembly (9).

2.2 Fig. 2 Installation Transport unit 2 (T 2)

Take on the transport unit 2 (T 2) with the auxiliary crane on the tackle points on the WA-bracket I-end section (3).
 Pin the transport unit 2 on the WA-bracket I pivot section (2).
 Pin the connector pin (10), on top and bottom, with the hydraulic pin pulling device and secure with the spring retainer (11).

2.3 Fig. 3 Installation Transport unit 3 (T 3)

Take on the transport unit 3 (T 3) with the auxiliary crane on the tackle points on the WA-bracket II-pivot section (5).
 Pin the WA-bracket II- pivot section (5) on the WA-bracket II end section (4).
 Pin the connector pin (12), on top and bottom, with the hydraulic pin pulling device and secure with the spring retainer (13).
 Disengage the rigging belts (14).
 Pull up the WA-bracket I and II and pin the WA-bracket II- pivot section (5) on the S-end section .
 Pin the connector pin (15) with the hydraulic pin pulling device and secure with the spring retainer (16).



3. Reeve the W - control cable between WA-bracket I and II

..... Auxiliary cable
 ----- Control cable

Fig. 1 Auxiliary cable routing when getting the control cable

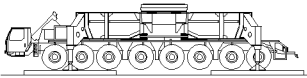
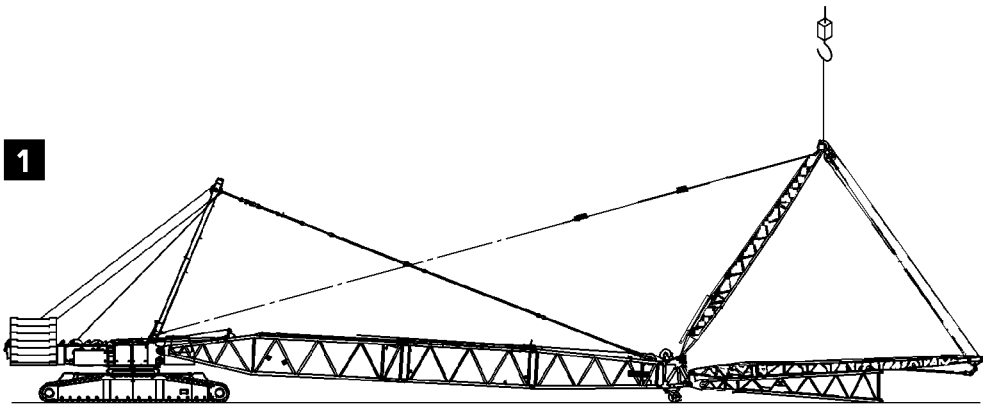
Pull the auxiliary cable (Z) of the auxiliary winch over the change over pulleys to the slewing platform. Connect the auxiliary cable (Z) with the W - control cable (X) of winch V . Spool up the auxiliary winch and at the same time, spool out winch V and pull the W - control cable (X) to the WA-bracket II - for cable routing, see **Fig.1**.

Fig. 2 Auxiliary cable routing when reeving in the control cable

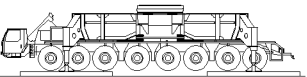
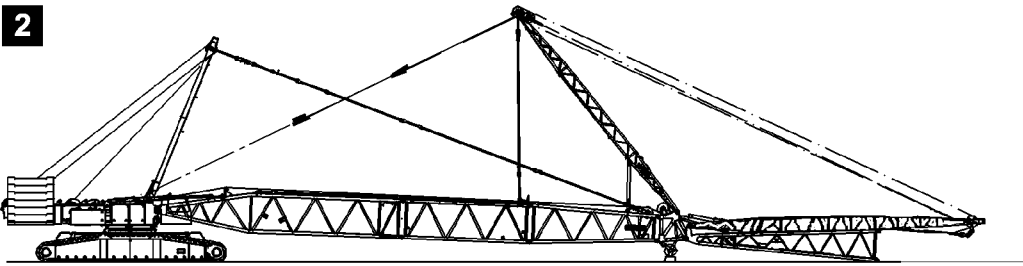
Connect the W - control cable (X) and the auxiliary cable (Z) with the already reeved reeving cable (W), between WA-I and II - for cable routing, see **Fig.2**. Spool up the auxiliary winch and at the same time, spool out winch V and reeve W - control cable (X) between the WA-bracket I and II - **For reeving, see chapter 4.06**.

C A U T I O N : When spooling the cable out, make sure that no slack cable forms. This could damage the cable!

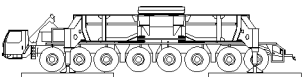
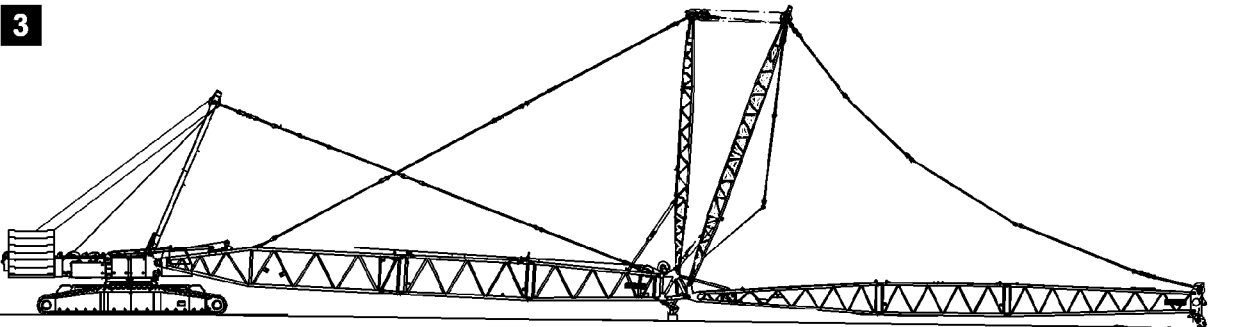
1



2



3



4. Installation procedure

Fig. 1

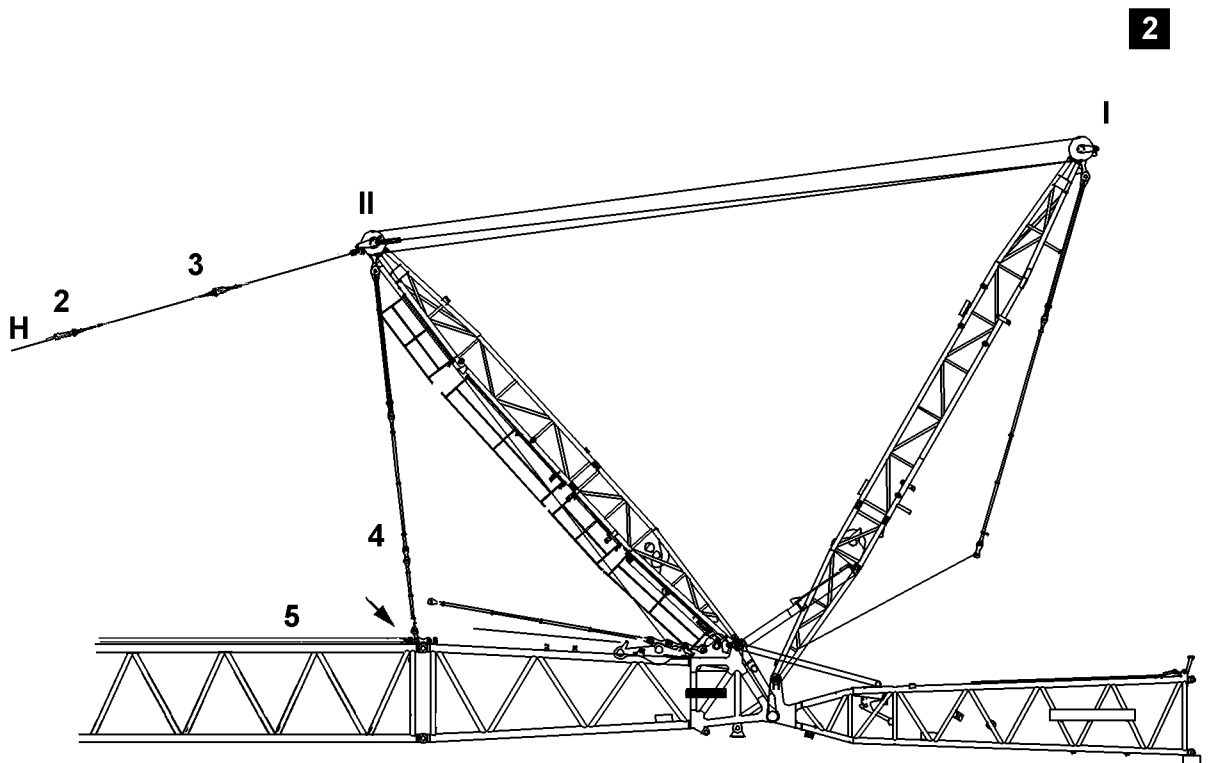
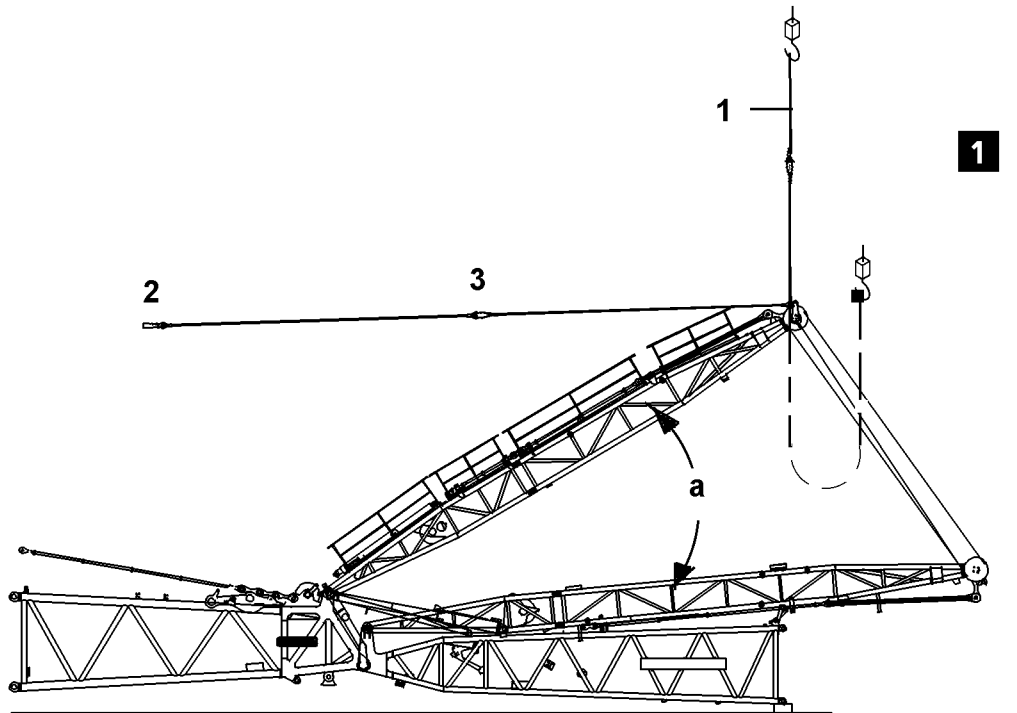
- 1.0 -Pin the W - installation unit on the S-boom.
- 1.1 -Reeve the W - control cable between the WA-bracket I and II.

Fig. 2

- 2.0 -Installation of guy rods from WA-bracket II to S-pivot section.

Fig. 3

- 3.0 -Erect the WA- brackets and tension the guy rods from the WA-bracket II to the S-pivot section .
- 3.1 -Install the lattice jib and guy rods from the WA-bracket I to the W-end section .



5. Erect the WA-bracket II

Fig. 1

Attach the auxiliary crane on the installation cable (1) and erect the WA-bracket II to approx. 45° (a) and then pull it further with the hoist cable (H) .

C A U T I O N : **The WA-bracket II must be raised to approx. 45° with an auxiliary crane.**

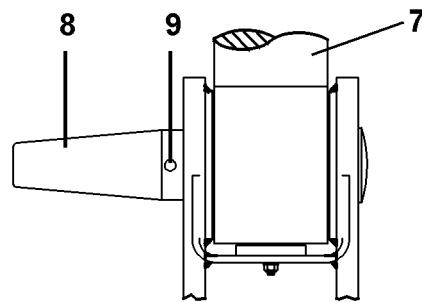
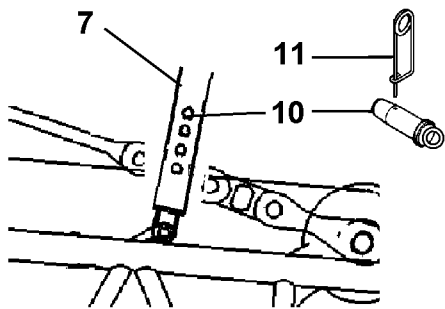
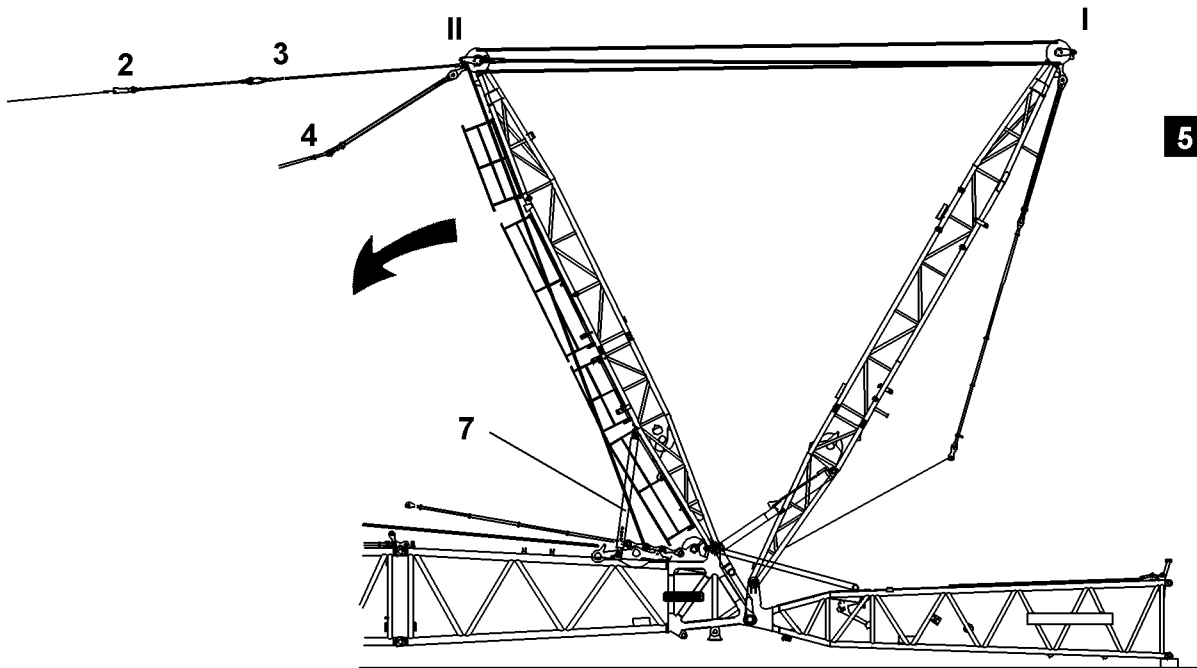
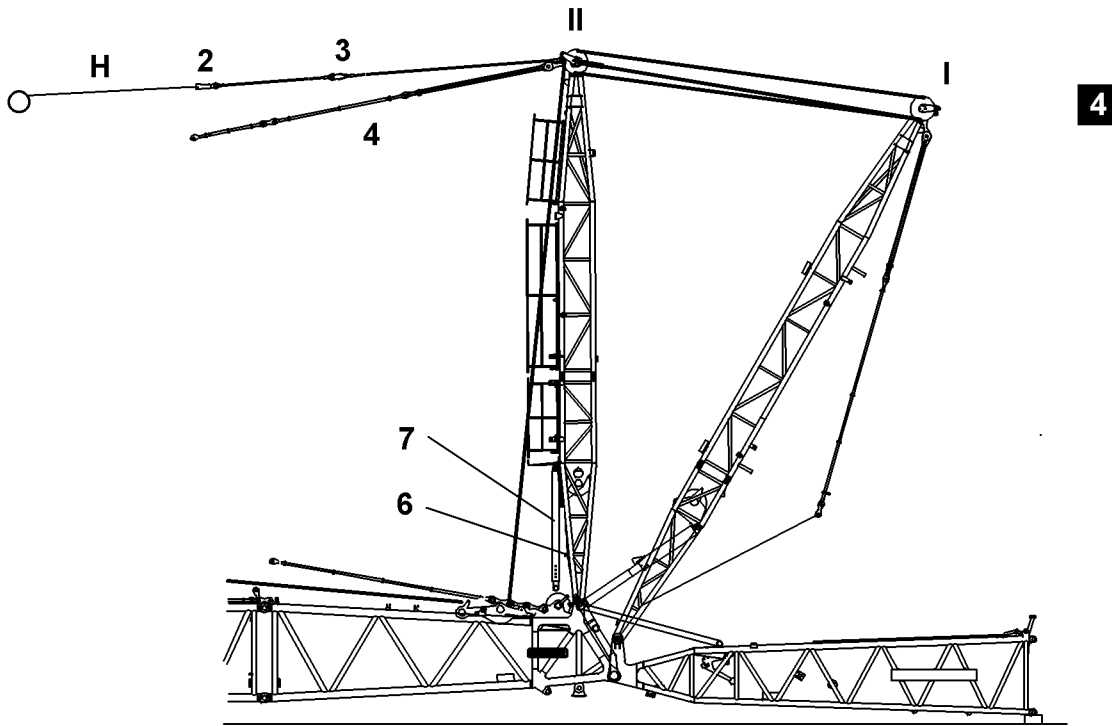
Fig. 2

Installation of guy rods from WA-bracket II to S-pivot section

Hang the hoist cable of winch I/II into the cable lock (2) on the installation cable (3) .

Spool up the hoist winch while **spooling out** the W-control winch at the same time, and pull the WA - bracket II back to the point were the guy rods (4) from WA-bracket II can be pinned and secured with the guy rods (5) of the S - pivot section.

Note: To prevent the WA - bracket I from pulling up, the control winch must be spooled out at the same time!



191615

5.1 Fig. 4

Tension the guy rods from the WA-bracket II to the S-pivot section

When the guy rods are pinned and secured to each other, then the hoist winch (H) must be **spooled out** and the W- control winch must be **spooled up** at the same time, until the WA-bracket II is positioned vertically.

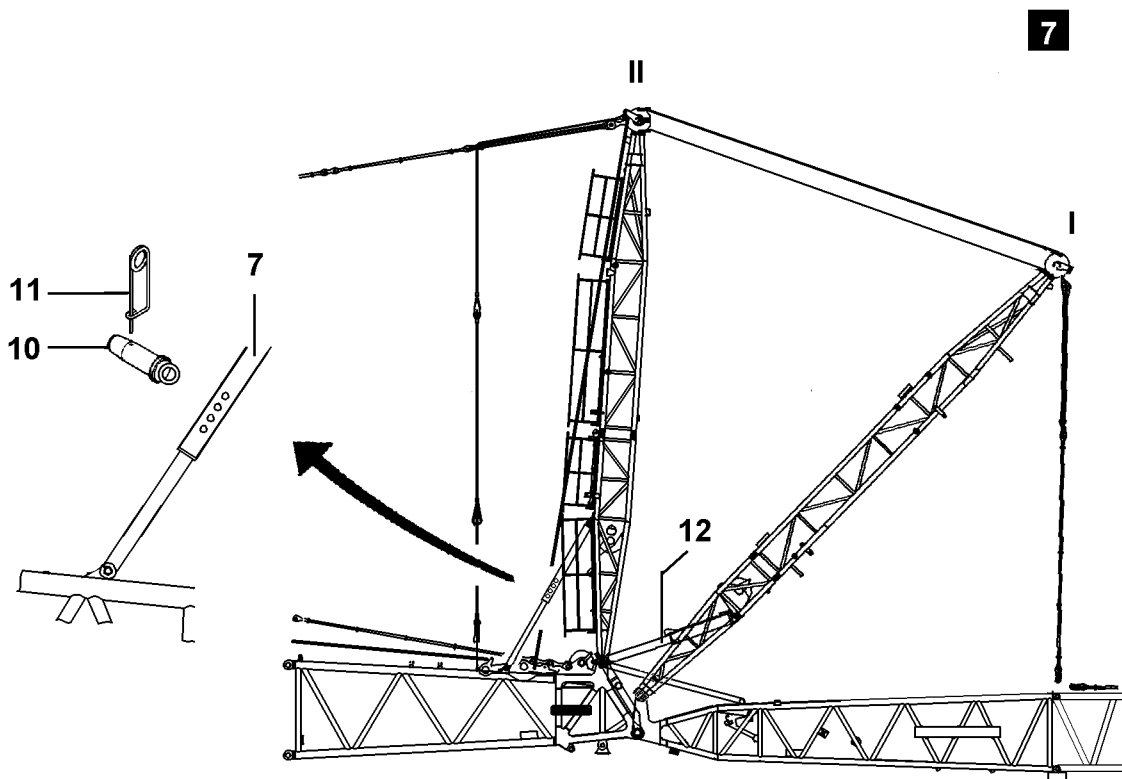
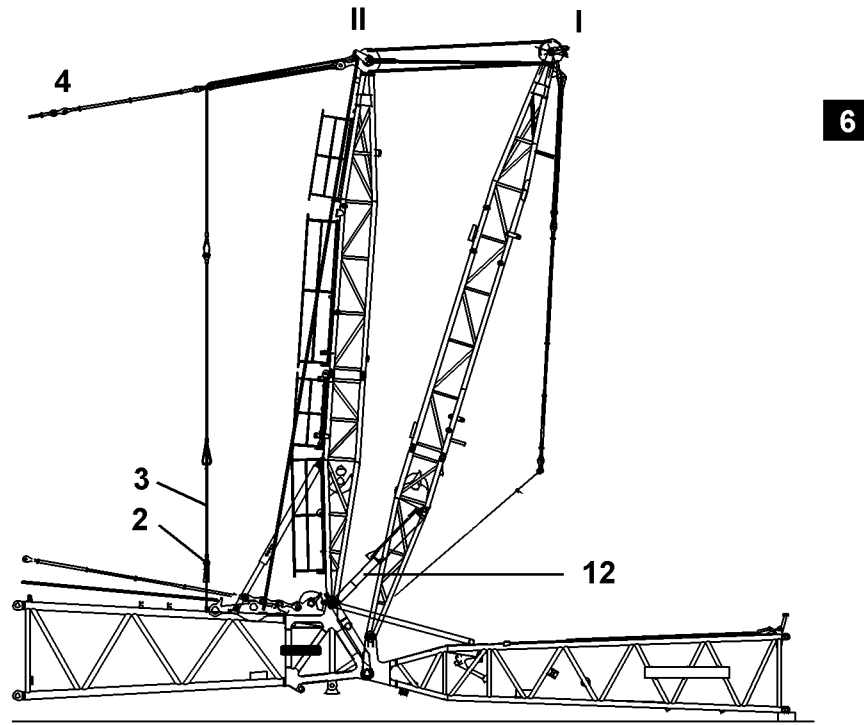
Unpin the transport retainer (6) for the mechanical relapse supports (7) on the WA-bracket II .

5.2 Fig. 5

Spool up the hoist winch while **spooling out** the W- control winch at the same time, and pull the WA - bracket II back to the point where the mechanical relapse supports (7) can be pinned on the S-end section with pins (8) and secured with spring retainers (9) .

After pinning, the pin (10) on the relapse supports (7) must be released and unpinned.

C A U T I O N : **Pin (7) must be unpinned, after the relapse support is pinned on the S - adapter , otherwise the WA - bracket II will be damaged when it is pulled back.**



5.3 Fig. 6
Tension guy rods from WA-bracket II to the S-pivot section

Establish the electrical connections to the limit switches of the W- relapse cylinder (12) .

When the guy rods are pinned and secured to each other, then the hoist winch must be **spooled out** and the W- control winch must be **spooled up** at the same time, until the guying of WA-bracket II (4) to the S-pivot section is tensioned by the counterpressure of the relapse cylinder (12).

Continue to spool out hoist winch, disengage the hoist cable on the cable lock (2) and attach the installation cables (3 and 1) on the S-end section or the WA-bracket II.

5.4 Fig. 7
Erect the WA-bracket I by spooling up the W-control winch until the limit switch on the W-relapse cylinder (12) is pushed.

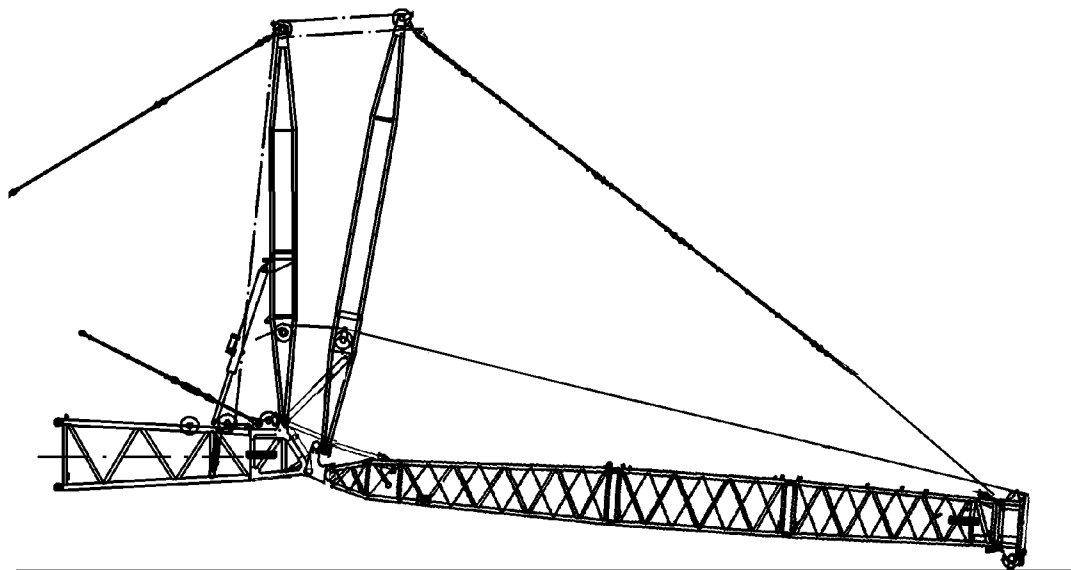
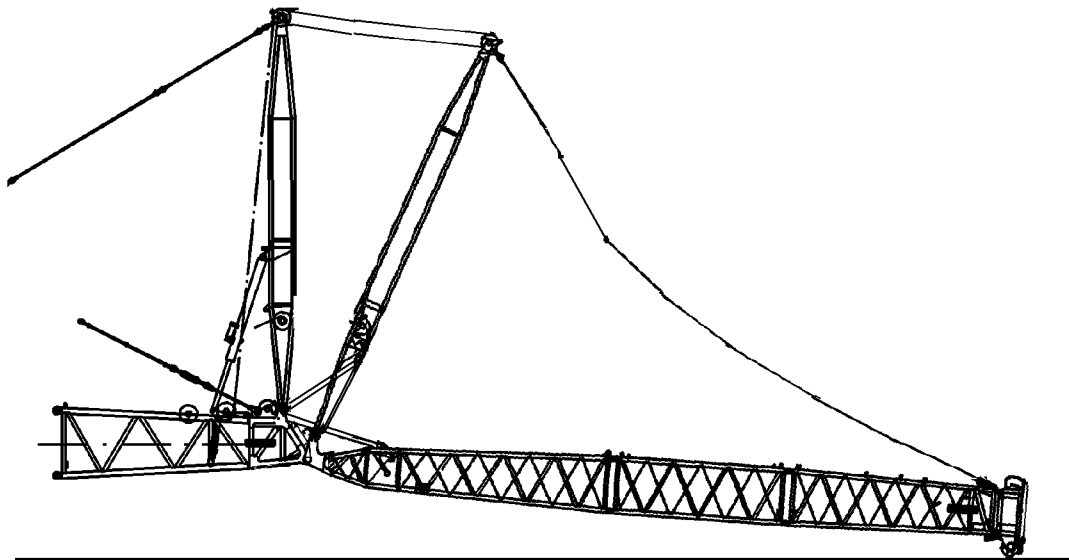
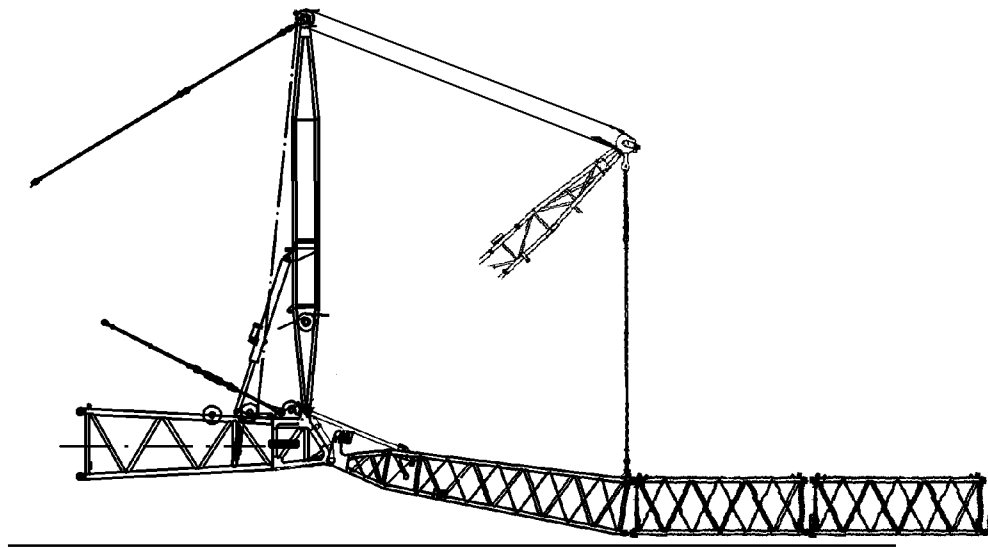
C A U T I O N : **The electrical connection to the limit switches on the W- relapse cylinder must be established.**

Before erection, manually actuate the limit switches on the relapse cylinders individually. The W- control winch movement "spool up" must turn off.

The symbol on the LICCON monitor bleft.

The WA - bracket I may not be pulled back to the mechanical stop on the relapse cylinder, otherwise it can be damaged!

Pin the WA-bracket II- relapse support (7) in the max. possible length on the next hole with pin (10) and secure with spring retainer (11) .



6. Install the W- lattice jib

Assemble the lattice jib to the required length, pin and secure.

D A N G E R: **The pins on the lattice sections must be secured with spring retainers. When removing or installing lattice sections, they must be supported with suitable, stable materials. No persons may remain under the lattice jib during the pinning and unpinning procedure of the lattice sections. This is strictly prohibited!**

Pull the hoist cable to the W-end section and attach it there.
Install the pulley car on the on the W-end section.

Note : Pulley car tire pressure = **9 bar**.

6.1 Install the guy rods from the WA-bracket I to the W-end section

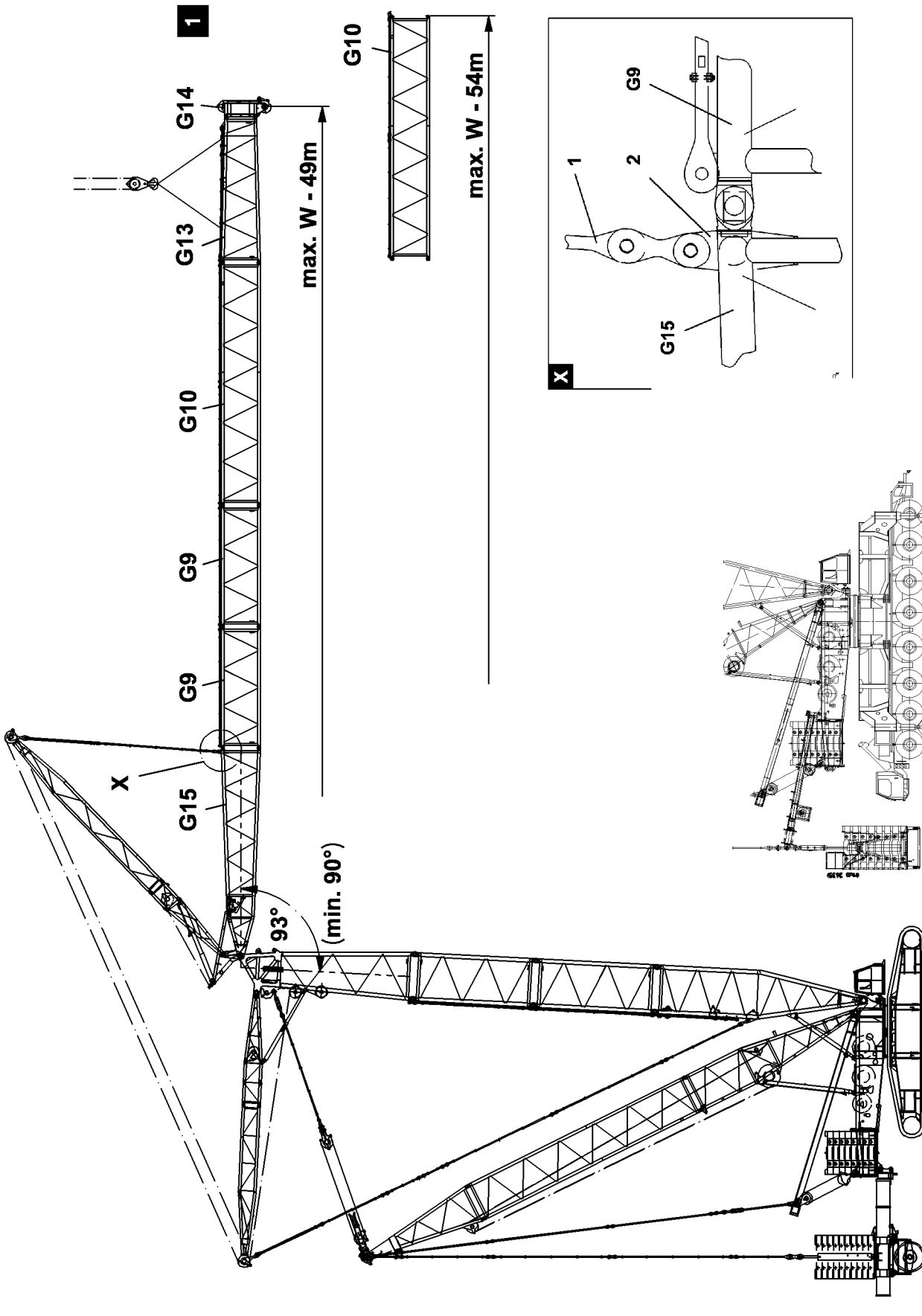
Assemble the guy rods according to the lattice jib length, pin and secure.

Note: The guy rods are placed and attached for transport on the intermediate sections. For installation, the transport retainers must be released.

Pin and secure the guy rods from the W - end section with the guy rods from the WA-bracket I .

Note: The guy rods must be installed and secured according to the installation drawings in chapter 5.03. The numbering on the installation drawing must be compared with the numbering on the guy rod.

D A N G E R: **All pins of the guy rods must be secured. The guy rods must be inspected regularly, see chapter " Inspection and maintenance of guy rods".**



198489

6.2 Flying installation of W - lattice jib on the W - pivot section

Installation

If the space requirements on the job site are limited for the installation of the W - lattice jib or is restricted due to nearby buildings, etc. then it is possible to install the W - lattice jib to the following **max. length** in flying mode:

Fig. 1	- max. W - 49 m	- with end section, without hook block
		- with WA - bracket I guy rods
	- max. W - 54 m	- without end section, without hook block
		- with WA - bracket I guy rods

DANGER: Install the slewing platform ballast, the central ballast and the derrickballast according to the data in the load charts.
Otherwise there is a danger of accidents!

For flying installation, the W - pivot section must be at an angle of at least 90° to the main boom, otherwise the flying installation is not permitted.

DANGER: For flying installation of the W-lattice jib, the W- pivot section must be at an angle of at least 90° to the main boom.
If this is not observed, there is a danger of accidents!

- Lower the WA - bracket I with the W - control and pin and secure the guy rods (1) from the WA - bracket I on the brackets (2) of the pivot section (G15) (fig. X)
- Swing the additional W - intermediate sections and the end section, individually or completely assembled with the auxiliary crane to the W - pivot section. Install the intermediate sections, pin and secure.

DANGER: It is strictly prohibited for anyone to remain under the lattice sections during the pinning or unpinning procedure.
There is a danger of accidents!

- The guy rods of the lattice sections must be pinned together, and then secured.

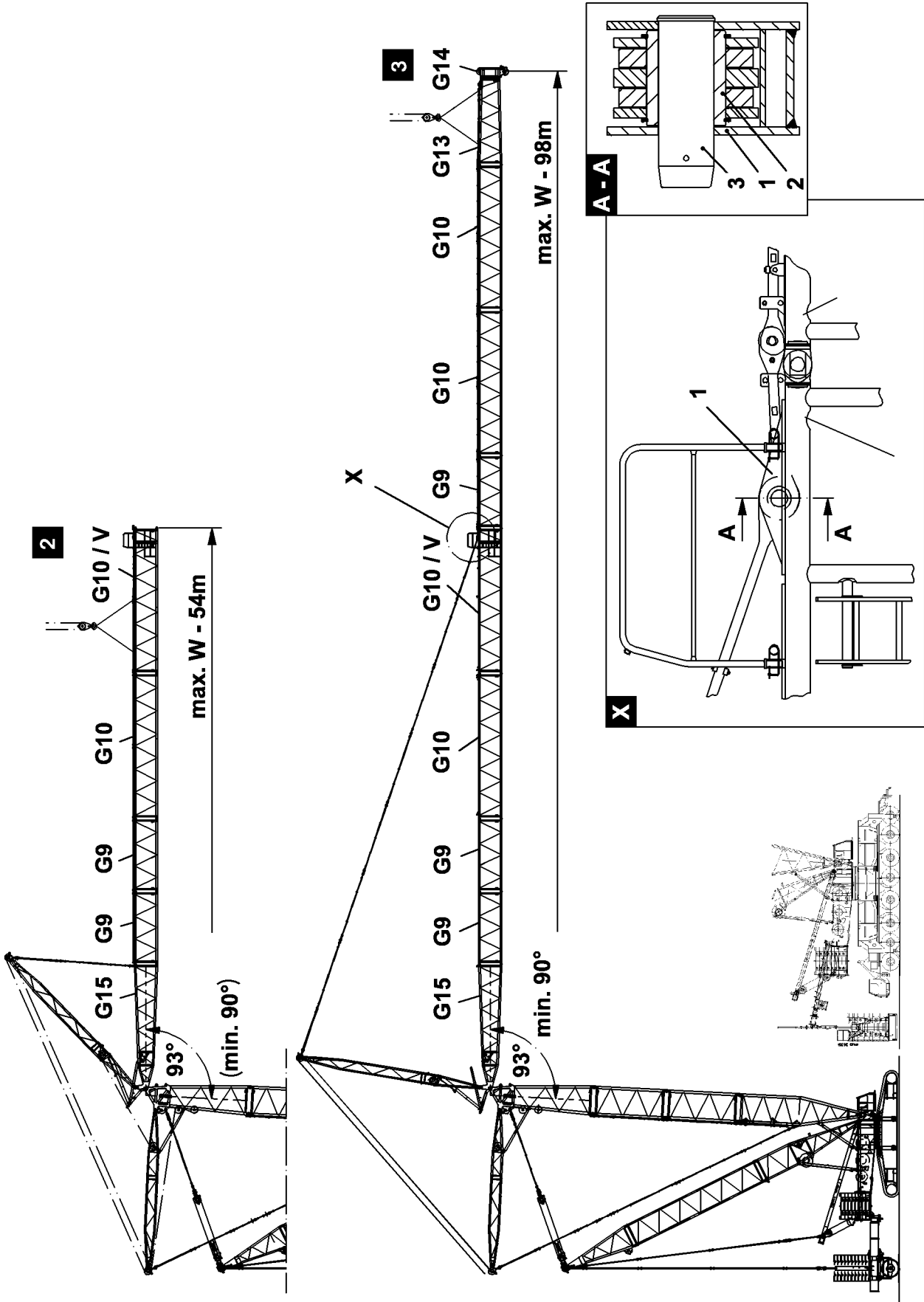
CAUTION: For W - lattice jib sections to a length of 49 m, the corresponding additional guy rods must be installed. See chapter 5.03.

Note: For the weight of the lattice sections with placed guy rods, see chapter 5.03

DANGER: For flying W - lattice jib installation, observe the following:

- the max. permissible W - lattice jib lengths
- the data in the load charts

If this is not observed, there is a danger of accidents!



6.3 Flying installation of the W - lattice jib on the intermediate section G10 / V

Montage

If the space requirements on the job site are limited for the installation of the W - lattice jib or is restricted due to nearby buildings, etc. then it is possible to install the W - lattice jib to the following **max. length** in flying mode:

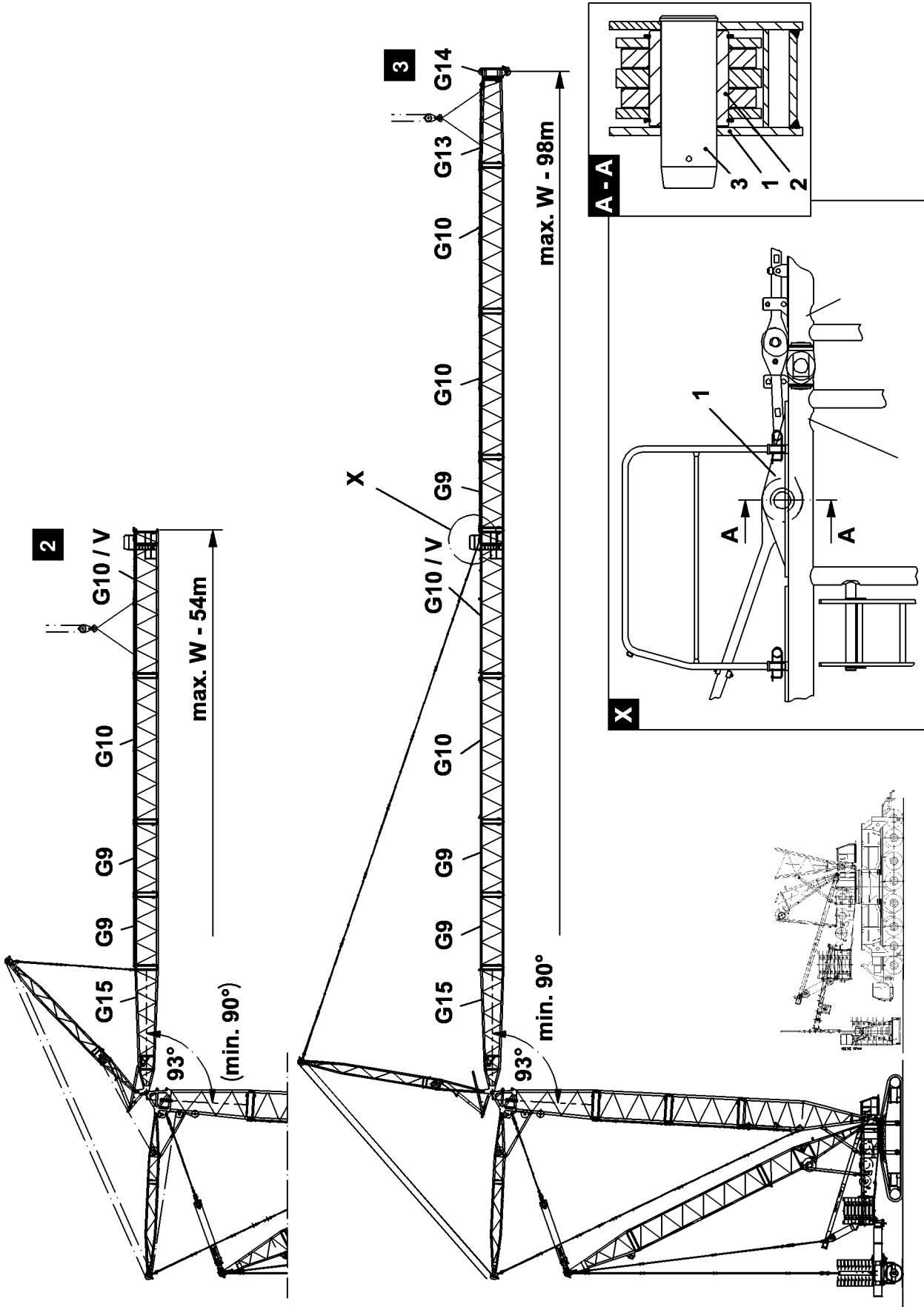
Fig. 2	- max. 54 m	- without end section, without hook block
		- with WA - bracket I guy rods
	- max. 98 m	- with end section, without hook block
		- with WA - bracket I and LI - guy rods

DANGER: Install the slewing platform ballast, the central ballast and the derrickballast according to the data in the load charts.
Otherwise there is a danger of accidents!

For flying installation, the W - pivot section must be at an angle of at least 90° to the main boom, otherwise the flying installation is not permitted.

DANGER: For flying installation of the W-lattice jib, the W- pivot section must be at an angle of at least 90° to the main boom.
If this is not observed, there is a danger of accidents!

- Lower the WA - bracket I with the W - control and pin and secure the guy rods (1) from the WA - bracket I on brackets (2) of the pivot section (G15) (fig. X, see 6.2).
- Swing the remaining W - intermediate sections to a max. length of 54 m, individually or fully assembled with the auxiliary crane to the W - pivot section, pin and secure (fig. 2)
- Attach the preassembled W - lattice jib on the front of the **reinforced** intermediate section (G10 / V) with the auxiliary crane and lift until the guy rods are relieved on the pivot section. Release and unpin the guy rods on the pivot section.
- Pin and secure the WA - bracket I guy rods with the guy rods of the intermediate section. The guy rods are connected on the bracket (1) (fig. X // A -A) with a hollow axle (2) and must be pinned and secured on the pin point of the brackets (1) with pins (3) (fig. A - A).
- Erect the WA - bracket I with the W - control until the guy rods are "**tensioned**" and the auxiliary crane is relieved. However, the W - lattice jib must remain in horizontal position.
- After the W - lattice jib is pinned, secured and tensioned, remove the auxiliary crane.
- Install the remaining intermediate sections and the end section individually or fully assembled with the auxiliary crane on the **reinforced** intermediate section (G 10 / V), pin and secure (fig. 3)
- The guy rods of the lattice sections must be pinned together, then secured.
- Attach the W - lattice jib on the front with the auxiliary crane until the guy rods between the WA - bracket I and the **reinforced** intermediate section (G10 / V) are relieved.
- Release and unpin the pin (3) on the brackets (1) (Abb. A - A).
- Erect the WA - bracket I with the W - control to the point where the guy rods between the WA - bracket I and the L - end section are tensioned.



D A N G E R : It is strictly prohibited for anyone to remain under the lattice sections during the pinning or unpinning procedure.
There is a danger of accidents!

C A U T I O N : For W - lattice jib length of up to 49 m, the corresponding, additional guy rods must be installed. See chapter 5.03.

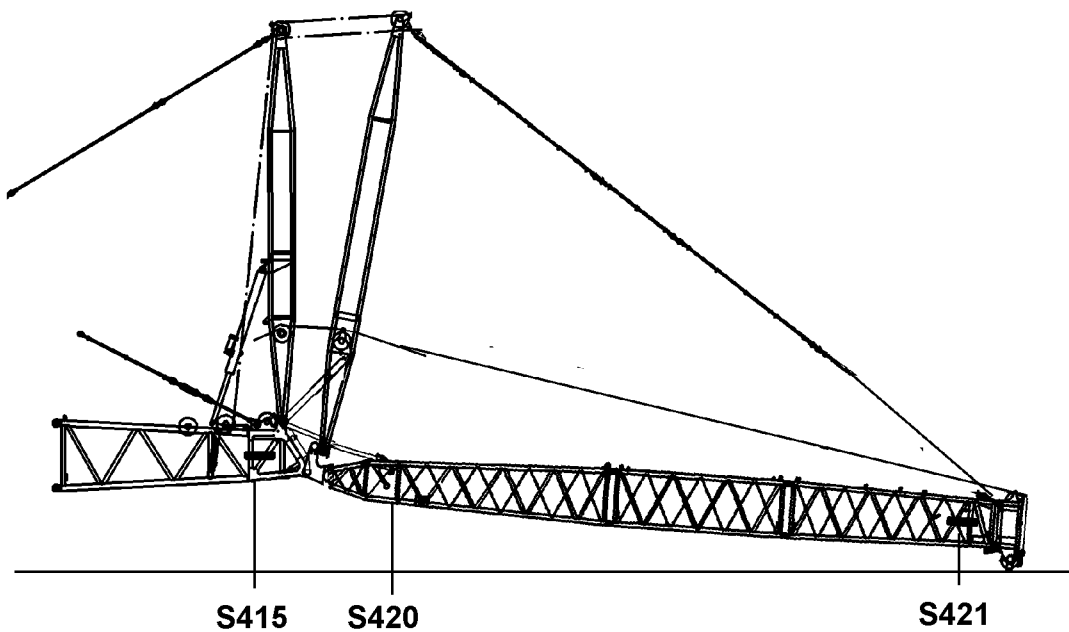
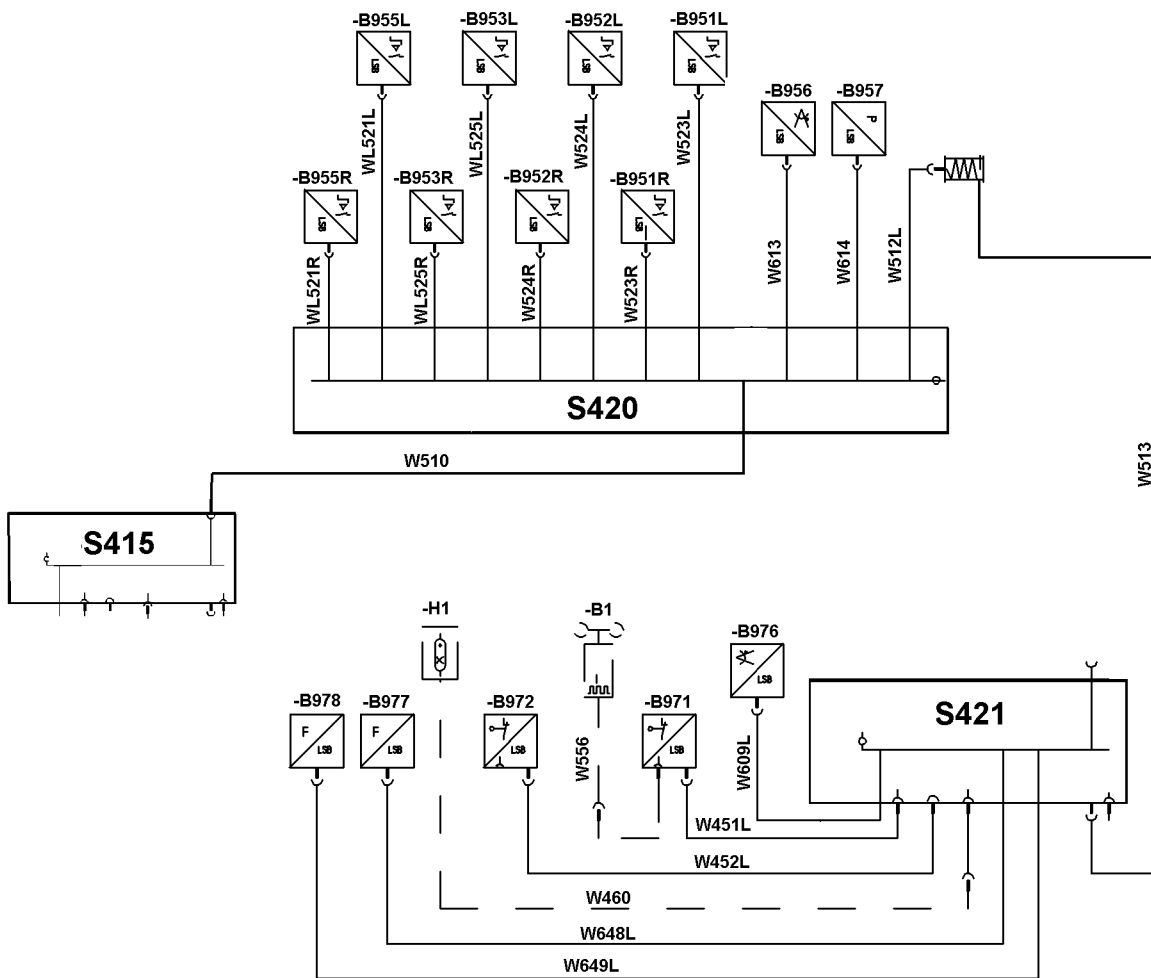
D A N G E R : For flying W - lattice jib installation, observe the following:

- the max. permissible W - lattice jib lengths
- the data in the load charts

If this is not observed, there is a danger of accidents!

Note: For the weight of the lattice sections with placed guy rods , see chapter 5.03

D A N G E R : The completely installed W - lattice jib must be held with an auxiliary crane before the pin (3) may be unpinned on the brackets (1) .
If this is not observed, there is a danger of accidents!



7. Electrical connections

Establish the electrical connection from the connector box (S 415) to (S 420). Plug in the cable plug (W510) on the connector box (S415) .

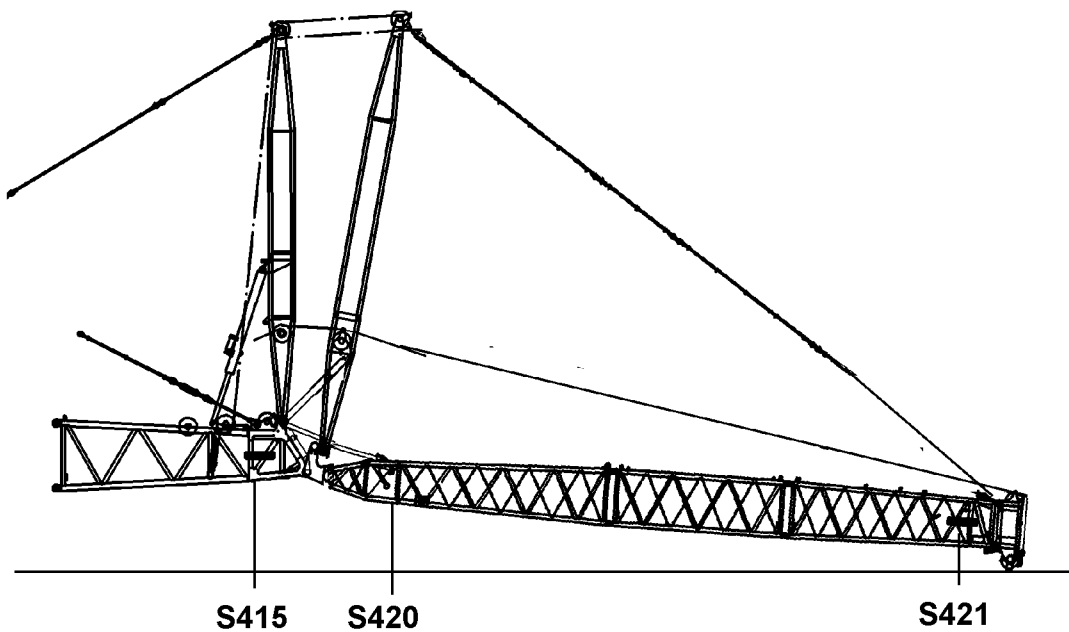
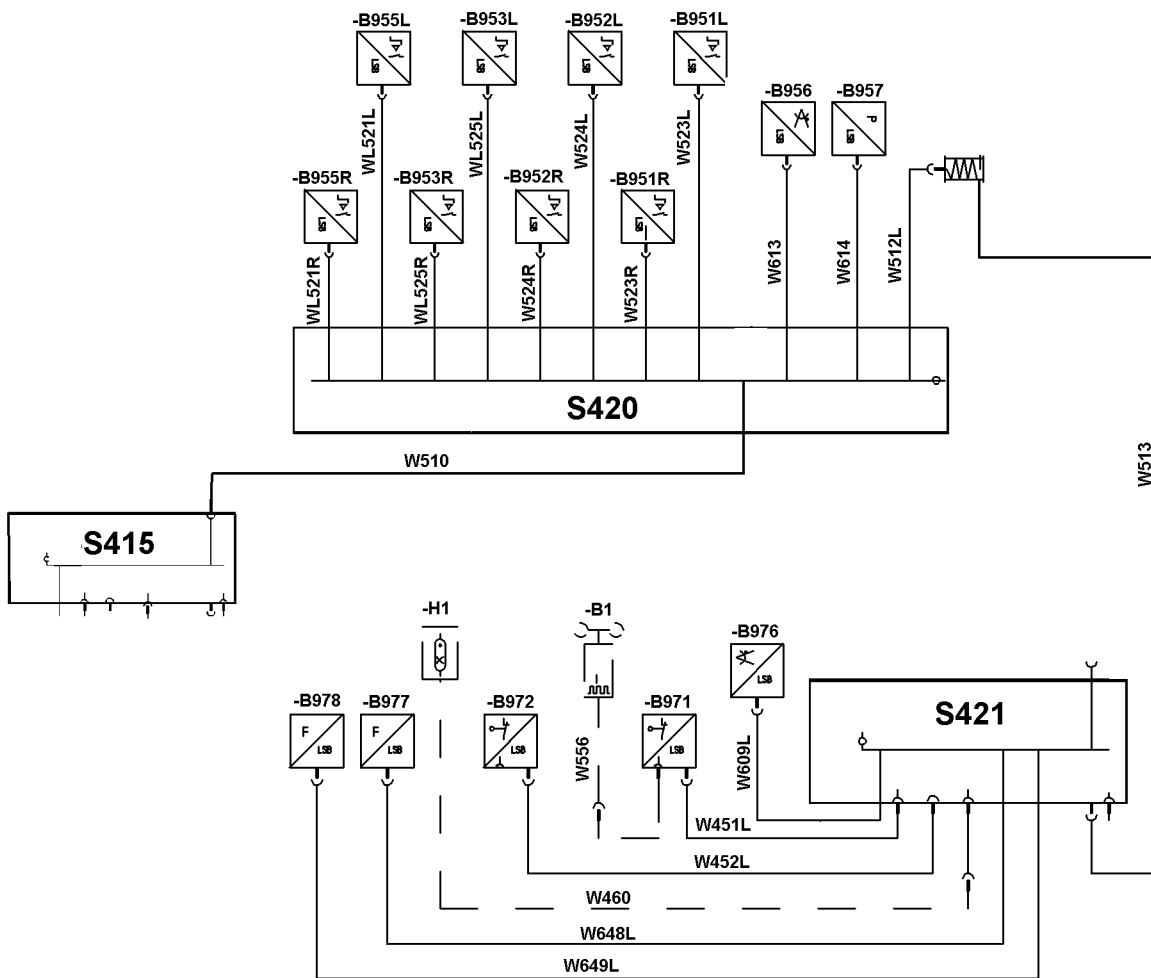
Establish the electrical connection from the cable drum in the W-pivot section, to the connector box (S421). Plug in the cable plug (W513) on the connector box (S421) .

Establish the electrical connection from the connector box (S420) to the cable drum . Plug in the cable plug (WL512) into the cable drum - socket.

Note: Establish the electrical connection from the connector box (S420) to the cable drum only when the cable from the cable drum is spooled out to the connector box (S421) .

Establish the electrical connection on the **connector box (S421)** :

-S971	W451L	Hoist limit switch 2A
-S972	W452L	Hoist limit switch 2B
-H1	W460	Beacon
-B977	W648L	Pull test bracket 2B right
-B978	W649L	Pull test bracket 2A left
-B976	W609L	Angle sensor, luffing jib top



7.1 Function check

Prerequisites:

- All electrical connections are established.
- The engine is running.

Airplane warning light

Turn on the airplane warning light , check function visually.

Wind speed sensor

Check the movement and function of the wind speed sensor.

Limit switch

C A U T I O N : **The limit switch functions must be checked individually before crane operation.**
The manual procedure is described below.
The function of the individual limit switch initiators must be determined in the test system - see Diagnostics Manual.

Hoist limit switch

Actuate the hoist limit switch manually.
 The hoist winch must turn off when lifting.
 The hoist "top" symbol on the LICCON indicator must blink.

Limit switch W - lattice jib "top", relapse cylinder

The W - control winch movement "spool up" must turn off.
 The symbol must appear on the LICCON monitor .

Limit switch W - lattice jib "low", relapse cylinder

The W - control winch movement "spool out" must turn off.
 The symbol must appear on the LICCON monitor .

Note: The shift point of the limit switches on the relapse cylinder must be checked before erection - see chapter 8.12, **Checking the safety controls on the relapse cylinder.**

Limit switch flamp in position and lattice jib , "steepest " position, mechanical relapse support

- Cover the limit switch initiators individually with a metal plate.
- The W- control winch movement "spool up" must turn off.
- The symbol must appear on the LICCON monitor .

C A U T I O N : **Before erection, the easy movement of the pendulum of the mechanical relapse retainer must be checked over the complete swing range of the pendulum. If this is not observed, the mechanical relapse support will not engage in steepest lattice jib position.**
There is a danger of accidents, as the lattice jib may tip backward!

8. Erection / take down procedure

The boom combinations must be erected or taken down according to the Erection and take down charts - see separate charts.

D A N G E R : **The erection and take down procedure must be made according to the data in the erection and take down chart.
If this is not observed, the crane can be overloaded or topple over.**

Prerequisites:

- The crane is horizontally aligned.
- The counterweight is installed on the slewing platform according to the load chart .
- The derrick ballast is placed according to the erection and take down charts.
- The lattice jib is installed according to the load chart and the operating manual .
- All limit switches are installed correctly and fully functioning.
- Before erection, the pendulum of the mechanical relapse retainer must be checked for easy movement over its complete swing range.
- All pin connections are secured.
- The hoist cable is placed correctly into the cable pulleys and secured with cable retaining pins to prevent them from jumping out.
- There are no persons within the danger zone.
- There are no loose parts on the boom and the lattice jib.
- In the cold season: Is the boom and the lattice jib and their components (limit switch, cable drum, airplane warning light, wind speed sensor, etc.) free of snow and ice.

D A N G E R : **Incorrectly installed and non-functioning limit switches as well as falling parts (pins, spring retainers, ice, etc.) can cause accidents!
Before erection, the pendulum of the mechanical relapse retainer must be checked for easy movement over its complete swing range. If this is not observed, the mechanical relapse support does not engage in steep lattice jib position.
There is a danger of accidents, the lattice jib may tip backward!**

		m > < t		CODE >XXXX< BXXX YYZZ.1(2)			
		35,0	35,0	35,0	35,0	35,0	35,0
12,0							
14,0	380,0	380,0	380,0	380,0			
16,0	372,0	372,0	372,0	372,0			
18,0	363,0	363,0	363,0	363,0			
20,0	350,0	350,0	349,0	349,0			
22,0	336,0	337,0	337,0	337,0			
24,0	305,0	313,0	312,0	312,0	307,0	319,0	328,0
26,0	278,0	283,0	283,0	283,0	284,0	301,0	310,0
* n *	* 29 *	* 29 *	* 29 *	* 29 *	* 23 *	* 24 *	* 25 *
xx	87,0	87,0	87,0	87,0	77,0	77,0	77,0
yy	13,0	15,0	18,0	20,0	13,0	15,0	18,0

<<

xx° SDBW
35m

W
28m

220
t

95
t

yy m

n
10 x

O.K.

LIEBHERR

7

8

9

4

5

6

1

2

3

0

.

P

K

F

C

i

<

>

O

SHIFT

F1

F2

F3

F4

F5

F6

F7

F8

ENTER

BXXX YYZZ

XXXX

0 1/min:1634 50 90 100 110 130%

max n = 10

t 156.0

1°

0.0

0.0

0.0

m/s

max: 12.8

t 28.3

191.99

m

2:1Y

191.99

m

1:1Y

1 4

0 t

0 0

2 3

BCD

V: 40%

0°

m 23.8

80.0°

m 28.0

35.0

m 60.0°

m 62.6

LIEBHERR

7

8

9

4

5

6

1

2

3

0

.

P

K

F

C

i

<

>

O

SHIFT

F1

F2

F3

F4

F5

F6

F7

F8

ENTER

8.1 Erection procedure

Prerequisite:

- Set the LICCON overload safety system according to the data given in the load charts and the equipment configuration (see chapter 4.02, 4.03).
- Actuate the installation keyed button, the indicator light "installation" lights up.
- The installation symbol on the LICCON indicator blinks.
- Attach the hoist cable on the end section .

C A U T I O N : **If the hoist cable is not attached, then the hoist cable might fall backward due to its own weight when the boom is erected.
DO NOT turn during the erection procedure, this is strictly prohibited.**

Adjust in the EQUIPMENT CONFIGURATION VIEW of the LICCON (see chapter 4.02)

Enter the (4-digit) code number, according to the required load chart, and confirm by pressing the ENTER key.

Enter the actual reeving.

Check the actual equipment configuration of the crane with the entered data to ensure it matches. Press the function key -F8- "o.k.", the OPERATING VIEW will appear.

D A N G E R : **Compare and check the LICCON settings with the actual equipment configuration!
If this is not observed, the crane will be overloaded or topple over!**

Indicators in the OPERATING VIEW during the erection procedure

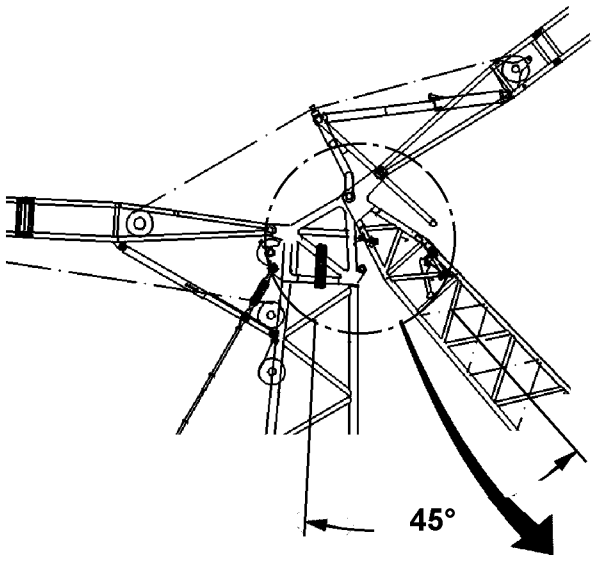
The following alarm functions are activated (blink) during the erection procedure, until the operating position is reached:

- "STOP"
- "HORN" + Acoustical signal

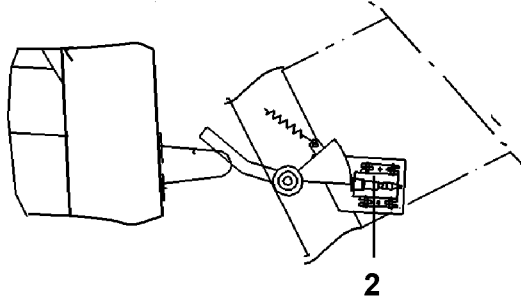
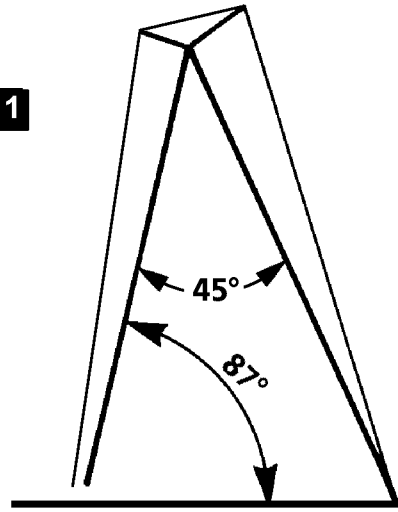
Note: The **lowest** operating position is reached when the indicators turn off and a load value (in tons - t -) appears in the symbol "MAX. LAST" instead of the question marks ("????").

Turn off the installation keyed button by pressing the button .
The installation symbol on the LICCON indicator turns off.

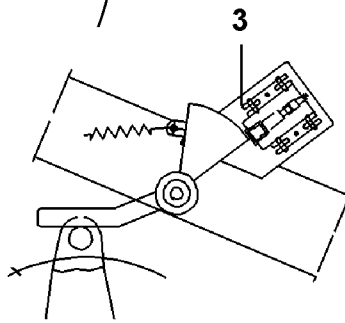
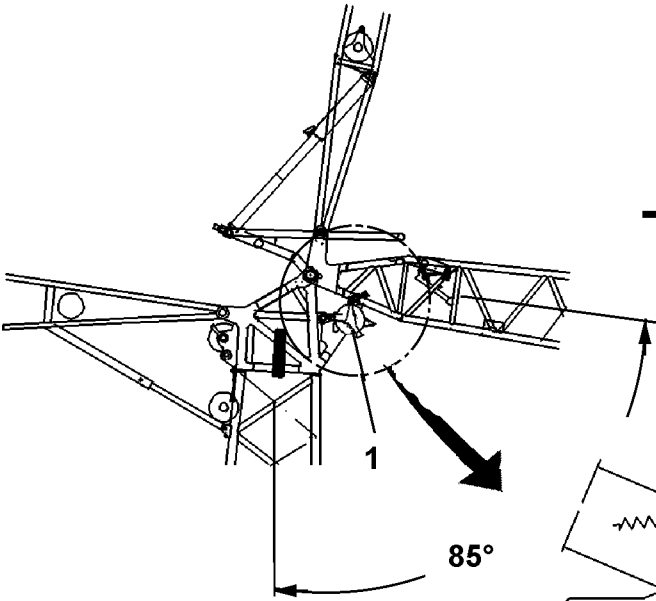
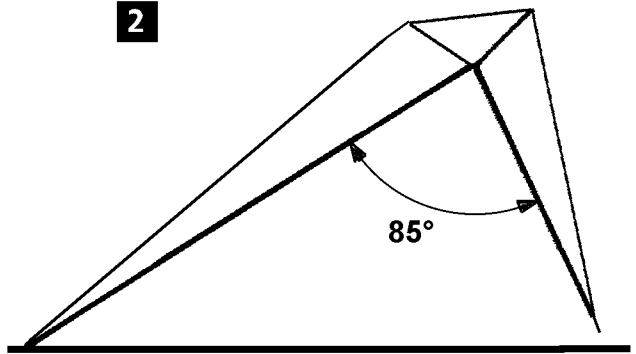
D A N G E R : **After the lowest operating position is reached, the installation keyed button must be turned off immediately.
The installation keyed button bypasses the safety devices!
The radii given in the load chart may not be exceeded nor fallen below, even without a load on the hook!
If this is not observed, the crane can topple over!**



1



2



8.2 Erection

Actuate the manual control lever and luff up the boom.

At the same time, spool out the lattice jib control winch to hold the W-end section, which is laying on the pulley cart on the ground.

The maximum forces in the W- guying (**only SW attachment**) may not be exceeded.

Note: For maximum forces in the W- guying (**only SW attachment**) - see **Erection and take down chart manual!**

D A N G E R : **When erecting the SW attachment, the maximum permissible forces in the W-guying (test point 2) may not be exceeded - see Erection and take down chart manual!**
Lower the W- lattice jib control in such a way that the maximum forces are not exceeded.
Watch for slack cable formation on the control winch !
If this is not observed, the crane will be overloaded or the crane can topple over!

Carry out this procedure until the S-boom and the W- lattice jib form an angle of (45° or 85°) or the W- end section has first lifted off the ground .

Note: **Fig. 1** $\geq 45^\circ$ without pulley assembly (1) on S- end section, limit switch (2)
Fig. 2 $\geq 85^\circ$ with bolted on pulley assembly (1) on S-end section, limit switch (3)

Remove the pulley cart on the W- end section .

Now luff up the boom and lift the W- lattice jib off the ground.

Release the hoist cable on the end section and reeve between the pulley head on the end section and the hook block and secure on the fixed point - **see Reeving plans.**

Attach the hoist limit switch weight .

Luff up the boom into the steepest position of 87° .

C A U T I O N : **When erecting, the hoist winch must be spooled out at the same time to prevent the hook block from colliding with the end section of the lattice jib.**

Luff up the lattice jib to operating position.

Turn the installation keyed button off. The installation symbol on the LICCON indicator turns off.

D A N G E R : **After reaching the operating position, the installation keyed button must be turned off immediately.**
The installation keyed button bypasses the safety devices!
The radii given in the load chart may not be exceeded nor fallen below, even without a load on the hook!
If this is not observed, the crane can topple over!

9. Crane operation with SW/SDW/SDWBW - boom system

C A U T I O N : Observe the notes in
chapter 4.02 " LICCON COMPUTER SYSTEM",
chapter 4.05 " CRANE OPERATION "
chapter 4.08 " WORKING WITH A LOAD ".

Prerequisite:

- The LICCON overload safety system is set according to the data given in the load chart.
- The installation keyed button is turned off . The installation symbol on the LICCON indicator is off.

D A N G E R : Check the horizontal position of the crane before and during operation.
If the crane operator leaves the crane operator's cab, even if only for a short time, then he is obligated to check all operating mode settings and to reset them, if necessary, before starting to work again.

Adjustments / checks

Check the function of the overload safety system by triggering the operating positions "on the top" and "on the bottom".

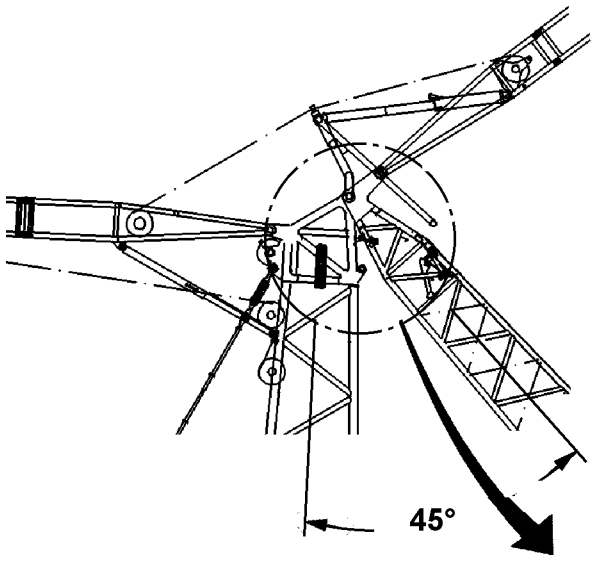
Check the function of the hoist limit switch "top" by running against the hoist limit switch weight.

Check the function of the limit switch "lattice jib steep" by running against the relapse retainer.

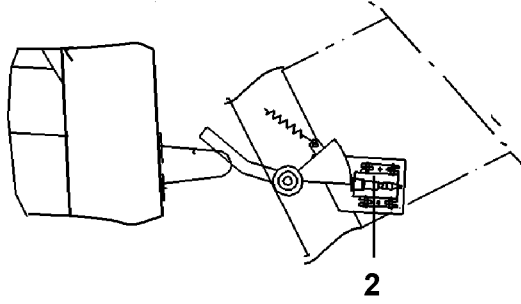
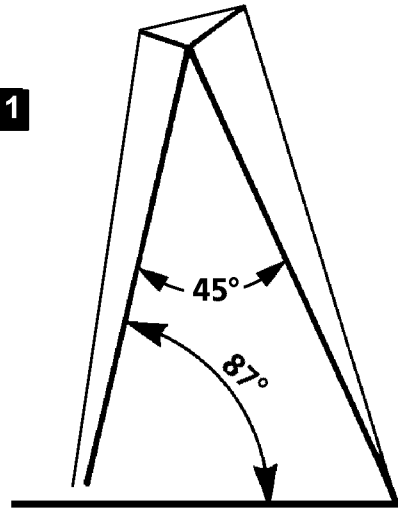
Set the boom to 67° or 77°

Before changing the boom to 67° or 77° , the boom must be raised to the steepest position of 87° and the lattice jib must also be in steepest operating position.

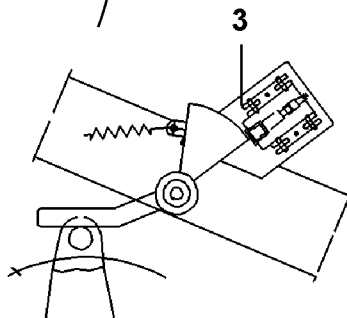
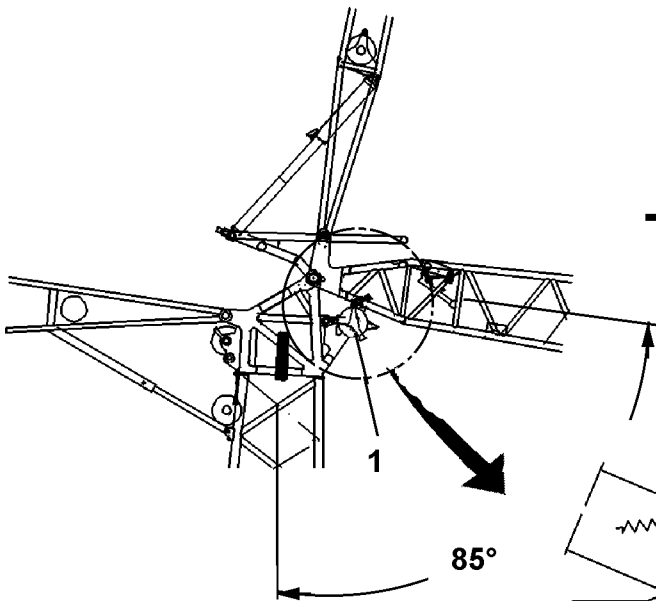
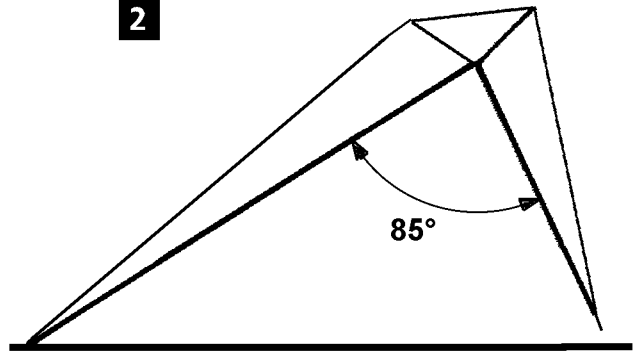
D A N G E R : When changing to 67° or in SDWB - operation, the suspended ballast might already be necessary, even without a load on the hook.



1



2



10. Take down procedure

The boom remains in steepest position , 87°.

Actuate the manual control lever and luff down the lattice jib to just before the **lowest** operating position.

Note: When the **lowest** operating position is reached, the luffing down movement is shut off.

C A U T I O N : **When luffing down, the hoist winch must be spooled out at the same time to prevent the hook block from colliding with the pulley head.**

Actuate the installation keyed button. The installation symbol on the LICCON indicator blinks.

D A N G E R : **The overload safety system is no longer effective.
The limit switch hoist "top" is bypassed.**

Continue to luff down the W- lattice jib until an angle of approx. 45° or 85° is reached between the S-boom and the W- lattice jib. The shut off is made via the limit switch "W- lattice jib bottom".
The limit switch symbol on the LICCON indicator blinks.

C A U T I O N : **When luffing down the lattice jib, make sure that the hook block does not collide with the end section !
The hook block may not be pulled along the ground.**

Luff down the S-boom until the hook block touches the ground.
Remove the hoist limit switch weight .
Unreeve the hook block.

D A N G E R : **When unreeving the hoist cable, make sure that no persons are in the danger zone.**

Luff down the S-boom until the W-end section of the lattice jib can be installed on the set up cart.

Note: If the lattice jib touches the set up cart vertically, then the lattice jib guying must be tensioned a little so that the set up cart can roll forward with the lattice jib .

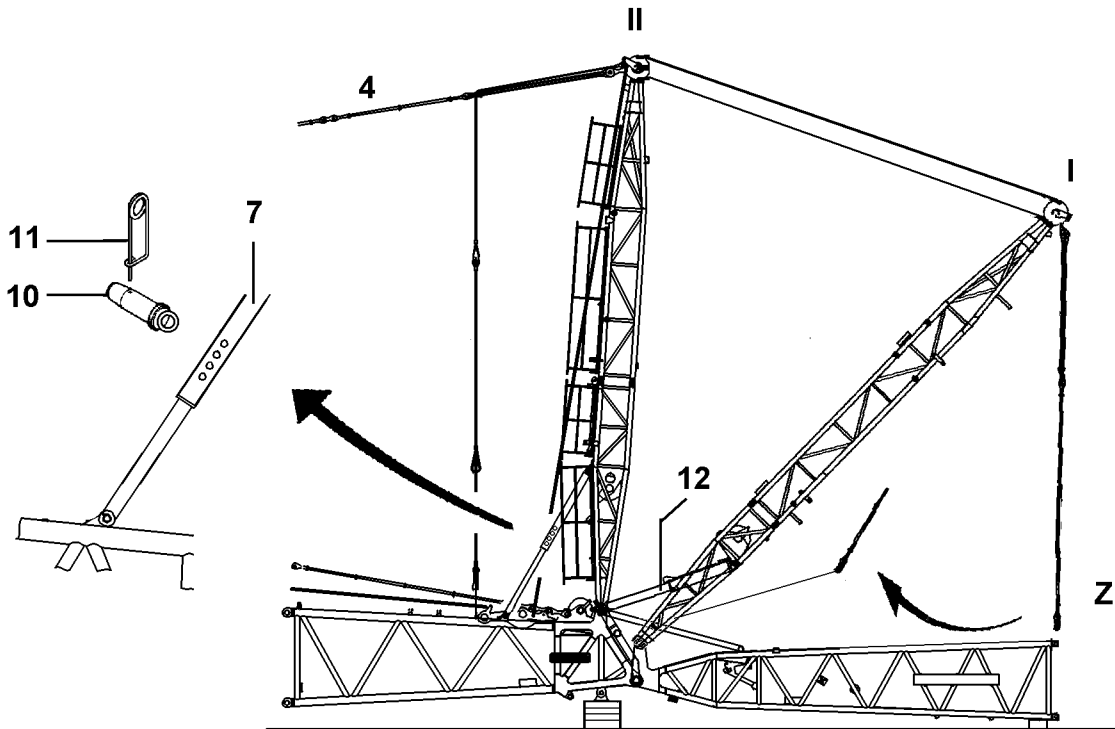
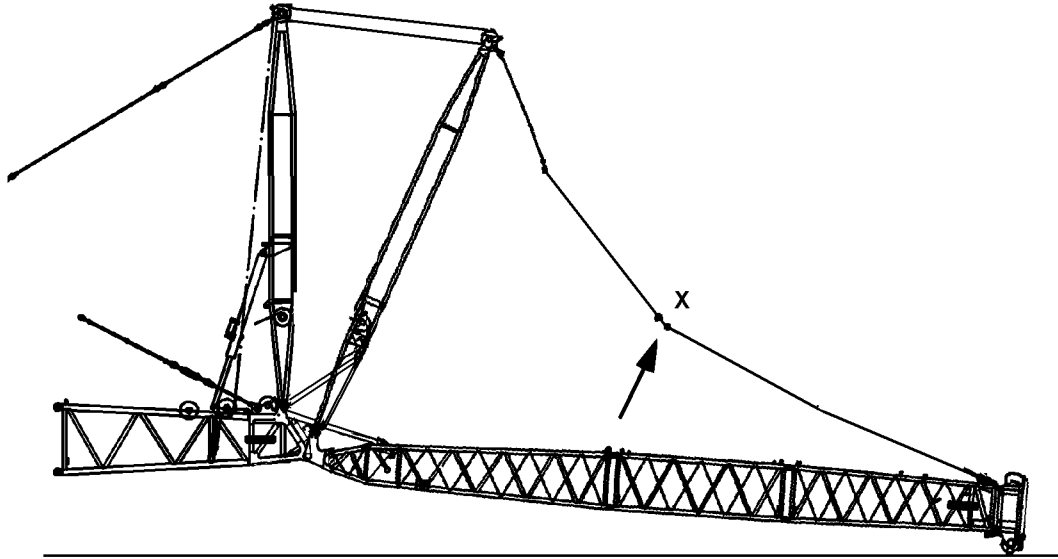
Continue to luff down the S-boom.

Note: For maximum forces in the W-guying (**only SW attachment**) - see **Erection and take down manual!**

D A N G E R : **When erecting the SW attachment, the maximum permissible forces in the W-guying (test point 2) may not be exceeded - see Erection and take down manual!
Lower the W-lattice jib control in such a way that the maximum forces are not exceeded.
Make sure to watch for slack cable formation on the control winch!
If this is not observed, the crane will be overloaded or can topple over!**

Remove the hoist cable.

D A N G E R : **When removing the hoist cable, make sure that there are no persons within the danger zone!**



10.1 Place down the WA- bracket I + II

Spool back the hoist cable via the cable pulleys in the WA- brackets to the S- head section.

D A N G E R : **Secure the hoist cable with the auxiliary rope and lower it slowly via the cable pulleys to the rear to the S- head section .
Make sure that no persons are within the danger zone.
This could cause a serious accident!**

Spool out the W- control winch, lower the WA- bracket I to the front. Unpin the guy rods on the connector brackets.

Note: The guy rods are placed for transport on the intermediate sections and secured with transport retainers.

Disconnect the guy rods on the connector bracket (X) . Unplug the spring retainers and pins. Pin the guy rod from the WA-bracket I on the bracket (Z) on the W- pivot section with pins and secure with spring retainers.

Pull the WA- bracket I up again until the guy rods are stretched between the WA-bracket I and the W- pivot section.

D A N G E R : **The W - end section may not be raised, it must remain on the ground.
If this is not observed, severe damage can occur.**

Unpin the W- pivot section "**on the bottom**". Release the pin and unpin .

Lower the W- pivot section until it rests on the ground.

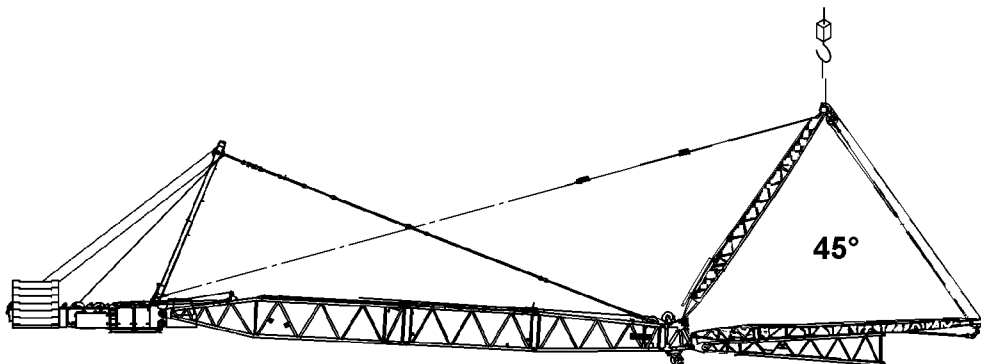
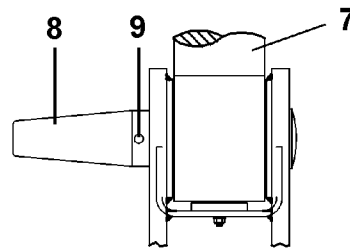
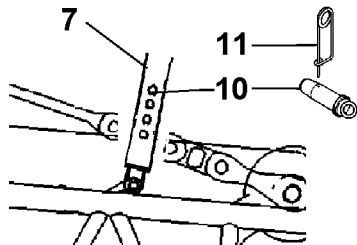
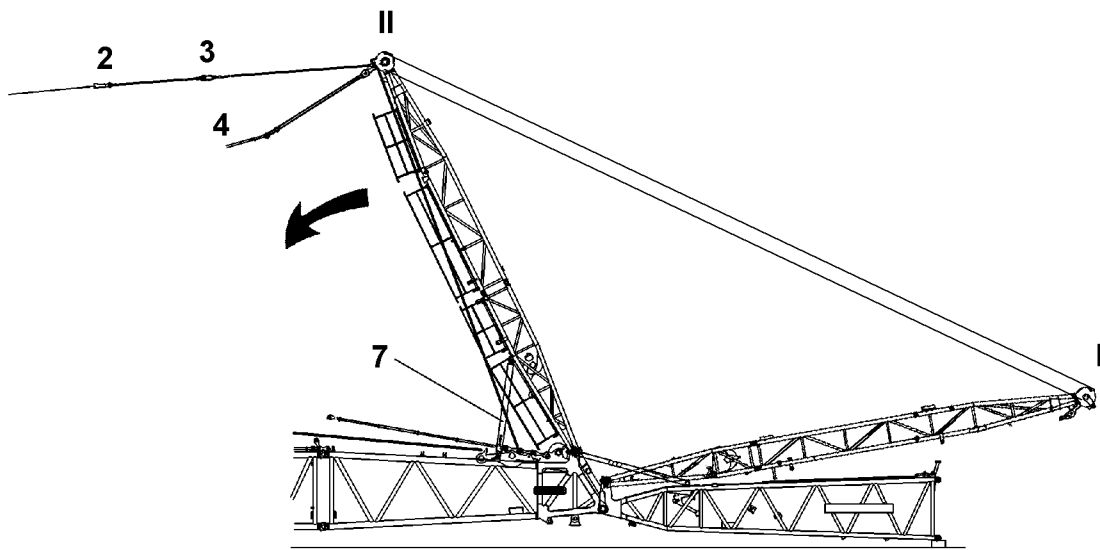
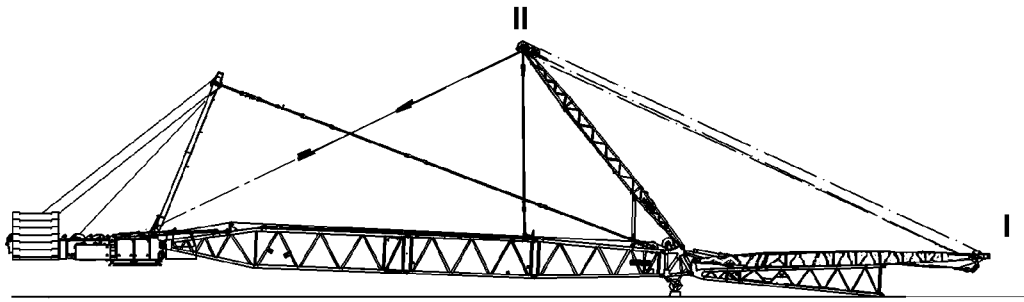
Unpin the W- pivot section "**on top**". Release the pin and unpin .

Remove the lattice jib.

D A N G E R : **Before unpinning, it must be ensured that the pivot section on the bracket (Z) is pinned and held by the guy rods, or that it is supported from below with suitable, stable material.
No one may remain under the lattice jib during the pinning and unpinning procedure of the lattice sections . This is strictly prohibited!
If this is not observed, there is a danger of accidents, as the lattice jib may suddenly fold down.**

Spool up the W- control winch (V) and pull up the WA- bracket I until the guying from the WA-bracket II to the zum S-pivot section is tensioned by counterpressure of the relapse cylinder (12). The relapse support (7) can now be unpinned. Remove the spring retainer (11) and pin (10).

C A U T I O N : **When pulling up, the limit switch on the W- relapse cylinder (12) can be actuated and the spooling up movement of the winch V can shut off, which prevents pulling to block .
The electrical connection to the limit switches on the W- relapse cylinder must be established.**



10.2 Place down the WA-bracket II

Lower the WA - bracket I until it is placed on the W- pivot section .

Attach the hoist cable of winch I/II into the cable lock (2) on the installation cable (3) .

Pull the WA- bracket II to the rear by spooling up the hoist winch and simultaneously spooling out the W- control winch and unpin the guy rods from the WA- bracket II to the S-pivot section .

Place the guy rods on the lattice sections and secure.

C A U T I O N : **Before pulling the WA-bracket II back , the pin (10) must be unpinned, otherwise it will be damaged when pulling the WA - brackets II back.**

Repin the pin (10) while it is pushed together .

Unpin the WA-relapse support (7) on the S- end section. Remove the pin (10) and spring retainer (11) .

Pull the WA- bracket II to the front by spooling out the hoist winch and simulteneously spooling up the W- control winch to vertical position and on to approx. 45° .

From approx. 45° , attach the auxiliary crane on the installation cable (1) .

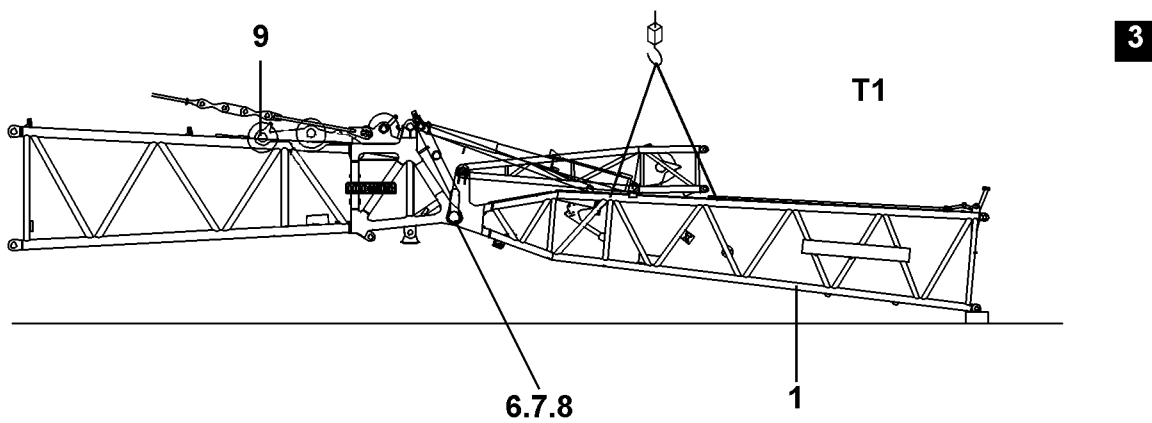
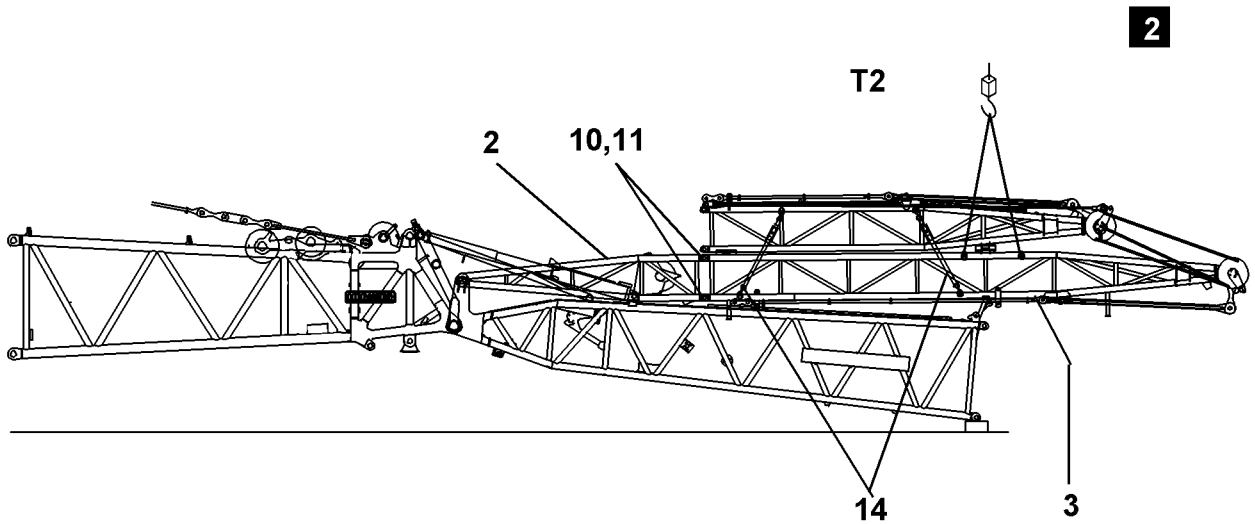
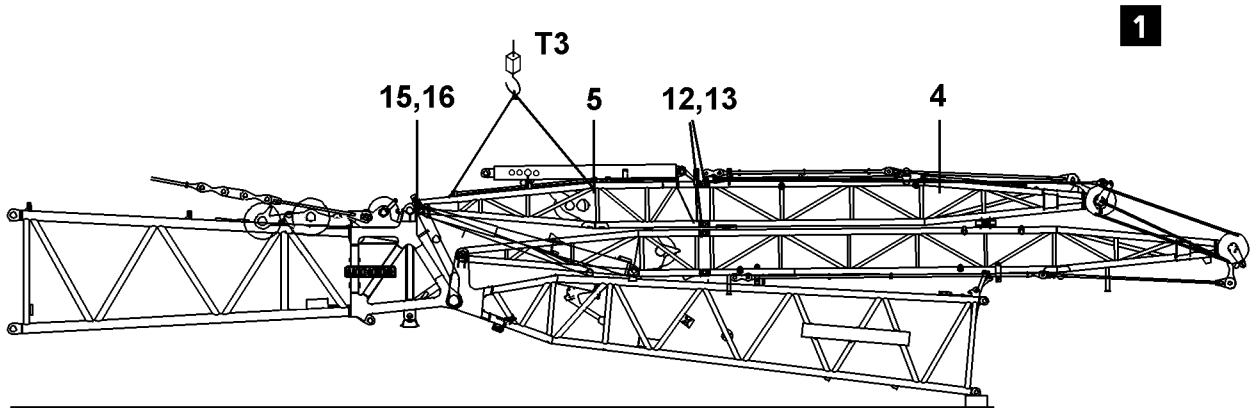
Lower the WA- bracket II by spooling up the W- control and and simultaneously spooling out the hoist cable until it is laying on the WA- bracket I .

D A N G E R : **From approx. 45° to the horizontal to the front, the WA- bracket II must be heldwith the auxiliary crane and continue to lower it with the crane. Otherwise the WA-bracket II will fold downward. There is a danger of accidents.**

Detach the hoist cable on the cable lock (2) of the installation cable (3) and attach the installation cable on the WA-bracket II.

Detach the installation cable (1) on the auxiliary crane and attach on the WA-bracket II .

Unreeve the control cable and reeve in the auxiliary cable for the reeving at the same time.



11. Removal

Note: Removal is in reverse order than installation.

D A N G E R: For installation and removal work:

- A safe installation scaffolding / working platform must be used. There is a danger of accidents due to falling.
- Improvisations are prohibited.
- The lattice sections must be supported underneath with suitable, stable materials.
- Nobody may remain under the lattice jib during the pinning and unpinning procedure of the lattice sections.

Fig. 1 Installation Transport unit 3 (T 3)

Take on the transport unit 3 (T 3) with the auxiliary crane on the tackle points on the WA-bracket II-pivot section (5) .

Attach the rigging belts (14) .

Unpin the WA-bracket II- pivot section (5) on the WA-bracket II end section (4) . Unpin the connector pins (15) with the hydraulic pin pulling device.

Unpin the connector pins (12), on top and bottom with the hydraulic pin pulling device.

Fig. 2 Installation Transport unit 2 (T 2)

Take on the transport unit 2 (T 2) with the auxiliary crane on the tackle points on the WA-bracket I- end section (3) .

Unpin the transport unit 2 on the WA-bracket I pivot section (2) .

Unpin the connector pins (10), on top and bottom with the hydraulic pin pulling device.

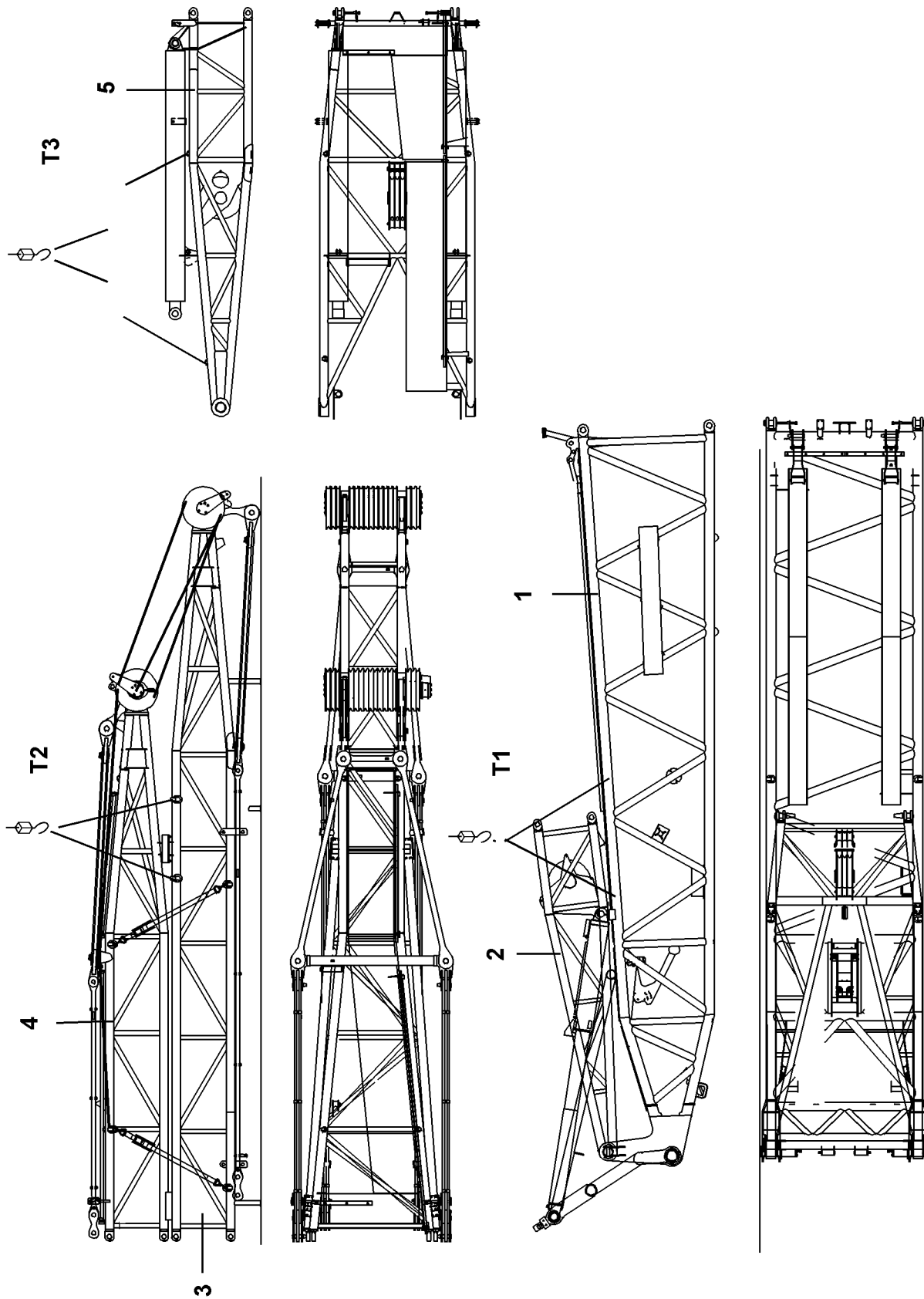
Fig. 3 Installation Transport unit 1 (T 1)

Take on the transport unit 1 (T 1) with the auxiliary crane on the tackle points on the W- pivot section (1).

Unpin the transport unit 1 - hanging down on the front - on the S-end section .

Unpin the connector pins (6) with the hydraulic pin pulling device. Remove the retaining plate (7) and spring retainer (8)

Unpin the pulley assembly (9) .



1. W- Installation unit

- 1 W-Pivot section
- 2 WA-Bracket I Pivot section
- 3 WA-Bracket I End section
- 4 WA-Bracket II End section
- 5 WA-Bracket II Pivot section

1.1 Transport units**Transport unit 1 (T 1)**

consists of:

- W-Pivot section
- WA-Bracket I Pivot section

Weight = 10600kg

Transport unit 2 (T 2)

consists of:

- WA-Bracket I End section
- WA-Bracket II End section

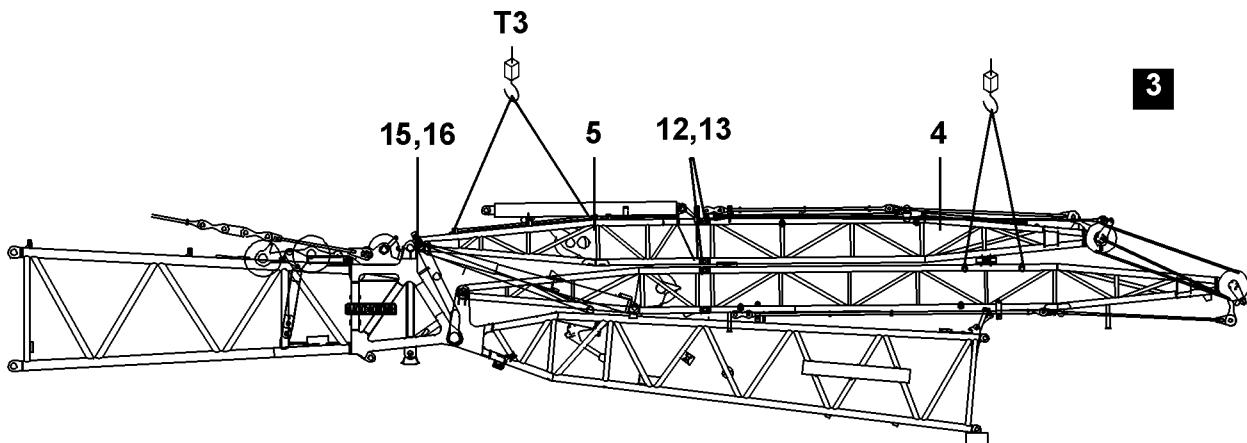
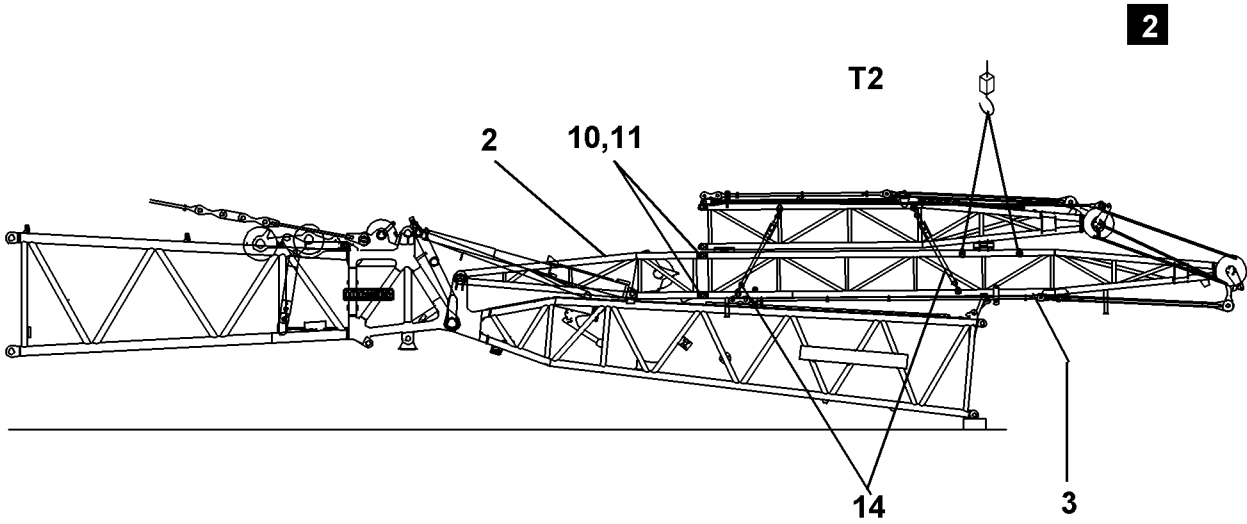
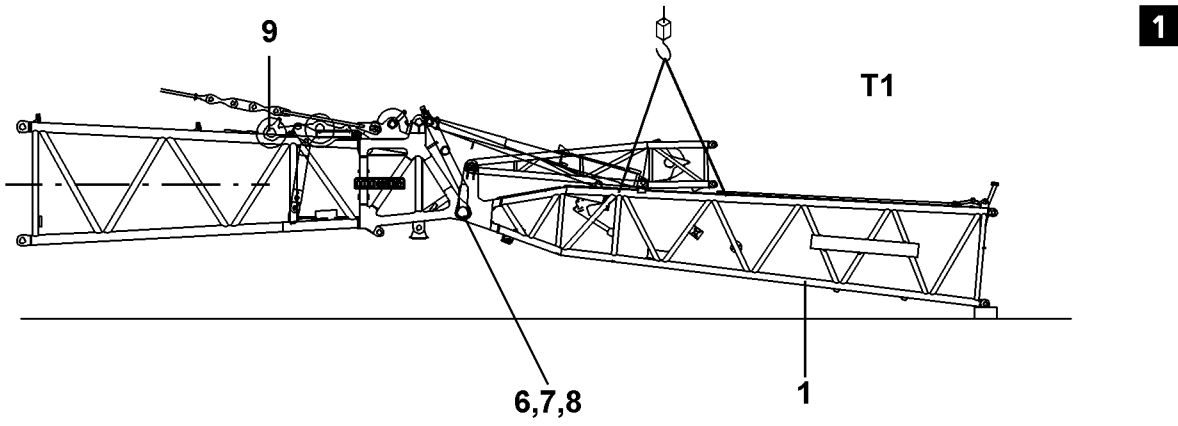
Weight = 8400kg

Transport unit 3 (T 3)

consists of:

- WA-Bracket II Pivot section

Weight = 3500kg



2. Installation

- D A N G E R :** For installation and removal work:
- A safe installation scaffolding / working platform must be used. There is a danger of accidents due to falling.
 - Improvisations are prohibited.
 - The lattice sections must be supported underneath with suitable, stable materials.
 - Nobody may remain under the lattice jib during the pinning and unpinning procedure of the lattice sections.

Prerequisites:

- The S-boom is installed and set in horizontal position.
- The crane is horizontally aligned.
- An auxiliary crane as well as an installation scaffolding / working platform is available.
- The LICCON system is set according to the data given in the load charts.
- The installation keyed button "Installation" is turned on, the indicator light "Installation" lights up .
- The installation symbol on the LICCON indicator blinks.

2.1 Fig. 1 Installation Transport unit 1 (T 1)

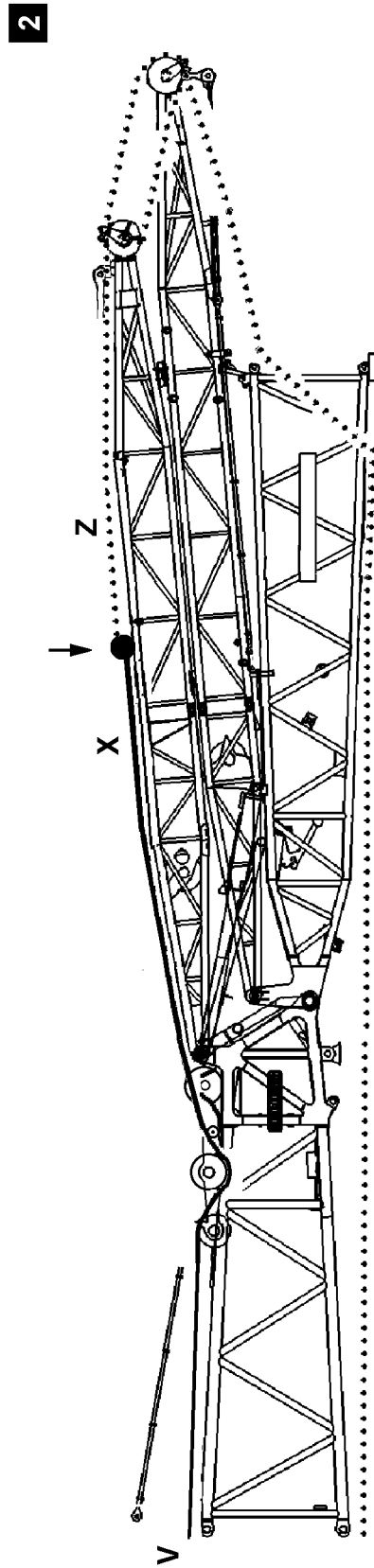
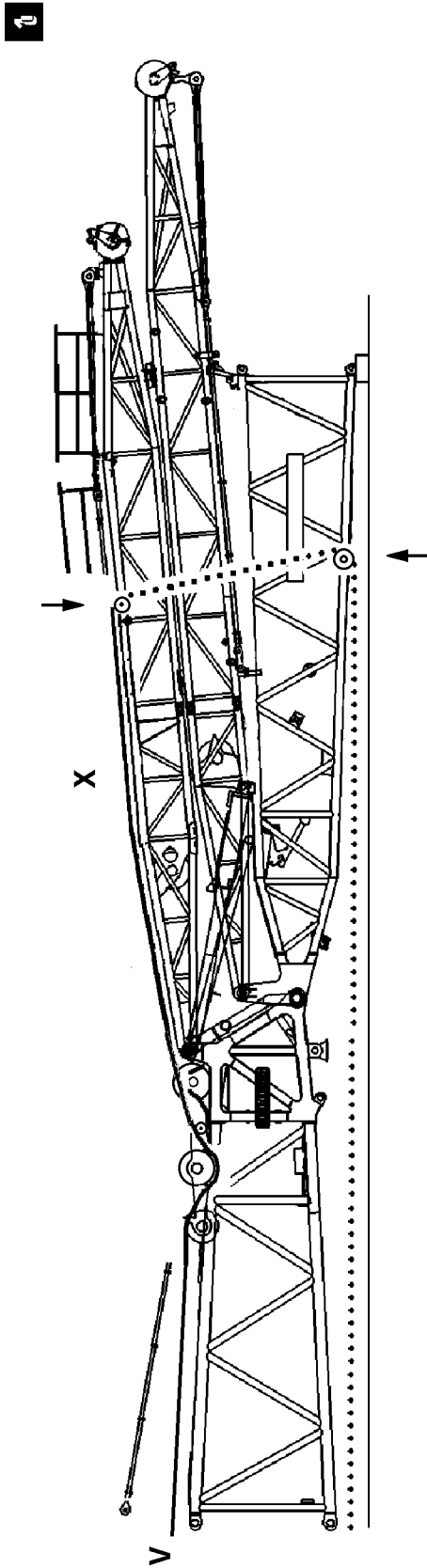
Take on the transport unit 1 (T 1) with the auxiliary crane on the tackle points on the W-pivot section (1) .
 Pin the transport unit 1 - hanging forward and downward - on the S- end section (Z).
 Pin the connector pins (6) with the hydraulic pin pulling device, place the retaining plate (7) and secure with pin retainers (8).
 Lower the transport unit with the auxiliary crane until it rests on the ground.
 Support the W - pivot section (1) from below.
 Pin on the roller set (9).

2.2 Fig. 2 Installation Transport unit 2 (T 2)

Take on the transport unit 2 (T 2) with the auxiliary crane on the tackle points on the WA- bracket I-end section (3) .
 Pin the transport unit 2 on the WA-bracket I pivot section (2) .
 Pin the connector pins (10), on top and bottom, with the hydraulic pin pulling device and secure with spring retainers (11) .

2.3 Fig. 3 Installation Transport unit 3 (T 3)

Take on the transport unit 3 (T 3) with the auxiliary crane on the tackle points on the WA- bracket II-pivot section (5) .
 Pin the WA-bracket II- pivot section (5) on the WA-bracket II end section (4) .
 Pin the connector pins (12), on top and bottom, with the hydraulic pin pulling device and secure with spring retainers (13).
 Pull up the WA-bracket I and II and pin the WA-bracket II- pivot section (5) on the S- end section .
 Pin the connector pins (15), on top and bottom, with the hydraulic pin pulling device and secure with spring retainers (16).
 Disengage the rigging belts (14) .



3. Reeve the W - control cables between the WA-bracket I and II

..... Auxiliary cable
 ----- Control cable

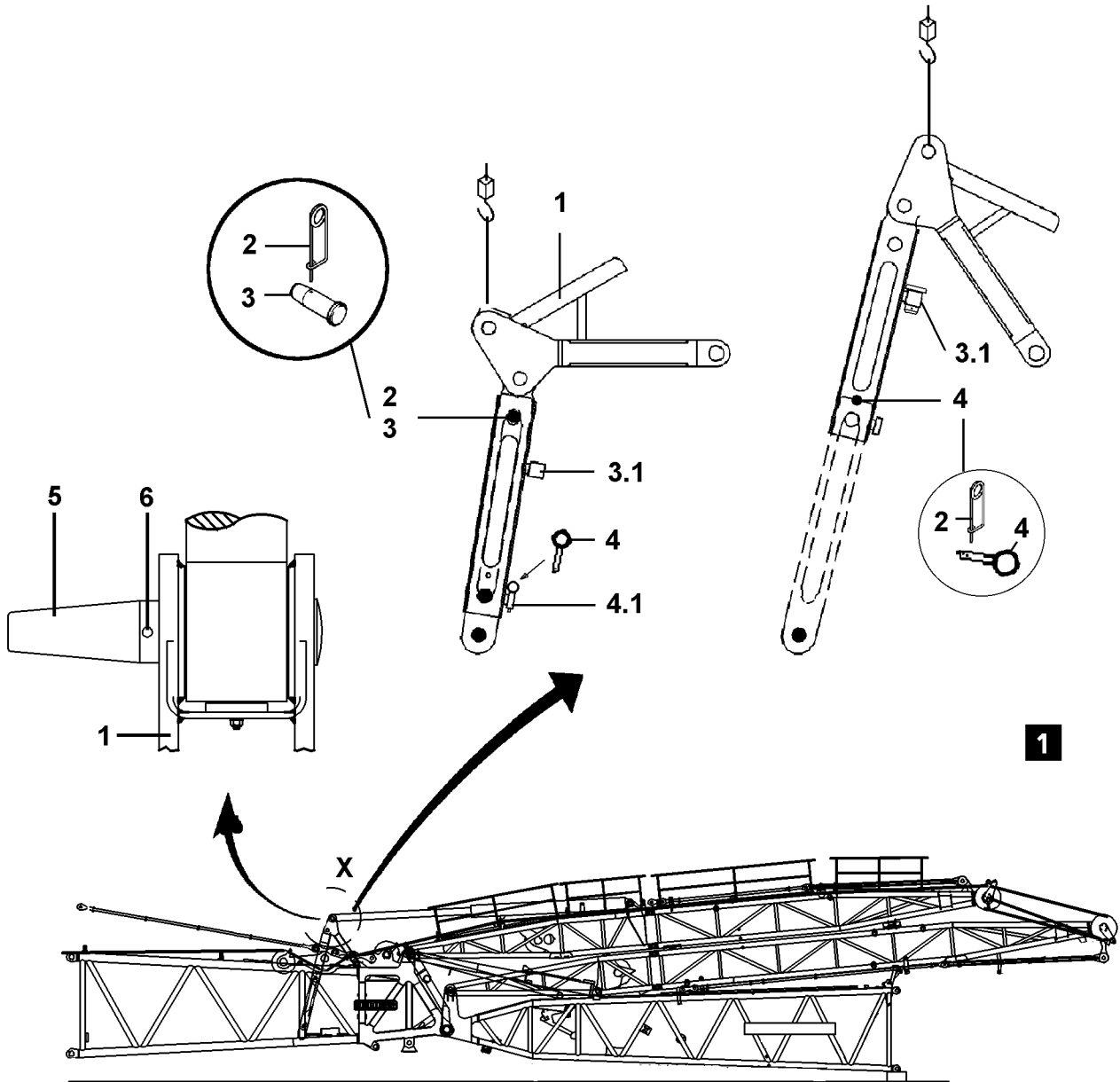
Fig. 1 Auxiliary cable routing when getting the control cable

Pull the auxiliary cable (Z) of the auxiliary winch over the change over pulley to the slewing platform. Connect the auxiliary cable (Z) with the W - control cable (X) from winch V. Spool up the auxiliary winch and at the same time, spool out winch V and pull the W - control cable (X) to the WA- bracket II - for cable routing, see **Fig.1**.

Fig. 2 Auxiliary cable routing when reeving the control cable

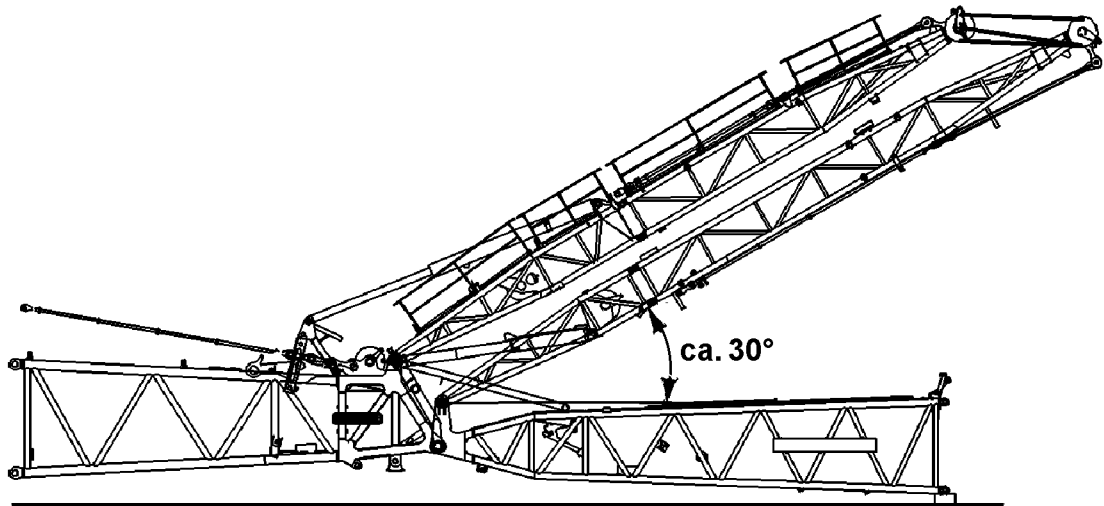
Connect the W - control cable (X) and the auxiliary cable (Z) with the already reeved reeving cable (W), between WA-I and II, - for cable routing, see **Fig.2**. Spool up the auxiliary winch and at the same time, spool out winch V and pull the W - control cable (X) between the WA- bracket I and II - **for reeving, see chapter 4.06**.

CAUTION: When spooling the cable out, make sure that no slack cable forms. This could damage the cable!



1

2



4. Pull the erection support (1) into installation position - Fig. 1

- 1 Erection support
- 2 Spring retainer
- 3 Locking pin for retracted erection support
- 3.1 Parking position for locking pin (3)
- 4 Securing pin for extended erection support
- 4.1 Parking position for locking pin (4)

Loosen the spring retainer (2) and unpin the locking pin (3) on the erection support (1).
Insert locking pins (3) in park position (3.1).

C A U T I O N: Before pulling the erection support (1) up, locking pin (3) must be unpinned!

Pull up the erection support with the auxiliary crane and secure with the Securing pin (4) in the pulled out position. Insert spring retainer (2).

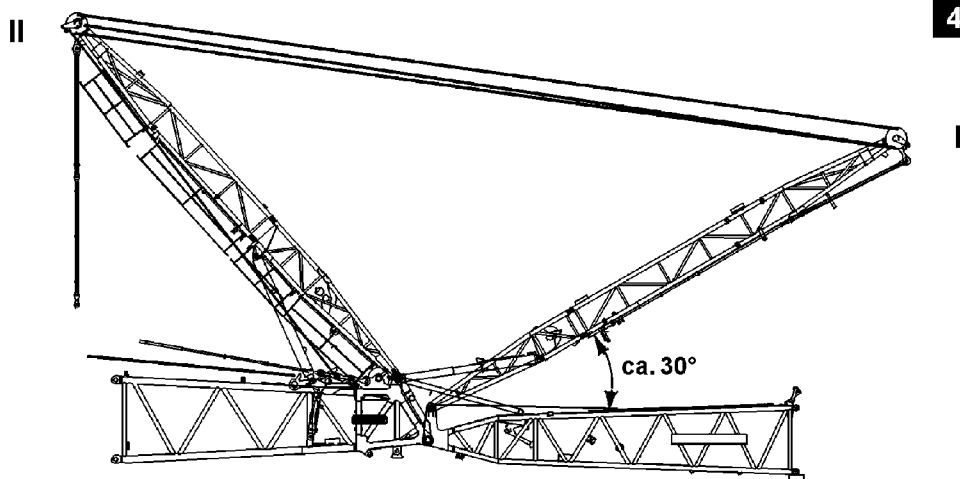
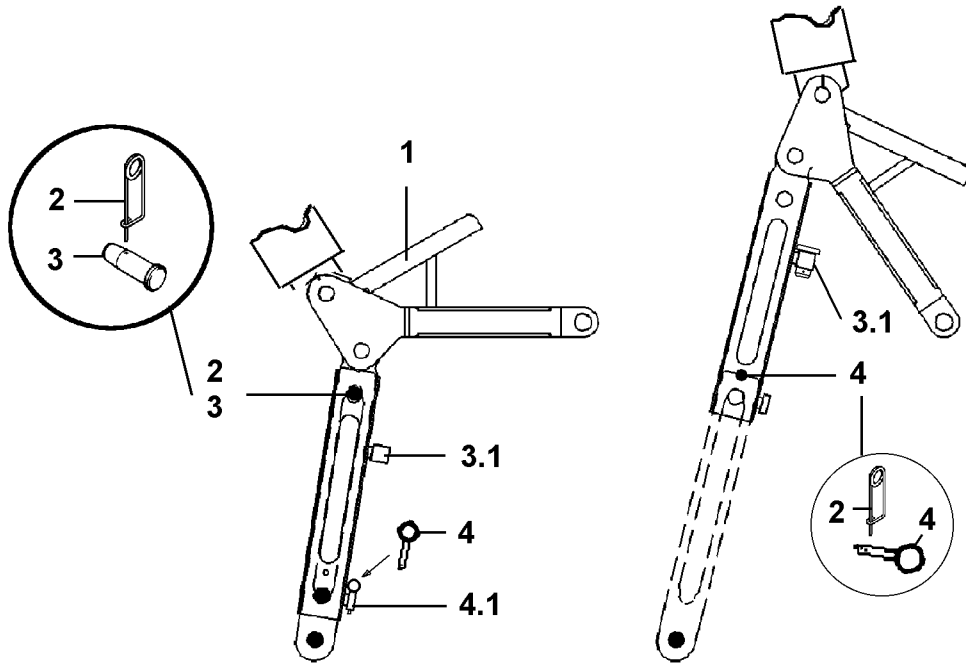
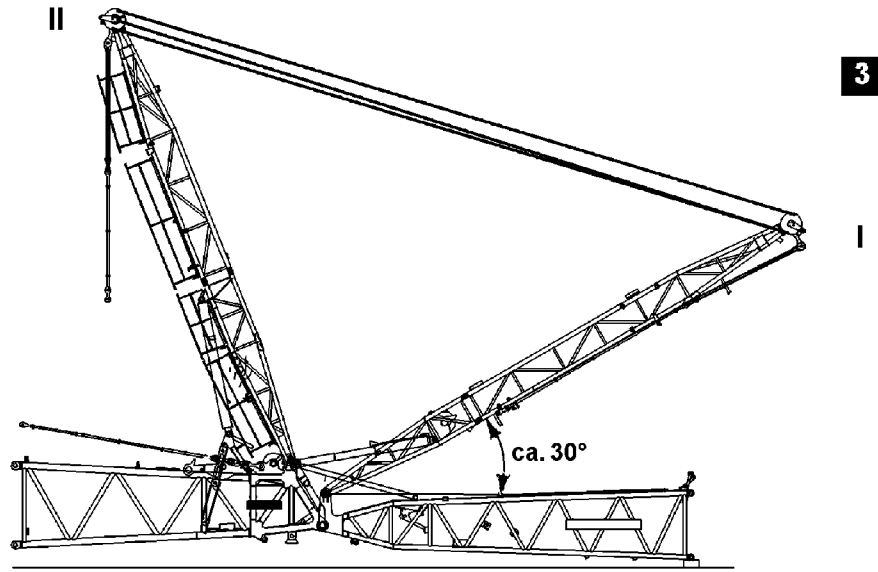
Connect the hydraulic lines between the hydraulic pin pulling device and the WA-bracket II - erection cylinder on the WA-bracket II.

Extend the cylinder until the piston rod can be pinned on the erection support (1). Pin the pin (5) and secure with spring retainer (6).

C A U T I O N: After the pinning, the pin (4), which secures the erection support in pulled out position, must be removed again and inserted in the park position (4.1) on the support.

4.1 Erect the WA-bracket II with the aid of the cylinder

Run the cylinder in and slowly raise WA-bracket I and II, up to appr. 30° to horizontal.



5. Erect the WA-bracket II**Fig. 3**

If the WA-bracket erection cylinders are run in all the way, the hydraulic line to a cylinder must be shut off by closing the corresponding ball cock.

C A U T I O N : **The retaining pin (4) must be unpinned.**

Then the cylinder which not yet shut off will be extended until the erection support (1) can be pinned in run in position. Pin the locking pins (3) and secure with spring retainers (2) .
Pin the erection support (1) and then lock the cylinder again with the ball cock.

Open the ball cock of the second cylinder.

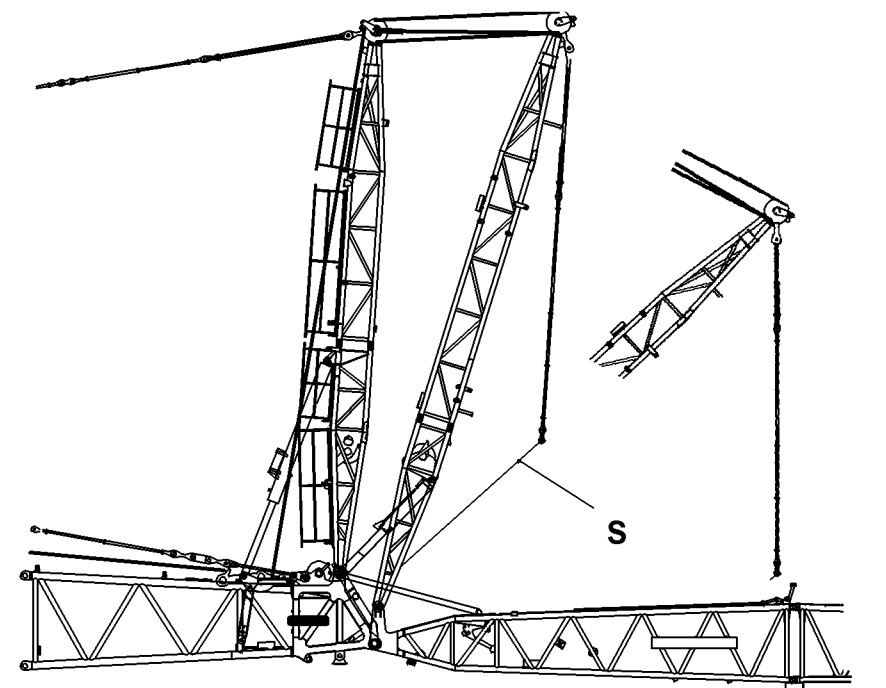
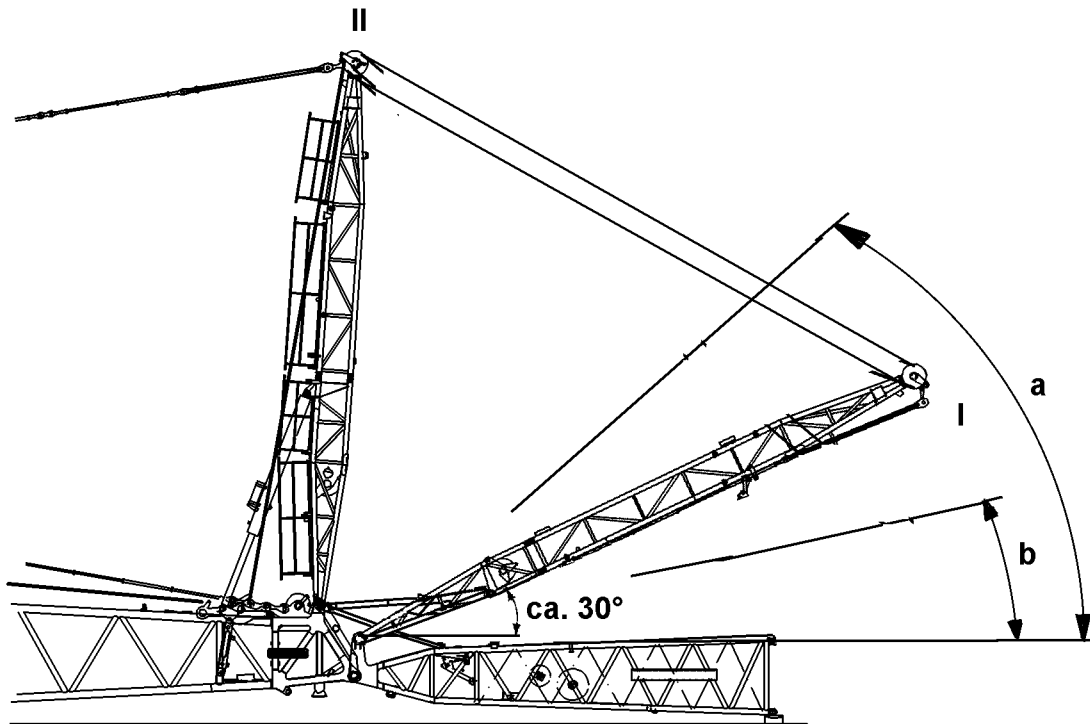
Extend the cylinder and pin the erection support (1) in the run in position. Pin the locking pins (3) and secure with spring retainers (2) .

Fig. 4

Release both cylinders again - open the ball cock - and , while spooling out the W-control winch at the same time, pull the WA- bracket II with the cylinders to the point to the rear until the WA-bracket guy rods can be pinned with the guy rods laying on the S- boom.

Note: For location of guy rods see chapter 5.03.

C A U T I O N : **During crane operation, lockingpin (3) - on erection support, must be unpinned!**



5.1 Erect the WA-bracket I

Extend the WA-bracketII erection cylinder and spool up the W - control at the same time, so that the WA-bracket I remains close over the W- pivot section. This must be done until no further angle change occurs on the WA- bracket II, which means the WA-bracket II guy II are tensioned .

Depending on the S-boom length, the WA-bracket I must be pulled up until the following angle position is reached:

S35 to S63: a = approx.10°

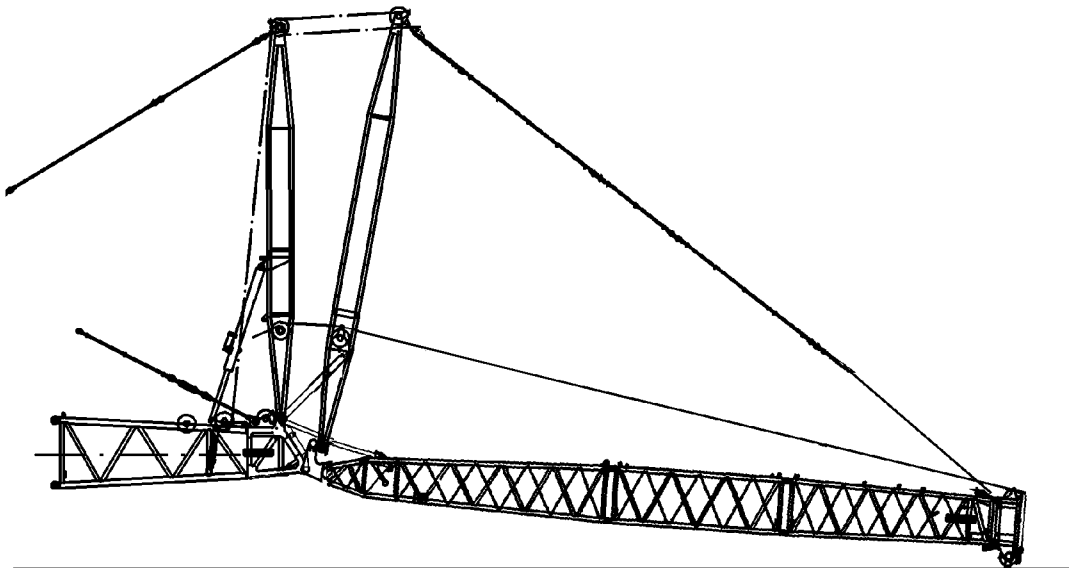
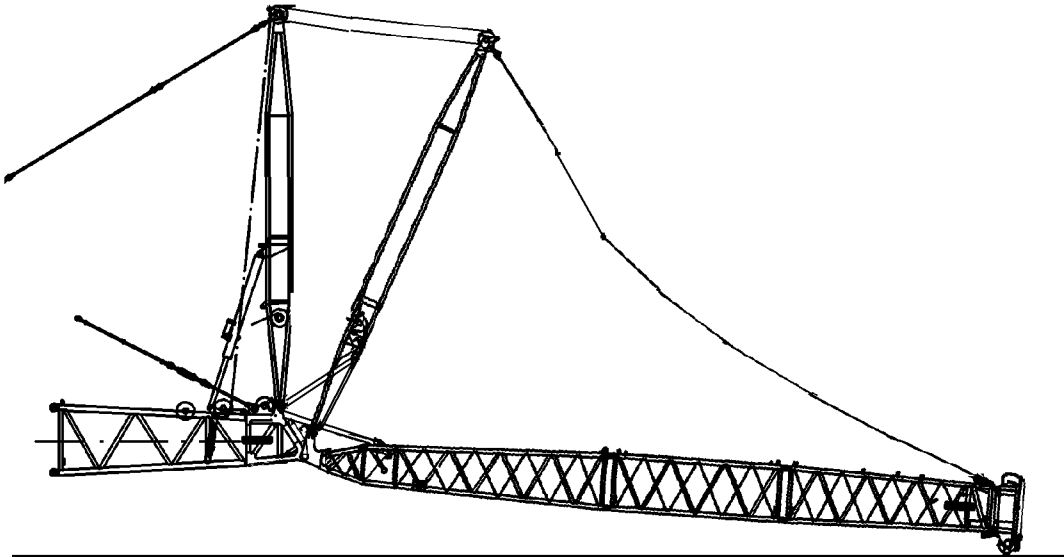
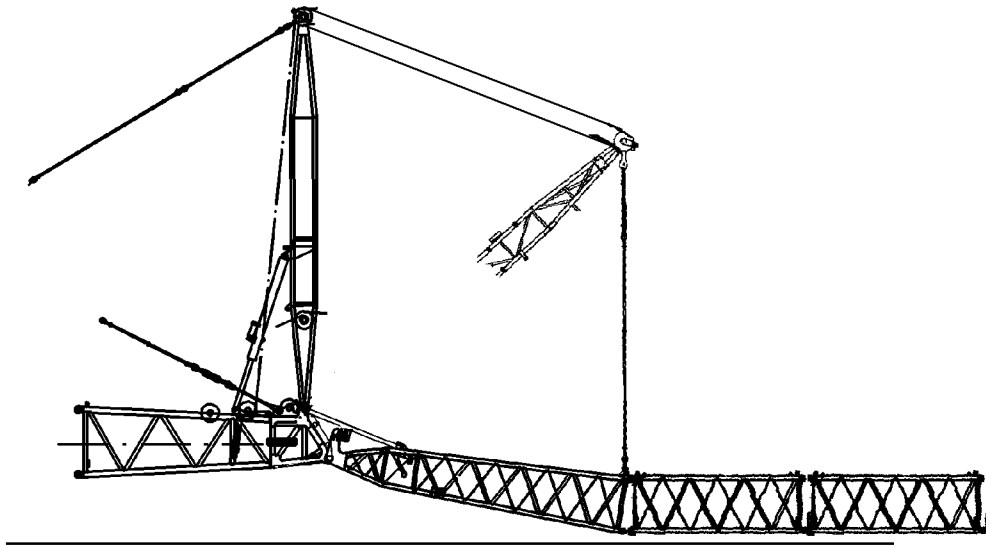
S70 to S91: b = approx.45°

After this position of the WA-bracket I is reached, extend the WA-bracket II erection cylinder all the way (Pressure 30 bar).

Release the hydraulic connection between the pin pulling device and the WA-bracket II erection cylinder.

Erect the WA-bracket I until the cable (S) can be disengaged.

Lower the WA- bracket I with W- controls until the guy rods hang from the WA-bracket I over the brackets on the W- pivit section.



6. Install the W- lattice jib

Assemble the lattice jib to the required length, pin and secure.

D A N G E R: **The pins on the lattice sections must be secured with spring retainers. When removing or installing the lattice sections, they must be supported from below with suitable, stable materials. No one may remain under the lattice jib during the pinning and unpinning procedure of the lattice sections . This is strictly prohibited!**

Pull the hoist cable to the W-end section and attach it there.
Install the set up cart on the W- end section .

Note: Set up cart tire pressure = **9 bar**.

6.1 Install the guy rods from the WA-bracket I to the W- end section

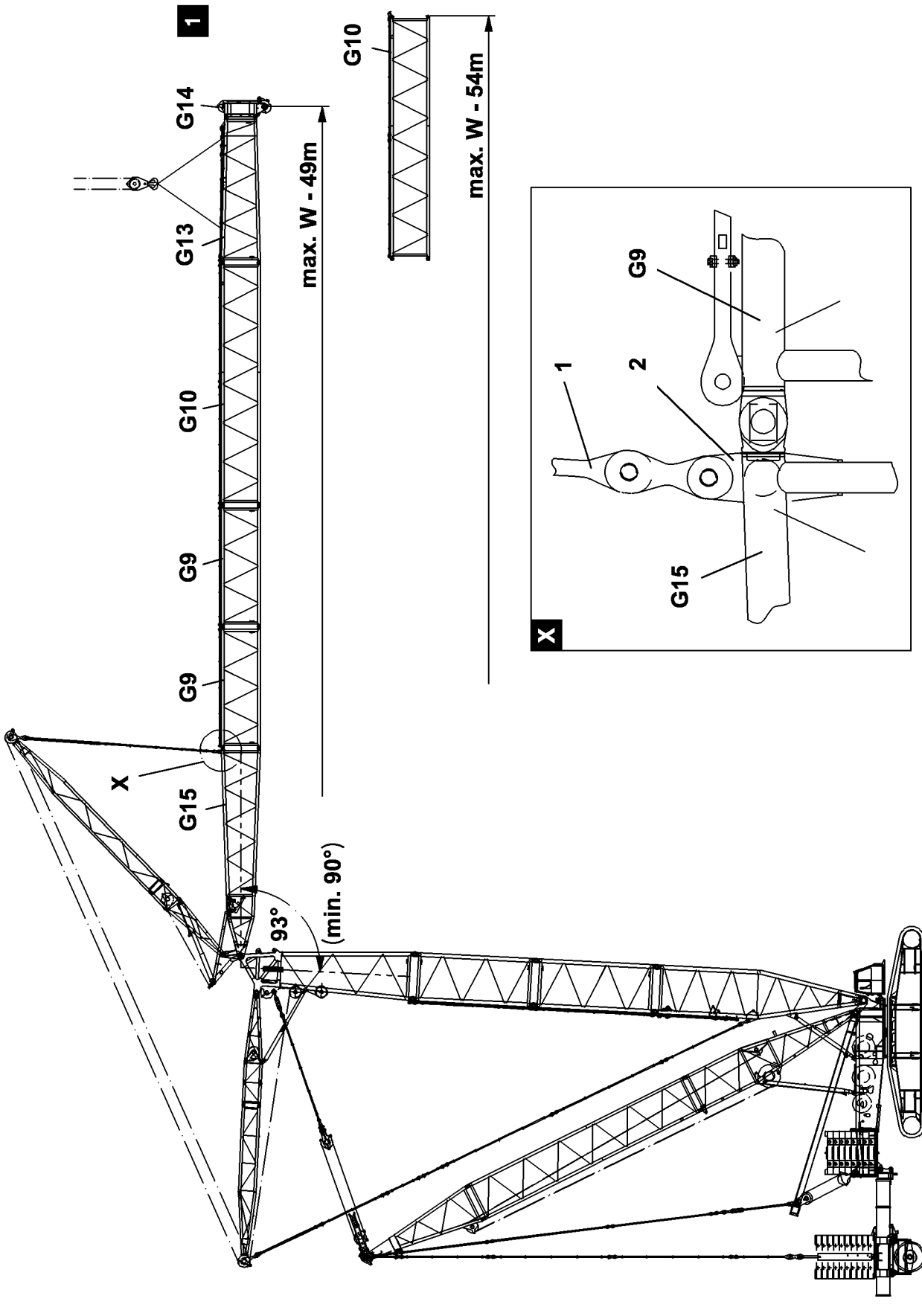
Assemble the guy rods according to the lattice jib lengths, pin and secure.

Note: The guy rods are placed and attached on the intermediate sections for transport . For installation, the transport retainers must be released.

Pin and secure the guy rods from the end section with the guy rods from the WA-bracket I .

Note: The guy rods must be installed and secured according to the installation drawing in chapter 5.03. The numbers on the installation drawing must be compared to the numbers on the guy rods.

D A N G E R: **All guy rod pins must be secured. The guy rods must be inspected regularly, see chapter "Inspection and maintenance of the guy rods".**



193118

6.2 Flying installation of W - lattice jib on the W - pivot section

Installation

If the space requirements on the job site are limited for the installation of the W - lattice jib or is restricted due to nearby buildings, etc. then it is possible to install the W - lattice jib to the following **max. length** in flying mode:

Fig. 1	- max. W - 49 m	- with end section, without hook block
		- with WA - bracket I guy rods
	- max. W - 54 m	- without end section, without hook block
		- with WA - bracket I guy rods

D A N G E R: Install the slewing platform ballast , the central ballast and the derrickballast according to the data in the load charts.
Otherwise there is a danger of accidents!

For flying installation , the W - pivot section must be at an angle of at least 90° to the main boom, otherwise the flying installation is not permitted.

D A N G E R: For flying installation of the W-lattice jib, the W- pivot section must be at an angle of at least 90° to the main boom.
If this is not observed, there is a danger of accidents!

- Lower the WA - bracket I with the W - control and pin and secure the guy rods (1) from the WA - bracket I on the brackets (2) of the pivot section (G15) (fig. X)
- Swing the additional W - intermediate sections and the end section, individually or completely assembled with the auxiliary crane to the W - pivot section . Install the intermediate sections , pin and secure.

D A N G E R: It is strictly prohibited for anyone to remain under the lattice sections during the pinning or unpinning procedure.
There is a danger of accidents!

- The guy rods of the lattice sections must be pinned together, and then secured.

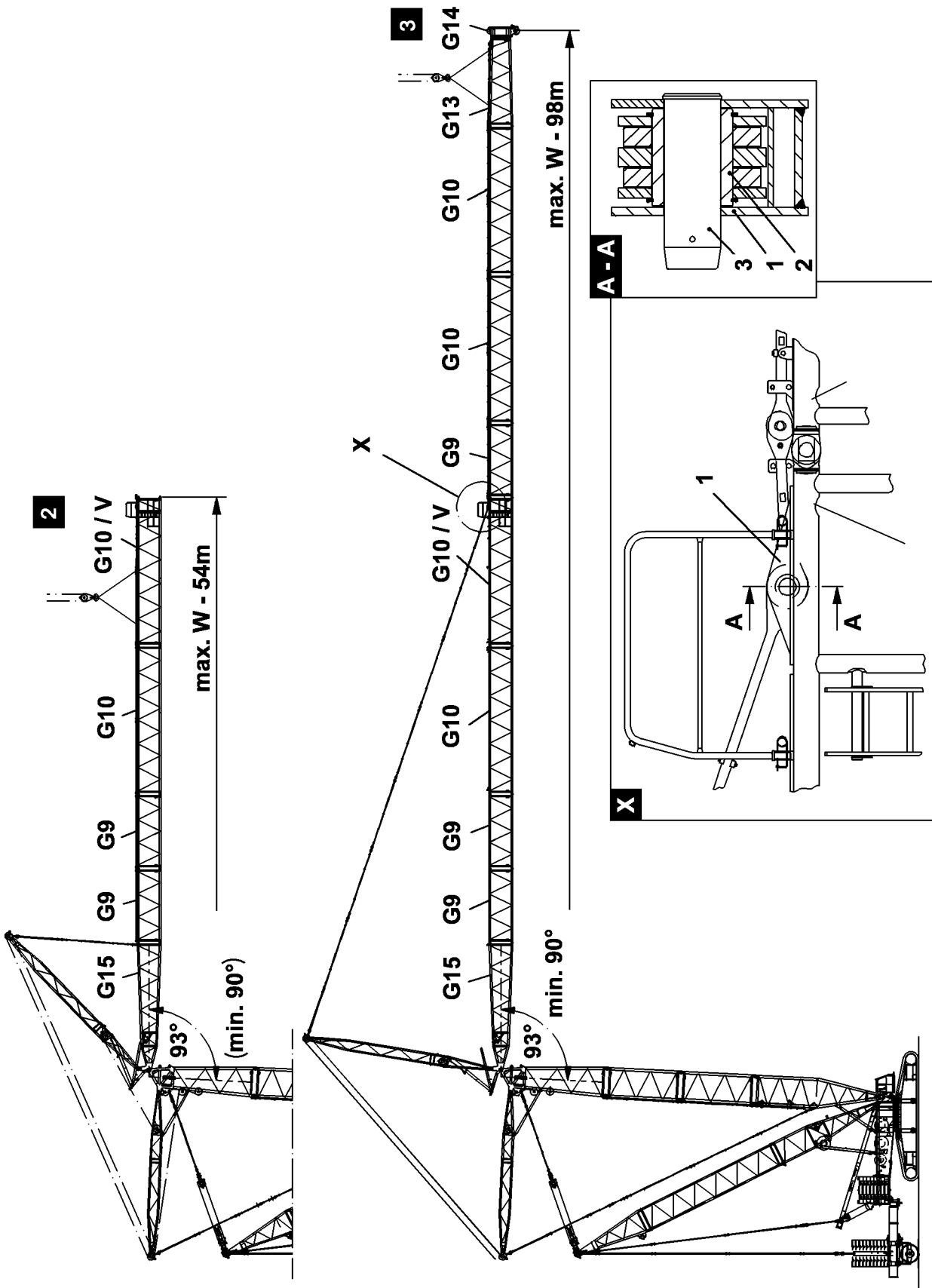
C A U T I O N: For W - lattice jib sections to a length of 49 m, the corresponding additional guy rods must be installed. See chapter 5.03.

Note: For the weight of the lattice sections with placed guy rods , see chapter 5.03

D A N G E R: For flying W - lattice jib installation, observe the following:

- the max. permissible W - lattice jib lengths
- the data in the load charts

If this is not observed, there is a danger of accidents!



6.3 Flying installation of the W - lattice jib on the intermediate section G10 / V

Montage

If the space requirements on the job site are limited for the installation of the W - lattice jib or is restricted due to nearby buildings, etc. then it is possible to install the W - lattice jib to the following **max. length** in flying mode:

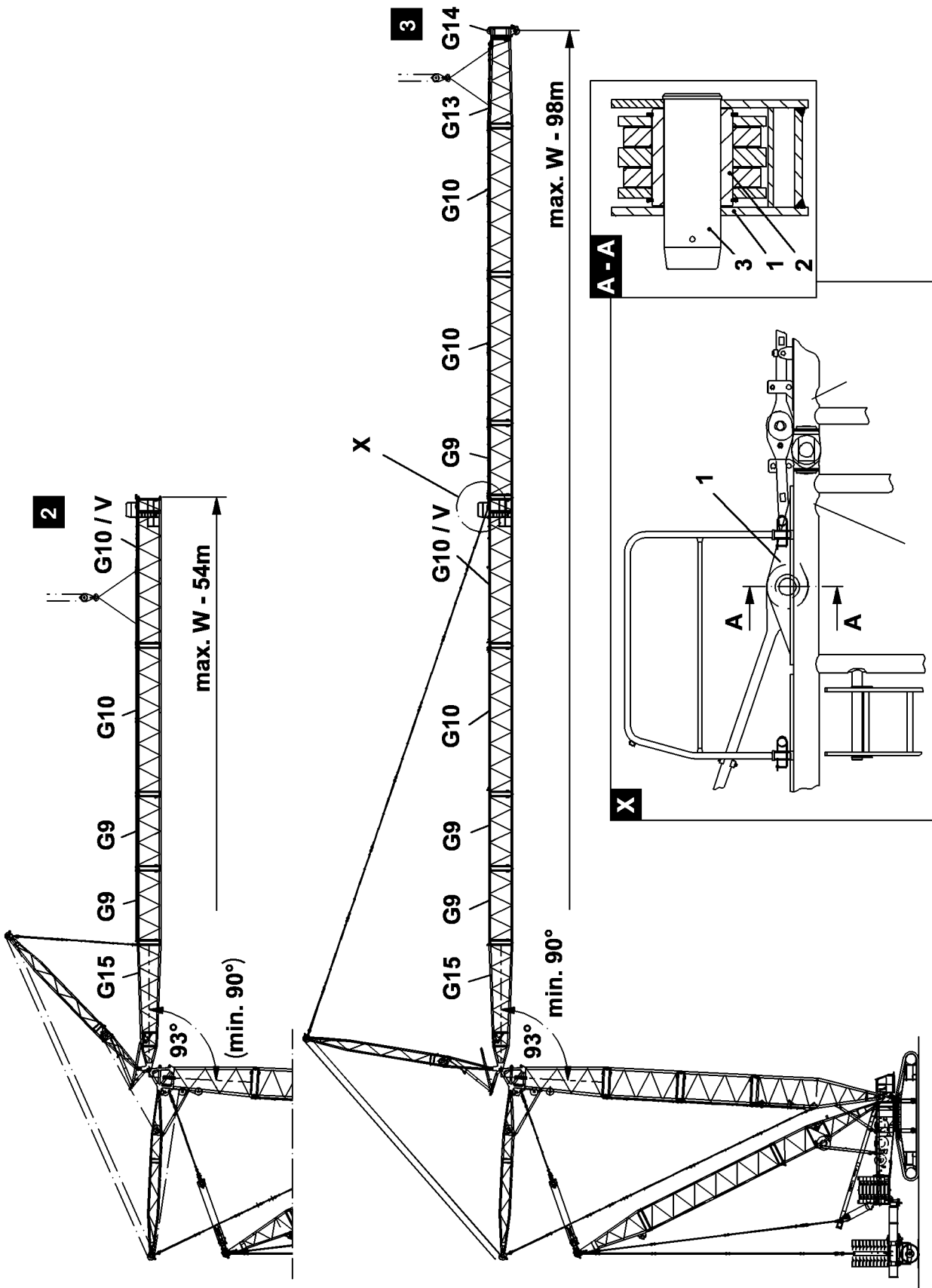
Fig. 2	- max. 54 m	- without end section, without hook block
		- with WA - bracket I guy rods
	- max. 98 m	- with end section, without hook block
		- with WA - bracket I and LI - guy rods

D A N G E R: Install the slewing platform ballast , the central ballast and the derrickballast according to the data in the load charts.
Otherwise there is a danger of accidents!

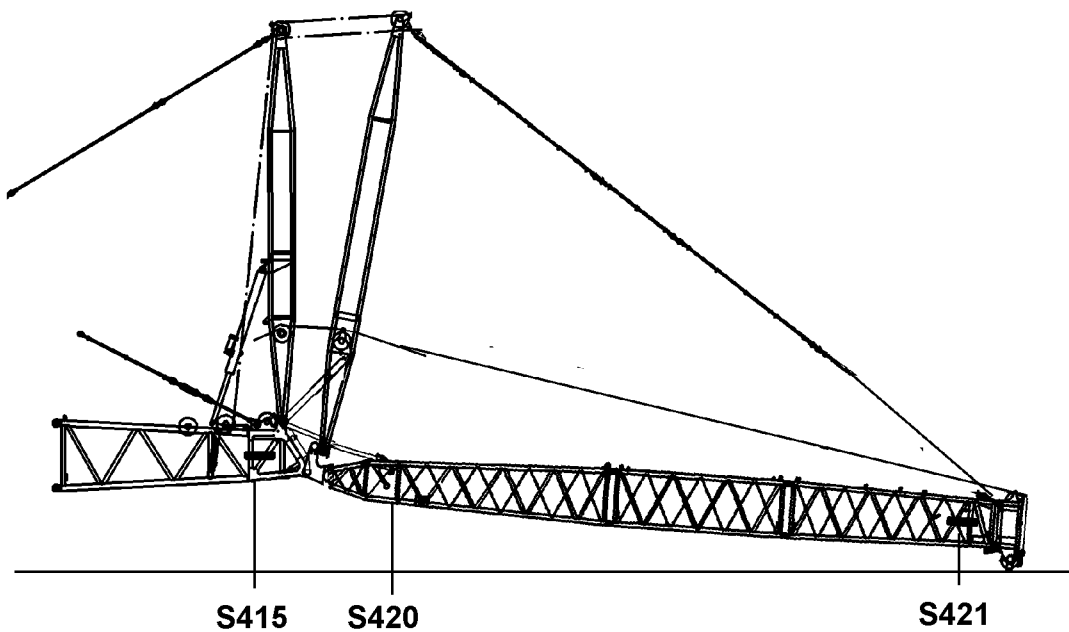
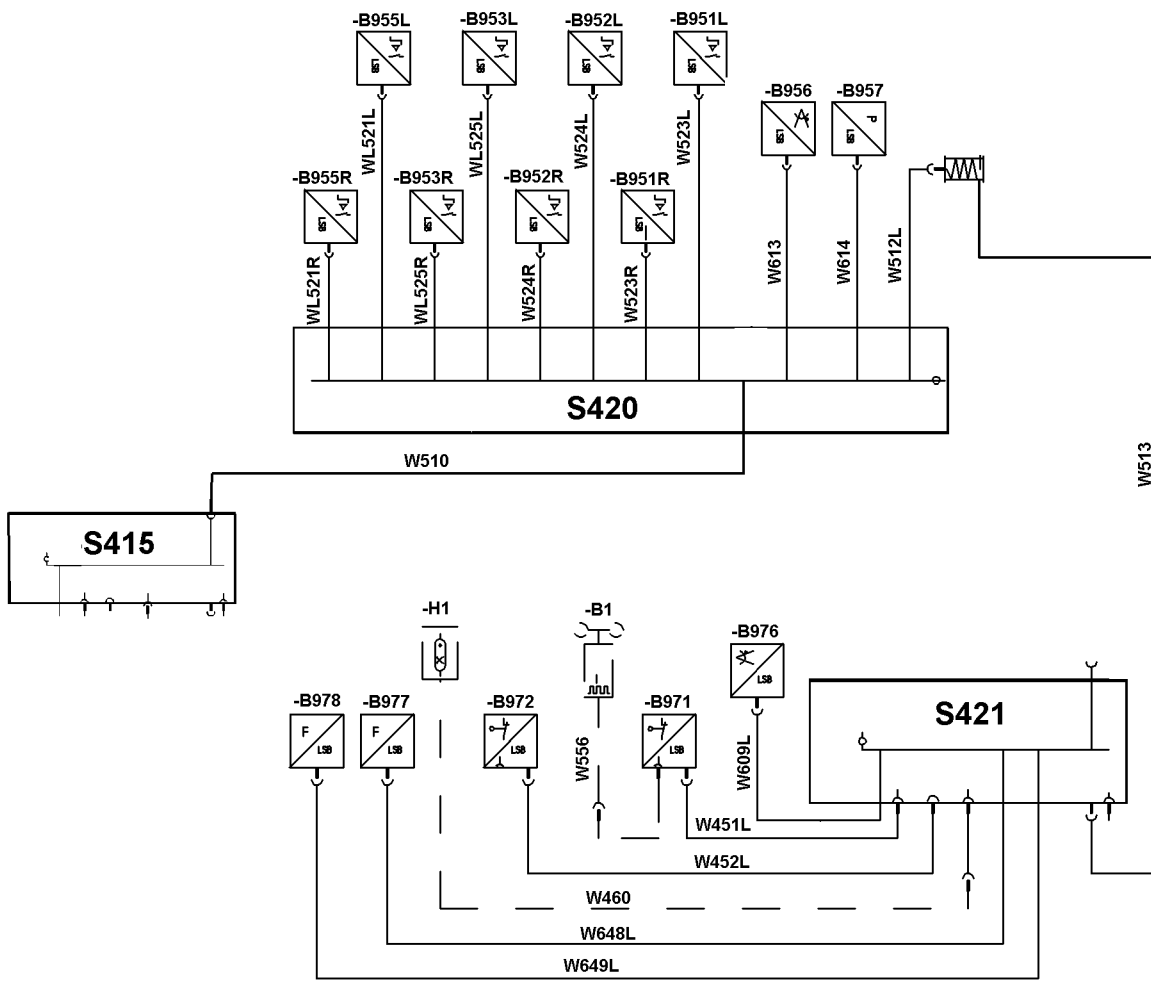
For flying installation , the W - pivot section must be at an angle of at least 90° to the main boom, otherwise the flying installation is not permitted.

D A N G E R: For flying installation of the W-lattice jib, the W- pivot section must be at an angle of at least 90° to the main boom.
If this is not observed, there is a danger of accidents!

- Lower the WA - bracket I with the W - control and pin and secure the guy rods (1) from the WA - bracket I on brackets (2) of the pivot section (G15) (fig. X, see 6.2).
- Swing the remaining W - intermediate sections to a max. length of 54 m, individually or fully assembled with the auxiliary crane to the W - pivot section , pin and secure (fig. 2)
- Attach the preassembled W - lattice jib on the front of the **reinforced** intermediate section (G10 / V) with the auxiliary crane and lift until the guy rods are relieved on the pivot section .Release and unpin the guy rods on the pivot section .
- Pin and secure the WA - bracket I guy rods with the guy rods of the intermediate section . The guy rods are connected on the bracket (1) (fig. X // A -A) with a hollow axle (2) and must be pinned and secured on the pin point of the brackets (1) with pins (3) (fig. A - A).
- Erect the WA - bracket I with the W - control until the guy rods are "**tensioned**" and the auxiliary crane is relieved. However, the W - lattice jib must remain in horizontal position.
- After the W - lattice jib is pinned, secured and tensioned, remove the auxiliary crane.
- Install the remaining intermediate sections and the end section individually or fully assembled with the auxiliary crane on the **reinforced** intermediate section (G 10 / V), pin and secure (fig. 3)
- The guy rods of the lattice sections must be pinned together, then secured.
- Attach the W - lattice jib on the front with the auxiliary crane until the guy rods between the WA - bracket I and the **reinforced** intermediate section (G10 / V) are relieved.
- Release and unpin the pin (3) on the brackets (1) (Abb. A - A) .
- Erect the WA - bracket I with the W - control to the point where the guy rods between the WA - bracket I and the L - end section are tensioned.



- D A N G E R:** It is strictly prohibited for anyone to remain under the lattice sections during the pinning or unpinning procedure.
There is a danger of accidents!
- C A U T I O N:** For W - lattice jib length of up to 49 m, the corresponding, additional guy rods must be installed. See chapter 5.03.
- D A N G E R:** For flying W - lattice jib installation, observe the following:
- the max. permissible W - lattice jib lengths
 - the data in the load charts
- If this is not observed, there is a danger of accidents!
- Note:** For the weight of the lattice sections with placed guy rods , see chapter 5.03
- D A N G E R:** The completely installed W - lattice jib must be held with an auxiliary crane before the pin (3) may be unpinned on the brackets (1) .
If this is not observed, there is a danger of accidents!



7. Electrical connections

Establish the electrical connection from the connector box (S 415) to (S 420). Plug in the cable plug (W510) on the connector box (S415) .

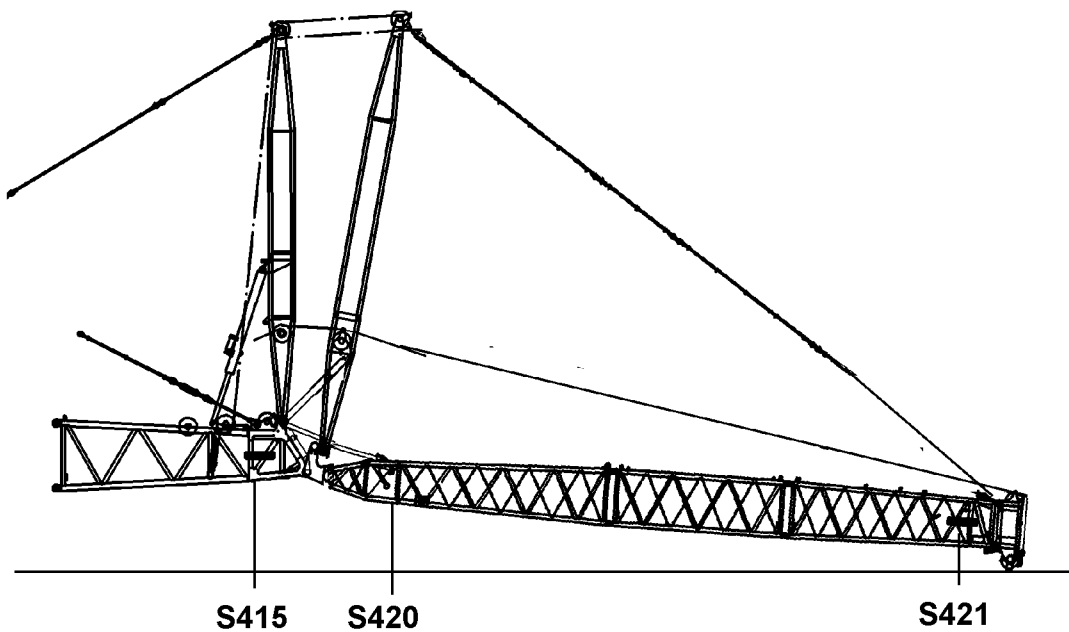
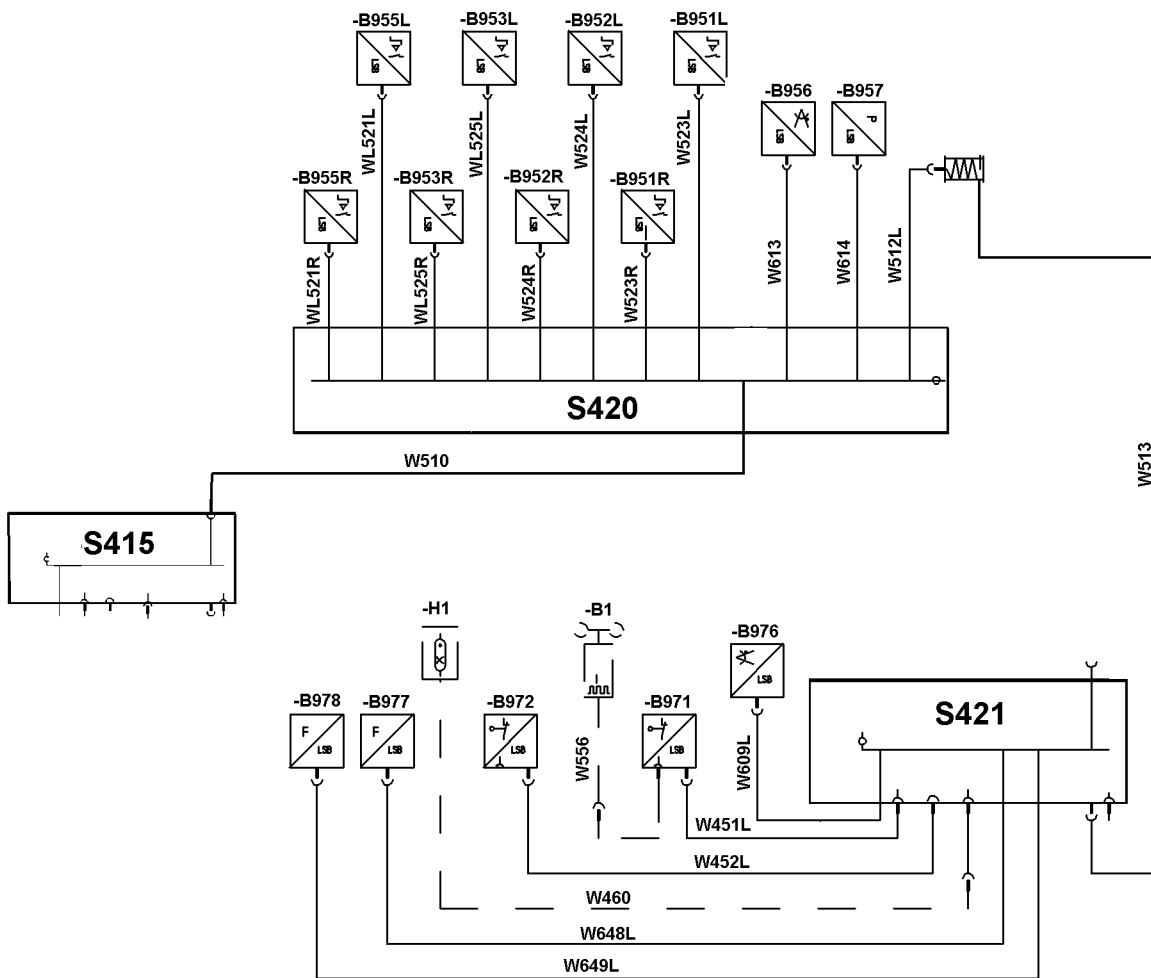
Establish the electrical connection from the cable drum in the W-pivot section, to the connector box (S421). Plug in the cable plug (W513) on the connector box (S421).

Establish the electrical connection from the connector box (S420) to the cable drum . Plug in the cable plug (WL512) into the cable drum - socket.

Note: Establish the electrical connection from the connector box (S420) to the cable drum only when the cable from the cable drum is spooled out to the connector box (S421) .

Establish the electrical connection on the connector box (-X421) :

-S971 W451L	Hoist limit switch 2A
-S972 W452L	Hoist limit switch 2B
-H1 W460	Beacon
-B977 W648L	Pull test bracket 2B right
-B978 W649L	Pull test bracket 2A left
-B976 W609L	Angle sensor, luffing jib top



7.1 Function check

Prerequisites:

- All electrical connections are established.
- The engine is running.

Airplane warning light

Turn on the airplane warning light , check function visually.

Wind speed sensor

Check the movement and function of the wind speed sensor.

Limit switch

C A U T I O N : **The limit switch functions must be checked individually before crane operation.**
The manual procedure is described below.
The function of the individual limit switch initiators must be determined in the test system - see chapter 7.10 Diagnostics, paragraph 3.

Hoist limit switch

- Actuate the hoist limit switch manually.
- The hoist winch must turn off when lifting.
- The hoist "top" symbol on the LICCON indicator must blink.

Limit switch W - lattice jib "top", relapse cylinder

- The W - control winch movement "spool up" must turn off.
- The symbol must appear on the LICCON monitor .

Limit switch W - lattice jib "low", relapse cylinder

- The W - control winch movement "spool out" must turn off.
- The symbol must appear on the LICCON monitor .

Note: The shift point of the limit switches on the relapse cylinder must be checked before erection
- see chapter 8.12, Checking the safety controls on the relapse cylinder.

Limit switch flamp in position and lattice jib , "steepest " position, mechanical relapse support

- Cover the limit switch initiators individually with a metal plate.
- The W- control winch movement "spool up" must turn off.
- The symbol must appear on the LICCON monitor .

C A U T I O N : **Before erection, the easy movement of the pendulum of the mechanical relapse retainer must be checked over the complete swing range of the pendulum. If this is not observed, the mechanical relapse support will not engage in steepest lattice jib position.**
There is a danger of accidents, as the lattice jib may tip backward!

8. Erection / take down procedure

The boom combinations must be erected or taken down according to the Erection and take down charts - see separate charts.

D A N G E R : **The erection and take down procedure must be made according to the data in the erection and take down chart.**
 If this is not observed, the crane can be overloaded or topple over.

Prerequisites:

- The crane is horizontally aligned.
- The counterweight is installed on the slewing platform according to the load chart .
- The derrick ballast is placed according to the erection and take down charts.
- The lattice jib is installed according to the load chart and the operating manual .
- All limit switches are installed correctly and fully functioning.
- Before erection, the pendulum of the mechanical relapse retainer must be checked for easy movement over its complete swing range.
- All pin connections are secured.
- The hoist cable is placed correctly into the cable pulleys and secured with cable retaining pins to prevent them from jumping out.
- There are no persons within the danger zone.
- There are no loose parts on the boom and the lattice jib.
- In the cold season: Is the boom and the lattice jib and their components (limit switch, cable drum, airplane warning light, wind speed sensor, etc.) free of snow and ice.

D A N G E R : **Incorrectly installed and non-functioning limit switches as well as falling parts (pins, spring retainers, ice, etc.) can cause accidents!**
 Before erection, the pendulum of the mechanical relapse retainer must be checked for easy movement over its complete swing range. If this is not observed, the mechanical relapse support does not engage in steep lattice jib position.
 There is a danger of accidents, the lattice jib may tip backward!

		m > < t		CODE >XXXX< BXXX YYZZ.1(2)			
		35,0	35,0	35,0	35,0	35,0	35,0
12,0							
14,0	380,0	380,0	380,0	380,0			
16,0	372,0	372,0	372,0	372,0			
18,0	363,0	363,0	363,0	363,0			
20,0	350,0	350,0	349,0	349,0			
22,0	336,0	337,0	337,0	337,0			
24,0	305,0	313,0	312,0	312,0	307,0	319,0	328,0
26,0	278,0	283,0	283,0	283,0	284,0	301,0	310,0
* n *	* 29 *	* 29 *	* 29 *	* 29 *	* 23 *	* 24 *	* 25 *
xx	87,0	87,0	87,0	87,0	77,0	77,0	77,0
yy	13,0	15,0	18,0	20,0	13,0	15,0	18,0
>>							

xx° SDBW
35m

W
28m

t

95
t

yy m

n
10 x

O.K.

LIEBHERR

7

8

9

4

5

6

1

2

3

0

.

P

K

F

C

i

<

>

O

SHIFT

F1

F2

F3

F4

F5

F6

F7

F8

ENTER

BXXX YYZZ
XXXX

max n = 10
t 156.0

0 1/min:1634 50 90 100 110 130%

t 28.3

1°
0.0
0.0

m/s
max: 12.8

m 23.8
80.0°

191.99
m

191.99
m

1 4
0 t
0 0
2 3
BCD

V: 40%
0°

m 28.0
60.0°

m 35.0
60.0°

m 62.6

LIEBHERR

7

8

9

4

5

6

1

2

3

0

.

P

K

F

C

i

<

>

O

SHIFT

F1

F2

F3

F4

F5

F6

F7

F8

ENTER

8.1 Erection procedure

Prerequisite :

- The LICCON overload safety device is set according to the data in the load chart and the equipment configuration. (see chapter 4.02, 4.03).
- Actuate the installation keyed button . The indicator light "Installation" lights up.
- The installation symbol on the LICCON indicator blinks.
- Attach the hoist cable on the end section .

C A U T I O N : **If the hoist cable is not attached, then the hoist cable might fall backward due to its own weight when the boom is erected.
DO NOT turn during the erection procedure, this is strictly prohibited.**

Adjustment on EQUIPMENT CONFIGURATION VIEW on the LICCON (see chapter 4.02)

Enter the 4-digit code number according to the required load chart and confirm with ENTER .

Enter the actual reeving.

Check the current equipment configuratoin with the entered data to make sure they match.

Press the function key -F8- "o.k." , the OPERATING VIEW will appear.

D A N G E R : **Compare the LICCON settings with the actual equipment configuration.
If this is not observed, there is a danger of overloading the crane or tipping the crane over!**

Indications in the OPERATING VIEW during the erection procedure

The following alarm functions are activated (blink) during the erection, until the operating position is reached:

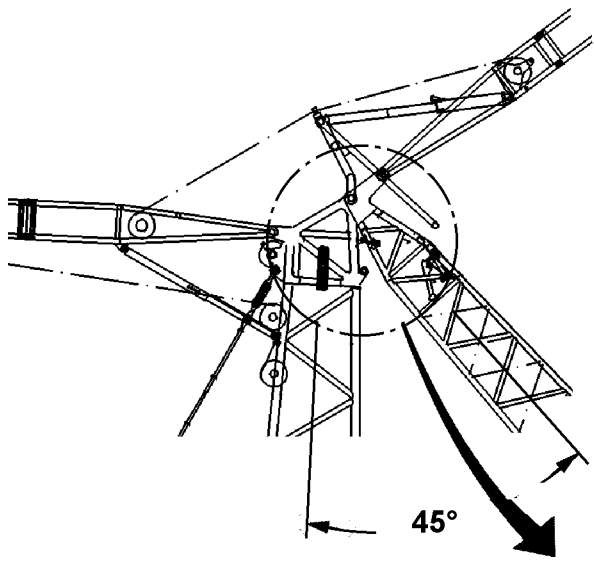
- "STOP"
- "HORN" + Acoustical signal

Note: The **lowest** operating position is reached if the indicators turn off and a load value in tons - t - appears in the symbol "MAX. LOAD" instead of the question marks ("???").

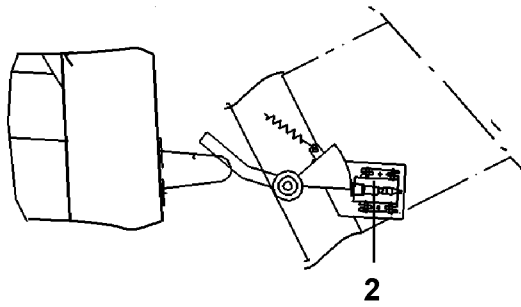
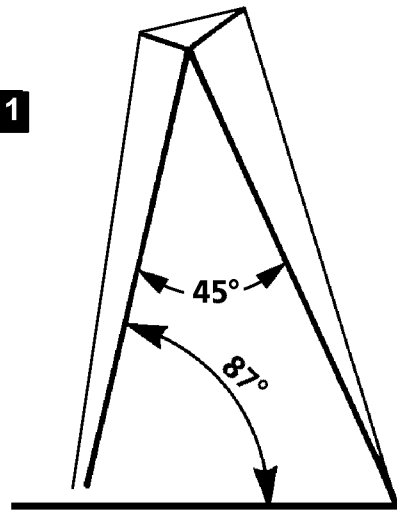
Turn off the installation keyed button by pressing the button.

The installation symbol on the LICCON indicator turns off.

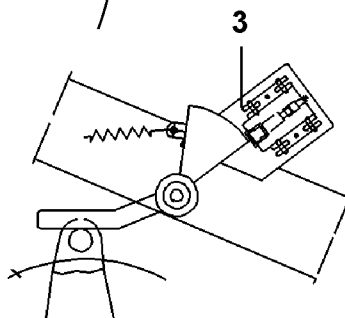
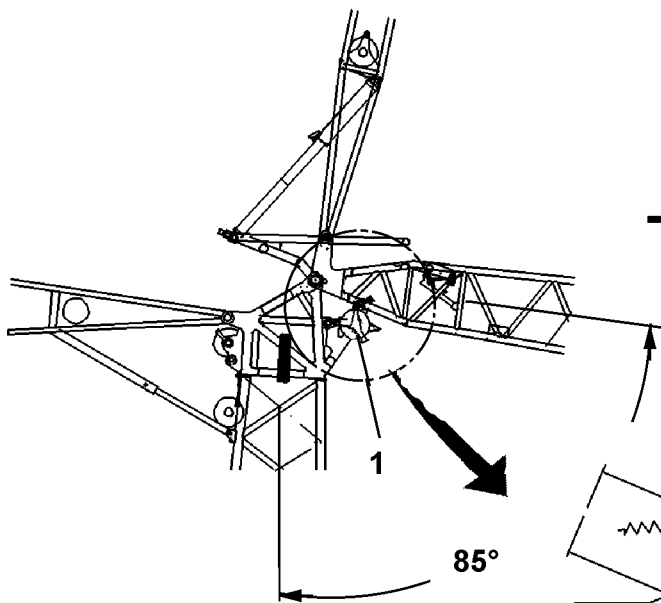
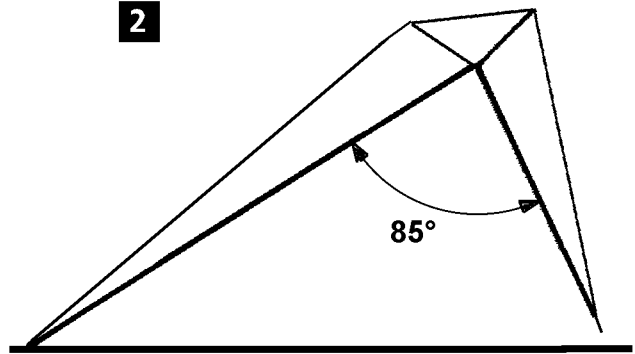
D A N G E R : **The installation keyed button must be turned off immediately after reaching the lowest operating position.
The installation keyed button bypasses the safety devices!
The radii given in the load chart may not be exceeded nor fallen below, even without a load on the hook!
If this is not observed, the crane can topple over!**



1



2



8.2 Erection

Actuate the manual control lever and luff up the boom.

At the same time, spool out the lattice jib control winch to hold the lattice jib with the W-end section supported on set up cart on the ground.

The maximum forces in the W-guying (**only SW attachment**) may not be exceeded.

Note: For maximum forces in the W-guying (**only SW attachment**) - see **Erection and take down manual!**

D A N G E R : **When erecting the SW attachment, the maximum permissible forces in the W-guying (test point 2) may not be exceeded - see Erection and take down manual!**
Lower the W-lattice jib control in such a way that the maximum forces are not exceeded.
Make sure to watch for slack cable formation on the control winch!
If this is not observed, the crane will be overloaded or can topple over!

Carry out this procedure until the boom and the lattice jib form an angle of ($\geq 45^\circ$ resp. 85°) or until the lattice jib has lifted off the ground.

Note: **Fig. 1 $\geq 45^\circ$** without pulley set (1) on S-head section, limit switch (2)
Fig. 2 $\geq 85^\circ$ with pinned pulley set (1) on S-head section, limit switch (3)

Remove the set up cart on the W - end section.

Now you can luff up the boom and lift the lattice jib off the ground.

Loosen the hoist cable on the end section and reeve in between the pulley head on the end section and the hook block and secure on the fixed point - **see reeving plans.**

Attach the hoist limit switch weight.

Luff up the boom to the steepest position of 87° .

C A U T I O N : **When erecting the boom, the hoist winch must be spooled up at the same time to prevent the hook block from colliding with the end section of the lattice jib .**

Luff up the lattice jib to operating position.

Turn off the installation keyed switch by pressing the button. The symbol on the LICCON indicator turn off.

D A N G E R : **After reaching the operating position, the installation keyed switch must be turned off immediately.**
The installation keyed switch bypasses safety devices!
The radii given in the load capacity chart may not be exceeded nor fallen below, even without a load on the hook!
If this is not observed, the crane can tip over!

9. Crane operation with SW/SDW/SDWBW - boom system

C A U T I O N : Observe the notes in
chapter 4.02" LICCON COMPUTERSYSTEM"
chapter 4.05 " CRANE OPERATION "
chapter 4.08 "WORKING WITH A LOAD "!

Prerequisites:

- The LICCON overload safety device is set according to the data in the load chart .
- The installation keyed button is turned off. The installation symbol on the LICCON indicator turns off.

D A N G E R : Check the horizontal position of the crane before and during operation.
If the crane operator leaves the crane operator's cab, even if only for a short time, then he is obligated to check all operating mode settings and to reset them, if necessary, before starting to work again

Adjustments / checks

Check the function of the overload system by running against the "top" and "bottom" operating positions.

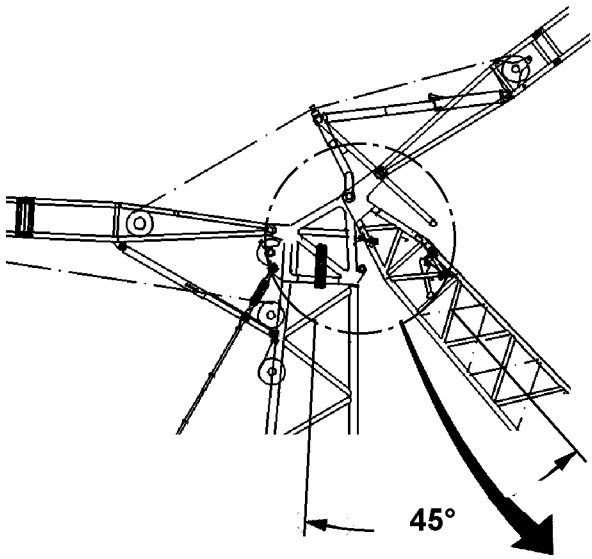
Check the function of the hoist limit switch "on top" by running against the hoist limit switch weight.

Check the function of the limit switch "Lattice jib steep" by running against the relapse retainer.

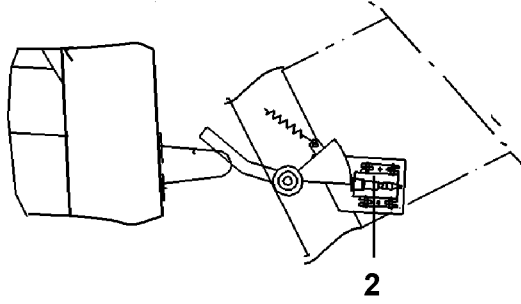
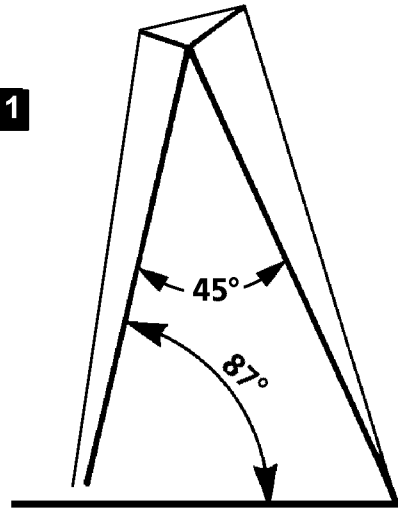
Set the boom to 67° or 77°

Before changing the boom to 67° or 77°, the boom must be erected into the steepest position of 87° and the lattice jib must also be in its steepest operating position.

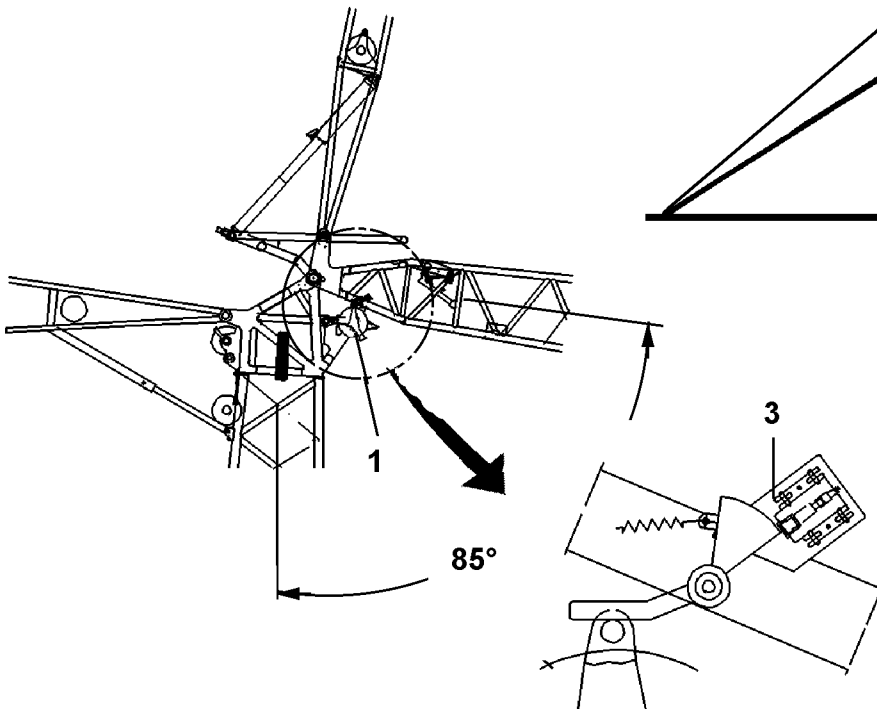
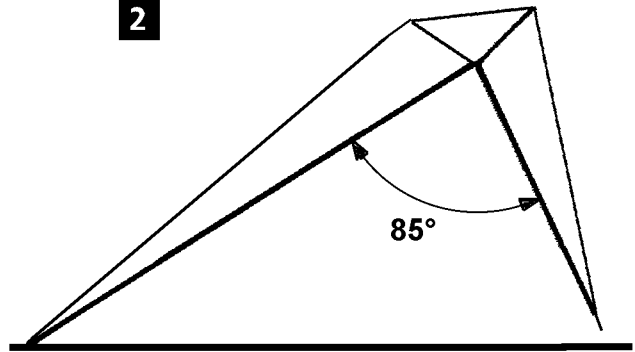
D A N G E R : When changing to 67° resp. 77° or in SDWB operation, a suspended ballast might be required already, even without a load on the hook.



1



2



10. Take down procedure

The boom remains in its steepest position, at 87°.

Actuate the manual control lever and luff down the W- lattice jib to just before the **lowest** operating position.

Note: When the **lowest** operating position is reached, the luffing down movement shuts off.

C A U T I O N: **When luffing down, spool out the hoist winch at the same time to prevent the hook block from colliding with the pulley head.**

Actuate the installation keyed switch. The installation symbol on the LICCON indicator blinks.

D A N G E R: **The safe load indicator is no longer effective.
The limit switch hoist "top" is bypassed!**

Continue to luff down the lattice jib until an angle of approx. 45° resp.85° is reached between the S-boom and the W-lattice jib. The shut off occurs via the limit switch "W-lattice jib - bottom".
The installation symbol on the LICCON indicator blinks.

C A U T I O N: **When luffing down the lattice jib, make sure that the hook block does not collide with the end section!
The hook block may not be pulled along the ground.**

Luff down the S-boom until the hook block touches the ground.
Remove the hoist limit switch weight.
Unreeve the hook block.

D A N G E R: **When unreeving the hoist cable, make sure that no persons are in the danger zone.**

Luff down the S-boom until the W-end section of the lattice jib can be installed on the set up cart.

Note: If the lattice jib touches the set up cart vertically, then the lattice jib guying must be tensioned a little so that the set up cart can roll forward with the lattice jib .

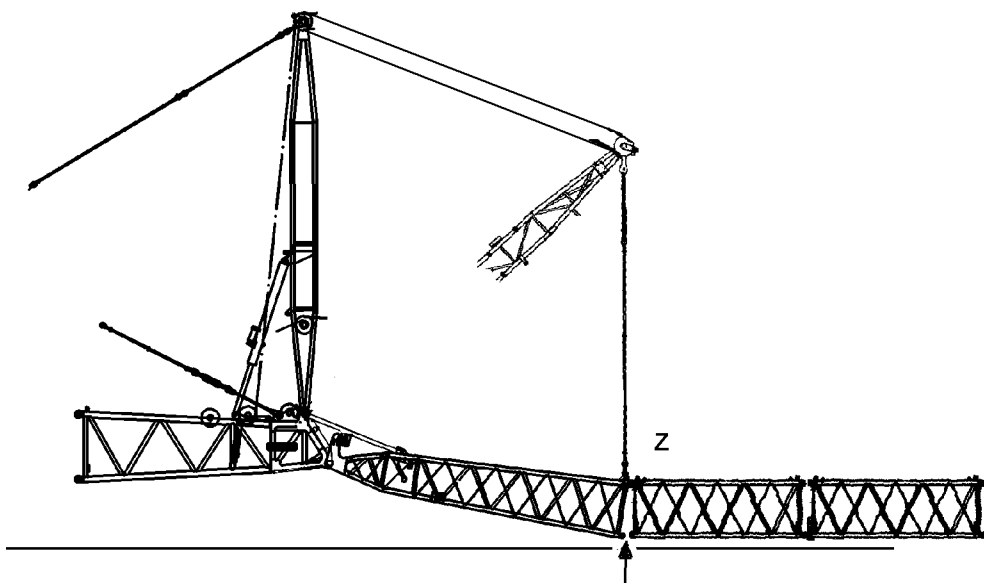
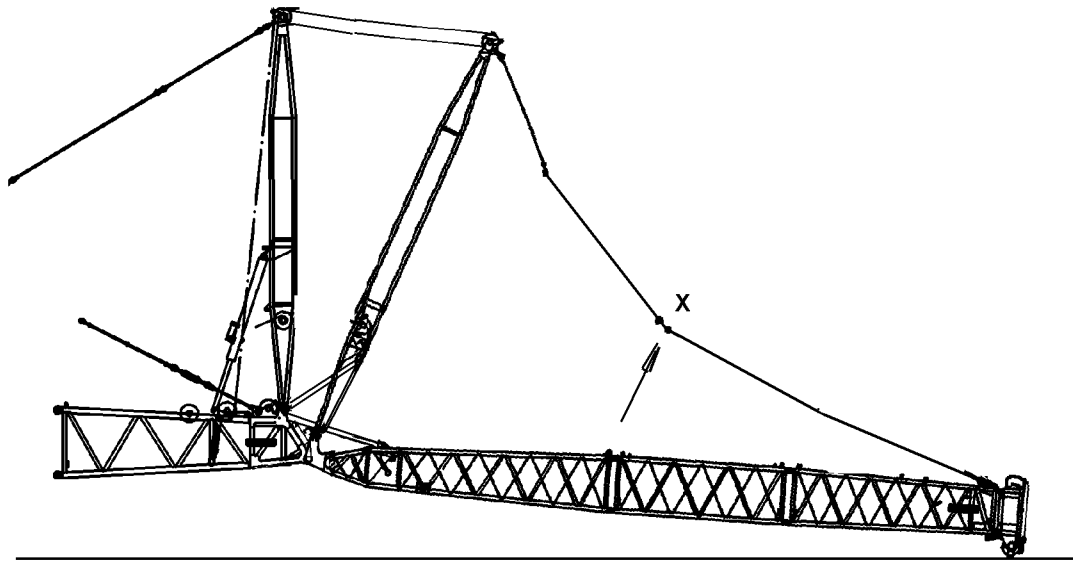
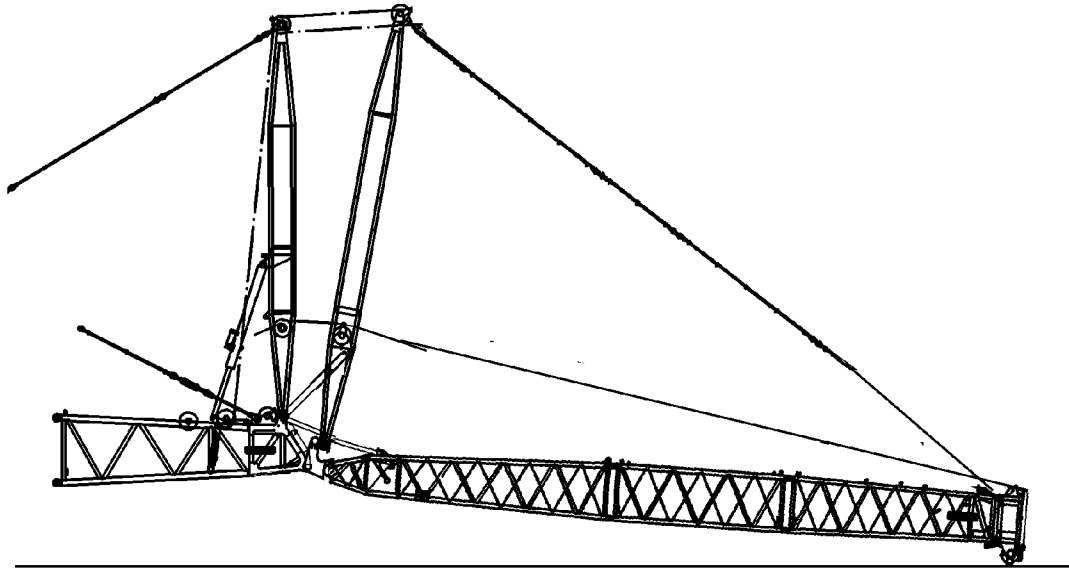
Continue to luff down the S-boom.

Note: For maximum forces in the W-guying (**only SW attachment**) - see **Erection and take down manual!**

D A N G E R: **When erecting the SW attachment, the maximum permissible forces in the W-guying (test point 2) may not be exceeded - see Erection and take down manual!
Lower the W-lattice jib control in such a way that the maximum forces are not exceeded.
Make sure to watch for slack cable formation on the control winch!
If this is not observed, the crane will be overloaded or can topple over!**

Remove the hoist cable.

D A N G E R: **When removing the hoist cable, make sure that no persons are in the danger zone!**



11. W-Remove the W-lattice jib

Spool back the hoist cable via the cable pulleys in the WA- brackets to the S- head section.

D A N G E R: **Secure the hoist cable with the auxiliary rope and lower it slowly via the cable pulleys to the rear to the S- head section .
Make sure that no persons are within the danger zone.
This could cause a serious accident!**

Spool out the W- control winch, lower the WA- bracket I to the front. Unpin the guy rods on the connector brackets.

Note: The guy rods are placed for transport on the intermediate sections and secured with transport retainers.

Disconnect the guy rods on the connector bracket (X) . Unplug the spring retainers and pins. Pin the guy rod from the WA-bracket I on the bracket (Z) on the W- pivot section with pins and secure with spring retainers.

Pull the WA- bracket I up again until the guy rods are stretched between the WA-bracket I and the W- pivot section.

D A N G E R: **The W - end section may not be raised, it must remain on the ground.
If this is not observed, severe damage can occur.**

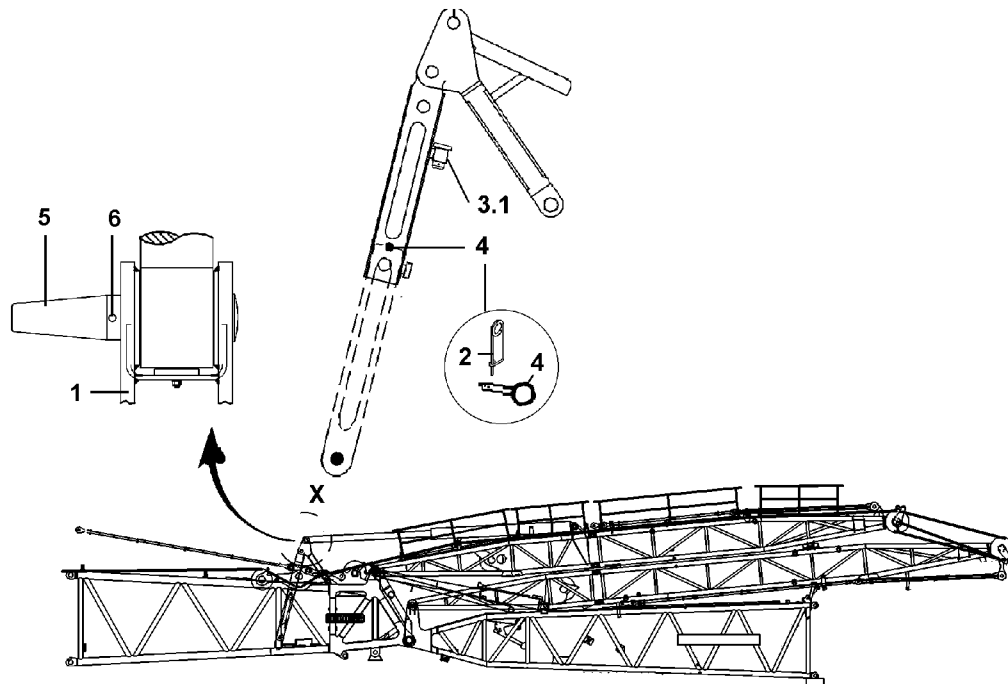
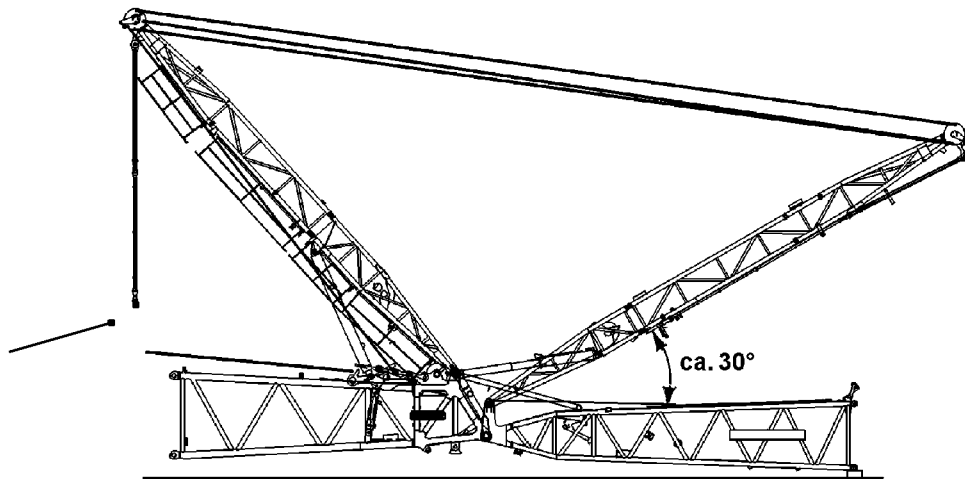
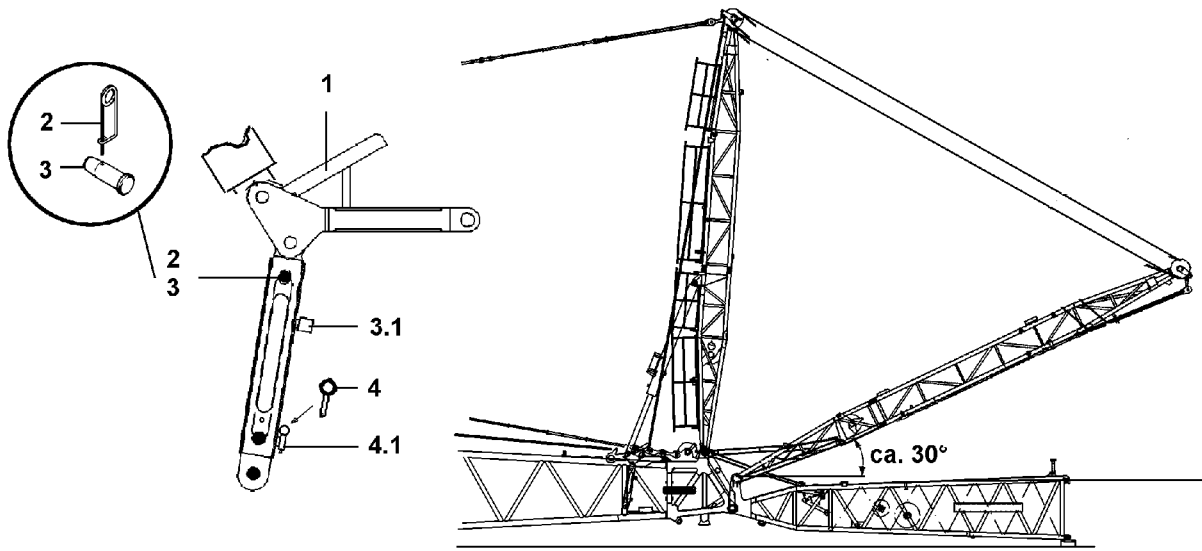
Unpin the W- pivot section "**on the bottom**". Release the pin and unpin .

Lower the W- pivot section until it rests on the ground.

Unpin the W- pivot section "**on top**". Release the pin and unpin .

Remove the lattice jib.

G E F A H R : **Before unpinning, it must be ensured that the pivot section on the bracket (Z) is pinned and held by the guy rods, or that it is supported from below with suitable, stable material.
No one may remain under the lattice jib during the pinning and unpinning procedure of the lattice sections . This is strictly prohibited!
If this is not observed, there is a danger of accidents, as the lattice jib may suddenly fold down.**



12. Take down procedure, WA-bracket I + II

Lower the WA- bracket I by lowering the W- pulley block until about 30° to the horizontal.

Set up and lock the placement bracket for the guy rods on the W- pivot section.

Establish the hydraulic connections between the hydraulic pin pulling device and the WA- bracket II - erection cylinder.

Pin the erection supports (1) in run in position. Pin the locking pins (3) and secure with spring retainer (2) .

The WA bracket Ii is pulled to the rear by running in the WA- bracket II erection cylinder. Lower the W-control to the point where the WA-bracket I remains about 30° over the W-pivot section.

Disconnect the WA- bracket II guy rods.

Note: Guy rods, see chapter 5.03.

Place the WA-bracket I on the support on the W-pivot section.

Unpin the locking pins (3) on the erection supports (1) .

Spool up the W- control until the WA bracket I is raised, i.e. the length slot on the WA- bracket II erection support is in fully extended position.

Extend the WA- bracket II erection cylinder and spool up the W-control winch at the same time so that the WA- bracket I remains about 30° over the W- pivot section.

Continue this procedure until the WA- bracket II is close to the WA bracket I, but does not touch.

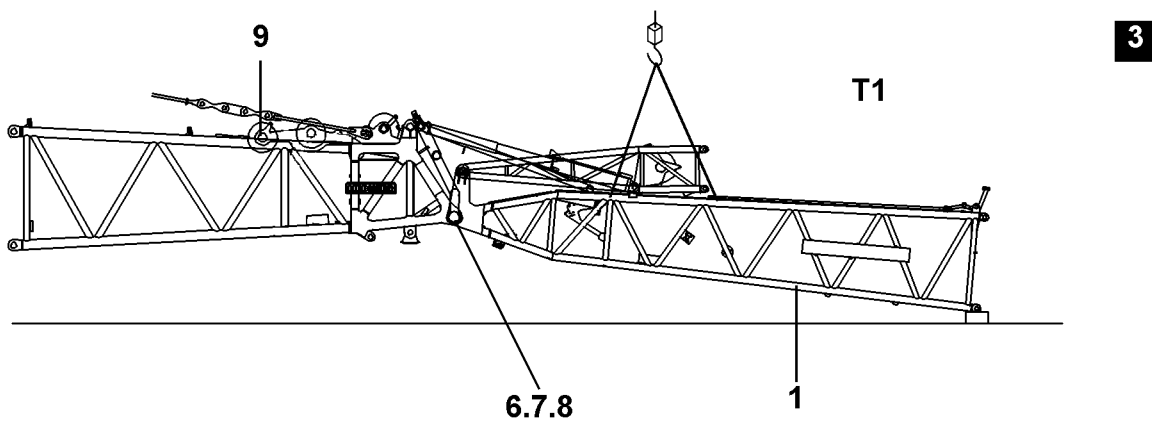
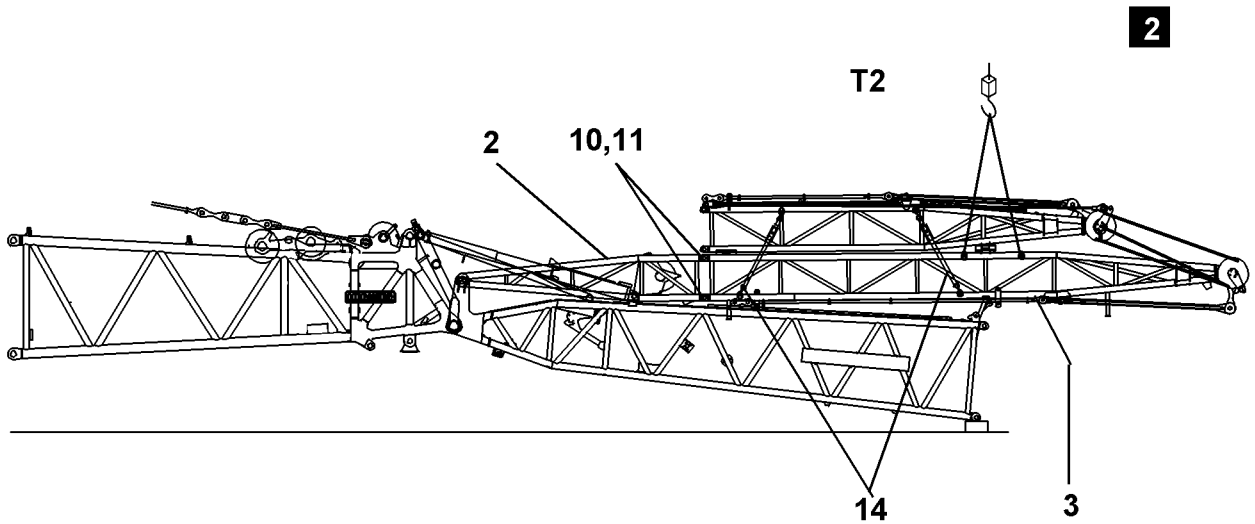
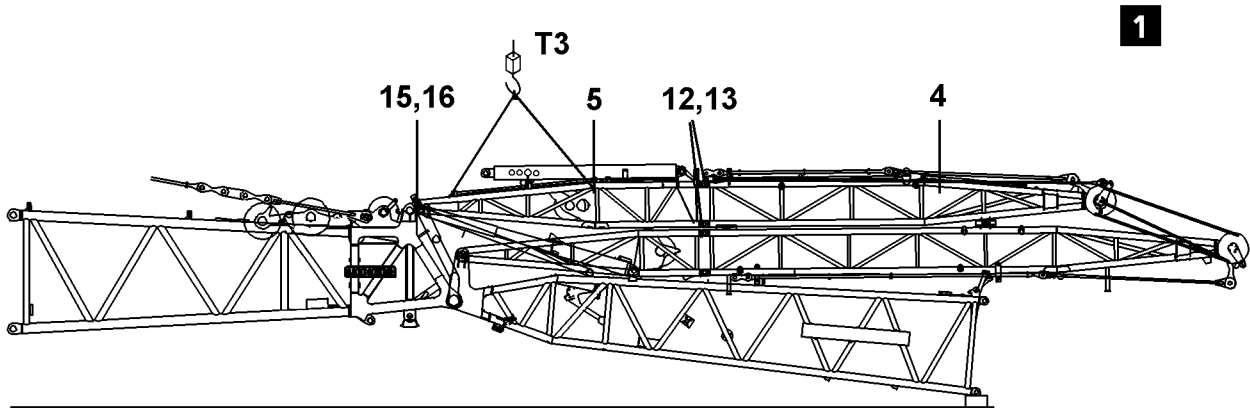
CAUTION: When placing down, always make sure there is enough distance between the WA- bracket I and II, until the WA bracket I is laying on the W-pivot section. As soon as the WA- bracket I and WA-bracket II touch, the W- control winch may NO LONGER be spooled up. Do not actuate the cylinder any more (spool out W-control).
If this is not observed, the WA- bracket I and II will be damaged!

Secure the WA- bracket II erection supports with retaining pins (4) in the pulled out position.

CAUTION: Do not move if the retaining pin is pinned!

Unpin and retract the WA-bracket II erection cylinder on the erection supports.

Hang the auxiliary crane to the corresponding erection support and lower each erection support into transport position and pin .



13. Removal work

Note: Removal work in reverse procedure as installation work.

D A N G E R: **For installation and removal work:**

- **A safe installation scaffolding / working platform must be used. There is a danger of accidents due to falling.**
- **Improvisations are prohibited.**
- **The lattice sections must be supported underneath with suitable, stable materials.**
- **Nobody may remain under the lattice jib during the pinning and unpinning procedure of the lattice sections.**

Fig. 1 Removal transport unit 3 (T 3)

Take on the transport unit 3 (T 3) with the auxiliary crane on the tackle points on the WA- bracket II- pivot section (5) .

Attach the rigging belts (14) .

Unpin the WA-bracket II- pivot section (5) on the WA-bracket II end section (4), with the hydraulic pin pulling device.

Unpin the connector pins (12), on top and bottom, with the hydraulic pin pulling device.

Fig. 2 Removal transport unit 2 (T 2)

Take on the transport unit 2 (T 2) with the auxiliary crane on the tackle points on the WA- bracket I-end section (3) .

Unpin the transport unit 2 on the WA-bracket I pivot section (2) .

Unpin the connector pins (10), on top and bottom, with the hydraulic pin pulling device.

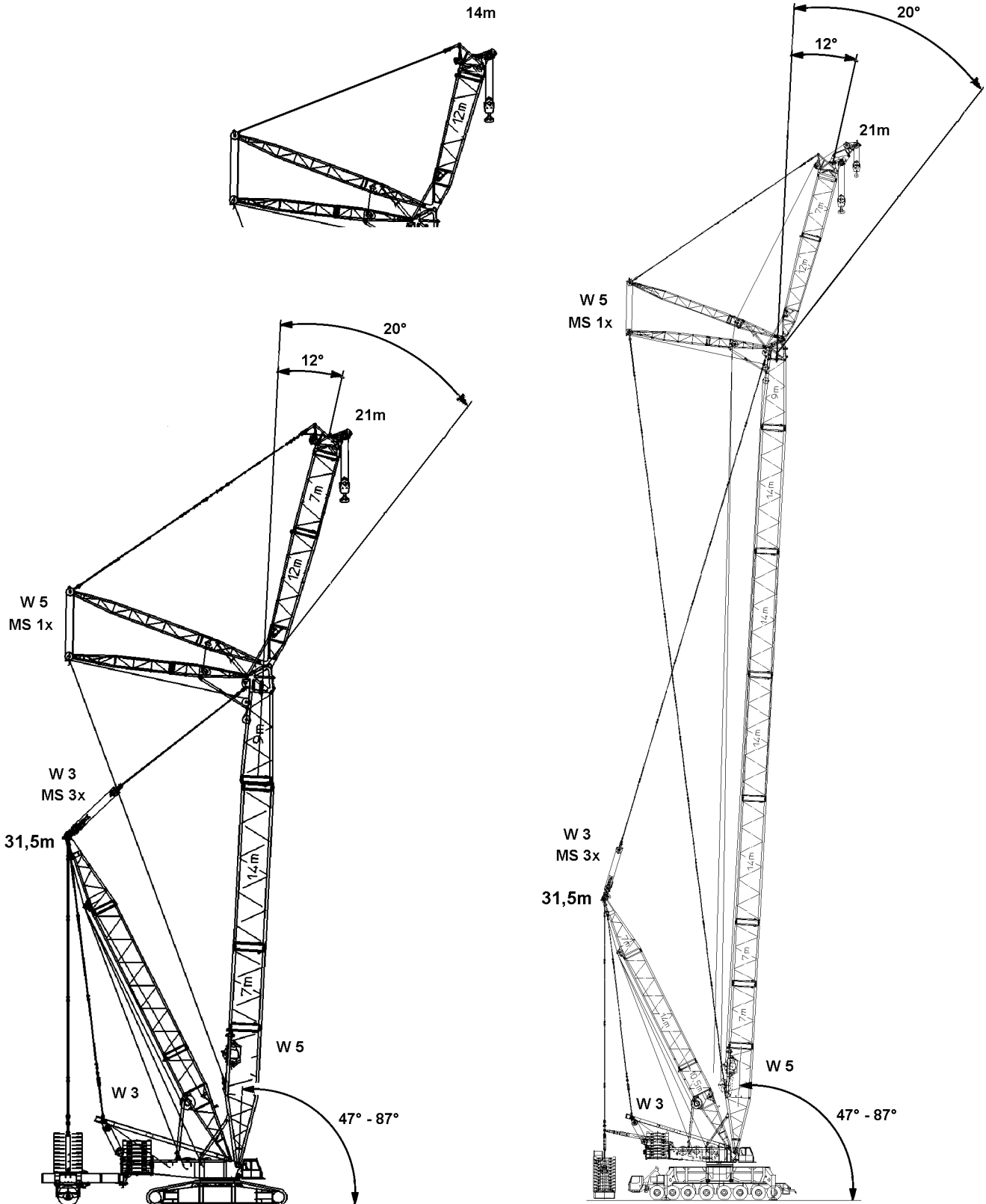
Fig. 3 Removal transport unit 1 (T 1)

Take on the transport unit 1 (T 1) with the auxiliary crane on the tackle points on the W-pivot section (1).

Unpin the transport unit 1 on the S- end section.

Unpin the connector pins (6) with the hydraulic pin pulling device, replace the retaining plate (7) and pin retainers (8) .

Unpin on the roller set (9) .



1. Description SDWV

Operating range is 12° bis 20° to the S- boom.

The 14 m or the 21m long WV - lattice jib can be adjusted over a range of 12° bis 20° to the S- boom .

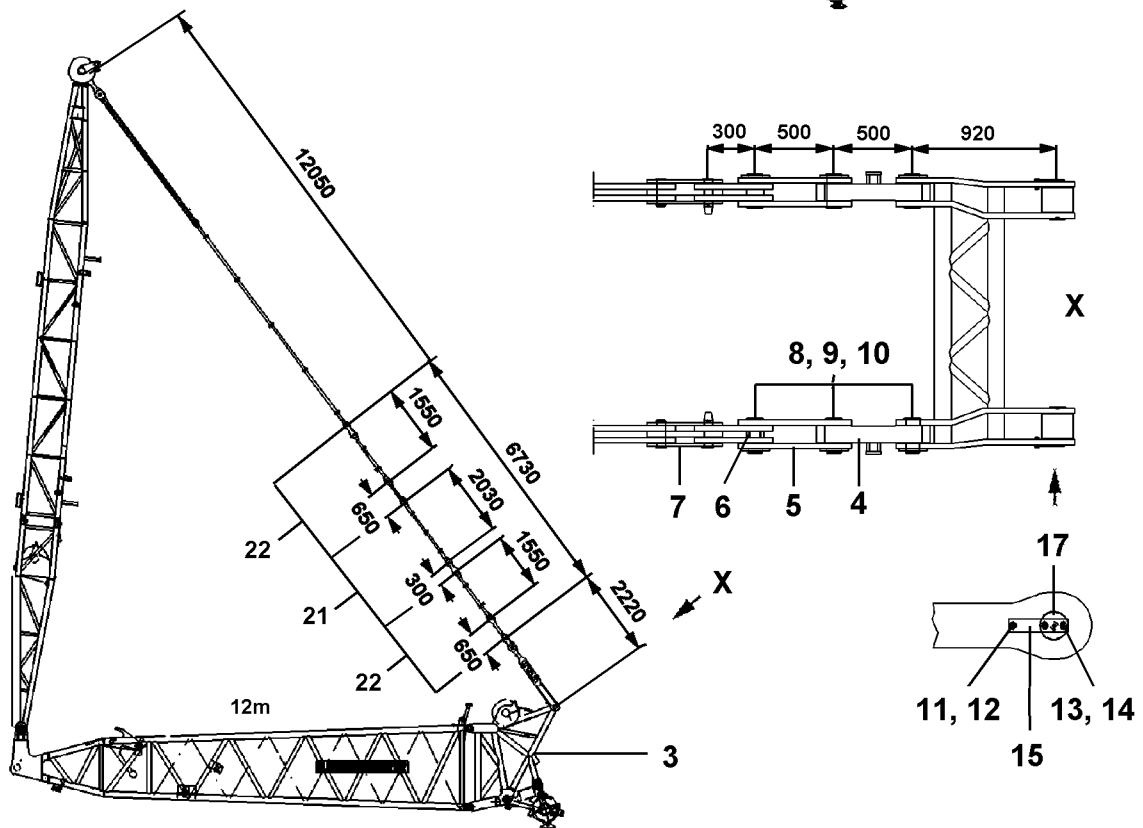
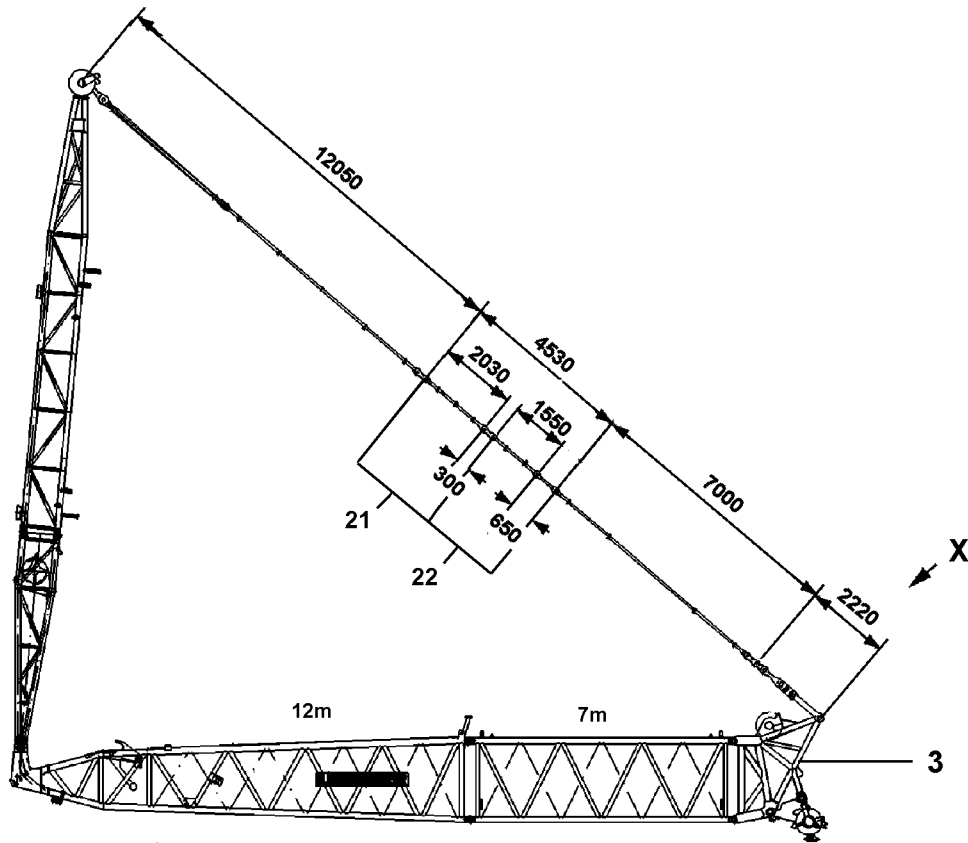
D A N G E R : The position of the WV-lattice jib may only be changed if the S- boom is between 87° and 47°.

The function of the W- relapse retainer remains!

The WV- lattice jib is controlled with winch 5 (W5) and master switch MS1x.

The S- boom is controlled with winch 3 (W3) and master switch MS3x.

**C A U T I O N : Observe the notes in
chapter 4.02 " LICCON COMPUTER SYSTEM",
chapter 4.05 " CRANE OPERATION "
chapter 4.08 " WORKING WITH A LOAD ".**



1.1 WV - guying

The following added guy rods, complete, must be installed:

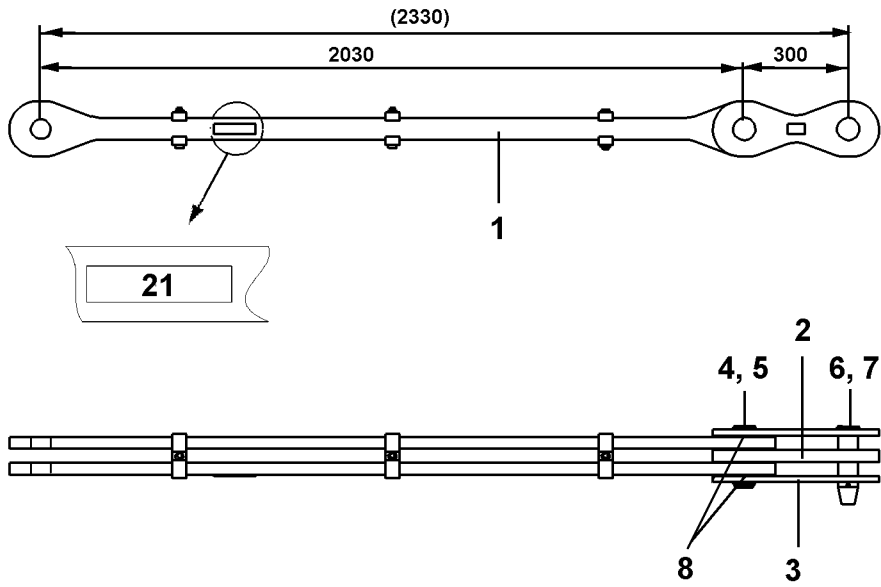
21m WV-Lattice jib 1 × rod, complete, item, **21**
 1 × rod, complete, item, **22**

14m WV-Lattice jib 1 × rod, complete, item, **21**
 2 × rod, complete, item, **22**

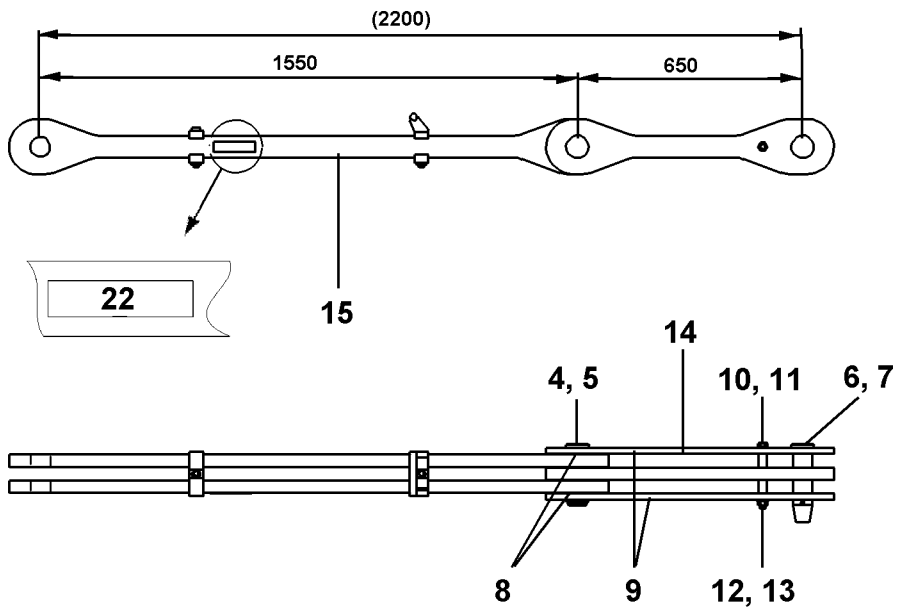
Components

- 1 Rod, complete (2.33m), see **fig. 1**
- 2 Rod, complete (2.20m), see **fig. 2**
- 3 W- adapter for pulley head 600t/400t
- 4 Pull test bracket 500mm
- 5 Bracket , complete 500mm
- 6 Pipe
- 7 Bracket, complete 300mm
- 8 Pin Rd. 90
- 9 Retaining ring
- 10 Washer
- 11 Nut M16
- 12 Screw M16×60
- 13 Spring ring A12
- 14 Screw M12×25
- 15 Plate
- 17 Pin Rd.90

1



2



1.2 Added guy rods**Fig. 1****21 Rod, complete (2330 mm) consists of:**

- 1 Rod 2030mm
- 2 Bracket 300mm
- 3 Bracket 300mm
- 4 Pin Rd.56
- 5 Retaining ring 55×3
- 6 Pin Rd.56
- 7 Spring retainer
- 8 Washer 70×2

Fig. 2**22 Rod, complete (2200 mm) consists of :**

- 4 Pin Rd.56
- 5 Retaining ring 55×3
- 6 Pin Rd.56
- 7 Spring retainer
- 8 Washer 70×2
- 9 Bracket 650mm
- 10 Screw M16×180
- 11 Pipe
- 12 Washer A17
- 13 Nut M16
- 14 Bracket 650mm
- 15 Rod 1550mm

1.3 Function check

Prerequisites:

- All electrical connections are established.
- The engine is running.

Airplane warning light

Turn on the airplane warning light , check function visually.

Wind speed sensor

Check the movement and function of the wind speed sensor.

Limit switch

C A U T I O N : **The limit switch functions must be checked individually before crane operation.**
The manual procedure is described below.
The function of the individual limit switch initiators must be determined in the test system - see Diagnostics Manual.

Hoist limit switch

- Actuate the hoist limit switch manually.
- The hoist winch must turn off when lifting.
- The hoist "top" symbol on the LICCON indicator must blink.

Limit switch WV - lattice jib "top", relapse cylinder

- The W - control winch movement "spool up" must turn off.
- The symbol must appear on the LICCON monitor .

Limit switch WV - lattice jib "low", relapse cylinder

- The W - control winch movement "spool out" must turn off.
- The symbol must appear on the LICCON monitor .

Note: The shift point of the limit switches on the relapse cylinder must be checked before erection - see chapter 8.12, **Checking the safety controls on the relapse cylinder.**

Limit switch flamp in position and lattice jib , "steepest " position, mechanical relapse support

- Cover the limit switch initiators individually with a metal plate.
- The W- control winch movement "spool up" must turn off.
- The symbol must appear on the LICCON monitor .

C A U T I O N : **Before erection, the easy movement of the pendulum of the mechanical relapse retainer must be checked over the complete swing range of the pendulum. If this is not observed, the mechanical relapse support will not engage in steepest lattice jib position.**
There is a danger of accidents, as the lattice jib may tip backward!

1.4 Erection / take down procedure

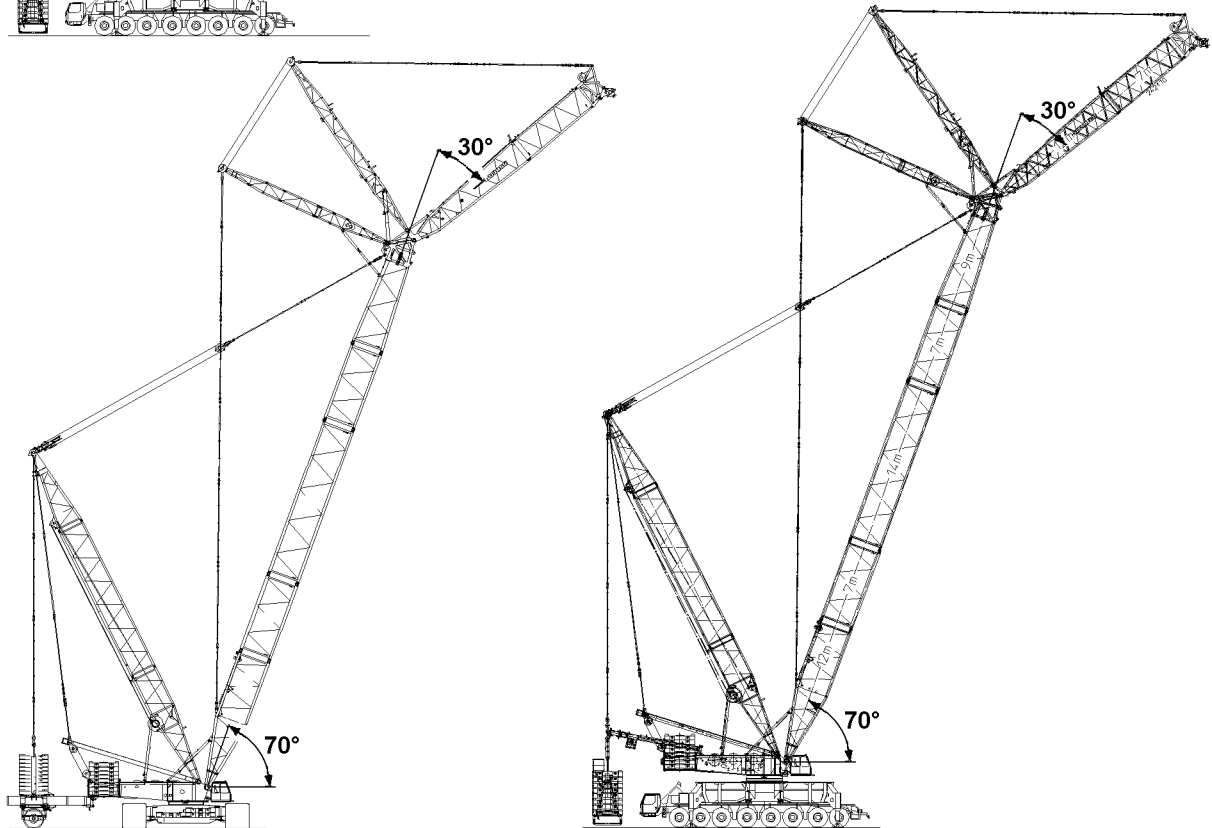
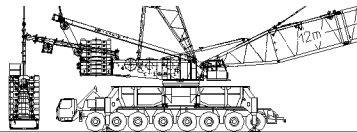
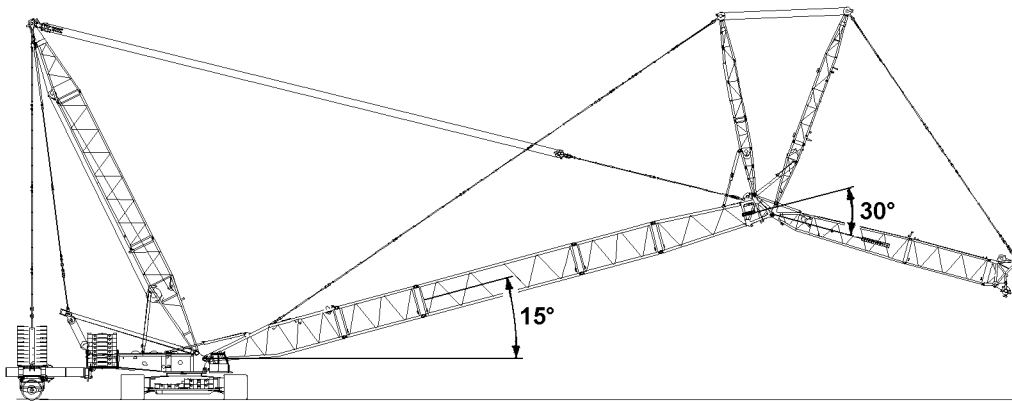
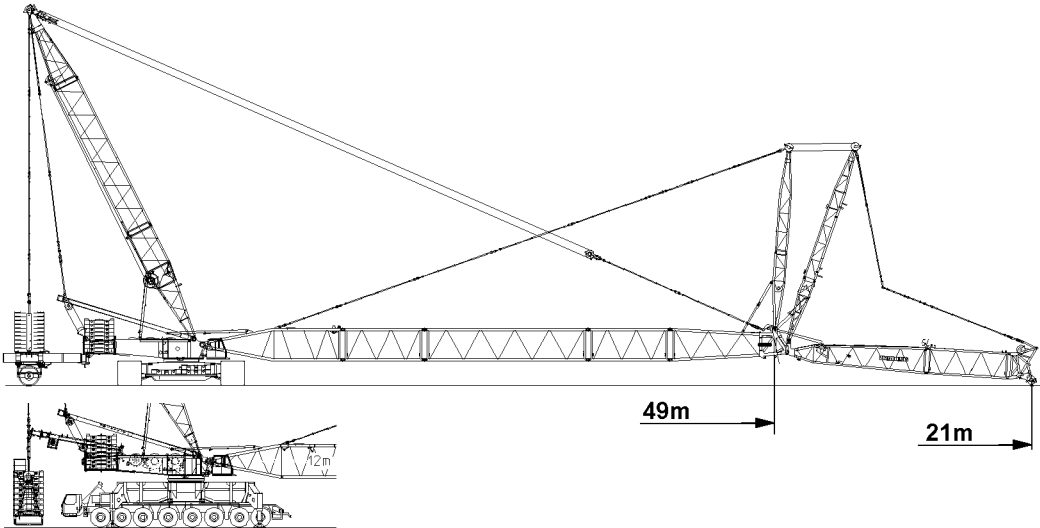
The boom combinations must be erected or taken down according to the Erection and take down charts - see separate charts.

D A N G E R: **The erection and take down procedure must be made according to the data in the erection and take down chart.
If this is not observed, the crane can be overloaded or topple over.**

Prerequisites:

- The crane is horizontally aligned.
- The counterweight is installed on the slewing platform according to the load chart .
- The derrick ballast is placed according to the erection and take down charts.
- The lattice jib is installed according to the load chart and the operating manual .
- All limit switches are installed correctly and fully functioning.
- Before erection, the pendulum of the mechanical relapse retainer must be checked for easy movement over its complete swing range.
- All pin connections are secured.
- The hoist cable is placed correctly into the cable pulleys and secured with cable retaining pins to prevent them from jumping out.
- There are no persons within the danger zone.
- There are no loose parts on the boom and the lattice jib.
- In the cold season: Is the boom and the lattice jib and their components (limit switch, cable drum, airplane warning light, wind speed sensor, etc.) free of snow and ice.

D A N G E R: **Incorrectly installed and non-functioning limit switches as well as falling parts (pins, spring retainers, ice, etc.) can cause accidents!
Before erection, the pendulum of the mechanical relapse retainer must be checked for easy movement over its complete swing range. If this is not observed, the mechanical relapse support does not engage in steep lattice jib position.
There is a danger of accidents, the lattice jib may tip backward!**



1.5 Erection procedure

Set the LICCON overload safety system according to the data given in the load charts.

Actuate the installation keyed button, the indicator light "installation" lights up.

The installation symbol on the LICCON indicator blinks.

Erection

Actuate the manual control lever and luff up the S - boom to approx. 15° .

At the same time, spool the lattice jib control winch out until the S-boom and the WV-lattice jib form an angle of ($\geq 30^\circ$) .

Reeve in the hoist cable between the pulley head on the end section and the hook block and secure on the fixed point - see chapter 4.06, Reeving plans.

Attach the hoist limit switch weight.

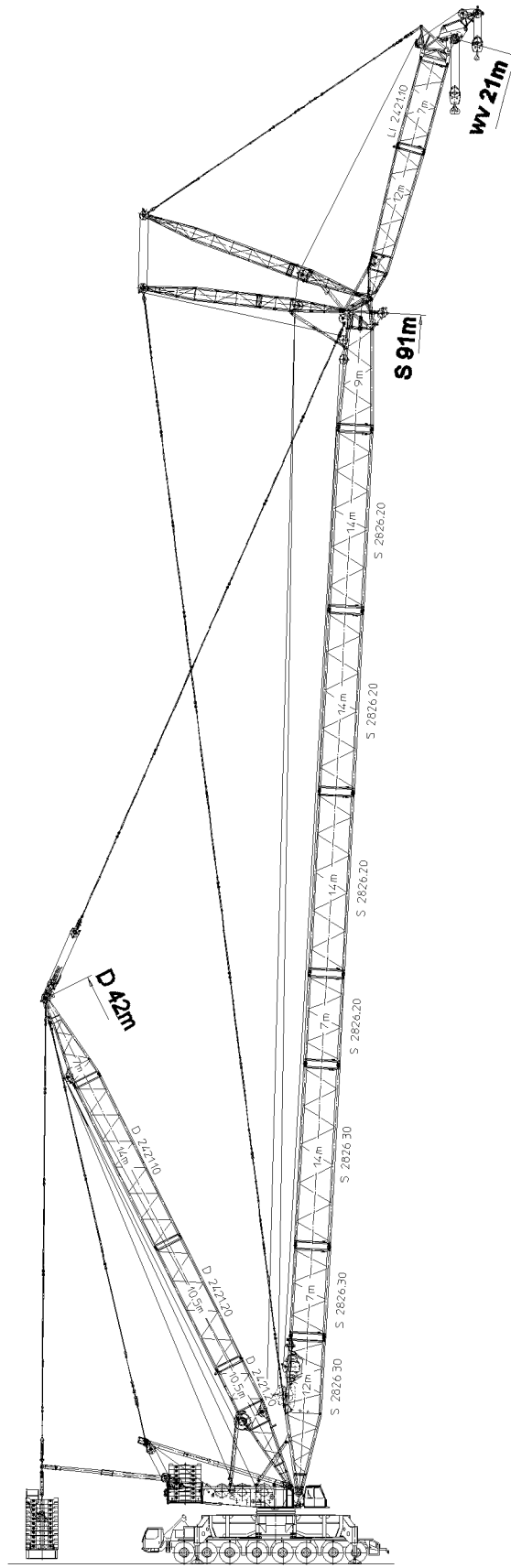
Luff up the S-boom to approx. 70° .

Then luff up the WV-lattice jib to operating position 12° or 20° .

D A N G E R : **The angle between the S-boom and the WV-lattice jib must be $\geq 30^\circ$ during the complete erection procedure.**

If this is not observed, the mechanical relapse support does not engage in steep lattice jib position.

There is a danger of accidents as the lattice jib can tip backward!



S6D2WV, S6D2WVB

2. Description S6D2WV (for LG 1750 only)

The difference between the SDWV and S6D2WV is the derrick length:

SD = 31,5m

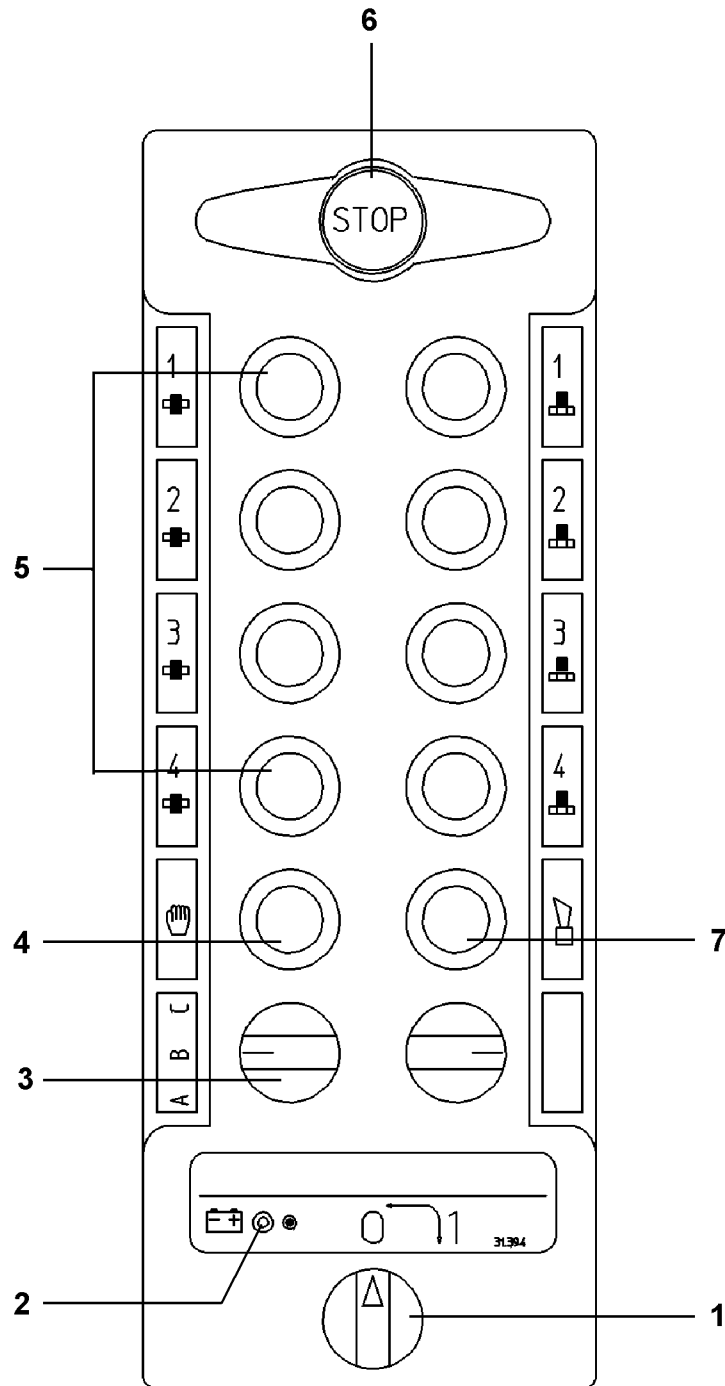
S6D2 = 42,0m

This operating mode is only possible with crane type LG 1750!

The WV-guying is the same.

Note: WV-guying, see paragraph 1.1
Auxiliary guy rods, see paragraph 1.2
Function check, erection - take down and erection procedure are the same as SDWV.

CAUTION: Observe the notes in
chapter 4.02 " LICCON COMPUTER SYSTEM",
chapter 4.05 " CRANE OPERATION "
chapter 4.08 " WORKING WITH A LOAD ".



1. Radio transmitter

Pinning and unpinning with a radio transmitter simplifies this task. But the operator must still get used to the remote control!

D A N G E R: **The operating manual "RADIO TRANSMITTER MICRON 4" issued by the manufacturer must be read completely, before working with the radio transmitter for the first time!**
If this is not observed, there is a danger of accidents!

2. Remote control**1 Main switch**

0 - Off
 1 - On

2 Akku - Indicator light**3 Preselection rotary switch**

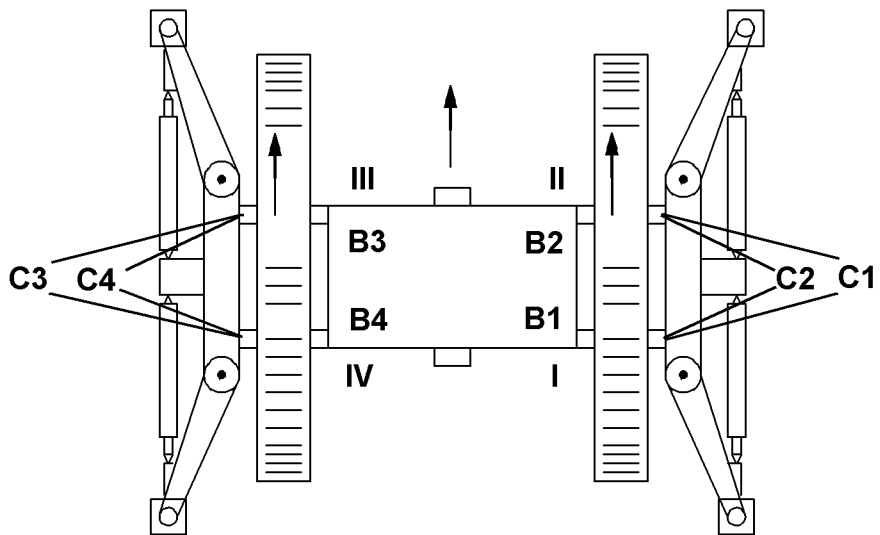
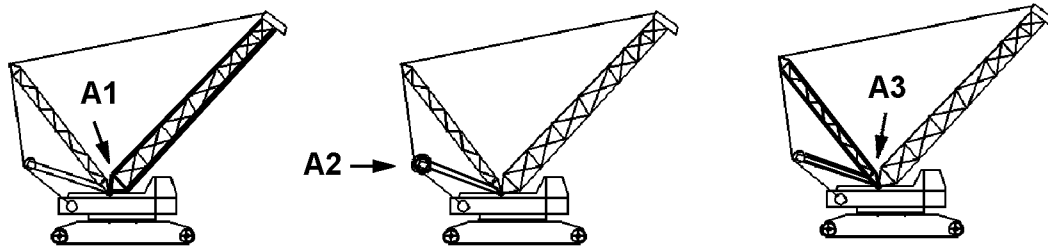
A = Pin on slewing platform
 B = Pin on crawler to center section
 C = Pin on crane supports to crawler or center section

4 Release switch for 2-Hand control

5 Button 1 - Pin
 Unpin
 Button 2 - Pin
 Unpin
 Button 3 - Pin
 Unpin
 Button 4 - Pin
 Unpin

6 EMERGENCY OFF

7 Signal - Horn



3. Pin points**A Pinning on slewing platform**

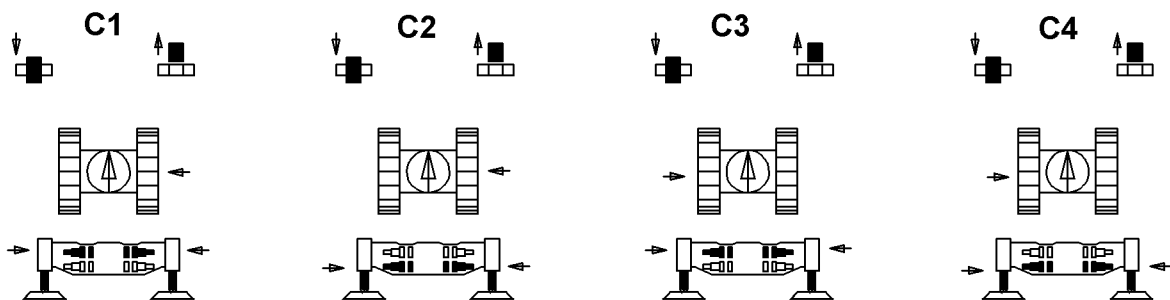
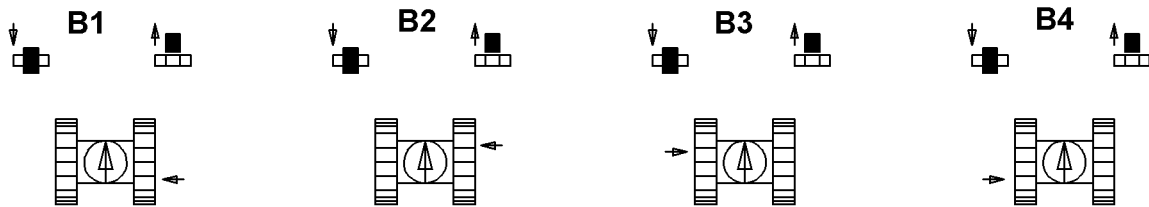
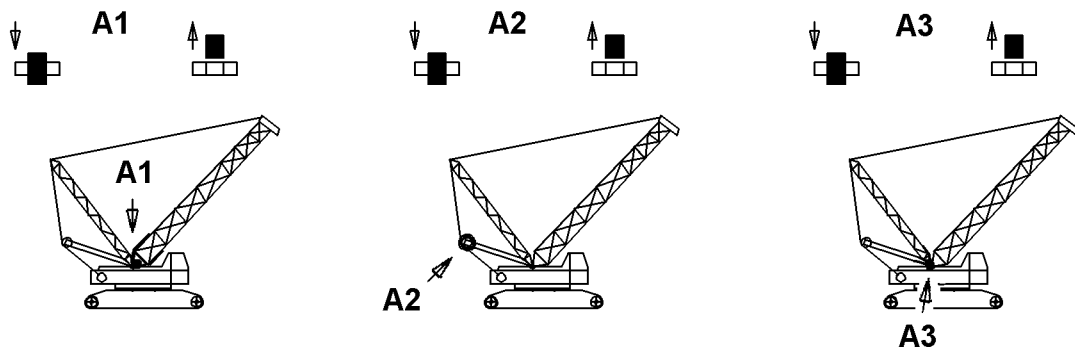
- A1 To pin S/L-pivot section
- A2 To pin pulley head on SA-bracket
- A3 To pin SA-bracket or derrick

B Pinning on crawler to center section

- B1 To pin crawler right rear
- B2 To pin crawler right front
- B3 To pin crawler left front
- B4 To pin crawler left rear

C Pinning on crane supports to crawler or center section

- C1 To pin crane support upper right
- C2 To pin crane support lower right
- C3 To pin crane support upper left
- C4 To pin crane support lower left



4. Prerequisite

The engine is off.

Turn on the radio remote control on the instrument panel in the crane cab, -see chapter 4.01.

Note: Pull to release the EMERGENCY OFF switch (6) on remote control.

Turn the radio transmitter on. Set the main switch into position 1.

Start the engine.

5. Control

Rotary switch, preselect A, B or C

Release switch for 2-Hand control and push the preselected pin or unpin button at the same time.

- left side = pin

- right side = unpin

Button A1 To pin S/L- pivot section

Button A2 To pin pulley head on SA - bracket

Button A3 To pin SA- bracket and derrick

Button B1 To pin crawler right rear

Button B2 To pin crawler right front

Button B3 To pin crawler left front

Button B4 To pin crawler left rear

Button C1 To pin crane support upper right

Button C2 To pin crane support lower right

Button C3 To pin crane support upper left

Button C4 To pin crane support lower left

DANGER: Select a safe location for remote control, from where you can see the complete working range.

Give an acoustical warning signal, to warn any personnel within the vicinity as not to endanger them during operation.

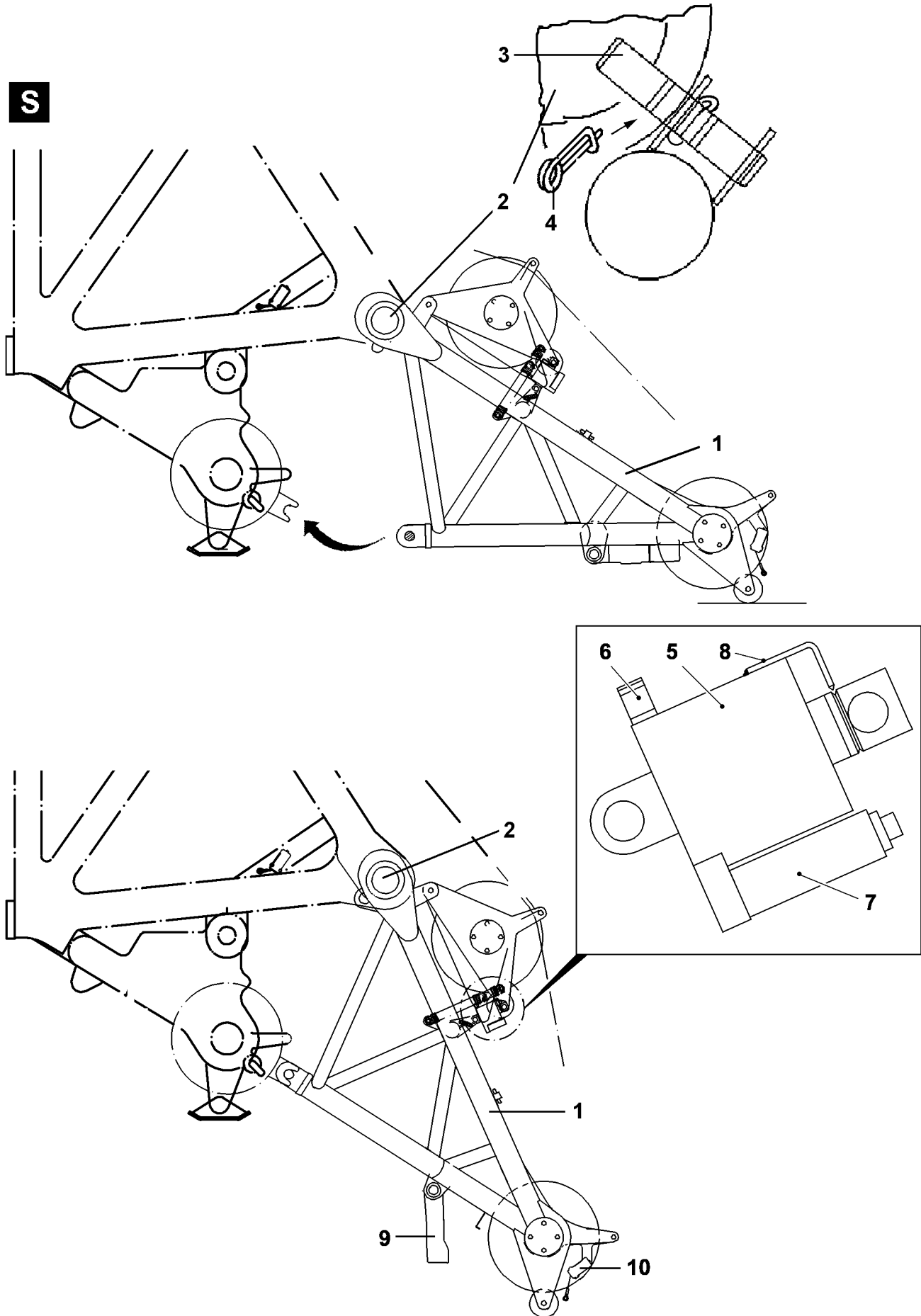
Before pinning, it must be ensured that the pin bore is clear.

The pin must be secured immediately after inserting the pin.

Before unpinning the crane supports they must be hung on to a auxiliary crane.

Before unpinning, the retainer on the pin which is to be unpinned must be removed. All other pins must remain secured.

If this is not observed, there is a danger of accidents!



Installation of boom nose on S- end section

Components

- 1 Boom nose
- 2 Pin Rd 170 mm
- 3 Retaining pin Rd 30 mm
- 4 Spring retainer Rd 4,0 mm
- 5 Test cylinder
- 6 Test connection
- 7 Pressure sensor
- 8 Pointer
- 9 Cable fixed point (cable lock)
- 10 Hoist limit switch

Note: Weight of boom nose = 1100 kg

D A N G E R: **Before putting the boom nose on the crane into service, it must be ensured that the pointer (8) is on the zero mark (notch) of the test cylinder (5). If this is not the case, oil must be pumped into the test cylinder via test connection (6) until the pointer is in the center of the zero mark.**

If this is not observed, the load indication on the LICCON monitor does not match the actual load on the hook block / load hook and there is a danger of accidents as the crane can be overloaded without noticing it!

Installation

The boom head is laying on the ground.

Attach the boom nose (1) to the auxiliary crane and pin the pin (2) on the end section **"on top"** with the pin pulling device and secure with retaining pin (3) and spring retainer (4) .

Place the boom nose on the ground, remove the auxiliary crane.

Pull the hoist cable over the cable pulleys - see fig. 1.

Luff up the boom until the pin of the boom nose on the end section **"on the bottom"** is positioned in the receptacle.

The electric connection to the pressure sensors is established.

Connect the hoist limit switch (7) .

C A U T I O N: **Monitor the hoist cable routing of the hook block on the end section during erection, to make sure that it does not link up with the boom nose.**

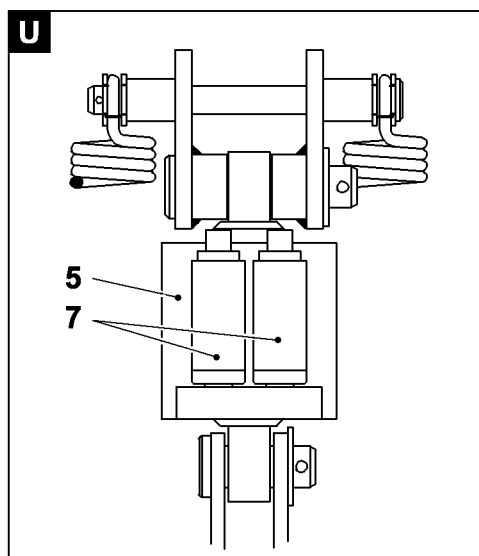
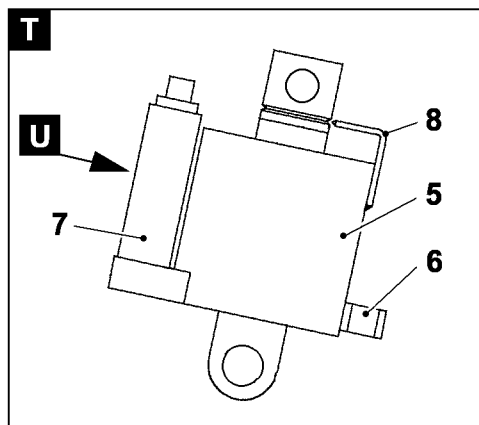
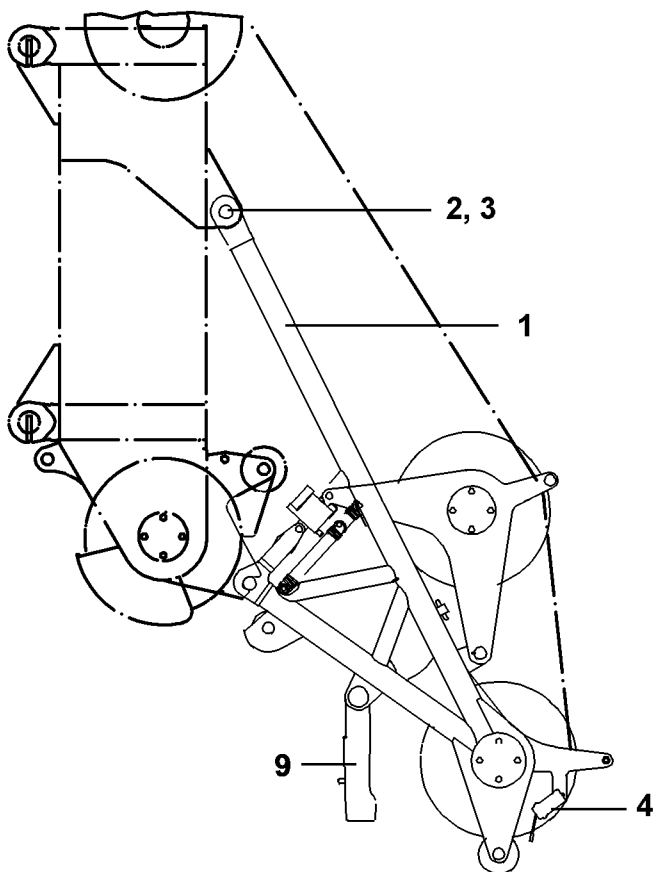
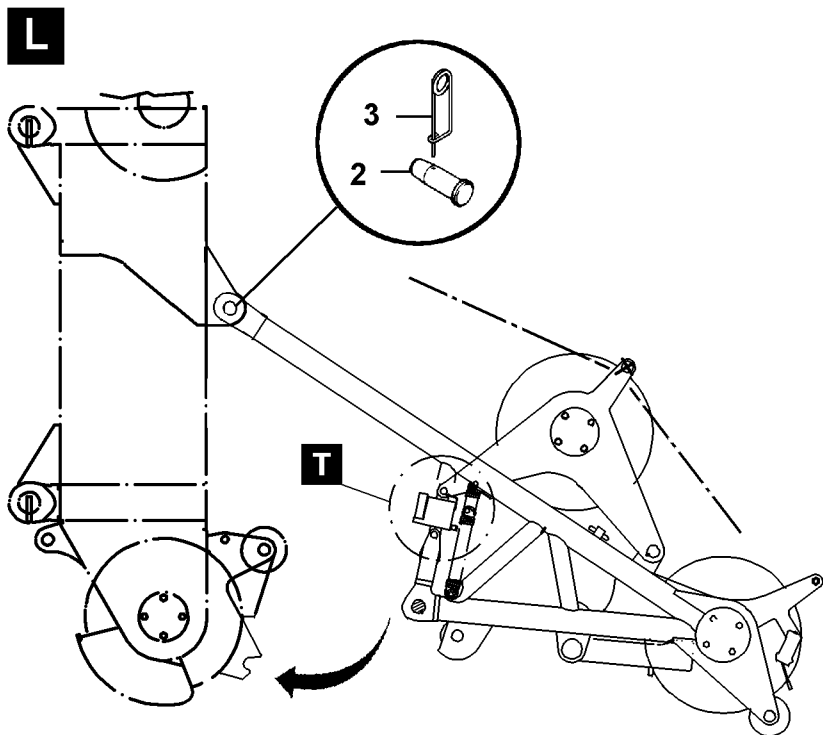
Removal

Luff down the S-boom and unreeve the hoist cable on the boom nose.

Continue to luff down the S-boom until it rests on the ground. The boom nose will fold up automatically from the fork connection.

Attach the boom nose (1) on the auxiliary crane.

Remove the spring retainer (4) and retaining pin (3) and unpin the pin (2) on the end section **"on top"** with the pin pulling device.



Installation of the boom nose on the L (W) - end section

Components

- 1 Boom nose
- 2 Pin Rd 55 mm
- 3 Spring retainer Rd 4.5 mm
- 4 Hoist limit switch
- 5 Test cylinder
- 6 Test connection
- 7 Pressure sensor
- 8 Pointer
- 9 Cable fixed point (cable lock)

Note: Weight of the boom nose = **770 kg**

D A N G E R: **Before putting the boom nose on the crane into service, it must be ensured that the pointer (8) is on the zero mark (notch) of the test cylinder (5). If this is not the case, oil must be pumped into the test cylinder via test connection (6) until the pointer is in the center of the zero mark.**

If this is not observed, the load indication on the LICCON monitor does not match the actual load on the hook block / load hook and there is a danger of accidents as the crane can be overloaded without noticing it!

Installation

The boom head is laying on the ground.

Attach the boom nose (1) to the auxiliary crane and pin the pin (2) on the end section **"on top"** and secure with spring retainer (3) .

Place the boom nose on the ground, remove the auxiliary crane.

Pull the hoist cable over the cable pulleys .

Luff up the boom until the pin of the boom nose on the end section **"on the bottom"** is positioned in the receptacle.

The electric connection to the pressure sensors is established.

Connect the hoist limit switch (4) .

C A U T I O N: **Monitor the hoist cable routing of the hook block on the end section during erection, to make sure that it does not link up with the boom nose.**

Removal

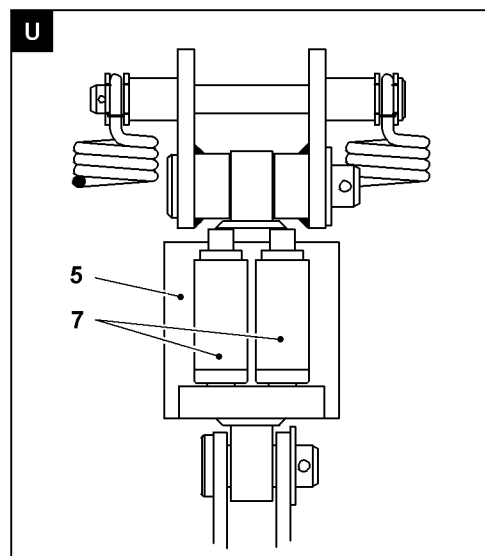
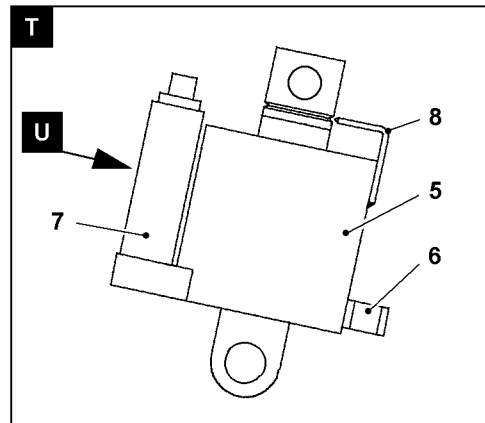
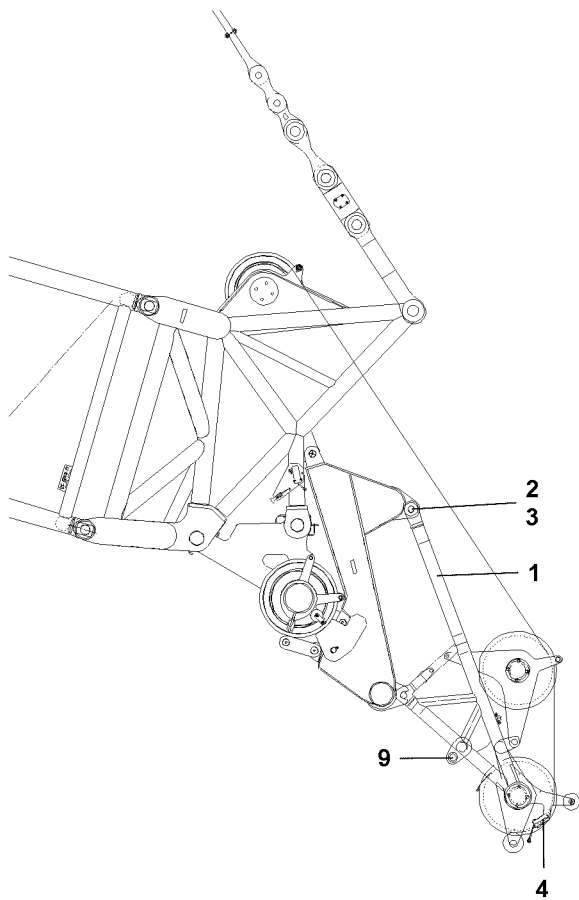
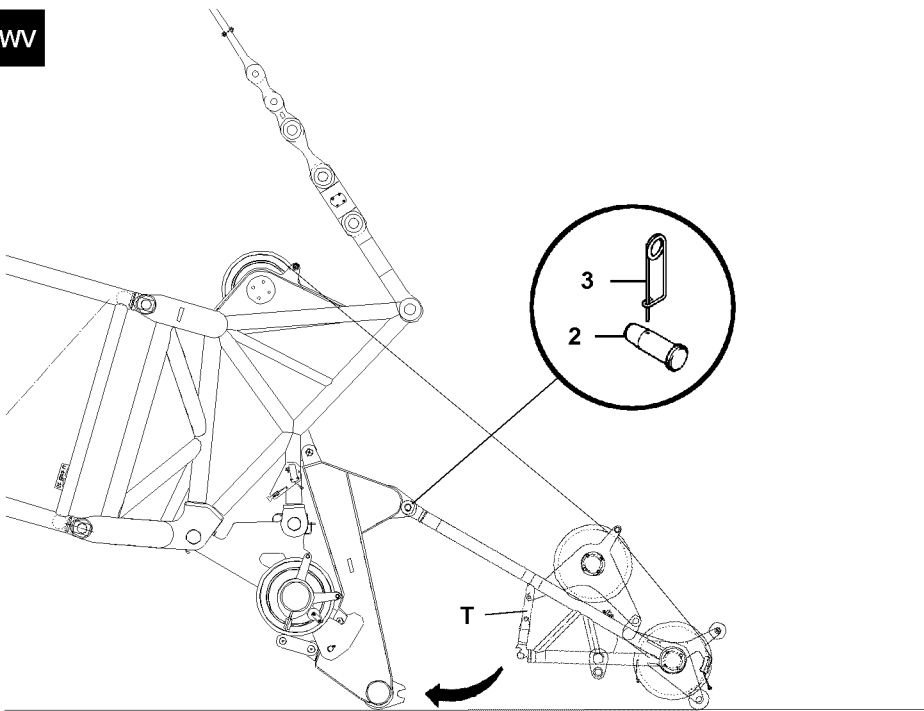
Luff down the S-boom and unreeve the hoist cable on the boom nose.

Continue to luff down the S-boom until it rests on the ground. The boom nose will fold up automatically from the fork connection.

Attach the boom nose (1) on the auxiliary crane.

Remove the spring retainer (4) and retaining pin (3) and unpin the pin (2) on the end section **"on top"** with the pin pulling device.

WV



104485

Installation of the boom nose on the WV - end section

Components

- 1 Boom nose
- 2 Pin Rd 55 mm
- 3 Spring retainer Rd 4.5 mm
- 4 Hoist limit switch
- 5 Test cylinder
- 6 Test connection
- 7 Pressure sensor
- 8 Pointer
- 9 Cable fixed point (cable lock)

Note: Weight of the boom nose = **770 kg**

D A N G E R: **Before putting the boom nose on the crane into service, it must be ensured that the pointer (8) is on the zero mark (notch) of the test cylinder (5). If this is not the case, oil must be pumped into the test cylinder via test connection (6) until the pointer is in the center of the zero mark.**

If this is not observed, the load indication on the LICCON monitor does not match the actual load on the hook block / load hook and there is a danger of accidents as the crane can be overloaded without noticing it!

Installation

The boom head is laying on the ground.

Attach the boom nose (1) to the auxiliary crane and pin the pin (2) on the end section **"on top"** and secure with spring retainer (3) .

Place the boom nose on the ground, remove the auxiliary crane.

Pull the hoist cable over the cable pulleys .

Luff up the boom until the pin of the boom nose on the end section **"on the bottom"** is positioned in the receptacle.

The electric connection to the pressure sensors is established.

Connect the hoist limit switch (4) .

C A U T I O N: **Monitor the hoist cable routing of the hook block on the end section during erection, to make sure that it does not link up with the boom nose.**

Removal

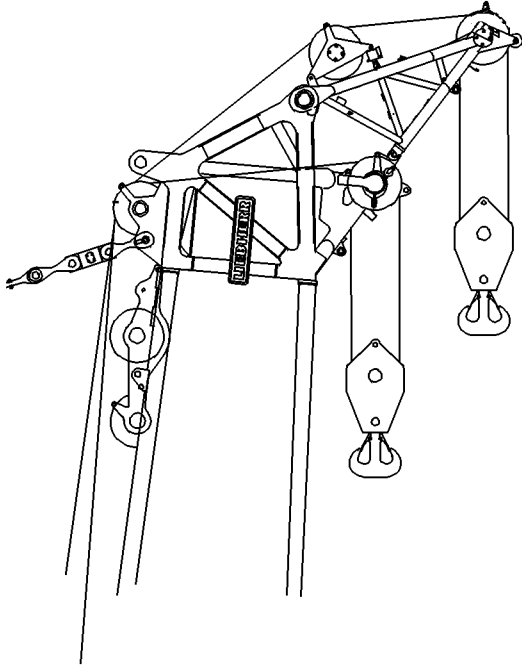
Luff down the S-boom and unreeve the hoist cable on the boom nose.

Continue to luff down the S-boom until it rests on the ground. The boom nose will fold up automatically from the fork connection.

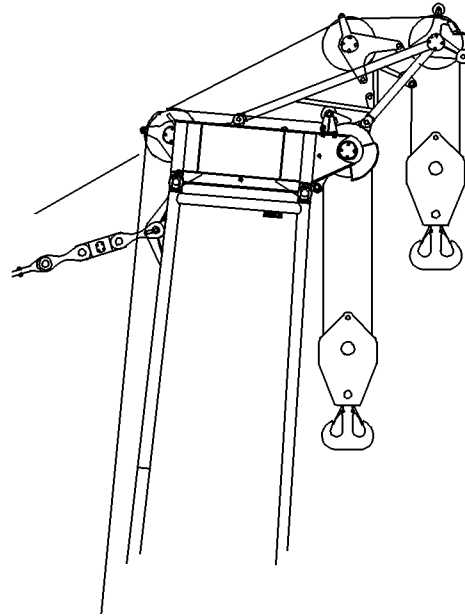
Attach the boom nose (1) on the auxiliary crane.

Remove the spring retainer (4) and retaining pin (3) and unpin the pin (2) on the end section **"on top"** with the pin pulling device.

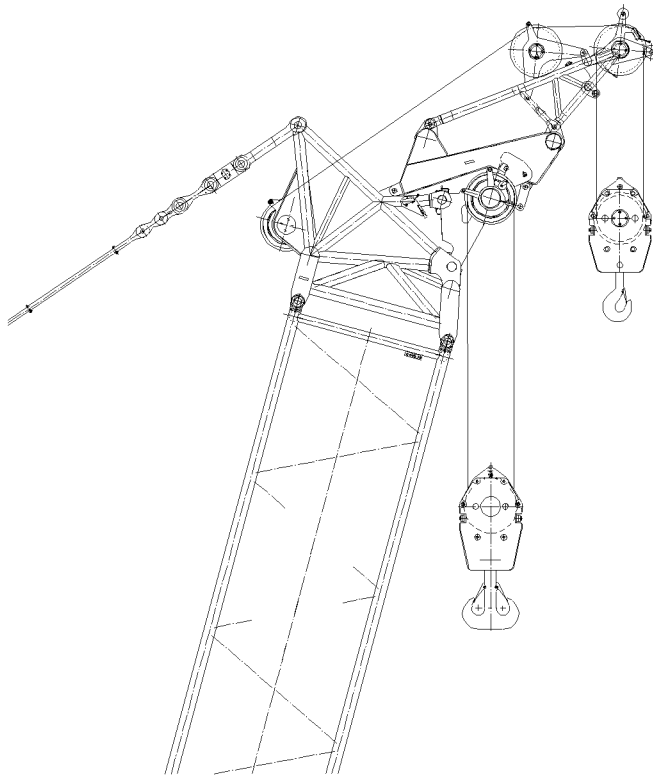
S



L (W)



WW



Operation with boom nose

Note: The boom combinations must be erected and taken down according to the erection and take down chart (see separate manual).

D A N G E R: **The crane must be erected and taken down according to the data in the chart. If this is not observed, the crane will be overloaded and can topple over!**

Description

This possibility is set up for quick lifts with winch V in S - operation and winch IV in SW, SDW - operation.

The hook block may remain reeved on the boom head.

Prerequisites:

- The LICCON system is set according to the load chart.
- The required operating mode has been set and confirmed on the LICCON.
- The electric connection to the pressure sensors is established.

Note : For hoist cable routing and reeving on the boom nose see chapter 4.06, Cable reeving.

Check the function of the hoist limit switches "on top" by running against the hoist limit switch weight.

Note : The type of boom nose is stored via the address of the hoist limit switch in the boom nose. When replacing a hoist limit switch on the boom nose it must be assured that the new hoist limit switch has the same address as the old one.

D A N G E R : **Under no circumstances may the hoist limit switch be installed from one boom nose to another one without matching the address. Otherwise the LMB would take on the wrong boom nose. The installed boom nose would then no longer be monitored sufficiently and could be overloaded inadvertently. This could cause a serious accident!**

Operation

In boom nose operation, the following must be observed.

D A N G E R : **Simultaneous operation with hook block on boom head and boom nose is not permitted in this case! The hoist limit switch on the boom nose must be connected. The load may not be raised off the ground by luffing up the boom. It must be raised off the ground via the hoist gear !**

- 1. Ballast trailer**
 - 1.1 General
 - 1.2 Dimensions, radii
 - 1.3 Weights

- 2. Control elements on control panels**

- 3. Installation**
 - 3.1 Pin ballast guide on ballast trailer
 - 3.2 Pin ballast guide on crane
 - 3.3 Install pull cylinder
 - 3.4 Ballasting the ballast trailer
 - 3.5 Raise and lower the ballast trailer

- 4. Telescoping the ballast trailer in or out**

- 5. Driving with the ballast trailer**
 - 5.1 General
 - 5.2 Driving in turns
 - 5.3 Towing
 - 5.4 Parallel driving
 - 5.5 Manual steering adjustment
 - 5.6 Manual operation for installation

- 6. Max. permissible uneven ground for towing, parallel driving or driving in turns**
 - 6.1 Compensation of maximum permissible uneven ground via pull cylinder

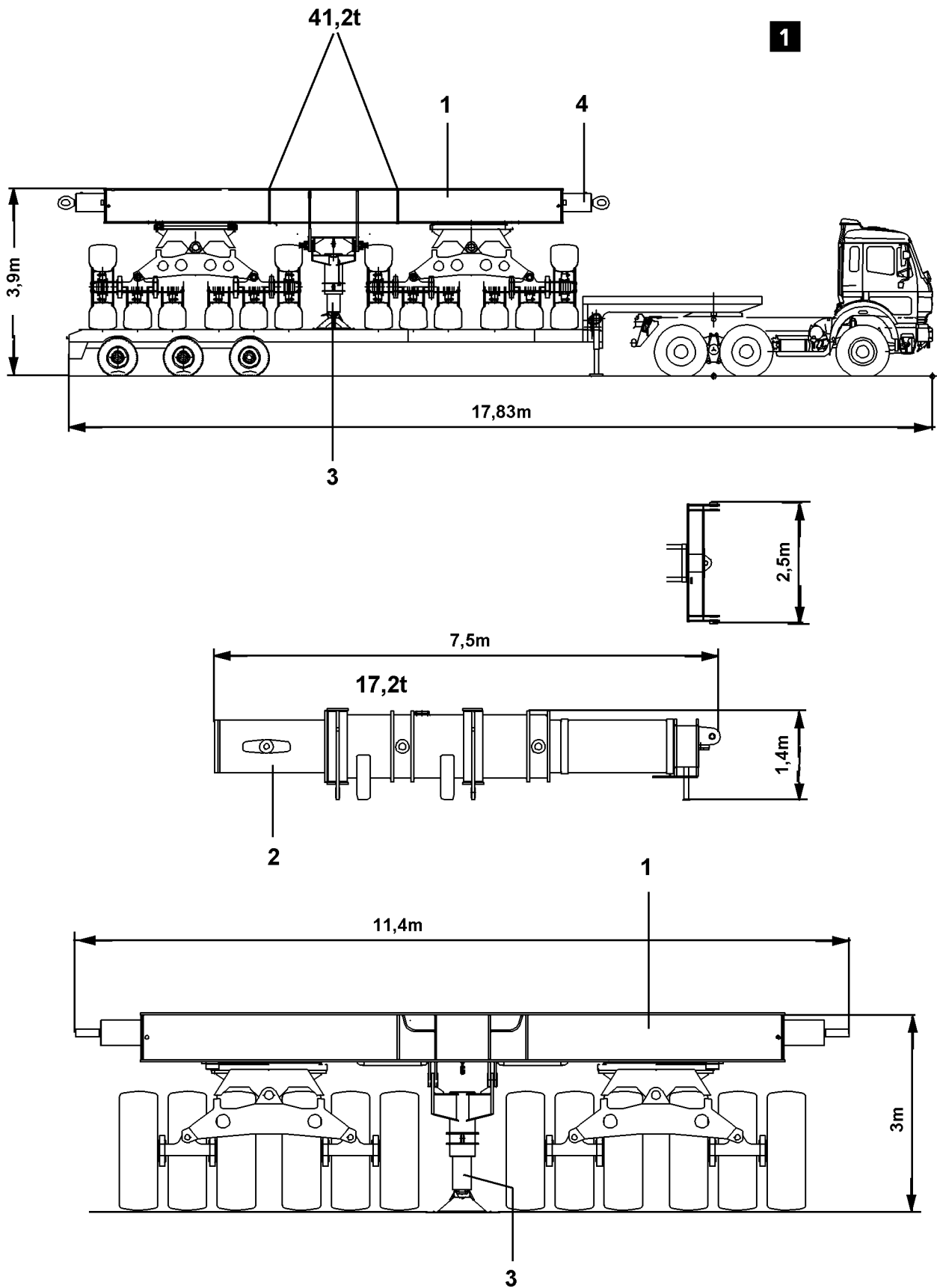
- 7. Safety guidelines for travel operation**
 - 7.1 Relapse cylinder
 - 7.2 Block position - relapse cylinder

- 8. LICCON overload safety device**
 - 8.1 General
 - 8.2 Safety guidelines
 - 8.3 Determination of forces in operating mode with ballast trailer
 - 8.4 Monitoring in operating mode with ballast trailer
 - 8.5 Shut off in crane operation with derrick ballast
 - 8.6 Load chart access procedure
 - 8.7 Checking the length sensor values on the ballast trailer
 - 8.8 Difference force monitoring of ballast guying
 - 8.9 The test system

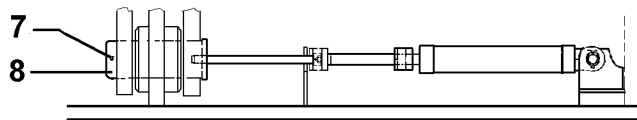
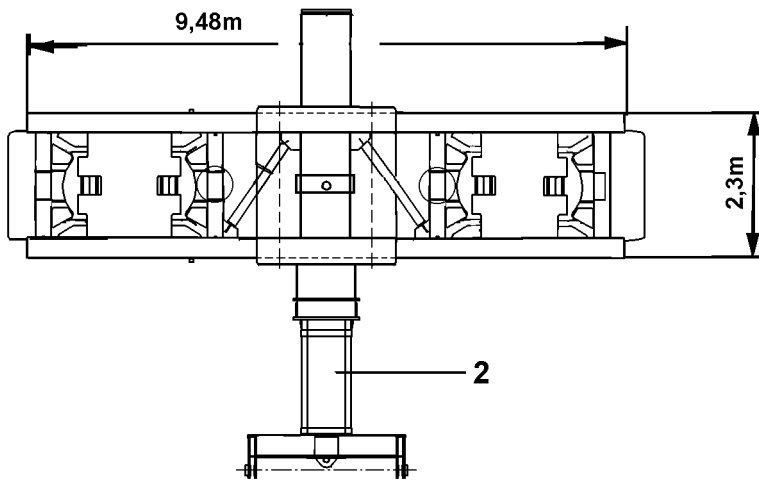
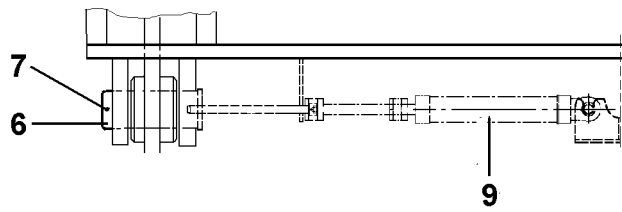
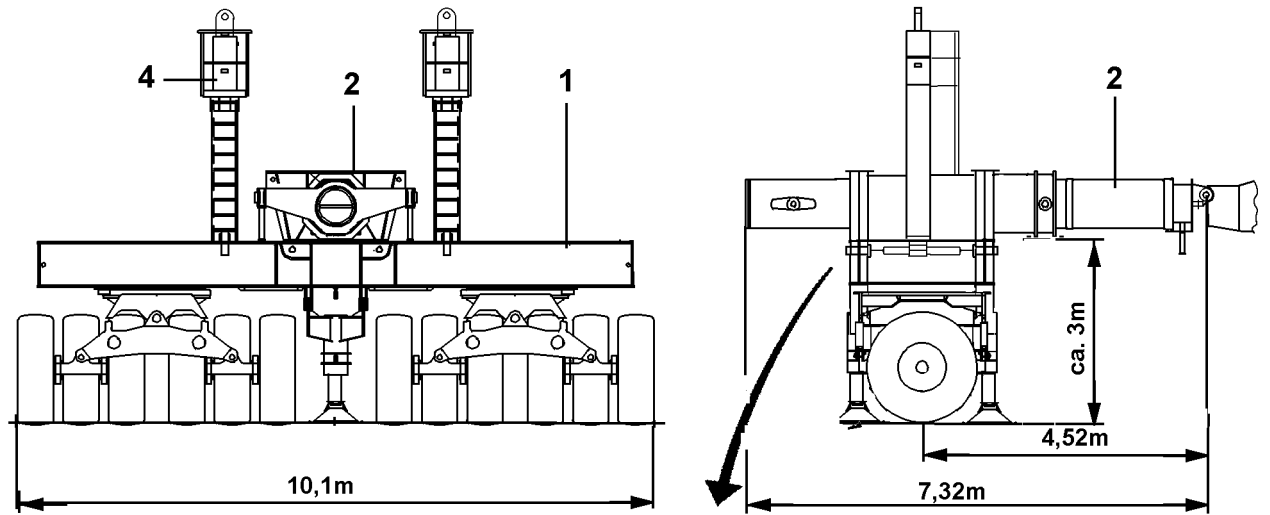
- 9. Removal of ballast trailer**
 - 9.1 Remove pull cylinder
 - 9.2 Unpin ballast trailer guide in crane
 - 9.3 Release supply lines
 - 9.4 Unpin ballast trailer guide on ballast trailer

- 10. Emergency operation**
 - 10.1 General
 - 10.2 Emergency operation - towing
 - 10.3 Emergency operation - driving in turns

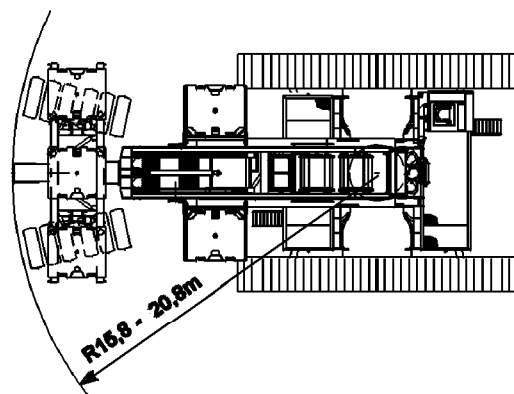
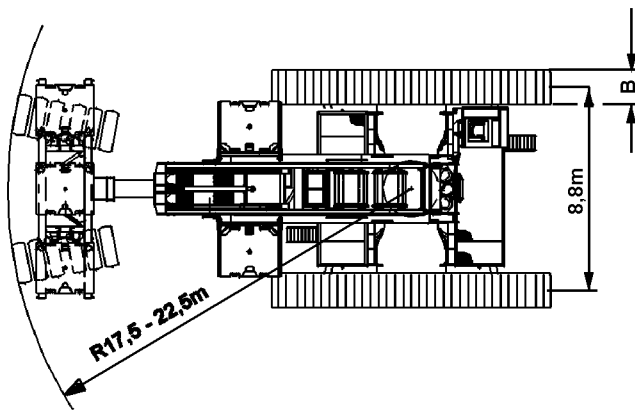
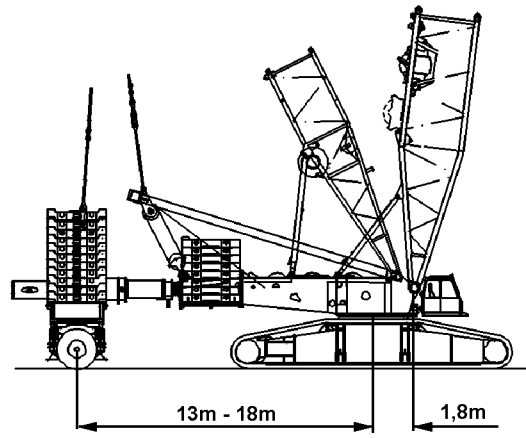
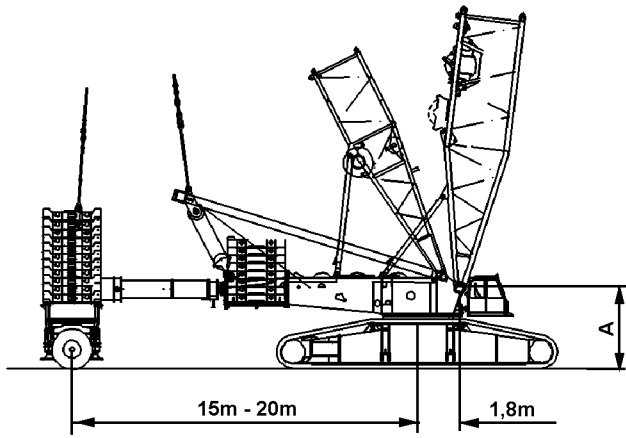
- 11. Maintenance**
 - 11.1 Maintenance intervals
 - 11.2 Slewing gear
 - 11.3 Central lubrication system
 - 11.4 Tires
 - 11.5 Lubrication schedule, quantities



2



3



1. Ballast trailer BW

1.1 General

Ballast trailer consists of:

2 axles with 2 each oscillating axles

Tires 12way, size 21.00 R 25

Hydraulic mechanical steering, electronically adjustable for

- towing
- driving in turns
- parallel operation
- manual steering adjustment

Hydraulically telescopable guide for radii of 13 - 18m or 15 - 20m.

Guy rods ballast trailer - derrick boom with 2 integrated expansion cylinders.

The compensation cylinders can be actuated under load.

1.2 Dimension [m], fig. 1 and 2
Radii [m], fig. 3

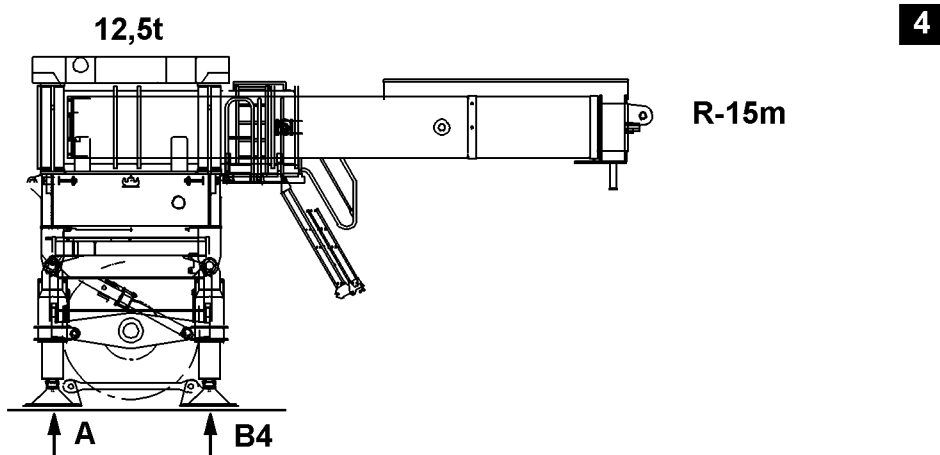
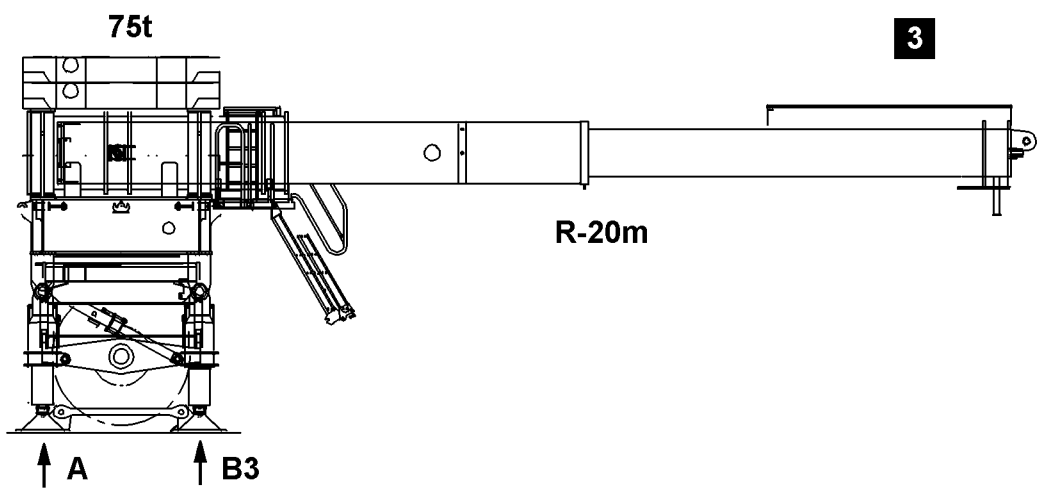
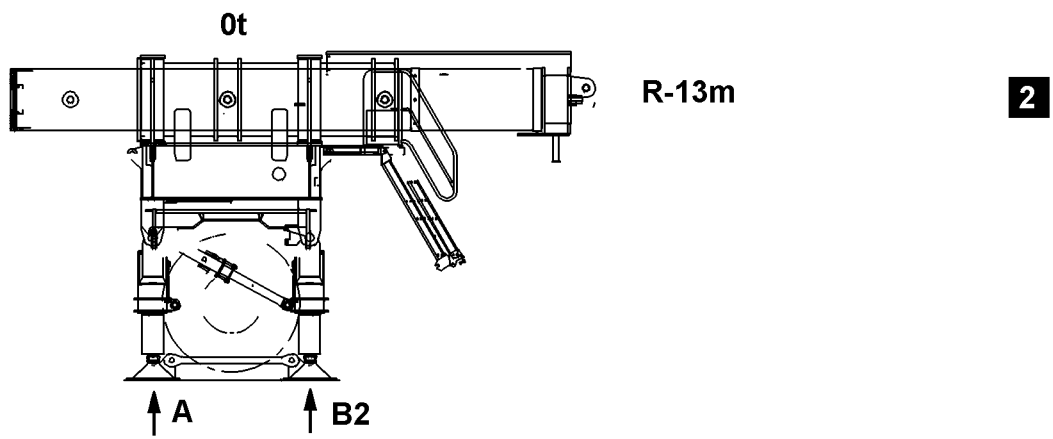
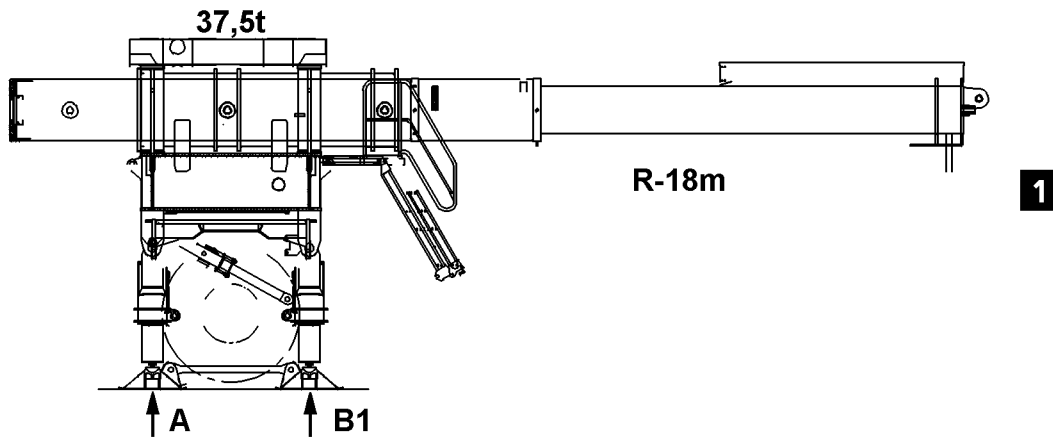
Note: The LICCON job planer calculates the turning radius of the ballast trailer only correctly for the ballast guide pinned in outer position, see illustration on the left, BW radius 15-20m.
 If the ballast guide is in the inner position, the guide tube extends about 30cm past the turning circuit of the tires, which means the calculated turning radius in the job planer is then about 30 cm too small.

1.3 Weights [t], fig.. 1 and 2

Ballast trailer approx. 41.2 t

Guide pipe approx. 17.2 t

Ballast trailer, compl. approx. 58.4 t



1.4 Stability and tipping safety if ballast trailer is not installed

- D A N G E R:**
- **The locking pin on the strut between the support cylinders must be pinned as long as the ballast trailer is not pinned on the slewing platform.**
 - **the ballast trailer must be supported in horizontal direction. Otherwise there is a danger of tipping!**

Fig. 1

- Guide extended - pinned to turning radius R - 18m
- Ballast trailer horizontally supported
- min. 37.5t ballast plates placed

B1 = 86.6t max. support pressure

Fig. 2

- Guide retracted - pinned to turning radius R - 13m
- Ballast trailer horizontally supported
- No ballast required

B2 = 38.6t max. support pressure

Fig. 3

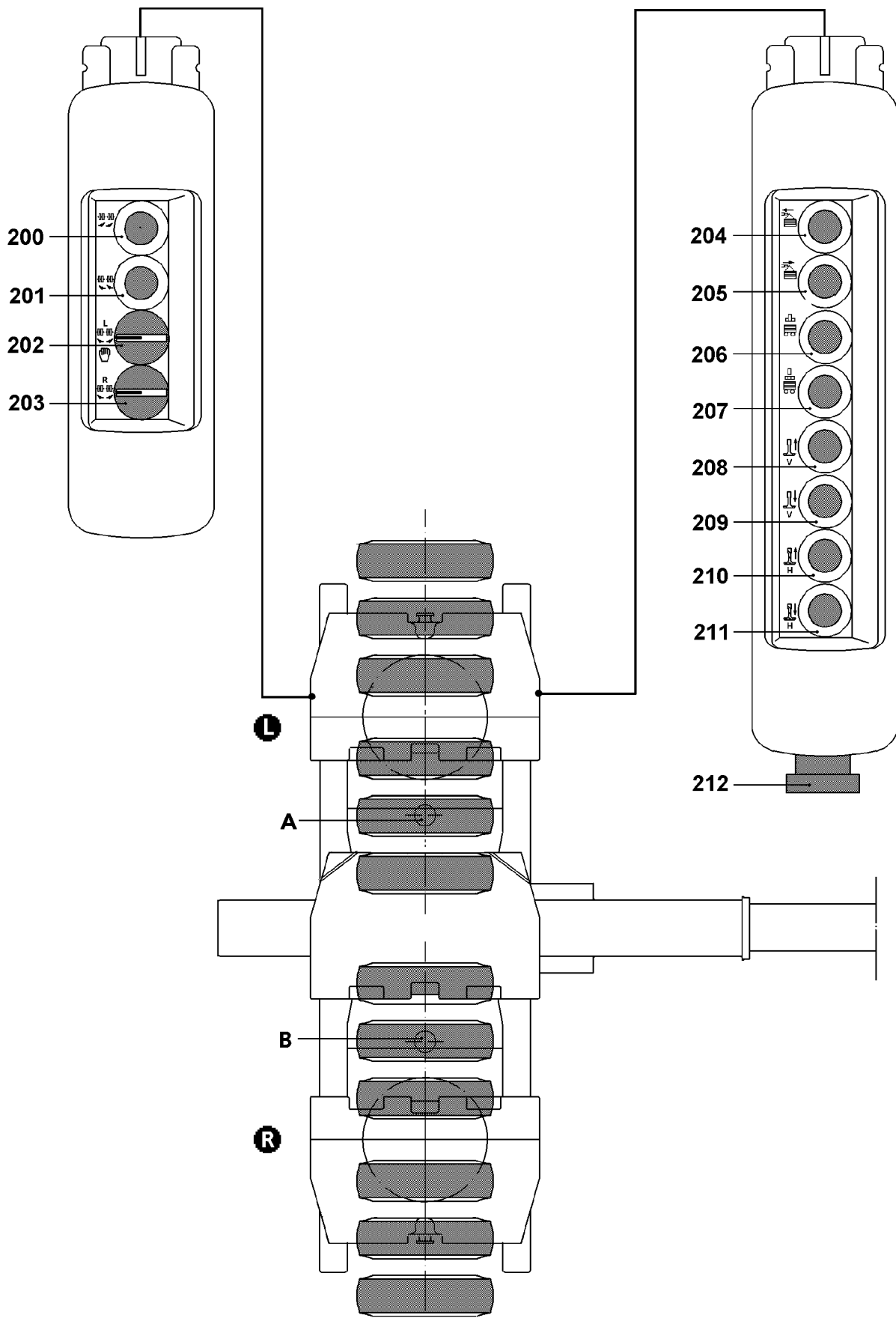
- Guide extended - pinned to turning radius R - 20m
- Ballast trailer horizontally supported
- min. 75t ballast plates placed

B3 = 122.5t max. support pressure

Fig. 4

- Guide retracted - pinned to turning radius R - 15m
- Ballast trailer horizontally supported
- min. 12,5t ballast plates placed

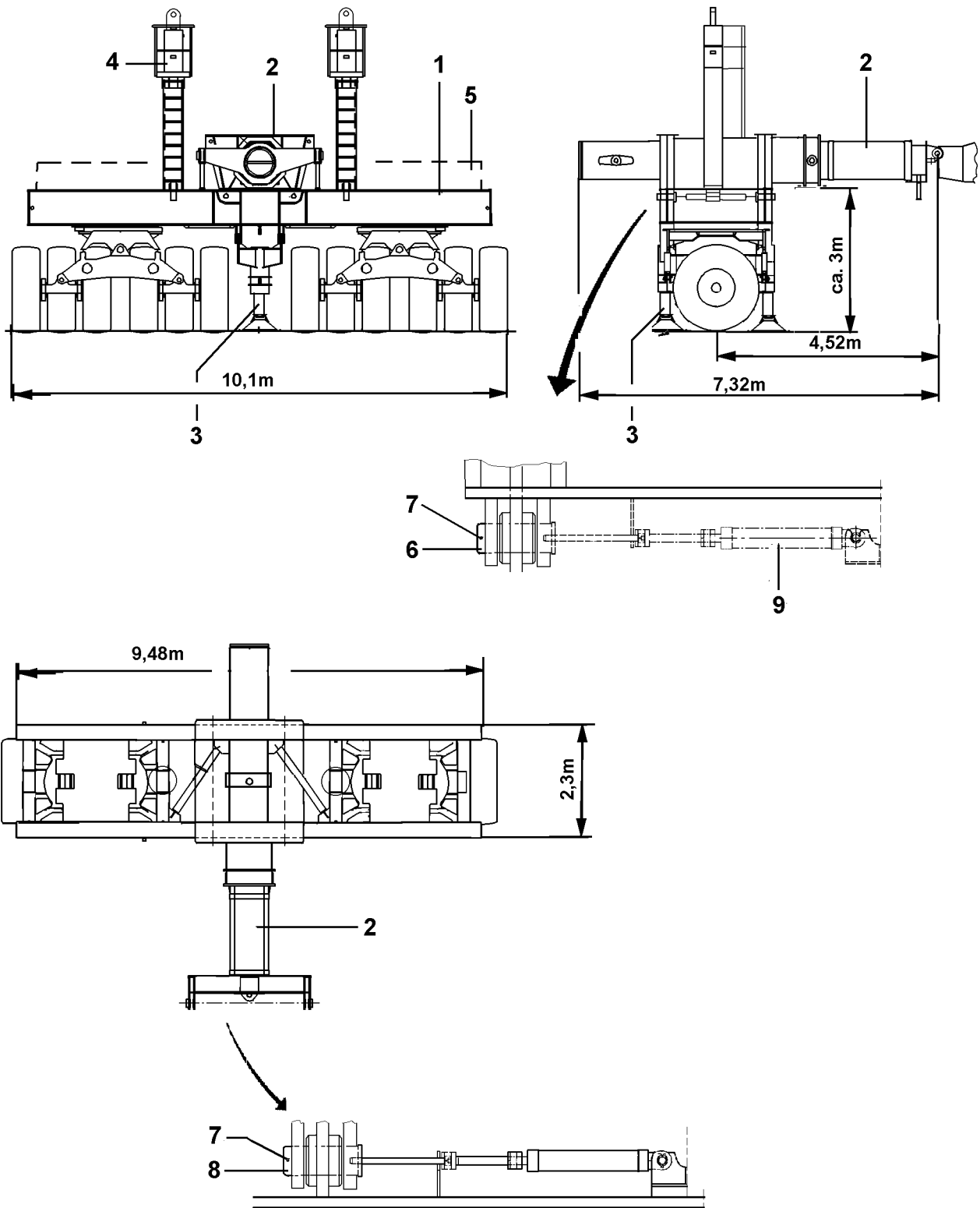
B4 = 62.0t max. support pressure



2. Control elements on control panels**Pos.:**

200	Button	-	Manual steering to the left
201	Button	-	Manual steering to the right
202	Knob	-	Turn wheel set left side to the right or left Manual operation for installation or emergency control
203	Knob	-	Turn wheel set right side to the right or left Manual operation for installation or emergency control
204	Button	-	Ballast trailer, retract sliding cylinder
205	Button	-	Ballast trailer, extend sliding cylinder
206	Button	-	Pinning - pin ballast trailer - slewing platform
207	Button	-	Pinning - unpin ballast trailer - slewing platform
208	Button	-	Retract support cylinder on the front
209	Button	-	Extend support cylinder on the front
210	Button	-	Retract support cylinder on the rear
211	Button	-	Extend support cylinder on the rear
212	Switch	-	Emergency off

2



3. Installation of ballast trailer

DANGER: The ballast trailer is not equipped with its own braking system. For that reason, it is imperative that it is supported if it is not installed .

The installation of the ballast trailer may only be carried out on level ground of sufficient load carrying capacity and only by authorized persons.

Components

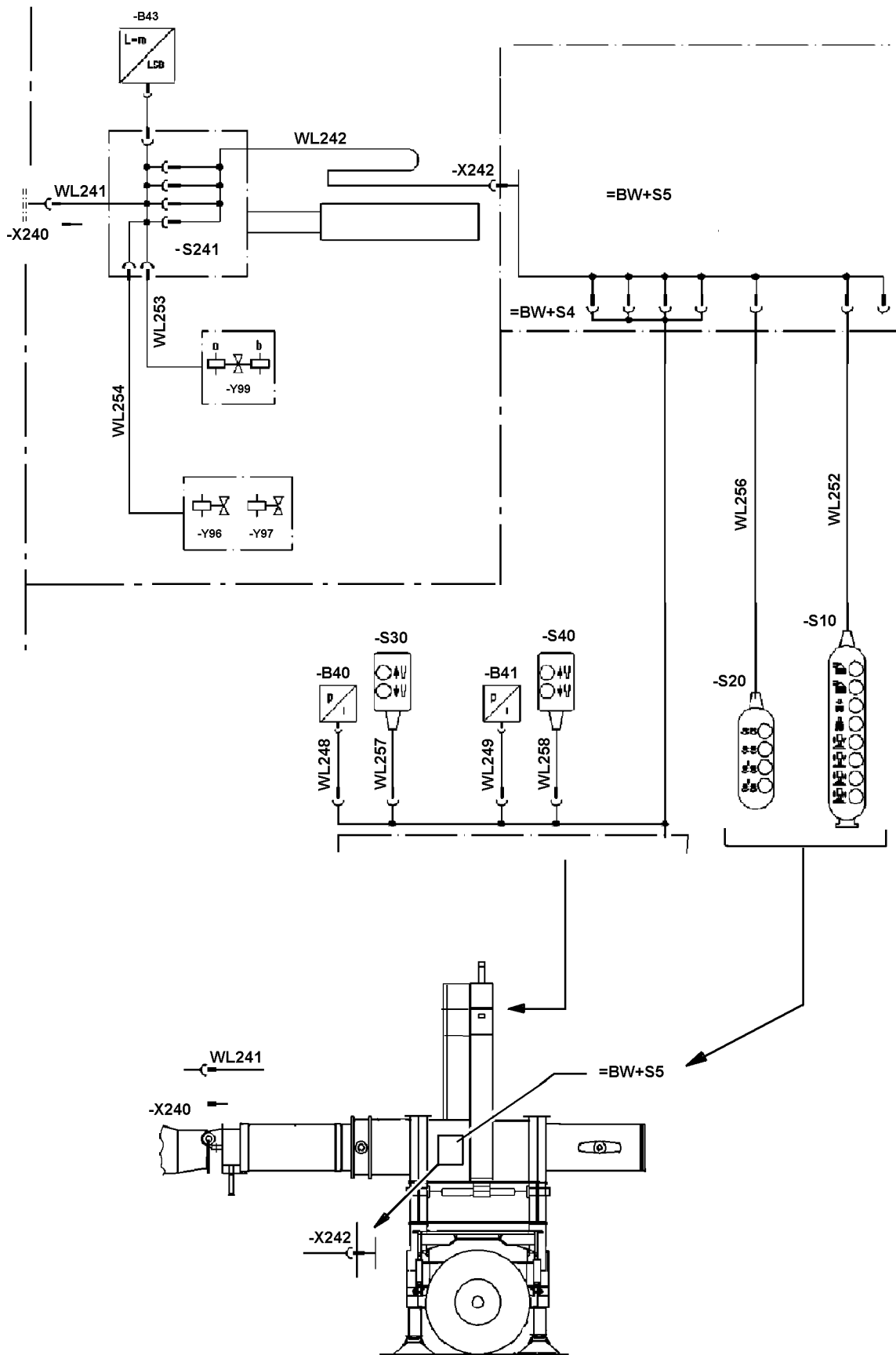
- 1 Ballast trailer
- 2 Ballast trailer guide
- 3 Support cylinder
- 4 Pull cylinder
- 5 Ballast plate
- 6 Pin, pinning of ballast trailer with guide
- 7 Spring retainer
- 8 Pin, pinning of ballast trailer with crane

3.1 Pin ballast trailer guide (2) on ballast trailer

- Unload the ballast trailer (1) with the auxiliary crane from the flatbed trailer
- The ballast trailer must be supported.
- Unload the ballast trailer guide (2) with the auxiliary crane and swing to the connector eyes on the ballast trailer .

- Lower the ballast trailer guide (2) and pin on the ballast trailer frame:
 - Connect the pin pulling device (9) with the hydraulic component.
 - Pin the pins (6) with the pin pulling device (9) on both sides and secure with the spring retainers (7).
 - Remove the pin pulling device.

CAUTION: The ballast trailer guide must be held with the auxiliary crane until it is pinned and secured on the ballast trailer and on the slewing platform .
Otherwise there is a danger of tipping over!



3.2 Pin the ballast trailer guide on the crane

- Drive the crane as close as possible to the ballast trailer guide.
- Turn the engine off.
- Connect the supply lines,

Note: For installation, the electrical connection can be established to be able to move the support cylinders as well as the pull cylinders, if necessary.
The releases "Ballast UP / DOWN" is available, if the conditions of the shut off diagrams are fulfilled, independent if the ballast trailer is installed.
The release "Ballast UP" allows retraction of the pull and support cylinders.
The release "Ballast DOWN" allows extension of the pull and support cylinders.
This means that the support cylinders and the pull cylinders can be moved at the same time, even if the signal "Ballast trailer pinned" has not yet been given.

3.2.1 Establish the electrical connection

- Remove the dummy plug on the socket -X 240 on the rear of slewing platform.
- Insert the cable WL 241 in socket -X 240.
- Insert the cable WL 242 in socket -X 242 on ballast trailer.

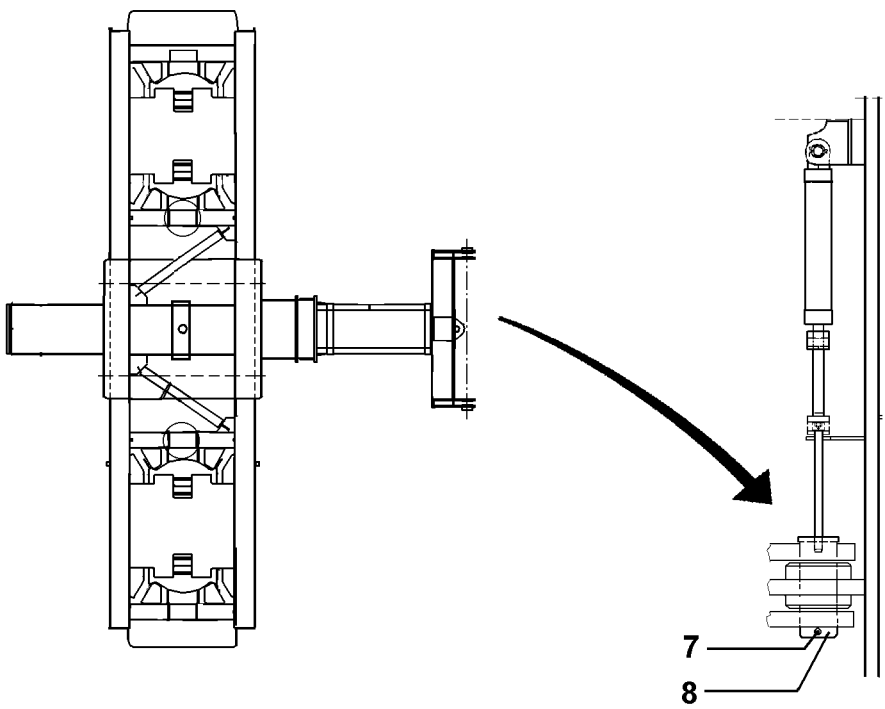
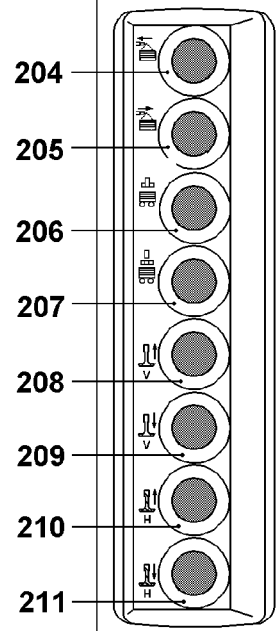
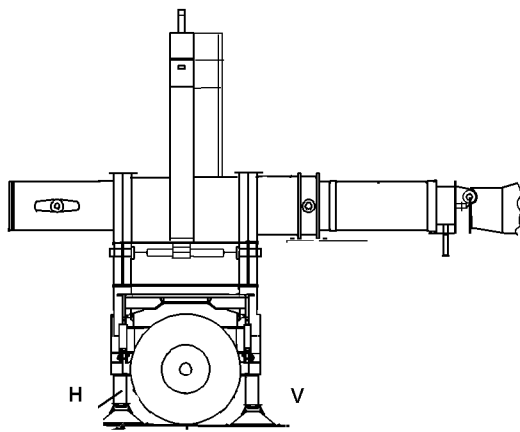
3.2.2 Establish the hydraulic connections

The hydraulic quick couplings, which belong together, are marked.

D A N G E R : When connecting or releasing the hydraulic lines with quick couplings, it must be ensured that the coupling procedure is carried out properly.
Prerequisite for correct coupling connection is:

- The pressure must be released from the hydraulic system before connecting or releasing the couplings (turn the engine off, wait for approx. 5 minutes).
- Interconnect the coupling sections (sleeve and plug) and connect them with the hand nut.
- Tighten the nut past the O-ring until you can feel a firm stop.
- The couplings may only be tightened by hand - without tools (or couplings will be damaged).

Improperly connected couplings can cause loss of pressure or sudden leakage and therefore can cause accidents!



3.2.3 Align the ballast trailer

The ballast trailer must be aligned by turning the slewing platform and by raising or lowering the two support cylinders (3) in such a way that the pins (8) can be pinned.

- Press button (208) to retract the support cylinder on the front
- Press button (209) to extend the support cylinder on the front
- Press button (210) to retract the support cylinder on the rear
- Press button (211) to extend the support cylinder on the rear

3.2.4 Pinning procedure

- Press button (206), the crane - ballast trailer guide is pinned to slewing platform on both sides.
- Secure pin (8) with spring retainers (7) on both sides.

Note: The crane control recognizes with the limit switch initiators on the left (10) and right (11), if the pins (15) are fully inserted on the turntable.

DANGER: After pinning, it must be rechecked if both pins are properly inserted and secured and if the connector lines are connected completely and correctly.

If both pins are pinned completely and correctly, then the crane control receives the message "Ballast trailer pinned", which means the turntable can be turned and the crawler can be driven.

The release is issued only when the ballast trailer wheels are in the required position:

- Circular travel
- Towing
- Parallel travel.

As long as only one pin is pinned, the crane control receives no message "Ballast trailer pinned", which means the turntable can be turned and the crawler can be driven, so that it is possible to insert the 2nd pin.

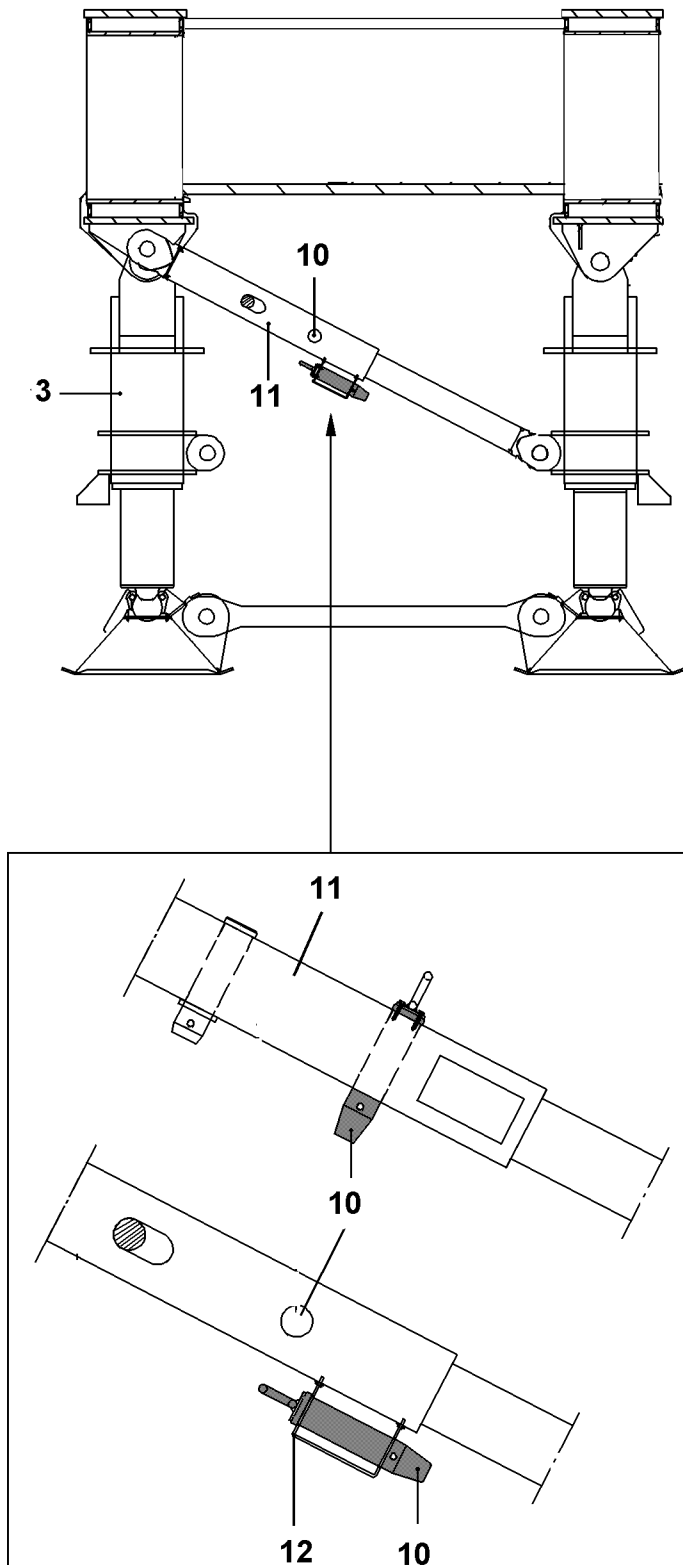
These movements must be carried out with utmost caution!

If this is not observed, damage can occur on the crane and the ballast trailer!

There is increased danger of accidents!

- Press button (208) to retract the support cylinder on the front all the way.
- Press button (210) to retract the support cylinder on the rear all the way.

Note: The support cylinders can be retracted and extended via the corresponding buttons in the cab.



3.2.5 Retract the support cylinder (3) . unpin the locking pin (10) on the strut (11)

If the ballast trailer is pinned on the slewing platform, the support cylinders (3) must be retracted.

Remove the spring retainer (S) on the support cylinder strut (11) and unpin the locking pin (10) on the strut (11) .

Insert the locking pin (10) into the receptacle (12) .

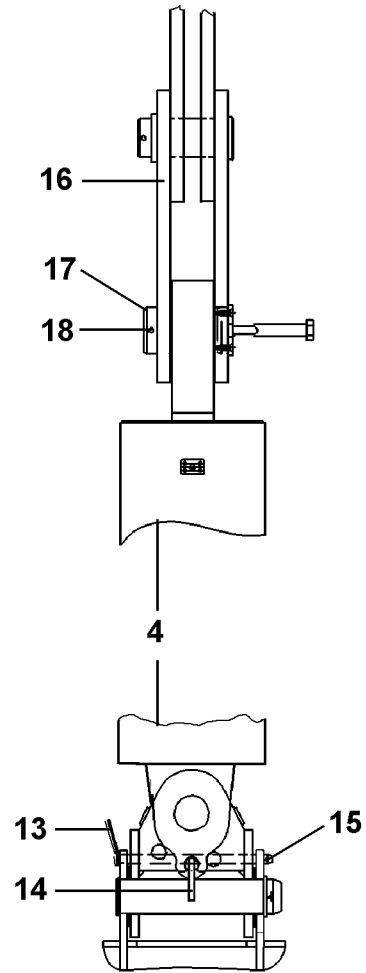
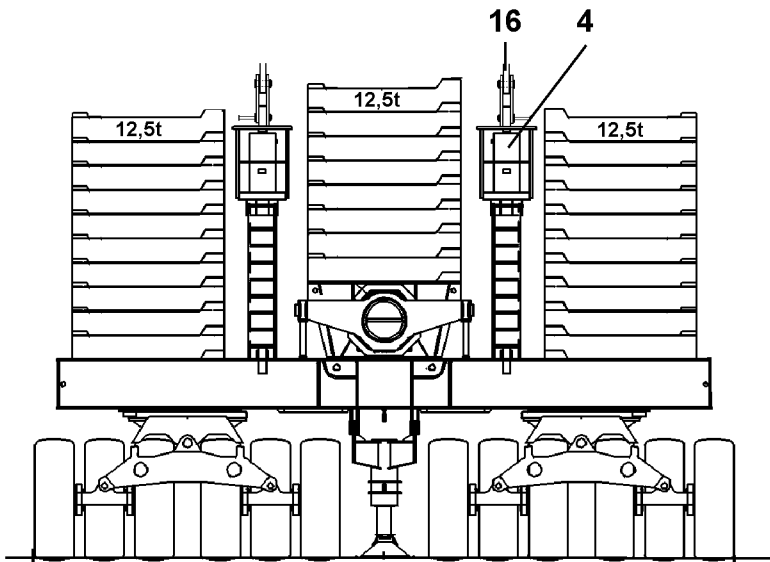
Note: The locking pin (10) can only be unpinned if support cylinders (3) are retracted.

C A U T I O N: **Before placing the ballast plates on the ballast trailer , it must be ensured that the support cylinders (3) are retracted and the locking pin (10) is removed on the strut (11) .**

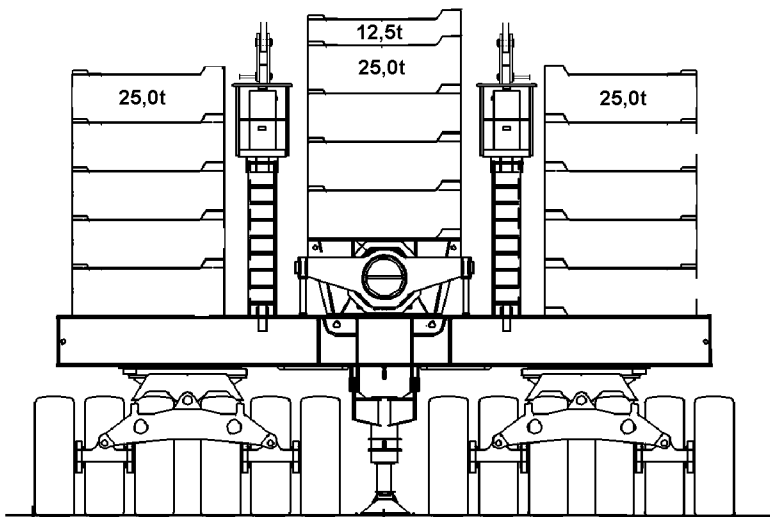
It is imperative that the locking pin is unpinned, so that there is a compensation between the strut and the support cylinders when the ballast plates are placed.

Otherwise the ballast trailer will be damaged!

1



2



3.3 Set up the pull cylinder

Set up the pull cylinder (4) with the auxiliary crane and lock with two pins crosswise and lengthwise.

- Insert the handle pin (13) and secure with spring retainers (15) .
- Insert the handle pin (14) and secure with spring retainers (15) .

Note: The weight of the pull cylinder is approx. 1500kg
 On each cylinder is a working platform. On this platform is a switch housing with button "Cylinder OFF" and "Cylinder ON" .
 With this buttons, only the one cylinder can be moved on which the switch is installed.

Extend the piston rod and connect the guy rod (16) with cylinder (4), insert pin (17) and secure with spring retainer (18) .

C A U T I O N : Unpin locking pin (13) when guy rods are pinned to the cylinder, therefore cylinders can move transvers.
 Otherwise the ballast trailer will be damaged!

3.4 Ballasting of the ballast trailer

C A U T I O N : Before placing the ballast plates on the ballast trailer, it must be ensured that the support cylinders are retracted and the locking pin (10) is removed on the support cylinder strut (11) .
 Otherwise the ballast trailer will be damaged!

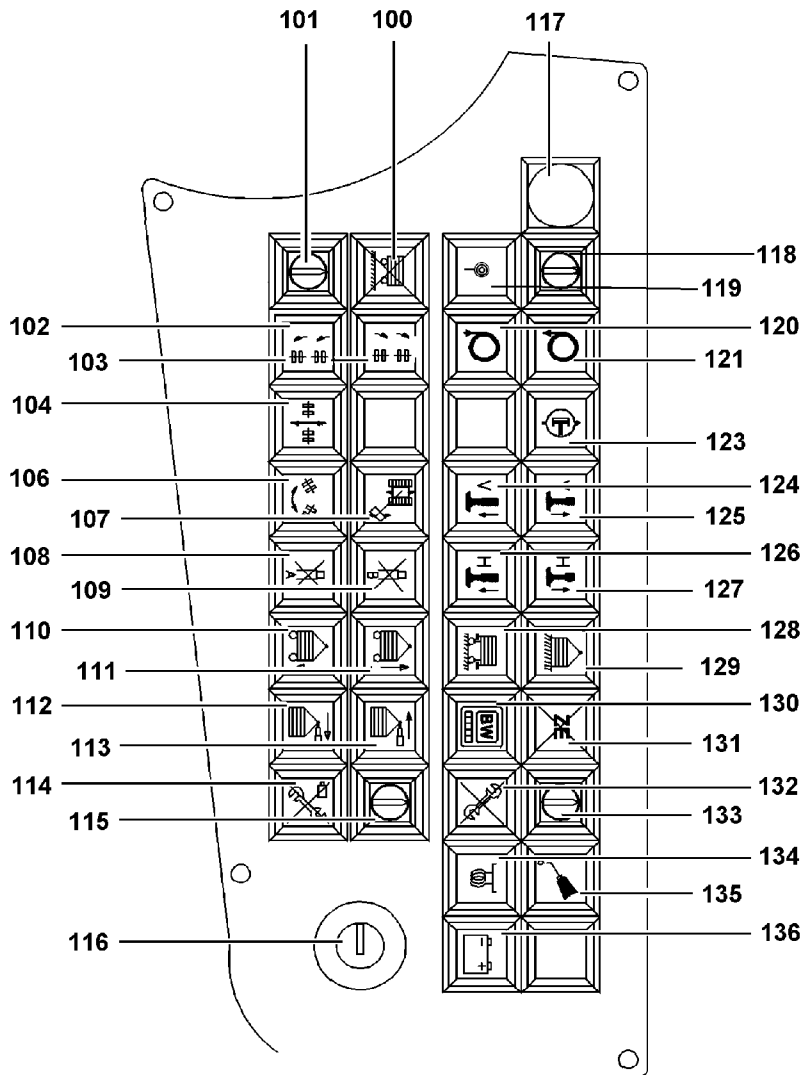
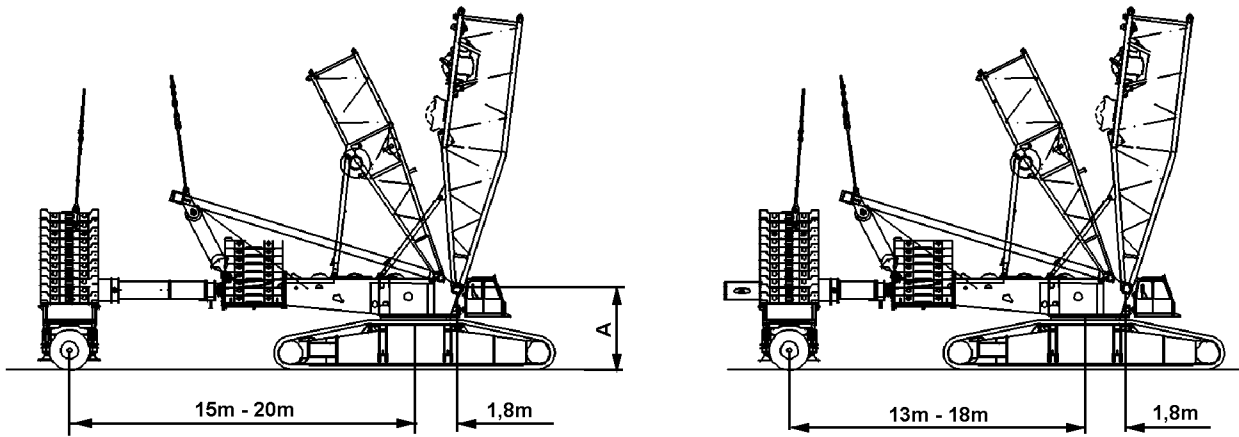
Fig. 1	28 plates	each	12.5t
* Fig. 2	14 plates	each	25.0t
	1 plate		12.5t

Place the ballast plates with the auxiliary crane onto the ballast trailer .

D A N G E R: When loading the ballast trailer, make sure the ballast plates are placed correctly.
 The ballast plates must be distributed evenly when placed on the ballast trailer .

Note: To determine the correct ballast weight, use the LICCON job planner.

* Optional



3.5 Raising and lowering the ballast trailers with the pull cylinders

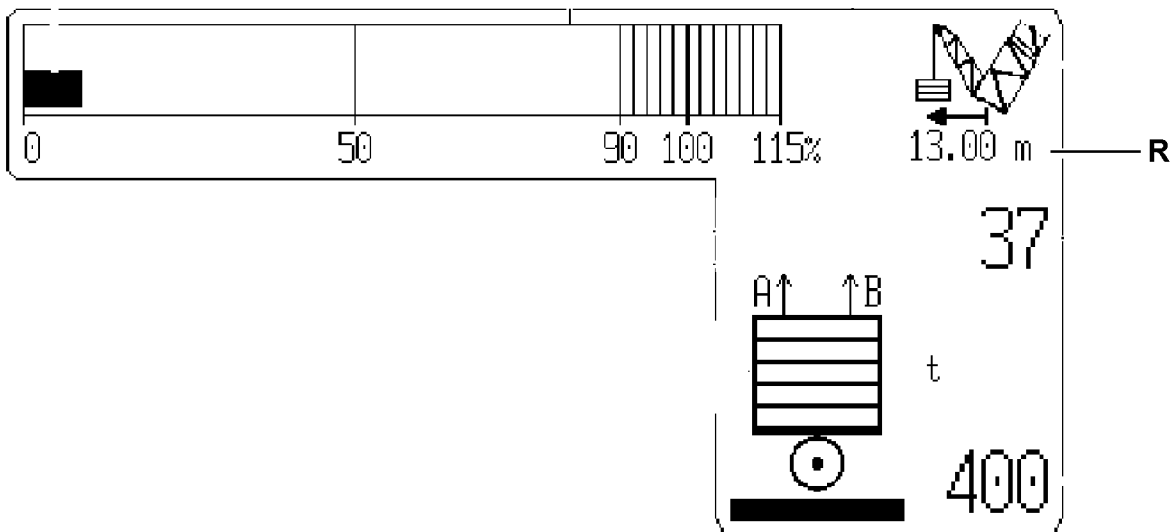
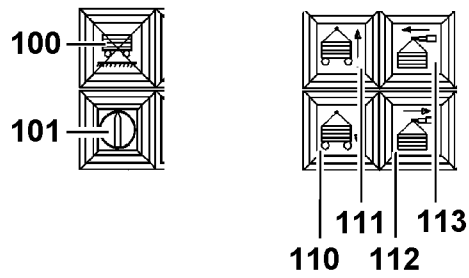
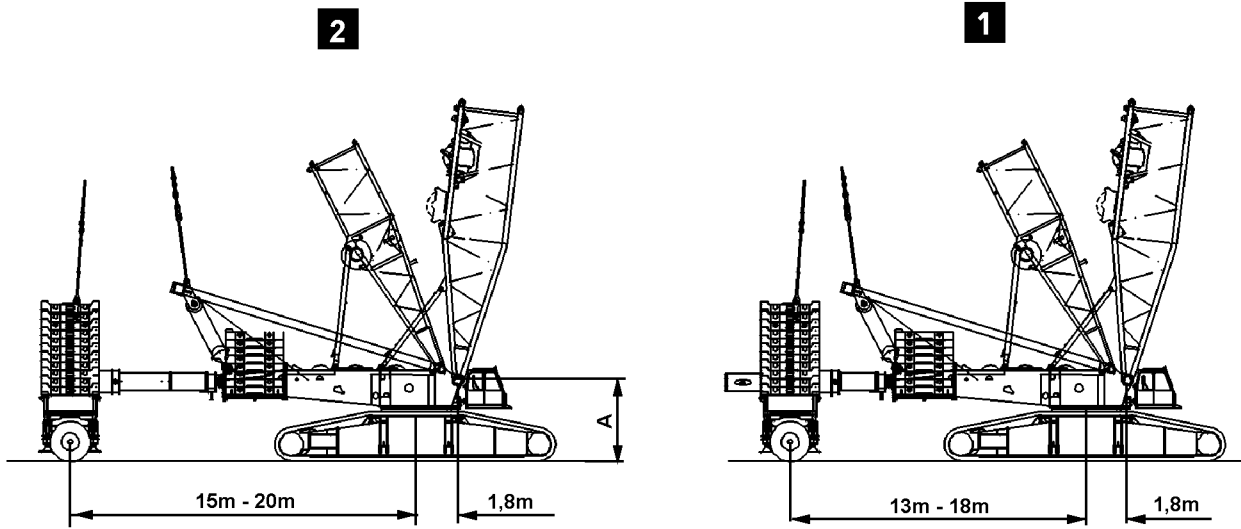
- Press the button (111) in the cab, the ballast trailer is raised with the pull cylinders ;
- Press the button (110) in the cab, the ballast trailer is lowered with the pull cylinders.

D A N G E R: **If the ballast trailer is raised or lowered, make sure the ballast trailer is positioned horizontally.**
When the guide is on top, the alignment is automatically carried out with the aid of the level sensor when raising and lowering the ballast trailer.

Note: The ballast trailer can be manually aligned in horizontal direction with buttons (108) "A-Stop" and (109) "B-Stop" .

- Press the button (108) in the cab, the ballasting cylinder (A) on the left hand side is blocked;
- Press the button (109) in the cab, the ballasting cylinder (B) on the right hand side is blocked.

D A N G E R: **The control panel on the ballast trailer may only be used for the installation. During crane operation, the crane operator may not raise or lower the ballast trailer from the control panels on the pull cylinders because the monitors cannot be seen from that point.**
Raising or lowering during crane operation may only be made from the cab.
When raising or lowering the ballast trailer, it must be ensured that the difference of forces in the ballast guying is not too great.
The LICCON shows both forces and issues a warning if the difference of forces is too great.
See also paragraph 8.8, Difference force monitoring of ballast guying.



4. Telescoping the ballast trailer in and out

The ballast trailer is equipped with a telescopable ballast trailer guide, which allows the ballast trailer radius to be matched to the current environment or current hoisting task.

The length of the telescopable ballast trailer guide is:

Fig. 1 = min. 13m - max. 18m

Fig. 2 = min. 15m - max. 20m

The current actual length (R) is shown on the monitor .

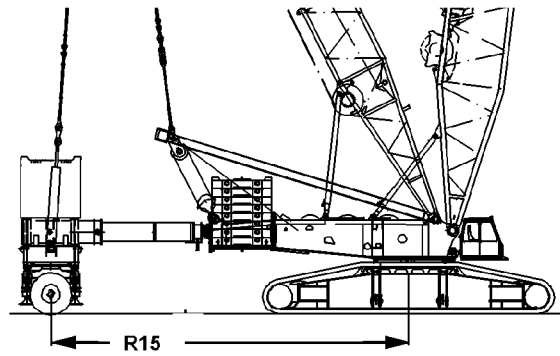
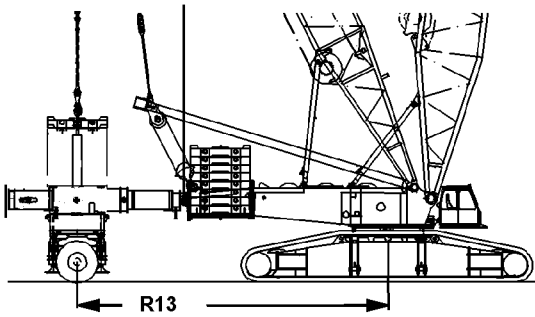
Note: Telescoping in and out is only possible if the wheels of the ballast trailer are in towing mode or if the ballast trailer is suspended and if the keyed button (101) has been switched to "**Ballast trailer raised**".
The warning light (100) "**Ballast trailer raised**" **blinks** if the keyed button (101) is turned on.
The condition "**Ballast trailer raised**" is turned off by pressing the button (100) .

D A N G E R: **If the wheels are not in towing mode or if the keyed button (101) has not been switched to "Ballast trailer raised" and the wheels of the ballast trailer scrape on the ground, then the ballast trailer can be severely damaged. There is an increased chance of having an accident!**

- Press the button (113) to telescope the ballast trailer out;
- Press the button (112) to telescope the ballast trailer in.

D A N G E R: **Make sure there are no persons or objects within the danger zone of the ballast trailer . There is a danger of accidents!**

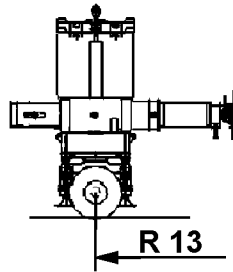
C A U T I O N: **When telescoping the ballast trailer in and out, the indicated actual length (R) must be monitored. The crane operator may not blindly rely on the measurement of the derrick ballast radius, he must think for himself and check if the measurement can be correct . See also paragraph 8.7, Checking the length value sensor on the ballast trailer.**



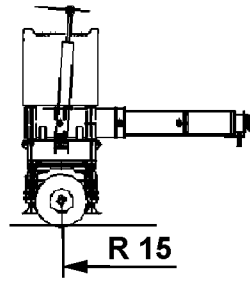
1

2

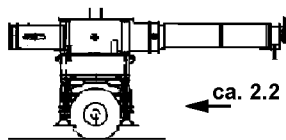
1.1



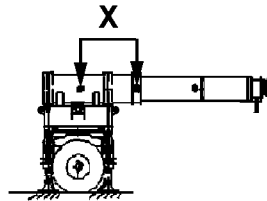
2.1



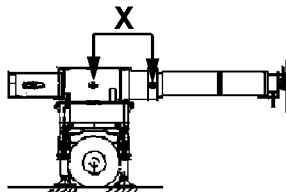
1.2



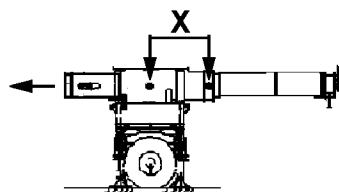
2.2



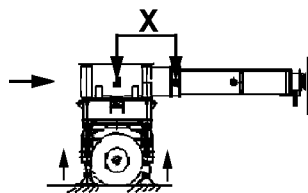
1.3



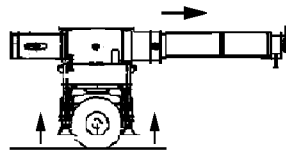
2.3



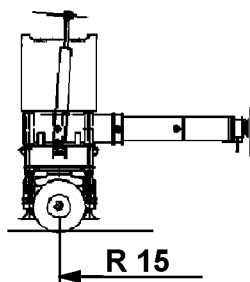
1.4



2.4



1.5



2.5

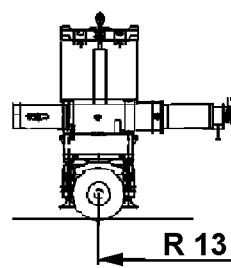
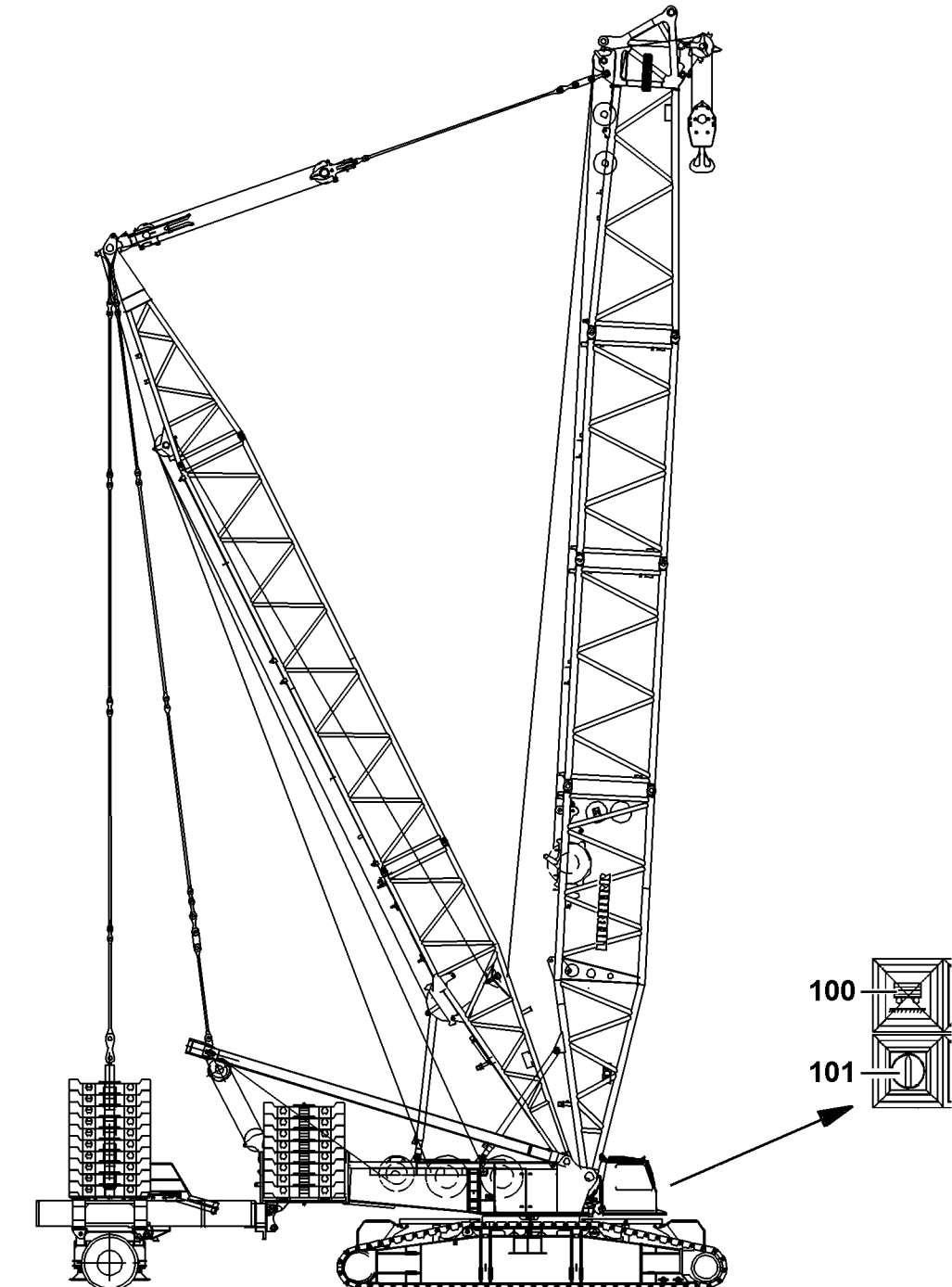


Fig. 1**1.0 Assembly from R 13m (18m) to R 15 (20m)**

- 1.1 Starting position R 13m
Loosen up guy rods
- 1.2 Extend ballast trailer appr. 2,2m
- 1.3 Pin support cylinder strut with locking pin
Support ballast trailer
Unpin guide pipe (X)
Adjust ballast trailerwith support cylinder - visual check on the guide
- 1.4 Retract guide pipe
Pin guide pipe (X)
Unpin support cylinder strut
Retract support cylinder
- 1.5 Operating position, R 15m

Fig. 2**2.0 Assembly from R 15m (20m) to R 13 (18m)**

- 2.1 Starting position R 15m
Loosen up guy rods
- 2.2 Pin support cylinder strut with locking pin
Support ballast trailer
Unpin guide pipe (X)
- 2.3 Adjust ballast trailerwith support cylinder - visual check on the guide
Extend guide pipe
Pin guide pipe (X)
- 2.4 Retract support cylinder
Unpin support cylinder strut
Retract guide pipe to an radius of R 13m
- 2.5 Operating position, R 13m



5. Driving with the ballast trailer

The ballast trailer is equipped with computer controlled steering programs.

- Driving in turns ;
- Towing;
- Parallel driving;
- Manual steering adjustment;
- Manual operation for installation.

5.1 General

The computer controlled steering programs driving in turns, towing and parallel driving can only be actuated from the cab.

Manual steering adjustment and support cylinders can be actuated from the cab or by remote control.

Manual operation for installation can only be actuated from the control panel.

Prerequisite

- The wheels of the ballast trailer must be in the required travel position.

Note: If the ballast trailer is operated on the ground, the wheels must be in the correct travel position.

If the ballast trailer is suspended, the wheels can be in any position, if the keyed button (101) was switched to "**Ballast trailer raised**". In this case, the crane operator must monitor that the wheels do not scrape.

DANGER: If the ballast trailer is on the ground, and the wheel position is not correct and the keyed button (101) had been switched to "**Ballast trailer raised**", the wheels of the ballast trailer and possible the crane can be damaged when "**driving the crawler**".

- The travel route for crane and ballast trailer must be level, horizontal and of sufficient load carrying capacity.

Note: During travel and slewing, a guide must monitor the crane, the luffed up boom, as well as the raised load.

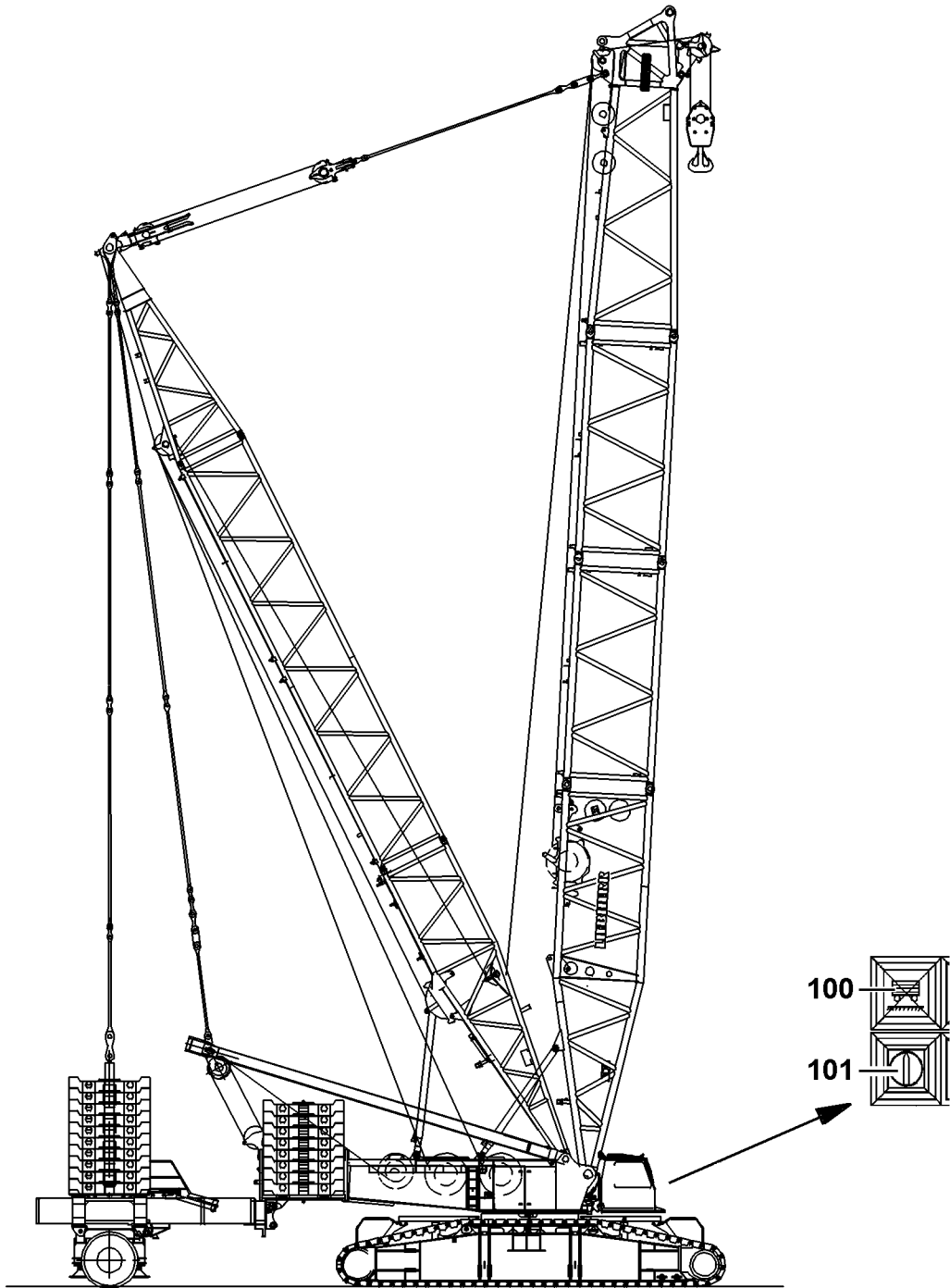
Driving with a load, see chapter 4.05 Crane operation, paragraph : Crawler operation.

- It is only permitted to drive at minimum speed, utmost caution and care, the least possible acceleration as well as careful braking action.

Note: If the ballast trailer is unloaded, the axles can be moved without relieving the tires. If the ballast trailer is loaded, the tires must be relieved by supporting the ballast trailer.

CAUTION: When supporting the loaded ballast trailer, it must be ensured that the pin on the strut of the support cylinders is unpinned. Otherwise the ballast trailer will be damaged.

DANGER: Make sure there are no persons or objects within the danger zone of the ballast trailer .
There is a danger of accidents!



5.1.1 Keyed button (101) "Ballast trailer raised"

When "driving crawler" and keyed button (101) is **not** actuated, and "ballast trailer is not raised", the slewing brake as well as the hydraulic slewing gear coasting is opened.

If proceeded at "driving crawler" with raised ballast trailer (constant visual check), the keyed button (101) "Ballast trailer raised" must be turned on.

D A N G E R: If the ballast trailer is raised off the ground (constant visual check), there is the danger that the wind turns the slewing platform away when "driving the crawler", for that reason, the keyed button (101) "Ballast trailer raised" must be turned on immediately.

In that case, when "driving the crawler", the slewing brake stays closed, the hydraulic slewing gear coasting, however, remains open.

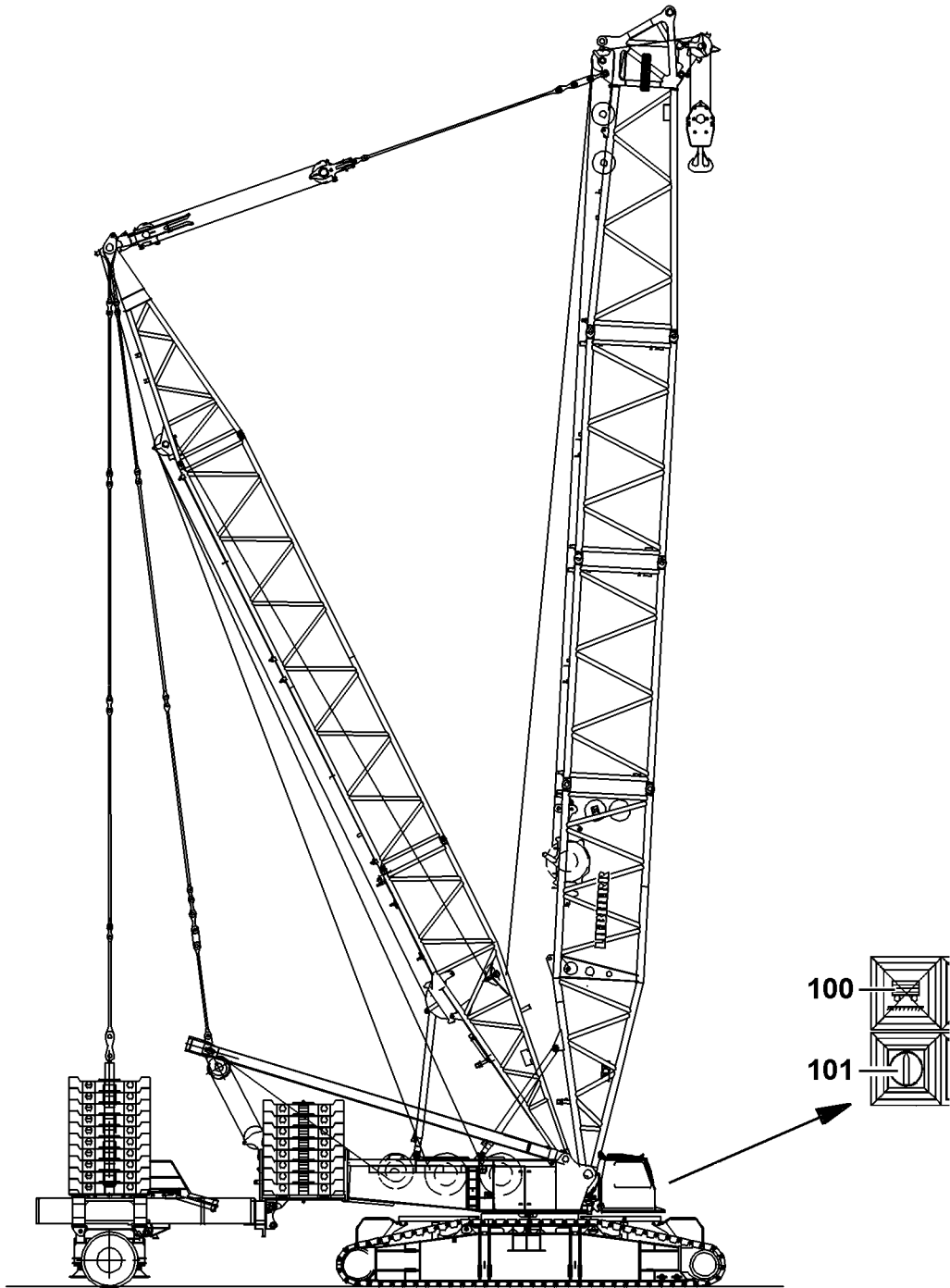
If the ballast trailer scrapes or gets stuck on the ground when "driving the crawler", so that the slewing platform turns with the ballast trailer against the crawler travel gear, the slewing brake will slip. The slewing gear will not be damaged. If the wheels of the ballast trailer are not on towing mode, the ballast trailer or the crane will be damaged.

C A U T I O N: If, with turned on function "Ballast trailer raised", the indicator light (100) blinks, it is possible to turn the crane superstructure or to drive the crane even though the wheels of the ballast trailer are not set to driving in turns, towing or parallel travel.

If "ballast trailer raised" is turned on with the keyed button (101), then this is shown by the blinking warning light (100). In addition, the ballast trailer symbol is shown on the monitor 1 in suspended condition.

Press the button (100) to turn off "ballast trailer raised". The warning light in the button (100) turns off.

The LICCON monitor shows the derrick ballast symbol on the ground.



5.1.1.1 Operate the ballast trailer in defined mode

The ballast trailer may not be raised or lowered while driving, this must be done before starting to drive.

The ballast trailer should either be

- 1) defined as set on the ground (keyed button (101) **not** actuated "ballast trailer not raised").
This means that the ballast trailer is sitting with a remaining load on the ballast trailer tires. This remaining load is so great that the wind cannot turn the crane superstructure if the slewing brake is open when actuating "driving the crawler " .

or

- 2) defined as raised off the ground (keyed button (101) actuated "ballast trailer raised").
This means that the slewing brake is not open when "driving the crawler " , and the wind cannot turn the superstructure when "driving the crawler " .

D A N G E R: **The ballast trailer must always be operated in defined mode (safely off or on the ground) . Operation of the ballast trailer when not in defined mode is prohibited.**
In case of non-defined (solid) setting down of the ballast trailer and non-defined lifting off of the ballast trailer, there is an increased risk of accidents.

C A U T I O N: **If the ballast trailer wheels scrape on the ground, they can be damaged despite the setting "ballast trailer raised" .**

5.1.1.2 Operate the ballast trailer in non-defined mode

D A N G E R: **The ballast trailer must always be operated in defined mode.**

Example:

Ballasted ballast trailer is still sitting on the ground with 1 t .

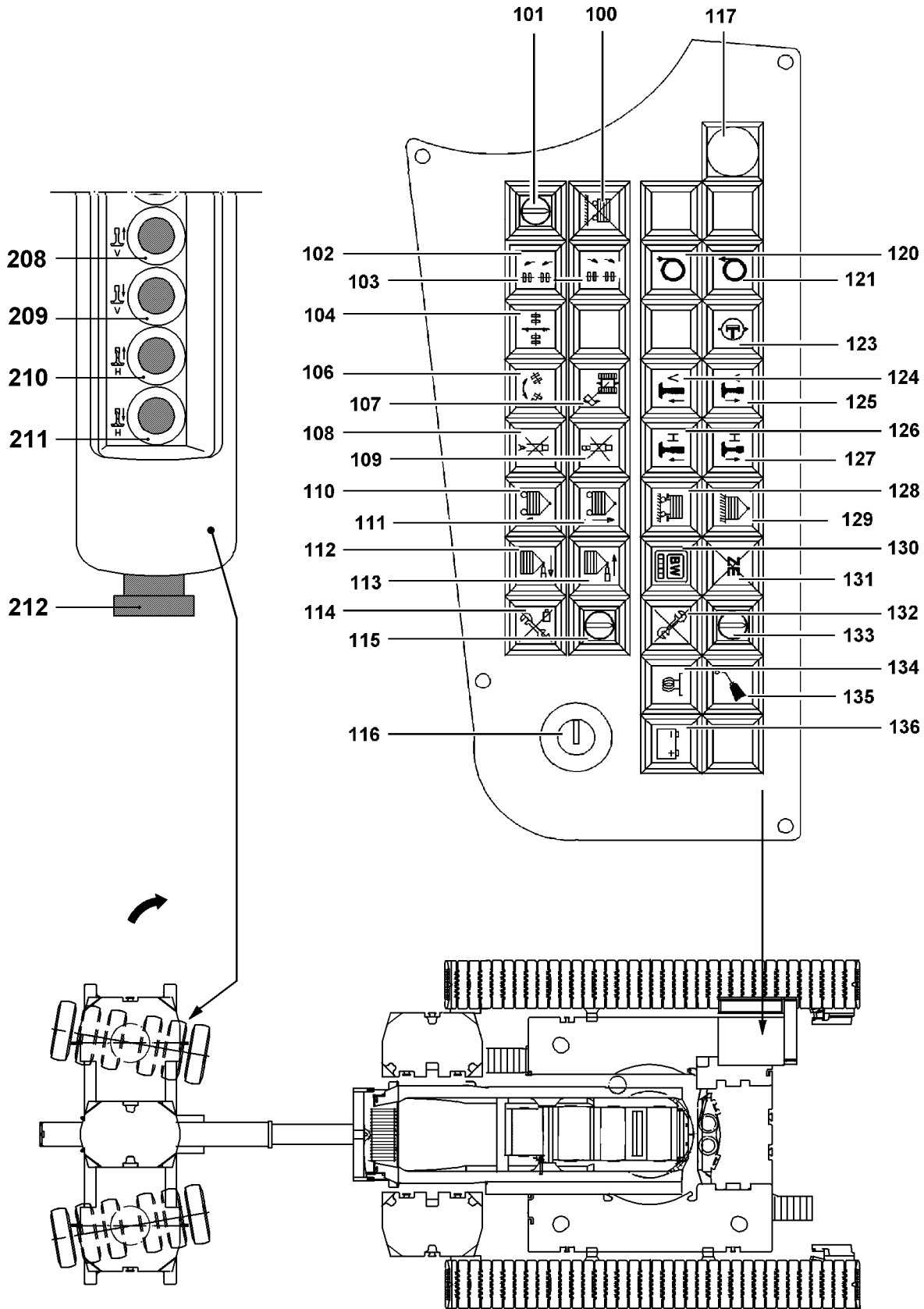
- 1) If the keyed button (101) is **not** actuated "Ballast trailer not raised"
The slewing brake opens when driving the crawler. The wind can turn the superstructure and the load can start to swing.

D A N G E R: **There is an increased danger of accidents due to collision.**

or

- 2) if keyed button (101) is actuated "Ballast trailer raised"
The slewing brake remains closed when driving the crawler . When driving the crawler (in curves), the ballast trailer tires or the slewing brake slip .

C A U T I O N: **There is the danger that the ballast trailer or the slewing gear will be damaged due to wear.**



5.2 Driving in turns

By telescoping the ballast trailer guide, various turning radii are possible.

Prerequisite

- The crane is at a standstill;
- The ballast trailer is properly installed.

Note: If the ballast trailer is operated on the ground, the wheels must be in the correct travel direction. See also paragraph 5.2.1 to 5.2.3.
If the ballast trailer is suspended, the wheels can be in any position, if the keyed button (101) was switched to "ballast trailer raised". In this case, the crane operator must monitor that the wheels do not scrape.

D A N G E R: If the ballast trailer is on the ground, the wheel position is not correct and the keyed button (101) was switched to "Ballast trailer raised", then the wheels of the ballast trailer can be damaged when turning.

5.2.1 Lift the ballast trailer with support cylinders

- Press button (124 and 126) or
press button (209 and 211), support cylinders front and rear extend.

D A N G E R: The support cylinders should be driven from the cab and the monitor indicators should be observed.
By lifting the ballast with the support cylinders, the force in the test point 1 = F 1 could increased to maximum value. The extension of the support cylinders is then turned off. Do not enter into the shut off, rather stop before that.

5.2.2 Set the axles in circle driving position

- Press the button (106), the axles are turned in turning direction;
the indicator light in the button blinks until the turning direction is reached;
the indicator light in the button lights up when the turning direction is reached.

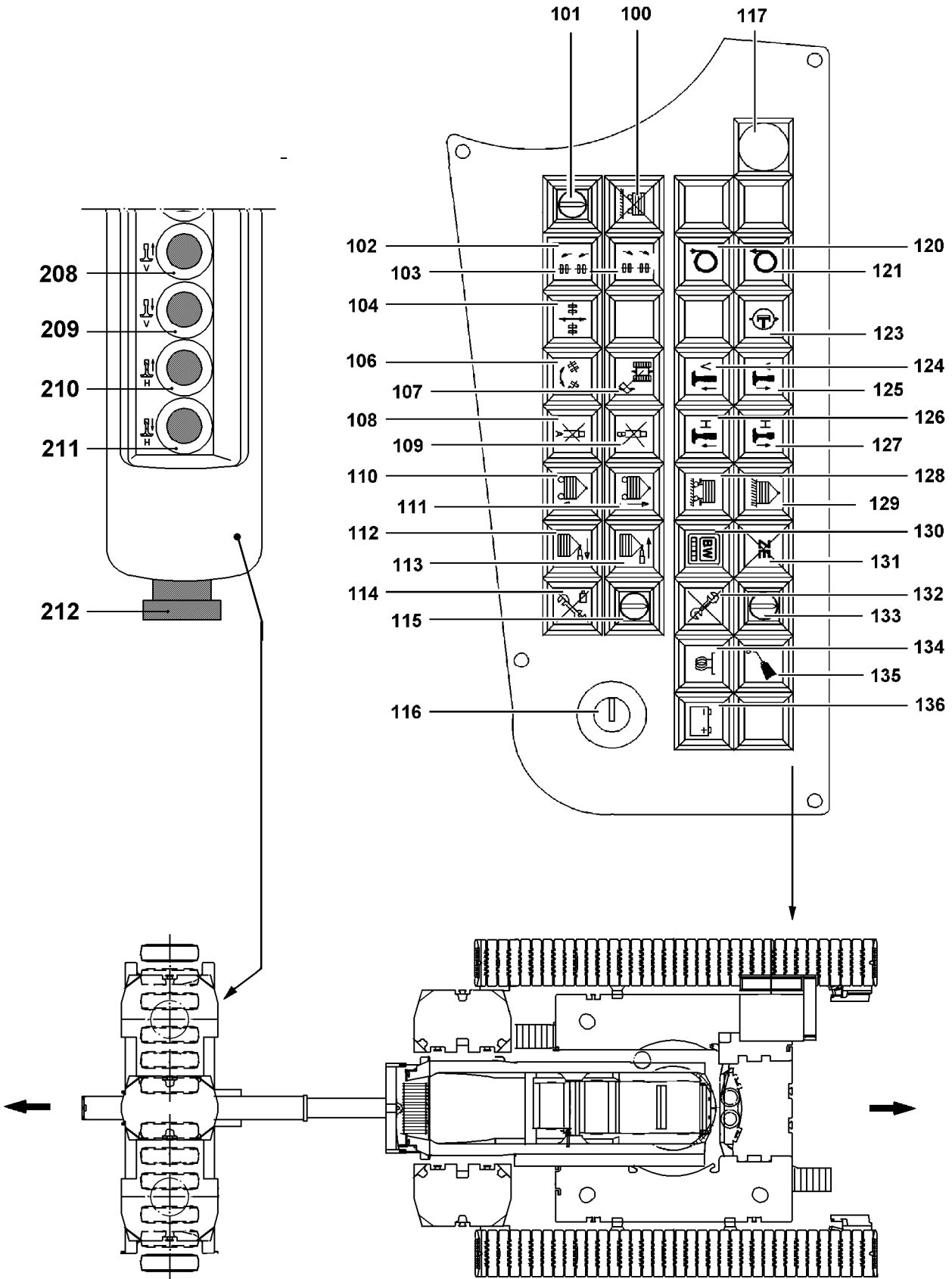
Note: If one of the sets of wheels leaves the stipulated angle, then the indicator light in the button (106) blinks and the axles must be reset as described above.

5.2.3 Lower the ballast trailer with the support cylinders

- Press the button (125 und 127) or
press the button (208 and 210), the support cylinders on the front and the rear retract;
- the indicator light (128) "supports ballast trailer are retracted" lights up.

Note: The release for "turning the slewing platform" is only given when both axles are in turning direction and the support cylinders are retracted.

D A N G E R: The support cylinders should be driven from the cab and the monitor indicators should be observed.
By lifting the ballast with the support cylinders, the force in the test point 1 = F 1 could increased to maximum value. The extension of the support cylinders is then turned off. Do not enter into the shut off, rather stop before that.



5.3 Towing

Prerequisite

- The crane is at a standstill;
- The ballast trailer is properly installed;
- The rocker switch (74) on the left armrest is on crawler operation.

Note: When the ballast trailer is operated on the ground, the wheels must be in the correct travel direction. See paragraph 5.3.1 to 5.3.3.
When the ballast trailer is suspended, the wheels can be in any position, if the keyed button (101) was switched to "Ballast trailer raised". In this case, the crane operator must monitor that the wheels do not scrape.

D A N G E R : If the ballast trailer is on the ground, the wheel position is not correct and the keyed button (101) was switched to "Ballast trailer raised", then the wheels of the ballast trailer and possibly the crane can be damaged when "Driving the crawler".

5.3.1 Raise the ballast trailer with support cylinders

- Press button (124 and 126) or
press button (209 and 211), support cylinders front and rear extend.

Note: see also 5.2.1

5.3.2 Set the axles to towing position

- Press button (104), the axles are turned in towing position;
the indicator light in the button blinks until the towing position is reached;
the indicator light in the button lights up when the towing position is reached.

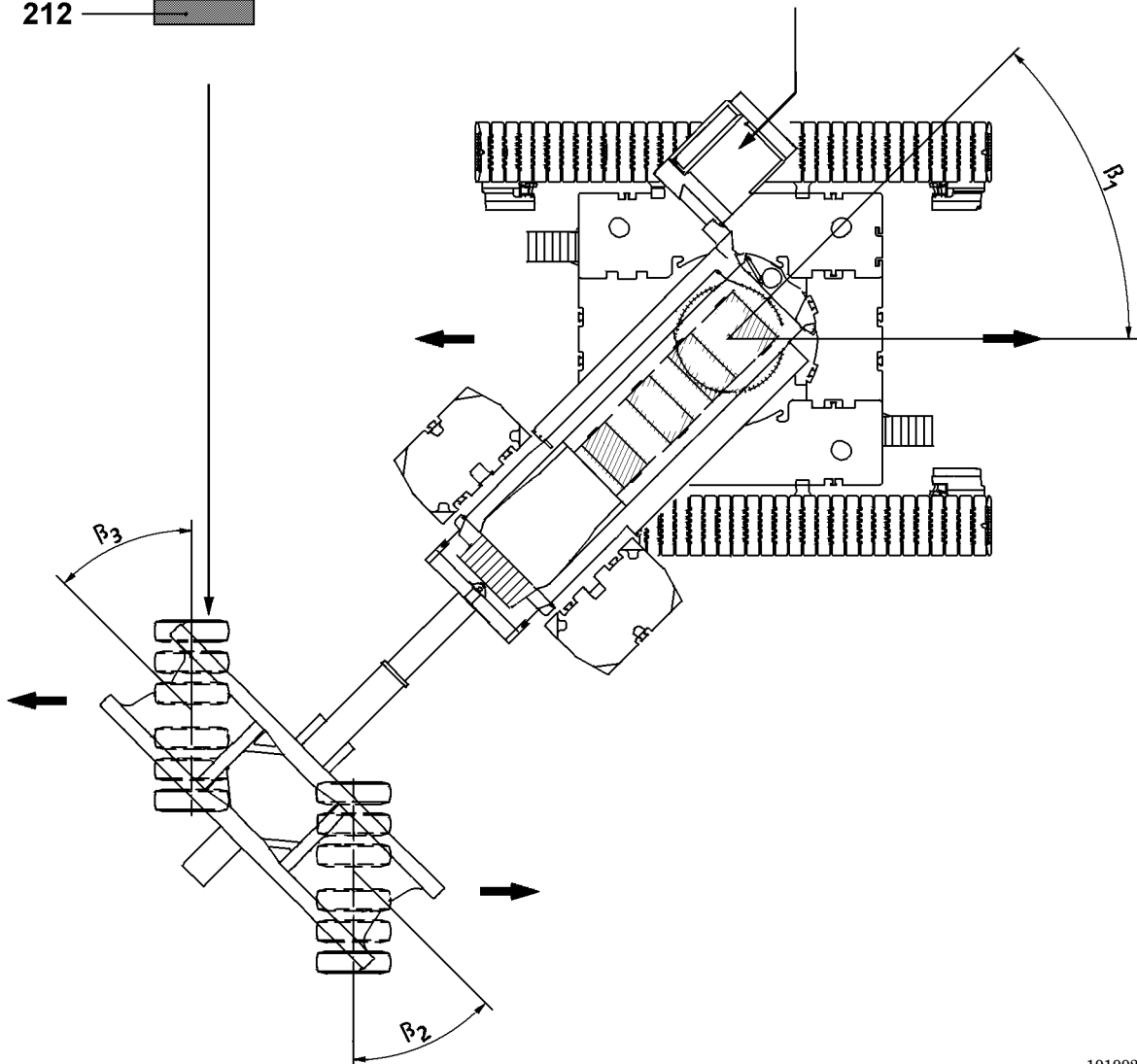
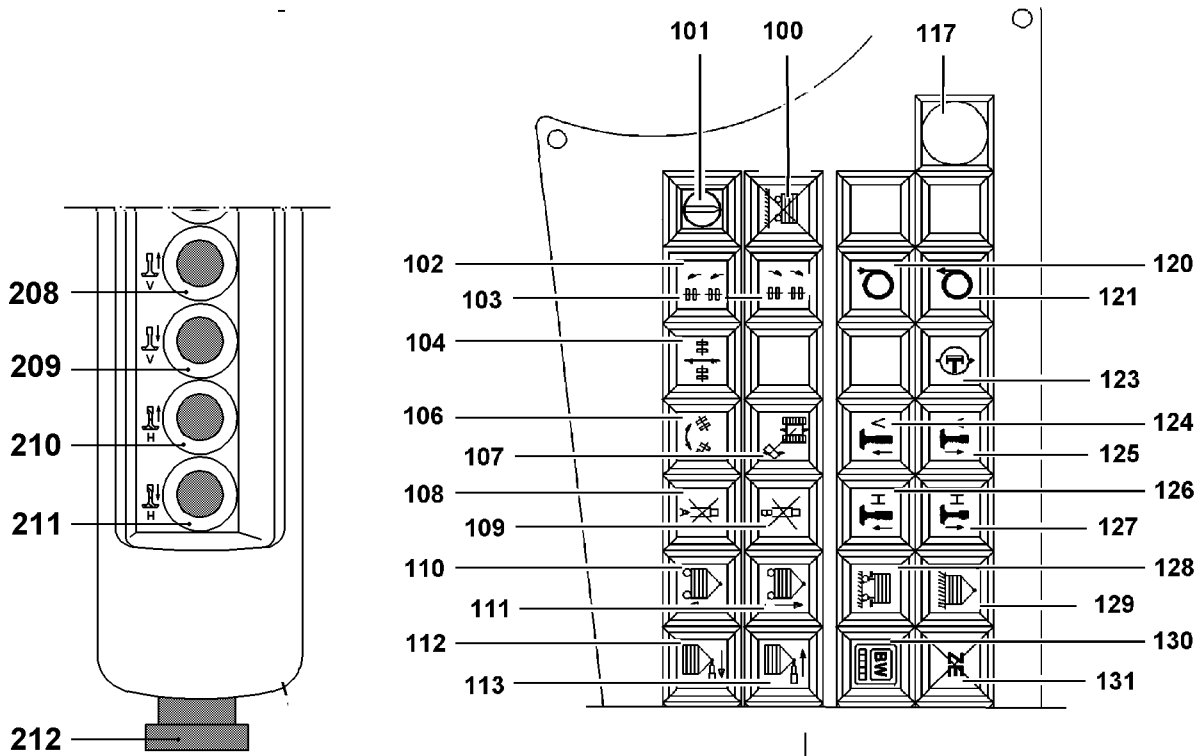
Note: It is possible to switch from operating mode towing, after reaching the towing position, to manual steering adjustment and back while driving the crawler.
If operating mode towing is selected from operating mode manual steering adjustment, then the indicator light in button (104) blinks until the towing position is reached.
If one of the sets of wheels leaves the stipulated angle, then the indicator light in the button (104) blinks and the axles must be reset as described above.

In general, the following applies: The sets of wheels only move if either button (102 or 103 or 104) or (200 or 201) on panel, are pressed in the corresponding operating mode or if the crawler is driven.

5.3.3 Lower the ballast trailer with support cylinders

- Press button (125 and 127) or
button (208 and 210), the support cylinders on front and rear retract;
- indicator light (128) "support ballast trailer are retracted" lights up.

Note: The release for "towing" is only made if both axles are in travel position (zero position) and the support cylinders are retracted.



191992

5.4 Parallel driving

Prerequisite

- The crane is at a standstill ;
- the ballast trailer is properly installed;
- the rocker switch (74) on the left armrest is on crawler operation.

Note: Regardless of "Ballast trailer on the ground" or "Ballast trailer suspended" , the ballast trailer must be in wheel position for parallel driving.
In any other wheel position, the control shifts to shut off as in towing.

D A N G E R: If the ballast trailer is on the ground, the wheel position is not correct and the keyed button (101) was switched to "Ballast trailer raised", then , when "Driving the crawler" , the wheels of the ballast trailer and possibly the crane will be damaged.

5.4.1 Raise the ballast trailer with the support cylinders

- Press button (124 and 126) or button (209 and 211) , the support cylinders front and rear extend.

5.4.2 Set the axles in parallel position

- Press button (107), the axles are turned to parallel position;
the indicator light in the button blinks until the parallel position is reached ;
the indicator light in the button lights up when the parallel position is reached.

Note: If one of the sets of wheels leaves the stipulated angle, the indicator light in the button (107) blinks and the axles must be reset as described above.

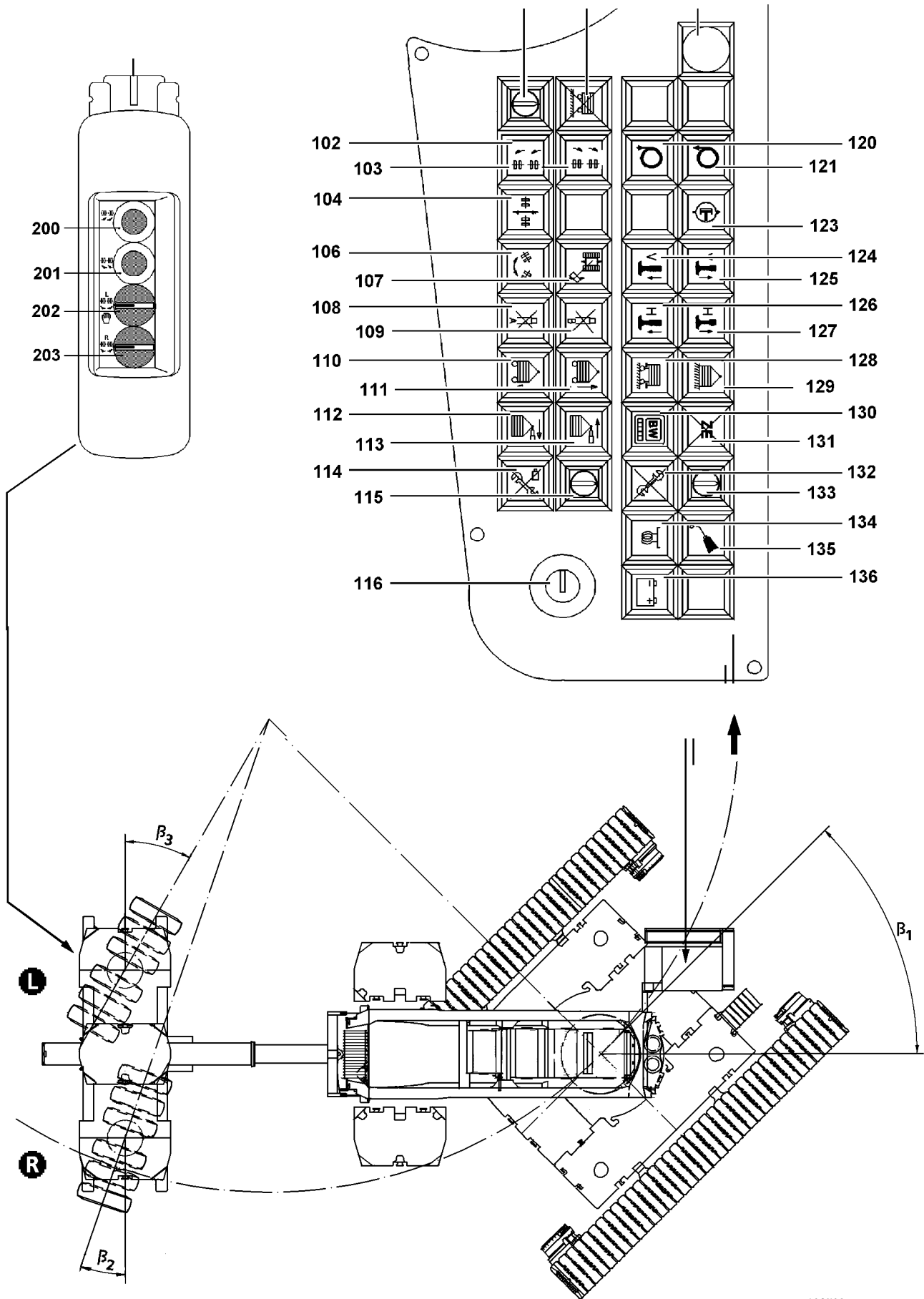
5.4.3 Lower the ballast trailer with support cylinders

- Press button (125 and 127) or button (208 and 210), the support cylinders front and rear retract;
- the indicator light (128), "Supports ballast trailer are retracted" lights up.

Note: The travel drive of the crawler is locked until the axles are in parallel position. When "driving the crawler", the slewing brake of the crane remains closed, the hydraulic coasting is opened.
If angles β_2, β_3 in relation to β_1 deviate by more than the permissible limit value, then the crawler gear is stopped.
The indicator light (107) blinks.
The crawler gear is only released if the axles are turned to the stipulated angle, as described above.
By turning on the rocker switch "Parallel operation of crawler " (79), the crawler drives exactly straight forward on proper ground. This makes it easier to drive with the ballast trailer in operating mode "Parallel travel "!

C A U T I O N: In parallel travel ,

the crawler may not be steered, but the function is not shut off.
If it is steered anyway, the mechanical slewing brake can slip, until the crawler travel gear is stopped due to the angle deviation.
A guide must monitor the side tire deformation. If the deformation is more than 100 mm, then the position of the axles must be corrected.



192593

5.5 Manual steering adjustment

Prerequisite

- The ballast trailer is properly installed;
- the rocker switch (74) is on crawler operation.

5.5.1 Steering and steering adjustment of axles

Prerequisite

- Operating mode towing has been preselected
and ballast trailer axles have reached towing position.
- Press button (103) or (201) to turn the ballast trailer wheels to the right;
- press button (102) or (200) to turn the ballast trailer wheels to the left.

The right set of wheels is regulated by the computer controlled steering program in such a way that there is always a steering center available. The angle β_1 is determined by driving the crawler and the angle β_3 by the steering motion made by the operator, whereby angle β_2 is continually adjusted. Changing from operating mode manual steering adjustment to operating mode towing and back, after reaching the towing position, is possible while driving the crawler. If the operating mode manual steering adjustment is selected from operating mode towing, the indicator lights in the buttons (102 and 103) light up.

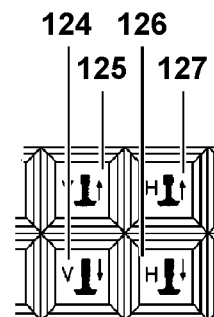
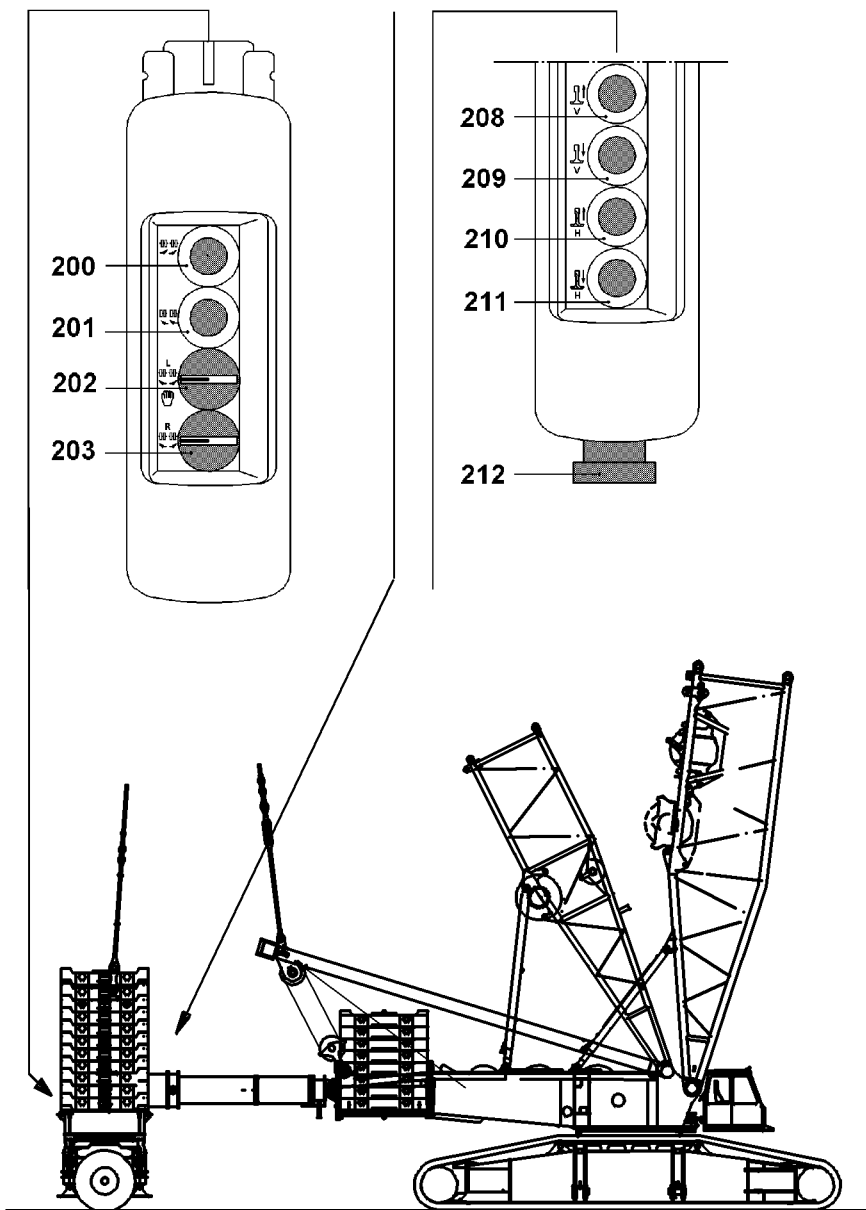
Note:

The left set of wheels can be steered to the stipulated angle β_3 . Further steering past this limit is not possible.

The right set of wheels is adjusted according to the steering center. If the adjusted right set of wheels cannot follow the steered left set of wheels, then the steered left set of wheels is stopped until the adjusted right set of wheels has caught up. If the right set of wheels leaves the stipulated angle, then the indicator lights in buttons (102 and 103) blink and towing mode must be started again.

If the angle β_1 of the slewing platform exceeds the given dimension, then the system shifts automatically to towing mode. The indicator lights in the buttons (102, 103 and 104) blink. If the towing position is reached, the steering can be adjusted manually. The indicator lights in buttons (102 and 103) light up.

Generally, the sets of wheels only move if either button (102 or 103 or 104) or (200 or 201) on panel is pressed in the corresponding operating mode or if the crawler is driven.



5.6 Manual operation for installation

The ballast trailer is equipped with a program with which each ballast trailer axle can be turned individually.

Prerequisite

- The crane is at a standstill;
- the ballast trailer is installed properly.

5.6.1 Raise the ballast trailer with support cylinders

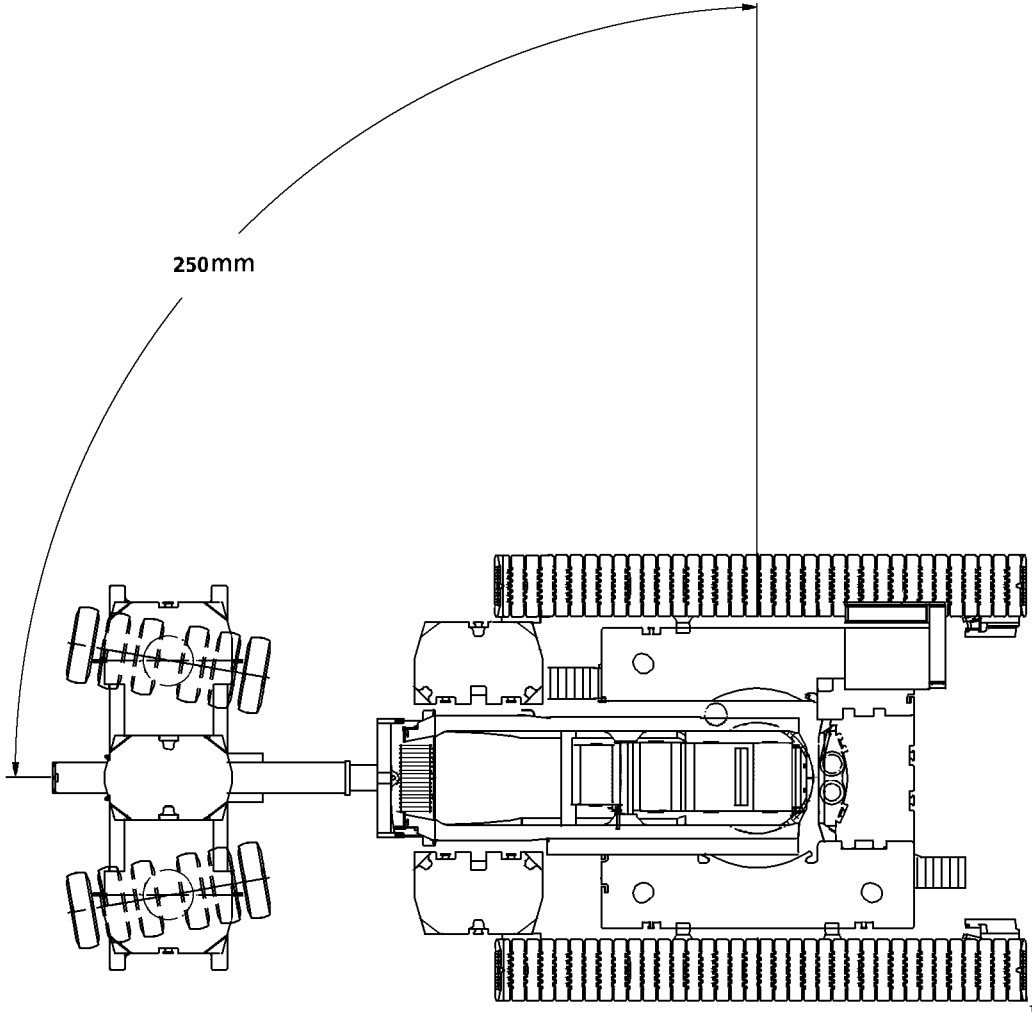
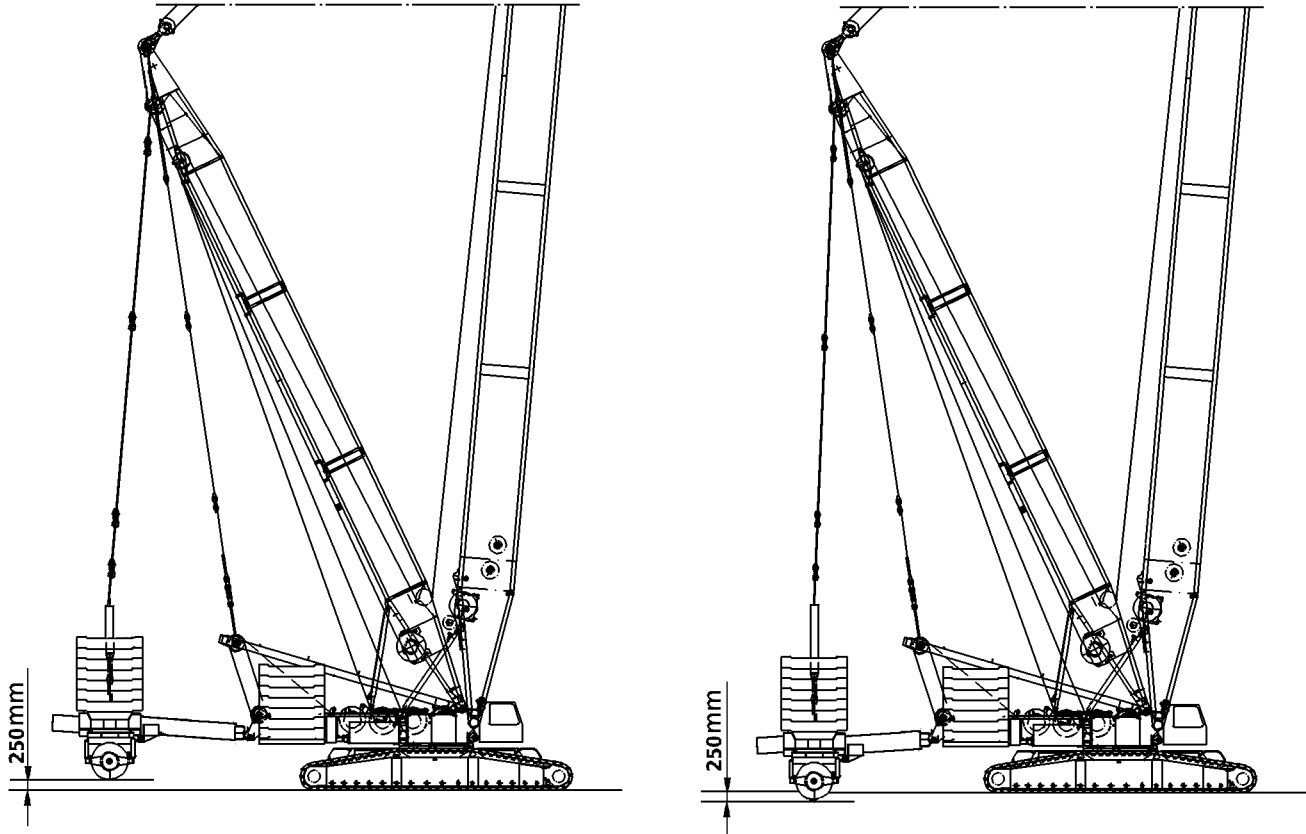
- Press button (124 and 126) **or** button (209 and 211), the support cylinders on the front and rear extend.

5.6.2 Set the axles

- Turn knob (202) to the right, the left axle turns to the right;
- Turn knob (202) to the left, the left axle turns to the left;
- Turn knob (203) to the right, the right axle turns to the right ;
- Turn knob (203) to the left, the right axle turns to the left.

5.4.3 Lower ballast trailer with support cylinders

- Press button (125 and 127) **or** button (208 and 210), the support cylinders on the front and rear retract;
- indicator light (128) 'supports ballast trailer are retracted' lights up.

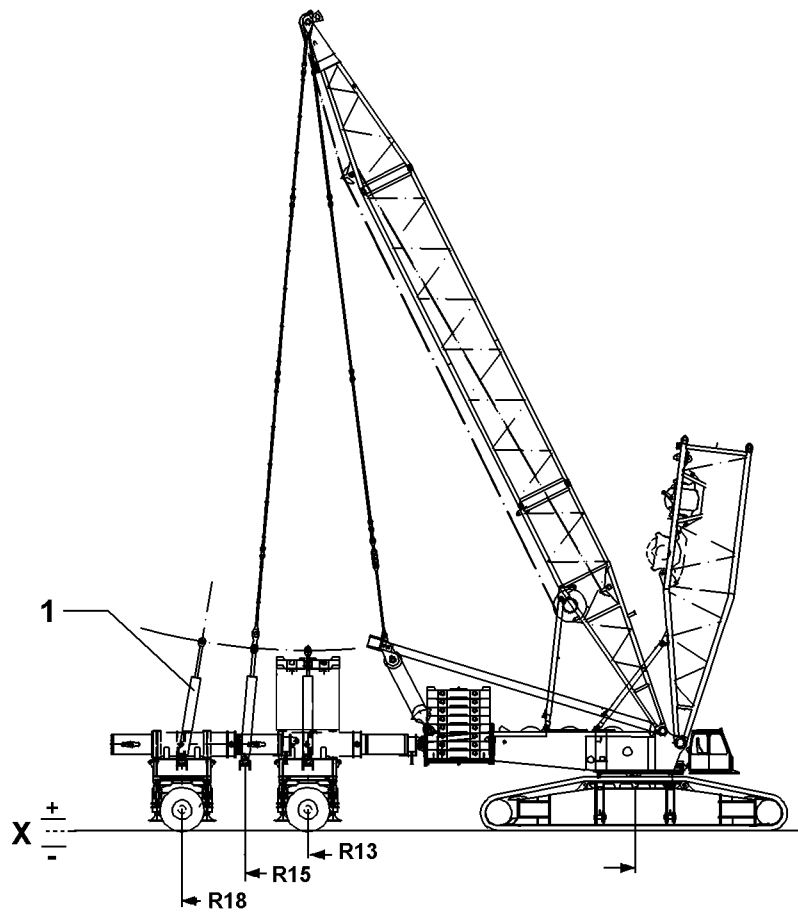
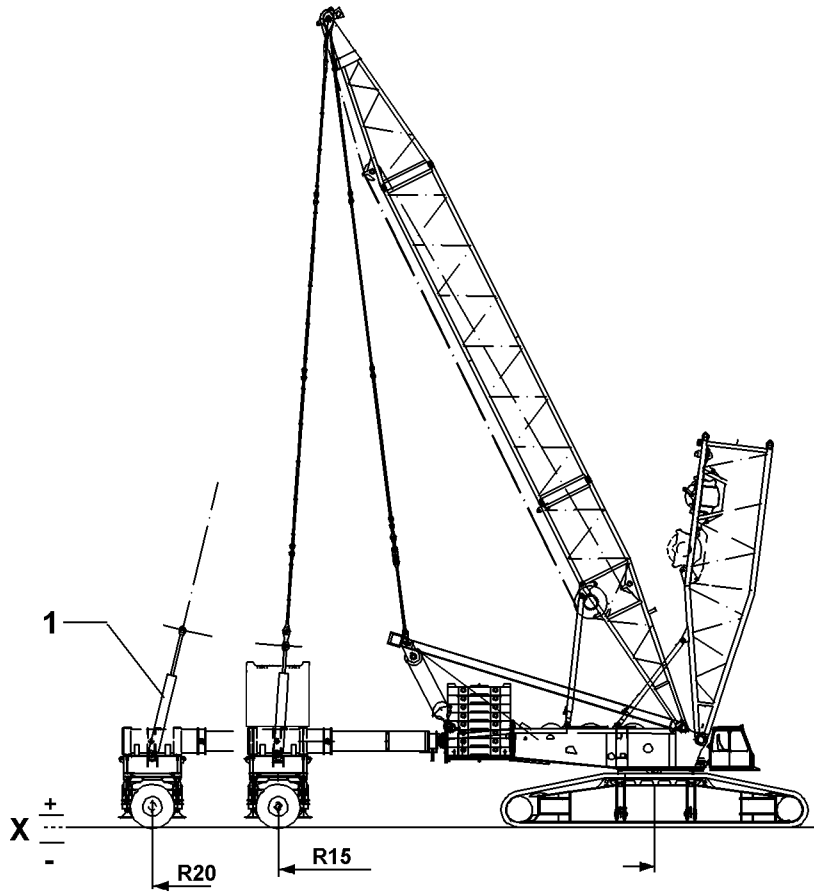


191995

6. Max. permissible uneven ground for towing, parallel driving and driving in turns and manual steering adjustment

Level change between standing surface of crane and ballast trailer when driving or turning.

D A N G E R: **The level change ballast trailer travel route surface in relation to the crane travel route surface for towing or parallel driving may not be more than max. ± 250 mm .**
The level difference of the ballast trailer travel route surface in relation to the crane travel route surface when driving in turns may not be more than max. ± 250 mm (constant incline or decline) over a 90° turning range.



6.1 Compensation of maximum permissible uneven ground via pull cylinders

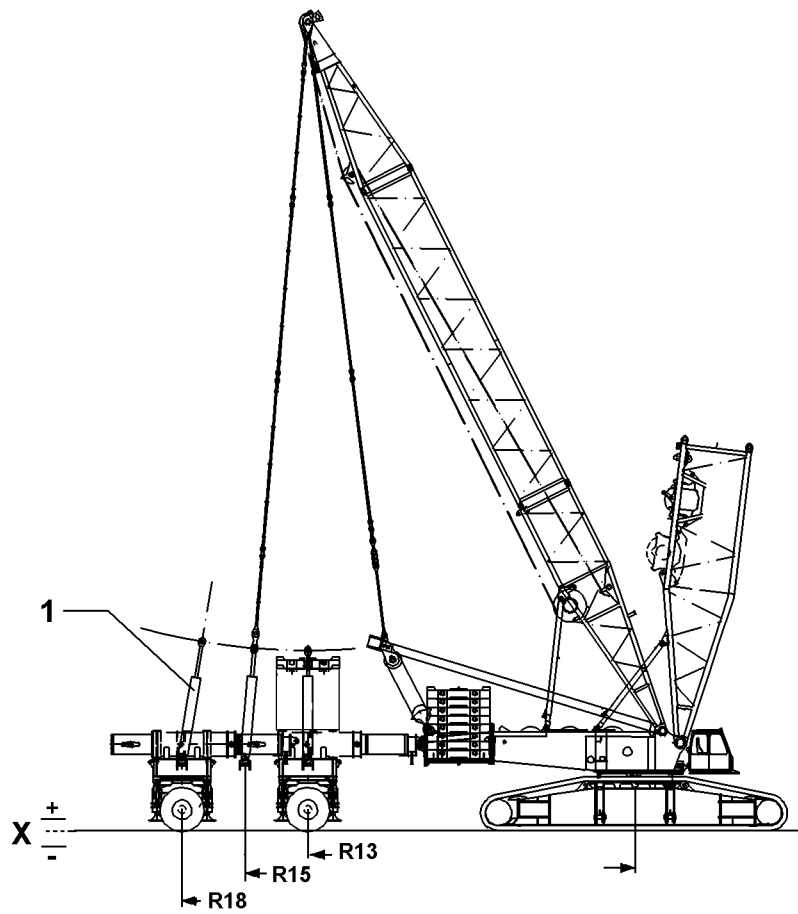
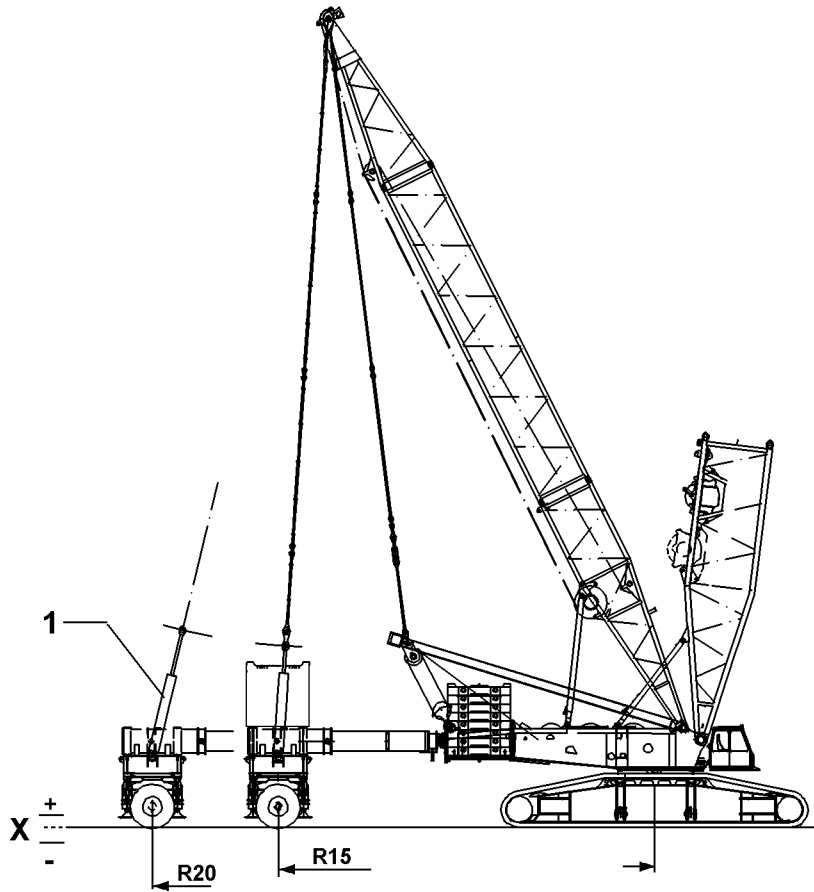
By lifting and lowering the pull cylinders (1), the maximum permissible uneven ground can be compensated for.

Ballast trailer radius 13 m

Ballast trailer radius R 13 m	with Quick connection		without Quick connection	
	Cylinder stroke mm	Dimension X mm	Cylinder stroke mm	Dimension X mm
Max. permissible uneven ground		± 250		± 250
Pull cylinder retracted	0	+ 1080	0	+ 810
Pull cylinder Nominal position	1080	0	810	0
Pull cylinder extended	2500	- 1380	2500	- 1650

Ballast trailer radius 15 m

Ballast trailer radius R 15 m	with Quick connection		without Quick connection	
	Cylinder stroke mm	Dimension X mm	Cylinder stroke mm	Dimension X mm
Max. permissible uneven ground		± 250		± 250
Pull cylinder retracted	0	+ 1155	0	+ 880
Pull cylinder Nominal position	1155	0	880	0
Pull cylinder extended	2500	- 1645	2500	- 1620

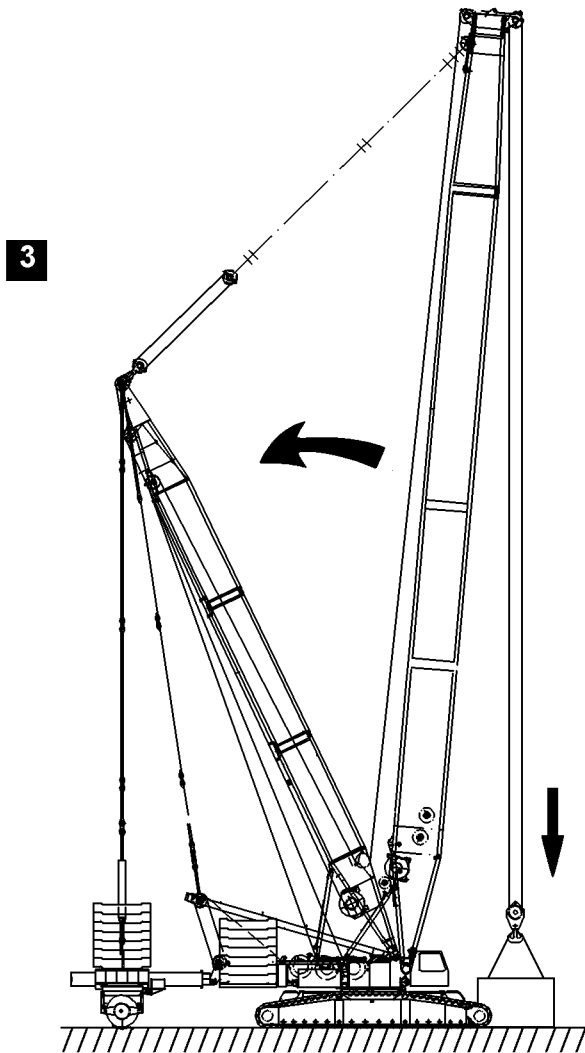
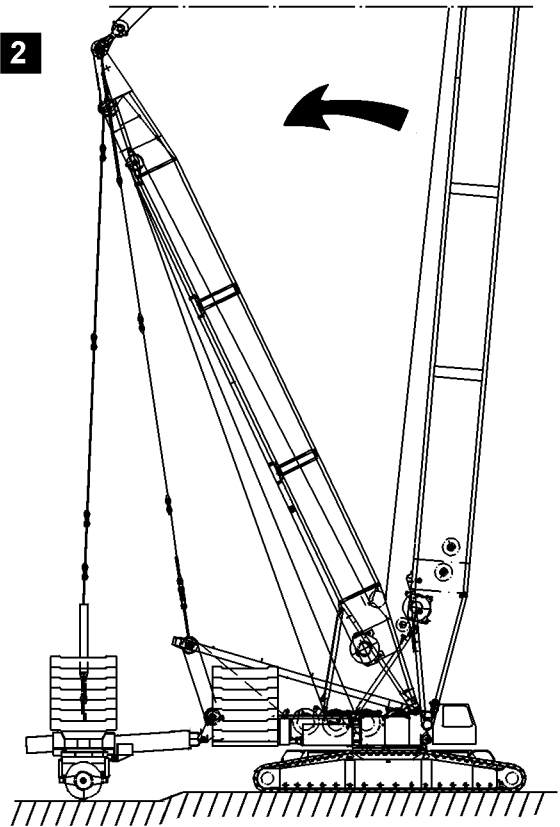
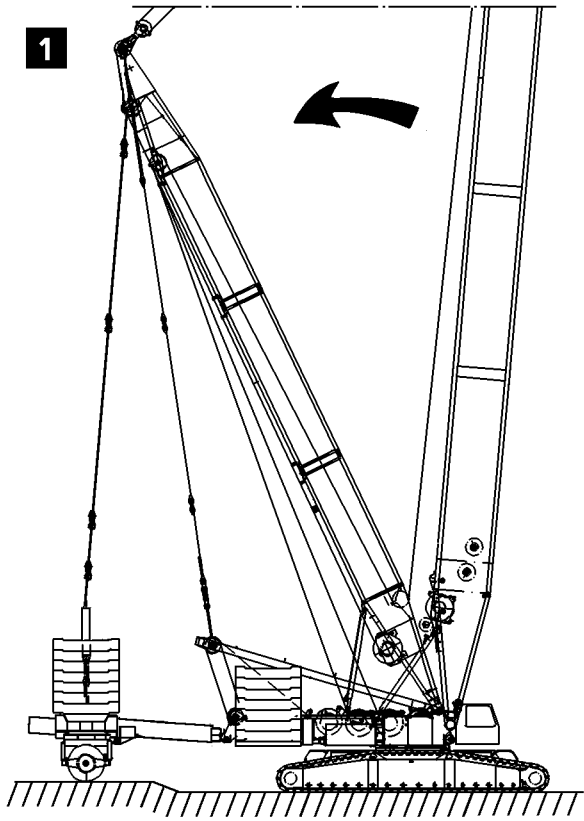


Ballast trailer radius 18 m

Ballast trailer radius R 18 m	with Quick connection		without Quick connection	
	Cylinder stroke mm	Dimension X mm	Cylinder stroke mm	Dimension X mm
Max. permissible uneven ground		± 250		± 250
Pull cylinder retracted	0	+ 995	0	+ 1235
Pull cylinder Nominal position	995	0	1235	0
Pull cylinder extended	2500	- 995	2500	- 1265

Ballast trailer radius 20 m

Ballast trailer radius R 20 m	with Quick connection		without Quick connection	
	Cylinder stroke mm	Dimension X mm	Cylinder stroke mm	Dimension X mm
Max. permissible uneven ground		± 250		± 250
Pull cylinder retracted	0	+ 1910	0	+ 1635
Pull cylinder Nominal position	1910	0	1635	0
Pull cylinder extended	2500	- 590	2500	- 865



7. Safety guidelines for travel operation

7.1 Relapse cylinder

When the steepest operating position of the main boom is reached, luffing up is shut off by the overload safety system in all operating modes.

Note: However, there are cases where the relapse cylinders move into block position due to a movement of the complete crane system to the rear.

7.2 Block position of relapse cylinder

In normal crane operation without bypass of the overload safety system, a block position is not possible. Should a block position occur anyway, the movement is shut off and the boom limit symbol in the operating view shows which block position has been triggered.

D A N G E R: If a block position on the relapse cylinders occurs in emergency operation, the horn will sound and an indicator light on the instrument panel will light up. In this case, the movements just carried out must be stopped immediately. There is an increased danger of accidents, since the movements are not automatically stopped.

Using the boom limit symbol, it must be determined which limit switch on which relapse cylinder has been actuated.

The last movement which was carried out must be retracted, until the corresponding limit switch is released again.

7.2.1 Case 1, fig. 1

When driving the crane with steeply positioned boom, the ballast trailer can drop down due to the level differences. This pulls the complete boom system to the rear and there is a danger that the relapse cylinder moves in block position.

The same danger occurs when turning, if the ballast trailer drops down due to level differences.

Note: Due to the signals "Main boom relapse cylinder on block" or "Derrick relapse cylinder on block", the movements "Driving the crawler" and "turning" are automatically shut off in operation with ballast trailer.

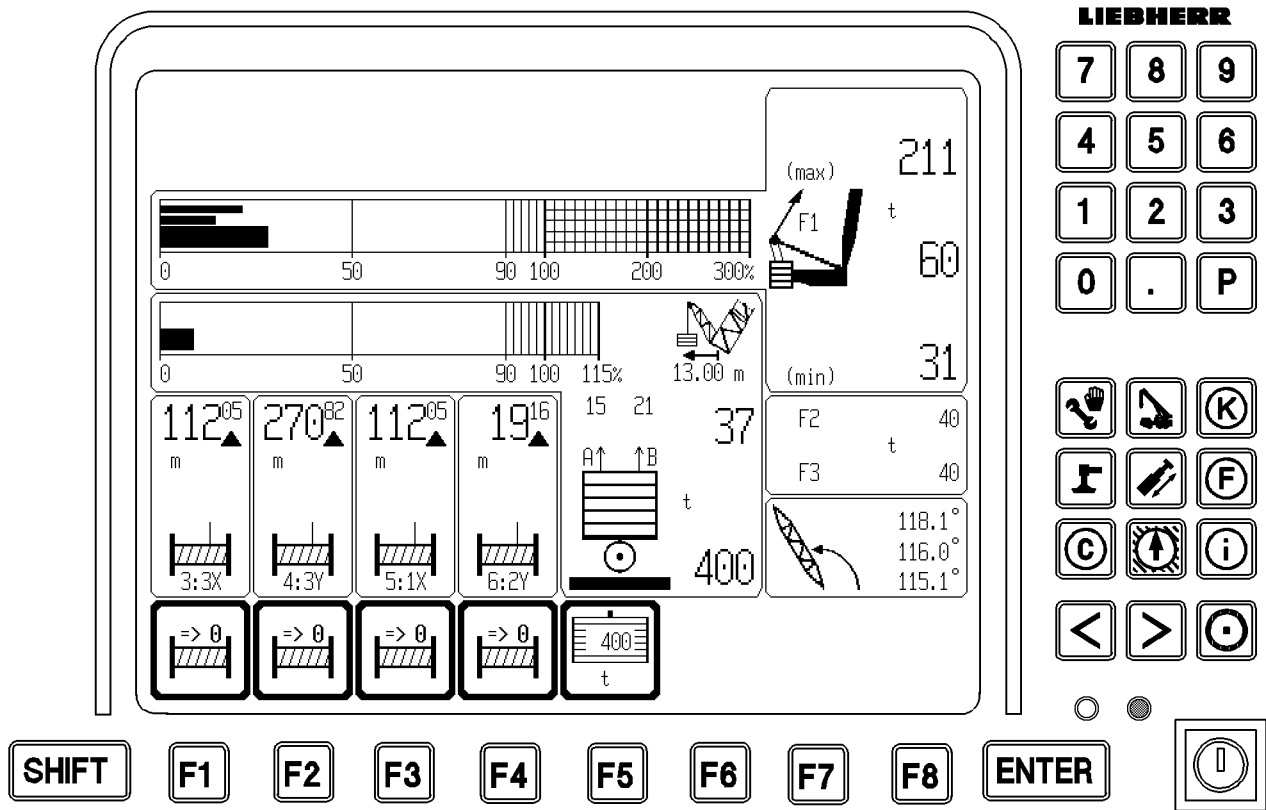
7.2.2 Case 2, fig. 2

If the level under the crane is increased, then the boom system is also pulled backwards. There is a danger that the relapse cylinder moves in block position.

Note: Due to the signals "Main boom relapse cylinder on block" or "Derrick relapse cylinder on block", the movements "Driving the crawler" and "turning" are automatically shut off in operation with ballast trailer.

7.2.3 Case 3, fig. 3

When setting down the load with the hoist gear, the crane is relieved. This causes the boom to move backward. **There is no shut off of the hoist gear.**



8. LICCON overload safety system

8.1 General

Prerequisite:

- The required derrick ballast according to the load chart is placed ;
- the derrick is in operating position.

8.1.1 Preadjustments

- Set the LICCON overload safety system according to the data in the load chart and confirm;
- Enter the actually present derrick ballast weight into the LICCON .

Note: Set the derrick ballast - see chapter 4.03, paragraph 8.
The required derrick ballast must be determined according to the data in the load chart.

D A N G E R: **The set derrick ballast must match the actually installed derrick ballast weight.**
An incorrect ballast weight entry can lead to dangerous operating situations.

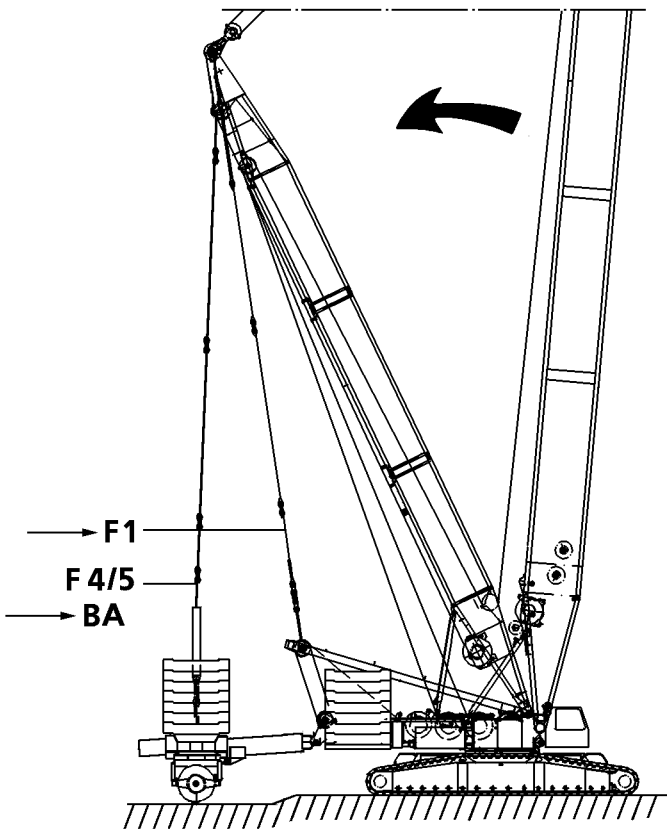
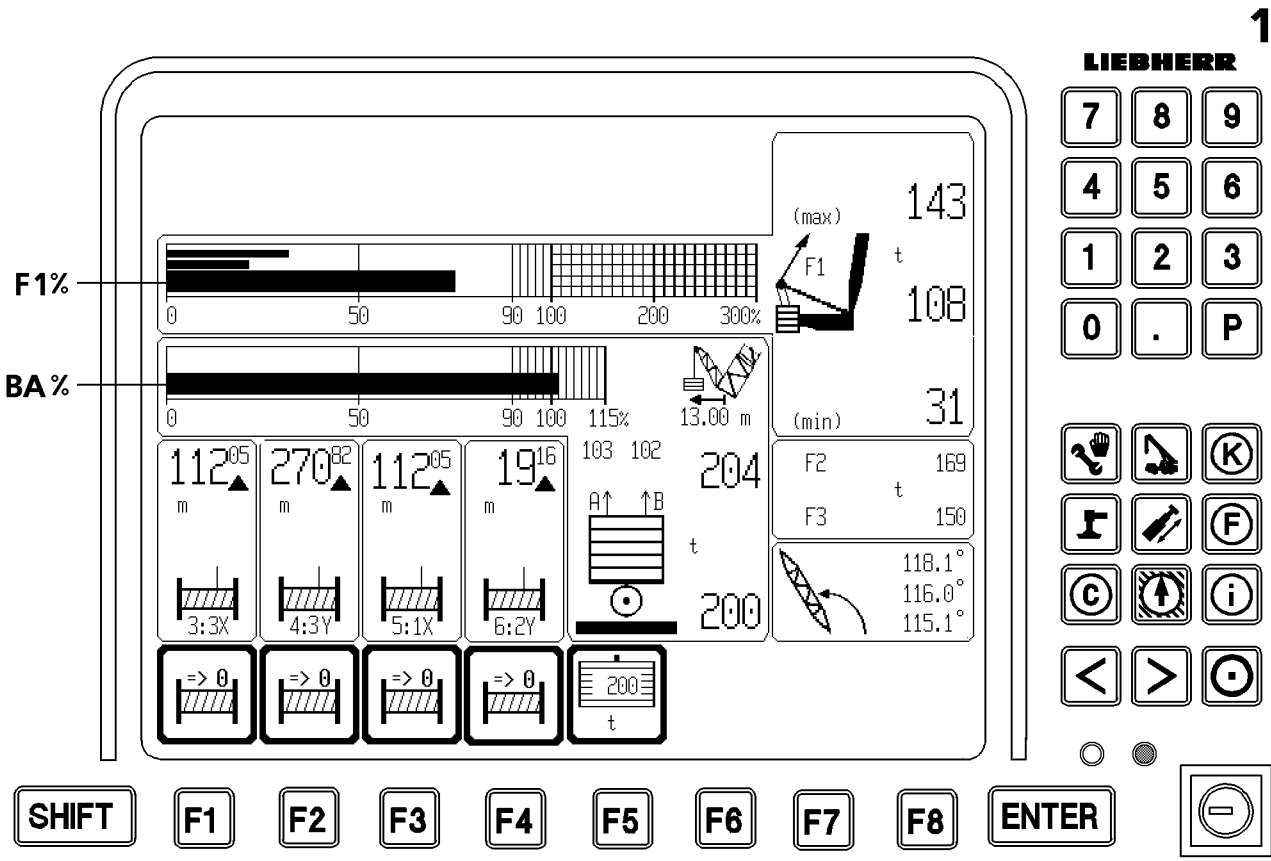
8.1.2 Operation

For the operation with derrick ballast, all data in chapter 4.02, paragraph 21 must be observed!

D A N G E R: **There may be no persons or obstacles within the turning range of the derrick ballast.**
During the turning movement, a guide must monitor the boom, derrick and derrick ballast to prevent a collision.
When turning with a load and suspended derrick ballast, the turning movement must be initiated or slowed down very sensitively . If the turning movement is initiated or slowed down too abruptly or jerkily, the load or the suspended derrick ballast could start to swing. This could cause the boom to break and / or cause the crane to topple over.

Note: If the **suspended derrick ballast** must swing over any obstacles or must be set down at a different level as the crane is, there is the possibility to lower or raise the **suspended derrick ballast** with the pull cylinders.
See paragraph 3.5 Raise and lower with pull cylinders and 8.8 Difference force monitoring of ballast guying.

D A N G E R: **The derrick ballast must always be in horizontal position when raising or lowering with pull cylinders, otherwise there is a danger of tipping over.**
Monitor the extension condition of the ballasting cylinders.



8.2 Safety guidelines

- The test points must be checked for proper function before crane operation.
- The crane must be aligned in horizontal direction at the job site.
- The weight of the load to be lifted must be known.
- The placement surface of the derrick ballast may be no more than max. 0.25 m above or 0.25 m below the standing surface of the crane.
- The placement surface of the suspended derrick ballast at the end of the load lift must be level, horizontal and of sufficient load carrying capacity to take on the weight safely.

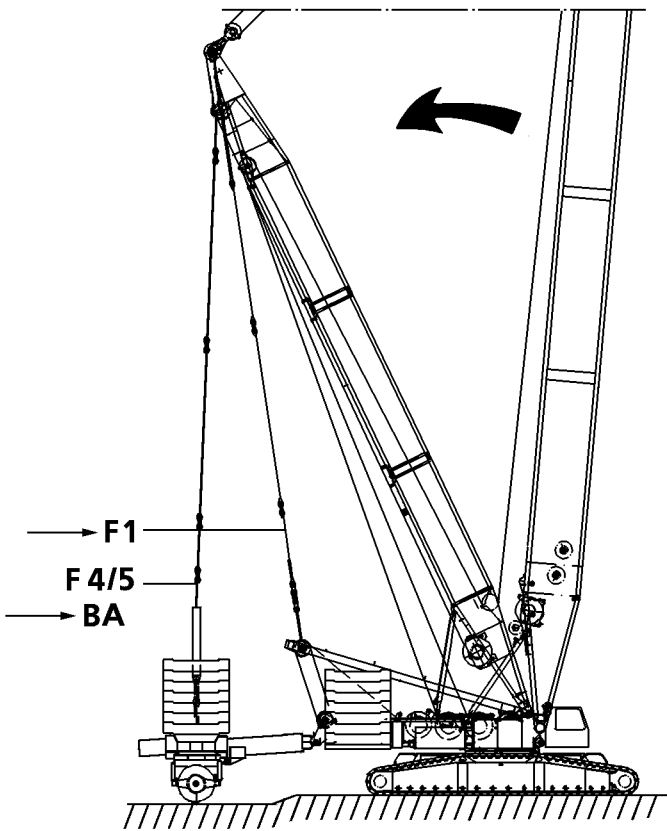
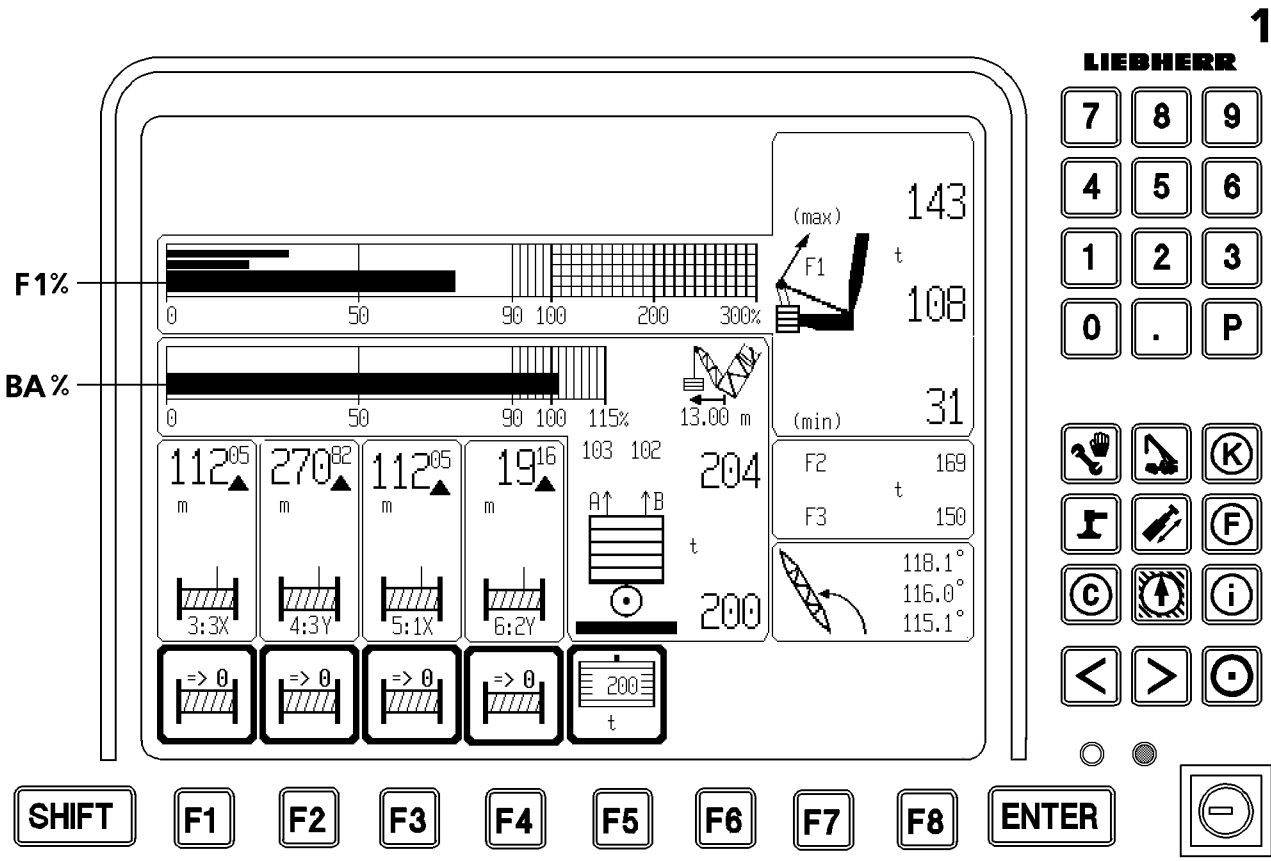
C A U T I O N: Before setting down the load and suspended derrick ballast, the crane operator must make sure that he can safely do so.

- There may be no obstacles within the slewing and turning range of crane, derrick ballast and load.
- A guide or the crane operator himself must watch the derrick ballast, if it is to be lifted.
- When taking on a load, **make sure to avoid** diagonal pull , which means the derrick ballast, center of rotation of the slewing platform and the load must always be on one line !
To ensure this, actuate the pull cylinders to lift the derrick ballast off the ground and set it down again **before** placing the ballast plates.

D A N G E R: If this is not observed, there is a danger of tipping over when lifting the placed ballast plates, which can cause the crane to topple over.

- When taking on the load, the guying of the derrick ballast to the derrick end section must be loose or just slightly tensioned so that the **Minimum force F1 min.** is initially exceeded on **test point 1.**
- The guying between the A- bracket and the derrick end section **test point 1** may **never** be untensioned.

D A N G E R: This could lead to uncontrolled movements of the boom system, which could cause a serious accident.



8.3 Determination of forces in operating mode with derrick ballast

In all operating modes with derrick ballast, the load is distributed onto the guy rods from the derrick end section to the A-bracket (F1) and to the derrick ballast (F4/5).

Note: See also the more detailed description in chapter 4.02 CONTROL AND INDICATOR UNIT OF THE "LICCON" OVERLOAD SAFETY SYSTEM.

8.3.1 Force F1 (Test point 1) between guying A-Bracket - derrick end section

Force F1 (test point 1) is determined in the guy rods from the A-bracket to the derrick end section via 2 force test boxes and indicated on the LICCON as total force at the guying.

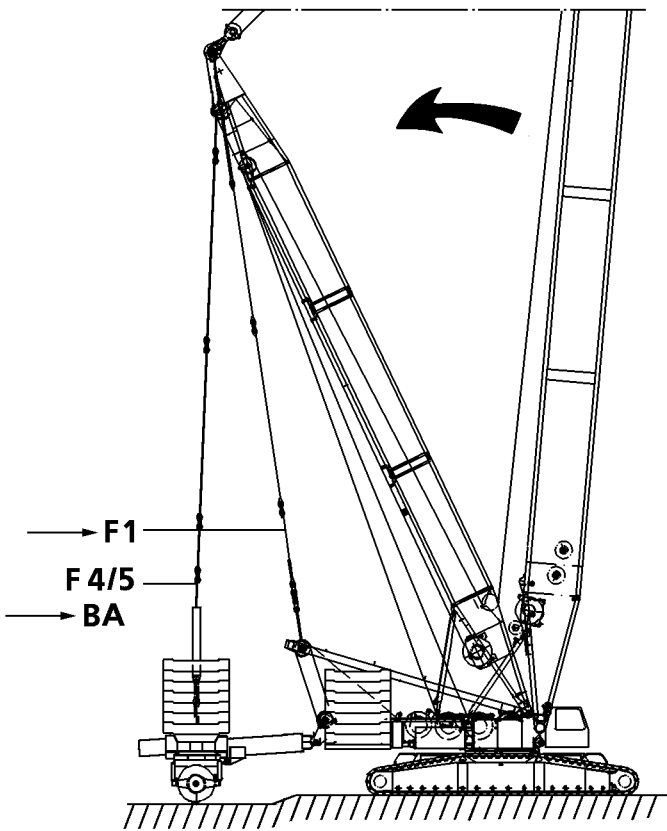
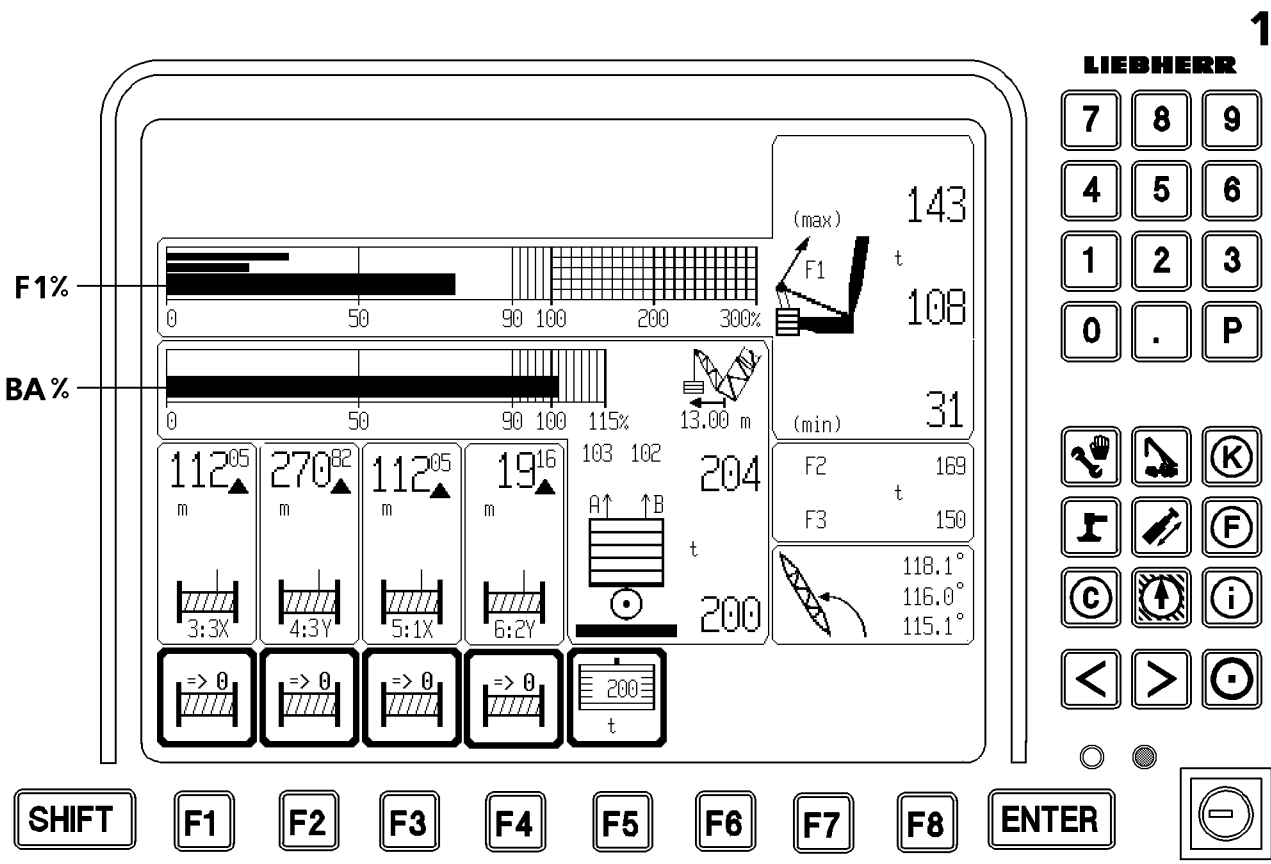
The F1 utilization is determined from operating force F1 and force F1- operation - max. force . This value is shown on the LICCON via a utilization bar graph (F1 %).

8.3.2 Force F4 / 5 (Test point 4 / 5) guying derrick ballast - derrick end section

Forces F4 / 5 (test point 4 / 5) acts in the guy rods from derrick ballast to derrick end section.

The existing forces in the guy rods (A = left and B = right) are calculated from three pressure sensors, which are installed on the pull cylinders and shown in the LICCON as individual forces.

From the forces of the individual guying, the pulled ballast is calculated, i.e. the part of the ballast which is pulled upward by the guying. The remaining part lays on the ground. The derrick ballast utilization is calculated from the pulled ballast and the placed ballast . This value is shown on the LICCON via a utilization bar graph (BA %).



8.3.3 Monitoring of minimum force F1 (Test point 1), F1 min.

Note: See also graphic view and description of shut offs in paragraph 8.5 Shut off in crane operation with derrick ballast.

If more than 50% is pulled by the set derrick ballast (ballast utilization bar > 50 %) and the minimum force F1 min. (Test point 1) is fallen below, all **load moment increasing** crane movements are shut off.

D A N G E R : It is prohibited to fall below the minimum force F1 min (test point 1) if more than 50 % of the derrick ballast is being pulled. If this is not observed, the derrick ballast may lift off the ground suddenly at slack guying from test point 1 (F1) and derrick ballast on the ground due to increasing load momentum and the boom system will suddenly move forward! This will cause the load to swing strongly, which can damage the boom and the crane.

If more than 90% is pulled by the set derrick ballast (ballast utilization bar > 90 %) and the minimum force F1 min. (Test point 1) is fallen below, all **load moment increasing and all load moment decreasing** crane movements are shut off.

The hoist gear "down" is also shut off.

D A N G E R : It is prohibited to fall below the minimum force F1 min (test point 1) if more than 90 % of the derrick ballast is being pulled. If this is not observed, the derrick ballast may set down on the ground suddenly at slack guying from test point 1 (F1) and suspended derrick ballast due to decreasing load momentum and the boom system will suddenly move backward! This can press the relapse cylinder on block and overload them. There is a danger of damage to the relapse cylinders boom and derrick. This also will cause the load to swing strongly, which can damage the boom and the crane.

Note: By actuating the installation keyed switch, test point 1 - minimum force (F1 min.) is lowered by a few tons, so that the reverse movement can be run out again if the F1min shut off has been triggered before. This is the only exception on the crane, in which a load moment increasing movement may be carried out with the installation keyed switch after a shut off .

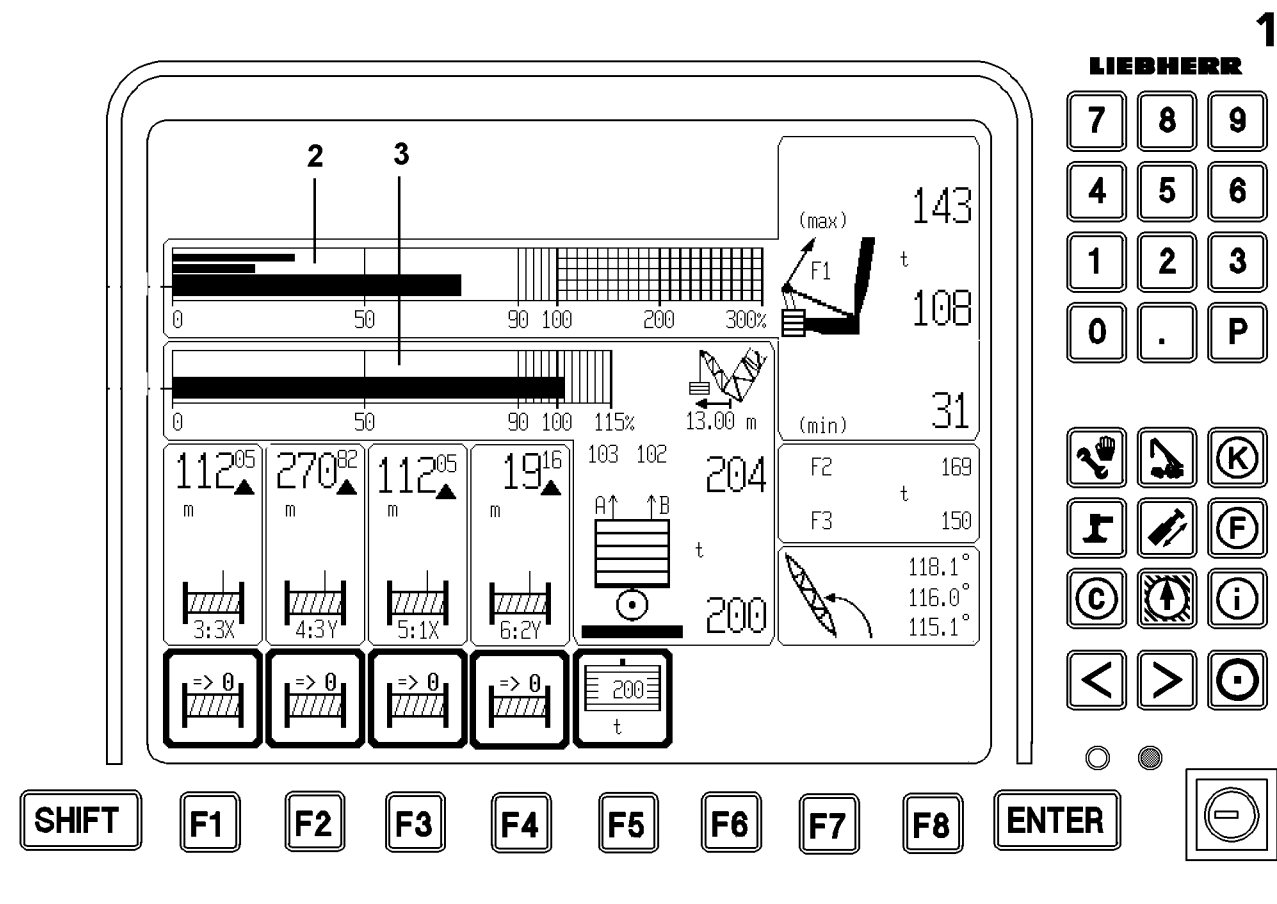
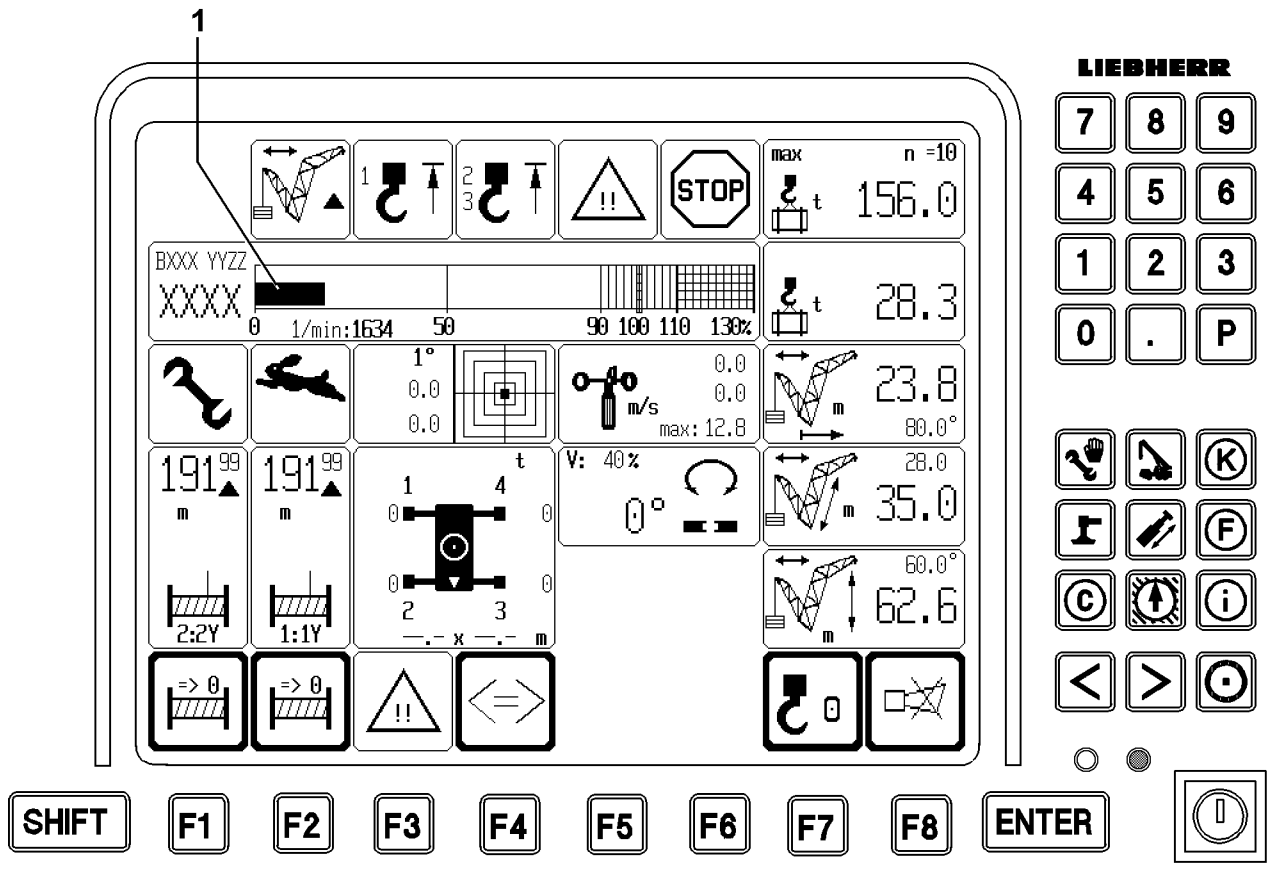
D A N G E R : If the overload system is bypassed, there is no further protection against overload of the crane. There is an increased danger of accidents!

After a shut off by F1 min, the force F1 must be increased by a movement. If the derrick ballast is suspended, then this can occur by luffing down or if the derrick ballast is on the ground, by setting down the ballast.

If the installation keyed switch has been actuated and the F1 force continues to drop further under the reduced F1 min force which was reduced by the installation keyed switch, then the F1 min shut off can no longer be bypassed.

One can only get out of this situation :

- by lowering the suspended derrick ballast via the pull cylinders onto the ground;
- or the ballast plates are unloaded to reduce the derrick ballast utilization and to increase the load on test point 1 (F1) .



8.4 Overload monitoring in operating mode with derrick ballast

Note: All words marked with quotation marks (" ") are explained in chapter 4.02 CONTROL AND INDICATOR UNIT OF THE "LICCON" OVERLOAD SAFETY SYSTEM in paragraph 12.1 Information about crane geometry and load. See also graphic view, paragraph 8.5 Shut offs in crane operation with derrick ballast.

In operating modes with derrick ballast, the monitoring of "maximum load of current crane condition" consists of 2 parts:

1. Monitoring of maximum load by LML overload safety system.
2. Monitoring of test point 1- operating maximum force by derrick ballast overload safety system.

8.4.1. The LML overload safety system monitors the "maximum load according to the load chart and reeving".

In operating modes with derrick ballast, this is the maximum load of the current crane condition with optimum derrick ballast. It is shown on monitor 0 . The current utilization of the crane with optimum derrick ballast results from the load utilization bar (1) on monitor 0.

At 90 % on the load utilization bar there is a prewarning with caution symbol and "SHORT HORN" on monitor 0.

At 100% on the load utilization bar there is a shut off of all load moment increasing movements with stop symbol and acoustical warning "HORN" on monitor 0.

The "maximum load of the current crane condition" can no longer be increased.

8.4.2 The derrick ballast overload safety system monitors the "Test point 1- operating maximum force (=F1max)". It is shown on monitor 1.

At 90 % F1max- utilization (utilization bar (2)) , a prewarning is issued with caution symbol and "SHORT HORN" on monitor 1.

At 100% F1max- utilization, there is a shut off of all load moment increasing movements with stop symbol and acoustical warning "HORN" on monitor 1.

If the "maximum load according to load chart and reeving" is not yet reached (Utilization bar (1)) , then the "maximum load of current crane condition" can still be increased by:

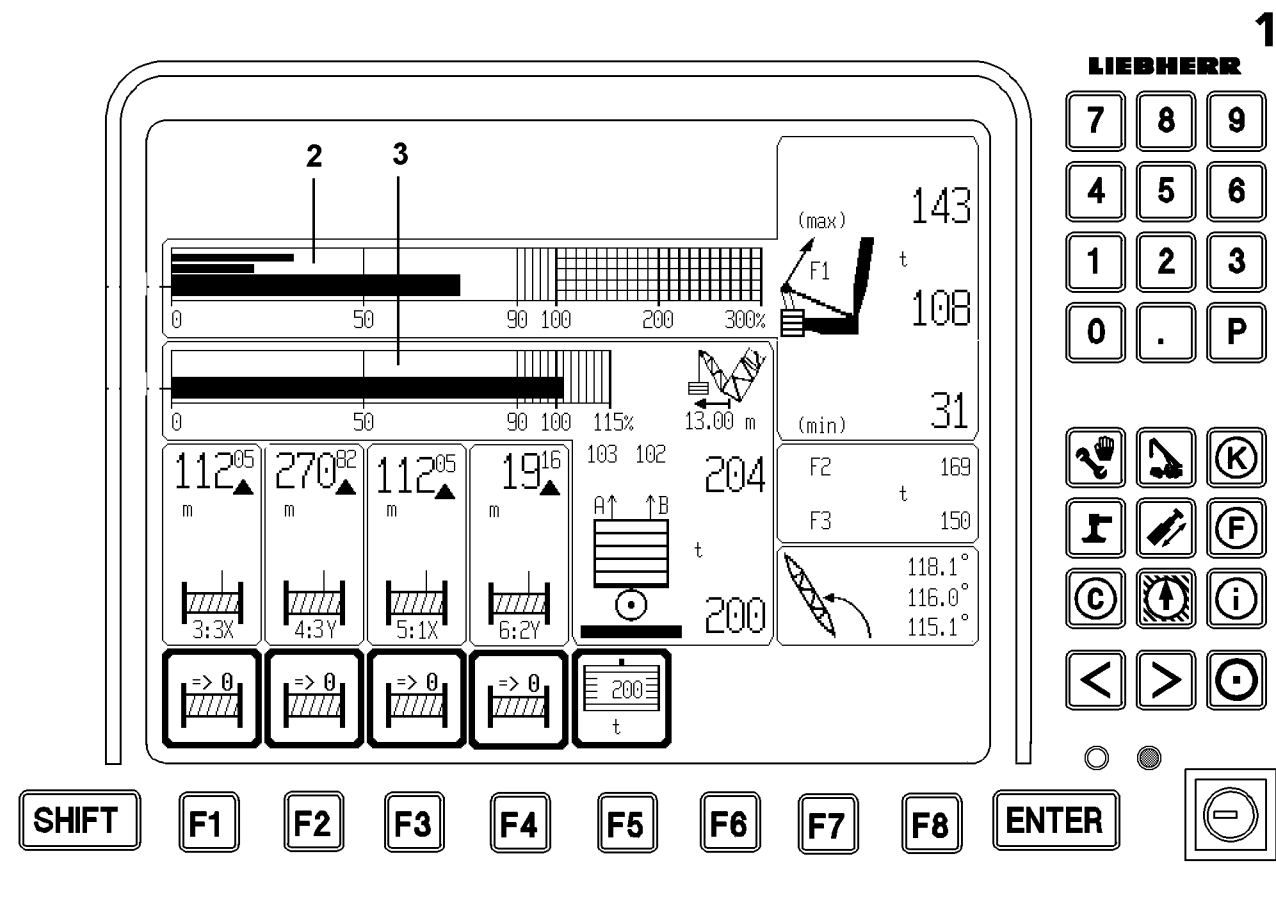
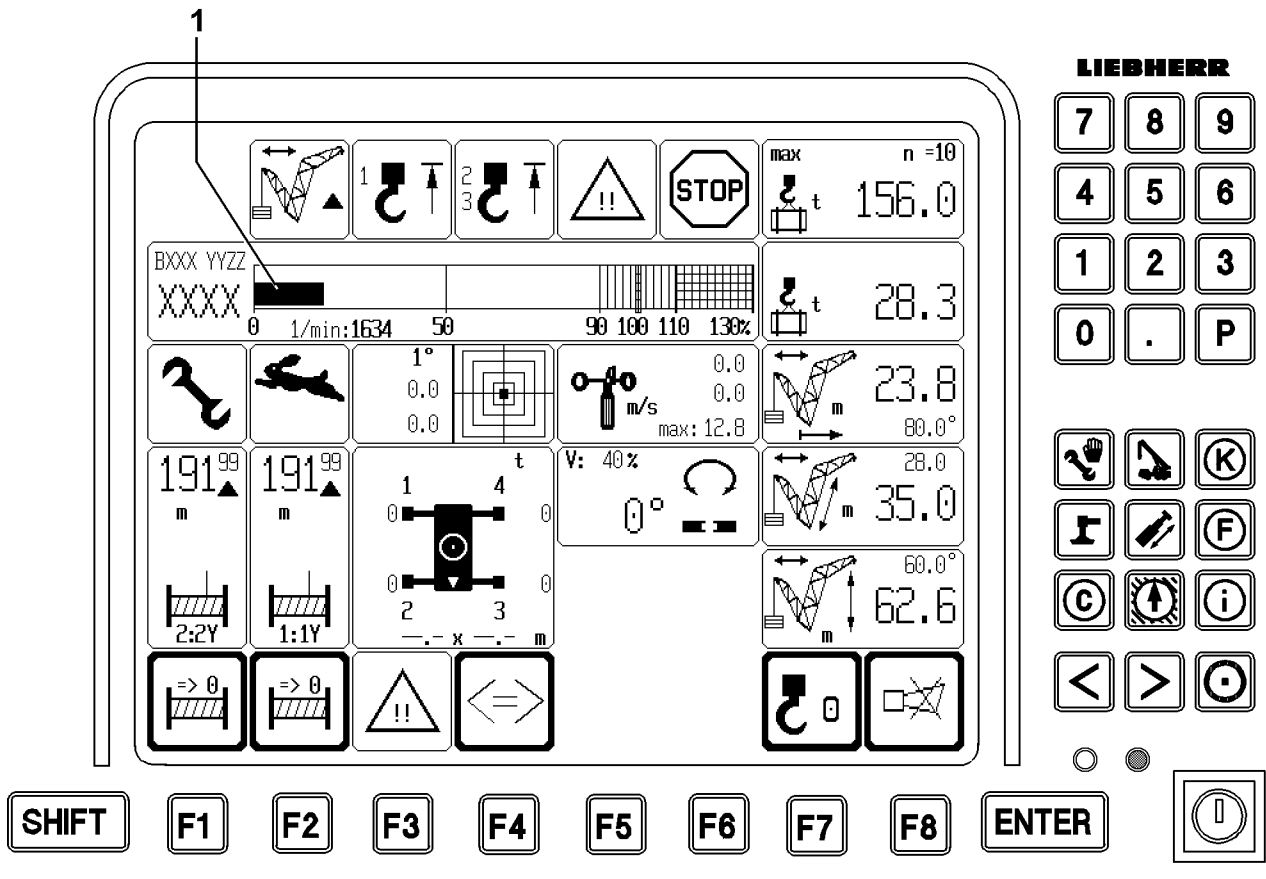
- pulling up the derrick ballast, if the derrick ballast is not yet suspended and the currently pulled ballast is still smaller than the optimum ballast;
- telescoping out the derrick ballast if the placed ballast is still smaller than the optimum ballast;
- increasing the derrick ballast by adding additional ballast plates, if the place ballast is still smaller than the optimum ballast.

CAUTION: The test point 1- operating maximum force depends in operating modes without moveable equipment (W- luffing jib) also for example SDB, SDBW operation not only on the equipment configuration, but also on the force of the pulled ballast measured with the ballasting cylinders.

If the pulled ballast is larger, then the permissible maximum F1 max- force normally decreases and reverse.

For that reason it is important to carefully observe the ballast weighing and the value for the pulled ballast, to check if the value can even be right.

DANGER: If a value would be determined for the pulled ballast which is too small then possibly the F1 max value would be calculated too high and the crane could be overloaded . There is a great DANGER!



8.4.3 Utilization conditions

The current utilization of the crane results from the load utilization bar (1) on monitor 0 **and** the F1-utilization bar (2) on monitor 1.

The "maximum load of the current **crane condition**" is reached when the load utilization bar (1) reaches 100 % **or** when the F1-utilization bar (2) reaches 100 %.

The "maximum load of the current **crane equipment**" is reached when the load utilization bar (1) reaches 100% **or** when the F1-utilization bar (2) reaches 100% and the derrick ballast is suspended (ballast utilization bar (3) at 100 %, when the ballast input value and the ballast weight is correct).

The "maximum load according to the load chart and reeving" (100% limit of load utilization bars) and the maximum load according to F1max-operation (100% limit of F1-utilization bar) can be bypassed by the following measures:

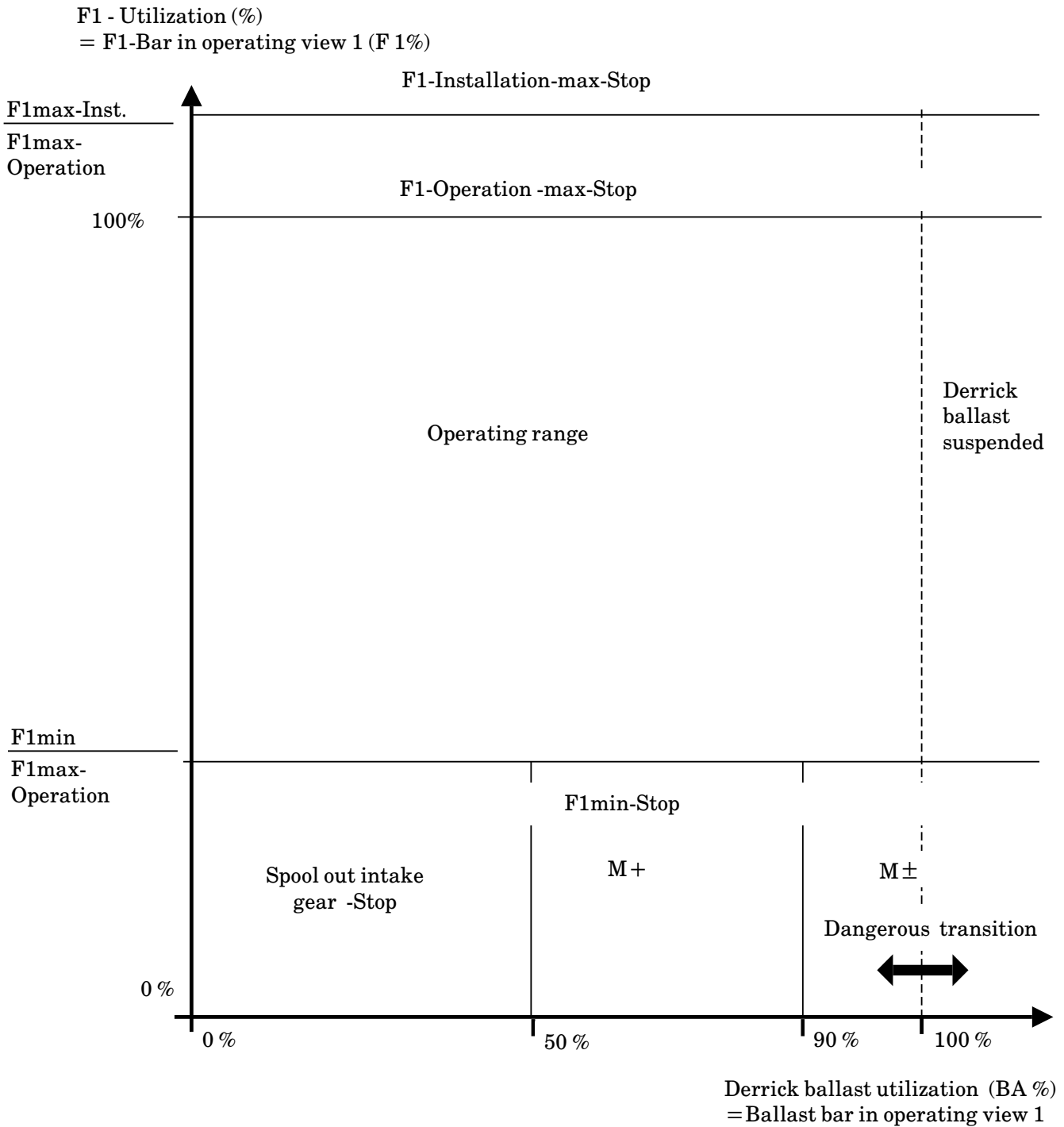
1. Hold the keyed button D₀ on monitor 0 in position "right touching" to bypass the "maximum load carrying capacity according to the load chart and reeving" (see also description in chapter 4.02, paragraph 12.7) and hoist limit switch.
2. Installation keyed button in instrument panel

This bypasses the "maximum load according to the load chart and reeving", test point 1- operation maximum force (= F1max-operation) and a number of other limit values and limit switches.

Test point 1- installation - maximum force (= F1max-installation) cannot be bypassed.

D A N G E R : **When the installation keyed button is turned on, only load moment reducing crane movements to a permissible operating and load range may be carried out.**
After reaching the permissible load range, the installation keyed button must be turned off immediately.
If the installation keyed button is turned on, the load moment limitation is no longer effective.
There is a danger of accidents!

The movement "lift ballast" or "lower ballast" requires utmost attention !



See also Operating view on monitor 1

8.5 Shut offs in crane operation with derrick ballast (suspended ballast or ballast trailer)

Graphic view of various ranges of utilization on test point 1 (F1% utilization bar) and utilization of derrick ballast (Ballast utilization bar, BA %)

8.5.1 F1-Installation-max-Stop

= Shut offs as for F1-Operations-max-Stop, but cannot be bypassed.

8.5.2 F1-Operations-max-Stop

= All load moment increasing crane movements ("lift load", "luff down boom", "luff up boom", "ballast down", "telescope ballast in") are shut off. These shut offs can be bypassed via the installation keyed button. The shut off "luff up boom" can also be bypassed with the button "luff up at overload".

8.5.3 Test point 1 - Minimum force (F1min)

The derrick ballast overload safety protects the crane from sudden lift off of the derrick ballast (the crane rocks forward) and from sudden set down of the derrick ballast (crane rocks backward). This is ensured by monitoring on test point 1 - Minimum force.

When the given limit F1min is approached, a prewarning is given. When this limit is reached or exceeded, the overload warning is triggered and the dangerous crane movements are shut off, see below.

Note: By actuating the installation keyed switch, the test point 1 - Minimum force (F1 min.) is reduced by a few tons, so that, if the F1min shut off has been triggered before, it can be moved out again via the reverse movement.

8.5.3.1 Spool out intake gear -Stop

= The crane movement "spool out intake gear (winch 4)" is shut off, at the same time, "telescope ballast out" is shut off.

8.5.3.2 M +

= The following load moment increasing crane movements are shut off: "Lift load", "luff down main boom / jib", "luff up main boom / jib", "spool out intake gear" and "telescope ballast in and out". The shut offs cannot be bypassed.

8.5.3.3 M ±

= The following load moment increasing crane movements are shut off: "Lift load", "lower load", "luff up boom", "luff down boom", "spool out intake gear", "spool up intake gear" and "telescope ballast in and out".

Only "lower ballast" or "unload ballast" remain possible.

Note: During operation, observe the notes in the crane operating manual and the shut offs in the shut off diagram in the switching diagram.

8.6 Load chart access procedure

For the:

- Main boom angle interpolation;
- Jib relative angle interpolation;
- Derrick ballast radius interpolation;
- Combination of main boom angle interpolation and derrick ballast radius interpolation
- Combination of jib relative angle interpolation and derrick ballast radius interpolation

see chapter 4.02 CONTROL AND INDICATOR UNIT OF "LICCON" SAFE LOAD INDICATOR SYSTEM, paragraph 30." Load chart access procedure ".

8.7 Check the length sensor value on the ballast trailer

When telescoping the derrick ballast in and out, carefully monitor the derrick ballast radius indicator.

When telescoping the derrick ballast, the indicator must change according to the movement. The crane operator can recognize immediately if the length sensor cable drum would get stuck when spooling up or out.

If the derrick ballast is fully extended or retracted, the derrick ballast indicator must show almost exactly the end position, for example: radius = 13 m or 20 m .

The crane operator may not blindly rely on the derrick ballast radius measurement, but he must think for himself and check if the measurement even still works correctly.

D A N G E R : **If the derrick ballast radius is measured incorrectly then a too large maximum load and a too large test point 1 -Operations-max-force can be calculated due to the incorrect radius.
The crane can be overload without recognizing it.
There is an increased danger of accidents!**

8.8 Difference force monitor of ballast guying

In operating modes with derrick ballast, the difference of forces from the derrickballast guying A and B, monitor 1, is monitored.

Note: If one or both pressure sensors in the ring surface of the ballasting cylinders (= test point 4A, 4B) are defective, then the LMB calculates the F1 max value for the most unfavorable case. This means the crane works safely, but then possibly requires more derrick ballast.

D A N G E R: **If the difference of these forces is too high, the derrick end section or other crane components will be damaged.
There is a danger of accidents!**

The forces in the derrick ballast guying A and B are shown on monitor 1 and compared. If the difference exceeds an impermissible value, an acoustical warning is given and the two force values blink. However, there is **no** shut off of movements.

If the difference of the forces of the derrick ballast guying A and B exceeds the given limit value, then this can have different causes:

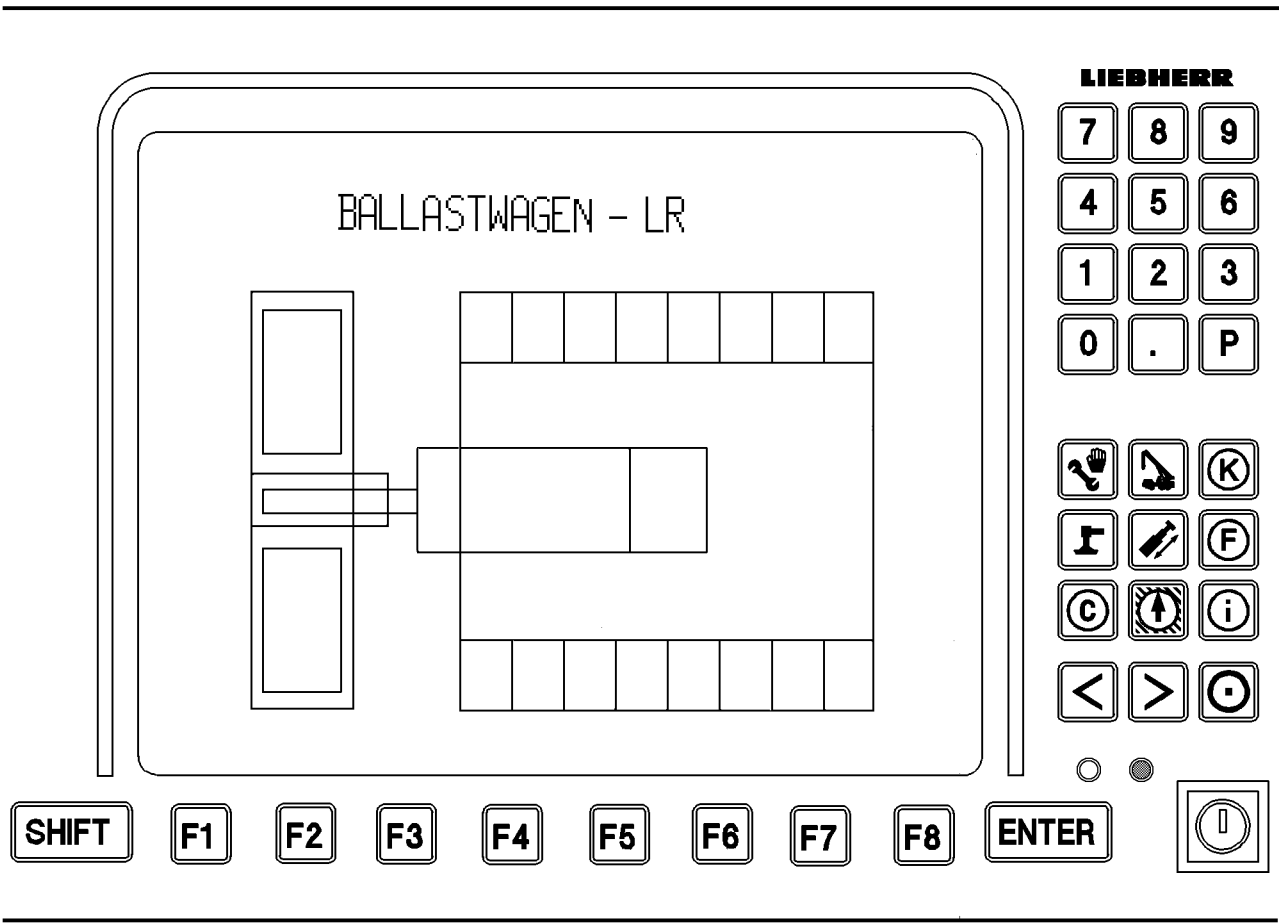
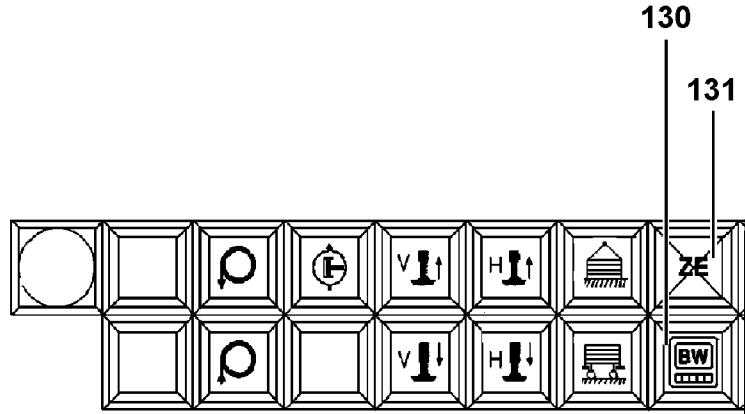
- Take on the load,
by relieving the tires on the ballast trailer or by flexation of the slewing platform ;
- The ground under the derrick ballast is uneven;
- The crane is positioned at a side incline;
- The derrickballast is loaded onesided;
- By raising or lowering the derrick ballast with the pull cylinders;
- The force measurement in the guying is incorrect.

The crane operator must recognize the correct cause and take counter -measures:

1. The error, which led to the one sided force must be removed.
2. The following measure is permitted only in **small** uneven ground conditions :
Lock a ballast cylinder and actuate with the other ballast cylinder "lift the ballast" or "lower the ballast" in such a way that the difference between the forces gets smaller. It must be ensured that the derrick ballast is not brought into an impermissible incline position in relation to the crane, otherwise the derrick ballast guide and components will be damaged.

D A N G E R: **The derrick ballast cylinder A may be extended by maximal 40 mm more or less than cylinder B!
There is a danger of accidents!**

3. If sensor values do not seem believable: check if the pressure sensor for the ballast weighing or the inputs of the ballast weighing on CPU 1 are defective, if necessary, pull the sensor or replace the CPU.



8.9 The "Test system" program

The ballast trailer is equipped with a test system . The test system is a Service and diagnostics tool which makes it possible to quickly and simply localize and fix any errors in the ballast trailer without using additional testing units.

Note: Some safety relevant functions of the test system can only be utilized by especially trained expert personnel, i.e. they are protected from **unauthorized** users.

LICCON in standard operation

Note: The programs and the program run of the LICCON computer system are not influenced, i.e. the ballast trailer continues to be fully functioning and the control can be checked with extensive auxiliary tools of the test system.
At the ballast trailer control with LICCON, the LICCON monitor is used only for the functions of the test system.

8.9.1 Starting the test system

In case of a functional problem, for example indicator light (131) lights up, monitor 1 can be assigned to the ballast trailer control for diagnostics purposes with switch (130).

- Turn the crane engine off;
- actuate the switch (130) ;

Note: The switch (130) may only be actuated if the crane engine is turned off!

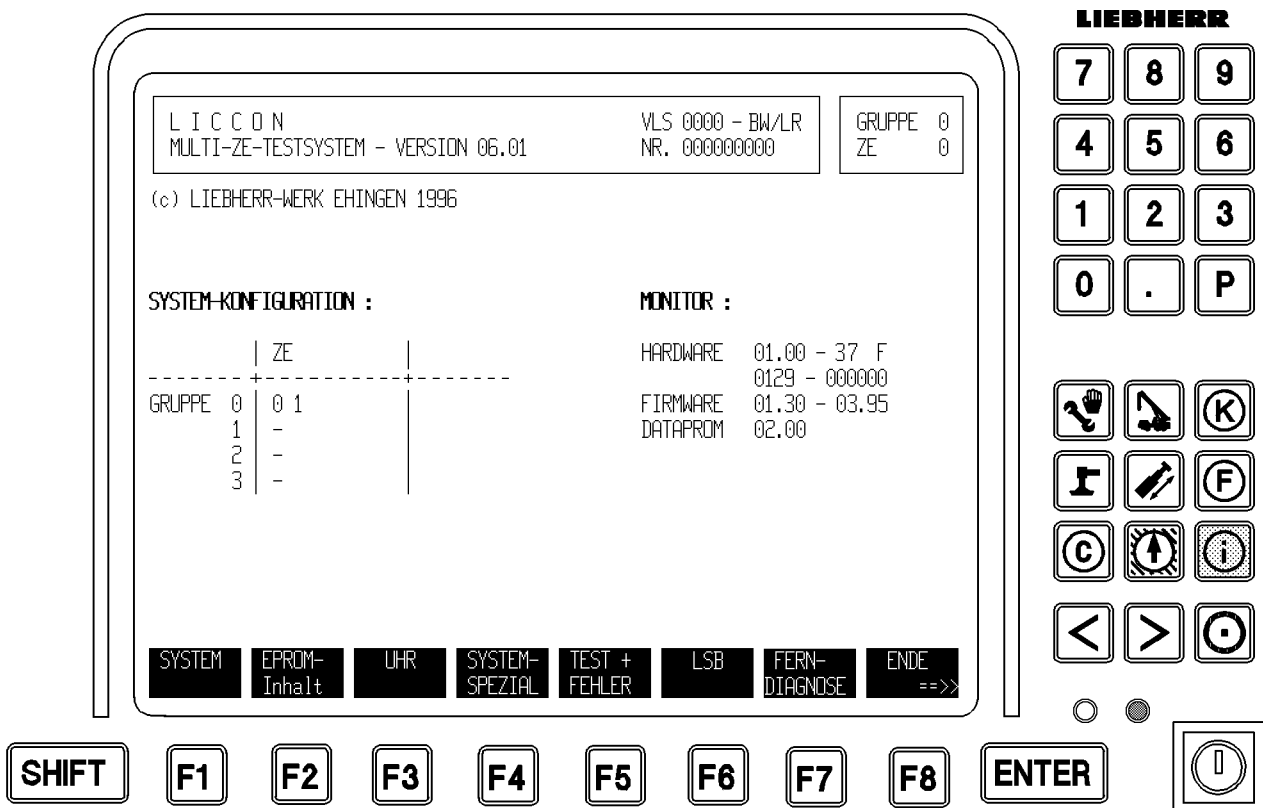
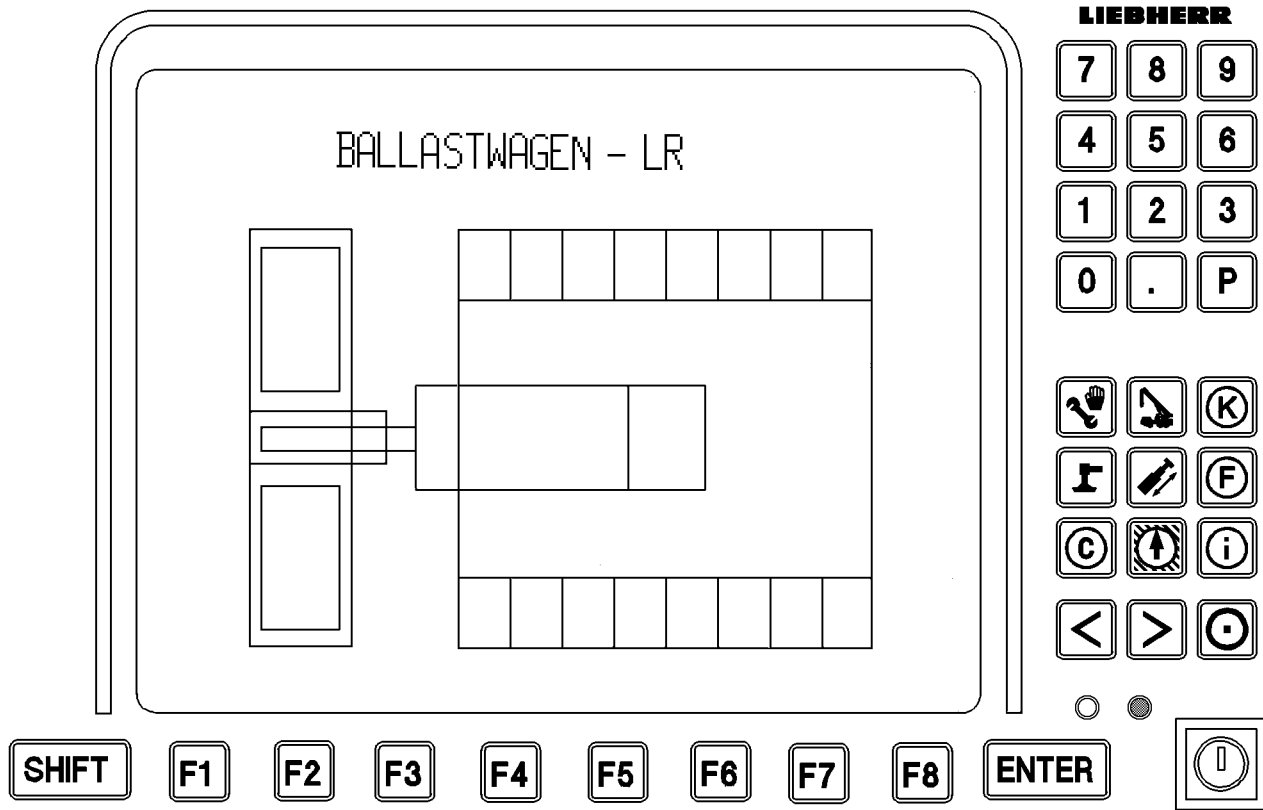
- Turn the crane engine on and wait until the monitor 1 shows the view "Ballast trailer - LR" ;
- call up the test system with the "i" button.
⇒ MULTI CPU TEST SYSTEM - VERSION XX.XX

8.9.1.1 The indicator light (131) lights up in case

- the LICCON fails;
- of an error - turn sensor set of wheels left;
- of an error - turn sensor set of wheels right;
- of an error - turn sensor slewing platform (boom direction);
- of an error - length sensor - sliding cylinder.

In case of erroneous or missing turn or length sensors, corresponding system error messages are also issued.

The indicator light blinks while the safety test of the ballast trailer control is carried out (after engine start).



8.9.2 Main menu

After the start of the LICCON test system, the main menu appears, which contains the basic data of the system. All sub functions can be called up via function keys "F1" to "F8".

8.9.2.1 Selection of central processing unit or group

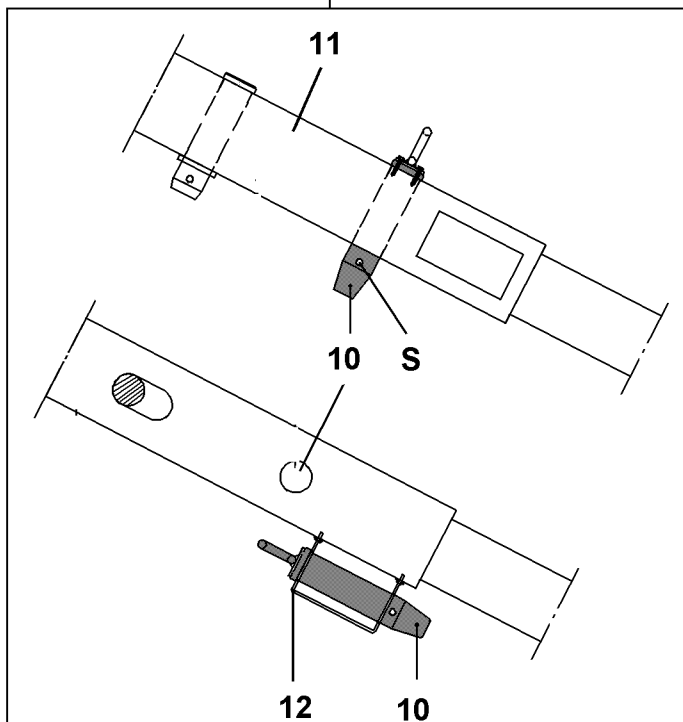
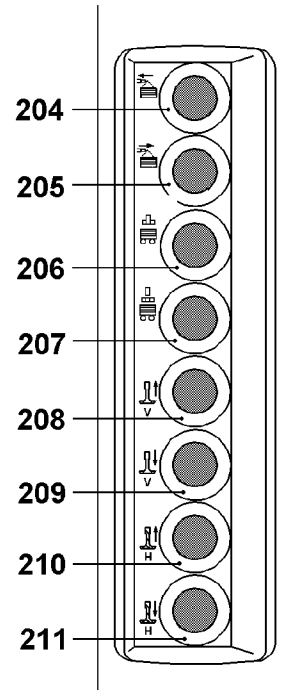
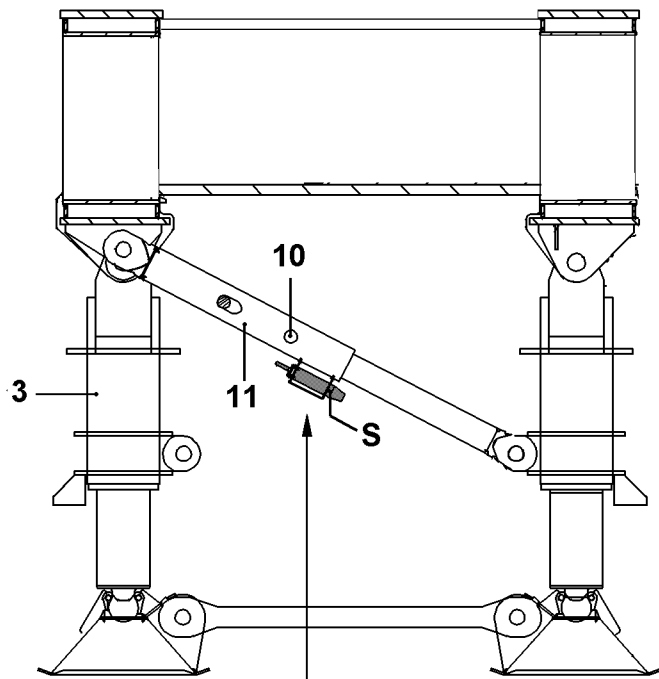
In the right upper window the cursor blinks to note the selection of the desired CPU.

- By pressing the "ENTER" key, the cursor changes from "CPU" to "Group" and back.
- Enter the desired group or CPU from the installed units with keys on the alpha numeric keyboard.

Note: The test system can only access installed units (Group, CPU).

8.9.2.2 Function key bar - main menu

"F1"	SYSTEM	Access of inputs and outlets, AWL-Operands, system internal "Specialities".
"F2"	EPROM-Inhalt	Software for LICCON-CPU's.
"F3"	UHR	Access protected function to set or stop or start the battery buffered real time clock.
"F4"	SYSTEM-SPEZIAL	To check the complete function units of the ballast trailer.
"F5"	TEST	
"F6"	EXTERN	Start of remote diagnostics
"F7"	EXTERN	
"F8"	ENDE intern	Program end



9. Removal of the ballast trailer

D A N G E R: The ballast trailer may only be removed on level ground of sufficient load carrying capacity and only by authorized persons.

Prerequisite:

- Ballast trailer guide is retracted.
- Ballast plates are removed.
- Pin the locking pins (10) on the strut (11) and secure with spring retainer (S).

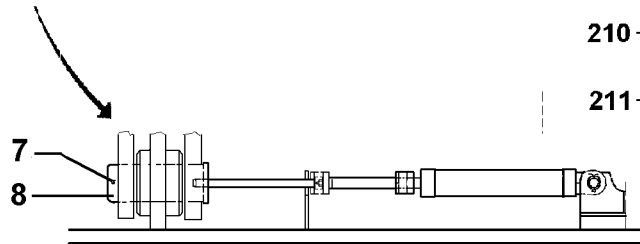
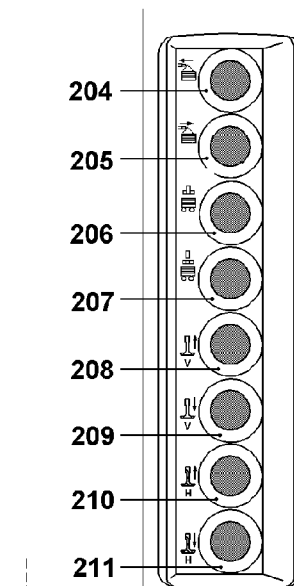
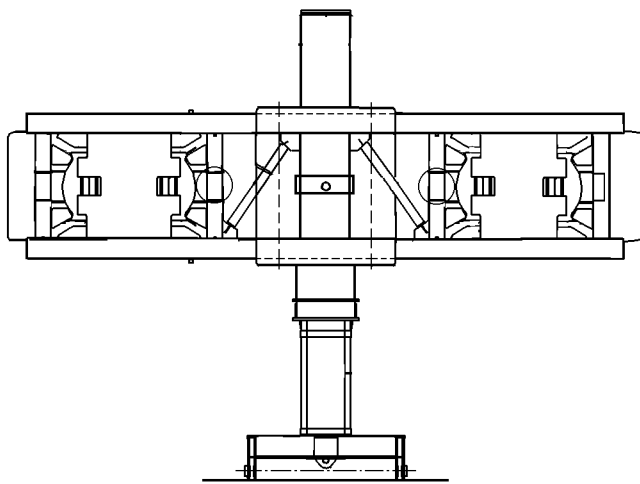
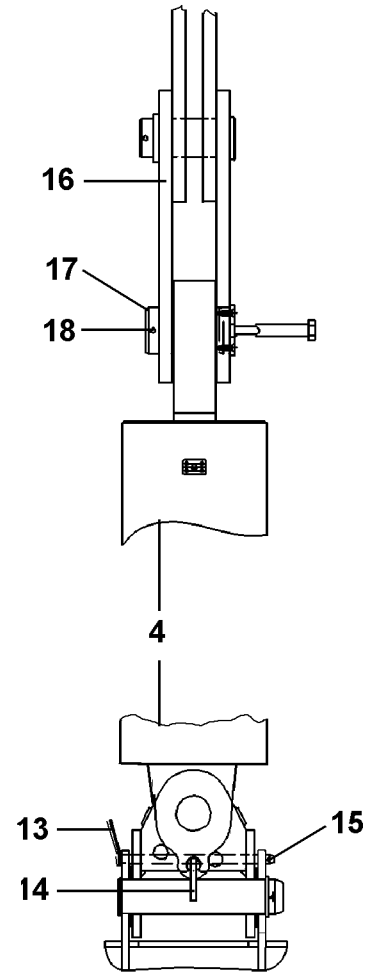
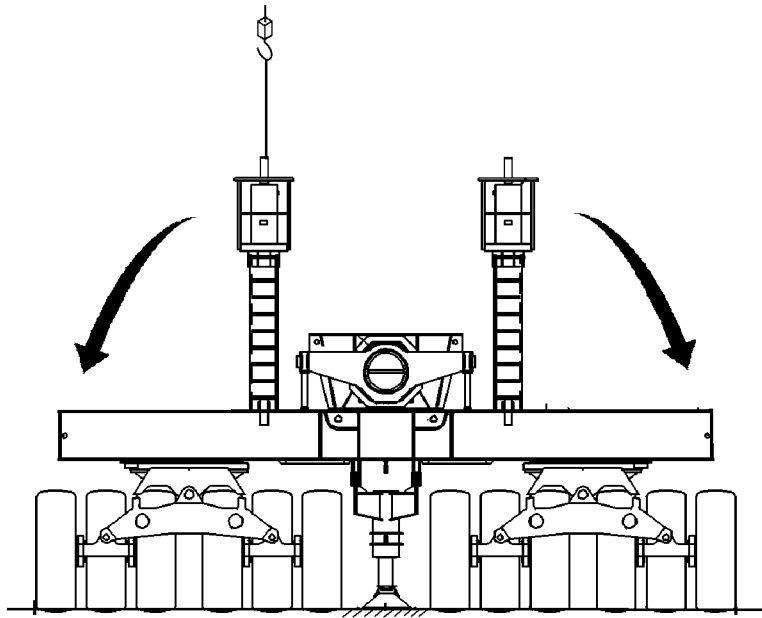
Support the ballast trailer

The ballast trailer must be supported before unpinning on the slewing platform .

Extend the support cylinder (3) :

- Press the button (209) to extend the support cylinder on the front
- Press the button (211) to extend the support cylinder on the rear

C A U T I O N: Before unpinning the ballast trailer on the slewing platform , it must be ensured that the locking pin (10) is inserted on the strut (11).
The locking pin must be pinned so that the ballast trailer does not tip over.



9.1 Remove the pull cylinder (4) on the guy rods (16)

Remove the spring retainer (18) and unpin the pin (17) on both sides.

D A N G E R: The pull cylinders must still be locked on the ballast trailer !

Retract the piston rod .

Note: On each cylinder is a working platform. On this platform is a switch housing with button "Cylinder **OFF**" and "Cylinder **ON**".
With this buttons, only the one cylinder can be moved on which the switch is installed.

9.1.1 Place down the pull cylinder

Attach the pull cylinder (4) on the auxiliary crane.

Note: Weight, pull cylinder approx. 1500kg

Unpin the locking pin crosswise and lengthwise.

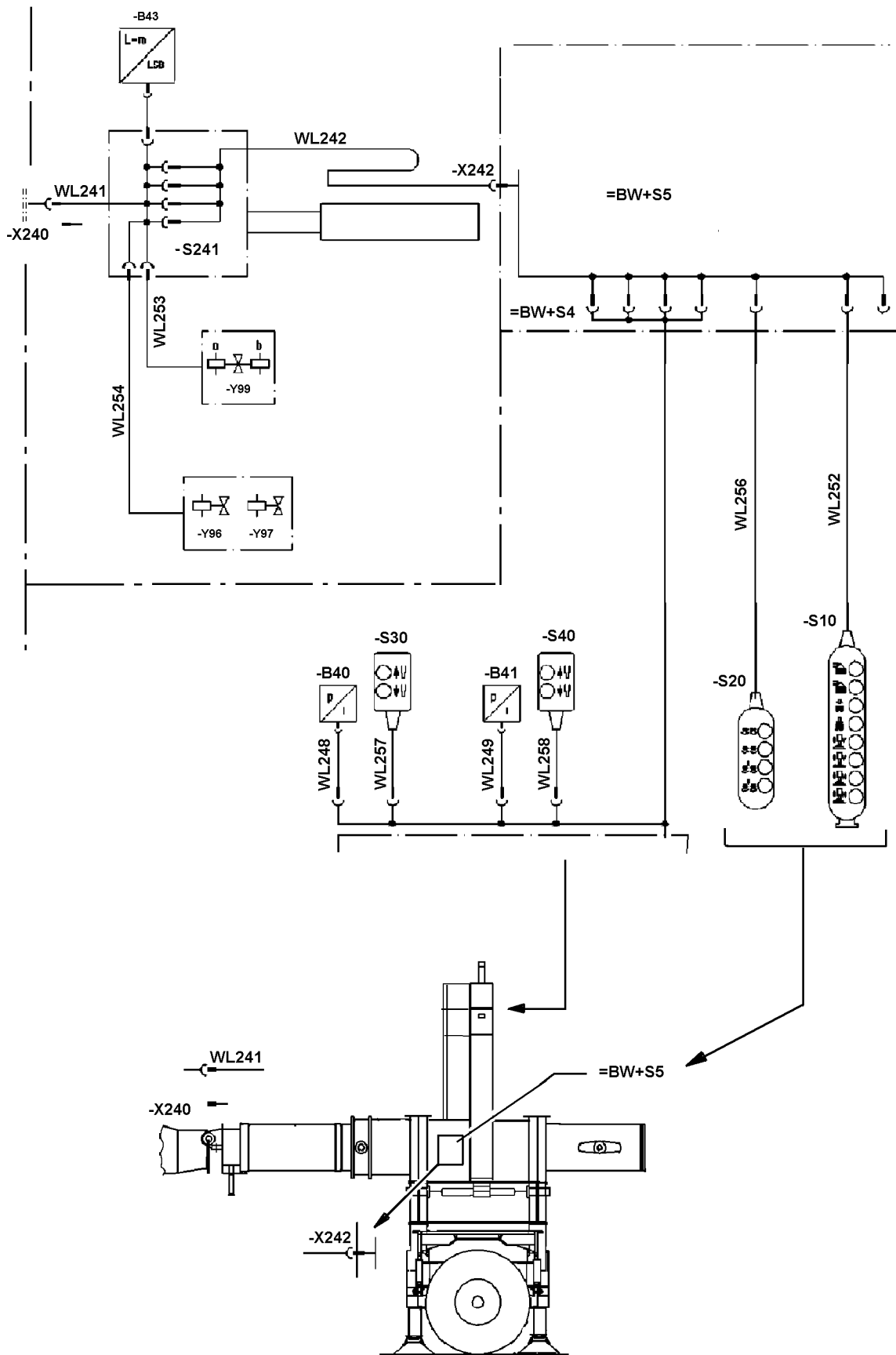
Remove the spring retainers (15) and unpin the handle pin (13, 14) .

Place the pull cylinder with the auxiliary crane on the ballast trailer .

9.2 Unpin the ballast trailer guide on the crane

Remove the spring retainers (7) on both sides.

Press the button (207) and unpin the pin (8) on both sides.



9.3 Loosen the supply lines

- Turn the engine off.

9.3.1 Release the pneumatic and hydraulic connections

- Loosen the coupling connections ;
- Screw the coupling connections with the plug.

D A N G E R : When connecting or releasing the hydraulic lines with quick couplings, it must be ensured that the coupling procedure is carried out properly.

Prerequisite for correct coupling connection is:

- The pressure must be released from the hydraulic system before connecting or releasing the couplings (turn the engine off, wait for approx. 5 minutes).
- Interconnect the coupling sections (sleeve and plug) and connect them with the hand nut.
- Tighten the nut past the O-ring until you can feel a firm stop.
- The couplings may only be tightened by hand - without tools (or couplings will be damaged).

Improperly connected couplings can cause loss of pressure or sudden leakage and therefore can cause accidents!

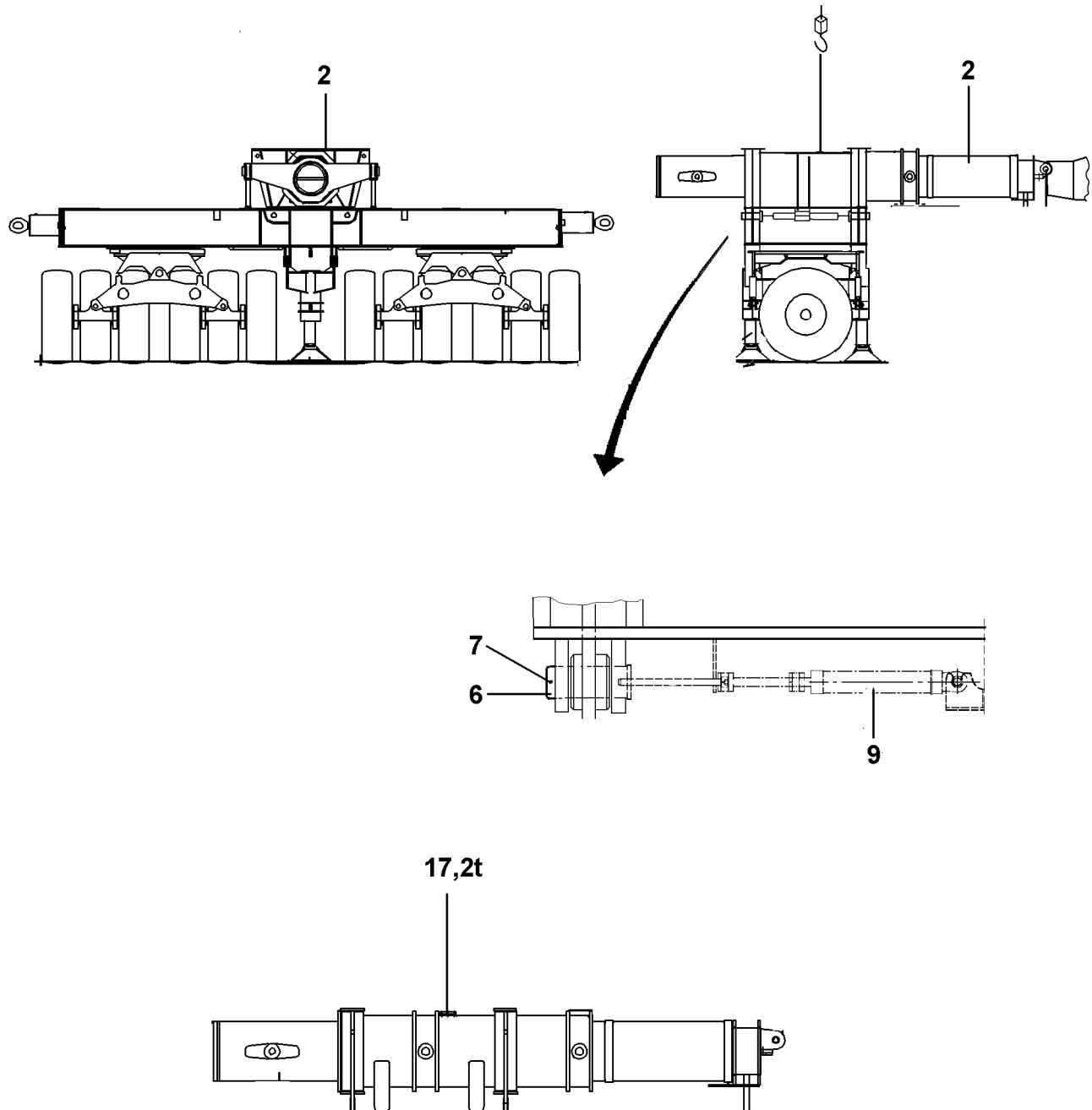
9.3.2 Release the electrical connection

- Unplug the cable WL 242 from socket -X 242 and insert into the dummy plug on the ballast trailer guide ;
- Unplug cable WL 241 from socket -X 240
- Insert the dummy plug in socket -X 240 .

D A N G E R : The electrical connections may only be released and inserted into the dummy plug if the ballast trailer guide is all the way unpinned on the crane. As soon as one of the two pins is unpinned from the guide frame, the crane control no longer recognizes that the ballast trailer is installed. Now, the crane can be turned and driven even though the ballast trailer is still installed on the crane (ballast trailer is still connected with a pin with the crane). There is a danger of damaging the ballast trailer or the crane if the crawler is driven off or the crane superstructure is turned.

9.3.3 Drive away the crane

To be able to remove the ballast trailer guide, the crane must be driven off.



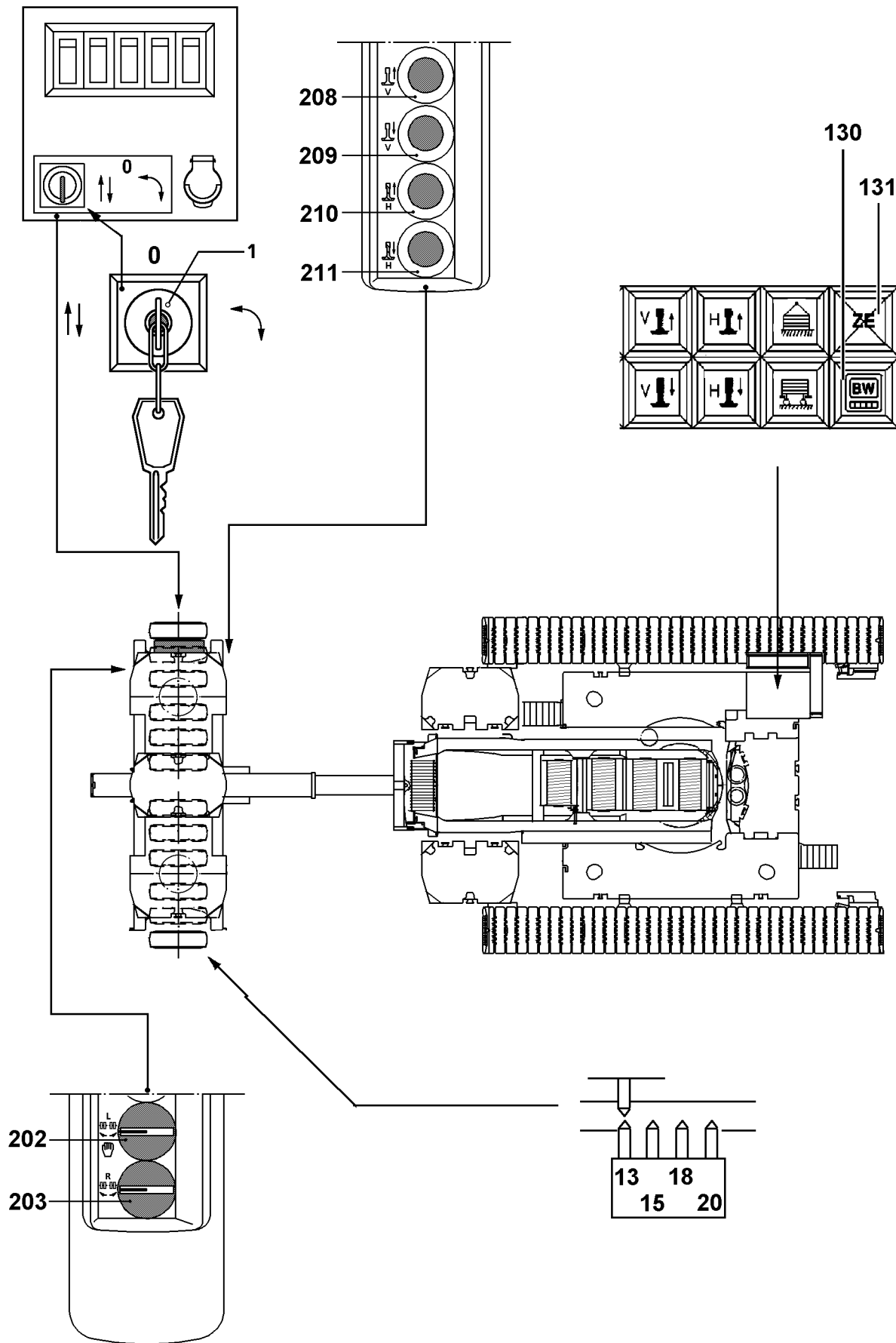
9.4 Unpin the ballast trailer guide (2) on the ballast trailer

- Hold the ballast trailer guide with the auxiliary crane;
- connect the pin pulling device (9) with the hydraulic component;
- remove the spring retainers (7) on pins (6) .
- Unpin the pins (6) with the pin pulling device (3) on both sides ;
- Remove the pin pulling device.
- Place down the ballast trailer guide (2) with the auxiliary crane on the transport vehicle;
- park the ballast trailer on the transport vehicle.

D A N G E R : **The ballast trailer and the ballast trailer guide must be attached properly for transport.**

Otherwise there is a danger of tipping over.

The ballast trailer is n o t e q u i p p e d with its own brake system. For that reason, it must be supported when not installed.



10. Emergency operation for ballast trailer**10.1 General**

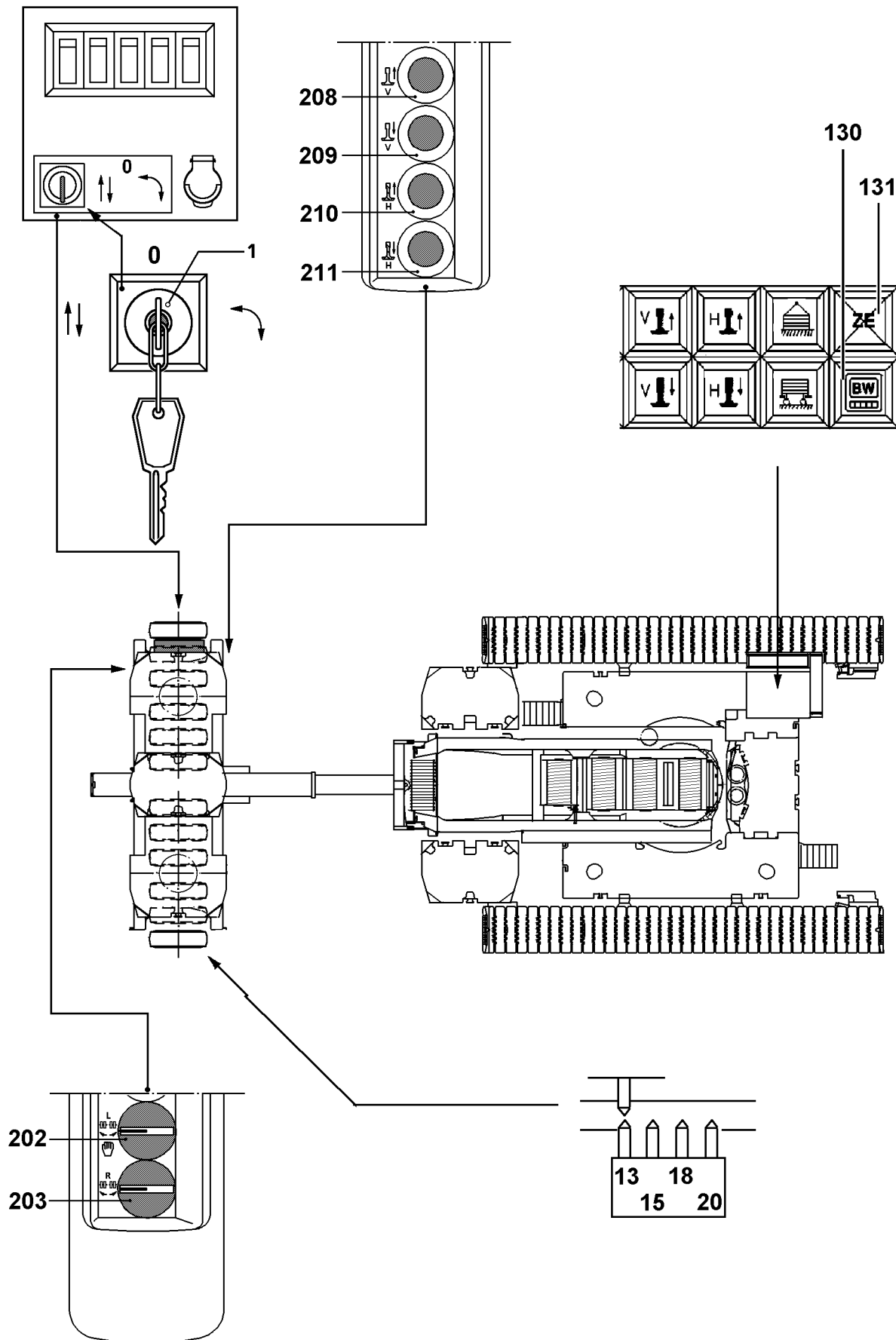
In case of failure or defect of a central processing unit on the ballast trailer (warning light 131 lights up), the electronic steering of the ballast trailer can not be actuated. The signal **towing** and **driving in turns** can no longer be sent from the ballast trailer control to the crane control.

By actuating the keyed button (1) in the connector box on the ballast trailer, the central unit can be bypassed.

D A N G E R: The following points must be observed for emergency operation :

- The emergency operation may only be carried out by authorized personnel ;
- no other persons may be within the danger zone of the ballast trailer;
- each individual travel movement may only be carried out with utmost caution and care, at the least possible acceleration and with careful braking action.
- The keyed button (1) may only be actuated in case of failure of the electronic.
- The signal "towing" and " driving in turns " is released to the crane, even though the wheels might be in the wrong position.
- The wheel position must be monitored manually. Watch the angle scale on the ballast trailer !

Note: In crane operation (not emergency operation), the keyed button (1) must be set to position 0 (center position) .



10.2 Emergency operation - towing

Prerequisite

- The crane is at a standstill;
- the ballast trailer is properly installed;
- the rocker switch (74) is on cawler operation.

10.2.1 Lift the ballast trailer with support cylinders

- Switch the keyed button (1) on the ballast trailer to the left;

Note: By turning the keyed button (1) to the left, the **Towing** command is forwarded to the crane and the emergency operation is turned on.

Press the button (209 and 211), the support cylinders on the front and rear extend.

In emergency operation the support can only be moved from the control panel on the ballast trailer .

10.2.2 Set the axles to towing position

- Switch the keyed button (1) on the ballast trailer to the left;

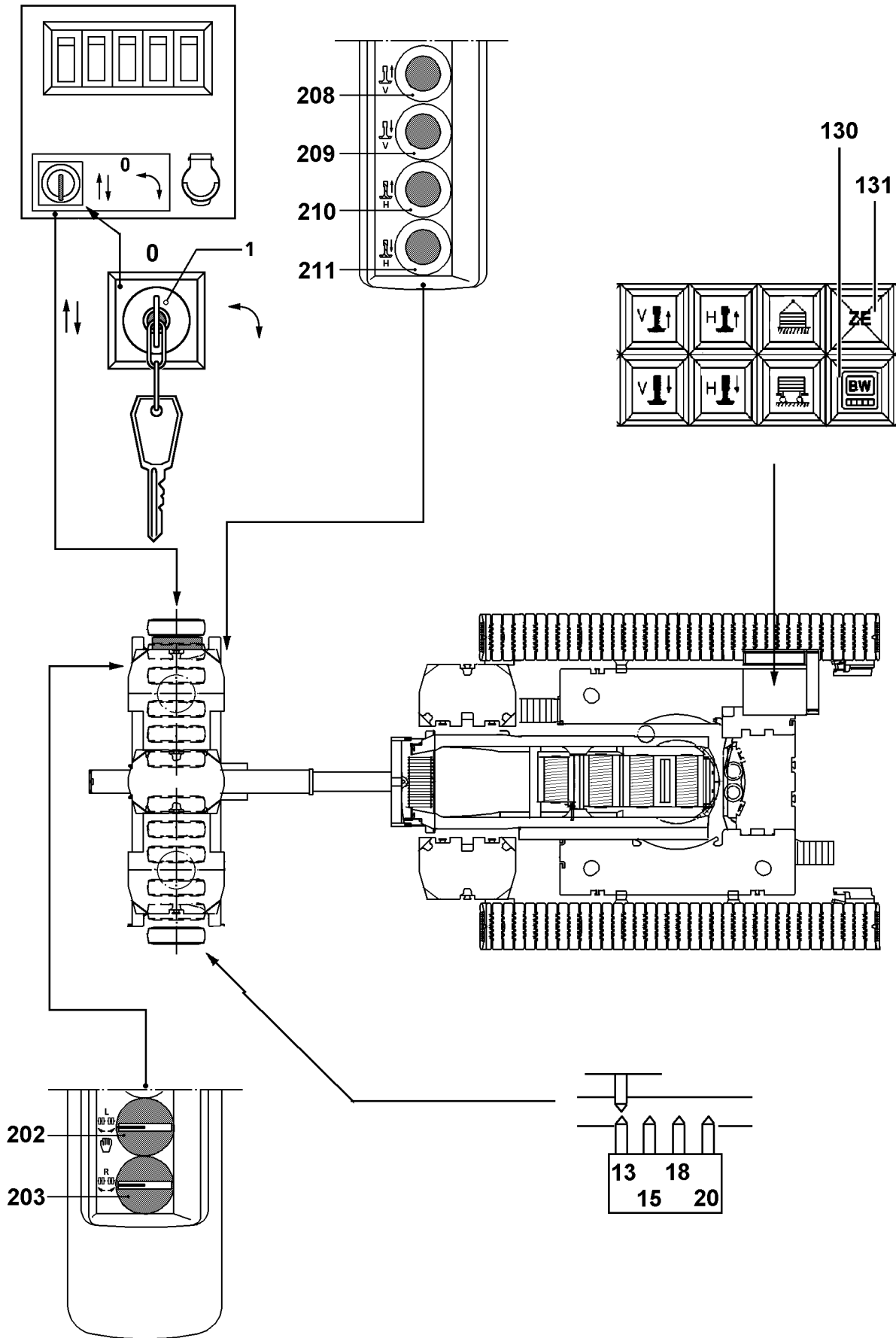
Note: By turning the keyed button (1) to the left, the **Towing** command is forwarded to the crane .

- Actuate the knob (202) to bring the left set of wheels to towing position ;
- Actuate the knob (203) to bring the right set of wheels to towing position .

D A N G E R : The wheel position of the set of wheels must be constantly monitored during travel. Watch the angle scale on the ballast trailer.
In case of excessive deformation of the tires, readjust the position.

10.2.3 Lower the ballast trailer with the support cylinders

- Press the button (208 and 210) , the front and rear support cylinders retract;
- the indicator light (128), supports ballast trailer are retracted, lights up.



10.3 Emergency operation - driving in turns

By telescoping the ballast trailer, various turning radii are possible.

Prerequisite

- The crane is at a standstill;
- the ballast trailer is properly installed.

10.3.1 Lift the ballast trailer with support cylinders

- Switch the keyed button (1) on the ballast trailer to the **right**;

Note: By turning the keyed button (1) to the **right**, the **Driving in turns** command is forwarded to the crane and the emergency operation is turned on.

Press the button (209 and 211), the support cylinders on the front and rear extend.

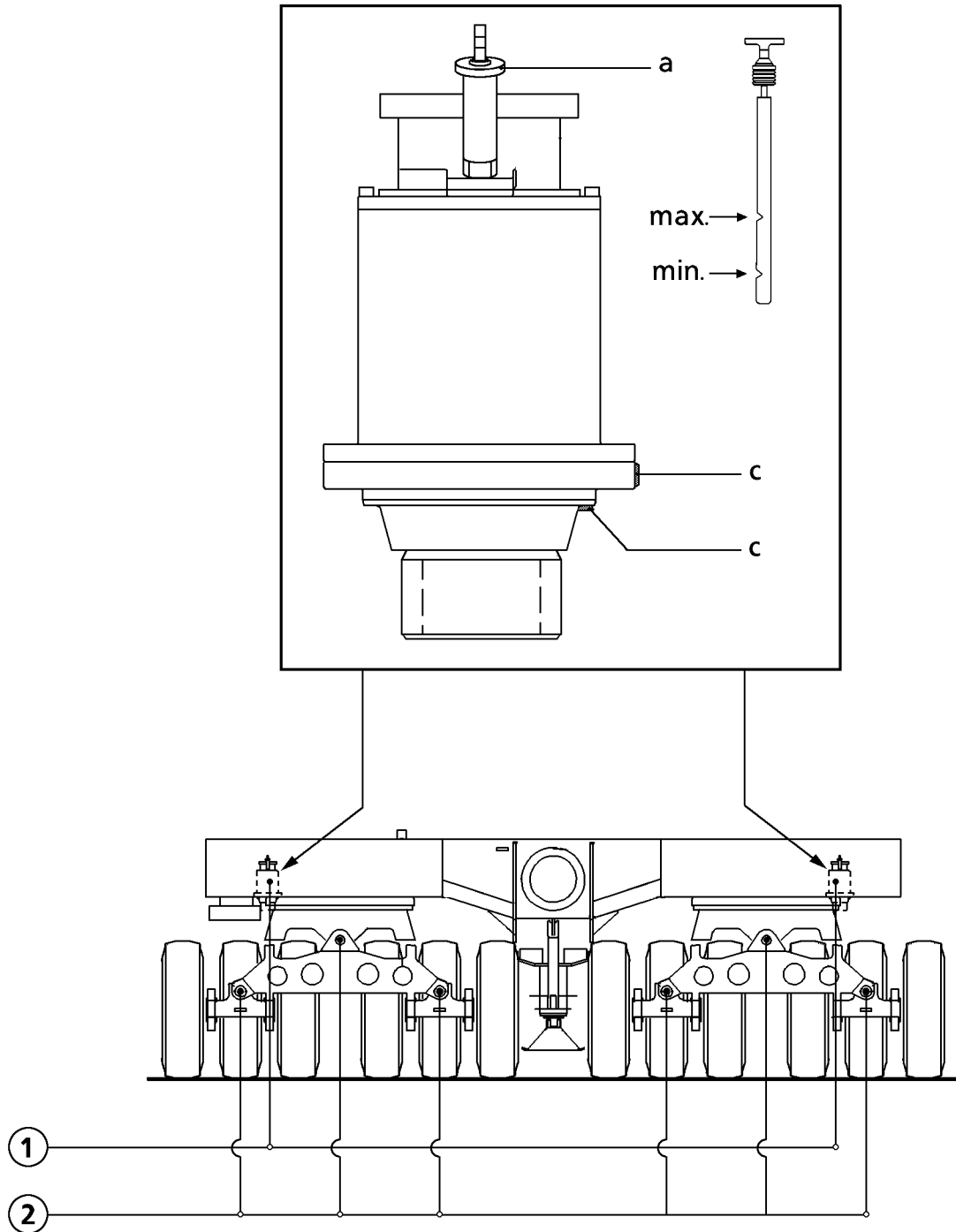
10.3.2 Set the axles to driving in turns position

- Actuate the knob (202) to bring the left set of wheels to driving in turns position until the marks according to the ballast trailer radius align ;
- Actuate the knob (203) to bring the right set of wheels to driving in turns position until the marks according to the ballast trailer radius align.

D A N G E R : The wheel position of the set of wheels must be constantly monitored during travel. Watch the marks on the ballast trailer .
In case of excessive deformation of the tires, readjust the position.

10.3.3 Lower the ballast trailer with the support cylinders

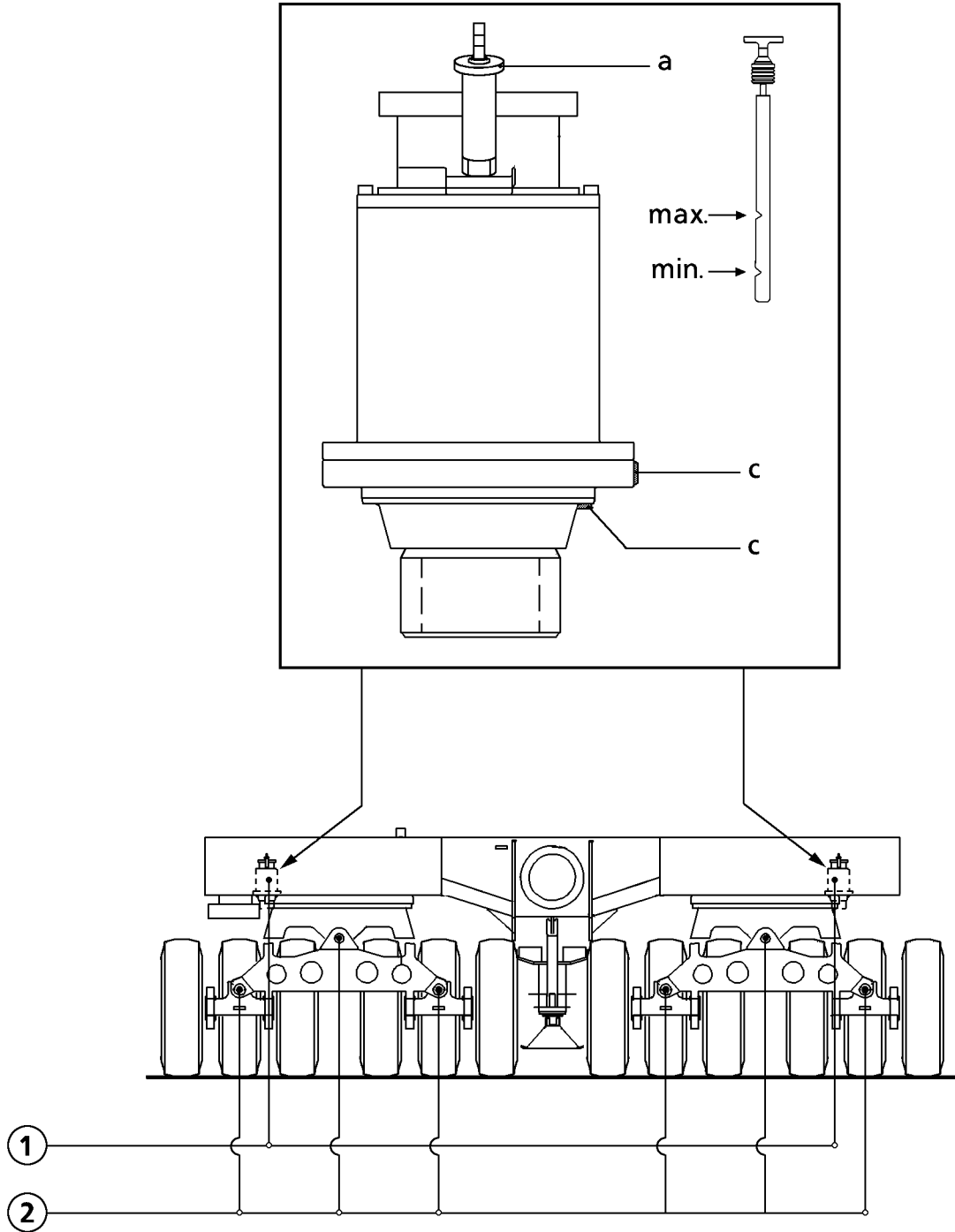
- Press the button (208 and 210) , the front and rear support cylinders retract;
- the indicator light (128), supports ballast trailer are retracted, lights up.



11. Maintenance

11.1 Maintenance intervals

	First main-tenance after	Regular maintenance every				Minimum main-tenance an-nually	Checks	
		100 hrs.	200 hrs.	400 hrs.	1200 hrs.		daily	weekly
<input type="checkbox"/> Slewing gear								
- Check for leaks							×	
- Check oil level								×
- Check mounting screws for tight seating	200 hrs.			×		×		
- Oil change					4000 hrs.	every 4 years		
<input type="checkbox"/> Axle swing								
- Lubricate			×			×		



11.2. Slewing gear

11.2.1 Check the oil level

The oil must be between the MIN and MAX mark on the dipstick.

- Check the oil level only if the crane is in horizontal position,
- pull the dipstick, wipe it off, reinsert it and pull it out again,
- Reinsert the dipstick into the test point after checking the oil level.
- Add oil **according to the lubrication chart**, as necessary.

CAUTION: If the oil level has dropped below the MIN mark, then oil must be added according to the lubrication chart, until the oil level is again between the MIN and MAX mark.

If no oil is added, the gear may be severely damaged.

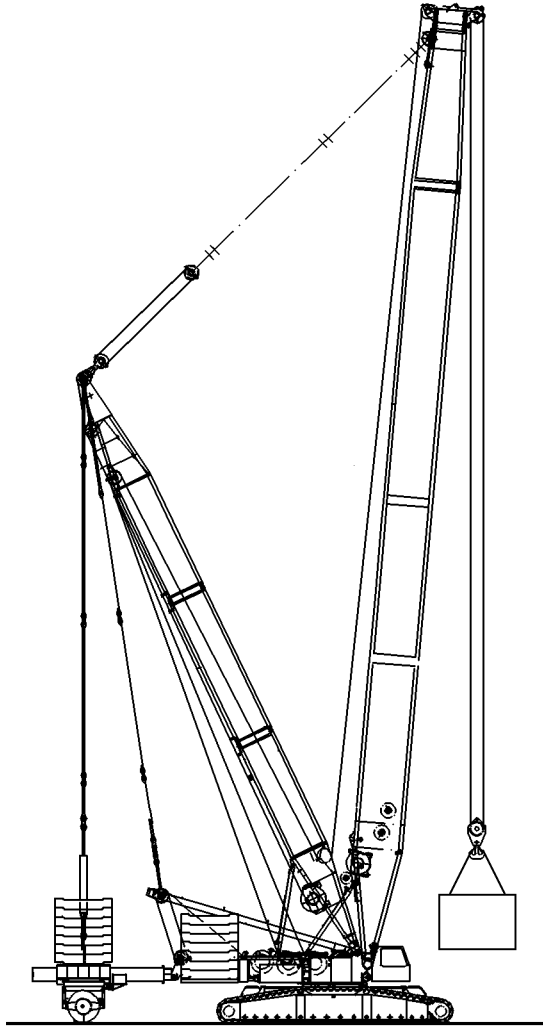
11.2.2 Oil change:

- a = oil dipstick and oil filler port
- Pull out the oil dipstick (a) ;
- Unscrew the drain plug (c) with seal ring and clean the sealing surface;
- drain the old oil ;
- reinsert the drain plug (c) with new seal ring and tighten;
- Add oil according to the lubrication chart on the oil filler port (b) ;
- wipe off the dipstick, reinsert it again and pull it out again.
- After checking the oil level, push the dipstick tightly into the test point ;
- repeat the procedure, if necessary.

CAUTION: Observe utmost cleanliness to ensure that no dirt and contamination gets into the inside of the gear.

11.3 Central lubrication system

For maintenance of central lubrication system, see chapter 7.05 MAINTENANCE GUIDELINES - CRANE SUPERSTRUCTURE.



11.4 Tires

- Check condition of tires , check for damage .
The depth of the tire tread may not fall below the minimum value.
- The tire pressure must be 10 bar .
The tire pressure must be checked when the tire is cold.
- Before inflation of tires, make sure that the tire is seated properly on the rim and that the lock ring is seated properly.

CAUTION: The highest permissible air pressure may not be exceeded!

DANGER: When adding air to the tires on the vehicle, make sure that nobody is within the danger zone to prevent injury due to flying parts.
If tires are damaged, if the tire tread is insufficient and the air pressure in the tires differs, there is an increased danger of accidents.

11.4.1 Safety and maintenance guidelines for the wheels (rims)

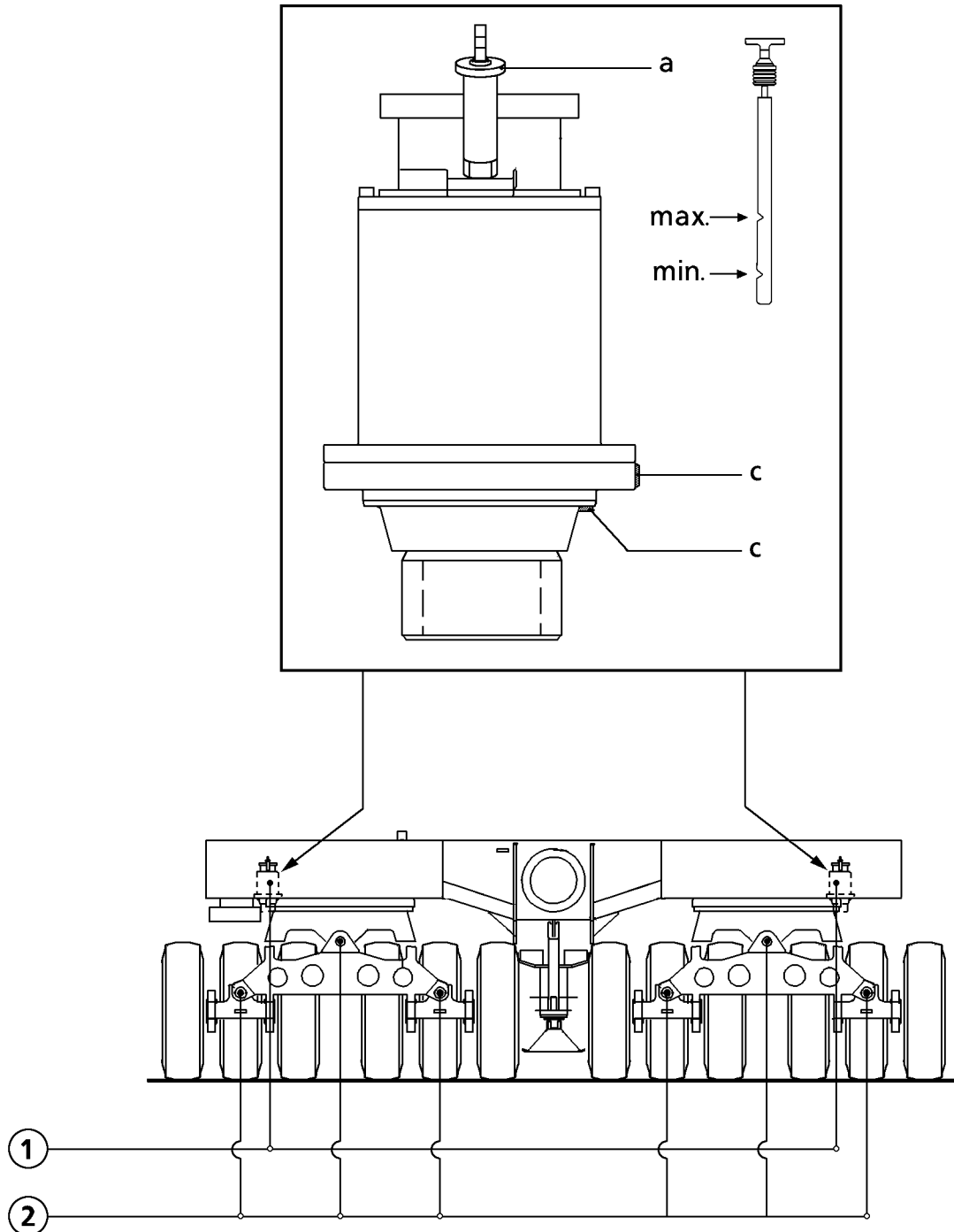
The below listed safety and maintenance guidelines are recommendations made by the manufacturer, in order to prevent any safety risks due to damaged wheels or rims.
In addition, the manufacturer states that the manufacturer's warranty is only valid if the guidelines noted below have been strictly observed and followed.

The wheel is one of the most important safety components of the vehicle. For this reasons, it is imperative that the following guidelines are followed. When changing the tires, the wheels must be checked, the rim as well as the complete dish, as follows:

- formation of excessive rust or corrosion
- bent rim flanges
- cracks in the rim
- cracks in the wheel dish
- damage on the side and lock rings
- damage to the lug nuts or bolts
- worn or damaged bolt holes
- rim components must match and fit.

If any damaged rim components are found, they must be replaced immediately with new components. If chipped paint or minor rust is found, the rust layer should be removed and the area should be repaired with commercially available paint. You must make sure that the surface is smooth, especially on the tire seating surface.

DANGER: Never perform or allow any welding on the wheel rim or wheel dish. It is strictly prohibited to repair deformed or worn bolt holes or to replace or repair the wheel center .
Any wheels with these defects must be scrapped immediately and replaced with new wheels.
Any repair to these highly stressed parts of the wheel causes structural changes in the material, which can lead to sudden fractures.



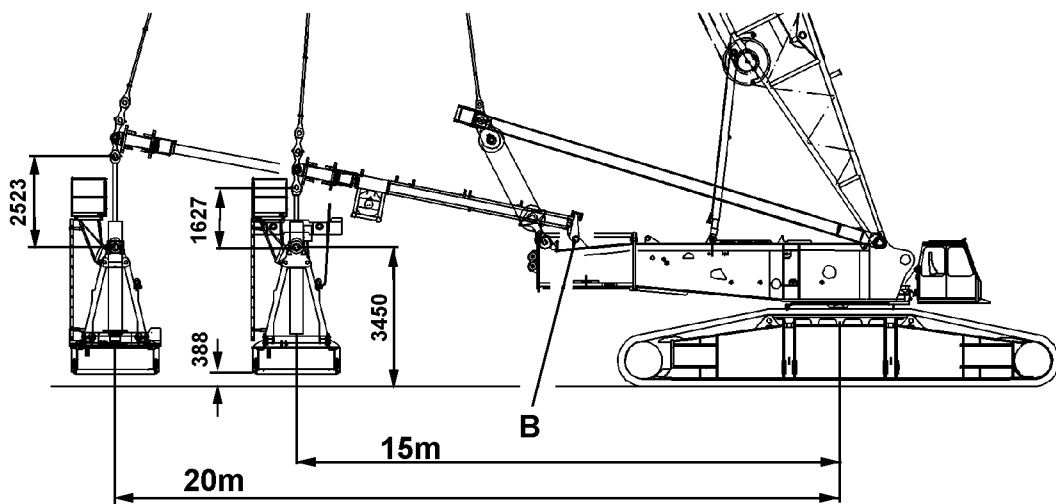
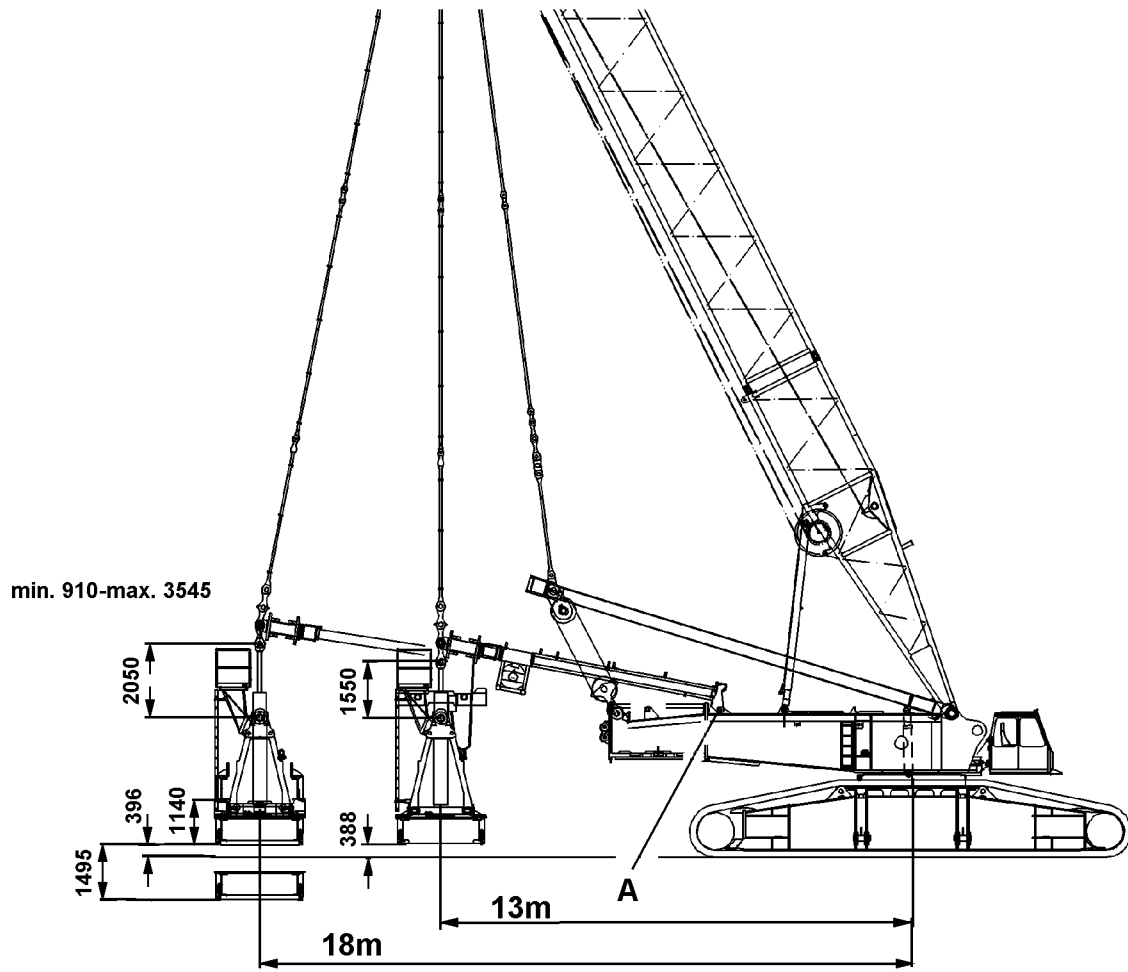
11.5 Lubrication schedule, quantities

Ballast trailer		
Slewing gear Synthetic gear oil		4.4 l
Central lubrication system Special grease		2.0 kg
Lubrication Special grease		0.1 kg

CAUTION: The given values are orientation values.
The marks on the dipstick and the control ports or sight gauges are the valid marks for the fluid levels.

Explanation for lubrication chart:

- 1 Synthetic gear oil
- 2 Grease



1. Suspended ballast B

for max. 400t derrick ballast
for max. 20m counter load

1.1 General

The suspended ballast consists of:

- 1 Hydraulically telescoping guide
- 2 Ballast pallet with 2 cylinders
- 3 Ballast plates

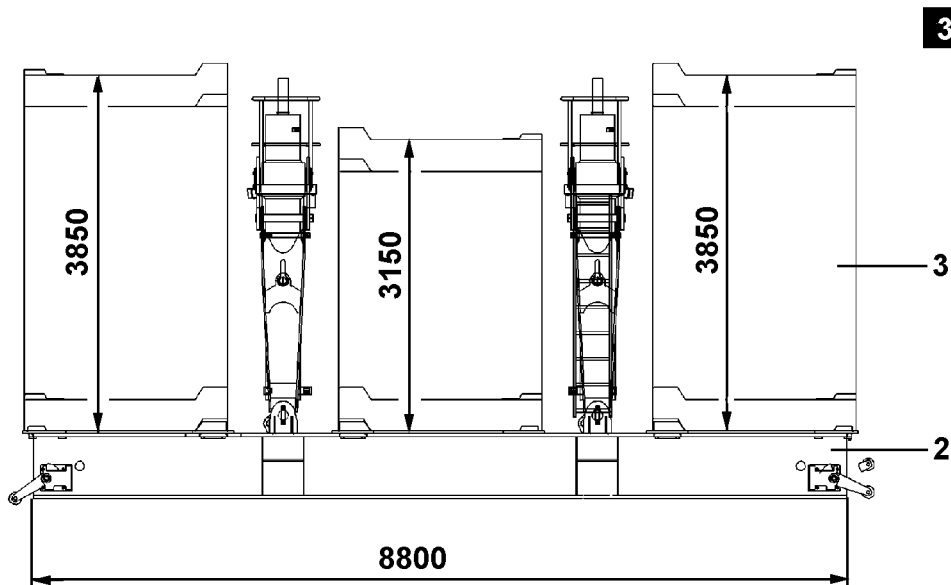
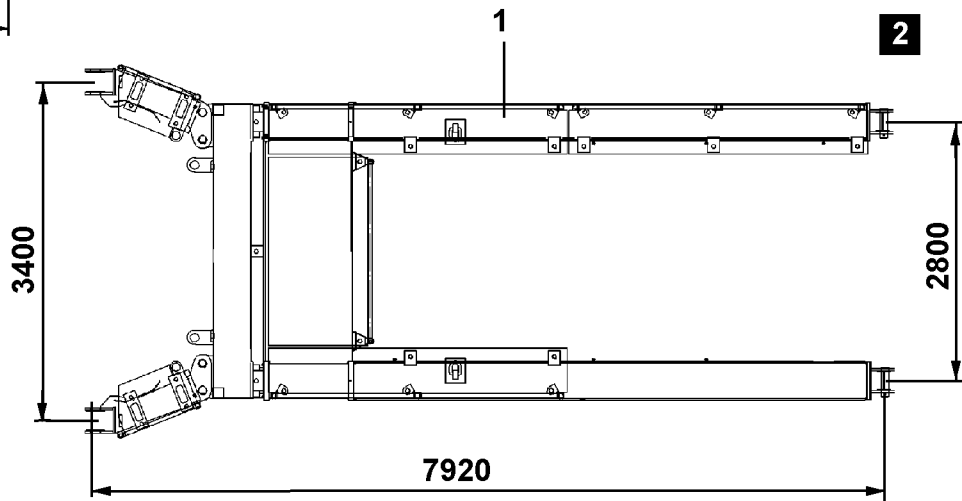
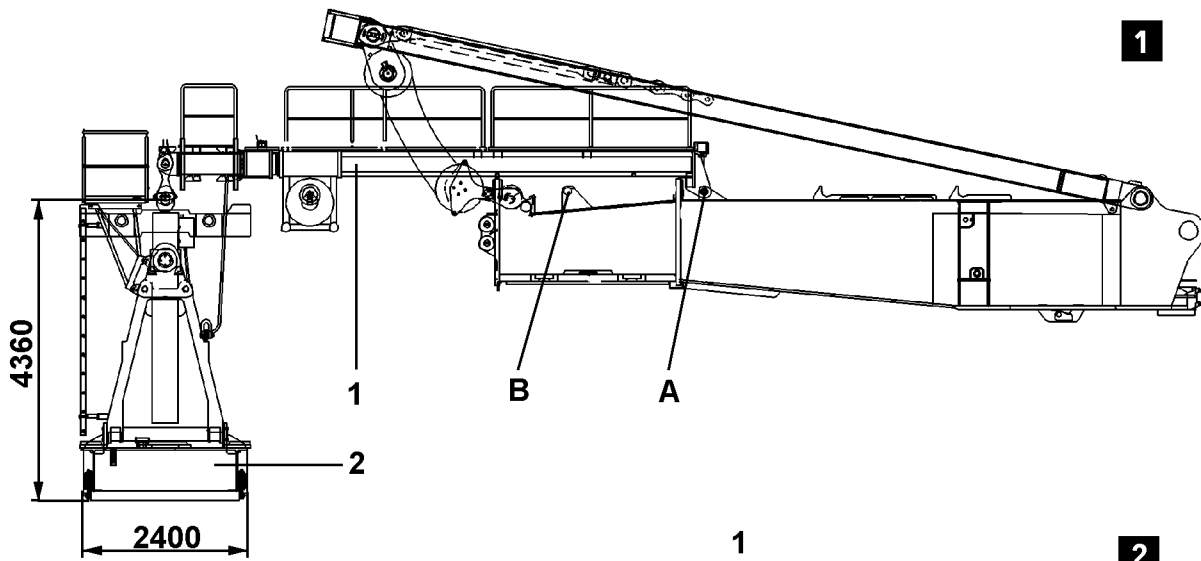
1.2 Radii

Pivot points for telescoping guide on the slewing platform:

A = 13 m to 18 m
B = 15 m to 20 m

1.3 Cylinder stroke

The cylinder stroke is min. 910 to max. 3545 mm



2. Components

Fig. 1

- 1 Guide
- 2 Ballast pallet

A =Pivot point for guide, radius 13 m to 18 m
B =Pivot point for guide, radius 15 m to 20 m

2.1 Dimensions / Weights [t]

Fig. 2

Guide (1)

Weight: approx. 8.5 t

Fig. 3

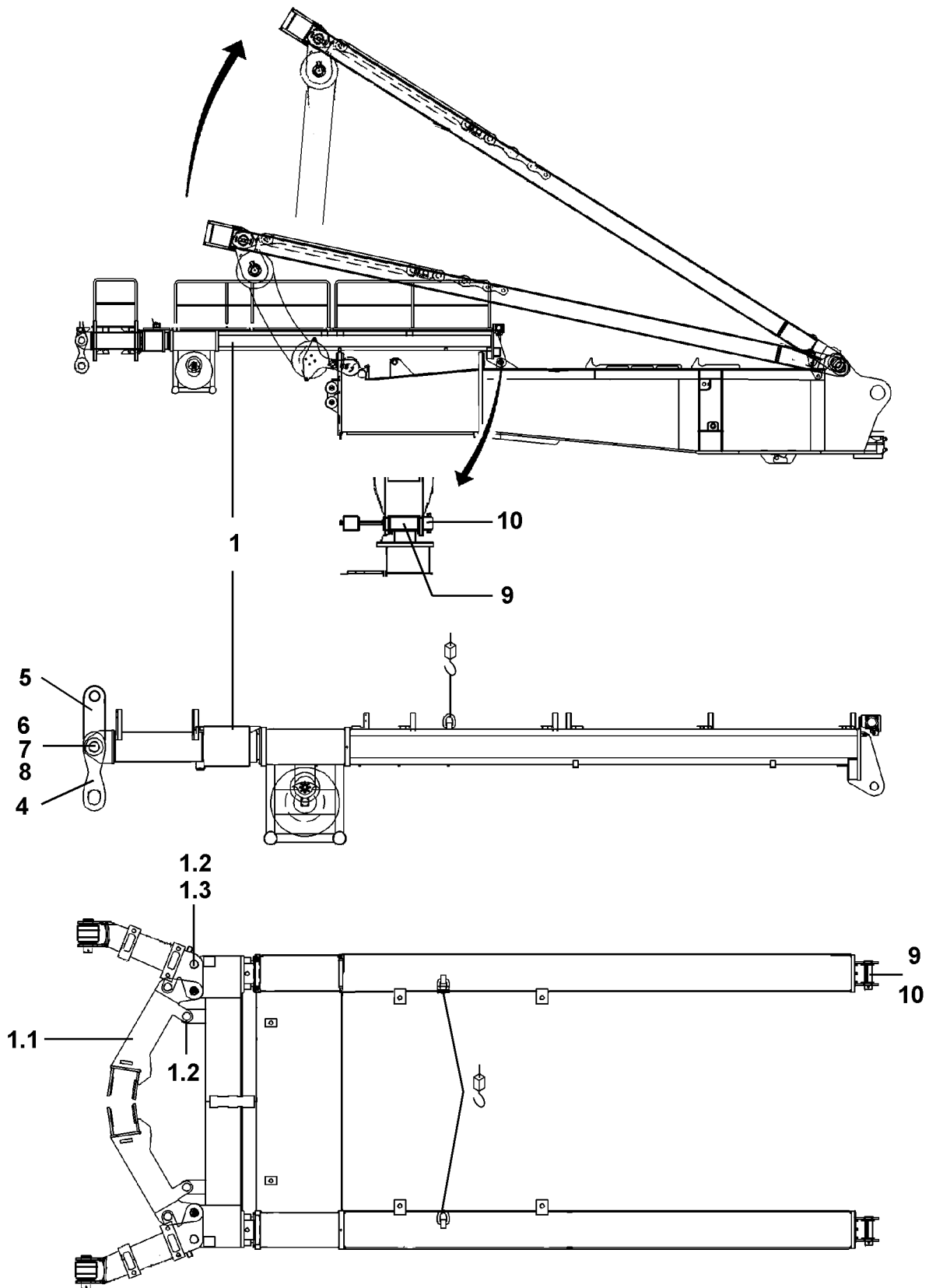
Ballast pallet (2)

Weight: approx. 13.5 t, with cylinder, without ballast plates

Fig. 3

31 each ballast plates (3)

Weight: each plate 12.5 t



3. Installation of the suspended ballast

Prerequisites:

- The boom and the derrick are installed.
- Set the derrick and the SA-bracket in such a way that the guide (1) can be installed on the slewing platform without restriction .

3.1 Preassemble the guide (1)

Due to the transport width, the arms (1.1) of the guide are swung inward.

Remove the locking pin (1.2) , fold the arms (1.1) out, reinsert the locking pin (1.2) and secure with spring retainer (1.3) .

Pin the brackets (4) and bracket (5) on the guide. Insert pin (6) , secure with washer (7) and cotter pin (8) . Release the hydraulic hoses on the guide.

3.2 Pin the guide (1) on the slewing platform

Attach the auxiliary crane to the 2 eye hooks (X) .

Swing the guide (1) to the pins ("A" or "B") on the slewing platform

Lower the guide (1) and pin .

Note: Pinning "A" = suspended ballast radius 13 - 18 m
 Pinning "B" = suspended ballast radius 15 - 20 m

Insert the pin (9) on both sides and secure with spring retainers (10) .

Lower the guide until it rests on the slewing platform.

Remove the auxiliary crane.

Establish the hydraulic and electrical connections from the guideto the slewing platform .

3.2.1 Establish the electrical connections

- Remove the dummy plug on the socket -X 240 on the slewing platform.
- Plug the cable WL 244 into the socket -X 240 .

3.2.2 Establish the hydraulic connections

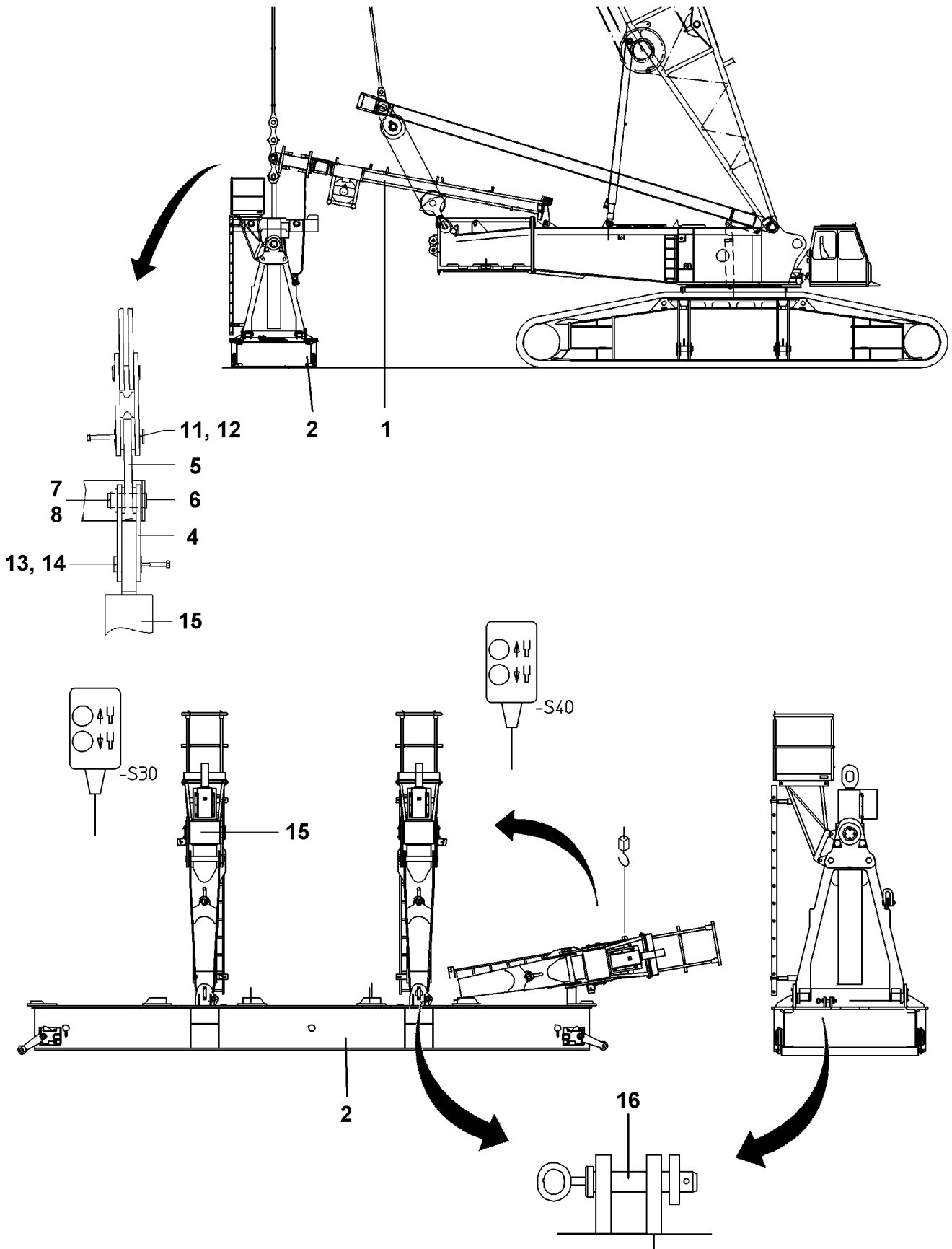
The hydraulic quick couplings, which belong together, are marked.

D A N G E R : **When connecting or releasing the hydraulic lines with quick couplings, it must be ensured that the coupling procedure is carried out properly.**

Prerequisite for correct coupling connection is:

- **The pressure must be released from the hydraulic system before connecting or releasing the couplings (turn the engine off, wait for approx. 5 minutes).**
- **Interconnect the coupling sections (sleeve and plug) and connect them with the hand nut.**
- **Tighten the nut past the O-ring until you can feel a firm stop.**
- **The couplings may only be tightened by hand - without tools (or couplings will be damaged).**

Improperly connected couplings can cause loss of pressure or sudden leakage and therefore can cause accidents!



3.3 Installation of the ballast pallet

Attach the auxiliary crane to the 4 eyehooks on the frame.

Place the ballast pallet (2) on the corresponding radius to the crane center of rotation and align.

Set up the cylinder (15) with the auxiliary crane and lock and secure with retaining pins (16) .

Note: The weight of the ballast pallet (2) without ballast plates, with cylinders is approx. 13.5 t.
The weight of each cylinder is approx. 1.6 t

Move the derrick into operating position.

Swing the slewing platform until the brackets (4) of the guide are over the cylinders (15) .

Establish the hydraulic and electrical connections to the ballast pallet.

- Remove the dummy plug on socket -X 246 .
- Plug the cable WL 246 into the socket -X 246 .

Start the engine.

Extend the piston rod of the cylinders and pin and secure on the brackets (4) with pin (13) and spring retainer (14).

The cylinder can be actuated from the crane cab or from the control panel on the cylinder .

Note: On each cylinder is a podium. On this podium is a control panel with buttons "Cylinder OFF" and "Cylinder ON" .
With these buttons, only that cylinder can be moved on which the control panel is installed.

CAUTION: The retaining pins (16) to lock the cylinders must be removed as soon as the piston rods are pinned on the brackets (4) .

Lift the guide (1) with the auxiliary crane and at the same time extend the piston rods and pin the brackets (5) with the guy rods. Pin the pin (11) and secure with spring retainer (12) .

Note: The guide weighs approx. 8.5 t

Lift the ballast pallet off the ground by actuating the cylinders and set down again.
This is to ensure that the ballast pallet is aligned vertically before placing it.

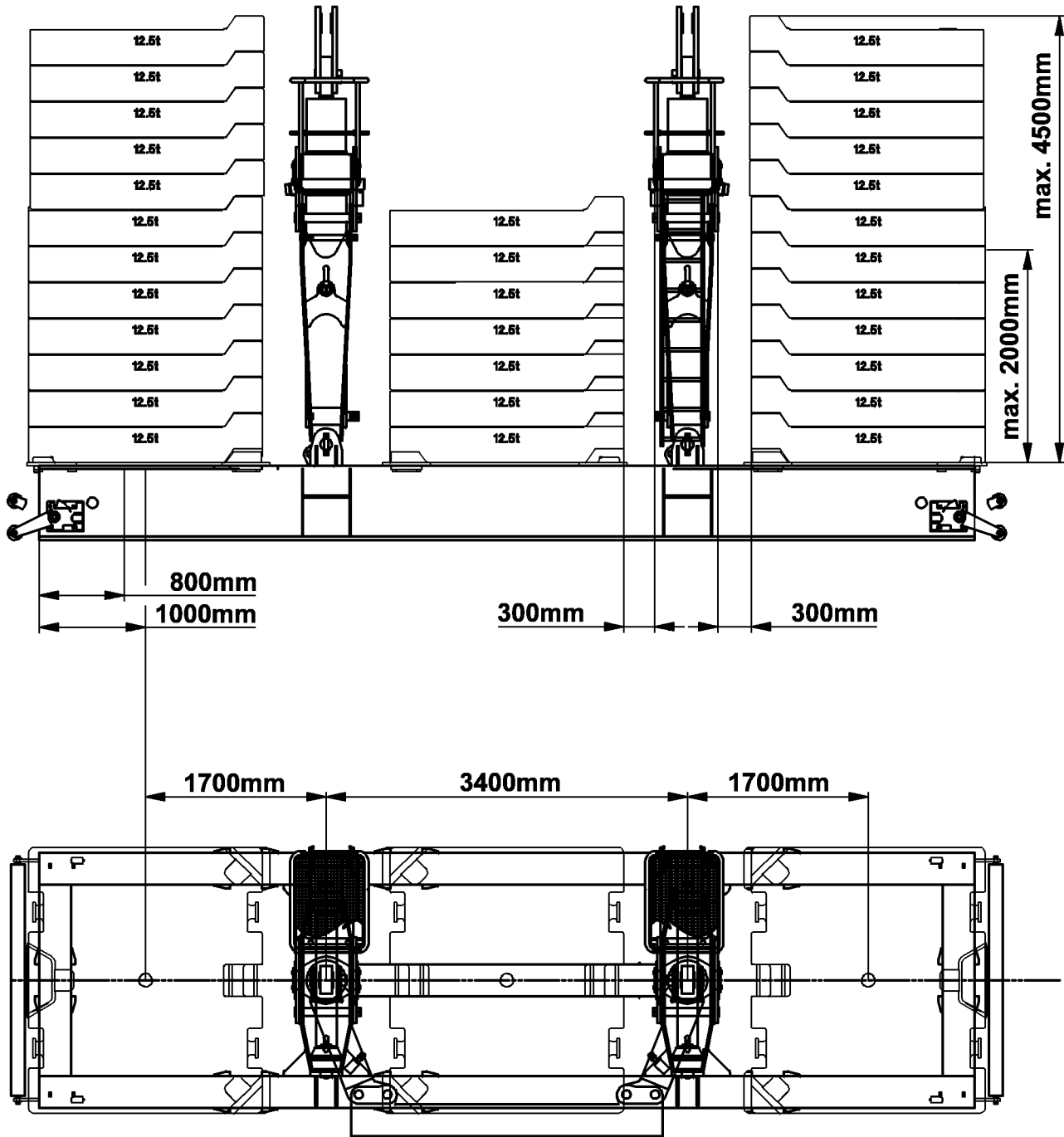
DANGER: If this is not observed, there is a danger of tipping over when lifting it with placed ballast plates.
The placement surface of the ballast pallet must be level, horizontal and of sufficient load carrying capacity.

3.4 Disassembly

DANGER: The suspended ballast may only be disassembled if:

- it is sitting on the ground .
- the pin (16) is locked and secured with the spring retainer.
The brackets (4) may only be unpinned after the pin (16) is locked and secured.

If the danger notes are not observed, there is an increased danger of accidents due to tipping over of the pull cylinder.



3.5 Ballasting the ballast trailer

Place the ballast plates with the auxiliary crane on the ballast pallet. The ballast pallet can be ballasted on the ground as well as in "suspended condition". When ballasting, it must be ensured that the height of the ballast center of gravity is not more than the **max. permitted 2000mm** - measured from the upper edge of the ballast pallet. The ballast stacks on the left and right may not be higher than the **max. permitted 4500mm**.

DANGER: The maximum height of the ballast center of gravity and the maximum total height of the ballast stack may not be exceeded!
If this is not observed, there is an increased danger of tipping the ballast pallet over!

CAUTION: The minimum distance from the ballast stacks to the pull cylinders must be at least a minimum of 300mm.
If this is not observed, there is an increased danger of damaging the pull cylinders!

Ballast weights

Distance from center of gravity	Ballast weight max. 152 t per stack (left and right)	Ballast weight max. 170 t per stack (left and right)
800mm	X	
1000mm		X

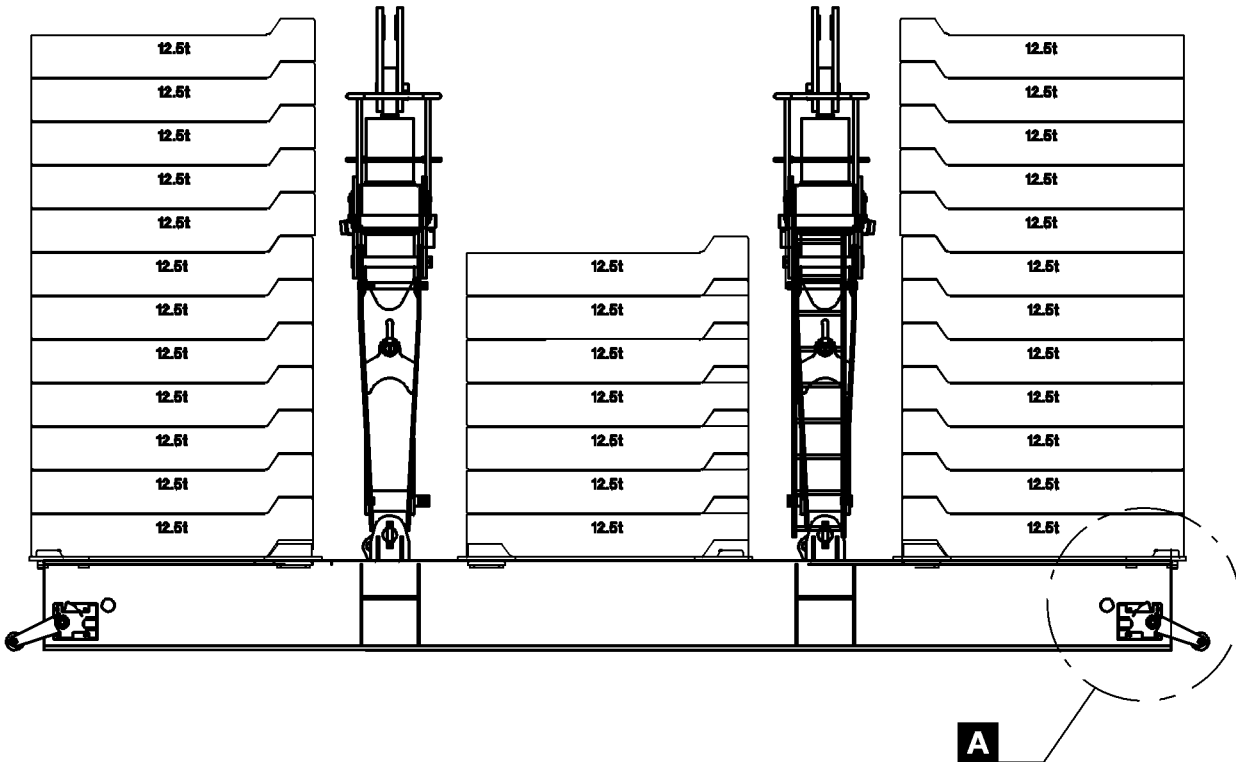
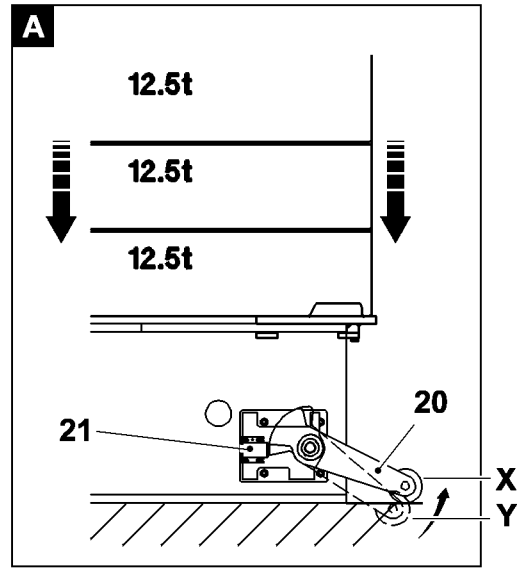
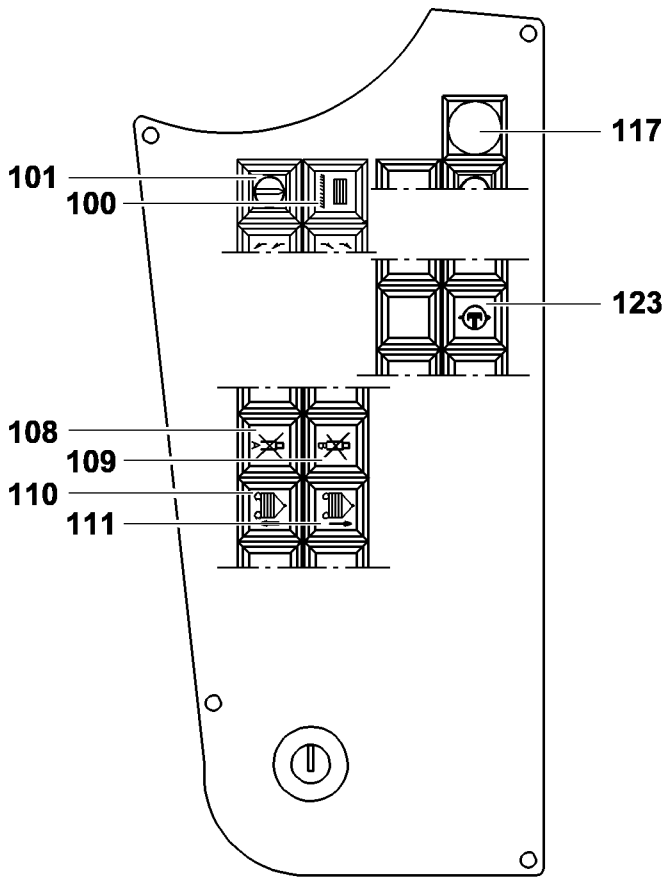
DANGER: When ballasting the ballast pallet, it must be ensured that :

- the ballast pallet is aligned in horizontal direction when ballasting on or off .
- the ballast plates are placed centered, in relation to the length axle of the ballast pallet.
- the weight difference between the left and the right ballast stack, when ballasting in suspended condition, is not more than 12,5 t .
- after ballasting, the ballast stacks on the left and right have the same weight.
- the ballast plates are secured to prevent them from falling off or from sliding.
- the distance from the center of gravity on the ballast stacks on the left and right hand side is the same.

If this is not observed, there is a danger of accidents!

A total of max. 31 ballast plates a´12,5 t (total weight 387,5 t) are permitted.

Note: To determine the correct ballast weight, use the LICCON job planer.



3.6 Lifting and lowering the suspended ballast with cylinders

- Actuate the button (111) in the cab, lift the suspended ballast with the cylinders;
- Actuate the button (110) in the cab, lower the suspended ballast with the cylinders ;

D A N G E R: **When the suspended ballast is raised or lowered, make sure that the ballast pallet remains in horizontal position. Use buttons "A - Stop" (108) and "B - Stop" (109) to align the suspended ballast in horizontal direction if it is pulled off center .**
D A N G E R!

- Press the button (108) in the cab, the left cylinder (A) is blocked;
- Press the button (109) in the cab, the right cylinder (B) is blocked.

D A N G E R: **During crane operation, the crane operator may not lift or lower the cylinder from the control panels, because he cannot see the monitors from that point.**
Lifting and lowering during crane operation may only be made from the crane cab.

When lifting and lowering, it must be ensured that the difference of the forces in the ballast guyings is not too large.

The LICCON shows both forces and issues a warning if the difference of forces is too large.

See also paragraph 8.8, Difference force monitoring of the ballast guying.

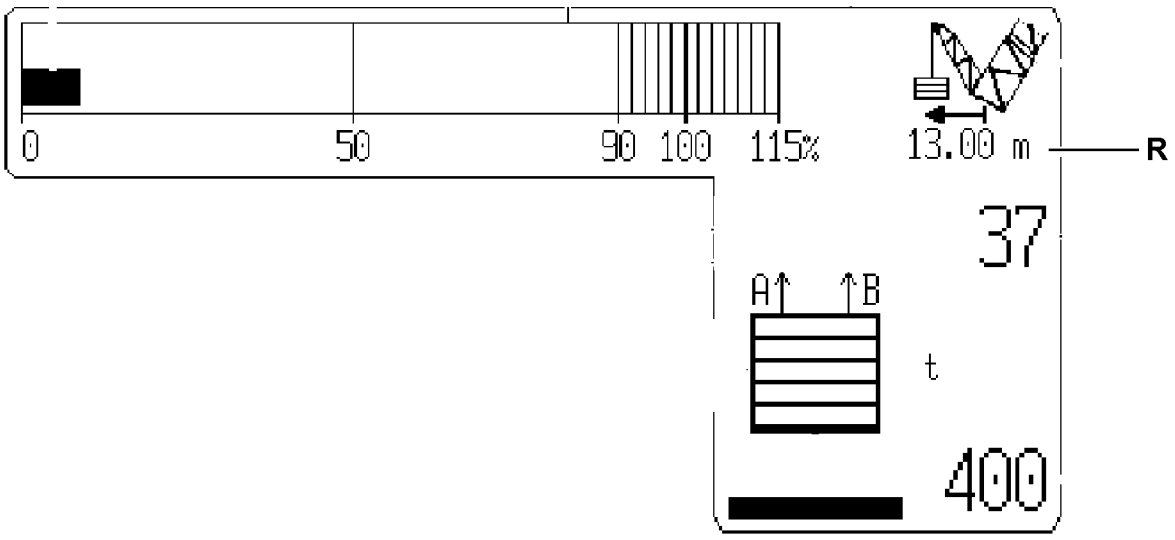
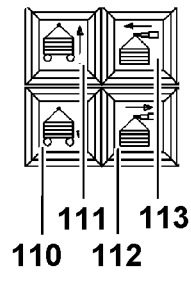
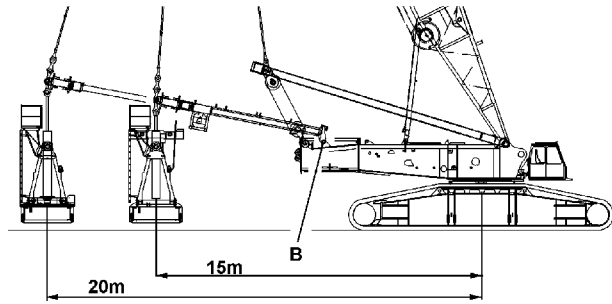
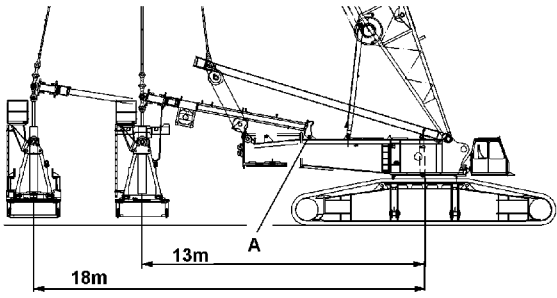
Note: If the suspended ballast is set on the ground, it must be ensured that **at least one** of the ground contact switches (21) is actuated (X) with the feeler roller (20) (fig. A). When the ground contact switch (21 / X) is actuated, the crane control recognizes the ballast condition "Ballast pallet on the ground" and the shut off for the crane movements "turn slewing platform" and "drive crawler" are activated. If no ground contact switch (21) is actuated (Y), then one of the feeler rollers (20) must be supported in such a way that the crane control clearly recognizes the ballast condition as "Ballast pallet on the ground" .

X	=	Ground contact switch actuated	---->	Shut off
Y	=	Ground contact switch not actuated	---->	no shut off

D A N G E R: **The crane operator must make sure, after setting the ballast pallet on the ground, that the ground contact switches (21) are actuated and the crane movements "turn slewing platform" and "drive crawler" are shut off. If this is not observed, there is an increased danger of accidents!**

1

2



3.7 Telescoping the suspended ballast in or out

The suspended ballast is equipped with a telescopable guide. This makes it possible to match the radius to the surrounding area or the present hoisting job:

Fig. 1 = min. 13 m - max. 18 m

Fig. 2 = min. 15 m - max. 20 m

The actual length (R) is shown on the monitor .

Note: Telescoping in and out is only possible if the limit switches on the ballast pallet are not actuated, i.e. the suspended ballast is raised.

D A N G E R: **Telescoping out and in is only possible if the suspended ballast is lifted off the ground!**
There is an increased danger of accidents!

- Press the button (113) , the suspended ballast is telesoped out;
- Press the button (112) betätigen, the suspended ballast is telescoped in.

D A N G E R: **Make sure there are no persons or obstacles in the danger zone of the suspended ballast.**
There is a danger of accidents!

C A U T I O N: **When telescoping the suspended ballast in and out, the actual length (R) must be monitoed.**
The crane operator may not rely blindly on the derrick ballast radius measurement, he must think for himself and check, if the measurement is still correct.
See also paragraph 8.7, Checking the length value sensor on the suspended ballast.

8. LICCON Overload safety system

8.1 General

Prerequisite:

- The required derrick ballast according to the load chart is placed ;
- the derrick is in operating position.

8.1.1 Preadjustments

- Set the LICCON overload safety system according to the data in the load chart and confirm;
- Enter the actually present derrick ballast weight into the LICCON .

Note: Set the derrick ballast - see chapter 4.03, paragraph 8.
The required derrick ballast must be determined according to the data in the load chart.

D A N G E R: **The set derrick ballast must match the actually installed derrick ballast weight.**
An incorrect ballast weight entry can lead to dangerous operating situations.

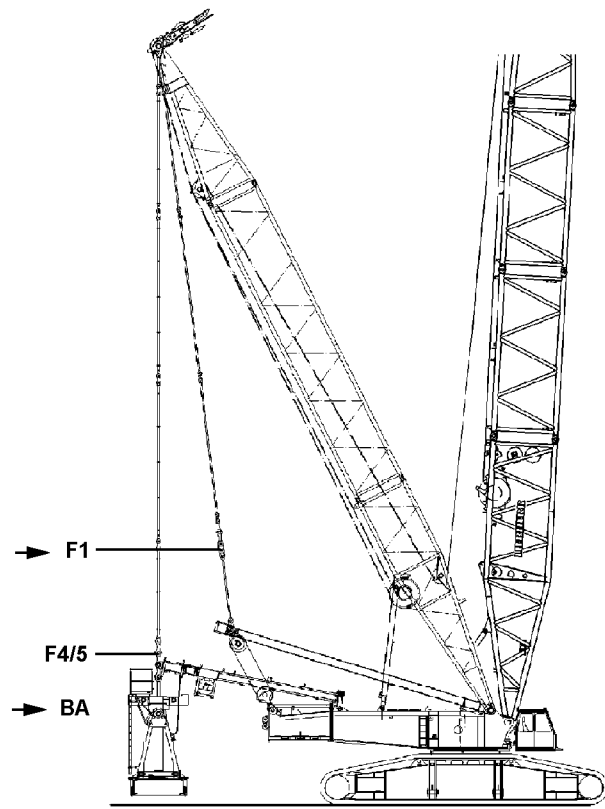
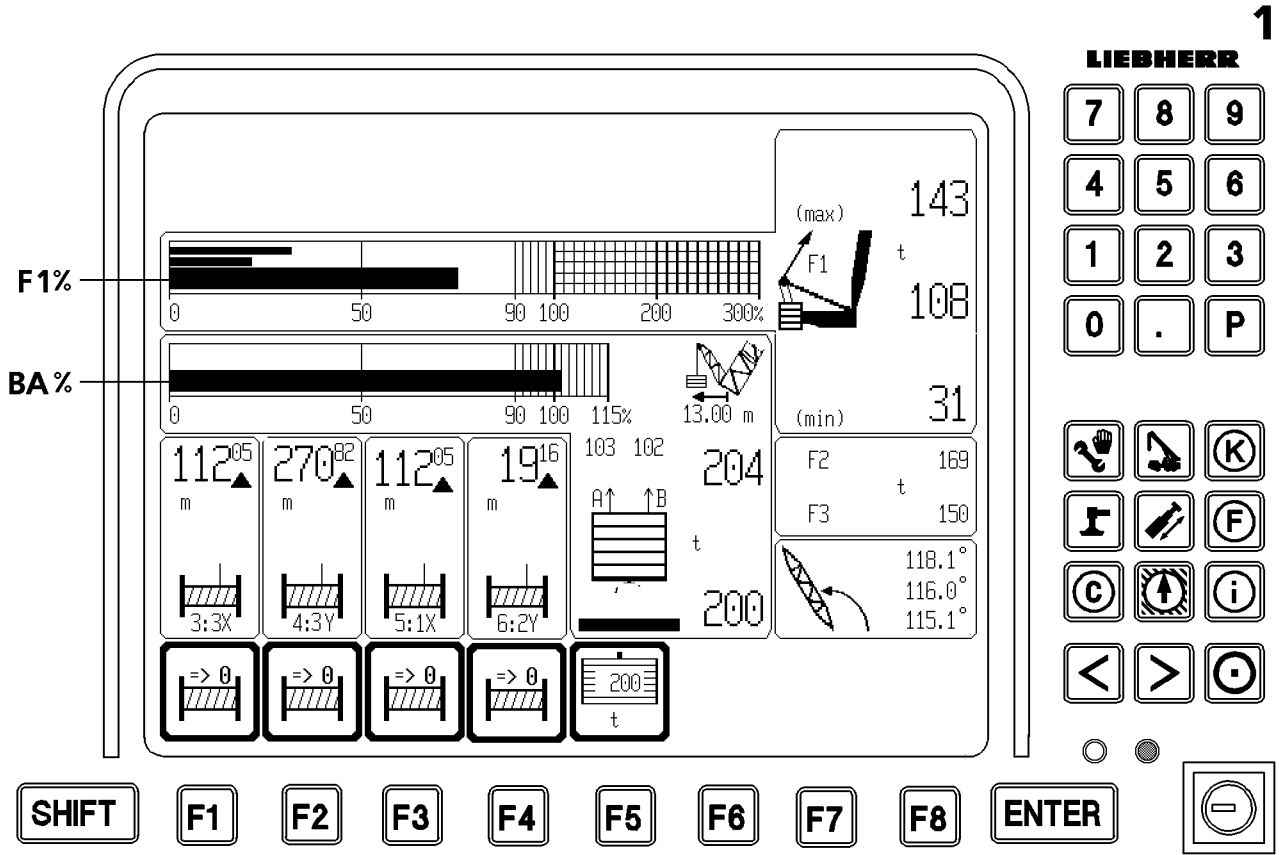
8.1.2 Operation

For the operation with derrick ballast, all data in chapter 4.02, paragraph 21 must be observed!

D A N G E R: **There may be no persons or obstacles within the turning range of the derrick ballast.**
During the turning movement, a guide must monitor the boom, derrick and derrick ballast to prevent a collision.
When turning with a load and suspended ballast (suspended derrick ballast), the turning movement must be initiated or slowed down very sensitively . If the turning movement is initiated or slowed down too abruptly or jerkily, the load or the suspended ballast (suspended derrick ballast) could start to swing. This could cause the boom to break and / or cause the crane to topple over.

Note: If the **suspended derrick ballast** must swing over any obstacles or must be set down at a different level as the crane is, there is the possibility to lower or raise the **suspended derrick ballast** with the pull cylinders.
See paragraph 3.5 Raise and lower with pull cylinders and 8.8 Difference force monitoring of ballast guying.

D A N G E R: **The derrick ballast must always be in horizontal position when raising or lowering with the cylinders, otherwise there is a danger of tipping over.**
Monitor the extension condition of the cylinders.



8.2 Safety guidelines

- The test points must be checked for proper function before crane operation.
- The crane must be aligned in horizontal direction at the job site.
- The weight of the load to be lifted must be known.
- The placement surface of the derrick ballast may be no more than max. 0.25 m above or 0.25 m below the standing surface of the crane.
- The placement surface of the suspended derrick ballast at the end of the load lift must be level, horizontal and of sufficient load carrying capacity to take on the weight safely.

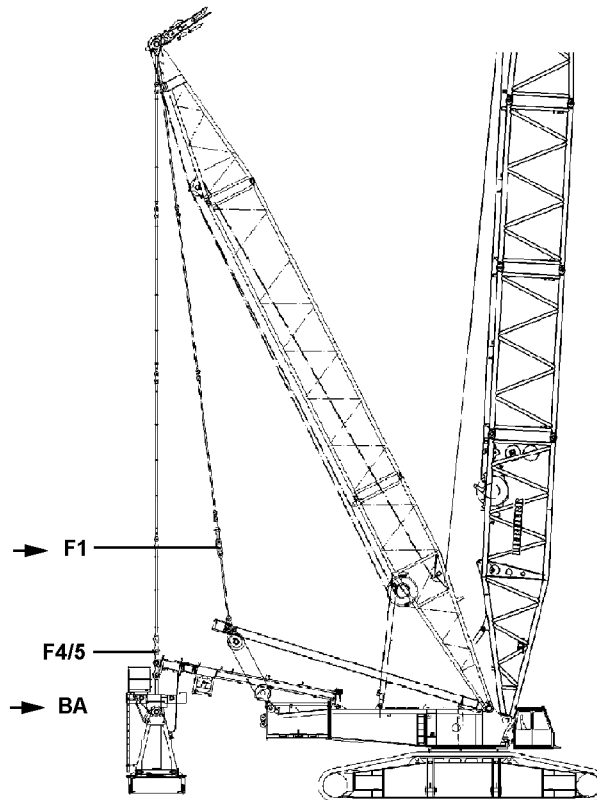
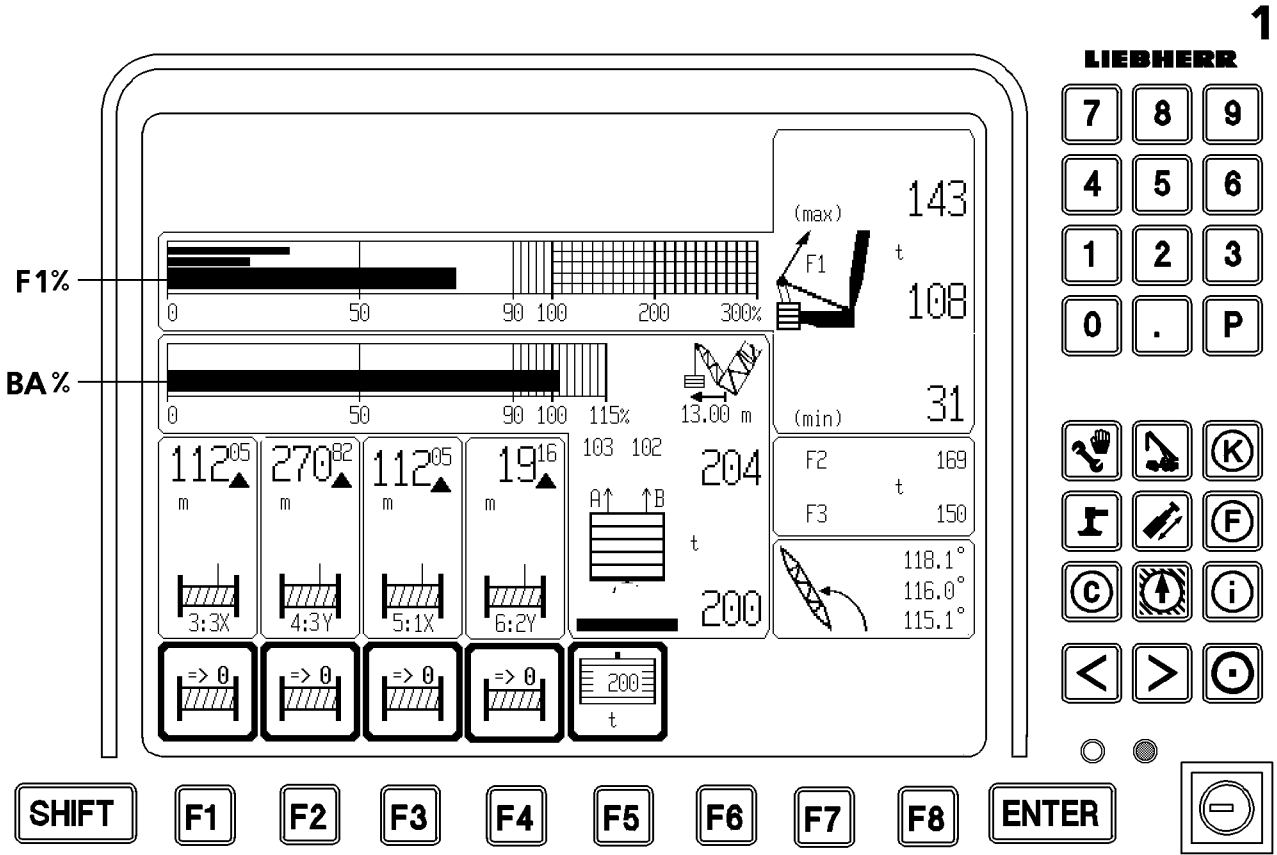
C A U T I O N: Before setting down the load and suspended derrick ballast, the crane operator must make sure that he can safely do so.

- There may be no obstacles within the slewing and turning range of crane, derrick ballast and load.
- A guide or the crane operator himself must watch the derrick ballast, if it is to be lifted.
- When taking on a load, **make sure to avoid** diagonal pull , which means the derrick ballast, center of rotation of the slewing platform and the load must always be on one line !
To ensure this, actuate the pull cylinders to lift the derrick ballast off the ground and set it down again **before** placing the ballast plates.

D A N G E R: If this is not observed, there is a danger of tipping over when lifting the placed ballast plates, which can cause the crane to topple over.

- When taking on the load, the guying of the derrick ballast to the derrick end section must be loose or just slightly tensioned so that the **Minimum force F1 min.** is initially exceeded on **test point 1** .
- The guying between the A- bracket and the derrick end section **test point 1** may **never** be untensioned.

D A N G E R: This could lead to uncontrolled movements of the boom system, which could cause a serious accident.



8.3 Determination of forces in operating mode with derrick ballast

In all operating modes with derrick ballast, the load is distributed onto the guy rods from the derrick end section to the A-bracket (F1) and to the derrick ballast (F4/5).

Note: See also the more detailed description in chapter 4.02 CONTROL AND INDICATOR UNIT OF THE "LICCON" OVERLOAD SAFETY SYSTEM.

8.3.1 Force F1 (Test point 1) between guying A-Bracket - derrick end section

Force F1 (test point 1) is determined in the guy rods from the A-bracket to the derrick end section via 2 force test boxes and indicated on the LICCON as total force at the guying.

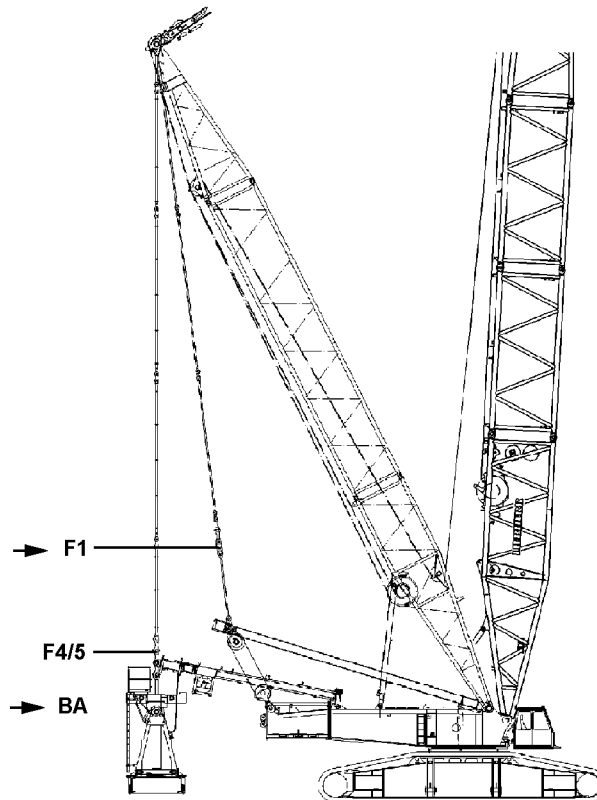
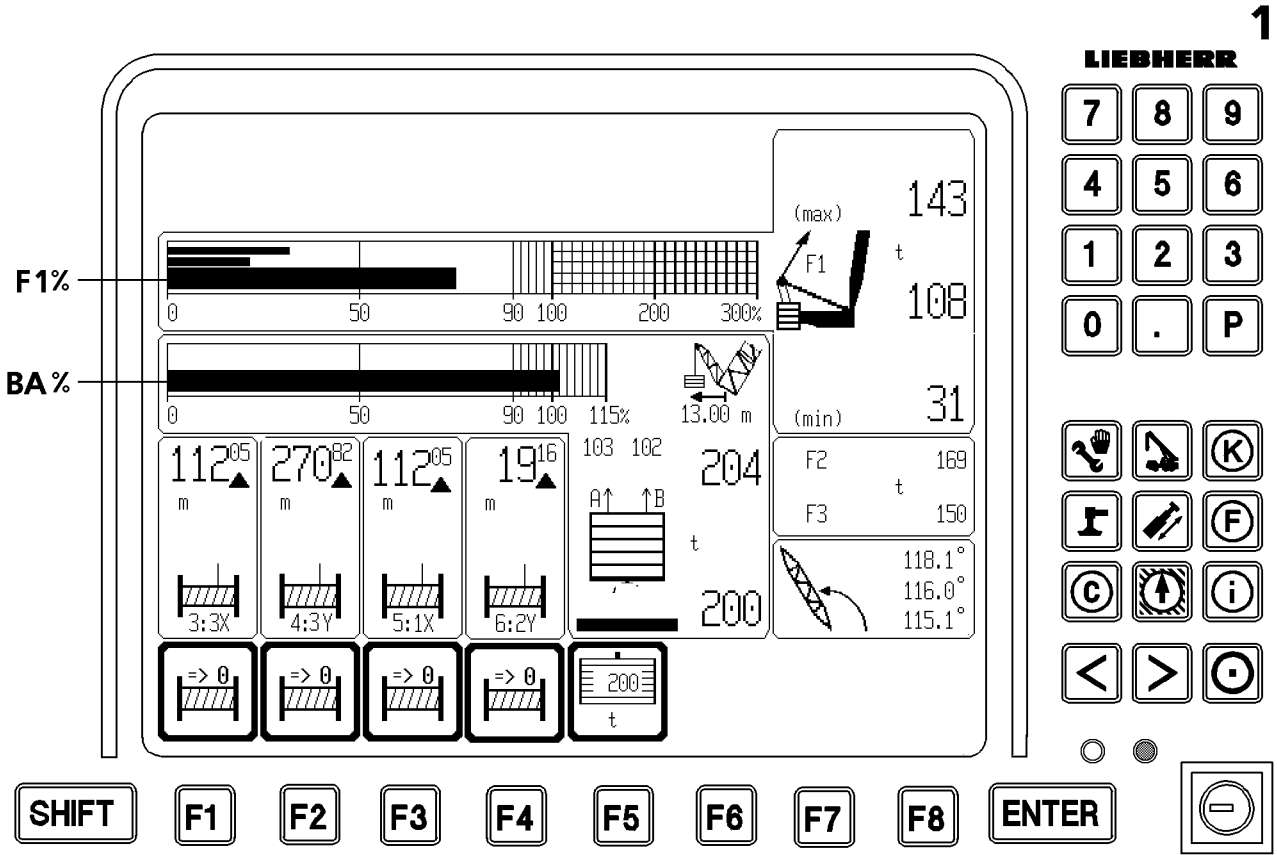
The F1 utilization is determined from operating force F1 and force F1- operation - max. force . This value is shown on the LICCON via a utilization bar graph (F1 %).

8.3.2 Force F4 / 5 (Test point 4 / 5) guying derrick ballast - derrick end section

Forces F4 / 5 (test point 4 / 5) acts in the guy rods from derrick ballast to derrick end section.

The existing forces in the guy rods (A = left and B = right) are calculated from three pressure sensors, which are installed on the pull cylinders and shown in the LICCON as individual forces.

From the forces of the individual guying, the pulled ballast is calculated, i.e. the part of the ballast which is pulled upward by the guying. The remaining part lays on the ground. The derrick ballast utilization is calculated from the pulled ballast and the placed ballast . This value is shown on the LICCON via a utilization bar graph (BA %).



8.3.3 Monitoring of minimum force F1 (Test point 1), F1 min.

Note: See also graphic view and description of shut offs in paragraph 8.5 Shut off in crane operation with derrick ballast.

If more than 50% is pulled by the set derrick ballast (ballast utilization bar > 50 %) and the minimum force F1 min. (Test point 1) is fallen below, all **load moment increasing** crane movements are shut off.

D A N G E R: It is prohibited to fall below the minimum force F1 min (test point 1) if more than 50 % of the derrick ballast is being pulled. If this is not observed, the derrick ballast may lift off the ground suddenly at slack guying from test point 1 (F1) and derrick ballast on the ground due to increasing load momentum and the boom system will suddenly move forward!
This will cause the load to swing strongly, which can damage the boom and the crane.

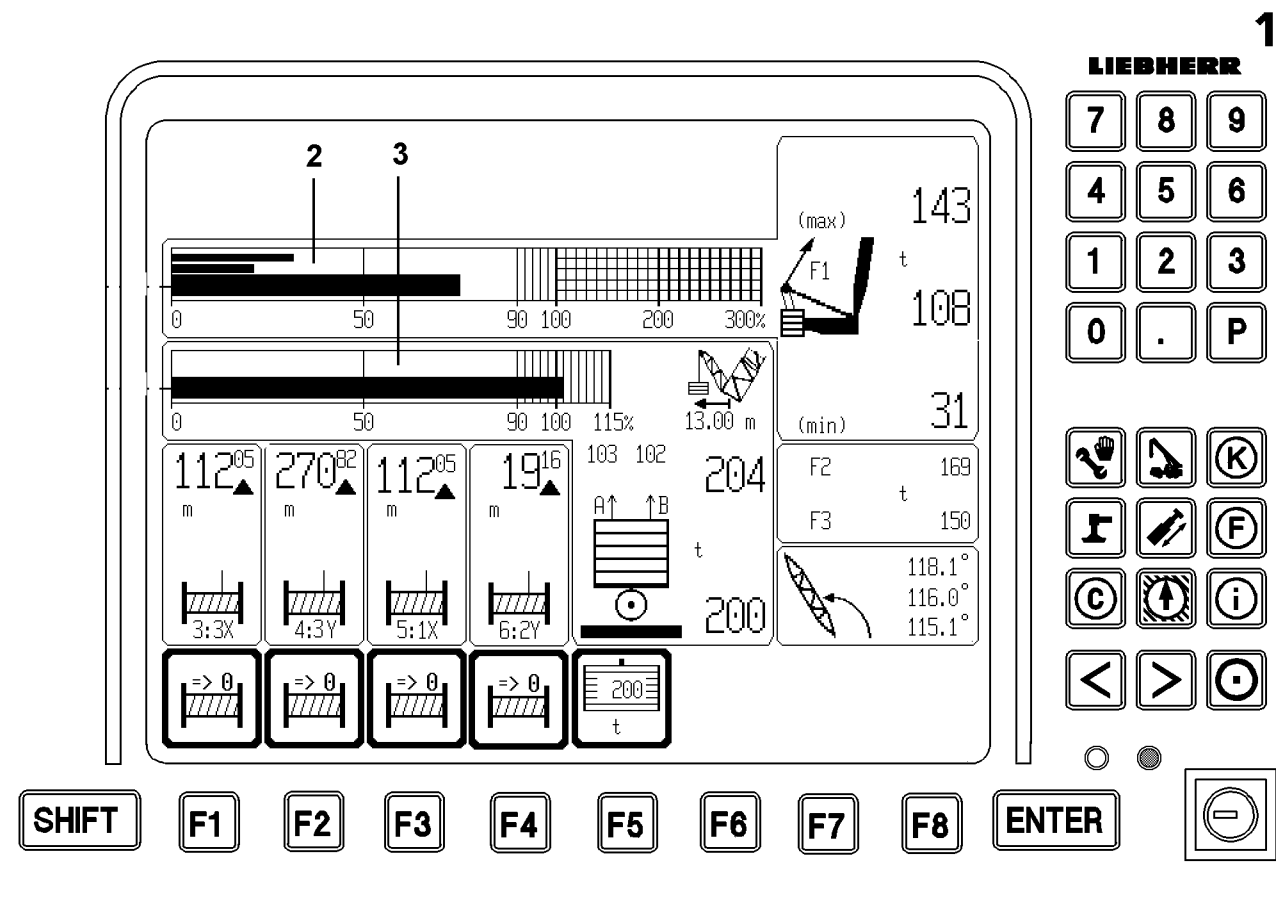
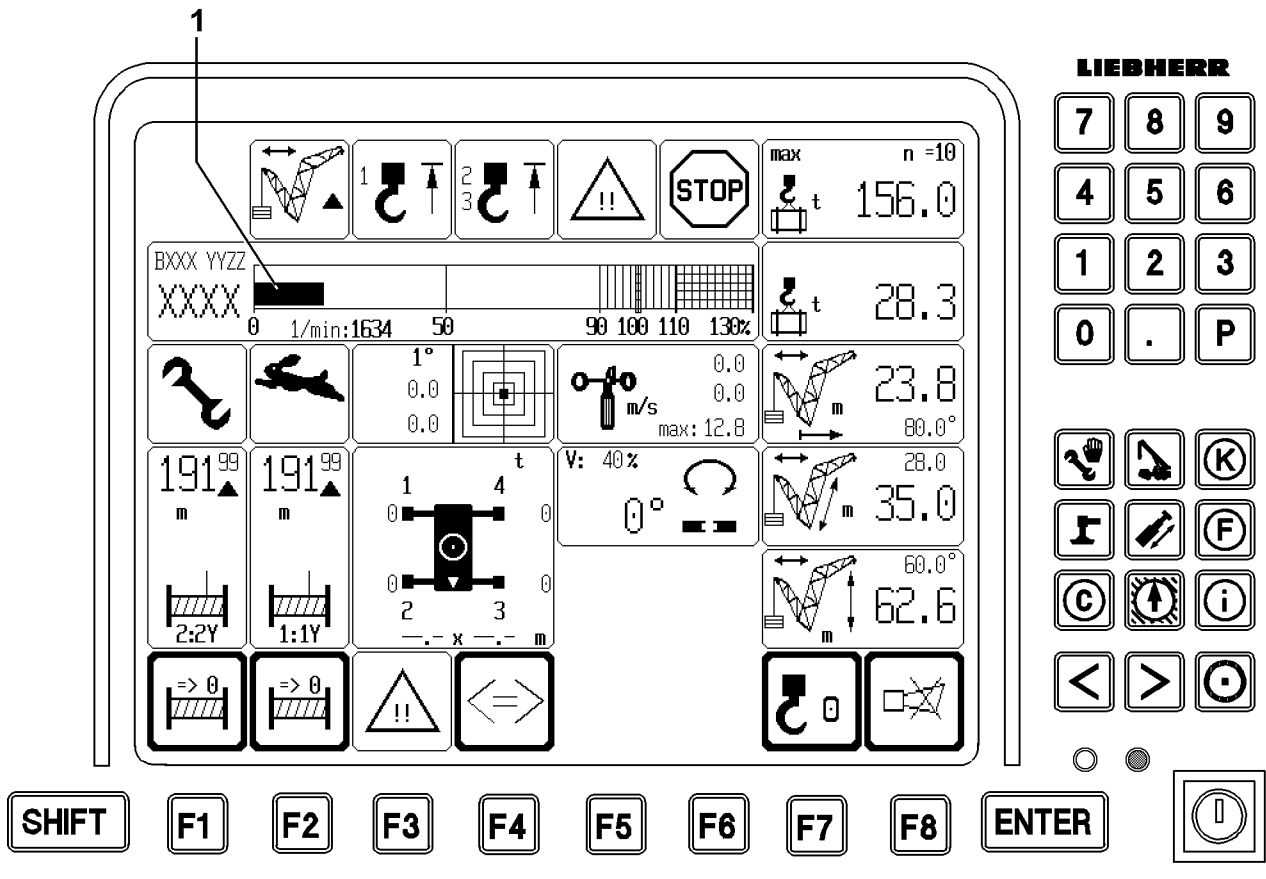
If more than 90% is pulled by the set derrick ballast (ballast utilization bar > 90 %) and the minimum force F1 min. (Test point 1) is fallen below, all **load moment increasing and all load moment decreasing** crane movements are shut off.

The hoist gear "down" is also shut off.

D A N G E R: It is prohibited to fall below the minimum force F1 min (test point 1) if more than 90 % of the derrick ballast is being pulled. If this is not observed, the derrick ballast may set down on the ground suddenly at slack guying from test point 1 (F1) and suspended derrick ballast due to decreasing load momentum and the boom system will suddenly move backward!
This can press the relapse cylinder on block and overload them. There is a danger of damage to the relapse cylinders boom and derrick.
This also will cause the load to swing strongly, which can damage the boom and the crane.

One can only get out of this situation :

- by lowering the suspended derrick ballast via the pull cylinders onto the ground;
- **or** the ballast plates are unloaded to reduce the derrick ballast utilization and to increase the load on test point 1 (F1) .



8.4 Overload monitoring in operating mode with derrick ballast

Note: All words marked with quotation marks (" ") are explained in chapter 4.02 CONTROL AND INDICATOR UNIT OF THE "LICCON" OVERLOAD SAFETY SYSTEM in paragraph 12.1 Information about crane geometry and load.
See also graphic view, paragraph 8.5 Shut offs in crane operation with derrick ballast.

In operating modes with derrick ballast, the monitoring of "maximum load of current crane condition" consists of 2 parts:

1. Monitoring of maximum load by LML overload safety system.
2. Monitoring of test point 1- operating maximum force by derrick ballast overload safety system.

8.4.1. The LML overload safety system monitors the "maximum load according to the load chart and reeving".

In operating modes with derrick ballast, this is the maximum load of the current crane condition with optimum derrick ballast. It is shown on monitor 0 . The current utilization of the crane with optimum derrick ballast results from the load utilization bar (1) on monitor 0.

At 90 % on the load utilization bar there is a prewarning with caution symbol and "SHORT HORN" on monitor 0.

At 100% on the load utilization bar there is a shut off of all load moment increasing movements with stop symbol and acoustical warning "HORN" on monitor 0.

The "maximum load of the current crane condition" can no longer be increased.

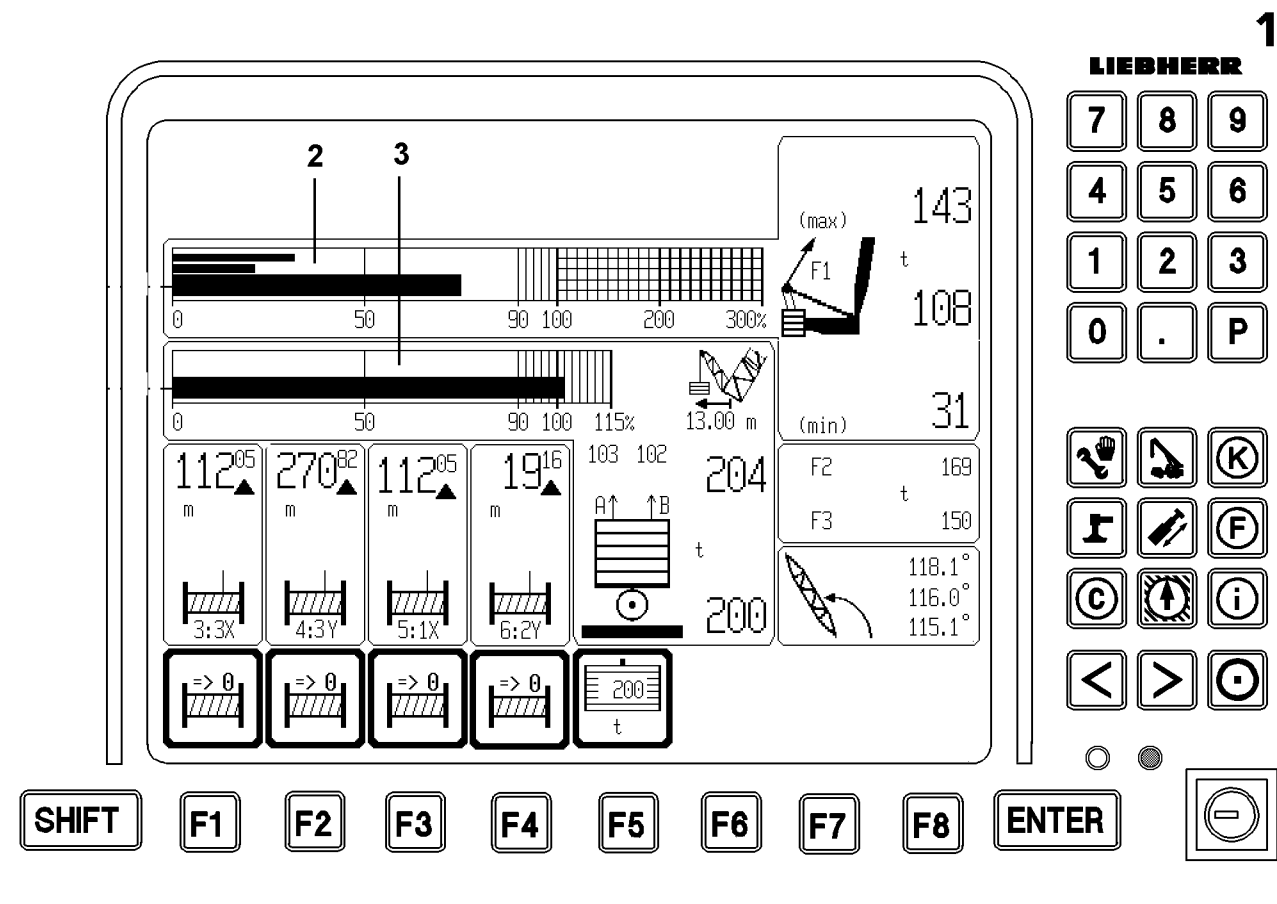
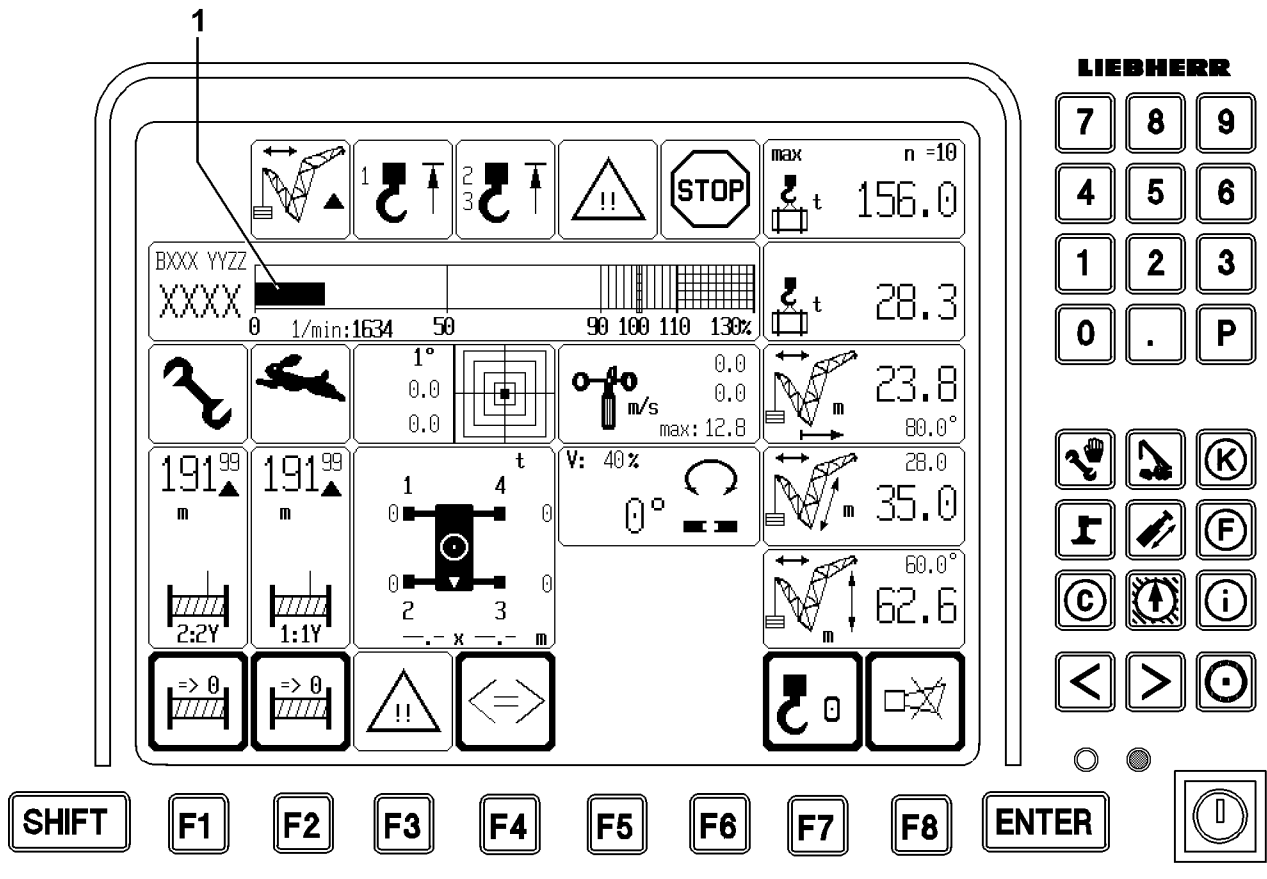
8.4.2 The derrick ballast overload safety system monitors the "Test point 1- operating maximum force (=F1max)". It is shown on monitor 1 .

At 90 % F1max- utilization (utilization bar (2)) , a prewarning is issued with caution symbol and "SHORT HORN" on monitor 1.

At 100% F1max- utilization, there is a shut off of all load moment increasing movements with stop symbol and acoustical warning "HORN" on monitor 1.

If the "maximum load according to load chart and reeving" is not yet reached (Utilization bar (1)) , then the "maximum load of current crane condition" can still be increased by:

- pulling up the derrick ballast, if the derrick ballast is not yet suspended and the currently pulled ballast is still smaller than the optimum ballast;
- telescoping out the derrick ballast if the placed ballast is still smaller than the optimum ballast;
- increasing the derrick ballast by adding additional ballast plates, if the place ballast is still smaller than the optimum ballast.



8.4.3 Utilization conditions

The current utilization of the crane results from the load utilization bar (1) on monitor 0 **and** the F1-utilization bar (2) on monitor 1.

The "maximum load of the current **crane condition**" is reached when the load utilization bar (1) reaches 100 % **or** when the F1-utilization bar (2) reaches 100 %.

The "maximum load of the current **crane equipment**" is reached when the load utilization bar (1) reaches 100% **or** when the F1-utilization bar (2) reaches 100% and the derrick ballast is suspended (ballast utilization bar (3) at 100 %, when the ballast input value and the ballast weight is correct).

The "maximum load according to the load chart and reeving" (100% limit of load utilization bars) and the maximum load according to F1max- operation (100% limit of F1-utilization bar) can be bypassed by the following measures:

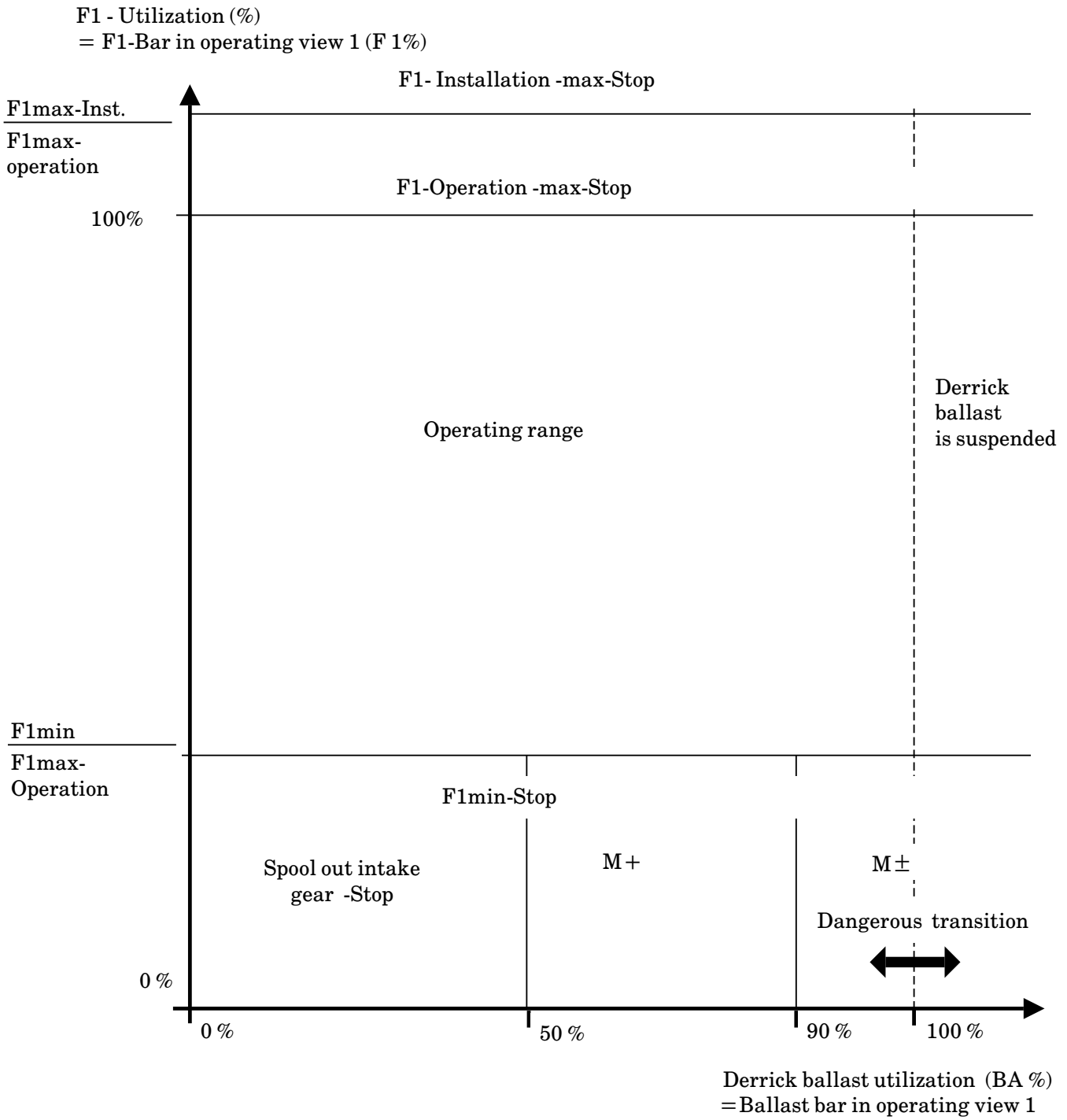
1. Hold the keyed button D₀ on monitor 0 in position "right touching" to bypass the "maximum load carrying capacity according to the load chart and reeving" (see also description in chapter 4.02, paragraph 12.7) and hoist limit switch.
2. Installation keyed button in instrument panel

This bypasses the "maximum load according to the load chart and reeving", test point 1- operation maximum force (= F1max-operation) and a number of other limit values and limit switches.

Test point 1- installation - maximum force (= F1max-installation) cannot be bypassed (see detailed description in chapter 4.04).

D A N G E R: **When the installation keyed button is turned on, only load moment reducing crane movements to a permissible operating and load range may be carried out.**
After reaching the permissible load range, the installation keyed button must be turned off immediately.
If the installation keyed button is turned on, the load moment limitation is no longer effective.
There is a danger of accidents!

The movement "lift ballast" or "lower ballast" requires utmost attention !



See also operating view on monitor 1

8.5 Shut offs in crane operation with derrick ballast (suspended ballast or derrick ballast)

Graphic view of various ranges of utilization on test point 1 (F1% utilization bar) and utilization of derrick ballast (Ballast utilization bar, BA %)

8.5.1 F1-Installation-max-Stop

= Shut offs as for F1-Operations-max-Stop, but cannot be bypassed.

8.5.2 F1-Operations-max-Stop

= All load moment increasing crane movements ("lift load", "luff down boom", "luff up boom", "ballast down", "telescope ballast in") are shut off. These shut offs can be bypassed via the installation keyed button. The shut off "luff up boom" can also be bypassed with the button "luff up at overload".

8.5.3 Test point 1 - Minimum force (F1min)

The derrick ballast overload safety protects the crane from sudden lift off of the derrick ballast (the crane rocks forward) and from sudden set down of the derrick ballast (crane rocks backward). This is ensured by monitoring on test point 1 - Minimum force.

When the given limit F1min is approached, a prewarning is given. When this limit is reached or exceeded, the overload warning is triggered and the dangerous crane movements are shut off, see below.

8.5.3.1 Spool out intake gear -Stop

= The crane movement "spool out intake gear (winch 4)" is shut off, at the same time, "telescope ballast out" is shut off.

8.5.3.2 M +

= The following load moment increasing crane movements are shut off: "Lift load", "luff down main boom / jib", "luff up main boom / jib", "spool out intake gear" and "telescope ballast in and out". The shut offs cannot be bypassed.

8.5.3.3 M ±

= The following load moment increasing crane movements are shut off: "Lift load", "lower load", "luff up boom", "luff down boom", "spool out intake gear", "spool up intake gear" and "telescope ballast in and out".

Only "lower ballast" or "unload ballast" remain possible.

Note:

During operation, observe the notes in the crane operating manual and the shut offs in the shut off diagram in the switch diagram.

8.6 Load chart access procedure

For the:

- Main boom angle interpolation;
- Jib relative angle interpolation;
- Derrick ballast radius interpolation;
- Combination of main boom angle interpolation and derrick ballast radius interpolation
- Combination of jib relative angle interpolation and derrick ballast radius interpolation

see chapter 4.02 CONTROL AND INDICATOR UNIT OF "LICCON" SAFE LOAD INDICATOR SYSTEM, paragraph 30." Load chart access procedure ".

8.7 Check the length sensor value on the ballast trailer

When telescoping the derrick ballast in and out, carefully monitor the derrick ballast radius indicator.

When telescoping the derrick ballast, the indicator must change according to the movement. The crane operator can recognize immediately if the length sensor cable drum would get stuck when spooling up or out.

If the derrick ballast is fully extended or retracted, the derrick ballast indicator must show almost exactly the end position, for example: radius = 13 m or 20 m .

The crane operator may not blindly rely on the derrick ballast radius measurement, but he must think for himself and check if the measurement even still works correctly.

D A N G E R: **If the derrick ballast radius is measured incorrectly then a too large maximum load and a too large test point 1 -Operations-max-force can be calculated due to the incorrect radius.**
 The crane can be overload without noticing it.
 There is an increased danger of accidents!

8.8 Difference force monitor of ballast guying

In operating modes with derrick ballast, the difference of forces from the derrickballast guying A and B, monitor 1, is monitored.

D A N G E R: **If the difference of these forces is too high, the derrick end section or other crane components will be damaged.
There is a danger of accidents!**

The forces in the derrick ballast guying A and B are shown on monitor 1 and compared. If the difference exceeds an impermissible value, an acoustical warning is given and the two force values blink. However, there is **no** shut off of movements.

If the difference of the forces of the derrick ballast guying A and B exceeds the given limit value, then this can have different causes:

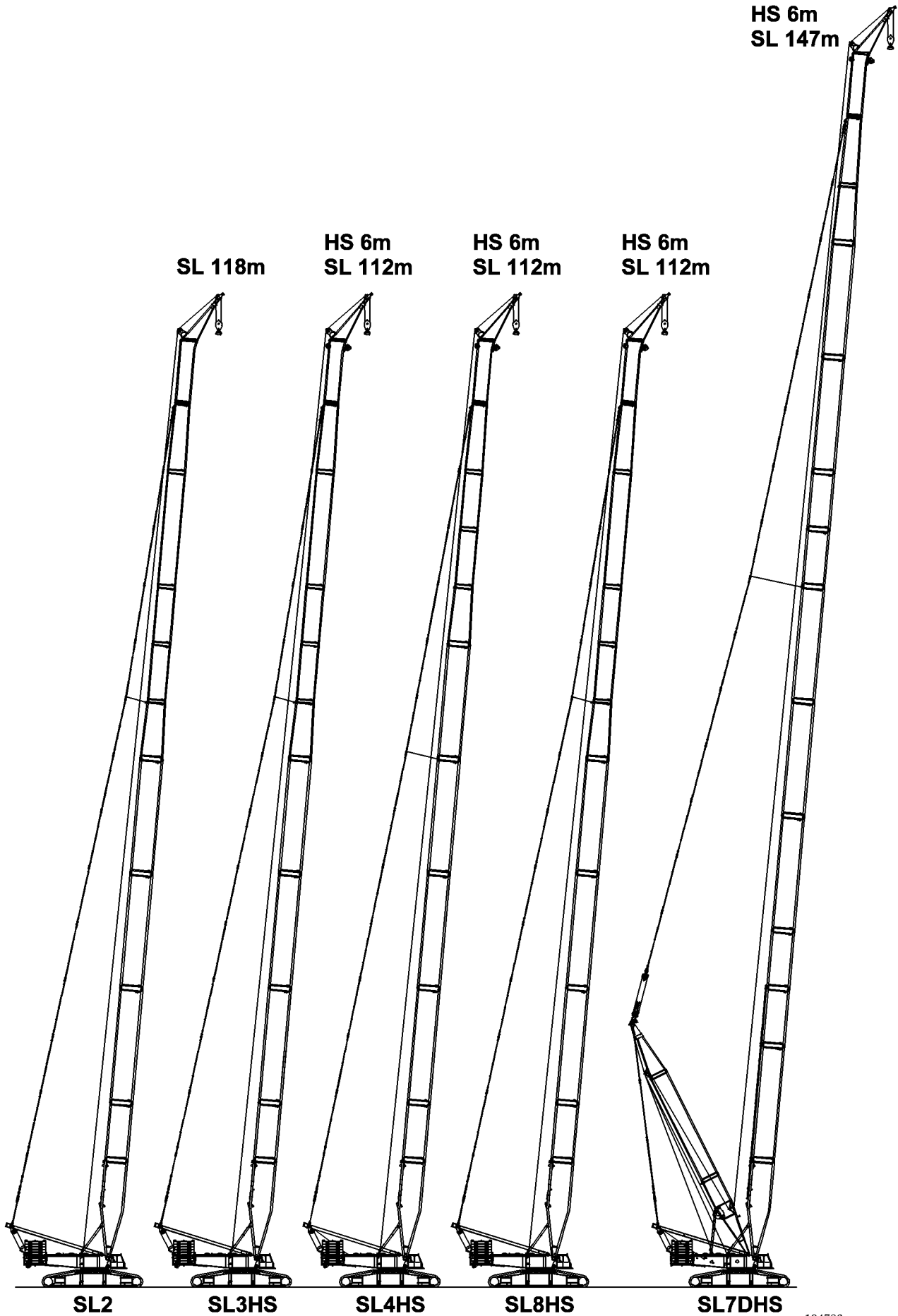
- Take on the load,
by relieving the tires on the ballast trailer or by flexation of the slewing platform ;
- The ground under the derrick ballast is uneven;
- The crane is positioned at a side incline;
- The derrickballast is loaded onesided;
- By raising or lowering the derrick ballast with the pull cylinders;
- The force measurement in the guying is incorrect.

The crane operator must recognize the correct cause and take counter -measures:

1. The error, which led to the one sided force must be removed.
2. The following measure is permitted only in **small** uneven ground conditions :
Lock a ballast cylinder and actuate with the other ballast cylinder "lift the ballast " or " lower the ballast " in such a way that the difference between the forces gets smaller. It must be ensured that the derrick ballast is not brought into an impermissible incline position in relation to the crane, otherwise the derrick ballast guide and components will be damaged.

D A N G E R: **The derrick ballast cylinder A may be extended by maximal 40 mm more or less than cylinder B!
There is a danger of accidents!**

3. If sensor values do not seem believable: check if the pressure sensor for the ballast weighing or the inputs of the ballast weighing on CPU 1 are defective, if necessary, pull the sensor or replace the CPU.



194786

1. **Operating mode overview for SL - operating modes with installed auxiliary jib HS**

Description:

There are various **SL..HS** - operating modes.

The operating modes **SL2, SL3HS, SL4HS, SL8HS, SL7DHS**, consist of **S** - or **L** - lattice sections and additional "adapter for the auxiliary jib" and installed auxiliary jib HS.

The operating mode **SL2** is viewed as a clear **SL** - operating mode. It has no pulley set on the "adapter for the auxiliary jib" , only the pulley set on the auxiliary jib HS.

The other operating modes differ in the assembly of the lattice sections for the corresponding boom systems, the guy points of the auxiliary guying and the different maximum load carrying capacities on the "Adapter for the auxiliary jib" (100t or 120t) to the different maximum load carrying capacities on the auxiliary jib HS (100t or 120t).

D A N G E R : For the installation of the boom, the assembly of the lattice sections for the boom systems must be strictly observed.

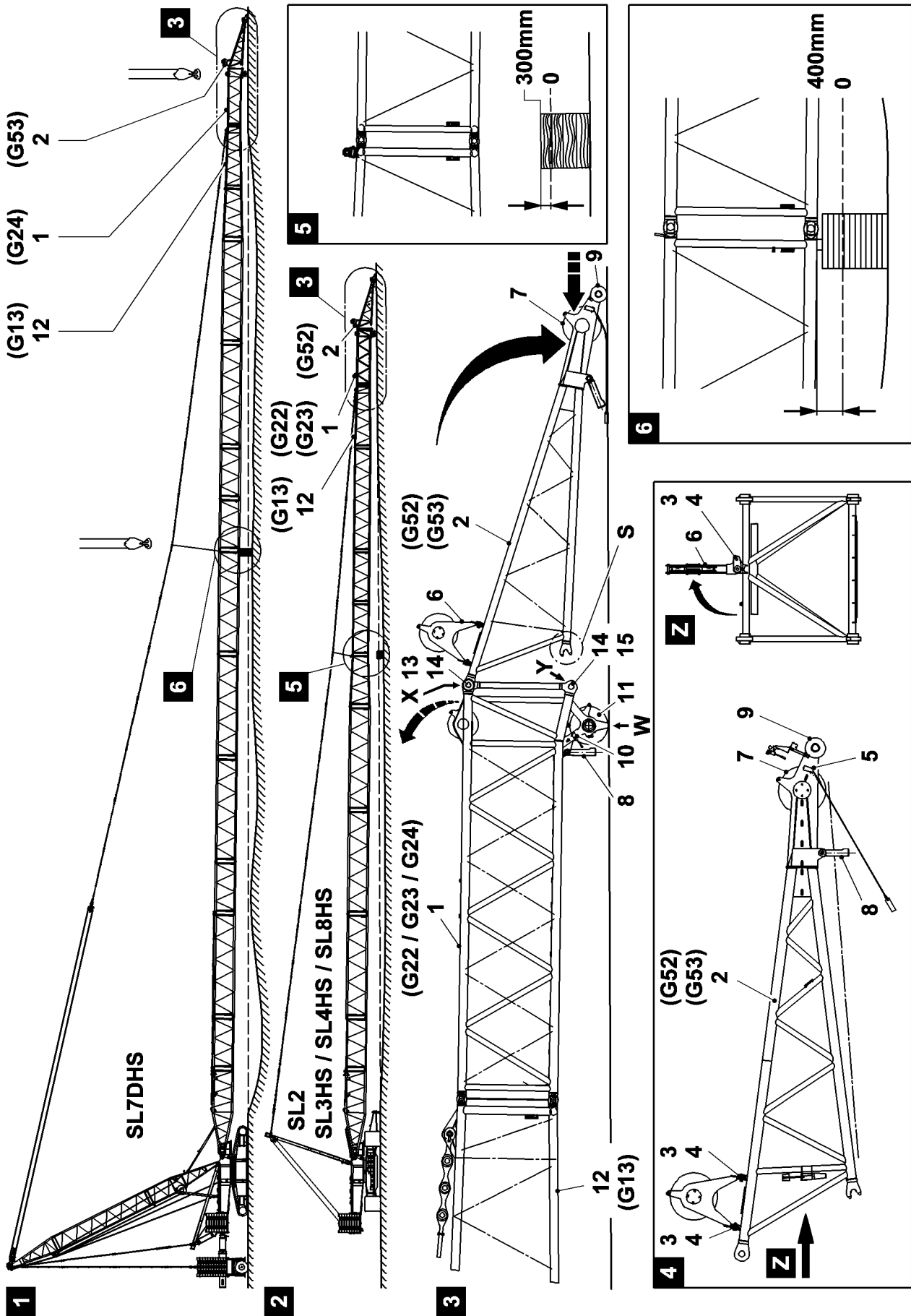
The welded on tags on the intermediate sections with the system descriptions must be strictly observed.

(see chapter 5.03 - Attachment - lattice mast systems)

If this is not observed, there is an increased danger of accidents!

Operating mode overview:

Operating modes	Attachments					
	Adapter			Auxiliary jib HS		Derrick + B / BW (only for erection)
	without pulley set (G22)	with pulley set (100t) (G23)	with pulley set (120t) (G24)	with pulley set (100t) (G52)	with pulley set (120t) (G53)	
SL2	X			X		
SL3HS		X		X		
SL4HS			X		X	
SL8HS			X		X	
SL7DHS			X		X	X



194840

2. Installation of the auxiliary jib HS (fig. 1 // fig. 2)

2.1 Component overview

Pos.	Description	Weight [t]
1	Adapter for auxiliary jib 100t / 120t (G22 - 100t / without pulley set) (G23 - 100t / with pulley set) (G24 - 120t / with pulley set)	approx. 3,66
2	auxiliary jib HS 100t / 120t (G52 - 100t) (G53 - 120t)	approx. 2,50
3	Pin $\varnothing 30 \times 95$ mm	
4	Spring retainer $\varnothing 3$ mm	
5	Hoist limit switch	
6	Pulley retainer	
7	Pulley set auxiliary jib HS	
8	Cable fixed point (cable lock)	
9	Run pulley	
10	Hoist limit switch	
11	Pulley set adapter	
12	L - Adapter (G13)	approx. 5,30
13	Pin $\varnothing 90 \times 200$ mm	
14	Spring retainer $\varnothing 8$ mm	
15	Pin $\varnothing 100 \times 180$ mm	

Prerequisite:

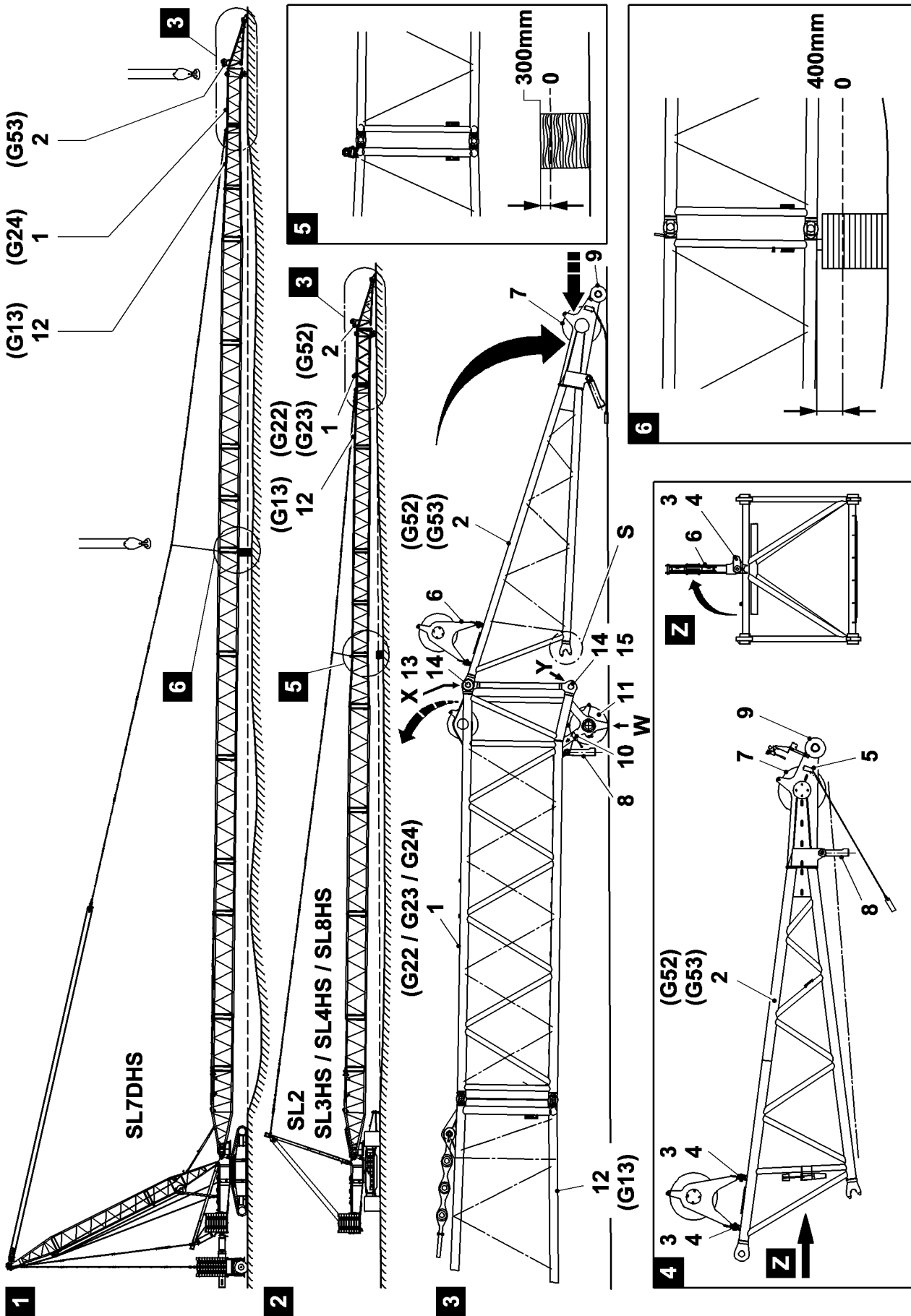
- The SL.. - booms are installed on the crane (see chapter 5.04) according to the installation drawings (see chapter 5.03 - Attachment lattice mast systems).
- The SL..D boom is installed on the crane (see chapter 5.05) according to the corresponding installation drawings (see chapter 5.03 - Attachment lattice mast systems).
- The required SL - boom length is installed.
- The SL- boom is guyed on the L-Adapter (12) (G13) (fig. 1 // fig. 2 // fig. 3) (see chapter 5.04).

C A U T I O N : The various boom systems must be supported from below with suitable material to prevent a large boom flexation .

- For the installation of the auxiliary jib HS, the SL (D) - boom (SL3HS / SL4HS / SL8HS / SL7DHS) is laying also on the support legs (W) of the "Adapter for the auxiliary jib" (1). The support legs are on the pulley mount of the "Adapter for the auxiliary jib" (fig. 1 // fig. 2 // fig. 3).
- The adapter (1) (G22 / G23 / G24) for the auxiliary jib HS (2) (G52 / G53) is pinned and secured on the L - Adapter (12) (G13) (fig. 2).

D A N G E R : The SL- / SL7DHS - boom combinations must be erected according to the data in the erection and take down charts.

If this is not observed, the crane will be overloaded or tip over!



2.2 Installation

- Attach the auxiliary jib HS (2) on the auxiliary crane.
- Pin and secure the auxiliary jib HS (2) on the adapter for the auxiliary jib (1) "on top" (X) (fig. 3). Insert the pin (13) with the pin pulling device. Secure the pin (13) with the spring retainer (14) .
- Place down the auxiliary jib HS (2) with the auxiliary crane on the ground (fig. 3), remove the auxiliary crane .
- Insert the pin (15) "on the bottom " (Y) on the adapter for the auxiliary jib and secure with spring retainer (14) .
- Erect the pulley retainer (6) on the auxiliary jib (2)., pin and secure. Use pin (3) and spring retainer (4) (fig. 4 // fig. Z).
- Pull the hoist cable over the cable pulley in the pulley retainer (6) to the cable pulley (7) on the auxiliary jib HS (2) .
(see chapter 4.06 - Cable reeving)

D A N G E R : **The SL - / SLD - boom combination must be erected according to the data in the erection and take down charts.**

If this is not observed, the crane will be overloaded or tip over!

- Slowly luff up the SL - / SLD - boom.
- The auxiliary jib HS (2) runs on the run pulleys (9) to the "inside" (fig. 3).
- Luff up the SL - boom until the auxiliary jib HS is lifted off the ground. The fork head (S) supports itself on the pin (15) (Y) ab (fig. 3).

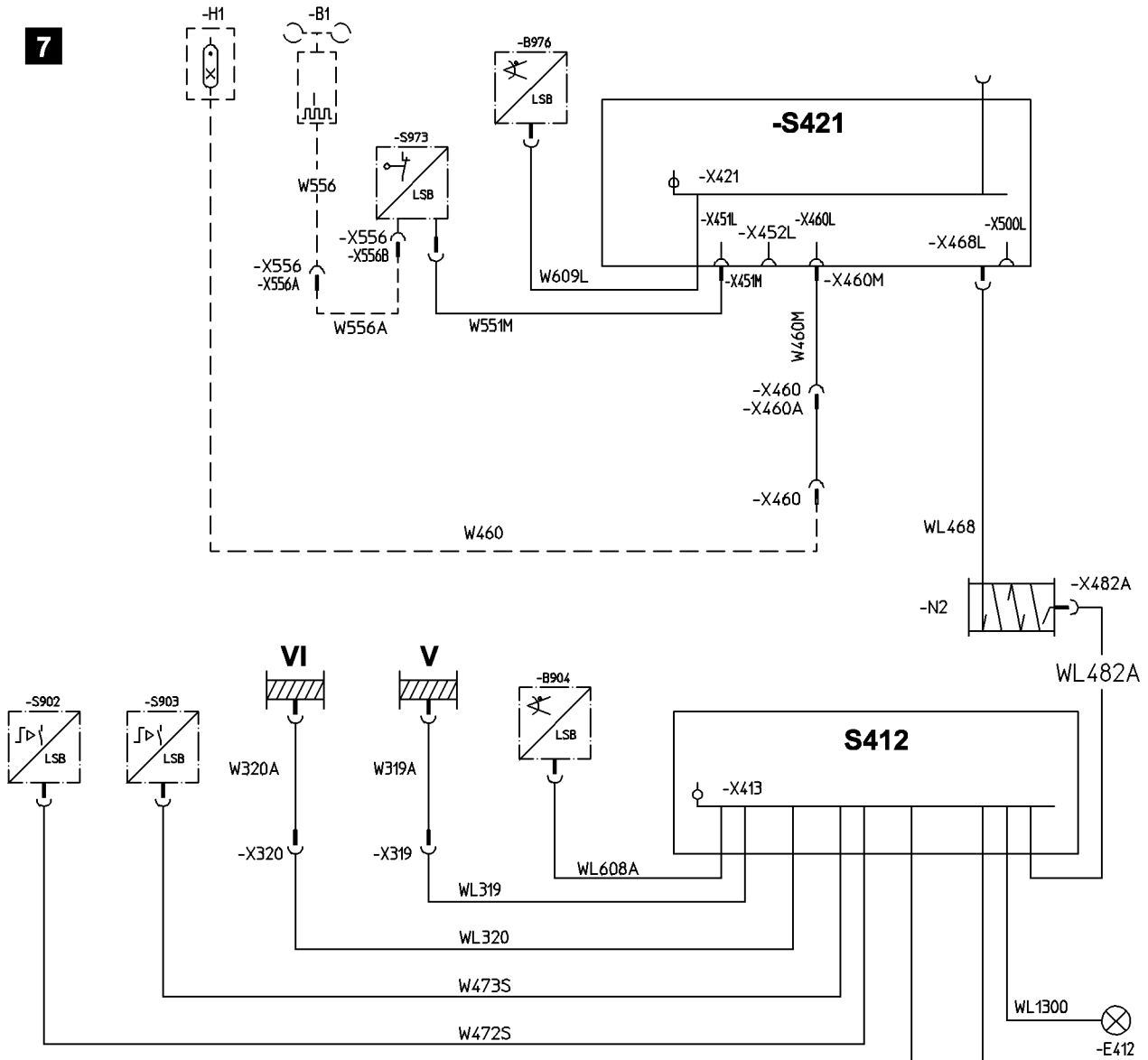
C A U T I O N : **After the auxiliary jib (2) has lifted off the ground, the SL - / SLD - boom may only be luffed down or placed down very carefully. When placing on the ground, the auxiliary jib HS (2) folds automatically from the fork connection and "runs" out on the run pulleys (9) .**

If this is not observed, the auxiliary jib HS (2) can be damaged!

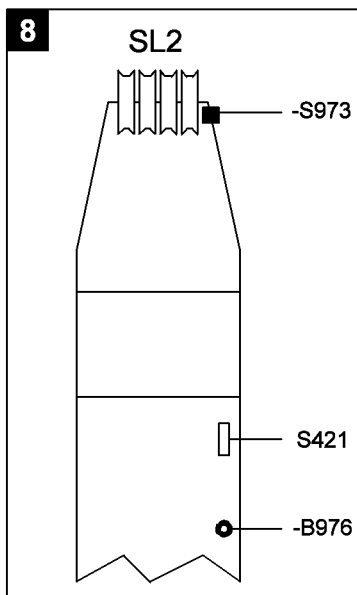
- Luff up the boom until it is at operating position, according to the load chart.

C A U T I O N : **The data in the load charts must be strictly observed.**
If this is not observed, the crane can be overloaded or tip over !

7



8



3. Electrical connections SL2 (fig. 7)**General S / SL**

- Establish the electrical connection from the control box (S1) on the slewing platform to the connector box (-S412).
- Establish the electrical connection from the cable drum (N2) to the connector box (-S421) .
- Plug the cable plug (WL482A) into the cable drum (-N2) .
- Plug in the cable plug (WL468) in connector box (-S421) .
- Establish the electrical connection from the connector box (-S412) to the S - relapse cylinder limit switches (-S902 and -S903) .
Plug in the cable plug (W472S) in (X902) and (W473S) in (X903) .
- Establish the electrical connection to the angle sensor (-B904) .
Plug in the cable plug (WL608A) .

Operating mode SL2

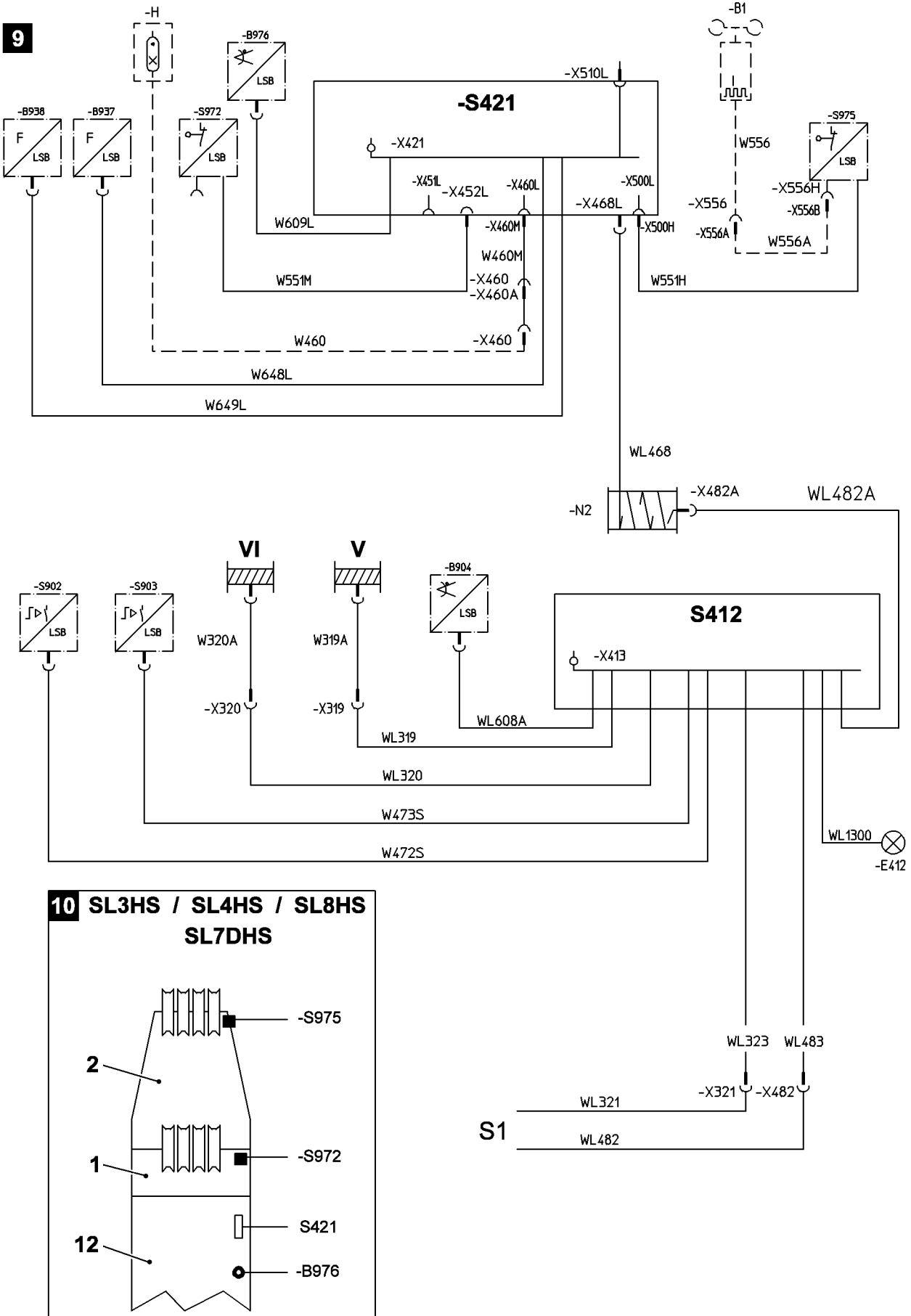
- Establish the electrical connection from the connector box (-S421) to the angle sensor (-B976) .
Plug in the cable plug (W609L) in the angle sensor (-B976) .
- Establish the electrical connection from the connector box (-S421) to the hoist limit switch (-S973) .
Plug in the cable plug (W551M) into the hoist limit switch (-S973) .
- Install the wind speed sensor (-B1) and airplane warning light (-H1) on the auxiliary jib (100 t) .
- Establish the electrical connection from the hoist limit switch (-S973) to the wind speed sensor (-B1) .
Plug the cable (W556A) into the cable plug (W556) of the wind speed sensor (-B1) and in the hoist limit switch (-S973) .
- Establish the electrical connection from the connector box (-S421) to the airplane warning light(-H1) .
Plug in the cable plug (W460) the the cable plug (W460M) into the connector box (-S421) .

3.1 Electrical safety devices / installation schematic (fig. 8)

- (-S973) Hoist limit switch: in the auxiliary jib HS (2) (G52 - 100t)
- (-S421) Terminal box: in the L - Adapter (12)
- (-B976) Angle sensor: in the L - Adapter (12)

3.2 Hydraulic connections

Establish the hydraulic connection (2 x quick connect couplings, Sk) to the S - relapse cylinders.



4. Electrical connections SL3HS / SL4HS / SL8HS / SL7DHS (fig. 9)**General S / SL**

- Establish the electrical connection from the control box (S1) on the slewing platform to the connector box (-S412).
- Establish the electrical connection from the cable drum (N2) to the connector box (-S421) .
- Plug the cable plug (WL482A) into the cable drum (-N2) .
- Plug in the cable plug (WL468) in connector box (-S421) .
- Establish the electrical connection from the connector box (-S412) to the S - relapse cylinder limit switches (-S902 and -S903) .
Plug in the cable plug (W472S) in (X902) and (W473S) in (X903) .
- Establish the electrical connection to the angle sensor (-B904) .
Plug in the cable plug (WL608A) .

Operating modes SL3HS / SL4HS / SL8HS / SL7DHS

- Establish the electrical connection from the connector box (-S421) to the angle sensor (-B976) .
Plug in the cable plug (W609L) in angle sensor (-B976) einstecken.
- Establish the electrical connection from the connector box (-S421) to the hoist limit switch (-S972) .
Plug the cable plug (W551M) into the connector box (-S421) .
- Install the wind speed sensor (-B1) and airplane warning light(-H) on the auxiliary jib 100 t .
- Establish the electrical connection from the connector box (-S421) to the airplane warning light(-H) .
Plug in the cable plug (W460) with the cable plug (W460M) in connector box (-S421) .
- Establish the electrical connection from the connector box (-S421) to the hoist limit switch (-S975) .
Plug the cable plug (W551H) into the connector box (-S421) .
- Establish the electrical connection from the hoist limit switch (-S975) to the wind speed sensor (-B1) .
Plug in the cable (W556A) into the cable plug (W556) of the wind speed sensor (-B1) and in the hoist limit switch (-S975).

4.1 Electrical safety devices / installation schematic (fig. 10)

- (-S975) Hoist limit switch: in the auxiliary jib (2) (G52 / G53 - 100 / 120t)
- (-S972) Hoist limit switch: in the adapter for the auxiliary jib HS (1) (G23 / G24 - 100t / 120t)
- (-S421) Terminal box: in the L - Adapter (12)
- (-B976) Angle sensor: in the L - Adapter (12)

4.2 Hydraulic connections

Establish the hydraulic connection (2 x quick connect couplings, Sk) to the S - relapse cylinders.

5. Function check

Prerequisite:

- All electrical connections have been established.
- The engine is running.
- The required operating mode has been set and confirmed on the LICCON.

Airplane warning light

Turn on the airplane warning light, check visually for function.

Wind speed sensor

Check the movement and the function of the wind speed sensor.

CAUTION: For SL2 / SL3HS / SL4HS / SL8HS / SL7DHS - operation, the removable wind speed sensor (-B1) must always be installed and connected (functioning), otherwise the LICCON overload safety system will report an error. The function must be checked after every installation!

Limit switches

CAUTION: The limit switch functions must be checked individually before crane operation. The manual procedure is described below. In the test system, the function of the individual limit switch initiators must be determined - See Diagnostics Manual.

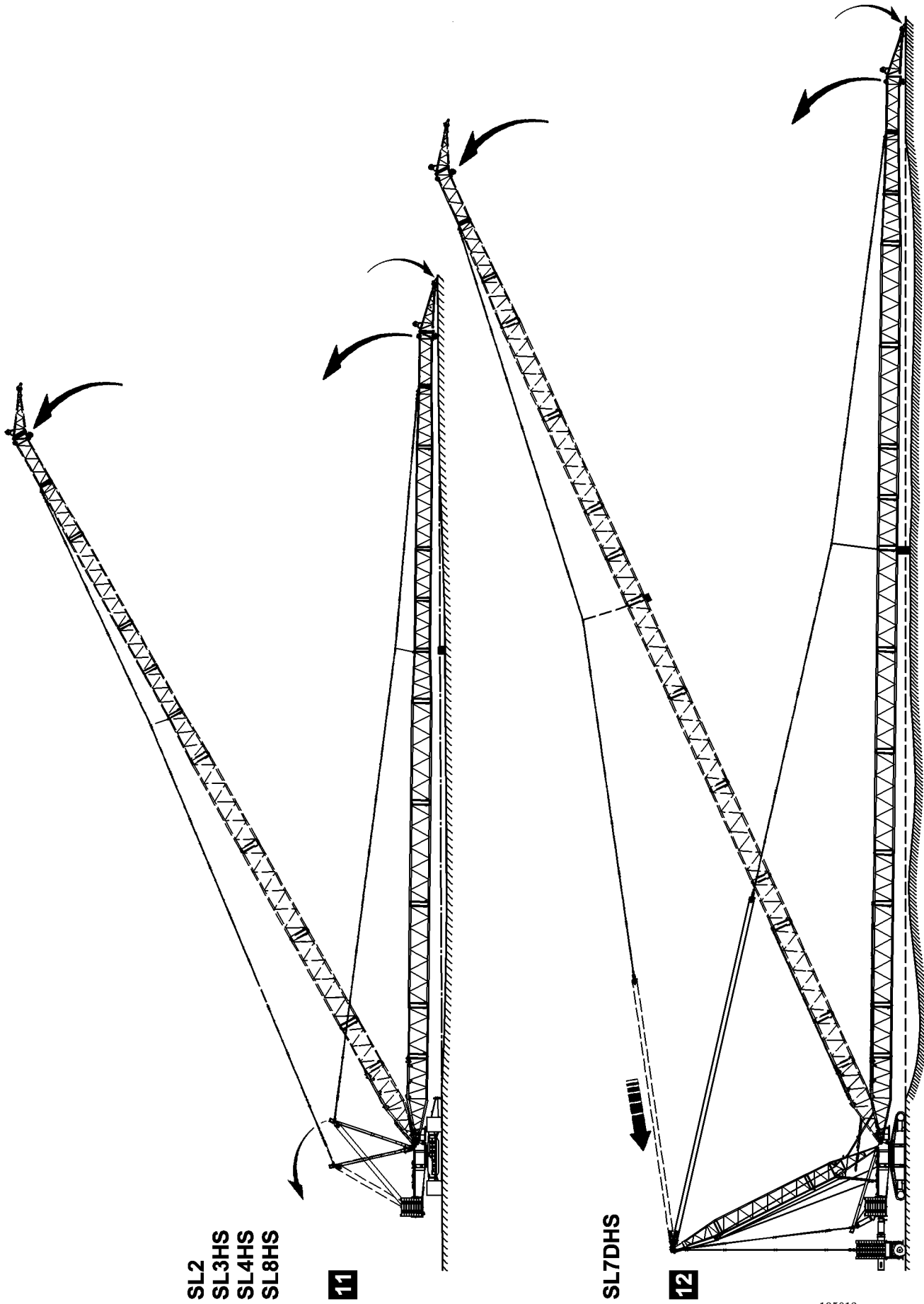
Hoist limit switch

Actuate the hoist limit switch manually.
The hoist winch must turn off in upward movement.
The hoist "top" symbol on the LICCON indicator must blink.

Note: When replacing or changing a hoist limit switch (HES), the HES must have the correct bus address as well as the correct software version to be recognized again by the bus system (LSB).

S - Relapse cylinder

Cover the limit switch initiators individually on the S - relapse cylinders with a metal plate. The S - control winch movement "spool up" must turn off. The symbol on the LICCON monitor must appear.



195013

6. Erect / take down the boom

D A N G E R : The SL- / SL..HS- / SL..DHS boom combinations must be erected according to the data in the erection and take down charts.

If this is not observed, the crane will be overloaded or tip over!

6.1 Erection or take down of SL2 - / SL..HS - boom combination (fig. 11)

The erection of the SL- / SL..HS - boom combinations is made as described in chapter 5.04.

Note: The data in chapter 5.04 must be observed and the **Danger** and **Caution** notes must be adhered to.

6.2 Erection or take down of SL7DHS - boom combination (fig. 12)**Erection**

Before erecting the SL7DHS - boom combination, the ballast trailer or the suspended ballast must be installed on the crane. Place the derrick ballast according to the erection and take down charts.

D A N G E R : The SL7DHS - boom combination m u s t always be erected with the derrick ballast, ballast trailer or suspended ballast, according to the erection and take down charts.

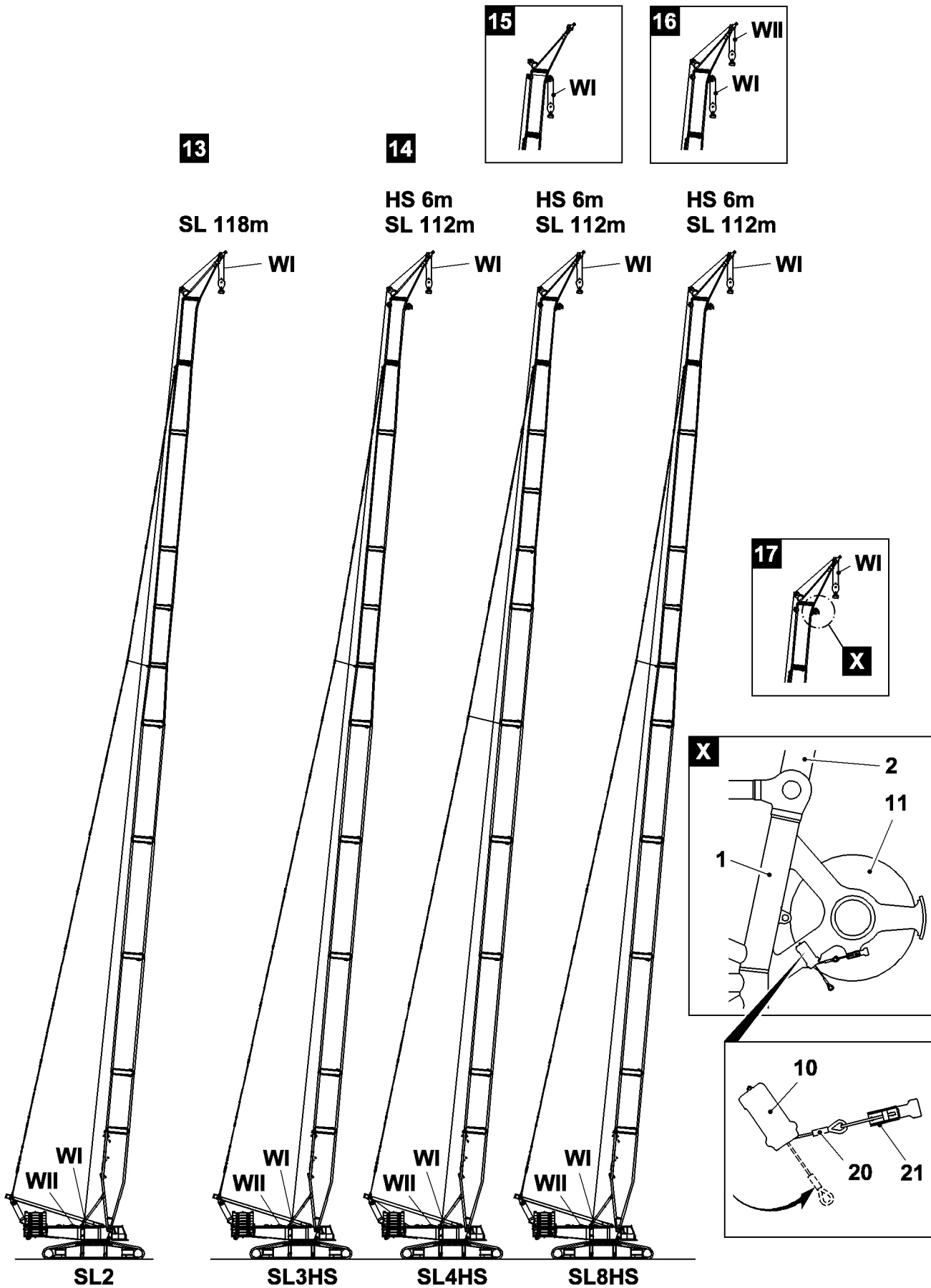
After erecting the SL7DHS - boom combination in operating position, the complete derrick ballast must be removed from the ballast trailer or from the suspended ballast pallet.

Before starting crane operation, the ballast trailer or the suspended ballast pallet must be removed from the crane .

The crane may only be operated in operating mode SL7DHS if the complete derrick ballast, including the ballast trailer or suspended ballast pallet have been removed .

Before placing down the SL7DHS - boom combination, the ballast trailer or the suspended ballast m u s t be installed on the crane and ballasted according to the erection and take down charts.

If this is not observed, there is a danger of accidents!



195014

7. Crane operation

D A N G E R: **The data in the load charts must be observed.
If this is not observed, there is a danger of accidents!**

- For hoist cable reevings, see chapter 4.06

7.1 SL2 (fig. 13)

Prerequisite:

- The LICCON overload safety system has been set according to the load chart.
- Die operating mode **SL2** is set and confirmed on the LICCON.

Note: In operating mode SL2, the hoist cable must be reeved from winch I on the auxiliary jib HS .

7.2 SL3HS / SL4HS / SL8HS / SL7DHS (fig. 14)

Prerequisite:

- The LICCON overload safety system has been set according to the load chart.
- Die corresponding operating mode is set and confirmed on the LICCON.

The operating modes **SL3HS / SL4HS / SL8HS / SL7DHS** offer various application possibilities for crane operation.

- Reeving of hoist cable (WI) on the auxiliary jib HS (2) (G52 / G53) (see fig. 14).
For crane operation with reeved auxiliary jib HS (2), winch I **m u s t** be reeved.
- Reeving of hoist cable (WI) on the adapter for the auxiliary jib (1) (G23 / G24) (see fig. 15).
For crane operation with reeved adapter for the auxiliary jib, winch I **m u s t** be reeved .
- Two hook operation (fig. 16).
For two hook operation, winch I **m u s t** be reeved on the adapter for the auxiliary jib (1) (G23 / G24) and winch II on the auxiliary jib HS (2) (G52 / G53) .

D A N G E R: **If winch II is reeved - the load indication is smaller than the actual load on the load hook in case of :**

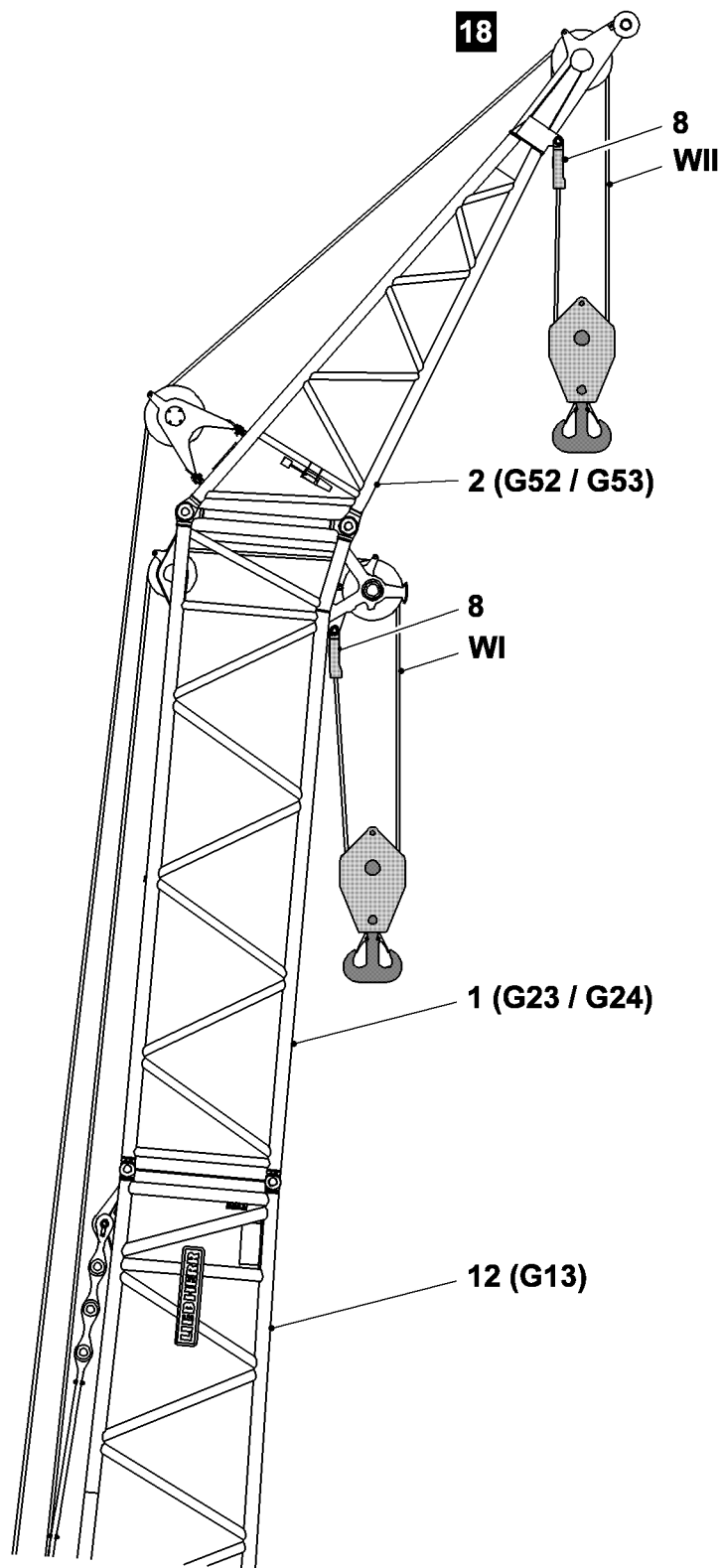
- **small reevings**
- **steep boom positions or small radii of the SL - boom!**

**This means the LMB recognizes as crane overload too late!
If this is not observed, there is an increased danger of
having an a c c i d e n t!**

If **no** hoist cable is reeved in operating modes **SL3HS / SL4HS / SL8HS / SL7DHS**, on the adapter for the auxiliary jib (1) (G23 / G24) (fig. 17 // fig. X) , then it must be noted that the hoist limit switch -S972 (10) on the adapter for the auxiliary jib (1), is "disactivated" (fig. 17 // fig. X).

C A U T I O N: **The hoist limit switch -S972 (10) on the adapter for auxiliary jib (1), must always be connected on the LICCON - System - Bus .**

- **Remove the hoist limit switch weight.**
- **Attach the hoist limit switch cable (20) with hook closure (21) under "pull" so the LMB can "disactivate" the hoist limit switch -S972 (10) (fig. X).**



8. Two hook operation for SL3HS / SL4HS / SL8HS / SL7DHS**Description**

For two hook operation, there is the possibility to operate the load hook on the auxiliary jib HS (2) (with winch II reeved) and the load hook on the adapter for the auxiliary jib (1), (with winch I reeved), at the same time (fig. 16).

This possibility has been designed for switching loads.

Prerequisite:

- The LICCON overload safety system has been set according to the load chart.
- The required operating mode, of example **SL3HS**, has been set and confirmed on the LICCON .
- The cable reeving has been entered on the LICCON according to the actual reeving number.

D A N G E R : **The load must always be lifted with the weakest component (auxiliary jib HS) by 100 % .**

C A U T I O N : **The reeving must be entered into the LICCON overload safety system according to the actual reeving on the pulley head.**

- For hoist cable reeving, see chapter 4.06

D A N G E R : **The reeving on the adapter for the auxiliary jib must be the same or larger than the reeving on the auxiliary jib HS.
If this is not observed, the crane can be overloaded!**

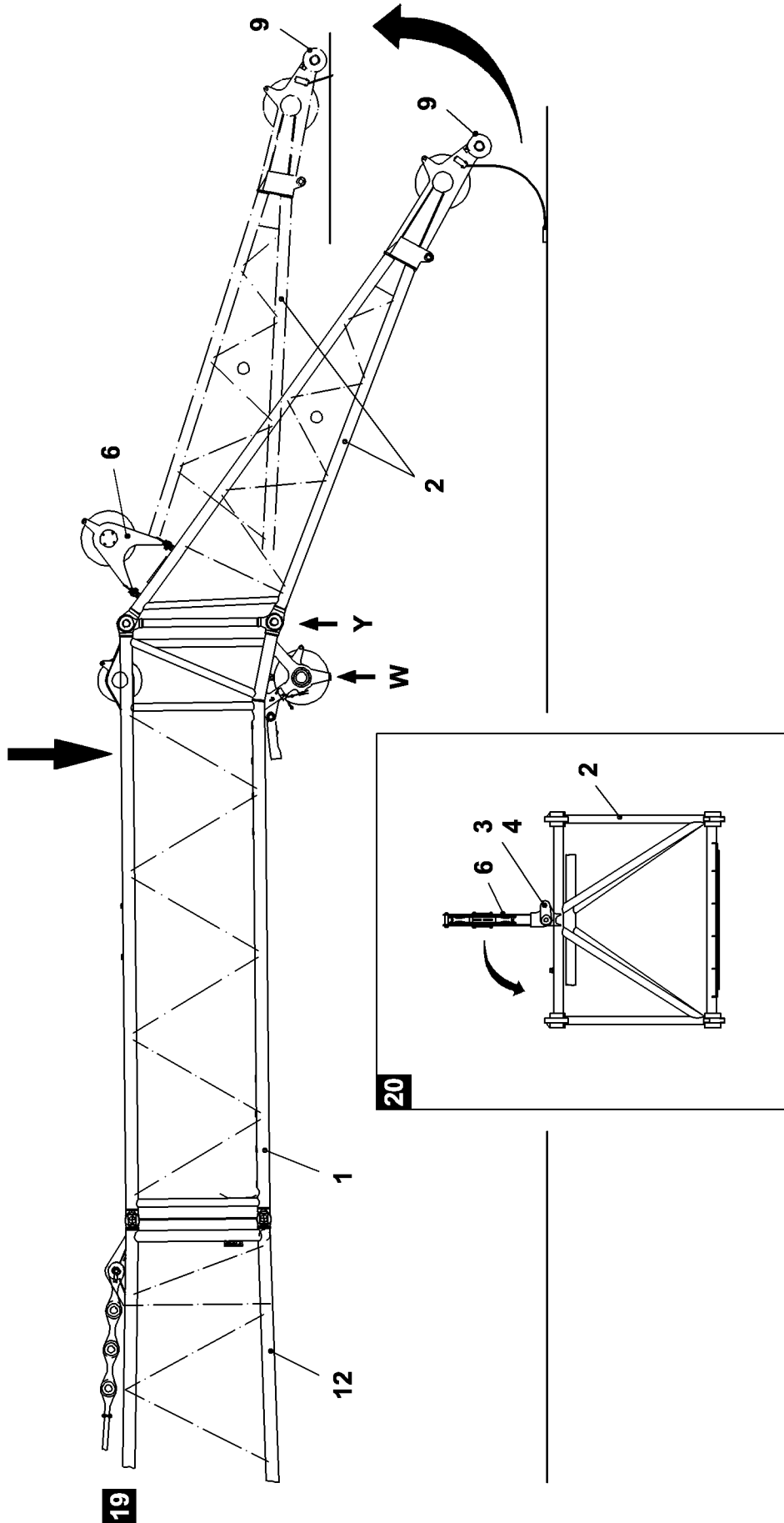
The maximum total load for two hook operation corresponds to the maximum load on the auxiliary jib HS as permitted in the load chart.

D A N G E R : **The data in the load charts must be observed.
If this is not observed, there is a danger of accidents!**

C A U T I O N : **The load carrying capacity is reduced by the weights of the load hook and the weights of the tackle!**

The weights of the load hook and the tackle must be added to the load to be lifted.
This results in a **reduction of load carrying capacity!**

C A U T I O N : **The radius indication is made according to the entered auxiliary jib HS.
The individual loading capacity per hook corresponds in two hook operation to the permissible load according to the load chart for operation with auxiliary jib HS.
The summation loading capacity corresponds in two hook operation to the permissible load according to the load chart for operation with auxiliary jib HS.**



9. Removal of auxiliary jib HS

D A N G E R: The SL - / SL..HS - / SL7DHS - boom combination must be taken down according to the data in the erection and take down charts.
If this is not observed, the crane will be overloaded or tip over!

C A U T I O N: It must be ensured that for take down, the boom combination is lowered to the ground carefully so that the auxiliary jib HS can automatically fold up on the fork connection (Y) and run "out" on the run pulleys (9) (fig. 19)
If this is not observed, the auxiliary jib HS can be damaged!

Prerequisite:

- The SL2 - / SL..HS - / SL7DHS - boom combination is placed down (see chapter 5.04 // chapter 5.05).

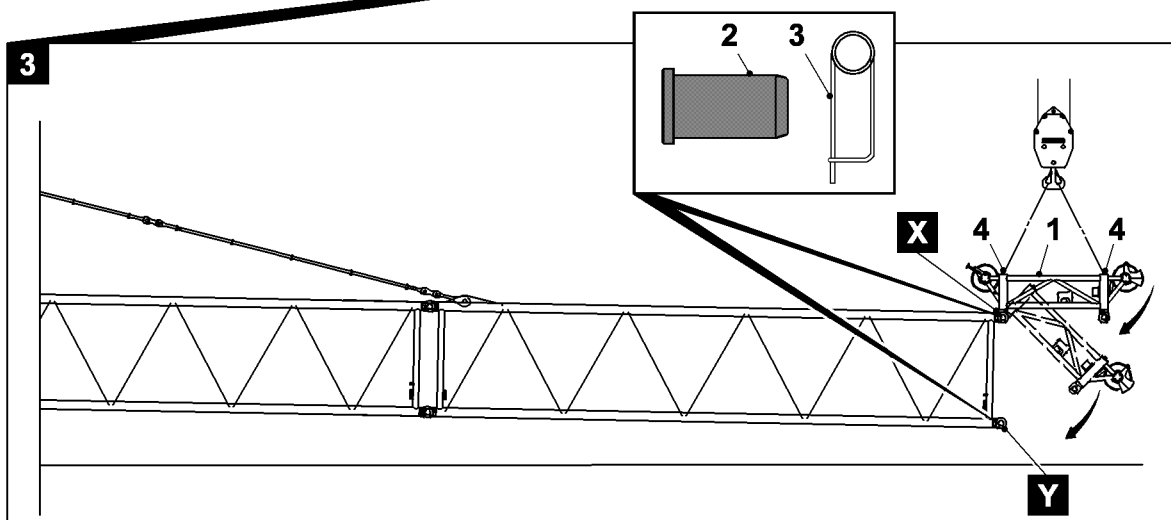
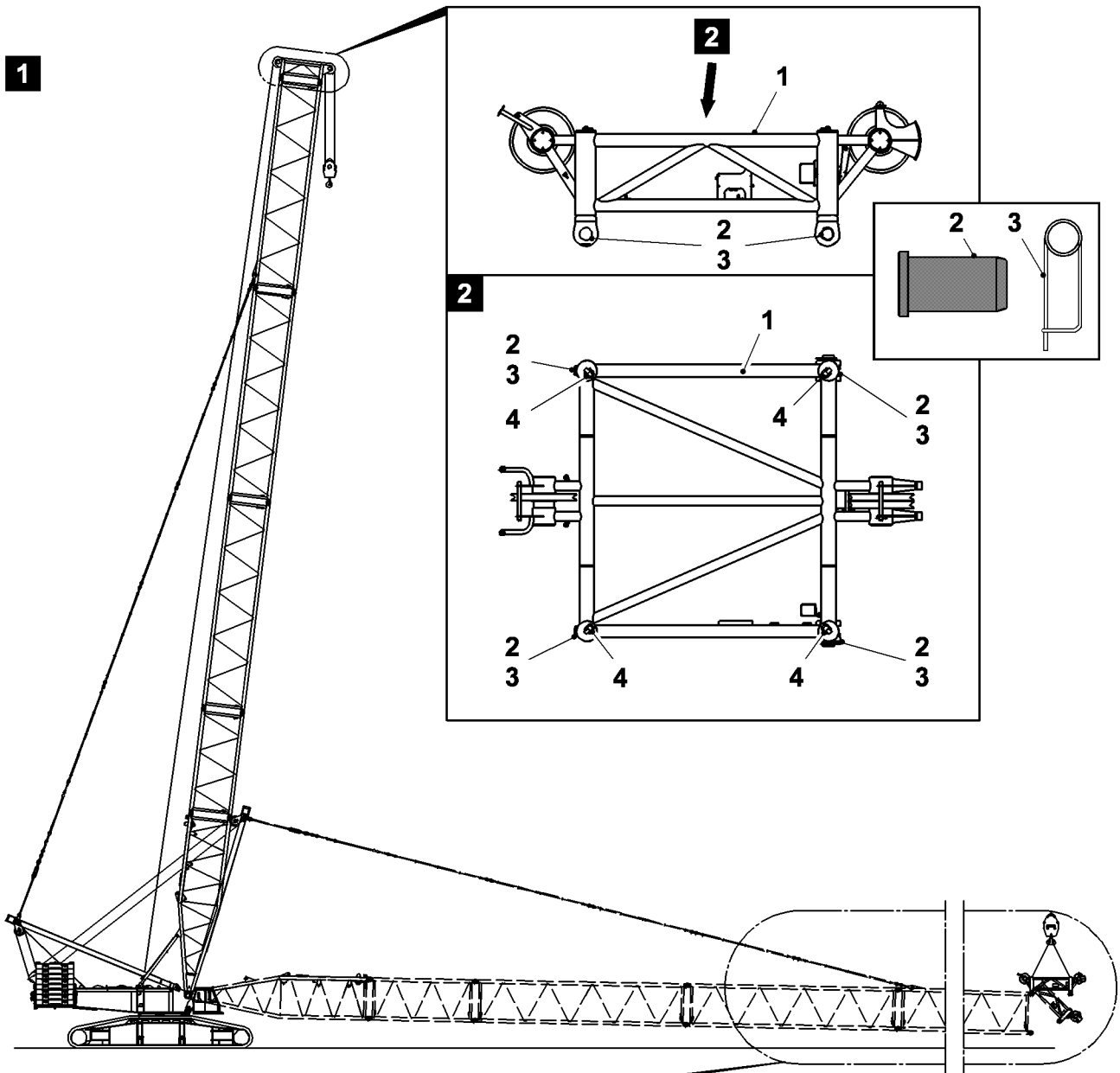
D A N G E R: Before the SL7DHS - boom combination is taken down, the ballast trailer or the suspended ballast pallet must be installed on the crane and ballasted according to the erection and take down charts.

If this is not observed, there is an increased danger of having an accident!

- The electrical connections to the auxiliary jib HS (2) are disconnected.
- The hoist limit switch weight on the auxiliary jib HS has been removed.
- The hoist cable on the auxiliary jib HS is unreeved.

Removal

- Release the pin (3) and unpin (fig. 20).
- Fold down the pulley retainer (6) (fig. 20).
- Hand the auxiliary jib HS (2) on the auxiliary crane.
- Release the pin "on top" (X) and unpin by using the pin pulling device.
- Remove the auxiliary jib HS .



1. Installation boom - S3 with installation head 47t

Description:

The installation boom - S3 is a shortened S - boom. Two boom lengths (48m and 62m) are permissible. With the installation boom - S3 it is possible to drive the crane without having to remove the complete boom. With this installation boom - S3, in connection with the 47t installation head (1), loads according to the data in the load charts can also be lifted. To drive the crane with the installation boom, the ground must be able to absorb any ground pressures which might occur .

D A N G E R: **The data in the load charts and in chapter**

- 4.05 - Crane operation

- 5.03 - Attachment - lattice mast systems

- 5.04 - S / SL - Boom combination

must be strictly observed.

If this is not observed, there is a danger of accidents!

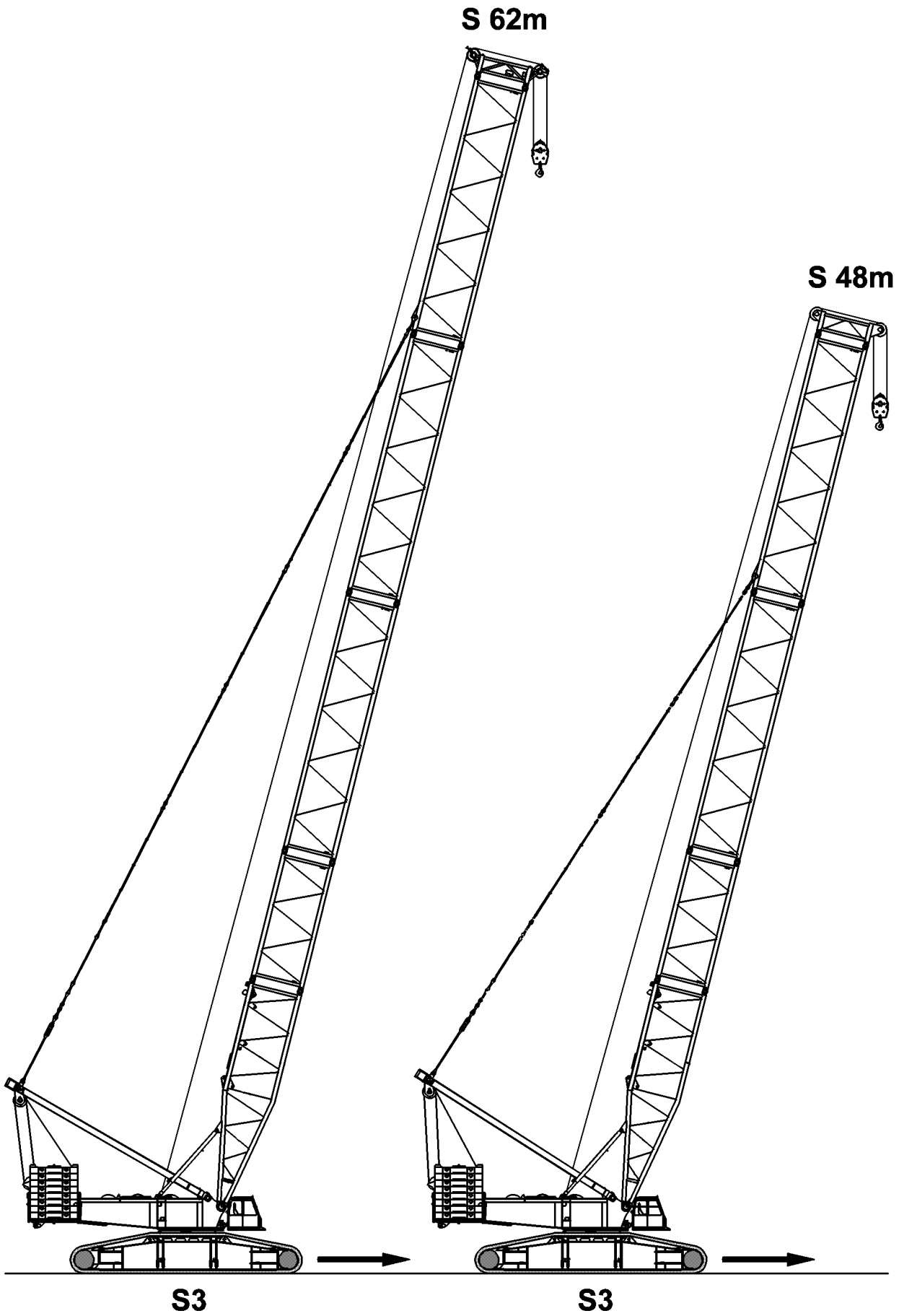
2. Installation of the 47t installation head (1)

Prerequisite:

- The SL2, SL3HS, SL4HS, SL..... boom is placed down on the ground.
- The S- / L- lattice sections have been removed except for the appropriate length for the installation boom-S3.
- The installation boom - S3 is guyed according to the data in **chapter 5.03**.
- The installation head (1) is installed with the installation lugs (4) with tackle on the auxiliary crane .

Installation of the 47t installation head (1)

- Pin the installation head (1) on the installation boom "**on top**" with the pin pulling device (Fig. 3 / X).
- Use pin (2) and spring retainer (3) .
- Luff up the installation boom (Fig. 3) until the boom has lifted approx. 0.5-1.0m off the ground .
- Slowly lower the installation head (1) with the auxiliary crane.
- Pin and secure the installation head on the installation boom "**on the bottom**" (Fig. 3 / Y).
- Loosen and remove the tackle from the installation lugs (4) .
- Remove the auxiliary crane.
- Reeve in the hoist cable on the installation head (1) and on the hook block (47t) .
- Connect the hoist limit switch .



3. Erection / take down**Description:**

The installation boom - S3 **must** be erected in the ballast conditions listed in the corresponding load chart for the installation boom - S3.

Note: There are no special or separate erection and take down charts for the installation boom - S3 !

D A N G E R: **The installation boom - S3 must be erected and taken down according to the ballast conditions in the load chart.
If this is not observed, the crane will be overloaded or tip over !**

4. Removal of the 47t installation head

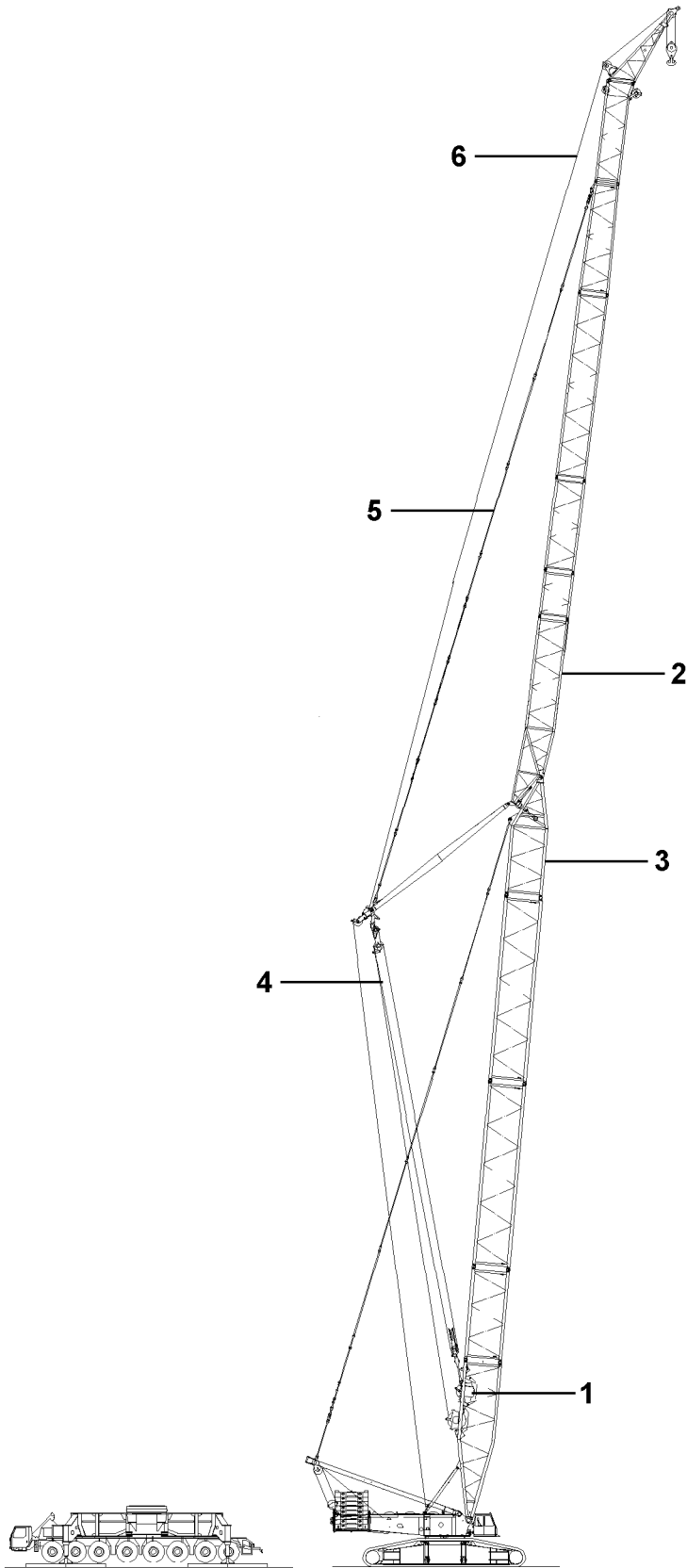
The removal of the installation head (1), is carried out in reverse order of the installation .

5. Driving with the installation boom - S3**Description:**

As a rule, the prerequisites for driving the crane (see chapter 4.05) must be met. The crane can be driven with installed installation boom - S3 within the scope of the loads given in the load charts. In any case, when driving the crane, an even ground pressure should always be achieved. The ground pressure can be influenced or changed by luffing the boom up or down .

C A U T I O N : **The occurring ground pressures must be determined with the job planer before driving the crane!**

D A N G E R: **The data in chapter 4.05 must be observed.
If this is not observed, there is a danger of accidents!**



1. Description

The SLK-articulated boom is used as a straight, long SL -boom for the installation of wind power plants.

Due to the length and without derrick, the articulated boom can be erected and taken down while folded down.

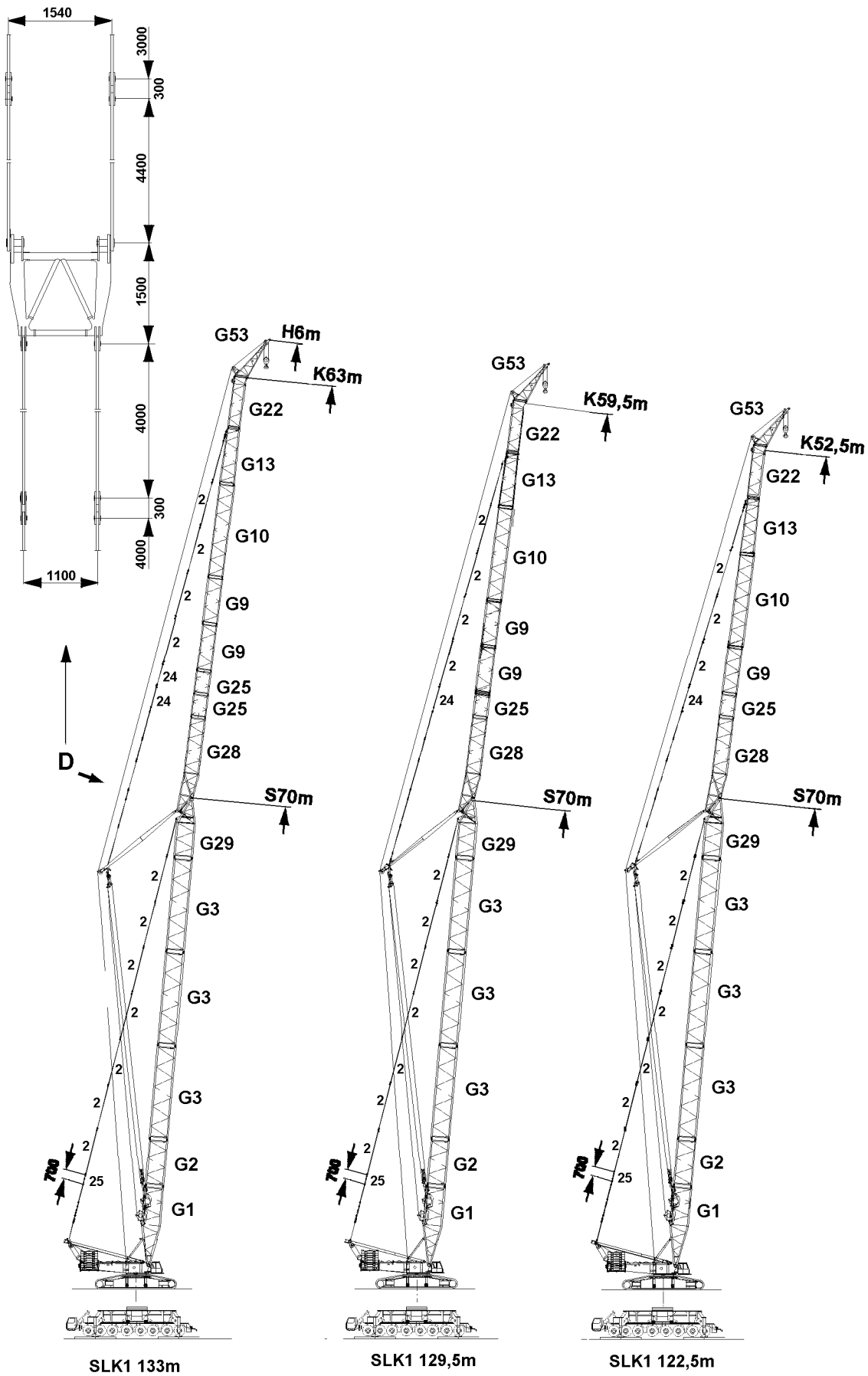
The articulated boom is fixed guyed in operation, via the KA-bracket to the S-pivot section with the pulley blocks and to the SL-adapter with the guy rods.

The articulated boom is secured with two mechanical relapse supports.

C A U T I O N : The lattice sections and the guy rods to the SL-adapter must be installed according to the data in chapter 5.03.

1.1 Components SLK

	Description	Length (m)	Weight (t)
1	K-pulley blocks		approx. 2,50
2	K - assembly unit with KA-bracket	15,14	approx. 15,70
3	K-adapter		approx. 9,00
4	K-control		
5	K-guy rods		
6	Hoist cable		



2. Combination of equipment

2.1 Guy rods

Pos.:	Description	Length
2	Guy rod	7,00 m
24	Guy rod	3,50 m
25	Guy rod	0,70 m

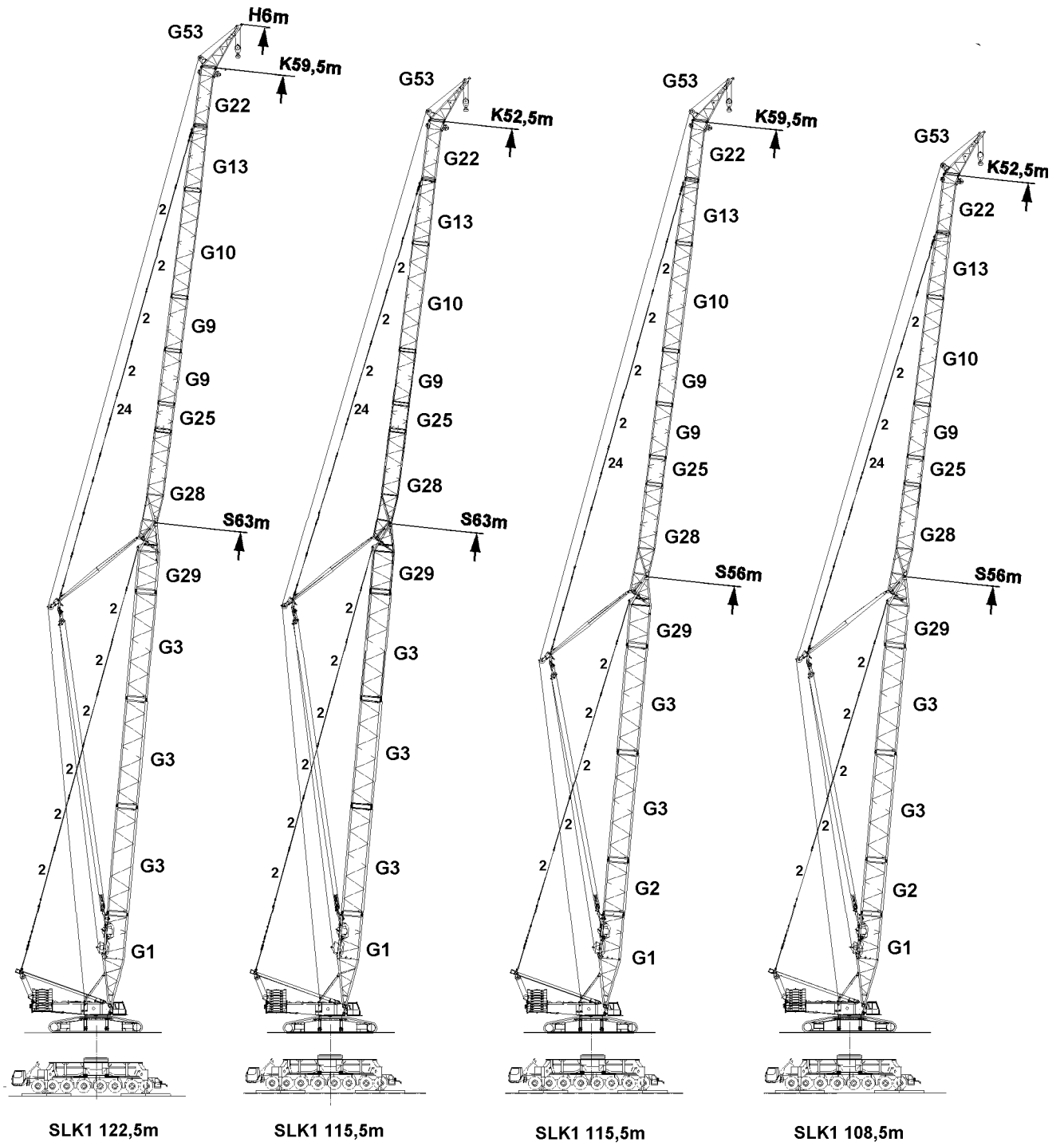
Note: Guy rods View D, see paragraph 2.4.

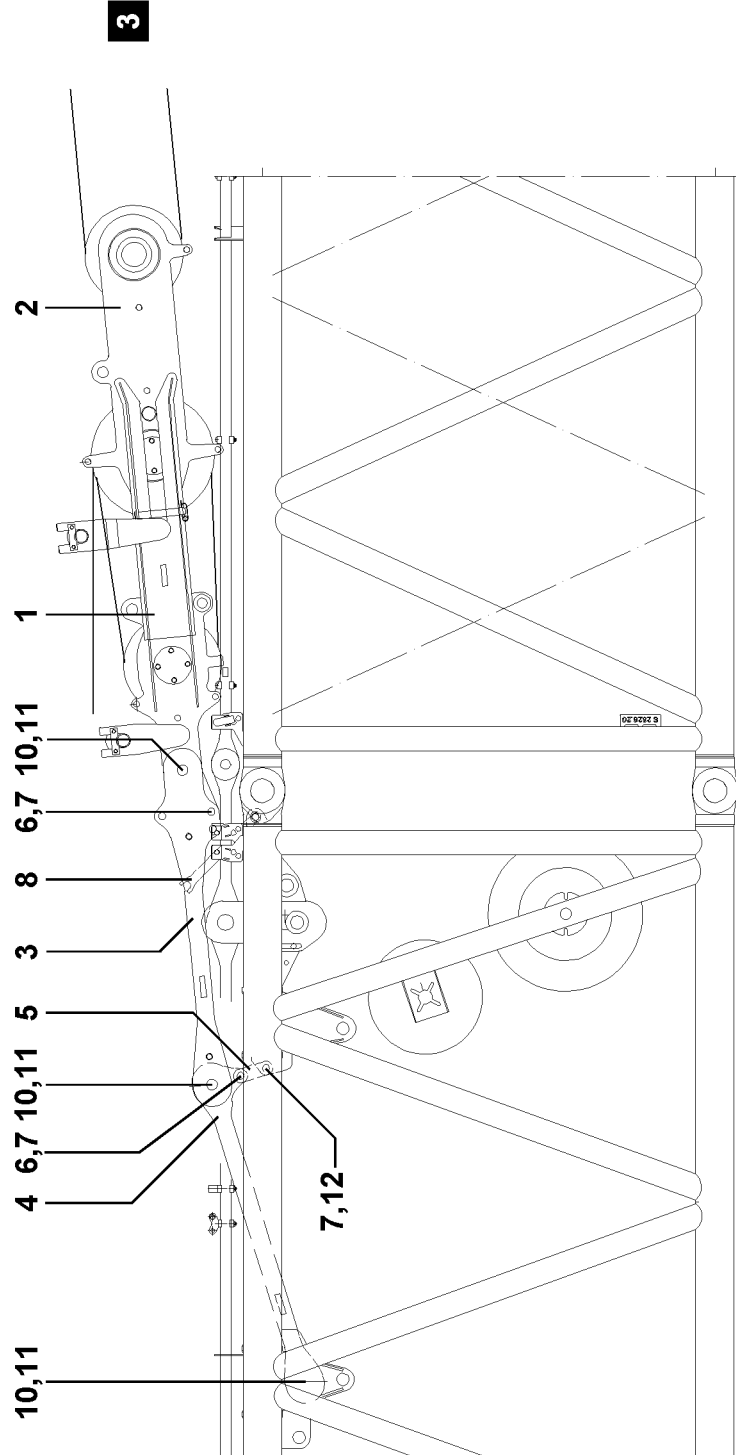
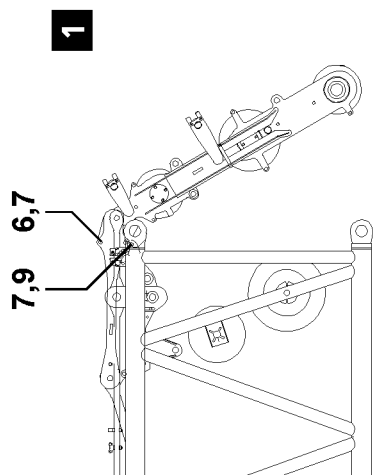
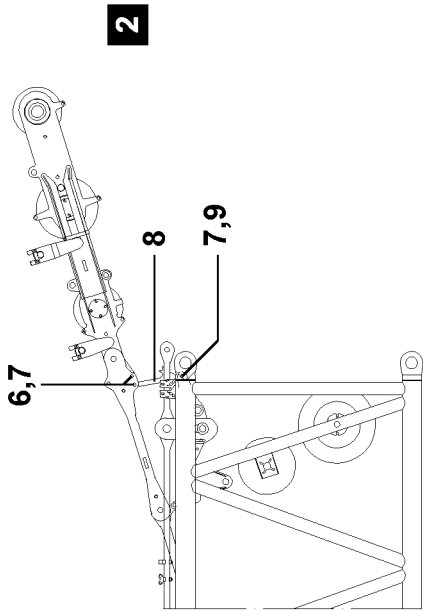
2.2 Equipment

	Description	System	Length (m)	Weight (t)
G 1	S - pivot section with S + W- rods, relapse cylinder	2826. 30	12,0	18,0
G 2	S - intermediate section	2826. 20	7,0	6,2
G 3	S - intermediate section	2826. 20	14,0	11,3
G 9	LI - intermediate section	2421. 10	7,0	3,8
G 10	LI - intermediate section	2421. 10	14,0	7,0
G 13	L - adapter		8,4	6,0
G 22	Adapter f. HS without pulley set		7,6	2,7
G 25	LI - intermediate section	2421. 10	3,5	2,2
G 28	K-assembly unit		15,4	15,7
G 29	K-adapter		9,0	9,0
G 53	Auxiliary jib HS (120t)		6,0	2,6

Note: For example : 2826.**20** = **.20** (welded on plate on intermediate section)
One 14 m intermediate section can be installed in place of two 7 m intermediate sections.

D A N G E R: Another assembly of the lattice sections and the guy rods then shown in the operating manual or installation drawings is prohibited!
There is a danger that the intermediate sections, which are different sized but do not differ externally can be mixed up!
They only differ by the welded on plates (.8, .10, .20, .30)
During installation of the boom it must be checked that the intermediate sections are installed according to their description. If this is not observed, there is a danger of accidents!





2.3 Components K-pulley blocks

K-Pulley blocks

Consists of:

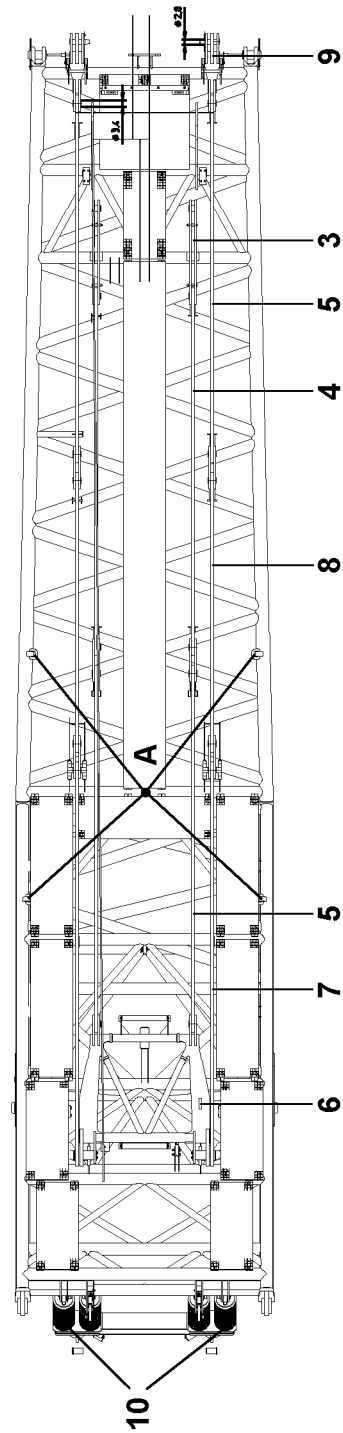
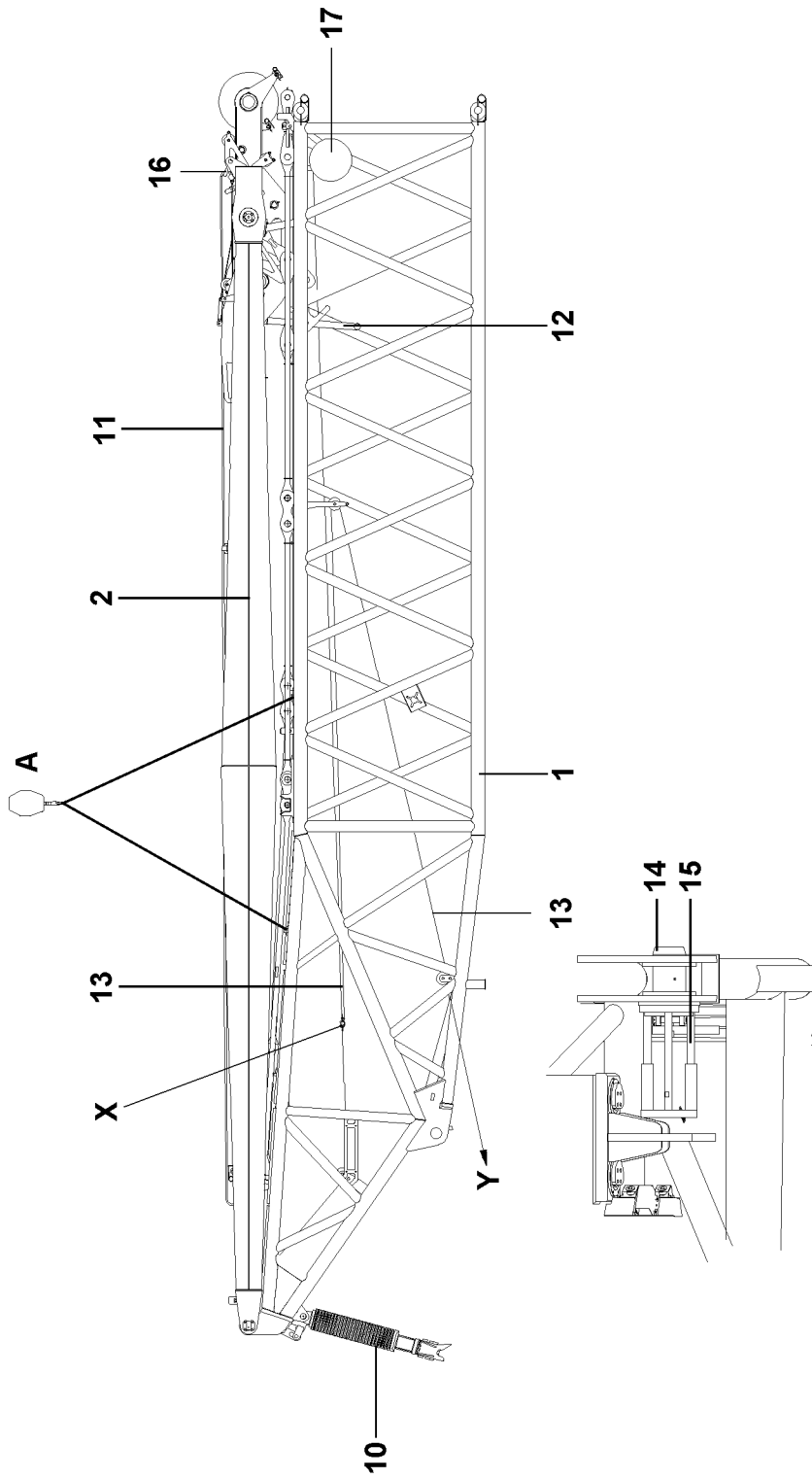
- 1 Pulley block 1
- 2 Pulley block 2
- 3 Guy rod 1,80m
- 4 Guy rod 1,77m
- 5 Support for guy rods
- 6 Pin $\varnothing 40 \times 107\text{mm}$
- 7 Spring retainer 5
- 8 Support - Assembly position
- 9 Pin $\varnothing 40 \times 140\text{mm}$
- 10 Pin $\varnothing 60 \times 143\text{mm}$
- 11 Spring retainer 6
- 12 Pin $\varnothing 40 \times 105\text{mm}$

Fig. 1 - Transport position

Fig. 2 - Assembly position

Fig. 3 - Operating position

CAUTION: In operating position, the support (8) must be folded in!



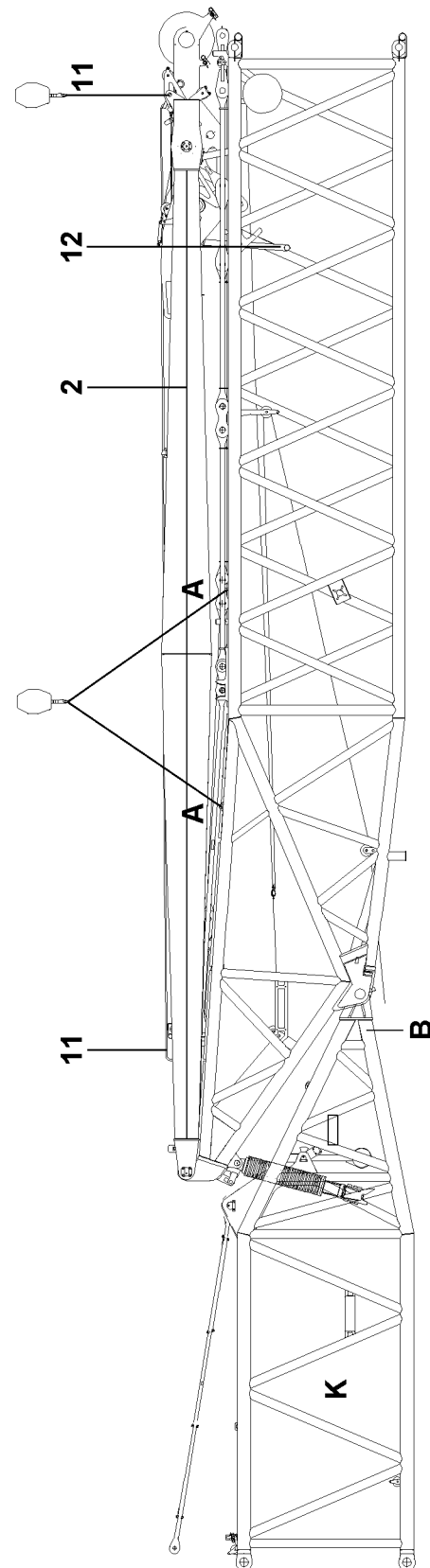
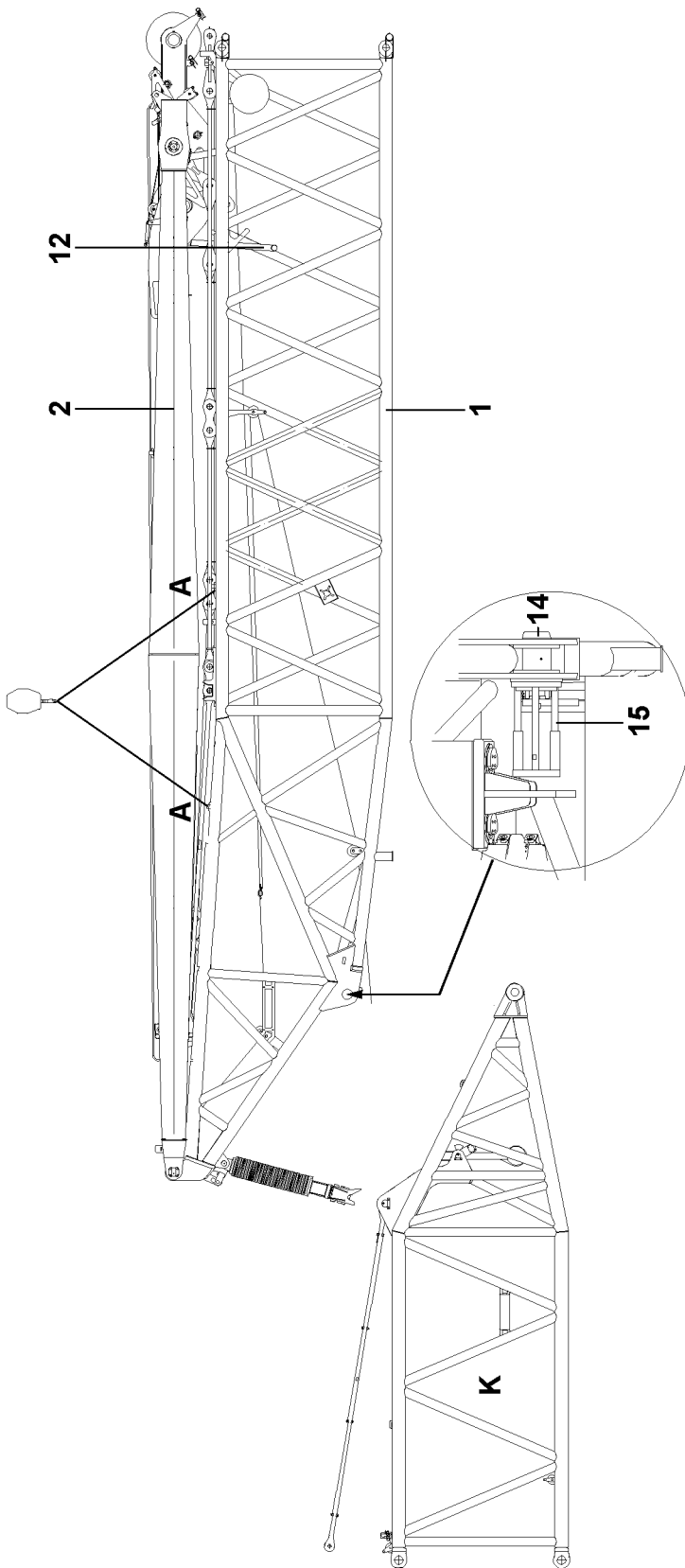
2.4 Components K-assembly unit

K-Assembly unit

Length 15,14m
Weight, approx. 15,70t

Consists of:

- 1 K-pivot section
 - 2 KA-bracket
 - 3 Bracket 1,0m
 - 4 Guy rod 4,0m
 - 5 Guy rod with bracket 4,3m
 - 6 Traverse 1,0m
 - 7 Guy rod 4,4m
 - 8 Guy rod with bracket 3,3m
 - 9 Bracket 0,7m
 - 10 K-relapse retainer, mechanical
 - 11 Tackle rope Ø18mm, 24m long, to erect and take down the KA-bracket with the auxiliary crane.
 - 12 Assembly support
 - 13 Cable from assembly winch
 - 14 Pin
 - 15 Pin pulling device
 - 16 Hook for pulley block retention
 - 17 Cable drum, spring loaded
- X Connector point :
- During operation, the cable from the spring loaded cable drum (17) must be connected with the hook control cable.
 - During assembly, the cable from the assembly winch (13) must be connected with the hook control cable.



196892

3. Assembly

D A N G E R: For the assembly and disassembly work:

- A safe installation scaffolding / working platform must be used. There is a danger of accidents due to falling.
- Improvisations are prohibited.
- The lattice sections must be supported underneath with suitable, stable materials.
- Nobody may remain under the lattice jib during the pinning and unpinning procedure of the lattice sections.

Prerequisite:

- The S-boom is installed.

Note: For installation of the S-boom, see chapter 5.04.

- The K-adapter is installed on the S-boom as the end section.
- The pulley blocks are installed on the S-pivot section .
- The crane is horizontally aligned.
- An auxiliary crane as well as an installation scaffolding / working platform are available.
- The LICCON overload safety system is set according to the data given in the load charts.
- The keyed button "Assembly" is actuated, the indicator light "Assembly" lights up.
- The assembly symbol on the LICCON display blinks.

3.1 Install the K-assembly unit

Luff up the S-boom somewhat for easier installation of the assembly unit.

Take up the K-assembly unit with the auxiliary crane on the tackle points (A) on the K-pivot section (1) .

Note: The total weight of the K-assembly unit is approx. 15,70t.
The cable (WL413K) must be plugged into the dummy plug on the K-adapter . This bypasses all movements when the assembly switch is turned on.

Pin and secure the K-assembly unit on the K- adapter (K) . Pin and secure all pins (14) with the hydraulic pin pulling device (15) .

Remove the auxiliary crane .

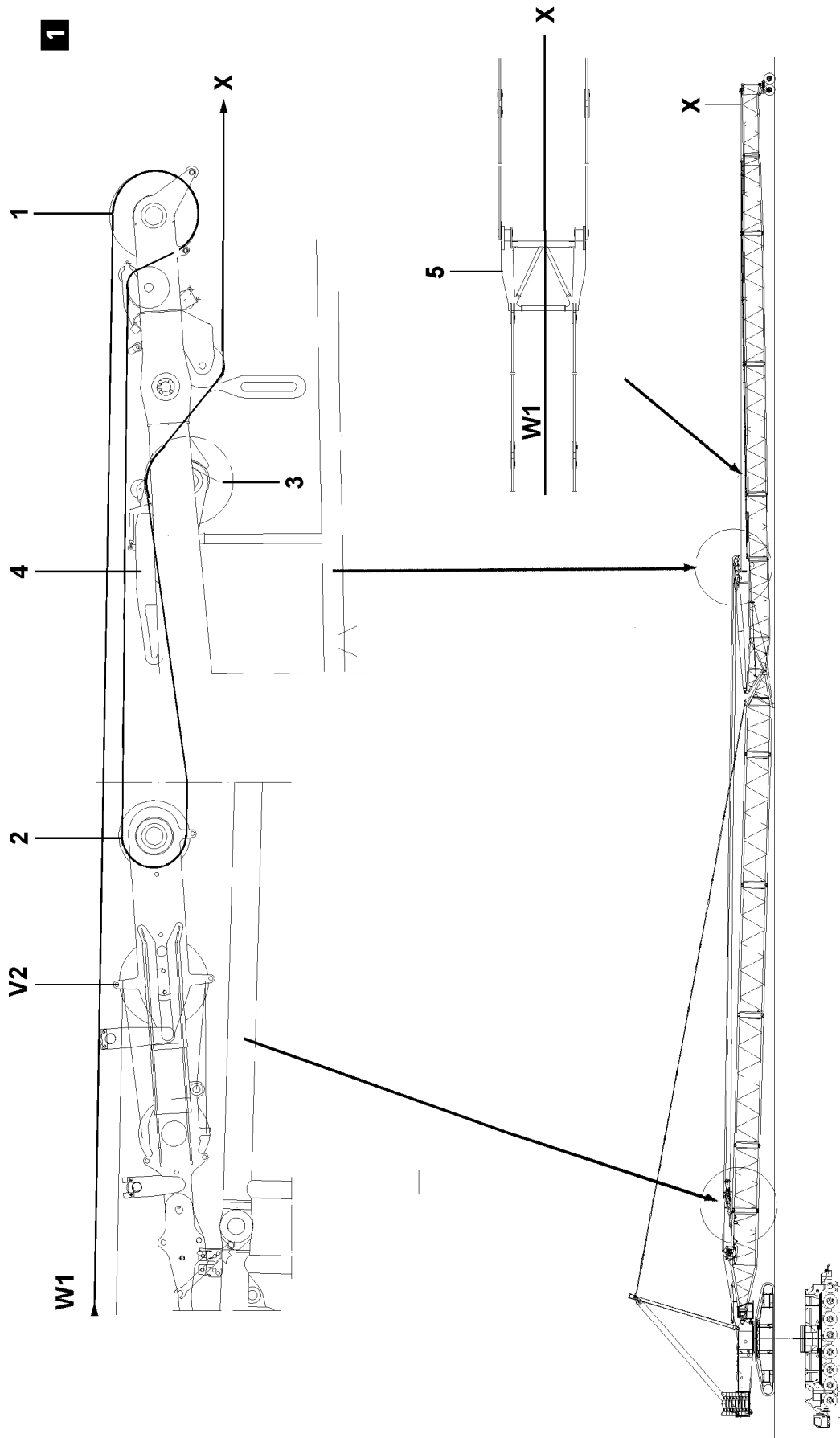
D A N G E R: Before removing the auxiliary crane, it must be ensured that the K-assembly unit is pinned and secured on the K- adapter (K) !
There is a danger of accidents!

Hang the assembly cable (11) on the hook of the auxiliary crane.

Lift the KA-bracket (2) and set it on the assembly support (12), so that the K-lattice jib can be installed.

Remove the auxiliary crane .

Install the K-lattice jib and place the K-end section on the pulley cart.



196893

3.2 Reeve in the hoist cable

Prerequisite: The pulley blocks are pinned and secured on the S-pivot section .

Reeve in the hoist cable (W1) on the pulley block (V2) and on the KA-bracket .

Guide the hoist cable (W1) over the front cable pulley (1) on the KA-bracket and pull it back to the cable pulley (2) on the pulley block (V2) .

From there, guide it over the cable pulley (3) in the KA-bracket to the front to the cable fixed point (X) on the L-adapter.

Pin and secure the hoist cable.

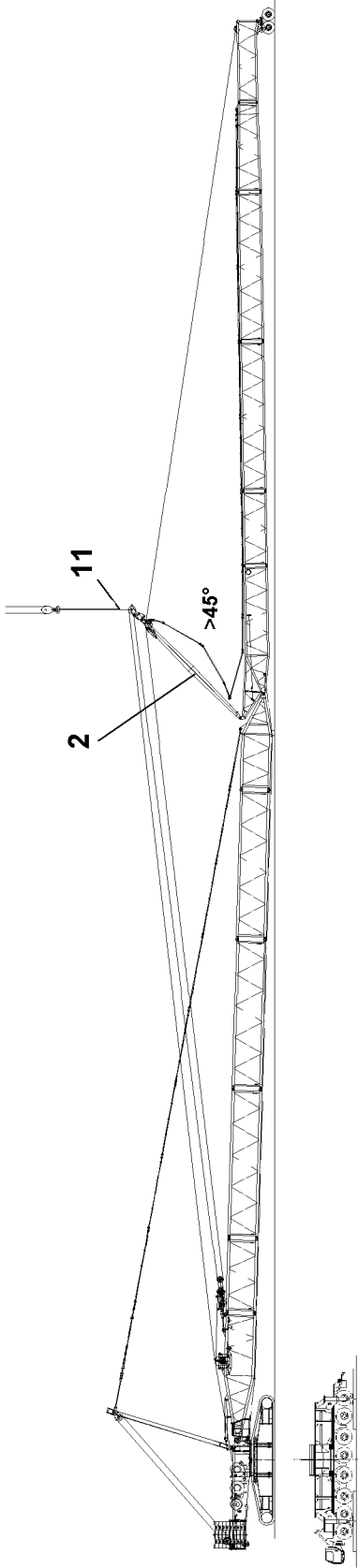
C A U T I O N: The hoist cable must be guided over the protective roller of the traverse (5) !

The pulley block (V2) is pulled to the hook (4) on the KA-bracket by the hoist cable pull.

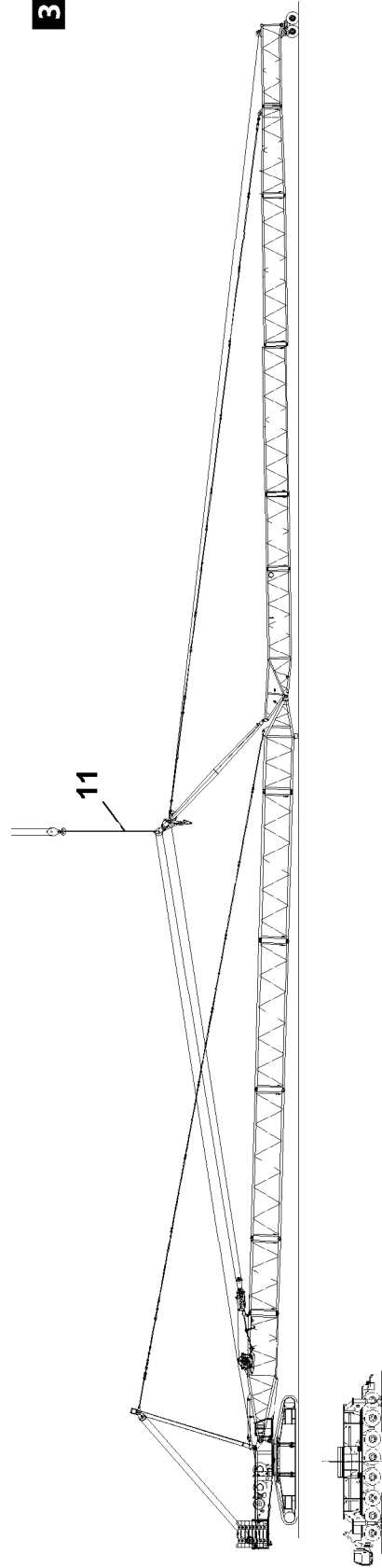
Note: See paragraph 4., Assembly process.

C A U T I O N: The hooks (4) on the KA-bracket must be pulled up with the cable of the assembly winch before pulling back the pulley block (V2).
Check visually!

2



3



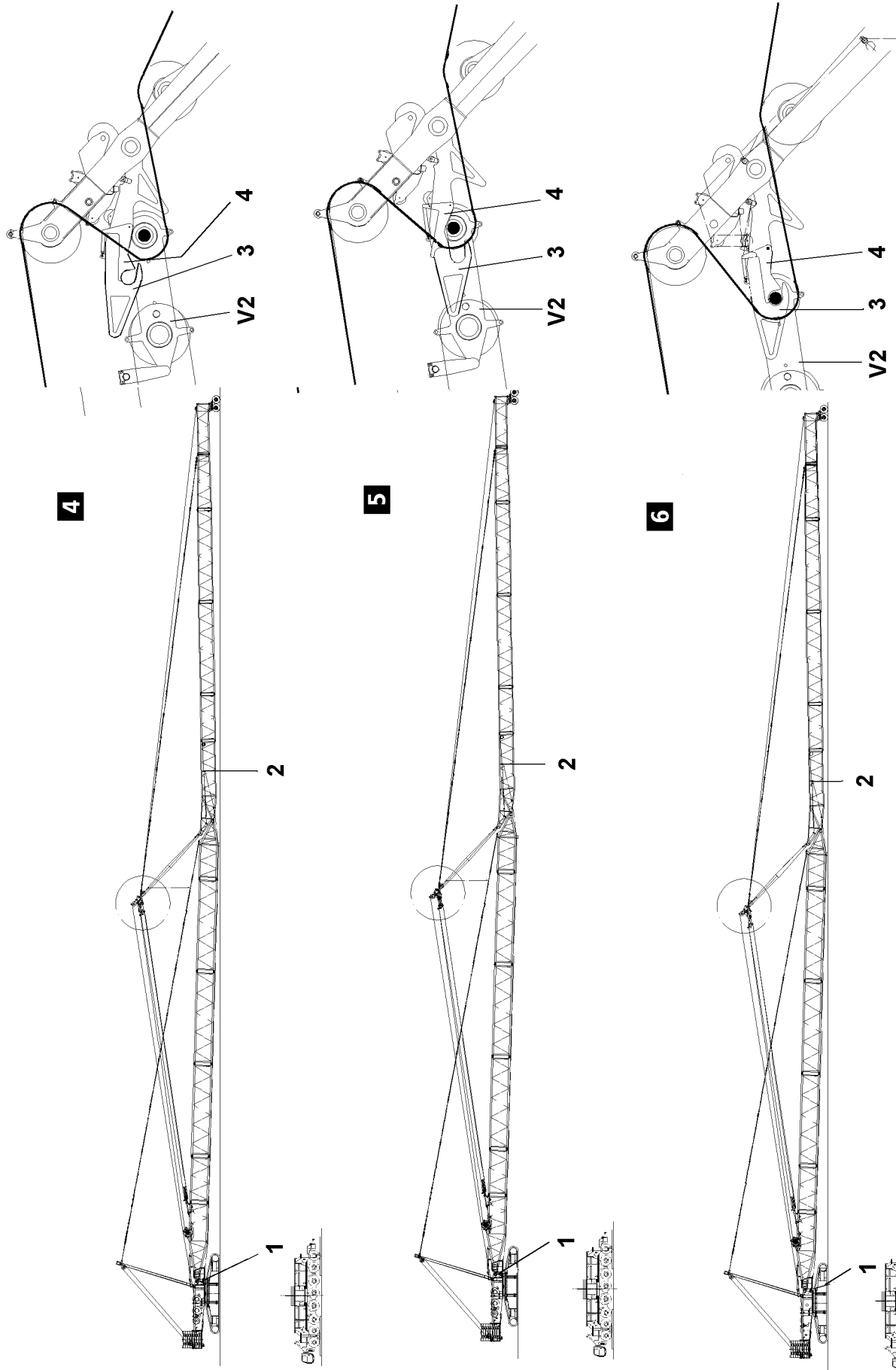
4. Assembly process

Fig. 2 Set up the KA-bracket (2) on the auxiliary crane and the tackle rope (11) .

Note: Lift the KA-bracket with the auxiliary crane to approx. 45° and then take it over with the hoist cable, by spooling up winch 1.

Fig. 3 Pull the KA-bracket (2) with the hoist cable and the tackle rope back until the K-guy rods are tensioned.

D A N G E R: When pulling back with the hoist cable, the KA-bracket must be held with the auxiliary crane until the guy rods are tensioned!
The tackle rope must always be tensioned slightly!
Otherwise there is the danger that the KA-bracket falls backward as long as the guy rods are not yet tensioned!



196895

4. Assembly process (Continuation)

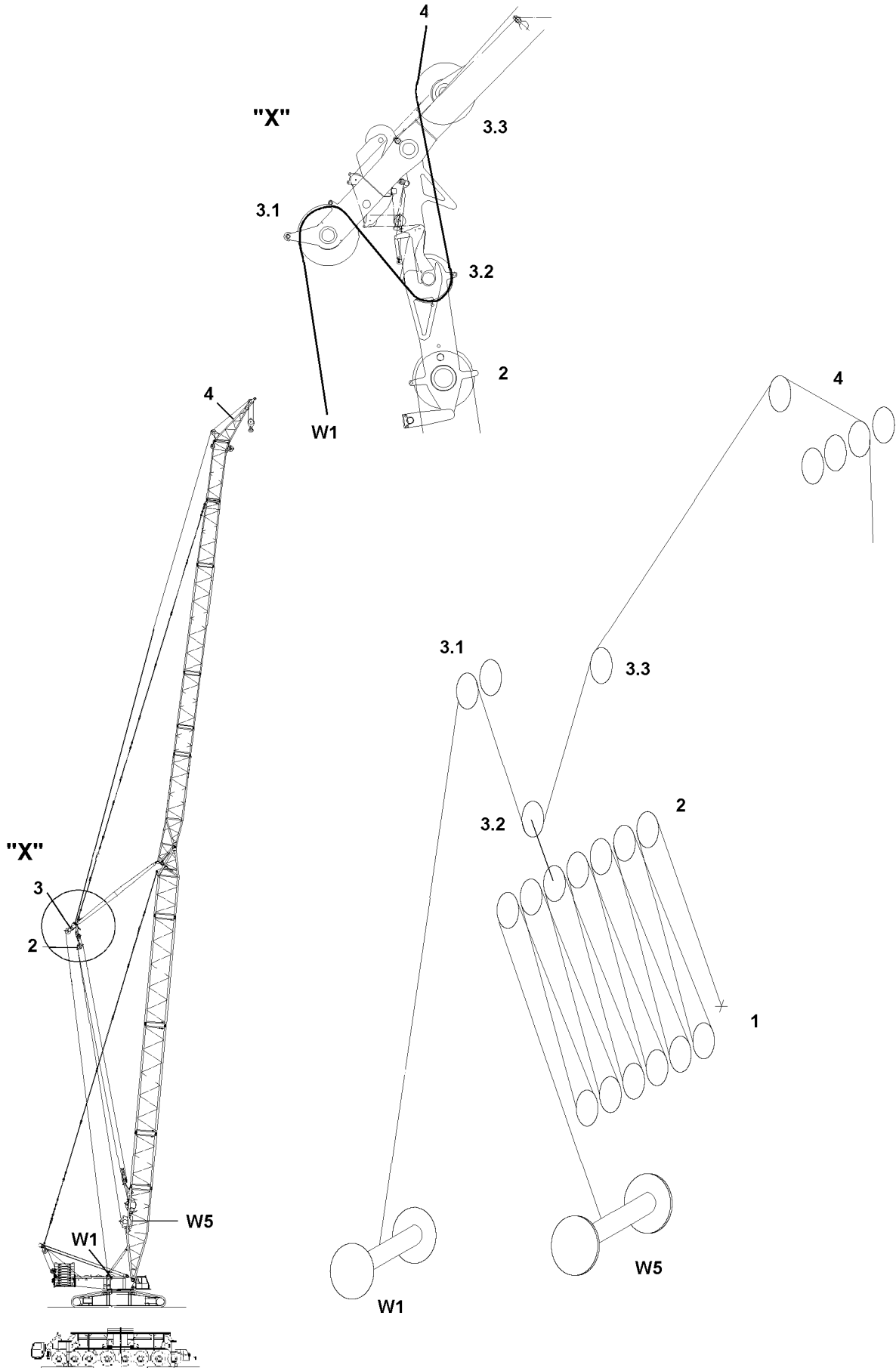
Fig. 4 Connect the cable from the assembly winch (1) on the slewing platform with the hook control cable (2) and pull the hook up with the assembly winch.
Pull the pulley block (V2) with the hoist cable to the hook (3) .

C A U T I O N: The hooks (3) must be pulled up with the cable of the assembly winch before retracting the pulley block (V2).
As soon as the pulley block (V2) is under the hook, lower the hook (3) so that it lies on the axle of the pulley block (V2) .
Pull the axle of the pulley block (V2) into the hook (3) and secure with the locking lever (4) .
Check visually!

Fig. 5 Lower the hook (3) with the assembly winch (1) so that it lies on the axle of the pulley block (V2).

Fig. 6 Pull the axle of the pulley block (V2) into the hook (3), the locking lever (4) engages and the pulley block (V2) is secured.
Disengage the cable of the assembly winch (1) on connection (2) and engage on the K-pivot section .

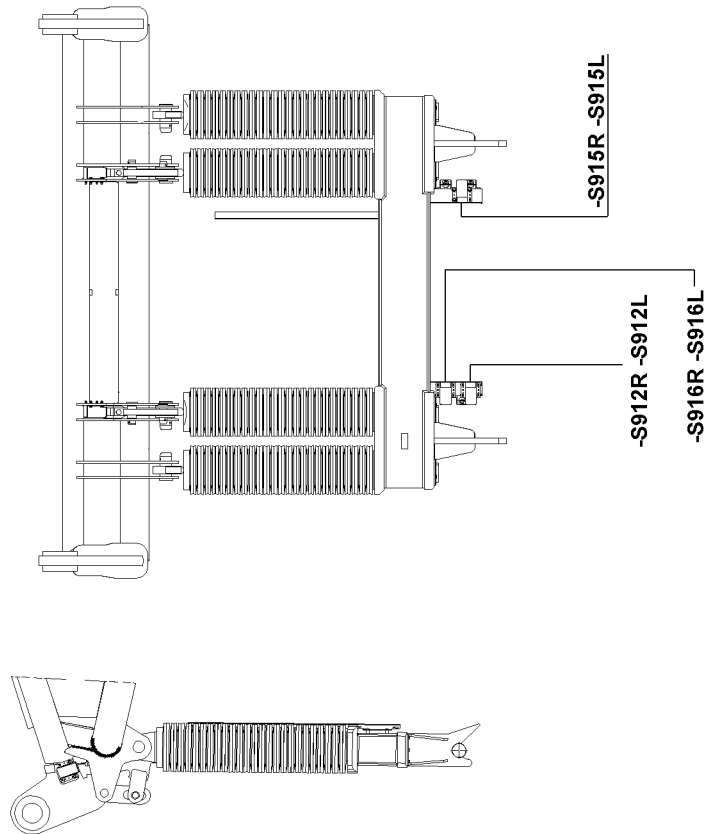
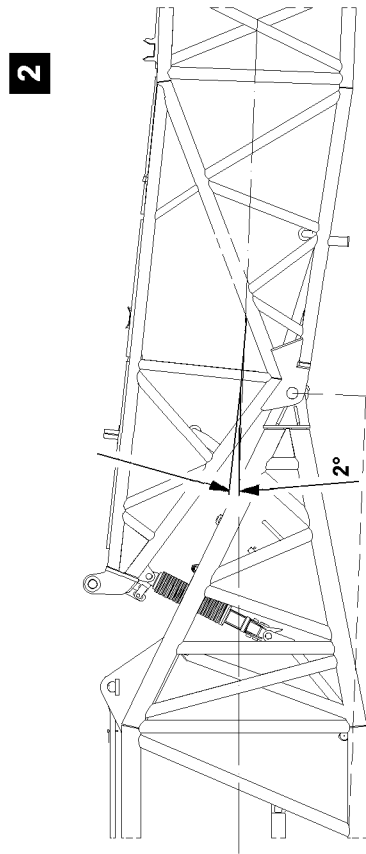
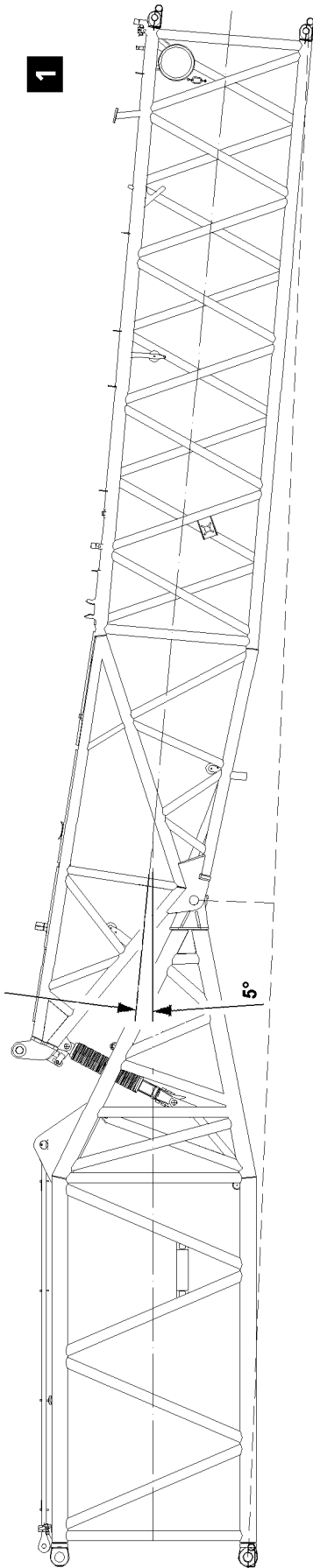
C A U T I O N: The locking lever (4) must be engaged so that the pulley block (V2) is secured!
Check visually!



5. Reeving

Reeving between the lower and the upper pulley block and hoist cable guide.

- 1 Cable pulleys "lower" pulley block
- 2 Cable pulleys "upper " pulley block
- 3 KA-bracket pulley head
 - 3.1 Cable pulleys on KA-bracket head
 - 3.2 Cable pulley upper pulley block
 - 3.3 Cable pulley in KA-bracket
- 4 Cable pulleys auxiliary jib



6. Relapse retainer**Description**

The operating range in SLK-operation is: $<4^\circ$ and $>1^\circ$

Limit switch initiators

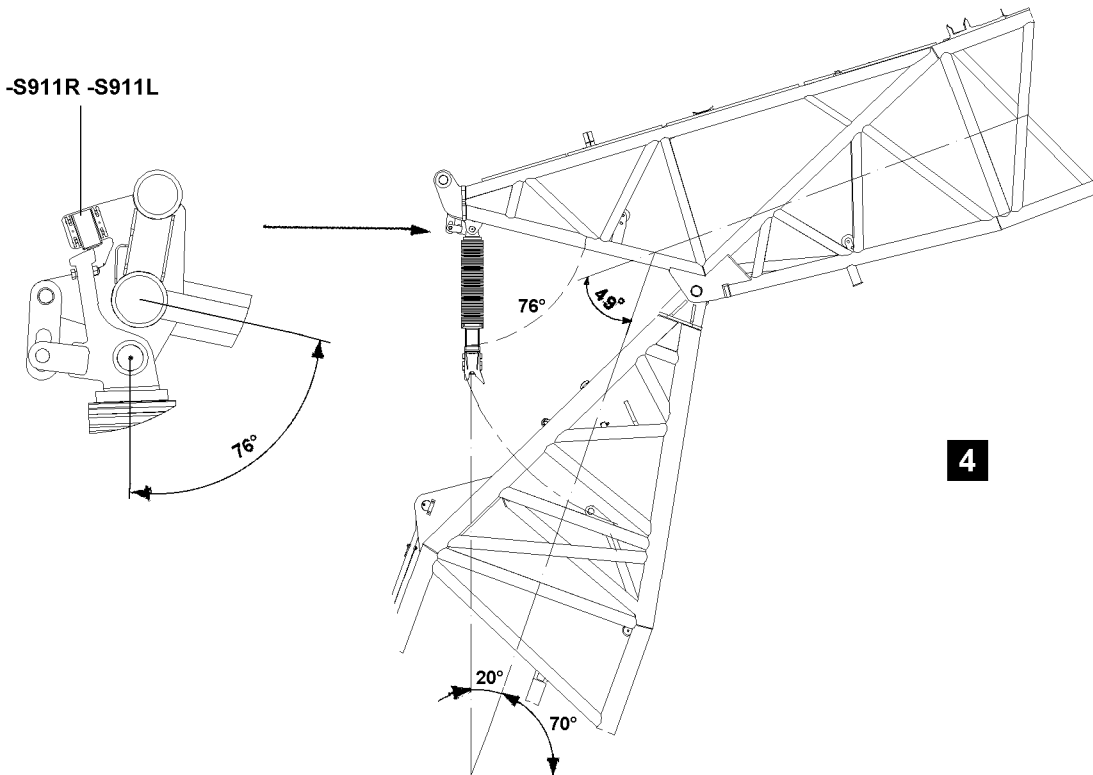
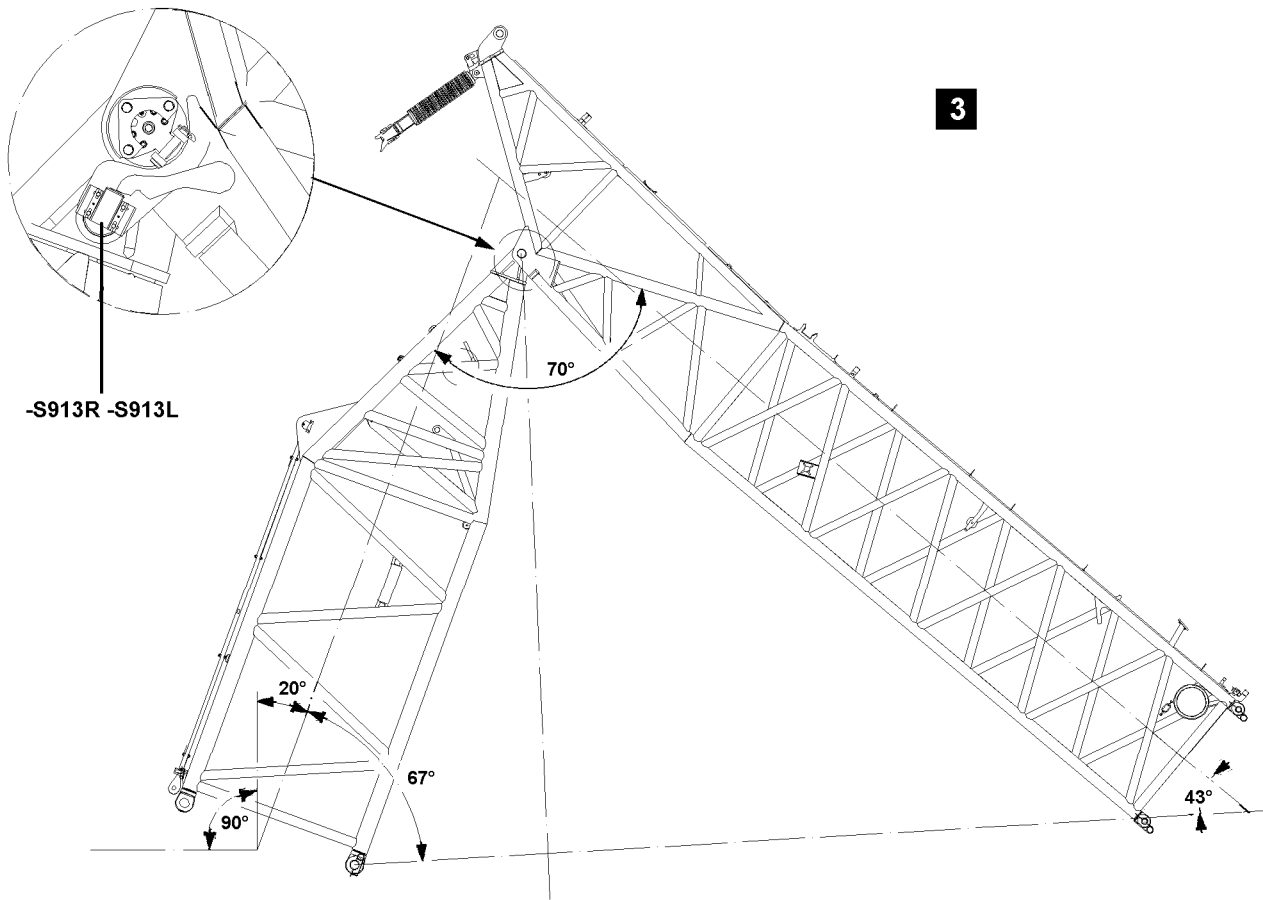
Flap of relapse supports in entry position,	-S911R/-S911L
Safety shut off $< 1^\circ$,	-S912R/-S912L
K-lattice jib "bottom",	-S913R/-S913L
Nominal position 2° ,	-S915R/-S915L
Operating range $<4^\circ$ and $>1^\circ$, window switch 4°	-S916R/-S916L

Fig. 1

5° Entry of relapse supports in K-adapter

Fig. 2

2° = Nominal position



6. Relapse retainer (Continuation)**Fig. 3**

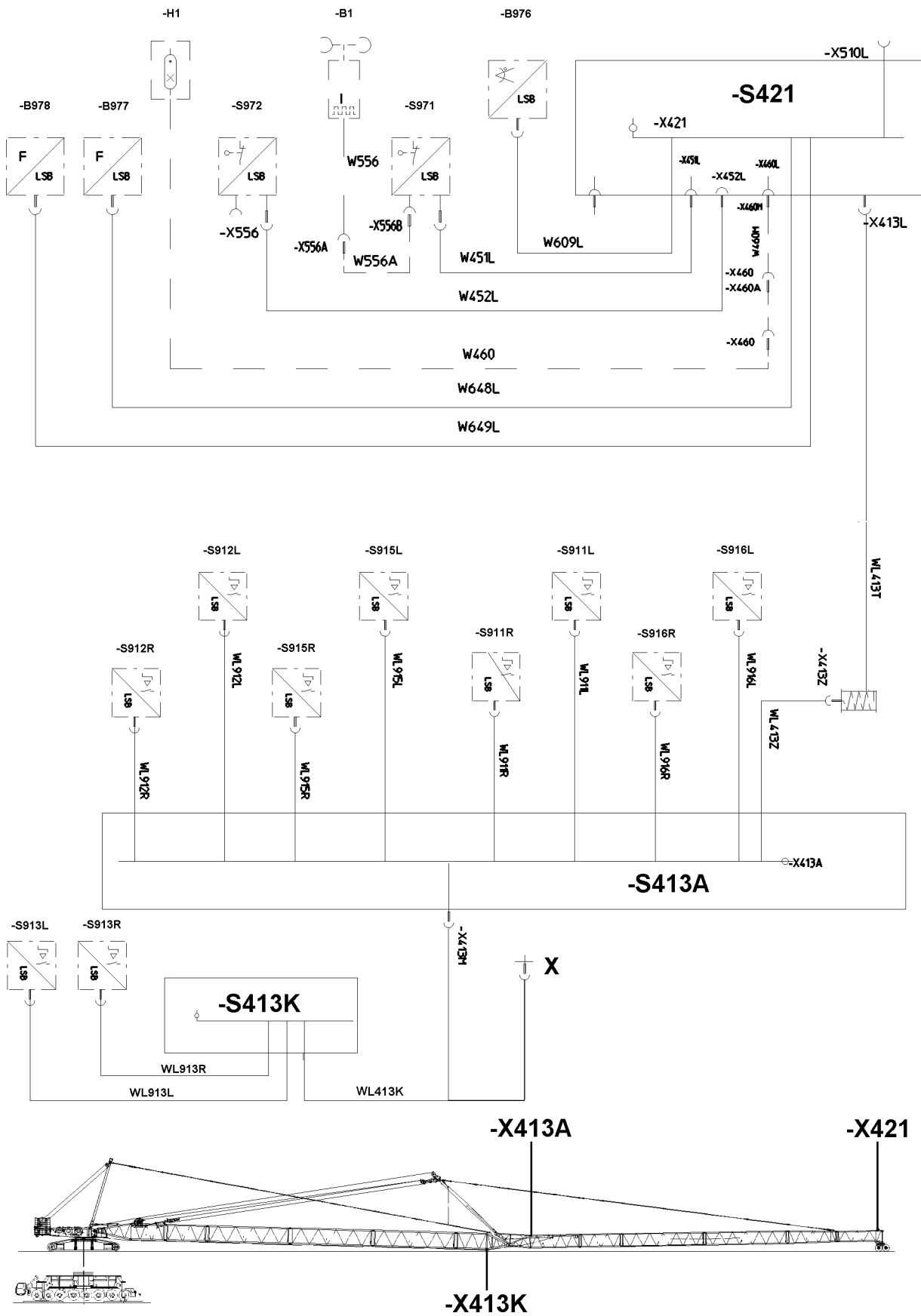
K-lattice jib "bottom" = 70°

Fig. 4

Flap of relapse supports in position

S-boom = 70°

K-lattice jib = 49°



7. Electrical connections

Establish the electrical connection from the connector box (-S413K) on the K-adapter to the connector box (-S413A) . Plug cable (WL413K) into socket -X413M .

Establish the electrical connection from the cable drum to the connector box (-S421) . Plug cable (WL413T) into socket -X413L on (-S421) .

Establish the electrical connection from the connector box (-S413A) to the cable drum. Plug cable (WL413Z) into the cable drum socket (-X413Z) .

Note: Establish the electrical connection from the connector box (S 413A) to the cable drum only if the cable from the cable drum to the connector box (S 421) is spooled out.

Install the airplane warning light on the K- end section.

Plug in cable plug (W 460) for the airplane warning light in socket (-X 460) on the connector box (S421) .

Plug in cable plug (W556A) from the wind speed sensor on the hoist limit switch (S971) .

Plug in cable plug (W451L) from the hoist limit switch (S971) on (X451L) .

Plug in cable plug (W452L) from the hoist limit switch (S972) on (X452L) .

Electrical connection on **connector box (S 421)**

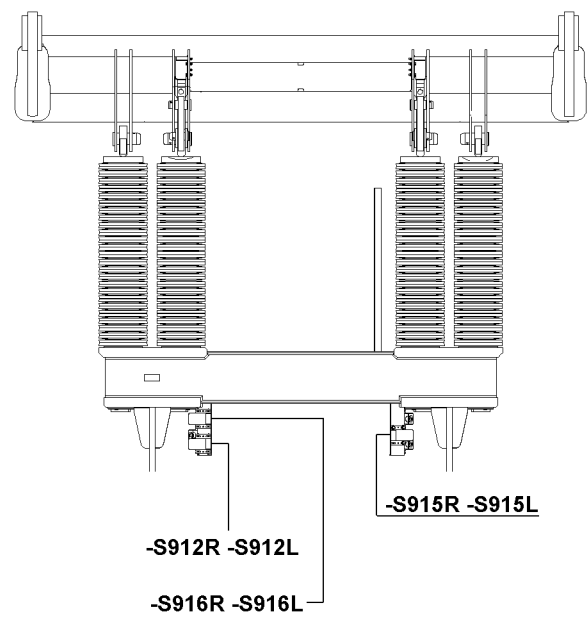
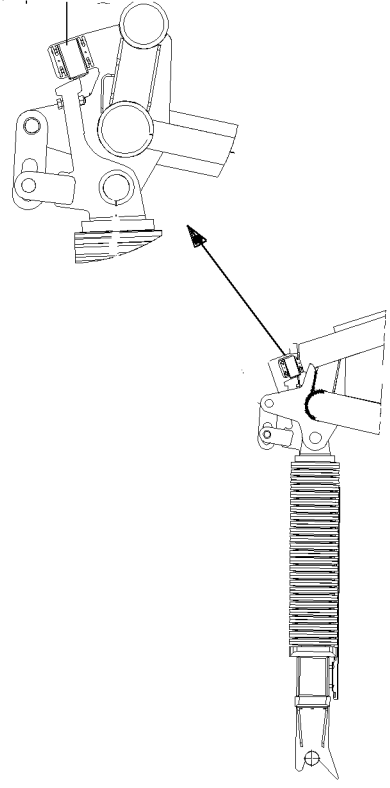
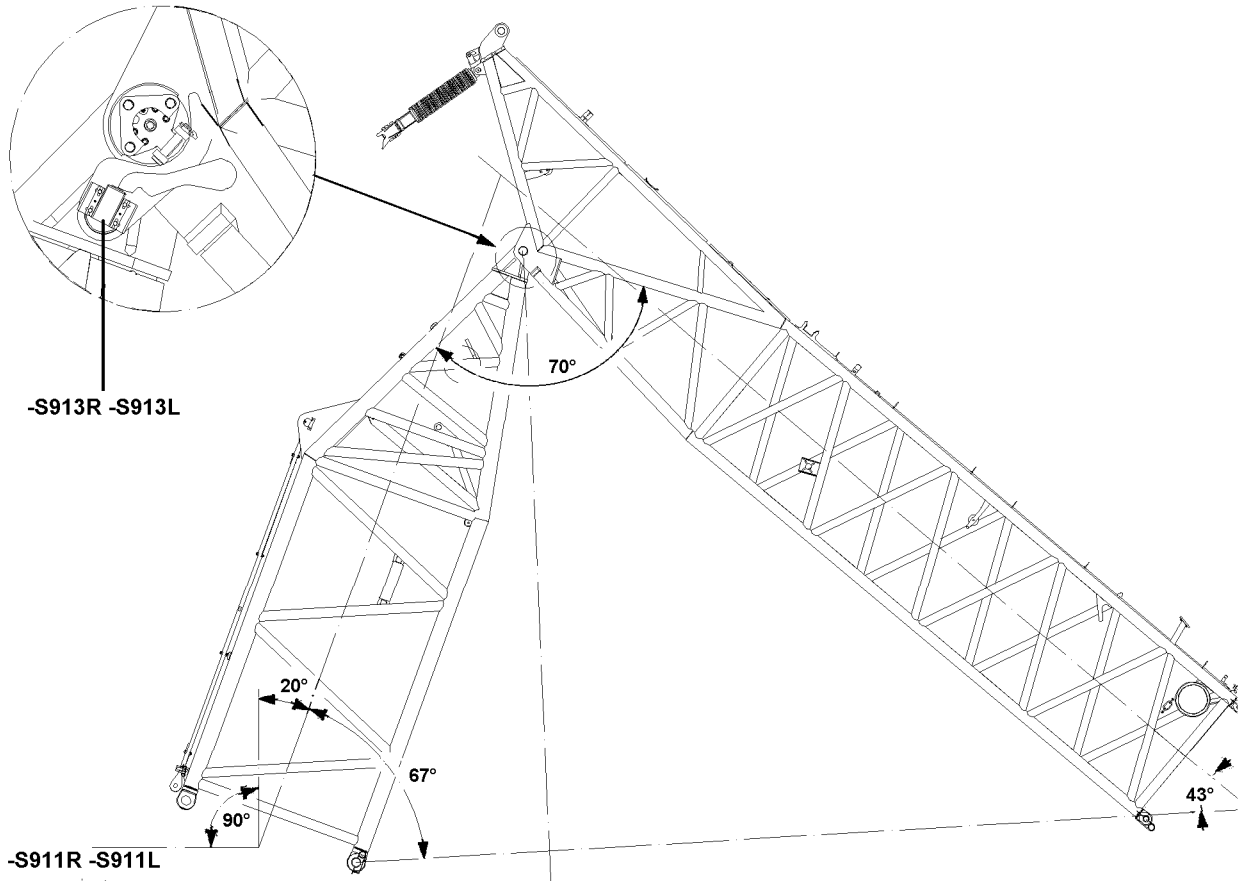
-S971	W451L	Hoist limit switch
-S972	W452L	Hoist limit switch
-H1	W460	Beacon
-B976	W609L	Angle sensor , K-lattice jib top
-B1	W556A	Angle sensor
-B977	W648L	Pull test bracket 2B right
-B978	W649L	Pull test bracket 2A left

Electrical connection on **connector box (S 413A)**

-S911L	WL911L	Flap in position
-S911R	WL911R	Flap in position
-S912L	WL912L	Operating position 1 left
-S912R	WL912R	Operating position 1 right
-S915L	WL915L	Operating position 2 left
-S915R	WL915R	Operating position 2 right
-S916L	WL916L	Operating position 4 left
-S916R	WL916R	Operating position 4 right

Electrical connection on **connector box (S 413K)**

-S913L	WL913L	K-lattice jib bottom
-S913R	WL913R	K-lattice jib bottom
X		Dummy socket at assembly



7.1 Function check**Prerequisite:**

- All electrical connections have been established.
- The engine is running.

Airplane warning light

Turn on the airplane warning light , check function visually.

Wind speed sensor

Check the wind speed sensor for easy movement and function.

Limit switch initiators

Hoist "top" - on auxiliary jib

Flap of relapse supports in entry position,	-S911R/-S911L
Safety shut off < 1°,	-S912R/-S912L
K-lattice jib "bottom",	-S913R/-S913L
Nominal position 2°,	-S915R/-S915L
Operating range < 4° and > 1°, window switch 4°	-S916R/-S916L

D A N G E R : **The limit switches may not be used as operational shut off function.**
If this is not observed, crane components can be destroyed in case of an erroneous function or the crane can topple over.
The limit switch functions must be checked individually before crane operation.
Cover the limit switch initiators individually with a metal plate.
The function of the individual limit switch initiators must be checked in the test system.

Hoist limit switch

- Actuate the hoist limit switch manually.
- The hoist winch must turn off in upward movement.
- The hoist "top" symbol on the LICCON display must blink.

Limit switch K-lattice jib, "top", mechanical relapse support

- The K- control winch movement "spool up" must turn off.
- The symbol must appear on the LICCON monitor .

Limit switch K-Lattice jib, "bottom"

- The K- control winch movement "spool out" must turn off .
- The symbol must appear on the LICCON monitor.

Limit switch flap in position and lattice jib, "steepest " position, mechanical relapse retainer

- Cover the limit switch initiators individually with a metal plate .
- The K- control winch movement "spool up" must turn off.
- The symbol must appear on the LICCON monitor.

D A N G E R : **Before erection, the pendulum of the mechanical relapse support flap must be checked for easy movement over the complete swing range of the pendulum.**
If this is not observed, the mechanical relapse support does not engage in steep K- lattice jib position.
There is a danger of accidents, as the K- lattice jib may tip backward!

8. Erection/ take down

The boom combinations must be erected according to chapter 5.03, Equipment Lattice mast systems!

The boom combinations must be erected or taken down according to the erection and take down charts!

D A N G E R: **The erection and take down procedure must be made according to the data in the erection and take down chart.**

If this is not observed, the crane will be overloaded and can topple over!

Prerequisite:

- The crane is horizontally aligned.
- The counterweight is installed on the slewing platform, according to the load chart.
- The K-lattice jib is installed according to the load chart and the operating manual.
- All limit switches are correctly installed and fully functioning.
- Before erection, the pendulum of the mechanical relapse supports must be checked for easy movement over its complete swing range.
- All pin connections are secured.
- The hoist cable has been correctly placed into the cable pulleys and secured with cable retaining pins to prevent it from jumping out.
- There are no persons within the danger zone.
- There are no loose parts on the telescopic boom and the lattice jib.
- In winter, the boom and the lattice jib and their components (limit switches, cable drum, airplane warning light, wind speed sensor, etc.) are free of ice and snow.

D A N G E R: **Incorrectly installed or non-functioning limit switches as well as falling parts *pins, spring retainers, ice, etc.) can cause accidents!**
Before erection, the pendulum of the mechanical relapse support must be checked for easy movement over the complete swing range of the pendulum.
If this is not observed, the mechanical relapse support does not engage in steep K- lattice jib position.
There is a danger of accidents, as the K- lattice jib may tip backward!

8.1 Erection procedure

Set the LICCON overload safety according to the data in the load chart and the equipment set up configuration (see chapter 4.02, 4.03).

Actuate the assembly key switch, the indicator light "Assembly" lights up.

The assembly symbol on the LICCON display blinks.

Adjust in the EQUIPMENT CONFIGURATION VIEW of the LICCON (see chapter 4.02)

Enter the code number according to the corresponding load chart and confirm with the ENTER key.

Enter the current reeving .

Check the current equipment configuration of the crane with the entered data to ensure they match.

Press the function key -F8- "o.k.", the OPERATING VIEW appears.

D A N G E R : Check and compare the LICCON settings with the actual equipment configuration .

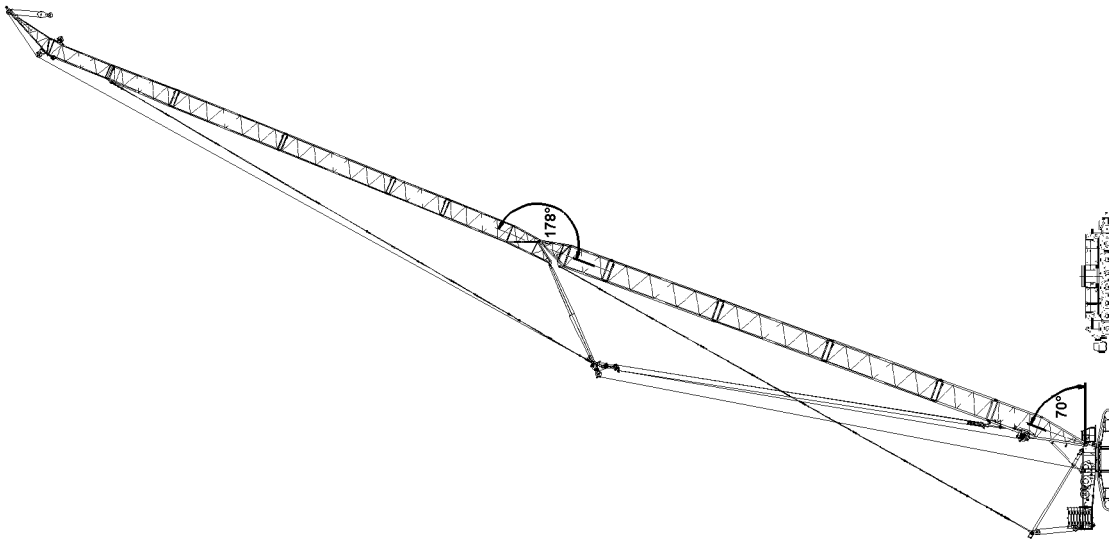
If this is not observed, the crane is overloaded or it can topple over!

8.2 Displays in the OPERATING VIEW during the erection procedure

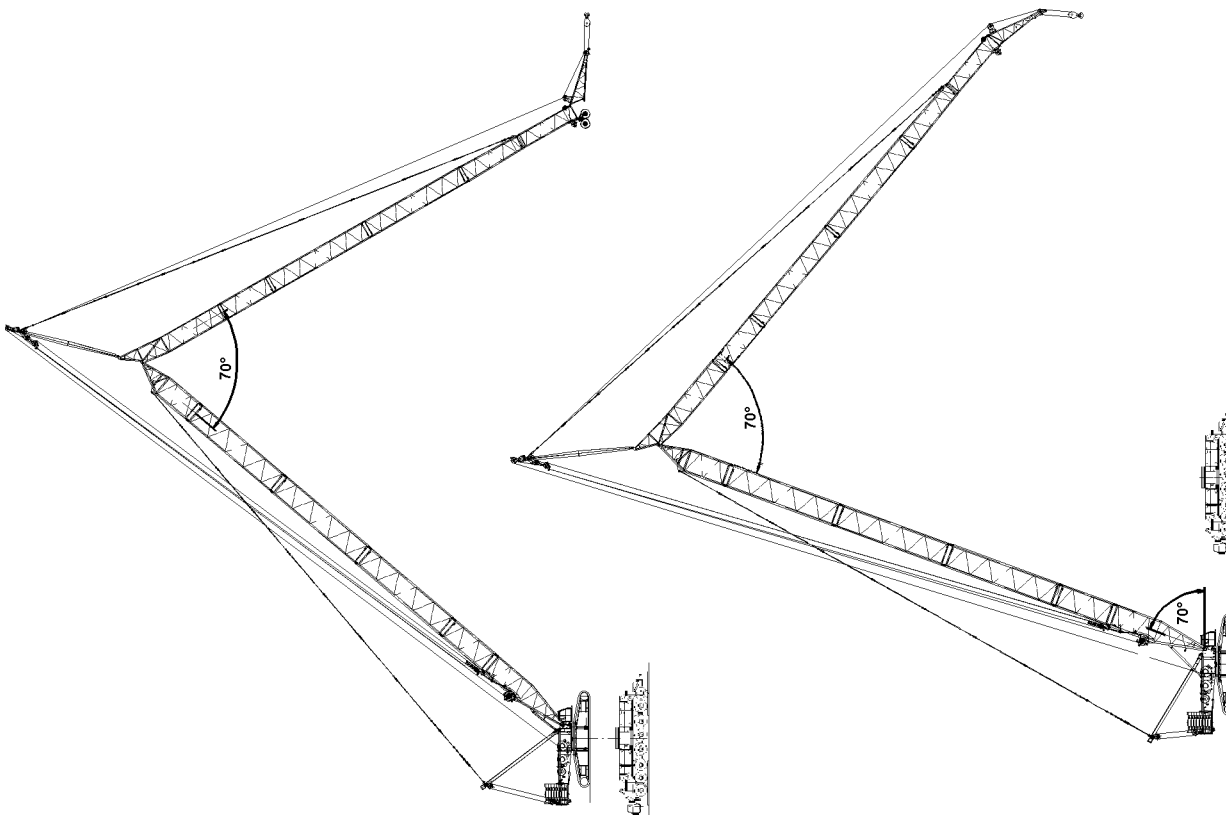
The following alarm functions are activated (blink) during the erection procedure, until the operating position is reached:

- "STOP"
- "HORN" + Acoustical signal

Note: The lowest operating position is reached when the indicators turn off and a load value (in tons - t -) appears in the symbol "MAX. LOAD" instead of the question marks (???) .



9



7

8

8.3 Erection

Actuate the manual control lever and luff up the SL-boom .

At the same time, spool out the K-lattice jib control winch 5 to hold the K-lattice jib with the K- end section on the pulley cart the ground.

D A N G E R: **The K- lattice jib must roll on the ground with its complete weight.
Lower the lattice jib control in such a way, that the guy rods always hang through slightly.
Make sure that no slack cable forms on the control winch!
If this is not observed, the crane can be overloaded or topple over!**

Carry out this procedure until the SL-boom and the K-lattice jib form an angle of approx. 70° or the K-end section has lifted off the ground first.

Remove the pulley cart on the K-end section.

Only now luff up the SL-boom and lift the K-lattice jib off the ground.

Reeve in the hoist cable between the pulley head on the K-end section and the hook block and secure on the fixed point - see **paragraph 6.,Reeving plans**.

Attach the hoist limit switch weight.

Luff up the SL-boom until 70° , then pull up the K-lattice jib .

C A U T I O N: **The release to pull up the K-lattice jib is given when the SL-boom is at 70° .
At an SL-boom angle of more than 72°, the winch 5 can no longer be spooled up and the K-lattice jib cannot be pulled up!**

Luff up the K-lattice jib until operating range .

Note: Operating range 4°-1°, window switch 4° , S916R/S916L

C A U T I O N: **When erecting, spool out the hoist winch at the same time to prevent a collision between the hook block and the end section of the lattice jib .**

Turn the assembly keyed button off. The assembly symbol on the LICCON display turns off.

D A N G E R: **After reaching the operating position, the assembly keyed button must be turned off immediately.
The assembly keyed button bypasses the safety devices!
The radii given in the load chart may not be exceeded nor fallen below, even without a load on the hook!
If this is not observed, the crane can topple over!**

9. Crane operation

CAUTION: Observe the notes in
Chapter 4.02 "LICCON COMPUTER SYSTEM"
Chapter 4.05 "CRANE OPERATION"
Chapter 4.08 "WORKING WITH A LOAD".

9.1 Prerequisite:

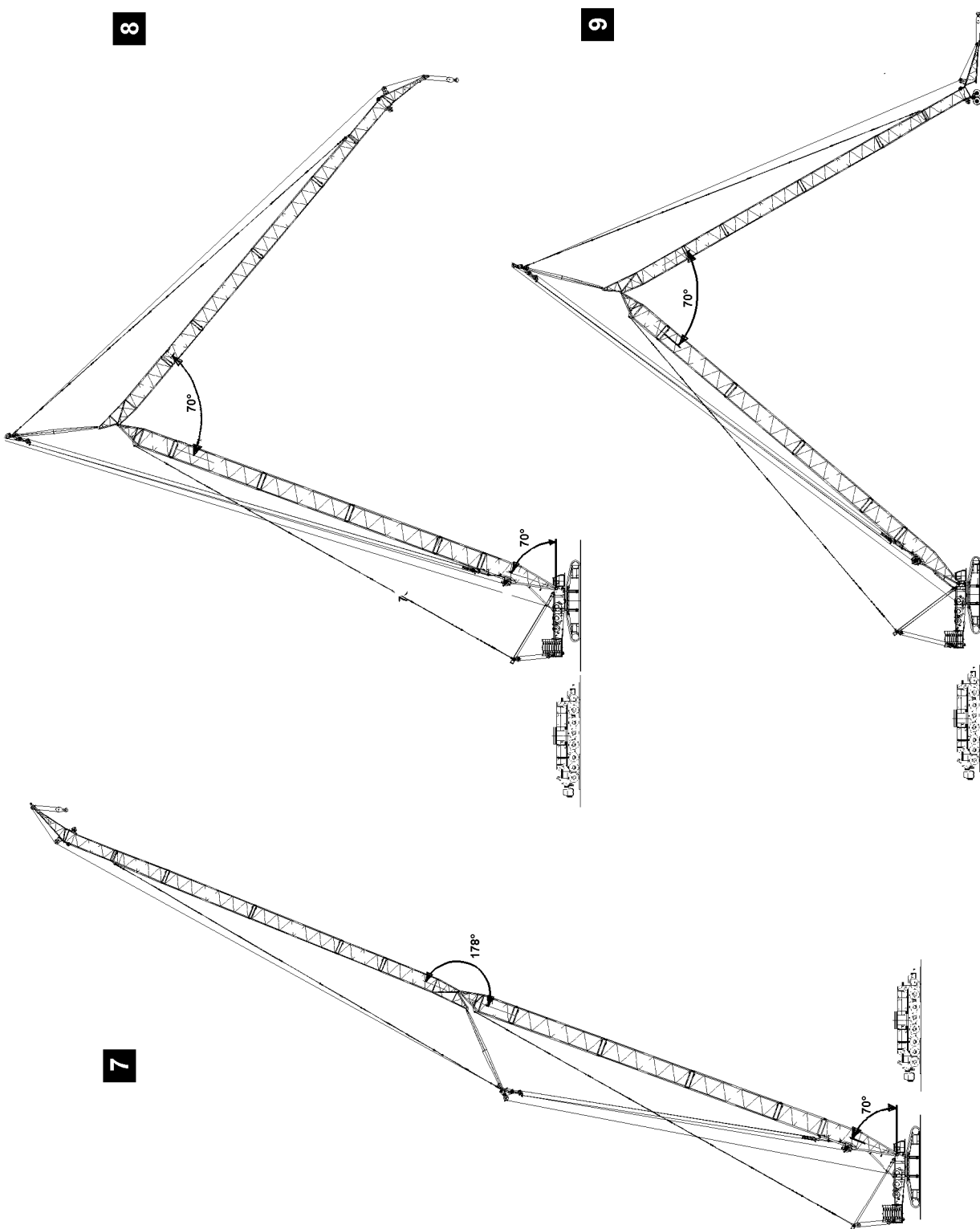
- The LICCON overload safety is set according to the data in the load chart.
- The assembly keyed button has been turned off by pressing the key. The indicator light and the "Assembly" symbol on the LICCON display turns off.

DANGER: Check the horizontal position of the crane before and during operation. If the crane operator leaves the crane operator's cab, even if only for a short time, then he is obligated to check all operating mode settings and to reset them, if necessary, before starting to work again.

9.2 Adjustments / checks

Check the function of the hoist limit switch "top" by running against the hoist limit switch weight.
Check the function of all limit switch initiators by triggering them.
Check the function of the mechanical relapse supports by triggering the 1° safety switching, check the block position.

DANGER: Before erection, the pendulum of the mechanical relapse support must be checked for easy movement over the complete swing range of the pendulum. If this is not observed, the mechanical relapse support does not engage in steep K- lattice jib position.
There is a danger of accidents, as the K- lattice jib may tip backward!



10. Take down

Luff down the SL-boom to approx. 70° .

Press the assembly keyed button, the indicator light "Assembly" lights up. The assembly symbol on the LICCON display blinks.

D A N G E R: **The overload safety system is no longer effective.
The limit switch hoist "top" is bypassed..**

Luff down the K-lattice jib until an angle of approx.70° between the SL-boom and the K-lattice jib is reached.

C A U T I O N: **The release to luff down the K-lattice jib is given when the SL-boom is at 70° .
At a SL-boom angle of more than 72°, the winch 5 cannot be spooled out any
more and the K-lattice jib cannot be luffed down!**

The shut off is made by the limit switch "K-lattice jib bottom".
The limit switch symbol on the LICCON display blinks.

C A U T I O N: **When luffing down, the hoist winch must be spooled out at the same time to
prevent a collision between the hook block and the pulley head.**

Actuate the manual control lever and continue to luff down the SL-boom until the hook block touches the ground.
Remove the hoist limit switch weight.
Unreeve the hook block.

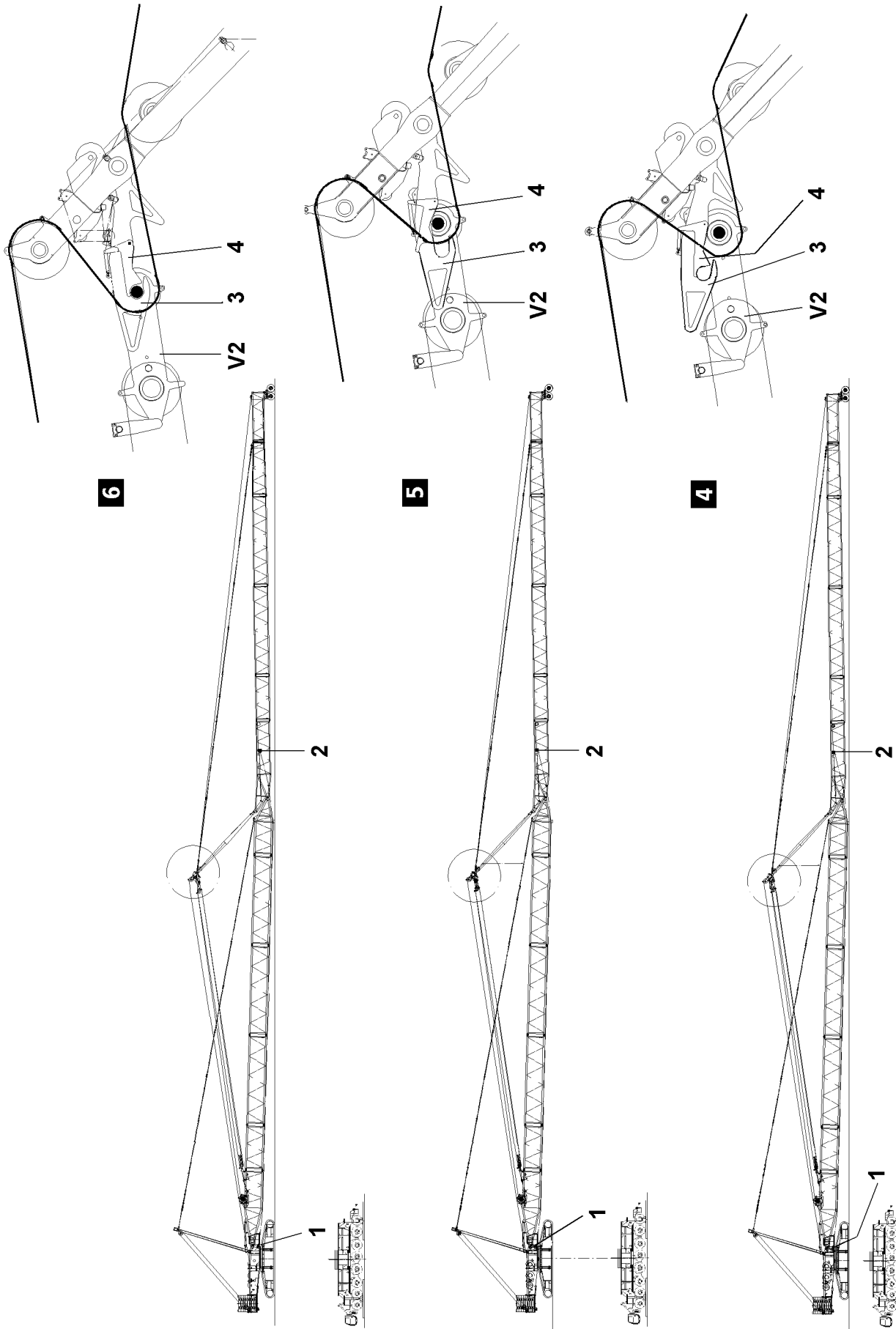
D A N G E R: **When unreeving the hoist cable, make sure that there are no persons within
the danger zone.
There is a danger of accidents!**

Luff down the SL-boom until the end section of the K-lattice jib can be installed on the pulley cart.

Note: If the K-lattice jib is laying vertically on the pulley cart, the K-guying must be tensioned somewhat so that the pulley cart rolls forward.

Continue to luff down the SL-boom .

D A N G E R: **The lattice jib must roll on the ground with its complete weight.
Lower the lattice jib control in such a way, that the guy rods always hang
through slightly.
Make sure that no slack cable forms on the control winch!
If this is not observed, the crane can be overloaded or topple over!**



196898

11. Disassembly

C A U T I O N: **The warning and danger notes for assembly must also be strictly observed at disassembly!**

Luff the SL-boom and the K-lattice jib all the way down until they are on the ground, support the K-adapter from below.

C A U T I O N: **When lowering, it must be ensured that the K-relapse supports do not collide with the cross carrier in the K-adapter!
Check visually!**

Pin and secure the hoist cable on the cable fixed point (X) on the L-adapter .

11.1 Disassembly process

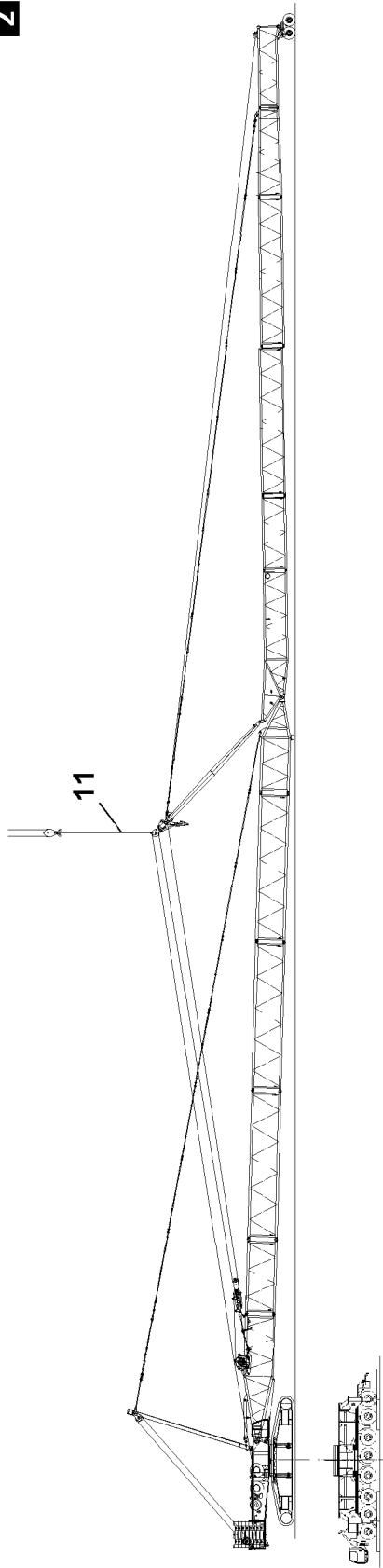
Fig. 6 Release the shut off lever (4) for the retention of the pulley block (V2), by pulling on the wire cables.
Pull the shut off lever (4) up, this releases the axle of the pulley block (V2) .

C A U T I O N: **The shut off lever (4) must be pulled up, so that the axle of the pulley block (V2) is free!
Check visually!**

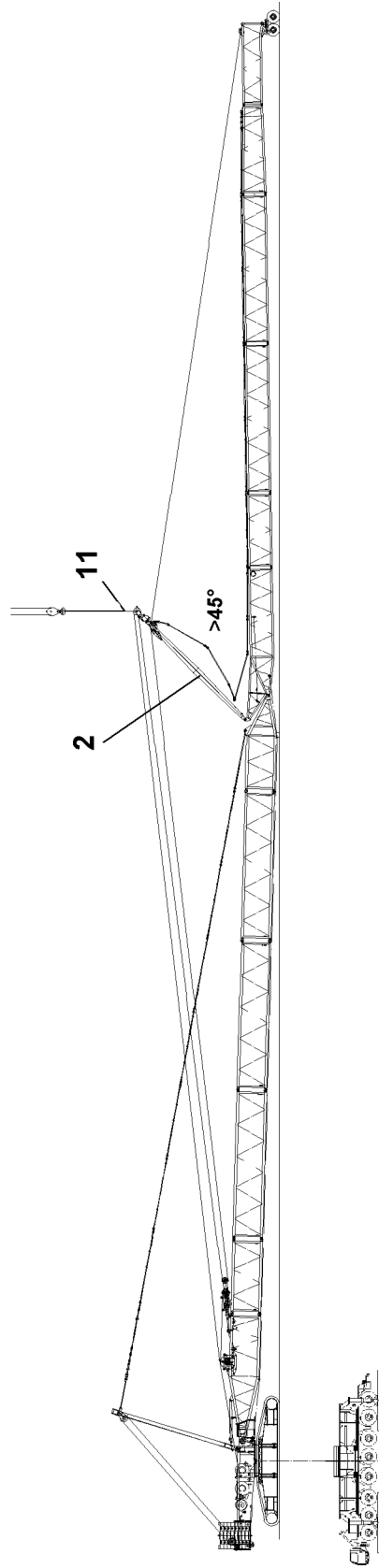
Fig. 5 Pull the pulley block (V2) with the hoist cable from the receptacle on the hook (3) .

Fig. 4 Connect the cable from the assembly winch (1) on the slewing platform with the hook control cable (2) and pull the hook up with the assembly winch.
Pull the pulley block (V2) to the slewing platform.

2



3



11.1 Disassembly process (Continuation)**Fig. 2 and Fig. 3**

Hang the assembly cable from the KA-bracket on the auxiliary crane.

Erect the KA-bracket with the auxiliary crane and the assembly cable, then lower it to the front and unpin the KA-bracket guy rods on the guy rods of the K-end section.

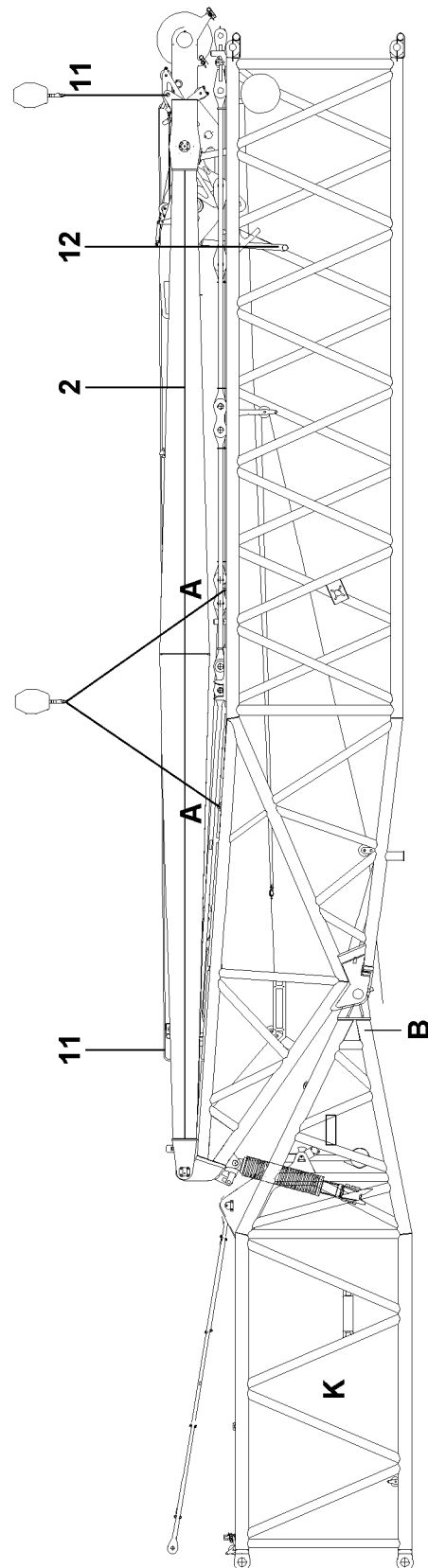
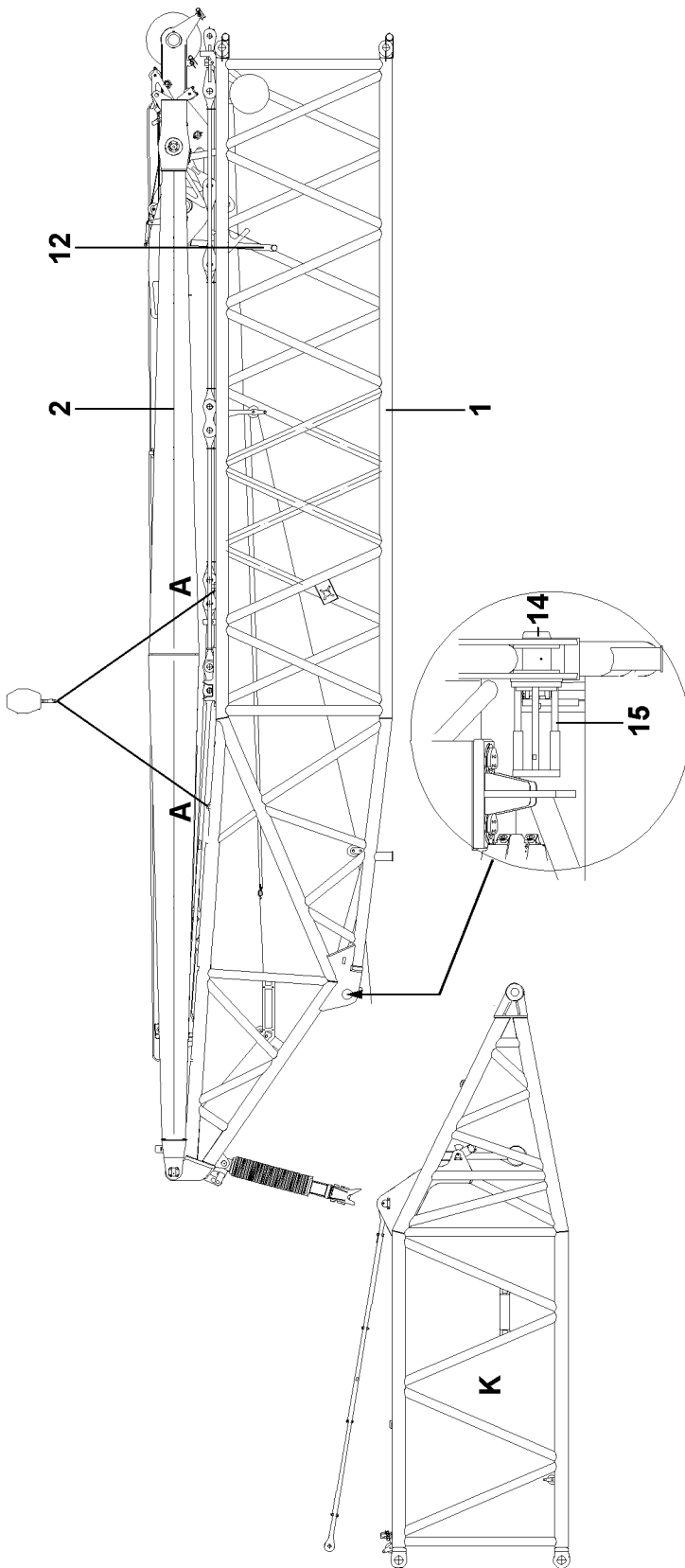
D A N G E R: No one may remain under the KA - bracket during the lowering procedure.

Continue to lower the KA-bracket with the auxiliary crane and the assembly cable (11) to the front, while spooling out the control winch at the same time, until the assembly support lies on the K-pivot section.

Release the hoist cable on the cable fixed point (X), on the L-adapter and unreeve.

D A N G E R: When unreeving the hoist cable, make sure that there are no persons within the danger zone.
There is a danger of accidents!

Remove the K-lattice jib.



196892

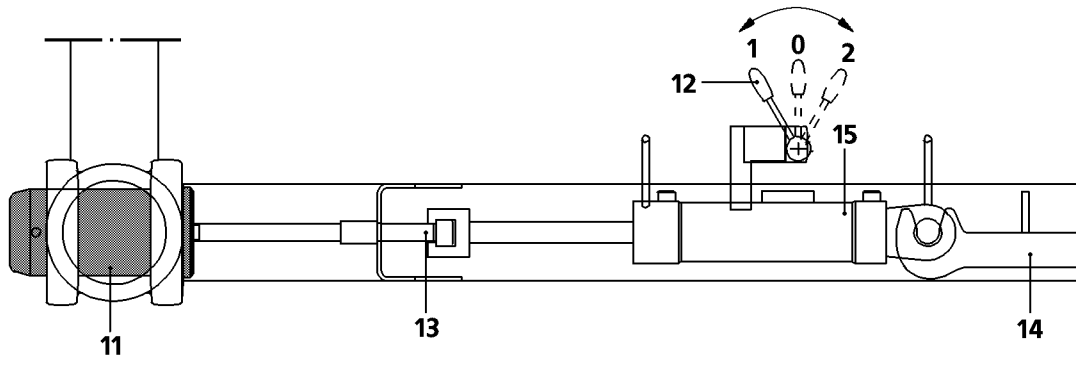
11.2 Remove the K - assembly unit

Take up the K-assembly unit with the auxiliary crane on the tackle points (A) on the K-pivot section (1) .

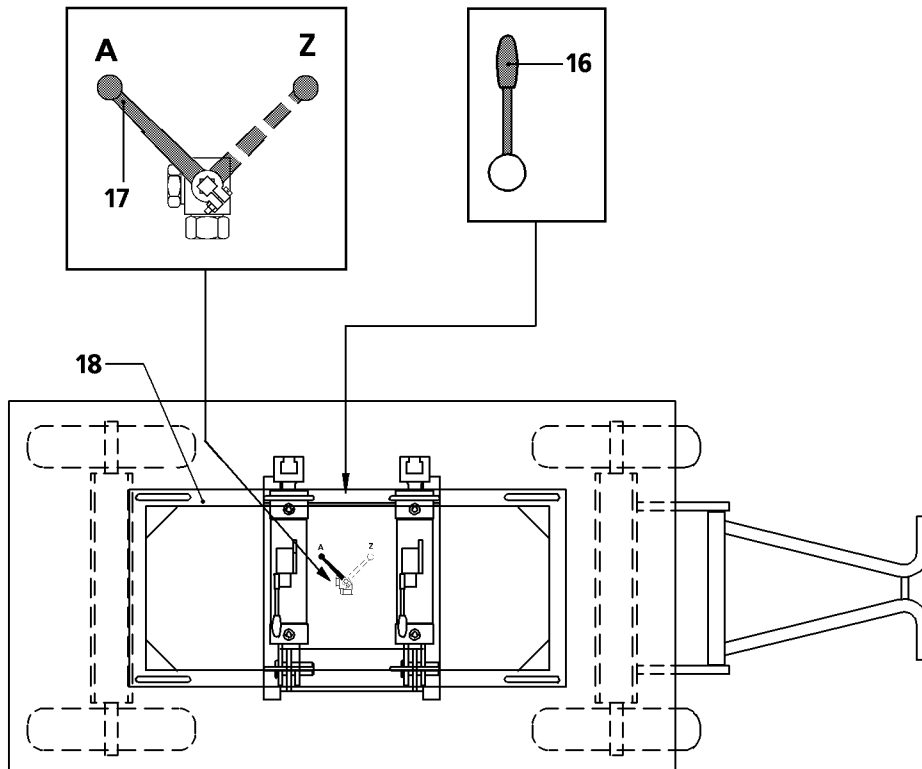
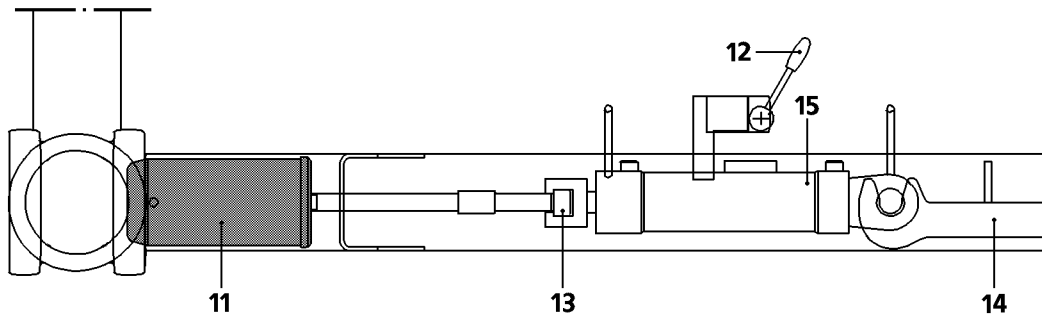
Note: The total weight of the K-assembly unit is approx. 15,70t.

Release the K-assembly unit on the K- adapter (K) and unpin. Pull the pin (14) with the hydraulic pin pulling device (15) .

3



4



2. Pin the boom sections

When pinning the boom sections, the pin pulling cylinder (15) must be coupled to a mobile pin pulling component (18) .

D A N G E R: **When pinning the boom sections, use the pin pulling device with the engaging manual lever (12) .**

Note: Position 0 Pin pulling cylinder in resting position
 Position 1 Extend the pin pulling cylinder
 Position 2 Retract the pin pulling cylinder

2.1 Preparations

- Remove the plug on the hydraulic connections.
- Establish the hydraulic connections from the pin pulling component (18) to the pin pulling cylinder (15) .
- Turn the crank to start the pin pulling component.
- Change the ball cock (17) to position Z.

Note: The engine RPM can be set via a separate engine speed regulation on the pin pulling component.

2.2 Pin the boom sections with the pin pulling device, fig. 3

- Attach the pin pulling device between the retainer (14) and the pull screw (13) .
- Move the manual control lever (12) to the front and preselect the pinning procedure.
- Move the manual control lever (16) and pin the pin (11) .

D A N G E R: **Make sure that no persons are within the danger zone or under the boom sections during the pinning and unpinning procedure!**

2.3 To unpin pins with the pin pulling device, fig. 4

- Attach the pin pulling device between the retainer (14) and the pull screw (13) .
- Move the manual control lever (12) to the rear and preselect the unpinning procedure.
- Move the manual control lever (16) and unpin the pin (11) .

D A N G E R: **Make sure that no persons are within the danger zone or under the boom sections during the pinning and unpinning procedure!**

2.4 Final tasks

- Turn the pin pulling component (18) off and close the ball cock (17) (position A).
- Release the hydraulic connections and install the plug.

2. Maintenance of pin pulling device

2.1 Maintenance intervals

	first main- tenance after	regular maintenance after				Minimum main- tenance annually	Controls	
		100 hrs.	200 hrs.	400 hrs.	1000 hrs.		daily	weekly
<input type="checkbox"/> Diesel engine								
- Check the oil level For all additional maintenance tasks, observe the engine manufacturer instructions							×	
<input type="checkbox"/> Hydraulic system								
- Check the oil level							×	
- check for leaks								×
- replace the return filter elements	50 hrs.			×				
- check the hydraulic oil (take oil samples and have them checked by the oil supplier)	400 hrs.				×	×		

2.2 Oil level in the hydraulic tank

CAUTION: If no oil is visible in the upper sight gauge, then oil must be added according to the lubrication chart (ATF 86) until the oil level is again in the center of the upper sight gauge.
If the oil level is too low, the hydraulic pump can be damaged.

2.2.1 Return filter on hydraulic tank

The return filter must be changed according to stated maintenance intervals.

2.3 Engine maintenance

C A U T I O N: Maintenance work on the engine as well as on the fuel, oil and air filters must be made according to the separately issued operation manual.

2.3.1 Check the engine oil level

The oil must be between the MIN and MAX mark on the dipstick.

C A U T I O N: Observe utmost cleanliness during all maintenance tasks to prevent dirt infiltration into the interior of the engine.

- Turn the engine off , wait 2 to 3 minutes until the oil has collected in the oil pan.
- Pull the dipstick, wipe it off and reinsert it and pull it out again.
- After checking the oil level, reinsert the dipstick again tightly into the test point.
- Add engine oil, if necessary.

C A U T I O N: If the oil level has dropped below the MIN mark, then engine oil must be added according to the lubrication chart, until the oil level is again between the MIN and MAX mark.
If no engine oil is added, then there is the danger of serious engine damage.

2.3.2 Change the engine oil

See separate operation manual.

2.4 Quantities

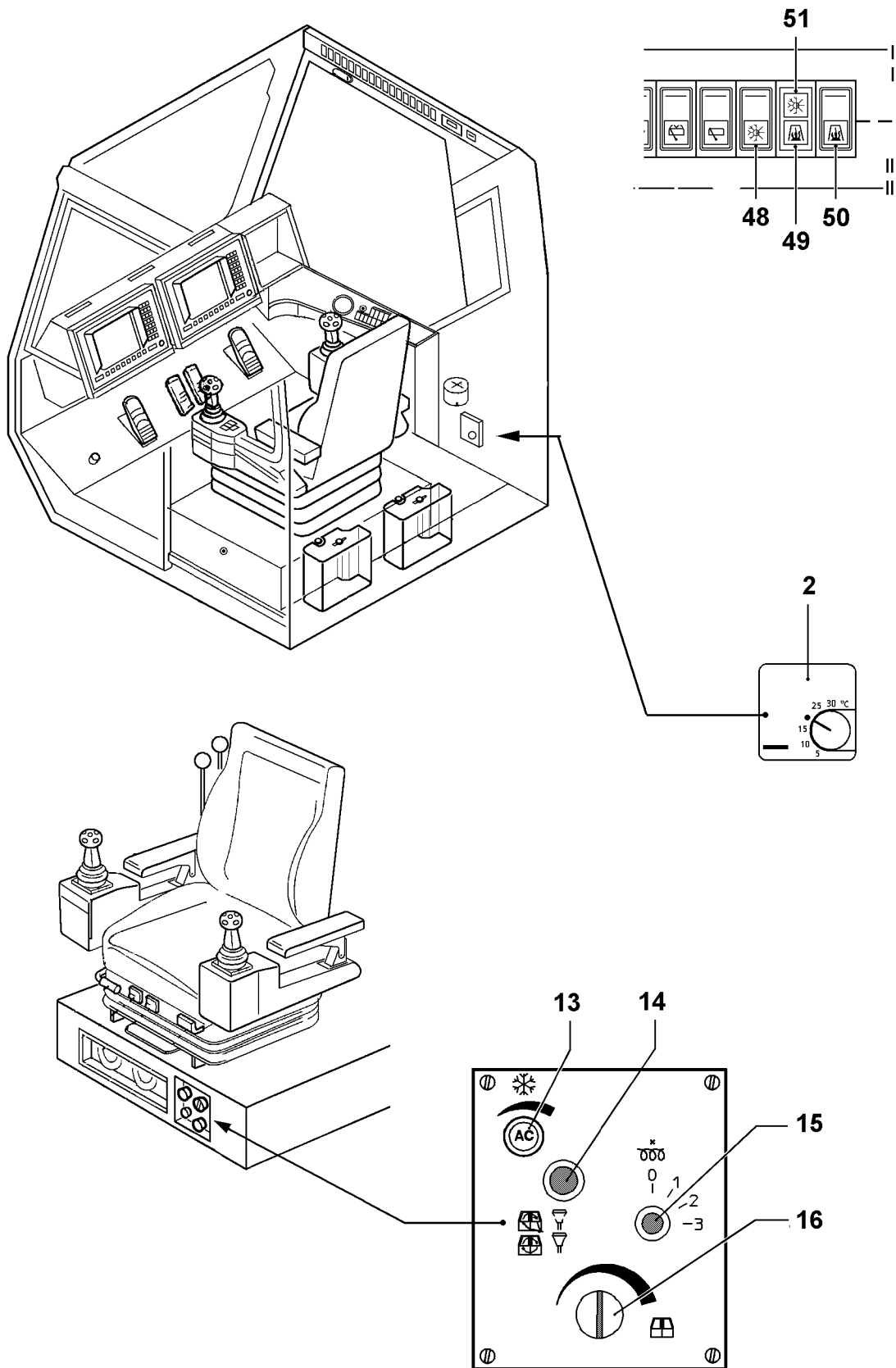
Pin pulling device	approx. Liter
Diesel engine Engine oil	1.2 l
1 Hydraulic tank ATF 86	40.0 l
2 Hydraulic tank * ATF 86	80.0 l

C A U T I O N: The given quantities are orientation values.
The determining factor for the addition of engine oil are the marks on the dipsticks, the inspection ports or sight gauges.

* Optional

Chapter 6

Additional Equipment



1. Crane cab heating

The cab can be heated with two* independent heating systems.

1.1 Engine- dependent heating

Cab heating is carried out with the engine coolant water. The amount of coolant water fed to the cab heating system is controlled with the temperature rotary controller (16).

The amount of warm air can be regulated with the 3- stage blower switch (15).

Fresh air or recirculated air can be chosen with the switch (14).

1.2 Engine-independent heating ¹⁾ (additional heating)

The engine- independent heating serves to preheat the diesel engine as well as to heat the driver's cab at engine standstill; it is also used for heating when outside temperatures are extreme and engine heating proves insufficient.

D A N G E R: The heater may not be operated in closed areas, such as garages or workshops, not even with timer operation ²⁾ or Tele start ²⁾.

If this rule is not followed, there is a danger of poison or suffocation!

The heater must be turned off at gasoline stations.

If this rule is not followed, there is a danger of causing an EXPLOSION!

1.2.1 Additional heating as standstill heating (with the engine at standstill)

Set blower switch (15) to step 1, temperature rotary controller (16) to "WARM", and switch on additional heating with switch (50). Indicator lamp (49) will come on.

With the temperature rotary controller (16), the amount of water can be controlled; with the blower switch (15), the amount of air can be controlled.

1.2.2 Engine preheating ²⁾ with additional heating

At temperatures less than $\leq -15^{\circ}\text{C}$, the engine can be preheated with the additional heating.

To operate engine preheating ²⁾, set the heating to "COLD" with the temperature rotary controller (16).

With switch (50), switch on additional heating; indicator lamp (49) will come on.

The diesel engine coolant water is now prewarmed via the additional heating.

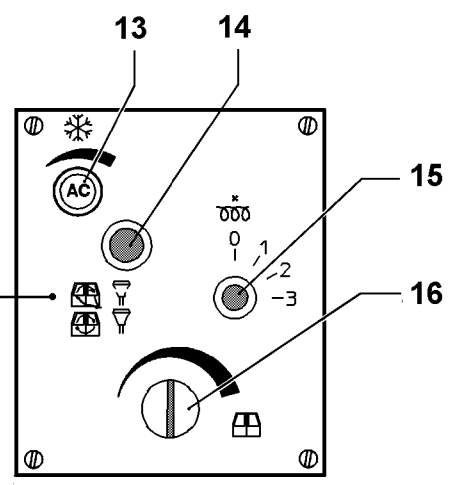
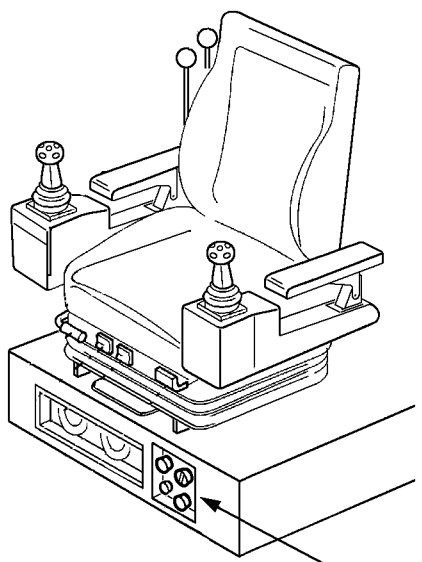
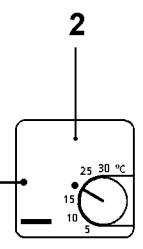
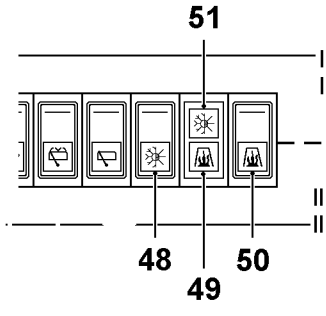
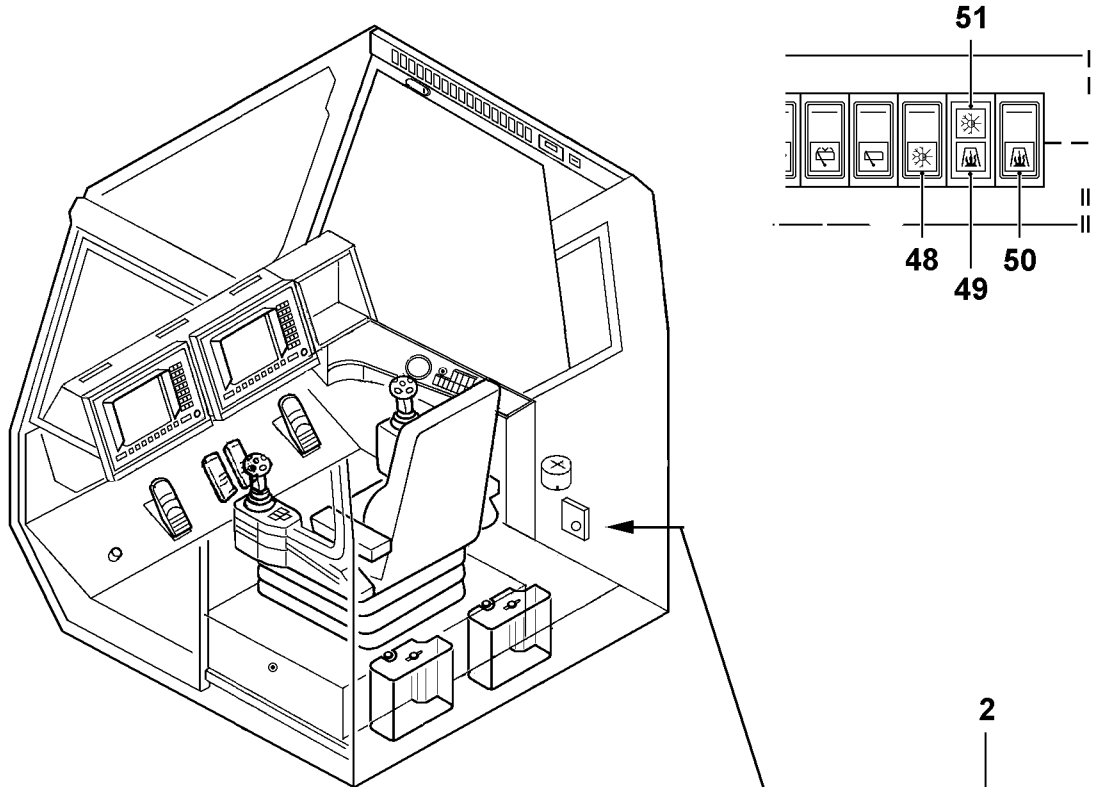
At extremely low temperatures, the time required to preheat the engine can be up to one hour.

1.2.3 Thermostat ³⁾

The desired cab temperature can be controlled with the thermostat (2).

The temperature rotary controller (16) must be set to "WARM".

1), 2) *) customers request.



Bleeding the system

The additional heating water circuit is within the engine circuit; i.e., when bleeding the engine coolant water, the contents of the heating system is also to be bled from the circuit.

When refilling the system, it must be carefully bled; the quickest way to carry this out is to bleed both engine and heating systems at the same time.

Fill the compensator reservoir with water, start the engine, set temperature rotary controller (16) to "WARM".

Observe the compensator reservoir to see if any air bubbles rise.

When no more air bubbles can be seen in the compensator reservoir, set the temperature rotary controller (16) to "COLD" - the circuit for engine preheating is then bled.

When no more air bubbles can be seen at this point in the compensator reservoir, this circuit is bled as well.

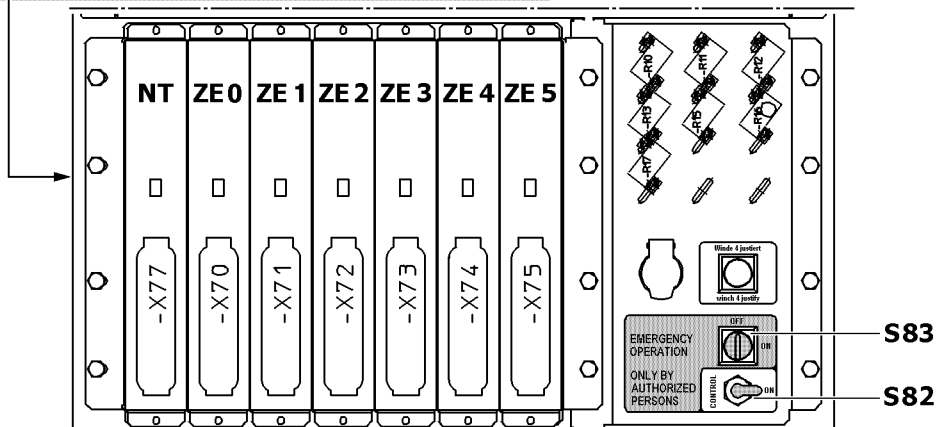
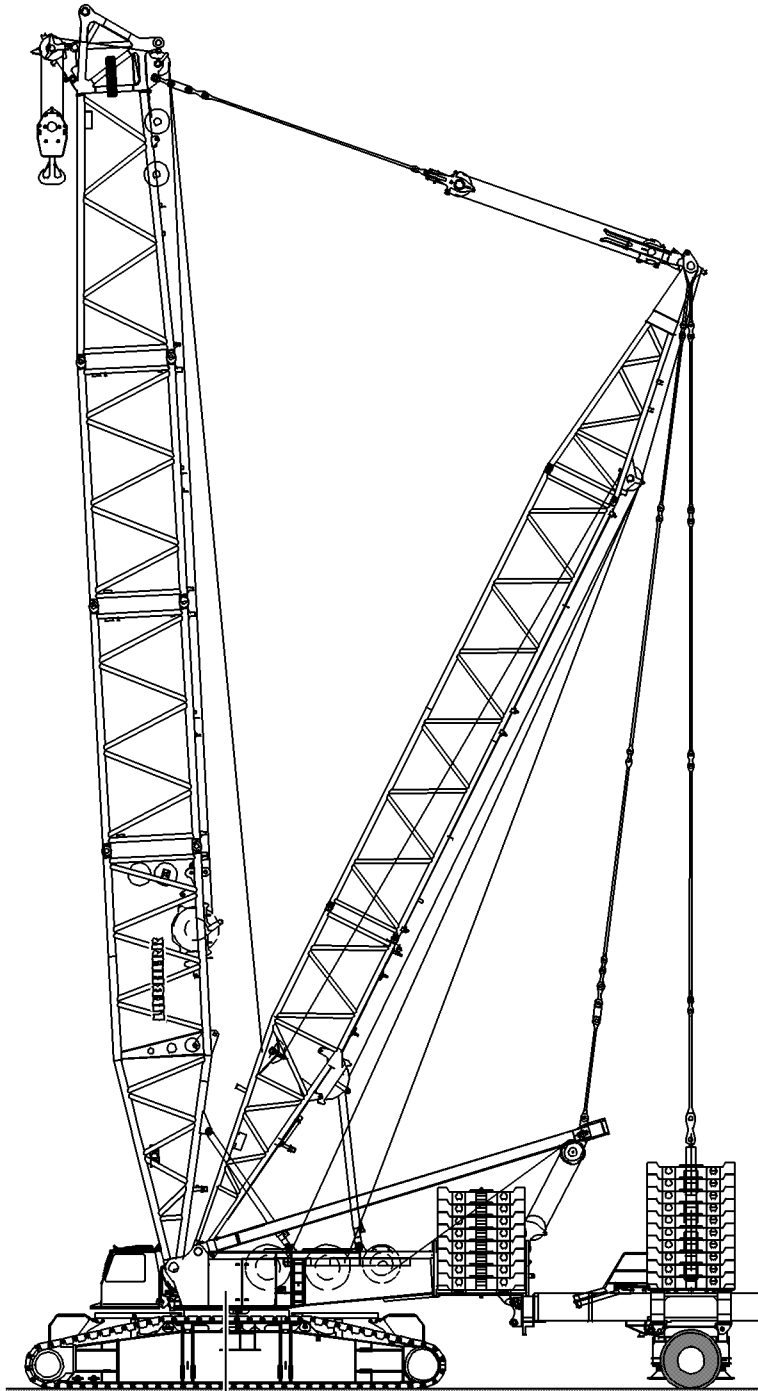
C A U T I O N: **The battery master switch may only be turned off after the heater has stopped running!**
If arc welding must be done on the crane, remove the negative and positive battery cable from the vehicle and the crane superstructure batteries to protect the heater control unit. Attach the positive cable to the vehicle ground.

Note:

For further notes on additional heating, see Webasto operating instructions.

The battery master switch (on the battery box) may only be switched off after conclusion of heating run-down.

In the summer months, run the additional heating once a month for approx. 15-20 minutes.



1. EMERGENCY CONTROL in case of problem or failure of the LICCON monitor or the LICCON overload safety system

The monitor on the control and indicator unit of the LICCON is not functioning, the working procedures are no longer shown optically.

1.1 Emergency control - general

The emergency control is turned on via the keyed switch (-S83) in the control box, position "ON". The bell on the slewing platform as well as the beacon on the roof of the cab are actuated.

In emergency operation, the LICCON outlets are disconnected from the control valves of the hydraulic pumps via the CPU -ok relay contacts. The hydraulic pumps are actuated via fixed resistors in connection with the corresponding direction contacts of the master switch (manual control lever). Only "black - white operation" is possible. It is possible to change the engine speed slightly with the throttle control.

D A N G E R : In emergency operation, all safety devices, such as the LICCON overload safety system, the straight run in parallel operation, the monitoring functions (limit switches) of the relapse cylinders, block positions, monitoring of forces (test brackets), hoist limit switches, monitoring of "Slewing" and "Driving" in ballast trailer operation, 10° limit switch SA bracket are all out of service.

1.2 Prerequisites for emergency control

- The crane engine must be running,
- the hydraulic system in the crane superstructure must be fully functioning.
- The keyed switch - S 83 (large control box) is set to "ON" position.

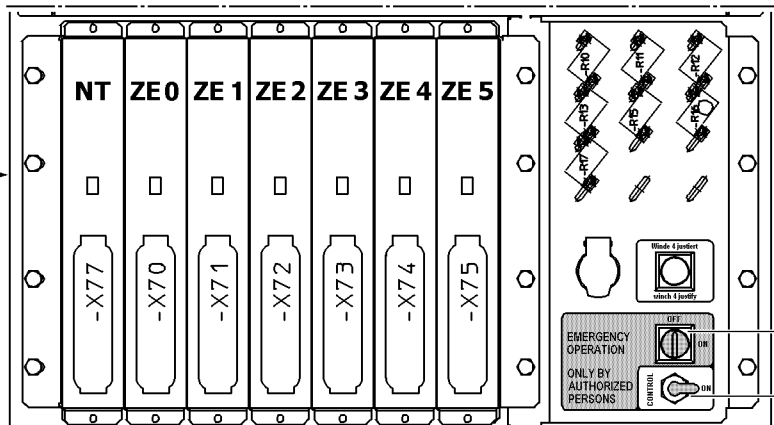
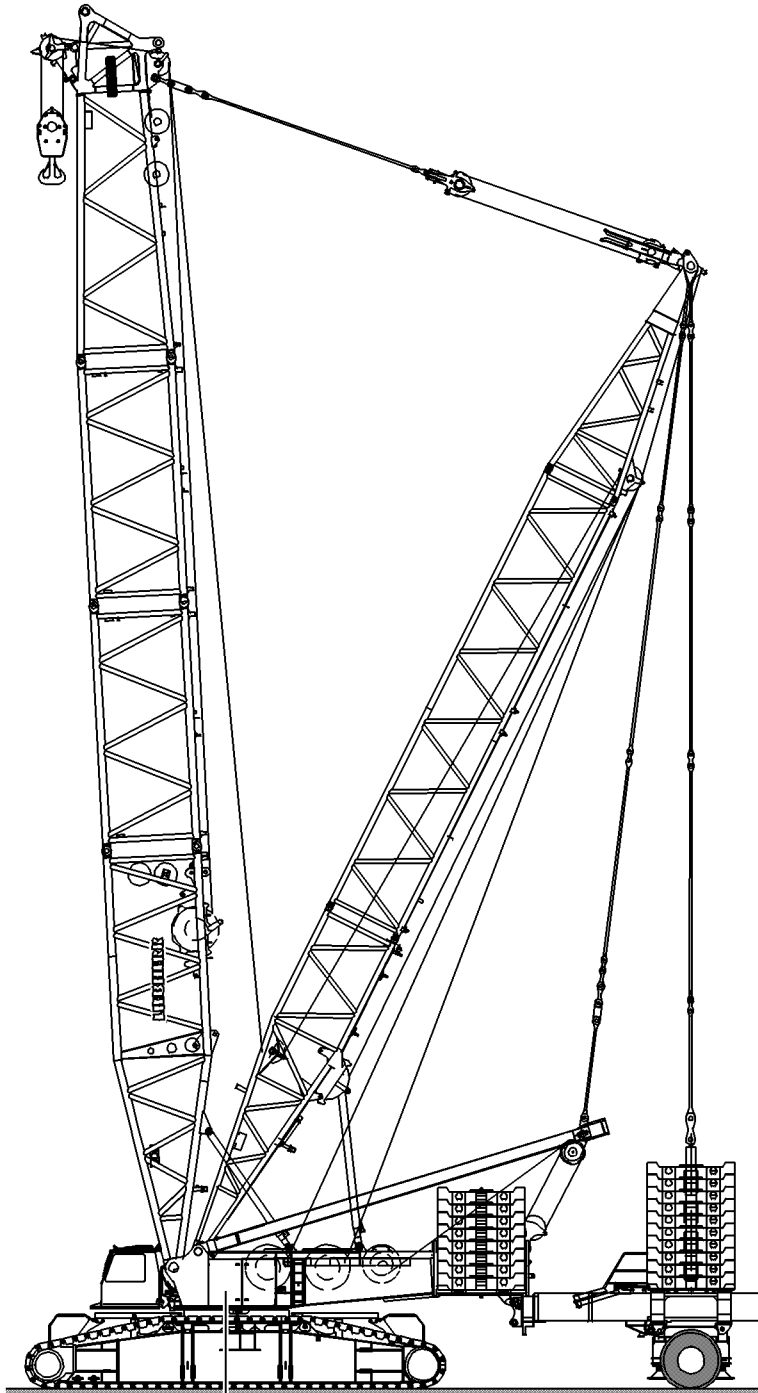
D A N G E R : The emergency control may only be carried out to bring the hoisting movement to an end if there is a problem, or to take care of a danger situation.

If a load is suspended from the hook, then it must be placed down first to relieve the boom. Only those crane movements may be carried out, which are required to set down the load, to place down the boom or to drive or turn the crane into a area, where it is no longer an obstacle. Since the monitor is not functioning if there is a problem or failure of the LICCON system, and the working procedures can no longer be shown optically, every step must be carried out and checked with extreme care and caution.

Check visually!

In emergency control, all safety devices are automatically bypassed. The emergency control of the crane may only be carried out by authorized personnel, which is aware of the effects of this bypass .

The hydraulic monitoring function of the replenishing pressures of the winches remains. If the replenishing pressure is not available, the brake on the corresponding winch cannot be released. In addition, it is also not possible to spool out the winches all the way, the safety coils on the winch remain.



S83

S82

Keyed switch - S 83:

D A N G E R : The keyed switch - S 83 (large control box) bypasses the LICCON overload safety device and may only be turned on in emergency situations by personnel, who is aware of the effects of this bypass!
Crane operation with turned on switch - S 83 is strictly prohibited.

After completion of the emergency operation and after the LICCON overload safety device is operational again, the keyed switch - S 83 (large control box) must be set again to the "OFF" position! The crane must also be turned off (engine stop). This is required so that the crane can be inspected for function and safety before continued operation. The key must be pulled after emergency operation and handed to an authorized person for safekeeping!

There is a DANGER OF LIFE AND DEATH!

D A N G E R : In emergency control, the movements are not controlled in proportion to the deflection of the manual control lever, but turned on or off digitally via the direction contacts of the manual control lever . This causes a jerky movement, on or off. The movement occurs at reduced, constant speed.

In emergency control, part of the transmitter is not active or the signals are not used.

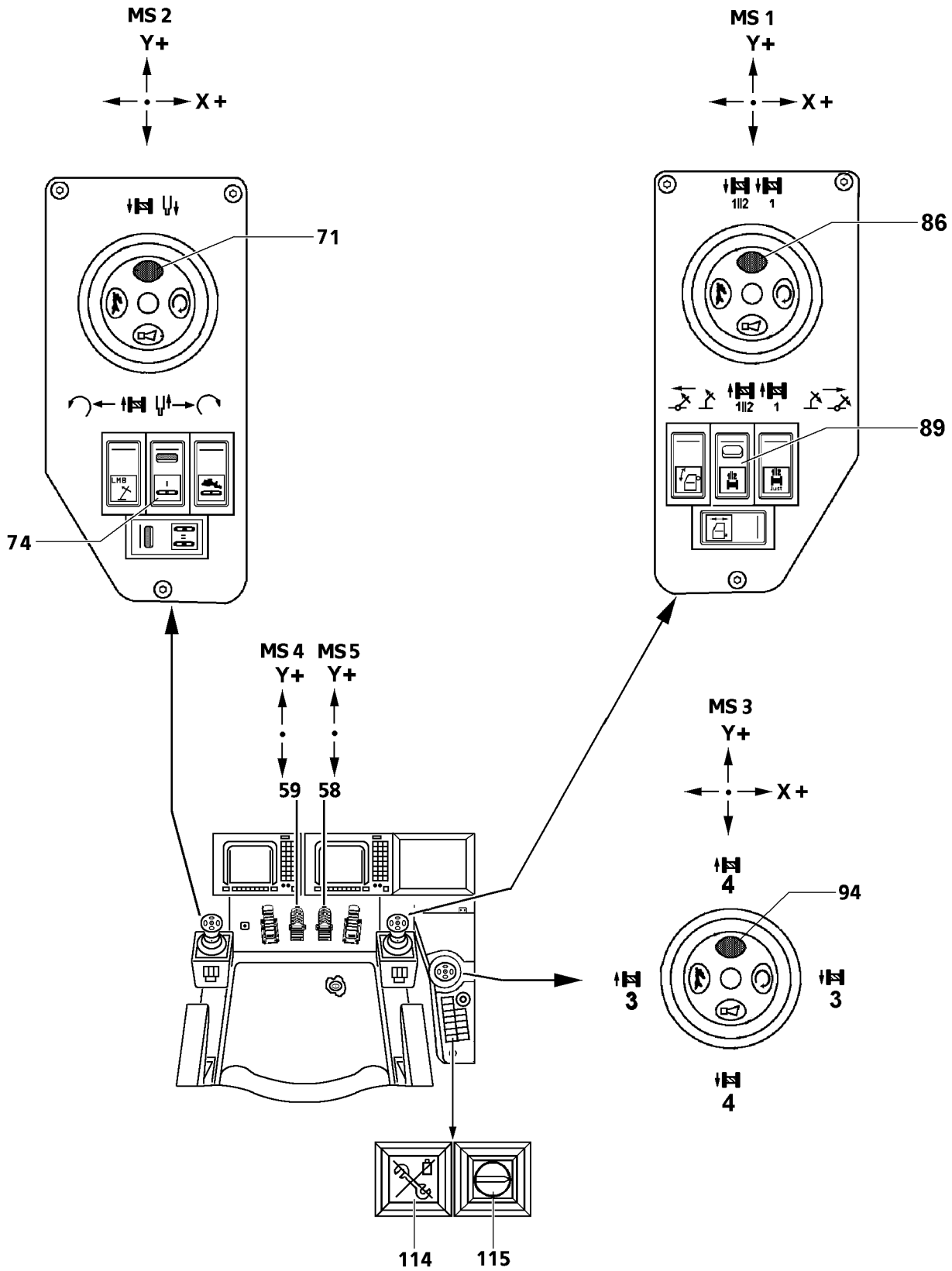
In emergency control, the crane control is carried out with the LICCON, which means the crane control works constantly as a relay control without computer controlling. In emergency control, even if the LICCON and the monitor indication is still functioning, all outlets of the LICCON and therefore all LICCON software emergency shut offs are ignored.

In emergency control, the crane operator is responsible for all movements he carries out. The instructions for emergency control must be strictly adhered to. Every step must be carefully thought through. If the LICCON is still functioning, only those movements may be carried out in emergency control, which cannot be carried out in normal operation due to a technical defect, but which would be permissible according to the operating instructions and the load condition.

The crane operator may never use the emergency control to bypass the safety shut offs of the LICCON system in normal operation !
There is a danger of accidents.

If a movement cannot be slowed down or stopped by resetting the manual control lever or by releasing the corresponding button, then the crane must be stopped immediately by pressing the EMERGENCY OFF button.

There is danger of LIFE AND DEATH!



1.3 Master switch (MS) assignment in emergency control

Winch 1:	MS1Y	
Winch 2:	MS2Y	Button (115) not actuated → installation cylinder locked
Winch 3:	MS1X	Switch (74) not turned on → crawler locked
Winch 4:	MS3X	Switch (74) and (89) not turned on → winch 6 locked
Winch 5:	MS3Y	
Winch 6:	MS3X	Switch (74) not turned on, wwitch (89) turned on → winch 4 locked

Slewing gear: MS2X

Installation cylinder: MS2Y Button (115) actuated → winch 2 locked

Crawler left: MS4Y Switch (74) turned on → winch 3, 4 and 6 locked.

Crawler right: MS5Y Switch (74) turned on → winch 3, 4 and 6 locked.

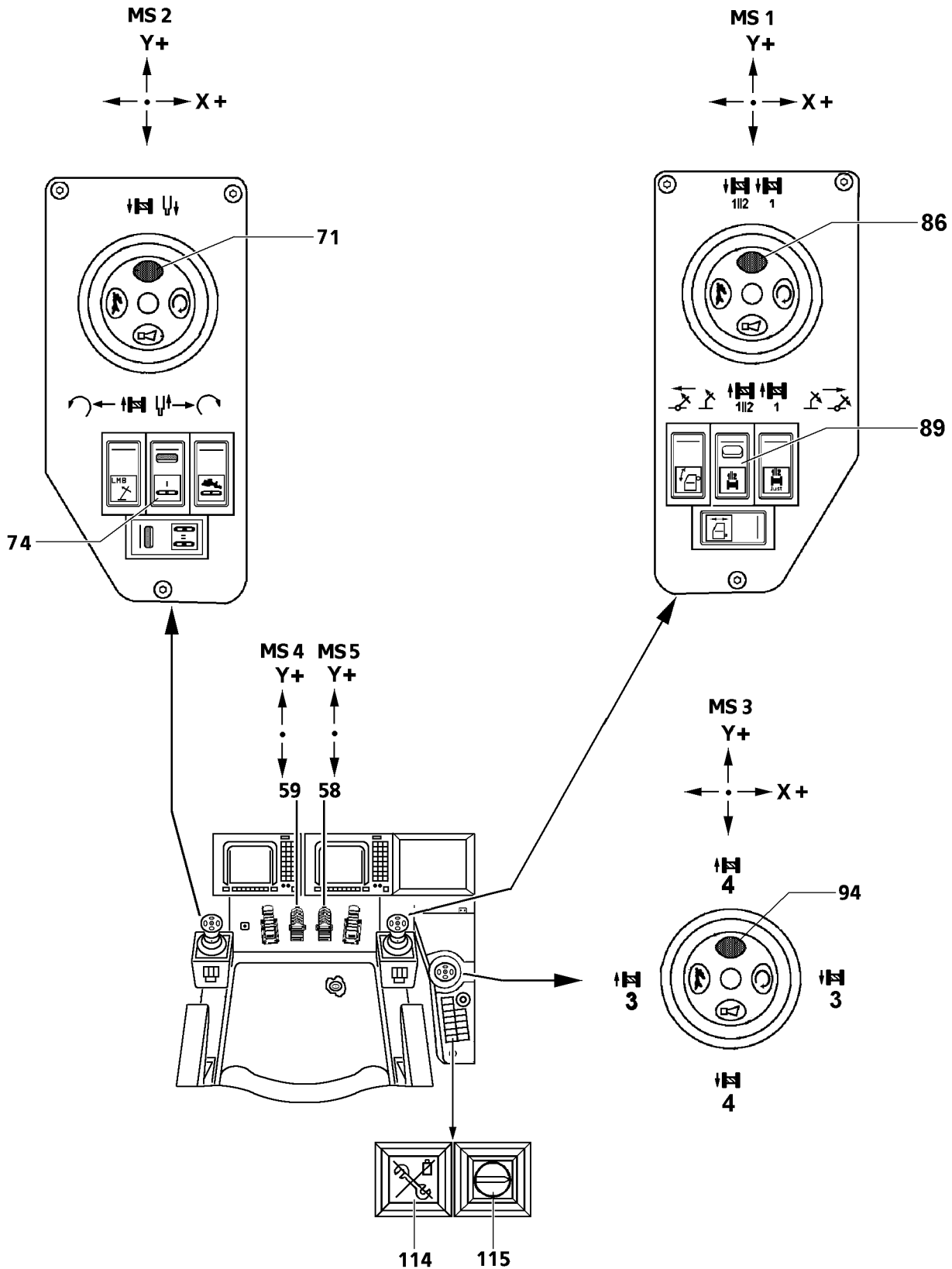
1.4 The following crane movements must be carried out:

Winch 1 - 6	spool up / out
Slewing gear	turn left / right
Installation cylinder	extend / retract
Crawler	drive

Note: Parallel operation of winch 1 || 2 is not possible!

CAUTION: If a double hook is reeved, the winches must be moved with MS1Y and MS2Y. The horizontal alignment of the two pulleys in the double hook must be monitored by the crane operator.

DANGER: If a load is suspended from the hook, then it must be placed down first and the boom must be relieved.
There may be no persons or objects in the danger zone.



1.4.1 Winch 1 to 6

Winch 1

Release of the manual control lever (MS1) with seat contact switch or by pushing the button (86) on the manual control lever.

Deflect the manual control lever (MS1) to the rear (Y -)	=	spool up
Deflect the manual control lever (MS1) to the front (Y +)	=	spool out
Manual control lever (MS1) in zero position	=	brake is applied, winch 1 stops.

Note: Winch 1 turns at reduced speed
If the limit switch "Winch spooled out" is triggered, then winch 1 can be spooled up again even in emergency control. The spool up direction remains clear.

Winch 2

Release of the manual control lever (MS2) with seat contact switch or by pressing the button (71) on the manual control lever.

Keyed button (115) not actuated, indicator light in the button (114) does not light up.

Deflect the manual control lever (MS2) to the rear (Y -)	=	spool up
Deflect the manual control lever (MS2) to the front (Y +)	=	spool out
Manual control lever (MS2) in zero position	=	brake is applied, winch 2 stops.

Note: Winch 2 turns at reduced speed
If the limit switch "Winch spooled out" is triggered, then winch 2 can be spooled up again even in emergency control. The spool up direction remains clear.

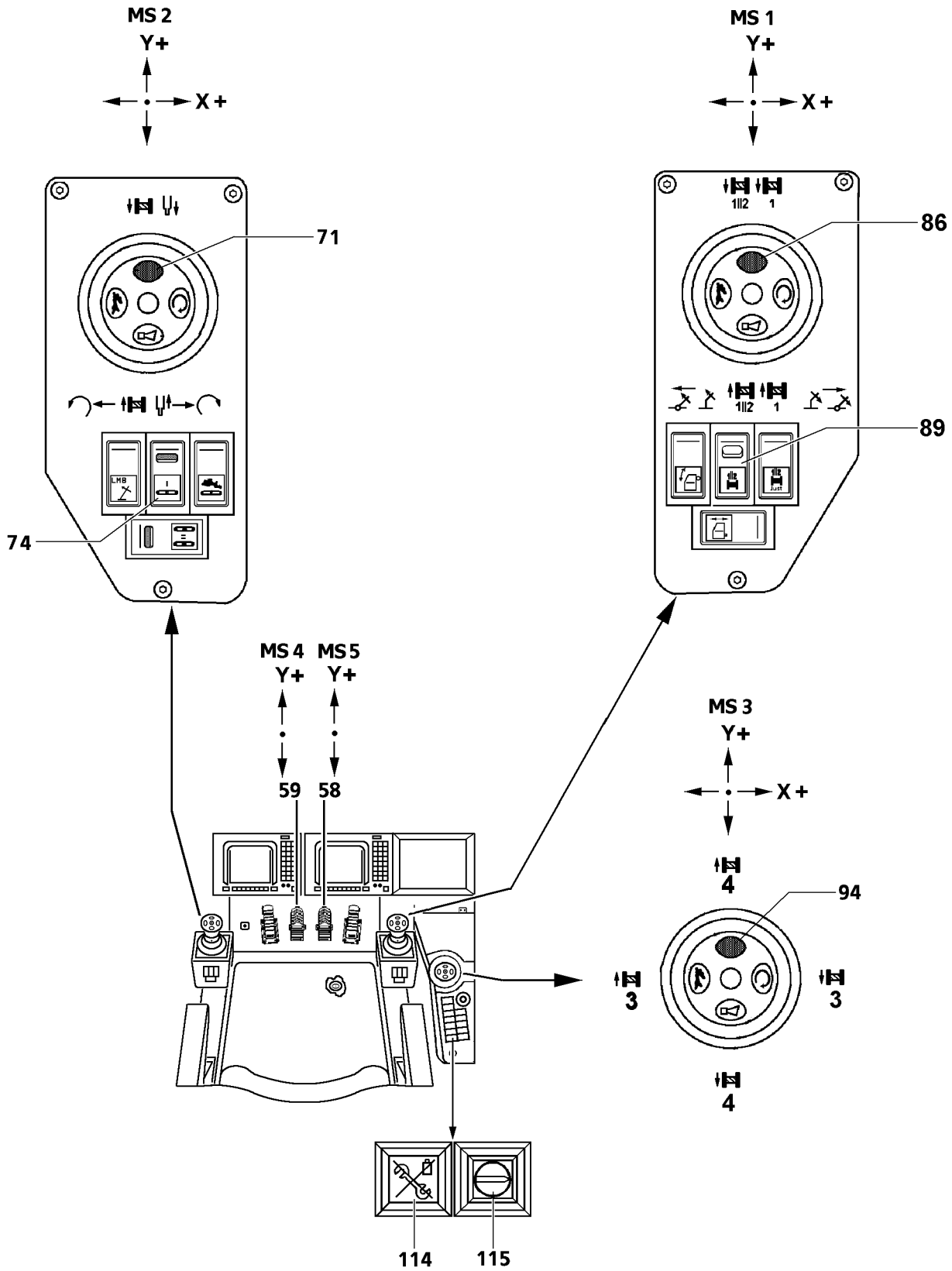
Winch 3

Release of the manual control lever (MS1) with seat contact switch or by pressing the button (86) on the manual control lever.

Switch (74) not turned on.

Deflect the manual control lever (MS1) to the left (X -)	=	spool up
Deflect the manual control lever (MS1) to the right (X +)	=	spool out
Manual control lever (MS1) in zero position	=	brake is applied, winch 3 stops.

Note: Winch 3 turns at reduced speed
If the limit switch "Winch spooled out" is triggered, then winch 3 can be spooled up again even in emergency control. The spool up direction remains clear.



Winch 4

Release of manual control lever (MS3) with seat contact switch or by pushing the button (94) on the manual control lever.

Switch (74) and (89) not turned on.

Deflect the manual control lever (MS3) to the left (Y -) = spool up

Deflect the manual control lever (MS3) to the right (Y +) = spool out

Manual control lever (MS3) in zero position = brake is applied, winch 4 stops.

Note:

Winch 4 turns at reduced speed

If the limit switch "Winch spooled out" is triggered, then winch 4 can be spooled up again even in emergency control. The spool up direction remains clear.

Winch 5

Release of manual control lever (MS3) with seat contact switch or by pushing the button (94) on the manual control lever.

Deflect the manual control lever (MS3) to the rear (Y -) = spool up

Deflect the manual control lever (MS3) to the front (Y +) = spool out

Manual control lever (MS3) in zero position = brake is applied, winch 5 stops.

Note:

Winch 5 turns at reduced speed

If the limit switch "Winch spooled out" is triggered, then winch 5 can be spooled up again even in emergency control. The spool up direction remains clear.

Winch 6

Release of manual control levers (MS3) with seat contact switch or by pushing the button (94) on the manual control lever.

Switch (74) not turned on.

Switch (89) turned on..

Deflect the manual control lever (MS3) to the left (X -) = spool up

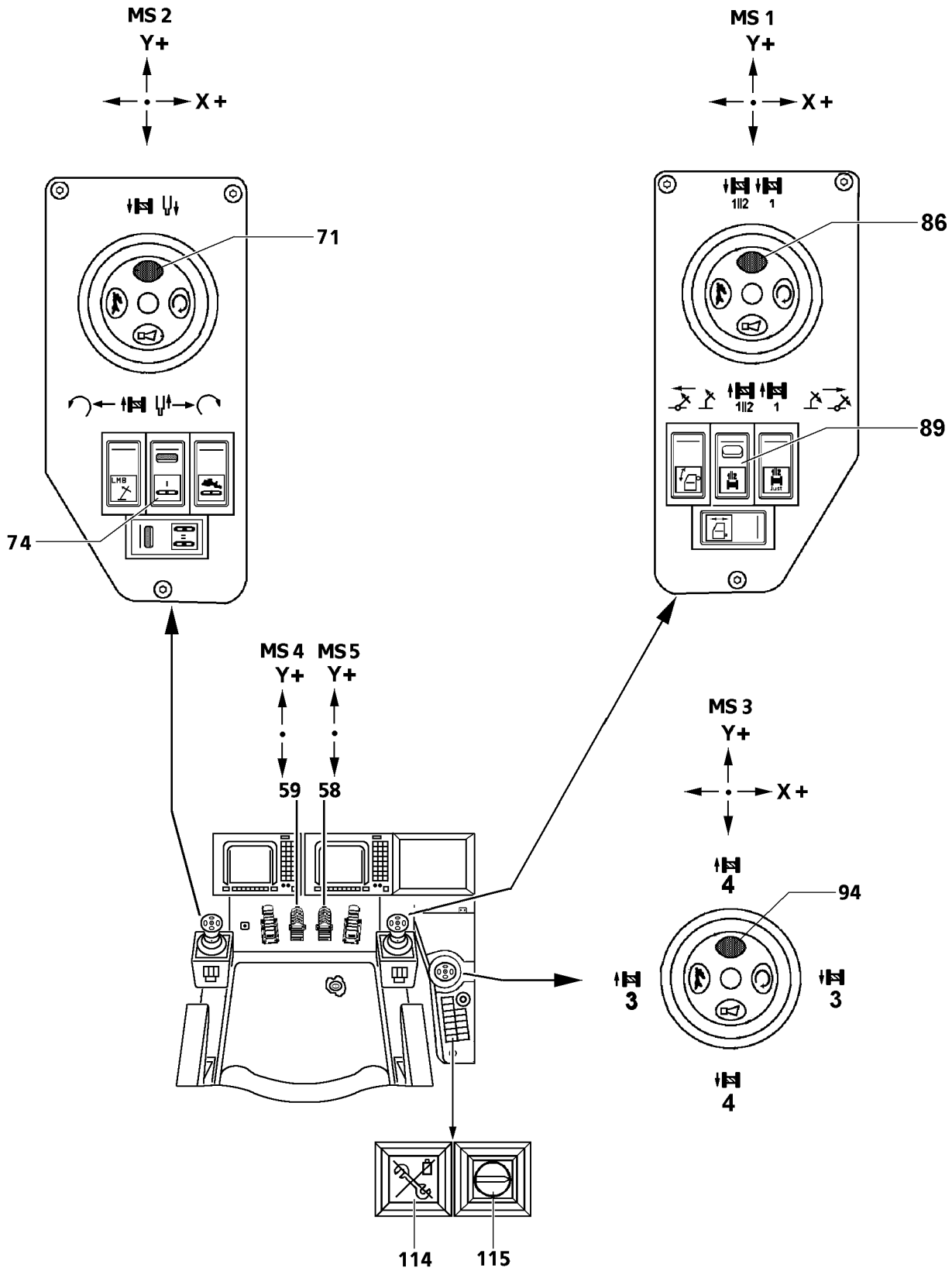
Deflect the manual control lever (MS3) to the right (X +) = spool out

Manual control lever (MS3) in zero position = brake is applied, winch 6 stops.

Note:

Winch 6 turns at reduced speed

If the limit switch "Winch spooled out" is triggered, then winch 6 can be spooled up again even in emergency control. The spool up direction remains clear.



1.4.2 Slewing gear

D A N G E R : Before initiating the "Slewing" crane movement, the crane operator must make sure that there are no persons or obstacles within the slewing range. If this is not observed, there is a danger of accidents .

Release of manual control lever (MS2) with seat contact switch or by pushing the button on the manual control lever.

Deflect the manual control lever (MS2) to the left (X -) = turn to the left

Deflect the manual control lever (MS2) to the right (X +) = turn to the right

Manual control lever (MS2) in zero position = brake is applied, slewing gear slows down softly (hydraulic accumulator).

Note: In emergency control, coasting is not possible. The slewing gear turns at reduced speed.

1.4.3 Installation cylinder

Release of manual control lever (MS2) with seat contact switch or by pushing the button (71) on the manual control lever (MS2).

Actuate the keyed button (115)

Deflect the manual control lever (MS2) to the rear (Y -) = Retract the installation cylinder

Deflect the manual control lever (MS2) to the front (Y +) = Extend the installation cylinder

Manual control lever (MS2) in zero position = Movement of installation cylinder stops

Note: Movement of installation cylinder is at reduced speed.

1.4.4 Crawler gear

Turn on the crawler gear with switch (74)

Crawler left

Press the foot pedal left (MS4 (59) to the front (Y +) = drive forward

Press the foot pedal left (MS4 (59) to the rear (Y -) = drive backward

Foot pedal left (MS4 (59) in zero position = brake is applied, the travel gear slows down softly (hydraulic accumulator).

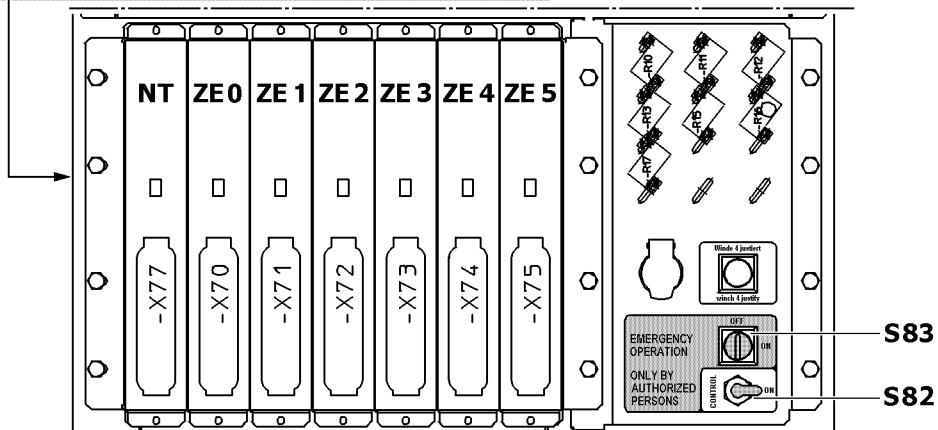
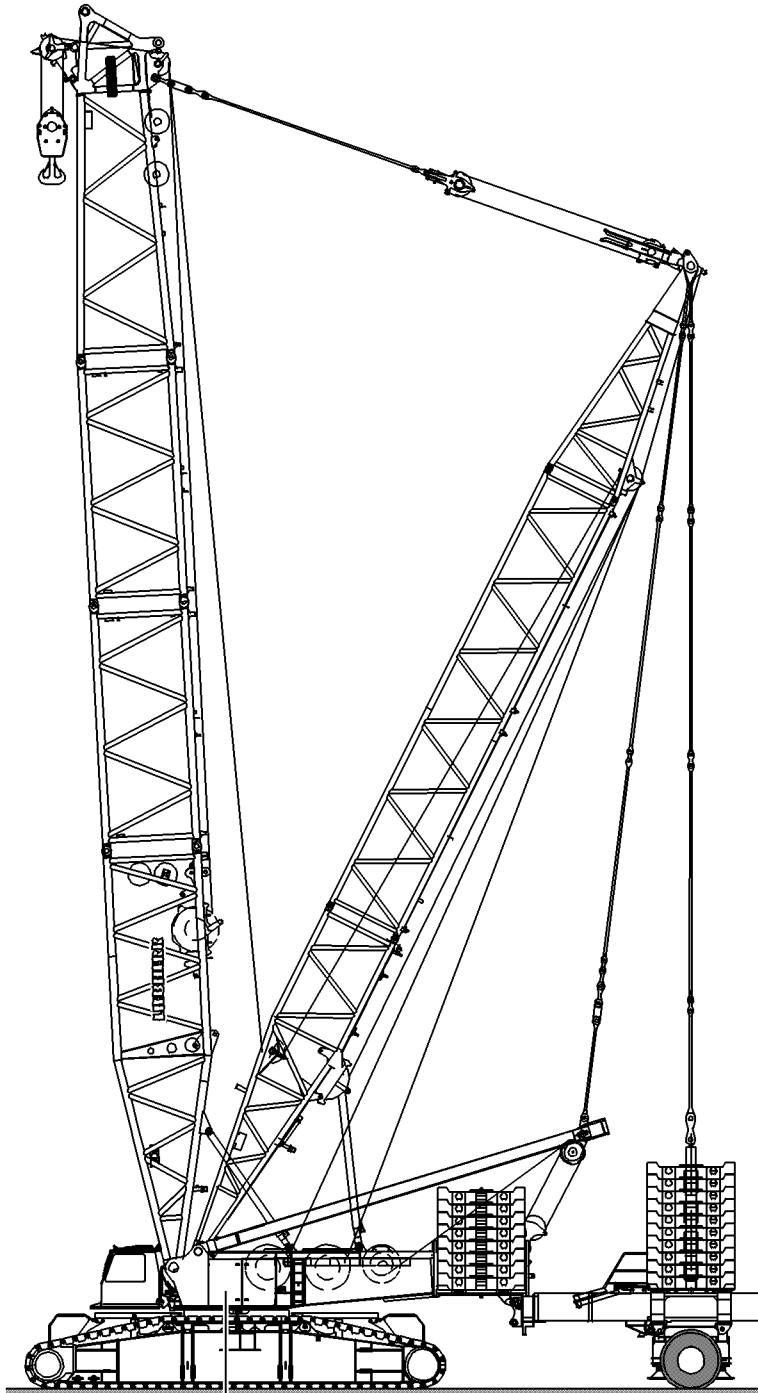
Crawler right

Press the foot pedal right (MS5 (58) to the front (Y +) = drive forward

Press the foot pedal right (MS5 (58) to the rear (Y -) = drive backward

Foot pedal right (MS5 (58) in zero position = brake is applied, the travel gear slows down softly (hydraulic accumulator).

Note: The crawler gear drives at reduced speed.



2. Emergency control with ballast trailer**Function - Ballast "Up or down"**

It is possible to raise or lower the ballast, however, without monitoring of test point 1 (KMD1 = force between A- bracket and derrick) and the S - and D - relapse cylinders.

Function "Turning"

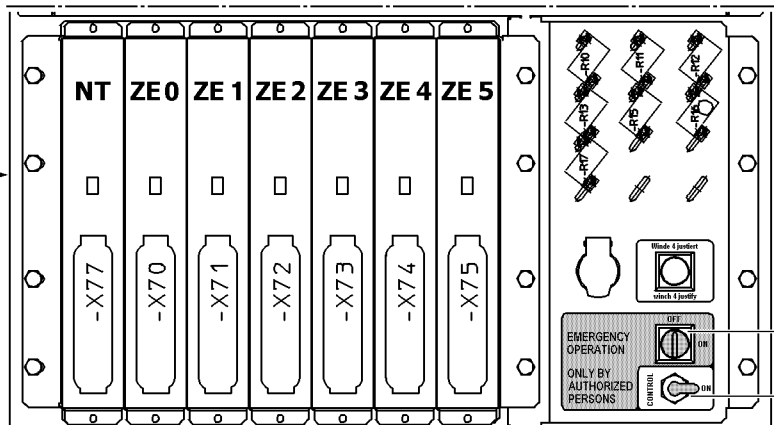
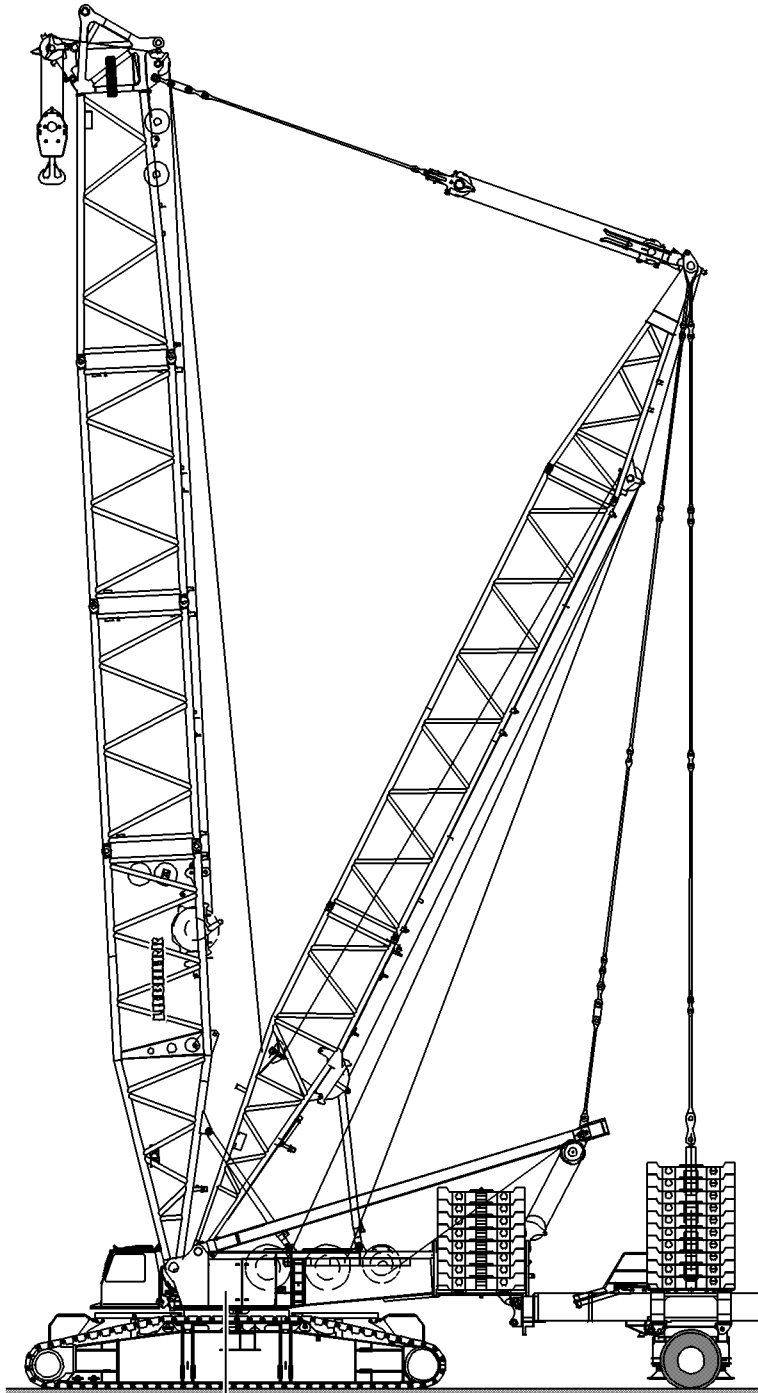
It is possible to turn , but without monitoring of the supports and the wheel positoin of the ballast trailer. For that reason it must be ensured that - **with non-suspended ballast trailer** - the wheels are in "Turning" position and the supports are retracted.

Function "Driving"**Towing :**

CAUTION: Towing is not possible, since the slewing gear coasting function cannot be turned on.

Parallel driving:

CAUTION: Is not possible, since the hydraulic coasting function of the slewing gear cannot be turned on.



192595

**3. EMERGENCY OPERATION in case of problem or failure of a central processing unit (CPU) or a power supply unit (NT)
⇒ basic component group error**

Note: Basic component group error, see Diagnostics Manual.

Possible causes

1. Central processing unit (CPU) defective

Note: All CPUs must be fully functioning.

2. Power supply unit defective

Error recognition

- Power supply unit indication
- CPU indication
- System error message

Remedy

- Replace the defective CPU with a spare CPU.
- Replace the defective power supply unit with a spare power supply unit.

Note: When replacing the CPU, take over the program memory from the removed CPU. When replacing the power supply unit, take over the common memory of the removed power supply unit.

Note: A spare CPU as well as a spare power supply unit is in the control box of the crane control. To change the CPU or the power supply unit, see Diagnostics Manual, paragraph System error.

CAUTION: When replacing the CPU or the power supply unit, the current must be turned off. When pulling the plug for the power supply unit or the central processing unit from the component group carrier, the Stand-by power supply for the component group is interrupted. This means, the system is rebooted. The stored equipment configuration data and the adjustment figures will be lost.

Chapter 7

Service and Maintenance

1. Liebherr Service for you

C A U T I O N : Damage to mobile crane components!

If the mobile crane components are not maintained according to the maintenance intervals and maintenance guidelines, or if other lubricants are used than specified in the lubrication chart, the corresponding mobile crane component can be damaged and/or lose its function.

The warranty for the corresponding mobile crane component will become void!

- Always maintain mobile crane components according to the data in the maintenance intervals, maintenance guidelines and lubrication chart!

D A N G E R : Danger to life due to damaged mobile crane components!

If damaged mobile crane components, for example due to maintenance errors, are not replaced immediately, personnel can be mortally injured!

- Always maintain mobile crane components according to the data in the maintenance intervals, maintenance guidelines and lubrication chart!

- Replace damaged mobile crane components immediately!

1.1 Liebherr service for you

Liebherr truck-mounted, mobile and crawler cranes are products incorporating mature engineering which is able to cope day in, day out with the roughest operating conditions to which a crane may be subjected.

The high standards of engineering embodied in these cranes are reflected in their operation reliability, their insusceptibility to faults and in their ease of servicing and maintenance.

Liebherr is constantly further developing their drive and control elements. The combination of tried and tested components and modern production methods produces cranes which are reliable operating partners with a range of convenient operating features.

We build many hundreds of cranes each year for the international market and provide the backup services for them worldwide, too. For "After Sales Service" ranks high at Liebherr to ensure that your crane is always available and operational.

Service at Liebherr begins from the moment the crane is handed over to you, the customer. We will provide your crane operators with the specialist training tailored to their particular needs.

Also we will train your maintenance personnel in all questions relating to crane servicing and repairs because we know that you are able not only to deal with all their minor repairs, but often have the specialists who can quickly and reliably perform major crane repairs.

A further benefit of our After Sales Service are our special Service Advisors who are only a telephone call away whenever a problem arises. This immediate contact saves you time and money and you should always take advantage of it whenever your crane is "down".

Our Field Technicians are also specialists with many year's experience who operate from strategically located bases. They bring with them their specialist knowledge and a range of special tools for the job. They are at your disposal as the last link in the range of Liebherr After Sales Services, although in most cases, your technical problems can be solved by contacting our Service Advisors.

Note: The buyer may submit warranty claims and receive possible reimbursement only if Original Liebherr spare parts are used in the Liebherr mobile crane. Original Liebherr spare parts have been tested and are designed specifically for crane operation and can be utilized without any safety concerns.

DANGER: **LIEBHERR-WERK EHINGEN GMBH, accepts no liability for utilization of replacement parts not manufactured originally by Liebherr. This applies to the functioning capability as well as to the actual parts!**

2. Cleaning and care of the crane

2.1 Care of sound-absorbing mats

Sound-absorbing mats in the engine area or other noise sources are an integrated part of the total design. They have the task, together with all sound-absorbing material and the constructive design of the machine, to keep the noise levels for vehicles - as specified by law - as well as noise levels on the work place within the specified levels. They are an integral part of the machine design and permission to operate. They may not be removed and in case of damage, they must always be replaced with Original spare parts.

They are designed to be maintenance free. They are made with dirt, oil and water repelling surfaces, they are fire retardent and in part, depending on the application, even non-flamable.

Therefore, these parts need no special care. Light deposits of dirt can be overlooked, since the acoustical properties of the mats are not reduced.

Crude dirt deposits can be removed with suitable tools (soft plastic scrapers). Tools with sharp edges are unsuitable. Steam cleaners may only be used with utmost care, i.e. with sufficient distance to the sound-absorbing mats and low water pressure. Cleaning solutions may not be used for cleaning.

It is especially dangerous if contaminants contain solutions or foreign matter, such as oils (engine oils, gear oils or hydraulic oils) and fuel, since these substances could ignite and / or significantly affect the flame retardent qualities of the mats.

For that reason, if any such substances are found on these mats, the mats must be removed and replaced immediately with Original replacement parts.

2.2 Care of the driver's cab and the crane operator's cab

The steering wheel, center console, control panel cover, floor covering and dirty upholstery in the driver's and crane operator's cab should be cleaned with warm water mixed with dish detergent.

Do not use scouring pads!

3. Putting the crane out of service for downtime

Note: Danger of corrosion on the hydraulic cylinders!
If the crane is out of service for an extended period of time, then it must be taken down.
In aggressive environmental conditions, such as on locations with sea climate and especially salty air, the hydraulic cylinders (support cylinder, luffing cylinder, telescoping cylinder) can corrode.

- Take down the crane equipment!
- Fully retract the hydraulic cylinders of the crane!
- Protect free sections of the piston rod from corrosion, for example by greasing these points!
- Grease the free sections of the piston rod of the luffing cylinder especially!

4. Maintenance instructions

Note: **Maintenance work on the crane chassis** is carried out according to the number of operating hours or kilometers covered.

Maintenance work on the crane superstructure is carried out according to the number of operating hours only.

Please, refer to following chapters before performing maintenance of the crane:

7.02 MAINTENANCE INTERVALS CRANE CHASSIS

7.03 MAINTENANCE INTERVALS CRANE SUPERSTRUCTURE

These chapters contain a list of maintenance intervals for all maintenance work. Only the relevant work must be carried out.

7.04 MAINTENANCE INSTRUCTIONS CRANE CHASSIS

7.05 MAINTENANCE INSTRUCTIONS CRANE SUPERSTRUCTURE

For individual assemblies note manufacturer's instructions.

7.06 LUBRICATION CHART, FILLING CAPACITIES

7.07 TABLE OF LUBRICANTS

	First main-tenance after	Regular maintenance every			Minimum main-tenance annually	Inspections	
		250 hr. 5000 km	500 hr. 10000 km	1000 hr. 20000 km		daily	weekly
<input type="checkbox"/> Diesel engine							
- Check oil level For all additional maintenance tasks, observe the instructions issued by the engine manufacturer						×	
- Check the coolant level in the expansion tank						×	
- Change the coolant					every 2 years		
<input type="checkbox"/> Air filter							
- Check the monitor						×	
- Clean the filter element (observe the instructions of the engine manufacturer)					as necessary		
- Change the filter element (after cleaning it 5×)					every 2 years		

	First maintenance after	Regular maintenance every			Minimum maintenance annually	Inspections	
		250 hr. 5000 km	500 hr. 10000 km	1000 hr. 20000 km		daily	weekly
<input type="checkbox"/> Hydraulic system							
- Check hydraulic system for leaks							×
- Hydraulic tank Check oil level							×
- Oil change (oil analysis)				×	×		
- Replace bleeder filter of hydraulic tank	100 hr.		×				
- Replace return filter	100 hr.		×				
- Replace filter insert	100 hr.		×				
- Check the hydraulic pressure, readjust, if necessary				×			
<input type="checkbox"/> Hydraulic hose lines							
- Check for leaks and damage						×	
- Check for safe working condition by expert					×		
<input type="checkbox"/> Steering							
- Test steering rod and tie rod tightness and split pin keepers		×					
- Check the hydraulic steering system for leaks						×	
- Check the track adjustment, readjust if necessary		×	*				
- Replace the hydraulic filter insert	100 hr.		×				
- Check the hydraulic steering stop, readjust if necessary				×			
- Check the steering with the test program							×

* In case of frequent off road application, every 500 to 2000 km.

	First main-tenance after	Regular maintenance every			Minimum main-tenance annually	Inspections	
		250 hr. 5000 km	500 hr. 10000 km	1000 hr. 20000 km		daily	weekly
<input type="checkbox"/> Hydraulic fan							
- Replace the air filter insert of the hydr. fans	100 hr.		×				
<input type="checkbox"/> Hydraulic supports							
- Check the sliding arms for easy movement / grease		×					
- Check the sliding arm ropes		×					
- Grease the mounting pins of the sliding arm cylinder							×
- Check the level, readjust, if necessary							×
<input type="checkbox"/> Axle suspension							
- Function check as blocking cylinder		×					
- Check the pressure accumulator pretension pressure (nitrogen)				×	×		

* Observe chapter 7.04, MAINTENANCE GUIDELINES FOR CRANE CHASSIS!

	First maintenance after	Regular maintenance every			Minimum maintenance annually	Inspections	
		250 hr. 5000 km	500 hr. 10000 km	1000 hr. 20000 km		daily	weekly
<input type="checkbox"/> Automatic transmission							
- Check oil level						×	
- Check oil pressure						×	
- Check operating temperature						×	
- Check for leaks							×
- Check the mounting screws retighten as necessary		×					
- Change the oil	100 hr.			×	×		
- Replace the oil filter	100 hr.			×	×		
<input type="checkbox"/> Powershift transmission							
- Check oil level						×	
- Check for leaks							×
- Change the oil	100 hr.		×		×		
- Replace the oil filter	100 hr.		×		×		
<input type="checkbox"/> Automatic control gear							
- Check oil level							×
- Check for leaks							×
- Change the oil					every 3 years *		
- Replace the oil filter					every 3 years *		
<input type="checkbox"/> Transducer clutch							
- Check oil level							×
- Change the oil					×		
- Replace the oil filter					×		

* only when using ZF-Ecofluid M, otherwise every 2 years.

	First main-tenance after	Regular maintenance every			Minimum main-tenance annually	Inspections	
		250 hr. 5000 km	500 hr. 10000 km	1000 hr. 20000 km		daily	weekly
<input type="checkbox"/> Drop box							
- Check for leaks							×
- Check mounting		×					
- Change the oil	1000 km			×	×		
<input type="checkbox"/> Distributor gear							
- Change the oil	1000 km	×		×	×		
- Check oil level							×
- Check for leaks						×	
- Check mounting screws, retighten, as necessary		×					
- Check function change over on road / off road gear							×
- Check function addition of all wheel drive							×
- Check speedometer connection		×					
- Clean bleeder nipple				×	×		
<input type="checkbox"/> Pump distributor gear							
- Check for leaks							×
- Check mounting		×					
- Change the oil	200 hr.			×	×		

	First maintenance after	Regular maintenance every			Minimum maintenance annually	Inspections	
		250 hr. 5000 km	500 hr. 10000 km	1000 hr. 20000 km		daily	weekly
<input type="checkbox"/> Gear shafts (drive shaft) and bearing bock							
- Check flange screws, tighten if necessary	100 km	2500 km					
<input type="checkbox"/> Axles, driven							
- Check for leaks						×	
- Oil level check at axle housing, differential housing and wheel hubs		×					
- Grease steering knuckle bearings				25000 km	every 2 years *		
- Check mounting		×					
- Change the oil	1000 km			×	every 2 years		
- Replace grease filling in wheel bearings (if lubricated with grease)					every 2 years		
- Clean bleeder nipple on axle housing				×	×		
<input type="checkbox"/> Axles, non- driven							
- Grease steering knuckle bearings				25000 km	every 2 years *		
- Check mounting		×					
- Replace grease filling in wheel bearings				×	×		
- Set wheel bearings				×	×		

* In case of frequent off road application, at least 1 × per year.

	First maintenance after	Regular maintenance every			Minimum maintenance annually	Inspections	
		250 hr. 5000 km	500 hr. 10000 km	1000 hr. 20000 km		daily	weekly
<input type="checkbox"/> Electrical system							
- Check vehicle lighting system for function						×	
- Check cable connections and battery acid level					×	*	
<input type="checkbox"/> Fuel system							
- Check for leaks						×	
- Check condition and mounting			×		×		
- Drain off water and sediments			×		×		
- Clean pre-filter for fuel auxiliary pump			×		×		
- Check fuel preliminary filter, drain off water if necessary		every 50 hrs.					
- Replace fuel preliminary filter				×			
<input type="checkbox"/> Tires							
- Check lug nut tightness, tighten if necessary	100 km	×					
- Check tire pressure							×
<input type="checkbox"/> Brake system							
- Check brake system					×		
- Check brake pad thickness		×					
- Adjust brakes, if necessary, replace linings		×					
- Grease		×					
- Oil fork head connections		×					
- Check function of service brake and hand brake						×	
<input type="checkbox"/> Eddy current retarder							
- Check mechanical and electric parts (Observe manufacturer's guidelines)	5000 km		×				

* in hot regions 2× per year

	First main-tenance after	Regular maintenance every			Minimum main-tenance annually	Inspections	
		250 hr. 5000 km	500 hr. 10000 km	1000 hr. 20000 km		daily	weekly
<input type="checkbox"/> Air pressure system							
- Check for leaks							×
- Check operating pressure of brake system						×	
- Check shut off pressure						×	
- Drain moisture from air pressure tank					×		
- Replace air dryer granule elements					×		
- Clean prefilter air dryer					×		
<input type="checkbox"/> Driver's cab							
- Check armatures / instruments for function						×	
- Check indicator lights for function						×	
- Check engine brake control						×	
- Check retarder control						×	
- Lubricate boom receptacle		×					
<input type="checkbox"/> Emergency control							
- Check for function					×		
<input type="checkbox"/> Support plates with compensation							
- Replace grease filling					×		
- Check for function					×		

Only for crawler cranes	Regular maintenance every			Minimum maintenance annually
	10 hr.	100 hr.	800 hr.	
<input type="checkbox"/> Travel gear				
- Change the oil			×	×
- Check for leaks	×			
- Grease sprocket bearing	×			
<input type="checkbox"/> Crawler track carrier				
- Check track rollers (with oil lubrication) for leaks	×			
- Grease track rollers (with grease lubrication)	×			
- Lubricate carrier rollers	×			
- Grease guide bars on sliding section				×
<input type="checkbox"/> Track pads				
- Check plate tension, retension if necessary	×			
- Check mounting tightness and for damage	×			

	First maintenance after	Regular maintenance every				Minimum maintenance annually	Inspections	
		125 hrs.	250 hrs.	500 hrs.	1500 hrs.		daily	weekly
<input type="checkbox"/> Diesel engine								
- Check oil level For all additional maintenance tasks, observe the instructions issued by the engine manufacturer							×	
- Check the coolant level in the expansion tank							×	
- Change the coolant						every 2 years		
<input type="checkbox"/> Air filter								
- Check the monitor							×	
- Clean or change (observe the instructions of the engine manufacturer)								
<input type="checkbox"/> Slewing ring								
- Grease gearing			×					
- Grease slewing ring						× ¹		
- Check screws for tight seating	250 hrs.				×	×		
- Check tilt play					×	×		
<input type="checkbox"/> Cable winches								
- Check for leaks							×	
- Check oil level								×
- Check mounting screws for tight seating	250 hrs.			×		×		
- Change the oil					3000 hrs.	every 4 years		
<input type="checkbox"/> Gear shafts								
- Check the flange screws		×						
- Lubricate		×				×		

¹ Every 3 months if the crane is not moved

	First maintenance after	Regular maintenance every				Minimum maintenance annually	Inspections	
		125 hrs.	250 hrs.	500 hrs.	1500 hrs.		daily	weekly
<input type="checkbox"/> Lattice sections								
- Check for cracks and damage						×		
<input type="checkbox"/> Guy rods								
- Check for cracks and damage						×		
<input type="checkbox"/> Relapse supports								
- Lubricate bearing				×		×		
<input type="checkbox"/> Relapse cylinder								
- Check for leaks	× 2, 6							
- Check pretension pressure (nitrogen)	× 2, 6			×		×		
- Check oil filling	× 2, 6			×		×		
<input type="checkbox"/> Pneumatic springs								
- Check funktion	× 2, 5, 6			×		×		
<input type="checkbox"/> A-bracket bearing								
- Lubricate				×				
<input type="checkbox"/> Counterweight								
- Check tightening torque of mounting screws	1000 km			or 10000 km		×		
<input type="checkbox"/> Ballasting								
- Lubricate bearings			×			×		
<input type="checkbox"/> Press on pulleys of cable winches								
- Grease guides			×			×		
<input type="checkbox"/> Cable pulleys								
- Check for wear and damage					×	×		
- Check and lubricate					×	×		
<input type="checkbox"/> Crane cables								
- Check, grease, if necessary			×			×		
<input type="checkbox"/> Hook blocks								
- Grease hook				×		×		
- Check distance gap (y)				×		×		

² Check visually before every operation

⁵ When necessary

⁶ During assembly

	First maintenance after	Regular maintenance every				Minimum maintenance annually	Inspections	
		125 hrs.	250 hrs.	500 hrs.	1500 hrs.		daily	weekly
<input type="checkbox"/> Crane operator's cab								
- Check armatures / instruments for function							×	
- Check indicator lights for function							×	
- Check fluid level in expansion tank of engine regulation							×	
<input type="checkbox"/> Crane cab, extendable								
- Check for function				×		×		
- Lubricate bearings				×		×		
<input type="checkbox"/> Overload safety system								
- Check for function							×	
<input type="checkbox"/> Electrical system								
- Check cable connections and battery acid level						×		
<input type="checkbox"/> Fuel system								
- Check for leaks							×	
- Check condition and mounting				×		×		
- Drain off water and sediments				×		×		
<input type="checkbox"/> Slewing gear								
- Check for leaks							×	
- Check oil level								×
- Check mounting screws for tight seating	250 hrs.			×		×		
- Change the oil					4000 hrs.	every 4 years		
<input type="checkbox"/> Turntable locking mechanism								
- Check for function				×		×		
- Lubricate				×		×		
<input type="checkbox"/> Pump distributor gear								
- Check for leaks							×	
- Check oil level								×
- Change the oil	500 hrs.				×	×		

³ In hot regions, 2× per year

	First maintenance after	Regular maintenance every				Minimum maintenance annually	Inspections	
		125 hrs.	250 hrs.	500 hrs.	1500 hrs.		daily	weekly
<input type="checkbox"/> Hydraulic hose lines								
- Check for leaks and damage							×	
- Check for safe condition by expert						×		
<input type="checkbox"/> Hydraulic system								
- Check oil level							×	
- Check for leaks								×
- Replace servo pressure and replenishing pressure filter inserts	250 hrs.			×		×		
- Replace return filter inserts (only for cranes with open hydraulic circuit)	250 hrs.			×		×		
- Replace bleeder filter of hydraulic tank	250 hrs.			×		×		
- Check hydraulic oil, required degree of purity: 20/18/15 (take oil sample and have it checked by oil supplier)	500 hrs.				×	×		
<input type="checkbox"/> Hydraulic cylinder								
- Check for leaks								×
<input type="checkbox"/> Hydraulic pressure accumulator (nitrogen)								
- Check pretension pressures				×		×		
<input type="checkbox"/> Air pressure system								
- Check for leaks								×
- Check operating pressure								×
- Check shut off pressure								×
- Check automatic drain valve for function								×
- Replace air dryer granule elements						×		
- Clean prefilter air dryer						×		

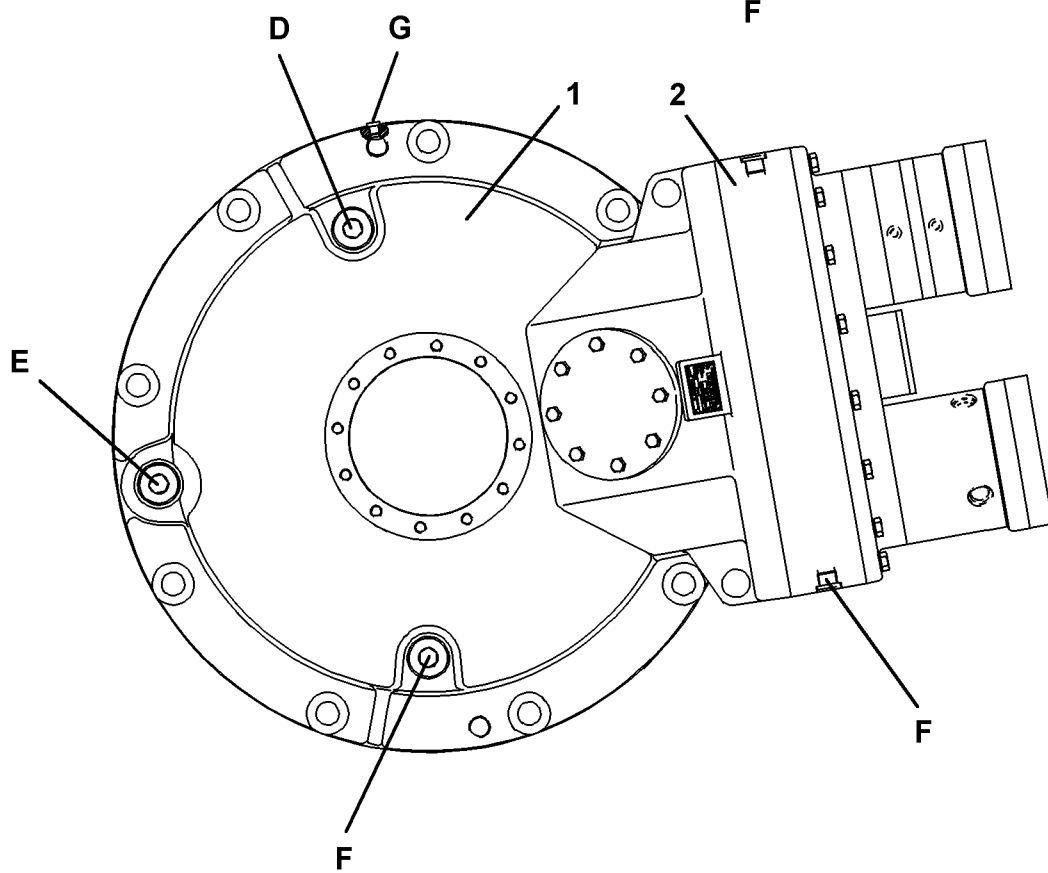
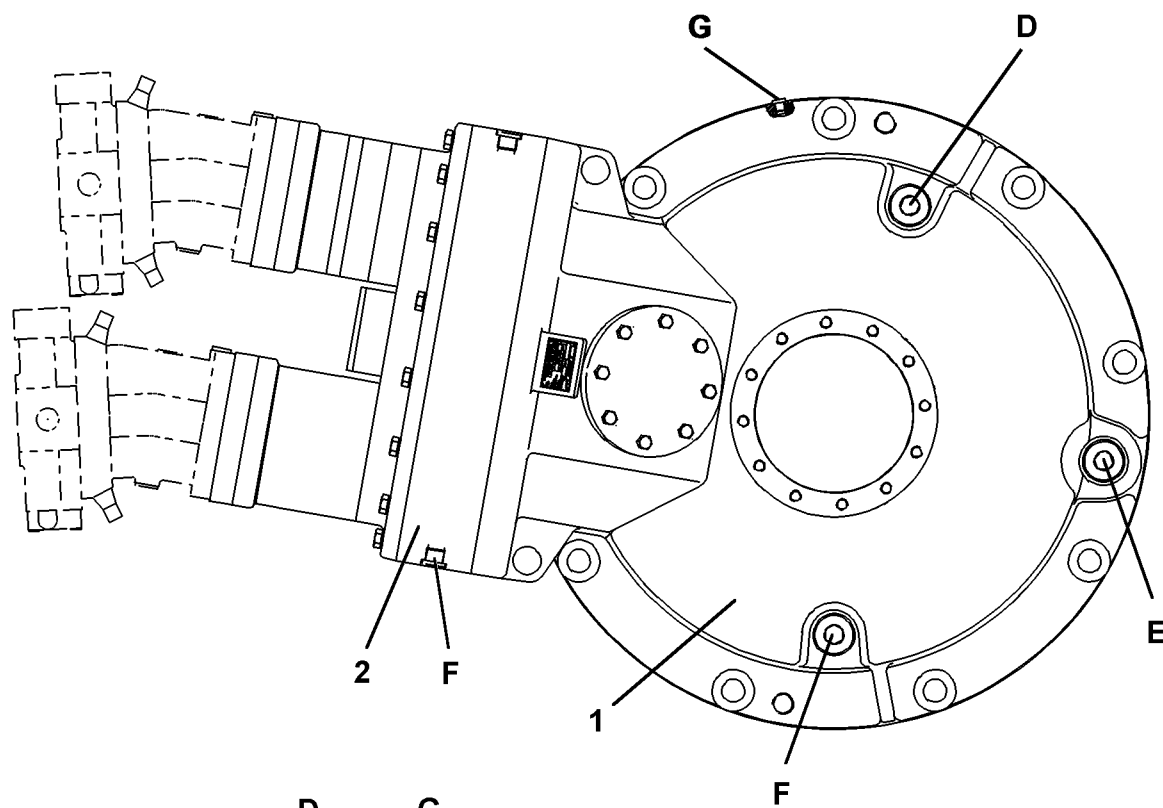
⁴ Observe chapter 7.05, MAINTENANCE GUIDELINES CRANE SUPERSTRUCTURE!

	First maintenance after	Regular maintenance every				Minimum maintenance annually	Inspections	
		125 hrs.	250 hrs.	500 hrs.	1500 hrs.		daily	weekly
<input type="checkbox"/> Central lubrication system								
- Check for function				×				
<input type="checkbox"/> Emergency control								
- Check for function						×		
<input type="checkbox"/> Telescopic boom with cable mechanism								
- Check telescopic boom for cracks						×		
- Lubricate sliding surfaces of telescopic boom bearing		×				×		
- Lubricate change over pulleys of telescoping mechanism		×				×		
- Check mounting screws on change over pulleys for tight seating		×				×		
- Check cable mechanism, readjust, if necessary	250 hrs.			×				
- Disassemble and check boom					20000 hrs.	every 10 years		
<input type="checkbox"/> Pneumatic boom lock								
- Clean air filter with air pressure		×				×		
- Check locking bores				×		×		
- Lubricate locking pins					×	×		

	First main-tenance after	Regular maintenance every				Minimum main-tenance annually	Inspections	
		125 hrs.	250 hrs.	500 hrs.	1500 hrs.		daily	weekly
<input type="checkbox"/> Telescopic boom system								
TELEMATIK								
- Check telescopic boom for distortions, cracks and leaks						×		
- Check hydraulic system components for leaks						×		
- Check telescoping cylinder for proper condition				×		×		
- Check push out rod for proper condition				×		×		
- Check locking pins and locking bores for proper condition				×		×		
- Check inner and outer sliding surfaces for proper condition				×		×		
- Lubricate sliding surfaces						×	⁵	
<input type="checkbox"/> Telescopic boom guying								
- Check for distortion and cracks						×		
- Lubricate grease fitting on the TA / TY-guying						every 3 months ^{5, 6}		
- Check the oil level on the guy winch								every 6 months
- Change the oil on the guy winch						every 4 years		
<input type="checkbox"/> Derrick ballast								
- Check frame, suspension and guide section for distortion and cracks						×		
- Check wheels for condition and tight seating						×		

⁵ And as necessary

⁶ At installation



1. Oil level in travel and angular gear

Check the oil level on the oil level plug (E) .

C A U T I O N: Make sure to observe utmost cleanliness, to prevent any dirt infiltration into the gear.

D = Oil fill for travel gear (1) and angular gear (2)

E = Oil level for travel gear and angular gear

F = Oil drain for travel gear and angular gear

G = Grease lubrication

1.1 Check the oil level

Prerequisites:

The crane is in horizontal position.

The travel and angular gear are at a standstill.

The oil chamber of the travel gear is connected with the oil chamber of the angular gear, so that the oil level for both gears can be checked at (E) .

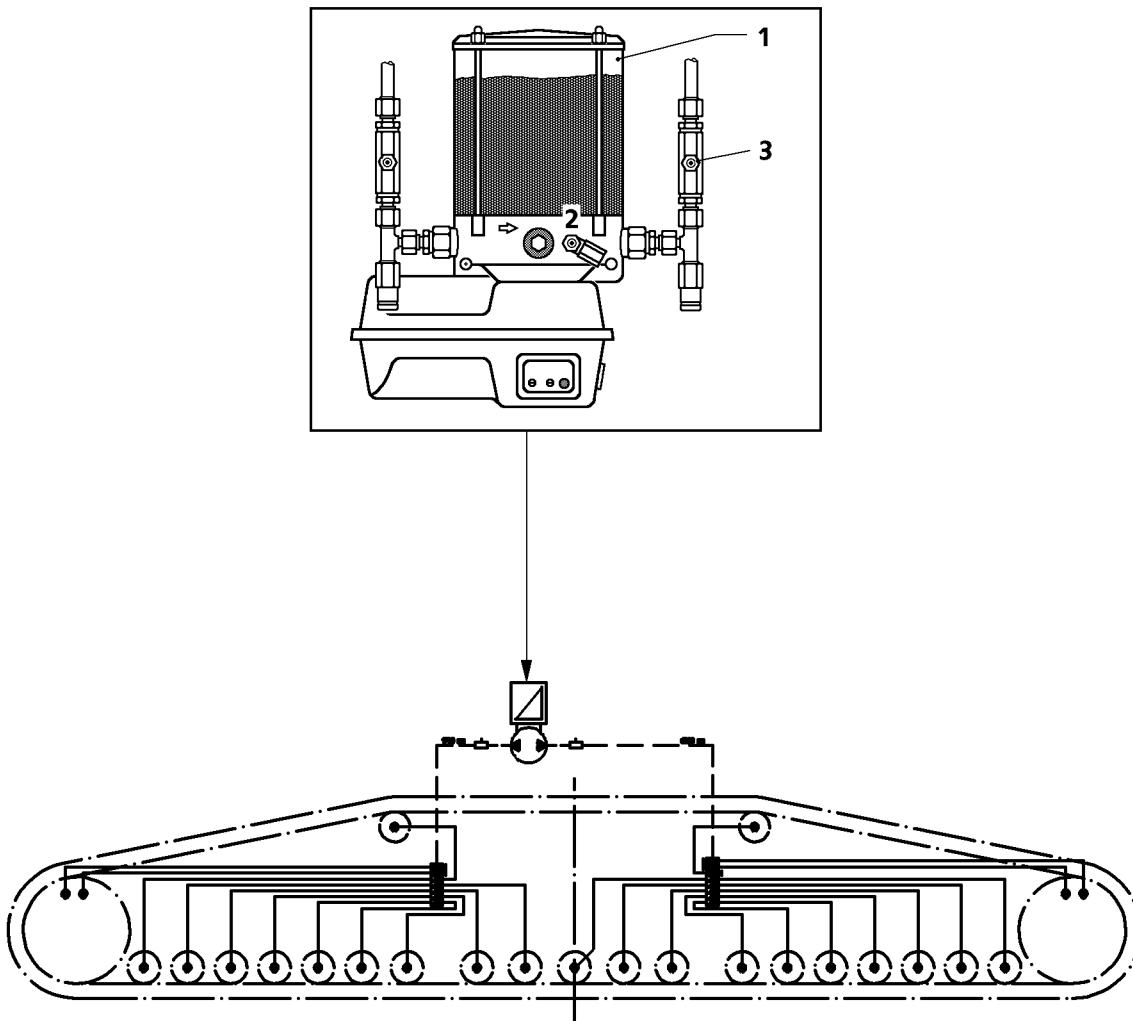
- Turn out the oil level plug (E)
- If oil runs out of the control port (E) or if the oil level reaches the lower edge of the control port (E), then the oil level is correct.
- Turn in the oil level plug and tighten.

Note: The oil level must be at the level of the oil level plug (E) .

C A U T I O N: If the oil level has dropped below the control port (E), then oil according to the lubrication chart must be added until the oil level is again at the lower edge of the control port (E) .
If no oil is added, there is the danger of causing serious gear damage.

1.2 To change the oil

- Open the oil filler plug (D)
- Turn out the oil drain plug (F) of the travel gear (1) with seal ring and drain oil into a suitable container. When the oil chamber of the travel gear is empty (1), clean the oil drain plug and sealing surface.
- Reinsert the oil drain plug with new seal ring and tighten.
- Turn out the oil drain plug (F) for the angular gear (2) with seal ring and drain oil into a suitable container. When the oil chamber of the angular gear is empty (2), clean the oil drain plug and sealing surface .
- Insert the oil drain plug with new seal ring and tighten.
- Turn out the oil level plug (E) .
- Add oil according to the lubrication chart on the oil filler port (D) until oil starts to run over on the oil level port (E) .
- After oil has been added on the oil filler port (D), wait approx. 2 minutes until the oil has distributed in the travel gear and the angular gear .
- Recheck the oil level , add oil as necessary.
- Clean the sealing surfaces. Clean the oil level plug (E) and oil filler plug (D), apply new seal ring, reinsert and tighten.



2. Central lubrication system for crawler

The crawler is equipped with a central lubrication system.

Grease points are:

- crawler rollers
- turras bearing

These points are supplied automatically with the correct amount of grease, when travelling with the crawler.

2.1 Fill the grease tank

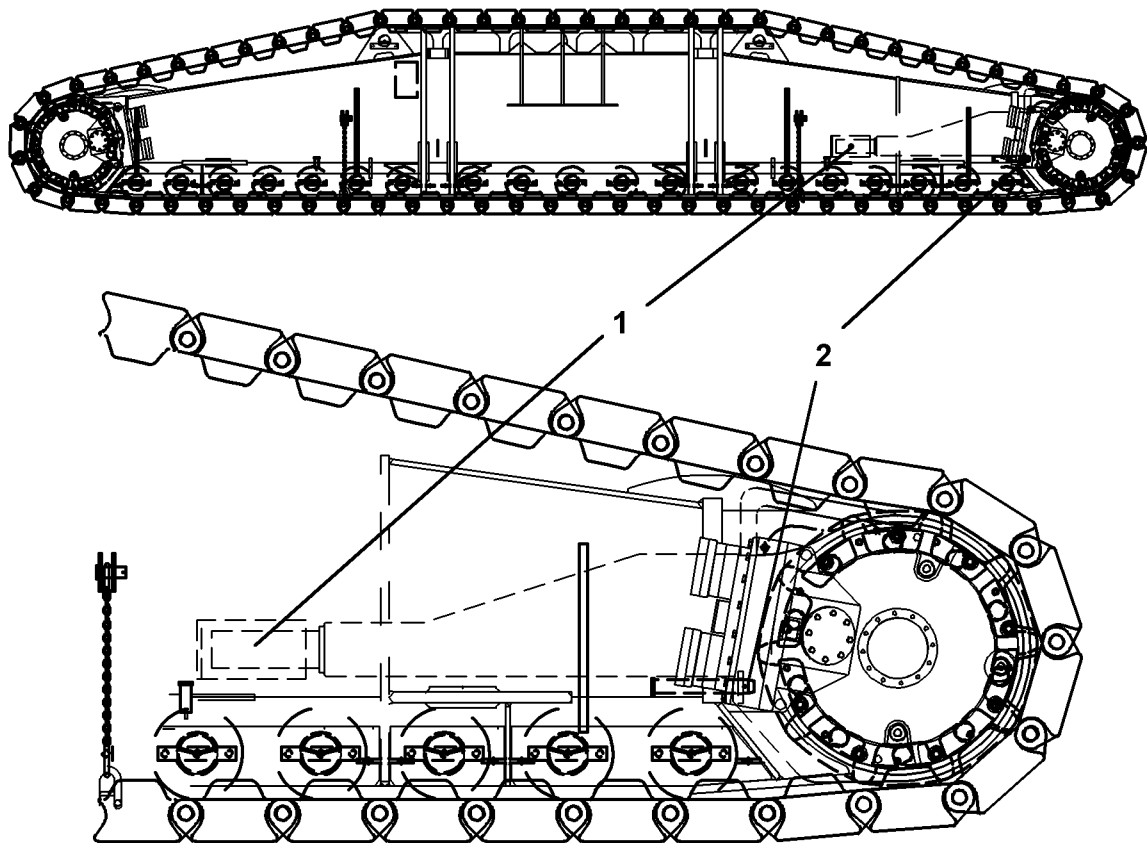
- With a commercially available grease pump, fill the tank (1) via the grease fitting (2) on the central lubrication pump.

**C A U T I O N : Make sure that the grease tank is always filled with grease, according to the lubrication chart.
When filling the grease tank, observe utmost cleanliness to prevent any dirt infiltration!**

2.2 Fill the lube lines

- Fill the lube lines with an external lube pump via the grease fitting (3).

C A U T I O N : Make sure that the grease lines are refilled after every repair on lubricated components. If this is not observed, the unit will run dry. When filling the lube lines, observe utmost cleanliness!

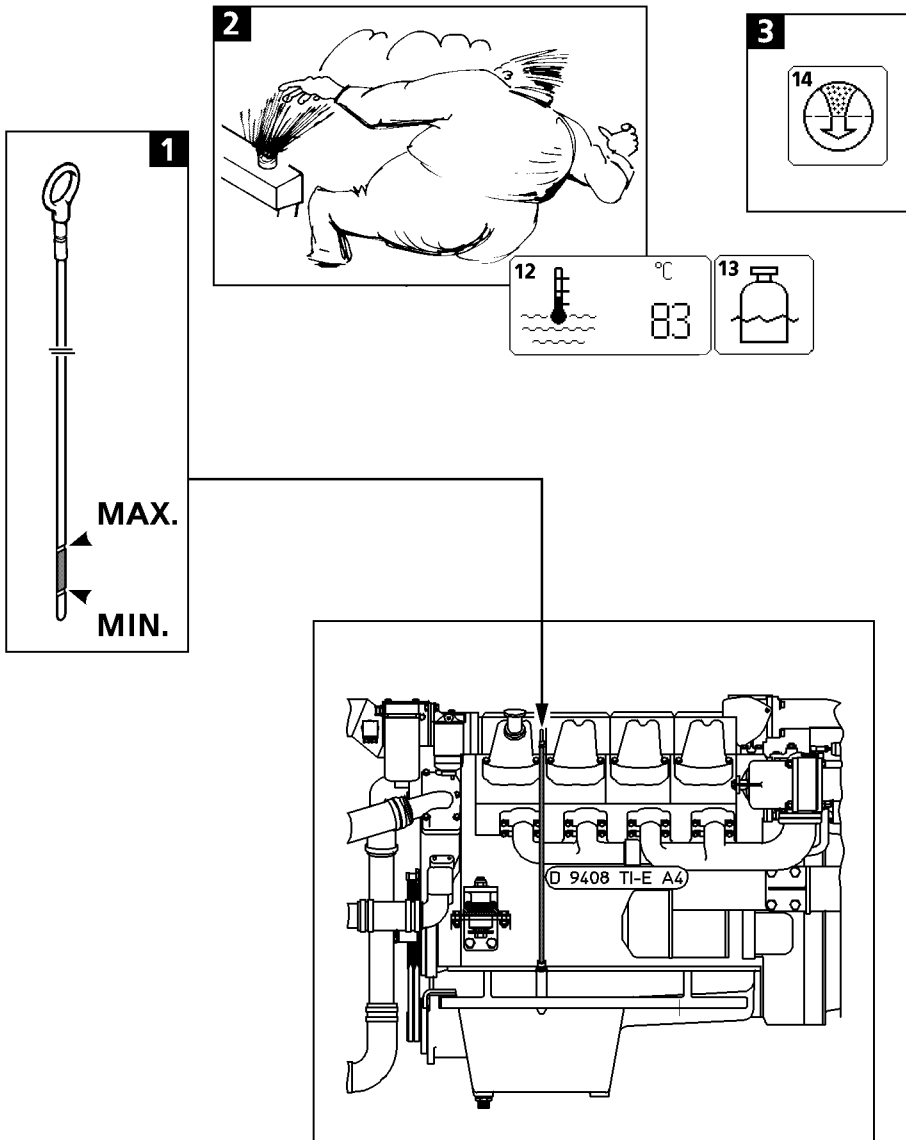


3. Tension the track chain

- The crane must be positioned on level ground.
- The track chain is tensioned with an hydraulic tensioning cylinder (1) .
- The tensioning cylinder and hand pump are in the tool box.

3.1 Tensioning procedure

- Install the tensioning cylinder (1) in the crawler carrier and extend with the hand pump until the tension resistance is greater than the force on the hand pump.
- Push the spacer plates (2) between the sliding section and the crawler carrier and secure with pin .
- Relieve the tensioning cylinder again.
- The crawler must be moved forward and backward at least by one crawler length to release the tension in the lower chain area.
- If necessary, repeat the tensioning procedure and place additional spacer plates (2) .



1. Crane engine

or maintenance and repairs in the engine area, the following must be observed:

Never step on fuel lines.

D A N G E R : It must be ensured that the engine area remains free of Diesel fuel,
D A N G E R OF FIRE !

Observe utmost cleanliness, especially when changing filters and bleeding the system! Dry up any spilled fuel immediately!

1.1 Engine oil, Fig. 1**1.1.1 Oil level****Prerequisites:**

The crane is in horizontal position.

The engine is turned off, wait for a few minutes until the oil has collected in the oil pan.

- Pull the dipstick, wipe it off,
- reinsert it and pull it out again.
- Check the oil level.

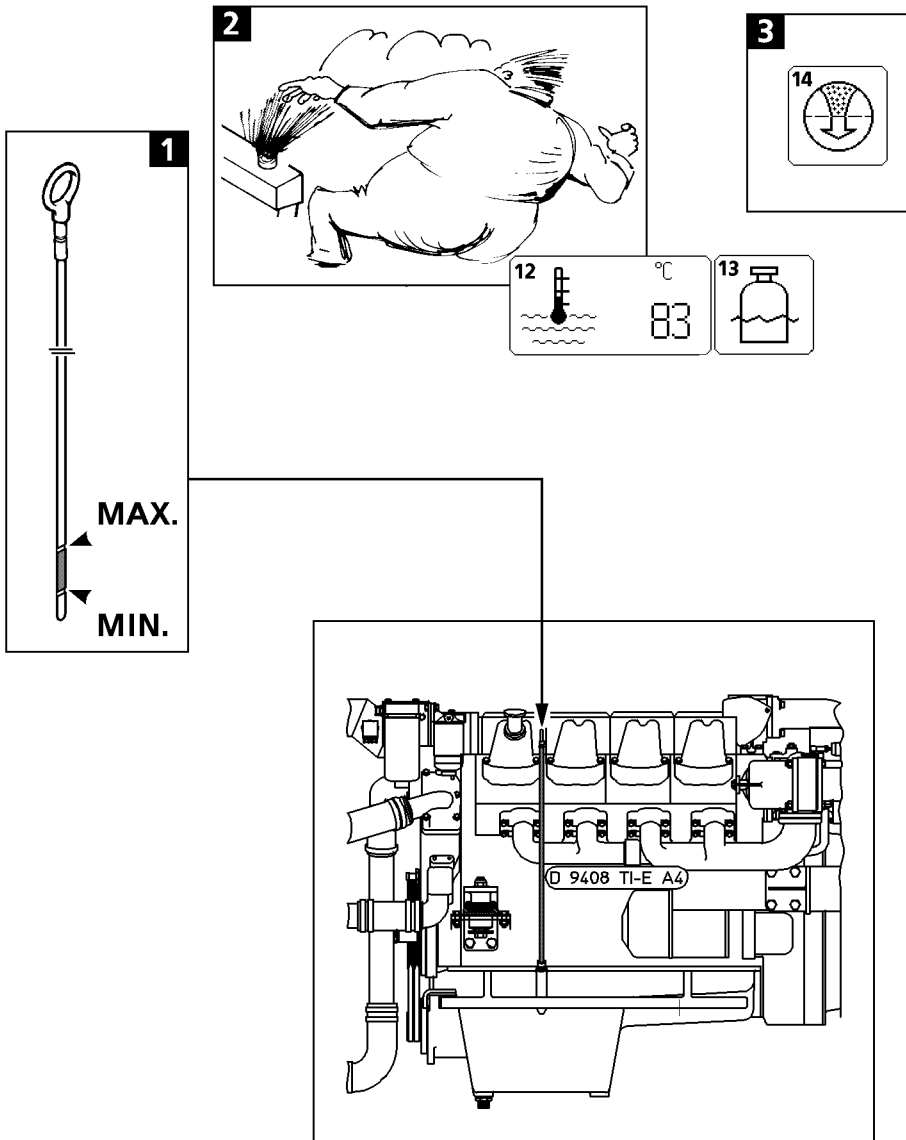
Note: The oil must be between the MIN.- and MAX.- mark on the dipstick.

C A U T I O N : If the oil level has dropped below the MIN. mark, then engine oil according to the lubrication chart must be added until the oil level is again between the MIN.- and the MAX. mark.
If no oil is added, there is the danger of causing serious engine damage due to insufficient lubrication.

- Reinsert the dipstick.

1.1.2 To change the oil

refer to the separate operation manual for "LIEBHERR Diesel engines"



1.2 Coolant, engine cooling, Fig. 2

The coolant level is monitored by the LICCON computer system. If the coolant level is too low, the symbol element "coolant level too low" (13) lights up on LICCON monitor . Add coolant in the same mixing ratio, according to the lubrication chart. The coolant temperature - crane engine can be read on symbol element "coolant temperature - engine" (12) on LICCON monitor in degrees [°].

D A N G E R : **Check the coolant only when the engine is cold, otherwise there is the DANGER OF INJURY, burns and scalding !**

- Turn the cover on the filler neck of the coolant expansion tank to the left or to the first notch and relieve the pressure.
- Remove the cover.
- If necessary, add coolant according to the lubrication chart until it runs over.

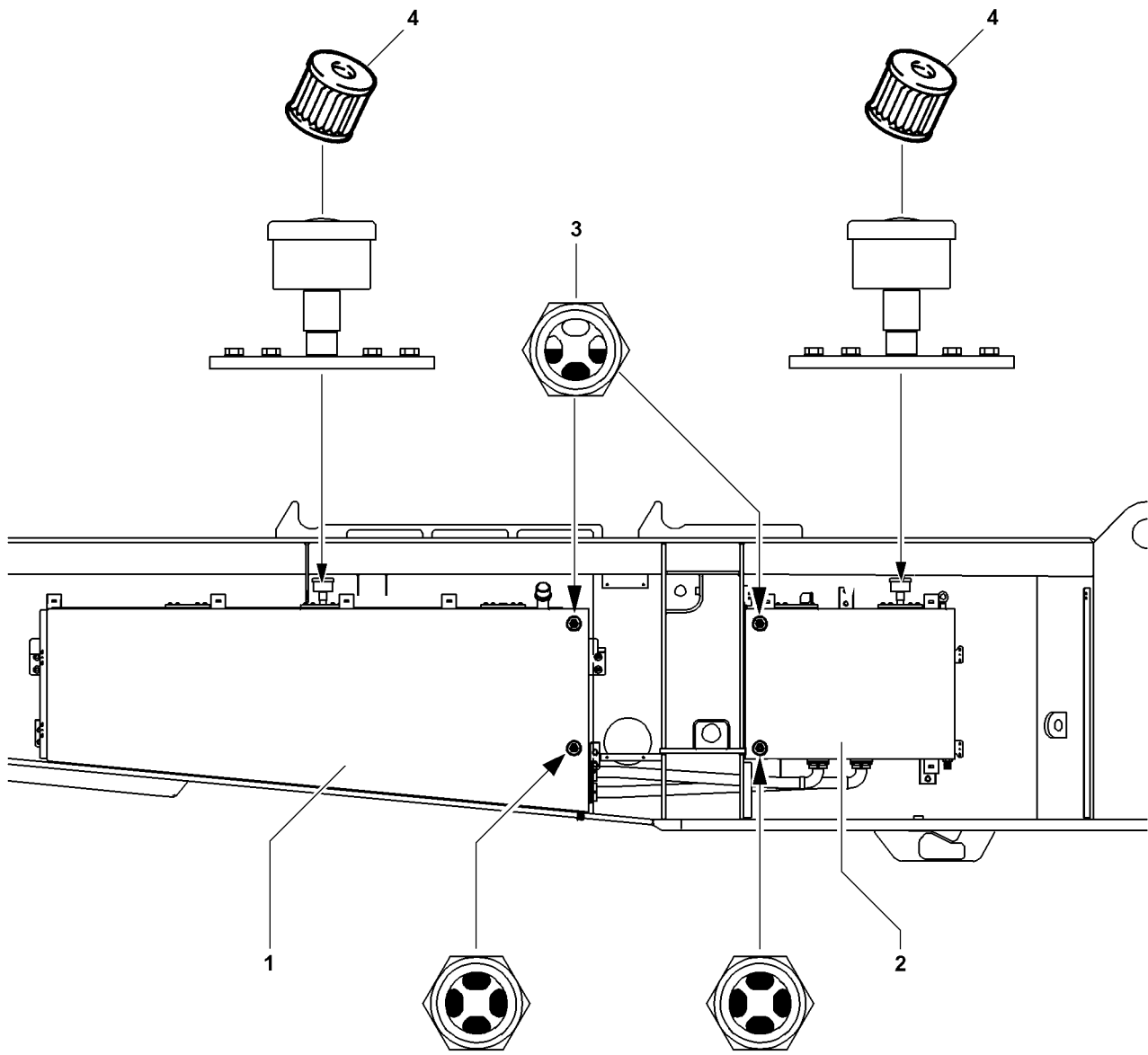
Note: The coolant expansion tank may only be refilled on the filler neck. Use coolant as specified on the lubrication chart. In case the coolant level is low, add coolant in the same mixing ratio.

Mixing ratio: 50 Vol % Corrosion inhibitor and antifreeze,
 50 Vol % Fresh water.

1.3 Air filter, Fig. 3

The air filters are electronically monitored by the LICCON system. If a vacuum is created in the intake line due to contaminated filter inserts, the symbol element "air filter contaminated" (14) on the LICCON monitor lights up. In this case, clean the filter inserts or replace them.

Note: For maintenance on air filters, refer to separately issued "LIEBHERR Diesel engines".



2. Oil level - hydraulic fluid reservoir

The cylinders must be completely retracted to check the fluid level.
The oil level must be in the middle of the glass view port.

A C H T U N G : If no oil is visible in the upper sight gauge (3) of the oil reservoir (1) or the auxiliary oil reservoir (2), then oil must be added according to the lubrication chart, until the oil level is again at the center of the sight gauge. If the fluid level is too low, the pumps could be damaged. The cylinders cannot be fully extended.

The cylinders must be completely retracted to check the fluid level. If they are extended, there is the danger of overfilling, that is, when retracting, the fluid will flow out of the aerator. If the jacks are retracted too quickly, the reservoir could be damaged.

Add oil

Add oil to the center of the upper sight gauge (3) on oil reservoir (1) . After adding oil, wait for 2 minutes until the oil had distributed evenly in the oil reservoirs (1 + 2). Recheck the oil level.

C A U T I O N : For filling, use a fine-mesh sieve.

Start the crane engine.
Start all crane movements slowly
Recheck fluid level and if necessary, top off.

2.1 Vent and bleed air filter

Open the cover with the turn lock and check the filters (4) of the oil reservoir (1) and auxiliary oil reservoir (2) for contamination. (Visual inspection)

Note: If the filters (4) are extremely dirty, they must be changed slowly.

Replace the cap.

2.2 Hydraulic hose lines

The operational safety of the hydraulic hoses must be checked at least once per year by a trained personnel.

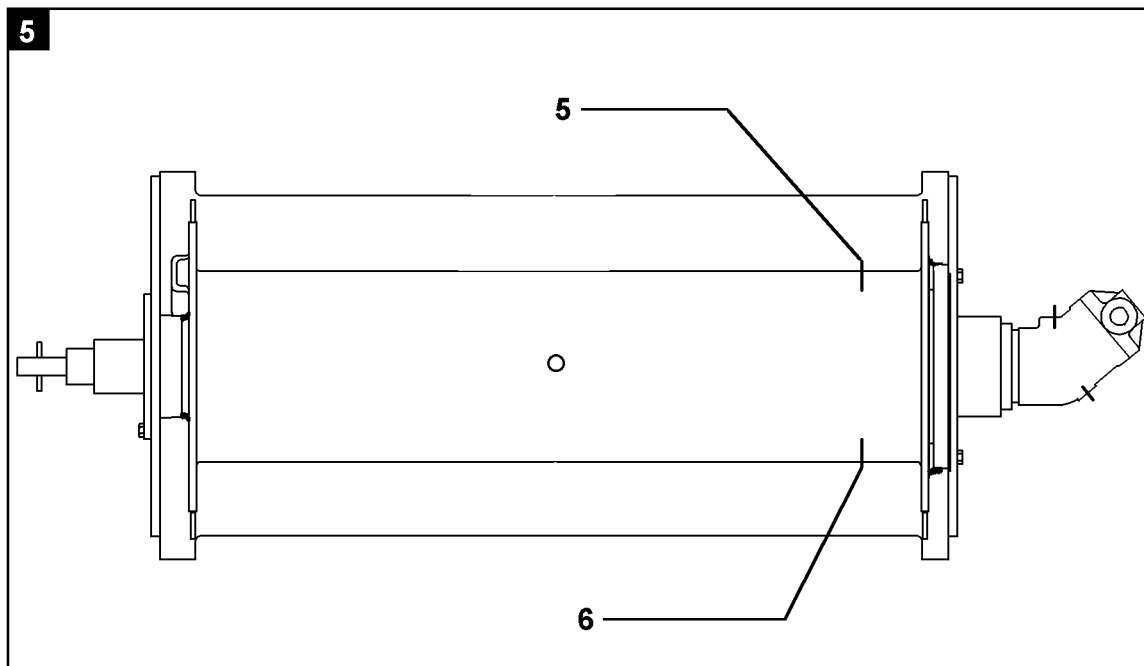
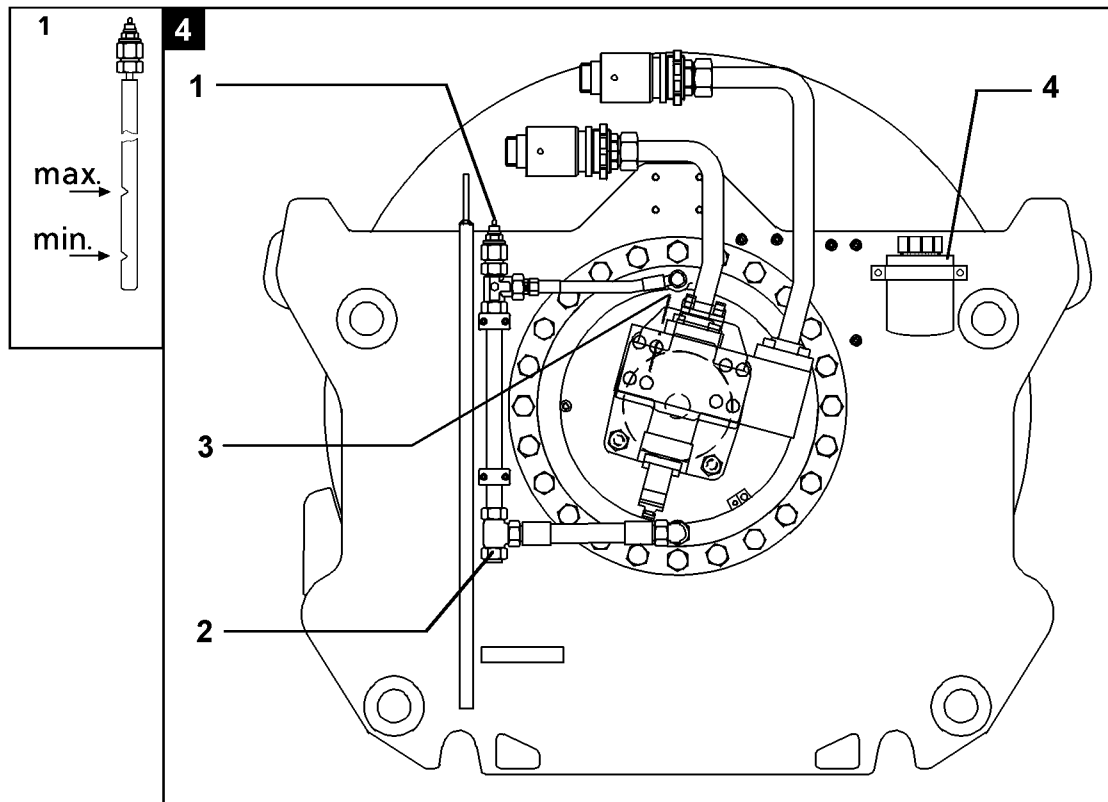
Replacing the hose lines

The hose lines must be replaced at appropriate intervals.

On the basis of our experience we recommend the following maximum periods of use:

Crane operation	Maximum period of use
in severe loading and unloading operation with high operating temperatures and frequent movement cycles	approx 3 years
in loading and unloading operation	approx 6 years
in assembly operation with infrequent maximum output	approx 12 years

C A U T I O N : The hoses on the suction ducts of the oil pan must be visually inspected monthly for tears and damage, and replaced, as necessary.



3. Rope winches Fig. 4

Check the oil level with the oil dipstick

- | | | |
|---|---|---|
| 1 | = | Oil dipstick, oil fill in hole, vent |
| 2 | = | Oil drain |
| 3 | = | Oil fill in hole for hydraulic motor-shaft (only at assembling) |
| 4 | = | Overflow reservoir |

CAUTION: Always observe utmost cleanliness, to prevent any dirt infiltration, so that the internal area of the gear or disk brake is not contaminated.

3.1 Check the oil level**Prerequisites:**

The hoist gear is at a standstill.
The crane is in horizontal position.

- Check the oil level with the oil dipstick (1).
- The oil must be at a level between the minimum and maximum markings on the oil dipstick.

Note: When checking the oil level, the dipstick must not be screwed in.

CAUTION: If the oil level is fallen below the minimum marking, oil **MUST** be refilled according to the lubrication table until it reaches a level between the Min. - Max. markings. If it is not refilled, the gear could be damaged.

Reinsert the dipstick.

3.2 Overflow reservoir (4)

When the oil of the hydraulic motor for the winches is warmed up, oil can get via a check valve into the overflow reservoir (4), but cannot return to the hydraulic system after it cools off. For that reason, the oil which has collected in the overflow reservoirs (4) must be disposed of in regular intervals.

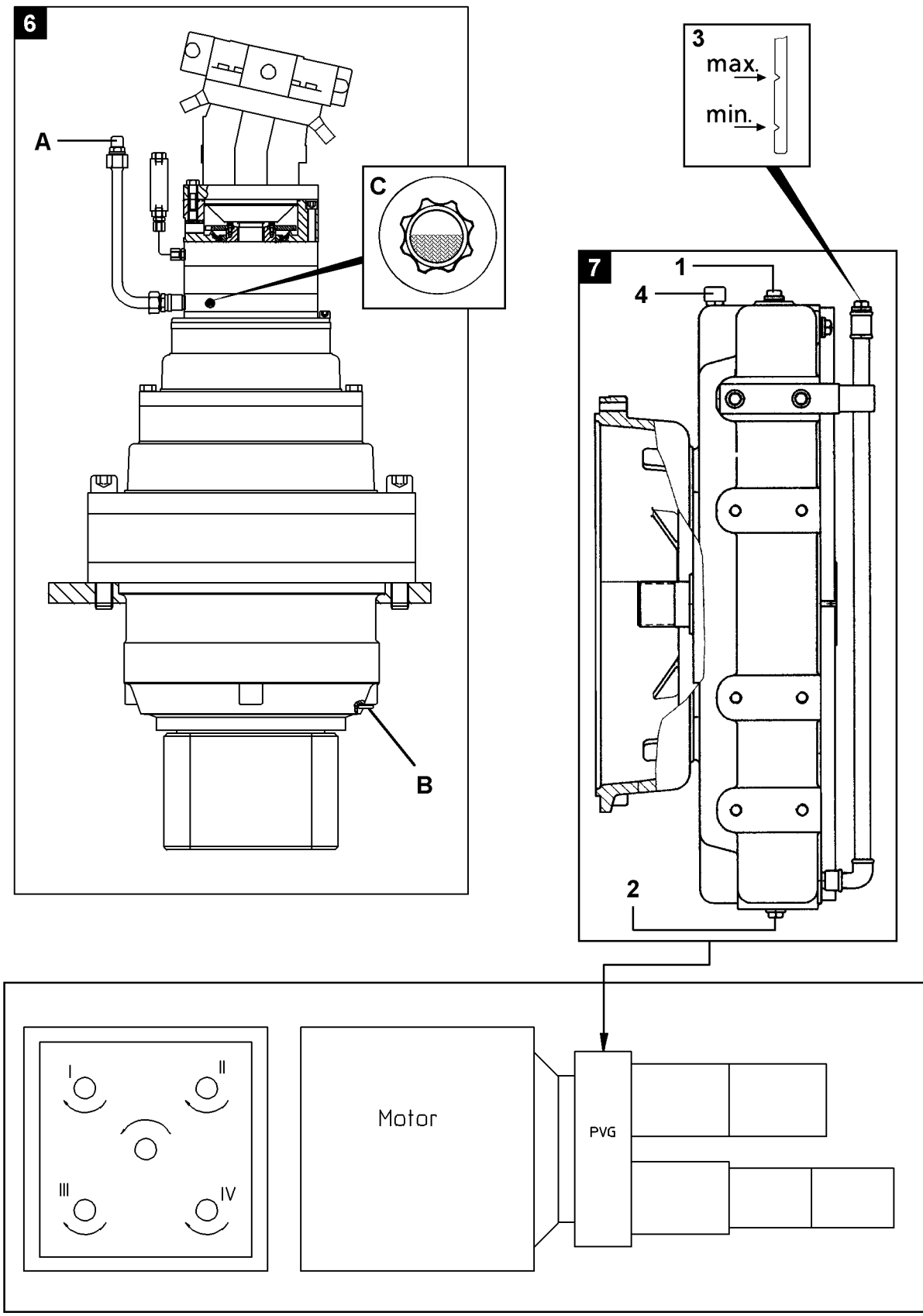
3.3 Change the oil

- Remove the oil filler plug (1) for venting.
- Remove the oil drain plug (2) with seal ring and drain the oil into a suitable container.
- Reinstall the oil drain plug (2) with new seal ring and tighten by hand.
- Add oil according to the lubrication chart on the oil filler port (1).
- Install the oil filler plug (1) and tighten.

3.4 Installation winch Fig. 5

- | | | |
|---|---|-----------------|
| 5 | = | Oil filler port |
| 6 | = | Oil drain |

Oil supply for initial installation or after repair of installation winch.



4. Slewing gear Fig 6

Check the oil level at the sight gauge (C)

CAUTION: Always observe utmost cleanliness, to prevent any dirt infiltration, so that the internal area of the gear is not contaminated.

A = Oil filler port, vent
B = Oil drain
C = Sight gauge

4.1 Check the oil level**Prerequisite:**

The crane is in horizontal position.

The slewing gear is at a standstill.

- Check for leaks (visually).
- Check the oil level at the sight gauge (C).

Note: The oil level must be in the middle of the sight gauge (C)

CAUTION: If the oil level has dropped below the sight gauge, then oil must be added according to the lubrication chart until the oil level is again in the middle of the sight gauge.
If no oil is added, there is a danger of severe gear damage.

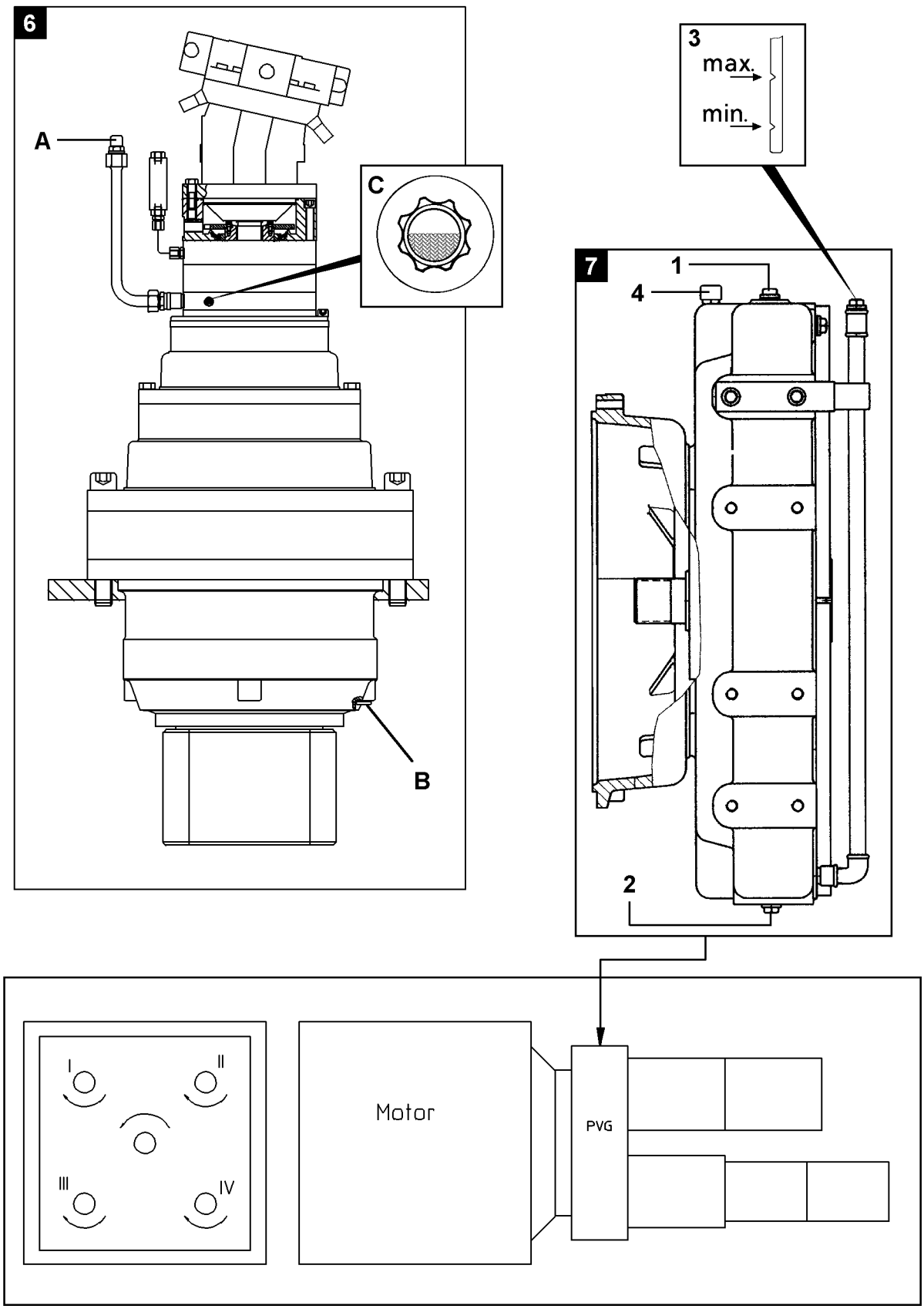
4.2 Oil change**Prerequisite:**

The crane is in horizontal position.

The slewing gear is at a standstill.

The gear is at operating temperature.

- Open the oil filler / vent (A)
- Unscrew the drain plug (B) with seal ring and drain the oil.
- Clean the drain plug (B) and sealing surface on the housing.
- Reinstall the drain plug (B) with new seal ring and tighten.
- Add oil according to the lubrication chart on the oil filler port until the oil reaches the middle of the sight gauge (C).
- Close the oil filler port / vent (A)
- Check the oil level as described above.



5. Pump transfer case Fig. 7

With the gears at a standstill, check the oil level with the oil dipstick (3).

The oil must be at a level between the minimum and maximum markings on the dipstick.

C A U T I O N: Always observe utmost cleanliness, to prevent any dirt infiltration, so that the internal area of the gear is not contaminated.

- 1 = oil filler port
- 2 = vent
- 3 = oil dipstick
- 4 = oil drain

5.1 Check the oil level**Prerequisite:**

The crane is in horizontal position.

The pump transfer case is at a standstill.

Oil is at operating temperature

- Check for leaks (visually).
- Check the oil level with the dipstick (3)

Note: When checking the oil level, do not screw in the dipstick .

C A U T I O N: Loss of oil indicates defective shaft seal rings or defective housing sealing. This must be taken care of immediately. If the oil level has fallen below the minimum mark, oil **MUST** be added according to the lubrication chart until the oil level is again between the Min. - Max. mark. If no oil is added, the gear could be damaged.

5.2 Change the oil**Prerequisite:**

The crane is in horizontal position.

The pump transfer case is at a standstill.

Oil operation temperature

- Open the oil fill in hole(1) and the vent(4)
- Remove the oil drain plug (2) with seal ring and drain the oil into a suitable container.
- Before refilling, rinse through with oil according to the lubrication table. Drain the oil into a suitable container.
- Clean the drain plug (2) and sealing surface on the housing.
- Reinstall the drain plug (2) with new seal ring and tighten.
- Add oil according to the lubrication chart on the oil filler port (1) until the oil reaches the center of the two notches.
- Reinstall the oil filler plug (1) and close the vent cap (4)
- Check the oil level as described above.

6. Slewing ring connection

CAUTION: Before and after longer down time, especially before and after downtime for winter, carry out the lubrication procedure especially carefully, to ensure the best possible protection from corrosion.

If the crane is not moved for longer than 3 months, then it must be lubricated every 3 months with an external lube pump on the grease fitting block , until grease emerges on all lube points. Then the corresponding crane movement must be repeated several times and the lubrication procedure must be repeated.

- Grease the slewing ring externally.
- The bearing is being lubricated by the central lubrication system.

6.1 Tilt play of slewing ring connection

The operational readiness of the slewing ring connection is limited by a **maximum permissible tilt play** of the slewing race. The wear dimension can be determined by measuring the tilt play with the slewing ring connection installed .

Tilt play	Permissible tilt play	DANGER ZONE! (max. permissible tilt play)
1.0 mm	2.0 mm	2.5 mm

Tilt play: Tilt play measured on new machine, with load.

Permissible tilt play: The slewing race can be reconditioned.
Reconditioning is permissible only 1x !!

DANGER ZONE: Maximum permissible tilt play.
If the danger zone is reached, the slewing ring connection must be replaced!!

DANGER : The permissible tilt play of 2.0 mm may not be exceeded. If the maximum permissible tilt play is reached or exceeded, there is a **DANGER OF ACCIDENTS!**
The slewing ring must be replaced!

7. Diaphragm reservoir in the hydraulic system

Following diaphragm reservoirs are equipped in the hydraulic system:

- Feed pressure (2 reservoir) each 10 bar

The pretension pressures for the reservoirs is noted in the hydraulic schematics and on each reservoir. The pretension pressure must be measured separately in each reservoir.

C A U T I O N : In strongly fluctuating ambient temperatures, such as in countries with extremely warm or cold temperatures, as well as in countries with large temperature differences between summer and winter, the pressures must be checked and corrected, as necessary.

Prerequisites:

The crane engine is at a standstill, this relieves the reservoirs on the fluid side.

- Check the pretension pressure with a test and inflation device. Correct pressure as necessary.

D A N G E R : When filling the diaphragm reservoir, NEVER use air or oxygen, this can cause an

E X P L O S I O N !!!

The pressure in the nitrogen cylinder must not exceed the maximum permissible operating pressure of the reservoir or the pressure gauge. Otherwise, a pressure reducing device must be connected between the cylinder and the inflating device.

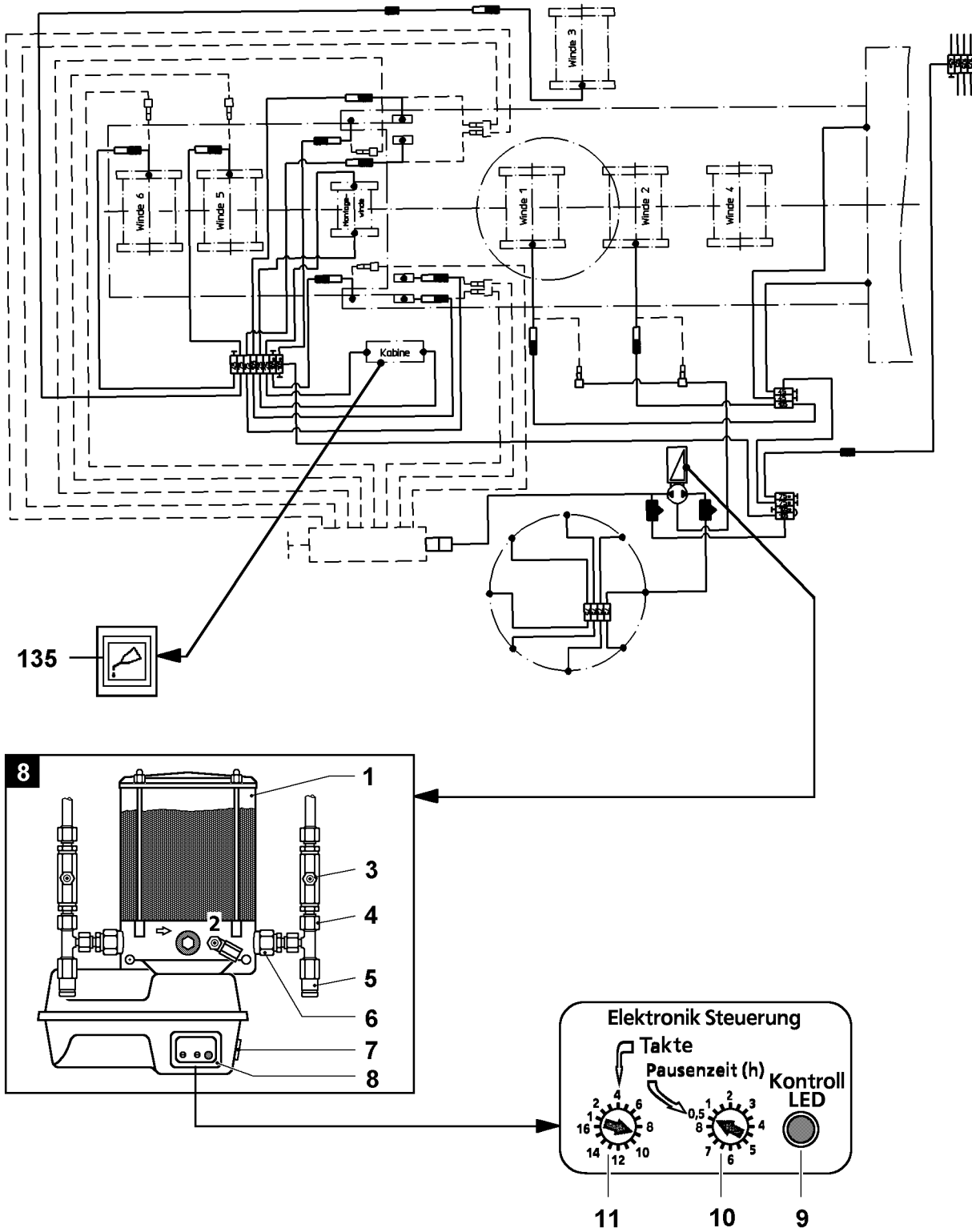
Note: In addition, all national and regional regulations regarding pressurized container checks and inspections must be observed.

7.1 Pressure filter in crane hydraulic

The pressure filter is equipped with a maintenance indicator. If the red bar is visible when the oil is at opening temperature, then the filter element must be changed .

To change the filter:

- Turn off the crane engine.
- Loosen the filter and catch emerging oil in a suitable container.
- Remove the filter element and dispose of it properly.
- Clean the sealing surface on the filter base,
- Lubricate the rubber seal ring on the new filter with oil.
- Install the filter and tighten .
- Start the engine and check for leaks.
- Run through all crane movements to bleed the hydraulic system,
- then recheck the oil level, add oil, as necessary.



8. Central lubrication system, Fig. 8

The crane superstructure is equipped with a central lubrication system. All lube points (see overview, left) on the slewing connection, the bearing on the pivot section, the bearings of the luffing cylinders and the hoist winches are automatically supplied with the correct amount of grease, depending on the operating hours.

Pump running time: 9 cycle
Break time: 0.5 hours

Note: Cleaning the crane car washes or steam is permissible.

CAUTION: If the crane is not moved for longer than 3 months, then it must be lubricated every 3 months with an external lube pump on the grease fitting block, until grease emerges on all lube points. Then the corresponding crane movement must be repeated several times and the lubrication procedure must be repeated.

8.1 Components of system**Pos. Description**

1	Grease container	
2	Grease fitting -	To supply the central lubrication pump
3	Grease fitting -	To supply the lube lines
4	Pump outlet	
5	Pressure relief valve	
6	Pump element	
7	Push button	
8	Control	
9	Illuminated diode (yellow)	
10	Notched switch -	Break time (hrs.)
11	Notched switch -	cycle

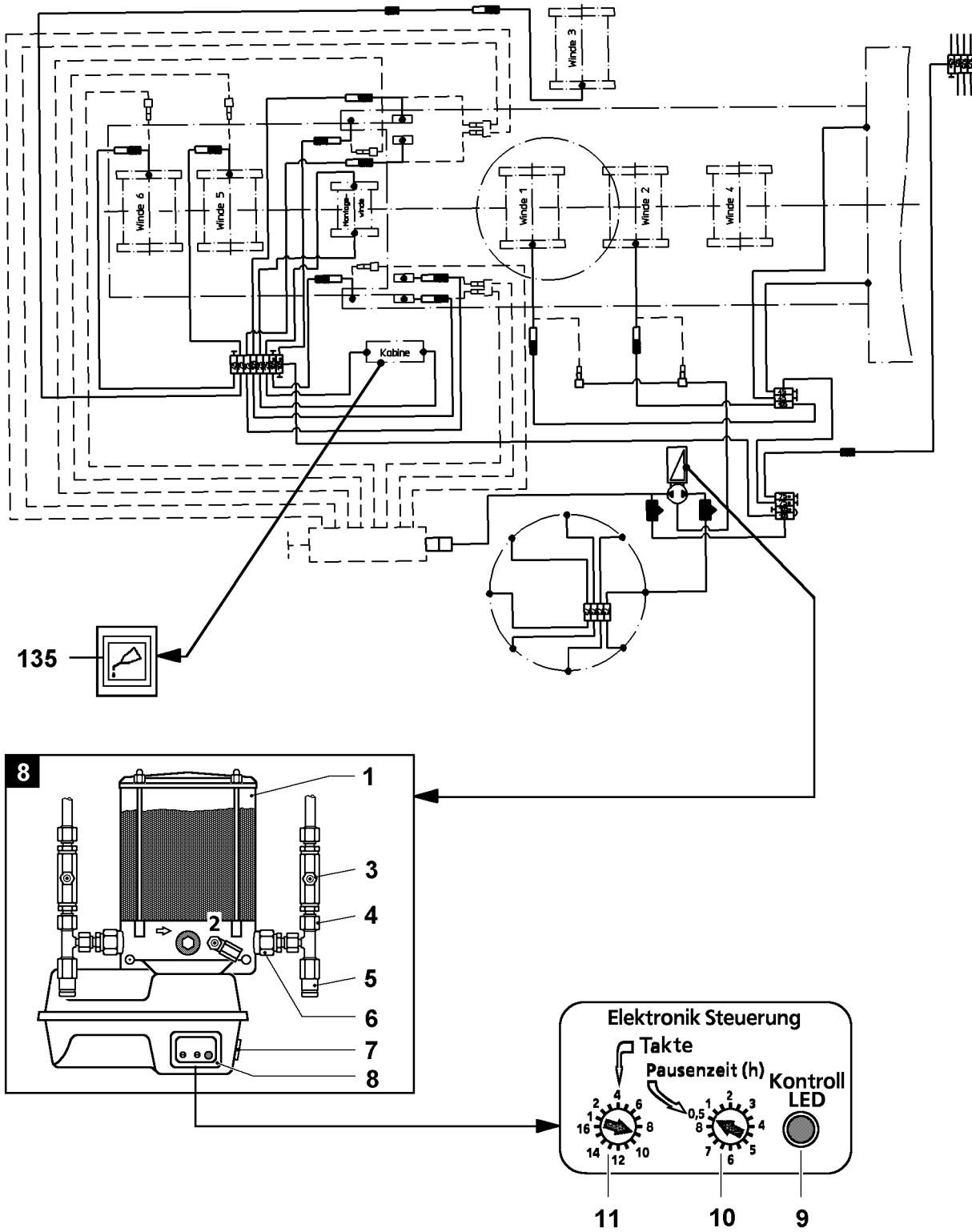
8.2 Set the lubrication and break time

- Turn on the ignition of the crane motor, when the ignition is turned on, the yellow diode (9) lights up for approx. 2 seconds to show the functional readiness of the control (8).

Note: During the lubrication procedure, the yellow diode (9) blinks on the housing in 0.5 second intervals. The lubrication and break time is set at the factory. The times can be changed on the switches (10,11), if necessary.

8.3 Function check

- With the ignition turned on, trigger 2 to 3 additional lubrication impulses, to check if grease emerges on all lube points.
- With the system blocked, but proper function of the electric pump, the lubricant emerges via the pressure relief valve (5). This feature has been designed to protect and to monitor the system.



8.4 Cycle control

The central lubrication system is being progressively monitored. This means that a proximity switch translates the piston strokes of the distributor in the central lubrication system into electrical control signals and directs them to the control unit. If the control signals are not available or if they are incomplete, then the indicator light (135) blinks to show that there is an erroneous function or other problem.

8.5 Blinker code, cycle control

During operation

Ignition ON, operational

Indicator light (135) lights up for 1.5 seconds and turns off.

Lubrication is active

Indicator light (135) lights up for 0.5 seconds and turns off for 0.5 seconds and is off for 0.5 seconds, etc.

In case of a problem

Error - too much pressure

Indicator light (135) lights up for 2 seconds and turns off for 4 seconds, then lights up again for 2 seconds and is off for 4 seconds, etc.

Error - engine

Indicator light (135) lights up continuously.

Error - monitoring time cycle input

Indicator light (135) lights up 0.5 sec. and is off 0.5 seconds, then the indicator light (135) lights up 0.5 seconds and is off 0.5 second, etc.

8.6 Entry into the automatic lubrication (intermediate lubrication)

- With ignition turned on, actuate the red button (7) on the protective motor housing of the pump.
- This function allows for intermediate lubrications to be made, for example after washing the crane, or to refill the grease lines after a repair.

8.7 Fill the grease tank

- With a commercially available grease pump, fill the tank (1) via the grease fitting (2) on the central lubrication pump.

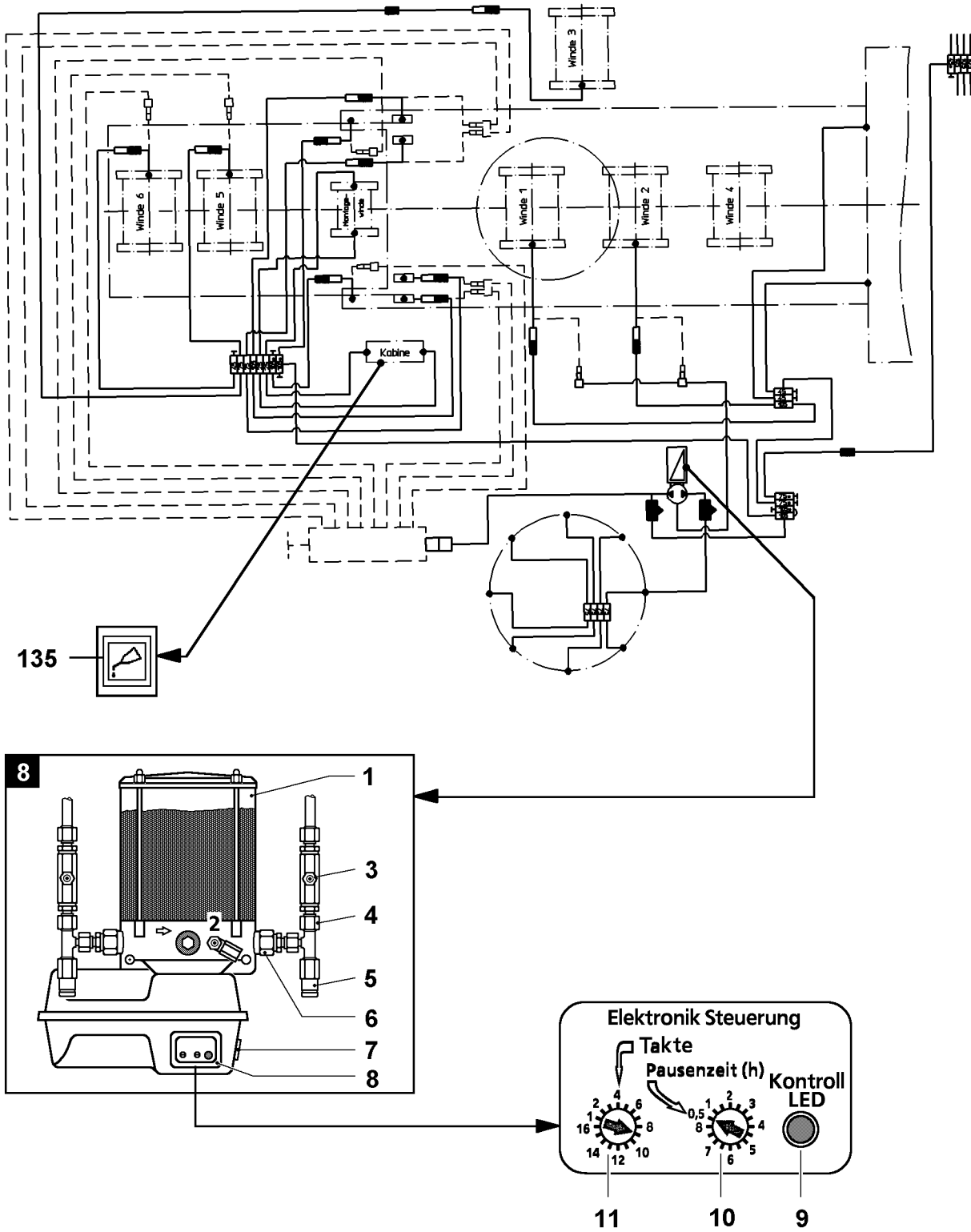
CAUTION: Make sure that the grease tank is always filled with grease, according to the lubrication chart.

When filling the grease tank, observe utmost cleanliness!

8.8 Bleeding the system

If the grease tank (1) has not been refilled and gets empty, then the system must be bled.

- Fill the grease tank.
- Unscrew the main line from the pump outlet (4).
- Actuate the auxiliary lube impulse until lubricant free of air bubbles emerges on the pump outlet (4).
- Reconnect the main line.
- Carry out an additional lubrication procedure.



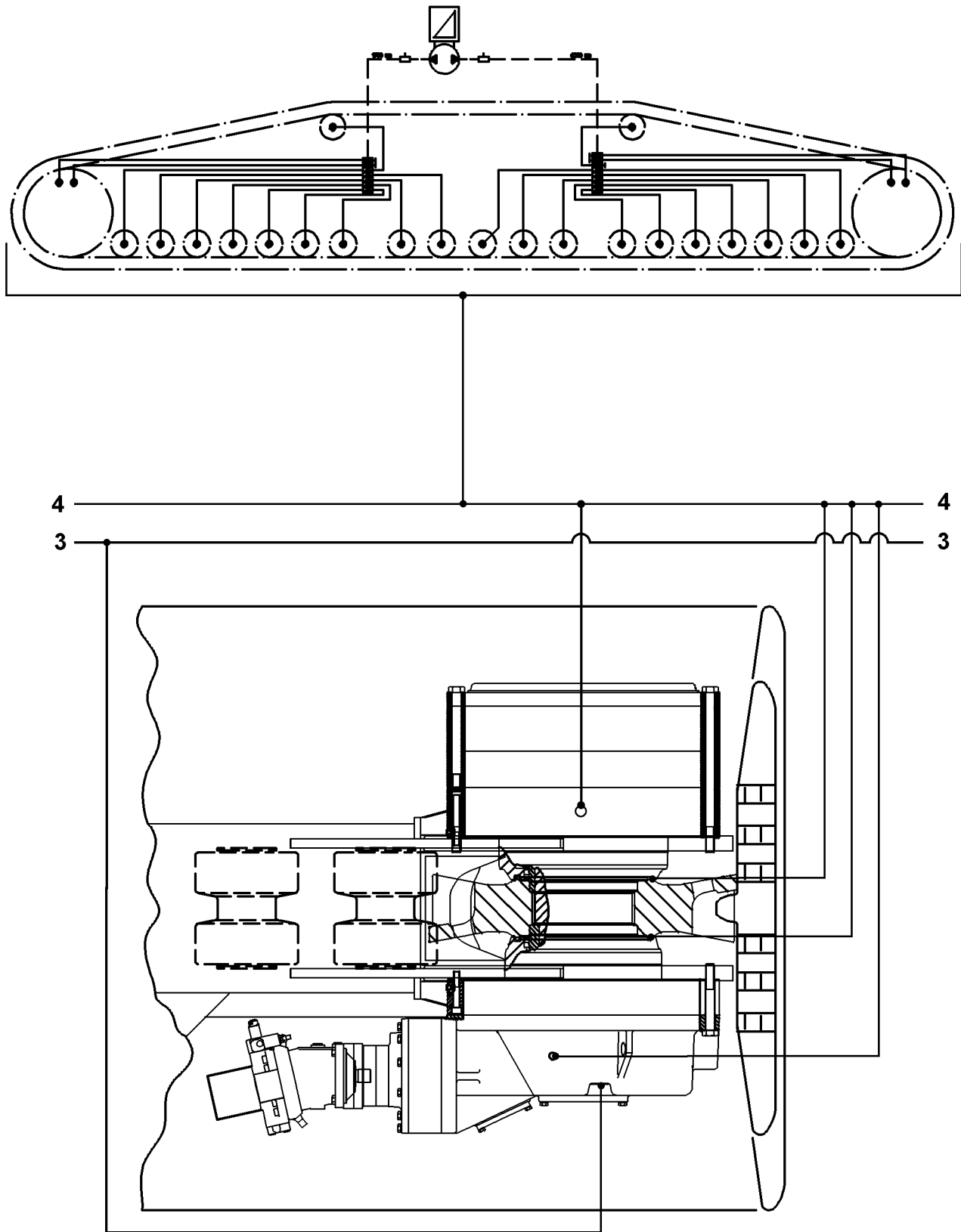
8.9 Fill the lube lines

- With an external lube pump, ass grease via the grease fitting (3) or,
- with the ignition turned on, press the red button (7) on the protective motor housing of the pump.

CAUTION: Make sure that the grease lines are refilled after every repair on lubricated components. If this is not observed, the unit will run dry. When filling the lube lines, observe utmost cleanliness!

8.10 Troubleshooting on the central lubrication system

Problem	Cause	Remedy
Pump is not working	integrated, electronic control is defective, electrical line is interrupted Pump is defective	Replace the lower part of the protective motor housing. Replace the electrical line. Replace the pump
Pump works but does not supply	Air cushion in supply piston fallen below minimum fill level Pump element is defective	Bleed the pump Fill the reservoir Change the pump element
No grease collar on all lube points	Pump is not working Break time is too high or lube time is too low System is blocked	see "Pump is not working" Reduce break time or increase lube time see "grease emerges on pressure relief valve"
No grease collar on several lube points	Supply lines to auxiliary distributor broken or leaky Screw fittings leak	Change lines Retighten screw fittings or change them
No grease collar on one lube point	Supply line broken or leaky Screw fittings leaks	Change line Retighten screw fittings or change it
Pump RPM decreases	High system pressure low ambient temperature	Check system / bearing points No damage (re-lubricate 1 or 2 x)
Grease emerges on pressure relief valve	System pressure too high Progressive distributor is blocked System is blocked Valve spring is defective	Check system Change distributor Fix plugged / tight bearing points Replace pressure relief valve
Indicator light lights up constantly	Motor overloaded	Contact your LIEBHERR or BekaMax service representative
Indicator light blinks constantly in 0.5 second intervals	Error in monitoring time from cycle input	Proximity switch is defective. Contact your LIEBHERR or BekaMax service representative, as necessary



1. Filling capacities (Crane chassis)

KRAN FAHRGESTELL		ca. Liter
Travel gear boxes Gear oil Typ VSG 220 (synthetic)	each	60,0
Central lubrication system - crawler rollers, turras bearing Special grease	appr.	4 kg

The given quantities are only orientation values.

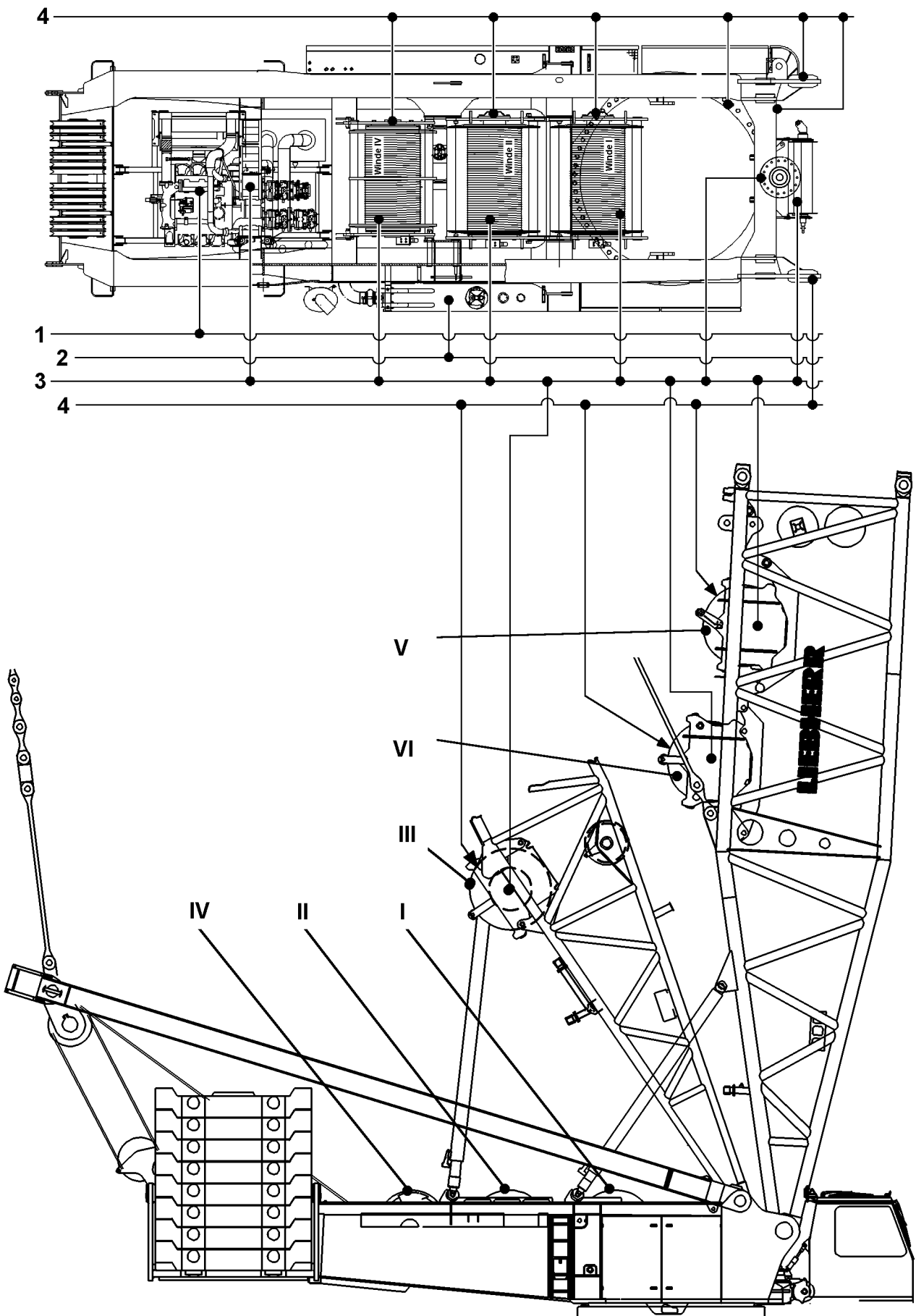
All filling requirements must be carried out and fulfilled according to the markings on the dip sticks, the glass view ports, etc.

*** Note:** When checking the oil level, all hydraulic jacks must be **retracted**.
The upper markings on the view ports must not be exceeded.

C A U T I O N: Synthetic oil and natural mineral oil cannot be mixed!

Explanation to the lubrication plan:

3 = Gear oil
4 = Grease



192331

2. Filling capacities (crane superstructure)

CRANE SUPERSTRUCTURE	appr. Liter
Crane engine Engine oil Coolant	32,0 80,0
Fuel tank Diesel	820,0
Pump distribution gear synthetic gear oil	6,0
Winch I, II, III, V, VI synthetic gear oil	per winch 23,0
Winch IV synthetic gear oil	32,0
Slewing gear Synthetic gear oil	36,0
Assembly winch synthetic gear oil	0,4
Hydraulic fluid tank, crane hydraulic* ATF without crane support ATF with crane support	770,0 1020,0
Central lubrication system - slewing connection Special grease	appr. 4 kg
Central lubrication system - winches etc. Special grease	appr. 4 kg

The given quantities are only orientation values.

All filling requirements must be carried out and fulfilled according to the markings on the dip sticks, the glass view ports, etc.

***Note:** When checking the oil level, all hydraulic jacks must be retracted.
The upper markings on the view ports must not be exceeded.

CAUTION: Synthetic oil and natural mineral oil cannot be mixed!

Explanation to the lubrication plan:

- 1 = Engine oil
- 2 = ATF
- 3 = Gear oil
- 4^ = Grease

Hinweis: Um die Kaltstartfähigkeit des Dieselmotors bei einer Umgebungstemperatur unter -10 °C zu verbessern, empfehlen wir die Verwendung von folgendem Motorenöl:
Viskositätsklasse SAE 5W-30 nach Spezifikation ACEA E4.

To improve the cold start ability of the Diesel engine at an ambient temperature below -10°C, we recommend the use of the following engine oil:
Viscosity grade SAE 5W-30 according to specification ACEA E4.

Afin d'améliorer la capacité de démarrage à froid du moteur Diesel à des températures ambiantes inférieures à -10 °C, nous recommandons l'utilisation de l'huile moteur suivante :
Classe de viscosité SAE 5W-30 selon spécification ACEA E4.

Vorgeschriebene Schmierstoffe für LIEBHERR Krane Approved lubricants for LIEBHERR cranes Lubrifiants prescrits pour les grues LIEBHERR			
	Verwendungszweck Intended use Application	Umgebungstemperatur für den Fahr- und Kranbetrieb Ambient temperature for travel and crane operation Température ambiante pour le mode translation et le mode grue	
		- 25 °C → + 50 °C	- 40 °C → + 30 °C
1	Dieselmotor diesel engine moteur Diesel	SAE 10W-40 API CG-4 ACEA E3-96, E4-96 LWE-Identnr.: 861005408 unter - 20 °C mit Vorwärmung below - 20 °C with preheating en-dessous de - 20 °C avec préchauffage	SAE 10W-40 API CG-4 ACEA E3-96, E4-96 LWE-Identnr.: 861005408 unter - 20 °C mit Vorwärmung below - 20 °C with preheating en-dessous de - 20 °C avec préchauffage

Vorgeschriebene Schmierstoffe für LIEBHERR Krane Approved lubricants for LIEBHERR cranes Lubrifiants prescrits pour les grues LIEBHERR			
	Verwendungszweck Intended use Application	Umgebungstemperatur für den Fahr- und Kranbetrieb Ambient temperature for travel and crane operation Température ambiante pour le mode translation et le mode grue	
		- 25 °C → + 50 °C	- 40 °C → + 30 °C
2	<p>Antriebsachse mit Differentialen, Planetengetrieben und angebautem Verteilergetriebe driving axle with differential, planetary gears and flanged transfer case essieu moteur à différentiel, réducteurs planétaires et boîte transfert</p> <p>Achsantrieb ZF DK-7 axle drive ZF DK-7 entraînement des essieux ZF DK-7</p> <p>Fahrzeug Verteilergetriebe transfer box boîte de transfert KESSLER VG 1800 / 2400 / 2550 / 2600 / 3750 W 3750 ZF Passau, STEYR PUCH VG 1200 / 1600 / 2000 / 3800</p> <p>Versatzgetriebe (drop box) drop box decaleur de boîte de transfert ZF Passau, STEYR PUCH</p>	<p>SAE 90 API GL 5 ZF TE-ML 05 LWE-Identnr.: 861901008</p>	<p>SAE 75W-90 API GL 5 ZF TE-ML 05 LWE-Identnr.: 861904014</p>
3	<p>Pumpen-Verteilergetriebe pump transfer cases boîtes transfert de pompes</p>	<p>SAE 90 API GL 5 ZF TE-ML 05 LWE-Identnr.: 861901008</p>	<p>SAE 75W-90 API GL 5 ZF TE-ML 05 LWE-Identnr.: 861904014</p>
	<p>Pumpen-Verteilergetriebe pump transfer cases boîtes transfert de pompes PVG 351 C 385</p>	<p>SAE 75W-90 API GL 5 ZF TE-ML 05 LWE-Identnr.: 861904014</p>	<p>SAE 75W-90 API GL 5 ZF TE-ML 05 LWE-Identnr.: 861904014</p>

Vorgeschriebene Schmierstoffe für LIEBHERR Krane Approved lubricants for LIEBHERR cranes Lubrifiants prescrits pour les grues LIEBHERR			
	Verwendungszweck Intended use Application	Umgebungstemperatur für den Fahr- und Kranbetrieb Ambient temperature for travel and crane operation Température ambiante pour le mode translation et le mode grue	
		- 25 °C → + 50 °C	- 40 °C → + 30 °C
4	<p>Wendegetriebe ZF reversing transmission ZF boîtes d'inversion ZF WG-120, WG-150, WG-180, WG-181, WG-200, WG-201</p> <p>Versatzgetriebe (drop box) drop box decaleur de boîte de transfert ALLISON</p> <p>Lastschaltgetriebe power shift gears boîtes de vitesse et d'inversion CLARK</p>	<p>SAE 10W-40 API CG-4 ACEA E2-96, E3-96, E4-96 ZF TE-ML 03 LWE-Identnr.: 861005408</p> <p>unter - 20 °C warmfahren gemäß Betriebsanleitung below - 20 °C warm up in accordance with operating instructions en-dessous de - 20 °C mise en température conformément aux instructions du manuel d'utilisation</p>	<p>ATF II D ALLISON C4 ZF TE-ML 03 LWE-Identnr.: 861900608</p> <p>unter - 20 °C warmfahren gemäß Betriebsanleitung below - 20 °C warm up in accordance with operating instructions en-dessous de - 20 °C mise en température conformément aux instructions du manuel d'utilisation</p>
5	<p>Automatikgetriebe automatic transmissions boîtes de vitesses automatiques ALLISON CLBT 740 / 750 / 754 / 755 HT 755 / HD 4560</p>	<p>ATF Dexron III ALLISON C4</p> <p>unter - 20 °C warmfahren gemäß Betriebsanleitung below - 20 °C warm up in accordance with operating instructions en-dessous de - 20 °C mise en température conformément aux instructions du manuel d'utilisation</p>	<p>CASTROL Transynd LWE-Identnr.: 861903708</p> <p>unter - 20 °C warmfahren gemäß Betriebsanleitung below - 20 °C warm up in accordance with operating instructions en-dessous de - 20 °C mise en température conformément aux instructions du manuel d'utilisation</p>
	<p>Automatikgetriebe ZF automatic transmissions ZF boîtes de vitesses automatiques ZF</p> <p>Wendegetriebe ZF reversing transmission ZF boîtes d'inversion ZF 6 WG-210, 6 WG-251*, 6 WG-260 ZF Ergopower 6 WG-310</p> <p>* auch bei Umgebungstemperaturen über -10 °C in case of an ambient temperature over -10°C as well aussi en cas d'une température ambiante au-dessous de -10°C</p>	<p>ATF II D ZF TE-ML 03 LWE-Identnr.: 861900608</p> <p>unter - 20 °C warmfahren gemäß Betriebsanleitung below - 20 °C warm up in accordance with operating instructions en-dessous de - 20 °C mise en température conformément aux instructions du manuel d'utilisation</p>	<p>ATF II D ZF TE-ML 03 LWE-Identnr.: 861900608</p> <p>unter - 20 °C warmfahren gemäß Betriebsanleitung below - 20 °C warm up in accordance with operating instructions en-dessous de - 20 °C mise en température conformément aux instructions du manuel d'utilisation</p>

Vorgeschriebene Schmierstoffe für LIEBHERR Krane Approved lubricants for LIEBHERR cranes Lubrifiants prescrits pour les grues LIEBHERR			
	Verwendungszweck Intended use Application	Umgebungstemperatur für den Fahr- und Kranbetrieb Ambient temperature for travel and crane operation Température ambiante pour le mode translation et le mode grue	
		- 25 °C → + 50 °C	- 40 °C → + 30 °C
6	Automatisiertes Schaltgetriebe automatic transmission boîte automatisée ZF AS-Tronic ZF TC-Tronic ZF TC-Tronic HD Wandlerschaltkupplung ZF TC HD Converter shifting clutch ZF TC HD Convertisseur-embayage ZF TC HD	ZF-Ecofluid M ZF TE-ML 02 LWE-Identnr.: 10218305	ZF-Ecofluid M ZF TE-ML 02 LWE-Identnr.: 10218305 unter – 35 °C Getriebe gemäß Betriebsanleitung vorwärmen below – 35 °C preheat gears in accordance with operating instructions en-dessous de – 35 °C préchauffer la boîte de vitesses conformément aux instructions du manuel d'utilisation
7	Wandlerschaltkupplung ZF TC 2 Converter shifting clutch ZF TC 2 Convertisseur-embayage ZF TC 2	ATF II D ZF TE-ML 14 LWE-Identnr.: 861900608	ATF II D ZF TE-ML 14 LWE-Identnr.: 861900608
8	Schaltgetriebe ZF gear box ZF boîte de vitesses ZF ECO-Split	Motorenöl oder Getriebeöl ZF TE-ML 02 LWE-Identnr.: 861004208	SAE 75W-90 ZF TE-ML 02 LWE-Identnr.: 861904014

Vorgeschriebene Schmierstoffe für LIEBHERR Krane Approved lubricants for LIEBHERR cranes Lubrifiants prescrits pour les grues LIEBHERR			
	Verwendungszweck Intended use Application	Umgebungstemperatur für den Fahr- und Kranbetrieb Ambient temperature for travel and crane operation Température ambiante pour le mode translation et le mode grue	
		- 25 °C → + 50 °C	- 40 °C → + 30 °C
9	<p>Seilwinde winch treuil</p> <p>Drehwerksgetriebe slewing gears mécanismes d'orientation</p> <p>TA-Abspannwinde mit Klinkensperre TA-pawl guy rope winch TA-treuil de haubanage à cliquet</p>	<p>ISO VSG 220 PGLP 220, DIN 51 502 LWE-Identnr.: 861901208</p> <p>nicht mischbar mit Mineralölen! do not mix with mineral oils! non miscible avec des huiles minérales!</p>	<p>ISO VSG 220 PGLP 220, DIN 51 502 LWE-Identnr.: 861901208</p> <p>nicht mischbar mit Mineralölen! do not mix with mineral oils! non miscible avec des huiles minérales!</p>
10	<p>Kranhydraulik für Kranfahrgestell und Kranoberwagen crane hydraulics for crane carrier and crane superstructure hydrauliques pour châssis porteur et partie tournante</p>	<p>ATF II D LWE-Identnr.: 861900608</p>	<p>AVILUB Artic 32 LWE-Identnr.: 10038346</p>
	<p>Kranhydraulik für LTC Krane crane hydraulics for LTC cranes hydrauliques pour grues LTC</p>	<p>Syntofluid PE-B 30 LWE-Identnr.: 10115282</p>	<p>Syntofluid PE-B 30 LWE-Identnr.: 10115282</p>
11	<p>Bremsanlage, wenn hydraulisch betätigt brake system if hydraulically actuated système de frein, si il est commandé hydrauliquement</p> <p>Kupplungsbetätigung clutch actuation commande du dispositif d'accouplement</p>	<p>DOT 4 SAE J 1703e LWE-Identnr.: 861000108</p>	<p>DOT 4 SAE J 1703e LWE-Identnr.: 861000108</p>

Vorgeschriebene Schmierstoffe für LIEBHERR Krane Approved lubricants for LIEBHERR cranes Lubrifiants prescrits pour les grues LIEBHERR			
	Verwendungszweck Intended use Application	Umgebungstemperatur für den Fahr- und Kranbetrieb Ambient temperature for travel and crane operation Température ambiante pour le mode translation et le mode grue	
		- 25 °C → + 50 °C	- 40 °C → + 30 °C
12	<p>Allgemeine Gleit- und Wälzlagerungen wälzgelagerte Gelenke general plain and roller bearings joints on rolling bearings paliers lisses et à rouleaux courants articulations à palier</p> <p>Zentralschmieranlage Kranoberwagen centralized lubricating system crane superstructure graissage central partie tournante</p> <p>Auslegerverriegelung boom locking verrouillage de la flèche</p> <p>Drehkranz-Wälzlagerungen slewing ring rolling bearings paliers couronnes d'orientation</p> <p>Gelenkwellen, wenn nicht wartungsfrei cardan shafts if not maintenance-free arbres articulés, si ils ne sont pas exempts d'entretien</p>	<p>Sondervorschrift: LIEBHERR Spezialfett 9610 PLUS LWE-Identnr.: 861301308</p> <p>special prescription: LIEBHERR special grease 9610 PLUS</p> <p>prescription spéciale: LIEBHERR graisse spéciale 9610 PLUS</p>	<p>Sondervorschrift: LIEBHERR Spezialfett 9610 PLUS LWE-Identnr.: 861301308</p> <p>special prescription: LIEBHERR special grease 9610 PLUS</p> <p>prescription spéciale: LIEBHERR graisse spéciale 9610 PLUS</p>
13	<p>Kunststoff-Gleitlagerungen des Teleskopauslegers synthetic sliding bearings of the telescopic boom paliers de guidage synthétique de la flèche télescopique</p> <p>Kunststoff-Gleitlagerungen der Schiebeholme synthetic sliding bearings of the outriggers paliers de guidage synthétique des stabilisateurs</p> <p>Abstützplatten mit Ausgleich Outrigger plates with compensation Patins de calage avec compensation</p>	<p>Sondervorschrift: LIEBHERR Spezialfett 9613 LWE-Identnr.: 861303608</p> <p>special prescription: LIEBHERR special grease 9613</p> <p>prescription spéciale: LIEBHERR graisse spéciale 9613</p>	<p>Sondervorschrift: LIEBHERR Spezialfett 1026 LS LWE-Identnr.: 861302608</p> <p>special prescription: LIEBHERR special grease 1026 LS</p> <p>prescription spéciale: LIEBHERR graisse spéciale 1026 LS</p>

Vorgeschriebene Schmierstoffe für LIEBHERR Krane Approved lubricants for LIEBHERR cranes Lubrifiants prescrits pour les grues LIEBHERR			
	Verwendungszweck Intended use Application	Umgebungstemperatur für den Fahr- und Kranbetrieb Ambient temperature for travel and crane operation Température ambiante pour le mode translation et le mode grue	
		- 25 °C → + 50 °C	- 40 °C → + 30 °C
14	<p>Außengleitlagerung des Teleskopauslegers external slide bearing application of the telescopic boom palier lisse extérieur de la flèche télescopique</p> <p>Innengleitlagerung des Teleskopauslegers (nur bei Montage) internal slide bearing application of the telescopic boom (only at assembly) palier lisse intérieur de la flèche télescopique (seulement lors du montage)</p>	<p>Sondervorschrift: LIEBHERR Spezialfett 1336 mit Lösungsmittel LM (Sprühfett) LWE-Identnr.: 861303308</p> <p>special prescription: LIEBHERR special grease1336 with LM carrier (spray grease)</p> <p>prescription spéciale: LIEBHERR graisse spéciale1336 à véhicule LM (graisse à pulvériser)</p>	<p>Sondervorschrift: LIEBHERR Spezialfett 1336 mit Lösungsmittel LM (Sprühfett) LWE-Identnr.: 861303308</p> <p>special prescription: LIEBHERR special grease1336 with LM carrier (spray grease)</p> <p>prescription spéciale: LIEBHERR graisse spéciale1336 à véhicule LM (graisse à pulvériser)</p>
15	<p>Offene Verzahnung der Drehkränze open toothing of slewing rings denture des couronnes d'orientation</p> <p>Laufende Seile running ropes câbles déroulants</p>	<p>Haftschmierstoff OGPF 2 S-30, DIN 51 502 (wasserbeständig) LWE-Identnr.: 861301508</p> <p>adhesive lubricant OGPF 2 S-30, DIN 51 502 (water resistant)</p> <p>lubrifiant adhésif OGPF 2 S-30, DIN 51 502 (résistant à l'eau)</p>	<p>Haftschmierstoff OGPF 2 S-30, DIN 51 502 (wasserbeständig) LWE-Identnr.: 861301508</p> <p>adhesive lubricant OGPF 2 S-30, DIN 51 502 (water resistant)</p> <p>lubrifiant adhésif OGPF 2 S-30, DIN 51 502 (résistant à l'eau)</p>

Vorgeschriebene Schmierstoffe für LIEBHERR Krane Approved lubricants for LIEBHERR cranes Lubrifiants prescrits pour les grues LIEBHERR			
	Verwendungszweck Intended use Application	Umgebungstemperatur für den Fahr- und Kranbetrieb Ambient temperature for travel and crane operation Température ambiante pour le mode translation et le mode grue	
		- 25 °C → + 50 °C	- 40 °C → + 30 °C
16	Kühlerfüllung für Dieselmotoren und Heizanlagen radiator filling for Diesel engines and heatings remplissage de radiateur pour moteurs Diesel et chauffages	Kühlerschutzmittel LIEBHERR-Norm 50 % Korrosions- / Frostschutzmittel LWE-Identnr.: 861600508 50 % Wasser radiator protective agent LIEBHERR standard 50 % corrosion preventatives / antifreeze fluids 50 % water agent de protection de radiateur norme LIEBHERR 50 % produit antigel / anticorrosion 50 % eau	Kühlerschutzmittel LIEBHERR-Norm 50 % Korrosions- / Frostschutzmittel LWE-Identnr.: 861600508 50 % Wasser radiator protective agent LIEBHERR standard 50 % corrosion preventatives / antifreeze fluids 50 % water agent de protection de radiateur norme LIEBHERR 50 % produit antigel / anticorrosion 50 % eau
17	Fahrgetriebe für Raupenkran travel gear transmission for crawler crane réducteur de translation pour grues sur chenilles	siehe Typenschild see gear rating plate voir la plaque signalétique	siehe Typenschild see gear rating plate voir la plaque signalétique
18	Bergwinde recovery winch treuil de remorquage	siehe Typenschild see gear rating plate voir la plaque signalétique	siehe Typenschild see gear rating plate voir la plaque signalétique
	Seil der Bergwinde rope of the recovery winch câble du treuil de remorquage	Sondervorschrift: special prescription: prescription spéciale: Motorex TW-Fluid LWE-Identnr.: 861008608	Sondervorschrift: special prescription: prescription spéciale: Motorex TW-Fluid LWE-Identnr.: 861008608

Chapter 8

Crane inspections

General

This crane has been inspected before delivery at the factory, according to the valid ISO, FEM and DIN standards or BGV D6 (BGG 905).

During crane operation, deviation may occur from the safety standard, which had existed at initial delivery. Such deviations can be the result of wear, corrosion, intentional force, environmental changes or application changes.

The operator must take care of the required tasks to maintain the same initial standard of safety at all times. For that reason, the crane must be inspected by an experienced technician, depending on conditions of application and operational conditions, at least once a year, counting from the day of initial service. See also: ISO 9927-1, EU machine guidelines (EWG Maschinenrichtlinie) 89/655, BGV D6.

The crane must be inspected by an expert engineer at least once every 4 years, counting from the day of initial service .

After the 12th year in operation, an expert engineer must check the crane annually.

C A U T I O N : **If significant changes had been made on the crane, or after repairs of load carrying part, the operator must have the crane inspected by an experienced technician before putting the crane back in service.**

In addition, national and regional regulations apply.

Experienced technicians are persons who, due to their vocational background and experience, have sufficient knowledge in the field of lifting appliances (cranes) and are sufficiently familiar with the relevant regulations, such as labor laws, OSHA regulations, accident preventions regulations, to determine deviations from the proper and safe conditions (they are specially trained personnel).

Expert engineers are engineers experienced in the design, construction and maintenance of lifting devices, such as cranes, with sufficient knowledge of the relevant regulations and standards, who have equipment necessary to carry out the inspection and are in a position to judge the safe condition of the lifting appliance (crane) and to decide which measures have to be taken in order to ensure further and continued safe operation.

A repeat crane inspection is generally a visual inspection, where the experienced technician / expert engineer inspects the condition of the crane and components. .

This inspection should prevent accidents through timely recognition of defects.

Any defects found by an experienced technician / expert engineer must be documents, remedied and reinspected.

Below, as an example, we have listed certain important items, which must be checked especially during repeat crane inspections. We note that the experienced technicians / expert engineers are solely responsible for carrying out the crane inspection. For that reason, we cannot list the complete range of inspections in this chapter.

Attached is a checklist for the inspector for repeat inspections of **LIEBHERR** mobile and crawler cranes.

If the inspector has any questions, they should be directed via our Service Dept. to the appropriate departments at LIEBHERR-WERK EHINGEN GMBH.

D A N G E R : **Non-observance of the following inspection guidelines or non-adherence of the inspection intervals can lead to a serious accident !**

1. Inspection of load bearing / load carrying steel constructions

The load bearing steel constructions, such as boom , slewing platform, chassis, support systems (sliding arms or folding supports) must be part of a careful inspection at least once a year. Even though the welding seams normally are not in high stress areas, it is nevertheless important to pay special attention to them during this repeat inspection.

We refer to DIN 15018, part 3, point 1, which lists permissible stress figures for highly resilient steel. They also determine the life expectancy of the steel frame work. It cannot only be calculated from the stress figures alone, but also depends on the collective load figures during time of operation. LIEBHERR cranes are designed and sized for installation operation, whereby the following design calculations have been used as a basis (DIN 15018, part 3):

Load collective : S_0 (light)

Stress figure: 25 000

For that reason, the load bearing or load carrying parts of the steel construction and the welding seams must be subjected to an especially intensive check during the repeat inspection by an expert engineer.

If the crane was subjected to excessive stress, for example an unusual shock or impact during its time in operation , the inspection of load bearing components must be carried out immediately.

If any damage, such as cracks, can be found at any point of the steel construction, then the extend of damage must be determined by expert personnel with the aid of material analysis methods, such as magnetic powder test, ultra sound or X-ray tests. Then it must be determined by expert personnel if the defective section can be repaired by repair welding or by other means.

The following drawings show examples of load bearing welding constructions. For example, welding seams which need to be checked can occur in multiple areas on the steel components and in a variety of shapes. The connections or zones around the points marked by arrows must be checked.

CAUTION: We note that all crane inspections, as far as content and extend, are the sole responsibility of the inspector. The following drawings are given only as an aid for the inspector. The drawings are only examples, and we do not claim that they are complete!

1.1 Repair welding

In case any problems, such as cracks or distortions are found on the load carrying steel construction, then they must be reported immediately to **LIEBHERR-WERK EHINGEN GMBH (LWE), Service Dept.**. In addition, the defect must be inspected immediately by an expert to evaluate the rules of welding techniques. For safety reasons and danger of accidents, he must immediately determine if it is possible to operate the crane until it can be repair welded.

CAUTION: In reference to repair welding, the following points must be noted:

1.1.1 Repair welding may only be carried out by the following persons or service stations:

1.1.1.1 Personnel of **LWE**, or personnel with the corresponding welding certifications according to EN 287-1 for the corresponding material (W 03) and welding procedure, as assigned by **LWE**.

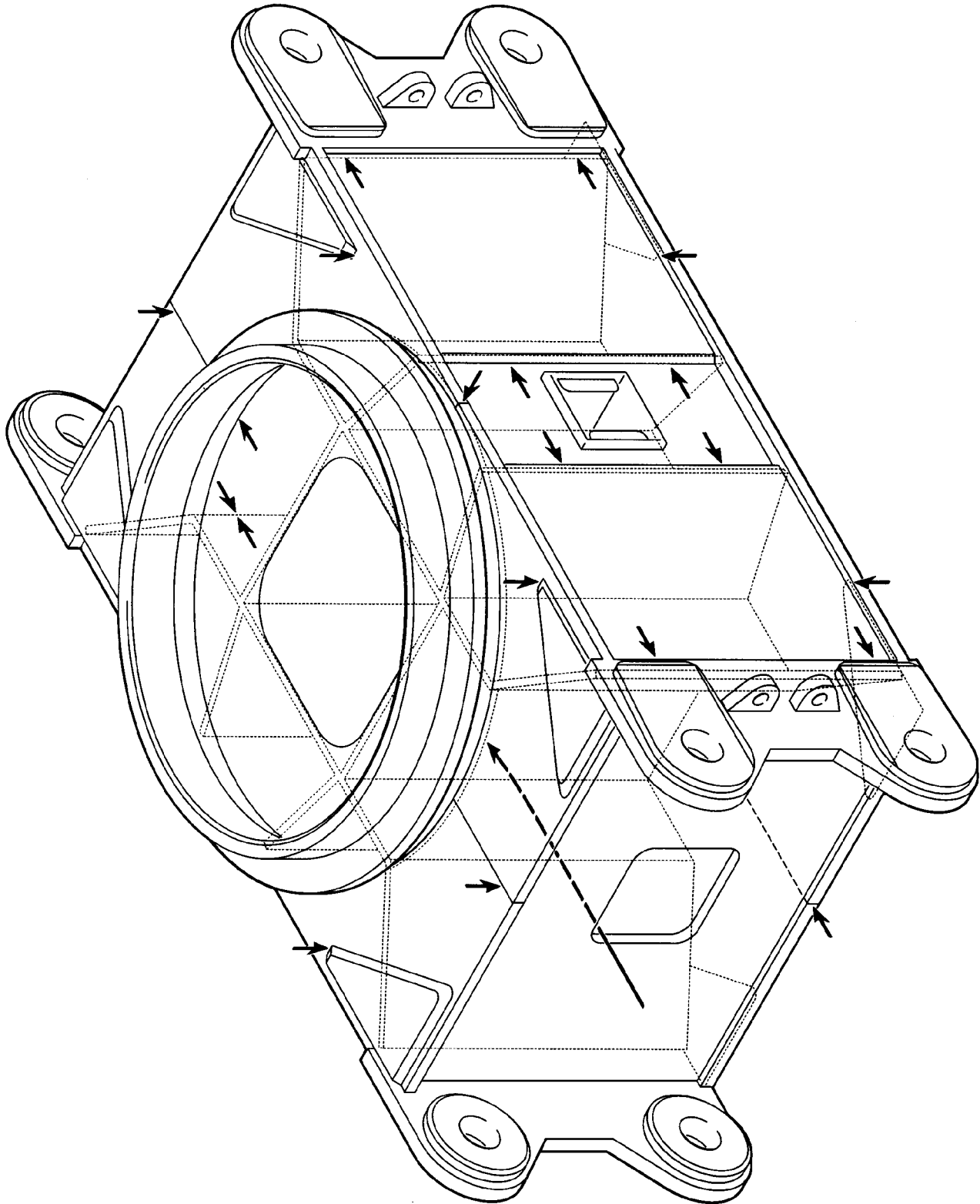
1.1.1.2 Service operations, which hold a Large Qualification certificate according to DIN 18800, Part 7, DIN 15018, and DIN 4132 with expansion for cranes, crane tracks and the following highly and highest tensile fine grained steel:

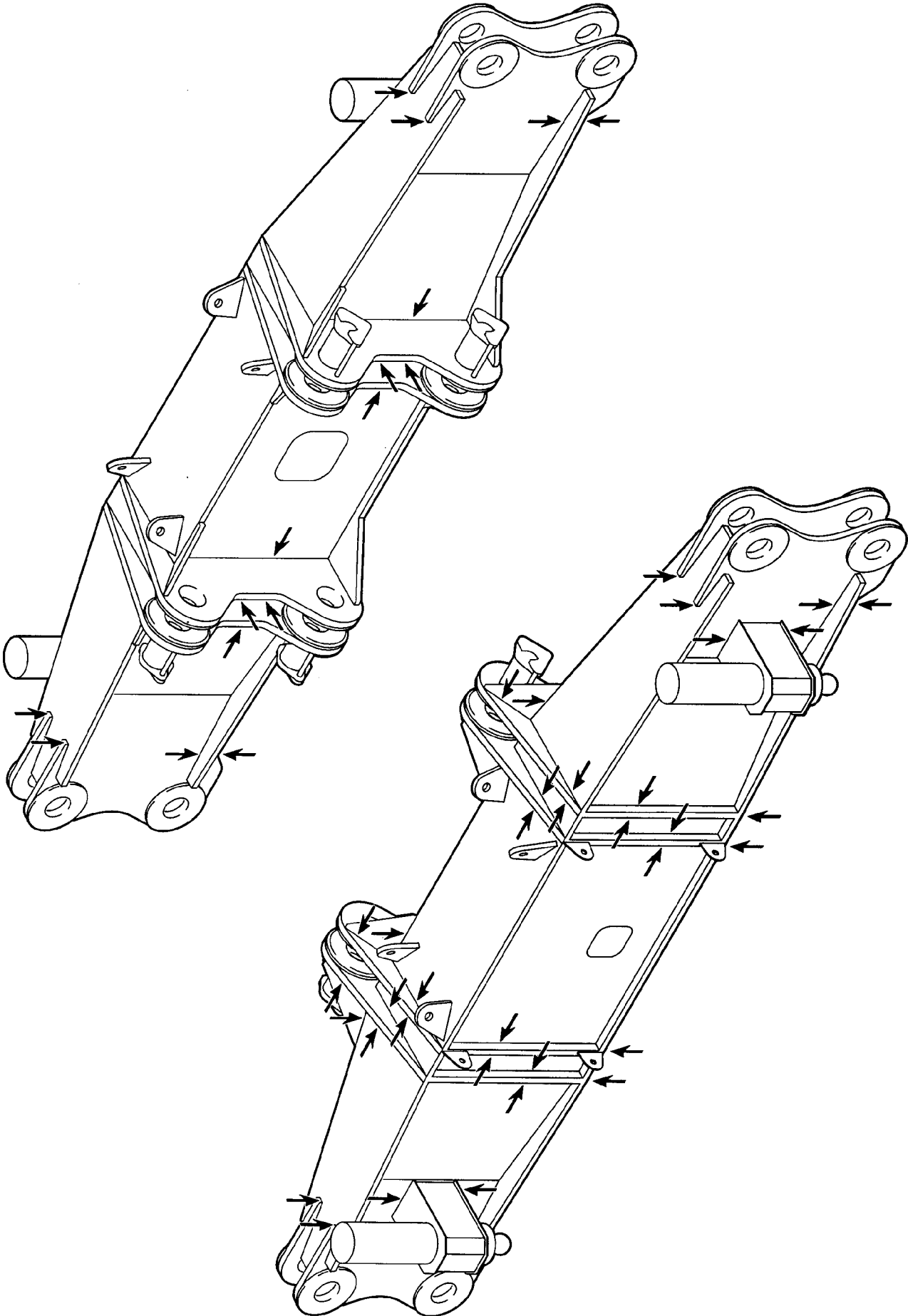
Sheet metal	S690QL1	W. Nr. 1.8988
Sheet metal	S690QL	W. Nr. 1.8928
Sheet metal	S700MC	W. Nr. 1.8974
Sheet metal	S960QL	W. Nr. 1.8933
Sheet metal	S960MC	W. Nr. -
Sheet metal	S1100QL	W. Nr. 1.8942
Pipes	S770QL	W. Nr. 1.8938
Pipes	S890QL1	W. Nr. 1.8925

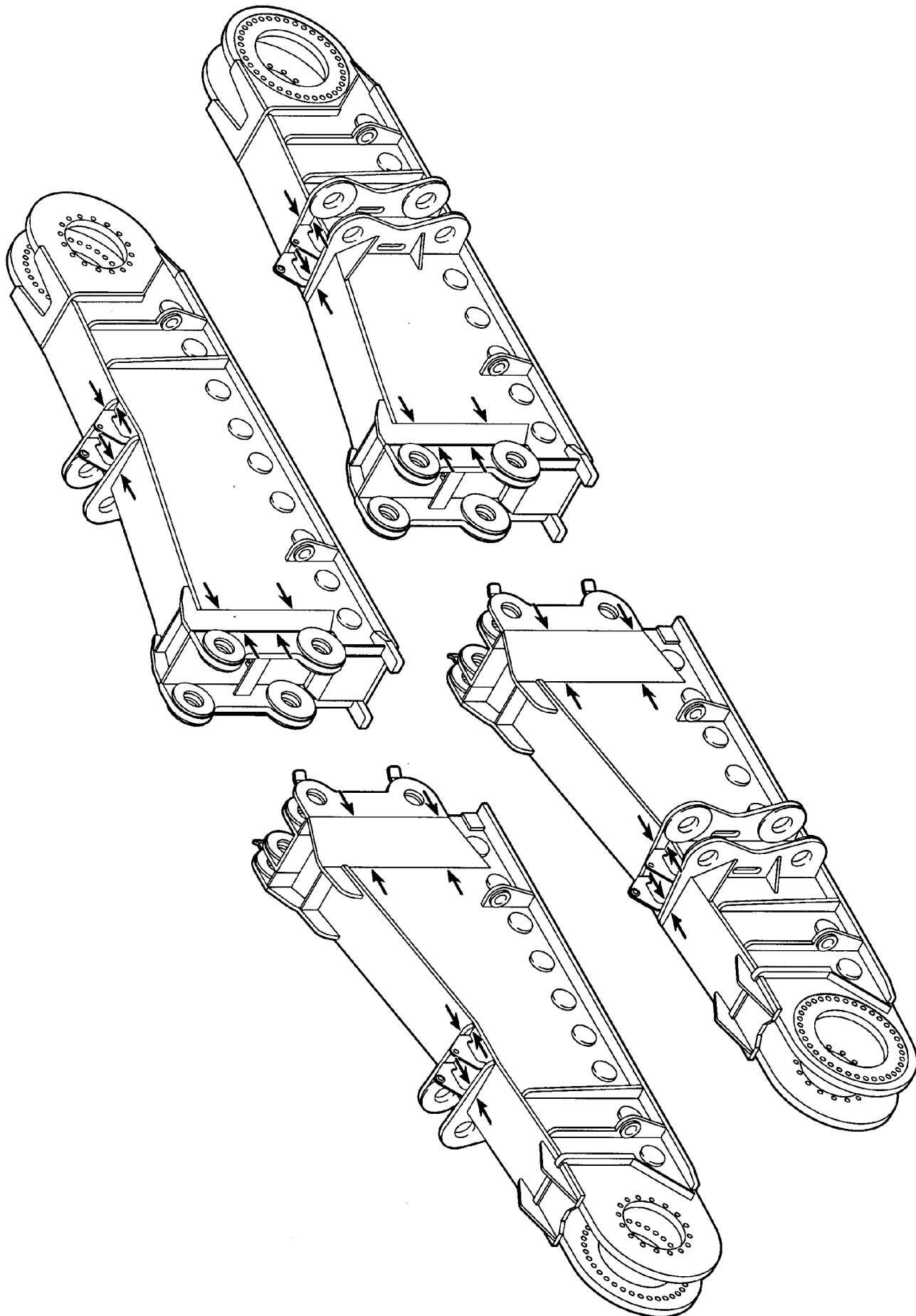
Experience in repairs of mobile and crawler cranes with the appropriate material and usage of welding procedures MAGM (135), as well as special arc welding E(111) is a must.

- 1.1.2 For the repair, a repair instruction with notation of the basic material and the corresponding welding additives and auxiliary materials must be requested. The required inspections (ZfP) must be carried out and documents.
- 1.1.3 The repair welding must be carried out according to the latest version of **LWE'** s internal welding guidelines ISR B 010!
- 1.1.4 The repaired component must be checked with a **stress test**:
The required test loads and boom configurations must be requested from **LWE Service**!
The successful test must be documented in the crane inspection handbook!
- 1.1.5 In addition, the accident prevention guidelines "**Basic rules for inspection of cranes by expert or trained personnel according to UVV "Kranen" (Cranes) BGV D6 and BGG 905**", (formerly VBG 9) must be observed !

D A N G E R : **Any violation against these regulations, especially non-observance of welding instructions, can cause severe personnel and property damage!**



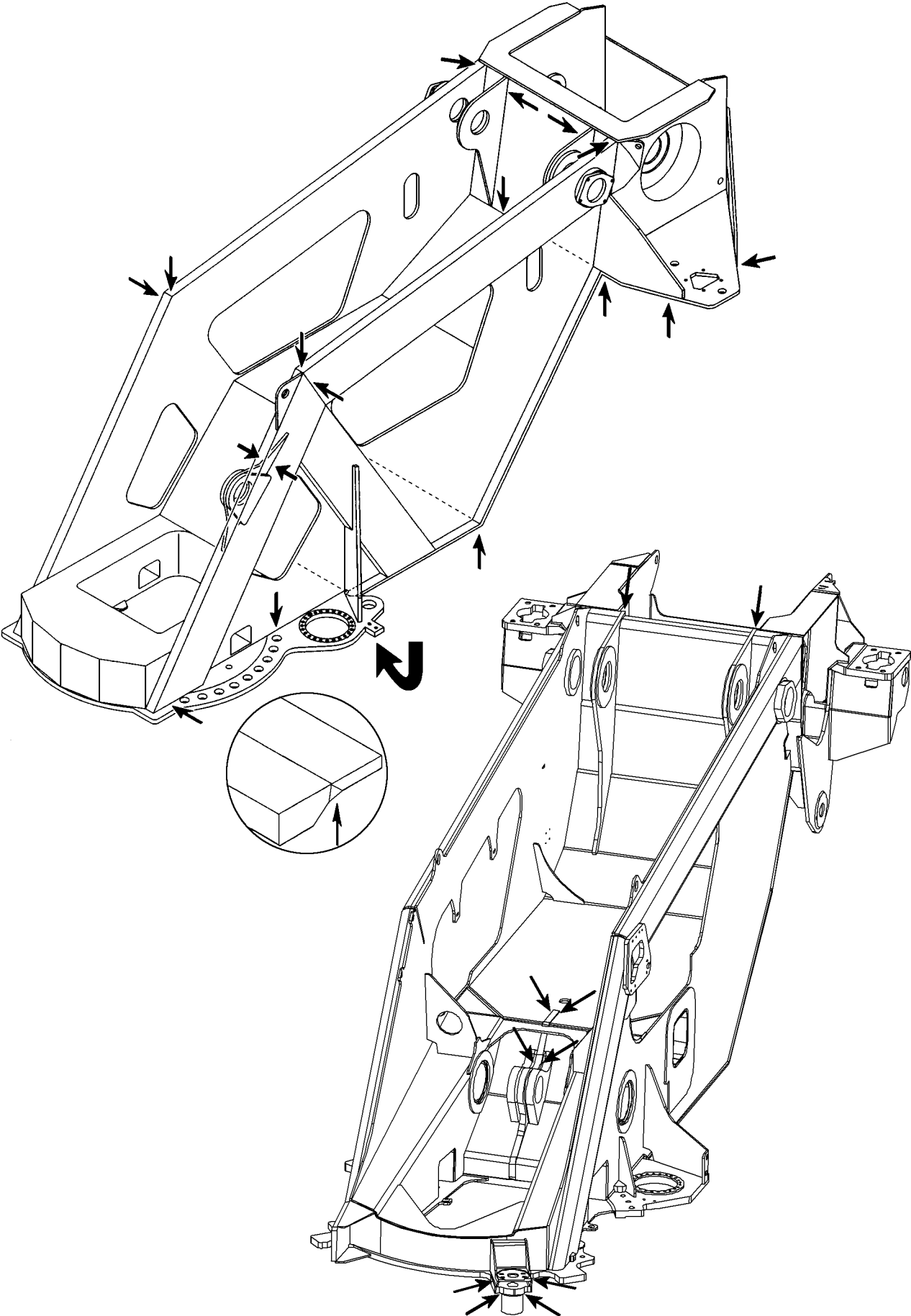




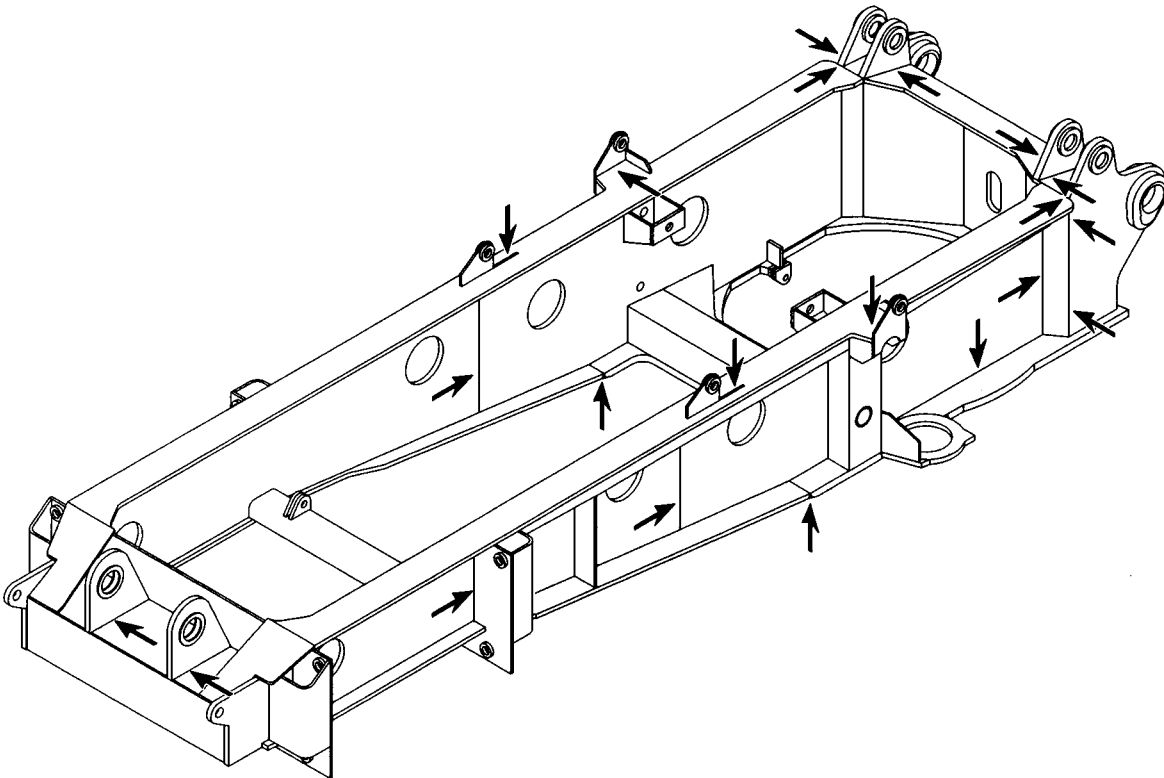
187349

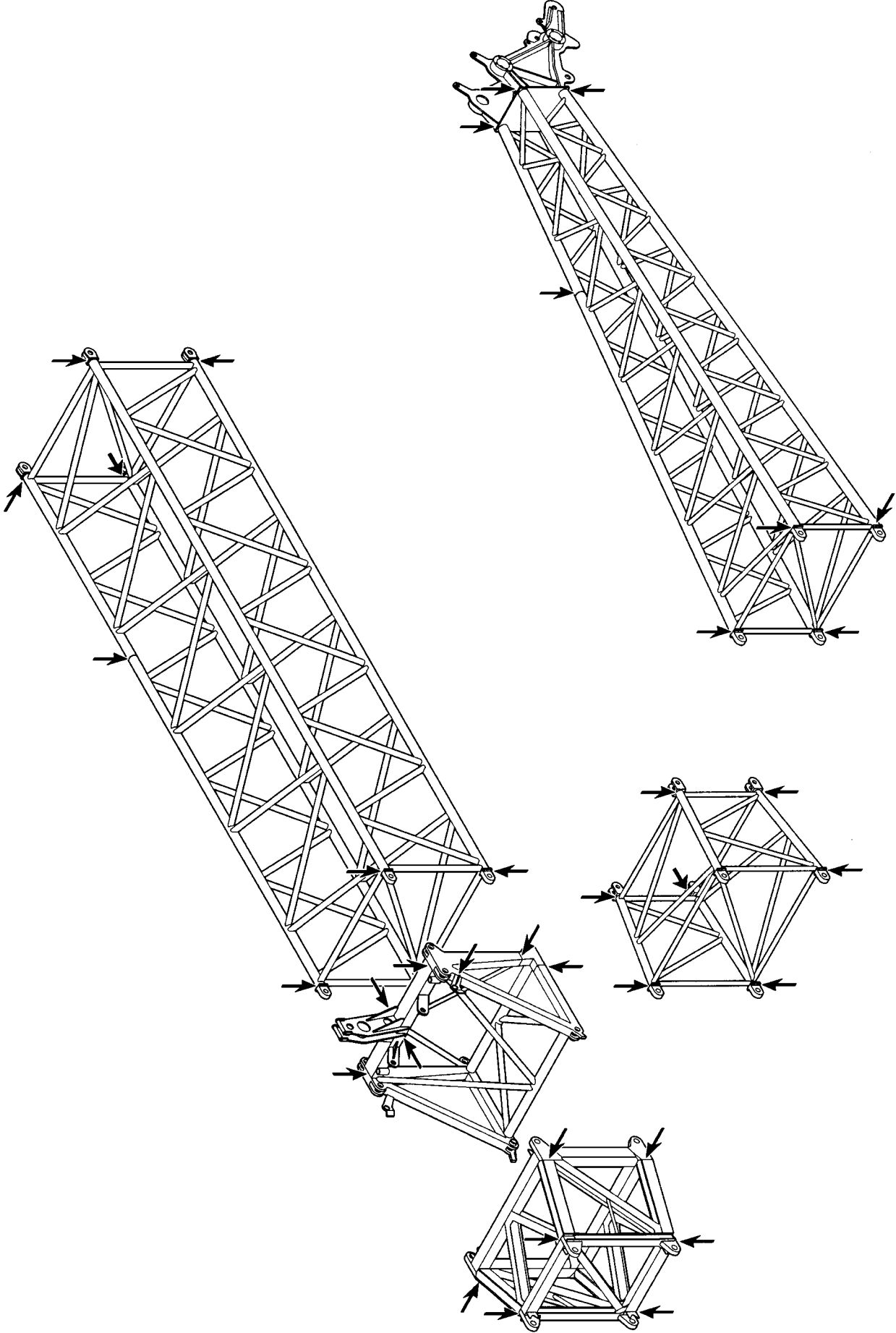
8.01 REPEAT CRANE INSPECTIONS
Slewing platform frame

024106-02

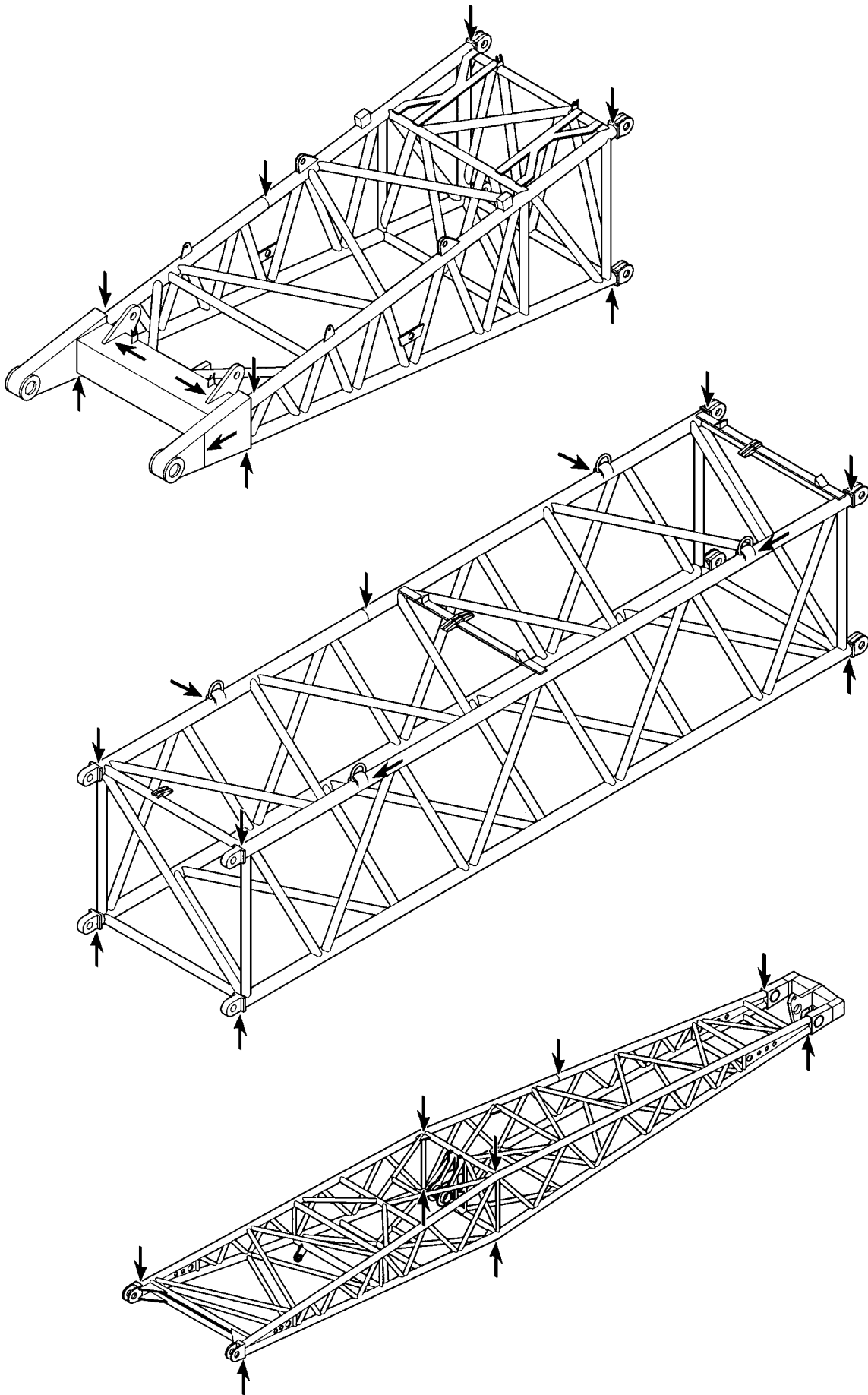


185048

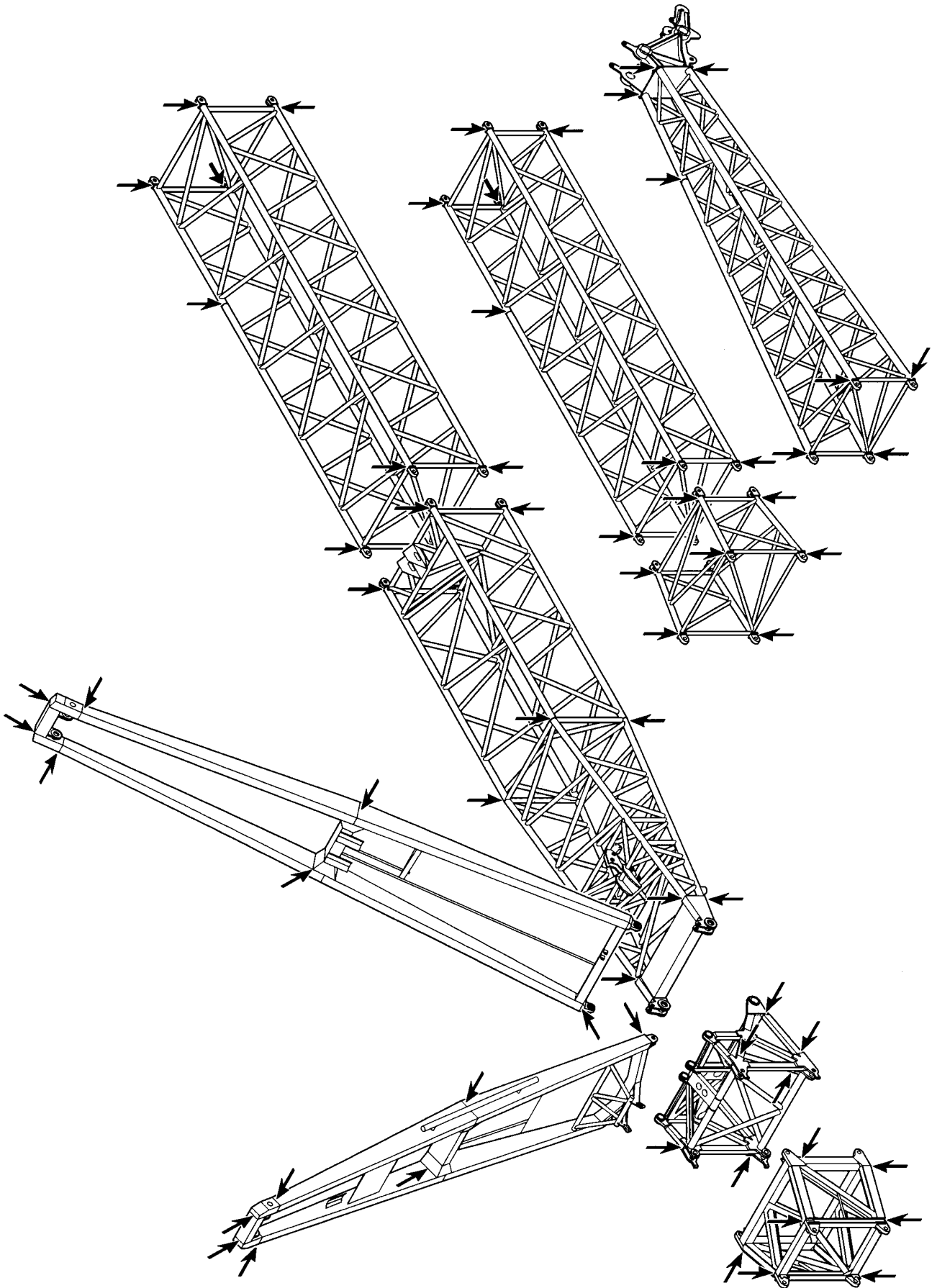




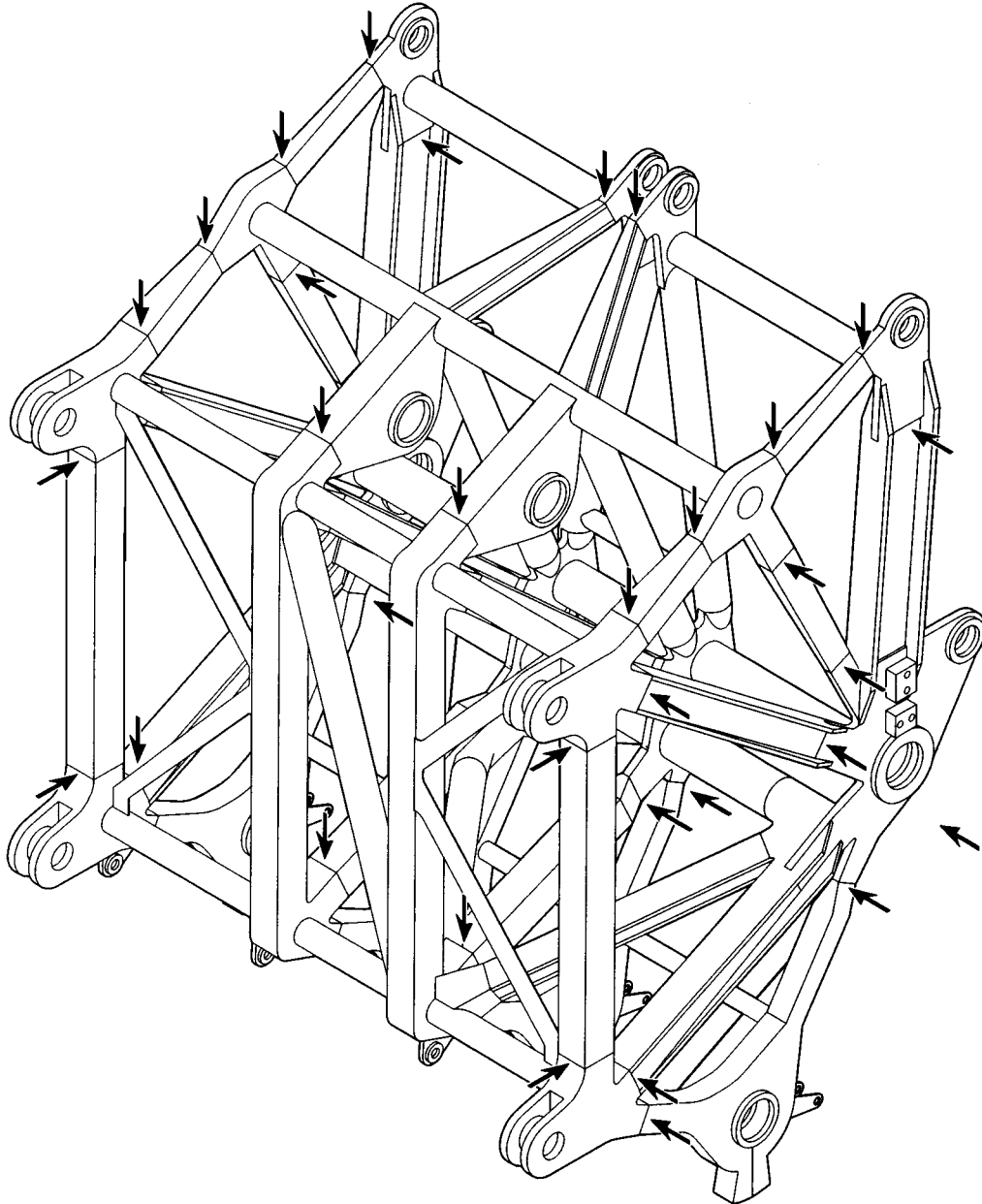
185051

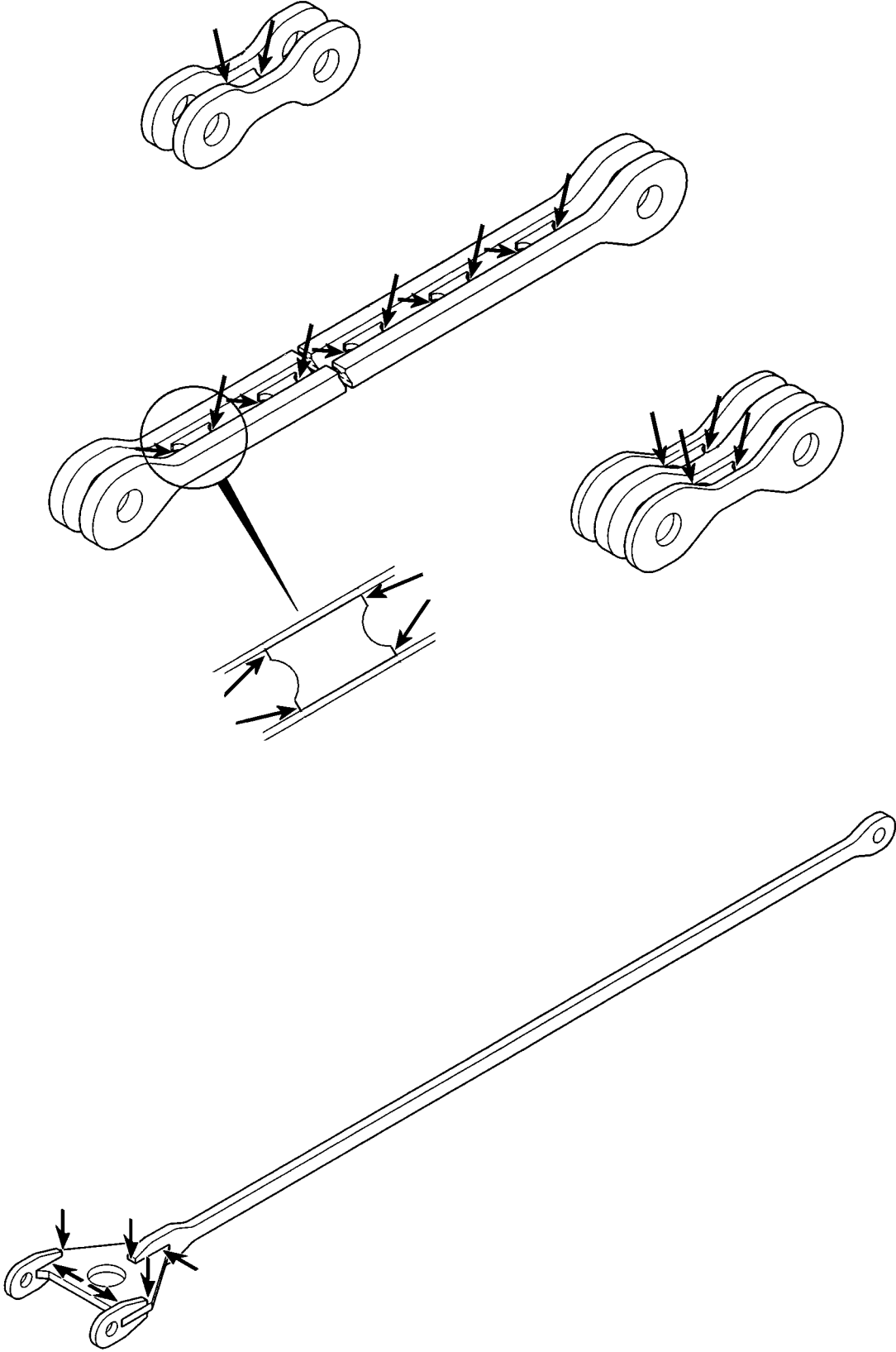


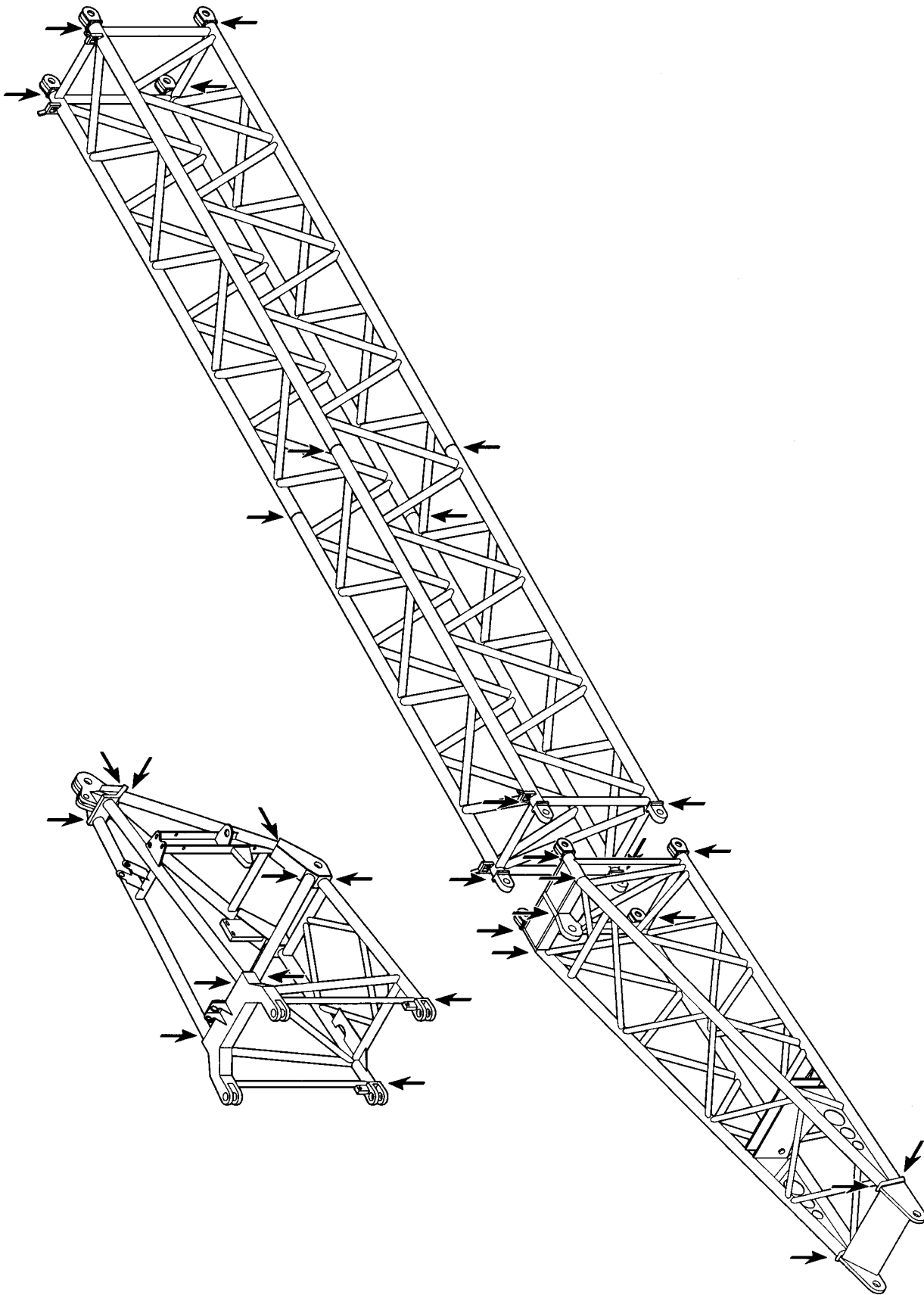
185052



185053







185056

2. Inspection of hoist and pull in winches

The hoist and pull in winches and slewing gears are closed planetary gear versions. These gears have been designed for long service life, drive shafts and gear wheels are also long lasting.

Even though these gears have been designed for long service life, an external visual inspection is not sufficient in this case, because the service life can be influenced by insufficient maintenance (lack of oil), defective seals, improper operation or overuse. For that reason, the inspection must be made by experienced technicians according to the following guidelines:

2.1 Inspections**2.1.1 Inspection intervals**

Every 1000 operating hours, at least once a year (annually)

2.1.2 Inspection

Check oil level. On hoist and pull in winches, we recommend to drain the oil and compare the amount with the stipulated oil quantity.

2.1.3 Check color of oil

If the oil is blackened and / or if the oil smells burnt, one can assume that the oil has been overheated. In that case, the oil must be changed.

2.1.4 Check for foreign particles

This test should be done in a qualified lab. The used oil is dropped onto specified filter paper. The oil sample is visually checked under a microscope for foreign particles. If any are found, then the oil must be analyzed by a qualified lab to determine the make up of the particles.

2.1.5 Evaluation of foreign particles found in oil

Maximum permissible foreign particle parts are 0.15% of the total oil quantity, by weight.

Maximum permissible foreign particle size from fine shavings to 0.25 my.

If the above values have been exceeded, remove the gear and check out the cause of increased contamination. Replace any damaged parts and fill the gear with new oil.

C A U T I O N : These repairs may only be made by expertly trained personnel.

2.1.6 Visual inspection

The gears must be checked for leaks, since any loss of oil - aside from environmental contamination - can also lead to gear failure.

2.1.7 Check brakes in gears

Check the brakes at the same time you check the gears.

If the brakes should not hold the required test load of +33% cable pull increase on single line and fully coiled drum, then they must be removed and the cause must be found. If the planetary gear is removed due to increased oil contamination, check the brakes at the same time.

C A U T I O N : Only expertly trained personnel may inspect gears and brakes!

2.1.8 Document completed inspection

The result of annual inspections and repair / reconditioning work, including all completed tasks, must be recorded by the expert or the trained service technician, if necessary, and signed off by the inspection station or specialty shop.

This documentation must be enclosed in the crane inspection booklet and must be recorded in the repeat inspection column.

2.2 Required measures to monitor the winches

2.2.1. Theoretical service life

When calculating and dimensioning the winches for your crane, the designer took certain operating conditions and a calculated total service life time into account, which resulted in a theoretical service life.

The winches in your crane are classified according to DIN report 1, ISO 4301/1 or FEM 9.511, as follows:

Drive group:	M3 (1 Bm)
Load collective:	Q1 (L1)
Factor of load collective Km:	0.125
Theoretical service life D:	3200 hrs.

CAUTION: The "theoretical service life" may not be equated with the real (actual) service life of a winch!

The real service life for a winch is influenced by many external matters, such as :

1. Overloads: because the crane was not utilized as intended
2. Insufficient maintenance: oil has not been changed at the proper intervals
3. Erroneous operation : extreme acceleration or deceleration of the load
Load fell into the cables
4. Maintenance errors: Use of wrong oil
Wrong quantity
Contamination during oil change
5. Installation errors during repair or maintenance
6. Leakages which were not taken care of
7. Improperly adjusted safety devices
8. Hidden accident damage
9. Extreme ambient conditions: Low or high temperatures
aggressive atmosphere
Dust and dirt

2.2.2 Used portion of theoretical service life

The crane operator is obligated to have the crane inspected at least once a year (ISO 9927-1 and BGV D8).

The used portion of the theoretical service life must also be determined. If necessary, the crane operator must call in an expert.

When determining the used portion of the theoretical service life, the actual operating conditions (load collective) and the operating hours of hoist gears per inspection interval must be determined. The user is responsible to have it documented in the crane inspection booklet.

2.2.2.1 Determining the operating conditions (Load collective)

The load collective of the crane is divided into groups; see also DIN report 1, ISO4301/1 or FEM 1.001.

From the determination of the actual operating conditions, choose one of the following load collectives and enter them in the crane inspection book for the corresponding inspection interval.

A more exact determination of the load collective is permissible (see FEM 9.755).

Note: For mobile cranes in assembly operation, we normally use the load collective L1 (Q1), with the load collective factor $K_m = 0.125$.

Load collective Classification	Definition	Service life portion	Factor of load collective	Graphic view
<p>Light Q 1 L 1</p>	<p>Drive gear or parts thereof, which run only at high utilization in exceptional cases , but are subjected to constant, but only light duty</p>	<p>10 % of running time with largest load (dead load + 1/1 load capacity) 40 % of running time with dead load + 1/3 load capacity) 50 % of running time with only dead load</p>	<p>$K_m = 0,125$</p>	<p>Load %</p> <p>Running time %</p>
<p>Medium Q 2 L 2</p>	<p>Drive gear or parts thereof, which often run at high utilization, but are subjected to light duty</p>	<p>1/6of running time with largest load (dead load + 1/1 load capacity) 1/6 of running time with dead load + 2/3 load capacity 1/6 of running time with dead load + 1/3 load capacity 50 % of running time only with dead load</p>	<p>$K_m = 0,25$</p>	<p>Load %</p> <p>Running time %</p>
<p>Heavy Q 3 L 3</p>	<p>Drive gear or parts thereof, which often run at high utilization, but are subjected to constant medium duty</p>	<p>50 % of running time with largest load (dead load + 1/1 load capacity) 50 % of running time only with dead load</p>	<p>$K_m = 0,5$</p>	<p>Load %</p> <p>Running time %</p>
<p>Very heavy Q 4 L 4</p>	<p>Drive gear or parts thereof, which regularly run at high utilization, and are subjected to constant heavy duty</p>	<p>90 % of running time with largest load (dead load + 1/1 load capacity) 10 %of running time only with dead load</p>	<p>$K_m = 1$</p>	<p>Load %</p> <p>Running time %</p>

2.2.2.2 Determining the effective operating hours T_i

The effective operating hours, as determined as follows, must be entered in the crane inspection booklet for the corresponding inspection interval.

Differentiation is made for the following 4 cases:

2.2.2.2.1 Hour meter is on every winch

If your crane is equipped with an hour meter on every winch, then the effective number of operating hours T_i per inspection interval can be read directly.

2.2.2.2.2 Hour meter for the total crane operation

The winch operation portion of the total operating hours of the superstructure must be guessed.

Note: For mobile cranes in assembly operation, normally, when hoist winches are used, 20% of the total superstructure operating hours can be contributed to winch operation.

2.2.2.2.3 Hour meter for both travel and crane operation

The winch operation portion of the total operating hours of the superstructure must be guessed.

Note: For mobile cranes in assembly operation, normally, 60% of the total operating hours can be contributed to superstructure operation. If 20% of the total superstructure operating hours can be contributed to winch operation (see paragraph 2.2.2.2.2), the result would be 12% of the **total** crane operating hours.

2.2.2.2.4 If there is no hour meter at all

In this case, the operator must guess and document the actual winch operating hours .

Note: The given percentage values apply normally for the main hoist winch. For auxiliary hoist winches or adjustable boom winches, the actual share of total operating hours can be significantly less and must therefore be guessed by the operator.

2.2.2.3 To determine the used portion of the theoretical service life

For an inspection interval i (max. 1 year after ISO 9927-1 or BGV D8), the used portion S_i of the theoretical service life is determined according to the following formula:

$$S_i = \frac{K_{m_i}}{K_m} \times T_i$$

K_m = Factor of load collective, which was the basis when calculating the winch. This factor can be taken from the Operation Manual.

K_{m_i} = Factor of load collective in the inspection interval i according to paragraph 2.2.2.1

T_i = effective operating hours in the inspection interval i according to paragraph 2.2.2.2

This used portion is taken off after each inspection interval from the remaining theoretical service life D_i (see example).

If the remaining theoretical service life is insufficient for the next operating period, then the winch must be reconditioned or overhauled.

When the theoretical service life D has been reached (see paragraph 2.2.1), then the winch may only be operated again after it has been reconditioned or overhauled.

A general overhaul must be made at least every 10 years after initial operation of the winch

The general overhaul must be scheduled by the operator and must be carried out by the manufacturer or personnel authorized by the manufacturer and must be documented in the inspection handbook.

After the general overhaul, a new theoretical service life D is issued by the manufacturer or the person authorized by the manufacturer.

If the theoretical service life is not expired after 10 years, then the winch can be operated without a general overhaul, if the crane expert has confirmed the purpose and the correctness of the determination of utilized part of the service life and signed the crane inspection book after every expert test or inspection.

In this case, the crane expert must subject the winch to another more extensive test. It includes at least the following:

1. External visual check (leakages, damage, distortions, etc.)
2. Oil check, especially for metallic residue
3. Stress test with minimum and maximum cable pull and each at maximum possible speed. At least one layer must be coiled up. During this stress test, any unusual noise must be noted.

This test must be confirmed by the expert in the crane inspection book and a notation must be made for continued operation of the winch. The next test must be made before the completion of the 12th year of operation and then annually thereafter.

2.2.3. Example

According to the Operation Manual, a mobile crane with separate hour meter for travel drive and crane operation is classified by the manufacturer as follows:

Drive gear group:	M 3
Load collective:	light L1, $K_m = 0.125$
Theoretical service life:	$D = 3200$ hrs.

The used part S of the theoretical service life can be calculated for the individual inspection intervals as follows:

1st Inspection (1st year)

The crane has been utilized during the past year for assembly work:

Load collective L1, which means $K_{m1} = 0.125$.

The superstructure hour meter read 800 hrs. Winch operation was about 20 % of that, which means $T_1 = 160$ hrs.

At the 1st inspection, the used part S of the theoretical service life is therefore as follows:

$$S_1 = \frac{0.125}{0.125} \times 160 \text{ hrs} = 160 \text{ hrs.}$$

remaining theoretical service life:

$$D_1 = 3200 \text{ hrs} - 160 \text{ hrs.} = 3040 \text{ hrs.}$$

The above values are entered in the chart in the crane inspection booklet, see paragraph 2.2.4)

2nd Inspection (2nd year)

The crane has been utilized for unloading ships in the harbor:

Load collective: L3, which means $K_{m2} = 0.5$

The superstructure hour meter read 2000 hrs, which means during this period:
2000 hrs. - 800 hrs. = 1200 hrs. (800 hrs. were used in the first year of operation)

Of that, the winch was used about 40 %, which means $T_2 = 480$ hrs.

The used portion S_2 of the theoretical service life can be calculated for the 2nd individual inspection interval as follows:

$$S_2 = \frac{0.5}{0.125} \times 480 \text{ hrs.} = 1920 \text{ hrs.}$$

remaining theoretical service life:

$$D_2 = 3040 \text{ hrs.} - 1920 \text{ hrs.} = 1120 \text{ hrs.}$$

3rd Inspection (3rd year)

The crane has been used for assembly work and sometimes for unloading work in the harbor:
Load collective: L2, which means $Km_3 = 0.25$

The superstructure hour meter reads 3000 hrs, which means that during this period:
3000 hrs. - 2000 hrs. = 1000 hrs. (2000 hrs. were used up in the first two years of operation)

Of that, the winch was used about 30 %, which means $T_3 = 300$ hrs.

The used portion S_3 of the theoretical service life can be calculated for the 3rd individual inspection interval as follows:

$$S_3 = \frac{0.25}{0.125} \times 300 \text{ hrs.} = 600 \text{ hrs.}$$

remaining theoretical service life:

$$D_3 = 1120 \text{ hrs.} - 600 \text{ hrs.} = 520 \text{ hrs.}$$

The above values are entered in the chart in the crane inspection booklet as shown in chart 1.

2.2.4. Addendum

Chart 1 shows an example.

Document the remaining theoretical service life on chart 2.

Chart to determine the remaining theoretical service life of winch No. 1 (Main hoist winch)

Crane type: LTM 1050
 Fabrication No.: 0010 540 08
 Put in service : 12345
 Serial number of winch according to data tag: 0815
 Last general overhaul performed on:
 Configuration data of winch (see Operating Manual):
 Drive gear group: M 3
 Load collective: Q 1 (L1)
 Factor of load collective Km: 0.125
 Theoretical service life D: 3200 hrs.

S_i = Used part of theoretical service life since last inspection
 D_i = Remaining theoretical service life
 D_{i-1} = Remaining theoretical service life after previous inspection
 Km = Factor of load collective, which was taken for calculation of winch.
 This factor is to be taken from the Operating Manual
 Km_i = Factor of load collective in inspection interval i according to paragraph 2.2.2.1
 T_i = Effective operating hours in inspection interval i according to paragraph 2.2.2.2

(*) In the following pages, carry over the last line from the previous page.

Inspection interval No. (max. annually) i	Date of initial service data of inspection	Operating conditions since last inspection (load collective)	Factor of load connective Km_i	Total crane operating hours [h]	Operating hours of super-structure [h]	Operating hours of super-structure since last inspection [h]	Operating hours of winch [h]	Operating hours of winch since last inspection T_i [h]	Used part of theoretical service life D: $S_i = \frac{Km_i}{Km} \times T_i$ [h]	Remaining theoretical service life $D_i = D_{i-1} - S_i$ [h]	Name of inspector	Signature	Remarks	Name of expert	Signature
(*) 0	10.06.90	-	-	-	0				0	3200					
1	05.06.91	L1	0,125	-	800	800	-	160 (20 % of 800)	160	3040	Müller				
2	20.05.92	L3	0,5	-	2000	1200	-	480 (40 % of 1200)	1920	1120	Huber				
3	18.05.93	L2	0,25	-	3000	1000	-	300 (30 % of 1000)	600	520	Maier				
4															

CAUTION: Perform general overhaul at least once every 10 years.

In case of deviation, see paragraph 2.2.2.3

General overhaul last performed on :

Chart to determine the remaining theoretical service life of winch No.

Crane type:
 Fabrication No.:
 Put in service:
 Serial number of winch according to data tag:
 Last general overhaul performed on:
 Configuration data of winch (see Operating Manual):
 Drive gear group: M.....
 Load collective: Q.....(L.....)
 Factor of load collective Km:
 Theoretical service life D:

S_i = Used part of theoretical service life since last inspection
 D_i = Remaining theoretical service life
 D_{i-1} = Remaining theoretical service life after previous inspection
 K_m = Factor of load collective, which was taken for calculation of winch.
 This factor is to be taken from the Operating Manual
 K_{m_i} = Factor of load collective in inspection interval i according to paragraph 2.2.2.1
 T_i = Effective operating hours in inspection interval i according to paragraph 2.2.2.2

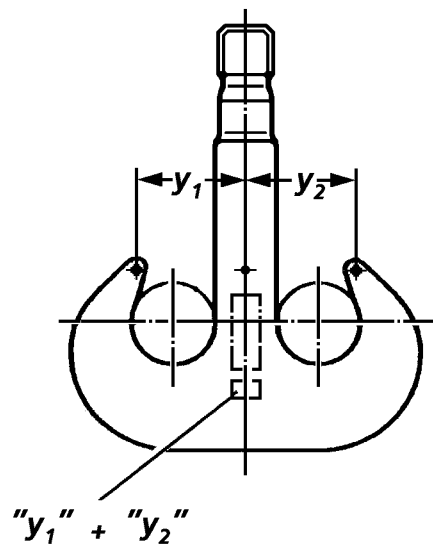
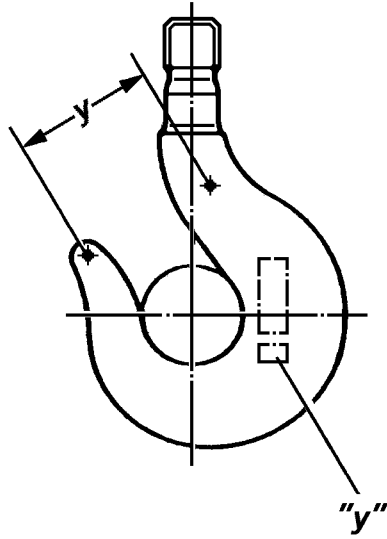
*) In the following pages, carry over the last line from the previous page.

Inspection interval No. (max. annually)	Date of initial service data of inspection	Operating conditions since last inspection (load collective)	Factor of load connective	Total crane operating hours	Operating hours of super-structure	Operating hours of super-structure since last inspection	Operating hours of winch	Operating hours of winch since last inspection	Used part of theoretical service life D: $S_i = \frac{K_{m_i}}{K_m} \times T_i$	Remaining theoretical service life $D_i = D_{i-1} - S_i$	Name of inspector	Signature	Remarks	Name of expert	Signature
i			K_{m_i}	[h]	[h]	[h]	[h]	[h]	[h]	[h]					
(*)															

CAUTION: Perform general overhaul at least once every 10 years.

In case of deviation, see paragraph 2.2.2.3

General overhaul last performed on :



3. Inspection of load hook

The load hooks must be regularly checked by an expert.

These inspections are made to prevent accidents through early detection of problems.

Any problems found during these inspections must be documented, remedied and then reinspected .

3.1 Inspections and monitoring procedures**3.1.1 Distortion**

Check for any distortions, for example on the open end of the hook, regularly, but at least on an annual basis.

The open end of the hook may not have stretched by more than 10% in relation to the initial measurement "y" or exceed "y1" and "y 2".

D A N G E R : **If the hook opening is now wider by more than 10 % of the initial measurement, then the load hook may no longer be used.
In that case, contact the Service Department at Liebherr Ehingen .**

Note: The initial measurements "y" or "y1" and "y2" are noted on the load hook. Measure from point to point, as shown.

3.1.2 Corrosion

For this test, the nut must be removed from the hook shaft, so that the threads can be checked for corrosion and wear.

D A N G E R : **In case corrosion and wear is found on the threads, the load hook may no longer be used.
In that case, contact the Service Department at Liebherr Ehingen .**

4. inapplicable

5. inapplicable

6. Check the safety control or the limit switch in the relapse support and the boom A-brackets, refer to chapter 8.12.

**7. Check the nitrogen reservoir for correct gas pressure, especially that of the relapse supports and suspension accumulators (observe instructions).
refer to chapter 7.04, 7.05, 8.13, 8.14.**

8. Check the cable pulleys

8.1 The cable pulleys must be checked once a year all around for damage and cracks.

If the cable pulleys have been hit during crane operation (for example on buildings, etc.) or if they were subjected to any other stress factors, then they must be extensively checked for damage or cracks.

D A N G E R : **If any damage or cracks are found, then the cable pulley must be replaced immediately. If this is not observed, there is great danger of causing a serious accident!**

8.2 In addition, check the wear in the cable groove. If the cable groove base is run in by more than $\frac{1}{4}$ of the cable diameter, then the pulley must be replaced.

9. Check the safe load system for function.

9.1 With the longest boom, move to the minimum and maximum radius: Check the load indication, take the hook block as a test weight.

The deviation may not be more than 10% of the load capacity in these two extreme positions.

9.2 The given radius must be measured again for the longest boom for the smallest radius and at a boom angle of 45°.

The deviation may not be more than 10% of the measured radius.

10. Check the slewing ring connection

10.1 For tilt play measurement, see chapter 7.05

11. Check the mounting tightness of the load carrying components

Check the mounting screws of the pulley rotary connection, winches, slewing gears and tackle couplings for tight seating.

11.1 The mounting screws of the rotary connections are pretensioned at the factory, and normally should not loosen up during normal operation.

However, if the crane has been overloaded or if the load broke off, then it is possible that the screw connection has been overloaded and the screw has been stretched.

For that reason, check these screws during the annual inspection or after an overload to make sure they are seated tightly.

Any loose screws, as well the the two screws next to them on both the left and right hand side should be completely removed and carefully checked for damage.

The screws must be especially inspected for cracks or distortion. If the screw has been stretched by more than 0.2% (in relation to it original length) or if cracks or other damage can be seen, then the damaged screws must be replaced. In case the screws were stretched or damaged, the screws next to the damaged screw should also be replaced.

12. Check the oil and fuel tanks

Check the oil and fuel tanks at least once a year and in subsequent inspections every 4 years all around for leaks.

Repairs may only be made by especially trained expert personnel.

Improper repairs, for example welding, brazing or soldering are not permitted without consulting the Service Dept. at LIEBHERR Ehingen!

13. Check the reeving auxiliary winch

Check the corresponding manufacturer for the life expectancy of the reeving auxiliary winch.

Addendum

To aid the inspector, attached find a check list for repeat inspections of **LIEBHERR** mobile and crawler cranes.

Inspection guidelines for repeat inspection of LIEBHERR mobile and crawler cranes according to §26(1) or (2) UV “Cranes“ (BGV D6)

Company: Inspector: Date:

Crane manufacturer: **LIEBHERR** Crane type: S/N:

Year: Inventory number:

Signature of inspector for No. 1 to 20:

1. Inspection group: Crane documentation						
Item to be checked	A	B	C	D	E	Remarks
Crane inspection book						
Operation- / installation manual						
Crane control book						
Load chart manual						
Work planer						
2. Inspection group: Decals / signs						
Item to be checked	A	B	C	D	E	Remarks
Data tag						
Load capacity data						
Decal for operating instructions						
Warning and safety decals						
Other safety signs						
3. Inspection group: Travel gear ¹⁾						
Item to be checked	A	B	C	D	E	Remarks
Frame ²⁾						
Supports ²⁾						
Axles						
Wheels						
Tires						
Bearing						
Gear						
Universal drive shaft						
Springs						
Shock absorber						
Steering						
Brakes						
Hydraulic axle suspension						

A: existing / complete
D: Repair / Replacement

B: Condition / Maintenance
E: Reinspection required

C: Function

done = × not done = - not required = 0

Inspection guidelines for repeat inspection of LIEBHERR mobile and crawler cranes according to §26(1) or (2) UV “Cranes“ (BGV D6)

Company: Inspector: Date:

Crane manufacturer: **LIEBHERR** Crane type: S/N:

Year: Inventory number:

Signature of inspector for No. 1 to 20:

4. Inspection group: Chassis ¹⁾						
Item to be checked	A	B	C	D	E	Remarks
Covers						
Steps						
Counterweight retainers ²⁾						
Tackle devices						
Ladders						
Retainer for hook block ²⁾						
Boom receptacle ²⁾						
5. Inspection group: Chassis - Driver's cab ¹⁾						
Item to be checked	A	B	C	D	E	Remarks
Doors						
Window / windshields						
Windshield wiper						
Mirror						
Seat						
Heater						
Ventilation						
Noise protection						
Recorder						
First aid kit						
Spare bulbs						
Warning triangle						
Warning vest						

A: existing / complete
D: Repair / Replacement

B: Condition / Maintenance
E: Reinspection required

C: Function

done = × not done = - not required = 0

Inspection guidelines for repeat inspection of LIEBHERR mobile and crawler cranes according to §26(1) or (2) UV "Cranes" (BGV D6)

Company: Inspector: Date:

Crane manufacturer: **LIEBHERR** Crane type: S/N:

Year: Inventory number:

Signature of inspector for No. 1 to 20:

6. Inspection group: Chassis - Drive ¹⁾						
Item to be checked	A	B	C	D	E	Remarks
Engine						
Exhaust system						
Fuel tank						
Filter						
Muffler						
Engine suspension						
Oil levels						
Fuel lines						
7. Inspection group: Chassis - Hydraulic system ¹⁾						
Item to be checked	A	B	C	D	E	Remarks
Oil tank						
Filter						
Pumps						
Motors						
Valves						
Lines						
Hoses						
Cylinder						
Pressure relief valves						
8. Inspection group: Chassis - Air pressure system ¹⁾						
Item to be checked	A	B	C	D	E	Remarks
Compressor						
Filter						
Air tank						
Valves						
Lines						
Hoses						
Cylinder						

A: existing / complete
D: Repair / Replacement

B: Condition / Maintenance
E: Reinspection required

C: Function

done = × not done = - not required = 0

Inspection guidelines for repeat inspection of LIEBHERR mobile and crawler cranes according to §26(1) or (2) UV "Cranes" (BGV D6)

Company: Inspector: Date:

Crane manufacturer: **LIEBHERR** Crane type: S/N:

Year: Inventory number:

Signature of inspector for No. 1 to 20:

9. Inspection group: Chassis - Electrical system ¹⁾						
Item to be checked	A	B	C	D	E	Remarks
Motors						
Generators / Alternators						
Battery						
Schalter						
Lines						
Fuses						
Resistors						
Lighting						
Brake lights						
Blinkers						
Tail lights						
Floodlights						
Signal devices						
Indicator lights						
Battery switch						
Limit switch: Gear, steering, drive						
Support force indicator ²⁾						

A: existing / complete
D: Repair / Replacement

B: Condition / Maintenance
E: Reinspection required

C: Function

done = × not done = - not required = 0

Inspection guidelines for repeat inspection of LIEBHERR mobile and crawler cranes according to §26(1) or (2) UV “Cranes“ (BGV D6)

Company: Inspector: Date:

Crane manufacturer: **LIEBHERR** Crane type: S/N:

Year: Inventory number:

Signature of inspector for No. 1 to 20:

10. Inspection group: Chassis - Control systems ¹⁾						
Item to be checked	A	B	C	D	E	Remarks
Engine regulation						
Gears						
Couplings / clutches						
Gear shifts						
Brakes						
Steering						
Indicators						
Engine stop line						
Control of outrigger supports ²⁾						
Axle suspension						
Crane leveling control						
Rear axle steering						
11. Inspection group: Superstructure						
Item to be checked	A	B	C	D	E	Remarks
Frame						
Covers						
Steps						
Mounting						
Counterweight						
Relapse retainer						
Slewing ring: tilt play						
Slewing ring: mounting screws						
Slewing ring: gear						
Slewing gear: Mounting screws						
Slewing gear: Gear						

A: existing / complete
D: Repair / Replacement

B: Condition / Maintenance
E: Reinspection required

C: Function

done = × not done = - not required = 0

Inspection guidelines for repeat inspection of LIEBHERR mobile and crawler cranes according to §26(1) or (2) UV “Cranes“ (BGV D6)

Company: Inspector: Date:

Crane manufacturer:**LIEBHERR** Crane type: S/N:

Year: Inventory number:

Signature of inspector for No. 1 to 20:

12. Inspection group: Superstructure - Crane operator’s cab						
Item to be checked	A	B	C	D	E	Remarks
Doors						
Windows / windshields						
Windshield wiper						
Mirror						
Seat						
Heater						
Ventilation						
Shock absorber						
Control lever for working functions						
Gear controls						
Retention: Scrapes / chafings/ kinks						
13. Inspection group: Superstructure - Retention and protective devices						
Item to be checked	A	B	C	D	E	Remarks
Handles and ladders / steps						to the cab and to drive gears
Covers						
Coverings						
Flaps						
14. Inspection group: Superstructure - Drive system						
Item to be checked	A	B	C	D	E	Remarks
Engine						
Exhaust system						
Fuel tank						
Filter						
Muffler						
Engine suspension						
Fuel lines						

A: existing / complete
D: Repair / Replacement

B: Condition / Maintenance
E: Reinspection required

C: Function

done = × not done = - not required = 0

Inspection guidelines for repeat inspection of LIEBHERR mobile and crawler cranes according to §26(1) or (2) UV "Cranes" (BGV D6)

Company: Inspector: Date:

Crane manufacturer: **LIEBHERR** Crane type: S/N:

Year: Inventory number:

Signature of inspector for No. 1 to 20:

15. Inspection group: Superstructure - Hydraulic system						
Item to be checked	A	B	C	D	E	Remarks
Oil tank						
Filter						
Pumps						
Motors						
Valves						
Lines						
Hoses						
Cylinder						
Pressure relief valves						
Brake lowering valves						
Brake control: Hoist gear						
Brake control: Slewing gear						
16. Inspection group: Superstructure - Electrical System						
Item to be checked	A	B	C	D	E	Remarks
Motors						
Generators / Alternators						
Batteries						
Switches						
Lines						
Fuses						
Resistors						
Lighting						

A: existing / complete
D: Repair / Replacement

B: Condition / Maintenance
E: Reinspection required

C: Function

done = × not done = - not required = 0

Inspection guidelines for repeat inspection of LIEBHERR mobile and crawler cranes according to §26(1) or (2) UV "Cranes" (BGV D6)

Company: Inspector: Date:

Crane manufacturer: **LIEBHERR** Crane type: S/N:

Year: Inventory number:

Signature of inspector for No. 1 to 20:

17. Inspection group: Superstructure - Control systems						
Item to be checked	A	B	C	D	E	Remarks
Engine regulation						
Gear						
Elastic couplings						
Controls						
Engine stop line						
Indicators						
18. Inspection group: Superstructure - Cable drive systems						
Item to be checked	A	B	C	D	E	Remarks
Winch I ³⁾						
Winch II ³⁾						
Winch III ³⁾						
Winch IV ³⁾						
Cable pulleys						
Cable end mounting						
Cable for winch I						
Cable for winch II						
Cable for winch III						
Cable for winch IV						
Guy ropes						
19. Inspection group: Superstructure - Hook						
Item to be checked	A	B	C	D	E	Remarks
Pulleys						
Cable guide bar on pulleys						
Axle retainer						
Load hook						
Load hook mounting						
Hook retainer						

A: existing / complete
D: Repair / Replacement

B: Condition / Maintenance
E: Reinspection required

C: Function

done = × not done = - not required = 0

Inspection guidelines for repeat inspection of LIEBHERR mobile and crawler cranes according to §26(1) or (2) UV "Cranes" (BGV D6)

Company: Inspector: Date:

Crane manufacturer: **LIEBHERR** Crane type: S/N:

Year: Inventory number:

Signature of inspector for No. 1 to 20:

20. Inspection group: Superstructure - Safety and Control devices						
Item to be checked	A	B	C	D	E	Remarks
Hoist limit switch I						
Hoist limit switch II						
Lowering limit switch I						
Lowering limit switch II						
Boom limit switch I						
Boom limit switch II						
Luffing jib: boom limit switch I						
Luffing jib: boom limit switch II						
Load moment limiter						
Angle indicator: Boom						
Angle indicator: Luffing jib						
Angle indicator: Slewing gear						
Safety devices: Steuerung						
Working range limitation						
Pressure sensor						
Speed sensor						
Wind velocity sensor						
Sliding arm monitor						
Support force monitor						
Incline monitor						
Length indicator: radius, boom length						
Emergency off						
Engine stop						

A: existing / complete
D: Repair / Replacement

B: Condition / Maintenance
E: Reinspection required

C: Function

done = × not done = - not required = 0

Inspection guidelines for repeat inspection of LIEBHERR mobile and crawler cranes according to §26(1) or (2) UV "Cranes" (BGV D6)

Company: Inspector: Date:

Crane manufacturer: **LIEBHERR** Crane type: S/N:

Year: Inventory number:

Signature of inspector for No. 1 to 20:

20. Inspection group: Boom						
Item to be checked	A	B	C	D	E	Remarks
Welding construction						
Cable pulleys						
Luffing cylinder						
Telescoping cylinder						
Push out cables						
Return pull cables						
Boom bearing / mounting						
Boom pinning						
Guy rods						
Relapse cylinder						

A: existing / complete
D: Repair / Replacement

B: Condition / Maintenance
E: Reinspection required

C: Function

done = × not done = - not required = 0

Remarks:

- 1) The inspection of the road safe condition of the carrier vehicle is also recommended if an error free expert inspection result according to highway safety regulations is available. For vehicle cranes, which are not cleared for use on public highways, the experienced technician or expert inspector should also check the vehicle for road safe condition (see also UVV "Vehicles" (BGV D29)).
- 2) These inspections must be made by an expert engineer even if an error free expert inspection result according to highway safety regulations is available.
- 3) Inspection of winches regarding used part of theoretical utilization time.

1. Introduction

In a crane, the rope should be regarded as an expendable component requiring replacement when examination shows its strength to have diminished to the point where its further use would be unwise. In all cases, however, the safe handling of loads by correctly operated equipment requires regular examination of the rope so that it is removed from service in adequate time.

In all conditions of use, the discard criteria relating to wire breaks, wear, corrosion and deformation can be applied immediately. These different factors are considered in ISO 4309, which is intended for the guidance of competent persons involved in the maintenance and examination of cranes.

The criteria outlined are aimed at retaining, until the rope is discarded, an adequate safety margin for the handling of loads by cranes.

D A N G E R : **Failure to recognize these criteria is dangerous.**

2. Wire rope

2.1 State before fitting

A rope of the same type as that initially fitted will normally be adopted for replacement purposes. If it is of a different type, the user shall ensure that it possesses properties at least equivalent to those of the rope being discarded.

Before re-equipping the appliance, all grooves in drums and pulleys should be checked to ensure that they will correctly accept the replacement rope (see clause 4).

2.2 Fitting

When drawing the wire rope from a reel or coil, every precaution should be taken to avoid the inducement of loss of turn, because to allow such a condition may result in loops, kinks or bends forming in the rope.

If the rope rubs against any part into operation on the appliance when it is not under tension, then the points of contact should be suitably protected.

Before bringing the rope into operation on the appliance, the user shall ensure that all the devices associated with the wire rope operation are set functioning correctly.

A number of operations of the crane shall be carried out at approximately 10 % of the normal load to stabilize the wire rope.

2.3 Maintenance

The maintenance of the wire rope shall be carried out relative to the lifting appliance, its use, the environment and the type of rope involved. Unless otherwise indicated by manufacturer either of the crane or the rope, the wire rope should be cleaned, where possible, and covered with a service dressing of grease or oil, particularly on those lengths which bend when passing over pulleys.

The service dressing shall be a suitable lubricant for steel wire ropes .

A shorter working life of the rope will result from lack of maintenance, particularly when the crane works in a corrosive environment and, in certain cases, for reasons connected with the operation, where no service dressing can be used.

2.4 Examination

2.4.1 Frequency

2.4.1.1 Daily observation

As far as possible, all visible parts of any rope should be observed each working day with the object of detecting general deterioration and deformation. Particular attention should be paid to the rope at points of attachment to the appliance. Any appreciable change suspected in the rope condition shall be reported and the rope examined by a competent person in accordance with 2.4.2.

If the lower rope layers on the drum are not used often or not at all, then they must be uncoiled from time to time and respooled under pretension. The rope is working most economically if it is always used over its complete length. For that reason, it is recommended to use the appropriately matched rope length when working for an extended time with the crane.

2.4.1.2 Special examination in accordance with 2.4.2

In all cases when an incident has occurred which may have caused damage to the rope and/or its termination, or on every occasion when the rope has been brought back into operation after dismantling followed by re-assembly, the rope shall be examined.

2.4.2 Points to be covered by examination

2.4.2.1 General

Although the wire rope shall be examined throughout its length, particular care shall be taken at the following positions:

- the termination points at the end of both moving and stationary ropes;
- that part of a rope which passes through the block or over pulleys; particular attention shall be paid, in the case of appliances performing a repetitive operation, to any part of the rope which lies over the pulleys while the appliance is in a loaded condition (see annex 1);
- that part of the rope which lies over a compensating pulley;
- any part of the rope which may be subject to abrasion by external features (for example hatch coamings);
- internal examination for corrosion and fatigue;
- any part of the rope exposed to heat.

The results of the examination shall be recorded in the examination record for the appliance (see clause 5 and annex 2 for a typical example).

2.4.2.2 Terminations – excluding slings

The rope shall be examined in the area where it passes out from the termination, as this position is critical for the onset of fatigue (wire breaks) and corrosion. The terminal fittings themselves shall also be examined for signs of distortion or wear.

Terminations involving pressed or swaged ferrules shall be similarly examined, and the ferrule checked for cracks in the material and possible slippage between the ferrule and the rope.

Detachable terminations (wedge sockets, grips) shall be examined for broken wires within and under the termination and to ensure the tightness of wedges and screwed grips. The examination shall also ensure that the requirements of the standards and codes of practice laid down for the termination of the rope have been met.

2.5 Discard criteria

The safe use of rope is qualified by the following criteria (see 2.5.1 to 2.5.9):

- 1) number of broken wires;
- 2) the localized grouping of wire breaks;
- 3) the rate of increase of wire breaks;
- 4) the fracture of strands;
- 5) reduction of rope diameter, including that resulting from core deterioration;
- 6) external and internal wear;
- 7) external and internal corrosion;
- 8) deformation;
- 9) damage due to heat or electric arcing;

All examinations shall take account of these individual factors, recognizing the particular criteria. However, deterioration will frequently result from a combination of factors giving a cumulative effect which shall be recognized by the competent person, and which will reflect on the decision to discard the rope or to allow it to remain in service.

In all cases, the examiner should investigate whether the deterioration has been caused by a defect in the appliance; if so, he should recommend action to overcome the defect before fitting a new rope.

2.5.1 Number of broken wires

The number of broken wires must be determined by a visual inspection on the whole rope length. When a broken wire is found, mark sections with a length of $30 \times d$ (d = nominal rope diameter) up and down the rope from this point. These sections must be examined very closely. All broken wires in each section are now carefully counted. Please compare the number of visible broken wires with annex 4. If the number of visible broken wires are less than mentioned in the table, mark the area where the most broken wires were found with the length of $6 \times d$. Count the visible broken wires once again and compare with annex 4. If the number of visible broken wires are less than mentioned in the table, the rope has not to be removed yet.

Note: Depending on the number of visible broken wires the period for the next examination has to be fixed.

2.5.2 Localized grouping of broken wires

Where broken wires are very close together, constituting local grouping of such breaks, the rope shall be discarded. If the grouping of such breaks occurs in a length less than **6 d** or is concentrated in any one strand, it will be prudent to discard the rope even if the number of wire breaks is smaller than the maximum number indicated in the tables.

2.5.3 Rate of increase of broken wires

In application where the predominant cause of rope deterioration is fatigue, the commencement of broken wires will begin after a certain period of usage, but the number of breaks will progressively increase at ever-shortening intervals. In these cases, it is recommended that careful examination and recording of the increase of broken wires should be undertaken.

2.5.4 Fracture of strands

If a complete strand fracture occurs, the rope shall be discarded.

2.5.5 Reduction of rope diameter resulting from core deterioration

Reduction of rope diameter resulting from deterioration of the core can be caused by:

- 1) internal wear and indentation;
- 2) internal wear caused by friction between individual strands and wires in the rope, particularly when it is subject to bending;
- 3) fracture of a steel core;
- 4) fracture of internal layers in a multi-strand construction.

If these factors cause the rope diameter (average of two diameter measurements normal to each other) to decrease by 3 % of the nominal rope diameter for rotation-resistant ropes, or 10 % for other ropes, the ropes shall be discarded even if no broken wires are visible.

Note: New ropes may have an actual diameter greater than the nominal diameter so that the wear permissible will therefore be greater by the same amount.

2.5.6 External wear

Abrasion of the crown wires of outer strands in the rope results from rubbing contact, under pressure, with the grooves in the pulleys and the drums. The condition is particularly evident on moving ropes at points of pulley contact when the load is being accelerated or decelerated, and shows itself as flat surfaces on the outer wires.

Wear is promoted by lack of lubrication, or incorrect lubrication, and also by the presence of dust and grit.

Wear reduces the strength of ropes by reducing the cross-sectional area of the steel.

When owing to external wear the actual rope diameter has decreased by 7% or more of the nominal rope diameter, the rope shall be discarded even if no wire breaks are visible.

2.5.7 External and internal corrosion

Corrosion occurs particularly in marine and industrial polluted atmospheres, and will not only diminish the breaking strength by reducing the metallic area of the rope but will also accelerate fatigue by causing the irregular surface from which stress cracking will commence. Severe corrosion may cause decreased elasticity of the rope.

1) External corrosion

Corrosion of the outer wires may be detected visually.

2) Internal corrosion

This condition is more difficult to detect than the external corrosion.

Note: If there is any suggestion of internal corrosion, the rope should be examined by a competent person.

CAUTION: Confirmation of severe internal corrosion is justification for immediate rope discard.

2.5.8 Deformation

Visible distortion of the rope from its normal formation is termed "deformation" and may create a change at the deformation position which will result in an uneven stress distribution in the rope. Distinction is made between the following main deformations of rope on the basis of their appearance (see 2.5.8.1 to 2.5.8.7):

- 1) waviness;
- 2) basket or lantern distortion;
- 3) strand extrusion;
- 4) wire extrusion;
- 5) flattened portions;
- 6) kinks or tightened loops;
- 7) bends.

2.5.8.1 Waviness (see annex 3, plate 1)

In the case of waviness (see figure 1), the wire rope shall be discarded if

$$d_1 > \frac{4d}{3}$$

where d is the nominal diameter of the rope and d_1 is the diameter corresponding to the envelope of the deformed rope, and the length of the rope under consideration does not exceed $25d$.

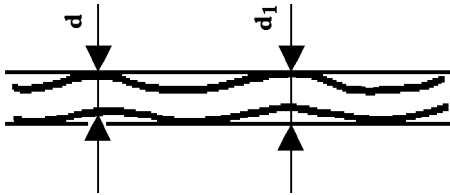


Figure 1 - Waviness

2.5.8.2 Basket or lantern distortion (see annex 3, plate 2)

A basket or lantern formation is justification for immediate discard.

2.5.8.3 Strand extrusion (see annex 3, plate 3)

Strand extrusion is justification for immediate discard.

2.5.8.4 Wire extrusion (see annex 3, plates 4 and 5)

In this condition, certain wires or groups of wires rise up, on the opposite side of the rope to the pulley groove, in the form of the loops – this feature usually results from shock loading. If the deformation is severe, there is justification for rope discard.

2.5.8.5 Flattened portions (see annex 3, plates 8 and 9)

Flattened portions occur as a result of mechanical damage; if severe, they are justification for rope discard.

2.5.8.6 Kinks or tightened loops (see annex 3, plates 6 and 7)

CAUTION: A kink or tightened loop is justification for immediate discard.

2.5.8.7 Bends (see annex 3, plate 10)

Bends are angular deformations of the rope caused by external influence. The condition is justification for immediate discard.

2.5.9 Damage due to heat or electric arcing

Wire ropes which have been subjected to exceptional thermal effects, externally recognized by the colors produced, shall be discarded.

3. Operating performance of wire rope

Accurate recording of information by the examiner can be used to predict the performance of a particular type of rope on a crane. Such information is useful in regulating maintenance procedures and also stock control of replacement rope. If such forecasting is used, it should not have the effect of relaxing examinations or prolonging the operating period beyond that indicated by the criteria specified in the preceding clauses of this code of practise for examination and discard of crane wire ropes.

4. Condition of equipment related to rope

Winding drums and pulleys shall be checked periodically to ensure that all these components rotate correctly in their bearings.

Stiff or jammed pulleys or rollers wear heavily and unevenly, causing severe abrasion of the rope.

Ineffective compensating pulleys can give rise to unequal loading in the rope reeving.

The radius at the bottom of the groove in all pulleys and the drum shall be appropriate to the nominal diameter of the rope. If the radius has become too great or too small, the groove shall be remachined or the pulley replaced.

Note: In no case the radius should be smaller than the actual wire rope diameter.

5. Rope examination record

For each periodic examination, users shall provide a record in which shall be recorded the information from each examination of the rope; see annex 2 for a typical example of a record.

6. Rope storage and identification

Clean and dry storage shall be provided to prevent deterioration of ropes not in use and means provided to enable ropes to be clearly identified with their examination records.

7. Wire ropes and rope end connections

The wire ropes and rope end connections in use are selected according to their use. It must be determined if a **torsion resistant** or a **non-torsion resistant** rope is required for the application. The selected rope type subsequently requires the corresponding rope end connections.

CAUTION: The correct selection and use of the wire ropes and rope end connections are deciding prerequisites for proper and accident free crane operation.

7.1 Torsion resistant ropes and their rope end connections

Torsion resistant ropes are special ropes, which, under load, create an extremely low torque or extremely low twist on the rope end connection. Due to this rope property, these ropes are used as **hoist ropes**.

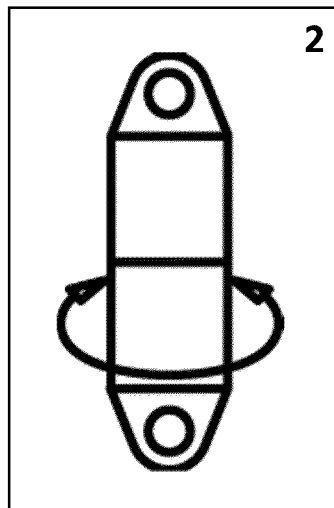
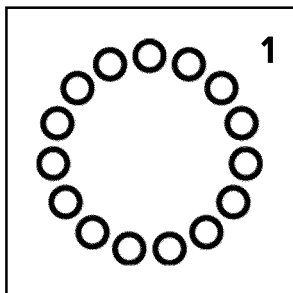
Typical torsion resistant wire rope construction designs are ropes with 15 to 18 outer strands. Torsion resistant ropes are shown symbolically with 15 outer strands (circles) (plate 1).

Torsion resistant ropes can be utilized with the following rope end connections :

- **Twistable** rope end connection in form of a PFEIFER rope lock with swivel or twist catch / swivel
- **Non-twistable** rope end connection in form of a PFEIFER rope lock **without** swivel or spline lock

If possible, for **torsion resistant** ropes, the use of a twistable rope end connection is favored to reduce torsional tensions. (plate 2).

DANGER: Twistable rope end connections may never be used with non-torsion resistant ropes!
If this is not observed, it can result in severe damage to personnel and property!



195653

Note: The user warning on the twistable PFEIFER rope lock with swivel shows that this rope end connection may **not** be used for non-torsion resistant ropes (plate3)!

7.2 Non-torsion resistant ropes and their rope end connections

Under load, non-torsion resistant ropes create high torque on the rope end connection. For that reason, the rope ends must be secured by a special cable end connection to prevent them from twisting, so that the rope cannot twist open when in use.

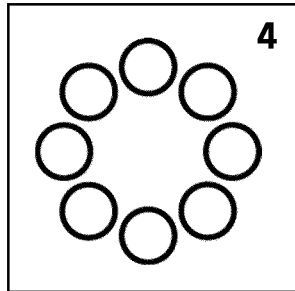
Due to this rope property, these ropes are used as **control, intake or retaining ropes**.

Typical non-torsion resistant wire rope construction designs are ropes with 8 or 10 outer strands. Non-torsion resistant ropes are shown symbolically with 8 outer strands (circles) (plate 4).

Non-torsion resistant ropes may only be utilized with the following rope end connections :

- **Non-twistable** rope end connection in form of a PFEIFER rope lock **without** swivel or spline lock
A non-twistable rope end connection is also the rope attachment on the fixed point of the winch drum.

DANGER: Non-torsion resistant ropes may never be used with twistable rope end connections!
No twist catch / swivel may be installed!
If this is not observed, it can result in severe damage to personnel and property!



195654

Note: The user warning on the PFEIFER rope lock **without** swivel and spline locks shows that this rope end connection may **not** be used for non-torsion resistant ropes **in connection with** a twist catch / swivel (plate5)!

8. Extension torsion in rotation resistant ropes and how to solve the problem

A T T E N T I O N : Be very carefull during the following operations!

1. The number of falls should be the number by which the hook block rotates the most.
2. The boom will be fully extendet and the block will be lowered.
3. The hook block is to be loaded with at least appr. 10-15 % of the nominal tension per fall.
4. Before this load is lifted, the following steps must be carried out by an assistant: The twisted hook block must be untwisted by hand to the straight position (the falls will not touch each other anymore). Afterwards the hook block will be further rotated by hand additionally with 360° (the falls will touch each other).
5. When the load is lifted, the hook block must be maintained in the given twisted position until the load clears the floor.

A T T E N T I O N : When the hook block comes under load, it will try to twist back to the straight position. Now release the hook block.

6. In the next step the load will be lifted to a height of approx. 15 m below the highest possible position. The boom remains fully extended.
7. Finally the load will be lowered and set down. The rotation of the hook block will now be much less or none at all.
8. If necessary repeat the above procedure.

C A U T I O N : If this is not observed, the rope can be damaged!

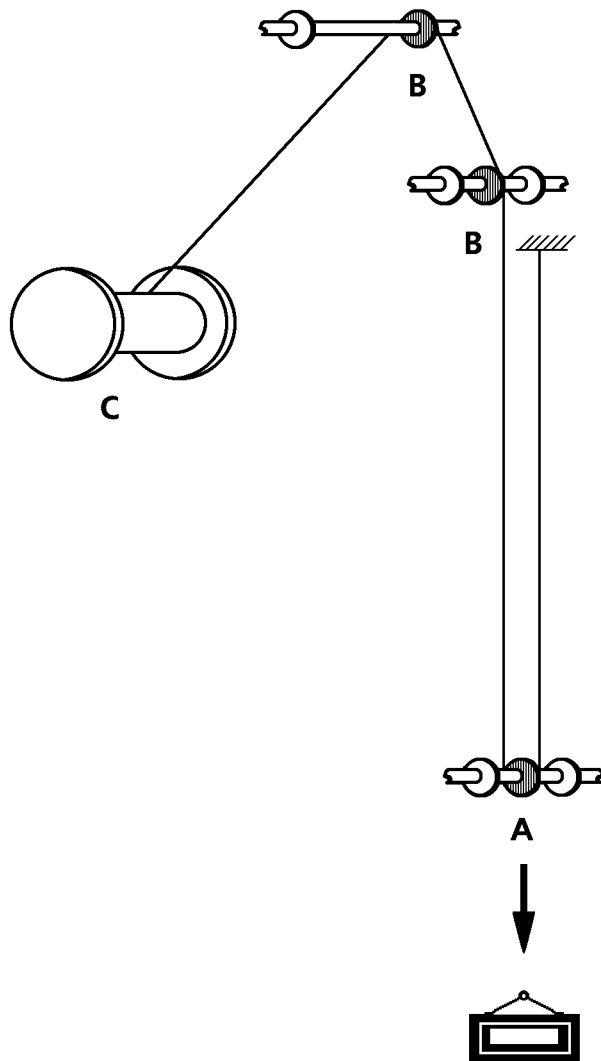


Fig. 1

Annex 1

Explanation for Fig. 1

- A:** Pulley block
- B:** Pulley
- C:** Drum

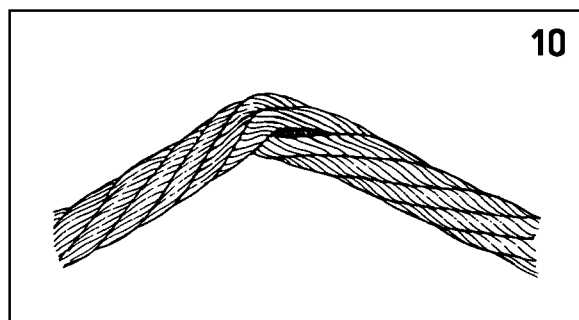
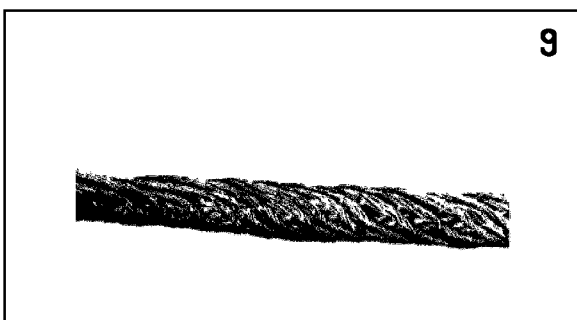
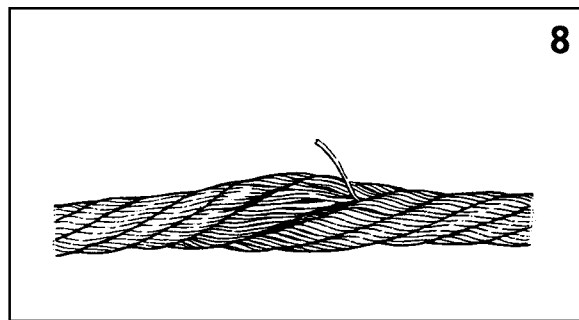
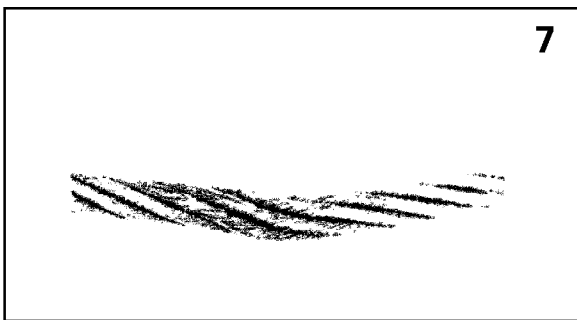
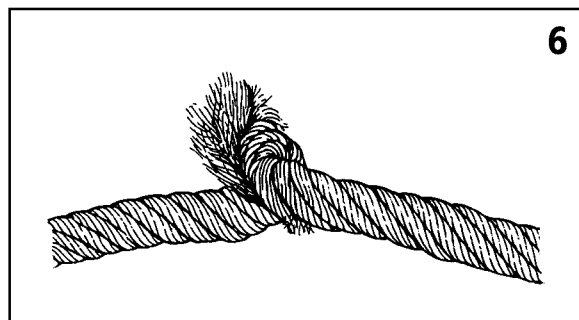
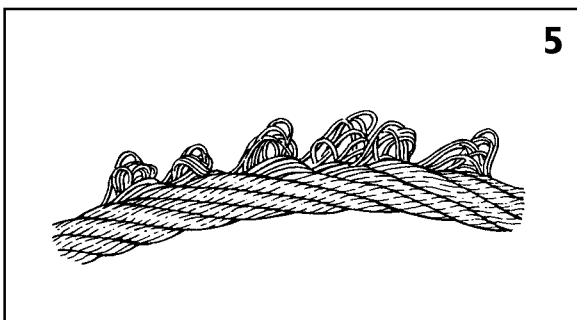
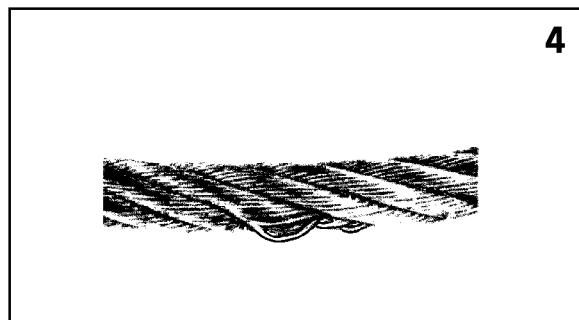
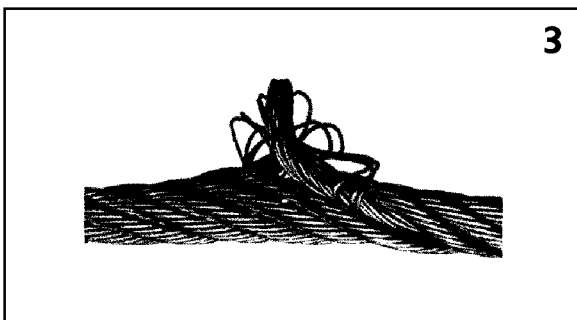
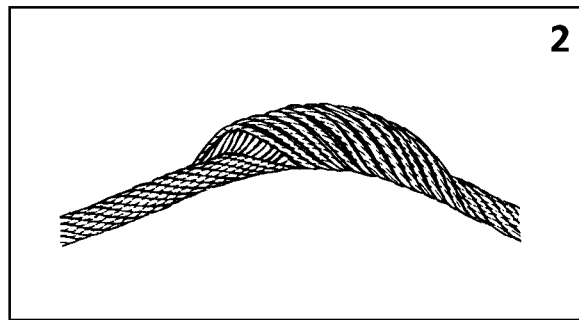
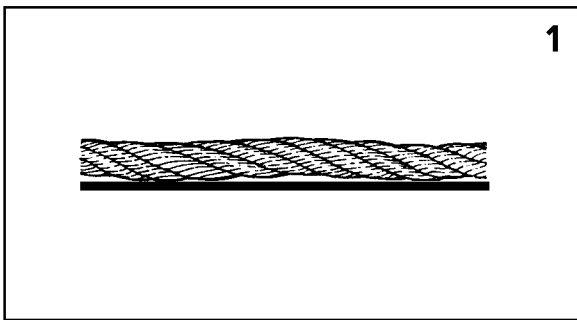
Diagrammatic illustration of possible defects to be considered during examination, with reference to different areas

- 1) Examine termination of rope at drum.
- 2) Examine for defective coiling, which causes deformations (flattened portions) and wear, which can be severe at cross-over positions.
- 3) Examine for wire breaks.
- 4) Examine for corrosion.
- 5) Look for deformations caused by snatch loading.
- 6) Examine portion which winds over pulley for wire breaks and wear.
- 7) Points of attachment:
 - check for wire breaks and corrosions;
 - similarly, check section of rope which lies on or adjacent to compensating pulleys.
- 8) Look for deformation.
- 9) Check rope diameter.
- 10) Examine carefully length which runs through pulley block, particularly that length which lies on the pulley when the appliance is in loaded condition.
- 11) Examine for wire breaks or surface wear.
- 12) Examine corrosion.

Annex 2

Typical example of examination record

Datasheet for ropes		Machine: Application:					
Construction: Direction of rope lay: RH / LH ¹⁾ Type of lay: Ordinary / Langs ¹⁾ Nominal diameter: Tensile grade: Quality: ungalvanized / galvanized ¹⁾ Type of core: steel / natural or synthetic textile / mixed ¹⁾ Preformation: Length of rope: Type of termination:		Date fitted: Date discarded: <hr/> Minimum breaking load: Working load: <hr/> Diameter measured: under a load of:					
Visible broken wires		Abrasion of outer wires	Corrosion	Reduction of rope diameter	Positions measured	Overall assessment	Damage and deformations
Number in length of 6 d	Number in length of 30 d	Degree of deterioration ²⁾	Degree of deterioration ²⁾	%		Degree of deterioration ²⁾	Nature
Date:					Signature:		
Rope supplier:		Number of working hours:					
Other observations:		Reasons for discard:					
1) Delete as appliropo.							
2) In these columns, describe the latter as:		slight, medium, high, very high, discard.					



Annex 3

Typical examples of defects that may occur in wire rope

Note: For emphasis many plates show exaggerated deterioration, and the ropes depicted should be discarded at an earlier stage.

- Plate 1** Waviness: a deformation where the longitudinal axis of the rope takes the shape of a helix
If the deformation exceeds the value indicated in 2.5.8.1, the rope shall be discarded
- Plate 2** Basket (bird cage) or lantern deformation of a multi -strand construction
Justification for immediate discard
- Plate 3** Extrusion of a steel core, generally associated with a basket or lantern deformation in adjacent position
Justification for immediate discard
- Plate 4** One strand only affected by wire extrusion, although examination over a length of rope shows that deformation is visible at regular intervals, normally of one lay length
Justification for immediate discard
- Plate 5** Aggravation of the previous fault (plate 4) (typical of a hoist rope on a piling machine) to a degree of severity
Justification for immediate discard
- Plate 6** A severe kink or tightened loop
Note the screwed-up lay, causing the extrusion of the fibre core
Justification for immediate discard
- Plate 7** A wire rope which has been kinked during installation but which has been placed in operation, and is now subject to localized wear and to wire slackness
Justification for discard
- Plate 8** Flattened portion due to local crushing, creating imbalance in the strands and associated with broken wires
Justification for discard
- Plate 9** Flattened portion of multi -strand rope caused by miscoiling on a drum
Note how the lay length of the outer layer of strands has increased. Again there will be imbalance of stress under load conditions
Justification for discard
- Plate 10** Example of severe bend
Justification for discard

Annex 4

Guidance for the number of broken wires according to ISO 4309;
Classification groups for M1, M2, M3 and M4 mechanisms

Hoist ropes

Crane type LG 1750 LR 1750	Rope Ø [mm]	Type of lay	Number of visible broken wires at time of discard over a length of	
			6 × Rope Ø	30 × Rope Ø
Winch 1	28	Lang lay (LL)	2	4
Winch 2	28	Lang lay (LL)	2	4

CAUTION: If a torsion resistant hoist rope is placed on winch 5, then the rope for winch 5 can be used for jib adjustment or as hoist rope for the boom nose.
If very frequent jib adjustment movements are necessary, then a non-torsion resistant adjusting rope must be placed on winch 5.
No twist catches or swivels may be used as rope end connection. The twist catch and - or swivel must be removed!

Crane type LG 1750 LR 1750	Rope Ø [mm]	Type of lay	Number of visible broken wires at time of discard over a length of	
			6 × Rope Ø	30 × Rope Ø
Winch 5 with hoist rope	28	Lang lay (LL)	2	4
Winch 5 with adjusting rope	28	Ordinary lay (OL)	9	18

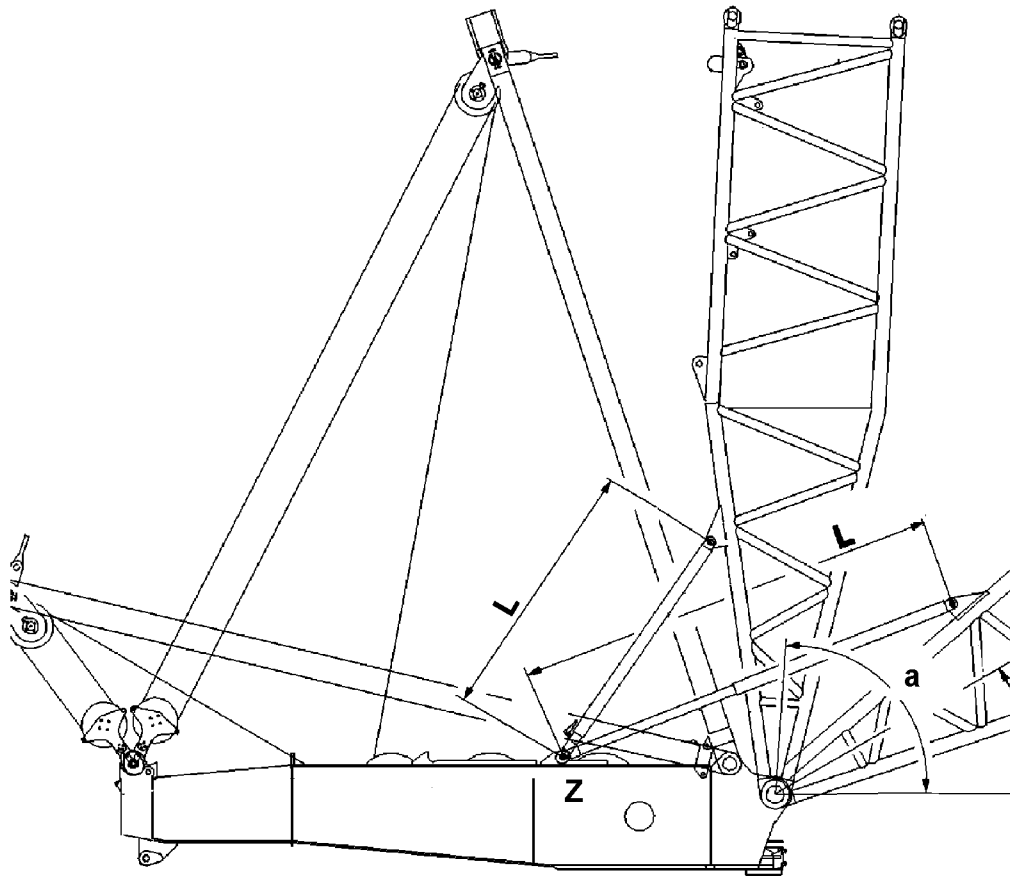
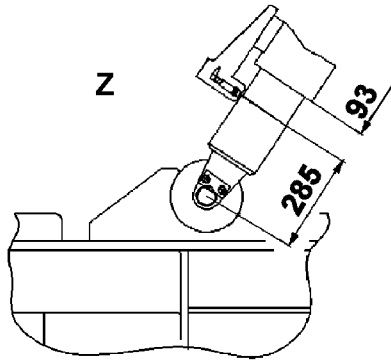
DANGER: Non-torsion resistant adjusting ropes may never be used with twistable rope end connections!
No twist catch/swivel may be installed!
If this is not observed, it can result in severe damage to personnel and property!

Adjusting-ropes

Crane type LG 1750 LR 1750	Rope Ø [mm]	Type of lay	Number of visible broken wires at time of discard over a length of	
			6 × Rope Ø	30 × Rope Ø
Winch 3	28	Ordinary lay (OL)	9	18
Winch 4	28	Ordinary lay (OL)	9	18

Assembly rope

Crane type LG 1750 LR 1750	Rope Ø [mm]	Type of lay	Number of visible broken wires at time of discard over a length of	
			6 × Rope Ø	30 × Rope Ø
Assembly winch	8	Ordinary lay (OL)	2	4



1. Relapse retainers

1.1 S - boom relapse cylinders

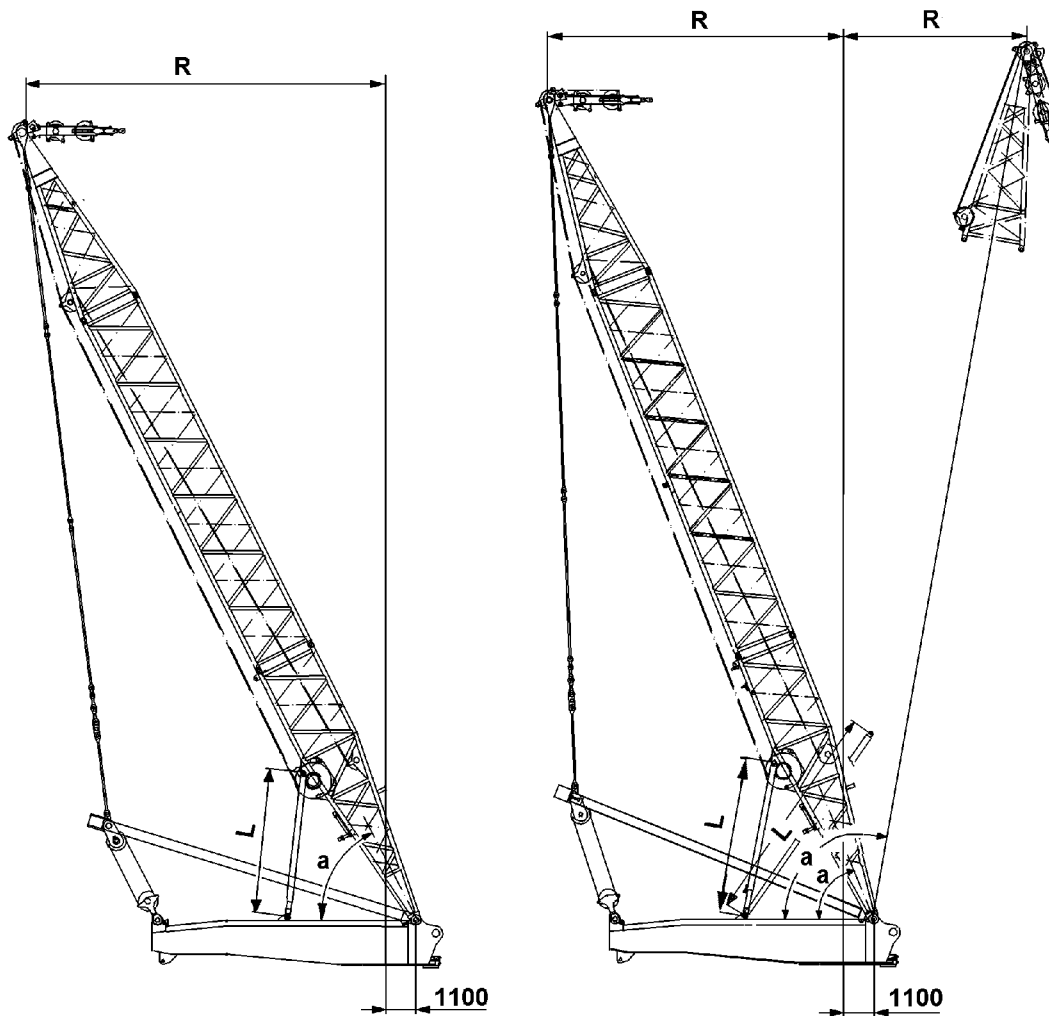
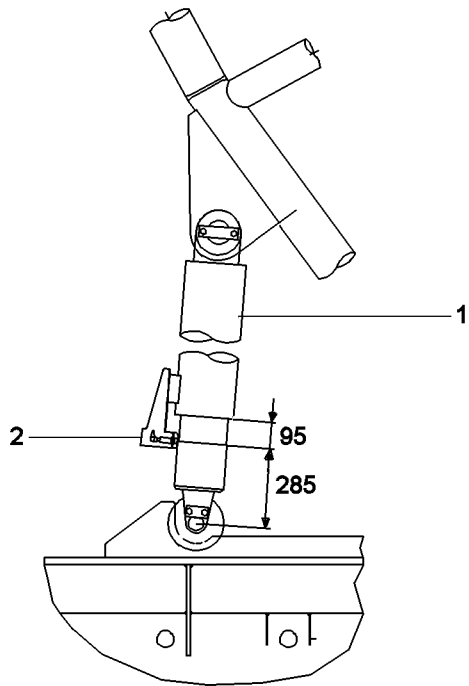
Two hydraulic cylinders prevent the boom from falling backward.

They are controlled to high or low pressure, depending on the operation mode or boom length.

In steepest boom position, the luffing up movement is shut off via the actuated limit switches in the cylinders.

The symbol appears on the LICCON monitor .

	Boom angle a °	Cylinder length L -mm
steepest position	87°	4051
electrical switch position	88°	3998
Block position	89°	3940
Cylinder length extended	29,7°	6490

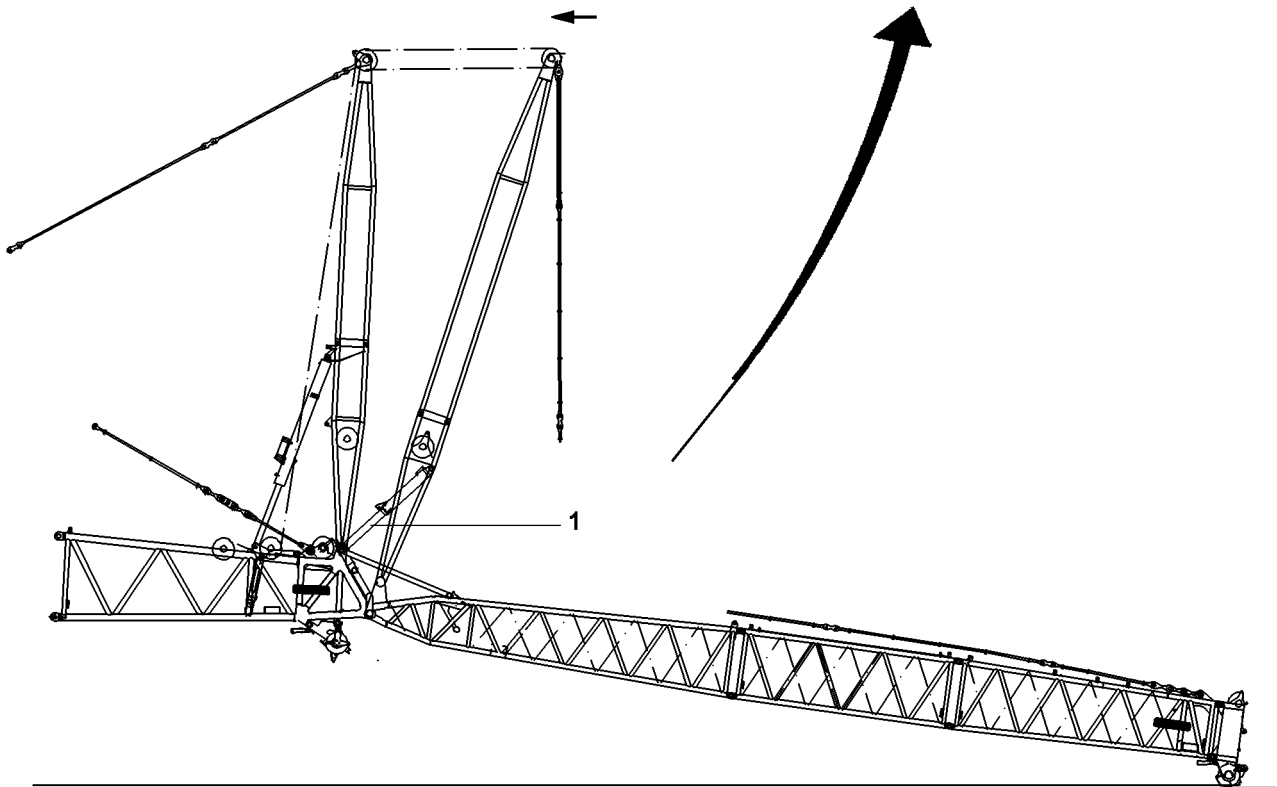
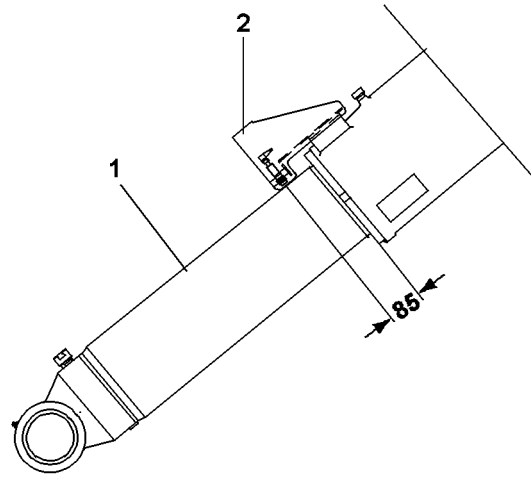


2. Derrick relapse retainer

Two hydraulic cylinders prevent the derrick from falling backward.

If the limit switches on the cylinders are actuated, the **"spool up"** function of winch IV is shut off
The symbol appears on the LICCON monitor .

	Swing radius R	Angle a	Cylinder length L
Cylinder extended	6,6 m	100°	7920 mm
R min. onlyLD, SLD, SD	10,5 m	68,4°	5582 mm
Nominal position	13,0 m	63,4°	5185mm
Electrical switch position	14,0 m	61,4°	5020 mm
Block position	14,4 m	60,5°	4950 mm



3. Functional test of limit switch initiators on hydro-accumulator cylinders**3.1 W-Relapse retainer**

Hydro -accumulator cylinder:

Note: Fig. = Relapse retainer with hydro -accumulator cylinder **Id. No.512381508**

3.1.1 Cover the limit switch initiators individually with a metal plate.

The control winch "**spool up**" movement must turn off.

The symbol on the LICCON monitor must appear.

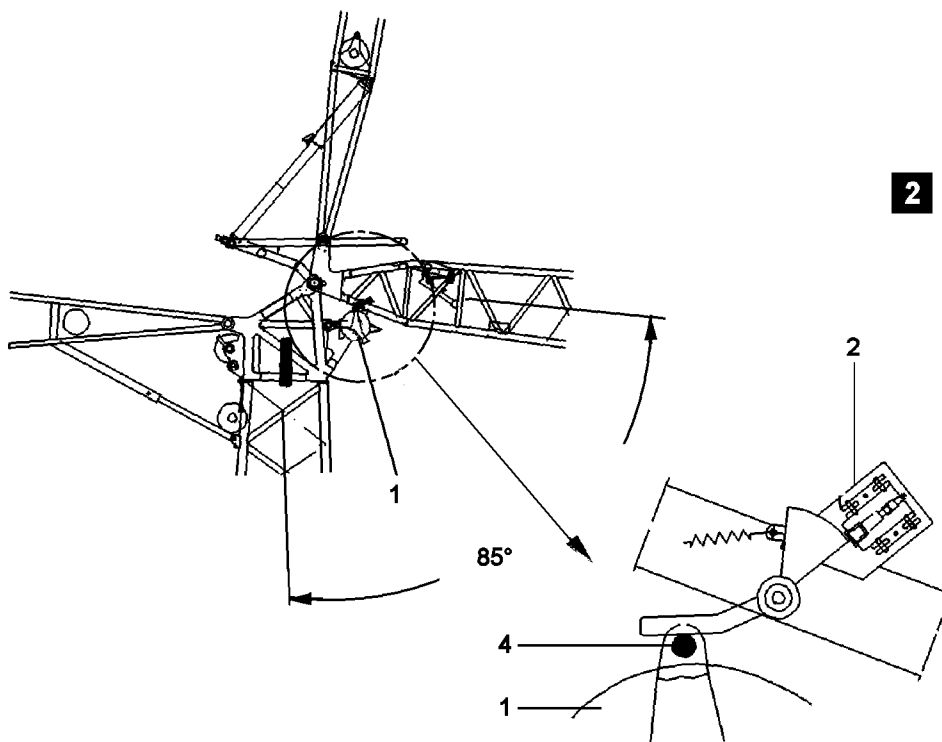
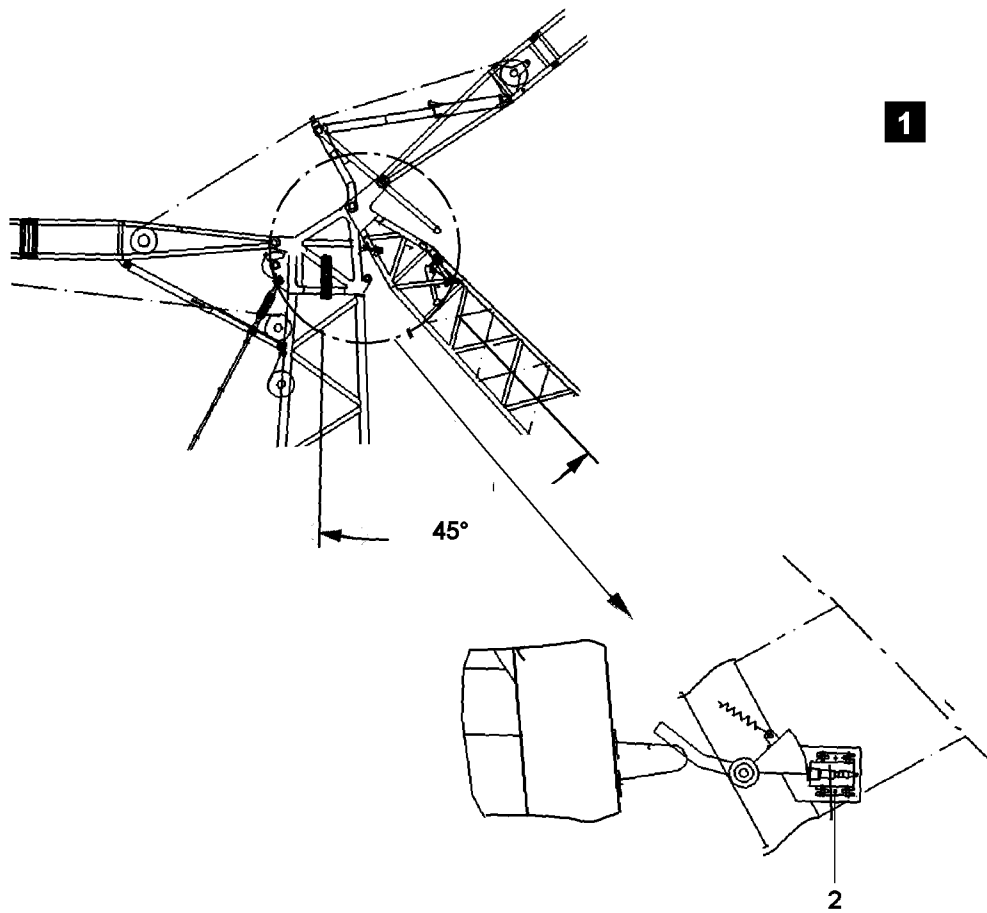
3.1.2 Check the shift point on the hydro-accumulator cylinders as follows:

- The function of the installed limit switch must be checked before erecting the boom. To do so, move the two A- brackets together resp. raise the A- brackets until they open the shift contact at the given dimension (see illustration) and the control winch "**spool up**" movement turns off.

After completing the test successfully, reset the A-brackets to erection condition.

D A N G E R: The crane can be put into service after all additional limit switches for lattice jib angle limitation have been checked for proper function.

There is a danger of accidents !



4. W-lattice jib

Fig. 1

Switch position "luffing jib bottom" without pulley set (1), approx. 45°.

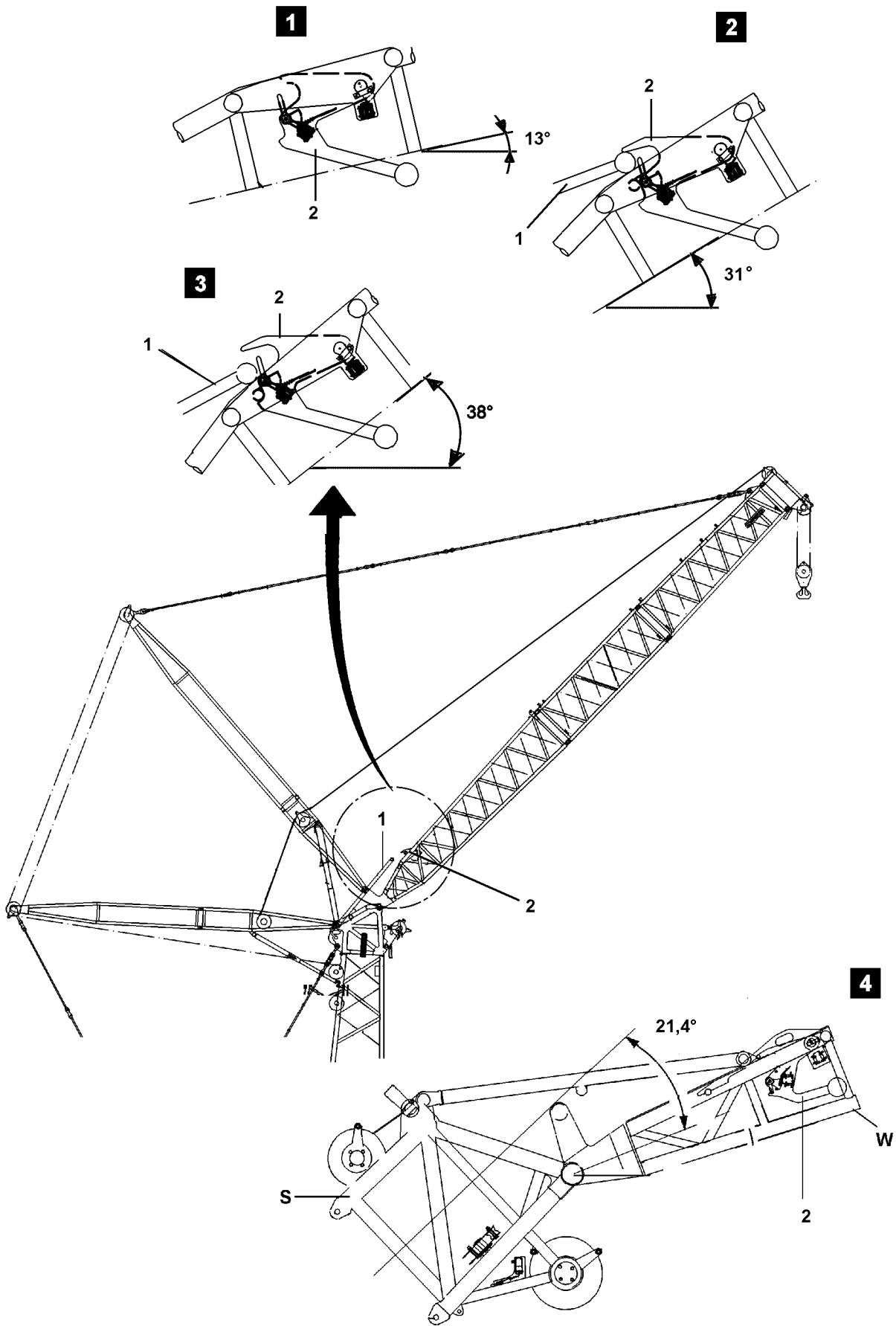
Limit switch (Initiator), Pos. 2

Fig. 2

Switch position "luffing jib bottom " with pulley set (1), approx. 85°.

Limit switch (Initiator), Pos. 3

D A N G E R: The cable protection tube must be installed for the limit switch actuation!



5. Mechanical W- lattice jib relapse retainer (2)

- 1 Mechanical relapse support
- 2 Flap for mechanical relapse support

In addition to the relapse accumulator cylinders, the lattice jib is also secured with a mechanical relapse support (1), which enters into the flap (3) on the pivot section in the steepest lattice jib position. Mechanical block position by relapse support.
The luffing movement is shut off by the actuated limit switches.

Depending on the lattice jib position (boom position = 87°), the flap (2) is swung out by the weight of the pendulum:

- fig. 1** = 13,0° the flap is swung in.
fig. 2 = 31,0° the flap can be pushed open.
fig. 3 = 38,0° the flap is swung out .

D A N G E R: Before erection, the easy movement of the pendulum of the mechanical relapse retainer must be checked over the complete swing range of the pendulum. If this is not observed, the mechanical relapse support will not engage in steepest lattice jib position.
There is a danger of accidents, as the lattice jib may tip backward!

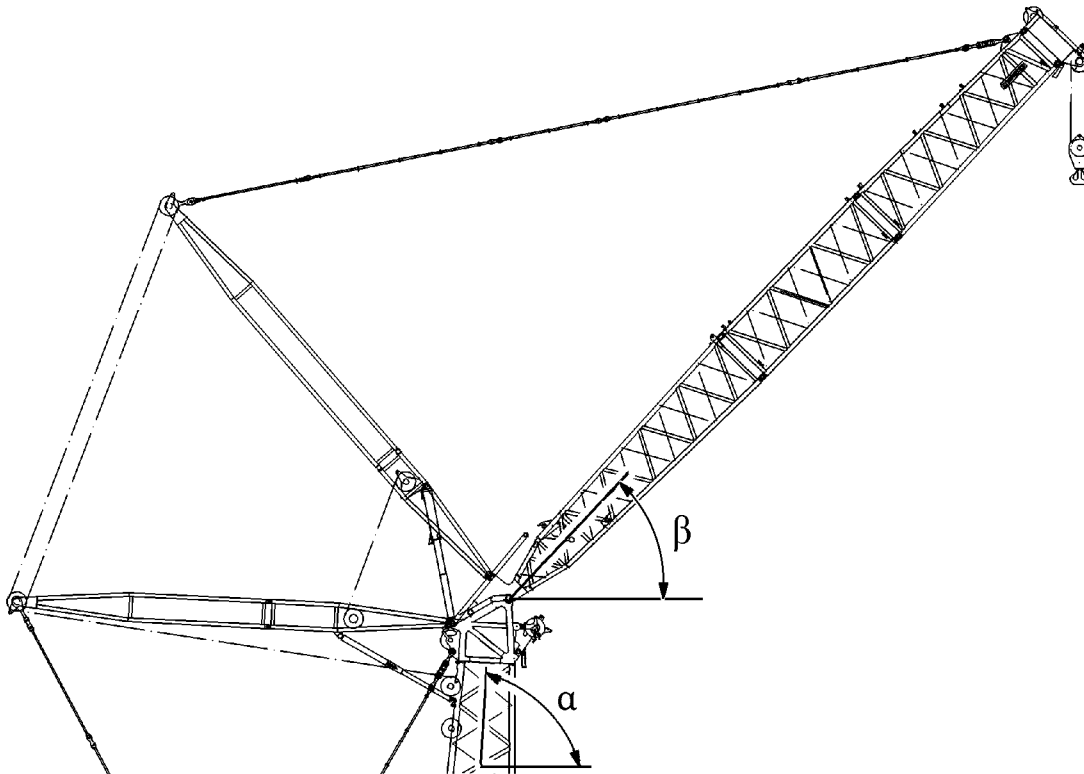
5.1 Flap on collision with mechanical relapse retainer**Fig. 4**

In position of boom and lattice jib, as shown in fig. 4, the flap (2) does not open and the mechanical relapse retainer collides with the flap.

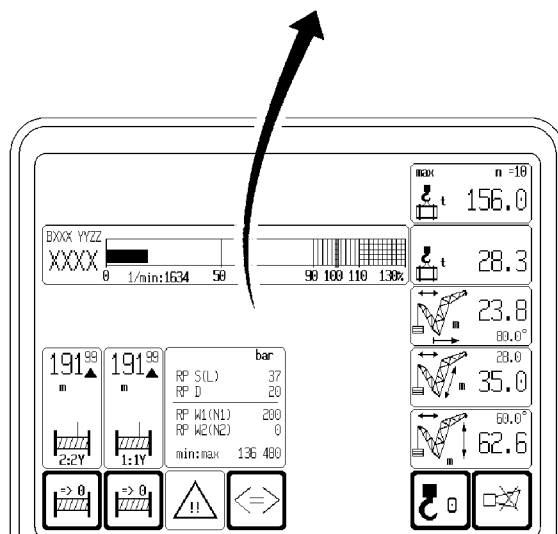
D A N G E R: The mechanical relapse support does not engage into the flap.
There is a danger of accidents as the lattice jib could tip backward!
Check visually!

8.14 CHECKING THE RELAPSE ACCUMULATOR CYLINDERS WITH PRESSURE MONITOR

025009-01



	bar
RP S(L)	37
RP D	20
RP W1(N1)	200
RP W2(N2)	0
min:max	136 480



190804

Hydro - accumulator cylinder used as a relapse cylinder for the lattice fly jib -W

When these cylinders are installed, the hydro accumulator pressure must be checked on LICCON monitor "0" operating view.

One pressure sensor each is installed in the hydraulic section of the cylinder. An electrical signal corresponding to the hydraulic pressure is forwarded to the LICCON monitor "0" in the crane cab.

The monitor "0" shows the corresponding cylinder pressure .

During operation, the **oil pressure = gas pressure.**

To check the specified cylinder pressure

The Hydro - accumulator cylinder must be checked before putting in operation, as follows:

1. Check the specified cylinder pressure at **assembly position**, boom and fly jib **not raised**. as well
2. Check the specified cylinder pressure at **operating position**, boom and fly jib **raised**

to 1. Check the specified cylinder pressure on assembly position, boom and fly jib not raised:

Checking position: boom and fly jib still on the ground, WA-bracket not raised, Hydro - accumulator cylinder fully extended.

The displayed operating pressure on monitor "0" must be the same as the nominal pressure noted on chart 1 below.

Chart 1

	Boom angle [a]	Fly jib angle [b]	Cylinder length [mm]	Stroke [mm]	Pressure (bar)				
					-40° C	-20° C	0° C	+20° C	+40° C
Checking position cylinder fully extended	87°	44,6°	5050	0	107,3	116,5	125,7	134,9	144,1

to 2. Check the specified cylinder pressure on operating position, boom and fly jib raised:

Checking position: Adjust the main boom and the lattice fly jib to an angle in relation to the horizontal line, as noted on the chart 2.

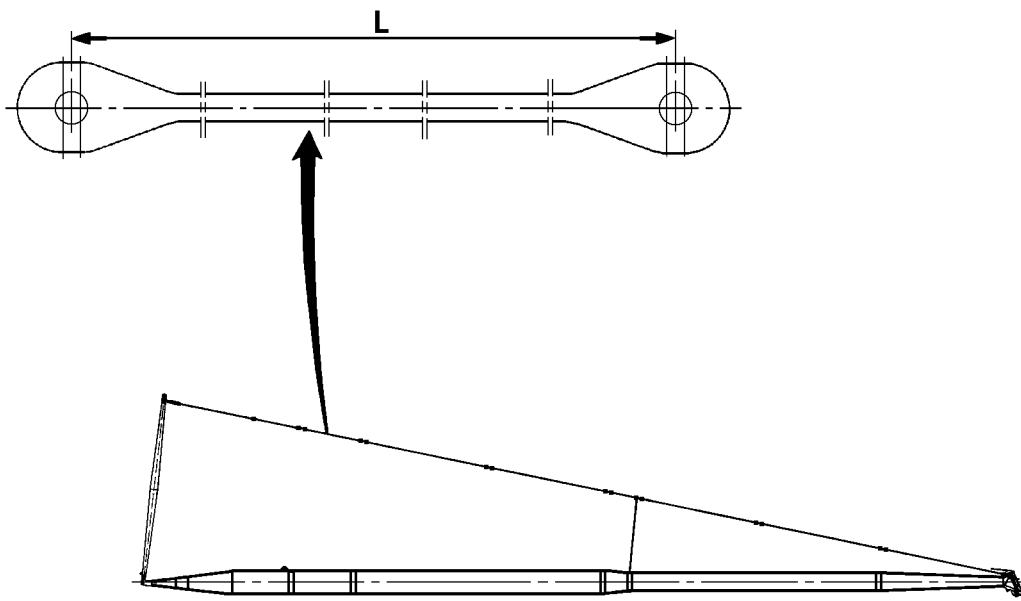
The displayed operating pressure on monitor "0" must be the same as the nominal pressure noted on chart 2 below.

Chart 2

	Boom angle [a]	Fly jib angle [b]	Cylinder length [mm]	Stroke [mm]	Pressure (bar)				
					-40° C	-20° C	0° C	+20° C	+40° C
Checking position	87°	46° + 2°	4997	53	110,0	119,5	129,0	138,4	147,9

CAUTION: The pressure noted depends on the ambient temperature. The actual pressure may not deviate more than +/- 10 bar from the nominal pressure.

Note: In case of a problem, it is possible to replace the pressure sensor, since the check valve prevents any emergence of oil.



Inspecting the tension rods / tension columns

The rods and columns must be inspected whenever they are attached.

The rods and columns must be inspected over their entire length, including concealed surfaces and bore holes.

Inspections:**1. Cracks and nicks**

The tension rods must be checked visually at least once a year to make sure there are no cracks or nicks. The rods must be replaced if there are any cracks. If there is any doubt, then the affected areas must be subjected to a closer inspection, for example with a magnetic powder test.

2. Elongation

The elongation of the rods and columns must be inspected by measurement. Maximum permissible elongation is **0.2%**; for example, over a length of 7000 mm (23 ft) = 14 mm (20/36").

Note: Initial dimension (L), refer to Chap. 5.03 (LG / LR cranes), Chap. 5.04 (LTM cranes)

3. Wear and abrasion

The bore holes and pins must be inspected for signs of wear and abrasion, including the spring keepers and cotter pins used for securing the pins.

4. Enamel coating

The rod/column coating must be inspected regularly for signs of corrosion. Eroded spots must be repainted. The rods and columns must not be stored in aggressive agents, such as sea water.

5. In case of distortion

for example, after being twisted, the rods and columns must not be used again and must immediately be replaced.

Inspection

The rods and columns must be inspected at least once a year by a specialist. In addition, they must also be inspected in accordance with the conditions at the operating site as well as actual operational applications as required.

The inspection intervals should be carried out in accordance with operational applications and should become shorter in accordance with more frequent use.

D A N G E R : If damage as described above is established, the rods and/or columns must not be used and must immediately be replaced.

A damaged guy rod / pull rod can cause serious accidents.

Chapter 9

General Notes

**9.02 GUIDELINES TO PREVENT FIRES IN THE ENGINE AREA
AND IMPORTANT SERVICE WORK TO BE PERFORMED**

022373-02

1. Inspections

- 1.1 Check the engine area daily before starting the crane, and check all oil and fuel lines for leaks and make sure they are dry. In addition, check the fuel and oil filter as well as the injection pump for leaks.
- 1.2 During the daily check up, also check all hydraulic components, the hydraulic motors for the fan drives and corresponding hydraulic lines to assure that they are tight and that there are no leaks.
- 1.3 Check the exhaust system, especially the exhaust flange and the exhaust flap brakes to assure that they are not leaking and are easily movable. The return springs to open the exhaust flaps must be functioning properly, as stuck and therefore closed exhaust flaps during engine operation cause great increases in temperatures and overheating.
- 1.4 Check if electrical lines are still routed and mounted properly, with sufficient distance to exhaust pipes, and assure that they are not damaged and still properly insulated.
- 1.5 To reduce noise emission, insulating baffle mats have been installed in the engine and gear compartments on some crane models. They are fire retardant and, depending on the job location, even inflammable.

It must be checked if the baffle mats are in any way contaminated with solutions, covered with oil and fuel or are damaged. In any of these cases, they must be removed immediately and replaced with original replacement parts.

When cleaning the engine or gear area, note the instructions for maintenance of these mats, see chapter 7.01.

2. Care during repairs and maintenance work

- 2.1 When changing the fuel and oil filters, you must observe utmost cleanliness and carefully clean up any spilled Diesel fuel or oil. Check the fuel and hydraulic system for leaks.
- 2.2 The V-area of the engine must be especially checked after repairs and service tasks, in addition to regular intervals, to assure it is free of oil and fuel. Any fuel in the V-area can run throughout the engine compartment during travel and cause a fire, if it hits hot engine parts.
- 2.3 We note again, that all electrical lines and wires must be properly routed and must be attached in their harnesses, any chafings or defects of the insulation and wiring covers must be taken care off immediately. Any improper installation lines must be replaced immediately.
- 2.4 Be aware that fuel and oil lines can become porous or brittle due to age. Any lines which look brittle or porous must be replaced immediately. (See also Guidelines about the life expectancy of hoses and lines).
- 2.5 Please note, while carrying out repairs and service task, that you do not step on any pipe or hose lines in the engine area. This applies especially to fuel injection lines. If you must step in that area during installation, then the engine must be covered with a board or similar support plate.

3. Important service tasks

- 3.1 Gear and engine oil levels must be checked regularly. Add oil to compensate for normal oil consumption. However, if an unusual amount of oil must be added or has been lost, you must check for and remedy the problem.

4. Maintenance guidelines for replacement components

4.1 When replacing drive components, such as Diesel engine, gear, axles, etc. you must observe the following:

- Before putting these components into service, make sure to add the specified oil to the max. mark; for type of oil, check data tag and lubrication chart.
- Perform the first maintenance check as noted in chapter MAINTENANCE INTERVALS; then carry out all regular maintenance intervals as noted.

4.2 Make sure to follow initial operational instructions.

5. Disposal

5.1 Engine, gear and hydraulic oils, grease, fuel:

To prevent pollution, these service fluids may not be spilled onto the ground, to prevent them from getting into ground water, sewage, or drainage systems.

Observe all state and local regulations applicable to the disposal of these items.

5.2 Radiator fluids for Diesel engines and heater systems:

For disposal, undiluted antifreeze fluids / corrosion protective oils must be handled as special hazardous material.

When disposing of used coolant fluids (mixture of antifreeze / corrosion protective oils and water, observe all state and local regulations applicable to the disposal of these items.