



Model:

Serial number:



Product ID

Commercial name: Crawler Crane
Type: LR 1006.01.06
Model/Version: V04.01

Document ID

Author: ORIGINAL OPERATOR'S MANUAL
Issued: LWN / Technical Publication Department
2016-03-07

Manufacturer

Liebherr-Werk Nenzing GmbH
P.O. Box 10
6710 Nenzing
Austria

LWN/LR-x/V04.01//Auslieferung/2016-03-07/en

EC Declaration of Conformity

Original

We hereby declare that the machine/equipment designated below is designed and built in the version sold by us in such a way as to comply with the relevant fundamental safety and health criteria of the applicable EC Directive(s). This declaration shall cease to be valid if alterations are made to the machine/equipment without our prior agreement.

Commercial name / Function:	Crawler Crane
Type:	LR 1006.01
Serial number:	138362
Model:	LR 1300 SX
Machine power [kW / rpm]:	390 / 1700
Measured sound power level [dB(A)]:	110,9
Guaranteed sound power level [dB(A)]:	111,0

1. Relevant regulations:

1.1 2006/42/EG

1.2 2014/30/EU

1.3 2000/14/EG

1.4 97/23/EG

Sound power level: Notified body: DGUV Test Prüf- und Zertifizierungsstelle, Fachbereich Bauwesen, Landsberger Straße 309, D-80687 München, Notified Body number: 0515; Process: Determination of sound power level according to 2000/14/EG Annex VIII; Technical documentation archive location: Technical office

2. Applied harmonised standards, in particular:

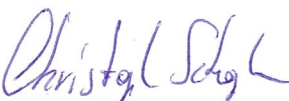
2.1 EN 13000

2.2 EN ISO 12100

Authorised person for the compilation of the technical documentation: Holger Streit, Liebherr-Werk Nenzing GmbH, Dr. Hans Liebherr Straße 1, 6710 Nenzing/Austria

Nenzing, 09.05.2016


Holger Streit
(Managing Director)


Christoph Schapler
(Department Manager Machine Safety)

Liebherr-Werk Nenzing GmbH
Dr. Hans Liebherr Straße 1, 6710 Nenzing/Austria
Tel.: +43 50809 41-0
Fax: +43 50809 41-500
Info.lwn@liebherr.com
www.liebherr.com

LIEBHERR

Article code: 11892331

Edition 19.05.2016 EN

Foreword

The name **Liebherr** doesn't just stand for products and services. It has become a byword for ideas and innovations. For progress which has proved its worth in the marketplace.

We constantly strive to extend and improve our diverse range of products and services. This requires ongoing cooperation and sharing of experience with our customers and business partners throughout the world. We are therefore grateful for any ideas and suggestions for improvements.

Inform Liebherr customer service if the machine is sold or bought by a previous owner.

Please contact:

Liebherr-Werk Nenzing GmbH

Postfach 10

Dr. Hans Liebherr Strasse 1

6710 Nenzing

Austria / Europe

Tel: +43 50809 41-0

Fax: +43 50809 41-500

E-mail: info.lwn@liebherr.com

Notes regarding the documentation

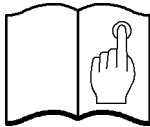
Using the documentation

The documentation supplied with the machine is designed to enable you to:

- operate the machine safely,
- use it in all permissible situations,
- carry out routine maintenance.

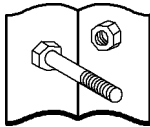
To do this, you will need to be able to find your way around the documentation, which is in several parts.

The documentation consists of:



Operation manual

This contains information on starting, operating and maintaining the machine.



Spare parts catalog

This contains information on procuring spare parts.



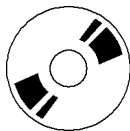
Technical information

This contains information about the electrical and hydraulic systems of the machine.



Load charts

This contains all the valid load charts for all machine setup options.



All the documentation can be found on the CD-ROM. The symbols printed on the CDs provide information on their contents.

Minimum requirements for using the CD-ROMs

Hardware:

- Intel® Pentium II® 500 MHz
- 128 MB RAM memory
- CD-ROM drive
- 800 x 600 pixel resolution, high color

Software:

- Windows 2000, XP
- Internet Explorer 5.5
- Acrobat Reader 7.0

Popup blockers may not be activated when working with Liebherr Parts. Note that the popup blocker functionality may be a part of certain web browsers and in

personal firewalls (software firewalls). The popup blocker functionality can usually be deactivated via the options in the respective program.

Latest version of the documentation

The delivered documentation is compiled solely for the listed serial number and can thus **not** be transferred onto other machines of the same series.

To ensure the documentation is always complete and up to date:

- Do not remove individual documents.
- Replace any missing, unreadable pages by reprinting them from the CD-ROM or request them from Liebherr after sales service.
- Insert immediately new documents supplied as a result of modifications.
- Replace amended documents and destroy the old version (particularly in the case of load charts).
- Always replace CD ROM with updated version, for example from the change documentation.
- With multilingual documents, always update **all languages**.

Storage of documentation

The **operation manual** must always be kept ready at hand in the cabin.

The currently required **load charts** must be kept in the cabin. These can be printed out from the CD-ROM.

The **spare parts catalogue** and the **technical information** must be available to the maintenance and service personnel as required.

Structure of the operating manual

The operating manual is made up of individual, serially numbered chapters.

The table of contents shows how the individual chapters are structured.



The documentation is supplied in paper form in a ring binder and in electronic form on a CD-ROM.

Display conventions




Numerical values and units

This machine was designed and built according to the metric system of units. Numerical values within the imperial system of units are converted and rounded.

Symbols

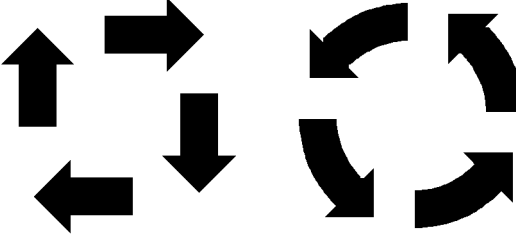
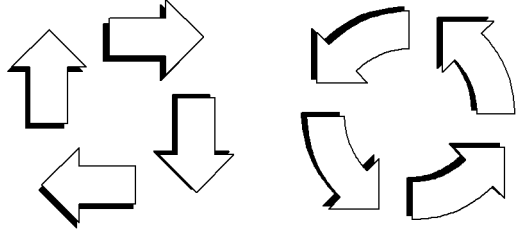
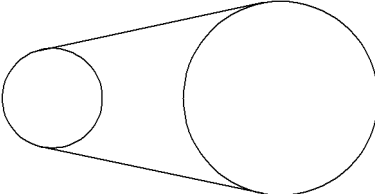
Symbol	Meaning
*	Optional additional equipment
	Requirement must be met
	Performing an action

LWNLR-x/V04.01//Auslieferung/2016-03-07/en

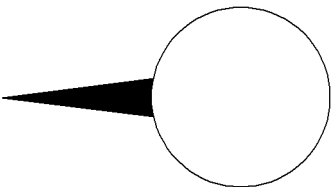
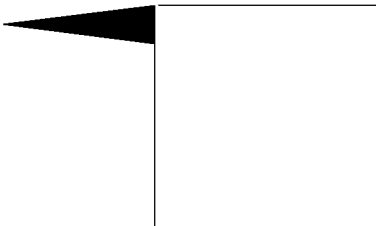
Symbol	Meaning
	Consequence of an action
	Specific characteristics or procedures on a machine with two multi-directional control levers
	Specific characteristics or procedures on a machine with a multi-directional control lever and a double T-lever

Symbols

Symbols in illustrations

Symbol	Meaning
	Actions
1 2 3 4 5 6 7 8 9 10	Imperative sequence of multiple actions in an illustration
A B C D E	Random sequence of multiple actions in an illustration
	Consequences of actions
1 2 3 4 5 6 7 8 9 10	Consequences of actions with imperative sequence
A B C D E	Consequences of actions with random sequence
	Exact enlargement of an area

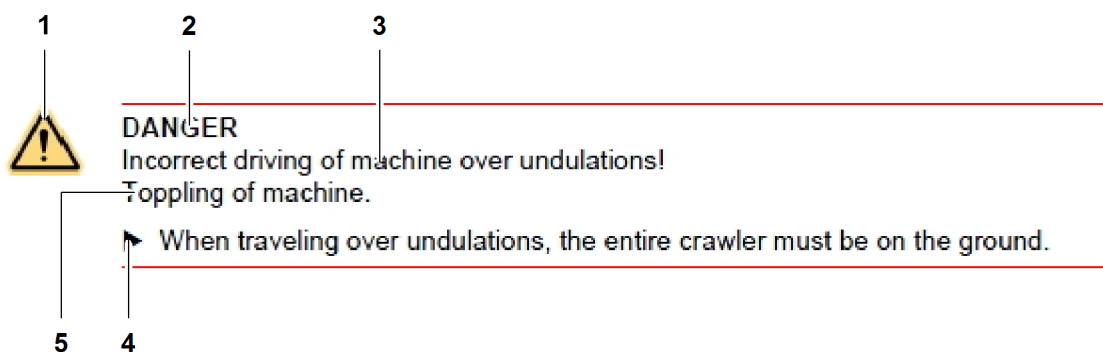
LWNLR.x/V04.01//Auslieferung/2016-03-07/en

Symbol	Meaning
	Enlargement of an area or a component in the same perspective as in the illustration
	Enlargement of an area or a component in a different perspective as in the illustration

Symbols in illustrations

Markings on warning signs

All warning signs in this operation manual conform to norm according to ANSI Z535.6.



Name		Description
1	Warning signs	Warns of possible injuries
2	Signal word	For further information see: Signal words
3	Danger source	Explanation of danger (contexts)
4	Measures	Measures to prevent the danger
5	Consequences of the danger	Consequences in case of non-observance and possibly additional information required for comprehension

Labelling of the warning notices

Signal words



DANGER

Denotes an immediate dangerous situation which will result in death or serious injury if it is not avoided.

- ▶ Refers to action to reduce or avoid the danger(s).



WARNING

Denotes a dangerous situation which could result in death or serious injury if it is not avoided.

- ▶ Refers to action to reduce or avoid the danger(s).



CAUTION

Denotes a dangerous situation which could result in minor or moderate injury if it is not avoided.

- ▶ Refers to action to reduce or avoid the danger(s).

NOTICE

Denotes a dangerous situation which could result in material damage if it is not avoided.

- ▶ Refers to action to reduce or avoid the danger(s).

Additional markings



Note

Denotes useful tips and hints.

- ▶ Refers to the current action and demonstrates how to perform tasks in a straightforward manner.

Publisher's imprint

Version

In the interest of our customers, we reserve the right to make changes in line with technical developments. This documentation therefore corresponds to the technical situation at the time of delivery of the machine, and not to the current state of development at the manufacturer.

Copyright notice

Litronic is a registered trademark of Liebherr.

The documentation is protected by copyright. The copying and duplication of load charts in connection with the operational planning and use of the machine is expressly permitted. Otherwise, the documentation may not be duplicated, reproduced, microfilmed, translated or converted for storage and processing in computer systems, either wholly or partially, without the written consent of Liebherr-Werk Nenzing GmbH.

© Copyright by

Liebherr-Werk Nenzing GmbH

6710 Nenzing / Austria

All rights reserved.

LWN/LR-x/V04.01//Auslieferung/2016-03-07/en

Technical terms and abbreviations

List of abbreviations

Abbreviation	Technical term
AGR	Abgasrückführung
ANSI	American National Standards Institute
ASME	American Society of Mechanical Engineers
BGV	Berufsgenossenschaftliche Vorschriften
CAN	Controller Area Network
DIN	Deutsches Institut für Normung
EN	European Norm
IEC	International Electrotechnical Commission
IP	International Protection
ISO	International Organization for Standardization
MDE	Maschinendatenerfassung
NRS	Nachrüstsatz
ÖNORM	Österreichische Norm
OSHA	Occupational Safety and Health Administration
PDE	Prozessdatenerfassung
SWL	Safe Working Load

List of abbreviations

Glossary

Technical term	Definition/explanation
Abgasrückführung	Serves for reducing the emission of nitrogen oxides that develop during the combustion of fuel in diesel engines.
American National Standards Institute	American National Standards Institute.
American Society of Mechanical Engineers	Professional association of mechanical engineers in the USA.
Berufsgenossenschaftliche Vorschriften	Accident prevention regulations issued by the German Mutual Indemnity Associations.
Controller Area Network	Serial data transmission system.
Deutsches Institut für Normung	Most important national standards organization in the Federal Republic of Germany.

LWNLR.x/V04.01//Auslieferung/2016-03-07/en

Technical term	Definition/explanation
European Norm	Regulations that were issued by one of the three European Standardization Committees (European Committee for Standardization, European Committee for Electrotechnical Standardization and European Telecommunications Standards Institute).
International Electrotechnical Commission	International Standardization Organization for standards in the field of electrotechnology and electronics.
International Organization for Standardization	International association of standardization organizations that drafts and issues international standards.
International Protection	The protection classes classified with IP define the suitability of electric operating materials for different ambient conditions (water, dust, etc.) as well as protective measures to protect against possible hazards during their use.
Lastmomentbegrenzung	Electronic overload protection system.
Litronic	Electrohydraulic proportional control of the machine. Crane control and management system.
Maschinendatenerfassung	Record and save the most important machine data (status, utilization, operating times, etc.).
Nachrüstsatz	Optional equipment of a machine.
Occupational Safety and Health Administration	American Federal Authority that was established to enforce the Federal Labor Safety Law and issues safety regulations for the industry.
Österreichische Norm	National standard issued by the Austrian Standards Institute.
Prozessdatenerfassung	System for electronic recording, saving and visualization of process data.
Safe Working Load	Maximum admissible load without consideration of dynamic forces.

Glossary

Contents

1	Product description	51
1.1	Type plate	51
1.2	Declaration of conformity	52
1.3	Appropriate use	53
1.4	Special modes of operation	55
1.5	Inappropriate use	56
1.6	Machine	58
1.6.1	Machine overview	58
1.6.2	Technical data	60
1.6.3	Safety equipment	65
1.6.4	Monitoring installations	66
1.7	Basic machine	68
1.7.1	Basic machine overview	68
1.7.2	A-frame1	76
1.7.3	Steel pendant straps on A-frame1	77
1.7.4	CF pendant straps on A-frame1	78
1.7.5	Uppercarriage	80
1.7.6	Cabin	82
1.7.7	Central power unit	83
1.7.8	Platforms on uppercarriage	85
1.7.9	Undercarriage	137
1.7.10	Crawler side frame	139
1.7.11	Platforms at undercarriage with fixed track width	143
1.7.12	Carbody counterweight	148
1.7.13	Rear counterweight	153
1.8	Information about boom designation	157
1.9	Distinguishing features main boom sections LR 1300 and LR 1300 SX	159
1.10	Main boom - overview	161
1.11	2821 main boom	162

1.11.1	Main boom base section 2821.30	162
1.11.2	Main boom section 2821 3 m (10 ft)	164
1.11.3	Main boom section 2821 6 m (20 ft)	168
1.11.4	Main boom section 2821 12 m (40 ft)	172
1.11.5	Main boom head section 2821.24	176
1.11.6	Rope guide (type A/B) on main boom 2821	179
1.11.7	Mid-point suspension on main boom 2821	182
1.11.8	Steel pendant straps on main boom 2821	191
1.11.9	CF pendant straps on main boom 2821	200
1.12	Reducing piece overview	219
1.13	2821/2316 reducing piece	220
1.13.1	2821/2316.24 reducing piece 12 m (40 ft)	220
1.13.2	Main boom section 2316.25 1 m (3 ft)	222
1.13.3	Mid-point suspension on reducing adapter 2821/2316	223
1.13.4	Steel pendant straps on reducing adapter 2821/2316	242
1.13.5	CF pendant straps on reducing adapter 2821/2316	244
1.14	Fixed jib - overview	247
1.15	1713 fixed jib	248
1.15.1	Jib base section 1713.22	248
1.15.2	1713.18 jib section 3 m (10 ft)	250
1.15.3	1713.18 jib section 6 m (20 ft)	251
1.15.4	1713.18 jib section 12 m (40 ft)	253
1.15.5	1713.21 jib head section	254
1.15.6	Steel pendant straps on fixed jib 1713	255
1.15.7	CF pendant straps on fixed jib 1713	262
1.16	1507 fixed jib	263
1.16.1	Jib 1507.20	263
1.16.2	Steel pendant straps on fixed jib 1507	264
1.16.3	CF pendant straps on fixed jib 1507	269
1.17	1008 fixed jib	270
1.17.1	Jib base section 1008.20	270
1.17.2	1008.17 jib section 3 m (10 ft)	272
1.17.3	1008.17 jib section 6 m (20 ft)	273
1.17.4	1008.20 jib head section	274
1.17.5	Steel pendant straps on fixed jib 1008	275

LWN/LR-x/V04.01//Auslieferung/2016-03-07/en

1.17.6	CF pendant straps on fixed jib 1008	281
1.18	0906 fixed jib	282
1.18.1	Jib 0906.21	282
1.18.2	Steel pendant straps on fixed jib 0906	283
1.18.3	CF pendant straps on fixed jib 0906	286
1.19	Luffing jib - overview	287
1.20	2316 luffing jib	288
1.20.1	Jib base section 2316.22	288
1.20.2	2316.20 jib section 3 m (10 ft)	290
1.20.3	2316.20 jib section 6 m (20 ft)	291
1.20.4	2316.20 jib section 12 m (40 ft)	293
1.20.5	2316.20 jib head section	295
1.20.6	Mid-point suspension on luffing jib 2316	296
1.20.7	Steel pendant straps on luffing jib 2316	306
1.20.8	CF pendant straps on luffing jib 2316	314
1.21	1916 luffing jib	327
1.21.1	Jib base section 1916.22	327
1.21.2	1916.18 jib section 3 m (10 ft)	329
1.21.3	1916.18 jib section 6 m (20 ft)	330
1.21.4	1916.18 jib section 12 m (40 ft)	332
1.21.5	1916.21 jib head section	334
1.21.6	Mid-point suspension on luffing jib 1916	335
1.21.7	Steel pendant straps on luffing jib 1916	345
1.21.8	CF pendant straps on luffing jib 1916	352
1.22	Midfall overview	364
1.23	2316.25 Midfall	365
1.23.1	Midfall 2316.25	365
1.23.2	Mid-point suspension on midfall 2316.25	366
1.23.3	Steel pendant straps on midfall 2316.25	367
1.23.4	CF pendant straps on midfall 2316.25	368
1.24	1916.32 Midfall	370
1.24.1	Midfall 1916.32	370
1.24.2	Mid-point suspension on midfall 1916.32	371
1.24.3	Steel pendant straps on midfall 1916.32	372
1.24.4	CF pendant straps on midfall 1916.32	373

1.25	Auxiliary jib* (36 t (79.300 lb))	374
1.26	Auxiliary jib* (30 t (66.000 lb))	377
1.27	Auxiliary jib* (15 t (33.000 lb))	379
1.28	Derrick equipment*	381
1.28.1	Overview of derrick equipment	381
1.28.2	Derrick boom 2220	382
1.28.3	Suspended counterweight	394
1.28.4	Counterweight carriage	400
1.29	Rope fixation	407
1.29.1	Main boom head	407
1.29.2	Fixed jib head	408
1.29.3	Luffing jib head	409
1.29.4	Auxiliary jib (36 t (79.300 lb)) on main boom head	410
1.29.5	Auxiliary jib (15 t (33.000 lb)) on jib head	410
1.29.6	Midfall	411
1.29.7	Pocket lock	411
1.29.8	Cross strap	413
1.29.9	Pins for the rope fixing point	414
1.30	Pulley block/hook*	415
1.30.1	Pulley block (300 t (661,377 lb))	415
1.30.2	Pulley block (160 t (352,734 lb))	416
1.30.3	Pulley block (100 t (220,459 lb))	418
1.30.4	Pulley block (50 t (110,230 lb))	419
1.30.5	Hook (16 t (35,273 lb))	420
1.31	Abseil rescue equipment*	422
1.32	Safety barrier*	423
1.33	Slinging plates on uppercarriage*	424
1.34	Suction flap*	425
1.35	Armrests* for operator's seat	426
1.36	Vertical Line Finder* assistance system	427
1.37	Outside mirror*	429
1.38	Counterweight carriage preparation unit*	430
1.38.1	Hydraulic connections and electricity connections for the counterweight carriage	430
1.38.2	Control panel X26 and mount	431

1.39	Tagline winch*	432
1.40	Refueling pump*	434
1.41	Cab roof protection guard*	435
1.42	Derrick preparation unit	436
	1.42.1 Hydraulic connections and electricity connections for the derrick	436
1.43	Lightning rods*	437
1.44	External power supply*	438
	1.44.1 External power supply obstacle warning light	438
	1.44.2 External supply low temperature package	440
1.45	Radio remote control*	443
1.46	Foot pedal adjuster*	446
1.47	GSM/GPRS/GPS modem	447
1.48	Hook fixing point *	448
1.49	Handrail* / wide steps*	450
1.50	Obstacle warning light*	451
1.51	Third hoist limit switch*	452
1.52	Hoist limit switch clamp* for auxiliary jib (36 t (79.300 lb))	453
1.53	Hydraulic cab elevation*	454
1.54	Cabin railing*	456
1.55	Cable remote control	458
1.56	Ventilation, heating and air-conditioning	460
	1.56.1 Cooling circuit	461
	1.56.2 Heating circuit	466
	1.56.3 Auxiliary air heating*	469
	1.56.4 Electric components	471
	1.56.5 Mechanic components	475
1.57	Catwalks* for boom	476
1.58	Leak oil return*	478
1.59	Ladder* for boom	479
1.60	Ladder* for uppercarriage	481
1.61	Reading light* for cabin	483
1.62	Litronic control system	484
1.63	Retrofit kits* for operation with two ropes over the jib head section	485
	1.63.1 Retrofit kit for luffing jibs 1008 / 1309 / 1713 / 1916 / 2316	485
	1.63.2 Retrofit kit for 1008 fixed jib	486

1.63.3	Retrofit kit for 0806 fixed jib	487
1.64	Luffing jib luffing winch as auxiliary winch*	488
1.65	By-pass flow filter system*	489
1.66	Emergency operation control*	490
1.67	Visual motion warning device*	491
1.68	Process data recording (PDR)*	493
1.69	Process data report (PDR)*	494
1.70	Pump wear indicator*	495
1.71	Quick latch couplings* on jib luffing winch	497
1.72	Socket* in cab	499
1.73	Falling object protection* for cabin	500
1.74	Vandalism protection*	502
1.74.1	Top cover	503
1.74.2	Rear cover	504
1.74.3	Front cover	505
1.74.4	Right front cover	506
1.74.5	Right rear cover	508
1.74.6	Left front cover	509
1.74.7	Left rear cover	510
1.74.8	Brackets for front cover	511
1.74.9	Barrier rod	511
1.75	Video monitoring system*	513
1.75.1	Cabin overview	513
1.75.2	Machine overview	514
1.75.3	Video surveillance - basic device	515
1.75.4	Video surveillance - boom	517
1.75.5	Quad monitor	518
1.75.6	Camera	520
1.75.7	Control panel zoom camera	521
1.75.8	Zoom camera	522
1.75.9	Mounts	523
1.75.10	Camera cable in main boom base section	529
1.75.11	Zoom camera in main boom head	530
1.75.12	Zoom camera in fixed jib head	531
1.75.13	Zoom camera in luffing jib head	533

LWN/LR-x/V04.01//Auslieferung/2016-03-07/en

1.75.14	Zoom camera in auxiliary jib 36 t (79300 lb)	534
1.75.15	Zoom camera in auxiliary jib 15 t (33000 lb)	534
1.75.16	Foot pedal* for zoom camera	536
1.76	Central lubrication system	537
1.77	Auxiliary floodlights*	538
1.77.1	Floodlights on uppercarriage	538
1.77.2	Floodlights on cabin	541
1.77.3	Adjustable floodlights on main boom base section	542
1.77.4	Floodlights on main boom	543
1.77.5	Floodlights on jib head	548
2	Safety instructions	553
2.1	Technical condition of the machine	553
2.2	Areas of responsibility	553
2.2.1	Manufacturer	553
2.2.2	Owner	553
2.2.3	Machine operator	554
2.2.4	Rigger	554
2.2.5	Banksman	554
2.2.6	Maintenance and service personnel	554
2.3	Requirements to personnel	555
2.3.1	Machine operator	555
2.3.2	Rigger	555
2.3.3	Banksman	556
2.3.4	Maintenance personnel	556
2.4	Personal protective equipment	556
2.5	Work area	557
2.6	Danger zone	558
2.7	Safety signs on the machine	559
2.8	Safety signs on the machine (US market)	566
2.9	Meaning of the safety signs	573
2.9.1	Mandatory signs	573
2.9.2	Prohibition signs	574
2.9.3	Warning signs	575
2.9.4	Rescue signs	577

2.9.5	Fire protection signs	578
2.10	Meaning of machine-specific signs	578
2.10.1	Safety signs	578
2.10.2	Notice signs	579
2.11	Hazards	583
2.11.1	Mechanical action	583
2.11.2	Electrical energy	584
2.11.3	Hydraulic energy	585
2.11.4	Burns	586
2.11.5	Chemical burns	587
2.11.6	Fire and explosion	587
2.11.7	Poisoning and suffocation	589
2.11.8	Electromagnetic influence	589
2.11.9	Exposure to wind	590
2.11.10	Snow and ice loads	595
2.11.11	Ground bearing strength	596
2.11.12	Lightning strike	597
2.11.13	Overhead power lines	598
2.11.14	Environment	600
2.12	What to do in dangerous situations	601
2.12.1	How to respond in the event of a current transfer	601
2.12.2	How to respond in the event of a fire	602
2.12.3	Firefighting	603
2.13	Working at heights	605
2.14	Application on floating devices	605
2.14.1	Operation of the machine on floating devices	606
2.14.2	Transport of the machine on floating devices	607
2.14.3	Higher risk of machine corrosion on floating devices	607
2.15	Use at low temperatures	608
2.15.1	Operation of the machine down to -20 °C (-4 °F) (standard)	608
2.15.2	Operation of the machine down to -25 °C (-13 °F)*	609
2.15.3	Operation of the machine down to -40 °C (-40 °F)*	609
2.16	Hand signals	609
2.16.1	General hand signals in accordance with BGV A8	610
2.16.2	Special hand signals for sling gear application	612

LWN/LR-x/V04.01//Auslieferung/2016-03-07/en

2.16.3	Hand signals for lifting gear application in accordance with ASME/ANSI B30.5	615
3	Control and operating elements	623
3.1	Operating elements on the undercarriage	623
3.1.1	Operating elements at undercarriage with fixed track width	623
3.1.2	Operating elements at undercarriage* with adjustable track width	624
3.2	Operating elements on the uppercarriage	625
3.3	Operating elements on counterweight carriage*	626
3.4	Cabin	627
3.5	Left control lever	628
3.5.1	Function assignment of the left control lever on machine without derrick equipment*	628
3.5.2	Function assignment of the left control lever on machine with derrick equipment*	638
3.6	Right control lever	653
3.6.1	Function assignment of the right control lever on machine without derrick equipment*	653
3.6.2	Function assignment of the right control lever on machine with derrick equipment*	668
3.7	Foot pedals and hand levers	684
3.8	Control panel X11	686
3.9	Control panel X12	688
3.10	Control panel X23	690
3.11	Control panel X26 for counterweight carriage*	693
3.11.1	Operating units	694
3.11.2	Buttons	694
3.12	Monitor	696
3.12.1	Status bar	696
3.12.2	Display section	704
3.12.3	Menu bar	704
3.12.4	Submenu bar	706
3.13	Screen <i>Start</i>	707
3.14	Screen <i>Mode</i>	708
3.15	Screen <i>Operation</i> in derrick mode	716
3.16	Screen <i>Aggregate</i>	721
3.17	Screen <i>Operating hours</i>	728

3.18	Setup screen	731
3.18.1	Setup - boom configuration screen	733
3.18.2	Setup - boom configuration 1 screen	735
3.18.3	Setup - boom configuration 2 screen	738
3.18.4	Setup - boom configuration 3 screen	741
3.18.5	Setup - boom configuration 4 screen	746
3.18.6	Setup - boom configuration 5 screen	750
3.18.7	Setup screen - boom configuration 6	755
3.18.8	Setup screen - boom configuration 8	758
3.18.9	Setup screen - boom configuration 9	763
3.18.10	Setup - load chart screen	768
3.19	Screen <i>Working range limitation</i>	770
3.19.1	Screen <i>Working range limitation - working range limitation</i>	770
3.19.2	Screen <i>Working range limitation - lifting height limitation</i>	777
3.20	Screen <i>Access control</i>	780
3.20.1	Without retrofit kit access control (black ignition keys)	780
3.20.2	Without retrofit kit access control (blue ignition keys)	781
3.20.3	With retrofit kit access control (red and blue ignition keys)*	782
3.21	<i>Mode</i> screen	785
3.22	<i>Settings</i> screen	787
3.22.1	Screen <i>Settings - components</i>	787
3.22.2	Settings - units screen	790
3.22.3	Screen <i>Settings - Litronic testing system</i>	793
3.23	<i>Error messages</i> screen	798
3.24	Cable remote control	800
3.24.1	Cable remote control on uppercarriage	800
3.24.2	Cable remote control on undercarriage*	800
3.25	Radio remote control*	802
3.25.1	Operating elements	802
3.25.2	Monitor	811
3.26	Emergency operation control*	819
3.27	Hydraulic cab elevation*	821
3.27.1	Operating elements in the cab	821
3.27.2	Operating elements on mast	822
3.27.3	Limit switches	822

3.28	Control unit <i>external air conditioning system*</i>	824
3.29	<i>Auxiliary heating*</i> control unit	826
3.30	Video monitoring system*	827
3.30.1	Quad monitor	827
3.30.2	Control panel zoom camera	828
3.31	Central lubrication*	830
3.32	Additional floodlights*	831
3.32.1	Cabin	831
3.32.2	Search floodlight	832
4	Operation	835
4.1	Checks before start up	835
4.1.1	Inspecting the machine	835
4.1.2	Checking position of main battery switch	836
4.2	Start-up	837
4.2.1	Adjusting the operator's seat	837
4.2.2	Switching on the ignition	837
4.2.3	Confirming the existing setup	837
4.2.4	Checking the fuel fill level	838
4.2.5	Checking the urea solution fill level	838
4.2.6	Checking the hydraulic oil tank gate valve	838
4.2.7	Starting the diesel engine	839
4.2.8	Adjusting the RPM of the diesel engine	840
4.2.9	Setting the constant engine RPM	842
4.2.10	Lowering the safety lever	844
4.2.11	Checking the tilting-back support cylinder	844
4.3	Control panels	845
4.3.1	Setting control panel X25* or control panel X26*	845
4.4	Operator's seat	847
4.4.1	Adjusting the control stand horizontally	848
4.4.2	Adjusting the operator's seat	848
4.4.3	Adjusting the dampening	852
4.4.4	Adjusting the ergonomics*	853
4.4.5	Safety belt*	855
4.5	Lighting	856

LWNLR-x/V04.01//Auslieferung/2016-03-07/en

4.5.1	Operating the floodlights on the uppercarriage	856
4.5.2	Operating the additional floodlights	856
4.5.3	Operating the cab lighting	857
4.5.4	Operating the engine compartment lighting	857
4.6	Windscreen wiper system	858
4.6.1	Operating the windscreen wipers	858
4.6.2	Operating the windscreen washer system	859
4.7	Ventilation, heating and air-conditioning	860
4.7.1	Setting the air vent	862
4.7.2	Adjusting the lamella vents	863
4.7.3	Setting recirculated air or fresh air	863
4.7.4	Operating the ventilation	863
4.7.5	Using the heater	864
4.7.6	Turning the air conditioning system on or off	864
4.7.7	Operating the external air conditioning system*	865
4.7.8	Auxiliary heating*	872
4.8	Additional cab equipment	876
4.8.1	Using the horn	876
4.8.2	Operating the safety lever	876
4.8.3	Operating the radio	877
4.8.4	Using the ashtray	878
4.8.5	Using the cigarette lighter	879
4.9	Cab tilting device*	880
4.9.1	Tilting the cabin	880
4.10	Hydraulic cabin elevation*	881
4.10.1	Adjusting the cabin	881
4.11	Central lubrication*	883
4.11.1	Set lubrication time	883
4.11.2	Set pause time	883
4.11.3	Interim lubrication	883
4.12	Mode	884
4.12.1	Activating/deactivating assembly functions on or off	884
4.12.2	Selecting the mode	884
4.13	Programming the setup	886
4.13.1	Call up the <i>Setup</i> screen	886

4.13.2	Selecting and changing settings	887
4.13.3	Calculating the revised set-up	887
4.13.4	Checking the programmed setup	888
4.14	Load moment limiter (LML)	889
4.14.1	General	889
4.14.2	Load moment limiter self-lock	892
4.14.3	Load moment limiter shut down (CE load chart)	894
4.14.4	Load moment limiter shut down (ANSI load chart)	895
4.15	Calculating load charts online	897
4.15.1	Calculating load charts	897
4.15.2	Boom configuration 4 - load position 1	898
4.15.3	Boom configuration 4 - load position 2	899
4.15.4	Boom configuration 5 - load position 1	900
4.15.5	Boom configuration 5 - load position 3	901
4.15.6	Boom configuration 6 - load position 2	902
4.15.7	Boom configuration 8 - load position 1	903
4.15.8	Boom configuration 8 - load position 2	904
4.15.9	Boom configuration 9 - load position 1	905
4.15.10	Boom configuration 9 - load position 2	906
4.16	Set the load capacity display to zero (taring)	907
4.16.1	Setting the load display of winch1 or winch2 to zero	907
4.17	Single hook operation/two-hook operation	908
4.17.1	Single-hook mode with one winch on one hook	910
4.17.2	Single-hook mode with two winches on one hook	912
4.17.3	Single-hook mode with two winches on two hooks	913
4.17.4	Twin-hook mode with two hooks on two loads	919
4.17.5	Twin-hook mode with two hooks on one load	921
4.18	Crawlers	925
4.18.1	Setting the crawler speed	925
4.18.2	Operating the travel gear	925
4.18.3	Operating the crawler with counterweight carriage*	929
4.18.4	Locking or unlocking the crawler	934
4.19	Swing	935
4.19.1	Setting the swing speed	935
4.19.2	Turning the swing free-wheel on or off	936

4.19.3	Operating the swing	937
4.19.4	Operating the swing with suspended counterweight*	941
4.19.5	Operating the swing with counterweight carriage*	942
4.19.6	Locking or unlocking the swing	943
4.20	Main boom	944
4.20.1	Operating the main boom	944
4.20.2	Locking or unlocking the main boom	948
4.21	Jib	949
4.21.1	Selecting the jib	949
4.21.2	Operating the jib	950
4.22	Winch 1/Winch 2	955
4.22.1	Operating winch 1	955
4.22.2	Operating winch 2	959
4.22.3	Locking or unlocking winch1/winch2	963
4.23	Counterweight carriage* radius adjustment	965
4.23.1	Activating the radius adjustment of the counterweight carriage	965
4.23.2	Increasing the radius of the counterweight carriage	966
4.23.3	Decreasing the radius of the counterweight carriage	966
4.23.4	Deactivating the radius adjustment of the counterweight carriage	967
4.24	Derrick hoist cylinder*	968
4.24.1	Selecting the derrick hoist cylinder	968
4.24.2	Operating the derrick hoist cylinder	968
4.25	Free-fall operation*	970
4.25.1	Switching on free-fall operation	970
4.25.2	Selecting free-fall mode	971
4.25.3	Operating free-fall operation	972
4.25.4	Switching off free-fall operation	975
4.26	Winch synchronization*	976
4.26.1	Activating winch synchronization	976
4.26.2	Operating the winch synchronization	977
4.26.3	Deactivating winch synchronization	979
4.27	Blocked crawlers*	980
4.27.1	Driving onto the support plates	981
4.27.2	Working with Blocked Crawlers	982
4.28	Assembly cylinder *	984

4.28.1	Select assembly cylinder	984
4.28.2	Operating the assembly cylinder	984
4.29	Filling machine with fuel	987
4.29.1	Filling the fuel tank	987
4.29.2	Filling up with urea solution*	988
4.30	Radio remote control*	989
4.30.1	rechargeable battery	989
4.30.2	battery charger	989
4.30.3	Starting the machine with the radio remote control	991
4.31	Rope measuring system*	997
4.31.1	Setting the rope length to zero	997
4.31.2	Calibrating the rope measuring system	997
4.32	Ground pressure display*	999
4.32.1	Operating the ground pressure display	999
4.33	Inclination display*	1000
4.33.1	Operating the inclinometer	1000
4.34	Working range limitation*	1001
4.34.1	Operating the edge limitation	1001
4.34.2	Operating the sector limitation	1003
4.34.3	Operating the radius limitation	1005
4.34.4	Operating the slewing range limitation	1008
4.34.5	Operating the lifting height limitation	1009
4.34.6	Cancelling the stop after crawler operation	1011
4.34.7	Resetting limitations	1011
4.35	Assistance system horizontal load path*	1012
4.35.1	Activating horizontal load path	1012
4.35.2	Activating horizontal load path	1013
4.35.3	Deactivating horizontal load path	1015
4.36	Vertical Line Finder* assistance system	1016
4.36.1	Setting deviations of the Vertical Line Finder to zero	1016
4.36.2	Activating the positioning of the boom head above the load's center of gravity	1016
4.36.3	Positioning the boom head above load's center of gravity	1016
4.36.4	Deactivating the positioning of the boom head above the load's center of gravity	1017
4.37	Rope reeving winch	1018

4.37.1	Setting the rope reeving winch to free-wheel	1018
4.37.2	Deactivating rope reeving winch free-fall	1019
4.37.3	Reeving the rope of the rope reeving winch	1019
4.38	Tagline winch*	1020
4.38.1	Putting the tagline winch into operation	1020
4.38.2	Turn the tagline winch on or off	1021
4.38.3	Set the constant tension of the tagline winch	1021
4.38.4	Setting the pull force of the tagline winch	1022
4.38.5	Select maximum pull force of the tagline winch	1023
4.38.6	Turning tagline winch free-wheel on or off	1023
4.39	Luffing jib luffing winch as auxiliary winch*	1025
4.39.1	Use as jib luffing winch	1025
4.39.2	Use as leader height adjusting winch	1026
4.39.3	Use as auxiliary winch	1026
4.40	Diesel engine automatic stop system*	1027
4.40.1	Switching the diesel engine automatic stop system on or off	1027
4.41	Sensitive hoisting*	1028
4.41.1	Turning the function sensitive lift on or off	1028
4.41.2	Operating sensitive hoisting	1028
4.42	Abseil rescue equipment*	1029
4.42.1	Using abseil rescue equipment	1029
4.43	Emergency stop	1031
4.43.1	Using emergency stop	1031
4.44	Shutdown	1032
4.44.1	Short work interruption	1032
4.44.2	Long work interruption	1033
4.44.3	Switching off battery main switch	1034
4.45	Hydraulic emergency mode*	1035
4.45.1	Winch 2 emergency mode	1035
4.45.2	Main boom adjusting winch emergency mode	1037
4.45.3	Swing emergency mode	1038
4.46	Emergency operation control*	1041
4.46.1	Operating the emergency control	1041

5	Operational faults, diagnosis	1045
----------	--------------------------------------	-------------

5.1	Malfunctions	1045
5.1.1	Identifying faults	1045
5.1.2	Error displays on monitor	1045
5.1.3	Troubleshooting	1050
5.2	Litronic testing system	1051
5.2.1	Litronic testing system overview	1051
5.2.2	Screen pages	1052
5.2.3	Starting the Litronic® testing system	1059
5.3	Fuses	1060
5.3.1	List of fuses	1060
5.3.2	Checking the fuses	1062
5.3.3	Replacing fuses	1064
6	Operational planning	1067
6.1	Assembly site	1067
6.2	Tools required	1070
6.2.1	Machine with self-assembly system	1070
6.2.2	Machine without self-assembly system	1070
6.3	Required length of winch1/winch2 rope	1071
6.3.1	Calculating the length of winch1/winch2 rope	1071
6.4	Choosing the correct hook or pulley block	1073
6.5	Positioning the hook or pulley block	1075
6.6	Choice of correct winch in derrick operation	1076
6.7	Restrictions due to exposure to wind	1077
6.7.1	Erecting the boom	1077
6.7.2	Reducing the load	1077
6.7.3	Parked positions of boom configurations	1096
6.7.4	Laying down the boom	1105
6.8	Traveling on gradients	1107
6.8.1	Permitted gradient for a machine without derrick equipment*	1109
6.8.2	Permitted gradient for a machine with derrick equipment*	1128
6.9	Rigging equipment and/or sling gear	1141
6.9.1	4-strand round sling rigging with chain shortening devices	1142
6.9.2	4-strand round sling gear	1143
6.9.3	Other lifting devices	1143

7	Assembly and dismantling	1147
7.1	Explanation of symbols used	1147
7.2	Implementation instructions for assembly and disassembly	1149
7.3	Locking elements - overview	1150
7.3.1	Split pin	1150
7.3.2	Linchpin	1151
7.3.3	Spring cotter pin	1152
7.3.4	Safety pin	1153
7.3.5	Locking washers	1155
7.4	Assembling the basic machine	1156
7.4.1	Notes	1156
7.4.2	Moving cabin platforms* into working position	1156
7.4.3	Swivel the cab to the working position	1160
7.4.4	Mounting the cabin railing*	1162
7.4.5	Putting the load moment limiter lamp and flashing light into working position	1169
7.4.6	Mounting the platforms on the uppercarriage	1171
7.4.7	Mounting the ladder on the uppercarriage	1186
7.4.8	Mounting the uppercarriage railing	1187
7.4.9	Fitting the exhaust pipe	1193
7.4.10	Checking the position of the bypass plug	1195
7.4.11	Putting the machine into operation	1196
7.4.12	Switching on assembly mode functions	1196
7.4.13	Switching on cylinder adjustment functions	1196
7.4.14	Extend the tilting back support cylinders	1197
7.4.15	Erecting A-frame1	1197
7.4.16	Unloading the machine	1198
7.4.17	Removing the uppercarriage lock	1214
7.4.18	Attaching the crawler side frame	1214
7.4.19	Using the machine as assembly crane	1246
7.4.20	Attach the carbody counterweight	1248
7.4.21	Installing platforms at undercarriage with fixed track width	1255
7.4.22	Fitting the rear counterweight	1256
7.5	Main boom 2821	1270
7.5.1	Configuration of main boom	1270

LWN/LR-x/V04.01//Auslieferung/2016-03-07/en

7.5.2	Lengths of mid-point suspensions	1272
7.5.3	Overview of main boom 2821 steel pendant straps	1273
7.5.4	Overview of main boom 2821 CF pendant straps	1274
7.5.5	Reeving diagrams for one rope across main boom head 2821 (load position1)	1276
7.5.6	Reeving diagrams for two ropes across main boom head 2821 (load position1)	1281
7.5.7	Reeving diagrams for one rope across auxiliary jib (36 t (79300 lb)) on main boom head 2821 (load position1)	1285
7.5.8	Reeving diagrams for two ropes across auxiliary jib (36 t (79300 lb)) and main boom head 2821 (load position 1)	1287
7.5.9	Reeving diagram - jib luffing winch as auxiliary winch	1288
7.6	Assembly of main boom without derrick equipment*	1290
7.6.1	Notes	1290
7.6.2	Programming the setup	1290
7.6.3	Unloading and positioning the main boom section	1290
7.6.4	Assembling the ladder* for the boom	1291
7.6.5	Bolting the boom head section to the boom sections	1293
7.6.6	Connecting catwalks* for booms	1295
7.6.7	Connecting and checking boom fall arrest*	1297
7.6.8	fit the rope guide	1297
7.6.9	Pinning the pendant straps	1299
7.6.10	Removing the jib backstay straps	1300
7.6.11	Installing mid-point suspension	1301
7.6.12	Installing mid-point suspension (with main boom length 80 m (262 ft), 83 m (272 ft) and 86 m (282 ft) and jib 1507 attached)	1304
7.6.13	Rigging and lifting the main boom base section	1305
7.6.14	Attaching the boom base section to the uppercarriage	1306
7.6.15	Connecting hydraulic lines to the uppercarriage	1309
7.6.16	Connecting electric cables to the uppercarriage	1313
7.6.17	Pinning the assembly cylinder to main boom base section	1313
7.6.18	Folding the front feet of the main boom base section upwards	1315
7.6.19	Bolting the boom base section to the main boom	1315
7.6.20	Bolting the equalizer on A-frame 1 to the main boom pendant straps	1317
7.6.21	Attaching the auxiliary jib (36 t (79300 lb)) to the boom head section	1317
7.6.22	Installing the hoist limit switch on auxiliary jib (36 t (79.300 lb))	1321
7.6.23	Folding down the link plates for the 11th pulley	1321

7.6.24	Installing second pulley to 3-fold reeve the auxiliary jib (36 t (79300 lb))	1322
7.6.25	Connect the electric cables	1323
7.6.26	Installing the obstacle warning light	1324
7.6.27	Fitting the anemometer	1326
7.6.28	Moving the lightning rods* into working position	1328
7.6.29	Reeving the rope	1330
7.6.30	Attaching the rope fixing point	1338
7.6.31	Installing the hoist limit switch weight	1343
7.6.32	Installing the hoist limit switch clamp* on auxiliary jib (36 t (79.300 lb))	1347
7.6.33	Bypass unused hoist limit switches.	1350
7.7	Erecting the main boom without derrick equipment*	1352
7.7.1	Erecting the main boom	1352
7.7.2	Switching off assembly mode functions	1355
7.7.3	Checking the main boom limit switch plate for proper adjustment	1356
7.8	Main boom 2821 + derrick boom 2220	1358
7.8.1	Configuration of main boom in derrick mode	1358
7.8.2	Lengths of mid-point suspensions	1360
7.8.3	Overview of main boom 2821 steel pendant straps + derrick boom 2220	1361
7.8.4	Overview of CF pendant straps of main boom 2821 + derrick boom 2220	1364
7.8.5	Reeving diagrams for one rope across main boom head 2821 (load position1)	1368
7.8.6	Reeving diagrams for two ropes across main boom head 2821 (load position1)	1373
7.8.7	Reeving diagrams for one rope across auxiliary jib (36 t (79300 lb)) on main boom head 2821 (load position1)	1377
7.8.8	Reeving diagrams for two ropes across auxiliary jib (36 t (79300 lb)) and main boom head 2821 (load position 1)	1379
7.8.9	Reeving diagram - jib luffing winch as auxiliary winch	1380
7.9	Assembly of main boom with derrick equipment*	1382
7.9.1	Assembly of derrick boom	1382
7.9.2	Assembling the main boom	1403
7.10	Assembly of suspended counterweight of derrick equipment*	1470
7.10.1	Positioning the counterweight frame	1470
7.10.2	Positioning the ballast slabs	1470
7.10.3	Release the pendant ropes from the derrick boom	1471
7.11	Assembly of counterweight carriage of derrick equipment*	1472

7.11.1	Positioning the wheeled counterweight carriage	1472
7.11.2	Attach the telescopic unit	1472
7.11.3	Connecting electric lines and hydraulic lines	1474
7.11.4	Placing ladder and floodlight in working position	1475
7.11.5	Installing the counterweight carriage on the basic machine	1476
7.11.6	Placing and lashing counterweight slabs	1486
7.12	Erecting the main boom with derrick equipment*	1489
7.12.1	Raising the derrick boom	1489
7.12.2	Checking the derrick boom tilting-back supports	1490
7.12.3	Pinning the suspended counterweight pendant ropes to the counterweight frame	1491
7.12.4	Pinning the spacer frame with the uppercarriage	1493
7.12.5	Pinning the counterweight carriage pendant straps to the counterweight carriage	1495
7.12.6	Erecting the main boom	1496
7.12.7	Switching off assembly mode functions	1499
7.12.8	Checking the main boom limit switch plate for proper adjustment	1500
7.13	Main boom 2821 + reducing adapter 2821/2316	1502
7.13.1	Configuration of main boom	1502
7.13.2	Lengths of mid-point suspensions	1505
7.13.3	Overview of main boom 2821 steel pendant straps + reducing adapter 2821/2316	1511
7.13.4	Overview of main boom 2821 CF pendant straps + reducing adapter 2821/2316	1513
7.13.5	Reeving diagrams for one rope across main boom head 2316 (load position1)	1515
7.13.6	Reeving diagrams for two ropes across main boom head 2316 (load position1)	1517
7.14	Assembling the main boom + reducing piece	1519
7.14.1	Notes	1519
7.14.2	Installing the reducing piece	1519
7.14.3	Installing mid-point suspension	1520
7.14.4	Moving the lightning rods* into working position	1525
7.14.5	Reeving the rope	1527
7.15	Fixed jib 1713	1536
7.15.1	Configuration of jib	1536
7.15.2	Configuration of main boom	1536

7.15.3	Overview of pendant straps on fixed jib 1713	1537
7.15.4	Reeving diagrams for one rope across jib head 1713 (load position1)	1539
7.15.5	Reeving diagrams for two ropes across jib head 1713 (load position1)	1540
7.15.6	Reeving diagrams for one rope across main boom head 2821 (load position2)	1541
7.16	Fixed jib 1507	1546
7.16.1	Configuration of jib	1546
7.16.2	Configuration of main boom	1546
7.16.3	Lengths of mid-point suspensions	1547
7.16.4	Composition of main boom in derrick mode with fixed jib 1507 attached	1548
7.16.5	Length of midpoint suspension in derrick mode with installed fixed jib 1507	1550
7.16.6	Overview of pendant straps on fixed jib 1507	1551
7.16.7	Reeving diagrams for one rope across jib head 1507 (load position1)	1553
7.16.8	Reeving diagrams for two ropes across jib head 1507 (load position1)	1555
7.16.9	Reeving diagrams for one rope across main boom head 2821 (load position2)	1556
7.17	Fixed jib 1008	1561
7.17.1	Configuration of jib	1561
7.17.2	Configuration of main boom	1561
7.17.3	Overview of pendant straps on fixed jib 1008	1562
7.17.4	Reeving diagrams for one rope across jib head 1008 (load position1)	1564
7.17.5	Reeving diagrams for two ropes across jib head 1008 (load position1)	1565
7.17.6	Reeving diagrams for one rope across main boom head 2821 (load position2)	1566
7.18	Fixed jib 0906	1571
7.18.1	Configuration of jib	1571
7.18.2	Configuration of main boom	1571
7.18.3	Overview of pendant straps on fixed jib 0906	1572
7.18.4	Reeving diagrams for one rope across jib head 0906 (load position1)	1573
7.18.5	Reeving diagrams for two ropes across jib head 0906 (load position1)	1575
7.18.6	Reeving diagrams for one rope across main boom head 2821 (load position2)	1575
7.19	Assembling the fixed jib	1580
7.19.1	Notes	1580
7.19.2	Programming the setup	1580
7.19.3	Unloading and positioning the jib components	1580

7.19.4	Bolting the jib head section to the jib sections	1581
7.19.5	Attaching the jib base section	1582
7.19.6	Pinning the jib to the jib base section	1585
7.19.7	Pinning the pendant straps	1585
7.19.8	Attaching connecting links to the boom head section	1586
7.19.9	Attaching the main boom (self-assembly system)	1588
7.19.10	Pinning the A-frame 2 equaliser to the main boom	1588
7.19.11	Pinning the jib backstay straps (jib 1507)	1589
7.19.12	Installing the connecting elements and spacer brackets on jib backstay straps (jib 1507)	1590
7.19.13	Pinning the equalizer of A-frame2 to the main boom (jib 1507)	1590
7.19.14	Connect the electric cables	1592
7.19.15	Installing the obstacle warning light	1593
7.19.16	Fitting the anemometer	1594
7.19.17	Moving the lightning rods* into working position	1596
7.19.18	Reeving the rope	1599
7.19.19	Attaching the rope fixing point	1607
7.19.20	Installing the hoist limit switch weight	1611
7.19.21	Bypass unused hoist limit switches.	1615
7.19.22	Erecting a main boom + fixed jib	1616
7.19.23	Switching off assembly mode functions	1619
7.19.24	Checking the main boom limit switch plate for proper adjustment	1620
7.20	Luffing jib 2316	1622
7.20.1	Configuration of jib	1622
7.20.2	Lengths of jib mid-point suspensions	1624
7.20.3	Configuration of main boom	1626
7.20.4	Overview of steel pendant straps on luffing jib 2316	1626
7.20.5	Overview of CF pendant straps on luffing jib 2316	1628
7.20.6	Reeving diagram A-frame2/A-frame3	1631
7.20.7	Reeving diagrams for one rope across jib head 2316 (load position1)	1632
7.20.8	Reeving diagrams for two ropes across jib head 2316, 1916, 1713, 1309, 1008 (load position1)	1634
7.20.9	Reeving diagrams for one rope across main boom head 2821 (load position2)	1635
7.20.10	Reeving diagrams for one rope across auxiliary jib (30 t (66.000 lb)) on jib head 2316 (load position1)	1640
7.21	Luffing jib 1916	1642

7.21.1	Configuration of jib	1642
7.21.2	Lengths of jib mid-point suspensions	1643
7.21.3	Configuration of main boom	1645
7.21.4	Overview of steel pendant straps on luffing jib 1916	1646
7.21.5	Overview of CF pendant straps on luffing jib 1916	1648
7.21.6	Rope reeving system for A-frame 2/A-frame 3	1651
7.21.7	Reeving diagrams for one rope across jib head 1916 (load position1)	1652
7.21.8	Reeving diagrams for two ropes across jib head 2316, 1916, 1713, 1309, 1008 (load position1)	1653
7.21.9	Reeving diagrams for one rope across main boom head 2821 (load position2)	1655
7.21.10	Reeving diagrams for one rope across auxiliary jib (15 t (33.000 lb)) on jib head 1916, 1713, 1309, 1008 (load position1)	1660
7.22	Assemble the luffing jib	1661
7.22.1	Notes	1661
7.22.2	Programming the setup	1661
7.22.3	Unloading and positioning the jib components	1661
7.22.4	Attaching the auxiliary jib (15 t (33.000 lb)) to the jib head section	1662
7.22.5	Attaching the auxiliary jib (30 t (66.000 lb)) to the jib head section	1664
7.22.6	Bolting the jib head section to the jib sections	1666
7.22.7	Attaching the jib base section	1667
7.22.8	Checking the pressure in the accumulator of the hydraulic tilting-back supports	1670
7.22.9	Attaching the main boom (self-assembly system)	1670
7.22.10	Connect A-frame2 with the rope of winch1/winch2.	1671
7.22.11	Reeving A-frame 2/A-frame 3	1671
7.22.12	Erecting A-frame2/A-frame3 with rope of winch1/winch2 and bolting the hydraulic tilting-back supports	1672
7.22.13	Bolting the equaliser on A-frame 2 to the jib backstay straps	1675
7.22.14	Connecting the equaliser on A-frame 3 to the jib base section	1676
7.22.15	Bolting the jib base section to the jib	1678
7.22.16	Bolting the equaliser on A-frame 3 to the jib pendant straps	1679
7.22.17	Installing mid-point suspension	1679
7.22.18	Pinning the pendant straps	1683
7.22.19	Connect the electric cables	1684
7.22.20	Installing the obstacle warning light	1685
7.22.21	Fitting the anemometer	1687

7.22.22	Moving the lightning rods* into working position	1689
7.22.23	Reeving the rope	1692
7.22.24	Attaching the rope fixing point	1701
7.22.25	Installing the hoist limit switch weight	1705
7.22.26	Bypass unused hoist limit switches.	1709
7.22.27	Erecting the main boom + luffing jib	1710
7.22.28	Switching off assembly mode functions	1715
7.22.29	Checking the top jib limit switch for function	1716
7.22.30	Checking the jib limit switch plate for proper adjustment	1718
7.23	Luffing jib 2316 + midfall 2316	1720
7.23.1	Configuration of jib	1720
7.23.2	Lengths of jib mid-point suspensions	1721
7.23.3	Configuration of main boom	1723
7.23.4	Overview of steel pendant straps on luffing jib 2316 + midfall 2316	1724
7.23.5	Overview of CF pendant straps on luffing jib 2316 + midfall 2316	1726
7.23.6	Reeving diagrams for one rope across jib head 2316 (load position1)	1729
7.23.7	Reeving diagrams for one rope across midfall 2316 (load position3)	1731
7.24	Luffing jib 1916 + midfall 1916	1733
7.24.1	Configuration of jib	1733
7.24.2	Lengths of jib mid-point suspensions	1734
7.24.3	Configuration of main boom	1736
7.24.4	Overview of steel pendant straps on luffing jib 1916 + midfall 1916	1737
7.24.5	Overview of CF pendant straps on luffing jib 1916 + midfall 1916	1739
7.24.6	Reeving diagrams for one rope across jib head 1916 (load position1)	1742
7.24.7	Reeving diagrams for one rope across midfall 1916 (load position3)	1744
7.25	Assembling the luffing jib + Midfall	1746
7.25.1	Notes	1746
7.25.2	Installing the midfall	1746
7.26	Adjusting the track	1752
7.26.1	Converting from wide track to medium or narrow track	1752
7.26.2	Converting from medium or narrow track to wide track	1760
7.27	Hydraulic cab elevation*	1761
7.27.1	Erecting and bolting the mast	1761
7.27.2	Setting the cab in the working position and bolting in place	1763
7.27.3	Dismantling	1764

7.28	Vertical Line Finder* assistance system	1765
7.28.1	Installing the Vertical Line Finder on the main boom head	1765
7.28.2	Installing the Vertical Line Finder on the jib head	1770
7.29	Vandalism protection*	1778
7.29.1	Installing the vandalism protection	1778
7.30	Jib luffing winch*	1780
7.30.1	Fixing rope end	1780
7.30.2	Lashing the jib luffing winch	1780
7.30.3	Installation of jib luffing winch	1781
7.30.4	Connect hydraulic lines	1782
7.30.5	Connect the electric cables	1783
7.31	Conversion to permanent auxiliary jib operation	1784
7.31.1	Converting auxiliary jib 36 t (79300 lb)	1785
7.31.2	Converting the main boom head	1786
7.32	Time-saving reconfiguring of the main boom	1790
7.32.1	Reconfiguring the main boom	1790
7.33	Disassembling the luffing jib + Midfall	1793
7.33.1	Brief summary	1793
7.34	Deinstalling the luffing jib	1794
7.34.1	Preparing the machine	1794
7.34.2	Lowering the jib up to load moment limiter stop	1796
7.34.3	Lowering the jib until wheels touch the ground or bottom jib limit switch is triggered	1797
7.34.4	Lowering the main boom and jib all the way to the ground	1799
7.35	Dismantling the fixed jib	1804
7.35.1	Brief summary	1804
7.36	Disassembling main boom + reducing piece	1806
7.36.1	Brief summary	1806
7.37	Disassembling the main boom	1807
7.37.1	Brief summary	1807
7.38	Disassembling the basic machine	1810
7.38.1	Brief summary	1810
8	Transport	1815
8.1	Loading the basic machine with an assist crane	1815

LWNLR-x/V04.01//Auslieferung/2016-03-07/en

8.1.1	Loading basic machine with undercarriage with fixed track width	1815
8.1.2	Loading basic machine with undercarriage with adjustable track width	1828
8.2	Transporting the basic machine with a transport vehicle	1840
8.2.1	Transporting basic machine with undercarriage with fixed track width with a transport vehicle	1840
8.2.2	Transporting basic machine with undercarriage* with adjustable track width with a transport vehicle	1843
8.3	Transporting the boom sections	1847
8.3.1	Adjusting and mounting the transport brackets for steel pendant straps	1847
8.3.2	Installing transport brackets for CF pendant straps	1848
8.3.3	Adjusting and mounting transport brackets for connecting links	1849
8.3.4	Insert pendant straps in transport bracket and secure	1850
8.3.5	Securing the pendant straps with transport bracket	1851
8.3.6	Preparing boom components for transport	1852
8.3.7	Transporting the pendant straps	1854
9	Maintenance	1857
9.1	Maintenance and inspection schedule	1857
9.2	Lubricants and consumables	1871
9.2.1	Lubrication diagram	1872
9.2.2	Filling capacity table	1874
9.2.3	Lubrication chart	1875
9.2.4	Diesel engine lubricating oil	1878
9.2.5	Fuel	1879
9.2.6	Urea solution	1879
9.2.7	Diesel engine coolant	1879
9.2.8	Hydraulic oil	1879
9.2.9	Preservation medium (anti-corrosion coating)	1880
9.2.10	Liebherr oil diagnosis system	1882
9.3	Air filter system	1885
9.3.1	Checking the negative pressure indicator	1885
9.3.2	Cleaning the air filter dust ejector	1886
9.3.3	Replacing the dry air filter main element and dry air filter safety element	1886
9.4	Distributor gearbox	1888
9.4.1	Checking the gearbox oil level	1888
9.4.2	Topping up the gearbox oil	1889

9.4.3	Checking the venting valve	1890
9.5	Swing	1891
9.5.1	Checking the gearbox oil level	1891
9.5.2	Topping up the gearbox oil	1891
9.6	Swing connection	1893
9.6.1	Lubricating external teeth	1893
9.6.2	Lubricating the bearing races via the central lubrication point	1893
9.7	winch1/winch2	1895
9.7.1	Checking the gearbox oil level	1895
9.7.2	Topping up the gearbox oil	1896
9.7.3	Lubricating the counter bearing	1896
9.7.4	Checking the rope end fastening for tight fit	1897
9.8	Boom luffing winches	1898
9.8.1	Checking the gearbox oil level	1898
9.8.2	Topping up the gearbox oil	1899
9.8.3	Lubricating the counter bearing	1899
9.8.4	Checking the rope end fastening for tight fit	1900
9.9	Rope reeving winch	1901
9.9.1	Lubricating the counter bearing	1901
9.9.2	Checking rope end attachment for tight fit when starting up rope reeving winch	1901
9.10	Tagline winch	1902
9.10.1	Checking the gearbox oil level	1902
9.10.2	Topping up the gearbox oil	1903
9.10.3	Lubricating the rope bracket on the boom base section and checking pulleys for damage	1903
9.10.4	Checking the rope end fastening for tight fit	1904
9.11	Crawlers	1905
9.11.1	Checking the gearbox oil level	1905
9.11.2	Check gearbox and hydraulic connections for leaks	1906
9.11.3	Cleaning the crawlers	1906
9.11.4	Checking that the crossbeam set screws on the crawler side frames are secure on telescopic undercarriages	1907
9.11.5	Check chain guides for wear and tight fit	1907
9.11.6	Checking the chain tension	1908
9.11.7	Retightening the chain	1910

9.11.8	Release pressure on hydraulic tension jack	1913
9.11.9	Checking locking screws of the track pads axes	1916
9.12	Lifting device	1917
9.12.1	Check transport lashing and round slings for wear (according to EN 1492-2).	1917
9.12.2	Check the round steel chains for wear and damage	1917
9.13	Hook/pulley block	1918
9.13.1	Checking all hooks/pulley blocks for damage, wear, corrosion and widening of the hook aperture	1918
9.13.2	Lubricating bearings and axels	1918
9.13.3	Check that the safety catch is present and working properly	1919
9.14	Hydraulic system	1920
9.14.1	Check the hydraulic system for leaks	1920
9.14.2	Checking the oil cooler for contamination	1920
9.15	Hydraulic oil tank	1921
9.15.1	Carrying out a hydraulic oil analysis	1921
9.15.2	Filling with hydraulic oil	1921
9.15.3	Draining the hydraulic oil	1922
9.15.4	Cleaning the magnetic rod in the return filter	1922
9.16	Hydraulic oil filter	1926
9.16.1	Exchanging the hydraulic oil filter elements	1926
9.17	Hydraulic cylinders	1928
9.17.1	Check that the hydraulic cylinder fits properly and does not leak	1928
9.17.2	Protecting the piston rods of the hydraulic cylinders from corrosion	1928
9.17.3	Preserving the piston rods of the hydraulic cylinders in case of longer periods of non-use	1928
9.18	Hydraulic hoses	1929
9.18.1	Checking the hydraulic hoses	1929
9.19	Bypass filter system	1930
9.19.1	Checking the bypass filter system	1930
9.19.2	Changing the filter elements	1930
9.20	Batteries	1933
9.20.1	Checking the fluid level in the cells	1933
9.20.2	Checking the battery fluid	1933
9.20.3	Exchanging the fuses on the battery	1934
9.21	Lighting	1935

9.21.1	Checking that the cabin lighting, floodlights and auxiliary floodlights are working properly	1935
9.21.2	Changing the cab lamp light bulb	1935
9.21.3	Changing the bulbs of floodlights on the cabin and on the uppercarriage	1935
9.21.4	Changing the bulbs of search floodlights	1938
9.21.5	Changing the bulbs of floodlights on main boom base section	1939
9.21.6	Exchanging the bulbs of floodlights on main boom or jib head	1942
9.22	Rope measuring system	1945
9.22.1	Checking the rope measuring system and height adjustment of all winches (if available) for correct function	1945
9.22.2	Readjusting layer change when changing ropes	1945
9.23	Limit switches	1946
9.23.1	Checking hoist limit switches, boom limit switches and, if necessary, limit switches of the piling and drilling rig to ensure they are working correctly	1946
9.24	Mechanical inclinometer	1947
9.24.1	Checking that the mechanical inclinometer is working properly	1947
9.25	Emergency stop	1948
9.25.1	Checking the emergency stop	1948
9.26	Obstacle warning light*	1949
9.26.1	Check obstacle warning light for function and damage, check mains cable and plug (if available) for damage	1949
9.27	Fire extinguishers	1950
9.27.1	Checking the seals and inspection dates on the fire extinguishers	1950
9.28	Personal protective equipment	1951
9.28.1	Checking personal protective gear	1951
9.29	Safety signs	1952
9.29.1	Checking that all required safety labels are mounted on the machine and are legible	1952
9.30	Access systems and railings	1953
9.30.1	Checking ladders, steps, platforms, and ascents for wear, damage and anti-slip surfaces	1953
9.30.2	Checking latches and hand rails for wear and damage	1953
9.30.3	Checking the spring tension of railing doors	1953
9.30.4	Setting the spring tension of railing doors	1954
9.30.5	Checking the function of the railing stabilization	1956
9.31	Steel structure	1958
9.31.1	Checking the machine steel structure for damage, cracks	1958

9.31.2	Repairs on the steel structure	1959
9.32	Main boom	1961
9.32.1	Check main boom base section, main boom head and main boom sections for damage and wear (cracks, notches, corrosion, plastic deformation, wear)	1961
9.32.2	Boom base section: checking that the knuckle pins and locking elements fit tightly	1962
9.32.3	Boom base section: lubricating knuckle pins	1962
9.32.4	Boom base section or A-frame 1: checking the operation of the mechanical boom angle indicator	1963
9.32.5	Checking the main boom head for function and damage	1964
9.32.6	Checking the anemometer for tight fit and function	1964
9.32.7	Checking the auxiliary jib for function and damage	1965
9.33	Jib	1966
9.33.1	Checking the jib base section, jib head and jib sections for damage and wear	1966
9.33.2	Filling the accumulators for the tilting-back supports on the jib	1966
9.33.3	Checking locking flaps for ease of movement	1972
9.33.4	Jib head: Checking wheels for ease of movement	1973
9.33.5	Checking the anemometer for tight fit and function	1973
9.33.6	Jib base section: Checking screw connections and pin connections for tight fit, checking that rope protection and locking springs are in place and undamaged	1974
9.34	A-frame1	1975
9.34.1	Checking A-frame 1	1975
9.34.2	Lubricating the bearings on A-frame 1	1975
9.34.3	Lubricating the bearings on the A-frame1 cylinder	1976
9.35	Tilting-back supports	1977
9.35.1	Checking the pressure in the tilting-back support piston area	1977
9.36	Steel pendant straps	1979
9.36.1	Checking steel pendant straps and pins for damage and wear and check that locking springs and split pins are present	1979
9.36.2	Checking the ease of movement of pin connections in the entire pendant strap strand	1980
9.36.3	Protecting steel pendant straps, connecting links and pins from corrosion	1980
9.36.4	Checking connecting links for damage and wear	1980
9.36.5	Checking tension load cells for damage and wear, checking electricity connections for tight fit	1980
9.37	Carbon-fibre pendant straps	1982

9.37.1	Checking CF pendant straps and pins for damage and wear and check that locking springs and split pins are present	1983
9.37.2	Checking the ease of movement of pin connections in the entire pendant strap strand	1985
9.37.3	Protecting CF pendant strap bushes, connecting links and pins from corrosion	1985
9.37.4	Checking connecting links for damage and wear	1986
9.37.5	Checking tension load cells for damage and wear, checking electricity connections for tight fit	1986
9.38	Pendant ropes	1987
9.38.1	Check pendant ropes and pins for damage and wear and check that locking springs and cotter pins are present (cracks, notches, corrosion, plastic deformation, wear, lubrication, etc.)	1987
9.38.2	Protecting pendant ropes, connecting links and pins from corrosion	1987
9.38.3	Checking connecting links for damage and wear	1988
9.39	Counterweight	1989
9.39.1	Checking the screws of the rear counterweight tie-down for tight fit (with exception of LR 1001.xx.xx)	1989
9.39.2	Checking the rear counterweight, fixing lugs and round steel chains for damage, wear and secure fit	1989
9.39.3	Checking locking elements for availability, damage, wear and tight fit	1990
9.39.4	Checking counterweight supports (pins, shackles) for damage and wear	1990
9.40	Lubrication system	1991
9.40.1	Checking the function of the central lubrication system	1991
9.40.2	Check fill level of the lubrication pump	1991
9.40.3	Checking the time intervals of the lubrication pump	1992
9.40.4	Checking the lubrication points	1992
9.41	Derrick equipment*	1993
9.41.1	Check derrick boom base section, derrick boom head and derrick boom sections for damage and wear (cracks, notches, corrosion, plastic deformation, wear)	1993
9.41.2	Greasing the bearing of the derrick boom base section	1993
9.41.3	Greasing the extension device of the counterweight carriage (strut, uppercarriage pin connection)	1994
9.41.4	Checking the air pressure of the counterweight carriage	1994
9.41.5	Checking the tires of the counterweight carriage for damage	1995
9.41.6	Lubricating the axes and swing arms of the counterweight carriage's wheel sets	1995
9.41.7	Lubricating the drive units of the counterweight carriage's wheel sets	1996
9.41.8	Checking the gearbox oil level in the counterweight carriage's axle gearbox	1997

9.41.9	Filling in gearbox oil at the counterweight carriage's axle gearbox	1999
9.41.10	Checking the hydraulic cylinders of the counterweight carriage's wheel sets for tightness	2000
9.41.11	Checking the hydraulic connections on the counterweight carriage for tightness	2000
9.41.12	Checking the screws of the counterweight tie-down for tight fit	2001
9.42	Ropes	2002
9.42.1	Assembly of a rope	2002
9.42.2	Visual inspection of the ropes for deterioration or mechanical damage	2002
9.42.3	Checking ropes for lubrication	2002
9.42.4	Rope lubrication	2003
9.42.5	Checking ropes for end of service life	2003
9.42.6	Storing ropes	2015
9.42.7	Transporting the ropes	2016
9.42.8	Selecting a rope	2016
9.42.9	Storing ropes	2018
9.42.10	Transporting ropes	2018
9.42.11	Unwind rope from rope reel	2019
9.42.12	Laying on the rope	2021
9.43	Drum	2029
9.43.1	Checking rope tensioning pulleys* of drum for wear	2029
9.43.2	Checking the groove diameter of the drum	2029
9.43.3	Checking drum for loose rope layers	2030
9.44	Rope pulleys	2031
9.44.1	Assembly of a pulley	2031
9.44.2	Checking the groove diameter of the pulley	2031
9.44.3	Checking the bottom of groove diameter of the pulley	2032
9.44.4	Checking the gap width of the pulley	2033
9.44.5	Checking bottom of pulley groove for sharp edges	2034
9.44.6	Checking pulleys for damage	2034
9.44.7	Checking the pulley bearings	2035
9.44.8	Lubricating the pulley bearings	2035
9.44.9	Checking the position of bearing and locking ring	2035
9.44.10	Cleaning plastic pulleys	2036
9.45	Rope suspension and rope fixation	2037

9.45.1	Checking rope suspensions (rope clamps, rope thimbles) for wire breaks, absence of corrosion and tight fit of screw fittings	2037
9.45.2	Checking the pocket locks	2038
9.45.3	Checking the rope end fittings for cracks	2039
9.45.4	Checking the rope fixing point	2040
9.46	Cab	2041
9.46.1	Check the windows of the cab for damage	2041
9.46.2	Checking that the cab door and the door lock work properly	2041
9.46.3	Check cabin roof protection guard for damage, locking (in case of foldable design)	2041
9.46.4	Changing the windscreen wipers	2041
9.46.5	Filling the windscreen cleaning system	2042
9.46.6	Checking outside mirrors and inside mirrors for damage	2043
9.46.7	Checking the operation of the hydraulic cab tilting device and for damage	2043
9.46.8	Checking hydraulic cabin elevation for function and damage	2044
9.46.9	Cleaning or replacing the filter insert in the cabin	2045
9.47	Ventilation, heating and air-conditioning	2047
9.47.1	Checking the recirculated air filter for contamination	2047
9.47.2	Replacing the recirculated air filter	2051
9.47.3	Checking the fresh air filter for contamination	2056
9.47.4	Replacing the fresh air filter	2057
9.47.5	Checking the coolant level in the inspection glass	2061
9.47.6	Checking the condenser for contamination	2062
9.47.7	Checking the condenser for loose leads, loos screws and corrosion	2063
9.47.8	Checking the fan on condenser for function, tight fit and damage	2063
9.47.9	Checking the climate box for contamination	2064
9.47.10	Checking the dryer for damage and corrosion	2065
9.47.11	Starting the ventilation, heating, air conditioning, external air conditioning system* and auxiliary heating system* and ensuring that sufficient antifreeze has been added to the water circuit	2065
9.47.12	Replacing the fuel filter of auxiliary water heating	2068
9.48	HATZ diesel engine* (see operation manual of the engine manufacturer on CD)	2070
9.48.1	Checking the belt drive	2070
9.48.2	Replacing the belt drive including vibration damper, deflection pulley and springs	2070
9.49	Machine care	2071

9.49.1	Cleaning the machine	2071
9.49.2	Preserving the machine	2072

1 Product description

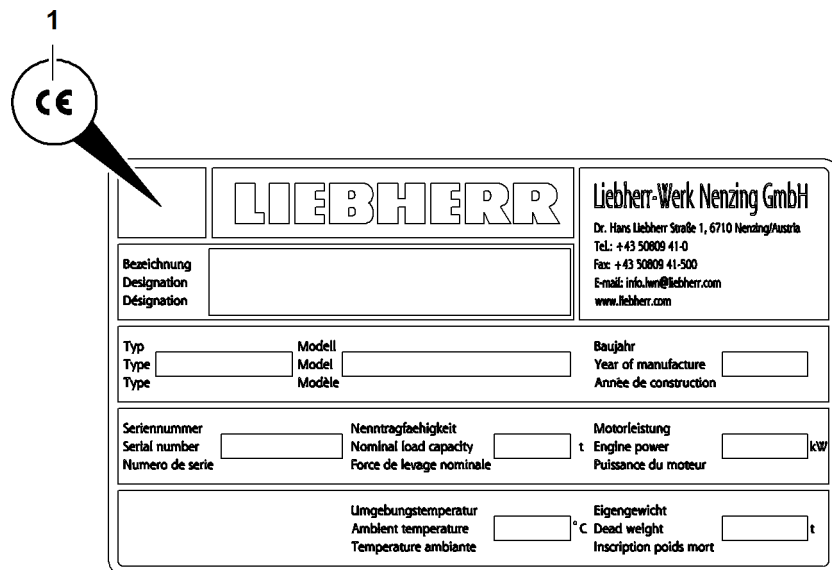
1 Product description

The chapter **Product description** deals with the following issues:

- Application options of the machine
- Wrong or improper use of the machine
- Machine components
- Technical data

The illustrations in this operation manual are for general information purposes. They may be shown as diagrams and do not necessarily correspond to the current machine setup.

1.1 Type plate



The illustration shows a type plate for a Liebherr machine. A callout bubble with the number '1' and the CE mark points to the top-left corner of the plate. The plate is divided into several sections:

- Top Left:** A box containing the CE mark.
- Top Center:** The brand name 'LIEBHERR' in large, bold, outlined letters.
- Top Right:** The manufacturer's name 'Liebherr-Werk Nenzing GmbH' and contact information: 'Dr. Hans Liebherr Straße 1, 6710 Nenzing/Austria', 'Tel.: +43 50809 41-0', 'Fax: +43 50809 41-500', 'E-mail: info.hwr@liebherr.com', and 'www.liebherr.com'.
- Middle Left:** A box for 'Bezeichnung / Designation / Désignation'.
- Middle Center:** A large empty box for the machine's designation.
- Middle Right:** A box for 'Baujahr / Year of manufacture / Année de construction'.
- Bottom Left:** A box for 'Typ / Type / Type'.
- Bottom Center:** A box for 'Modell / Model / Modèle'.
- Bottom Right:** A box for 'Motorleistung / Engine power / Puissance du moteur' in kW.
- Bottom Left (continued):** A box for 'Seriennummer / Serial number / Numero de serie'.
- Bottom Center (continued):** A box for 'Nenntragfähigkeit / Nominal load capacity / Force de levage nominale' in t.
- Bottom Right (continued):** A box for 'Umgebungstemperatur / Ambient temperature / Temperature ambiante' in °C.
- Bottom Center (continued):** A box for 'Eigengewicht / Dead weight / Inscription poids mort' in t.

Fig. 1: Type plate (illustration of principle)

1 CE label

If the machine corresponds to guideline 2006/42/EU, the type plate bears the CE label 1.

1.2 Declaration of conformity

Right behind the cover sheet, the documentation contains the EU declaration of conformity in acc. with guideline 2006/42/EU when delivering the machine with CE label. The EU declaration of conformity in its present version and language is valid in all countries of the European Union as well as in countries that recognize the guideline 2006/42/EU. Additional documentation may also be enclosed like documents relating to a prototype test or an international approval test. The test report for individual verification is archived with the manufacturer and can be requested if required.

1.3 Appropriate use

The supplied equipment determines the possible applications of the machine.

The machine is classified in crane group A1 in acc. with ISO 4301-1.

The machine is only designed and constructed for the intended use stated and described in the operation manual.

The machine may only be operated in admissible setup condition and mode.

Special machine tasks that deviate from the tasks described in the operation manual must be coordinated with the machine manufacturer beforehand.

Intended use of the machine is a basic requirement of safe operation.

Non-observation of the intended machine use results in grave consequences:

- Life-threatening or fatal injuries
- Severe damage to the machine, assets or contamination of the environment for which the manufacturer of the machine cannot be held liable.
- Loss of warranty and guarantee claims

Utilization not described in the operation manual must be authorized in writing by the manufacturer. Any other use of the machine without written consent of the manufacturer is deemed inappropriate use.

Appropriate use of the machine is exclusively defined as follows:

- Utilization in the work areas and on the conditions of use listed and described in the operation manual.
- Use of exchangeable equipment provided or approved by the machine manufacturer.
- Moving the machine without load with rigging equipment in line with the admissible load chart with supervision of a signalman.
- Moving the machine with lifted load in line with the admissible load chart with supervision of a signalman.
- A signalman must observe travelling of the machine within the admissible travelling range with suspended and admissible load and in admissible position of the uppercarriage and the boom.
- Lifting and lowering as well as horizontal transport of loads with the corresponding rigging equipment whose mass and center of gravity is known.

Appropriate use the machine observing the following specifications and requirements:

- Complete safety equipment is installed and functioning properly.
- All maintenance and repair work stated in the maintenance and inspection plan of the operation manual was performed according to specifications by qualified maintenance personnel or authorized qualified personnel.
- All safety instructions in this operation manual are being observed.
- All valid national and international safety regulations (e.g. oil or gas industry) are observed by the operator, if applicable.
- The operating materials listed in the operation manual are being used.
- All persons involved meet the requirements on staff according to the operation manual.
- All persons involved meet their responsibilities according to the operation manual.
- The technical information values are being observed.
- Load charts are being observed.
- The machine is operated exclusively with the rigging equipment approved by the manufacturer under consideration of the corresponding mode and load

- curve and observation of the operation manual, warning and safety equipment and the valid load chart.
- Operational restrictions are being observed.
 - “ISO 12480-1 Cranes-Safe use-Part 1: General” is observed with respect to lifting gear.
 - Intended and inappropriate use of the exchangeable equipment is being observed.

1.4 Special modes of operation

The following applies to special modes of operation:

- Special modes of operation may significantly reduce the service life of the machine.
- Special operating modes may result in excessive stress on the machine causing premature damage.
- Special modes of operation are the sole responsibility of the machine operator.
- Special modes of operation may result in undefined loading conditions with high dynamic stresses and excessive diagonal pulls, which may lead to immediate or early damage.

Special modes include:

- Vibrator mode or hammer mode
 - Leader-mounted vibrators and hammers
 - Free-hanging vibrators and hammers
 - Vibrator lances/probes
- Installation of exchangeable equipment:
 - Fixed leader
 - Swinging leader
 - Crane mount drill
- Free-fall operation
- Utilization on floating constructions



Note

- ▶ For more information regarding special modes of operation: contact Liebherr service department.
-

1.5 Inappropriate use

Inappropriate use of the machine includes any reasonably foreseeable misuse in line with the machine directive 2006/42/EG.

Use of the machine is deemed not according to purpose under the following conditions:

- Any structural modification of the machine and equipment that affects operational safety and that has been carried out without the written declaration of approval of the manufacturer.
- Installation of spare parts and use of media or exchangeable equipment not approved and authorized by the manufacturer.
- Operation of the machine outside of the limit values approved by the machine's manufacturer, like e.g. ambient temperature range, load chart (load/radius), wind speed, operating restrictions and diagonal pull.
- Start-up or operation of the machine without knowledge of the operation manual and/or without qualification of the machine operator demanded by national regulations.
- Start-up or operation of the machine if operation is not admissible according to the specifications of the machine's location due to explosion hazard indicated on the machine's type plate.
- Machine operator does not possess the necessary skills to comprehend the operation manual.
- Start-up or operation of the machine by persons not authorized by the operator.
- Any kind of work with the machine that endangers operational safety.
- Start-up or operation of the machine without approval test or recurring inspection if this is prescribed by national or international directives and standards.
- Start-up or operation of the machine without properly installed or not properly functioning safety installations and safety equipment.
- Performance of repairs not authorized by the manufacturer.
- Bypass or conversion of the required safety installations set in the factory.
- Transport of persons along with the load or with rigging equipment not intended for this purpose.
- Operation of the machine in an unapproved mode.
- Operation of the machine with open cabin door.
- Pulling or dragging a load on the ground.
- Breakaway of stuck loads under slack rope or with other components besides the hoisting gear intended for this purpose.
- Breakaway of stuck tools, rigging equipment or equipment parts (e.g. drilling equipment, piling equipment or grab).
- Start-up or operation of the machine if other persons apart from the machine operator are located outside of the cabin or on the machine.
- Start-up or operation of the machine with incomplete operation manual (e.g. missing or illegible pages).
- Start-up or operation of the machine if the operation manual is not available in the contractually agreed language.
- Lifting of loads attached to several load lifting devices without consideration of ISO 12480-1.
- Lifting of persons with the exception of machines with valid EC-type examination certificate and the corresponding machine configuration or approval by national authorities.
- Lifting of persons for entertainment purposes, for example shows, "bungee jumping", "suspended restaurants" or lifting of other devices on or beneath which persons are located.

- Use of the machine in special modes not listed in the operation manual, not approved by the manufacturer and without the corresponding adaptations on the machine.
- Tilting the machine.
- Use of the machine on uneven, undulating, non-compacted, soft ground or on ground not suited for the arising pressure.
- Moving the machine without adequate vision and without signalman.
- Use of the machine as tractor with the exception of machines with towing attachment or drawbar eye under observation of the admissible supported loads, trailing loads or trailer loads.
- Increasing the mass of already lifted loads.
- Operation of the machine not in conformity with the current machine configuration (e.g. counterweight weights, boom components, reeving) with the programed setup.
- Lifting of loads in emergency mode (except for failure of the energy supply).
- Lifting loads on the ground with other components/kinematics than the hoisting gear intended for this purpose.
- Start-up or operation of the machine below ground (mining).
- Initial start-up of machine.
- Use of the machine for earth-moving work (e.g. leveling).
- Sea travel without observation of the specifications in the operation manual.
- Operation of the machine in assembly mode or with activated assembly functions instead of the mode intended for operation.
- Operation of machine above the specified crane group without reduction of loads.
- Installation of exchangeable equipment (e.g. fixed leader, swinging leader or crane mount drills) not previously agreed with the manufacturer.

1.6 Machine

1.6.1 Machine overview

Machine without derrick equipment*

The diagram below provides an overview of the machine components.

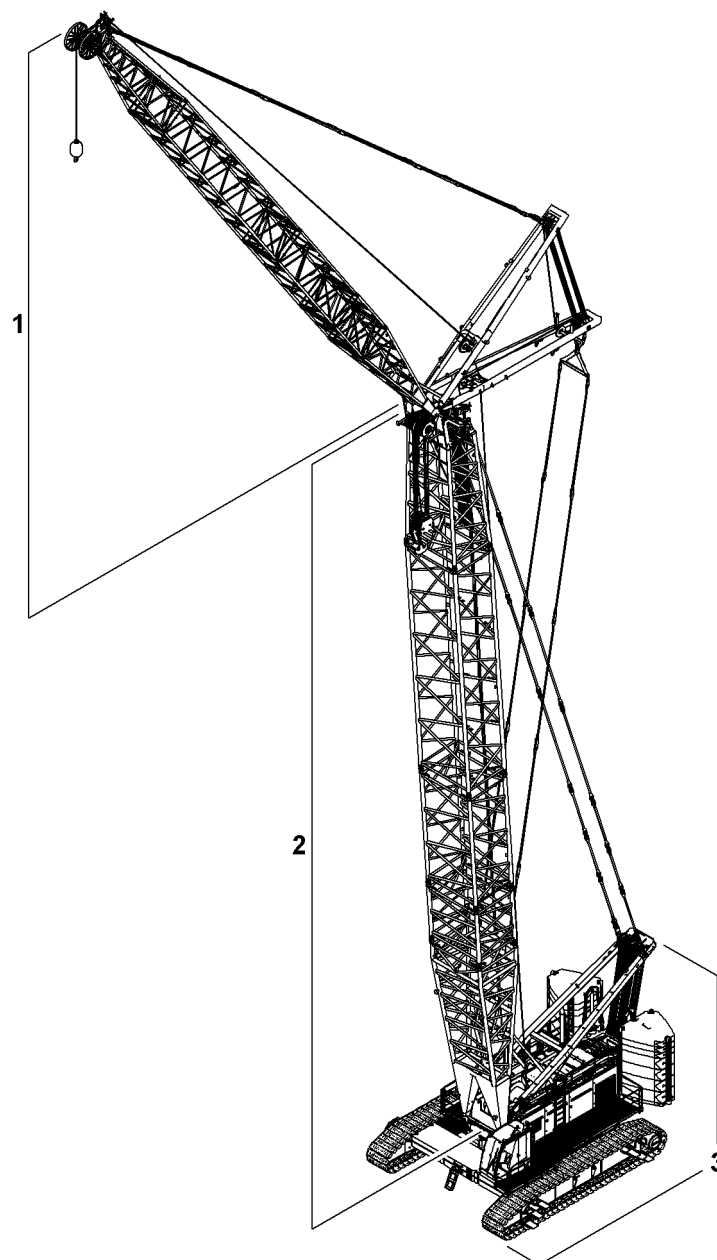


Fig. 2: Machine without derrick equipment*

- | | | | |
|---|--------------------------|---|---------------|
| 1 | Fixed jib or luffing jib | 3 | Basic machine |
| 2 | Main boom | | |

LWN/LR-x/V04.01//Auslieferung/2016-03-07/en

Machine with derrick equipment*

The diagram below provides an overview of the machine components with derrick equipment.

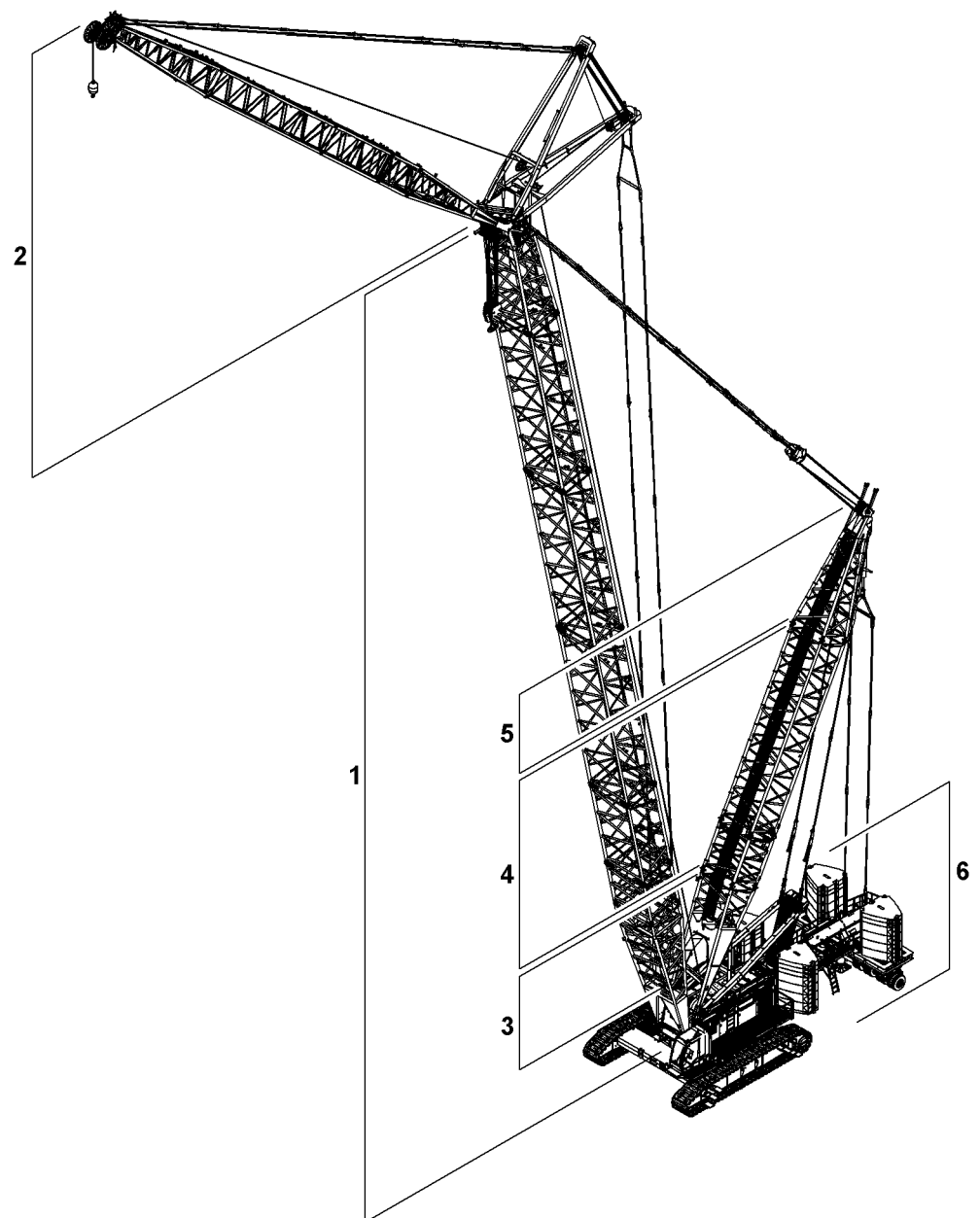


Fig. 3: Machine with derrick equipment*

- | | | | |
|---|---------------------------|---|---|
| 1 | Main boom | 4 | Derrick boom sections |
| 2 | Fixed jib or luffing jib | 5 | Derrick boom head |
| 3 | Derrick boom base section | 6 | Suspended counterweight or counterweight carriage |

1.6.2 Technical data

Application conditions

Ambient temperatures

Name	Value
Storage	-40 °C (-40 °F) to 40 °C (104 °F)
Operation	-20 °C (-4 °F) to 40 °C (104 °F)
Operation at low temperatures*	to -25 °C (-13 °F) (For more information see: 2.15.2 Operation of the machine down to -25 °C (-13 °F)* , page 609)
	to -40 °C (-40 °F) (For more information see: 2.15.3 Operation of the machine down to -40 °C (-40 °F)* , page 609)

Tab. 1: Technical data ambient temperatures

Application height

The exhaust gas turbocharger of the diesel engine reduces the influence of falling air pressure on the engine output at high altitude. Still, a performance reduction is to be expected with the diesel engine when operating the machine at high altitude above sea level and at high air temperatures.

When using the machine at high altitudes above sea level: The diesel engine control unit adjusts the engine characteristic curve automatically. A membrane located on the side of the control unit measures air pressure.

Emissions

Noise measurement data

Name	Value
Guaranteed sound pressure level L_{PA} in cabin	72.4 dB(A) 72.4 db(A)
Guaranteed sound output level L_{WA} of machine	see notice signs on cabin

Tab. 2: Technical data noise measurement data

The noise measurement data was determined in accordance with the standard EN 13000 Appendix G.

Reflections may increase the sound pressure level by 5 dB(A) (5 db(A)) to 10 dB(A) (10 db(A)) when working in confined spaces.

Vibrations

Name	Value
Vibrations on the upper limbs of the machine operator	< 2.5 m/s ² (8.2 ft/s ²)
Vibrations on entire body of machine operator	< 0.5 m/s ² (1.64 ft/s ²)

Tab. 3: Technical data vibrations

The measuring inaccuracy is defined in standard EN 12096:1997, table D.1 "Inaccuracy K for various measured values a".

Diesel engine

Name	Value
Type	D 946 A7
Manufacturer	Liebherr-Machines Bulle S.A
For further information please refer to the operation manual of the engine manufacturer on CD.	

Tab. 4: Technical data diesel engine

Interfaces

External power supply obstacle warning light*

Name	Value
Nominal voltage	AC 230 V, 50 Hz, ±15 %
	AC 115 V, 60 Hz, ±15 %
Phases	1 + N + PE
(For more information see: 1.44.1 External power supply obstacle warning light, page 438)	

Tab. 5: Technical data external power supply obstacle warning light

External power supply low temperature package*

Name	Value
Nominal voltage	AC 230 V, 50 Hz, ±15 %
	AC 115 V, 60 Hz, ±15 %
Phases	3 + N + PE
(For more information see: 1.44.2 External supply low temperature package, page 440)	

Tab. 6: Technical data external power supply low temperature package

Lubricants and consumables

Detailed information about lubricants and consumables (For more information see: [9.2 Lubricants and consumables, page 1871](#)).

Winches

winch1/winch2

Winch1/winch2	as crane winch	as free-fall winch
Nominal line pull (7th layer)	150 kN 33,720 lb _f	130 kN 29,230 lb _f
Rope Ø	28 mm 1.10" in	28 mm 1.10" in
Drum Ø	730 mm 2' 5" ft-in	730 mm 2' 5" ft-in

Tab. 7: Technical data winch1/winch2

- A) The load moment limiter (LML) limits the line pull in crane operation to a nominal value of 150 kN (33,720 lb_f). The nominal line pull must not be exceeded.



WARNING

Operating winches in the 8th rope layer is not permitted!
Severe injuries, damage to machine.

- Only ever wind the rope to the eighth layer for transport purposes.

Rope layer(s)	Winding length	Remark
1	7 m 23' ft-in	3 safety windings
1	62 m 203' 5" ft-in	Effective length with 1 rope layer
2	135 m 442' 11" ft-in	Effective length with 2 rope layers
3	213 m 698' 10" ft-in	Effective length with 3 rope layers
4	296 m 971' 2" ft-in	Effective length with 4 rope layers
5	383 m 1256' 7" ft-in	Effective length with 5 rope layers
6	474 m 1555' 1" ft-in	Effective length with 6 rope layers
7	571 m 1873' 4" ft-in	Total effective length

Tab. 8: Technical data winch1/winch2

Main boom luffing winch

Name	Value
Nominal line pull (1st layer)	180 kN 40,470 lb _f
Rope Ø	24 mm 0.94" in
Drum Ø	480 mm 1' 7" ft-in
Rope length	441 m 1446' 10" ft-in

Tab. 9: Technical data main boom luffing winch

Jib luffing winch

Name	Value
Nominal line pull (5th layer)	82 kN 18,430 lb _f
Rope Ø	20 mm 0.79" in
Drum Ø	490 mm 1' 7" ft-in
Rope length	385 m 1263' 1" ft-in ^{A)}

Tab. 10: Technical data jib luffing winch

A) When fitting the luffing jib 1916, it is admissible up to a main boom length of 71 m (232' 11" ft-in) to use the rope of the jib luffing winch with a length of 310 m (1017' 1" ft-in). As of a main boom length of 74 m (242' 9" ft-in) the rope of the jib luffing winch with a length of 385 m (1263' 1" ft-in) must be used.

Rope reeving winch*

Name	Value
Nominal line pull (7th layer)	17.5 kN 3,930 lb _f
Rope Ø	8 mm 0.31" in
Drum Ø	198 mm 7.80" in
Rope length	240 m 787' 5" ft-in

Tab. 11: Technical data rope reeving winch

Swing

Name	Value
Maximum rotation speed	2 min ⁻¹ 2 rpm

Tab. 12: Technical data swing gear

Crawler

Name	Value
Maximum travel speed	1.22 km/h 1 mph
Pull force machine	1893 kN 425,570 lb _f
Climbing ability with reduced load (see load chart)	maximum 1 %

Tab. 13: Technical data crawler

When travelling on inclines with a main boom and jib but no load, the gradient limits relating to the climbing ability of the machine are shown in the following tables in the “Work planning” section ([For more information see: 6 Operational planning, page 1067](#)) .

1.6.3 Safety equipment

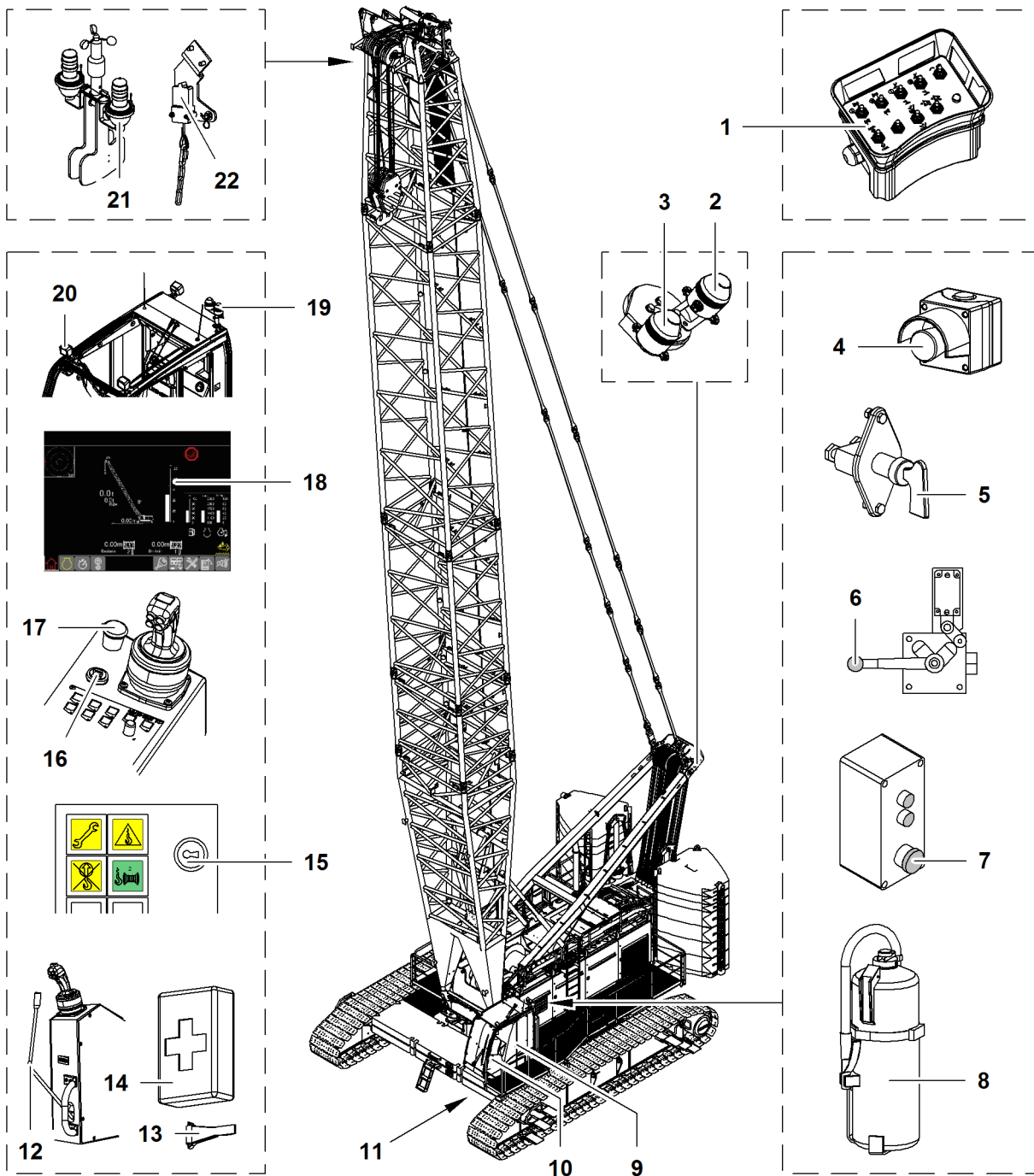


Fig. 4: Safety equipment

- | | | | | | |
|---|-------------------------------------|----|--|----|--|
| 1 | Emergency control system* | 9 | Door arrester | 17 | Emergency stop (cabin) |
| 2 | Load moment limiter lamp | 10 | Door lock | 18 | Display load moment utilization on the monitor |
| 3 | Flashing light | 11 | Vehicle horn, load moment limiter horn and acoustic signaling device | 19 | Load moment limiter lamp and flashing light |
| 4 | Emergency stop (engine compartment) | 12 | Safety lever | 20 | Floodlight (3x) |
| 5 | Main battery switch | 13 | Emergency hammer | 21 | Obstacle warning light* |

See next page for continuation of the image legend

LWNLR-x/V04.01//Auslieferung/2016-03-07/en

6 Gate valve <i>free-fall operation</i>	14 First-aid box	22 Hoist limit switch (2x)
7 Emergency stop (refueling pump)	15 Lock of control panel X12	
8 Fire extinguisher (2x)	16 Ignition lock (ignition key)	



Note

Fire extinguishers are subject to national regulations!

- ▶ Arrange for the plant operator to provide fire extinguishers, replace them as necessary and inspect them periodically.

1.6.4 Monitoring installations

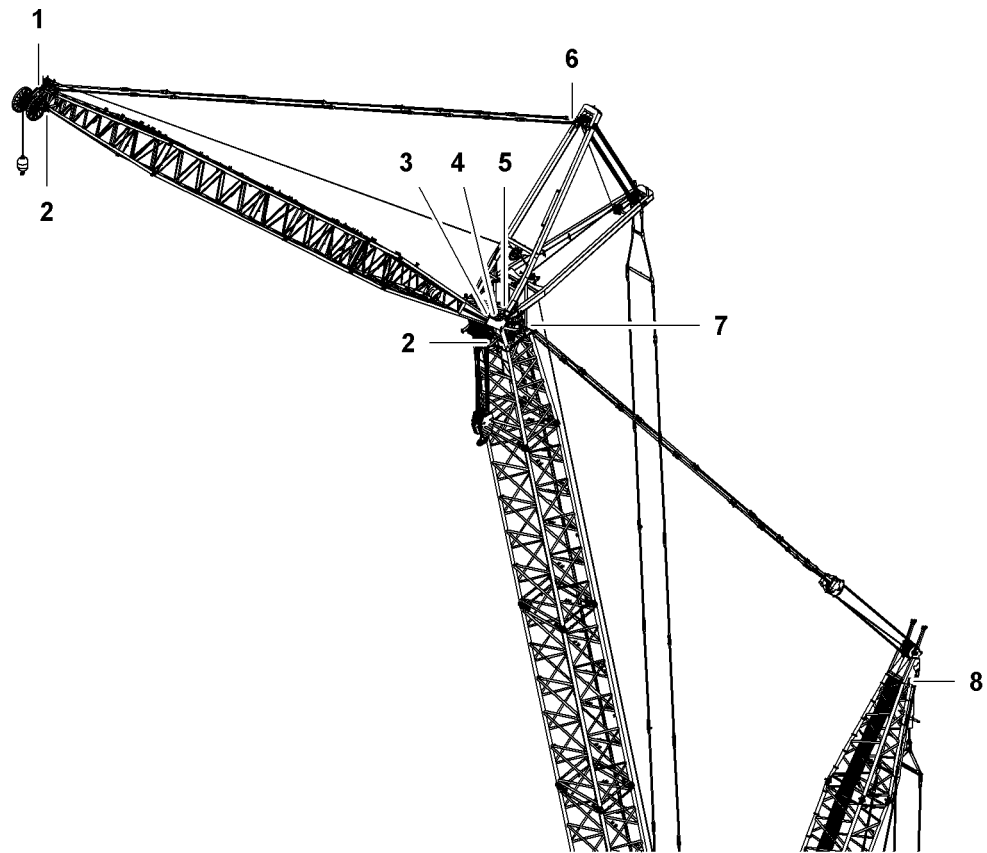


Fig. 5: Monitoring installations on the boom

1 Anemometer	5 Proximity switch for locking flaps
2 Hoist limit switch	6 Tension load cell (2x)
3 Jib, bottom limit switch	7 Tension load cell (2x)
4 Jib, top limit switch	8 Tension load cell (2x)

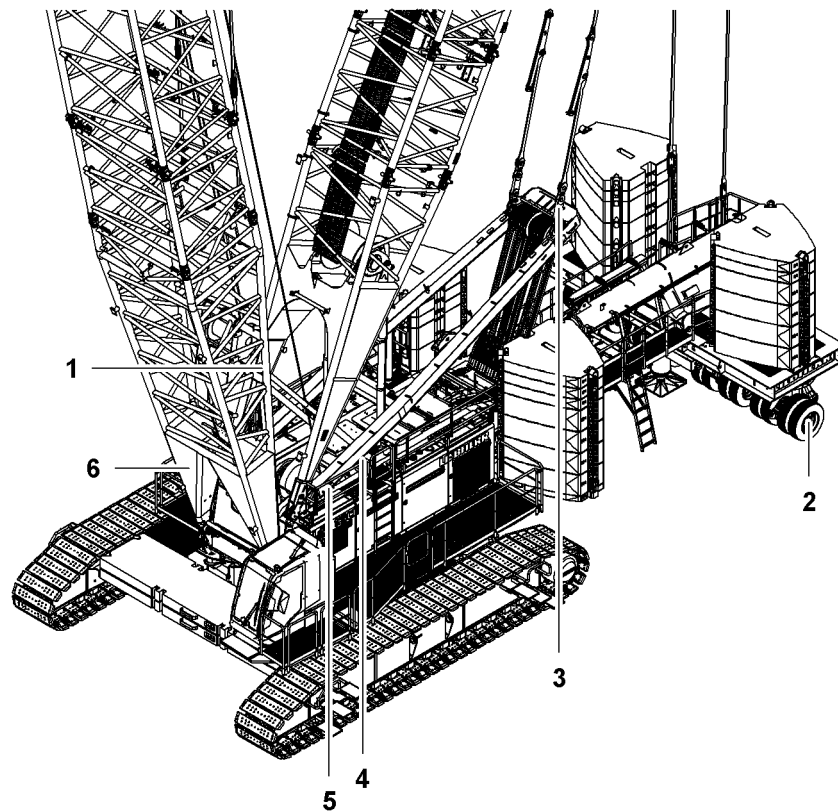


Fig. 6: Monitoring installations on basic machine

- | | | | |
|---|--------------------------------------|---|--|
| 1 | Control switch tilting-back supports | 4 | 3-windings limit switch (on all winches) |
| 2 | Angle sensor (on each wheel set) | 5 | Mechanical angle indicator |
| 3 | Tension load cell (2x) | 6 | Main boom, top limit switch |

1.7 Basic machine

1.7.1 Basic machine overview

Basic machine with undercarriage with fixed track width

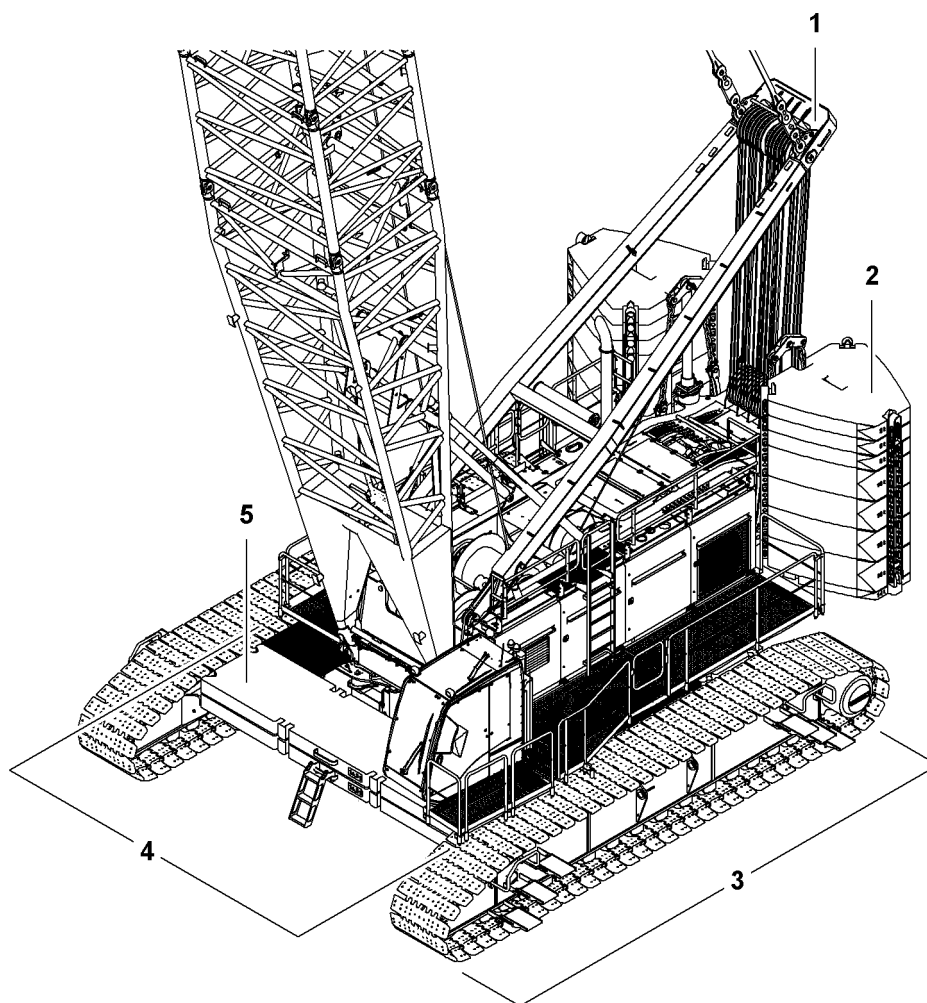


Fig. 7: Basic machine with undercarriage with fixed track width

- | | | | |
|---|--------------------|---|-----------------------|
| 1 | A-frame1 | 4 | Uppercarriage |
| 2 | Rear counterweight | 5 | Carbody counterweight |
| 3 | Undercarriage | | |

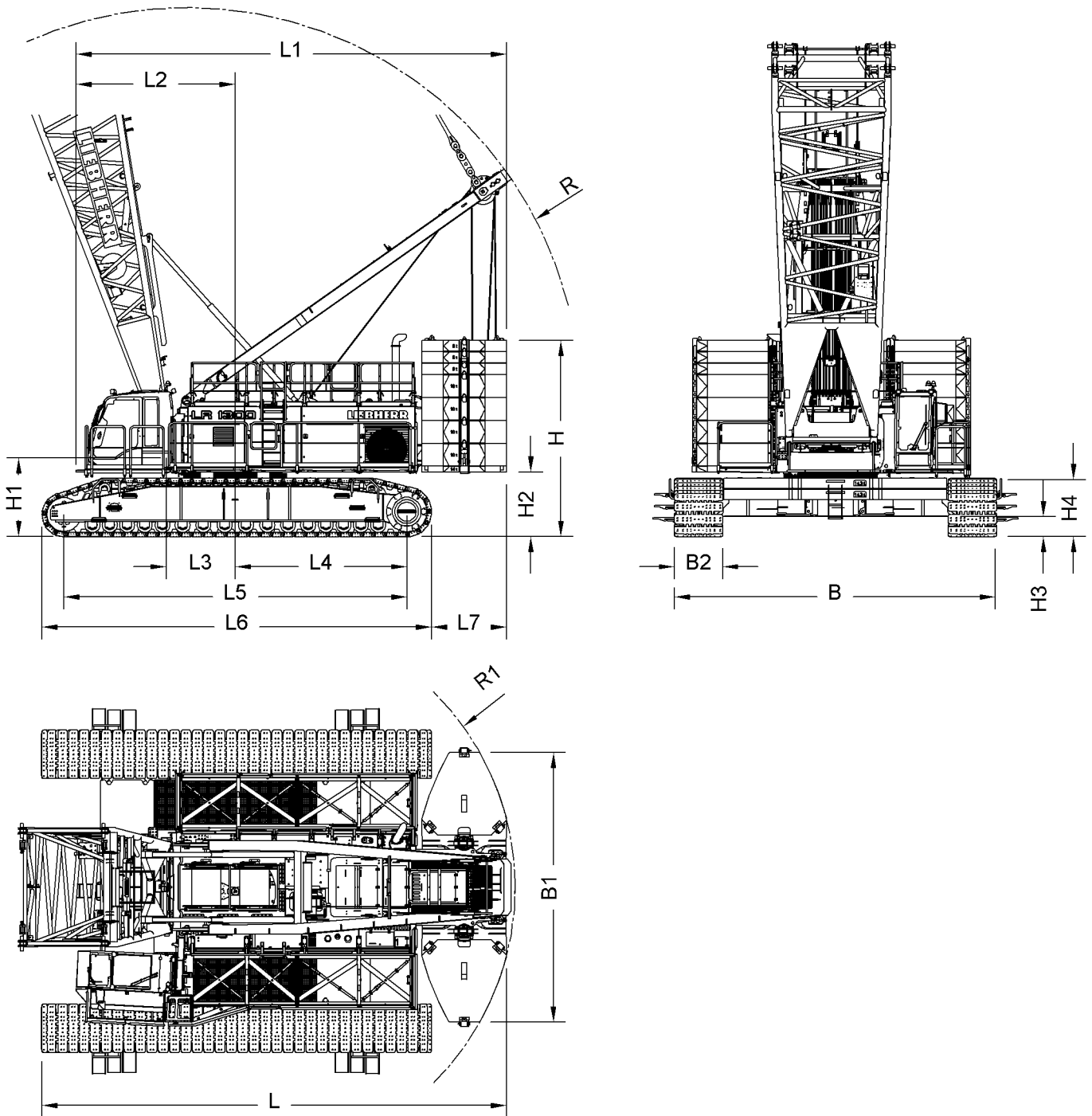


Fig. 8: Dimensions basic machine with undercarriage with fixed track width

Name		Value
L	Length basic machine	11560 mm 37' 11" ft-in
B	Width basic machine	8000 mm 26' 3" ft-in
H	Height basic machine with maximum rear counterweight	5000 mm 16' 5" ft-in
Detailed dimensions:		

LWNLR.x/V04.01//Auslieferung/2016-03-07/en

Product description

Basic machine

Name		Value
L1	Length uppercarriage with rear counterweight	10700 mm 35' 1" ft-in
L2	Rotation axis to front edge of cabin	3960 mm 13' ft-in
L3	Rotation axis to pivot point of main boom base section	1700 mm 5' 7" ft-in
L4	Rotation axis to center of tumbler	4260 mm 14' ft-in
L5	Wheelbase (center idler wheel to center tumbler)	8520 mm 27' 11" ft-in
L6	Length crawler side frame	9700 mm 31' 10" ft-in
L7	Rear edge crawler side frame to rear edge rear counterweight	1870 mm 6' 2" ft-in
B1	Width rear counterweight	6930 mm 22' 9" ft-in
B2	Width base plates	1200 mm 3' 11" ft-in
H1	Height main boom base section pivot point	2250 mm 7' 5" ft-in
H2	Ground clearance rear counterweight	1600 mm 5' 3" ft-in
H3	Ground clearance undercarriage	500 mm 1' 8" ft-in
H4	Height crawler side frame	1460 mm 4' 9" ft-in
R	A-frame1 swing radius	9750 mm 32' ft-in
R1	Rear counterweight swing radius	6980 mm 22' 11" ft-in
Dimensions basic machine with 1500 mm (4' 11" ft-in) base plates:		
B(1500)	Width basic machine with 1500 mm (4' 11" ft-in) base plates	8300 mm 27' 3" ft-in
B2(1500)	Width 1500 mm (4' 11" ft-in) base plates	1500 mm 4' 11" ft-in
H4(1500)	Height crawler side frame with 1500 mm (4' 11" ft-in) base plates	1485 mm 4' 10" ft-in

Tab. 14: Technical data basic machine with undercarriage with fixed track width

LWNLR-x\04.01\Auslieferung\2016-03-07\en

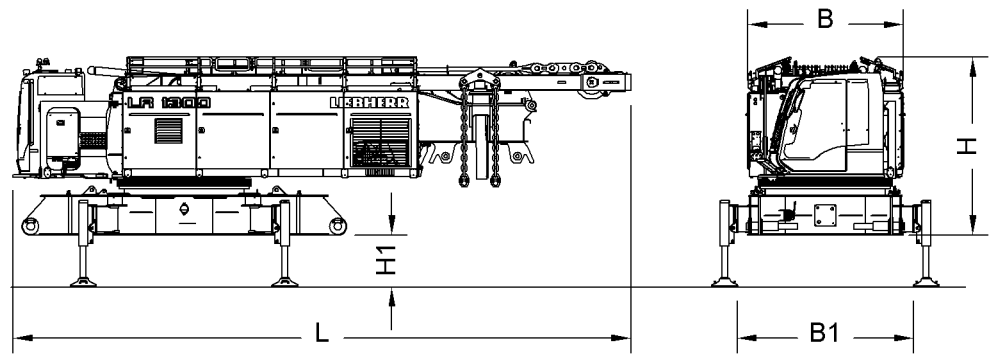


Fig. 9: Dimensions of basic machine in transport position on jacks

Name		Value
L	Length basic machine in transport position	11850 mm 38' 11" ft-in
B	Width basic machine in transport position	2990 mm 9' 10" ft-in
H	Height basic machine in transport position	3400 mm 11' 2" ft-in
Detailed dimensions:		
B1	Width between support pads	3360 mm 11' ft-in
H1	Ground clearance basic machine	975 mm 3' 2" ft-in
	Ground clearance basic machine with telescopic jack	1415 mm 4' 8" ft-in

Tab. 15: Technical data basic machine in transport position on jacks

Basic machine with undercarriage* with adjustable track width

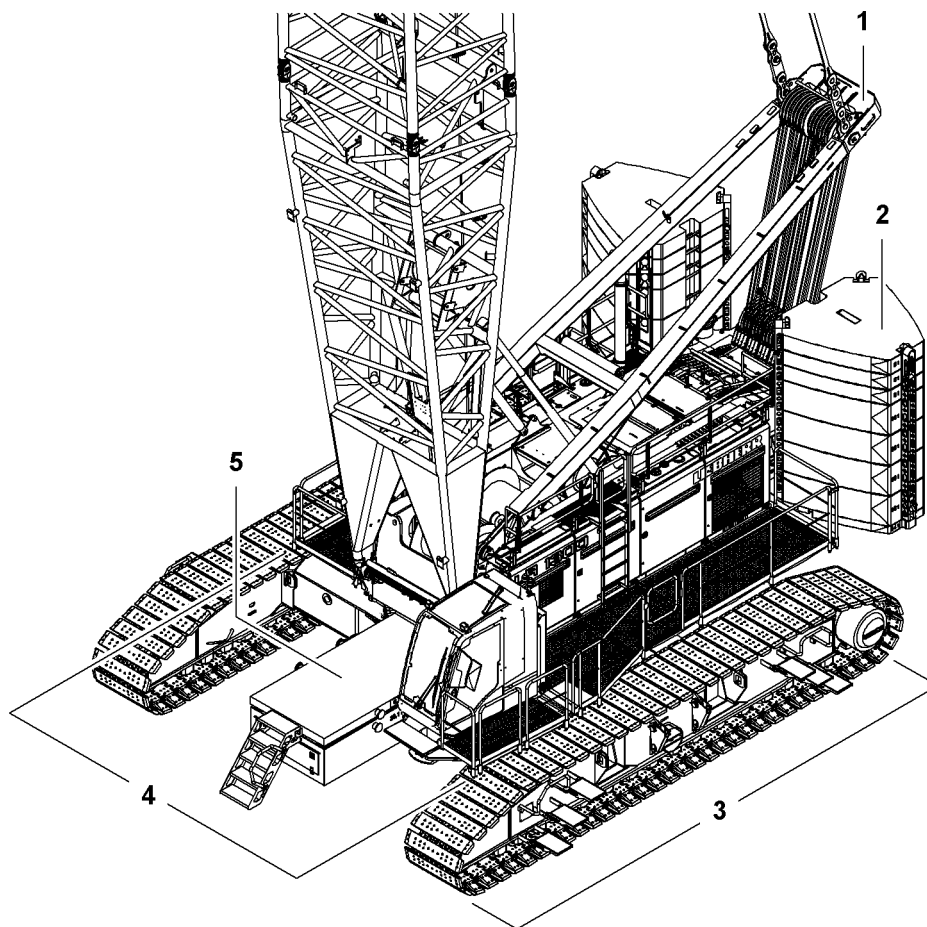


Fig. 10: Basic machine with undercarriage* with adjustable track width

- | | | | |
|---|--------------------|---|-----------------------|
| 1 | A-frame1 | 4 | Uppercarriage |
| 2 | Rear counterweight | 5 | Carbody counterweight |
| 3 | Undercarriage | | |

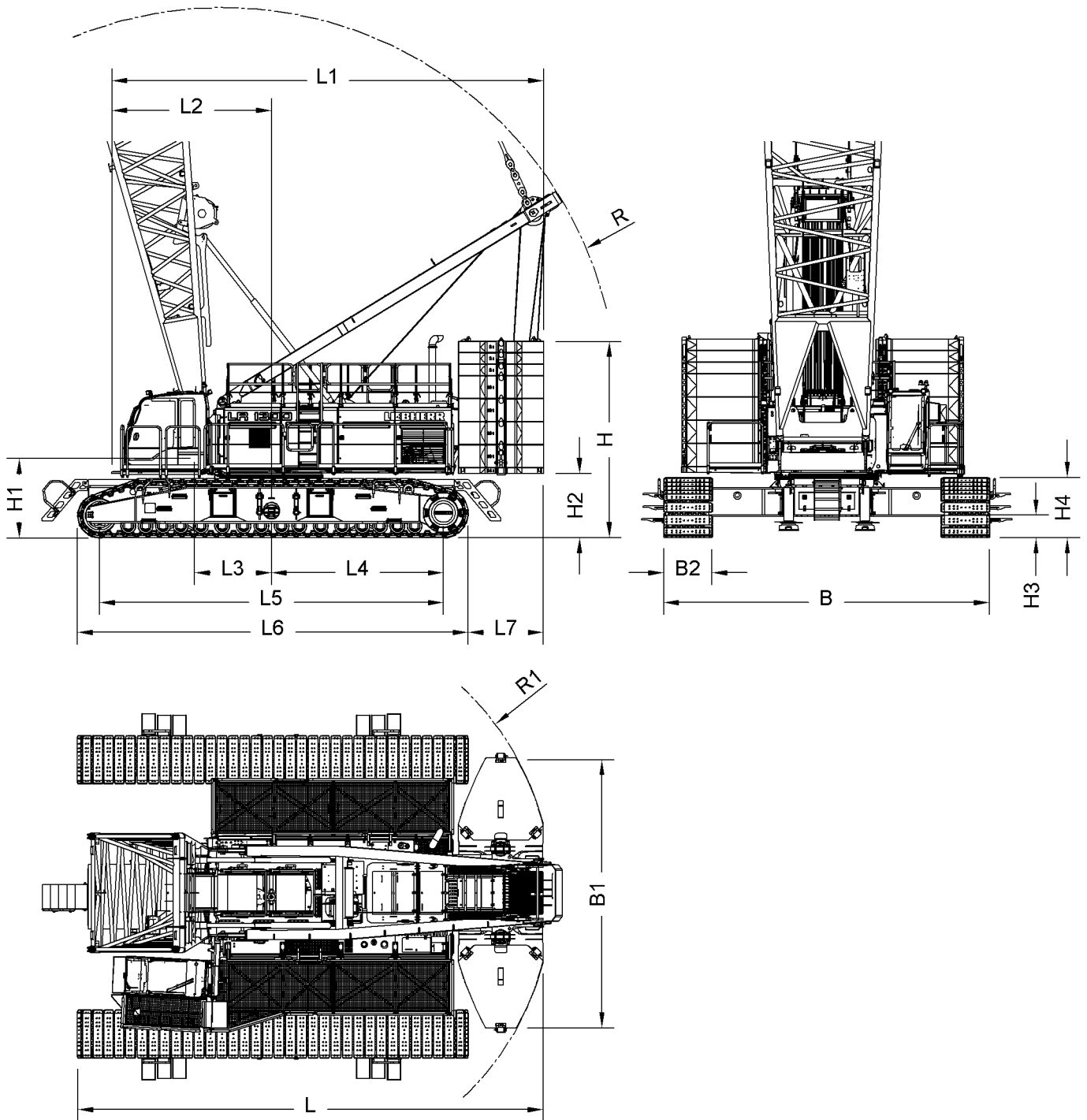


Fig. 11: Dimensions basic machine with undercarriage* with adjustable track width

Name		Value
L	Length basic machine	11560 mm 37' 11" ft-in
B	Width basic machine	8000 mm 26' 3" ft-in
H	Height basic machine with maximum rear counterweight	5160 mm 16' 11" ft-in

Detailed dimensions:

LWNLR-x/V04.01//Auslieferung/2016-03-07/en

Product description

Basic machine

Name		Value
L1	Length uppercarriage with rear counterweight	10700 mm 35' 1" ft-in
L2	Rotation axis to front edge of cabin	3960 mm 13' ft-in
L3	Rotation axis to pivot point of main boom base section	1700 mm 5' 7" ft-in
L4	Rotation axis to center of tumbler	4260 mm 14' ft-in
L5	Wheelbase (center idler wheel to center tumbler)	8520 mm 27' 11" ft-in
L6	Length crawler side frame	9683 mm 31' 9" ft-in
L7	Rear edge crawler side frame to rear edge rear counterweight	1870 mm 6' 2" ft-in
B1	Width rear counterweight	6930 mm 22' 9" ft-in
B2	Width base plates	1200 mm 3' 11" ft-in
H1	Height main boom base section pivot point	2400 mm 7' 10" ft-in
H2	Ground clearance rear counterweight	1760 mm 5' 9" ft-in
H3	Ground clearance undercarriage	520 mm 1' 8" ft-in
H4	Height crawler side frame	1474 mm 4' 10" ft-in
R	A-frame1 swing radius	9750 mm 32' ft-in
R1	Rear counterweight swing radius	6980 mm 22' 11" ft-in
Dimensions basic machine with 1500 mm (4' 11" ft-in) base plates:		
B(1500)	Width basic machine with 1500 mm (4' 11" ft-in) base plates	8300 mm 27' 3" ft-in
L6(1500)	Length crawler side frame with 1500 mm (4' 11" ft-in) base plates	9703 mm 31' 10" ft-in
B2(1500)	Width 1500 mm (4' 11" ft-in) base plates	1500 mm 4' 11" ft-in
H4(1500)	Height crawler side frame with 1500 mm (4' 11" ft-in) base plates	1482 mm 4' 10" ft-in

Tab. 16: Technical data basic machine with undercarriage with adjustable track width

LWN/LR-x/V04.01//Auslieferung/2016-03-07/en

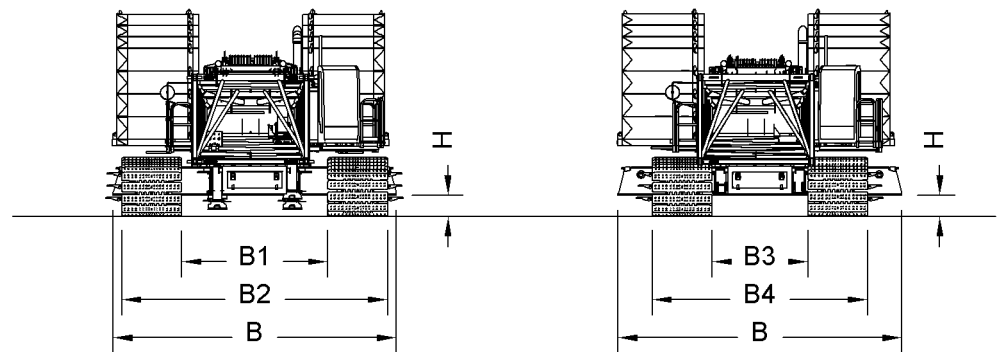


Fig. 12: Dimensions basic machine with track width adjustment

Name		Value
B	Width undercarriage	7100 mm 23' 4" ft-in
H	Ground clearance undercarriage	520 mm 1' 8" ft-in
Detailed dimensions:		
B1	Width inside edges of base plate with medium track	3970 mm 13' ft-in
B2	Width outer edges of base plate with medium track	6370 mm 20' 11" ft-in
B3	Width inside edges of base plates when narrow track is used	2400 mm 7' 10" ft-in
B4	Width outside edges of base plates when narrow track is used	4800 mm 15' 9" ft-in

Tab. 17: Technical data basic machine with track width adjustment

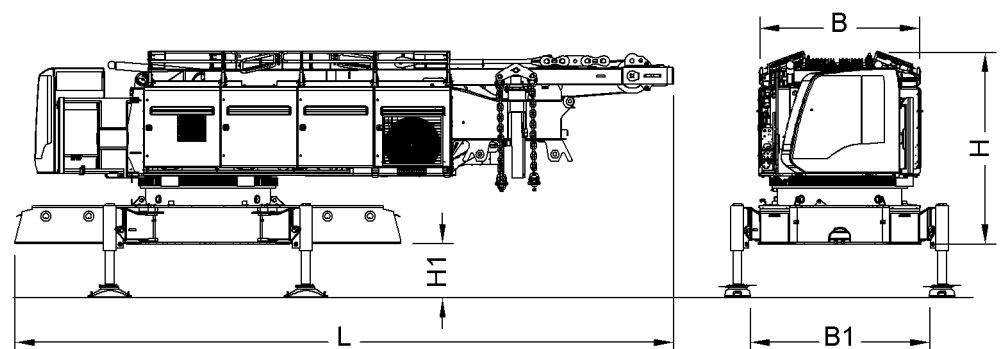


Fig. 13: Dimensions basic machine in transport position on jacks

Name		Value
L	Length basic machine in transport position	12300 mm 40' 4" ft-in
B	Width basic machine in transport position	3000 mm 9' 10" ft-in
H	Height basic machine in transport position	3500 mm 11' 6" ft-in

LWNLR-x/V04.01//Auslieferung/2016-03-07/en

Name		Value
Detailed dimensions:		
B1	Width between support pads	3285 mm 10' 9" ft-in
H1	Ground clearance basic machine	970 mm 3' 2" ft-in

Tab. 18: Technical data basic machine in transport position on jacks

1.7.2 A-frame1

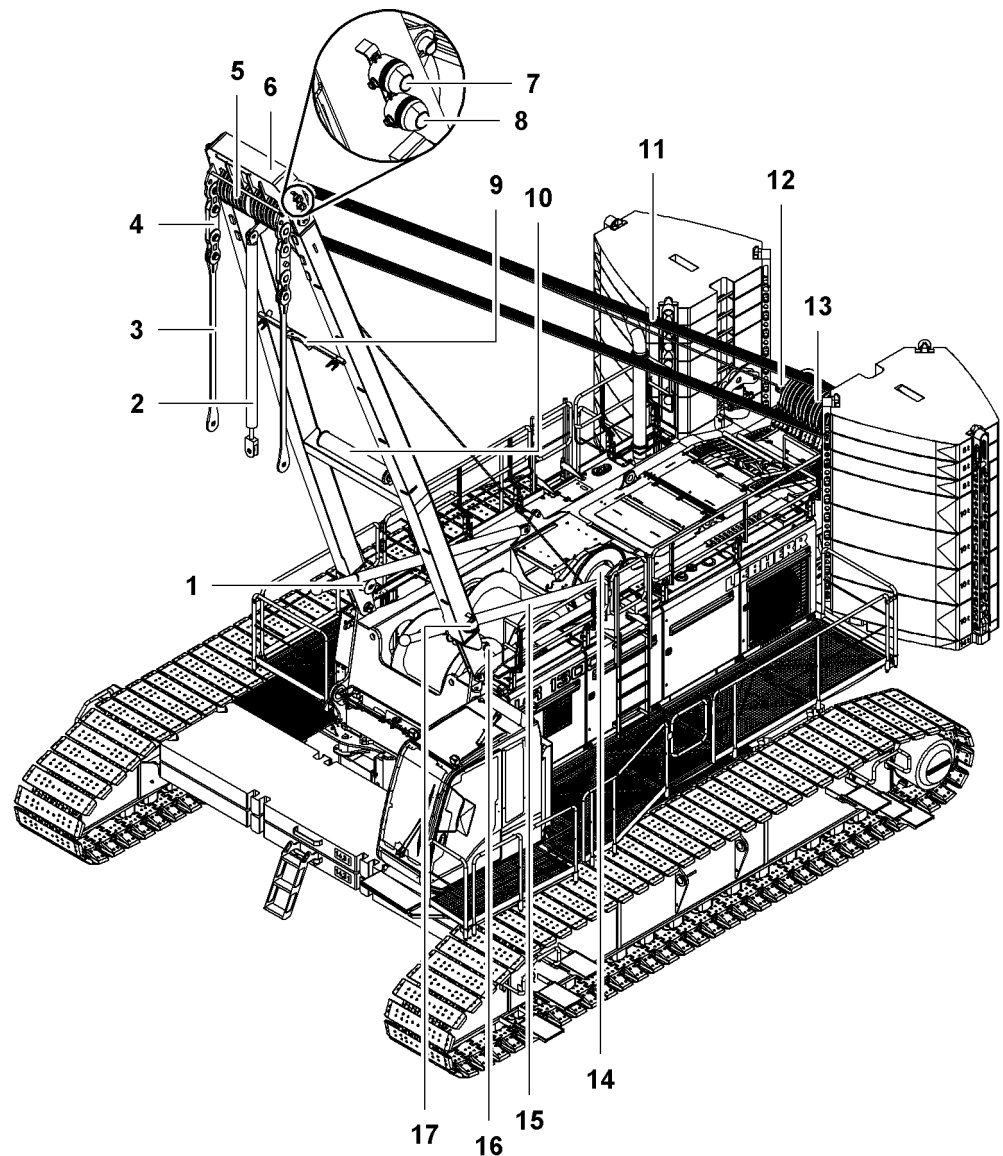


Fig. 14: A-frame1

- | | | | |
|---|--|----|---------------------------------|
| 1 | Supporting roll (2x) for main boom tilting-back supports | 10 | Rope protection roller |
| 2 | Assembly cylinder | 11 | Rope of main boom luffing winch |
| 3 | A-frame1 equalizer | 12 | Rope fixing point |
| 4 | Tension load cell (2x) | 13 | Uppercarriage pulley set |

See next page for continuation of the image legend

5	A-frame1 pulley set	14	Main boom luffing winch
6	A-frame1	15	Main boom tilting-back support (2x)
7	Load moment limiter lamp	16	A-frame1 cylinder (2x)
8	Flashing light	17	Mechanical angle indicator
9	Crossbar		

Below a certain main boom angle (or if the main boom is not installed), the main boom tilting-back supports **15** rest on the supporting rolls **1**. The main boom tilting-back supports **15** run in guide rails on the main boom base section and prevent the main boom from tipping backwards.

The assembly cylinder **2** serves for all lifting jobs when using the self-assembly system. If A-frame1 is tilted backwards, the crossbar **9** prevents the assembly cylinder from falling through A-frame1.

The A-frame1 equalizer **3** and the main boom pendant straps connect A-frame1 to the boom head.

A-frame1 **6**:

- is coupled to the front of the uppercarriage.
- is used for erecting, adjusting and laying down the main boom.
- is laid down backwards on the uppercarriage for transport.

The rope protection roller **10** protects A-frame1 from damage caused by the main boom luffing winch.

The main boom luffing winch **14** adjusts A-frame1. The rope of the main boom luffing winch **11** is reeved between the uppercarriage pulley set **13**, the A-frame1 pulley set **5** and the main boom luffing winch **14** and fastened to the rope fixing point **12** on the uppercarriage.

The A-frame1 cylinders **17**:

- prevent A-frame1 from falling back onto the uppercarriage.
- lift A-frame1 out of its transport position on the uppercarriage, or lower it into its transport position.

The mechanical boom angle indicator **18** shows the machine operator the current angular position of A-frame1.

1.7.3 Steel pendant straps on A-frame1

A-frame1 equalizer

Installation site in crane operation:

- Main boom 2821 ([For more information see: Pendant straps A-frame1 to main boom head 2821, page 1273](#))
- Main boom 2821 + derrick boom 2220 ([For more information see: A-frame1 to 2220 derrick boom head pendant straps, page 1361](#))
- Main boom 2821 + reducing adapter 2821/2316 ([For more information see: Pendant straps A-frame1 to main boom head 2316, page 1511](#))

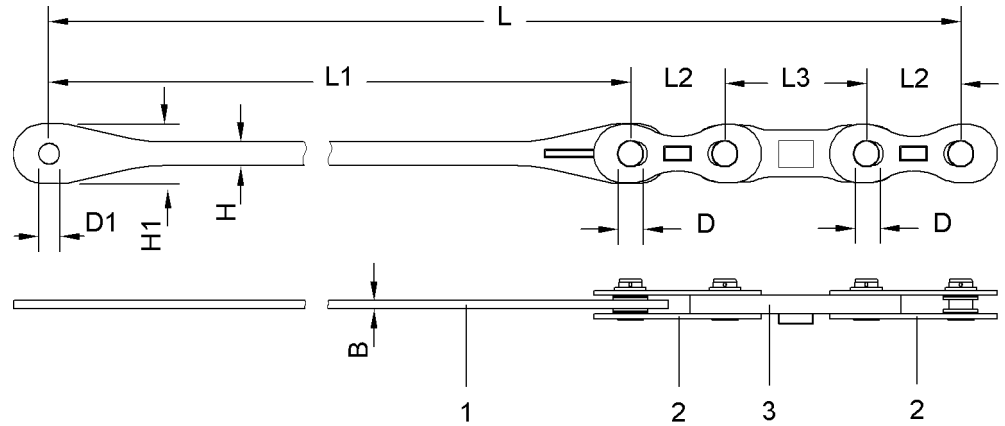


Fig. 15: Dimensions equalizer on A-frame1

- 1 Pendant strap
 2 Connecting links
 3 Tension load cell

Name		Value
L	Length	3730 mm 12' 3" ft-in
L1	Length of pendant strap	2680 mm 8' 10" ft-in
L2	Length of connecting link	300 mm 1' ft-in
L3	Length of tension load cell	450 mm 1' 6" ft-in
W	Width of pendant strap	25 mm 0.98" in
H	Height of pendant strap	77 mm 3.03" in
H1	Height of pendant strap	190 mm 7.48" in
D	Pin Ø	75 mm 2.95" in
D1	Pin Ø	65 mm 2.56" in
Weight		155 kg 342 lb

Tab. 19: Technical data equalizer of A-frame1

1.7.4 CF pendant straps on A-frame1

A-frame1 equalizer

Installation site in crane operation:

- Main boom 2821 (For more information see: [Pendant straps A-frame1 to main boom head 2821, page 1274](#))
- Main boom 2821 + derrick boom 2220 (For more information see: [A-frame1 to 2220 derrick boom head pendant straps, page 1365](#))

LWNLR-x\04.01\Auslieferung\2016-03-07\en

- Main boom 2821 + reducing adapter 2821/2316 (For more information see: [Pendant straps A-frame1 to main boom head 2316, page 1513](#))

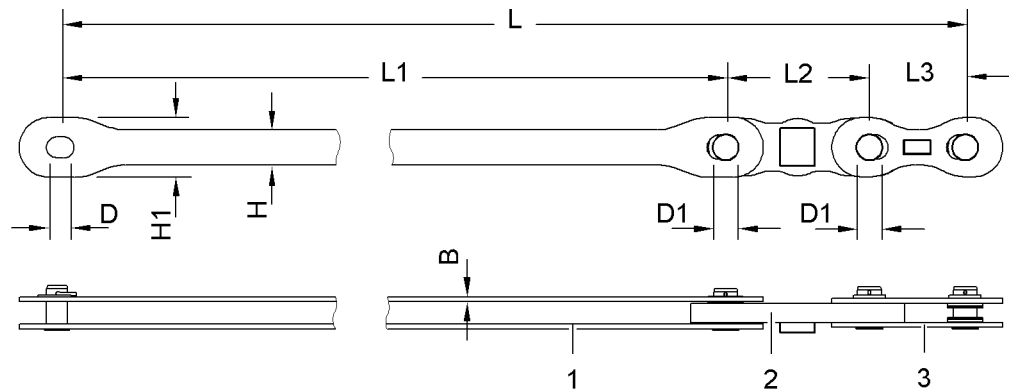


Fig. 16: Dimensions equalizer on A-frame1

- 1 Pendant straps
- 2 Tension load cell
- 3 Connecting links

Name		Value
L	Length	3700 mm 12' 2" ft-in
L1	Length of pendant strap	2950 mm 9' 8" ft-in
L2	Length of tension load cell	450 mm 1' 6" ft-in
L3	Length of connecting link	300 mm 1' ft-in
B	Width of pendant strap	15 mm 0.59" in
H	Height of pendant strap	110 mm 4.33" in
H1	Height of pendant strap	185 mm 7.28" in
D	Pin Ø	65 mm 2.56" in
D1	Pin Ø	75 mm 2.95" in
Weight		122 kg 269 lb

Tab. 20: Technical data equalizer of A-frame1

LWNLR.x/V04.01//Auslieferung/2016-03-07/en

1.7.5 Uppercarriage

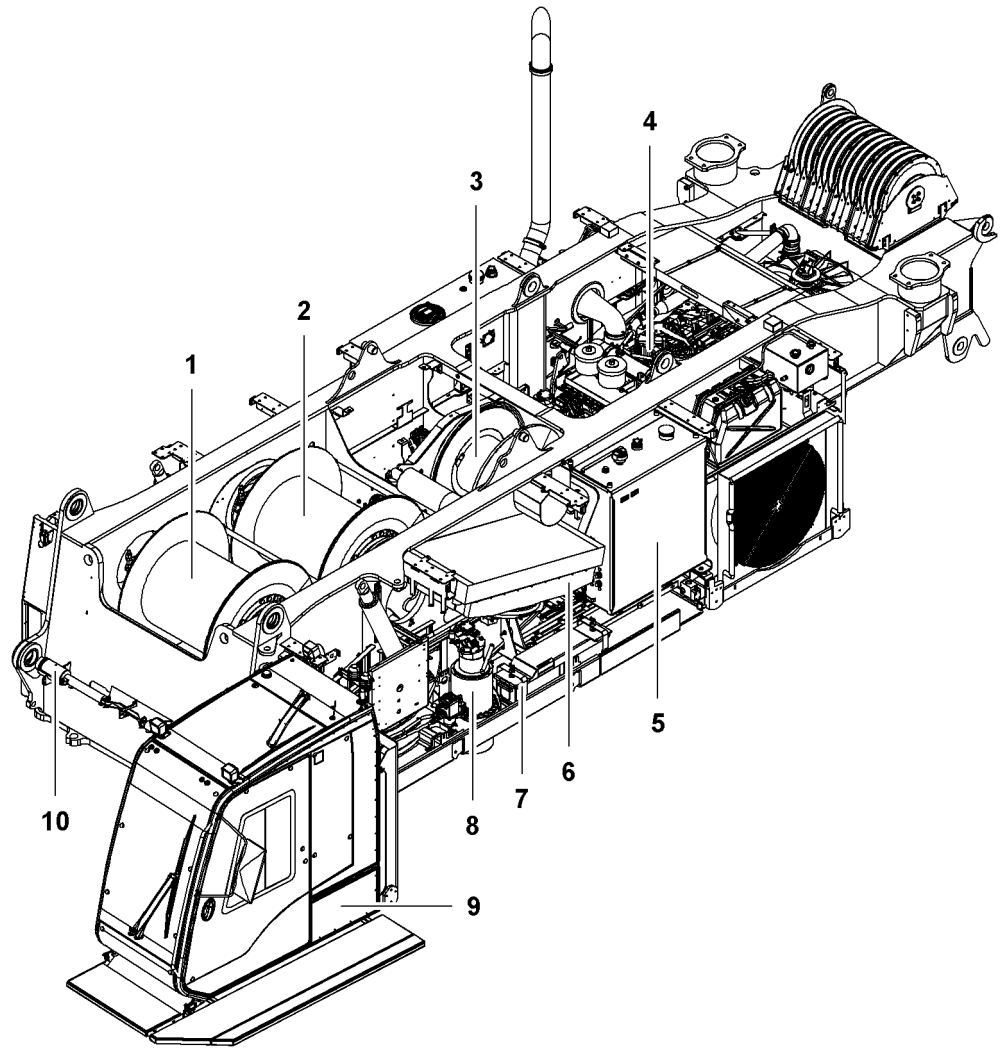


Fig. 17: Uppercarriage viewed from front left

1	Winch2	6	Hydraulic oil cooler
2	Winch1	7	Battery box
3	Main boom luffing winch	8	Swing gear (2x)
4	Central power unit	9	Cabin
5	Fuel tank	10	Pin connection cylinder for main boom base section

The uppercarriage:

- is a self-supporting, torsion-resistant structure.
- accommodates the winches, swings, the central power unit, cabin, A-frame1 and the main boom.
- is connected to the undercarriage by a roller-bearing swing ring.

Winch1 2 and winch2 1 control the lifting/lowering of the hook/pulley block.

The main boom is adjusted using the main boom luffing winch 3.

The central power unit 4:

- is located in the sealed machine housing and protected from weather influences and dirt.
- consists of a diesel engine and hydraulic pumps of the hydraulic system.
- supplies all consumers through the hydraulic line network.

The fuel tank **5** supplies fuel to the diesel engine. The optional refueling pump makes it easier to fill the fuel tank.

The swing gears **8**:

- are positioned on the uppercarriage, on the left behind the cabin.
- engage with the roller-bearing swing ring on the undercarriage.

The cabin **9**:

- contains all required control elements and operating elements.
- has a large safety-glass window and is sound-proofed.
- is equipped with an ergonomic operator's seat.
- can be tilted back by as much as 18.5° using hydraulic cylinders.
- can be folded in sideways for transport.

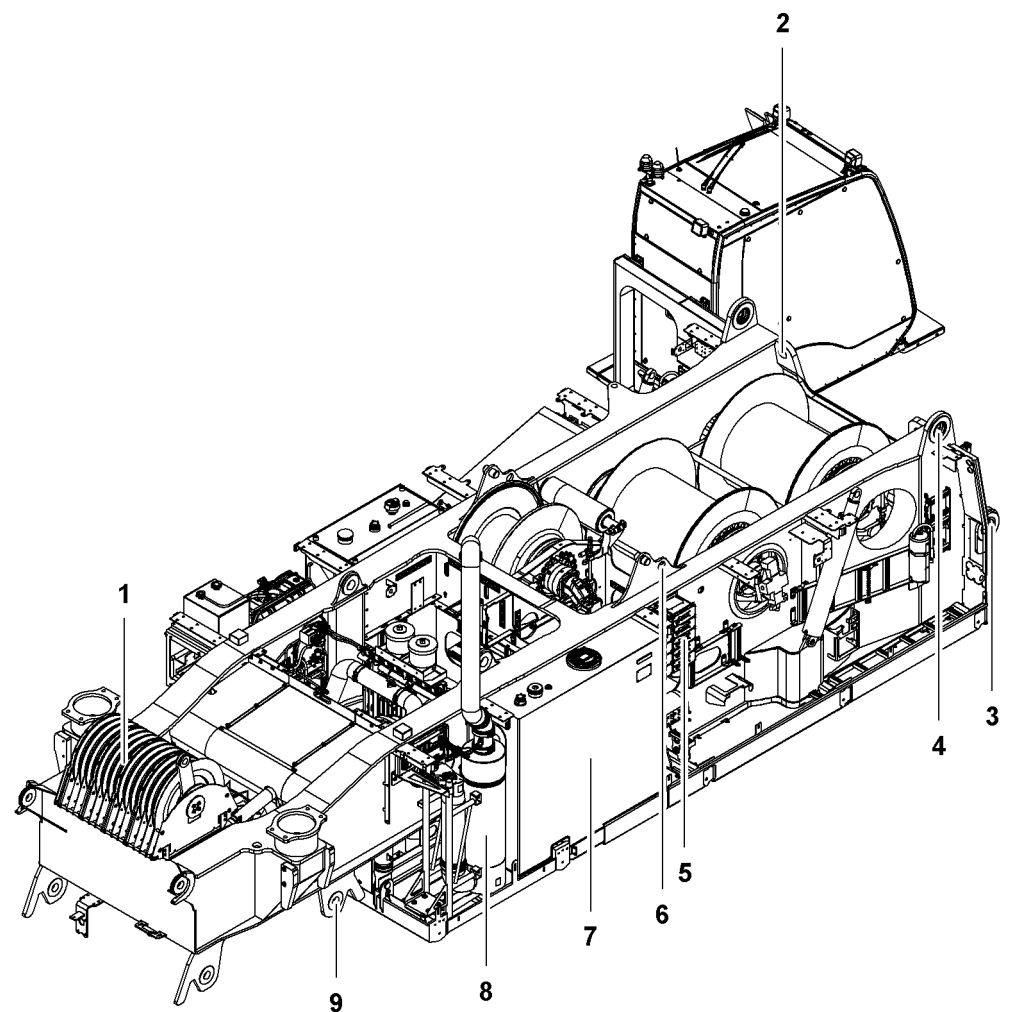


Fig. 18: Uppercarriage viewed from rear right

- | | | | |
|----------|--|----------|--|
| 1 | Pulley set | 6 | Pivot point (2x) for main boom tilting-back supports |
| 2 | Rigging point (2x) for loading basic machine | 7 | Hydraulic oil tank |
| 3 | Pivot point (2x) for main boom base section | 8 | Exhaust system |
| 4 | Pivot point (2x) for A-frame1 | 9 | Pin connection point (4x) for rear counterweight |
| 5 | CAN modules | | |

The hydraulic oil tank 7:

- supplies the entire hydraulic system.
- is equipped with a return circuit filter and a venting filter.
- has inspection glasses and an electric fill level sensor.

1.7.6 Cabin

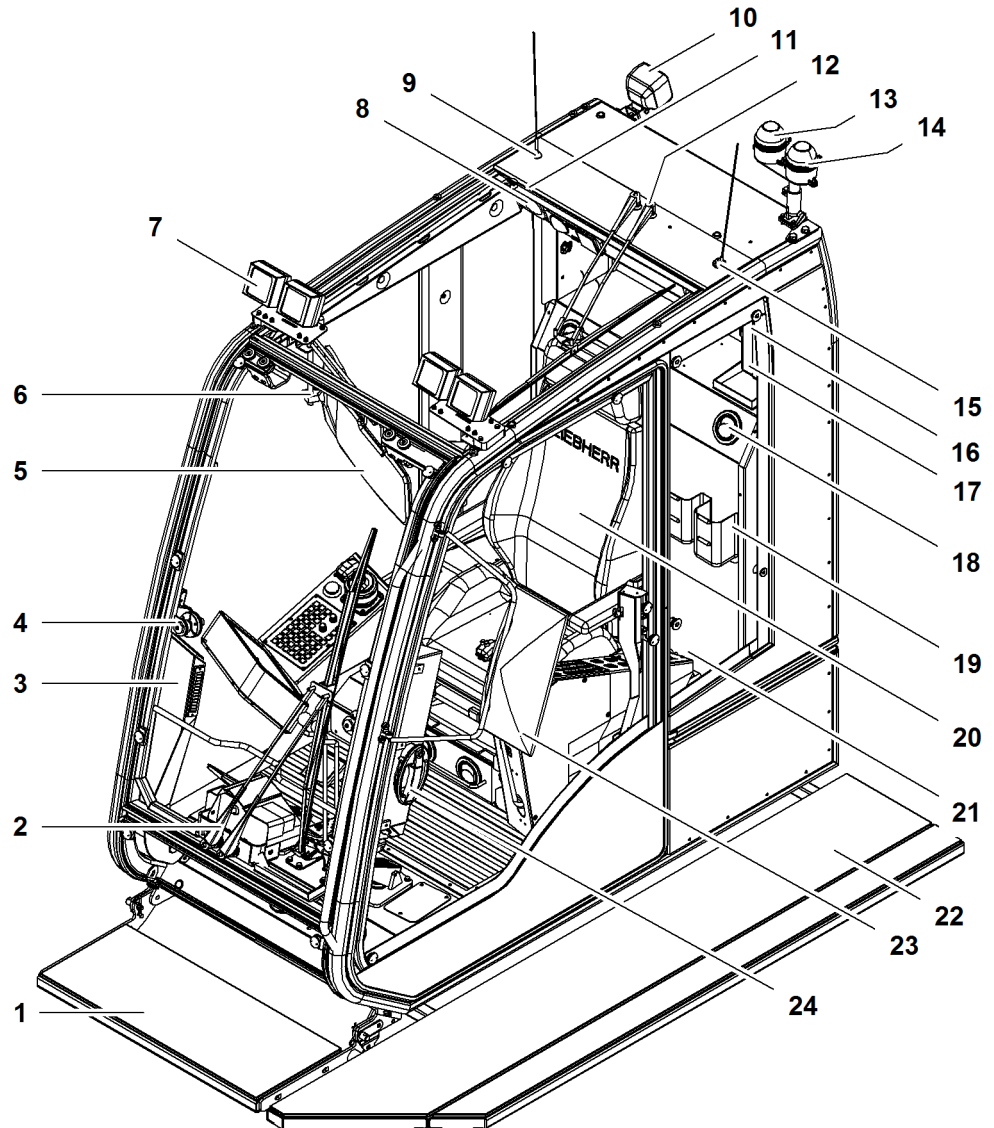


Fig. 19: Cabin

- | | | | |
|----|---------------------------|----|-----------------------------|
| 1 | Front platform | 13 | Flashing light |
| 2 | Front windscreen wiper | 14 | Load moment limiter lamp |
| 3 | Air nozzle | 15 | GSM antenna |
| 4 | Window lock (both sides) | 16 | First-aid box |
| 5 | Sun blind | 17 | Emergency hammer |
| 6 | Internal rearview mirror | 18 | Air nozzle |
| 7 | Front floodlight (4x) | 19 | Drink holder |
| 8 | Reading lamp | 20 | Operator's seat |
| 9 | Radio antenna | 21 | Screen wash fluid tank (2x) |
| 10 | Rear floodlight | 22 | Side platform |
| 11 | Sun blind for roof window | 23 | External rearview mirror |
| 12 | Roof windscreen wiper | 24 | Door lock |

1.7.7 Central power unit

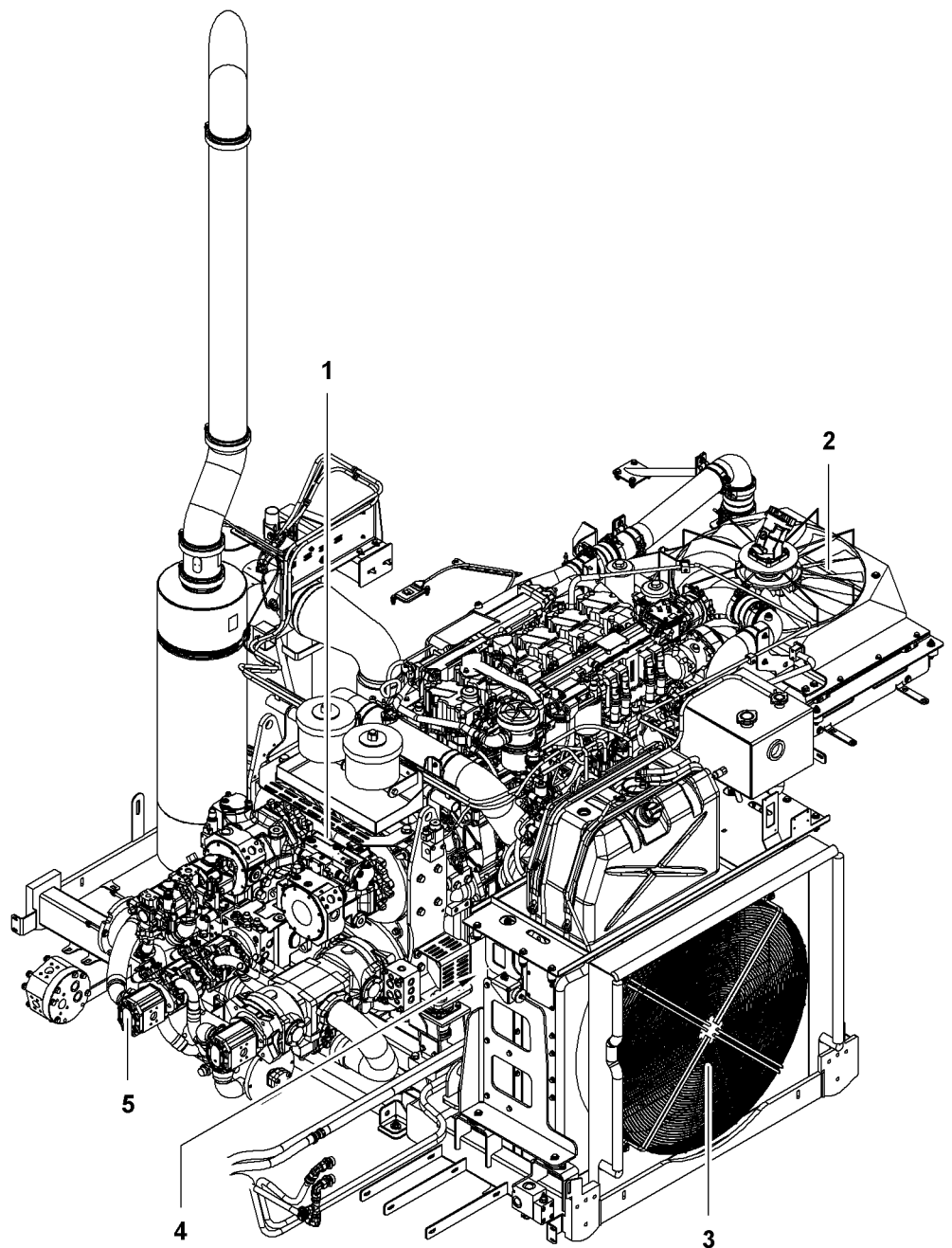


Fig. 20: Central power unit viewed from front left

- | | | | |
|---|----------------------|---|----------------|
| 1 | Distribution gearbox | 4 | Air filter |
| 2 | Charge air cooler | 5 | Pump equipment |
| 3 | Water cooler | | |

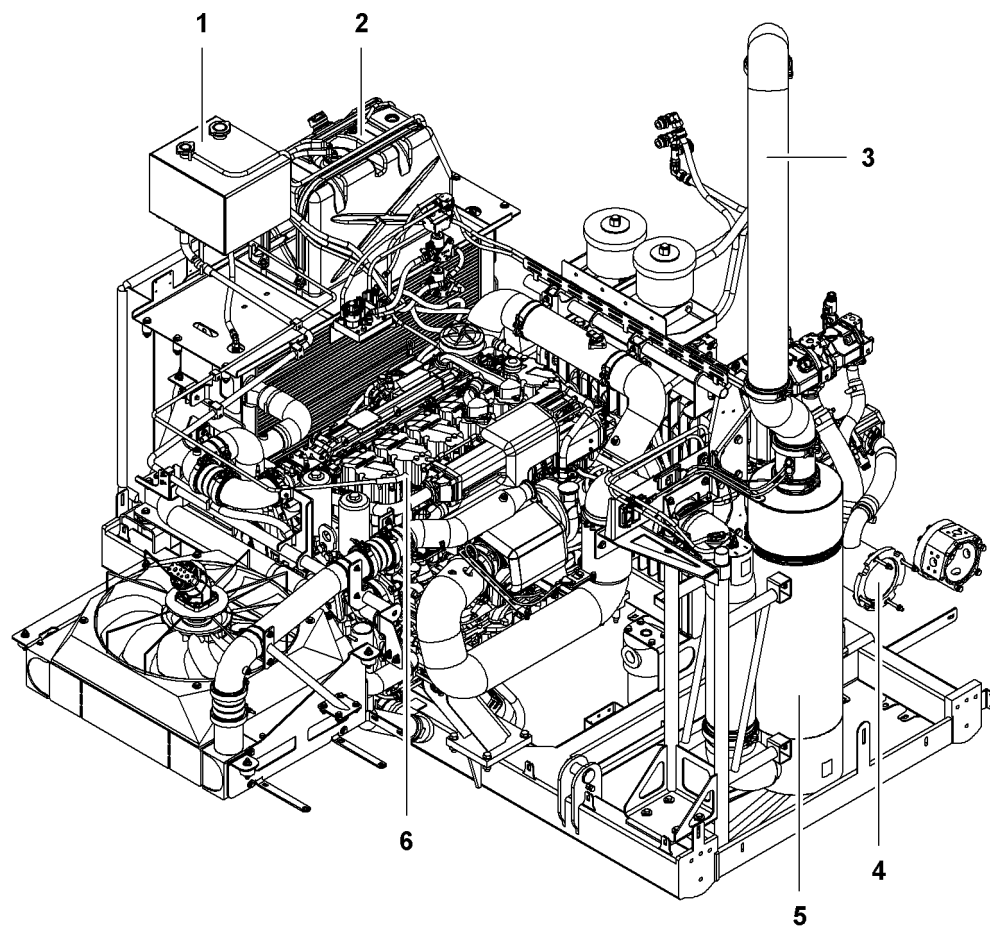


Fig. 21: Central power unit viewed from right rear

- | | | | |
|---|-------------------|---|--------------------------------|
| 1 | Compensation tank | 4 | Hydraulic oil suction pipe |
| 2 | Urea tank* | 5 | Exhaust aftertreatment system* |
| 3 | Exhaust pipe | 6 | Diesel engine |

1.7.8 Platforms on uppercarriage

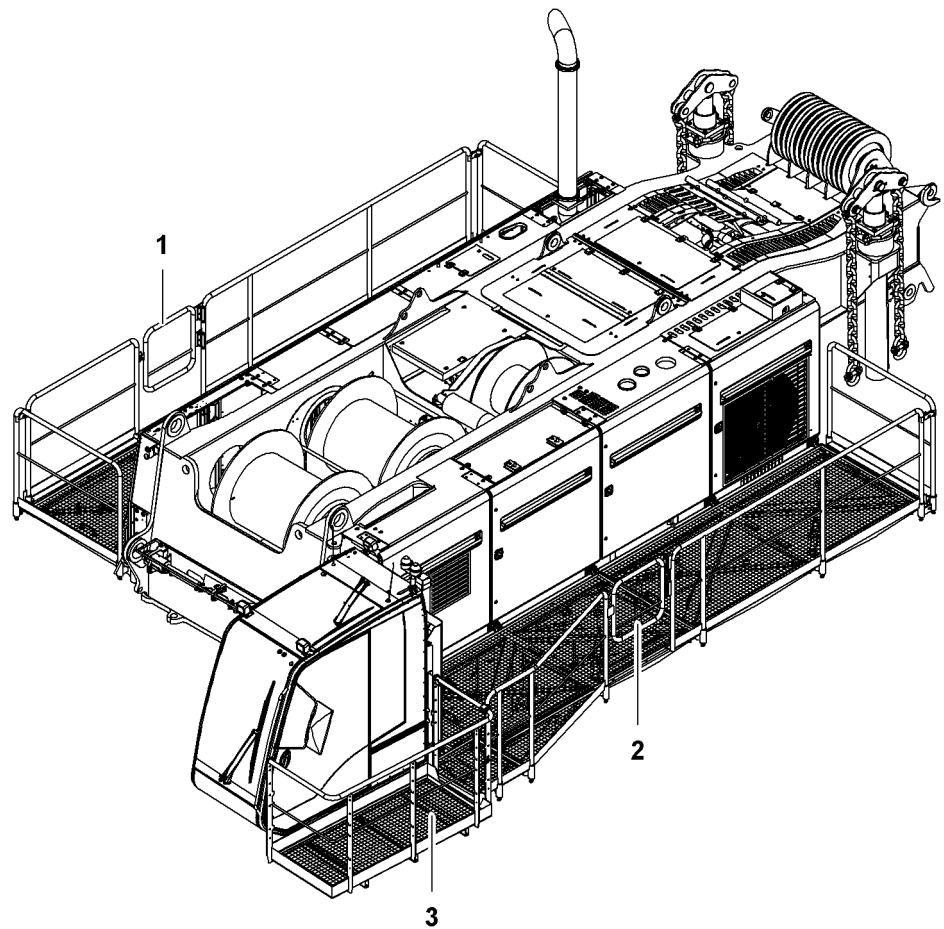


Fig. 22: Platforms on uppercarriage

- 1 Right platform
- 2 Left platform

- 3 Platform on cabin

Platform on cabin

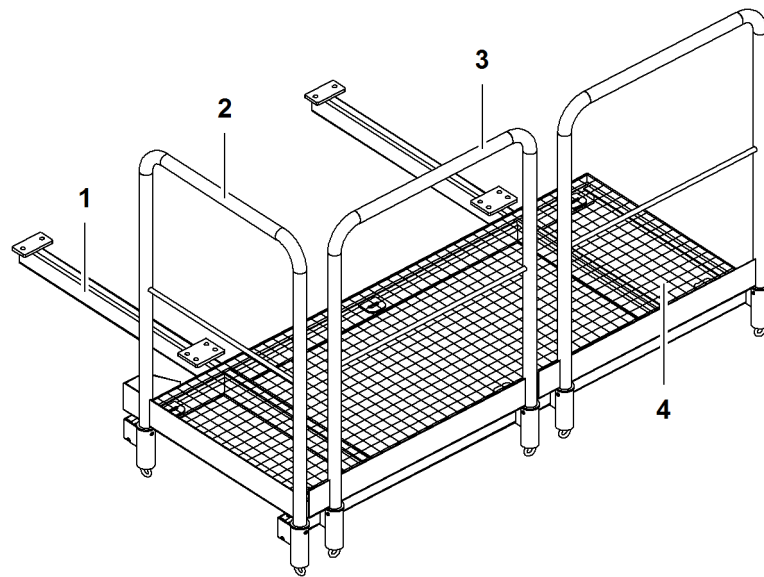


Fig. 23: Platform on cabin

- 1 Frame
- 2 Railing part A
- 3 Railing part B (2x)
- 4 Catwalk grating

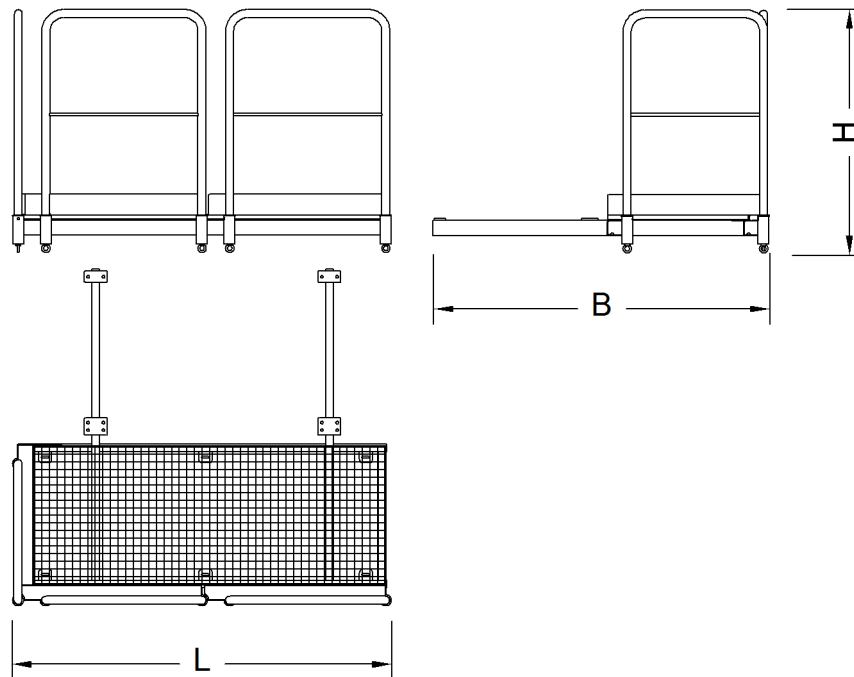


Fig. 24: Dimensions platform on cabin

Name	Value
L Length	1986 mm 6' 6" ft-in
B Width	1764 mm 5' 9" ft-in

LWNLR-x/V04.01//Auslieferung/2016-03-07/en

Name		Value
H	Height	1273 mm 4' 2" ft-in
Weight		125 kg 276 lb

Tab. 21: Technical data platform on cabin

Frame

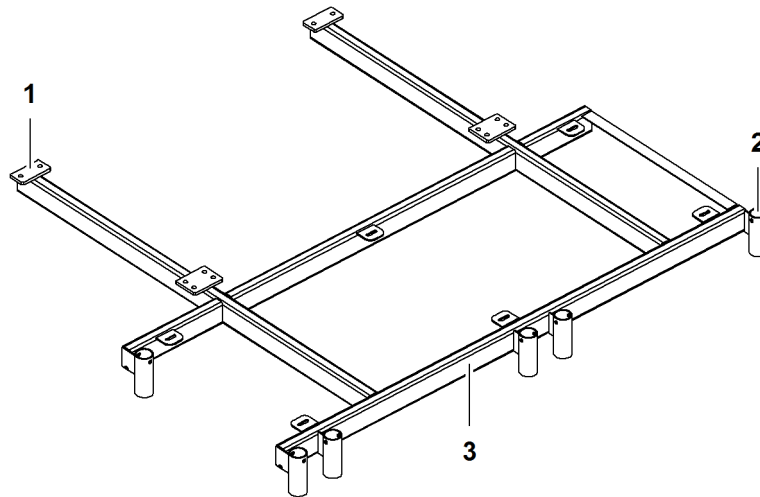


Fig. 25: Frame

- 1 Attachment point
- 2 Support for railing part

3 Frame

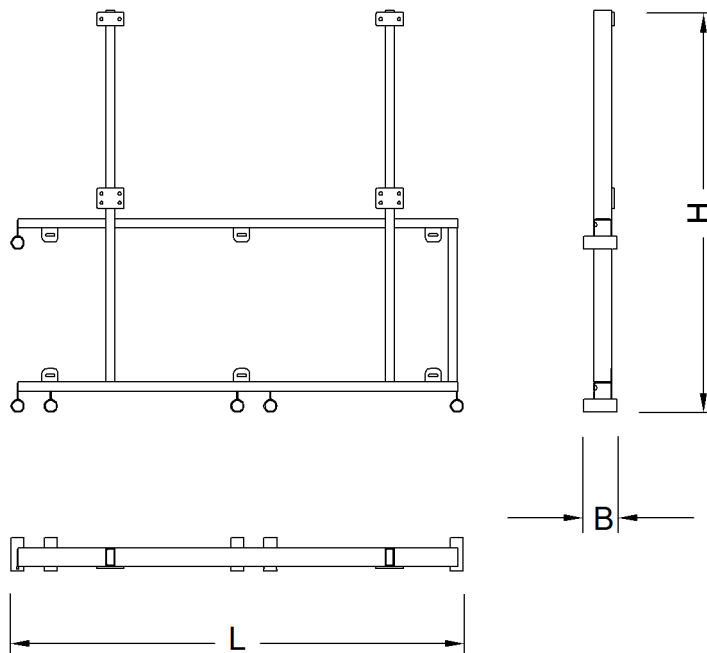


Fig. 26: Frame dimensions

LWNLR.x/V04.01//Auslieferung/2016-03-07/en

Name		Value
L	Length	1983 mm 6' 6" ft-in
B	Width	146 mm 5.75" in
H	Height	1792 mm 5' 11" ft-in
Weight		57 kg 126 lb

Tab. 22: Technical data frame

Railing part A

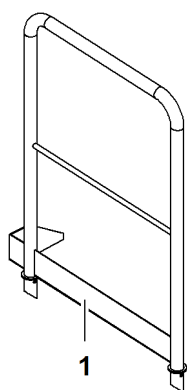


Fig. 27: Railing part A

1 Railing part A

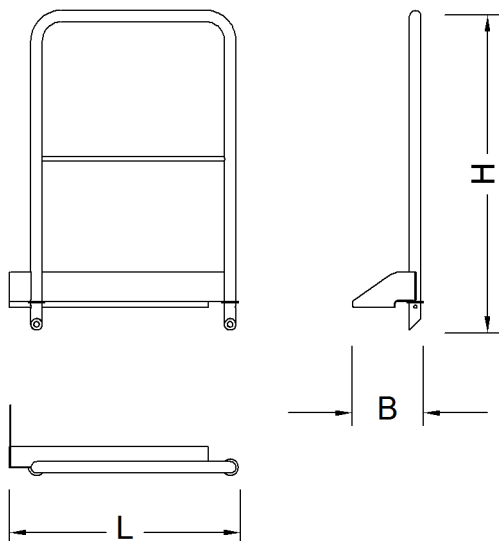


Fig. 28: Dimensions railing part A

Name		Value
L	Length	846 mm 2' 9" ft-in

LWNLR-x/V04.01//Auslieferung/2016-03-07/en

Name		Value
B	Width	260 mm 10.24" in
H	Height	1182 mm 3' 11" ft-in
Weight		15 kg 33.07 lb

Tab. 23: Technical data railing part A

Railing part B

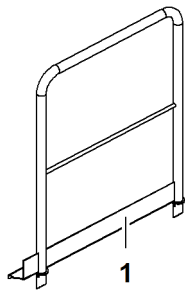


Fig. 29: Railing part B

1 Railing part B

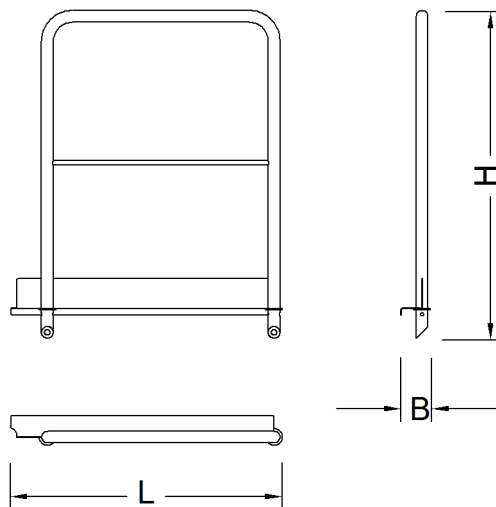


Fig. 30: Dimensions railing part B

Name		Value
L	Length	978 mm 3' 3" ft-in
B	Width	107 mm 4.21" in
H	Height	1182 mm 3' 11" ft-in

Name	Value
Weight	16 kg 35.27 lb

Tab. 24: Technical data railing part B

Catwalk grating

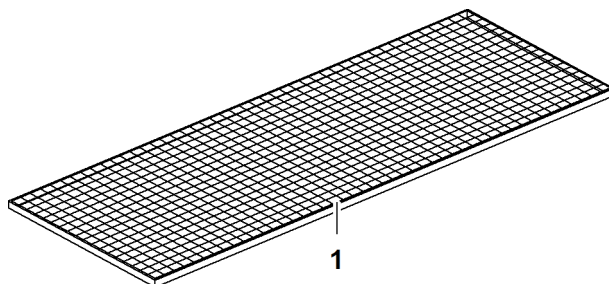


Fig. 31: Catwalk grating

1 Catwalk grating

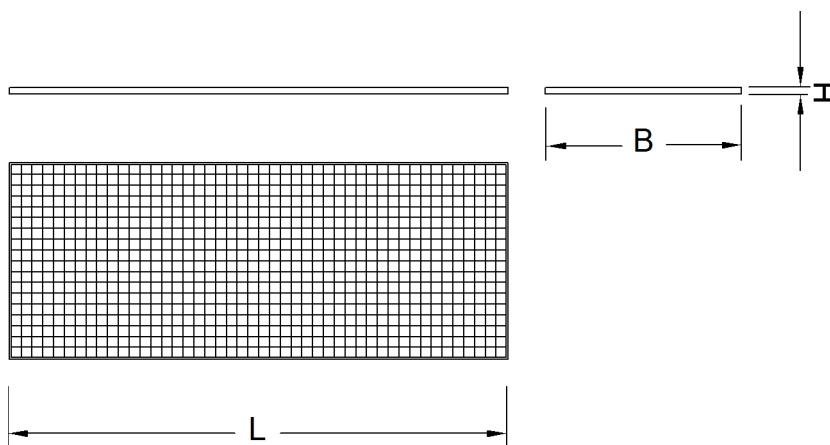


Fig. 32: Dimensions catwalk grating

Name	Value
L Length	1847 mm 6' 1" ft-in
B Width	727 mm 2' 5" ft-in
H Height	25 mm 0.98" in
Weight	16 kg 35.27 lb

Tab. 25: Technical data catwalk grating

Right platform on uppercarriage

The right platform on the uppercarriage consists of the following components:

- Bracket supports

LWN/LR-x/V04.01//Auslieferung/2016-03-07/en

- Brackets
- Sheet metal
- Diagonals
- Railing parts
- Catwalk grating
- Strap supports
- Straps

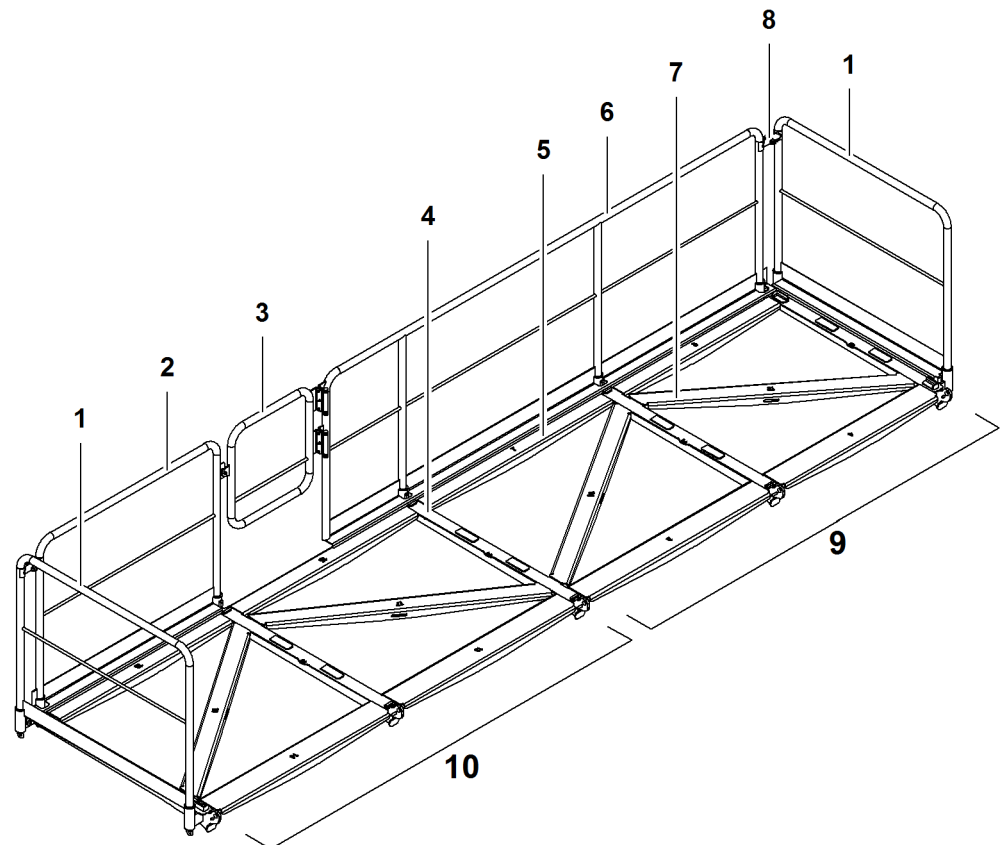


Fig. 33: Right platform on uppercarriage

- | | | | |
|---|---------------|----|--------------------|
| 1 | Railing part1 | 6 | Railing part3 |
| 2 | Railing part2 | 7 | Diagonal (4x) |
| 3 | Access | 8 | Railing joint (2x) |
| 4 | Bracket (5x) | 9 | Catwalk grating B |
| 5 | Plate (8x) | 10 | Grating A |

The straps and strap supports are not illustrated.

Brackets, plates and diagonals are marked with part numbers.

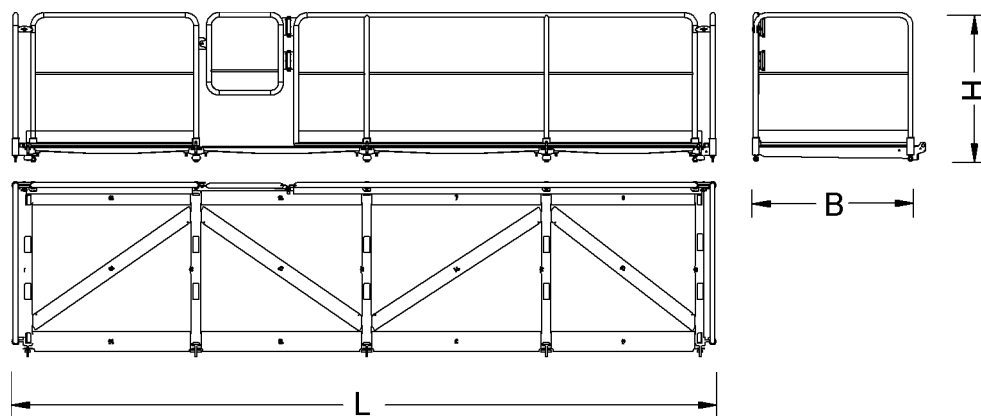


Fig. 34: Dimensions right platform on uppercarriage

Name		Value
L	Length	6019 mm 19' 9" ft-in
B	Width	1513 mm 5' ft-in
H	Height	1275 mm 4' 2" ft-in
Weight		550 kg 1,213 lb

Tab. 26: Technical data right platform on uppercarriage

Railing part1 for right platform

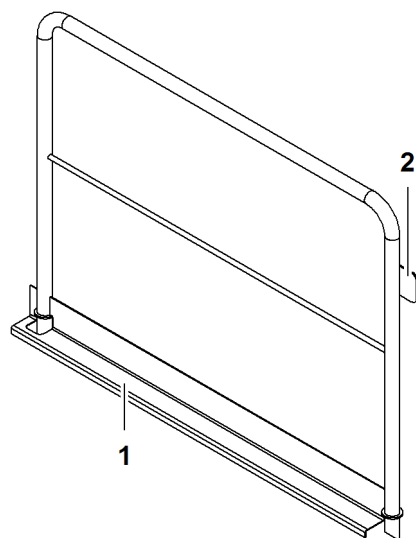


Fig. 35: Railing part1 for right platform

1 Railing part1

2 Stop for access

LWN/LR-x/V04.01//Auslieferung/2016-03-07/en

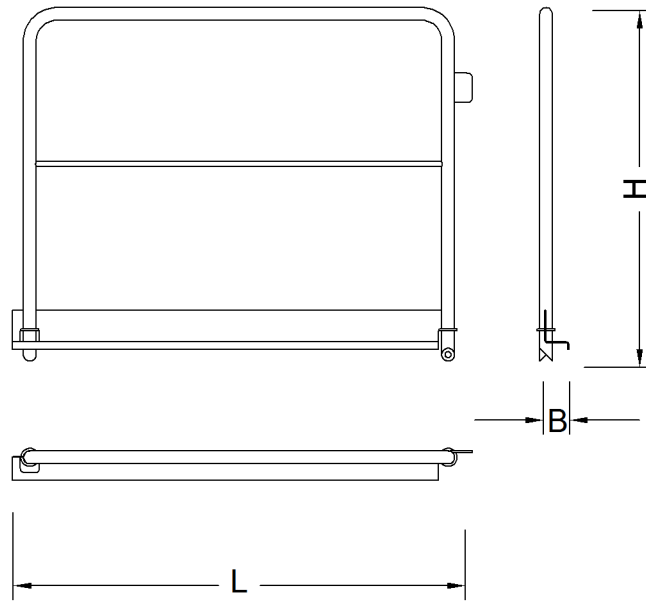


Fig. 36: Dimensions railing part1 for right platform

Name		Value
L	Length	1534 mm 5' ft-in
B	Width	107 mm 4.21" in
H	Height	1177 mm 3' 10" ft-in
Weight		40 kg 88.18 lb

Tab. 27: Technical data railing part1 for right platform

Railing part2 for right platform

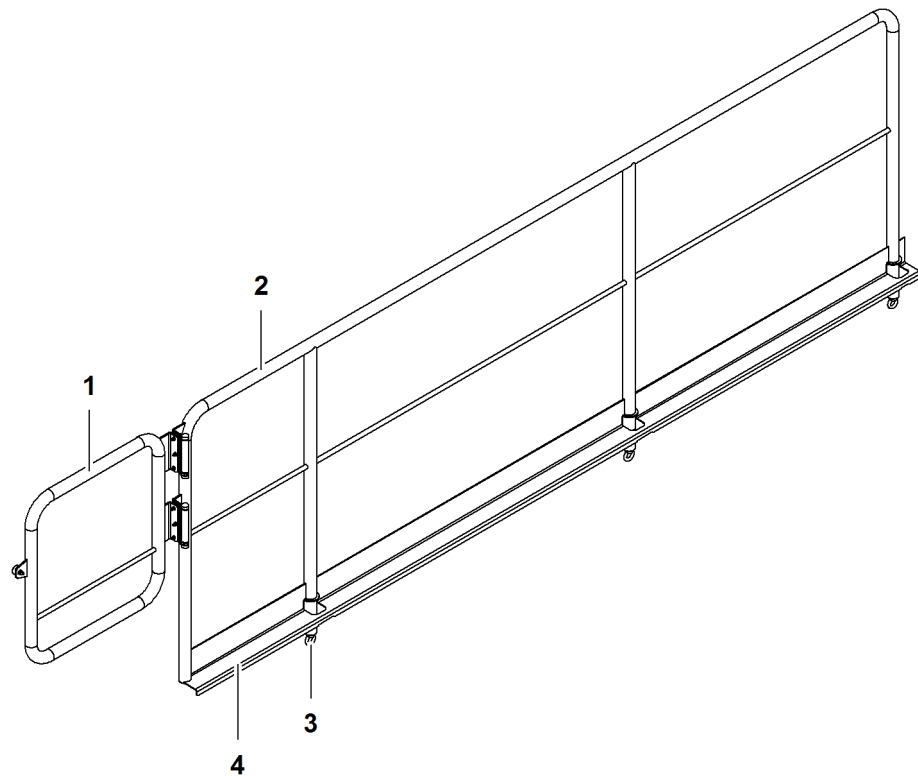


Fig. 37: Railing part2 for right platform

- 1 Support for access 2 Railing part2

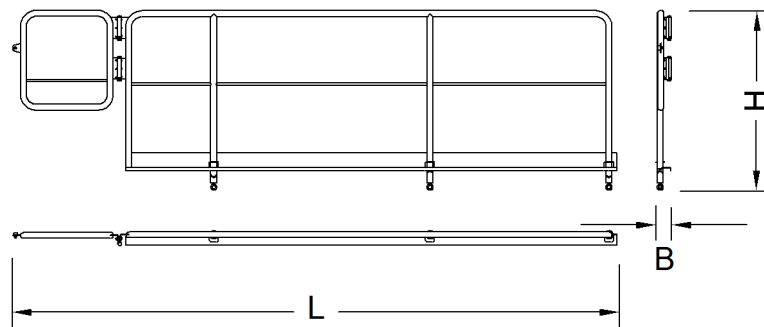


Fig. 38: Dimensions railing part2 for right platform

Name		Value
L	Length	4290 mm 14' 1" ft-in
B	Width	107 mm 4.21" in
H	Height	1278 mm 4' 2" ft-in
Weight		48 kg 106 lb

Tab. 28: Technical data railing part2 for right platform

LWNLR-x/V04.01//Auslieferung/2016-03-07/en

Railing part3 for right platform

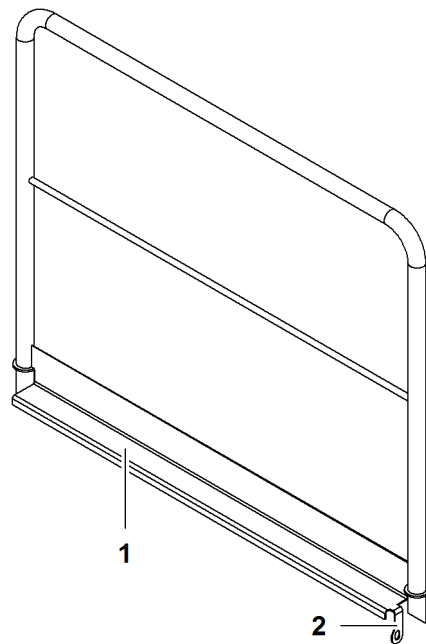


Fig. 39: Railing part3 for right platform

1 Railing part3

2 Securing element

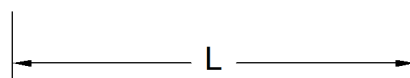
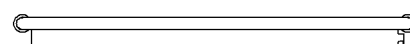
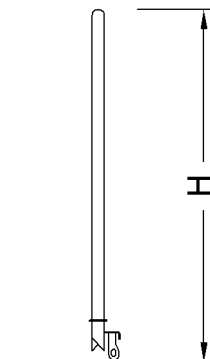
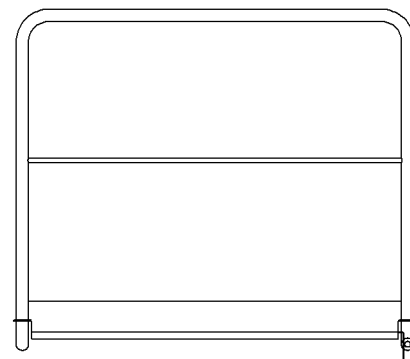


Fig. 40: Dimensions railing part3 for right platform

Name		Value
L	Length	1390 mm 4' 7" ft-in
B	Width	98 mm 3.86" in
H	Height	1208 mm 4' ft-in

LWNLR.x/V04.01//Auslieferung/2016-03-07/en

Name	Value
Weight	21 kg 46.30 lb

Tab. 29: Technical data railing part3 for right platform

Grating A for right platform

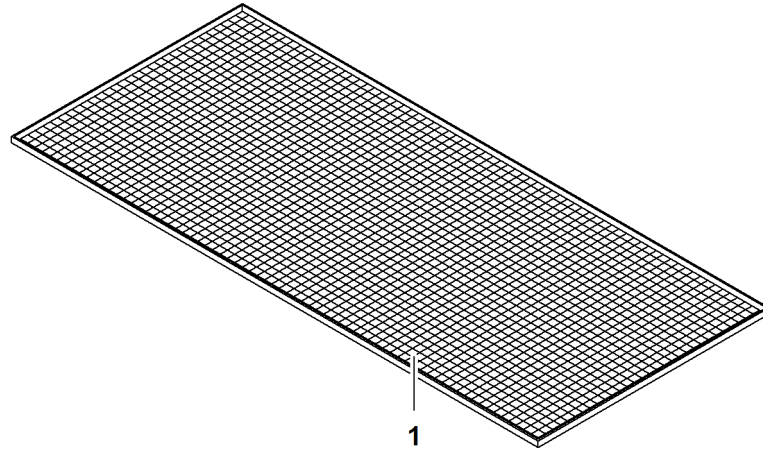


Fig. 41: Grating A for right platform

1 Grating A

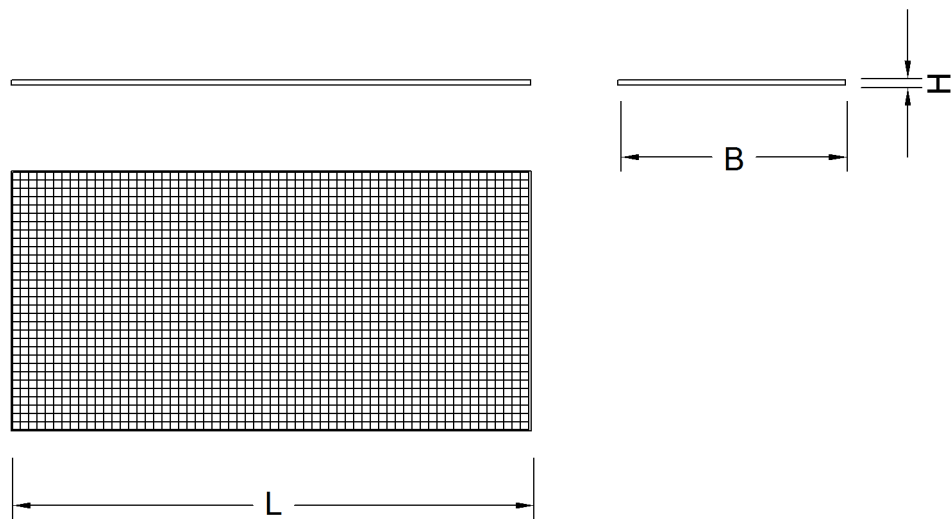


Fig. 42: Dimensions grating A for right platform

Name	Value
L Length	2847 mm 9' 4" ft-in
B Width	1247 mm 4' 1" ft-in
H Height	30 mm 1.18" in

LWN/LR-x/V04.01//Auslieferung/2016-03-07/en

Name	Value
Weight	50.5 kg 111 lb

Tab. 30: Technical data grating A for right platform

Grating B for right platform

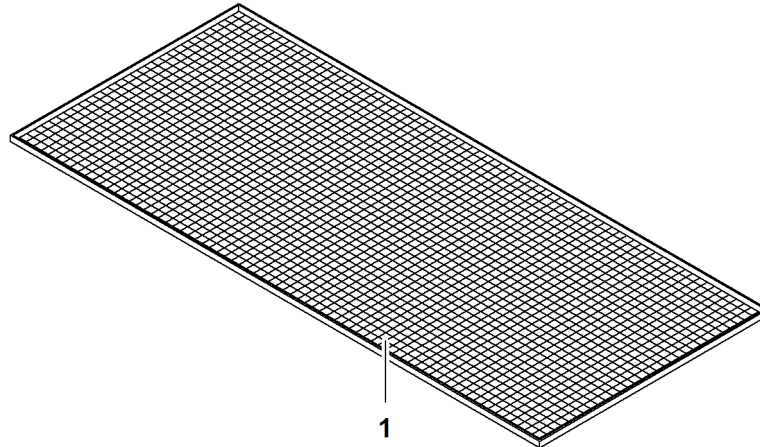


Fig. 43: Grating B for right platform

1 Grating B

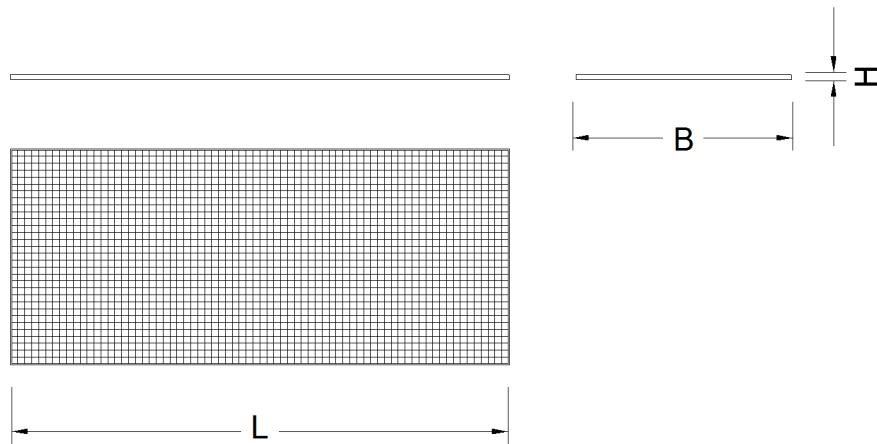


Fig. 44: Dimensions grating B for right platform

Name	Value
L Length	2887 mm 9' 6" ft-in
B Width	1247 mm 4' 1" ft-in
H Height	30 mm 1.18" in
Weight	49.5 kg 109 lb

Tab. 31: Technical data grating B for right platform

LWNLR.x/V04.01//Auslieferung/2016-03-07/en

Left platform on uppercarriage

The left platform on the uppercarriage consists of the following components:

- Bracket supports
- Brackets
- Sheet metal
- Diagonals
- Railing parts
- Grating
- Strap supports
- Straps

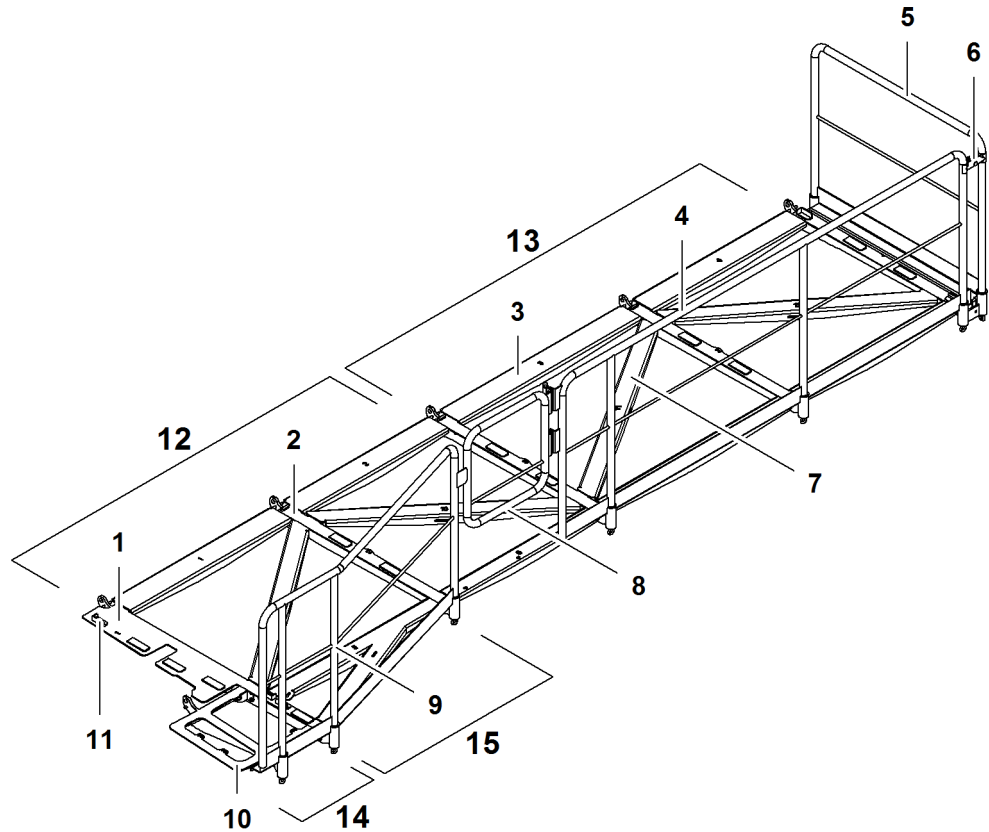


Fig. 45: Left platform on uppercarriage

- | | | | |
|---|--------------------|----|-------------------|
| 1 | Bracket1 | 9 | Railing part6 |
| 2 | Bracket (4x) | 10 | Bracket KnK1 |
| 3 | Plate (8x) | 11 | Support for grate |
| 4 | Railing part5 | 12 | Grating C |
| 5 | Railing part4 | 13 | Grating D |
| 6 | Railing connection | 14 | Grating A |
| 7 | Diagonal (4x) | 15 | Grating B |
| 8 | Access | | |

The straps and strap supports are not illustrated.

Brackets, plates and diagonals are marked with part numbers.

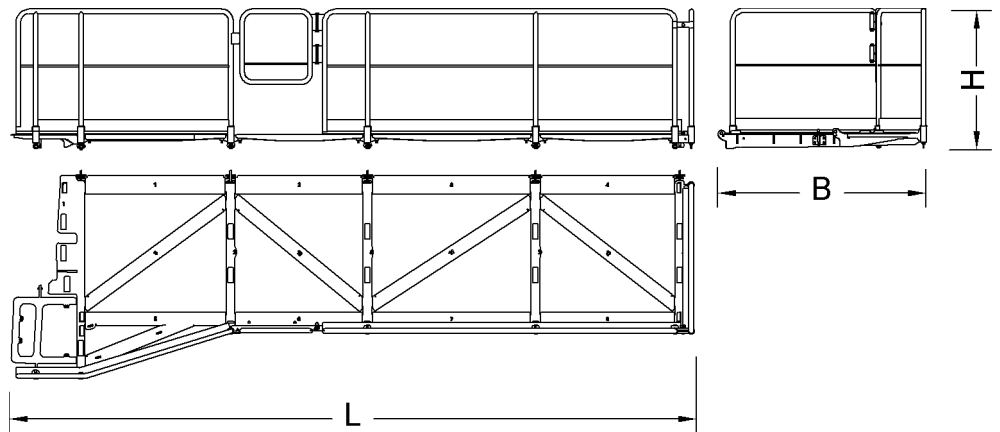


Fig. 46: Dimensions left platform on uppercarriage

Name		Value
L	Length	6241 mm 20' 6" ft-in
B	Width	1771 mm 5' 10" ft-in
H	Height	1275 mm 4' 2" ft-in
Weight		570 kg 1,257 lb

Tab. 32: Technical data left platform on uppercarriage

Railing part6 for left platform

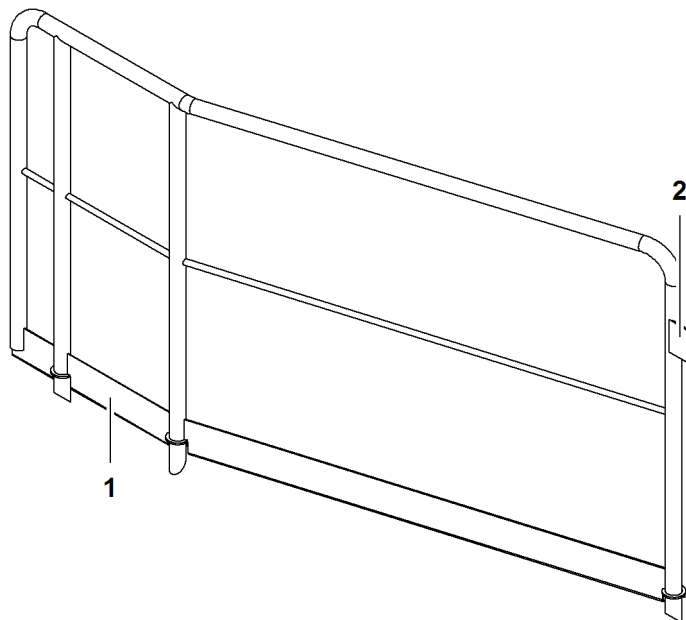


Fig. 47: Railing part6 for left platform

1 Railing part6

2 Stop for access

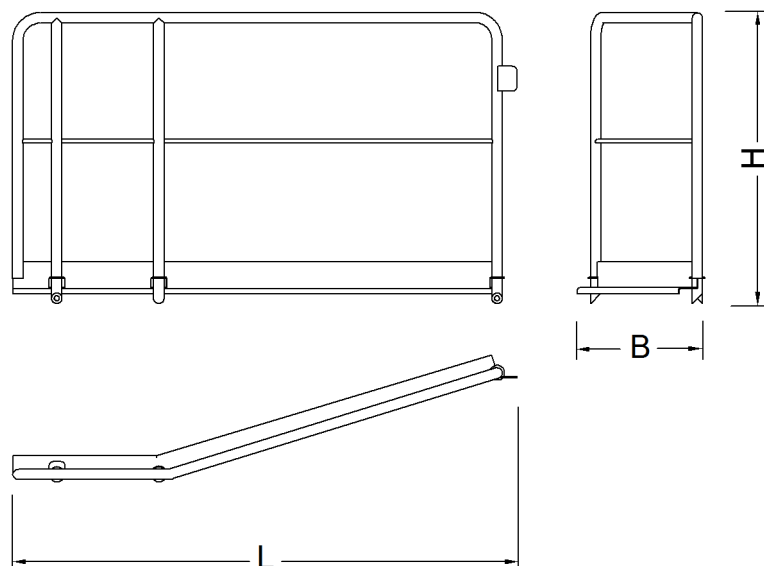


Fig. 48: Dimensions railing part6 for left platform

Name		Value
L	Length	2042 mm 6' 8" ft-in
B	Width	505 mm 1' 8" ft-in
H	Height	1177 mm 3' 10" ft-in
Weight		32 kg 70.55 lb

Tab. 33: Technical data railing part6 for left platform

Railing part5 for left platform

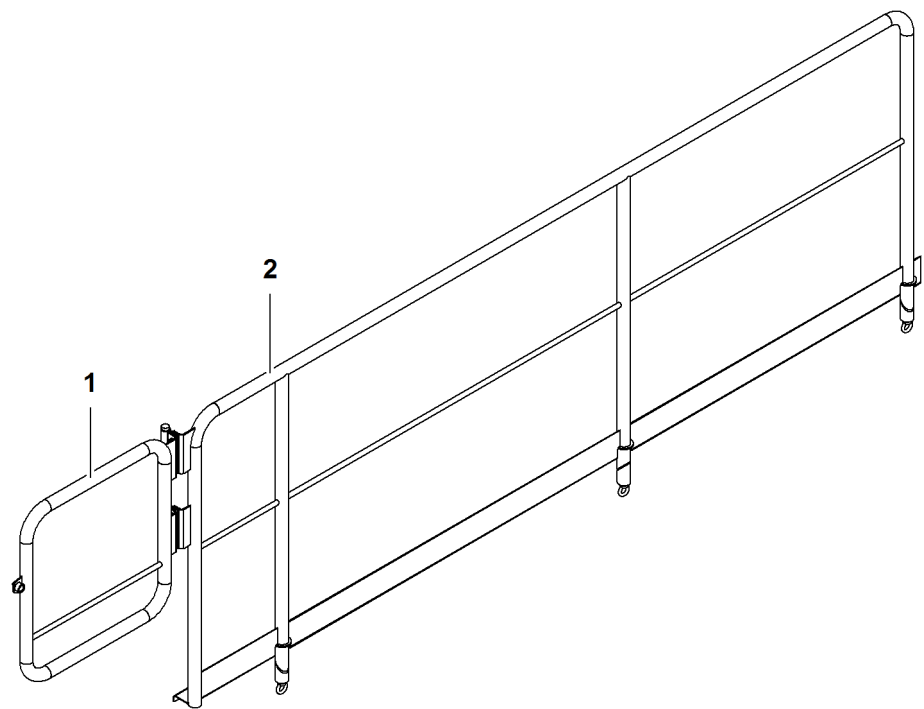


Fig. 49: Railing part5 for left platform

1 Access

2 Railing part5

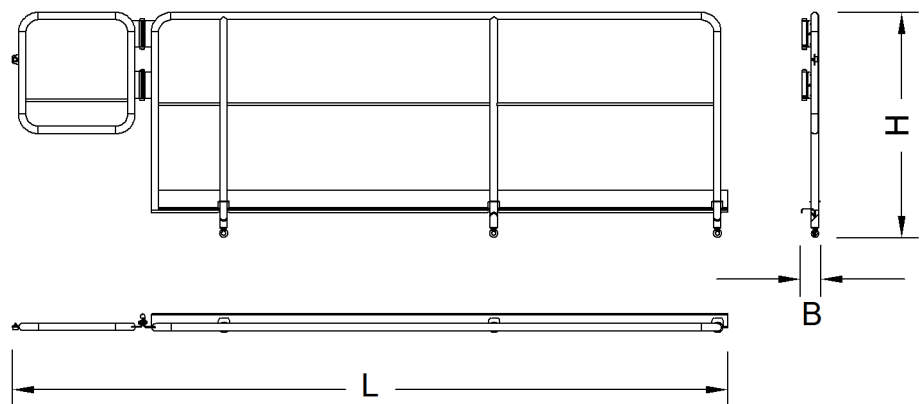


Fig. 50: Dimensions railing part5 for left platform

Name		Value
L	Length	4066 mm 13' 4" ft-in
B	Width	107 mm 4.21" in
H	Height	1275 mm 4' 2" ft-in
Weight		47 kg 104 lb

Tab. 34: Technical data railing part5 for left platform

Railing part4 for left platform

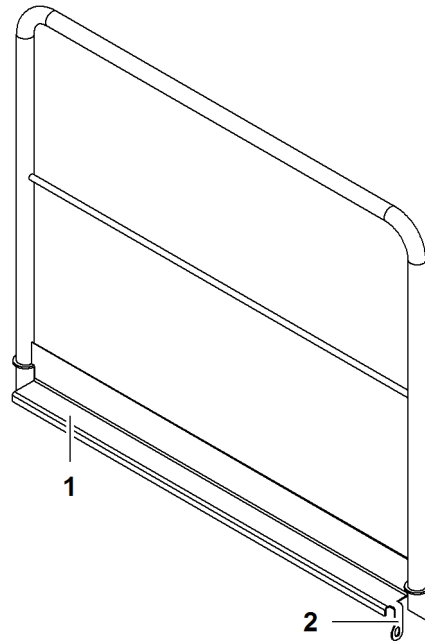


Fig. 51: Railing part4 for left platform

1 Railing part4

2 Securing element

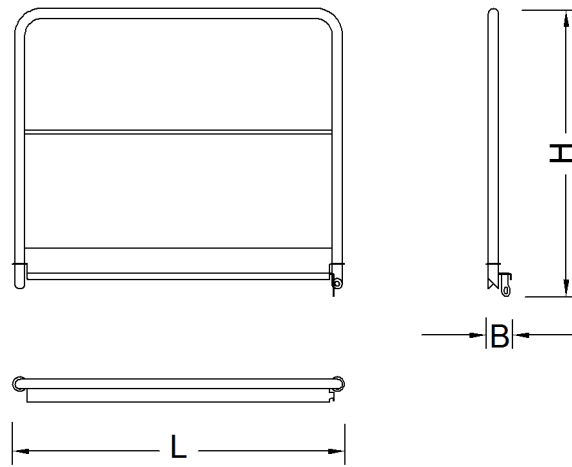


Fig. 52: Dimensions railing part4 for left platform

Name		Value
L	Length	1390 mm 4' 7" ft-in
B	Width	98 mm 3.86" in
H	Height	1208 mm 4' ft-in
Weight		20 kg 44.09 lb

Tab. 35: Technical data railing part4 for left platform

LWN/LR-x/V04.01//Auslieferung/2016-03-07/en

Grating A for left platform

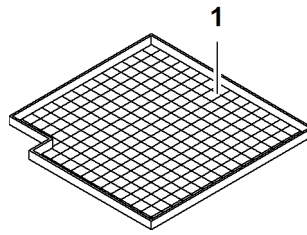


Fig. 53: Grating A for left platform

1 Grating A

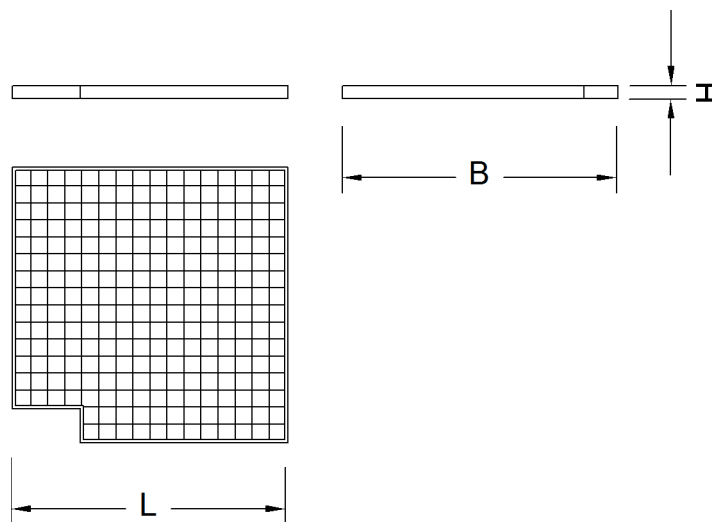


Fig. 54: Dimensions grating A for left platform

Name		Value
L	Length	647 mm 2' 1" ft-in
B	Width	647 mm 2' 1" ft-in
H	Height	30 mm 1.18" in

Tab. 36: Technical data grating A for left platform

Grating B for left platform

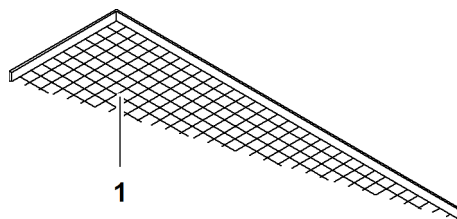


Fig. 55: Grating B for left platform

1 Grating B

LWNLR.x/V04.01//Auslieferung/2016-03-07/en

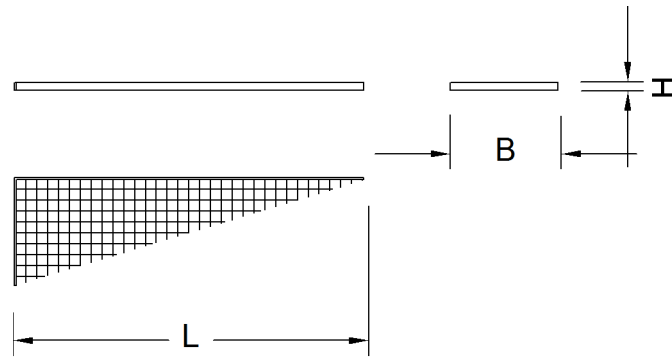


Fig. 56: Dimensions grating B for left platform

Name		Value
L	Length	1287 mm 4' 3" ft-in
B	Width	197 mm 7.76" in
H	Height	30 mm 1.18" in

Tab. 37: Technical data grating B for left platform

Grating C for left platform

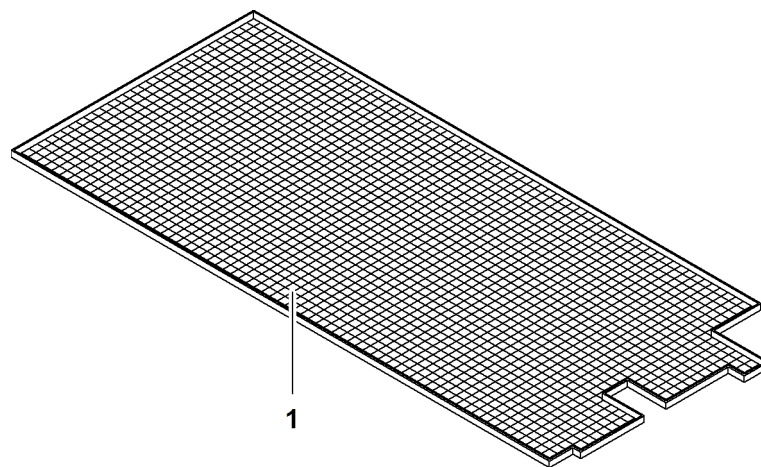


Fig. 57: Grating C for left platform

1 Grating C

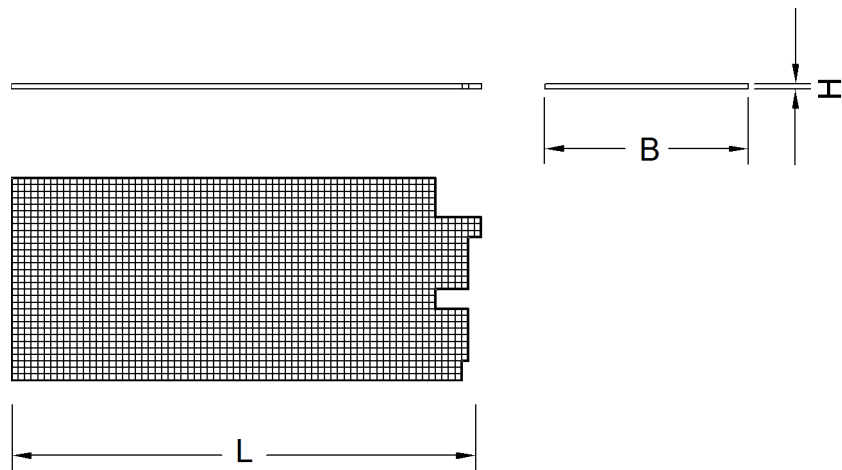


Fig. 58: Dimensions grating C for left platform

Name		Value
L	Length	2887 mm 9' 6" ft-in
B	Width	1247 mm 4' 1" ft-in
H	Height	30 mm 1.18" in
Weight		50.5 kg 111 lb

Tab. 38: Technical data grating C for left platform

Grating D for left platform

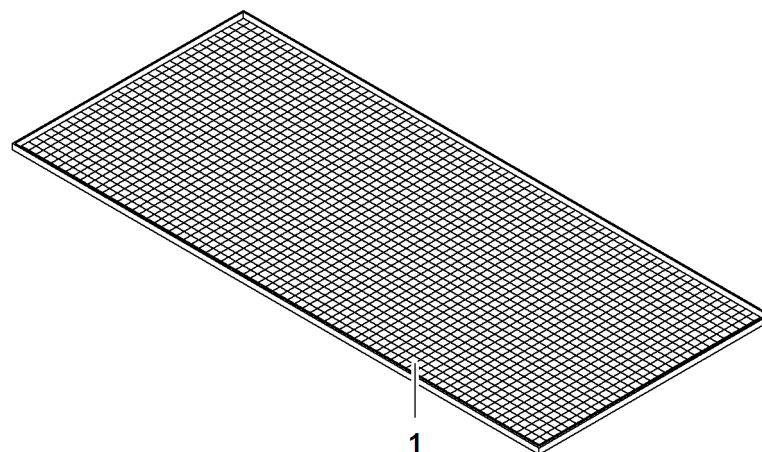


Fig. 59: Grating D for left platform

1 Grating D

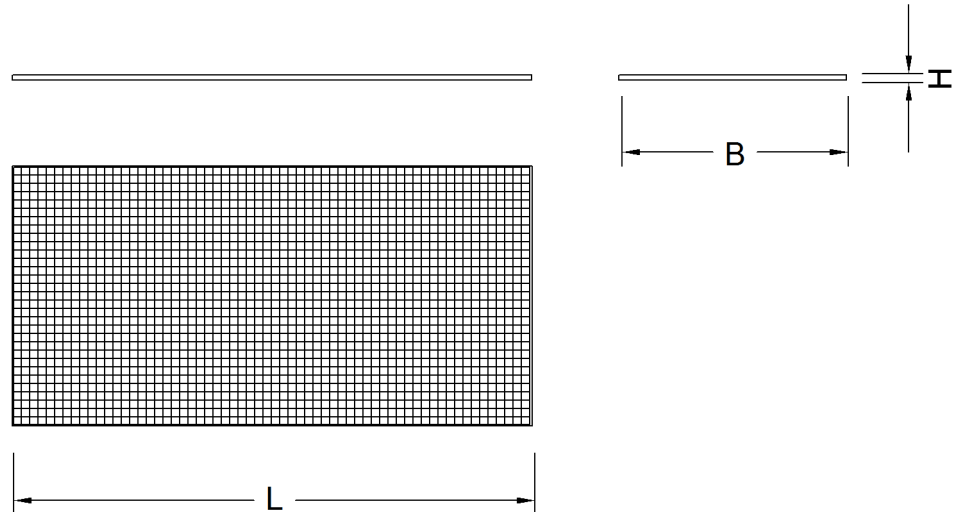


Fig. 60: Dimensions grating D for left platform

Name		Value
L	Length	2847 mm 9' 4" ft-in
B	Width	1247 mm 4' 1" ft-in
H	Height	30 mm 1.18" in
Weight		49.5 kg 109 lb

Tab. 39: Technical data grating D for left platform

Bracket1

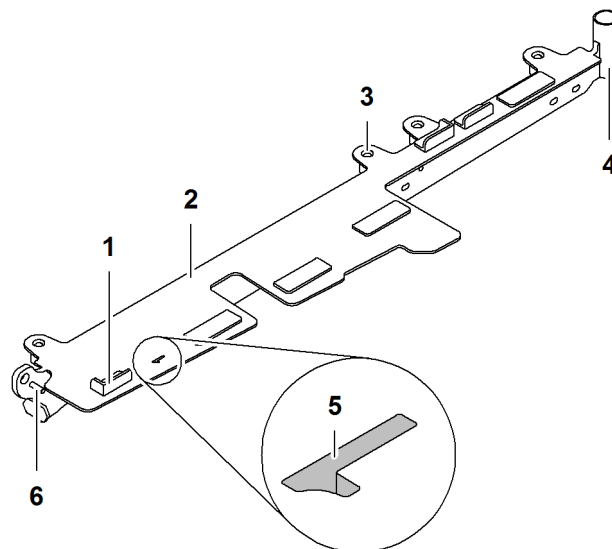


Fig. 61: Bracket1

- | | | | |
|---|------------------------|---|---------------------|
| 1 | Guide (3x) for grating | 4 | Support for railing |
| 2 | Bracket1 | 5 | Part number |

See next page for continuation of the image legend

LWN/LR-x/V04.01//Auslieferung/2016-03-07/en

3 Pin connection point (4x) for plates and diagonals

6 Pin connection point for bracket support

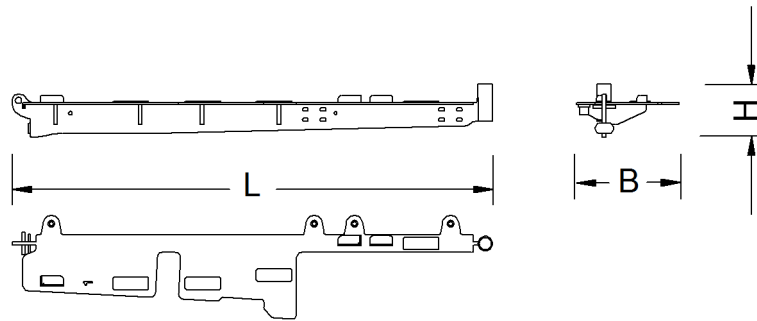


Fig. 62: Dimensions bracket1

Name	Value	
L	Length	1902 mm 6' 3" ft-in
B	Width	409 mm 1' 4" ft-in
H	Height	209 mm 8.23" in
Weight		47 kg 104 lb

Tab. 40: Technical data bracket1

Bracket KnK1

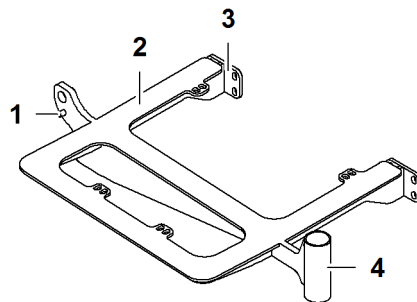


Fig. 63: Bracket KnK1

1 Pin connection point for bracket support K3
2 Bracket KnK1

3 Pin connection point (2x) for bracket1
4 Support for railing part

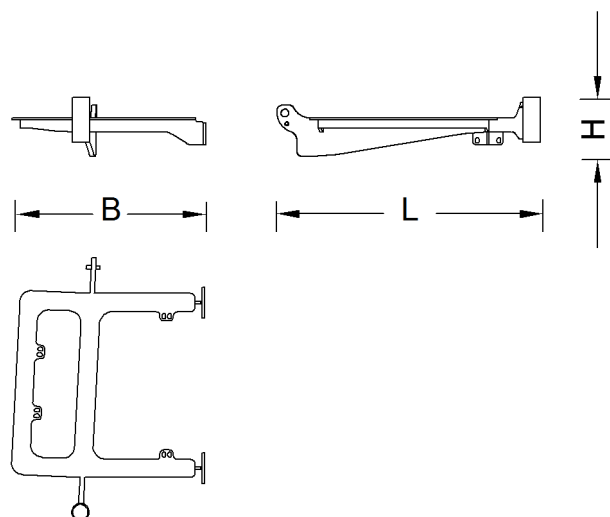


Fig. 64: Dimensions bracket KnK1

Name		Value
L	Length	857 mm 2' 10" ft-in
B	Width	631 mm 2' 1" ft-in
H	Height	192 mm 7.56" in
Weight		22 kg 48.50 lb

Tab. 41: Technical data bracket KnK1

Bracket2

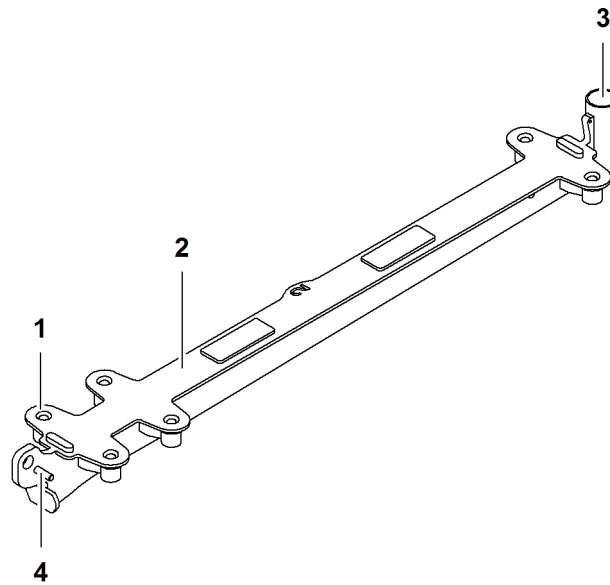


Fig. 65: Bracket2

- | | |
|---|---|
| <p>1 Pin connection point (6x) for plates and diagonals</p> <p>2 Bracket2</p> | <p>3 Support for railing part</p> <p>4 Pin connection point for bracket support</p> |
|---|---|

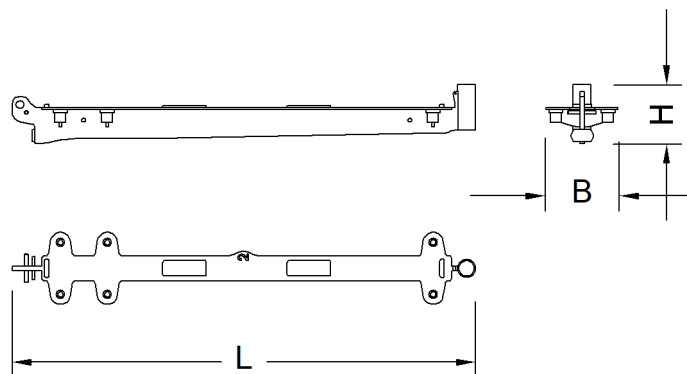


Fig. 66: Dimensions bracket2

Name		Value
L	Length	1491 mm 4' 11" ft-in
B	Width	232 mm 9.13" in
H	Height	189 mm 7.44" in
Weight		25.3 kg 55.78 lb

Tab. 42: Technical data bracket2

LWNLR.x/V04.01//Auslieferung/2016-03-07/en

Bracket3

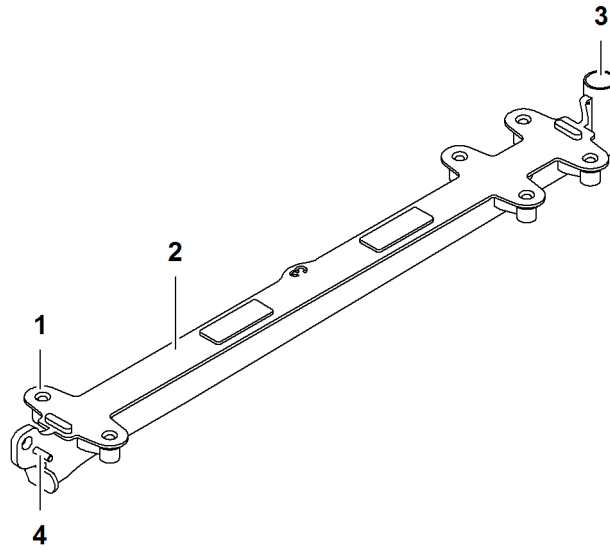


Fig. 67: Bracket3

- | | |
|---|---|
| <p>1 Pin connection point (6x) for plates and diagonals</p> <p>2 Bracket3</p> | <p>3 Support for railing part</p> <p>4 Pin connection point for bracket support</p> |
|---|---|

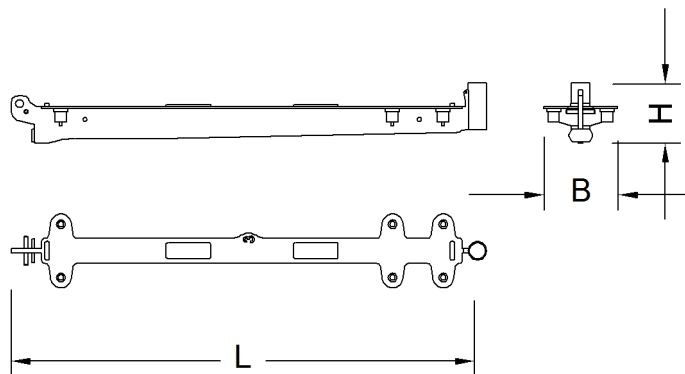


Fig. 68: Dimensions bracket3

Name		Value
L	Length	1491 mm 4' 11" ft-in
B	Width	232 mm 9.13" in
H	Height	189 mm 7.44" in
Weight		25.5 kg 56.22 lb

Tab. 43: Technical data bracket3

LWNLR-x/V04.01//Auslieferung/2016-03-07/en

Bracket4

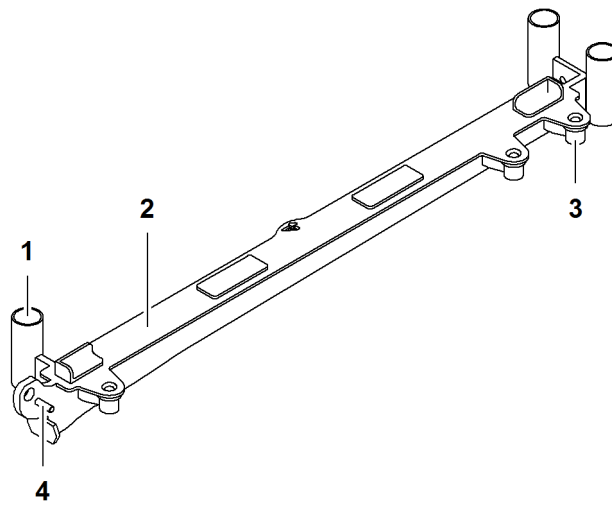


Fig. 69: Bracket4

- | | |
|--|---|
| <p>1 Support (3x) for railing part</p> <p>2 Bracket4</p> | <p>3 Pin connection point (3x) for plates and diagonals</p> <p>4 Pin connection point for bracket support</p> |
|--|---|

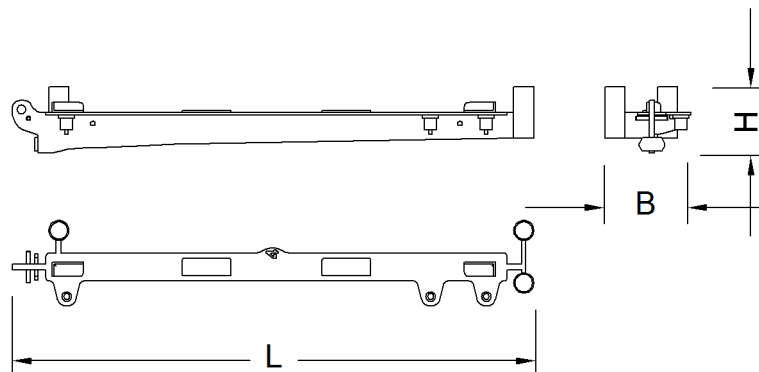


Fig. 70: Dimensions bracket4

Name		Value
L	Length	1491 mm 4' 11" ft-in
B	Width	245 mm 9.65" in
H	Height	189 mm 7.44" in
Weight		25 kg 55.11 lb

Tab. 44: Technical data bracket4

Bracket5

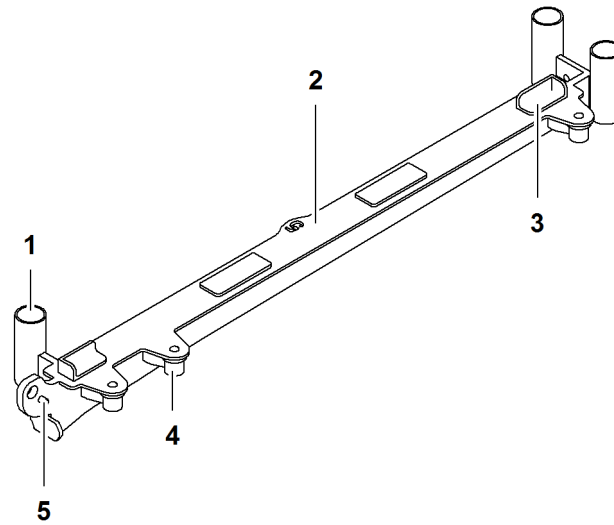


Fig. 71: Bracket5

- | | | | |
|---|-------------------------------|---|--|
| 1 | Support (3x) for railing part | 4 | Pin connection point (3x) for plates and diagonals |
| 2 | Bracket5 | 4 | Pin connection point for bracket support |
| 3 | Guide for grating | | |

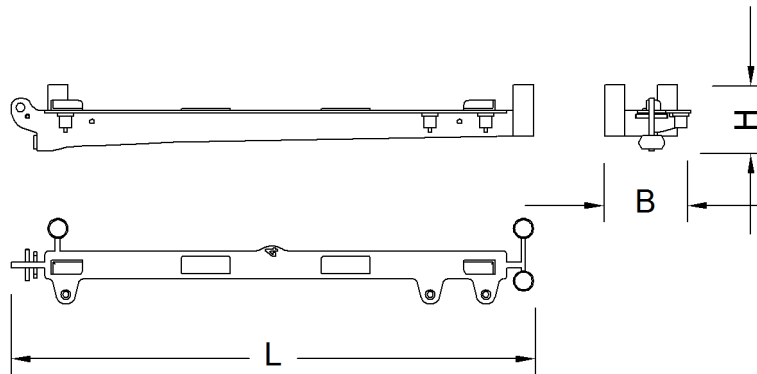


Fig. 72: Dimensions bracket5

Name		Value
L	Length	1491 mm 4' 11" ft-in
B	Width	245 mm 9.65" in
H	Height	189 mm 7.44" in
Weight		25.5 kg 56.22 lb

Tab. 45: Technical data bracket5

LWNLR-x/V04.01//Auslieferung/2016-03-07/en

Bracket6

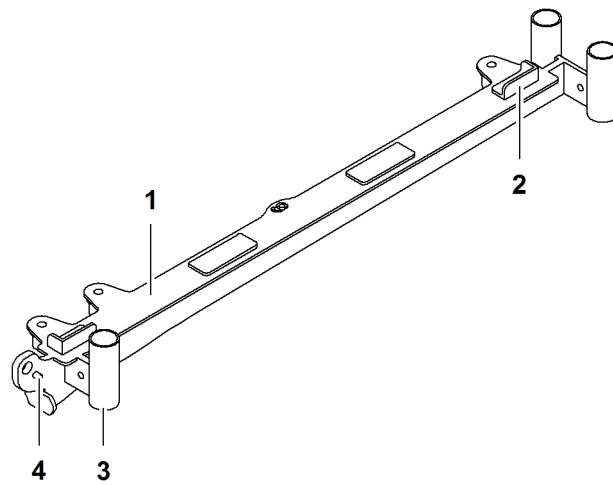


Fig. 73: Bracket6

- 1 Bracket6
- 2 Guide for grating
- 3 Support for railing part
- 4 Pin connection point for bracket support

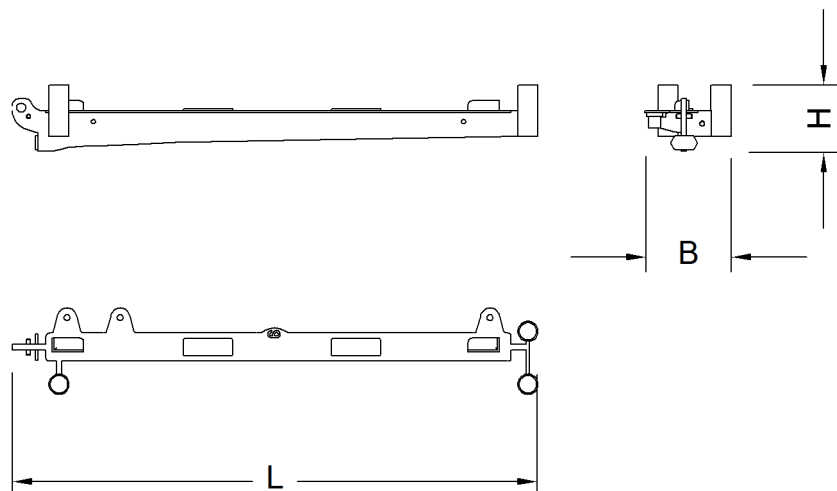


Fig. 74: Dimensions bracket6

Name		Value
L	Length	1491 mm 4' 11" ft-in
B	Width	245 mm 9.65" in
H	Height	189 mm 7.44" in
Weight		25 kg 55.11 lb

Tab. 46: Technical data bracket6

LWNLR.x/V04.01//Auslieferung/2016-03-07/en

Plate1

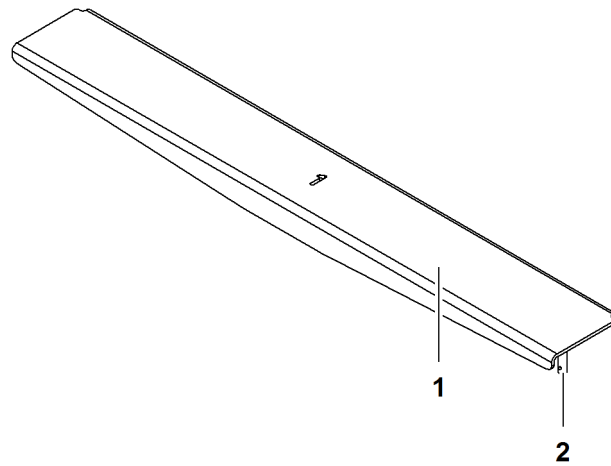


Fig. 75: Plate1

1 Plate1

2 Pin

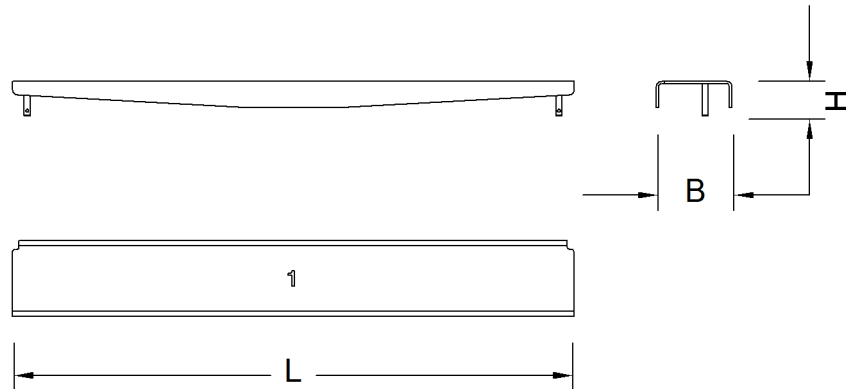


Fig. 76: Dimensions plate1

Name		Value
L	Length	1275 mm 4' 2" ft-in
B	Width	172 mm 6.77" in
H	Height	79 mm 3.11" in
Weight		12 kg 26.46 lb

Tab. 47: Technical data plate1

LWN/LR-x/V04.01//Auslieferung/2016-03-07/en

Plate2

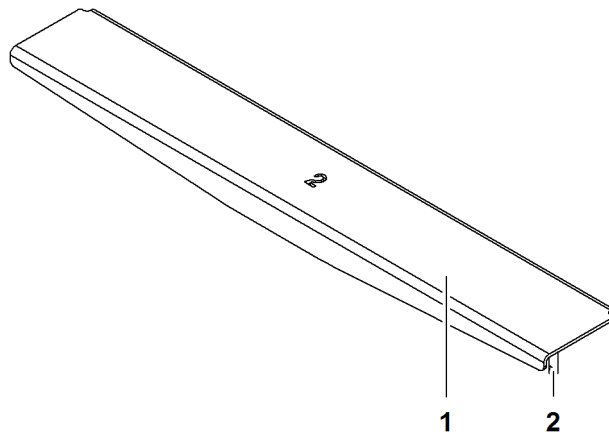


Fig. 77: Plate2

1 Plate2

2 Pin

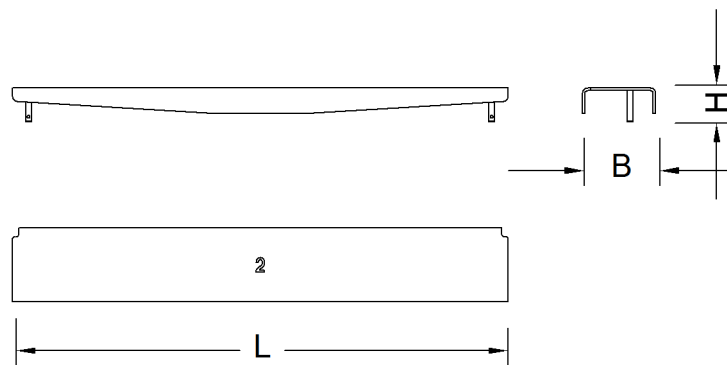


Fig. 78: Dimensions plate2

Name		Value
L	Length	1158 mm 3' 10" ft-in
B	Width	172 mm 6.77" in
H	Height	79 mm 3.11" in
Weight		11 kg 24.25 lb

Tab. 48: Technical data plate2

Plate3

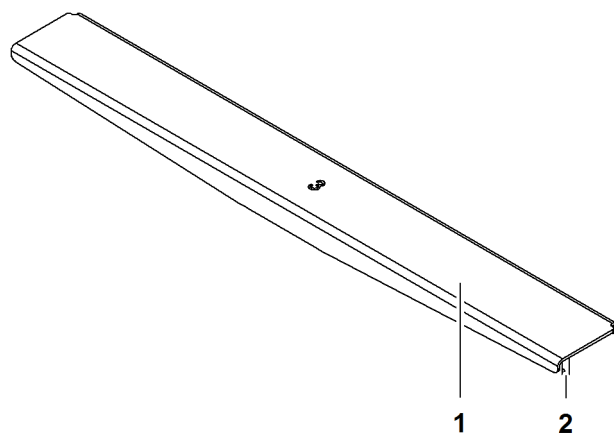


Fig. 79: Plate3

1 Plate3

2 Pin

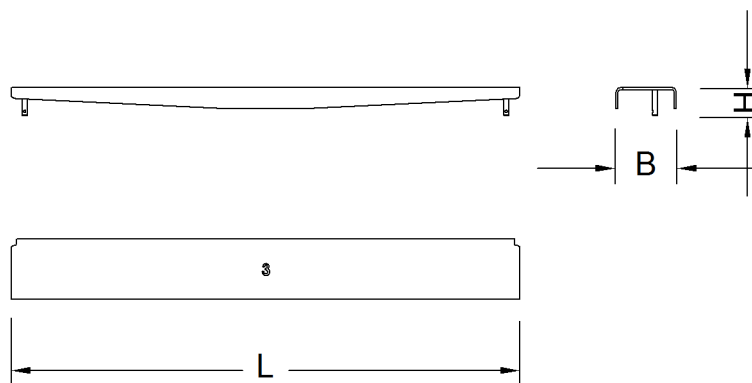


Fig. 80: Dimensions plate3

Name		Value
L	Length	1446 mm 4' 9" ft-in
B	Width	172 mm 6.77" in
H	Height	79 mm 3.11" in
Weight		17 kg 37.48 lb

Tab. 49: Technical data plate3

LWN/LR-x/V04.01//Auslieferung/2016-03-07/en

Plate5

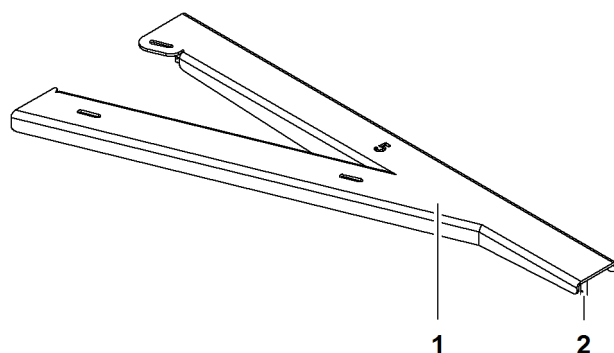


Fig. 83: Plate5

1 Plate5

2 Pin

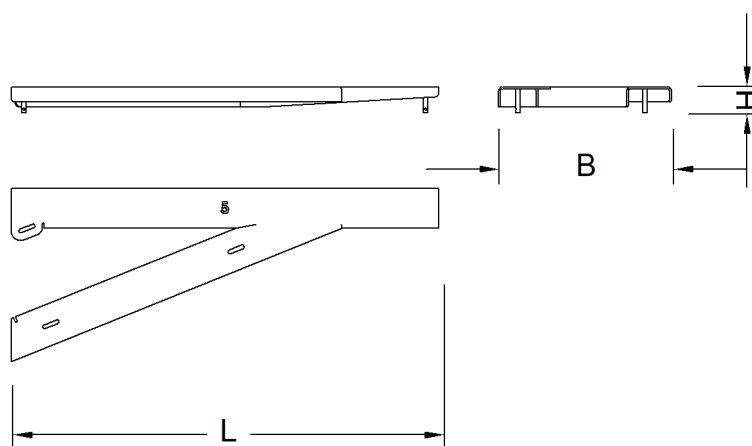


Fig. 84: Dimensions plate5

Name		Value
L	Length	1284 mm 4' 3" ft-in
B	Width	521 mm 1' 9" ft-in
H	Height	79 mm 3.11" in
Weight		22 kg 48.50 lb

Tab. 51: Technical data plate5

LWN/LR-x/V04.01//Auslieferung/2016-03-07/en

Plate6

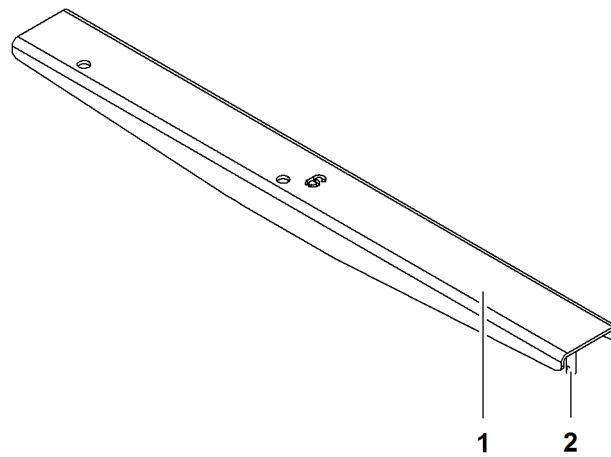


Fig. 85: Plate6

- 1** Plate6
- 2** Pin

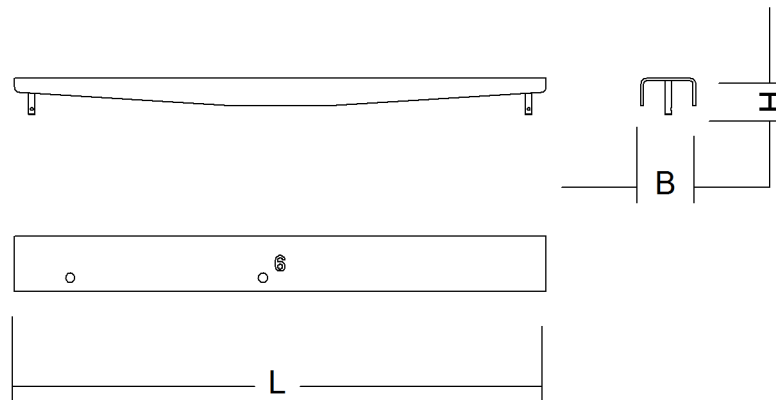


Fig. 86: Dimensions plate6

Name		Value
L	Length	1158 mm 3' 10" ft-in
B	Width	120 mm 4.72" in
H	Height	79 mm 3.11" in
Weight		11 kg 24.25 lb

Tab. 52: Technical data plate6

LWNLR.x/V04.01//Auslieferung/2016-03-07/en

Plate7

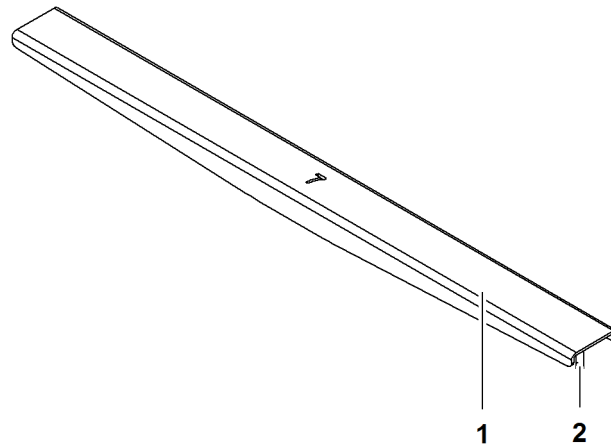


Fig. 87: Plate7

1 Plate7

2 Pin

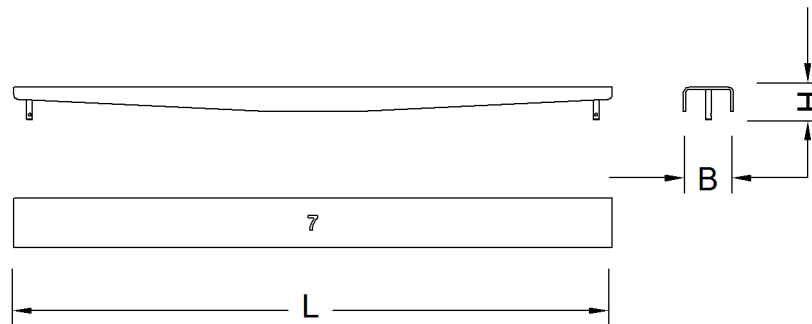


Fig. 88: Dimensions plate7

Name		Value
L	Length	1446 mm 4' 9" ft-in
B	Width	120 mm 4.72" in
H	Height	79 mm 3.11" in
Weight		13.3 kg 29.32 lb

Tab. 53: Technical data plate7

LWNLR-x/V04.01//Auslieferung/2016-03-07/en

Plate8

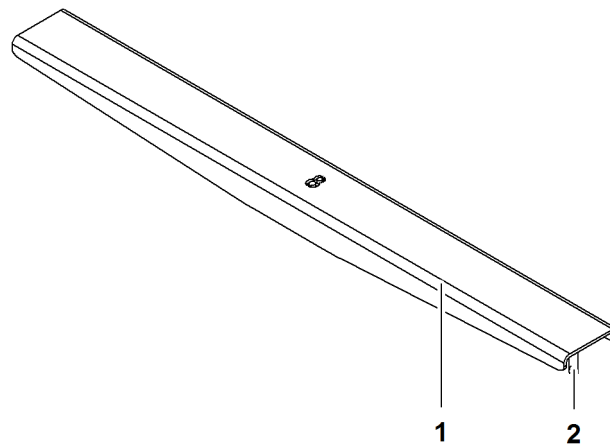


Fig. 89: Plate8

1 Plate8

2 Pin

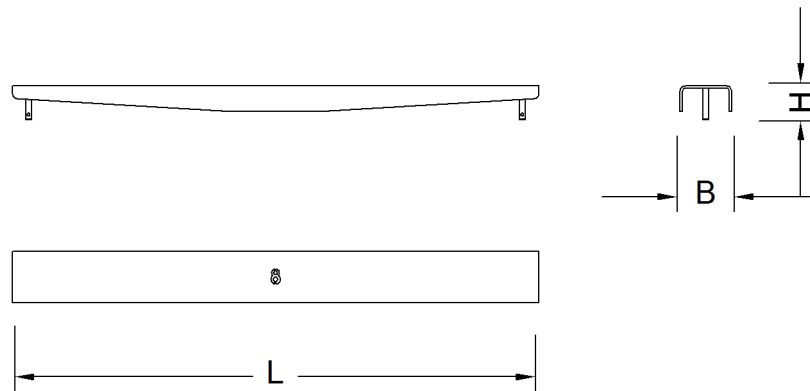


Fig. 90: Dimensions plate8

Name		Value
L	Length	1227 mm 4' ft-in
B	Width	120 mm 4.72" in
H	Height	79 mm 3.11" in
Weight		11.4 kg 25.13 lb

Tab. 54: Technical data plate8

LWNLR.x/V04.01//Auslieferung/2016-03-07/en

Plate13

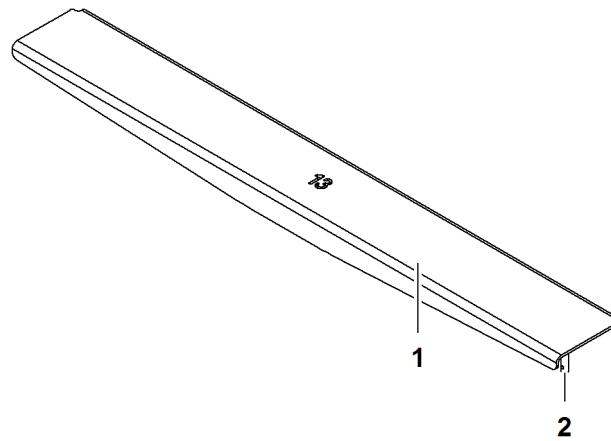


Fig. 91: Plate13

1 Plate13

2 Pin

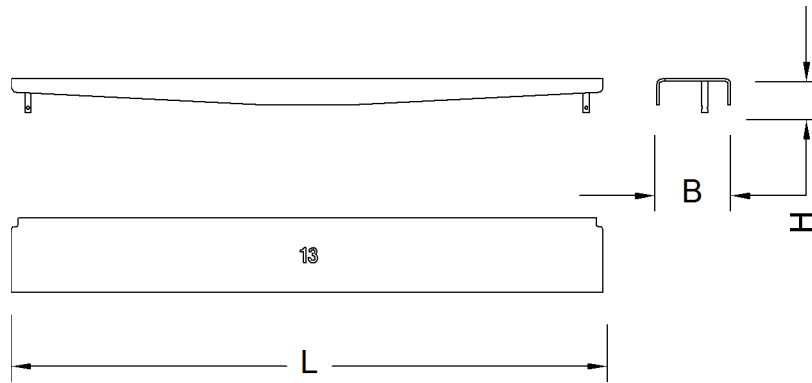


Fig. 92: Dimensions plate13

Name		Value
L	Length	1371 mm 4' 6" ft-in
B	Width	172 mm 6.77" in
H	Height	79 mm 3.11" in
Weight		16 kg 35.27 lb

Tab. 55: Technical data plate13

LWNLR-x\04.01\Auslieferung\2016-03-07/en

Plate14

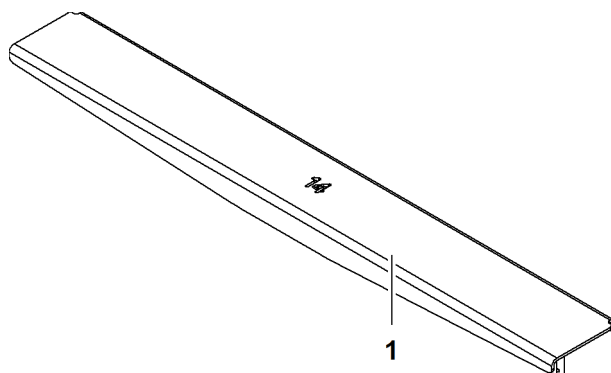


Fig. 93: Plate14

1 Plate14

2 Pin

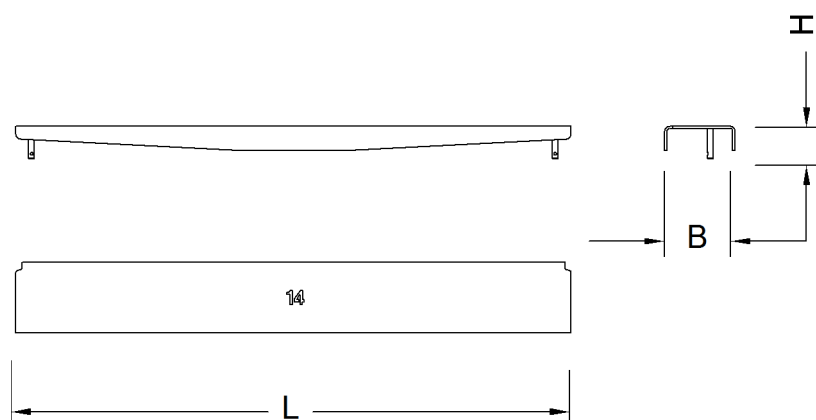


Fig. 94: Dimensions plate14

Name		Value
L	Length	1349 mm 4' 5" ft-in
B	Width	172 mm 6.77" in
H	Height	79 mm 3.11" in
Weight		15.7 kg 34.61 lb

Tab. 56: Technical data plate14

LWNLR.x/V04.01//Auslieferung/2016-03-07/en

Plate15

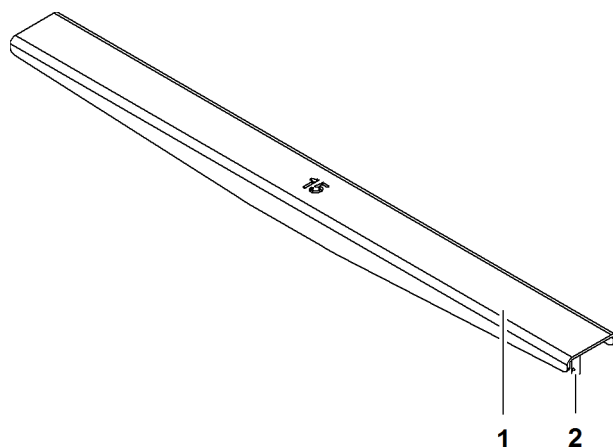


Fig. 95: Plate15

1 Plate15

2 Pin

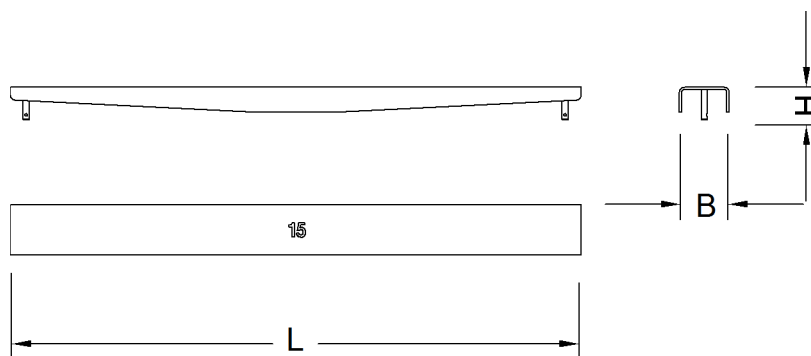


Fig. 96: Dimensions plate15

Name		Value
L	Length	1371 mm 4' 6" ft-in
B	Width	120 mm 4.72" in
H	Height	79 mm 3.11" in
Weight		12.7 kg 28.00 lb

Tab. 57: Technical data plate15

Plate16

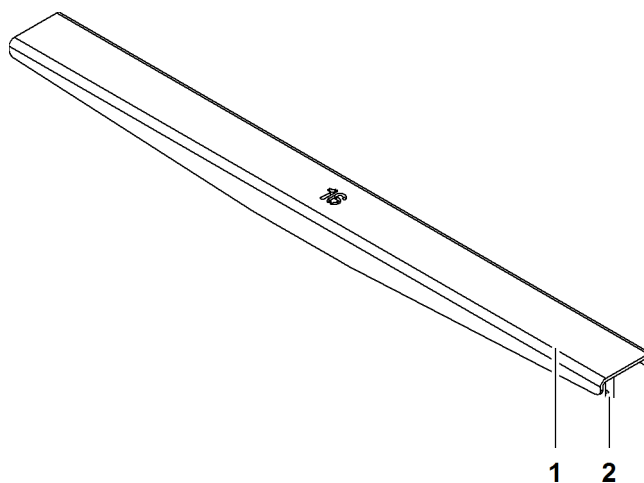


Fig. 97: Plate16

1 Plate16

2 Pin

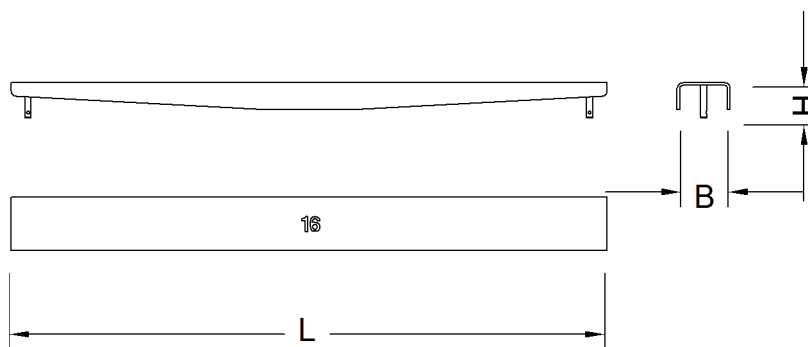


Fig. 98: Dimensions plate16

Name		Value
L	Length	1349 mm 4' 5" ft-in
B	Width	120 mm 4.72" in
H	Height	79 mm 3.11" in
Weight		12.5 kg 27.56 lb

Tab. 58: Technical data plate16

Diagonal9

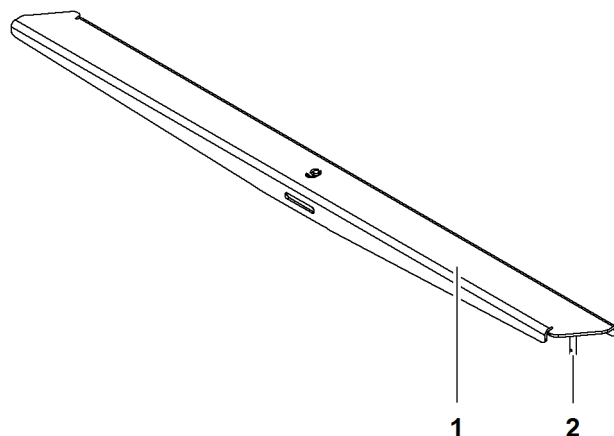


Fig. 99: Diagonal9

1 Diagonal9

2 Pin

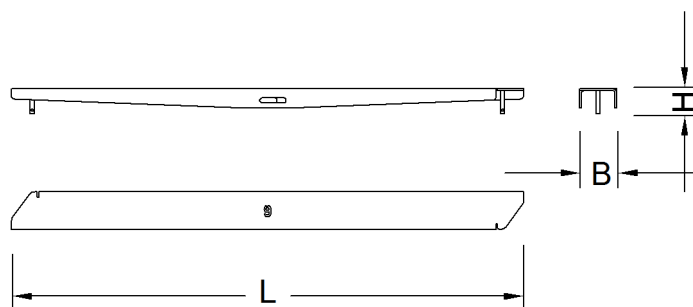


Fig. 100: Dimensions diagonal9

Name		Value
L	Length	1634 mm 5' 4" ft-in
B	Width	120 mm 4.72" in
H	Height	79 mm 3.11" in
Weight		14.5 kg 31.97 lb

Tab. 59: Technical data diagonal9

LWNLR-x/V04.01//Auslieferung/2016-03-07/en

Diagonal10

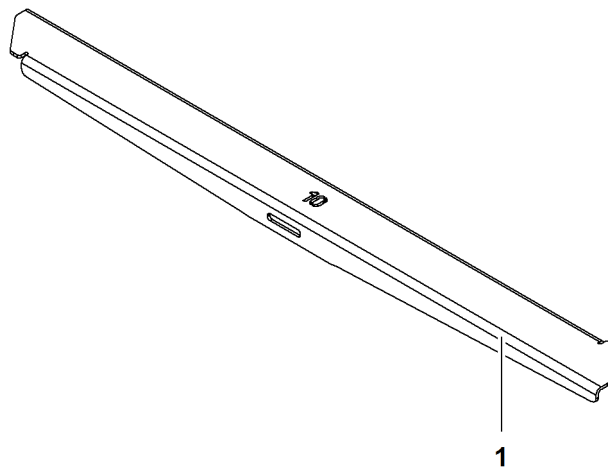


Fig. 101: Diagonal10

1 Diagonal10

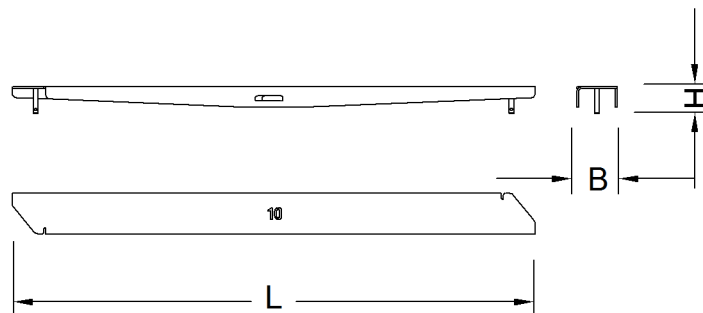


Fig. 102: Dimensions diagonal10

Name		Value
L	Length	1539 mm 5' 1" ft-in
B	Width	120 mm 4.72" in
H	Height	79 mm 3.11" in
Weight		13.6 kg 29.98 lb

Tab. 60: Technical data diagonal10

Diagonal11

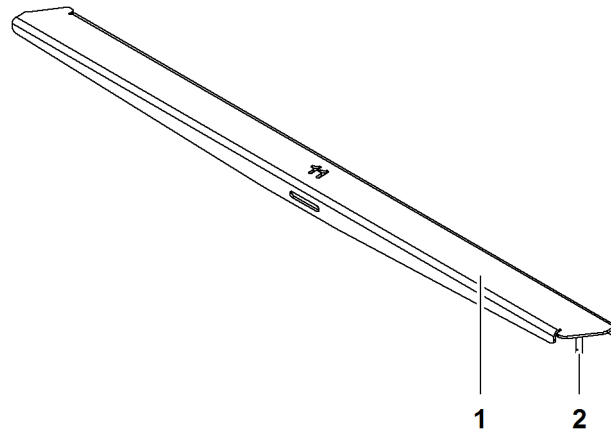


Fig. 103: Diagonal11

1 Diagonal11

2 Pin

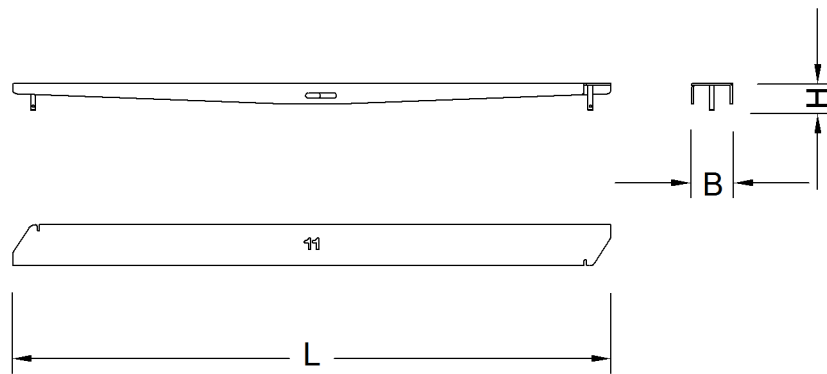


Fig. 104: Dimensions diagonal11

Name		Value
L	Length	1752 mm 5' 9" ft-in
B	Width	120 mm 4.72" in
H	Height	79 mm 3.11" in
Weight		15.7 kg 34.61 lb

Tab. 61: Technical data diagonal11

LWN/LR-x/V04.01//Auslieferung/2016-03-07/en

Diagonal12

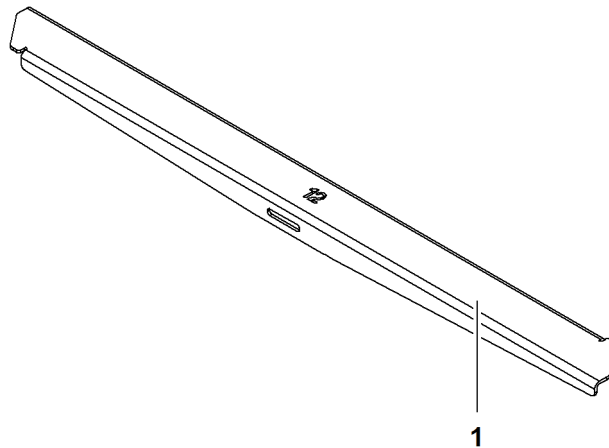


Fig. 105: Diagonal12

1 Diagonal12

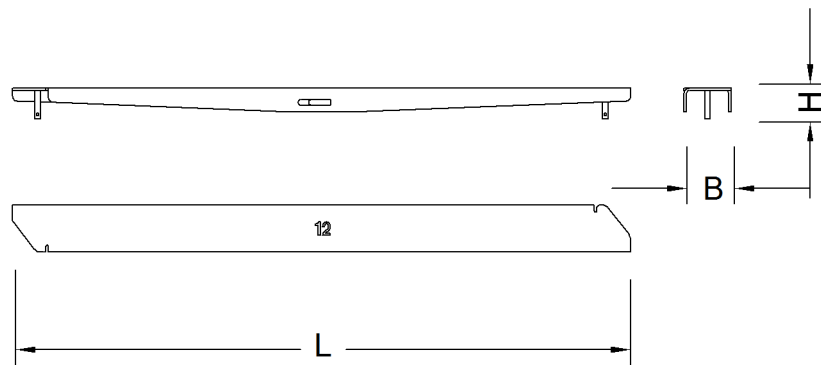


Fig. 106: Dimensions diagonal12

Name		Value
L	Length	1584 mm 5' 2" ft-in
B	Width	120 mm 4.72" in
H	Height	79 mm 3.11" in
Weight		14.1 kg 31.08 lb

Tab. 62: Technical data diagonal12

Diagonal17

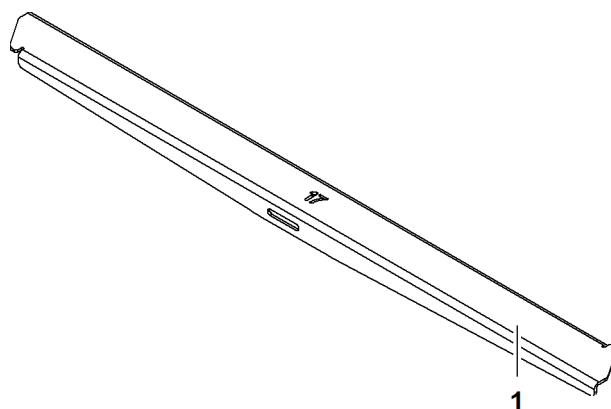


Fig. 107: Diagonal17

1 Diagonal17

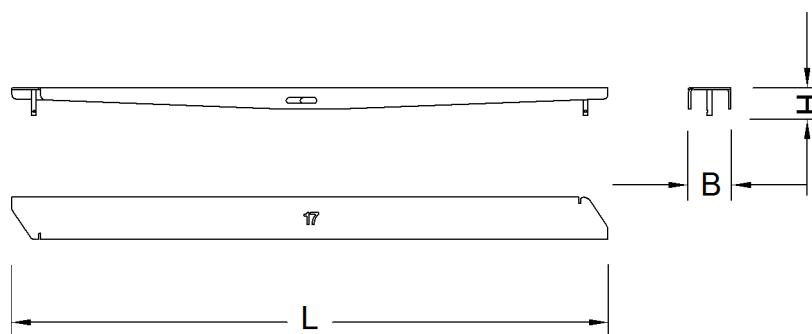


Fig. 108: Dimensions diagonal17

Name		Value
L	Length	1696 mm 5' 7" ft-in
B	Width	120 mm 4.72" in
H	Height	79 mm 3.11" in
Weight		15.1 kg 33.29 lb

Tab. 63: Technical data diagonal17

Diagonal18

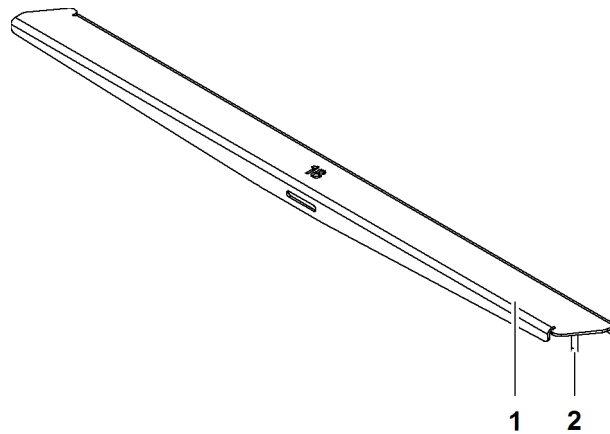


Fig. 109: Diagonal18

- 1 Diagonal18
- 2 Pin

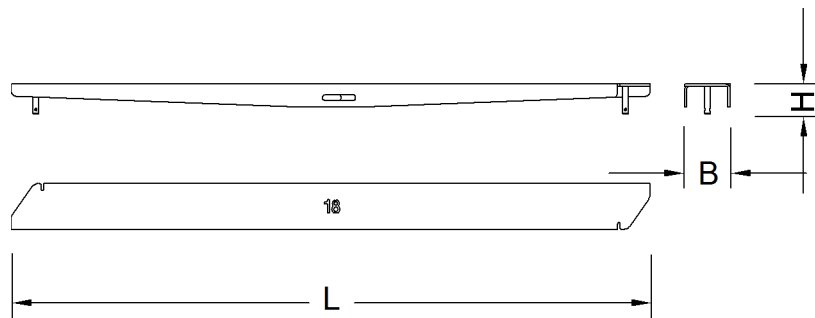


Fig. 110: Dimensions diagonal18

Name		Value
L	Length	1678 mm 5' 6" ft-in
B	Width	120 mm 4.72" in
H	Height	79 mm 3.11" in
Weight		15 kg 33.07 lb

Tab. 64: Technical data diagonal18

LWNLR.x/V04.01//Auslieferung/2016-03-07/en

Bracket support K1

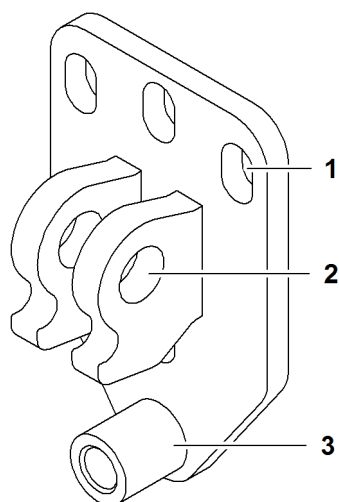


Fig. 111: Bracket support K1

- 1 Attachment point uppercarriage
- 2 Attachment point bracket
- 3 Adjusting screw bracket

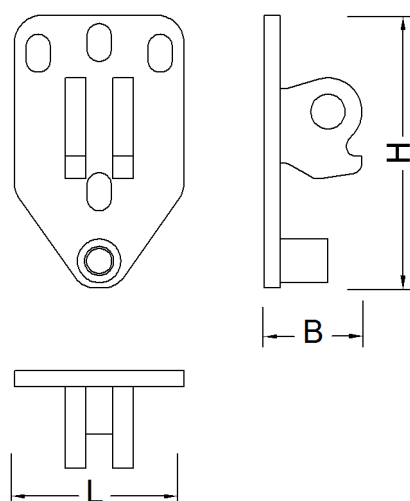


Fig. 112: Dimensions bracket support K1

Name		Value
L	Length	125 mm 4.92" in
B	Width	72 mm 2.83" in
H	Height	201 mm 7.91" in

Tab. 65: Technical data bracket support K1

LWNLR-x/V04.01//Auslieferung/2016-03-07/en

Bracket support K2

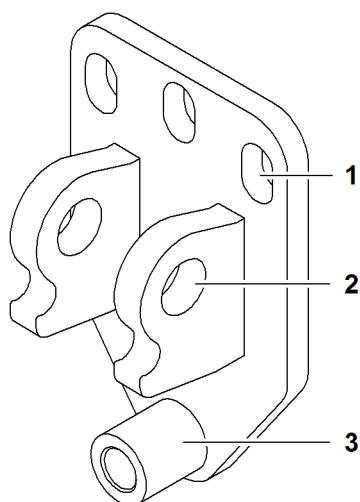


Fig. 113: Bracket support K2

- 1** Attachment point uppercarriage
- 2** Attachment point bracket
- 3** Adjusting screw bracket

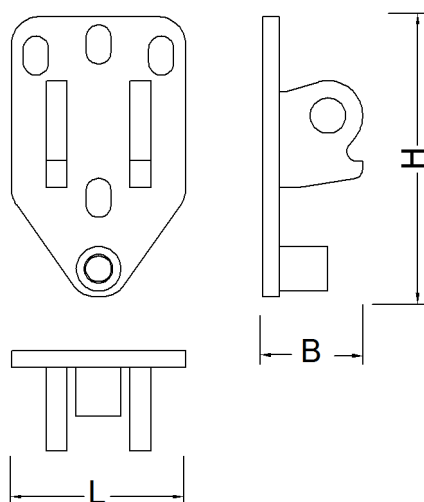


Fig. 114: Dimensions bracket support K2

Name		Value
L	Length	125 mm 4.92" in
B	Width	72 mm 2.83" in
H	Height	201 mm 7.91" in

Tab. 66: Technical data bracket support K2

LWNLR.x/V04.01//Auslieferung/2016-03-07/en

Bracket support K3

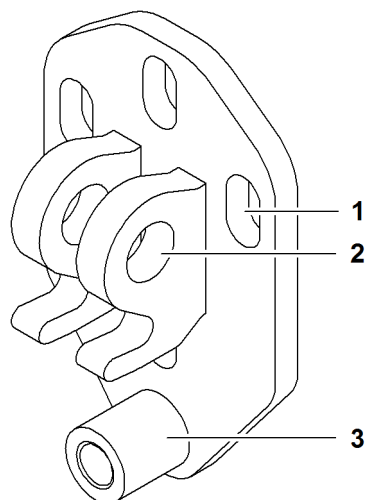


Fig. 115: Bracket support K3

- 1 Attachment point uppercarriage
- 2 Attachment point bracket
- 3 Adjusting screw bracket

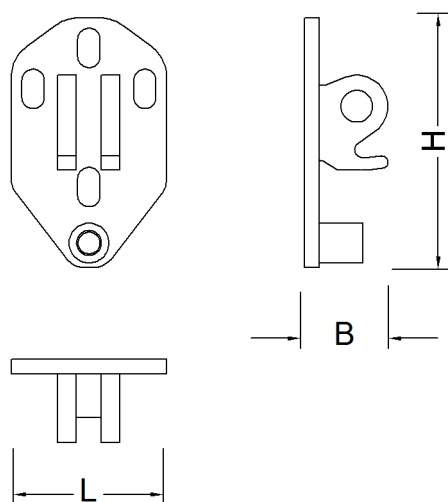


Fig. 116: Dimensions bracket support K3

Name		Value
L	Length	125 mm 4.92" in
B	Width	67 mm 2.64" in
H	Height	201 mm 7.91" in

Tab. 67: Technical data bracket support K3

LWNLR-x\04.01\Auslieferung\2016-03-07\en

Railing connection

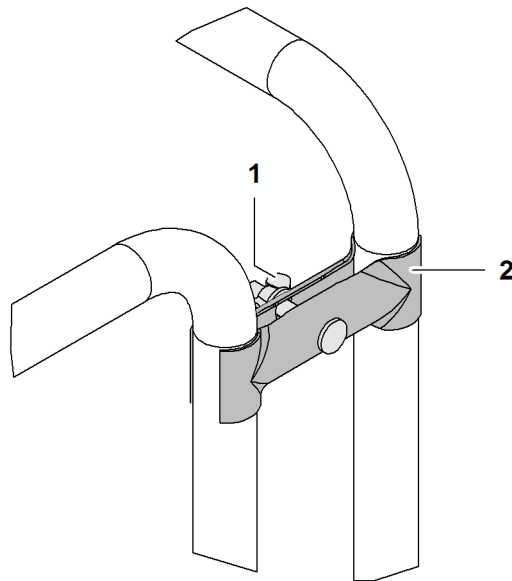


Fig. 117: Railing connection

1 Wing nut

2 Railing connection

Strap

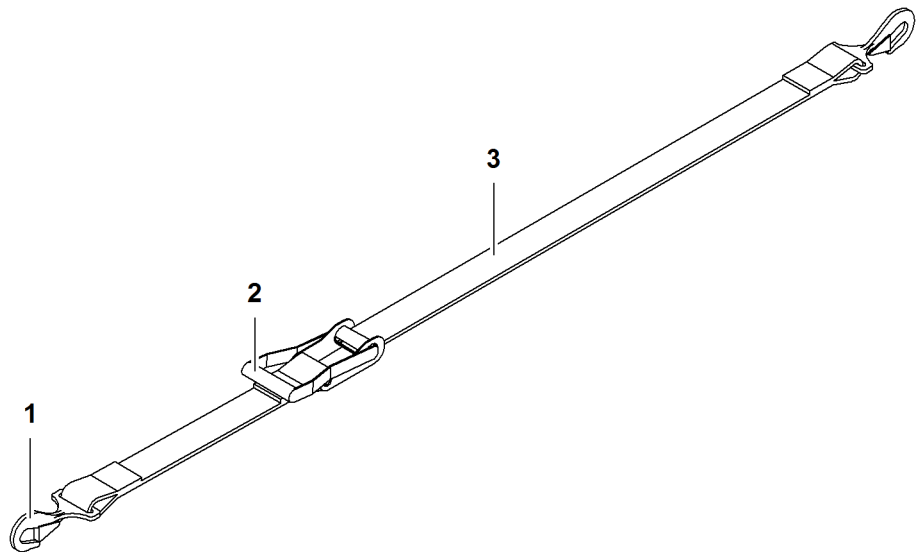


Fig. 118: Strap

1 Hook (2x)

2 Ratchet

3 Strap

Name	Value
Minimum length	1684 mm 5' 6" ft-in
Belt width	50 mm 1.97" in

Name	Value
SWL	2.5 t 5,511 lb

Tab. 68: Technical data strap

Strap support

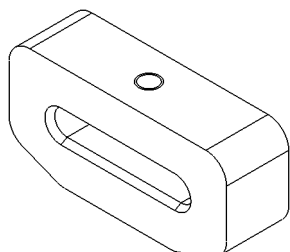


Fig. 119: Strap support

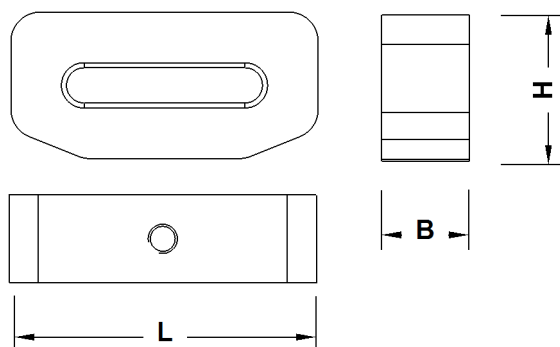


Fig. 120: Dimensions strap support

Name	Value
L Length	105 mm 4.13" in
B Width	30 mm 1.18" in
H Height	50 mm 1.97" in

Tab. 69: Technical data strap support

LWNLR-x\04.01\Auslieferung\2016-03-07\en

1.7.9 Undercarriage

Undercarriage with fixed track width

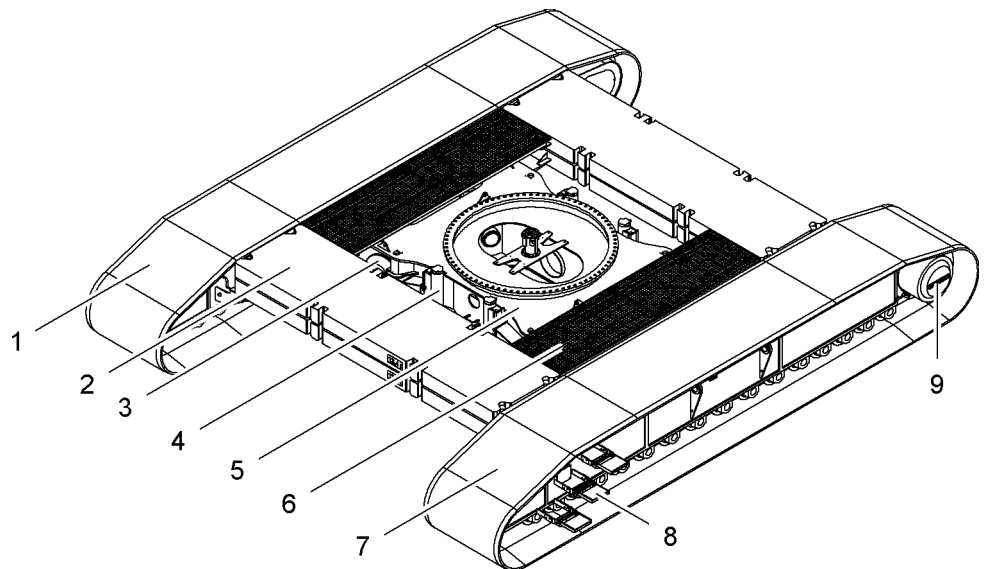


Fig. 121: Undercarriage with fixed track width

1	Right crawler side frame	6	Platforms
2	Carbody counterweight slab (4x)	7	Left crawler side frame
3	Base plate for jack (4x)	8	Steps
4	Jack (4x)	9	Tumbler (2x)
5	Center part		

The crawler side frames **1 + 7**

- are attached to the center part by two pins at the front and the back.
- can be detached from the center part for transport.

The four carbody counterweight slabs **2**

- are attached to the front and rear of the undercarriage.
- ensure increased stability.

The base plates **3** for the jacks are located on the center part.

The jacks **4** support the basic machine when necessary.

The center part **5** of the undercarriage

- is a welded structure.
- supports the rotatable uppercarriage.

The folding steps **6** and platforms **6** allow safe access to the cabin and the uppercarriage.

Undercarriage* with adjustable track width

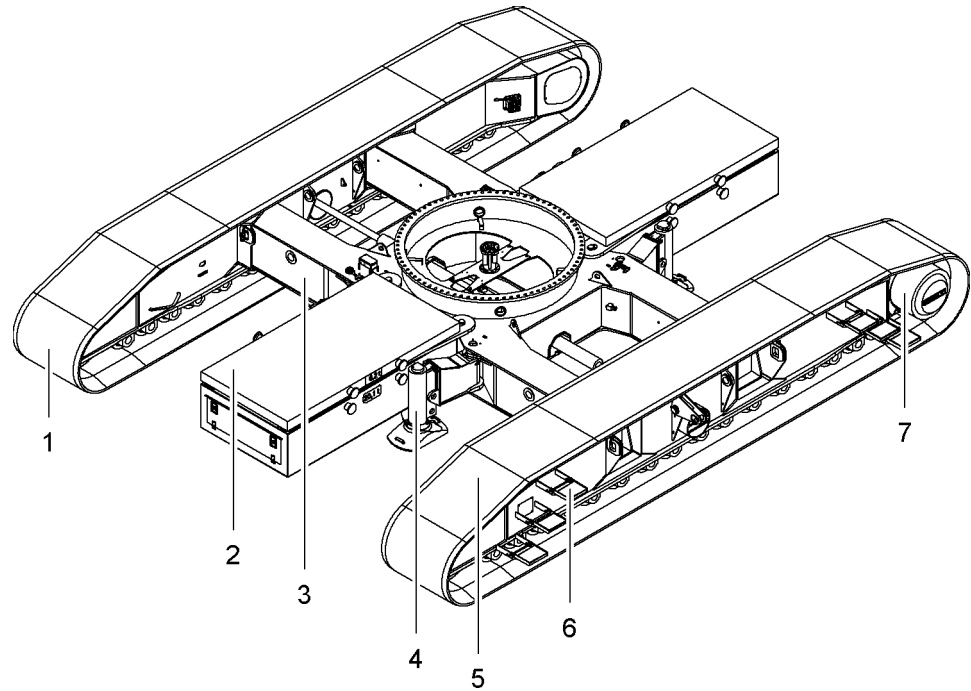


Fig. 122: Undercarriage* with adjustable track width

- | | | | |
|----------|---------------------------------|----------|-------------------------|
| 1 | Right crawler side frame | 5 | Left crawler side frame |
| 2 | Carbody counterweight slab (4x) | 6 | Steps |
| 3 | Center part | 7 | Tumbler (2x) |
| 4 | Jack (4x) | | |

The crawler side frames **1 + 5**:

- are attached to the center part by two pins at the front and the back.
- can be detached from the center part for transport.
- can be pinned as narrow, medium or wide track.

The four carbody counterweight slabs **2**:

- are attached to the front and rear of the undercarriage.
- ensure increased stability.

The jacks **4** support the basic machine when necessary.

The center part **3** of the undercarriage:

- is a welded structure.
- supports the rotatable uppercarriage.

The folding steps **6** allow safe access to cabin and uppercarriage.

1.7.10 Crawler side frame

Crawler side frame for undercarriage with fixed track width

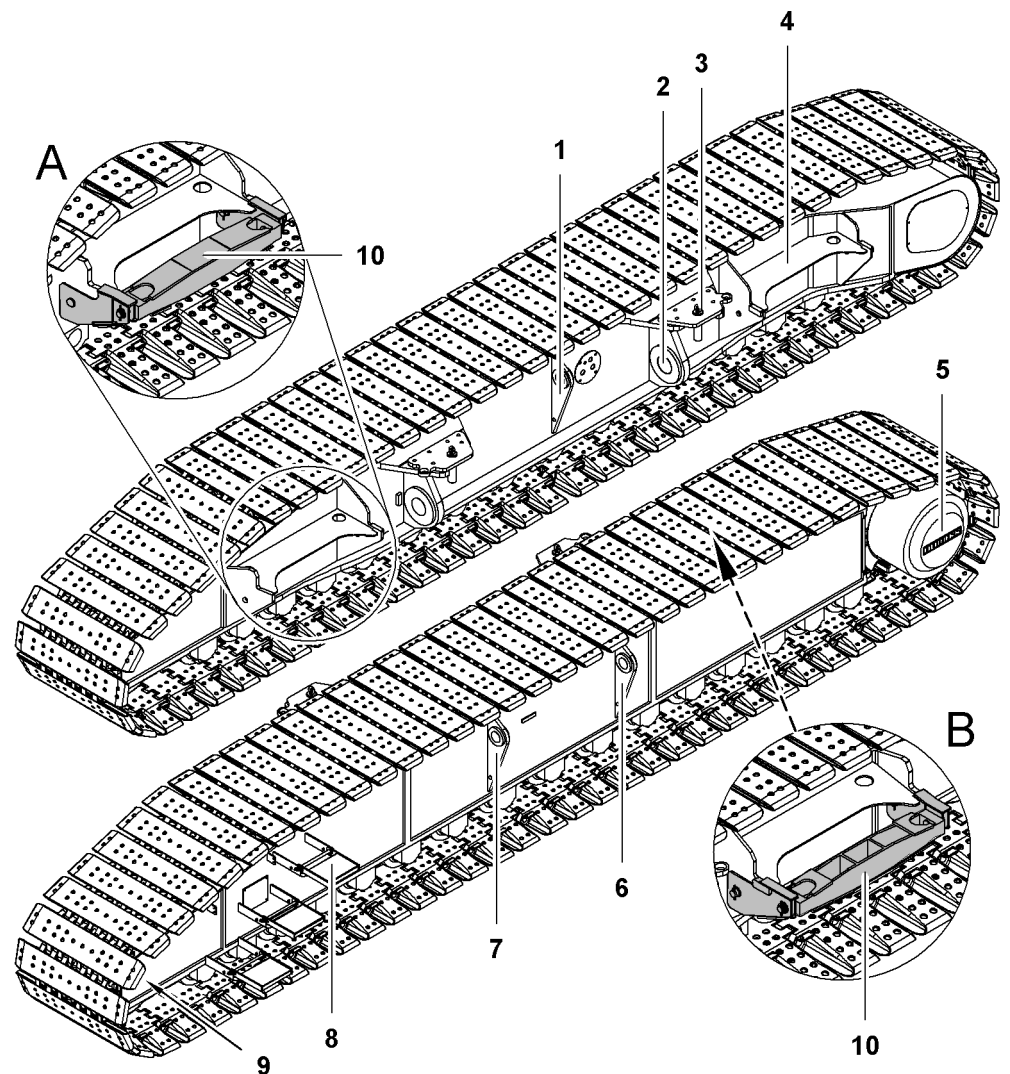


Fig. 123: Crawler side frame for undercarriage with fixed track width

- | | | | |
|---|---|----|--|
| 1 | Pivot point for folding bracket | 7 | Pivot point for folding bracket |
| 2 | Pin connection point (4x) for center part | 8 | Step (6x) |
| 3 | Pins (4x) for pin connection with center part | 9 | Idler wheel (2x) |
| 4 | Support (4x) for carbody counter-weight | 10 | Support (4x) for carbody counter-weight (1500 mm (4' 11" ft-in) base plates) |
| 5 | Tumbler (2x) | A | Detail right crawler side frame (1500 mm (4' 11" ft-in) base plates) |
| 6 | Pivot point for folding bracket | B | Detail left crawler side frame (1500 mm (4' 11" ft-in) base plates) |

The following base plates are available for the crawler side frames:

- 1200 mm (3' 11" ft-in) base plates
- 1500 mm (4' 11" ft-in) base plates

Detail **A + B** shows the additional supports **10** for the carbody counterweight slabs for crawler side frames with 1500 mm (4' 11" ft-in) base plates.

Foldable brackets are attached to the pivot points **1 + 6 + 7** onto which crawler side frames are attached for loading.

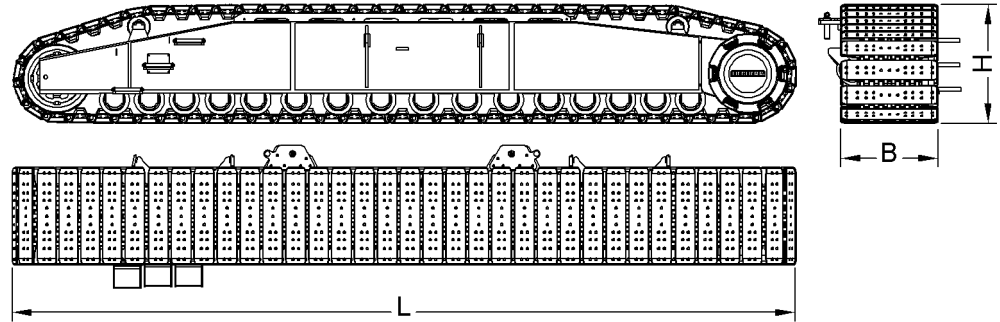


Fig. 124: Dimensions crawler side frame for undercarriage with fixed track width

The technical data apply per crawler side frame.

Name		Value	
L	Length crawler side frame	with 1200 mm (3' 11" ft-in) base plates	9674 mm 31' 9" ft-in
		with 1500 mm (4' 11" ft-in) base plates	9694 mm 31' 10" ft-in
B	Width crawler side frame	with 1200 mm (3' 11" ft-in) base plates	1200 mm 3' 11" ft-in
		with 1500 mm (4' 11" ft-in) base plates	1500 mm 4' 11" ft-in
H	Height crawler side frame	with 1200 mm (3' 11" ft-in) base plates	1462 mm 4' 10" ft-in
		with 1500 mm (4' 11" ft-in) base plates	1482 mm 4' 10" ft-in
Weight crawler side frame with 1200 mm (3' 11" ft-in) base plates		21880 kg 48,236 lb	
Weight crawler side frame with 1500 mm (4' 11" ft-in) base plates		25702 kg 56,662 lb	

Tab. 70: Technical data crawler side frame for undercarriage with fixed track width

LWNLR-x\04.01\Auslieferung\2016-03-07\en

Crawler side frame for undercarriage* with adjustable track width

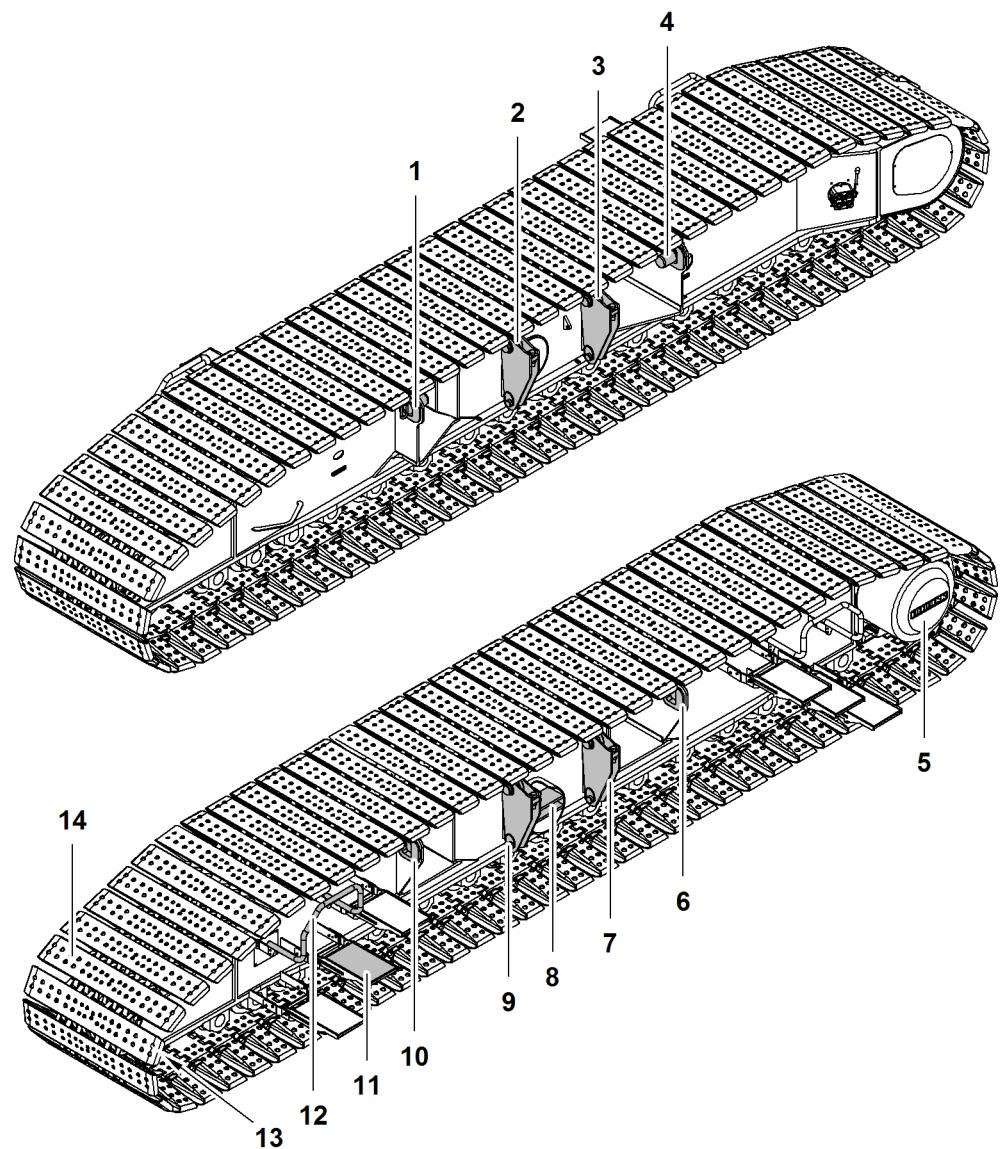


Fig. 125: Crawler side frame for undercarriage* with adjustable track width

1	Pin connection point for center part	8	Pin connection point (2x) for track width adjusting cylinder
2	Folding bracket	9	Folding bracket
3	Folding bracket	10	Pin connection point for center part
4	Pin connection point for center part	11	Steps (12x)
5	Tumbler (2x)	12	Handrail (4x)
6	Pin connection point for center part	13	Idler wheel (2x)
7	Folding bracket	14	Base plates

The following base plates are available for the crawler side frames:

- 1200 mm (3' 11" ft-in) base plates
- 1500 mm (4' 11" ft-in) base plates

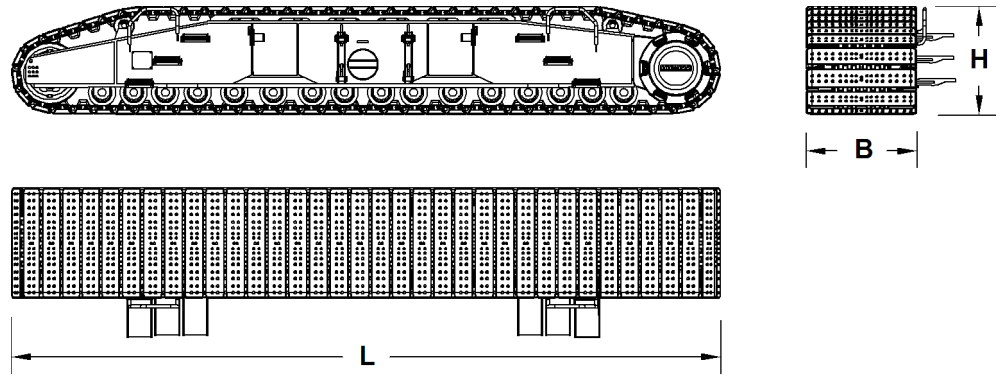


Fig. 126: Dimensions crawler side frames for undercarriages with adjustable track width

The technical data apply per crawler side frame.

Name		Value	
L	Length crawler side frame	with 1200 mm (3' 11" ft-in) base plates	9683 mm 31' 9" ft-in
		with 1500 mm (4' 11" ft-in) base plates	9703 mm 31' 10" ft-in
B	Width crawler side frame	with 1200 mm (3' 11" ft-in) base plates	1200 mm 3' 11" ft-in
		with 1500 mm (4' 11" ft-in) base plates	1500 mm 4' 11" ft-in
H	Height crawler side frame	with 1200 mm (3' 11" ft-in) base plates	1474 mm 4' 10" ft-in
		with 1500 mm (4' 11" ft-in) base plates	1482 mm 4' 10" ft-in
Weight crawler side frame with 1200 mm (3' 11" ft-in) base plates		22600 kg 49,824 lb	
Weight crawler side frame with 1500 mm (4' 11" ft-in) base plates		26200 kg 57,760 lb	

Tab. 71: Technical data crawler side frame for undercarriage with adjustable track width

1.7.11 Platforms at undercarriage with fixed track width

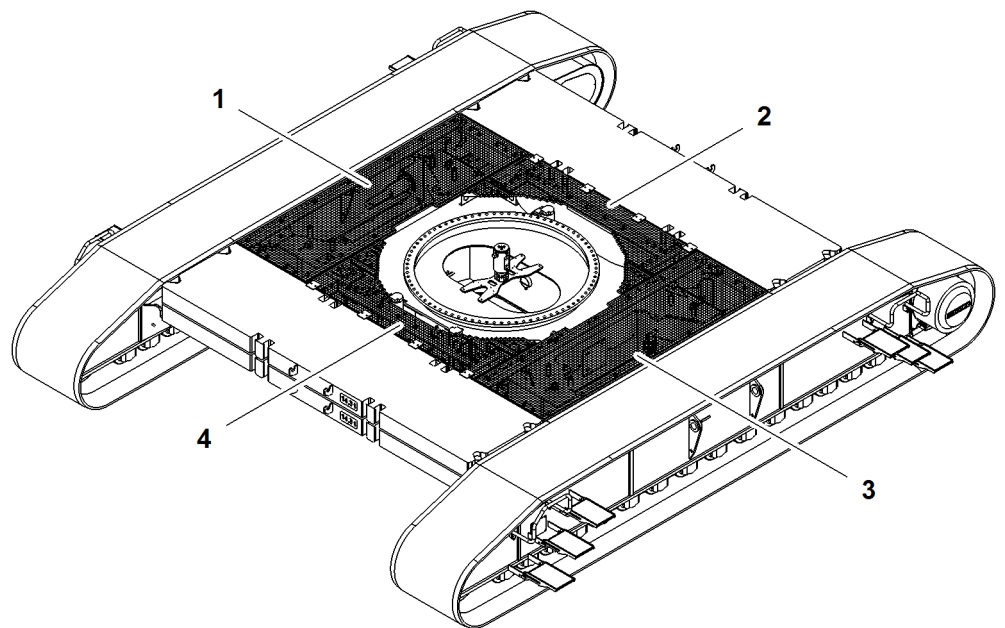


Fig. 127: Platforms at undercarriage with fixed track width

- | | | | |
|---|----------------|---|----------------|
| 1 | Right platform | 3 | Left platform |
| 2 | Rear platform | 4 | Front platform |

The platforms 1 + 3 are placed on brackets on the carbody counterweight (For more information see: [Carbody counterweight for undercarriage with fixed track width](#), page 148) .

The platforms 2 + 4 are placed on brackets on the undercarriage.

The platforms have support brackets.

The platforms 1 + 3 are fitted with distancers. The distancers are located on the undercarriage to prevent sagging.

Right and left platform

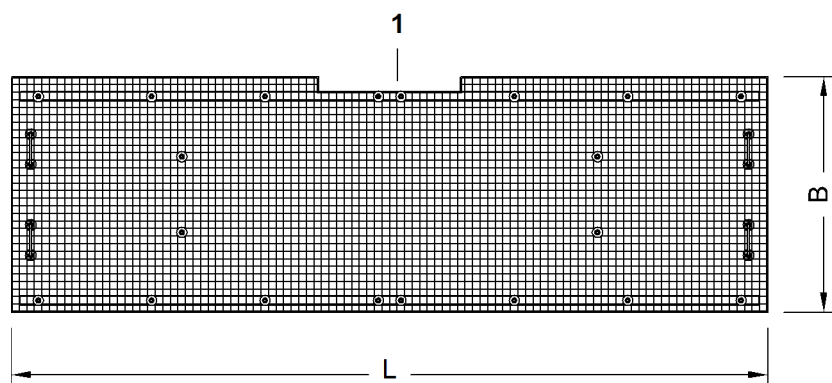


Fig. 128: Dimensions right and left platform

- | | |
|---|--------|
| 1 | Recess |
|---|--------|

Name		Value	
L	Length	with 1200 mm (3' 11" ft-in) base plates	4007 mm 13' 2" ft-in
		with 1500 mm (4' 11" ft-in) base plates	4010 mm 13' 2" ft-in
B	Width	with 1200 mm (3' 11" ft-in) base plates	1247 mm 4' 1" ft-in
		with 1500 mm (4' 11" ft-in) base plates	1005 mm 3' 4" ft-in
Weight platform with 1200 mm (3' 11" ft-in) base plates			100 kg 220 lb
Weight platform with 1500 mm (4' 11" ft-in) base plates			75 kg 165 lb

Tab. 72: Technical data right and left platform

Front and rear platform

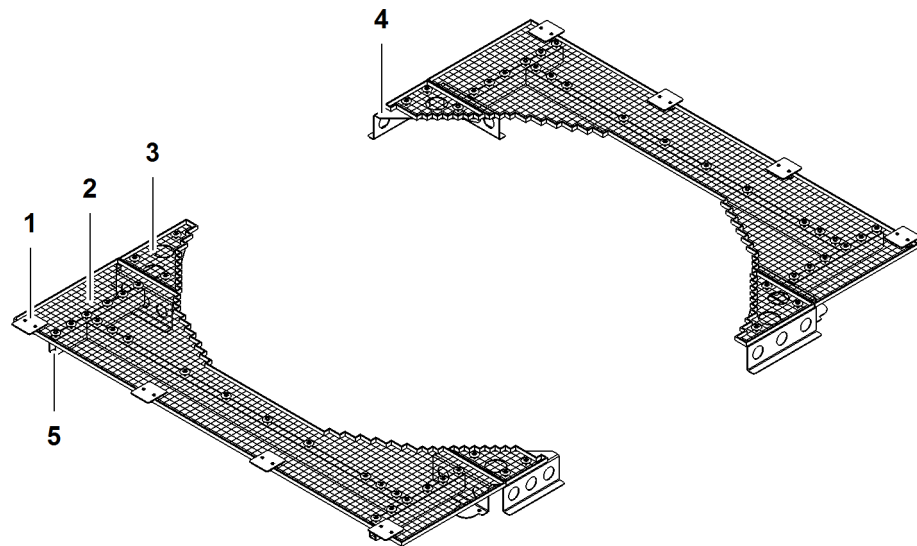


Fig. 129: Front and rear platform

- | | |
|-------------------------------|---------------------------|
| 1 Support plate (8x) | 4 Steel plate (4x) |
| 2 Platform (2x) | 5 Frame (2x) |
| 3 Corner platform (4x) | |

The frames **5** and support plates **1** are already mounted upon delivery.

Platform

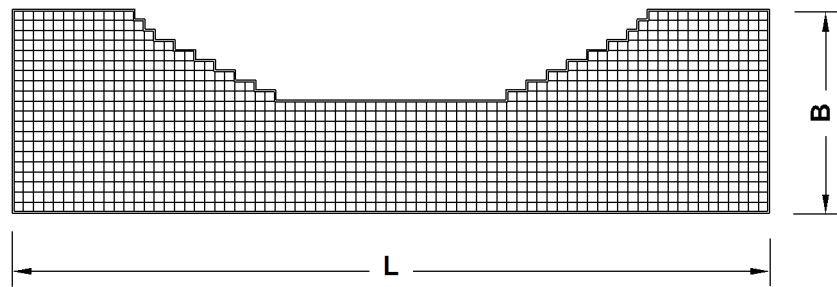


Fig. 130: Platform dimensions

Name		Value
L	Length	3007 mm 9' 10" ft-in
B	Width	807 mm 2' 8" ft-in
Weight		82 kg 181 lb

Tab. 73: Technical data platform

Right corner platform

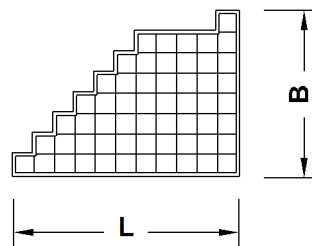


Fig. 131: Dimensions right corner platform

Name		Value
L	Length	447 mm 1' 6" ft-in
B	Width	327 mm 1' 1" ft-in
Weight		2.5 kg 5.51 lb

Tab. 74: Technical data right corner platform

LWNLR.x/V04.01//Auslieferung/2016-03-07/en

Left corner platform

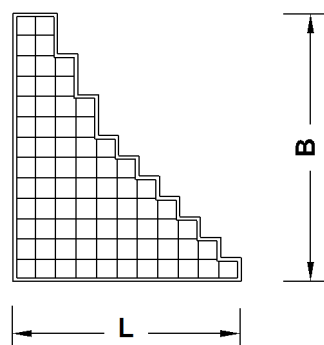


Fig. 132: Left corner platform

Name		Value
L	Length	447 mm 1' 6" ft-in
B	Width	527 mm 1' 9" ft-in
Weight		3 kg 6.61 lb

Tab. 75: Technical data left corner platform

Steel plates

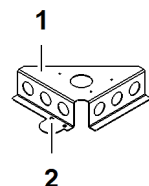


Fig. 133: Steel plates

1 Plate

2 Attachment shackle

Left steel plate

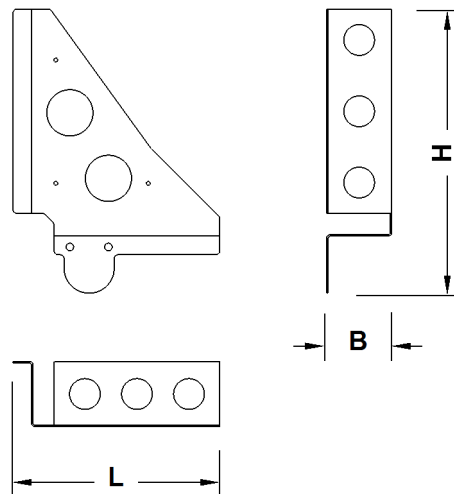


Fig. 134: Dimensions left steel plate

Name		Value
L	Length	537 mm 1' 9" ft-in
B	Width	169 mm 6.65" in
H	Height	737 mm 2' 5" ft-in
Weight		20.5 kg 45.19 lb

Tab. 76: Technical data left steel plate

Right steel plate

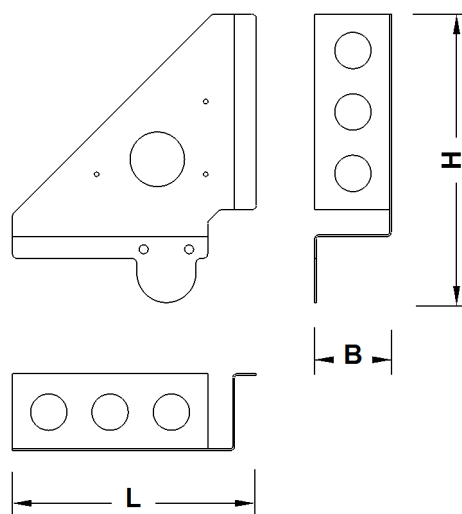


Fig. 135: Dimensions right steel plate

LWNLR.x/V04.01//Auslieferung/2016-03-07/en

Name		Value
L	Length	537 mm 1' 9" ft-in
B	Width	169 mm 6.65" in
H	Height	634 mm 2' 1" ft-in
Weight		18.5 kg 40.78 lb

Tab. 77: Technical data right steel plate

1.7.12 Carbody counterweight

Carbody counterweight for undercarriage with fixed track width

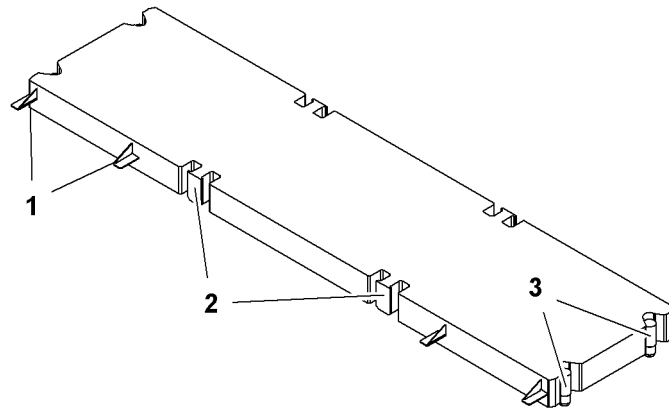


Fig. 136: Carbody counterweight for undercarriage with fixed track width

- 1 Support (4x) for platforms
- 2 Rigging point (4x)
- 3 Locking device (4x)

Carbody counterweight slab 14.3 t (31,526 lb)

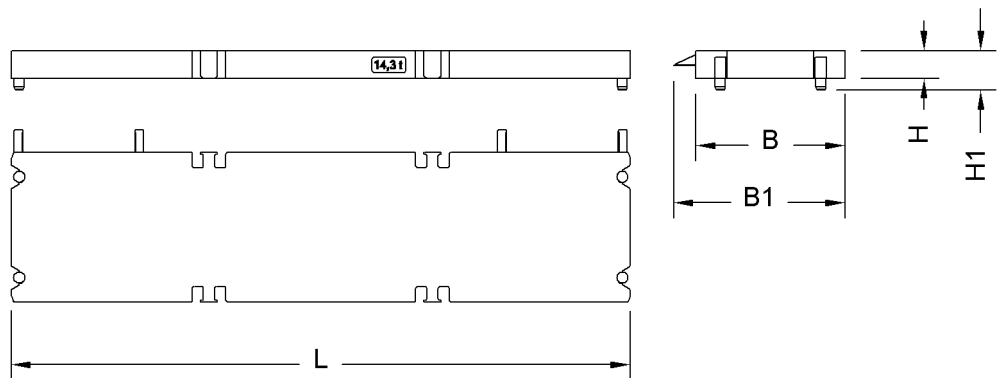


Fig. 137: Dimensions of carbody counterweight slab 14.3 t (31,526 lb)

LWNLR-x/V04.01//Auslieferung/2016-03-07/en

Name		Value
L	Length	5540 mm 18' 2" ft-in
W	Width	1335 mm 4' 5" ft-in
W1	Width incl. platform supports	1535 mm 5' ft-in
H	Height	250 mm 9.84" in
H1	Height incl. locking devices	350 mm 1' 2" ft-in
Weight		14300 kg 31,526 lb

Tab. 78: Technical data carbody counterweight slab 14.3 t (31,526 lb)

Carbody counterweight slab 13.4 t (29,542 lb)*

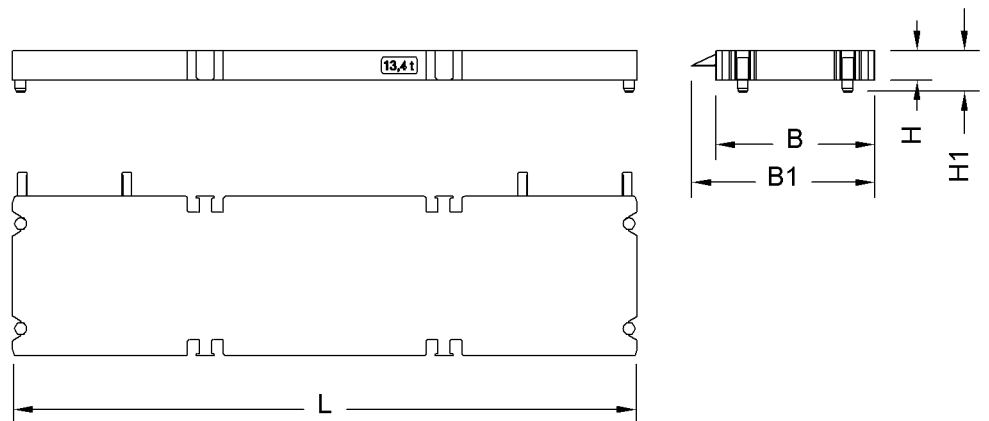


Fig. 138: Dimensions carbody counterweight slab 13.4 t (29,542 lb)

Name		Value
L	Length	5240 mm 17' 2" ft-in
B	Width	1335 mm 4' 5" ft-in
B1	Width incl. platform supports	1535 mm 5' ft-in
H	Height	250 mm 9.84" in
H1	Height incl. locking devices	350 mm 1' 2" ft-in
Weight		13400 kg 29,542 lb

Tab. 79: Technical data carbody counterweight slab 13.4 t (29,542 lb)

Carbody counterweight for undercarriage* with adjustable track width

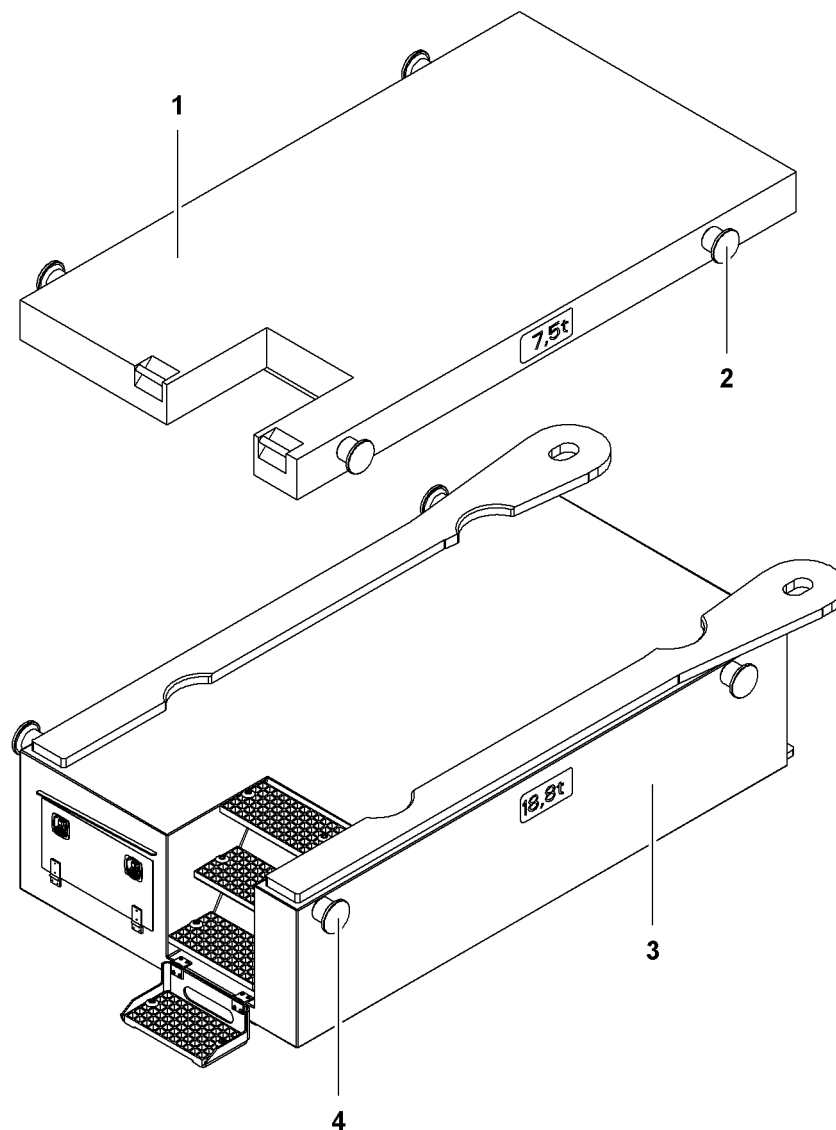


Fig. 139: Carbody counterweight for undercarriage* with adjustable track width

- | | |
|---|--|
| <p>1 Carbody counterweight slab
7.5 t (16,534 lb)</p> | <p>3 Carbody counterweight slab
18.8 t (41,446 lb)</p> |
| <p>2 Rigging point (4x)</p> | <p>4 Rigging point (4x)</p> |

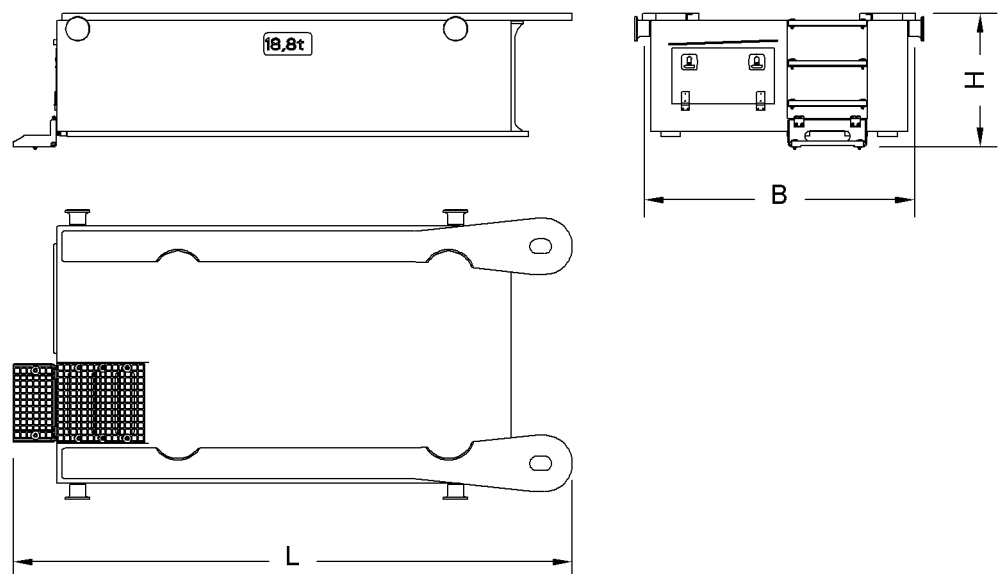
Carbody counterweight slab 18.8 t (41,446 lb)

Fig. 140: Dimensions carbody counterweight slab 18.8 t (41,446 lb)

Name		Value
L	Length	3484 mm 11' 5" ft-in
B	Width	1700 mm 5' 7" ft-in
H	Height	833 mm 2' 9" ft-in
Weight		18800 kg 41,446 lb

Tab. 80: Technical data carbody counterweight slab 18.8 t (41,446 lb)

Carbody counterweight slab 7.5 t (16,534 lb)

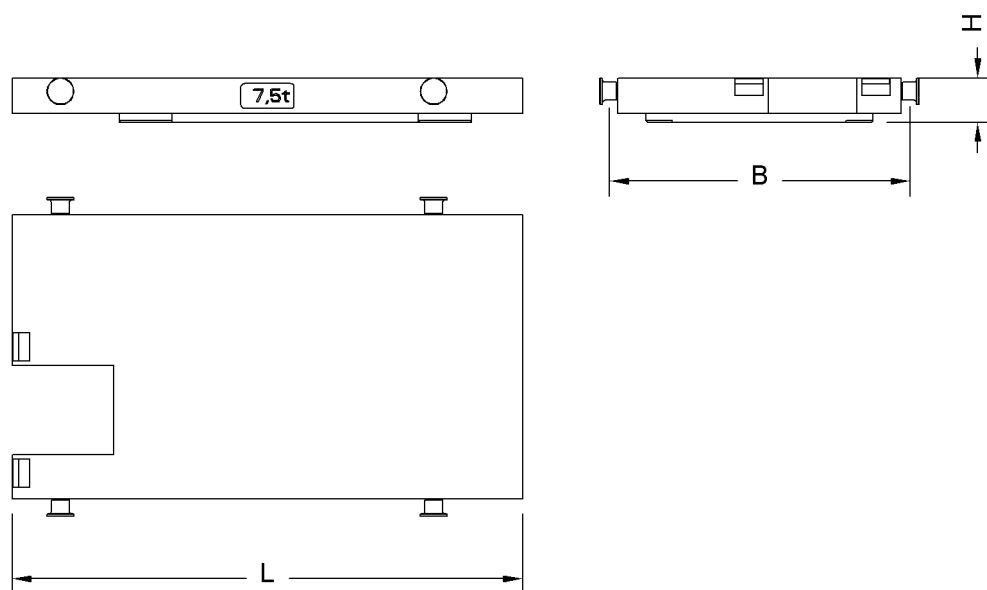


Fig. 141: Dimensions carbody counterweight slab 7.5 t (16,534 lb)

Name		Value
L	Length	2880 mm 9' 5" ft-in
B	Width	1600 mm 5' 3" ft-in
H	Height	200 mm 7.87" in
Weight		7500 kg 16,534 lb

Tab. 81: Technical data carbody counterweight slab 7.5 t (16,534 lb)

LWN/LR-x/V04.01//Auslieferung/2016-03-07/en

1.7.13 Rear counterweight

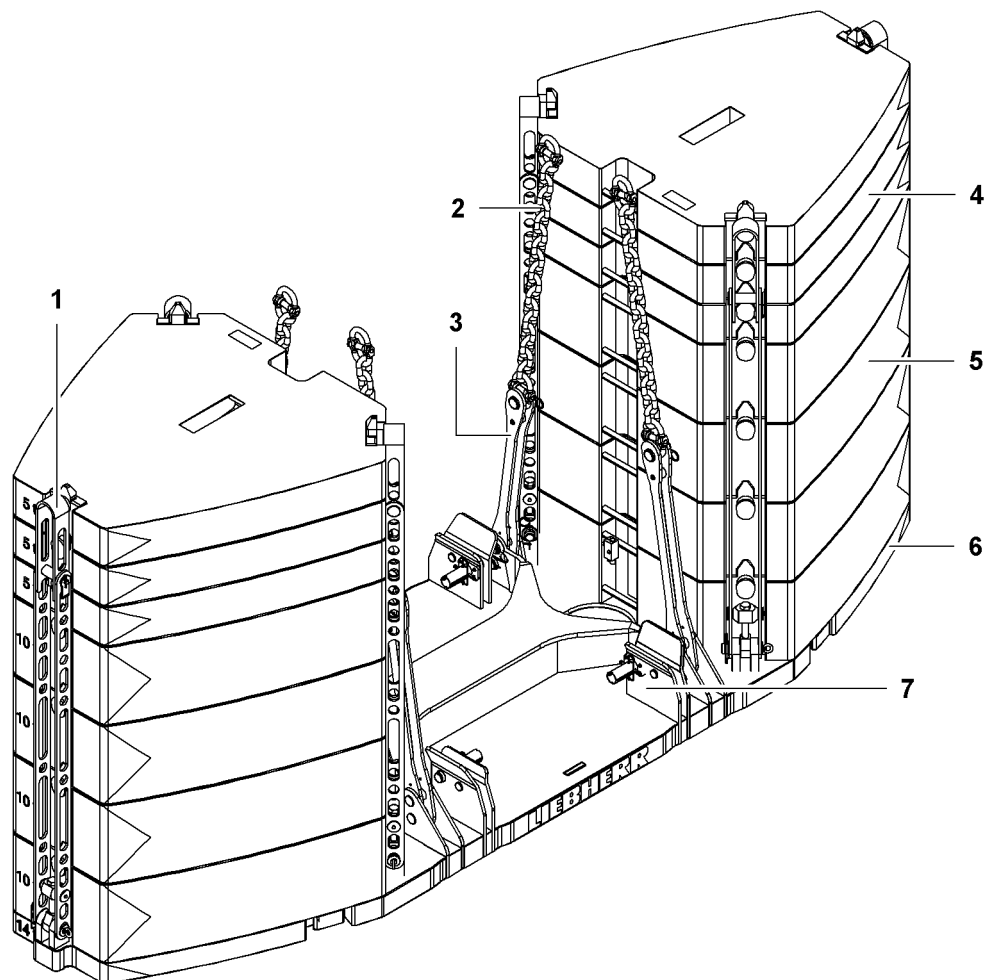


Fig. 142: Rear counterweight overview from rear left

- | | | | |
|---|---|---|---|
| 1 | Rear counterweight tie-down (6x) | 5 | Counterweight slab
10 t (22,046 lb) (max. 8x) |
| 2 | Counterweight hoisting chain (4x) | 6 | Basic counterweight slab
14 t (30,864 lb) |
| 3 | Slings (4x) | 7 | Pin connection point (4x) with
locking devices |
| 4 | Counterweight slab 5 t (11,023 lb)
(max. 6x) | | |

The rear counterweight:

- is a basic requirement for stability.
- is lifted by the two counterweight hoisting cylinders.
- is pinned onto the rear of the uppercarriage.

Basic counterweight slab 14 t (30,864 lb)

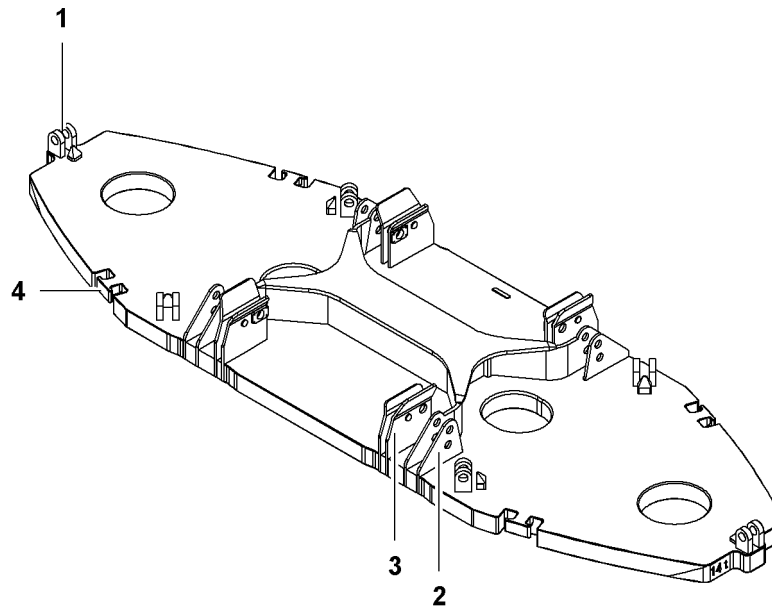


Fig. 143: Basic counterweight slab 14 t (30,864 lb)

- | | |
|--|---|
| <p>1 Pin connection point counterweight tie-down (6x)</p> <p>2 Pin connection point slinging plates (4x)</p> | <p>3 Pin connection point (4x) with locking devices</p> <p>4 Rigging point (4x)</p> |
|--|---|

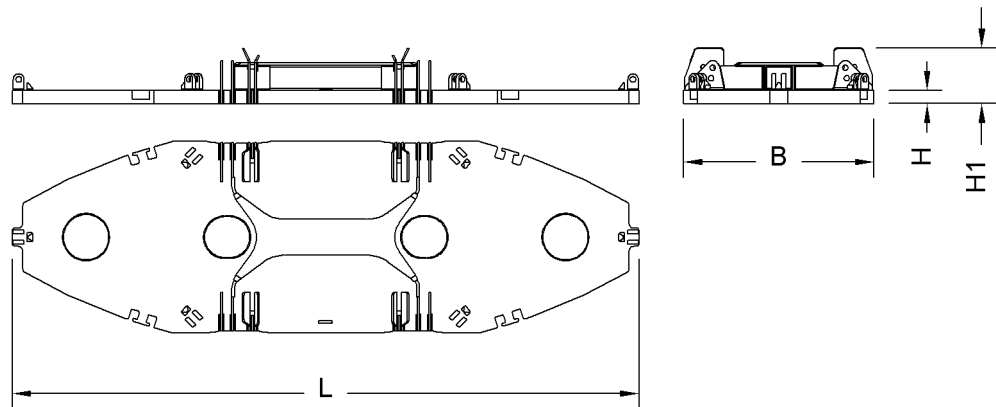


Fig. 144: Dimensions basic counterweight slab 14 t (30,864 lb)

Name		Value
L	Length incl. counterweight tie-down pin connection points	6930 mm 22' 9" ft-in
W	Width	2106 mm 6' 11" ft-in
H	Height	150 mm 5.91" in
H1	Height incl. pin connection points and locking devices	615 mm 2' ft-in

LWNLR-x/V04.01//Auslieferung/2016-03-07/en

Name	Value
Weight	14000 kg 30,864 lb

Tab. 82: Technical data basic counterweight slab 14 t (30,864 lb)

Counterweight slab 10 t (22,046 lb)

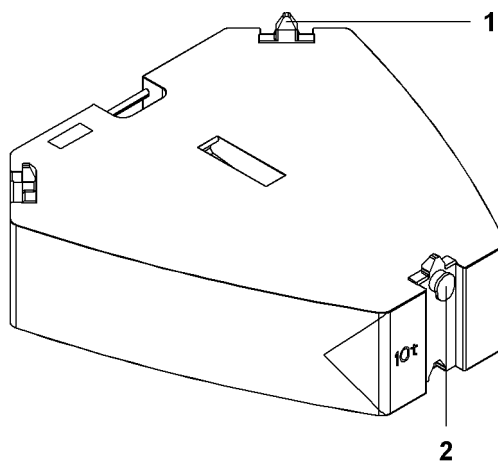


Fig. 145: Counterweight slab 10 t (22,046 lb)

- 1** Locking device (3x) **2** Rigging point (3x)

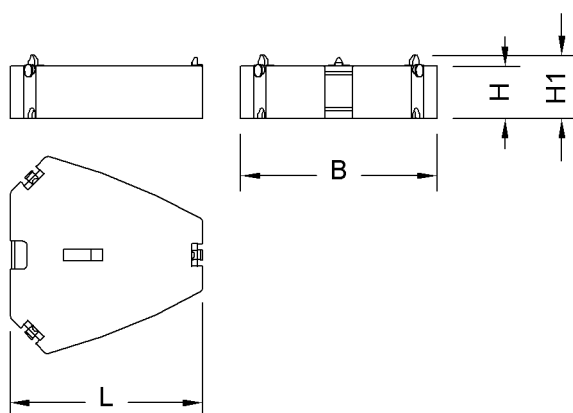


Fig. 146: Dimensions counterweight slab 10 t (22,046 lb)

Name	Value
L Length	2050 mm 6' 9" ft-in
B Width	2117 mm 6' 11" ft-in
H Height	560 mm 1' 10" ft-in
H1 Height incl. locking devices	680 mm 2' 3" ft-in

LWNLR.x/V04.01//Auslieferung/2016-03-07/en

Name	Value
Weight	10000 kg 22,046 lb

Tab. 83: Technical data counterweight slab 10 t (22,046 lb)

Counterweight slab 5 t (11,023 lb)

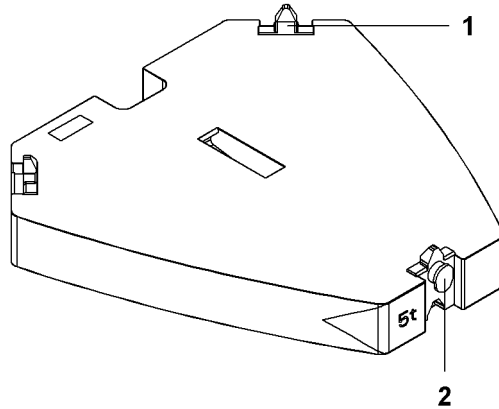


Fig. 147: Counterweight slab 5 t (11,023 lb)

- 1 Locking device (3x)
- 2 Rigging point (3x)

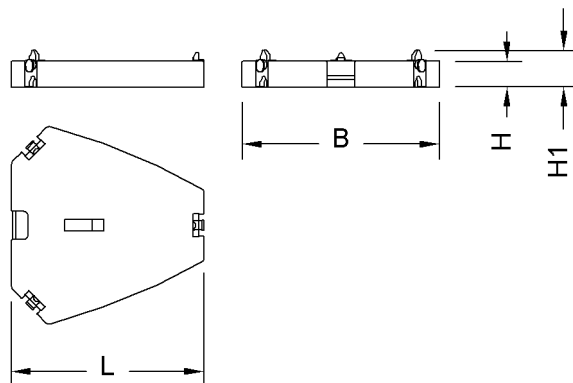


Fig. 148: Dimensions counterweight slab 5 t (11,023 lb)

Name	Value
L Length	2050 mm 6' 9" ft-in
B Width	2117 mm 6' 11" ft-in
H Height	275 mm 10.83" in
H1 Height incl. locking devices	395 mm 1' 4" ft-in
Weight	5000 kg 11,023 lb

Tab. 84: Technical data counterweight slab 5 t (11,023 lb)

LWNLR-x\04.01\Auslieferung\2016-03-07/en

1.8 Information about boom designation

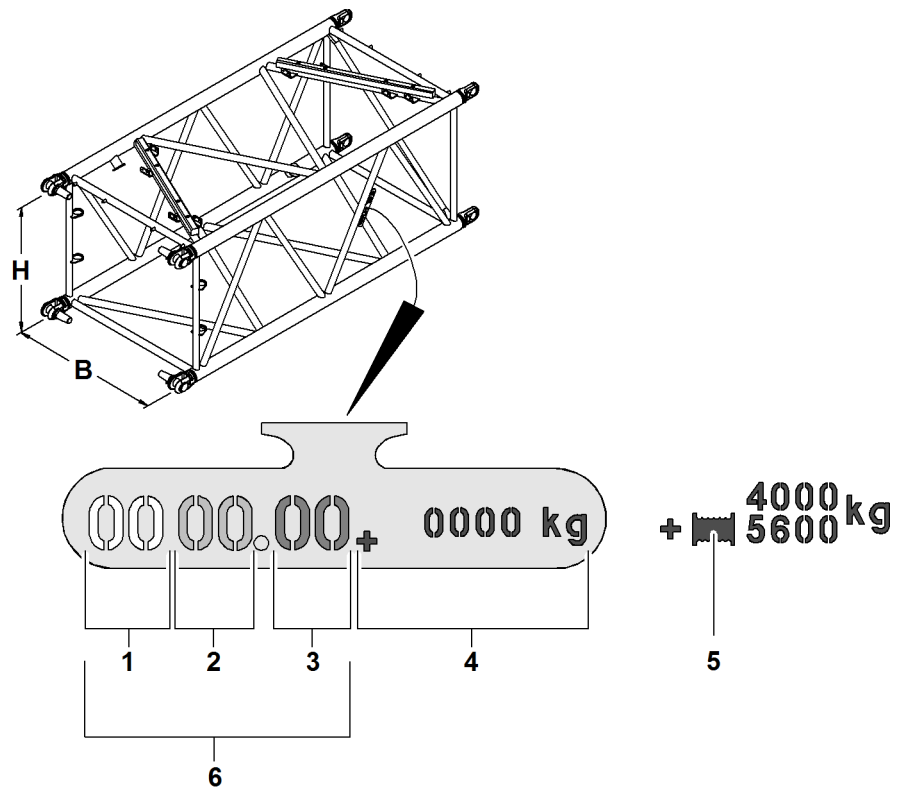


Fig. 149: Boom identification plate symbolic

1	System width of the part in [dm]	5	Weight of the part with and without jib luffing winch
2	System height of the part in [dm]	6	System number
3	Wall thickness code	B	System width
4	Weight of the part	H	System height

The **system number 6** marks boom components. The system number is used to distinguish between the different boom sections in the LR series.

Each boom section is marked with the system number.

The **system width B** indicates the width of the boom section.

The **system height H** refers to the height of the boom section.

The **wall thickness code 3** corresponds to a specific wall thickness.

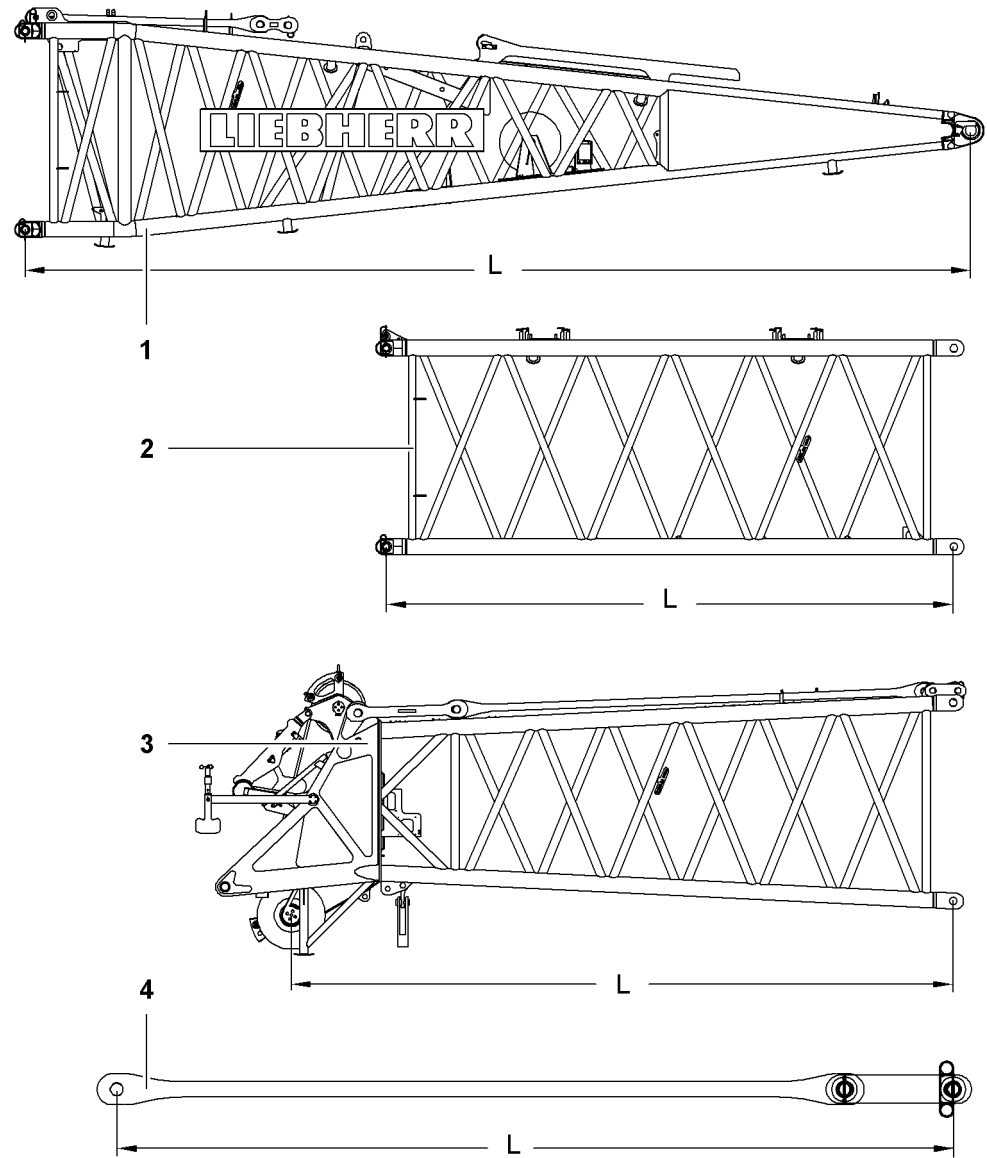


Fig. 150: System length of the boom sections

- | | | | |
|---|-------------------|---|---|
| 1 | boom base section | 4 | Pendant strap (including connecting link) |
| 2 | Boom section | L | System length |
| 3 | Boom head | | |

The **system length L**:

- refers to the pin connection points for the boom sections or pendant straps
- is used to calculate the total length of the boom

1.9 Distinguishing features main boom sections LR 1300 and LR 1300 SX

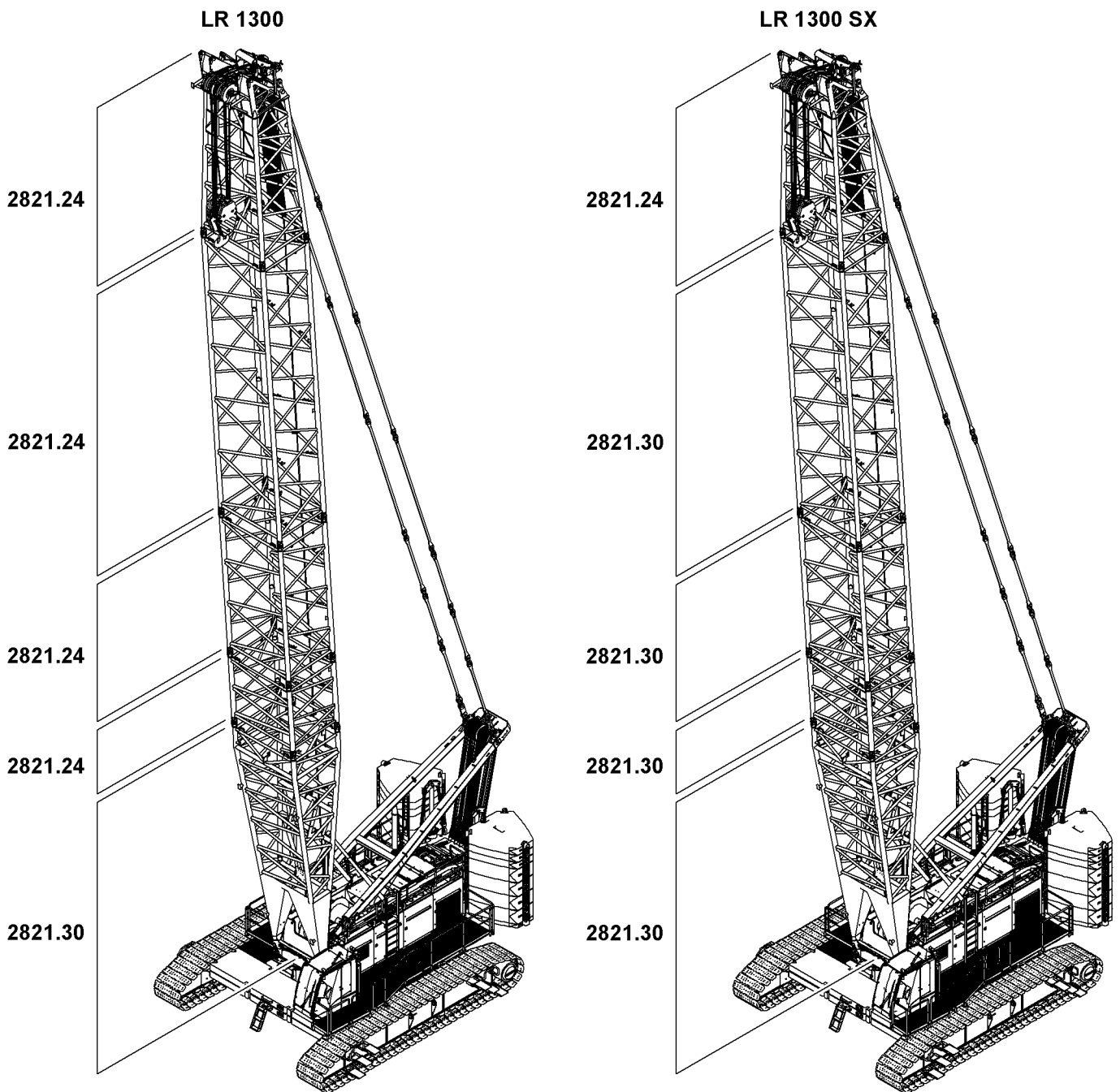


Fig. 151: Distinguishing features main boom sections LR 1300 and LR 1300 SX

The main boom sections differ with respect to wall thickness code and weight.

LWNLR_x/V04.01//Auslieferung/2016-03-07/en

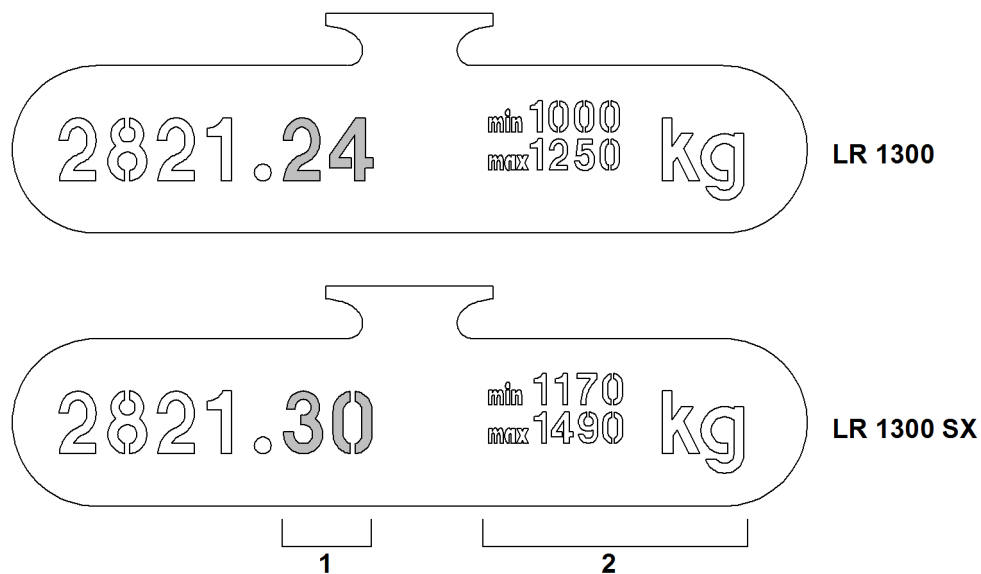


Fig. 152: Type plates of main boom sections LR 1300 and LR 1300 SX

1 Wall thickness code

2 Weight

1.10 Main boom - overview

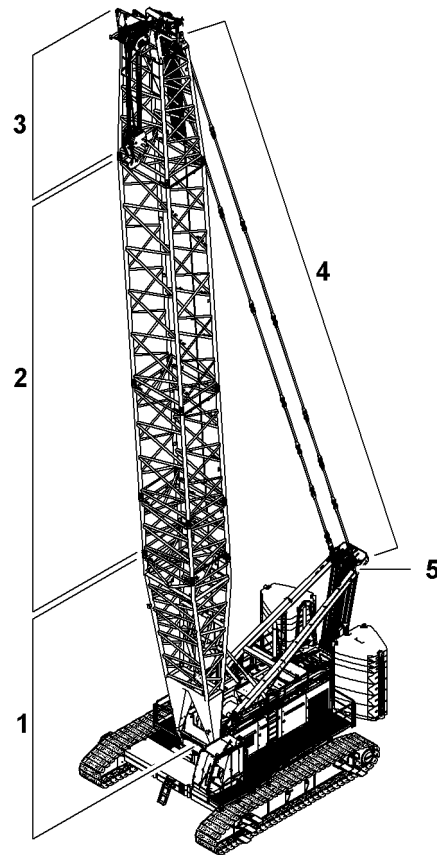


Fig. 153: Main boom - overview

- | | | | |
|---|------------------------|---|--------------------------|
| 1 | Main boom base section | 4 | Main boom pendant straps |
| 2 | Main boom sections | 5 | A-frame1 |
| 3 | Main boom head | | |

The main boom is composed of:

- Boom base section 1
- Boom sections (3 m (10 ft), 6 m (20 ft), 12 m (40 ft)) 2
- Boom head section 3

The main boom pendant straps 4 connect A-frame 1 5 to the boom head section 3.

1.11 2821 main boom

1.11.1 Main boom base section 2821.30

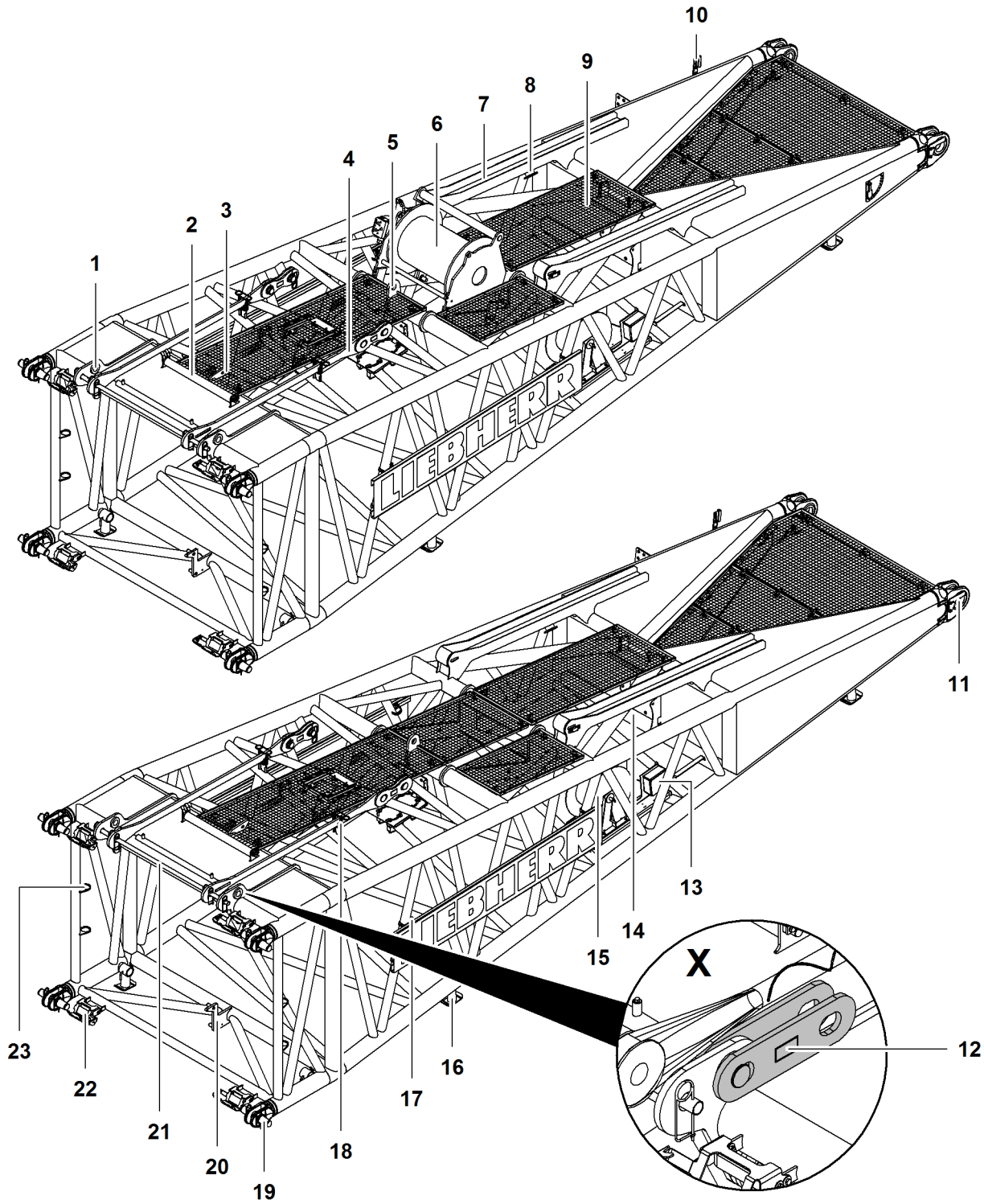


Fig. 154: Main boom base section 2821.30

LWNLR-x/V04.01//Auslieferung/2016-03-07/en

- | | | | | | |
|---|---|----|---|----|---|
| 1 | Pivot point (2x) for jib backstay straps | 9 | Platform (4x) | 17 | Boom identification plate |
| 2 | Rope protection roller | 10 | Limit switch plate for main boom limit switch, top angle limiter | 18 | Transport bracket (2x) for main boom pendant straps |
| 3 | Rope pulley for rope reeving winch | 11 | Pivot point (2x) on uppercarriage | 19 | Pin connection point (4x) with double-taper pins (4x) |
| 4 | Transport position (2x) of main boom pendant straps | 12 | Connecting link (350 mm (1' 2" ft-in)) (2x) for CF pendant straps | 20 | Rope pulley (2x) for rope of rope reeving winch |
| 5 | Pin connection point for assembly cylinder | 13 | Rope reeving winch | 21 | Transport bracket for main boom pendant straps |
| 6 | Jib luffing winch | 14 | Terminal box | 22 | Catch (4x) for double-taper pins |
| 7 | Guide rail (2x) for main boom tilting-back supports | 15 | Cable drum | 23 | Transport bracket (4x) for double-taper pins |
| 8 | Rigging point (4x) | 16 | Foot (6x, two of which hinged) | | |

Detail X shows the connecting links (350 mm (1' 2" ft-in)) **12** installed on the machine with CF pendant straps on the main boom base section by the factory. The connecting links (350 mm (1' 2" ft-in)) **12** are part of the jib backstay straps.

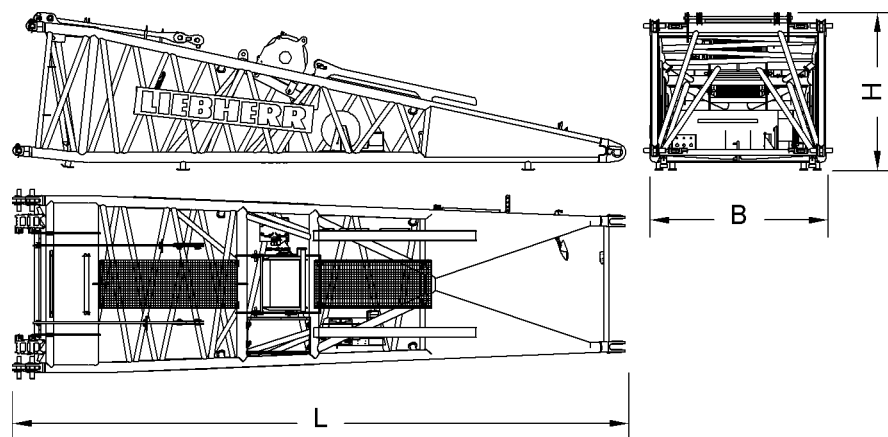


Fig. 155: Dimensions main boom base section 2821.30

Name		Value
System length		10000 mm 32' 10" ft-in
System width		2800 mm 9' 2" ft-in
System height		2100 mm 6' 11" ft-in
L	Length	10300 mm 33' 10" ft-in
W	Width	2970 mm 9' 9" ft-in
H	Height	2650 mm 8' 8" ft-in

LWNLR.x/V04.01//Auslieferung/2016-03-07/en

Name	Value
Weight (incl. pendant straps, jib luffing winch and rope)	7400 kg 16,314 lb
Weight (incl. pendant straps, without jib luffing winch)	5700 kg 12,566 lb
Double-taper pins Ø	80 mm 3.15" in

Tab. 85: Technical data main boom base section 2821.30

1.11.2 Main boom section 2821 3 m (10 ft)

Main boom section 2821.30 3 m (10 ft) for LR 1300 SX

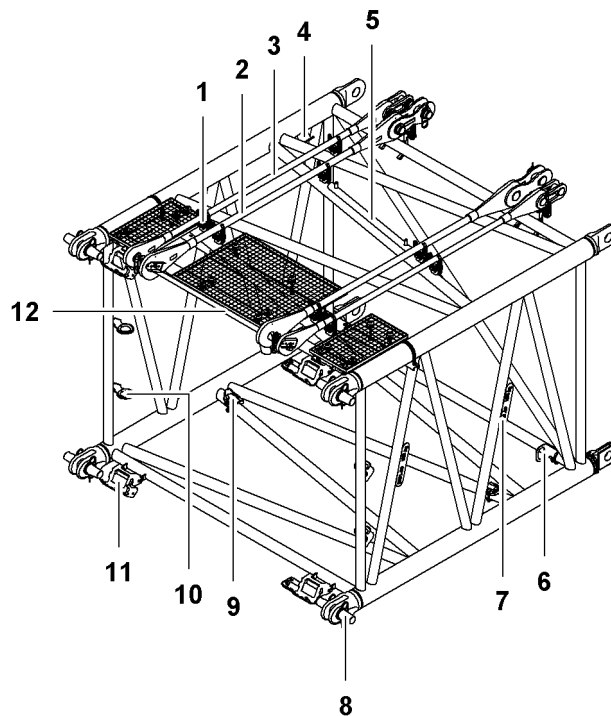


Fig. 156: Main boom section 2821.30 3 m (10 ft) for LR 1300 SX

- | | | | |
|---|--|----|---|
| 1 | Transport bracket (8x) for pendant straps | 7 | Boom identification plate (2x) |
| 2 | Transport position of main boom pendant straps 3 m (10 ft) (2x) | 8 | Pin connection point (8x) with double-taper pin (4x) |
| 3 | Transport position of jib backstay straps 3 m (10 ft) (2x) | 9 | Support (4x) for retracted jib section during transport |
| 4 | Rigging point (4x) | 10 | Transport bracket (4x) for double taper pin |
| 5 | Rope protection guard | 11 | Catch (4x) for double-taper pins |
| 6 | Pin connection point (2x) for retracted jib section during transport | 12 | Transport bracket for pendant straps |

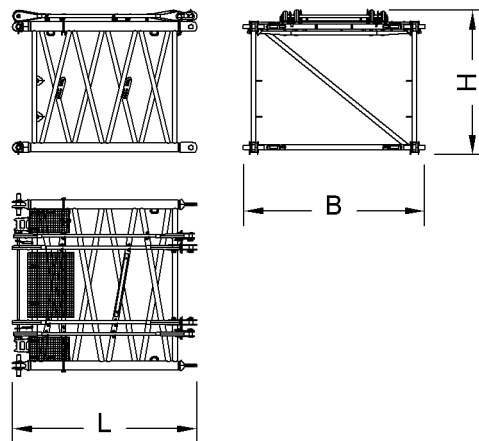


Fig. 157: Dimensions main boom section 2821.30 3 m (10 ft) for LR 1300 SX

Name		Value
System length		3000 mm 9' 10" ft-in
System width		2800 mm 9' 2" ft-in
System height		2100 mm 6' 11" ft-in
L	Length	3220 mm 10' 7" ft-in
B	Width	2970 mm 9' 9" ft-in
H	Height (incl. pendant straps)	2420 mm 7' 11" ft-in
Weight (incl. pendant straps)		1476 kg 3,254 lb
Double taper pin Ø		80 mm 3.15" in

Tab. 86: Technical data main boom section 2821.30 3 m (10 ft) for LR 1300 SX

Main boom section 2821.24 3 m (10 ft) for LR 1300

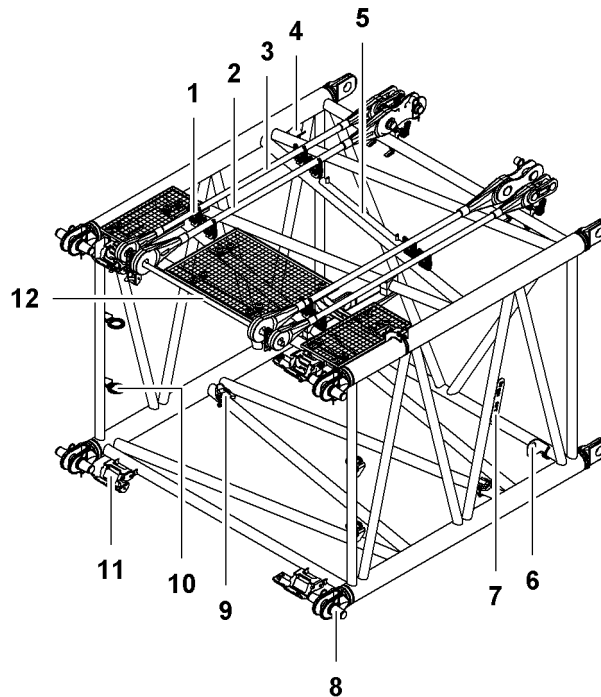


Fig. 158: Main boom section 2821.24 3 m (10 ft) for LR 1300

- | | | | |
|---|--|----|---|
| 1 | Transport bracket (8x) for pendant straps | 7 | Boom identification plate |
| 2 | Transport position of main boom pendant straps 3 m (10 ft) (2x) | 8 | Pin connection point (8x) with double-taper pin (4x) |
| 3 | Transport position of jib backstay straps 3 m (10 ft) (2x) | 9 | Support (4x) for retracted jib section during transport |
| 4 | Rigging point (4x) | 10 | Transport bracket (4x) for double taper pin |
| 5 | Rope protection guard | 11 | Catch (4x) for double-taper pins |
| 6 | Pin connection point (2x) for retracted jib section during transport | 12 | Transport bracket for pendant straps |

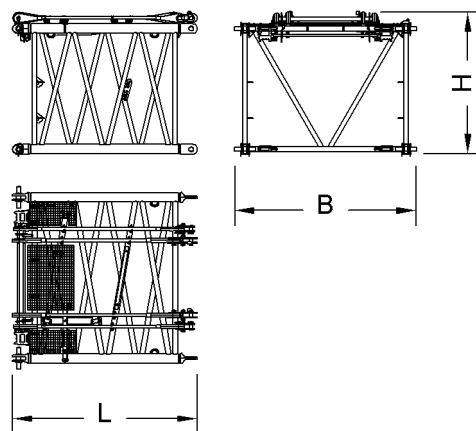


Fig. 159: Dimensions main boom section 2821.24 3 m (10 ft) for LR 1300

Name		Value
System length		3000 mm 9' 10" ft-in
System width		2800 mm 9' 2" ft-in
System height		2100 mm 6' 11" ft-in
L	Length	3220 mm 10' 7" ft-in
B	Width	2970 mm 9' 9" ft-in
H	Height (incl. pendant straps)	2420 mm 7' 11" ft-in
Weight (incl. pendant straps)		1284 kg 2,831 lb
Double taper pin Ø		80 mm 3.15" in

Tab. 87: Technical data main boom section 2821.24 3 m (10 ft) for LR 1300

1.11.3 Main boom section 2821 6 m (20 ft)

Main boom section 2821.30 6 m (20 ft) for LR 1300 SX

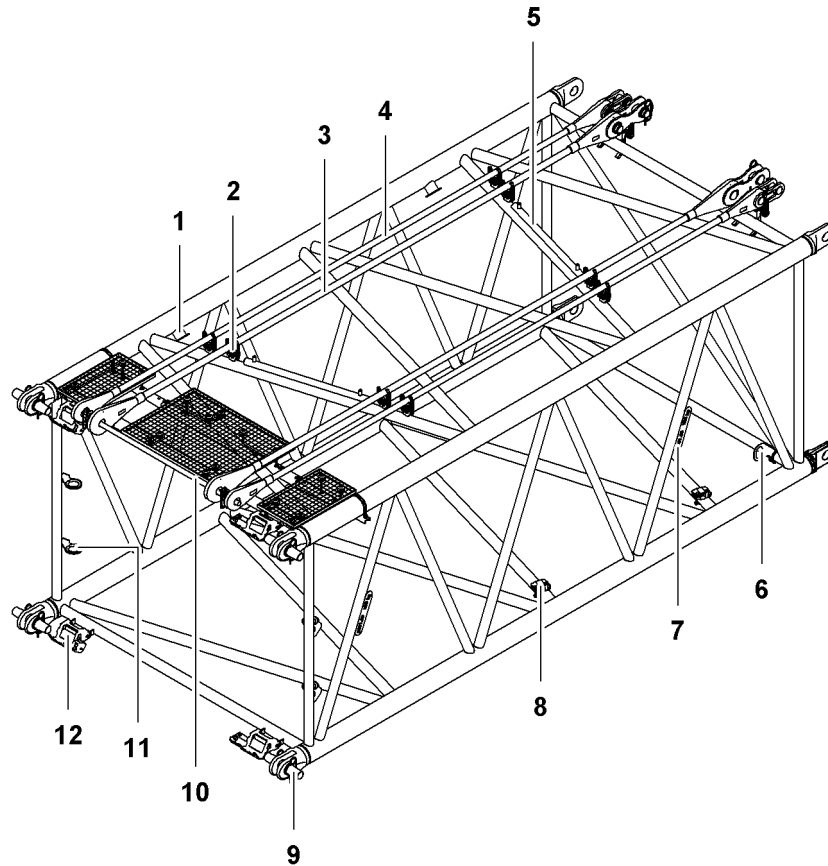


Fig. 160: Main boom section 2821.30 6 m (20 ft) for LR 1300 SX

- | | | | |
|---|--|----|---|
| 1 | Rigging point (4x) | 7 | Boom identification plate (2x) |
| 2 | Transport bracket (8x) for pendant straps | 8 | Support (4x) for retracted jib section during transport |
| 3 | Transport position of main boom pendant straps 6 m (20 ft) (2x) | 9 | Pin connection point (8x) with double-taper pin (4x) |
| 4 | Transport position of jib backstay straps 6 m (20 ft) (2x) | 10 | Transport bracket for pendant straps |
| 5 | Rope protection guard (2x) | 11 | Transport bracket (4x) for double taper pin |
| 6 | Pin connection point (2x) for retracted jib section during transport | 12 | Catch (4x) for double-taper pins |

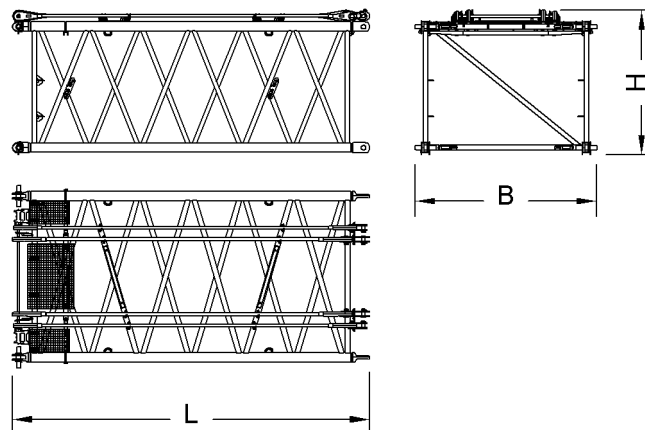


Fig. 161: Dimensions main boom section 2821.30 6 m (20 ft) for LR 1300 SX

Name		Value
System length		6000 mm 19' 8" ft-in
System width		2800 mm 9' 2" ft-in
System height		2100 mm 6' 11" ft-in
L	Length	6220 mm 20' 5" ft-in
B	Width	2970 mm 9' 9" ft-in
H	Height (incl. pendant straps)	2420 mm 7' 11" ft-in
Weight (incl. pendant straps)		2304 kg 5,079 lb
Double taper pin Ø		80 mm 3.15" in

Tab. 88: Technical data main boom section 2821.30 6 m (20 ft) for LR 1300 SX

Main boom section 2821.24 6 m (20 ft) for LR 1300

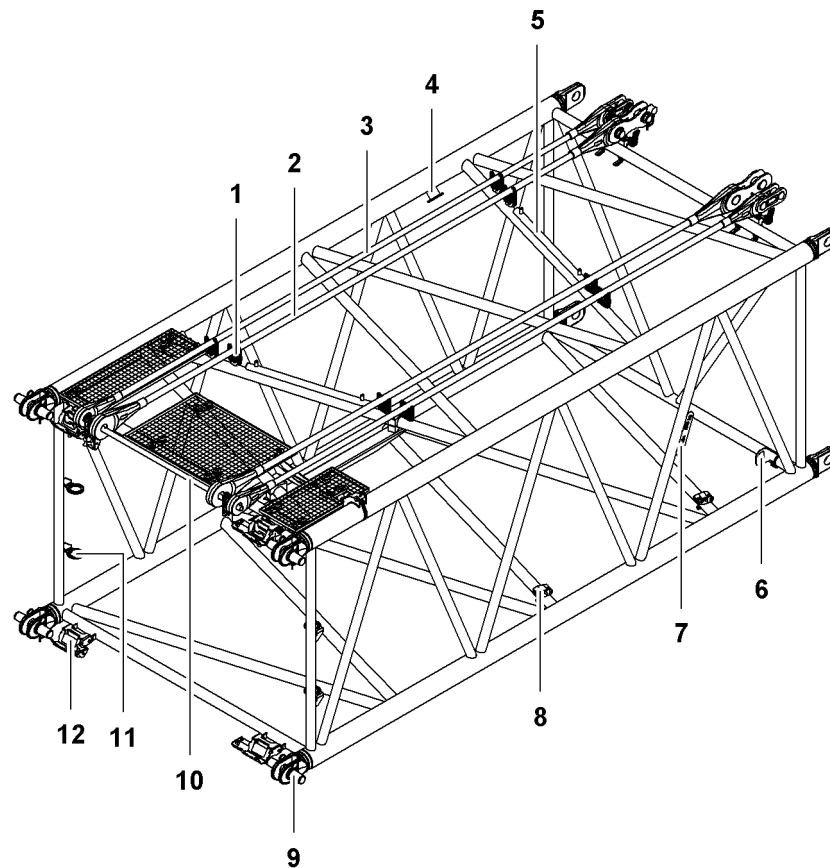


Fig. 162: Main boom section 2821.24 6 m (20 ft) for LR 1300

- | | | | |
|---|--|----|---|
| 1 | Transport bracket (8x) for pendant straps | 7 | Boom identification plate |
| 2 | Transport position of main boom pendant straps 6 m (20 ft) (2x) | 8 | Support (4x) for retracted jib section during transport |
| 3 | Transport position of jib backstay straps 6 m (20 ft) (2x) | 9 | Pin connection point (8x) with double-taper pin (4x) |
| 4 | Rigging point (4x) | 10 | Transport bracket for pendant straps |
| 5 | Rope protection guard (2x) | 11 | Transport bracket (4x) for double taper pin |
| 6 | Pin connection point (2x) for retracted jib section during transport | 12 | Catch (4x) for double-taper pins |

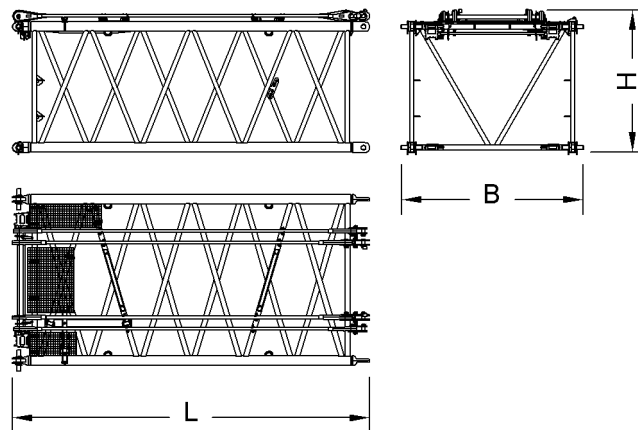


Fig. 163: Dimensions main boom section 2821.24 6 m (20 ft) for LR 1300

Name		Value
System length		6000 mm 19' 8" ft-in
System width		2800 mm 9' 2" ft-in
System height		2100 mm 6' 11" ft-in
L	Length	6220 mm 20' 5" ft-in
B	Width	2970 mm 9' 9" ft-in
H	Height (incl. pendant straps)	2420 mm 7' 11" ft-in
Weight (incl. pendant straps)		1977 kg 4,358 lb
Double taper pin Ø		80 mm 3.15" in

Tab. 89: Technical data main boom section 2821.24 6 m (20 ft) for LR 1300

1.11.4 Main boom section 2821 12 m (40 ft)

Main boom section 2821.30 12 m (40 ft) for LR 1300 SX

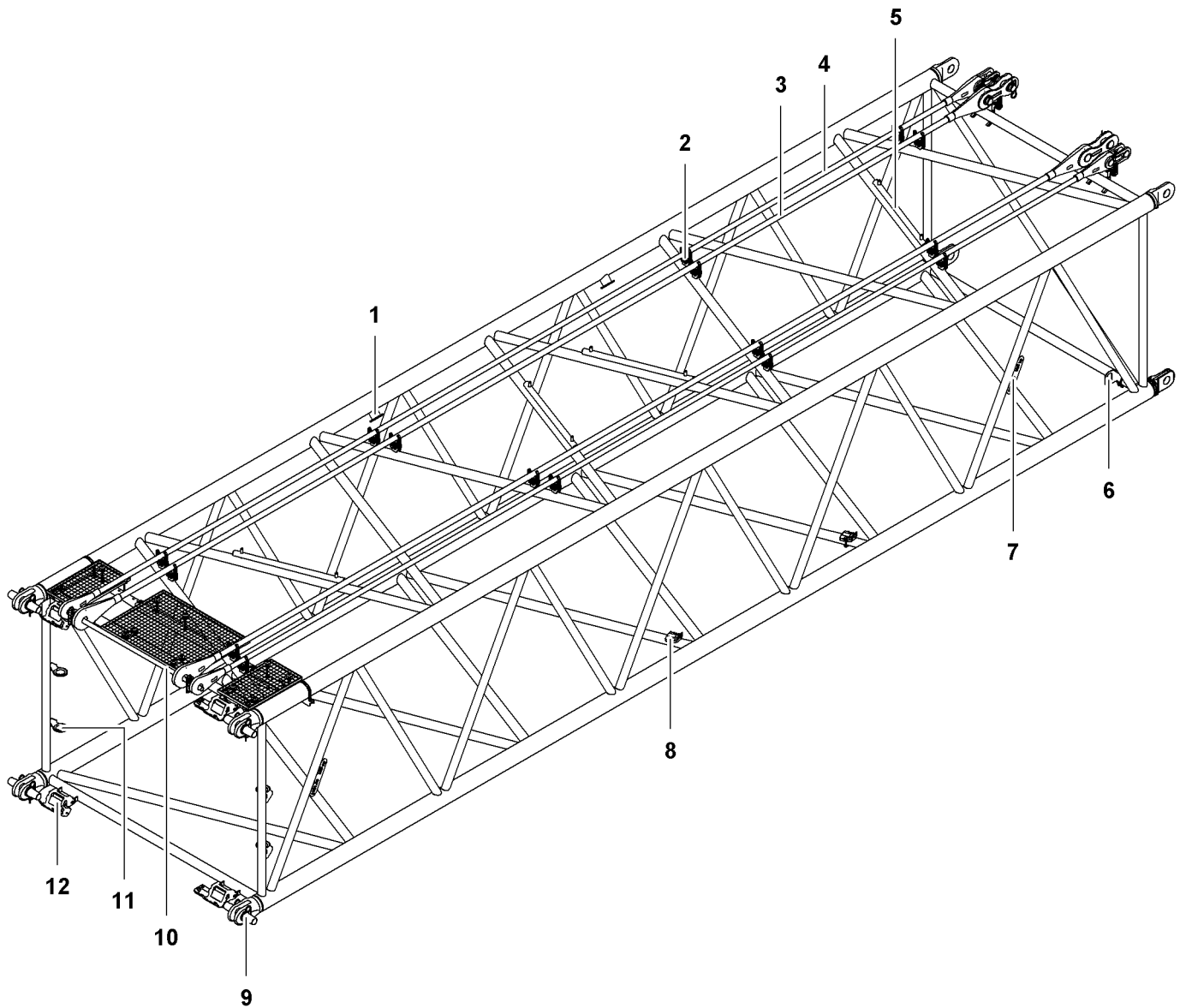


Fig. 164: Main boom section 2821.30 12 m (40 ft) for LR 1300 SX

- | | | | | | |
|---|--|---|--|----|--|
| 1 | Rigging point (4x) | 5 | Rope protection guard (3x) | 9 | Pin connection point (8x) with double-taper pin (4x) |
| 2 | Transport bracket (16x) for pendant straps | 6 | Pin connection point (2x) for retracted jib section during transport | 10 | Transport bracket for pendant straps |
| 3 | Transport position of main boom pendant straps 12 m (40 ft) (2x) | 7 | Boom identification plate (2x) | 11 | Transport bracket (4x) for double taper pin |
| 4 | Transport position of jib back-stay straps 12 m (40 ft) (2x) | 8 | Support (4x) for retracted jib section during transport | 12 | Catch (4x) for double-taper pins |

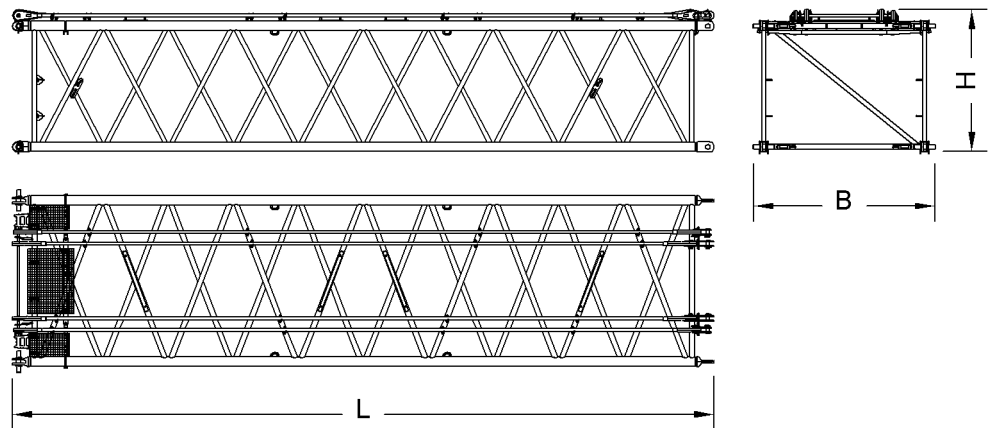


Fig. 165: Dimensions main boom section 2821.30 12 m (40 ft) for LR 1300 SX

Name		Value
System length		12000 mm 39' 4" ft-in
System width		2800 mm 9' 2" ft-in
System height		2100 mm 6' 11" ft-in
L	Length	12220 mm 40' 1" ft-in
B	Width	2970 mm 9' 9" ft-in
H	Height (incl. pendant straps)	2420 mm 7' 11" ft-in
Weight (incl. pendant straps)		4236 kg 9,339 lb
Double taper pin Ø		80 mm 3.15" in

Tab. 90: Technical data main boom section 2821.30 12 m (40 ft) for LR 1300 SX

Main boom section 2821.24 12 m (40 ft) for LR 1300

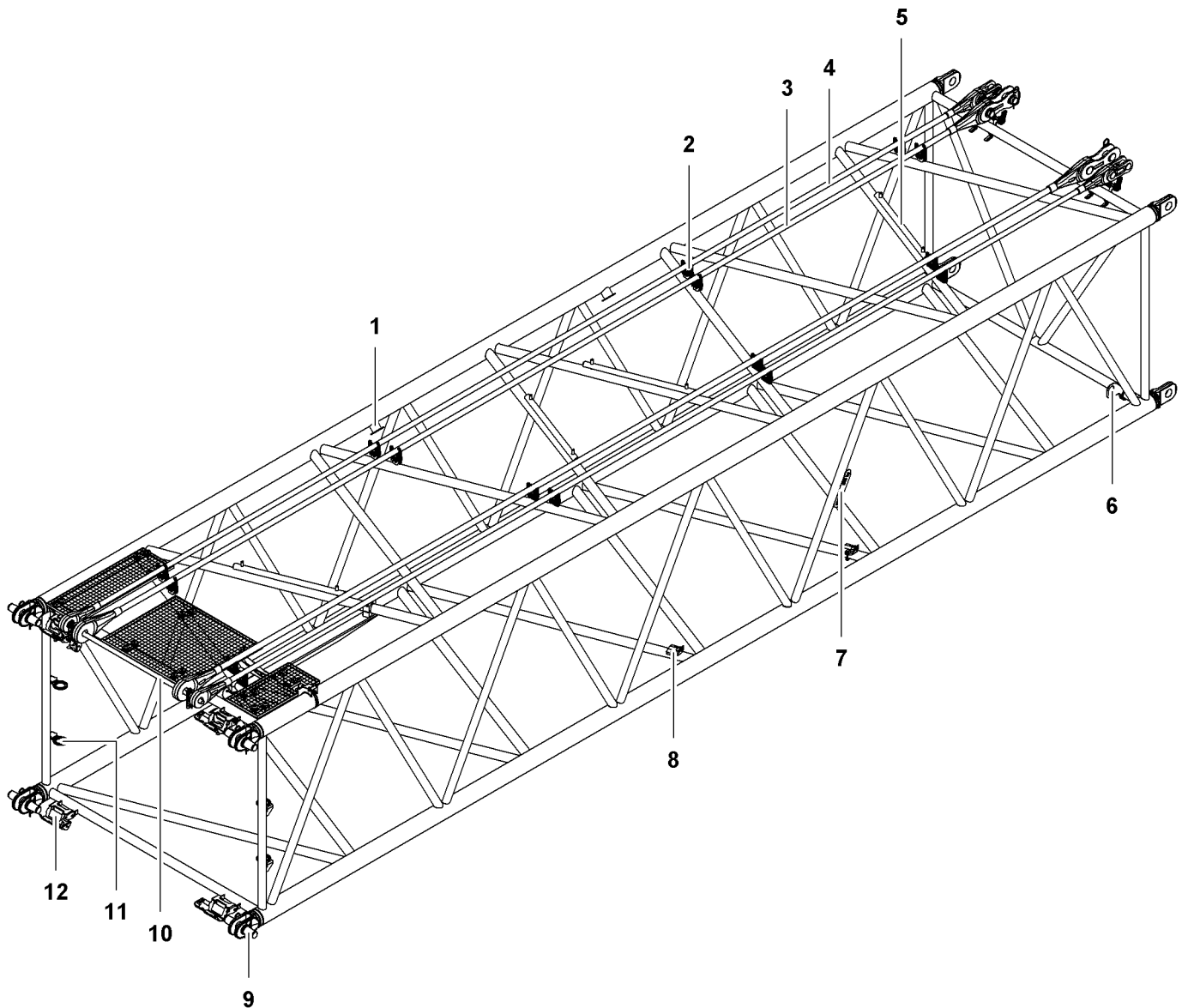


Fig. 166: Main boom section 2821.24 12 m (40 ft) for LR 1300

- | | | | | | |
|---|--|---|--|----|--|
| 1 | Rigging point (4x) | 5 | Rope protection guard (3x) | 9 | Pin connection point (8x) with double-taper pin (4x) |
| 2 | Transport bracket (16x) for pendant straps | 6 | Pin connection point (2x) for retracted jib section during transport | 10 | Transport bracket for pendant straps |
| 3 | Transport position of main boom pendant straps 12 m (40 ft) (2x) | 7 | Boom identification plate | 11 | Transport bracket (4x) for double taper pin |
| 4 | Transport position of jib backstay straps 12 m (40 ft) (2x) | 8 | Support (4x) for retracted jib section during transport | 12 | Catch (4x) for double-taper pins |

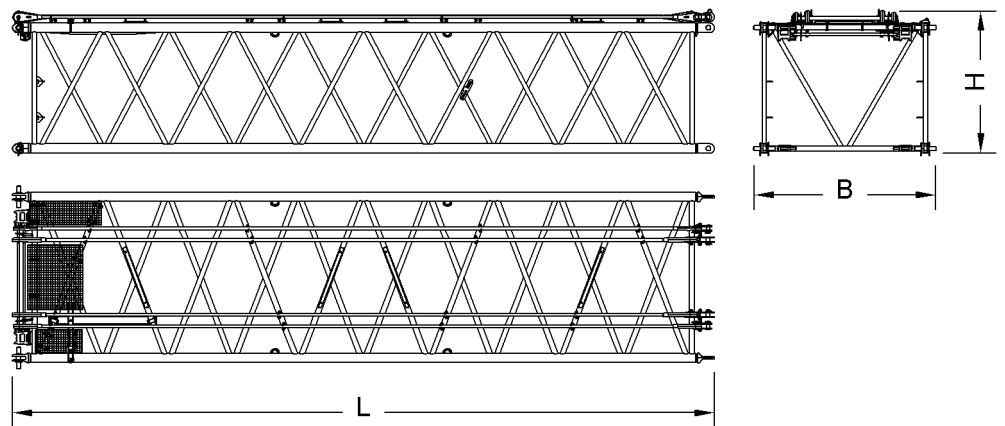


Fig. 167: Dimensions main boom section 2821.24 12 m (40 ft) for LR 1300

Name		Value
System length		12000 mm 39' 4" ft-in
System width		2800 mm 9' 2" ft-in
System height		2100 mm 6' 11" ft-in
L	Length	12220 mm 40' 1" ft-in
B	Width	2970 mm 9' 9" ft-in
H	Height (incl. pendant straps)	2420 mm 7' 11" ft-in
Weight (incl. pendant straps)		4091 kg 9,019 lb
Double taper pin Ø		80 mm 3.15" in

Tab. 91: Technical data main boom section 2821.24 12 m (40 ft) for LR 1300

1.11.5 Main boom head section 2821.24

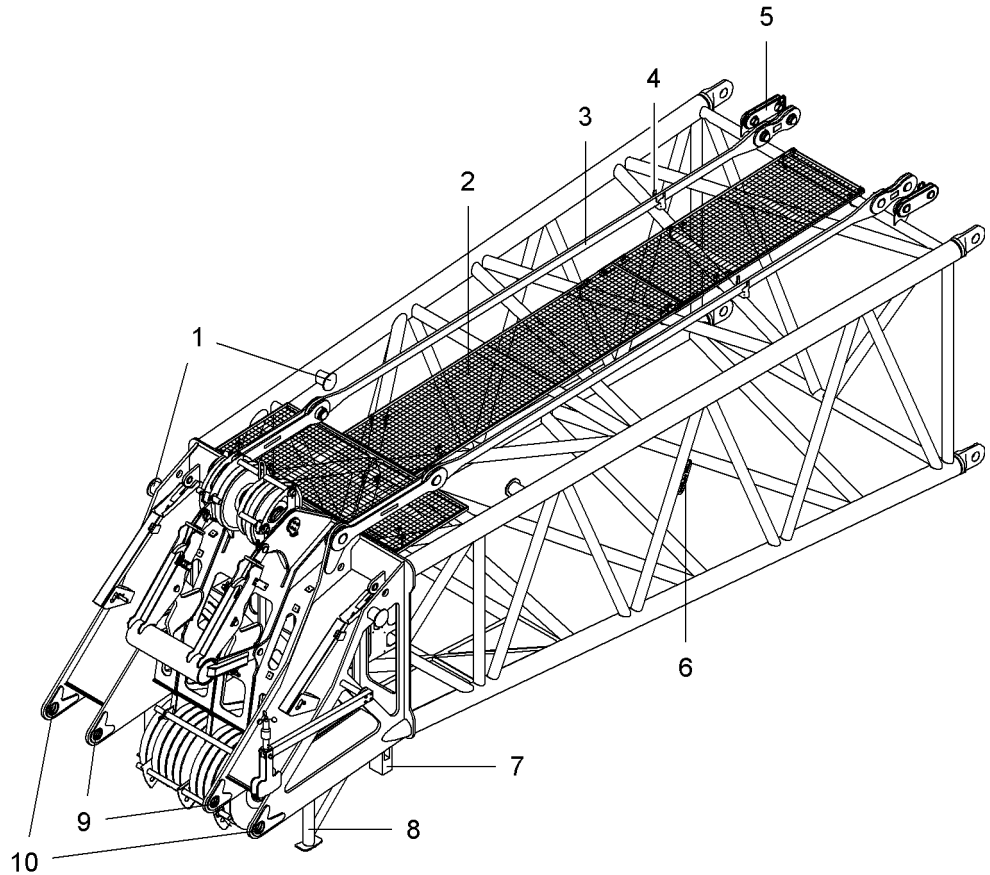


Fig. 168: Main boom head section 2821.24

- | | | | |
|---|--|----|--|
| 1 | Lifting point (4x) | 6 | Boom identification plate |
| 2 | Platform (3x) | 7 | Rope fixation |
| 3 | Transport position of main boom pendant straps (2x) | 8 | Base (2x) |
| 4 | Transport fixation (2x) for pendant straps | 9 | Pin connection point (2x) for jib or auxiliary jib |
| 5 | Connecting link (2x) for jib backstay straps (if jib not attached) | 10 | Pin connection point (2x) for jib |

The jib backstay straps that are not required are pinned to the connecting links **5** if no jib has been attached and the jib backstay straps remain on the main boom. Observe the guidelines regarding the location of the jib backstay straps on the main boom as outlined in the foreword to the load chart.

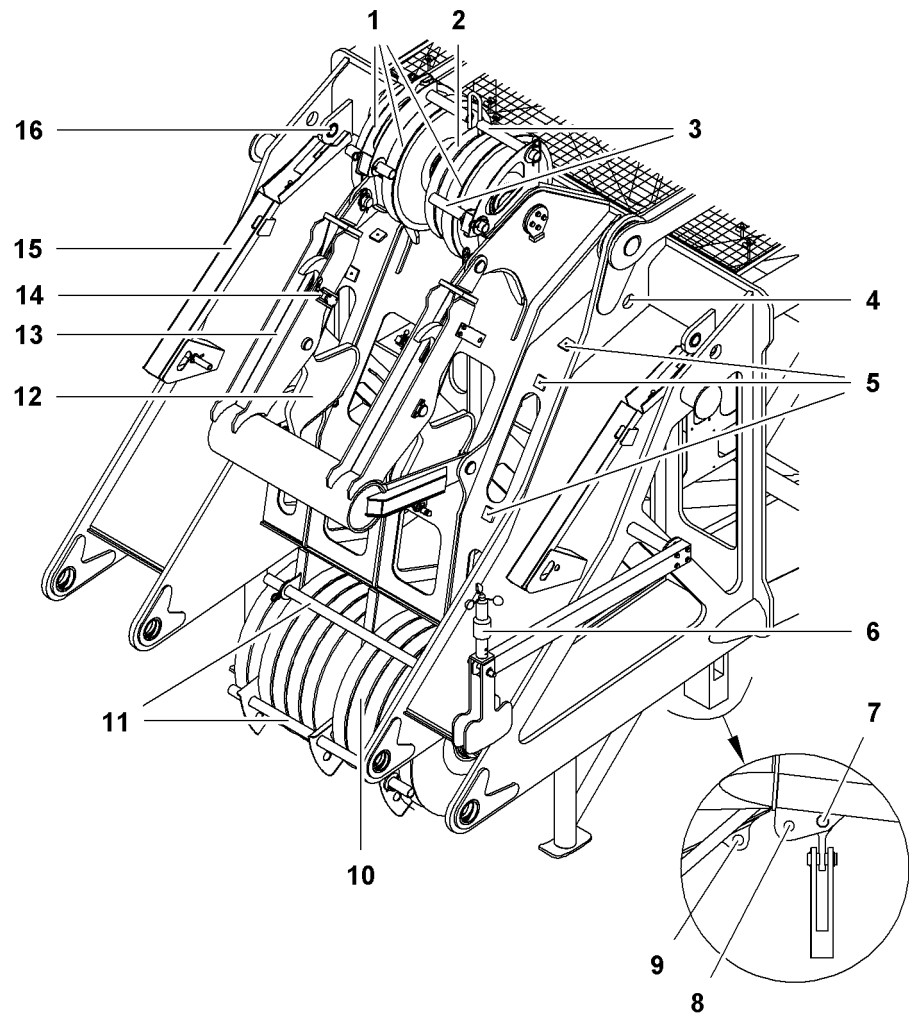


Fig. 169: Main boom head section 2821.24 detail

- | | | | |
|----------|---|-----------|---|
| 1 | Gantry pulley (3x) for rope of winch 1/winch 2 | 9 | Pivot point (2x) for the rope fixing point at low reevings |
| 2 | Small gantry pulley for rope of luffing jib luffing winch | 10 | Pulley (10x) |
| 3 | Rope protection pipe (3x) | 11 | Rope protection pipe (2x) |
| 4 | Pin connection point (2x) for hydraulic tilting-back supports of 1916 luffing jib | 12 | Locking flaps (2x) for rigid jib tilting-back supports |
| 5 | Fastening point (8x) of guide rails for hydraulic tilting-back supports of the 1916 luffing jib | 13 | Guide rail (2x) for rigid jib tilting-back supports |
| 6 | Anemometer | 14 | Upper jib limit switch (2x) |
| 7 | Pivot point (2x) for rope fixing point | 15 | Guide rail (2x) for hydraulic tilting-back supports of 2316 luffing jib |
| 8 | Pivot point (2x) for jib head member | 16 | Pin connection point (2x) for hydraulic tilting-back supports of 2316 luffing jib |

NOTICE

Inadmissible reeving of the rope of winch1/winch2 via small gantry pulley!
Damage to small gantry pulley.

- Only guide rope of the luffing jib luffing winch across small gantry pulley 2.

For 21-fold and 22-fold reeving, an additional pulley (11th pulley) has to be fit to the 2821.24 boom head section.

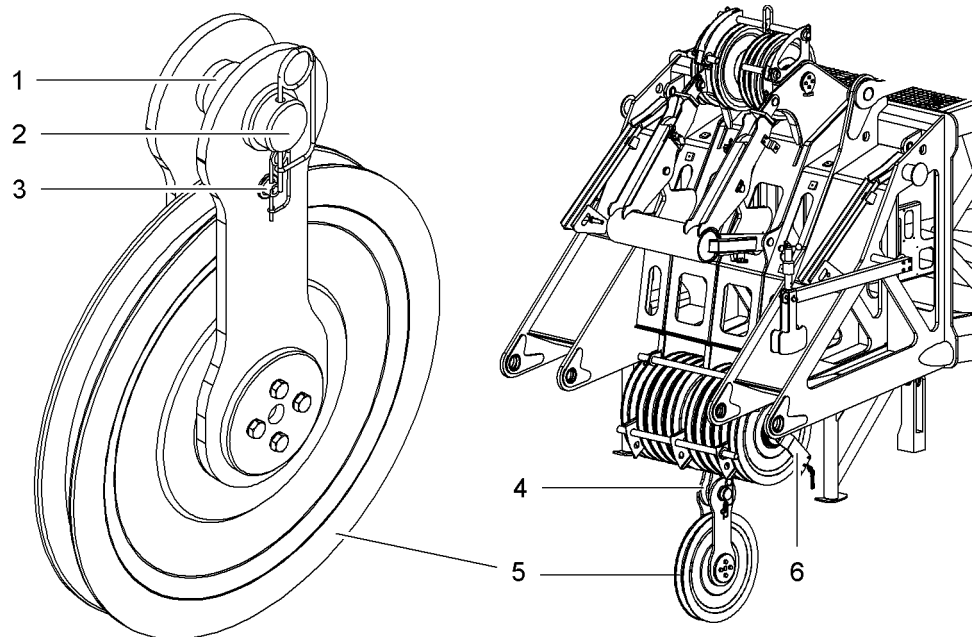


Fig. 170: 11th pulley for 21-fold and 22-fold reeving

- | | | | |
|---|-----------------------------------|---|--|
| 1 | Spacer (width = 45 mm (1.77" in)) | 4 | Bracket (2x) on main boom head section |
| 2 | Pin with washer and safety pin | 5 | 11th pulley |
| 3 | Rope protection pipe | 6 | Hoist limit switch |

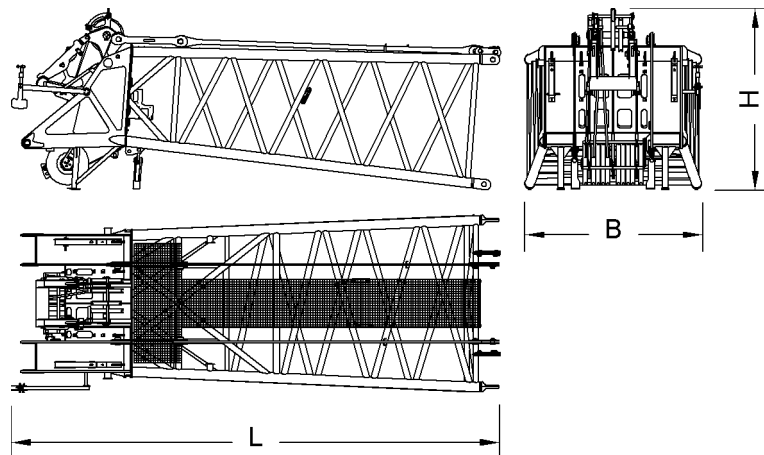


Fig. 171: Main boom head section 2821.24 dimensions

Name	Value
System length	7000 mm 23' ft-in
System width	2800 mm 9' 2" ft-in
System height	2100 mm 6' 11" ft-in

LWNLR-x\04.01\Auslieferung\2016-03-07/en

Name		Value
L	Length	8055 mm 26' 5" ft-in
B	Width	2970 mm 9' 9" ft-in
H	Height	2960 mm 9' 9" ft-in
Weight (incl. pendant straps)		5400 kg 11,905 lb

Tab. 92: Technical data main boom head section 2821.24

Name		Value
11th pulley Ø		720 mm 2' 4" ft-in
Height (incl. brackets)		960 mm 3' 2" ft-in
Weight (incl. brackets)		94 kg 207 lb
Pin Ø		80 mm 3.15" in

Tab. 93: Technical data 11th pulley

1.11.6 Rope guide (type A/B) on main boom 2821

The rope guide:

- must be installed on a main boom with a specified length.
- improves the winding properties of the rope on the winches.
- prolongs the service life of the ropes.

Prescribed use of rope guide (type A) or rope guide (type B):

Boom configuration no.	Rope guide (type A)	Rope guide (type B)
1	x	
2	x	
3	x	
4	x	
5	x	
6		x
8		x
9		x

Tab. 94: Prescribed use of rope guide (type A) or rope guide (type B)

Rope guide (type A)

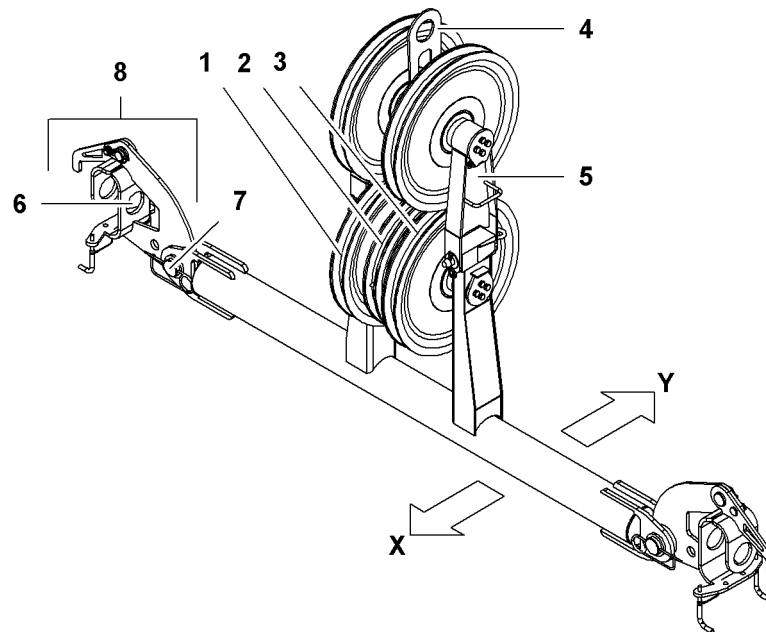


Fig. 172: Rope guide (type A)

- | | | | |
|---|--------------------------------------|---|---|
| 1 | Pulley for rope of winch1 | 6 | Pin connection point (2x) for rope guide forks with main boom section |
| 2 | Pulley for rope of jib luffing winch | 7 | Pin connection point (2x) for rope guide forks with rope guide |
| 3 | Pulley for rope of winch2 | 8 | Rope guide fork (2x) |
| 4 | Rigging point | X | Towards main boom head |
| 5 | Top part of rope guide (hinged) | Y | Towards uppercarriage |

To enable rope reeving, the top part of the rope guide 5 can be unfolded.

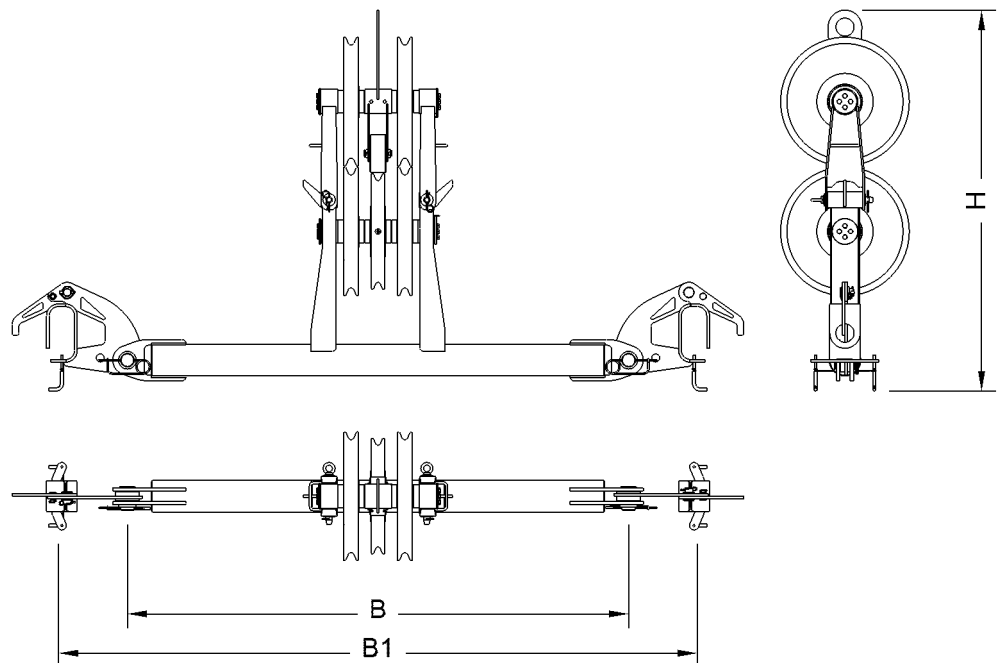


Fig. 173: Dimensions of rope guide (type A)

LWNLR-x/V04.01//Auslieferung/2016-03-07/en

Name		Value
1+3	Pulleys for rope of winch1 and rope of winch2	500 mm (1' 8" ft-in) x 15 mm (0.59" in) x 90 mm (3.54" in)
2	Pulley for rope of jib luffing winch	450 mm (1' 6" ft-in) x 11 mm (0.43" in) x 90 mm (3.54" in)
W	Width	2220 mm 7' 3" ft-in
W1	Width (main boom section system dimension)	2800 mm 9' 2" ft-in
H	Height	1650 mm 5' 5" ft-in
Weight		251 kg 553 lb

Tab. 95: Rope guide (type A) technical data

Rope guide (type B)

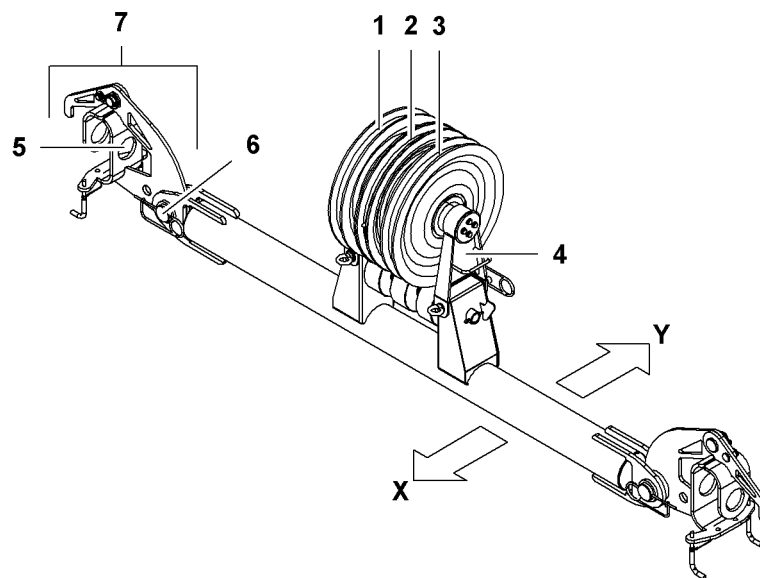


Fig. 174: Rope guide (type B)

- | | | | |
|----------|---|----------|--|
| 1 | Pulley for rope of winch1 | 6 | Pin connection point (2x) for rope guide forks with rope guide |
| 2 | Pulley for rope of jib luffing winch | 7 | Rope guide fork (2x) |
| 3 | Pulley for rope of winch2 | X | Towards main boom head |
| 4 | Top part of rope guide (hinged) | Y | Towards uppercarriage |
| 5 | Pin connection point (2x) for rope guide forks with main boom section | | |

To enable rope reeving, the top part of the rope guide 4 can be unfolded.

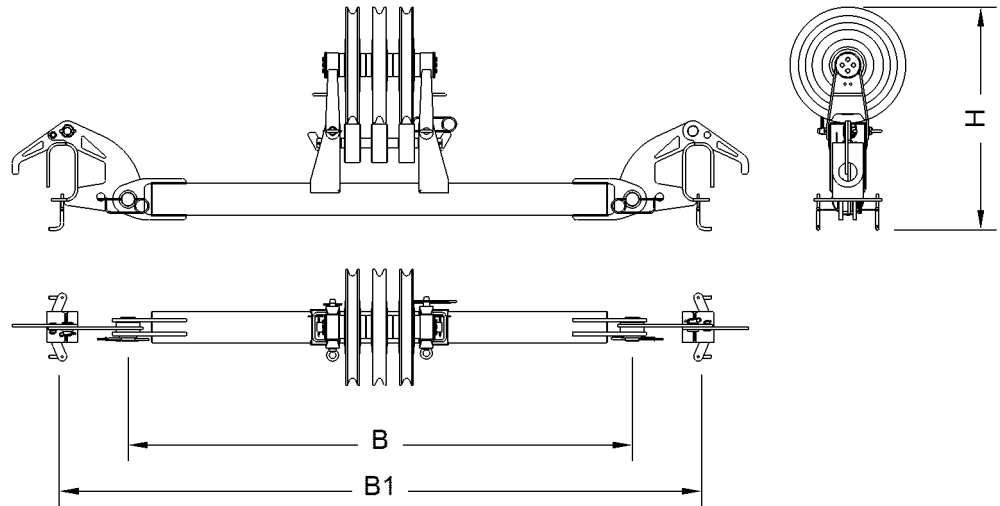


Fig. 175: Dimensions of rope guide (type B)

Name		Value
1+3	Pulleys for rope of winch1 and rope of winch2	450 mm (1' 6" ft-in) x 15 mm (0.59" in) x 90 mm (3.54" in)
2	Pulley for rope of jib luffing winch	450 mm (1' 6" ft-in) x 11 mm (0.43" in) x 90 mm (3.54" in)
W	Width	2220 mm 7' 3" ft-in
W1	Width (main boom section system dimension)	2800 mm 9' 2" ft-in
H	Height	940 mm 3' 1" ft-in
Weight		180 kg 397 lb

Tab. 96: Rope guide (type B) technical data

1.11.7 Mid-point suspension on main boom 2821

The mid-point suspensions on main boom 2821 differ with steel pendant straps and CF pendant straps.

LWNLR-x\04.01\Auslieferung\2016-03-07/en

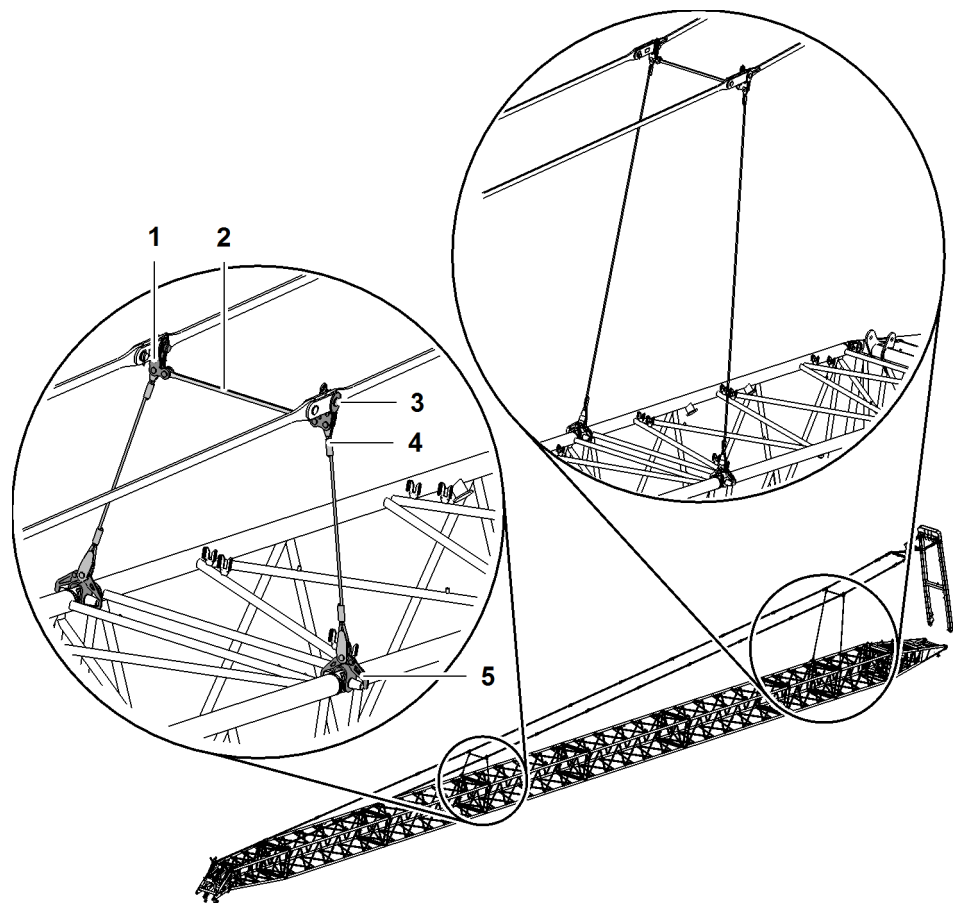


Fig. 176: Mid-point suspension on main boom 2821 (illustration of principle)

- | | | | |
|---|-----------------------------|---|------------|
| 1 | Connecting element (2x) | 4 | Stay ropes |
| 2 | Spacer bracket | 5 | Fork (2x) |
| 3 | Pin (2x) for pendant straps | | |

Connecting elements for steel pendant straps

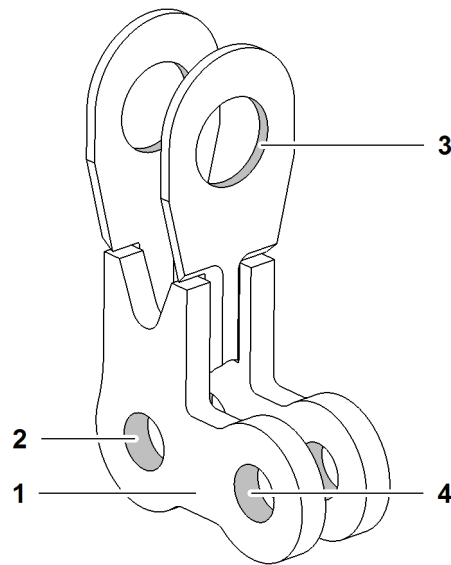


Fig. 177: Connecting elements for steel pendant straps (illustration of principle)

- | | | | |
|---|------------------------------------|---|---|
| 1 | Connecting element | 3 | Pin connection point for pendant strap |
| 2 | Pin connection point for stay rope | 4 | Pin connection point for spacer bracket |

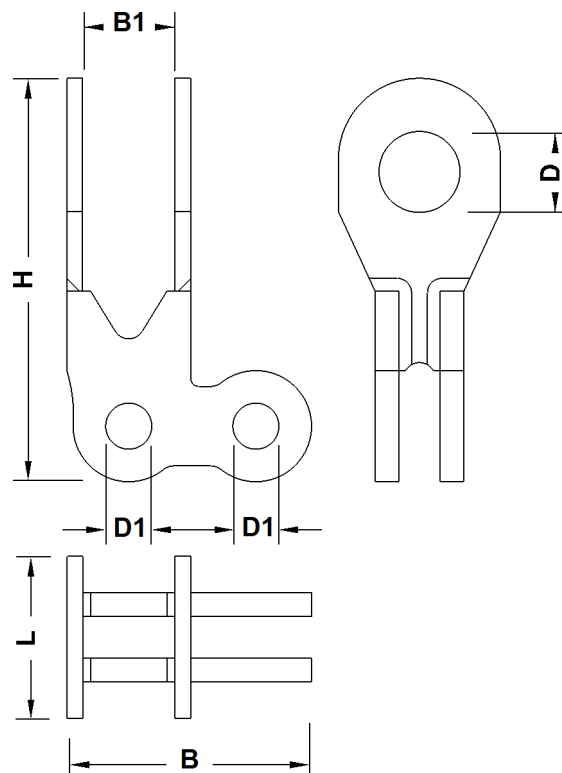


Fig. 178: Dimensions connecting elements for steel pendant straps

LWN/LR-x/V04.01//Auslieferung/2016-03-07/en

Name		Value
L	Length	112 mm 4.41" in
H	Height	361 mm 1' 2" ft-in
B	Width	190 mm 7.48" in
B1	Width between link	58 mm 2.28" in
D	Pin Ø	65 mm 2.56" in
D1	Pin Ø	35 mm 1.38" in

Tab. 97: Technical data connecting elements for steel pendant straps

Connecting elements for CF pendant straps

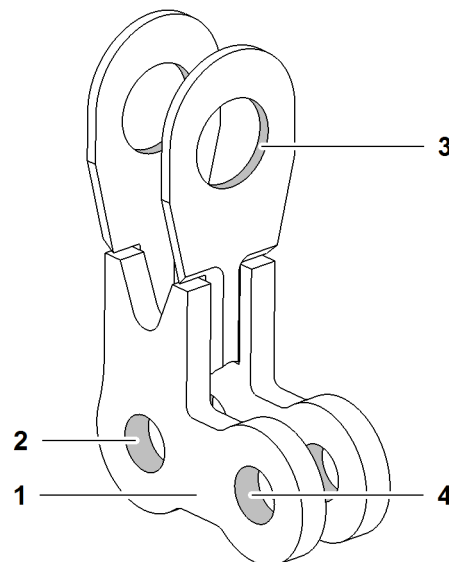


Fig. 179: Connecting elements for CF pendant straps (illustration of principle)

- | | | | |
|----------|------------------------------------|----------|---|
| 1 | Connecting element | 3 | Pin connection point for pendant strap |
| 2 | Pin connection point for stay rope | 4 | Pin connection point for spacer bracket |

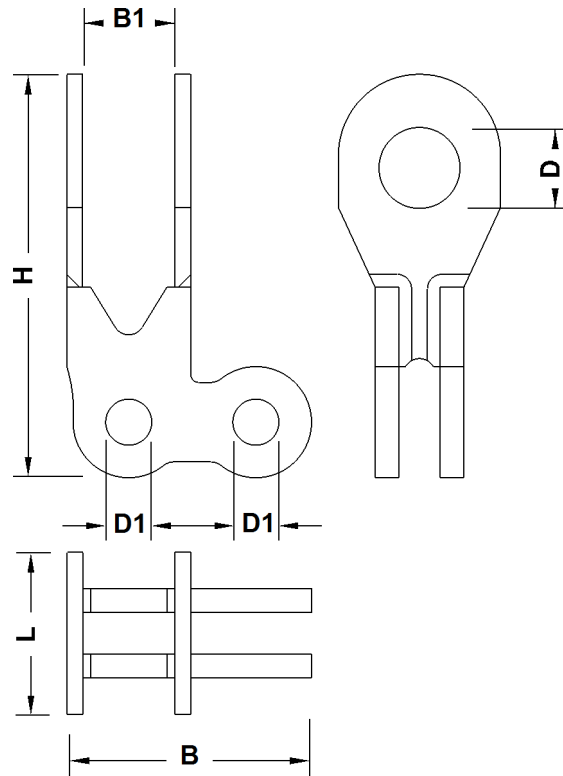


Fig. 180: Dimensions connecting elements for CF pendant straps

Name		Value
L	Length	110 mm 4.33" in
H	Height	358 mm 1' 2" ft-in
B	Width	207 mm 8.15" in
B1	Width between link	104 mm 4.09" in
D	Pin Ø	65 mm 2.56" in
D1	Pin Ø	35 mm 1.38" in

Tab. 98: Technical data connecting elements for CF pendant straps

LWN/LR-x/V04.01//Auslieferung/2016-03-07/en

Fork

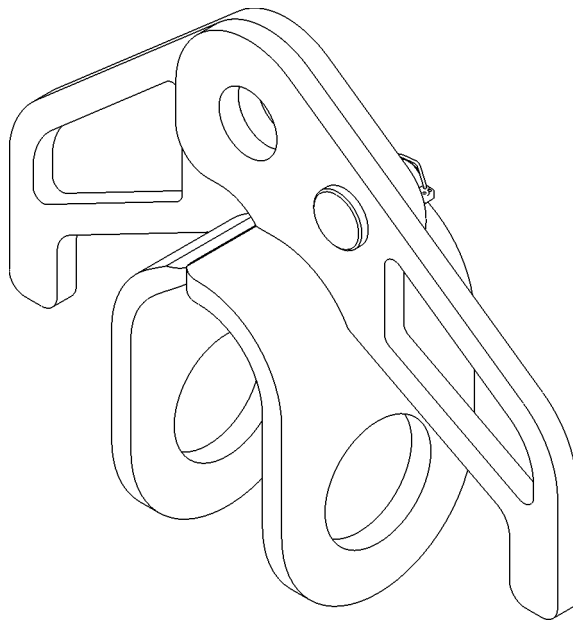


Fig. 181: Forks (illustration of principle)

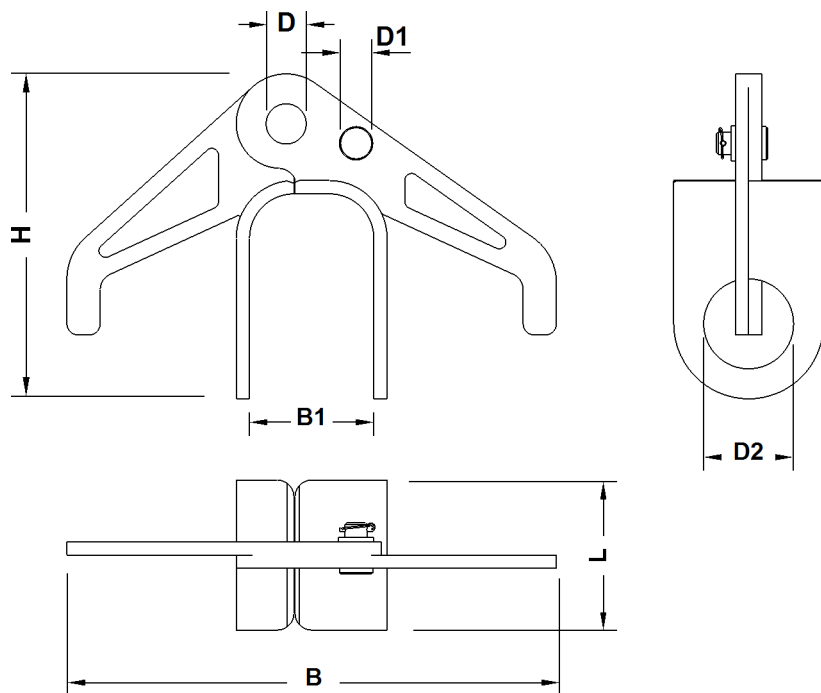


Fig. 182: Fork dimensions

Name		Value
L	Length of fork	135 mm 5.31" in
B	Width	441 mm 1' 5" ft-in

LWNLR.x/V04.01//Auslieferung/2016-03-07/en

Name		Value
B1	Width of fork	112 mm 4.41" in
H	Height	293 mm 1' ft-in
D	Pin Ø	35 mm 1.38" in
D1	Pin Ø	20 mm 0.79" in
D2	Pin Ø	80 mm 3.15" in

Tab. 99: Technical data forks

Spacer bracket

The spacer brackets are identical with steel pendant straps and CF pendant straps.

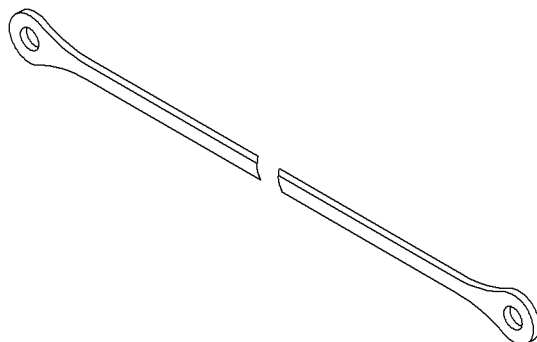


Fig. 183: Spacer brackets (illustration of principle)

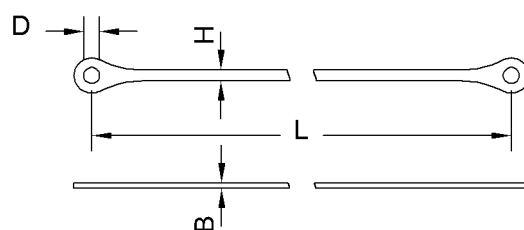


Fig. 184: Dimensions spacer brackets

Name		Value
L	Length	1100 mm 3' 7" ft-in
B	Width	10 mm 0.39" in
H	Height	40 mm 1.57" in
D	Pin Ø	35 mm 1.38" in

Tab. 100: Technical data spacer brackets

LWNLR-x\04.01\Auslieferung\2016-03-07\en

Stay ropes

Several stay ropes are assembled to achieve defined rope lengths.

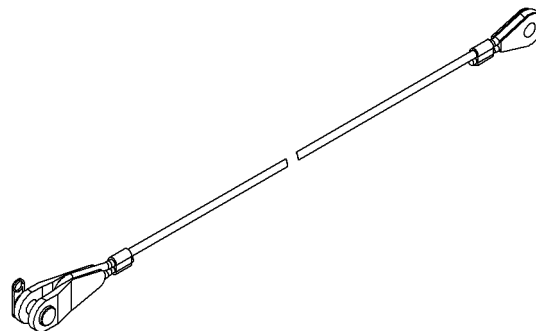


Fig. 185: Stay ropes (illustration of principle)

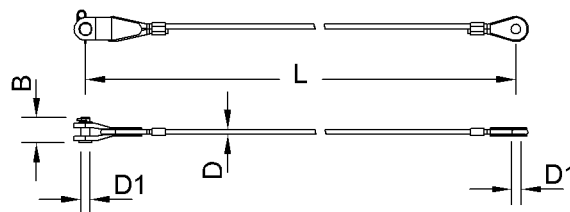


Fig. 186: Dimensions stay ropes

Name		Value
L	Length of stay rope	1100 mm 3' 7" ft-in
		1300 mm 4' 3" ft-in
		1600 mm 5' 3" ft-in
		2100 mm 6' 11" ft-in
		2600 mm 8' 6" ft-in
		3000 mm 9' 10" ft-in
D	Ø of stay rope	18 mm 0.71" in
D1	Pin Ø	35 mm 1.38" in
B	Length of pin	80 mm 3.15" in

Tab. 101: Technical data stay ropes

Pins for steel pendant straps

The pins supplied with the pendant straps must be exchanged for longer pins.

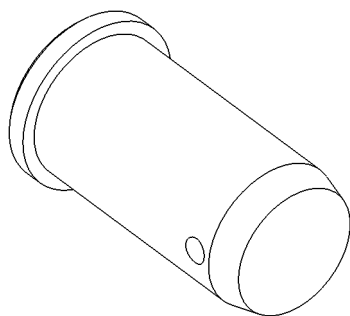


Fig. 187: Pins for steel pendant straps (illustration of principle)

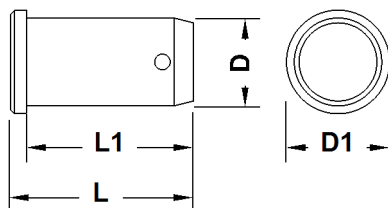


Fig. 188: Dimensions pins for steel pendant straps

Name		Value
L	Total length	140 mm 5.51" in
L1	Length	128 mm 5.04" in
D	Diameter	65 mm 2.56" in
D1	Outer diameter	80 mm 3.15" in

Tab. 102: Technical data pins for steel pendant straps

Pins for CF pendant straps

The pins supplied with the pendant straps must be exchanged for longer pins.

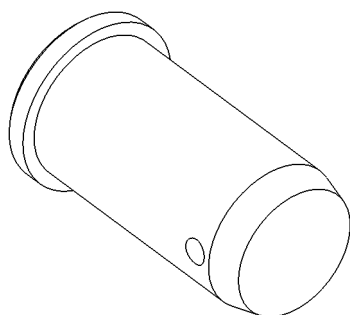


Fig. 189: Pins for CF pendant straps (illustration of principle)

LWN/LR-x/V04.01//Auslieferung/2016-03-07/en

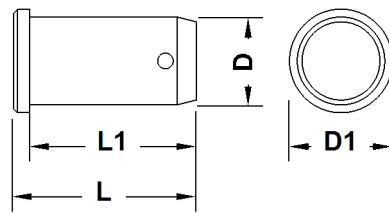


Fig. 190: Dimensions pins for CF pendant straps

Name		Value
L	Total length	170 mm 6.69" in
L1	Length	160 mm 6.30" in
D	Diameter	65 mm 2.56" in
D1	Outer diameter	85 mm 3.35" in

Tab. 103: Technical data pins for CF pendant straps

1.11.8 Steel pendant straps on main boom 2821

Steel pendant straps on main boom base section 2821.30

Equalizer of main boom base section 2821.30

Installation site in crane operation:

- Main boom 2821 (For more information see: [Pendant straps A-frame1 to main boom head 2821](#), page 1273)
- Main boom 2821 + derrick boom 2220 (For more information see: [2821 main boom head to 2220 derrick boom head pendant straps](#), page 1362)
- Main boom 2821 + reducing adapter 2821/2316 (For more information see: [Pendant straps A-frame1 to main boom head 2316](#), page 1511)

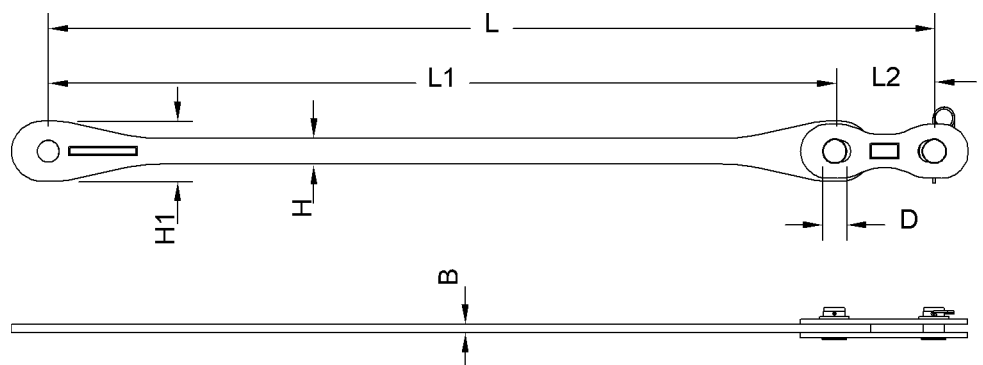


Fig. 191: Dimensions of equalizer of main boom base section 2821.30

Name		Value
L	Length	2670 mm 8' 9" ft-in
L1	Length of pendant strap	2370 mm 7' 9" ft-in
L2	Length of connecting link	300 mm 1' ft-in
W	Width of pendant strap	25 mm 0.98" in
H	Height of pendant strap	77 mm 3.03" in
H1	Height of pendant strap	180 mm 7.09" in
D	Pin Ø	65 mm 2.56" in
Weight		67 kg 148 lb

Tab. 104: Technical data equalizer of main boom base section 2821.30

Steel pendant straps on main boom section 2821.30 3 m (10 ft)

Main boom pendant strap 3 m (10 ft)

Installation site in crane operation:

- Main boom 2821 (For more information see: [Pendant straps A-frame1 to main boom head 2821, page 1273](#))
- Main boom 2821 + derrick boom 2220 (For more information see: [2821 main boom head to 2220 derrick boom head pendant straps, page 1362](#))
- Main boom 2821 + reducing adapter 2821/2316 (For more information see: [Pendant straps A-frame1 to main boom head 2316, page 1511](#))

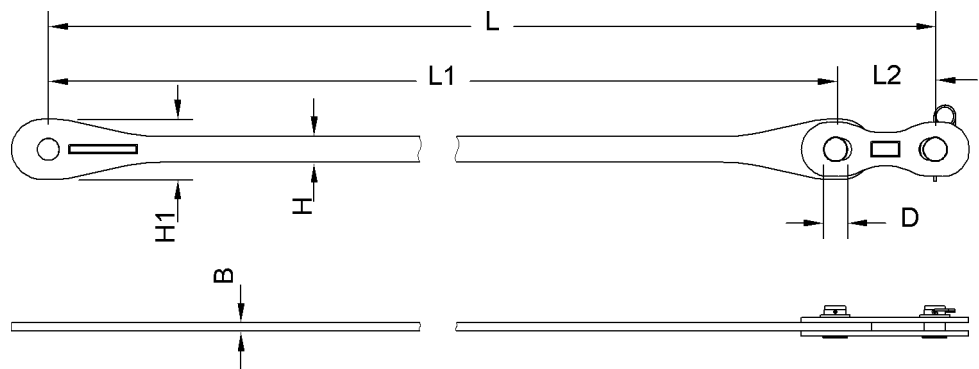


Fig. 192: Dimensions main boom pendant strap 3 m (10 ft)

Name		Value
L	Length	3000 mm 9' 10" ft-in

LWN/LR-x/V04.01//Auslieferung/2016-03-07/en

Name		Value
L1	Length of pendant strap	2700 mm 8' 10" ft-in
L2	Length of connecting link	300 mm 1' ft-in
H	Height of pendant strap	77 mm 3.03" in
H1	Height of pendant strap	180 mm 7.09" in
W	Width of pendant strap	25 mm 0.98" in
D	Pin Ø	65 mm 2.56" in
Weight		72 kg 159 lb

Tab. 105: Technical data main boom pendant strap 3 m (10 ft)

Jib backstay strap 3 m (10 ft)

Installation site in crane operation:

- Luffing jib 2316 (For more information see: [Jib backstay straps A-frame2 to main boom base section 2821, page 1627](#))
- Luffing jib 1916 (For more information see: [Jib backstay straps A-frame2 to main boom base section 2821, page 1646](#))
- Luffing jib 2316 + midfall 2316 (For more information see: [Jib backstay straps A-frame2 to main boom base section 2821, page 1724](#))
- Luffing jib 1916 + midfall 1916 (For more information see: [Jib backstay straps A-frame2 to main boom base section 2821, page 1737](#))

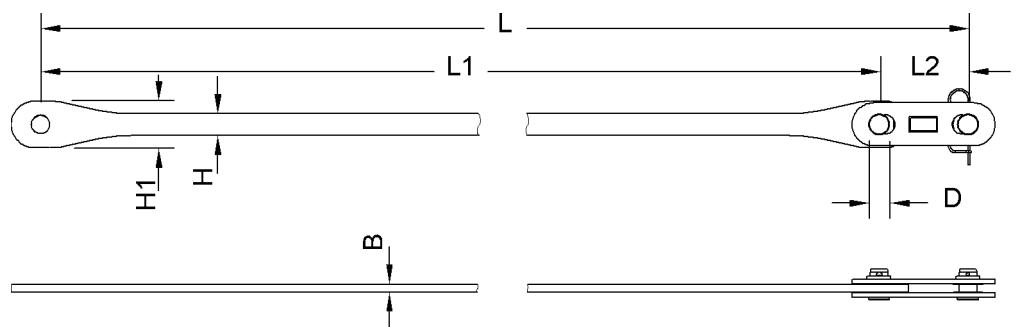


Fig. 193: Dimensions jib backstay strap 3 m (10 ft)

Name		Value
L	Length	3000 mm 9' 10" ft-in
L1	Length of pendant strap	2730 mm 8' 11" ft-in
L2	Length of connecting link	270 mm 10.63" in

Name		Value
W	Width of pendant strap	22 mm 0.87" in
H	Height of pendant strap	66 mm 2.60" in
H1	Height of pendant strap	140 mm 5.51" in
D	Pin Ø	55 mm 2.17" in
Weight		53 kg 117 lb

Tab. 106: Technical data jib backstay strap 3 m (10 ft)

Steel pendant straps on main boom section 2821.30 6 m (20 ft)

Main boom pendant strap 6 m (20 ft)

Installation site in crane operation:

- Main boom 2821 (For more information see: [Pendant straps A-frame1 to main boom head 2821](#), page 1273)
- Main boom 2821 + derrick boom 2220 (For more information see: [2821 main boom head to 2220 derrick boom head pendant straps](#), page 1362)
- Main boom 2821 + reducing adapter 2821/2316 (For more information see: [Pendant straps A-frame1 to main boom head 2316](#), page 1511)

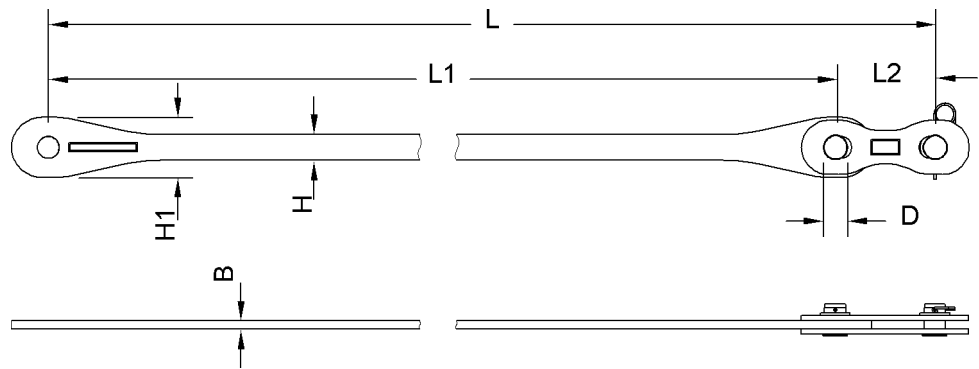


Fig. 194: Dimensions main boom pendant strap 6 m (20 ft)

Name		Value
L	Length	6000 mm 19' 8" ft-in
L1	Length of pendant strap	5700 mm 18' 8" ft-in
L2	Length of connecting link	300 mm 1' ft-in
H	Height of pendant strap	77 mm 3.03" in

LWN/LR-x/V04.01//Auslieferung/2016-03-07/en

Name		Value
H1	Height of pendant strap	180 mm 7.09" in
W	Width of pendant strap	25 mm 0.98" in
D	Pin Ø	65 mm 2.56" in
Weight		118 kg 260 lb

Tab. 107: Technical data main boom pendant strap 6 m (20 ft)

Jib backstay strap 6 m (20 ft)

Installation site in crane operation:

- Luffing jib 2316 (For more information see: Jib backstay straps A-frame2 to main boom base section 2821, page 1627)
- Luffing jib 1916 (For more information see: Jib backstay straps A-frame2 to main boom base section 2821, page 1646)
- Luffing jib 2316 + midfall 2316 (For more information see: Jib backstay straps A-frame2 to main boom base section 2821, page 1724)
- Luffing jib 1916 + midfall 1916 (For more information see: Jib backstay straps A-frame2 to main boom base section 2821, page 1737)

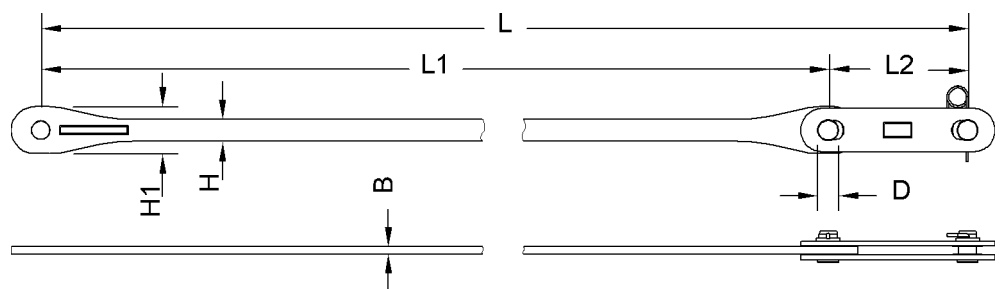


Fig. 195: Dimensions jib backstay strap 6 m (20 ft)

Name		Value
L	Length	6000 mm 19' 8" ft-in
L1	Length of pendant strap	5580 mm 18' 4" ft-in
L2	Length of connecting link	420 mm 1' 5" ft-in
W	Width of pendant strap	22 mm 0.87" in
H	Height of pendant strap	66 mm 2.60" in
H1	Height of pendant strap	140 mm 5.51" in
D	Pin Ø	55 mm 2.17" in

Name	Value
Weight	89 kg 196 lb

Tab. 108: Technical data jib backstay strap 6 m (20 ft)

Steel pendant straps on main boom section 2821.30 12 m (40 ft)

Main boom pendant strap 12 m (40 ft)

Installation site in crane operation:

- Main boom 2821 (For more information see: [Pendant straps A-frame1 to main boom head 2821](#), page 1273)
- Main boom 2821 + derrick boom 2220 (For more information see: [2821 main boom head to 2220 derrick boom head pendant straps](#), page 1362)
- Main boom 2821 + reducing adapter 2821/2316 (For more information see: [Pendant straps A-frame1 to main boom head 2316](#), page 1511)

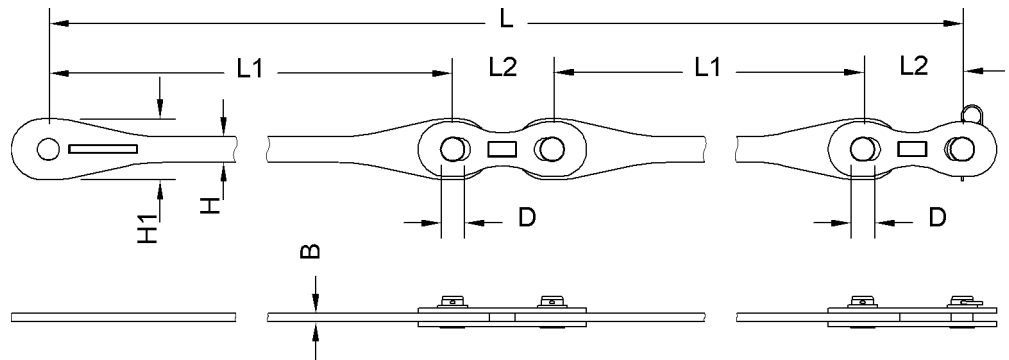


Fig. 196: Dimensions main boom pendant strap 12 m (40 ft)

Name	Value
L Length	12000 mm 39' 4" ft-in
L1 Length of pendant strap	5700 mm 18' 8" ft-in
L2 Length of connecting link	300 mm 1' ft-in
W Width of pendant strap	25 mm 0.98" in
H Height of pendant strap	77 mm 3.03" in
H1 Height of pendant strap	180 mm 7.09" in
D Pin Ø	65 mm 2.56" in
Weight	228 kg 503 lb

Tab. 109: Technical data main boom pendant strap 12 m (40 ft)

LWNLR-x\04.01\Auslieferung\2016-03-07\en

Jib backstay strap 12 m (40 ft)

Installation site in crane operation:

- Luffing jib 2316 (For more information see: [Jib backstay straps A-frame2 to main boom base section 2821, page 1627](#))
- Luffing jib 1916 (For more information see: [Jib backstay straps A-frame2 to main boom base section 2821, page 1646](#))
- Luffing jib 2316 + midfall 2316 (For more information see: [Jib backstay straps A-frame2 to main boom base section 2821, page 1724](#))
- Luffing jib 1916 + midfall 1916 (For more information see: [Jib backstay straps A-frame2 to main boom base section 2821, page 1737](#))

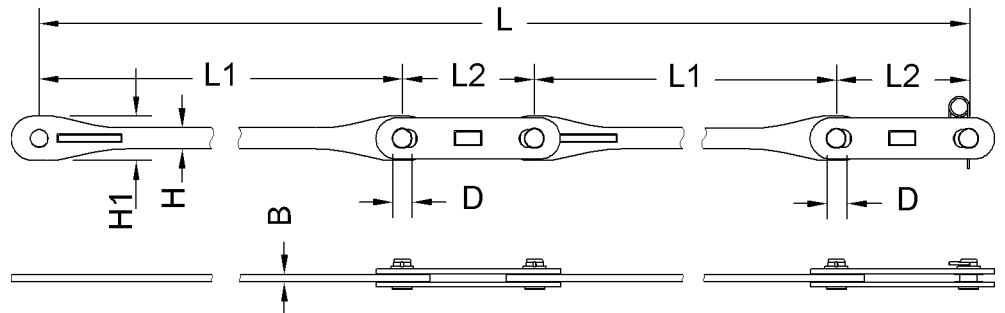


Fig. 197: Dimensions jib backstay strap 12 m (40 ft)

Name		Value
L	Length	12000 mm 39' 4" ft-in
L1	Length of pendant strap	5580 mm 18' 4" ft-in
L2	Length of connecting link	420 mm 1' 5" ft-in
W	Width of pendant strap	22 mm 0.87" in
H	Height of pendant strap	66 mm 2.60" in
H1	Height of pendant strap	140 mm 5.51" in
D	Pin Ø	55 mm 2.17" in
Weight		178 kg 392 lb

Tab. 110: Technical data jib backstay strap 12 m (40 ft)

Steel pendant straps on main boom head 2821.24

Main boom pendant strap on main boom head 2821.24

Installation site in crane operation:

- Main boom 2821 (For more information see: [Pendant straps A-frame1 to main boom head 2821, page 1273](#))

- Main boom 2821 + derrick boom 2220 (For more information see: 2821 main boom head to 2220 derrick boom head pendant straps, page 1362)

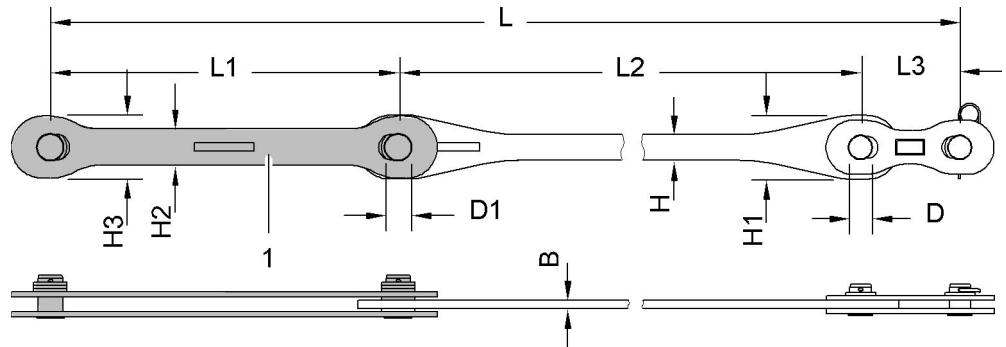


Fig. 198: Dimensions of main boom pendant strap on main boom head 2821.24

1 Connecting link (2x)



Note

If the machine is equipped with a derrick boom:

- Replace connecting links 1 on main boom head 2821.24 with connecting links with tension load cell (For more information see: Connecting links with tension load cell, page 199) .

Name		Value
L	Length	6300 mm 20' 8" ft-in
L1	Length of connecting link	1050 mm 3' 5" ft-in
L2	Length of pendant strap	4950 mm 16' 3" ft-in
L3	Length of connecting link	300 mm 1' ft-in
W	Width of pendant strap	25 mm 0.98" in
H	Height of pendant strap	77 mm 3.03" in
H1	Height of pendant strap	180 mm 7.09" in
H2	Height of connecting link	110 mm 4.33" in
H3	Height of connecting link	185 mm 7.28" in
D	Pin Ø	65 mm 2.56" in
D1	Pin Ø	75 mm 2.95" in

LWNLR-x/V04.01//Auslieferung/2016-03-07/en

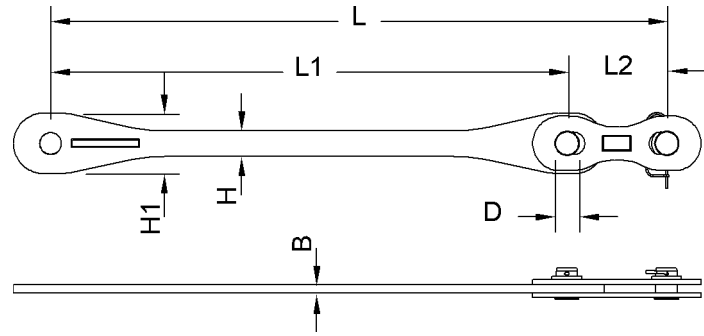


Fig. 200: Dimensions pendant strap with connecting link

Name		Value
L	Length	1855 mm 6' 1" ft-in
L1	Length of pendant strap	1555 mm 5' 1" ft-in
L2	Length of connecting link	300 mm 1' ft-in
B	Width of pendant strap	25 mm 0.98" in
H	Height of pendant strap	77 mm 3.03" in
H1	Height of pendant strap	180 mm 7.09" in
D	Pin Ø	65 mm 2.56" in
Weight		37 kg 81.57 lb

Tab. 113: Technical data pendant strap with connecting link

1.11.9 CF pendant straps on main boom 2821

CF pendant straps on main boom base section 2821.30

Equalizer of main boom base section 2821.30

Installation site in crane operation:

- Main boom 2821 (For more information see: [Pendant straps A-frame1 to main boom head 2821, page 1274](#))
- Main boom 2821 + derrick boom 2220 (For more information see: [2821 main boom head to 2220 derrick boom head pendant straps, page 1365](#))
- Main boom 2821 + reducing adapter 2821/2316 (For more information see: [Pendant straps A-frame1 to main boom head 2316, page 1513](#))

Generation A of equalizer for main boom base section 2821.30

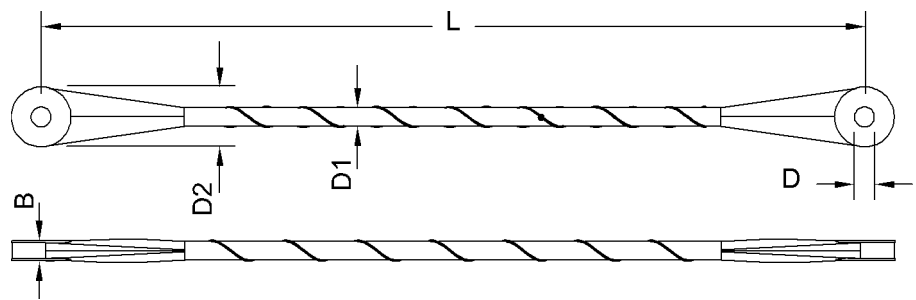


Fig. 201: Dimensions of equalizer of main boom base section 2821.30

Name	Value	
L	Length of pendant strap	2700 mm 8' 10" ft-in
W	Width	66 mm 2.60" in
D	Pin Ø	65 mm 2.56" in
D1	Pendant strap Ø	60 mm 2.36" in
D2	Pendant strap Ø	196 mm 7.72" in
Weight		29 kg 63.93 lb

Tab. 114: Technical data equalizer of main boom base section 2821.30

Generation B of equalizer for main boom base section 2821.30

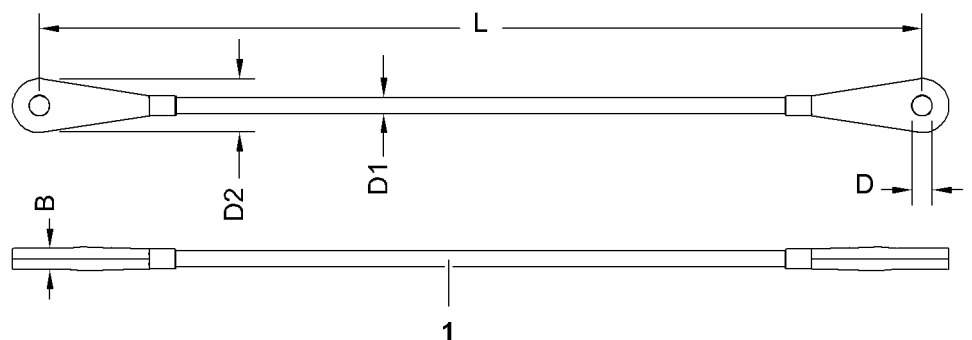


Fig. 202: Dimensions equalizer of main boom base section 2821.30

- 1 Wire mesh hose as protective sheath

Name	Value	
L	Length of pendant strap	2700 mm 8' 10" ft-in

LWNLR.x/V04.01//Auslieferung/2016-03-07/en

Name		Value
B	Width	63 mm 2.48" in
D	Pin Ø	65 mm 2.56" in
D1	Pendant strap Ø	52 mm 2.05" in
D2	Pendant strap Ø	207 mm 8.15" in
Weight		29 kg 63.93 lb

Tab. 115: Technical data equalizer of main boom base section 2821.30

Connecting link

Installation site in crane mode:

- Fixed jib 1507 (For more information see: Jib backstay straps A-frame2 to main boom base section 2821, page 1551)
- Luffing jib 2316 (For more information see: Jib backstay straps A-frame2 to main boom base section 2821, page 1629)
- Luffing jib 1916 (For more information see: Jib backstay straps A-frame2 to main boom base section 2821, page 1648)
- Luffing jib 2316 + midfall 2316 (For more information see: Jib backstay straps A-frame2 to main boom base section 2821, page 1726)
- Luffing jib 1916 + midfall 1916 (For more information see: Jib backstay straps A-frame2 to main boom base section 2821, page 1739)

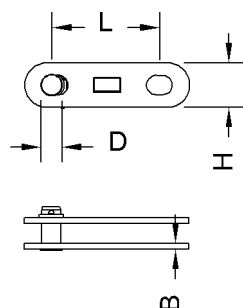


Fig. 203: Dimensions connecting link

Name		Value
L	Length of connecting link	350 mm 1' 2" ft-in
W	Width of connecting link	18 mm 0.71" in
H	Height of connecting link	140 mm 5.51" in
D	Pin Ø	60 mm 2.36" in

LWNLR-x/V04.01//Auslieferung/2016-03-07/en

Name	Value
Weight	6 kg 13.23 lb

Tab. 116: Technical data connecting link

CF pendant straps on main boom section 2821.30 3 m (10 ft)

Main boom pendant strap 3 m (10 ft)

Installation site in crane operation:

- Main boom 2821 (For more information see: [Pendant straps A-frame1 to main boom head 2821](#), page 1274)
- Main boom 2821 + derrick boom 2220 (For more information see: [2821 main boom head to 2220 derrick boom head pendant straps](#), page 1365)
- Main boom 2821 + reducing adapter 2821/2316 (For more information see: [Pendant straps A-frame1 to main boom head 2316](#), page 1513)

Generation A of main boom pendant strap 3 m (10 ft)

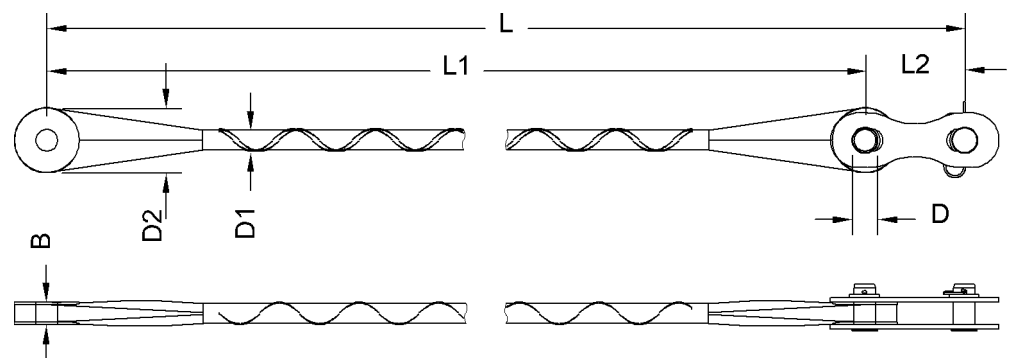


Fig. 204: Dimensions main boom pendant strap 3 m (10 ft)

Name	Value
L Length	3000 mm 9' 10" ft-in
L1 Length of pendant strap	2700 mm 8' 10" ft-in
L2 Length of connecting link	300 mm 1' ft-in
W Width	66 mm 2.60" in
D Pin Ø	65 mm 2.56" in
D1 Pendant strap Ø	60 mm 2.36" in
D2 Pendant strap Ø	196 mm 7.72" in

Name	Value
Weight	51 kg 112 lb

Tab. 117: Technical data main boom pendant strap 3 m (10 ft)

Generation B of main boom pendant strap 3 m (10 ft)

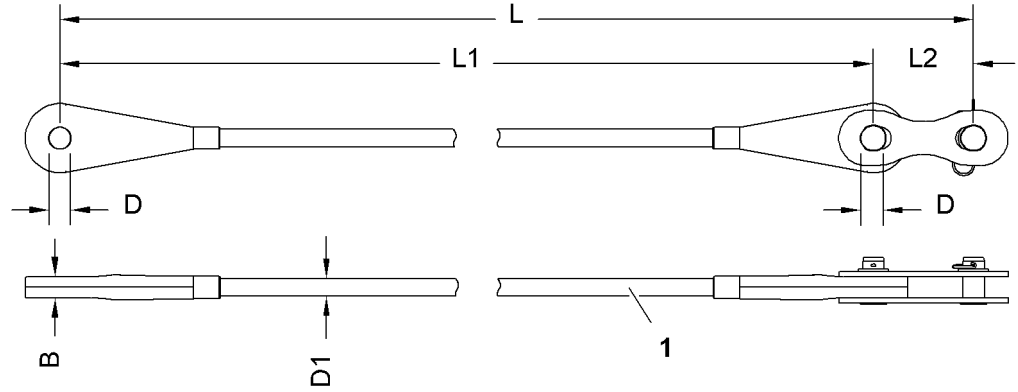


Fig. 205: Dimensions main boom pendant strap 3 m (10 ft)

- 1 Wire mesh hose as protective sheath

Name	Value
L Length	3000 mm 9' 10" ft-in
L1 Length of pendant strap	2700 mm 8' 10" ft-in
L2 Length of connecting link	300 mm 1' ft-in
W Width	63 mm 2.48" in
D Pin Ø	65 mm 2.56" in
D1 Pendant strap Ø	52 mm 2.05" in
Weight	51 kg 112 lb

Tab. 118: Technical data main boom pendant strap 3 m (10 ft)

Jib backstay strap 3 m (10 ft)

Installation site in crane mode:

- Fixed jib 1507 (For more information see: Jib backstay straps A-frame2 to main boom base section 2821, page 1551)
- Luffing jib 2316 (For more information see: Jib backstay straps A-frame2 to main boom base section 2821, page 1629)
- Luffing jib 1916 (For more information see: Jib backstay straps A-frame2 to main boom base section 2821, page 1648)

LWNLR-x/V04.01//Auslieferung/2016-03-07/en

- Luffing jib 2316 + midfall 2316 (For more information see: Jib backstay straps A-frame2 to main boom base section 2821, page 1726)
- Luffing jib 1916 + midfall 1916 (For more information see: Jib backstay straps A-frame2 to main boom base section 2821, page 1739)

Generation A of jib backstay strap 3 m (10 ft)

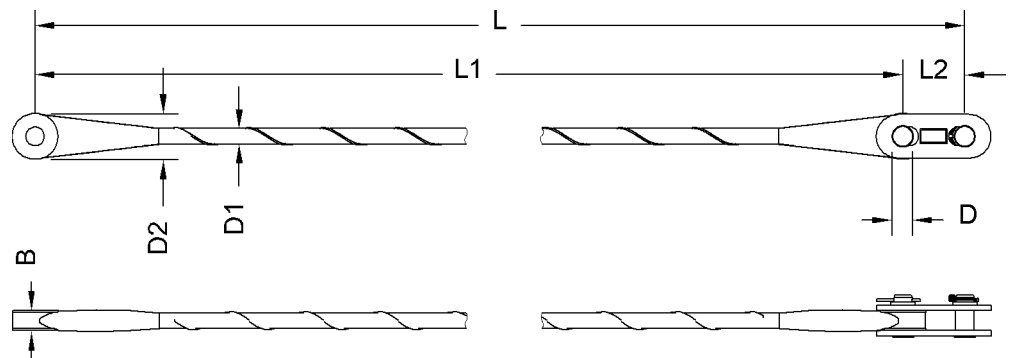


Fig. 206: Dimensions jib backstay strap 3 m (10 ft)

Name		Value
L	Length	3000 mm 9' 10" ft-in
L1	Length of pendant strap	2800 mm 9' 2" ft-in
L2	Length of connecting link	200 mm 7.87" in
W	Width	64 mm 2.52" in
D	Pin Ø	60 mm 2.36" in
D1	Pendant strap Ø	50 mm 1.97" in
D2	Pendant strap Ø	148 mm 5.83" in
Weight		35 kg 77.16 lb

Tab. 119: Technical data jib backstay strap 3 m (10 ft)

Generation B of jib backstay strap 3 m (10 ft)

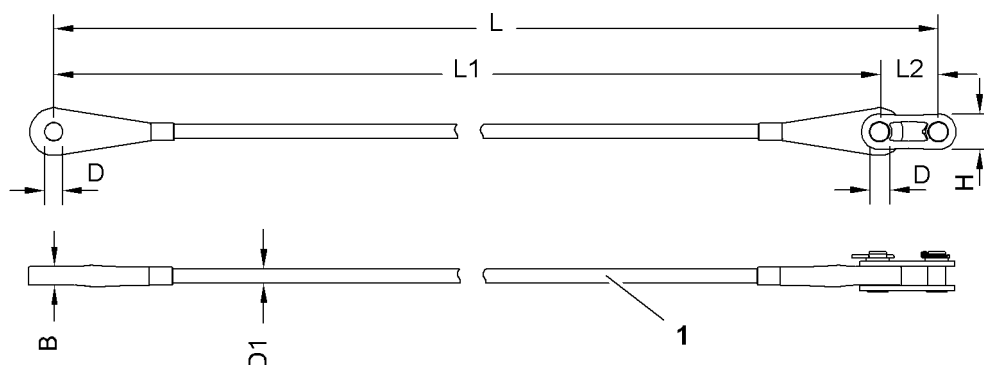


Fig. 207: Dimensions jib backstay strap 3 m (10 ft)

- 1 Wire mesh hose as protective sheath

Name		Value
L	Length	3000 mm 9' 10" ft-in
L1	Length of pendant strap	2800 mm 9' 2" ft-in
L2	Length of connecting link	200 mm 7.87" in
W	Width	63 mm 2.48" in
H	Height of connecting link	121 mm 4.76" in
D	Pin Ø	60 mm 2.36" in
D1	Pendant strap Ø	48 mm 1.89" in
Weight		26 kg 57.32 lb

Tab. 120: Technical data jib backstay strap 3 m (10 ft)

**CF pendant straps on main boom section 2821.30
6 m (20 ft)**

Main boom pendant strap 6 m (20 ft)

Installation site in crane mode:

- Main boom 2821 (For more information see: [Pendant straps A-frame1 to main boom head 2821, page 1274](#))
- Main boom 2821 + derrick boom 2220 (For more information see: [2821 main boom head to 2220 derrick boom head pendant straps, page 1365](#))
- Main boom 2821 + reducing adapter 2821/2316 (For more information see: [Pendant straps A-frame1 to main boom head 2316, page 1513](#))

LWN/LR-x/V04.01//Auslieferung/2016-03-07/en

Generation A of main boom pendant strap 6 m (20 ft)

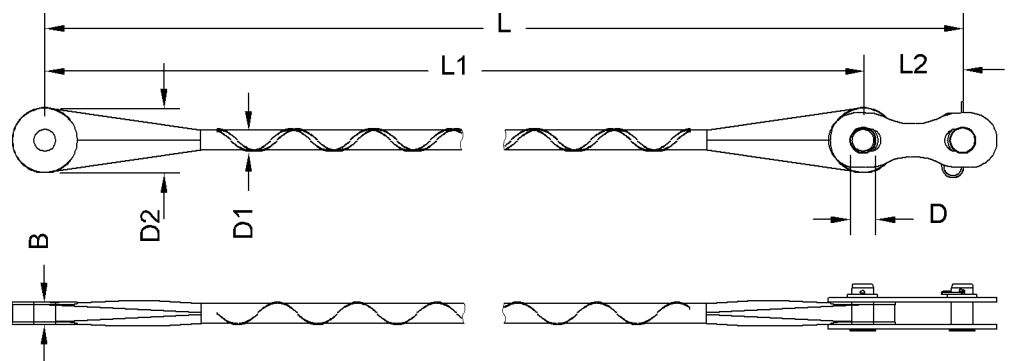


Fig. 208: Dimensions main boom pendant strap 6 m (20 ft)

Name		Value
L	Length	6000 mm 19' 8" ft-in
L1	Length of pendant strap	5700 mm 18' 8" ft-in
L2	Length of connecting link	300 mm 1' ft-in
W	Width	66 mm 2.60" in
D	Pin Ø	65 mm 2.56" in
D1	Pendant strap Ø	60 mm 2.36" in
D2	Pendant strap Ø	196 mm 7.72" in
Weight		62 kg 137 lb

Tab. 121: Technical data main boom pendant strap 6 m (20 ft)

Generation B of main boom pendant strap 6 m (20 ft)

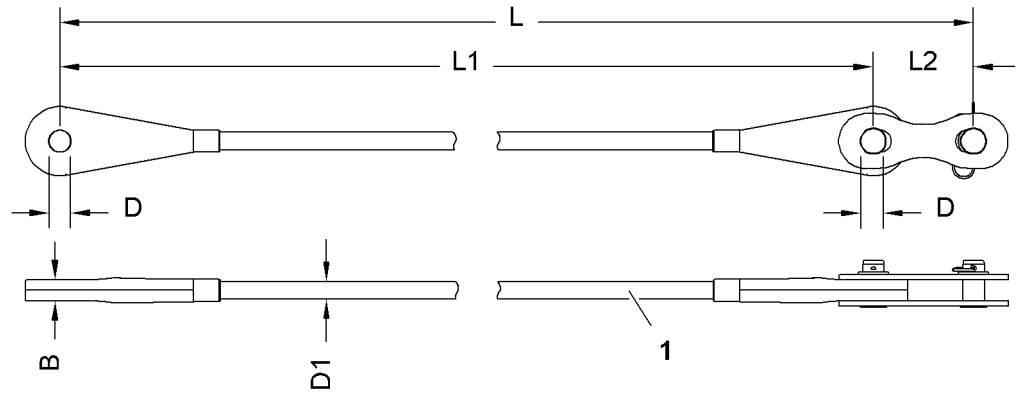


Fig. 209: Dimensions main boom pendant strap 6 m (20 ft)

1 Wire mesh hose as protective sheath

Name		Value
L	Length	6000 mm 19' 8" ft-in
L1	Length of pendant strap	5700 mm 18' 8" ft-in
L2	Length of connecting link	300 mm 1' ft-in
W	Width	63 mm 2.48" in
D	Pin Ø	65 mm 2.56" in
D1	Pendant strap Ø	52 mm 2.05" in
Weight		62 kg 137 lb

Tab. 122: Technical data main boom pendant strap 6 m (20 ft)

Jib backstay strap 6 m (20 ft)

Installation site in crane mode:

- Fixed jib 1507 (For more information see: Jib backstay straps A-frame2 to main boom base section 2821, page 1551)
- Luffing jib 2316 (For more information see: Jib backstay straps A-frame2 to main boom base section 2821, page 1629)
- Luffing jib 1916 (For more information see: Jib backstay straps A-frame2 to main boom base section 2821, page 1648)
- Luffing jib 2316 + midfall 2316 (For more information see: Jib backstay straps A-frame2 to main boom base section 2821, page 1726)
- Luffing jib 1916 + midfall 1916 (For more information see: Jib backstay straps A-frame2 to main boom base section 2821, page 1739)

LWNLR-x/V04.01/Auslieferung/2016-03-07/en

Generation A of jib backstay strap 6 m (20 ft)

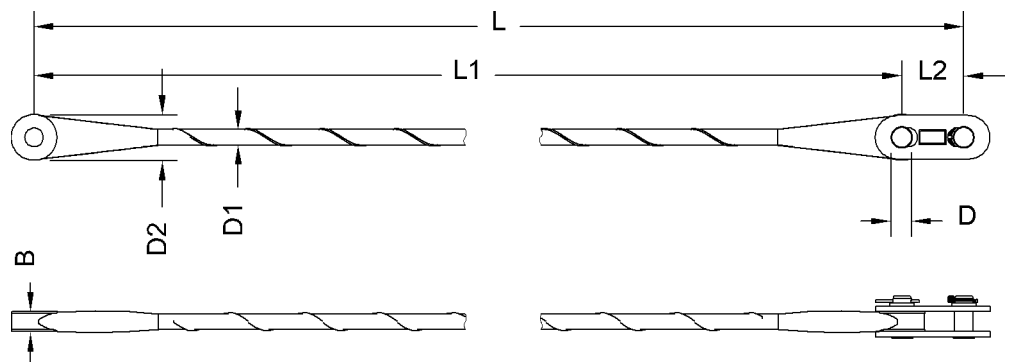


Fig. 210: Dimensions jib backstay strap 6 m (20 ft)

Name		Value
L	Length	6000 mm 19' 8" ft-in
L1	Length of pendant strap	5800 mm 19' ft-in
L2	Length of connecting link	200 mm 7.87" in
W	Width	64 mm 2.52" in
D	Pin Ø	60 mm 2.36" in
D1	Pendant strap Ø	50 mm 1.97" in
D2	Pendant strap Ø	148 mm 5.83" in
Weight		43 kg 94.80 lb

Tab. 123: Technical data jib backstay strap 6 m (20 ft)

Generation B of jib backstay strap 6 m (20 ft)

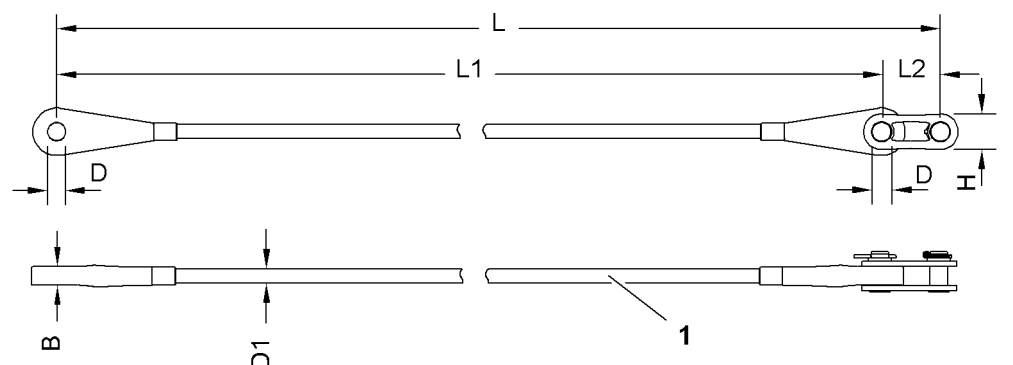


Fig. 211: Dimensions jib backstay strap 6 m (20 ft)

- 1 Wire mesh hose as protective sheath

LWNLR.x/V04.01//Auslieferung/2016-03-07/en

Name		Value
L	Length	6000 mm 19' 8" ft-in
L1	Length of pendant strap	5800 mm 19' ft-in
L2	Length of connecting link	200 mm 7.87" in
W	Width	63 mm 2.48" in
H	Height of connecting link	121 mm 4.76" in
D	Pin Ø	60 mm 2.36" in
D1	Pendant strap Ø	48 mm 1.89" in
Weight		32 kg 70.55 lb

Tab. 124: Technical data jib backstay strap 6 m (20 ft)

CF pendant straps on main boom section 2821.30 12 m (40 ft)

Main boom pendant strap 12 m (40 ft)

Installation site in crane operation:

- Main boom 2821 (For more information see: [Pendant straps A-frame1 to main boom head 2821, page 1274](#))
- Main boom 2821 + derrick boom 2220 (For more information see: [2821 main boom head to 2220 derrick boom head pendant straps, page 1365](#))
- Main boom 2821 + reducing adapter 2821/2316 (For more information see: [Pendant straps A-frame1 to main boom head 2316, page 1513](#))

Generation A of main boom pendant strap 12 m (40 ft)

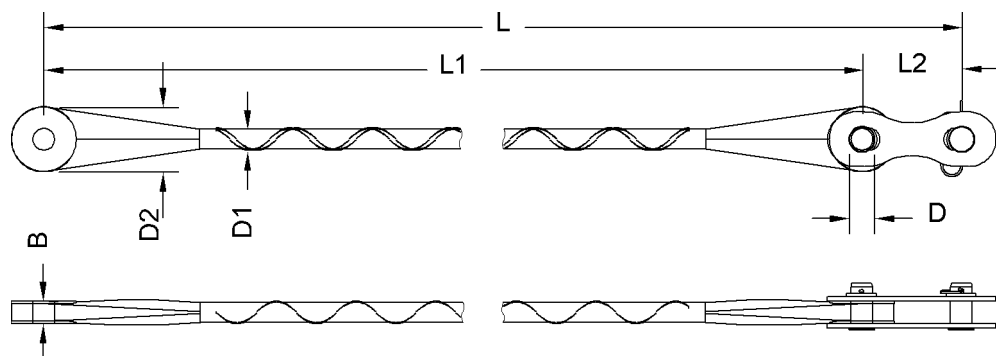


Fig. 212: Dimensions main boom pendant strap 12 m (40 ft)

LWNLR-x/V04.01//Auslieferung/2016-03-07/en

Name		Value
L	Length	12000 mm 39' 4" ft-in
L1	Length of pendant strap	11700 mm 38' 5" ft-in
L2	Length of connecting link	300 mm 1' ft-in
W	Width	66 mm 2.60" in
D	Pin Ø	65 mm 2.56" in
D1	Pendant strap Ø	60 mm 2.36" in
D2	Pendant strap Ø	196 mm 7.72" in
Weight		85 kg 187 lb

Tab. 125: Technical data main boom pendant strap 12 m (40 ft)

Generation B of main boom pendant strap 12 m (40 ft)

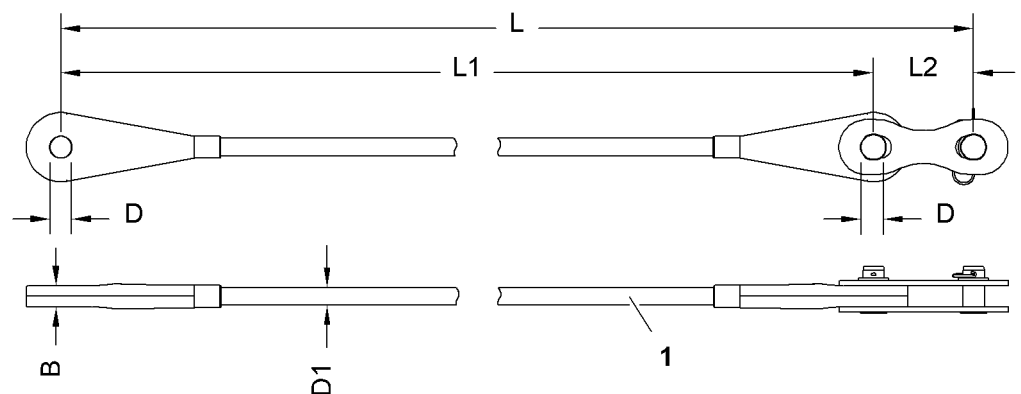


Fig. 213: Dimensions main boom pendant strap 12 m (40 ft)

- 1 Wire mesh hose as protective sheath

Name		Value
L	Length	12000 mm 39' 4" ft-in
L1	Length of pendant strap	11700 mm 38' 5" ft-in
L2	Length of connecting link	300 mm 1' ft-in
W	Width	63 mm 2.48" in
D	Pin Ø	65 mm 2.56" in

LWNLR.x/V04.01//Auslieferung/2016-03-07/en

Name		Value
D1	Pendant strap \varnothing	52 mm 2.05" in
Weight		85 kg 187 lb

Tab. 126: Technical data main boom pendant strap 12 m (40 ft)

Jib backstay strap 12 m (40 ft)

Installation site in crane operation:

- Fixed jib 1507 (For more information see: Jib backstay straps A-frame2 to main boom base section 2821, page 1551)
- Luffing jib 2316 (For more information see: Jib backstay straps A-frame2 to main boom base section 2821, page 1629)
- Luffing jib 1916 (For more information see: Jib backstay straps A-frame2 to main boom base section 2821, page 1648)
- Luffing jib 2316 + midfall 2316 (For more information see: Jib backstay straps A-frame2 to main boom base section 2821, page 1726)
- Luffing jib 1916 + midfall 1916 (For more information see: Jib backstay straps A-frame2 to main boom base section 2821, page 1739)

Generation A of jib backstay strap 12 m (40 ft)

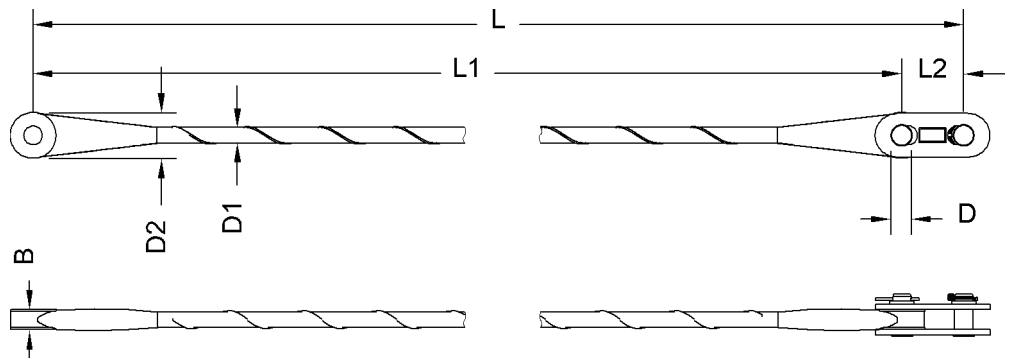


Fig. 214: Dimensions jib backstay strap 12 m (40 ft)

Name		Value
L	Length	12000 mm 39' 4" ft-in
L1	Length of pendant strap	11800 mm 38' 9" ft-in
L2	Length of connecting link	200 mm 7.87" in
W	Width	64 mm 2.52" in
D	Pin \varnothing	60 mm 2.36" in
D1	Pendant strap \varnothing	50 mm 1.97" in

LWN/LR-x/V04.01//Auslieferung/2016-03-07/en

Name		Value
D2	Pendant strap \varnothing	148 mm 5.83" in
Weight		60 kg 132 lb

Tab. 127: Technical data jib backstay strap 12 m (40 ft)

Generation B of jib backstay strap 12 m (40 ft)

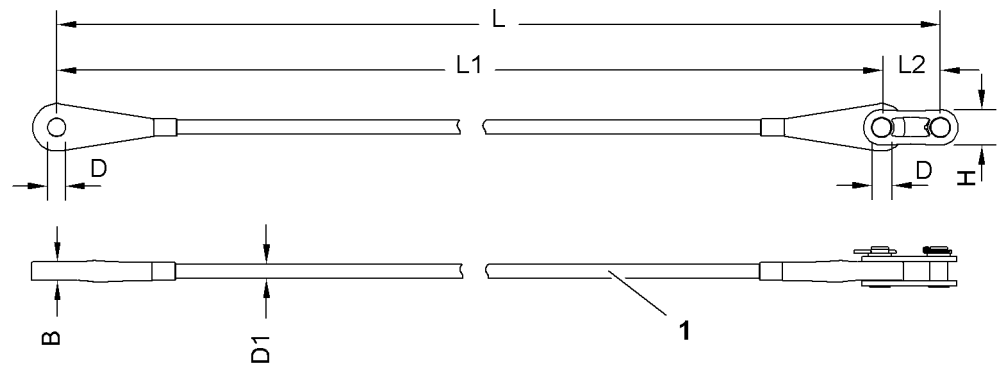


Fig. 215: Dimensions jib backstay strap 12 m (40 ft)

- 1 Wire mesh hose as protective sheath

Name		Value
L	Length	12000 mm 39' 4" ft-in
L1	Length of pendant strap	11800 mm 38' 9" ft-in
L2	Length of connecting link	200 mm 7.87" in
W	Width	63 mm 2.48" in
H	Height of connecting link	121 mm 4.76" in
D	Pin \varnothing	60 mm 2.36" in
D1	Pendant strap \varnothing	48 mm 1.89" in
Weight		43 kg 94.80 lb

Tab. 128: Technical data jib backstay strap 12 m (40 ft)

LWNLR.x/V04.01//Auslieferung/2016-03-07/en

CF pendant straps on main boom head 2821.24

Main boom pendant strap on main boom head 2821.24

Installation site in crane operation:

- Main boom 2821 (For more information see: [Pendant straps A-frame1 to main boom head 2821](#), page 1274)
- Main boom 2821 + derrick boom 2220 (For more information see: [2821 main boom head to 2220 derrick boom head pendant straps](#), page 1365)

Generation A of main boom pendant strap on main boom head 2821.24

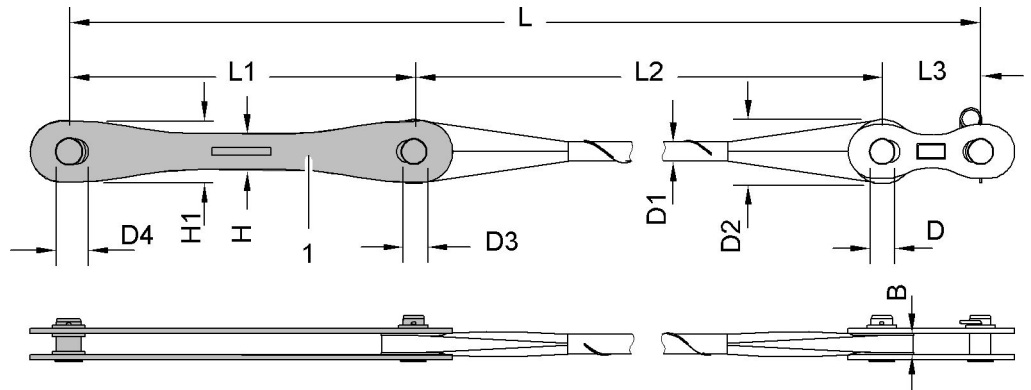


Fig. 216: Dimensions of main boom pendant strap on main boom head 2821.24

1 Connecting link (2x)



Note

If the machine is equipped with a derrick boom:

- Replace connecting links **1** on main boom head 2821.24 with connecting links with tension load cell (For more information see: [Connecting links with tension load cell](#), page 216) .

Name		Value
L	Length	6300 mm 20' 8" ft-in
L1	Length of connecting link	1050 mm 3' 5" ft-in
L2	Length of pendant strap	4950 mm 16' 3" ft-in
L3	Length of connecting link	300 mm 1' ft-in
W	Width of pendant strap	66 mm 2.60" in
H	Height of connecting link	110 mm 4.33" in
H1	Height of connecting link	185 mm 7.28" in
D	Pin Ø	65 mm 2.56" in

LWN/LR-x/V04.01//Auslieferung/2016-03-07/en

Name		Value
D1	Pendant strap \varnothing	66 mm 2.60" in
D2	Pendant strap \varnothing	195 mm 7.68" in
D3	Pin \varnothing	65 mm 2.56" in
D4	Pin \varnothing	75 mm 2.95" in
Weight		109 kg 240 lb

Tab. 129: Technical data main boom pendant strap on main boom head 2821.24

Generation B of main boom pendant strap on main boom head 2821.24

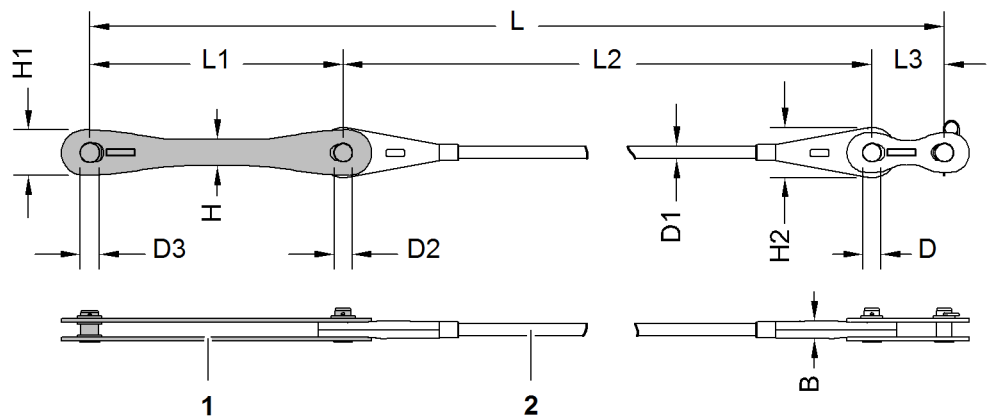


Fig. 217: Dimensions of main boom pendant strap on main boom head 2821.24

- 1** Connecting link (2x)
- 2** Wire mesh hose as protective sheath



Note

If the machine is equipped with a derrick boom:

- ▶ Replace connecting links **1** on main boom head 2821.24 with connecting links with tension load cell (For more information see: [Connecting links with tension load cell, page 216](#)).

Name		Value
L	Length	6300 mm 20' 8" ft-in
L1	Length of connecting link	1050 mm 3' 5" ft-in
L2	Length of pendant strap	4950 mm 16' 3" ft-in
L3	Length of connecting link	300 mm 1' ft-in

LWNLR.x/V04.01//Auslieferung/2016-03-07/en

Name		Value
B	Width of pendant strap	63 mm 2.48" in
H	Height of connecting link	110 mm 4.33" in
H1	Height of connecting link	187 mm 7.36" in
H2	Height of pendant strap	207 mm 8.15" in
D	Pin Ø	65 mm 2.56" in
D1	Pendant strap Ø	52 mm 2.05" in
D2	Pin Ø	65 mm 2.56" in
D3	Pin Ø	75 mm 2.95" in
Weight		108 kg 238 lb

Tab. 130: Technical data main boom pendant strap on main boom head 2821.24

Additional pendant straps/connecting links/tension load cells

Connecting links with tension load cell

Installation site in crane mode:

- Main boom 2821 + derrick boom 2220 (For more information see: [2821 main boom head to 2220 derrick boom head pendant straps, page 1365](#))

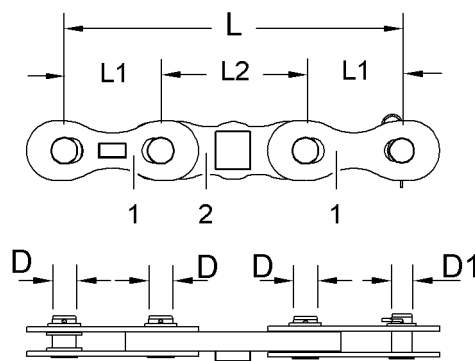


Fig. 218: Dimensions connecting links with tension load cell

- 1 Connecting links 2 Tension load cell

Name		Value
L	Length	1050 mm 3' 5" ft-in

Name		Value
L1	Length of connecting link	300 mm 1' ft-in
L2	Length of tension load cell	450 mm 1' 6" ft-in
D	Pin Ø	75 mm 2.95" in
D1	Pin Ø	65 mm 2.56" in
Weight		75 kg 165 lb

Tab. 131: Technical data connecting links with tension load cell

Connecting links

Installation site in crane mode:

- Main boom 2821 + derrick boom 2220 (For more information see: [2821 main boom head to 2220 derrick boom head pendant straps](#), page 1365)

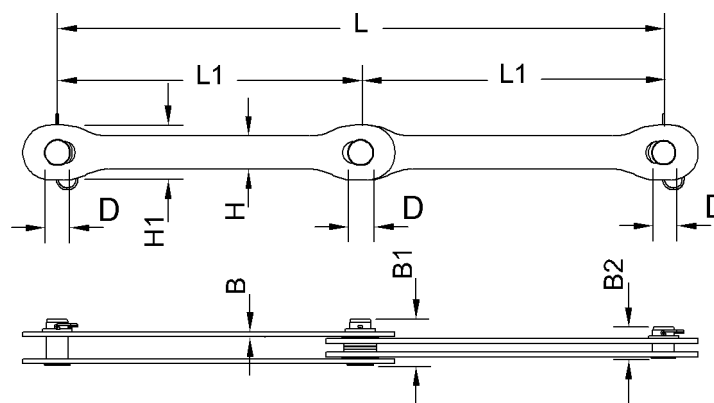


Fig. 219: Dimensions connecting links

Name		Value
L	Length	1825 mm 6' ft-in
L1	Length of connecting link	912.5 mm 3' ft-in
B	Width of connecting link	15 mm 0.59" in
B1	Length of pin	140 mm 5.51" in
B2	Length of pin	95 mm 3.74" in
H	Height of pendant strap	100 mm 3.94" in
H1	Height of pendant strap	165 mm 6.50" in

Product description

2821 main boom

Name		Value
D	Pin Ø	65 mm 2.56" in
Weight		53 kg 117 lb

Tab. 132: Technical data connecting links

LWNLR-x/V04.01//Auslieferung/2016-03-07/en

1.12 Reducing piece overview

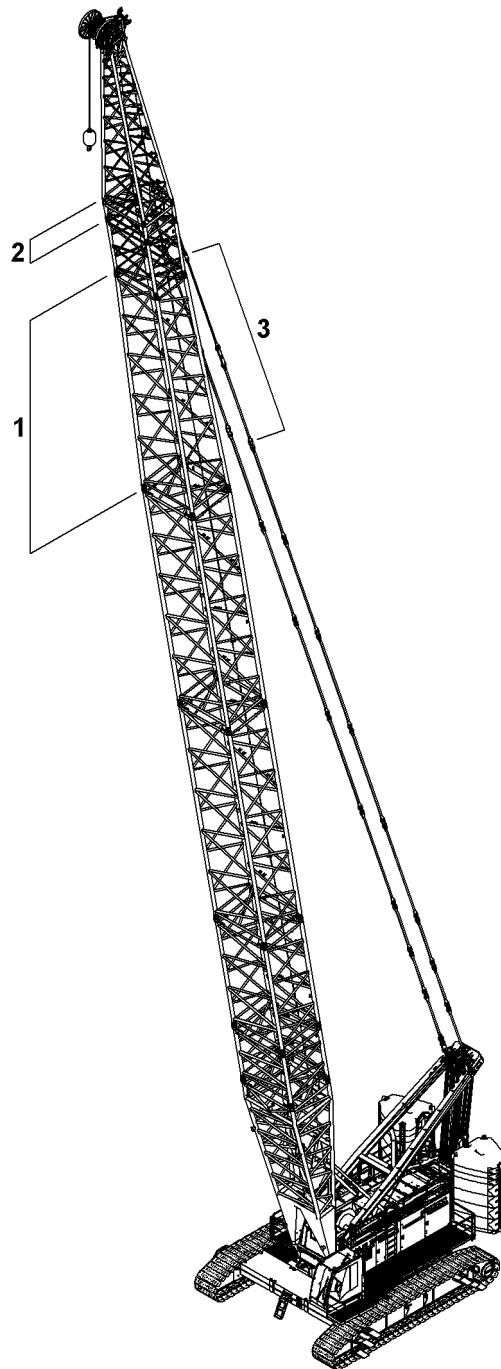


Fig. 220: Reducing adapter overview

- 1 Reducing adapter
- 2 Main boom section
- 3 Reducing adapter pendant strap

1.13 2821/2316 reducing piece

1.13.1 2821/2316.24 reducing piece 12 m (40 ft)

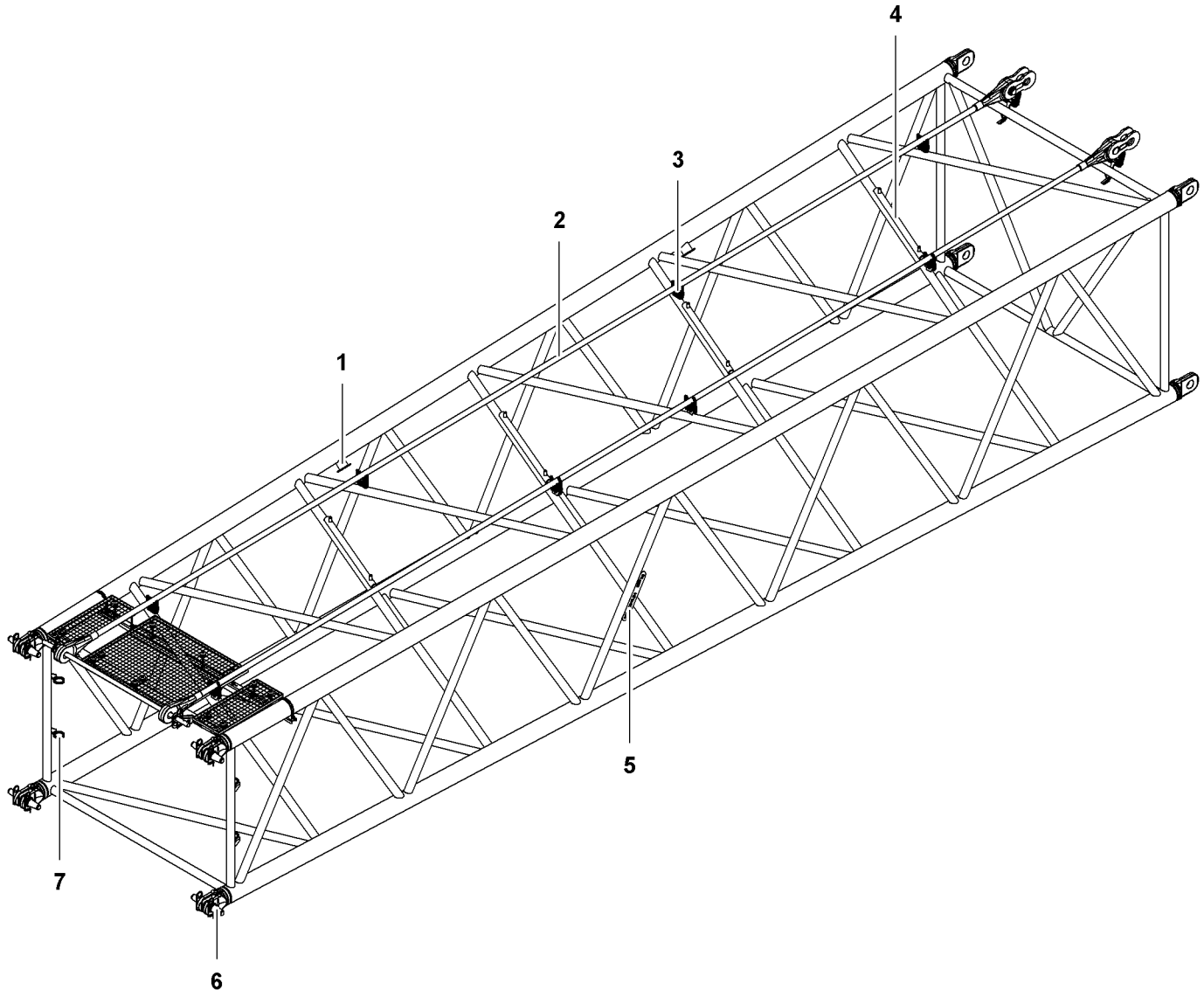


Fig. 221: Reducing adapter 2821/2316.24 12 m (40 ft)

- | | | | | | |
|---|--|---|--|---|---|
| 1 | Rigging point (4x) | 4 | Rope protection guard (6x) | 7 | Transport bracket (4x) for double taper pin |
| 2 | Transport position of reducing adapter pendant straps 12 m (40 ft) | 5 | Boom identification plate | | |
| 3 | Transport bracket (6x) for pendant straps | 6 | Pin connection point (8x) with double-taper pin (4x) | | |

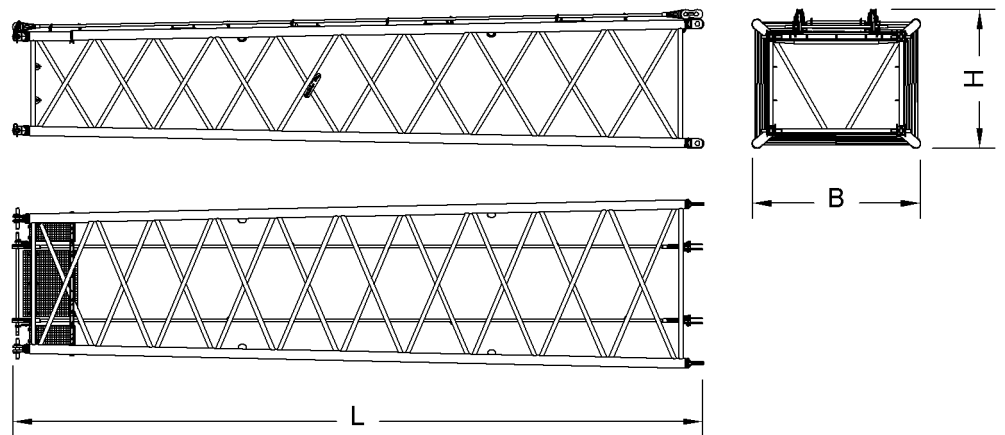


Fig. 222: Dimensions reducing adapter 2821/2316.24 12 m (40 ft)

Name		Value
System length		12000 mm 39' 4" ft-in
System width		2800 mm (9' 2" ft-in)/ 2290 mm (7' 6" ft-in)
System height		2100 mm (6' 11" ft-in)/ 1650 mm (5' 5" ft-in)
L	Length	12180 mm 40' ft-in
B	Width	2970 mm 9' 9" ft-in
H	Height (incl. pendant straps)	2470 mm 8' 1" ft-in
Weight (incl. pendant straps)		3630 kg 8,003 lb
Double-taper pins Ø		80 mm (3.15" in)/ 65 mm (2.56" in)

Tab. 133: 2821/2316.24 reducing piece technical data 12 m (40 ft)

1.13.2 Main boom section 2316.25 1 m (3 ft)

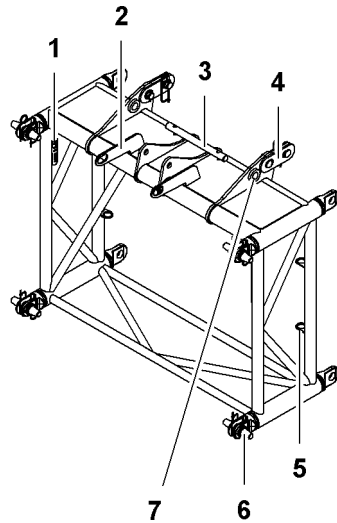


Fig. 223: Main boom section 2316.25 1 m (3 ft)

- | | | | |
|---|---|---|---|
| 1 | Boom identification plate | 5 | Transport bracket (4x) for double-taper pins |
| 2 | Link plate (2x) for main boom pendant straps | 6 | Pin connection point (8x) with double-taper pins (4x) |
| 3 | Rope protection support | 7 | Pin connection point for CF pendant straps |
| 4 | Connecting link (2x) for main boom pendant straps | | |

Machine with steel pendant straps: Connecting links 4 have a length of 200 mm (7.87" in) and a pin diameter of 55 mm (2.17" in).

Machine with CF pendant straps: Connecting links 4 have a length of 350 mm (1' 2" ft-in) and a pin diameter of 60 mm (2.36" in). The connecting links must be pinned to the pin connection point 7.

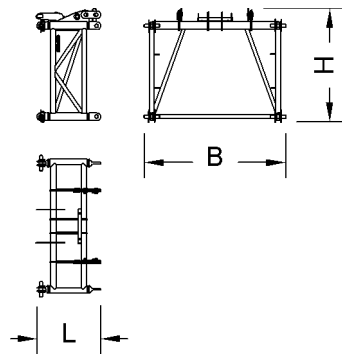


Fig. 224: Dimensions main boom section 2316.25 1 m (3 ft)

Name	Value
System length	1000 mm 3' 3" ft-in
System width	2290 mm 7' 6" ft-in

LWNLR-x/V04.01//Auslieferung/2016-03-07/en

Name		Value
System height		1650 mm 5' 5" ft-in
L	Length	1150 mm 3' 9" ft-in
W	Width	2430 mm 8' ft-in
H	Height	2010 mm 6' 7" ft-in
Weight		642 kg 1,415 lb
Double-taper pins Ø		65 mm 2.56" in

Tab. 134: Technical data main boom section 2316.25 1 m (3 ft)

1.13.3 Mid-point suspension on reducing adapter 2821/2316

The mid-point suspensions on reducing adapter 2821/2316 differ with steel pendant straps and CF pendant straps.

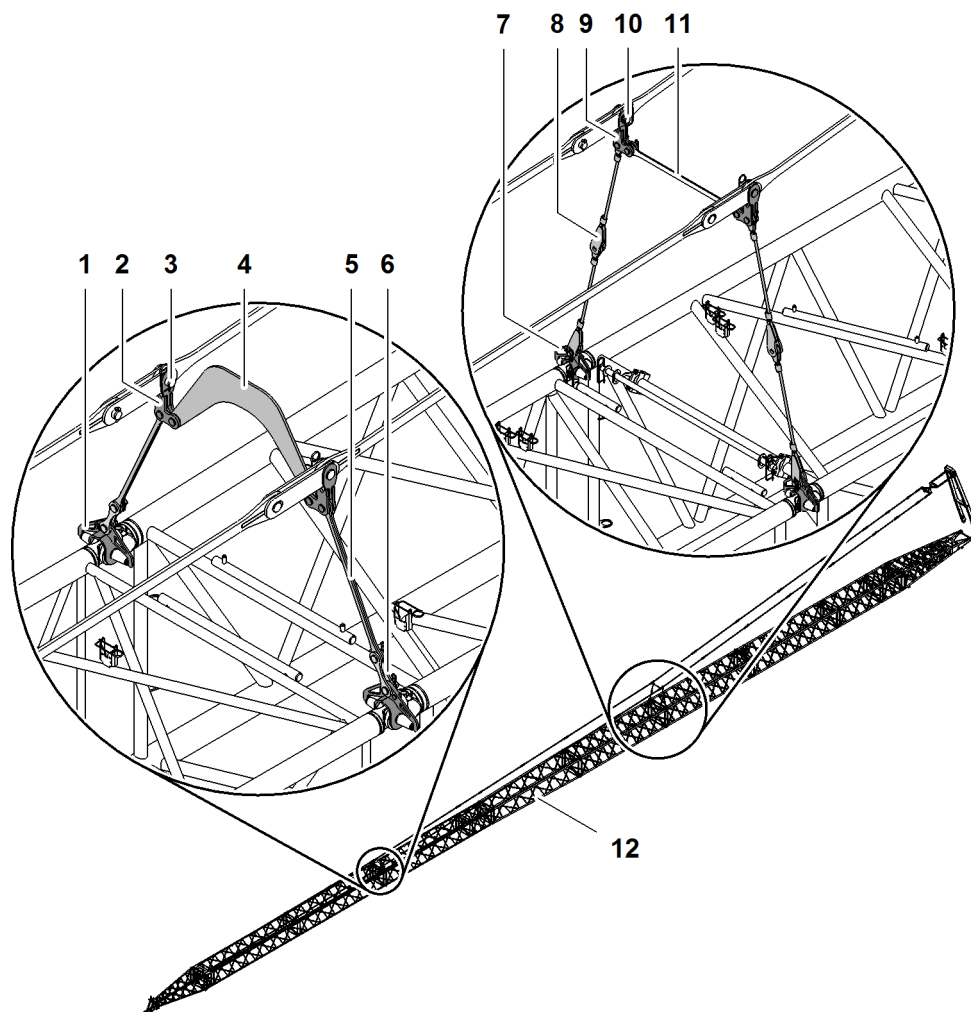


Fig. 225: Mid-point suspension on reducing adapter 2821/2316 (illustration of principle)

- | | | | |
|---|---|----|--|
| 1 | Fork (2x) behind reducing adapter | 7 | Fork (2x) in front of reducing adapter |
| 2 | Connecting element (2x) behind reducing adapter | 8 | Stay ropes |
| 3 | Pin (2x) for pendant straps behind reducing adapter | 9 | Connecting element (2x) in front of reducing adapter |
| 4 | Spacer bracket behind reducing adapter | 10 | Pin (2x) for pendant straps in front of reducing adapter |
| 5 | Top backstay shackles | 11 | Spacer bracket in front of reducing adapter |
| 6 | Bottom backstay shackles | 12 | Reducing adapter |

Connecting elements for steel pendant straps in front of reducing adapter

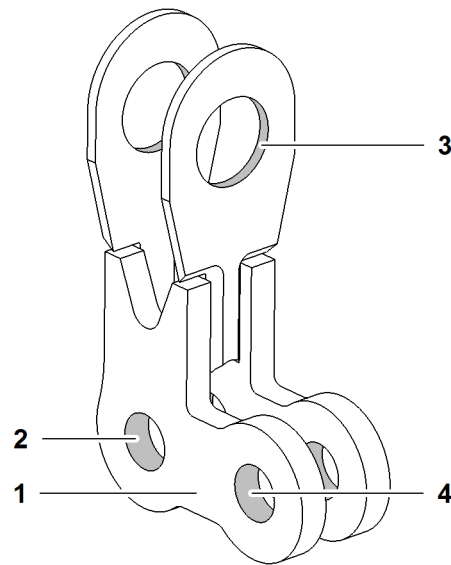


Fig. 226: Connecting elements for steel pendant straps in front of reducing adapter (illustration of principle)

- | | | | |
|---|------------------------------------|---|---|
| 1 | Connecting element | 3 | Pin connection point for pendant strap |
| 2 | Pin connection point for stay rope | 4 | Pin connection point for spacer bracket |

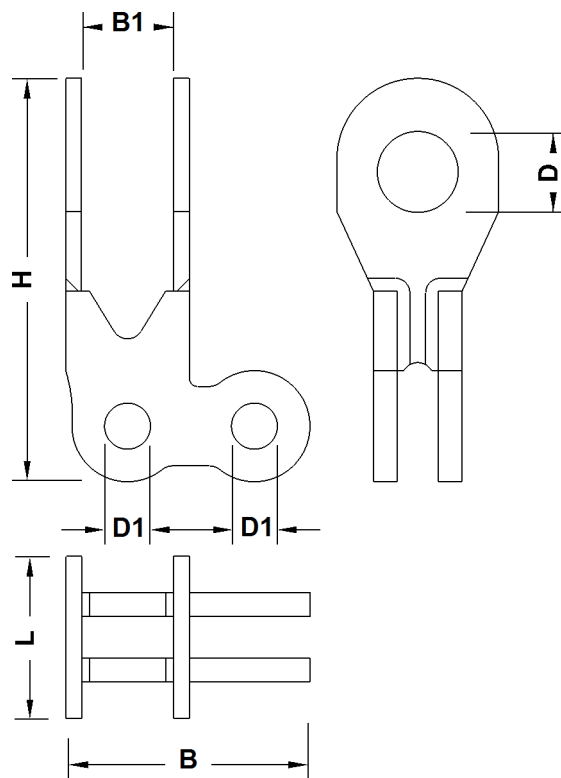


Fig. 227: Dimensions connecting elements for steel pendant straps in front of reducing adapter

Name		Value
L	Length	112 mm 4.41" in
H	Height	361 mm 1' 2" ft-in
B	Width	190 mm 7.48" in
B1	Width between links	58 mm 2.28" in
D	Pin Ø	65 mm 2.56" in
D1	Pin Ø	35 mm 1.38" in

Tab. 135: Technical data connecting elements for steel pendant straps in front of reducing adapter

Connecting elements for CF pendant straps in front of reducing adapter

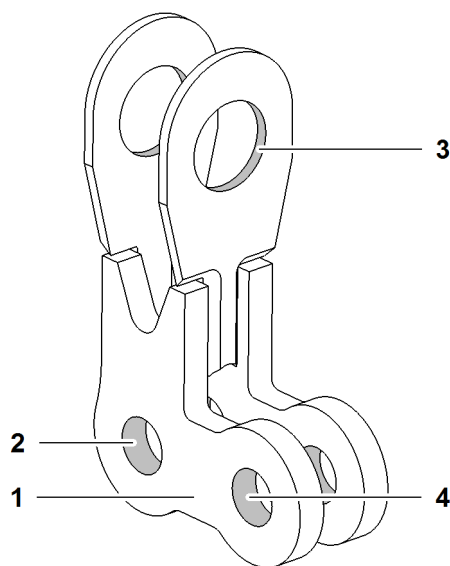


Fig. 228: Connecting elements for CF pendant straps in front of reducing adapter (illustration of principle)

- | | | | |
|---|------------------------------------|---|---|
| 1 | Connecting element | 3 | Pin connection point for pendant strap |
| 2 | Pin connection point for stay rope | 4 | Pin connection point for spacer bracket |

LWNLR-x/V04.01//Auslieferung/2016-03-07/en

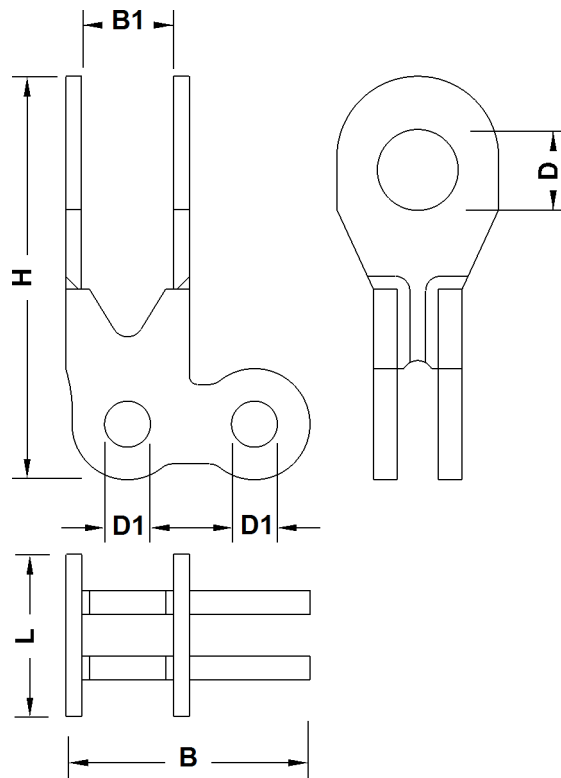


Fig. 229: Dimensions connecting elements for CF pendant straps in front of reducing adapter

Name		Value
L	Length	110 mm 4.33" in
H	Height	358 mm 1' 2" ft-in
B	Width	207 mm 8.15" in
B1	Width between links	104 mm 4.09" in
D	Pin Ø	65 mm 2.56" in
D1	Pin Ø	35 mm 1.38" in

Tab. 136: Technical data connecting elements for CF pendant straps in front of reducing adapter

LWNLR.x/V04.01//Auslieferung/2016-03-07/en

Connecting elements for steel pendant straps behind reducing adapter

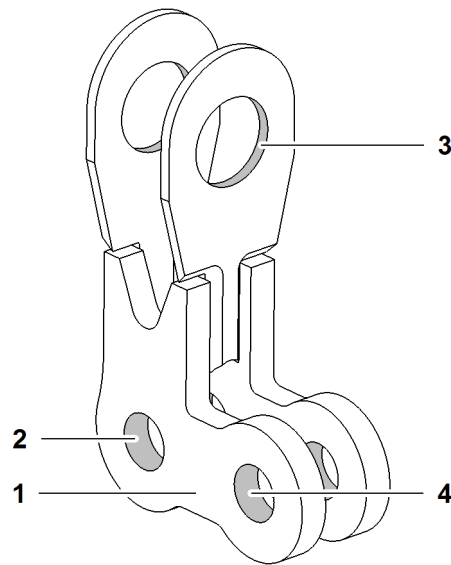


Fig. 230: Connecting elements for steel pendant straps behind reducing adapter (illustration of principle)

- | | | | |
|---|------------------------------------|---|---|
| 1 | Connecting element | 3 | Pin connection point for pendant strap |
| 2 | Pin connection point for stay rope | 4 | Pin connection point for spacer bracket |

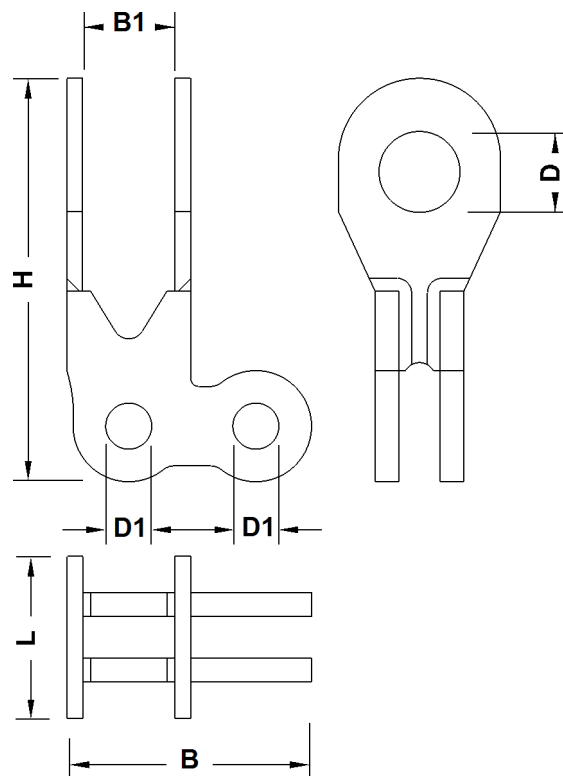


Fig. 231: Dimensions connecting elements for steel pendant straps behind reducing adapter

LWN/LR-x/V04.01//Auslieferung/2016-03-07/en

Name		Value
L	Length	102 mm 4.02" in
H	Height	354 mm 1' 2" ft-in
B	Width	190 mm 7.48" in
B1	Width between links	58 mm 2.28" in
D	Pin Ø	55 mm 2.17" in
D1	Pin Ø	35 mm 1.38" in

Tab. 137: Technical data connecting elements for steel pendant straps behind reducing adapter

Connecting elements for CF pendant straps behind reducing adapter

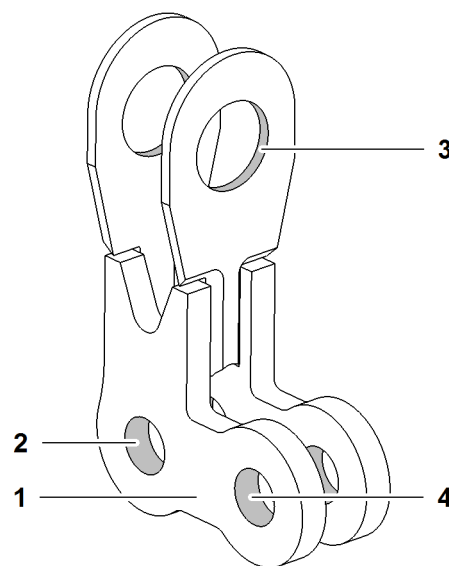


Fig. 232: Connecting elements for CF pendant straps behind reducing adapter (illustration of principle)

- | | | | |
|----------|------------------------------------|----------|---|
| 1 | Connecting element | 3 | Pin connection point for pendant strap |
| 2 | Pin connection point for stay rope | 4 | Pin connection point for spacer bracket |

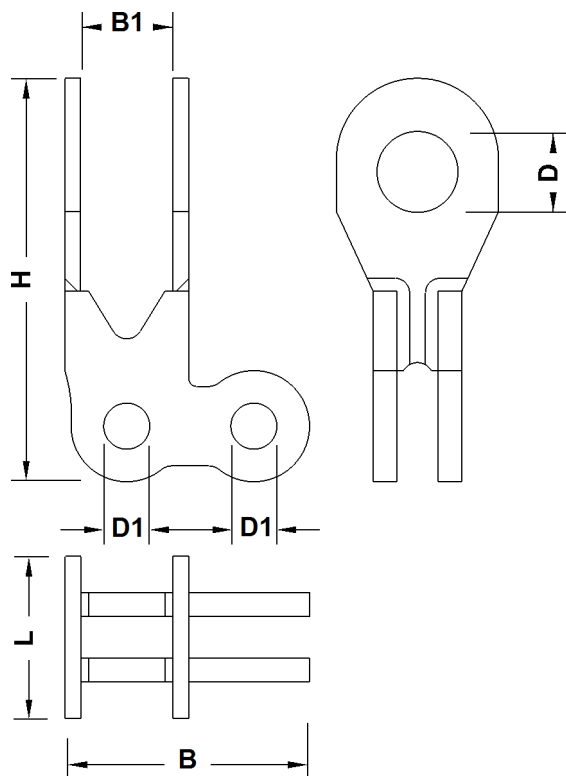


Fig. 233: Dimensions connecting elements for CF pendant straps behind reducing adapter

Name		Value
L	Length	110 mm 4.33" in
H	Height	358 mm 1' 2" ft-in
B	Width	207 mm 8.15" in
B1	Width between links	104 mm 4.09" in
D	Pin Ø	60 mm 2.36" in
D1	Pin Ø	35 mm 1.38" in

Tab. 138: Technical data connecting elements for CF pendant straps behind reducing adapter

LWNLR-x\04.01\Auslieferung\2016-03-07\en

Forks in front of reducing adapter

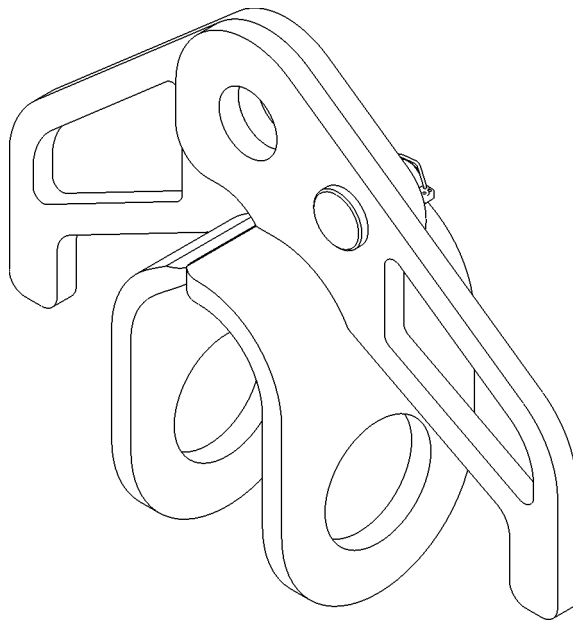


Fig. 234: Forks in front of reducing adapter (illustration of principle)

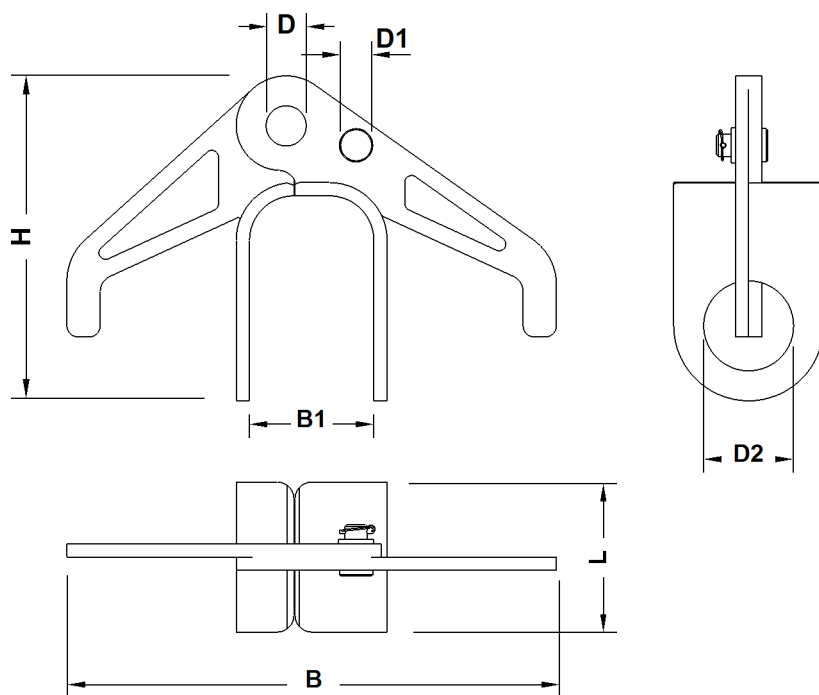


Fig. 235: Dimensions forks in front of reducing adapter

Name		Value
L	Length of fork	135 mm 5.31" in
B	Width	441 mm 1' 5" ft-in

Name		Value
B1	Width of fork	112 mm 4.41" in
H	Height	293 mm 1' ft-in
D	Pin Ø	35 mm 1.38" in
D1	Pin Ø	20 mm 0.79" in
D2	Pin Ø	80 mm 3.15" in

Tab. 139: Technical data forks in front of reducing adapter

Forks behind reducing adapter

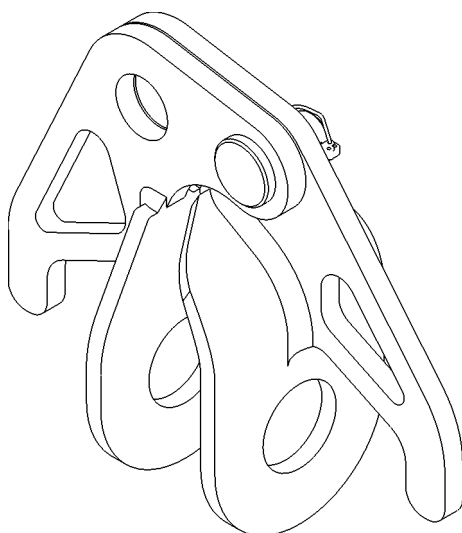


Fig. 236: Forks behind reducing adapter (illustration of principle)

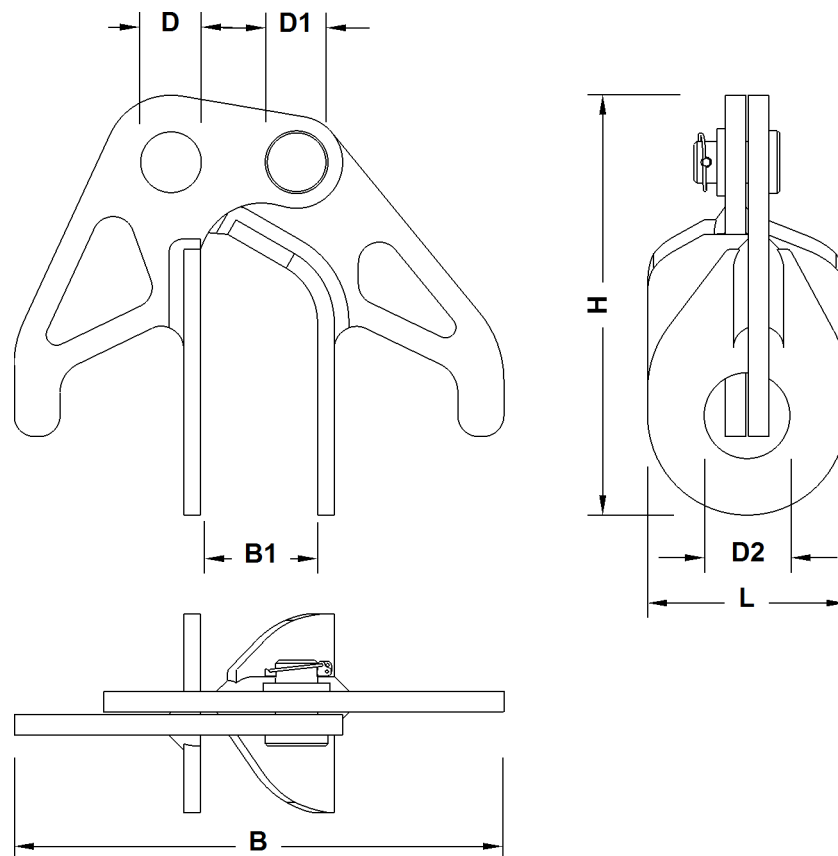


Fig. 237: Dimensions forks behind reducing adapter

Name		Value
L	Length of fork	120 mm 4.72" in
B	Width	354 mm 1' 2" ft-in
B1	Width of fork	82 mm 3.23" in
H	Height	270 mm 10.63" in
D	Pin Ø	35 mm 1.38" in
D1	Pin Ø	20 mm 0.79" in
D2	Pin Ø	65 mm 2.56" in

Tab. 140: Technical data forks behind reducing adapter

Spacer bracket in front of reducing adapter

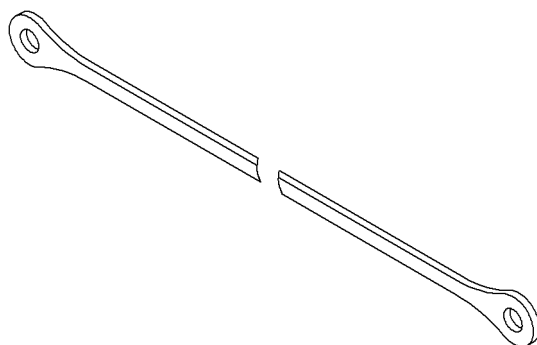


Fig. 238: Spacer bracket in front of reducing adapter (illustration of principle)

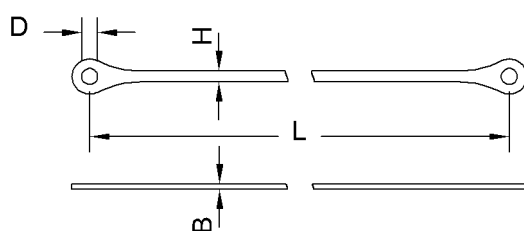


Fig. 239: Dimensions spacer bracket in front of reducing adapter

Name		Value
L	Length	1100 mm 3' 7" ft-in
B	Width	10 mm 0.39" in
H	Height	40 mm 1.57" in
D	Pin Ø	35 mm 1.38" in

Tab. 141: Technical data spacer bracket in front of reducing adapter

Spacer bracket behind reducing adapter

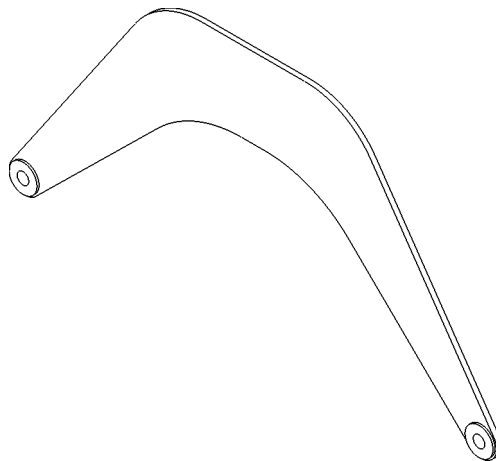


Fig. 240: Spacer bracket behind reducing adapter (illustration of principle)

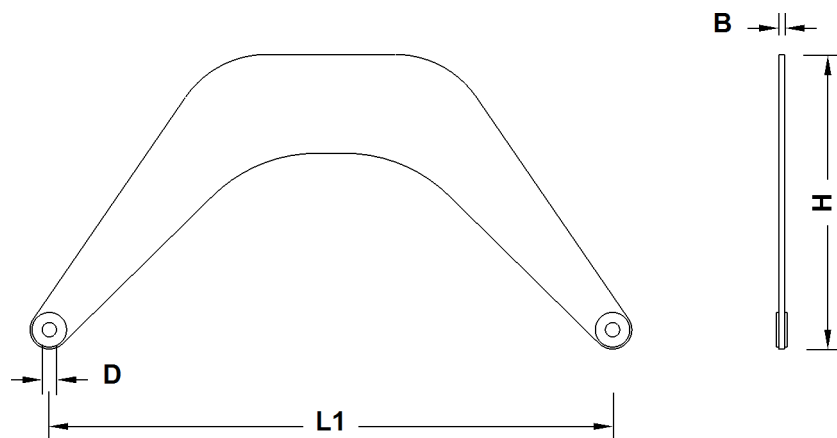


Fig. 241: Dimensions spacer bracket behind reducing adapter

Name		Value
L1	Length	1100 mm 3' 7" ft-in
B	Width	15 mm 0.59" in
H	Height	602 mm 2' ft-in
D	Pin Ø	35 mm 1.38" in

Tab. 142: Technical data spacer bracket behind reducing adapter

LWNLR.x/V04.01//Auslieferung/2016-03-07/en

Backstay shackles

Top backstay shackle

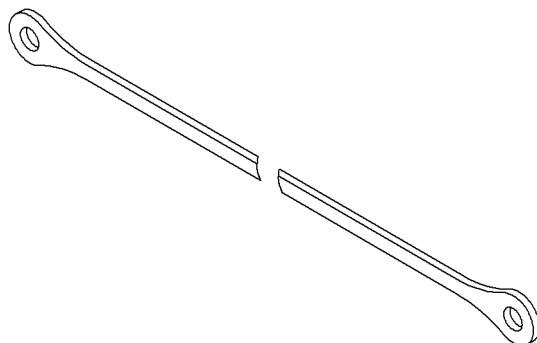


Fig. 242: Top backstay shackle (illustration of principle)

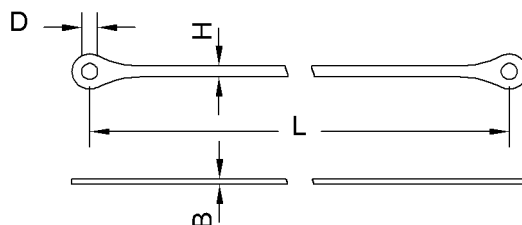


Fig. 243: Dimensions top backstay shackle

Name		Value
L	Length	420 mm 1' 5" ft-in
		540 mm 1' 9" ft-in
		730 mm 2' 5" ft-in
		950 mm 3' 1" ft-in
B	Width	12 mm 0.47" in
H	Height	80 mm 3.15" in
D	Pin Ø	35 mm 1.38" in

Tab. 143: Technical data top backstay shackle

Bottom backstay shackle

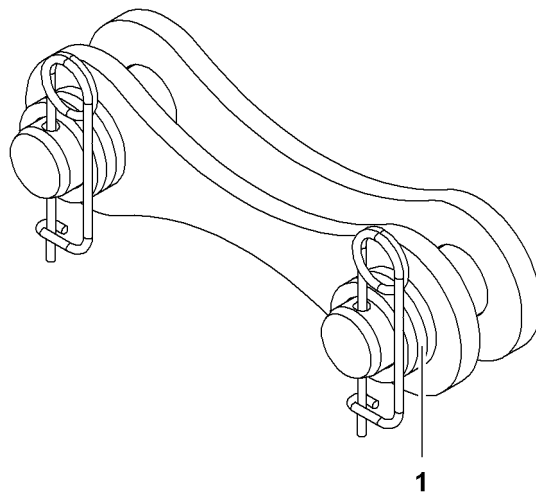


Fig. 244: Bottom backstay shackle (illustration of principle)

1 Washer (3x each)

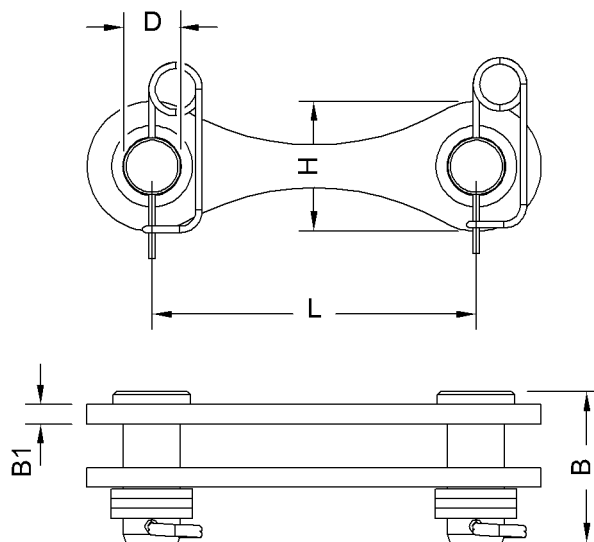


Fig. 245: Dimensions bottom backstay shackle

Name		Value
L	Length	200 mm 7.87" in
B1	Width	12 mm 0.47" in
H	Height	80 mm 3.15" in
B	Length of pin	90 mm 3.54" in
D	Pin Ø	35 mm 1.38" in

Tab. 144: Technical data bottom backstay shackle

Stay ropes

Several stay ropes are assembled to achieve defined rope lengths.

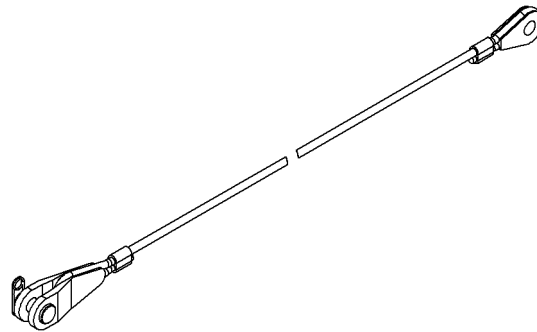


Fig. 246: Stay ropes (illustration of principle)

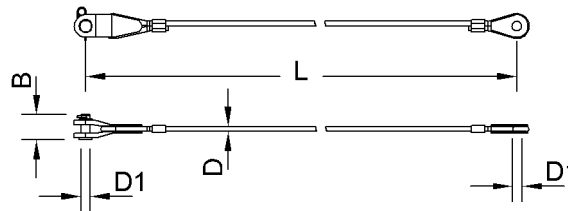


Fig. 247: Dimensions stay ropes

Name		Value
L	Length of stay rope	1100 mm 3' 7" ft-in
		1300 mm 4' 3" ft-in
		1600 mm 5' 3" ft-in
		2100 mm 6' 11" ft-in
		2600 mm 8' 6" ft-in
		3000 mm 9' 10" ft-in
D	Ø of stay rope	18 mm 0.71" in
B	Length of pin	90 mm 3.54" in
D1	Pin Ø	35 mm 1.38" in

Tab. 145: Technical data stay ropes

LWNLR-x/V04.01//Auslieferung/2016-03-07/en

Pins for steel pendant straps in front of reducing adapter

The pins supplied with the pendant straps must be exchanged for longer pins.

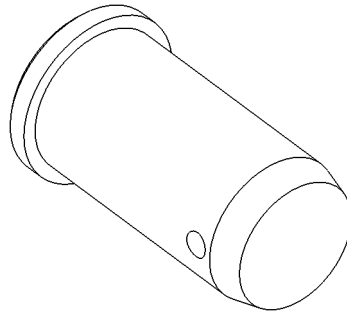


Fig. 248: Pins for steel pendant straps in front of reducing adapter (illustration of principle)

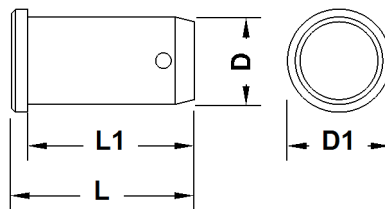


Fig. 249: Dimensions pins for steel pendant straps in front of reducing adapter

Name		Value
L	Total length	140 mm 5.51" in
L1	Length	128 mm 5.04" in
D	Diameter	65 mm 2.56" in
D1	Outer diameter	80 mm 3.15" in

Tab. 146: Technical data pins for steel pendant straps in front of reducing adapter

Pins for CF pendant straps in front of reducing adapter

The pins supplied with the pendant straps must be exchanged for longer pins.

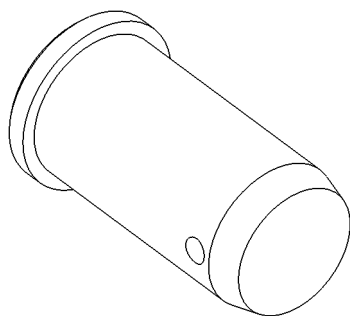


Fig. 250: Pins for CF pendant straps in front of reducing adapter (illustration of principle)

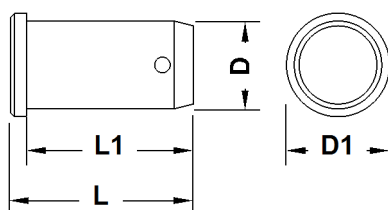


Fig. 251: Dimensions pins for CF pendant straps in front of reducing adapter

Name		Value
L	Total length	170 mm 6.69" in
L1	Length	160 mm 6.30" in
D	Diameter	65 mm 2.56" in
D1	Outer diameter	85 mm 3.35" in

Tab. 147: Technical data pins for CF pendant straps in front of reducing adapter

Pins for steel pendant straps behind reducing adapter

The pins supplied with the pendant straps must be exchanged for longer pins.

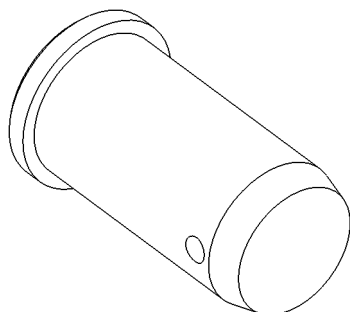


Fig. 252: Pins for steel pendant straps behind reducing adapter (illustration of principle)

LWN/LR-x/V04.01//Auslieferung/2016-03-07/en

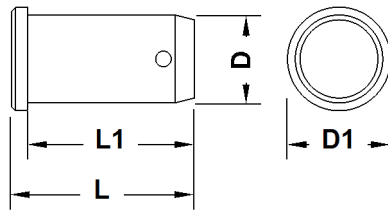


Fig. 253: Dimensions pins for steel pendant straps behind reducing adapter

Name		Value
L	Total length	120 mm 4.72" in
L1	Length	112 mm 4.41" in
D	Diameter	55 mm 2.17" in
D1	Outer diameter	63 mm 2.48" in

Tab. 148: Technical data pins for steel pendant straps behind reducing adapter

Pins for CF pendant straps behind reducing adapter

The pins supplied with the pendant straps must be exchanged for longer pins.

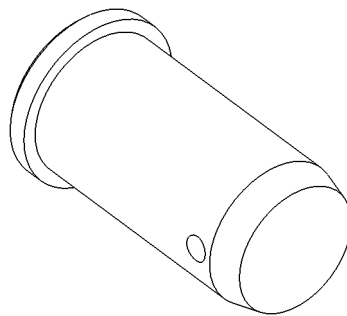


Fig. 254: Pins for CF pendant straps behind reducing adapter (illustration of principle)

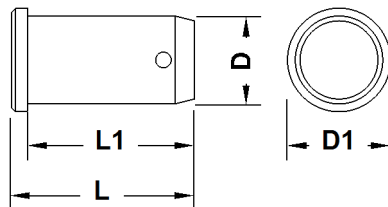


Fig. 255: Dimensions pins for CF pendant straps behind reducing adapter

Name		Value
L	Total length	158 mm 6.22" in

Name		Value
L1	Length	153 mm 6.02" in
D	Diameter	60 mm 2.36" in
D1	Outer diameter	68 mm 2.68" in

Tab. 149: Technical data pins for CF pendant straps behind reducing adapter

1.13.4 Steel pendant straps on reducing adapter 2821/2316

Steel pendant straps on reducing adapter 2821/2316.24 12 m (40 ft)

Reducing adapter pendant strap 12 m (40 ft)

Installation site in crane operation:

- Main boom 2821 + reducing adapter 2821/2316 (For more information see: [Pendant straps A-frame1 to main boom head 2316, page 1511](#))

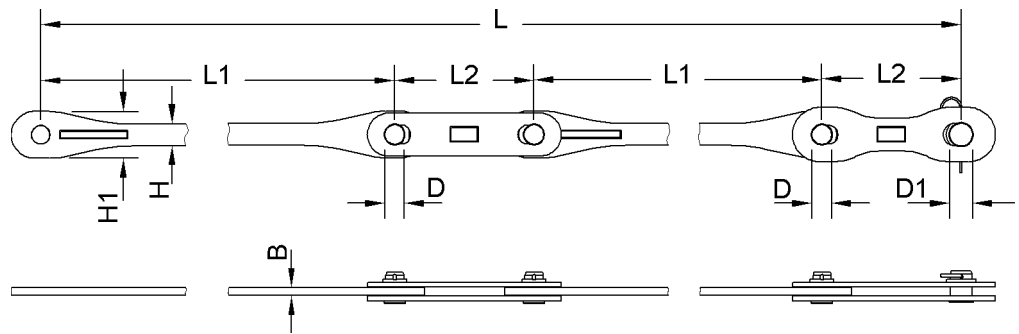


Fig. 256: Dimensions reducing adapter pendant strap 12 m (40 ft)

Name		Value
L	Length	12000 mm 39' 4" ft-in
L1	Length of pendant strap	5580 mm 18' 4" ft-in
L2	Length of connecting link	420 mm 1' 5" ft-in
W	Width of pendant strap	22 mm 0.87" in
H	Height of pendant strap	66 mm 2.60" in
H1	Height of pendant strap	140 mm 5.51" in
D	Pin Ø	55 mm 2.17" in

LWNLR-x/V04.01//Auslieferung/2016-03-07/en

Name		Value
D1	Pin Ø	65 mm 2.56" in
Weight		181 kg 399 lb

Tab. 150: Technical data reducing adapter pendant strap 12 m (40 ft)

Steel pendant straps on main boom section 2316.25 1 m (3 ft)

Connecting link

Installation site in crane operation:

- Main boom 2821 + reducing adapter 2821/2316 (For more information see: [Pendant straps A-frame1 to main boom head 2316, page 1511](#))

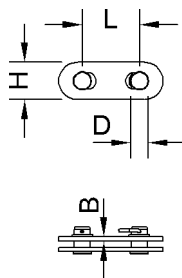


Fig. 257: Dimensions connecting link

Name		Value
L	Length of connecting link	200 mm 7.87" in
W	Width of connecting link	15 mm 0.59" in
H	Height of connecting link	130 mm 5.12" in
D	Pin Ø	55 mm 2.17" in
Weight		6 kg 13.23 lb

Tab. 151: Technical data connecting link

1.13.5 CF pendant straps on reducing adapter 2821/2316

CF pendant straps on reducing adapter 2821/2316.24 12 m (40 ft)

Reducing adapter pendant strap 12 m (40 ft)

Installation site in crane operation:

- Main boom 2821 + reducing adapter 2821/2316 (For more information see: [Pendant straps A-frame1 to main boom head 2316, page 1513](#))

Generation A of reducing adapter pendant strap 12 m (40 ft)

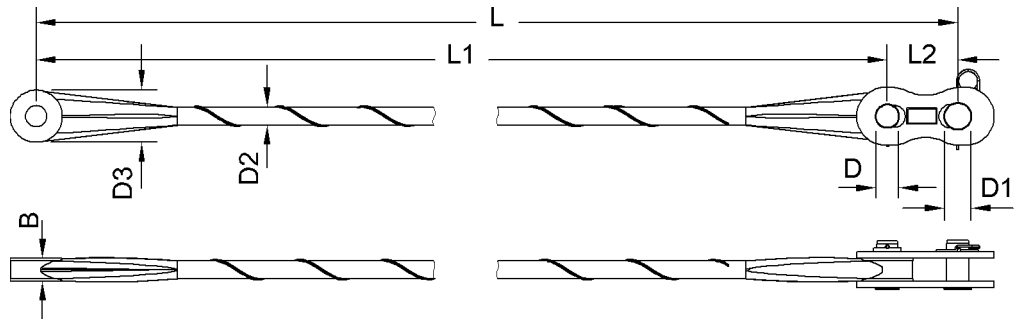


Fig. 258: Reducing adapter pendant strap 12 m (40 ft)

Name		Value
L	Length	12000 mm 39' 4" ft-in
L1	Length of pendant strap	11800 mm 38' 9" ft-in
L2	Length of connecting link	200 mm 7.87" in
W	Width	64 mm 2.52" in
D	Pin Ø	60 mm 2.36" in
D1	Pin Ø	65 mm 2.56" in
D2	Pendant strap Ø	50 mm 1.97" in
D3	Pendant strap Ø	148 mm 5.83" in
Weight		62 kg 137 lb

Tab. 152: Technical data reducing adapter pendant strap 12 m (40 ft)

LWNLR-x\04.01\Auslieferung\2016-03-07\en

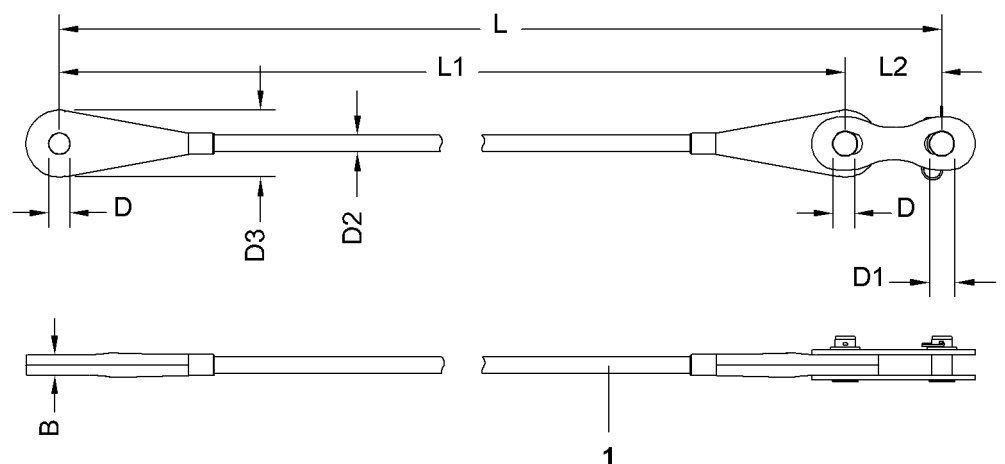
Generation B of reducing adapter pendant strap 12 m (40 ft)

Fig. 259: Dimensions reducing adapter pendant strap 12 m (40 ft)

- 1 Wire mesh hose as protective sheath

Name	Value
L Length	12000 mm 39' 4" ft-in
L1 Length of pendant strap	11800 mm 38' 9" ft-in
L2 Length of connecting link	200 mm 7.87" in
B Width	63 mm 2.48" in
D Pin Ø	60 mm 2.36" in
D1 Pin Ø	65 mm 2.56" in
D2 Pendant strap Ø	48 mm 1.89" in
D3 Pendant strap Ø	161 mm 6.34" in
Weight	51 kg 112 lb

Tab. 153: Technical data reducing adapter pendant strap 12 m (40 ft)

CF pendant straps on main boom section 2316.25 1 m (3 ft)

Connecting link

Installation site in crane operation:

- Main boom 2821 + reducing adapter 2821/2316 (For more information see: [Pendant straps A-frame1 to main boom head 2316, page 1513](#))

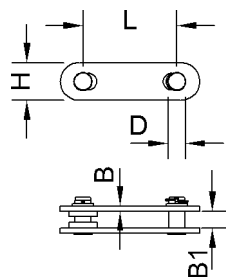


Fig. 260: Dimensions connecting link

Name		Value
L	Length of connecting link	350 mm 1' 2" ft-in
W	Width of connecting link	18 mm 0.71" in
H	Height of connecting link	140 mm 5.51" in
D	Pin Ø	60 mm 2.36" in
Weight		8 kg 17.64 lb

Tab. 154: Technical data connecting link

1.14 Fixed jib - overview

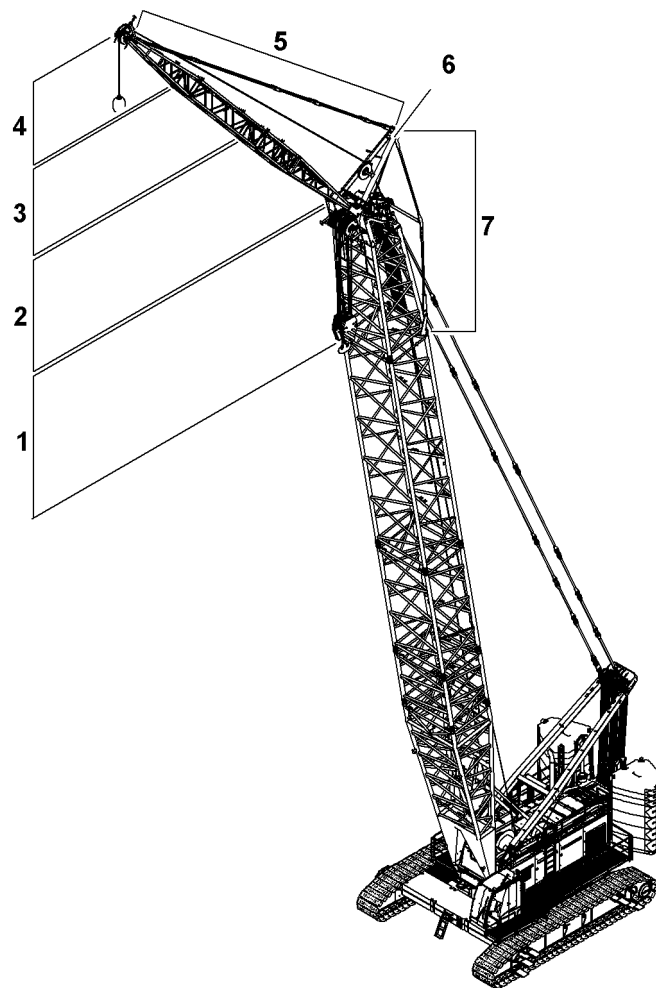


Fig. 261: Fixed jib - overview

- | | | | |
|---|-------------------|---|---------------------|
| 1 | Boom head section | 5 | Jib pendant straps |
| 2 | Jib base section | 6 | A-frame 2 |
| 3 | Jib sections | 7 | Jib backstay straps |
| 4 | Jib head section | | |

The fixed jib is composed of:

- Jib base section 2
- Jib sections (3 m (10 ft), 6 m (20 ft), 12 m (40 ft)) 3
- Jib head section 4

The jib pendant straps 5 connect A-frame 2 6 to the jib head section 4.

The jib backstay straps 7 connect A-frame 2 6 to the boom head section 1.

The fixed jib can be tensioned to 15° or 30°.

1.15 1713 fixed jib

1.15.1 Jib base section 1713.22

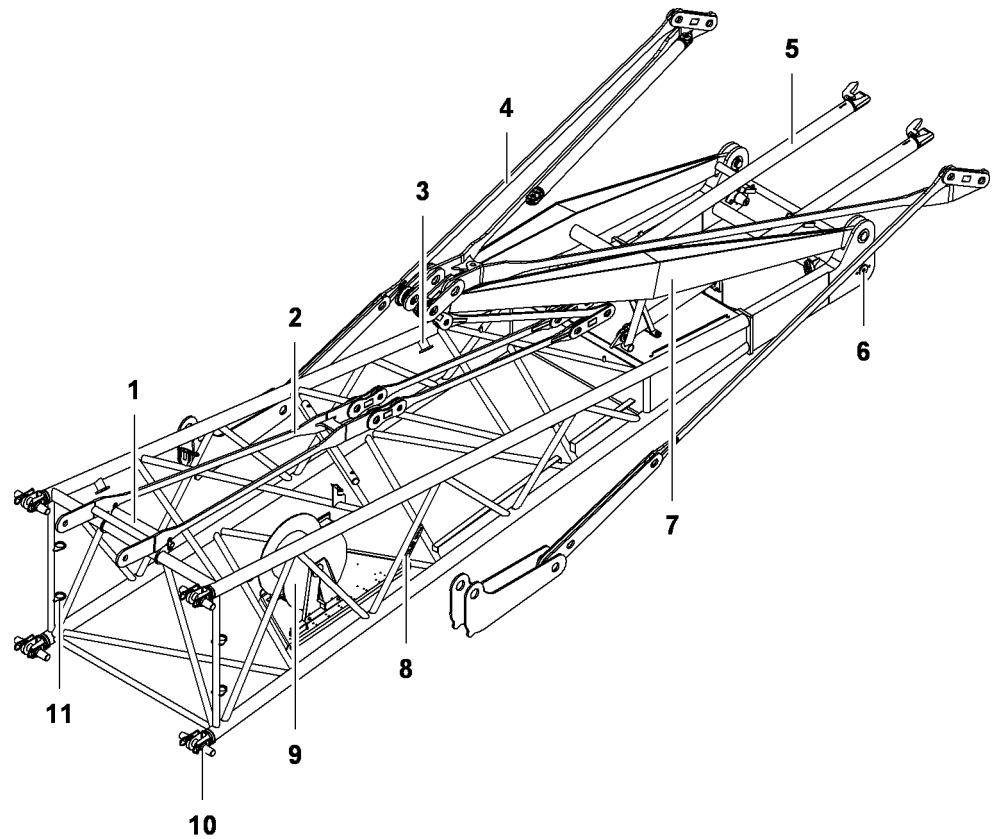


Fig. 262: Jib base section 1713.22

- | | | | |
|---|---|----|---|
| 1 | Rope protection roller | 7 | A-frame 2 |
| 2 | Transport position (2x) of jib pendant straps | 8 | Boom identification plate |
| 3 | Lifting point (4x) | 9 | Cable drum |
| 4 | Transport position of the equalizer on A-frame 2 (jib backstay strap) | 10 | Pin connection point (4x) with double-taper pins (4x) |
| 5 | Rigid tilting-back support (2x) | 11 | Transport bracket (4x) for double-taper pins |
| 6 | Pivot point (2x) for main boom head section | | |

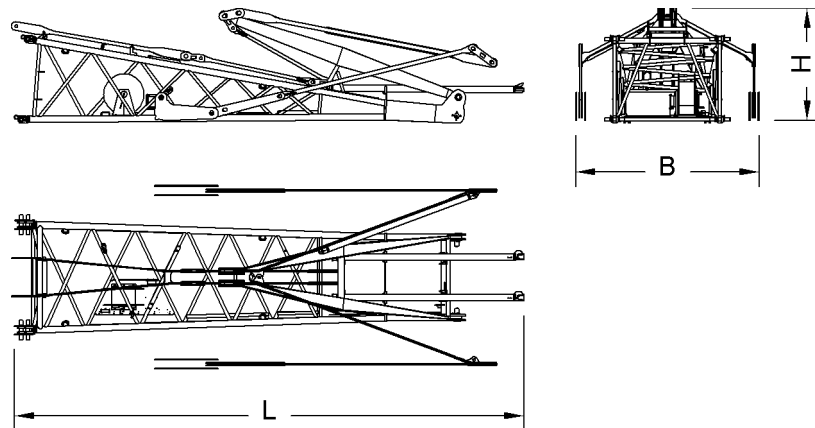


Fig. 263: Dimensions of jib base section 1713.22

Name		Value
System length		7000 mm 23' ft-in
System width		1700 mm 5' 7" ft-in
System height		1300 mm 4' 3" ft-in
L	Length	9550 mm 31' 4" ft-in
B	Width	2450 mm 8' ft-in
H	Height	1900 mm 6' 3" ft-in
Weight (incl. pendant straps, tilting-back supports and jib backstay straps)		2495 kg 5,500 lb
Double-taper pins Ø		60 mm 2.36" in

Tab. 155: Technical data jib base section 1713.22

1.15.2 1713.18 jib section 3 m (10 ft)

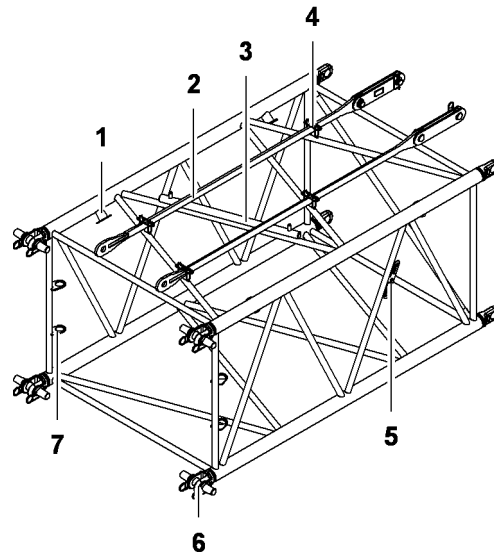


Fig. 264: 1713.18 jib section 3 m (10 ft)

- | | |
|--|--|
| <ul style="list-style-type: none"> 1 Lifting point (4x) 2 Transport position (2x) of the jib pendant straps 3 m (10 ft) 3 Rope protection support 4 Transport brackets (4x) for pendant straps | <ul style="list-style-type: none"> 5 Boom identification plate 6 Pin connection point (8x) with double-taper pins (4x) 7 Transport bracket (4x) for double-taper pins |
|--|--|

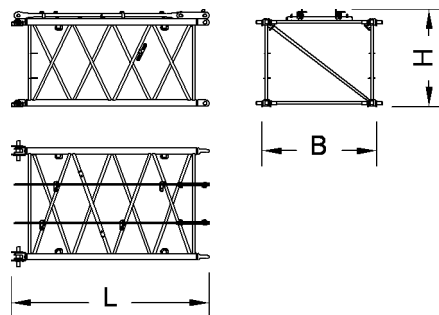


Fig. 265: Dimensions of 1713.18 jib section 3 m (10 ft)

Name		Value
System length		3000 mm 9' 10" ft-in
System width		1700 mm 5' 7" ft-in
System height		1300 mm 4' 3" ft-in
L	Length	3150 mm 10' 4" ft-in
B	Width	1820 mm 6' ft-in

LWN/LR-x/V04.01//Auslieferung/2016-03-07/en

Name		Value
H	Height (incl. pendant straps)	1500 mm 4' 11" ft-in
Weight (incl. pendant straps)		430 kg 948 lb
Double-taper pins Ø		60 mm 2.36" in

Tab. 156: Technical data for 1713.18 jib section 3 m (10 ft)

1.15.3 1713.18 jib section 6 m (20 ft)

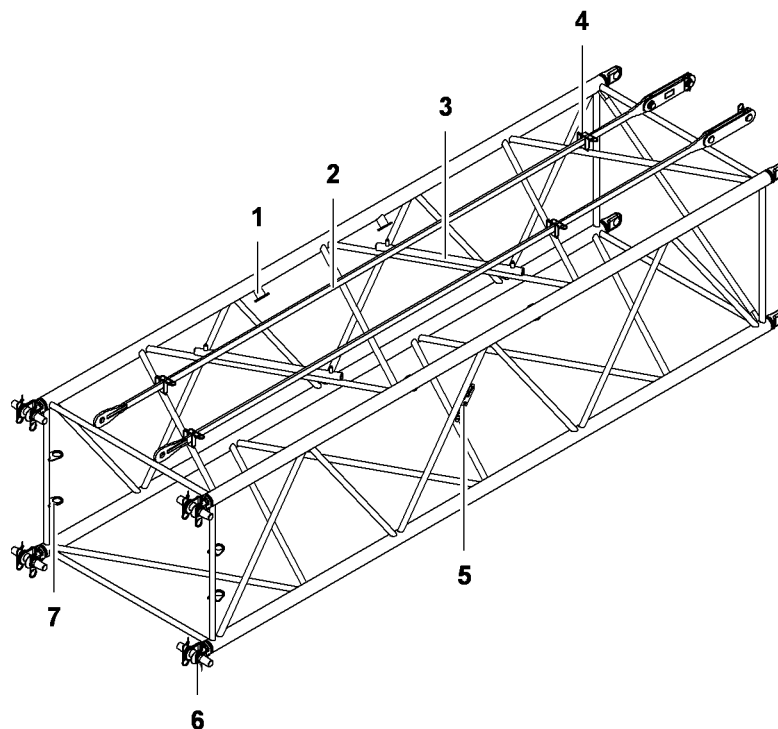


Fig. 266: 1713.18 jib section 6 m (20 ft)

- | | | | |
|---|---|---|---|
| 1 | Lifting point (4x) | 5 | Boom identification plate |
| 2 | Transport position (2x) of the jib pendant straps 6 m (20 ft) | 6 | Pin connection point (8x) with double-taper pins (4x) |
| 3 | Rope guard support (2x) | 7 | Transport bracket (4x) for double-taper pins |
| 4 | Transport brackets (4x) for pendant straps | | |

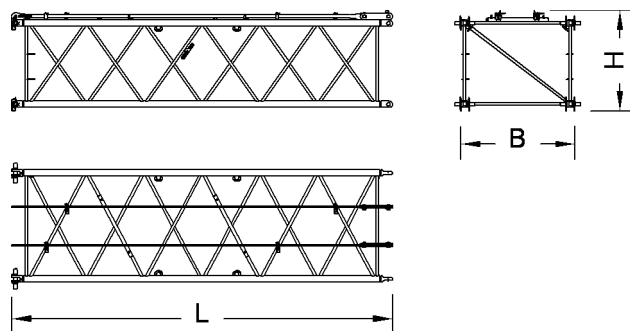


Fig. 267: Dimensions of 1713.18 jib section 6 m (20 ft)

Name		Value
System length		6000 mm 19' 8" ft-in
System width		1700 mm 5' 7" ft-in
System height		1300 mm 4' 3" ft-in
L	Length	6150 mm 20' 2" ft-in
B	Width	1820 mm 6' ft-in
H	Height (incl. pendant straps)	1500 mm 4' 11" ft-in
Weight (incl. pendant straps)		630 kg 1,389 lb
Double-taper pins Ø		60 mm 2.36" in

Tab. 157: Technical data for 1713.18 jib section 6 m (20 ft)

1.15.4 1713.18 jib section 12 m (40 ft)

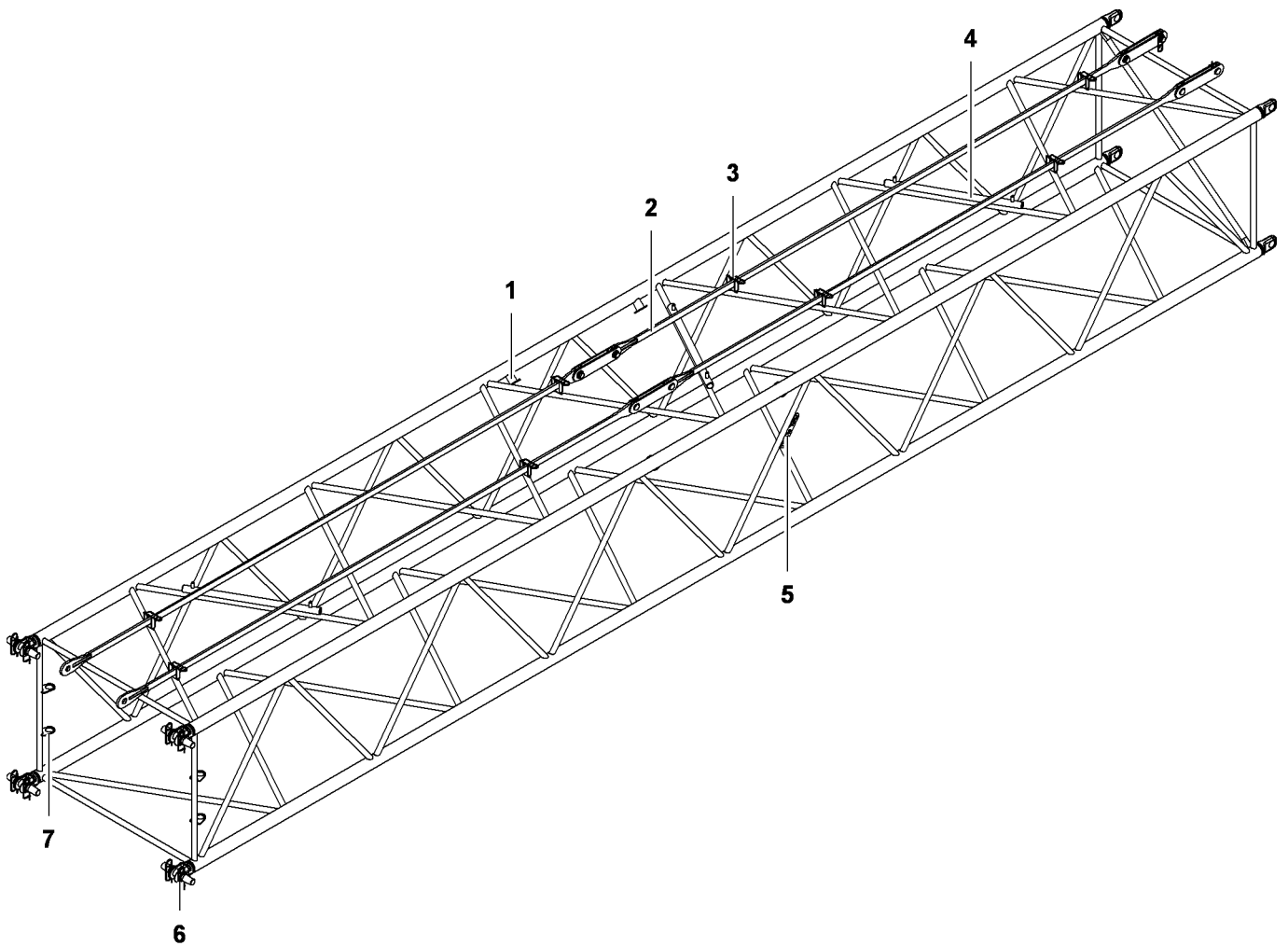


Fig. 268: 1713.18 jib section 12 m (40 ft)

- | | | | | | |
|---|--|---|---|---|--|
| 1 | Lifting point (4x) | 4 | Rope protection support (3x) | 7 | Transport bracket (4x) for double-taper pins |
| 2 | Transport position (2x) of the jib pendant straps 12 m (40 ft) | 5 | Boom identification plate | | |
| 3 | Transport bracket (8x) for pendant straps | 6 | Pin connection point (8x) with double-taper pins (4x) | | |

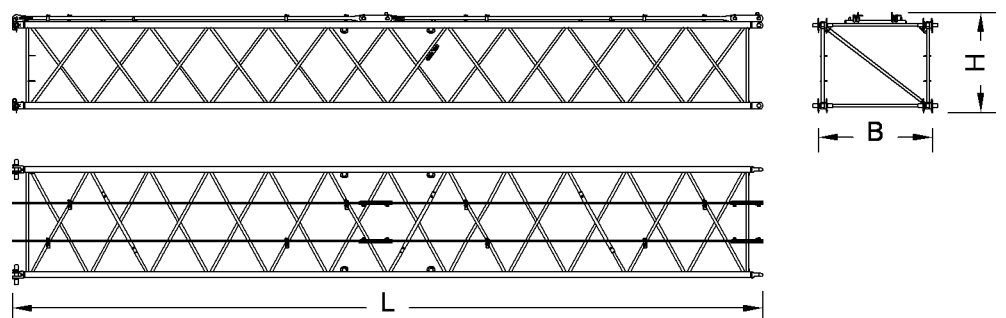


Fig. 269: Dimensions of 1713.18 jib section 12 m (40 ft)

LWNLR.x/V04.01//Auslieferung/2016-03-07/en

Name		Value
System length		12000 mm 39' 4" ft-in
System width		1700 mm 5' 7" ft-in
System height		1300 mm 4' 3" ft-in
L	Length	12150 mm 39' 10" ft-in
B	Width	1820 mm 6' ft-in
H	Height (incl. pendant straps)	1500 mm 4' 11" ft-in
Weight (incl. pendant straps)		1140 kg 2,513 lb
Double-taper pins Ø		60 mm 2.36" in

Tab. 158: Technical data for 1713.18 jib section 12 m (40 ft)

1.15.5 1713.21 jib head section

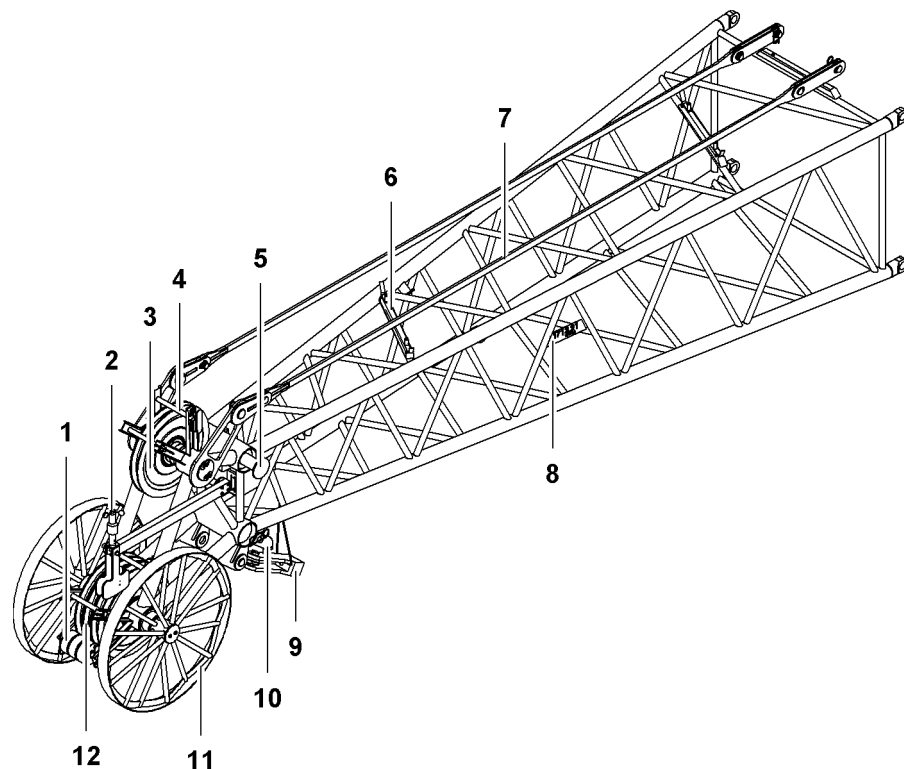


Fig. 270: 1713.21 jib head section

- | | | | |
|---|-----------------------------|---|---|
| 1 | Rope protection roller (3x) | 7 | Transport position (2x) of jib pendant straps |
| 2 | Anemometer | 8 | Boom identification plate |
| 3 | Pulley | 9 | Rope fixation |

See next page for continuation of the image legend

- | | | | |
|---|---------------------------|----|-------------------------|
| 4 | Rope protection pipe (2x) | 10 | Hoist limit switch (2x) |
| 5 | Lifting point (4x) | 11 | Wheel (2x) |
| 6 | Rope guard support (2x) | 12 | Pulley (3x) |

This jib head section is designed to allow an auxiliary jib to be attached ([For more information see: 1.27 Auxiliary jib* \(15 t \(33.000 lb\)\), page 379](#)).

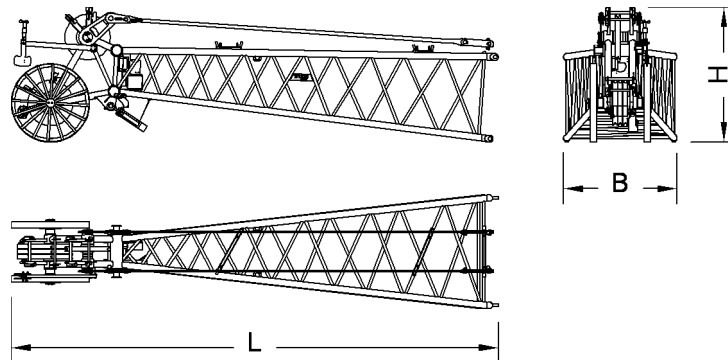


Fig. 271: 1713.21 jib head section dimensions

Name		Value
System length		7000 mm 23' ft-in
System width		1700 mm 5' 7" ft-in
System height		1300 mm 4' 3" ft-in
L	Length	7750 mm 25' 5" ft-in
B	Width	1820 mm 6' ft-in
H	Height (incl. pendant straps)	2150 mm 7' 1" ft-in
Weight (incl. pendant straps)		1353 kg 2,983 lb

Tab. 159: 1713.21 jib head section, technical data

1.15.6 Steel pendant straps on fixed jib 1713

Steel pendant straps on A-frame2

Equalizer A-frame2 (jib backstay strap)

Installation site in crane operation:

- Fixed jib 1713 ([For more information see: Backstay straps A-frame2 to main boom head 2821, page 1537](#))

Product description

1713 fixed jib

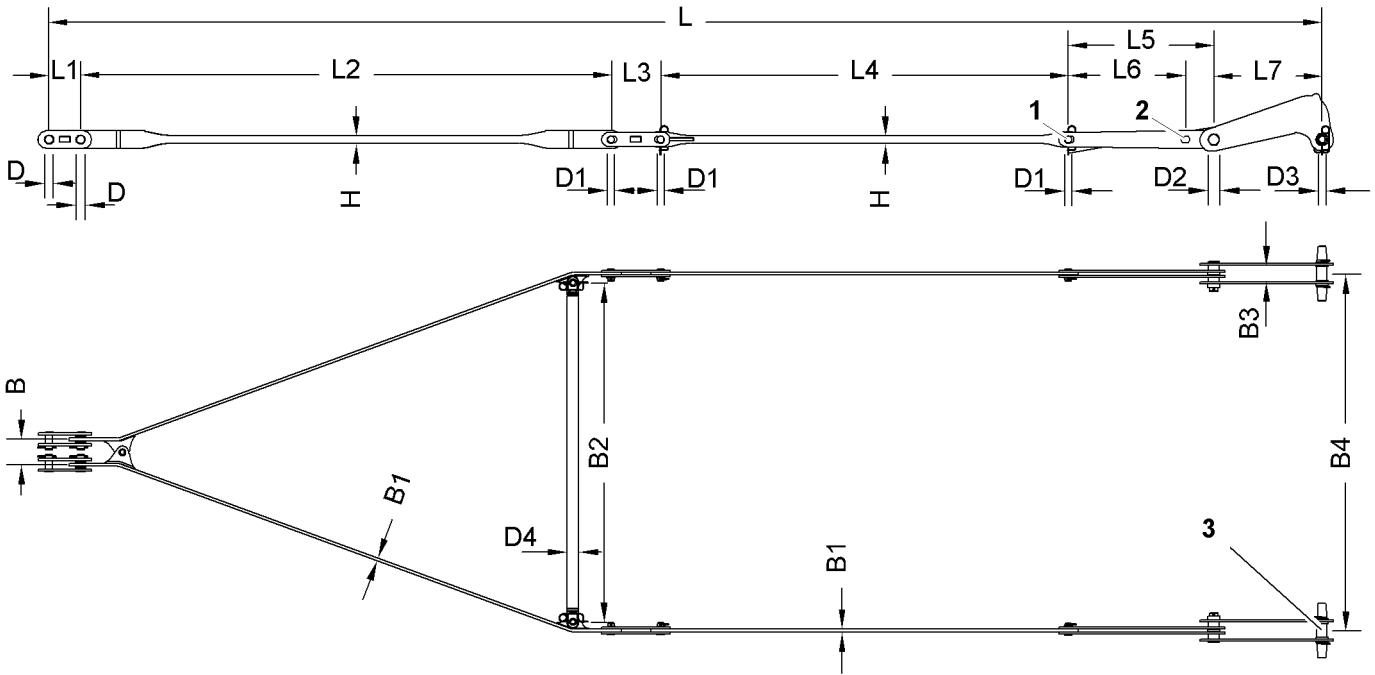


Fig. 272: Dimensions equalizer on A-frame2 (jib backstay strap)

- 1 Pin connection point 30° (30°) 2 Pin connection point 15° (15°) 3 Double-taper pins
 431 mm (1' 5" ft-in)/
 Ø80 mm (3.15" in) (2x)

The double-taper pins (431 mm (1' 5" ft-in) x Ø80 mm (3.15" in)) 3 replace the top double-taper pins on the main boom head.

Name		Value
L	Length	at 30° (30°) 10000 mm 32' 10" ft-in
		at 15° (15°) 9090 mm 29' 10" ft-in
L1	Length of connecting link	250 mm 9.84" in
L2	Length of crossbar	4165 mm 13' 8" ft-in
L3	Length of connecting link	390 mm 1' 3" ft-in
L4	Length of pendant strap	3202 mm 10' 6" ft-in
L5	Length of connecting link (30° (30°))	1143 mm 3' 9" ft-in
L6	Length of connecting link (15° (15°))	910 mm 3' ft-in
L7	Length of connecting link	850 mm 2' 9" ft-in

LWNLR-x/V04.01//Auslieferung/2016-03-07/en

Name		Value
W	Width	200 mm 7.87" in
W1	Width of pendant strap	22 mm 0.87" in
W2	Width	2660 mm 8' 9" ft-in
W3	Width	132 mm 5.20" in
W4	Width	2800 mm 9' 2" ft-in
H	Height of pendant strap	62 mm 2.44" in
D	Pin Ø	60 mm 2.36" in
D1	Pin Ø	50 mm 1.97" in
D2	Pin Ø	70 mm 2.76" in
D3	Double-taper pins Ø	80 mm 3.15" in
D4	Spacer bar Ø	90 mm 3.54" in
Weight		582 kg 1,283 lb

Tab. 160: Technical data equalizer on A-frame2 (jib backstay strap)

Equalizer on A-frame2 (jib pendant strap)

Installation site in crane operation:

- Fixed jib 1713 (For more information see: [Pendant straps A-frame2 to jib head 1713](#), page 1538)

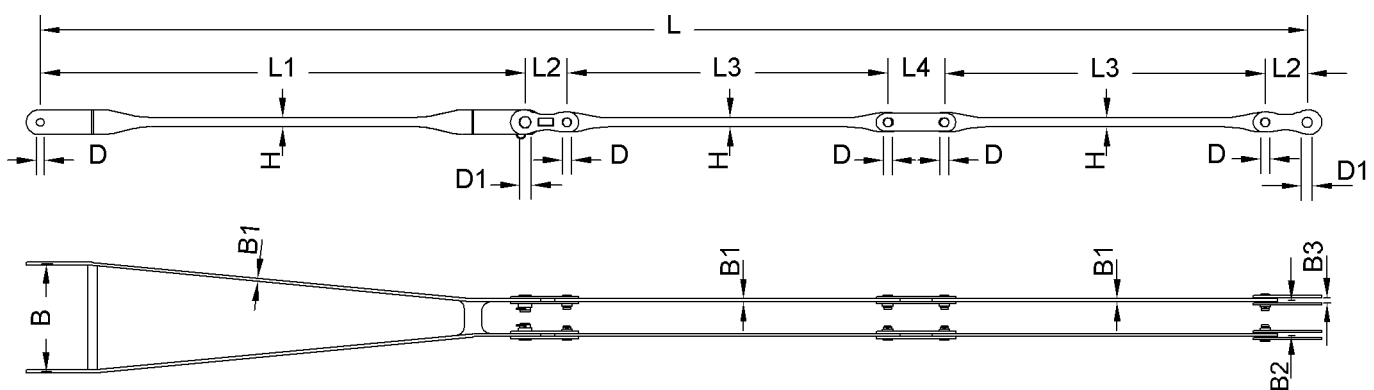


Fig. 273: Dimensions of equalizer on A-frame2 (jib pendant strap)

Name		Value
L	Length	7275 mm 23' 10" ft-in
L1	Length of crossbar	2785 mm 9' 2" ft-in
L2	Length of connecting link	240 mm 9.45" in
L3	Length of pendant strap	1842 mm 6' 1" ft-in
L4	Length of connecting link	326 mm 1' 1" ft-in
W	Width	618 mm 2' ft-in
W1	Width of pendant strap	18 mm 0.71" in
W2	Width	200 mm 7.87" in
W3	Width	30 mm 1.18" in
H	Height of pendant strap	54 mm 2.13" in
D	Pin Ø	45 mm 1.77" in
D1	Pin Ø	60 mm 2.36" in
Weight		198 kg 437 lb

Tab. 161: Technical data equalizer on A-frame2 (jib pendant strap)

Steel pendant straps on jib section 1713.18 3 m (10 ft)

Jib pendant strap 3 m (10 ft)

Installation site in crane operation:

- Fixed jib 1713 (For more information see: [Pendant straps A-frame2 to jib head 1713, page 1538](#))

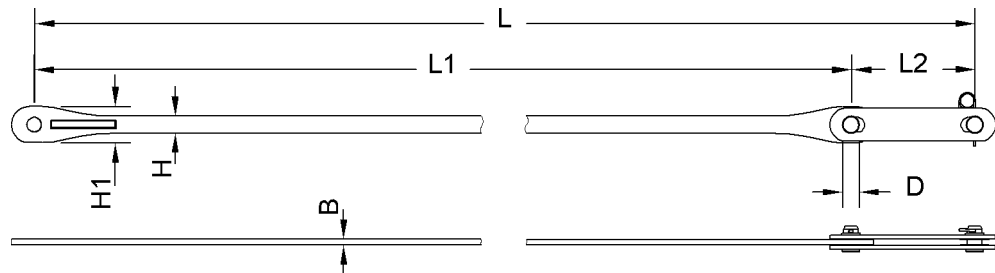


Fig. 274: Dimensions jib pendant strap 3 m (10 ft)

LWN/LR-x/V04.01//Auslieferung/2016-03-07/en

Name		Value
L	Length	3000 mm 9' 10" ft-in
L1	Length of pendant strap	2610 mm 8' 7" ft-in
L2	Length of connecting link	390 mm 1' 3" ft-in
W	Width of pendant strap	18 mm 0.71" in
H	Height of pendant strap	54 mm 2.13" in
H1	Height of pendant strap	113 mm 4.45" in
D	Pin Ø	45 mm 1.77" in
Weight		48 kg 106 lb

Tab. 162: Technical data jib pendant strap 3 m (10 ft)

Steel pendant straps on jib section 1713.18 6 m (20 ft)

Jib pendant strap 6 m (20 ft)

Installation site in crane operation:

- Fixed jib 1713 (For more information see: [Pendant straps A-frame2 to jib head 1713](#), page 1538)

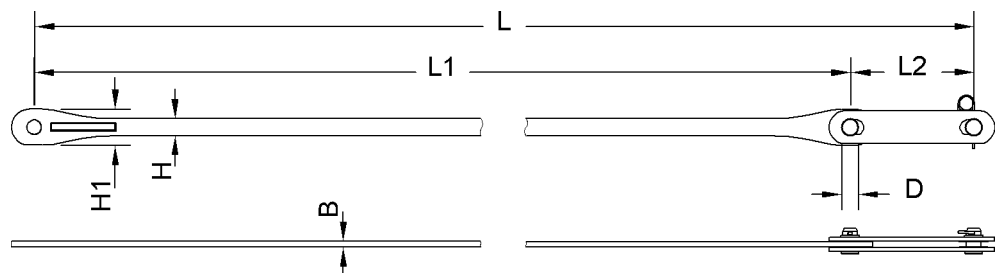


Fig. 275: Dimensions jib pendant strap 6 m (20 ft)

Name		Value
L	Length	6000 mm 19' 8" ft-in
L1	Length of pendant strap	5610 mm 18' 5" ft-in
L2	Length of connecting link	390 mm 1' 3" ft-in
W	Width of pendant strap	18 mm 0.71" in

Name		Value
H	Height of pendant strap	54 mm 2.13" in
H1	Height of pendant strap	113 mm 4.45" in
D	Pin Ø	45 mm 1.77" in
Weight		58 kg 128 lb

Tab. 163: Technical data jib pendant strap 6 m (20 ft)

Steel pendant straps on jib section 1713.18 12 m (40 ft)

Jib pendant strap 12 m (40 ft)

Installation site in crane mode:

- Fixed jib 1713 (For more information see: [Pendant straps A-frame2 to jib head 1713, page 1538](#))

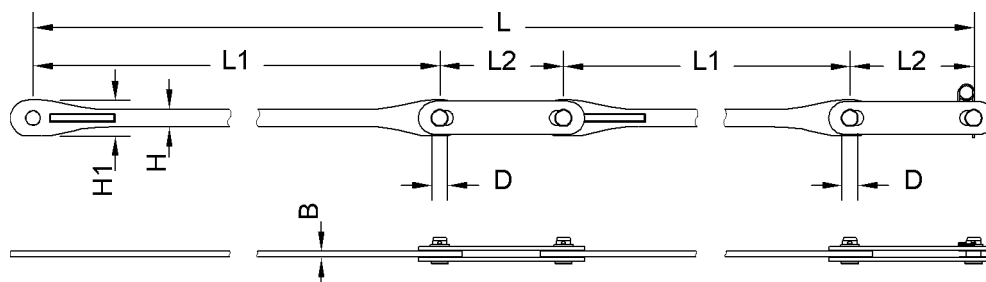


Fig. 276: Dimensions jib pendant strap 12 m (40 ft)

Name		Value
L	Length	12000 mm 39' 4" ft-in
L1	Length of pendant strap	5610 mm 18' 5" ft-in
L2	Length of connecting link	390 mm 1' 3" ft-in
W	Width of pendant strap	18 mm 0.71" in
H	Height of pendant strap	54 mm 2.13" in
H1	Height of pendant strap	113 mm 4.45" in
D	Pin Ø	45 mm 1.77" in
Weight		58 kg 128 lb

Tab. 164: Technical data jib pendant strap 12 m (40 ft)

LWN/LR-x/V04.01//Auslieferung/2016-03-07/en

Steel pendant straps on jib head 1713.21

Jib pendant strap on jib head 1713.21

Installation site in crane operation:

- Fixed jib 1713 (For more information see: [Pendant straps A-frame2 to jib head 1713, page 1538](#))

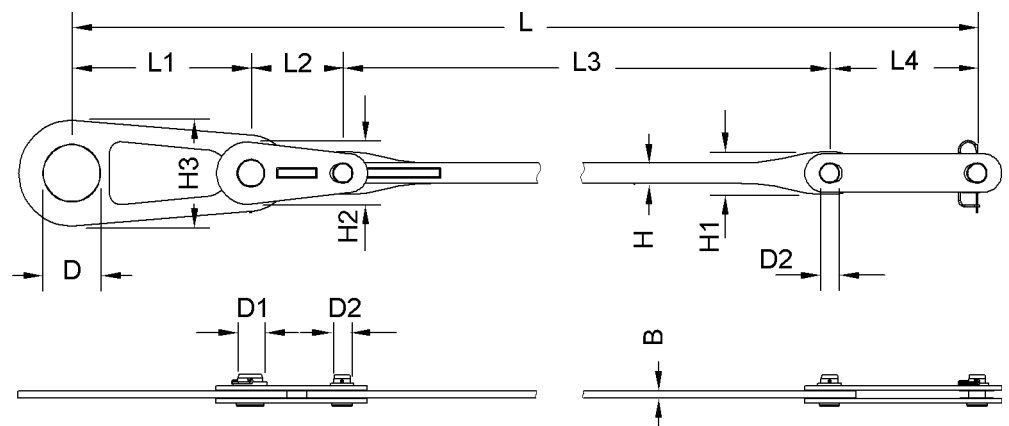


Fig. 277: Dimensions jib pendant strap on jib head 1713.21

Name		Value
L	Length	6500 mm 21' 4" ft-in
L1	Length of connecting link	474 mm 1' 7" ft-in
L2	Length of connecting link	243 mm 9.57" in
L3	Length of pendant strap	5393 mm 17' 8" ft-in
L4	Length of connecting link	390 mm 1' 3" ft-in
W	Width of pendant strap	18 mm 0.71" in
H	Height of pendant strap	54 mm 2.13" in
H1	Height of pendant strap	113 mm 4.45" in
H2	Height of connecting link	166 mm 6.54" in
H3	Height of connecting link	280 mm 11.02" in
D	Pin Ø	150 mm 5.91" in
D1	Pin Ø	65 mm 2.56" in

Name		Value
D2	Pin Ø	45 mm 1.77" in
Weight		75 kg 165 lb

Tab. 165: Technical data jib pendant strap on jib head 1713.21

1.15.7 CF pendant straps on fixed jib 1713

When installing the fixed jib 1713 on the machine with CF pendant straps, use the steel pendant straps and the steel backstay straps ([For more information see: 1.15.6 Steel pendant straps on fixed jib 1713, page 255](#)).

1.16 1507 fixed jib

1.16.1 Jib 1507.20

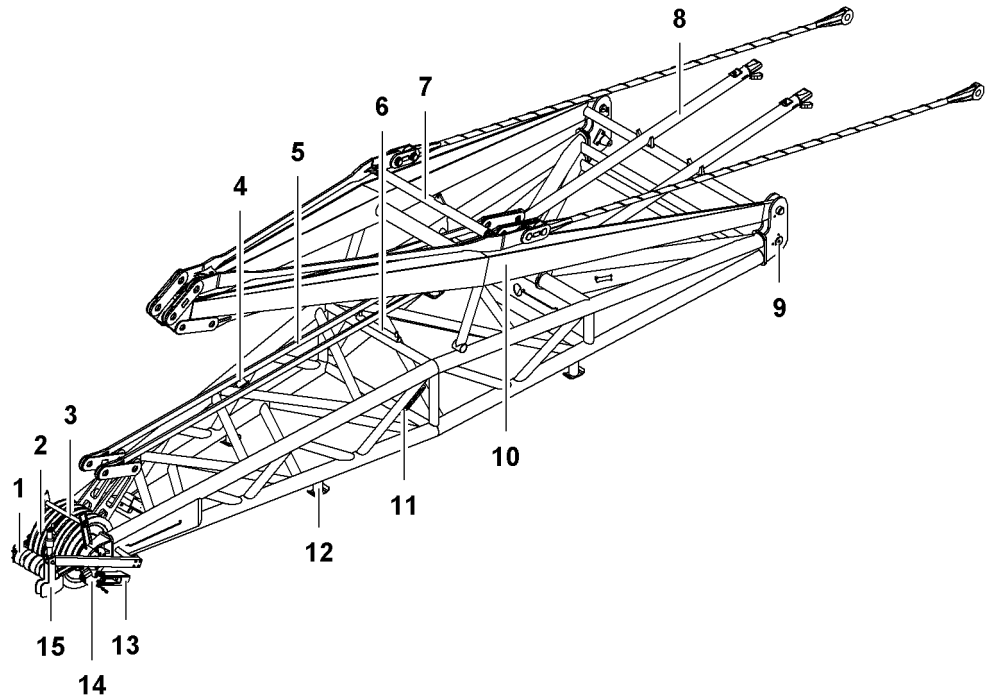


Fig. 278: Jib 1507.20

- | | | | |
|---|---|----|---|
| 1 | Rope protection roller (4x) | 9 | Pivot point (2x) for main boom head section |
| 2 | Pulley (4x) | 10 | A-frame 2 |
| 3 | Rope protection pipe | 11 | Boom identification plate |
| 4 | Lifting point (4x) | 12 | Foot (4x) |
| 5 | Transport position (2x) of jib pendant straps | 13 | Rope fixation |
| 6 | Rope protection support (3x) | 14 | Hoist limit switch (2x) |
| 7 | Transport position of the equalizer on A-frame 2 (jib backstay strap) | 15 | Anemometer |
| 8 | Rigid tilting-back support (2x) | | |

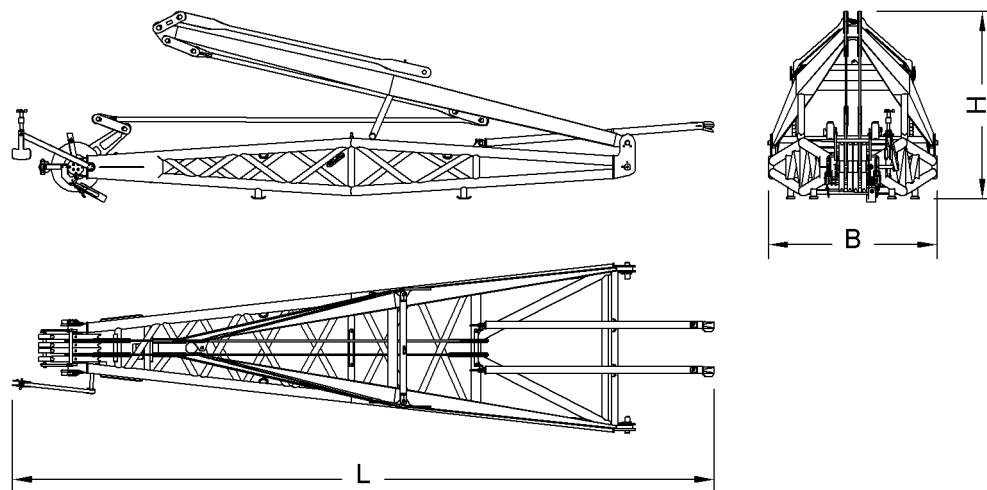


Fig. 279: Dimensions of 1507.20 jib

Name		Value
System length		8000 mm 26' 3" ft-in
System width		1500 mm 4' 11" ft-in
System height		700 mm 2' 4" ft-in
L	Length	10178 mm 33' 5" ft-in
B	Width	2470 mm 8' 1" ft-in
H	Height	2712 mm 8' 11" ft-in
Weight (incl. pendant straps, tilting-back supports and jib backstay straps)		3023 kg 6,664 lb

Tab. 166: Technical data fly jib 1507.20

1.16.2 Steel pendant straps on fixed jib 1507

Steel pendant straps on A-frame2

Equalizer A-frame2 (jib backstay strap)

Installation site in crane operation:

- Fixed jib 1507 (For more information see: Jib backstay straps A-frame2 to main boom base section 2821, page 1551)

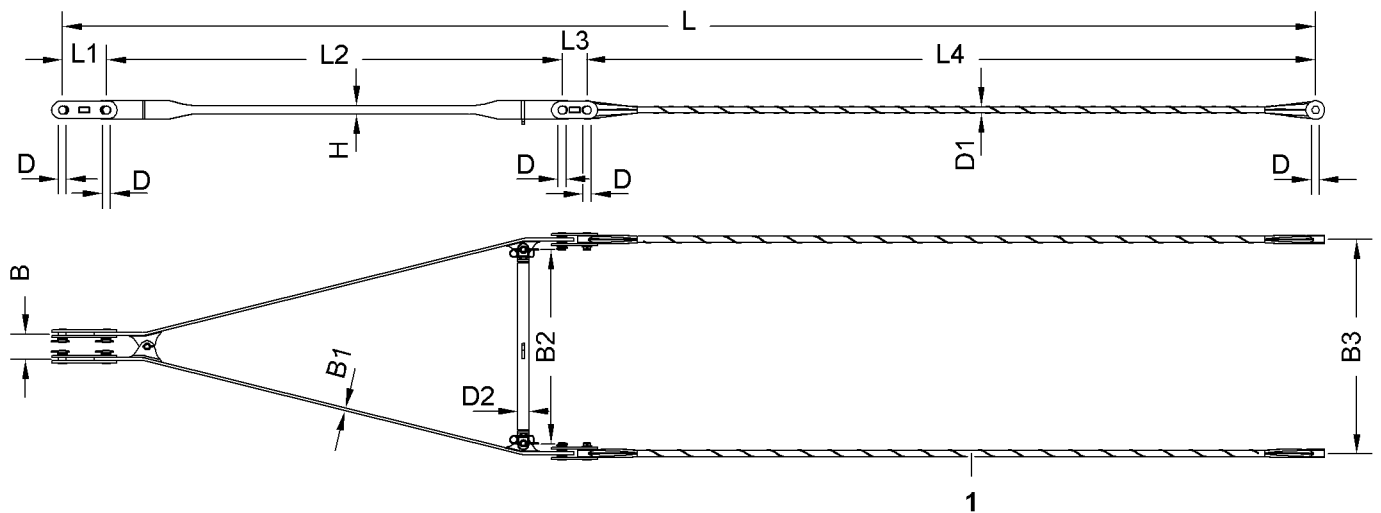


Fig. 280: Dimensions equalizer on A-frame2 (jib backstay strap)

1 CF pendant strap

Name		Value
L	Length	9980 mm 32' 9" ft-in
L1	Length of connecting link	350 mm 1' 2" ft-in
L2	Length of crossbar	3630 mm 11' 11" ft-in
L3	Length of connecting link	200 mm 7.87" in
L4	Length of pendant strap	5800 mm 19' ft-in
W	Width	200 mm 7.87" in
W1	Width of pendant strap	22 mm 0.87" in
W2	Width of spacer bar	1540 mm 5' 1" ft-in
W3	Width	1700 mm 5' 7" ft-in
H	Height of pendant strap	66 mm 2.60" in
D	Pin Ø	60 mm 2.36" in
D1	Pendant strap Ø	50 mm 1.97" in
D2	Spacer bar Ø	89 mm 3.50" in

LWNLR.x/V04.01//Auslieferung/2016-03-07/en

Name	Value
Weight	287 kg 633 lb

Tab. 167: Technical data equalizer on A-frame2 (jib backstay strap)

Jib pendant strap (A-frame2 to jib head 1507)

Installation site in crane operation:

- Fixed jib 1507 (For more information see: [Pendant straps A-frame2 to jib head 1507](#), page 1552)

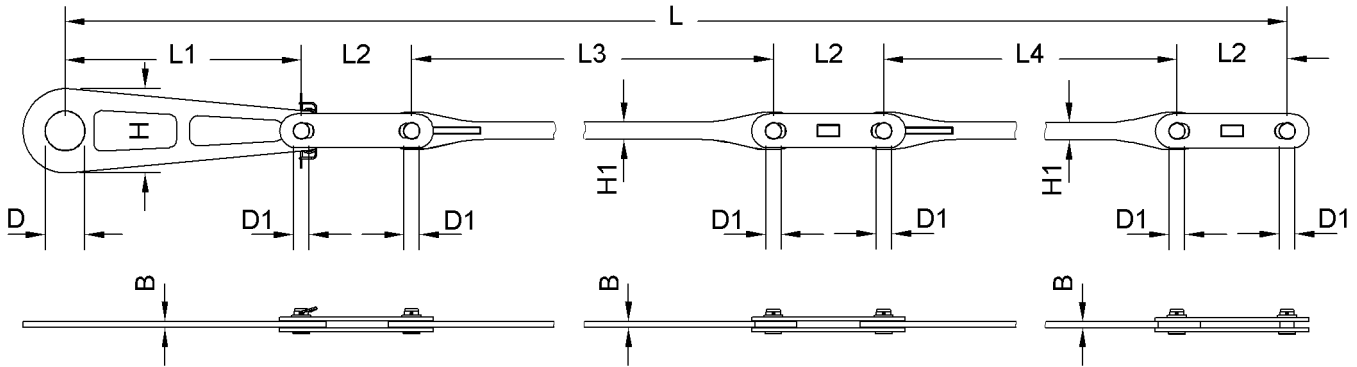


Fig. 281: Dimensions of jib pendant strap (A-frame2 to jib head 1507)

Name	Value
L Length	11615 mm 38' 1" ft-in
L1 Length of connecting link	900 mm 2' 11" ft-in
L2 Length of connecting link	420 mm 1' 5" ft-in
L3 Length of pendant strap	5580 mm 18' 4" ft-in
L4 Length of connecting link	3875 mm 12' 9" ft-in
W Width of pendant strap	22 mm 0.87" in
H Height of connecting link	320 mm 1' 1" ft-in
H1 Height of connecting link	66 mm 2.60" in
D Pin Ø	150 mm 5.91" in
D1 Pin Ø	55 mm 2.17" in
Weight	194 kg 428 lb

Tab. 168: Technical data jib pendant strap (A-frame2 to jib head 1507)

LWNLR-x\04.01\Auslieferung\2016-03-07\en

Additional connecting elements/spacer brackets for fixed jib 1507

Backstay straps connecting element on fixed jib 1507

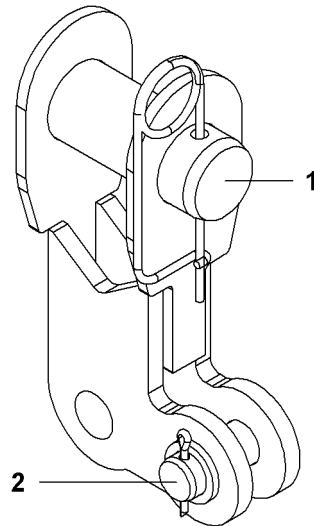


Fig. 282: Backstay straps connecting element on fixed jib 1507

- 1 Pin connection point with pendant strap 2 Pin connection point with spacer bracket

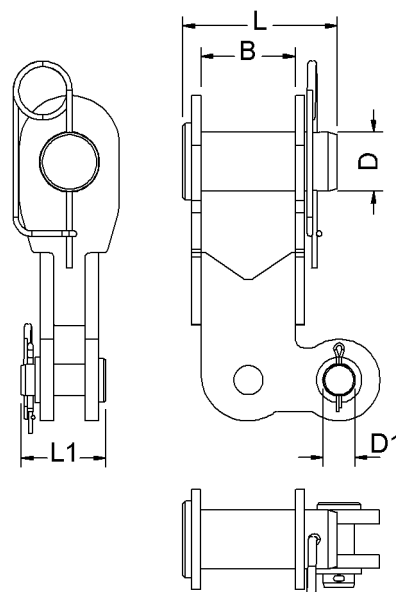


Fig. 283: Dimensions of backstay straps connecting element on fixed jib 1507

Name		Value
L	Length of pin	158 mm 6.22" in
L1	Length of pins	85 mm 3.35" in

Name		Value
W	Width	104 mm 4.09" in
D	Pin Ø	60 mm 2.36" in
D1	Pin Ø	35 mm 1.38" in

Tab. 169: Technical data backstay straps connecting elements on fixed jib 1507

Backstay straps spacer brackets on fixed jib 1507

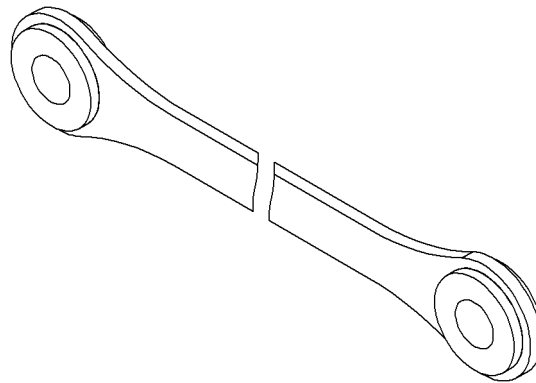


Fig. 284: Backstay straps spacer brackets on fixed jib 1507

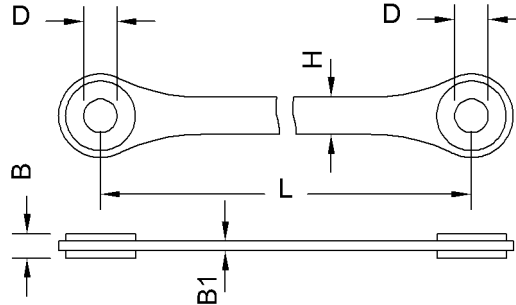


Fig. 285: Dimensions of backstay straps spacer brackets on fixed jib 1507

Name		Value
L	Length of spacer bracket	1500 mm 4' 11" ft-in
W	Width	26 mm 1.02" in
W1	Width	10 mm 0.39" in
H	Height	40 mm 1.57" in
D	Pin Ø	35 mm 1.38" in

Tab. 170: Technical data backstay straps spacer brackets on fixed jib 1507

LWN/LR-x/V04.01//Auslieferung/2016-03-07/en

1.16.3 CF pendant straps on fixed jib 1507

When installing the fixed jib 1507 on the machine with CF pendant straps, use the steel pendant straps and steel/CF backstay straps ([For more information see: 1.16.2 Steel pendant straps on fixed jib 1507, page 264](#)).

1.17 1008 fixed jib

1.17.1 Jib base section 1008.20

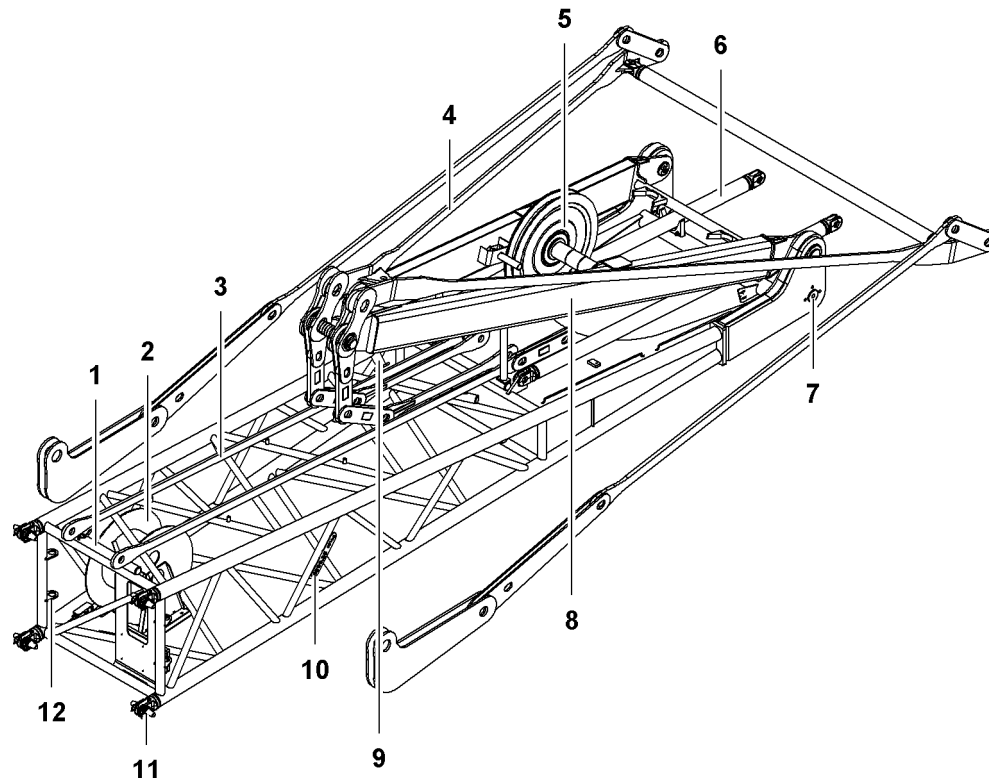


Fig. 286: Jib base section 1008.20

- | | | | |
|---|---|----|---|
| 1 | Rope guard support (2x) | 7 | Pivot point (2x) for main boom head section |
| 2 | Cable drum | 8 | A-frame 2 |
| 3 | Transport position of jib pendant straps (2x) | 9 | Lifting point (6x) |
| 4 | Transport position of the equalizer on A-frame 2 (jib backstay strap) | 10 | Boom identification plate |
| 5 | Pulley for rope of winch1/winch2 | 11 | Pin connection point (4x) with double-taper pins (4x) |
| 6 | Rigid tilting-back support (2x) | 12 | Transport bracket (4x) for double-taper pins |

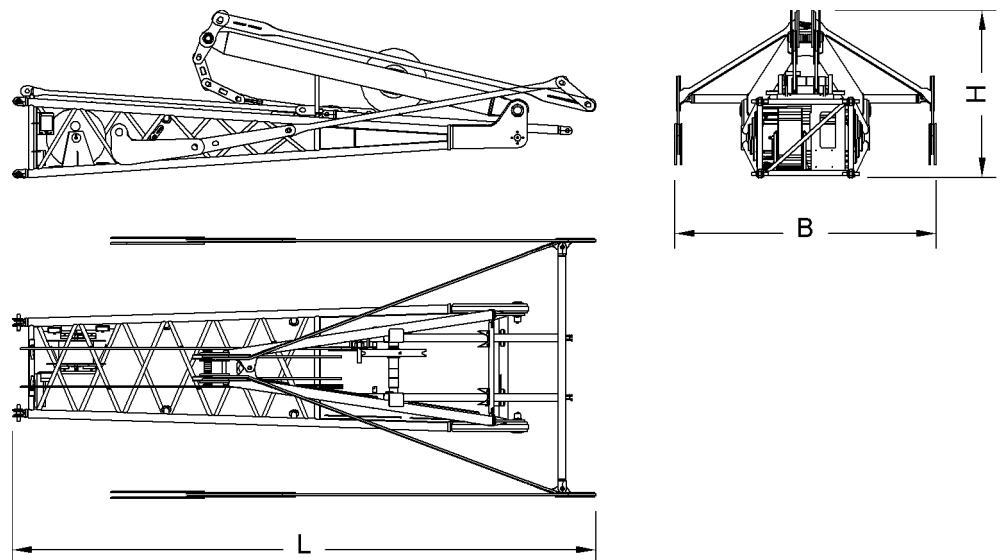


Fig. 287: Dimensions of jib base section 1008.20

Name		Value
System length		5500 mm 18' 1" ft-in
System width		1000 mm 3' 3" ft-in
System height		800 mm 2' 7" ft-in
L	Length	6620 mm 21' 9" ft-in
B	Width	2200 mm 7' 3" ft-in
H	Height	1850 mm 6' 1" ft-in
Weight (incl. pendant straps, tilting-back supports and jib backstay straps)		1950 kg 4,299 lb
Double-taper pins Ø		40 mm 1.57" in

Tab. 171: Technical data jib base section 1008.20

LWNLR.x/V04.01//Auslieferung/2016-03-07/en

1.17.2 1008.17 jib section 3 m (10 ft)

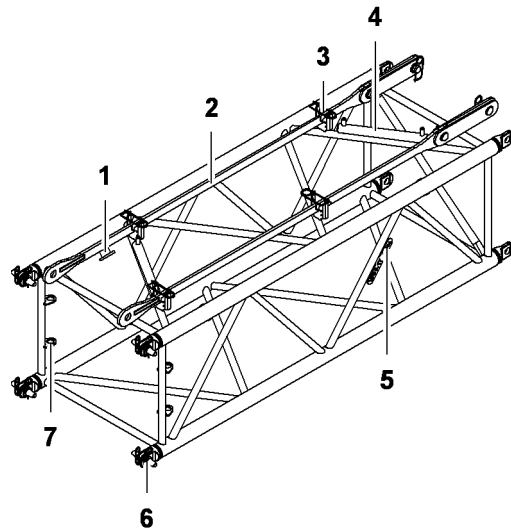


Fig. 288: 1008.17 jib section 3 m (10 ft)

- | | |
|--|--|
| <ul style="list-style-type: none"> 1 Lifting point (4x) 2 Transport position (2x) of the jib pendant straps 3 m (10 ft) 3 Transport brackets (4x) for pendant straps 4 Rope guard support (2x) | <ul style="list-style-type: none"> 5 Boom identification plate 6 Pin connection point (8x) with double-taper pins (4x) 7 Transport bracket (4x) for double-taper pins |
|--|--|

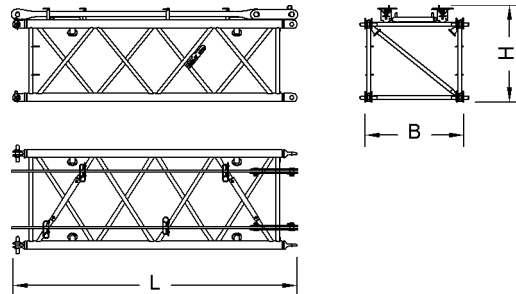


Fig. 289: Dimensions of 1008.17 jib section 3 m (10 ft)

Name		Value
System length		3000 mm 9' 10" ft-in
System width		1000 mm 3' 3" ft-in
System height		800 mm 2' 7" ft-in
L	Length	3120 mm 10' 3" ft-in
B	Width	1090 mm 3' 7" ft-in
H	Height (incl. pendant straps)	1020 mm 3' 4" ft-in

LWNLR-x/V04.01//Auslieferung/2016-03-07/en

Name	Value
Weight (incl. pendant straps)	300 kg 661 lb
Double-taper pins Ø	40 mm 1.57" in

Tab. 172: Technical data for 1008.17 jib section 3 m (10 ft)

1.17.3 1008.17 jib section 6 m (20 ft)

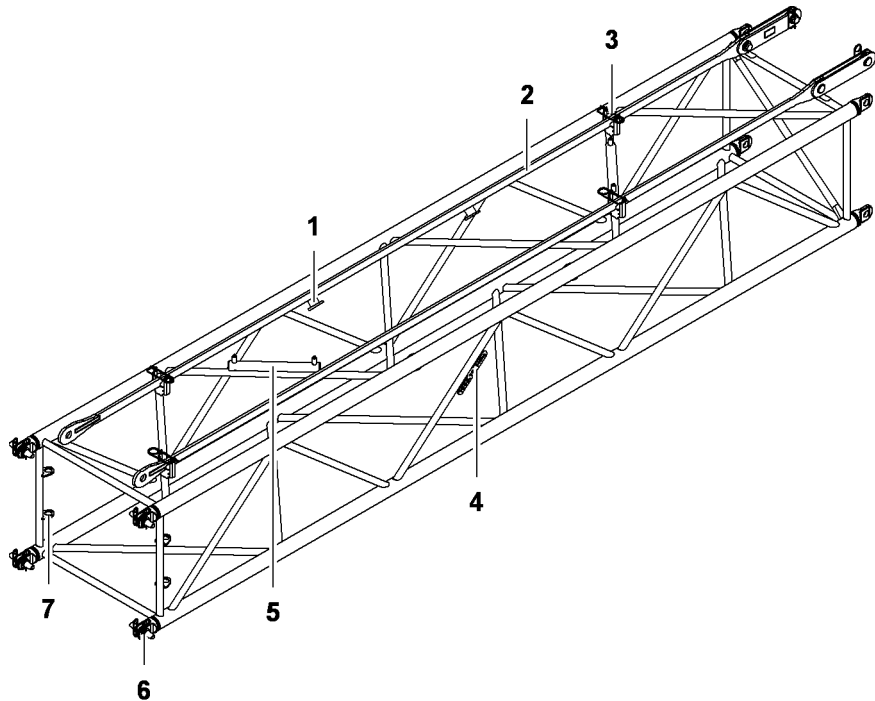


Fig. 290: 1008.17 jib section 6 m (20 ft)

- | | | | |
|---|---|---|---|
| 1 | Lifting point (4x) | 5 | Rope guard support (2x) |
| 2 | Transport position (2x) of the jib pendant straps 6 m (20 ft) | 6 | Pin connection point (8x) with double-taper pins (4x) |
| 3 | Transport brackets (4x) for pendant straps | 7 | Transport bracket (4x) for double-taper pins |
| 4 | Boom identification plate | | |

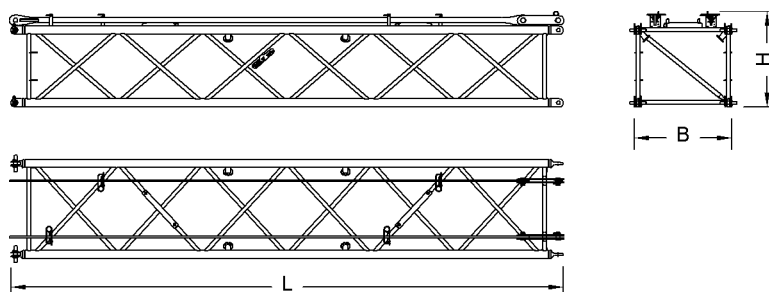


Fig. 291: Dimensions of 1008.17 jib section 6 m (20 ft)

LWNLR.x/V04.01//Auslieferung/2016-03-07/en

Name		Value
System length		6000 mm 19' 8" ft-in
System width		1000 mm 3' 3" ft-in
System height		800 mm 2' 7" ft-in
L	Length	6120 mm 20' 1" ft-in
B	Width	1090 mm 3' 7" ft-in
H	Height (incl. pendant straps)	1020 mm 3' 4" ft-in
Weight (incl. pendant straps)		455 kg 1,003 lb
Double-taper pins Ø		40 mm 1.57" in

Tab. 173: Technical data for 1008.17 jib section 6 m (20 ft)

1.17.4 1008.20 jib head section

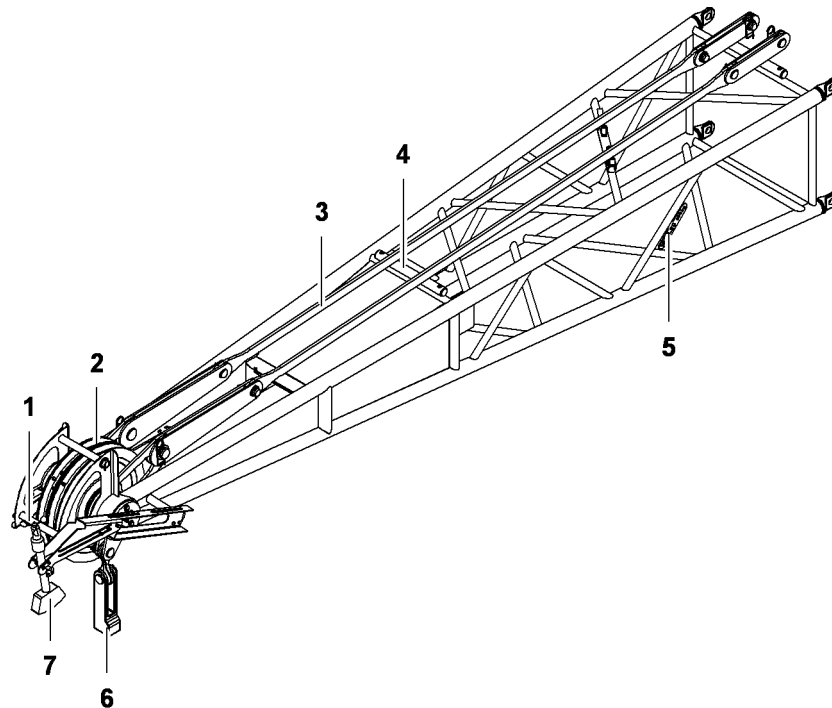


Fig. 292: 1008.20 jib head section

- | | | | |
|---|---|---|---------------------------|
| 1 | Rope protection pipe (2x) | 5 | Boom identification plate |
| 2 | Pulley (2x) | 6 | Rope fixation |
| 3 | Transport position (2x) of jib pendant straps | 7 | Anemometer |
| 4 | Rope guard support (2x) | | |

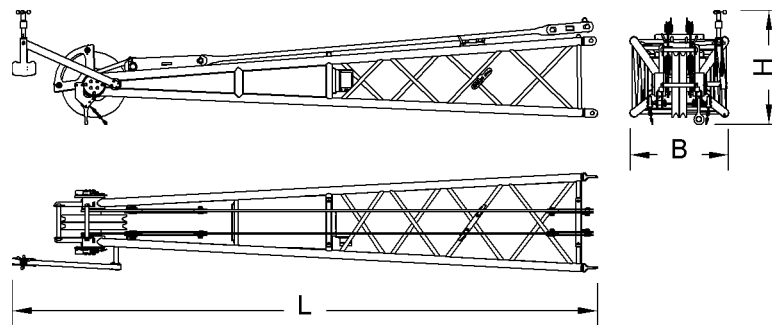


Fig. 293: 1008.20 jib head section dimensions

Name		Value
System length		5500 mm 18' 1" ft-in
System width		1000 mm 3' 3" ft-in
System height		800 mm 2' 7" ft-in
L	Length	6500 mm 21' 4" ft-in
B	Width	1090 mm 3' 7" ft-in
H	Height	1020 mm 3' 4" ft-in
Weight (incl. pendant straps)		920 kg 2,028 lb

Tab. 174: 1008.20 jib head section, technical data

1.17.5 Steel pendant straps on fixed jib 1008

Steel pendant straps on A-frame2

Equalizer A-frame2 (jib backstay strap)

Installation site in crane operation:

- Fixed jib 1008 ([For more information see: Jib backstay straps A-frame2 to main boom head 2821, page 1562](#))

Product description

1008 fixed jib

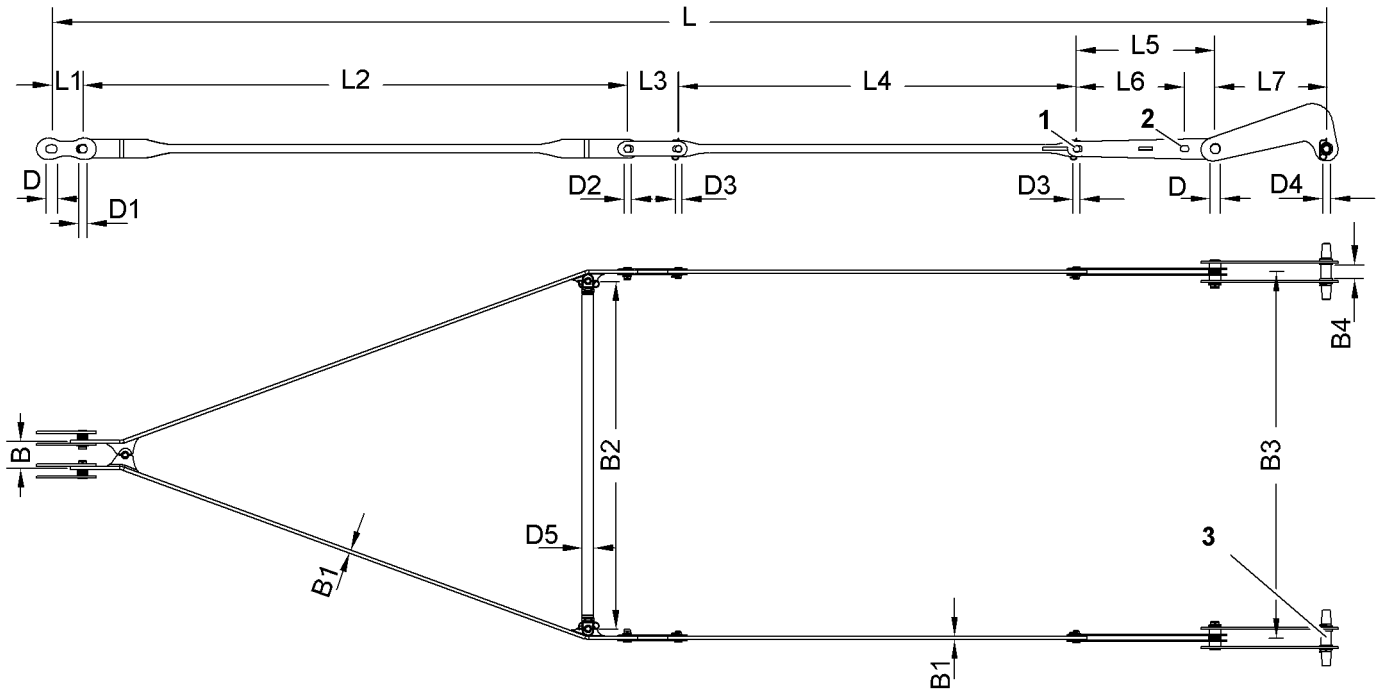


Fig. 294: Dimensions equalizer on A-frame2 (jib backstay strap)

- 1 Pin connection point 30° (30°) 2 Pin connection point 15° (15°) 3 Double-taper pins
 431 mm (1' 5" ft-in)/
 Ø80 mm (3.15" in) (2x)

The double-taper pins (431 mm (1' 5" ft-in) x Ø80 mm (3.15" in)) **3** replace the top double-taper pins on the main boom head.

Name		Value
L	Length	at 30° (30°) 9760 mm 32' ft-in
		at 15° (15°) 8943 mm 29' 4" ft-in
L1	Length of connecting link	250 mm 9.84" in
L2	Length of crossbar	4165 mm 13' 8" ft-in
L3	Length of connecting link	390 mm 1' 3" ft-in
L4	Length of pendant strap	3045 mm 10' ft-in
L5	Length of connecting link (30° (30°))	1060 mm 3' 6" ft-in
L6	Length of connecting link (15° (15°))	817 mm 2' 8" ft-in
L7	Length of connecting link	850 mm 2' 9" ft-in

LWNLR-x/V04.01//Auslieferung/2016-03-07/en

Name		Value
W	Width	200 mm 7.87" in
W1	Width of pendant strap	22 mm 0.87" in
W2	Width	2660 mm 8' 9" ft-in
W3	Width	108 mm 4.25" in
W4	Width	2800 mm 9' 2" ft-in
H	Height of pendant strap	62 mm 2.44" in
D	Pin Ø	65 mm 2.56" in
D1	Pin Ø	60 mm 2.36" in
D2	Pin Ø	50 mm 1.97" in
D3	Pin Ø	45 mm 1.77" in
D4	Double-taper pins Ø	80 mm 3.15" in
D5	Spacer bar Ø	90 mm 3.54" in
Weight		548 kg 1,208 lb

Tab. 175: Technical data equalizer on A-frame2 (jib backstay strap)

Equalizer on A-frame2 (jib pendant strap)

Installation site in crane operation:

- Fixed jib 1008 (For more information see: [Pendant straps A-frame2 to jib head 1008, page 1562](#))

LWNLR.x/V04.01//Auslieferung/2016-03-07/en

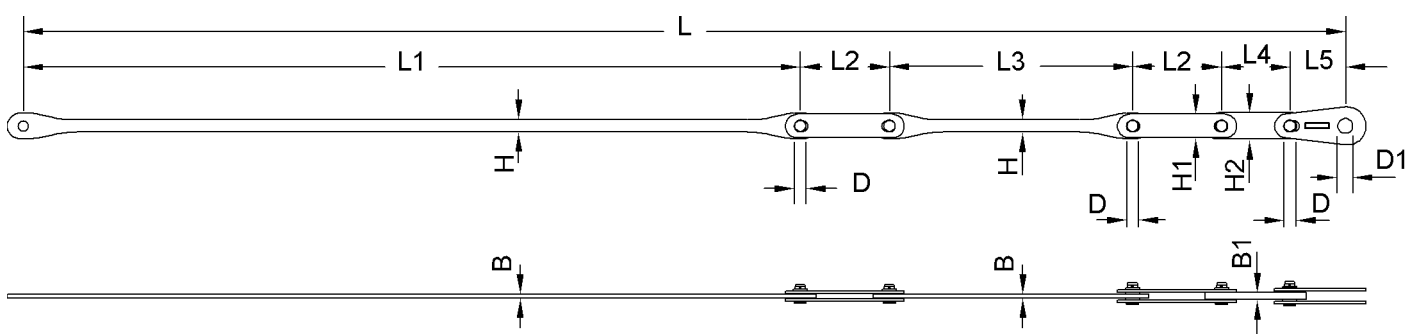


Fig. 295: Dimensions of equalizer on A-frame2 (jib pendant strap)

Name		Value
L	Length	5785 mm 19' ft-in
L1	Length of pendant strap	3400 mm 11' 2" ft-in
L2	Length of connecting link	390 mm 1' 3" ft-in
L3	Length of pendant strap	1064 mm 3' 6" ft-in
L4	Length of connecting link	298 mm 1' ft-in
L5	Length of connecting link	243 mm 9.57" in
W	Width of pendant strap	18 mm 0.71" in
W1	Width of connecting link	30 mm 1.18" in
H	Height of pendant strap	54 mm 2.13" in
H1	Height of connecting link	103 mm 4.06" in
H2	Height of connecting link	116 mm 4.57" in
D	Pin Ø	45 mm 1.77" in
D1	Pin Ø	65 mm 2.56" in
Weight		85 kg 187 lb

Tab. 176: Technical data equalizer on A-frame2 (jib pendant strap)

Steel pendant straps on jib section 1008.17 3 m (10 ft)

Jib pendant strap 3 m (10 ft)

Installation site in crane operation:

- Fixed jib 1008 (For more information see: [Pendant straps A-frame2 to jib head 1008, page 1562](#))

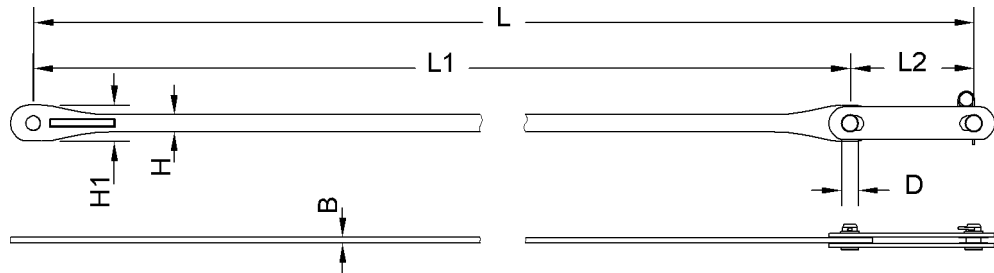


Fig. 296: Dimensions jib pendant strap 3 m (10 ft)

Name		Value
L	Length	3000 mm 9' 10" ft-in
L1	Length of pendant strap	2610 mm 8' 7" ft-in
L2	Length of connecting link	390 mm 1' 3" ft-in
W	Width of pendant strap	18 mm 0.71" in
H	Height of pendant strap	54 mm 2.13" in
H1	Height of pendant strap	113 mm 4.45" in
D	Pin Ø	45 mm 1.77" in
Weight		48 kg 106 lb

Tab. 177: Technical data jib pendant strap 3 m (10 ft)

Steel pendant straps on jib section 1008.17 6 m (20 ft)

Jib pendant strap 6 m (20 ft)

Installation site in crane operation:

- Fixed jib 1008 (For more information see: [Pendant straps A-frame2 to jib head 1008](#), page 1562)

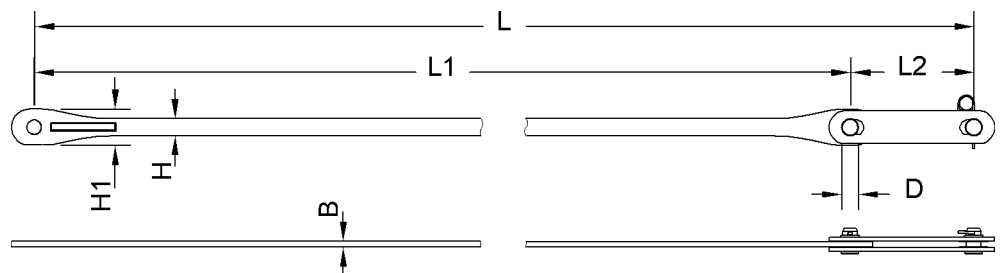


Fig. 297: Dimensions jib pendant strap 6 m (20 ft)

Name		Value
L	Length	6000 mm 19' 8" ft-in
L1	Length of pendant strap	5610 mm 18' 5" ft-in
L2	Length of connecting link	390 mm 1' 3" ft-in
W	Width of pendant strap	18 mm 0.71" in

Name		Value
H	Height of pendant strap	54 mm 2.13" in
H1	Height of pendant strap	113 mm 4.45" in
D	Pin Ø	45 mm 1.77" in
Weight		58 kg 128 lb

Tab. 178: Technical data jib pendant strap 6 m (20 ft)

Steel pendant straps on jib head 1008.20

Jib pendant strap on jib head 1008.20

Installation site in crane operation:

- Fixed jib 1008 (For more information see: [Pendant straps A-frame2 to jib head 1008, page 1562](#))

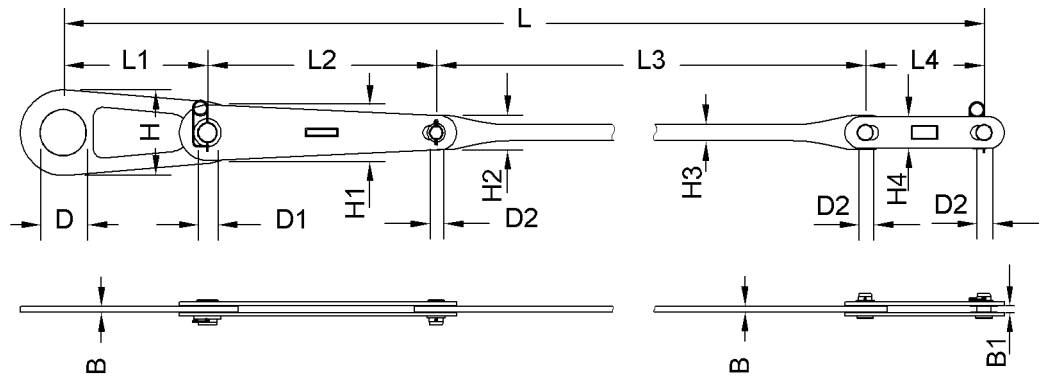


Fig. 298: Dimensions jib pendant strap on jib head 1008.20

Name		Value
L	Length	5515 mm 18' 1" ft-in
L1	Length of connecting link	474 mm 1' 7" ft-in
L2	Length of connecting link	751 mm 2' 6" ft-in
L3	Length of pendant strap	3900 mm 12' 10" ft-in
L4	Length of connecting link	390 mm 1' 3" ft-in
W	Width of pendant strap	18 mm 0.71" in
W1	Width	22 mm 0.87" in

LWNLR-x/V04.01//Auslieferung/2016-03-07/en

Name		Value
H	Height of connecting link	280 mm 11.02" in
H1	Height of connecting link	182 mm 7.17" in
H2	Height of pendant strap	113 mm 4.45" in
H3	Height of pendant strap	54 mm 2.13" in
H4	Height of connecting link	103 mm 4.06" in
D	Pin Ø	150 mm 5.91" in
D1	Pin Ø	65 mm 2.56" in
D2	Pin Ø	45 mm 1.77" in
Weight		78 kg 172 lb

Tab. 179: Technical data jib pendant strap on jib head 1008.20

1.17.6 CF pendant straps on fixed jib 1008

When installing the fixed jib 1008 on the machine with CF pendant straps, use the steel pendant straps and the steel backstay straps ([For more information see: 1.17.5 Steel pendant straps on fixed jib 1008, page 275](#)).

1.18 0906 fixed jib

1.18.1 Jib 0906.21

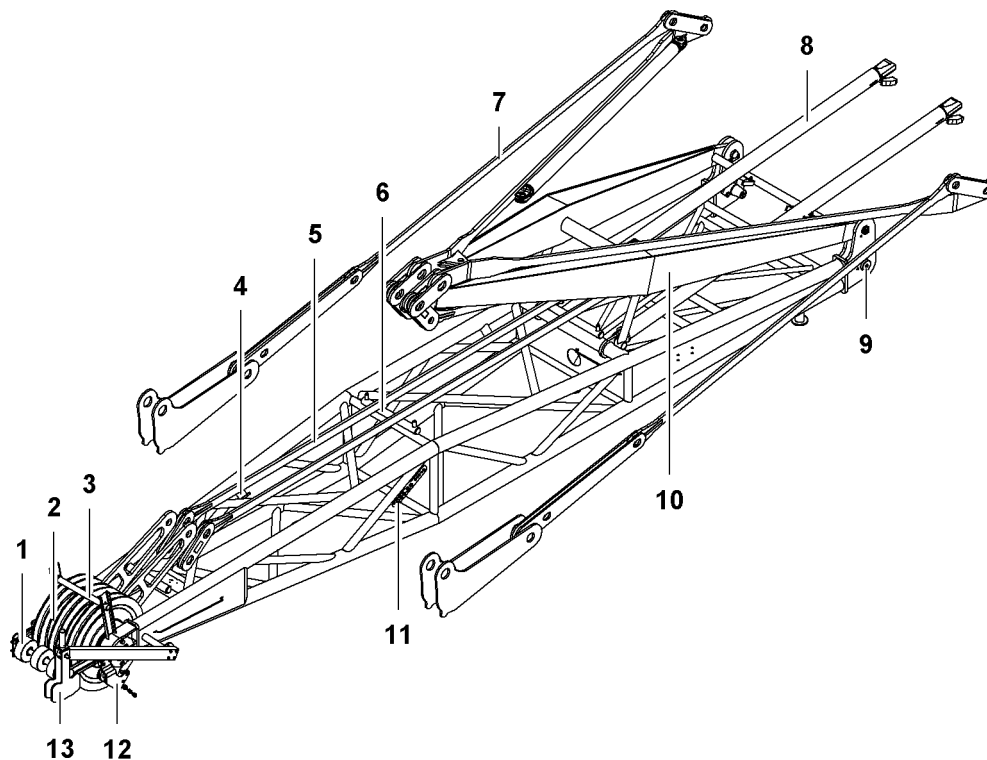


Fig. 299: Jib 0906.21

- | | | | |
|---|---|----|---|
| 1 | Rope protection roller (3x) | 8 | Rigid tilting-back support (2x) |
| 2 | Pulley (3x) | 9 | Pivot point (2x) for main boom head section |
| 3 | Rope protection pipe | 10 | A-frame 2 |
| 4 | Lifting point (4x) | 11 | Boom identification plate |
| 5 | Transport position (2x) of jib pendant straps | 12 | Hoist limit switch |
| 6 | Rope protection support (3x) | 13 | Anemometer |
| 7 | Transport position of the equalizer on A-frame 2 (jib backstay strap) | | |

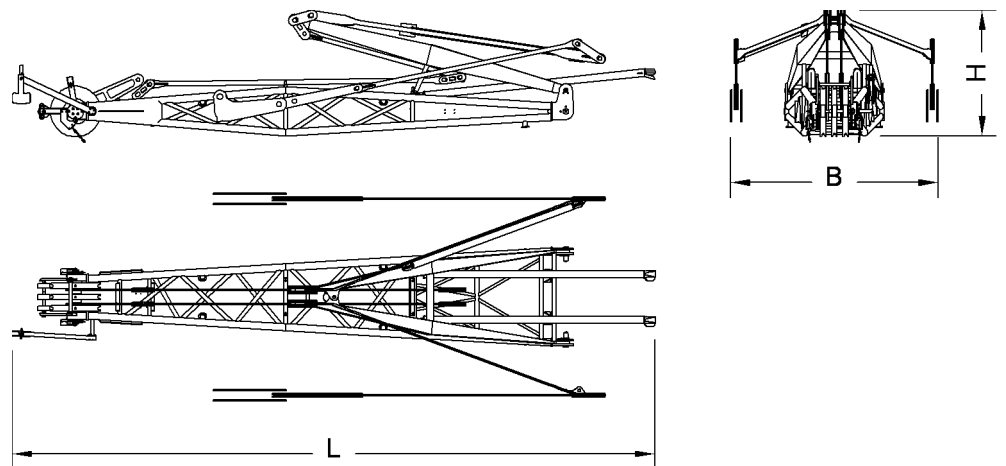


Fig. 300: Dimensions jib 0906.21

Name		Value
System length		7000 mm 23' ft-in
System width		900 mm 2' 11" ft-in
System height		600 mm 2' ft-in
L	Length	9190 mm 30' 2" ft-in
B	Width	2960 mm 9' 9" ft-in
H	Height	1800 mm 5' 11" ft-in
Weight (incl. pendant straps, tilting-back supports and jib backstay straps)		2388 kg 5,265 lb

Tab. 180: Technical data jib 0906.21

1.18.2 Steel pendant straps on fixed jib 0906

Steel pendant straps on A-frame2

Equalizer A-frame2 (jib backstay strap)

Installation site in crane operation:

- Fixed jib 0906 (For more information see: [Jib backstay straps A-frame2 to main boom head 2821](#), page 1572)

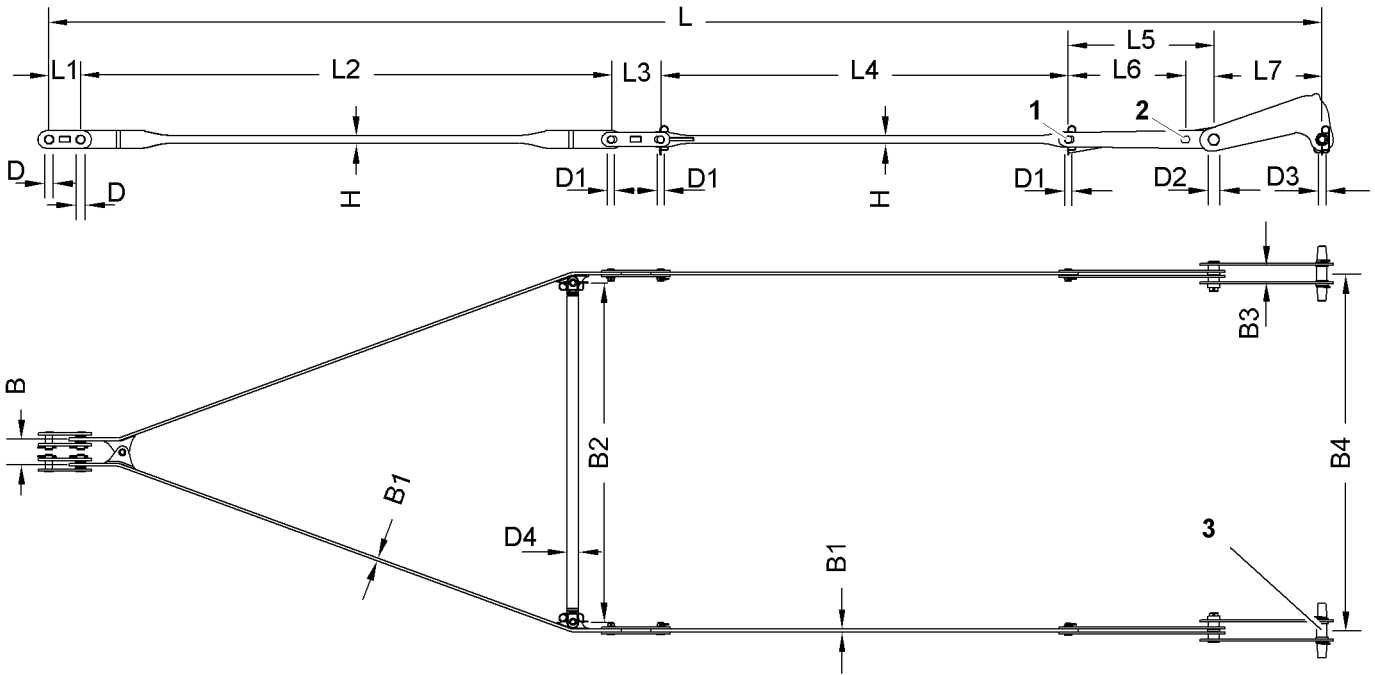


Fig. 301: Dimensions equalizer on A-frame2 (jib backstay strap)

- 1 Pin connection point 30° (30°)
- 2 DO NOT use pin connection point
- 3 Double-taper pins 431 mm (1' 5" ft-in)/ Ø80 mm (3.15" in) (2x)

The double-taper pins (431 mm (1' 5" ft-in) x Ø80 mm (3.15" in)) 3 replace the top double-taper pins on the main boom head.

Name		Value
L	Length	at 30° (30°) 10000 mm 32' 10" ft-in
L1	Length of connecting link	250 mm 9.84" in
L2	Length of crossbar	4165 mm 13' 8" ft-in
L3	Length of connecting link	390 mm 1' 3" ft-in
L4	Length of pendant strap	3202 mm 10' 6" ft-in
L5	Length of connecting link (30° (30°))	1143 mm 3' 9" ft-in
L6	Length of connecting link (DO NOT use pin connection point)	910 mm 3' ft-in
L7	Length of connecting link	850 mm 2' 9" ft-in
W	Width	200 mm 7.87" in
W1	Width of pendant strap	22 mm 0.87" in

LWNLR-x/V04.01//Auslieferung/2016-03-07/en

Name		Value
W2	Width	2660 mm 8' 9" ft-in
W3	Width	132 mm 5.20" in
W4	Width	2800 mm 9' 2" ft-in
H	Height of pendant strap	62 mm 2.44" in
D	Pin Ø	60 mm 2.36" in
D1	Pin Ø	50 mm 1.97" in
D2	Pin Ø	70 mm 2.76" in
D3	Double-taper pins Ø	80 mm 3.15" in
D4	Spacer bar Ø	90 mm 3.54" in
Weight		582 kg 1,283 lb

Tab. 181: Technical data equalizer on A-frame2 (jib backstay strap)

Jib pendant strap (A-frame2 to jib head 0906.21)

Installation site in crane operation:

- Fixed jib 0906 (For more information see: [Pendant straps A-frame2 to jib head 0906](#), page 1572)

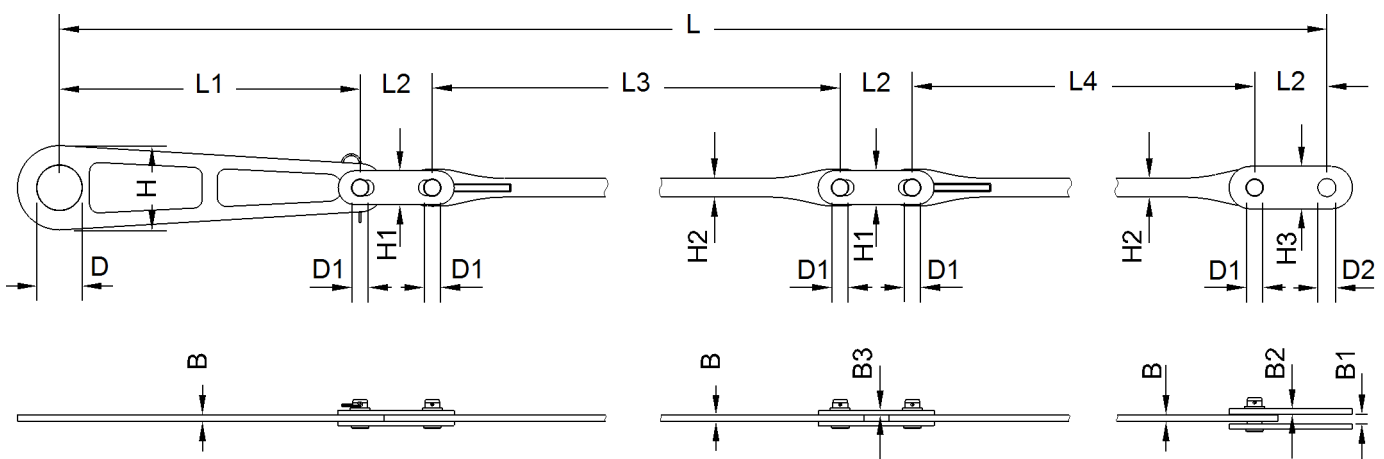


Fig. 302: Dimensions jib pendant strap (A-frame2 to jib head 0906.21)

Name		Value
L	Length	8235 mm 27' ft-in

LWNLR.x/V04.01//Auslieferung/2016-03-07/en

Name		Value
L1	Length of connecting link	1000 mm 3' 3" ft-in
L2	Length of connecting link	240 mm 9.45" in
L3	Length of pendant strap	4200 mm 13' 9" ft-in
L4	Length of connecting link	2315 mm 7' 7" ft-in
W	Width of pendant strap	22 mm 0.87" in
W1	Width	30 mm 1.18" in
H	Height of connecting link	280 mm 11.02" in
H1	Height of connecting link	113 mm 4.45" in
H2	Height of pendant strap	62 mm 2.44" in
H3	Height of connecting link	141 mm 5.55" in
D	Pin Ø	150 mm 5.91" in
D1	Pin Ø	50 mm 1.97" in
D2	Pin Ø	60 mm 2.36" in
Weight		134 kg 295 lb

Tab. 182: Technical data jib pendant strap (A-frame2 to jib head 0906.21)

1.18.3 CF pendant straps on fixed jib 0906

When installing the fixed jib 0906 on the machine with CF pendant straps, use the steel pendant straps and the steel backstay straps ([For more information see: 1.18.2 Steel pendant straps on fixed jib 0906, page 283](#)) .

1.19 Luffing jib - overview

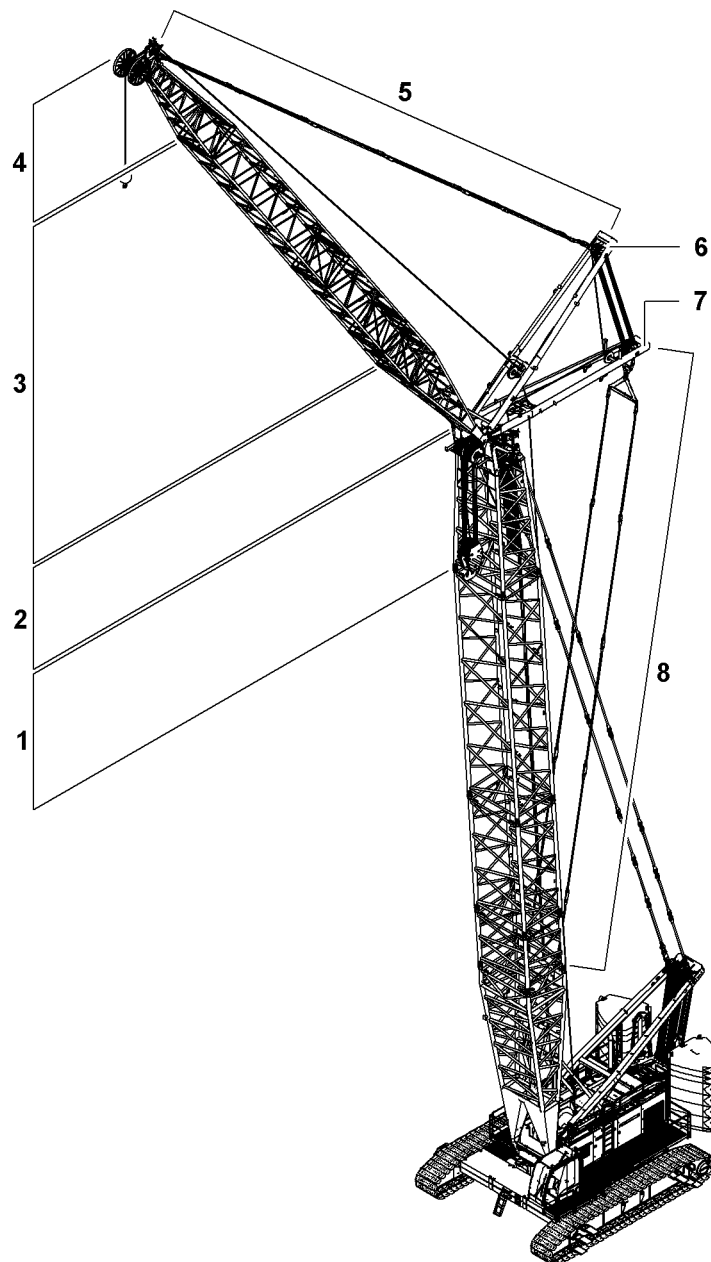


Fig. 303: Luffing jib - overview

- | | | | |
|----------|------------------|----------|---------------------|
| 1 | Main boom head | 5 | Jib pendant straps |
| 2 | Jib base section | 6 | A-frame3 |
| 3 | Jib sections | 7 | A-frame2 |
| 4 | Jib head | 8 | Jib backstay straps |

The luffing jib is composed of:

- Jib base section **2**
- Jib sections (3 m (10 ft), 6 m (20 ft), 12 m (40 ft)) **3**
- Jib head section **4**

The jib pendant straps **5** connect A-frame **3** **6** to the jib head section **4**.

The jib backstay straps **8** connect A-frame **2** **7** to the boom base section.

1.20 2316 luffing jib

1.20.1 Jib base section 2316.22

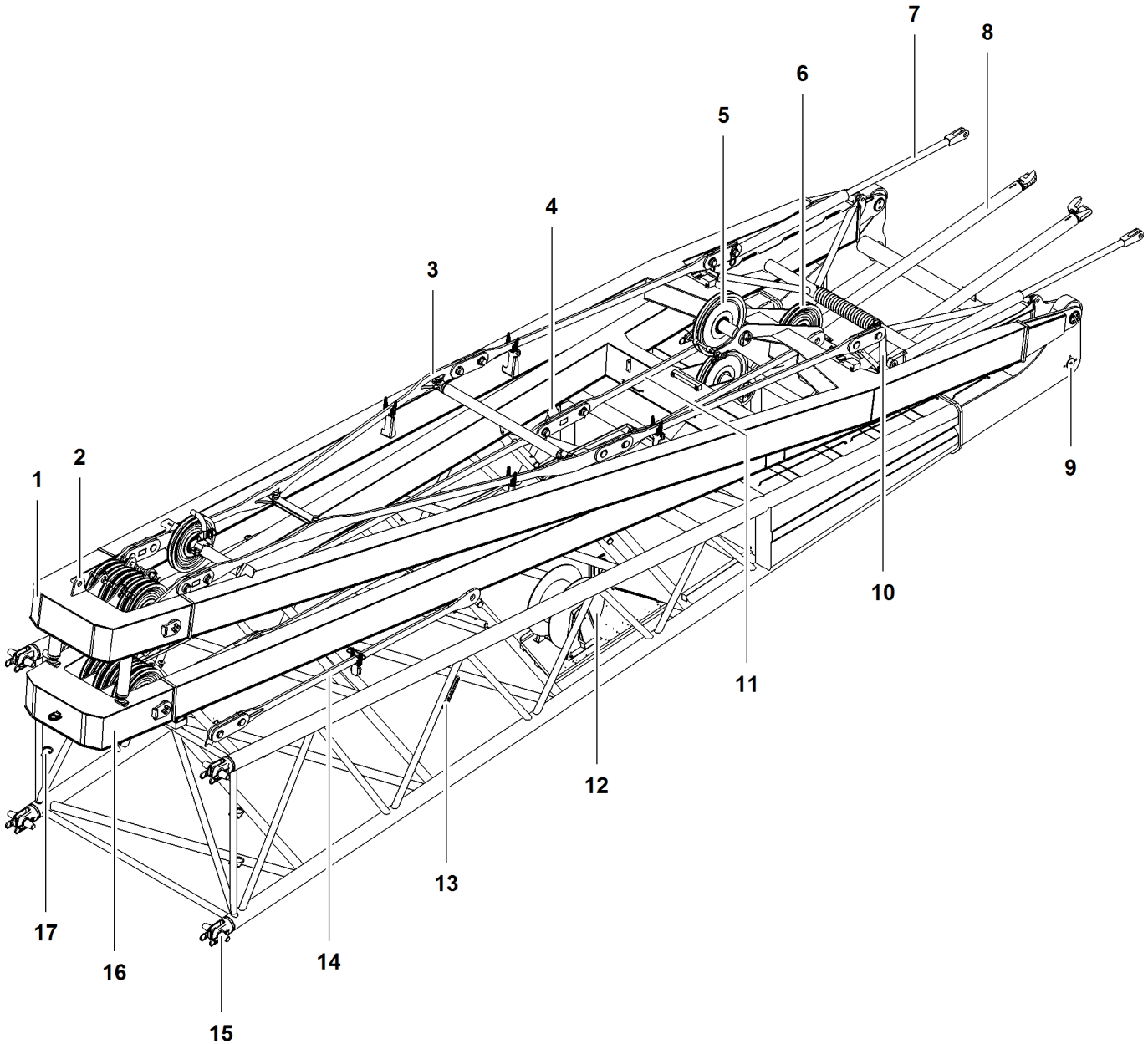


Fig. 304: Jib base section 2316.22

- | | | | | | |
|---|--|----|---|----|---|
| 1 | A-frame2 | 7 | Rigid tilting-back support (2x) | 13 | Boom identification plate |
| 2 | Shackle | 8 | Hydraulic tilting-back support (2x) | 14 | Transport position (2x) for 3 m (10 ft) pendant strap |
| 3 | Transport position of A-frame2 equalizer (jib backstay straps) | 9 | Pivot point (2x) for main boom head | 15 | Pin connection point (4x) with double-taper pin (4x) |
| 4 | Rigging point (4x) | 10 | Transport brackets (2x) of A-frame2 equalizer | 16 | A-frame3 |

See next page for continuation of the image legend

- 5 Pulley (2x) for rope of winch1/
winch2
- 6 Pulley (2x) for rope of jib
luffing winch
- 11 Transport position of A-
frame3 equalizer (jib pendant
strap)
- 12 Cable drum
- 17 Transport bracket (4x) for
double-taper pins

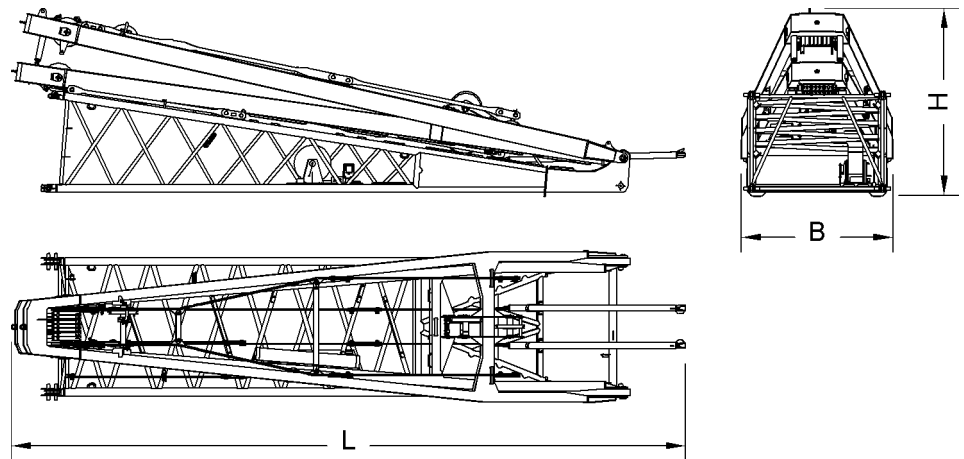


Fig. 305: Dimensions of jib base section 2316.22

Name		Value
System length		10000 mm 32' 10" ft-in
System width		2290 mm 7' 6" ft-in
System height		1650 mm 5' 5" ft-in
L	Length	11720 mm 38' 5" ft-in
B	Width	2670 mm 8' 9" ft-in
H	Height	3300 mm 10' 10" ft-in
Weight (incl. pendant straps, tilting-back supports and jib backstay straps)		8060 kg 17,769 lb
Double-taper pins Ø		65 mm 2.56" in

Tab. 183: Technical data jib base section 2316.22

LWNLR.x/V04.01//Auslieferung/2016-03-07/en

1.20.2 2316.20 jib section 3 m (10 ft)

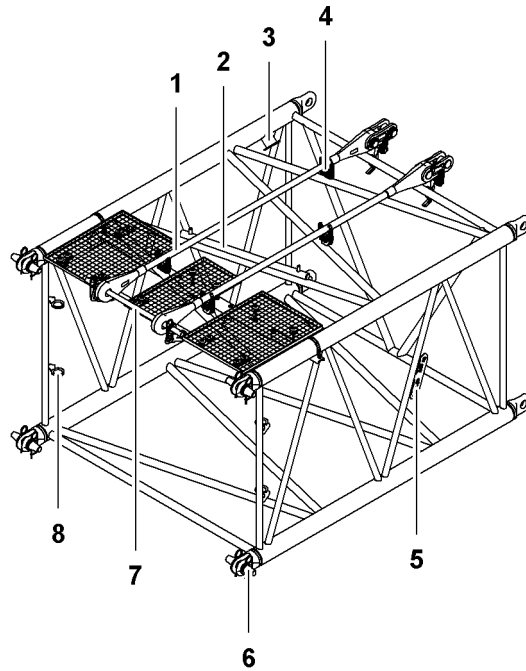


Fig. 306: Jib section 2316.20 3 m (10 ft)

- | | |
|---|--|
| <ul style="list-style-type: none"> 1 Transport position (2x) of jib pendant straps 3 m (10 ft) 2 Rope protection guard 3 Rigging point (4x) 4 Transport bracket (4x) for pendant straps | <ul style="list-style-type: none"> 5 Boom identification plate 6 Pin connection point (8x) with double-taper pin (4x) 7 Transport bracket for pendant straps 8 Transport bracket (4x) for double taper pin |
|---|--|

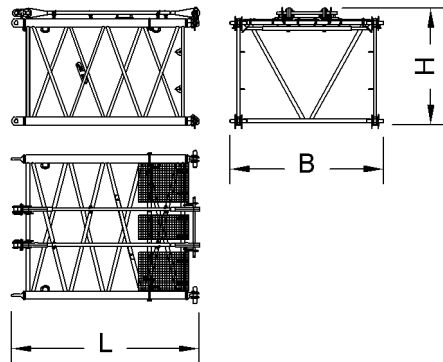


Fig. 307: Dimensions jib section 2316.20 3 m (10 ft)

Name	Value
System length	3000 mm 9' 10" ft-in
System width	2290 mm 7' 6" ft-in

LWNLR-x\04.01\Auslieferung\2016-03-07/en

Name		Value
System height		1650 mm 5' 5" ft-in
L	Length	3150 mm 10' 4" ft-in
B	Width	2430 mm 8' ft-in
H	Height (incl. pendant straps)	1910 mm 6' 3" ft-in
Weight (incl. pendant straps)		600 kg 1,323 lb
Double-taper pins Ø		65 mm 2.56" in

Tab. 184: Technical data for 2316.20 jib section 3 m (10 ft)

1.20.3 2316.20 jib section 6 m (20 ft)

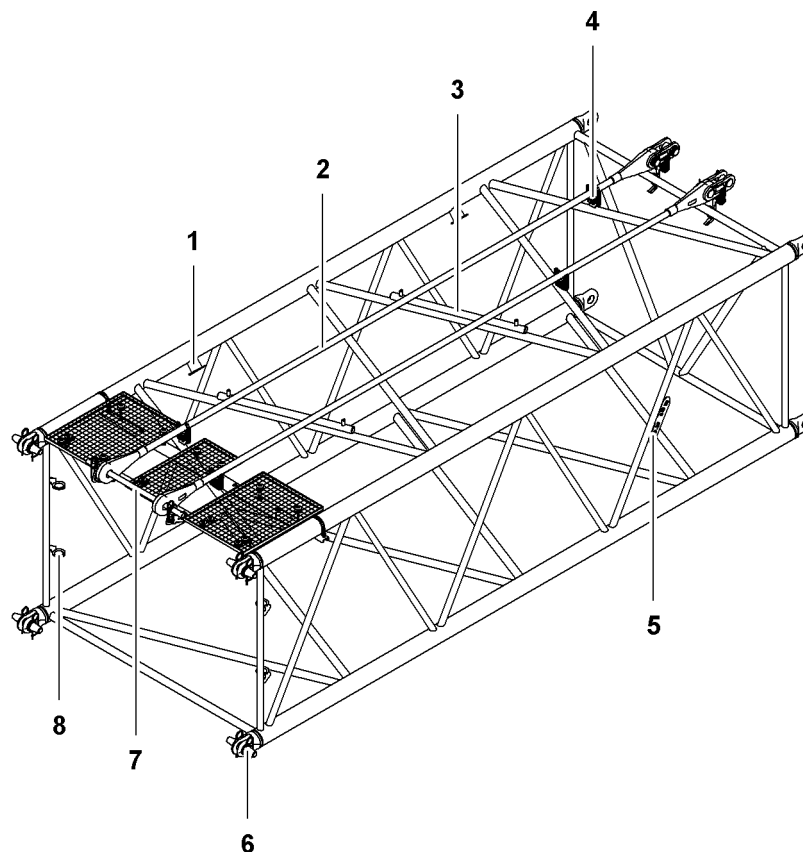


Fig. 308: Jib section 2316.20 6 m (20 ft)

- | | | | |
|---|---|---|--|
| 1 | Rigging point (4x) | 5 | Boom identification plate |
| 2 | Transport position (2x) of jib pendant straps 6 m (20 ft) | 6 | Pin connection point (8x) with double-taper pin (4x) |
| 3 | Rope protection guard (2x) | 7 | Transport bracket for pendant straps |
| 4 | Transport bracket (4x) for pendant straps | 8 | Transport bracket (4x) for double taper pin |

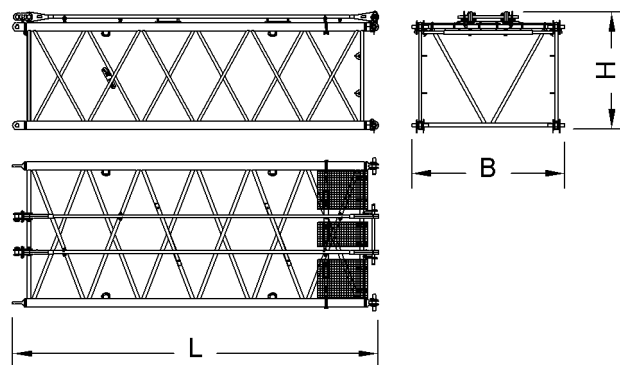


Fig. 309: Dimensions jib section 2316 6 m (20 ft)

Designation		Value
System length		6000 mm 19' 8" ft-in
System width		2290 mm 7' 6" ft-in
System height		1650 mm 5' 5" ft-in
L	Length	6150 mm 20' 2" ft-in
B	Width	2430 mm 8' ft-in
H	Height (incl. pendant straps)	1910 mm 6' 3" ft-in
Weight (incl. pendant straps)		950 kg 2,094 lb
Double-taper pins Ø		65 mm 2.56" in

Tab. 185: Technical data for 2316 jib section 6 m (20 ft)

1.20.4 2316.20 jib section 12 m (40 ft)

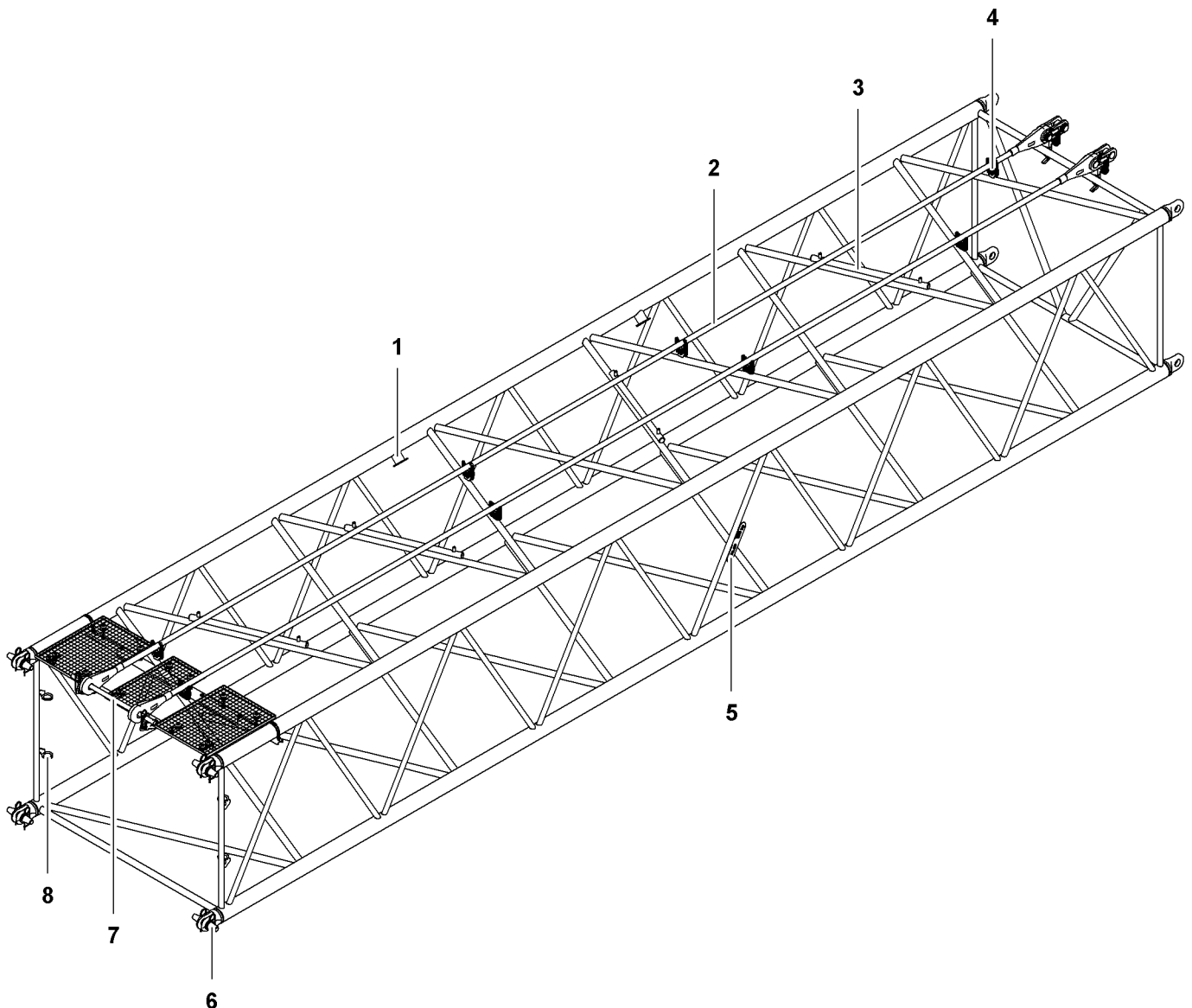


Fig. 310: Jib section 2316.20 12 m (40 ft)

- | | | | | | |
|---|--|---|--|---|---|
| 1 | Rigging point (4x) | 4 | Transport bracket (8x) for pendant straps | 7 | Transport bracket for pendant straps |
| 2 | Transport position (2x) of jib pendant straps 12 m (40 ft) | 5 | Boom identification plate | 8 | Transport bracket (4x) for double taper pin |
| 3 | Rope protection guard (3x) | 6 | Pin connection point (8x) with double-taper pin (4x) | | |

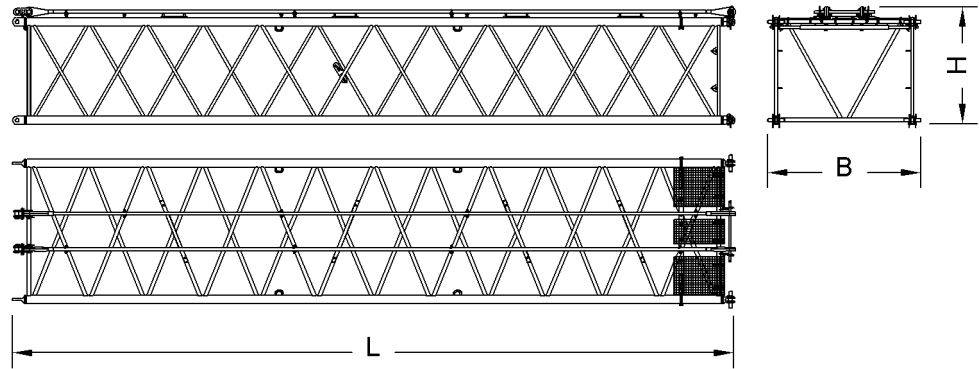


Fig. 311: Dimensions jib section 2316.20 12 m (40 ft)

Name		Value
System length		12000 mm 39' 4" ft-in
System width		2290 mm 7' 6" ft-in
System height		1650 mm 5' 5" ft-in
L	Length	12150 mm 39' 10" ft-in
B	Width	2430 mm 8' ft-in
H	Height (incl. pendant straps)	1910 mm 6' 3" ft-in
Weight (incl. pendant straps)		1750 kg 3,858 lb
Double-taper pins Ø		65 mm 2.56" in

Tab. 186: Technical data for 2316.20 jib section 12 m (40 ft)

1.20.5 2316.20 jib head section

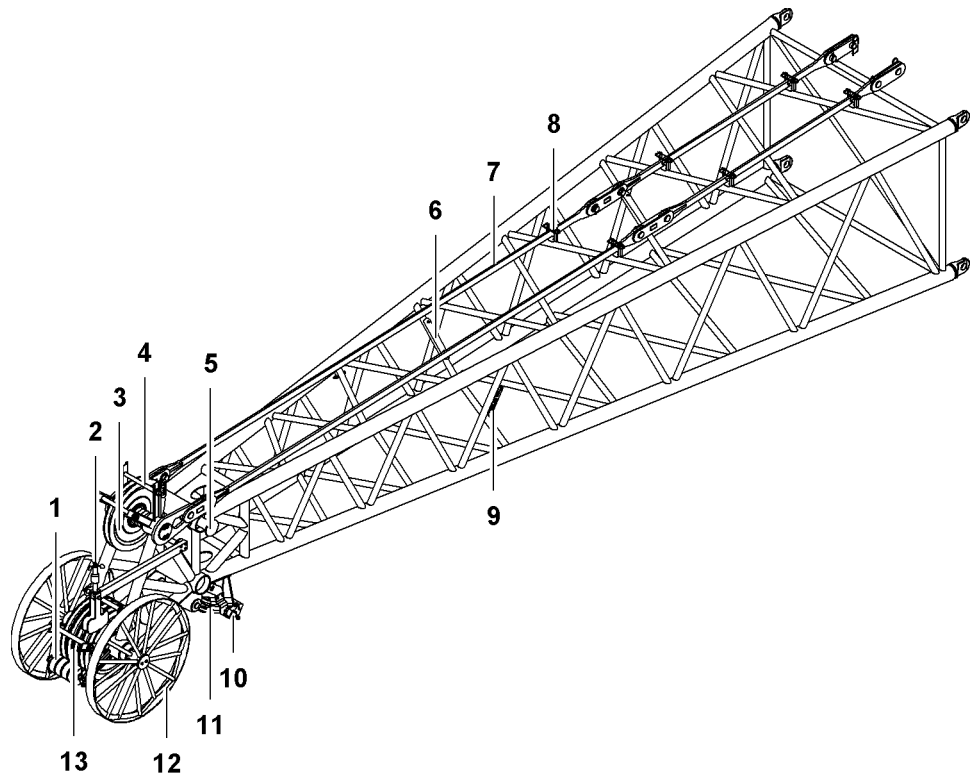


Fig. 312: 2316.20 jib head section

- | | | | |
|---|---|----|---|
| 1 | Rope protection roller (4x) | 8 | Transport bracket (6x) for pendant straps |
| 2 | Anemometer | 9 | Boom identification plate |
| 3 | Gantry pulley | 10 | Hoist limit switch (2x) |
| 4 | Rope protection pipe (2x) | 11 | Rope fixation |
| 5 | Lifting point (4x) | 12 | Wheel (2x) |
| 6 | Rope guard support (2x) | 13 | Pulley (4x) |
| 7 | Transport position (2x) of jib pendant straps | | |

This jib head section is designed to allow an auxiliary jib to be attached ([For more information see: 1.26 Auxiliary jib* \(30 t \(66.000 lb\)\), page 377](#)).

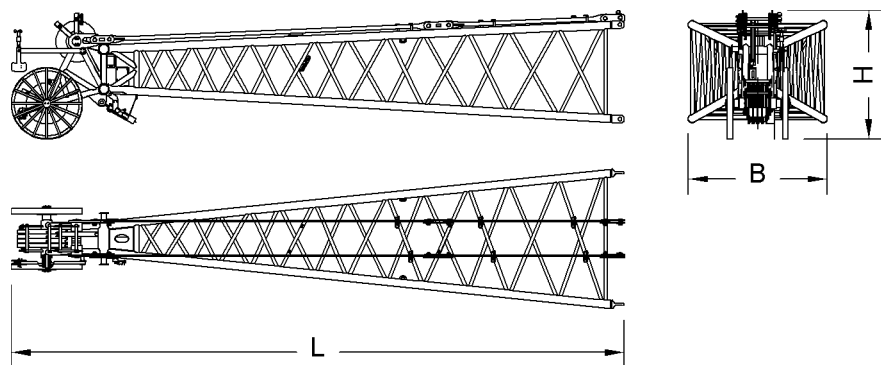


Fig. 313: 2316.20 jib head section dimensions

Name		Value
System length		10000 mm 32' 10" ft-in
System width		2290 mm 7' 6" ft-in
System height		1650 mm 5' 5" ft-in
L	Length	10750 mm 35' 3" ft-in
B	Width	2430 mm 8' ft-in
H	Height	2180 mm 7' 2" ft-in
Weight (incl. pendant straps)		2270 kg 5,004 lb

Tab. 187: 2316.20 jib head section, technical data

1.20.6 Mid-point suspension on luffing jib 2316

The mid-point suspensions on luffing jib 2316 differ with steel pendant straps and CF pendant straps.

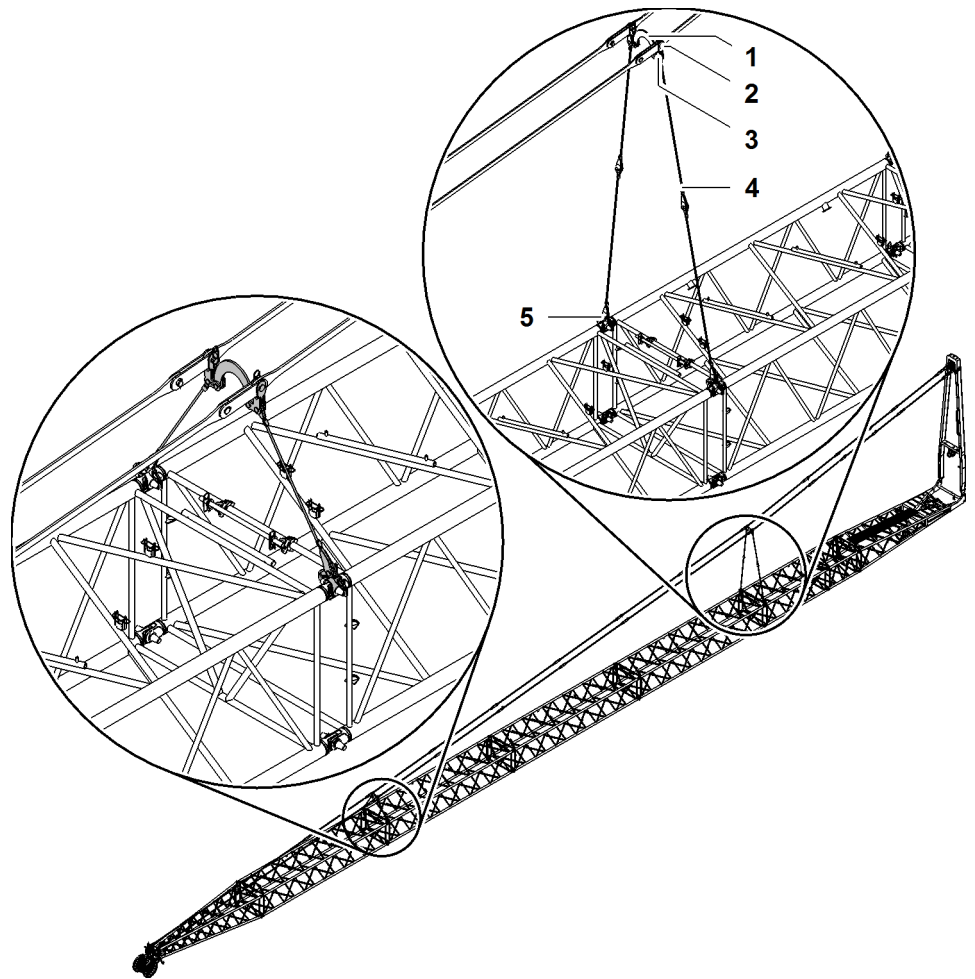


Fig. 314: Mid-point suspension on luffing jib 2316 (illustration of principle)

- | | | | |
|---|-----------------------------|---|------------|
| 1 | Connecting element (2x) | 4 | Stay ropes |
| 2 | Spacer bracket | 5 | Fork (2x) |
| 3 | Pin (2x) for pendant straps | | |

Connecting elements for steel pendant straps

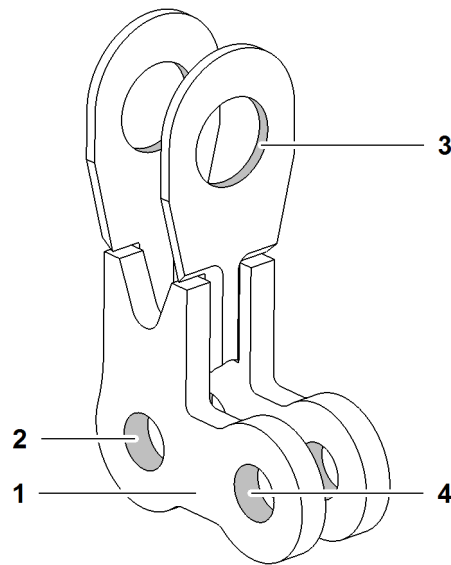


Fig. 315: Connecting elements for steel pendant straps (illustration of principle)

- | | | | |
|---|------------------------------------|---|---|
| 1 | Connecting element | 3 | Pin connection point for pendant strap |
| 2 | Pin connection point for stay rope | 4 | Pin connection point for spacer bracket |

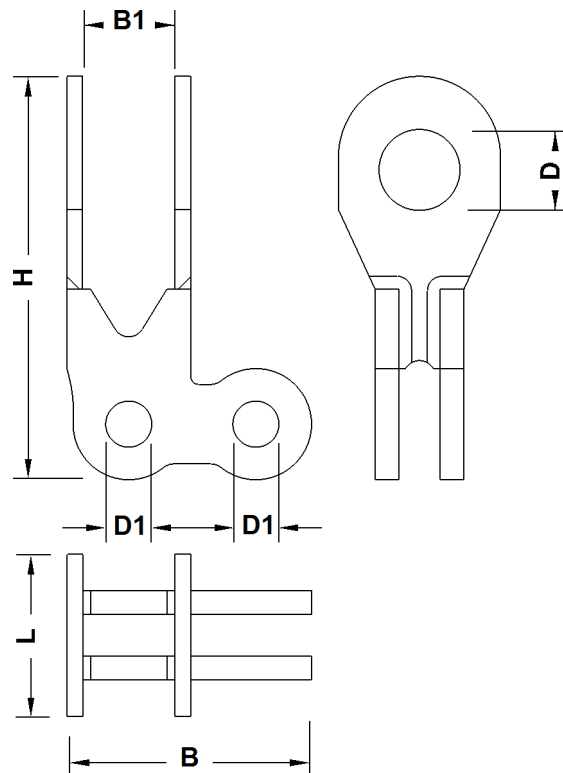


Fig. 316: Dimensions connecting elements for steel pendant straps

LWNLR-x/V04.01//Auslieferung/2016-03-07/en

Name		Value
L	Length	102 mm 4.02" in
H	Height	354 mm 1' 2" ft-in
B	Width	190 mm 7.48" in
B1	Width between links	58 mm 2.28" in
D	Pin Ø	55 mm 2.17" in
D1	Pin Ø	35 mm 1.38" in

Tab. 188: Technical data connecting elements for steel pendant straps

Connecting elements for CF pendant straps

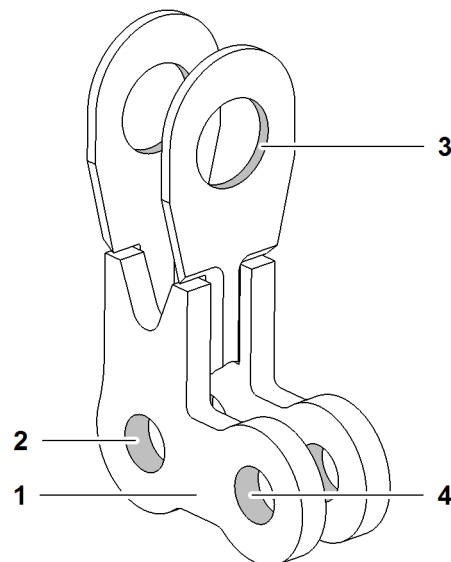


Fig. 317: Connecting elements for CF pendant straps (illustration of principle)

- | | | | |
|----------|------------------------------------|----------|---|
| 1 | Connecting element | 3 | Pin connection point for pendant strap |
| 2 | Pin connection point for stay rope | 4 | Pin connection point for spacer bracket |

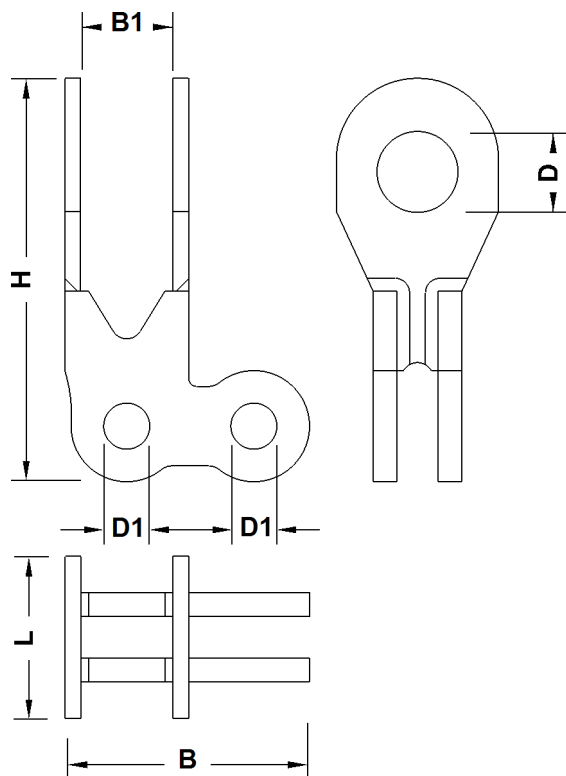


Fig. 318: Dimensions connecting elements for CF pendant straps

Name		Value
L	Length	110 mm 4.33" in
H	Height	358 mm 1' 2" ft-in
B	Width	207 mm 8.15" in
B1	Width between link	104 mm 4.09" in
D	Pin Ø	60 mm 2.36" in
D1	Pin Ø	35 mm 1.38" in

Tab. 189: Technical data connecting elements for CF pendant straps

LWNLR-x\04.01\Auslieferung\2016-03-07\en

Forks

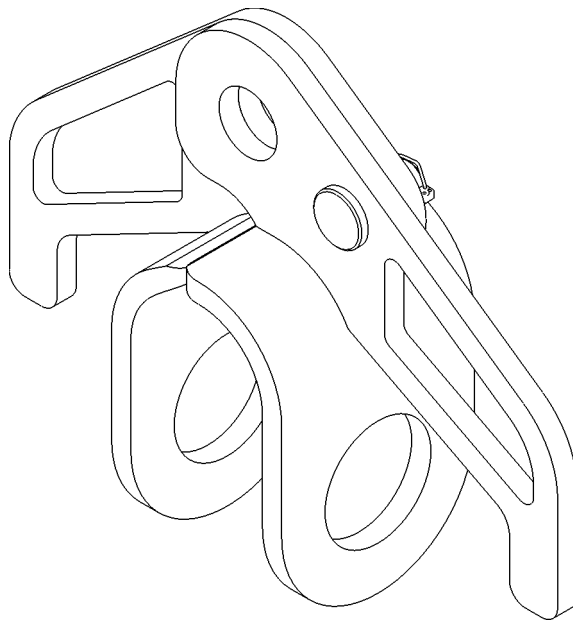


Fig. 319: Forks (illustration of principle)

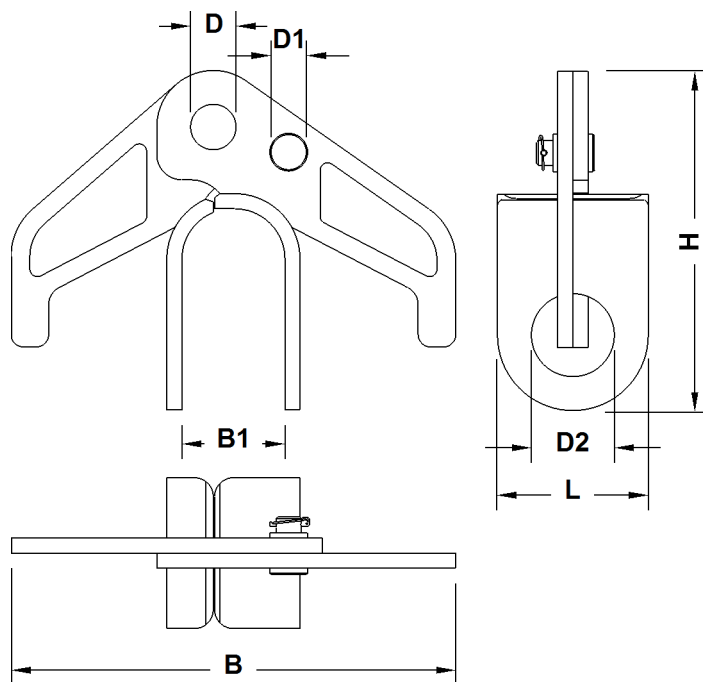


Fig. 320: Fork dimensions

Name	Value	
L	Length	120 mm 4.72" in
B	Width	354 mm 1' 2" ft-in

LWNLR.x/V04.01//Auslieferung/2016-03-07/en

Name		Value
B1	Inner width	82 mm 3.23" in
H	Height	270 mm 10.63" in
D	Pin Ø	35 mm 1.38" in
D1	Pin Ø	20 mm 0.79" in
D2	Pin Ø	65 mm 2.56" in

Tab. 190: Technical data forks

Spacer bracket

The spacer brackets are identical with steel pendant straps and CF pendant straps.

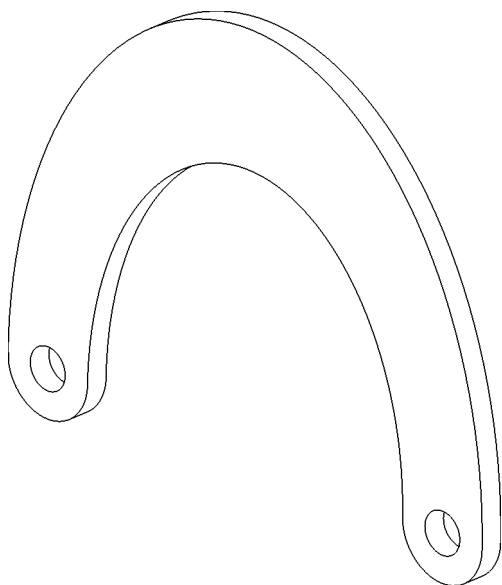


Fig. 321: Spacer brackets (illustration of principle)

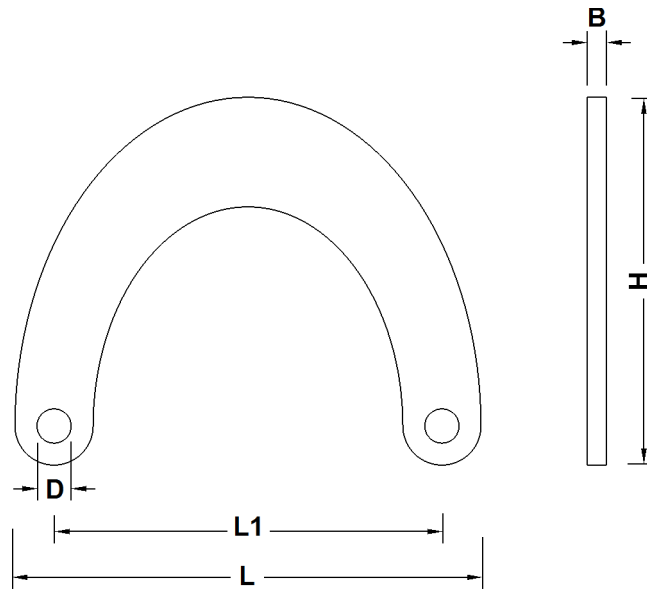


Fig. 322: Dimensions spacer brackets

Name		Value
L	Length	489 mm 1' 7" ft-in
L1	Distance between pins	407 mm 1' 4" ft-in
B	Width	20 mm 0.79" in
H	Height	386 mm 1' 3" ft-in
D	Pin Ø	35 mm 1.38" in

Tab. 191: Technical data spacer brackets

Stay ropes

Several stay ropes are assembled to achieve defined rope lengths.

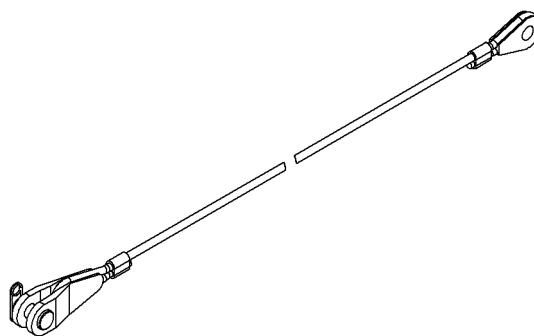


Fig. 323: Stay ropes (illustration of principle)

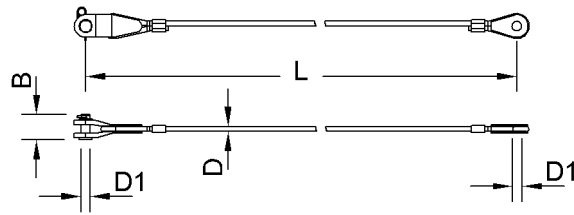


Fig. 324: Dimensions stay ropes

Name		Value
L	Length of stay rope	1100 mm 3' 7" ft-in
		1300 mm 4' 3" ft-in
		1600 mm 5' 3" ft-in
		2100 mm 6' 11" ft-in
		2600 mm 8' 6" ft-in
		3000 mm 9' 10" ft-in
D	Ø of stay rope	18 mm 0.71" in
D1	Pin Ø	35 mm 1.38" in
B	Length of pin	90 mm 3.54" in

Tab. 192: Technical data stay ropes

Pins for steel pendant straps

The pins supplied with the pendant straps must be exchanged for longer pins.

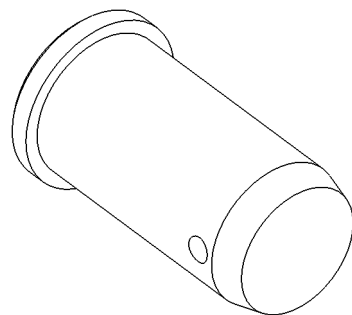


Fig. 325: Pins for steel pendant straps (illustration of principle)

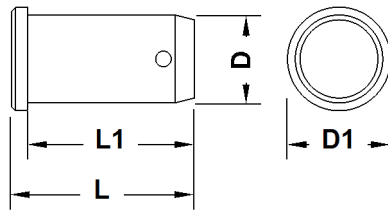


Fig. 326: Dimensions pins for steel pendant straps

Name		Value
L	Total length	120 mm 4.72" in
L1	Length	112 mm 4.41" in
D	Diameter	55 mm 2.17" in
D1	Outer diameter	63 mm 2.48" in

Tab. 193: Technical data pins for steel pendant straps

Pins for CF pendant straps

The pins supplied with the pendant straps must be exchanged for longer pins.

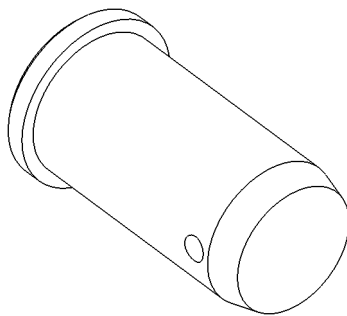


Fig. 327: Pins for CF pendant straps (illustration of principle)

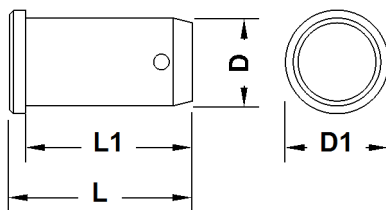


Fig. 328: Dimensions pins for CF pendant straps

Name		Value
L	Total length	158 mm 6.22" in
L1	Length	153 mm 6.02" in

Name		Value
D	Diameter	60 mm 2.36" in
D1	Outer diameter	68 mm 2.68" in

Tab. 194: Technical data pins for CF pendant straps

1.20.7 Steel pendant straps on luffing jib 2316

Steel pendant straps on jib base section 2316.20

Jib pendant strap 3 m (10 ft)

Installation site in crane operation:

- Luffing jib 2316 (For more information see: Pendant straps A-frame3 to jib head 2316, page 1627)
- Luffing jib 2316 + midfall 2316 (For more information see: Pendant straps A-frame3 to jib head 2316, page 1725)

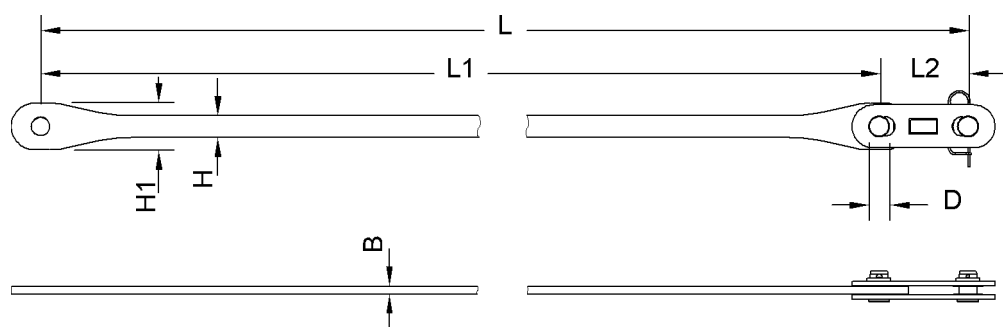


Fig. 329: Dimensions jib pendant strap 3 m (10 ft)

Name		Value
L	Length	3000 mm 9' 10" ft-in
L1	Length of pendant strap	2730 mm 8' 11" ft-in
L2	Length of connecting link	270 mm 10.63" in
W	Width of pendant strap	22 mm 0.87" in
H	Height of pendant strap	66 mm 2.60" in
H1	Height of pendant strap	140 mm 5.51" in
D	Pin Ø	55 mm 2.17" in

LWNLR-x/V04.01//Auslieferung/2016-03-07/en

Name	Value
Weight	53 kg 117 lb

Tab. 195: Technical data jib pendant strap 3 m (10 ft)

Steel pendant straps on A-frame2

Equalizer A-frame2 (jib backstay strap)

Installation site in crane operation:

- Luffing jib 2316 (For more information see: Jib backstay straps A-frame2 to main boom base section 2821, page 1627)
- Luffing jib 2316 + midfall 2316 (For more information see: Jib backstay straps A-frame2 to main boom base section 2821, page 1724)

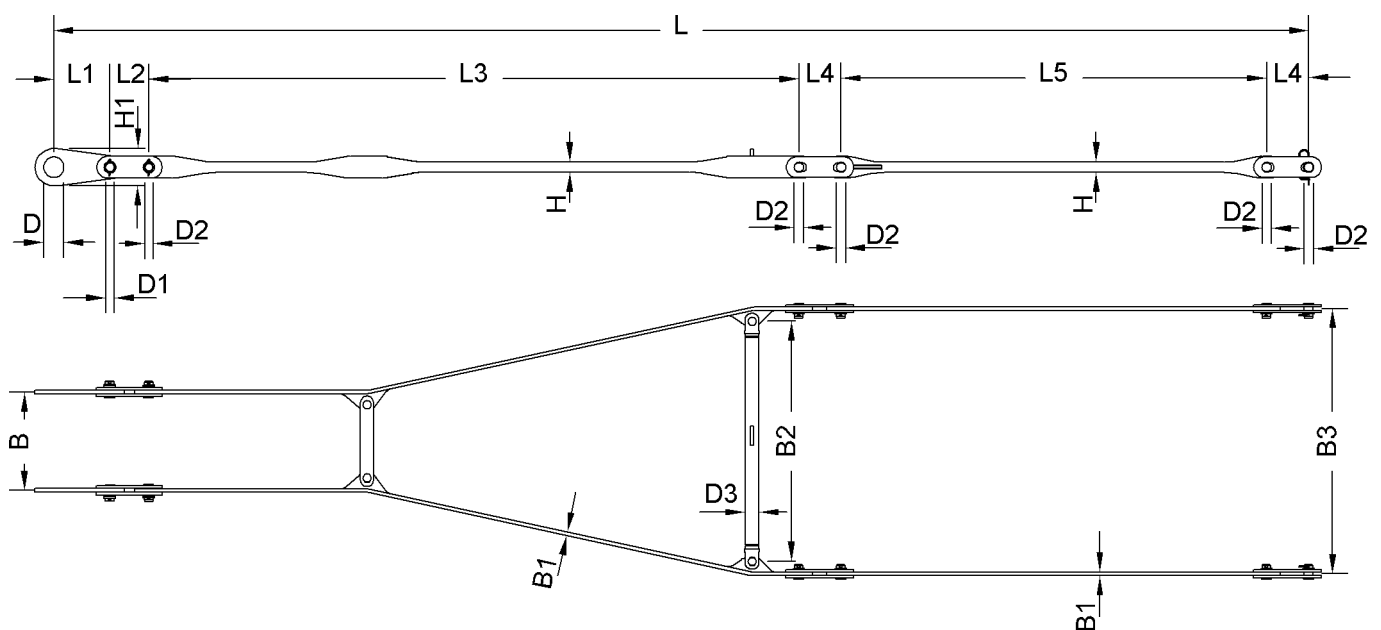


Fig. 330: Dimensions equalizer on A-frame2 (jib backstay strap)

Name	Value
L Length	8050 mm 26' 5" ft-in
L1 Length of connecting link	360 mm 1' 2" ft-in
L2 Length of connecting link	250 mm 9.84" in
L3 Length of crossbar	4170 mm 13' 8" ft-in
L4 Length of connecting link	270 mm 10.63" in
L5 Length of pendant strap	2730 mm 8' 11" ft-in

Name		Value
W	Width	630 mm 2' 1" ft-in
W1	Width of pendant strap	22 mm 0.87" in
W2	Width of spacer bar	1540 mm 5' 1" ft-in
W3	Width	1700 mm 5' 7" ft-in
H	Height of pendant strap	66 mm 2.60" in
H1	Height of connecting link	281 mm 11.06" in
D	Pin Ø	150 mm 5.91" in
D1	Pin Ø	60 mm 2.36" in
D2	Pin Ø	55 mm 2.17" in
D3	Spacer bar Ø	89 mm 3.50" in
Weight		343 kg 756 lb

Tab. 196: Technical data equalizer on A-frame2 (jib backstay strap)

Steel pendant straps on A-frame3

A-frame3 equalizer (jib pendant strap)

Installation site in crane operation:

- Luffing jib 2316 (For more information see: [Pendant straps A-frame3 to jib head 2316, page 1627](#))
- Luffing jib 2316 + midfall 2316 (For more information see: [Pendant straps A-frame3 to jib head 2316, page 1725](#))

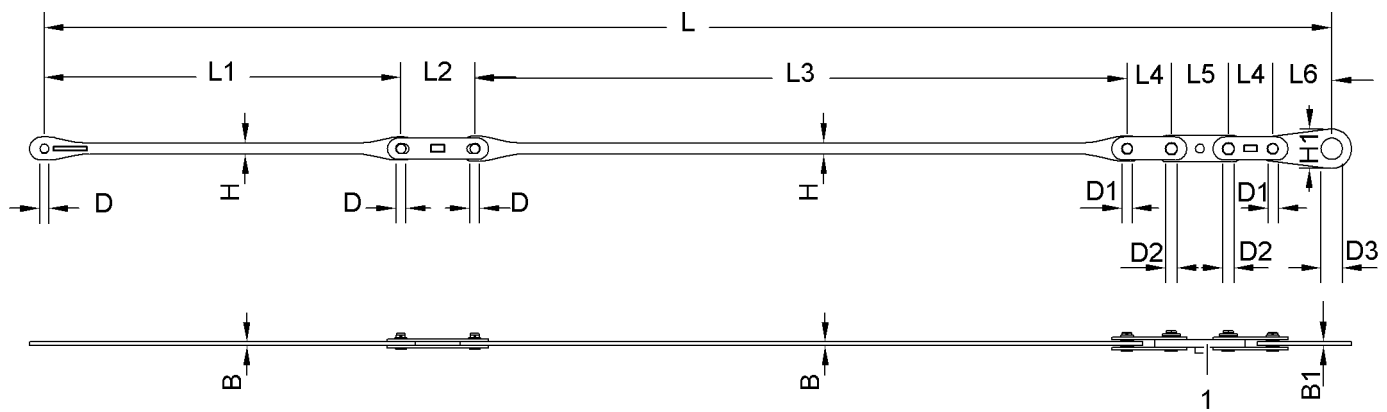


Fig. 331: Dimensions equalizer on A-frame3 (jib pendant strap)

1 Tension load cell

Name		Value
L	Length	7850 mm 25' 9" ft-in
L1	Length of pendant strap	2175 mm 7' 2" ft-in
L2	Length of connecting link	450 mm 1' 6" ft-in
L3	Length of pendant strap	3977 mm 13' 1" ft-in
L4	Length of connecting link	270 mm 10.63" in
L5	Length of tension load cell	348 mm 1' 2" ft-in
L6	Length of connecting link	360 mm 1' 2" ft-in
W	Width of pendant strap	22 mm 0.87" in
W1	Width of connecting link	25 mm 0.98" in
H	Height of pendant strap	66 mm 2.60" in
D	Pin Ø	55 mm 2.17" in
D1	Pin Ø	60 mm 2.36" in
D2	Pin Ø	62 mm 2.44" in
D3	Pin Ø	150 mm 5.91" in
Weight		167 kg 368 lb

Tab. 197: Technical data A-frame3 equalizer (jib pendant strap)

LWNLR.x/V04.01//Auslieferung/2016-03-07/en

Steel pendant straps on jib section 2316.20 3 m (10 ft)

Jib pendant strap 3 m (10 ft)

Installation site in crane operation:

- Luffing jib 2316 (For more information see: [Pendant straps A-frame3 to jib head 2316, page 1627](#))
- Luffing jib 2316 + midfall 2316 (For more information see: [Pendant straps A-frame3 to jib head 2316, page 1725](#))

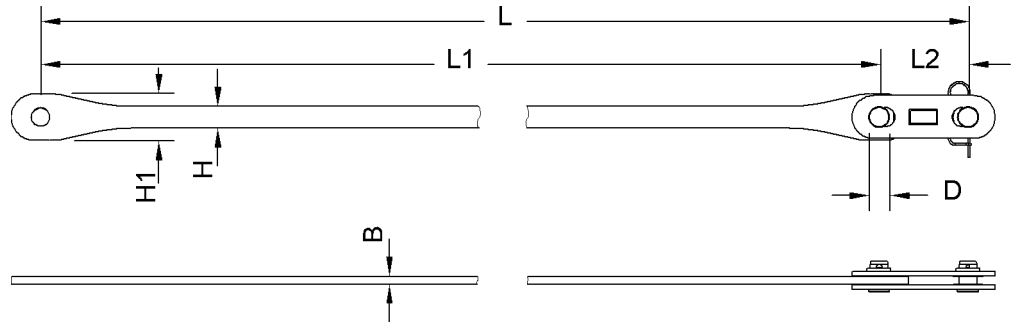


Fig. 332: Dimensions jib pendant strap 3 m (10 ft)

Name		Value
L	Length	3000 mm 9' 10" ft-in
L1	Length of pendant strap	2730 mm 8' 11" ft-in
L2	Length of connecting link	270 mm 10.63" in
W	Width of pendant strap	22 mm 0.87" in
H	Height of pendant strap	66 mm 2.60" in
H1	Height of pendant strap	140 mm 5.51" in
D	Pin Ø	55 mm 2.17" in
Weight		53 kg 117 lb

Tab. 198: Technical data jib pendant strap 3 m (10 ft)

Steel pendant straps on jib section 2316.20 6 m (20 ft)

Jib pendant strap 6 m (20 ft)

Installation site in crane operation:

- Luffing jib 2316 (For more information see: [Pendant straps A-frame3 to jib head 2316, page 1627](#))
- Luffing jib 2316 + midfall 2316 (For more information see: [Pendant straps A-frame3 to jib head 2316, page 1725](#))

LWNLR-x/V04.01//Auslieferung/2016-03-07/en

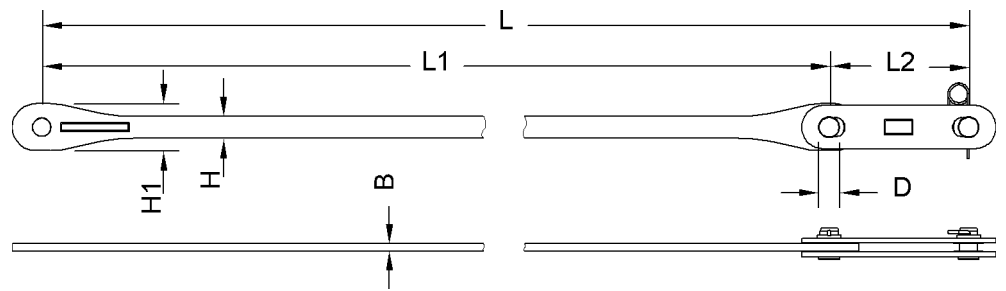


Fig. 333: Dimensions jib pendant strap 6 m (20 ft)

Name		Value
L	Length	6000 mm 19' 8" ft-in
L1	Length of pendant strap	5580 mm 18' 4" ft-in
L2	Length of connecting link	420 mm 1' 5" ft-in
W	Width of pendant strap	22 mm 0.87" in
H	Height of pendant strap	66 mm 2.60" in
H1	Height of pendant strap	140 mm 5.51" in
D	Pin Ø	55 mm 2.17" in
Weight		89 kg 196 lb

Tab. 199: Technical data jib pendant strap 6 m (20 ft)

Steel pendant straps on jib section 2316.20 12 m (40 ft)

Jib pendant strap 12 m (40 ft)

Installation site in crane operation:

- Luffing jib 2316 (For more information see: [Pendant straps A-frame3 to jib head 2316, page 1627](#))
- Luffing jib 2316 + midfall 2316 (For more information see: [Pendant straps A-frame3 to jib head 2316, page 1725](#))

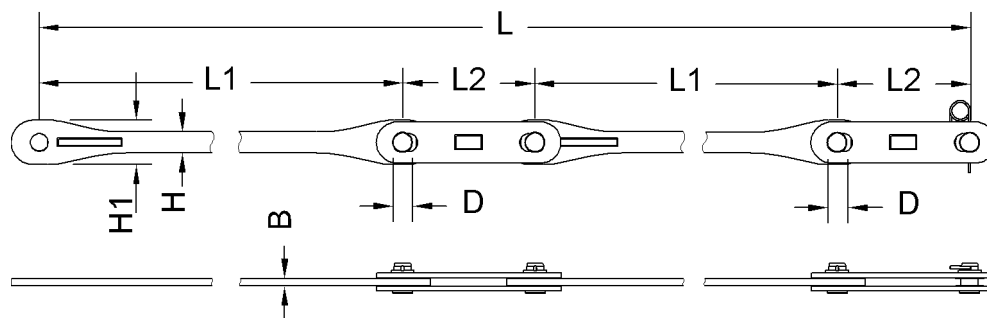


Fig. 334: Dimensions jib pendant strap 12 m (40 ft)

Name		Value
L	Length	12000 mm 39' 4" ft-in
L1	Length of pendant strap	5580 mm 18' 4" ft-in
L2	Length of connecting link	420 mm 1' 5" ft-in
W	Width of pendant strap	22 mm 0.87" in
H	Height of pendant strap	66 mm 2.60" in
H1	Height of pendant strap	140 mm 5.51" in
D	Pin Ø	55 mm 2.17" in
Weight		178 kg 392 lb

Tab. 200: Technical data jib pendant strap 12 m (40 ft)

Steel pendant straps on jib head 2316.20

Jib pendant strap on jib head 2316.20

Installation site in crane operation:

- Luffing jib 2316 (For more information see: [Pendant straps A-frame3 to jib head 2316, page 1627](#))
- Luffing jib 2316 + midfall 2316 (For more information see: [Pendant straps A-frame3 to jib head 2316, page 1725](#))

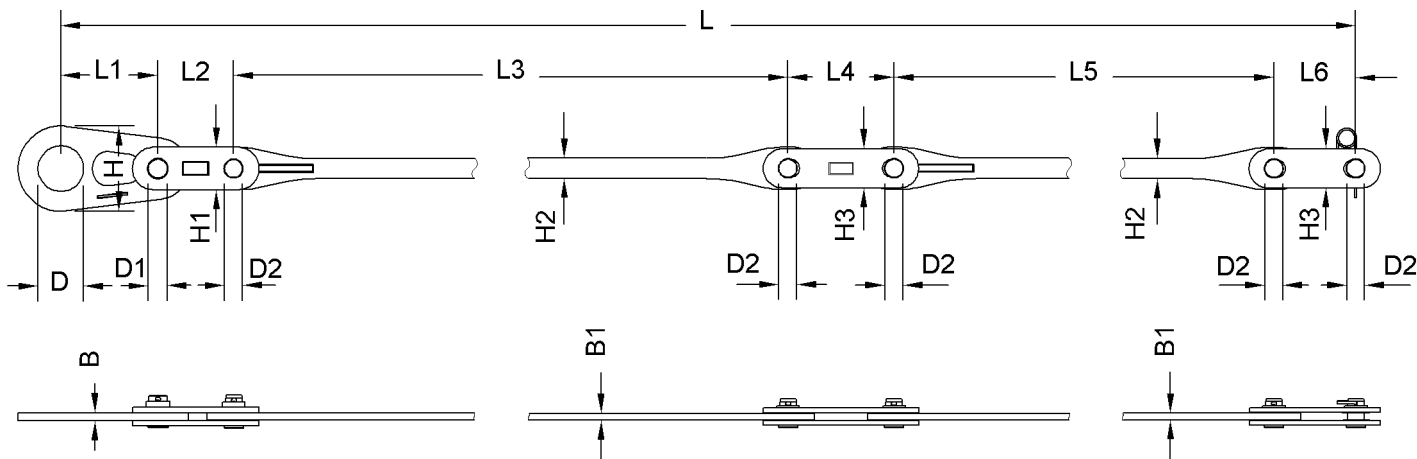


Fig. 335: Dimensions jib pendant strap on jib head 2316.20

Name		Value
L	Length	9500 mm 31' 2" ft-in
L1	Length of connecting link	320 mm 1' 1" ft-in
L2	Length of connecting link	250 mm 9.84" in
L3	Length of pendant strap	5580 mm 18' 4" ft-in
L4	Length of connecting link	350 mm 1' 2" ft-in
L5	Length of pendant strap	2730 mm 8' 11" ft-in
L6	Length of connecting link	270 mm 10.63" in
W	Width of connecting link	25 mm 0.98" in
W1	Width of pendant strap	22 mm 0.87" in
H	Height of connecting link	280 mm 11.02" in
H1	Height of connecting link	130 mm 5.12" in
H2	Height of pendant strap	66 mm 2.60" in
H3	Height of connecting link	140 mm 5.51" in
D	Pin Ø	150 mm 5.91" in
D1	Pin Ø	60 mm 2.36" in

Name		Value
D2	Pin Ø	55 mm 2.17" in
Weight		325 kg 716 lb

Tab. 201: Technical data jib pendant strap on jib head 2316.20

1.20.8 CF pendant straps on luffing jib 2316

CF pendant straps on jib base section 2316.22

Jib pendant strap 3 m (10 ft)

Installation site in crane mode:

- Luffing jib 2316 (For more information see: [Pendant straps A-frame3 to jib head 2316, page 1630](#))
- Luffing jib 2316 + midfall 2316 (For more information see: [Pendant straps A-frame3 to jib head 2316, page 1727](#))

Generation A of jib pendant strap 3 m (10 ft)

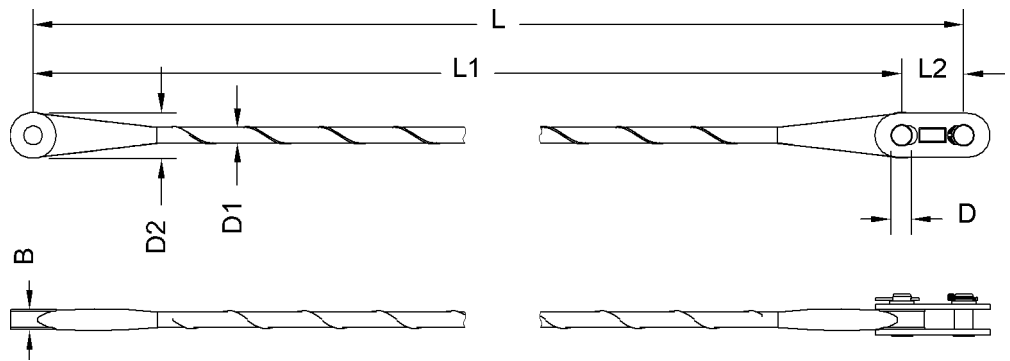


Fig. 336: Dimensions jib pendant strap 3 m (10 ft)

Name		Value
L	Length	3000 mm 9' 10" ft-in
L1	Length of pendant strap	2800 mm 9' 2" ft-in
L2	Length of connecting link	200 mm 7.87" in
W	Width	64 mm 2.52" in
D	Pin Ø	60 mm 2.36" in
D1	Pendant strap Ø	50 mm 1.97" in
D2	Pendant strap Ø	148 mm 5.83" in

LWNLR-x/V04.01//Auslieferung/2016-03-07/en

Name	Value
Weight	35 kg 77.16 lb

Tab. 202: Technical data jib pendant strap 3 m (10 ft)

Generation B of jib pendant strap 3 m (10 ft)

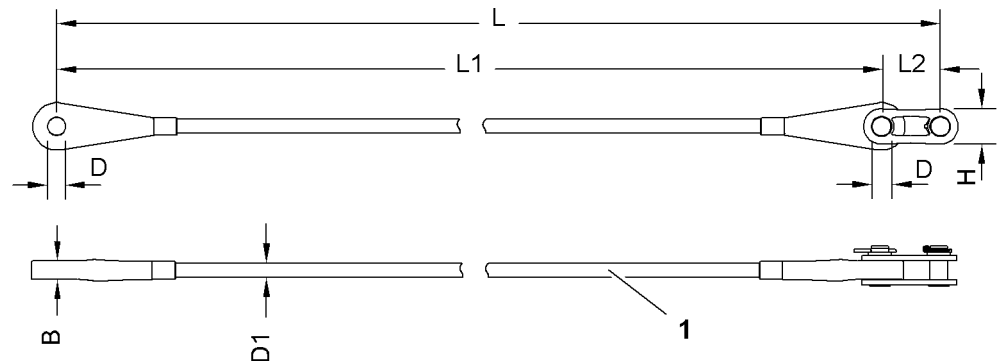


Fig. 337: Dimensions jib pendant strap 3 m (10 ft)

- 1 Wire mesh hose as protective sheath

Name	Value
L Length	3000 mm 9' 10" ft-in
L1 Length of pendant strap	2800 mm 9' 2" ft-in
L2 Length of connecting link	200 mm 7.87" in
B Width	63 mm 2.48" in
H Height of connecting link	121 mm 4.76" in
D Pin Ø	60 mm 2.36" in
D1 Pendant strap Ø	48 mm 1.89" in
Weight	26 kg 57.32 lb

Tab. 203: Technical data jib pendant strap 3 m (10 ft)

CF pendant straps on A-frame2

Equalizer A-frame2 (jib backstay strap)

Installation site in crane operation:

- Luffing jib 2316 (For more information see: [Jib backstay straps A-frame2 to main boom base section 2821, page 1629](#))

LWNLR.x/V04.01//Auslieferung/2016-03-07/en

- Luffing jib 2316 + midfall 2316 (For more information see: Jib backstay straps A-frame2 to main boom base section 2821, page 1726)

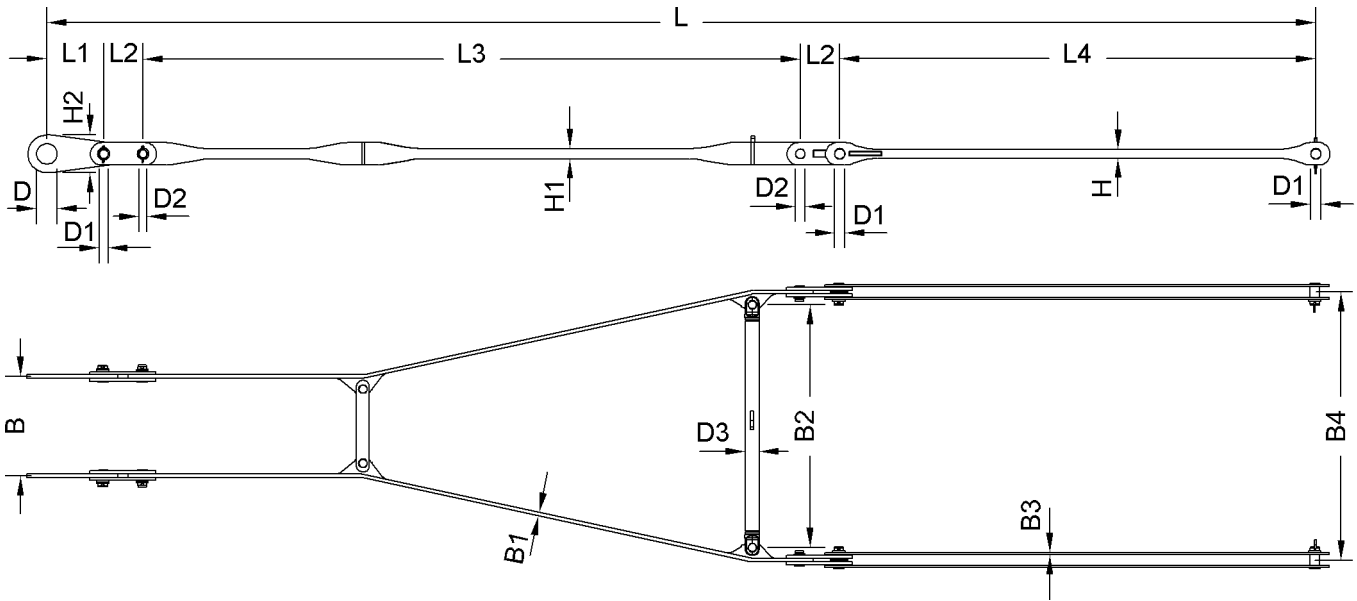


Fig. 338: Dimensions equalizer on A-frame2 (jib backstay strap)

Name		Value
L	Length	8050 mm 26' 5" ft-in
L1	Length of connecting link	360 mm 1' 2" ft-in
L2	Length of connecting link	250 mm 9.84" in
L3	Length of crossbar	4170 mm 13' 8" ft-in
L4	Length of pendant strap	3020 mm 9' 11" ft-in
W	Width	630 mm 2' 1" ft-in
W1	Width of pendant strap	22 mm 0.87" in
W2	Width of spacer bar	1540 mm 5' 1" ft-in
W3	Width of pendant strap	15 mm 0.59" in
W4	Width	1700 mm 5' 7" ft-in
H	Height of pendant strap	55 mm 2.17" in
H1	Height of pendant strap	64 mm 2.52" in

LWNLR-x/V04.01//Auslieferung/2016-03-07/en

Name		Value
H2	Height of connecting link	240 mm 9.45" in
D	Pin Ø	130 mm 5.12" in
D1	Pin Ø	60 mm 2.36" in
D2	Pin Ø	55 mm 2.17" in
D3	Spacer bar Ø	89 mm 3.50" in
Weight		358 kg 789 lb

Tab. 204: Technical data equalizer on A-frame2 (jib backstay strap)

CF pendant straps on A-frame3

A-frame3 equalizer (jib pendant strap)

Installation site in crane operation:

- Luffing jib 2316 (For more information see: [Pendant straps A-frame3 to jib head 2316, page 1630](#))
- Luffing jib 2316 + midfall 2316 (For more information see: [Pendant straps A-frame3 to jib head 2316, page 1727](#))

Generation A of A-frame3 equalizer (jib pendant strap)

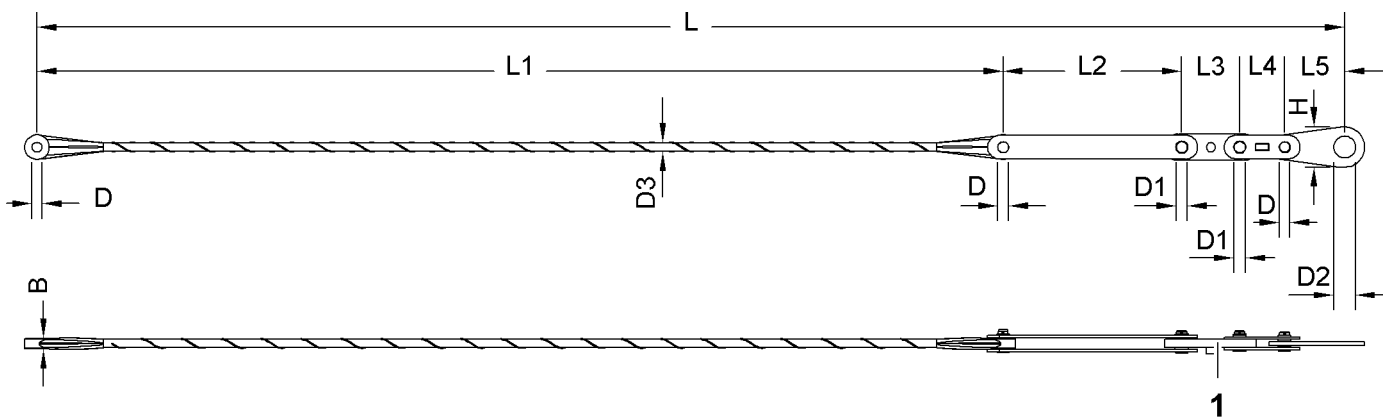


Fig. 339: Dimensions equalizer on A-frame3 (jib pendant strap)

1 Tension load cell

Name		Value
L	Length	7850 mm 25' 9" ft-in
L1	Length of pendant strap	5800 mm 19' ft-in

LWNLR.x/V04.01/Auslieferung/2016-03-07/en

Name		Value
L2	Length of connecting link	1072 mm 3' 6" ft-in
L3	Length of tension load cell	348 mm 1' 2" ft-in
L4	Length of connecting link	270 mm 10.63" in
L5	Length of connecting link	360 mm 1' 2" ft-in
W	Width of pendant strap	64 mm 2.52" in
H	Height of connecting link	240 mm 9.45" in
D	Pin Ø	60 mm 2.36" in
D1	Pin Ø	62 mm 2.44" in
D2	Pin Ø	130 mm 5.12" in
D3	Pendant strap Ø	50 mm 1.97" in
Weight		129 kg 284 lb

Tab. 205: Technical data A-frame3 equalizer (jib pendant strap)

Generation B of A-frame3 equalizer (jib pendant strap)

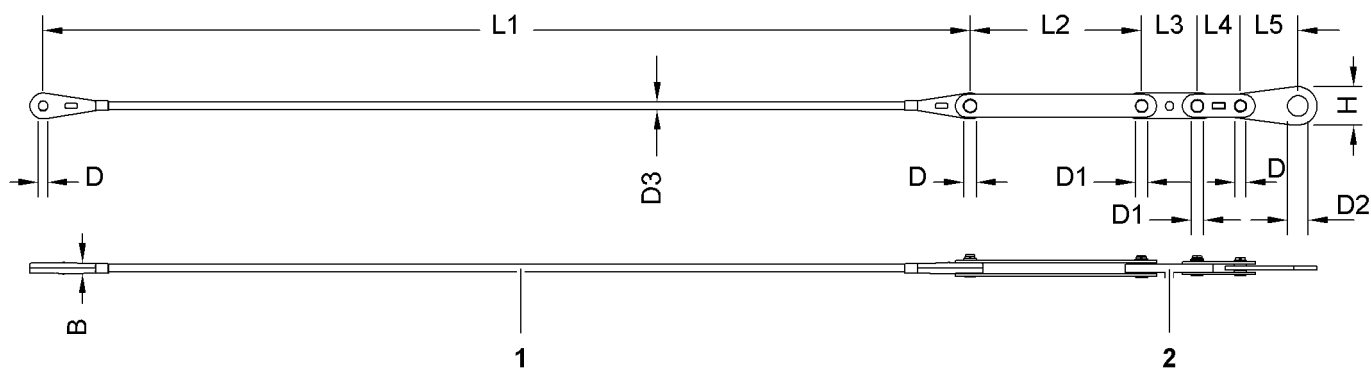


Fig. 340: Dimensions equalizer on A-frame3 (jib pendant strap)

- 1 Wire mesh hose as protective sheath
- 2 Tension load cell

Name		Value
L	Length	7850 mm 25' 9" ft-in
L1	Length of pendant strap	5800 mm 19' ft-in

LWN/LR-x/V04.01//Auslieferung/2016-03-07/en

Name		Value
L2	Length of connecting link	1072 mm 3' 6" ft-in
L3	Length of tension load cell	348 mm 1' 2" ft-in
L4	Length of connecting link	270 mm 10.63" in
L5	Length of connecting link	360 mm 1' 2" ft-in
B	Width of pendant strap	63 mm 2.48" in
H	Height of connecting link	240 mm 9.45" in
D	Pin Ø	60 mm 2.36" in
D1	Pin Ø	62 mm 2.44" in
D2	Pin Ø	130 mm 5.12" in
D3	Pendant strap Ø	48 mm 1.89" in
Weight		85 kg 187 lb

Tab. 206: Technical data A-frame3 equalizer (jib pendant strap)

CF pendant straps on jib section 2316.20 3 m (10 ft)

Jib pendant strap 3 m (10 ft)

Installation site in crane mode:

- Luffing jib 2316 (For more information see: [Pendant straps A-frame3 to jib head 2316, page 1630](#))
- Luffing jib 2316 + midfall 2316 (For more information see: [Pendant straps A-frame3 to jib head 2316, page 1727](#))

Generation A of jib pendant strap 3 m (10 ft)

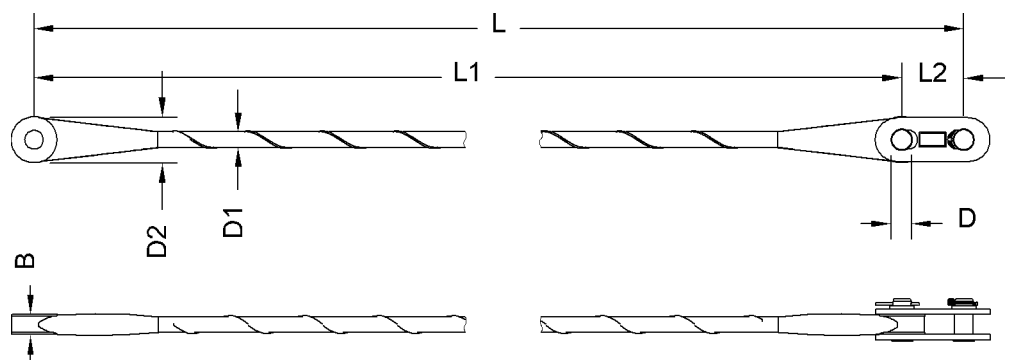


Fig. 341: Dimensions jib pendant strap 3 m (10 ft)

Name		Value
L	Length	3000 mm 9' 10" ft-in
L1	Length of pendant strap	2800 mm 9' 2" ft-in
L2	Length of connecting link	200 mm 7.87" in
B	Width	64 mm 2.52" in
D	Pin Ø	60 mm 2.36" in
D1	Pendant strap Ø	50 mm 1.97" in
D2	Pendant strap Ø	148 mm 5.83" in
Weight		35 kg 77.16 lb

Tab. 207: Technical data jib pendant strap 3 m (10 ft)

Generation B of jib pendant strap 3 m (10 ft)

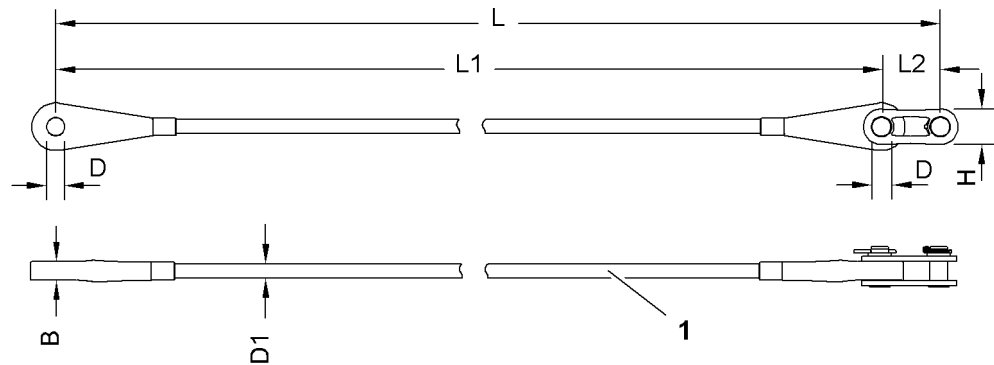


Fig. 342: Dimensions jib pendant strap 3 m (10 ft)

- 1 Wire mesh hose as protective sheath

Name		Value
L	Length	3000 mm 9' 10" ft-in
L1	Length of pendant strap	2800 mm 9' 2" ft-in
L2	Length of connecting link	200 mm 7.87" in
B	Width	63 mm 2.48" in
H	Height of connecting link	121 mm 4.76" in

LWNLR-x/V04.01//Auslieferung/2016-03-07/en

Name		Value
D	Pin Ø	60 mm 2.36" in
D1	Pendant strap Ø	48 mm 1.89" in
Weight		26 kg 57.32 lb

Tab. 208: Technical data jib pendant strap 3 m (10 ft)

CF pendant straps on jib section 2316.20 6 m (20 ft)

Jib pendant strap 6 m (20 ft)

Installation site in crane mode:

- Luffing jib 2316 (For more information see: [Pendant straps A-frame3 to jib head 2316, page 1630](#))
- Luffing jib 2316 + midfall 2316 (For more information see: [Pendant straps A-frame3 to jib head 2316, page 1727](#))

Generation A of jib pendant strap 6 m (20 ft)

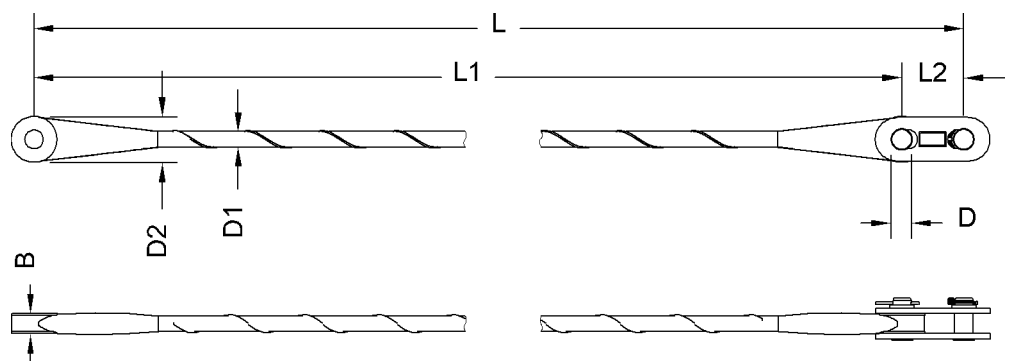


Fig. 343: Dimensions jib pendant strap 6 m (20 ft)

Name		Value
L	Length	6000 mm 19' 8" ft-in
L1	Length of pendant strap	5800 mm 19' ft-in
L2	Length of connecting link	200 mm 7.87" in
B	Width	64 mm 2.52" in
D	Pin Ø	60 mm 2.36" in
D1	Pendant strap Ø	50 mm 1.97" in
D2	Pendant strap Ø	148 mm 5.83" in

Name	Value
Weight	43 kg 94.80 lb

Tab. 209: Technical data jib pendant strap 6 m (20 ft)

Generation B of jib pendant strap 6 m (20 ft)

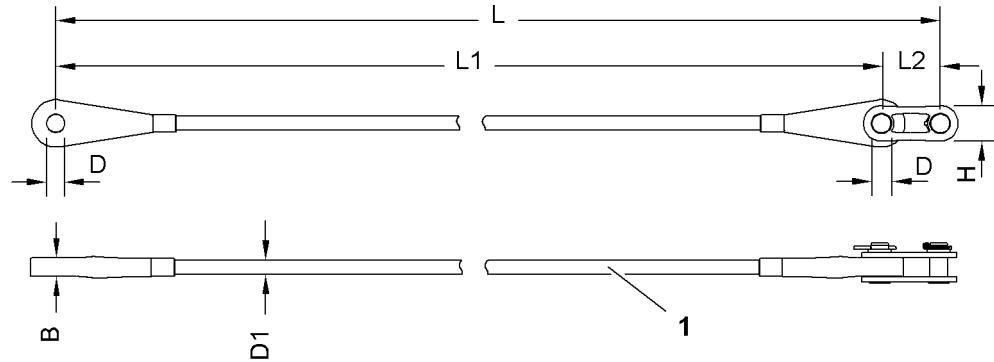


Fig. 344: Dimensions jib pendant strap 6 m (20 ft)

- 1 Wire mesh hose as protective sheath

Name	Value
L Length	6000 mm 19' 8" ft-in
L1 Length of pendant strap	5800 mm 19' ft-in
L2 Length of connecting link	200 mm 7.87" in
B Width	63 mm 2.48" in
H Height of connecting link	121 mm 4.76" in
D Pin Ø	60 mm 2.36" in
D1 Pendant strap Ø	48 mm 1.89" in
Weight	32 kg 70.55 lb

Tab. 210: Technical data jib pendant strap 6 m (20 ft)

CF pendant straps on jib section 2316.20 12 m (40 ft)

Jib pendant strap 12 m (40 ft)

Installation site in crane mode:

- Luffing jib 2316 (For more information see: [Pendant straps A-frame3 to jib head 2316, page 1630](#))

LWNLR-x\04.01\Auslieferung\2016-03-07\en

- Luffing jib 2316 + midfall 2316 (For more information see: [Pendant straps A-frame3 to jib head 2316](#), page 1727)

Generation A of jib pendant strap 12 m (40 ft)

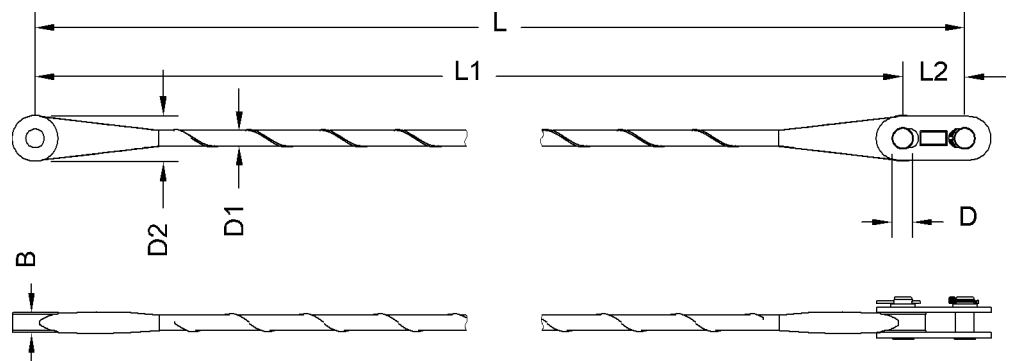


Fig. 345: Dimensions jib pendant strap 12 m (40 ft)

Name		Value
L	Length	12000 mm 39' 4" ft-in
L1	Length of pendant strap	11800 mm 38' 9" ft-in
L2	Length of connecting link	200 mm 7.87" in
B	Width	64 mm 2.52" in
D	Pin Ø	60 mm 2.36" in
D1	Pendant strap Ø	50 mm 1.97" in
D2	Pendant strap Ø	148 mm 5.83" in
Weight		60 kg 132 lb

Tab. 211: Technical data jib pendant strap 12 m (40 ft)

Generation B of jib pendant strap 12 m (40 ft)

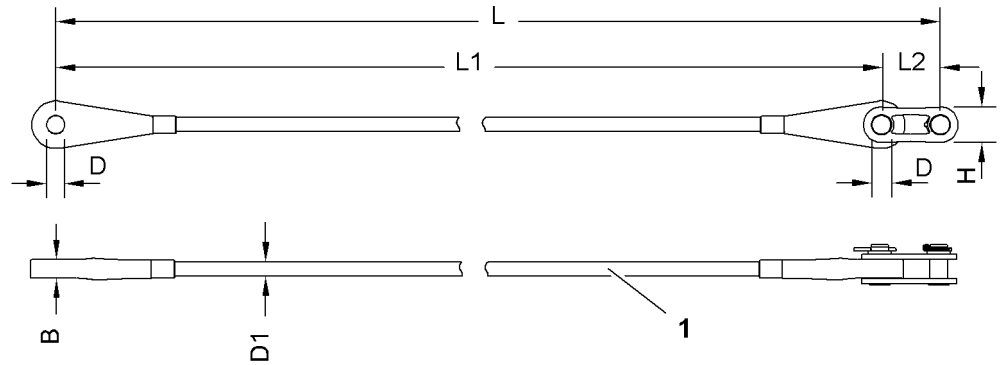


Fig. 346: Dimensions jib pendant strap 12 m (40 ft)

- 1 Wire mesh hose as protective sheath

Name		Value
L	Length	12000 mm 39' 4" ft-in
L1	Length of pendant strap	11800 mm 38' 9" ft-in
L2	Length of connecting link	200 mm 7.87" in
B	Width	63 mm 2.48" in
H	Height of connecting link	121 mm 4.76" in
D	Pin Ø	60 mm 2.36" in
D1	Pendant strap Ø	48 mm 1.89" in
Weight		43 kg 94.80 lb

Tab. 212: Technical data jib pendant strap 12 m (40 ft)

CF pendant straps on jib head 2316.20

Jib pendant strap on jib head 2316.20

Installation site in crane operation:

- Luffing jib 2316 (For more information see: [Pendant straps A-frame3 to jib head 2316, page 1630](#))
- Luffing jib 2316 + midfall 2316 (For more information see: [Pendant straps A-frame3 to jib head 2316, page 1727](#))

Generation A of jib pendant strap on jib head 2316.20

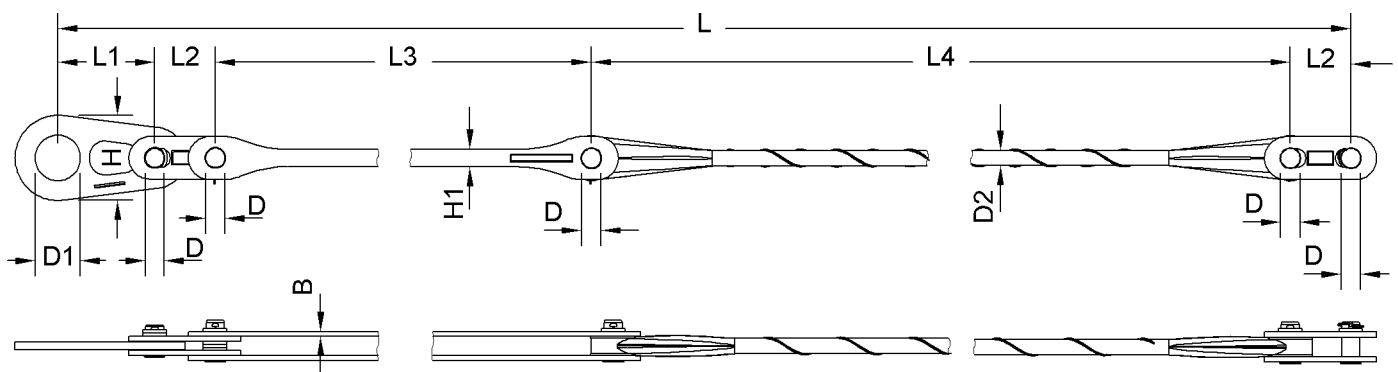


Fig. 347: Dimensions jib pendant strap on jib head 2316.20

Name		Value
L	Length	9540 mm 31' 4" ft-in
L1	Length of connecting link	320 mm 1' 1" ft-in
L2	Length of connecting link	200 mm 7.87" in
L3	Length of pendant strap	3020 mm 9' 11" ft-in
L4	Length of pendant strap	6000 mm 19' 8" ft-in
W	Width of pendant strap	15 mm 0.59" in
H	Height of connecting link	280 mm 11.02" in
H1	Height of connecting link	55 mm 2.17" in
D	Pin Ø	60 mm 2.36" in
D1	Pin Ø	150 mm 5.91" in
D2	Pendant strap Ø	50 mm 1.97" in
Weight		119 kg 262 lb

Tab. 213: Technical data jib pendant strap on jib head 2316.20

Generation B of jib pendant strap on jib head 2316.20

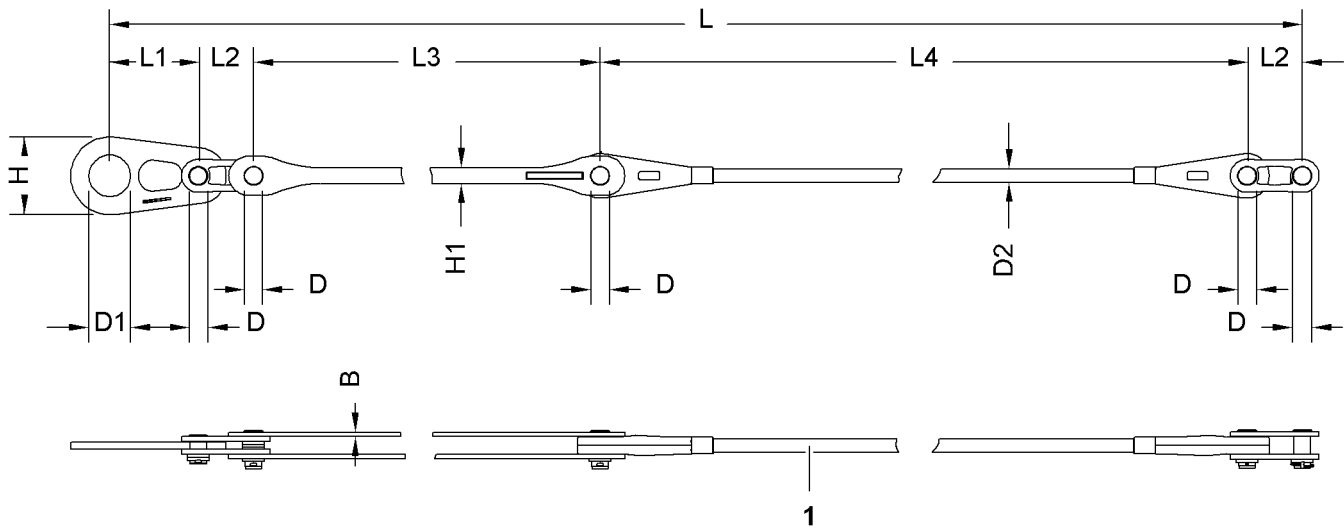


Fig. 348: Dimensions jib pendant strap on jib head 2316.20

- 1 Wire mesh hose as protective sheath

Name		Value
L	Length	9540 mm 31' 4" ft-in
L1	Length of connecting link	320 mm 1' 1" ft-in
L2	Length of connecting link	200 mm 7.87" in
L3	Length of pendant strap	3020 mm 9' 11" ft-in
L4	Length of pendant strap	6000 mm 19' 8" ft-in
B	Width of pendant strap	15 mm 0.59" in
H	Height of connecting link	280 mm 11.02" in
H1	Height of pendant strap	57 mm 2.24" in
D	Pin Ø	60 mm 2.36" in
D1	Pin Ø	150 mm 5.91" in
D2	Pendant strap Ø	48 mm 1.89" in
Weight		111 kg 245 lb

Tab. 214: Technical data jib pendant strap on jib head 2316.20

LWNLR-x/V04.01//Auslieferung/2016-03-07/en

1.21 1916 luffing jib

1.21.1 Jib base section 1916.22

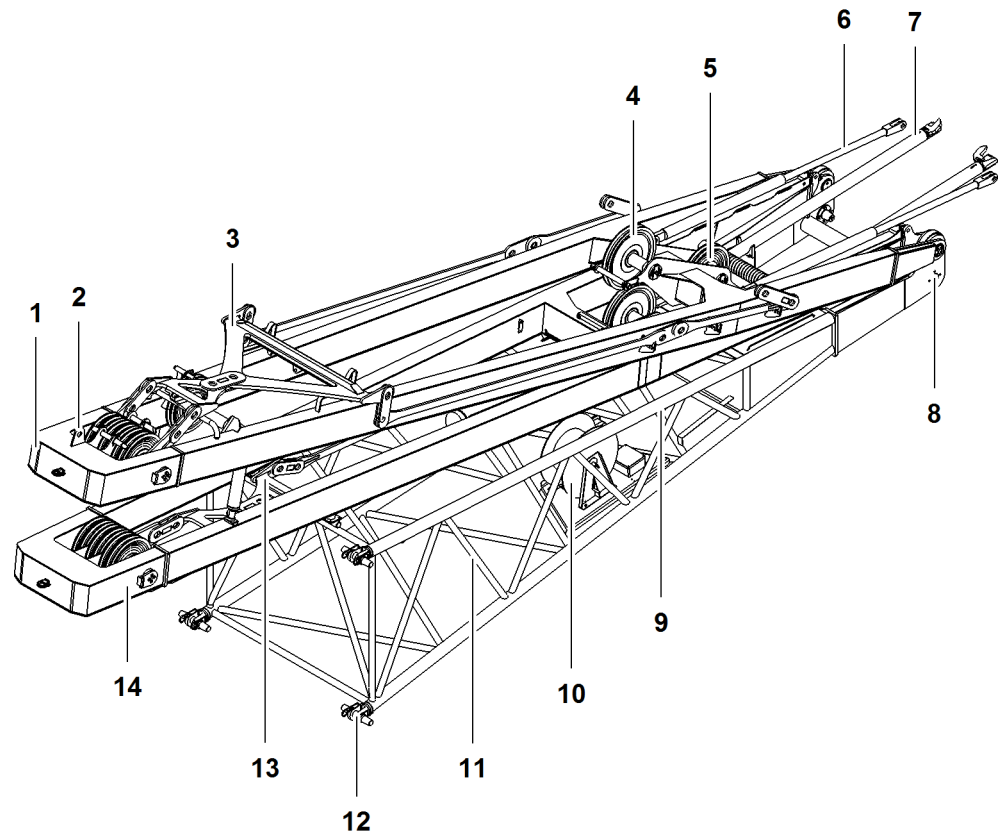


Fig. 349: Jib base section 1916.22

- | | | | |
|---|--|----|--|
| 1 | A-frame2 | 8 | Pivot point (2x) for main boom head |
| 2 | Shackle | 9 | Rigging point (4x) |
| 3 | Transport position of A-frame2 equalizer (jib backstay straps) | 10 | Cable drum |
| 4 | Pulley (2x) for rope of winch1/ winch2 | 11 | Boom identification plate |
| 5 | Pulley (2x) for rope of jib luffing winch | 12 | Pin connection point (4x) with double-taper pin (4x) |
| 6 | Rigid tilting-back support (2x) | 13 | Transport position of A-frame3 equalizer (jib pendant strap) |
| 7 | Hydraulic tilting-back support (2x) | 14 | A-frame3 |

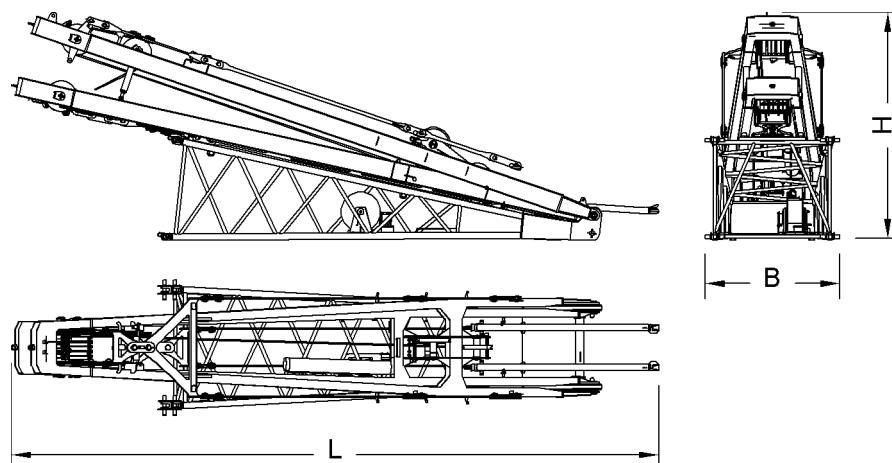


Fig. 350: Dimensions of jib base section 1916.22

Name		Value
System length		7000 mm 23' ft-in
System width		1900 mm 6' 3" ft-in
System height		1600 mm 5' 3" ft-in
L	Length	10850 mm 35' 7" ft-in
B	Width	2010 mm 6' 7" ft-in
H	Height	3150 mm 10' 4" ft-in
Weight (incl. pendant straps, tilting-back supports and jib backstay straps)		6000 kg 13,228 lb
Double-taper pins Ø		60 mm 2.36" in

Tab. 215: Technical data jib base section 1916.22

1.21.2 1916.18 jib section 3 m (10 ft)

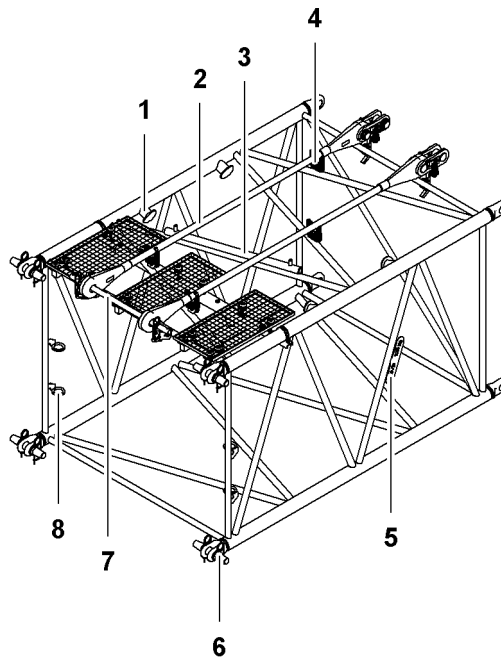


Fig. 351: Jib section 1916.18 3 m (10 ft)

- | | | | |
|---|---|---|--|
| 1 | Rigging point (4x) | 5 | Boom identification plate |
| 2 | Transport position (2x) of jib pendant straps 3 m (10 ft) | 6 | Pin connection point (8x) with double-taper pin (4x) |
| 3 | Rope protection guard | 7 | Transport bracket for pendant straps |
| 4 | Transport bracket (4x) for pendant straps | 8 | Transport bracket (4x) for double taper pin |

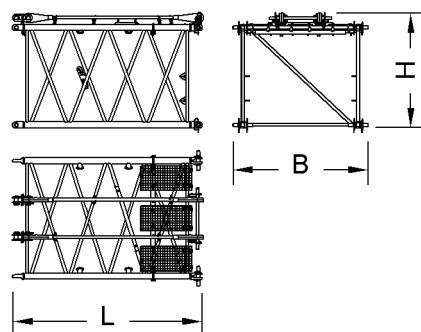


Fig. 352: Dimensions of 1916.18 jib section 3 m (10 ft)

Name	Value
System length	3000 mm 9' 10" ft-in
System width	1900 mm 6' 3" ft-in
System height	1600 mm 5' 3" ft-in

Name		Value
L	Length	3150 mm 10' 4" ft-in
B	Width	2010 mm 6' 7" ft-in
H	Height (incl. pendant straps)	1850 mm 6' 1" ft-in
Weight (incl. pendant straps)		475 kg 1,047 lb
Double-taper pins Ø		60 mm 2.36" in

Tab. 216: Technical data for 1916.18 jib section 3 m (10 ft)

1.21.3 1916.18 jib section 6 m (20 ft)

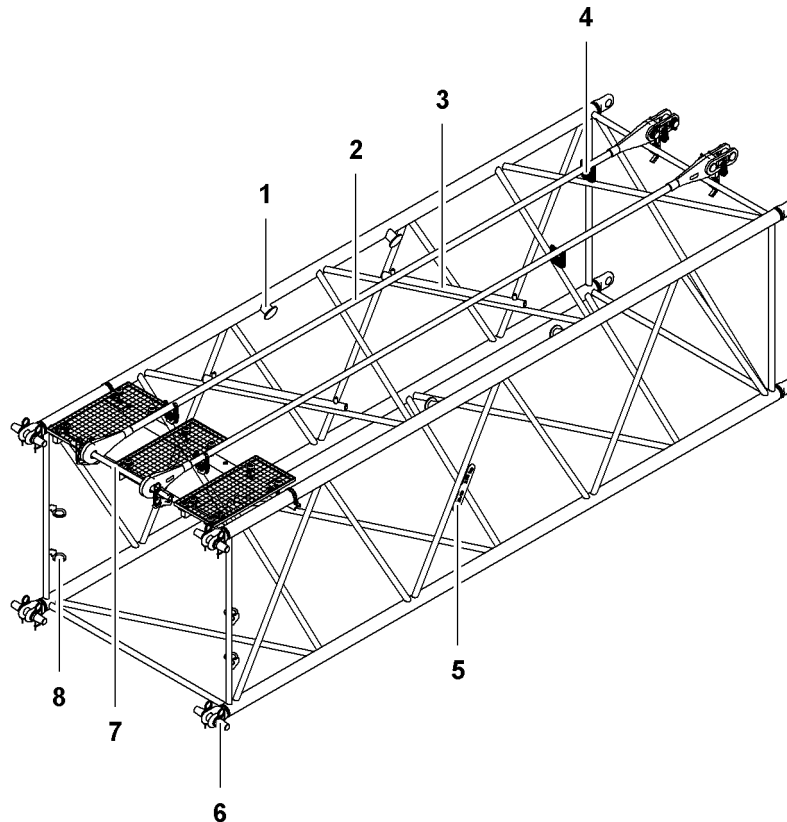


Fig. 353: Jib section 1916.18 6 m (20 ft)

- | | | | |
|---|---|---|--|
| 1 | Rigging point (4x) | 5 | Boom identification plate |
| 2 | Transport position (2x) of jib pendant straps 6 m (20 ft) | 6 | Pin connection point (8x) with double-taper pin (4x) |
| 3 | Rope protection guard (2x) | 7 | Transport bracket for pendant straps |
| 4 | Transport bracket (4x) for pendant straps | 8 | Transport bracket (4x) for double taper pin |

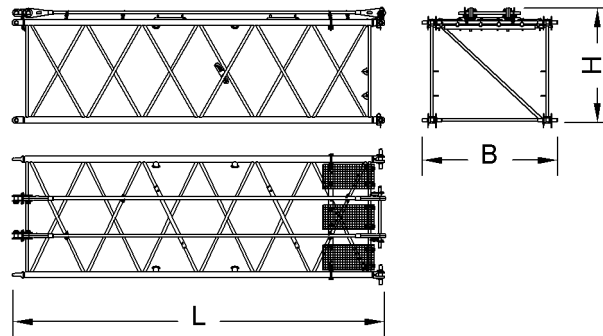


Fig. 354: Dimensions jib section 1916.18 6 m (20 ft)

Name		Value
System length		6000 mm 19' 8" ft-in
System width		1900 mm 6' 3" ft-in
System height		1600 mm 5' 3" ft-in
L	Length	6150 mm 20' 2" ft-in
B	Width	2010 mm 6' 7" ft-in
H	Height (incl. pendant straps)	1850 mm 6' 1" ft-in
Weight (incl. pendant straps)		690 kg 1,521 lb
Double-taper pins Ø		60 mm 2.36" in

Tab. 217: Technical data for 1916.18 jib section 6 m (20 ft)

1.21.4 1916.18 jib section 12 m (40 ft)

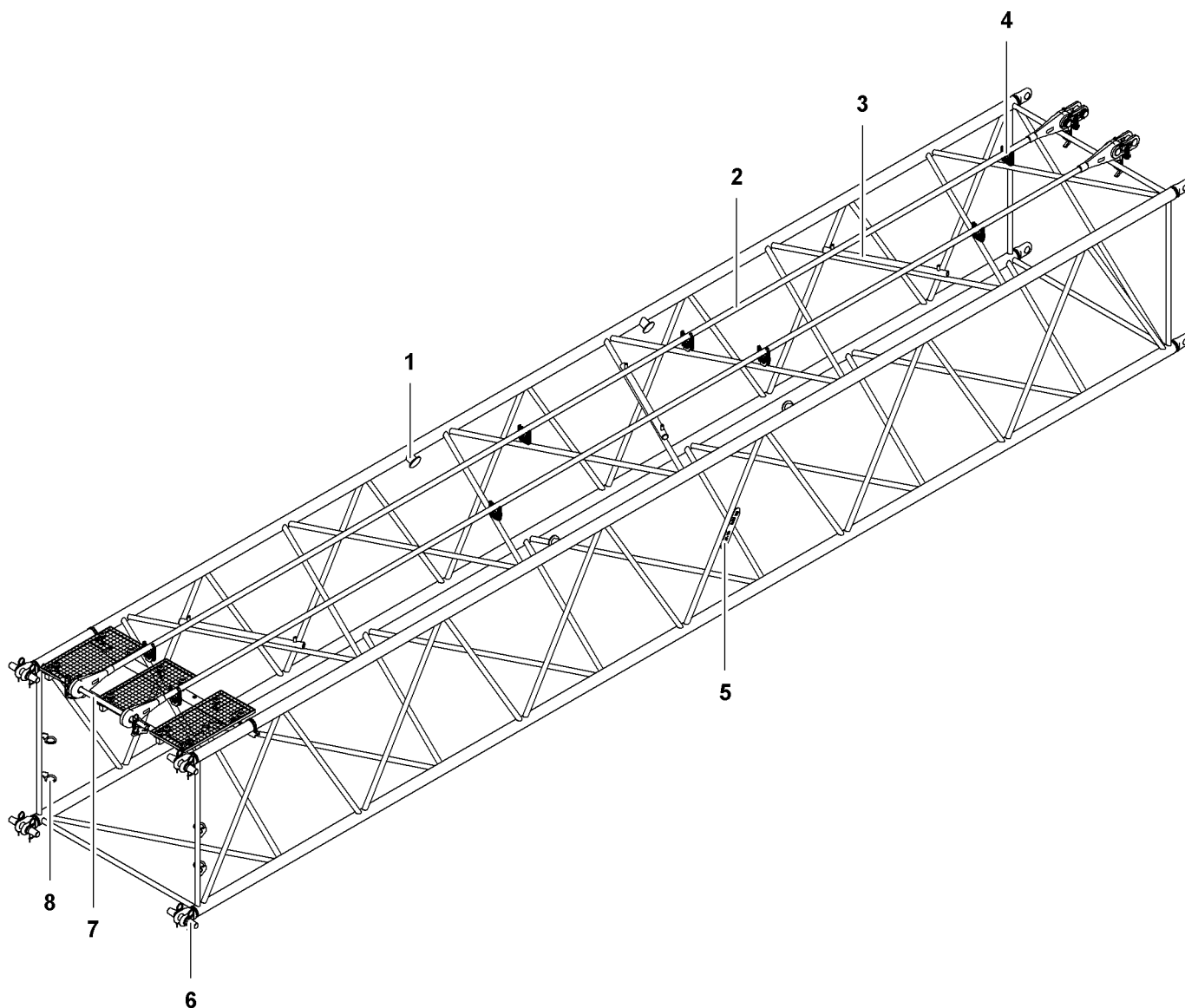


Fig. 355: Jib section 1916.18 12 m (40 ft)

- | | | | | | |
|---|--|---|--|---|---|
| 1 | Rigging point (4x) | 4 | Transport bracket (8x) for pendant straps | 7 | Transport bracket for pendant straps |
| 2 | Transport position (2x) of jib pendant straps 12 m (40 ft) | 5 | Boom identification plate | 8 | Transport bracket (4x) for double taper pin |
| 3 | Rope protection guard (3x) | 6 | Pin connection point (8x) with double-taper pin (4x) | | |

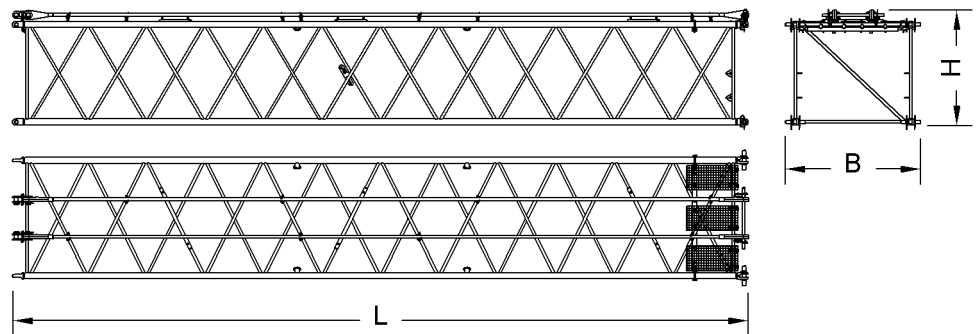


Fig. 356: Dimensions jib section 1916.18 12 m (40 ft)

Name		Value
System length		12000 mm 39' 4" ft-in
System width		1900 mm 6' 3" ft-in
System height		1600 mm 5' 3" ft-in
L	Length	12150 mm 39' 10" ft-in
B	Width	2010 mm 6' 7" ft-in
H	Height (incl. pendant straps)	1850 mm 6' 1" ft-in
Weight (incl. pendant straps)		1250 kg 2,756 lb
Double-taper pins Ø		60 mm 2.36" in

Tab. 218: Technical data for 1916.18 jib section 12 m (40 ft)

1.21.5 1916.21 jib head section

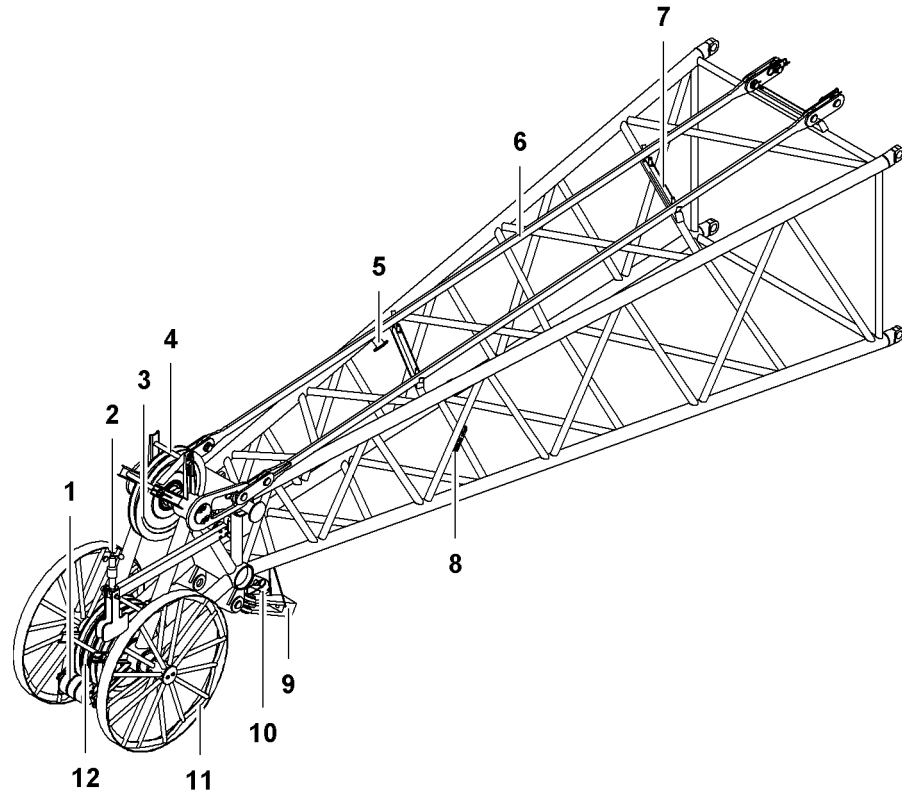


Fig. 357: 1916.21 jib head section

- | | | | |
|---|---|----|---------------------------|
| 1 | Rope protection roller (3x) | 7 | Rope guard support (2x) |
| 2 | Anemometer | 8 | Boom identification plate |
| 3 | Pulley | 9 | Rope fixation |
| 4 | Rope protection pipe (2x) | 10 | Hoist limit switch (2x) |
| 5 | Lifting point (4x) | 11 | Wheel (2x) |
| 6 | Transport position (2x) of jib pendant straps | 12 | Pulley (3x) |

This jib head section is designed to allow an auxiliary jib to be attached (For more information see: [1.27 Auxiliary jib* \(15 t \(33.000 lb\)\)](#), page 379) .

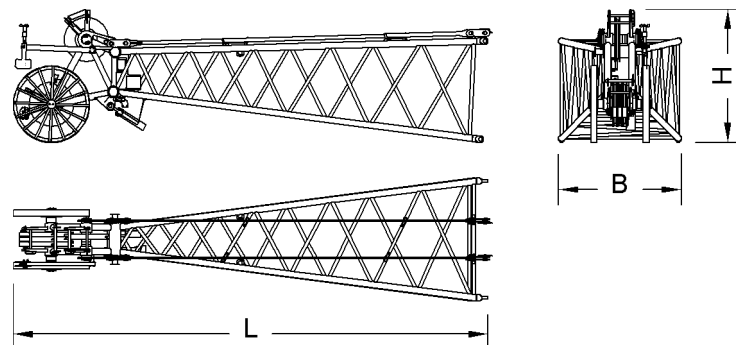


Fig. 358: 1916.21 jib head section dimensions

LWNLR-x\04.01\Auslieferung\2016-03-07\en

Name		Value
System length		7000 mm 23' ft-in
System width		1900 mm 6' 3" ft-in
System height		1600 mm 5' 3" ft-in
L	Length	7750 mm 25' 5" ft-in
B	Width	2010 mm 6' 7" ft-in
H	Height	2200 mm 7' 3" ft-in
Weight (incl. pendant straps)		1420 kg 3,131 lb

Tab. 219: 1916.21 jib head section, technical data

1.21.6 Mid-point suspension on luffing jib 1916

The mid-point suspensions on luffing jib 1916 differ with steel pendant straps and CF pendant straps.

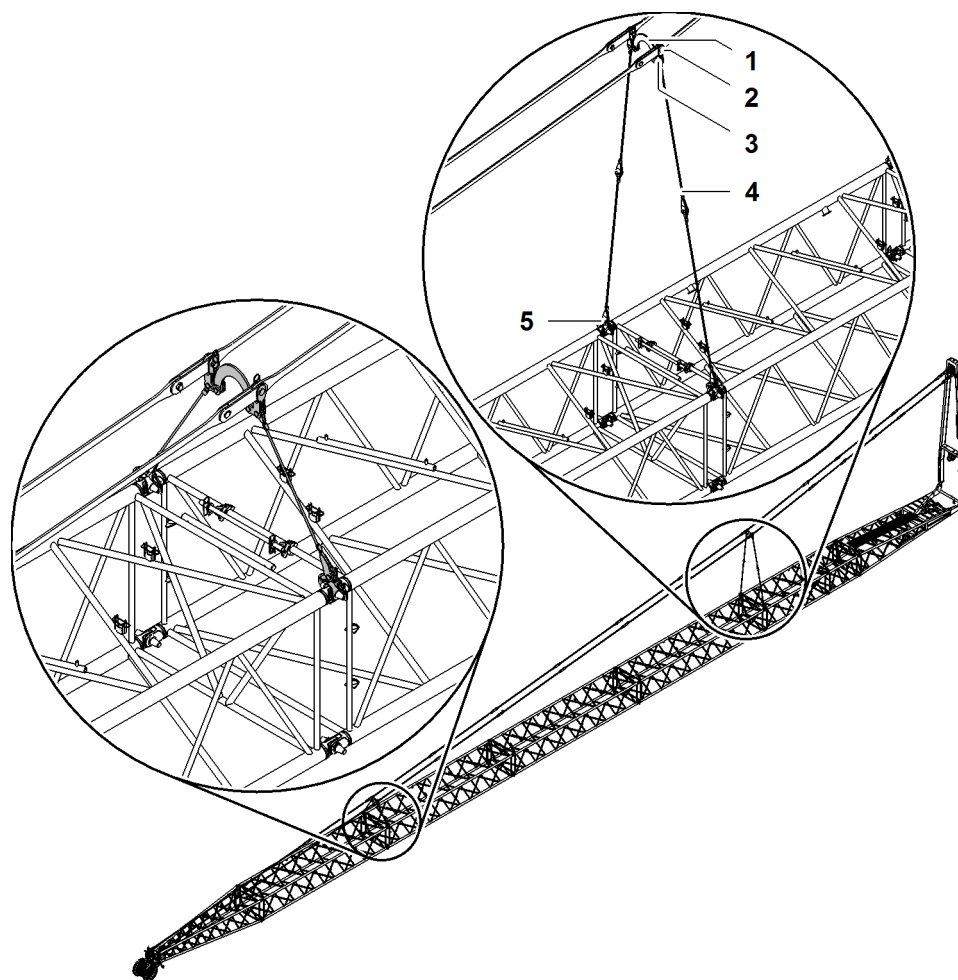


Fig. 359: Mid-point suspension on luffing jib 1916 (illustration of principle)

- | | | | |
|---|-----------------------------|---|------------|
| 1 | Connecting element (2x) | 4 | Stay ropes |
| 2 | Spacer bracket | 5 | Fork (2x) |
| 3 | Pin (2x) for pendant straps | | |

Connecting elements for steel pendant straps

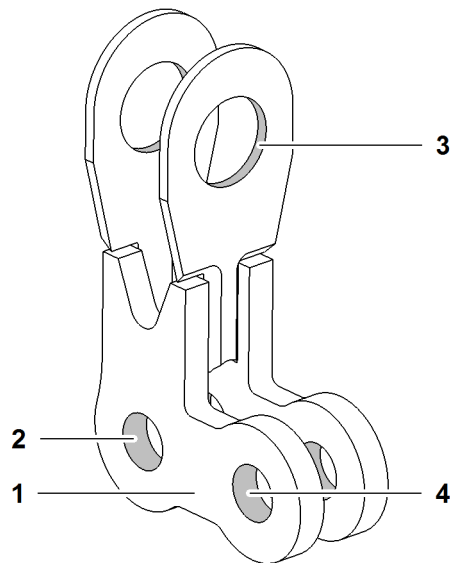


Fig. 360: Connecting elements for steel pendant straps (illustration of principle)

- | | | | |
|---|------------------------------------|---|---|
| 1 | Connecting element | 3 | Pin connection point for pendant strap |
| 2 | Pin connection point for stay rope | 4 | Pin connection point for spacer bracket |

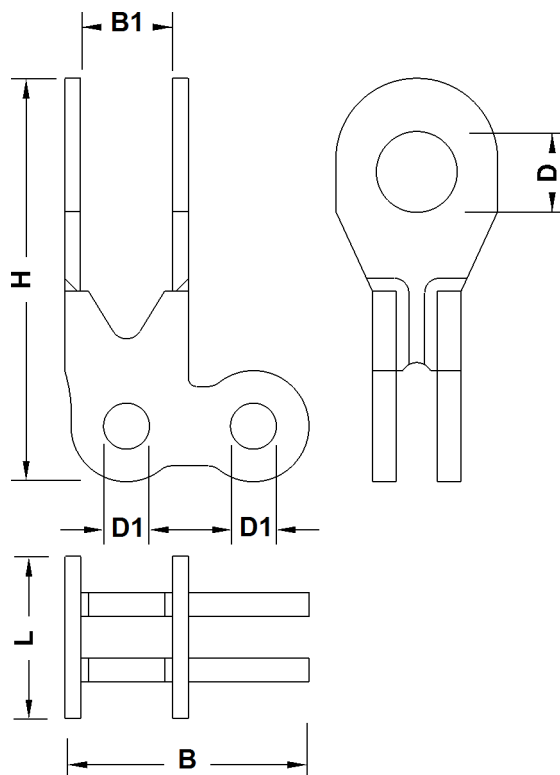


Fig. 361: Dimensions connecting elements for steel pendant straps

Name		Value
L	Length	102 mm 4.02" in
H	Height	354 mm 1' 2" ft-in
B	Width	190 mm 7.48" in
B1	Width between links	58 mm 2.28" in
D	Pin Ø	50 mm 1.97" in
D1	Pin Ø	35 mm 1.38" in

Tab. 220: Technical data connecting elements for steel pendant straps

Connecting elements for CF pendant straps

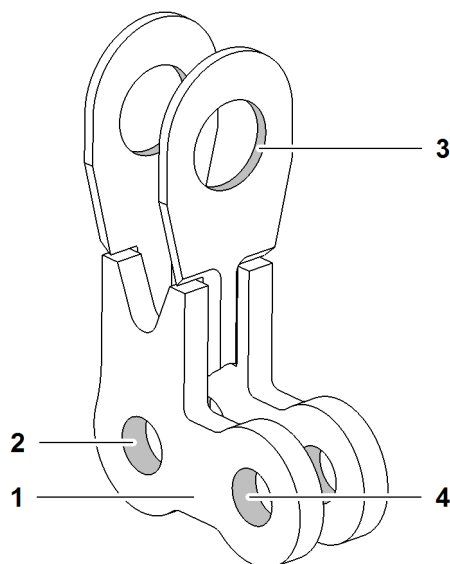


Fig. 362: Connecting elements for CF pendant straps (illustration of principle)

- | | | | |
|----------|------------------------------------|----------|---|
| 1 | Connecting element | 3 | Pin connection point for pendant strap |
| 2 | Pin connection point for stay rope | 4 | Pin connection point for spacer bracket |

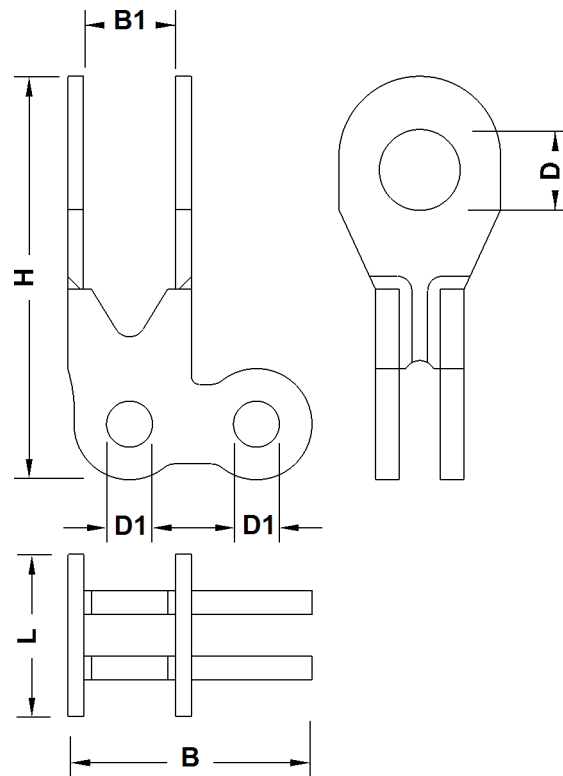


Fig. 363: Dimensions connecting elements for CF pendant straps

Name		Value
L	Length	110 mm 4.33" in
H	Height	358 mm 1' 2" ft-in
B	Width	207 mm 8.15" in
B1	Width between link	104 mm 4.09" in
D	Pin Ø	60 mm 2.36" in
D1	Pin Ø	35 mm 1.38" in

Tab. 221: Technical data connecting elements for CF pendant straps

Forks

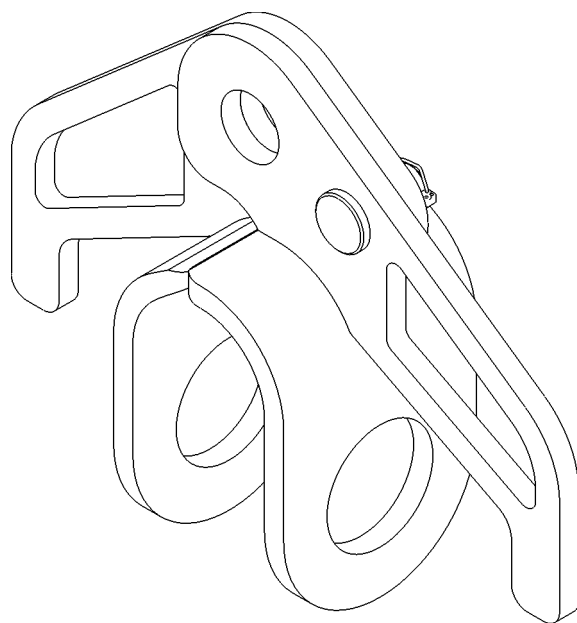


Fig. 364: Forks (illustration of principle)

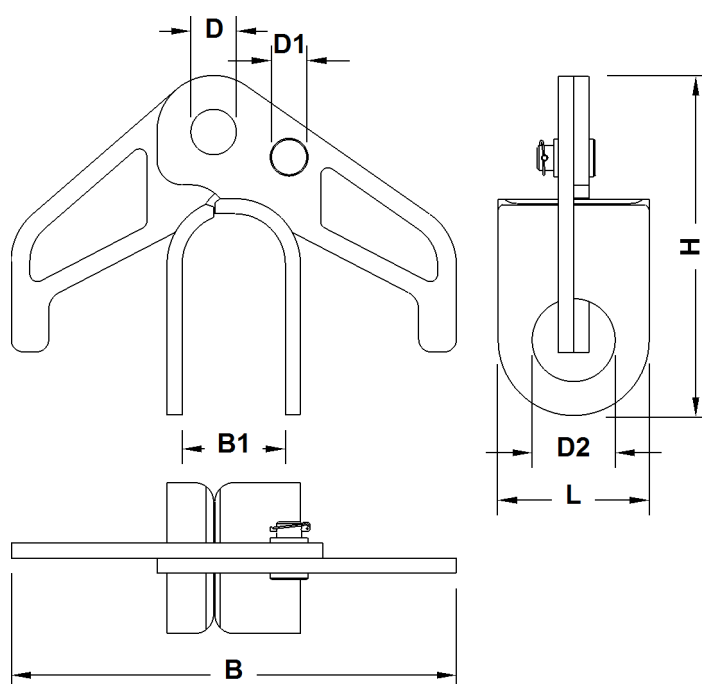


Fig. 365: Fork dimensions

Name		Value
L	Length	100 mm 3.94" in
B	Width	395 mm 1' 4" ft-in

LWN/LR-x/V04.01//Auslieferung/2016-03-07/en

Name		Value
B1	Inner width	106 mm 4.17" in
H	Height	260 mm 10.24" in
D	Pin Ø	35 mm 1.38" in
D1	Pin Ø	20 mm 0.79" in
D2	Pin Ø	60 mm 2.36" in

Tab. 222: Technical data forks

Spacer bracket

The spacer brackets are identical with steel pendant straps and CF pendant straps.

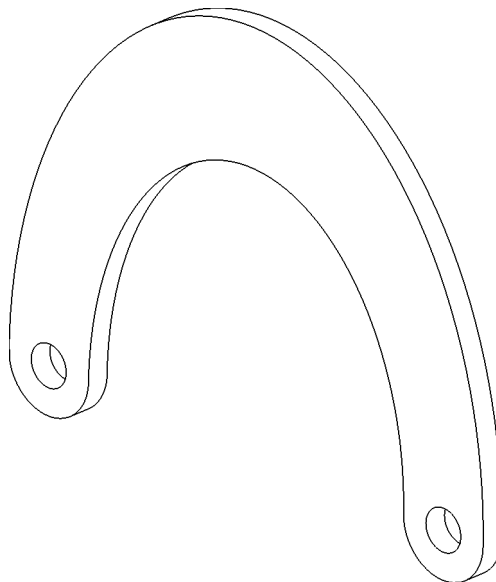


Fig. 366: Spacer brackets (illustration of principle)

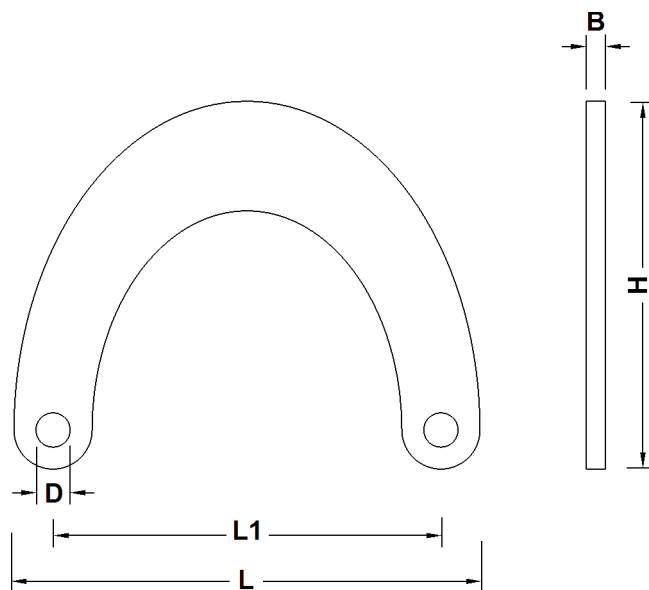


Fig. 367: Dimensions spacer brackets

Name		Value
L	Length	489 mm 1' 7" ft-in
L1	Distance between pins	407 mm 1' 4" ft-in
B	Width	20 mm 0.79" in
H	Height	386 mm 1' 3" ft-in
D	Pin Ø	35 mm 1.38" in

Tab. 223: Technical data spacer brackets

Stay ropes

Several stay ropes are assembled to achieve defined rope lengths.

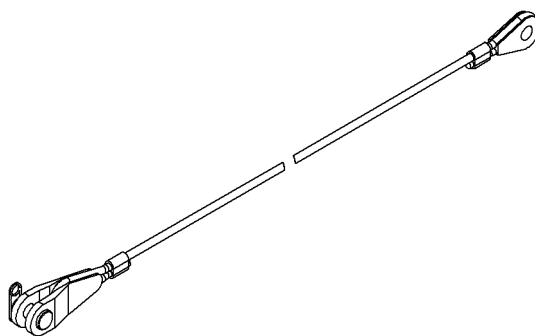


Fig. 368: Stay ropes (illustration of principle)

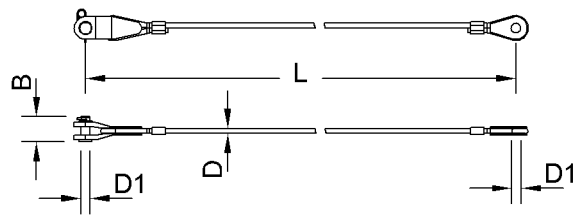


Fig. 369: Dimensions stay ropes

Name		Value
L	Length of stay rope	1100 mm 3' 7" ft-in
		1300 mm 4' 3" ft-in
		1600 mm 5' 3" ft-in
		2100 mm 6' 11" ft-in
		2600 mm 8' 6" ft-in
		3000 mm 9' 10" ft-in
D	Ø of stay rope	18 mm 0.71" in
D1	Pin Ø	35 mm 1.38" in
B	Length of pin	90 mm 3.54" in

Tab. 224: Technical data stay ropes

Pins for steel pendant straps

The pins supplied with the pendant straps must be exchanged for longer pins.

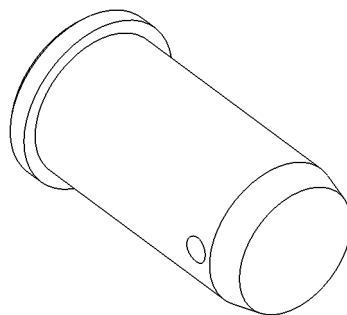


Fig. 370: Pins for steel pendant straps (illustration of principle)

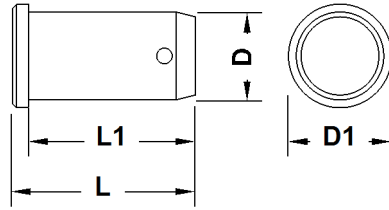


Fig. 371: Dimensions pins for steel pendant straps

Name		Value
L	Total length	120 mm 4.72" in
L1	Length	112 mm 4.41" in
D	Pin Ø	50 mm 1.97" in
D1	Collar Ø	58 mm 2.28" in

Tab. 225: Technical data pins for steel pendant straps

Pins for CF pendant straps

The pins supplied with the pendant straps must be exchanged for longer pins.

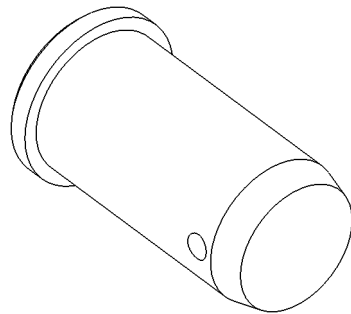


Fig. 372: Pins for CF pendant straps (illustration of principle)

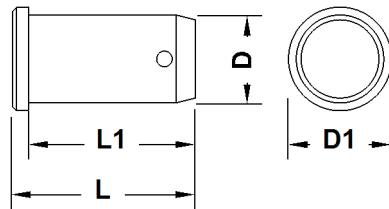


Fig. 373: Dimensions pins for CF pendant straps

Name		Value
L	Total length	158 mm 6.22" in
L1	Length	153 mm 6.02" in

LWN/LR-x/V04.01//Auslieferung/2016-03-07/en

Name		Value
D	Pin Ø	60 mm 2.36" in
D1	Collar Ø	68 mm 2.68" in

Tab. 226: Technical data pins for CF pendant straps

1.21.7 Steel pendant straps on luffing jib 1916

Steel pendant straps on A-frame2

Equalizer A-frame2 (jib backstay strap)

Installation site in crane operation:

- Luffing jib 1916 (For more information see: Jib backstay straps A-frame2 to main boom base section 2821, page 1646)
- Luffing jib 1916 + midfall 1916 (For more information see: Jib backstay straps A-frame2 to main boom base section 2821, page 1737)

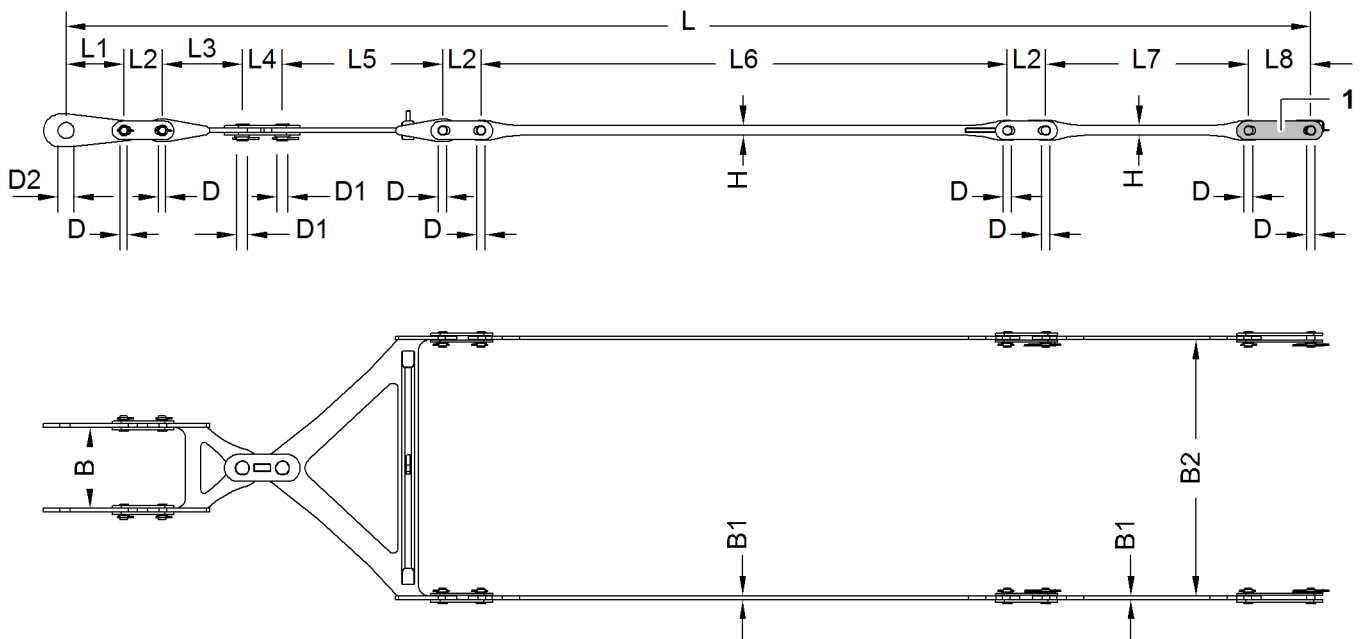


Fig. 374: Dimensions equalizer on A-frame2 (jib backstay strap)

1 Connecting link (4x)

When attaching the luffing jib 1916 to the machine, replace the connecting link 1 with a "connecting link (conversion kit)" (For more information see: Connecting link (conversion kit), page 351) .

Name		Value
L	Length	7769 mm 25' 6" ft-in
L1	Length of connecting link	360 mm 1' 2" ft-in

Name		Value
L2	Length of connecting link	240 mm 9.45" in
L3	Length of rocker	500 mm 1' 8" ft-in
L4	Length of connecting link	250 mm 9.84" in
L5	Length of rocker	1000 mm 3' 3" ft-in
L6	Length of pendant strap	3284 mm 10' 9" ft-in
L7	Length of pendant strap	1265 mm 4' 2" ft-in
L8	Length of connecting link	390 mm 1' 3" ft-in
B	Width	527 mm 1' 9" ft-in
B1	Width of pendant strap	22 mm 0.87" in
B2	Width of spacer bar	1620 mm 5' 4" ft-in
H	Height of pendant strap	62 mm 2.44" in
D	Pin Ø	50 mm 1.97" in
D1	Pin Ø	70 mm 2.76" in
D2	Pin Ø	100 mm 3.94" in
Weight		462 kg 1,019 lb

Tab. 227: Technical data equalizer on A-frame2 (jib backstay strap)

Steel pendant straps on A-frame3

A-frame3 equalizer (jib pendant strap)

Installation site in crane operation:

- Luffing jib 1916 (For more information see: [Pendant straps A-frame3 to jib head 1916, page 1647](#))
- Luffing jib 1916 + midfall 1916 (For more information see: [Pendant straps A-frame3 to jib head 1916, page 1738](#))

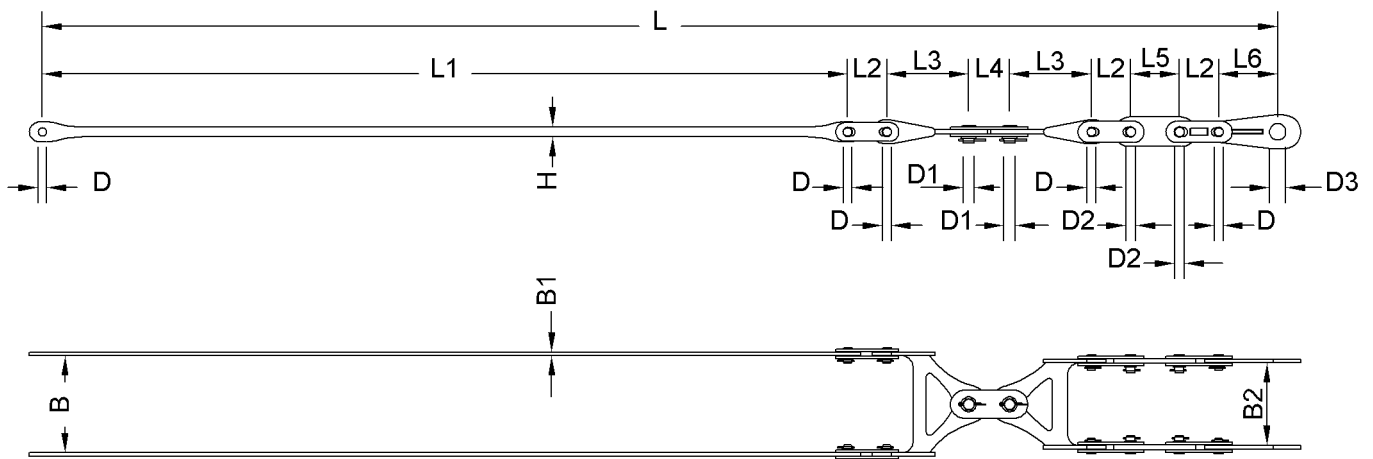


Fig. 375: Dimensions equalizer on A-frame3 (jib pendant strap)

Name		Value
L	Length	7550 mm 24' 9" ft-in
L1	Length of pendant strap	4922 mm 16' 2" ft-in
L2	Length of connecting link	240 mm 9.45" in
L3	Length of rocker	500 mm 1' 8" ft-in
L4	Length of connecting link	250 mm 9.84" in
L5	Length of tension load cell	298 mm 1' ft-in
L6	Length of connecting link	360 mm 1' 2" ft-in
B	Width	614 mm 2' ft-in
B1	Width of pendant strap	22 mm 0.87" in
B2	Width	527 mm 1' 9" ft-in
H	Height of pendant strap	62 mm 2.44" in
D	Pin Ø	50 mm 1.97" in
D1	Pin Ø	70 mm 2.76" in
D2	Pin Ø	55 mm 2.17" in
D3	Pin Ø	100 mm 3.94" in

Name	Value
Weight	332 kg 732 lb

Tab. 228: Technical data A-frame3 equalizer (jib pendant strap)

Steel pendant straps on jib section 1916.18 3 m (10 ft)

Jib pendant strap 3 m (10 ft)

Installation site in crane operation:

- Luffing jib 1916 (For more information see: Pendant straps A-frame3 to jib head 1916, page 1647)
- Luffing jib 1916 + midfall 1916 (For more information see: Pendant straps A-frame3 to jib head 1916, page 1738)

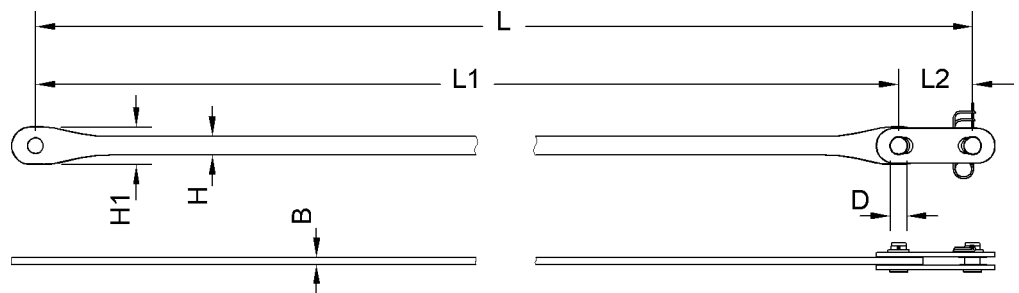


Fig. 376: Dimensions jib pendant strap 3 m (10 ft)

Name	Value
L Length	3000 mm 9' 10" ft-in
L1 Length of pendant strap	2760 mm 9' 1" ft-in
L2 Length of connecting link	240 mm 9.45" in
W Width of pendant strap	22 mm 0.87" in
H Height of pendant strap	62 mm 2.44" in
H1 Height of pendant strap	120 mm 4.72" in
D Pin Ø	50 mm 1.97" in
Weight	46 kg 101 lb

Tab. 229: Technical data jib pendant strap3 m (10 ft)

LWNLR-x/V04.01//Auslieferung/2016-03-07/en

Steel pendant straps on jib section 1916.18 6 m (20 ft)

Jib pendant strap 6 m (20 ft)

Installation site in crane operation:

- Luffing jib 1916 (For more information see: [Pendant straps A-frame3 to jib head 1916, page 1647](#))
- Luffing jib 1916 + midfall 1916 (For more information see: [Pendant straps A-frame3 to jib head 1916, page 1738](#))

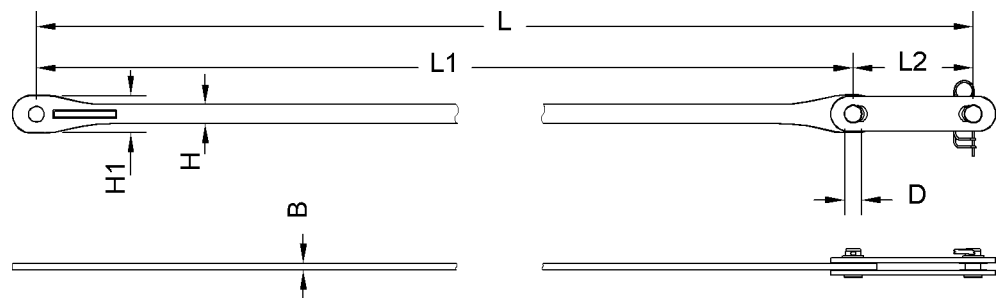


Fig. 377: Dimensions jib pendant strap 6 m (20 ft)

Name		Value
L	Length	6000 mm 19' 8" ft-in
L1	Length of pendant strap	5610 mm 18' 5" ft-in
L2	Length of connecting link	390 mm 1' 3" ft-in
W	Width of pendant strap	22 mm 0.87" in
H	Height of pendant strap	62 mm 2.44" in
H1	Height of pendant strap	120 mm 4.72" in
D	Pin Ø	50 mm 1.97" in
Weight		80 kg 176 lb

Tab. 230: Technical data jib pendant strap 6 m (20 ft)

Steel pendant straps on jib section 1916.18 12 m (40 ft)

Jib pendant strap 12 m (40 ft)

Installation site in crane operation:

- Luffing jib 1916 (For more information see: [Pendant straps A-frame3 to jib head 1916, page 1647](#))
- Luffing jib 1916 + midfall 1916 (For more information see: [Pendant straps A-frame3 to jib head 1916, page 1738](#))

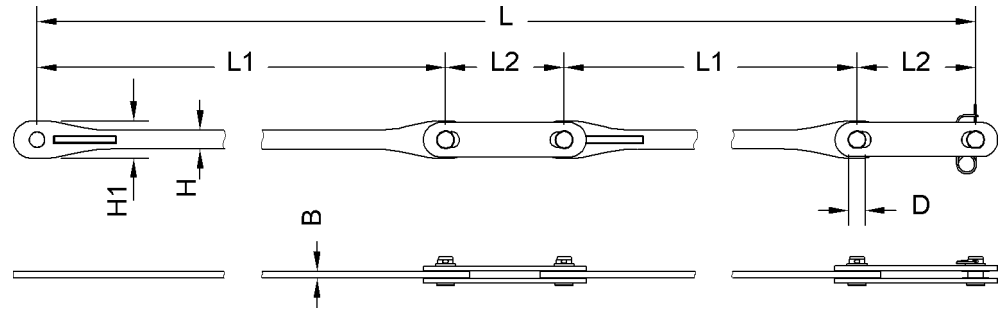


Fig. 378: Dimensions jib pendant strap 12 m (40 ft)

Name		Value
L	Length	12000 mm 39' 4" ft-in
L1	Length of pendant strap	5610 mm 18' 5" ft-in
L2	Length of connecting link	390 mm 1' 3" ft-in
W	Width of pendant strap	22 mm 0.87" in
H	Height of pendant strap	62 mm 2.44" in
H1	Height of pendant strap	120 mm 4.72" in
D	Pin Ø	50 mm 1.97" in
Weight		160 kg 353 lb

Tab. 231: Technical data jib pendant strap 12 m (40 ft)

Steel pendant straps on jib head 1916.21

Jib pendant strap on jib head 1916.21

Installation site in crane operation:

- Luffing jib 1916 (For more information see: [Pendant straps A-frame3 to jib head 1916, page 1647](#))
- Luffing jib 1916 + midfall 1916 (For more information see: [Pendant straps A-frame3 to jib head 1916, page 1738](#))

LWN/LR-x/V04.01//Auslieferung/2016-03-07/en

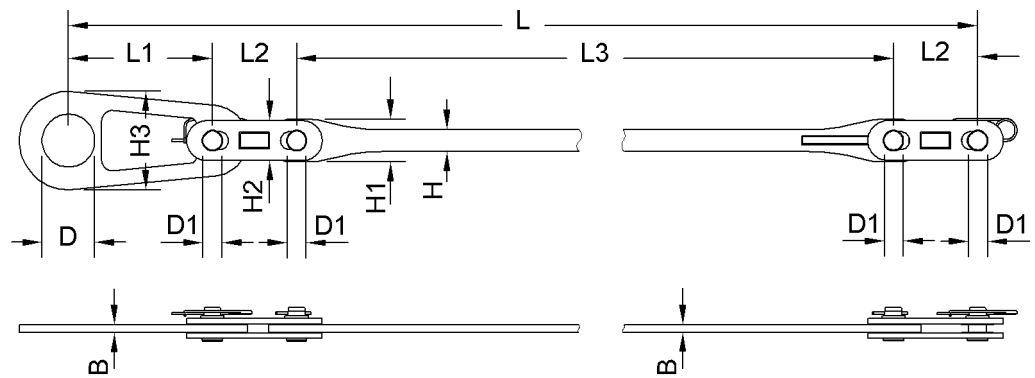


Fig. 379: Dimensions jib pendant strap on jib head 1916.21

Name		Value
L	Length	6500 mm 21' 4" ft-in
L1	Length of connecting link	410 mm 1' 4" ft-in
L2	Length of connecting link	240 mm 9.45" in
L3	Length of pendant strap	6090 mm 20' ft-in
W	Width of pendant strap	22 mm 0.87" in
H	Height of pendant strap	62 mm 2.44" in
H1	Height of pendant strap	122 mm 4.80" in
H2	Height of connecting link	113 mm 4.45" in
H3	Height of connecting link	240 mm 9.45" in
D	Pin Ø	150 mm 5.91" in
D1	Pin Ø	50 mm 1.97" in
Weight		95 kg 209 lb

Tab. 232: Technical data jib pendant strap on jib head 1916.21

Additional pendant straps/connecting links for luffing jib 1916

Connecting link (conversion kit)

Installation site in crane operation:

- Luffing jib 1916 ([For more information see: Pendant straps A-frame3 to jib head 1916, page 1647](#))

- Luffing jib 1916 + midfall 1916 (For more information see: Pendant straps A-frame3 to jib head 1916, page 1738)

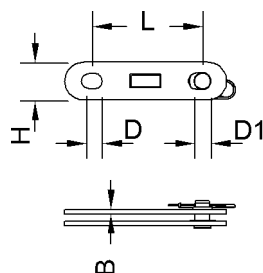


Fig. 380: Dimensions connecting link (conversion kit)

Name		Value
L	Length of connecting link	390 mm 1' 3" ft-in
W	Width of connecting link	15 mm 0.59" in
H	Height of connecting link	130 mm 5.12" in
D	Pin Ø	50 mm 1.97" in
D1	Pin Ø	55 mm 2.17" in
Weight		16.5 kg 36.38 lb

Tab. 233: Technical data connecting link (conversion kit)

1.21.8 CF pendant straps on luffing jib 1916

CF pendant straps on A-frame2

Equalizer A-frame2 (jib backstay strap)

Installation site in crane operation:

- Luffing jib 1916 (For more information see: Jib backstay straps A-frame2 to main boom base section 2821, page 1648)
- Luffing jib 1916 + midfall 1916 (For more information see: Jib backstay straps A-frame2 to main boom base section 2821, page 1739)

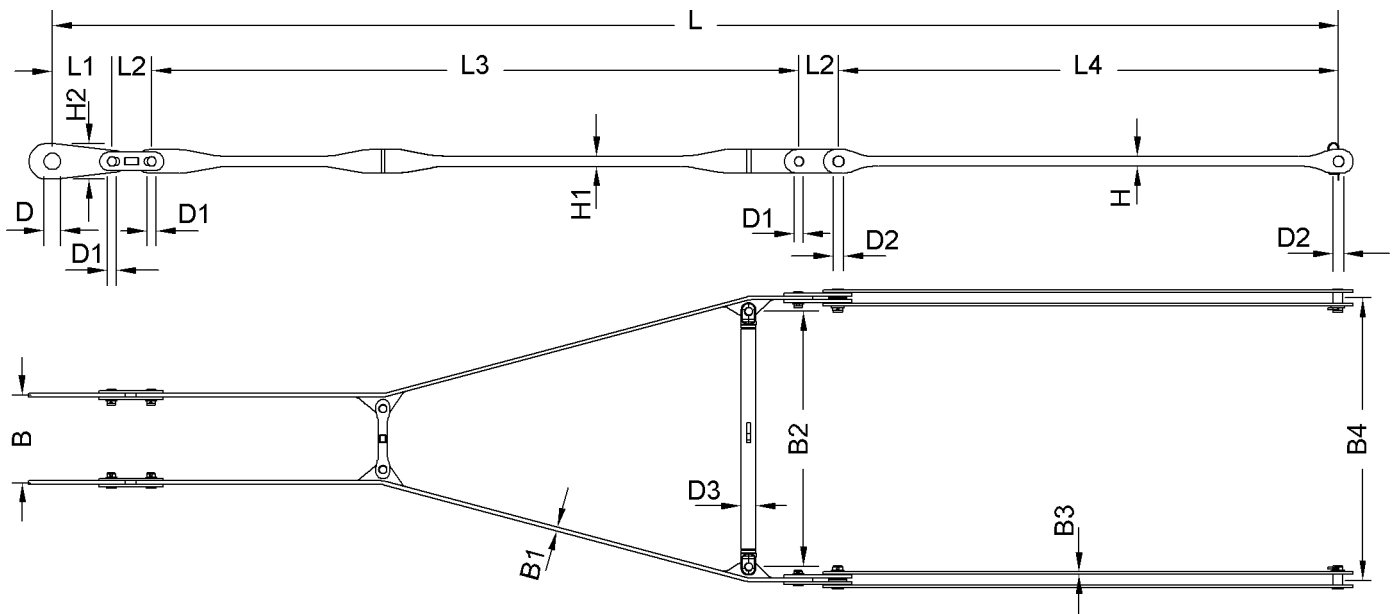


Fig. 381: Dimensions equalizer on A-frame2 (jib backstay strap)

Name		Value
L	Length	7769 mm 25' 6" ft-in
L1	Length of connecting link	360 mm 1' 2" ft-in
L2	Length of connecting link	240 mm 9.45" in
L3	Length of pendant strap	3909 mm 12' 10" ft-in
L4	Length of pendant strap	3020 mm 9' 11" ft-in
W	Width	527 mm 1' 9" ft-in
W1	Width of pendant strap	22 mm 0.87" in
W2	Width of spacer bar	1540 mm 5' 1" ft-in
W3	Width of pendant strap	15 mm 0.59" in
W4	Width	1700 mm 5' 7" ft-in
H	Height of pendant strap	55 mm 2.17" in
H1	Height of pendant strap	62 mm 2.44" in
H2	Height of connecting link	280 mm 11.02" in

LWNLR.x/V04.01//Auslieferung/2016-03-07/en

Name		Value
D	Pin Ø	140 mm 5.51" in
D1	Pin Ø	50 mm 1.97" in
D2	Pin Ø	60 mm 2.36" in
D2	Spacer bar Ø	90 mm 3.54" in
Weight		191 kg 421 lb

Tab. 234: Technical data equalizer on A-frame2 (jib backstay strap)

CF pendant straps on A-frame3

A-frame3 equalizer (jib pendant strap)

Installation site in crane mode:

- Luffing jib 1916 (For more information see: Pendant straps A-frame3 to jib head 1916, page 1649)
- Luffing jib 1916 + midfall 1916 (For more information see: Pendant straps A-frame3 to jib head 1916, page 1740)

Generation A of A-frame3 equalizer (jib pendant strap)

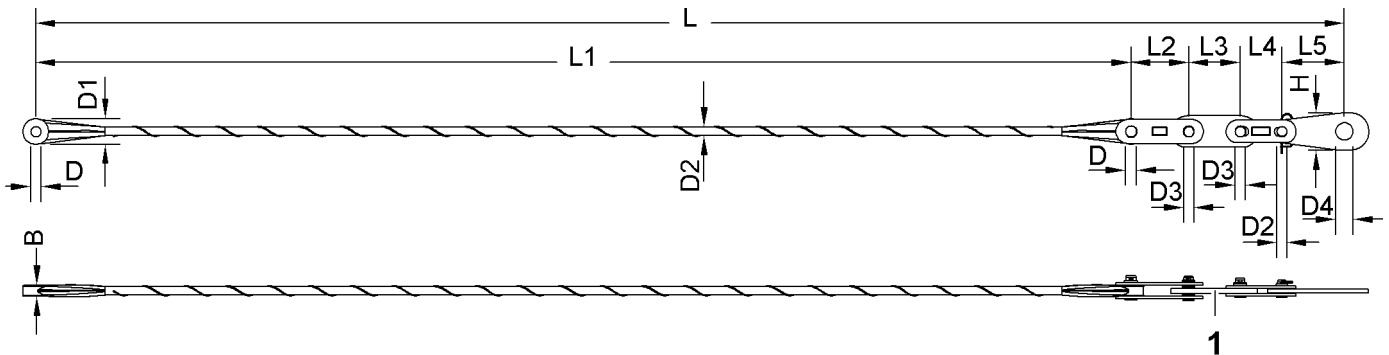


Fig. 382: Dimensions equalizer on A-frame3 (jib pendant strap)

1 Tension load cell

Name		Value
L	Length	7550 mm 24' 9" ft-in
L1	Length of pendant strap	6320 mm 20' 9" ft-in
L2	Length of connecting link	332 mm 1' 1" ft-in
L3	Length of tension load cell	298 mm 1' ft-in

LWNLR-x\04.01\Auslieferung\2016-03-07\en

Name		Value
L4	Length of connecting link	240 mm 9.45" in
L5	Length of connecting link	360 mm 1' 2" ft-in
W	Width	64 mm 2.52" in
H	Height of connecting link	216 mm 8.50" in
D	Pin Ø	60 mm 2.36" in
D1	Pendant strap Ø	148 mm 5.83" in
D2	Pendant strap Ø	50 mm 1.97" in
D3	Pin Ø	55 mm 2.17" in
D4	Pin Ø	100 mm 3.94" in
Weight		205 kg 452 lb

Tab. 235: Technical data A-frame3 equalizer (jib pendant strap)

Generation B of A-frame3 equalizer (jib pendant strap)

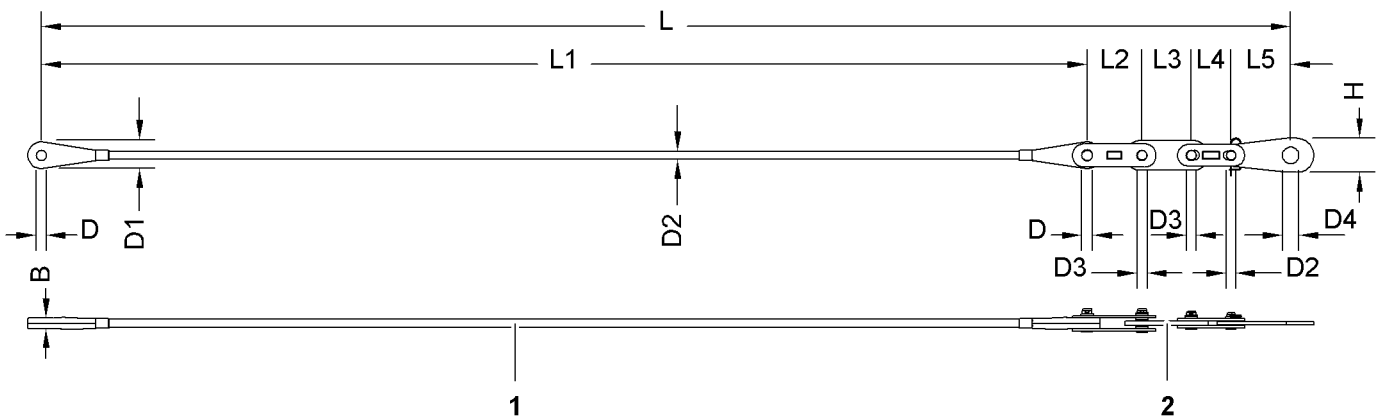


Fig. 383: Dimensions equalizer on A-frame3 (jib pendant strap)

- 1 Wire mesh hose as protective sheath
- 2 Tension load cell

Name		Value
L	Length	7550 mm 24' 9" ft-in
L1	Length of pendant strap	6320 mm 20' 9" ft-in

LWNLR.x/V04.01//Auslieferung/2016-03-07/en

Name		Value
L2	Length of connecting link	332 mm 1' 1" ft-in
L3	Length of tension load cell	298 mm 1' ft-in
L4	Length of connecting link	240 mm 9.45" in
L5	Length of connecting link	360 mm 1' 2" ft-in
B	Width	63 mm 2.48" in
H	Height of connecting link	216 mm 8.50" in
D	Pin Ø	60 mm 2.36" in
D1	Pendant strap Ø	161 mm 6.34" in
D2	Pendant strap Ø	48 mm 1.89" in
D3	Pin Ø	55 mm 2.17" in
D4	Pin Ø	100 mm 3.94" in
Weight		125 kg 276 lb

Tab. 236: Technical data A-frame3 equalizer (jib pendant strap)

CF pendant straps on jib section 1916.18 3 m (10 ft)

Jib pendant strap 3 m (10 ft)

Installation site in crane operation:

- Luffing jib 1916 (For more information see: [Pendant straps A-frame3 to jib head 1916, page 1649](#))
- Luffing jib 1916 + midfall 1916 (For more information see: [Pendant straps A-frame3 to jib head 1916, page 1740](#))

Generation A of jib pendant strap 3 m (10 ft)

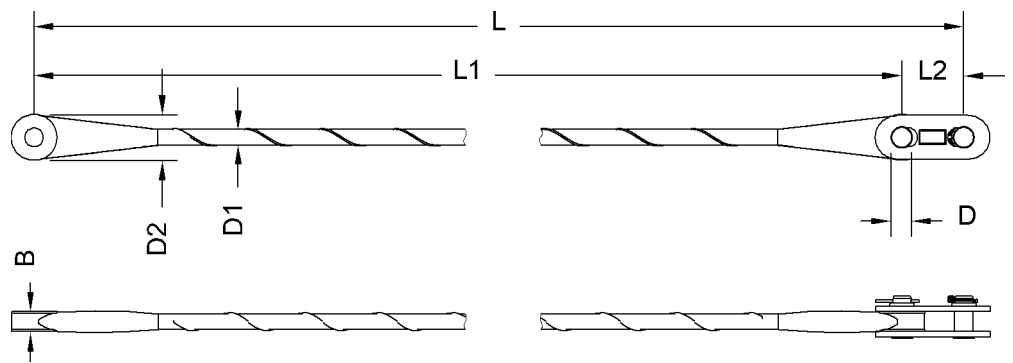


Fig. 384: Dimensions jib pendant strap 3 m (10 ft)

Name		Value
L	Length	3000 mm 9' 10" ft-in
L1	Length of pendant strap	2800 mm 9' 2" ft-in
L2	Length of connecting link	200 mm 7.87" in
B	Width	64 mm 2.52" in
D	Pin Ø	60 mm 2.36" in
D1	Pendant strap Ø	50 mm 1.97" in
D2	Pendant strap Ø	148 mm 5.83" in
Weight		35 kg 77.16 lb

Tab. 237: Technical data jib pendant strap 3 m (10 ft)

Generation B of jib pendant strap 3 m (10 ft)

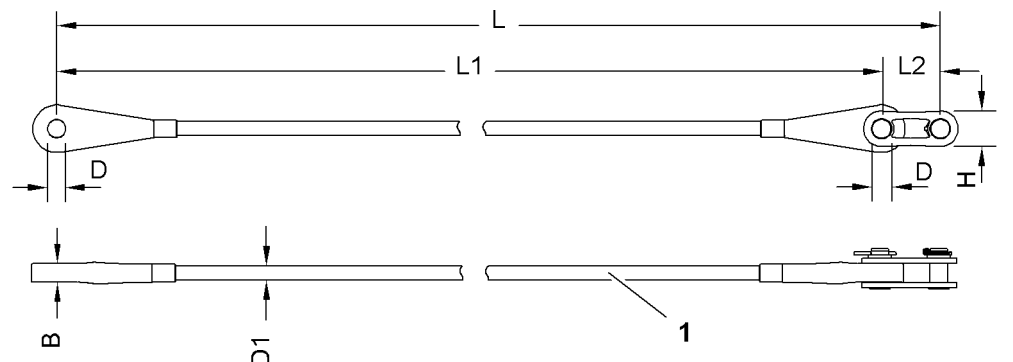


Fig. 385: Dimensions jib pendant strap 3 m (10 ft)

- 1 Wire mesh hose as protective sheath

LWNLR.x/V04.01//Auslieferung/2016-03-07/en

Name		Value
L	Length	3000 mm 9' 10" ft-in
L1	Length of pendant strap	2800 mm 9' 2" ft-in
L2	Length of connecting link	200 mm 7.87" in
B	Width	63 mm 2.48" in
H	Height of connecting link	121 mm 4.76" in
D	Pin Ø	60 mm 2.36" in
D1	Pendant strap Ø	48 mm 1.89" in
Weight		26 kg 57.32 lb

Tab. 238: Technical data jib pendant strap 3 m (10 ft)

CF pendant straps on jib section 1916.18 6 m (20 ft)

Jib pendant strap 6 m (20 ft)

Installation site in crane mode:

- Luffing jib 1916 (For more information see: [Pendant straps A-frame3 to jib head 1916, page 1649](#))
- Luffing jib 1916 + midfall 1916 (For more information see: [Pendant straps A-frame3 to jib head 1916, page 1740](#))

Generation A of jib pendant strap 6 m (20 ft)

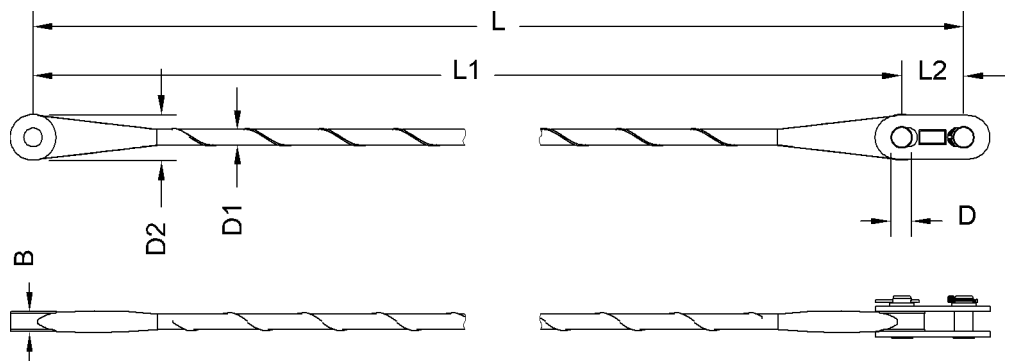


Fig. 386: Dimensions jib pendant strap 6 m (20 ft)

Name		Value
L	Length	6000 mm 19' 8" ft-in
L1	Length of pendant strap	5800 mm 19' ft-in

LWNLR-x\04.01\Auslieferung\2016-03-07/en

Name		Value
L2	Length of connecting link	200 mm 7.87" in
B	Width	64 mm 2.52" in
D	Pin Ø	60 mm 2.36" in
D1	Pendant strap Ø	50 mm 1.97" in
D2	Pendant strap Ø	148 mm 5.83" in
Weight		43 kg 94.80 lb

Tab. 239: Technical data jib pendant strap 6 m (20 ft)

Generation B of jib pendant strap 6 m (20 ft)

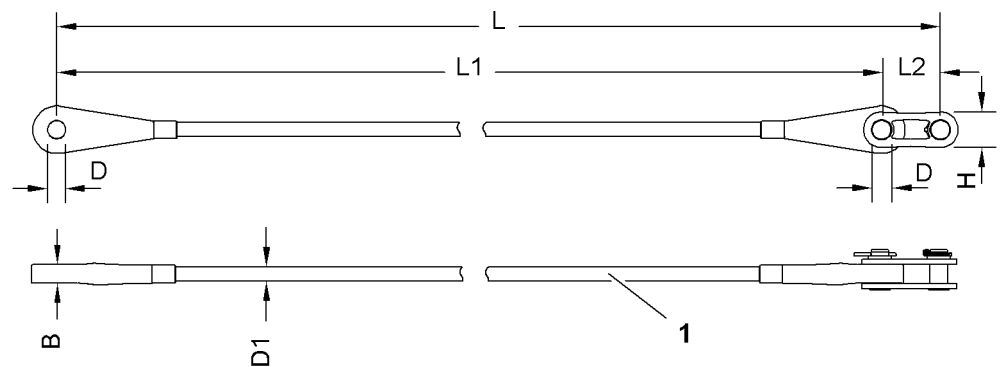


Fig. 387: Dimensions jib pendant strap 6 m (20 ft)

- 1 Wire mesh hose as protective sheath

Name		Value
L	Length	6000 mm 19' 8" ft-in
L1	Length of pendant strap	5800 mm 19' ft-in
L2	Length of connecting link	200 mm 7.87" in
B	Width	63 mm 2.48" in
H	Height of connecting link	121 mm 4.76" in
D	Pin Ø	60 mm 2.36" in
D1	Pendant strap Ø	48 mm 1.89" in

LWNLR.x/V04.01//Auslieferung/2016-03-07/en

Name	Value
Weight	32 kg 70.55 lb

Tab. 240: Technical data jib pendant strap 6 m (20 ft)

CF pendant straps on jib section 1916.18 12 m (40 ft)

Jib pendant strap 12 m (40 ft)

Installation site in crane mode:

- Luffing jib 1916 (For more information see: Pendant straps A-frame3 to jib head 1916, page 1649)
- Luffing jib 1916 + midfall 1916 (For more information see: Pendant straps A-frame3 to jib head 1916, page 1740)

Generation A of jib pendant strap 12 m (40 ft)

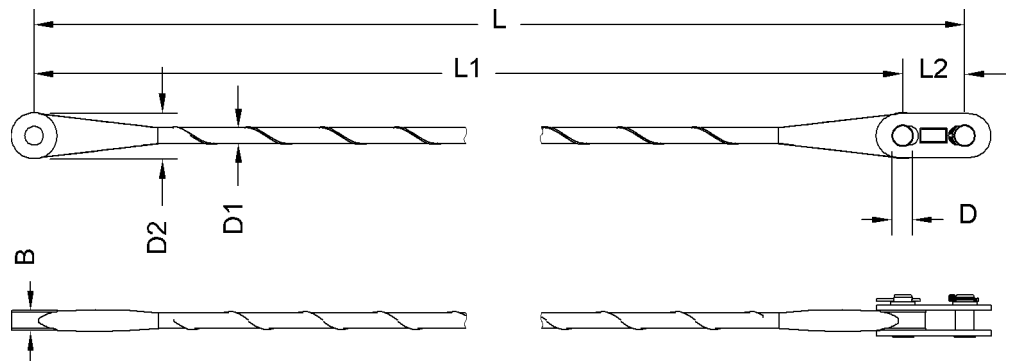


Fig. 388: Dimensions jib pendant strap 12 m (40 ft)

Name	Value
L Length	12000 mm 39' 4" ft-in
L1 Length of pendant strap	11800 mm 38' 9" ft-in
L2 Length of connecting link	200 mm 7.87" in
B Width	64 mm 2.52" in
D Pin Ø	60 mm 2.36" in
D1 Pendant strap Ø	50 mm 1.97" in
D2 Pendant strap Ø	148 mm 5.83" in
Weight	60 kg 132 lb

Tab. 241: Technical data jib pendant strap 12 m (40 ft)

LWN/LR-x/V04.01//Auslieferung/2016-03-07/en

Generation B of jib pendant strap 12 m (40 ft)

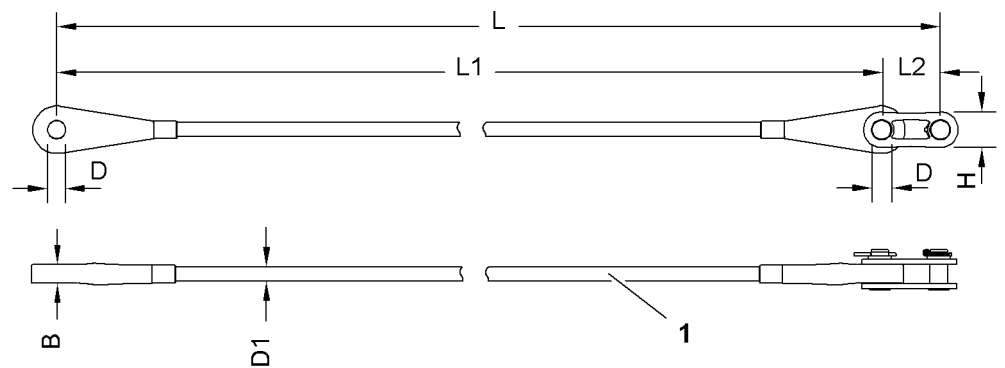


Fig. 389: Dimensions jib pendant strap 12 m (40 ft)

- 1 Wire mesh hose as protective sheath

Name		Value
L	Length	12000 mm 39' 4" ft-in
L1	Length of pendant strap	11800 mm 38' 9" ft-in
L2	Length of connecting link	200 mm 7.87" in
B	Width	63 mm 2.48" in
H	Height of connecting link	121 mm 4.76" in
D	Pin Ø	60 mm 2.36" in
D1	Pendant strap Ø	48 mm 1.89" in
Weight		43 kg 94.80 lb

Tab. 242: Technical data jib pendant strap 12 m (40 ft)

CF pendant straps on jib head 1916.21

Jib pendant strap on jib head 1916.21

Installation site in crane operation:

- Luffing jib 1916 (For more information see: [Pendant straps A-frame3 to jib head 1916, page 1649](#))
- Luffing jib 1916 + midfall 1916 (For more information see: [Pendant straps A-frame3 to jib head 1916, page 1740](#))

Generation A of jib pendant strap on jib head 1916.21

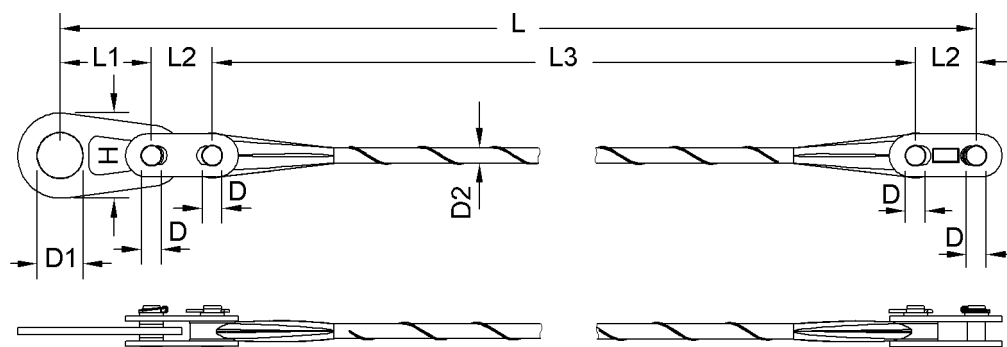


Fig. 390: Dimensions jib pendant strap on jib head 1916.21

Name		Value
L	Length	6500 mm 21' 4" ft-in
L1	Length of connecting link	300 mm 1' ft-in
L2	Length of connecting link	200 mm 7.87" in
L3	Length of pendant strap	5800 mm 19' ft-in
H	Height of connecting link	280 mm 11.02" in
D	Pin Ø	60 mm 2.36" in
D1	Pin Ø	150 mm 5.91" in
D2	Pendant strap Ø	50 mm 1.97" in
Weight		69 kg 152 lb

Tab. 243: Technical data jib pendant strap on jib head 1916.21

Generation B of jib pendant strap on jib head 1916.21

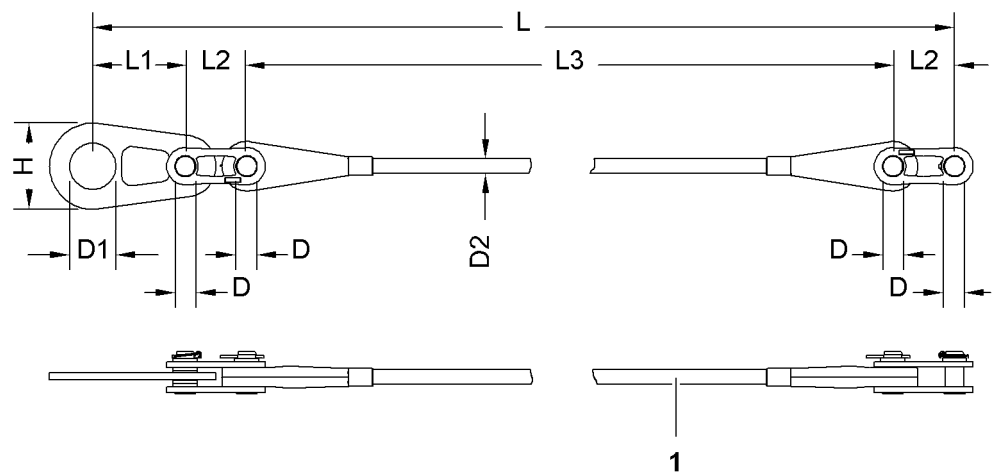


Fig. 391: Dimensions jib pendant strap on jib head 1916.21

- 1 Wire mesh hose as protective sheath

Name	Value
L Length	6500 mm 21' 4" ft-in
L1 Length of connecting link	300 mm 1' ft-in
L2 Length of connecting link	200 mm 7.87" in
L3 Length of pendant strap	5800 mm 19' ft-in
H Height of connecting link	280 mm 11.02" in
D Pin Ø	60 mm 2.36" in
D1 Pin Ø	150 mm 5.91" in
D2 Pendant strap Ø	48 mm 1.89" in
Weight	69 kg 152 lb

Tab. 244: Technical data jib pendant strap on jib head 1916.21

1.22 Midfall overview

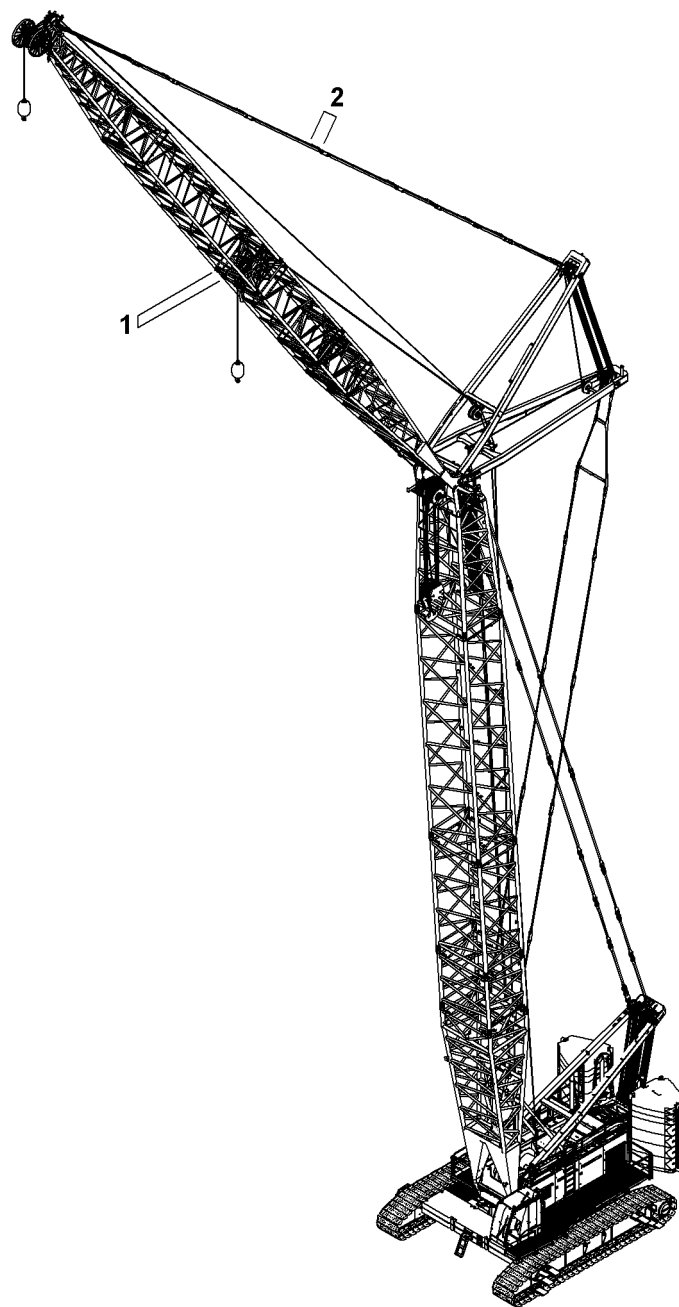


Fig. 392: Midfall overview

1 Midfall

2 Midfall connecting link

The Midfall connecting link 2 replaces the first connecting link of the first jib pendant strap 12 m (40 ft) beyond the Midfall assembly position.

1.23 2316.25 Midfall

1.23.1 Midfall 2316.25

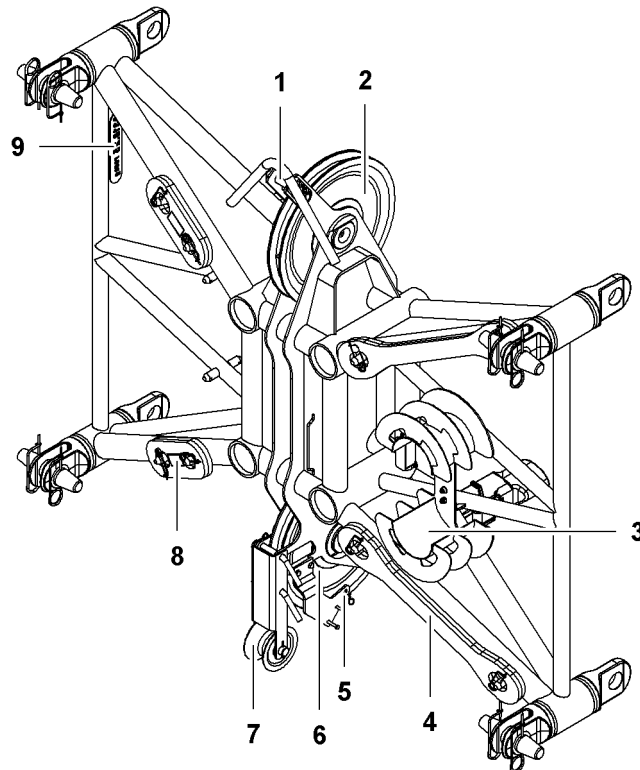


Fig. 393: Midfall 2316.25

- | | | | |
|---|---|---|---|
| 1 | Rope protection pipe | 6 | Bottom pulley |
| 2 | Top pulley | 7 | Rope pulley |
| 3 | Cable bracket | 8 | Storage position of connecting links 420 mm (1' 5" ft-in) or of connecting links 200 mm (7.87" in) (4x) |
| 4 | Transport position of connecting links 920 mm (3' ft-in) or of connecting links 700 mm (2' 4" ft-in) (4x) | 9 | Boom identification plate |
| 5 | Hoist limit switch | | |

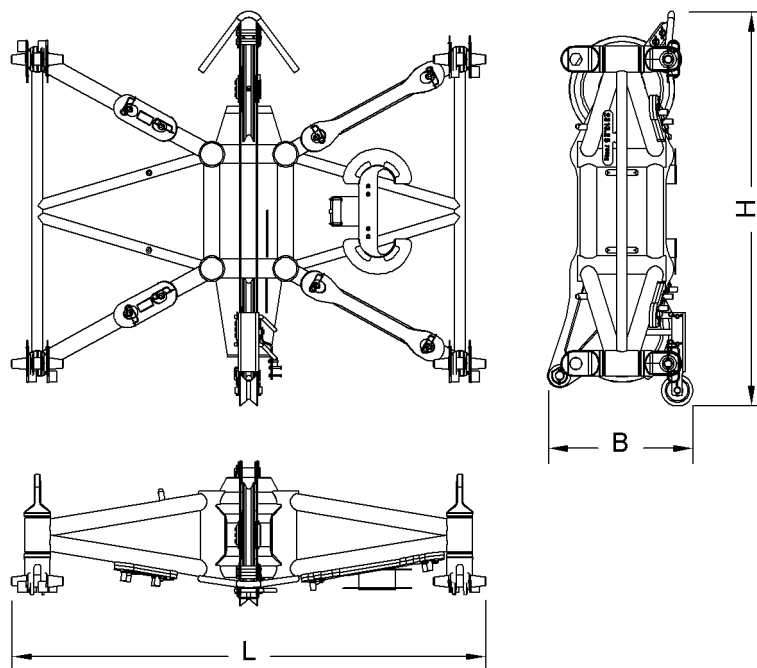


Fig. 394: Midfall 2316.25 dimensions

Name		Value
System length		500 mm 1' 8" ft-in
System width		2290 mm 7' 6" ft-in
System height		1650 mm 5' 5" ft-in
L	Length	2600 mm 8' 6" ft-in
W	Width	800 mm 2' 7" ft-in
H	Height	2100 mm 6' 11" ft-in
Weight (incl. connecting links)		690 kg 1,521 lb
Double-taper pins Ø		65 mm 2.56" in

Tab. 245: Midfall 2316.25 technical data

1.23.2 Mid-point suspension on midfall 2316.25

The mid-point suspensions on midfall 2316.25 differ with steel pendant straps and CF pendant straps.

LWNLR-x\04.01\Auslieferung\2016-03-07/en

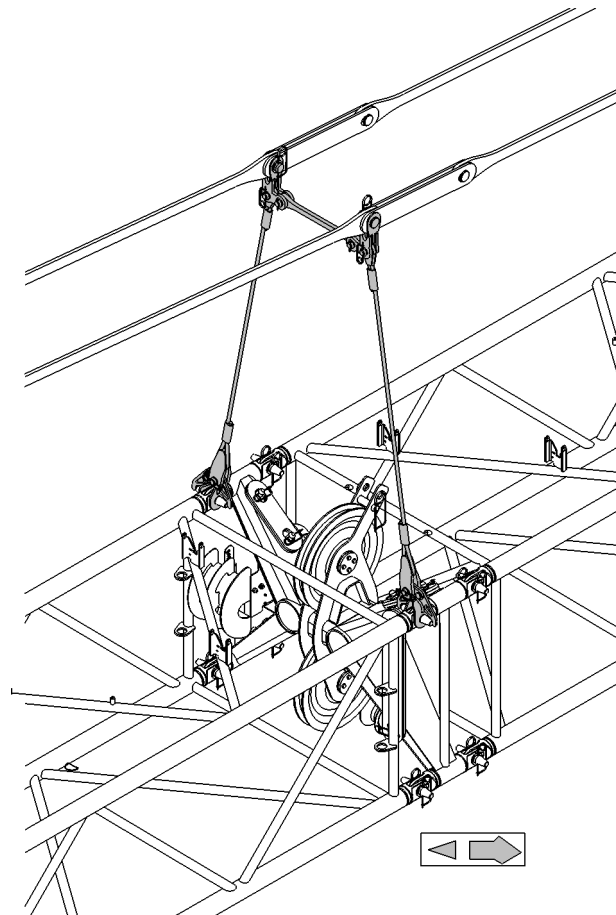


Fig. 395: Mid-point suspension on midfall 2316.25 (illustration of principle)

The mid-point suspension on midfall 2316.25 is identical with the mid-point suspension on luffing jib 2316 (For more information see: [1.20.6 Mid-point suspension on luffing jib 2316](#), page 296) .

1.23.3 Steel pendant straps on midfall 2316.25

Midfall connecting link

Installation site in crane operation:

- Luffing jib 2316 + midfall 2316 (For more information see: [Pendant straps A-frame3 to jib head 2316](#), page 1725)

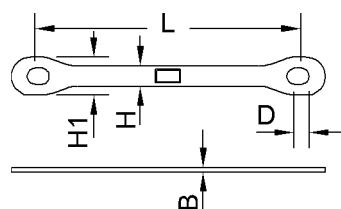


Fig. 396: Dimensions midfall connecting link

The midfall connecting link replaces the first connecting link of the first jib pendant strap 12 m (40 ft) behind the midfall installation position.

Name		Value
L	Length of connecting link	920 mm 3' ft-in
W	Width of connecting link	15 mm 0.59" in
H	Height of connecting link	70 mm 2.76" in
H1	Height of connecting link	130 mm 5.12" in
D	Pin Ø	55 mm 2.17" in
Weight		10.1 kg 22.27 lb

Tab. 246: Technical data midfall connecting link

1.23.4 CF pendant straps on midfall 2316.25

Midfall connecting link

Installation site in crane operation:

- Luffing jib 2316 + midfall 2316 (For more information see: Pendant straps A-frame3 to jib head 2316, page 1727)

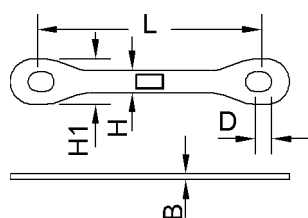


Fig. 397: Dimensions midfall connecting link

The midfall connecting link replaces the first connecting link of the first jib pendant strap 12 m (40 ft) behind the midfall installation position.

Name		Value
L	Length of connecting link	700 mm 2' 4" ft-in
W	Width of connecting link	18 mm 0.71" in
H	Height of connecting link	70 mm 2.76" in
H1	Height of connecting link	142 mm 5.59" in
D	Pin Ø	60 mm 2.36" in

LWNLR-x/V04.01//Auslieferung/2016-03-07/en

Name	Value
Weight	2.6 kg 5.73 lb

Tab. 247: Technical data midfall connecting link

1.24 1916.32 Midfall

1.24.1 Midfall 1916.32

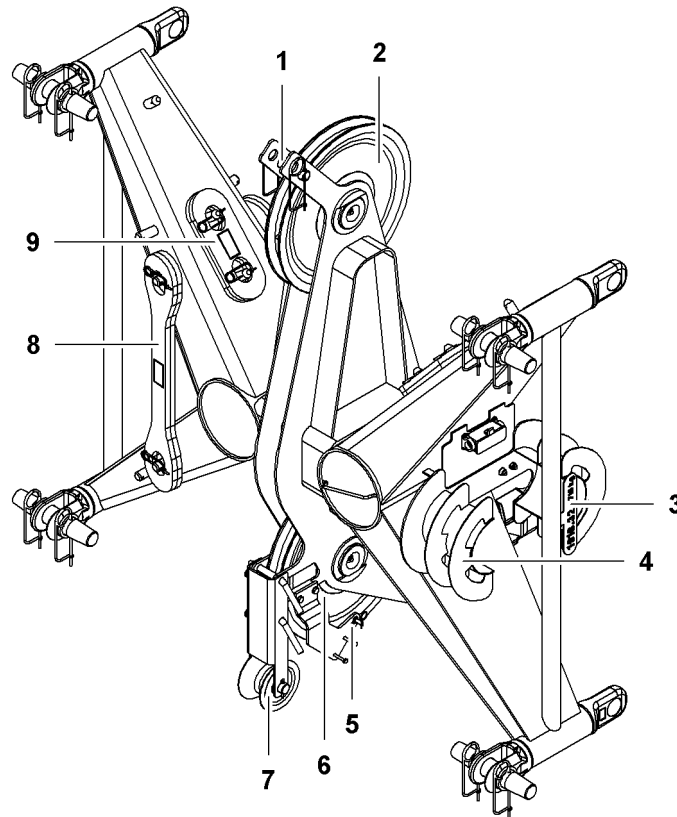


Fig. 398: 1916.32 Midfall

- | | | | |
|---|---------------------------|---|---|
| 1 | Rope protection pipe | 6 | Lower pulley |
| 2 | Upper pulley | 7 | Rope pulley |
| 3 | Boom identification plate | 8 | Transport position of connecting links 890 mm (2' 11" ft-in) or of connecting links 700 mm (2' 4" ft-in) (4x) |
| 4 | Wire bracket | 9 | Storage position (4x) of connecting links 390 mm (1' 3" ft-in) or of connecting links 200 mm (7.87" in) |
| 5 | Hoist limit switch | | |

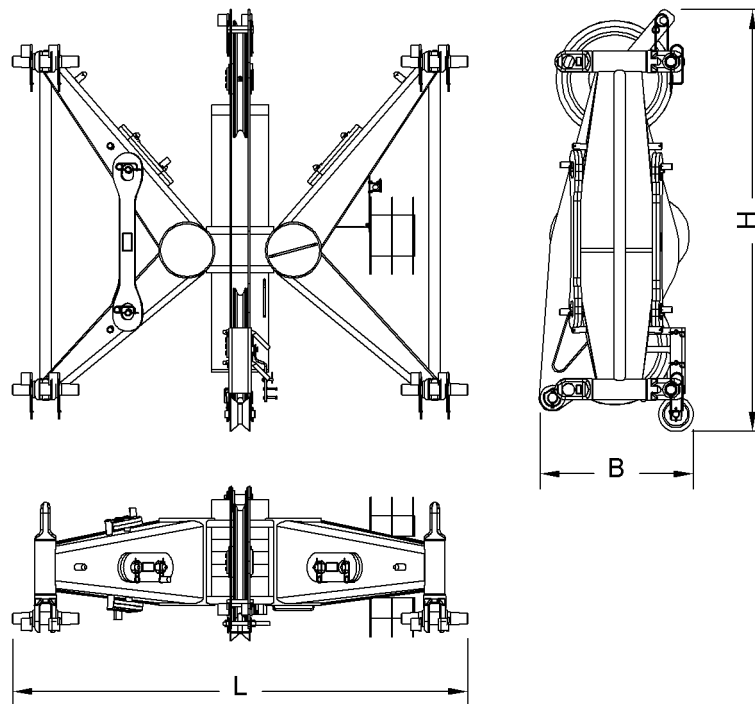


Fig. 399: Midfall 1916.32 dimensions

Name		Value
System length		500 mm 1' 8" ft-in
System width		1900 mm 6' 3" ft-in
System height		1600 mm 5' 3" ft-in
L	Length	2000 mm 6' 7" ft-in
B	Width	750 mm 2' 6" ft-in
H	Height	2060 mm 6' 9" ft-in
Weight (incl. connecting links)		670 kg 1,477 lb
Double-taper pins Ø		60 mm 2.36" in

Tab. 248: Technical data 1916.32 Midfall

1.24.2 Mid-point suspension on midfall 1916.32

The mid-point suspensions on midfall 1916.32 differ with steel pendant straps and CF pendant straps.

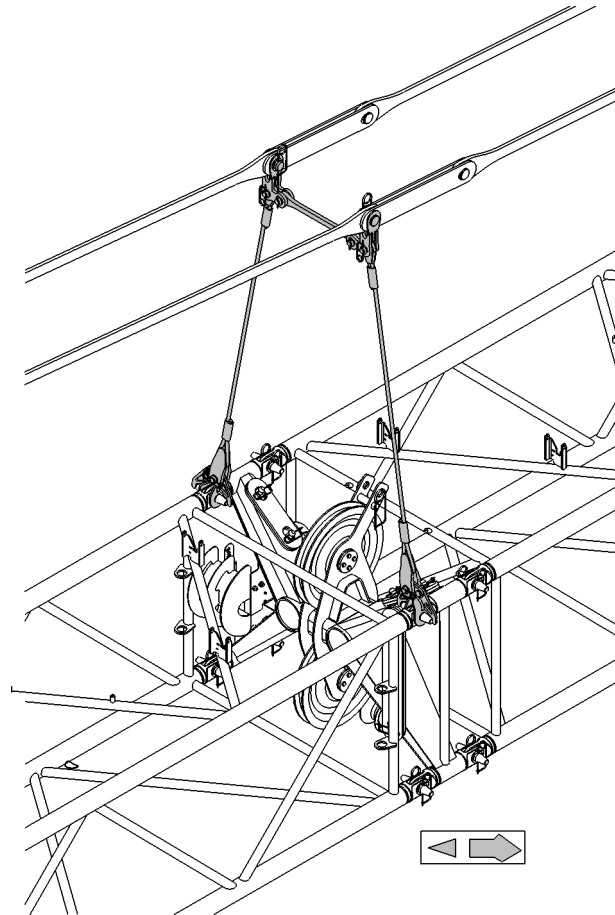


Fig. 400: Mid-point suspension on midfall 1916.32 (illustration of principle)

The mid-point suspension on midfall 1916.32 is identical with the mid-point suspension on luffing jib 1916 (For more information see: [1.21.6 Mid-point suspension on luffing jib 1916, page 335](#)).

1.24.3 Steel pendant straps on midfall 1916.32

Midfall connecting link

Installation site in crane operation:

- Luffing jib 1916 + midfall 1916 (For more information see: [Pendant straps A-frame3 to jib head 1916, page 1738](#))

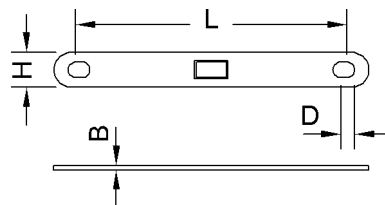


Fig. 401: Dimensions midfall connecting link

The midfall connecting link replaces the first connecting link of the first jib pendant strap 12 m (40 ft) behind the midfall installation position.

Name		Value
L	Length of connecting link	890 mm 2' 11" ft-in
W	Width of connecting link	15 mm 0.59" in
H	Height of connecting link	114 mm 4.49" in
D	Pin Ø	50 mm 1.97" in
Weight		12.8 kg 28.22 lb

Tab. 249: Technical data midfall connecting link

1.24.4 CF pendant straps on midfall 1916.32

Midfall connecting link

Installation site in crane operation:

- Luffing jib 1916 + midfall 1916 (For more information see: [Pendant straps A-frame3 to jib head 1916, page 1740](#))

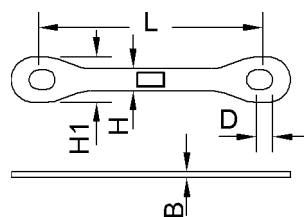


Fig. 402: Dimensions midfall connecting link

The midfall connecting link replaces the first connecting link of the first jib pendant strap 12 m (40 ft) behind the midfall installation position.

Name		Value
L	Length of connecting link	700 mm 2' 4" ft-in
W	Width of connecting link	18 mm 0.71" in
H	Height of connecting link	70 mm 2.76" in
H1	Height of connecting link	142 mm 5.59" in
D	Pin Ø	60 mm 2.36" in
Weight		2.6 kg 5.73 lb

Tab. 250: Technical data midfall connecting link

1.25 Auxiliary jib* (36 t (79.300 lb))

This auxiliary jib can be attached to any boom head section.

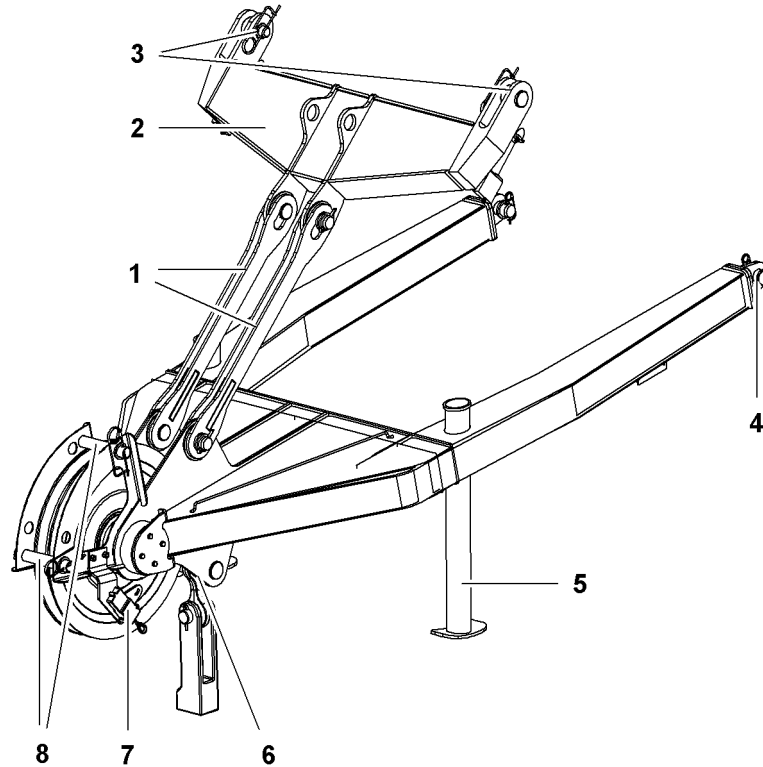


Fig. 403: Auxiliary jib (36 t (79.300 lb)) for the boom head section

- | | | | |
|---|--|---|---------------------------|
| 1 | Pendant strap (2x) | 5 | Support base (2x) |
| 2 | Crossbar | 6 | Rope fixation |
| 3 | Top pin connection point (2x) on main boom head | 7 | Hoist limit switch |
| 4 | Bottom pin connection point (2x) on main boom head | 8 | Rope protection pipe (2x) |

The auxiliary jib is designed for a maximum load of 36 t (79.300 lb). A second, optional pulley (3-fold reeving) is required if the maximum lifting capacity is to be achieved.

The radius change and the weight increase of the main boom head due to the auxiliary jib are taken into account by the Load moment limiter. Due to this weight increase, it is not possible to erect the main boom to all possible heights.

Recommended values for radius enlargement using the auxiliary jib:

Machine type	Main boom angle			
	15°	20°	45°	86°
LR 1001	1380 mm 4' 6" ft-in	-	1900 mm 6' 3" ft-in	1760 mm 5' 9" ft-in
LR 1002	1210 mm 4' ft-in	-	1890 mm 6' 2" ft-in	2000 mm 6' 7" ft-in

Machine type	Main boom angle			
	15°	20°	45°	86°
LR 1003	1210 mm 4' ft-in	-	1890 mm 6' 2" ft-in	2000 mm 6' 7" ft-in
LR 1004	1210 mm 4' ft-in	-	1780 mm 5' 10" ft-in	1800 mm 5' 11" ft-in
LR 1006	-	1320 mm 4' 4" ft-in	1780 mm 5' 10" ft-in	1790 mm 5' 10" ft-in

Tab. 251: Guideline values for radius enlargement through auxiliary jib (36 t (79.300 lb)) for main boom head

NOTICE

Incorrectly hoisted load with the 2821 main boom and an auxiliary jib attached ($L = 1034 \text{ mm}$ (3' 5" ft-in)) and main boom angle less than 20°!
Risk of damage to the rope.

- Hoist a load with the main boom exclusively when the main boom angle is greater than 20°.

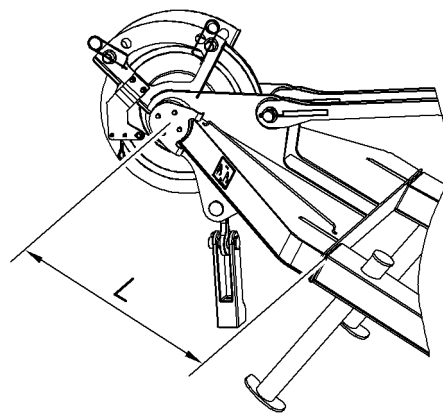


Fig. 404: Dimension L on auxiliary jib (36 t (79.300 lb))

Dimension L on auxiliary jib	Is a load allowed to be hoisted with a 2821 main boom when an auxiliary jib is fit and the main boom angle is less than 20°?
1034 mm 3' 5" ft-in	NO
954 mm 3' 2" ft-in	YES

Tab. 252: Dimension L on auxiliary jib (36 t (79.300 lb))

LWNLR.x/V04.01//Auslieferung/2016-03-07/en

Product description

Auxiliary jib* (36 t (79.300 lb))

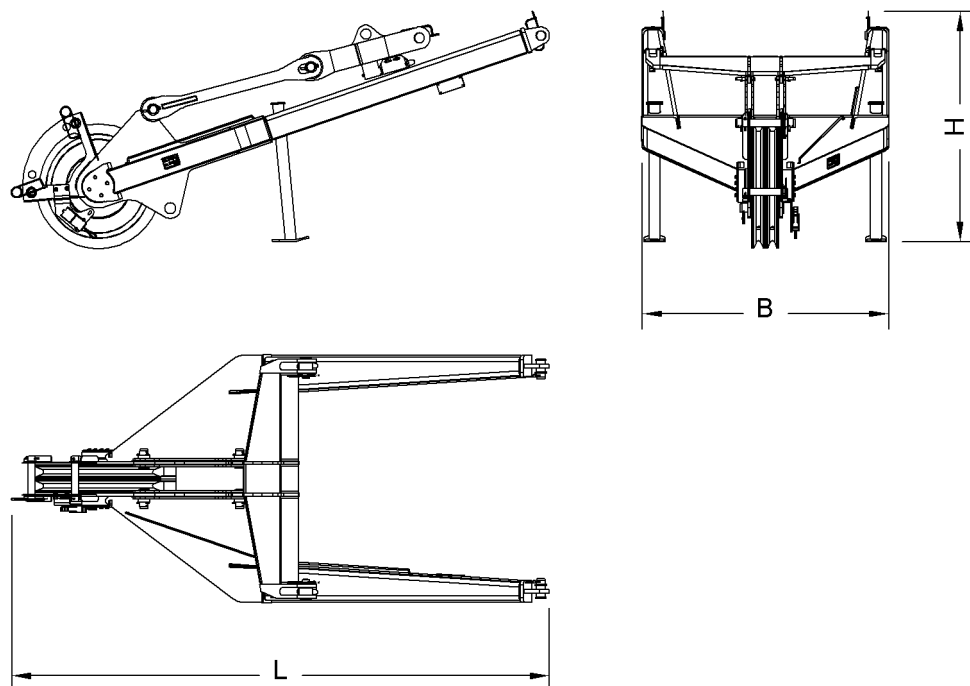


Fig. 405: Dimensions of auxiliary jib (36 t (79.300 lb)) for the boom head section

Designation		Value
L	Length	3190 mm 10' 6" ft-in
B	Width	1520 mm 5' ft-in
H	Height	1400 mm 4' 7" ft-in
Weight		590 kg 1,301 lb

Tab. 253: Technical data for auxiliary jib (36 t (79.300 lb)) for the boom head section

LWNLR-x\04.01\Auslieferung\2016-03-07\en

1.26 Auxiliary jib* (30 t (66.000 lb))

This auxiliary jib can be attached to the 2316 luffing jib head section.

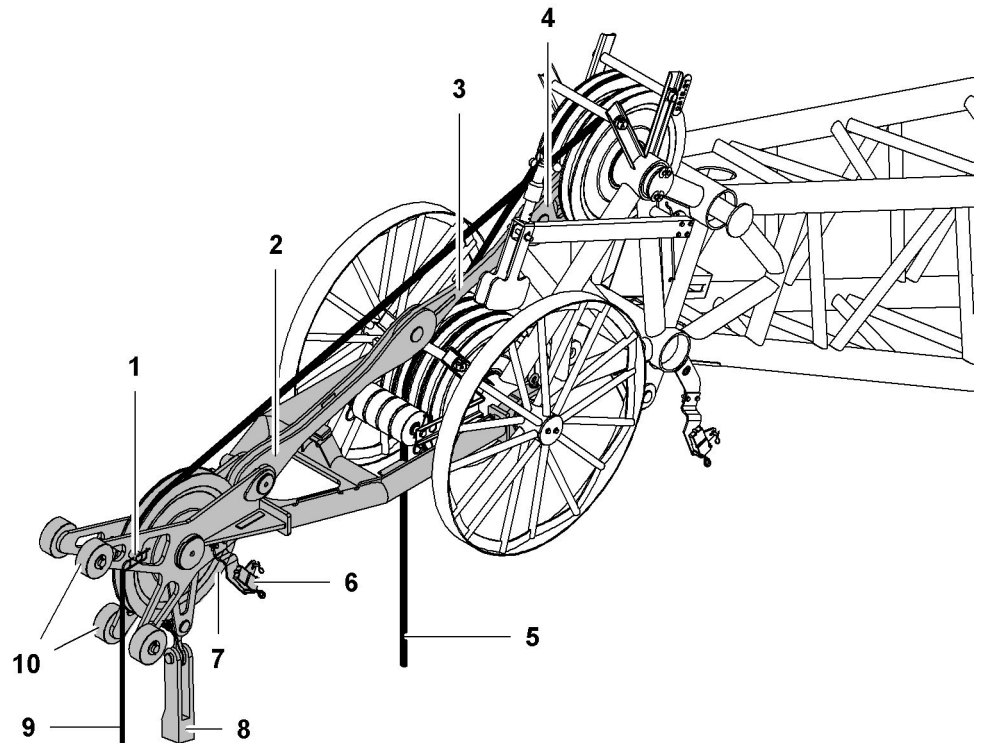


Fig. 406: Auxiliary jib (30 t (66.000 lb)) for luffing jib head 2316

- | | | | |
|---|----------------------------|----|----------------------|
| 1 | Rope protection pipes (2x) | 6 | Hoist limit switch |
| 2 | Connecting links (2x) | 7 | Pulley |
| 3 | Pendant strap | 8 | Rope fixation |
| 4 | Connecting links (2x) | 9 | Winch 2 hoist rope |
| 5 | Winch 1 hoist rope | 10 | Running rollers (4x) |

The auxiliary jib is designed with a maximum lifting capacity of 30 t (66,138 lb).

The increase in weight of the jib head section caused by the auxiliary jib has been taken into account in the Load Moment Limiter (LML).

Recommended values for radius enlargement using the auxiliary jib:

Jib angle	Radius enlargement
15°	1773 mm
15°	5' 10" ft-in
45°	1692 mm
45°	5' 7" ft-in
78°	1083 mm
78°	3' 7" ft-in

Tab. 254: Guideline values for radius enlargement by the auxiliary jib (30 t (66.000 lb)) for luffing jib head 2316

Product description

Auxiliary jib* (30 t (66.000 lb))

Designation		Value
L	Length	2600 mm 8' 6" ft-in
B	Width	850 mm 2' 9" ft-in
H	Height	750 mm 2' 6" ft-in
Weight		408 kg 899 lb

Tab. 255: Technical data: auxiliary jib for 2316 luffing jib head section

LWNLR-x/V04.01//Auslieferung/2016-03-07/en

1.27 Auxiliary jib* (15 t (33.000 lb))

This auxiliary jib can be attached to the 1916, 1713, 1309, 1008 luffing jib head sections.

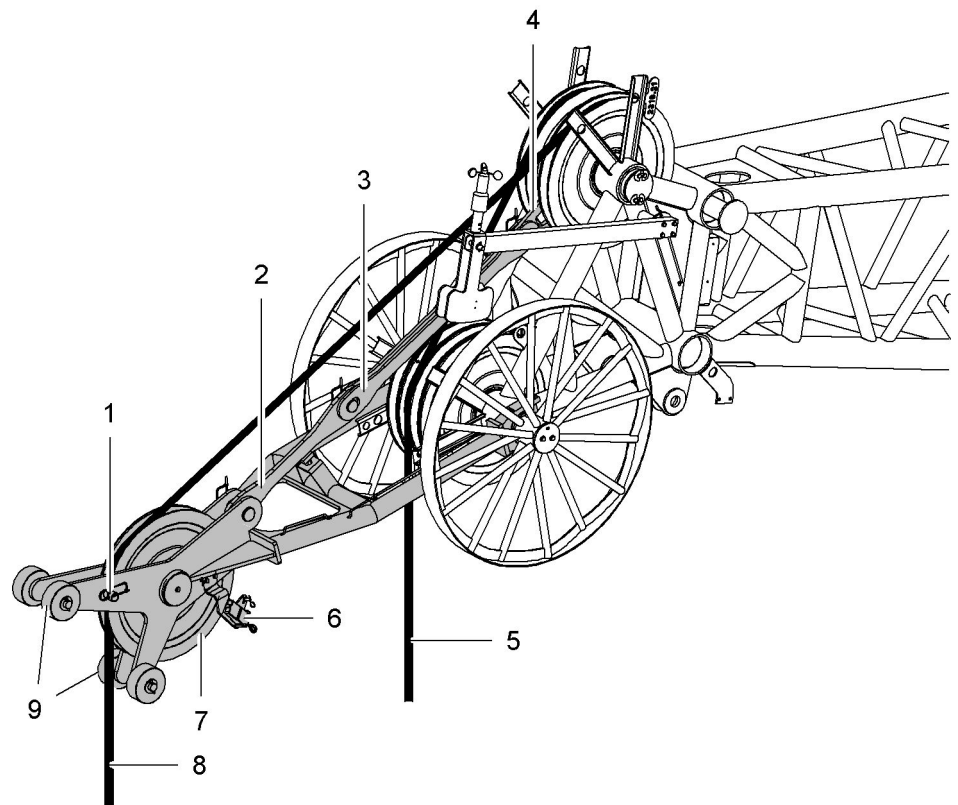


Fig. 407: Auxiliary jib (15 t (33.000 lb)) for luffing jib head 1916, 1713, 1309, 1008

- | | | | |
|---|----------------------|---|---------------------|
| 1 | Rope protection pipe | 6 | Hoist limit switch |
| 2 | Pendant strap | 7 | Pulley |
| 3 | Connecting link (2x) | 8 | Winch 2 rope |
| 4 | Connecting link | 9 | Running roller (4x) |
| 5 | Winch 1 rope | | |

The auxiliary jib is designed with a maximum lifting capacity of 15 t (33,069 lb).

The increase in weight of the jib head section caused by the auxiliary jib has been taken into account in the Load Moment Limiter.

Recommended values for radius enlargement using the auxiliary jib:

Jib angle	Radius enlargement
15°	1773 mm
15°	5' 10" ft-in
45°	1691 mm
45°	5' 7" ft-in
78°	1083 mm
78°	3' 7" ft-in

Tab. 256: Guideline values for radius enlargement by the auxiliary jib (15 t (33.000 lb)) for luffing jib head 1916, 1713, 1309, 1008

Product description

Auxiliary jib* (15 t (33.000 lb))

Designation		Value
L	Length	2600 mm 8' 6" ft-in
B	Width	720 mm 2' 4" ft-in
H	Height	750 mm 2' 6" ft-in
Weight		350 kg 772 lb

Tab. 257: Technical data: auxiliary jib for 1916, 1713, 1309, 1008 luffing jib head sections

LWNLR-x/V04.01//Auslieferung/2016-03-07/en

1.28 Derrick equipment*

1.28.1 Overview of derrick equipment

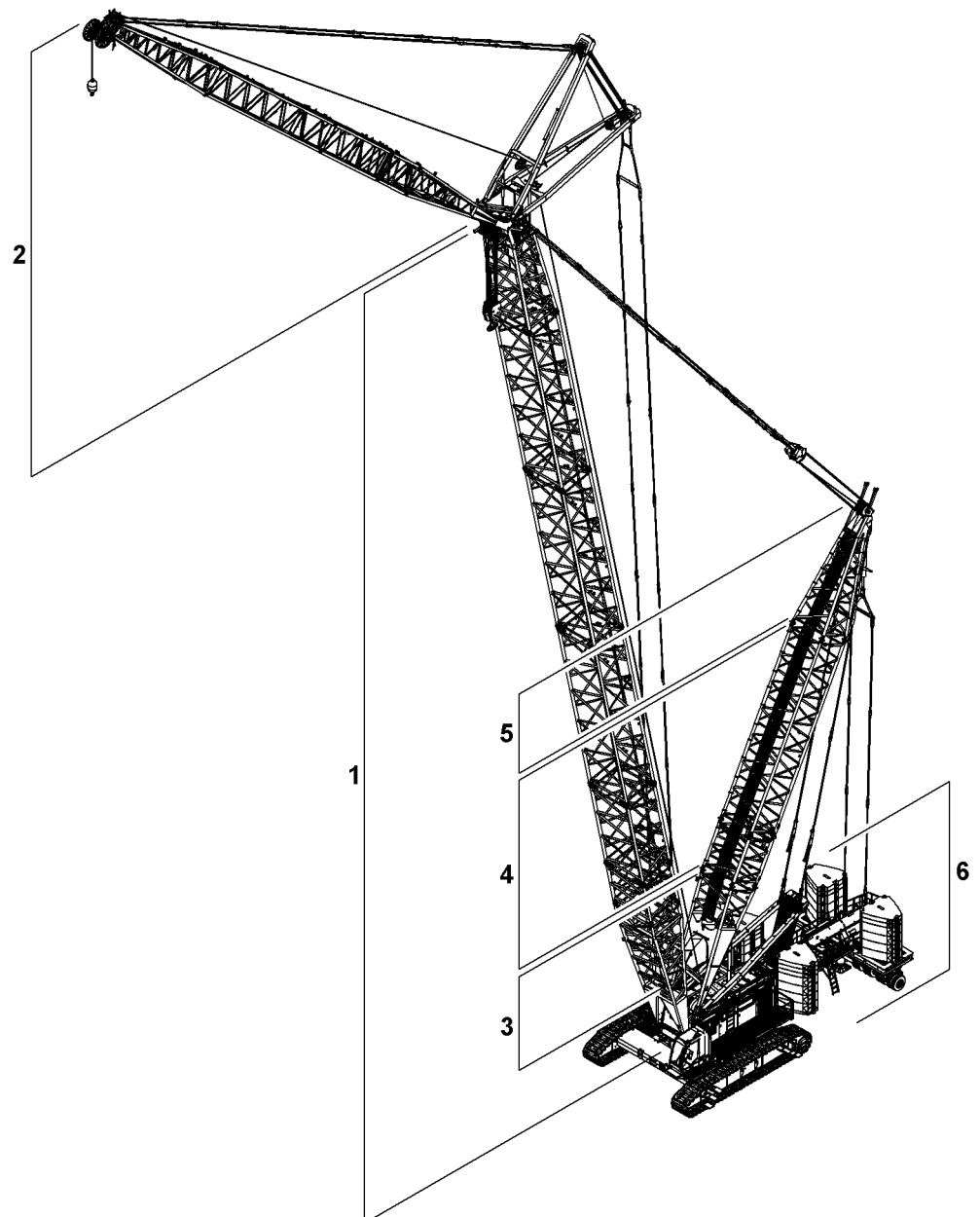


Fig. 408: Overview of derrick equipment

- | | | | |
|---|---------------------------|---|---|
| 1 | Main boom | 4 | Derrick boom sections |
| 2 | Fixed jib or luffing jib | 5 | Derrick boom head |
| 3 | Derrick boom base section | 6 | Suspended counterweight or counterweight carriage |

1.28.2 Derrick boom 2220

Derrick boom base section 2220.24

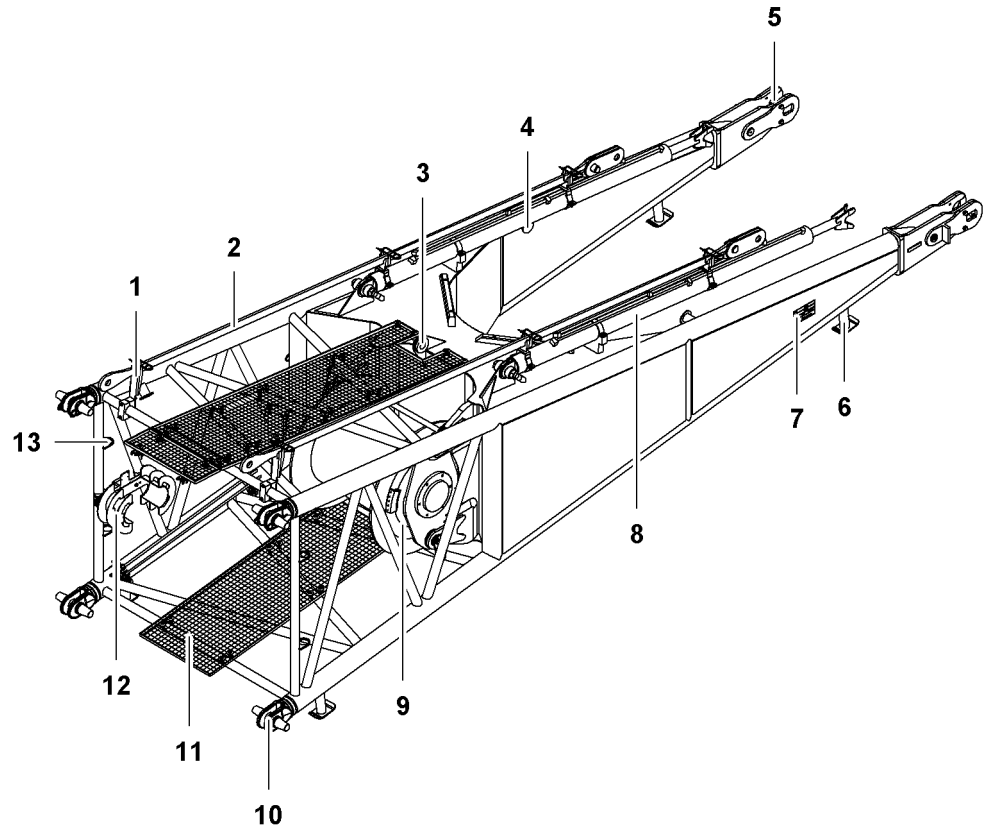


Fig. 409: Derrick boom base section 2220.24

- | | | | |
|---|--|----|--|
| 1 | Transport bracket (6x) for main boom pendant straps | 8 | Derrick tilting-back support (2x) |
| 2 | Transport position (2x) of main boom pendant straps for main boom head 2220.24 (LR 1005.xx.xx) | 9 | Derrick winch |
| 3 | Pin connection point for assembly cylinder | 10 | Pin connection point (4x) with double-taper pin (4x) |
| 4 | Rigging point (4x) | 11 | Catwalk (2x) |
| 5 | Pivot point (2x) for uppercarriage | 12 | Cable bracket for electric cable |
| 6 | Foot (4x) | 13 | Transport bracket (4x) for double taper pin |
| 7 | Derrick type plate | | |

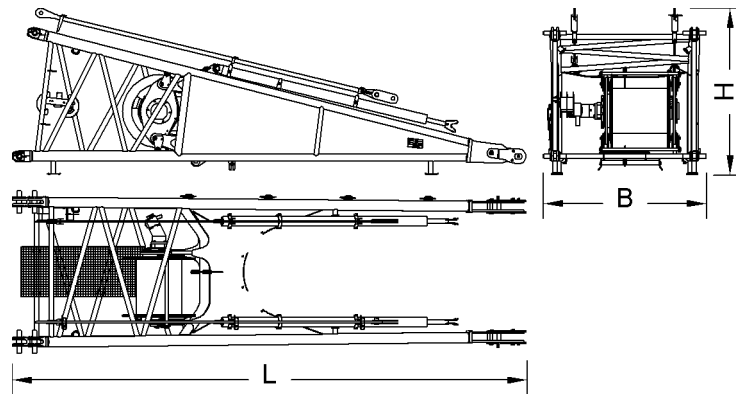


Fig. 410: Dimensions of derrick boom base section 2220.24

Name		Value
System length		8000 mm 26' 3" ft-in
System width		2250 mm 7' 5" ft-in
System height		2000 mm 6' 7" ft-in
L	Length	8290 mm 27' 2" ft-in
B	Width	2450 mm 8' ft-in
H	Height (incl. pendant straps)	2680 mm 8' 10" ft-in
Weight (incl. derrick tilting-back supports, derrick pendant straps, derrick winch, rope of derrick winch)		8100 kg 17,857 lb
Double taper pin Ø		80 mm 3.15" in

Tab. 258: Technical data derrick boom base section 2220.24

Derrick boom section 2220.24 3 m (10 ft)

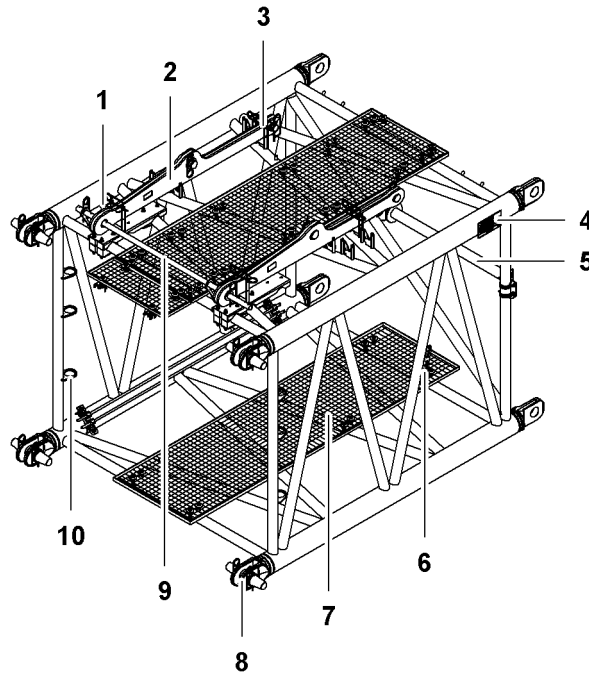


Fig. 411: Derrick boom section 2220.24 3 m (10 ft)

- | | | | |
|---|---|----|--|
| 1 | Rigging point (4x) | 6 | Boom identification plate |
| 2 | Transport position (2x) of adapter connecting links | 7 | Catwalk (2x) |
| 3 | Transport bracket (4x) for adapter connecting links | 8 | Pin connection point (8x) with double-taper pin (4x) |
| 4 | Derrick type plate | 9 | Transport bracket for adapter connecting links |
| 5 | Rope protection roller | 10 | Transport bracket (4x) for double taper pin |

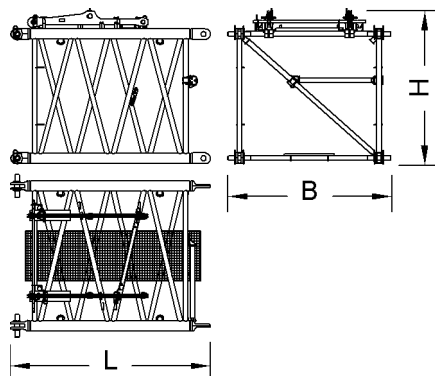


Fig. 412: Dimensions of derrick boom section 2220.24 3 m (10 ft)

Name	Value
System length	3000 mm 9' 10" ft-in

Name		Value
System width		2250 mm 7' 5" ft-in
System height		2000 mm 6' 7" ft-in
L	Length	3220 mm 10' 7" ft-in
B	Width	2420 mm 7' 11" ft-in
H	Height (incl. connecting link adapters)	2460 mm 8' 1" ft-in
Weight (incl. connecting link adapters)		1100 kg 2,425 lb
Double taper pin Ø		80 mm 3.15" in

Tab. 259: Technical data derrick boom section 2220.24 3 m (10 ft)

Derrick boom section 2220.22 11.7 m (38 ft)

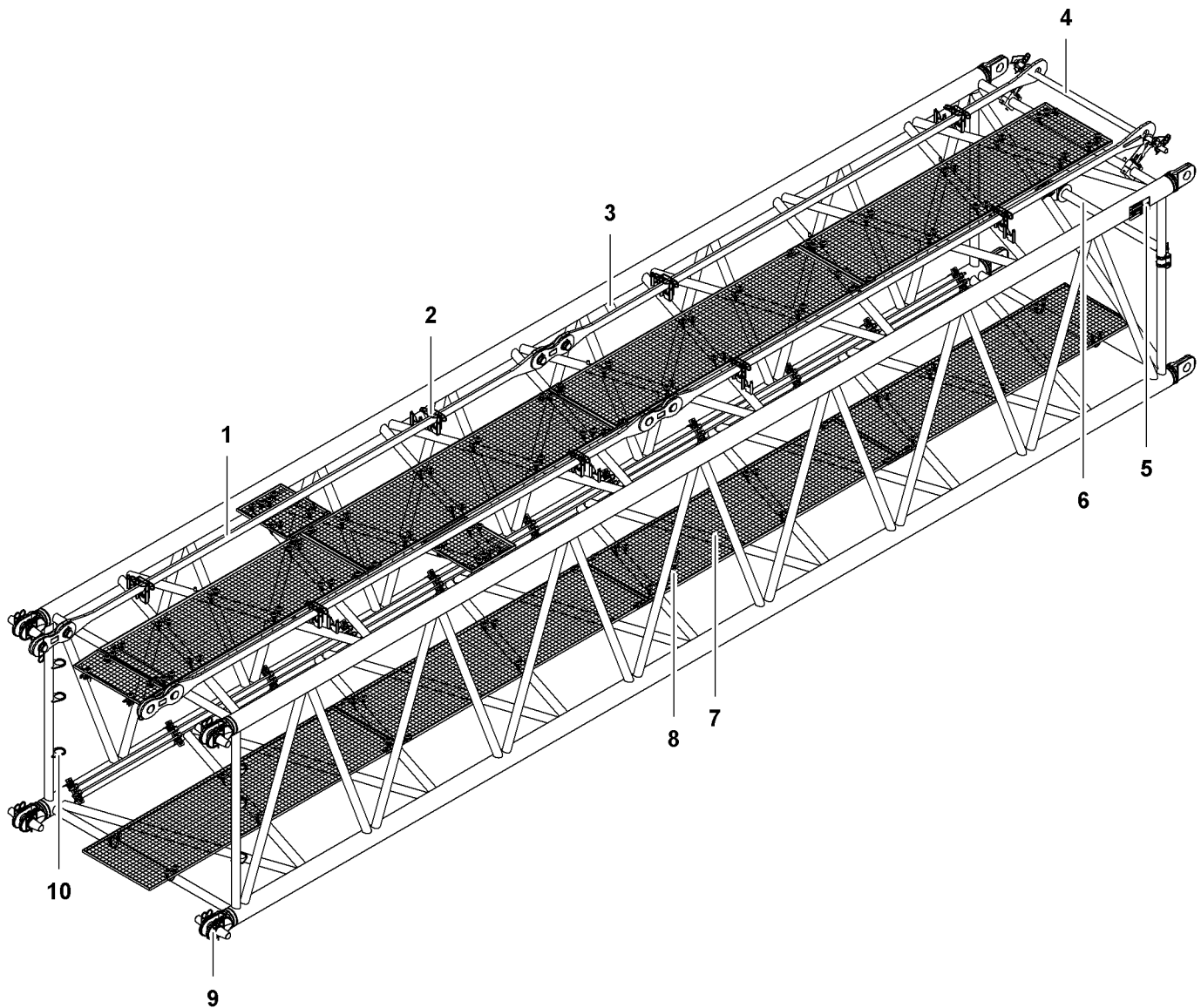


Fig. 413: Derrick boom section 2220.22 11.7 m (38 ft)

- | | | | | | |
|---|---|---|---------------------------|----|--|
| 1 | Transport position (2x) of derrick boom pendant straps 12 m (40 ft) | 5 | Derrick type plate | 9 | Pin connection point (8x) with double-taper pin (4x) |
| 2 | Transport bracket (8x) for derrick boom pendant straps 12 m (40 ft) | 6 | Rope protection roller | 10 | Transport bracket (4x) for double taper pin |
| 3 | Rigging point (4x) | 7 | Catwalk (8x) | | |
| 4 | Transport bracket derrick boom pendant straps | 8 | Boom identification plate | | |

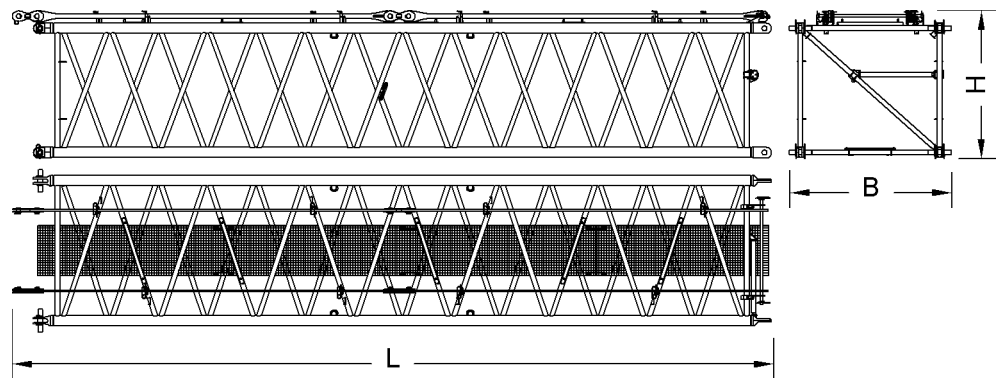


Fig. 414: Dimensions of derrick boom section 2220.22 11.7 m (38 ft)

Name		Value
System length		11700 mm 38' 5" ft-in
System width		2250 mm 7' 5" ft-in
System height		2000 mm 6' 7" ft-in
L	Length	11920 mm 39' 1" ft-in
B	Width	2420 mm 7' 11" ft-in
H	Height (incl. pendant straps)	2370 mm 7' 9" ft-in
Weight (incl. pendant straps)		3604 kg 7,945 lb
Double taper pin Ø		80 mm 3.15" in

Tab. 260: Technical data derrick boom section 2220.22 11.7 m (38 ft)

Derrick boom head 2220.22

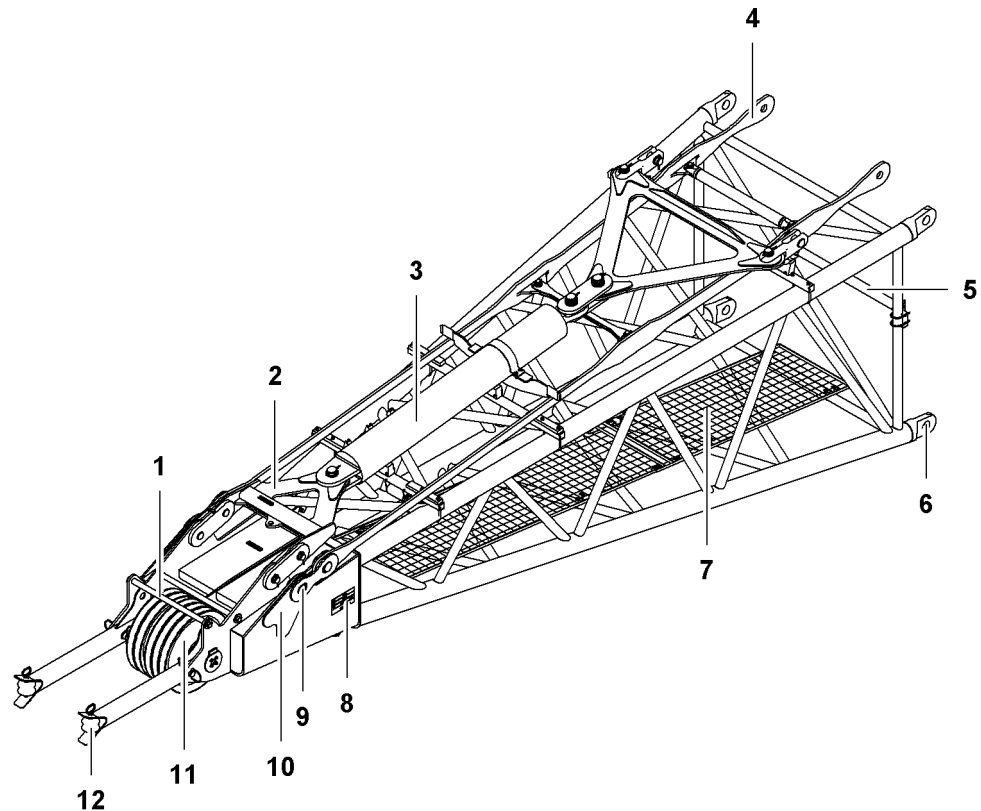


Fig. 415: Derrick boom head 2220.22

- | | | | |
|---|-------------------------------------|----|---|
| 1 | Rope protection pipe (2x) | 7 | Catwalk (2x) |
| 2 | Crossbar for derrick hoist cylinder | 8 | Derrick type plate |
| 3 | Derrick hoist cylinder | 9 | Crossbar pin connection (2x) with derrick boom head |
| 4 | Crossbar with connecting link | 10 | Reinforcement (4x) on the derrick boom head |
| 5 | Rope protection roller | 11 | Pulley (5x) |
| 6 | Pin connection point (4x) | 12 | Transport bracket (2x) for derrick rope rigging |

The crossbar 2 for the derrick hoist cylinder 3 is bolted onto a side of the derrick boom head with tension load cells.

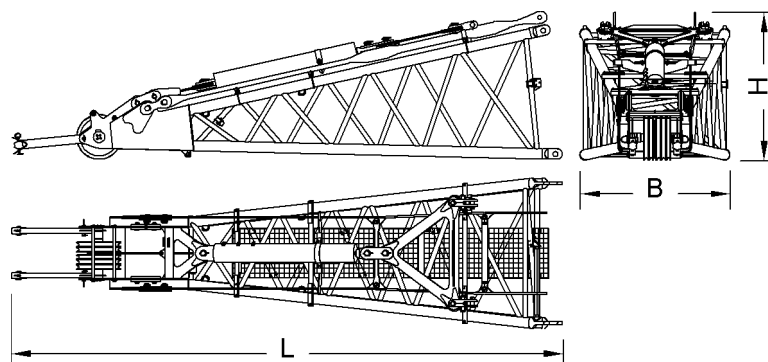


Fig. 416: Dimensions of the derrick boom head 2220.22

Name		Value
System length		7300 mm 23' 11" ft-in
System width		2250 mm 7' 5" ft-in
System height		2000 mm 6' 7" ft-in
L	Length	8880 mm 29' 2" ft-in
B	Width	2420 mm 7' 11" ft-in
H	Height (incl. pendant straps)	2380 mm 7' 10" ft-in
Weight (incl. pendant straps, crossbars, derrick hoist cylinder)		4490 kg 9,899 lb

Tab. 261: Technical data derrick boom head 2220.22

Derrick rope rigging with crossbar

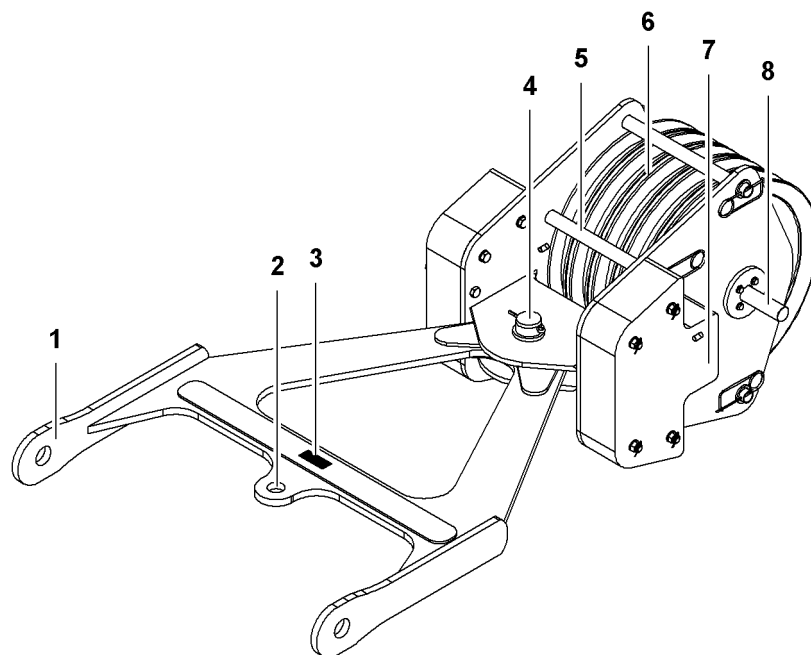


Fig. 417: Derrick rope rigging with crossbar

- | | | | |
|----------|---|----------|---------------------------|
| 1 | Crossbar | 5 | Rope protection pipe (4x) |
| 2 | Pivot point (max. 16 t (35,273 lb))
for hoist work during assembly | 6 | Pulley (5x) |
| 3 | Type designation LR 1300 | 7 | Counterweight weight (2x) |
| 4 | Pin Ø80 mm (3.15" in) | 8 | Axis |

For assembly work with the derrick rope rigging, a shackle or a swivel is attached to the pivot point **2** on the crossbar **1**.

For transport, the derrick rope rigging with the axis **8** is attached on both sides on the transport bracket on the derrick boom head.

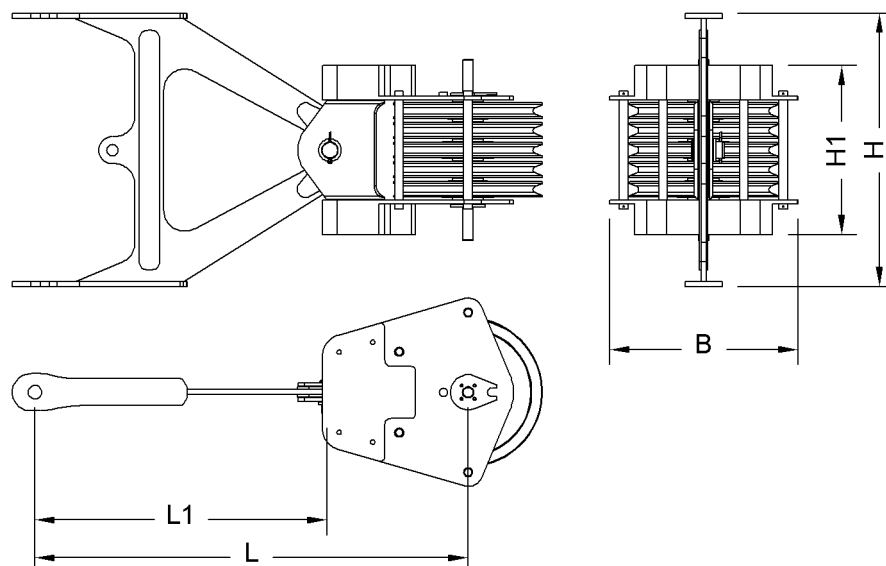


Fig. 418: Dimensions derrick rope rigging with crossbar

Name		Value
L	Length	2145 mm 7' ft-in
L1	Length of crossbar	1475 mm 4' 10" ft-in
B	Width of derrick rope rigging	914 mm 3' ft-in
H	Height of crossbar	1300 mm 4' 3" ft-in
H1	Height of derrick rope rigging	821 mm 2' 8" ft-in
Pulleys Ø		630 mm 2' 1" ft-in
Weight		1781 kg 3,926 lb

Tab. 262: Technical data derrick rope rigging with crossbar

Pendant straps on derrick boom 2220

Pendant straps on derrick boom section 2220.24 3 m (10 ft)

Adapter connecting link

Installation site in crane mode:

- Main boom 2821 + derrick boom 2220 (steel pendant straps) ([For more information see: A-frame1 to 2220 derrick boom head pendant straps, page 1361](#))
- Main boom 2821 + derrick boom 2220 (CF pendant straps) ([For more information see: A-frame1 to 2220 derrick boom head pendant straps, page 1365](#))

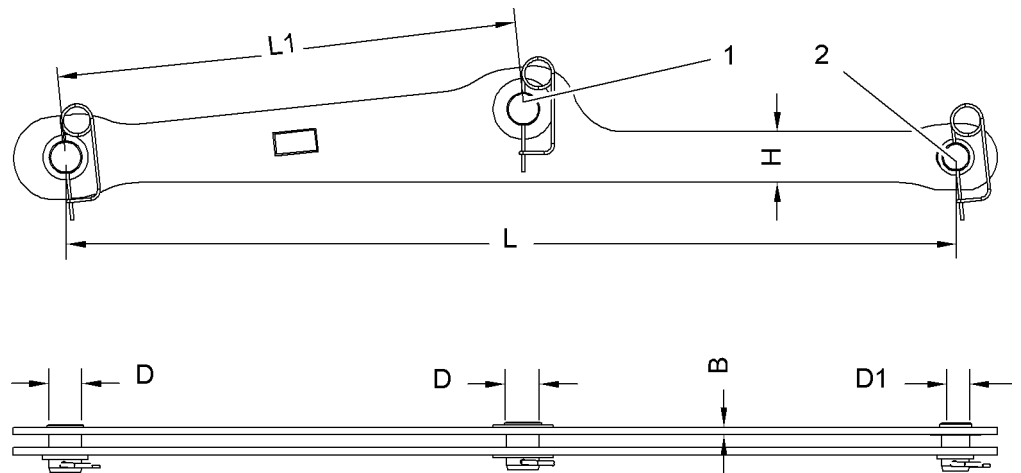


Fig. 419: Dimensions adapter connecting link

- 1 Pin connection point of A-frame1 equalizer - LR 1006 2 Pin connection point of A-frame1 equalizer - LR 1005

Name		Value
L	Length	1765 mm 5' 9" ft-in
L1	Length	913 mm 3' ft-in
B	Width	15 mm 0.59" in
H	Height	100 mm 3.94" in
D	Pin Ø	65 mm 2.56" in
D1	Pin Ø	55 mm 2.17" in
Weight		15 kg 33.07 lb

Tab. 263: Technical data adapter connecting links

Pendant straps on derrick boom section 2220.22 11.7 m (38 ft)

Derrick boom pendant strap 12 m (40 ft)

Installation site in crane mode:

- Main boom 2821 + derrick boom 2220 (steel pendant straps) ([For more information see: A-frame1 to 2220 derrick boom head pendant straps, page 1361](#))
- Main boom 2821 + derrick boom 2220 (CF pendant straps) ([For more information see: A-frame1 to 2220 derrick boom head pendant straps, page 1365](#))

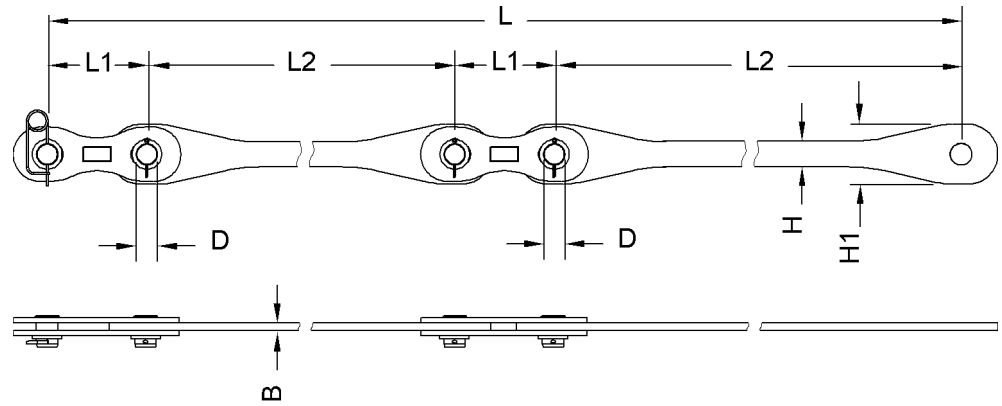


Fig. 420: Dimensions derrick boom pendant strap 12 m (40 ft)

Name		Value
L	Length	12000 mm 39' 4" ft-in
L1	Length of connecting link	300 mm 1' ft-in
L2	Length of pendant strap	5700 mm 18' 8" ft-in
B	Width of pendant strap	25 mm 0.98" in
H	Height of pendant strap	77 mm 3.03" in
H1	Height of pendant strap	180 mm 7.09" in
D	Pin Ø	65 mm 2.56" in
Weight		228 kg 503 lb

Tab. 264: Technical data derrick boom pendant strap 12 m (40 ft)

Pendant straps on derrick boom head 2220.22

Derrick boom pendant strap (crossbar)

Installation site in crane mode:

- Main boom 2821 + derrick boom 2220 (steel pendant straps) (For more information see: [A-frame1 to 2220 derrick boom head pendant straps, page 1361](#))
- Main boom 2821 + derrick boom 2220 (CF pendant straps) (For more information see: [A-frame1 to 2220 derrick boom head pendant straps, page 1365](#))

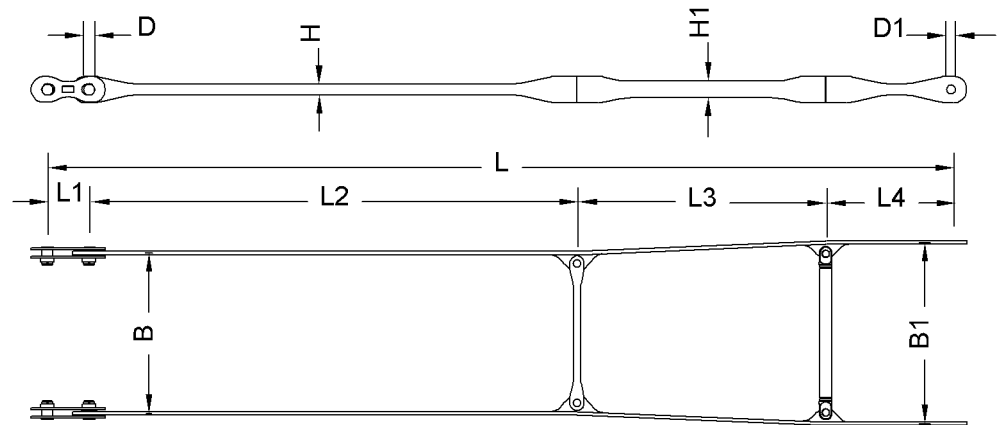


Fig. 421: Dimensions derrick boom pendant strap (crossbar)

Name		Value
L	Length	6500 mm 21' 4" ft-in
L1	Length of connecting link	300 mm 1' ft-in
L2	Length	3510 mm 11' 6" ft-in
L3	Length	1790 mm 5' 10" ft-in
L4	Length	900 mm 2' 11" ft-in
B	Width of crossbar	1150 mm 3' 9" ft-in
B1	Width of crossbar	1300 mm 4' 3" ft-in
H	Height of pendant strap	77 mm 3.03" in
H1	Height of pendant strap	120 mm 4.72" in
D	Pin Ø	75 mm 2.95" in
D1	Pin Ø	65 mm 2.56" in
Weight		175 kg 386 lb

Tab. 265: Technical data derrick boom pendant strap (crossbar)

1.28.3 Suspended counterweight

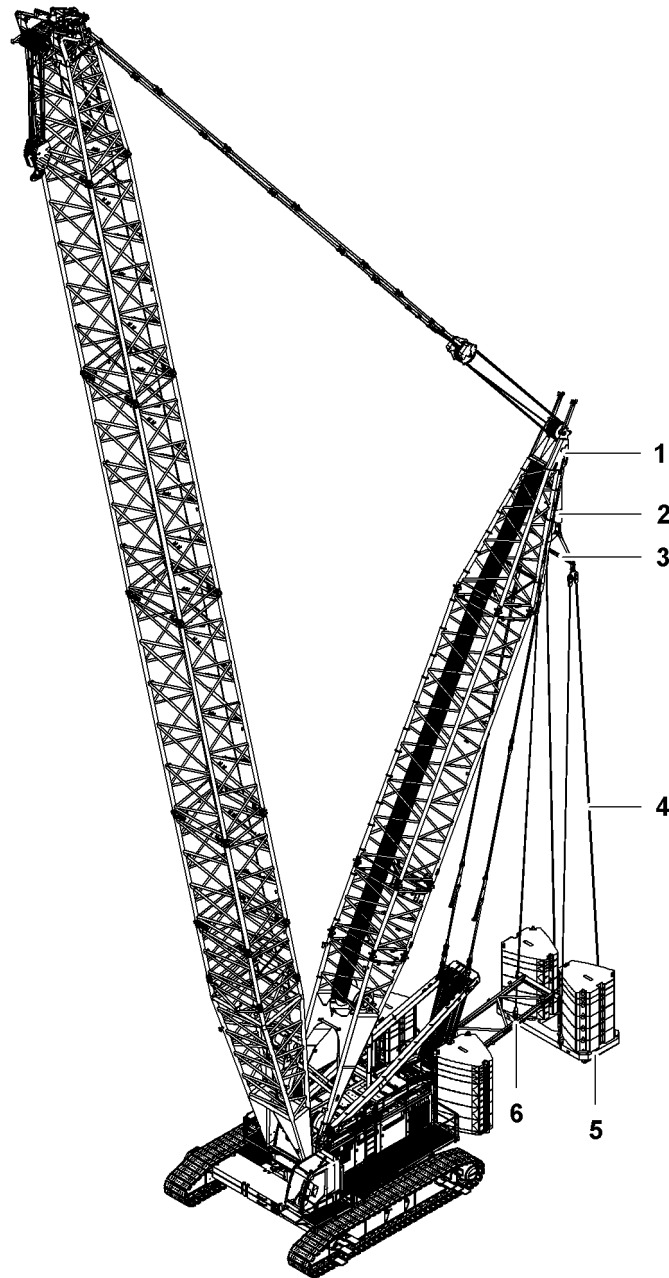


Fig. 422: Overview suspended counterweight

- | | | | |
|---|------------------------|---|---------------------------------------|
| 1 | Derrick boom | 4 | Suspended counterweight pendant ropes |
| 2 | Derrick hoist cylinder | 5 | Counterweight frame |
| 3 | Crossbar | 6 | Spacer frame |

The spacer frame **6** defines the radius of the suspended counterweight during rotating and moving. It is installed between the uppercarriage and the suspended counterweight **4** pendant ropes. To ensure correct positioning of the spacer frame **6**, it is installed with folding brackets and rope clamps on the front suspended counterweight pendant ropes **4**.

The four suspended counterweight pendant ropes **4** have a diameter of 34 mm (1.34" in) and a length of 21.5 m (70' 6" ft-in). They are installed between the spacer frame **6** and the crossbar **3**.

LWNLR-x\04.01\Auslieferung\2016-03-07/en

The derrick hoist cylinder **1** installed on the derrick boom **2** allows lifting of the suspended counterweight by up to 2 m (6' 7" ft-in).

By placing counterweight slabs on the counterweight frame **5**, a maximum counterweight of 120 t (264,551 lb) can be realized.

Spacer frame

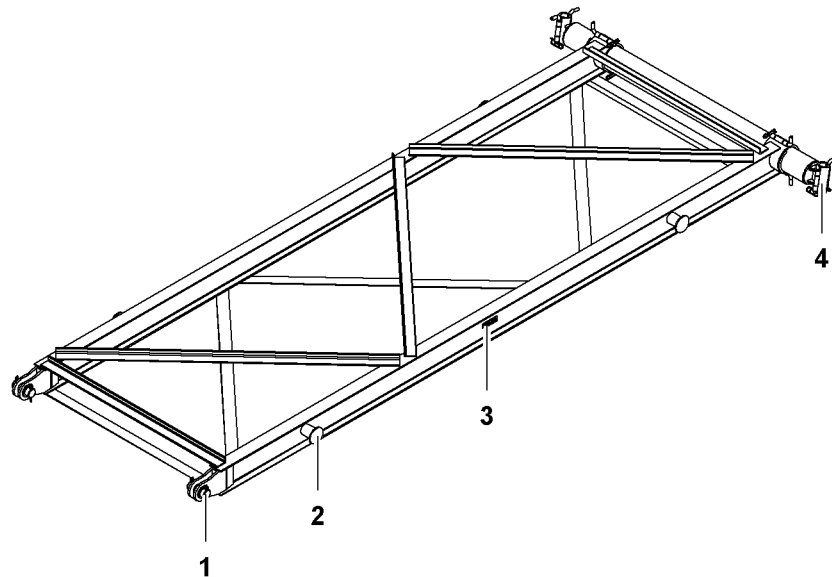


Fig. 423: Spacer frame

- | | | | |
|----------|------------------------------------|----------|--------------------------|
| 1 | Pivot point (2x) for uppercarriage | 3 | Type designation LR 1300 |
| 2 | Rigging point (4x) | 4 | Rope attachment (2x) |

The pendant ropes are connected with the spacer frame on the two rope attachments **4**.

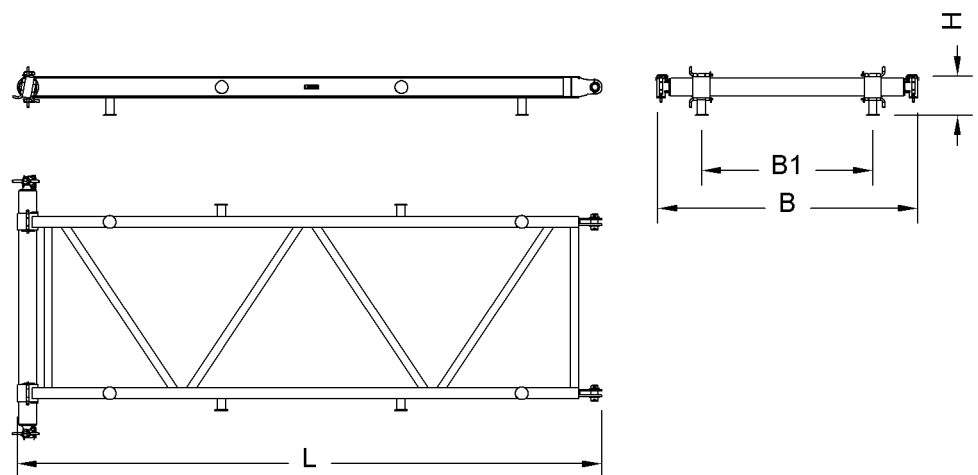


Fig. 424: Dimensions of spacer frame

Name		Value
L	Length	5533 mm 18' 2" ft-in

LWNLR.x/V04.01//Auslieferung/2016-03-07/en

Name		Value
B	Width	2469 mm 8' 1" ft-in
B1	Width	1620 mm 5' 4" ft-in
H	Height	368 mm 1' 2" ft-in
Weight		484 kg 1,067 lb

Tab. 266: Technical data spacer frame

Counterweight frame

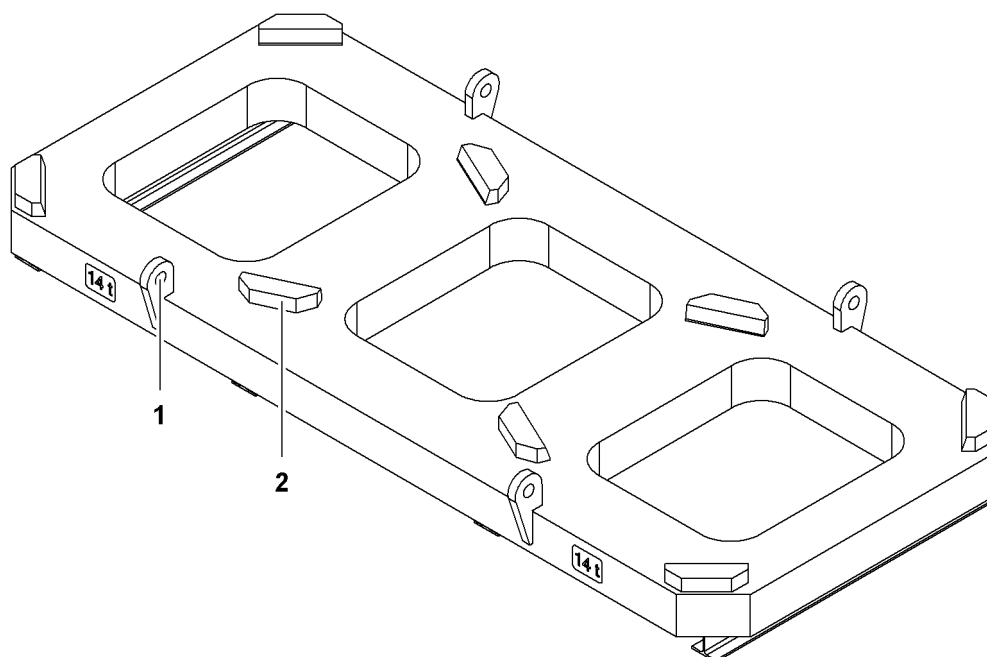


Fig. 425: Counterweight frame

- 1** Pin connection point (4x) for pendant ropes **2** Locking device (8x)

The Locking devices **2** prevent sliding of the counterweight slabs.

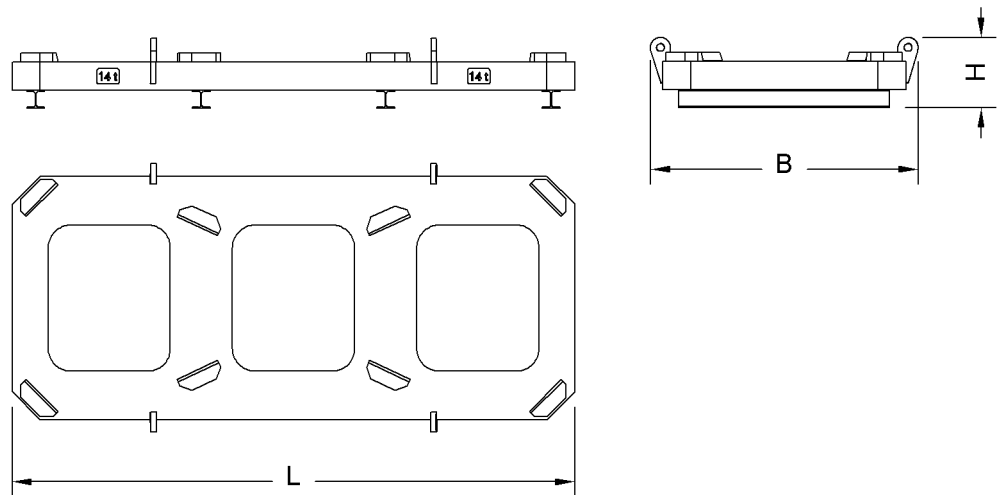


Fig. 426: Dimensions counterweight frames

Name		Value
L	Length	2170 mm 7' 1" ft-in
B	Width	5020 mm 16' 6" ft-in
H	Height	626 mm 2' 1" ft-in
Weight		13700 kg 30,203 lb

Tab. 267: Technical data counterweight frame

Counterweight slab 10 t (22,046 lb)

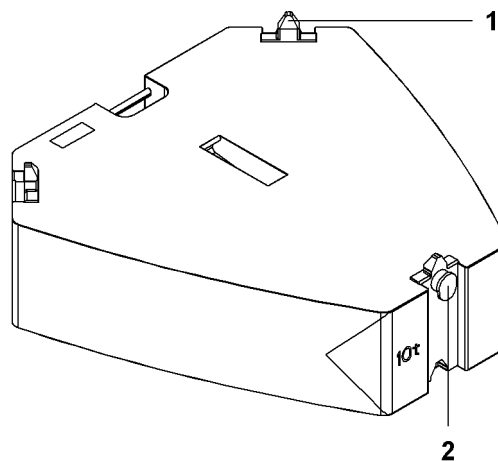


Fig. 427: Counterweight slab 10 t (22,046 lb)

- 1** Locking device (3x)
- 2** Rigging point (3x)

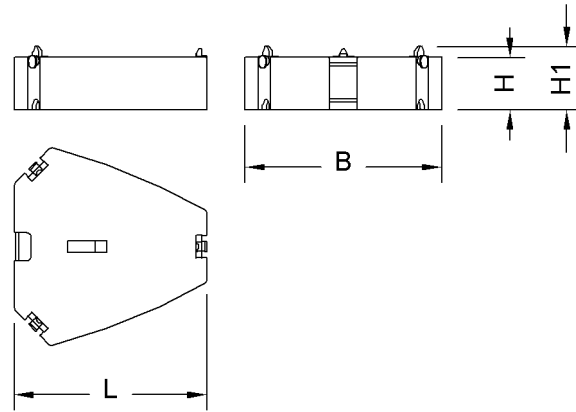


Fig. 428: Dimensions counterweight slab 10 t (22,046 lb)

Name		Value
L	Length	2050 mm 6' 9" ft-in
B	Width	2117 mm 6' 11" ft-in
H	Height	560 mm 1' 10" ft-in
H1	Height incl. locking devices	680 mm 2' 3" ft-in
Weight		10000 kg 22,046 lb

Tab. 268: Technical data counterweight slab 10 t (22,046 lb)

Counterweight slab 5 t (11,023 lb)

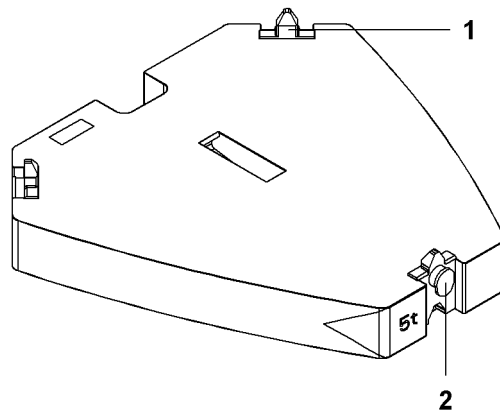


Fig. 429: Counterweight slab 5 t (11,023 lb)

- 1 Locking device (3x) 2 Rigging point (3x)

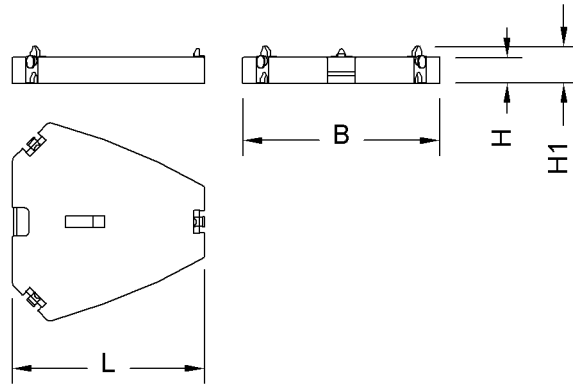


Fig. 430: Dimensions counterweight slab 5 t (11,023 lb)

Name		Value
L	Length	2050 mm 6' 9" ft-in
B	Width	2117 mm 6' 11" ft-in
H	Height	275 mm 10.83" in
H1	Height incl. locking devices	395 mm 1' 4" ft-in
Weight		5000 kg 11,023 lb

Tab. 269: Technical data counterweight slab 5 t (11,023 lb)

1.28.4 Counterweight carriage

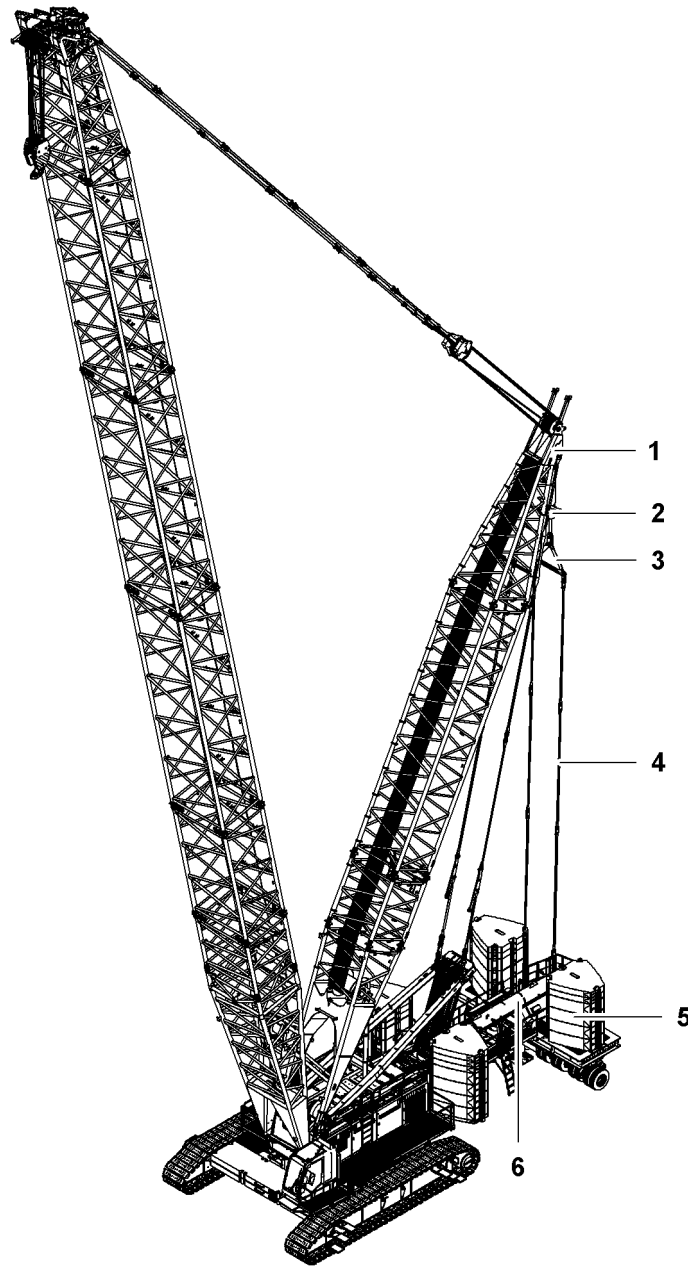


Fig. 431: Overview of counterweight carriage

- | | | | |
|---|------------------------|---|---------------------------------------|
| 1 | Derrick boom | 4 | Counterweight carriage pendant straps |
| 2 | Derrick hoist cylinder | 5 | Counterweight carriage |
| 3 | Crossbar | 6 | Extension device |

The counterweight carriage **5** is permanently pinned to the uppercarriage.

The wheel sets allow the counterweight to be pulled along and turned, even when the counterweight carriage pendant straps **4** are slack.

The counterweight carriage pendant straps **4** are installed with the connecting links between the counterweight carriage **5** and the crossbar **3**.

The derrick hoist cylinder **1** installed on the derrick boom **2** allows lifting the counterweight carriage **5** and/or careful addition of counterweight to the derrick boom **1**.

The hydraulic telescopic extension device **5** of the counterweight carriage **5** allows adjusting the radius between rotation axis and counterweight from 12.15 m (39' 10" ft-in) to 15.75 m (51' 8" ft-in).

By placing counterweight slabs on the counterweight carriage **6**, a maximum counterweight of 120 t (264,551 lb) can be realized.

Extension device

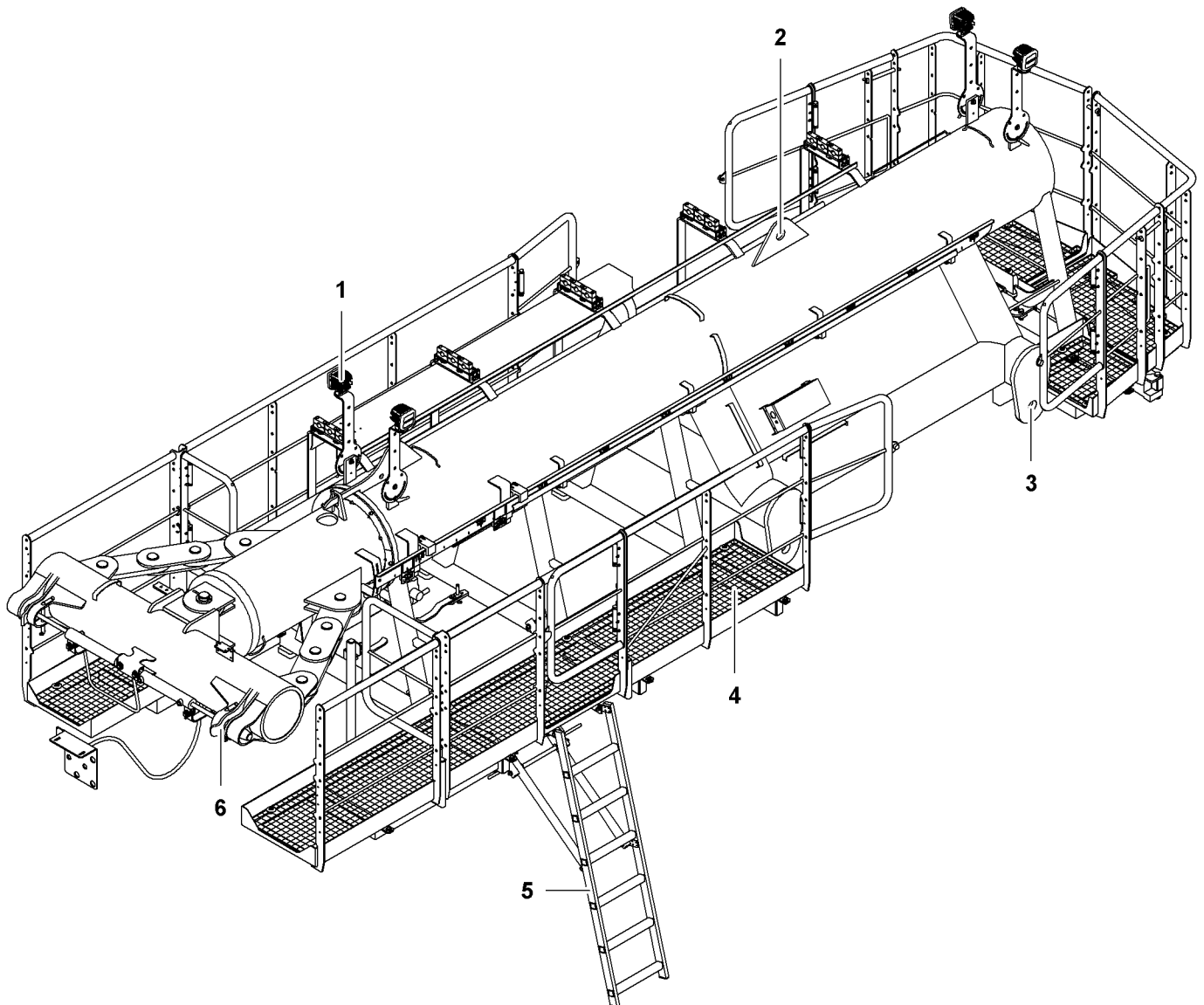


Fig. 432: Extension device

- | | | | | | |
|----------|--------------------|----------|--|----------|---|
| 1 | Floodlight (4x) | 3 | Pin connection point (4x) for counterweight carriage | 5 | Ladder |
| 2 | Rigging point (2x) | 4 | Platform and catwalks | 6 | Pin connection point (2x) for basic machine |

Product description

Derrick equipment*

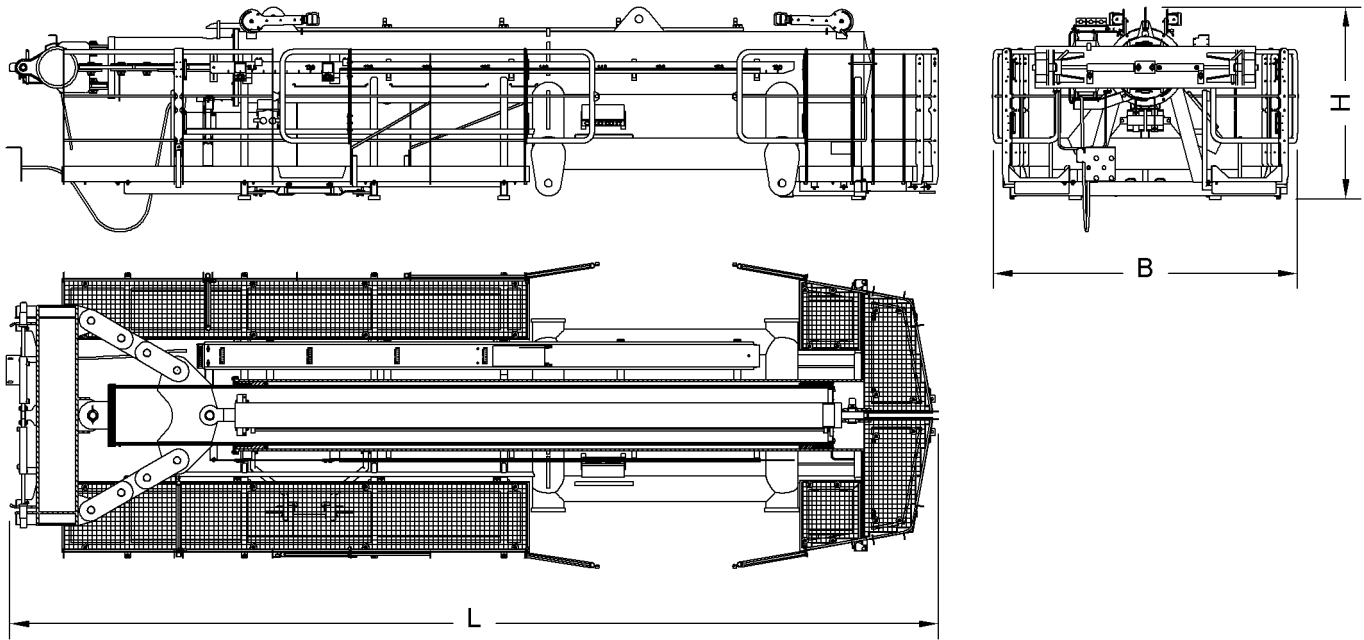


Fig. 433: Dimensions extension device

Name		Value
L	Length	7950 mm 26' 1" ft-in
B	Width	2620 mm 8' 7" ft-in
H	Height	1645 mm 5' 5" ft-in
Weight		6700 kg 14,771 lb

Tab. 270: Technical data extension device

LWNLR-x/V04.01//Auslieferung/2016-03-07/en

Counterweight carriage

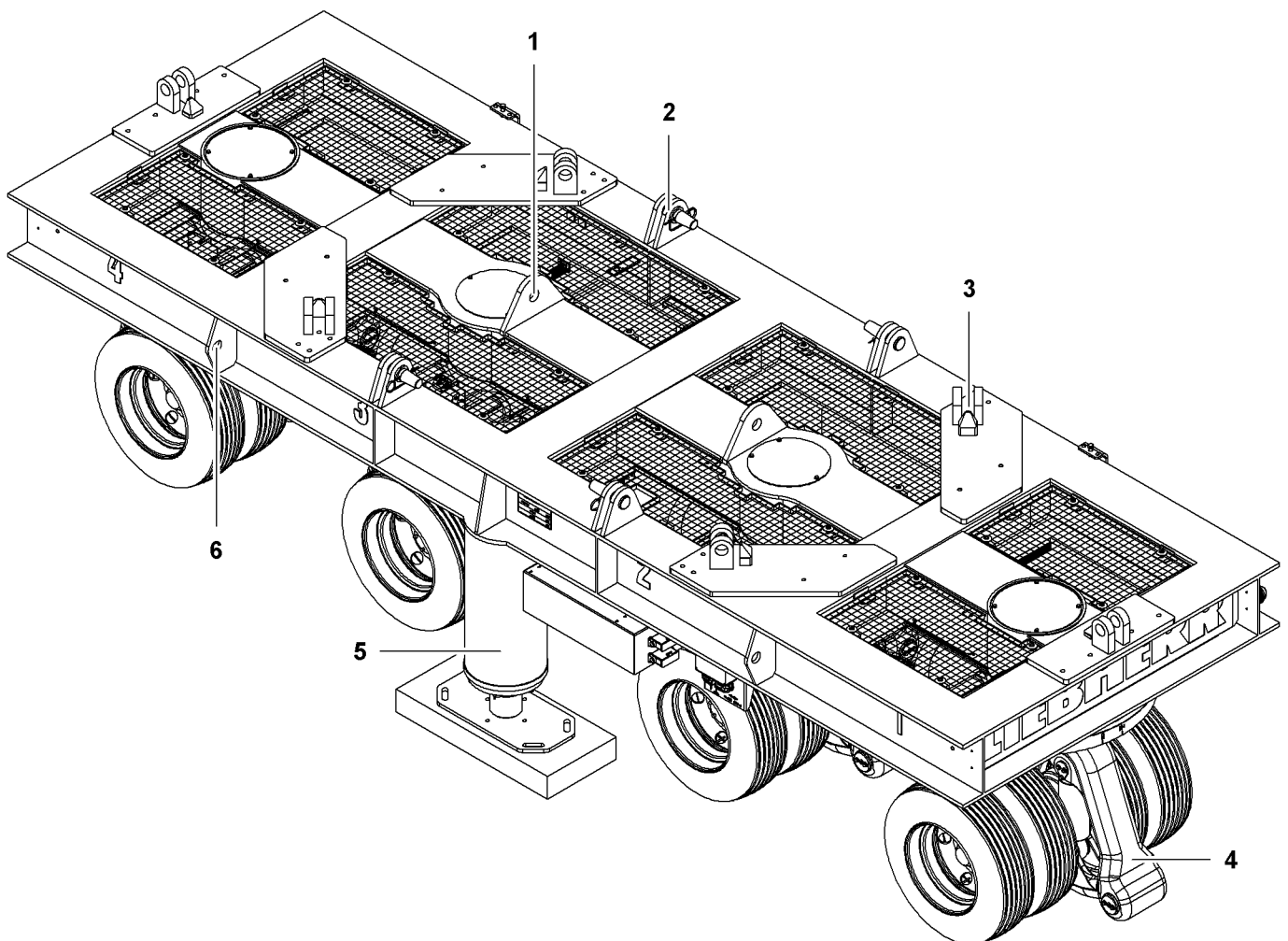


Fig. 434: Counterweight carriage

- | | | | | | |
|---|---|---|--|---|--------------------|
| 1 | Pin connection point (2x) for counterweight carriage pendant straps | 3 | Locking device aid and backstay shackle (6x) | 5 | Jack (2x) |
| 2 | Pin connection point (4x) for extension device | 4 | Wheel set (4x) | 6 | Rigging point (4x) |

The counterweight carriage is equipped with four turning wheel sets **4**, which enable the uppercarriage to be moved and turned.

In order to also be able to align the wheel sets **4** when fully ballasted, all wheel sets **4** must be suspended using both jacks **5**.

The Locking device aids **3** prevent the counterweight slabs from sliding to the side. The counterweight slabs are additionally lashed on the backstay shackles **3**.

Product description

Derrick equipment*

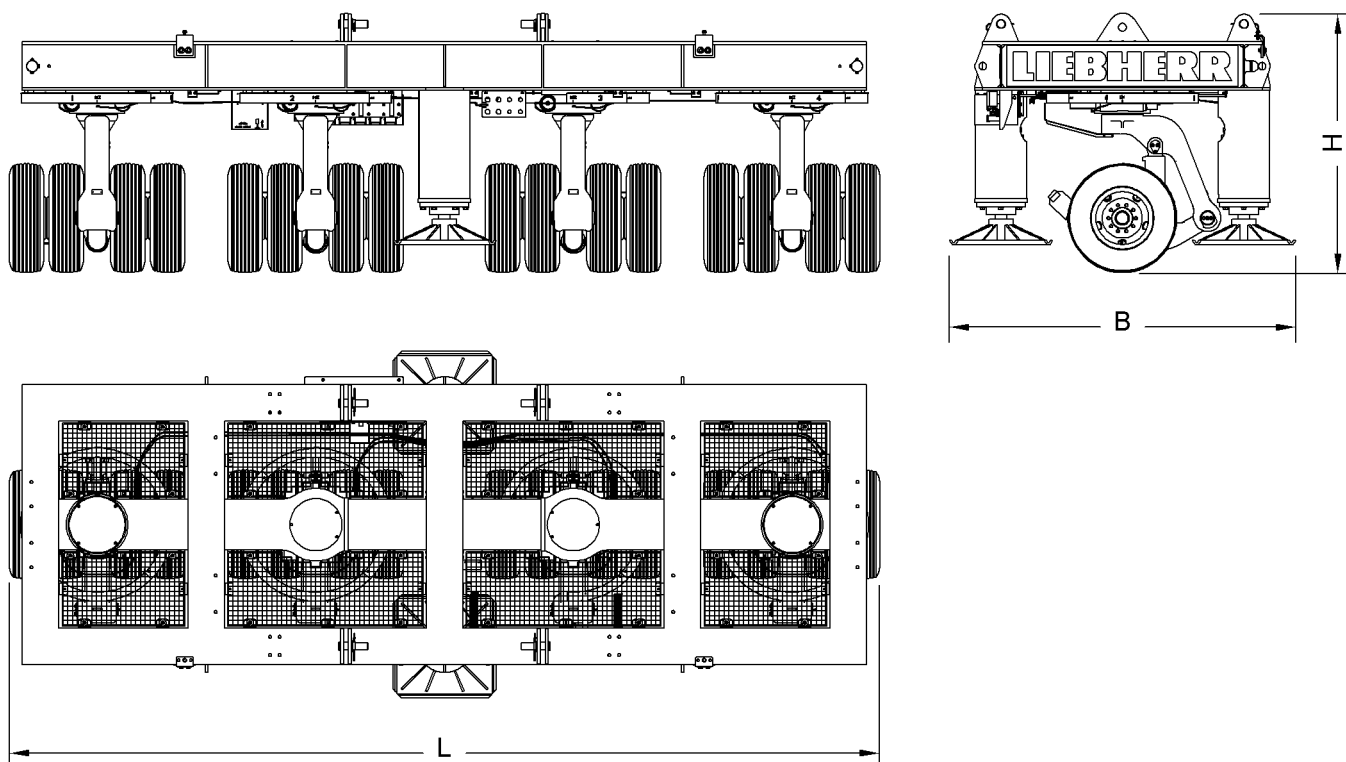


Fig. 435: Dimensions counterweight carriage

Name		Value
L	Length	7167 mm 23' 6" ft-in
B	Width	2850 mm 9' 4" ft-in
H	Height	2130 mm 7' ft-in
Weight		12187 kg 26,867 lb

Tab. 271: Technical data counterweight carriage

LWNLR-x/V04.01//Auslieferung/2016-03-07/en

Counterweight slab 10 t (22,046 lb)

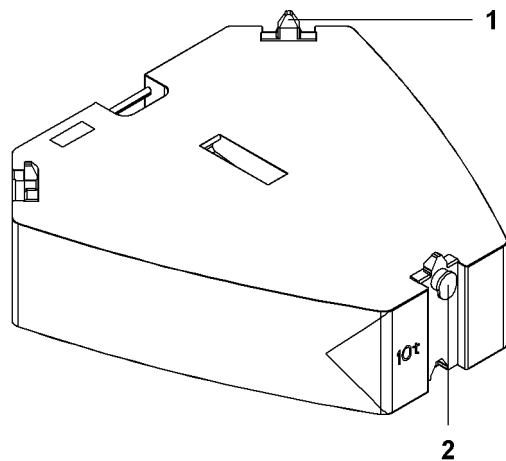


Fig. 436: Counterweight slab 10 t (22,046 lb)

- 1 Locking device (3x)
- 2 Rigging point (3x)

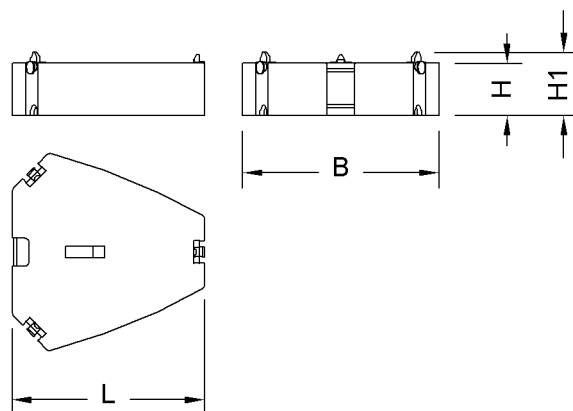


Fig. 437: Dimensions counterweight slab 10 t (22,046 lb)

Name		Value
L	Length	2050 mm 6' 9" ft-in
B	Width	2117 mm 6' 11" ft-in
H	Height	560 mm 1' 10" ft-in
H1	Height incl. locking devices	680 mm 2' 3" ft-in
Weight		10000 kg 22,046 lb

Tab. 272: Technical data counterweight slab 10 t (22,046 lb)

LWNLR.x/V04.01//Auslieferung/2016-03-07/en

Counterweight slab 5 t (11,023 lb)

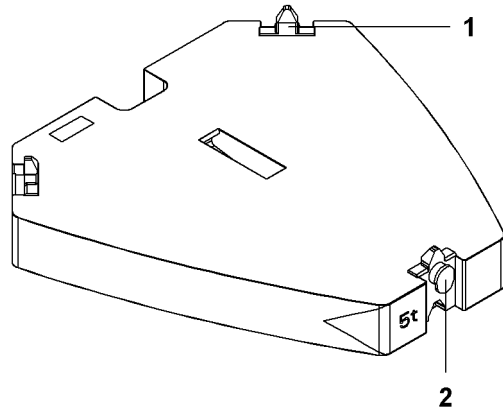


Fig. 438: Counterweight slab 5 t (11,023 lb)

- 1 Locking device (3x) 2 Rigging point (3x)

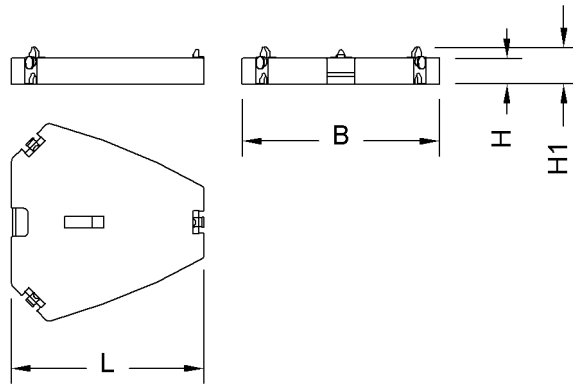


Fig. 439: Dimensions counterweight slab 5 t (11,023 lb)

Name		Value
L	Length	2050 mm 6' 9" ft-in
B	Width	2117 mm 6' 11" ft-in
H	Height	275 mm 10.83" in
H1	Height incl. locking devices	395 mm 1' 4" ft-in
Weight		5000 kg 11,023 lb

Tab. 273: Technical data counterweight slab 5 t (11,023 lb)

LWNLR-x/V04.01//Auslieferung/2016-03-07/en

1.29 Rope fixation

1.29.1 Main boom head

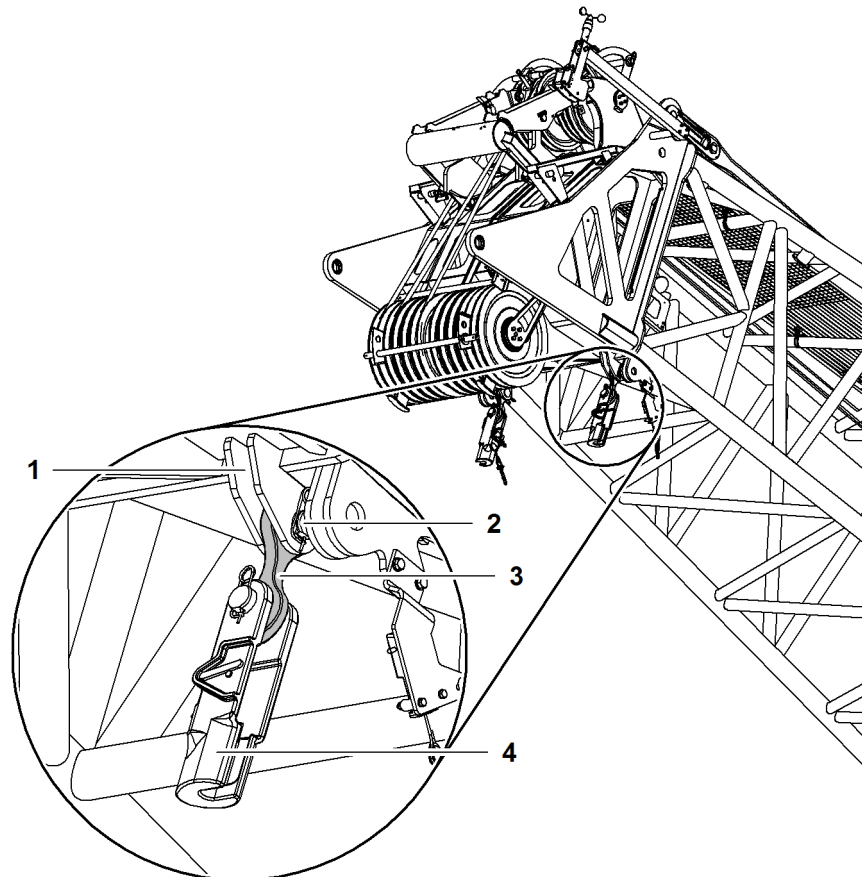


Fig. 440: Rope fixing point on main boom head (illustration of principle)

- | | | | |
|---|--|---|-------------|
| 1 | Pivot point (4x) for rope fixing point | 3 | Cross link |
| 2 | Pin for rope fixing point | 4 | Pocket lock |

1.29.2 Fixed jib head

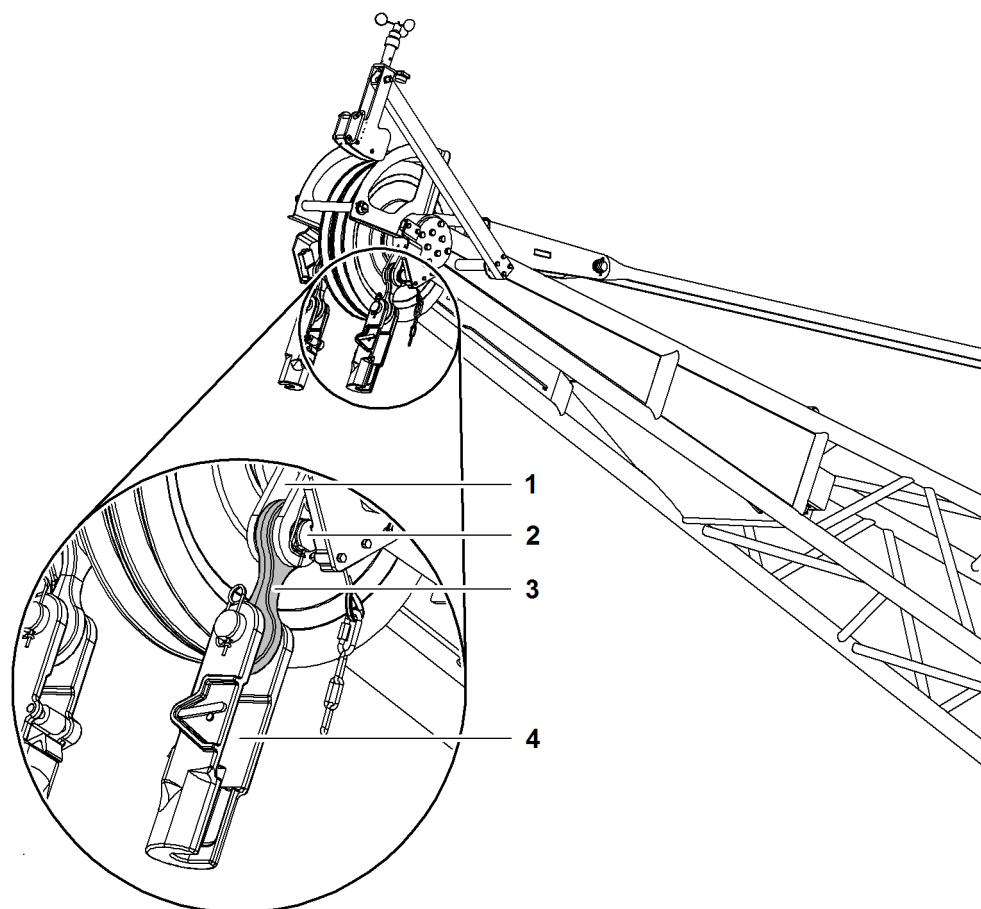


Fig. 441: Rope fixing point on fixed jib head (illustration of principle)

- | | | | |
|---|--|---|-------------|
| 1 | Pivot point (2x) for rope fixing point | 3 | Cross link |
| 2 | Pin for rope fixing point | 4 | Pocket lock |

The components of the rope fixing point are identical for the main boom head and the jib head.

1.29.3 Luffing jib head

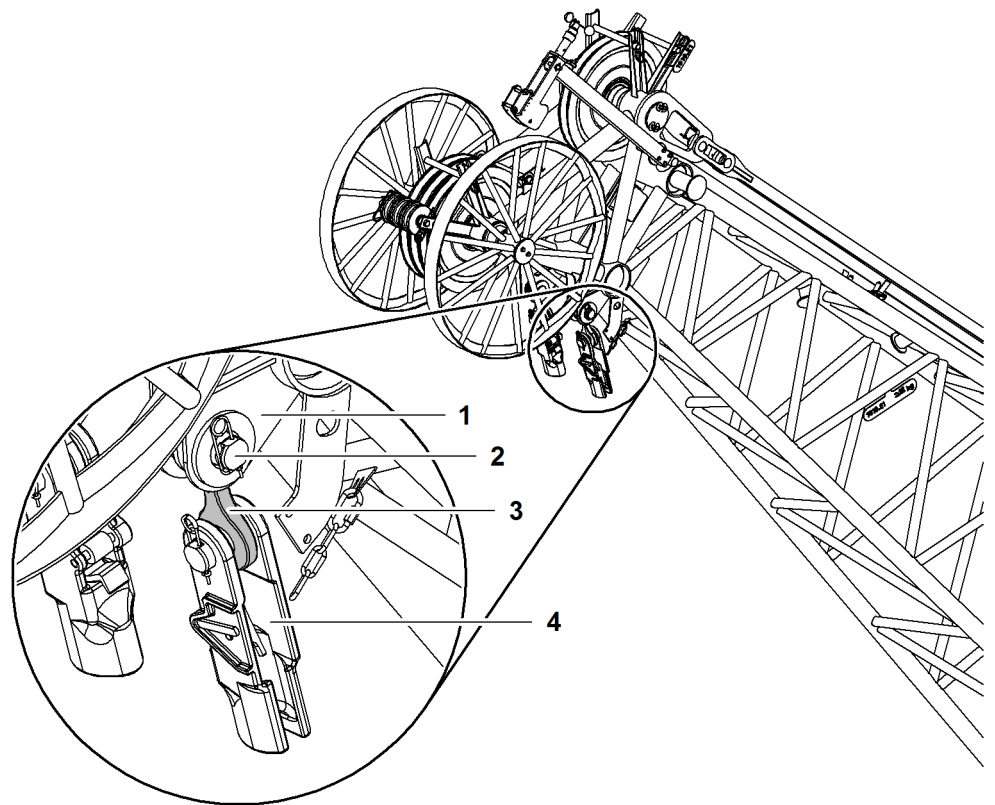


Fig. 442: Rope fixing point on luffing jib head (illustration of principle)

- | | | | |
|---|--|---|-------------|
| 1 | Pivot point (2x) for rope fixing point | 3 | Cross link |
| 2 | Pin for rope fixing point | 4 | Pocket lock |

The components of the rope fixing point are identical for the main boom head and the jib head.

1.29.4 Auxiliary jib (36 t (79.300 lb)) on main boom head

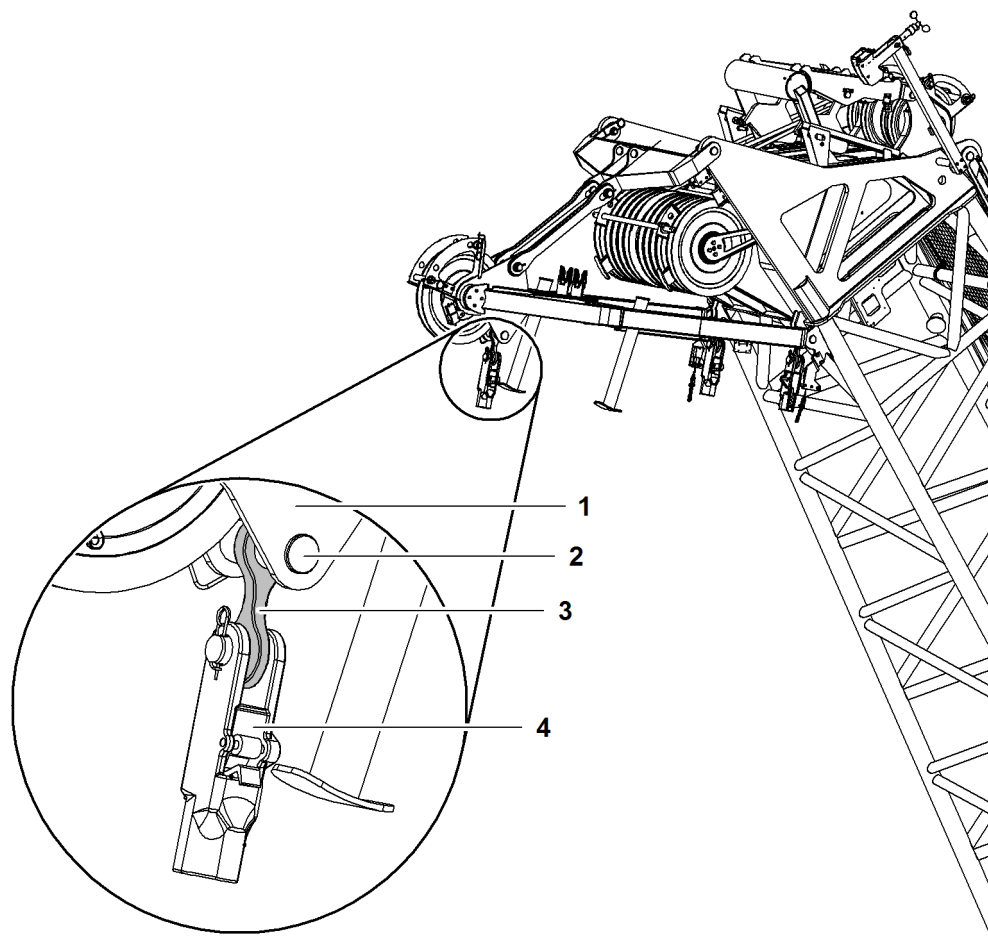


Fig. 443: Rope fixing point on auxiliary jib (36 t (79.300 lb)) (illustration of principle)

- | | | | |
|---|-----------------------------------|---|-------------|
| 1 | Pivot point for rope fixing point | 3 | Cross link |
| 2 | Pin for rope fixing point | 4 | Pocket lock |

The components of the rope fixing point are identical for the main boom head and the auxiliary jib (36 t (79.300 lb)).

1.29.5 Auxiliary jib (15 t (33.000 lb)) on jib head

There is no rope fixing point on the auxiliary jib (15 t (33.000 lb)) because reeving is only done once.

1.29.6 Midfall

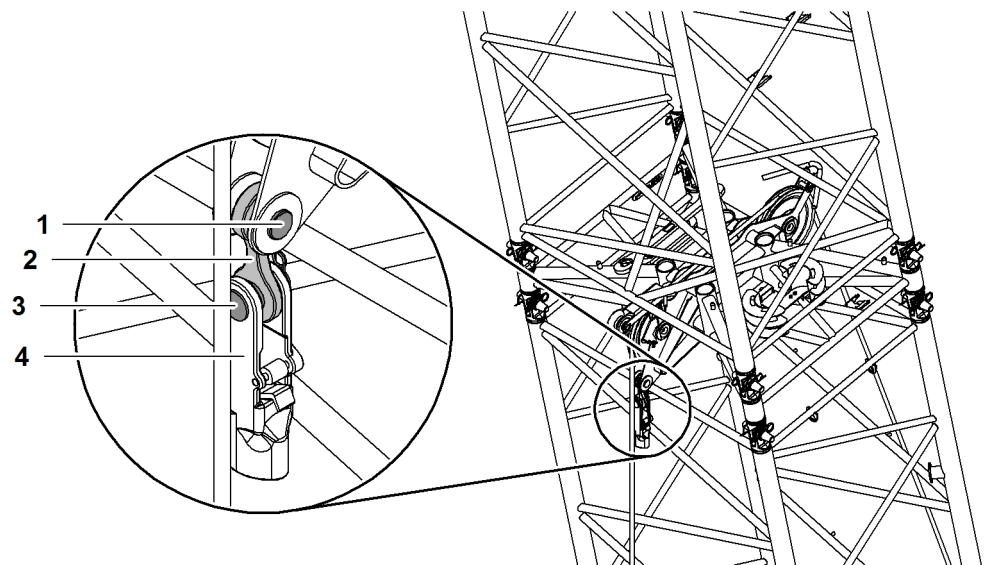


Fig. 444: Rope fixing point on midfall (illustration of principle)

- | | |
|-----------------------------|------------------------|
| 1 Pin for rope fixing point | 3 Pins for pocket lock |
| 2 Cross link | 4 Pocket lock |

The components of the rope fixing point are identical for the jib head and the midfall.

1.29.7 Pocket lock

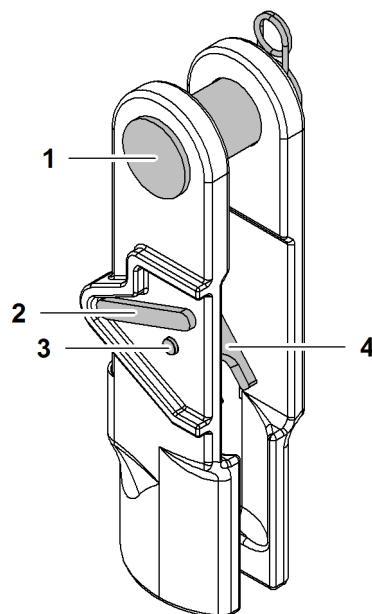


Fig. 445: Pocket lock

- | | |
|----------------|------------------|
| 1 Pin | 3 Safety button |
| 2 Safety latch | 4 Locking device |

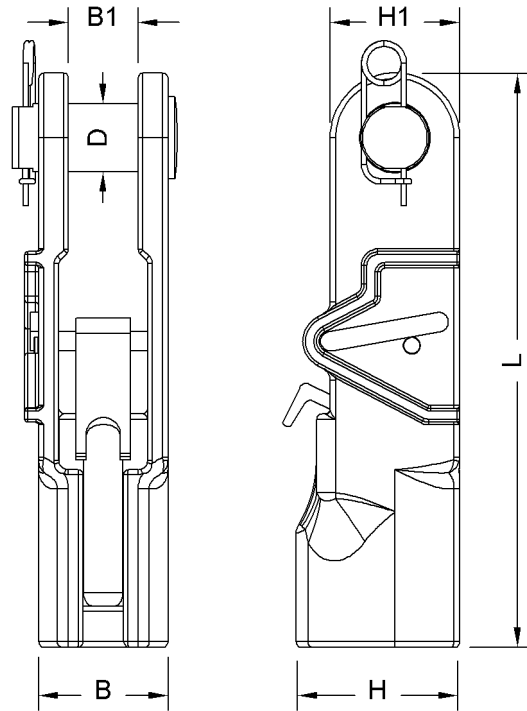


Fig. 446: Pocket lock dimensions

Designation		Value
L	Length	533 mm 1' 9" ft-in
B	Width	107 mm 4.21" in
B1	Width	57 mm 2.24" in
H	Height	142 mm 5.59" in
H1	Height	95 mm 3.74" in
D	Pin Ø	57 mm 2.24" in
Weight		28.8 kg 63.49 lb
Rope Ø		27 mm (1.06" in) to 29 mm (1.14" in)

Tab. 274: Pocket lock technical data

LWN/LR-x/V04.01//Auslieferung/2016-03-07/en

1.29.8 Cross strap

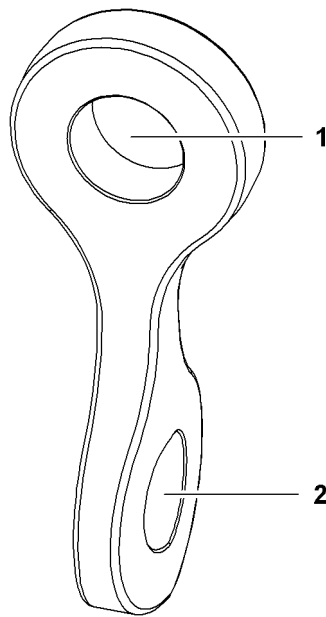


Fig. 447: Cross strap

1 Pivot point on boom head (Ø 52 mm (2.05" in))

2 Pivot point on pocket lock (Ø 58 mm (2.28" in))

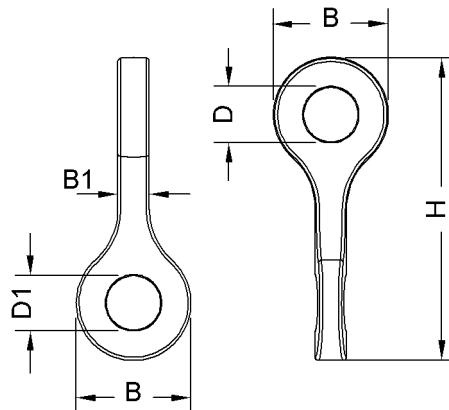


Fig. 448: Cross strap dimensions

Designation		Value
B	Width	110 mm 4.33" in
B1	Width	30 mm 1.18" in
H	Height	290 mm 11.42" in
D	Pin Ø	52 mm 2.05" in
D1	Pin Ø	58 mm 2.28" in

LWNLR.x/V04.01/Auslieferung/2016-03-07/en

Designation	Value
Weight	4.7 kg 10.36 lb

Tab. 275: Cross strap technical data

1.29.9 Pins for the rope fixing point

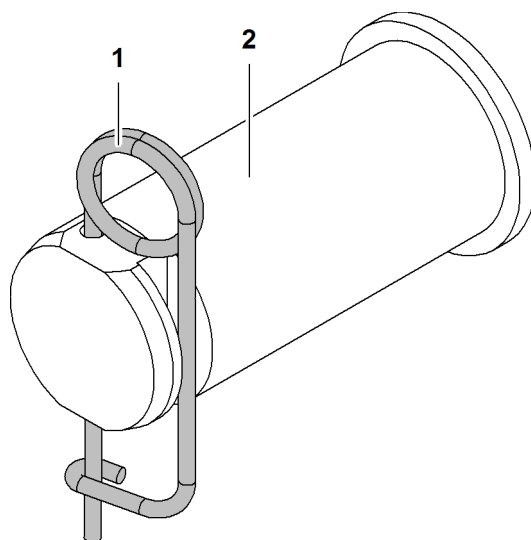


Fig. 449: Pins for the rope fixing point

- 1 Locking spring
- 2 Pin
- 3 Pin collar

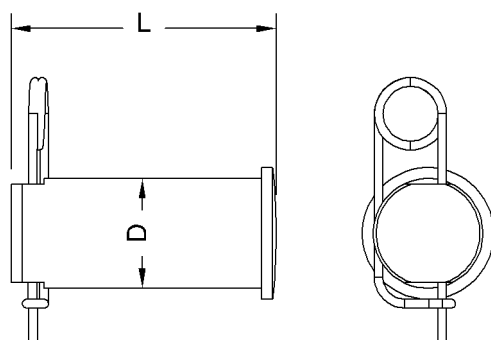


Fig. 450: Dimensions of the pins for the rope fixing point

Designation	Value
L Length	115 mm 4.53" in
D Pin Ø	50 mm 1.97" in
Weight	2 kg 4.41 lb

Tab. 276: Technical data: rope fixing point pins

LWNLR-x/V04.01//Auslieferung/2016-03-07/en

1.30 Pulley block/hook*

1.30.1 Pulley block (300 t (661,377 lb))

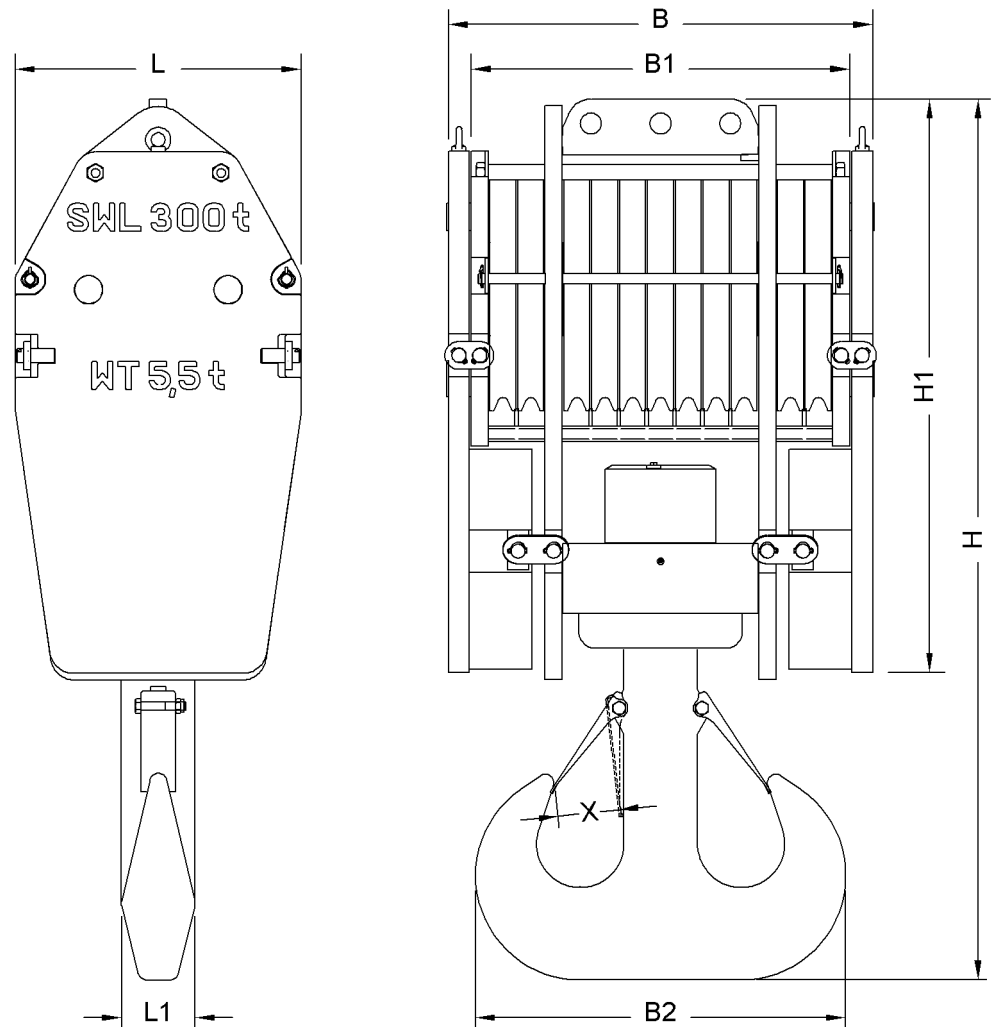


Fig. 451: Pulley block dimensions (300 t (661,377 lb))

Name		Value
L	Pulley block length	820 mm 2' 8" ft-in
L1	Hook length	212 mm 8.35" in
B	Pulley block width with additional weights	1227 mm 4' ft-in
B1	Width of pulley block without additional weights	1097 mm 3' 7" ft-in
B2	Hook width	1062 mm 3' 6" ft-in

Name		Value
H	Height of pulley block with hook	2523 mm 8' 3" ft-in
H1	Height of pulley block without hook	1665 mm 5' 6" ft-in
X	Jaw width	175 mm 6.89" in
Weight with additional weights		5500 kg 12,125 lb
Weight without additional weights		3200 kg 7,055 lb
Maximum reeving		23
Rope Ø		28 mm 1.10" in

Tab. 277: Technical data pulley block (300 t (661,377 lb))

1.30.2 Pulley block (160 t (352,734 lb))

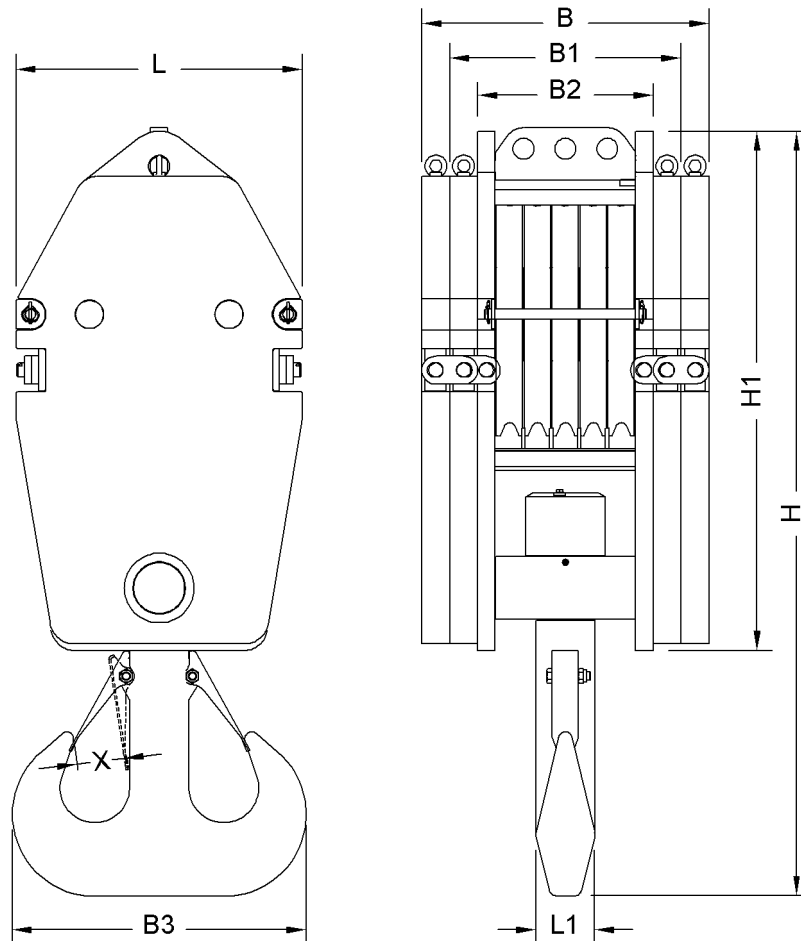


Fig. 452: Pulley block dimensions (160 t (352,734 lb))

LWNLR-x/V04.01//Auslieferung/2016-03-07/en

Name		Value
L	Pulley block length	820 mm 2' 8" ft-in
L1	Hook length	170 mm 6.69" in
B	Pulley block width with four additional weights	823 mm 2' 8" ft-in
B1	Pulley block width with two additional weights	663 mm 2' 2" ft-in
B2	Width of pulley block without additional weights	503 mm 1' 8" ft-in
B3	Hook width	842 mm 2' 9" ft-in
H	Height of pulley block with hook	2205 mm 7' 3" ft-in
H1	Height of pulley block without hook	1490 mm 4' 11" ft-in
X	Jaw width	135 mm 5.31" in
Weight with four additional weights		4000 kg 8,818 lb
Weight with two additional weights		2800 kg 6,173 lb
Weight without additional weights		1600 kg 3,527 lb
Maximum reeving		11
Rope Ø		28 mm 1.10" in

Tab. 278: Technical data pulley block (160 t (352,734 lb))

1.30.3 Pulley block (100 t (220,459 lb))

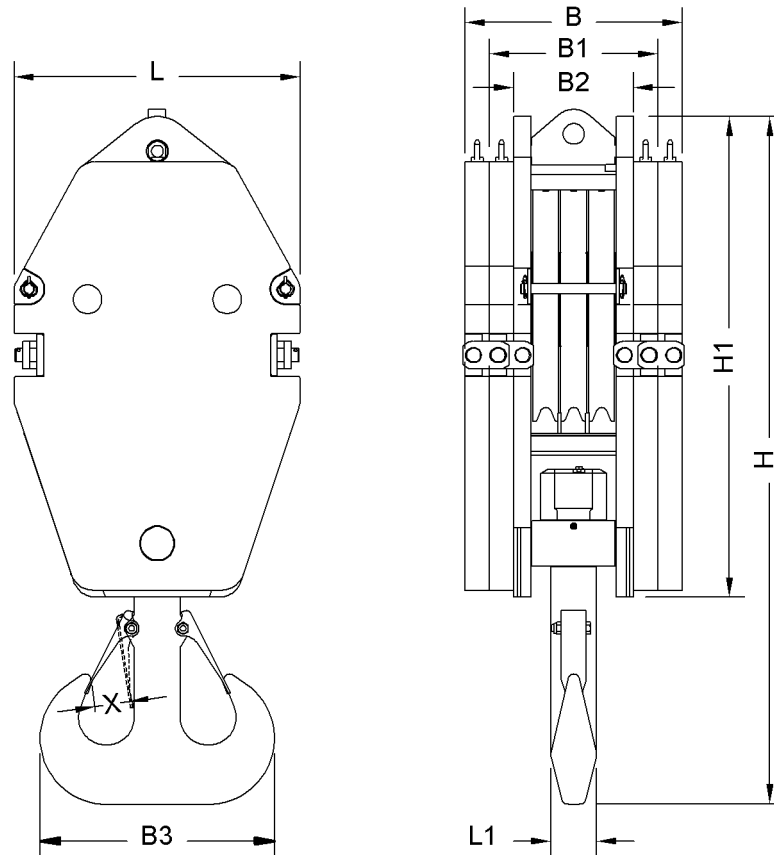


Fig. 453: Pulley block dimensions (100 t (220,459 lb))

Name		Value
L	Pulley block length	820 mm 2' 8" ft-in
L1	Hook length	132 mm 5.20" in
B	Pulley block width with four additional weights	623 mm 2' 1" ft-in
B1	Pulley block width with two additional weights	483 mm 1' 7" ft-in
B2	Width of pulley block without additional weights	343 mm 1' 2" ft-in
B3	Hook width	672 mm 2' 2" ft-in
H	Height of pulley block with hook	1994 mm 6' 7" ft-in
H1	Height of pulley block without hook	1380 mm 4' 6" ft-in
X	Jaw width	100 mm 3.94" in

LWNLR-x\04.01\Auslieferung\2016-03-07/en

Name	Value
Weight with four additional weights	3000 kg 6,614 lb
Weight with two additional weights	2050 kg 4,519 lb
Weight without additional weights	1100 kg 2,425 lb
Maximum reeving	7
Rope Ø	28 mm 1.10" in

Tab. 279: Technical data pulley block (100 t (220,459 lb))

1.30.4 Pulley block (50 t (110,230 lb))

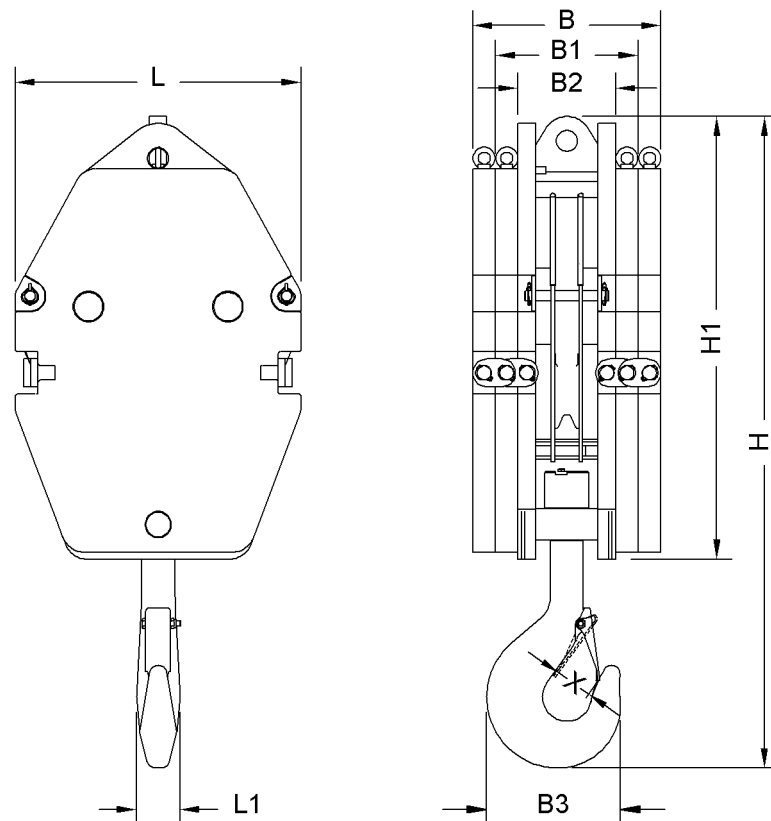


Fig. 454: Pulley block dimensions (50 t (110,230 lb))

Name	Value
L Pulley block length	820 mm 2' 8" ft-in
L1 Hook length	125 mm 4.92" in
B Pulley block width with four additional weights	540 mm 1' 9" ft-in

LWNLR.x/V04.01//Auslieferung/2016-03-07/en

Name		Value
B1	Pulley block width with two additional weights	410 mm 1' 4" ft-in
B2	Width of pulley block without additional weights	280 mm 11.02" in
B3	Hook width	384 mm 1' 3" ft-in
H	Height of pulley block with hook	1852 mm 6' 1" ft-in
H1	Height of pulley block without hook	1270 mm 4' 2" ft-in
X	Jaw width	100 mm 3.94" in
Weight with four additional weights		2400 kg 5,291 lb
Weight with two additional weights		1600 kg 3,527 lb
Weight without additional weights		800 kg 1,764 lb
Maximum reeving		3
Rope Ø		28 mm 1.10" in

Tab. 280: Technical data pulley block (50 t (110,230 lb))

1.30.5 Hook (16 t (35,273 lb))

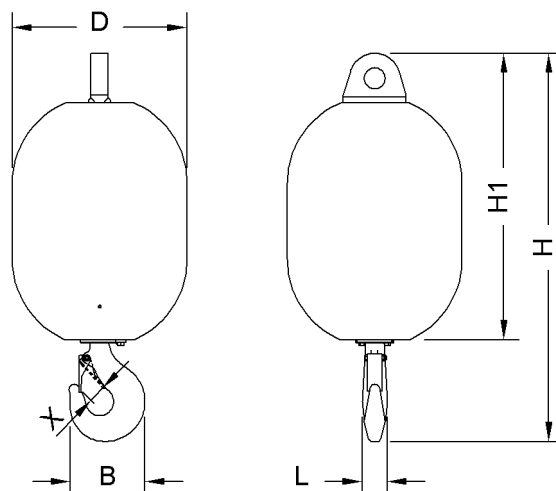


Fig. 455: Hook dimensions (16 t (35,273 lb))

Name		Value
L	Hook length	71 mm 2.80" in

LWNLR-x/V04.01/Auslieferung/2016-03-07/en

Name		Value
B	Hook width	217 mm 8.54" in
H	Height of pulley block with hook	1115 mm 3' 8" ft-in
H1	Height of pulley block without hook	822 mm 2' 8" ft-in
D	Hook Ø	500 mm 1' 8" ft-in
X	Jaw width	50 mm 1.97" in
Weight		900 kg 1,984 lb
Maximum reeving		1
Suitable for pocket lock for rope Ø		27 mm (1.06" in) to 29 mm (1.14" in)

Tab. 281: Technical data hook (16 t (35,273 lb))

1.31 Abseil rescue equipment*

The abseil rescue equipment BORNACK KE 10 St crane is behind the driver's seat in the cab.

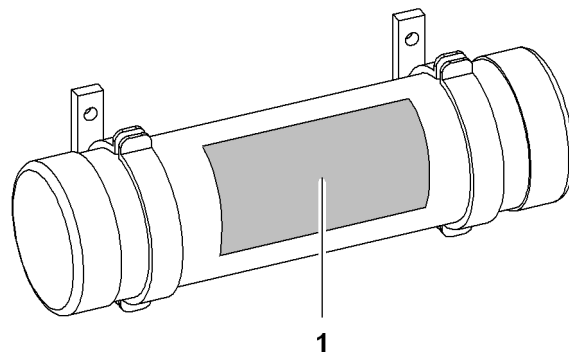


Fig. 456: Abseil rescue equipment

1 Operating instructions

1.32 Safety barrier*

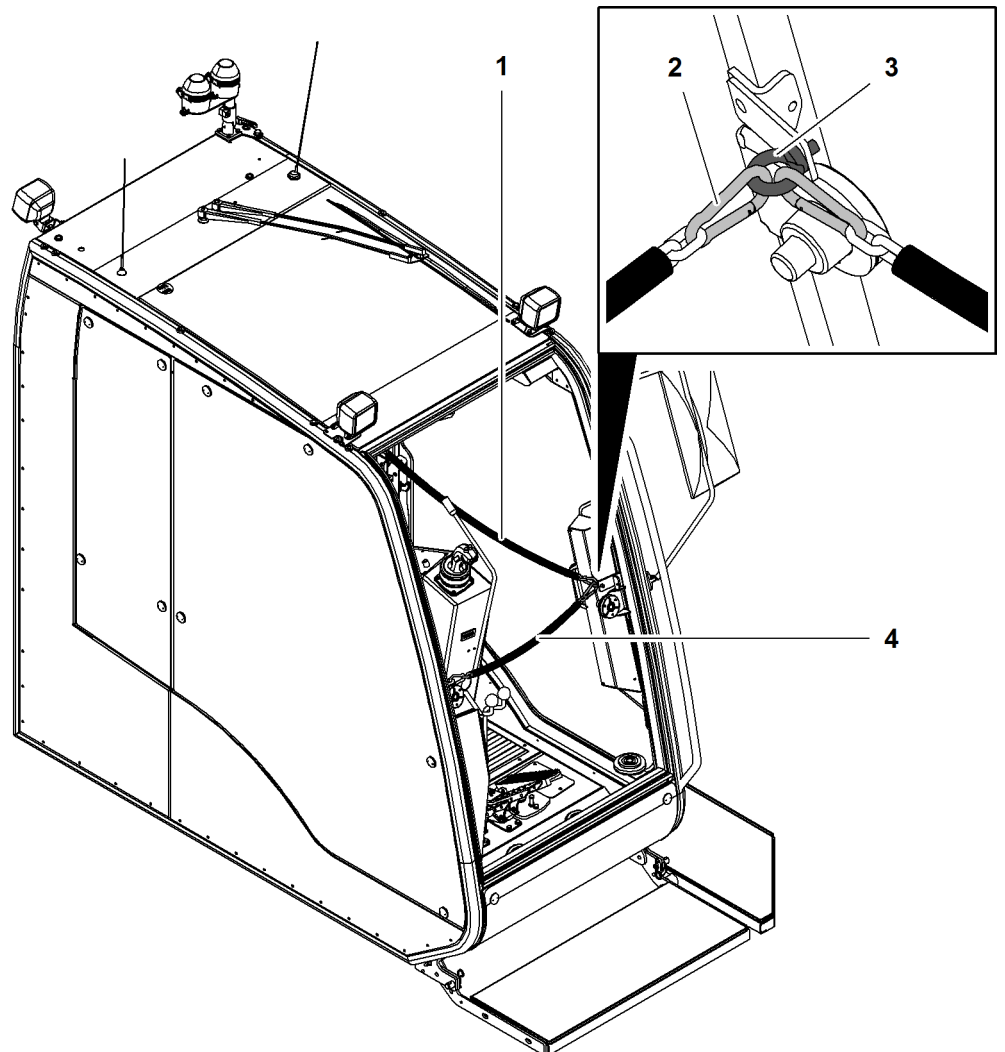


Fig. 457: Fall arrest

1 Chain
2 Carabiner (4x)

3 Eye bolt (3x)
4 Chain



WARNING

No safety barrier on the operator's platform!
risk of falling from the cab.

► Ensure that the chains are attached properly when entering the cab.

The safety barrier consists of 2 chains:

- Chain 1 is fitted in front of the cab door.
- Chain 4 is fitted in front of the front windscreen.

1.33 Slings plates on uppercarriage*

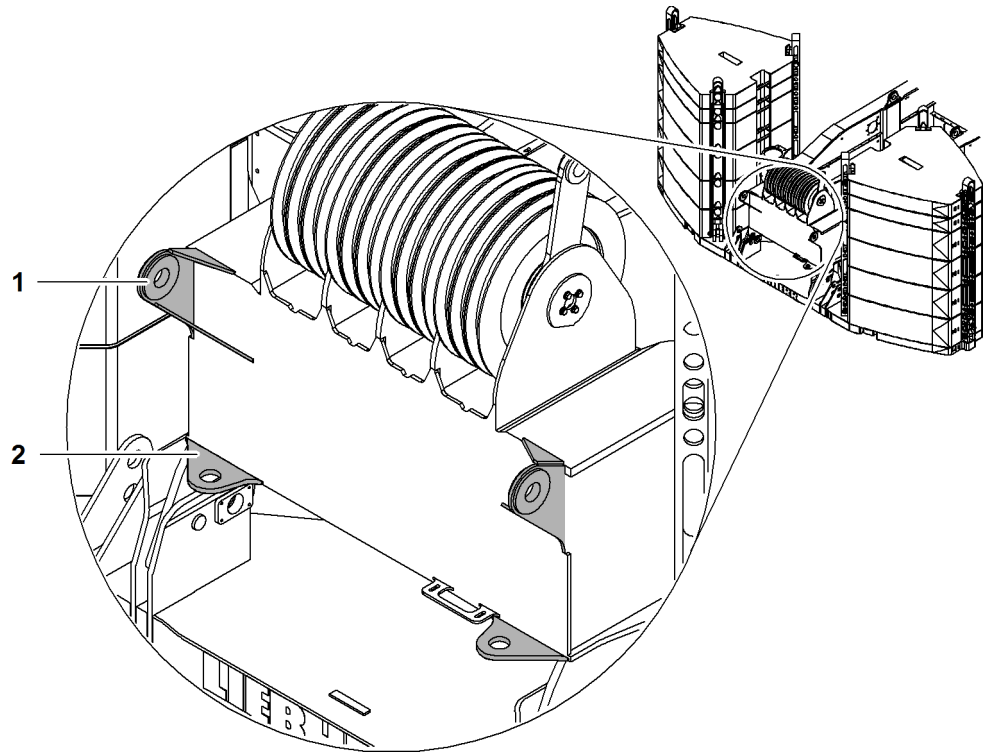


Fig. 458: Uppercarriage rear

1 Slings plate (2x)

2 Limit stop (2x)



WARNING

Incorrect use of slinging plates!
Serious injury.
Damage to machine.

- ▶ Only use slinging plates to install a power pack.
- ▶ When installing a power pack: Contact Liebherr customer service.



WARNING

Inadmissible stress of the limit stops with tensile and vertical forces!
Serious injury.
Damage to machine.

- ▶ Only stress limit stop with slinging plates with compression forces.



WARNING

Inadmissible pin strength!
Serious injury.
Damage to machine.

- ▶ Only use pins made of 34 CrNiMo6 material.

1.34 Suction flap*

The suction flap closes the suction pipe when the ignition is switched off. This prevents the undesired effect of the diesel engine 'running on'.

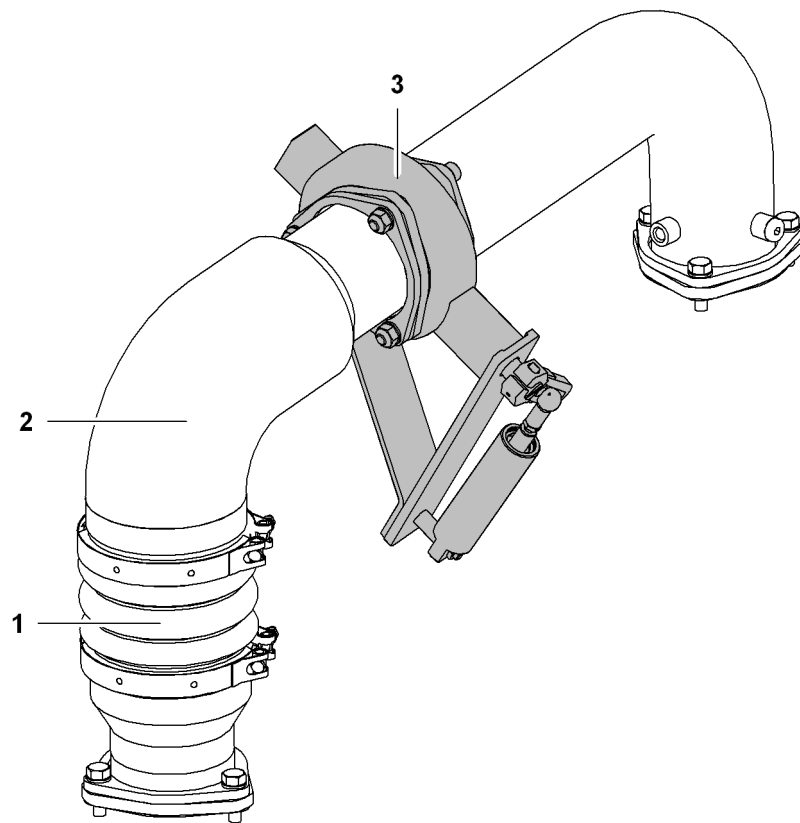


Fig. 459: Suction flap

- 1 Charge air hose
- 2 Charge air pipe

- 3 Shut-off device

1.35 Armrests* for operator's seat

The armrests in the optional special equipment are movable and can be adjusted to match the machine operator's exact needs.

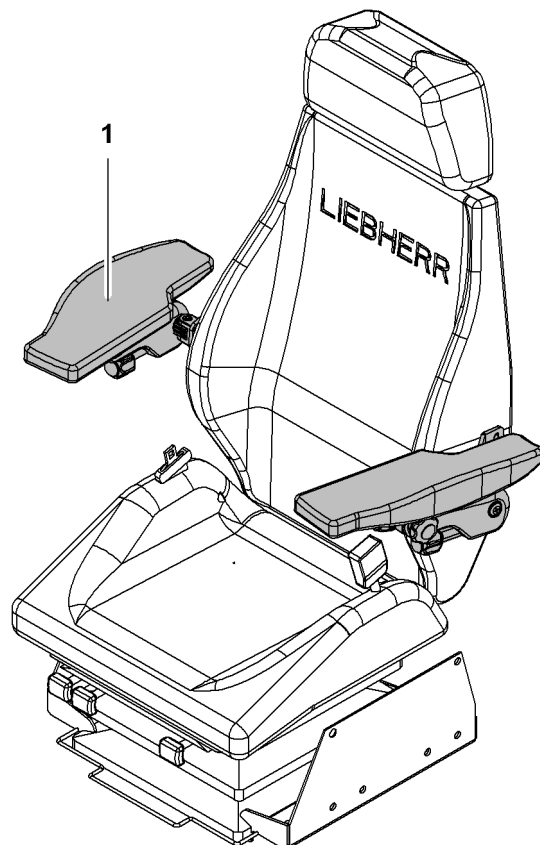


Fig. 460: Armrests for operator's seat

1 Armrests (2x)

1.36 Vertical Line Finder* assistance system

The Vertical Line Finder assistance system serves to determine the rope's angle of departure on the boom head. The determined angle of departure of the rope is displayed on the monitor. This allows the machine operator to detect and prevent a diagonal pull.

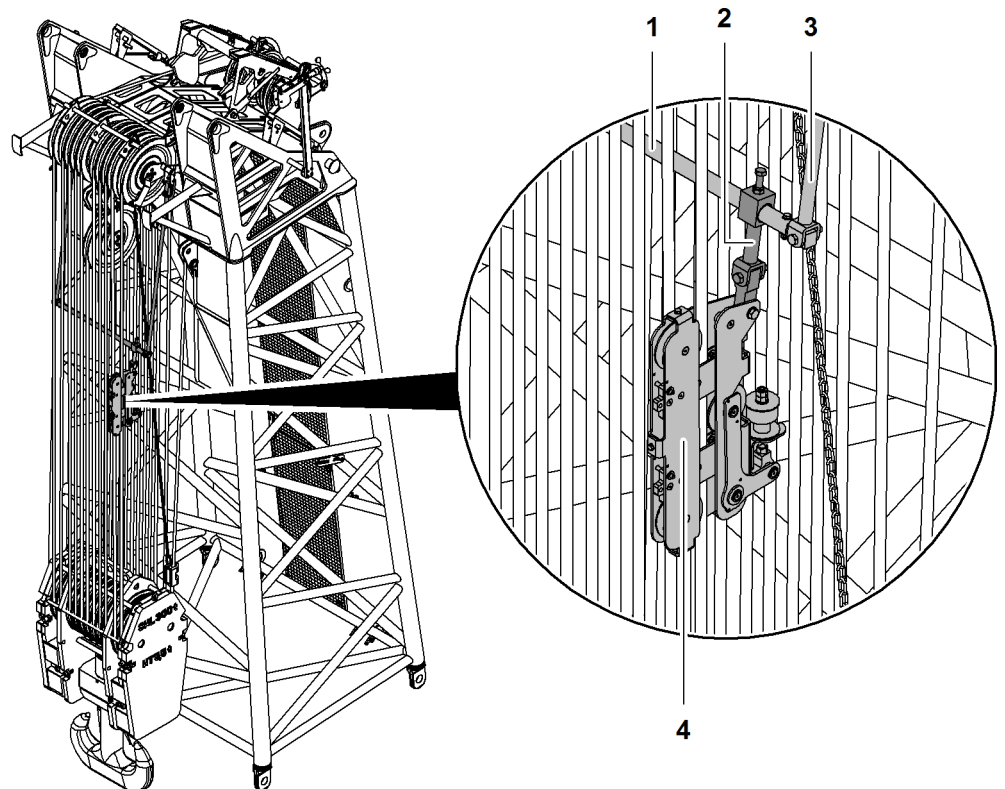


Fig. 461: Vertical Line Finder on main boom head (illustration of principle)

- | | | | |
|---|--------------------------|---|--------------------|
| 1 | Transverse pipe | 3 | Vertical pipe (2x) |
| 2 | Bracket for rope opening | 4 | Rope opening |

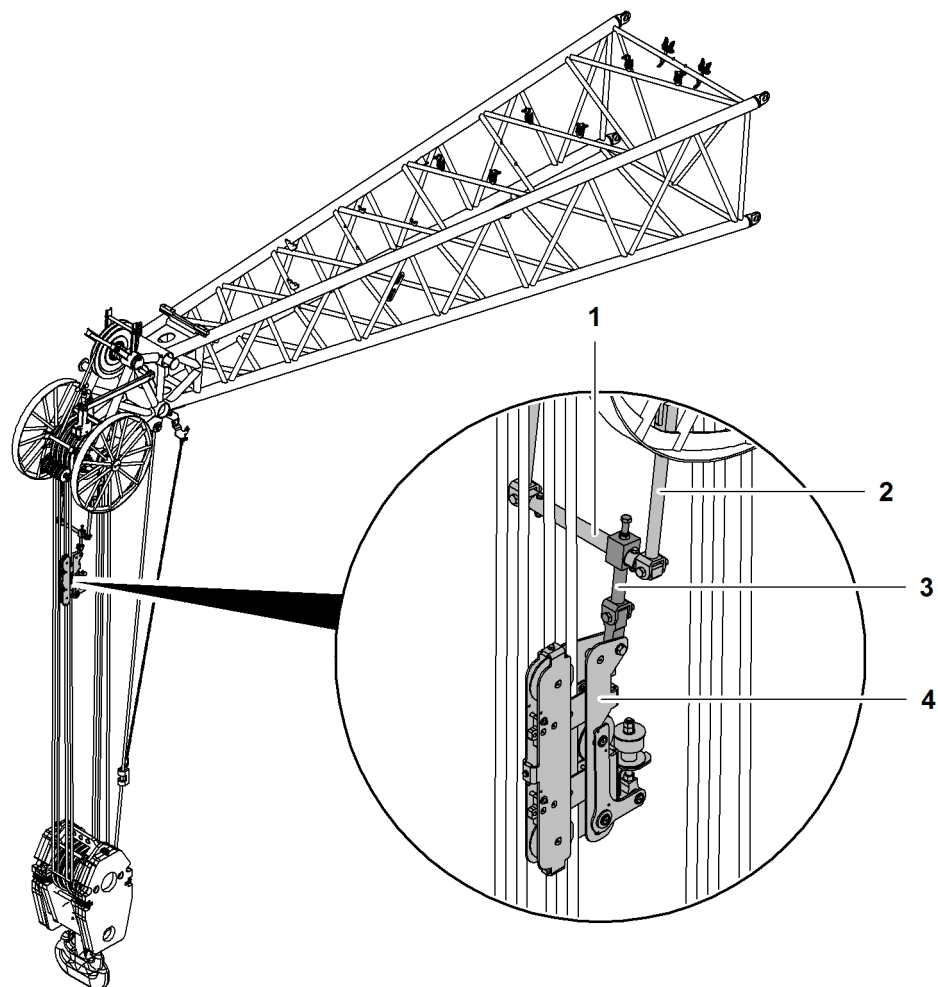


Fig. 462: Vertical Line Finder on jib head (illustration of principle)

- | | | | |
|---|--------------------|---|--------------------------|
| 1 | Transverse pipe | 3 | Bracket for rope opening |
| 2 | Vertical pipe (2x) | 4 | Rope opening |

1.37 Outside mirror*

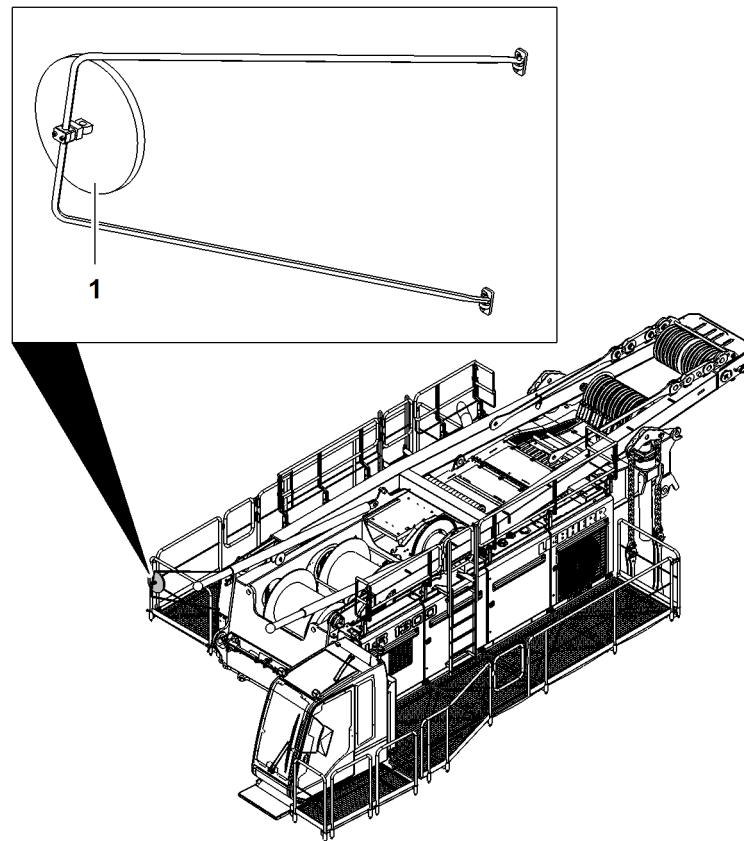


Fig. 463: Outside mirror (illustration of principle)

1 Outside mirror

The outside mirror 1 is installed on the right side of the uppercarriage.

The outside mirror 1 is folded in or deinstalled for transport.

1.38 Counterweight carriage preparation unit*

In order to transport the counterweight carriage from one basic machine to another basic machine, the machine is equipped with a counterweight carriage preparation unit.

The counterweight carriage preparation unit consists of:

- Hydraulic connections and electricity connections for the rear counterweight carriage on the uppercarriage
- Control panel X26 with mount

1.38.1 Hydraulic connections and electricity connections for the counterweight carriage

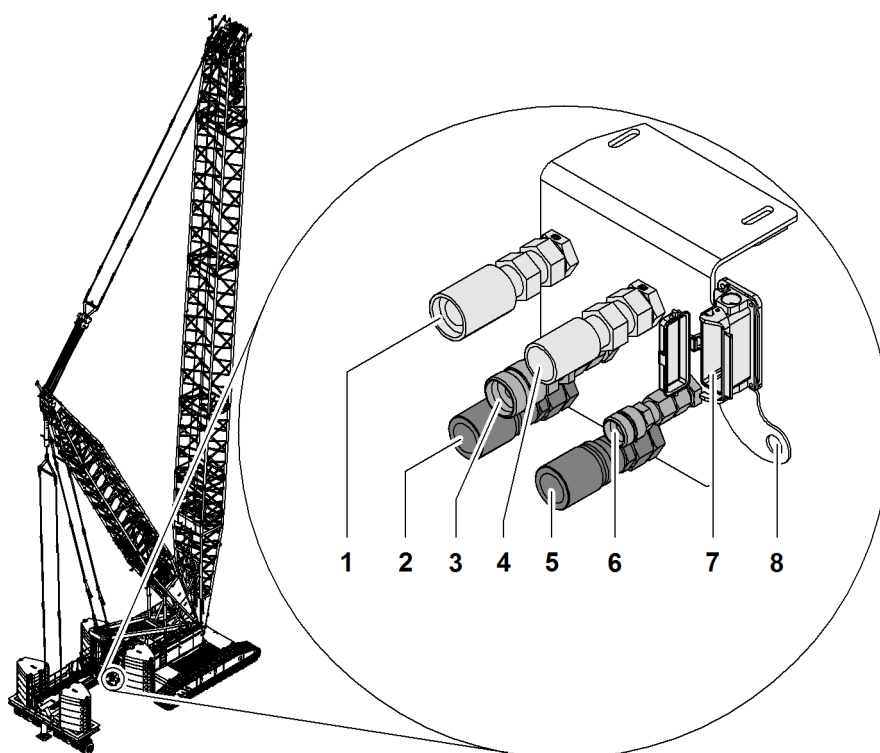


Fig. 464: Counterweight carriage preparation unit

- | | | | |
|---|-----------------------|---|--------------------------|
| 1 | Lower (red) | 5 | Leak oil (blue) |
| 2 | Leak oil (blue) | 6 | Control pressure (black) |
| 3 | High pressure (green) | 7 | Electric plug |
| 4 | Lift (yellow) | 8 | CAN bus plug |

1.38.2 Control panel X26 and mount

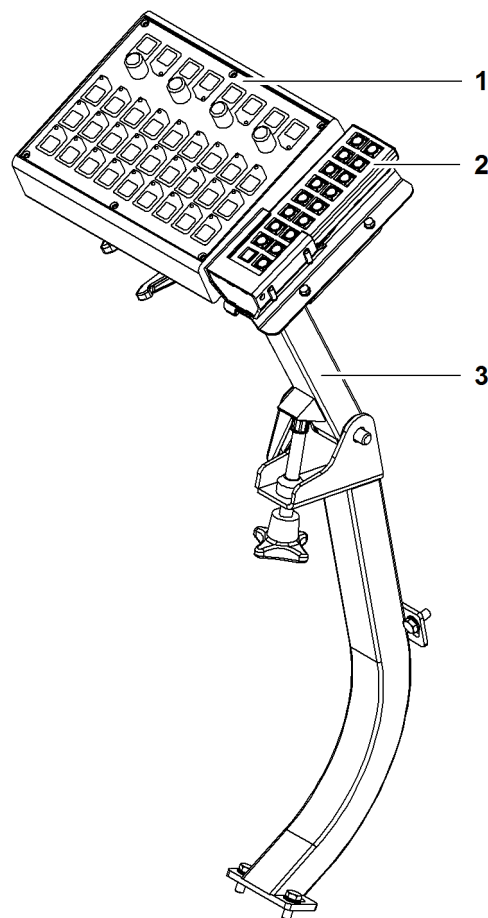


Fig. 465: Control panel X26 with mount

- | | | | |
|---|---|---|-------|
| 1 | Control panel X26 | 3 | Mount |
| 2 | Remote control panel (not part of the delivery) | | |

1.39 Tagline winch*

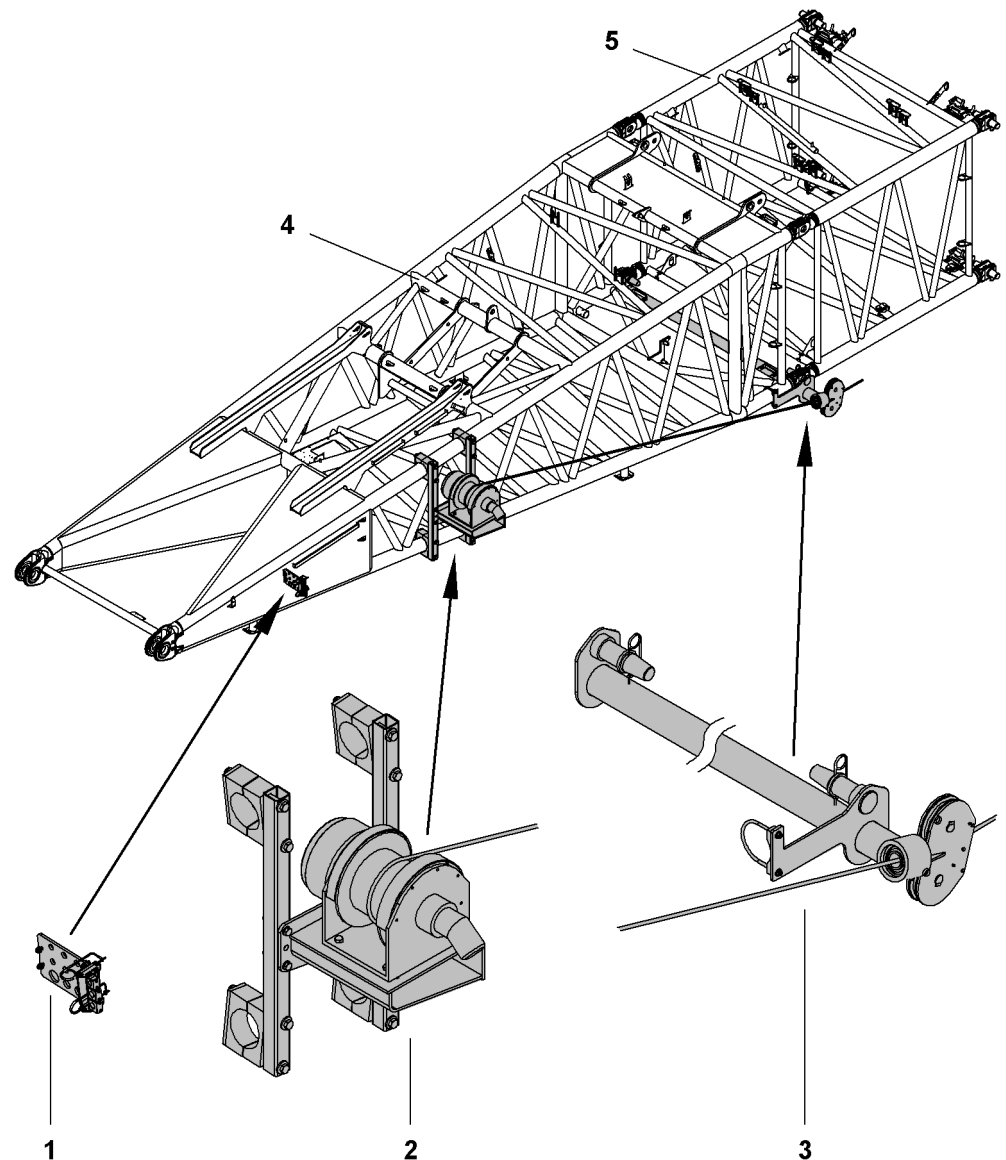


Fig. 466: Tagline winch

- | | | | |
|---|----------------|---|-------------------|
| 1 | Bulkhead plate | 4 | Boom base section |
| 2 | Tagline winch | 5 | Main boom section |
| 3 | Rope bracket | | |

The tagline winch:

- is driven by a hydraulic motor via a planetary gearbox.
- is equipped with a fixed-caliper disc brake.

The tagline is attached to the rigging material with an adjustable pull force. The tagline winch 2 dampens the swinging movements of the rigging material by winding and unwinding the tagline.

The rotatable rope bracket 3 prevents the tagline from being damaged if the rope runs unevenly.

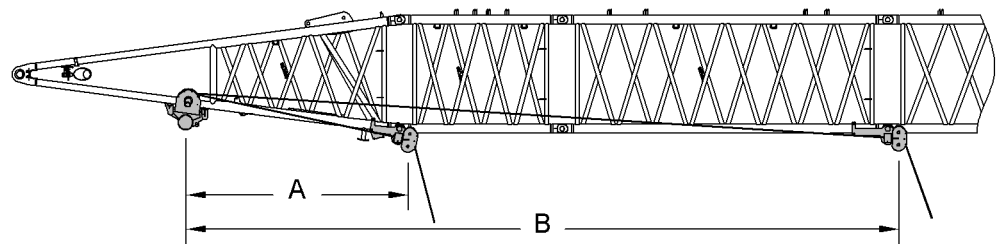


Fig. 467: Assembly position of the rope bracket (schematic diagram)

A Minimum distance

B Maximum distance

Because of the special way the winch unwinds, there is a minimum distance **A** of 3700 mm (12' 2" ft-in) and a maximum distance **B** of 13000 mm (42' 8" ft-in) between the winch and rope bracket.

The rope bracket may be mounted in the following positions:

- after the boom base section
- after the 3 m (10 ft) boom section
- after the first 6 m (20 ft) boom section
- after the 3 m (10 ft) boom section and the first 6 m (20 ft) boom section

Name	Winch with one caliper	Winch with two calipers
Maximum winch line pull	15 kN 3,370 lb _f	28 kN 6,290 lb _f
Minimum constant tension	2 kN 450 lb _f	2 kN 450 lb _f
Rope Ø	14 mm 0.55" in	14 mm 0.55" in
Drum Ø	270 mm 10.63" in	270 mm 10.63" in
Maximum rope speed (full load)	110 m/min 360' 11" ft-in/min	110 m/min 360' 11" ft-in/min
Maximum rope speed (empty hook)	124 m/min 406' 10" ft-in/min	124 m/min 406' 10" ft-in/min
Rope length	80 m 262' 6" ft-in	80 m 262' 6" ft-in

Tab. 282: Technical data tagline winch

1.40 Refueling pump*

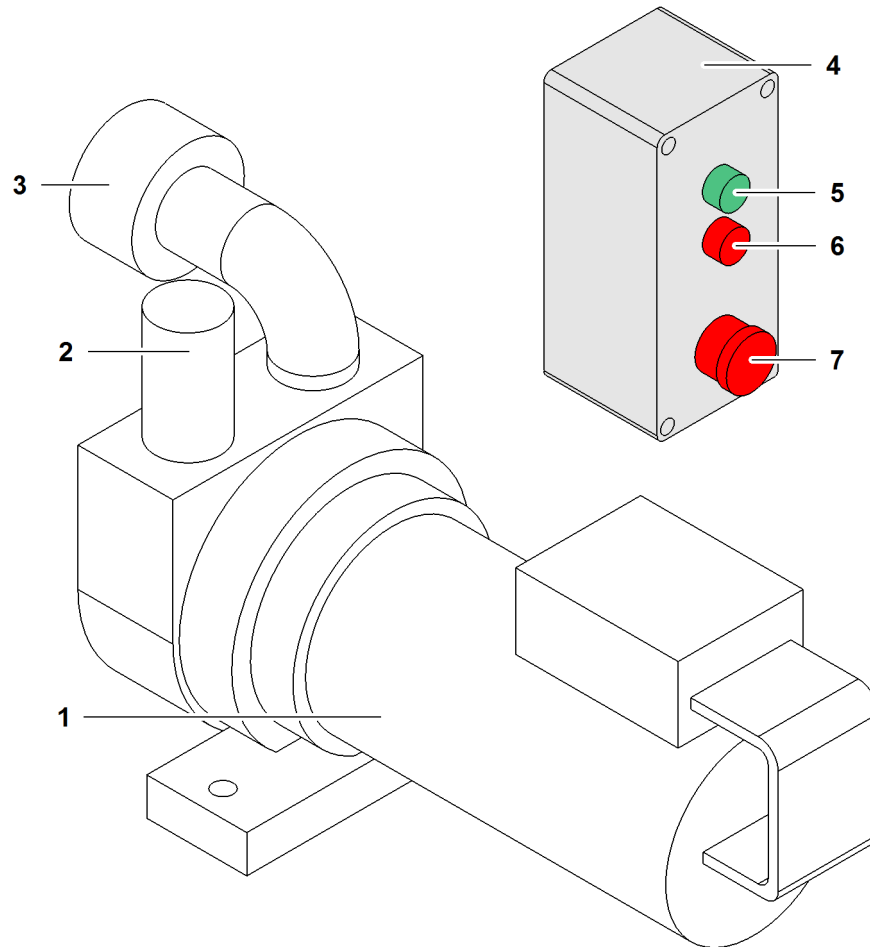


Fig. 468: Refuelling pump

- | | | | |
|---|-----------------------------|---|--------------------------|
| 1 | Motor | 5 | "Pump on" button (green) |
| 2 | Supply line to fuel tank | 6 | "Pump off" button (red) |
| 3 | Connection for suction hose | 7 | Emergency stop |
| 4 | Control panel | | |

The refueling pump is fitted to the right-hand side of the uppercarriage, next to the fuel tank.

Designation	Value
Suction height	max. 4 m (13' 1" ft-in)
Delivery rate	50 l/min 13.21 gal/min
Operating time	max. 20 min (20 min)
Idling time	max. 30 s (30 sec)

Tab. 283: Refueling pump technical data

LWNLR-x/V04.01//Auslieferung/2016-03-07/en

1.41 Cab roof protection guard*

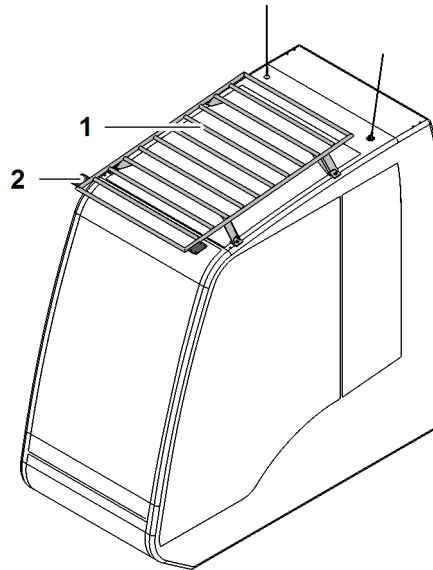


Fig. 469: Cab roof protection guard

1 Cab roof protection guard

2 Mountings (2x) for floodlights

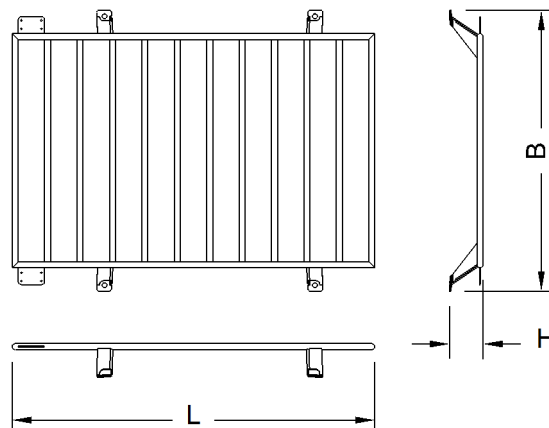


Fig. 470: Dimensions of cab roof protection guard

Designation		Value
L	Length	1208 mm 4' ft-in
B	Width	936 mm 3' 1" ft-in
H	Height	112 mm 4.41" in
Weight		30 kg 66.14 lb

Tab. 284: Technical data: cab roof protection guard

1.42 Derrick preparation unit

In order to transport the derrick from one basic machine to another basic machine, the machine is equipped with a derrick preparation unit.

The derrick preparation unit consists of hydraulic connections and electricity connections for the derrick.

The connections are located on the front right of the uppercarriage.

1.42.1 Hydraulic connections and electricity connections for the derrick

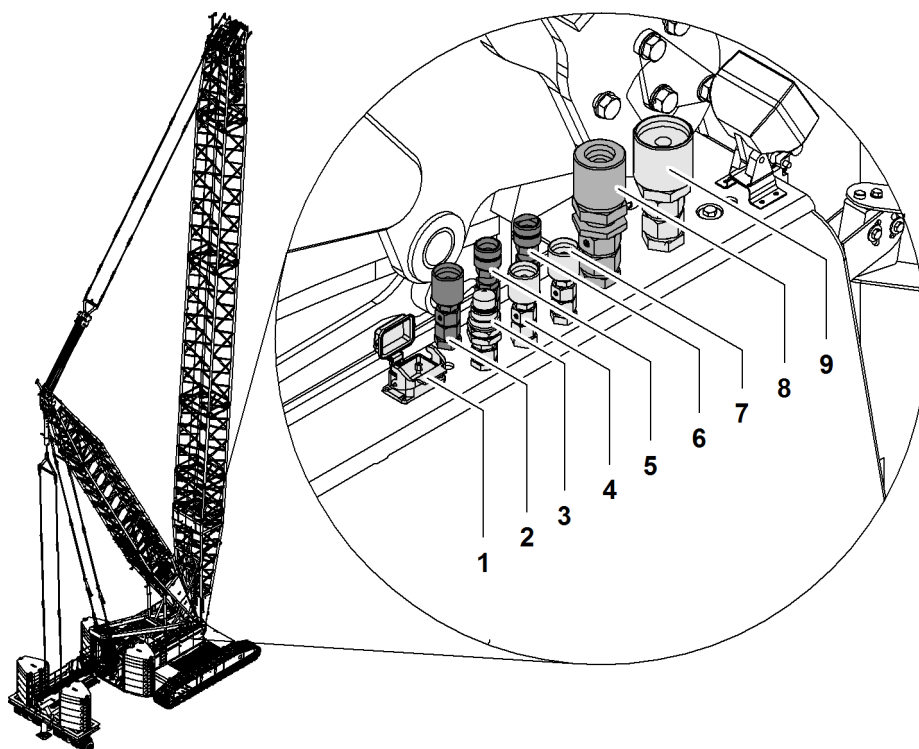


Fig. 471: Derrick preparation unit

- | | | | |
|---|-------------------------------------|---|--------------------------------------|
| 1 | Electric plug | 6 | Lift derrick hoist cylinder (green) |
| 2 | Feed pressure | 7 | Lower derrick hoist cylinder (green) |
| 3 | Leakage oil | 8 | Lower derrick winch |
| 4 | Derrick tilting-back supports (red) | 9 | Lift derrick winch |
| 5 | Derrick tilting-back supports (red) | | |

1.43 Lightning rods*

The lightning rods facilitate directed conduction of lightning flashes through the steel structure of the machine.

Depending on the machine configuration, the lightning rods are installed in the following positions:

- Main boom head
- Jib head
- A-frame2
- A-frame3
- Derrick boom head

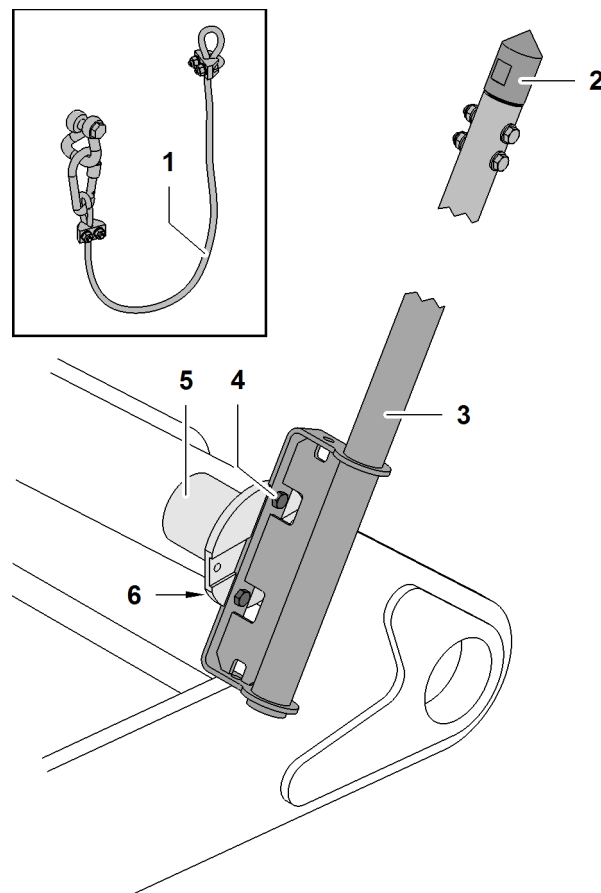


Fig. 472: Lightning rod

- | | | | |
|---|--|---|----------------|
| 1 | Safety rope with shackle and carabiner | 4 | Screw (2x) |
| 2 | Tip | 5 | Mounting plate |
| 3 | Lightning rod | 6 | Nut (2x) |

The lightning rod **3** is attached with screws **4** on the mounting plate **5** and locked with nuts **6**.

The safety rope **1** prevents dropping of the lightning rod **3**.

The tip **2** is made of bronze.

1.44 External power supply*

The external supply is required for the following components:

- Obstacle warning light
- Cold weather kit

A power unit may also ensure external supply.

1.44.1 External power supply obstacle warning light

The role of the external power supply is to charge, trickle charge or support the batteries when the machine is switched off. The supply voltage is 230 V or 115 V.

The “external power supply obstacle warning light” operates the obstacle warning light ([For more information see: 1.50 Obstacle warning light*, page 451](#)).

NOTICE

Main battery switch is OFF, batteries will not be charged!
Damage to batteries.

- ▶ Do not turn off the battery main switch whilst charging is in progress.
-

The obstacle warning light is supplied with power via the batteries and the generator of the machine. With the “external power supply obstacle warning light”, the obstacle warning light can be operated overnight when the ignition is off as well as over longer periods, e.g. during the weekend.

Supply

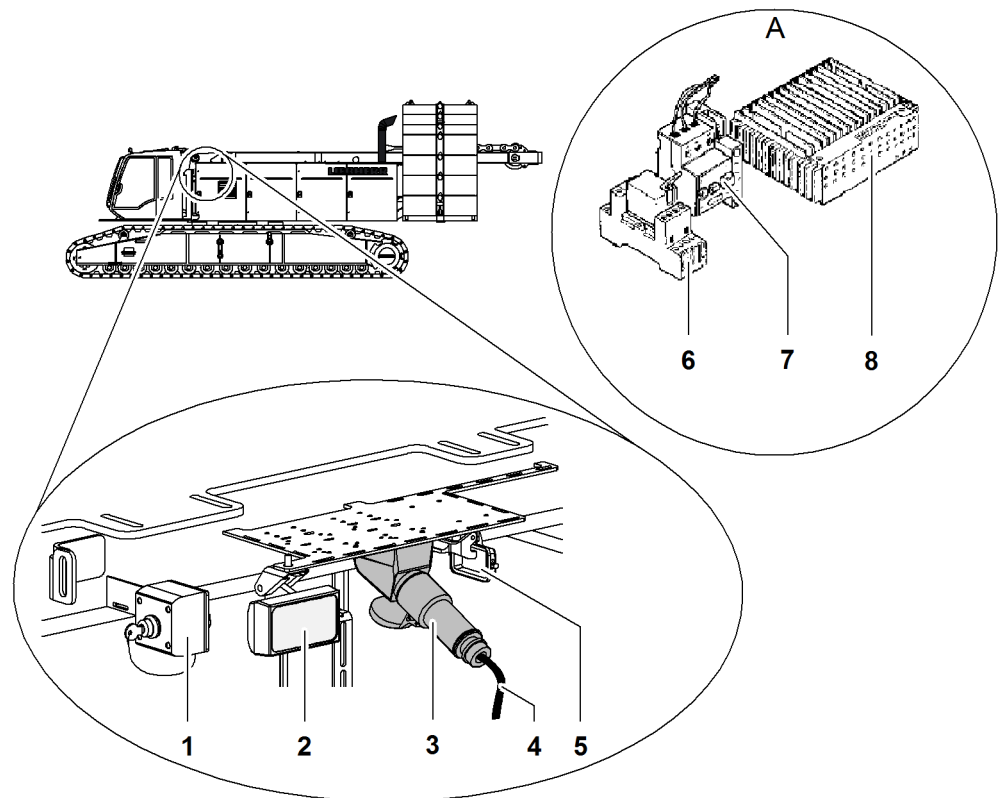


Fig. 473: External power supply

- | | | | |
|---|--|---|---|
| 1 | Key switch load moment limiter shut-down | 5 | Anschlussstecker des Bedienpults Notbetriebssteuerung |
| 2 | Floodlight | 6 | Circuit breaker |
| 3 | External supply connection plug | 7 | Engine protection switch |
| 4 | Mains cable | 8 | Charger |

Detail A is located in the switching cabinet behind the cabin.

Charger

Name	Value
Nominal voltage	115/230 V, 50/60 Hz
Output voltage	28.8 V / 27.6 V
Maximum output current	25 A

Tab. 285: Technical data charger

Power cable



WARNING

Faulty power cable!
risk of electric shock.

- ▶ Arrange for a qualified electrician to manufacture the mains cable.
- ▶ Make sure that the power cable complies with national safety regulations.
- ▶ Make sure that the power cable is suitable for use on a construction site.



WARNING

Damaged mains cable!
Electric shock.

- ▶ Make sure that the mains cable is installed in such a way that no damage occurs.

The requisite mains cable for external connection is not supplied with the machine. A matching plug is situated in the outlet in the uppercarriage.

Mains cable:

- One phase
- One neutral conductor
- One protective conductor

1.44.2 External supply low temperature package

The external supply serves to charge, trickle-charge or support the batteries. Some components of the cold weather kit are supplied directly. The supply voltage is 3 x 230 V.

The “external cold weather kit supply” operates the following:

- Obstacle warning light ([For more information see: 1.50 Obstacle warning light*](#), [page 451](#))
- Low temperature package
- Socket in cabin ([For more information see: 1.72 Socket* in cab, page 499](#))

NOTICE

Main battery switch is OFF, batteries will not be charged!
Damage to batteries.

- ▶ Do not turn off the battery main switch whilst charging is in progress.

The obstacle warning light and the auxiliary heating are supplied with power via the batteries and the generator of the machine. With the “external power supply low temperature package”, the obstacle warning light and the auxiliary heating can be operated overnight when the ignition is off and even for longer periods, e.g. over weekends.

The socket in the cabin and other components of the low temperature package (e.g. engine pre-heater, ...) are only supplied with power if the “external supply low temperature package” is plugged in.

Supply

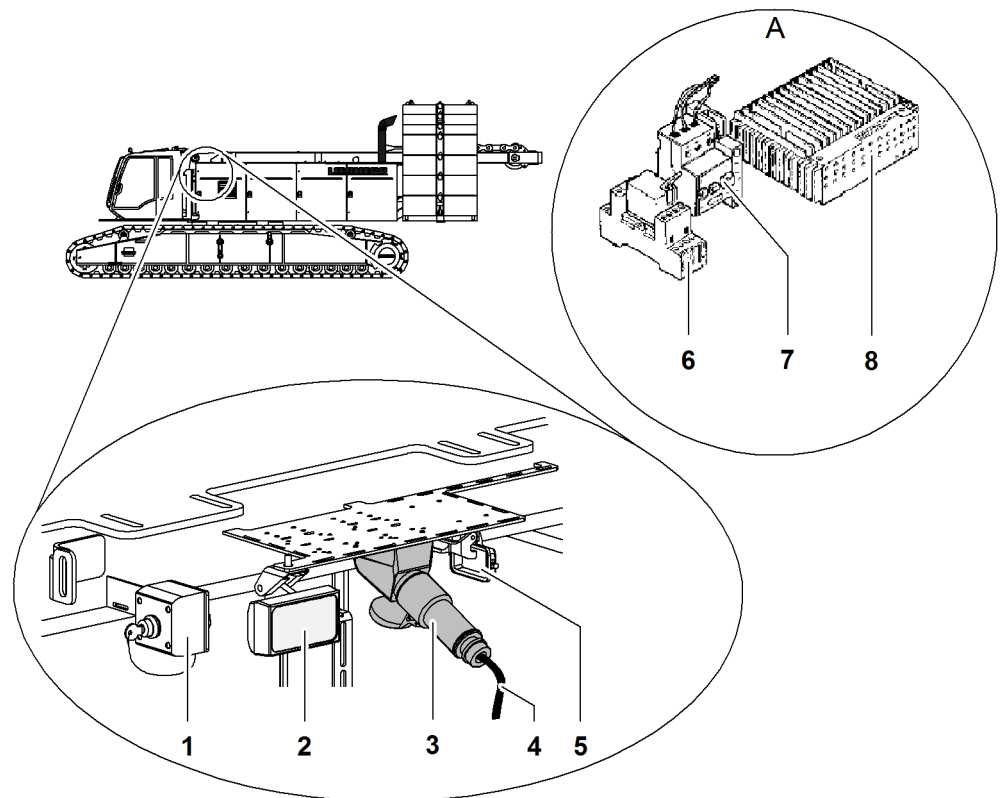


Fig. 474: External power supply

- | | | | |
|---|--|---|--|
| 1 | Key switch load moment limiter shut-down | 5 | Control panel emergency control system connection plug |
| 2 | Floodlight | 6 | Circuit breaker |
| 3 | External supply connection plug | 7 | Engine protection switch |
| 4 | Mains cable | 8 | Charger |

Detail A is located in the switching cabinet behind the cabin.

Charger

Name	Value
Nominal voltage	115/230 V, 50/60 Hz
Output voltage	28.8 V / 27.6 V
Maximum output current	25 A

Tab. 286: Technical data charger

Mains cable



WARNING

Faulty mains cable!
Electric shock.

- ▶ Arrange for a qualified electrician to manufacture the mains cable.
 - ▶ Make sure that the mains cable complies with national safety regulations.
 - ▶ Make sure that the mains cable is suitable for use on a construction site.
-



WARNING

Damaged mains cable!
Electric shock.

- ▶ Make sure that the mains cable is installed in such a way that no damage occurs.
-

The requisite mains cable for external connection is not supplied with the machine. A matching plug is situated in the outlet in the uppercarriage.

Mains cable:

- Three phases
- One neutral conductor
- One protective conductor

1.45 Radio remote control*

The radio transmitter is manufactured in conformance with regulations and rules laid down by BGV D6 for cranes, ZH 1/547 "Directives for operating cranes by remote control" and DIN EN 13557. The radio transmitter conforms to EMC guidelines and meets the relevant standards regarding emitted interference and interference immunity in industry.

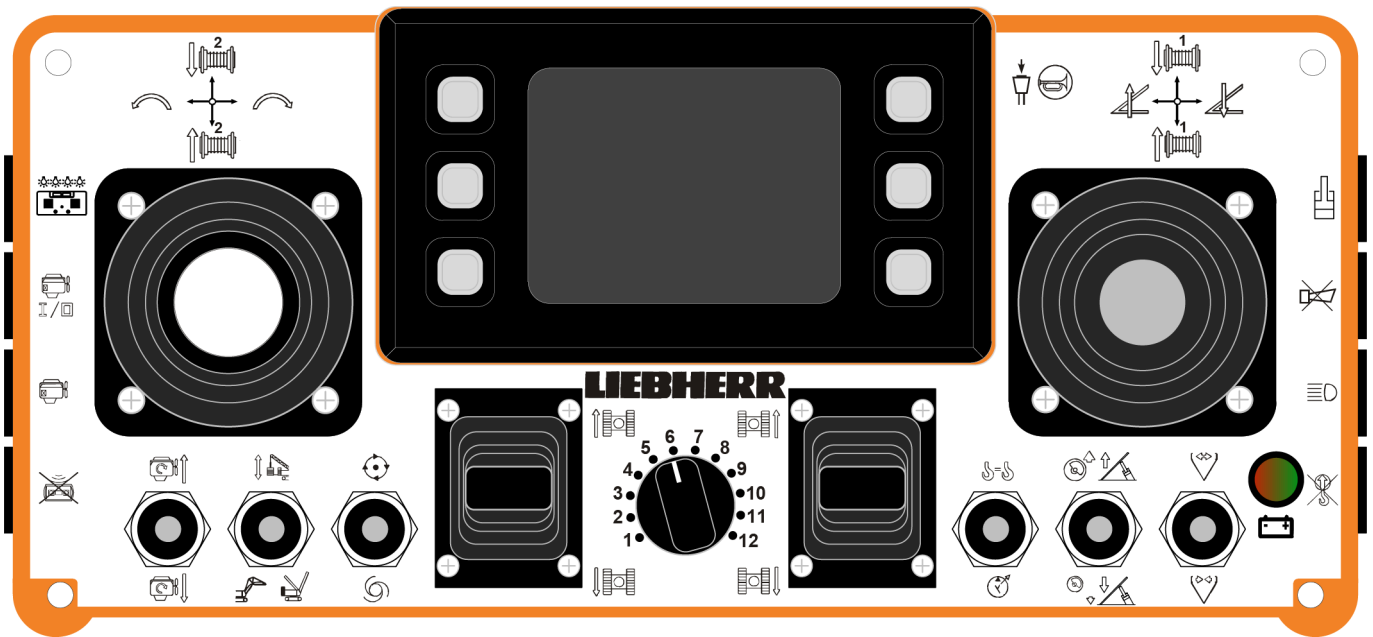


Fig. 475: Radio remote control

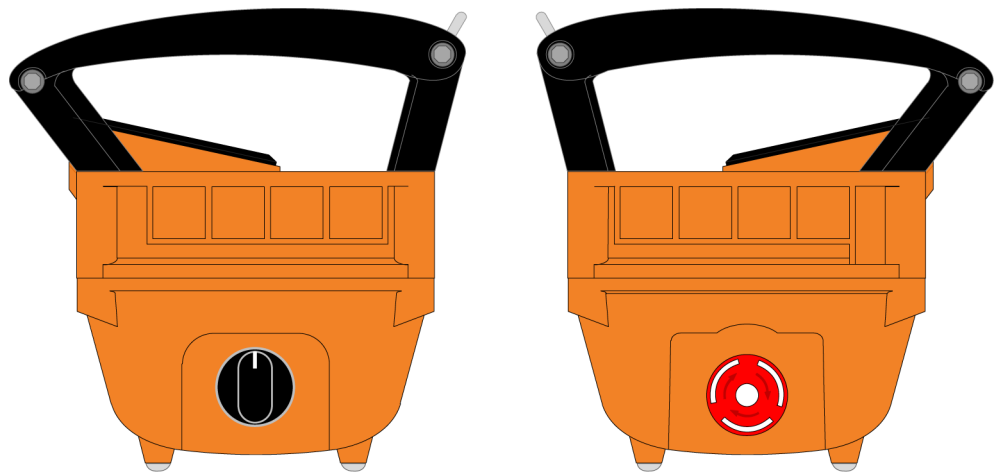


Fig. 476: Radio remote control

Name	Value
Length	358 mm 1' 2" ft-in
Width	182 mm 7.17" in

Name	Value
Height	178 mm 7.01" in
Frequency range	1790 MHz (1790 MHz) to 1930 MHz (1930 MHz)
Transmission power	< 10 mW (10 mW)
Operating temperature	-20 °C (-4 °F) to 70 °C (158 °F)
Battery charging time	max. 4 h (4 h)
Operating time	approx. 9 h (9 h) with permanent operation
Weight	3 kg 6.61 lb

Tab. 287: Technical data radio remote control

Name	Value
Length	270 mm 10.63" in
Width	160 mm 6.30" in
Height	115 mm 4.53" in
Operating temperature	-20 °C (-4 °F) to 70 °C (158 °F)
Weight	3.5 kg 7.72 lb

Tab. 288: Technical data receiver module (radio receiver on machine)

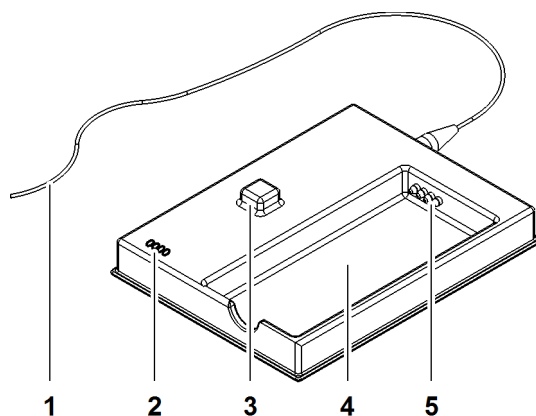


Fig. 477: Battery charger

- | | | | |
|---|---------------|---|---------------------|
| 1 | Cable | 4 | Loading compartment |
| 2 | LED (4x) | 5 | Contact pin (4x) |
| 3 | Unload button | | |

The battery charger is installed on the machine's back shelf.

Name	Value
Length	186 mm 7.32" in
Width	140 mm 5.51" in
Height	42 mm 1.65" in
Operating voltage	100 V (100 V) to 240 V (240 V)
Power consumption	12 W 12 W
Output voltage	< 10 V (10 V)
Output current	0.4 A 0.4 A
Weight	0.85 kg 1.87 lb
Compatible batteries	NiCd batteries type FuB 10 AA and FuB 10 XL NiMh batteries type BA214061

Tab. 289: Technical data battery charger

1.46 Foot pedal adjuster*

The foot pedal adjuster* ensures the optimum position of the foot pedals for the respective machine operator.

Additional foot pedal plates are mounted on the foot pedal *Brake free-fall winch1* and the foot pedal *Brake free-fall winch2*.

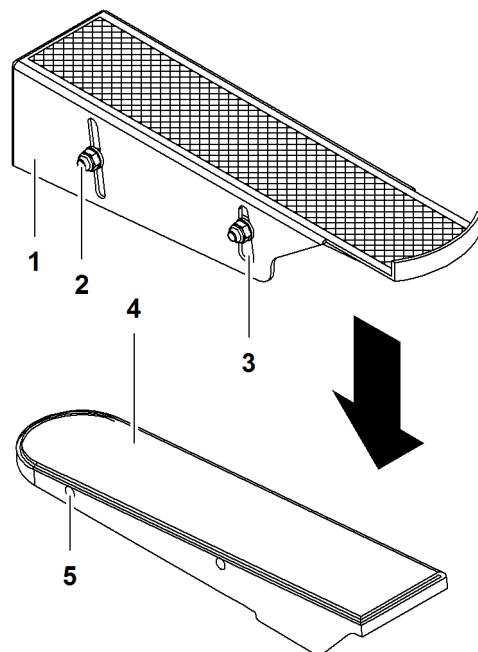


Fig. 478: Foot pedal adjuster*

- | | | | |
|---|------------------------|---|----------------------|
| 1 | Foot pedal plate | 4 | Foot pedal |
| 2 | Screw (2x) | 5 | Boring (2) for screw |
| 3 | Longitudinal hole (2x) | | |

The height and inclination of the foot pedals can be adjusted with the screws **2** in the longitudinal holes **3**.

1.47 GSM/GPRS/GPS modem

A GSM/GPRS/GPS modem is connected to the Litronic control system.

The modem is located in switching cabinet X1. This enables the latest operating data, position data and the stored machine data to be transmitted to Liebherr after sales service.

Subject to certain conditions, Liebherr after sales service can use a diagnostic system to determine the reasons behind faults, to prepare accordingly for engineers to attend and to organize the spare parts supply quickly and efficiently.

Name	Value
Frequency	850 MHz (850 MHz), 900 MHz (900 MHz), 1800 MHz (1800 MHz), 1900 MHz (1900 MHz)
Nominal voltage	6.5 V (6.5 V) to 48 V (48 V)

Tab. 290: Technical data for GSM/GPRS/GPS modem

1.48 Hook fixing point *

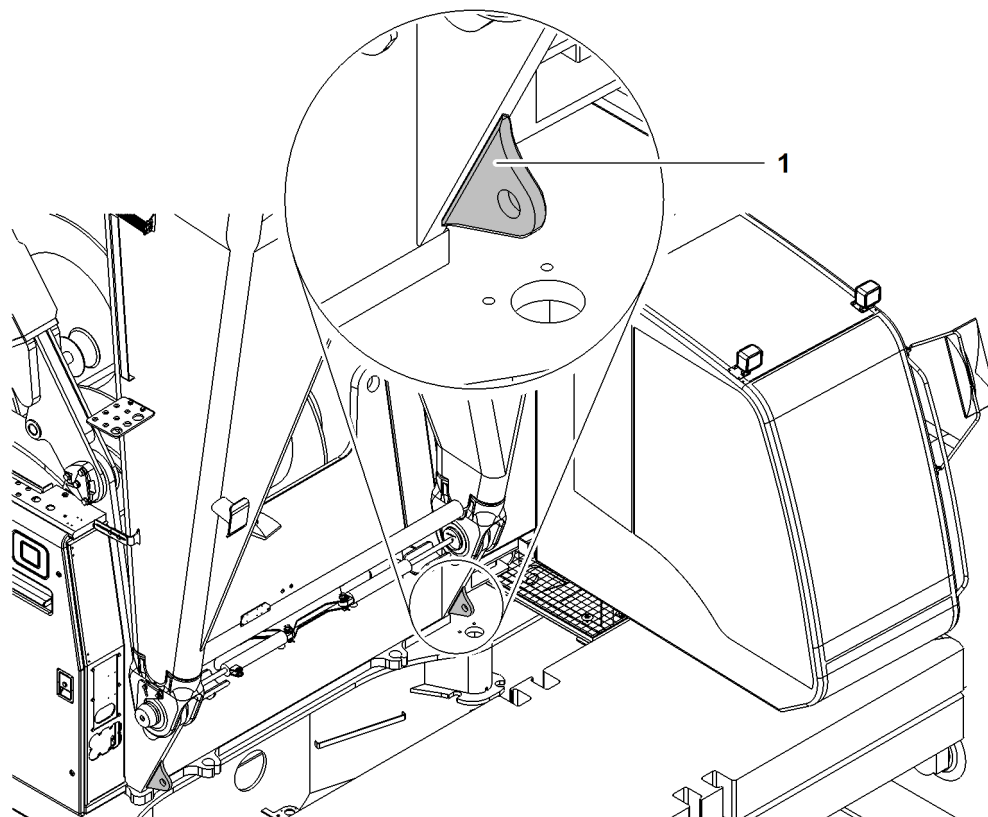


Fig. 479: Hook fixing point (illustration of principle)

1 Link (2x)

NOTICE

Inadmissible use of hook fixing point links 1!
Damage to the uppercarriage.

- ▶ Only use links 1 as hook fixing point.



WARNING

Incorrect procedure when using the hook fixing point!
Severe injuries through rope rupture, damage to the structure.

- ▶ Hook fixing point must exclusively be used in parked positions.
- ▶ Only attach hook with stay rope on link plates 1.

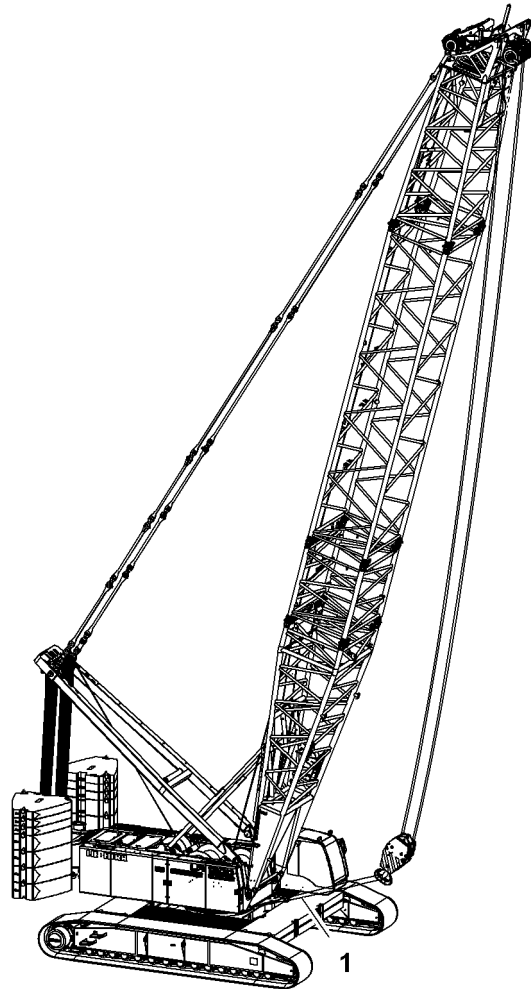


Fig. 480: Hook fixing point (illustration of principle)

- 1 Safety retaining rope

1.49 Handrail* / wide steps*

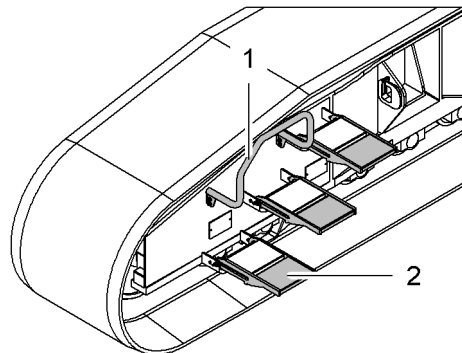


Fig. 481: Handrail / wide steps

1 handrail

2 Wide steps

The handrail 1 and the wide steps 2 allow personnel to climb onto the crawler side frame more easily.

1.50 Obstacle warning light*



Note

Use of the obstacle warning light is prescribed by national or regional regulations!

- ▶ Before using the machine, familiarise yourself with national and local regulations.

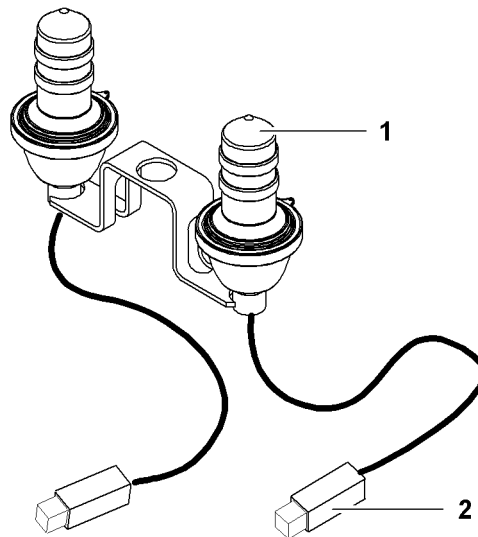


Fig. 482: Obstacle warning light

1 Obstacle warning light (2x)

2 Plug (2x)

The obstacle warning light:

- is installed on the main boom head section.
- is installed on the jib head section with attached jib.
- is attached onto the same fixture as the anemometer.
- is lit when the button *Obstacle warning light* is activated.
- lights up if an external power supply is connected.

1.51 Third hoist limit switch*

If a third rope is guided across a main boom or jib head section (e.g. auxiliary winch on main boom base section), the third hoist limit switch is required.

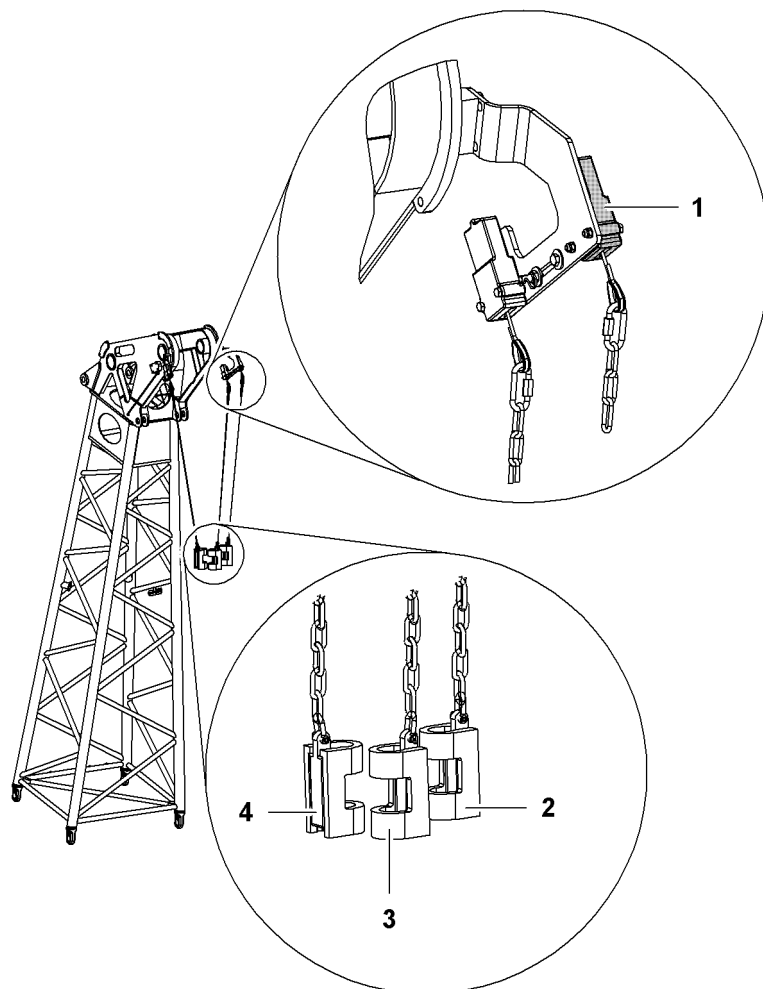


Fig. 483: Third hoist limit switch

- | | | | |
|---|----------------------------------|---|---|
| 1 | Hoist limit switches (2x) | 3 | Hoist limit switch weight auxiliary winch |
| 2 | Hoist limit switch weight winch1 | 4 | Hoist limit switch weight winch2 |

1.52 Hoist limit switch clamp* for auxiliary jib (36 t (79.300 lb))

The hoist limit switch clamp replaces the hoist limit switch weight on the auxiliary jib (36 t (79.300 lb)).

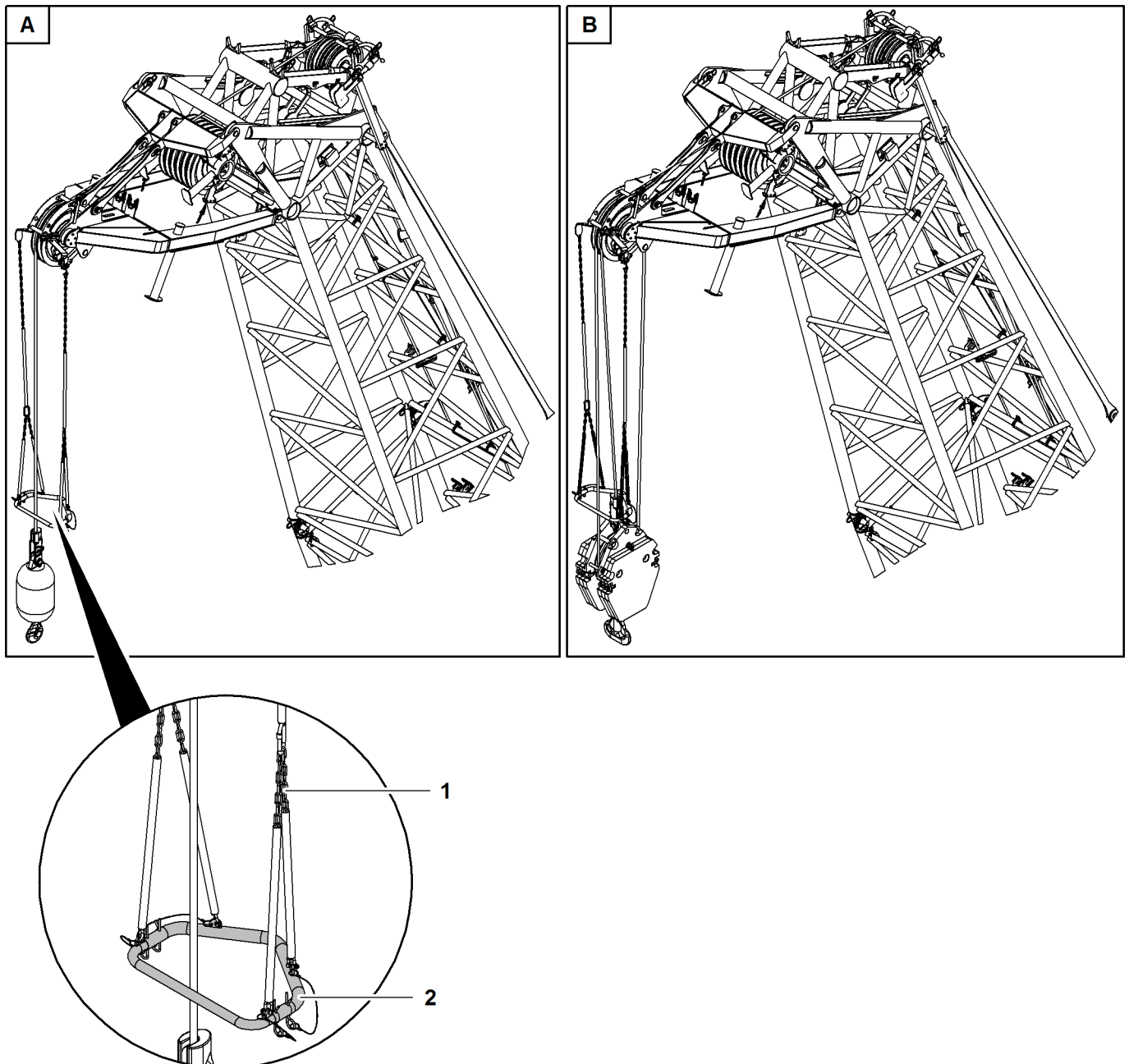


Fig. 484: Hoist limit switch clamp* for auxiliary jib (36 t (79.300 lb))

- | | | | |
|---|--------------------------|---|---|
| 1 | Chain (4x) | A | Auxiliary jib (36 t (79.300 lb))
with single reeving |
| 2 | Hoist limit switch clamp | B | Auxiliary jib (36 t (79.300 lb))
with double or triple reeving |

1.53 Hydraulic cab elevation*

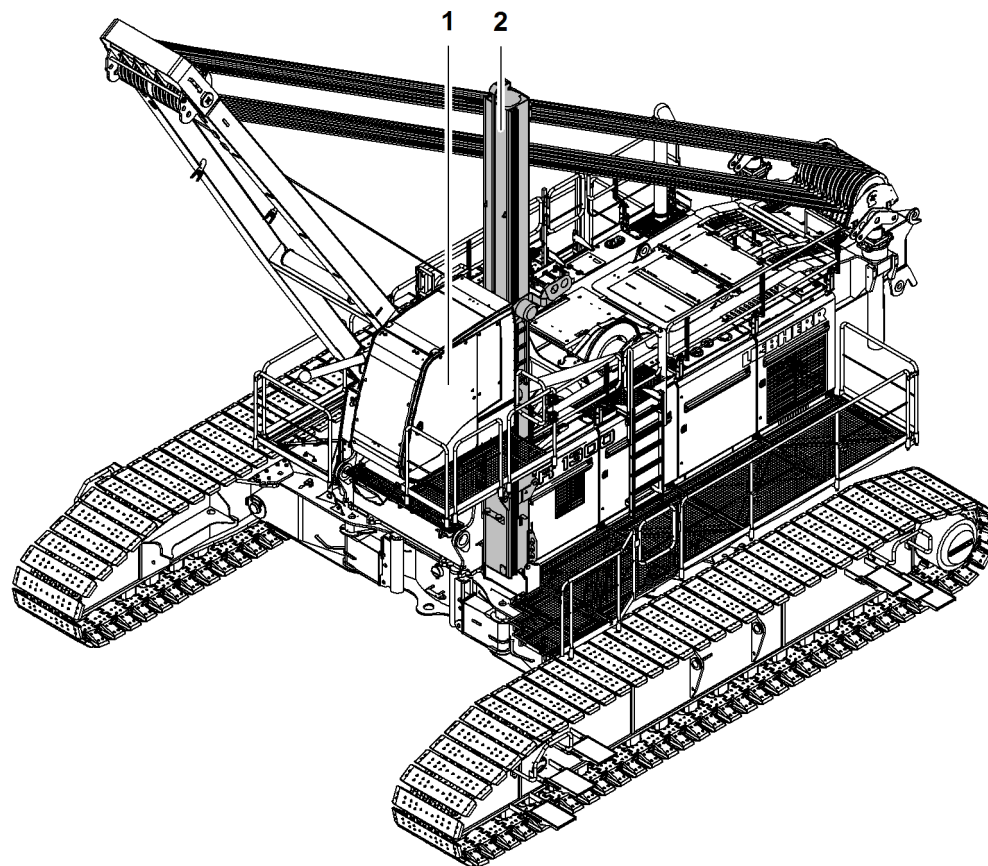


Fig. 485: Hydraulic cabin elevation (illustration of principle)

1 Cabin

2 Mast

The hydraulic cabin elevation allows continuous, vertical adjustment of the cabin 1.

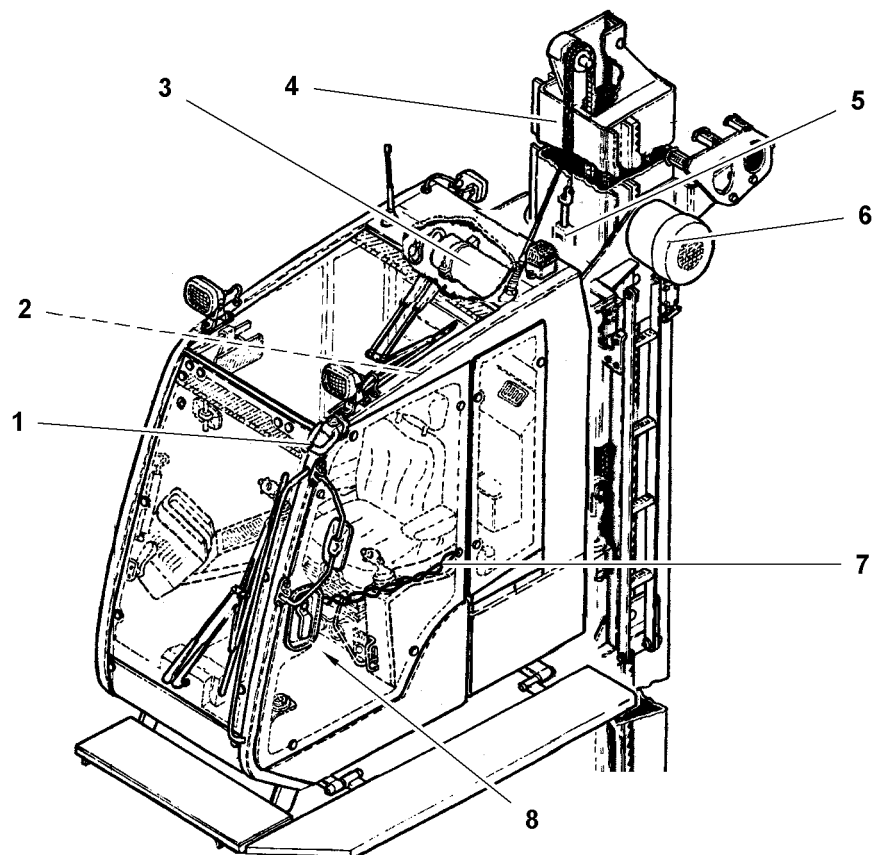


Fig. 486: Hydraulic cabin elevation - detail

- | | | | |
|---|--|---|---|
| 1 | Suspension point for emergency descent rescue equipment | 5 | Chain |
| 2 | Suspension point for emergency descent rescue equipment (with installed cabin roof protection guard) | 6 | Overrun brake |
| 3 | Abseil rescue equipment | 7 | Safety chain |
| 4 | Mast | 8 | Operating elements for the cab elevation system |

Name	Value
Maximum adjusting height	6 m 19' 8" ft-in
Lifting speed of cabin	8 m/min 26' 3" ft-in/min
Lowering speed of cabin	11 m/min 36' 1" ft-in/min
Fall arrester responds at rate of fall	0.69 m/s 2.26 ft/s
Lowering speed of cabin during emergency lowering	4.5 m/min 14' 9" ft-in/min

Tab. 291: Technical data hydraulic cabin elevation

LWNLR.x/V04.01//Auslieferung/2016-03-07/en

1.54 Cabin railing*

The cabin railing consists of the following components:

- Front cabin railing
- Rear cabin railing
- Brackets on platform
- Brackets below cabin

The cabin railing serves as fall arrest and ascension aid.

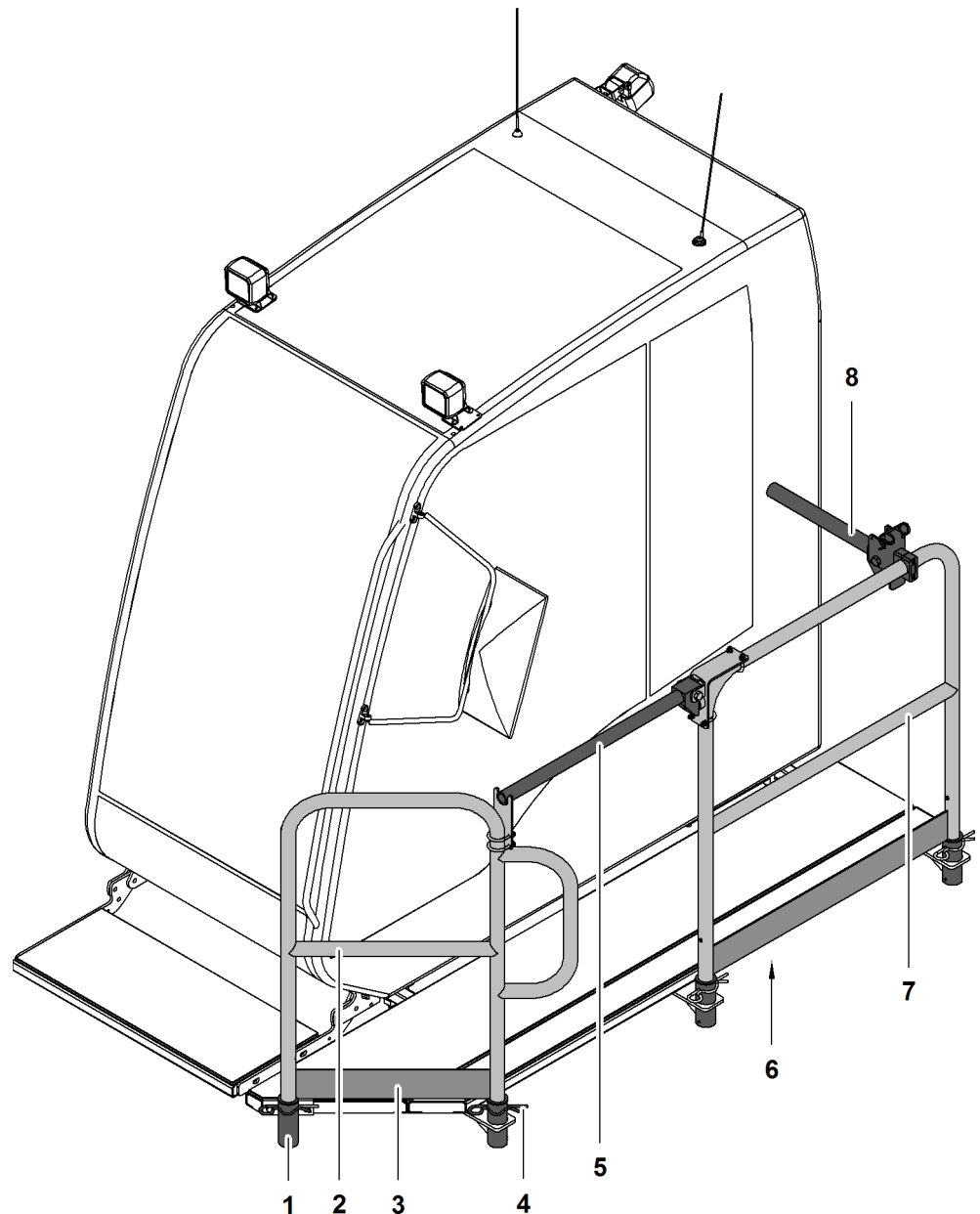


Fig. 487: Cabin railing

- | | | | |
|---|------------------------|---|--------------------------|
| 1 | Bracket (4x) | 5 | Chopper bar |
| 2 | Front cabin railing | 6 | Bracket below cabin (2x) |
| 3 | Foot board (2x) | 7 | Rear cabin railing |
| 4 | Spring cotter pin (4x) | 8 | Chopper bar |

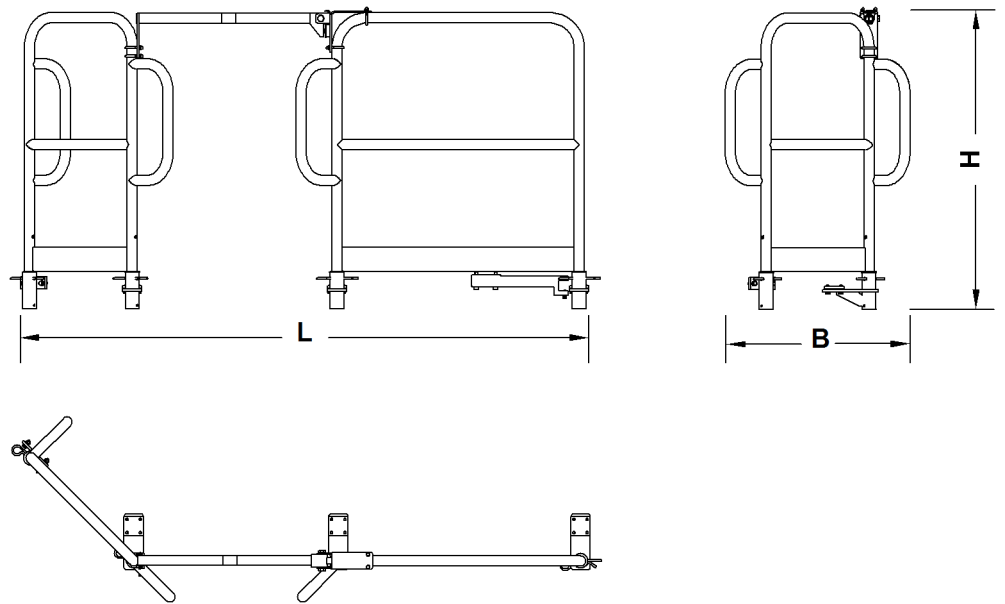


Fig. 488: Cabin railing

Name		Value
L	Length	2347 mm 7' 8" ft-in
W	Width	764 mm 2' 6" ft-in
H	Height	1237 mm 4' 1" ft-in
Weight		55 kg 121 lb

Tab. 292: Technical data cabin railing

1.55 Cable remote control

The cable remote control serves to control the counterweight hoisting cylinders, jacks, track width adjusting cylinders, and pin connection cylinders of the hydraulic pin connection of the main boom base section.

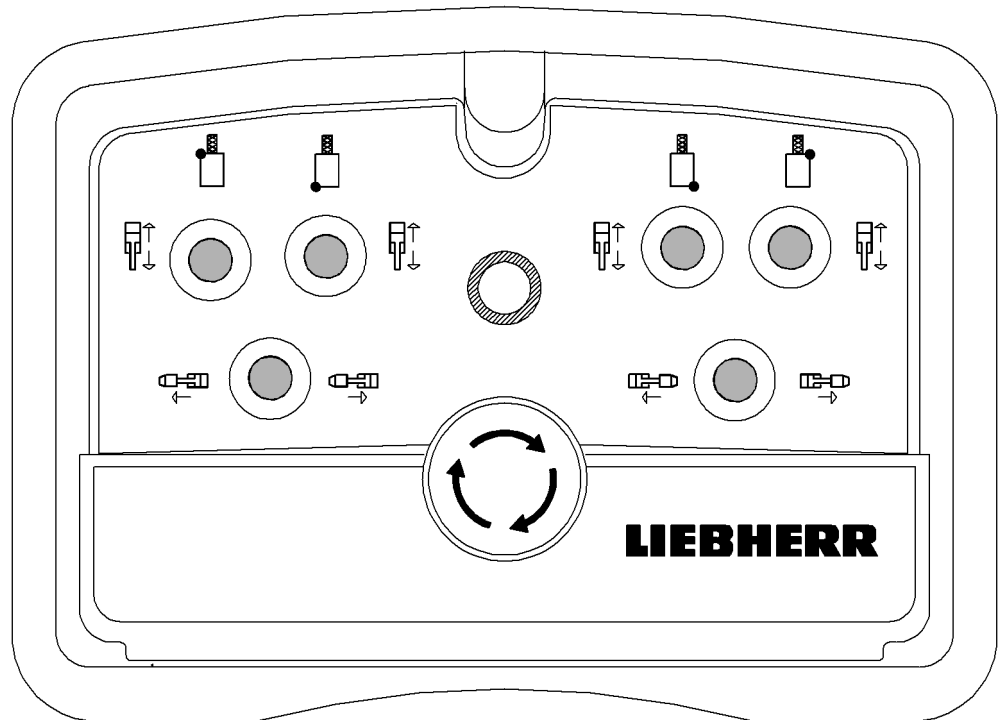


Fig. 489: Cable remote control

The continuation of the electric cable with its connector is not shown.

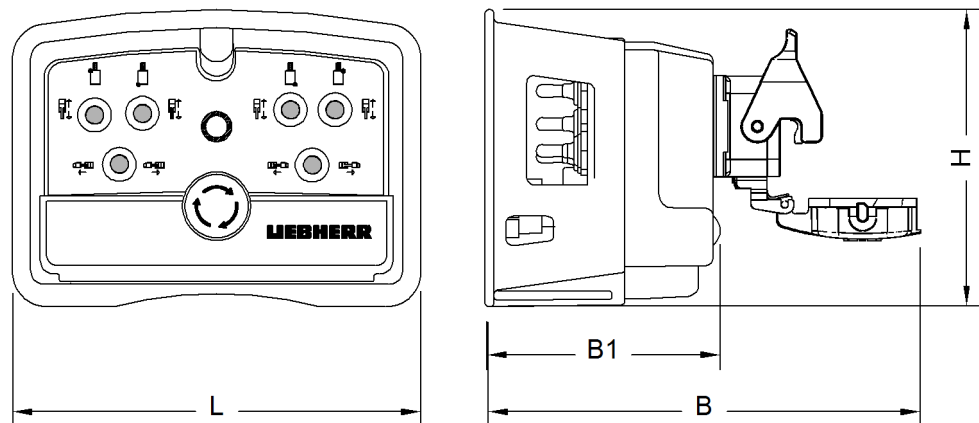


Fig. 490: Dimensions cable remote control

Name		Value
L	Length	175 mm 6.89" in

LWNLR-x\04.01\Auslieferung\2016-03-07/en

Name		Value
B	Width	184 mm 7.24" in
B1	Width	99 mm 3.90" in
H	Height	127 mm 5.00" in
Weight (without electric cable)		1 kg 2.20 lb

Tab. 293: Technical data cable remote control

1.56 Ventilation, heating and air-conditioning

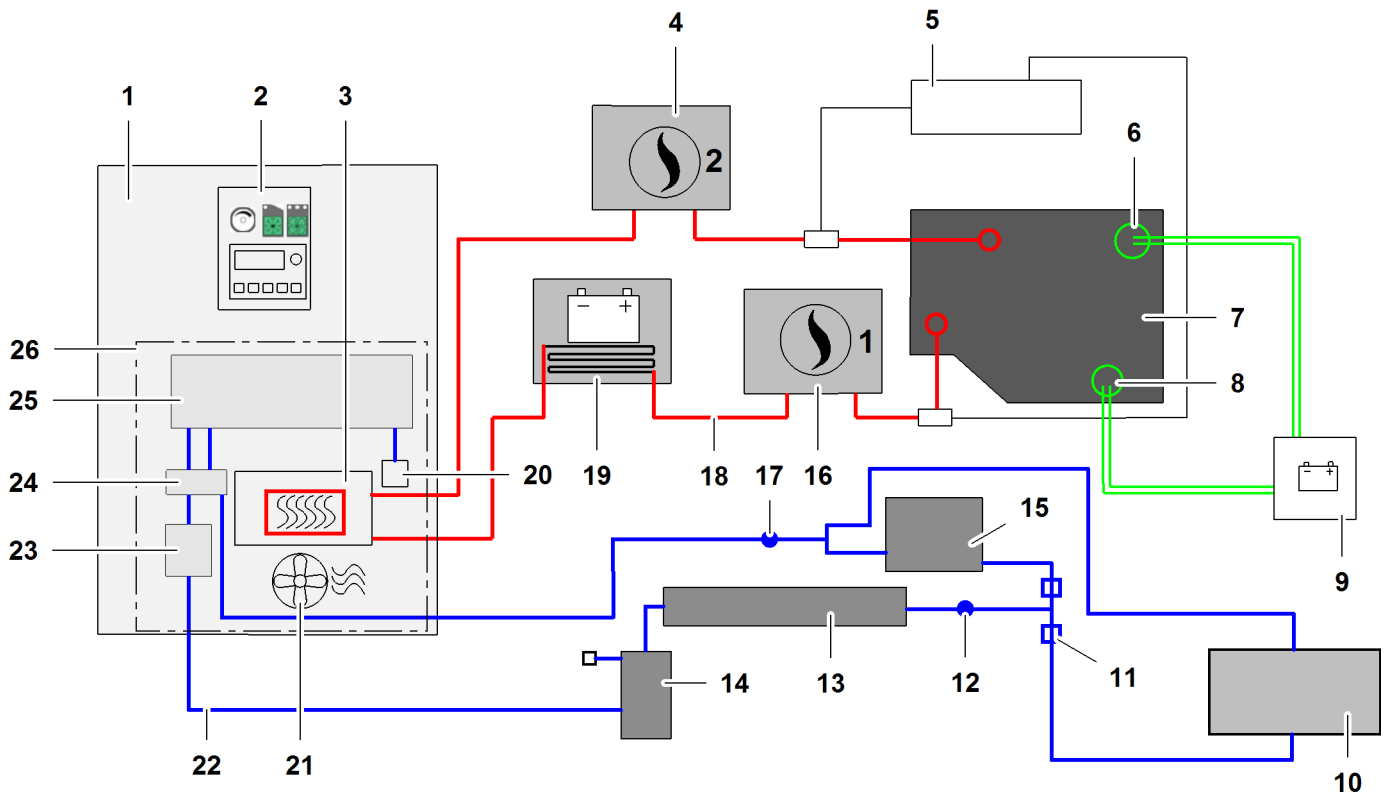


Fig. 491: Ventilation, heating and air-conditioning (illustration of principle)

1	Cabin	10	External air conditioning system*	19	Battery heating*
2	Operating elements in cabin	11	Non-return valve (2x)	20	Thermostat
3	Heat exchanger in climatic box	12	Filling coupling (high pressure)	21	Blower
4	Auxiliary water heating*	13	Condenser	22	Cooling circuit (shown in blue)
5	Urea tank	14	Dryer	23	Solenoid valve
6	Diesel engine coolant heating*	15	A/C compressor	24	Expansion valve
7	Diesel engine	16	Auxiliary water heating*	25	Evaporator
8	Diesel engine lubrication oil heating*	17	Filling coupling (low pressure)	26	Climatic box
9	Switch cabinet X1	18	Heating circuit (shown in red)		

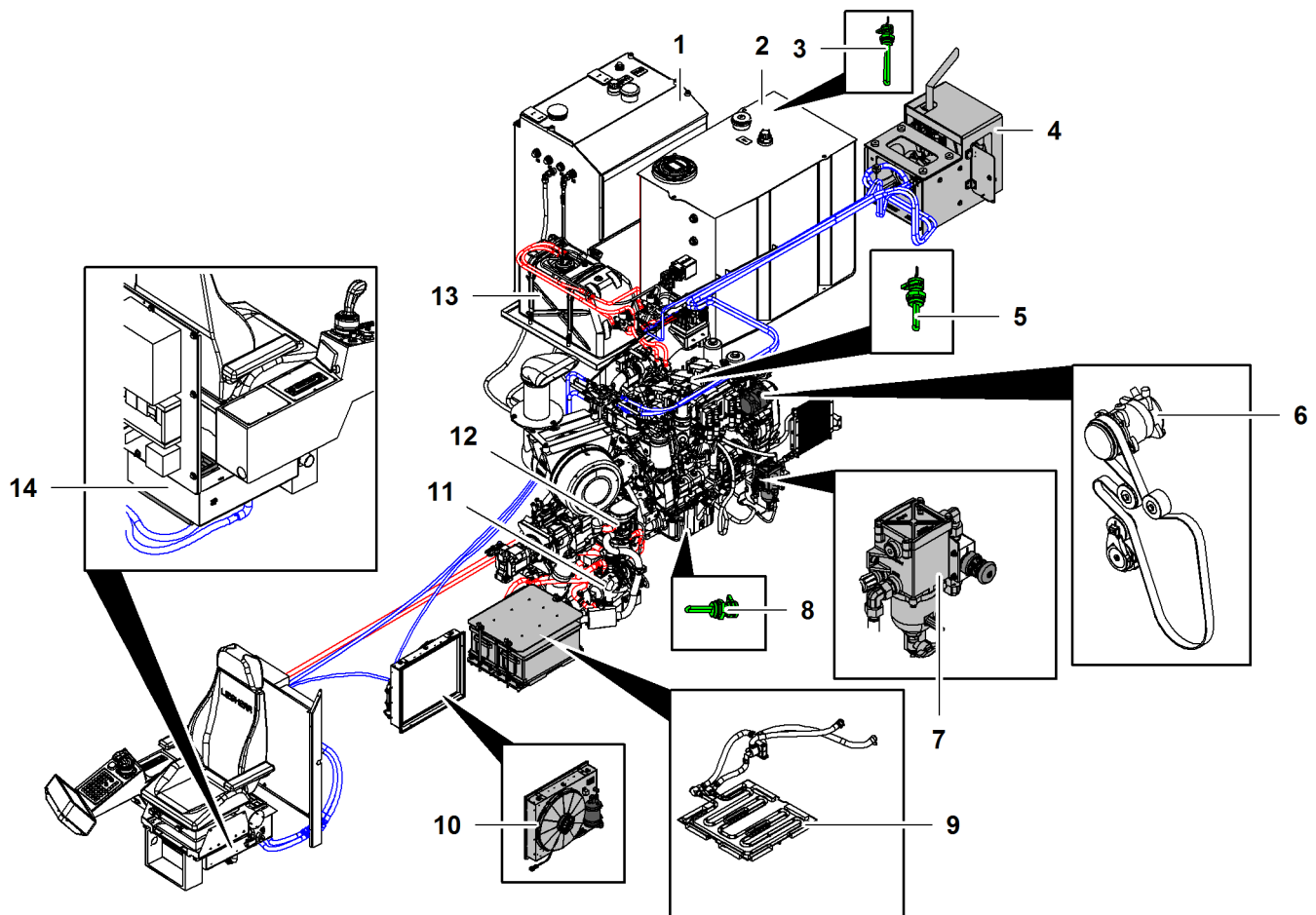


Fig. 492: Installation situation ventilation, heating and air-conditioning (illustration of principle)

1	Fuel tank	6	A/C compressor	11	Auxiliary water heating*
2	Hydraulic oil tank	7	Fuel pre-filter heating	12	Auxiliary water heating*
3	Immersion heater of hydraulic oil tank heating*	8	Immersion heater of diesel engine lubrication oil heating*	13	Urea tank
4	External air conditioning system*	9	Battery heating*	14	Climatic box
5	Immersion heater of diesel engine coolant heating*	10	Condenser		

The components may be installed individually or in groups.

1.56.1 Cooling circuit

The air conditioning system is combined with the heating and ventilation systems of the operator's cabin. The heating and air conditioning system only work when the diesel engine is running.

The external air conditioning system is connected to the air conditioning system, which is why only the diesel engine may be in operation.

Air conditioning system

The air conditioning system consists of the following components:

- Condenser on uppercarriage door
- Dryer on condenser
- A/C compressor on diesel engine

- Climatic box beneath cabin

Condenser on uppercarriage door/dryer on condenser

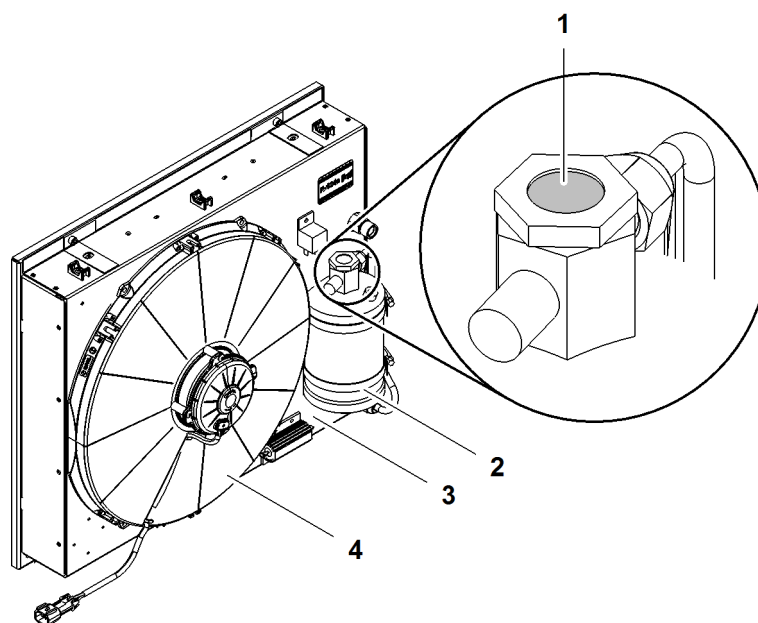


Fig. 493: Condenser on uppercarriage door/dryer on condenser

- | | | | |
|---|------------------|---|-----------|
| 1 | Inspection glass | 3 | Condenser |
| 2 | Dryer | 4 | Fan |

Name	Value
Maximum cooling output	10.1 kW 14 HP
Nominal voltage	24 V
Maximum nominal current	8.7 A
Fan capacity	3650 m ³ /h (4,773.98 yd ³ /h) (free-blowing)
Fan motor	dual-stage
Coolant	R134 A without CFC
Weight	10.5 kg 23.15 lb

Tab. 294: Technical data condenser

LWNLR-x\04.01\Auslieferung\2016-03-07\en

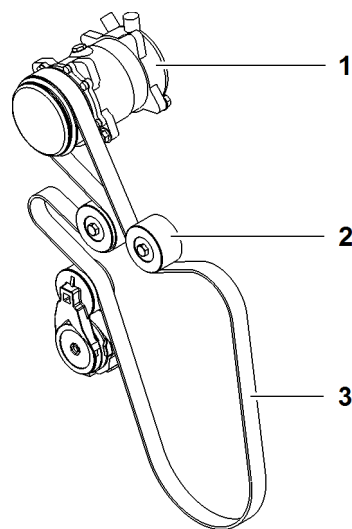
A/C compressor on diesel engine

Fig. 494: A/C compressor on diesel engine

- | | | | |
|----------|------------------------|----------|-------------|
| 1 | A/C compressor | 3 | Drive belts |
| 2 | Deflection pulley (3x) | | |

The A/C compressor **1** is installed on the diesel engine. The A/C compressor **1** is driven via the drive belt **3**.

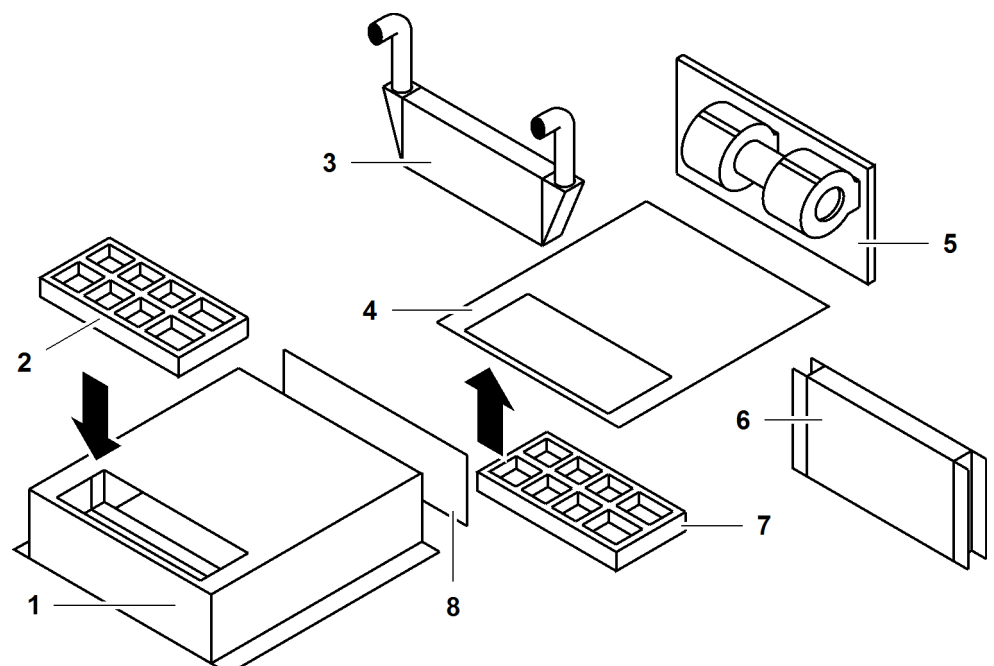
Climatic box beneath cabin

Fig. 495: Climatic box beneath cabin (illustration of principle)

- | | | | |
|----------|------------------------------|----------|---------------------------------|
| 1 | Climatic box | 5 | Blower |
| 2 | Recirculated air filter | 6 | Evaporator |
| 3 | Heat exchanger | 7 | Fresh air filter |
| 4 | Bottom plate of climatic box | 8 | Flap recirculated air/fresh air |

The cabin is supplied with warm air by the heat exchanger **3**.

The cabin is supplied with cold air by the evaporator **6**.

The air flow is controlled with the recirculated air/fresh air flap **8**.

External air conditioning system*

The external air conditioning system consists of the following components:

- Drive unit
- Control unit *external air conditioning system*

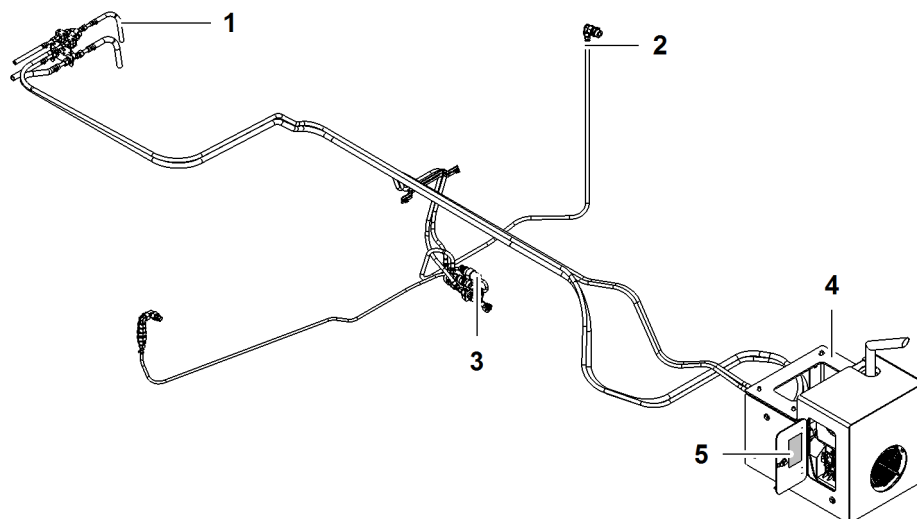


Fig. 496: External air conditioning system (illustration of principle)

- | | | | |
|---|--------------------------|---|----------------------------|
| 1 | Coolant line | 4 | Drive unit |
| 2 | Connection for fuel tank | 5 | Maintenance intervals sign |
| 3 | Diesel pump | | |

The external air conditioning system cools down or heats up the cabin without operation of the diesel engine.

Drive unit

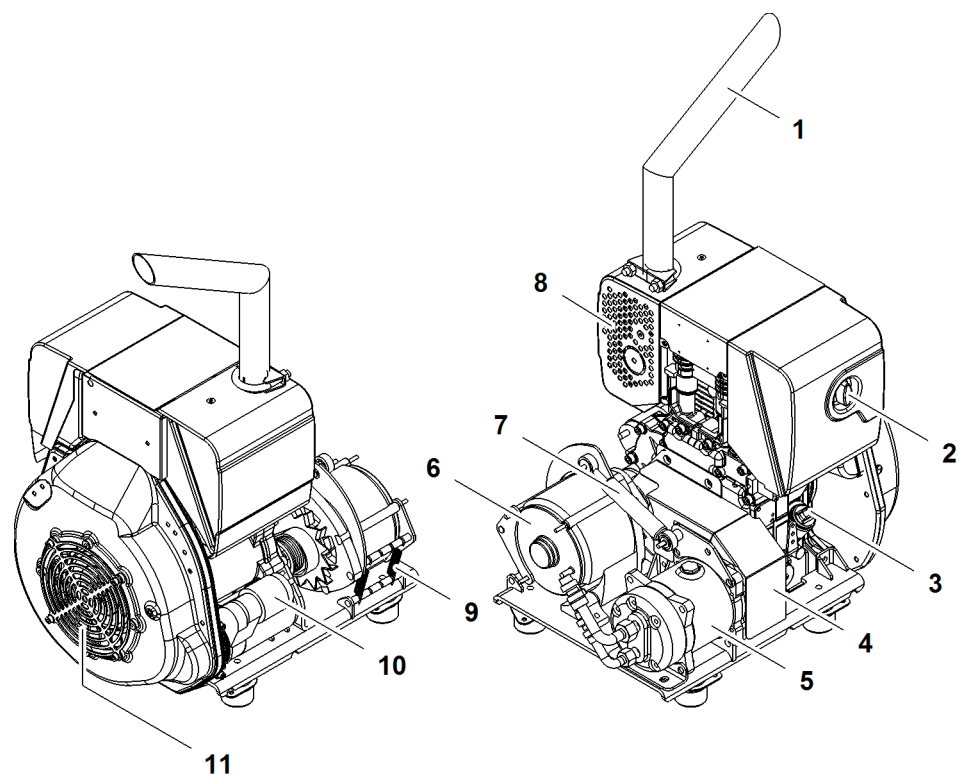


Fig. 497: Drive unit

- | | | | |
|---|---------------------|----|----------------------------------|
| 1 | Exhaust system | 7 | Vibration damper of belt tension |
| 2 | Air filter cover | 8 | Cover |
| 3 | Oil dipstick | 9 | Spring (2x) for belt tension |
| 4 | Cover of belt drive | 10 | Starter |
| 5 | Compressor | 11 | Fan |
| 6 | Generator | | |

The drive unit is depicted without cover.

The cooling air and the combustion air for the diesel engine are sucked in through the fan 11.

The belt drive is located behind the cover 4.

The springs 9 guarantee optimum belt tension. Shocks are absorbed by the vibration damper 7.

The generator 6 charges the batteries when the machine is turned off.

Name	Value
Engine type	HATZ 1B40 CARB
Fuel	Diesel
Nominal voltage	24 V
Charging current	40 A
Engine output	5.6 kW 8 HP
Cooling capacity	4.7 kW 6 HP

Name	Value
Coolant	R134 A without CFC
Weight	78 kg 172 lb

Tab. 295: Technical data drive unit

Control unit external air conditioning system

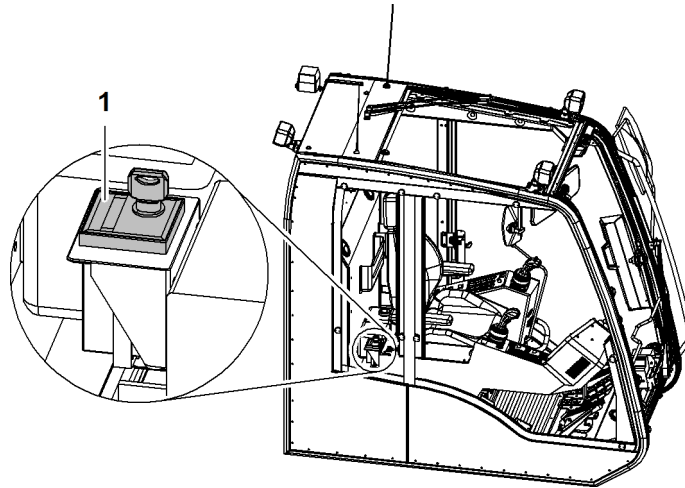


Fig. 498: Control unit external air conditioning system

- 1 Control unit External air conditioning system with ignition key

1.56.2 Heating circuit

Auxiliary water heating*

The auxiliary water heating serves to preheat the diesel engine, heat the cabin and switch cabinet X1 and to defrost the windows.

Warm water is generated through diesel combustion. The water is pumped into the coolant circuit of the diesel engine with a circulation pump. This heats the diesel engine and the heating circuit heats the cabin.

The auxiliary water heating can be programmed with the operating element *auxiliary heating* in the cabin .

No external power supply is required for operating the auxiliary water heating.

An auxiliary heating system allows operation down to -25 °C (-13 °F). Two auxiliary heating system allow operation down to -40 °C (-40 °F).

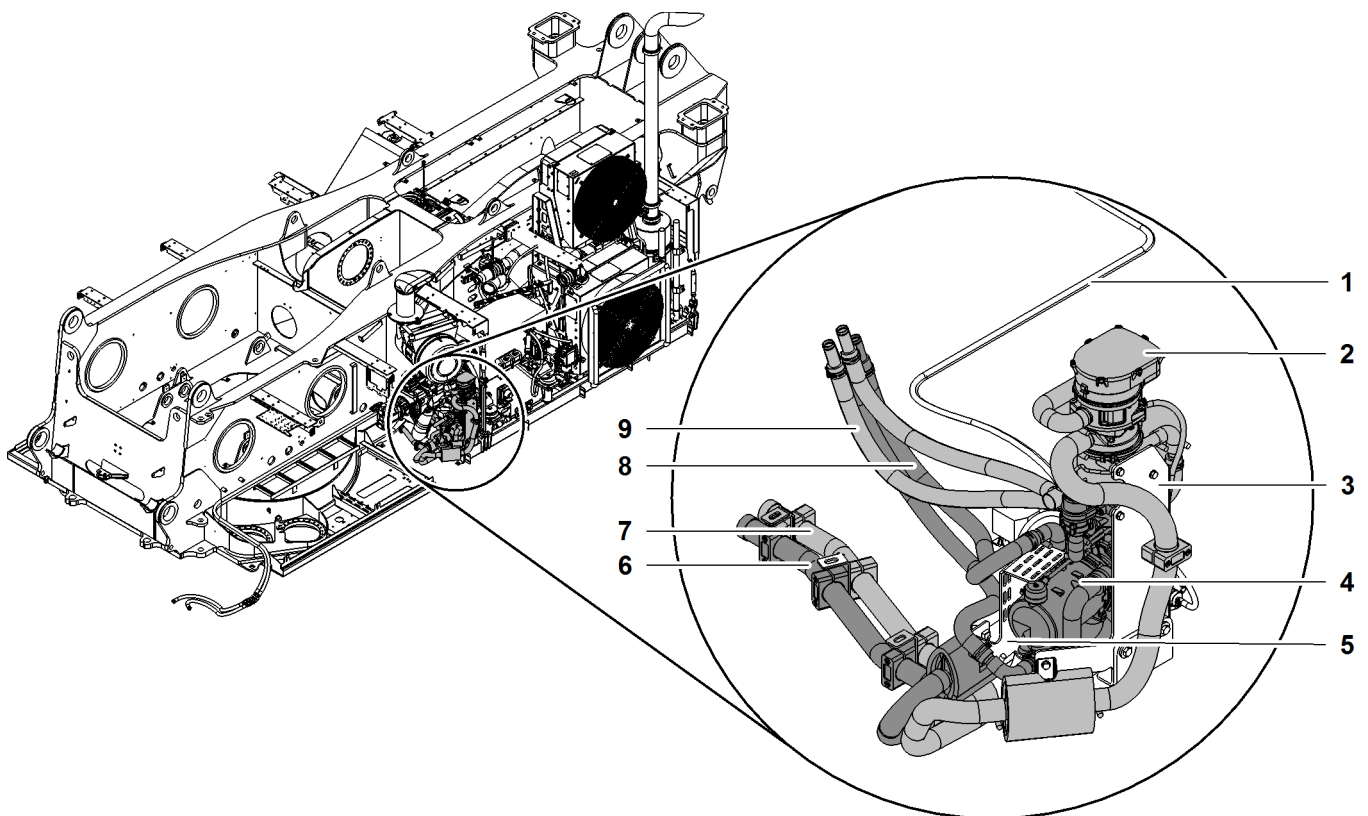


Fig. 499: Installation positions auxiliary water heating (LR 1002, LR 1003 und LR 1004) (illustration of principle)

- | | | | | | |
|---|--------------------------|---|--------------------------|---|----------------------|
| 1 | Fuel line | 4 | Auxiliary water heating* | 7 | Exhaust pipe |
| 2 | Auxiliary water heating* | 5 | Bracket | 8 | Warm water pipe (2x) |
| 3 | Bracket | 6 | Exhaust pipe | 9 | Warm water pipe (2x) |

Mufflers are installed on the exhaust pipes **6 + 7**. A fuel filter is installed on the fuel line **1**.

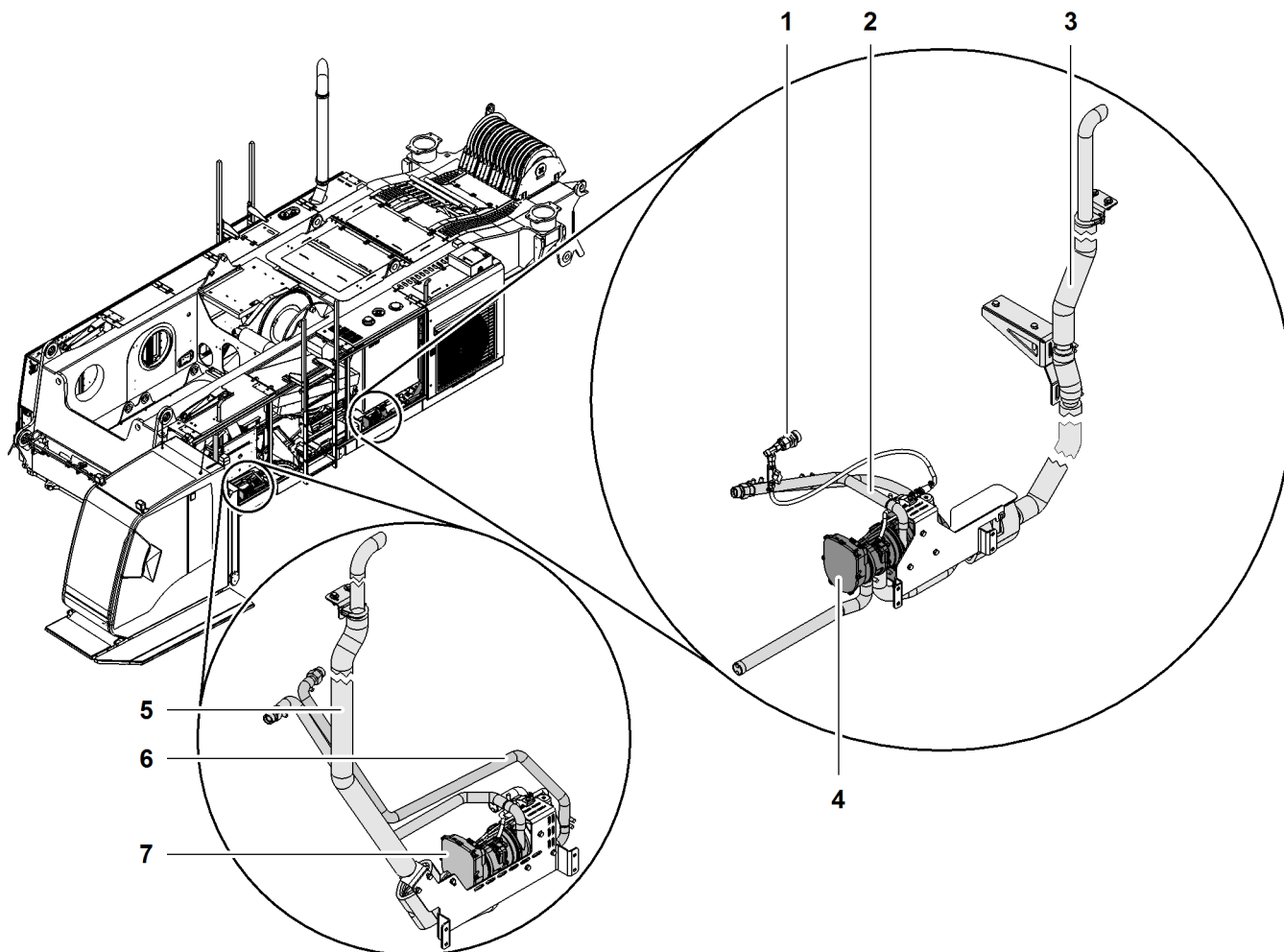


Fig. 500: Installation position auxiliary water heating (LR 1006)

- | | | | | | |
|---|-----------------|---|--------------------------|---|--------------------------|
| 1 | Fuel line | 4 | Auxiliary water heating* | 7 | Auxiliary water heating* |
| 2 | Warm water pipe | 5 | Exhaust pipe | | |
| 3 | Exhaust pipe | 6 | Warm water pipe | | |

Mufflers are installed on the exhaust pipes 3 + 5. A fuel filter is installed on the fuel line 1.

Name	Value
Webasto auxiliary heating Thermo Pro 90	
Maximum heating output	9.1 kW 12 HP
Nominal voltage	24 V
Nominal power consumption	80 W
Automatic height adjustment	down to 3500 m (11482' 11" ft-in)
Weight	4.9 kg 10.80 lb
Operating temperature	-40 °C (-40 °F) to 80 °C (176 °F)

Tab. 296: Technical data auxiliary water heating

LWNLR-x/V04.01//Auslieferung/2016-03-07/en

Battery heating*

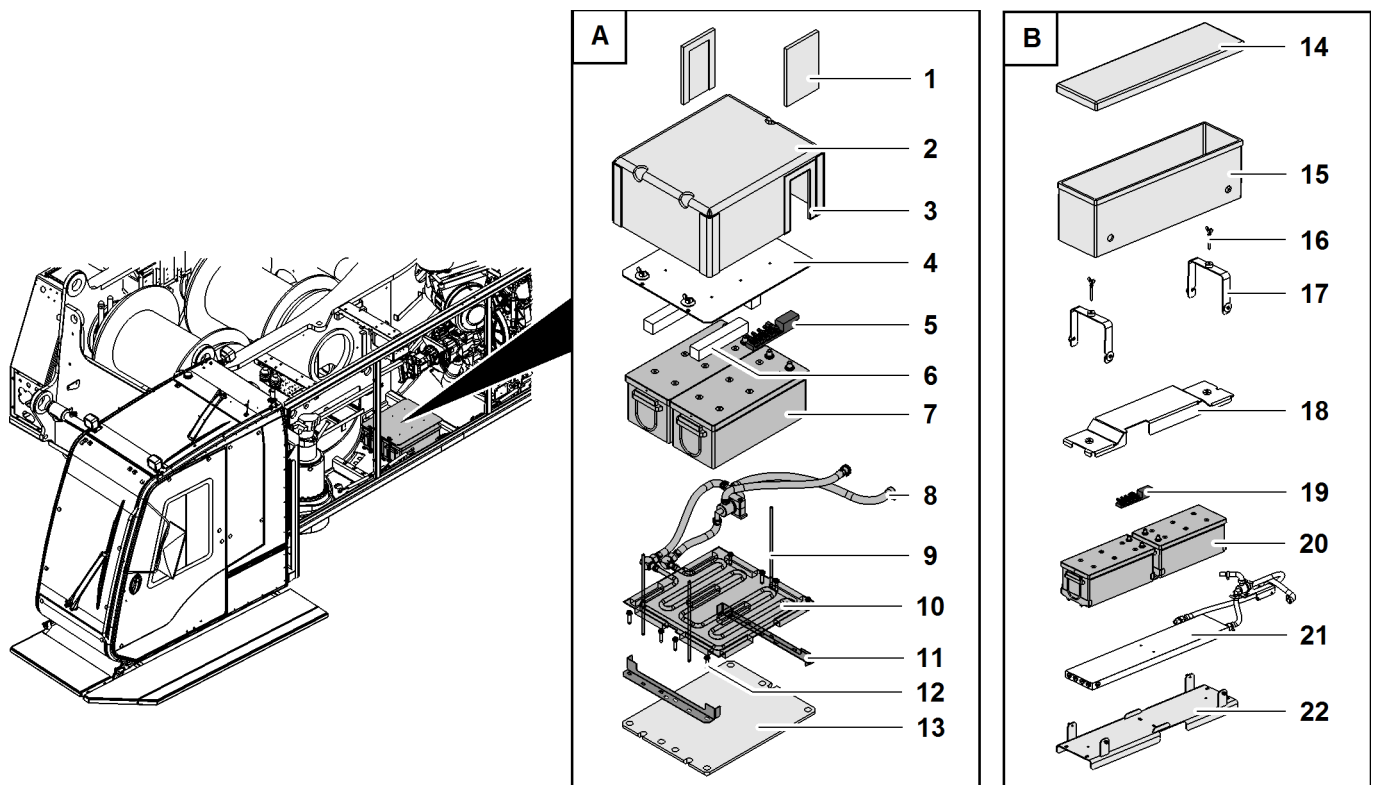


Fig. 501: Battery heating (illustration of principle)

1	Lateral insulation (2x)	9	Threaded bar (3x) with screw fitting	17	Bracket (2x)
2	Insulation	10	Heating coil	18	Cover
3	Velcro fastener	11	Battery holder	19	Fuse block
4	Cover	12	Screws	20	Battery (2x)
5	Fuse block	13	Plate	21	Heating coil
6	Wooden block (3x)	14	Top insulation	22	Plate
7	Battery (2x)	15	Insulation	A	Installation variant LR 1002, LR 1003, LR 1004
8	Connection diesel engine cooling circuit	16	Screw (2x)	B	Installation variant LR 1006

Via the connection **8** on the diesel engine's coolant circuit, a heating coil **10 + 21** warms the batteries **7 + 20**.

1.56.3 Auxiliary air heating*

The auxiliary air heating serves to heat the cabin and switch cabinet X1 and to defrost the windows.

Warm air is generated through diesel combustion. The air is blown into the cabin by the blower. This heats the cabin.

The auxiliary air heating can be programmed with the operating element *auxiliary heating* in the cabin .

No external power supply is required for operating the auxiliary air heating.

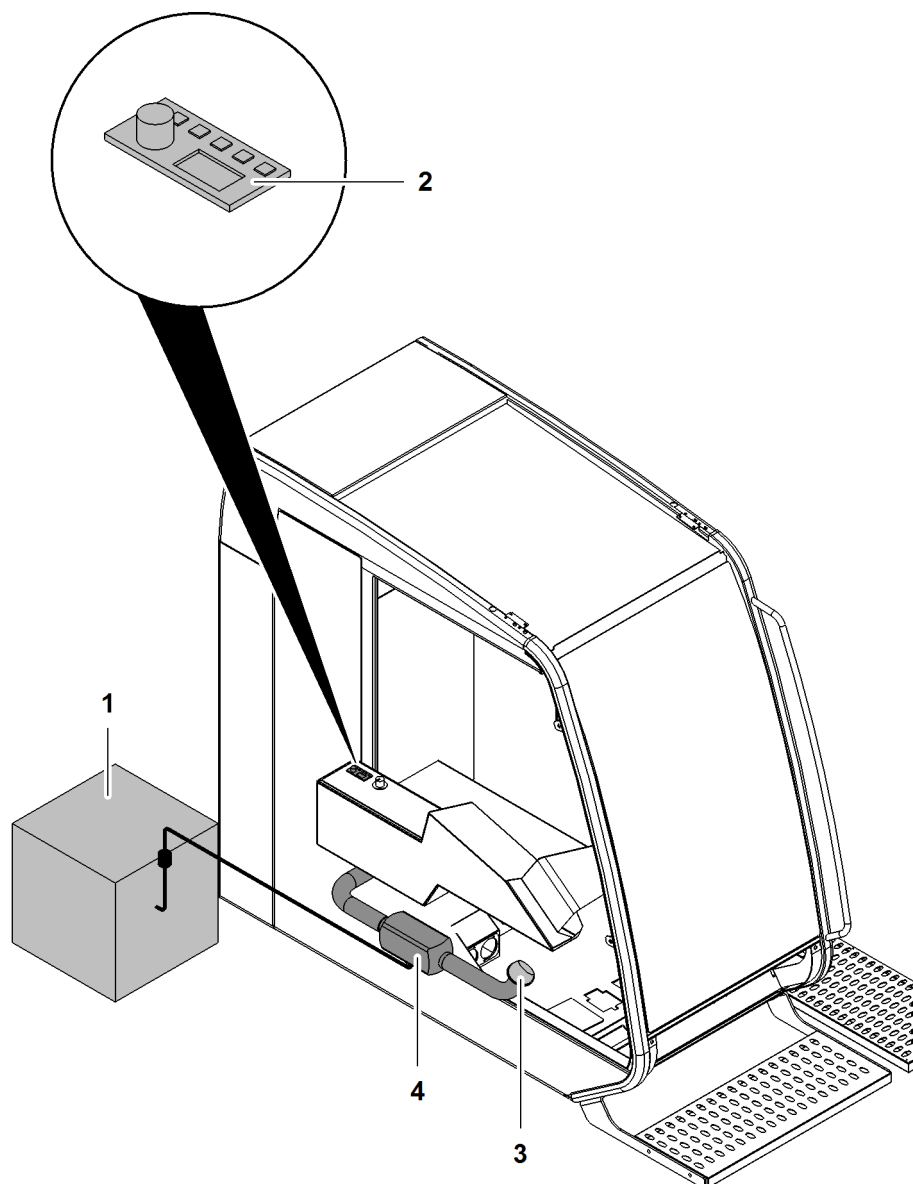


Fig. 502: Auxiliary air heating installation position (illustration of principle)

- | | | | |
|---|--------------------------------|---|-------------------|
| 1 | Fuel tank | 3 | Air vent |
| 2 | Auxiliary heating control unit | 4 | Auxiliary heating |

Name	Value
Webasto air heater Airtronik D2	
Maximum heating output	2.2 kW 3 HP
Nominal voltage	24 V
Maximum nominal output	34 W
Operating temperature	-40 °C (-40 °F) to 70 °C (158 °F)
Weight	2.7 kg 5.95 lb

Tab. 297: Technical data auxiliary air heating

LWNLR-x/V04.01//Auslieferung/2016-03-07/en

Auxiliary heating control unit

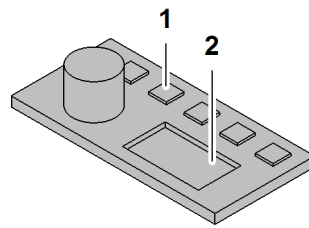


Fig. 503: Auxiliary heating control unit

1 Buttons

2 Display

Auxiliary heating altitude kit*

The auxiliary heating altitude kit is required when operating the machine at high altitudes.

After starting the heater, the air pressure sensor measures the atmospheric air pressure at intervals. It then transfers the measuring values to the heater's control unit. The control unit analyzes the measurement values and adapts the fuel flow rate of the dosing pump to the current atmospheric air pressure. Reduction of the flow rate starts as from 1400 m (4593' 2" ft-in). At the same time, this requires a reduction of the heating output of 9% per 1000 m (3280' 10" ft-in).

Name	Value
Altitude kit for Webasto air heater Airtronik D2	
Maximum permitted height	4000 m 13123' 4" ft-in
Measuring range	60 kPa (8.70 psi) to 115 kPa (16.68 psi)
Nominal voltage	8 V to 32 V
Dimensions	76 mm (2.99" in) x 76 mm (2.99" in) x 29 mm (1.14" in)
Operating temperature	-40 °C (-40 °F) to 85 °C (185 °F)

Tab. 298: Technical data auxiliary heating altitude kit

1.56.4 Electric components

An external power supply with the national nominal mains voltage is needed to operate the electric components.

Diesel engine coolant heating*

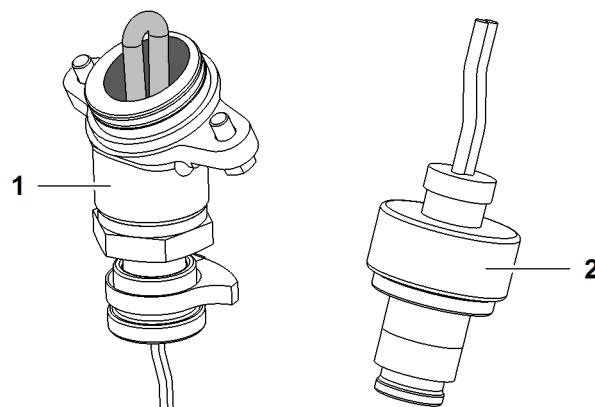


Fig. 505: Diesel engine coolant heating

1 Immersion heater

2 Thermostat

The immersion heater 1 is installed in the diesel engine's coolant circuit.

The temperature of the coolant rises by approx. 3 °C (37 °F) per hour. The thermostat on the diesel engine adjusts the temperature between 50 °C (122 °F) and 60 °C (140 °F).

Name	Value
Output	1 kW 1 HP
Nominal voltage	200 V to 254 V
Nominal voltage	4.2 A
Length	84 mm 3.31" in
Heater diameter	38 mm 1.50" in

Tab. 300: Technical data diesel engine coolant heating

Diesel engine lubrication oil heating*

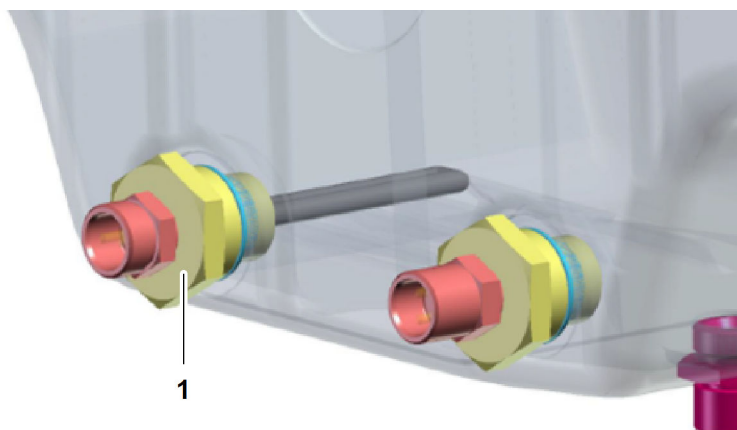


Fig. 506: Diesel engine lubrication oil heating

1 Immersion heater

The immersion heater 1 is installed in the oil sump of the diesel engine.

Name	Value
Output	300 W
Nominal voltage	200 V to 254 V
Weight	0.5 kg 1.10 lb
Control thermostat	37 °C (99 °F) to 48 °C (118 °F)

Tab. 301: Technical data diesel engine lubrication oil heating

1.56.5 Mechanic components

Fuel pre-filter heating

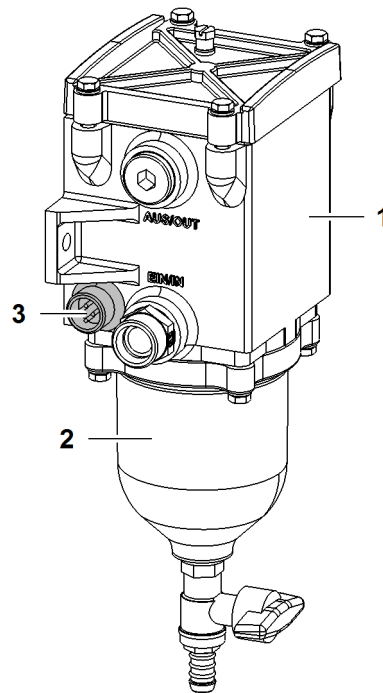


Fig. 507: Fuel pre-filter heating

- | | |
|---|-------------------------|
| <p>1 Fuel pre-filter</p> <p>2 Condensate trap</p> | <p>3 Voltage supply</p> |
|---|-------------------------|

The fuel pre-filter heater warms up the fuel. The fuel pre-filter heater is not active until the ignition is switched on.

Hydraulic oil heater*

If the diesel engine is running and the hydraulic oil temperature drops below a certain value, the hydraulic oil heater is activated automatic via the Litronic control.

The hydraulic oil heater is turned off automatically once the hydraulic oil temperature has reached a certain value.

Low temperature function lock*

A temperature sensor is installed on the machine.

If the external temperature drops below -25 °C (-13 °F), the machine cannot be put into operation.

If the outside temperature falls below -25 °C (-13 °F) during operation, the following movements are blocked:

- Winch1 and winch2
- Main boom luffing winch
- Jib luffing winch
- Slewing gear
- Crawler

1.57 Catwalks* for boom

Catwalks are available for main boom components and derrick components.

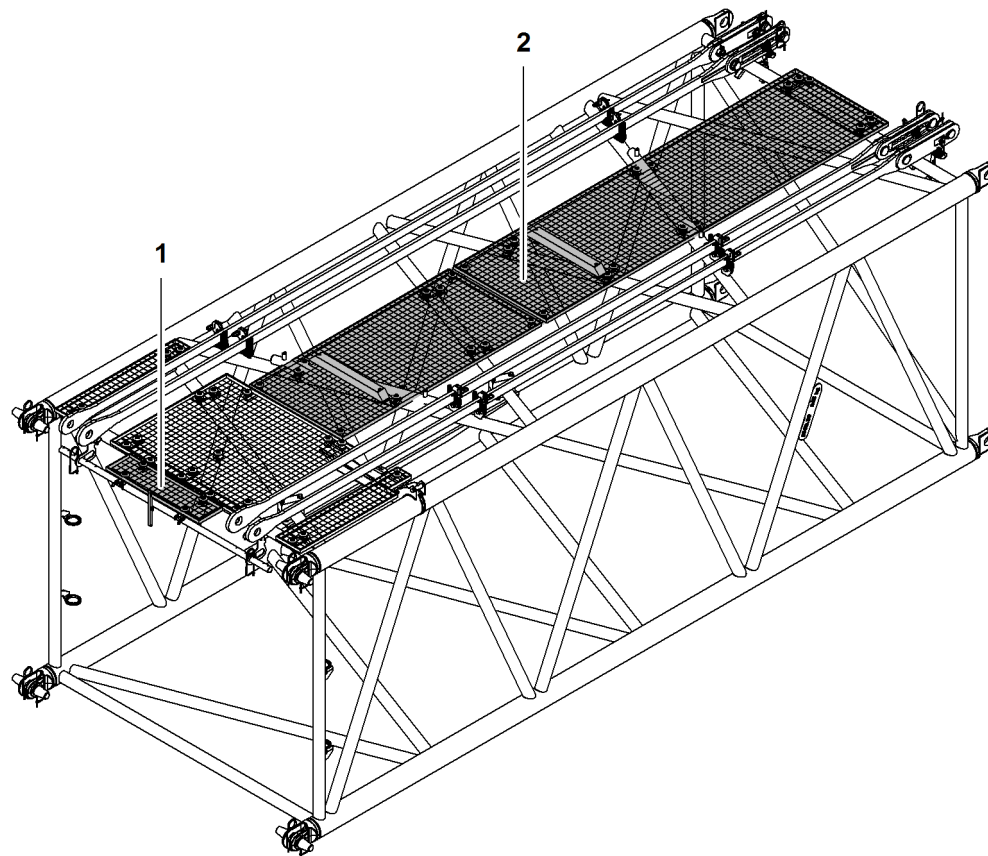


Fig. 508: Catwalks for booms without fall arrest (illustration of principle)

1 Catwalk (hinged)

2 Catwalk

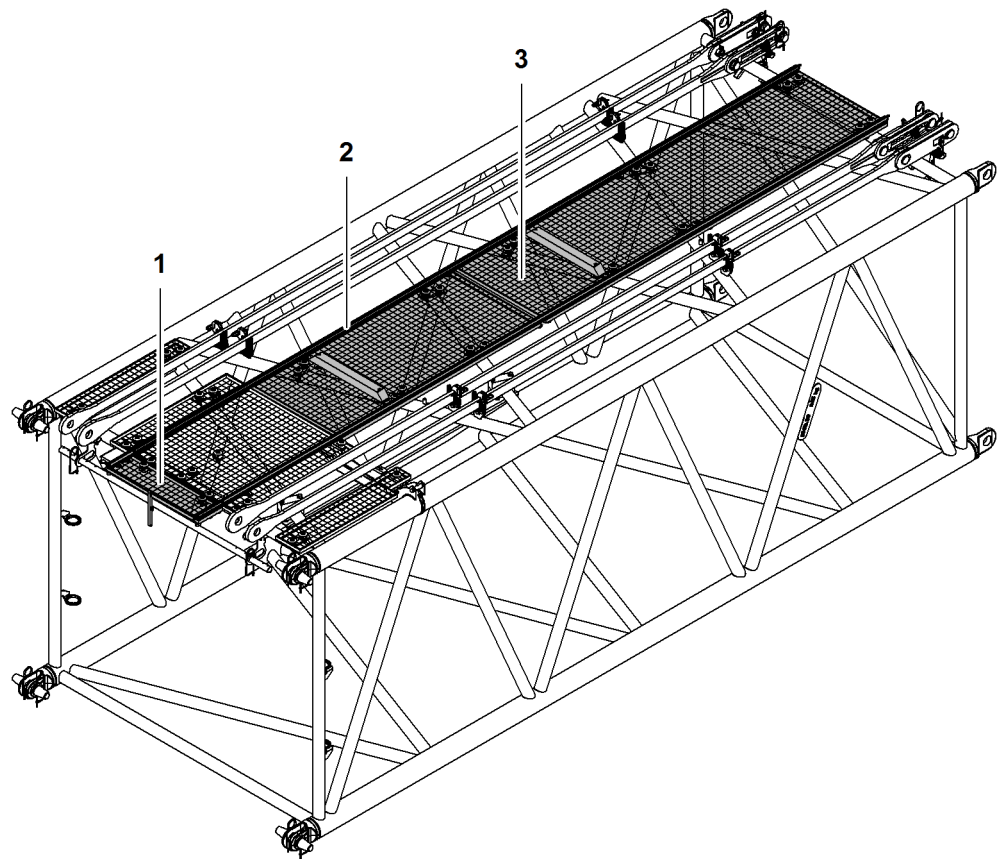


Fig. 509: Catwalks for booms with fall arrest (illustration of principle)

- | | | | |
|---|------------------|---|---------|
| 1 | Catwalk (hinged) | 3 | Catwalk |
| 2 | Fall arrest | | |

1.58 Leak oil return*

The leak oil return (also called leak oil collector) collects the leak oils of equipment and other consumers on the main boom base section. The leak oils are returned to the hydraulic oil tank.

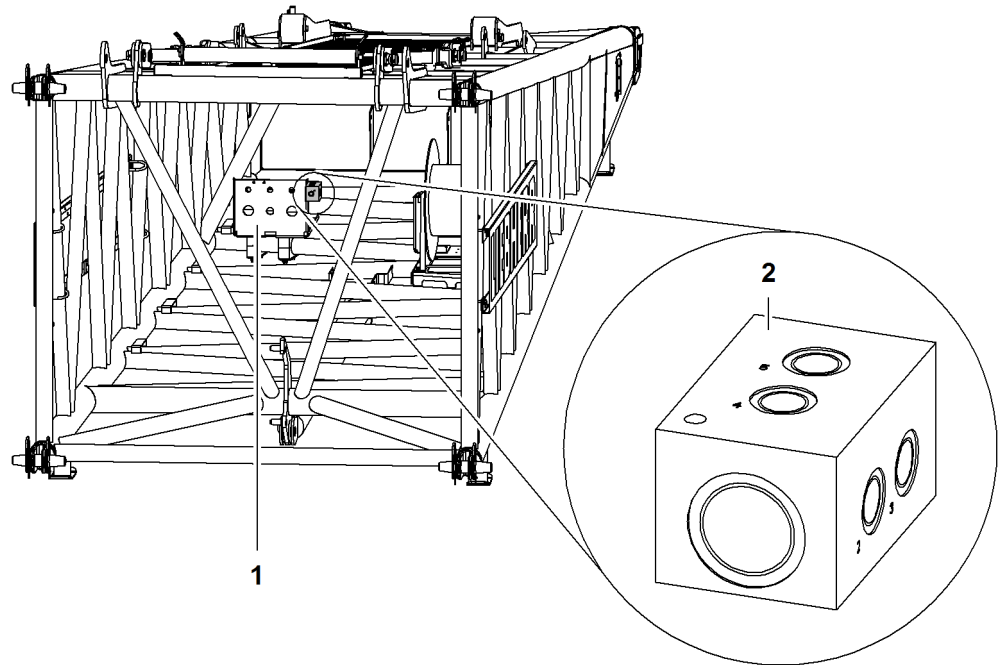


Fig. 510: Leak oil return

- 1** Bulkhead plate in the main boom base section **2** Leak oil return block

Numbers from 1 to 8 are embossed on the leak oil return block **2**.

1. Leak oil return to hydraulic tank
2. [Reserve]
3. Leak oil hose winch right (only HS devices)
4. [Reserve]
5. [Reserve]
6. Leak oil rope reeving winch
7. Leak oil hose winch left (only HS devices)
8. Leak oil leader winch

Optionally available:

- Leak oil jib luffing winch
- Leak oil tagline winch

1.59 Ladder* for boom

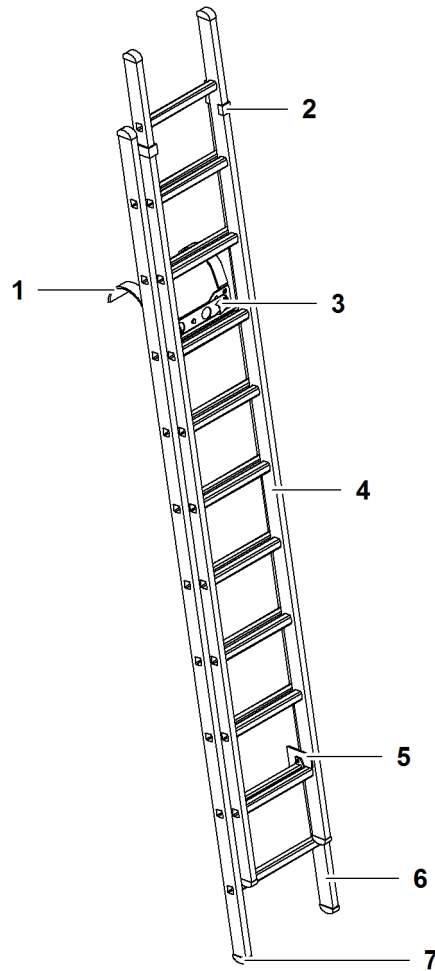


Fig. 511: Ladder for boom

- | | | | |
|---|------------------------|---|-----------------------------|
| 1 | Support for boom | 5 | Locking element (2x) |
| 2 | Guide rail (2x) | 6 | Ladder |
| 3 | Locking element (2x) | 7 | Adjustable rubber foot (2x) |
| 4 | Adjustable ladder part | | |

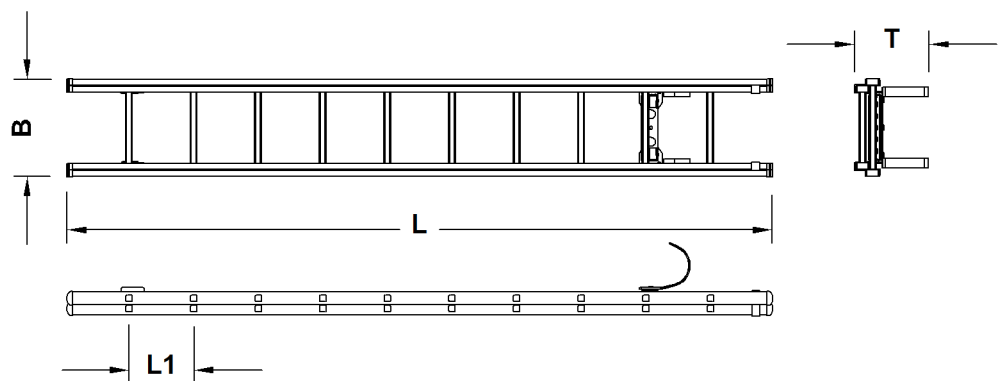


Fig. 512: Ladder for boom dimensions

LWNLR.x/V04.01//Auslieferung/2016-03-07/en

Product description

Ladder* for boom

Name		Value
L	Minimum length	3060 mm 10' ft-in
	Maximum length	4920 mm 16' 2" ft-in
L1	Spoke distance	280 mm 11.02" in
B	Width	420 mm 1' 5" ft-in
T	Depth	320 mm (1' 1" ft-in) (2x)
Maximum working height		6000 mm 19' 8" ft-in
Number of spokes		2 x 10 spokes
Weight		15.2 kg 33.51 lb

Tab. 302: Ladder for boom technical data

LWNLR-x/V04.01//Auslieferung/2016-03-07/en

1.60 Ladder* for uppercarriage

A ladder for the uppercarriage is supplied with each machine. A second ladder is optionally available to fit a ladder on each side of the uppercarriage.

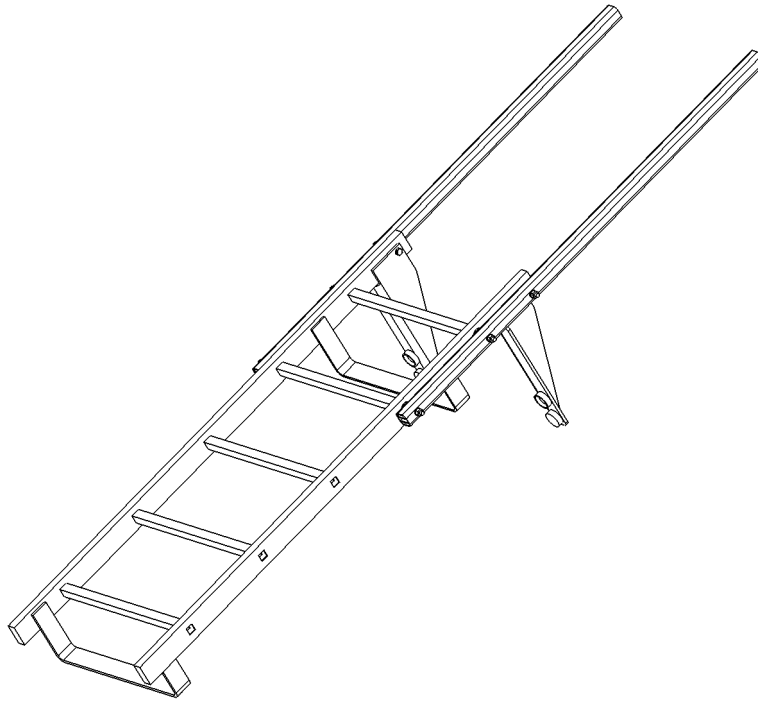


Fig. 513: Ladder for uppercarriage

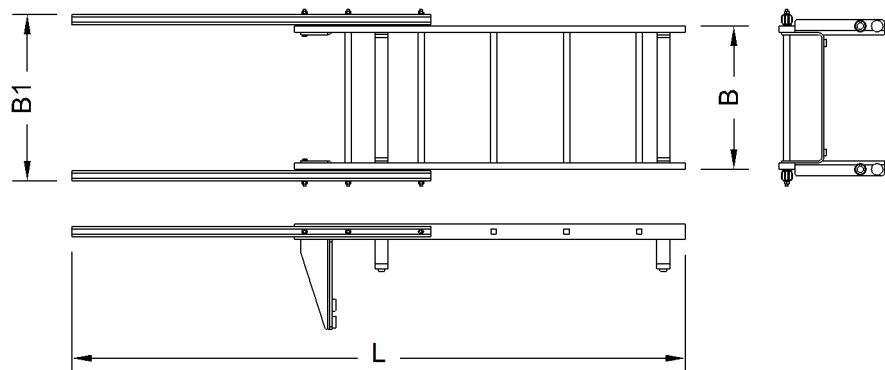


Fig. 514: Dimensions of ladder for uppercarriage

Name		Value
L	Length	2574 mm 8' 5" ft-in
W	Width	550 mm 1' 10" ft-in
W1	Width	604 mm 2' ft-in

Product description

Ladder* for uppercarriage

Name	Value
Weight	15 kg 33.07 lb

Tab. 303: Technical data ladder for uppercarriage

LWNLR-x/V04.01//Auslieferung/2016-03-07/en

1.61 Reading light* for cabin

The reading light serves for additional illumination of the control panels. The reading light is turned into the desired position with its bendable swan neck.

The exact installation position varies according to machine type.

The following control panels are illuminated:

- Control panel X23
- Control panel X25

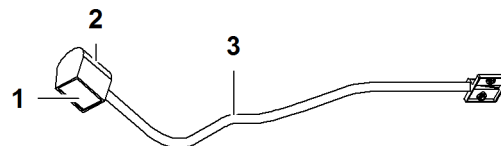


Fig. 515: Reading light

- | | |
|-------------------------------|--------------------|
| <p>1 Lamp</p> <p>2 Switch</p> | <p>3 Swan neck</p> |
|-------------------------------|--------------------|

Name	Value
Length of swan neck	500 mm 1' 8" ft-in
Illuminant	Xenon bulb
Nominal voltage	24 V
Power consumption of illuminant	7.5 W

Tab. 304: Technical data reading light

1.62 Litronic control system

The Litronic control system in the machine permits electrohydraulic proportional control, which in turn means that several main movements can be carried out. This control system has been designed to provide effective and economical operation.

The central unit of the Litronic control system is located in the switch cabinet of the machine and is connected via the CAN bus to the engine control unit, and all the sensors, transmitters and limit switches.

Litronic control system I/O devices in the cab:

- Monitor:
 - is in the form of a touch screen.
 - shows the current screens, machine setups, load charts and error protocols.
 - enables a function to be selected by touching the symbols with the finger.
- Control lever
- Keyboards and the Litronic service panel
- Safety lever at the front of the left-hand control panel
- Foot pedals
- Process data recording (PDE) combined with an external PCMCIA drive and a needle printer
- Machine data acquisition (MDE)

The central unit of the Litronic control system includes two drives for PCMCIA storage media and interfaces. The switch cabinet to the side contains the GSM/GPRS/GPS modem used for data transmission.

I/O devices outside the cab:

- Tension load cells and angle sensors
- Sensors, limit switches and transmitters that are situated at various locations on the machine or its equipment
- Warning signal (horn)
- Warning device (siren)
- Load moment limiter (LML)
- Reversing alarm
- Flashing light on the cab roof

The Litronic control system receives the latest data from the tension load cells, angle sensors, sensors, limit switches and transmitters, compares them, performs some calculations and outputs the results.

Some machine data are collected by the system. Liebherr uses the stored data to improve the operation and reliability.

1.63 Retrofit kits* for operation with two ropes over the jib head section

1.63.1 Retrofit kit for luffing jibs 1008 / 1309 / 1713 / 1916 / 2316

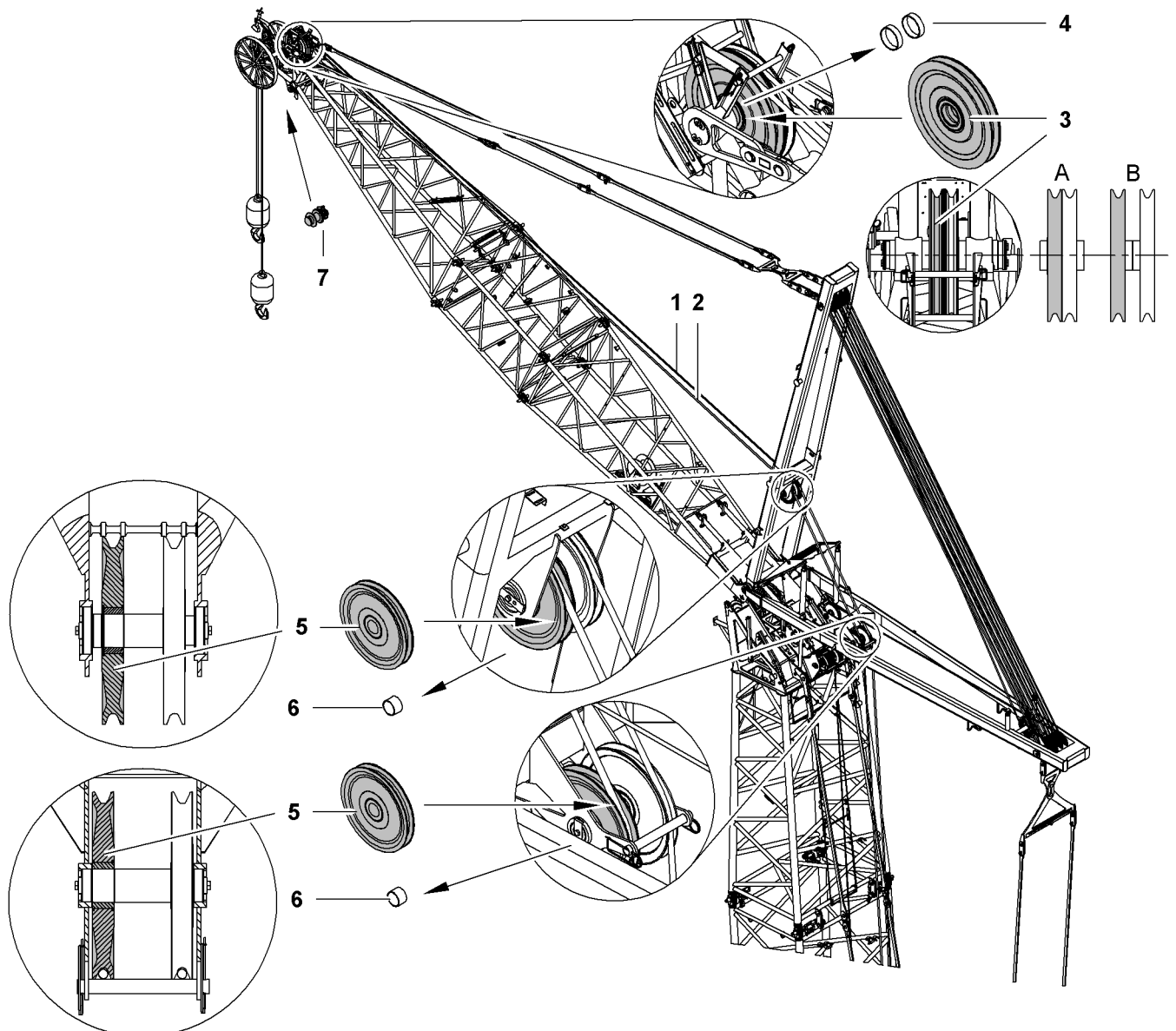


Fig. 516: Additional pulleys and rope fixing point with two ropes over luffing jib head section

1	Winch2 rope	4	Bush (2x)	7	Pins, washers and safety pins for rope fixing point
2	Winch1 rope	5	Pulley (2x)	A	Assembly position A
3	Pulley	6	Bush (2x)	B	Assembly position B

The pulley 3 (630 mm (2' 1" ft-in) x 15 mm (0.59" in) x 140 mm (5.51" in)) replaces the two bushes 4 (152 mm (5.98" in) x 141 mm (5.55" in) x 40 mm (1.57" in)).

Product description

Retrofit kits* for operation with two ropes over the jib head section

The pulleys **5** (500 mm (1' 8" ft-in) x 15 mm (0.59" in) x 90 mm (3.54" in)) replace the bushes **6** (101.6 mm (4.00" in) x 90.5 mm (3.56" in) x 67 mm (2.64" in)).

Assembly position	Type of jib
A	Luffing jib 1008
	Luffing jib 1309
	Luffing jib 1713
	Luffing jib 1916
B	Luffing jib 2316

Tab. 305: Assembly position for pulley on the jib head section

1.63.2 Retrofit kit for 1008 fixed jib

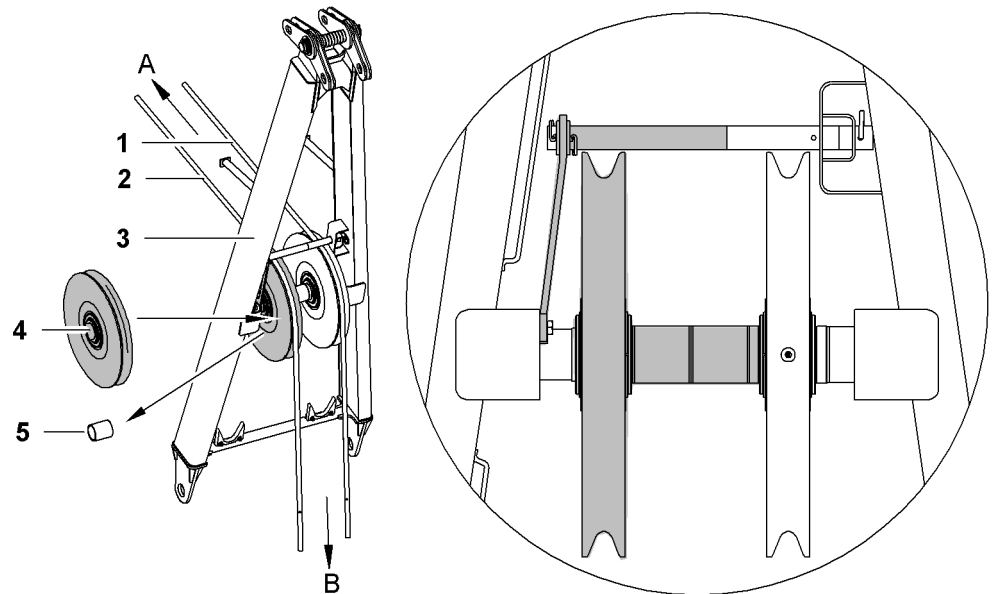


Fig. 517: Retrofit kit for 1008 fixed jib

- | | | | |
|----------|-------------------------------|----------|-----------|
| A | Direction of jib head section | 3 | A-frame 2 |
| B | Direction of main boom | 4 | Pulley |
| 1 | Winch1 rope | 5 | Socket |
| 2 | winch2 rope | | |

The pulley **4** (630 mm (2' 1" ft-in) x 15 mm (0.59" in) x 140 mm (5.51" in)) and all the components shown in grey in the detailed drawing replace the bush **5** (101.6 mm (4.00" in) x 90.5 mm (3.56" in) x 120 mm (4.72" in)).

LWNLR-x\04.01\Auslieferung\2016-03-07\en

1.63.3 Retrofit kit for 0806 fixed jib

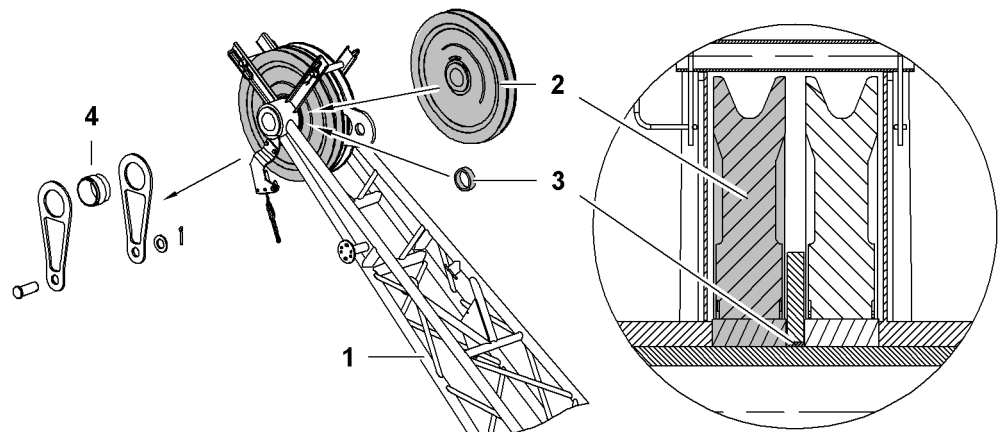


Fig. 518: Retrofit kit for 0806 fixed jib

- | | | | |
|---|-----------------------|---|------------------------------|
| 1 | 0806 jib head section | 3 | Socket |
| 2 | Pulley | 4 | Rope fixing point components |

The pulley **2** (630 mm (2' 1" ft-in) x 15 mm (0.59" in) x 140 mm (5.51" in)) and the bush **3** (150 mm (5.91" in) x 140 mm (5.51" in) x 19 mm (0.75" in)) replace all the rope fixing point components **4**.

1.64 Luffing jib luffing winch as auxiliary winch*

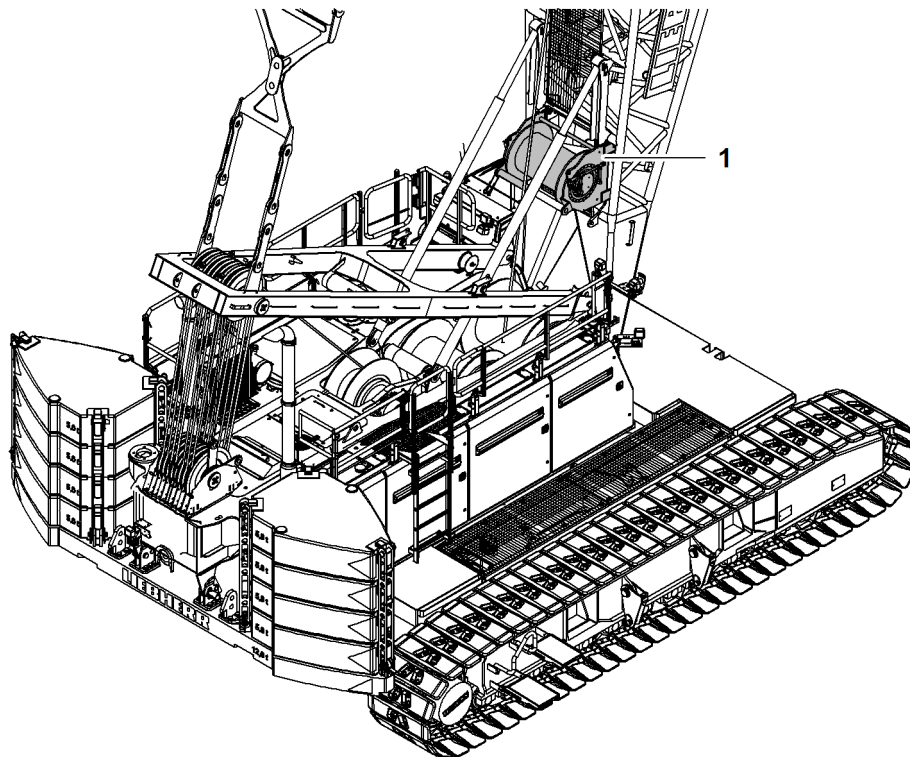


Fig. 519: Luffing jib luffing winch as auxiliary winch

1 Jib luffing winch

The jib adjustment winch **1** is used to adjust the jib.

With the retrofitting kit "jib luffing winch as auxiliary winch," the jib luffing winch **1** can also be used as auxiliary winch.

1.65 By-pass flow filter system*

The SDU-H350 RK/TWIN by-pass flow filter system comprises two filter housings with filter elements (SDFC), a dynamic pressure manometer, the hoses and an oil sump with drain screw.

The exact installation position varies according to machine type.

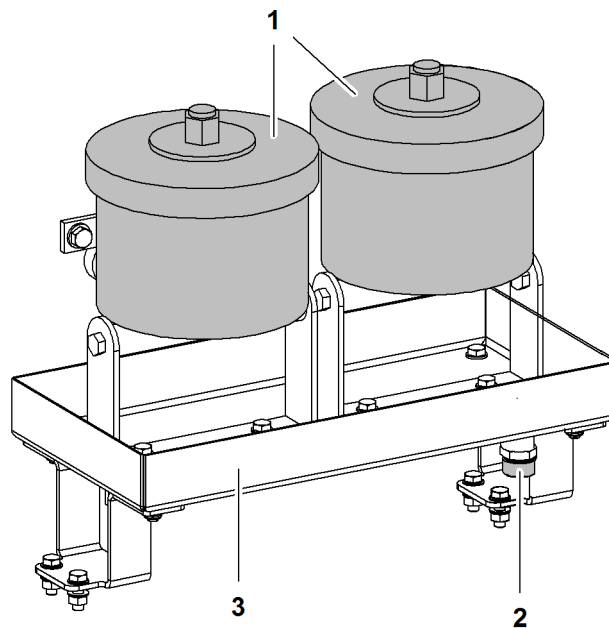


Fig. 520: By-pass flow filter system

- | | | | |
|---|---------------------|---|----------|
| 1 | Filter housing (2x) | 3 | Oil sump |
| 2 | Drain plug | | |

The cellulose-based filter elements (SDFC) absorb abrasive and catalytic contamination, foreign matter ($> 1 \mu\text{m}$ ($1 \mu\text{m}$)) and free water content from pressure liquids and other lubricants. Despite the fact that the filters are very fine ($< 1 \mu\text{m}$ ($1 \mu\text{m}$)), oil additives and admixtures are not filtered out, as the filtration occurs at very low and gentle pressure levels ($< 5 \text{ bar}$ (72.52 psi)). Read the counter pressure off the dynamic pressure manometer situated under the left filter housing.

1.66 Emergency operation control*

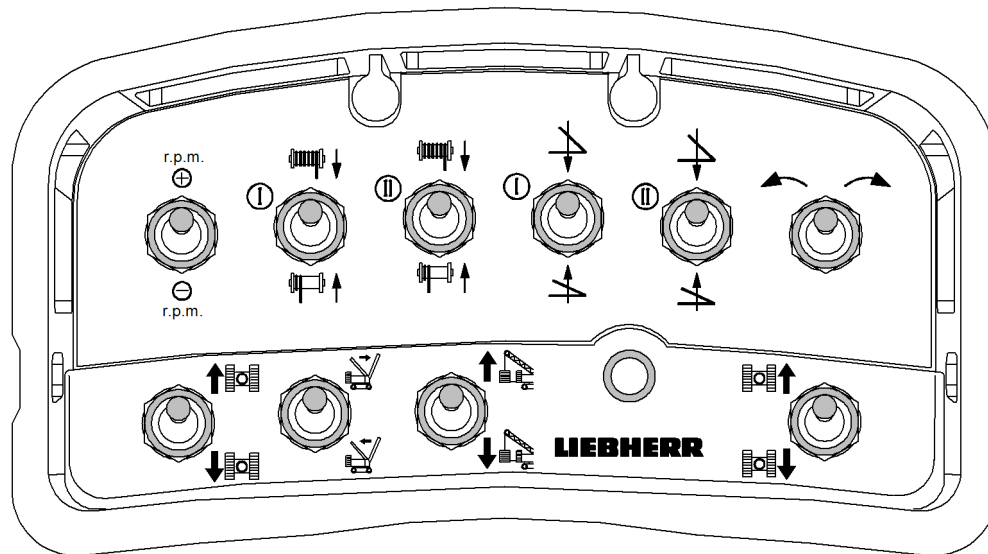


Fig. 521: Emergency control system

Name	Value
Length	248 mm 9.76" in
Width	118 mm 4.65" in
Height	137 mm 5.39" in
Nominal voltage	18 V to 36 V
Operating temperature	-40 °C (-40 °F) to 90 °C (194 °F)
Storage temperature	-50 °C (-58 °F) to 90 °C (194 °F)
Weight	5.5 kg 12.13 lb

Tab. 306: Technical data emergency control system

1.67 Visual motion warning device*

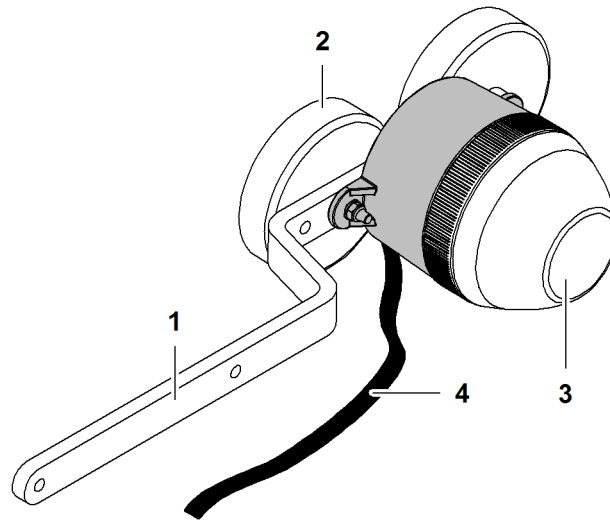


Fig. 522: Visual motion warning device

- | | | | |
|---|-------------|---|----------------|
| 1 | Handle | 3 | Flashing light |
| 2 | Magnet (2x) | 4 | Electric cable |

The visual motion warning devices on the rear counterweight are an additional safety feature and emit a warning when the crawlers are moving or the crane is swinging.

The visual motion warning devices are flashing lights that are fitted in suitable locations on the rear counterweight using magnets.

The plug is located in the periphery of acoustic motion detectors.

The electric connection is established with the following plugs:

- 4A / H 1.1
- 4A / H 1.2

NOTICE

Incorrect assembly/disassembly of the visual motion warning devices!
Risk of damage to the visual motion warning devices.

- ▶ Do not trap or crush the electric cable.
- ▶ Only fit the visual warning devices after the rear counterweight has been attached.
- ▶ Always remove the visual motion warning devices before removing the rear counterweight.

Name	Value
Illuminant	Xenon
Nominal voltage	24 V
Current consumption	0.3 A
Output	5 W
Flashing frequency	60 flashes/minute

Product description

Visual motion warning device*

Name	Value
Temperature range	-30 °C (-22 °F) to 50 °C (122 °F)

Tab. 307: Visual motion warning device technical data

Name	Value
Illuminant	LED
Nominal voltage	24 V
Current consumption	0.3 A
Temperature range	-40 °C (-40 °F) to 60 °C (140 °F)

Tab. 308: Visual motion warning device technical data

LWN/LR-x/V04.01//Auslieferung/2016-03-07/en

1.68 Process data recording (PDR)*

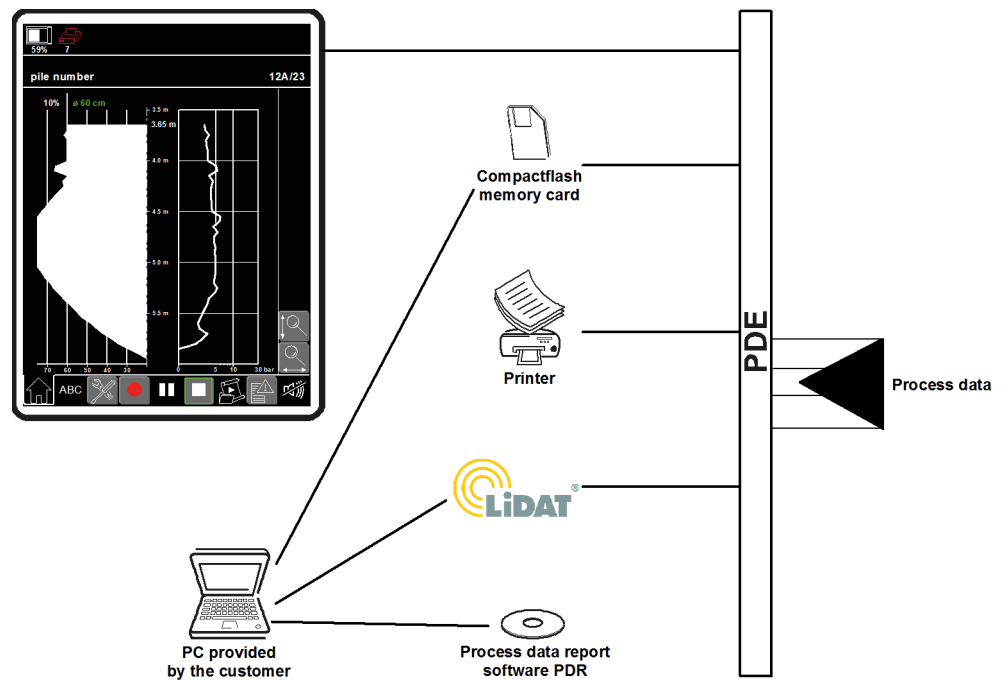


Fig. 523: Process data recording (illustration of principle)

Process data recording (PDR) is described in the operation manual for process data recording.

1.69 Process data report (PDR)*

The process data report (PDR) is described in the operation manual for the process data report.

1.70 Pump wear indicator*

Chip controls enable early detection of wear on hydraulic pumps.

The magnet in the chip control draws dirt particles out of the hydraulic oil. In case of inadmissible contamination, an error message appears on the monitor.

The following pumps are equipped with a chip control:

- Winch1
- Winch2
- Swing
- LPVD-pump

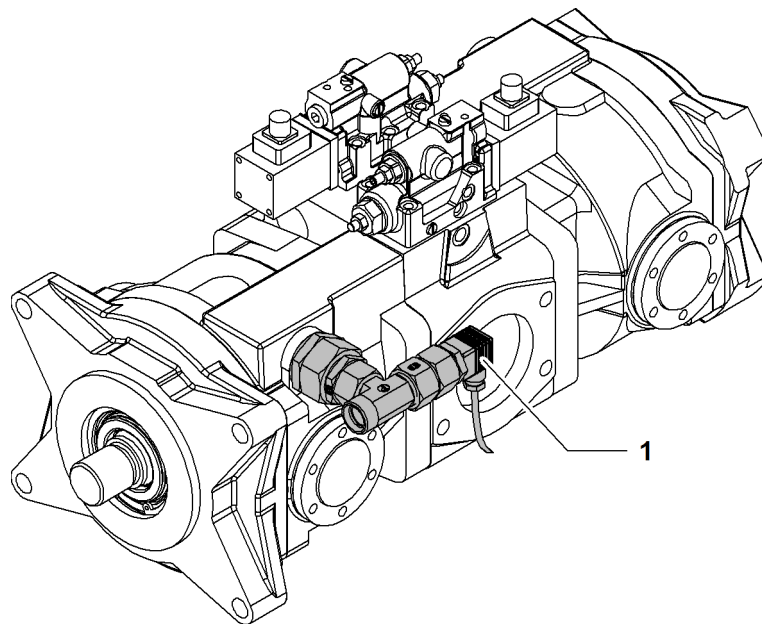


Fig. 524: Pump wear indicator (illustration of principle)

1 Chip control

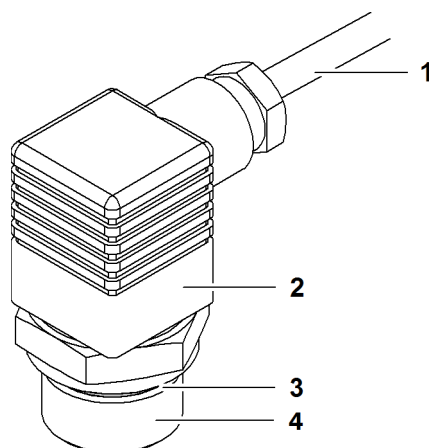


Fig. 525: Chip control

1 Electric cable
2 Plug

3 Seal ring
4 Magnet

Product description

Pump wear indicator*

Name	Value
Maximum switching voltage	30 V
Maximum switching current	0.2 A
Maximum oil pressure	6 bar 87.02 psi
Ambient temperature	-25 °C (-13 °F) to 90 °C (194 °F)
Maximum torque	60 Nm 44 ft-lb

Tab. 309: Technical data chip control

LWNLR-x/V04.01//Auslieferung/2016-03-07/en

1.71 Quick latch couplings* on jib luffing winch

Quick latch couplings ease the installation or dismantling of the jib luffing winch on the main boom base section.

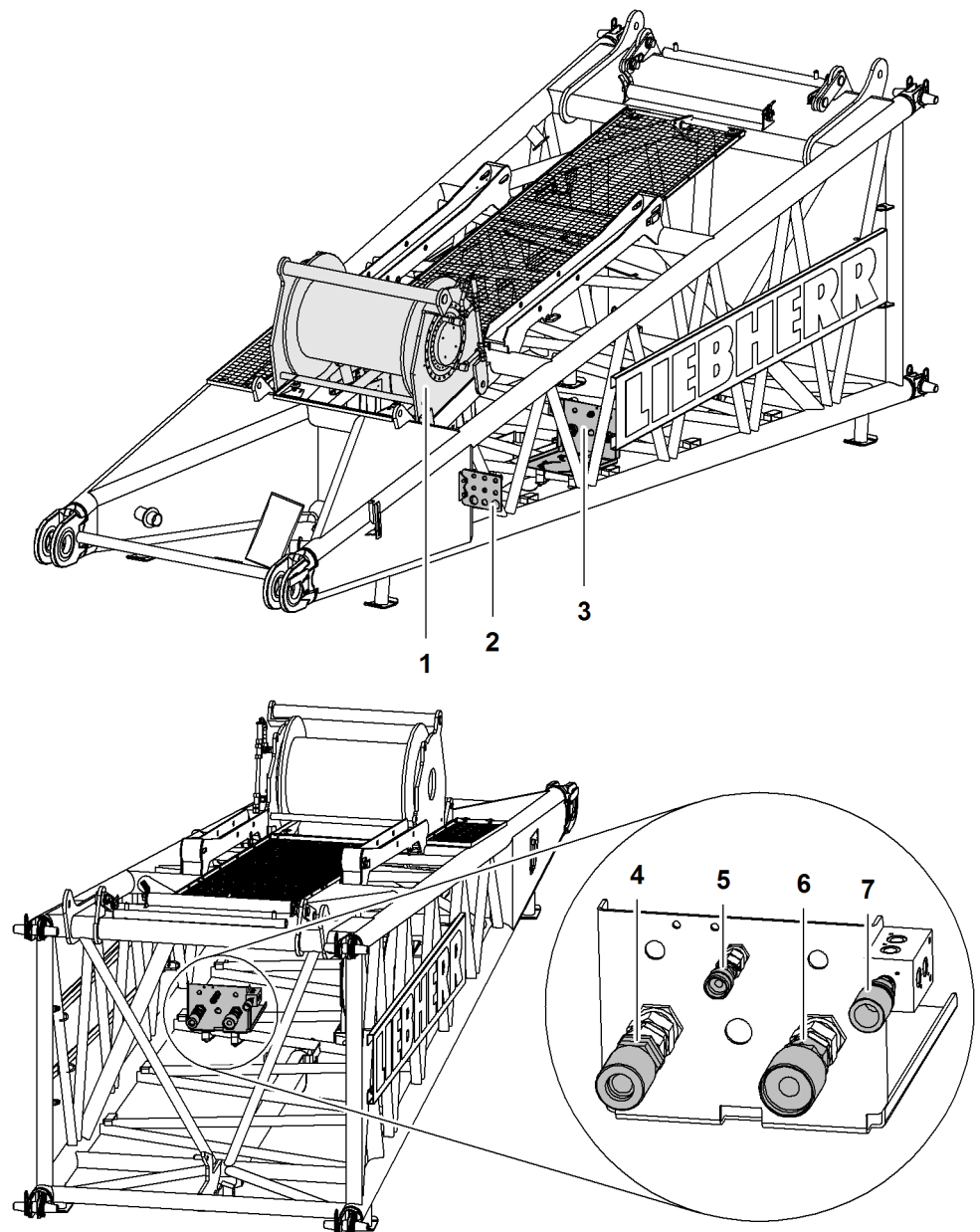


Fig. 526: Quick latch couplings on jib luffing winch

- | | | | |
|---|--|---|---------------------------------|
| 1 | Luffing jib luffing winch | 5 | Hydraulic line for flushing oil |
| 2 | Bulkhead plate 1 | 6 | Hydraulic line lifting |
| 3 | Bulkhead plate 2 with quick latch coupling | 7 | Hydraulic line for leak oil |
| 4 | Hydraulic line lowering | | |

With the main boom base sections with a length of 10 m (32' 10" ft-in), the quick latch couplings are mounted backwards.

Bulkhead plate 2 3 features hydraulic connections for:

- Assembly cylinder

Product description

Quick latch couplings* on jib luffing winch

- Rope reeving winch
- Luffing jib luffing winch
- Tagline winch

Only the hydraulic connections of the jib luffing winch are designed with quick latch couplings. The hydraulic connections vary in size and shape to prevent wrong connection.

Screw connections:

- Hydraulic line lifting
- Hydraulic line lowering

Plug-type connections:

- Hydraulic line for leak oil
- Hydraulic line for flushing oil

1.72 Socket* in cab

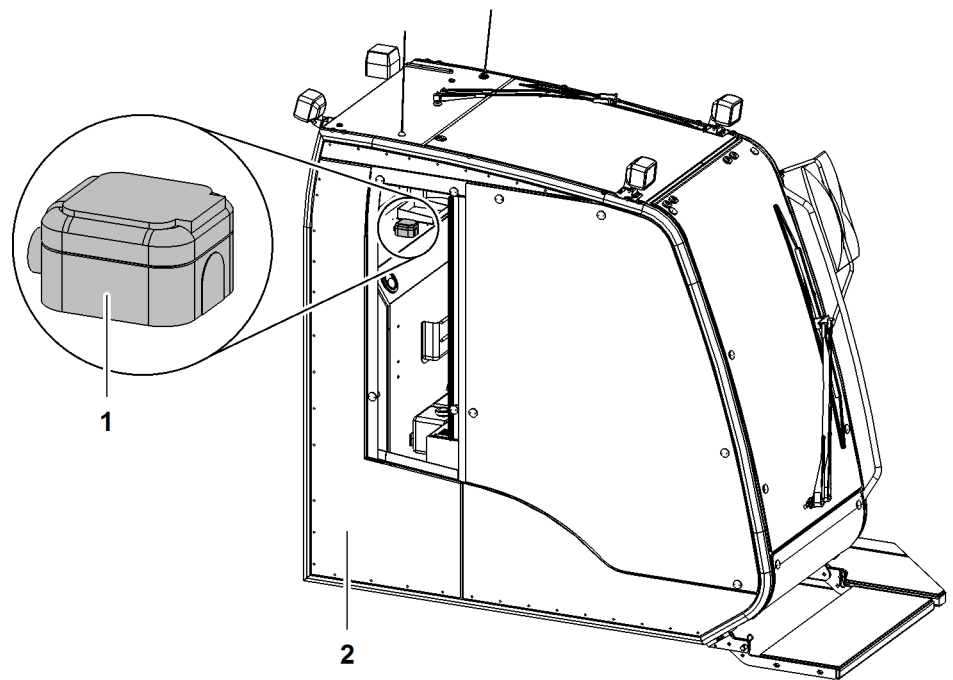


Fig. 527: Socket* in cab

1 Socket

2 Cab

The mains voltage socket is installed on the rear shelf in the cabin.

In order to use the socket in the cab the external power supply retrofit kit is also required.

The mains socket only works when the external feed is connected.

1.73 Falling object protection* for cabin

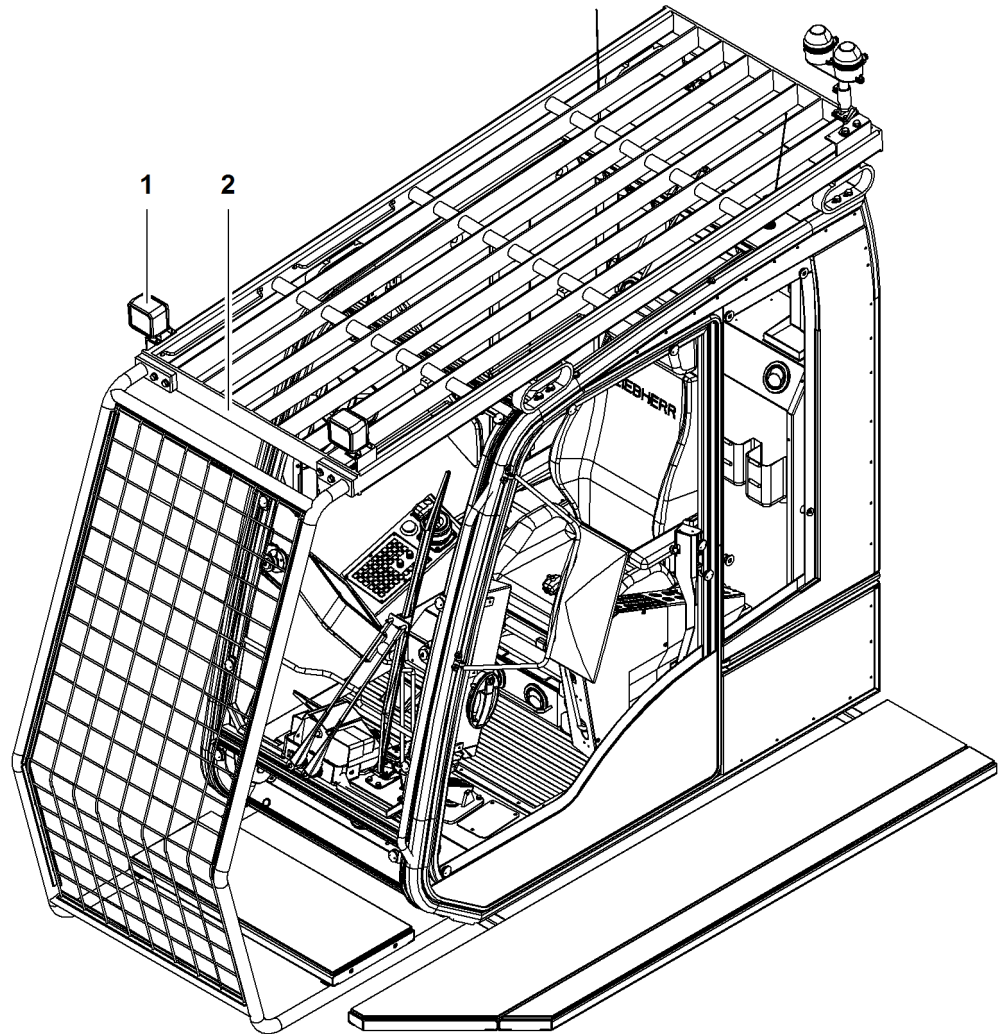


Fig. 528: Falling object protection for cabin

1 Floodlight (2x)

2 Falling object protection

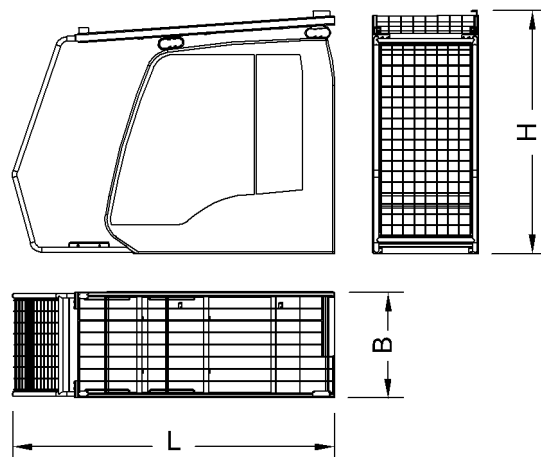


Fig. 529: Dimensions of falling object protection for cabin

LWNLR-x/V04.01//Auslieferung/2016-03-07/en

Name		Value
L	Length	2889 mm 9' 6" ft-in
W	Width	945 mm 3' 1" ft-in
H	Height	2184 mm 7' 2" ft-in
Weight		167 kg 368 lb

Tab. 310: Technical data: falling object protection for cabin

1.74 Vandalism protection*

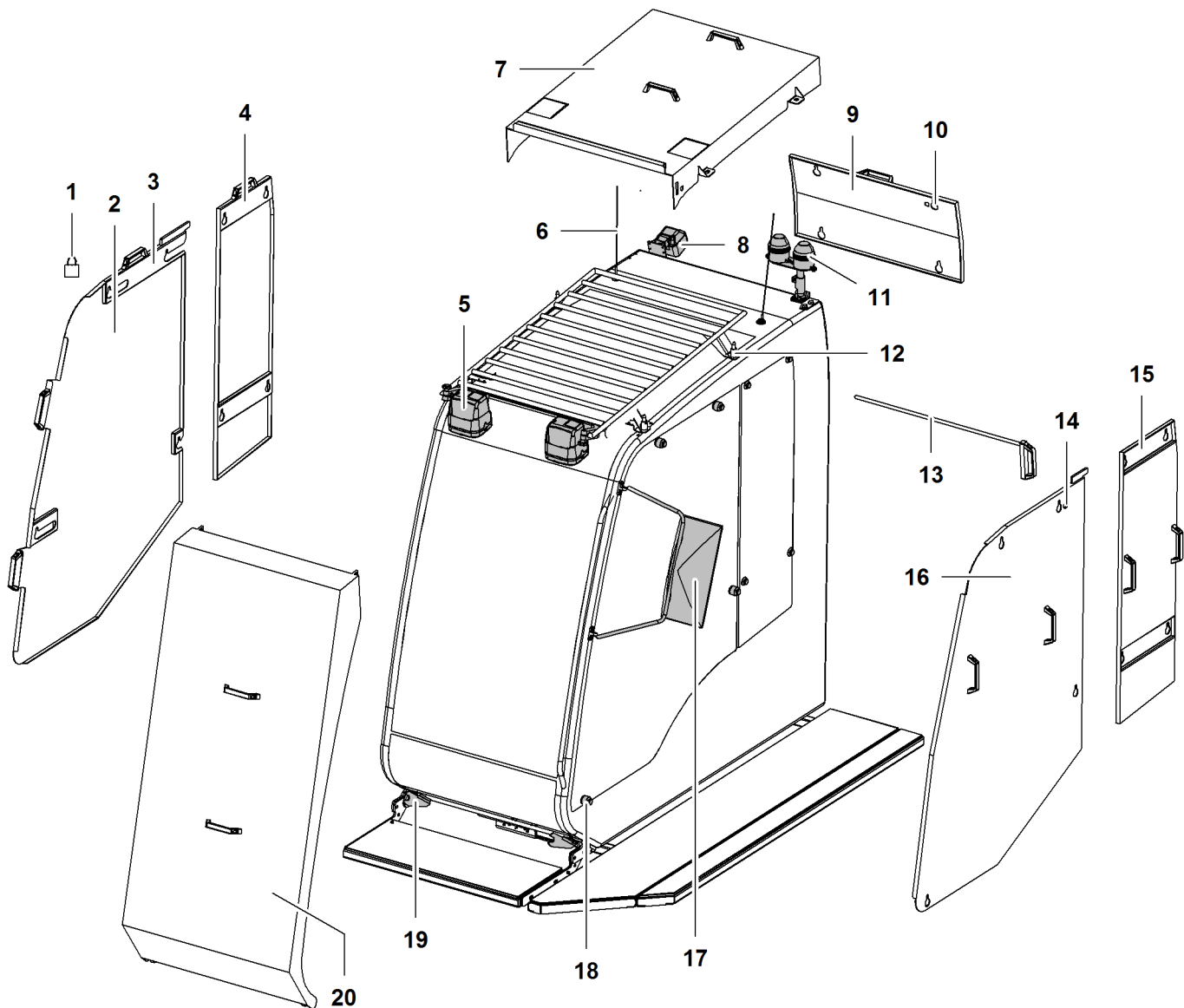


Fig. 530: Vandalism protection

- | | | | | | |
|---|-----------------------|----|---|----|------------------------------|
| 1 | Padlock | 8 | Rear floodlight | 15 | Left rear cover |
| 2 | Right front cover | 9 | Rear cover | 16 | Left front cover |
| 3 | Lock | 10 | Lock | 17 | Side mirror |
| 4 | Right rear cover | 11 | Flashing light/load moment limiter lamp | 18 | Suspension equipment (8x) |
| 5 | Front floodlight (2x) | 12 | Bracket (4x) for top cover | 19 | Bracket (2x) for front cover |
| 6 | Antenna (2x) | 13 | Barrier rod | 20 | Front cover |
| 7 | Top cover | 14 | Lock | | |

1.74.1 Top cover

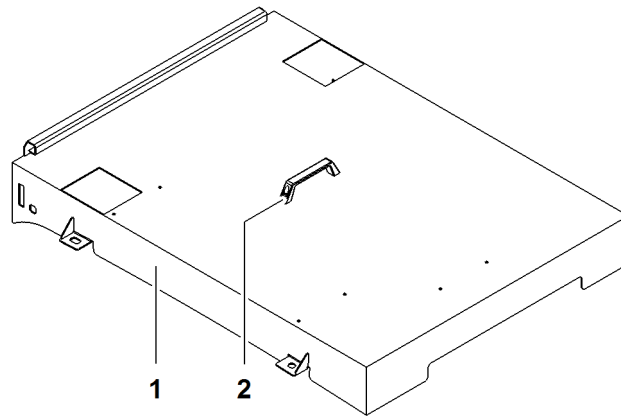


Fig. 531: Top cover

1 Top cover

2 Carrier handle

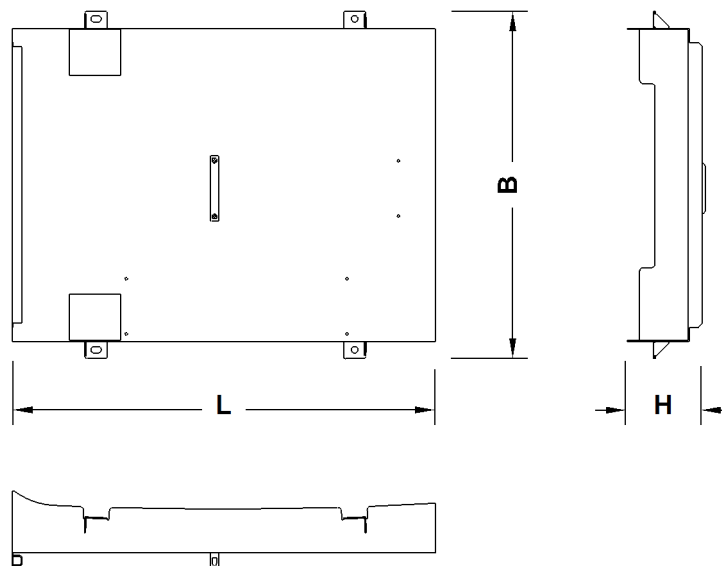


Fig. 532: Dimensions top cover

Name		Value
L	Length	1150 mm 3' 9" ft-in
B	Width	944 mm 3' 1" ft-in
H	Height	212 mm 8.35" in
Weight		11 kg 24.25 lb

Tab. 311: Technical data top cover

LWNLR.x/V04.01//Auslieferung/2016-03-07/en

1.74.2 Rear cover

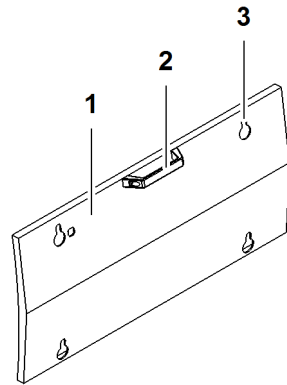


Fig. 533: Rear cover

- 1 Rear cover
- 2 Carrier handle
- 3 Suspension equipment (4x)

The lock for locking is not illustrated.

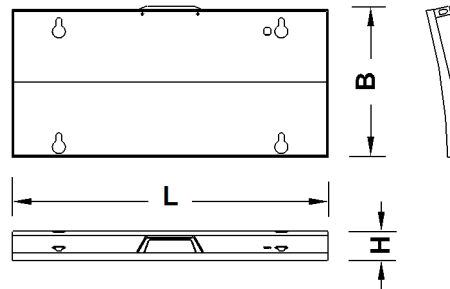


Fig. 534: Dimensions rear cover

Name		Value
L	Length	850 mm 2' 9" ft-in
B	Width	408 mm 1' 4" ft-in
H	Height	79 mm 3.11" in
Weight		3 kg 6.61 lb

Tab. 312: Technical data rear cover

LWNLR-x\04.01\Auslieferung\2016-03-07/en

1.74.3 Front cover

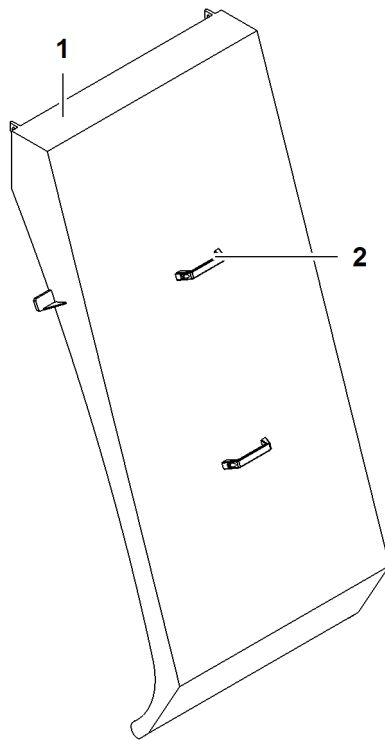


Fig. 535: Front cover

1 Front cover

2 Carrier handle (2x)

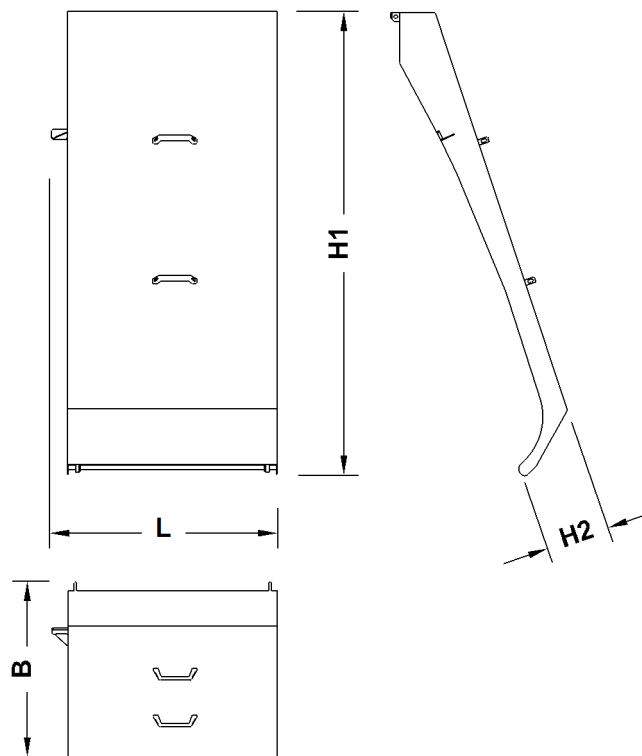


Fig. 536: Dimensions front cover

LWNLR.x/V04.01//Auslieferung/2016-03-07/en

Name		Value
L	Length	915 mm 3' ft-in
B	Width	717 mm 2' 4" ft-in
H1	Height	1880 mm 6' 2" ft-in
H2	Height	264 mm 10.39" in
Weight		19 kg 41.89 lb

Tab. 313: Technical data front cover

1.74.4 Right front cover

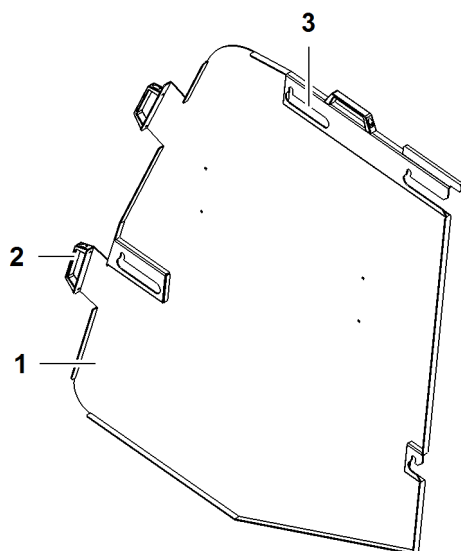


Fig. 537: Right front cover

- 1 Right front cover
- 2 Carrier handle (3x)

- 3 Suspension equipment (4x)

The lock for locking is not illustrated.

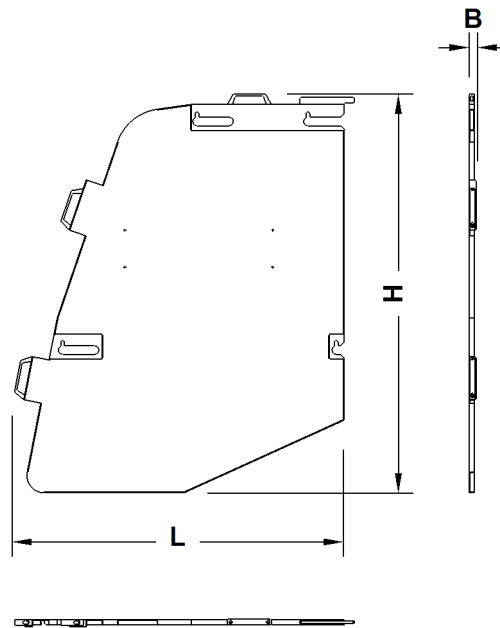


Fig. 538: Dimensions right front cover

Name		Value
L	Length	1377 mm 4' 6" ft-in
B	Width	29 mm 1.14" in
H	Height	1605 mm 5' 3" ft-in
Weight		14 kg 30.86 lb

Tab. 314: Technical data right front cover

1.74.5 Right rear cover

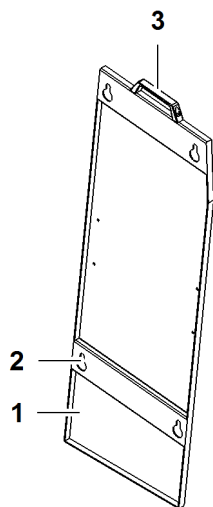


Fig. 539: Right rear cover

- 1 Right rear cover
- 2 Suspension equipment (4x)
- 3 Carrier handle

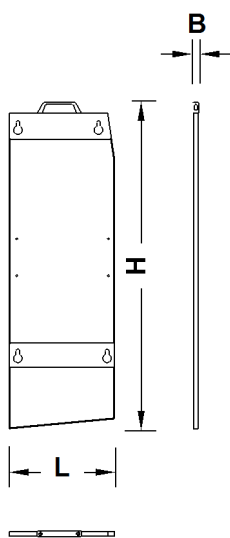


Fig. 540: Dimensions right rear cover

Name		Value
L	Length	425 mm 1' 5" ft-in
B	Width	23 mm 0.91" in
H	Height	1323 mm 4' 4" ft-in
Weight		5 kg 11.02 lb

Tab. 315: Technical data right rear cover

LWN/LR-x/V04.01//Auslieferung/2016-03-07/en

1.74.6 Left front cover

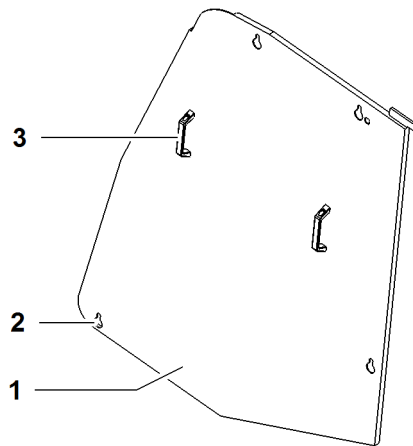


Fig. 541: Left front cover

- 1 Left front cover
- 2 Suspension equipment (4x)
- 3 Carrier handle (2x)

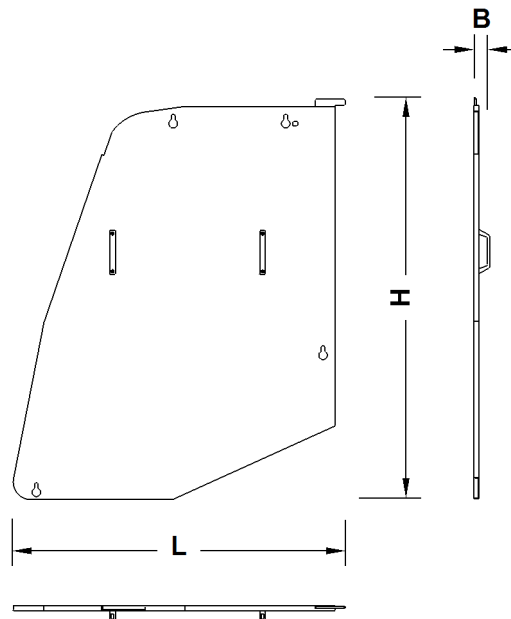


Fig. 542: Dimensions left front cover

Name		Value
L	Length	1327 mm 4' 4" ft-in
B	Width	63 mm 2.48" in
H	Height	1605 mm 5' 3" ft-in
Weight		14 kg 30.86 lb

Tab. 316: Technical data left front cover

LWNLR.x/V04.01//Auslieferung/2016-03-07/en

1.74.7 Left rear cover

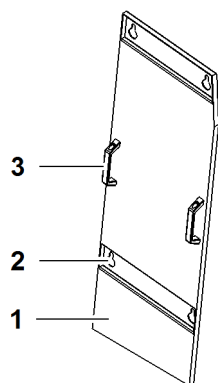


Fig. 543: Left rear cover

- 1 Left rear cover
- 2 Suspension equipment (4x)
- 3 Carrier handle (2x)

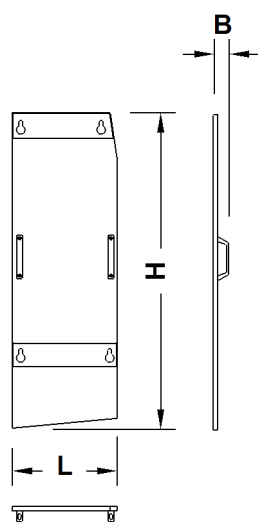


Fig. 544: Dimensions left rear cover

Name		Value
L	Length	425 mm 1' 5" ft-in
B	Width	63 mm 2.48" in
H	Height	1280 mm 4' 2" ft-in
Weight		5 kg 11.02 lb

Tab. 317: Technical data left rear cover

LWNLR-x/V04.01//Auslieferung/2016-03-07/en

1.74.8 Brackets for front cover

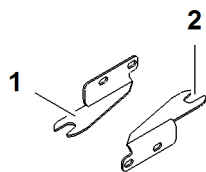


Fig. 545: Brackets for front cover

1 Bracket (2x) for front cover

2 Suspension equipment (2x)

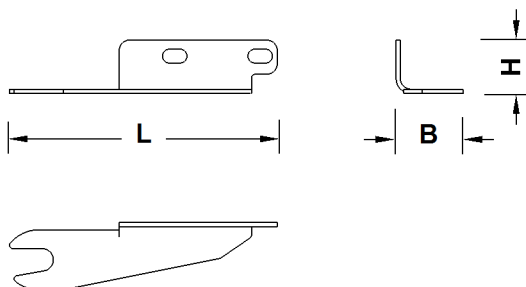


Fig. 546: Dimensions brackets for front cover

Name		Value
L	Length	250 mm 9.84" in
B	Width	63 mm 2.48" in
H	Height	50 mm 1.97" in
Weight		0.5 kg 1.10 lb

Tab. 318: Technical data brackets for front cover

1.74.9 Barrier rod

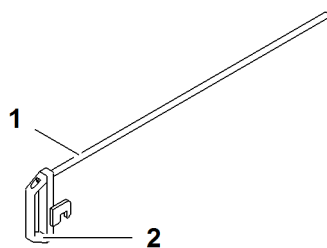


Fig. 547: Barrier rod

1 Barrier rod

2 Carrier handle

A padlock is supplied with the barrier rod 1.

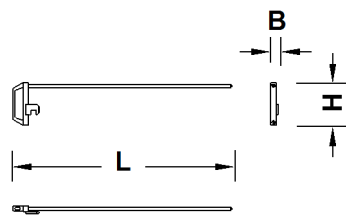


Fig. 548: Dimensions barrier rod

Name		Value
L	Length	913 mm 3' ft-in
B	Width	33 mm 1.30" in
H	Height	178 mm 7.01" in
Weight		1.8 kg 3.97 lb

Tab. 319: Technical data barrier rod

1.75 Video monitoring system*

The video surveillance system is divided into:

- Video surveillance - basic device
- Video surveillance - boom

1.75.1 Cabin overview

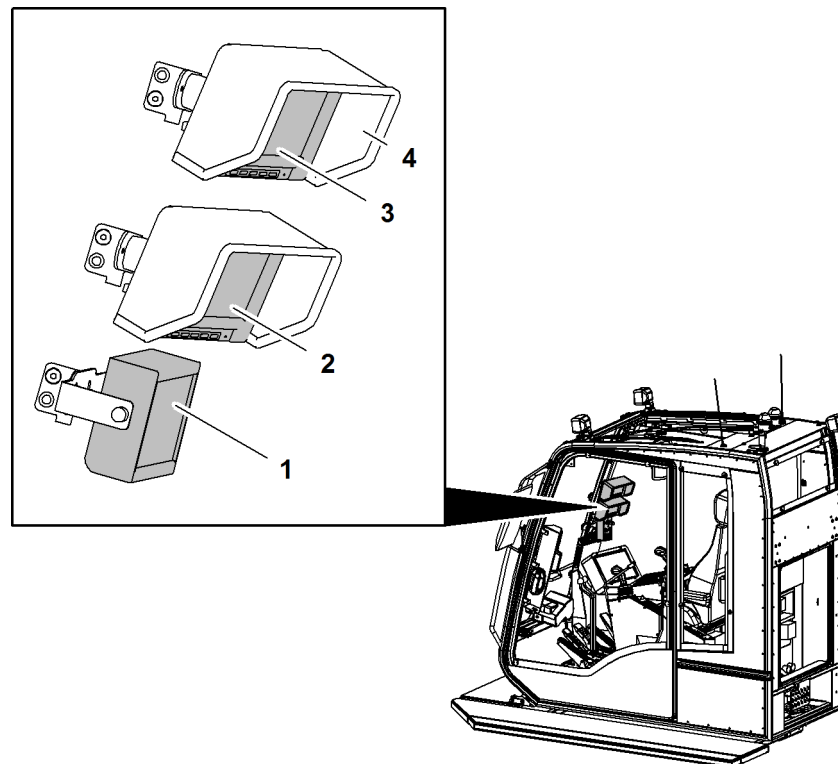


Fig. 549: Cabin overview

- | | | | |
|---|-----------------------------------|---|---|
| 1 | Control panel zoom camera | 3 | Monitor video surveillance - basic device |
| 2 | Monitor video surveillance - boom | 4 | Light protection cover |

1.75.2 Machine overview

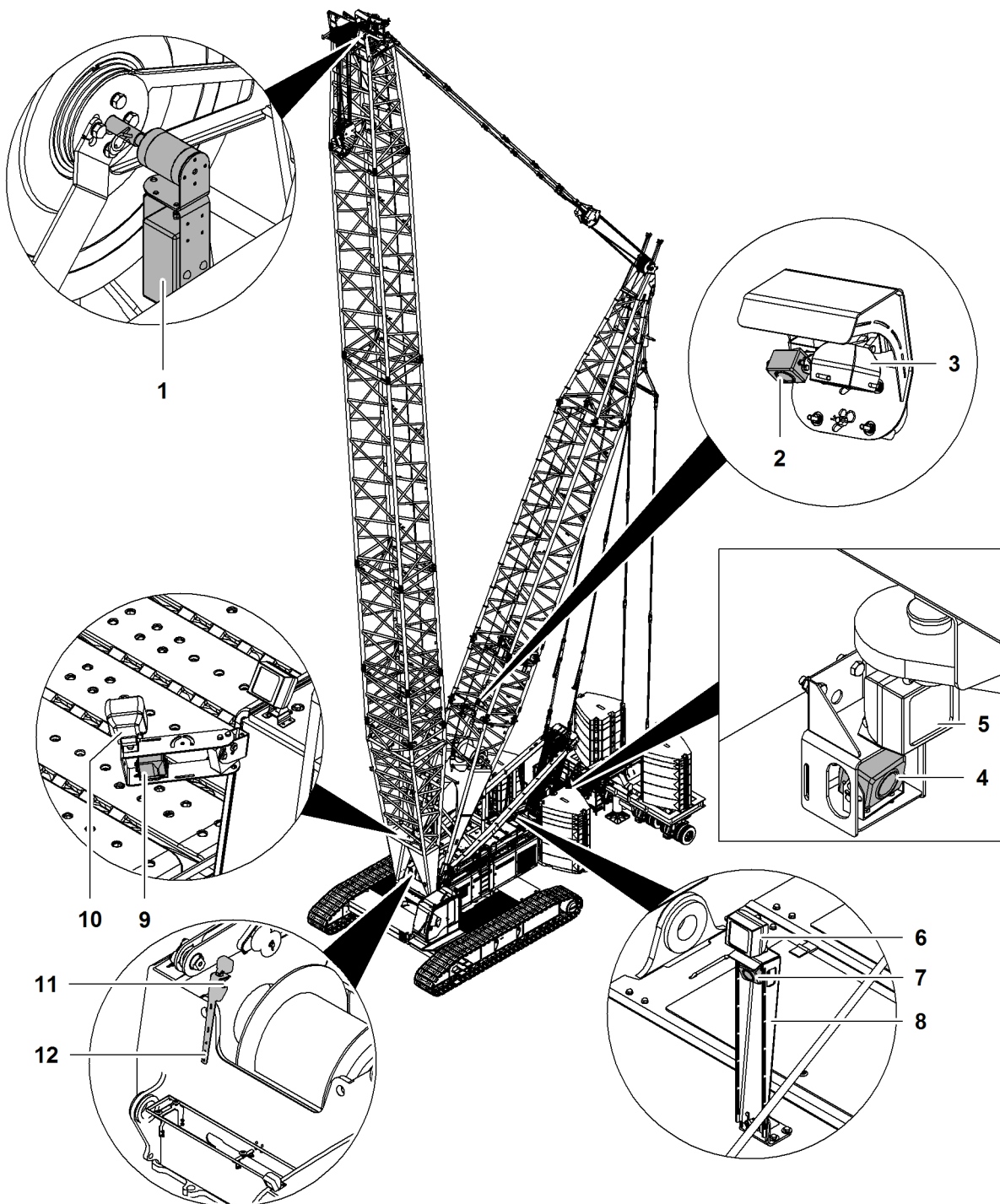


Fig. 550: Machine overview (illustration of principle)

- | | | | | | |
|---|--|---|----------------------|----|-------------------------|
| 1 | Zoom camera in boom head | 5 | Floodlight | 9 | Floodlight |
| 2 | Derrick winch camera | 6 | Floodlight | 10 | Right camera |
| 3 | Floodlight | 7 | Camera winch1/winch2 | 11 | Camera winch1/winch2 |
| 4 | Rearview camera/counterweight carriage | 8 | Mount | 12 | Bracket with floodlight |

Either camera winch1/winch2 7 or camera winch1/winch2 11 are installed.

Name	Monitor	Camera
Video surveillance - basic device	Quad monitor	Right camera 10
		Rearview camera/counter-weight carriage 4
		Camera winch1/winch2 7 or camera winch1/winch2 11
		Derrick winch camera 2
Video surveillance - boom	Quad monitor with control panel	Zoom camera 1

Tab. 320: Overview of video surveillance system

1.75.3 Video surveillance - basic device

Up to four cameras are connected directly to the monitor.

Video surveillance system basic device consists of:

- Quad monitor
- Camera

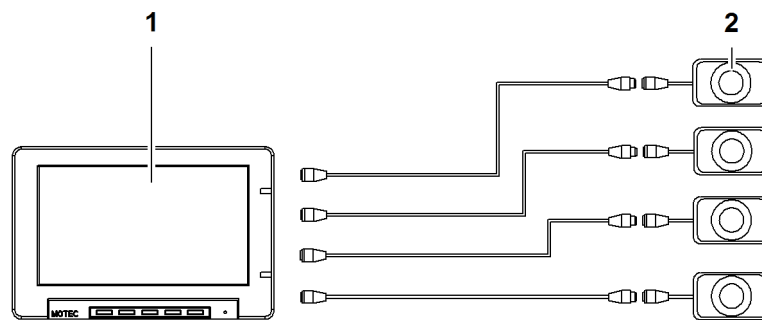


Fig. 551: Diagram video surveillance system basic device

1 Quad monitor in cabin

2 Camera (max. 4x)

Angle of view on the side

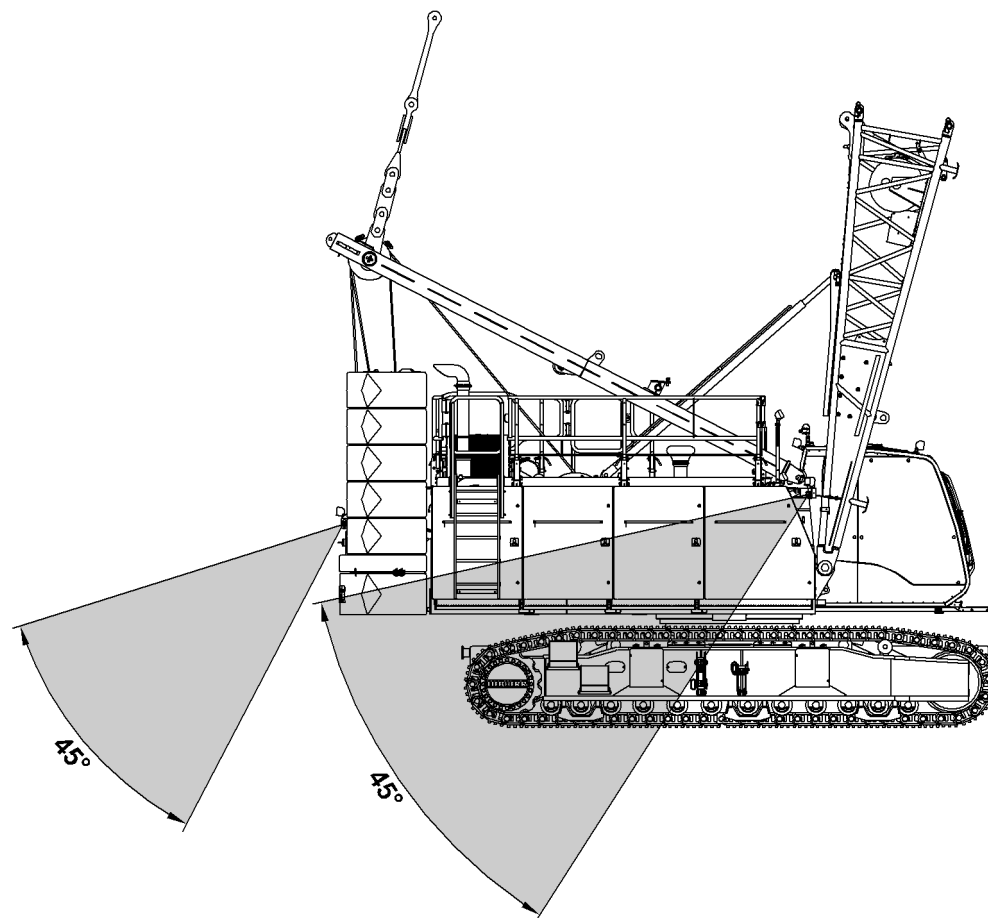


Fig. 552: Angle of view camera right and camera reverse drive/counterweight carriage (illustration of principle)

Angle of view rear

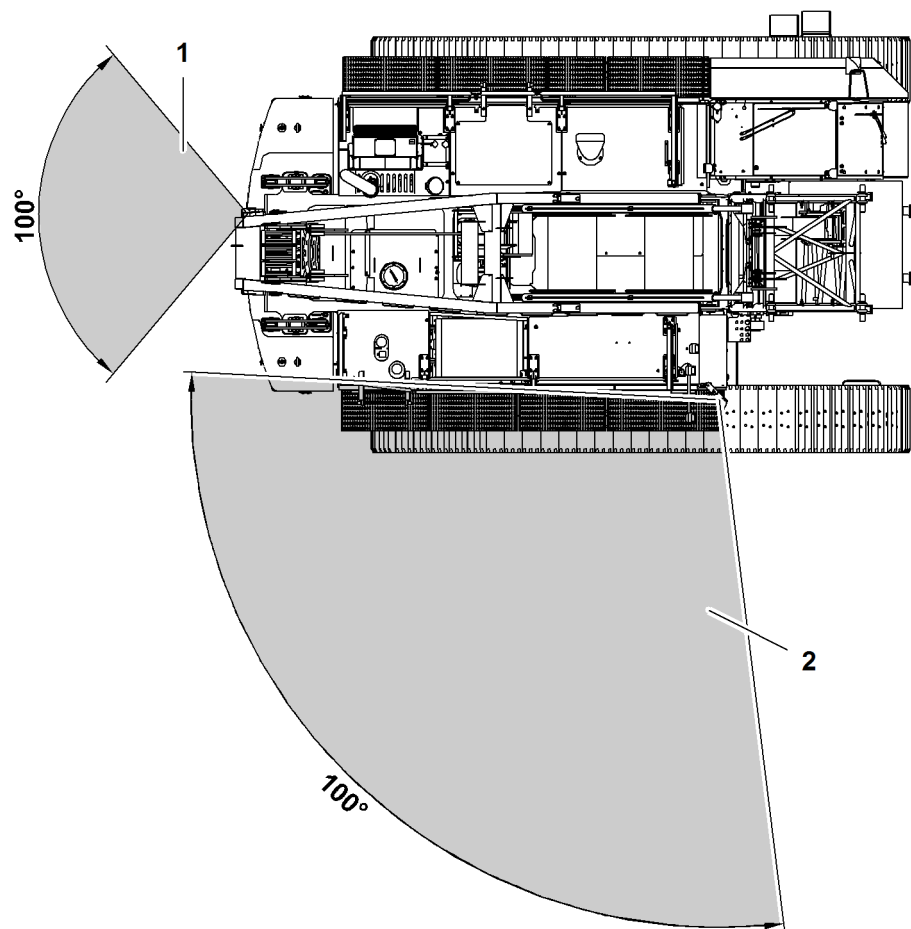


Fig. 553: Angle of view camera right and camera reverse drive/counterweight carriage (illustration of principle)

1.75.4 Video surveillance - boom

Only one camera is connected. This camera is located at the boom head.

The boom video surveillance system device consists of:

- Quad monitor
- Control panel
- Zoom camera

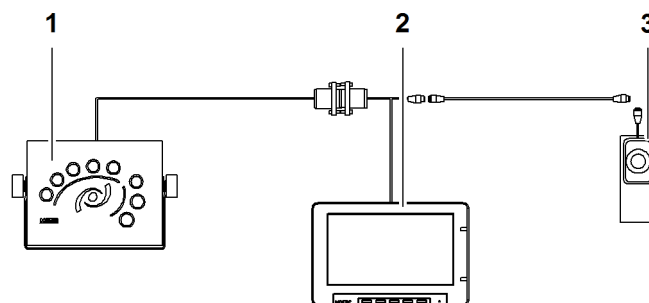


Fig. 554: Diagram boom video surveillance

- | | | | |
|---|-----------------------|---|-------------|
| 1 | Control panel | 3 | Zoom camera |
| 2 | Quad monitor in cabin | | |

1.75.5 Quad monitor

Contained in the kit:

- Color monitor
- Mount with ball joint
- Light protection cover

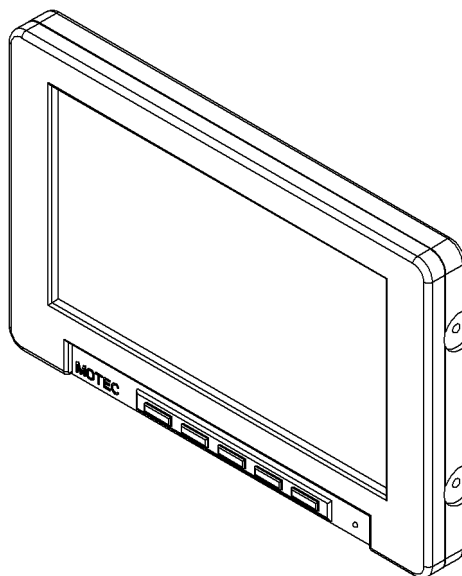


Fig. 555: Quad monitor

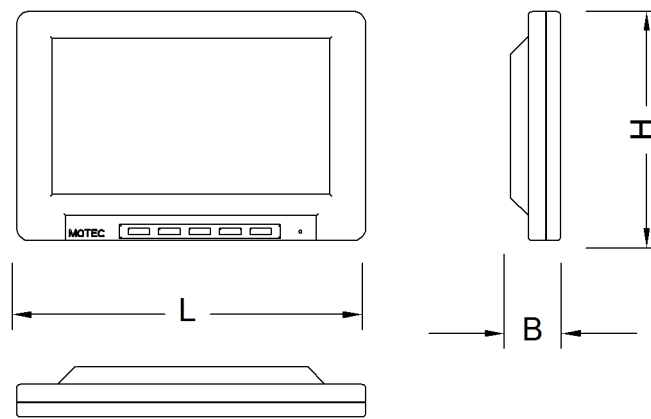


Fig. 556: Dimensions quad monitor

Name		Value
L	Length	195 mm 7.68" in
B	Width	28 mm 1.10" in
H	Height	128 mm 5.04" in
Screen diagonal		17.8 cm 7.01" in
Resolution		234 (v) x 1440 (h)
Nominal voltage		12 V
Power consumption (4 cameras)		max. 1,600 mA
Protection class		IP 30
Shock resistance		> 20 g
Operating temperature		-30 °C (-22 °F) to 80 °C (176 °F)
Storage temperature		-35 °C (-31 °F) to 85 °C (185 °F)
Weight		600 g 1.32 lb

Tab. 321: Technical data quad monitor

LWNLR.x/V04.01//Auslieferung/2016-03-07/en

1.75.6 Camera

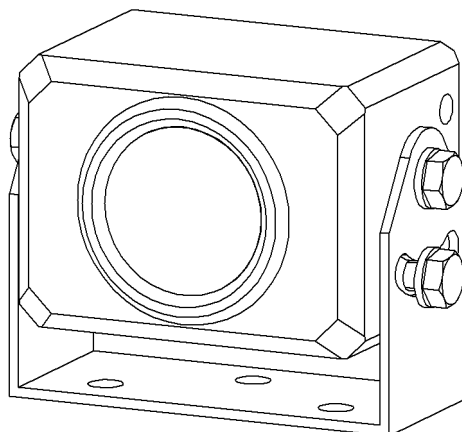


Fig. 557: Camera

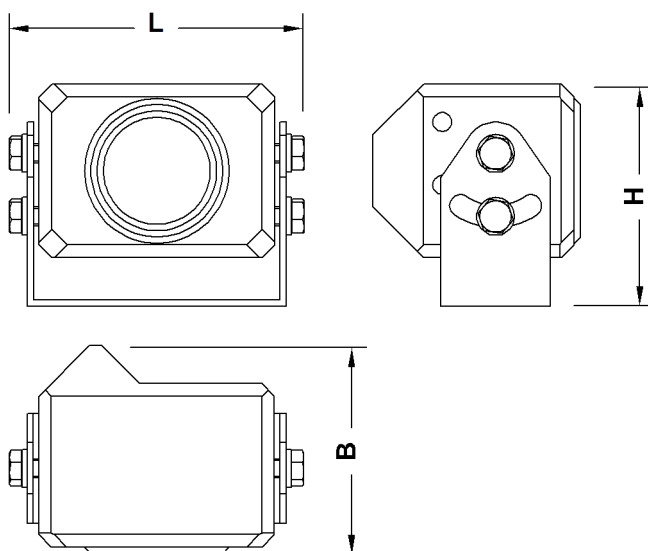


Fig. 558: Dimensions camera

Name		Value
L	Length	92 mm 3.62" in
B	Width	61 mm 2.40" in
H	Height	55 mm 2.17" in
Resolution		320,000 pixels
Nominal voltage		12 V
Current consumption		0.25 A
Protection class		IP 69K
Shock resistance		> 50 g

LWN/LR-x/V04.01//Auslieferung/2016-03-07/en

Name	Value
Operating temperature	-35 °C (-31 °F) to 75 °C (167 °F)
Storage temperature	-40 °C (-40 °F) to 80 °C (176 °F)
Windscreen heater	Automatically controlled
Brightness adjustment	Automatic

Tab. 322: Technical data camera

1.75.7 Control panel zoom camera

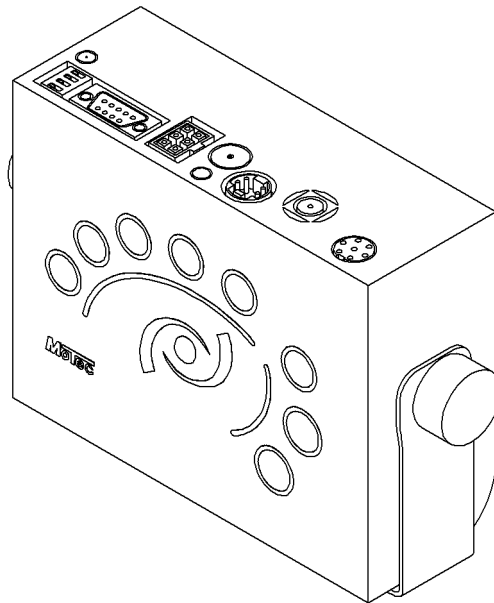


Fig. 559: Control panel zoom camera

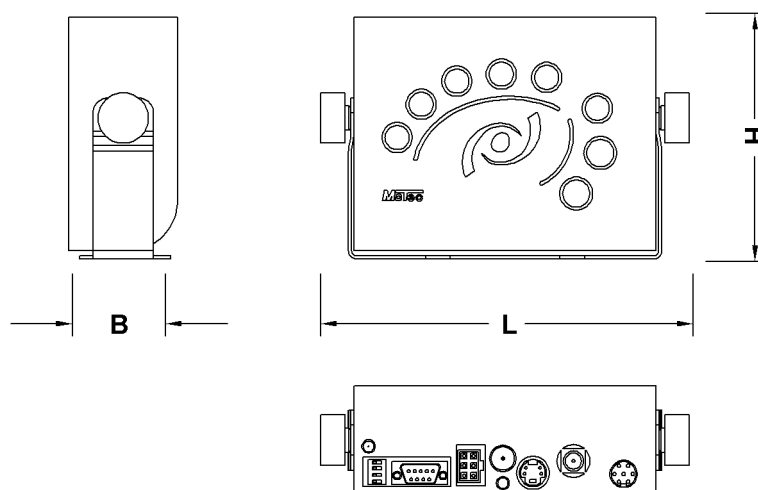


Fig. 560: Dimensions control panel zoom camera

Name		Value
L	Length	175 mm 6.89" in
B	Width	54 mm 2.13" in
H	Height	120 mm 4.72" in
Nominal voltage		24 V
Current consumption		max. 0.5 A
Protection class		IP 54
Operating temperature		-30 °C (-22 °F) to 60 °C (140 °F)
Storage temperature		-40 °C (-40 °F) to 85 °C (185 °F)
Weight (without electric cable)		0.75 kg 1.65 lb

Tab. 323: Technical data control panel zoom camera

1.75.8 Zoom camera

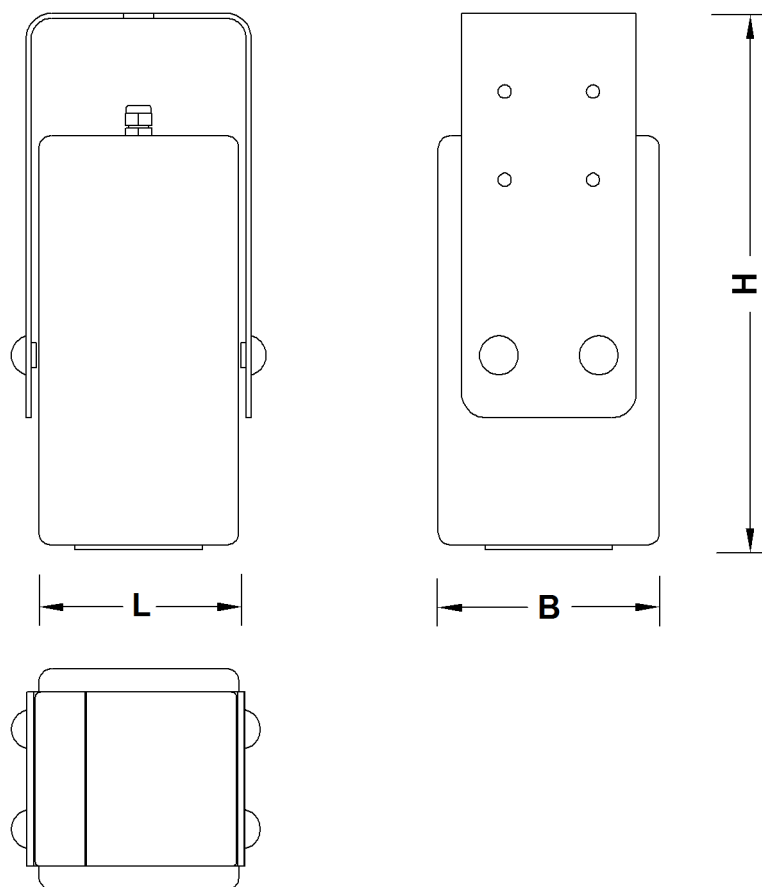


Fig. 561: Dimensions zoom camera

LWNLR-x/V04.01//Auslieferung/2016-03-07/en

Name		Value
L	Length	80 mm 3.15" in
B	Width	90 mm 3.54" in
H	Height	234 mm 9.21" in
Resolution		440,000 pixels
Zoom factors		18 x optical, 12 x digital
Nominal voltage		24 V
Current consumption		max. 0.45 mA
Protection class		IP 68
Operating temperature		-35 °C (-31 °F) to 60 °C (140 °F)
Storage temperature		-40 °C (-40 °F) to 85 °C (185 °F)
Heating		Windscreen heater, elec- tronically controlled. Acti- vation point: < 15 °C (59 °F)
Weight (with tip mount)		5 kg 11.02 lb

Tab. 324: Technical data zoom camera

1.75.9 Mounts

The mounts are tip mounts.

A different mount may be required depending on the installation site of the zoom camera. There are three different mounts.

If the camera is transported to another installation site, the corresponding mount must be installed.

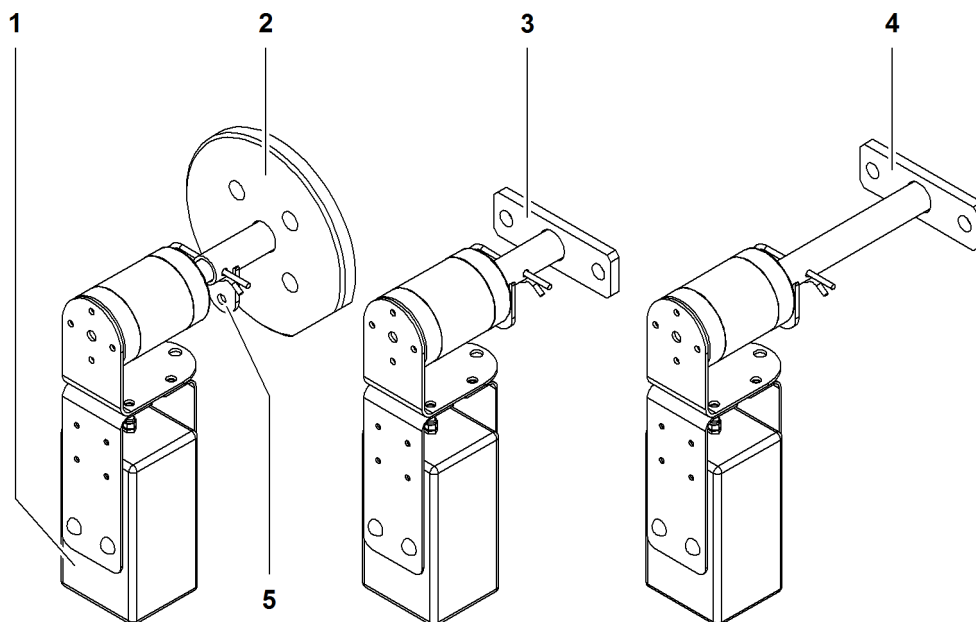


Fig. 562: Mounts A, B and C for zoom camera

- | | | | |
|---|-------------|---|------------------------------------|
| 1 | Zoom camera | 4 | Mount C |
| 2 | Mount A | 5 | Connecting link for securing chain |
| 3 | Mount B | | |

The chain for securing the camera is hooked into the connecting link 5 with a carabiner.

Mount A

Zoom camera with mount A is installed on:

- Main boom head 1311
- Main boom head 2017
- Main boom head 2018
- Main boom head 2220
- Main boom head 2320
- Main boom head 2821

The mount can be installed on the left or the right.

The axle support of the main boom head is exchanged for mount A here.

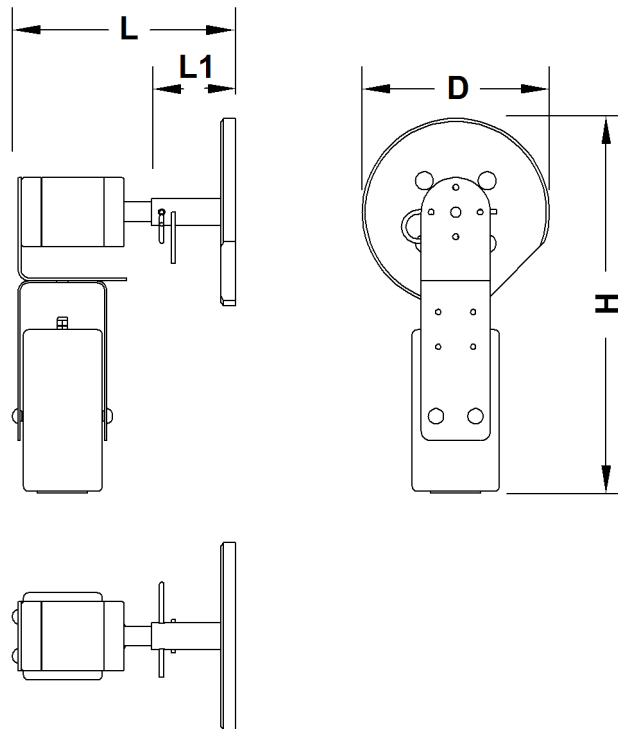


Fig. 563: Dimensions mount A

Name		Value
D	Diameter	190 mm 7.48" in
L	Total length	227 mm 8.94" in
L1	Length	85 mm 3.35" in
H	Height	380 mm 1' 3" ft-in

Tab. 325: Technical data mount A

Mount B

Zoom camera with mount B is installed on:

- Auxiliary jib 36 t (79,365 lb)
- Auxiliary jib 15 t (33,069 lb)
- Fixed jib head 0806
- Fixed jib head 1713
- Luffing jib head 1008
- Luffing jib head 1309
- Luffing jib head 1713
- Luffing jib head 1916
- Luffing jib head 2316

The mount can be installed on the left or the right.

With the auxiliary jib 36 t (79,365 lb), the mount is installed on the axle support.

With auxiliary jib 15 t (33,069 lb), a plate must be installed additionally.

An angle has to be installed additionally with fixed jib head 0806.

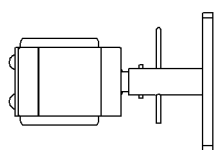
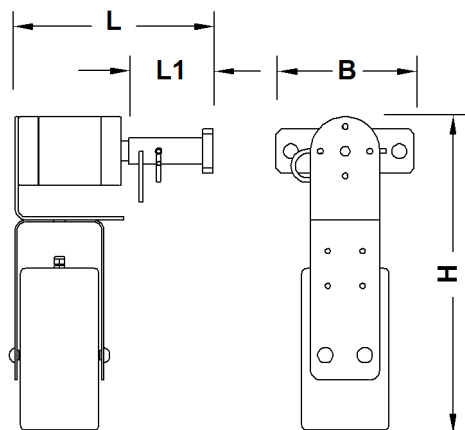


Fig. 564: Dimensions mount B

Name		Value
L	Total length	207 mm 8.15" in
L1	Length	85 mm 3.35" in
B	Width	140 mm 5.51" in
H	Height	320 mm 1' 1" ft-in

Tab. 326: Technical data mount B

Mount C

Zoom camera with mount C is installed on:

- Fixed jib head 0906
- Fixed jib head 1008
- Fixed jib head 1507

The mount can be installed on the left or the right.

An angle has to be installed additionally with fixed jib head 1008.

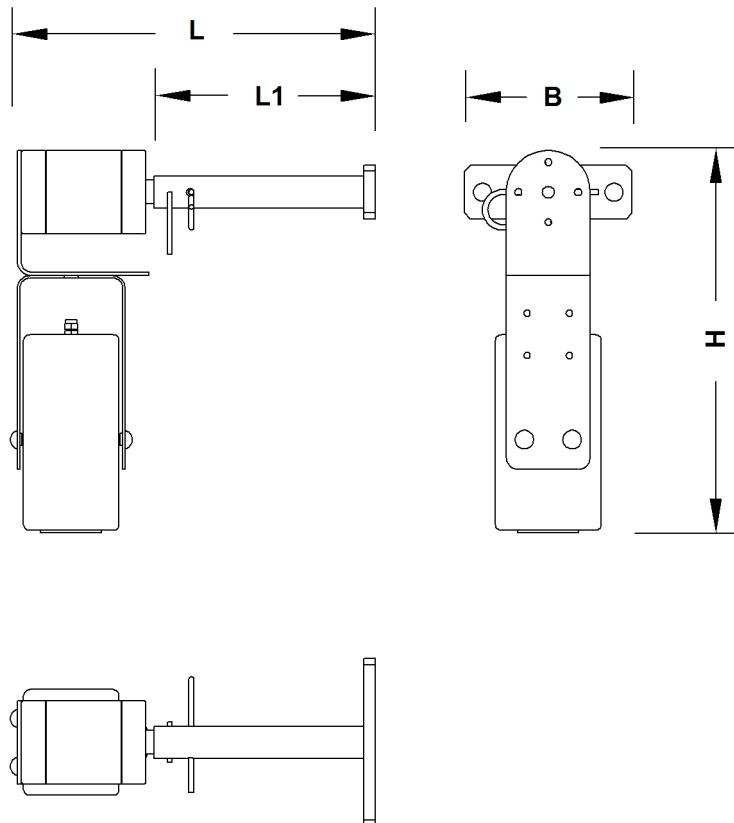


Fig. 565: Dimensions mount C

Name		Value
L	Total length	306 mm 1' ft-in
L1	Length	183 mm 7.20" in
B	Width	140 mm 5.51" in
H	Height	320 mm 1' 1" ft-in

Tab. 327: Technical data mount C

LWNLR.x/V04.01//Auslieferung/2016-03-07/en

Plate

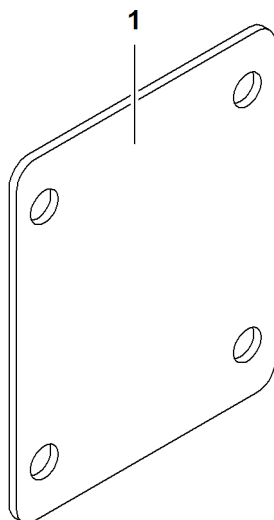


Fig. 566: Plate

1 Plate

Name		Value
L	Length	140 mm 5.51" in
B	Width	4 mm 0.16" in
H	Height	170 mm 6.69" in

Tab. 328: Technical data plate

Angle

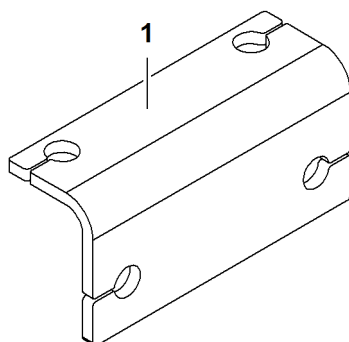


Fig. 567: Angle

1 Angle

Name		Value
L	Length	150 mm 5.91" in

LWN/LR-x/V04.01//Auslieferung/2016-03-07/en

Name		Value
B	Width	50 mm 1.97" in
H	Height	70 mm 2.76" in
Material thickness		6 mm 0.24" in

Tab. 329: Technical data angle

1.75.10 Camera cable in main boom base section

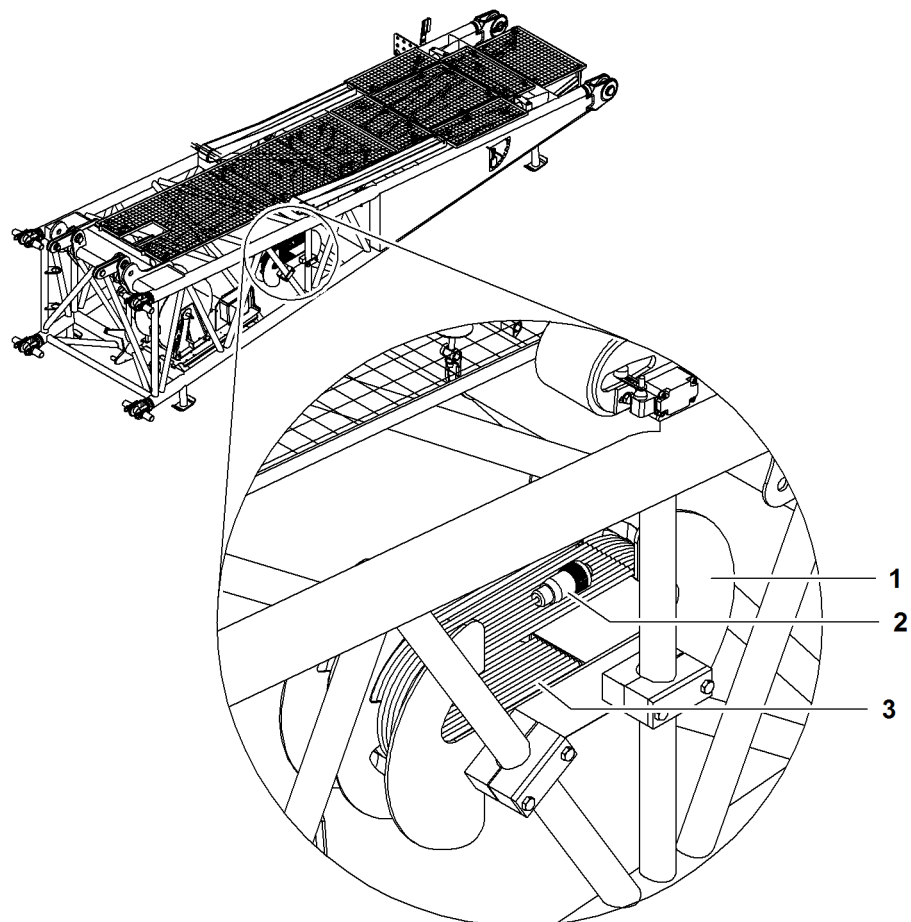


Fig. 568: Camera cable in main boom base section

- 1** Camera cable
- 2** Electric screw connection
- 3** Cable drum

A cable drum **3** with the camera cable **1** is located in the main boom base section. The electric screw connection **2** is guided into the uppercarriage with the electrics of the main boom base section.

Name	Value
Conductor resistance	< 76 mΩ/m
Capacity	< 80 pF/m

Name	Value
Operating temperature	-40 °C (-40 °F) to 70 °C (158 °F)
Bending radius	> 80 mm (3.15" in)
Weight	approx. 0.82 kg/m (0.55 lb/ft)

Tab. 330: Technical data camera cable

1.75.11 Zoom camera in main boom head

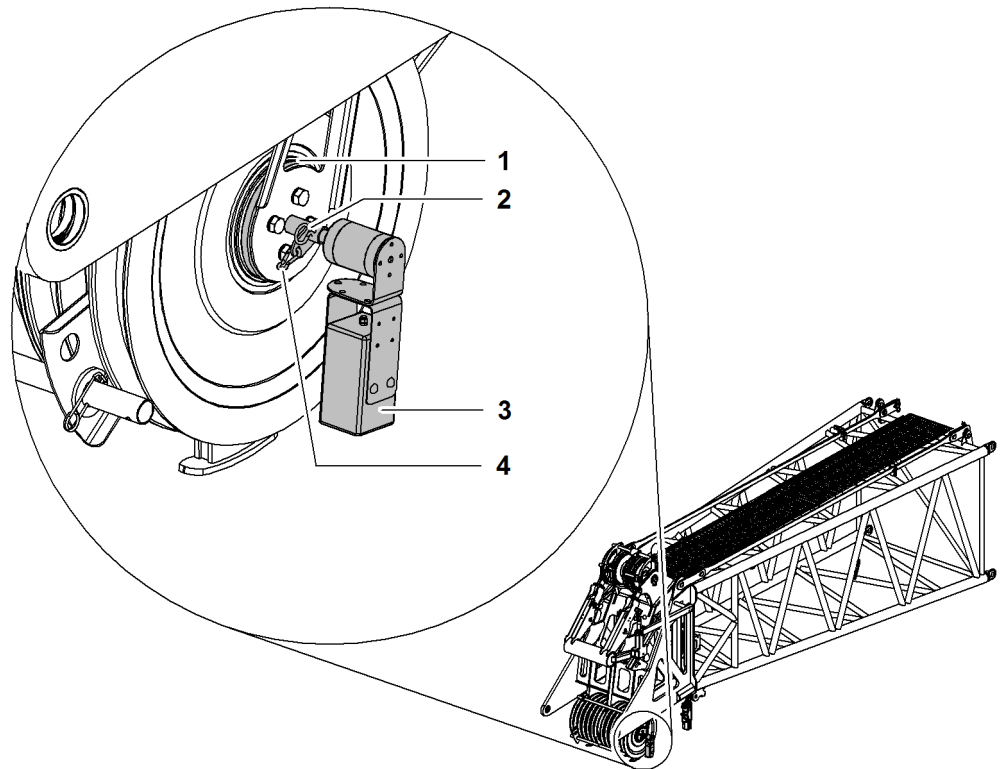


Fig. 569: Zoom camera in main boom head

- | | | | |
|---|-------------------|---|-------------|
| 1 | Mount A | 3 | Zoom camera |
| 2 | Spring cotter pin | 4 | Carabiner |

1.75.12 Zoom camera in fixed jib head

Fixed jib head 1008

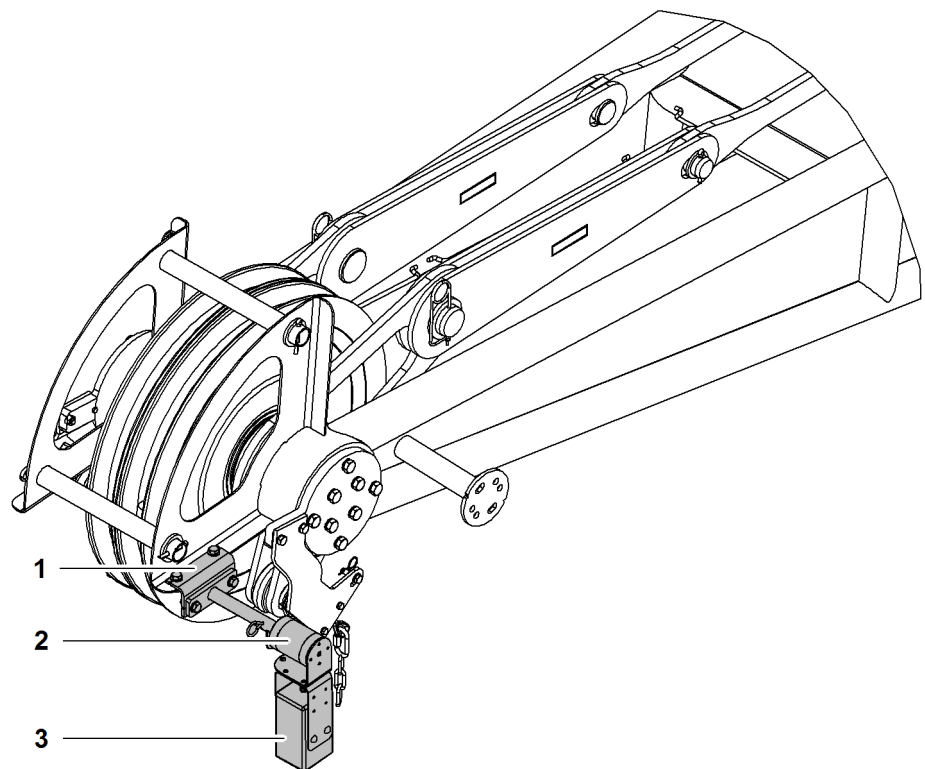


Fig. 570: Zoom camera in fixed jib head 1008

- | | | | |
|---|---------|---|-------------|
| 1 | Angle | 3 | Zoom camera |
| 2 | Mount C | | |

Fixed jib head 0906 and 1507

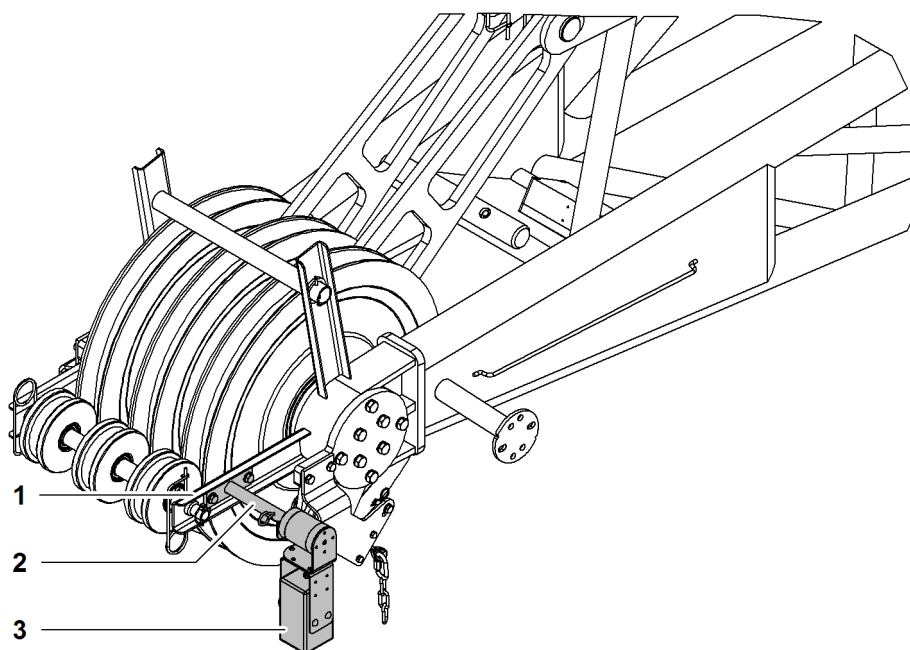


Fig. 571: Zoom camera in fixed jib head 0906 and 1507

- | | | | |
|---|----------------------------------|---|-------------|
| 1 | Mount rope protection pulley set | 3 | Zoom camera |
| 2 | Mount C | | |

1.75.13 Zoom camera in luffing jib head

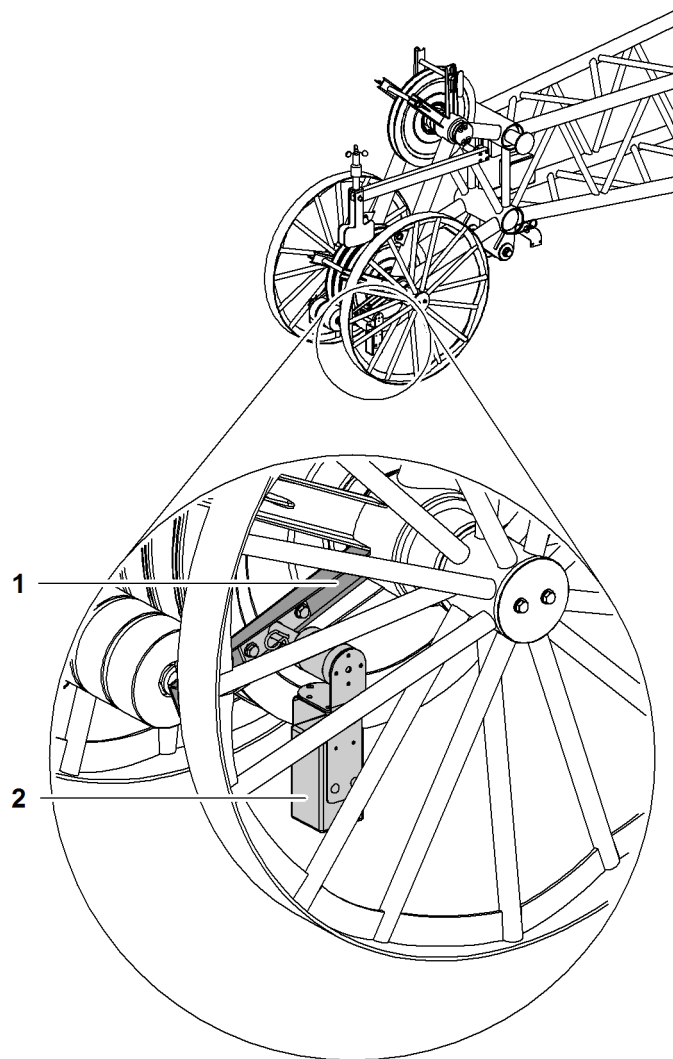


Fig. 572: Zoom camera in luffing jib head

- 1 Mount rope protection pulley set 2 Zoom camera with mount B

1.75.14 Zoom camera in auxiliary jib 36 t (79300 lb)

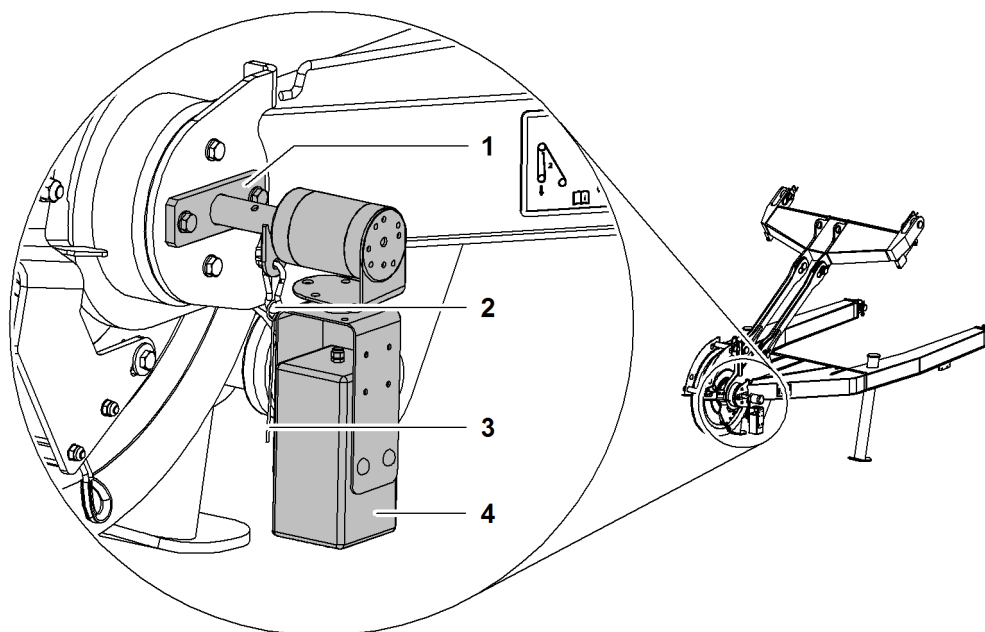


Fig. 573: Zoom camera in auxiliary jib 36 t (79300 lb)

- | | | | |
|---|-----------|---|----------------|
| 1 | Mount B | 3 | Securing chain |
| 2 | Carabiner | 4 | Zoom camera |

1.75.15 Zoom camera in auxiliary jib 15 t (33000 lb)

The zoom camera in the auxiliary jib 15 t (33000 lb) is mounted with a plate on the jib head.

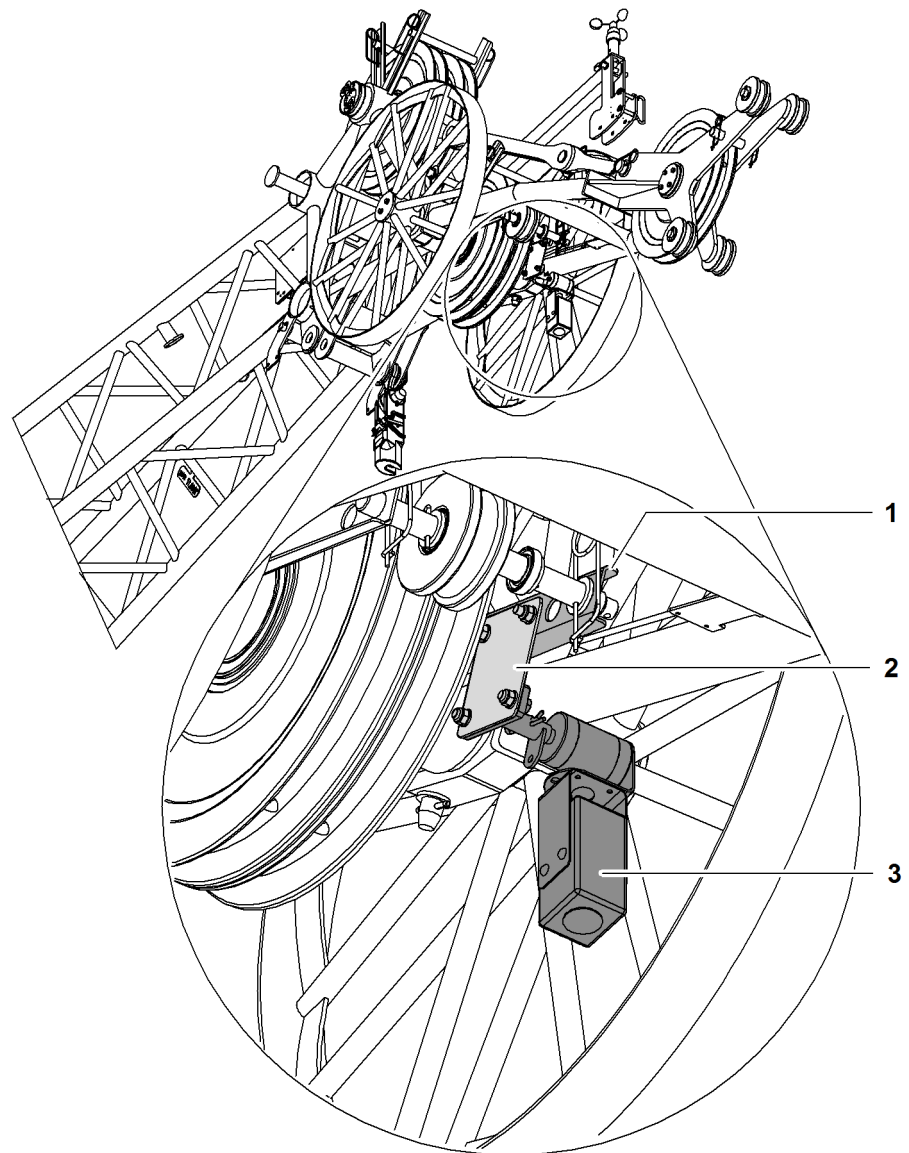


Fig. 574: Zoom camera in auxiliary jib 15 t (33000 lb)

- | | | | |
|---|----------------------------|---|--------------------------|
| 1 | Rope protection pipe mount | 3 | Zoom camera with mount B |
| 2 | Plate | | |

1.75.16 Foot pedal* for zoom camera

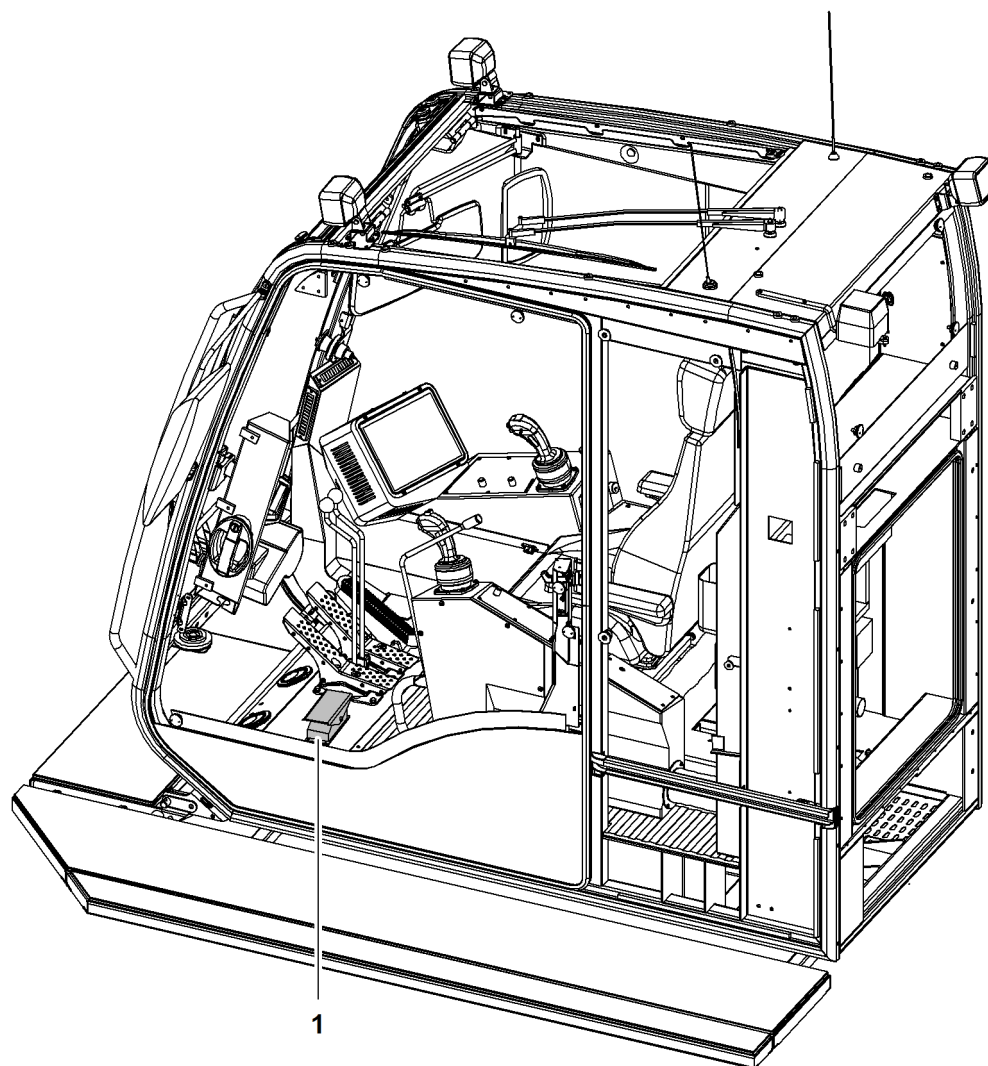


Fig. 575: Foot pedal for zoom camera*

1 Foot pedal

The camera zoom can be operated with the foot pedal **1** besides the control panel.

1.76 Central lubrication system

The central lubrication system lubricates the swing ring bearing. With the corresponding retrofit kit, the swing ring tooth flank is also lubricated via the central lubrication system.

The central lubrication system's lubricating pump is located in the uppercarriage.

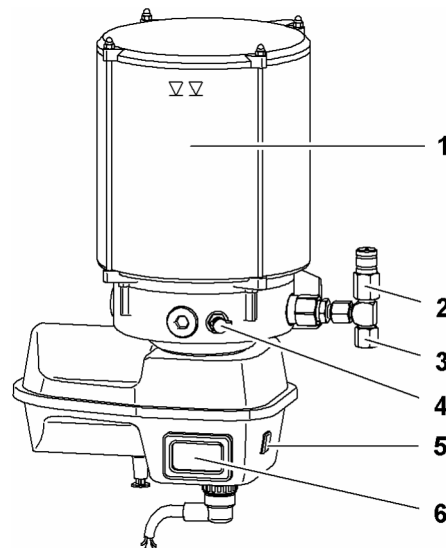


Fig. 576: Central lubrication system

- | | | | |
|---|--------------------------------|---|-----------------------------------|
| 1 | Supply container | 4 | Filling nipple |
| 2 | Positive pressure relief valve | 5 | Button <i>Interim lubrication</i> |
| 3 | Pump outlet | 6 | Control unit |

1.77 Auxiliary floodlights*

The following auxiliary floodlights are available:

- Floodlights on uppercarriage
- Floodlights on cabin
- Adjustable floodlights on main boom base section
- Floodlights on main boom
- Floodlights on jib head

1.77.1 Floodlights on uppercarriage

The following illuminants are available:

- Halogen bulb H3
- LED

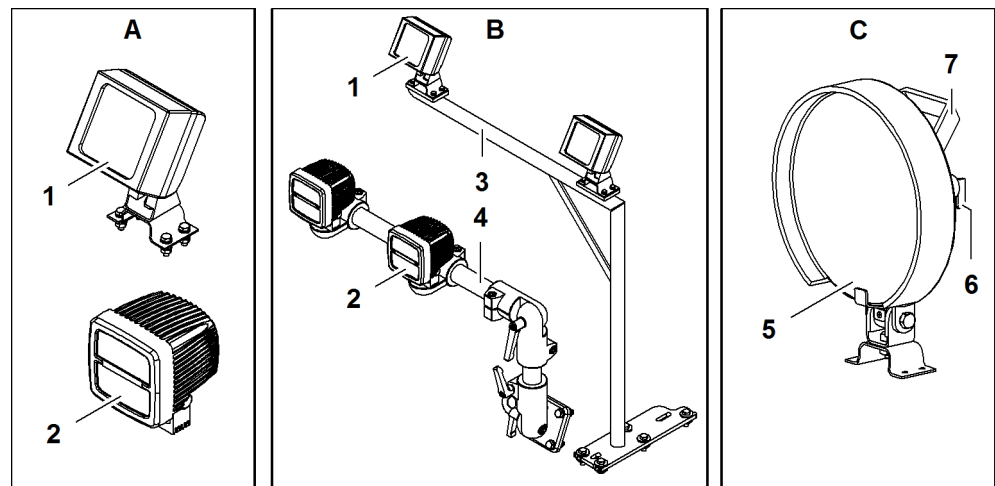


Fig. 577: Floodlights on uppercarriage

- | | | | |
|---|-------------------------|---|-----------------------|
| 1 | Floodlight with bulb H3 | 6 | Switch |
| 2 | Floodlight with LED | 7 | Handle |
| 3 | Stayer | A | Floodlight on cabin |
| 4 | Stayer | B | Floodlight with frame |
| 5 | Search floodlight | C | Search floodlight |

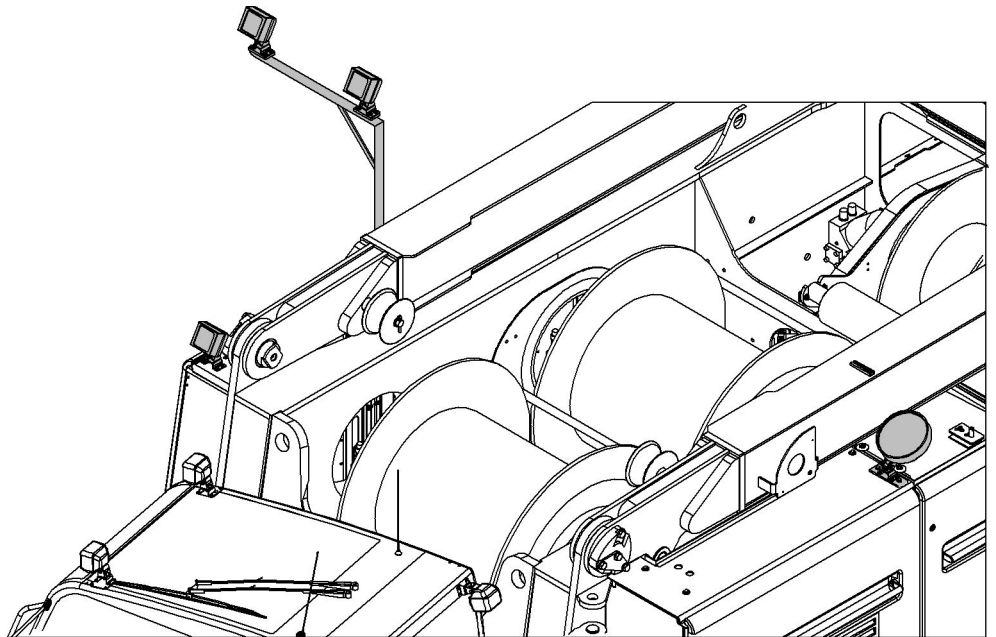


Fig. 578: Floodlights on uppercarriage

The exact installation position of the search floodlight varies according to machine type.

Name	Value
Illuminant	Halogen bulb H3
Weight of each floodlight	0.7 kg 1.54 lb
Power consumption per floodlight	70 W
Nominal voltage	24 V
Width of stayer	700 mm 2' 4" ft-in
Height of stayer	700 mm 2' 4" ft-in

Tab. 331: Technical data floodlight with bulb H3

Name	Value
Illuminant	LED
Weight per floodlight	1.5 kg 3.31 lb
Power consumption per floodlight	50 W
Nominal voltage	24 V
Width of stayer	700 mm 2' 4" ft-in
Height of stayer	470 mm 1' 7" ft-in

Tab. 332: Technical data floodlight with LED

Product description

Auxiliary floodlights*

Name	Value
Illuminant	Halogen bulb H3
Weight	1.5 kg 3.31 lb
Power consumption	70 W
Nominal voltage	24 V

Tab. 333: Technical data search floodlight

LWN/LR-x/V04.01//Auslieferung/2016-03-07/en

1.77.2 Floodlights on cabin

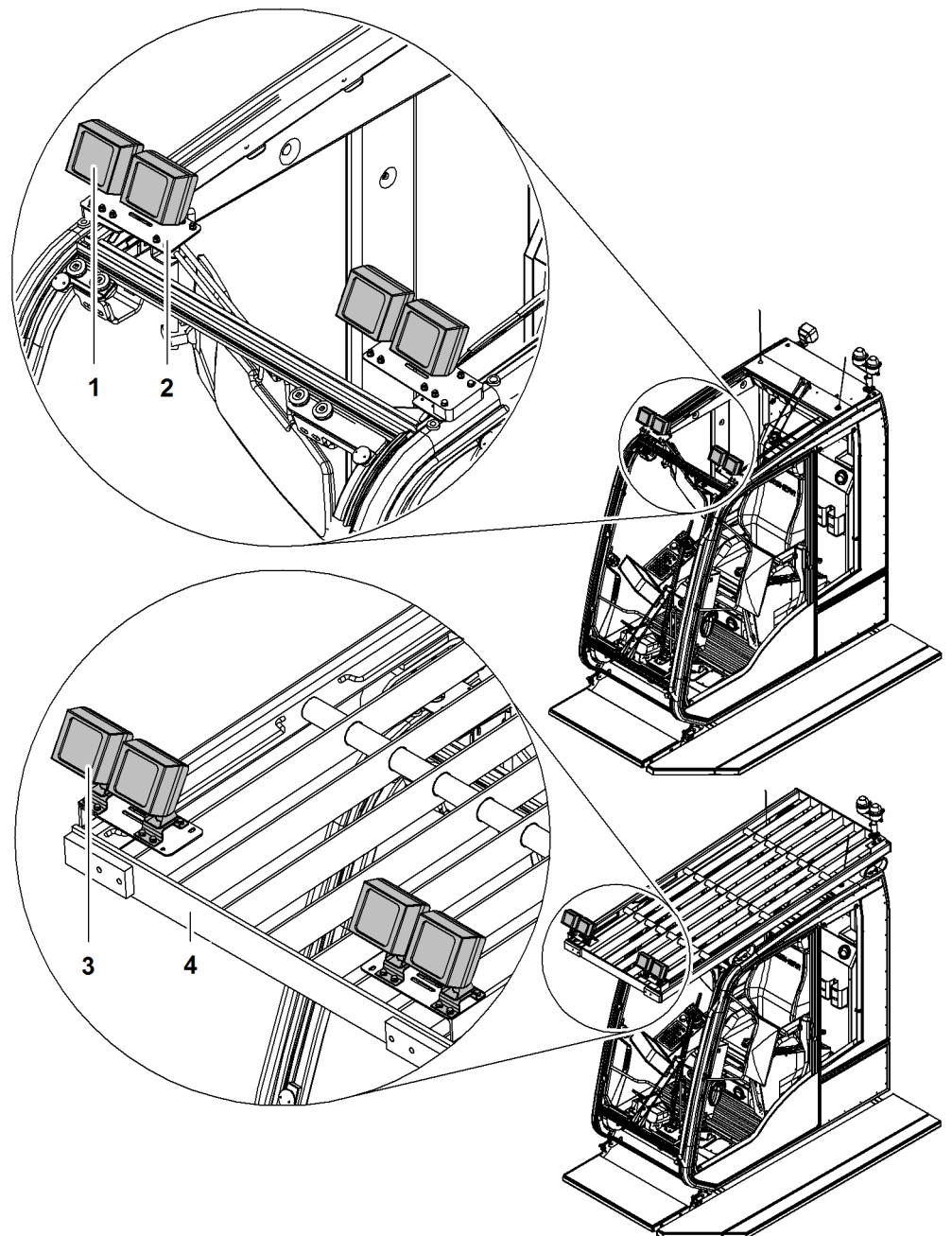


Fig. 579: Floodlights on cabin

- | | |
|---|--|
| <p>1 Floodlight (4x)
2 Bracket (2x)</p> | <p>3 Floodlight (4x)
4 Falling object protection</p> |
|---|--|

Name	Value
Illuminant	Halogen bulb H3
Weight of each floodlight	0.7 kg 1.54 lb
Nominal voltage	24 V 24 V

Name	Value
Power consumption per floodlight	70 W 70 W

Tab. 334: Technical data floodlight with bulb H3

Name	Value
Illuminant	LED
Weight of each floodlight	1.5 kg 3.31 lb
Nominal voltage	24 V 24 V
Power consumption per floodlight	50 W 50 W

Tab. 335: Technical data floodlight with LED

1.77.3 Adjustable floodlights on main boom base section

The following floodlights are available:

- Xenon gas discharge lamp
- LED

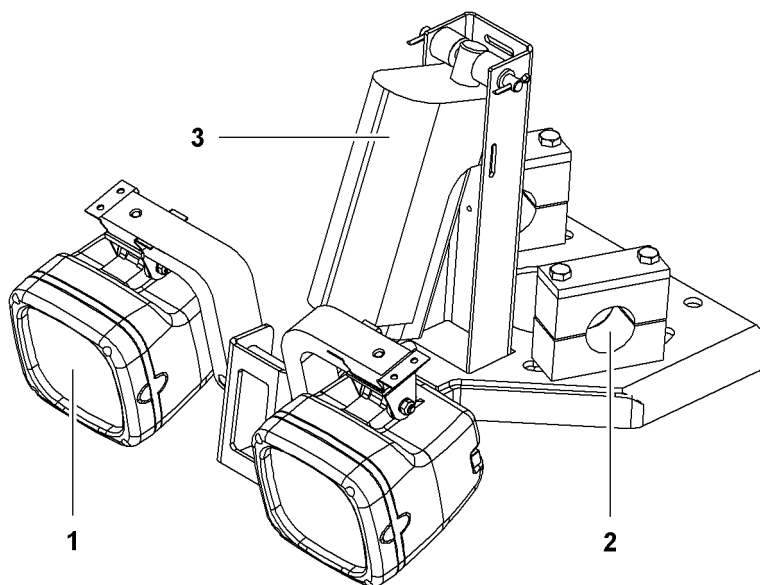


Fig. 580: Adjustable floodlights on main boom base section

- | | | | |
|----------|------------------|----------|-----------------------------|
| 1 | Floodlights (2x) | 3 | Variable displacement motor |
| 2 | Bracket (2x) | | |

The variable displacement motor 1 can be used to tilt the floodlights 3 by 141°.

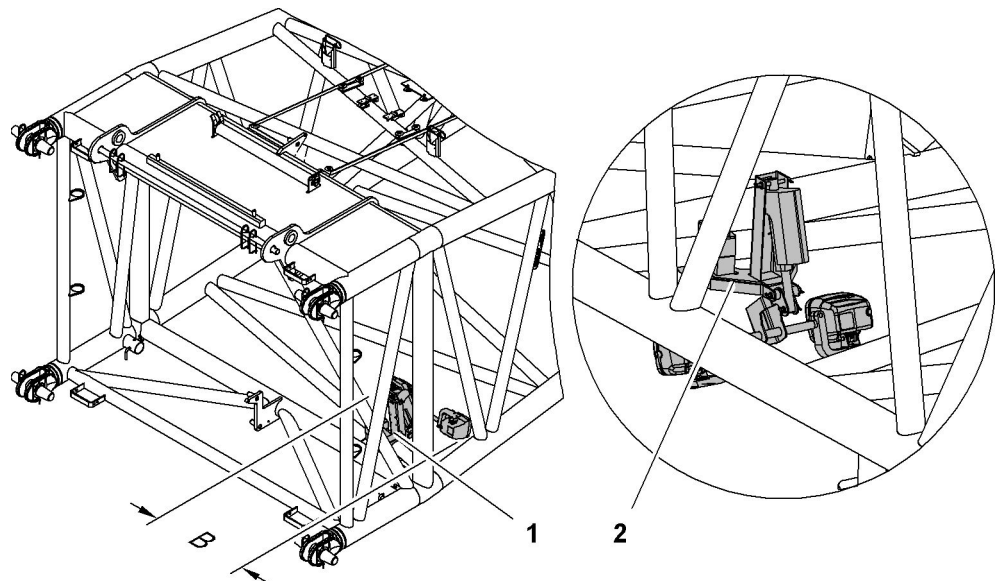


Fig. 581: Adjustable floodlights on main boom base section

1 Floodlight folded in

2 Floodlight folded out

The exact installation position of the floodlights varies according to machine type.

Name		Value
Illuminant		Xenon gas discharge lamp
B	Width	740 mm 2' 5" ft-in
Weight		14.5 kg 31.97 lb
Nominal voltage		24 V
Power consumption per floodlight		42 W

Tab. 336: Technical data floodlight with xenon gas discharge lamp

Name		Value
Illuminant		LED
B	Width	668 mm 2' 2" ft-in
Weight		15.5 kg 34.17 lb
Nominal voltage		24 V
Power consumption per floodlight		50 W

Tab. 337: Technical data floodlight with LED

1.77.4 Floodlights on main boom

The following floodlights are available at the main boom:

- High-pressure sodium vapor lamp
- LED floodlight

High-pressure sodium vapor lamp

Several pairs of high-pressure sodium vapor lamps can be installed on the main boom.

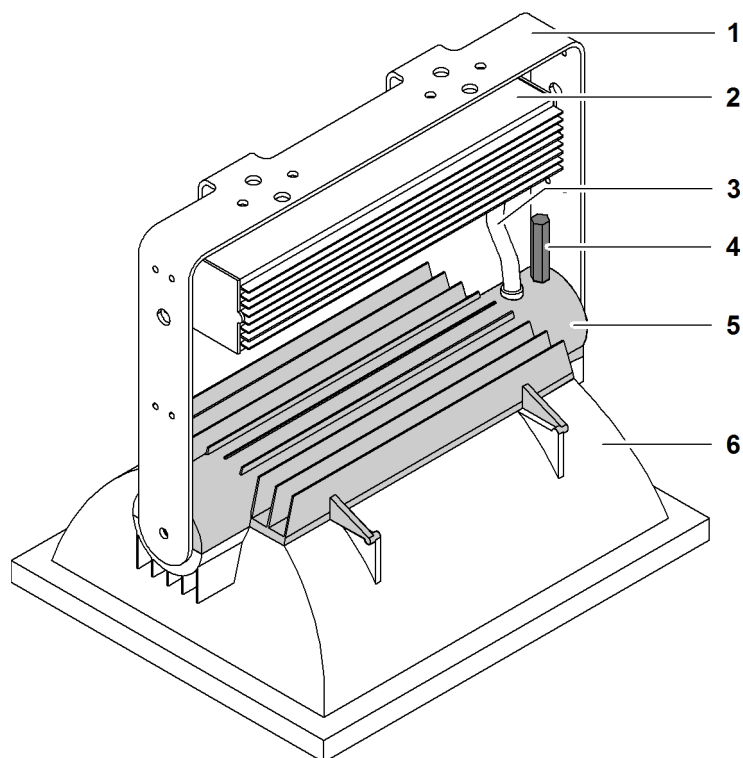


Fig. 582: High-pressure sodium vapor lamp on main boom

- | | | | |
|---|----------------|---|----------------|
| 1 | Bracket | 4 | Lever (2x) |
| 2 | Control gear | 5 | Cover |
| 3 | Electric cable | 6 | Main reflector |

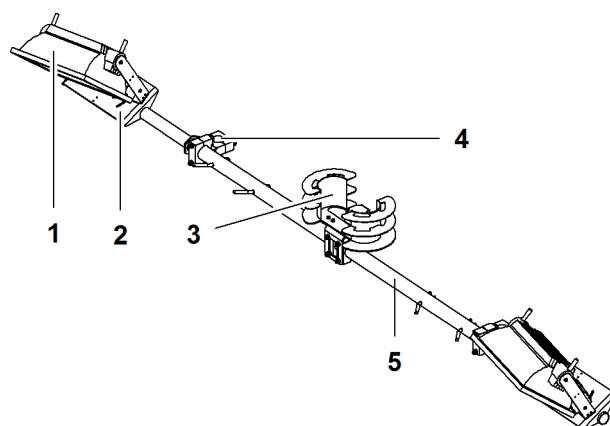


Fig. 583: Bracket high-pressure sodium vapor lamp on main boom

- | | | | |
|---|-------------------|---|-----------------------|
| 1 | Floodlights (2x) | 4 | Mounts (2x) main boom |
| 2 | Fixing bases (2x) | 5 | Traverse |
| 3 | Cable bracket | | |

The fixing bases **2** can be inclined by 60° (60°).

The maximum cable length is 25 m (82' ft-in).

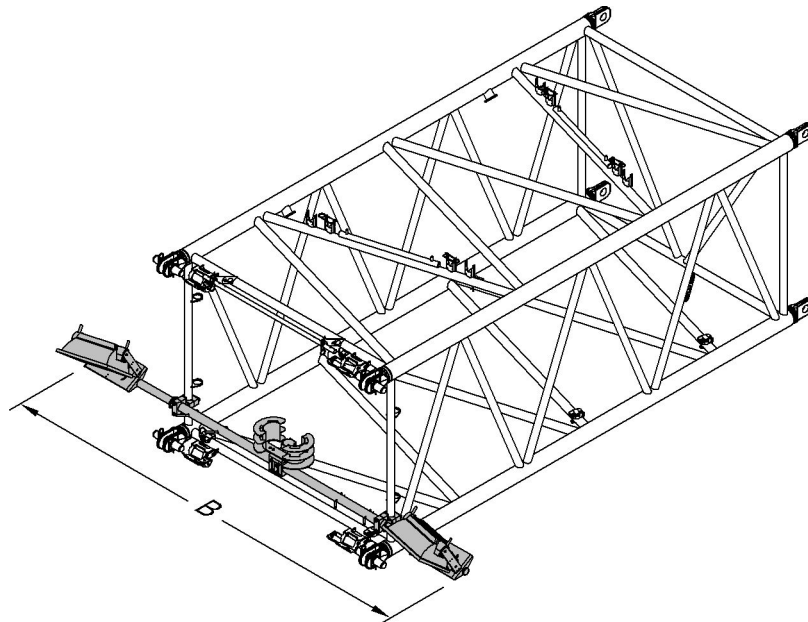


Fig. 584: High-pressure sodium vapor lamp installed on main boom

Name		Value
B	Width floodlights	5150 mm 16' 11" ft-in
Weight		101 kg 223 lb
Illuminant		High-pressure sodium vapor lamp
Nominal voltage		230 V
Power consumption per floodlight		1000 W

Tab. 338: Technical data floodlights on main boom

LED floodlight

Only one pair of LED floodlights can be installed on the main boom.

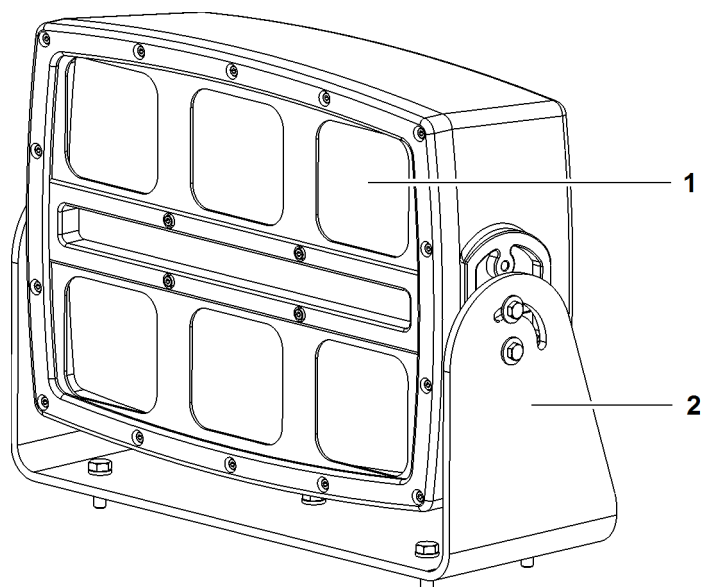


Fig. 585: LED floodlight on main boom

- | | | | |
|---|----------------------------|---|---------|
| 1 | LED illumination unit (6x) | 1 | Bracket |
|---|----------------------------|---|---------|

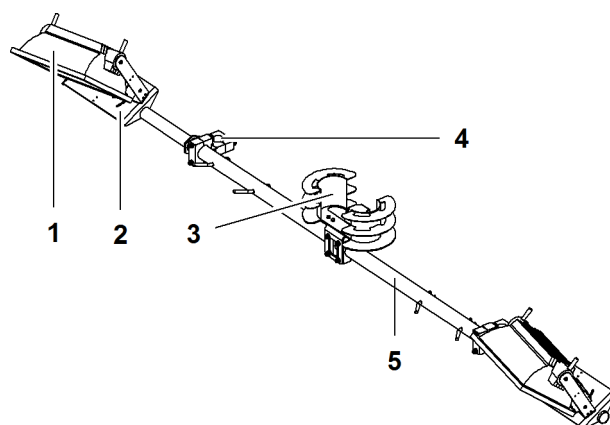


Fig. 586: LED floodlight on main boom

- | | | | |
|---|-------------------|---|-----------------------|
| 1 | Floodlight (2x) | 4 | Mounts (2x) main boom |
| 2 | Fixing bases (2x) | 5 | Traverse |
| 3 | Cable bracket | | |

The fixing bases **2** can be inclined by 60° (60°).

The maximum cable length is 25 m (82' ft-in).

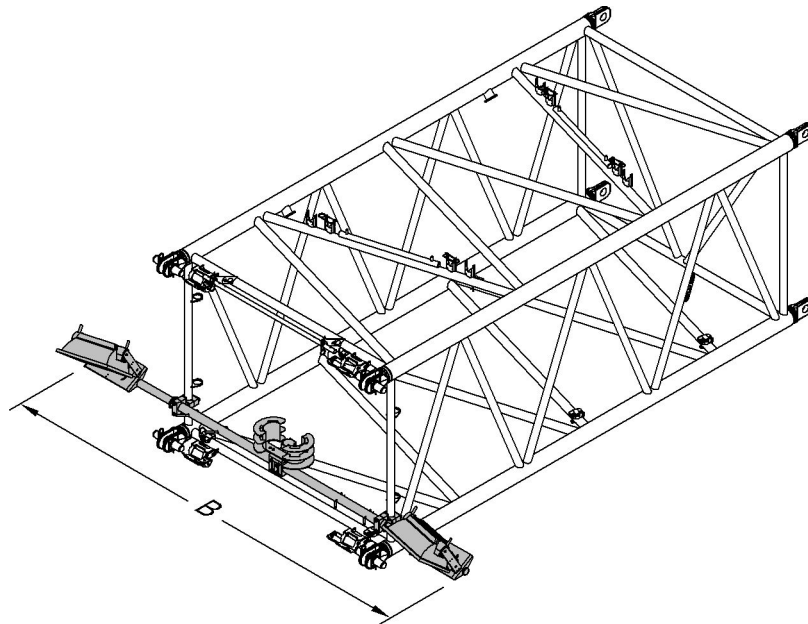


Fig. 587: LED floodlight installed on main boom

Name		Value
B	Width floodlights	5150 mm 16' 11" ft-in
	Weight	165 kg 364 lb
	Illuminant	LED
	Nominal voltage	24 V
	Power consumption per floodlight	300 W

Tab. 339: Technical data LED floodlights on main boom

1.77.5 Floodlights on jib head

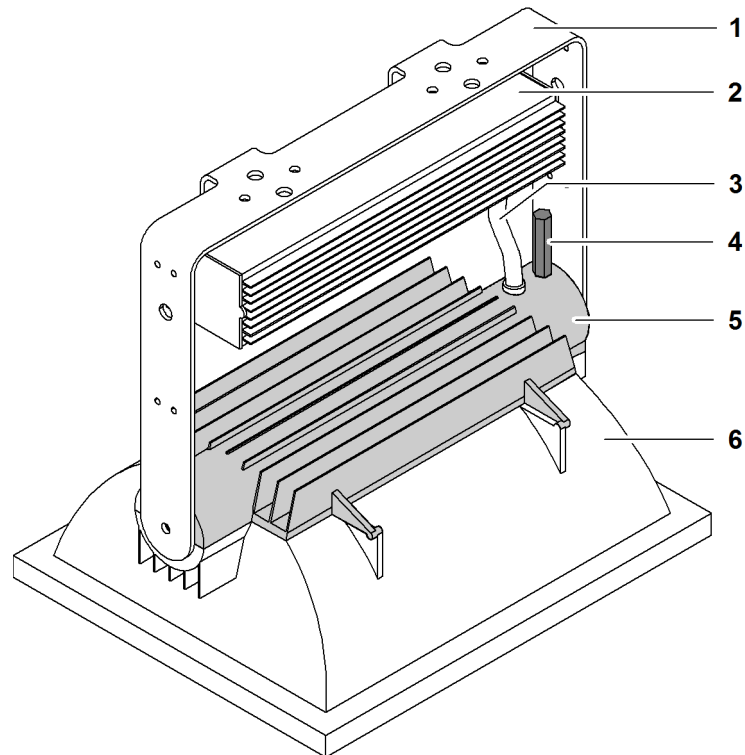


Fig. 588: Floodlights on jib head

- | | | | |
|---|----------------|---|----------------|
| 1 | Bracket | 4 | Lever (2x) |
| 2 | Control gear | 5 | Cover |
| 3 | Electric cable | 6 | Main reflector |

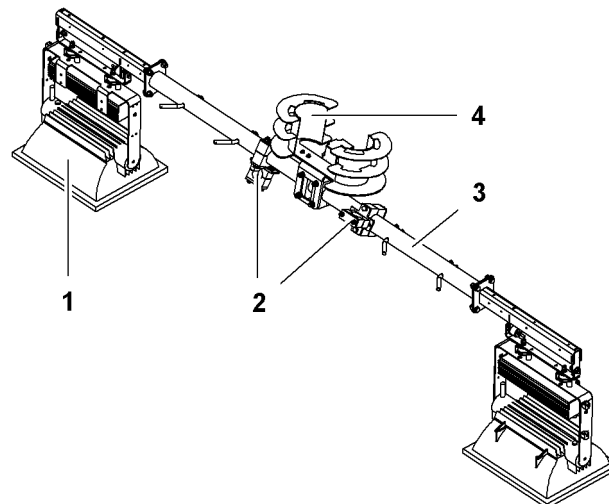


Fig. 589: Floodlights on jib head

- | | | | |
|---|-----------------|---|---------------|
| 1 | Floodlight (2x) | 3 | Traverse |
| 2 | Bracket (2x) | 4 | Cable bracket |

The cable length is 25 m (82' ft-in).

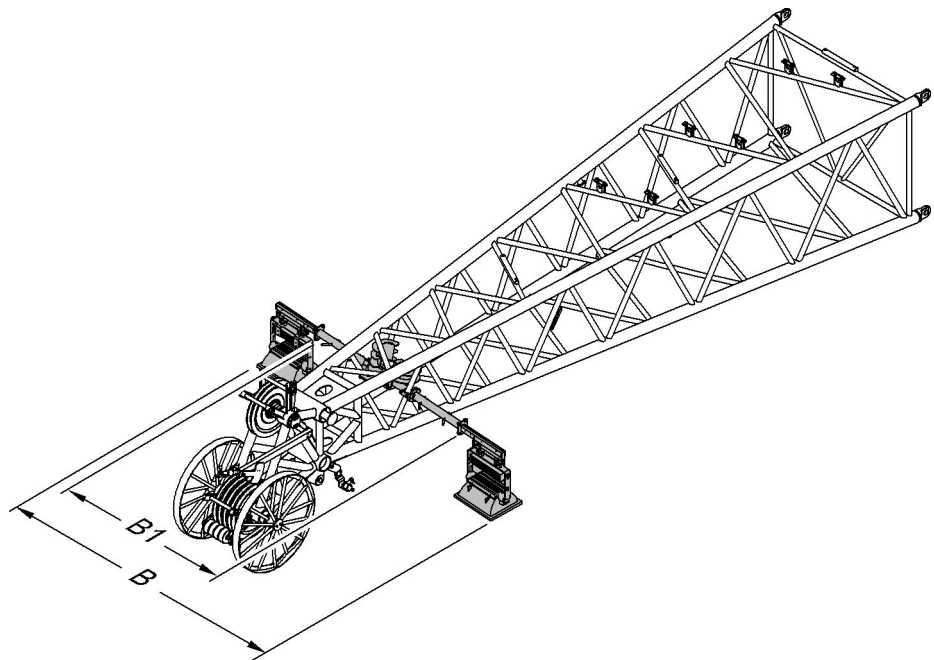


Fig. 590: Floodlights on jib head

Name		Value
Illuminant		High-pressure sodium vapor lamp
B	Width	4028 mm 13' 3" ft-in
B1	Width	2409 mm 7' 11" ft-in
Weight		233 kg 514 lb
Nominal voltage		230 V
Power consumption per floodlight		1000 W

Tab. 340: Technical data floodlight on jib head

Product description

Auxiliary floodlights*

LWN/LR-x/V04.01//Auslieferung/2016-03-07/en

Safety instructions 2

2 Safety instructions

2 Safety instructions

The chapter **Safety instructions** deals with the following issues:

- Areas of responsibility and required personnel
- Dangers and remaining risks despite proper use
- Measures to prevent danger

2.1 Technical condition of the machine

For the machine to be operated safely, the following requirements in terms of its technical condition must be met:

- The machine must be in perfect condition
- Unauthorised conversion or modification is not permitted
- Maintenance must be performed regularly
- Safety devices must be in good working order

2.2 Areas of responsibility

2.2.1 Manufacturer

The manufacturer:

- is responsible for the impeccable safety state of the machine with accessories and documentation when surrendering to the operator.
- is aware of its duty to monitor product performance and document all maintenance and repair work carried out by authorized service personnel.
- ensures that the machine is kept in an operational state by a worldwide maintenance and repair service.
- runs a training center and provides training for the owner's operating and maintenance personnel as a service.

2.2.2 Owner

The owner:

- ensures that the machine is operated and maintained by qualified personnel only.
- checks that all individuals who come into contact with the machine are fully qualified, and authorises them to work.
- specifies the skills and responsibilities of all those working with or near the machine.
- provides all necessary protective equipment to individuals working with or near the machine.

- regularly checks that personnel carry out their work in a safety-conscious manner.
- is responsible for the impeccable safety state of the machine with accessories and documentation as of surrender from the manufacturer.
- completely removes the machine from use upon the discovery of any faults that may affect safety.
- performs inspections on the machine based on national regulations in addition to the inspections stipulated by Liebherr.
- informs the manufacturer of any accident involving the machine leading to serious injury or major damage to property.
- allows authorized service personnel unlimited access to the machine in order that they may fulfill their duty to monitor the product.
- carefully and conscientiously carries out work planning for the machine.
- will not carry out any alterations on the machine without first consulting the manufacturer.
- must only use original Liebherr spare parts.

2.2.3 Machine operator

The machine operator:

- have read and understood the operation manual.
- operates the machine for the purposes intended, within the limit values specified in the load chart and in accordance with the setup and the operation manual.
- wear personal protective equipment.
- reports to the owner any alteration to the machine that affects safety.
- halts operation immediately if safe operation is no longer possible.
- will not carry out any alterations on the machine without first consulting the manufacturer.
- must only use original Liebherr spare parts.
- must ensure that a co-driver rides in the intended seat and wears a safety belt (if a co-driver is intended and permitted by the manufacturer).

2.2.4 Rigger

The rigger:

- is responsible for the correct selection and fitting/removal of the lifting device on the load or rigging material.
- gives the machine operator signals relating to the movement of the machine and loads.
- is responsible for ensuring that only one person gives signals to the machine operator and that the machine operator knows who this person is.
- wear personal protective equipment.

2.2.5 Banksman

The banksman:

- forwards signals from the rigger to the machine operator if the rigger has no visual contact with the machine operator.
- wear personal protective equipment.

2.2.6 Maintenance and service personnel

The maintenance and service personnel:

- maintain the machine to ensure that it remains in a safe and reliable condition.

- have read and understood the operation manual.
- wear personal protective equipment.
- perform all specified maintenance work.
- will not carry out any alterations on the machine without first consulting the manufacturer.
- must only use original Liebherr spare parts.

2.3 Requirements to personnel

2.3.1 Machine operator

The machine operator:

- are of the statutory minimum age.
- must be physically capable (adequate eyesight and hearing, quick reactions) of safely operating the machine.
- is authorised to operate the machine.
- is capable of accurately estimating distances, heights and clearances.
- is trained:
 - to operate this type of machine
 - in attaching and signalling
 - to operate fire extinguishing equipment
- is aware of the escape routes in the event of an emergency.
- do not suffer from any physical or psychological ailments that lower any of the specified requirements.
- are not under the influence of alcohol or drugs.

2.3.2 Rigger

The rigger:

- are of the statutory minimum age.
- is physically capable (adequate eyesight and hearing, quick reactions) of safely using/moving lifting devices.
- is authorised to rig loads.
- is capable:
 - of accurately estimating distances, heights and clearances
 - of accurately estimating mass and load distribution
 - of operating walkie-talkies and using them to give clear instructions
 - of guiding the load and ensuring the safe movement of the load and the machine
- is trained:
 - in attaching lifting devices
 - in signalling and knows the signal signs
 - in selecting the correct lifting device
 - in securing against unexpected detachment
 - in preventing damage to lifting devices
- do not suffer from any physical or psychological ailments that lower any of the specified requirements.
- are not under the influence of alcohol or drugs.

2.3.3 Banksman

The banksman:

- are of the statutory minimum age.
- are physically capable (adequate eyesight and hearing, quick reactions).
- is authorised to give signal signs.
- is capable:
 - of accurately estimating distances, heights and clearances
 - of operating walkie-talkies and using them to give clear instructions
 - of guiding the load and ensuring the safe movement of the load and the machine
- is trained in signalling and knows the signal signs.
- do not suffer from any physical or psychological ailments that lower any of the specified requirements.
- are not under the influence of alcohol or drugs.

2.3.4 Maintenance personnel

Maintenance personnel:

- are of the statutory minimum age.
- are physically capable (adequate eyesight and hearing, quick reactions).
- are familiar with the machine and the hazards.
- are familiar with all maintenance procedures and measures.
- are trained to perform maintenance duties, including on specialist equipment.
- do not suffer from any physical or psychological ailments that lower any of the specified requirements.
- are not under the influence of alcohol or drugs.

2.4 Personal protective equipment

The machine operator, slinger, signalman and maintenance personnel must take personal responsibility for:

- Wearing the required personal protective gear.
- Regular cleaning and care of the protective gear.
- Replacing any defective items of protective gear promptly.

The personal protective gear comprises:

- **Safety helmet**, if head injuries are possible due to:
 - collision,
 - swinging, falling, toppling or flying objects
- **Safety goggles**, if eye injuries are possible due to:
 - corrosive or pressurised liquids
 - loose flying parts
- **Ear protection**, if the sound level is likely to be excessive
- **Breathing mask**, where there is danger from health-threatening gases, vapour, smoke or dust in the working environment
- **Protective gloves**, if hand injuries are possible due to:
 - Burns
 - pointed or sharp objects
- **Reflective, boldly-coloured clothing** if prompt recognition by other personnel is necessary.
- **Safety shoes**, if foot injuries are possible due to:
 - collision or trapping
 - pointed or sharp objects

- swaying or falling objects
- **Special protective clothing**, where there is a risk of burns, hypothermia, chemical burns, stabbing or cutting injuries to the body

2.5 Work area

Operation of the machine is defined for one operator.

The workplace is the cab on the uppercarriage.

Ensure that the following conditions are satisfied:

- No one other than the machine operator is on the machine or within the danger zone around the machine.
- The machine operator must remain in the cab all the time.

Use operating elements exclusively from the operator's seat.

Requirements for a safe working environment:

- Keep cab clean.
- Do not place any articles on the control panels.
- Do not keep tools in the cab.
- Hang any clothing on the hook provided for this purpose.
- Keep the entrance to the cabin clean and free of snow and ice; do not obstruct the entrance with objects or block the escape routes.
- Keep the screens and mirrors (internal and external) clean and free of condensation and ice.

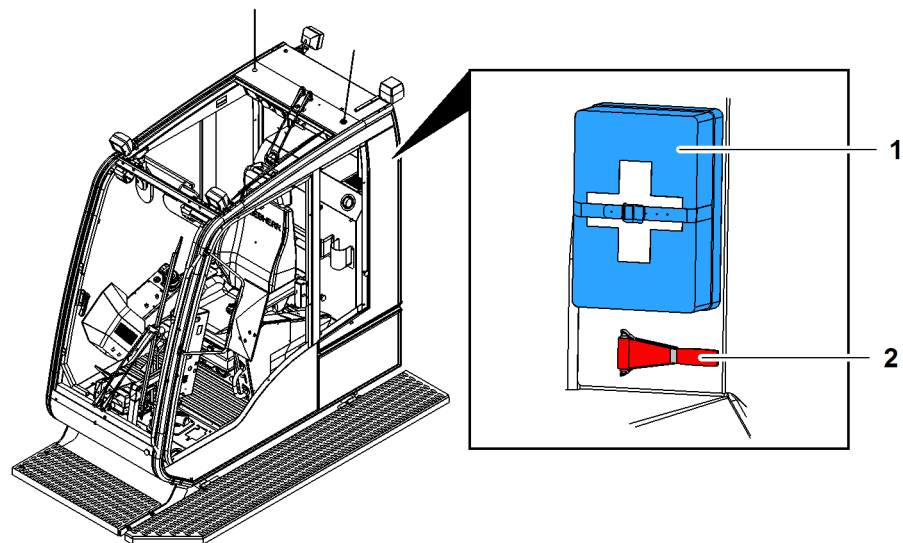


Fig. 591: Emergency devices

1 First-aid box

2 Emergency hammer

The first-aid box 1 supplied with the machine is equipped in accordance with ÖNORM V 5101.



Note

- ▶ All sterile items and plasters are to be replaced after use or as required.
- ▶ All "First Aid" measures and national regulations are to be followed.

If the cabin door will not open, use the emergency hammer **2** to break the side windows to create an emergency exit.

2.6 Danger zone



WARNING

Machine in use!
Death, grave injury.

- ▶ Make sure that no-one is standing in the danger area.
- ▶ Leave the danger area.

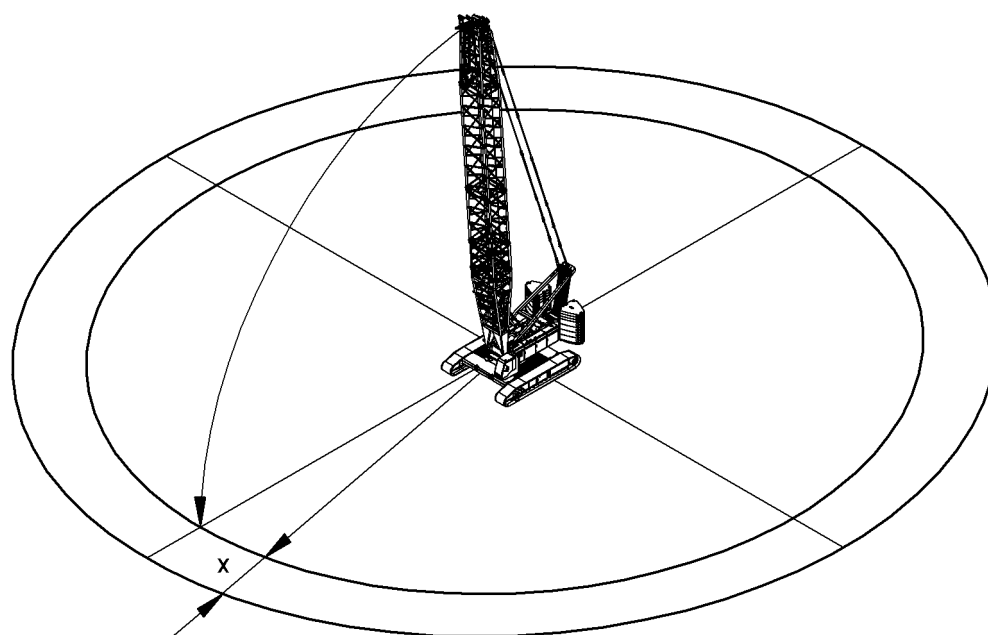


Fig. 592: Danger zone of machine

x Travel of swinging load

Danger area = length of equipment + x

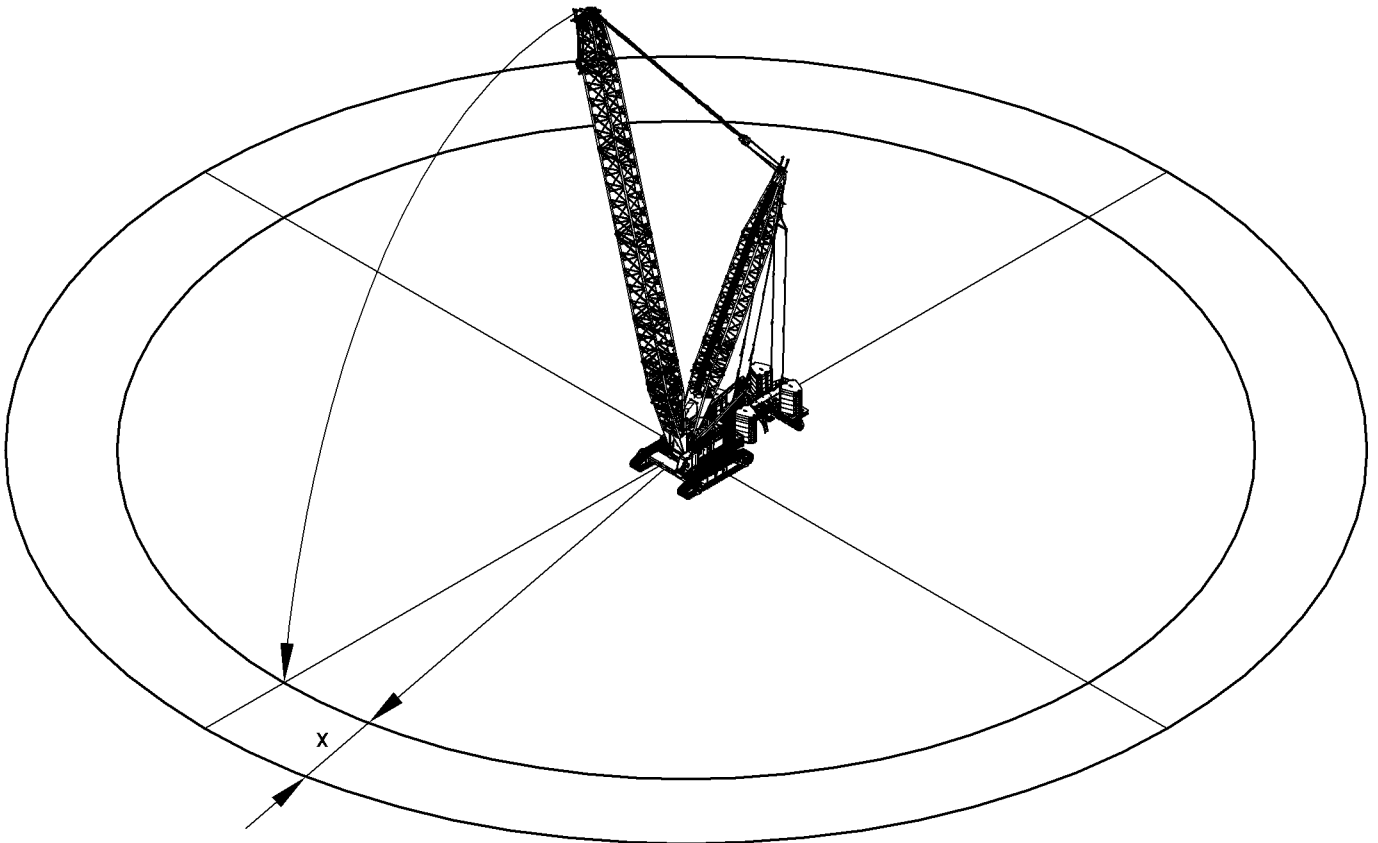


Fig. 593: Danger zone of machine with derrick equipment

x Travel of swinging load

Danger zone = length of equipment + x

2.7 Safety signs on the machine



WARNING

Missing, damaged or illegible safety signs!

- ▶ Check safety signs to ensure they are complete and legible.
- ▶ Replace missing or illegible safety signs with new, original ones.

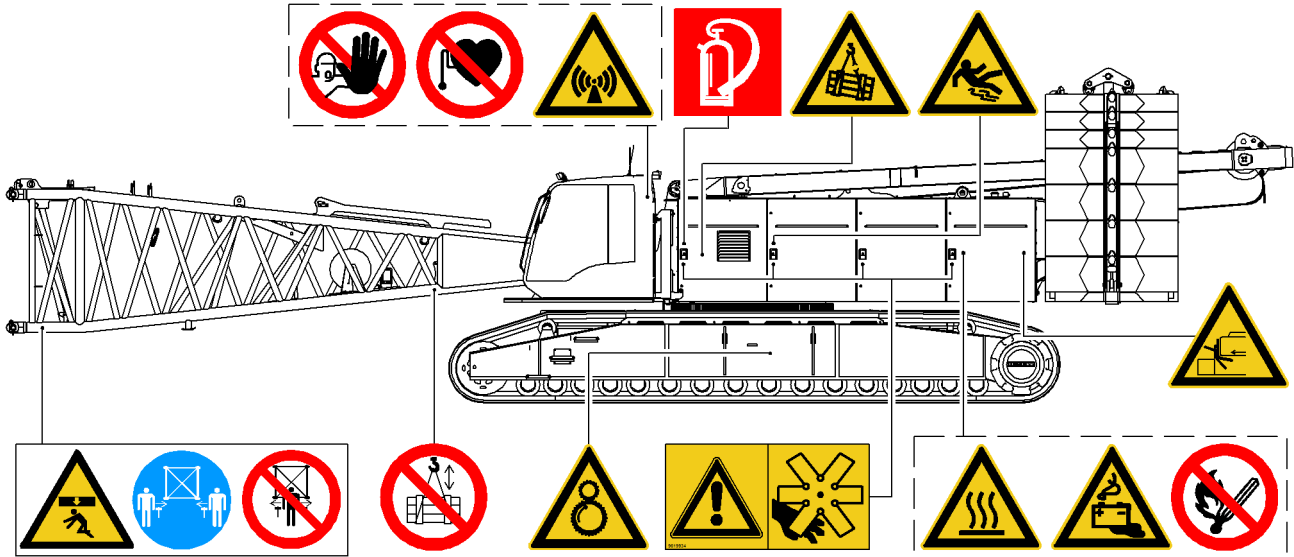


Fig. 594: Safety signs on the left-hand side of the machine

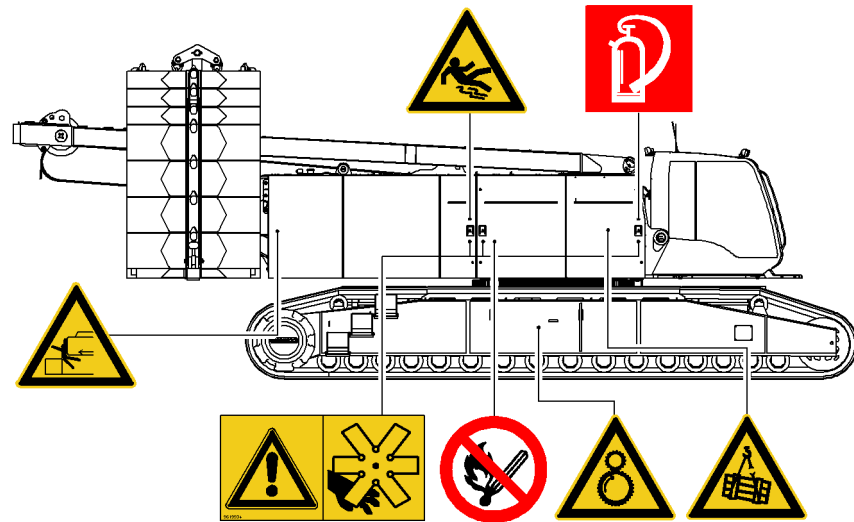


Fig. 595: Safety signs on the right-hand side of the machine

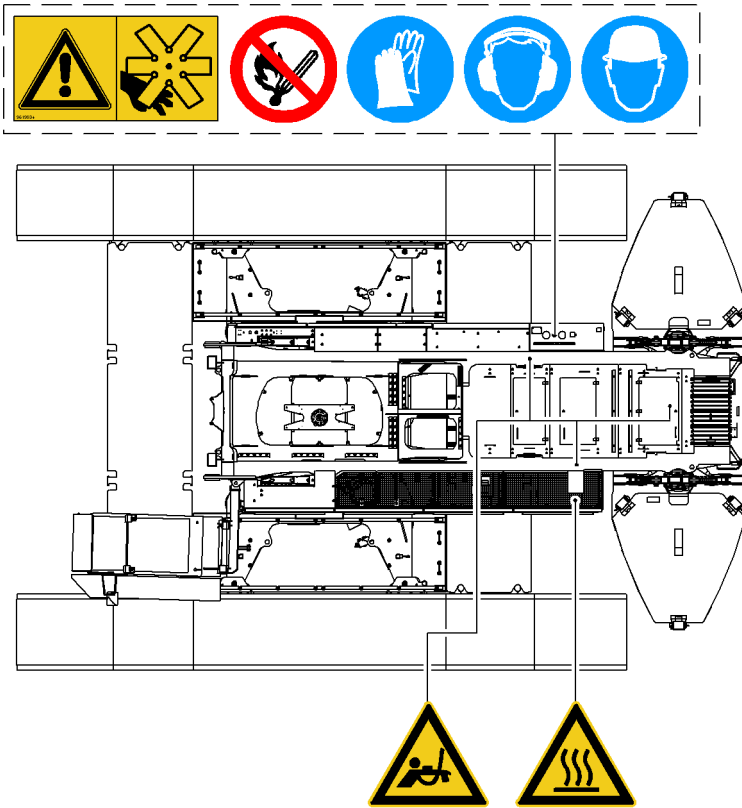


Fig. 596: Safety signs on the top of the machine

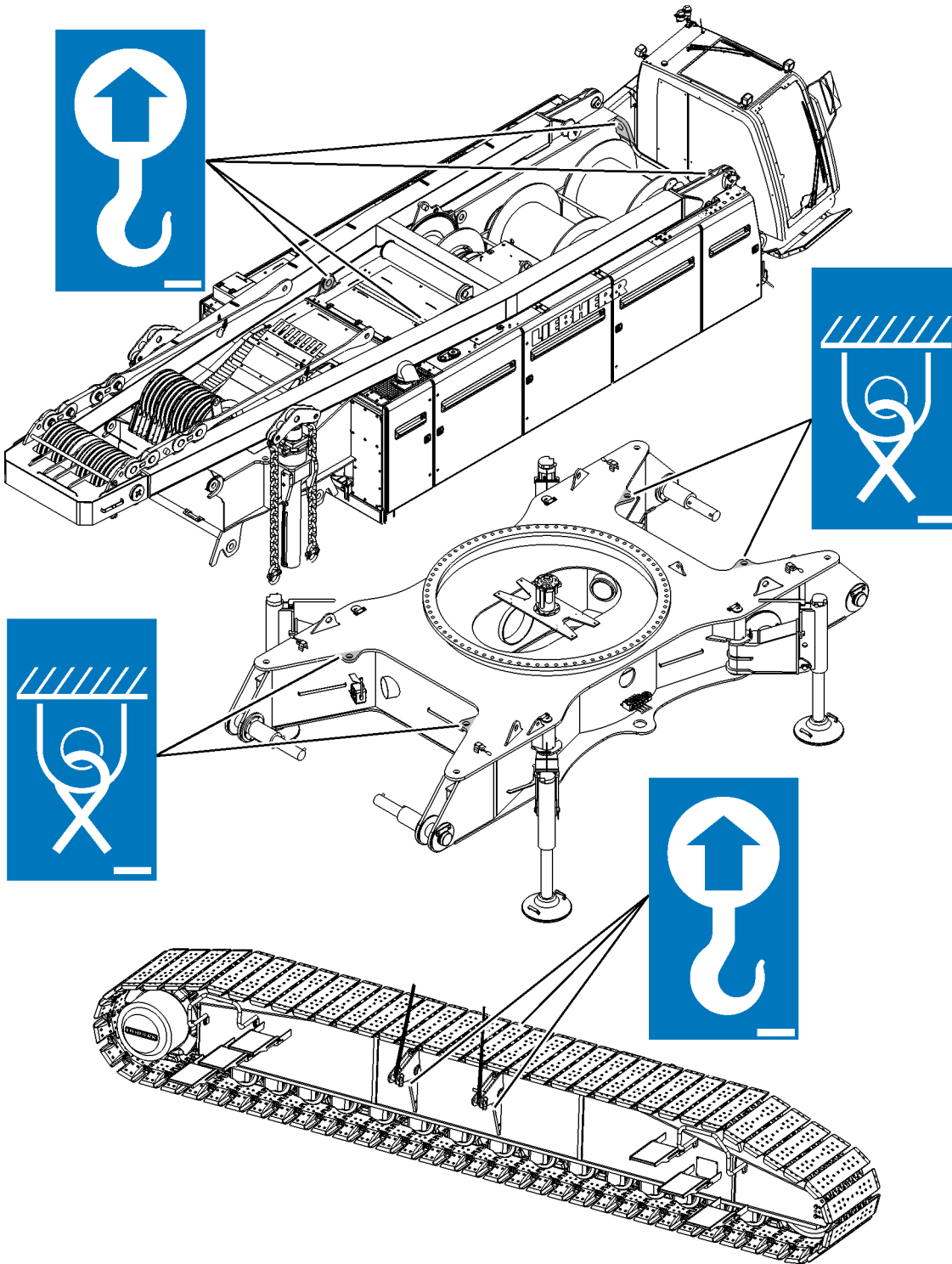
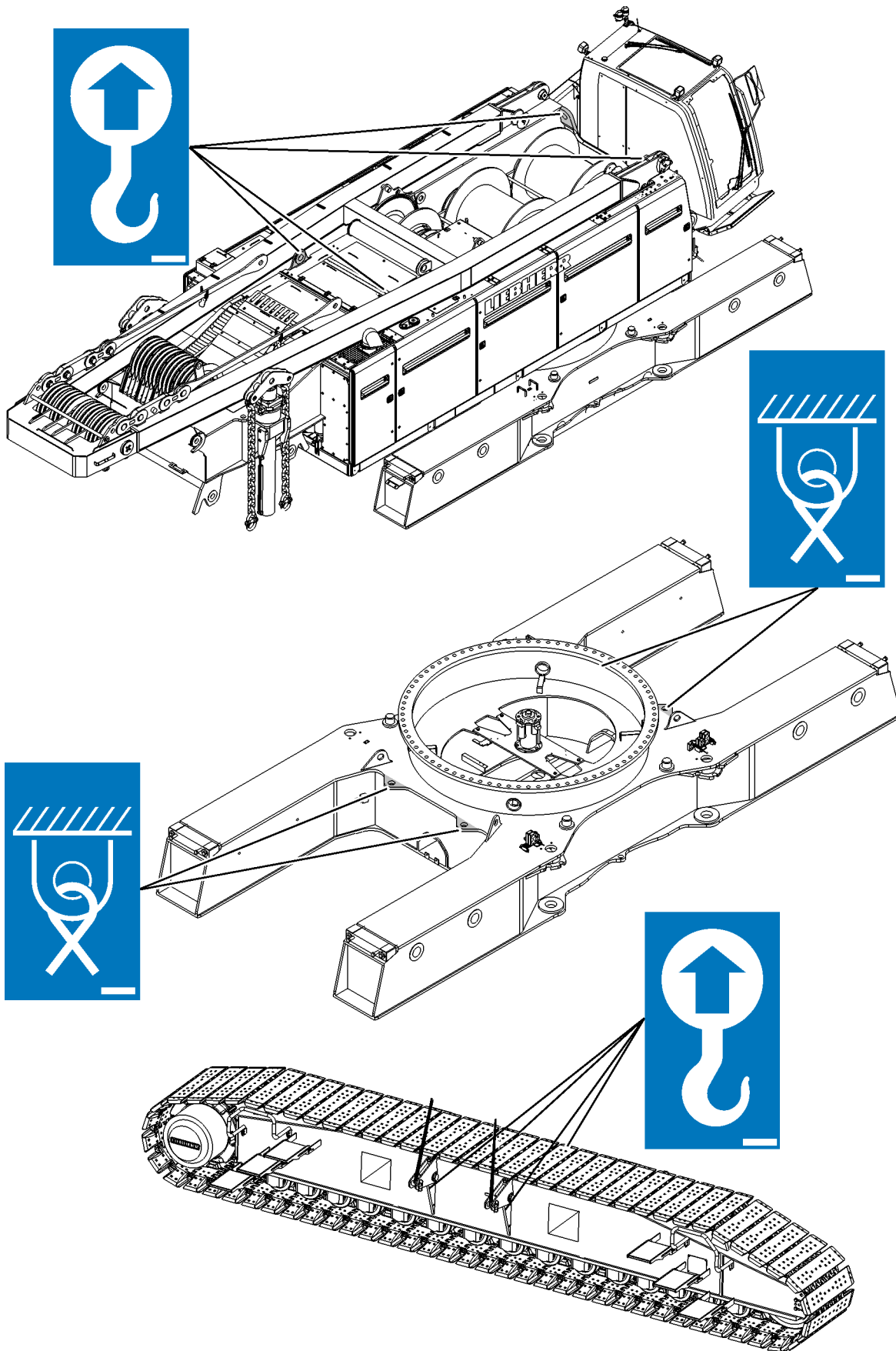


Fig. 597: Labelling of lashing points and rigging points for undercarriage with fixed track width

LWNLR-x/V04.01//Auslieferung/2016-03-07/en



LWNLR_x/V04.01//Auslieferung/2016-03-07/en

Fig. 598: Labelling of lashing points and rigging points for undercarriage* with adjustable track width

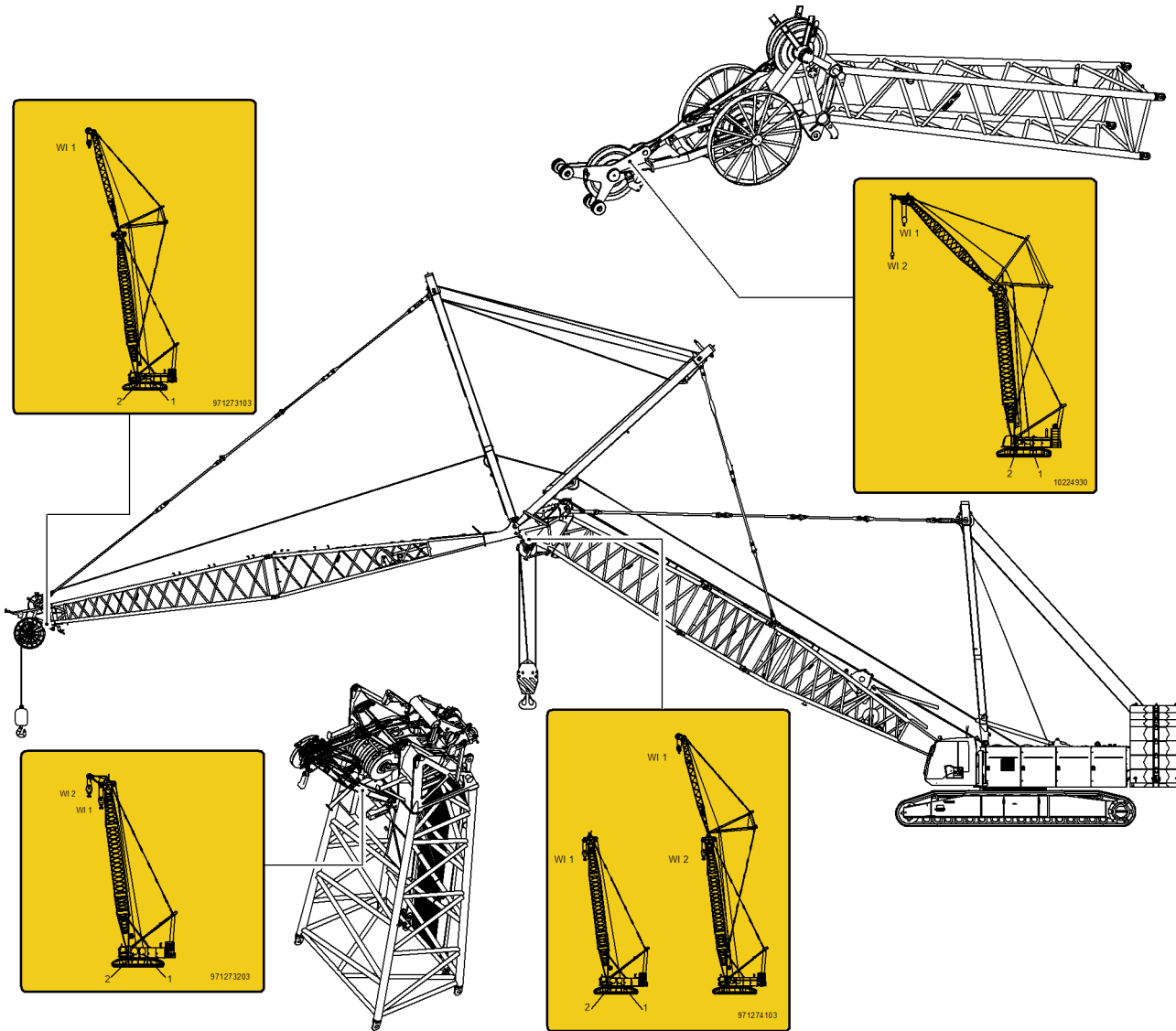


Fig. 599: Safety signs on boom

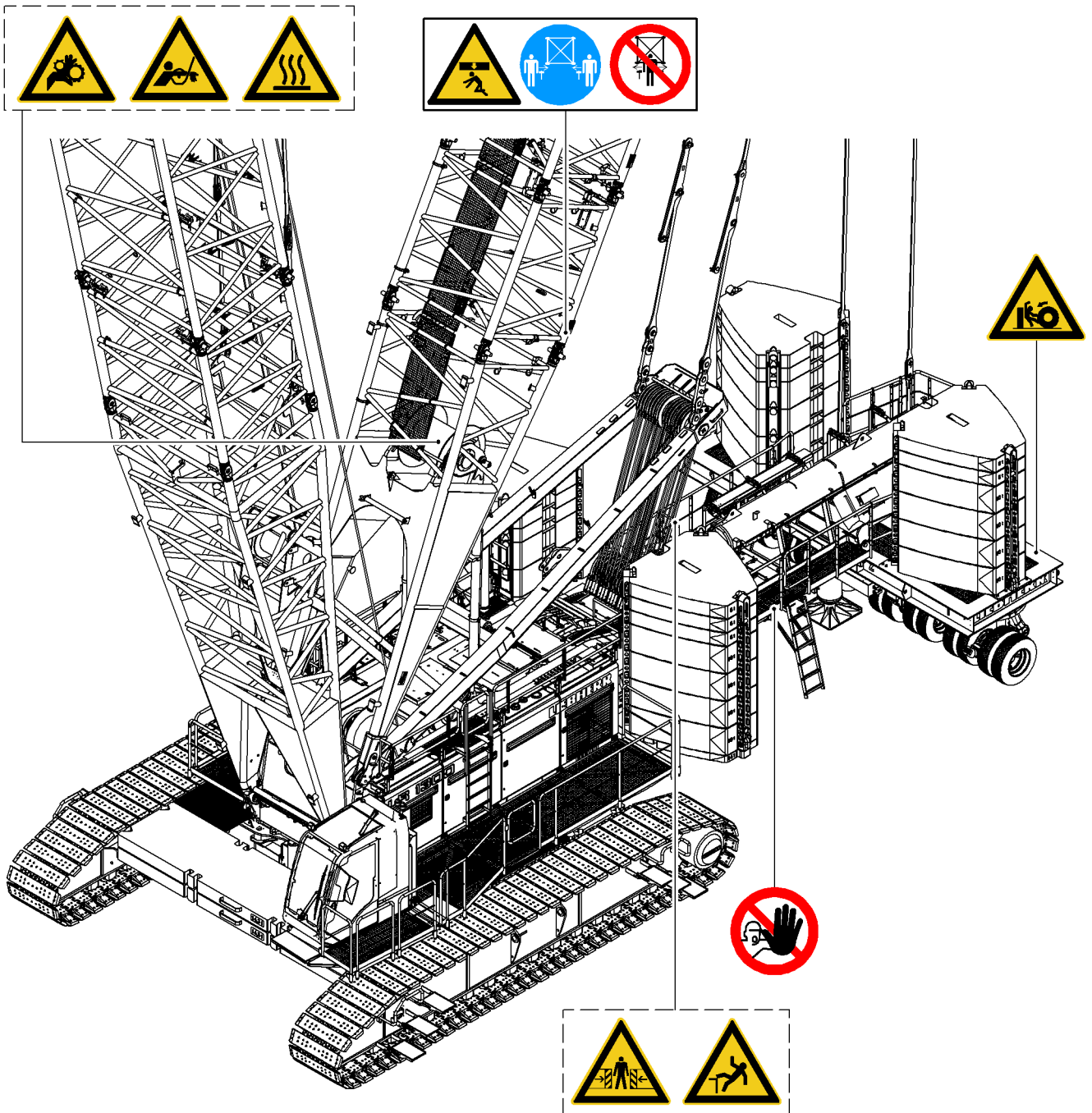


Fig. 600: Safety signs on machine with derrick equipment*

LWNLR_x/V04.01//Auslieferung/2016-03-07/en

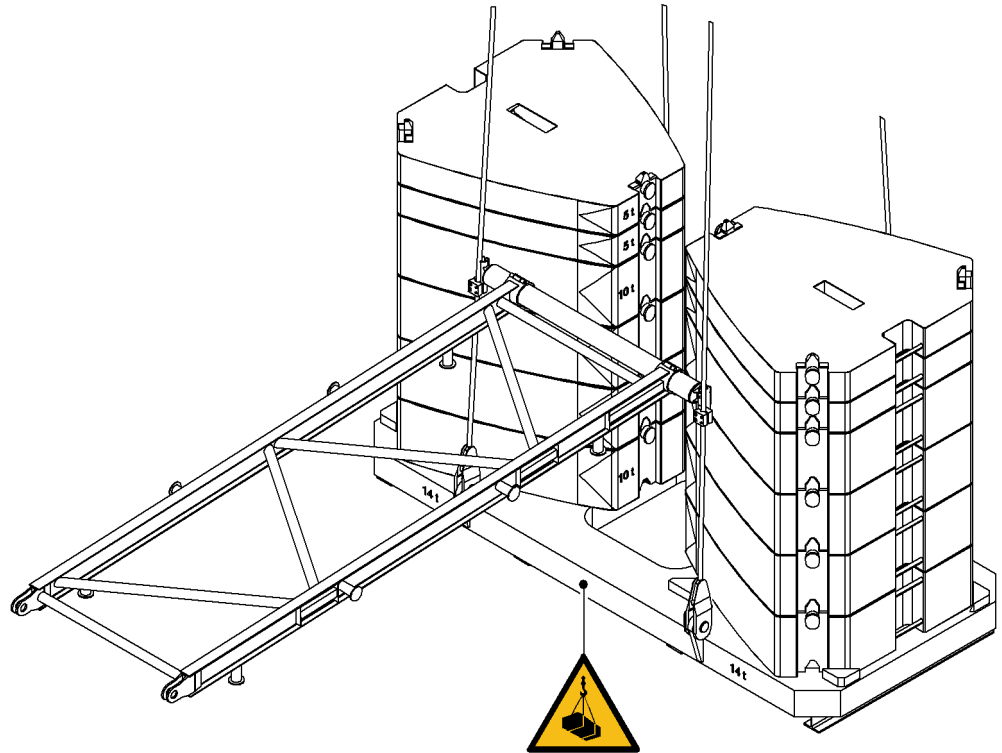


Fig. 601: Safety signs on suspended counterweight of derrick equipment*

The warning sign on the suspended counterweight is attached on all sides of the counterweight frame.

2.8 Safety signs on the machine (US market)



WARNING

Missing, damaged or illegible safety signs!

- ▶ Check safety signs to ensure they are complete and legible.
- ▶ Replace missing or illegible safety signs with new, original ones.

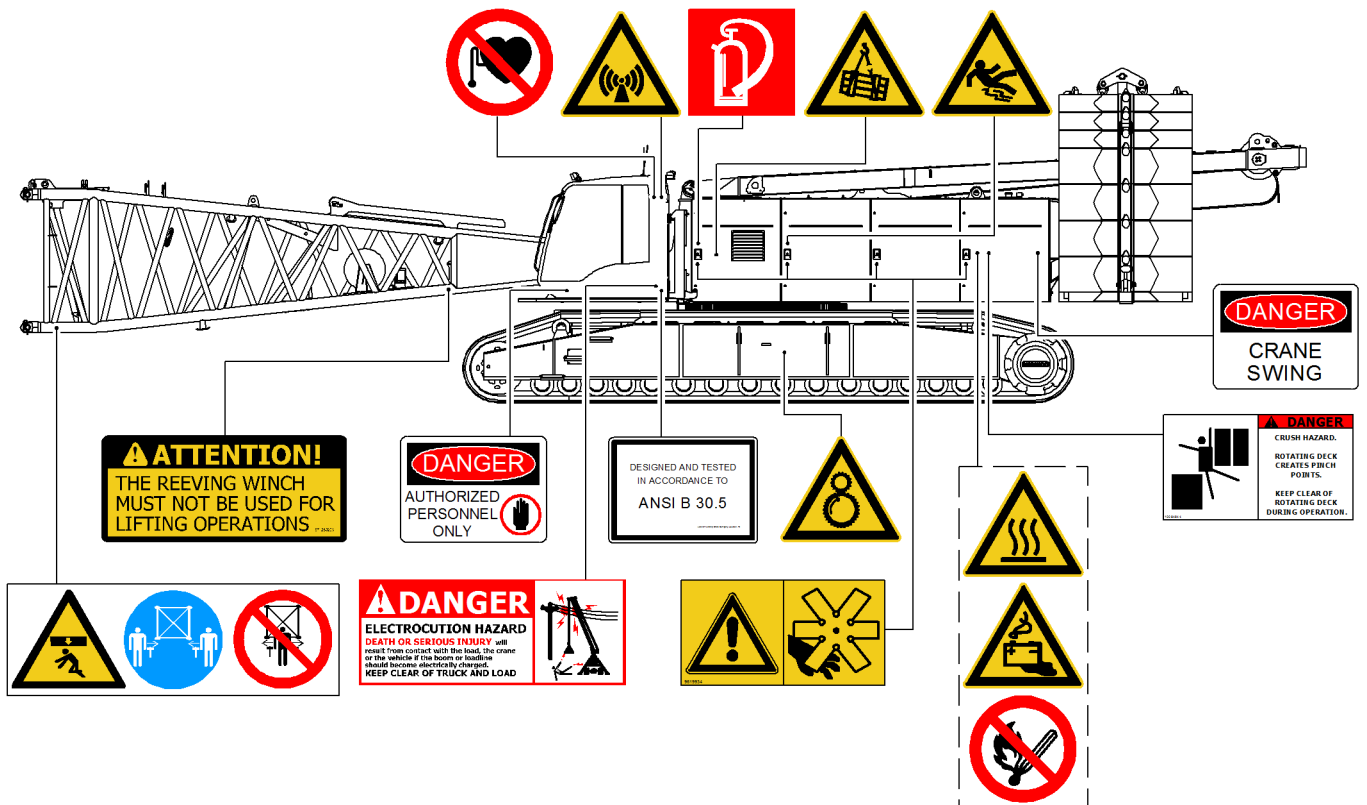


Fig. 602: Safety signs on the left-hand side of the machine

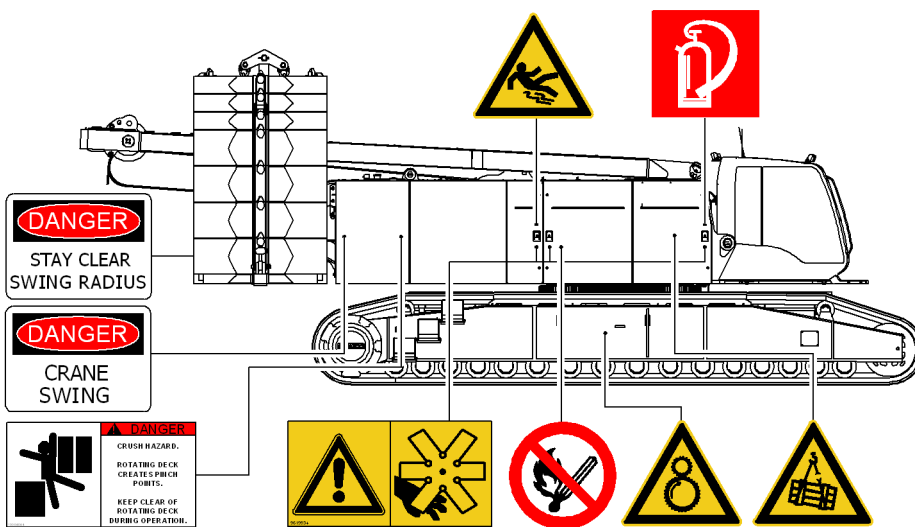


Fig. 603: Safety signs on the right-hand side of the machine

LWNLR_x/V04.01//Auslieferung/2016-03-07/en

Safety instructions

Safety signs on the machine (US market)

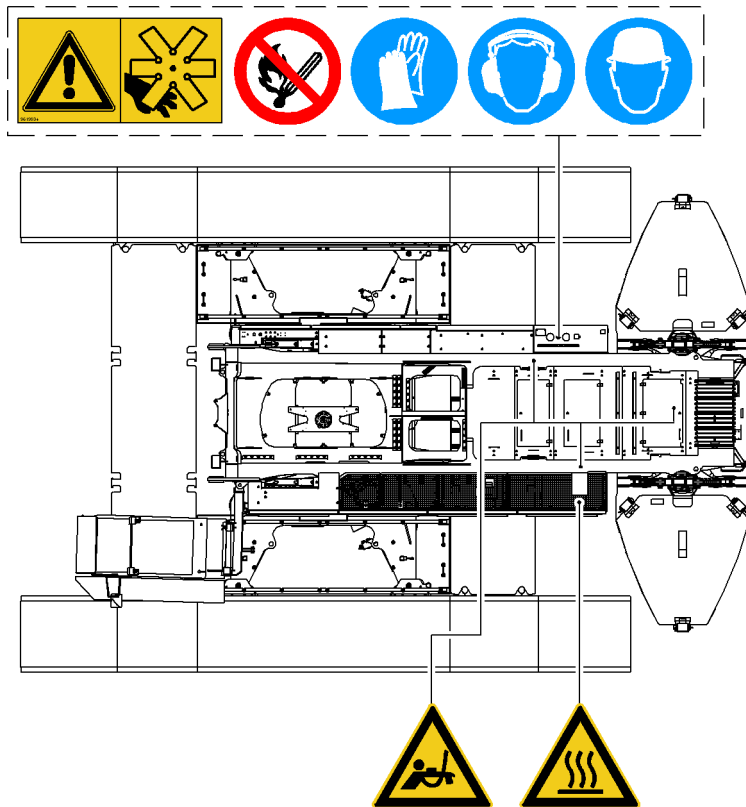


Fig. 604: Safety signs on the top of the machine

LWN/LR-x/V04.01//Auslieferung/2016-03-07/en

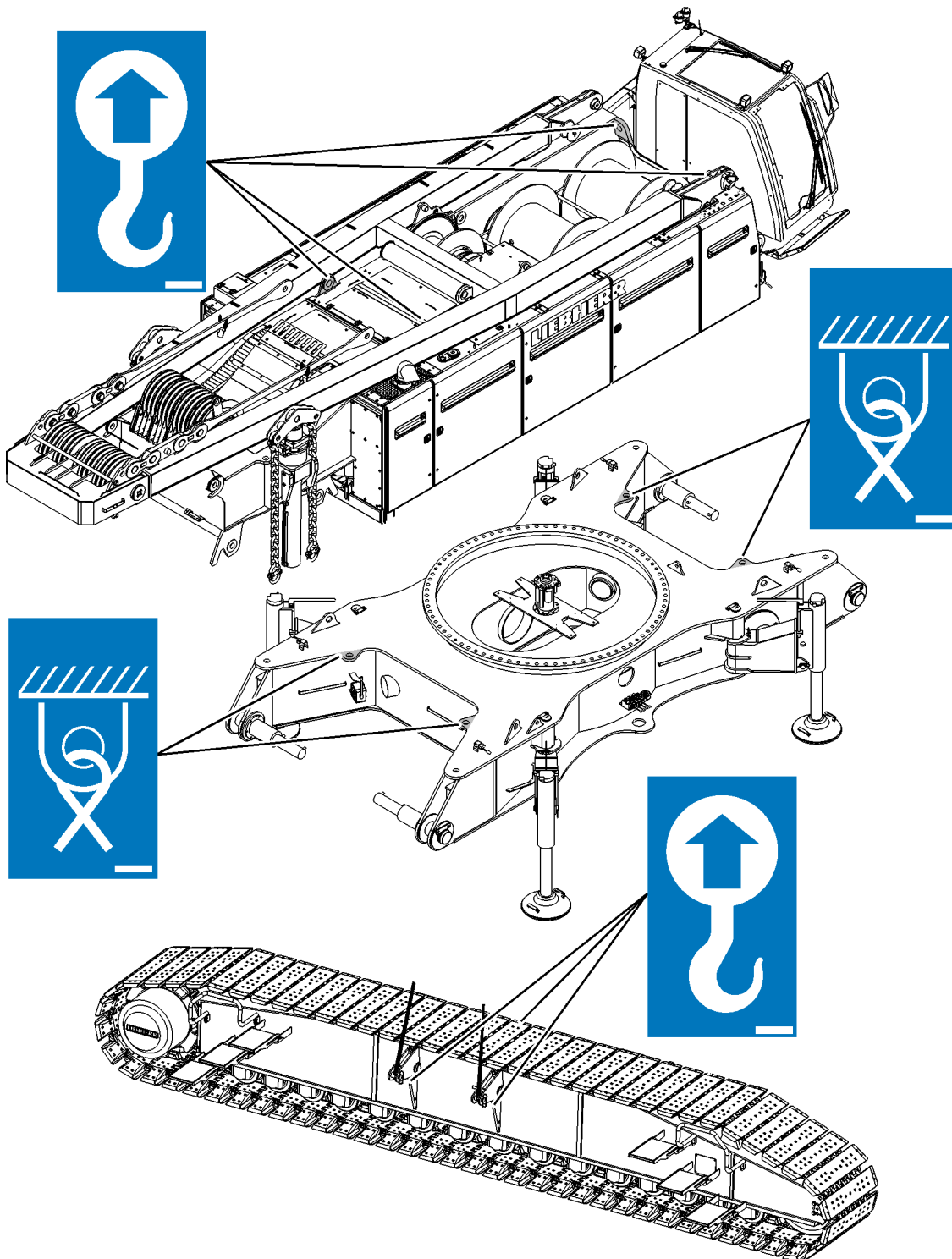


Fig. 605: Labelling of lashing points and rigging points for undercarriage with fixed track width

LWNLR.x/V04.01//Auslieferung/2016-03-07/en

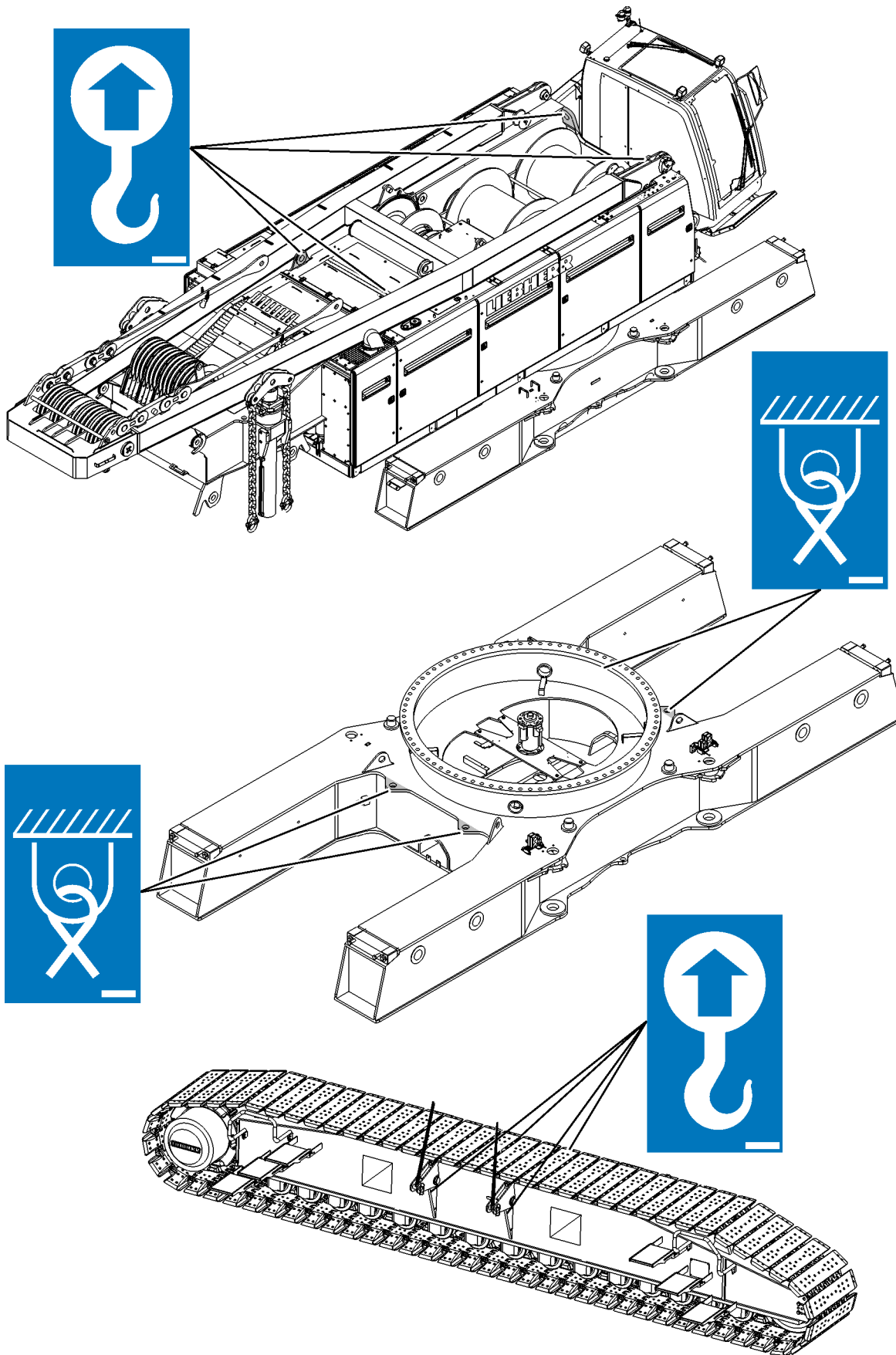


Fig. 606: Labelling of lashing points and rigging points for undercarriage* with adjustable track width

LWNLR-x/V04.01//Auslieferung/2016-03-07/en

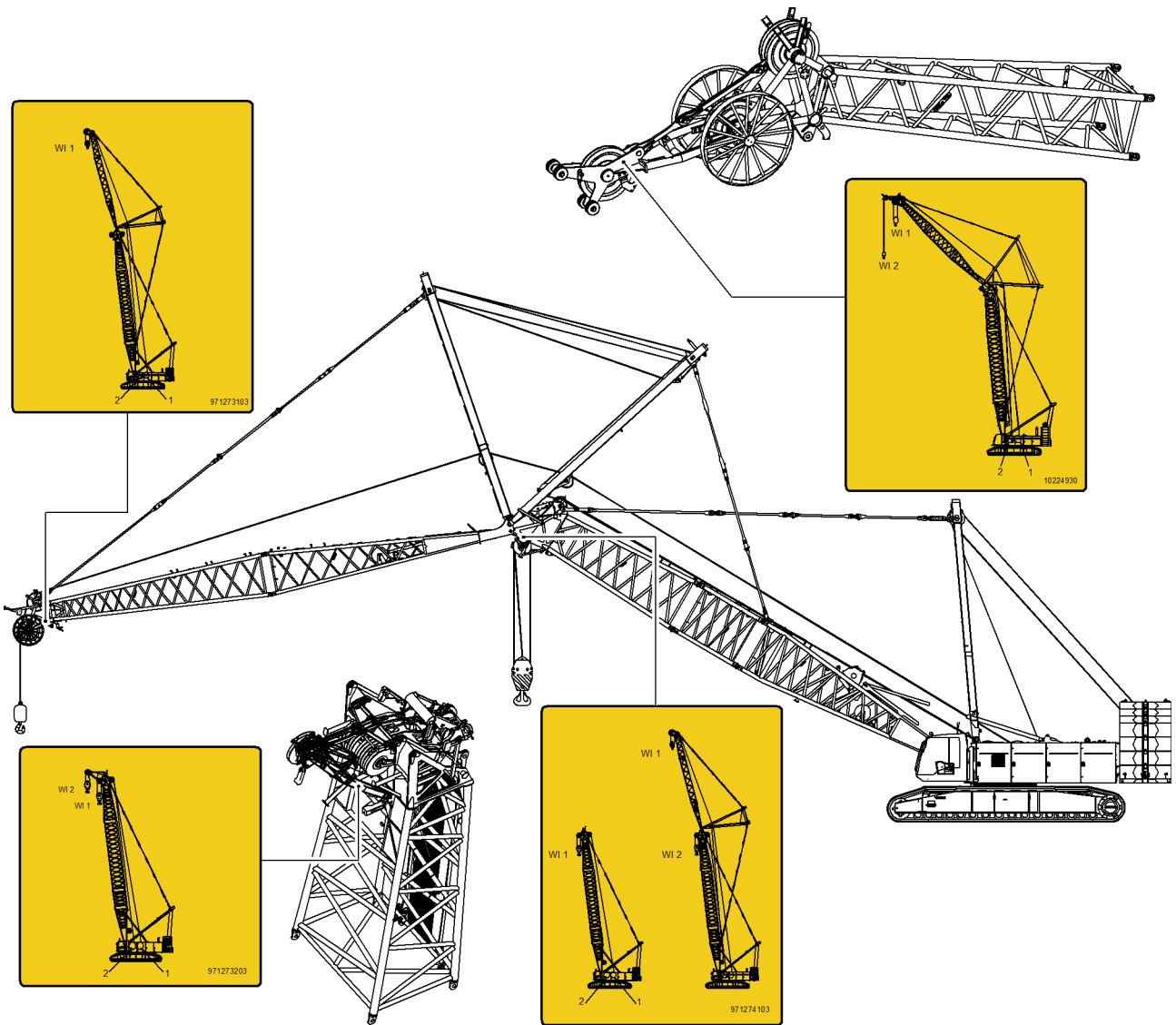


Fig. 607: Safety signs on boom

LWNLR-x/V04.01//Auslieferung/2016-03-07/en

Safety instructions

Safety signs on the machine (US market)

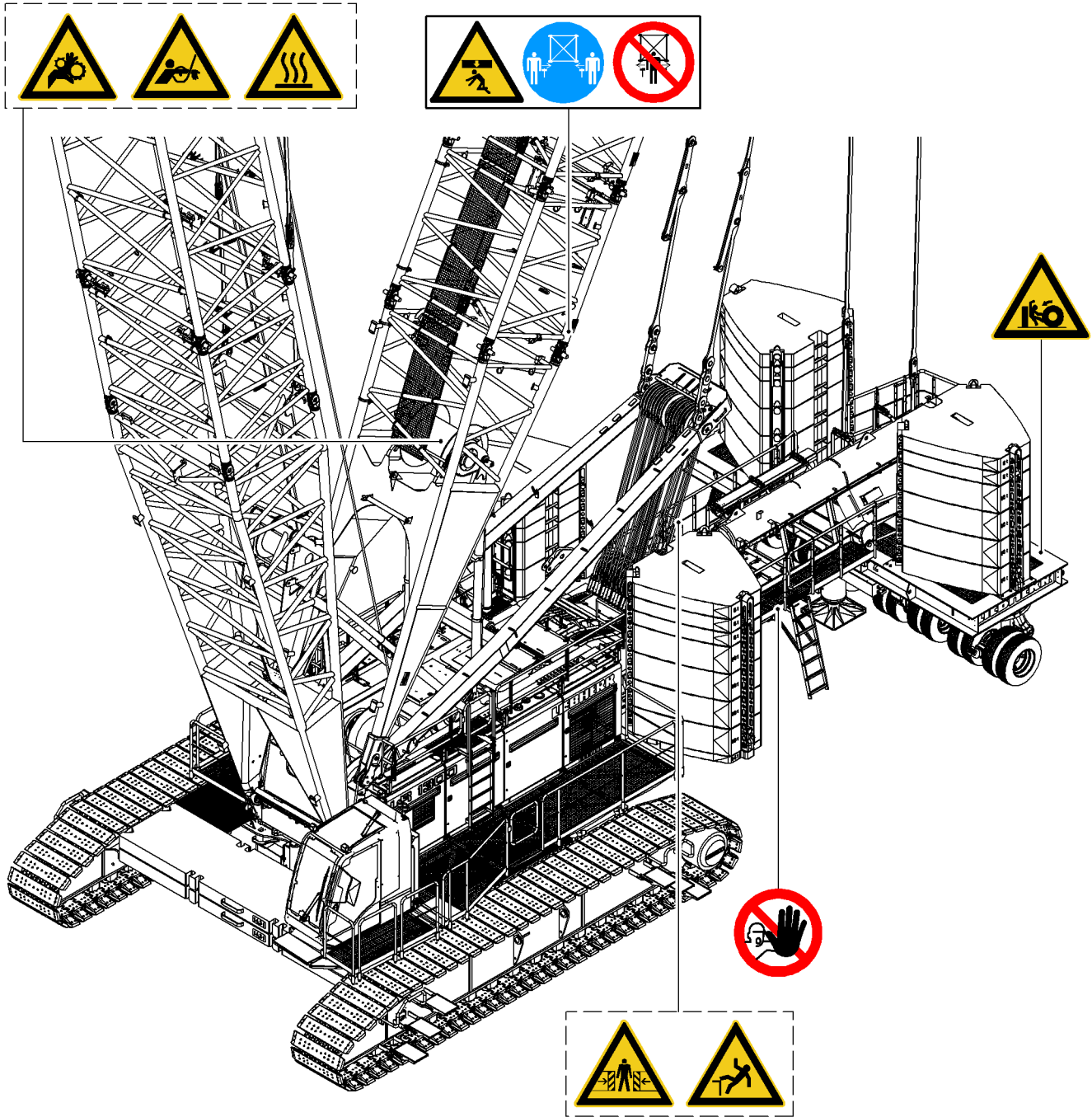


Fig. 608: Safety signs on machine with derrick equipment*

LWNLR-x\04.01\Auslieferung\2016-03-07\en

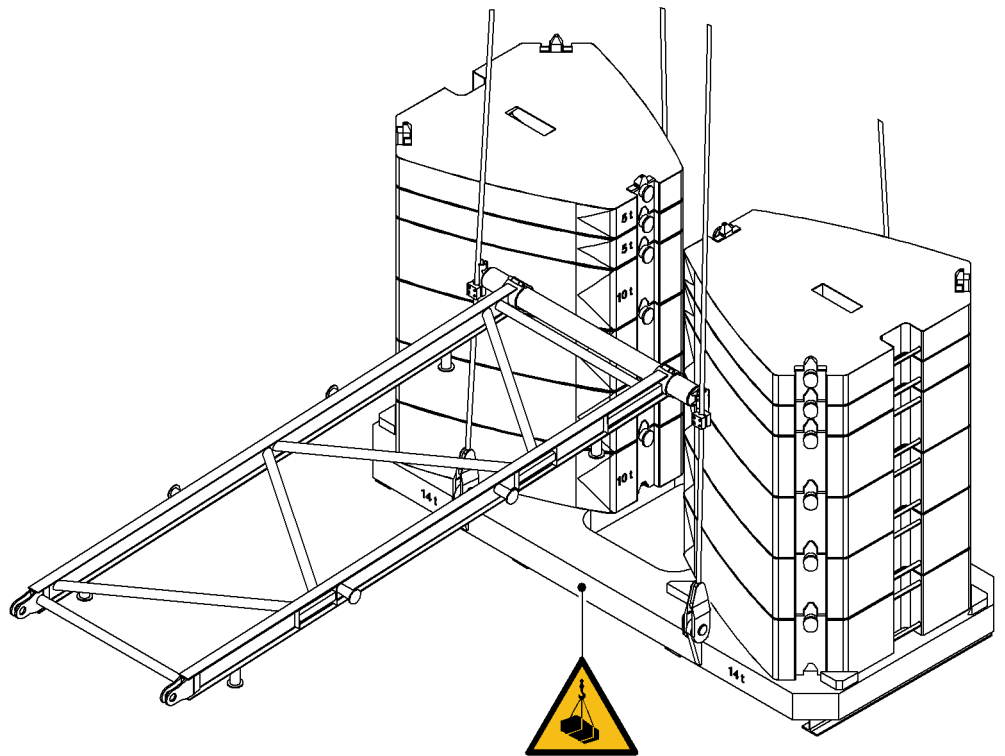


Fig. 609: Safety signs on suspended counterweight of derrick equipment*

The warning sign on the suspended counterweight is attached on all sides of the counterweight frame.

2.9 Meaning of the safety signs

Safety signs are divided into different groups that differ with respect to shape and colour.

2.9.1 Mandatory signs

Characteristics of instruction signs:

- Round
- No rim
- Blue background
- White pictogram

Instruction signs indicate safety-relevant behavior.

General mandatory signs



Observe operation manual





Use hearing protection



Use eye protection



Use foot protection



Use hand protection



Use protective clothing



Use face protection



Use head protection



Use safety harness



Use restraint system

2.9.2 Prohibition signs

Characteristics of prohibition signs:

- Round
- Red rim
- Red diagonal bar
- White background
- Black pictogram

Prohibition signs prohibit behavior that causes danger.

General prohibition signs





Smoking prohibited



Fire, open ignition sources and smoking prohibited



Pedestrians forbidden



Prohibited for ground conveyors



Access for persons with pacemakers or implanted defibrillators prohibited



No access for unauthorised personnel



Entering the area prohibited



Switching prohibited



Do not lift load



No climbing for unauthorised personnel



High-pressure cleaning prohibited



Transport of persons prohibited

2.9.3 Warning signs

Characteristics of warning signs:

- Triangular

- Black rim
- Yellow background
- Black pictogram

Warning signs indicate risks or hazards.

General warning signs



Observe operation manual



Warning of non-ionizing radiation



Warning of obstacles on the ground



Warning of fall hazard



Warning of slipping hazard



Warning of electric voltage



Warning of suspended loads



Warning of hot surfaces



Warning of crushing hazard



Warning of crushing hazard when falling



Warning of hand injuries



Warning of counter-rotating rollers



Warning against staying the swing range



Warning of crushing hazard from above



Warning of crushing hazard from above



Warning of getting rolled over



Warning of getting rolled over



Warning of getting drawn into winches



Warning of dangers through pressure container



Warning of hazards through battery charging



Warning of dangers through hydraulic oil

2.9.4 Rescue signs

Features of rescue signs:

- Square
- No frame
- Green background
- White pictogram

Rescue signs mark the locations of first aid equipment and emergency exits.



First aid



Emergency exit



Emergency exit

2.9.5 Fire protection signs

Characteristics of fire protection signs:

- Square
- No rim
- Red background
- White pictogram

Fire protection signs mark the location of fire alarms or fire extinguishing equipment.



Fire extinguishers



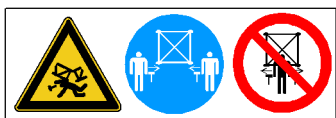
Fire detector

2.10 Meaning of machine-specific signs

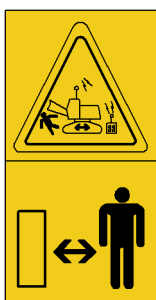
2.10.1 Safety signs



Warning indicating rotating machine parts



Do not stand inside the boom sections



Keep your distance to the machine if it is operated with the radio remote control



Lifting load using the rope reeving winch is prohibited



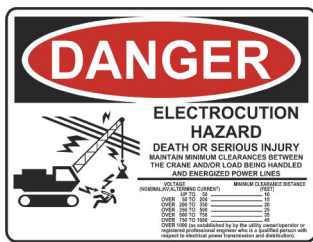
No access for unauthorised personnel



Danger of crushing



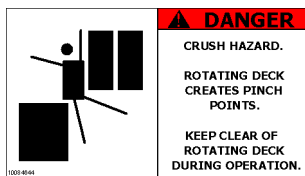
Standing within the slewing range is prohibited



Warning indicating dangerous electrical voltage



Warning indicating dangerous electrical voltage



Standing within the slewing range is prohibited

2.10.2 Notice signs



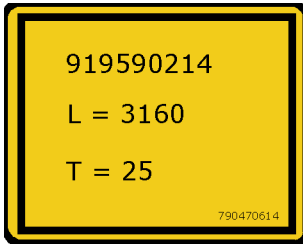
Fuel up with diesel



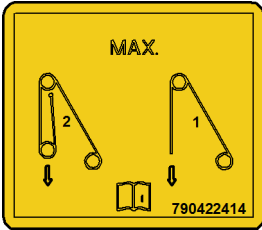
Prior to fueling turn off auxiliary heating* and external air conditioning system*

Safety instructions

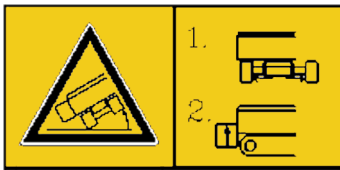
Meaning of machine-specific signs



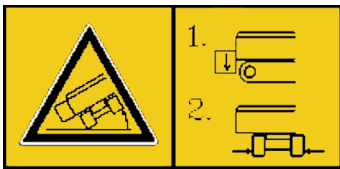
Technical data falling-back supports



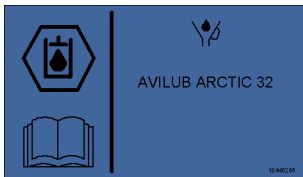
Observe auxiliary jib reeving



Caution danger of toppling



Caution danger of toppling



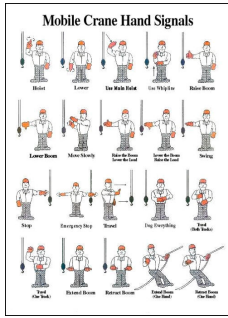
Initial filling of hydraulic oil



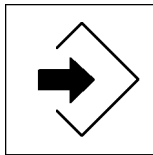
Designed and tested in accordance with ANSI B 30.5



Guaranteed sound output level L_{WA} of machine



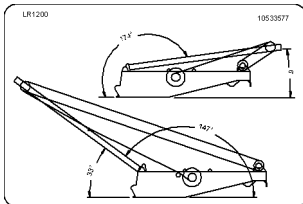
Hand signs in acc. with ASME/ANSI B30.5



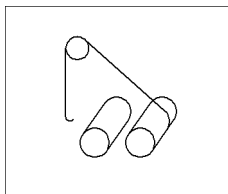
Data recording



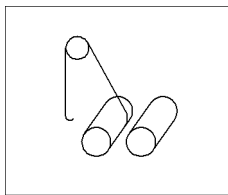
Liebherr data recording



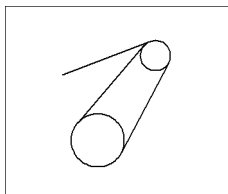
Angle limitation A-frame1



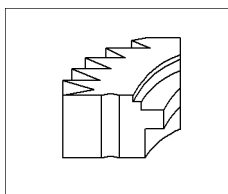
Grease nipple - winch 1



Grease nipple - winch 2



Grease nipple - main boom winch

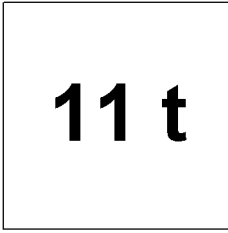


Grease nipple - swing ring

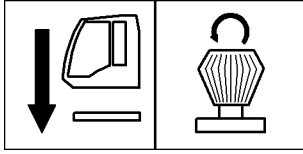
LWNLR_x/V04.01//Auslieferung/2016-03-07/en

Safety instructions

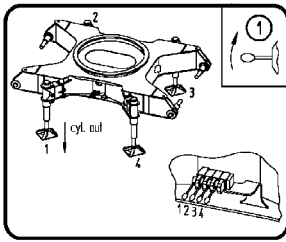
Meaning of machine-specific signs



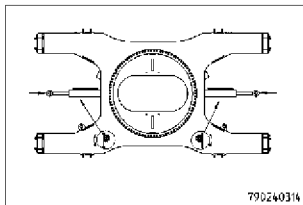
Weight details stops



Emergency lowering valve cabin elevation



Support cylinder undercarriage

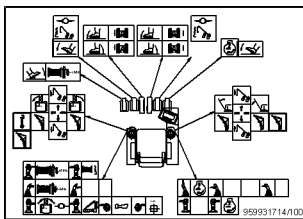


Track width adjustment cylinder undercarriage

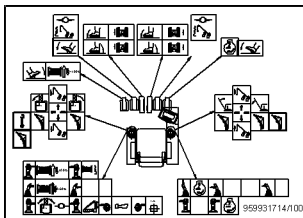
-20 °C	0 °C	+20 °C	+40 °C
100bar	110bar	120bar	130bar
-4 °F	32 °F	68 °F	104 °F
1450 PSI	1595 PSI	1740 PSI	1885 PSI

790360214

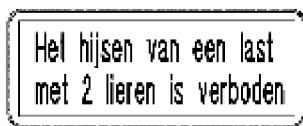
Pressure store jib



Pictogram cross control lever



Pictogram double T-control lever



Operation with both booms



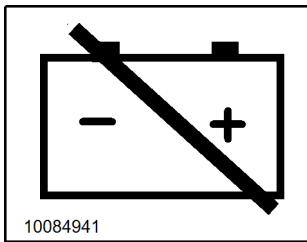
Lifting point



Lashing points



Only use synthetic round slings here



Main battery switch

2.11 Hazards

2.11.1 Mechanical action



WARNING

Mechanical actions due to moving machinery!

When operating the machine, numerous hazards and situations can arise that can cause life-threatening injuries.

- ▶ Observe handling and situation-specific safety notes.



Note

Observe the following safety notes:

- ▶ Wear suitable personal protective equipment.
- ▶ Only work on non-moving parts.

Examples of mechanical actions:



Standing under a suspended load.



Danger of being drawn in by moving drive units or machine parts.



Danger of falling when working without safety gear.



Danger of crushing due to unsecured components such as doors or sliding elements.



First aid

1. Protection/personal safety
 - Identify - what is the nature of the emergency?
 - Think - what are the dangers for the injured party or the helper?
 - Act - make the situation safe.
2. Emergency call
3. Emergency life-saving measures
 - Recovery position
 - Cardiac massage, artificial respiration and defibrillation
 - Staunch bleeding, shock prevention
4. Additional first aid

2.11.2 Electrical energy



WARNING

Electricity in conductive machine parts!

- ▶ Observe handling and situation-specific safety notes.



Note

Observe the following safety notes:

- ▶ Only carry out work with the electrical supply switched off.
- ▶ Secure the machine to prevent unauthorised startup.

Examples of electrical energy:

- External power supply
- Generator



WARNING

Live machine parts!
risk of electric shock.

- ▶ Before recovering an injured party ensure that there is no further risk of electrocution.



First aid

1. Protection/personal safety
 - Identify - what is the nature of the emergency?
 - Think - what are the dangers for the injured party or the helper?
 - Act - make the situation safe.
2. Emergency call
3. Emergency life-saving measures
 - Recovery position
 - Cardiac massage, artificial respiration and defibrillation
 - Staunch bleeding, shock prevention
4. Additional first aid



Note

- ▶ Seek medical attention after electrical accidents. The person affected may experience symptoms of an irregular heartbeat some time after the accident.

2.11.3 Hydraulic energy



WARNING

Escaping hydraulic oil under high pressure!
Leakages in hydraulic lines can cause injuries to skin, destroy tissue and can cause blood poisoning due to the high pressures involved.

- ▶ Observe handling and situation-specific safety notes.



Note

Observe the following safety notes:

- ▶ Repairs to hydraulic systems may only be carried out by qualified technicians with specialised knowledge and experience of hydraulics.
- ▶ Before starting work ensure that the whole system has been depressurised.
- ▶ Never attempt to locate the leakage point with your hand or other part of the body
- ▶ Damaged hydraulic components must be replaced immediately with original Liebherr spare parts.

Examples of hydraulic energy:



Tissue damage from leaks.



Sepsis from hydraulic oil entering bloodstream.



First aid

1. Protection/personal safety
 - Identify - what is the nature of the emergency?
 - Think - what are the dangers for the injured party or the helper?
 - Act - make the situation safe.
2. Emergency call

3. Emergency life-saving measures
 - Recovery position
 - Cardiac massage, artificial respiration and defibrillation
 - Staunch bleeding, shock prevention
4. Additional first aid
 - Gently cover injured area(s) with a sterile anti-bacterial bandage.
 - Rinse eyes with pure drinking water.

2.11.4 Burns



CAUTION

Contact with hot surfaces and consumables!
High surface and equipment temperatures can lead to burns or scalding.

- ▶ Observe handling and situation-specific safety notes.



Note

Observe the following safety notes:

- ▶ Always wear suitable protective gloves when working on hot components.
- ▶ Only carry out work on the machine after it has cooled down and is stopped.

Examples of burns and scalding:



Burns from contact with the entire drive system.



Scalding from steam exiting from the cooling system or hydraulic oil from the drive system.



First aid

1. Protection/personal safety
 - Identify - what is the nature of the emergency?
 - Think - what are the dangers for the injured party or the helper?
 - Act - make the situation safe.
2. Emergency call
3. Emergency life-saving measures
 - Recovery position
 - Cardiac massage, artificial respiration and defibrillation
 - Staunch bleeding, shock prevention
4. Additional first aid

With first-degree burns (redness of the skin):

 - Cool the affected body part by rinsing with cold fresh water.
 - Gently cover injured area(s) with a sterile anti-bacterial bandage.

With second-degree burns (blisters on the skin):

 - Cool the affected body part by rinsing with cold fresh water.
 - Gently cover the area using a sterile anti-bacterial bandage. Do not apply pressure.

With third-degree burns (charring of the skin and tissue):

 - Gently cover the area using a sterile anti-bacterial bandage. Do not apply pressure.

2.11.5 Chemical burns



CAUTION

Contact with corrosive consumables!

Acids and bases cause chemical burns to skin and tissue, and blindness if they come in contact with the eye.

Acids and bases will damage clothing.

- ▶ Observe handling and situation-specific safety notes.



Note

Observe the following safety notes:

- ▶ When working with acids always wear suitable safety goggles or face protection, protective clothing and gloves.

Examples of chemical burns:



Chemical burns from handling acidic consumables.



Chemical burns from leaking battery acid.



First aid

1. Protection/personal safety
 - Identify - what is the nature of the emergency?
 - Think - what are the dangers for the injured party or the helper?
 - Act - make the situation safe.
2. Emergency call
3. Emergency life-saving measures
 - Recovery position
 - Cardiac massage, artificial respiration and defibrillation
 - Staunch bleeding, shock prevention
4. Additional first aid
 - Removing clothing from injured body parts.
 - Rinse injured areas with drinking water.
 - Gently cover the area with a sterile anti-bacterial bandage.

2.11.6 Fire and explosion



WARNING

No fire, naked flames or electrostatic discharges!

Danger of fire and danger of explosion due to easily flammable operating materials or gas mixtures resulting from these.

- ▶ Observe handling-specific and situation-specific safety notes.



WARNING

Improper handling of the machine in dusty environments (e.g. dust formation when unloading bulk goods)!
Increased risk of fire.

- ▶ Make sure that the operator prevents dust formation through technical or organizational measures.
- ▶ Shorten cleaning intervals and maintenance intervals.



Note

Observe the following safety notes:

- ▶ Do not store any flammable materials or carry them in the machine, only in fire-proof containers.
- ▶ Wipe any spilled diesel fuel off the machine and neutralise it on the ground with bonding agents
- ▶ Do not clean the machine with flammable fluids.
- ▶ Do not store any cleaning cloths in the engine compartment and remove flammable residues, e.g. oil spills, coal dust and paper residues.
- ▶ Only fuel up the machine in a well-ventilated place or ensure fresh air supply.
- ▶ Make sure there is good metallic contact between the pump nozzle and the filler neck during refuelling. If possible, ground the machine at the fuelling station while it is being refuelled.
- ▶ No open fire when handling flammable materials.

Examples for dangers of fire and dangers of explosion:



Escaped fuel is a fire hazard.



- Detonating gas in combination with a spark when charging or discharging batteries.
- Vapourised fuel in combination with an electrostatic discharge between the machine and the fuel rig.



First aid

1. Protection/personal safety
 - Identify - what is the nature of the emergency?
 - Think - what are the dangers for the injured party or the helper?
 - Act - make the situation safe.
2. Emergency call
3. Emergency life-saving measures
 - Recovery position
 - Cardiac massage, artificial respiration and defibrillation
 - Staunch bleeding, shock prevention
4. Additional first aid
 - [\(For more information see: 2.11.4 Burns, page 586\)](#)
 - [\(For more information see: 2.12.3 Firefighting, page 603\)](#)

2.11.7 Poisoning and suffocation



WARNING

Inadequate ventilation or fresh air!

Poisonous vapours or other atmospheres hazardous to health can lead to poisoning or suffocation.

- ▶ Observe handling and situation-specific safety notes.



Note

Observe the following safety notes:

- ▶ Ensure adequate ventilation in the cab.
- ▶ Use breathing apparatus when working with hazardous materials.



Examples of poisoning and dangers of asphyxiation:

- Engine exhaust gases contain carbon monoxide and other hazardous gases.
- If the machine is used in areas where hazardous substances are present, contact with hazardous gases is a possibility.
- The refrigerant from the air conditioning system circuit displaces the oxygen in the air.



First aid

1. Protection/personal safety
 - Identify - what is the nature of the emergency?
 - Think - what are the dangers for the injured party or the helper?
 - Act - make the situation safe.
2. Emergency call
3. Emergency life-saving measures
 - Recovery position
 - Cardiac massage, artificial respiration and defibrillation
 - Staunch bleeding, shock prevention
4. Additional first aid

2.11.8 Electromagnetic influence



WARNING

Electromagnetic influence when the machine is deployed near transmitting stations, radar stations or directional radio systems!

Malfunions or failure of electronic implants (pacemakers).

Malfunction or failure of the control system.

- ▶ Observe handling and situation-specific safety notes.



Note

Observe the following safety notes:

- ▶ The machine must be stopped if there is suspected electromagnetic interference to the controls.



Examples of electromagnetic influence:

- Malfunction or failure of control systems if operating the machine near transmitters, directional radio systems or radar stations.
- Environmental influence through the use of electromagnetic rigging material or integrated radio devices.

2.11.9 Exposure to wind



DANGER

Exposure to wind can have fatal consequences!
Machine toppling over, structural breakdown.

- ▶ Observe handling-specific and situation-specific safety notes.



DANGER

Inadmissible machine operation when exceeding the maximum permitted wind speed according to foreword of the valid load chart!
Machine toppling over, structural breakdown.

- ▶ Make sure that the machine is only operated at admissible wind speeds.
- ▶ In case of higher wind speeds, reduce load, put boom into parked position, lay boom down (For more information see: [6.7 Restrictions due to exposure to wind, page 1077](#)).



Note

Observe the following safety notes:

- ▶ Make sure that each lifting operation is planned and performed by trained and experienced personnel.
- ▶ Prior to each load, carefully determine and consider the geometric form factor (air resistance factor) and the projection of the streamed surface.
- ▶ Observe that the wind speed is entered squared in the calculation of the wind load. A slight increase of the wind speed results in an enormous increase of the wind load.
- ▶ Keep in mind that cat walks fitted to boom sections magnify the wind load.
- ▶ Note that the wind speed, shape and size of the load have an essential influence on the stability and load of the machine (see: [tab. 342, page 595](#)).
- ▶ Inform yourself about wind conditions at the work site (ground profiles and building profiles, areas with slipstream, meteorological data, relevant ambient conditions) as well as weather forecasts for the planned working time and take these into consideration.
- ▶ Inform yourself about the weather report and the current wind speed at the site where the machine is operating before starting work. If excessive wind speeds are expected within the next few hours, work must not start and precautions must be taken to protect against storm damage.
- ▶ Observe admissible wind speeds and the prescribed reductions of the load in the foreword of the valid load chart.
- ▶ Note that the area exposed to wind of the load considered in the load calculation is 1.2 m²/t (cw value as factor already considered). If the load's area that is exposed to wind is larger: Calculate maximum permissible wind speed (see: [fig. 724, page 594](#)) or contact Liebherr customer service. Loads may not be picked up until this evaluation has been performed.
- ▶ Check current wind speed on the monitor in the cabin.
- ▶ Watch out for dangerous gusts of wind during operation.
- ▶ Hoist the loads slowly and carefully and do not let them become unstable.

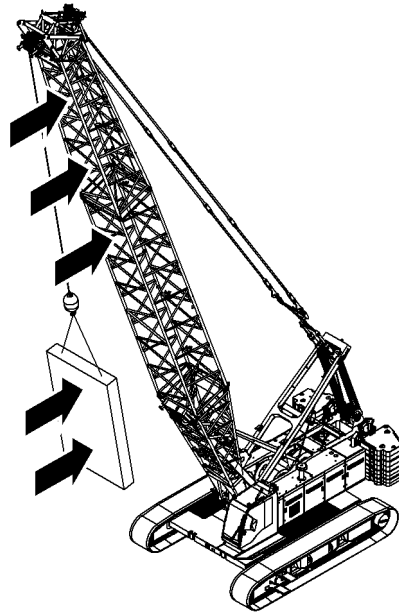


Fig. 721: Exposure to wind on the front of the machine and the load (illustration of principle)

Exposure to wind on the front of the machine and the load has the following effects:

- reduced stability of the machine.
- Higher risk of machine toppling.
- With maximum main boom angle without load, tilting-back supports may be overstrained and main boom may be destroyed.
- Load swings and damages or destroys main boom.

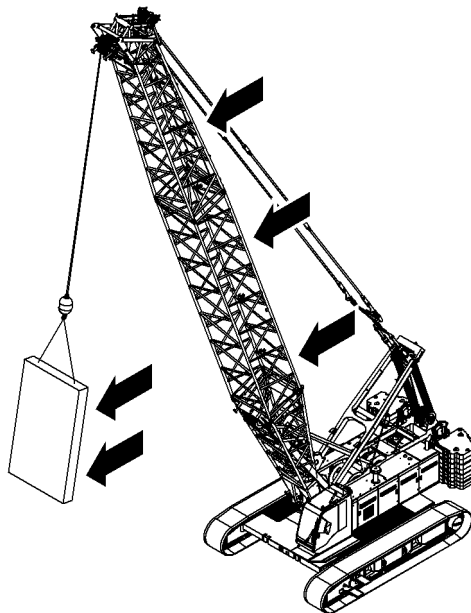


Fig. 722: Exposure to wind on the rear of the machine and the load (illustration of principle)

Exposure to wind on the rear of the machine and the load has the following effects:

- reduced stability of the machine.
- Higher risk of machine toppling.
- Wind load behaves like an additional load on the load hook or pulley block.
- Pivoting radius becomes larger.

- Load swings and damages or destroys main boom.

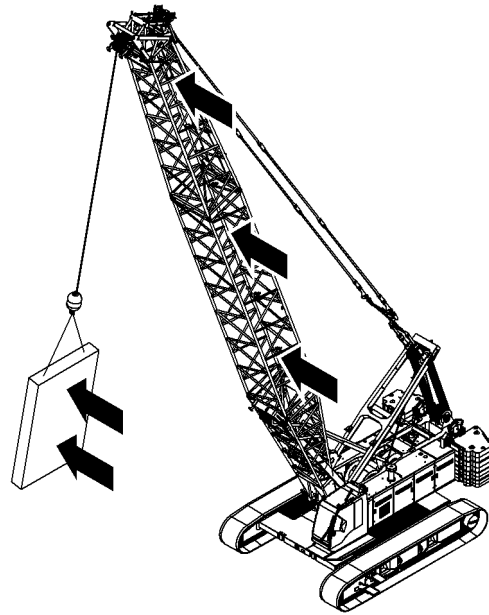


Fig. 723: Exposure to wind on the side of the machine and the load (illustration of principle)

Exposure to wind on one side of the machine and the load has the following effects:

- reduced stability of the machine.
- Higher risk of machine toppling.
- Additional diagonal pull is generated.
- Failure of main boom structure.
- Load swings and damages or destroys main boom.



Note

For rough estimation of the wind speed at maximum boom height:

- ▶ Ask the weather office in charge for the maximum wind speed to be expected.
- ▶ Note that the wind speeds provided by the weather office are averaged values measured at a height of 10 m (32' 10" ft-in).
- ▶ Determine the 3 second wind gust speed at maximum boom height with averaged values by the weather office and the following chart.
- ▶ Make sure that the machine is only operated at permissible wind speeds in accordance with the foreword of the load chart.

Beaufort degree	3	4	5	6	7	8	9	10
v(d) ^{A)}	5.4 m/s 17.72 ft/s	7.9 m/s 25.92 ft/s	10.7 m/s 35.1 ft/s	13.8 m/s 45.28 ft/s	17.1 m/s 56.1 ft/s	20.7 m/s 67.91 ft/s	24.4 m/s 80.05 ft/s	28.4 m/s 93.18 ft/s
z ^{B)}	v(z) ^{C)}							
10 m 32' 10" ft-in	7.6 m/s 24.93 ft/s	11.1 m/s 36.42 ft/s	15.0 m/s 49.21 ft/s	19.3 m/s 63.32 ft/s	23.9 m/s 78.41 ft/s	29.0 m/s 95.14 ft/s	34.2 m/s 112.2 ft/s	39.8 m/s 130.58 ft/s
20 m 65' 7" ft-in	8.1 m/s 26.57 ft/s	11.9 m/s 39.04 ft/s	16.1 m/s 52.82 ft/s	20.7 m/s 67.91 ft/s	25.7 m/s 84.32 ft/s	31.1 m/s 102.03 ft/s	36.6 m/s 120.08 ft/s	42.7 m/s 140.09 ft/s

LWN/LR-x/V04.01//Auslieferung/2016-03-07/en

Beaufort degree	3	4	5	6	7	8	9	10
v(d)^{A)}	5.4 m/s 17.72 ft/s	7.9 m/s 25.92 ft/s	10.7 m/s 35.1 ft/s	13.8 m/s 45.28 ft/s	17.1 m/s 56.1 ft/s	20.7 m/s 67.91 ft/s	24.4 m/s 80.05 ft/s	28.4 m/s 93.18 ft/s
z^{B)}	v(z)^{C)}							
30 m 98' 5" ft-in	8.5 m/s 27.89 ft/s	12.4 m/s 40.68 ft/s	16.8 m/s 55.12 ft/s	21.6 m/s 70.87 ft/s	26.8 m/s 87.93 ft/s	32.4 m/s 106.3 ft/s	38.2 m/s 125.33 ft/s	44.5 m/s 146 ft/s
40 m 131' 3" ft-in	8.7 m/s 28.54 ft/s	12.8 m/s 41.99 ft/s	17.3 m/s 56.76 ft/s	22.3 m/s 73.16 ft/s	27.6 m/s 90.55 ft/s	33.4 m/s 109.58 ft/s	39.4 m/s 129.27 ft/s	45.8 m/s 150.26 ft/s
50 m 164' ft-in	8.9 m/s 29.2 ft/s	13.1 m/s 42.98 ft/s	17.7 m/s 58.07 ft/s	22.8 m/s 74.8 ft/s	28.3 m/s 92.85 ft/s	34.2 m/s 112.2 ft/s	40.3 m/s 132.22 ft/s	46.9 m/s 153.87 ft/s
60 m 196' 10" ft-in	9.1 m/s 29.86 ft/s	13.3 m/s 43.64 ft/s	18.0 m/s 59.06 ft/s	23.3 m/s 76.44 ft/s	28.8 m/s 94.49 ft/s	34.9 m/s 114.5 ft/s	41.1 m/s 134.84 ft/s	47.9 m/s 157.15 ft/s
70 m 229' 8" ft-in	9.3 m/s 30.51 ft/s	13.5 m/s 44.29 ft/s	18.3 m/s 60.04 ft/s	23.6 m/s 77.43 ft/s	29.3 m/s 96.13 ft/s	35.5 m/s 116.47 ft/s	41.8 m/s 137.14 ft/s	48.7 m/s 159.78 ft/s
80 m 262' 6" ft-in	9.4 m/s 30.84 ft/s	13.7 m/s 44.95 ft/s	18.6 m/s 61.02 ft/s	24.0 m/s 78.74 ft/s	29.7 m/s 97.44 ft/s	36.0 m/s 118.11 ft/s	42.4 m/s 139.11 ft/s	49.4 m/s 162.07 ft/s
90 m 295' 3" ft-in	9.5 m/s 31.17 ft/s	13.9 m/s 45.6 ft/s	18.8 m/s 61.68 ft/s	24.3 m/s 79.72 ft/s	30.1 m/s 98.75 ft/s	36.4 m/s 119.42 ft/s	42.9 m/s 140.75 ft/s	50.0 m/s 164.04 ft/s
100 m 328' 1" ft-in	9.6 m/s 31.5 ft/s	14.1 m/s 46.26 ft/s	19.1 m/s 62.66 ft/s	24.6 m/s 80.71 ft/s	30.4 m/s 99.74 ft/s	36.9 m/s 121.06 ft/s	43.4 m/s 142.39 ft/s	50.6 m/s 166.01 ft/s
110 m 360' 11" ft-in	9.7 m/s 31.82 ft/s	14.2 m/s 46.59 ft/s	19.2 m/s 62.99 ft/s	24.8 m/s 81.36 ft/s	30.8 m/s 101.05 ft/s	37.2 m/s 122.05 ft/s	43.9 m/s 144.03 ft/s	51.1 m/s 167.65 ft/s
120 m 393' 8" ft-in	9.8 m/s 32.15 ft/s	14.3 m/s 46.92 ft/s	19.4 m/s 63.65 ft/s	25.1 m/s 82.35 ft/s	31.1 m/s 102.03 ft/s	37.6 m/s 123.36 ft/s	44.3 m/s 145.34 ft/s	51.6 m/s 169.29 ft/s
130 m 426' 6" ft-in	9.9 m/s 32.48 ft/s	14.5 m/s 47.57 ft/s	19.6 m/s 64.3 ft/s	25.3 m/s 83.01 ft/s	31.3 m/s 102.69 ft/s	37.9 m/s 124.34 ft/s	44.7 m/s 146.65 ft/s	52.0 m/s 170.6 ft/s
140 m 459' 4" ft-in	10.0 m/s 32.81 ft/s	14.6 m/s 47.9 ft/s	19.8 m/s 64.96 ft/s	25.5 m/s 83.66 ft/s	31.6 m/s 103.67 ft/s	38.2 m/s 125.33 ft/s	45.1 m/s 147.97 ft/s	52.5 m/s 172.24 ft/s
150 m 492' 2" ft-in	10.0 m/s 32.81 ft/s	14.7 m/s 48.23 ft/s	19.9 m/s 65.29 ft/s	25.7 m/s 84.32 ft/s	31.8 m/s 104.33 ft/s	38.5 m/s 126.31 ft/s	45.4 m/s 148.95 ft/s	52.9 m/s 173.56 ft/s
160 m 524' 11" ft-in	10.1 m/s 33.14 ft/s	14.8 m/s 48.56 ft/s	20.1 m/s 65.94 ft/s	25.9 m/s 84.97 ft/s	32.1 m/s 105.31 ft/s	38.8 m/s 127.3 ft/s	45.7 m/s 149.93 ft/s	53.2 m/s 174.54 ft/s
170 m	10.2 m/s 33.46 ft/s	14.9 m/s 48.88 ft/s	20.2 m/s 66.27 ft/s	26.0 m/s 85.3 ft/s	32.3 m/s 105.97 ft/s	39.1 m/s 128.28 ft/s	46.0 m/s 150.92 ft/s	53.6 m/s 175.85 ft/s
180 m	10.3 m/s 33.79 ft/s	15.0 m/s 49.21 ft/s	20.3 m/s 66.6 ft/s	26.2 m/s 85.96 ft/s	32.5 m/s 106.63 ft/s	39.3 m/s 128.94 ft/s	46.3 m/s 151.9 ft/s	53.9 m/s 176.84 ft/s
190 m	10.3 m/s 33.79 ft/s	15.1 m/s 49.54 ft/s	20.4 m/s 66.93 ft/s	26.4 m/s 86.61 ft/s	32.7 m/s 107.28 ft/s	39.5 m/s 129.59 ft/s	46.6 m/s 152.89 ft/s	54.2 m/s 177.82 ft/s
200 m	10.4 m/s 34.12 ft/s	15.2 m/s 49.87 ft/s	20.6 m/s 67.59 ft/s	26.5 m/s 86.94 ft/s	32.8 m/s 107.61 ft/s	39.8 m/s 130.58 ft/s	46.9 m/s 153.87 ft/s	54.6 m/s 179.13 ft/s

Tab. 341: 3 second wind gust speed in dependence of average wind speed according to Beaufort scale and height

A) Wind speed **v(d)** at 10 m (32' 10" ft-in) height (top limit of Beaufort stage) averaged over 10 minutes.

B) Height **z** above level ground.

C) Speed (**v**)**z** of a 3 second wind gust acting at a height of **z** decisive for the calculation.

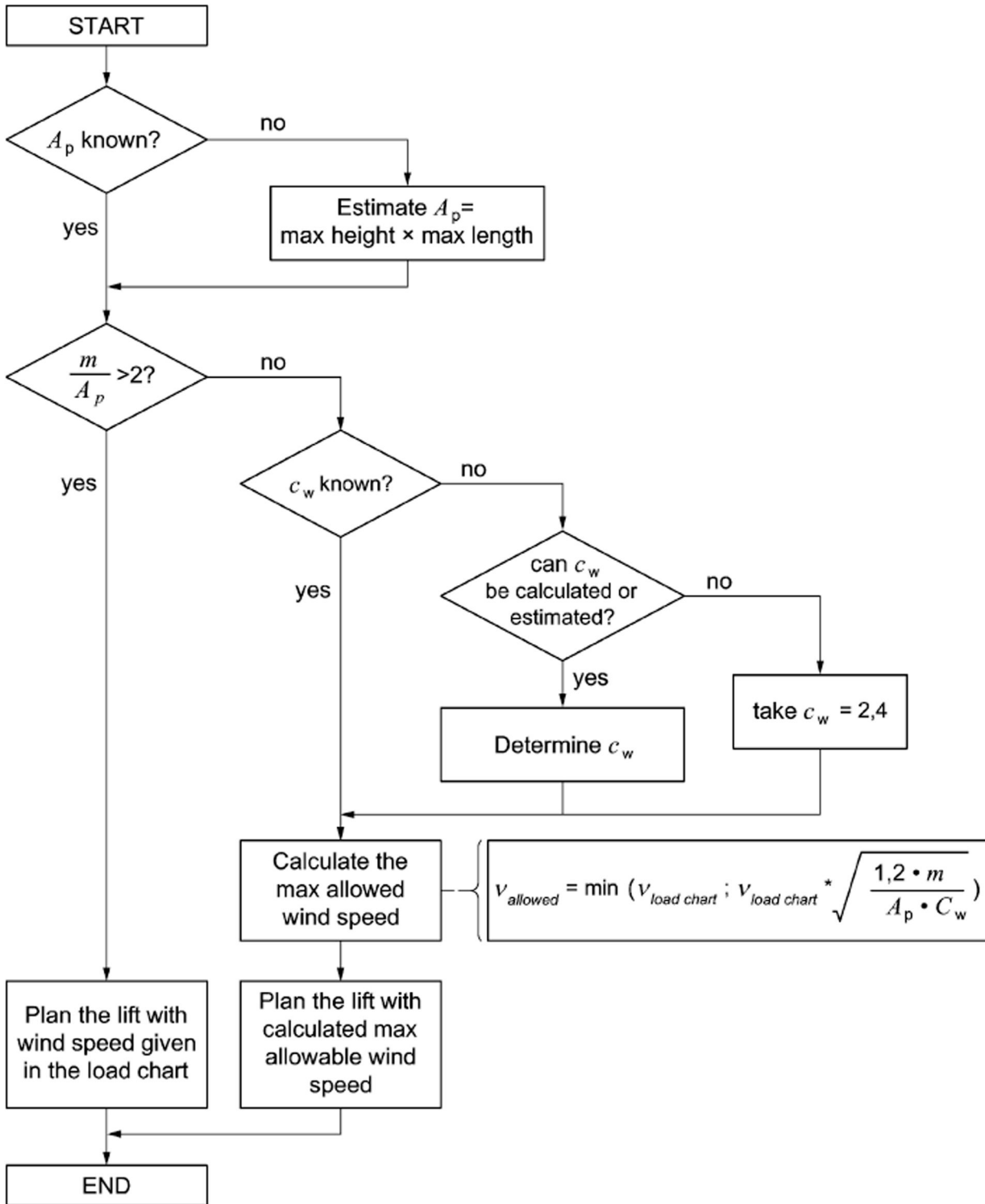


Fig. 724: Simplified method to determine the maximum admissible wind speed in accordance with EN 13000 Appendix N

m Working load

A_p Projected area

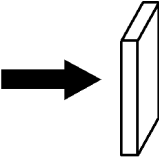
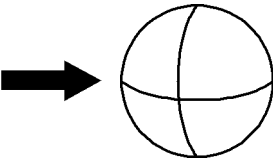
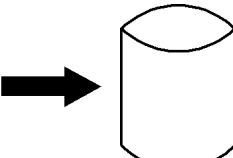
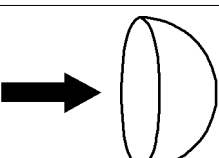
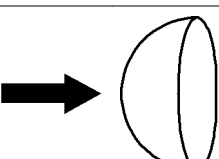
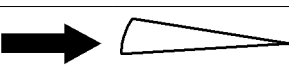
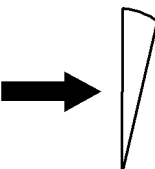
c_w Drag coefficient

v_{allowed} Maximum 3-second wind gust speed on boom head in [m/s]

v_{load chart} Wind speed from the load chart in [m/s]

LWNLR-x\04.01\Auslieferung\2016-03-07\en

The factor 2 (mentioned in the equation $m/A_p > 2$) corresponds to the ratio between the maximum drag coefficient of 2.4 and the usual drag coefficient of 1.2 used for loads.

Shape	Example	Drag coefficient: c_w
	Slab, formwork or sheet pile	1.1 to 2.0
	Sphere, sphere-shaped container	0.3 to 0.4
	Silo, reactor container	0.6 to 1.0
	Semi-sphere	0.8 to 1.2
	Semi-sphere	0.2 to 0.3
	Wind generator blade or complete rotor	0.05 to 0.1
	Wind generator blade or complete rotor	Approximately 1.6

Tab. 342: Typical shapes and the corresponding c_w values in accordance with EN 13000 Appendix N

2.11.10 Snow and ice loads



DANGER

Snow or ice on the machine!
Structural breakdown.

- ▶ Observe handling and situation-specific safety notes.

LWNLR.x/V04.01//Auslieferung/2016-03-07/en



WARNING

Falling chunks of snow and ice!
Serious injury.

- ▶ Make sure that the boom is free of snow and ice.



Note

Observe the following safety notes:

- ▶ Lay down the boom and carefully remove any large accumulations of ice and snow.
- ▶ Remove snow and ice from all sensitive parts like e.g. limit switches and guides.
- ▶ Snow and ice loads increase the boom weight and the area exposed to the wind.
- ▶ Avoid dynamic movement of the load: clear the load of snow and ice.

These factors lead to premature switching off of the Load Moment Limiter (LMB).
Work with the maximum admissible load is no longer possible.

2.11.11 Ground bearing strength



DANGER

Ground has a limited bearing strength!
Machine toppling over.

- ▶ Carry out work planning.
- ▶ Observe handling and situation-specific safety notes.



Note

Observe the following safety notes:

- ▶ Values for permitted ground pressure must be determined by officially-certified specialist engineers.
- ▶ During work planning, calculate the ground pressure exerted when the machine is in use. Observe the values in the valid load chart and/or request the required data from the manufacturer.
- ▶ Use crane mats if necessary.
- ▶ Reinforce the ground if necessary.



DANGER

Improper use of crane mats!
Machine toppling over.

- ▶ Lay crane mats next to each other without any gaps between them.
- ▶ Place digger mats diagonal to the crawler chain.
- ▶ Ensure that the crawler side frames lie fully on the crane mats.

2.11.12 Lightning strike



WARNING

Electric shock from lightning!

Coming into contact with a direct or indirect current flow caused by a voltage flash-over or step voltage can be fatal.

Fall hazard when working at heights.

It can also cause a total loss of control, damage to the electronics or to local welding spots on supports, especially on the swing ring.

- ▶ Observe handling-specific and situation-specific safety notes.



Note

Observe the following safety notes:

- ▶ Lay down the boom before a storm breaks.
- ▶ Disconnect electric lines and main boom base section from uppercarriage.
- ▶ Always stay away from large, free-standing metal parts (e.g. machine) during a thunderstorm.
- ▶ Machines without direct contact between steel structure and ground must be grounded.
- ▶ Only evacuate the cab in the case of fire.

The closed machine operator's cab acts as a Faraday cage. The charge is channeled through the machine and into the ground.

Promptly lay down the boom if any of the following criteria apply:

- On sites that experience frequent storms
- With long boom combinations
- On exposed sites

Measures to take after a lightning strike on the machine has been observed or is suspected:

- Thoroughly inspect the machine paying particular attention to any damaged cables, hoses and ropes.
- Check the operational capability of the control system.
- Slowly move the slewing gear and listen for any unusual noises.
- Inspect the boom for damage.
- Contact Liebherr after sales service.



First aid

1. Protection/personal safety
 - Identify - what is the nature of the emergency?
 - Think - what are the dangers for the injured party or the helper?
 - Act - make the situation safe.
2. Emergency call
3. Emergency life-saving measures
 - Recovery position
 - Cardiac massage, artificial respiration and defibrillation
 - Staunch bleeding, shock prevention
4. Additional first aid
 - [\(For more information see: 2.12.1 How to respond in the event of a current transfer, page 601\)](#)

2.11.13 Overhead power lines



WARNING

Electrical energy and fire hazard!

Coming into contact with a direct or indirect current flow caused by a voltage flash-over or step voltage can be fatal.

- ▶ Observe handling and situation-specific safety notes.



Note

Observe the following safety notes:

- ▶ Inform power supply company before starting work. The power supply company representative issues written approval for setting up and operating the machine.
- ▶ Maintain a safe distance as specified in national guidelines or by a representative from the power supply company.
- ▶ Make sure that the danger zone of the machine does not overlap with the prescribed safety distance.
- ▶ Inform all employees on the site where the machine is to be used about the dangers of electrical voltage.
- ▶ When operating the machine look out for uneven ground as this can reduce the clearance to the power line.
- ▶ Assign a signaller to observe the machine and the line, monitor the safe distance and maintain continuous contact with the machine operator.



Examples of current transfer from overhead power lines:

- Coming into direct contact with an overhead power line.
- If the safety distance is not maintained, an arc will form.
- An overhead power line comes down and a dangerous resistance area forms in the ground around it.

The safety systems of the different national electricity grids react differently in the event of a fault. One may not assume that the overhead power line will be automatically and permanently shut down after a short to earth. A resistance area develops around the machine and/or the damaged overhead power line ([For more information see: 2.12.1 How to respond in the event of a current transfer, page 601](#)).



First aid

1. Protection/personal safety
 - Identify - what is the nature of the emergency?
 - Think - what are the dangers for the injured party or the helper?
 - Act - make the situation safe.
2. Emergency call
3. Emergency life-saving measures
 - Recovery position
 - Cardiac massage, artificial respiration and defibrillation
 - Staunch bleeding, shock prevention
4. Additional first aid
 - ([For more information see: 2.12.1 How to respond in the event of a current transfer, page 601](#))

Guideline values for safe distances from overhead power lines

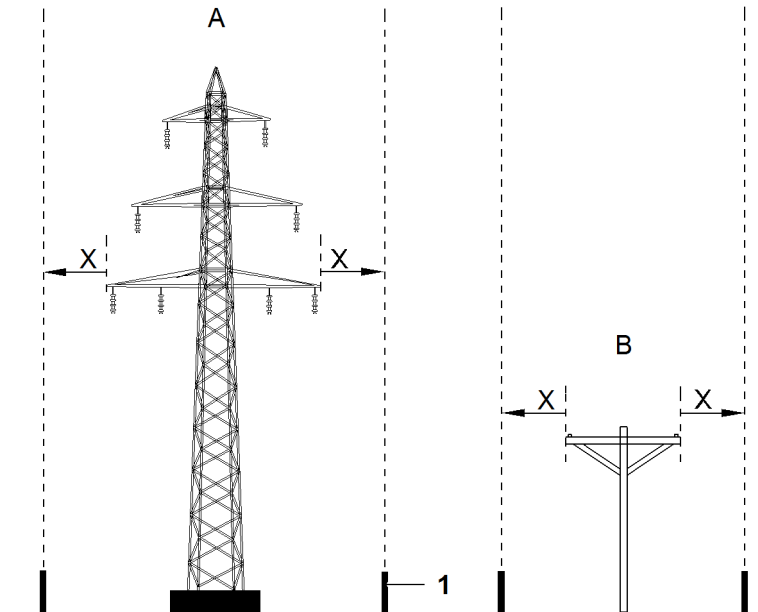


Fig. 742: Overhead power lines (diagram)

- A** High-voltage lines
- B** Low-voltage and medium-voltage lines
- 1** Shut-off

The necessary safe distance depends on the rated mains voltage of the power line. Safety distances to overhead power lines are listed exemplary in ISO 12480-1 and OSHA Part 1926.

These are benchmark values. The respective nationally prescribed safety distances must be observed.

Exact information on nominal line voltage is provided by the power supply company.

Overhead power line		Safe distance X
B	Low-voltage lines	3000 mm 9' 10" ft-in
	Medium-voltage lines	
A	High-voltage lines	6000 mm 19' 8" ft-in

Tab. 343: Safety distances (acc. to ISO 12480-1 Cranes - Safe use)

Nominal line voltage	Safe distance X
up to 350 kV (350 kV)	6100 mm 20 ft
above 350 kV (350 kV)	15250 mm 50 ft

Tab. 344: Safety distances (acc. to Occupational Safety and Health Administration OSHA Part 1926.1408 and 1926.1409)

2.11.14 Environment

NOTICE

Risk of damage to the environment caused by pollutants!

If their release is not controlled, fuels, oils, cleaning agents, coolant, etc. can enter the ground or rivers and cause environmental damage.

- ▶ Observe handling and situation-specific safety notes.
-



Note

Observe the following safety notes:

- ▶ If the machine leaks, immediately collect the escaping liquid and seal the leak.
 - ▶ Bind any spilled liquid with binding agent or neutralise it with suitable agents.
 - ▶ When draining or catching liquids use suitable containers (capacities and resistant to chemicals).
 - ▶ Carry out cleaning work on firm well-drained ground.
 - ▶ Observe the national and international environmental regulations for the disposal of chemicals or waste.
 - ▶ Notify the emergency services and authorities if large amounts of substances that are harmful to the environment escape.
-



Examples of environmental hazards:

- Leakages
- Refilling consumables incorrectly

2.12 What to do in dangerous situations

2.12.1 How to respond in the event of a current transfer

Resistance area, step voltage

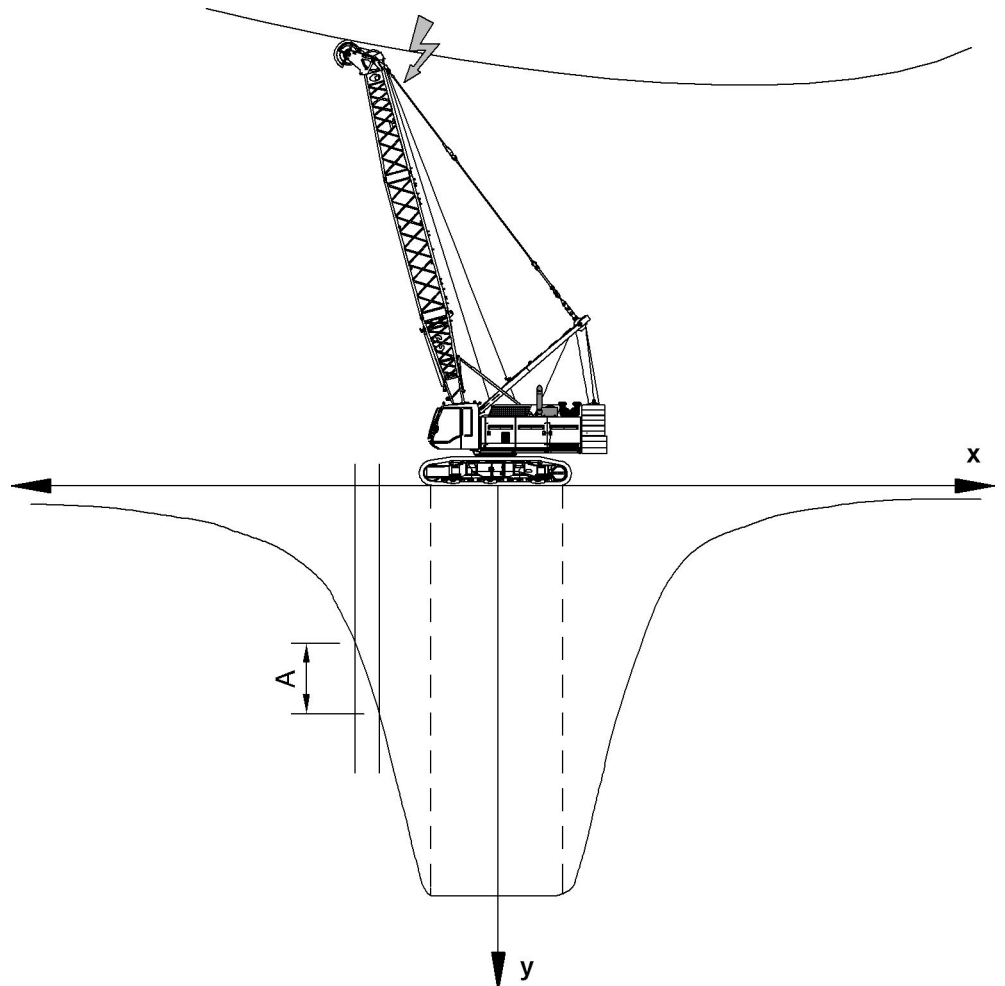


Fig. 744: Resistance area, step voltage

x Extent
y Voltage

A Step voltage

In the event that current is conducted to the machine from coming into contact with a power line, the current is distributed from the point of entry in the earth. The voltage decreases according to a funnel-shaped curve - a resistance area is formed.

The extent of the resistance area depends on:

- Voltage
- Current
- Ground resistance

If a person moves within the resistance area, a potential difference forms between his feet (step voltage **A**).

The step voltage increases:

- the closer the person is to the current transfer location.

- the greater the step length.

First response to a current transfer

- Remain calm.
- Alert the relevant power supply company.
Do not leave the cab.
 - It is relatively safe to remain in the closed operator's cab as it acts as a Faraday cage.
 - Only evacuate the cab in the case of fire.
- If the Litronic control system is still functioning:
 - Move the machine out of the danger area.
 - Remain in the cab until current is no longer being conducted through the machine.

Leaving the machine in event of current transfer with fire

- Never touch live parts of the machine (hoist rope, load, crawler, etc) if you are in contact with the ground.
- Jump in a direction that avoids any contact with live parts.
- Jump to a safe distance from the machine and land on both feet at the same time.
- Land on both feet at the same time with legs closed (do not straddle).
- Never hold on to the machine or any live parts.
- Hop away on both feet with both legs pressed together.
- While hopping away, keep well clear of any live parts.



First aid

- Alert the emergency services.
- Personnel are to be rescued by experts only.



Note

- ▶ Seek medical attention after electrical accidents. The person affected may experience symptoms of an irregular heartbeat some time after the accident.

2.12.2 How to respond in the event of a fire



WARNING

Incorrect behaviour in event of fire!

- ▶ Observe handling and situation-specific safety notes.

- Switch off the engine.
- Alert the emergency services.
- Move people out of the danger zone, administer first aid if required ([For more information see: 2.11.4 Burns, page 586](#)) .
- Only start to fight the fire if there is no risk to your personal safety ([For more information see: 2.12.3 Firefighting, page 603](#)) .



WARNING

Danger of backflash!
Even if the fire appears to be extinguished, escaping fuel or oil coming in contact with hot components may reignite.

Once the risk of backflashing no longer persists:

- ▶ Start assessing the damage.

2.12.3 Firefighting

Fire classes



WARNING

Appropriate extinguishers must be used!
If unsuitable extinguishers are used, they may be ineffective or even introduce additional hazards.

- ▶ Use an extinguisher that is appropriate for the fire class.



Fires involving solid and chiefly organic materials that normally smoulder



Fires involving liquids or liquefying materials



Fires involving gases



Fires involving metals

Use of the fire extinguisher













Note

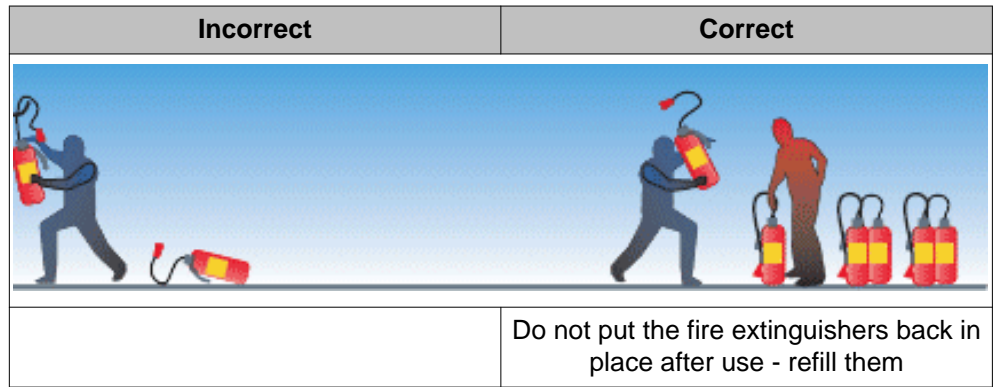
Fire extinguishers are subject to national regulations!

- ▶ Arrange for the plant operator to provide fire extinguishers, replace them as necessary and inspect them periodically.

- Take fire extinguishers on the machine off the holders and ready them for operation.
- Fight the source of the fire with several short bursts.
- While fighting the fire, ask your colleagues to alert the fire brigade.

Incorrect	Correct
	
<p>Fight the fire with the wind behind you</p>	
	
<p>Extinguish the fire from the front to the back and from the bottom to the top</p>	
	
<p>But: Extinguish dropping and liquid fires from the top to the bottom</p>	
	
<p>Do not use extinguishers in succession but use several extinguishers at the same time</p>	
	
<p>Make sure that the fire does not reignite - always extinguish glowing embers with water</p>	

LWNLR-x/V04.01//Auslieferung/2016-03-07/en



Tab. 345: Use of the fire extinguisher

2.13 Working at heights



WARNING

Working at heights without precautions!
Fall from machine.

- ▶ Only perform work on the machine on the ground.

If work at heights is necessary:

- ▶ Secure yourself against falling.
- ▶ Observe international and national regulations.



Note

Liebherr recommends:

- ▶ When working at heights use suitable working platforms.

2.14 Application on floating devices

Liebherr crawler cranes were exclusively developed as assembly cranes and are designed for a limited number of load cycles.

The crane structure was constructed and calculated under assumption of certain conditions, like for example:

- No permanent use.
- Very slight dynamic influences through individual movements.
- Load conditions correspond to the standard EN 13000 “Cranes - Vehicle Cranes” and other similar standards.

Liebherr duty cycle crawler cranes are developed as transport cranes and intended for special use (e.g. grab operation).

Duty cycle crawler cranes are designed and calculated for higher dynamic influences, but are also subject to a limited number of load cycles. The construction of these duty cycle crawler cranes corresponds to the standard EN 474-12 “Earth-moving Machinery - Safety, Requirements for Cable Excavators” and other comparable standards.

Liebherr crawler cranes and Liebherr duty cycle crawler cranes are not designed and developed for offshore conditions acc. to the standard EN 13852-2 "Cranes - Offshore Cranes".



DANGER

Improper use of Liebherr crawler cranes and Liebherr duty cycle crawler cranes on floating devices!

Machine toppling over, structural breakdown.

- ▶ Observe the manufacturer's guidelines and regulations.
- ▶ Observe the industrial safety guidelines and regulations.
- ▶ Perform application planning and risk assessment.
- ▶ Observe international and national guidelines and regulations.

2.14.1 Operation of the machine on floating devices



DANGER

Improper operation of the machine on floating devices!

Machine toppling over, structural breakdown.

- ▶ Only operate the machine according to all following regulations.

In general, the machine must be operated the same way on floating devices as on land.

Operation of the machine on floating devices is only permitted at calm sea without waves.

The only admissible boom configurations are "main boom" or "main boom + auxiliary jib". The use of main booms in combination with fixed or luffing jibs or with heavy load equipment like e.g. a derrick with suspended counterweight and/or wheeled counterweight carriage is prohibited.

The lifting and lowering of loads can be regarded the same way as operation on land under the following prerequisites:

- Calm sea.
- Minimal movement of the floating device.
- Load is constantly vertically suspended.
- There is no inadmissible diagonal pull due to a movement of the floating device.

The maximum admissible load according to the valid load chart may not be exceeded under any circumstances during operation. All notices in the foreword of the load chart must be observed.

The maximum longitudinal and diagonal incline of the floating device must be calculated by a shipbuilding engineer. The load must be reduced if the incline of the floating device exceeds 1% (0.57°). These reduced load charts (for inclines of 1°, 2° or 3°) are available from the Liebherr customer service. These incline charts are only valid for the boom configuration "main boom". The maximum incline may never exceed 3°.

It is not permitted to lower the load hook or the pulley block below water level with crawler cranes.

With duty cycle crawler cranes, it is permissible to also work below water level with a specially suited load lifting device.

The decision of whether the conditions for operation on floating devices are given is at the sole discretion and responsibility of the operator. The manufacturer expressly recommends consulting a shipbuilding engineer.

The forces resulting from operation must be safely borne by the structure of the floating device.

Prior to operating the machine, the operator must ensure the following conditions:

- Machine is properly secured .
- All functional, technical and static interactions between the machine and the floating device are tested and approved.

2.14.2 Transport of the machine on floating devices

The operator bears sole responsibility for transporting the machine.

The machine must be secured while being transported on the floating device.

The machine must be secured on the floating device in such a way that the following consequences are ruled out:

- Damage to machine
- Sliding of machine
- Rotation of uppercarriage
- Capsizing of the floating device

Forces may result during transport through acceleration or deformation of the floating device. These forces may have an incalculable influence on the machine structure and impair the support structure, stability or service life of the machine, for example.

NOTICE

Improper transport of the machine on floating devices!
Damage to machine.

- ▶ Put down main boom.
 - ▶ Secure main boom against lateral movement.
 - ▶ Secure main boom against lifting.
 - ▶ Make sure that the main boom is not distorted, because distortions of the floating device may lead to damage to the boom structure or machine.
 - ▶ Deinstall counterweight from the uppercarriage and secure on floating device.
-

Erecting and dismantling the machine on the floating device is the sole responsibility of the operator.

2.14.3 Higher risk of machine corrosion on floating devices

The possibly higher risk of corrosion on machines in a maritime environment is the sole responsibility of the operator.

The following components may be damaged prematurely due to corrosion in a maritime environment (examples):

- Hydraulic cylinders
- Steel ropes
- Electric and electronic components
- Cabin

Therefore, the main components and the structure of the machine must be checked periodically by a qualified person.

The machine structure may not come into direct contact with saltwater.

2.15 Use at low temperatures

The following measures must be performed and all requirements and conditions fulfilled when operating Liebherr duty cycle crawler cranes, crawler excavators and deep foundation machines at low temperatures.

Prerequisites for start-up at sub-zero temperatures:

- Ensure unobstructed view from the cabin. The cabin's windows are clean and the mirrors properly adjusted.
- Check that snow and ice have been removed from the cabin, uppercarriage, crawler side frames, platforms, limit switches, ropes, drums, pulleys, load, and also, where possible, from the booms and/or leader and accessory equipment.
- Sling gear is approved for the prevailing ambient temperatures.
- Load rigging points are approved for the prevailing ambient temperatures.
- Load drop-off site can safely bear the load and is permitted for the prevailing outdoor temperatures.

Conditions for operation at sub-zero temperatures:

- Use antifreeze.
- Heat machine to operating temperature.
- At the start, perform all machine movements without load to mix cold hydraulic oil with pre-heated hydraulic oil until the gearbox and its components are pre-heated to approx. 0 °C (32 °F).
- Do not subject the machine to any impact loads.
- Operate machine slowly and continuously.
- Operate machine within the limits of the load chart.
- When moving the machine, ensure that snow or ice along the path and/or on the crawler side frames do not lead to abrupt machine movements.
- Operate the machine in line with all specifications and guidelines contained in the operation manual.



DANGER

Improper use of Liebherr duty cycle crawler cranes, crawler excavators and deep foundation machines at low temperatures!

Structural breakdown, load breakaway, damage to machine.

- ▶ Observe the manufacturer's guidelines and specifications.

2.15.1 Operation of the machine down to -20 °C (-4 °F) (standard)

Admissible ambient temperatures			
Operation:	down to -20 °C (-4 °F)	Storage:	down to -40 °C (-40 °F)

Tab. 346: Admissible ambient temperatures for operation and storage

Measures:

- Note and observe all generally admissible prerequisites and requirements.

2.15.2 Operation of the machine down to -25 °C (-13 °F)*

Admissible ambient temperatures			
Operation:	down to -25 °C (-13 °F)	Storage:	down to -40 °C (-40 °F)

Tab. 347: Admissible ambient temperatures for operation and storage

Measures (in addition to all other topics addressed beforehand):

- Install low temperature package (engine pre-heating, auxiliary heating (water)) and external power supply.

Additional prerequisites for start-up:

- Cabin with electronic modules and displays is pre-heated prior to start-up using the provided equipment (low temperature package).
- Diesel engine and power units are pre-heated prior to start-up using the provided equipment (low temperature package).

2.15.3 Operation of the machine down to -40 °C (-40 °F)*

Admissible ambient temperatures			
Operation:	down to -40 °C (-40 °F)	Storage:	down to -40 °C (-40 °F)

Tab. 348: Admissible ambient temperatures for operation and storage

Measures (in addition to all other topics addressed beforehand):

- Exchange hydraulic oil, gearbox oil, fuels and lubricants.
- Exchange hydraulic cylinders and hydraulic accumulators.
- Install low-temperature package (engine pre-heating), improved insulation (e.g. of the fuel system), auxiliary heating (water) battery pre-heater, fuel pre-filter heater, oil pre-heating unit and external power supply.
- Exchange attachment parts (in part).
- Exchange undercarriage components (cam rollers, carrier rollers, idler wheel).
- Exchange electric/electronic components (e.g. battery).
- Exchange gearbox (in part).
- Exchange rubber elements and plastic elements (e.g. v-belts, radiator fans).
- Perform changes to the steel structure and load-bearing parts so that all used parts in the load chain meet the necessary requirements as well as use of special welding additives.
- Ensure that pins, screws and ropes including end fittings correspond to ambient temperatures.

Additional prerequisites for start-up:

- Start diesel engine at least 20 minutes prior to starting work.

2.16 Hand signals

The hand signals:

- serve to communicate during visual contact between the machine operator and the signalman or additional personnel
- are clearly defined in national and international standards



Note

- ▶ The hand signals to be used must be coordinated with all persons involved.

The following overview includes:

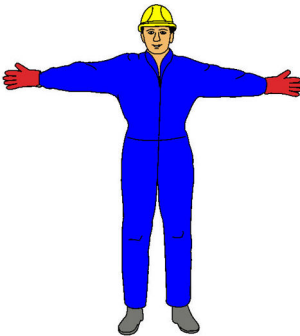
- the hand signals in accordance with BGV A8 (Germany)
- the hand signals in accordance with ASME/ANSI B30.5 (United States of America)

2.16.1 General hand signals in accordance with BGV A8



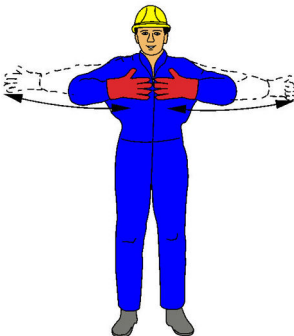
Attention, start, stop

- Extend right arm upward
- Palm faces forward



Stop, pause

- Extend both arms horizontally at your side
- Palms face forward



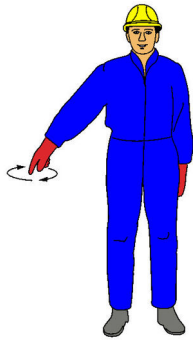
Stop - danger

- First extend both arms horizontally at your side
- Palms face forward
- Now angle and extend both arms alternately



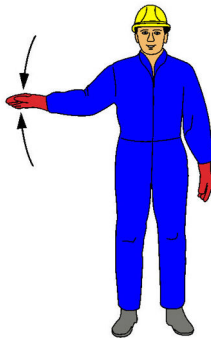
Hoist

- Angle right arm upwards
- Palm faces forward
- Make slow circular motions with hand



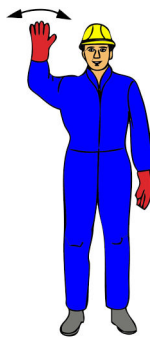
Lower

- Extend right arm downward
- Palm faces inward
- Make slow circular motions with hand



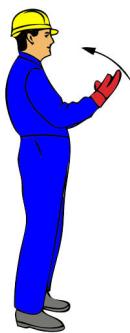
Slow

- Extend right arm horizontally
- Palm faces down
- Slowly move hand up and down



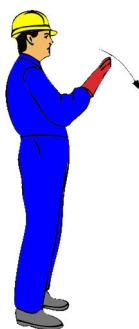
Travel

- Angle right arm upwards
- Palm faces forward
- Move arm back and forth at your side



Approach

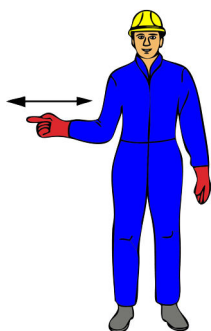
- Bend both arms
- Palms face inward
- Wave towards you with forearms



Leave

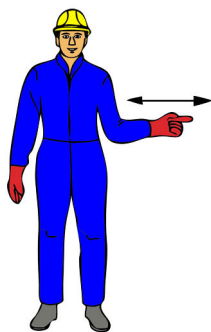
- Bend both arms
- Palms face outward
- Wave away from you with forearms

LWNLR.x/V04.01//Auslieferung/2016-03-07/en



Travel to right (from the point of view of the signalman)

- Slightly angle right arm in horizontal position
- Move arm back and forth at your side



Travel to left (from the point of view of the signalman)

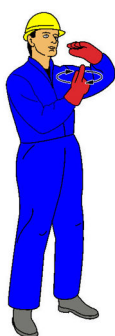
- Slightly angle left arm in horizontal position
- Move arm back and forth at your side



Reduce distance

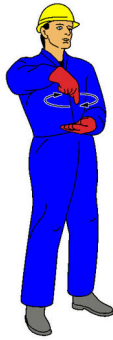
- Keep both palms parallel and bring together corresponding to the distance

2.16.2 Special hand signals for sling gear application



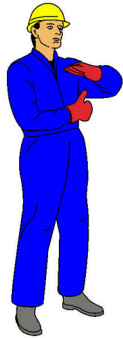
Raise load slowly

- Angle right arm upwards
- Extended finger points upwards
- Right hand makes small circular motions
- Extend left hand and hold over right hand



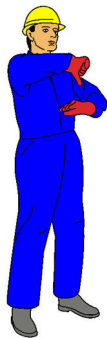
Lower load slowly

- Keep right arm downward
- Extended finger points downwards
- Right hand makes small circular motions
- Place left hand under right hand



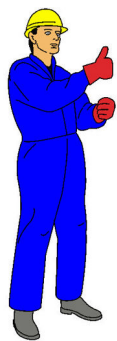
Lift main boom

- Angle right arm upwards
- Extended thumb points upwards
- Extend left hand and hold over right hand



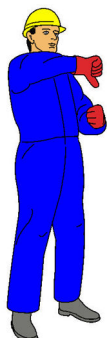
Lower main boom

- Angle right arm
- Extended thumb points down
- Extend left hand and hold underneath right hand



Raise main boom and hold load

- Angle right arm upwards
- Extended thumb points upwards
- Make a fist with left hand and hold underneath right hand



Lower main boom and maintain load

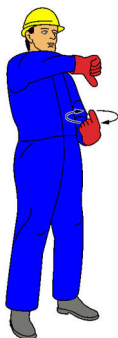
- Angle right arm
- Extended thumb points down
- Make a fist with left hand and hold underneath right hand

LWNLR.x/V04.01//Auslieferung/2016-03-07/en



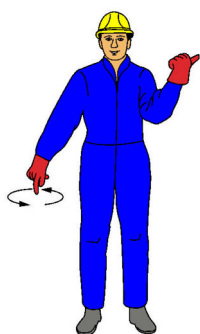
Raise main boom and lower load

- Angle right arm upwards
- Extended thumb points upwards
- Extend left arm, index finger points downward
- Make circular motions with left hand and hold underneath right hand



Lower main boom and lift load

- Angle right arm
- Extended thumb points down
- Angle left arm, index finger points upward
- Make circular motions with left hand and hold underneath right hand



Slew uppercarriage to the right

- Angle left arm and hold up
- Extended thumb points upward in slewing direction
- Extend right arm downward
- Index finger points down and makes circular motions



Slew uppercarriage to the left

- Angle right arm and hold up
- Extended thumb points upward in slewing direction
- Extend left arm downward
- Index finger points down and makes circular motions



Open grab

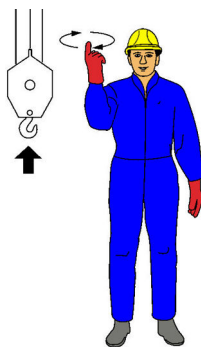
- Extend right arm horizontally
- Open hand downward



Close grab

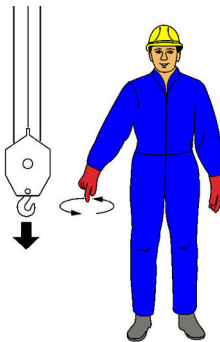
- Extend right arm horizontally
- Make a fist

2.16.3 Hand signals for lifting gear application in accordance with ASME/ANSI B30.5



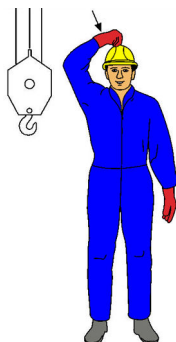
Lift load

- Angle right arm upwards
- Extended index finger points upwards
- Make slow circular motions with hand



Lower load

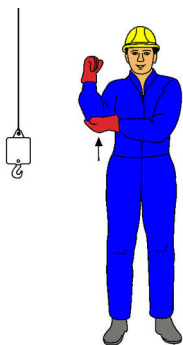
- Extend right arm downward
- Extended index finger points down
- Make slow circular motions with hand



Use of main winch

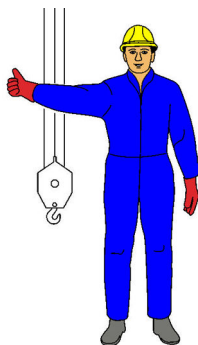
- Knock with fist on hardhat
- Then give more hand signals

LWNLR.x/V04.01//Auslieferung/2016-03-07/en



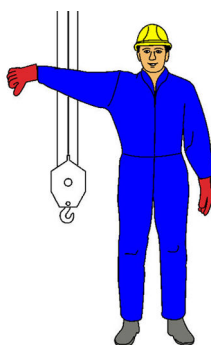
Use of auxiliary winch

- Angle right arm upwards
- Knock on your right elbow from below with left hand
- Then give more hand signals



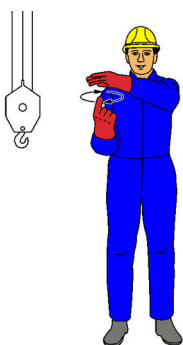
Lift main boom

- Extend right arm horizontally
- Extended thumb points upwards



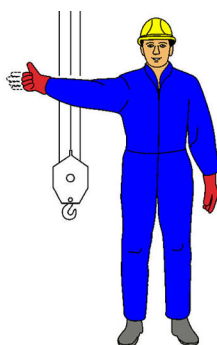
Lower main boom

- Extend right arm horizontally
- Extended thumb points down



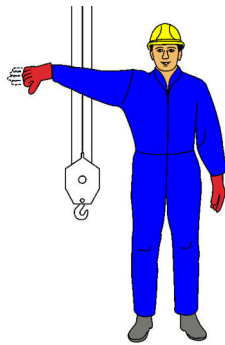
Moving slowly

- Use one hand to give required hand signal. (E.g. lift load)
- Hold one hand over or underneath other hand



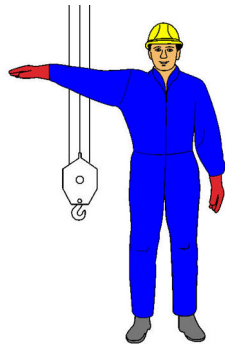
Raise main boom and lower load

- Extend right arm horizontally
- Extended thumb points upwards
- Extend/angle the other fingers alternately as long as the load is supposed to be lowered



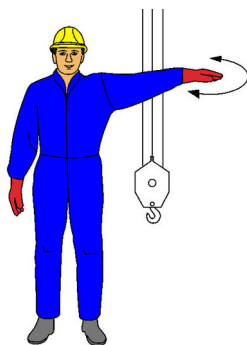
Lower main boom and lift load

- Extend right arm horizontally
- Extended thumb points down
- Extend/angle the other fingers alternately as long as the load is supposed to be lifted



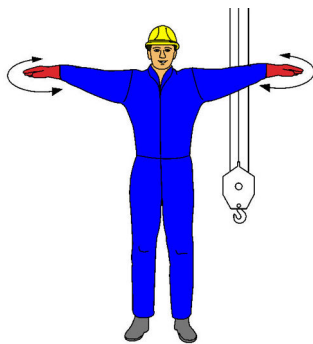
Rotate

- Extend right arm horizontally
- Palm faces down
- Extended finger points in rotation direction



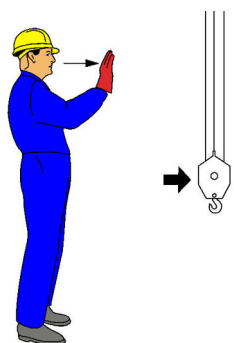
Stop

- Extend one arm horizontally
- Palm faces down
- Move arm back and forth horizontally



Emergency stop

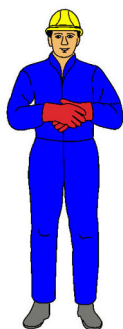
- Extend both arms horizontally
- Palms face down
- Swing both arms back and forth horizontally



Travel

- Angle one arm
- Palm faces forward
- Make a motion in the direction of travel with one open hand

LWNLR.x/V04.01//Auslieferung/2016-03-07/en



Park and secure machine

- Hook hands in front of your body



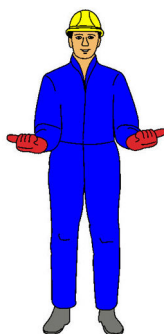
Traveling with both crawler chains

- Hold both fists in front of your body
- Indicate travel direction with circular motions



Traveling with one crawler chain

- Angle arm, keep fist raised on the side of the stationary crawler chain
- Angle other arm in front of body on the side of the crawler chain to be moved
- Indicate travel direction making circular motions with fist



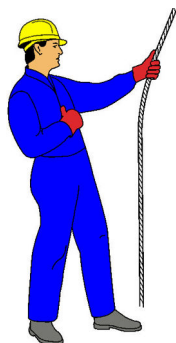
Telescope boom out

- Hold both fists in front of body
- Thumbs face outward



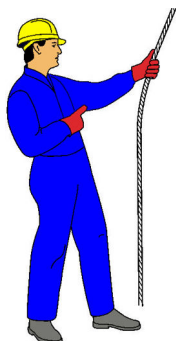
Telescope boom in

- Hold both fists in front of body
- Thumbs point towards each other



Telescope boom in (single hand signal)

- Hold one fist in front of chest
- Thumb points toward chest



Telescope boom out (single hand signal)

- Hold one fist in front of chest
- Thumbs point outward

Control and operating elements 3

3 Control and operating elements

3 Control and operating elements

The chapter **Control and operating elements** deals with the following issues:

- Alignment of control and operating elements
- Names of control and operating elements

3.1 Operating elements on the undercarriage

3.1.1 Operating elements at undercarriage with fixed track width

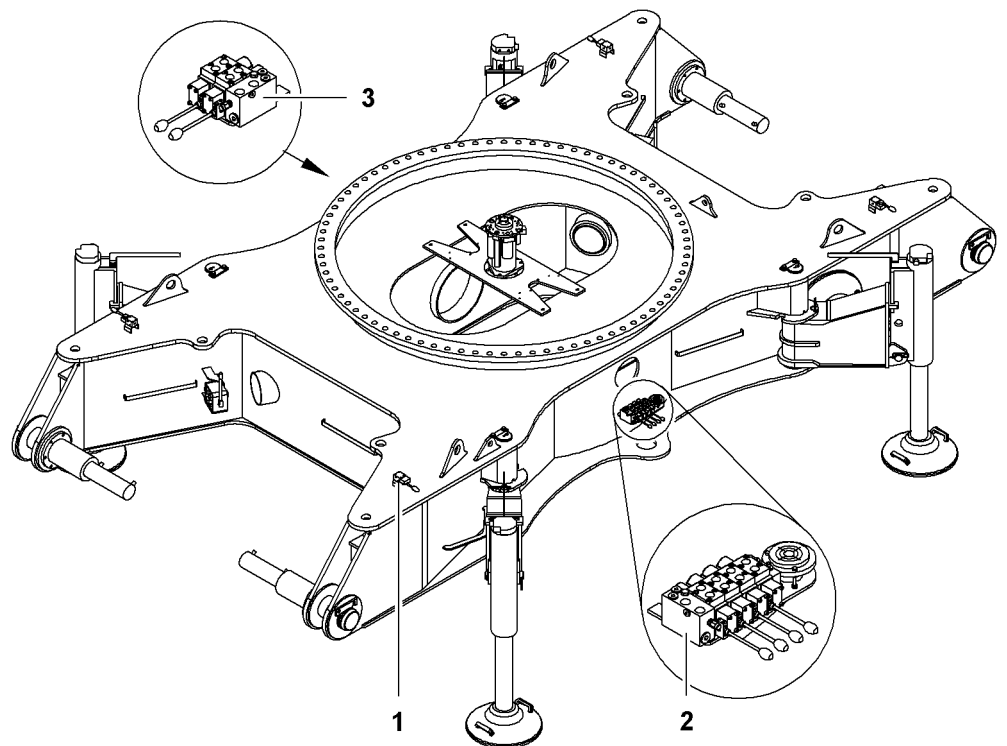


Fig. 800: Operating elements at undercarriage with fixed track width

- | | | | |
|---|---|---|--|
| 1 | Control lever (4x) for crawler side frame-pin connection cylinder | 3 | Control lever (2x) for jack (optional) |
| 2 | Control lever (4x) for jack with tilt display | | |

3.1.2 Operating elements at undercarriage* with adjustable track width

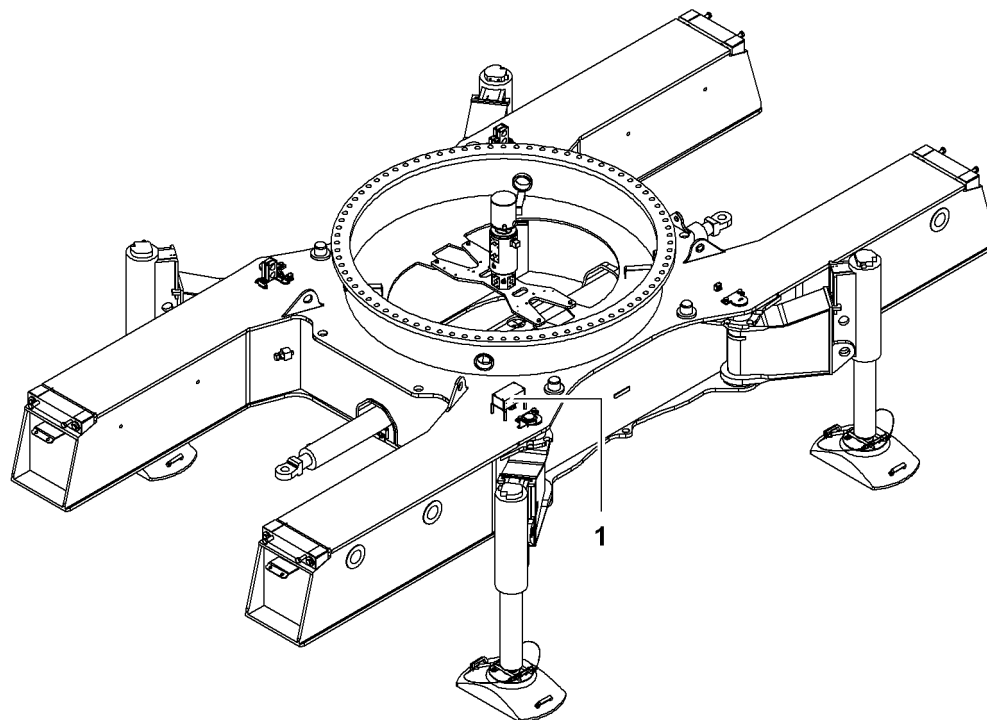


Fig. 801: Operating elements at undercarriage with adjustable track width*

- 1 Connection plug of cable remote control

3.2 Operating elements on the uppercarriage

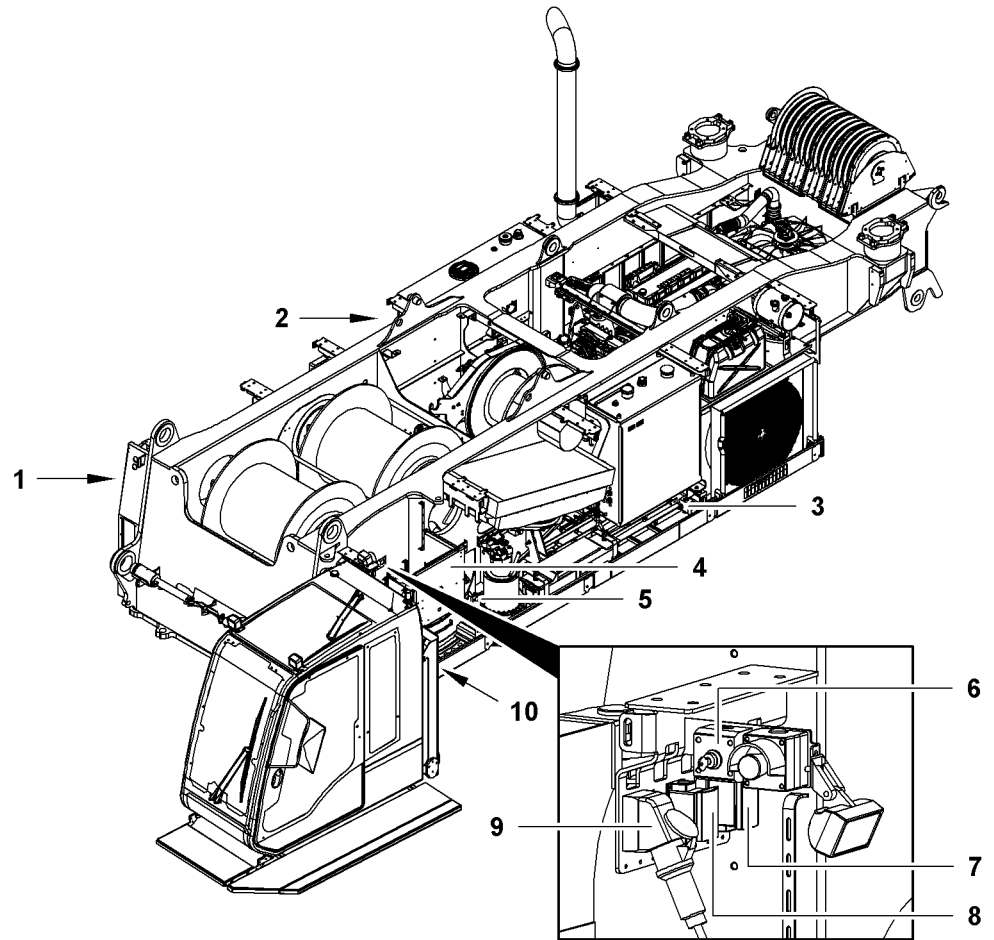


Fig. 802: Operating elements on the uppercarriage

- | | | | |
|---|---|----|---|
| 1 | Connection plug of cable remote control | 6 | Key switch load moment limiter shut-down |
| 2 | Refueling pump control panel | 7 | Control panel emergency control system connection plug |
| 3 | Connection plug of cable remote control | 8 | Control panel emergency control system connection plug |
| 4 | Gate valve free-fall operation | 9 | External supply connection plug |
| 5 | Main battery switch | 10 | Cable remote control oddments tray and control panel emergency control system |

The *load moment limiter shut down* key switch **6** has no effect on machines with an ANSI load chart.

3.3 Operating elements on counterweight carriage*

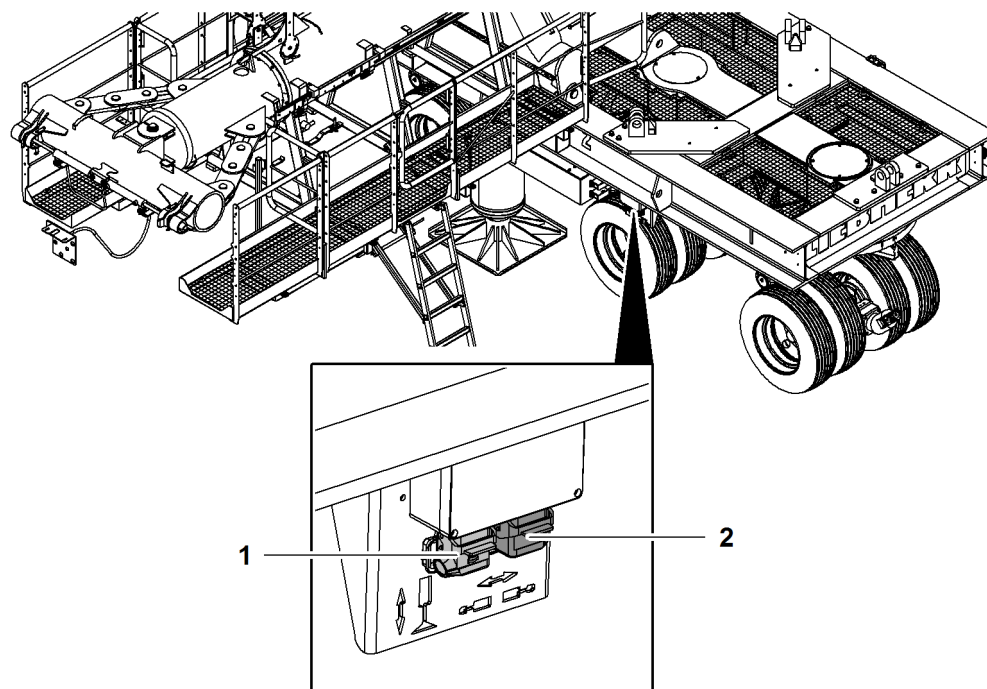


Fig. 803: Operating elements on counterweight carriage

1 Plug for jack

2 Plug for pin connection cylinder

3.4 Cabin

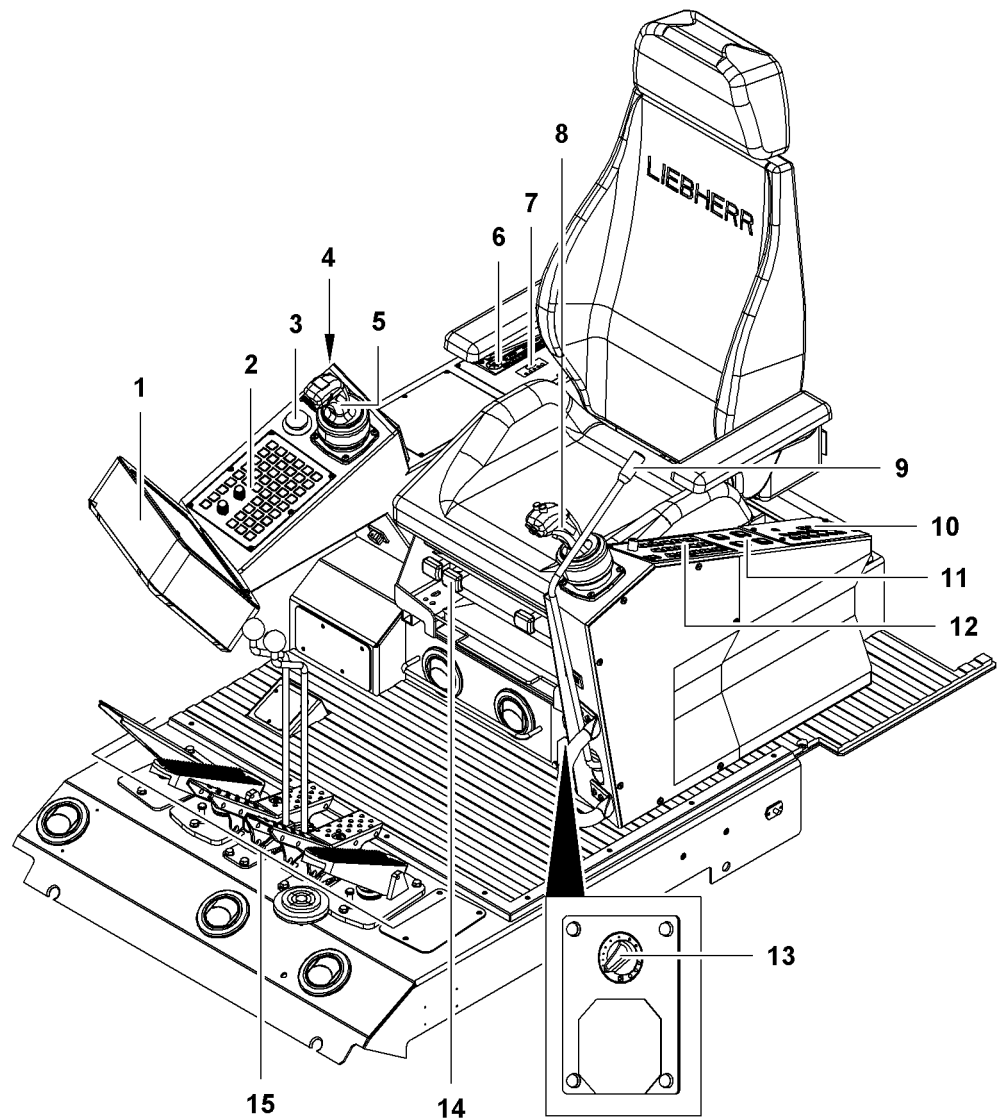


Fig. 804: Cabin

- | | | | |
|---|---|----|--|
| 1 | Monitor | 9 | Safety lever |
| 2 | Control panel X23 | 10 | Control panel X12 |
| 3 | Emergency stop | 11 | Buttons <i>Additional floodlights</i> |
| 4 | Ignition key/ignition lock | 12 | Control panel X11 |
| 5 | Multi-directional control lever or right double T-lever | 13 | Switch <i>Recirculated air/fresh air</i> |
| 6 | Radio | 14 | Lever <i>operator's seat adjustment</i> (3x) |
| 7 | Operating element <i>auxiliary heating</i> | 15 | Foot pedals and hand levers |
| 8 | Left multi-directional control lever | | |

3.5 Left control lever

3.5.1 Function assignment of the left control lever on machine without derrick equipment*

Left multi-directional control lever



Assigned functions of control levers on a machine with two multi-directional control levers.

Function assignment of buttons on left multi-directional control lever

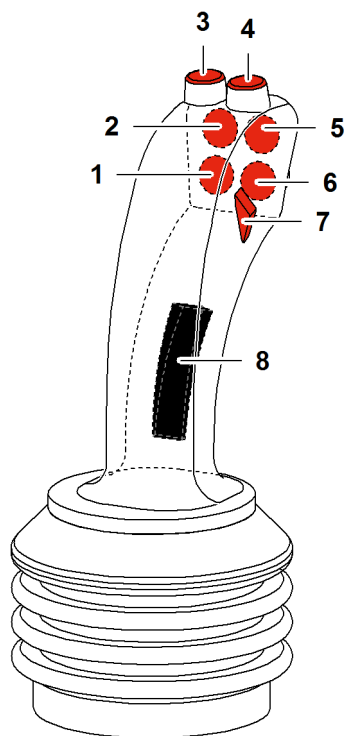






















Fig. 806: Function assignment of buttons on left multi-directional control lever

Button	Mode	Preselection or additional button	Name and function
1	 Crane mode		[not used]
	 Assembly functions		[not used]

LWN/LR-x/V04.01//Auslieferung/2016-03-07/en

Button	Mode	Preselection or additional button	Name and function
2	 Crane mode		Tagline winch free-wheel Activate/deactivate tagline winch free-wheel.
	 Assembly functions		Tagline winch free-wheel Activate/deactivate tagline winch free-wheel.
3	 Crane mode		Horn Sound horn.
	 Assembly functions		Horn Sound horn.
4	 Crane mode		[not used]
	 Assembly functions		[not used]
5	 Crane mode		Maximum pull force tagline winch Select maximum pull force of tagline winch.
	 Assembly functions		Maximum pull force tagline winch Select maximum pull force of tagline winch.

Button	Mode	Preselection or additional button	Name and function
6	 Crane mode		Swing free-wheel Activate/deactivate swing free-wheel.
	 Crane mode	 Vertical Line Finder	Vertical Line Finder Position boom head above load's center of gravity.
	 Assembly functions		Swing free-wheel Activate/deactivate swing free-wheel.
	 Assembly functions	 Vertical Line Finder	Vertical Line Finder Position boom head above load's center of gravity.
7	 Crane mode		Constant tension tagline winch Set constant tension of tagline winch.
	 Assembly functions		Constant tension tagline winch Set constant tension of tagline winch.
8	 Crane mode		[not used]
	 Assembly functions		[not used]

Tab. 349: Function assignment of buttons on left multi-directional control lever

Assigned functions for movement directions on left-hand multi-directional joystick

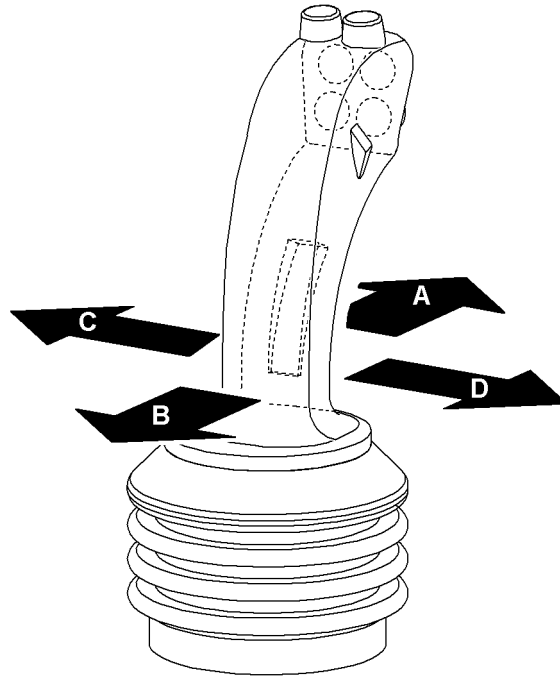











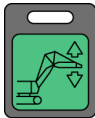
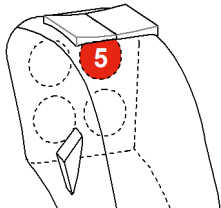


Fig. 827: Function assignment for movement directions on left multi-directional control lever




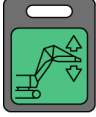
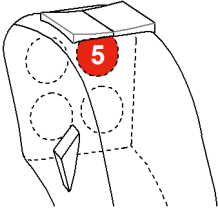
Direction of movement	Mode	Preselection or additional button	Function
A	 Crane mode		Lower winch2
	 Assembly functions		Lower winch2
	 Assembly functions	 Assembly cylinder	Extend assembly cylinder

Control and operating elements

Left control lever

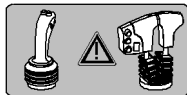
Direction of movement	Mode	Preselection or additional button	Function
B	 Crane mode		Lifting winch2
	 Assembly functions		Lifting winch2
	 Assembly functions	 Assembly cylinder	Retract assembly cylinder
C	 Crane mode		Swing uppercarriage to the left
	 Assembly functions		Swing uppercarriage to the left
	 Assembly functions	 Jib luffing winch or 	Lower jib

LWNLR-x/V04.01//Auslieferung/2016-03-07/en

Direction of movement	Mode	Preselection or additional button	Function
D	 Crane mode		Swing uppercarriage to the right
	 Assembly functions		Swing uppercarriage to the right
	 Assembly functions	 Jib luffing winch or 	Lift jib

Tab. 350: Function assignment for movement directions on left multi-directional control lever

Left multi-directional control lever



Assigned functions of the control levers on a machine with a multi-directional control lever and a double T-lever.

Assigned functions for buttons on left-hand multi-directional joystick

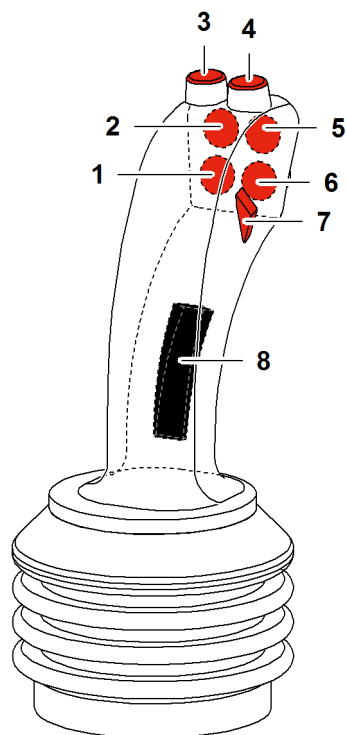


























Fig. 847: Function assignment of buttons on left multi-directional control lever

Button	Mode	Preselection or additional button	Name and function
1	 Crane mode		[not used]
	 Assembly functions		[not used]
2	 Crane mode		Tagline winch free-wheel Activate/deactivate tagline winch free-wheel.
	 Assembly functions		Tagline winch free-wheel Activate/deactivate tagline winch free-wheel.

LWN/LR-x/V04.01//Auslieferung/2016-03-07/en

Button	Mode	Preselection or additional button	Name and function
3	 Crane mode		Horn Sound horn.
	 Assembly functions		Horn Sound horn.
4	 Crane mode		[not used]
	 Assembly functions		[not used]
5	 Crane mode		Maximum pull force tagline winch Select maximum pull force of tagline winch.
	 Assembly functions		Maximum pull force tagline winch Select maximum pull force of tagline winch.
6	 Crane mode		Swing free-wheel Activate/deactivate swing free-wheel.
	 Crane mode	 Vertical Line Finder	Vertical Line Finder Position boom head above load's center of gravity.
	 Assembly functions		Swing free-wheel Activate/deactivate swing free-wheel.
	 Assembly functions	 Vertical Line Finder	Vertical Line Finder Position boom head above load's center of gravity.

Button	Mode	Preselection or additional button	Name and function
7	 Crane mode		Constant tension tagline winch Set constant tension of tagline winch.
	 Assembly functions		Constant tension tagline winch Set constant tension of tagline winch.
8	 Crane mode	 Horizontal load path/ Vertical Line Finder winch1 or  Horizontal load path/ Vertical Line Finder winch2	Activate horizontal load path horizontal load path for winch1 or winch2.
	 Assembly functions	 Horizontal load path/ Vertical Line Finder winch1 or  Horizontal load path/ Vertical Line Finder winch2	Activate horizontal load path horizontal load path for winch1 or winch2.

Tab. 351: Function assignment of buttons on left multi-directional control lever

LWNLR-x/V04.01//Auslieferung/2016-03-07/en

Assigned functions for movement directions on left-hand multi-directional joystick

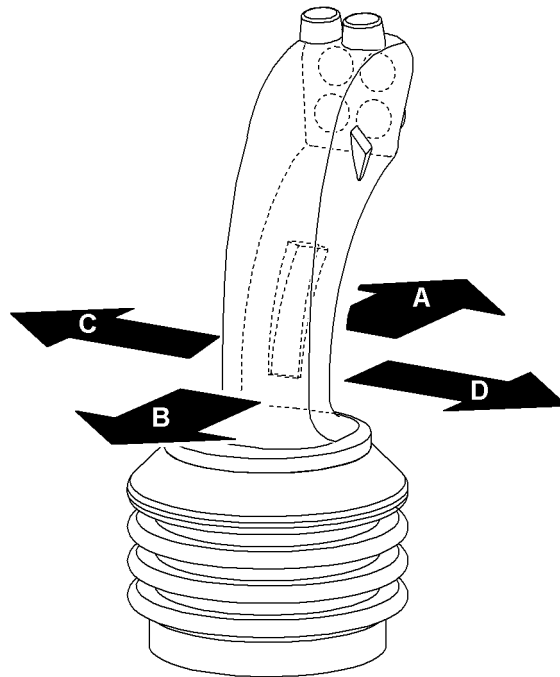










Fig. 872: Function assignment for movement directions on left multi-directional control lever

Direction of movement	Mode	Preselection or additional button	Function
A	 Crane mode		Lower main boom
	 Assembly functions		Lower main boom
B	 Crane mode		Lift main boom
	 Assembly functions		Lift main boom

Direction of movement	Mode	Preselection or additional button	Function
C	 Crane mode		Swing uppercarriage to the left
	 Assembly functions		Swing uppercarriage to the left
D	 Crane mode		Swing uppercarriage to the right
	 Assembly functions		Swing uppercarriage to the right

Tab. 352: Function assignment for movement directions on left multi-directional control lever

3.5.2 Function assignment of the left control lever on machine with derrick equipment*

Left multi-directional control lever



Function assignment of control levers on a machine with two multi-directional control levers

Function assignment of buttons on left multi-directional control lever

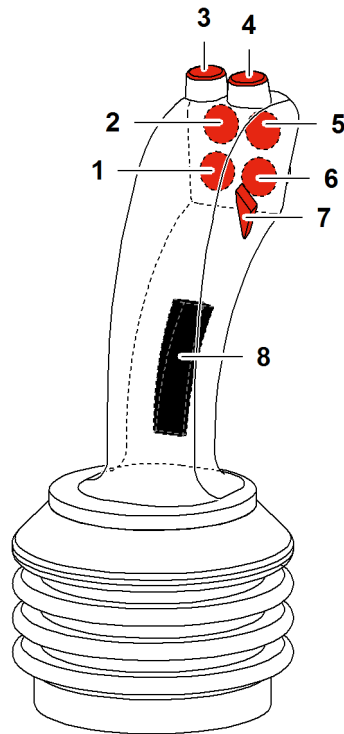


















Fig. 882: Function assignment of buttons on left multi-directional control lever

Button	Mode	Preselection or additional button	Name and function
1	 Crane mode		Derrick hoist cylinder Activates/deactivates derrick hoist cylinder.
	 Assembly functions		Derrick hoist cylinder Activates/deactivates derrick hoist cylinder.
2	 Crane mode		Tagline winch free-wheel Activate/deactivate tagline winch free-wheel.
	 Assembly functions		Tagline winch free-wheel Activate/deactivate tagline winch free-wheel.





LWNLR.x/V04.01//Auslieferung/2016-03-07/en

Control and operating elements

Left control lever

Button	Mode	Preselection or additional button	Name and function
3	 Crane mode		Horn Sound horn.
	 Assembly functions		Horn Sound horn.
4	 Crane mode		[not used]
	 Assembly functions		[not used]
5	 Crane mode		Maximum pull force tagline winch Select maximum pull force of tagline winch.
	 Assembly functions		Maximum pull force tagline winch Select maximum pull force of tagline winch.
6	 Crane mode		Swing free-wheel Activate/deactivate swing free-wheel.
	 Crane mode	 Vertical Line Finder	Vertical Line Finder Position boom head above load's center of gravity.
	 Assembly functions		Swing free-wheel Activate/deactivate swing free-wheel.
	 Assembly functions	 Vertical Line Finder	Vertical Line Finder Position boom head above load's center of gravity.

LWNLR-x/V04.01//Auslieferung/2016-03-07/en

Button	Mode	Preselection or additional button	Name and function
7	 Crane mode		Constant tension tagline winch Set constant tension of tagline winch.
	 Assembly functions		Constant tension tagline winch Set constant tension of tagline winch.
8	 Crane mode		[not used]
	 Assembly functions		[not used]

Tab. 353: Function assignment of buttons on left multi-directional control lever

Function assignment for movement directions on left multi-directional control lever

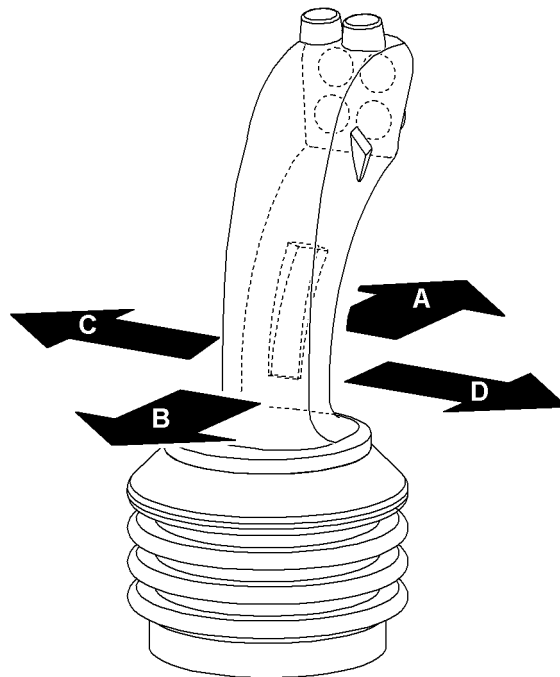


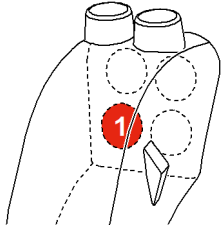


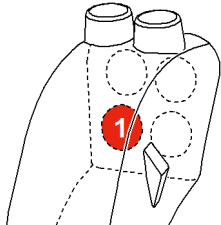

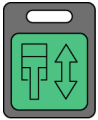




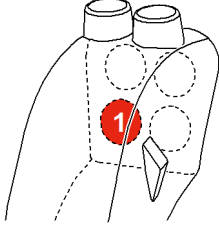


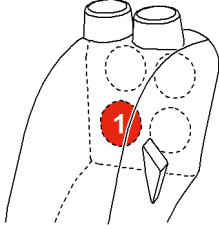


Fig. 903: Function assignment for movement directions on left multi-directional control lever

Control and operating elements

Left control lever

Direction of movement	Mode	Preselection or additional button	Function
A	 Crane mode		Lower winch2
	 Crane mode		Extending the derrick hoist cylinder
	 Assembly functions		Lower winch2
	 Assembly functions		Extending the derrick hoist cylinder
	 Assembly functions	 Assembly cylinder	Extend assembly cylinder



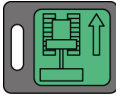




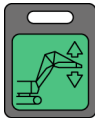
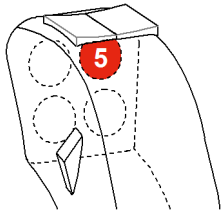
LWNLR-x/V04.01//Auslieferung/2016-03-07/en

Direction of movement	Mode	Preselection or additional button	Function
B	 Crane mode		Lifting winch2
	 Crane mode		Retracting the derrick hoist cylinder
	 Assembly functions		Lifting winch2
	 Assembly functions		Retracting the derrick hoist cylinder
	 Assembly functions	 Assembly cylinder	Retract assembly cylinder



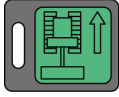





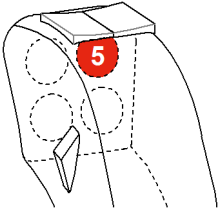
LWNLR.x/V04.01//Auslieferung/2016-03-07/en

Control and operating elements

Left control lever

Direction of movement	Mode	Preselection or additional button	Function
C	 Crane mode		Swing uppercarriage to the left
	 Crane mode	 Trailer travel mode	Steer wheel sets of counterweight carriage to the left
	 Assembly functions		Swing uppercarriage to the left
	 Assembly functions	 Derrick winch	Lower main boom ^{A)}
	 Assembly functions	 Jib luffing winch or 	Lower jib

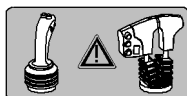
LWNLR-x/V04.01//Auslieferung/2016-03-07/en

Direction of movement	Mode	Preselection or additional button	Function
D	 Crane mode		Swing uppercarriage to the right
	 Crane mode	 Trailer travel mode	Steer wheel sets of counterweight carriage to the right
	 Assembly functions		Swing uppercarriage to the right
	 Assembly functions	 Derrick winch	Lift main boom ^{A)}
	 Assembly functions	 Jib luffing winch or 	Lift jib

Tab. 354: Function assignment for movement directions on left multi-directional control lever

A) By default, this function is on the left multi-directional control lever. "Jib luffing winch" must be additionally selected to enable this function on the right multi-directional control lever.

Left multi-directional control lever



Function assignment of control levers on a machine with a multi-directional control lever and a double T-lever

Function assignment of buttons on left multi-directional control lever

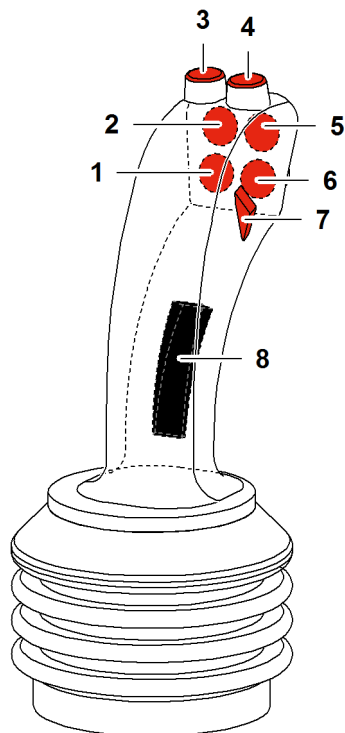


























Fig. 939: Function assignment of buttons on left multi-directional control lever

Button	Mode	Preselection or additional button	Name and function
1	 Crane mode		Derrick hoist cylinder Activates/deactivates derrick hoist cylinder.
	 Assembly functions		Derrick hoist cylinder Activates/deactivates derrick hoist cylinder.
2	 Crane mode		Tagline winch free-wheel Activate/deactivate tagline winch free-wheel.
	 Assembly functions		Tagline winch free-wheel Activate/deactivate tagline winch free-wheel.

LWN/LR-x/V04.01//Auslieferung/2016-03-07/en

Button	Mode	Preselection or additional button	Name and function
3	 Crane mode		Horn Sound horn.
	 Assembly functions		Horn Sound horn.
4	 Crane mode		[not used]
	 Assembly functions		[not used]
5	 Crane mode		Maximum pull force tagline winch Select maximum pull force of tagline winch.
	 Assembly functions		Maximum pull force tagline winch Select maximum pull force of tagline winch.
6	 Crane mode		Swing free-wheel Activate/deactivate swing free-wheel.
	 Crane mode	 Vertical Line Finder	Vertical Line Finder Position boom head above load's center of gravity.
	 Assembly functions		Swing free-wheel Activate/deactivate swing free-wheel.
	 Assembly functions	 Vertical Line Finder	Vertical Line Finder Position boom head above load's center of gravity.

Button	Mode	Preselection or additional button	Name and function
7	 Crane mode		Constant tension tagline winch Set constant tension of tagline winch.
	 Assembly functions		Constant tension tagline winch Set constant tension of tagline winch.
8	 Crane mode	 Horizontal load path/ Vertical Line Finder winch1 or  Horizontal load path/ Vertical Line Finder winch2	Activate horizontal load path horizontal load path for winch1 or winch2.
	 Assembly functions	 Horizontal load path/ Vertical Line Finder winch1 or  Horizontal load path/ Vertical Line Finder winch2	Activate horizontal load path horizontal load path for winch1 or winch2.

Tab. 355: Function assignment of buttons on left multi-directional control lever

LWNLR-x/V04.01//Auslieferung/2016-03-07/en

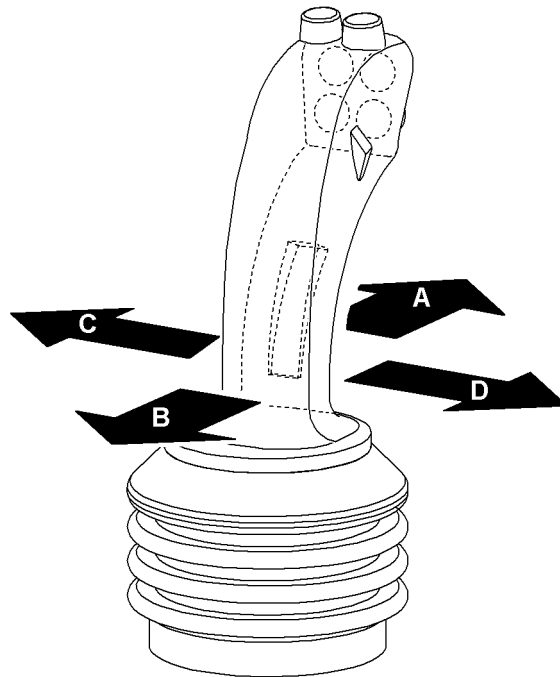



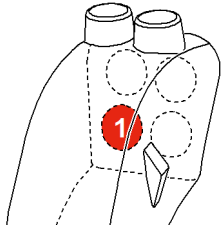

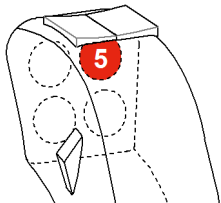



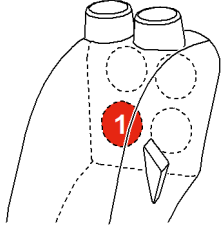
Function assignment for movement directions on left multi-directional control lever




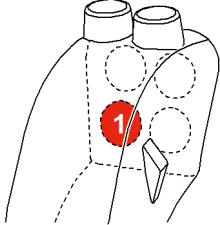


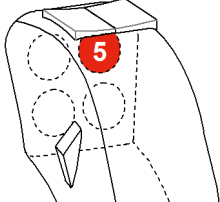




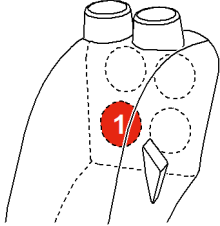
Fig. 964: Function assignment for movement directions on left multi-directional control lever

Control and operating elements



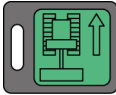



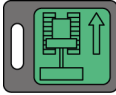

Left control lever

Direction of movement	Mode	Preselection or additional button	Function
A	 Crane mode	 Derrick winch	Lower main boom ^{A)}
	 Crane mode		Extending the derrick hoist cylinder
	 Assembly functions	Jib luffing winch or 	Lower main boom ^{B)}
	 Assembly functions	Extend A-frame1 cylinder and  Cylinder adjustment functions	Lower derrick boom
	 Assembly functions		Extending the derrick hoist cylinder

LWNLR-x/V04.01//Auslieferung/2016-03-07/en

Direction of movement	Mode	Preselection or additional button	Function
B	 Crane mode	 Derrick winch	Lift main boom ^{A)}
	 Crane mode		Retracting the derrick hoist cylinder
	 Assembly functions	 Jib luffing winch or 	Lift main boom ^{B)}
	 Assembly functions	 Extend A-frame1 cylinder and  Cylinder adjustment functions	Lift derrick boom
	 Assembly functions		Retracting the derrick hoist cylinder

LWNLR.x/V04.01//Auslieferung/2016-03-07/en

Direction of movement	Mode	Preselection or additional button	Function
C	 Crane mode		Swing uppercarriage to the left
	 Crane mode	 Trailer travel mode	Steer wheel sets of counterweight carriage to the left
	 Assembly functions		Swing uppercarriage to the left
D	 Crane mode		Swing uppercarriage to the right
	 Crane mode	 Trailer travel mode	Steer wheel sets of counterweight carriage to the right
	 Assembly functions		Swing uppercarriage to the right

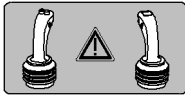
Tab. 356: Function assignment for movement directions on left multi-directional control lever

- A) In crane mode, "Derrick winch" is automatically activated.
- B) By default, this function is on the outer T-lever. "Jib luffing winch" must be additionally selected to enable this function on the left multi-directional control lever.

3.6 Right control lever

3.6.1 Function assignment of the right control lever on machine without derrick equipment*

Right multi-directional control lever



Assigned functions of control levers on a machine with two multi-directional control levers.

Function assignment of buttons on right multi-directional control lever

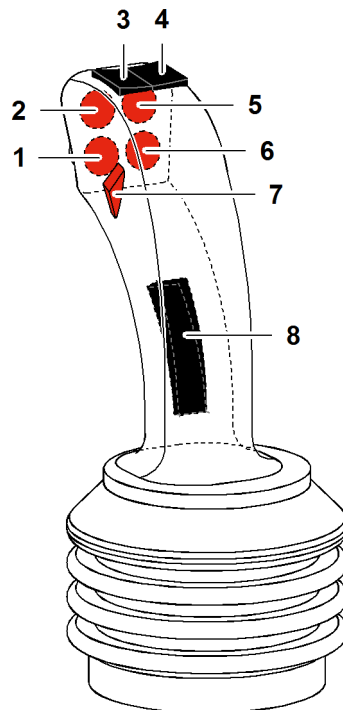














Fig. 998: Function assignment of buttons on right multi-directional control lever









Button	Mode	Preselection or additional button	Name and function
1	 Crane mode		[not used]
	 Assembly functions		[not used]

Control and operating elements

Right control lever

Button	Mode	Preselection or additional button	Name and function
2	 Crane mode		Save/delete constant engine RPM Save current diesel engine RPM as constant engine RPM or delete saved constant engine RPM.
	 Assembly functions		Save/delete constant engine RPM Save current diesel engine RPM as constant engine RPM or delete saved constant engine RPM.
3	 Crane mode		Increase RPM Increase diesel engine RPM.
	 Assembly functions		Increase RPM Increase diesel engine RPM.
4	 Crane mode		Decrease RPM Decrease diesel engine RPM.
	 Assembly functions		Decrease RPM Decrease diesel engine RPM.
5	 Crane mode		Jib luffing winch Activate/deactivate jib luffing winch.
	 Assembly functions		Jib luffing winch Activate/deactivate jib luffing winch.
6	 Crane mode		Winch synchronization Activates/deactivates winch synchronization.
	 Assembly functions		Winch synchronization Activates/deactivates winch synchronization.

LWN/LR-x/V04.01//Auslieferung/2016-03-07/en

Button	Mode	Preselection or additional button	Name and function
7	 Crane mode		[not used]
	 Assembly functions		[not used]
8	 Crane mode	 Horizontal load path/ Vertical Line Finder winch1 or  Horizontal load path/ Vertical Line Finder winch2	Activate horizontal load path horizontal load path for winch1 or winch2.
	 Assembly functions	 Horizontal load path/ Vertical Line Finder winch1 or  Horizontal load path/ Vertical Line Finder winch2	Activate horizontal load path horizontal load path for winch1 or winch2.

Tab. 357: Function assignment of buttons on right multi-directional control lever

Assigned functions for movement directions on right-hand multi-directional joystick

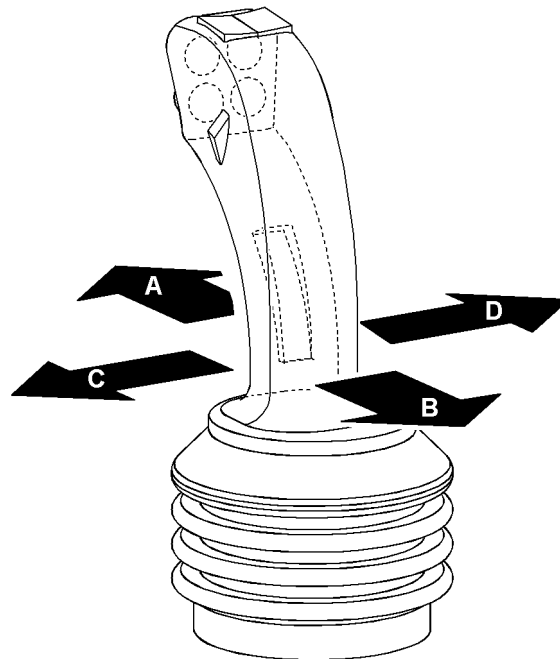



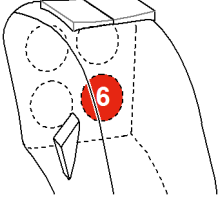



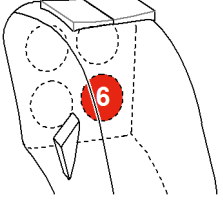





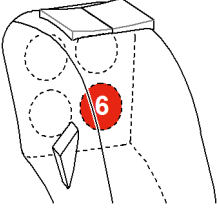



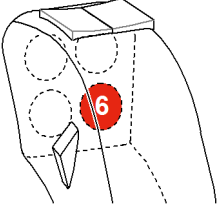
Fig. 1019: Function assignment of movement directions on right multi-directional control lever

Direction of movement	Mode	Preselection or additional button	Function
A	 Crane mode		Lower winch1
	 Crane mode	 Winch synchronization or 	Lower winch1 and winch2
	 Assembly functions		Lower winch1
	 Assembly functions	 Winch synchronization or 	Lower winch1 and winch2




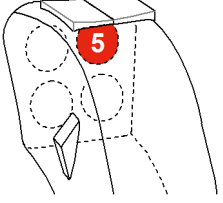


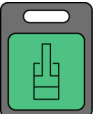
LWNLR.x/V04.01//Auslieferung/2016-03-07/en

Control and operating elements




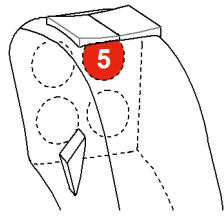



Right control lever

Direction of movement	Mode	Preselection or additional button	Function
B	 Crane mode		Lifting winch1
	 Crane mode	 Winch synchronization or 	Lift winch1 and winch2
	 Assembly functions		Lifting winch1
	 Assembly functions	 Winch synchronization or 	Lift winch1 and winch2

LWNLR-x/V04.01//Auslieferung/2016-03-07/en

Direction of movement	Mode	Preselection or additional button	Function
	 Crane mode		Lift main boom
C	 Crane mode	 Jib luffing winch or 	Lift jib
	 Assembly functions	 Extend A-frame1 cylinder and  Cylinder adjustment functions	Lift main boom

LWNLR.x/V04.01//Auslieferung/2016-03-07/en

Direction of movement	Mode	Preselection or additional button	Function
D	 Crane mode		Lower main boom
	 Crane mode	 Jib luffing winch or 	Lower jib
	 Assembly functions	 Extend A-frame1 cylinder and  Cylinder adjustment functions	Lower main boom

Tab. 358: Function assignment of movement directions on right multi-directional control lever

Right double T-lever



Assigned functions of the control levers on a machine with a multi-directional control lever and a double T-lever.

Function assignment of buttons on right double T-lever

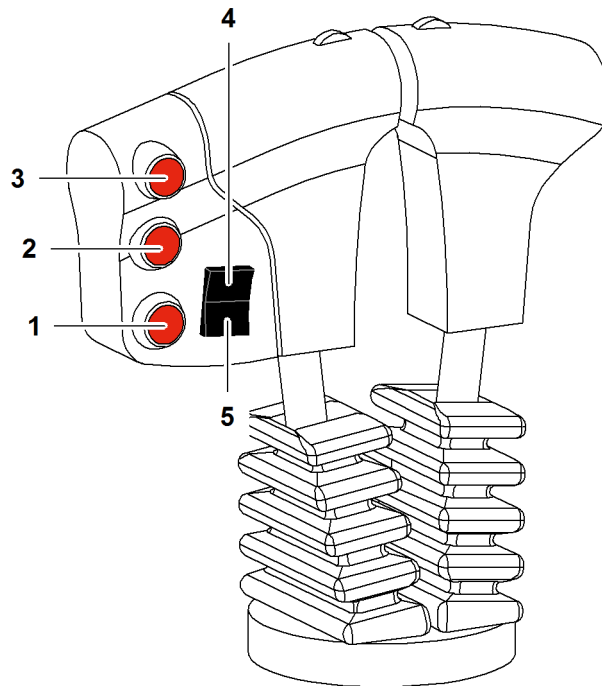












Fig. 1051: Function assignment of buttons on right double T-lever

Button	Mode	Preselection or additional button	Name and function
1	 Crane mode		Save/delete constant engine RPM Save current diesel engine RPM as constant engine RPM or delete saved constant engine RPM.
	 Assembly functions		Save/delete constant engine RPM Save current diesel engine RPM as constant engine RPM or delete saved constant engine RPM.
2	 Crane mode		Winch synchronization Activates/deactivates winch synchronization.
	 Assembly functions		Winch synchronization Activates/deactivates winch synchronization.

Button	Mode	Preselection or additional button	Name and function
3	 Crane mode		Jib luffing winch Activate/deactivate jib luffing winch.
	 Assembly functions		Jib luffing winch Activate/deactivate jib luffing winch.
4	 Crane mode		Increase RPM Increase diesel engine RPM.
	 Assembly functions		Increase RPM Increase diesel engine RPM.
5	 Crane mode		Decrease RPM Decrease diesel engine RPM.
	 Assembly functions		Decrease RPM Decrease diesel engine RPM.

Tab. 359: Function assignment of buttons on right double T-lever

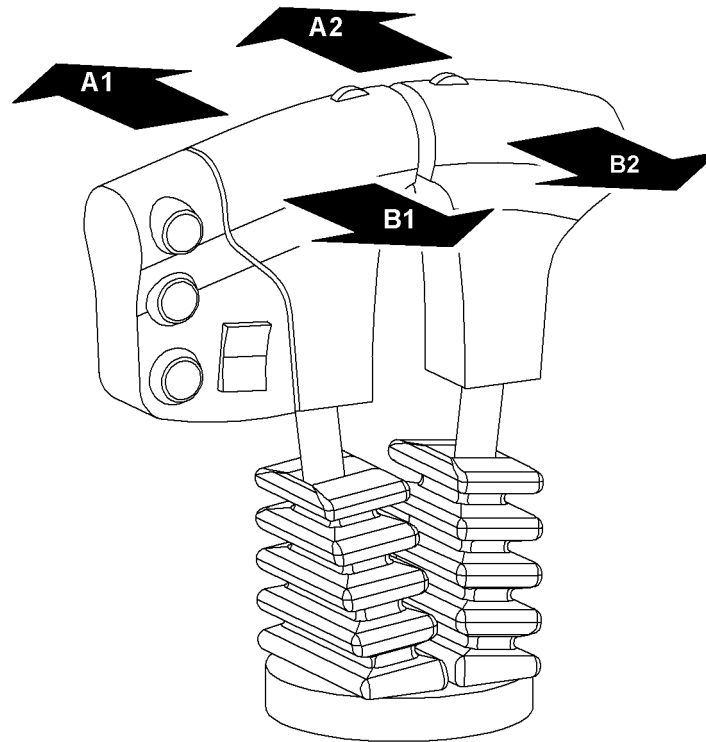



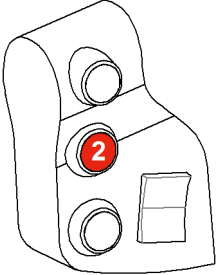



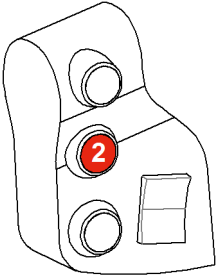
Assigned functions for movement directions on right-hand double T-lever




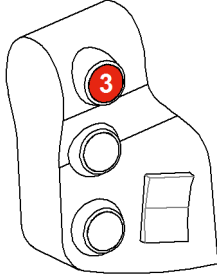



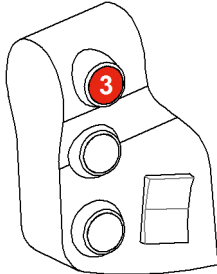


Fig. 1062: Function assignment for movement directions on right double T-lever

Control and operating elements

Right control lever

Direction of movement	Mode	Preselection or additional button	Function
A1	 Crane mode		Lower winch1
	 Crane mode	 Winch synchronization or 	Lower winch1 and winch2
	 Assembly functions		Lower winch1
	 Assembly functions	 Winch synchronization or 	Lower winch1 and winch2




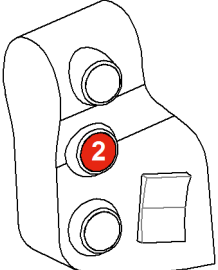



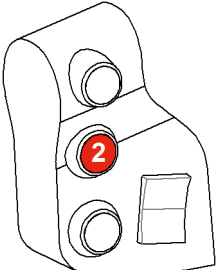
LWNLR-x/V04.01//Auslieferung/2016-03-07/en

Direction of movement	Mode	Preselection or additional button	Function
	 Crane mode		Lower winch2
	 Crane mode	 Jib luffing winch or 	Lower jib
A2	 Assembly functions		Lower winch2
	 Assembly functions	 Jib luffing winch or 	Lower jib
	 Assembly functions	 Assembly cylinder	Extend assembly cylinder




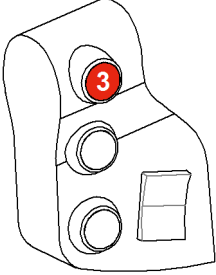


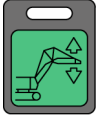
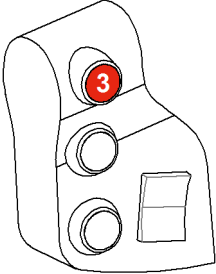

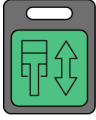
LWNLR.x/V04.01//Auslieferung/2016-03-07/en

Control and operating elements

Right control lever

Direction of movement	Mode	Preselection or additional button	Function
B1	 Crane mode		Lifting winch1
	 Crane mode	 Winch synchronization or 	Lift winch1 and winch2
	 Assembly functions		Lifting winch1
	 Assembly functions	 Winch synchronization or 	Lift winch1 and winch2

LWNLR-x/V04.01//Auslieferung/2016-03-07/en

Direction of movement	Mode	Preselection or additional button	Function
B2	 Crane mode		Lifting winch2
	 Crane mode	 Jib luffing winch or 	Lift jib
	 Assembly functions		Lifting winch2
	 Assembly functions	 Jib luffing winch or 	Lift jib
	 Assembly functions	 Assembly cylinder	Retract assembly cylinder

Tab. 360: Function assignment for movement directions on right double T-lever

LWNLR.x/V04.01//Auslieferung/2016-03-07/en

3.6.2 Function assignment of the right control lever on machine with derrick equipment*

Right multi-directional control lever



Function assignment of control levers on a machine with two multi-directional control levers

Function assignment of buttons on right multi-directional control lever

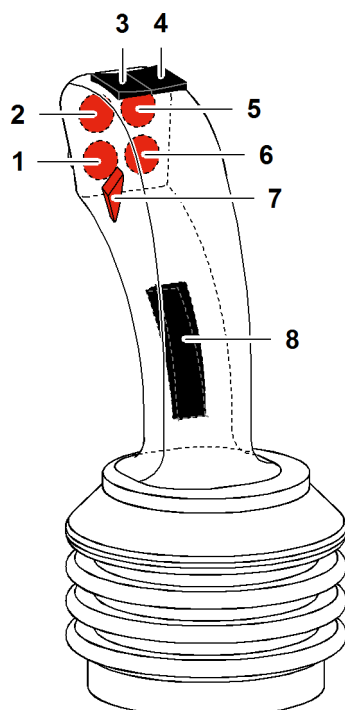






















Fig. 1100: Function assignment of buttons on right multi-directional control lever

Button	Mode	Preselection or additional button	Name and function
1	 Crane mode		[not used]
	 Assembly functions		[not used]

LWN/LR-x/V04.01//Auslieferung/2016-03-07/en

Button	Mode	Preselection or additional button	Name and function
2	 Crane mode		Save/delete constant engine RPM Save current diesel engine RPM as constant engine RPM or delete saved constant engine RPM.
	 Assembly functions		Save/delete constant engine RPM Save current diesel engine RPM as constant engine RPM or delete saved constant engine RPM.
3	 Crane mode		Increase RPM Increase diesel engine RPM.
	 Assembly functions		Increase RPM Increase diesel engine RPM.
4	 Crane mode		Decrease RPM Decrease diesel engine RPM.
	 Assembly functions		Decrease RPM Decrease diesel engine RPM.
5	 Crane mode		Jib luffing winch Activate/deactivate jib luffing winch.
	 Assembly functions		Jib luffing winch Activate/deactivate jib luffing winch.
6	 Crane mode		Winch synchronization Activates/deactivates winch synchronization.
	 Assembly functions		Winch synchronization Activates/deactivates winch synchronization.

Button	Mode	Preselection or additional button	Name and function
7	 Crane mode		[not used]
	 Assembly functions		[not used]
8	 Crane mode	 Horizontal load path/ Vertical Line Finder winch1 or  Horizontal load path/ Vertical Line Finder winch2	<p>Activate horizontal load path</p> <p>horizontal load path for winch1 or winch2.</p>
	 Assembly functions	 Horizontal load path/ Vertical Line Finder winch1 or  Horizontal load path/ Vertical Line Finder winch2	<p>Activate horizontal load path</p> <p>horizontal load path for winch1 or winch2.</p>

Tab. 361: Function assignment of buttons on right multi-directional control lever

LWNLR-x/V04.01//Auslieferung/2016-03-07/en

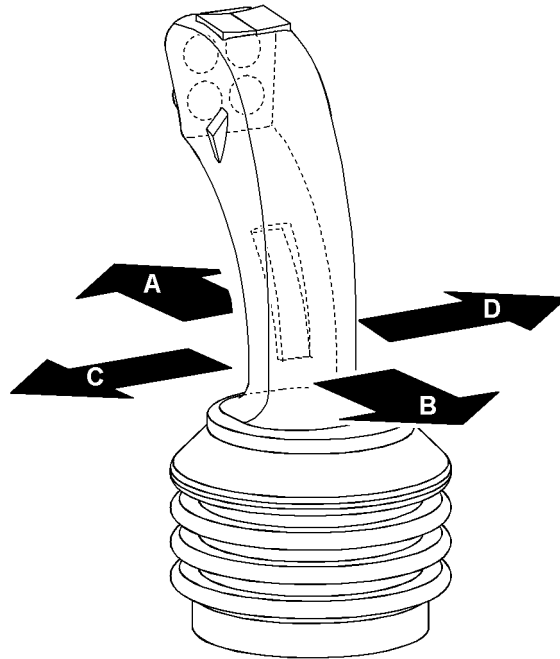



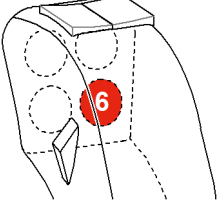



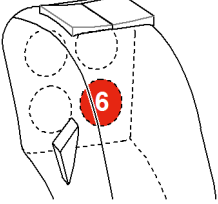
Function assignment of movement directions on right multi-directional control lever




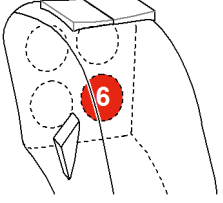



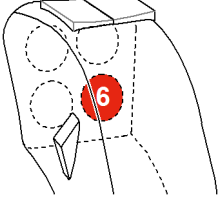
Fig. 1121: Function assignment of movement directions on right multi-directional control lever

Control and operating elements

Right control lever

Direction of movement	Mode	Preselection or additional button	Function
A	 Crane mode		Lower winch1
	 Crane mode	 Winch synchronization or 	Lower winch1 and winch2
	 Assembly functions		Lower winch1
	 Assembly functions	 Winch synchronization or 	Lower winch1 and winch2




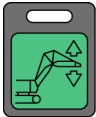
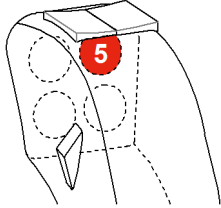


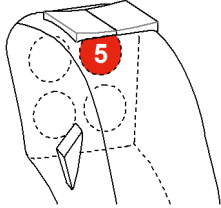


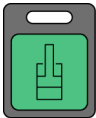
LWNLR-x/V04.01//Auslieferung/2016-03-07/en

Direction of movement	Mode	Preselection or additional button	Function
B	 Crane mode		Lifting winch1
	 Crane mode	 Winch synchronization or 	Lift winch1 and winch2
	 Assembly functions		Lifting winch1
	 Assembly functions	 Winch synchronization or 	Lift winch1 and winch2





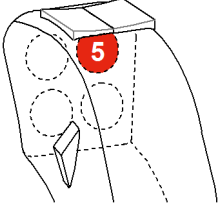


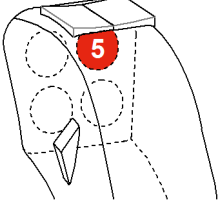



LWNLR.x/V04.01//Auslieferung/2016-03-07/en

Control and operating elements

Right control lever

Direction of movement	Mode	Preselection or additional button	Function
C	 Crane mode	 Derrick winch	Lift main boom ^{A)}
	 Crane mode	 Jib luffing winch or 	Lift jib
	 Assembly functions	 Jib luffing winch or 	Lift main boom ^{B)}
	 Assembly functions	 Extend A-frame1 cylinder and  Cylinder adjustment functions	Lift derrick boom

LWNLR-x/V04.01//Auslieferung/2016-03-07/en

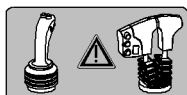
Direction of movement	Mode	Preselection or additional button	Function
D	 Crane mode	 Derrick winch	Lower main boom ^{A)}
	 Crane mode	 Jib luffing winch or 	Lower jib
	 Assembly functions	 Jib luffing winch or 	Lower main boom ^{B)}
	 Assembly functions	 Extend A-frame1 cylinder and  Cylinder adjustment functions	Lower derrick boom

Tab. 362: Function assignment of movement directions on right multi-directional control lever

A) In crane mode, "Derrick winch" is automatically activated.

B) By default, this function is on the left multi-directional control lever. "Jib luffing winch" must be additionally selected to enable this function on the right multi-directional control lever.

Right double T-lever



Function assignment of control levers on a machine with a multi-directional control lever and a double T-lever

Function assignment of buttons on right double T-lever

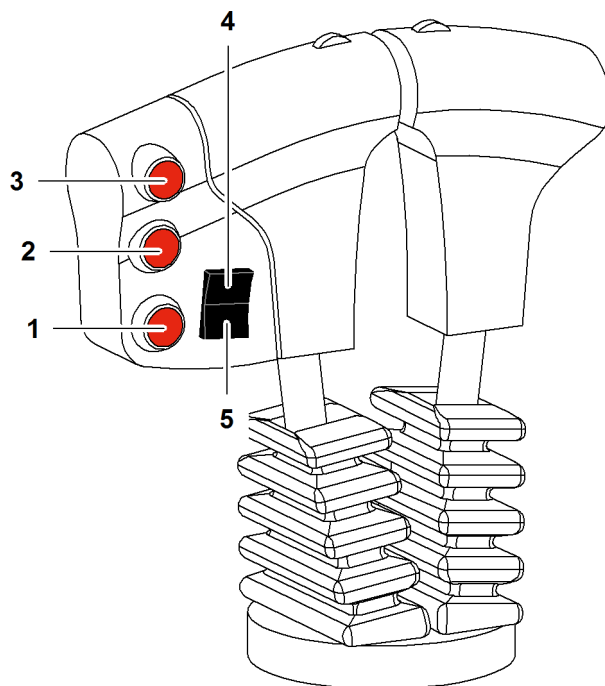












Fig. 1161: Function assignment of buttons on right double T-lever

Button	Mode	Preselection or additional button	Name and function
1	 Crane mode		Save/delete constant engine RPM Save current diesel engine RPM as constant engine RPM or delete saved constant engine RPM.
	 Assembly functions		Save/delete constant engine RPM Save current diesel engine RPM as constant engine RPM or delete saved constant engine RPM.
2	 Crane mode		Winch synchronization Activates/deactivates winch synchronization.
	 Assembly functions		Winch synchronization Activates/deactivates winch synchronization.

LWNLR-x/V04.01//Auslieferung/2016-03-07/en

Button	Mode	Preselection or additional button	Name and function
3	 Crane mode		Jib luffing winch Activate/deactivate jib luffing winch.
	 Assembly functions		Jib luffing winch Activate/deactivate jib luffing winch.
4	 Crane mode		Increase RPM Increase diesel engine RPM.
	 Assembly functions		Increase RPM Increase diesel engine RPM.
5	 Crane mode		Decrease RPM Decrease diesel engine RPM.
	 Assembly functions		Decrease RPM Decrease diesel engine RPM.

Tab. 363: Function assignment of buttons on right double T-lever

Function assignment for movement directions on right double T-lever

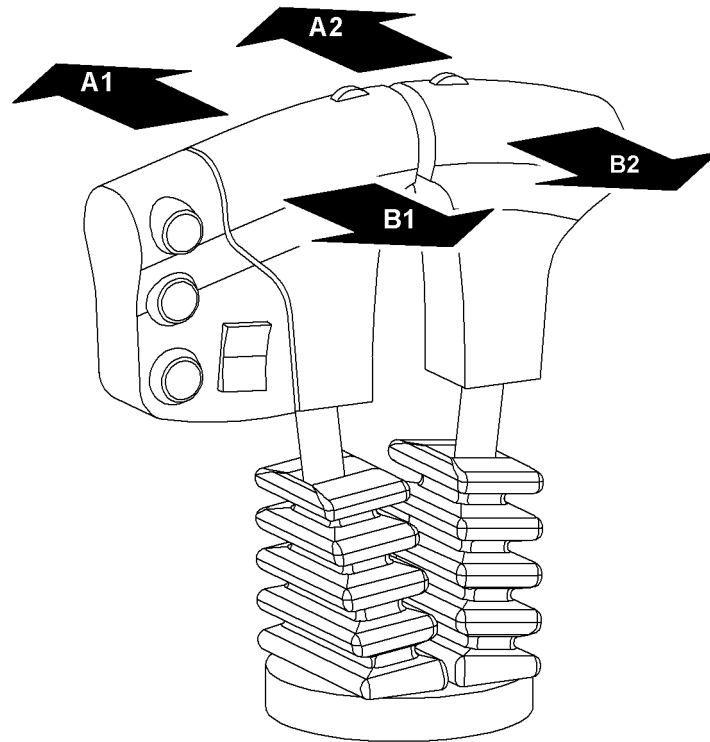



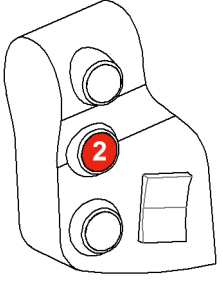



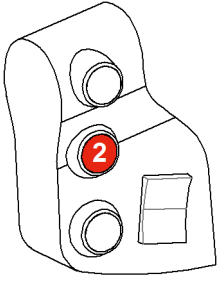





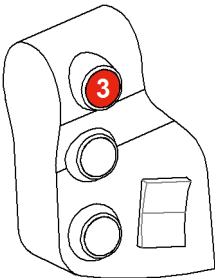




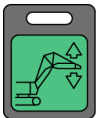
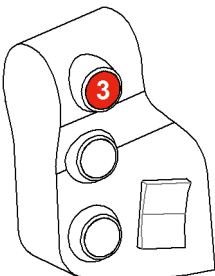


Fig. 1172: Function assignment for movement directions on right double T-lever

Direction of movement	Mode	Preselection or additional button	Function
A1	 Crane mode		Lower winch1
	 Crane mode	 Winch synchronization or 	Lower winch1 and winch2
	 Assembly functions		Lower winch1
	 Assembly functions	 Winch synchronization or 	Lower winch1 and winch2




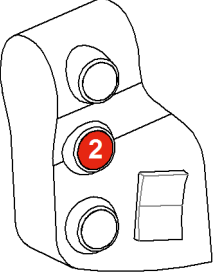



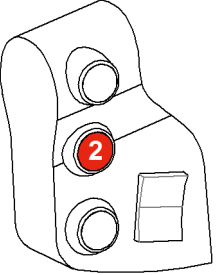
LWNLR.x/V04.01//Auslieferung/2016-03-07/en

Control and operating elements

Right control lever

Direction of movement	Mode	Preselection or additional button	Function
A2	 Crane mode		Lower winch2
	 Crane mode	 Jib luffing winch or 	Lower jib
	 Assembly functions		Lower winch2
	 Assembly functions	 Derrick winch	Lower main boom ^{A)}
	 Assembly functions	 Jib luffing winch or 	Lower jib
	 Assembly functions	 Assembly cylinder	Extend assembly cylinder




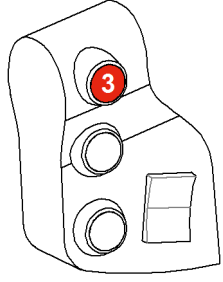





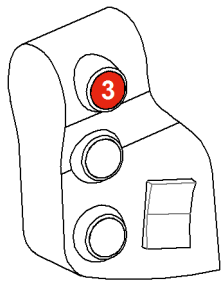


LWNLR-x/V04.01//Auslieferung/2016-03-07/en

Direction of movement	Mode	Preselection or additional button	Function
B1	 Crane mode		Lifting winch1
	 Crane mode	 Winch synchronization or 	Lift winch1 and winch2
	 Assembly functions		Lifting winch1
	 Assembly functions	 Winch synchronization or 	Lift winch1 and winch2

LWNLR.x/V04.01//Auslieferung/2016-03-07/en

Control and operating elements

Right control lever

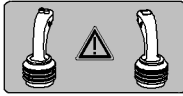
Direction of movement	Mode	Preselection or additional button	Function
B2	 Crane mode		Lifting winch2
	 Crane mode	 Jib luffing winch or 	Lift jib
	 Assembly functions		Lifting winch2
	 Assembly functions	 Derrick winch	Lift main boom ^{A)}
	 Assembly functions	 Jib luffing winch or 	Lift jib
	 Assembly functions	 Assembly cylinder	Retract assembly cylinder

Tab. 364: Function assignment for movement directions on right double T-lever

LWNLR-x/V04.01//Auslieferung/2016-03-07/en

- A) By default, this function is on the outer T-lever. "Jib luffing winch" must be additionally selected to enable this function on the left multi-directional control lever.

3.7 Foot pedals and hand levers



Assigned functions of the foot pedals and hand lever on a machine with two multi-directional joysticks.

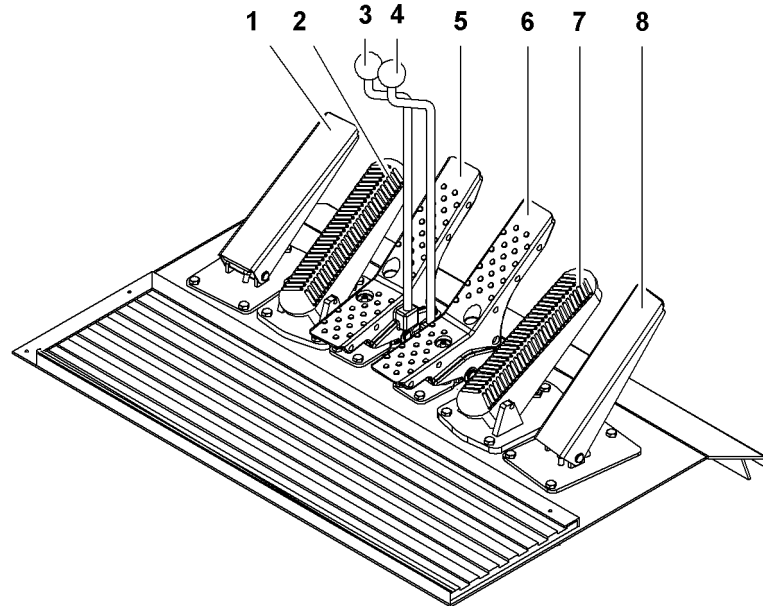
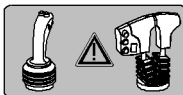


Fig. 1214: Foot pedals and hand levers (multi-directional joystick)

- | | | | |
|---|-------------------------------------|---|--------------------------------------|
| 1 | Foot pedal for <i>tagline winch</i> | 5 | Foot pedal for <i>left crawler</i> |
| 2 | Foot pedal <i>brake winch2</i> | 6 | Foot pedal for <i>right crawler</i> |
| 3 | Hand lever for <i>left crawler</i> | 7 | Foot pedal <i>brake winch1</i> |
| 4 | Hand lever for <i>right crawler</i> | 8 | Foot pedal for <i>rotation speed</i> |



Assigned functions of the foot pedals and hand levers on a machine with a multi-directional joystick and a double T-lever.

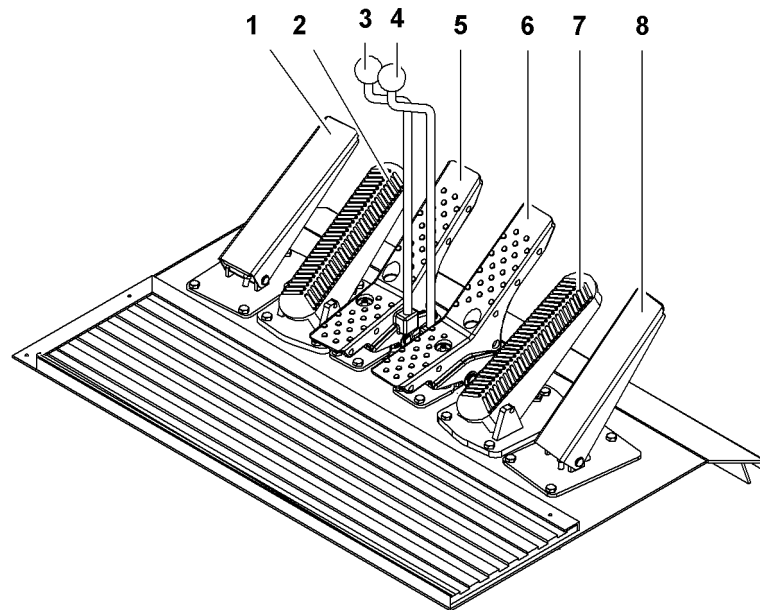


Fig. 1216: Foot pedals and hand levers (double T-lever)

- | | | | |
|---|-------------------------------------|---|--------------------------------------|
| 1 | Foot pedal for <i>tagline winch</i> | 5 | Foot pedal for <i>left crawler</i> |
| 2 | Foot pedal <i>brake winch1</i> | 6 | Foot pedal for <i>right crawler</i> |
| 3 | Hand lever for <i>left crawler</i> | 7 | Foot pedal <i>brake winch2</i> |
| 4 | Hand lever for <i>right crawler</i> | 8 | Foot pedal for <i>rotation speed</i> |

3.8 Control panel X11

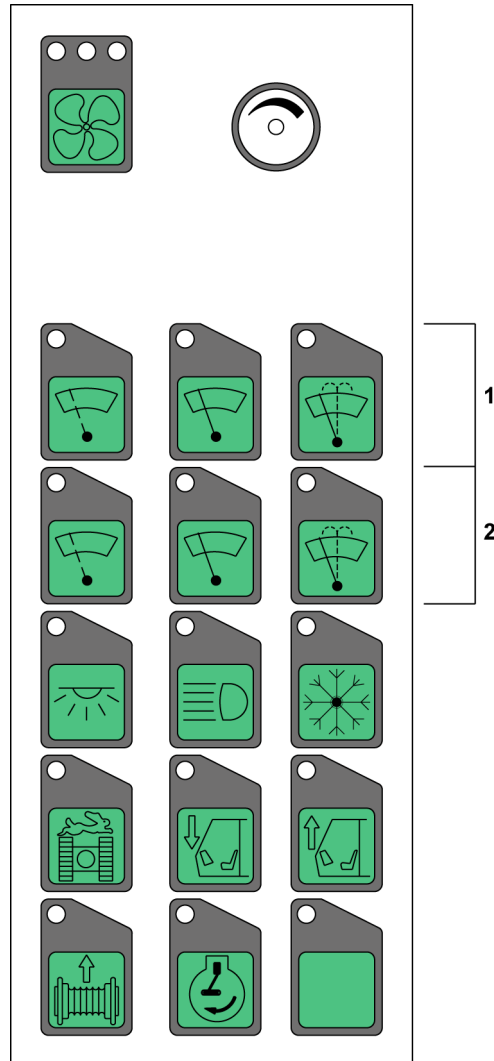
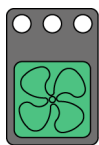


Fig. 1217: Control panel X11

- 1 Front windscreen wiper
- 2 Roof windscreen wiper

All buttons and switches contain LEDs that visibly indicate which function or settings are currently active.



Heating and air conditioning system fan speed

Controlling the blower stages for heating or air conditioning system.



Heating and air conditioning system temperature

Controlling the temperature for heating or air conditioning system.



Intermittent windscreen wiper

Switching the pertaining windscreen wiper to interval mode.

LWNLR-x/V04.01//Auslieferung/2016-03-07/en

**Windscreen wiper**

Switching the pertaining windshield wiper on or off.

**Windscreen wash system**

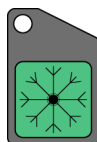
Turning the windscreen wiper system on or off.

**Engine compartment lighting**

Turn the engine compartment lighting on or off.

**Floodlights on uppercarriage**

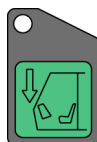
Turning the floodlight on the uppercarriage on or off.

**Air conditioning**

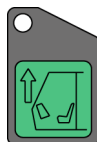
Turning the air conditioning system on or off.

**Crawlers overdrive**

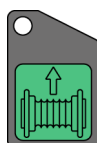
Turning the overdrive of the crawler on or off.

**Cab tilting device down**

Tilting the cabin downwards.

**Cab tilting device up**

Tilting the cabin upwards.

**Rope reeving winch**

Turning the rope reeving winch on or off with activated assembly functions.

**Additional compressor**

Turning the additional compressor on or off.

3.9 Control panel X12

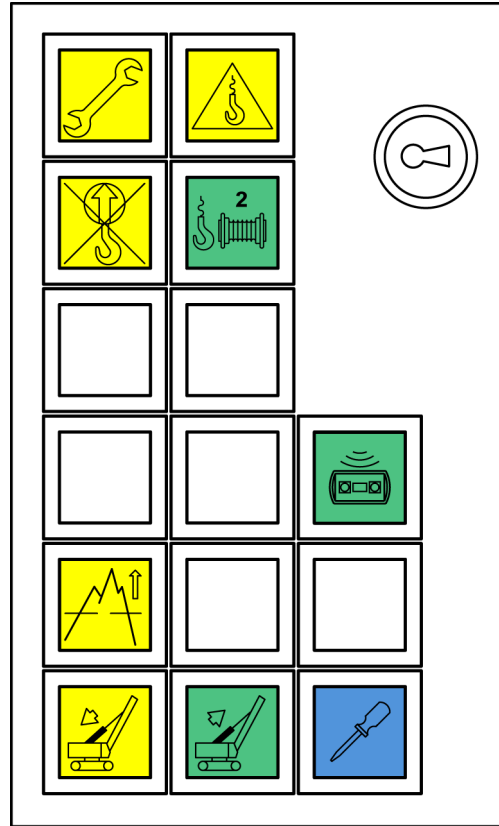


Fig. 1231: Control panel X12

All buttons and switches contain LEDs that visibly indicate which function or settings are currently active.



Assembly functions

Turning assembly functions on or off.



Unsecured free-fall operation

Turning unsecured free-fall mode for winch1 and winch2 on or off.



Load moment limitation shut down key switch release

Switch the function of the button *Load moment limiter assembly/self-lock* on control panel X23 to the function *Load moment limiter shutdown*.

The *load moment limiter shut down enable* switch has no effect on machines with a CE load chart.



Interlock control winch2

[Not assigned]



Radio remote control

The function of the ignition key on the machine is replicated on the key switch on the radio remote control.

LWN/LR-x/V04.01//Auslieferung/2016-03-07/en

**Retract the tilting back support cylinders**

Retracting the tilting-back support cylinders for the main boom. Manual operation is exclusively possible when assembly mode functions are switched on.

**Extend the tilting back support cylinders**

Extending the tilting-back support cylinders for the main boom.

**Mode**

Switch mode.

**Application height**

Switching the application height of the auxiliary heating.

If the machine is used at altitudes above 2800 m (9186' 4" ft-in), the auxiliary heating must be switched.

3.10 Control panel X23

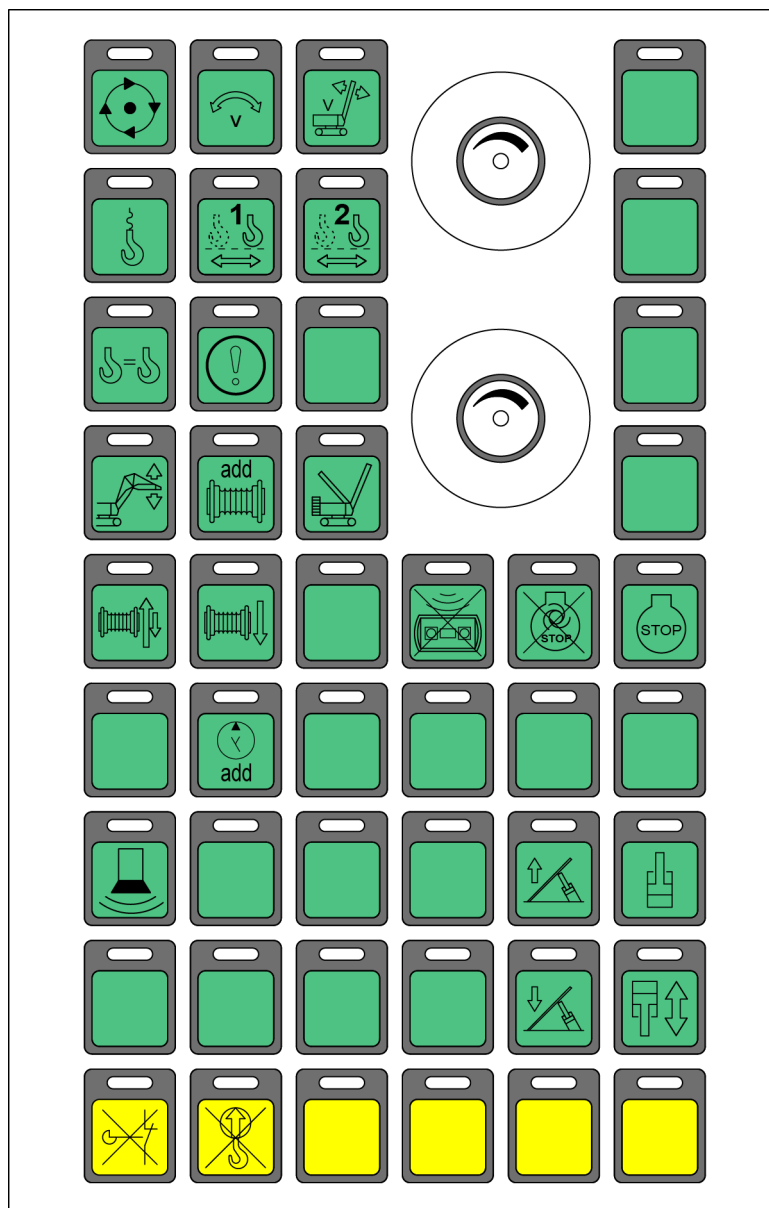


Fig. 1241: Control panel X23

All buttons and switches contain LEDs that visibly indicate which function or settings are currently active.



Swing free-wheel

Turn the swing free-wheel on or off.



Swing speed level

Select speed level for the slewing gear.

**Speed level boom adjustment**

Selects the speed level for boom adjustment.

**Free fall**

Turn free-fall mode for winch1 and winch2 on or off.

**Horizontal load path/Vertical Line Finder winch1**

Activate or deactivate horizontal load path for winch1.

Activate or deactivate Vertical Line Finder for winch1.

**Horizontal load path/Vertical Line Finder winch2**

Activate or deactivate horizontal load path for winch2.

Activate or deactivate Vertical Line Finder for winch2.

**Winch synchronization**

Turn the winch synchronization on or off.

**Sensitive lift**

Activates/deactivates the function sensitive lift.

**Jib luffing winch**

Activates/deactivates the jib luffing winch.

**Additional winch**

Turn the additional winch on or off.

**Derrick winch**

Activates/deactivates the derrick winch.

**Tagline winch**

Turns the tagline winch on or off.

**Constant pull**

Turns the constant pull for winch1 or winch2 on or off.

**Take/cede control**

Take or release control of/on the radio remote control.

**Diesel engine automatic stop system**

Switch diesel engine automatic stop system on or off.



Engine stop

Switch off diesel engine.



Generator

Turn the generator on or off.



Hammer/vibrator

Turns the hammer/vibrator on or off.



Extend A-frame1 cylinder

Extend A-frame1 cylinder. Works exclusively when assembly mode functions are switched on.



Cylinder adjustment functions

Activate/deactivate cylinder adjustment functions on undercarriage/uppercarriage.



Retract A-frame1 cylinder

Retract A-frame1 cylinder. Works exclusively when assembly mode functions are switched on.



Assembly cylinder

Activates/deactivates the assembly cylinder.



Bypass limit switch

Bypasses certain limit switches when rigging, converting and unrigging the boom with activated assembly function.



Load moment limiter assembly/self-lock

Turns the function load moment limiter assembly or load moment limiter self-lock on and off.

With machines with an ANSI load chart and after selection of the *Load moment limiter shut down enable*, the *Load moment limiter assembly/self-lock* button enables the load moment limiter shut down function.

3.11 Control panel X26 for counterweight carriage*

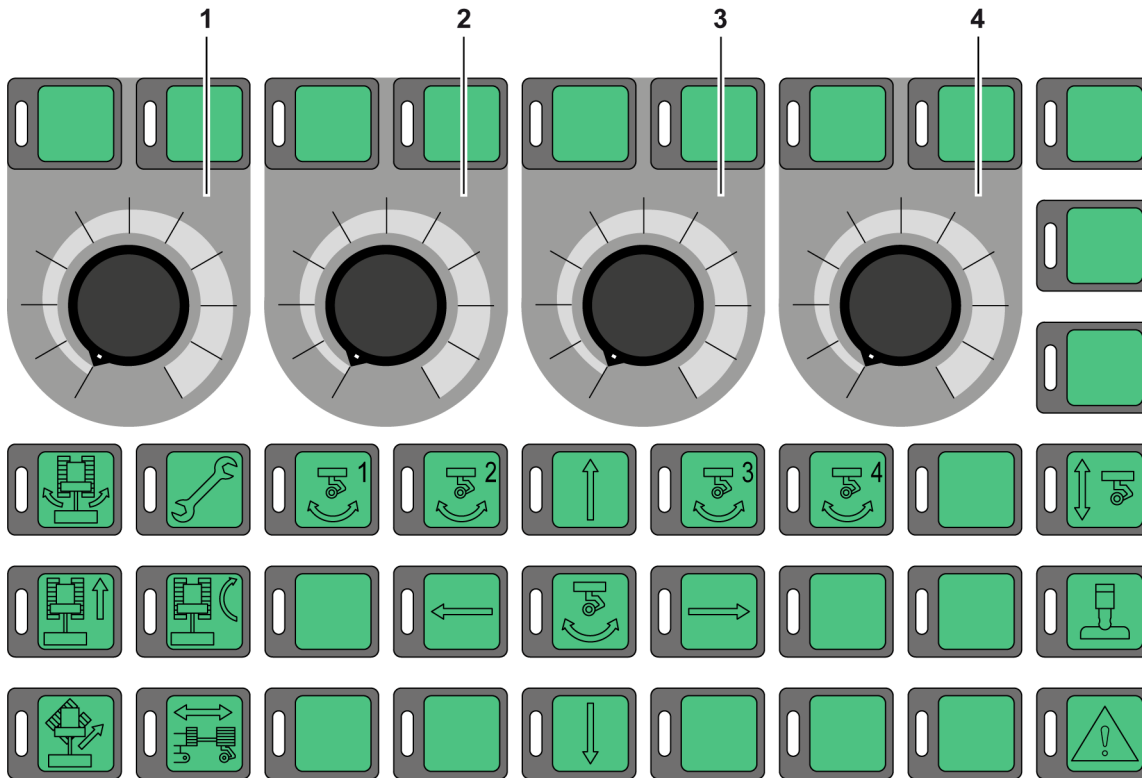


Fig. 1266: Control panel X26 for counterweight carriage*

- | | | | |
|---|--------------------------------------|---|--------------------------------------|
| 1 | Control unit <i>first wheel set</i> | 3 | Control unit <i>third wheel set</i> |
| 2 | Control unit <i>second wheel set</i> | 4 | Control unit <i>fourth wheel set</i> |

All buttons and switches contain LEDs that visibly indicate which function or settings are currently active.

3.11.1 Operating units

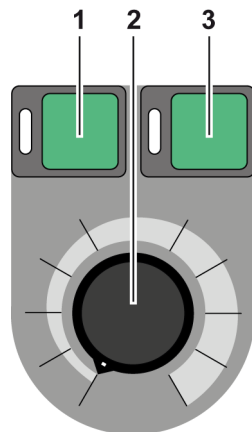
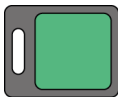


Fig. 1267: Wheel set operating unit

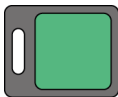
- | | |
|---|---|
| <p>1 Turn the button <i>wheel set counter-clockwise</i></p> <p>2 [Not used]</p> | <p>3 Turn the button <i>wheel set clockwise</i></p> |
|---|---|



Turn wheel set counter-clockwise

Button not used.

LED in the button is lit when the wheel set moves counter-clockwise.

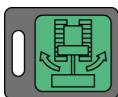


Turn wheel set clockwise

Button not used.

LED in the button is lit when the wheel set turns clockwise.

3.11.2 Buttons



Mode rotate uppercarriage

Activates/deactivates rotate uppercarriage mode.

Wheel sets align to uppercarriage swing.



Counterweight carriage assembly functions

Activate/deactivate assembly functions of counterweight carriage.



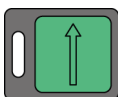
First wheel set

Select first wheel set (e.g. for service purposes).



Second wheel set

Select second wheel set (e.g. for service purposes).



Decreasing radius/support

Decrease radius of counterweight carriage.

Decrease support of counterweight carriage.

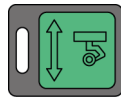


Third wheel set

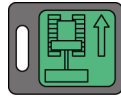
Select third wheel set (e.g. for service purposes).

**Fourth wheel set**

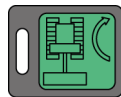
Select fourth wheel set (e.g. for service purposes).

**Wheel set height adjustment**

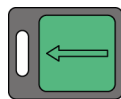
Activates/deactivates height adjustment of the wheel sets.
Height adjustment is operated on counterweight carriage.

**Trailer travel mode**

Activates/deactivates trailer travel mode.

**Follower travel mode**

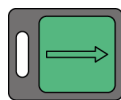
Activates/deactivates follower travel mode.

**Turning the wheel sets counter-clockwise**

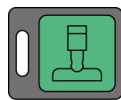
Turns the wheel sets counter-clockwise.

**Align wheel sets**

Align wheel sets in line with selected mode.
If no mode was selected, all wheel sets can be aligned manually.

**Turning the wheel sets clockwise**

Turns the wheel sets clockwise.

**Counterweight carriage support**

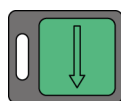
Activates/deactivates counterweight carriage support.

**Crab mode**

Activates/deactivates crab mode.

**Counterweight carriage radius adjustment**

Activates/deactivates radius adjustment of counterweight carriage.

**Increasing radius/support**

Increases the radius of the counterweight carriage.
Increases the support of the counterweight carriage.

**Confirming error message**

Confirms error message and releases operating lock.

3.12 Monitor

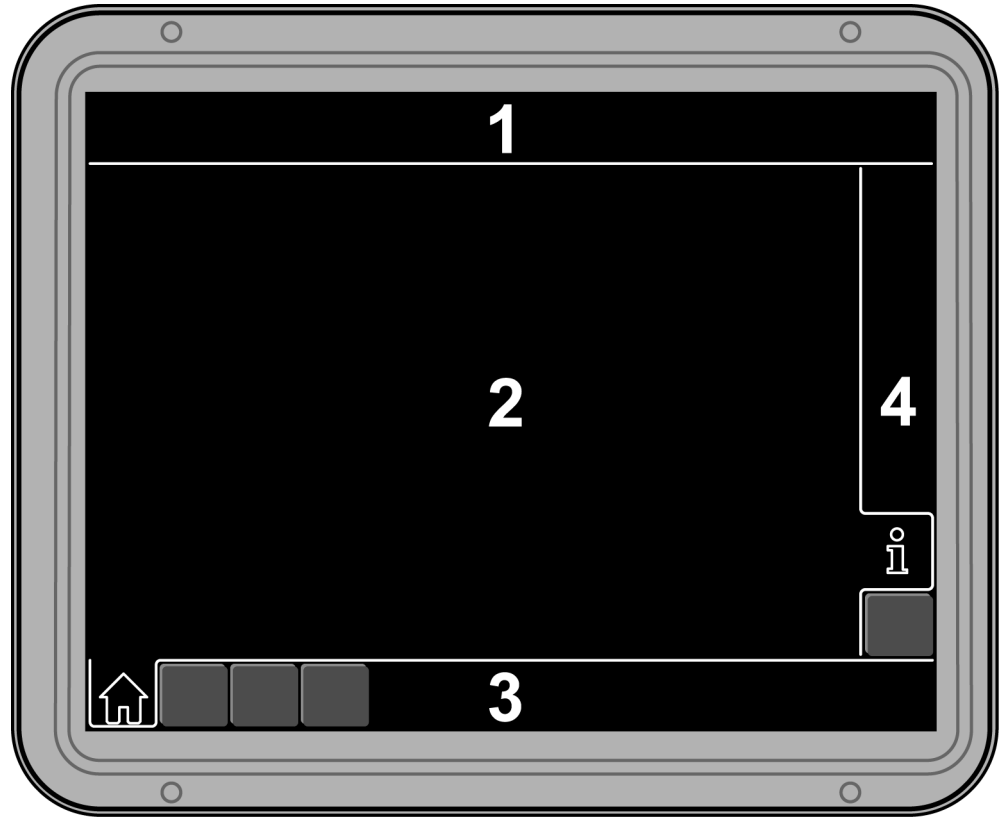


Fig. 1288: Monitor sections

- | | | | |
|---|-----------------|---|-------------|
| 1 | Status bar | 3 | Menu bar |
| 2 | Display section | 4 | Submenu bar |

3.12.1 Status bar

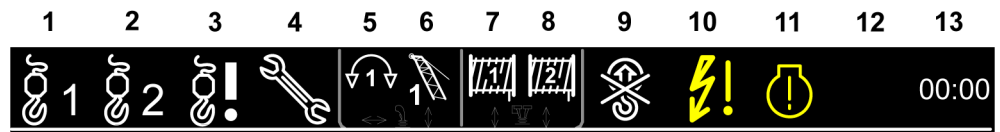


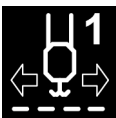
Fig. 1289: Status bar - positioning

Position 1



Free fall winch 1

Winch 1 is in free fall.



Horizontal load path winch1

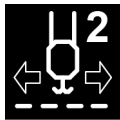
Horizontal load path for winch1 is activated.

**Sensitive lift (blinks)**

Sensitive lift is activated.

Position 2**Free fall winch 2**

Winch 2 is in free fall.

**Horizontal load path winch2**

Horizontal load path for winch2 is activated.

Position 3**Secured free-fall operation**

Secured free-fall mode activated.

**Unsecured free-fall operation**

Unsecured free-fall mode activated.

**Radio remote control* active**

Radio remote control is turned on.

Machine functions are controlled with the radio remote control.

If the symbol blinks, the control of the machine function is suspended.

**Radio remote control* inactive**

Radio remote control is turned on.

Machine functions are controlled from the cabin.

**Radio remote control* connection error**

Connection to radio remote control not possible.

Position 4**Assembly functions**

Assembly functions are switched on.

**Emergency operation control***

Control panel of the emergency operation control is connected.

Position 5



Swing speed level

Speed level 1 for the swing is set.



Swing speed level

Speed level 2 for the swing is set.



Swing speed level

Speed level 3 for the swing is set.



Swing free-wheel

Swing free-wheel is switched on.



Swing locked

Swing is locked.

Position 6



Assignment on a machine with two multi-directional control levers



Winch2

Winch2 is selected.



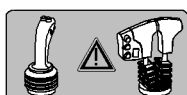
Winch2 locked

Winch2 is locked.



Derrick hoist cylinder (only in derrick mode)

Derrick hoist cylinder is selected.



Assignment on a machine with a multi-directional control lever and a double T-lever.



Speed level main boom

Speed level 1 is selected for the main boom.



Speed level main boom

Speed level 2 is selected for the main boom.



Speed level main boom

Speed level 3 is selected for the main boom.



Main boom locked

Main boom is locked.

**Speed level jib**

Speed level 1 is set for the jib.

**Speed level jib**

Speed level 2 is set for the jib.

**Speed level jib**

Speed level 3 is set for the jib.

**Derrick boom** (only in derrick mode)

Derrick boom is selected.

**Derrick hoist cylinder** (only in derrick mode)

Derrick hoist cylinder is selected.

Position 7**Assignment on a machine with two multi-directional control levers****Speed level main boom**

Speed level 1 is selected for the main boom.

**Speed level main boom**

Speed level 2 is selected for the main boom.

**Speed level main boom**

Speed level 3 is selected for the main boom.

**Main boom locked**

Main boom is locked.

**Speed level jib**

Speed level 1 is set for the jib.

**Speed level jib**

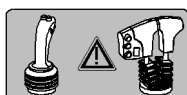
Speed level 2 is set for the jib.

**Speed level jib**

Speed level 3 is set for the jib.

**Derrick boom** (only in derrick mode)

Derrick boom is selected.

**Assignment on a machine with a multi-directional control lever and a double T-lever.**



winch1

Winch1 is selected.



Winch1 locked

Winch1 is locked.



Winch synchronization

Winch synchronization is switched on.

Position 8



Assignment on a machine with two multi-directional control levers



Winch1

Winch1 is selected.



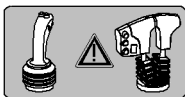
Winch1 locked

Winch1 is locked.



Winch synchronization

Winch synchronization is switched on.



Assignment on a machine with a multi-directional control lever and a double T-lever.



Winch2

Winch2 is selected.



Winch2 locked

Winch2 is locked.

Position 9



Deactivating the load moment limiter

Load moment limiter is turned off.



Load moment limiter warning (lit yellow)

Load moment is utilized to more than 90% capacity.



Stop load moment limiter (blinks red)

Load moment is utilized to more than 100 % capacity.

**Danger of toppling backwards** (lit red)

Machine may topple backwards due to insufficient radius.

Position 10**Electrical system warning** (lit yellow)

An error has occurred in the electronics.

**Electrical system error** (blinks red)

An error has occurred in the electrical system.

Position 11**General diesel engine error** (lit yellow)

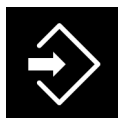
General diesel engine error has occurred.

**Grave diesel engine error** (blinks red)

A grave diesel engine error has occurred.

Position 12**Assist crane required** (blinks)

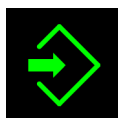
Assist crane is required to erect the boom or lay down the boom.

**Data recording active**

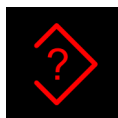
Data are recorded.

**Initialize data recording** (lit yellow)

Data recording is being initialized.

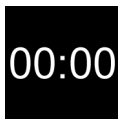
**Data recording successfully initialized** (lit green)

Data recording was initialized successfully.

**Data recording error** (lit red)

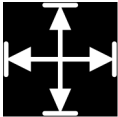
Error in data recording.

Position 13



Time

Current time.



Drive limited (blinks)

Several limit switches block the current movement direction of the control lever. If only one limit switch blocks the current movement direction of the control lever, the symbol of the corresponding limit switch blinks in place of the symbol *Drive limited*.



A-frame1, rear limit switch (blinks)

Minimum A-frame1 angle reached. Lift main boom is blocked.



Main boom, top limit switch (blinks)

Maximum main boom angle reached. Lift main boom is blocked.



Main boom, bottom limit switch (blinks)

Minimum main boom angle reached. Lower main boom is blocked.



Main boom, top angle limiter (blinks)

Maximum main boom angle exceeded. Lift main boom is blocked.



Main boom, bottom angle limiter (blinks)

Minimum main boom angle exceeded. Lower main boom is blocked.



Jib, top limit switch (blinks)

Maximum jib angle reached. Lift jib is blocked.



Jib, bottom limit switch (blinks)

Minimum jib angle reached. Lower jib is blocked.



Jib, top angle limiter (blinks)

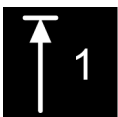
Maximum jib angle exceeded. Lift jib and lower jib are locked.

Jib can only be lowered with the *Bypass limit switch* button on control panel X23.



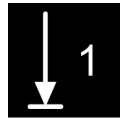
Jib, bottom angle limiter (blinks)

Minimum jib angle exceeded. Lower jib is blocked.

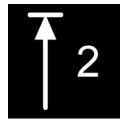


Winch1, top limit switch (blinks)

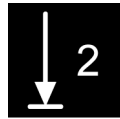
Maximum lifting height of winch1 reached. Lift winch1, lower main boom and lower jib are blocked.

**Winch1, bottom limit switch** (blinks)

Only three windings left on rope drum of winch1. Lower winch1 is blocked.

**Winch2, top limit switch** (blinks)

Maximum lifting height of winch2 reached. Lift winch2, lower main boom and lower jib are blocked.

**Winch2, bottom limit switch** (blinks)

Only three windings left on rope drum of winch2. Lower winch2 is blocked.

**Auxiliary winch, top limit switch** (blinks)

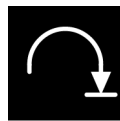
Maximum lifting height of auxiliary winch reached. Lift auxiliary winch is blocked.

**Auxiliary winch, bottom limit switch** (blinks)

Only three windings left on rope drum of auxiliary winch. Lower auxiliary winch is blocked.

**Swing, slewing range limitation counter-clockwise** (blinks)

Counter-clockwise slewing range limitation has been reached. Turning the upper-carriage counter-clockwise is locked.

**Swing, slewing range limitation clockwise** (blinks)

Clockwise slewing range limitation has been reached. Turning the uppercarriage clockwise is locked.

**Tilting back supports cylinder** (blinks)

Tilting-back support cylinders are not fully extended. Lift main boom is blocked.

**A-frame1 cylinder** (blinks)

A-frame1 cylinders are not fully extended (only if assembly mode functions are switched on). Lift and lower main boom are blocked.

**Locking flaps error** (blinks)

Main boom with luffing jib erected above a specified angle and locking flaps are not yet in proper position. Lift main boom and jib are blocked.

**Winch blocked due to selection of different load position** (blinks)

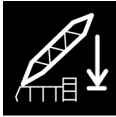
Winch is blocked due to different load position.

**Slack rope monitoring** (blinks)

Stop due to slack rope monitoring has triggered.

**Derrick boom, rear limit switch** (blinks, only in derrick mode)

Minimum derrick boom angle has been reached (only with activated assembly functions). Lift derrick boom is blocked.



Derrick boom, working position limit switch (blinks, only in derrick mode)

Derrick boom is not in working position.



Derrick winch, bottom limit switch (blinks, only in derrick mode)

Only three windings left on rope drum of Derrick winch. Lower derrick winch is blocked.



External control limit switch (blinks)

Limit switch was triggered by external control.

3.12.2 Display section

The display section provides information about current machine parameters.

3.12.3 Menu bar

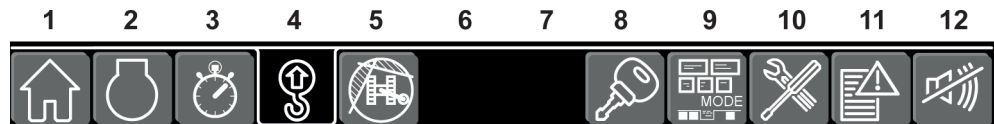


Fig. 1382: Menu bar - positioning

Position 1



Operation

Switch to the *Operation* screen.



Operation (blinks yellow)

Switch to the screen *Operation*. There is at least one warning.



Operation (blinks red)

Switch to the *Operation* screen. There is at least one operation error.

Position 2



Aggregate

Switch to the *Aggregate* screen.



Aggregate (blinks yellow)

Switch to the *Aggregate* screen. There is at least one warning.



Aggregate (blinks red)

Switch to the *Aggregate* screen. There is at least one operation error.

Position 3



Operating hours

Switch to the *Operating hours* screen.



Operating hours (blinks yellow)

Switch to the *Operating hours* screen. There is at least one warning.



Operating hours (blinks red)

Switch to the *Operating hours* screen. There is at least one operation error.

Position 4



Setup

Switch to the *Setup* screen.

Position 5



Working range limitation

Switch to the *Working range limitation* screen.



Working range limitation (blinks yellow)

Switch to the *Working range limitation* screen. Machine was moved and working range limitation must be reprogrammed.

Position 8



Access control

Switch to the *Access control* screen.

Position 9



Mode

Switch to the *Mode* screen.

Position 10



Settings

Switch to the *Settings* screen.

Position 11



Error messages

Switch to the *Error messages* screen.



Error messages (blinks red)

Switch to the screen *Error messages*. At least one unconfirmed error message is present.

Position 12



Warning buzzer

Turn off warning buzzer and confirm error message. Only visible if an operation error occurs.

3.12.4 Submenu bar



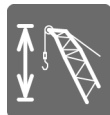
Setup - load chart

Switch to the screen *Setup - load chart*.



Working range limitation - working range limitation

Switch to the *Working range limitation - working range limitation* screen.



Working range limitation - lifting height limitation

Switch to the *Working range limitation - lifting height limitation* screen.



Settings - Litronic testing system

Switch to the *Settings - Litronic testing system* screen.



Settings - units

Switch to the *Settings - units* screen.



Settings - components

Switch to the *Settings - components* screen.

3.13 Screen Start

These symbols appear on the start screen as soon as the machine is switched on. No action possible during start-up.

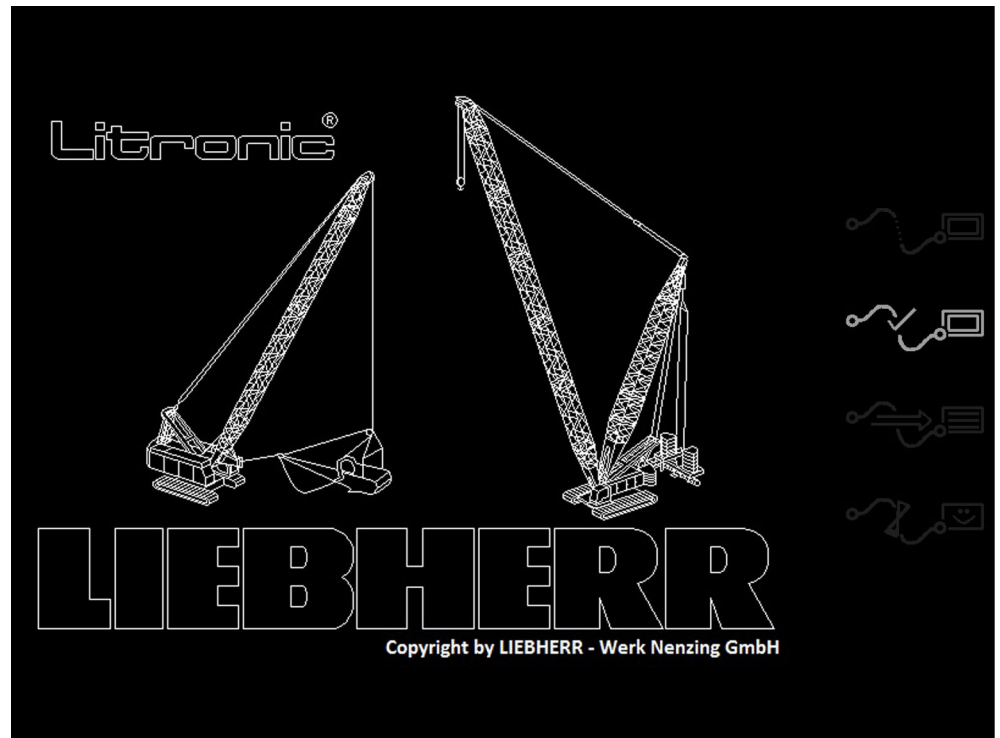
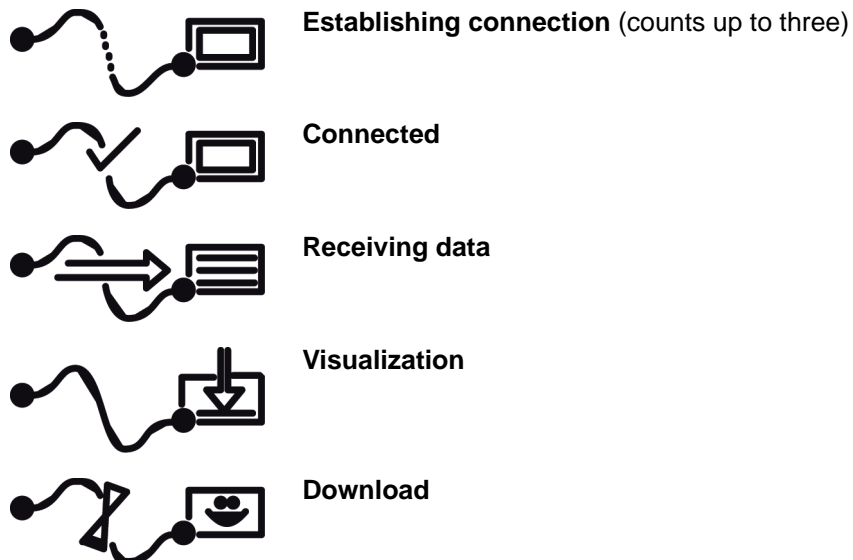


Fig. 1407: Start screen



3.14 Mode screen



Operation

Switch to the *Operation* screen.

The *Operation* screen informs the machine operator about the most important information during operation.

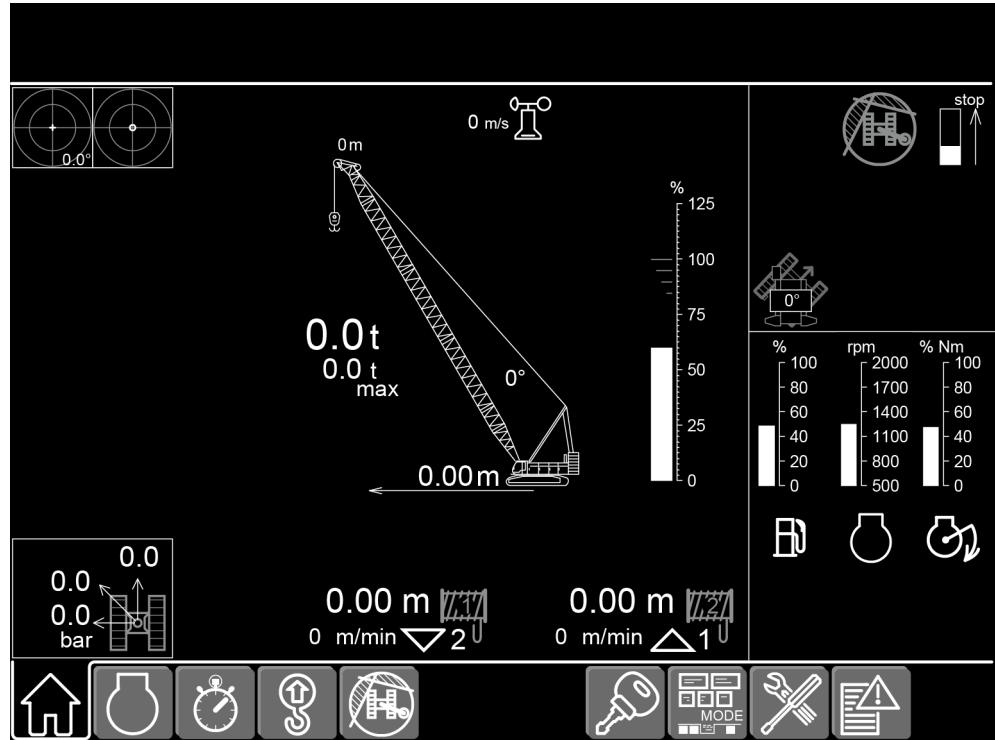


Fig. 1414: Operation screen

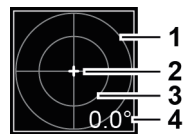


Fig. 1415: Screen section Inclination display

- | | | | |
|---|------------------------|---|---------------------------------------|
| 1 | Inclination circle 4° | 3 | Inclination circle 2° |
| 2 | Inclination of machine | 4 | Absolute inclination angle of machine |

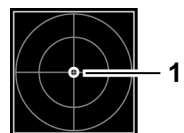
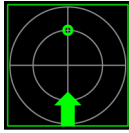


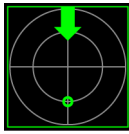
Fig. 1416: Screen section Vertical Line Finder

- | | |
|---|--|
| 1 | Deviation of the boom head to the load's center of gravity |
|---|--|



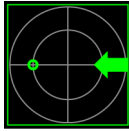
Vertical Line Finder - lower boom

Machine lowers the boom to correct the deviation.



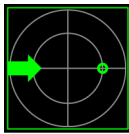
Vertical Line Finder - lift boom

Machine lifts the boom to correct the deviation.



Vertical Line Finder - swing uppercarriage to the left

Machine swings the uppercarriage to the left to correct the deviation.



Vertical Line Finder - swing uppercarriage to the right

Machine swings the uppercarriage to the right to correct the deviation.

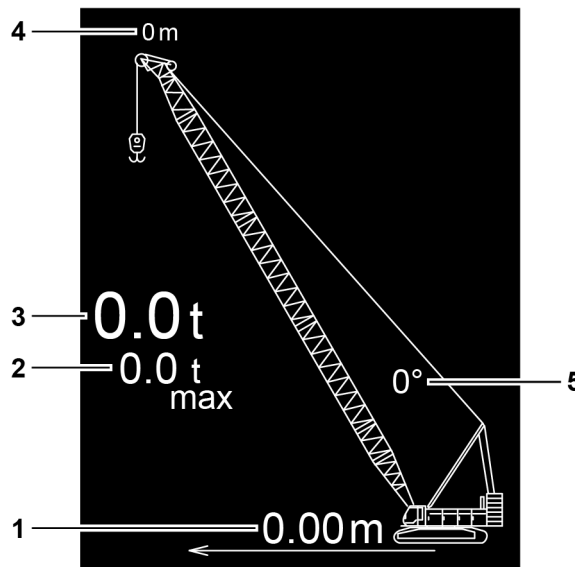


Fig. 1421: Screen section Operation

- | | | | |
|---|---------------------------------|---|---------------------------------|
| 1 | Radius of the load on main boom | 4 | Rope pulley height at main boom |
| 2 | Maximum load on main boom | 5 | Main boom angle |
| 3 | Load on main boom | | |

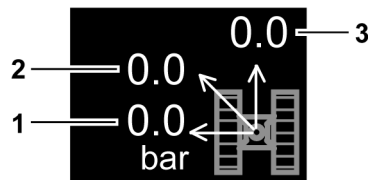


Fig. 1422: Screen section Ground pressure

- | | | | |
|---|---|---|---------------------------------|
| 1 | Maximum ground pressure to the side | 3 | Maximum ground pressure forward |
| 2 | Maximum ground pressure across one edge | | |

LWNLR.x/V04.01//Auslieferung/2016-03-07/en

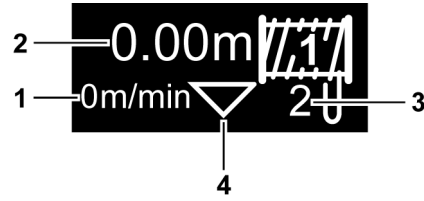


Fig. 1423: Screen section Winch1

- 1 Speed of load on winch1
- 2 Load travel path on winch1
- 3 Reeving of winch1 rope
- 4 Movement direction of load on winch1

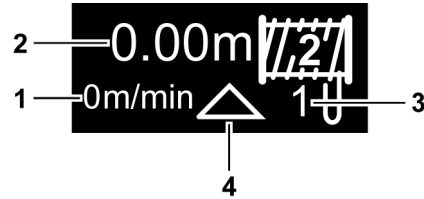


Fig. 1424: Screen section Winch2

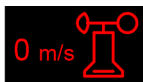
- 1 Speed of load on winch2
- 2 Load travel path on winch2
- 3 Reeving of winch2 rope
- 4 Movement direction of load on winch2



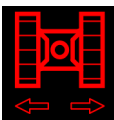
Wind speed
Current wind speed.



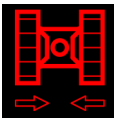
Wind speed (lit yellow)
Wind speed is high.



Wind speed (blinks red)
Wind speed too high.



Track monitoring (blinks red)
Narrow track selected as track width and wide track is set up.



Track monitoring (blinks red)
Wide track selected as track width and narrow track is set up.



No valid load chart available
No valid load chart available for the current boom position.



Warning danger of toppling (lit yellow)
Risk of machine toppling.



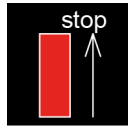
Danger of toppling stop (lit red)
Risk of machine toppling.

**Slewing range limitation**

Slewing range limitation is active. Rotate uppercarriage is locked.

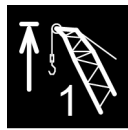
**Working range limitation**

Working range limitation is active.

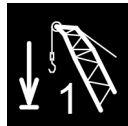
**Working range limitation stop**

Distance up to the stop of the working range limitation.

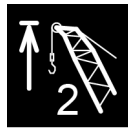
If the symbol is lit red, a stop of the working range limitation has been reached.

**Top lifting height limitation winch1**

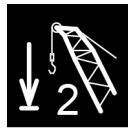
Top lifting height limitation of winch1 is active. Lift winch1 is locked.

**Bottom lifting height limitation winch1**

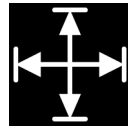
Bottom lifting height limitation of winch1 is active. Lower winch1 is blocked.

**Top lifting height limitation winch2**

Top lifting height limitation of winch2 is active. Lift winch2 is locked.

**Bottom lifting height limitation winch2**

Bottom lifting height limitation of winch2 is active. Lower winch2 is blocked.

**General limitation**

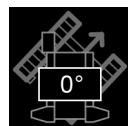
General limitation is active. Movements that change the radius are locked.

**Radius limitation maximum radius**

Radius limitation maximum radius is activated. Movements that enlarge the radius are locked.

**Radius limitation minimum radius**

Radius limitation minimum radius is active. Movements that decrease the radius are locked.

**Uppercarriage slewing angle**

Slewing angle of uppercarriage.

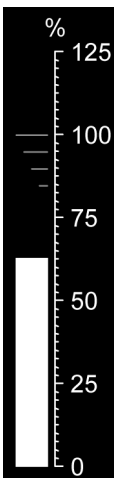
**External control**

External control mode is activated.



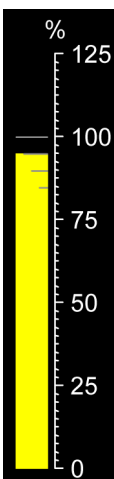
External control (lit yellow)

Communication problem between external control and machine.



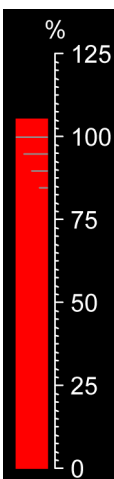
Load moment utilization

Utilization of the load moment.



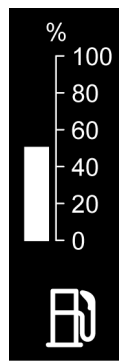
Load moment utilization (lit yellow)

Load moment is used to more than 90 % capacity.

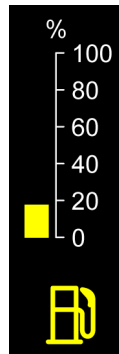


Load moment utilization (blinks red)

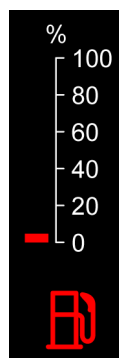
Load moment is used to more than 100 % capacity.

**Fuel fill level**

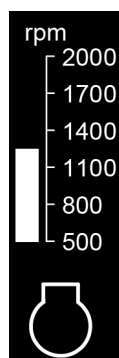
Fill level of the fuel tank as percentage of the maximum filling capacity.

**Fuel fill level (lit yellow)**

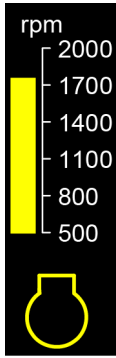
Fill level of the fuel tank is less than 15 % of the maximum filling capacity.

**Fuel fill level (blinks red)**

Fill level of the fuel tank is less than 5 % of the maximum filling capacity.

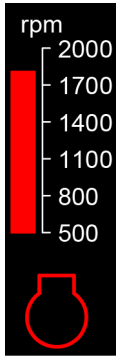
**Diesel engine RPM**

RPM of the diesel engine.



Diesel engine RPM (lit yellow)

High diesel engine RPM.



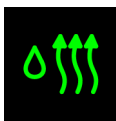
Diesel engine RPM (blinks red)

Diesel engine RPM is too high.



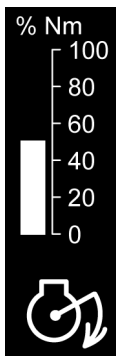
Battery charge (blinks red)

Battery is not charged.



Hydraulic oil heater (lit green)

The temperature of the hydraulic oil is increased automatically with the hydraulic oil heater (if fit).



Diesel engine utilization

Utilization of the diesel engine as percentage of the currently possible maximum utilization.



Diesel engine (lit yellow)

Diesel engine is preheated.



Diesel engine (lit green)

Diesel engine is ready to start.



Diesel engine

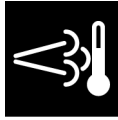
Diesel engine is post-heated.

**Exhaust aftertreatment** (lit yellow)

Fill level of urea tank is low or error in exhaust aftertreatment system.

**Exhaust aftertreatment** (blinks red)

Fill level of urea tank is too low or error in exhaust aftertreatment system.

**Exhaust gas temperature**

Exhaust gas temperature is increased.

**Exhaust aftertreatment system** (lit yellow)

Fill level of urea tank is low or error in exhaust aftertreatment system.

**Exhaust aftertreatment system** (blinks red)

Fill level of urea tank is too low or error in exhaust aftertreatment system.

3.15 Screen *Operation* in derrick mode



Operation

Switch to the *Operation* screen.

The *Operation* screen informs the machine operator about the most important information during operation.

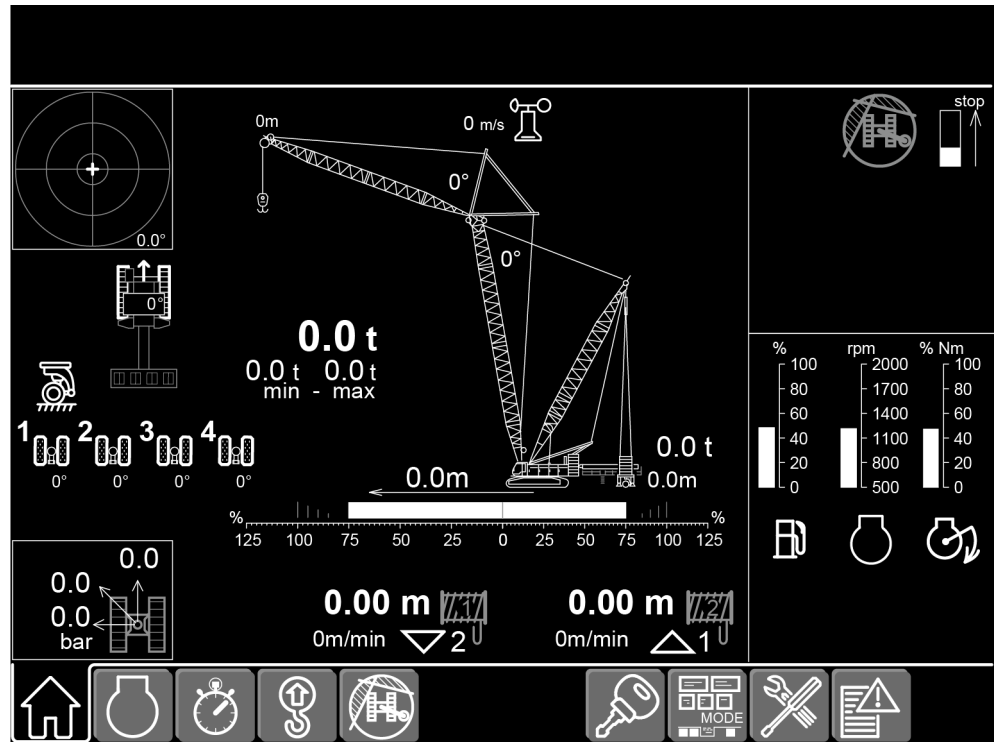


Fig. 1467: Screen *Operation* in derrick mode

The symbols of the *Operation* screen in derrick mode are identical with the symbols of the *Operation* (For more information see: 3.14 *Mode* screen, page 708) screen.

The additional symbols of the *Operation* screen in derrick mode are described in the following.

LWN/LR-x/V04.01//Auslieferung/2016-03-07/en

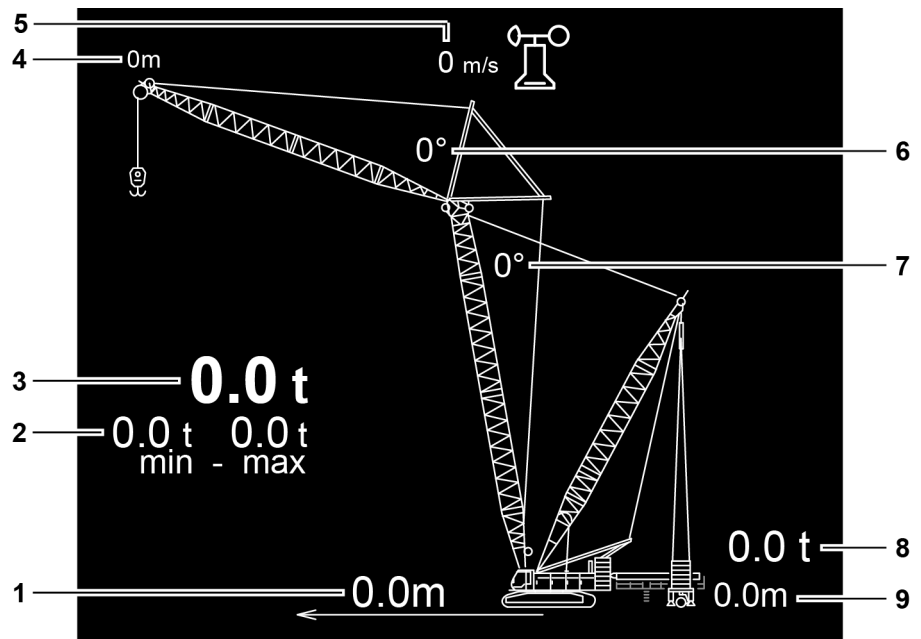


Fig. 1468: Screen section Operation with counterweight carriage

- | | | | |
|---|----------------------------------|---|----------------------------------|
| 1 | Radius of load on boom | 6 | Jib angle |
| 2 | Minimum and maximum load on boom | 7 | Main boom angle |
| 3 | Load on boom | 8 | Load on derrick boom |
| 4 | Pulley height on boom | 9 | Radius of counterweight carriage |
| 5 | Wind speed | | |

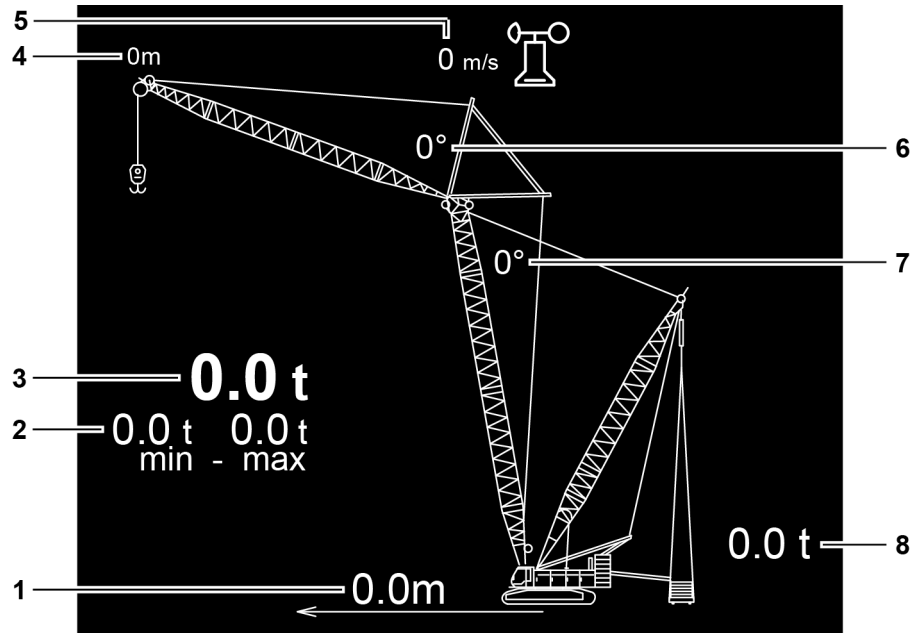


Fig. 1469: Screen section Operation with suspended counterweight

- | | | | |
|---|----------------------------------|---|----------------------|
| 1 | Radius of load on boom | 5 | Wind speed |
| 2 | Minimum and maximum load on boom | 6 | Jib angle |
| 3 | Load on boom | 7 | Main boom angle |
| 4 | Pulley height on boom | 8 | Load on derrick boom |

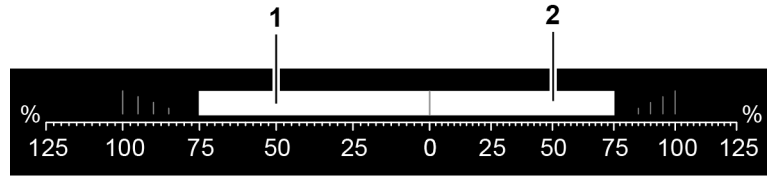


Fig. 1470: Screen section Load moment utilization

- 1 Utilization of load moment on boom
- 2 Utilization of load moment on derrick boom

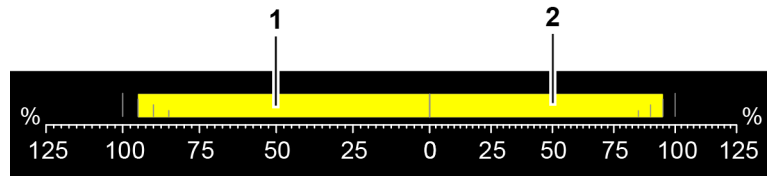


Fig. 1471: Screen section Load moment utilization (lit yellow)

- 1 Load moment on boom is used to more than 90% capacity
- 2 Load moment on derrick boom is used to more than 90% capacity

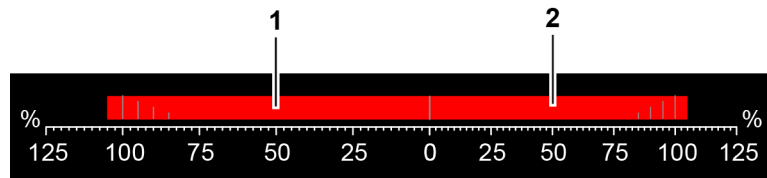


Fig. 1472: Screen section Load moment utilization (blinks red)

- 1 Load moment on boom is used to more than 100% capacity
- 2 Load moment on derrick boom is used to more than 100% capacity

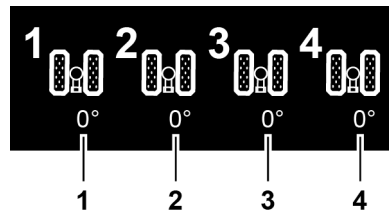


Fig. 1473: Screen section wheel sets

- 4 Angle of first wheel set
- 4 Angle of second wheel set
- 4 Angle of third wheel set
- 4 Angle of fourth wheel set



Wheel set (lit yellow)

Wheel set must be aligned.



Wheel set (lit red)

Wheel set is not aligned.



Operation of counterweight carriage blocked (lit yellow)

Operation of counterweight carriage is blocked due to an error.



Wheel sets are down

Wheel sets are down.

**Wheel sets are down** (lit yellow)

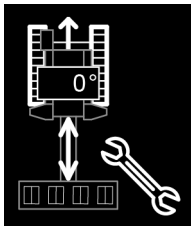
Pressure in wheel sets is too high and at least one wheel set must be aligned.

**Wheel sets are lifted**

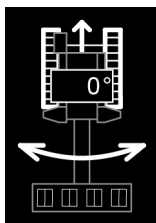
Wheel sets are lifted.

**Wheel sets are lifted** (lit yellow)

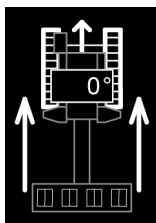
Wheel sets in unknown position.

**Assembly functions counterweight carriage**

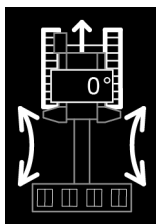
Assembly functions counterweight carriage are activated.

**Swing uppercarriage mode**

Swing uppercarriage mode is activated.

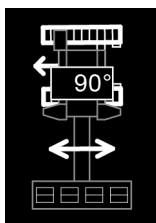
**Trailer travel mode**

Trailer travel mode is activated.

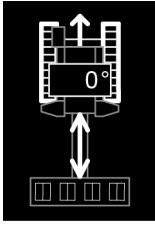
**Follower travel mode**

Follower travel mode is activated.

The arrows are indicated either on the left or on the right side.

**Crab mode**

Crab mode is activated.



Radius adjustment counterweight carriage

Radius adjustment counterweight carriage is activated.

3.16 Aggregate screen



Aggregate

Switch to the *Aggregate* screen.

The *Aggregate* screen provides information on the operating status of the main aggregate.

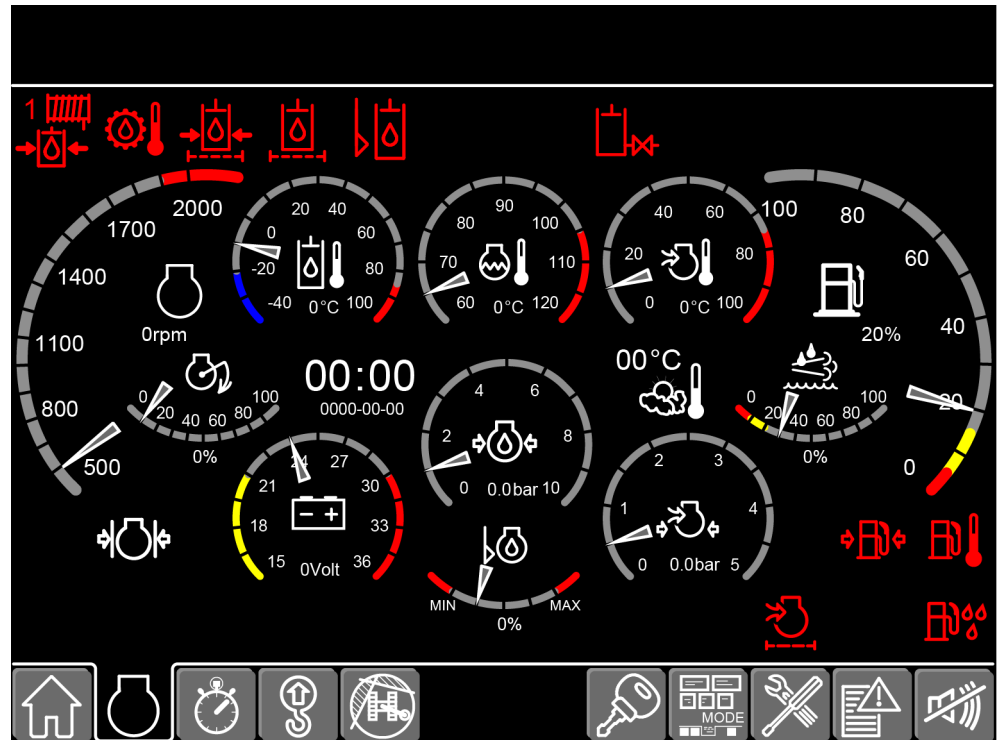
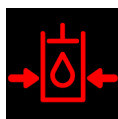
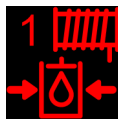


Fig. 1488: Aggregate screen



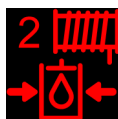
Supply pressure (blinks red)

Supply pressure is too low.



Supply pressure winch1 (blinks red)

Supply pressure on winch1 is too low.



Supply pressure winch2 (blinks red)

Supply pressure on winch2 is too low.



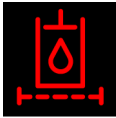
Gearbox oil temperature (blinks red)

Temperature of the gearbox oil in the distribution gearbox is too high.



Supply pressure oil filter (blinks red)

Supply pressure oil filter does not work correctly.



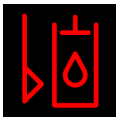
Hydraulic oil filter (blinks red)

Hydraulic oil filter does not work correctly.



Hydraulic oil fill level (lit yellow)

Fill level of the hydraulic oil tank is low.



Hydraulic oil fill level (blinks red)

Fill level of the hydraulic oil tank is too low.



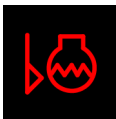
Hydraulic oil fill level (lit yellow)

Fill level of the hydraulic oil tank is high.



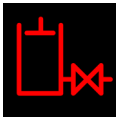
Coolant fill level (lit yellow)

Coolant fill level is low.



Coolant fill level (blinks red)

Coolant fill level is too low.



Gate valve hydraulic oil tank (blinks red)

Gate valve *hydraulic oil tank* is closed.



Exhaust aftertreatment (lit yellow)

Fill level of urea tank is low or error in exhaust aftertreatment system.



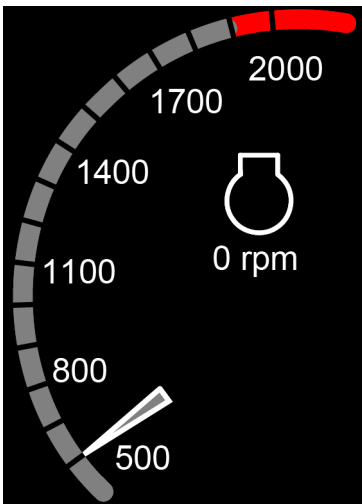
Exhaust aftertreatment (blinks red)

Fill level of urea tank is too low or error in exhaust aftertreatment system.



Exhaust gas temperature

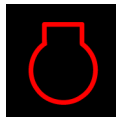
Exhaust gas temperature is increased.

**RPM**

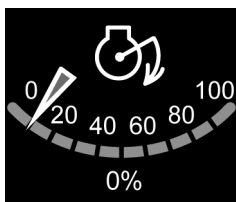
RPM of the diesel engine.

**RPM (lit yellow)**

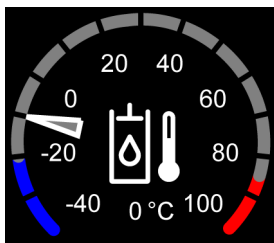
Diesel engine RPM is high.

**RPM (blinks red)**

Diesel engine RPM is too high.

**Diesel engine utilization**

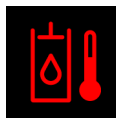
Utilization of the diesel engine as percentage of the currently possible maximum utilization.

**Hydraulic oil temperature**

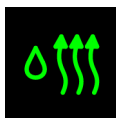
Temperature of the hydraulic oil.

**Hydraulic oil temperature (lit yellow)**

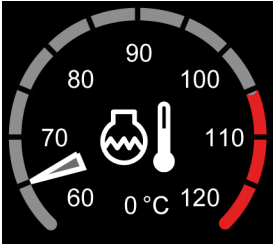
Hydraulic oil temperature is high.

**Hydraulic oil temperature (blinks red)**

Hydraulic oil temperature is too high.

**Hydraulic oil heater (lit green)**

The hydraulic oil heater (if fit) automatically raises the hydraulic oil temperature to -10 °C (14 °F).



Coolant temperature

Temperature of the diesel engine coolant.



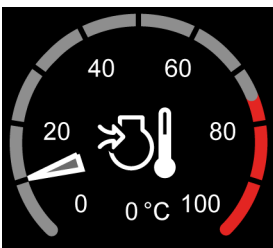
Coolant temperature (lit yellow)

Temperature of the diesel engine coolant is high.



Coolant temperature (blinks red)

Temperature of the diesel engine coolant is too high.



Charge air temperature

Temperature of the diesel engine charge air.



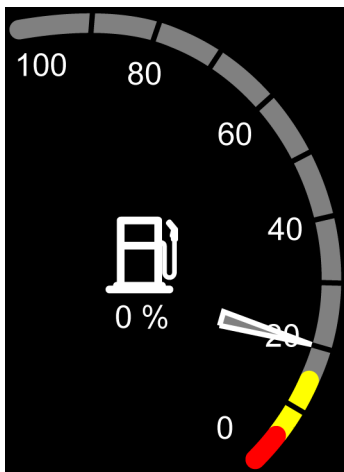
Charge air temperature (lit yellow)

Temperature of the diesel engine charge air is high.



Charge air temperature (blinks red)

Temperature of the diesel engine charge air is too high.



Fuel fill level

Fill level of the fuel tank as percentage of the maximum filling capacity.



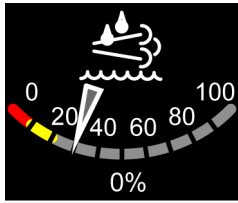
Fuel fill level (lit yellow)

Fill level of the fuel tank is less than 15 % of the maximum filling capacity.



Fuel fill level (blinks red)

Fill level of the fuel tank is less than 5 % of the maximum filling capacity.

**Urea solution fill level**

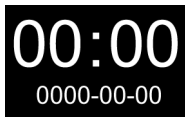
Fill level of the urea tank as percentage of the maximum filling capacity.

**Exhaust aftertreatment system (lit yellow)**

Fill level of urea tank is low or error in exhaust aftertreatment system.

**Exhaust aftertreatment system (blinks red)**

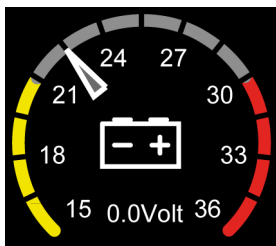
Fill level of urea tank is too low or error in exhaust aftertreatment system.

**Time**

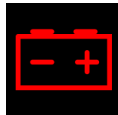
Current time.

**Outside temperature**

Current outside temperature.

**Battery voltage**

Voltage of the battery.

**Battery charge (blinks red)**

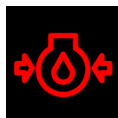
Battery is not charged.

**Lubrication oil pressure**

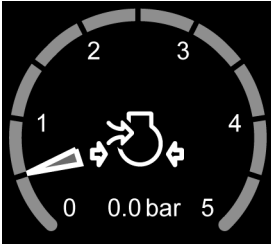
Pressure of the lubrication oil of the diesel engine.

**Lubrication oil pressure (lit yellow)**

Pressure of the lubrication oil of the diesel engine is low.

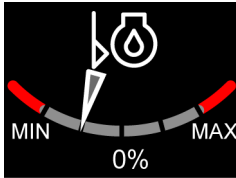
**Lubrication oil pressure (blinks red)**

Pressure of the lubrication oil of the diesel engine is too low.



Charge air pressure

Pressure of the diesel engine charge air.



Lubrication oil fill level

Fill level of the lubrication oil of the diesel engine as percentage of the maximum filling capacity.



Lubricant fill level (lit yellow)

Fill level of diesel engine lubrication oil is low.



Lubrication oil fill level (blinks red)

Fill level of the lubrication oil of the diesel engine is too low.



Lubricant fill level (lit yellow)

Fill level of diesel engine lubrication oil is high.



Lubrication oil fill level (blinks red)

Fill level of the lubrication oil of the diesel engine is too high.



Power limitation

Power limitation of diesel engine is active due to utilization height.



Power limitation (lit yellow)

Power limitation of diesel engine is active due to an operational error.



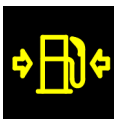
Charge air filter (lit yellow)

Charge air filter does not work correctly.



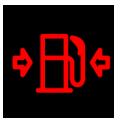
Charge air filter (blinks red)

Charge air filter does not work correctly.



Fuel pressure (lit yellow)

Fuel pressure is low or high.



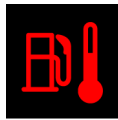
Fuel pressure (blinks red)

Fuel pressure is too low or too high.



Fuel temperature (lit yellow)

Fuel temperature is high.



Fuel temperature (blinks red)

Fuel temperature is too high.



Fuel filter (blinks red)

Water in the fuel filter.

3.17 Operating hours screen



Operating hours

Switch to the *Operating hours* screen.

The *Operating hours* screen informs the machine operator about the operating hours of the various machine components.

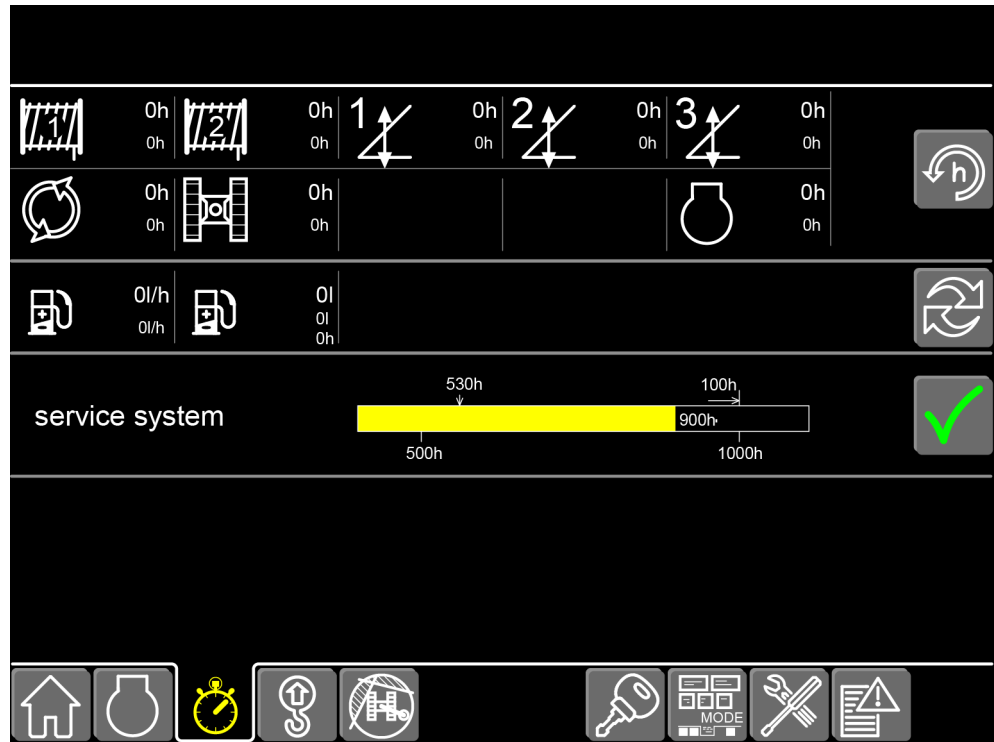


Fig. 1547: Operating hours screen



Resetting the operating hours

Reset relative operating hours to zero.



Resetting the fuel consumption

Reset the fuel consumption to zero.



Confirming the maintenance interval

Confirm completed maintenance interval.

This button is only displayed to authorized users.



Operating hours winch1

Absolute and relative operating hours of winch1.



0h
0h

Operating hours winch2

Absolute and relative operating hours of winch2.



0h
0h

Operating hours main boom luffing winch

Absolute and relative operating hours of the main boom luffing winch.



0h
0h

Operating hours jib luffing winch

Absolute and relative operating hours of the jib luffing winch.



0h
0h

Operating hours auxiliary winch

Absolute and relative operating hours of the auxiliary winch.



0h
0h

Operation hours of the derrick winch

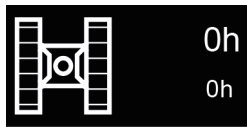
Absolute and relative operating hours of the derrick winch.



0h
0h

Operating hours swing

Absolute and relative operating hours of the swing.



0h
0h

Operating hours crawler

Absolute and relative operating hours of the crawler.



0h
0h

Diesel engine operating hours

Absolute and relative operating hours of diesel engine.



0l/h
0l/h

Average fuel consumption

Absolute and relative average fuel consumption.



0l
0l
0h

Total fuel consumption

Absolute total fuel consumption.

Relative total fuel consumption in the displayed period.



Fig. 1562: Maintenance intervals (lit green)

- | | | | |
|---|--|---|---------------------------------|
| 1 | Last maintenance interval | 4 | Current machine operating hours |
| 2 | Last maintenance performed | 5 | Next maintenance interval |
| 3 | Operating hours until next maintenance | | |

LWNLR.x/V04.01//Auslieferung/2016-03-07/en



Fig. 1563: Maintenance intervals - maintenance intervals pending shortly (lit yellow)



Fig. 1564: Maintenance intervals - maintenance interval past due (lit red)

3.18 Setup screen



Setup

Switch to the *Setup* screen.

The *Setup* screen serves to define and confirm the setup of the machine.

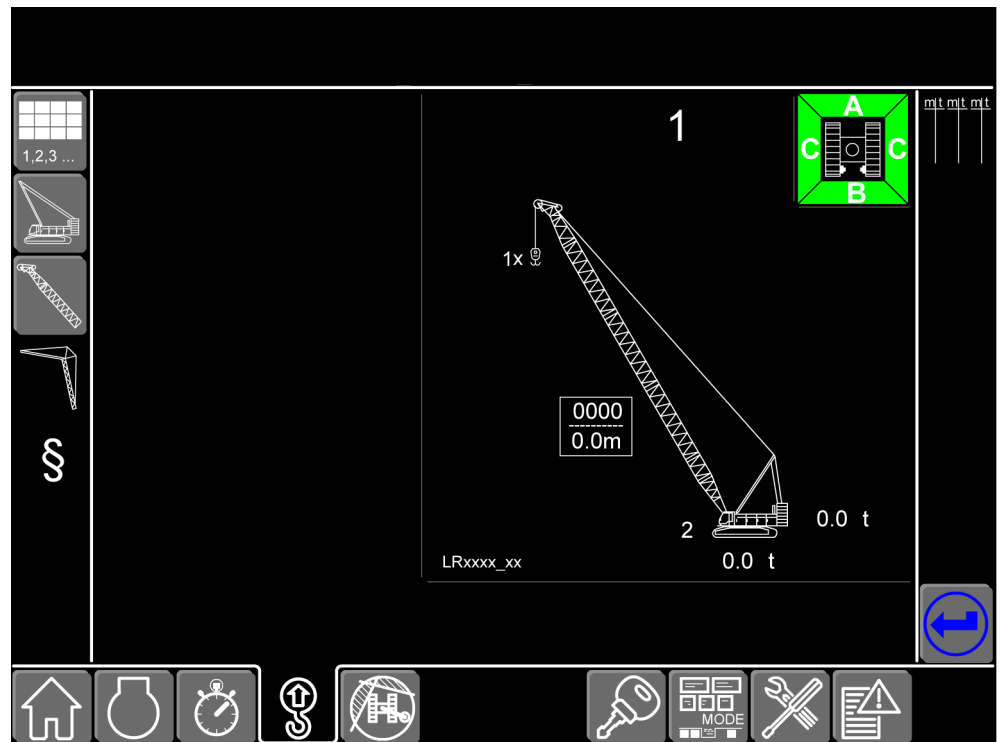


Fig. 1566: Setup screen



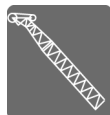
Boom configuration

Switch to the *Setup - boom configuration* screen.



Basic machine

Switch to the *Setup - basic machine* screen.



Main boom

Switch to the *Setup - main boom* screen.



Jib

Switch to the *Setup - jib* screen.



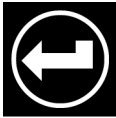
Calculation rules

Switch to the *Setup - calculation rules* screen.



Load chart

Switch to the *Setup - load chart* screen.



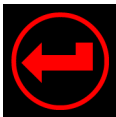
Calculating load charts

Calculate load chart. No calculation required.



Calculate load chart) (lit blue).

Calculate load chart. Symbol is lit blue if the setup is changed and a recalculation of the load chart is required.



Calculate load chart (blinks red)

Calculate load chart. Symbol blinks red if the entered setup is invalid.



Calculating load charts

Calculate load chart. Symbol is crossed out if the load moment exceeds 50 % and if the recalculation of the load chart is not possible.



Hourglass

Load chart is calculated.

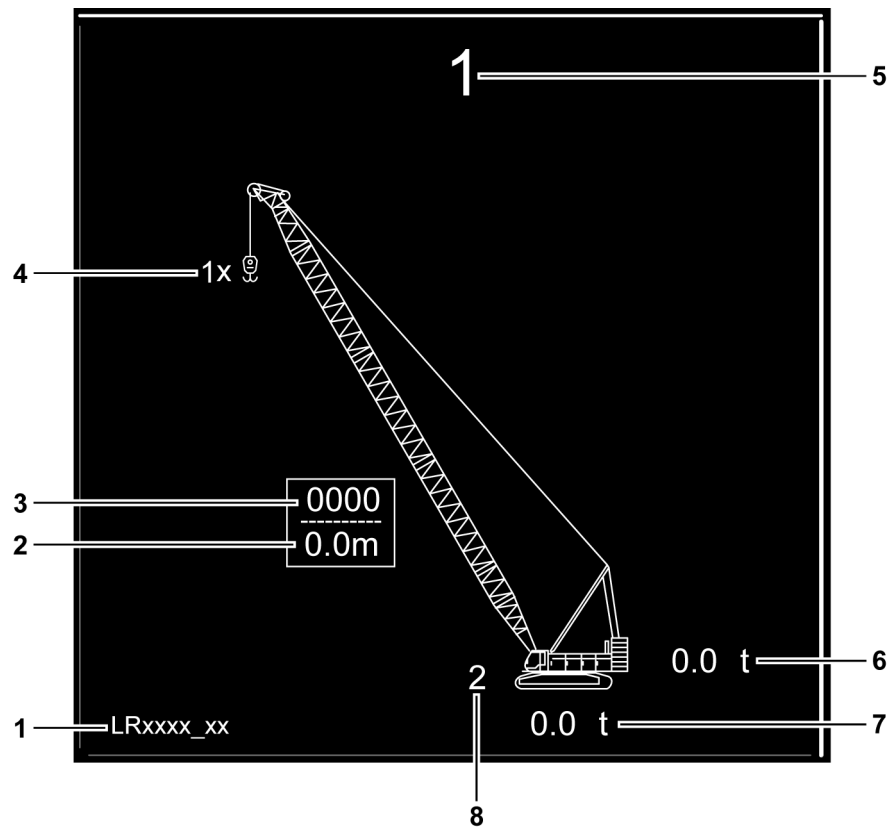


Fig. 1578: Setup screen clipping

- | | | | |
|---|------------------|---|--------------------|
| 1 | Machine type | 5 | Boom configuration |
| 2 | Main boom length | 6 | Rear counterweight |

See next page for continuation of the image legend

- 3 System dimension main boom
- 4 Rope reeving
- 7 Carbody counterweight
- 8 Track width

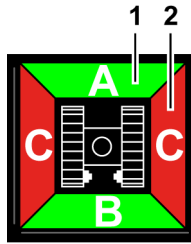


Fig. 1579: Screen clipping Erectability

- 1 Boom configuration can be erected (green area)
- 2 Boom configuration cannot be erected (red area)
- A Can be erected via idler wheel
- B Can be erected via tumbler
- C Can be erected across the side

3.18.1 Setup - boom configuration screen



Boom configuration setup

Switch to the *Setup - boom configuration* screen.

The *Setup - boom configuration* screen serves to define and confirm the boom configuration.

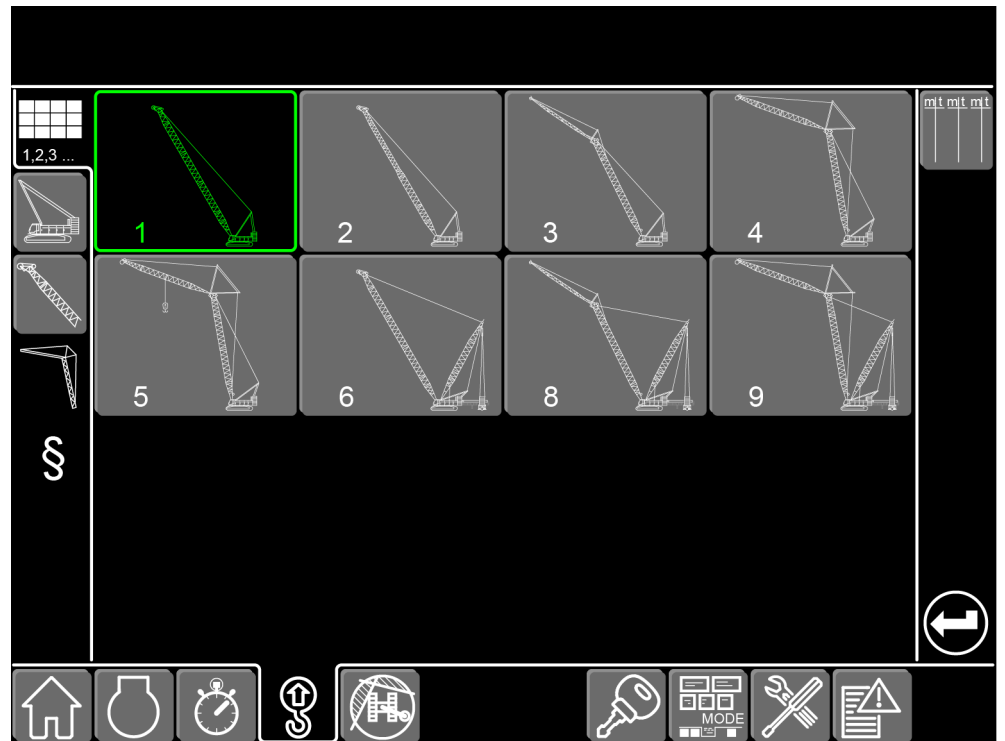
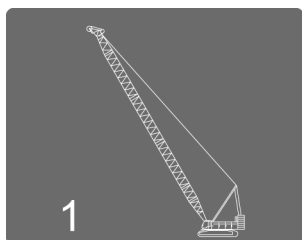
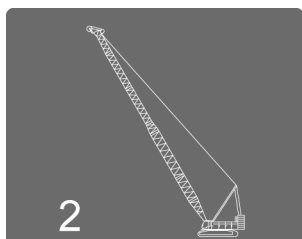


Fig. 1581: Screen Setup boom configuration



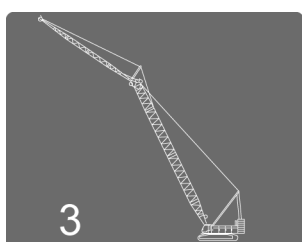
Boom configuration 1 - main boom

Select boom configuration 1 - main boom.



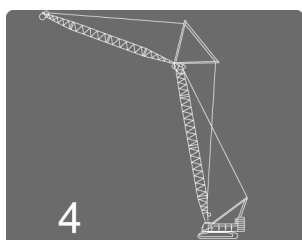
Boom configuration 2 - main boom + reducing adapter

Select boom configuration 2 - main boom + reducing adapter.



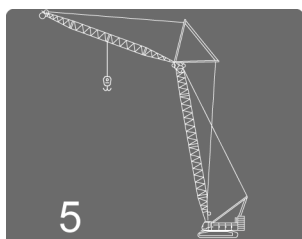
Boom configuration 3 - main boom + fixed jib

Select boom configuration 3 - main boom + fixed jib.



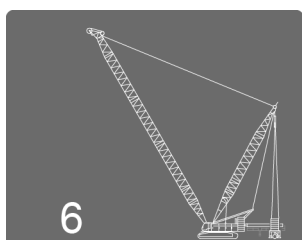
Boom configuration 4 - main boom + luffing jib

Select boom configuration 4 - main boom + luffing jib.



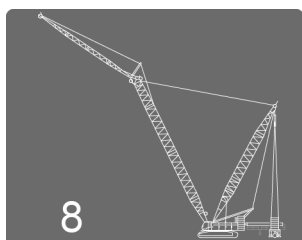
Boom configuration 5 - main boom + luffing jib + midfall

Select boom configuration 5 - main boom + luffing jib + midfall.



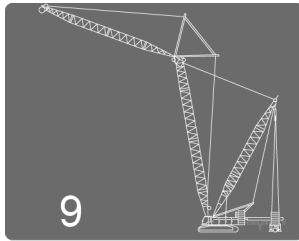
Boom configuration 6 - main boom + derrick

Select boom configuration 6 - main boom + derrick.



Boom configuration 8 - main boom + fixed jib + derrick

Select boom configuration 8 - main boom + fixed jib + derrick.



Boom configuration 9 - main boom + luffing jib + derrick

Select boom configuration 9 - main boom + luffing jib + derrick.

3.18.2 Setup - boom configuration 1 screen

Setup - basic machine screen



Setup - basic machine

Switch to the *Setup - basic machine* screen.

The *Setup - basic machine* screen serves to define and confirm the track width and counterweights.

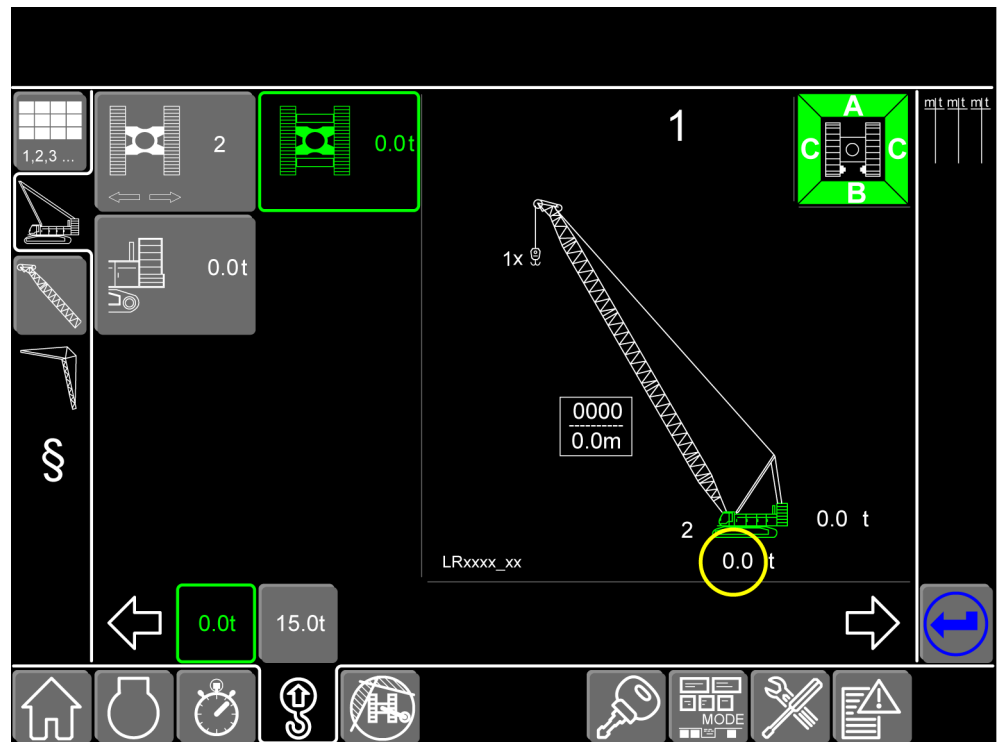
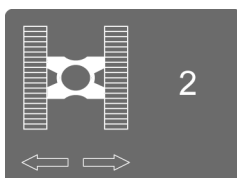


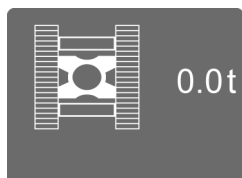
Fig. 1591: Setup - basic machine screen



Track width

Select the track width.

- 1: Narrow track
- 2: Wide track
- 3: Blocked Crawlers



Carbody counterweight

Select the weight of carbody counterweight.



Rear counterweight

Select the weight of rear counterweight.



Smaller values

Switch to next smaller values.



Larger values

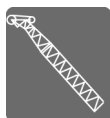
Switch to next larger values.



Value

Select value.

Setup - main boom screen



Setup - main boom

Switch to the *Setup - main boom* screen.

The *Setup - main boom* screen serves to define and confirm the main boom head, the main boom length and the reeving of the load hook.

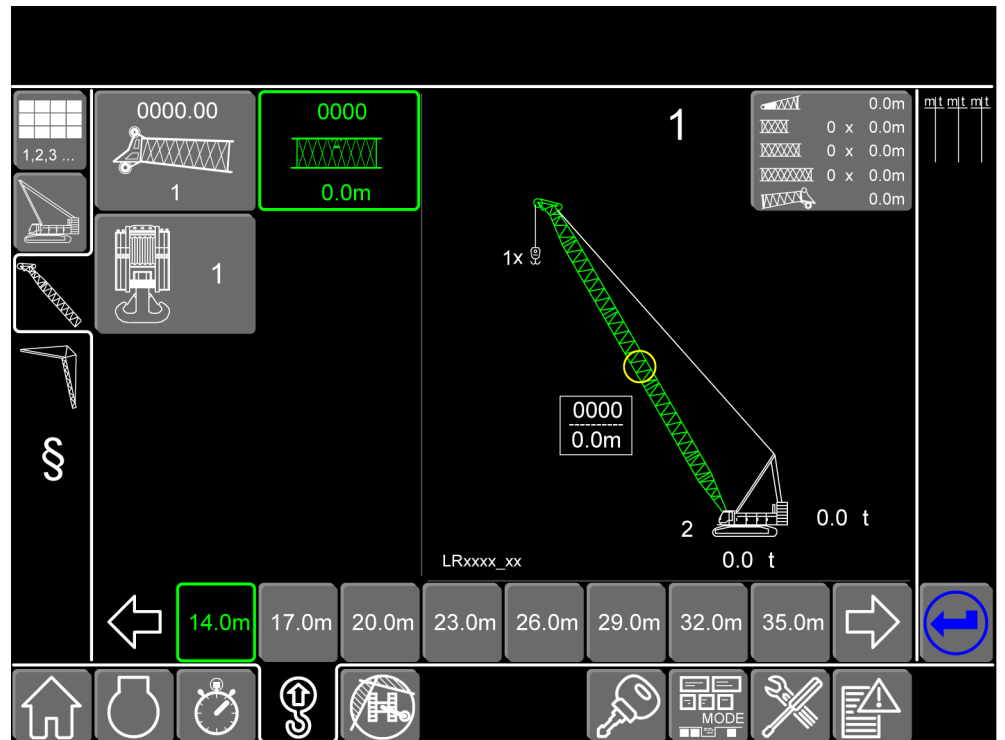
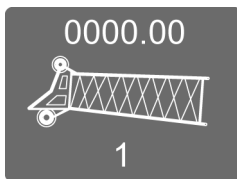
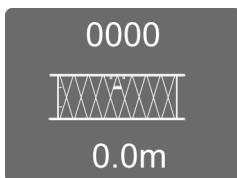


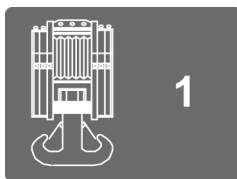
Fig. 1599: Setup - main boom screen

**Main boom head**

Select main boom head in line with foreword to the valid load chart.

**Main boom length**

Select the main boom length.

**Rope reeving**

Select rope reeving.

**Smaller values**

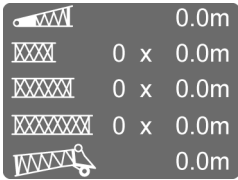
Switch to next smaller values.

**Larger values**

Switch to next larger values.

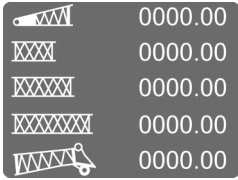
**Value**

Select value.



Main boom components

Button shows the composition of the main boom components and their lengths.
Switch to composition of the main boom components and their system dimensions.



Main boom components

Button shows the composition of the main boom components and their system dimensions.
Switch to composition of the main boom components and their lengths.

3.18.3 Setup - boom configuration 2 screen

Setup - basic machine screen



Setup - basic machine

Switch to the *Setup - basic machine* screen.

The *Setup - basic machine* screen serves to define and confirm the track width and counterweights.

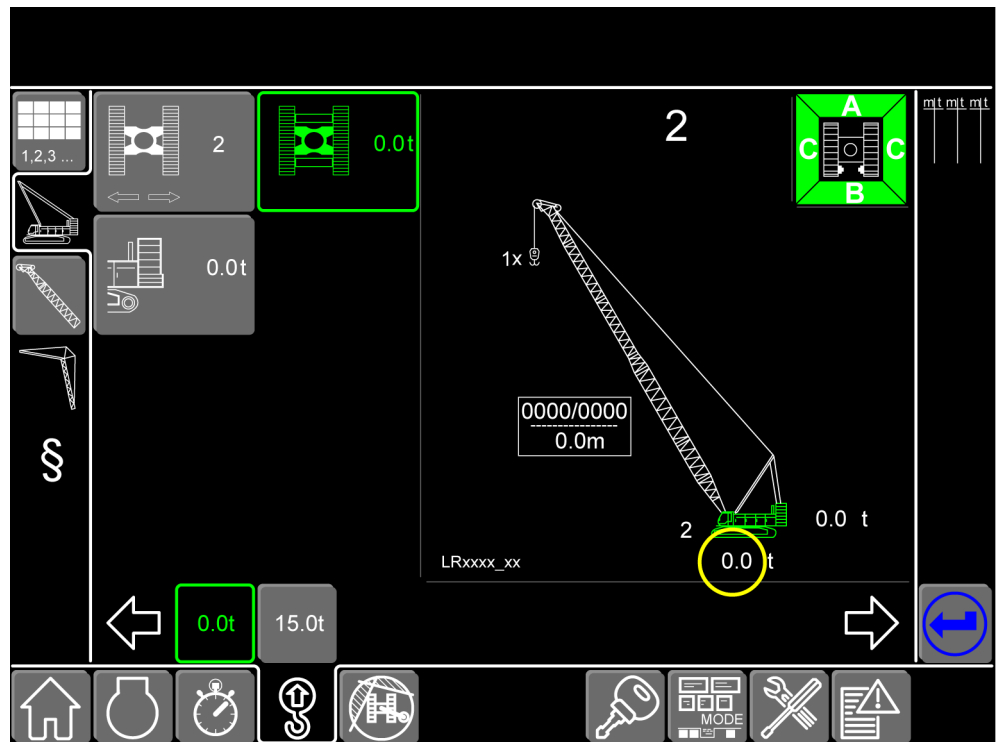
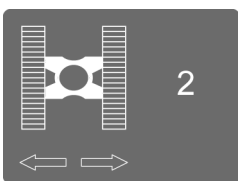


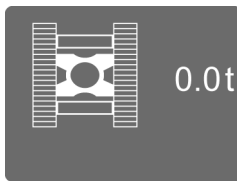
Fig. 1609: Setup - basic machine screen



Track width

Select the track width.

- 1: Narrow track
- 2: Wide track
- 3: Blocked Crawlers

**Carbody counterweight**

Select the weight of carbody counterweight.

**Rear counterweight**

Select the weight of rear counterweight.

**Smaller values**

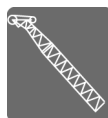
Switch to next smaller values.

**Larger values**

Switch to next larger values.

**Value**

Select value.

Setup - main boom screen**Setup - main boom**

Switch to the *Setup - main boom* screen.

The *Setup - main boom* screen serves to define and confirm the main boom head, the main boom length and the reeving of the load hook.

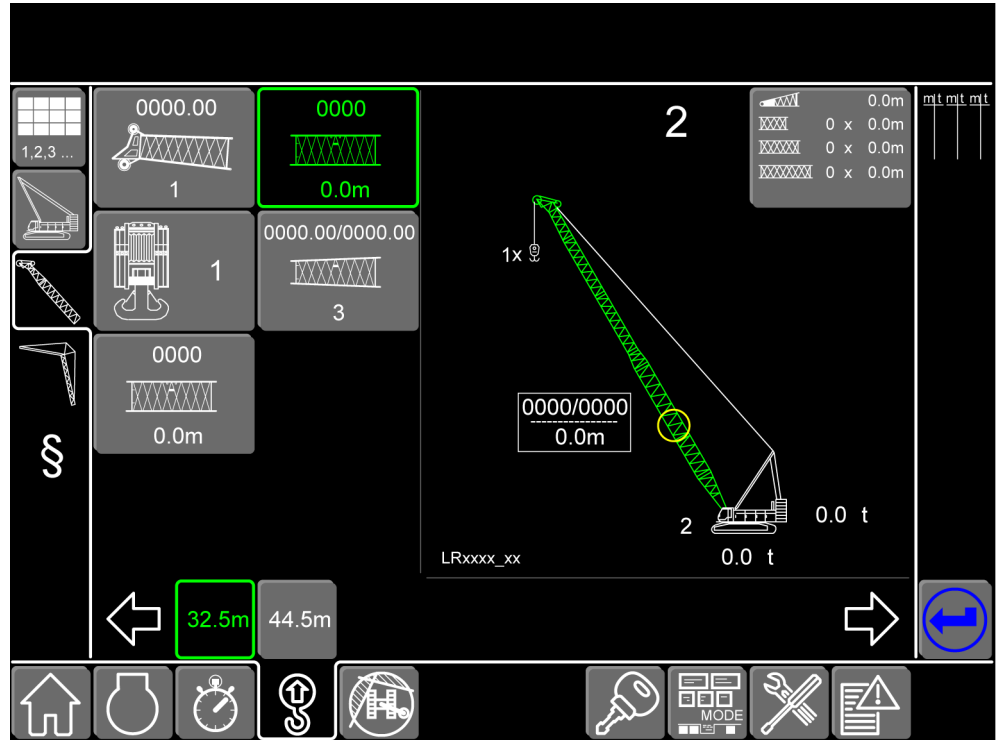
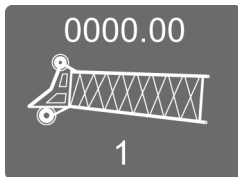
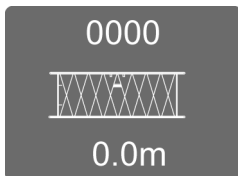


Fig. 1617: Setup - main boom screen



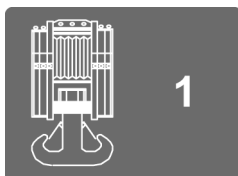
Main boom head

Select main boom head in line with foreword to the valid load chart.



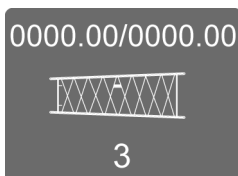
Main boom length up to reducing adapter

Select main boom length up to reducing adapter.



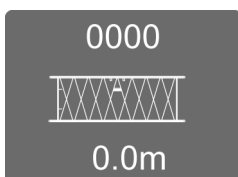
Rope reeving

Select rope reeving.



Reducing adapter

Select reducing adapter.



Main boom length beyond reducing adapter

Select main boom length beyond reducing adapter.

LWN/LR-x/V04.01//Auslieferung/2016-03-07/en

**Smaller values**

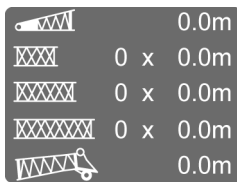
Switch to next smaller values.

**Larger values**

Switch to next larger values.

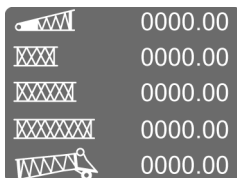
**Value**

Select value.

**Main boom components**

Button shows the composition of the main boom components and their lengths.

Switch to composition of the main boom components and their system dimensions.

**Main boom components**

Button shows the composition of the main boom components and their system dimensions.

Switch to composition of the main boom components and their lengths.

3.18.4 Setup - boom configuration 3 screen

Setup - basic machine screen

**Setup - basic machine**

Switch to the *Setup - basic machine* screen.

The *Setup - basic machine* screen serves to define and confirm the track width and counterweights.

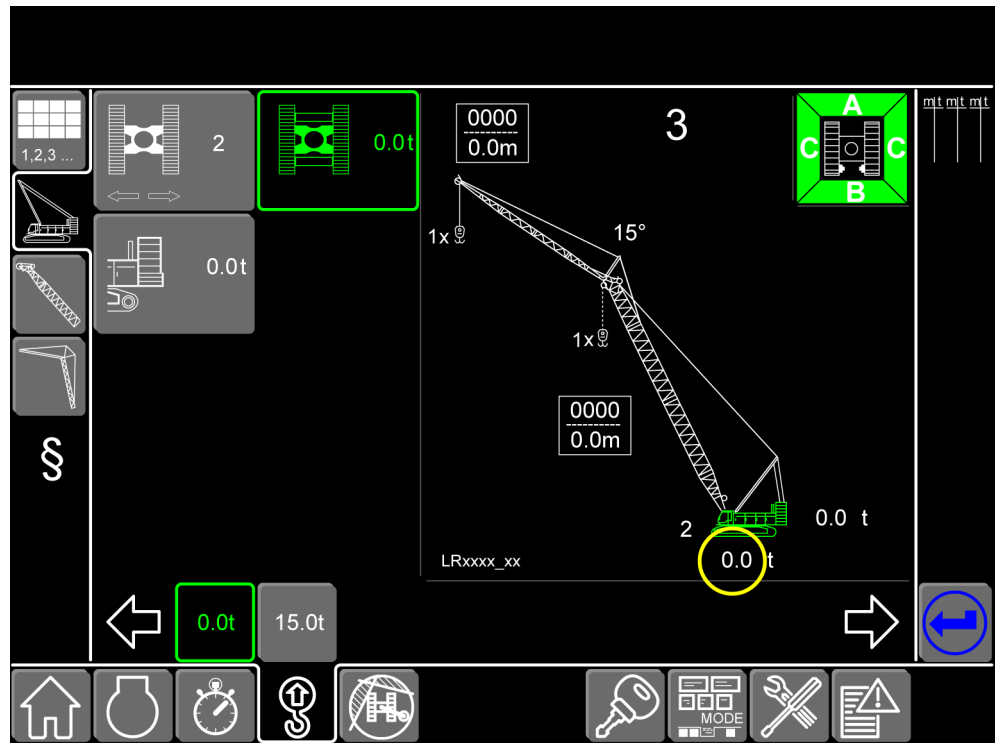
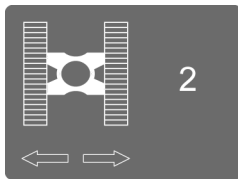


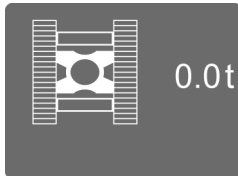
Fig. 1629: Setup - basic machine screen



Track width

Select the track width.

- 1: Narrow track
- 2: Wide track
- 3: Blocked Crawlers



Carbody counterweight

Select the weight of carbody counterweight.



Rear counterweight

Select the weight of rear counterweight.



Smaller values

Switch to next smaller values.



Larger values

Switch to next larger values.



Value

Select value.

Setup - main boom screen



Setup - main boom

Switch to the *Setup - main boom* screen.

The *Setup - main boom* screen serves to define and confirm the main boom head, the main boom length and the reeving of the load hook.

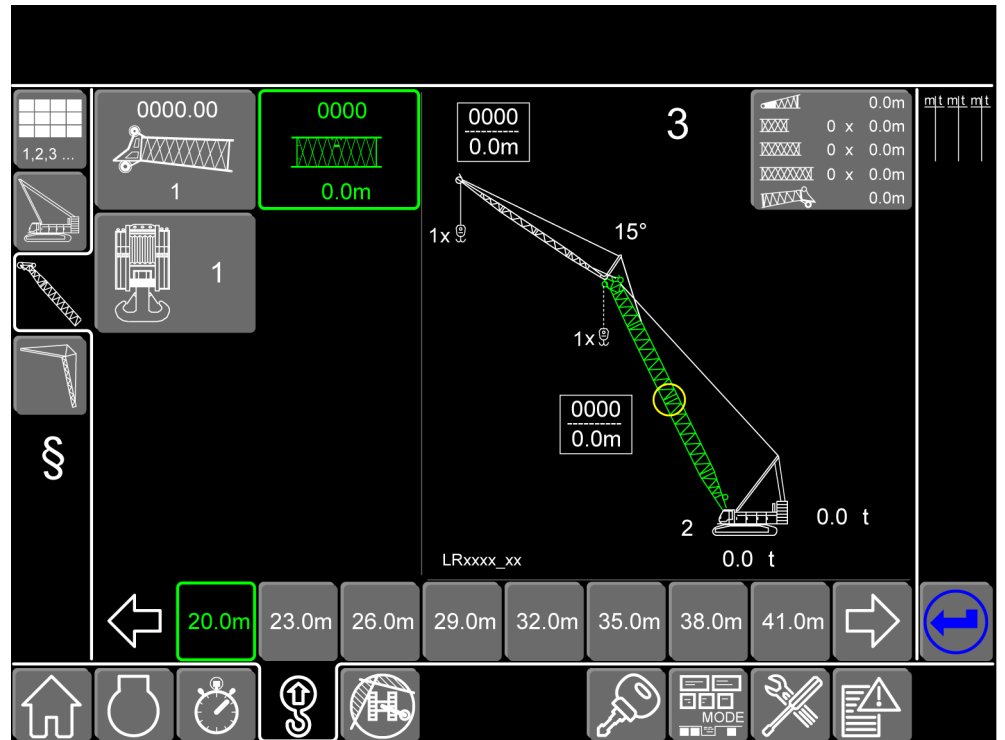
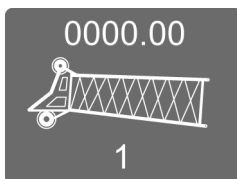
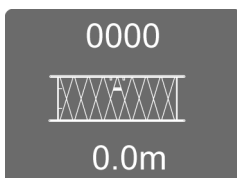


Fig. 1637: Setup - main boom screen



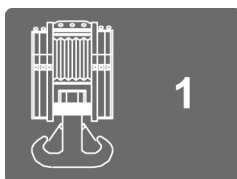
Main boom head

Select main boom head in line with foreword to the valid load chart.



Main boom length

Select the main boom length.



Rope reeving

Select rope reeving.



Smaller values

Switch to next smaller values.



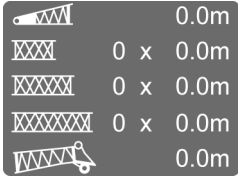
Larger values

Switch to next larger values.



Value

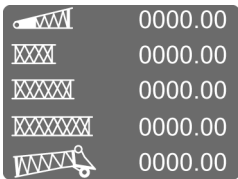
Select value.



Main boom components

Button shows the composition of the main boom components and their lengths.

Switch to composition of the main boom components and their system dimensions.



Main boom components

Button shows the composition of the main boom components and their system dimensions.

Switch to composition of the main boom components and their lengths.

Setup - jib screen



Setup - jib

Switch to the *Setup - jib* screen.

The *Setup - jib* screen serves to define and confirm the jib head, the jib length and the reeving of the load hook.

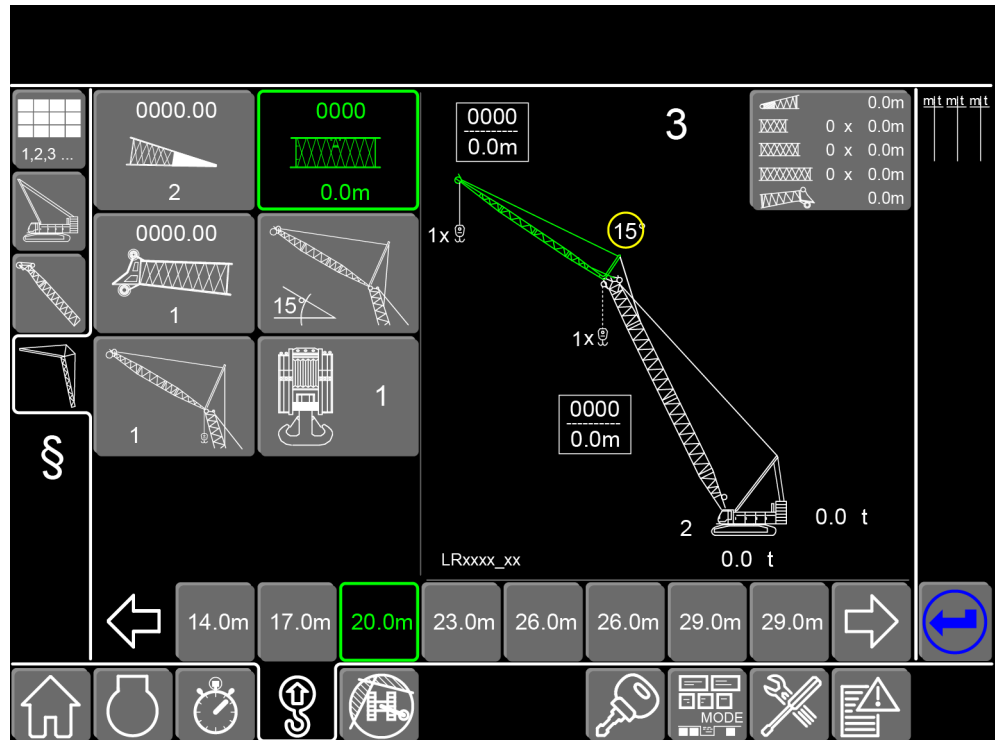
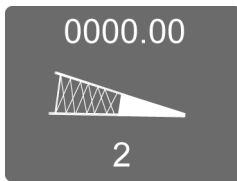
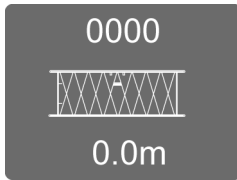


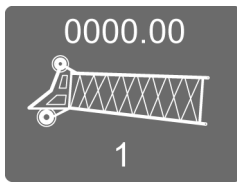
Fig. 1647: Setup - jib screen



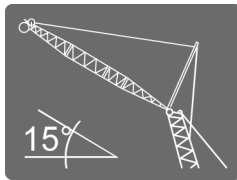
System dimension of the jib
Select system dimension of the jib.



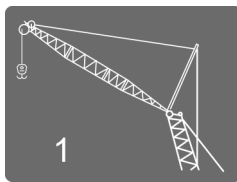
Jib length
Select jib length.



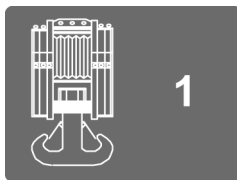
Jib head
Select jib head in line with foreword to the valid load chart.



Tensioning position
Select tensioning position between jib and main boom in degrees.



Load position
Select load position.



Rope reeving
Select rope reeving.



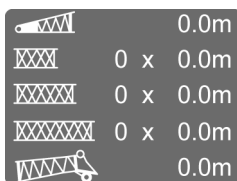
Smaller values
Switch to next smaller values.



Larger values
Switch to next larger values.

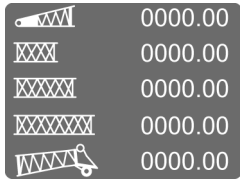


Value
Select value.



Jib components
Button shows the composition of the jib components and their lengths.
Switch to composition of the jib components and their system dimensions.

LWNLR.x/V04.01//Auslieferung/2016-03-07/en



Jib components

Button shows the composition of the jib components and their system dimensions.
Switch to composition of the jib components and their lengths.

3.18.5 Setup - boom configuration 4 screen

Setup - basic machine screen



Setup - basic machine

Switch to the *Setup - basic machine* screen.

The *Setup - basic machine* screen serves to define and confirm the track width and counterweights.

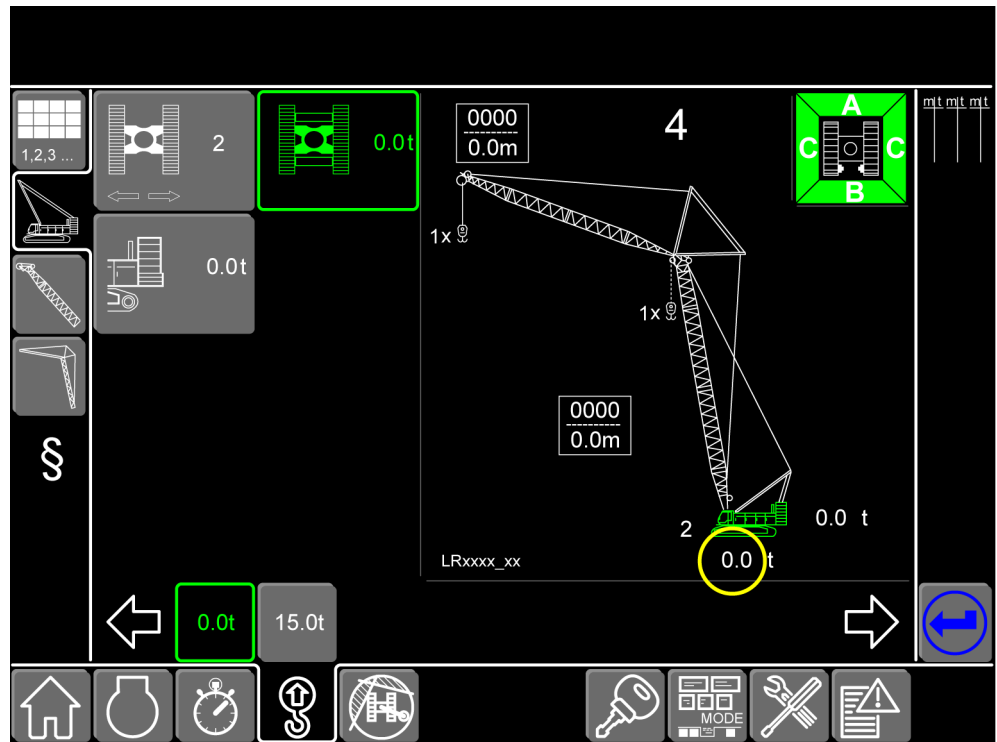
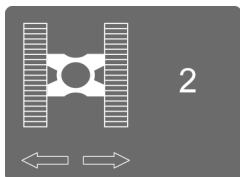


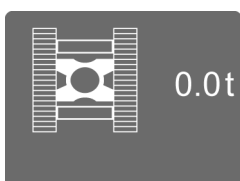
Fig. 1660: Setup - basic machine screen



Track width

Select the track width.

- 1: Narrow track
- 2: Wide track
- 3: Blocked Crawlers



Carbody counterweight

Select the weight of carbody counterweight.

LWN/LR-x/V04.01//Auslieferung/2016-03-07/en



Rear counterweight

Select the weight of rear counterweight.



Smaller values

Switch to next smaller values.



Larger values

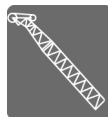
Switch to next larger values.



Value

Select value.

Setup - main boom screen



Setup - main boom

Switch to the *Setup - main boom* screen.

The *Setup - main boom* screen serves to define and confirm the main boom head, the main boom length and the reeving of the load hook.

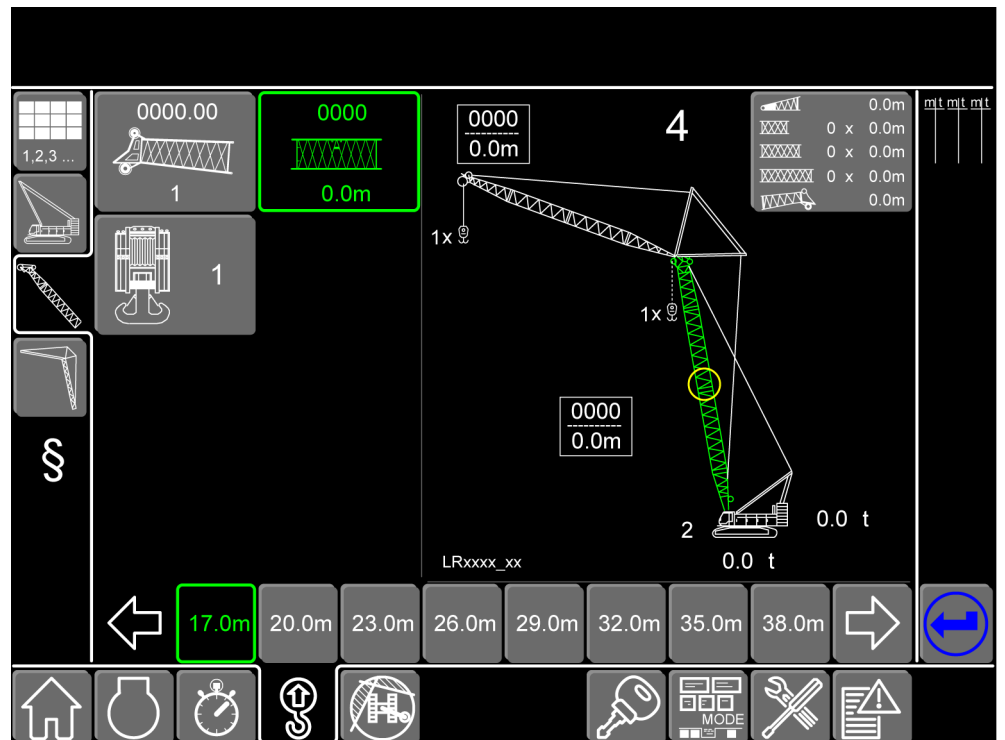
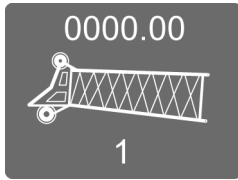


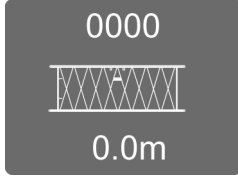
Fig. 1668: Setup - main boom screen

LWNLR_x/V04.01//Auslieferung/2016-03-07/en



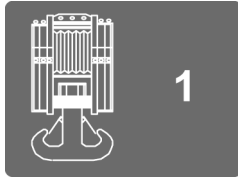
Main boom head

Select main boom head in line with foreword to the valid load chart.



Main boom length

Select the main boom length.



Rope reeving

Select rope reeving.



Smaller values

Switch to next smaller values.



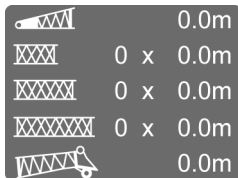
Larger values

Switch to next larger values.



Value

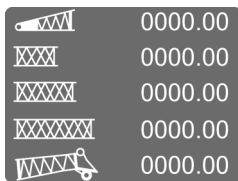
Select value.



Main boom components

Button shows the composition of the main boom components and their lengths.

Switch to composition of the main boom components and their system dimensions.



Main boom components

Button shows the composition of the main boom components and their system dimensions.

Switch to composition of the main boom components and their lengths.

Setup - jib screen



Setup - jib

Switch to the *Setup - jib* screen.

The *Setup - jib* screen serves to define and confirm the jib head, the jib length and the reeving of the load hook.

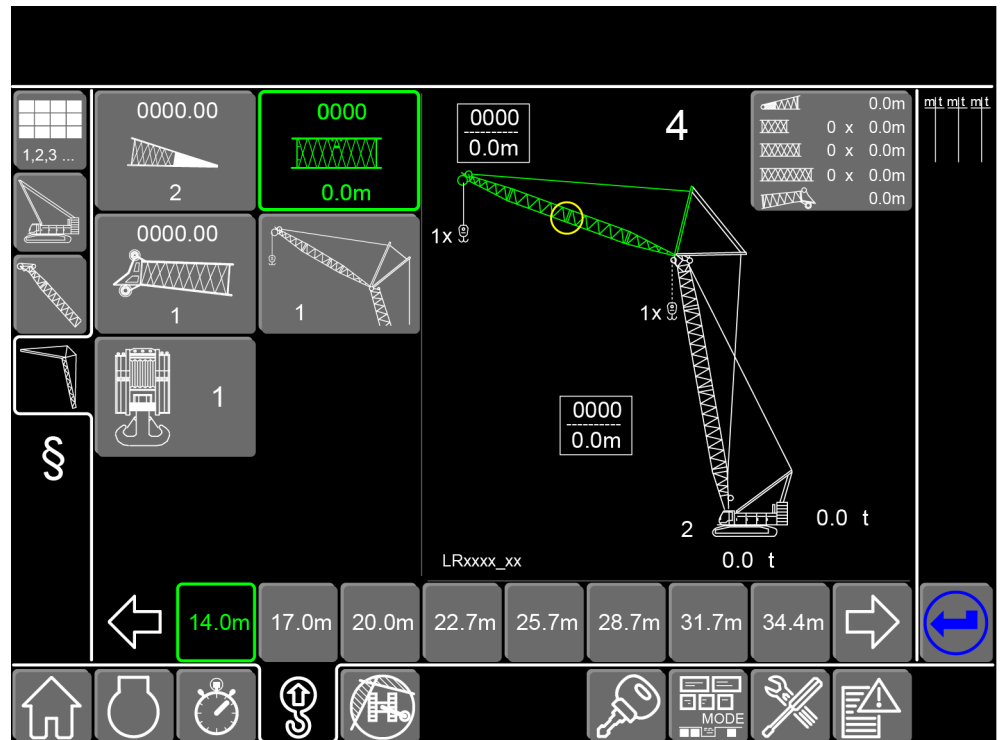
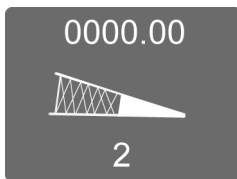
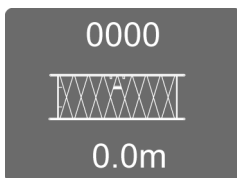


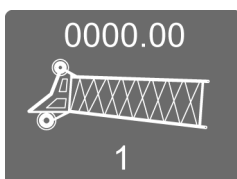
Fig. 1678: Setup - jib screen

**System dimension of the jib**

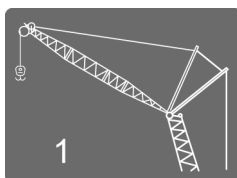
Select system dimension of the jib.

**Jib length**

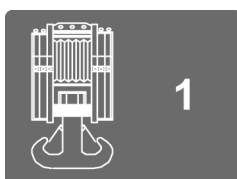
Select jib length.

**Jib head**

Select jib head in line with foreword to the valid load chart.

**Load position**

Select load position.

**Rope reeving**

Select rope reeving.



Smaller values

Switch to next smaller values.



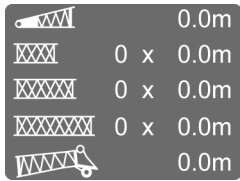
Larger values

Switch to next larger values.



Value

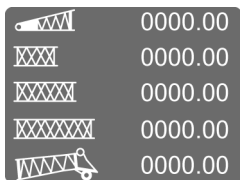
Select value.



Jib components

Button shows the composition of the jib components and their lengths.

Switch to composition of the jib components and their system dimensions.



Jib components

Button shows the composition of the jib components and their system dimensions.

Switch to composition of the jib components and their lengths.

3.18.6 Setup - boom configuration 5 screen

Setup - basic machine screen



Setup - basic machine

Switch to the *Setup - basic machine* screen.

The *Setup - basic machine* screen serves to define and confirm the track width and counterweights.

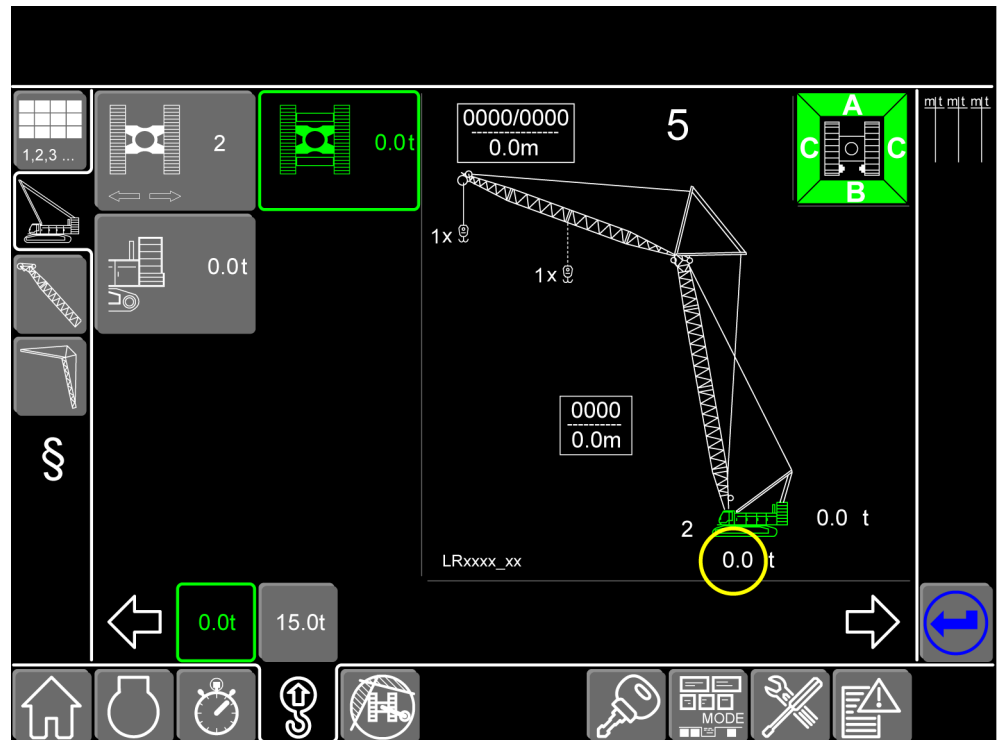
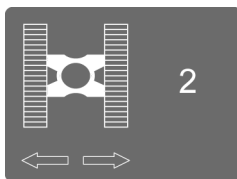
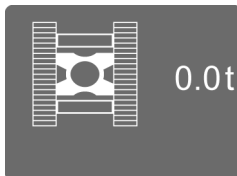


Fig. 1690: Setup - basic machine screen

**Track width**

Select the track width.

- 1: Narrow track
- 2: Wide track
- 3: Blocked Crawlers

**Carbody counterweight**

Select the weight of carbody counterweight.

**Rear counterweight**

Select the weight of rear counterweight.

**Smaller values**

Switch to next smaller values.

**Larger values**

Switch to next larger values.

**Value**

Select value.

Setup - main boom screen



Setup - main boom

Switch to the *Setup - main boom* screen.

The *Setup - main boom* screen serves to define and confirm the main boom head, the main boom length and the reeving of the load hook.

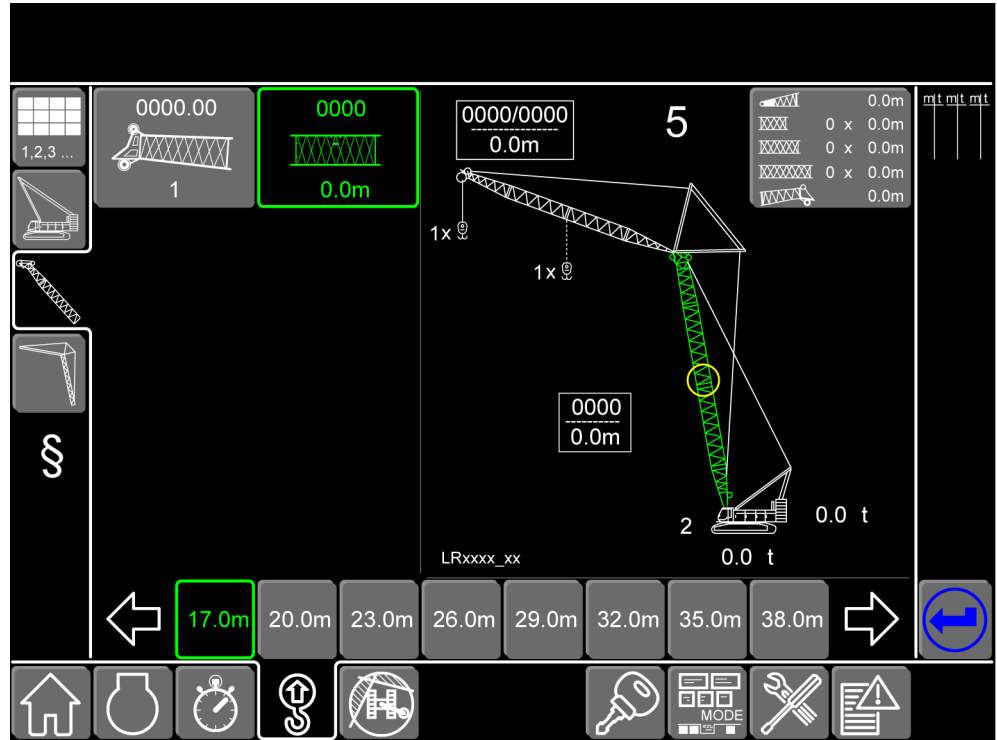
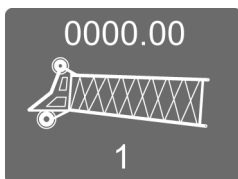
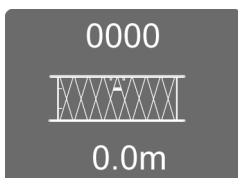


Fig. 1698: Setup - main boom screen



Main boom head

Select main boom head in line with forward to the valid load chart.



Main boom length

Select the main boom length.



Smaller values

Switch to next smaller values.



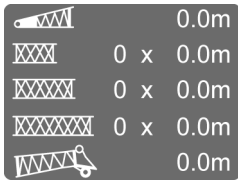
Larger values

Switch to next larger values.



Value

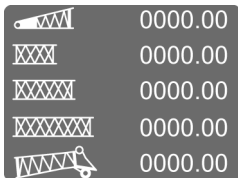
Select value.



Main boom components

Button shows the composition of the main boom components and their lengths.

Switch to composition of the main boom components and their system dimensions.



Main boom components

Button shows the composition of the main boom components and their system dimensions.

Switch to composition of the main boom components and their lengths.

Setup - jib screen



Setup - jib

Switch to the *Setup - jib* screen.

The *Setup - jib* screen serves to define and confirm the jib head, the jib length and the reeving of the load hook.

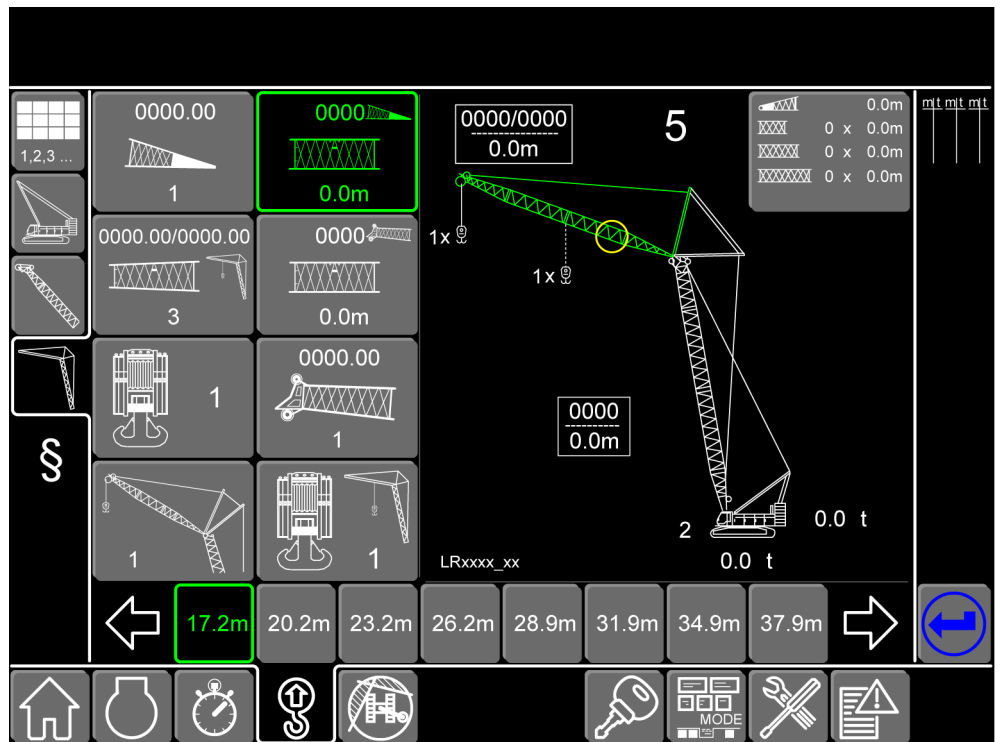
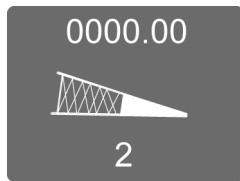


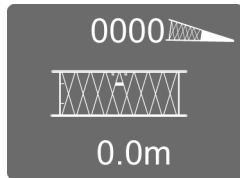
Fig. 1707: Setup - jib screen

LWNLR_x/V04.01//Auslieferung/2016-03-07/en



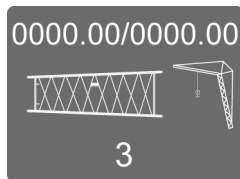
System dimension of the jib

Select system dimension of the jib.



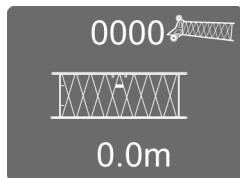
Jib length up to Midfall

Select jib length up to midfall.



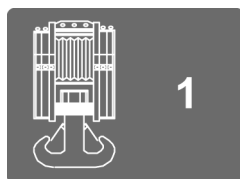
Midfall

Select midfall. The control system displays the midfall as a reducing adapter.



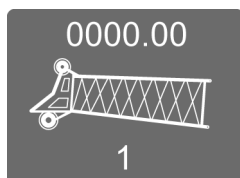
Jib length after midfall

Select jib length after midfall.



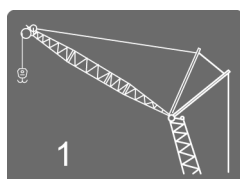
Rope reeving

Select rope reeving.



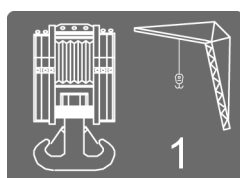
Jib head

Select jib head in line with foreword to the valid load chart.



Load position

Select load position.



Reeving midfall

Select reeving of midfall.



Smaller values

Switch to next smaller values.

**Larger values**

Switch to next larger values.

**Value**

Select value.

	0.0m
	0 x 0.0m
	0 x 0.0m
	0 x 0.0m
	0.0m

Jib components

Button shows the composition of the jib components and their lengths.

Switch to composition of the jib components and their system dimensions.

	0000.00
	0000.00
	0000.00
	0000.00
	0000.00

Jib components

Button shows the composition of the jib components and their system dimensions.

Switch to composition of the jib components and their lengths.

3.18.7 Setup screen - boom configuration 6

Setup - basic machine screen

**Setup - basic machine**

Switch to the *Setup - basic machine* screen.

The *Setup - basic machine* screen serves to define and confirm the track width and counterweights.

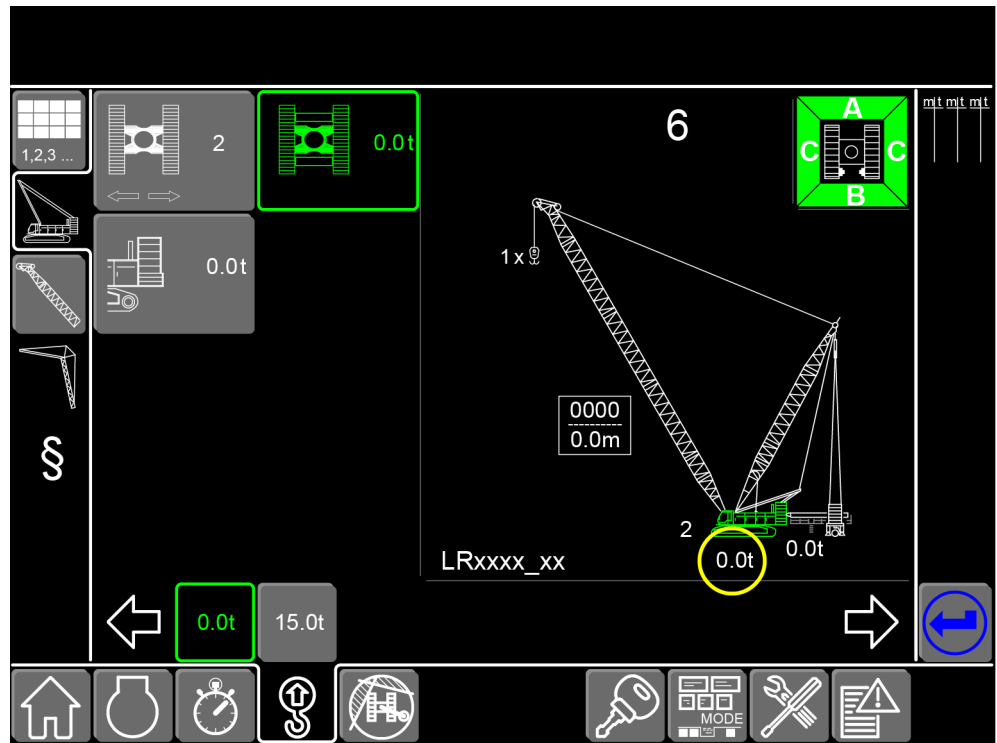
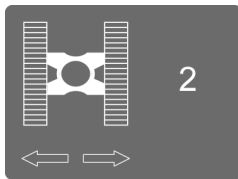


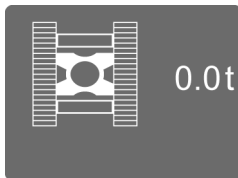
Fig. 1722: Screen Setup - basic machine



Track width

Select the track width.

- 1: Narrow track
- 2: Wide track
- 3: Blocked Crawlers



Carbody counterweight

Select the weight of carbody counterweight.



Rear counterweight

Select the weight of rear counterweight.



Smaller values

Switch to next smaller values.



Larger values

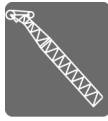
Switch to next larger values.



Value

Select value.

Setup - main boom screen



Setup - main boom

Switch to the *Setup - main boom* screen.

The *Setup - main boom* screen serves to define and confirm the main boom head, the main boom length and the reeving of the load hook.

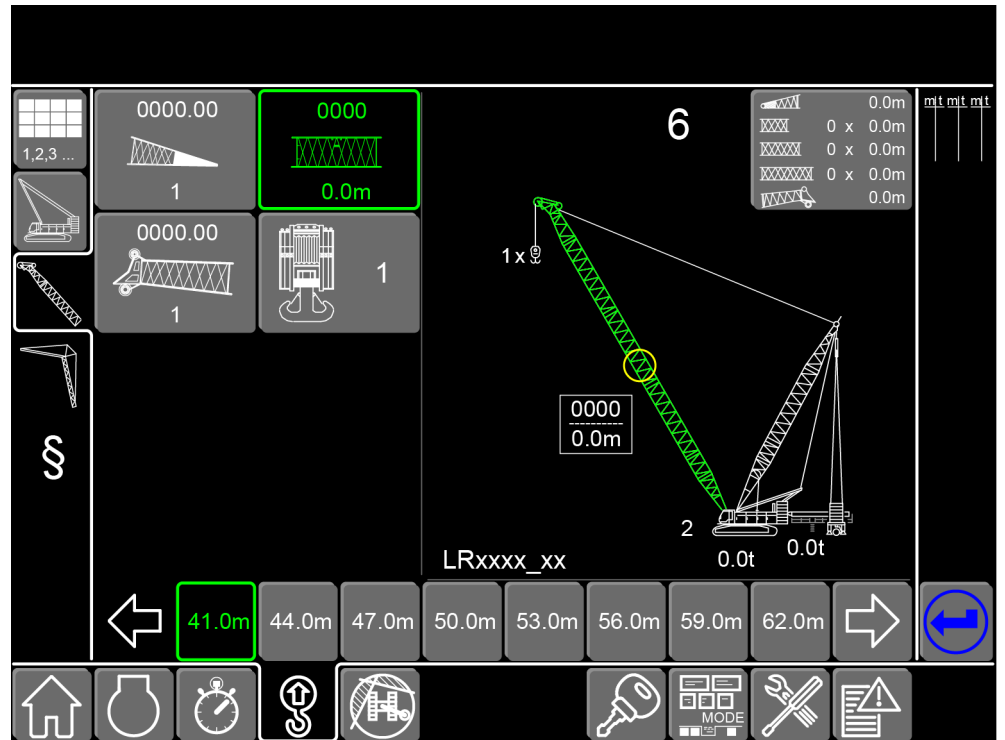
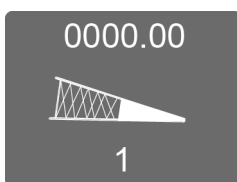
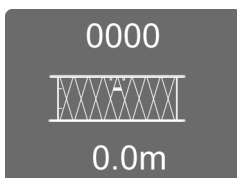


Fig. 1730: Setup - main boom screen



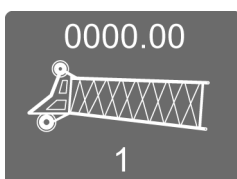
Main boom system dimension

Select main boom system dimension.



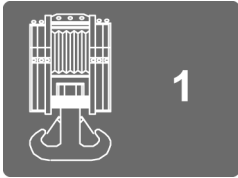
Main boom length

Select the main boom length.



Main boom head

Select main boom head in line with foreword to the valid load chart.



Rope reeving

Select rope reeving.



Smaller values

Switch to next smaller values.



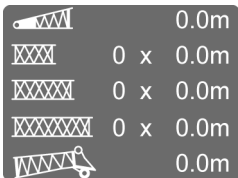
Larger values

Switch to next larger values.



Value

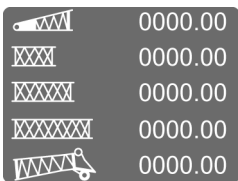
Select value.



Main boom components

Button shows the composition of the main boom components and their lengths.

Switch to composition of the main boom components and their system dimensions.



Main boom components

Button shows the composition of the main boom components and their system dimensions.

Switch to composition of the main boom components and their lengths.

3.18.8 Setup screen - boom configuration 8

Screen Setup - basic machine



Setup - basic machine

Switch to *Setup - basic machine* screen.

The screen *Setup - basic machine* serves to define and confirm the track width and counterweights.

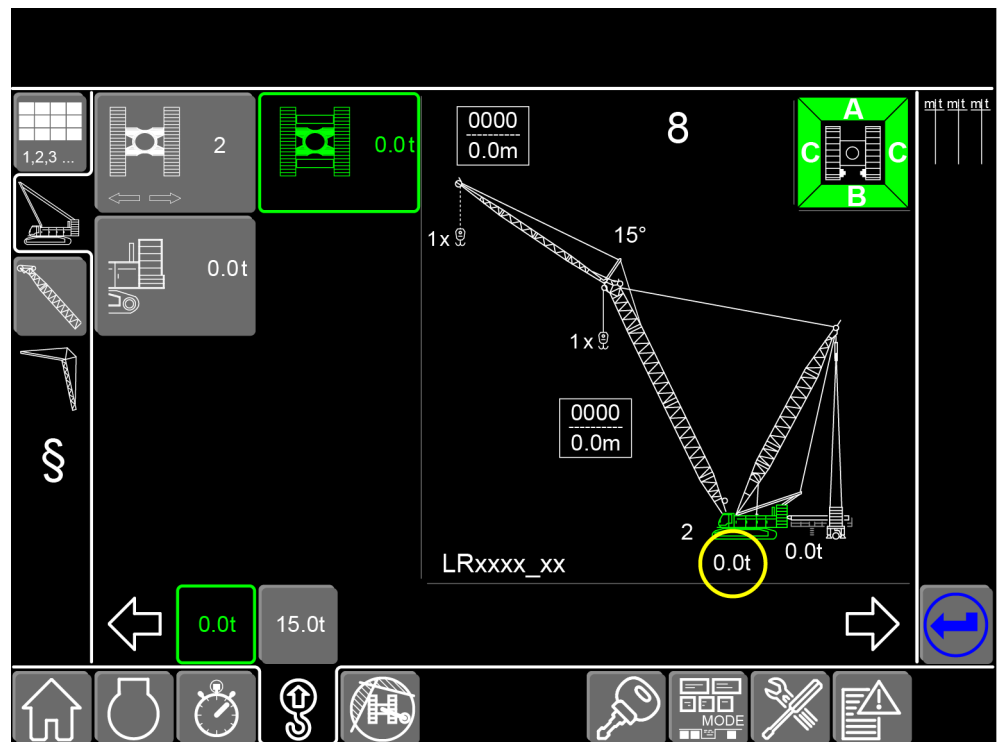
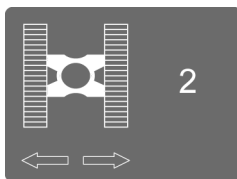
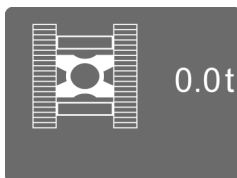


Fig. 1741: Screen Setup - basic machine

**Track width**

Select track width.

- 1: Narrow track
- 2: Wide track
- 3: Blocked crawlers

**Carbody counterweight**

Select weight of carbody counterweight.

**Rear counterweight**

Select weight of rear counterweight.

**Smaller values**

Switch to next smaller values.

**Larger values**

Switch to next larger values.

**Value**

Select value.

Screen Setup - main boom



Setup - main boom

Switch to *Setup - main boom* screen.

The screen *Setup - main boom* serves to define and confirm the main boom head, the main boom length and the reeving of the hook.

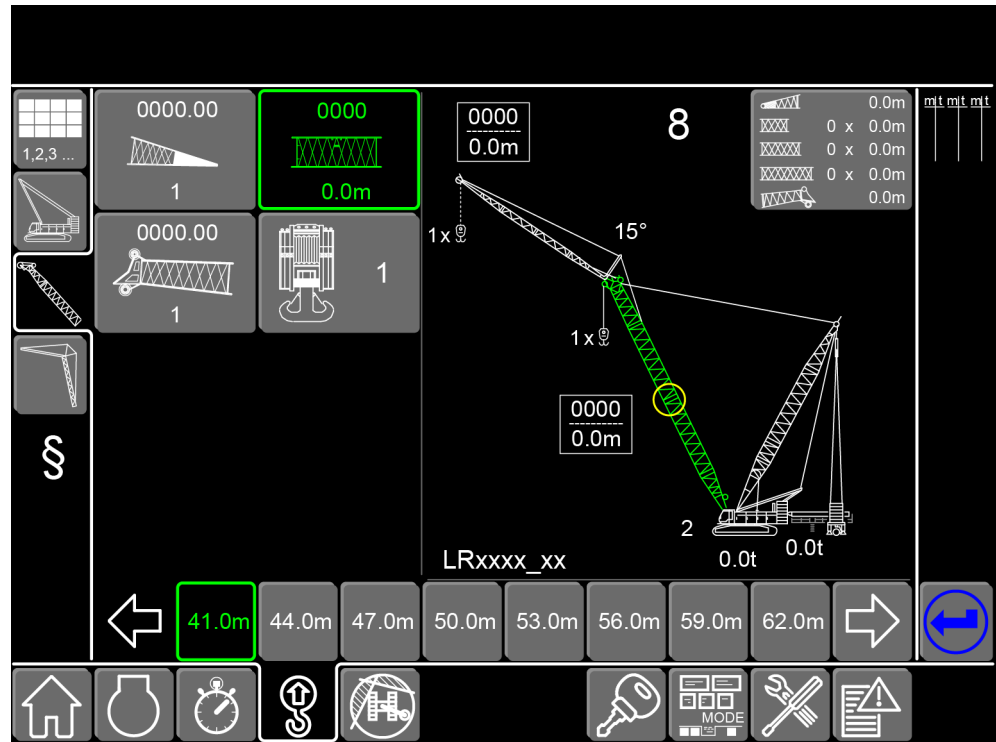
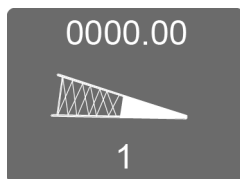
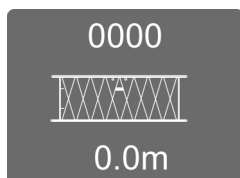


Fig. 1749: Screen Setup - main boom



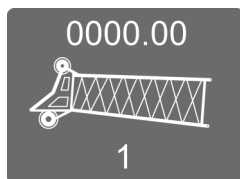
Main boom system dimension

Select main boom system dimension.



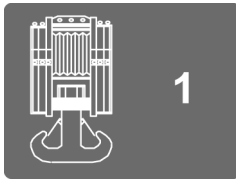
Main boom length

Select main boom length.



Main boom head

Select main boom head in line with foreword to the valid load chart.

**Rope reeving**

Select rope reeving.

**Smaller values**

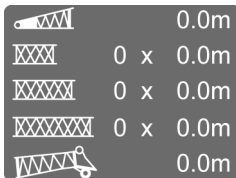
Switch to next smaller values.

**Larger values**

Switch to next larger values.

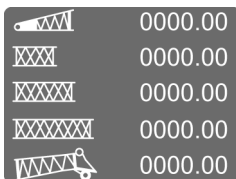
**Value**

Select value.

**Main boom components**

Button shows the composition of the main boom components and their lengths.

Switch to composition of the main boom components and their system dimensions.

**Main boom components**

Button shows the composition of the main boom components and their system dimensions.

Switch to composition of the main boom components and their lengths.

Setup - jib screen**Setup - jib**

Switch to the *Setup - jib* screen.

The *Setup - jib* screen serves to define and confirm the jib head, the jib length and the reeving of the load hook.

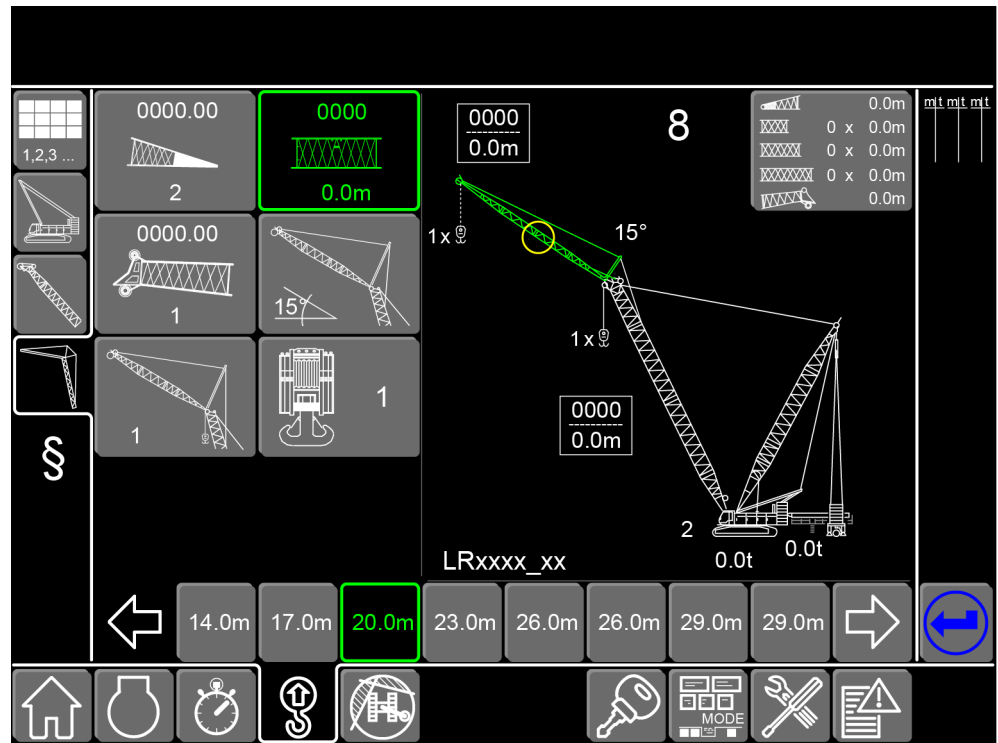
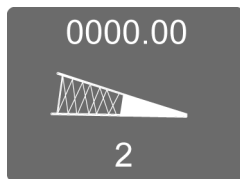
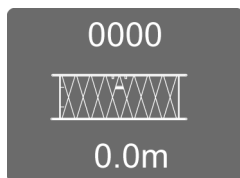


Fig. 1760: Screen Setup - jib



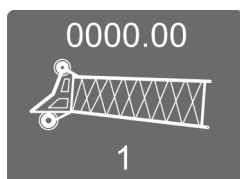
System dimension of the jib

Select system dimension of the jib.



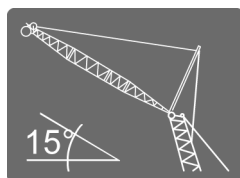
Jib length

Select jib length.



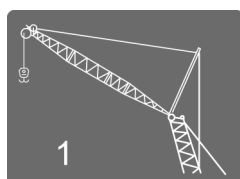
Jib head

Select jib head in line with foreword to the valid load chart.



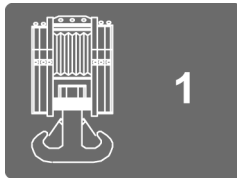
Tensioning position

Select tensioning position between jib and main boom in degrees.



Load position

Select load position.

**Rope reeving**

Select rope reeving.

**Smaller values**

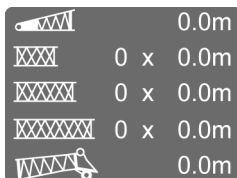
Switch to next smaller values.

**Larger values**

Switch to next larger values.

**Value**

Select value.

**Jib components**

Button shows the composition of the jib components and their lengths.

Switch to composition of the jib components and their system dimensions.

**Jib components**

Button shows the composition of the jib components and their system dimensions.

Switch to composition of the jib components and their lengths.

3.18.9 Setup screen - boom configuration 9

Screen Setup - basic machine

**Setup - basic machine**

Switch to *Setup - basic machine* screen.

The screen *Setup - basic machine* serves to define and confirm the track width and counterweights.

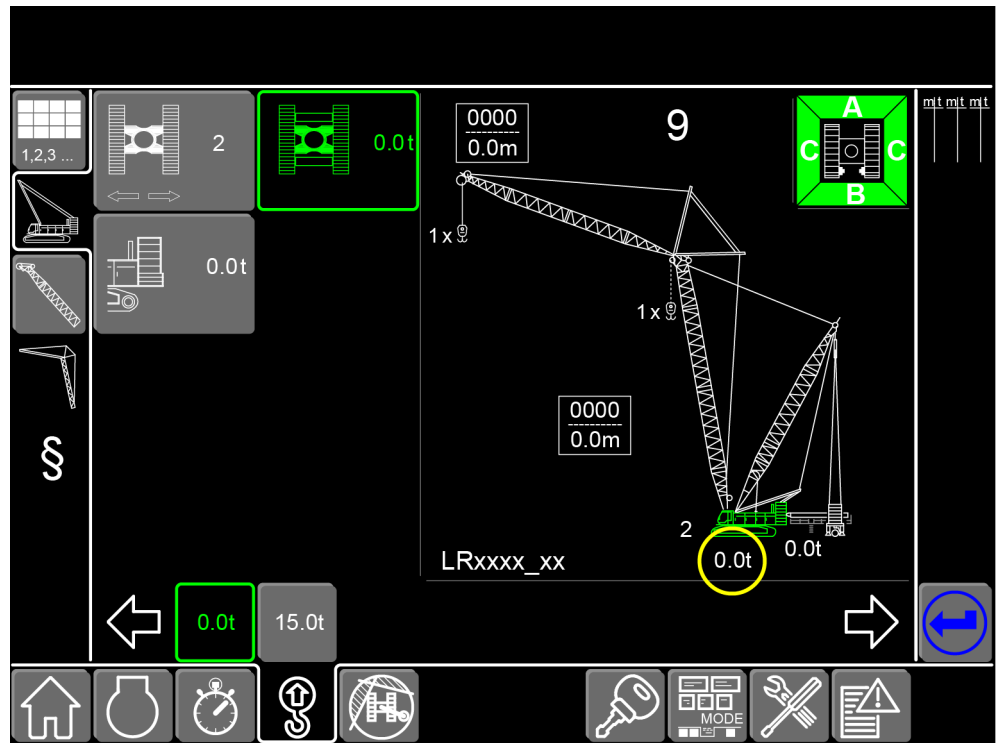
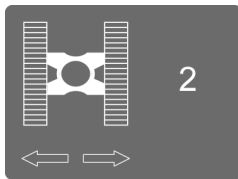


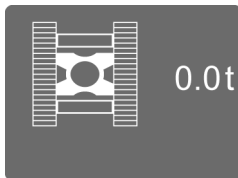
Fig. 1773: Screen Setup - basic machine



Track width

Select track width.

- 1: Narrow track
- 2: Wide track
- 3: Blocked crawlers



Carbody counterweight

Select weight of carbody counterweight.



Rear counterweight

Select weight of rear counterweight.



Smaller values

Switch to next smaller values.



Larger values

Switch to next larger values.



Value

Select value.

Screen Setup - main boom



Setup - main boom

Switch to *Setup - main boom* screen.

The screen *Setup - main boom* serves to define and confirm the main boom head, the main boom length and the reeving of the hook.

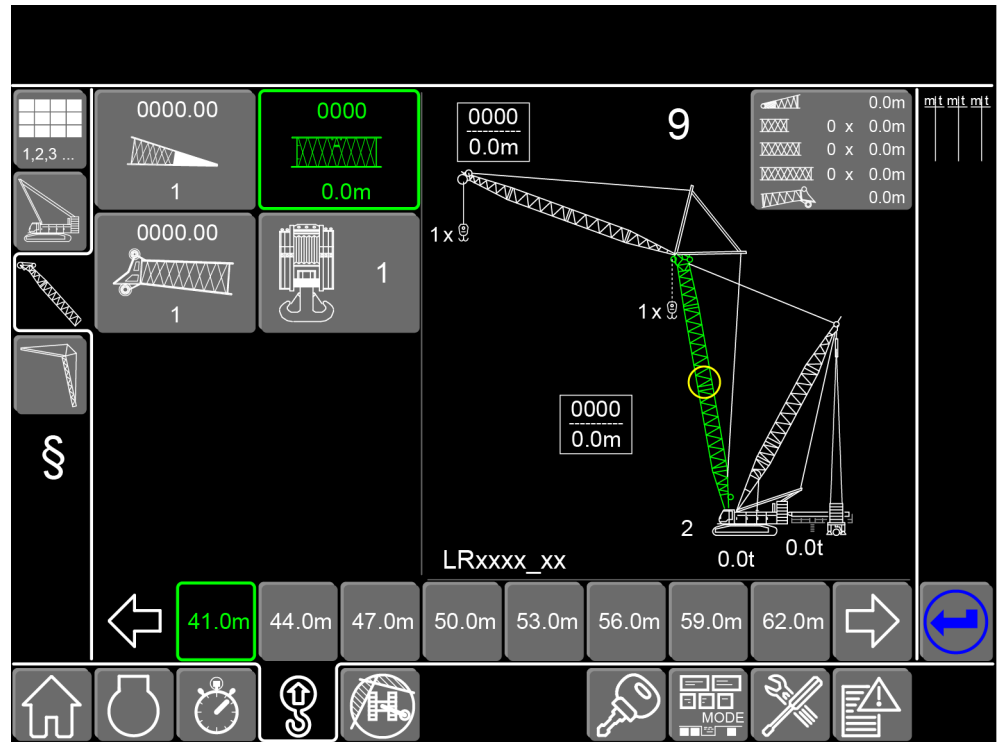
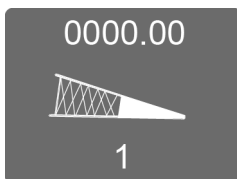
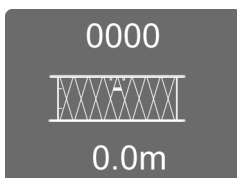


Fig. 1781: Screen *Setup - main boom*



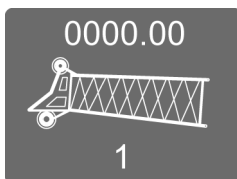
Main boom system dimension

Select main boom system dimension.



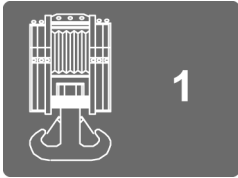
Main boom length

Select main boom length.



Main boom head

Select main boom head in line with foreword to the valid load chart.



Rope reeving

Select rope reeving.



Smaller values

Switch to next smaller values.



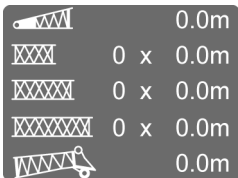
Larger values

Switch to next larger values.



Value

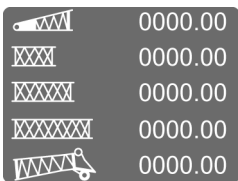
Select value.



Main boom components

Button shows the composition of the main boom components and their lengths.

Switch to composition of the main boom components and their system dimensions.



Main boom components

Button shows the composition of the main boom components and their system dimensions.

Switch to composition of the main boom components and their lengths.

Setup - jib screen



Setup - jib

Switch to the *Setup - jib* screen.

The *Setup - jib* screen serves to define and confirm the jib head, the jib length and the reeving of the load hook.

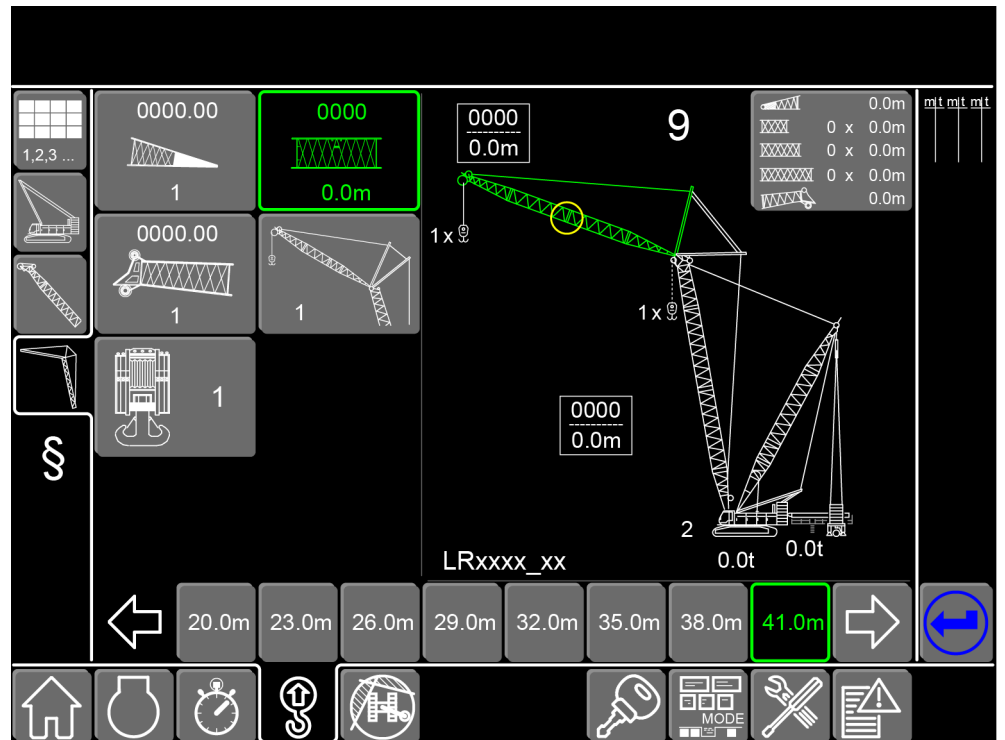
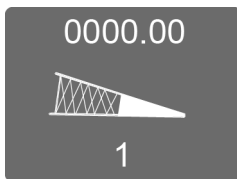
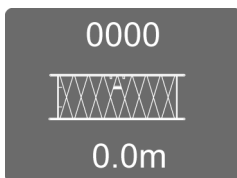


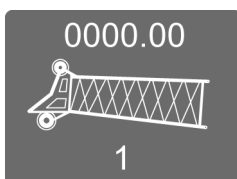
Fig. 1792: Screen Setup - jib

**System dimension of the jib**

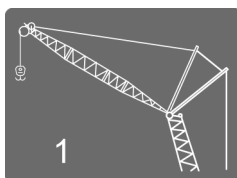
Select system dimension of the jib.

**Jib length**

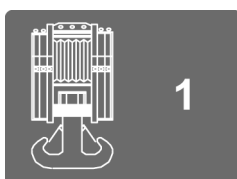
Select jib length.

**Jib head**

Select jib head in line with foreword to the valid load chart.

**Load position**

Select load position.

**Rope reeving**

Select rope reeving.



Smaller values

Switch to next smaller values.



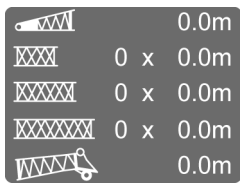
Larger values

Switch to next larger values.



Value

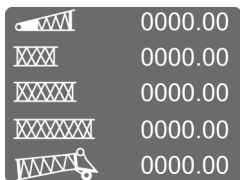
Select value.



Jib components

Button shows the composition of the jib components and their lengths.

Switch to composition of the jib components and their system dimensions.

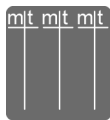


Jib components

Button shows the composition of the jib components and their system dimensions.

Switch to composition of the jib components and their lengths.

3.18.10 Setup - load chart screen



Switch to the *Setup - load chart* screen.

The *Setup - load chart* screen shows the radius and corresponding lifting capacity for the programmed setup.

VERSION: 00000000 | 000000 / ALPHA = 0.0°

m		t		m		t		m		t	
31.9	5.0	40.0	3.6	48.5	2.6	0.0	0.0				
32.0	5.0	40.5	3.5	49.0	2.5	0.0	0.0				
32.5	4.9	41.0	3.4	49.5	2.5	0.0	0.0				
33.0	4.8	41.5	3.4	50.0	2.4	0.0	0.0				
33.5	4.7	42.0	3.3	50.5	2.4	0.0	0.0				
34.0	4.6	42.5	3.2	51.0	2.3	0.0	0.0				
34.5	4.5	43.0	3.2	51.5	2.3	0.0	0.0				
35.0	4.4	43.5	3.1	52.0	2.2	0.0	0.0				
35.5	4.3	44.0	3.1	52.5	2.2	0.0	0.0				
36.0	4.2	44.5	3.0	53.0	2.1	0.0	0.0				
36.5	4.1	45.0	2.9	53.5	2.1	0.0	0.0				
37.0	4.0	45.5	2.9	54.0	2.0	0.0	0.0				
37.5	4.0	46.0	2.8	54.5	2.0	0.0	0.0				
38.0	3.9	46.5	2.8	0.0	0.0	0.0	0.0				
38.5	3.8	47.0	2.7	0.0	0.0	0.0	0.0				
39.0	3.7	47.5	2.7	0.0	0.0	0.0	0.0				
39.5	3.7	48.0	2.6	0.0	0.0	0.0	0.0				

Fig. 1804: Setup - load chart screen

- | | | | |
|---|------------------------------|---|---|
| 1 | Value of the smallest radius | 3 | Main boom angle alpha or differential angle gamma |
| 2 | Load chart version | 4 | Invalid values |

The value of the smallest radius is specified exactly. All other values are rounded to whole numbers.

Invalid values are listed in the table with a 0.0

Gamma is the calculated difference in angle between main boom angle Alpha and jib angle Beta.

3.19 Screen *Working range limitation*



Working range limitation

Switch to the *Working range limitation* screen.

3.19.1 Screen *Working range limitation - working range limitation*



Working range limitation - working range limitation

Switch to the *Working range limitation - working range limitation* screen.

The *Working range limitation - working range limitation* screen provides settings for limiting the working range of the swing and the booms of the machine. The working range limitations are programed by approaching the stop positions and pressing the button stop position.

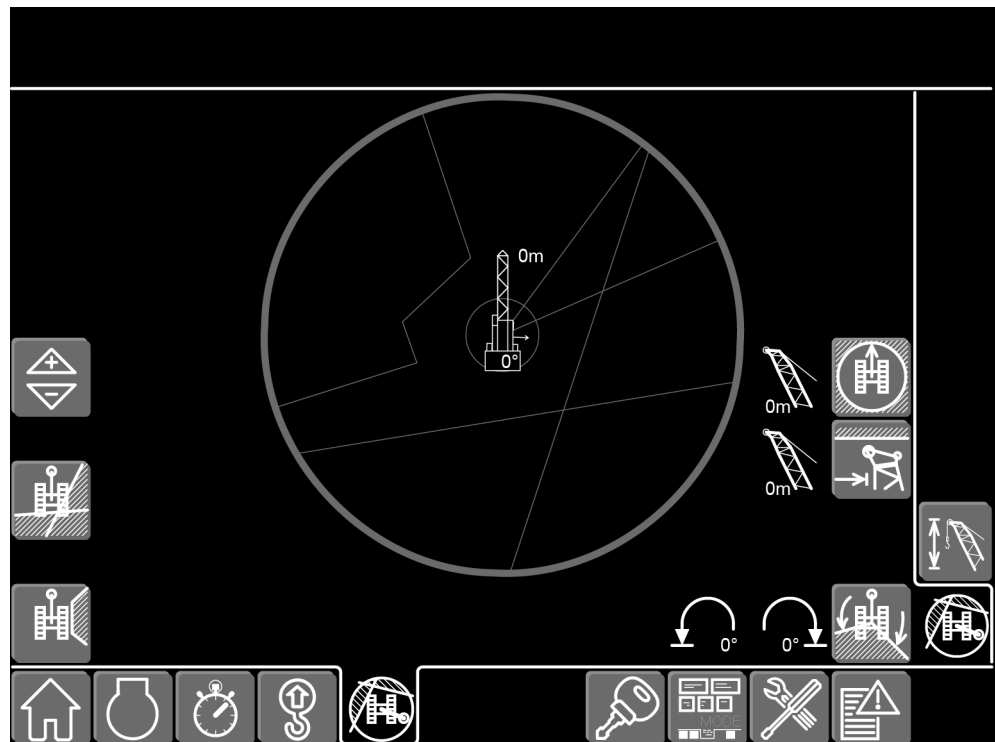


Fig. 1807: Screen *Working range limitation - working range limitation - main boom - limitations turned off*

LWNLR-x\04.01\Auslieferung\2016-03-07\en

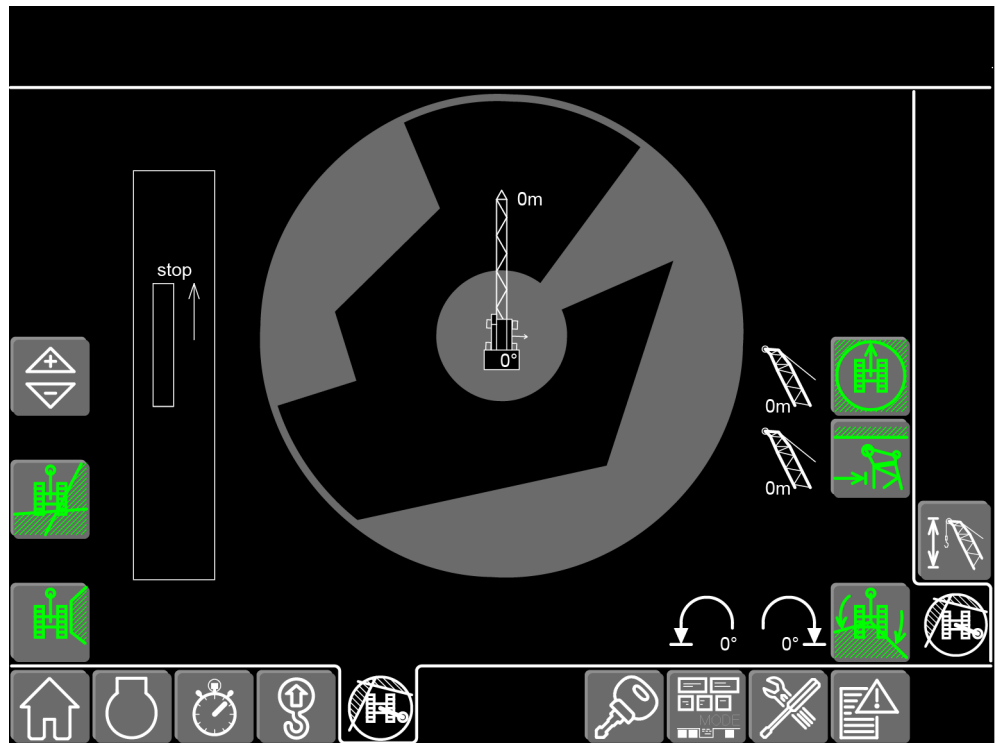


Fig. 1808: Screen Working range limitation - working range limitation - main boom - limitations turned on

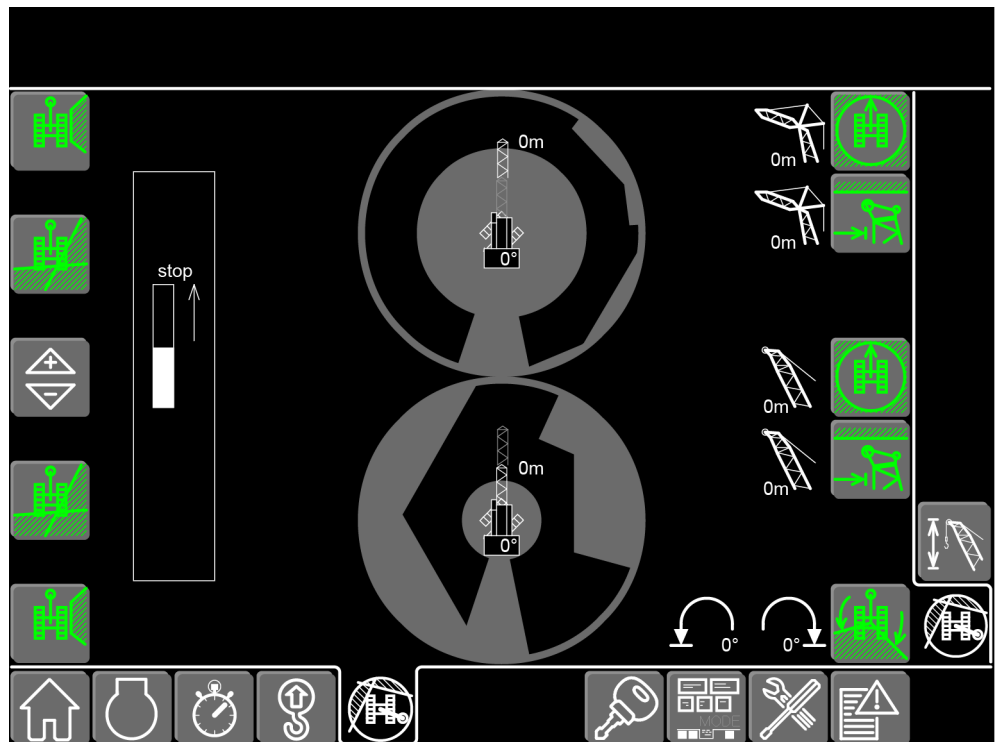


Fig. 1809: Screen Working range limitation - working range limitation - main boom and jib - limitations turned on

LWNLR-x/V04.01//Auslieferung/2016-03-07/en

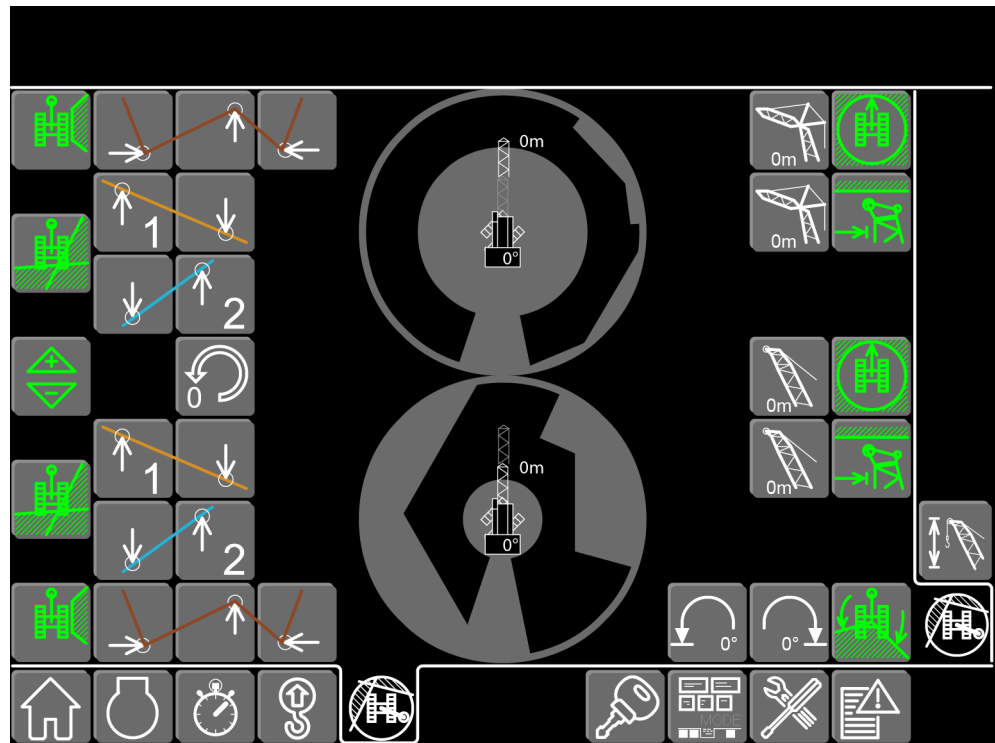


Fig. 1810: Screen Working range limitation - working range limitation - main boom and jib - program stop positions

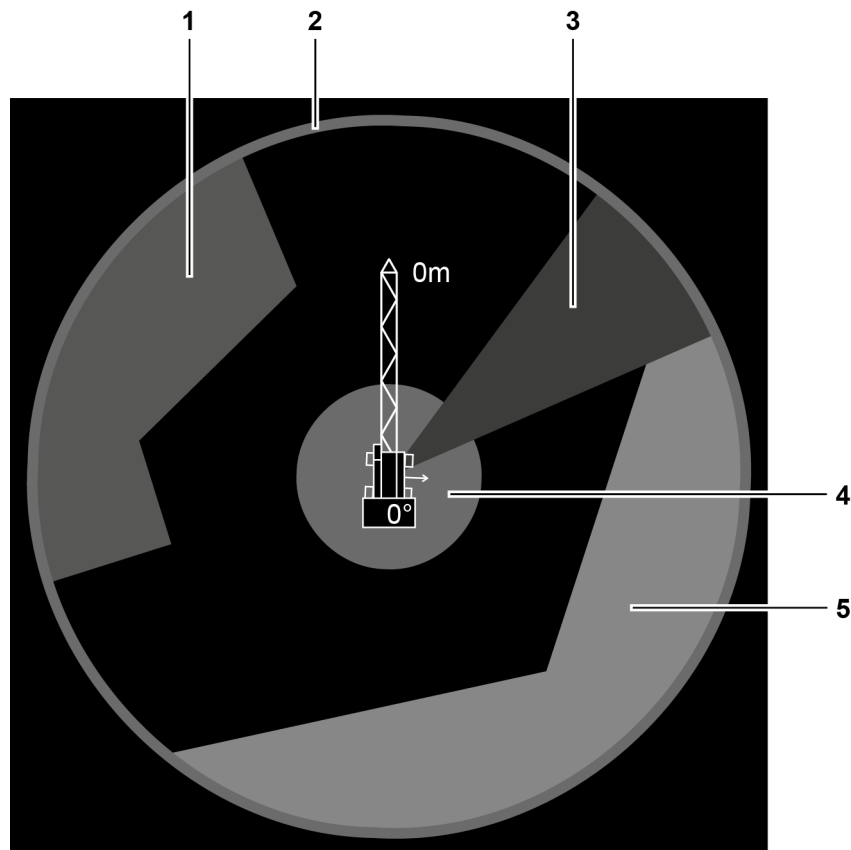


Fig. 1811: Screen section Working range limitation (illustration of principle)

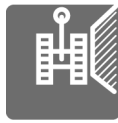
1 Sector limitation

4 Radius limitation minimum radius

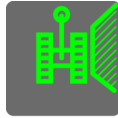
See next page for continuation of the image legend

LWNLR-x\04.01\Auslieferung\2016-03-07/en

- 2 Radius limitation maximum radius 5 Edge limitation
 3 Slewing range limitation

**Sector limitation**

Activate last programmed sector limitation.

**Sector limitation (lit green)**

Deactivate last programmed sector limitation.

**Sector limitation - stop position1**

Program stop position1 of the sector limitation.

**Sector limitation - stop position2**

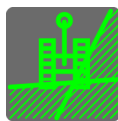
Program stop position2 of the sector limitation.

**Sector limitation - stop position3**

Program stop position3 of the sector limitation.

**Edge limitation**

Activate last programmed edge limitation.

**Edge limitation (lit green)**

Deactivate last programmed edge limitation.

**Edge limitation - edge1 - stop position1**

Edge1 - program stop position1 of edge limitation.

**Edge limitation - edge1 - stop position2**

Edge1 - program stop position2 of edge limitation.

**Edge limitation - edge2 - stop position1**

Edge2 - program stop position1 of edge limitation.

**Edge limitation - edge2 - stop position2**

Edge2 - program stop position2 of edge limitation.

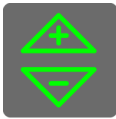
**Programming**

Show buttons of the stop positions.

The following stop positions are available:

- Edge limitation
- Sector limitation
- Boom radius limitation

– Swing limitation



Programming (lit green)

Hide buttons of the stop positions.



Programming (lit red)

Machine was moved and working range limitation must be reprogrammed.



Resetting limitations

Reset all limitations. Button must be pressed for more than 1 second.



Stop position maximum radius jib

Shows the last programmed stop position of the jib's maximum radius.



Stop position maximum radius jib

Program the stop position of the jib's maximum radius.



Radius limitation maximum jib radius

Activate last programmed radius limitation maximum jib radius.



Radius limitation maximum jib radius (lit green)

Deactivate last programmed radius limitation maximum jib radius.



Stop position minimum radius jib

Shows the last programmed stop position of the jib's minimum radius.



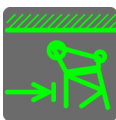
Stop position minimum radius jib

Program the stop position of the jib's minimum radius.



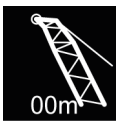
Radius limitation minimum jib radius

Activate last programmed radius limitation minimum jib radius.



Radius limitation minimum jib radius (lit green)

Deactivate last programmed radius limitation minimum jib radius.



Stop position maximum radius main boom

Shows the last programmed stop position of the main boom's maximum radius.

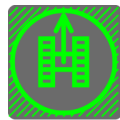


Stop position maximum radius main boom

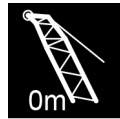
Program the stop position of the main boom's maximum radius.

**Radius limitation maximum main boom radius**

Activate last programmed radius limitation maximum main boom radius.

**Radius limitation maximum main boom radius (lit green)**

Deactivate last programmed radius limitation maximum main boom radius.

**Stop position minimum radius main boom**

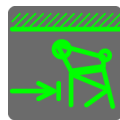
Shows the last programmed stop position of the main boom's minimum radius.

**Stop position minimum radius main boom**

Program the stop position of the main boom's minimum radius.

**Radius limitation minimum main boom radius**

Activate last programmed radius limitation minimum main boom radius.

**Radius limitation minimum main boom radius (lit green)**

Deactivate last programmed radius limitation minimum main boom radius.

**Slewing range limitation**

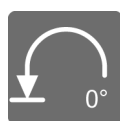
Activate last programmed slewing range limitation.

**Slewing range limitation (lit green)**

Deactivate last programmed slewing range limitation.

**Slewing range limitation - left stop position**

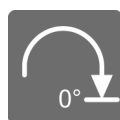
Shows the last programmed left stop position of the slewing range limitation.

**Slewing range limitation - left stop position**

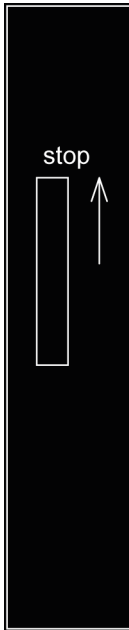
Program left stop position of slewing range limitation.

**Slewing range limitation -right stop position**

Shows the last programmed right stop position of the slewing range limitation.

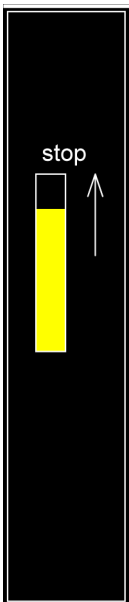
**Slewing range limitation -right stop position**

Program right stop position of slewing range limitation.



Bar display working range limitation

Stop position is more than 5 m (16' 5" ft-in) away.



Bar display working range limitation (lit yellow)

Stop position reached.



Bar display working range limitation (lit red)

Stop position reached.

The reached stop positions are displayed.

3.19.2 Screen *Working range limitation - lifting height limitation*



Working range limitation - lifting height limitation

Switch to the *Working range limitation - lifting height limitation* screen.

The screen *Working range limitation - lifting height limitation* offers settings for the lifting height limitation of winch1 and winch2.

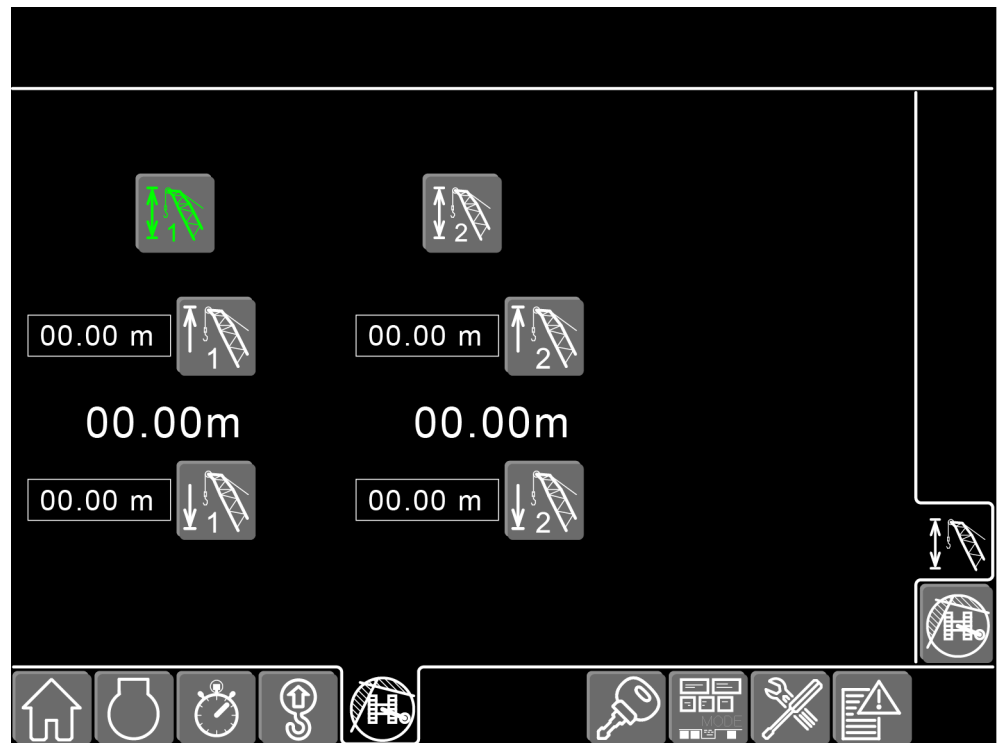


Fig. 1853: Screen Working range limitation - lifting height limitation

LWNLR.x/V04.01//Auslieferung/2016-03-07/en

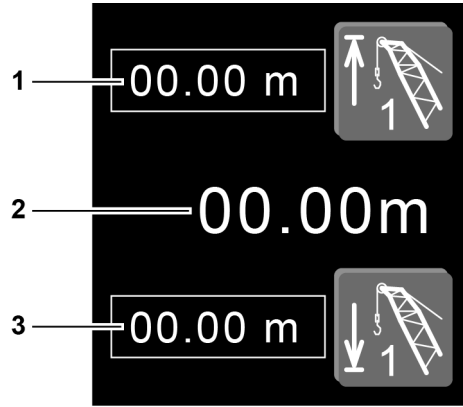


Fig. 1854: Screen section Lifting height limitation winch1

- 1 Top stop position of winch1
- 2 Current lifting height of winch1
- 3 Bottom stop position of winch1

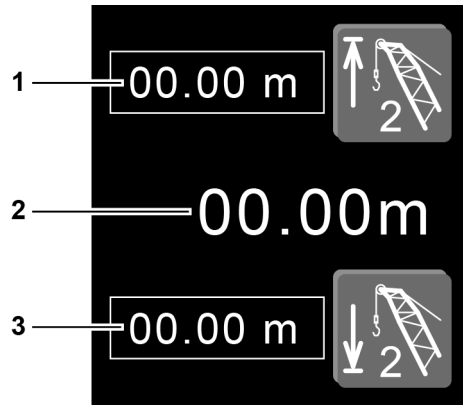
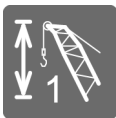


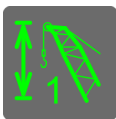
Fig. 1855: Screen section Lifting height limitation winch2

- 1 Top stop position of winch2
- 2 Current lifting height of winch2
- 3 Bottom stop position of winch2



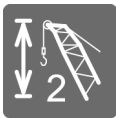
Lifting height limitation winch1

Activate last programmed lifting height limitation of winch1.



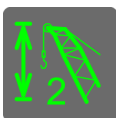
Lifting height limitation winch1 (lit green)

Deactivate last programmed lifting height limitation of winch1.



Lifting height limitation winch2

Activate last programmed lifting height limitation of winch2.



Lifting height limitation winch2 (lit green)

Deactivate last programmed lifting height limitation of winch2.



Lifting height limitation winch1 - top stop position

Program top stop position of lifting height limitation of winch1.



Lifting height limitation winch1 - bottom stop position

Program bottom stop position of lifting height limitation of winch1.



Lifting height limitation winch2 - top stop position

Program top stop position of lifting height limitation of winch2.



Lifting height limitation winch2 - bottom stop position

Program bottom stop position of lifting height limitation of winch2.

3.20 Screen Access control



Access control

Switch to the *Access control* screen.

The *Access control* screen serves to manage and/or control access to the machine.

3.20.1 Without retrofit kit access control (black ignition keys)

This situation occurs under the following conditions:

- Machine was delivered with software without the *Access control* screen.
- Machine was delivered with black ignition keys.
- Machine receives a retrospective software update and now features the *Access control* screen.
- Retrofit kit access control was not purchased.

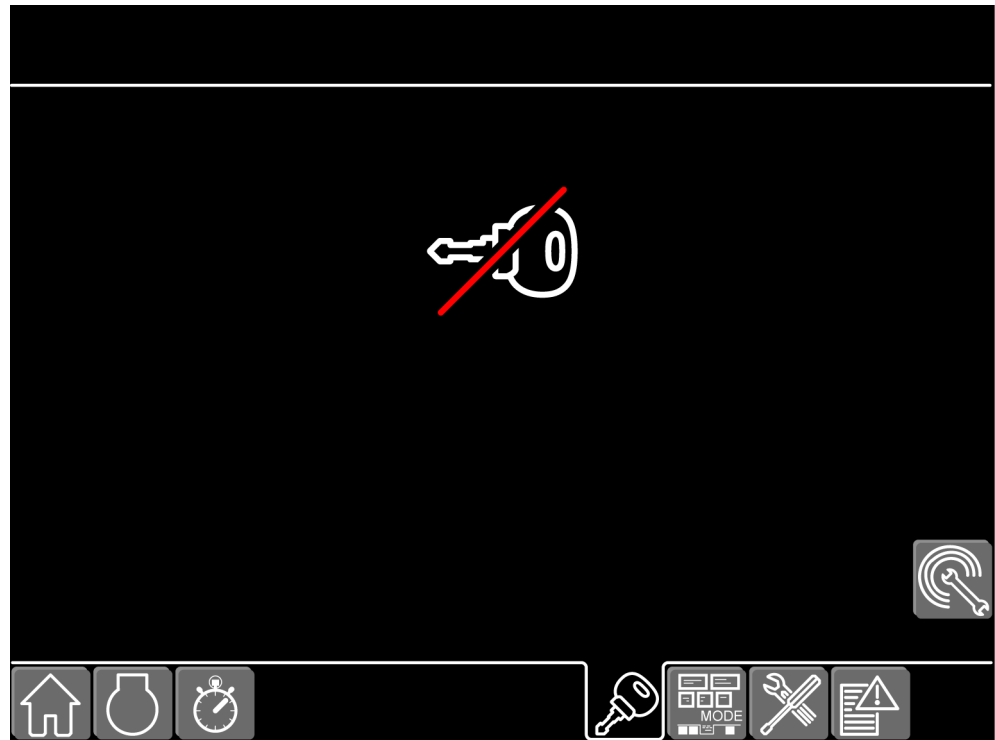


Fig. 1865: Access control screen - without retrofit kit access control (black ignition keys)



Remote service

Turn on the remote service.



Remote service (lit green)

Turn off the remote service.

3.20.2 Without retrofit kit access control (blue ignition keys)

This situation occurs under the following conditions:

- Machine was delivered with current software with the *Access control* screen.
- Machine was delivered with blue, user-specific ignition keys.
- Retrofit kit access control was not purchased.

Each blue, user-specific ignition key allows operating the machine.

Each blue, user-specific ignition key can be assigned a name.

An access control of an individual ignition key cannot be defined.

The maximum number of blue, user-specific ignition keys is 50.



Fig. 1868: Access control screen - without retrofit kit access control (blue ignition keys)

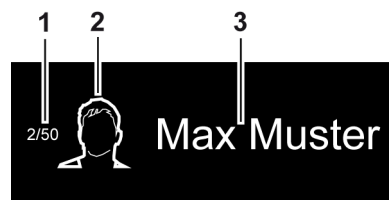


Fig. 1869: Screen section User

- | | |
|--|----------------------------------|
| <p>1 Second ignition key of max. 50 possible ones</p> <p>2 User without access control</p> | <p>3 Name of the user</p> |
|--|----------------------------------|

Keypad

Show keyboard for changing the name.





Remote service

Turn on the remote service.



Remote service (lit green)

Turn off the remote service.

3.20.3 With retrofit kit access control (red and blue ignition keys)*

This situation occurs under the following conditions:

- Machine was delivered with current software with the *Access control* screen.
- Machine was delivered with a red administrator ignition key and blue, user-specific ignition keys.
- Retrofit kit access control was purchased.

Only the red administrator ignition key functions when the machine is commissioned.

Each blue, user-specific ignition key must first be authorized by the administrator, thus guaranteeing access control.

The maximum number of blue, user-specific ignition keys is 50.



Fig. 1873: Screen Access control - with retrofit kit access control (access with red administrator ignition key)

LWN/LR-x/V04.01//Auslieferung/2016-03-07/en

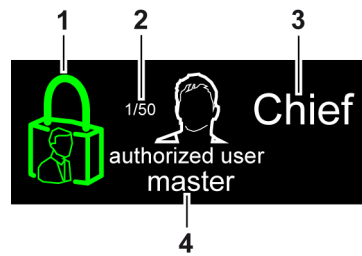


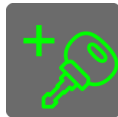
Fig. 1874: Screen section Administrator

- | | |
|---|--|
| <p>1 Retrofit kit access control</p> <p>2 First ignition key of max. 50 possible ones</p> | <p>3 Name of administrator</p> <p>4 Administrator with access control (red ignition key)</p> |
|---|--|



Keypad

Show keyboard for changing the name.



Authorize ignition key (lit green)

Authorize blue, user-specific ignition key.



Delete authorization of an ignition key (lit red)

Remove the authorization of a blue, user-specific ignition key.



Delete authorization of all ignition keys (lit red)

Delete authorization of all blue, user-specific ignition keys.



Remote service

Turn on the remote service.



Remote service (lit green)

Turn off the remote service.



Fig. 1881: Access control screen - with retrofit kit access control (access with blue, user-specific ignition key)

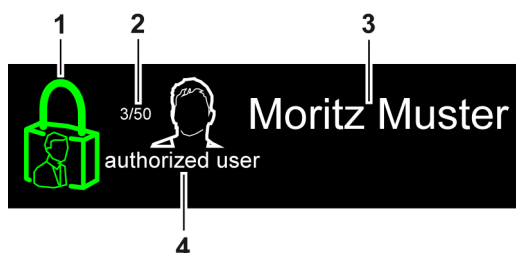


Fig. 1882: Screen section Authorized user

- | | | | |
|---|---|---|-----------------------------|
| 1 | Retrofit kit access control | 3 | Name of the authorized user |
| 2 | Third ignition key of max. 50 possible ones | 4 | Authorized user |



Keypad

Show keyboard for changing the name.



Remote service

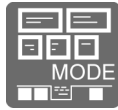
Turn on the remote service.



Remote service (lit green)

Turn off the remote service.

3.21 Mode screen



Mode

Switch to the *Mode* screen.

The *Mode* screen informs the machine operator about the modes that can be selected on this machine. The currently selected mode is displayed in green.

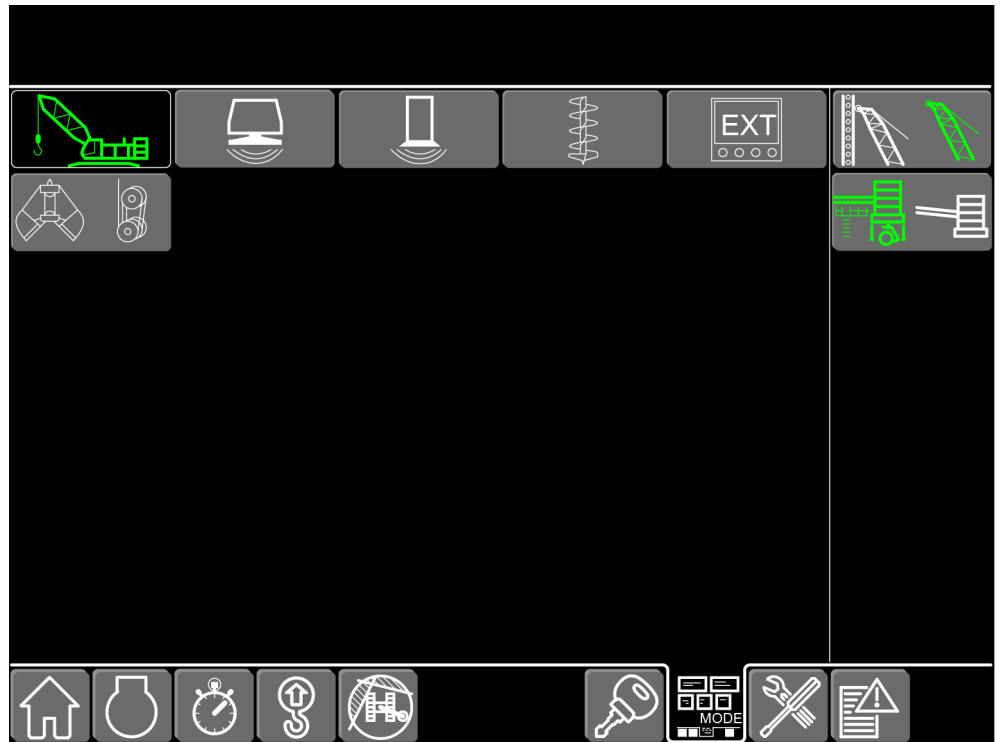


Fig. 1887: Mode screen



Crane mode

Select crane mode.



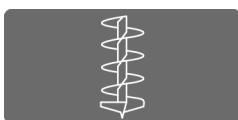
Vibrator mode

Select vibrator mode.



Hammer mode

Select hammer mode.



Drilling operation

Select rotary drive mode.



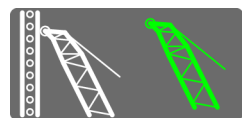
External control

Select external control mode.



Mechanical grab mode

Select mechanical grab mode.



Leader mode

Select leader mode.



Counterweight carriage/suspended counterweight (only in derrick mode)

Select counterweight carriage or suspended counterweight.



Confirmation

Confirm input.



Restart machine

Restart machine to save the selected mode.

3.22 Settings screen



Settings

Switch to the *Settings* screen.

3.22.1 Screen *Settings - components*



Settings - components

Switch to the *Settings - components* screen.

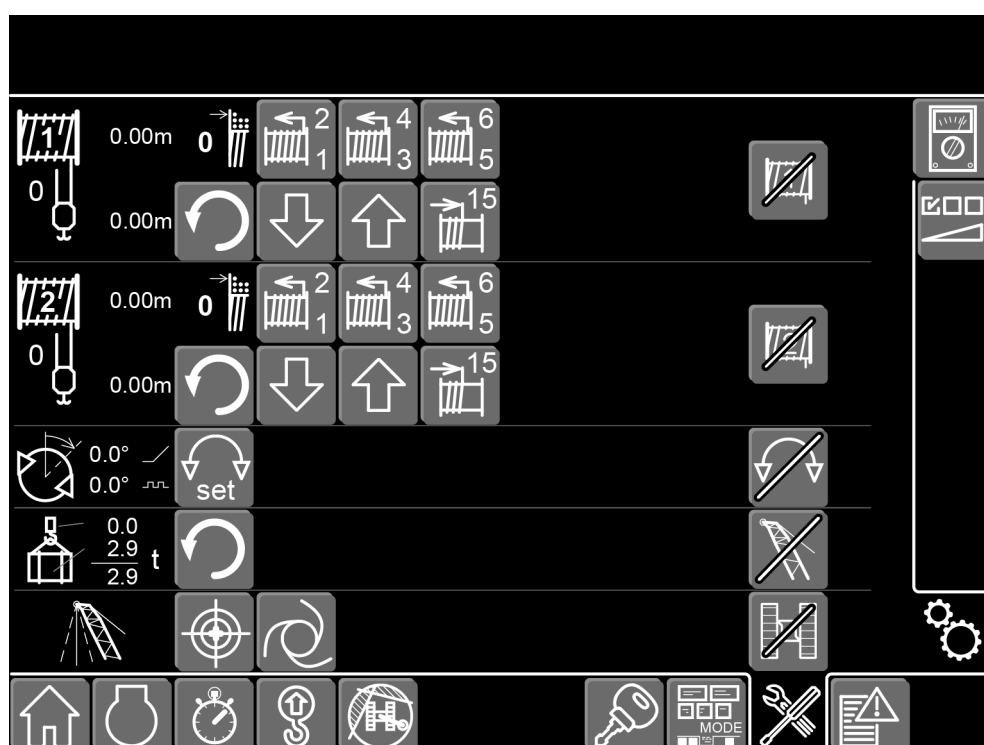


Fig. 1900: *Settings - components* screen

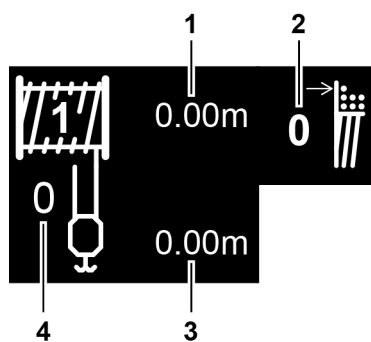


Fig. 1901: *Screen clipping Winch1*

- | | | | |
|---|--------------------------------|---|--------------------------------|
| 1 | Absolute length of winch1 rope | 3 | Relative length of winch1 rope |
| 2 | Position of winch1 rope | 4 | Reeving of winch1 rope |

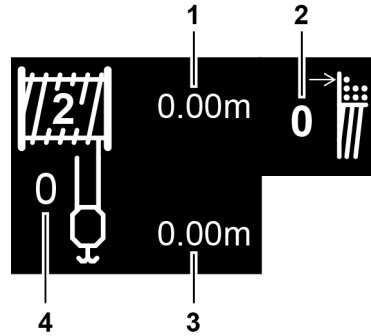


Fig. 1902: Screen clipping Winch2

- | | | | |
|---|--------------------------------|---|--------------------------------|
| 1 | Absolute length of winch2 rope | 3 | Relative length of winch2 rope |
| 2 | Position of winch2 rope | 4 | Reeving of winch2 rope |



Fig. 1903: Swing angle transmitter screen clipping

- | | | | |
|---|---------------------------|---|----------------------------|
| 1 | Analog swing angle signal | 2 | Digital swing angle signal |
|---|---------------------------|---|----------------------------|

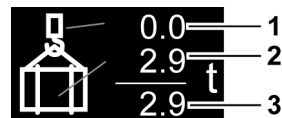


Fig. 1904: Load display screen clipping

- | | | | |
|---|--|---|--------------|
| 1 | Weight of empty hook and rope of winch1/winch2 | 3 | Total weight |
| 2 | Weight of load | | |



Setting to zero

Set relative rope length of the selected winch to zero. Button must be pressed for more than 1 s (1 sec).

On the load display, set the weight of winch1/winch2 rope and pulley block and/or empty hook to zero.



Reset load display (lit green)

Reset load display to total weight. Button must be pressed for more than 1 s (1 sec).



Programming rope layer change 1-2

Program layer change of selected winch from first to second rope layer. Button must be pressed for more than 1 s (1 sec).



Programming rope layer change 3-4

Program layer change of selected winch from third to fourth rope layer. Button must be pressed for more than 1 s (1 sec).



Programming rope layer change 5-6

Program layer change of selected winch from fifth to sixth rope layer. Button must be pressed for more than 1 s (1 sec).

**Reducing reeving**

Reduce reeving of the selected winch.

**Increasing reeving**

Increase reeving of the selected winch.

**Setting the rope length to 15 windings**

Set length of rope of selected winch to 15 windings. Button must be pressed for more than 1 s (1 sec).

**Synchronizing the swing angle transmitter**

Synchronize the digital swing angle signal with the analog swing angle signal. Button must be pressed for more than 1 s (1 sec).

**Setting the deviation of the Vertical Line Finder to zero**

Set deviations of Vertical Line Finder to zero. Button must be pressed for more than 1 s (1 sec).

**Vertical Line Finder**

Activate positioning of boom head above load's center of gravity. Button must be pressed for more than 1 s (1 sec).

**Vertical Line Finder (lit green)**

Deactivate positioning of boom head above load's center of gravity. Button must be pressed for more than 1 s (1 sec).

**Vertical Line Finder (lit red)**

Positioning the boom head above the load's center of gravity is locked. Deviations of the Vertical Line Finder must be corrected.

**Locking or unlocking winch1**

Lock winch1. Button must be pressed for more than 1 s (1 sec).

**Locking or unlocking winch1 (lit red)**

Unlock winch1. Button must be pressed for more than 1 s (1 sec).

**Locking or unlocking winch2**

Lock winch2. Button must be pressed for more than 1 s (1 sec).

**Locking or unlocking winch2 (lit red)**

Unlock winch2. Button must be pressed for more than 1 s (1 sec).

**Locking or unlocking the swing**

Lock the swing. Button must be pressed for more than 1 s (1 sec).



Locking or unlocking swing (lit red)

Unlock swing. Button must be pressed for more than 1 s (1 sec).



Locking or unlocking boom

Lock boom. Button must be pressed for more than 1 s (1 sec).



Locking or unlocking boom (lit red)

Unlock boom. Button must be pressed for more than 1 s (1 sec).



Locking or unlocking the crawler

Lock crawler. Button must be pressed for more than 1 s (1 sec).



Locking or unlocking crawler (lit red)

Unlock crawler. Button must be pressed for more than 1 s (1 sec).

3.22.2 Settings - units screen



Settings - units

Switch to the *Settings - units* screen.

The screen *Settings - units* offers settings for the monitor and the control levers.

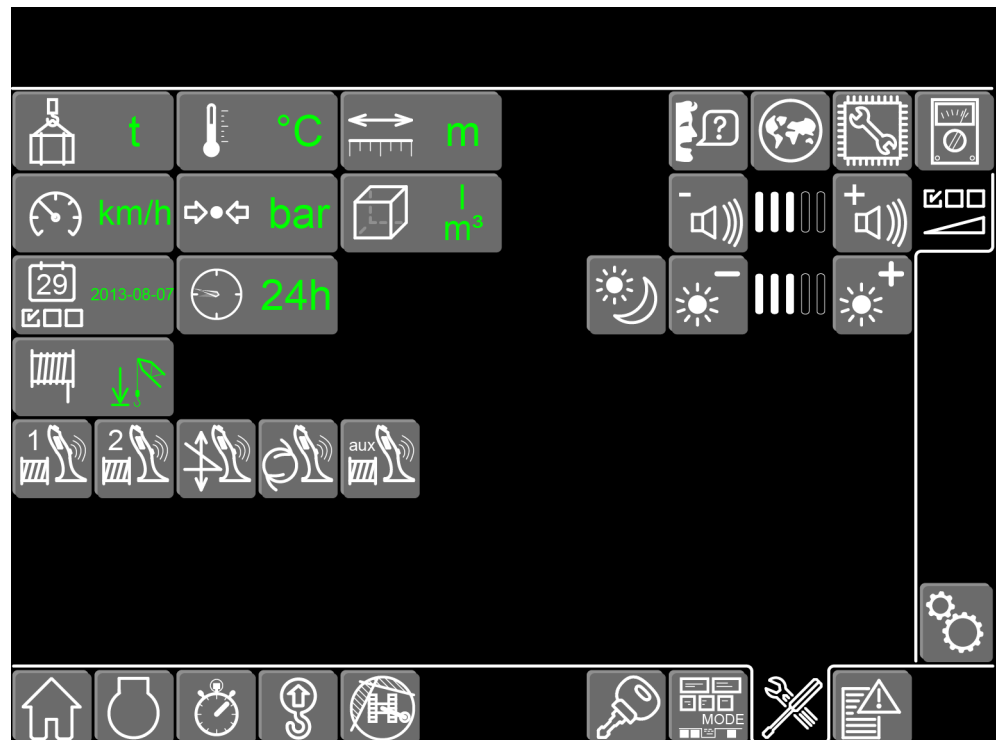


Fig. 1929: Settings - units screen

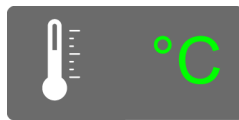
LWN/LR-x/V04.01//Auslieferung/2016-03-07/en

**Unit weight**

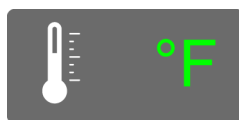
Switch the weight unit.

**Unit weight**

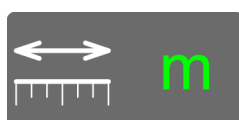
Switch the weight unit.

**Unit temperature**

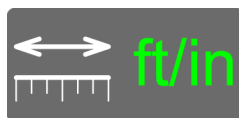
Switch the temperature unit.

**Unit temperature**

Switch the temperature unit.

**Unit length**

Switch the length unit.

**Unit length**

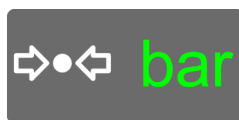
Switch the length unit.

**Unit speed**

Switch the speed unit.

**Unit speed**

Switch the speed unit.

**Unit pressure**

Switch the pressure unit.

**Unit pressure**

Switch the pressure unit.

**Unit volume**

Switch the volume unit.

**Unit volume**

Switch the volume unit.

**Format date**

Switch the date format.



Format date
Switch the date format.



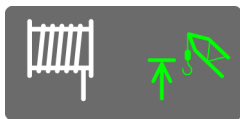
Format date
Switch the date format.



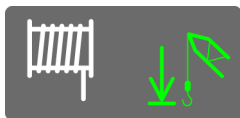
Format time
Switch the time format to 24 hours.



Format time
Switch the time format to 12 hours.



Rope length measurement
Switch to rope length measurement.



Lifting height measurement
Switch to lifting height measurement.



Vibrator winch1
Activate the vibrator on the control lever for winch1.



Vibrator winch1 (lit green)
Deactivate the vibrator on the control lever for winch1.



Vibrator winch2
Activate the vibrator on the control lever for winch2.



Vibrator winch2 (lit green)
Deactivate the vibrator on the control lever for winch2.



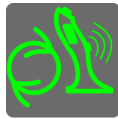
Boom vibrator
Activate the vibrator on the control lever for the boom.



Boom vibrator (lit green)
Deactivate the vibrator on the control lever for the boom.



Swing vibrator
Activate the vibrator on the control lever for the swing.

**Swing vibrator (lit green)**

Deactivate the vibrator on the control lever for the swing.

**Vibrator additional winch**

Activate the vibrator on the control lever for the additional winch.

**Additional winch vibrator (lit green)**

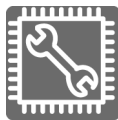
Deactivate the vibrator on the control lever for the additional winch.

**SCOTTI language**

Switch to the *SCOTTI language* screen.

**SCOTTI time zone**

Switch to the *SCOTTI time zone* screen.

**SCOTTI start page**

Switch to the *SCOTTI start page* screen.

**Reducing the volume**

Reduces the volume of the warning signal.

**Increasing the volume**

Increases the volume of the warning signal.

**Inverting the monitor**

Inverts the monitor for night work.

**Reducing the brightness**

Reduces the brightness of the monitor.

**Increasing the brightness**

Increases the brightness of the monitor.

3.22.3 Screen Settings - Litronic testing system

**Settings - Litronic testing system**

Switch to the *Settings - Litronic testing system* screen.

The *Settings - Litronic testing system* screen shows inputs and outputs, markers, intrasystem variables and machine statuses.

Menu bar

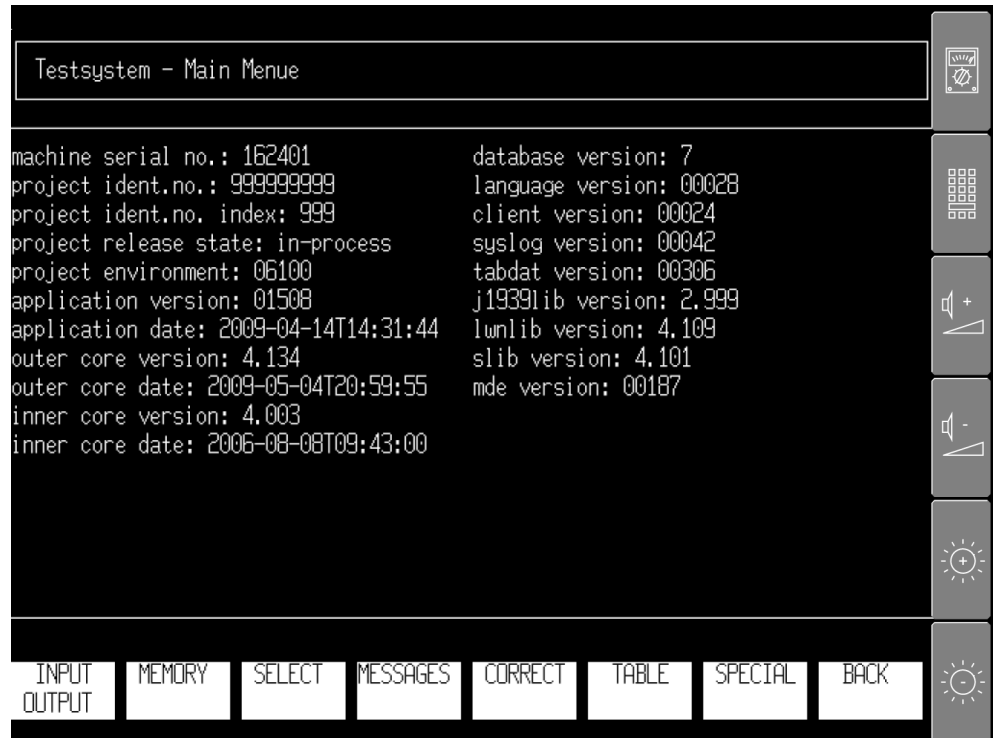


Fig. 1968: Settings - Litronic testing system screen with menu bar



Settings - Litronic testing system

Switch to the *Settings - Litronic testing system* screen.



Keyboard menu

Switch to keypad menu ([For more information see: Keyboard menu, page 795](#)).



Increasing the volume of the warning buzzer

Increase the volume of the warning buzzer.



Decreasing the volume of the warning buzzer

Decrease the volume of the warning buzzer.

**Increasing the brightness of the monitor**

Increase the brightness of the monitor (3 stages).

**Decreasing the brightness of the monitor**

Decrease the brightness of the monitor (3 stages).

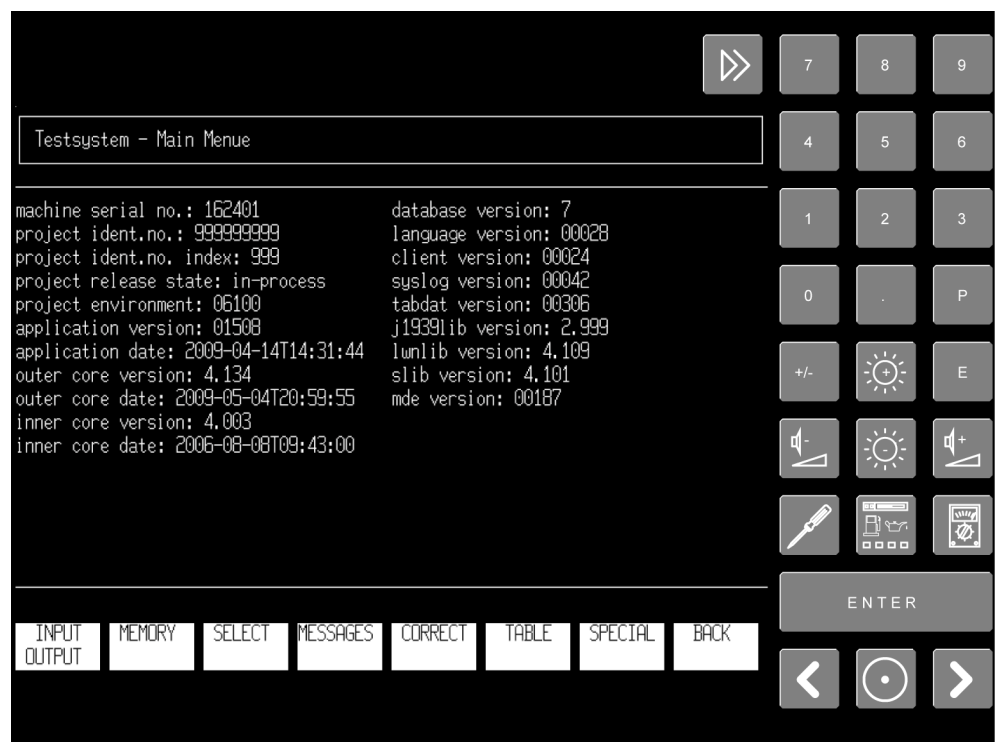
Keyboard menu

Fig. 1975: Settings - Litronic testing system screen with keyboard menu

**Minimize**

Switch to menu bar (For more information see: [Menu bar, page 794](#)).



Numbers

Enter numbers.



Decimal point

Enter comma.



Powers

Select potencies.



Inverting numbers

Invert numbers.



Exponential numbers

Select exponents.



Increasing the brightness of the monitor

Increase the brightness of the monitor (3 stages).



Decreasing the brightness of the monitor

Decrease the brightness of the monitor (3 stages).



Increasing the volume of the warning buzzer

Increase the volume of the warning buzzer.



Decreasing the volume of the warning buzzer

Decrease the volume of the warning buzzer.



Settings - Litronic testing system - correction values

Switch to the *Settings - Litronic testing system - correction values* screen.



Screen

Switch to the last selected screen.



Settings - Litronic testing system

Switch to screen *Settings - Litronic testing system*.



Enter

Apply entered values.



Back

Change to previous input field.



Continue

Change to next input field.



Testing system screen

Switch to the monitor testing system.

3.23 Error messages screen



Error messages

Switch to the *Error messages* screen.

The *Error messages* screen informs in the local language about errors in/on the machine.

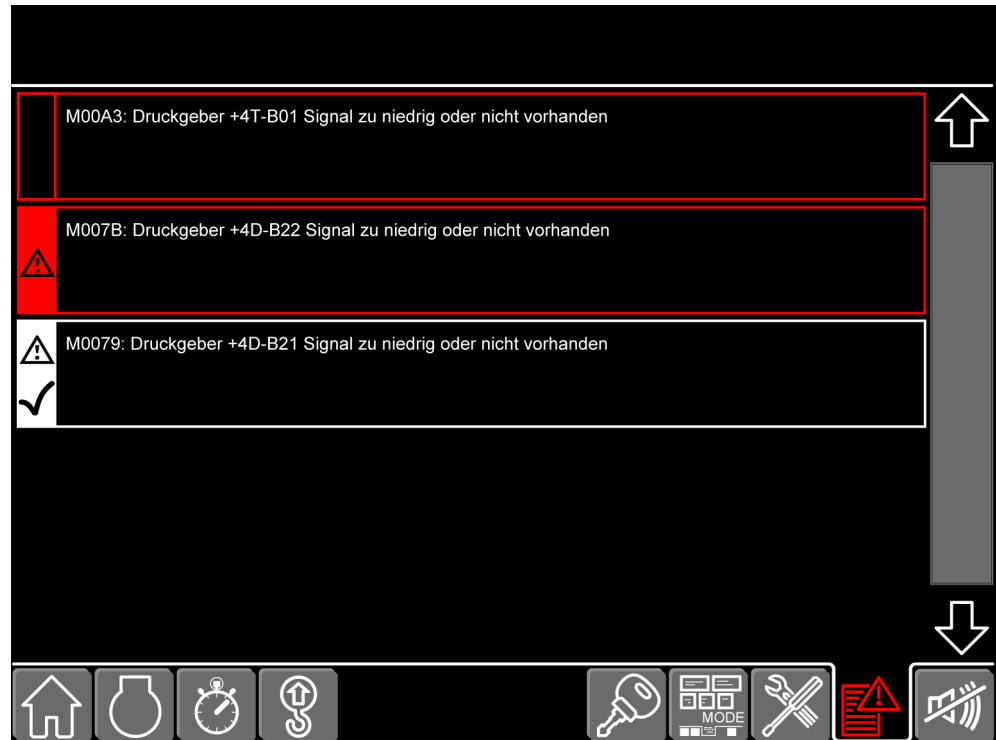



Fig. 1994: Error messages screen



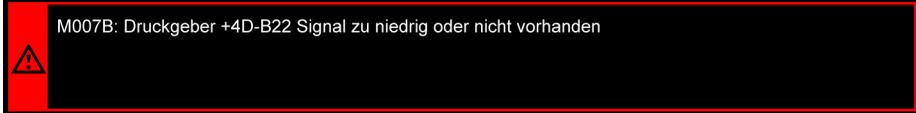
Scrollbar

Navigate through the error messages. The scrollbar is activated as of five error messages.



M00A3: Druckgeber +4T-B01 Signal zu niedrig oder nicht vorhanden

Fig. 1996: Error already remedied - not yet acknowledged (lit red)



M007B: Druckgeber +4D-B22 Signal zu niedrig oder nicht vorhanden

Fig. 1997: Error message - not acknowledged (lit red)



M0079: Druckgeber +4D-B21 Signal zu niedrig oder nicht vorhanden

Fig. 1998: Error message - acknowledged

3.24 Cable remote control

The cable remote control can be connected on the uppercarriage or on the undercarriage.

3.24.1 Cable remote control on uppercarriage

If the cable remote control is connected to the uppercarriage, the pin connection cylinders for the main boom base section and the counterweight hoisting cylinders can be operated.

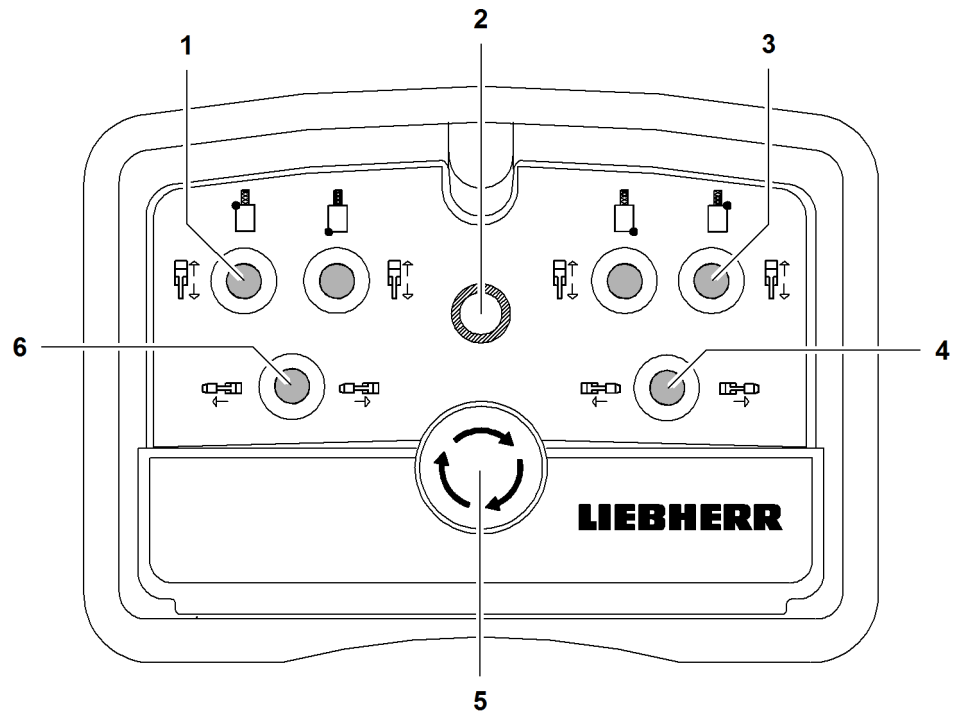


Fig. 1999: Cable remote control on uppercarriage

- | | | | |
|---|--|---|--|
| 1 | Toggle switch <i>Left counterweight hoisting cylinder</i> | 4 | Toggle switch <i>Left pin connection cylinder</i> |
| 2 | Control lamp | 5 | Emergency stop |
| 3 | Toggle switch <i>Right counterweight hoisting cylinder</i> | 6 | Toggle switch <i>Right pin connection cylinder</i> |

3.24.2 Cable remote control on undercarriage*

If the cable remote control is connected to the undercarriage, the jacks and the track width adjusting cylinders can be operated.

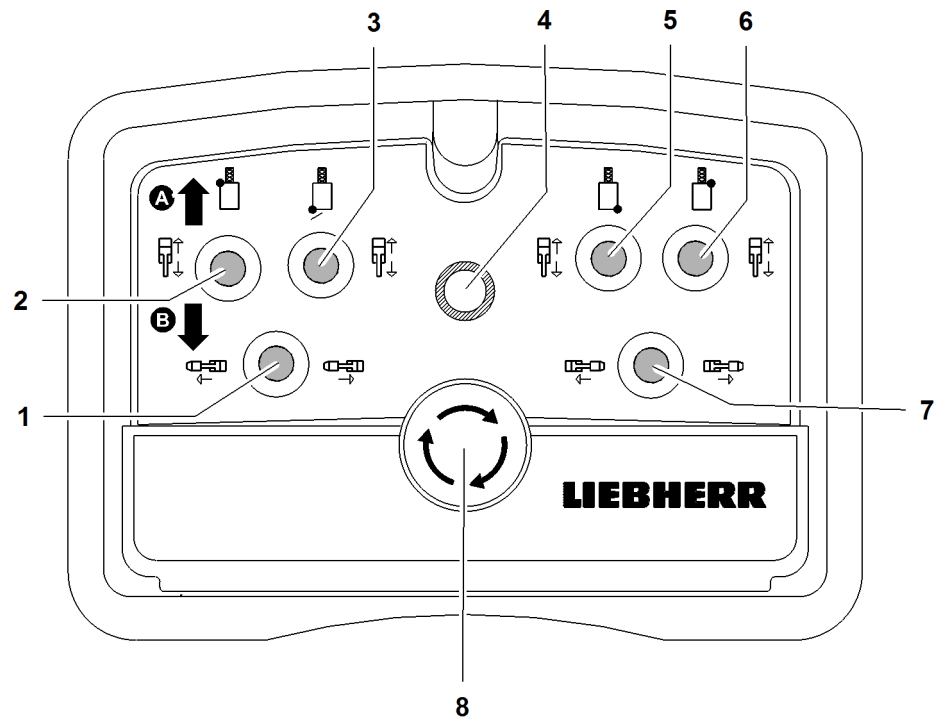


Fig. 2000: Cable remote control on undercarriage*

- | | | | |
|---|---|---|--|
| 1 | Toggle switch left track width adjusting cylinder | 6 | Toggle switch right front jack |
| 2 | Toggle switch left front jack | 7 | Toggle switch right track width adjusting cylinder |
| 3 | Toggle switch left rear jack | 8 | Emergency stop |
| 4 | Control lamp | A | Extend jacks |
| 5 | Toggle switch right rear jack | B | Retract jacks |

3.25 Radio remote control*

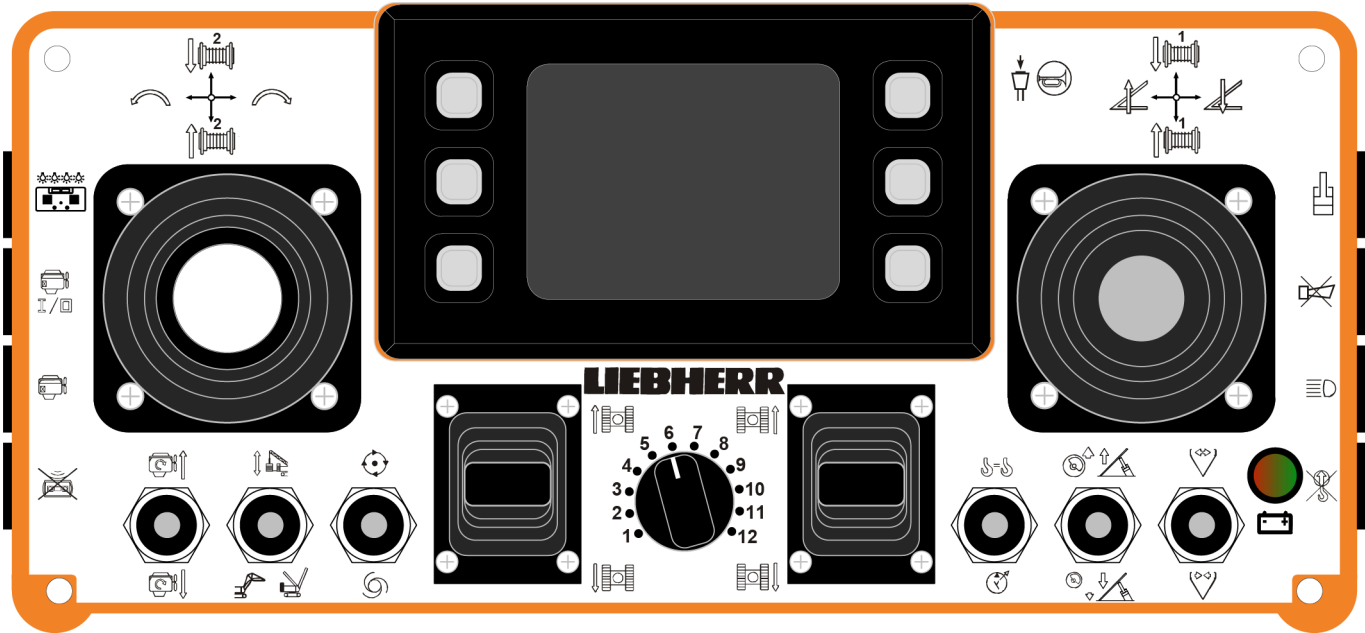


Fig. 2001: Radio remote control (view from top)

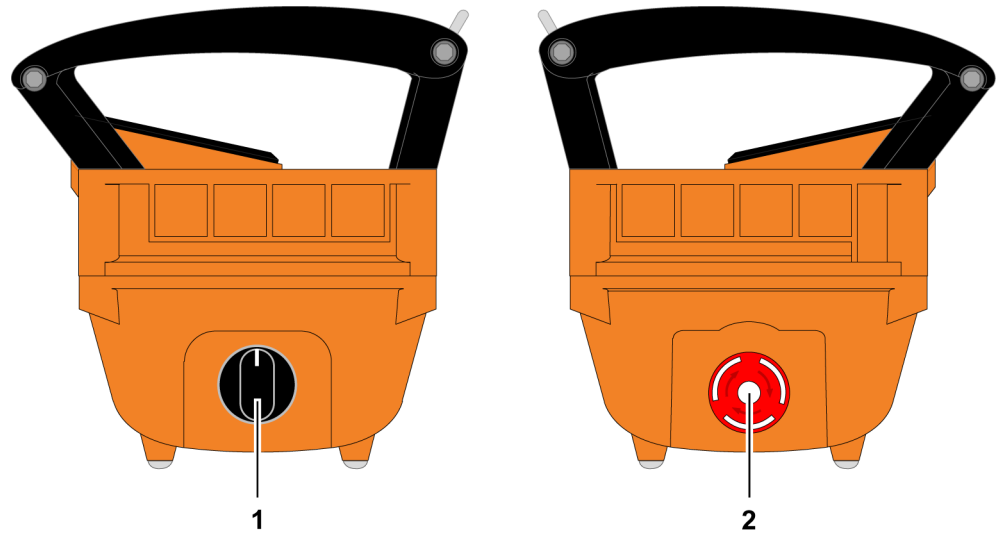


Fig. 2002: Radio remote control (view from side)

- 1 Rotary switch ON/OFF
- 2 Emergency stop

3.25.1 Operating elements



Rotary switch
[not used]



Battery charge state

LED green: battery charge state OK.

LED red: battery charge state low.

Left control lever

Function assignment movement direction of left control lever

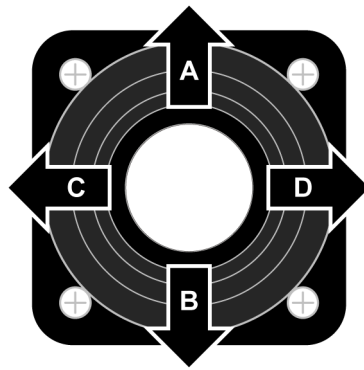


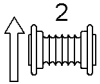


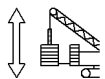





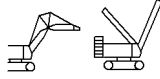

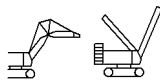
Fig. 2005: Function assignment movement direction of left control lever

Direction of movement	Pictogram	Mode	Toggle switch ^{A)}	Function
A		 Crane mode		Lower winch2
		 Crane mode		Retract derrick hoist cylinder
		 Assembly functions		Lower winch2





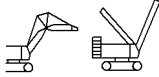

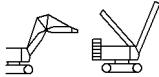
LWNLR.x/V04.01//Auslieferung/2016-03-07/en

Control and operating elements

Radio remote control*

Direction of movement	Pictogram	Mode	Toggle switch ^{A)}	Function
B		 Crane mode		Lift winch2
		 Crane mode		Extend derrick hoist cylinder
		 Assembly functions		Lift winch2
C		 Crane mode		Swing uppercarriage to the left
		 Assembly functions		Swing uppercarriage to the left
		 Assembly functions		Lower jib
		 Assembly functions		Lower main boom in derrick mode ^{B)}

LWN/LR-x/V04.01//Auslieferung/2016-03-07/en

Direction of movement	Pictogram	Mode	Toggle switch ^{A)}	Function
D		 Crane mode		Swing uppercarriage to the right
		 Assembly functions		Swing uppercarriage to the right
		 Assembly functions		Lift jib
		 Assembly functions		Lift main boom in derrick mode ^{B)}

Tab. 365: Function assignment movement direction of left control lever

- A) Some toggle switches have several functions. The desired function can be selected by repeatedly actuating the toggle switch.
- B) By default, this function is assigned to the left control lever. This function is only active on the right control lever after selecting "Jib luffing winch".

Right control lever

Function assignment buttons of right control lever

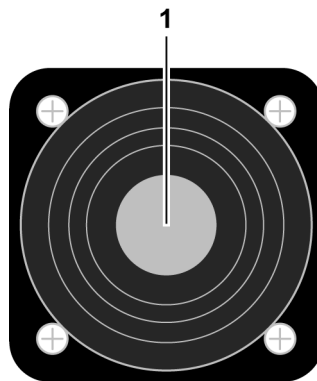





Fig. 2030: Function assignment buttons of right control lever

Button	Pictogram	Mode	Toggle switch	Name and function
1		 Crane mode		Horn Sound horn.
		 Assembly functions		Horn Sound horn.

Tab. 366: Function assignment buttons of right control lever

Function assignment movement direction of right control lever

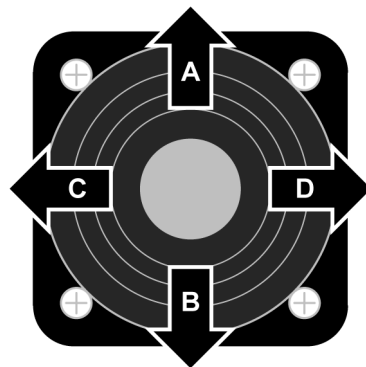









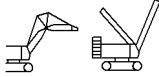



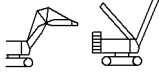



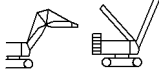



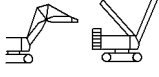


Fig. 2034: Function assignment movement direction of right control lever

Direction of movement	Pictogram	Mode	Toggle switch ^{A)}	Function
A		 Crane mode		Lower winch1
		 Assembly functions		Lower winch1
B		 Crane mode		Lift winch1
		 Assembly functions		Lift winch1

LWN/LR-x/V04.01//Auslieferung/2016-03-07/en

Direction of movement	Pictogram	Mode	Toggle switch ^{A)}	Function
C		 Crane mode		Lift main boom
		 Crane mode		Lift jib
		 Assembly functions		Lift main boom
		 Assembly functions		Lift derrick boom in derrick mode
		 Assembly functions		Lift main boom in derrick mode ^{B)}
D		 Crane mode		Lower main boom
		 Crane mode		Lower jib
		 Assembly functions		Lower main boom
		 Assembly functions		Lower derrick boom in derrick mode
		 Assembly functions		Lower main boom in derrick mode ^{B)}

Tab. 367: Function assignment movement direction of right control lever

A) Some toggle switches have several functions. The desired function can be selected by repeatedly actuating the toggle switch.

- B) By default, this function is assigned to the left control lever. This function is only active on the right control lever after selecting "Jib luffing winch".

Left linear control lever

Function assignment for movement directions on left linear control lever

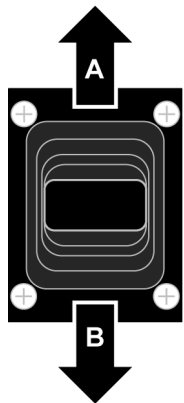


Fig. 2057: Function assignment for movement directions on left linear control lever

Direction of movement	Pictogram	Mode	Toggle switch	Function
A		 Crane mode		Move left crawler forward
		 Assembly functions		Move left crawler forward
B		 Crane mode		Move left crawler backward
		 Assembly functions		Move left crawler backward

Tab. 368: Function assignment for movement directions on left linear control lever

Right linear control lever

Function assignment of movement directions on right linear control lever

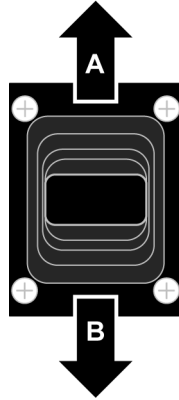


Fig. 2064: Function assignment of movement directions on right linear control lever

Direction of movement	Pictogram	Mode	Toggle switch	Function
A		 Crane mode		Move right crawler forward
		 Assembly functions		Move right crawler forward
B		 Crane mode		Move right crawler backward
		 Assembly functions		Move right crawler backward

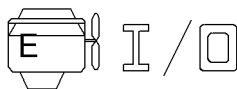
Tab. 369: Function assignment of movement directions on right linear control lever

Buttons on the side



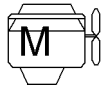
Lighting

Turn illumination of radio remote control on for 10 seconds.



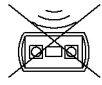
Diesel engine

Turn the diesel engine on or off.



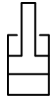
Save/delete constant engine RPM

Save current diesel engine RPM as constant engine RPM or delete saved constant engine RPM.



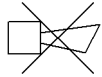
Take/cede control

Take or release control of/on the radio remote control.



Cylinder adjustment functions

Activate/deactivate cylinder adjustment functions on undercarriage and uppercarriage.



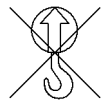
Warning buzzer

Deactivate warning buzzer.



Floodlights on uppercarriage

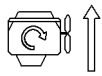
Turn the floodlight on the uppercarriage on or off.



Load moment limiter assembly/self-lock

Activating or deactivating the function load moment limiter assembly or load moment limiter self-lock (This is the only function of this button even with machines with an ANSI load chart. The switch *Load moment limiter shut-down* on control panel X12 has no influence on this function).

Toggle switch



Increase RPM

Increase the RPM of the diesel engine.



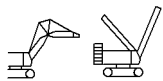
Reduce RPM

Reduce the RPM of the diesel engine.



Derrick hoist cylinder

Select Derrick hoist cylinder (not possible with activated assembly function).



Jib luffing winch/derrick winch

Select jib luffing winch.

In derrick mode: select Derrick winch.



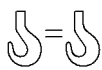
Slewing free-wheel

Activating swing free-wheel.



Automatic mode preselect

[not used]



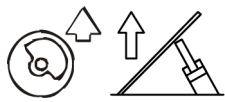
Winch synchronisation

Activate winch synchronization.



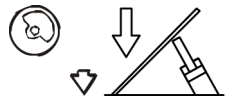
Additional hydraulics

[not used]



Extend A-frame1 cylinder

Extends A-frame1 cylinder. Works exclusively when assembly mode functions are activated.



Retract A-frame1 cylinder

Retracts A-frame1 cylinder. Works exclusively when assembly mode functions are activated.



Open clamp

[not used]



Close clamp

[not used]

3.25.2 Monitor

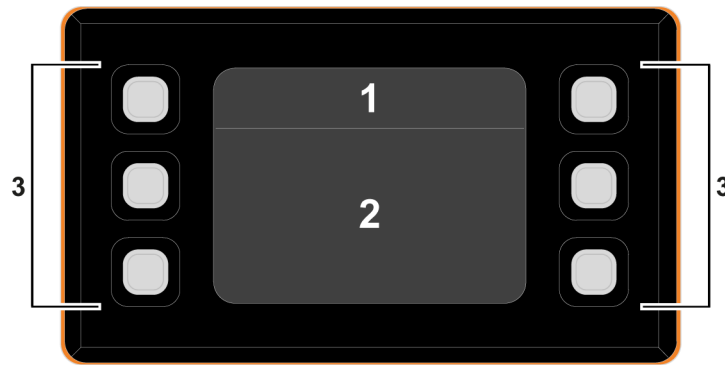


Fig. 2091: Monitor sections

- 1 Status bar
- 2 Display area
- 3 Monitor buttons

Status bar

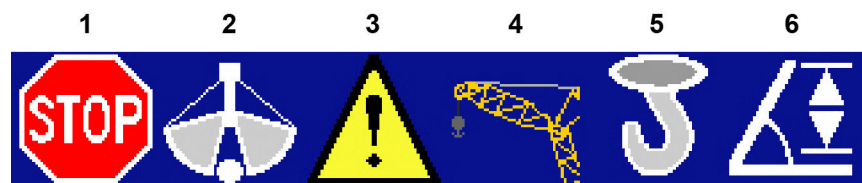


Fig. 2092: Status bar - positioning

Position 1



Winch synchronization

Winch synchronization is switched on.



Load moment limiter warning (lit yellow)

Load moment is used to more than 90 % capacity.



Load moment limiter stop (lit red)

Load moment is used to more than 100 % capacity.



Deactivating the load moment limiter

Load moment limiter is turned off.



Radio remote control locked

Radio remote control is locked. Machine cannot be operated via radio remote control.

Position 2



Swing speed level

Speed level 1 for the swing is set.



Swing speed level

Speed level 2 for the swing is set.



Swing speed level

Speed level 3 for the swing is set.



Swing free-wheel

Swing free-wheel is turned on.



Derrick hoist cylinder

Derrick hoist cylinder is selected.

Position 3



Speed level main boom

Speed level 1 selected for main boom.

**Speed level main boom**

Speed level 2 selected for main boom.

**Speed level main boom**

Speed level 3 selected for main boom.

**Speed level jib**

Speed level 1 is selected for jib.

**Speed level jib**

Speed level 2 is selected for jib.

**Speed level jib**

Speed level 3 is selected for jib.

**Auxiliary winch**

Auxiliary winch is selected.

Position 4**Battery charge**

Battery is not charging.

**Fuel fill level (lit yellow)**

Fill level of the fuel tank is less than 15% of the maximum filling capacity.

**Fuel fill level (lit red)**

Fill level of the fuel tank is less than 5% of the maximum filling capacity.

**Hydraulic oil fill level**

Fill level of hydraulic oil tank is too low.

**Lubrication oil pressure**

Pressure of the lubrication oil of the diesel engine is too high.

Position 5



Diesel engine

Diesel engine is being pre-heated or post-heated.



Drive is limited

Several limit switches block the current movement direction of the control lever.



Limit switch bypassed

Certain limit switches when rigging, converting and unrigging the boom with activated assembly functions are bypassed.

Position 6



Error messages

At least one confirmed error message is present.



Error messages

At least one unconfirmed error message is present.



Feed pressure winch1

Feed pressure on winch1 is too low.



Feed pressure winch2

Feed pressure on winch2 is too low.



General error

General error has occurred.

Display area

Mode screen

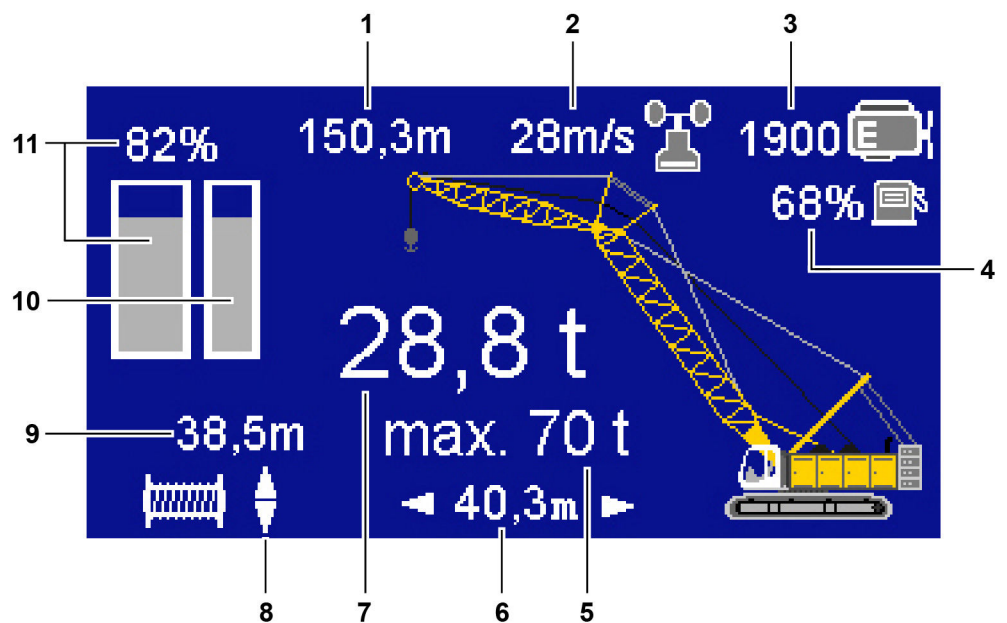


Fig. 2123: Mode screen

- | | | | |
|----------|------------------------|-----------|---|
| 1 | Pulley height on boom | 7 | Load on boom |
| 2 | Wind speed | 8 | Reeving direction of winch1/
winch2 rope |
| 3 | RPM | 9 | Length of winch1/winch2 rope |
| 4 | Fuel fill level | 10 | Load moment limiter to the rear |
| 5 | Maximum load on boom | 11 | Load moment limiter to the front |
| 6 | Radius of load on boom | | |

Screen Operation with activated assembly functions

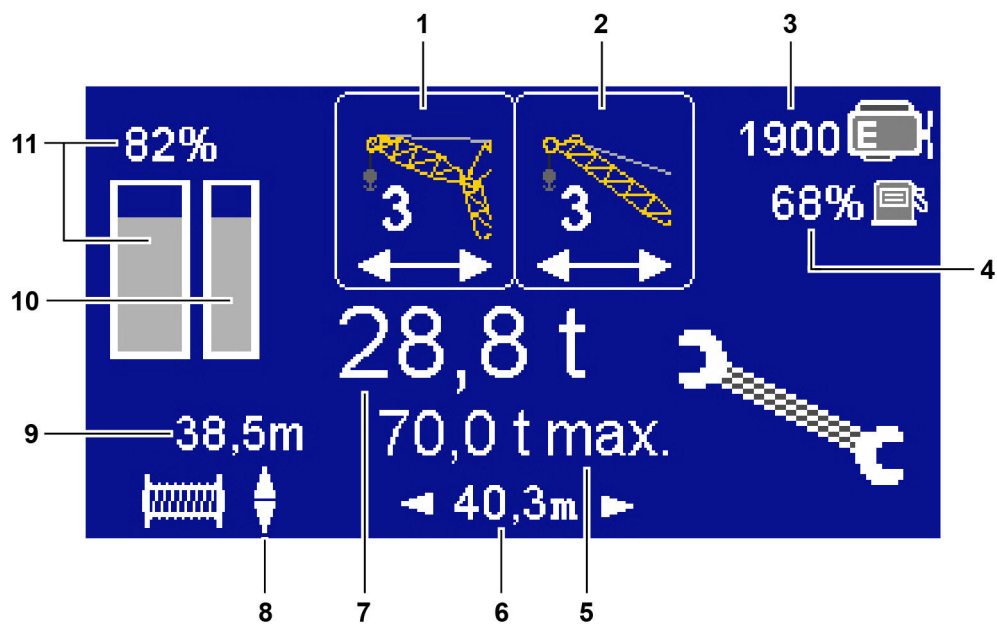


Fig. 2124: Screen Operation with activated assembly functions

- | | | | |
|---|---|----|--|
| 1 | Horizontal function assignment of left control lever | 7 | Load on boom |
| 2 | Horizontal function assignment of right control lever | 8 | Reeving direction of winch1/ winch2 rope |
| 3 | RPM | 9 | Length of winch1/winch2 rope |
| 4 | Fuel fill level | 10 | Load moment limiter to the rear |
| 5 | Maximum load | 11 | Load moment limiter to the front |
| 6 | Radius of load on boom | | |

Stop screen



Fig. 2125: Stop screen

The *Stop* screen appears on the monitor if free-fall mode was selected on the machine.

Screen *Confirm connection*



Fig. 2126: Screen *Confirm connection*

The screen *Connection established confirmed* appears in the following situations:

- Activating the radio remote control
- Disconnection for more than 8 seconds
- Emergency stop

Monitor buttons



Fig. 2127: Monitor buttons

Button	Screen	Name and function
1	Mode	Setting the rope length to zero Set rope length of winch1/winch2 to zero.
	Operation with activated assembly functions	Setting the rope length to zero Set rope length of winch1/winch2 to zero.
2	Mode	Setting the load display to zero Set weight of winch1 rope, winch2 rope and the pulley block and/or empty hook to zero.
	Operation with activated assembly functions	Setting the load display to zero Set weight of winch1 rope, winch2 rope and the pulley block and/or empty hook to zero.
3	Mode	Monitor settings Configure monitor settings.
	Operation with activated assembly functions	Monitor settings Configure monitor settings.
4	Mode	[not used]
	Operation with activated assembly functions	[not used]
5	Mode	Speed level boom adjustment Control speed level for boom adjustment.
	Operation with activated assembly functions	Speed level boom adjustment Control speed level for boom adjustment.
6	Mode	Swing speed level Controls swing speed level.
	Operation with activated assembly functions	Swing speed level Controls swing speed level.

Tab. 370: Function assignment of monitor buttons

3.26 Emergency operation control*

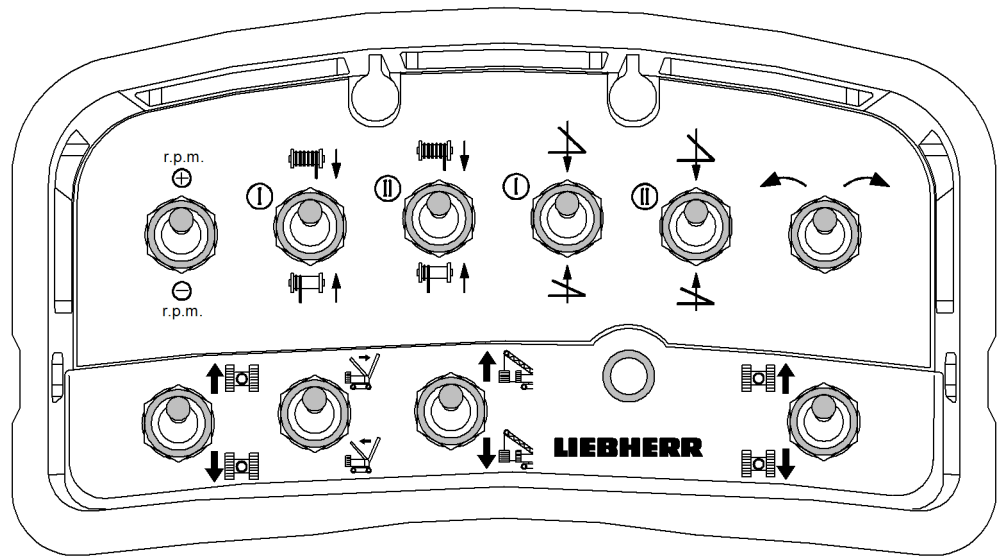


Fig. 2128: Emergency control system

The toggle switches on the control panel are touch-sensitive, meaning that a function is performed for as long as the toggle switch is pressed. The toggle switch for RPM control is a maintained-contact button.

r.p.m.



Increase RPM

Increase the RPM of the diesel engine.



Reduce RPM

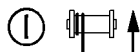
r.p.m.

Reduce the RPM of the diesel engine.



Lower winch 1

Lower winch1.



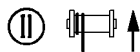
Raise winch 1

Lift winch1.



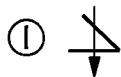
Lower winch 2

Lower winch2.



Raise winch 2

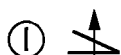
Lift winch2.



Lower the main boom

Lower the main boom.

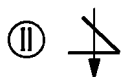
In derrick mode, lower the derrick boom.



Raise the main boom

Lift the main boom.

In derrick mode, lift the derrick boom.



Lower jib

Lower jib.

-   **Raise jib**
Lift jib.
-  **Swing uppercarriage to the left**
Swing uppercarriage to the left.
-  **Swing uppercarriage to the right**
Swing uppercarriage to the right.
-  **Move left crawler forward**
Move left crawler forward.
-  **Move left crawler backward**
Move left crawler backward.
-  **Lower derrick winch**
In derrick mode, lower the main boom.
-  **Raise derrick winch**
In derrick mode, lift the main boom.
-  **Retracting the derrick hoist cylinder**
In derrick mode, retract derrick hoist cylinder.
-  **Extend derrick hoist cylinder**
In derrick mode, extend derrick hoist cylinder.
-  **Move right crawler forward**
Move right crawler forward.
-  **Move right crawler backward**
Move right crawler backward.
-  **Status display (LED)**
The status display (LED) lights up when the ignition is switched on.

3.27 Hydraulic cab elevation*

3.27.1 Operating elements in the cab



Raising the cabin

Raise cabin.



Lowering the cabin downward

Lower cabin.

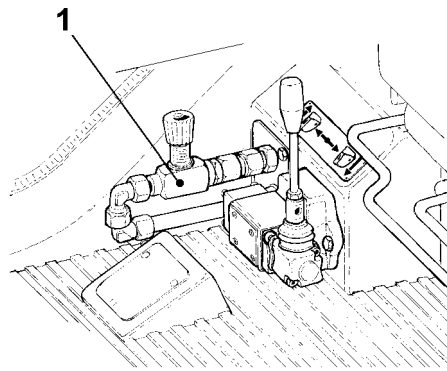


Fig. 2152: Operating elements in the cabin

- 1 Emergency lowering valve for cabin

3.27.2 Operating elements on mast

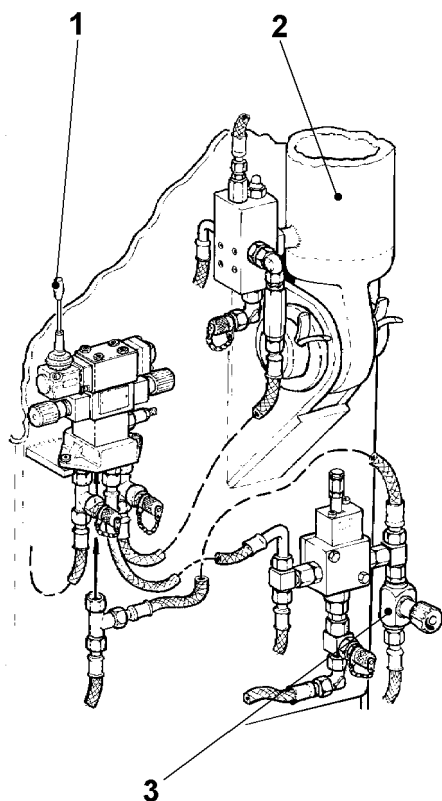


Fig. 2153: Operating elements on mast

- 1 Adjusting lever for the leader
- 2 Adjustment cylinder for the leader
- 3 Emergency lowering valve for the cab

3.27.3 Limit switches

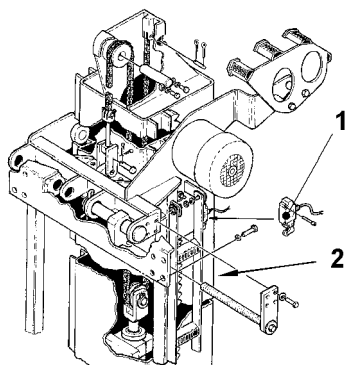


Fig. 2154: Limit switches

- 1 Limit switches
- 2 Limit switches

LWNLR-x/V04.01//Auslieferung/2016-03-07/en

The limit switch **1** monitors whether the cab is in the lowered position.

The limit switch **2** monitors whether the cab has been extended laterally.

3.28 Control unit *external air conditioning system**

The control unit *External air conditioning system* serves to control and monitor the diesel engine of the external air conditioning system.

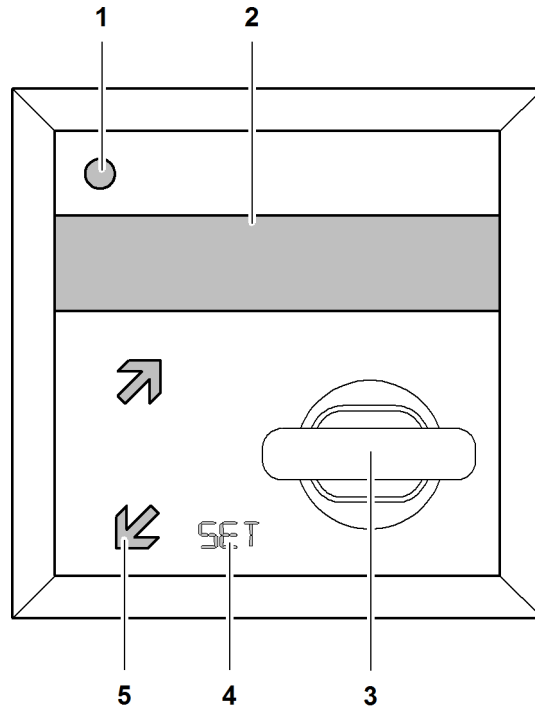
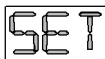


Fig. 2155: Control unit *external air conditioning system*

- | | | | |
|---|-------------------------|---|----------------------|
| 1 | Operating LED/error LED | 4 | Button <i>SET</i> |
| 2 | Display | 5 | Button <i>F1, F2</i> |
| 3 | Ignition key | | |

The following values are shown on the display:

- Software version
- Oil pressure
- Operating hours
 - Total operating hours
 - Daily operating hours
- Engine temperature
- Diesel engine RPM
- Error messages



SET

Display changes.

Confirm input.



F1

Change to next display.

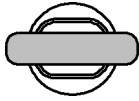
Increase value.



F2

Change to previous display.

Decrease value.



Ignition key

- Position 0: OFF
- Position 1: ON
- Position 2: Start

3.29 Auxiliary heating* control unit

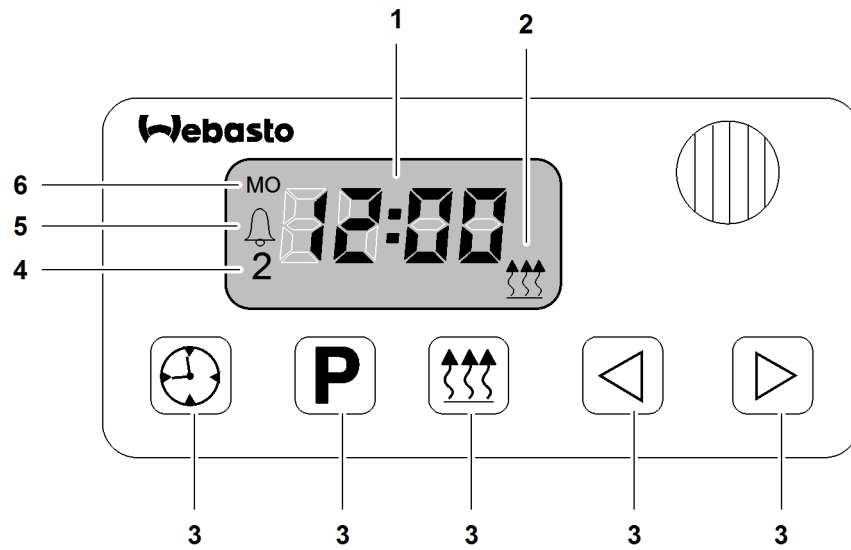


Fig. 2160: Auxiliary heating control unit

- | | | | |
|---|----------------|---|--------------------|
| 1 | Time display | 4 | Code number memory |
| 2 | Status display | 5 | Alarm indicator |
| 3 | Button | 6 | Day |



Time



Program



Immediate heating



Back



Next

3.30 Video monitoring system*

3.30.1 Quad monitor

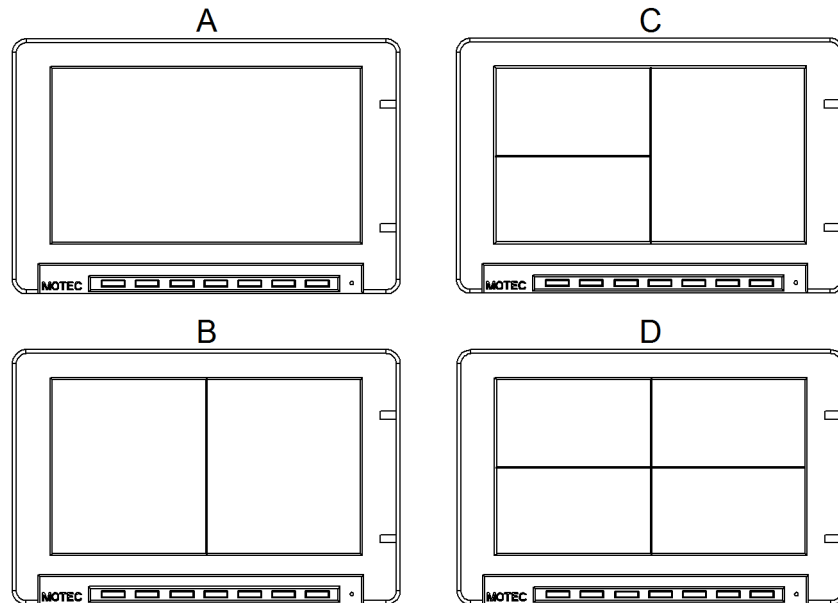


Fig. 2166: Quad monitor

A Single image mode
B Split image mode

C Three-image mode
D Four-image mode



Monitor

Turn the monitor on or off.



Calling up and switching the menu

Switch between the following menu items:

- Color
- Brightness
- Contrast
- Volume
- Language
- Standard (reset to factory setting)



Plus

Move values up.



Minus

Move values down.



Day/night mode

Switch monitor between day mode and night mode.



Camera switching

Switch between the cameras.

In single image mode, switch between the following camera images:

- Camera 1
- Camera 2
- Camera 3

- Camera 4

In split image mode, switch between the following camera images:

- Camera 1 and camera 2
- Camera 2 and camera 3
- Camera 3 and camera 4
- Camera 4 and camera 1

This button has no function in 3-image and 4-image mode.

MODE

Image mode

Switch between image modes:

- Single image mode
- Split image mode
- Three-image mode
- Four-image mode

3.30.2 Control panel zoom camera

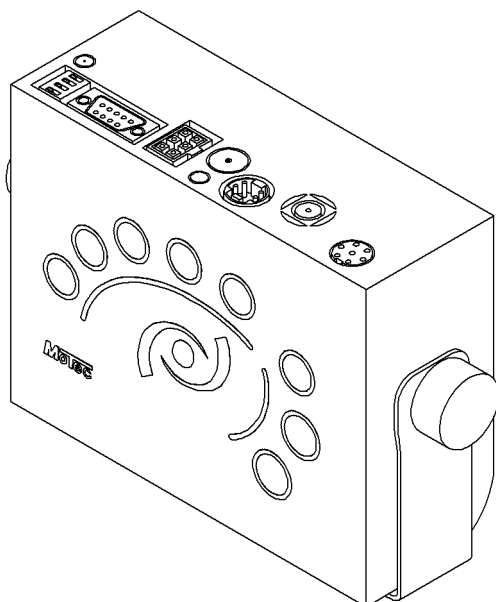


Fig. 2174: Control panel zoom camera



Video monitoring system

Turn the video surveillance system on or off.



Gain

Turn the camera brightness on or off.



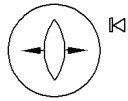
Automatic focus/function button

Turn the automatic focus of the camera on or off.
Function button in combination with other buttons.



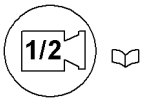
Manual focus

Focus the camera image.
Function button in combination with other buttons.

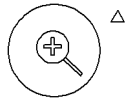
**Manual focus**

Focus the camera image.

Function button in combination with other buttons.

**Camera selector switch**

Switch from zoom camera (camera 1) to optional camera (camera 2).

**Zoom out**

Zoom the camera image out.

Function button in combination with other buttons.

**Zoom in**

Zoom the camera image in.

Function button in combination with other buttons.

3.31 Central lubrication*

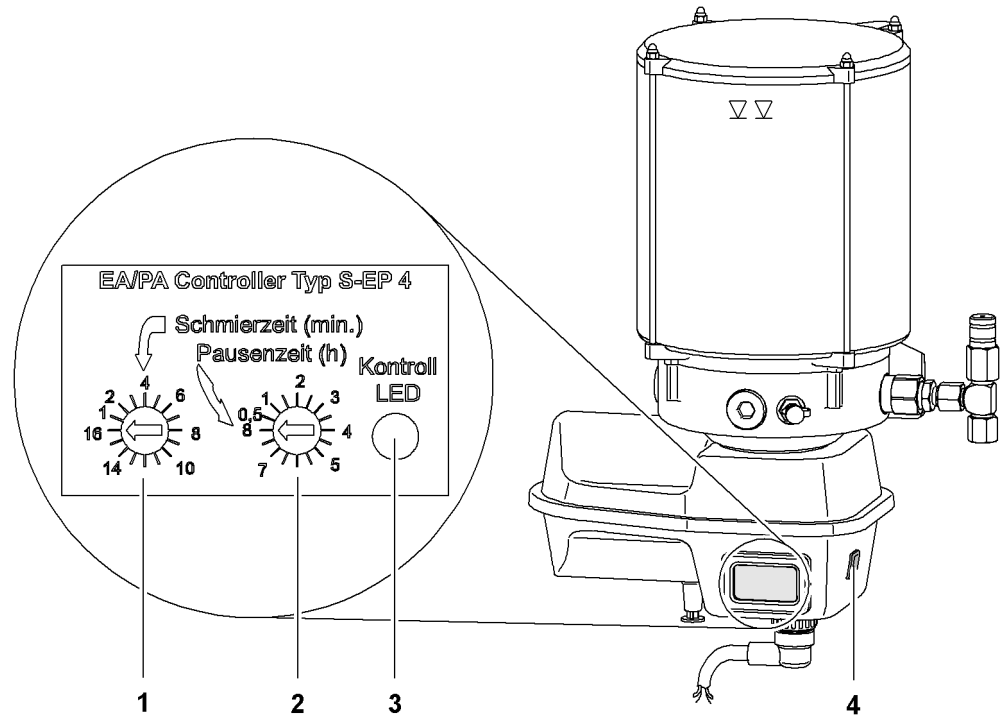
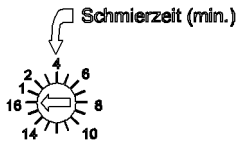


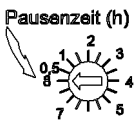
Fig. 2183: Central lubrication operating elements

- | | | | |
|---|--|---|----------------------------|
| 1 | Set lubrication time rotary control knob | 3 | Yellow indicator light |
| 2 | Set pause time rotary control knob | 4 | Interim lubrication button |



Set lubrication time

Set lubrication interval.



Set pause time

Set pause interval.



Yellow indicator light

Lights up for 1.5 seconds after the ignition is switched on to signal that the control system is ready for operation.



Interim lubrication

Perform interim lubrication.

LWNLR-x/V04.01//Auslieferung/2016-03-07/en

3.32 Additional floodlights*

3.32.1 Cabin

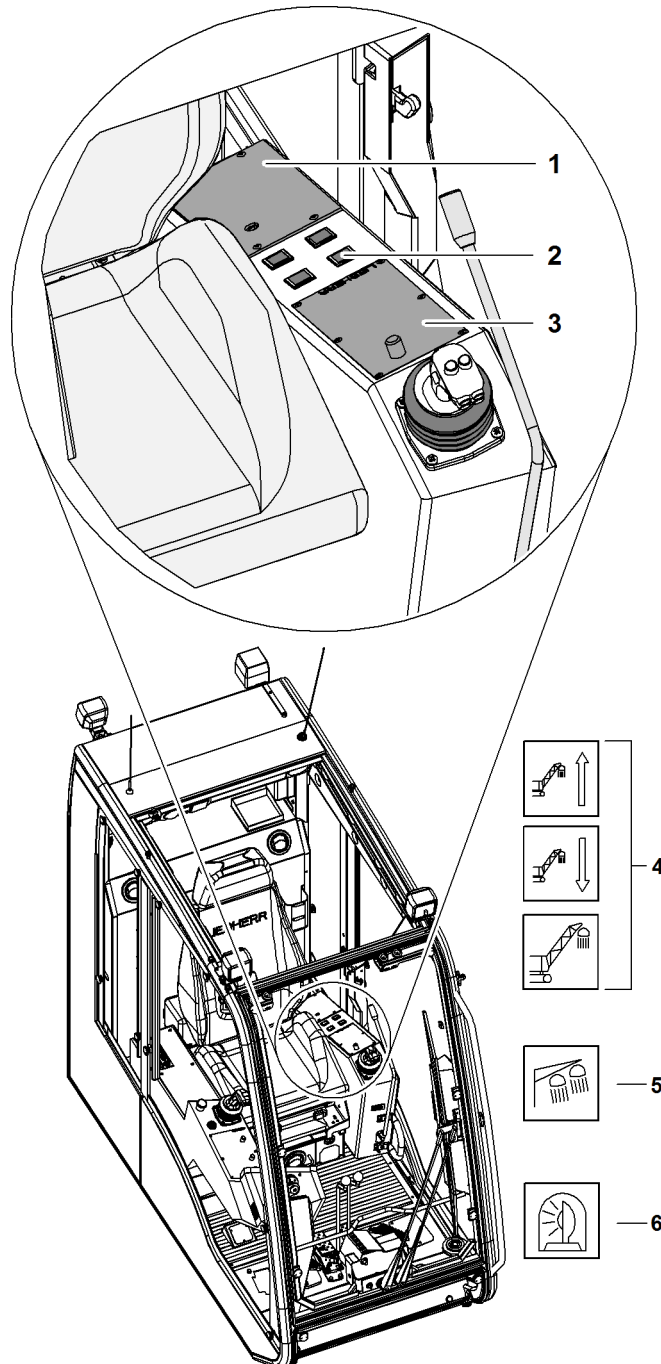


Fig. 2188: Buttons Additional floodlights

- 1 Control panel X12
- 2 Buttons Additional floodlights
- 3 Control panel X11

- 4 Button Floodlight main boom base section (3x)
- 5 Button Boom searchlight
- 6 Button Obstacle warning light



Boom base section floodlights

Turn the floodlight on the main boom base section on or off.



Move the floodlights upwards

Move the floodlight in the main boom base section upwards.



Move the floodlights downwards

Move the floodlight in the main boom base section downwards.



Boom floodlight

Turn all boom floodlights on or off.



Obstacle warning light

Activates/deactivates the obstacle warning light.

3.32.2 Search floodlight

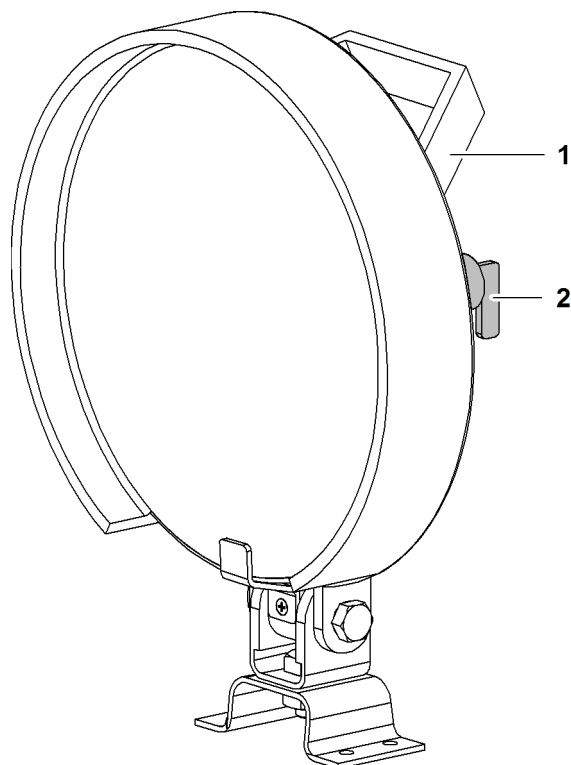


Fig. 2194: Search floodlights on uppercarriage

1 Handle

2 Switch search floodlight

Switch search floodlight

Turn the search floodlight on or off.

The button *Uppercarriage floodlights* on control panel X11 must be turned on for the search floodlight function.

4 Operation

4 Operation

The chapter **Handling, operation** deals with the following issues:

- Safe commissioning of the machine
- Secondary machine functions
- Main machine functions
- Safe shutdown of the machine

4.1 Checks before start up



DANGER

Unauthorized use of a damaged machine!

- ▶ Do not use a machine that is damaged in any way.
 - ▶ Defects and errors are to be reported to the relevant supervisor and to Liebherr customer service.
-



DANGER

Improper change of counterweights during operation of the machine!
Toppling of machine.

- ▶ Make sure that the set-up boom configuration can be put down at any time with the installed counterweights.
 - ▶ Observe erectability charts.
-

NOTICE

Do not use a preserved machine if it has been preserved for storage for up to/more than 7 months!

Damage to machine.

- ▶ Ensure that the machine is treated with permitted lubricants.
 - ▶ Make sure that all oil levels are correct.
-

Ensure that the following conditions are fulfilled:

- Maintenance and inspection work has been carried out according to specifications.
- Operation manual has been read and understood.
- Operation manual is at hand in cabin.
- Current load chart needed to operate the machine is at hand in cabin.

4.1.1 Inspecting the machine

The machine must be inspected prior to each start-up.

- ▶ Make sure that there are no leaks (hydraulic oil, engine oil, gearbox oil, coolant, fuel).
- ▶ Make sure that there is no damage.
- ▶ Make sure that safety installations are in place and functioning.
- ▶ Make sure that locking elements are in place.
- ▶ Make sure that pin connections and screw connections have a tight fit.
- ▶ Make sure that ropes and pulleys do not show any wear.
- ▶ Make sure that there are no obstacles in the working range.
- ▶ Make sure that uppercarriage can be turned without restrictions.
- ▶ Make sure that boom cannot come into contact with overhead lines.
- ▶ Make sure that safety signs are in place and legible.
- ▶ Make sure that fire extinguishers are in place, ready for operation (intact seal, test date has not expired), and freely accessible at all times.
- ▶ Remove coarse dirt from machine.
- ▶ Remove snow and ice from the cabin, uppercarriage, crawler side frames, platforms, limit switches, ropes, rope drums, pulleys and booms.
- ▶ Make sure that vision in the cabin is clear.
- ▶ Clean windows and mirrors of the cabin and adjust them properly.
- ▶ Make sure that mechanic angle indicator on main boom base section or on a-frame1 can be moved freely.

4.1.2 Checking position of main battery switch

NOTICE

Battery main switch is switched off while the machine is in use!
Damage to the electrical system.

- ▶ Only switch the battery main switch off when the machine is switched off.
-

- ▶ Check position of main battery switch.

If the battery main switch is not switched on:

- ▶ Switch on the battery main switch.

4.2 Start-up

4.2.1 Adjusting the operator's seat

- ▶ Check the seat position and adjust if necessary.

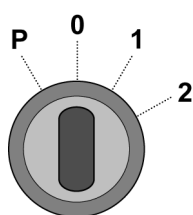


Note

Liebherr recommends:

- ▶ use the safety belt while the machine is in operation.

4.2.2 Switching on the ignition



- ▶ Insert ignition key in ignition lock and turn to position "1".
 - ▷ *Start* screen is displayed on the monitor.
 - ▷ The *Setup* screen appears once the Litronic control system is operational.

Troubleshooting

Error message appears?

Voltage drops during the start-up process may cause error messages to appear on the monitor.

- ▶ Switch ignition off and leave it off for at least 10 seconds.
- ▶ Turn ignition key to position "1" again.

Troubleshooting

Error message appears after several attempts?

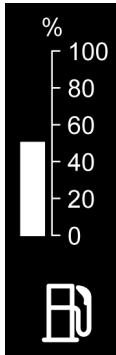
- ▶ Contact Liebherr customer service.

4.2.3 Confirming the existing setup

The last defined *setup* screen appears on the monitor.

- ▶ Check all values and change to the current setup where necessary ([For more information see: 4.13 Programming the setup, page 886](#)) .
- ▶ Confirm the setup.
 - ▷ The *Operation* screen is displayed on the monitor.

4.2.4 Checking the fuel fill level



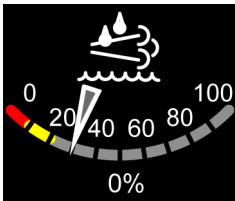
The current fuel fill level is displayed on the *Operation* screen and on the *Engine monitoring* screen.

▶ Check the fuel fill level.

If the fuel level is not sufficient:

▶ top up with fuel.

4.2.5 Checking the urea solution fill level



The urea solution fill level indicator is shown on the *Aggregate* screen.

▶ Check the urea solution fill level.

If the urea solution fill level is not sufficient:

▶ top up with urea solution.

4.2.6 Checking the hydraulic oil tank gate valve

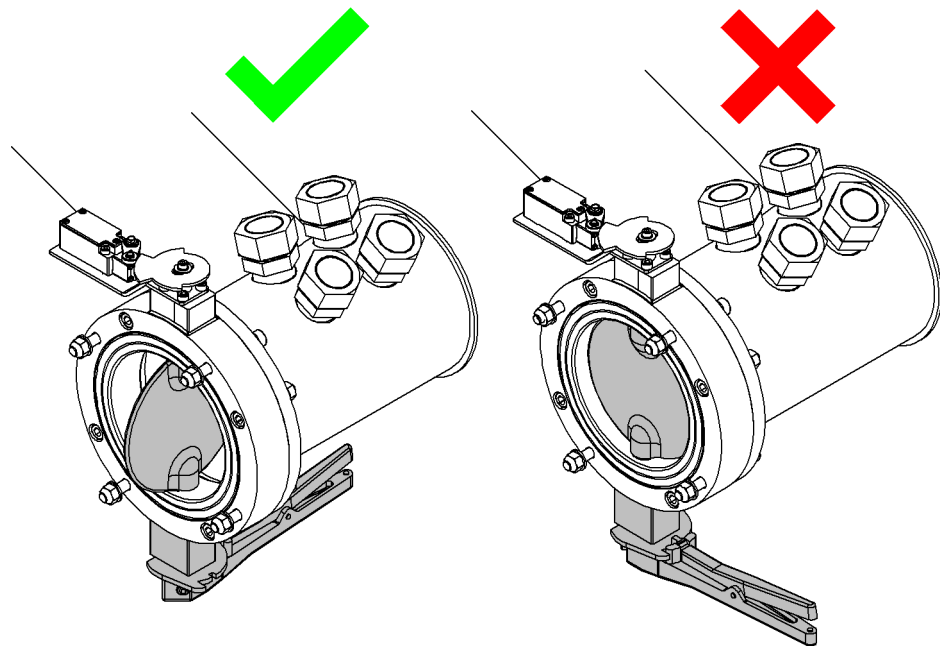


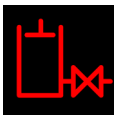
Fig. 2198: Checking the hydraulic oil tank gate valve

With closed gate valve of *hydraulic oil tank* the diesel engine cannot be started.

▶ Check the gate valve of the *hydraulic oil tank*.

If the symbol *Gate valve hydraulic oil tank* blinks on screen:

▶ Open gate valve of the *hydraulic oil tank*.



4.2.7 Starting the diesel engine

NOTICE

Starting aids contain ether!
Damage to the diesel engine.

- ▶ Do not use any starting aids containing ether.

Ensure that the following conditions are fulfilled:

- Pre-start checks were carried out.
- No one other than the machine operator is on the machine or within the danger zone around the machine.
- Safety lever is pulled up.
- All emergency stops are unlocked.
- Operation* screen is displayed on the monitor.
- Uppercarriage door, cabin door and cabin windows are closed.
- Communication between machine operator, slinger and signalman is ensured.



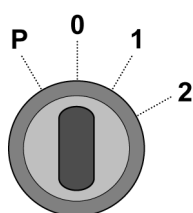
Fig. 2200: Symbol Diesel engine (lit green)

The *Diesel engine* symbol appears on the monitor after the ignition is switched on. At low outside temperatures, the diesel engine is automatically preheated by the flame start system and made ready to start. If the *Diesel engine* symbol is lit green, the machine is ready to start.

NOTICE

Ignition process too long!
Damage to the starter motor.

- ▶ Hold the ignition key in position "2" for a maximum of 10 seconds.



- ▶ Briefly turn the ignition key to position "2".

When the diesel engine has started:

- ▶ release the ignition key.
 - ▷ The symbol *Diesel engine* disappears on screen.

Troubleshooting

The engine has not started successfully?

- ▶ Wait for at least 20 seconds.
- ▶ Repeat the start-up process.

4.2.8 Adjusting the RPM of the diesel engine

NOTICE

Warm-up period of the diesel engine too short!
Damage to the diesel engine.

- ▶ The diesel engine should be allowed a short warm-up period before being subjected to full load.

The current RPM is displayed on the *Operation* screen and on the *Engine monitoring* screen.

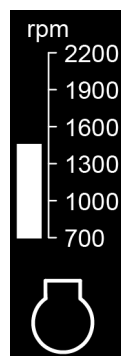


Fig. 2202: Screen section RPM on the screen Operation

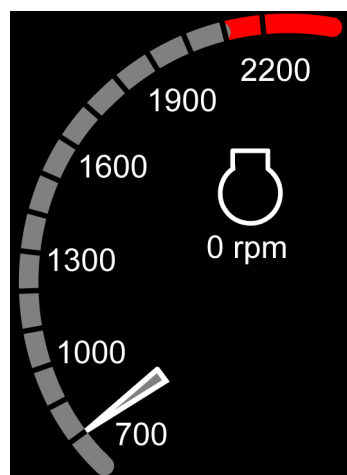


Fig. 2203: Screen section RPM on the screen Power unit

Adjusting the RPM of the diesel engine with the control lever

Procedure on a machine with two multi-directional control levers



Adjusting the RPM of the diesel engine with the foot pedal

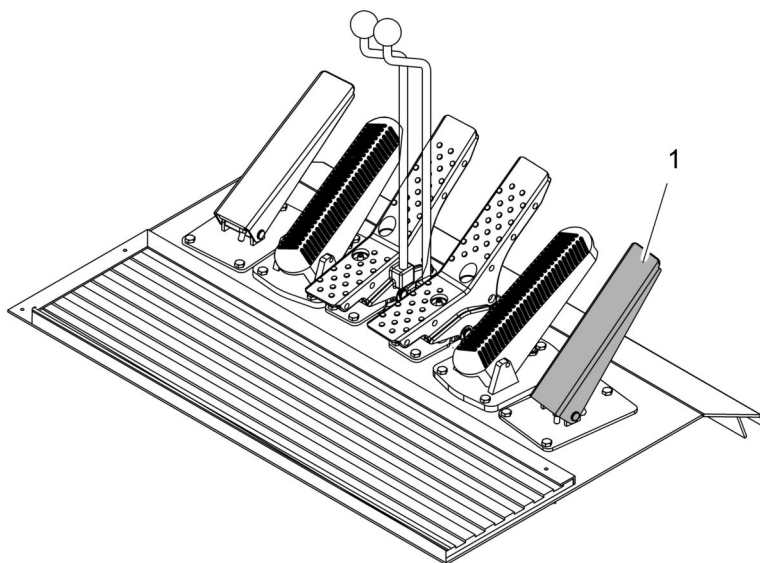


Fig. 2208: Adjusting the RPM of the diesel engine with the foot pedal

1 Foot pedal for RPM

The foot pedal *RPM 1* serves to adjust the RPM from a set constant engine RPM or from idling RPM up to maximum RPM. The constant engine RPM remains stored in memory.

- ▶ Press the foot pedal for *RPM 1* downwards.
 - ▷ The diesel engine RPM increases.
- ▶ Release the foot pedal for *RPM 1*.
 - ▷ The diesel engine RPM decreases until it reaches the set constant RPM value or idle value.

4.2.9 Setting the constant engine RPM



Note

Efficient operation of the diesel engine:

- ▶ Ensure that the constant engine RPM is at least 1400 min^{-1} (1400 rpm).

A specific RPM value can be selected from across the entire speed range and stored in the memory.

Procedure on a machine with two multi-directional control levers



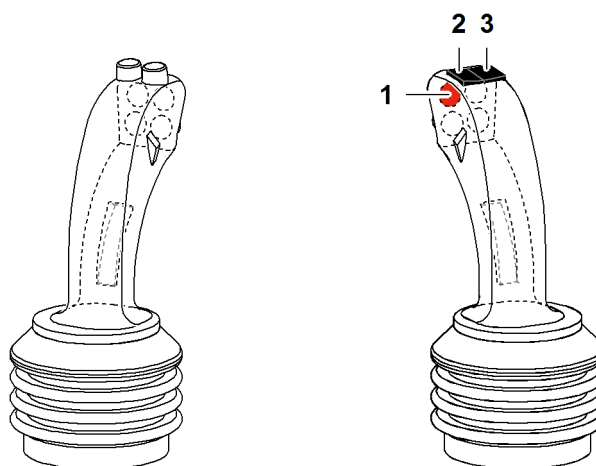


Fig. 2210: Setting a constant engine RPM using the multi-directional control lever

- | | |
|--|-------------------------------------|
| 1 Button <i>Save/delete constant engine RPM</i> | 3 Button <i>decrease RPM</i> |
| 2 Button <i>increase RPM</i> | |

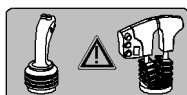
- ▶ Set the required RPM using the *Increase RPM 2* and *Decrease RPM 3* buttons on the right multi-directional control lever.

Once the required RPM has been reached:

- ▶ Press the button *Save/delete constant engine RPM 1* on the right multi-directional control lever.
 - ▷ The input is confirmed by a short signal tone and is saved.

Deleting the set constant engine RPM:

- ▶ Press the button *Save/delete constant engine RPM 1* on the right multi-directional control lever.



Procedure on a machine with a multi-directional control lever and a double T-lever.

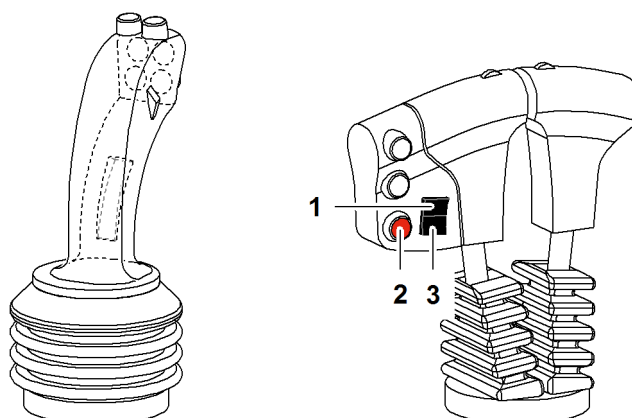


Fig. 2212: Setting the constant engine RPM using the double T-lever

- | | |
|--|-------------------------------------|
| 1 Button <i>increase RPM</i> | 3 Button <i>decrease RPM</i> |
| 2 Button <i>Save/delete constant engine RPM</i> | |

- ▶ Set the required RPM using the *Increase RPM 1* and *Decrease RPM 3* buttons on the right double T-lever.

Once the required RPM has been reached:

- ▶ Press the button *Save/delete constant engine RPM 2* on the right double T-lever.
 - ▷ The input is confirmed by a short signal tone and is saved.

Deleting the set constant engine RPM:

- ▶ Press the button *Save/delete constant engine RPM 2* on the right double T-lever again.

4.2.10 Lowering the safety lever



WARNING

Improper use of the operating elements!
Severe injury.

- ▶ The operating elements must only be operated from the operator's seat.

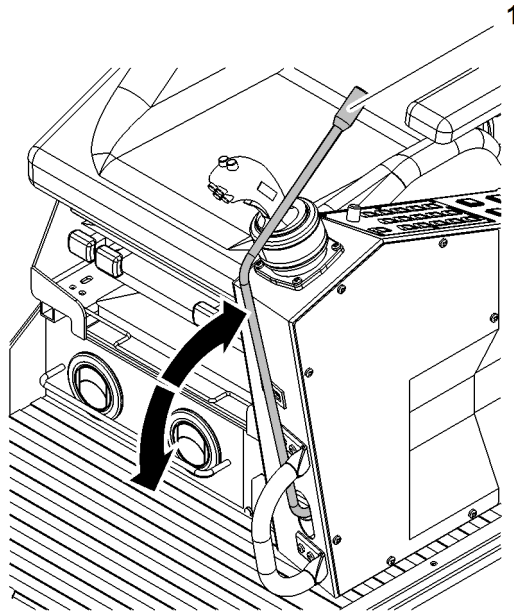


Fig. 2213: Lowering the safety lever

1 Safety lever

- ▶ Move into sitting position in cabin.
- ▶ Lower the safety lever 1.
 - ▷ Operating elements in cabin are enabled.

4.2.11 Checking the tilting-back support cylinder



The switch *Extend tilting-back support cylinder* switch on control panel X12 must be lit.

- ▶ Check the *Extend tilting-back support cylinder* switch on control panel X12.

If the switch *Extend tilting-back support cylinder* switch on control panel X12 is not lit:

- ▶ Press the *Extend tilting-back support cylinder* switch on control panel X12.

LWNLR-x/V04.01//Auslieferung/2016-03-07/en

4.3 Control panels

4.3.1 Setting control panel X25* or control panel X26*

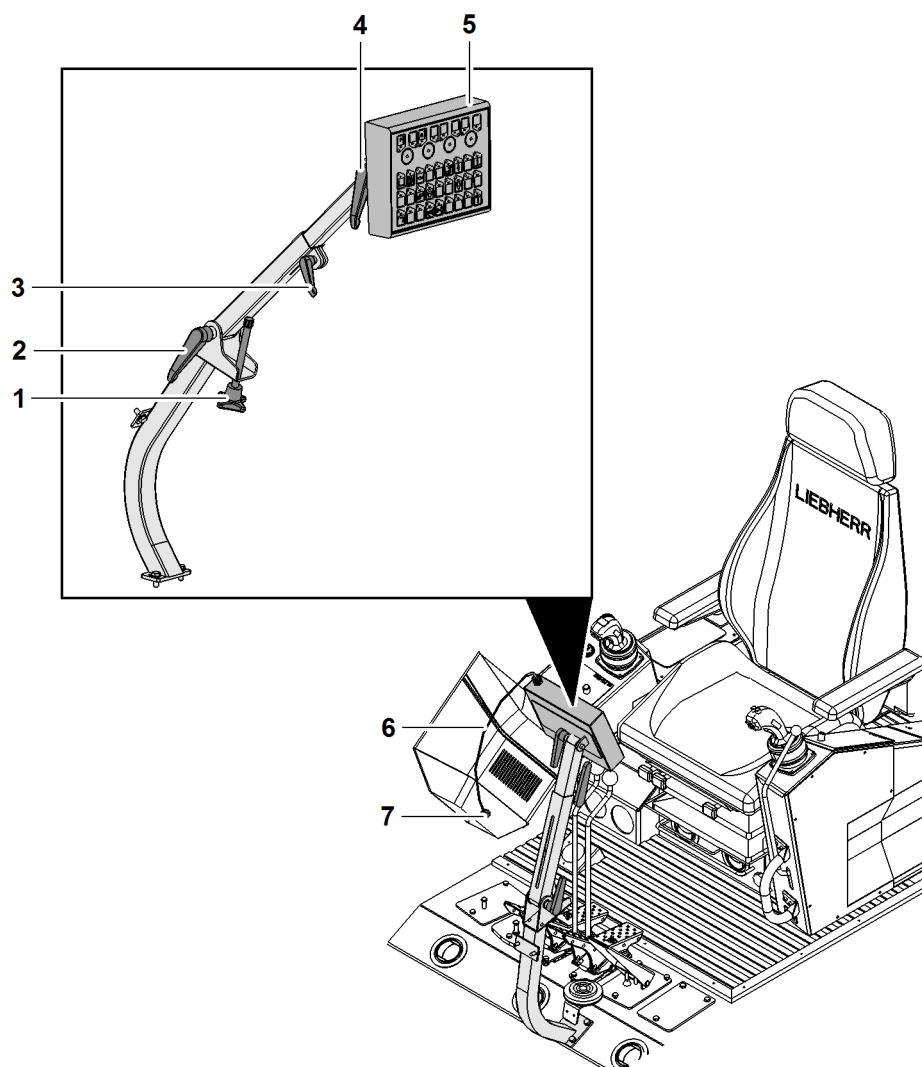


Fig. 2215: Setting control panel X25 or control panel X26

- | | | | |
|---|--|---|--|
| 1 | Inclination adjuster of the support | 5 | Control panel X25 or control panel X26 |
| 2 | Clamping device inclination adjuster | 6 | Cable for control panel X25 or control panel X26 |
| 3 | Clamping device height adjuster of support | 7 | Socket on the monitor for control panel X25 or control panel X26 |
| 4 | Clamping device inclination adjustment control panel | | |

Clamping devices

The clamping devices 2 + 3 + 4 are ratchets and can be turned in any desired position.

- ▶ Pull out clamping device.

- ▶ Turn clamping device into the desired position.
- ▶ Let go of clamping device.
 - ▷ Clamping device engages.

Mount

Adjusting the inclination of the support

- ▶ Undo clamping device **2**.
- ▶ Turn inclination adjuster **1** until the desired position has been reached.
- ▶ Tighten clamping device **2**.

Adjusting the height of the support

- ▶ Undo clamping device **3**.
- ▶ Pull out control panel **X25** or control panel **X26 5** until the desired position has been reached.
- ▶ Tighten clamping device **3**.

Adjusting the tilt of control panel **X25** or control panel **X26**

- ▶ Undo the inclination adjuster **4**.
- ▶ Adjust control panel **X25** or control panel **X26 5** until the desired position has been reached.
- ▶ Tighten the inclination adjuster **4**.
- ▶ Insert cable **6** into socket **7**.

4.4 Operator's seat



CAUTION

Incorrect operator's seat settings!
Wrong operation of operating elements.

► Adjust operator's seat and control stand.

Ensure that the following conditions are fulfilled:

- Operating elements are easily reached.
- Control elements and operating elements are well-visible.

When the operator's seat is correctly adjusted and properly used, it conforms to the requirements of ISO 2631-1 for protection against whole-body vibration.



Fig. 2216: Operator's seat

- | | | | |
|---|--|----|--|
| 1 | Lever <i>Adjust rear seat height</i> | 7 | Clasp* |
| 2 | Seat belt buckle* | 8 | Lever <i>Adjust backrest tilt</i> |
| 3 | Armrest (2x) | 9 | Adjusting wheel <i>Adjust dampening</i> |
| 4 | Headrest | 10 | Lever <i>Adjust operator's seat horizontally</i> |
| 5 | Backrest | 11 | Lever <i>Adjust control stand horizontally</i> |
| 6 | Adjusting wheel <i>Adjust armrest (2x)</i> | 12 | Lever <i>Adjust front seat height</i> |

4.4.1 Adjusting the control stand horizontally

Ensure that the following conditions are fulfilled:

- Safety lever is pulled up.

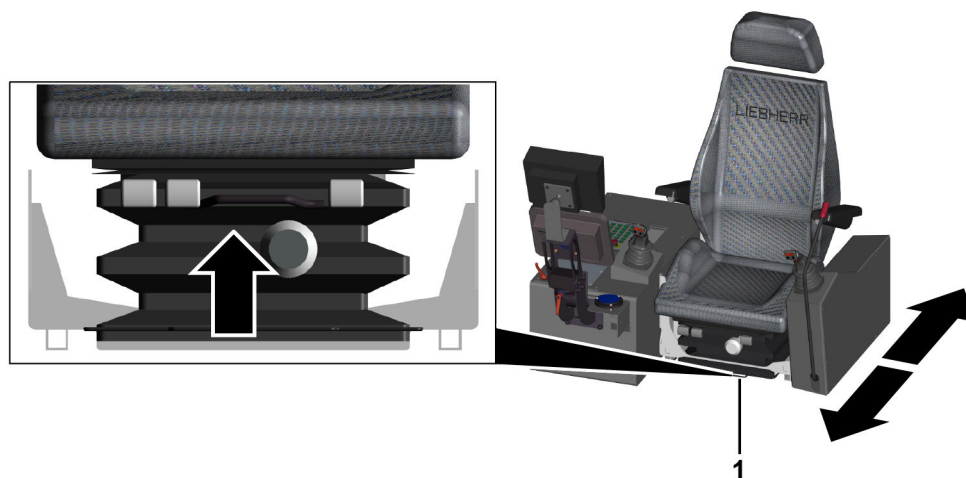


Fig. 2217: Adjusting the control stand horizontally (illustration of principle)

1 Lever *Adjust control stand horizontally*

- ▶ Pull up and hold the lever *Adjust control stand horizontally 1*.
- ▶ Adjust control stand horizontally.
- ▶ Release the lever *Adjust control stand horizontally 1*.
 - ▷ Control stand engages automatically.

4.4.2 Adjusting the operator's seat

Ensure that the following conditions are fulfilled:

- Safety lever is pulled up.



Fig. 2218: Adjusting the operator's seat horizontally

1 Lever *Adjust operator's seat horizontally*

- ▶ Pull up and hold the lever *Adjust operator's seat horizontally 1*.
- ▶ Adjust operator's seat horizontally.
- ▶ Release the lever *Adjust operator's seat horizontally 1*.
 - ▷ Operator's seat engages automatically.

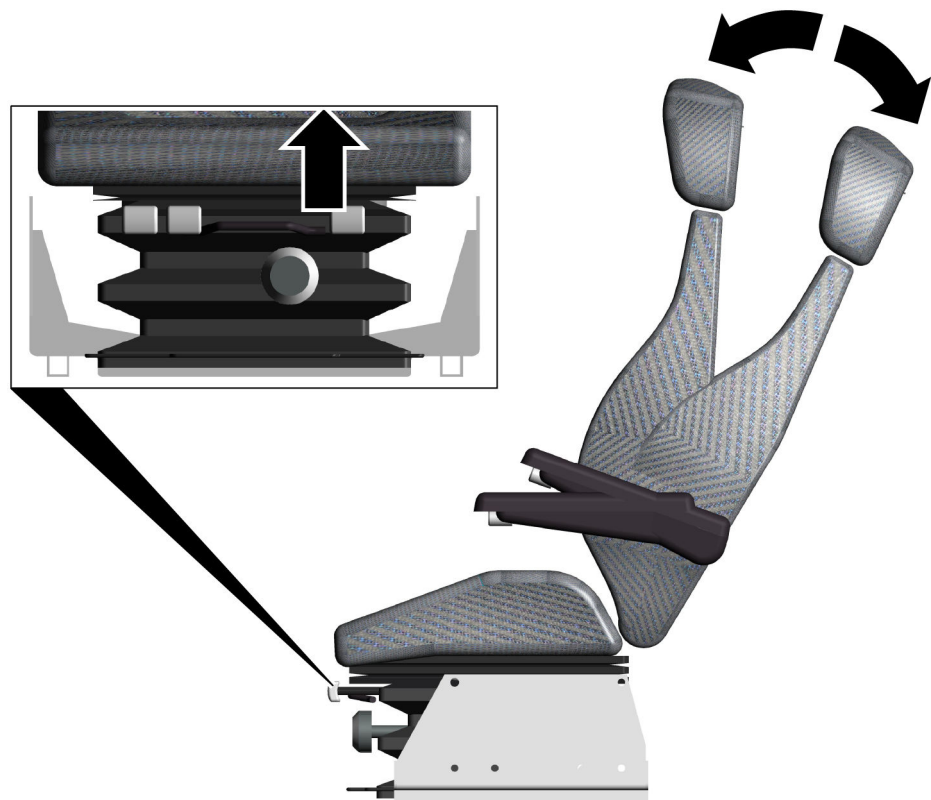


Fig. 2219: Adjusting the backrest tilt

- ▶ Pull up the lever *Adjust backrest tilt*.
- ▶ Press back gently against seat back.
 - ▷ Seat back inclines backwards.
- ▶ Lower the lever *Adjust backrest tilt*.
 - ▷ Backrest tilts forward.

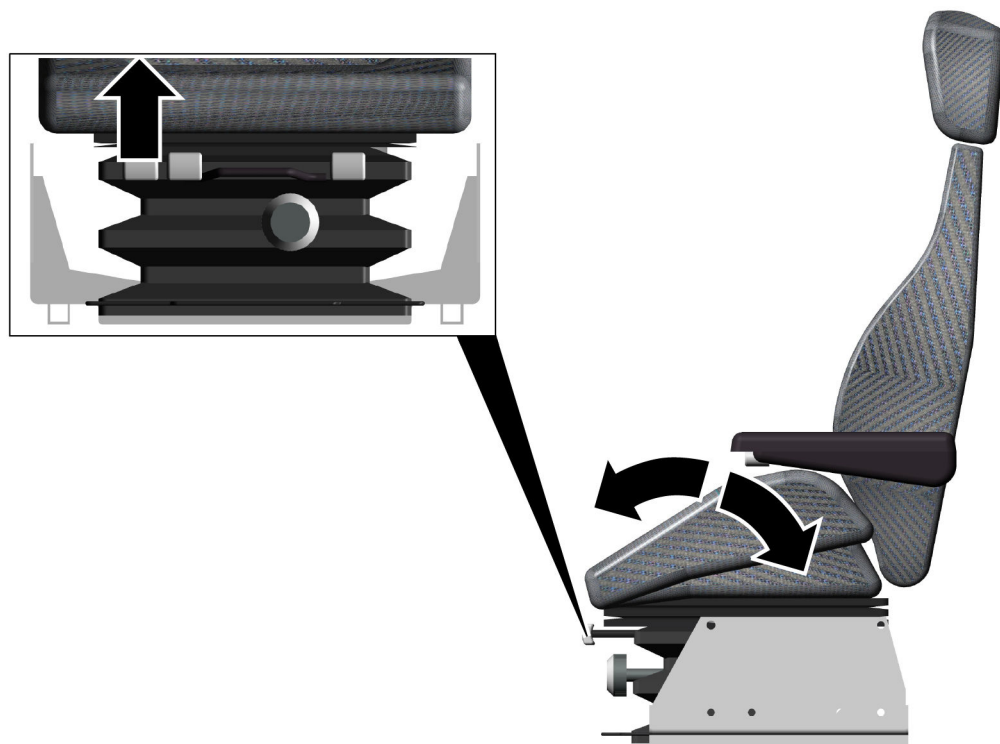


Fig. 2220: Adjusting the rear seat height

- ▶ Pull up the lever *Adjust rear seat height*.
- ▶ Adjust rear seat height by putting on weight or taking weight off.

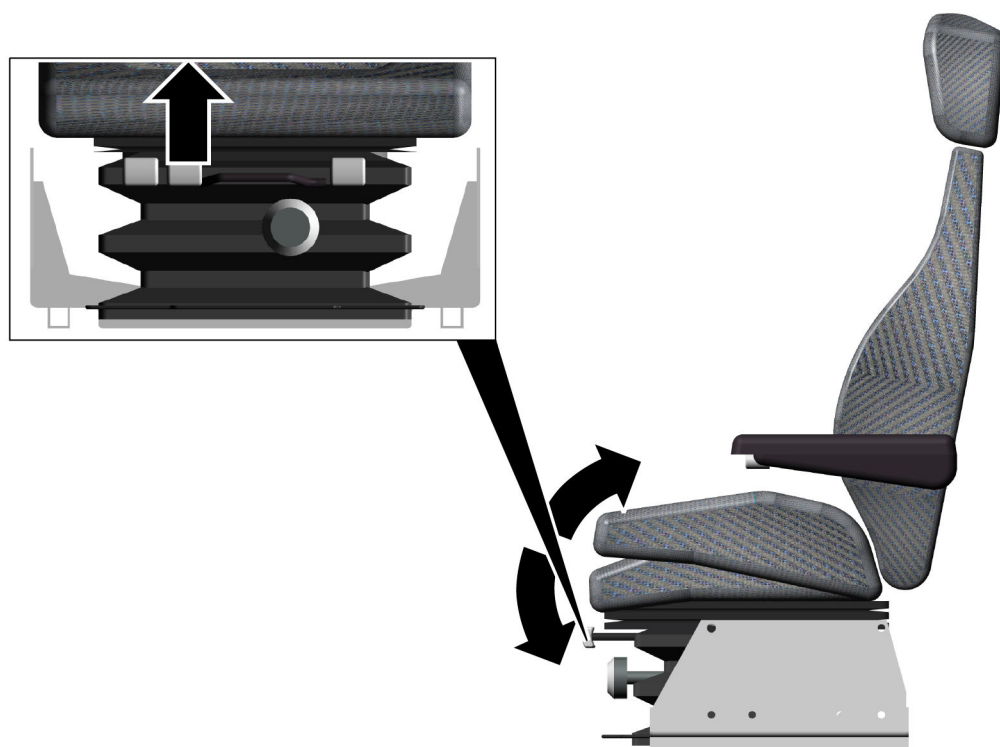


Fig. 2221: Adjusting the front seat height

- ▶ Pull up the lever *Adjust front seat height*.

- ▶ Adjust front seat height by putting on weight or taking weight off.

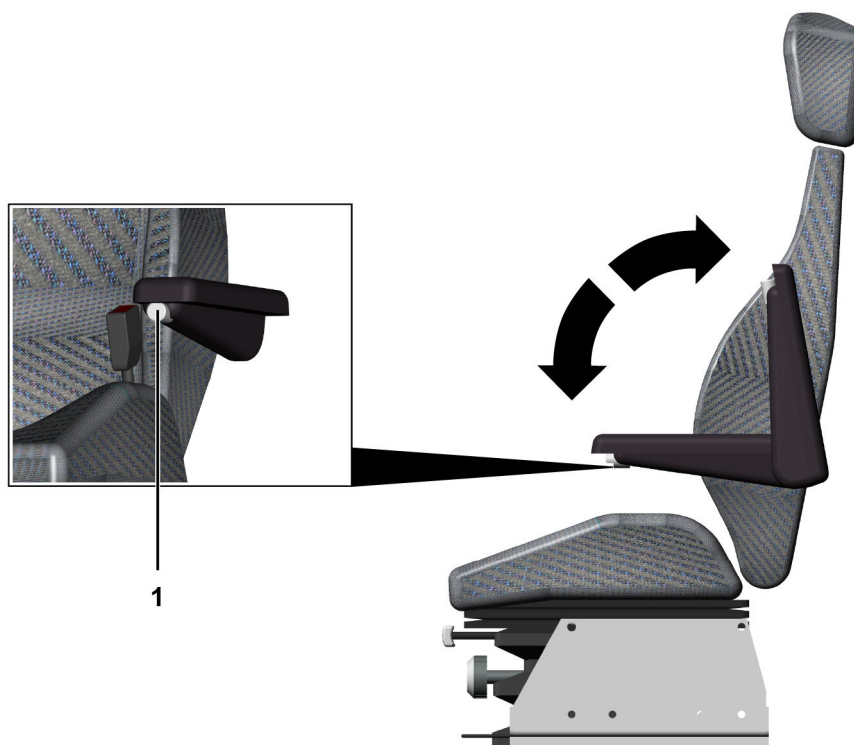


Fig. 2222: Adjusting the armrests

- 1 Adjusting wheel *Adjust armrest* (2x)

- ▶ Adjust armrest.
- ▶ Turn adjusting wheel *Adjust armrest* 1 clockwise.
- ▶ Repeat procedure with second armrest.
 - ▷ Armrests are adjusted.

4.4.3 Adjusting the dampening



Fig. 2223: Decreasing the dampening

- ▶ Decreasing the dampening: Turn adjusting wheel *Adjust dampening* clockwise.
 - ▷ Dampening is decreased.

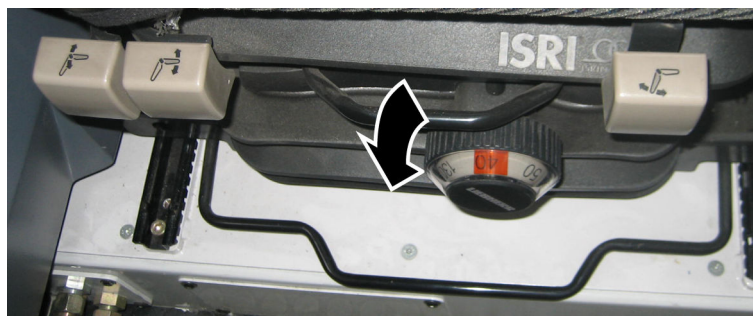


Fig. 2224: Increasing the dampening

- ▶ Increasing the dampening: Turn adjusting wheel *Adjust dampening* counter-clockwise.
 - ▷ Dampening is increased.

4.4.4 Adjusting the ergonomics*

The operator's seat with air suspension has two air chambers that can be filled or emptied separately.

The operator's seat with seat heating* has heaters in the seat cushion and in the backrest.

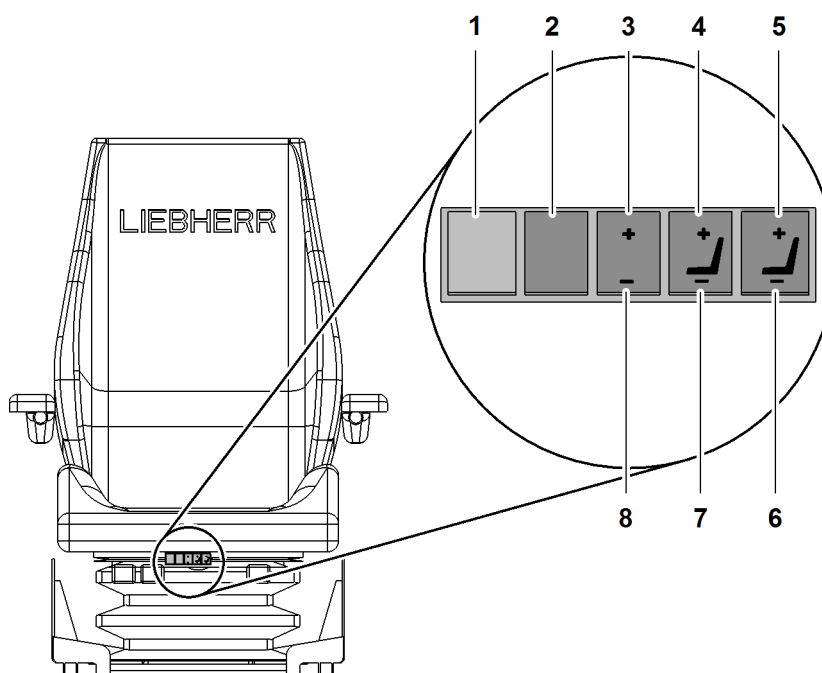


Fig. 2225: Adjusting the ergonomics*

- | | |
|--|--|
| <p>1 [not used]</p> <p>2 Button <i>Seat heating</i></p> <p>3 Button <i>Increase weight</i></p> <p>4 Button <i>Increase bottom lumbar vertebrae support</i></p> | <p>5 Button <i>Increase top lumbar vertebrae support</i></p> <p>6 Button <i>Decrease top lumbar vertebrae support</i></p> <p>7 Button <i>Decrease bottom lumbar vertebrae support</i></p> <p>8 Button <i>Decrease weight</i></p> |
|--|--|

Turning the seat heating on or off

- ▶ Press the button *Seat heating 2* on the operator's seat.
 - ▷ Seat heating is switched on.
- ▶ Press the button *Seat heating 2* on the operator's seat again.
 - ▷ Seat heating is switched off.

Increasing or decreasing the weight

- ▶ Press the button *Increase weight 3* on the operator's seat.
 - ▷ Weight is being increased.
- ▶ Press the button *Decrease weight 8* on the operator's seat.
 - ▷ Weight is being decreased.

Increasing or decreasing the lumbar vertebrae support

- ▶ Press the button *Increase bottom lumbar vertebrae support 4* on the operator's seat.
 - ▷ Bottom lumbar vertebrae support is being increased.
- ▶ Press the button *Decrease bottom lumbar vertebrae support 7* on the operator's seat.
 - ▷ Bottom lumbar vertebrae support is being decreased.
- ▶ Press the button *Increase top lumbar vertebrae support 5* on the operator's seat.
 - ▷ Top lumbar vertebrae support is being increased.
- ▶ Press the button *Decrease top lumbar vertebrae support 6* on the operator's seat.
 - ▷ Top lumbar vertebrae support is being decreased.

4.4.5 Safety belt*



Fig. 2226: Safety belt

1 Belt buckle

2 Clasp

Putting on safety belt

In case of abrupt movement, the belt retractor blocks so that the belt cannot be pulled out further.

The belt has an automatic belt tightener.

It is not necessary to adjust the belt length.

- ▶ Pull belt buckle 1 out of belt retainer.
- ▶ Pull belt across body at height of pelvis.
- ▶ Insert seat belt buckle 1 into snap lock 2.
 - ▷ Safety belt is put on.

Releasing safety belt

- ▶ Press latch release on snap-lock 2.
 - ▷ Belt automatically winds up in belt mounting.

4.5 Lighting

4.5.1 Operating the floodlights on the uppercarriage

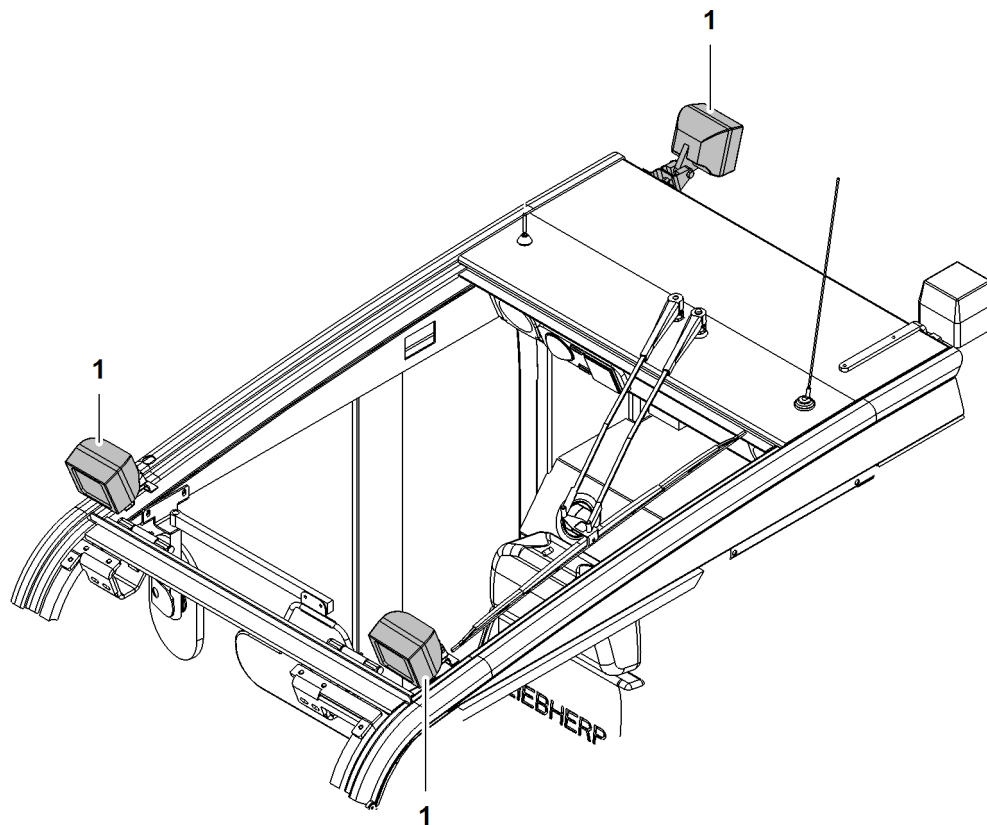


Fig. 2227: Operating the floodlights on the uppercarriage

1 Floodlights on uppercarriage



- ▶ Press the *Floodlights on uppercarriage* button on control panel X11.
- ▷ Floodlights on uppercarriage 1 light up.

4.5.2 Operating the additional floodlights



CAUTION

Lamps are extremely bright and very hot!
Can damage eyes and cause burns.

- ▶ Do not look directly into the light emitted by the floodlights.
- ▶ Do not touch the hot glass in front of the floodlight.

Operating the floodlights on the boom base section



- ▶ Press the *Boom base section floodlights* button.
- ▷ The floodlights on the boom base section light up.



- ▶ Press the *Move the floodlights upwards* button.
 - ▷ The floodlights on the boom base section move upwards.



- ▶ Press the *Move the floodlights down* button.
 - ▷ The floodlights on the boom base section move down.

Operating all the floodlights on the boom



- ▶ Press the *Boom floodlights* button.
 - ▷ All the floodlights on the boom light up.

4.5.3 Operating the cab lighting

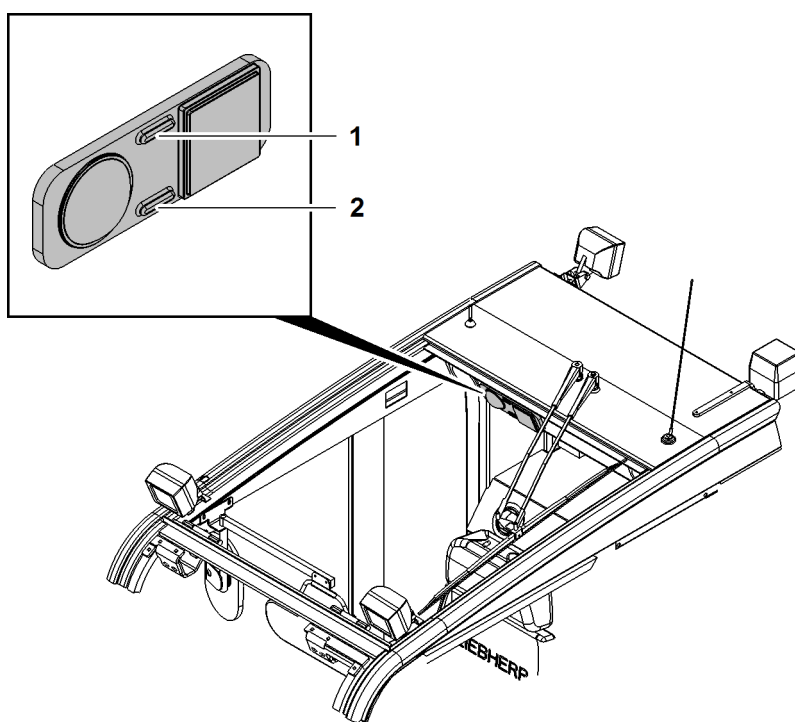


Fig. 2233: Operating the cab lighting

- 1** Press the reading lamp *button* **2** Press the Interior lighting *button*

The *interior lighting* is either set to “automatic”, “off” or “on”.

- ▶ Press the *Reading lamp 1* button.
 - ▷ The reading lamp is switched on.
- ▶ Press the *Interior lighting 2* button.
 - ▷ The interior lighting is switched on.

4.5.4 Operating the engine compartment lighting



- ▶ Press the *Engine compartment lighting* button on control panel X11.
 - ▷ The work lights in the engine compartment light up.

4.6 Windscreen wiper system

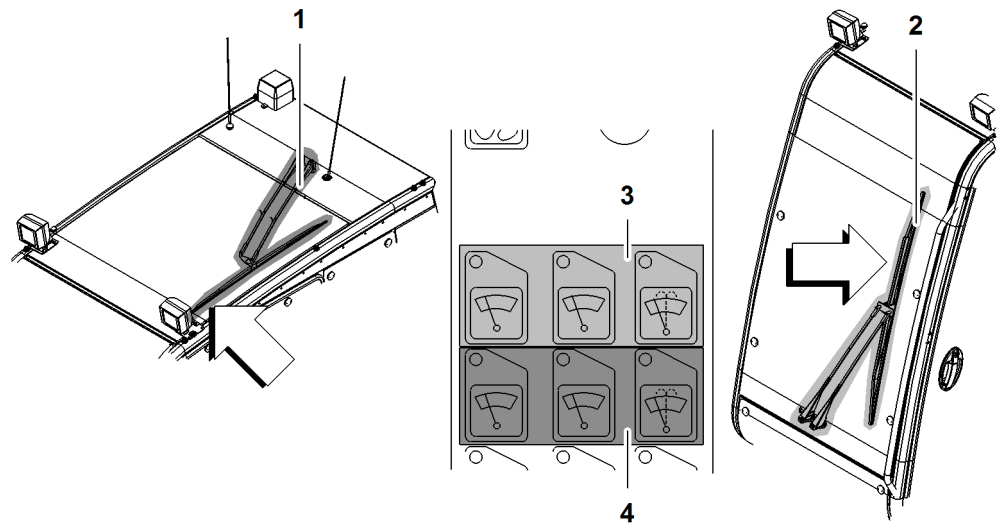
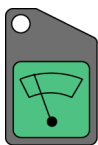


Fig. 2235: Windscreen wiper system

- | | | | |
|---|-----------------------------------|---|--|
| 1 | Windscreen wiper for roof window | 3 | Operating elements on control panel X11 for front windscreen wiper |
| 2 | Windscreen wiper for front window | 4 | Operating elements on control panel X11 for roof windscreen wiper |

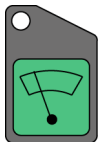
4.6.1 Operating the windscreen wipers

Activates/deactivates continuous mode of the windscreen wiper.



- ▶ Press the *Windscreen wiper* button on control panel X11.

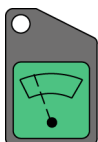
▷ Continuous mode of windscreen wiper is activated.



- ▶ Press the *Windscreen wiper* button on control panel X11 again.

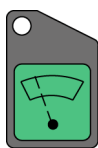
▷ Continuous mode of windscreen wiper is deactivated.

Activates/deactivates interval mode of the windscreen wiper



- ▶ Press the *Intermittent windscreen wiper* button on control panel X11.

▷ Interval mode of the windscreen wiper is activated.



▶ Press the button *Interval mode windscreen wiper* on control panel X11 again.

▷ Interval mode of the windscreen wiper is deactivated.

4.6.2 Operating the windscreen washer system



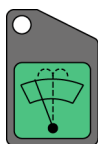
WARNING

Flammable fluid in windscreen washer bottle!
Fire, explosion.

▶ Fill windscreen washer bottle exclusively with non-flammable fluids.

Ensure that the following conditions are fulfilled:

- Container for windscreen washer system is filled.
- At low ambient temperatures: sufficient antifreeze for windscreen wiper system has been added.



▶ Press and hold the button *Windscreen wiper system* on control panel X11.
▷ Windscreen wiper runs continuously and windscreen cleaning fluid is sprayed on.

4.7 Ventilation, heating and air-conditioning

The following table shows the recommended settings for ventilation, heating and air conditioning.

Button <i>Fan speed heating/air conditioning system</i>	Rotary control knob <i>Temperature heating/air conditioning system</i>	Button <i>Air conditioning system</i>	Switch <i>Recirculated air/fresh air</i>	Position of the air vents		
					Left	Right
at least level 1	all the way to the left (blue zone)	Off	as required	Rear air vents	as required	as required
				Bottom air vents	as required	as required
				Front air vents	as required	as required
				Ventilation duct	as required	as required

Tab. 371: Recommended ventilation setting

Button <i>Fan speed heating/air conditioning system</i>	Rotary control knob <i>Temperature heating/air conditioning system</i>	Button <i>Air conditioning system</i>	Switch <i>Recirculated air/fresh air</i>	Position of the air vents		
					Left	Right
at least level 1	All the way to the right (red zone)	Off	as required	Rear air vents	as required	as required
				Bottom air vents	open	open
				Front air vents	open	open
				Ventilation duct	as required	as required

Tab. 372: Recommended heating setting

LWNLR-x/V04.01//Auslieferung/2016-03-07/en

Button <i>Fan speed heating/air conditioning system</i>	Rotary control knob <i>Temperature heating/air conditioning system</i>	Button <i>Air conditioning system</i>	Switch <i>Recirculated air/fresh air</i>	Position of the air vents		
					Left	Right
at least level 1	all the way to the left (blue zone)	On	as required	Rear air vents	open to the top	open to the top
				Bottom air vents	closed	closed
				Front air vents	closed	open to the top
				Ventilation duct	open to the top	open to the top

Tab. 373: Recommended cooling setting

Button <i>Fan speed heating/air conditioning system</i>	Rotary control knob <i>Temperature heating/air conditioning system</i>	Button <i>Air conditioning system</i>	Switch <i>Recirculated air/fresh air</i>	Position of the air vents		
					Left	Right
at least level 1	all the way to the right (red zone)	On	Recirculated air	Rear air vents	open lateral towards window	open lateral towards window
				Bottom air vents	closed	closed
				Front air vents	open towards window	open towards window
				Ventilation duct	open towards window front	open lateral towards window

Tab. 374: Recommended dehumidification setting

LWNLR.x/V04.01//Auslieferung/2016-03-07/en

4.7.1 Setting the air vent

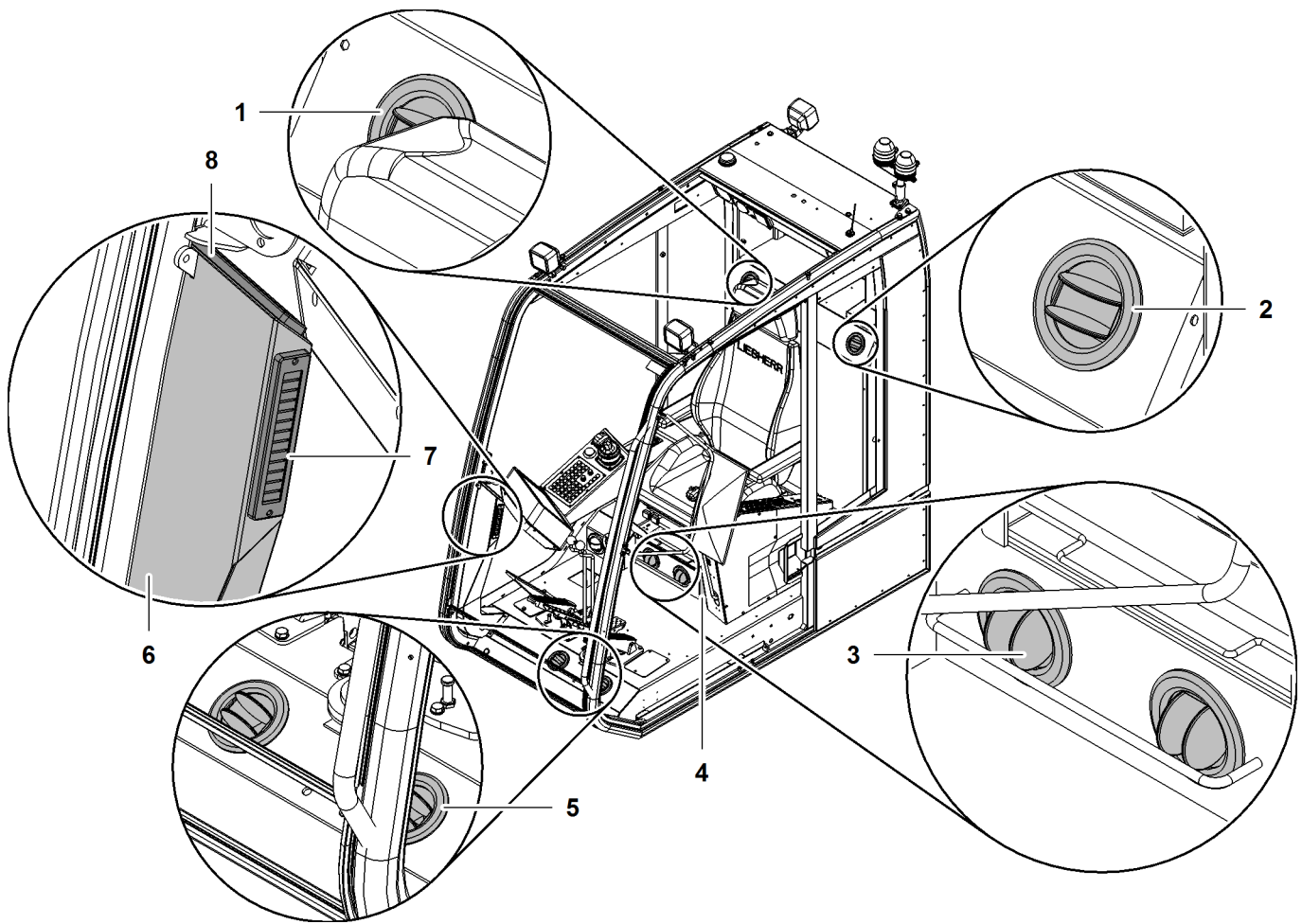


Fig. 2241: Air vent overview

- | | | | | | |
|---|----------------------|---|--|---|----------------------|
| 1 | Right rear air vent | 4 | Switch <i>Recirculated air/fresh air</i> | 7 | Lateral lamella vent |
| 2 | Left rear air vent | 5 | Front air vent (2x) | 8 | Top lamella vent |
| 3 | Bottom air vent (2x) | 6 | Ventilation duct | | |

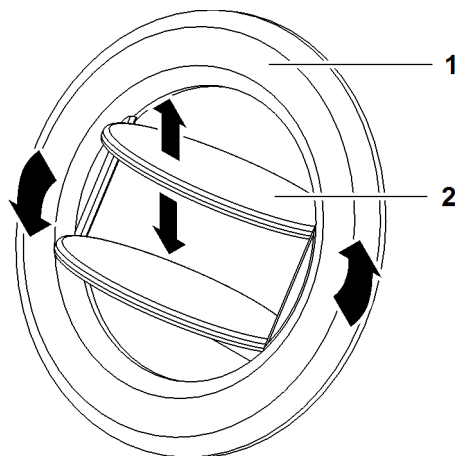


Fig. 2242: Setting the air vent

- | | | | |
|---|------|---|-----------|
| 1 | Ring | 2 | Flap (2x) |
|---|------|---|-----------|

LWNLR-x/V04.01//Auslieferung/2016-03-07/en

- ▶ Turn ring 1 into desired position.
- ▶ Set flaps 2 to desired position.

4.7.2 Adjusting the lamella vents

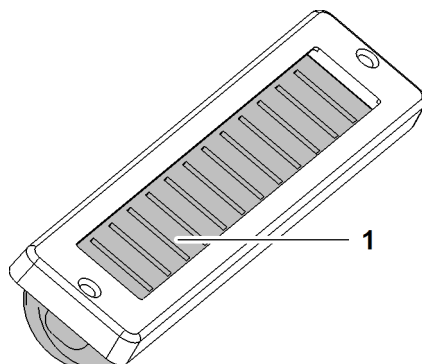


Fig. 2243: Adjusting the lamella vents

1 Lamella

- ▶ Turn lamella 1 into desired position.

4.7.3 Setting recirculated air or fresh air

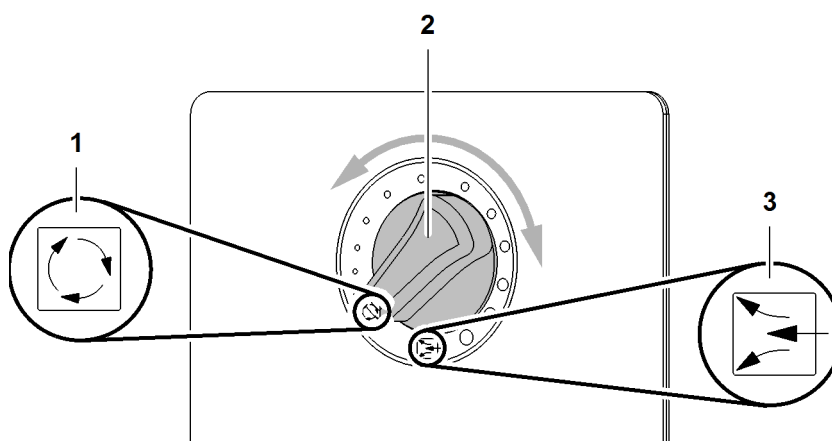


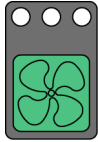
Fig. 2244: Setting recirculated air or fresh air

1 Recirculated air "position" 3 Fresh air "position"
 2 Switch *Recirculated air/fresh air*

- ▶ Set the switch *Recirculated air/fresh air* 2 to the position "Recirculated air" 1.
 - ▷ The air is circulated around the cab.
- ▶ Set *Recirculated air/fresh air switch* to 2 Fresh air "position" 3.
 - ▷ The blower conveys fresh air from the outside into the cabin.

4.7.4 Operating the ventilation

The LED of the buttons indicate the selected blower level. Three different fan speeds are possible.



- ▶ Press the *Heating/air conditioning fan speed* button on control panel X11.
 - ▷ The fan blows.

4.7.5 Using the heater

Ensure that the following conditions are fulfilled:

- Diesel engine is switched on.
- Ventilation is switched on.



- ▶ Turn the *Heating temperature/air conditioning* rotary control knob on the X11 control panel to the right (red zone).
 - ▷ The heating is turned up.



- ▶ Turn the *Heating temperature/air conditioning* rotary control knob on the X11 control panel to the left (blue zone).
 - ▷ The heating is turned down.

4.7.6 Turning the air conditioning system on or off



WARNING

Leaks in the air conditioning coolant circuit in an enclosed space!
Risk of suffocation.

If there is a high coolant concentration in the air:

- ▶ Immediately leave the closed room (cab).



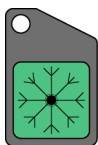
CAUTION

Rotating parts!
Risk of injury to limbs.

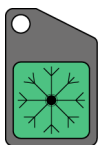
- ▶ Make sure that there are no persons in the vicinity of the fan on the condenser.

Ensure that the following conditions are fulfilled:

- Diesel engine is switched on.
- Ventilation is switched on.



- ▶ Press the *Air conditioning system* button on control panel X11.
 - ▷ The air conditioning is switched on.



- ▶ Press the button *Air conditioning system* on control panel X11 again.
 - ▷ Air conditioning system is switched off.

4.7.7 Operating the external air conditioning system*

NOTICE

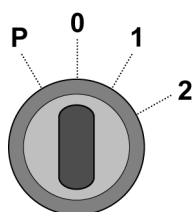
Inadmissible operation of both diesel engines!
Overpressure in the cooling circuit.
Coolant leak.

- ▶ Ensure that only one diesel engine is in operation.

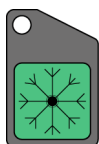
Turning the external air conditioning system* on or off

Preparing the operating of the external air conditioning system

- ▶ Turn ignition key of machine to position "1".



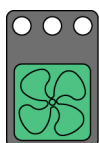
- ▶ Press the *Air conditioning system* button on control panel X11.



- ▶ Turn rotary control knob *Temperature heating/air conditioning system* on control panel X11 to the left (blue zone).

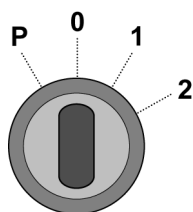


- ▶ Press the button *Fan speed heating/air conditioning system* on control panel X11 until the desired fan speed is set.



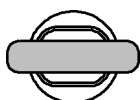
- ▶ Set the button *Recirculated air/fresh air* beneath operator's seat to the position "Recirculated air".

- ▶ Turn ignition key of machine to position "0".
 - ▷ Operation of the external air conditioning system has been prepared.



Turning the external air conditioning system on

- ▶ Turn ignition key on control unit *External air conditioning system* to position "1".



- ▷ Software version is displayed for two seconds on the display of control unit *External air conditioning system*:

H A T Z multiflex
 S 0 5 2 0 4 4 3 / 2 0 1 1

Fig. 2256: Software version

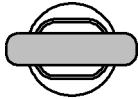
- ▷ Operating state before start is shown on the display of control unit *External air conditioning system*:

!!! OIL !!!	0,0 h
00°	0000

Fig. 2257: Operating state before start

The following parameters appear:

- Display top left: Error oil pressure indicator
- Display top right: Operating hours
- Display bottom left: Engine temperature
- Display bottom right: Diesel engine RPM



- ▶ Turn ignition key on control unit *External air conditioning system* briefly to position "2".

- ▷ Diesel engine is switched on.
- ▷ External air conditioning system is in operation.
- ▷ Operating state after start is shown on the display of control unit *External air conditioning system*.

OIL ✓	0,0 h
25°	1000

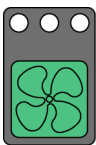
Fig. 2259: Operating state after start

The following parameters appear:

- Display top left: Oil pressure indicator OK
- Display top right: Operating hours
- Display bottom left: Engine temperature
- Display bottom right: Diesel engine RPM

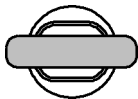


- ▶ Turn rotary control knob *Temperature heating/air conditioning system* on control panel X11 to the desired temperature.



- ▶ Press the button *Fan speed heating/air conditioning system* on control panel X11 until the desired fan speed is set.
 - ▷ External air conditioning system cools down or heats up cabin to the desired temperature.

Turning the external air conditioning system off



- ▶ Turn ignition key on control unit *External air conditioning system* to position "0".
 - ▷ External air conditioning system is turned off.

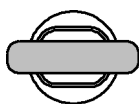
Setting manual start or automatic start

With manual start, the external air conditioning system can be turned on or off manually at any time with the ignition key.

With automatic start, the external air conditioning system is turned on or off automatically with the machine's diesel engine.

Make sure the following prerequisites are met:

- Operation of the external air conditioning system* has been prepared.



- ▶ Turn ignition key on control unit *External air conditioning system* to position “1”.

- ▷ Software version is displayed for two seconds on the display of control unit *External air conditioning system*:

H A T Z multiflex S 0 5 2 0 4 4 3 / 2 0 1 1
--

Fig. 2264: Software version

- ▷ Operating state before start is shown on the display of control unit *External air conditioning system*:

!!! OIL !!! 00°	0,0 h 0000
--------------------	---------------

Fig. 2265: Operating state before start



- ▶ Press button *F1* on control unit *External air conditioning system*.

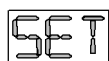
- ▷ Start mode/daily operating hours is shown on the display of control unit *External air conditioning system*:

a u t o m a t i k TagBSZ: 0,0 h

Fig. 2267: Start mode/daily operating hours

The following parameters appear:

- Top display: Automatic start
- Bottom display: Daily operating hours



- ▶ Press button *SET* on control unit *External air conditioning system*.

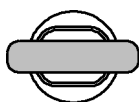
- ▷ Start mode/daily operating hours is shown on the display of control unit *External air conditioning system*:

m a n u e l l TagBSZ: 0,0 h

Fig. 2269: Start mode/daily operating hours

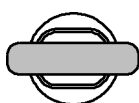
The following parameters appear:

- Top display = manual start
- Bottom display = daily operating hours



- ▶ Turn ignition key on control unit *External air conditioning system* to position “0”.
 - ▷ Settings are saved.
 - ▷ The new settings are active at the next start.

Requesting the operating hours



- ▶ Turn ignition key on control unit *External air conditioning system* to position “1”.

- ▷ Software version is displayed for two seconds on the display of control unit *External air conditioning system*:

HATZ multiflex S 0 5 2 0 4 4 3 / 2 0 1 1

Fig. 2272: Software version

- ▷ Operating state before start is shown on the display of control unit *External air conditioning system*:

!!! OIL !!!	0,0 h
00°	0000

Fig. 2273: Operating state before start



- ▶ Press button *F1* on control unit *External air conditioning system*.

- ▷ Start mode/daily operating hours is shown on the display of control unit *External air conditioning system*:

manuell	
TagBSZ:	0,0 h

Fig. 2275: Start mode/daily operating hours

The following parameters appear:

- Top display = manual start
- Bottom display = daily operating hours



- ▶ Press button *F1* on control unit *External air conditioning system*.

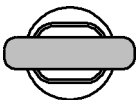
- ▷ Total operating time/diesel engine RPM are shown on the display of control unit *External air conditioning system*:

Gesamt	0,0 h
Drehzahl:	0000

Fig. 2277: Total operating time/diesel engine RPM

The following parameters appear:

- Top display: Total operating hours
- Bottom display: Diesel engine RPM



- ▶ Turn ignition key on control unit *External air conditioning system* to position "0".

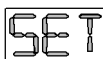
Operating the menu



Note

Change of basic settings!
Loss of warranty.

- ▶ Make sure that no basic settings are changed.



- ▶ Press and hold the button *SET* on control unit *External air conditioning system* and turn ignition key on control unit *External air conditioning system* to position "1".
- ▷ Menu is shown on the display of control unit *External air conditioning system*:

*** SETUP - MENUE***
[1] Einstellungen

Fig. 2280: Menu

The following parameters appear:

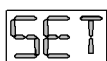
- Top display: Menu
- Bottom display: [1] Settings

The following menus can be selected:

- [1] Settings
- [2] Service
- [3] Safety
- [4] Daily operating hours
- [5] Total operating hours
- [6] Exit

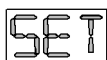


- ▶ Press the button *F1* on control unit *External air conditioning system* until the desired menu is displayed.



- ▶ Press button *SET* on control unit *External air conditioning system*.
 - ▷ Desired menu is selected.

Resetting daily operating hours



- ▶ Press and hold the button *SET* on control unit *External air conditioning system* and turn ignition key on control unit *External air conditioning system* to position "1".
 - ▷ Menu is shown on the display of control unit *External air conditioning system*:

*** SETUP - MENUE***
[1] Einstellungen

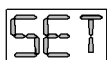
Fig. 2284: Menu

The following parameters appear:

- Top display: Menu
- Bottom display: [1] Settings



- ▶ Press the button *F1* on control unit *External air conditioning system* until the menu "[4] Daily operating hours" is displayed.



- ▶ Press button *SET* on control unit *External air conditioning system*.
 - ▷ The menu "[4] Daily operating hours" is shown on the display of control unit *External air conditioning system*:

*** Tageszaehler***
Pin-Nr.: _ _ _ _

Fig. 2287: Menu [4] Daily operating hours

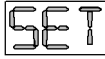
The following parameters appear:

- Top display: Daily operating hours
- Bottom display: Pin number query

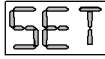
The PIN number is 4000.



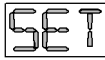
- ▶ Press the button *F1* on control unit *External air conditioning system* until “4” is displayed in the first PIN number field.



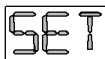
- ▶ Press button *SET* on control unit *External air conditioning system*.
 - ▷ First PIN number field is selected.
 - ▷ Second PIN number field blinks and shows “0”.



- ▶ Press button *SET* on control unit *External air conditioning system*.
 - ▷ Second PIN number field is selected.
 - ▷ Third PIN number field blinks and shows “0”.



- ▶ Press button *SET* on control unit *External air conditioning system*.
 - ▷ Third PIN number field is selected.
 - ▷ Fourth PIN number field blinks and shows “0”.



- ▶ Press button *SET* on control unit *External air conditioning system*.
 - ▷ Fourth PIN number field is selected.
 - ▷ The menu “Delete day counter” is shown on the display of control unit *External air conditioning system*:

Tageszaehler
Löschen

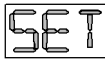
Fig. 2293: Menu Delete day counter

The following parameters appear:

- Top display: Daily operating hours
- Bottom display: Delete

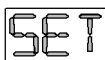


- ▶ Press button *F1* on control unit *External air conditioning system*.



- ▶ Press button *SET* on control unit *External air conditioning system*.
 - ▷ Daily operating hours are reset.

Displaying error messages



- ▶ Press and hold the button *SET* on control unit *External air conditioning system* and turn ignition key on control unit *External air conditioning system* to position “1”.
 - ▷ Menu is shown on the display of control unit *External air conditioning system*:

*** SETUP - MENUE***
[1] Einstellungen

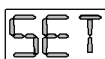
Fig. 2297: Menu

The following parameters appear:

- Top display: Menu
- Bottom display: [1] Settings



- ▶ Press the button *F1* on control unit *External air conditioning system* until the menu “[2] Service” is displayed.



- ▶ Press button *SET* on control unit *External air conditioning system*.

- ▷ The menu “[2] Service” is shown on the display of control unit *External air conditioning system*:

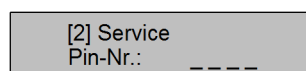


Fig. 2300: Menu [2] Service

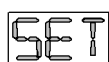
The following parameters appear:

- Top display: Service
- Bottom display: Pin number query

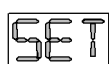
The PIN number is 2000.



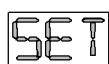
- ▶ Press the button *F1* on control unit *External air conditioning system* until “2” is displayed in the first PIN number field.



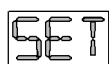
- ▶ Press button *SET* on control unit *External air conditioning system*.
 - ▷ First PIN number field is selected.
 - ▷ Second PIN number field blinks and shows “0”.



- ▶ Press button *SET* on control unit *External air conditioning system*.
 - ▷ Second PIN number field is selected.
 - ▷ Third PIN number field blinks and shows “0”.



- ▶ Press button *SET* on control unit *External air conditioning system*.
 - ▷ Third PIN number field is selected.
 - ▷ Fourth PIN number field blinks and shows “0”.



- ▶ Press button *SET* on control unit *External air conditioning system*.
 - ▷ Fourth PIN number field is selected.
 - ▷ The menu “[2] Service/[1] Service settings” is shown on the display of control unit *External air conditioning system*:

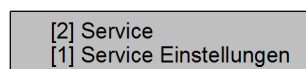


Fig. 2306: Menu [2] Service/[1] Service settings

The following parameters appear:

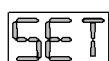
- Top display: [2] Service
- Bottom display: [1] Service settings

The following menus can be selected:

- [1] Service settings
- Error memory
- Exit



- ▶ Press the button *F1* on control unit *External air conditioning system* until the menu “Error memory” is displayed.



- ▶ Press button *SET* on control unit *External air conditioning system*.
 - ▷ The menu “[2] Service/Error memory” is shown on the display of control unit *External air conditioning system*:

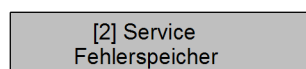
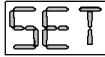


Fig. 2309: Menu [2] Service/Error memory

The following parameters appear:

- Display top line: [2] Service
- Display bottom line: Error memory



▶ Press button *SET* on control unit *External air conditioning system*.

▷ The first error message is shown on the display of control unit *External air conditioning system*:

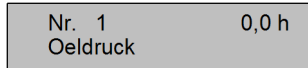


Fig. 2311: First error message

The following parameters appear:

- Display top left: Error number
- Display top right: Operating hour at which the error occurred
- Bottom display: Type of error



▶ Press button *F1* on control unit *External air conditioning system*.

▷ Error messages are displayed in sequence.

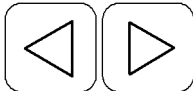
4.7.8 Auxiliary heating*

A heating start time can be preset within a seven day period with control unit *Auxiliary heating*. Three start times can be programmed, however only one can be activated.

The control unit *Auxiliary heating* has an alarm function.

When the ignition is switched on, the clock displays the current time and the day. The display and buttons are illuminated when the heating system is in operation.

All symbols on the display flash after the power supply has been connected. The time and weekday must be set.



The clock has been designed so that all flashing symbols can be set with the button *Back* or with the button *Next*. The displayed time is saved if no button is pressed for a period of five seconds. Time-scrolling is accelerated if either the *Back* or *Next* buttons are pressed for longer than two seconds.

If the ignition is switched off while the heating system is in continuous heating mode, a remaining operating time of 15 minutes is displayed and the heating system remains active.

Switching on auxiliary heating

Switching on auxiliary heating manually



▶ Press the button *Instant heating* on control unit *Auxiliary heating*.

When ignition is switched off:

▷ Auxiliary heating is switched on for programmed duration.

When ignition is switched on:

▷ Permanent auxiliary heating operation is turned on.

Switching on auxiliary heating automatically

▶ Set start of heating ([For more information see: Setting start of heating, page 873](#)).

Switching off auxiliary heating

Switching off auxiliary heating manually



- ▶ Press the button *Instant heating* on control unit *Auxiliary heating*.
 - ▷ Auxiliary heating is turned off.

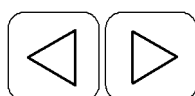
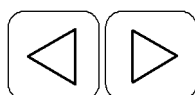
Switching off auxiliary heating automatically

- ▶ Set activation time (For more information see: [Setting the activation time, page 874](#)).

Switching off auxiliary heating using remaining operating time

- ▶ Set remaining operating time (For more information see: [Setting remaining operating time, page 874](#)).

Setting the time and day



- ▶ Press the button *Time* on control unit *Auxiliary heating* for more than two seconds.
 - ▷ Time blinks on the display of control unit *Auxiliary heating*.
- ▶ Set time using *Back* or *Next* buttons.
- ▶ Wait five seconds.
 - ▷ Time is set.
 - ▷ Day blinks on the display of control unit *Auxiliary heating*.
- ▶ Set day using *Back* or *Next* buttons.
- ▶ Wait five seconds.
 - ▷ Day is set.

Calling up time and day

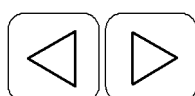
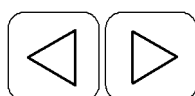
Time and day are always on the display when ignition is switched on.



When ignition is switched off:

- ▶ Press the button *Time* on control unit *Auxiliary heating*.
 - ▷ Time and day are shown on the display of control unit *Auxiliary heating* for five seconds.

Setting start of heating



- ▶ Press the button *Program* on control unit *Auxiliary heating*.
 - ▷ Indicator memory slot1 blinks on the display of control unit *Auxiliary heating*.
- ▶ Set start of heating using *Back* or *Next* buttons.
- ▶ Wait five seconds.
 - ▷ Time is set.
 - ▷ Day blinks on the display of control unit *Auxiliary heating*.
- ▶ Set day using *Back* or *Next* buttons.
- ▶ Wait five seconds.
 - ▷ Day is set.
 - ▷ Indicator memory slot1 is shown on the display of control unit *Auxiliary heating*.

- ▷ Start of heating is set.
- ▶ If required, repeat procedure at indicator memory slot2 and memory slot3.
 - ▷ Start of heating is set.

Displaying or deleting start of heating

Displaying start of heating



- ▶ Press the button *Program* on control unit *Auxiliary heating* until desired memory slot is shown on the display of control unit *Auxiliary heating*.
 - ▷ Start of heating is shown on the display of control unit *Auxiliary heating*.

Deleting start of heating



- ▶ Press the button *Program* on control unit *Auxiliary heating* until no memory slot is shown on the display of control unit *Auxiliary heating*.
 - ▷ Time is shown on the display of control unit *Auxiliary heating*.
 - ▷ Start of heating is deleted.

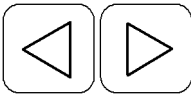
Setting the activation time

Make sure the following prerequisites are met:

- Heater is switched off.



- ▶ Press the button *Back* on control unit *Auxiliary heating* for three seconds.
 - ▷ Activation time blinks on the display of control unit *Auxiliary heating*.



- ▶ Program activation time to between one and 120 minutes using *Back* or *Next* buttons.
- ▶ Wait five seconds.
 - ▷ Activation time is set.

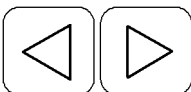
Setting remaining operating time

Make sure the following prerequisites are met:

- Ignition is turned off.
- Heater is switched on.



- ▶ Press the button *Back* on control unit *Auxiliary heating*.
 - ▷ Remaining time blinks on the display of control unit *Auxiliary heating*.



- ▶ Program remaining time to between one and 120 minutes using *Back* or *Next* buttons.
- ▶ Wait five seconds.
 - ▷ Remaining time is set.

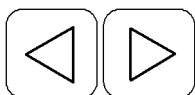
Setting the alarm

The alarm is not linked to any specific day.

The alarm switches itself off after five minutes, or if a button is pressed.



- ▶ Press the button *Program* on control unit *Auxiliary heating* until the bell symbol is shown on the display of control unit *Auxiliary heating*.



- ▶ Set alarm time using *Back* or *Next* buttons.
 - ▷ Alarm time is set.

Displaying or deleting alarm times

Displaying the alarm time



- ▶ Press the button *Program* on control unit *Auxiliary heating* until the bell symbol is shown on the display of control unit *Auxiliary heating*.
 - ▷ Alarm time is shown on the display of control unit *Auxiliary heating*.

Deleting alarm time



- ▶ Press the button *Program* on control unit *Auxiliary heating* until the bell symbol is no longer shown on the display of control unit *Auxiliary heating*.
 - ▷ Alarm time is deleted.

4.8 Additional cab equipment

4.8.1 Using the horn

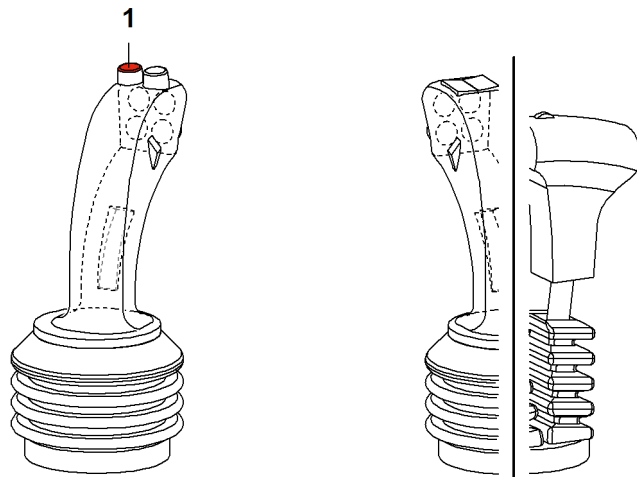


Fig. 2333: Operating the horn

1 Button *Horn*

- ▶ Press the button *Horn* 1 on left multi-directional control lever.
 - ▷ The horn sounds.

4.8.2 Operating the safety lever



WARNING

Drives may still be moving after having been switched off!
 Serious injury.

- ▶ Fold safety lever up only when drives have stopped.

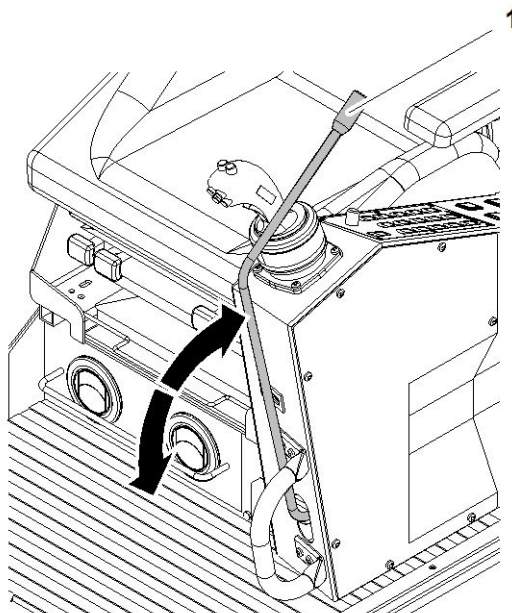


Fig. 2334: Operating the safety lever

1 Safety lever

- ▶ Lift safety lever 1.
 - ▷ This blocks the foot pedals, control lever and buttons.

The safety lever 1 must be lifted in the following situations:

- When leaving the cabin.
- During breaks (even if the machine operator is still in the cabin).
- When reading the operating manual.

- ▶ Lower safety lever 1 for operation.

4.8.3 Operating the radio

Ensure that the following conditions are fulfilled:

- Ignition key is in position “1” or position “P”.

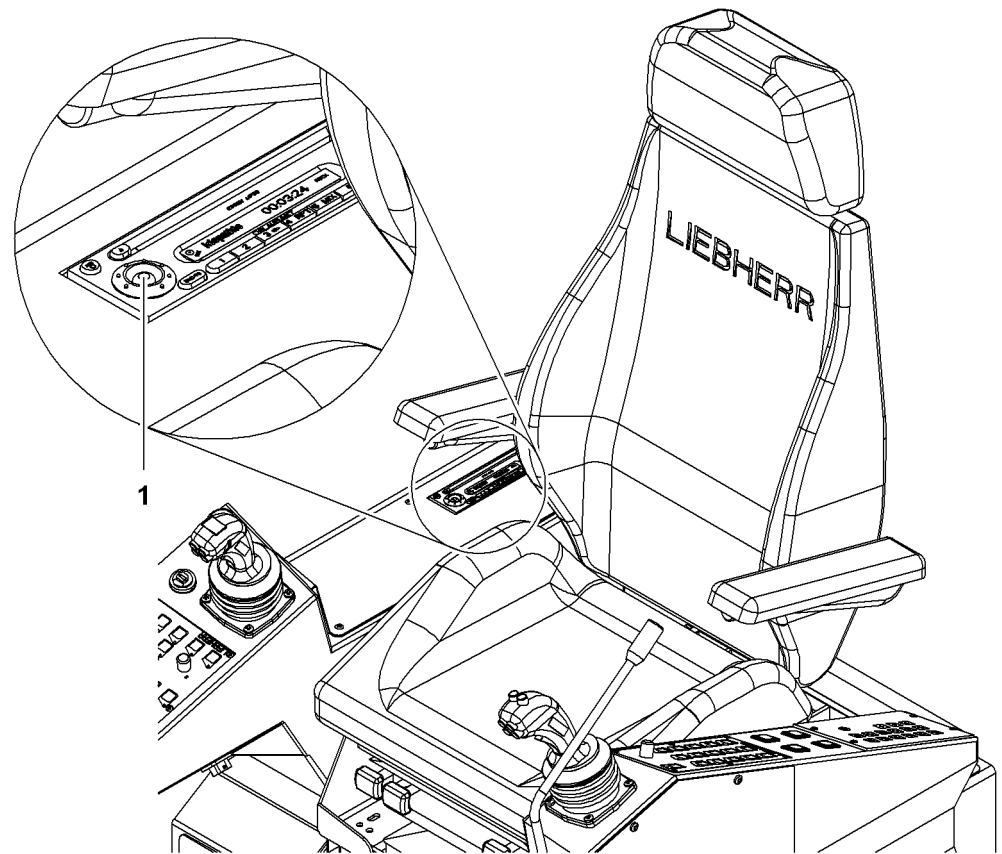


Fig. 2335: Operating the radio

1 Installed radio

► Please refer to the radio 1 operating manual.

4.8.4 Using the ashtray



WARNING

Flammable waste is in the ashtray!
Risk of fire, explosion.

► Do not place any flammable waste in the ashtray.

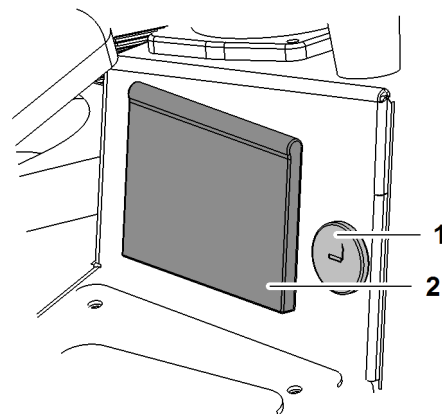


Fig. 2336: Using the ashtray

1 Cigarette lighter

2 Ashtray

- ▶ To use the ashtray **2**, fold it out.
- ▶ To empty the ashtray: lightly press the clip in the middle downwards.

4.8.5 Using the cigarette lighter

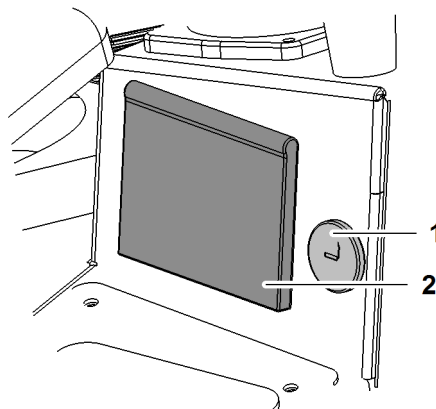


Fig. 2337: Using the cigarette lighter

- 1** Cigarette lighter **2** Ashtray

- ▶ Press the handle of the cigarette lighter **1** until it engages.
 - ▷ After about 1 minute the handle disengages automatically and the surface of the cigarette lighter glows.

4.9 Cab tilting device*

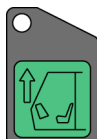


WARNING

Danger if attempting to enter or leave the cab when tilted!
Risk of falling off the uppercarriage.

- ▶ Only enter and leave the cab when it is in a horizontal or lowered position.

4.9.1 Tilting the cabin



- ▶ Press the *Tilt cabin up* button on control panel X11.
 - ▷ The cab can tilt up to a maximum of 20° (20°).



- ▶ Press the *Tilt cabin down* button on control panel X11.
 - ▷ The cab can tilt down to a maximum of 0° (0°).

4.10 Hydraulic cabin elevation*

4.10.1 Adjusting the cabin



WARNING

Incorrect operation of hydraulic cabin elevation system!
Severe injuries, damage to machine.

- ▶ Ensure that only the machine operator is in the cabin.
- ▶ Check the function of all safety devices before adjusting the cabin.
- ▶ Do not move the machine when the cabin is elevated.



WARNING

Personnel or objects underneath the cabin when it is lowered!
Severe injuries, damage to machine.

- ▶ Make sure that no-one is standing in the danger zone.
- ▶ Ensure that there are no objects underneath the cabin.
- ▶ Check the area under the cabin before lowering it.

Ensure that the following conditions are fulfilled:

- Mast is erected and pinned.
- Emergency lowering valves are closed.
- Cabin is in working position.
- Chain guide is removed.
- Chain is pinned to cabin.
- Crane operation is selected.
- Diesel engine is switched on.
- Cylinder adjustment functions are on.
- Safety chain is attached.

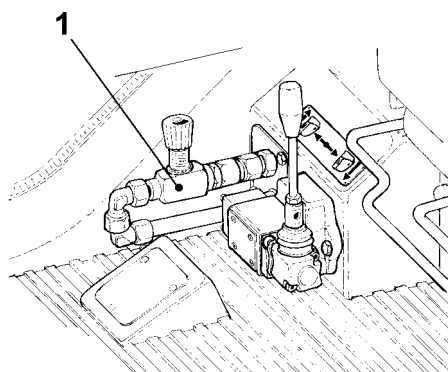


Fig. 2340: Adjusting the cabin

- 1 Emergency lowering valve for cabin

- ▶ Press and hold the button *Raise cabin* on the right control panel.
 - ▷ Cabin moves upwards.





- ▶ Press and hold the button *Lower cabin* on the right control panel.
 - ▷ Cabin moves down.



Note

If cabin can no longer be lowered with the button *Lower cabin*:

- ▶ Lower cabin with emergency lowering valve **1** in cabin or emergency lowering valve on mast.

Abseiling rescue device

If the safety gear of the hydraulic cabin elevation has triggered, the cabin can not longer be adjusted. The machine operator in this instance must abseil down using the abseiling rescue device.

If the cabin can no longer be adjusted:

- ▶ Use abseiling rescue device ([For more information see: 4.42.1 Using abseil rescue equipment, page 1029](#)).
- ▶ Contact Liebherr customer service.

4.11 Central lubrication*

The central swing ring bearing lubrication system lubricates automatically at the programmed lubrication times and break times. The lubrication process is stated when starting the diesel engine and works during the operation of the machine and with lowered safety lever.

The central swing ring tooth flank lubrication system lubricates automatically at the programmed lubrication times and break times. The lubrication process is stated when operating the swing and works during the operation of the machine and with lowered safety lever.

NOTICE

Insufficient lubrication!

the swing ring bearings and/or swing ring tooth flanks may be damaged.

- ▶ Do not exceed the lubrication times and break times set by the factory.

NOTICE

Incorrect adjustment of the positive pressure relief valve!

Central lubrication system may be damaged.

- ▶ Retain manufacturer's settings on the positive pressure relief valve.

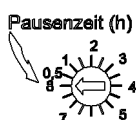
4.11.1 Set lubrication time



The range of adjustment for lubrication time is from 1 to 16 minutes. The factory setting for lubrication time is 2 minutes.

- ▶ Turn the *Set lubrication time* rotary control knob to the desired lubrication time.

4.11.2 Set pause time



The range of adjustment for pause time is from 0.5 to 8 hours. The factory setting for pause time is 1 hour.

- ▶ Turn the *Set pause time* rotary control knob to the desired pause time.

4.11.3 Interim lubrication



- ▶ Press the *Interim lubrication* button.

4.12 Mode

4.12.1 Activating/deactivating assembly functions on or off



- ▶ Press the *Assembly functions* switch on control panel X12.

- ▷ Assembly functions are activated.
- ▷ Symbol *Assembly functions* appears on screen:



Fig. 2347: Symbol *Assembly functions*



- ▶ Press the *Assembly functions* switch on control panel X12 again.

- ▷ Assembly functions are deactivated.
- ▷ The symbol *Assembly functions* disappears on screen.

4.12.2 Selecting the mode

Crane operation is the standard operation mode of the machine. The machine is automatically in crane operation if no assembly mode functions or special mode of operation is selected. The electronic load moment limiter (LML) and all safety devices are activated.

Ensure that the following conditions are fulfilled:

- The machine has been fully set up.
- Tilting-back support cylinders are extended.



- ▶ Press the *Mode* button on the monitor.
- ▷ The *Mode* screen is displayed on the monitor.



- ▶ Press button for desired mode (e.g. crane mode) on the monitor.



- ▶ Press and hold *Mode* button on control panel X12.



- ▶ Press *Confirm* button on the monitor.

- ▶ Let go of the *Mode* button on control panel X12.
- ▷ The symbol *Restart machine* is displayed on the monitor:



Fig. 2353: Symbol Restart machine

- ▶ Turn off the ignition.
- ▶ Start diesel engine after approx. 10 seconds.
 - ▷ Desired mode is selected.

4.13 Programming the setup



DANGER

Unacceptable setup!

Toppling of machine, structural breakdown.

- ▶ Only program a set-up on the machine that is in accordance with the load chart.
- ▶ Re-calculate the setup if there is any change to the setup. This includes changes during operation, (e.g. rope of winch1/winch2, reeving, or change of load position).



Note

The only load chart that is permitted and applicable for operational purposes is the electronic load chart on the machine. The printed load chart and the load chart on the CD are copies of the electronic load chart on the machine.

If the identification numbers and revision numbers of the two load charts do not match:

- ▶ Order new printed/CD versions of the load charts from Liebherr after sales service.

The set-up is retained when the ignition is switched off.

Ensure that you understand what the symbols on the *setup* screen mean ([For more information see: 3.18 Setup screen, page 731](#)).

4.13.1 Call up the *Setup* screen



- ▶ Press the *Setup* button on the monitor.
 - ▷ The *setup* screen with the current configuration appears.

4.13.2 Selecting and changing settings

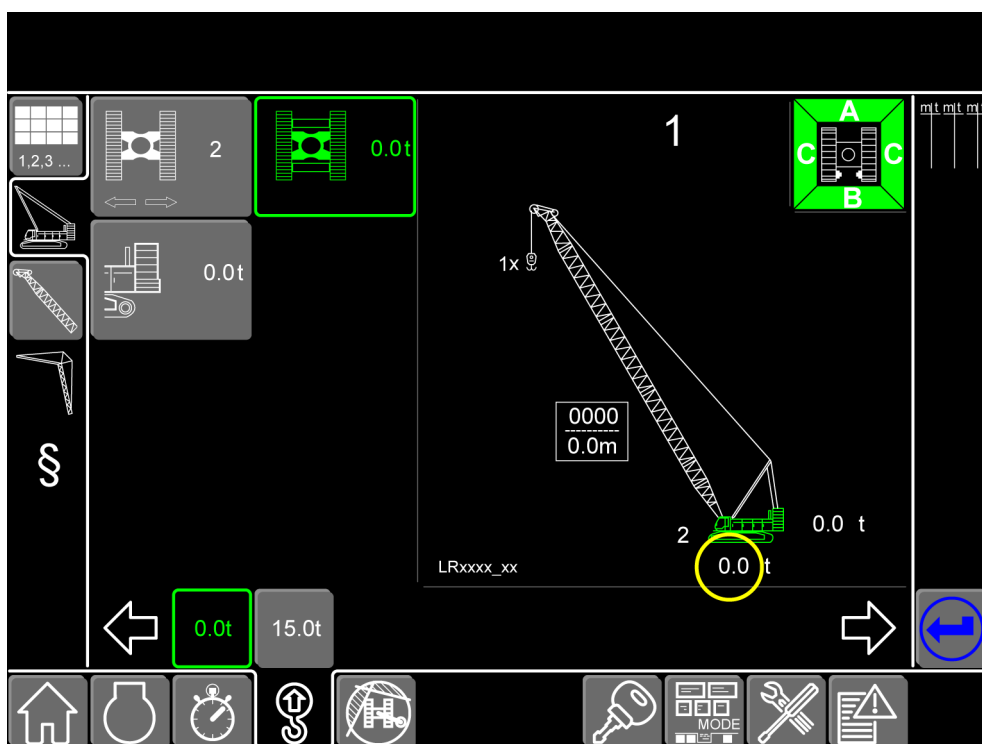
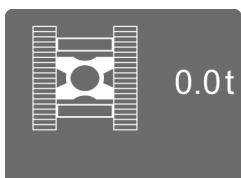


Fig. 2355: Example of a Setup screen



► Press the *Basic machine* button on the monitor.



► Press the button for the desired setting on the monitor.



► Press the *Value* button on the monitor.
 ▷ Selected value is applied.



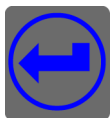
When wanting to switch to the next larger values:
 ► Press the *Higher values* button on the monitor.



When wanting to switch to the next smaller values:
 ► Press the *Lower values* button on the monitor.

4.13.3 Calculating the revised set-up

Do not press any keys during the calculation. This will cancel the calculation.



- ▶ Press the button *Calculate load chart* (lit blue) on the monitor.

- ▷ Calculation starts.
- ▷ During calculation, the *hourglass* symbol appears instead of the *Calculate load chart* button.



Fig. 2362: Hourglass symbol

- ▷ Once the calculation is completed, the symbol *Calculate load chart* appears:



Fig. 2363: Symbol *Calculate load chart*

Troubleshooting

Symbol *Calculate load chart* blinks red?

The entry was incorrect.

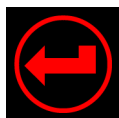


Fig. 2364: Symbol *Calculate load chart* (blinks red)

- ▶ Locate and change wrong input on *setup* screen.
- ▶ Restart the calculation.

4.13.4 Checking the programmed setup



- ▶ Switch to the *Operation* screen: Press the *Mode* button on the monitor.

If the setup was changed:

- ▶ drive one load circle without load.

4.14 Load moment limiter (LML)

4.14.1 General



DANGER

Incorrect procedure!

Machine toppling over, structural breakdown.

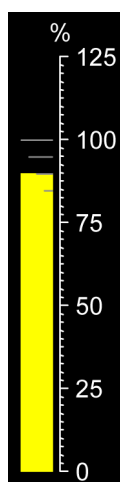
- ▶ Ensure that the machine operator knows the weight of the load, the radius of the boom and the values of the applicable load chart.
- ▶ Work only with permitted values of the load chart.
- ▶ Never use the load moment limiter as a routine way of switching the machine off.

The load moment limiter:

- is an electronic limiter of the load moment.
- is adapted to the application in question through input of the setup.
- when the maximum load moment is reached, stops and prevents all machine movements that could further increase the load moment; it also prevents the “raise main boom” and “raise jib” functions.

The load moment limiter has various information displays:

- Load moment limiter on screen *Operation* on monitor
- Load moment limiter lamps on roof of the cab and on A-frame 1
- Warning buzzer inside the cab
- Load moment limiter signal to warn people in the danger zone around the machine

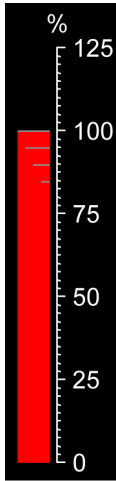


The **90% mark** of the load moment utilization on the *Operation* screen is reached:

- The *Load moment limiter warning* symbol appears on the monitor.
- Load moment limiter lamps light up orange.
- The warning buzzer inside the cabin sounds (interval: short sound, long pause). The warning buzzer can be suppressed after 5 seconds using the *Warning buzzer* button.



Fig. 2367: Symbol Load moment limiter warning (lit yellow)



The **100% mark** of the load moment utilization on the *Operation* screen is reached:

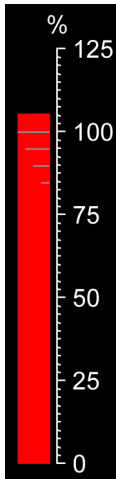
- The *Load moment limiter stop* symbol appears on the monitor.
- The following machine movements are disabled:
 - Raise winch 1.
 - Raise winch 2.
 - Lower the main boom.
 - Lower jib.
 - Lower suspended counterweight.
 - Reduce the wheeled counterweight carriage radius.
 - Raise wheeled counterweight carriage support.
- "Raise main boom" is permitted up to 105% of the maximum permitted load moment.
- "Raise jib" is permitted up to 105% of the maximum permitted load moment.
- Load Moment Limiter lamps light up red.
- The load moment limiter signal sounds.
- The warning buzzer inside the cabin sounds (interval: short sound, short interval). The warning buzzer can be suppressed after 5 seconds using the *Warning buzzer* button.



Fig. 2369: Load moment limiter stop symbol



To circumvent a deadlock, the maximum permitted load moment can be increased by 5% using the *load moment limiter assembly/self-lock* button.

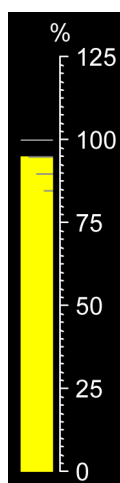


The **105% mark** of the load moment utilization on the *Operation* screen is reached:

- The *Load moment limiter stop* symbol appears on the monitor.
- The following machine movements are disabled:
 - Raise winch 1.
 - Raise winch 2.
 - Lower the main boom.
 - Lower jib.
 - Lower suspended counterweight.
 - Reduce the wheeled counterweight carriage radius.
 - Raise wheeled counterweight carriage support.
- "Raise main boom" is permitted up to 110% of the maximum permitted load moment.
- "Raise jib" is permitted up to 110% of the maximum permitted load moment.
- Load Moment Limiter lamps light up red.
- The load moment limiter signal sounds.
- The warning buzzer inside the cabin sounds (interval: short sound, short interval). The warning buzzer can be suppressed after 5 seconds using the *Warning buzzer* button.



Fig. 2372: Load moment limiter stop symbol

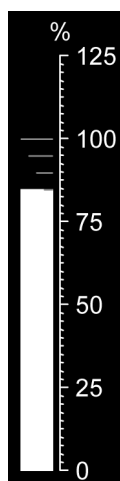


The **95% mark** of the load moment utilization on the *Operation* screen is undercut:

- The *Load moment limiter warning* symbol appears on the monitor.
- Load moment limiter lamps light up orange.
- The warning buzzer inside the cabin sounds (interval: short sound, long pause). The warning buzzer can be suppressed after 5 seconds using the *Warning buzzer* button.



Fig. 2374: Symbol Load moment limiter warning (lit yellow)



The **85% mark** of the load moment utilization on the *Operation* screen is undercut:

- The *Load moment limiter warning* symbol disappears on the monitor.
- Load Moment Limiter lamps light up green.
- Warning buzzer inside the cab falls silent.



Symbol **Danger of toppling backwards** appears on monitor:

- Machine may topple backwards due to insufficient load.
- The “raise main boom” and/or “raise jib” functions are disabled. In an emergency, the function blocks can be disabled using the *load moment limiter shut down* key switch (machines with CE load chart) or the *load moment limiter shut down* button (machines with ANSI load chart).

If the “Load moment limitation self-lock” or “Load moment limitation shut down” function is active, machine data are recorded as specified in the guidelines. A storage medium for this purpose is located in switch cabinet X1. The machine operator is responsible for ensuring that the storage medium is not removed.

4.14.2 Load moment limiter self-lock



DANGER

Inappropriate use of the “Load moment limiter self-lock” function!
Machine toppling over, structural breakdown.

- ▶ Only use the “load moment limiter self-lock” function to enable the machine from a self-lock (Deadlock) situation.



When pressing the button *Load moment limiter assembly/self-blockade* on control panel X23, the load moment limiter decides which function will be activated according to the current machine geometry. If no load chart exists for the current geometry, the “load moment limiter assembly” function is activated ([For more information see: 7 Assembly and dismantling, page 1147](#)). If a load chart exists for the current geometry, the “load moment limiter self-blockade” function is activated.

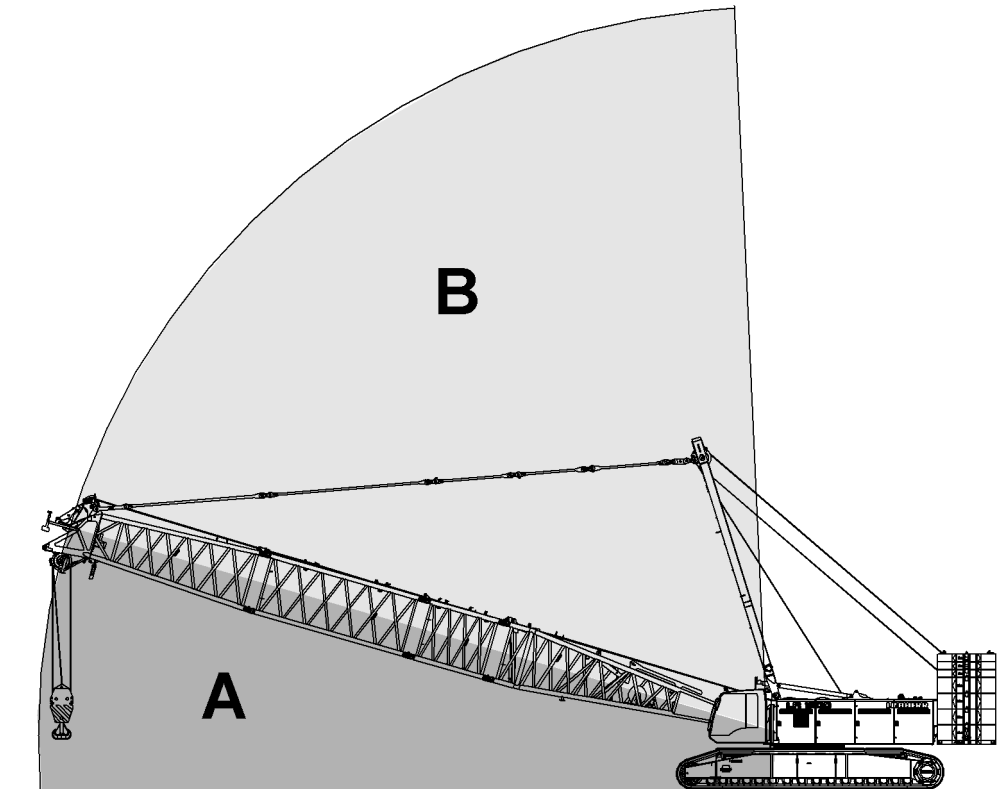


Fig. 2378: Diagram: Geometry of the machine inside and outside the load chart

- | | |
|--|---|
| <p>A Geometry of the machine outside the load chart</p> | <p>B Geometry of the machine inside the load chart</p> |
|--|---|

Example of a self-lock (Deadlock): A load close to the maximum permitted load moment is lowered from a great height. The increasing weight of the rope between the pulley block and the boom head increases the load moment and results in a load moment limiter stop followed by a self-lock, as the following movements are disabled:

- Raise winch 1.
- Raise winch 2.
- Lower the main boom.
- Raise main boom (above 105% utilization).
- Lower jib.

LWNLR-x/V04.01//Auslieferung/2016-03-07/en

- Raise jib (above 105% utilization).
- Lower suspended counterweight.
- Reduce the wheeled counterweight carriage radius.
- Raise wheeled counterweight carriage support.

The “load moment limiter self-blocking” function reenables all movements up to 105% utilization of the maximum permitted load moment (raise main boom/jib up to 110% utilization). The speed of the movements is reduced on machines with a CE load chart.

Ensure that the following conditions are fulfilled:

- Load Moment Limiter is functioning properly.
- Control levers are in zero position.



- ▶ Press the *Load moment limiter assembly/self-lock* button on control panel X23.

There is a load chart for machines geometry:

- ▷ Function “Load moment limiter self-lock” is active.
- ▷ The LED on the button *Load moment limiter assembly/self-lock* lights up.
- ▷ Machine movements up to 105% utilization of the maximum permitted load moment are permitted.
- ▷ “Raise main boom” is permitted up to 110% of the maximum permitted load moment.
- ▷ The speed of the machine movements (raise/lower winch 1, raise/lower winch 2, raise/lower main boom, raise/lower jib, raise/lower auxiliary winch, swing right/left) is reduced to 15%.
- ▷ The speed of the crawler is reduced to 25%.
- ▷ Load Moment Limiter lamps light up orange.
- ▷ The *Load moment limiter warning* symbol appears on the monitor:



Fig. 2380: Symbol Load moment limiter warning (lit yellow)

- ▷ If the machine is using a CE load chart, the *Data recording active* symbol appears on the monitor:

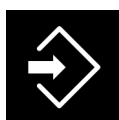


Fig. 2381: Data recording active symbol

The “load moment limiter self-lock” function is deactivated in the following situations:

- There is no load chart for machines geometry.
- Load Moment Limiter is not functioning properly.
- The machine operator does not carry out any machine movements for more than 10 seconds.
- The diesel engine is switched off and 10 seconds have passed.
- The machine operator operates the *load moment limiter shut down* key switch.
- Machine operator presses the button *Load moment limiter assembly/self-blockade* on control panel X23.



- ▶ Press the *Load moment limiter assembly/self-lock* button on control panel X23.
 - ▷ Function “Load moment limiter self-lock” is deactivated.
 - ▷ The LED on the button *Load moment limiter assembly/self-lock* goes out.
 - ▷ Load moment limiter is active.
 - ▷ Load moment limiter lamps light up according to the current status of the Load Moment Limiter system.
 - ▷ If the machine is using a CE load chart, the *Data recording active* symbol disappears on the monitor.

4.14.3 Load moment limiter shut down (CE load chart)

The following description of the “load moment limiter shut down” function applies exclusively to machines with a CE load chart.



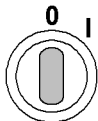
DANGER

Inappropriate use of the “Load moment limiter shut-down” function!
Machine toppling over, structural breakdown.

- ▶ The “load moment limiter shut down” function is to be used exclusively for checking the machine using a test load or when the load moment limiter fails. These checks may only be carried out by specialists from the national, certified testing institute.
- ▶ If the load moment limiter fails, use the “load moment limiter shut down” function to move the machine out of the danger area.

Ensure that the following conditions are fulfilled:

- Diesel engine is switched on.
- Control levers are in zero position.
- ▶ Leave the cab and open the uppercarriage door.
- ▶ Activate the *Load moment limitation shut down* key switch.



- ▷ Load moment limiter is turned off.
- ▷ Any preselection of the button *Load moment limiter assembly/self-blockade* on control panel X23 is deselected.
- ▷ The speed of the machine movements (raise winch 1, raise winch 2, lower main boom, lower jib, raise auxiliary winch) is reduced to 15%.
- ▷ Load Moment Limiter lamps flash red.
- ▷ The load moment limiter signal sounds continuously.
- ▷ The *Load moment limiter off* symbol appears on the monitor:



Fig. 2384: Load moment limiter off symbol

- ▷ The *Data recording active* symbol appears on the monitor:

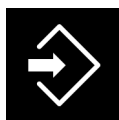


Fig. 2385: Data recording active symbol

The “load moment limiter shut down” function is deactivated in the following situations:

- Diesel engine is switched off.
- 30 minutes have passed since the function was activated and the control levers are in zero position.
- The machine operator operates the *load moment limiter shut down* key switch.
- ▶ Activate the *Load moment limitation shut down* key switch.
 - ▷ Load moment limiter is active.
 - ▷ Load moment limiter lamps light up according to the current status of the Load Moment Limiter system.
 - ▷ Load moment limiter signal sounds according to the current status of the Load Moment Limiter system.
 - ▷ The *Load moment limiter off* symbol disappears on the monitor.
 - ▷ The *Data recording active* symbol disappears on the monitor:

4.14.4 Load moment limiter shut down (ANSI load chart)

The following description of the “load moment limiter shut down” function applies exclusively to machines with an ANSI load chart.



DANGER

Inappropriate use of the “Load moment limiter shut-down” function!
Machine toppling over, structural breakdown.

- ▶ The “load moment limiter shut down” function is to be used exclusively for checking the machine using a test load or when the load moment limiter fails. These checks may only be carried out by specialists from the national, certified testing institute.
- ▶ If the load moment limiter fails, use the “load moment limiter shut down” function to move the machine out of the danger area.

Ensure that the following conditions are fulfilled:

- Diesel engine is switched on.
- Control levers are in zero position.
- ▶ Unlock control panel X12.
- ▶ Press the *Load moment limiter shut down enable* button on control panel X12.
 - ▷ The lamp in the *load moment limiter shut down enable* switch lights up.
 - ▷ The LED on the button *Load moment limiter assembly/self-lock* flashes.
- ▶ Press the *Load moment limiter assembly/self-lock* button on control panel X23.
 - ▷ Load moment limiter is turned off.
 - ▷ The LED on the button *Load moment limiter assembly/self-lock* lights up.
 - ▷ Load Moment Limiter lamps flash red.
 - ▷ The load moment limiter signal sounds continuously.



- ▷ The *Load moment limiter off* symbol appears on the monitor:



Fig. 2388: *Load moment limiter off* symbol

The “load moment limiter shut down” function is deactivated in the following situations:

- The machine operator actuates the safety lever.
- Machine operator presses the button *Load moment limiter assembly/self-blockade* on control panel X23.



- ▶ Press the *Load moment limiter assembly/self-lock* button on control panel X23.
 - ▷ The LED on the button *Load moment limiter assembly/self-lock* flashes.
 - ▷ Load moment limiter is active.
 - ▷ Load moment limiter lamps light up according to the current status of the Load Moment Limiter system.
 - ▷ Load moment limiter signal sounds according to the current status of the Load Moment Limiter system.
 - ▷ The *Load moment limiter off* symbol disappears on the monitor.



- ▶ Press the *Load moment limiter shut down enable* button on control panel X12.
 - ▷ Load Moment Limiter lamps go out.
 - ▷ The lamp in the *load moment limiter shut down enable* switch goes out.
- ▶ Lock control panel X12 and remove the key.
- ▶ Ensure that the key is kept by an authorized person outside of the cab.

4.15 Calculating load charts online

The Litronic control system simulates load charts for any setup online. The currently selected setup is used for the calculation.

Depending on the specified setup and load position, additional values will be required.

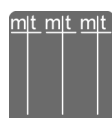
No additional values need to be entered for boom configurations 1, 2 and 3.

With boom configuration 4, 5 and 9, a load chart can only be calculated for one main boom angle (alpha). The main boom angle must be entered manually prior to calculation.

4.15.1 Calculating load charts



- ▶ Press the *Setup* button on the monitor.
 - ▷ The *Setup* screen appears on the monitor.



- ▶ Press the *Load chart* button on the monitor.
 - ▷ The *Setup - load chart* screen appears on the monitor.

- ▶ Press input field on the monitor.
 - ▷ Input field selected.



- ▶ Increasing the value in selected input field by +1: press the *Increase value +1* button on the monitor.



- ▶ Increasing the value in selected input field by +0.1: press the *Increase value +0.1* button on the monitor.



- ▶ Decreasing the value in selected input field by -0.1: press the *Decrease value -0.1* button on the monitor.



- ▶ Decreasing the value in selected input field by -1: press the *Decrease value -1* button on the monitor.

- ▶ Press input field on the monitor again.
 - ▷ Input confirmed.

- ▶ Repeat the process until all the values have been entered.



- ▶ Press the *Load chart* button on the monitor.
 - ▷ Calculation starts.
 - ▷ The load chart with the calculated values is displayed.

4.15.2 Boom configuration 4 - load position 1

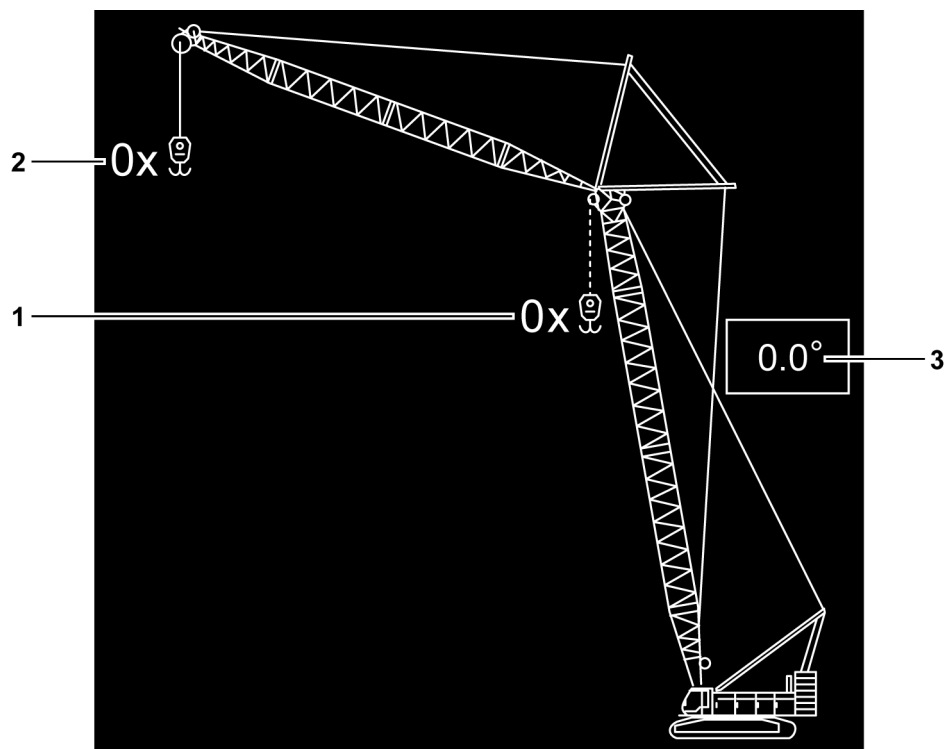


Fig. 2398: Boom configuration 4 - load position 1

- 1 Reeving load position 2 (main boom head).
- 2 Reeving load position 1 (jib head).
- 3 Main boom angle (alpha)

When calling up the screen *Load chart* in boom configuration 4 with load position 1, the screen for entering the main boom angle (Alpha) 3 appears.

4.15.3 Boom configuration 4 - load position 2

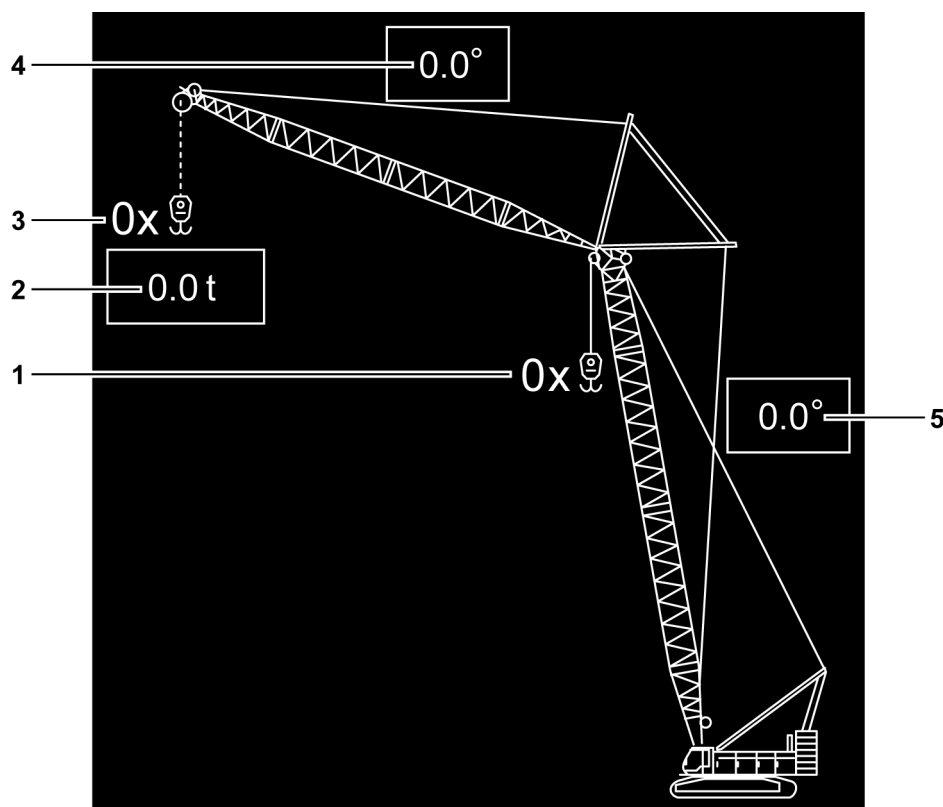


Fig. 2399: Boom configuration 4 - load position 2

- | | | | |
|---|---|---|-------------------------|
| 1 | Reeving load position 2 (main boom head). | 4 | Jib angle (alpha) |
| 2 | Load on load position 1 (jib head). | 5 | Main boom angle (alpha) |
| 3 | Reeving load position 1 (jib head). | | |

When calling up the screen *Load chart* in boom configuration 4 with load position 2, a screen for entering the main boom angle (alpha) **5**, the jib angle (beta) **4** and the load in load position 1 (jib head) **2** appears.

The permitted values for load on load position 1 (jib head) **2** can be found in the foreword to the valid load chart.

4.15.4 Boom configuration 5 - load position 1

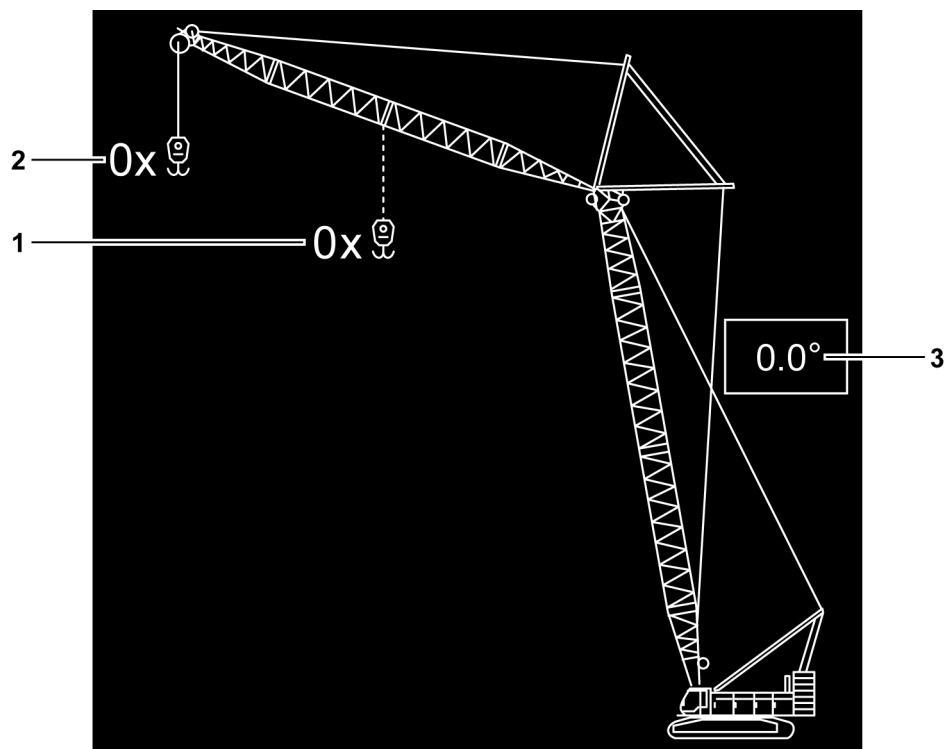


Fig. 2400: Boom configuration 5 - load position 1

- 1 Reeving load position 3 (midfall) 3 Main boom angle (alpha)
- 2 Reeving load position 1 (jib head).

When calling up the screen *Load chart* in boom configuration 5 with load position 1, the screen for entering the main boom angle (Alpha) 3 appears.

4.15.5 Boom configuration 5 - load position 3

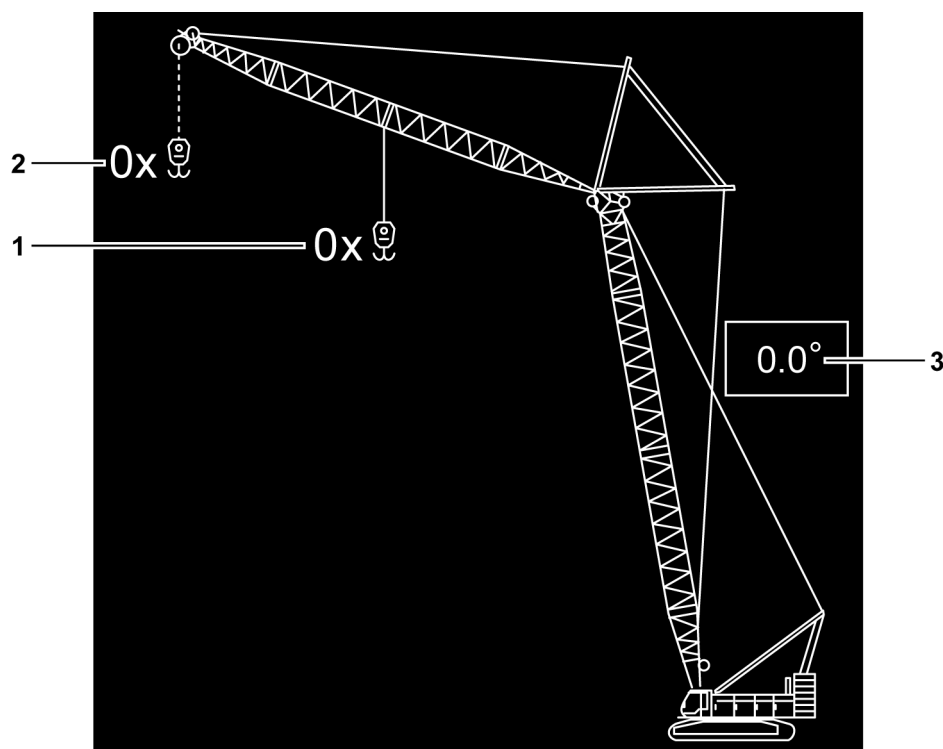


Fig. 2401: Boom configuration 5 - load position 3

- | | | | |
|---|-------------------------------------|---|-------------------------|
| 1 | Reeving load position 3 (midfall) | 3 | Main boom angle (alpha) |
| 2 | Reeving load position 1 (jib head). | | |

When calling up the screen *Load chart* in boom configuration 5 with load position 3, the screen for entering the main boom angle (Alpha) 3 appears.

4.15.6 Boom configuration 6 - load position 2

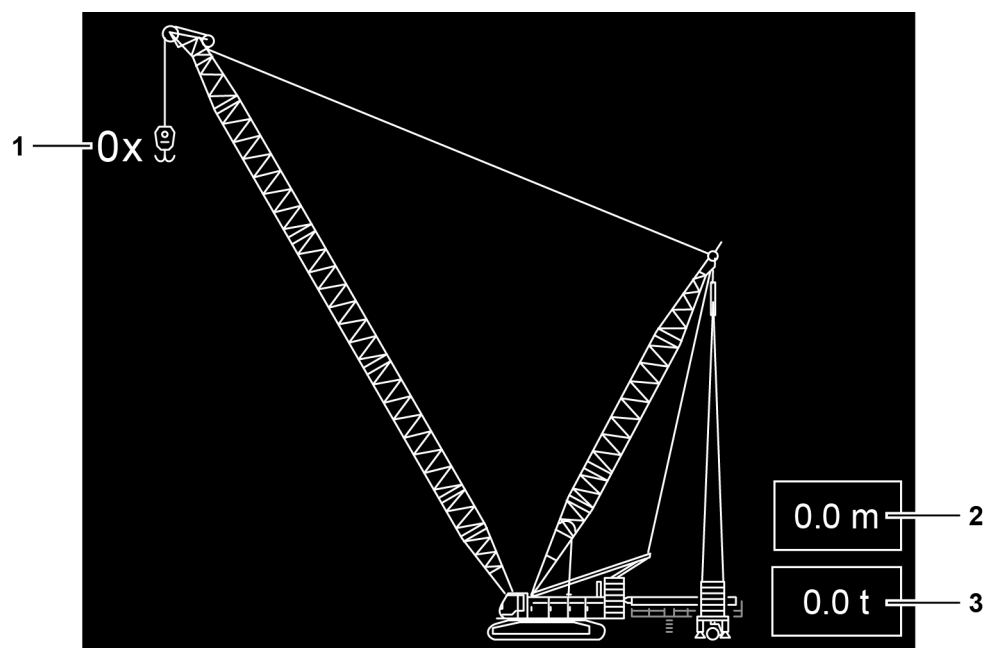


Fig. 2402: Boom configuration 6 - load position 2

- | | |
|---|---------------------------------|
| <p>1 Reeving load position 2 (main boom head)</p> <p>2 Radius of counterweight carriage</p> | <p>3 Weight on derrick boom</p> |
|---|---------------------------------|

When calling up the screen *load chart* in boom configuration 6 with load position 2, a screen appears for entering the radius of counterweight carriage **2** and the weight on the derrick boom **3**.

The admissible values are stated in the valid load chart.

4.15.7 Boom configuration 8 - load position 1

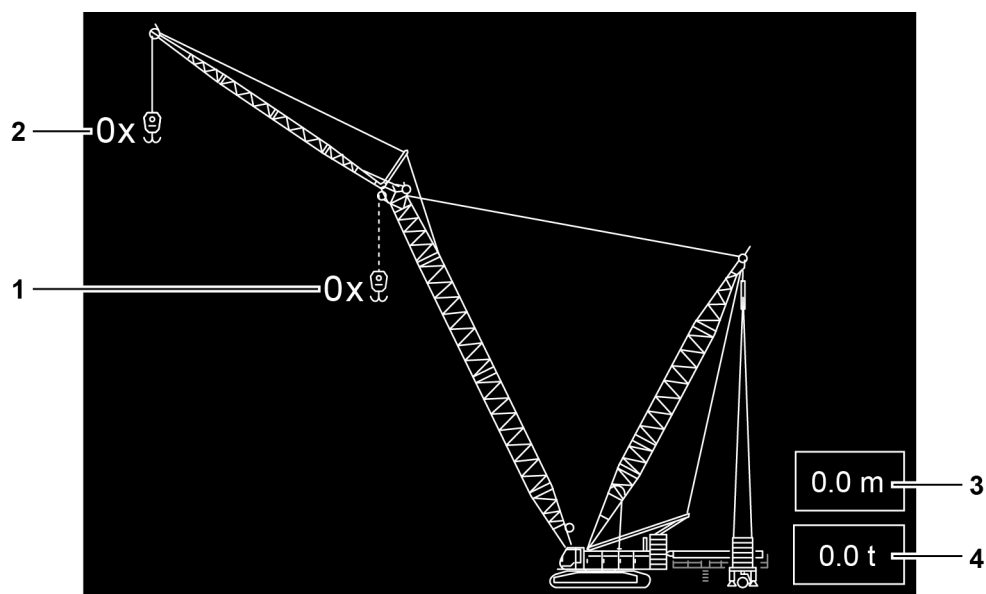


Fig. 2403: Boom configuration 8 - load position 1

- | | | | |
|---|--|---|----------------------------------|
| 1 | Reeving load position 2 (main boom head) | 3 | Radius of counterweight carriage |
| 2 | Reeving load position 1 (jib head) | 4 | Weight on derrick boom |

When calling up the screen *load chart* in boom configuration 8 with load position 1, a screen appears for entering the radius of counterweight carriage **3** and the weight on the derrick boom **4**.

The admissible values are stated in the valid load chart.

4.15.8 Boom configuration 8 - load position 2

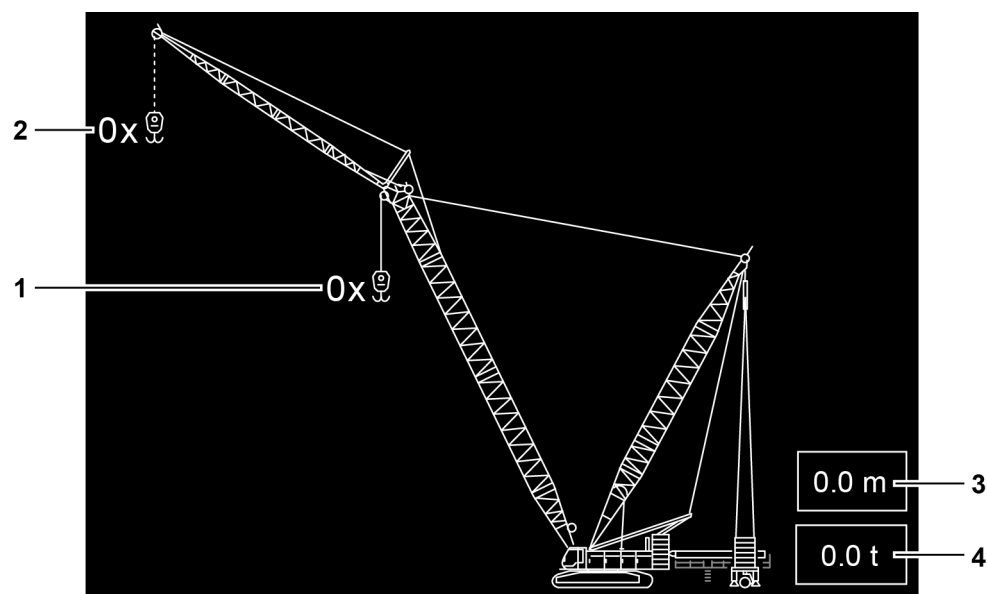


Fig. 2404: Boom configuration 8 - load position 2

- | | | | |
|---|--|---|----------------------------------|
| 1 | Reeving load position 2 (main boom head) | 3 | Radius of counterweight carriage |
| 2 | Reeving load position 1 (jib head) | 4 | Weight on derrick boom |

When calling up the screen *load chart* in boom configuration 8 with load position 2, a screen appears for entering the radius of counterweight carriage **3** and the weight on the derrick boom **4**.

The admissible values are stated in the valid load chart.

4.15.9 Boom configuration 9 - load position 1

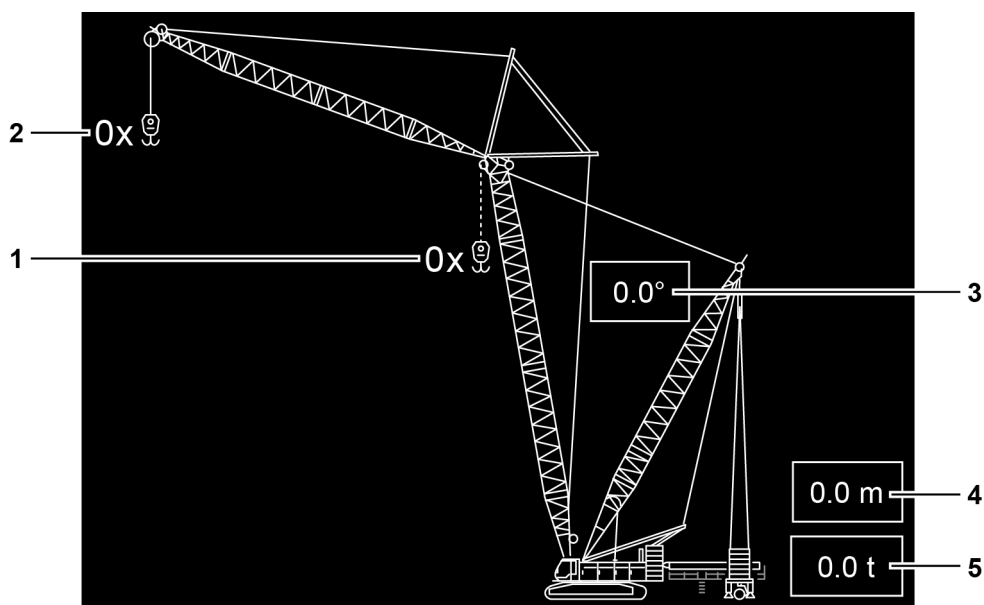


Fig. 2405: Boom configuration 9 - load position 1

- | | | | |
|---|--|---|----------------------------------|
| 1 | Reeving load position 2 (main boom head) | 4 | Radius of counterweight carriage |
| 2 | Reeving load position 1 (jib head) | 5 | Weight on derrick boom |
| 3 | Main boom angle (alpha) | | |

When calling up the screen *Load chart* in boom configuration 9 with load position 1, a screen appears for entering the main boom angle (alpha) **3**, the radius of the counterweight carriage **4** and the weight on the derrick boom **5**.

The admissible values for the radius of the counterweight carriage **4** and the weight on the derrick boom **5** are stated in the valid load chart.

4.15.10 Boom configuration 9 - load position 2

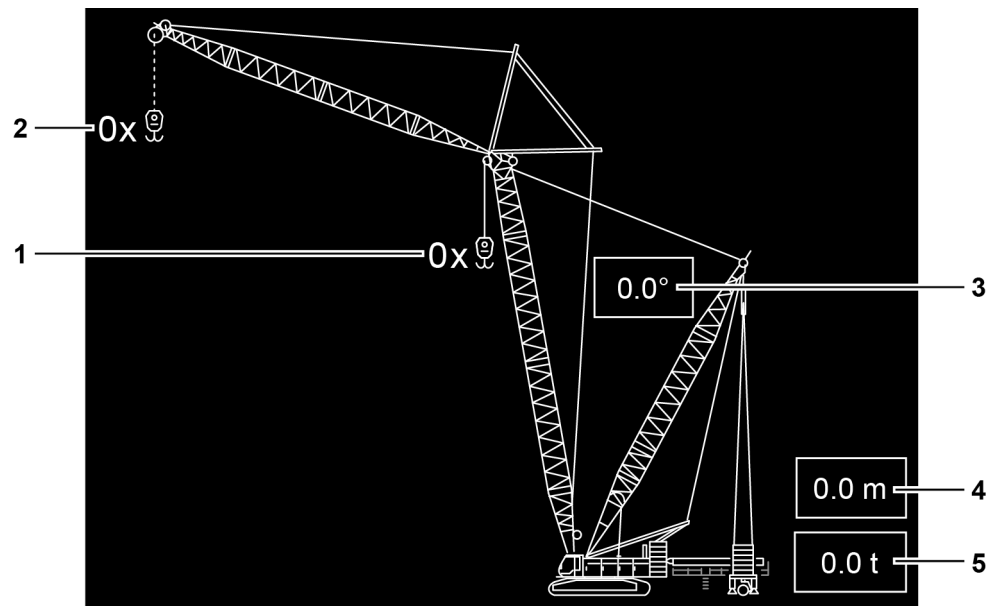


Fig. 2406: Boom configuration 9 - load position 2

- | | | | |
|---|--|---|----------------------------------|
| 1 | Reeving load position 2 (main boom head) | 4 | Radius of counterweight carriage |
| 2 | Reeving load position 1 (jib head) | 5 | Weight on derrick boom |
| 3 | Main boom angle (alpha) | | |

When calling up the screen *Load chart* in boom configuration 9 with load position 2, a screen appears for entering the main boom angle (alpha) **3**, the radius of the counterweight carriage **4** and the weight on the derrick boom **5**.

The admissible values for the radius of the counterweight carriage **4** and the weight on the derrick boom **5** are stated in the valid load chart.

4.16 Set the load capacity display to zero (taring)

During taring the weight of winch1 and winch2 rope and of the pulley block is set to zero so that only the actual weight of the hoisting load is displayed.

Load taring:

- can be done at any time.
- is best done just before slinging the load.

4.16.1 Setting the load display of winch1 or winch2 to zero



- ▶ Press the *Settings* button on the monitor.



- ▶ Press the *Set to zero* button at winch1 or winch2 for more than 1 second on the monitor.
 - ▷ Load display shows zero.



- ▶ Press the *Reset load display* button at winch1 or winch2 for more than 1 second on the monitor.
 - ▷ Load display shows total load.

4.17 Single hook operation/two-hook operation

The following hook operations are permitted:

- Single hook operation
- Twin hook operation

In single hook operation, only one hook/pulley block may be moved at any given time. In two-hook operation, two hooks/pulley blocks may be moved at the same time.

Single hook operation is permitted in the following versions:

- Single-hook mode with one winch on one hook
- Single-hook mode with two winches on one hook
- Single-hook mode with two winches on two hooks

Two-hook operation is permitted in the following versions:

- Twin-hook mode with two hooks on two loads
- Twin-hook mode with two hooks on one load

All the permitted hook operations are demonstrated on the diagrams below.



WARNING

Using an unauthorised hook operation!
Severe injuries, damage to machine.

- ▶ Only use authorised hook operations.



DANGER

Improper reeving of winch1 or winch2 rope!
Structural breakdown, load breakaway.

- ▶ Reeve the rope according to the rope reeving system.

If a deviation from the rope reeving systems is necessary or no rope reeving system is available:

- ▶ Ensure that the selected rope reeving system loads the boom head and entire boom symmetrically.
- ▶ Make sure that winch1 or winch2 rope do not contact anywhere.
- ▶ Make sure that the diagonal pull of the winch1 or winch2 rope do not exceed 2°.
- ▶ Ensure that the pulley blocks/hooks do not collide.
- ▶ Fit the hoist limit switch weight for winch1 on the winch1 rope.
- ▶ Fit the hoist limit switch weight for winch2 on the winch2 rope.
- ▶ It is preferable to fit the hoist limit switch weight when the rope is stationary.
- ▶ Ensure that the hoist limit switch chains do not cross over.
- ▶ Ensure that the hoist limit switch chains do not touch at any point.
- ▶ Only ever bypass unused hoist limit switches.

For special loads, the appropriate rope reeving systems may be obtained from Liebherr after sales service **exclusively on providing the following information:**

- Machine type
- Serial number
- Full details of the boom configuration and counterweight in place
- Details of the pulley block/hook in use

– A detailed description of the work to be carried out

Notes on the diagrams and symbols used

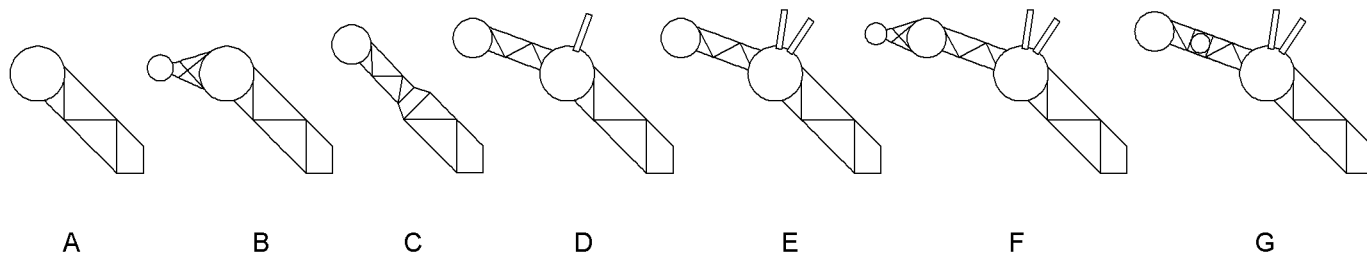
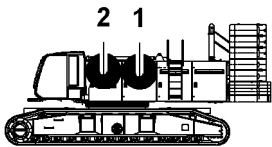


Fig. 2410: Diagram of the boom configurations

- A** Main boom
- B** Main boom with auxiliary jib attached
- C** Main boom + reducing piece
- D** Main boom + fixed jib
- E** Main boom + luffing jib
- F** Main boom + luffing jib with auxiliary jib attached
- G** Main boom + luffing jib + Midfall

Symbol	Meaning
1 ②	<p>The numbers 1 or 2 denote winch1 or winch2 rope.</p>  <p>The circle marks the rope of winch1 or winch2 whose reeving must be preselected when programming the setup.</p>
①=②	Select reeving of winch1 or winch2 rope when programming the setup. Rope reeving is symmetrical.
①+②	Select total reeving of winch1 and winch2 rope when programming the setup.
①②	Select the lower reeving when programming the setup.
●	Select the relevant reeving with this boom head/load position.
┆	Empty hook
┆ ■	Load
┆ □	Empty hook with specified dead weight
┆ ┆ ■	Twin-hook mode with two hooks on one load
┆ ┆ ┆ ■	Single-hook mode with two winches on one hook
Directional instructions are given from the machine operator's point of view in the cabin.	

Tab. 375: Meaning of the symbols

LWNLR-x/V04.01//Auslieferung/2016-03-07/en

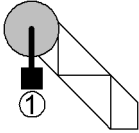
4.17.1 Single-hook mode with one winch on one hook

Ensure that the following conditions are fulfilled:

- Only winch1 rope is reeved.

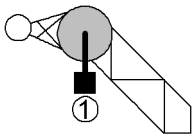
Main boom

Load on boom head section (winch1 rope)



- ▶ Reeve winch1 rope on the boom head section.
- ▶ Select main boom head.
- ▶ Select reeving of winch1 rope at main boom head.

Load on boom head section (winch1 rope) with auxiliary jib attached



No load chart exists for this configuration. The static moment of the auxiliary jib reduces the valid lifting capacities of the main boom.

The auxiliary jib falsifies the load display on the *Operation* screen. The load moment limiter switches off at the maximum permitted load moment.

- ▶ Reeve winch1 rope on the boom head section.
- ▶ Select main boom head.
- ▶ Select reeving of winch1 rope at main boom head.
- ▶ Calculate the reduced lifting capacity before every lifting operation.

For a rough calculation of the reduced lifting capacity with auxiliary jib attached (36 t (79300 lb)):

$$SWL_{RED} = SWL_{HPT} - 1000 \text{ kg (2,205 lb)}$$

SWL_{RED} = reduced lifting capacity for hoisting with the boom head section

SWL_{HPT} = lifting capacity for hoisting with the boom head section according to the load chart

To precisely calculate the reduced lifting capacity:

$$SWL_{RED} = \frac{SWL_{HPT} * (R_{HPT} - X) - (SWL_{SP} + m_{SP}) * (R_{HPT} - X + R_{SP})}{(R_{HPT} - X)}$$

Fig. 2424: How to calculate the reduced load

SWL_{RED} = reduced lifting capacity for hoisting with the boom head section

SWL_{HPT} = maximum lifting capacity for main boom from the load chart at R_{HPT}

R_{HPT} = radius of the main boom

X = Distance between rotation axis and main boom pivot point

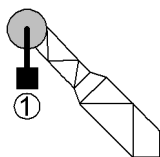
SWL_{SP} = Load on auxiliary jib (in this case no weight)

m_{SP} = weight of the auxiliary jib

R_{SP} = Radius enlargement through auxiliary jib

- ▶ Note the reductions in the valid lifting capacities due to the auxiliary jib attached.

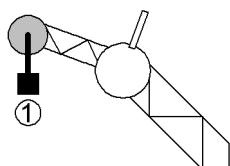
Main boom + reducing piece



Load on boom head section (winch1 rope)

- ▶ Reeve winch1 rope on the boom head section.
- ▶ Select main boom head.
- ▶ Select reeving of winch1 rope at main boom head.

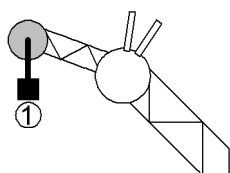
Main boom + fixed jib



Load on jib head section (winch1 rope)

- ▶ Reeve winch1 rope on jib head section.
- ▶ Select reeving of winch1 rope at jib head.
- ▶ Select load position 1 (jib head).

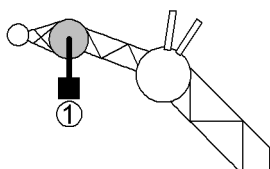
Main boom + luffing jib



Load on jib head section (winch1 rope)

- ▶ Reeve winch1 rope on jib head section.
- ▶ Select reeving of winch1 rope at jib head.
- ▶ Select load position 1 (jib head).

Load on jib head section (winch1 rope) with auxiliary jib attached



No load chart exists for this configuration. The static moment of the auxiliary jib reduces the valid lifting capacities of the jib.

The auxiliary jib falsifies the load display on the *Operation* screen. The load moment limiter switches off at the maximum permitted load moment.

- ▶ Reeve winch1 rope on jib head section.
- ▶ Select reeving of winch1 rope at jib head.
- ▶ Select load position 1 (jib head).
- ▶ Calculate the reduced lifting capacity before every lifting operation.

For a rough calculation of the reduced lifting capacity with auxiliary jib attached (30 t (66.000 lb)):

$$SWL_{RED} = SWL_{NDL} - 500 \text{ kg (1,102 lb)}$$

For a rough calculation of the reduced lifting capacity with auxiliary jib attached (15 t (33.000 lb)):

$$SWL_{RED} = SWL_{NDL} - 400 \text{ kg (882 lb)}$$

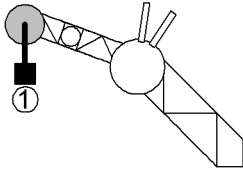
SWL_{RED} = reduced lifting capacity for hoisting with the jib head section

SWL_{NDL} = lifting capacity for hoisting with the jib head section according to the load chart

- ▶ Note the reductions in the valid lifting capacities due to the auxiliary jib attached.

Main boom + luffing jib + Midfall

Load on jib head section (winch1 rope)



- ▶ Reeve winch1 rope on jib head section.
- ▶ Select reeving of winch1 rope at jib head.
- ▶ Select load position 1 (jib head).

4.17.2 Single-hook mode with two winches on one hook

With long main booms and multiple reeving, the winch1 or winch2 rope may become too short. Under certain circumstances it is permitted for winch1 and winch2 rope to be reeved via the boom head section or the jib head section 1507 on a single hook.

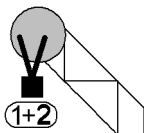


DANGER

Wrong procedure in single-hook mode with two winches on one hook!
Structural failure, load breakaway.

- ▶ Use ropes of the same length and quality for winch1 and winch2.
- ▶ Winch1 and winch2 ropes must only be reeved in accordance with the rope reeving diagrams.
- ▶ Winch1 and winch2 ropes must only be reeved on a pulley block.
- ▶ Select the total of winch1 and winch2 rope reeving with the main boom head or jib head.
- ▶ Activate winch synchronization on control panel X23.

Load on main boom head (winch1 and winch2 rope)



- ▶ Winch1 and winch2 ropes must only be reeved in accordance with the rope reeving diagrams.
- ▶ Select main boom head.
- ▶ Select total reeving of winch1 and winch2 rope at main boom head.
- ▶ In order to obtain an accurate rope measuring system value on the *Operation* screen: adjust reeving of winch2 rope to the actual number of reeves of winch2 rope (For more information see: 4.31 Rope measuring system*, page 997) .

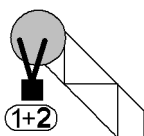


Note

The value displayed by the rope measuring system for winch1 is incorrect!

- ▶ Pay attention only to the value displayed by the rope measuring system for winch 2.

Load on jib head 1507 (winch1 and winch2 rope)



- ▶ Winch1 and winch2 ropes must only be reeved in accordance with the rope reeving diagrams.
- ▶ Select 1507 jib head.
- ▶ Select total reeving of winch1 and winch2 rope at jib head 1507.

- ▶ In order to obtain an accurate rope length measurement value on the *Operation* screen: adjust reeving of winch2 rope to the actual number of reeves of winch2 rope (For more information see: 4.31 Rope measuring system*, page 997) .

**Note**

The value displayed by the rope measuring system for winch1 is incorrect!

- ▶ Pay attention only to the value displayed by the rope measuring system for winch 2.

4.17.3 Single-hook mode with two winches on two hooks

With single-hook mode with two winches on two loads, winch1 rope and winch2 rope are reeved. However, the load is moved with one rope only. The second rope stands still.

The ropes may be reeved in a non-symmetrical manner.

**DANGER**

Wrong procedure in single-hook mode with two winches on two hooks!
Structural failure, load breakaway.

- ▶ Only move the load using one rope.
- ▶ Only move with one rope at any given time.

If the load is moved with the other rope or the load position changes:

- ▶ Reprogram the setup.

**DANGER**

Maximum permissible lifting capacity is exceeded!
Risk of machine toppling over, structural breakdown.

- ▶ Take into account all relevant weights as the total load.
- ▶ Do not exceed the maximum permitted lifting capacity.

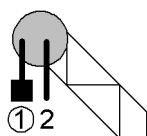
The total load consists of:

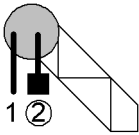
- the weight of the load to be lifted
- Weight of both hooks or pulley blocks
- The weight of all suspended ropes
- The weight of the load pick-up equipment
- Weight of the auxiliary jib (if attached)

Main boom

Load on boom head section (winch1 rope)

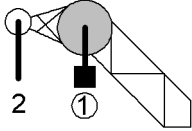
- ▶ Reeve winch1 rope on the boom head section.
- ▶ Reeve winch2 rope on the boom head section.
- ▶ Select main boom head.
- ▶ Select reeving of winch1 rope at main boom head.





Load on boom head section (winch2 rope)

- ▶ Reeve winch1 rope on the boom head section.
- ▶ Reeve winch2 rope on the boom head section.
- ▶ Select main boom head.
- ▶ Select reeving of winch2 rope at main boom head.



Load on boom head section (winch1 rope)

No load chart exists for this configuration. The static moment of the auxiliary jib reduces the valid lifting capacities of the main boom.

The auxiliary jib falsifies the load display on the *Operation* screen. The load moment limiter switches off at the maximum permitted load moment.

- ▶ Reeve winch1 rope on the boom head section.
- ▶ Guide the left winch2 rope over the boom head section and reeve onto the auxiliary jib.
- ▶ Select main boom head.
- ▶ Select reeving of winch1 rope at main boom head.
- ▶ Calculate the reduced lifting capacity before every lifting operation.

For a rough calculation of the reduced lifting capacity at auxiliary jib attached (36 t (79300 lb)) and empty hook with 600 kg (1,323 lb):

$$SWL_{RED} = SWL_{HPT} - 2000 \text{ kg (4,409 lb)}$$

For a rough calculation of the reduced lifting capacity at auxiliary jib attached (36 t (79300 lb)) and empty hook with 1500 kg (3,307 lb):

$$SWL_{RED} = SWL_{HPT} - 3250 \text{ kg (7,165 lb)}$$

SWL_{RED} = reduced lifting capacity for hoisting with the boom head section

SWL_{HPT} = lifting capacity for hoisting with the boom head section according to the load chart

To precisely calculate the reduced lifting capacity:

$$SWL_{RED} = \frac{SWL_{HPT} * (R_{HPT} - X) - (SWL_{SP} + m_{SP}) * (R_{HPT} - X + R_{SP})}{(R_{HPT} - X)}$$

Fig. 2435: How to calculate the reduced load

SWL_{RED} = reduced lifting capacity for hoisting with the boom head section

SWL_{HPT} = maximum lifting capacity for main boom from the load chart at R_{HPT}

R_{HPT} = radius of the main boom

X = Distance between rotation axis and main boom pivot point

SWL_{SP} = Load on auxiliary jib (in this case the empty hook weight)

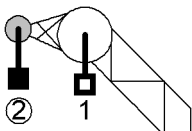
m_{SP} = weight of the auxiliary jib

R_{SP} = Radius enlargement through auxiliary jib

- ▶ Note the reductions in the valid lifting capacities due to the auxiliary jib attached.

Load on auxiliary jib (winch2 rope)

- ▶ Reeve winch1 rope on the boom head section.
- ▶ Guide the left winch2 rope over the boom head section and reeve onto the auxiliary jib.
- ▶ Select auxiliary jib.



- ▶ Select reeving of winch2 rope at auxiliary jib.



CAUTION

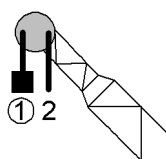
Empty hook weight on the boom head section is not permitted!
Incorrect load display. The Load Moment Limiter switches off at the maximum permitted load moment.

- ▶ Keep to the specified empty hook weight on the main boom head stipulated in the foreword to the valid load chart.

- ▶ Keep to the specified empty hook weight on the main boom head stipulated in the foreword to the valid load chart.

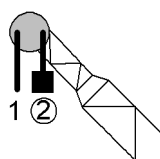
Main boom + reducing piece

Load on main boom head (winch1 rope)



- ▶ Reeve winch1 rope on the boom head section.
- ▶ Reeve winch2 rope on the boom head section.
- ▶ Select main boom head.
- ▶ Select reeving of winch1 rope at main boom head.

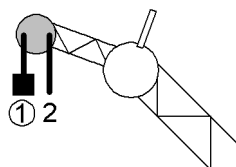
Load on boom head section (winch2 rope)



- ▶ Reeve winch1 rope on the boom head section.
- ▶ Reeve winch2 rope on the boom head section.
- ▶ Select main boom head.
- ▶ Select reeving of winch2 rope at main boom head.

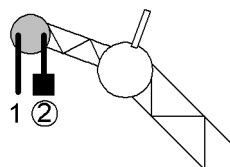
Main boom + fixed jib

Load on jib head section (winch1 rope)



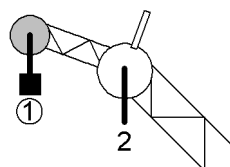
- ▶ Reeve winch1 rope on jib head section.
- ▶ Reeve winch2 rope on jib head section.
- ▶ Select reeving of winch1 rope at jib head.
- ▶ Select load position 1 (jib head).

Load on jib head section (winch2 rope)



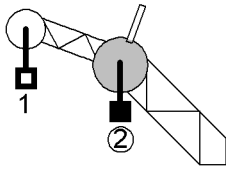
- ▶ Reeve winch1 rope on jib head section.
- ▶ Reeve winch2 rope on jib head section.
- ▶ Select reeving of winch2 rope at jib head.
- ▶ Select load position 1 (jib head).

Load on jib head section (winch1 rope)



- ▶ Reeve winch1 rope on jib head section.
- ▶ Reeve winch2 rope on the boom head section.
- ▶ Select reeving of winch1 rope at jib head.
- ▶ Select load position 1 (jib head).

LWNLR.x/V04.01//Auslieferung/2016-03-07/en



Load on boom head section (winch2 rope)

- ▶ Reeve winch1 rope on jib head section.
- ▶ Reeve winch2 rope on the boom head section.
- ▶ Select reeving of winch2 rope at main boom head.
- ▶ Select load position 2 (main boom head).



CAUTION

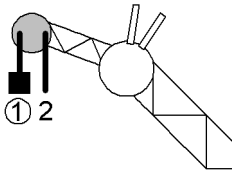
Empty hook weight at load position 1 (jib head section) is not permitted! Incorrect load display. The Load Moment Limiter switches off at the maximum permitted load moment.

- ▶ Keep to the specified empty hook weight at load position 1 (jib head) stipulated in the foreword to the load chart.
- ▶ Ensure that the empty hook weight does not exceed the jib lifting capacity.
- ▶ Ensure that the empty hook weight is more than the permitted minimum weight of the pulley block/hook (For more information see: [6.4 Choosing the correct hook or pulley block, page 1073](#)).

- ▶ Keep to the specified empty hook weight at load position 1 (jib head) stipulated in the foreword to the load chart.
 - ▷ Winch1 is locked.

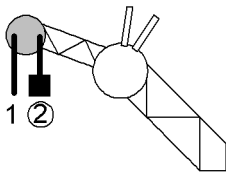
Main boom + luffing jib

Load on jib head section (winch1 rope)



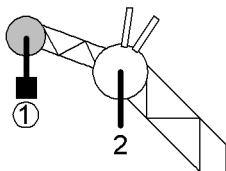
- ▶ Reeve winch1 rope on jib head section.
- ▶ Reeve winch2 rope on jib head section.
- ▶ Select reeving of winch1 rope at jib head.
- ▶ Select load position 1 (jib head).

Load on jib head section (winch2 rope)

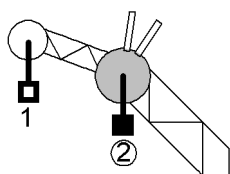


- ▶ Reeve winch1 rope on jib head section.
- ▶ Reeve winch2 rope on jib head section.
- ▶ Select reeving of winch2 rope at jib head.
- ▶ Select load position 1 (jib head).

Load on jib head section (winch1 rope)



- ▶ Reeve winch1 rope on jib head section.
- ▶ Reeve winch2 rope on the boom head section.
- ▶ Select reeving of winch1 rope at jib head.
- ▶ Select load position 1 (jib head).



Load on boom head section (winch2 rope)

- ▶ Reeve winch1 rope on jib head section.
- ▶ Reeve winch2 rope on the boom head section.
- ▶ Select reeving of winch2 rope at main boom head.
- ▶ Select load position 2 (main boom head).



CAUTION

Exceeding of admissible empty hook weight on load position 1 (jib head)!
The Load Moment Limiter switches off at the maximum permitted load moment.

- ▶ Do not exceed the specified empty hook weight at load position 1 (jib head) stipulated in the foreword to the load chart.
- ▶ Ensure that the empty hook weight does not exceed the jib lifting capacity.
- ▶ Ensure that the empty hook weight is more than the permitted minimum weight of the pulley block/hook (For more information see: 6.4 Choosing the correct hook or pulley block, page 1073) .

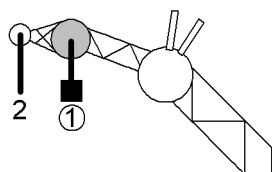
- ▶ Do not exceed the specified empty hook weight at load position 1 (jib head) stipulated in the foreword to the load chart.



Note

- ▶ To maximise the valid lifting capacities for hoisting using the main boom: raise the luffing jib to the maximum angle.

Load on jib head section (winch1 rope) with auxiliary jib attached



No load chart exists for this configuration. The static moment of the auxiliary jib including the empty hook reduces the valid lifting capacities of the jib.

The auxiliary jib including the empty hook falsify the load display on the *Operation* screen. The load moment limiter switches off at the maximum permitted load moment.

- ▶ Reeve winch1 rope on jib head section.
- ▶ Guide the left winch2 rope over the jib head section and reeve onto the auxiliary jib.
- ▶ Select reeving of winch1 rope at jib head.
- ▶ Select load position 1 (jib head).
- ▶ Calculate the reduced lifting capacity before every lifting operation.

For a rough calculation of the reduced lifting capacity at auxiliary jib attached (30 t (66.000 lb)) and empty hook with 900 kg (1,984 lb):

$$SWL_{RED} = SWL_{NDL} - 1400 \text{ kg (3,086 lb)}$$

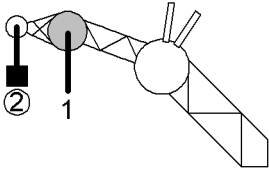
For a rough calculation of the reduced lifting capacity at auxiliary jib attached (15 t (33.000 lb)) and empty hook with 600 kg (1,323 lb):

$$SWL_{RED} = SWL_{NDL} - 1100 \text{ kg (2,425 lb)}$$

SWL_{RED} = reduced lifting capacity for hoisting with the jib head section

SWL_{NDL} = lifting capacity for hoisting with the jib head section according to the load chart

- ▶ Note the reductions in the valid lifting capacities due to the auxiliary jib attached.



Load on auxiliary jib (winch2 rope)

No load chart exists for this configuration. The static moment of the auxiliary jib and the empty hook reduce the valid lifting capacities of the jib.

The auxiliary jib and the empty hook falsify the load display on the *Operation* screen. The load moment limiter switches off at the maximum permitted load moment.

The auxiliary jib falsifies the radius display on the *Operation* screen. The auxiliary jib falsifies the lifting height display on the *Operation* screen.

- ▶ Reeve winch1 rope on jib head section.
- ▶ Guide the left winch2 rope over the jib head section and reeve onto the auxiliary jib.
- ▶ Select reeving of winch2 rope at jib head.
- ▶ Select load position 1 (jib head).
- ▶ Calculate the reduced lifting capacity before every lifting operation.

For a rough calculation of the reduced lifting capacity with auxiliary jib attached (30 t (66.000 lb)):

$$SWL_{RED} = SWL_{NDL} - 500 \text{ kg (1,102 lb)}$$

For a rough calculation of the reduced lifting capacity with auxiliary jib attached (15 t (33.000 lb)):

$$SWL_{RED} = SWL_{NDL} - 400 \text{ kg (882 lb)}$$

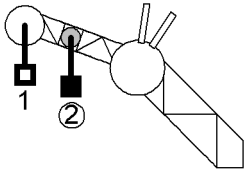
SWL_{RED} = reduced lifting capacity for hoisting with the auxiliary jib

SWL_{NDL} = lifting capacity for hoisting with the jib head section according to the load chart

- ▶ Note the reductions in the valid lifting capacities due to the auxiliary jib attached.

Main boom + luffing jib + Midfall

Load on midfall (winch2 rope)



- ▶ Reeve winch1 rope on jib head section.
- ▶ Reeve winch2 rope on midfall.
- ▶ Select reeving of winch2 rope at midfall.
- ▶ Select load position 3 (midfall).



CAUTION

Empty hook weight at load position 1 (jib head section) is not permitted! Incorrect load display. The Load Moment Limiter switches off at the maximum permitted load moment.

- ▶ Keep to the specified empty hook weight at load position 1 (jib head) stipulated in the foreword to the load chart.
- ▶ Ensure that the empty hook weight does not exceed the jib lifting capacity.
- ▶ Ensure that the empty hook weight is more than the permitted minimum weight of the pulley block/hook (For more information see: [6.4 Choosing the correct hook or pulley block, page 1073](#)).

- ▶ Do not exceed the specified empty hook weight at load position 1 (jib head) stipulated in the foreword to the load chart.

▷ Winch1 is locked.

4.17.4 Twin-hook mode with two hooks on two loads

Twin-hook mode with two hooks on two loads represents the principle of main hoist + auxiliary hoist.



DANGER

Maximum permissible lifting capacity is exceeded!
Structural breakdown, toppling of machine.

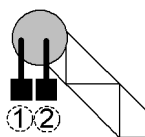
- ▶ Take into account all relevant weights as the total load.
- ▶ Do not exceed the maximum permitted lifting capacity.

The total load consists of:

- Weight of the loads to be lifted
- Weight of both hooks or pulley blocks
- The weight of all suspended ropes
- The weight of the load pick-up equipment
- Weight of the auxiliary jib (if attached)

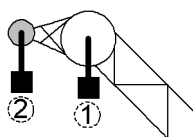
Main boom

Load on boom head section (winch1 rope) + load on boom head section (winch2 rope)



- ▶ Reeve winch1 rope on the boom head section.
- ▶ Reeve winch2 rope on the boom head section.
- ▶ Select main boom head.
- ▶ Select lower reeving of the two ropes at the main boom head.

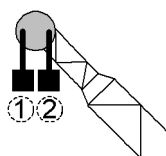
Load on boom head section (winch1 rope) + load on auxiliary jib (winch2 rope)



- ▶ Reeve winch1 rope on the boom head section.
- ▶ Guide the left winch2 rope over the boom head section and reeve onto the auxiliary jib.
- ▶ Select auxiliary jib.
- ▶ Select lower reeving of the two ropes at the auxiliary jib.

Main boom + reducing piece

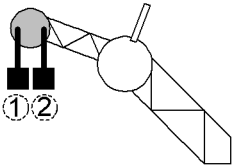
Load on boom head section (winch1 rope) + load on boom head section (winch2 rope)



- ▶ Reeve winch1 rope on the boom head section.
- ▶ Reeve winch2 rope on the boom head section.
- ▶ Select main boom head.
- ▶ Select lower reeving of the two ropes at the main boom head.

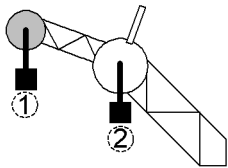
Main boom + fixed jib

Load on jib head section (winch1 rope) + load on jib head section (winch2 rope)



- ▶ Reeve winch1 rope on jib head section.
- ▶ Reeve winch2 rope on jib head section.
- ▶ Select lower reeving of the two ropes at the jib head.
- ▶ Select load position 1 (jib head).

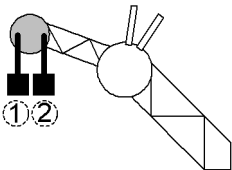
Load on jib head section (winch1 rope) + load on main boom head section (winch2 rope)



- ▶ Reeve winch1 rope on jib head section.
- ▶ Reeve winch2 rope on the boom head section.
- ▶ Select lower reeving of the two ropes at the jib head.
- ▶ Select load position 1 (jib head).

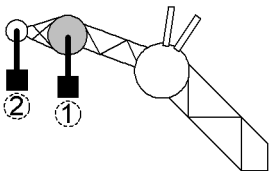
Main boom + luffing jib

Load on jib head section (winch1 rope) + load on jib head section (winch2 rope)



- ▶ Reeve winch1 rope on jib head section.
- ▶ Reeve winch2 rope on jib head section.
- ▶ Select lower reeving of the two ropes at the jib head.
- ▶ Select load position 1 (jib head).

Load on jib head section (winch1 rope) + load on auxiliary jib (winch2 rope)



No load chart exists for this configuration. The static moment of the auxiliary jib reduces the valid lifting capacities of the jib.

The auxiliary jib falsifies the load display on the *Operation* screen. The load moment limiter switches off at the maximum permitted load moment.

The auxiliary jib falsifies the radius display on the *Operation* screen. The auxiliary jib falsifies the lifting height display on the *Operation* screen.

- ▶ Reeve winch1 rope on jib head section.
- ▶ Guide the left winch2 rope over the boom head section and reeve onto the auxiliary jib.
- ▶ Select lower reeving of the two ropes at the jib head.
- ▶ Select load position 1 (jib head).
- ▶ Calculate the reduced lifting capacity before every lifting operation.

For a rough calculation of the reduced lifting capacity at auxiliary jib attached (30 t (66.000 lb)) and empty hook with 600 kg (1,323 lb):

$$SWL_{RED} = SWL_{NDL} - 900 \text{ kg (1,984 lb)}$$

For a rough calculation of the reduced lifting capacity at auxiliary jib attached (15 t (33.000 lb)) and empty hook with 600 kg (1,323 lb):

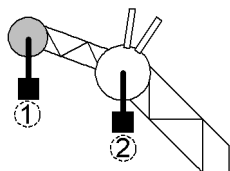
$$SWL_{RED} = SWL_{NDL} - 800 \text{ kg (1,764 lb)}$$

SWL_{RED} = reduced lifting capacity for hoisting with the jib head section

SWL_{NDL} = lifting capacity for hoisting with the jib head section according to the load chart

- ▶ Note the reductions in the valid lifting capacities due to the auxiliary jib attached.

Load on jib head section (winch1 rope) + load on main boom head section (winch2 rope)



- ▶ Reeve winch1 rope on jib head section.
- ▶ Reeve winch2 rope on the boom head section.
- ▶ Select lower reeving of the two ropes at the jib head.
- ▶ Select load position 1 (jib head).

4.17.5 Twin-hook mode with two hooks on one load

Twin-hook mode moves a load using two hooks. Twin-hook mode falsifies the load display on the *Operation* screen. The load moment limiter switches off at the maximum permitted load moment.

Two hooks on one load is admissible.

Moving two hooks at the same time is admissible.

Winch synchronisation is permitted.



DANGER

Wrong procedure in twin-hook mode with two hooks on one load!

- ▶ Avoid longitudinal diagonal pull.
- ▶ Do not exceed maximum lateral diagonal pull of 1 %.
- ▶ Ensure that the load can be raised by the two hooks in unison.

If both ropes are reeved at the same boom head/load position:

- ▶ Reeve the ropes symmetrically.

If both ropes are reeved at the different boom heads/load positions:

- ▶ Reeve both ropes at least as often as has been selected on the relevant boom head/load position.

If winch synchronisation is used:

- ▶ Activate winch synchronization on control panel X23.



DANGER

Maximum permissible lifting capacity is exceeded!

Risk of machine toppling over, structural breakdown.

- ▶ Take into account all relevant weights as the total load.
- ▶ Do not exceed the maximum permitted lifting capacity.

The total load consists of:

- the weight of the load to be lifted
- Weight of both hooks or pulley blocks
- The weight of all suspended ropes
- The weight of the load pick-up equipment
- Weight of the auxiliary jib (if attached)

Swinging the load when load is on different boom heads/load positions



DANGER

Wrong procedure swinging the load in twin-hook mode!
Risk of machine toppling over, structural breakdown.

- ▶ The load must only be swung in the direction that most reduces the load moment.

Ensure that the following conditions are fulfilled:

- The load with the largest radius is suspended on the boom head/load position.

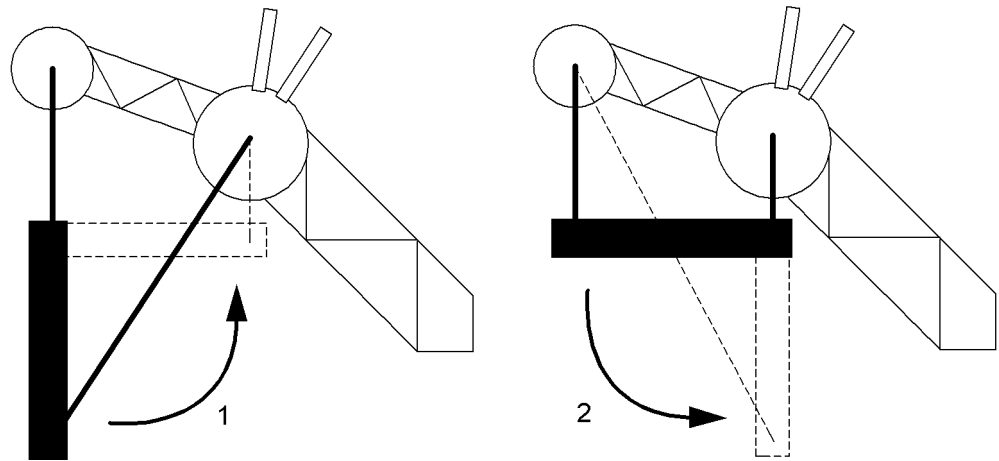


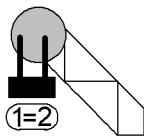
Fig. 2458: Diagram of the swinging process with the lowest load moment

- | | |
|---|---|
| <p>1 Swinging the load towards the basic machine</p> | <p>2 Swinging the load towards the basic machine</p> |
|---|---|

- ▶ Only swing the load towards the basic machine.
 - ▷ The load moment is reduced.

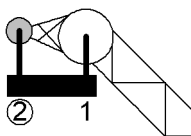
Main boom

Load on boom head section (winch1 and winch2 rope)



- ▶ Reeve winch1 rope on the boom head section.
- ▶ Reeve winch2 rope on the boom head section.
- ▶ Reeve winch2 rope as often as winch1 rope.
- ▶ Select main boom head.
- ▶ Select reeving of winch1 rope (= reeving of winch2 rope) at main boom head.
- ▶ Activate winch synchronization on control panel X23 if required.

Load on boom head section (winch1 rope) + auxiliary jib (winch2 rope)

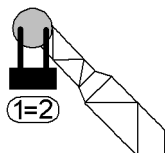


- ▶ Reeve winch1 rope on the boom head section.
- ▶ Guide the left winch2 rope over the boom head section and reeve onto the auxiliary jib.
- ▶ Reeve winch1 rope at the boom head section at least as often as winch2 rope on the auxiliary jib.

- ▶ Select auxiliary jib.
- ▶ Select reeving of winch2 rope at auxiliary jib.
- ▶ Activate winch synchronization on control panel X23 if required.

Main boom + reducing piece

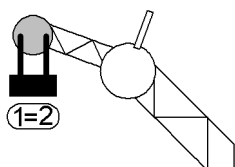
Load on boom head section (winch1 and winch2 rope)



- ▶ Reeve winch1 rope on the boom head section.
- ▶ Reeve winch2 rope on the boom head section.
- ▶ Reeve winch2 rope as often as winch1 rope.
- ▶ Select main boom head.
- ▶ Select reeving of winch1 rope (= reeving of winch2 rope) at main boom head.
- ▶ Activate winch synchronization on control panel X23 if required.

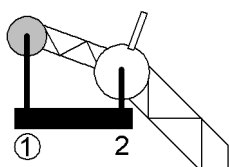
Main boom + fixed jib

Load on jib head section (winch1 and winch2 rope)



- ▶ Reeve winch1 rope on jib head section.
- ▶ Reeve winch2 rope on jib head section.
- ▶ Reeve winch2 rope as often as winch1 rope.
- ▶ Select reeving of winch1 rope (= reeving of winch2 rope) at jib head.
- ▶ Select load position 1 (jib head).
- ▶ Activate winch synchronization on control panel X23 if required.

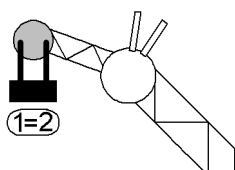
Load on jib head section (winch1 rope) + on main boom head section (winch2 rope)



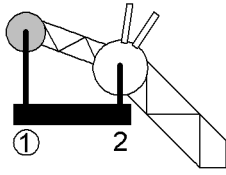
- ▶ Reeve winch1 rope on jib head section.
- ▶ Reeve winch2 rope on the boom head section.
- ▶ Reeve winch2 rope at the boom head section at least as often as winch2 rope on the jib head section.
- ▶ Select load position 1 (jib head).
- ▶ Select reeving of winch1 rope at jib head.
- ▶ Activate winch synchronization on control panel X23 if required.

Main boom + luffing jib

Load on jib head section (winch1 and winch2 rope)

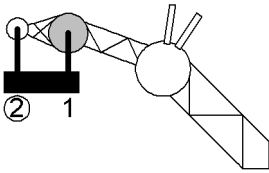


- ▶ Reeve winch1 rope on jib head section.
- ▶ Reeve winch2 rope on jib head section.
- ▶ Reeve winch2 rope as often as winch1 rope.
- ▶ Select reeving of winch1 rope (= reeving of winch2 rope) at jib head.
- ▶ Select load position 1 (jib head).
- ▶ Activate winch synchronization on control panel X23 if required.



Load on jib head section (winch1 rope) + on main boom head section (winch2 rope)

- ▶ Reeve winch1 rope on jib head section.
- ▶ Reeve winch2 rope on the boom head section.
- ▶ Reeve winch2 rope at the boom head section at least as often as winch2 rope on the jib head section.
- ▶ Select load position 1 (jib head).
- ▶ Select reeving of winch1 rope at jib head.
- ▶ Activate winch synchronization on control panel X23 if required.



Load on jib head section (winch1 rope) + auxiliary jib (winch2 rope)

No load chart exists for this configuration. The static moment of the auxiliary jib reduces the valid lifting capacities of the jib.

The auxiliary jib falsifies the load display on the *Operation* screen. The load moment limiter switches off at the maximum permitted load moment.

The auxiliary jib falsifies the radius display on the *Operation* screen. The auxiliary jib falsifies the lifting height display on the *Operation* screen.

- ▶ Reeve winch1 rope on jib head section.
- ▶ Guide the left winch2 rope over the jib head section and reeve onto the auxiliary jib.
- ▶ Reeve winch1 rope at the jib head section at least as often as winch2 rope on the auxiliary jib.
- ▶ Select reeving of winch2 rope at jib head.
- ▶ Select load position 1 (jib head).
- ▶ Activate winch synchronization on control panel X23 if required.
- ▶ Calculate the reduced lifting capacity before every lifting operation.

For a rough calculation of the reduced lifting capacity at auxiliary jib attached (30 t (66.000 lb)) and empty hook with 900 kg (1,984 lb):

$$SWL_{RED} = SWL_{NDL} - 1400 \text{ kg (3,086 lb)}$$

For a rough calculation of the reduced lifting capacity at auxiliary jib attached (15 t (33.000 lb)) and empty hook with 600 kg (1,323 lb):

$$SWL_{RED} = SWL_{NDL} - 1100 \text{ kg (2,425 lb)}$$

SWL_{RED} = reduced lifting capacity for hoisting with the jib head section

SWL_{NDL} = lifting capacity for hoisting with the jib head section according to the load chart

- ▶ Note the reductions in the valid lifting capacities due to the auxiliary jib attached.

4.18 Crawlers

4.18.1 Setting the crawler speed

The crawlers can be operated in normal gear or overdrive. In overdrive, the speed can be continuously controlled from 0 to 1.5 km/h (1 mph) using the crawler pedals.



- ▶ Press the *Crawler overdrive* button on control panel X11.
 - ▷ Crawler overdrive selected.
 - ▷ The LED in the *Crawler overdrive* button lights up.
- ▶ Press the *Crawler overdrive* button on control panel X11 again.
 - ▷ Normal crawler gear selected.
 - ▷ The LED in the *Crawler overdrive* button goes off.

4.18.2 Operating the travel gear



DANGER

Ground load-bearing capacity is not known!
Machine toppling over.

- ▶ Only travel on ground where the load-bearing capacity is known.
- ▶ If in doubt, contact Liebherr after sales service.



WARNING

Areas that the operator cannot see when moving!
Severe injuries, damage to machine.

- ▶ Do not drive on areas that the driver cannot see without the aid of a signalman.



DANGER

Incorrect traveling of machine on gradients!
Toppling of machine.

- ▶ Observe restrictions when traveling on gradients .



Note

Stated movement directions apply exclusively if the crawler drives (tumblers) of the crawler side frames are at the rear!

Reverse driving (idler wheel in the rear, tumbler in the front) causes significantly higher wear due to the higher chain tension.

- ▶ Pay attention to the direction of travel.

Driving with a load on the boom is allowed exclusively with reduced lifting capacity. This reduced lifting capacity is shown in the foreword to the load chart.

Hand levers are be screwed onto the foot pedals (inside). The hand levers are operated in the same way as the foot pedals.

Make sure the following prerequisites are met:

- Suspended counterweight (if available) is lifted.

Moving the machine forward

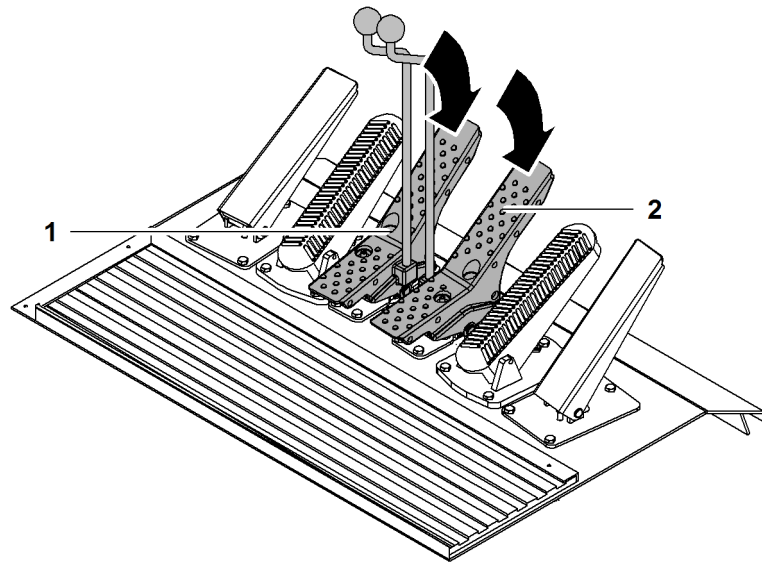


Fig. 2468: Moving the machine forward

1 Foot pedal for *left crawler*

2 Foot pedal for *right crawler*

- ▶ Press foot pedal *left crawler 1* and foot pedal *right crawler 2* forward at the same time.
 - ▷ A movement buzzer sounds.
 - ▷ Machine moves forward:

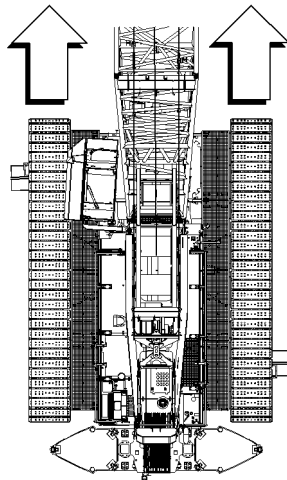


Fig. 2469: Machine moves forward

Moving the machine backwards

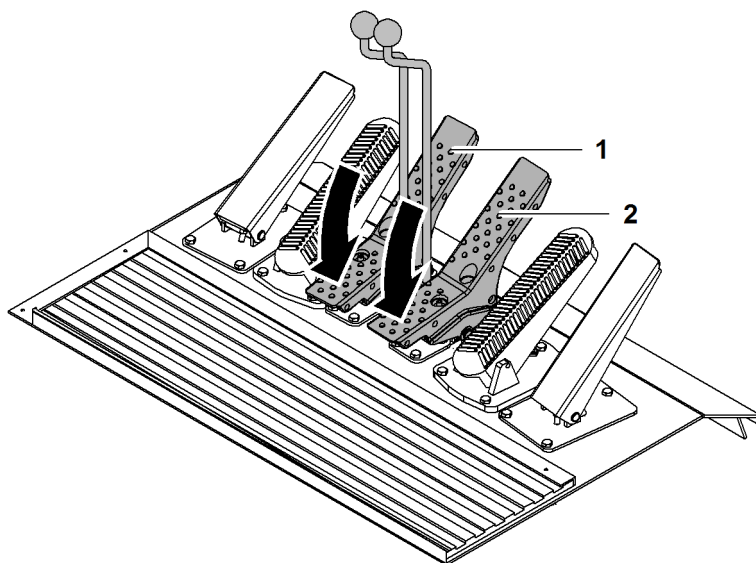


Fig. 2470: Moving the machine backwards

1 Foot pedal for *left crawler* 2 Foot pedal for *right crawler*

- ▶ Press foot pedal *left crawler 1* and foot pedal *left crawler 2* backward at the same time.
 - ▷ A movement buzzer sounds.
 - ▷ Machine moves backward:

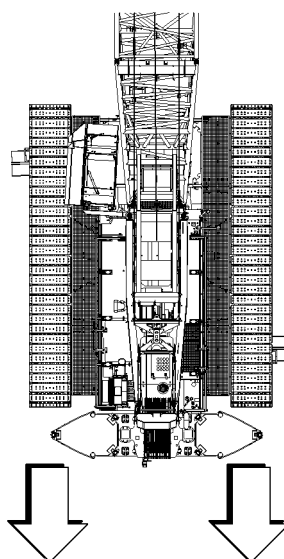


Fig. 2471: Machine moves backward

Swinging the machine to the left

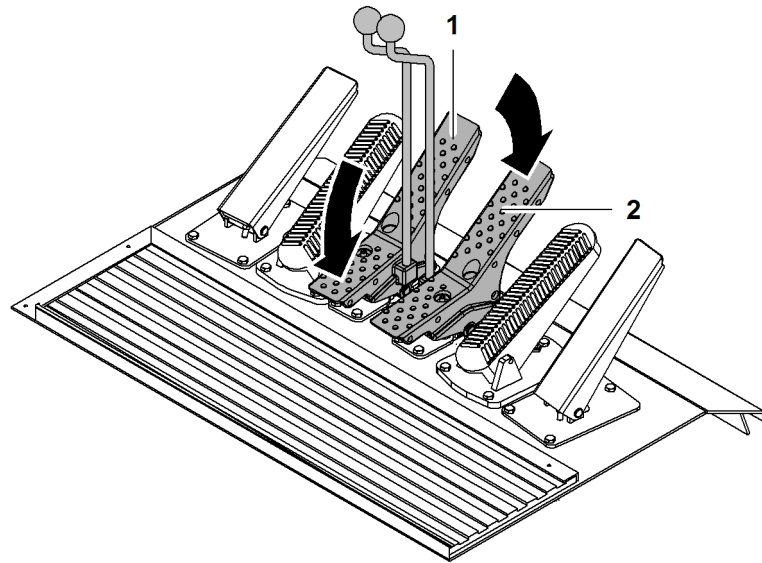


Fig. 2472: Swinging the machine to the left

1 Foot pedal for *left crawler*

2 Foot pedal for *right crawler*

- ▶ Press foot pedal *left crawler* 1 backward and foot pedal *right crawler* 2 forward at the same time.
 - ▷ A movement buzzer sounds.
 - ▷ Machine swings to the left:

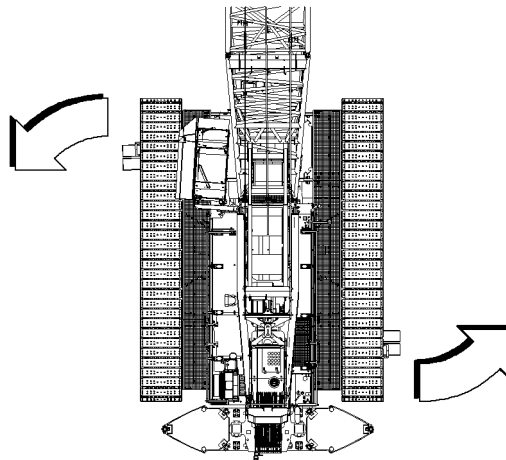


Fig. 2473: Machine swings to the left

Swinging the machine to the right

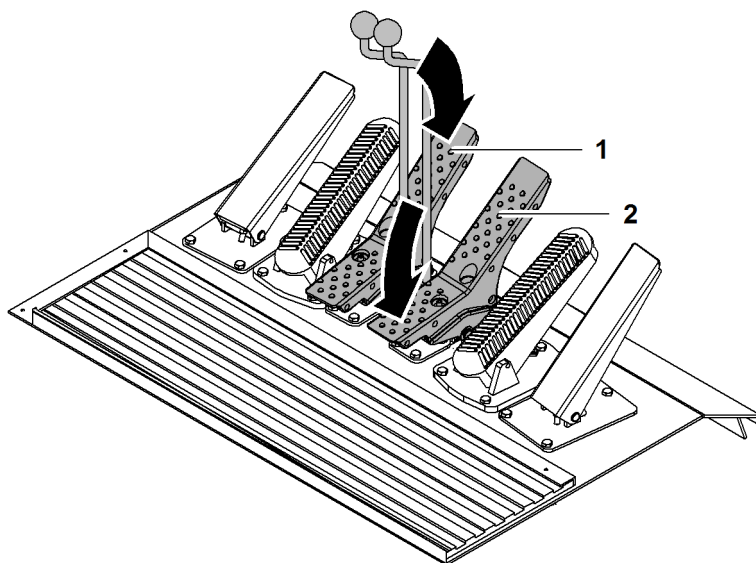


Fig. 2474: Swinging the machine to the right

1 Foot pedal for left crawler

2 Foot pedal for right crawler

- ▶ Press foot pedal *left crawler* 2 forward and foot pedal *right crawler* 1 backward at the same time.
 - ▷ A movement buzzer sounds.
 - ▷ Machine swings to the right:

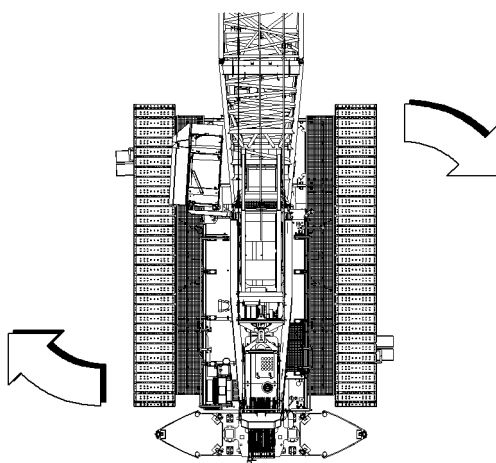


Fig. 2475: Machine swings to the right

4.18.3 Operating the crawler with counterweight carriage*

Three modes are possible when traveling with counterweight carriage:

- Trailer mode
- Follower mode
- Crab mode

Operating the crawler with counterweight carriage is identical to operating the crawler without counterweight carriage ([For more information see: 4.18.2 Operating the travel gear, page 925](#)).

The wheel sets of the counterweight carriage are in free-wheel.

Swing is locked.

Moving the machine in trailer mode

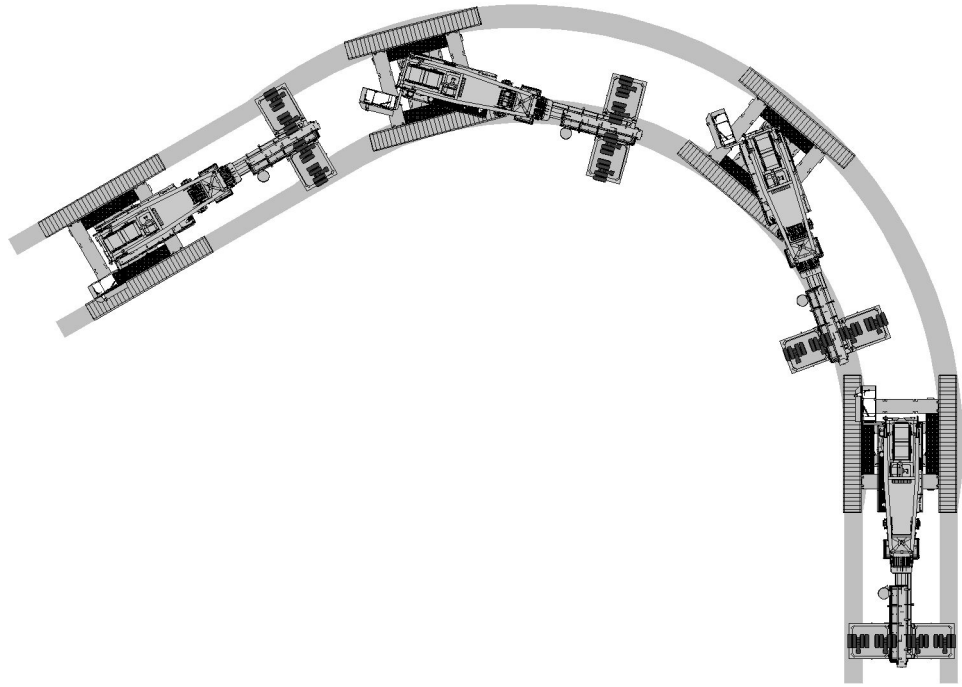


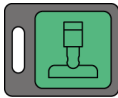
Fig. 2476: Moving the machine in trailer mode

In trailer mode, the counterweight carriage is towed behind the basic machine.

The wheel sets are aligned in the direction of travel. The wheel sets are not adjusted automatically during travel. Manual adjustment in a range of $\pm 10^\circ$ is possible.

Make sure the following prerequisites are met:

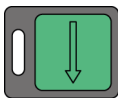
- There is no load on the boom that would prohibit supporting the counterweight carriage.
- Support of counterweight carriage is possible due to soil conditions.
- ▶ Press the *Counterweight carriage support* button on control panel X26.



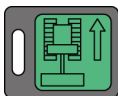
Note

Liebherr recommends:

- ▶ Monitor procedure with video equipment and/or a signalman.



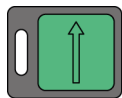
- ▶ Press and hold the button *Increase radius/support* on control panel X26 until jacks are fully extended.
 - ▷ Counterweight carriage is supported.



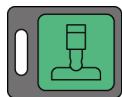
- ▶ Press the button *Trailer mode* on control panel X26.



- ▶ Press the button *Align wheel sets* on control panel X26.
 - ▷ Wheel sets are being aligned.



- ▶ Press and hold the button *Decrease radius/support* on control panel X26 until jacks are fully retracted.
 - ▷ Counterweight carriage rests on wheel sets.



- ▶ Press the button *Counterweight carriage support* on control panel X26 again.

- ▶ Operate crawler.

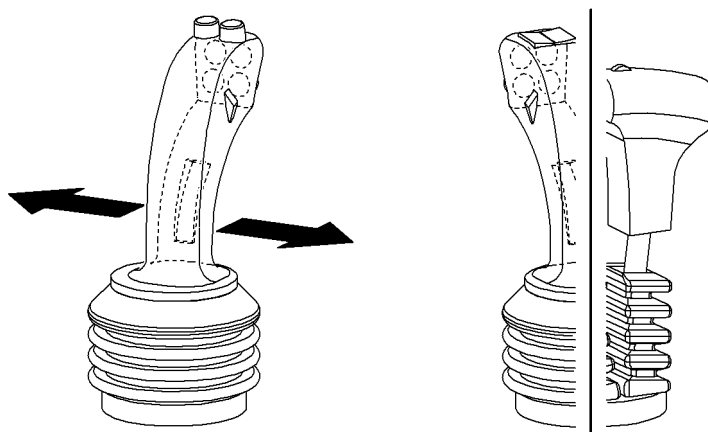


Fig. 2483: Readjusting the wheel sets

- ▶ If required, steer wheel sets to the right: Move left multi-directional control lever to the left.
- ▶ If required, steer wheel sets to the left: Move left multi-directional control lever to the right.

Moving the machine in follower mode

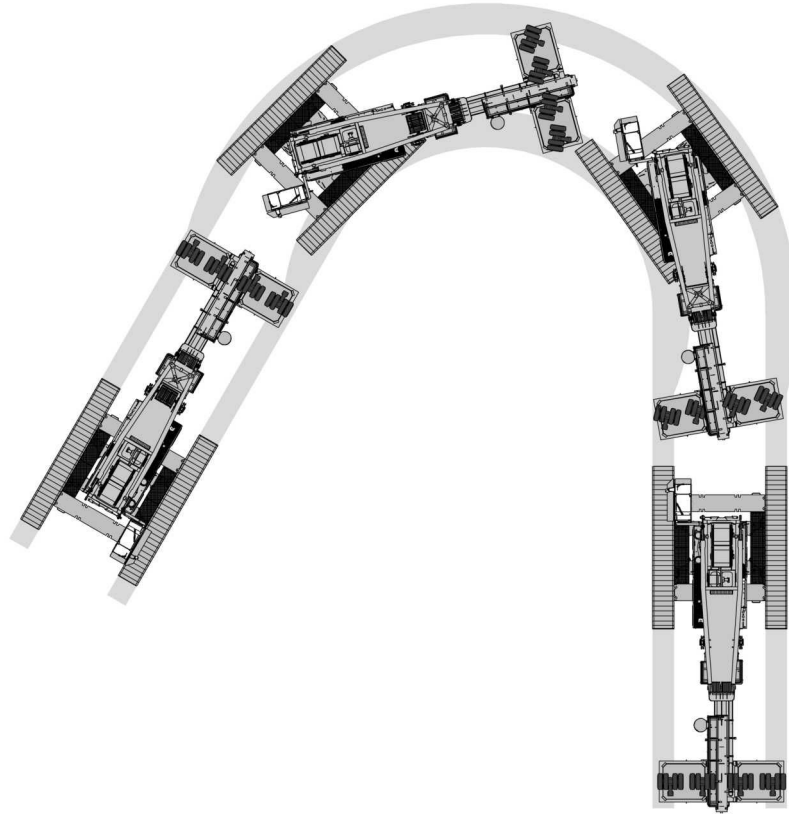


Fig. 2484: Moving the machine in follower mode

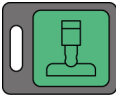
In follower mode, the counterweight carriage is towed behind the basic machine.

The wheel sets are aligned in the direction of travel. The wheel sets are readjusted automatically to ensure following in the track of the basic machine.

Follower mode is permitted in an angle range of 330° to 30° and 150° to 210°.

Make sure the following prerequisites are met:

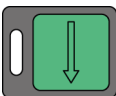
- There is no load on the boom that would prohibit supporting the counterweight carriage.
- Support of counterweight carriage is possible due to soil conditions.
- ▶ Press the *Counterweight carriage support* button on control panel X26.



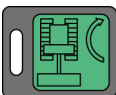
Note

Liebherr recommends:

- ▶ Monitor procedure with video equipment and/or a signalman.



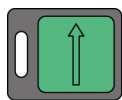
- ▶ Press and hold the button *Increase radius/support* on control panel X26 until jacks are fully extended.
 - ▷ Counterweight carriage is supported.



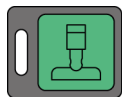
- ▶ Press the button *Follower mode* on control panel X26.



- ▶ Press the button *Align wheel sets* on control panel X26.
 - ▷ Wheel sets are being aligned.



- ▶ Press and hold the button *Decrease radius/support* on control panel X26 until jacks are fully retracted.
 - ▷ Counterweight carriage rests on wheel sets.



- ▶ Press the button *Counterweight carriage support* on control panel X26 again.

- ▶ Operate crawler.

Moving the machine in crab mode

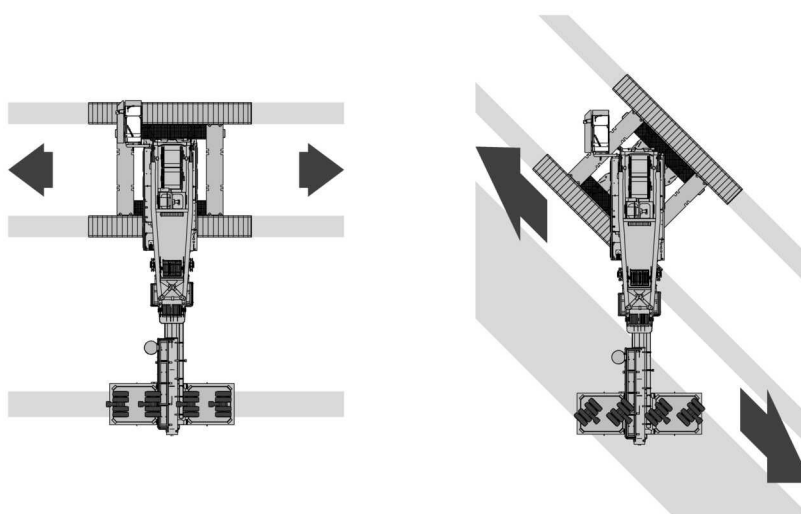


Fig. 2491: Moving the machine in crab mode

In crab mode, the counterweight carriage is aligned parallel to the crawler side frame and pulled along.

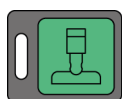
The wheel sets align parallel to the undercarriage in the direction of travel. The wheel sets are automatically adjusted and driven during travel.

Crab mode is permitted in an angle range of 60° to 120° and 240° to 300°.

Make sure the following prerequisites are met:

- There is no load on the boom that would prohibit supporting the counterweight carriage.
- Support of counterweight carriage is possible due to soil conditions.

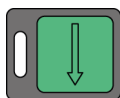
- ▶ Press the *Counterweight carriage support* button on control panel X26.



Note

Liebherr recommends:

- ▶ Monitor procedure with video equipment and/or a signalman.



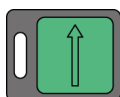
- ▶ Press and hold the button *Increase radius/support* on control panel X26 until jacks are fully extended.
 - ▷ Counterweight carriage is supported.



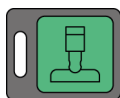
- ▶ Press the button *Crab mode* on control panel X26.



- ▶ Press the button *Align wheel sets* on control panel X26.
 - ▷ Wheel sets are being aligned.



- ▶ Press and hold the button *Decrease radius/support* on control panel X26 until jacks are fully retracted.
 - ▷ Counterweight carriage rests on wheel sets.



- ▶ Press the button *Counterweight carriage support* on control panel X26 again.

- ▶ Operate crawler.

4.18.4 Locking or unlocking the crawler

The crawlers can be locked to prevent them from being operated accidentally.



- ▶ Press the *Settings* button on screen.
 - ▷ The *Settings* screen appears.



- ▶ Press the *Lock crawler* button on screen for more than 1 second.
 - ▷ Crawlers are locked.



- ▶ Press the *Unlock crawler* button on screen for more than 1 second.
 - ▷ Crawler is unlocked.

4.19 Swing



WARNING

People or obstacles in the swing range!
Severe injuries, damage to machine.

- ▶ Ensure that there are no people or obstacles in the swing range.
- ▶ Leave the danger area.

4.19.1 Setting the swing speed

The crawler crane has no safety devices to limit the swing speed.

The maximum swing speeds for the speed settings are shown in the technical data for the swing.

In derrick mode, slewing of the uppercarriage is possible at speed level 1 exclusively.



DANGER

Excessive swing speed!
Machine toppling over, structural breakdown.

- ▶ Determine the maximum permitted swing speed for the current load and radius before any swing movement.
- ▶ Check that the preset speed is appropriate before any swing movement.
- ▶ Ensure that the maximum swing speed for the selected speed setting does not exceed the maximum permissible swing speed.

The diagram below shows the maximum permitted swing speed depending on the radius.

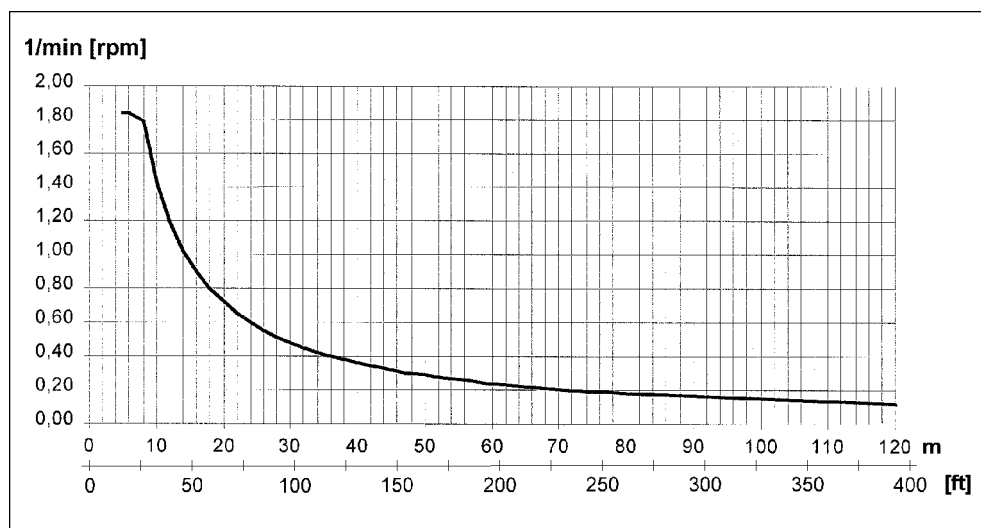


Fig. 2501: Setting the swing speed



DANGER

Swing speed too fast for an emergency stop!
 An emergency stop brings about additional dangers resulting from the inertia of moving masses (e.g. the load swinging).
 Machine toppling over, structural breakdown.

- ▶ Select swing speed so that the admissible diagonal pull is not exceeded in case of an emergency stop.

The lifting capacity must also be reduced in the following circumstances:

- Large boom lengths.
- Loads close to the maximum permitted load.
- In windy conditions; especially if the load to be lifted has a large area exposed to the wind.

The swing speed level is retained when the ignition is switched off.



- ▶ Press the *Swing speed level* button on control panel X23.

- ▷ Symbol *Swing speed level* appears on screen:



Fig. 2503: Symbol *Swing speed level*

- ▶ Press the *Swing speed level* button on control panel X23 again.
 - ▷ The number (1 to 3) in the symbol *Swing speed level* changes.

4.19.2 Turning the swing free-wheel on or off

If the free swing is switched on, the swing brake remains open.



WARNING

Open swing brake!
 Severe injuries, damage to machine.

If the uppercarriage turns further than intended:

- ▶ Slow/stop the rotary movement by moving the control lever in the opposite direction.

Ensure that the following conditions are fulfilled:

- Swing is stationary.
- No control lever function is active.

Turning swing free-wheel on/off on control panel X23



- ▶ Press the *Swing free-wheel* button on control panel X23.

- ▷ Free swing is switched on.
- ▷ Symbol *Swing free-wheel* appears on screen:



Fig. 2505: Free swing symbol

- ▶ Press the *Swing free-wheel* button on control panel X23 again.
 - ▷ Free swing is switched off.
 - ▷ The symbol *Swing free-wheel* disappears on screen.

Switching swing free-wheel on/off using the control lever

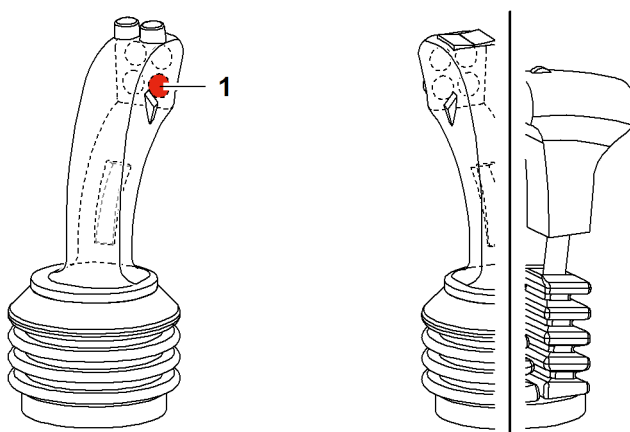


Fig. 2506: Switching swing free-wheel on/off using the multi-directional control lever

1 Button *Swing free-wheel*

Swing free-wheel is active for as long as you hold down the button *Swing free-wheel 1*.

- ▶ Press and hold the button *Swing free-wheel 1* on the left multi-directional control lever.
 - ▷ Free swing is switched on.
 - ▷ Symbol *Swing free-wheel* appears on screen:



Fig. 2507: Free swing symbol

- ▶ Release the button *Swing free-wheel 1*.
 - ▷ Free swing is switched off.
 - ▷ The symbol *Swing free-wheel* disappears on screen.

4.19.3 Operating the swing



DANGER

Incorrect use of the swing!
Risk of machine toppling over, structural breakdown.

- ▶ Accelerate and brake the swing slowly.

NOTICE

A-frame1 protrudes beyond rear counterweight!
 Damage to A-frame1.

- ▶ Check position of A-frame1 prior to turning uppercarriage.
- ▶ Consider the values in the following table.

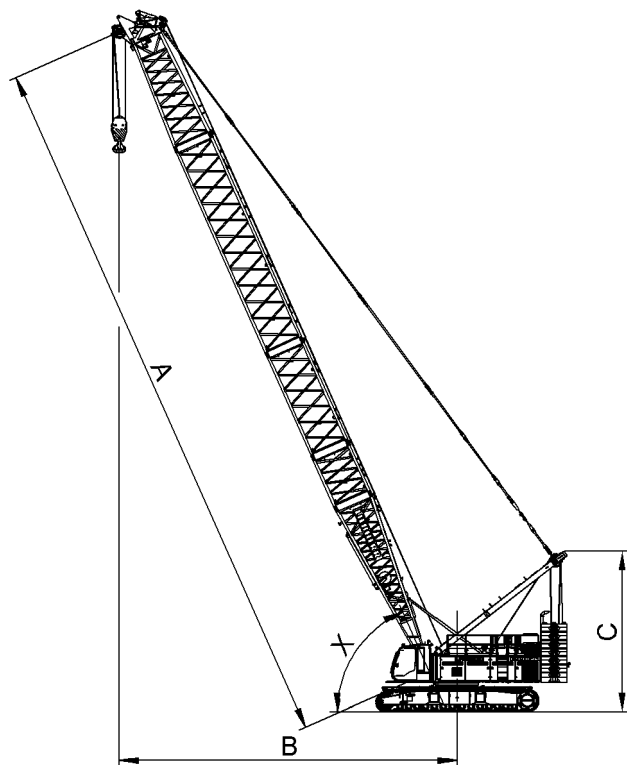


Fig. 2508: Position of A-frame1 in dependence on main boom angle (illustration of principle)

As of the stated main boom angle, A-frame1 protrudes beyond the rear counterweight. This angle changes depending on the main boom length.

Main boom length A	Radius B	Height A-frame1 C	Main boom angle X
LR 1006			
20 m 66 ft	5.8 m 19' ft-in	9.3 m 30' 6" ft-in	81.5°
38 m 125 ft	12.4 m 40' 8" ft-in	9.3 m 30' 6" ft-in	75.5°
50 m 164 ft	17.1 m 56' 1" ft-in	9.4 m 30' 10" ft-in	73.5°
74 m 243 ft	25.7 m 84' 4" ft-in	9.4 m 30' 10" ft-in	72°
98 m 322 ft	33.1 m 108' 7" ft-in	9.2 m 30' 2" ft-in	72°
LR 1004			

LWN/LR-x/V04.01//Auslieferung/2016-03-07/en

Main boom length A	Radius B	Height A-frame1 C	Main boom angle X
20 m 66 ft	9 m 29' 6" ft-in	8.6 m 28' 3" ft-in	71.5°
38 m 125 ft	18.1 m 59' 5" ft-in	8.6 m 28' 3" ft-in	66°
62 m 203 ft	30.2 m 99' 1" ft-in	8.7 m 28' 7" ft-in	63.5°
74 m 243 ft	36.2 m 118' 9" ft-in	8.7 m 28' 7" ft-in	63°
86 m 282 ft	43 m 141' 1" ft-in	8.6 m 28' 3" ft-in	63°
LR 1003			
25.7 m 84 ft	8.3 m 27' 3" ft-in	7.4 m 24' 3" ft-in	77°
40.4 m 133 ft	13.6 m 44' 7" ft-in	7.4 m 24' 3" ft-in	74°
58.1 m 191 ft	19 m 62' 4" ft-in	7.3 m 23' 11" ft-in	73.5°
69.8 m 229 ft	24 m 78' 9" ft-in	7.4 m 24' 3" ft-in	72°
87.5 m 287 ft	29.5 m 96' 9" ft-in	7.3 m 23' 11" ft-in	72°
LR 1002			
20 m 66 ft	2.9 m 9' 6" ft-in	5.5 m 18' 1" ft-in	88°
38 m 125 ft	4.9 m 16' 1" ft-in	5.3 m 17' 5" ft-in	86°
50 m 164 ft	6.2 m 20' 4" ft-in	5.2 m 17' 1" ft-in	85.5°
68 m 223 ft	9.4 m 30' 10" ft-in	5.3 m 17' 5" ft-in	84°
80 m 262 ft	10.6 m 34' 9" ft-in	5.3 m 17' 5" ft-in	84°
LR 1001			
17 m 56 ft	4.4 m 14' 5" ft-in	6.5 m 21' 4" ft-in	82.5°
32 m 105 ft	9.1 m 29' 10" ft-in	6.5 m 21' 4" ft-in	77.5°
41 m 135 ft	12 m 39' 4" ft-in	6.5 m 21' 4" ft-in	76°
56 m 184 ft	16.1 m 52' 10" ft-in	6.5 m 21' 4" ft-in	75.5°

Main boom length A	Radius B	Height A-frame1 C	Main boom angle X
68 m 223 ft	19.1 m 62' 8" ft-in	6.4 m 21' ft-in	75.5°

Tab. 376: Position of A-frame1 in dependence of main boom angle with different main boom lengths

Swinging the uppercarriage to the left

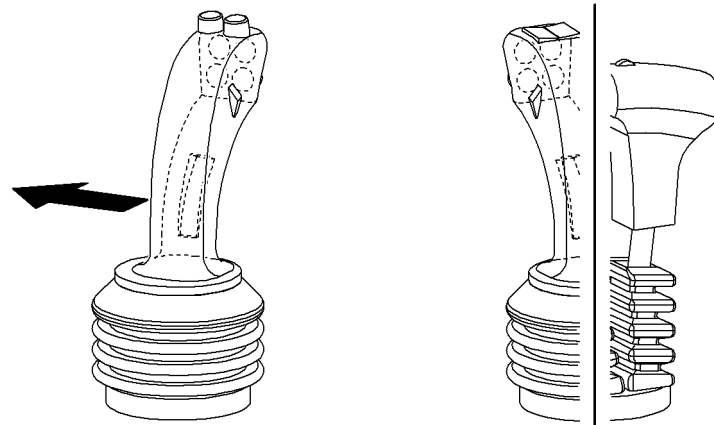


Fig. 2509: Swinging the uppercarriage to the left

- ▶ Push the left multi-directional joystick to the left.
 - ▷ Uppercarriage swings to the left (counter-clockwise).
 - ▷ A movement buzzer sounds.

Swinging the uppercarriage to the right

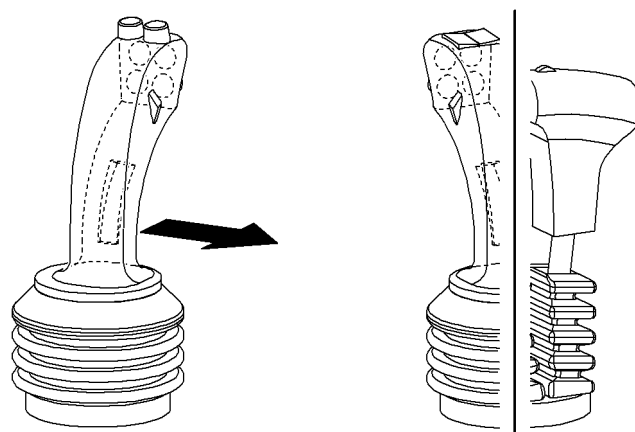


Fig. 2510: Swinging the uppercarriage to the right

- ▶ Move the left-hand multi-directional control lever to the right.
 - ▷ Uppercarriage swings to the right (clockwise).
 - ▷ A movement buzzer sounds.

4.19.4 Operating the swing with suspended counterweight*



DANGER

Improper use of swing!
Toppling of machine, structural breakdown.

- ▶ Accelerate and brake the swing slowly.
- ▶ Lift suspended counterweight before turning the uppercarriage.

Swinging the uppercarriage to the left



DANGER

Improper lifting of suspended counterweight!
Toppling of machine.

- ▶ Monitor load moment limiter continuously.
- ▶ Lower boom if necessary.

- ▶ Lift suspended counterweight.

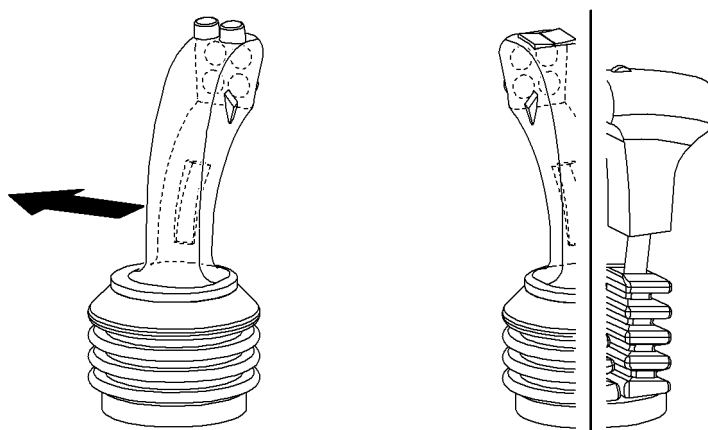


Fig. 2511: Swinging the uppercarriage to the left

- ▶ Push the left multi-directional joystick to the left.
 - ▷ Uppercarriage swings to the left (counter-clockwise).
 - ▷ A movement buzzer sounds.
- ▶ Lay down suspended counterweight.

Swinging the uppercarriage to the right



DANGER

Improper lifting of suspended counterweight!
Toppling of machine.

- ▶ Monitor load moment limiter continuously.
- ▶ Lower boom if necessary.

- ▶ Lift suspended counterweight.

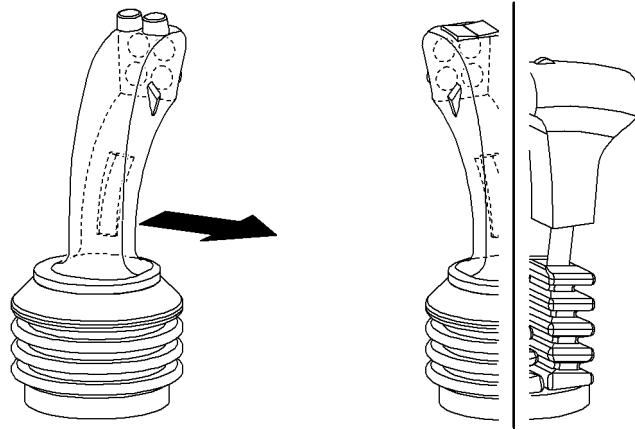


Fig. 2512: Swinging the uppercarriage to the right

- ▶ Move the left-hand multi-directional control lever to the right.
 - ▷ Uppercarriage swings to the right (clockwise).
 - ▷ A movement buzzer sounds.
- ▶ Lay down suspended counterweight.

4.19.5 Operating the swing with counterweight carriage*

Operating the swing with counterweight carriage is identical to operating the swing without counterweight carriage ([For more information see: 4.19.3 Operating the swing, page 937](#)).

The wheel sets of the counterweight carriage are driven.

Crawler is locked.



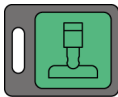
DANGER

Improper use of swing!
Toppling of machine, structural breakdown.

- ▶ Accelerate and brake the swing slowly.
- ▶ Align wheel sets before turning the uppercarriage.

Make sure the following prerequisites are met:

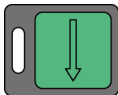
- There is no load on the boom that would prohibit supporting the counterweight carriage.
- Support of counterweight carriage is possible due to soil conditions.
- ▶ Press the *Counterweight carriage support* button on control panel X26.



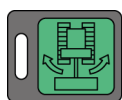
Note

Liebherr recommends:

- ▶ Monitor procedure with video equipment and/or a signalman.



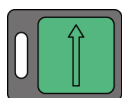
- ▶ Press and hold the button *Increase radius/support* on control panel X26 until jacks are fully extended.
 - ▷ Counterweight carriage is supported.



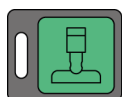
- ▶ Press the button *Rotate uppercarriage mode* on control panel X26.



- ▶ Press the button *Align wheel sets* on control panel X26.
 - ▷ Wheel sets are being aligned.



- ▶ Press and hold the button *Decrease radius/support* on control panel X26 until jacks are fully retracted.
 - ▷ Counterweight carriage rests on wheel sets.



- ▶ Press the button *Counterweight carriage support* on control panel X26 again.

- ▶ Operate swing.

4.19.6 Locking or unlocking the swing

The swing can be locked to prevent accidental operation.



- ▶ Press the *Settings* button on screen.
 - ▷ The *Settings* screen appears.



- ▶ Press the *Lock swing* button on screen for more than 1 second.
 - ▷ Swing is locked.



- ▶ Press the *Unlock swing* button on screen for more than 1 second.
 - ▷ Swing is unlocked.

4.20 Main boom

The main boom is adjusted using the boom winch.

In derrick mode, the main boom is adjusted using the derrick winch and derrick rope rigging. A-frame¹ and derrick boom remain in a fixed position.

The adjustment range of the main boom can also be limited by the radius limiter, limit switch or load moment limiter.

4.20.1 Operating the main boom

Ensure that the following conditions are fulfilled:

- No limit switch is active and blocking a movement.
- There are no persons or obstacles in the danger zone.
- Derrick winch is selected (only in derrick mode).

Lifting the main boom



Procedure on a machine with two multi-directional control levers

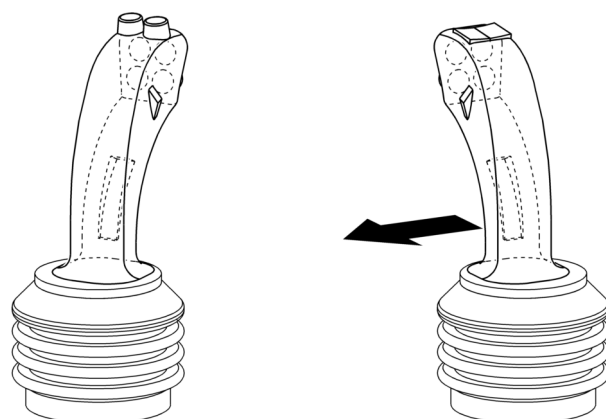


Fig. 2523: Lifting the main boom using the multi-directional control lever

- ▶ Push the right multi-directional joystick to the left.
 - ▷ The main boom rises:

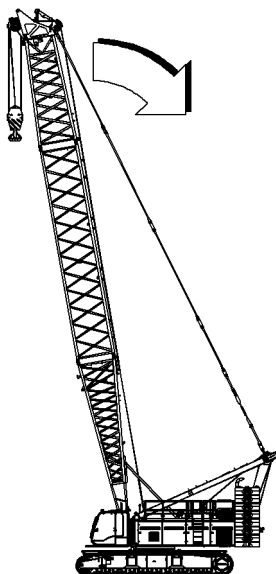
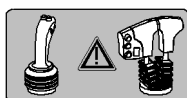


Fig. 2524: The main boom rises



Procedure on a machine with a multi-directional control lever and a double T-lever.

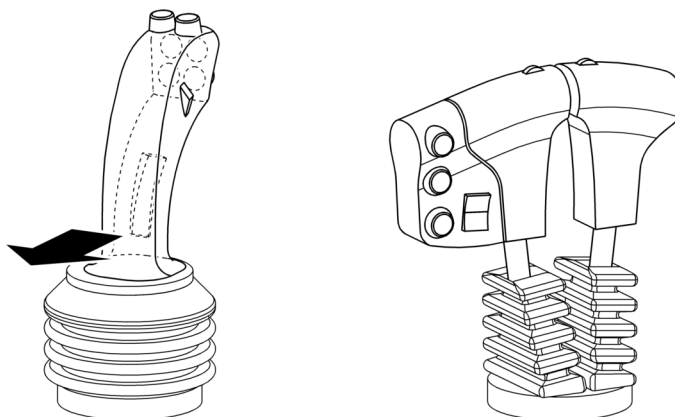


Fig. 2526: Lifting the main boom using the double T-lever

- ▶ Push the left multi-directional joystick backwards.
- ▷ The main boom rises:

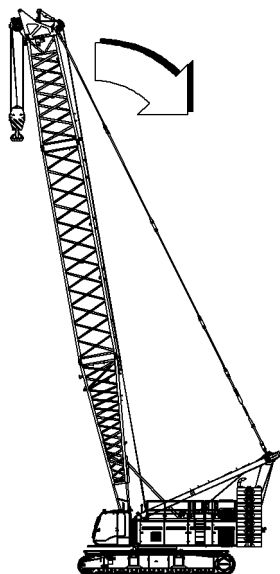


Fig. 2527: The main boom rises

Lowering the main boom



Procedure on a machine with two multi-directional control levers

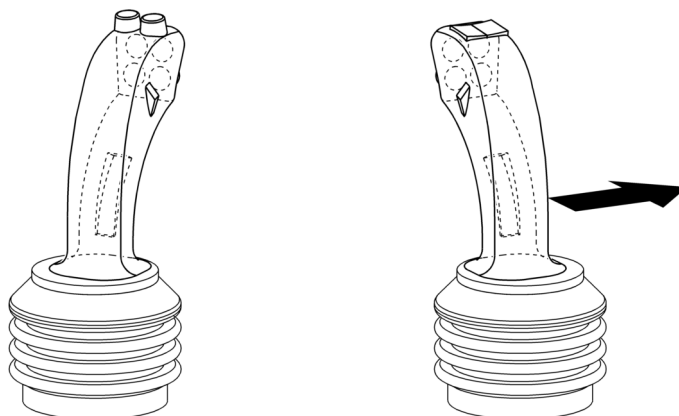


Fig. 2529: Lowering the main boom using the multi-directional control lever

- ▶ Push the right multi-directional joystick to the right.
 - ▷ The main boom lowers:

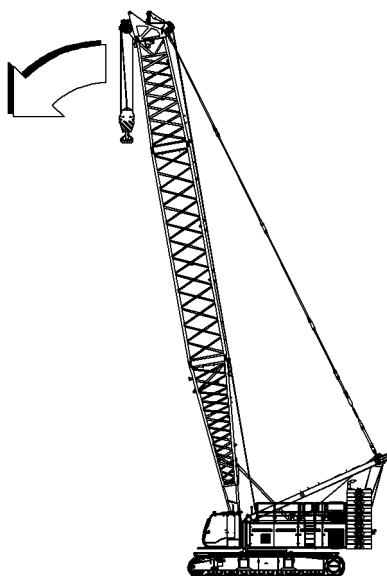
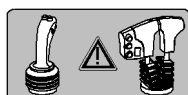


Fig. 2530: The main boom lowers



Procedure on a machine with a multi-directional control lever and a double T-lever.

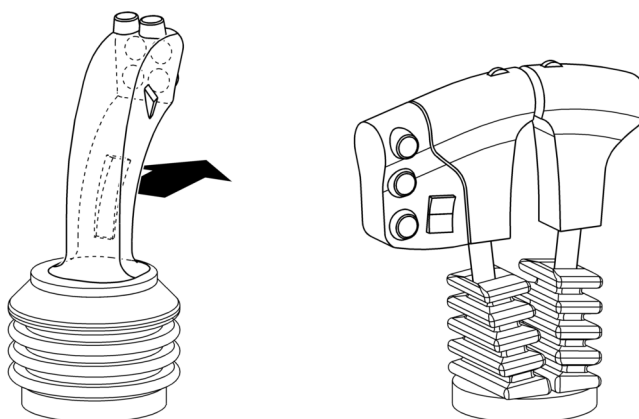


Fig. 2532: Lowering the main boom using the double T-lever

- ▶ Push the left multi-directional joystick forwards.
- ▷ The main boom lowers:

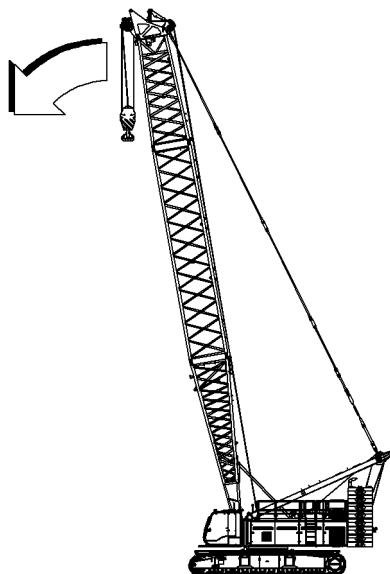


Fig. 2533: The main boom lowers

4.20.2 Locking or unlocking the main boom

The main boom can be locked to prevent it from being operated accidentally.



- ▶ Press the *Settings* button on screen.
 - ▷ The *Settings* screen appears.



- ▶ Press the *Lock main boom* button on screen for more than 1 second.
 - ▷ Main boom is locked.



- ▶ Press the *Unlock main boom* button on screen for more than 1 second.
 - ▷ Main boom is unlocked.

4.21 Jib

The jib is adjusted using the jib luffing winch.

The adjustment range of the jib can also be limited by the Load Moment Limiter, boom radius limitation or limit switch.

4.21.1 Selecting the jib

The selected boom is identified on the screen by a symbol.

The selection remains stored even after the machine is restarted.

Selecting jib on control lever

Procedure on a machine with two multi-directional control levers

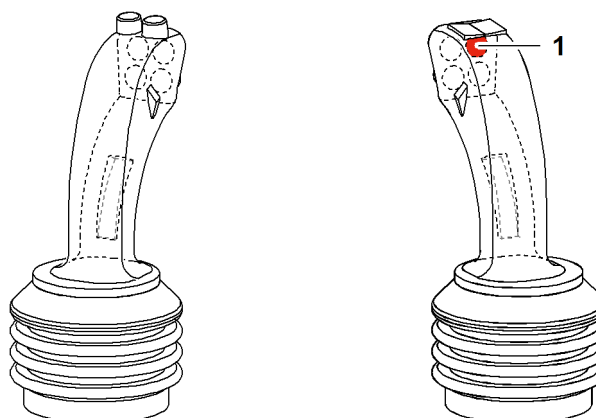


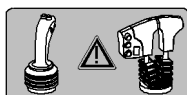
Fig. 2538: Selecting the jib

1 Button *Jib luffing winch*

- ▶ Press the button *jib luffing winch* 1 on the right multi-directional control lever.
 - ▷ Jib luffing winch is selected.
 - ▷ Symbol *Jib speed level adjustment* is displayed on the monitor:



Fig. 2539: Symbol *Jib speed level adjustment*



Procedure on a machine with a multi-directional control lever and a double T-lever.

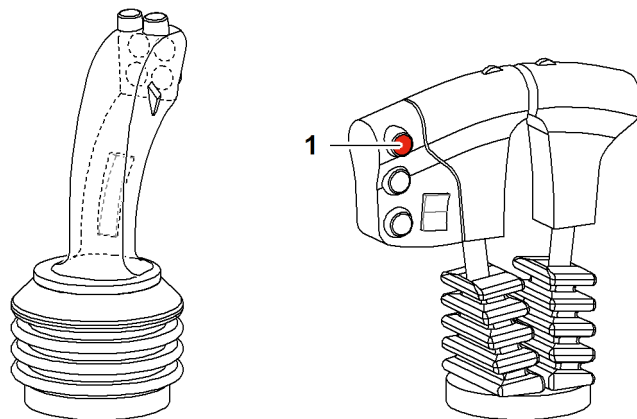


Fig. 2541: Selecting the jib

1 Button *Jib luffing winch*

- ▶ Press the button *jib luffing winch* 1 on the right double T-lever.
 - ▷ Jib luffing winch is selected.
 - ▷ Symbol *Jib speed level adjustment* is displayed on the monitor:



Fig. 2542: Symbol *Jib speed level adjustment*

Selecting the jib on control panel X23



- ▶ Press the button *Jib luffing winch* on control panel X23.

- ▷ Jib luffing winch is selected.
- ▷ Symbol *Jib speed level adjustment* is displayed on the monitor:



Fig. 2544: Symbol *Jib speed level adjustment*

4.21.2 Operating the jib

Ensure that the following conditions are fulfilled:

- No limit switch is active and blocking a movement.
- There are no persons or obstacles in the danger zone.

Lift jib



Procedure on a machine with two multi-directional control levers

Simultaneous adjustment of the main boom and the jib is not possible in crane mode.

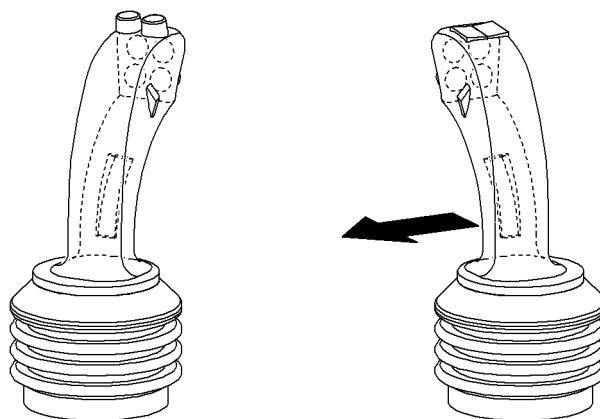


Fig. 2546: Lifting the jib

- ▶ Push the right multi-directional joystick to the left.
- ▷ The jib rises:

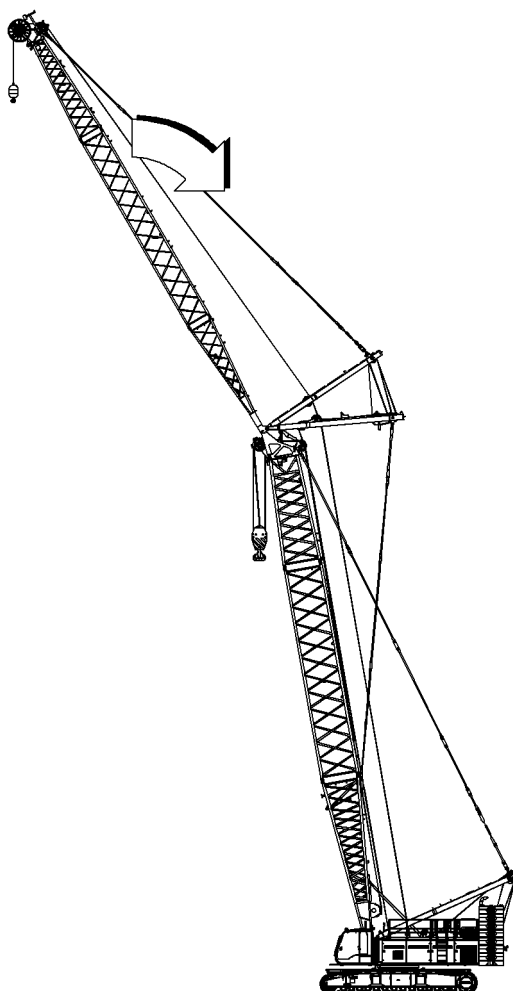
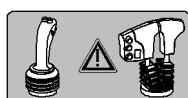


Fig. 2547: The jib rises



Procedure on a machine with a multi-directional control lever and a double T-lever.

Simultaneous adjustment of the jib and winch2 is not possible.

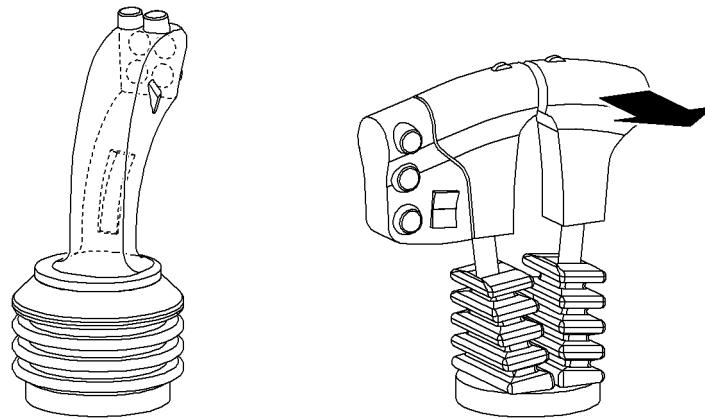


Fig. 2549: Lifting the jib

- ▶ Push the outer T-lever backwards.
- ▷ The jib rises:

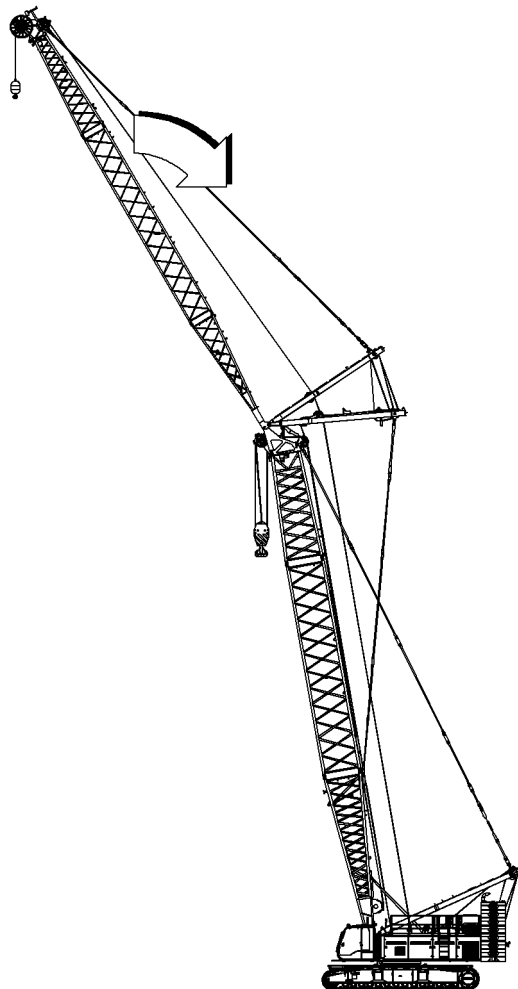


Fig. 2550: The jib rises

Lower jib



Procedure on a machine with two multi-directional control levers

Simultaneous adjustment of the main boom and the jib is not possible in crane mode.

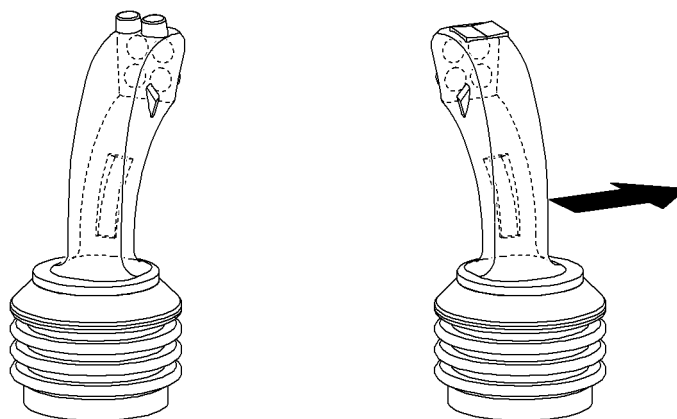


Fig. 2552: Lowering the jib

- ▶ Push the right multi-directional joystick to the right.
- ▷ The jib lowers:

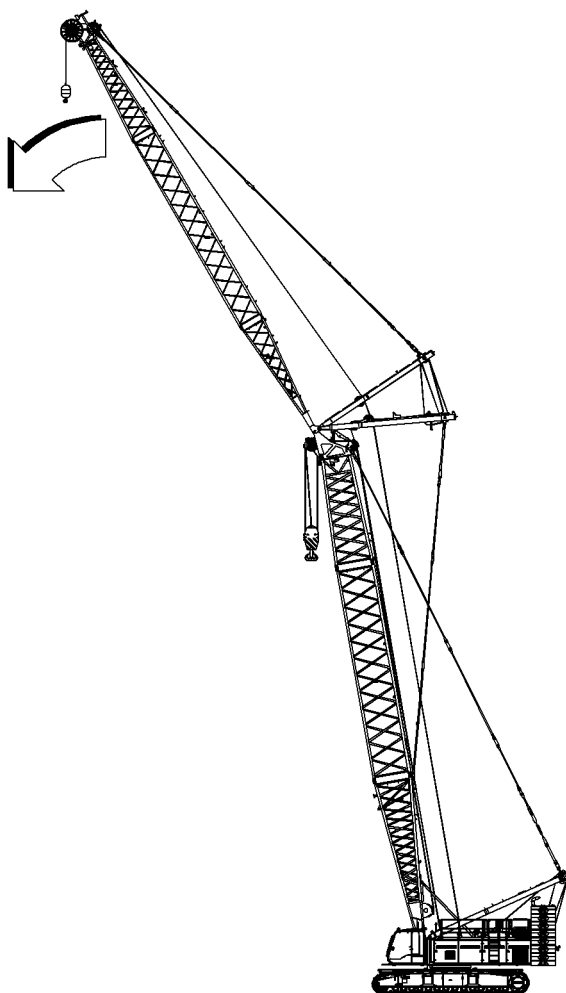
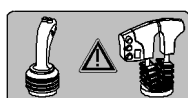


Fig. 2553: The jib lowers



Procedure on a machine with a multi-directional control lever and a double T-lever.

Simultaneous adjustment of the jib and winch2 is not possible.

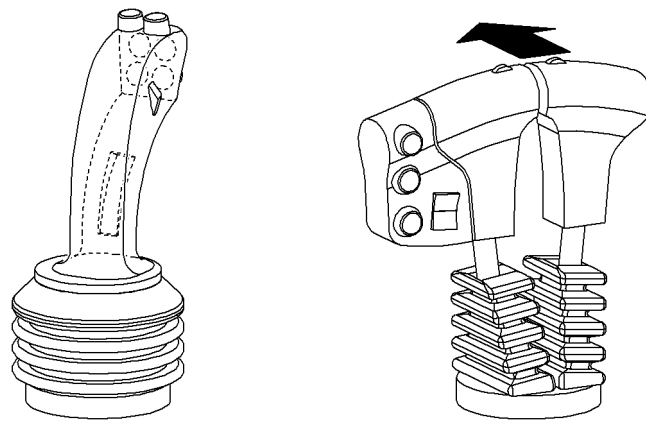


Fig. 2555: Lowering the jib

- ▶ Push the outer T-lever forwards.
- ▷ The jib lowers:

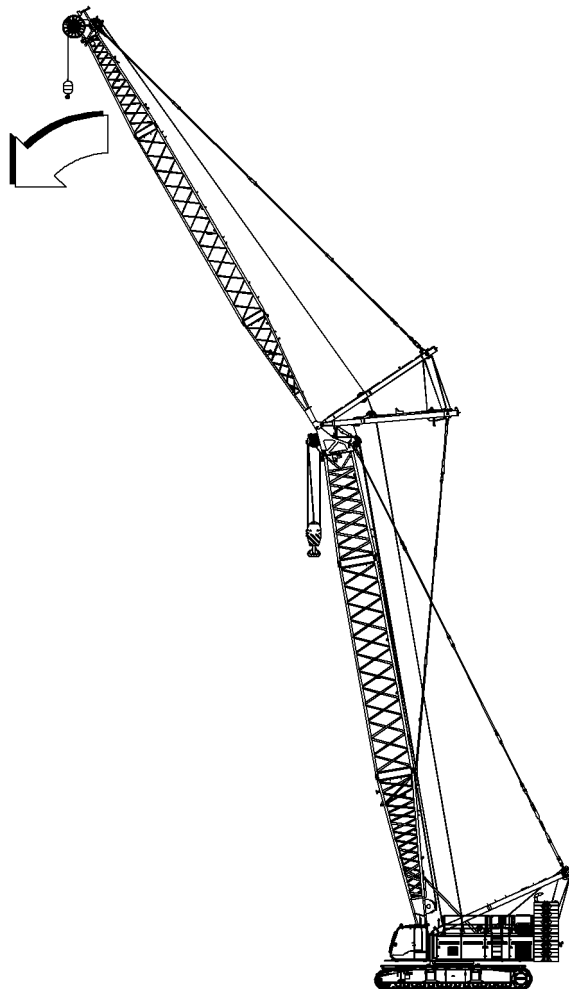


Fig. 2556: The jib lowers

4.22 Winch 1/Winch 2



WARNING

Pulling out of the ropes!

- ▶ Do not turn the winches unless a rope is reeved.
- ▶ Ensure that the rope is tight and evenly positioned on the winch.
- ▶ Have Liebherr after sales service set the 3 rope windings limit switch.

The adjustment range is defined by the set-up, is load-dependent, and is monitored by the LML (load moment limiter). The hoist limit switch and 3 rope windings limit switch restrict the adjustment range. The 3 rope windings limit switch is a safety device that prevents the rope from being pulled out of the rope fixing point on the winch.

4.22.1 Operating winch 1

Lifting the load on winch1



Procedure on a machine with two multi-directional control levers

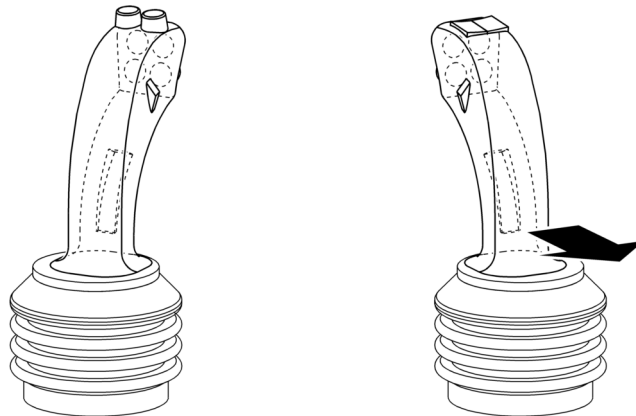


Fig. 2558: Lifting the load on winch1 with the multi-directional control lever

- ▶ Push the right multi-directional joystick backwards.
 - ▷ Load on winch1 is lifted:

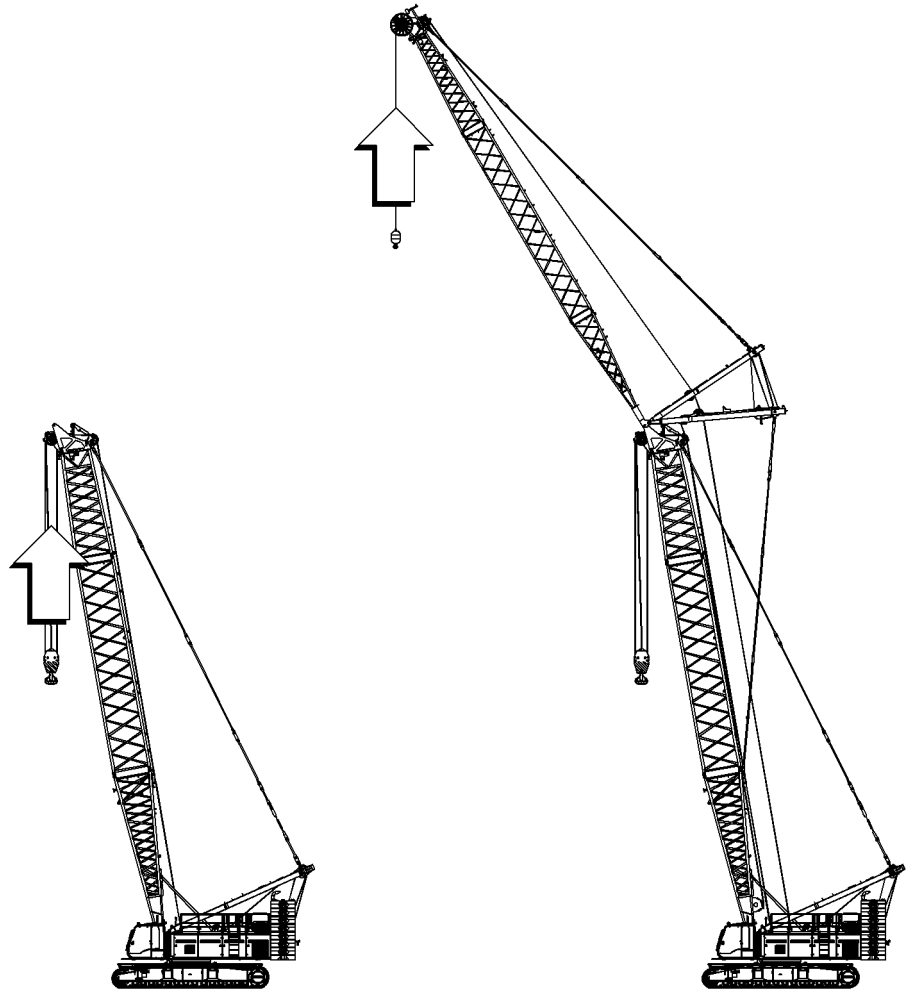
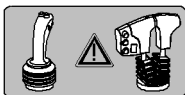


Fig. 2559: Load on winch1 is lifted



Procedure on a machine with a multi-directional control lever and a double T-lever.

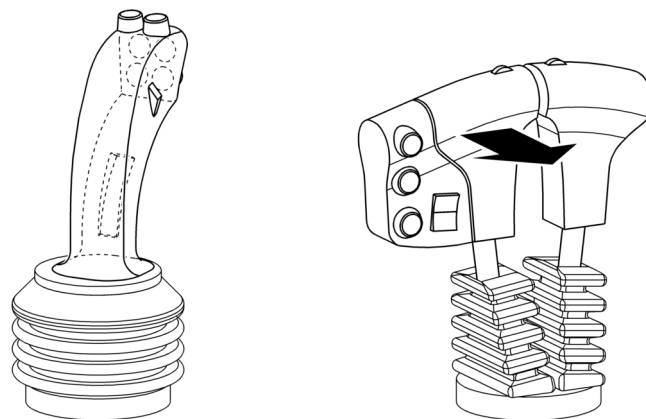


Fig. 2561: Lifting the load on winch1 with the double T-lever

- ▶ Push the inner T-bar control lever backwards.
- ▷ Load on winch1 is lifted:

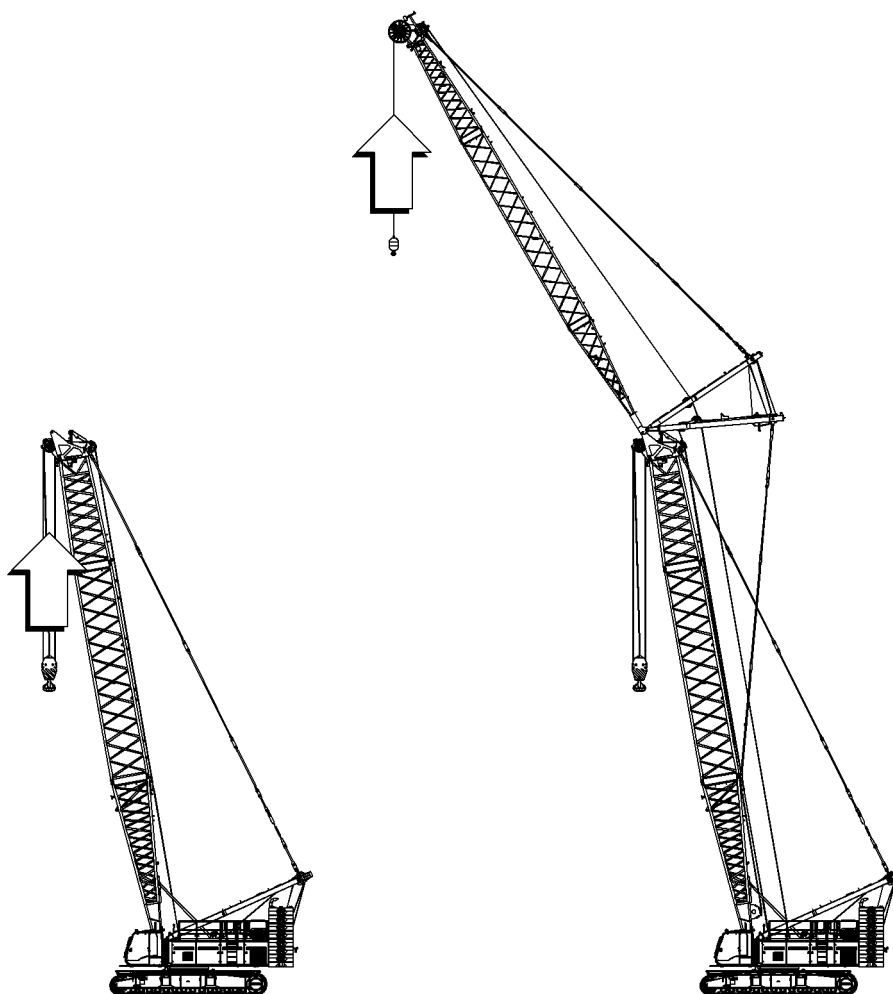


Fig. 2562: Load on winch1 is lifted

Lowering the load on winch1

Procedure on a machine with two multi-directional control levers

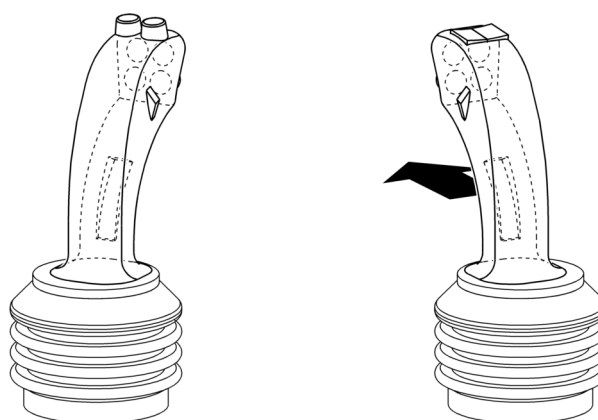


Fig. 2564: Lowering the load on winch1 with the multi-directional control lever

- ▶ Push the right multi-directional control lever forwards.

▷ Load on winch1 is lowered:

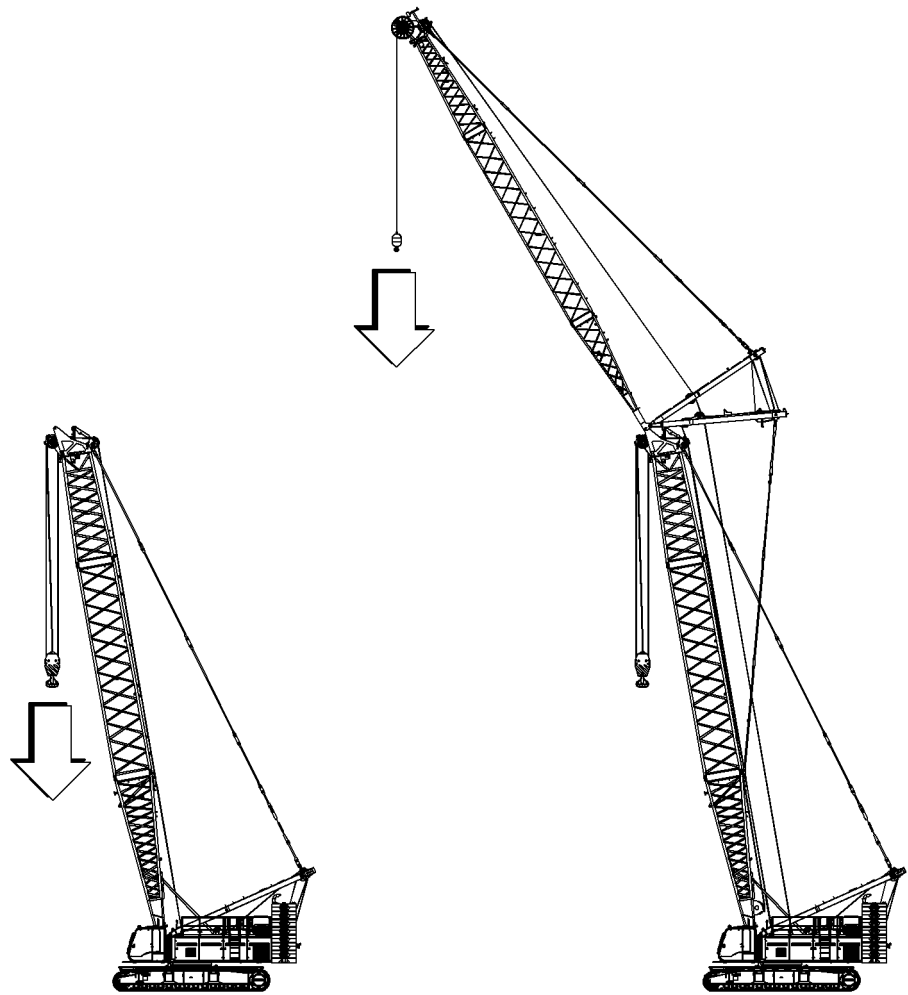
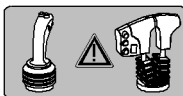


Fig. 2565: Load on winch1 is lowered



Procedure on a machine with a multi-directional control lever and a double T-lever.

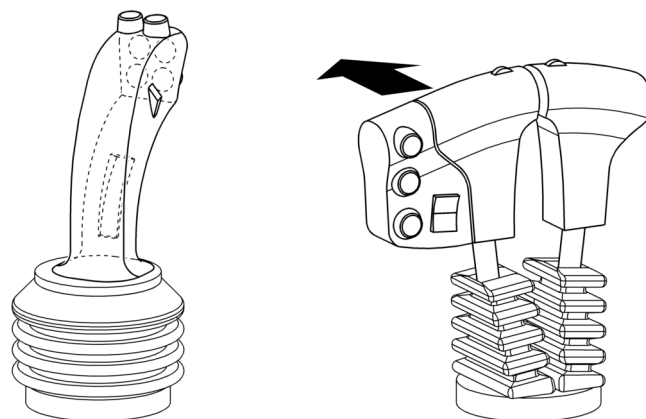


Fig. 2567: Lowering the load on winch1 with the double T-lever

▶ Push the inner T-bar control lever forwards.
▷ Load on winch1 is lowered:

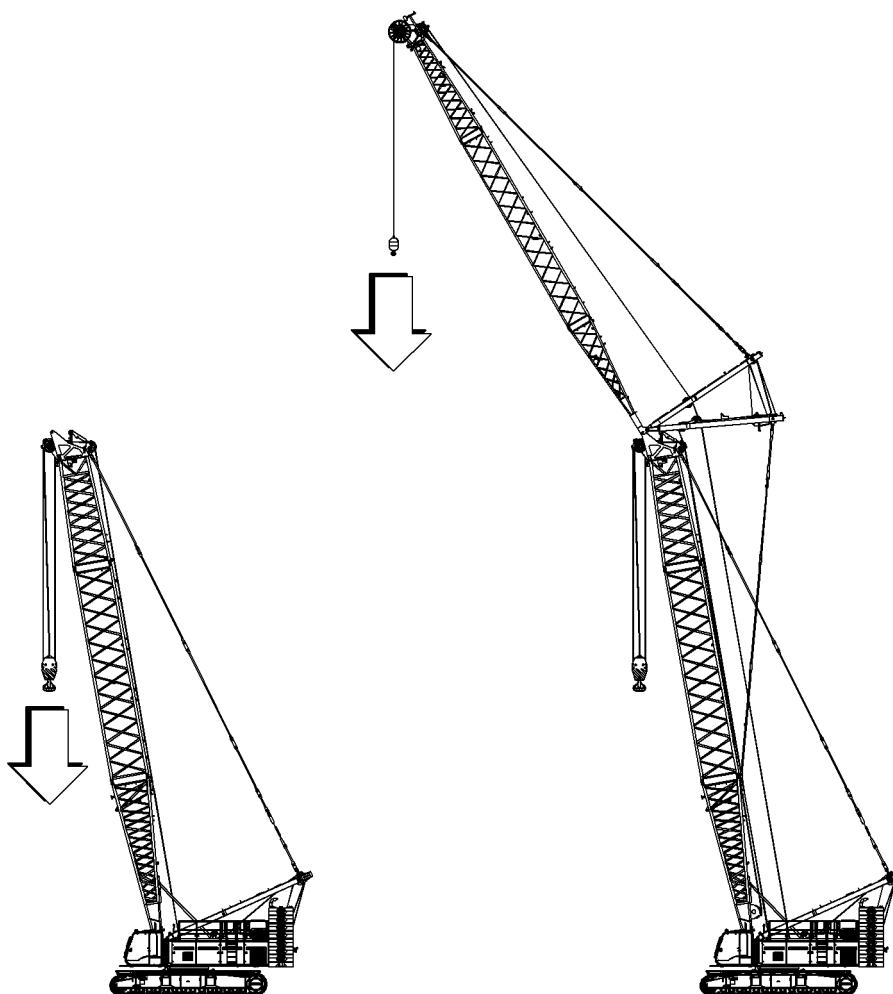


Fig. 2568: Load on winch1 is lowered

4.22.2 Operating winch 2

Lifting the load on winch2

Procedure on a machine with two multi-directional control levers



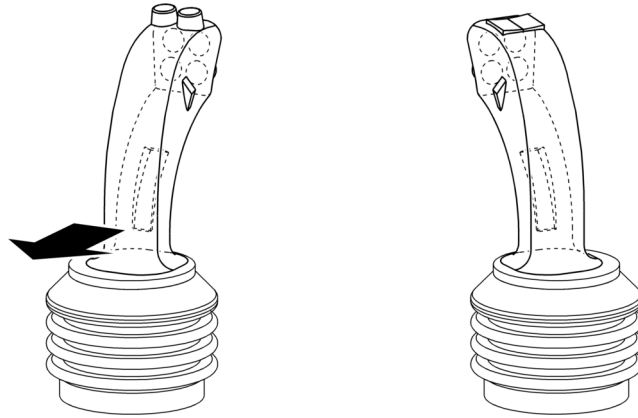


Fig. 2570: Lifting the load on winch2 with the multi-directional control lever

- ▶ Push the left multi-directional joystick backwards.
- ▷ Load on winch2 is lifted:

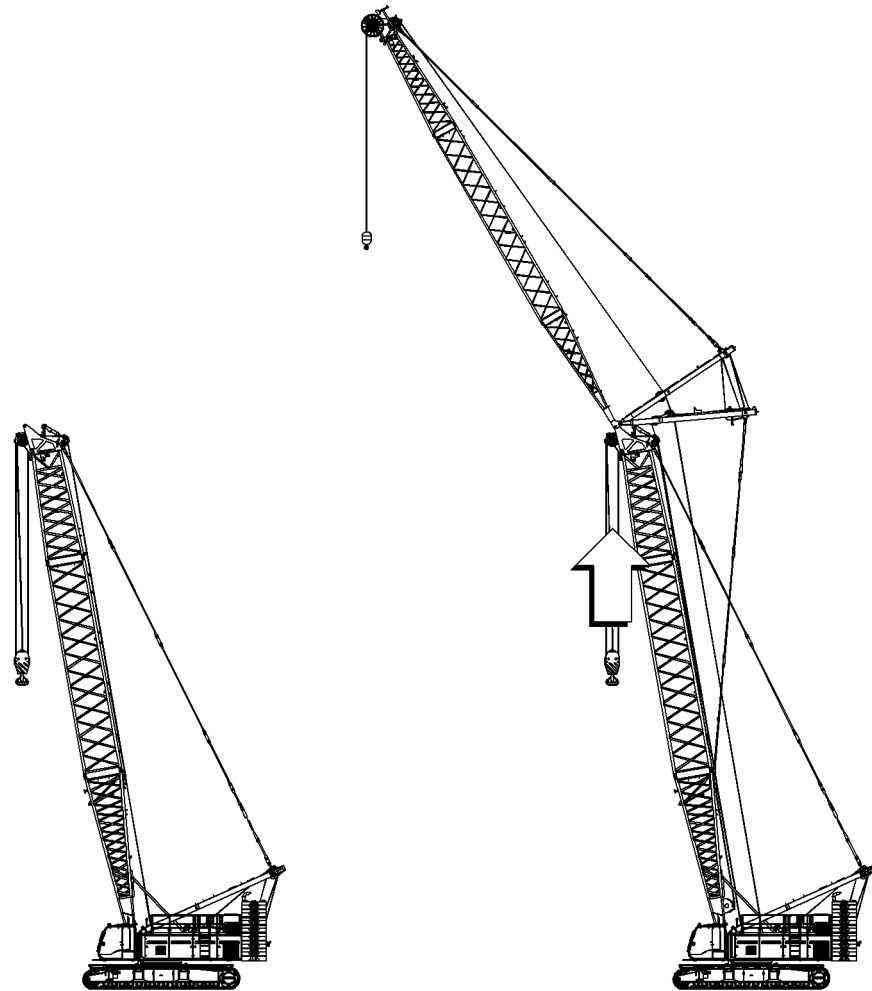
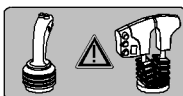


Fig. 2571: Load on winch2 is lifted



Procedure on a machine with a multi-directional control lever and a double T-lever.

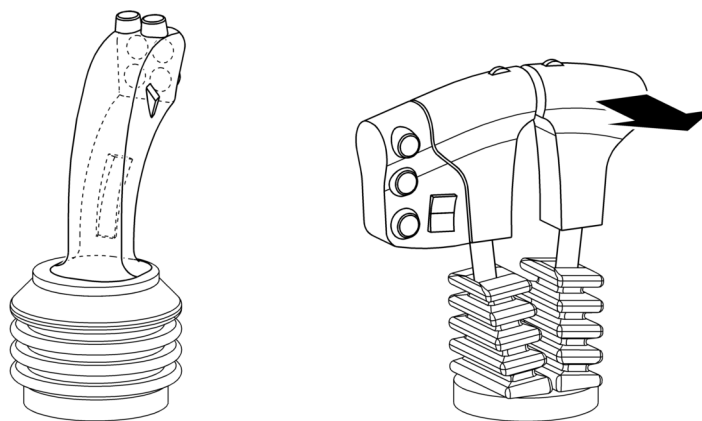


Fig. 2573: Lifting the load on winch2 with the double T-lever

- ▶ Push the outer T-lever backwards.
- ▷ Load on winch2 is lifted:

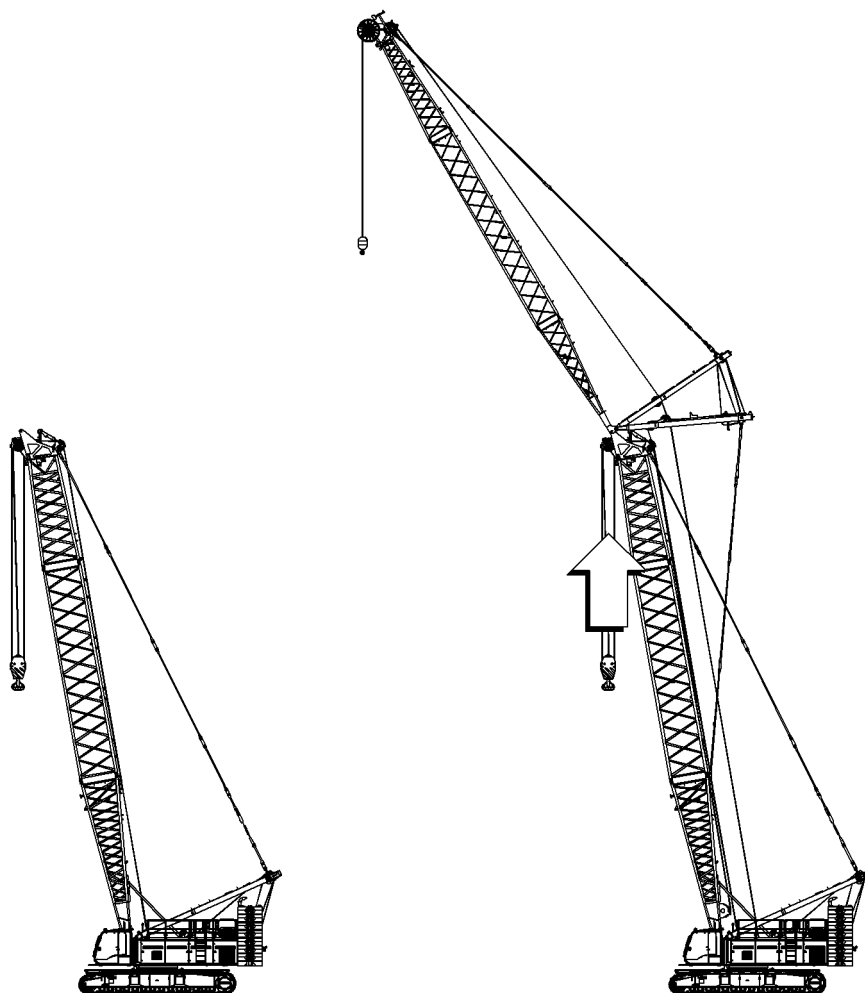


Fig. 2574: Load on winch2 is lifted

Lowering the load on winch2

Procedure on a machine with two multi-directional control levers



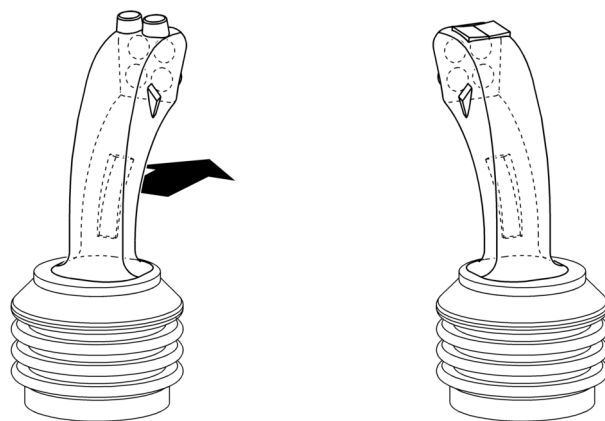


Fig. 2576: Lowering the load on winch2 with the multi-directional control lever

- ▶ Push the left multi-directional control lever forwards.
- ▷ Load on winch2 is lowered:

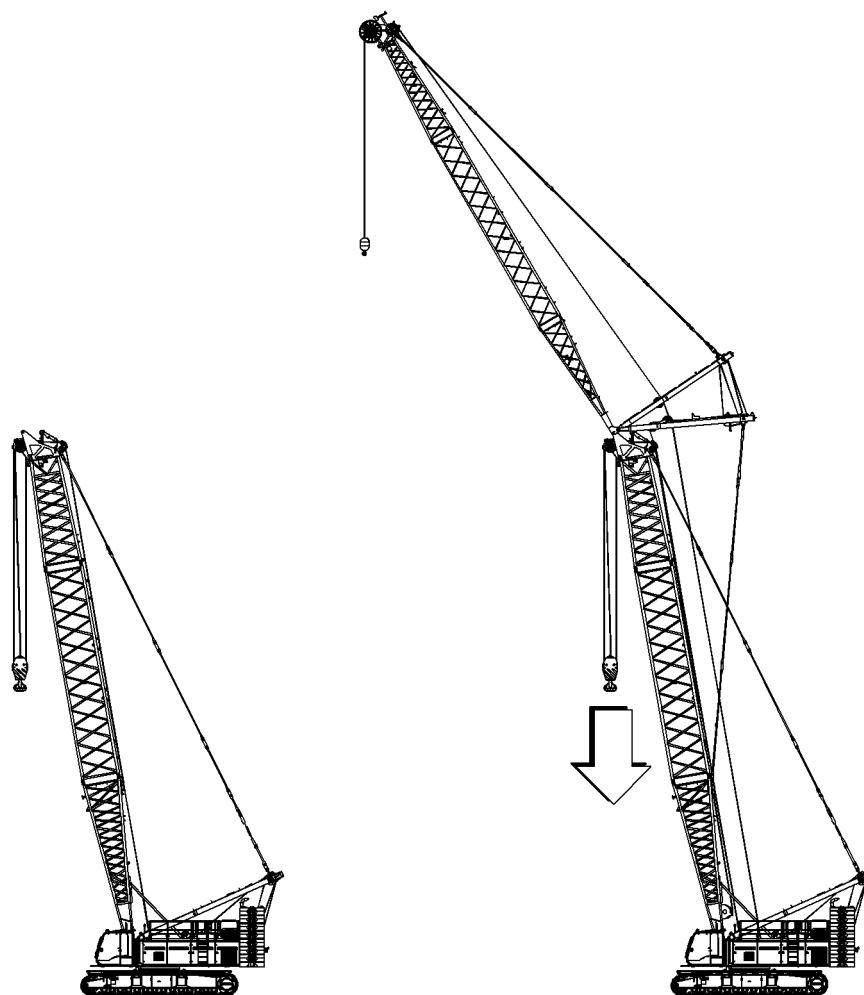
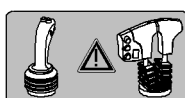


Fig. 2577: Load on winch2 is lowered



Procedure on a machine with a multi-directional control lever and a double T-lever.

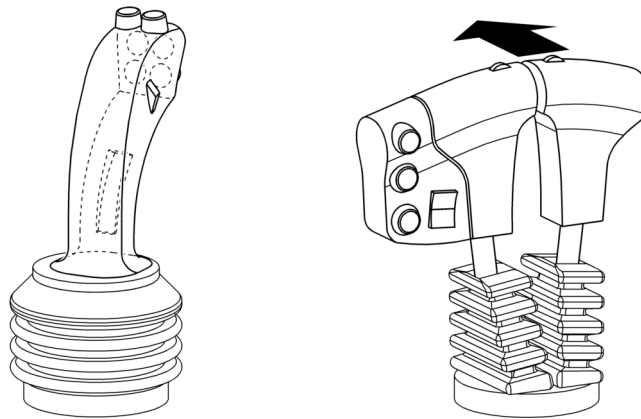


Fig. 2579: Lowering the load on winch2 with the double T-lever

- ▶ Push the outer T-lever forwards.
- ▷ Load on winch2 is lowered:

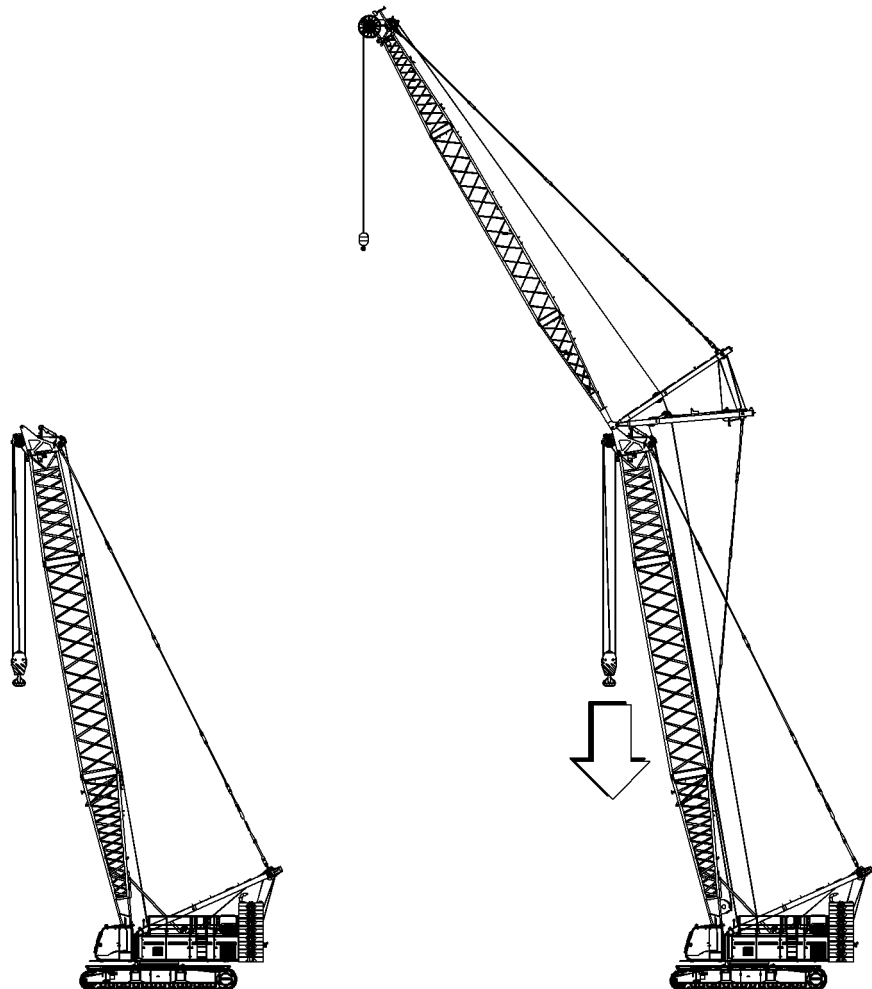


Fig. 2580: Load on winch2 is lowered

4.22.3 Locking or unlocking winch1/winch2

To prevent accidental operation of the winches, winch1 or winch2 can be locked.



- ▶ Press the *Settings* button on screen.
 - ▷ The *Settings* screen appears.



- ▶ Press the *Lock winch1* button on screen for more than 1 second.
 - ▷ Winch1 is locked.



- ▶ Press the *Lock winch2* button on screen for more than 1 second.
 - ▷ Winch2 is locked.



- ▶ Press the *Unlock winch1* button on screen for more than 1 second.
 - ▷ Winch1 is unlocked.



- ▶ Press the *Unlock winch2* button on screen for more than 1 second.
 - ▷ Winch2 is unlocked.

4.23 Counterweight carriage* radius adjustment



WARNING

Persons or obstacles in the adjustment range!
Severe injuries, damage to machine.

- ▶ Ensure that there are no persons or obstacles in the adjustment range.
- ▶ Leave the danger area.

Refer to the valid load chart for the admissible radius values of the counterweight carriage.

The radius of the counterweight carriage is considered in the load calculation.

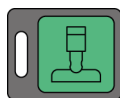
4.23.1 Activating the radius adjustment of the counterweight carriage

The wheel sets of the wheeled counterweight carriage free-wheel.

Crawler and swing are locked.

Ensure that the following conditions are fulfilled:

- No load on the boom support that would prevent the wheeled counterweight carriage being jacked up.
- The ground conditions are such that the wheeled counterweight carriage can be jacked up.



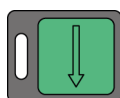
- ▶ Press the *Counterweight carriage support* button on control panel X26.



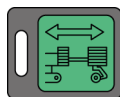
Note

Liebherr recommends:

- ▶ This procedure must be monitored by video and/or by the signalman.



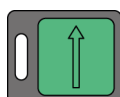
- ▶ Press and hold the button *Increase radius/support* on control panel X26 until jacks are fully extended.
 - ▷ Counterweight carriage is supported.



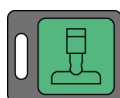
- ▶ Press the button *Counterweight carriage radius adjustment* on control panel X26.



- ▶ Press the button *Align wheel sets* on control panel X26.
 - ▷ Wheel sets are being aligned.

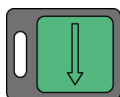


- ▶ Press and hold the button *Decrease radius/support* on control panel X26 until jacks are fully retracted.
 - ▷ Counterweight carriage rests on wheel sets.



- ▶ Press the button *Counterweight carriage support* on control panel X26 again.

4.23.2 Increasing the radius of the counterweight carriage



▶ Press and hold the button *Increase radius/support* on control panel X26.

▷ Radius of counterweight carriage increases:

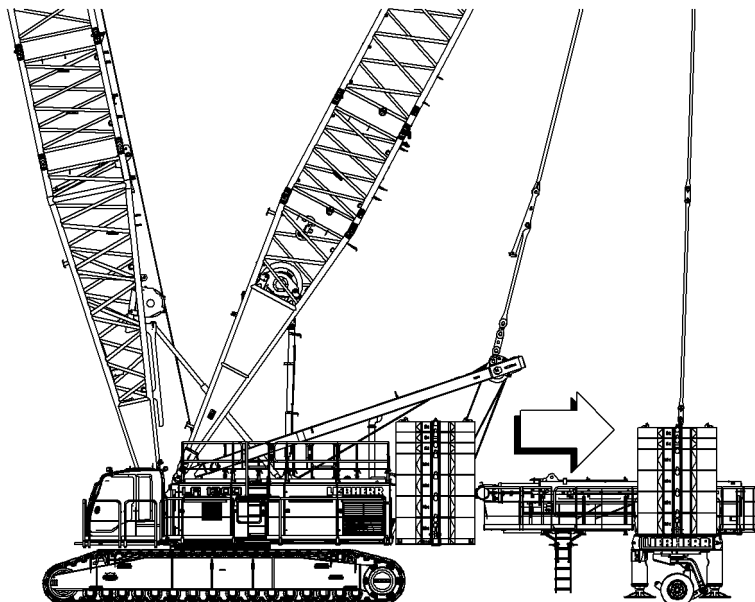
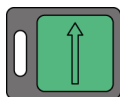


Fig. 2593: Radius of counterweight carriage increases

4.23.3 Decreasing the radius of the counterweight carriage



▶ Press and hold the button *Decrease radius/support* on control panel X26.

▷ Radius of counterweight carriage decreases:

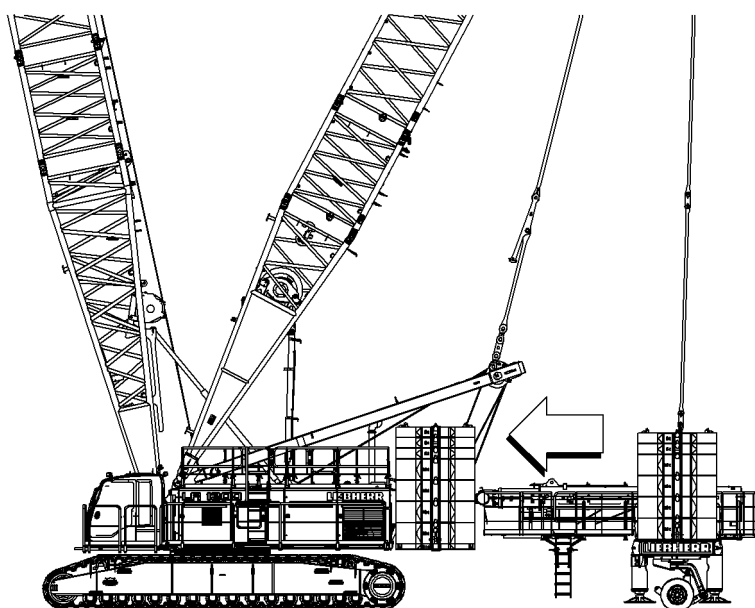
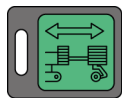


Fig. 2595: Radius of counterweight carriage decreases

4.23.4 Deactivating the radius adjustment of the counterweight carriage



- ▶ Press the button *Counterweight carriage radius adjustment* on control panel X26 again.

4.24 Derrick hoist cylinder*

The suspended counterweight or counterweight carriage can be lifted/lowered using the derrick hoist cylinder.

4.24.1 Selecting the derrick hoist cylinder

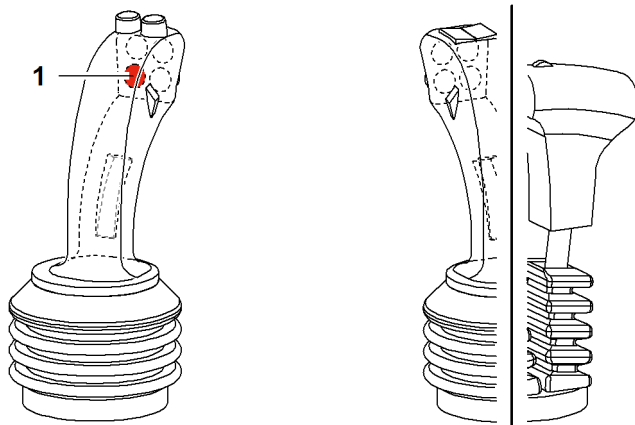


Fig. 2597: Selecting the derrick hoist cylinder

1 Button *Derrick hoist cylinder*

- ▶ Press the button *derrick hoist cylinder* 1 on the left multi-directional control lever.
 - ▷ *Derrick hoist cylinder* has been selected.
 - ▷ The symbol *derrick hoist cylinder* is displayed on the monitor:



Fig. 2598: Symbol *derrick hoist cylinder*

4.24.2 Operating the derrick hoist cylinder

Extending the derrick hoist cylinder

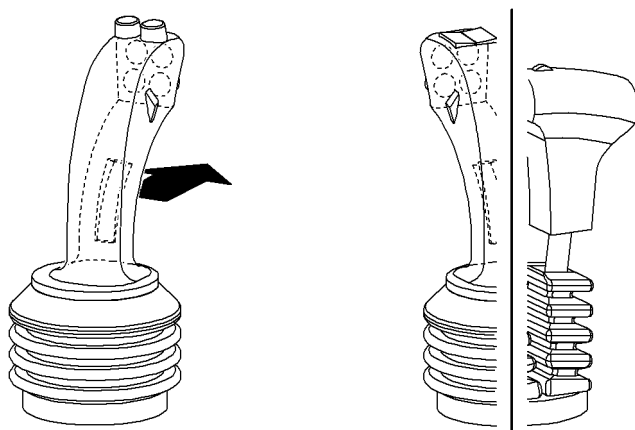


Fig. 2599: Extending the derrick hoist cylinder

- ▶ Push the left multi-directional joystick forwards.
 - ▷ Derrick lifting cylinder extends.

Retracting the derrick hoist cylinder

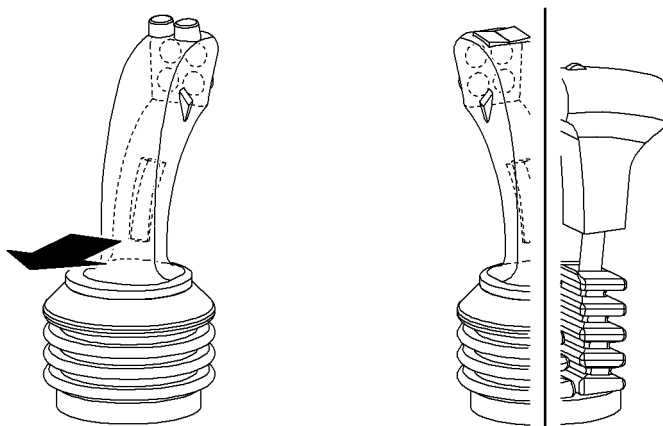


Fig. 2600: Retracting the derrick hoist cylinder

- ▶ Push left multi-directional control lever backwards.
 - ▷ Derrick hoist cylinder retracts.

4.25 Free-fall operation*

In free-fall operation rapid lowering of the empty hook is possible.



DANGER

Incorrect use of free-fall operation!

Risk of machine toppling over, structural breakdown.

- ▶ Use the free-fall operation at load position 1 (boom head section) only.
- ▶ Use free-fall operation with empty hooks only.
- ▶ All braking operations must be carried out carefully and sensitively.
- ▶ While braking the empty hook in free-fall operation, the permitted lifting capacity must not be exceeded.
- ▶ Permanently observe the load moment limitation on the *Operation* screen when braking.
- ▶ Ensure that free-fall operation is carried out by experienced and specially-trained personnel only.

4.25.1 Switching on free-fall operation

Ensure that the following conditions are fulfilled:

- Diesel engine is turned off.
- Machine is equipped with free-fall winches.

NOTICE

Incorrect switching-on of the free-fall operation!

Damage to the hydraulic system.

- ▶ Only adjust *free-fall operation* gate valve when the diesel engine is switched off.

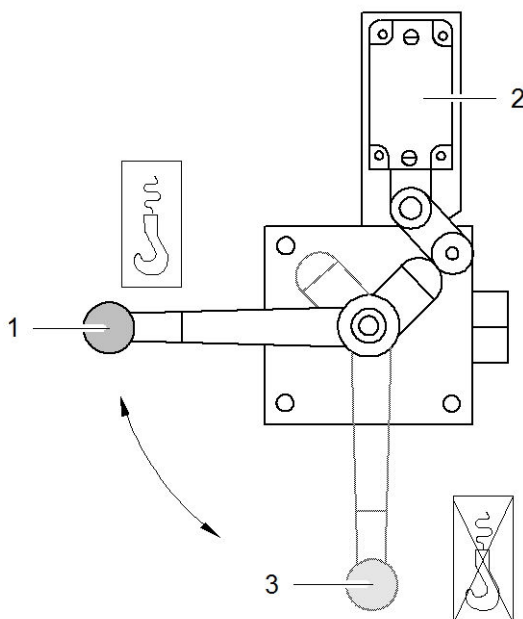


Fig. 2601: Switching on free-fall operation

- 1 On "position" 3 Off "position"
- 2 Limit switches

- ▶ Set the *free-fall operation* gate valve to "ON" 1.
 - ▷ The limit switch 2 tells the Litronic control system that free-fall operation has been switched on.
 - ▷ Symbol *Secured free-fall operation* appears on screen:



Fig. 2602: Secured free-fall operation symbol

4.25.2 Selecting free-fall mode

Ensure that the following conditions are fulfilled:

- Free-fall operation* gate valve is set to "ON".

Selecting secured free-fall operation

Secured free-fall mode is selected by default.



If the switch *Unsecured free-fall operation* is lit on control panel X12:

- ▶ Actuate the *unsecured free-fall operation* switch on control panel X12.

- ▷ Secured free-fall mode selected.
- ▷ Symbol *Secured free-fall operation* appears on screen:



Fig. 2604: Secured free-fall operation symbol

Selecting unsecured free-fall operation



▶ Actuate the *unsecured free-fall operation* switch on control panel X12.

- ▷ Unsecured free-fall mode is selected.
- ▷ Symbol *Unsecured free-fall operation* appears on screen:



Fig. 2606: Unsecured free-fall mode symbol

4.25.3 Operating free-fall operation

Ensure that the following conditions are fulfilled:

- Free-fall operation* gate valve is set to "ON".



Assigned functions of the foot pedals on a machine with two multi-directional control levers

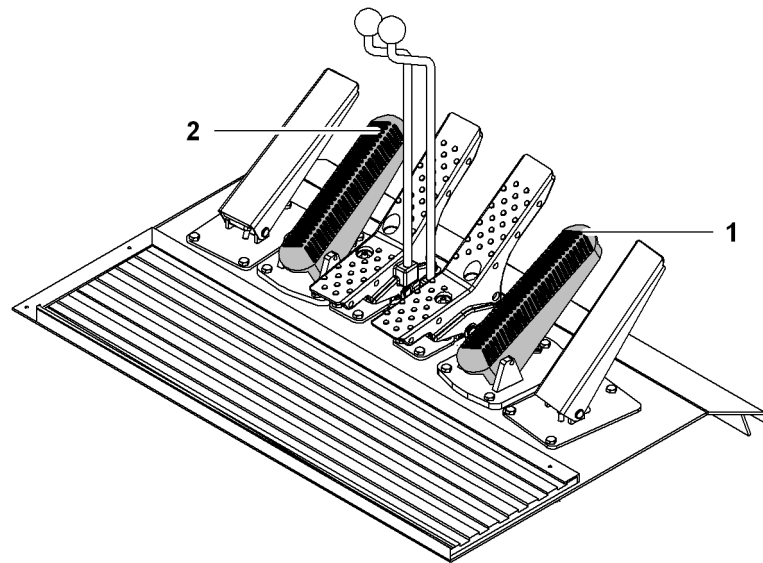
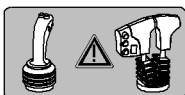


Fig. 2608: Foot pedals

1 Foot pedal *brake winch1*

2 Foot pedal *brake winch2*



Assigned functions of the foot pedals on a machine with a multi-directional control lever and a double T-lever

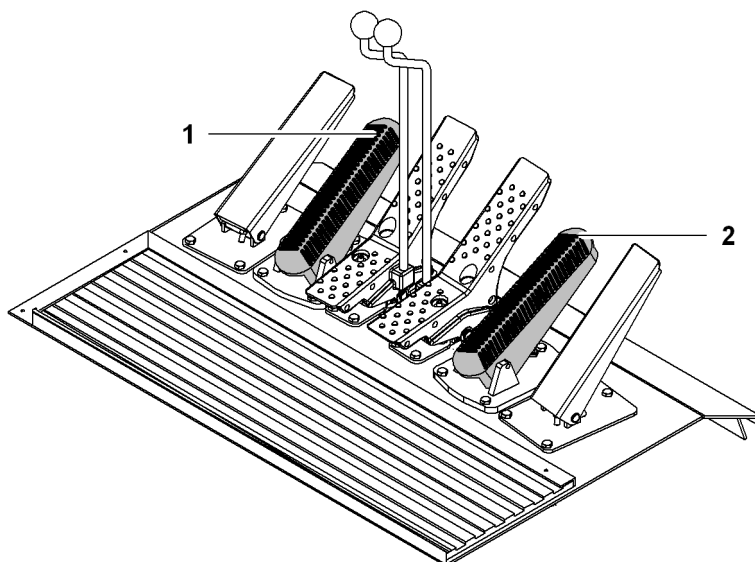


Fig. 2610: Foot pedals

1 Foot pedal *brake winch1*

2 Foot pedal *brake winch2*

The following sequence and procedure must be adhered to.

Selecting free-fall operation for winch1



▶ Press and hold the *Free-fall* button on control panel X23.

▶ Fully press down on the foot pedal *Brake free-fall winch1 1*.
 ▷ The symbol *Free-fall winch1* appears on screen:



Fig. 2612: Free-fall winch 1 symbol

If the symbol *Free-fall winch1* appears on screen:

▶ Release the *Free-fall* button on control panel X23.

Selecting free-fall operation for winch2



▶ Press and hold the *Free-fall* button on control panel X23.

▶ Fully press down on the foot pedal *Brake free-fall winch2 2*.
 ▷ The symbol *Free-fall winch2* appears on screen:



Fig. 2614: Free-fall winch 2 symbol

If the symbol *Free-fall winch2* appears on screen:

- ▶ Release the *Free-fall* button on control panel X23.

Lifting the empty hook in free-fall operation



WARNING

Opened multi-disk brake is in unsecured free-fall mode after raising the empty hook!

The free-fall winch is immediately back in free-fall as soon as the control lever is placed in neutral.

- ▶ Keep empty hook with completely depressed foot pedal *Free-fall brake winch1* or foot pedal *Free-fall brake winch2* in position.

- ▶ Move the appropriate control lever. The foot pedal *Free-fall brake winch1* or the foot pedal *Free-fall brake winch2* can be released, but does not have to be.

Troubleshooting

The load cannot be raised?

A winch stop monitor checks the swing movement of the free fall winches. The load can only be lifted again after the corresponding free-fall winch is at a stop.

If winch1 does not stand still:

- ▶ depress foot pedal *brake free-fall winch1* stronger.

If winch2 does not stand still:

- ▶ depress foot pedal *brake free-fall winch2* stronger.

If the problem persists:

- ▶ Contact Liebherr after sales service.

Lowering the empty hook in free-fall operation



CAUTION

Overrunning of winch1/winch2 rope!

Slacking of the rope

Loose and irregular winding on the free-fall winch.

3 rope windings limit switch and rope measuring system altered.

- ▶ Stop the free-fall winch with the appropriate foot pedal *Free-fall brake winch1* or the foot pedal *Free-fall winch2* immediately once the empty hook has touched the ground.

- ▶ Lowering empty hook on winch1: Release foot pedal *Brake free-fall winch1*.

- ▶ Lowering empty hook on winch2: Release foot pedal *Brake free-fall winch2*.

Stopping the empty hook in free-fall operation

- ▶ Stopping empty hook on winch1: Press foot pedal *Brake free-fall winch1*.
 - ▷ Winch1 is braked until it comes to a stop.

- ▶ Stopping empty hook on winch2: Press foot pedal *Brake free-fall winch2*.
 - ▷ Winch2 is braked until it comes to a stop.

4.25.4 Switching off free-fall operation

Ensure that the following conditions are fulfilled:

- Winch1 and winch2 stand still.



DANGER

Winches will turn when the safety lever is pulled up!

Free-fall operation is not locked.

Machine toppling over, structural breakdown.

- ▶ Make sure that winches are stationary before the safety lever is pulled up.



- ▶ Press the *Free-fall* button on control panel X23.

- ▶ Lift safety lever.

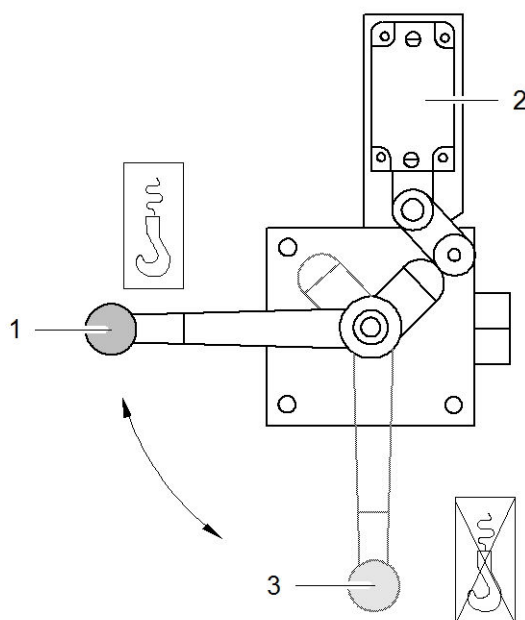


Fig. 2616: Switching off free-fall operation

1 On "position"

2 Limit switch

3 Off "position"

- ▶ Set the *free-fall operation* gate valve to "OFF".
 - ▷ Free-fall mode is switched off.
 - ▷ Symbols for free-fall mode no longer appear on the monitor.

4.26 Winch synchronization*

Winch synchronization involves synchronizing the rope speeds of winch1 and winch2.

Using the winch synchronization:

- Single hook mode with two winches on one hook
- Twin hook mode with two winches on one load
- Working with crossbeams

4.26.1 Activating winch synchronization

Ensure that the following conditions are fulfilled:

- Winch1 rope and winch2 rope have the same length.
- Winch1 rope and winch2 rope are reeved evenly.
- Load is distributed evenly on winch1 and winch2.
- Winch1 and winch2 stand still.

Activate winch synchronization on control lever

Procedure on a machine with two multi-directional control levers

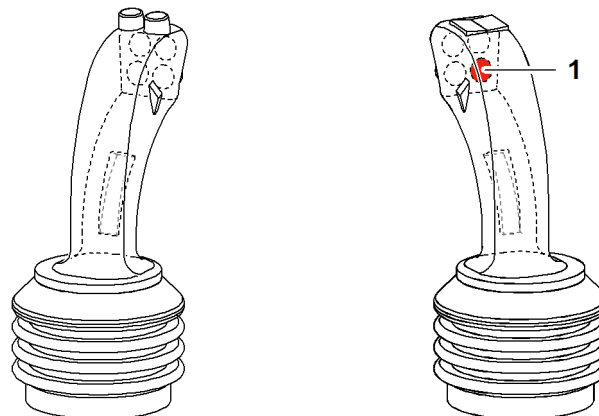


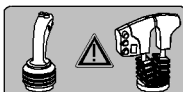
Fig. 2618: Activate winch synchronization on multi-directional control lever

1 Button Winch synchronization

- ▶ Press and hold the *Winch synchronization 1* button on the right multi-directional control lever.
 - ▷ Winch synchronization is activated until the button *Winch synchronization* is no longer pushed and winch1 and winch2 stand still.
 - ▷ The symbol *Winch synchronization* appears on screen:



Fig. 2619: Winch synchronization symbol



Procedure on a machine with a multi-directional control lever and a double T-lever.

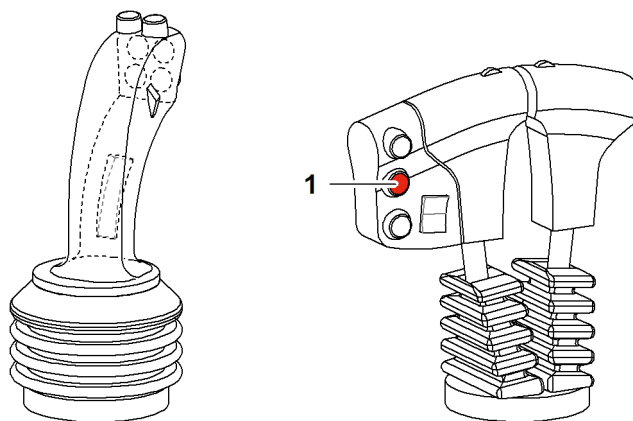


Fig. 2621: Switching the winch synchronization on using the double T-lever

1 Button Winch synchronization

- ▶ Press and hold the *Winch synchronization 1* button on the right double T-lever.
 - ▷ Winch synchronization is activated until the button *Winch synchronization* is no longer pushed and winch1 and winch2 stand still.
 - ▷ The symbol *Winch synchronization* appears on screen:



Fig. 2622: Winch synchronization symbol

Activating the winch synchronization on control panel X23



- ▶ Press the *Winch synchronization* button on control panel X23.

- ▷ Winch synchronization is activated and remains on after winch1 and winch2 stand still.
- ▷ The symbol *Winch synchronization* appears on screen:



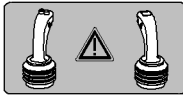
Fig. 2624: Winch synchronization symbol

4.26.2 Operating the winch synchronization

NOTICE

Incorrect adjustment of the main boom when winch synchronization is activated!
Tilting of the hook or the crossbar.
Damage to machine.

- ▶ Only adjust the main boom when lifting or lowering winch1 and winch2 simultaneously.



Procedure on a machine with two multi-directional control levers

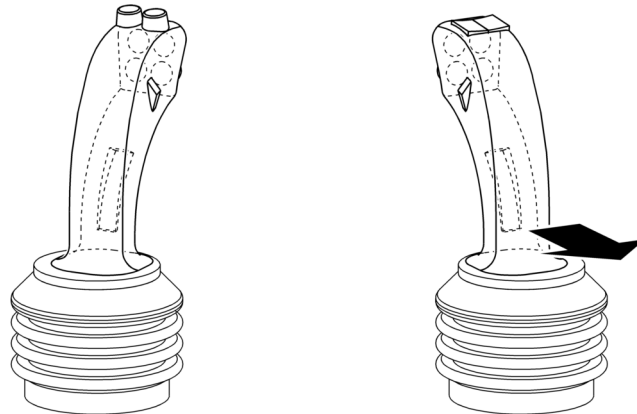


Fig. 2626: Lifting winch1 and winch2 with the multi-directional control lever

- ▶ Lifting winch1 and winch2: push the right multi-directional control lever backwards.
 - ▷ Winch1 and winch2 lift.

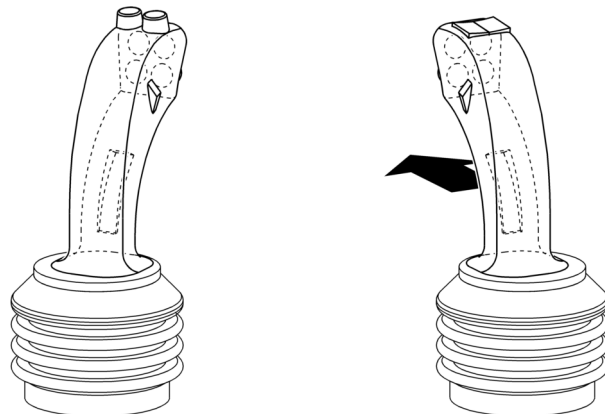
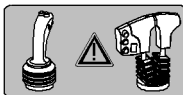


Fig. 2627: Lowering winch1 and winch2 with the multi-directional control lever

- ▶ Lowering winch1 and winch2: push the right multi-directional control lever forwards.
 - ▷ Winch1 and winch2 lower.



Procedure on a machine with a multi-directional control lever and a double T-lever.

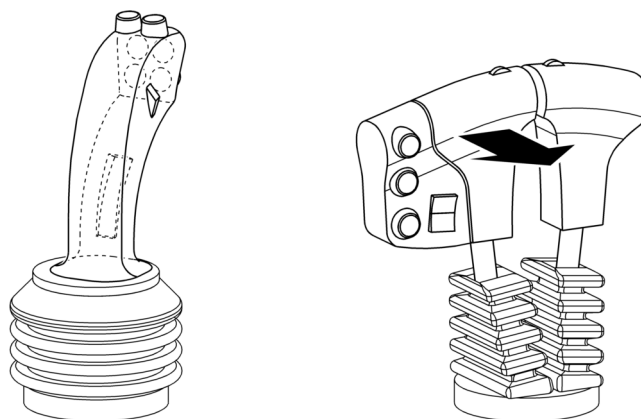


Fig. 2629: Lifting winch1 and winch2 with the double T-lever

- ▶ Lifting winch1 and winch2: push the inner T-bar control lever backwards.
 - ▷ Winch1 and winch2 lift.

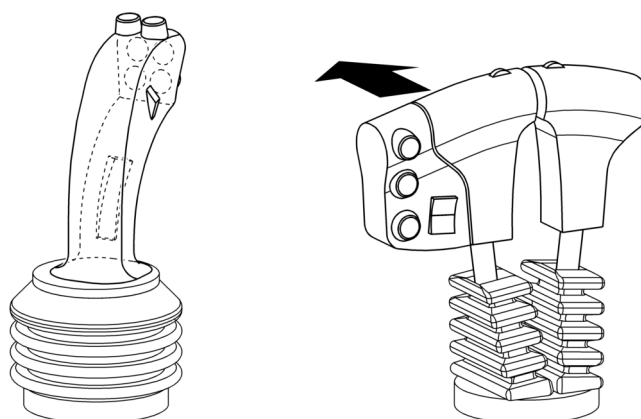


Fig. 2630: Lowering winch1 and winch2 with the double T-lever

- ▶ Lowering winch1 and winch2: push the inner T-bar control lever forwards.
 - ▷ Winch1 and winch2 lower.

4.26.3 Deactivating winch synchronization

Ensure that the following conditions are fulfilled:

- Winch1 and winch2 stand still.

Deactivate winch synchronization on control lever

- ▶ Release the *Winch synchronization* button on the right control lever.
 - ▷ Winch synchronization is switched off.

Deactivating the winch synchronization on control panel X23

- ▶ Press the *Winch synchronization* button on control panel X23 again.
 - ▷ Winch synchronization is switched off.



4.27 Blocked crawlers*

To extend the tipping line of the machine, steel plates of a precise thickness can be inserted underneath the tumbler or idler. The difference in height between the running rollers and the tumbler (or the running rollers and the idler) is evened out.

Properties of blocked crawlers:

- Extension of tilting edge
- Increased load-bearing capacity
- Swing radius limitation of uppercarriage
- Traveling with machine is prohibited
- Can lead to higher ground pressures

The example below explains the system. This example only applies to one machine configuration.



DANGER

Incorrect operation of blocked crawlers!
Structural breakdown.

The structure curve specifies the minimum loading limit of the components (swing, pendant straps, A-frames, chord pipes, diagonals, etc.).

► Work only with values that are within the structure curve (grey load chart value).

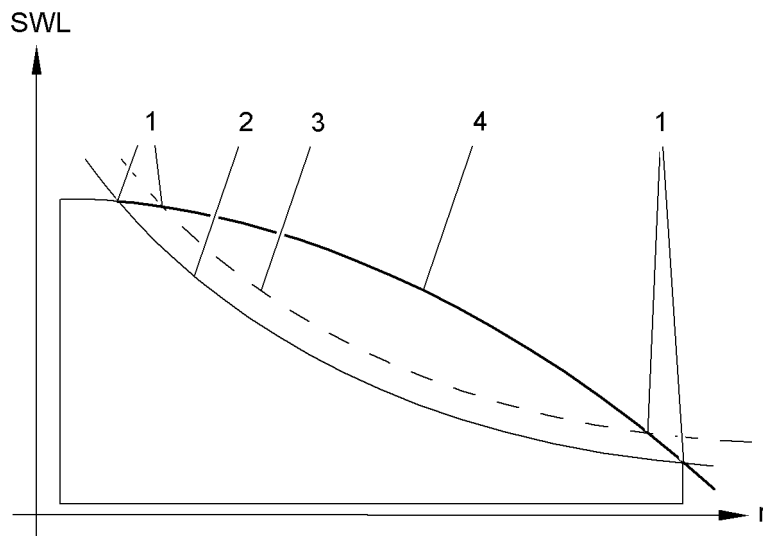


Fig. 2632: Diagram

- | | |
|---|--|
| <p>1 Intersection between tilt curve and structure curve</p> <p>2 Tilt curve for maximum counterweight (360°)</p> | <p>3 Tilt curve for blocked crawlers (limited swing angle)</p> <p>4 Structure curve of the machine</p> |
|---|--|

The tilt curve is calculated from the equilibrium of weights rotating forwards and backwards (dead weight + load weights). The minimum of the two curves gives the valid load capacity chart.

Blocked crawlers can extend the normal lifting capacity range that is limited by the machine tilt curve 2. It may be the case that the extended tilt curve 3 is intersected by the falling structure curve 4. If this is the case, the structure curve takes precedence with respect to the maximum radius.

Make sure that the support plates are laid out in the required thickness.

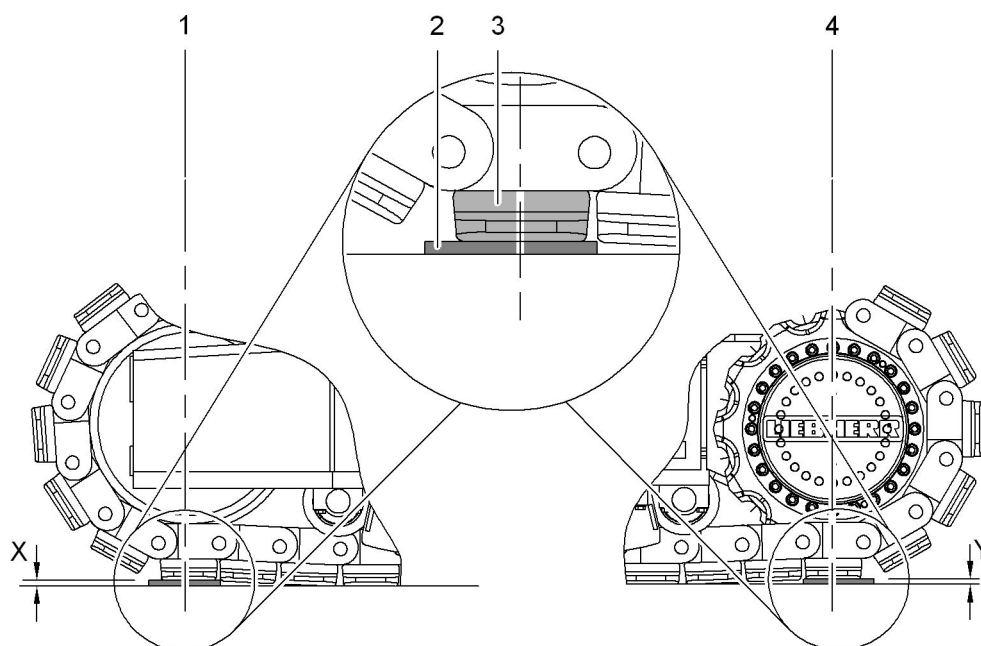


Fig. 2633: Positioning of the support plates

- 1 Center line of idler
- 2 Support plate
- 3 Ground plate
- 4 Center line of tumbler

Machine type	Idler wheel X	Tumbler Y
LR 1001	20 mm 0.79" in	20 mm 0.79" in
LR 1002	25 mm 0.98" in	25 mm 0.98" in
LR 1003	20 mm 0.79" in	20 mm 0.79" in
LR 1004	22 mm 0.87" in	15 mm 0.59" in
LR 1006	25 mm 0.98" in	17 mm 0.67" in

Tab. 377: Positioning of support pads

4.27.1 Driving onto the support plates



DANGER

Inappropriate driving onto support plates!
Machine toppling over.

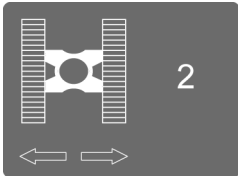
- ▶ The left and right base plates of the crawler side frames must be positioned exactly the same so they are both driven onto the support plates at the same time.
- ▶ Equalize the crawler position on both sides simultaneously. When necessary, move the crawler side frames towards one another.
- ▶ Place support plates in front of the crawler side frames.

LWNLR.x/V04.01//Auslieferung/2016-03-07/en

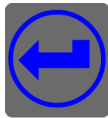
- ▶ Move precisely onto the support plates (see: fig. 2633, page 981) .
- ▶ Lock and disable the crawler.
- ▶ Press the *Setup* button on the monitor.
 - ▷ The *Setup* screen appears on the monitor.



- ▶ Press the *Setup - basic machine* button on the monitor.
 - ▷ The *Setup - basic machine* screen appears on the monitor.



- ▶ Press the button *Track width* on the monitor and select value "3".



- ▶ Press the button *Calculate load chart* (lit blue) on the monitor.
 - ▷ Load chart is being recalculated.

4.27.2 Working with Blocked Crawlers

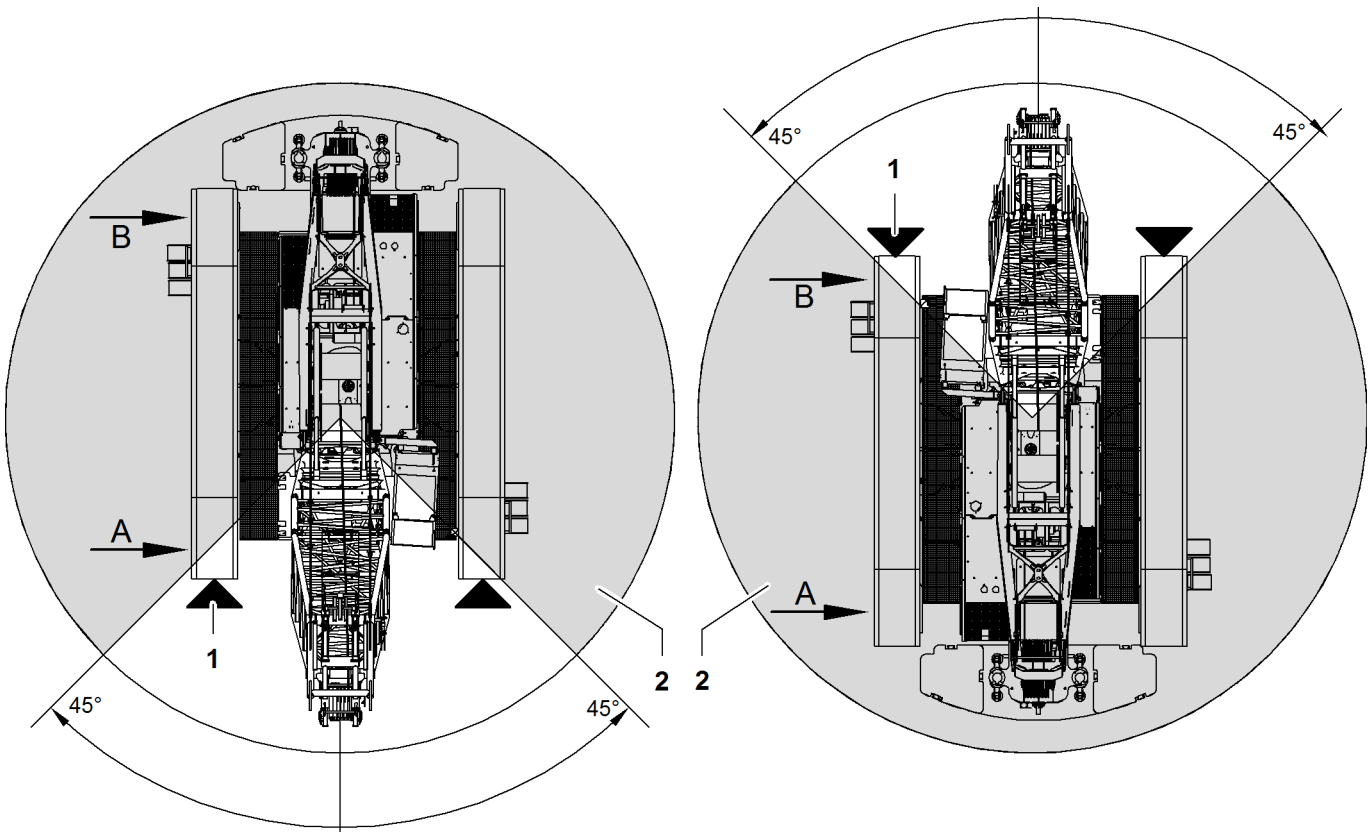


Fig. 2638: Working with blocked crawlers

- | | | | |
|---|-----------------|---|--------------|
| 1 | Base plate (2x) | A | Tumbler (2x) |
| 2 | Blocked area | B | Idler (2x) |

LWNLR-x\04.01\Auslieferung\2016-03-07\en

**DANGER**

Uppercarriage swing angle is too great!
Machine toppling over.

- ▶ Rotation is permitted only up to an angle of $\pm 45^\circ$ along the crawler side frames.
- ▶ Do not move into the blocked area **2**.

In EU load charts, the swing movement of the uppercarriage will be automatically restricted via the swing angle transmitter.

With ANSI load charts, responsibility for swinging the uppercarriage rests with the machine operator.

4.28 Assembly cylinder *

4.28.1 Select assembly cylinder



- ▶ Press the *Assembly cylinder* button on control panel X23.

4.28.2 Operating the assembly cylinder



WARNING

Individuals in the swing range of the assembly cylinder!
Severe injury.

- ▶ Ensure that there is nobody in the swing range of the assembly cylinder.
- ▶ Leave the danger area.

Extend assembly cylinder



Procedure on a machine with two multi-directional control levers

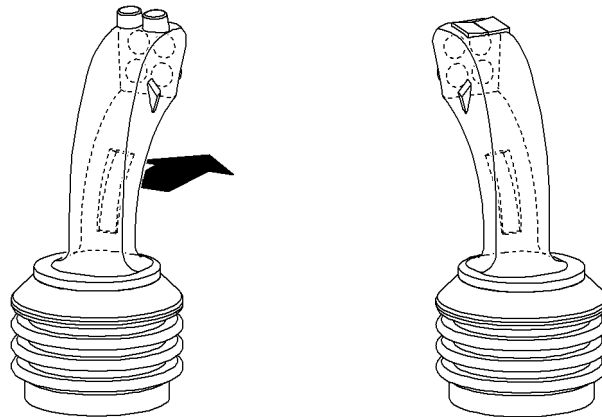
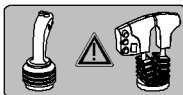


Fig. 2641: Extending the assembly cylinder with multi-directional control lever

- ▶ Push left multi-directional control lever forward.
 - ▷ The assembly cylinder extends.



Procedure on a machine with a multi-directional control lever and a double T-lever.

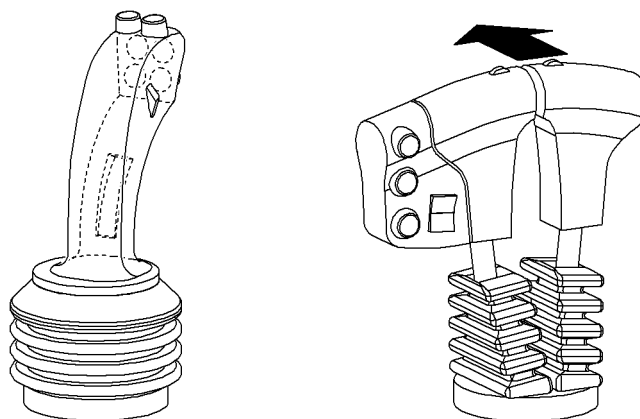


Fig. 2643: Extending the assembly cylinder using the double T-lever

- ▶ Push the outer T-lever forwards.
 - ▷ The assembly cylinder extends.

Retract assembly cylinder

Procedure on a machine with two multi-directional control levers

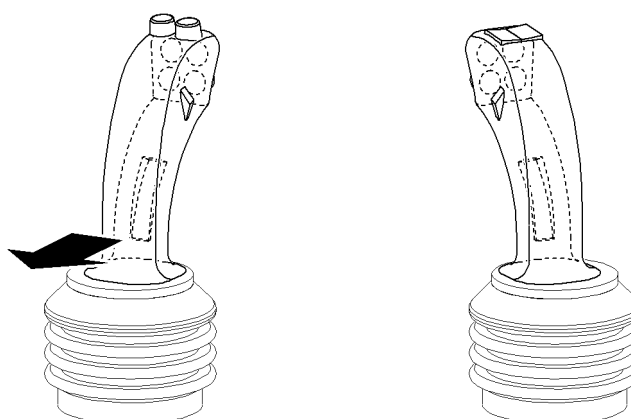
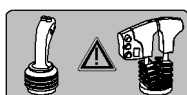


Fig. 2645: Retracting the assembly cylinder with multi-directional control lever

- ▶ Push the left multi-directional control lever backwards.
 - ▷ The assembly cylinder retracts.

Procedure on a machine with a multi-directional control lever and a double T-lever.



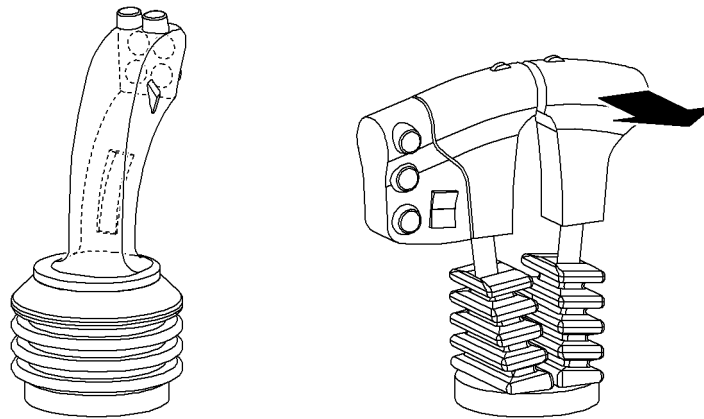


Fig. 2647: Extending the assembly cylinder using the double T-lever

- ▶ Push the outer T-lever backwards.
- ▷ The assembly cylinder retracts.

4.29 Filling machine with fuel

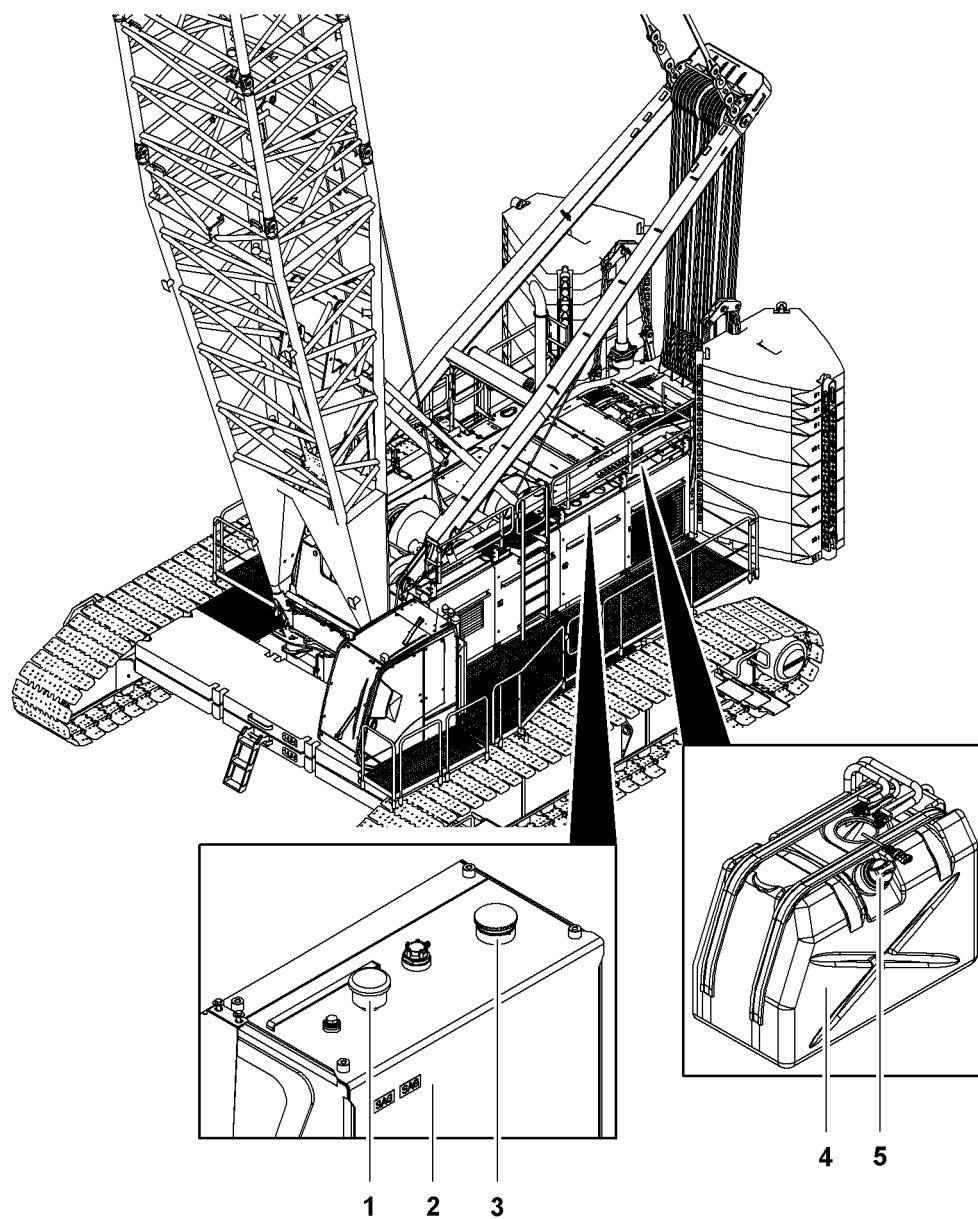


Fig. 2648: Filling machine with fuel

- | | | | |
|---|----------------|---|------------|
| 1 | Venting filter | 4 | Urea tank |
| 2 | Fuel tank | 5 | Tank cover |
| 3 | Tank cover | | |

4.29.1 Filling the fuel tank

Make sure the following prerequisites are met:

- Auxiliary heating* is turned off.
- External air conditioning system* is turned off.

Filling machine with fuel from a tank truck

- ▶ Switch off diesel engine.

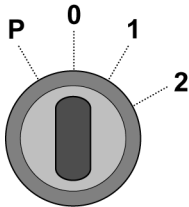
- ▶ Direct tank truck to the refueling point.
- ▶ Unlock and remove the tank cover **3**.
- ▶ Check the filler screen underneath for dirt, clean and replace if necessary.
- ▶ Fill the fuel tank **2** with the appropriate fuel according to the season (summer or winter diesel) (For more information see: 9.2.5 Fuel, page 1879) .
- ▶ Close and lock tank cover **3**.

Filling the machine with fuel from a refueling pump

NOTICE

Incorrect use of refueling pump!
Damage to the refueling pump.

- ▶ Refueling pump must only be used for pumping fuel.
- ▶ Only use the supplied suction hose.
- ▶ Ensure that the refueling pump does not run dry.



- ▶ Switch off diesel engine.
- ▶ Turn ignition key to position "1".
- ▶ Position fuel container.
- ▶ Open the center right uppercarriage door.
- ▶ Remove cover from refueling pump.
- ▶ Attach suction hose to refueling pump connector.
- ▶ Totally immerse other end of the hose with the fuel filter in the fuel.
- ▶ Press the *Pump ON* (green) button on the control panel of the refueling pump.
 - ▷ Pump starts to run.
 - ▷ As soon as the maximum filling capacity is reached, the refueling pump shuts off automatically.
- ▶ Remove the suction hose from the refueling pump and hold it up, allowing the remaining fuel to flow back into the fuel container.
- ▶ Roll up suction hose and stow it away.
- ▶ Replace cover on refueling pump.
- ▶ Close the center right uppercarriage door.

4.29.2 Filling up with urea solution*

- ▶ Switch off diesel engine.
- ▶ Open cover of urea tank **4**.
- ▶ Remove tank cover **5**.
- ▶ Fill urea tank **4** with urea solution.
- ▶ Close tank cover **5**.

4.30 Radio remote control*

4.30.1 rechargeable battery

The battery's service life depends on its age and the ambient temperature. Older batteries lose power over time. At temperatures below 0 °C (32 °F) the battery will not reach its full capacity.

NOTICE

Incorrect handling of rechargeable battery!
Risk of damage to the rechargeable battery.

- ▶ Completely charge the battery before first use.
 - ▶ Only recharge the battery after it has been completely drained.
 - ▶ Protect the charger against overheating, dust and humidity.
 - ▶ Only store the charger at room temperature (20 °C (68 °F)).
 - ▶ When putting into storage, use the protective caps provided.
 - ▶ Charge the battery before use if it has been stored for a long time.
-

4.30.2 battery charger

NOTICE

Incorrect handling of the battery charger!
Risk of damage to battery charger or rechargeable battery.

- ▶ Protect the charger against overheating, dust and humidity.
- ▶ Do not make any technical modifications to the charger or power cable.

If a defect occurs in the charger or power cable:

- ▶ Take the battery charger out of service immediately.
 - ▶ Ensure that repairs are carried out by qualified personnel only.
-

Charging the rechargeable battery with a battery charger

NOTICE

Incorrect charging of the rechargeable battery!
Risk of damage to battery charger or rechargeable battery.

- ▶ Only charge batteries of type FuB 10 AA or FuB 10 XL with the battery charger QA115600.
 - ▶ Only operate the battery charger in explosion-protected areas.
 - ▶ Only use the battery charger at the permitted mains voltage (marking on the bottom of the battery charger).
 - ▶ Operate the charger in enclosed spaces only.
 - ▶ Only operate the charger at room temperature (20 °C (68 °F)).
 - ▶ Do not cover the charger while it is in use.
-

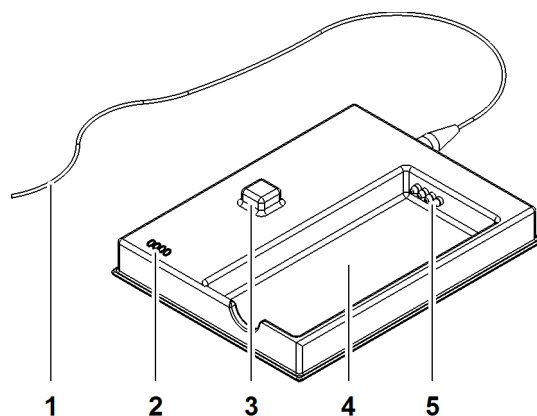


Fig. 2650: Battery charger

- | | | | |
|---|------------------|---|---------------------|
| 1 | Connection cable | 4 | Loading compartment |
| 2 | LED (4x) | 5 | Contact pin (4x) |
| 3 | Unload button | | |

Double-check that the polarity of the battery is correct.

- ▶ Insert battery with label on the outside into charging slot 4.
- ▷ Charging begins automatically.

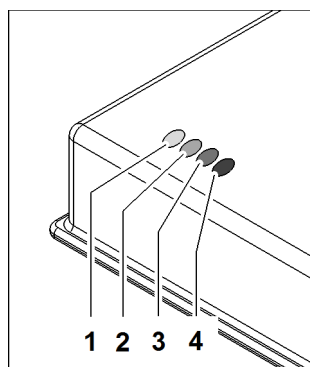


Fig. 2651: LEDs on battery charger

- | | | | |
|---|------|---|------|
| 1 | LED1 | 3 | LED3 |
| 2 | LED2 | 4 | LED4 |

Function of LED1 1:

- lit red
- Battery is defective

Function of LED2 2:

- lit yellow
- Battery is charging

Function of LED3 3:

- lit green
- Battery is charged

Function of LED4 4:

- lit yellow
- Battery is discharging

If the battery is to be discharged:

- ▶ Insert battery.
- ▶ Press the *discharge* button.
- ▷ Battery is completely discharged and automatically charged again.

4.30.3 Starting the machine with the radio remote control



WARNING

Improper use of the radio remote control!
Severe injuries, damage to machine.

- ▶ Ensure that the working range is visible from all sides.
- ▶ Ensure visual contact with the machine and the load at all times.
- ▶ Turn radio remote control off when changing location, during work breaks or at the end of work.
- ▶ Only stow away completely turned off radio remote control.
- ▶ Only remain outside the danger zone.
- ▶ Ensure that only authorised and instructed persons operate the radio remote control.



WARNING

Errors or defects while operating the radio remote control!
Inadmissible operational safety and reliability.
Severe injuries, damage to machine.

- ▶ Turn radio remote control off.
- ▶ Secure radio remote control against unauthorized startup.
- ▶ Press the *Radio remote control* switch on control panel X12.
- ▶ Contact Liebherr after sales service.



WARNING

Improper procedure with occurring error message!
Severe injuries, damage to machine.

In case of an error message:

- ▶ Adjust the mode with the radio remote control.
- ▶ Remedy error message on the monitor in the cabin.

The use of a radio remote control has the following disadvantages:

- Machine reactions seem delayed.
- The movement direction may be confusing depending on location and view-point.

Preparing the machine with the radio remote control

Ensure that the following conditions are fulfilled:

- Ignition is switched off.
- Safety lever is lowered.



- ▶ Press the *Radio remote control* switch on control panel X12.
 - ▷ The function of the ignition key on the machine is replicated on the rotary control knob *ON/OFF* of the radio remote control.
 - ▷ The control levers in the cabin are deactivated.
 - ▷ The monitor in the cabin is activated to display error messages.

Activating the radio remote control

Ensure that the following conditions are fulfilled:

- Battery of the radio remote control is charged and in perfect state.
- Radio remote control battery is inserted in radio remote control.
- Control levers are in zero position.
- ▶ Set the rotary control knob *ON/OFF* on the radio remote control to “ON”.
 - ▷ Connection established between radio remote control and machine.
 Once the radio connection has been established:
 - ▷ The screen *Confirm connection* appears on the monitor of the radio remote control:



Fig. 2653: Screen Confirm connection

- ▶ Press the *Horn* button on the right control lever of the radio remote control.
 - ▷ Machine functions are controlled with the radio remote control.
 - ▷ The *Mode* screen is displayed on the monitor of the radio remote control:



Fig. 2654: Operation screen

- ▷ The symbol *Preheat* is displayed on the monitor of the radio remote control:



Fig. 2655: Preheat symbol

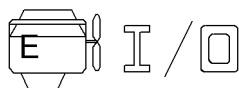
Turning the diesel engine on or off

Ensure that the following conditions are fulfilled:

Symbol *Preheat* is hidden on the monitor of the radio remote control.

- ▶ Press the button *Diesel engine* on the radio remote control.
 - ▷ Diesel engine is turned on.

- ▶ Press the button *Diesel engine* on the radio remote control again.
 - ▷ The diesel engine is switched off.



Take/cede control

Ensure that the following conditions are fulfilled:

Control levers are in zero position.

Take/cede control to/from radio remote control



- ▶ Press the button *Take/cede control* on the radio remote control.

- ▷ Control of machine functions is suspended.
- ▷ All machine functions are stopped.
- ▷ Symbol *Radio remote control locked* is displayed on the monitor of the radio remote control:



Fig. 2658: Symbol Radio remote control blocked (blinks)

- ▷ Symbol *Radio remote control* inactive* blinks on cabin monitor:



Fig. 2659: Symbol Radio remote control* inactive



- ▶ Press the button *Take/cede control* on the radio remote control again.

- ▷ Control of the machine functions is ceded to the radio remote control.
- ▷ Symbol *Radio remote control locked* is hidden on the monitor of the radio remote control.
- ▷ Symbol *Radio remote control* active* is displayed on the cabin monitor:



Fig. 2661: Symbol Radio remote control* active

Taking/ceding control in cabin



- ▶ Press the *Take/cede control* button on control panel X23.

- ▷ Control of machine functions is suspended.
- ▷ All machine functions are stopped.
- ▷ Symbol *Radio remote control locked* is displayed on the monitor of the radio remote control:



Fig. 2663: Symbol Radio remote control blocked (blinks)

- ▷ Symbol *Radio remote control* inactive* blinks on cabin monitor:



Fig. 2664: Symbol Radio remote control* inactive



- ▶ Press the button *Take/cede control* on control panel X23 again.

- ▷ Control of the machine functions is ceded to the cabin.
- ▷ Symbol *Radio remote control locked* is lit on the monitor of the radio remote control:



Fig. 2666: Symbol Radio remote control blocked (lit)

- ▷ Symbol *Radio remote control* inactive* is lit on cabin monitor:



Fig. 2667: Symbol Radio remote control* inactive

Connection interruptions

Remedying radio transmission interruptions of less than 8 seconds

Machine functions are controlled with the radio remote control.

- ▶ Radio connection is interrupted.
 - ▷ Winches, swing and crawlers are disabled.
 - ▷ Movements are braked using integration times.
 - ▷ Symbol *Radio remote control* connection error* is displayed on the cabin monitor:



Fig. 2668: Symbol *Radio remote control* connection error*

- ▷ Radio connection is automatically reestablished within 8 seconds.
- ▶ Put control lever to zero position.
 - ▷ Control of machine functions is released.

Remedying radio transmission interruptions longer than 8 seconds

Machine functions are controlled with the radio remote control.

- ▶ Connection interruption lasts longer than 8 seconds.
 - ▷ Receiver of radio remote control triggers emergency stop.
 - ▷ Symbol *Radio remote control* connection error* is displayed on the cabin monitor:



Fig. 2669: Symbol *Radio remote control* connection error*

- ▷ Radio connection is reestablished automatically.
 - ▷ The screen *Confirm connection* appears on the monitor of the radio remote control:



Fig. 2670: Screen Confirm connection

- ▶ Press the *Horn* button on the right control lever of the radio remote control.
 - ▷ The machine control is switched on.
 - ▷ Connection between receiver of radio remote control and machine control is established.
 - ▷ If the connection is successfully established, the screen *Mode* appears on the monitor of the radio remote control:

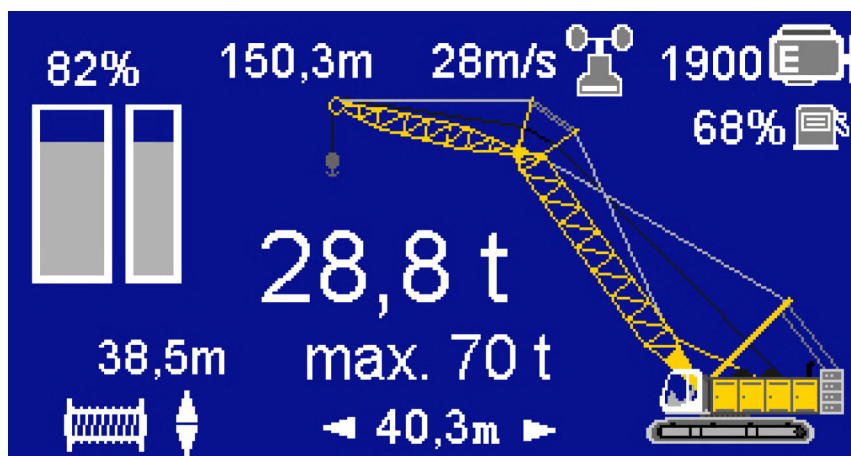


Fig. 2671: Mode screen

4.31 Rope measuring system*

The rope measuring system:

- displays the calculated rope length between the boom head and the load on the *Operation* screen and the *Settings* screen.
- keeps the machine operator constantly informed of the exact position of the load
- is displayed separately for each winch.

4.31.1 Setting the rope length to zero

Setting the rope length of winch1 to zero



- ▶ Press the *Settings* button on the monitor.



- ▶ Press the *Set to zero* button at winch1 for more than 1 second on the monitor.
 - ▷ Rope length of winch1 is set to zero

Setting the rope length of winch2 to zero



- ▶ Press the *Settings* button on the monitor.



- ▶ Press the *Set to zero* button at winch2 for more than 1 second on the monitor.
 - ▷ Rope length of winch2 is set to zero

4.31.2 Calibrating the rope measuring system

Programming layer change

To display the rope length exactly, a layer change must be programmed for the winch concerned.

The layer change:

- is programmed when the machine leaves the factory.
- normally only has to be reprogrammed after a rope change or winch repair.

Ensure that the following conditions are fulfilled:

- An assistant is available.
- Unobstructed eye contact between the assistant and the machine operator.

Programing rope layer change 1-2



- ▶ Press the *Settings* button on the monitor.



- ▶ Operate winch1 or winch2 until the rope moves from the first to the second layer.
- ▶ Stop winch1 or winch2 precisely at the layer change.
- ▶ Press the *Program rope layer change 1-2* button at winch1 or winch2 for more than 1 second on the monitor.
 - ▷ Layer change is programmed.

Programing rope layer change 3-4



- ▶ Press the *Settings* button on the monitor.



- ▶ Operate winch1 or winch2 until the rope moves from the third to the fourth layer.
- ▶ Stop winch1 or winch2 precisely at the layer change.
- ▶ Press the *Program rope layer change 3-4* button at winch1 or winch2 for more than 1 second on the monitor.
 - ▷ Layer change is programmed.

Programing rope layer change 5-6



- ▶ Press the *Settings* button on the monitor.



- ▶ Operate winch1 or winch2 until the rope moves from the fifth to the sixth layer.
- ▶ Stop winch1 or winch2 precisely at the layer change.
- ▶ Press the *Program rope layer change 5-6* button at winch1 or winch2 for more than 1 second on the monitor.
 - ▷ Layer change is programmed.

Setting the rope length to 15 windings

With short ropes with which the second layer cannot be reached, the rope measuring system can be calibrated with 15 windings on the first layer.



- ▶ Press the *Settings* button on the monitor.



- ▶ Operate winch1 or winch2 until there are exactly 15 windings on the first layer.
- ▶ Press the button *Set rope length to 15 windings* on winch1 or winch2 for more than 1 second on the monitor.
 - ▷ Rope measuring system is calibrated.

4.32 Ground pressure display*

4.32.1 Operating the ground pressure display



DANGER

Ground has a limited bearing strength!
Machine toppling over.

- ▶ Observe the safety notes regarding the load-bearing capacity of the ground (For more information see: [2.11.11 Ground bearing strength, page 596](#)).



DANGER

Idealized, theoretical ground pressure display values.
Machine toppling over.

- ▶ Note that considerably higher ground pressure values can occur in the field.

The ground pressure indicator on the *Operation* screen shows the ground pressure in bar (psi) calculated by the control independent of the position of the uppercarriage.

The displayed values are theoretical maximum values based on current load and radius.

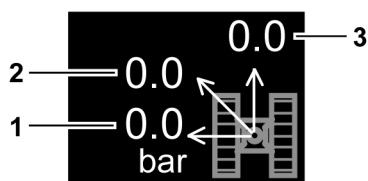


Fig. 2684: Screen clipping Ground pressure

- | | |
|---|---|
| <p>1 Maximum ground pressure to the side</p> <p>2 Maximum ground pressure across one edge</p> | <p>3 Maximum ground pressure forward</p> |
|---|---|
- Maximum ground pressure to the side **1**: Uppercarriage slewed diagonal to direction of travel ($90^{\circ}/270^{\circ}$)
 - Maximum ground pressure across one edge **2**: Uppercarriage slewed across one of the four undercarriage edges ($45^{\circ}/135^{\circ}/225^{\circ}/315^{\circ}$)
 - Maximum ground pressure forward **3**: Uppercarriage slewed in or opposite to direction of travel ($0^{\circ}/180^{\circ}$)

4.33 Inclination display*

4.33.1 Operating the inclinometer

The inclination indicator on the screen *Operation* shows the angle of the uppercarriage in the x and y axis in degrees.

Values up to $\pm 5^\circ$ can be displayed.

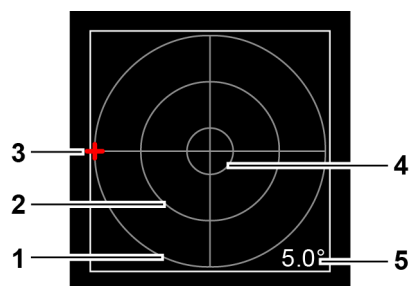


Fig. 2685: Screen clipping Inclination display

- | | | | |
|---|-----------------------|---|------------------------------|
| 1 | Inclination circle 5° | 4 | Inclination circle 1° |
| 2 | Inclination circle 3° | 5 | Inclination angle of machine |
| 3 | Spirit level | | |

4.34 Working range limitation*



WARNING

Exceeding of working range limitation through dynamic and inertia!
Severe injuries, collision of machine with obstacles.

- ▶ Program working range limitation with safety distance.
- ▶ Approach the working range limitations slowly.



WARNING

Incorrect working range limitations after moving the machine!
Severe injuries, damage to machine.

- ▶ Check working range limitations after each time the machine is moved and reprogram if necessary.

4.34.1 Operating the edge limitation

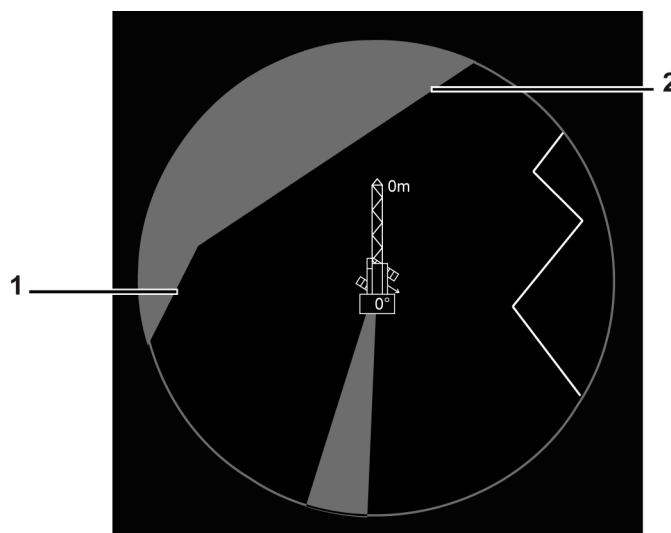


Fig. 2686: Screen section Working range limitation - edge limitation

1 Edge1

2 Edge2

Programming the edge limitation

The procedure for programming the edge limitation is identical for the main boom and the jib.



- ▶ Press the *Working range limitation* button on the monitor.
 - ▷ Screen *Working range limitation - working range limitation* is displayed.



- ▶ Press the *Programming* button on the monitor.
 - ▷ The stop positions buttons appear.

- ▶ Edge1 - approach stop position1.



▶ Press the button *Edge limitation - edge1 - stop position1* on the monitor.

▶ Edge1 - approach stop position2.



▶ Press the button *Edge limitation - edge1 - stop position2* on the monitor.
▷ Edge1 is programmed.

▶ Edge2 - approach stop position1.



▶ Press the button *Edge limitation - edge2 - stop position1* on the monitor.

▶ Edge2 - approach stop position2.



▶ Press the button *Edge limitation - edge2 - stop position2* on the monitor.
▷ Edge2 is programmed.

Turning the edge limitation on or off



▶ Press the *Edge limitation* button on the monitor.

▷ Edge limitation is activated:

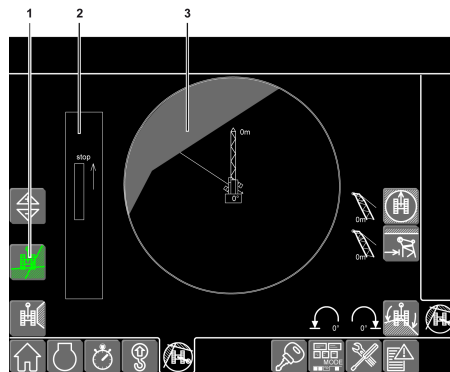


Fig. 2694: Screen Working range limitation - working range limitation - edge limitation activated

- | | |
|---|-------------------------------------|
| <p>1 Button <i>Edge limitation</i></p> <p>2 Bar display</p> | <p>3 Programmed edge limitation</p> |
|---|-------------------------------------|



▶ Press the button *Edge limitation* (lit green) on the monitor.
▷ The edge limitation is switched off.

4.34.2 Operating the sector limitation

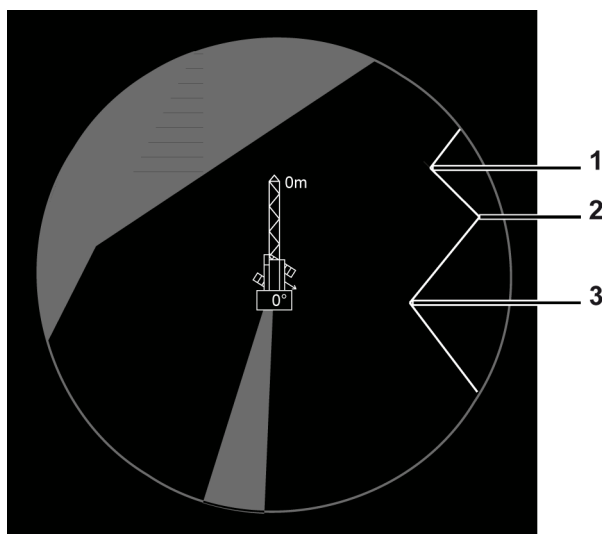


Fig. 2696: Screen section Working range limitation - sector limitation

- 1 Stop position1
- 2 Stop position2
- 3 Stop position3

Programing the sector limitation

The procedure for programing the sector limitation is identical for the main boom and the jib.



- ▶ Press the *Working range limitation* button on the monitor.
 - ▷ Screen *Working range limitation - working range limitation* is displayed.



- ▶ Press the *Programming* button on the monitor.
 - ▷ The stop positions buttons appear.



- ▶ Approach stop position1.
- ▶ Press the button *Sector limitation - stop position1* on the monitor.



- ▶ Approach stop position2.
- ▶ Press the button *Sector limitation - stop position2* on the monitor.



- ▶ Approach stop position3.
- ▶ Press the button *Sector limitation - stop position3* on the monitor.
 - ▷ Sector limitation is programed.

LWNLR.x/V04.01//Auslieferung/2016-03-07/en

Turning the sector limitation on or off



▶ Press the *Sector limitation* button on the monitor.

▷ Sector limitation is activated:

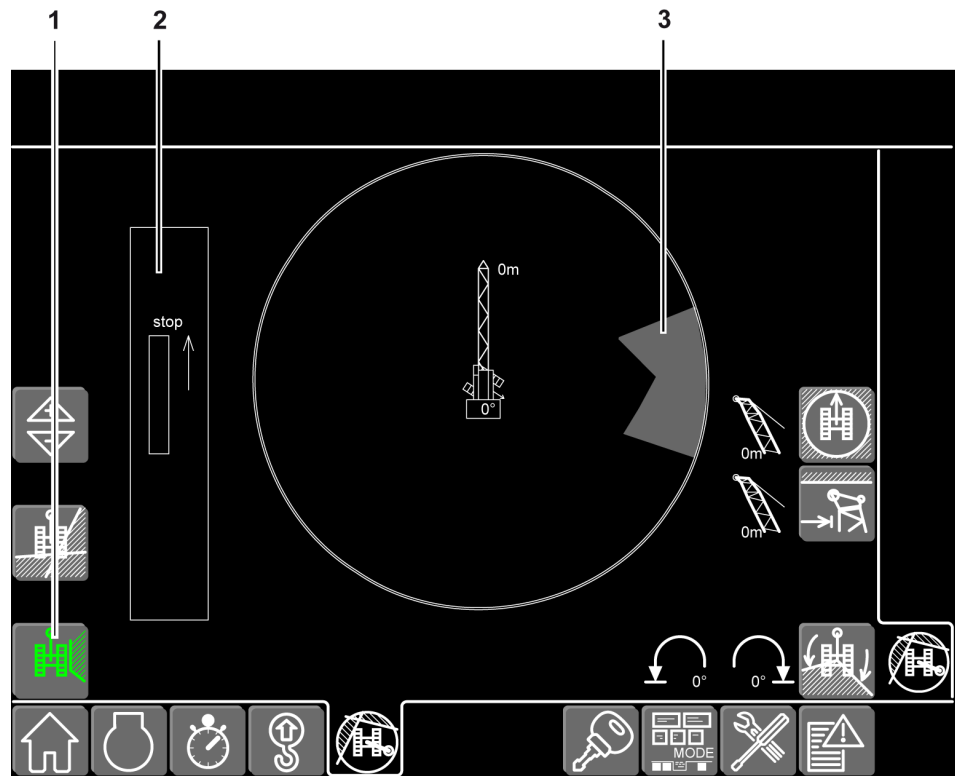
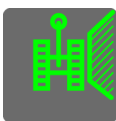


Fig. 2703: Screen Working range limitation - working range limitation - sector limitation activated

- | | | | |
|---|---------------------------------|---|------------------------------|
| 1 | Button <i>Sector limitation</i> | 3 | Programmed sector limitation |
| 2 | Bar display | | |



▶ Press the button *Sector limitation* (lit green) on the monitor.
▷ Sector limitation is switched off.

4.34.3 Operating the radius limitation

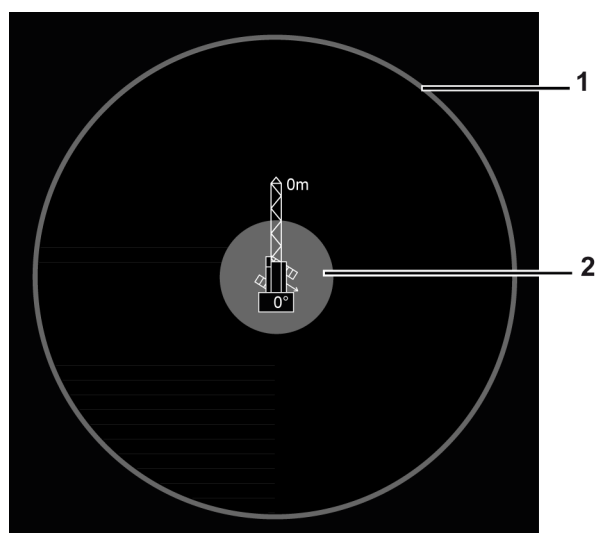


Fig. 2705: Screen section Working range limitation - radius limitation

1 Maximum radius

2 Minimum radius

Programing the main boom radius limitation



- ▶ Press the *Working range limitation* button on the monitor.
 - ▷ Screen *Working range limitation - working range limitation* is displayed.



- ▶ Press the *Programming* button on the monitor.
 - ▷ The stop positions buttons appear.



- ▶ Approach the stop position of the maximum main boom radius.
- ▶ Press the button *Stop position maximum main boom radius* next to the button *Radius limitation maximum main boom radius* on the monitor.
 - ▷ Radius limitation maximum main boom radius is programed.



- ▶ Approach the stop position of the minimum main boom radius.
- ▶ Press the button *Stop position minimum main boom radius* next to the button *Radius limitation minimum main boom radius* on the monitor.
 - ▷ Radius limitation minimum main boom radius is programed.

Programing the jib radius limitation



- ▶ Press the *Working range limitation* button on the monitor.
 - ▷ Screen *Working range limitation - working range limitation* is displayed.



- ▶ Press the *Programming* button on the monitor.
 - ▷ The stop positions buttons appear.

- ▶ Approach the stop position of the maximum jib radius.



- ▶ Press the button *Stop position maximum jib radius* next to the button *Radius limitation maximum jib radius* on the monitor.
 - ▷ Radius limitation maximum jib radius is programmed.



- ▶ Approach the stop position of the minimum jib radius.
- ▶ Press the button *Stop position minimum jib radius* next to the button *Radius limitation minimum jib radius* on the monitor.
 - ▷ Radius limitation minimum jib radius is programmed.

Activating/deactivating the radius limitation

Activating/deactivating the minimum radius radius limitation



- ▶ Press the button *Radius limitation minimum radius* for main boom or jib on the monitor.

- ▷ Radius limitation minimum radius is activated for main boom or jib:

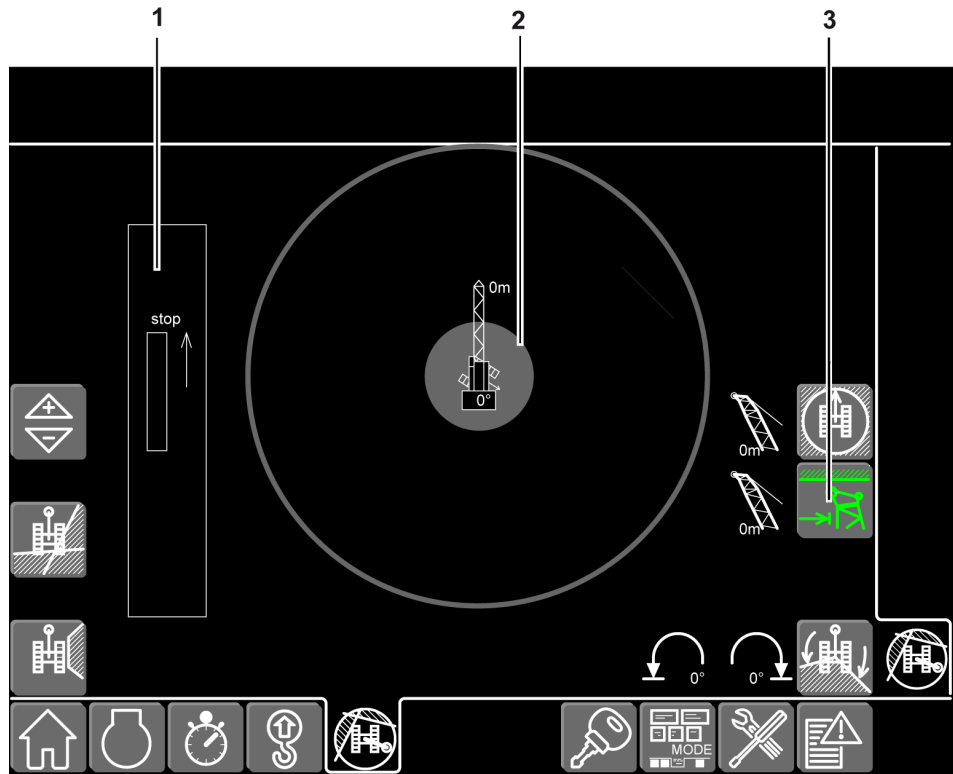
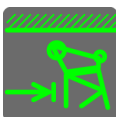


Fig. 2715: Screen Working range limitation - working range limitation - radius limitation minimum radius activated

- 1 Bar display
- 2 Programmed radius limitation minimum radius
- 3 Button *Radius limitation minimum radius*



- ▶ Press the button *Radius limitation minimum radius* (lit green) for main boom or jib on the monitor.
 - ▷ Radius limitation minimum radius is deactivated for main boom or jib.

Activating/deactivating the maximum radius limitation



- ▶ Press the button *Radius limitation maximum radius* for main boom or jib on the monitor.

▷ Radius limitation maximum radius is activated for main boom or jib:

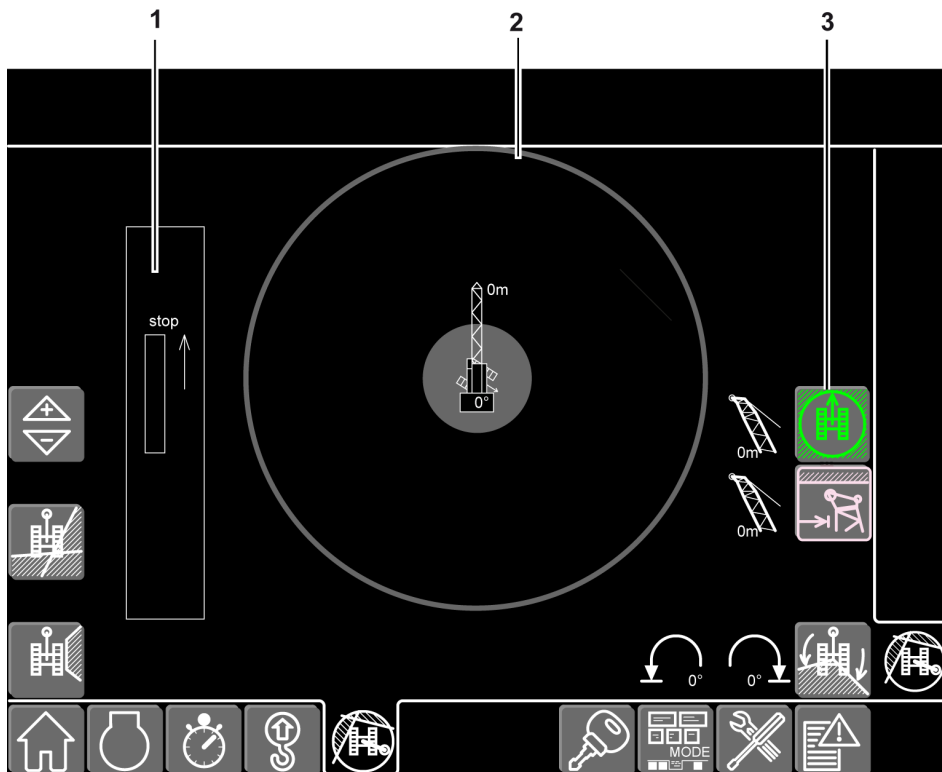


Fig. 2718: Screen Working range limitation - working range limitation - radius limitation maximum radius activated

- | | |
|--|--|
| <ul style="list-style-type: none"> 1 Bar display 2 Programmed radius limitation maximum radius | <ul style="list-style-type: none"> 3 Button <i>Radius limitation maximum radius</i> |
|--|--|



- ▶ Press the button *Radius limitation maximum radius* (lit green) for main boom or jib on the monitor.
- ▷ Radius limitation maximum radius is deactivated for main boom or jib.

4.34.4 Operating the slewing range limitation

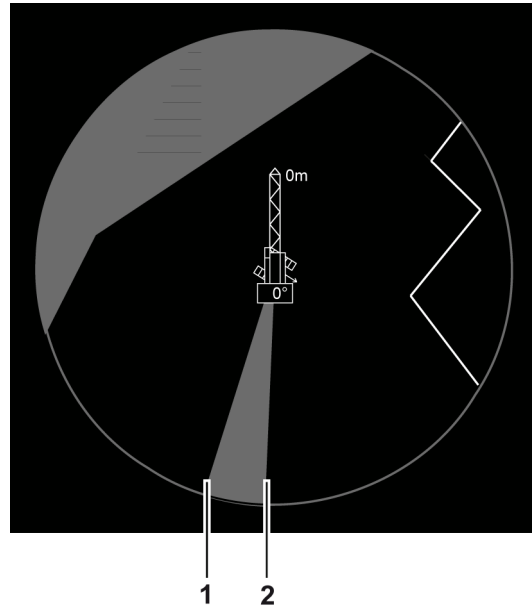


Fig. 2720: Screen section Working range limitation - slewing range limitation

1 Left stop position

2 Right stop position

Programming the slewing range limitation



- ▶ Press the button *Working range limitation* on the monitor.
 - ▷ Screen *Working range limitation - working range limitation* is displayed.



- ▶ Press the *Programming* button on the monitor.
 - ▷ The stop positions buttons appear.



- ▶ Approach left stop position.
- ▶ Press the button *Slewing range limitation - left stop position* on the monitor.

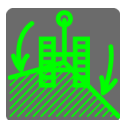


- ▶ Approach right stop position.
- ▶ Press the button *Slewing range limitation - right stop position* on the monitor.
 - ▷ Slewing range limitation is programmed.

Activating/deactivating the slewing range limitation



- ▶ Press the *Slewing range limitation* button on the monitor.
 - ▷ Slewing range limitation is activated.



- ▶ Press the button *Slewing range limitation* (lit green) on the monitor.
- ▷ Slewing range limitation is deactivated.

4.34.5 Operating the lifting height limitation

Programming the lifting height limitation



- ▶ Press the button *Working range limitation* on the monitor.
- ▷ Screen *Working range limitation - working range limitation* is displayed.



- ▶ Press the button *Working range limitation - lifting height limitation* on the monitor.
- ▷ Screen *Working range limitation - lifting height limitation* is displayed.

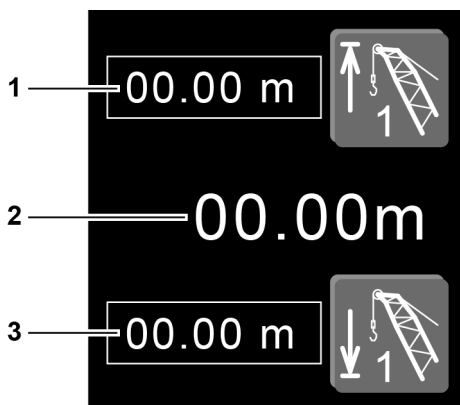


Fig. 2729: Screen section *Lifting height limitation winch1*

- 1 Top stop position of winch1
- 2 Current lifting height of winch1
- 3 Bottom stop position of winch1

- ▶ Click Top stop position **1** of winch1 on the monitor and enter the desired value.
- or**



Press the button *Lifting height limitation winch1 - top stop position* on the monitor.

- ▷ Current lifting height **2** of winch1 is programmed as top stop position **1** of winch1.

- ▶ Click Bottom stop position **3** of winch1 on the monitor and enter the desired value.
- or**



Press the button *Lifting height limitation winch1 - bottom stop position* on the monitor.

- ▷ Current lifting height **2** of winch1 is programmed as bottom stop position **3** of winch1.

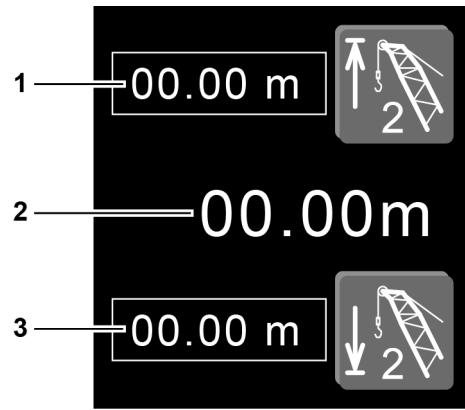


Fig. 2732: Screen section Lifting height limitation winch2

- 1 Top stop position of winch2
- 2 Current lifting height of winch2
- 3 Bottom stop position of winch2

► Click Top stop position 1 of winch2 on the monitor and enter the desired value.
or



Press the button *Lifting height limitation winch2 - top stop position* on the monitor.

▷ Current lifting height 2 of winch2 is programmed as top stop position 1 of winch2.

► Click Bottom stop position 3 of winch2 on the monitor and enter the desired value.
or



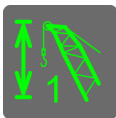
Press the button *Lifting height limitation winch2 - bottom stop position* on the monitor.

▷ Current lifting height 2 of winch2 is programmed as bottom stop position 3 of winch2.

Activating/deactivating the lifting height limitation



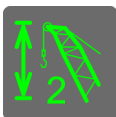
► Press the button *Lifting height limitation winch1* on the monitor.
▷ Lifting height limitation of winch1 is activated.



► Press the button *Lifting height limitation winch1* (lit green) on the monitor.
▷ Lifting height limitation of winch1 is deactivated.



► Press the button *Lifting height limitation winch2* on the monitor.
▷ Lifting height limitation of winch2 is activated.



► Press the button *Lifting height limitation winch2* (lit green) on the monitor.
▷ Lifting height limitation of winch2 is deactivated.

4.34.6 Cancelling the stop after crawler operation

Movements of the swing and the booms are stopped after operating the crawler.



- ▶ Press the button *Working range limitation* on the monitor (blinks yellow).
 - ▷ Screen *Working range limitation - working range limitation* is displayed.



- ▶ Press the button *Program* (lit red) on the monitor.
 - ▷ The stop positions buttons appear.



If the stop positions are still valid despite moving the machine:

- ▶ Press the button *Program* (lit red) on the monitor again.

- ▷ The button *Programming* is lit green.
- ▷ Working range limitations are confirmed.
- ▷ Movements of the swing and the booms are cleared.

If the stop positions are no longer valid because of moving the machine:

- ▶ Reprogram the working range limitations.

4.34.7 Resetting limitations



- ▶ Press the button *Working range limitation* on the monitor.
 - ▷ Screen *Working range limitation - working range limitation* is displayed.



- ▶ Press the *Programming* button on the monitor.
 - ▷ The stop positions buttons appear.



- ▶ Press the *Reset limitations* button on the monitor for more than 1 second.
 - ▷ All limitations are reset.

4.35 Assistance system horizontal load path*

The assistance system horizontal load path makes it possible to keep the lifting height of the load constant when the radius is changed. The assistance system horizontal load path functions when adjusting the main boom, adjusting the job and when simultaneously adjusting both booms.

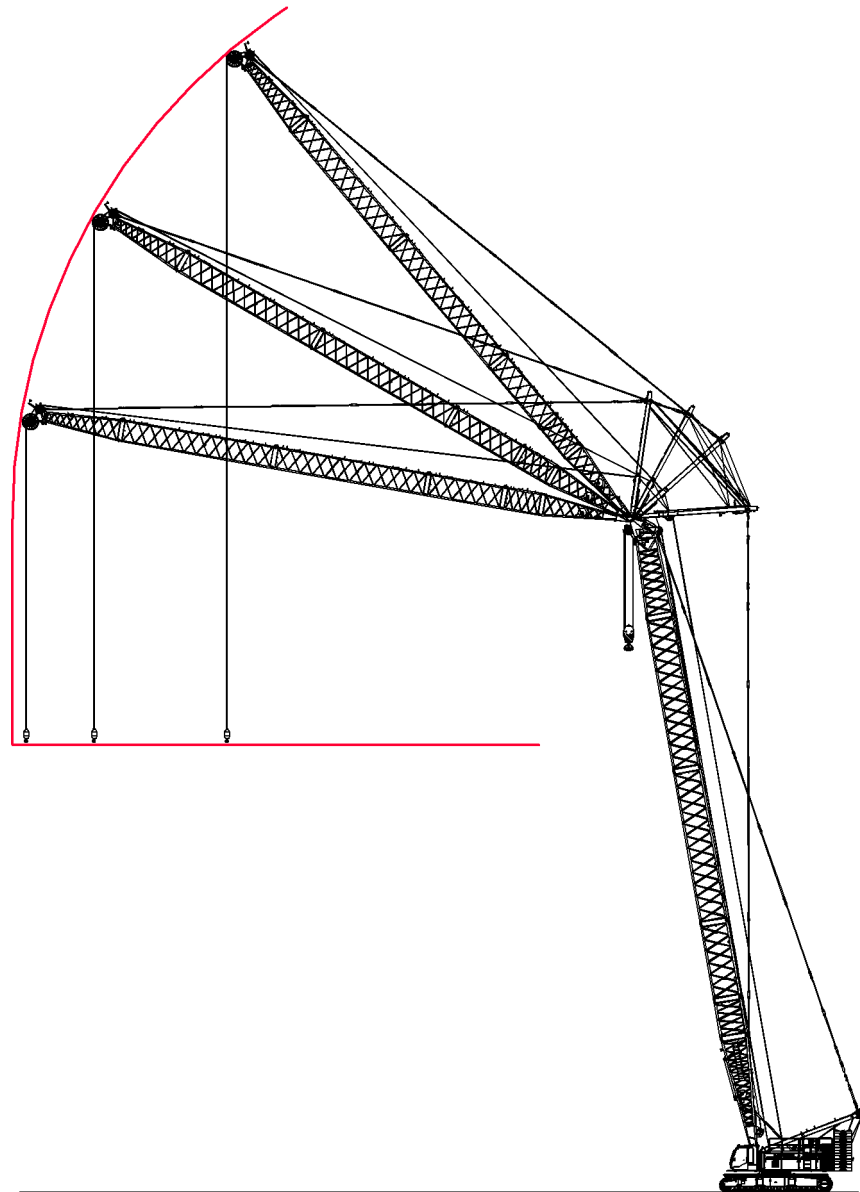


Fig. 2745: Assistance system horizontal load path (illustration of principle)

4.35.1 Activating horizontal load path

Activating horizontal load path for winch1

Make sure the following prerequisites are met:

- Winch1 stands still.
- Control lever is in zero position.



- ▶ Press the button *Horizontal load path/Vertical line finder winch1* on control panel X23.
 - ▷ Horizontal load path for winch1 is activated.

Activating horizontal load path for winch2

Make sure the following prerequisites are met:

- Winch2 stands still.
- Control lever is in zero position.

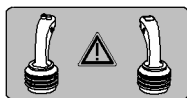


- ▶ Press the button *Horizontal load path/Vertical line finder winch2* on control panel X23.
 - ▷ Horizontal load path for winch2 is activated.

4.35.2 Activating horizontal load path

Make sure the following prerequisites are met:

- Horizontal load path for winch1 or winch2 is activated.
- Control lever is in zero position.



Procedure on a machine with two multi-directional control levers

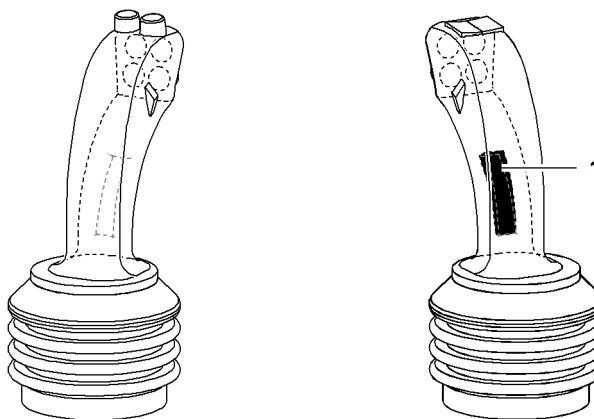


Fig. 2749: Activating horizontal load path with multi-directional control lever

1 Button *Horizontal load path*

- ▶ Press and hold the *Horizontal load path 1* button on the right multi-directional control lever.
- ▶ Adjust main boom (For more information see: 4.20.1 Operating the main boom, page 944) or jib (For more information see: 4.21.2 Operating the jib, page 950) .
 - ▷ Lifting height of load is kept constant.
 - ▷ If horizontal load path is activated for winch1:
 - ▷ The symbol *Horizontal load path winch1* is displayed on the monitor:



Fig. 2750: Symbol *Horizontal load path winch 1*

If horizontal load path is activated for winch2:

- ▷ The symbol *Horizontal load path winch2* is displayed on the monitor:

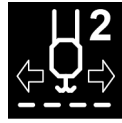
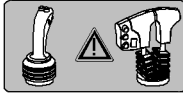


Fig. 2751: Symbol *Horizontal load path winch2*

- ▶ Release the *Horizontal load path* button on the right multi-directional control lever.



Procedure on a machine with a multi-directional control lever and a double T-lever

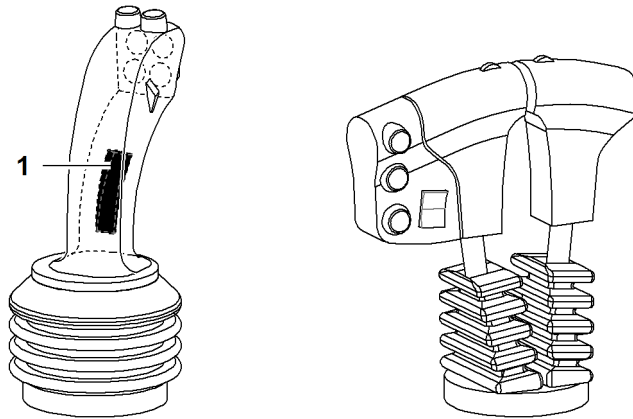


Fig. 2753: Activating horizontal load path with double-T lever

1 Button *Horizontal load path*

- ▶ Press and hold the *Horizontal load path 1* button on the left multi-directional control lever.
- ▶ Adjust main boom (For more information see: [4.20.1 Operating the main boom, page 944](#)) or jib (For more information see: [4.21.2 Operating the jib, page 950](#)) .
 - ▷ Lifting height of load is kept constant.

If horizontal load path is activated for winch1:

- ▷ The symbol *Horizontal load path winch1* is displayed on the monitor:

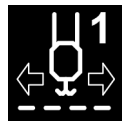


Fig. 2754: Symbol *Horizontal load path winch1*

If horizontal load path is activated for winch2:

- ▷ The symbol *Horizontal load path winch2* is displayed on the monitor:



Fig. 2755: Symbol *Horizontal load path winch2*

- ▶ Release the *Horizontal load path* button on the left multi-directional control lever.

4.35.3 Deactivating horizontal load path

Deactivating horizontal load path for winch1

Make sure the following prerequisites are met:

- Winch1 stands still.
- Control lever is in zero position.



- ▶ Press the button *Horizontal load path/Vertical line finder winch1* on control panel X23 again.
 - ▷ Horizontal load path for winch1 is deactivated.

Deactivating horizontal load path for winch2

Make sure the following prerequisites are met:

- Winch2 stands still.
- Control lever is in zero position.



- ▶ Press the button *Horizontal load path/Vertical line finder winch2* on control panel X23 again.
 - ▷ Horizontal load path for winch2 is deactivated.

4.36 Vertical Line Finder* assistance system

The Vertical Line Finder assistance system serves to determine the rope's angle of departure on the boom head. The determined angle of departure of the rope is displayed on the monitor. This allows the machine operator to detect and prevent a diagonal pull.

With the Vertical Line Finder assistance system, the boom head can be positioned above the center of gravity of the load while lifting the load.

4.36.1 Setting deviations of the Vertical Line Finder to zero

Make sure the following prerequisites are met:

- Load is lifted and does not swing.
- Minimum load weight is 2 t (4,409 lb) x the number of reevings.

The deviations of the Vertical Line Finder must be set to zero at each change of reeving or change of the boom configuration.



- ▶ Press the *Settings* button on the monitor.
 - ▷ The *Settings* screen appears on the monitor.



- ▶ Press the *Set deviation of Vertical Line Finder to zero* button for more than 1 second on the monitor.
 - ▷ Deviation of the Vertical Line Finder is set to zero.

4.36.2 Activating the positioning of the boom head above the load's center of gravity



- ▶ Press the *Settings* button on the monitor.
 - ▷ The *Settings* screen appears on the monitor.



- ▶ Press the *Vertical Line Finder* button on the monitor for more than 1 second.
 - ▷ Positioning of the boom head above the load's center of gravity is activated.

4.36.3 Positioning the boom head above load's center of gravity

Make sure the following prerequisites are met:

- Load is on the ground.
- Load is rigged to hook.
- Vertical Line Finder is installed on the boom head with the rigged load.
- Machine operates in single-hook mode.

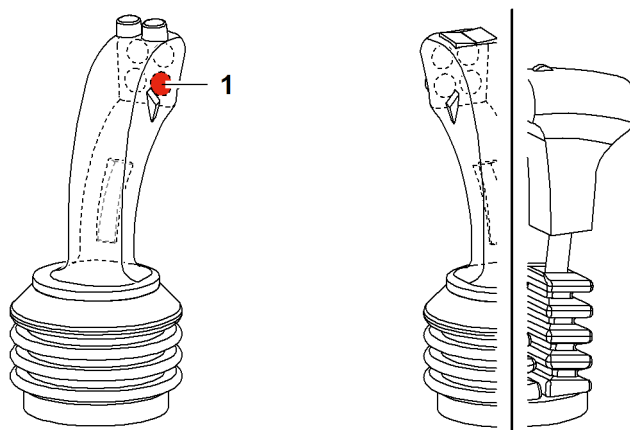


Fig. 2762: Positioning the boom head above load's center of gravity

1 Button Vertical Line Finder



If load is rigged to winch1:

- ▶ Press the button *Horizontal load path/Vertical line finder winch1* on control panel X23.
- ▶ Lift load on winch1 and at the same time press and hold the button *Vertical Line Finder 1* on the left multi-directional control lever.



If load is rigged to winch2:

- ▶ Press the button *Horizontal load path/Vertical line finder winch2* on control panel X23.
- ▶ Lift load on winch2 and at the same time press and hold the button *Vertical Line Finder 1* on the left multi-directional control lever.
 - ▷ Machine adjusts the boom and turns the uppercarriage until the boom head is positioned above the load's center of gravity.
 - ▷ The screen section *Vertical Line Finder* on the *Operation* screen is displayed in green:

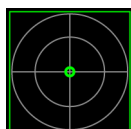


Fig. 2765: Screen section Vertical Line Finder

When the load lifts off the ground:

- ▶ Release the button *Vertical Line Finder 1* button on the left multi-directional control lever.

4.36.4 Deactivating the positioning of the boom head above the load's center of gravity



- ▶ Press the *Settings* button on the monitor.
 - ▷ The *Settings* screen appears on the monitor.



- ▶ Press the *Vertical Line Finder* button (lit green) on the monitor for more than 1 second.
 - ▷ Positioning of the boom head above the load's center of gravity is deactivated.

4.37 Rope reeving winch



WARNING

Improper use of rope reeving winch!
Severe injuries, damage to machine.

- ▶ Only use rope reeving winch to reeve ropes.
- ▶ Do not install any swivels in the reeving winch rope.

4.37.1 Setting the rope reeving winch to free-wheel

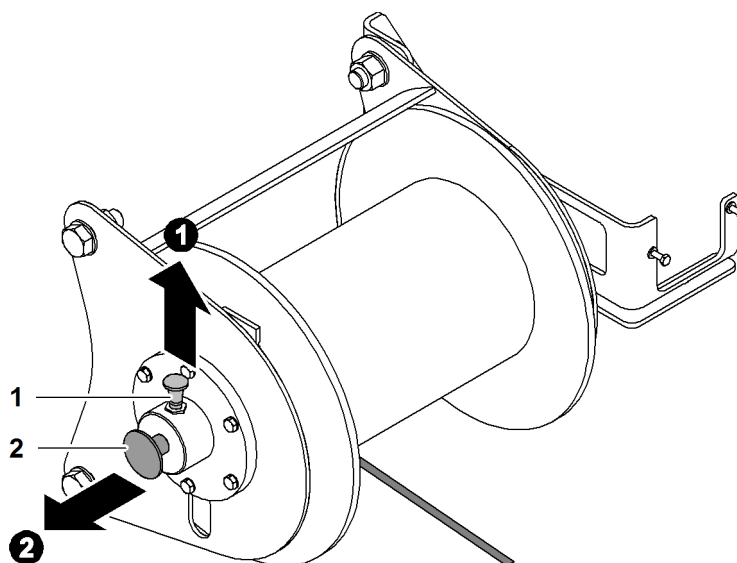


Fig. 2768: Setting the rope reeving winch to free-wheel

1 Securing element

2 Axis



Note

Liebherr recommends:

- ▶ To facilitate extension of the axis **2**: Move rope reeving winch forward and backward by hand.
- ▶ Pull up securing element **1** and pull out axis **2** at the same time.
 - ▷ Rope reeving winch is set to free-fall.

4.37.2 Deactivating rope reeving winch free-fall

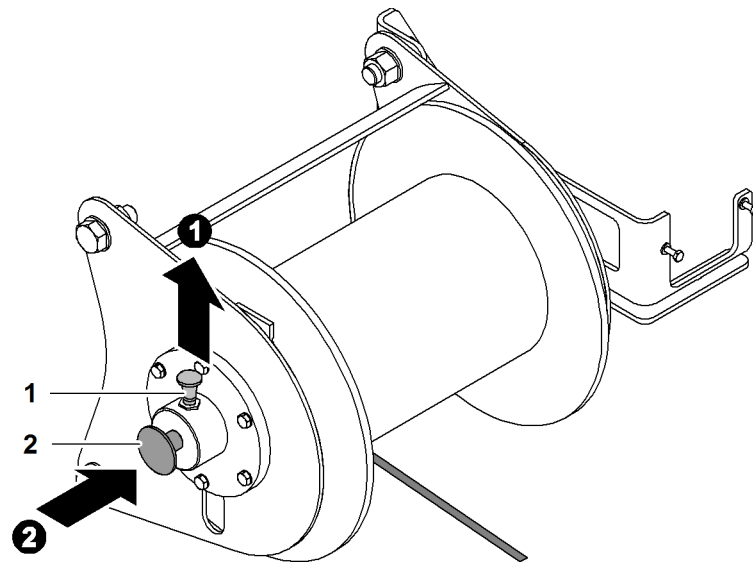


Fig. 2769: Deactivating rope reeving winch free-fall

1 Securing element

2 Axis



Note

Liebherr recommends:

- ▶ To facilitate pushing in the axis 2: Move rope reeving winch forward and backward by hand.
- ▶ Pull up securing element 1 and push in axis 2 at the same time.
 - ▷ Rope reeving winch free-wheel is deactivated.

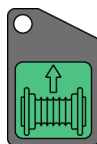
4.37.3 Reeving the rope of the rope reeving winch



WARNING

Do not stand in close proximity to the rope reeving winch and the rope of the rope reeving winch!
Severe injury.

- ▶ Make sure that nobody is located in the danger zone.
- ▶ Leave danger zone.



- ▶ Press and hold the *Rope reeving winch* button on control panel X11.
 - ▷ Rope of rope reeving winch is reeved.
- ▶ Press the *Rope reeving winch* button on control panel X11.
 - ▷ Rope reeving winch is deactivated.

4.38 Tagline winch*



WARNING

Use of the tagline winch requires a special mode of operation!
Severe injuries, damage to machine.

- ▶ For more information regarding special modes of operation: Contact Liebherr after sales service.



WARNING

The tagline winch must not be used as an auxiliary winch!
The tagline winch fixed-caliber disc brake is released in case of an emergency stop or after switching off the diesel engine.
Severe injuries, damage to machine.

- ▶ Only use the tagline winch for its intended purpose.



WARNING

Inadmissible pulling up of safety lever with activated tagline winch!
Tagline winch is not addressed and automatically switches to free-wheel.
Severe injuries, damage to machine.

- ▶ Only work with tagline winch when safety lever is lowered.

4.38.1 Putting the tagline winch into operation

- ▶ Unwind tagline rope manually from the tagline winch.

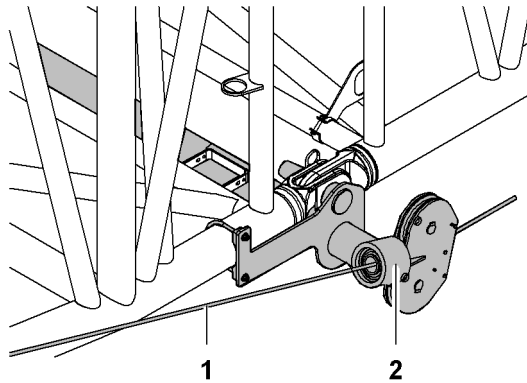


Fig. 2771: Feed tagline through rope bracket

- | | | | |
|---|--------------------|---|--------------|
| 1 | Tagline winch rope | 2 | Rope bracket |
|---|--------------------|---|--------------|

- ▶ Feed tagline winch rope 1 through rope bracket 2.

NOTICE

Incorrect use of the machine with tagline winch switched off and tagline winch rope 1 attached to the rigging material!
Damage to the tagline winch.

When the tagline winch rope 1 is attached to the rigging material:

- ▶ Only operate machine with tagline winch switched on.

- ▶ Attach tagline winch rope **1** properly to rigging material.
- ▶ Check the oil level of the tagline winch

4.38.2 Turn the tagline winch on or off

Immediately after the tagline winch is switched on, the tagline is wound up and tensioned with the preset constant tension (For more information see: 4.38.3 Set the constant tension of the tagline winch, page 1021) .



CAUTION

The rigging material may suddenly swing out when the tagline winch is switched on!

- ▶ As the tagline winch is switched on and while it is being used, ensure that no one is near the rigging material or between the tagline winch and the rigging material.
- ▶ Watch the reaction of the rigging material when the tagline winch is switched on.



- ▶ Press the *Tagline* button on control panel X23.
 - ▷ The tagline winch is switched on.
- ▶ Press the *Tagline* button on control panel X23 again.
 - ▷ The tagline winch is switched off.

4.38.3 Set the constant tension of the tagline winch

The constant tension is at least 2 kN (450 lb,) and no more than 50% of the maximum pull force.

Increasing the constant pull of the tagline winch

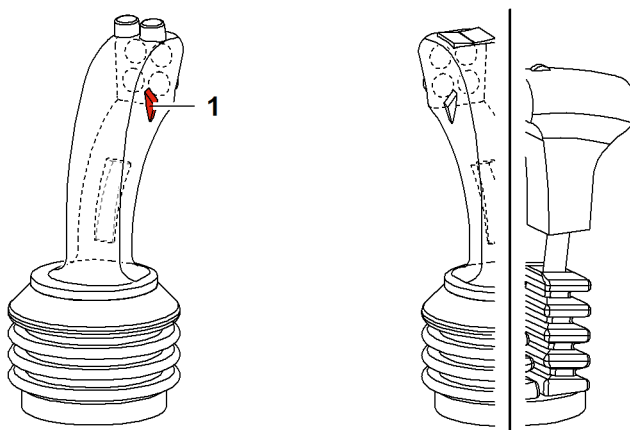


Fig. 2773: Increasing the constant pull of the tagline winch

- 1 Rotary control knob *Constant pull tagline winch*
- ▶ Turn up rotary control knob *Constant pull tagline winch* 1 on left multi-directional control lever.
 - ▷ The constant tension of the tagline winch increases to a maximum of 50% of the maximum pull force.

Reducing the constant pull of the tagline winch

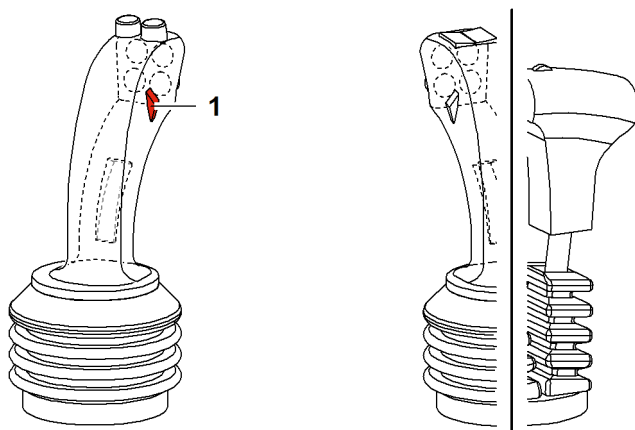


Fig. 2774: Reducing the constant pull of the tagline winch

1 Rotary control knob *Constant pull tagline winch*

- ▶ Turn down rotary control knob *Constant pull tagline winch 1* on left multi-directional control lever.
 - ▷ The constant pull of the tagline winch reduces to a minimum of the minimum pull force.

4.38.4 Setting the pull force of the tagline winch

The *tagline winch* foot pedal is used to adjust the pull force of the tagline winch between the preset constant pull and the maximum pull force.

Increasing the pull force of the tagline winch

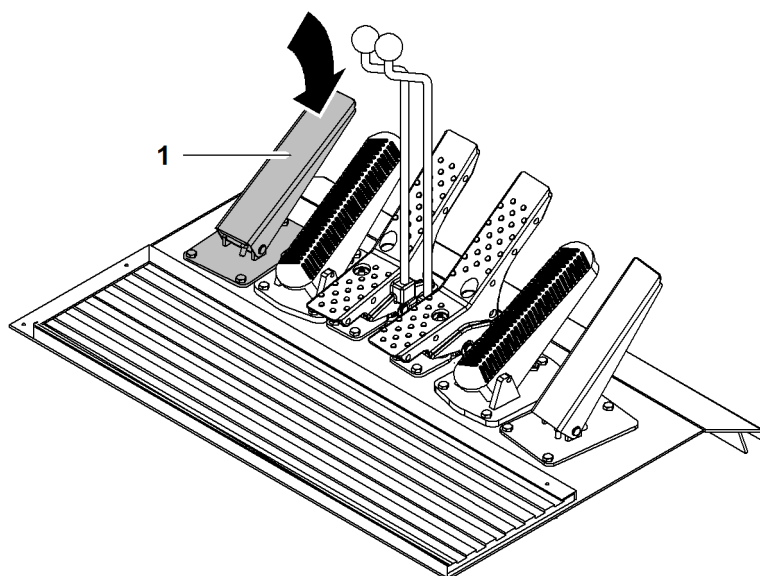


Fig. 2775: Increasing the pull force of the tagline winch

1 Foot pedal for *tagline winch*

- ▶ Press the foot pedal of the *tagline winch 1* forwards.
 - ▷ Pull force of tagline winch is increased.

Decreasing the pull force of the tagline winch

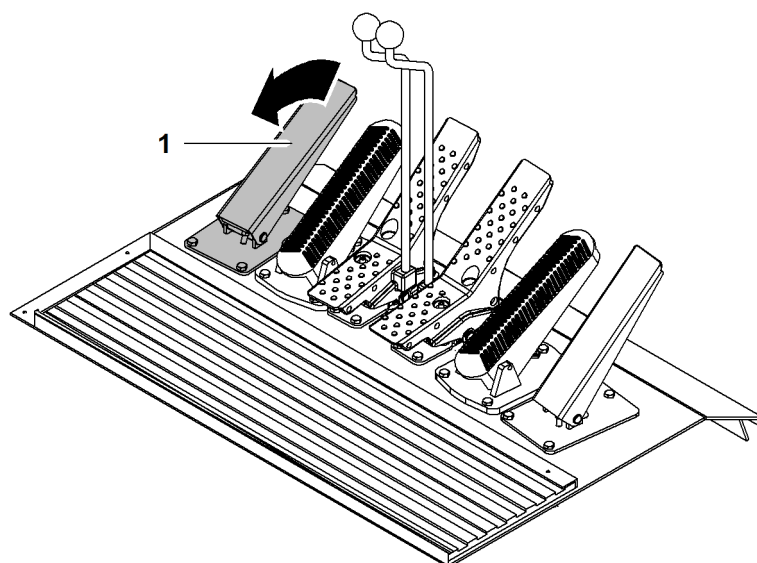


Fig. 2776: Decreasing the pull force of the tagline winch

1 Foot pedal for tagline winch

- ▶ Let the foot pedal of the tagline winch 1 move backwards.
- ▷ Pull force of tagline winch is reduced.

4.38.5 Select maximum pull force of the tagline winch

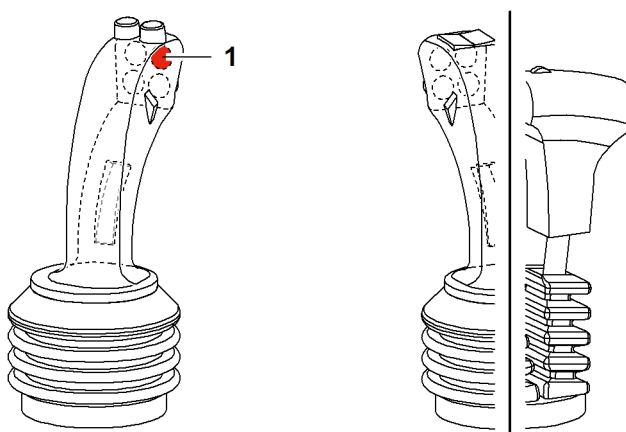


Fig. 2777: Select maximum pull force of the tagline winch

1 Button Maximum pull force tagline winch

- ▶ Press and hold the button Maximum pull force tagline winch 1 on the left multi-directional control lever.
- ▷ Tagline winch winds up the tagline with maximum pull force.
- ▶ Release button Maximum pull force tagline winch 1.
- ▷ Tagline winch winds up the tagline with set constant pull.

4.38.6 Turning tagline winch free-wheel on or off

The free-wheel unwinds the tagline from the tagline winch without braking.

Free-wheel serves for fast release or slewing off of the rigging material.

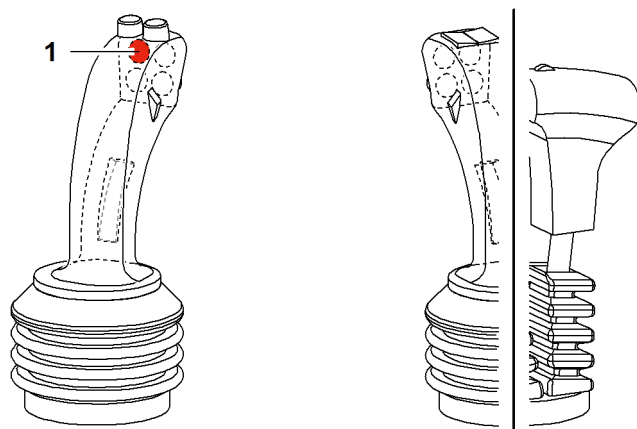


Fig. 2778: Turning tagline winch free-wheel on or off

1 Button *Tagline winch free-wheel*

- ▶ Press and hold the button *Tagline winch free-wheel 1* on the left multi-directional control lever.
 - ▷ Tagline winch is freewheeling.

NOTICE

Freewheeling must not be switched off when the tagline winch is rotating!
Damage to the tagline winch.

- ▶ Do not switch freewheeling off until the tagline winch has stopped moving.

-
- ▶ Let go of the button *Tagline winch free-wheel 1*.
 - ▷ Tagline winch winds up the tagline with constant pull.

4.39 Luffing jib luffing winch as auxiliary winch*



DANGER

Inadmissible rope on luffing jib luffing winch!
Load breakaway.

- ▶ Make sure that the correct rope for the respective application of the luffing jib luffing winch is used.



Note

Liebherr recommends:

- ▶ Only use original Liebherr ropes.

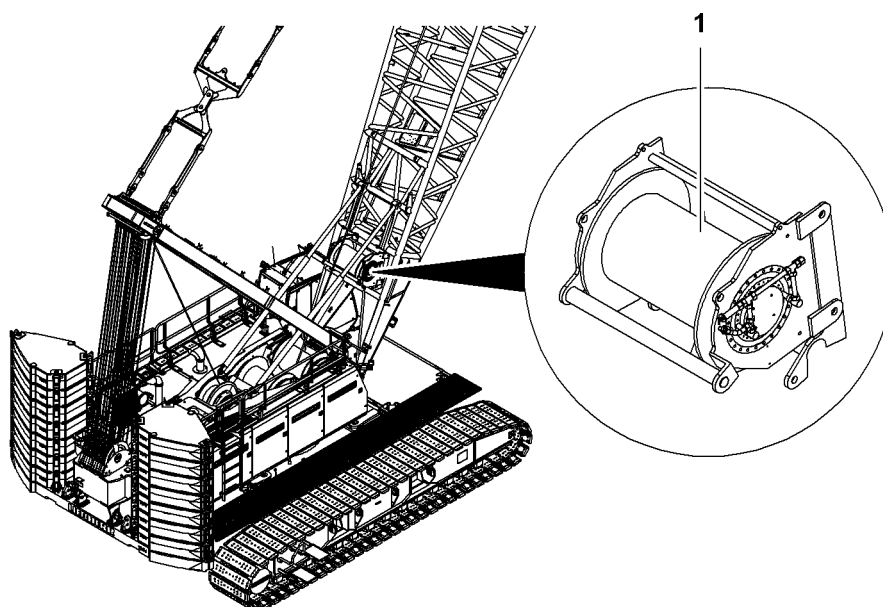


Fig. 2779: Luffing jib luffing winch as auxiliary winch

1 Jib luffing winch

4.39.1 Use as jib luffing winch

Ensure that the following conditions are satisfied:

- Boom configuration 4 "Main boom with luffing jib" is selected.
- Rope on jib luffing winch is not **rotation-resistant**.
- Rope on jib luffing winch complies with break force.
- Rope on jib luffing winch has the required rope safety.
- Rope on jib luffing winch complies with standard **ISO 4308** or **ANSI B30.5**.
- Rope on jib luffing winch has a diameter of 20 mm (0.79" in).
- Rope fixing point is located on A-frame2.

4.39.2 Use as leader height adjusting winch



WARNING

Use of the jib luffing winch as leader height adjusting winch constitutes a special operating mode!

Severe injuries, damage to machine.

- ▶ For more information regarding special modes: Contact Liebherr customer service.

Make sure the following prerequisites are met:

- Boom configuration 1 "Main boom" is selected.
- Control panel X25 for leader* is plugged in.
- Rope on jib luffing winch is not **rotation-resistant**.
- Rope on jib luffing winch complies with break force.
- Rope on jib luffing winch has the required degree of rope safety.
- Rope on jib luffing winch complies with standard **ISO 4308** or **ANSI B30.5**.
- Rope on jib luffing winch has a diameter of 20 mm (0.79" in).
- Rope fixing point is located on the leader.
- No swivel is attached to rope fixing point.

- ▶ Use jib luffing winch as leader height adjusting winch.

4.39.3 Use as auxiliary winch



DANGER

Improper use!

Damage to machine.

- ▶ Observe proper use.

Ensure that the following conditions are satisfied:

- A boom configuration **except for** boom configuration 4 "Luffing jib" is selected.
- Control panel X25 for leader* is unplugged.
- Retrofitting kit "Third hoist limit switch" is mounted to boom head.
- 3 rope windings limit switch is mounted to jib luffing winch.
- Rope on jib luffing winch is **rotation-resistant**.
- Rope on jib luffing winch complies with break force.
- Rope on jib luffing winch has the required rope safety.
- Rope on jib luffing winch complies with standard **ISO 4308** or **ANSI B30.5**.
- Rope on jib luffing winch has a diameter of 20 mm (0.79" in).

The retrofit kit "jib luffing winch as auxiliary winch" consists of:

- 3-rope windings limit switch
- Hydraulic pressure limiter
- Pocket lock (with rope fixing point)
- Cross strap

The retrofitting kit "Third hoist limit switch" is required to operate the jib luffing winch as an auxiliary winch.

- ▶ Use jib luffing winch as auxiliary winch.

4.40 Diesel engine automatic stop system*

The diesel engine automatic stop system works automatically to reduce the fuel consumption during idle phases.

The diesel engine is shut off automatically when the safety lever is pulled up and the stop time has run down.

The LED in the button *Diesel engine automatic stop system* displays the status of the diesel engine automatic stop system.

LED status	Description
Lit	Diesel engine automatic stop system is activated and there is nothing preventing the shut-off of the diesel engine.
Blinks regularly	Diesel engine automatic stop system is active and the diesel engine was switched off by the diesel engine automatic stop system.
Blinks irregularly	Diesel engine automatic stop system is activated and there is something preventing the shut-off of the diesel engine.
Not lit	Diesel engine automatic stop system is deactivated.

Tab. 378: Diesel engine automatic stop system

4.40.1 Switching the diesel engine automatic stop system on or off

The diesel engine automatic stop system is automatically active as soon as the ignition is switched on.



- ▶ Press the *Diesel engine automatic stop system* button on control panel X23.
 - ▷ Diesel engine automatic stop system is switched off.



- ▶ Press the *Diesel engine automatic stop system* button on control panel X23 again.
 - ▷ Diesel engine automatic stop system is activated.

4.41 Sensitive hoisting*

The “Sensitive hoisting” function allows loads to be gently hoisted.

The function applies the following safety limitations to the crane operation:

- Winch 1 and Winch 2 are limited to a maximum speed of 30 m/min (98' 5" ft-in/min).
- The load chart values are reduced by 50%.

The load chart that is called up on-screen is not changed and displays the standard lifting capacities.

4.41.1 Turning the function sensitive lift on or off

Ensure that the following conditions are fulfilled:

- The gate valve *Free-fall mode* is located in the “OFF” position.



- ▶ Press the button *Sensitive lift* on control panel X23.

- ▷ Sensitive lift is activated.
- ▷ The symbol *Sensitive lift* appears on screen:



Fig. 2783: Symbol *Sensitive lift*

- ▶ Press the button *Sensitive lift* on control panel X23 again.
 - ▷ Sensitive lift is deactivated.
 - ▷ The symbol *Sensitive lift* disappears on screen.

4.41.2 Operating sensitive hoisting

Ensure that the following conditions are fulfilled:

- Speed level 1 for the swing is set.
- Speed level 1 is selected for the boom.
- ▶ Operate sensitive hoisting.

4.42 Abseil rescue equipment*

4.42.1 Using abseil rescue equipment



WARNING

Incorrect use of the abseil rescue equipment BORNACK KE 10 St crane!
risk of falling from the cab.

- ▶ Observe operating manual of the abseil rescue equipment.

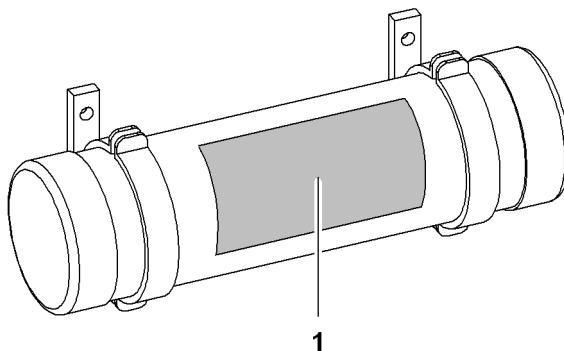


Fig. 2784: Abseil rescue equipment

1 Operating instructions

- ▶ Read operating manual 1 for abseil rescue equipment.
- ▶ Take abseil rescue equipment out of storage box.
- ▶ Put on abseil rescue equipment.
- ▶ Open the cab door.

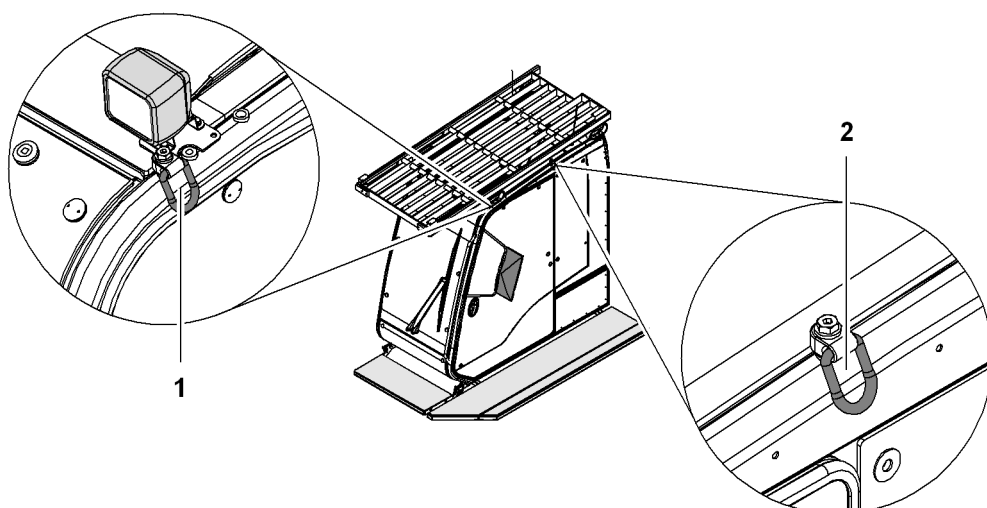


Fig. 2785: Suspension points of abseil rescue equipment

1 Suspension point on cab with cab roof protection guard 2 Suspension point on cab with falling object protection

- ▶ Attach abseil rescue equipment to suspension point 1, 2.

- ▶ Open the fall-arrest chain on the cab door (if one is fitted).
- ▶ Abseil down as described in the operating instructions.

4.43 Emergency stop

4.43.1 Using emergency stop



DANGER

Machine under extreme stress under load during an emergency stop!
Toppling of machine, structural breakdown.

- ▶ Only use emergency stop for emergency cut-off of the machine.



DANGER

Unauthorized unlocking of the emergency stop!

- ▶ Clear up and remedy reason for emergency stop prior to unlocking.



Fig. 2786: Emergency stop on control panel

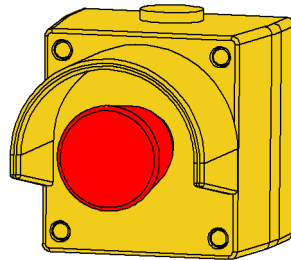


Fig. 2787: Emergency stop in engine compartment

If an emergency stop is triggered while a load is being moved:

- ▶ Have the multi-disc holding brakes inspected by Liebherr after sales service.
- ▶ Unlocking the activated emergency stop: gently depress the emergency stop and turn to the right.
- ▶ Perform visual inspection for damage on steel structure, ropes and pulleys.

After actuating the emergency-stop, the exhaust aftertreatment system is no longer blown out by the compressor. The exhaust aftertreatment system gets clogged through crystallizing of the urea solution.

- ▶ Contact Liebherr customer service.

4.44 Shutdown



WARNING

Unauthorised use of machine!
Severe injuries, damage to machine.

- ▶ When leaving the machine, it must be protected against unauthorised use, vandalism and any possible adverse environmental impact.

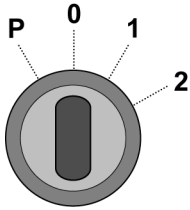
When shutting down the machine, distinguish between:

- **Short work interruption**
 - Waiting time or breaks
 - The machine operator remains on site.
- **Long work interruption**
 - Overnight or several days
 - The machine operator leaves the site.

4.44.1 Short work interruption

Machine operator remains in cab

- ▶ Set down the load.
- ▶ Pull up safety lever.
- ▶ Turn ignition key to position “P” (parked position).
 - ▷ Diesel engine is turned off.
 - ▷ Litronic control system is switched off.

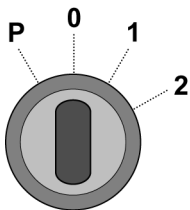


The following components continue to be supplied with power:

- ▷ Engine compartment lighting
- ▷ Cab lighting
- ▷ Windscreen wiper
- ▷ Horn
- ▷ Radio
- ▷ Heater blower
- ▷ Socket in cabin
- ▷ Cigarette lighter

Machine operator leaves cab

- ▶ Set down the load.
- ▶ With derrick operation, lower suspended counterweight/wheeled counterweight carriage on the ground.
- ▶ Tilt cabin downward all the way.
- ▶ Pull up safety lever.
- ▶ Turn ignition key to position “0”.
 - ▷ Diesel engine is switched off.
 - ▷ Litronic control system is switched off.

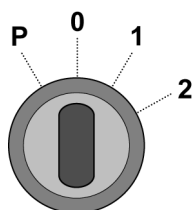


- ▶ Lock cab after leaving.

4.44.2 Long work interruption

Ensure that the following conditions are fulfilled:

- Machine is not obstructing traffic.
 - The place where the machine is left is adequately secured.
 - External energy supply for the safety equipment is secured (e.g. obstacle warning light).
- ▶ Set down and secure the load.
 - ▶ Place the boom in its parked position.
 - ▶ Draw the empty hook upwards or use the hook fixing point if there is one.
 - ▶ With derrick operation, lower suspended counterweight/wheeled counterweight carriage on the ground.
 - ▶ Tilt cabin downward all the way.
 - ▶ Pull up safety lever.
 - ▶ Turn ignition key to position "0".
 - ▷ Diesel engine is switched off.
 - ▷ Litronic control system is switched off.
-
- ▶ Switch off the auxiliary heating, or program it correctly.
 - ▶ Remove the ignition key and keep it in a safe place.
 - ▶ Lock the cabin and doors to the machinery area.



4.44.3 Switching off battery main switch

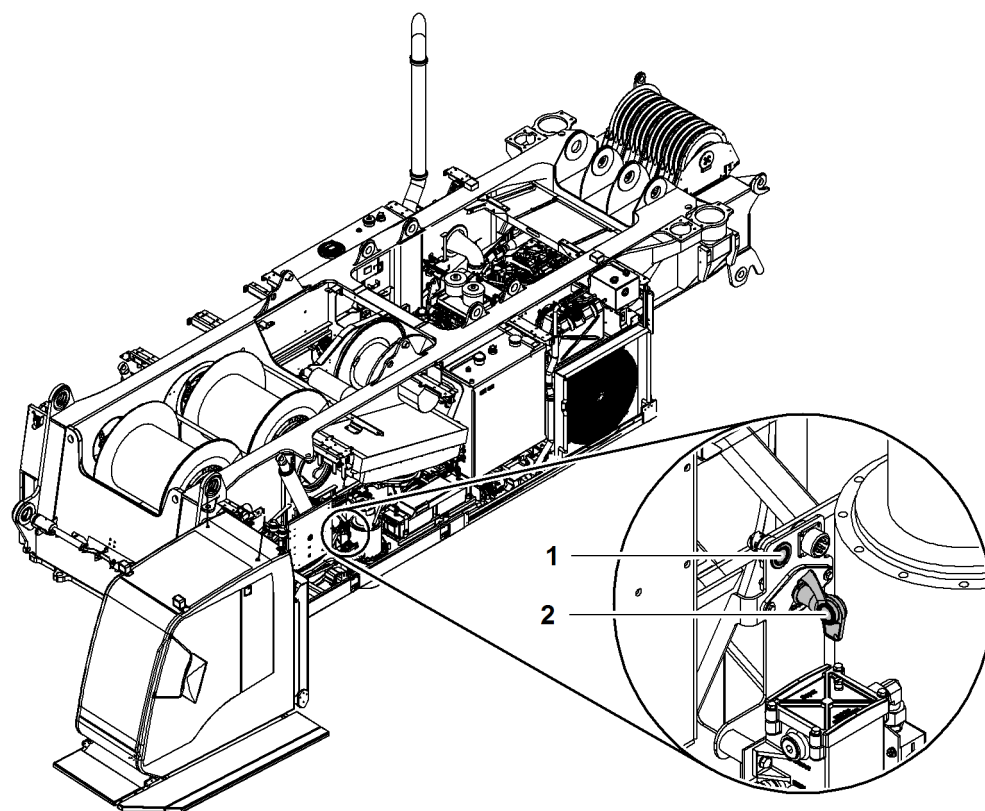


Fig. 2791: Turning off the main battery switch (illustration of principle)

1 Warning light

2 Main battery switch

NOTICE

Incorrect switching off of main battery switch **2**!
Damage to machine

- ▶ Do not switch off main battery switch **2** until warning light **1** is turned off.
-

Once warning light **1** is off:

- ▶ Switching off battery main switch **2**: Turn battery main switch **2** to the left.

4.45 Hydraulic emergency mode*

Hydraulic emergency mode allows winch 2, the main boom winch and swing to be controlled using an external hydraulic power pack.

4.45.1 Winch 2 emergency mode

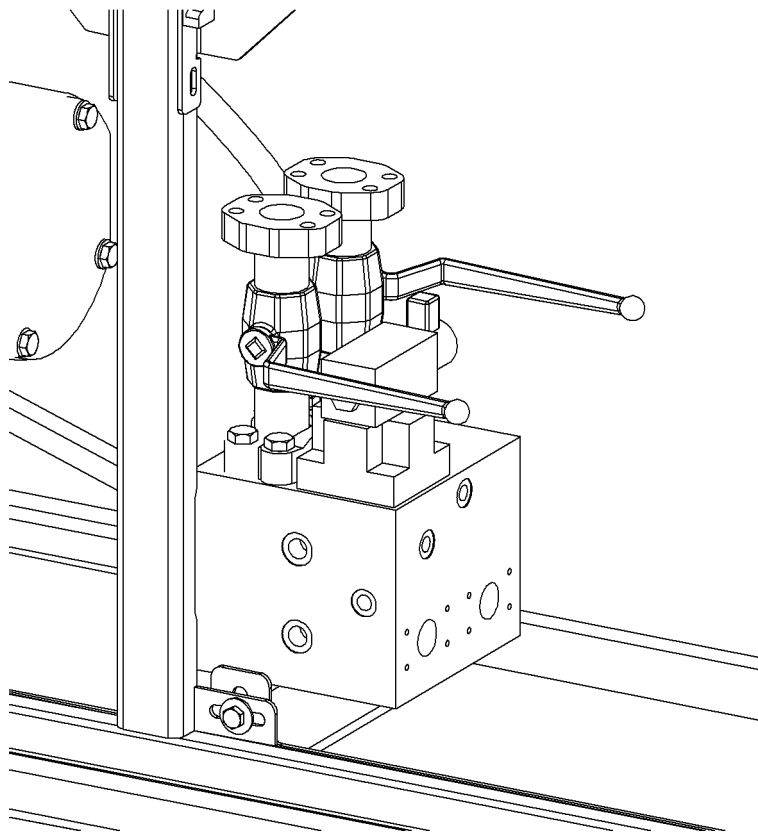


Fig. 2792: High-pressure lines winch 2 gate valves closed

Ensure that the following conditions are fulfilled:

- High-pressure lines winch 2 gate valves are closed.
- An external hydraulic power pack is connected.

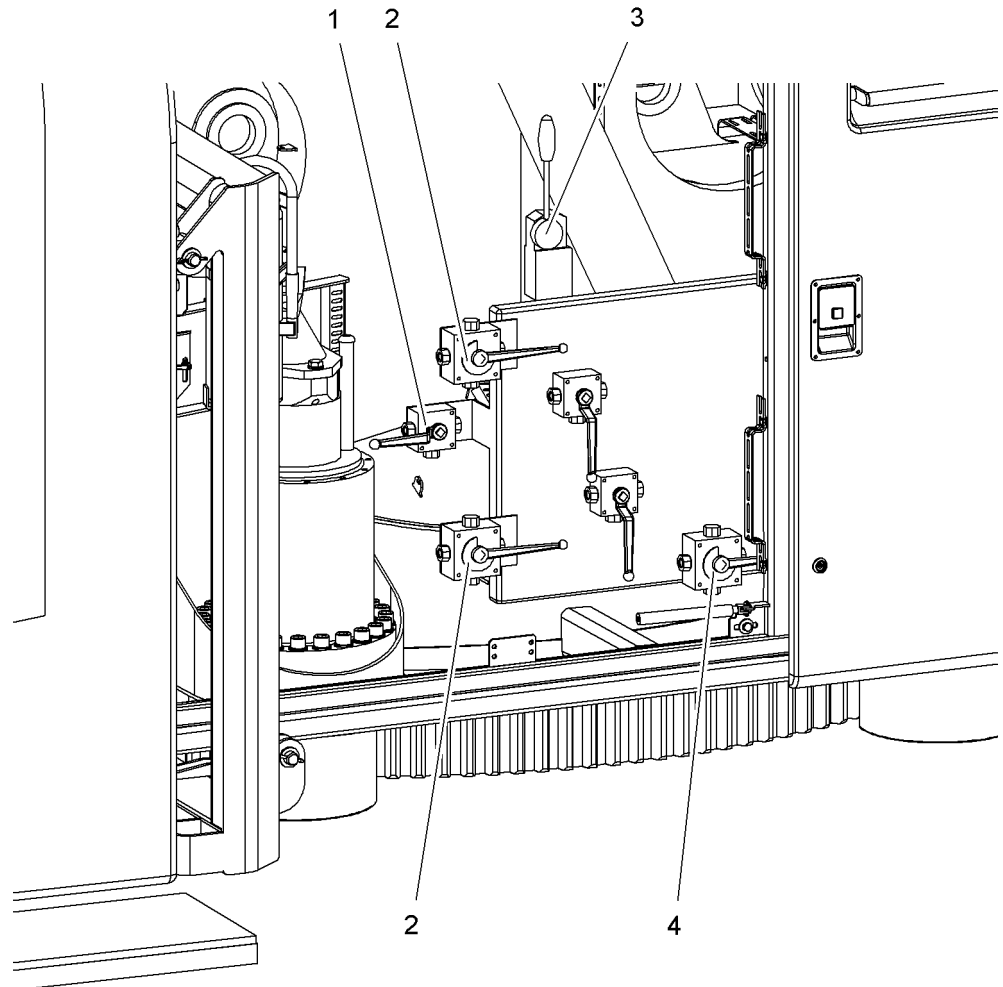


Fig. 2793: Emergency mode gate valves in "Control winch 2" position

- | | | | |
|---|--|---|--------------------------------------|
| 1 | Brake winch 2 gate valve | 3 | Control lever |
| 2 | Function selection high-pressure lines gate valve (2x) | 4 | Function selection brake gate valves |

- ▶ Turn *Function selection High-pressure lines* gate valves **2** to "Control winch 2" position.
- ▶ Turn *Function selection brake* gate valves **4** to "Control winch 2" position.
- ▶ Turn *Brake winch 2* gate valve **1** to "Control winch 2" position.
- ▶ Move the control lever **3** to the right.
 - ▷ The load hook/pulley block rises.
- ▶ Move the control lever **3** to the left.
 - ▷ The load hook/pulley block lowers.

4.45.2 Main boom adjusting winch emergency mode

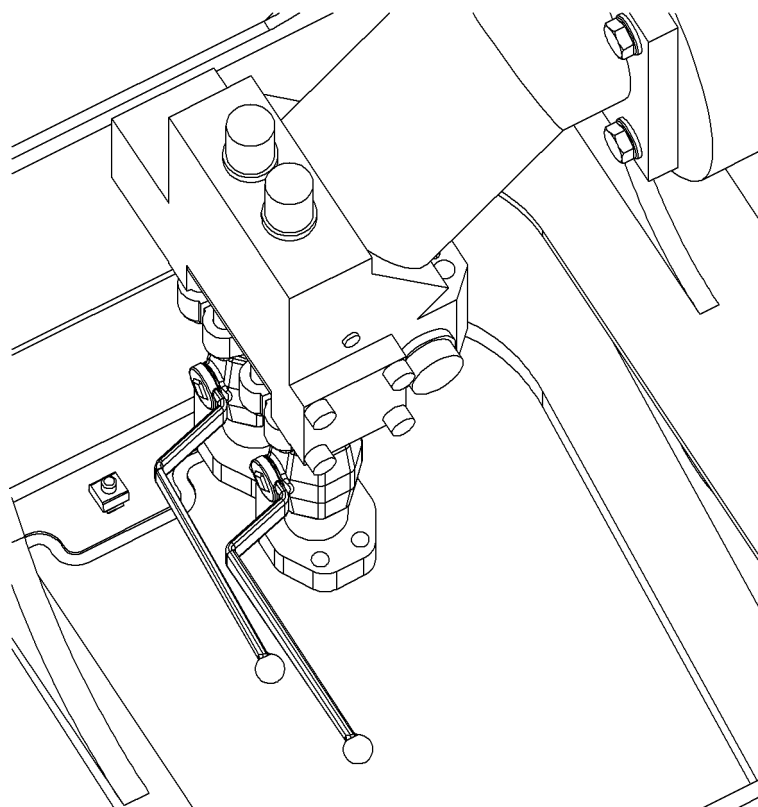


Fig. 2794: High-pressure lines main boom adjusting winch gate valves closed

Ensure that the following conditions are fulfilled:

- High-pressure lines main boom adjusting winch gate valves are closed.
- An external hydraulic power pack is connected.

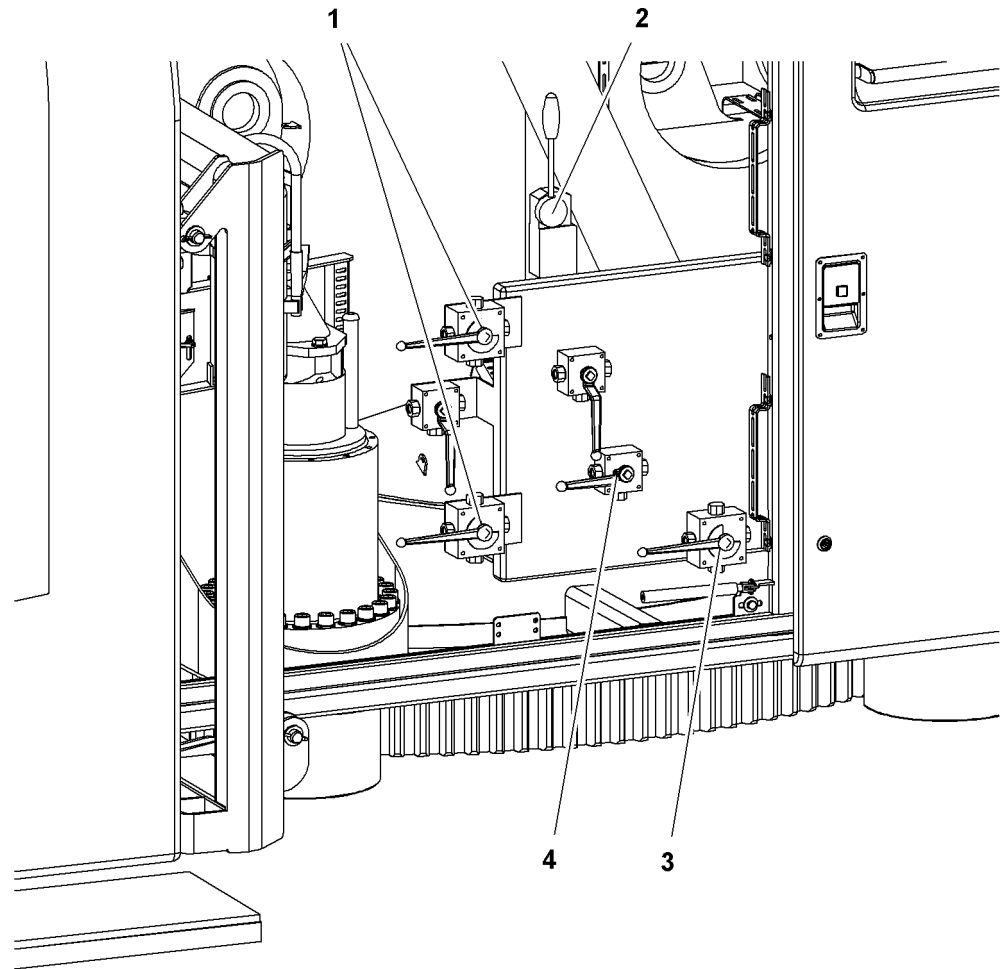


Fig. 2795: Emergency mode gate valves in "Control main boom winch" position

- | | |
|--|--|
| <p>1 Function selection high-pressure lines gate valve (2x)</p> <p>2 Control lever</p> | <p>3 Function selection brake gate valves</p> <p>4 ,Brake main boom winch gate valve</p> |
|--|--|

- ▶ Turn *Function selection High-pressure lines* gate valves **1** to "Control main boom winch" position.
- ▶ Turn *Function selection brake* gate valves **3** to "Control main boom winch" position.
- ▶ Turn *Brake main boom adjusting winch* gate valve **4** to "Control main boom winch" position.
- ▶ Move the control lever **2** to the right.
 - ▷ The main boom rises.
- ▶ Move the control lever **2** to the left.
 - ▷ The main boom lowers.

4.45.3 Swing emergency mode

Swing emergency mode controls a single swing gear. If a second swing gear is present, only the brakes are released.

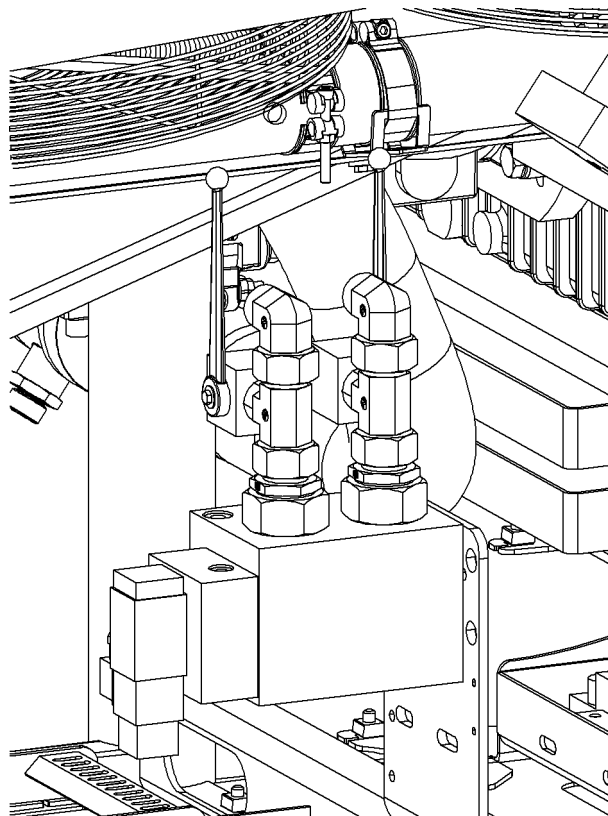


Fig. 2796: Swing high-pressure lines gate valves closed

Ensure that the following conditions are fulfilled:

- Swing high-pressure lines gate valves are closed.*
- An external hydraulic power pack is connected.*

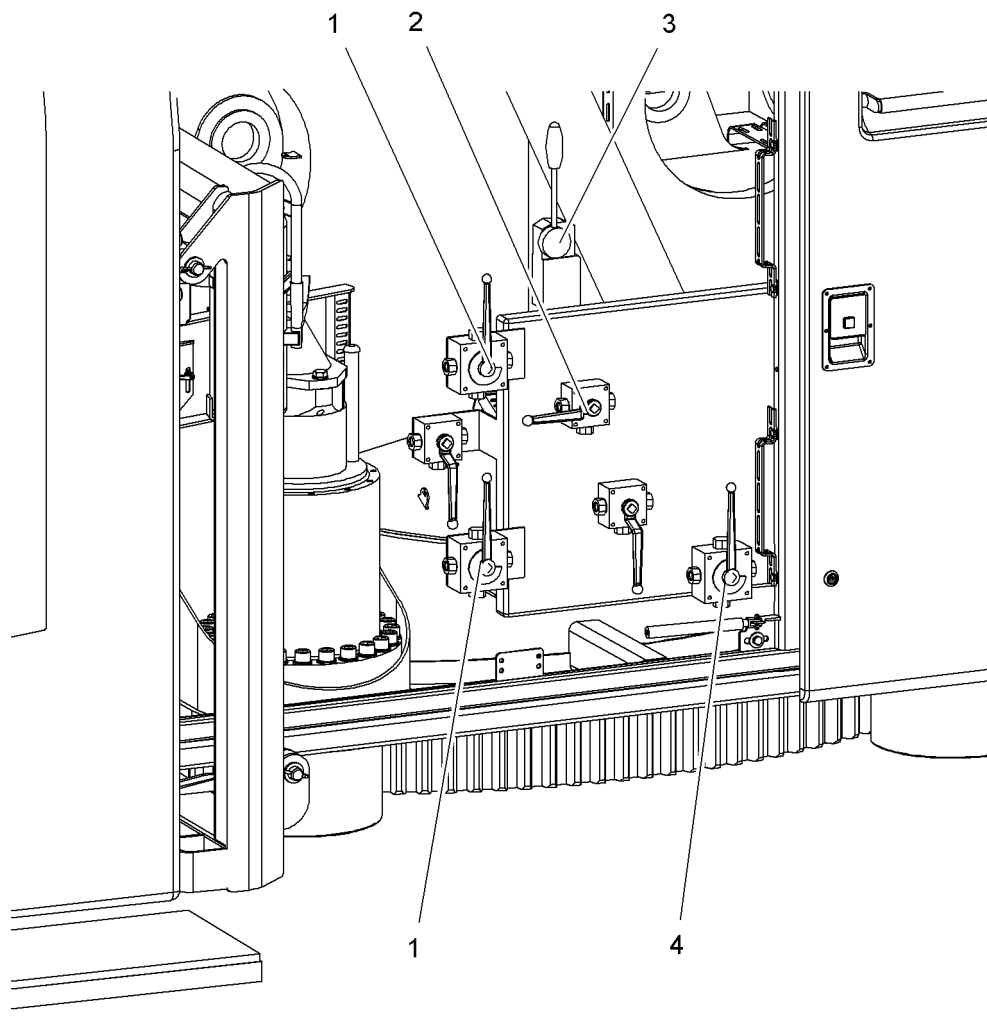


Fig. 2797: Emergency mode gate valves in "Control swing" position

- | | | | |
|---|--|---|--------------------------------------|
| 1 | Function selection high-pressure lines gate valve (2x) | 3 | Control lever |
| 2 | Brake swing gate valve | 4 | Function selection brake gate valves |

- ▶ Turn *Function selection High-pressure lines gate valves 1* to "Control swing" position.
- ▶ Turn *Function selection brake gate valves 4* to "Control swing" position.
- ▶ Turn *Brake swing gate valve 2* to "Control swing" position.
- ▶ Move the control lever **3** to the right.
 - ▷ Uppercarriage turns to the left.
- ▶ Move the control lever **3** to the left.
 - ▷ Uppercarriage turns to the right.

4.46 Emergency operation control*

Should a fault occur that causes the Litronic control system to fail, the emergency operation controller allows the machine to be moved out of the danger area.



WARNING

Unauthorized or improper use of the emergency operation controller!

- ▶ Do not use the emergency operation controller unless an emergency has arisen.
- ▶ Cordon off a large area around the danger zone.
- ▶ Employ a signalman to direct the movements.
- ▶ Exercise the utmost care when using the emergency operation controller.
- ▶ Remember that all safety features are bypassed and will not work.

In the case of long booms and when operating the swing, remember that control of the functions is not integrated.

All speeds are reduced by two thirds. Speeds cannot be adjusted on the control panel except for RPM.

NOTICE

Unauthorized use of the emergency operation controller when a wheeled counterweight carriage is attached!

Damage to the machine and the counterweight carriage.

- ▶ Never use emergency operation when a wheeled counterweight carriage is attached.

4.46.1 Operating the emergency control

- ▶ Switching off the machine: turn ignition key to position "0".
- ▶ Open the front most left uppercarriage door.
- ▶ Plug in and lock emergency control system.



WARNING

Unauthorized use of the emergency operation controller!
Severe injury.

- ▶ Only operate emergency control in the cabin.

- ▶ Sit in the cabin.

The status display (LED) of the emergency control system lights up as soon as the ignition is switched on.

- ▶ Start the diesel engine using the ignition key.
- ▶ Lower control safety lever in cabin.
- ▶ Operate the emergency control.

When the machine has been moved out of the danger area:

- ▶ Switch off machine.

- ▶ Unplug emergency control system.
- ▶ Close front left uppercarriage door.

Operational faults, diagnosis 5

5 Operational faults, diagnosis

5 Operational faults, diagnosis

The chapter **Operation errors, diagnosis** deals with the following issues:
– Operation errors of the machine and the corresponding diagnosis

5.1 Malfunctions

5.1.1 Identifying faults

Faults are very often caused by incorrect operation or inadequate maintenance of the machine.

NOTICE

Improper procedure with occurring error message!
Damage to machine.

In case of an error message:

- ▶ Concentrate on work process and continue it while permanently monitoring until risk-free stopping of all machine movements is possible.

Once all machine movements have stopped:

- ▶ remedy all error causes and acknowledge error messages. Acknowledging the error messages alone will not remedy the causes of the errors.

-
- ▶ Observe all symbols and error messages on the monitor.

- ▶ Observe all acoustic warning signals from the monitor.


5.1.2 Error displays on monitor





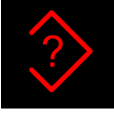
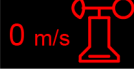


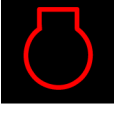
NOTICE








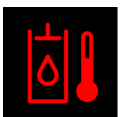

Serious engine error messages are ignored!
Damage to the diesel engine.






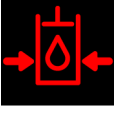
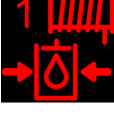
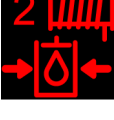

If serious engine error message is displayed:

- ▶ Switch off diesel engine.
-


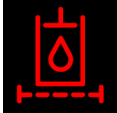
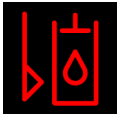
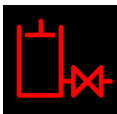




Symbol/status	Cause	Remedy
 blinks red	Admissible load moment was exceeded.	Reduce load moment.

Symbol/status	Cause	Remedy
 lit red	Machine may topple backwards due to insufficient radius.	Increase radius.
 blinks red	Error in the electrical system.	Contact Liebherr customer service.
 blinks red	Serious engine error has occurred.	Perform troubleshooting and remedy error (For more information see: Rectifying grave engine error message, page 1050).
 lit yellow	General engine error has occurred.	Perform troubleshooting and remedy error (For more information see: Rectifying general engine error messages, page 1050).
 blinks red	Data recording error.	Contact Liebherr customer service.
 blinks red	Wind speed too high.	Lay down boom.
 lit red	Danger of toppling.	Reduce radius.
 blinks red	Battery is not charging.	Contact Liebherr customer service.
 blinks red	Diesel engine RPM is too high.	Reduce RPM.

Symbol/status	Cause	Remedy
 lit yellow	Fill level of urea tank is less than 10 % of the maximum filling capacity or error in exhaust aftertreatment system.	Fill in urea solution or contact Liebherr customer service.
 lit yellow  lit yellow	Fill level of urea tank is less than 5 % of the maximum filling capacity or error in exhaust aftertreatment system.	Fill in urea solution or contact Liebherr customer service.
 lit yellow  blinks red	Fill level of urea tank is less than 2.5 % of the maximum filling capacity or error in exhaust aftertreatment system.	Fill in urea solution or contact Liebherr customer service.
 blinks red  blinks red	Fill level of urea tank is less than 0 % of the maximum filling capacity or error in exhaust aftertreatment system.	Fill in urea solution or contact Liebherr customer service.
 blinks red	Hydraulic oil temperature is too high.	Contact Liebherr customer service.
 blinks red	Temperature of diesel engine coolant is too high.	Contact Liebherr customer service.

Symbol/status	Cause	Remedy
 blinks red	Temperature of diesel engine charge air is too high.	Contact Liebherr customer service.
 blinks red	Fill level of fuel tank is less than 5 % of the maximum filling capacity.	Fill in fuel.
 blinks red	Pressure of diesel engine lubrication oil is too low.	Contact Liebherr customer service.
 blinks red	Fill level of diesel engine lubrication oil is too low.	Fill in lubrication oil.
 blinks red	Fill level of diesel engine lubrication oil is too high.	Drain lubrication oil.
 blinks red	Supply pressure is too low.	Contact Liebherr customer service.
 blinks red	Feed pressure on winch1 is too low.	Contact Liebherr customer service.
 blinks red	Feed pressure on winch2 is too low.	Contact Liebherr customer service.
 blinks red	Temperature of gearbox oil in the distribution gearbox is too high.	Contact Liebherr customer service.

LWNLR-x\04.01\Auslieferung\2016-03-07\en

Symbol/status	Cause	Remedy
 blinks red	Supply pressure oil filter does not work correctly.	Contact Liebherr customer service.
 blinks red	Hydraulic oil filter does not work correctly.	Contact Liebherr customer service.
 blinks red	Fill level of hydraulic oil tank is too low.	Fill in hydraulic oil.
 blinks red	Coolant fill level is too low.	Fill in coolant.
 blinks red	<i>Hydraulic oil tank gate valve is closed.</i>	Ensure there is no danger. Open <i>hydraulic oil tank gate valve</i> .
 blinks red	Fuel pressure is too low or too high.	Contact Liebherr customer service.
 blinks red	Fuel temperature is too high.	Contact Liebherr customer service.
 blinks red	Water in the fuel filter.	Drain water into condensation trap.
 blinks red	Charge air filter does not work correctly.	Contact Liebherr customer service.

Tab. 379: Error displays

5.1.3 Troubleshooting

Rectifying grave engine error message

The cause of the error appears either on the *Engine* screen or on the *Error messages* screen.

Possible error causes are:

- Coolant temperature > 104 °C (219 °F)
- Charge air temperature > 80 °C (176 °F)
- Fuel temperature > 90 °C (194 °F)
- Oil pressure safety curve undercut
- Coolant level too low
- Hydraulic oil level too low
- Water in fuel
- Problem with the high-pressure control
- Fuel pressure too low
- Fuel rail pressure too high

The speeds of these functions and movements are reduced by 50 % in the event of an error message:

- Lift winch1 and winch2
- Raise feed
- Rotary drive
- Crawler
- Hammer
- Grab
- Cutting wheels

- ▶ Stop the dangerous movement.
- ▶ Place the load on the ground.
- ▶ Switch off diesel engine.
- ▶ Determine and rectify cause of error.

If the cause of the error cannot be determined and rectified:

- ▶ Contact Liebherr customer service.

Rectifying general engine error messages

- ▶ Carry out troubleshooting in the Litronic® testing system.
- ▶ Determine and rectify cause of error.

If the cause of the error cannot be determined and rectified:

- ▶ Contact Liebherr customer service.

5.2 Litronic testing system

5.2.1 Litronic testing system overview



WARNING

Unauthorized changes to Litronic testing system!
Damage to machine.

- ▶ Only have adjustment values or correction values changed by Liebherr service personnel.
-

The Litronic testing system is an extensive diagnosis tool and service tool available on the monitor, on a service notebook or via a modem connection (if available). The Litronic testing system serves to view the inputs and outputs, markers, internal variables and statuses.

The Litronic® testing system provides the following functions:

- Display of the ID number of the installed software and the software version
- Display of the inputs and outputs of the modules with comment text
- Display of the internal variables with comment text
- Displays a selection list
- Displays correction values (machine parameters)
- Displays messages (message stack)
- Displays special functions:
 - Modem configuration
 - Memory card control (CF)
 - CAN configuration status

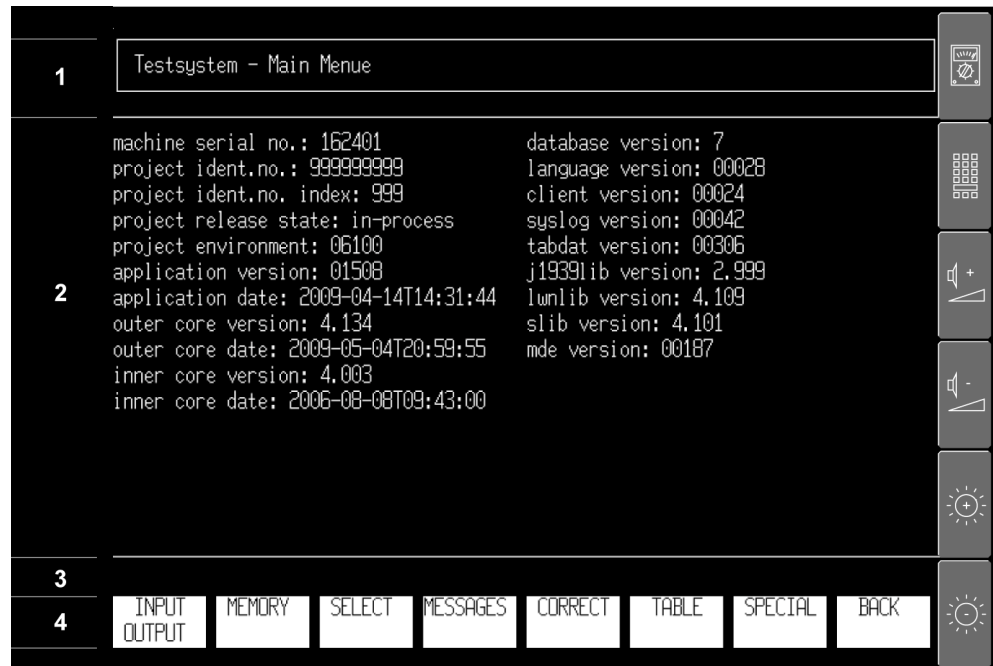


Fig. 2835: Litronic® testing system overview

- | | |
|--|--|
| <p>1 Header: Name of the current screen</p> <p>2 Main window: Displays information</p> | <p>3 Input line: For display and correction of entered values, display of status messages and input prompts</p> <p>4 Menu bar: Buttons</p> |
|--|--|

The Litronic® testing system comprises a number of screen pages; the buttons are used to move from page to page. Some pages have two menu bars that you can toggle between using the button *MENU 1/2*. The first menu bar always appears when a page is opened. When the Litronic® testing system is first started, the homepage (Main Menu) is displayed. On each subsequent start, the page last open when the system was exited is loaded. The other settings are also retained.

Certain commands can be executed several times in succession by entering the number of repetitions (these appear in the input line) or by pressing the required button. This includes *PREVIOUS* and *NEXT* for example.

5.2.2 Screen pages

Main screen page

Switch from the main screen to the different screens of the Litronic testing system. Exit the current screen with the *BACK* button.

The following pages can be reached from the main screen page:

- Screen *INPUT/OUTPUT*
- Screen *MEMORY*
- Screen *SELECT*
- Screen *CORRECTION*
- Screen *MESSAGES*
- Screen *SPECIAL FUNCTIONS*

Screen *INPUT/OUTPUT*

The *INPUT/OUTPUT* screen serves to view the inputs and outputs of the modules.

Description of the buttons:

- *NEXT CAN LINE* moves to the next CAN line.
- *PREVIOUS MODULE* and *NEXT MODULE* switches between the modules of the selected CAN line.
- *PREVIOUS* and *NEXT* move the Cursor up and down to highlight a channel in the selected module. The highlighted channel is displayed as an inverse I or O.
- The marked channel can be taken over into the select list with *SELECT*. If the channel was already selected, the channel is deleted from the list again. The inverse display shows whether a channel has been selected.
- *MENU 1/2* switches between the two menu bars.
- *DOCUMENT* displays 16 channels (inputs or outputs) with comment text on one page. With digital modules (32 channels) use *PREVIOUS* and *NEXT* to switch to the second page.
- *UNDOCUM* displays all inputs or outputs on one page.
- *IDENTIFY* displays 16 inputs or outputs on one page with the identifier on one page. With digital modules (32 channels) use *PREVIOUS* and *NEXT* to switch to the second page.
- *BACK* returns to the main screen.

Screen *MEMORY*

The *MEMORY* screen shows the internally used buffer stores (markers).

Description of the buttons:

- *NEXT SECTION* moves between the 16 flag sections: X-B-W-D, 1-2-3-4.
- *PREVIOUS PAGE* and *NEXT PAGE* to switch between the pages. One page contains 16 markers of the selected section.
- *PREVIOUS* and *NEXT* move between the flags. The highlighted flag is displayed as an inverse M.
- The marked marker can be taken over into the select list with *SELECT*. If the marker was already selected, the marker is deleted from the list again. The inverse display of the marker shows whether a marker has been selected.
- *MENU 1/2* switches between the two menu bars.
- *DOCUMENT* displays the markers with comment text.
- *IDENTIFY* displays the flags with the identifier.
- *BACK* returns to the main screen.

Screen *SELECT*

The values can be entered in the select list to prevent having to switch between the input menu, output menu and marker menu pages. Now the entries can be viewed and edited on the *SELECT* screen. The select screen may consist of several pages. If the list is full and a new value is entered, the oldest value is deleted from the list. The select lists can also be saved on memory cards and loaded from there.

How to add entries to the Select list:

- With the *SELECT* button on the *INPUT/OUTPUT*, *MEMORY* screens or *CORRECTION*
- With the *ADD* button on the *SELECT* screen by entering the IEC address
- With the *LOAD FROM CARD* button on the *SELECT* screen from a file

How to delete entries from the Select list:

- Reselect a selected value with the *SELECT* button on the *INPUT/OUTPUT*, *MEMORY* or *CORRECTION* screens.
- Delete the marked entry with the *DELETE* button on the *SELECT* screen.

Description of the buttons:

- *ADD* adds a new entry to the Select list. A menu bar is displayed in which the IEC address is entered.

- *DELETE* deletes the marked entry from the select list.
- *PREVIOUS* and *NEXT* to switch between the individual select entries. The marked entry is displayed with an inverted I, O or M.
- *NEXT PAGE* moves to the next page of the Select list so that more values can be viewed.
- *IDENTIFY* displays the inputs, outputs and markers with the identifier.
- *DOCUMENT* displays the inputs, outputs and markers with comment text.
- *LOAD FROM CARD* loads a new Select list from a file A menu is then displayed. The menu contains a list of files, one of which can be selected, and also allows a specific file name to be entered .
- *SAVE TO CARD* saves the current Select list in a file. A menu appears from which the name of the file can be selected .
- *MENU 1/2* switches between the two menu bars.
- *BACK* returns to the main screen.

Screen *Add Selection*

The *Add Selection* screen is called up with the *ADD* button on the *SELECT* screen. The IEC address of a new select entry can be entered this way. The ICE address is entered with the corresponding buttons in the input field.

Example:

- Desired IEC address: %QW1.17.1
- %, Q and W are entered using the appropriate buttons.
- 1.17.1 is entered as a normal number and can be edited as necessary using the button *TAKE & BACK* to apply the address.

Description of the buttons:

- Use M, I or Q to select the IEC type flag, input or output. These change each time a key is pressed and appear in the input bar. A correction can be made by pressing another type.
- Use X, B, W and D to select the size of the IEC entry. These change each time a key is pressed and appear in the input bar. A correction is made by pressing another size.
- *TAKE & BACK* returns to the *SELECT* screen and applies the IEC address from the entry bar.

Screen *Select File Load*

A saved select list can be loaded from the memory card on the *Select File Load* screen.

Description of the buttons:

- *CHARACTER NEXT* adds a new character to the end of the input bar. New characters can also be added by entering numbers and letters.
- *CHARACTER DOWN* and *CHARACTER UP* change the last character on the input bar.
- *PREVIOUS* and *NEXT* move the cursor up and down in the select list. When selecting a file, the name of the file is taken over into the entry bar.
- *LOAD* loads the selected file displayed in the entry bar and returns to the *SELECT* screen.
- *BACK* cancels the process and returns to the *SELECT* screen.

Screen *Select File Save*

A select list can be saved on the memory card on the *Select File Save* screen.

Description of the buttons:

- *CHARACTER NEXT* adds a new character to the end of the input bar. New characters can also be added by entering numbers and letters.

- *CHARACTER DOWN* and *CHARACTER UP* change the last character on the input bar.
- *PREVIOUS* and *NEXT* move the cursor up and down in the select list. When selecting a file, the name of the file is taken over into the entry bar.
- *SAVE* saves the select list in a file (enter file name in the entry bar) and returns to the *SELECT* screen.
- *BACK* cancels the process and returns to the *SELECT* screen.

Screen **CORRECTION**

The *CORRECTION* screen displays correction values.

Description of the buttons:

- *NEXT SECTION* switches between the four correction value sections: X-B-W-D.
- *PREVIOUS PAGE* and *NEXT PAGE* to switch between the pages. One page contains 16 correction values of the selected section.
- *PREVIOUS* and *NEXT* move between the correction values. The highlighted correction value is displayed as an inverse M.
- *DOCUMENT* displays the correction values with comment text.
- *IDENTIFY* displays the correction values with the identifier.
- *BASE MIN & MAX* displays the correction values with the default value and upper and lower limits.
- *SAVE TO CARD* saves the current correction values in a file. The file name can be selected from the menu that now appears. A standard file name (created from the current date) is suggested. This name can be changed if required .
- Use *SELECT* to add the highlighted entry to the Select list. If the entry is already selected, it will be removed from the list. The name of a correction value will be displayed inverse if it is selected.
- *MENU 1/2* switches between the two menu bars.
- *BACK* returns to the main screen.

Screen **MESSAGES**

The *MESSAGES* screen shows the saved application messages (e.g. sensor errors) and all system errors (e.g. CAN bus, modules, central unit). The application messages are buffered internally.

Description of the buttons:

- *ALL* lists all saved messages (maximum 15,000).
- *PREVIOUS START* and *NEXT START* move between all messages saved at each start-up.
- *PRIORITY MAXFILTER* and *PRIORITY MINFILTER* list the saved messages filtered by priority.
- *GROUP FILTER* lists the saved messages filtered by certain groups.
- *SINCE START* lists only the messages since the current machine start-up.
- *LANGUAGE* enables a different language for the messages. Messages that are not found in the selected language will be displayed in English. Switching only has an effect on the *MESSAGES* screen .
- *PREVIOUS* and *NEXT* move between the messages.
- *SAVE TO CARD* saves all messages (*ALL* or *SINCE START*) in a file. The file name can be selected from the menu that now appears. A standard file name (created from the current date) is suggested. This name can be changed if required .
- *MENU 1/2* switches between the two menu bars.
- *BACK* returns to the main screen.

Screen *Language Selection*

The message language can be selected on the *Language Selection* screen.

Description of the buttons:

- *PREVIOUS* and *NEXT* move between the different languages.
- *SELECT* is used to select and load the highlighted language.

Screen *SPECIAL FUNCTIONS*

From the *SPECIAL FUNCTIONS* screen, you can access various additional screens or return to the main screen with the *BACK* button.

Screen *Modem Function*

The GSM modem can be configured and operated on the *Modem Function* screen.

The current modem status (e.g. Online, Offline, False PIN) can be viewed in the entry bar.

Description of the buttons:

- *DIAL* dials a previously entered phone number.
- *HANGUP* terminates an active modem connection (hang up handset).
- *RLP ON/OFF* activates or deactivates the radio link protocol for GSM modem connections. The settings first become effective after the next program start.
- *V32/V110* activates the V32 protocol or V110 protocol for GSM modem connections. The settings first become effective after the next program start.
- *PREVIOUS* and *NEXT* change between the interfaces; the default Modem Client is COM2.
- *PIN INPUT* allows the PIN codes for the GSM modem to be entered manually.
- *MODEM CONNECT* enables the modem server programme to be started on an unused interface.
- *MENU 1/2* switches between the two menu bars.
- *BACK* returns to the *SPECIAL FUNCTIONS* screen.

Screen *Drive Function*

The *Drive Function* screen displays information about the current drive.

Description of the buttons:

- *REMOVE CARD* must be performed before removing a memory card from the drive. Switching off the Litronic control system is another option. The system automatically recognises when a new card has been inserted.
- *DIR LIST* displays the files and directories (no subdirectories) of the current drive.
- *PREVIOUS DRIVE* and *NEXT DRIVE* switch between the individual drives known to the Litronic control system.
- *CHECK CARD* checks the current drive for errors.
- *BACK* returns to the *SPECIAL FUNCTIONS* screen.

Screen *Time Function*

The *Time Function* screen shows the date and time.

Description of the buttons:

- *DAYLIGHT SAVING* switches to the summer time setting.
- *TIMEZONE MOVE WEST* moves the time zone setting one hour westwards.
- *BACK* returns to the *SPECIAL FUNCTIONS* screen.

Priority Level screen (for Liebherr service personnel only)

The Litronic code can be entered on the *Priority Level* screen to access supervisor level. The supervisor level is required to e.g. set the time.

Description of the buttons:

- When the *LEVEL CHANGE* key is pressed, the value in the input bar is copied and examined to see whether it is a valid Litronic® code.
- *BACK* returns to the *SPECIAL FUNCTIONS* screen.

Screen CAN Configuration

The *CAN Configuration* screen shows all installed CAN modules with utilization status.

Description of the buttons:

- *NEXT PAGE* switches to the next screen.
- *BACK* returns to the *SPECIAL FUNCTIONS* screen.

Screen CAN Line Information

The *CAN Line Information* screen shows the used CAN lines and settings.

Description of the buttons:

- *MODULE INFO* switches to the *CAN Configuration* screen.
- *BACK* returns to the *SPECIAL FUNCTIONS* screen.

Screen Display Configuration

On the *Display Configuration* screen, you can select options for the display of the *INPUT/OUTPUT* screen.

Description of the buttons:

- *ALL MODULES* displays all CAN modules on the *INPUT/OUTPUT* screen.
- *ONLY USED MODULES* only displays the CAN modules set to “used” on the *INPUT/OUTPUT* screen.
- With *NUMBER STYLE* the inputs, outputs and markers are switched between standard display and hexadecimal display.
- *UPDATE INTERVAL* changes the update speed of the input, output and marker display.
- *BACK* returns to the *SPECIAL FUNCTIONS* screen.

Screen System Language Selection

The system language can be selected on the *System Language Selection* screen, whereby a language is selected or the internal standard language loaded.

The selected system language is only activated once the Litronic control system is switched back on.

Description of the buttons:

- *PREVIOUS* and *NEXT* move between the different languages.
- *SELECT* loads the marked language as new system language and returns to the *SPECIAL FUNCTIONS* screen.
- *USE DEFAULT* loads the English language as new system language and returns to the *SPECIAL FUNCTIONS* screen.
- *MENU 1/2* switches between the two menu bars.
- *BACK* cancels the process and returns to the *SPECIAL FUNCTIONS* screen.

Screen *Sampling Trace*

The *Sampling Trace* screen is used for the online data recording of previously defined inputs and outputs. The *Sampling Trace* screen displays information about the “sampling trace” and allows to change the status and save the recorded data.

Description of the buttons:

- *SAMPLE ACTIVE* activates “sampling trace” after the options were defined. Serves to record and check the trigger conditions.
- *TRIGGER MANUAL* simulates the trigger conditions. *TRIGGER MANUAL* is only available if “Sampling Trace” is activated and the trigger conditions were not yet fulfilled.
- *END MANUAL* stops recording of the “sampling trace” and automatically leads to ready state. *END MANUAL* is only available if the “sampling trace” is activated.
- *LOAD FROM CARD* loads a configuration from a saved “Sampling Trace” file. A menu appears from which the name of the file can be selected .
- *SAVE TO CARD* saves the recorded data and the “Sampling Trace” configuration in a file. A menu appears from which the name of the file can be selected .
- *SAVE TO SELECT* saves the variables used in the “Sampling Trace” in the Select list. Existing entries in the Select list are deleted.
- *LOAD FROM SELECT* loads the selected variables into the “sampling trace” list.
- *PREVIOUS* and *NEXT* switch between the configuration data. The marked entry is displayed inverted.
- *CHANGE* changes the marked entry to the value in the entry bar. The value must lie within the valid limits.
- *MENU 1/2* switches between the two menu bars.
- *BACK* returns to the *SPECIAL FUNCTIONS* screen.

Screen *System Status*

The *System Status* screen shows the current system status (e.g. running, stopped) and the timing of the SPS tasks.

Description of the buttons:

- *SYSTEM TASKS* displays information about the system tasks.
- *BOARD INFO* displays information about the circuit board (e.g. voltage, temperature).
- *BACK* returns to the *SPECIAL FUNCTIONS* screen.

Screen *MDE/PDE*

The *MDE/PDE* screen displays the status of the MDR (Machine Data Recording), the PDR (Process Data Recording), and the data logger.

Description of the buttons:

- *MDE* displays the MDR data.
- *PDE* displays the PDR data.
- *SELECT GRAPHIC* lists saved graphics (e.g. company logo) for printout of the PDR data. The desired graphic can be selected.
- *LOGGER* displays the data logger.
- *BACK* returns to the *SPECIAL FUNCTIONS* screen.

Screen *Clients*

The *Clients* screen displays the status of the individual communication interfaces (clients).

Description of the buttons:

- *PREVIOUS* and *NEXT* move between the interfaces.
- *BACK* returns to the *SPECIAL FUNCTIONS* screen.

5.2.3 Starting the Litronic® testing system



WARNING

No error messages from the Litronic control displayed in the Litronic® testing system!

- ▶ Only perform crane work on the *Operation* screen.



- ▶ Press the *Settings* button on the screen.
 - ▷ The *Settings* screen appears on the monitor.



- ▶ Press the *Litronic testing system* button on the monitor.
 - ▷ The Litronic testing system main screen is displayed on the monitor.

5.3 Fuses

5.3.1 List of fuses

The following table lists the fuses by rating and module.

Fuse	Rating	Module
F1	50 A	Main fuse module
F2	50 A	Main fuse ignition on
F3	50 A	Main fuse additional supply engine control
F4	10 A	Main fuse fuel pre-filter heating
F5	20 A	Engine control device
F6	20 A	Voltage supply exhaust aftertreatment system
F7		
F8	13 A	Main fuse parked position
F9	13 A	Main fuse LD+, cabin tilt (LED+)
F10	13 A	Main fuse measurement supply
F21	10 A	Radio, horn, camera surveillance, switching cabinet ventilation, PA system
F22	10 A	Cabin lighting, engine compartment lighting
F23	5 A	Voltage supply control panel X11
F24	10 A	Cigarette lighter, windscreen wash system, heating control valve, charger for radio remote control
F25	5 A	Front windscreen wiper
F26	5 A	Top windscreen wiper
F31	5 A	Boom voltage supply
F32	10 A	CAN bus input module 33
F33	10 A	CAN bus input module 41
F34	10 A	CAN bus input module 42
F35	10 A	CAN bus input module 34 + 43
F36	10 A	Reserve
F41	10 A	Voltage supply engine electronics, control of fuel pre-filter heating
F42	10 A	Voltage supply modem
F43	10 A	Voltage supply assembly functions (tilting-back supports, cylinder adjustments)
F44	10 A	Safety lever, emergency operation
F45	10 A	Voltage supply CAN bus line 1 + 2
F46	10 A	Voltage supply CAN bus line 3 + 4
F47	5 A	PDR screen

Fuse	Rating	Module
F48	10 A	Voltage supply control panel X12, control auxiliary heating clock, key switch <i>Load moment limiter shutoff</i>
F49	15 A	Floodlights on cabin
F50	15 A	Floodlights on uppercarriage
F51	15 A	Additional floodlight on uppercarriage
F52	15 A	Refueling pump
F53	10 A	Supply leader electronics
F54	10 A	Reserve
F55	15 A	Additional equipment
F56	10 A	Additional equipment, electronic seat heating and positioning
F71	10 A	CAN-bus output module 17, register 4, safety valves, relay control LD+
F72	10 A	CAN-bus output module 9, register 4, emergency stop engine
F73	10 A	CAN bus output module 9, register 3
F74	10 A	Control computer + control computer PDE, emergency stop
F75	10 A	CAN bus output module 18, register 2
F76	15 A	Cabin ventilator, interior cabin lighting, voltage supply, engine diagnosis plug
F81	10 A	CAN bus output module 17, register 1-3
F82	10 A	CAN bus output module 18, register 1, 3, 4
F83	10 A	CAN bus output module 19
F84	10 A	CAN bus output module 9, register 1
F85	10 A	CAN bus output module 9, register 2
F86	10 A	CAN bus output module 10, register 1
F87	10 A	CAN bus output module 10, register 2
F88	10 A	CAN bus output module 10, register 3
F89	10 A	CAN bus output module 10, register 4
F90	10 A	Monitoring relay LED+, cabin tilt
F90.1	10 A	Hydraulic grab
F90.2	10 A	CAN bus output module 20
F91	10 A	Optional fuse OLN, SCR hose heaters
F92	10 A	AGR fuse
F93	10 A	AGR fuse
F94	10 A	DK fuse
F95	10 A	Lambda fuse
F96	10 A	Lambda fuse

Tab. 380: List of fuses

Fuse	Rating	Module
F11	10 A	Auxiliary heating
F12	16 A	Auxiliary heating
F13	10 A	Cabin elevation
F14	6 A	Obstacle warning light
F15	16 A	Hydraulic grab, slurry wall grab
F16	20 A	Hydraulic grab
F17	50 A	Slurry wall grab
F18	10 A	Floodlights on boom
F19	25 A	Refueling pump
F20	16 A	Floodlights on main boom head
F61	20 A	Slurry wall grab
F62		Slurry wall grab
F63	10 A	Slurry wall grab
F64	10 A	Slurry wall grab
F65	10 A	Slurry wall grab
F66	10 A	Slurry wall grab
F101	10 A	Counterweight limit switch, Diseko module
F102	10 A	Counterweight limit switch, Diseko module
F103	10 A	Counterweight limit switch, Diseko module
F104	10 A	Counterweight limit switch
F105		
F106		
F111	10 A	Counterweight limit switch, Diseko module
F112	10 A	Counterweight limit switch, Diseko module
F113	10 A	Counterweight limit switch, Diseko module
F114		
F115		
F116		

Tab. 381: List of fuses - optional additional equipment

5.3.2 Checking the fuses

The switching cabinet is located behind the cabin.

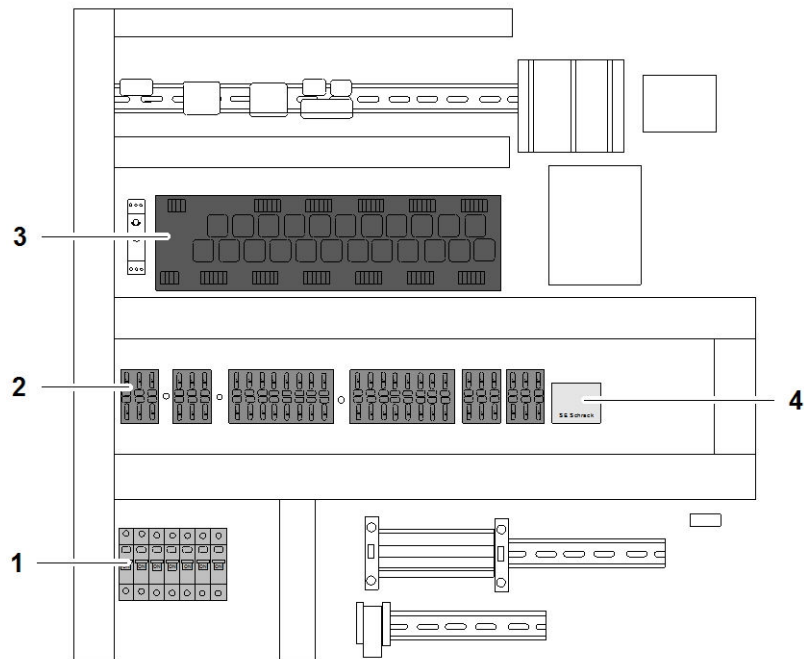


Fig. 2838: Switch cabinet

- | | |
|--|---|
| <p>1 Circuit breakers</p> <p>2 Flat fuse links</p> | <p>3 Change-over relay</p> <p>4 Fuse box with spare fuses, fuse tester and holder</p> |
|--|---|

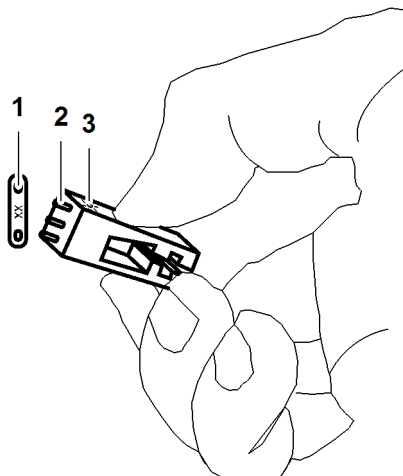


Fig. 2839: Checking the fuses

- | | |
|-----------------------------------|--------------|
| <p>1 Fuse</p> <p>2 Metal pins</p> | <p>3 LED</p> |
|-----------------------------------|--------------|

If the green LED 3 on the fuse tester lights, the fuse is OK.

► To check the fuse: press the fuse tester with metal pins 2 onto the live fuse 1.

Troubleshooting

The green LED 3 on the fuse tester does not light up?

► Replace the fuse.

5.3.3 Replacing fuses

NOTICE

Wrong fuses are used!
Damage to the electrical system.

- ▶ Switch off the battery main switch.
 - ▶ Only use fuses that have the amp rating (colour coding) prescribed by the manufacturer.
-
- ▶ Switch off the battery main switch.
 - ▶ Remove the fuse from the fuse box.

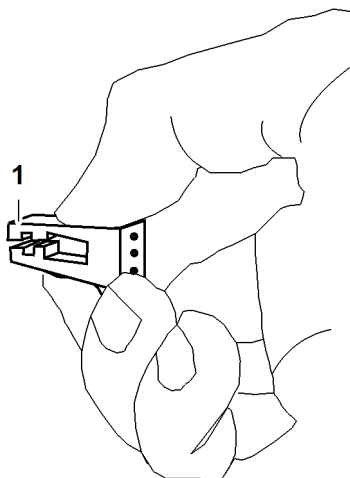


Fig. 2840: Replacing the fuse

1 Fuse holder

- ▶ To replace the fuse: use the fuse holder **1** to pull faulty fuses out of the socket.
- ▶ Use the fuse holder **1** to plug the new fuse into the socket.

Operational planning 6

6 Operational planning

6 Operational planning

The chapter **Work planning** deals with the following subjects:

- Planning basics for secure and problem-free application



WARNING

Incorrect work planning!
Severe injuries, damage to the machine.

- ▶ Always create a work plan before using the machine. Operational planning is vital for safe and problem-free operation of the machine.
-

Exemplary procedure:

- Plan how the machine and equipment are to be transported.
- Specify the type of application and the relevant operating mode.
- Discuss the weights and dimensions of the loads to be lifted.
- Note the load-bearing capacity of the ground.
- Plan the assembly site and note any spatial restrictions (such as buildings).
- Note overhead cables and underground pipes and cables, and the relevant safety distances.
- Note the influence of aircraft, transmitter and radar systems, the weather, etc.

This is just a small selection of the most important points in work planning.

6.1 Assembly site



DANGER

Ground has a limited bearing strength!
Machine toppling over.

- ▶ Observe the safety notes regarding the load-bearing capacity of the ground ([For more information see: 2.11.11 Ground bearing strength, page 596](#)).
-

The ground pressure being exerted by the machine in operation can be read off the optional ground pressure display.

The following maximum ground pressures occur below the jacks of the basic machine during assembly and when utilizing the self-assembly system:

Type	Maximum ground pressure
LR 1001	12 kg/cm ² 170.68 psi
LR 1002	12 kg/cm ² 170.68 psi

Type	Maximum ground pressure
LR 1003	18 kg/cm ² 256.02 psi
LR 1004	12 kg/cm ² 170.68 psi
LR 1006	18.8 kg/cm ² 267.40 psi

Tab. 382: Ground pressures under the basic machine's jacks

Maximum ground pressures depending on counterweight of counterweight carriage*:

Counterweight carriage weight	Maximum ground pressure
19.2 t 42,328 lb	5.5 kg/cm ² 78.23 psi
33.6 t 74,074 lb	6.3 kg/cm ² 89.61 psi
48 t 105,820 lb	7.2 kg/cm ² 102.41 psi
62.4 t 137,566 lb	8.1 kg/cm ² 115.21 psi
76.8 t 169,313 lb	8.8 kg/cm ² 125.16 psi
91.2 t 201,059 lb	9.3 kg/cm ² 132.28 psi
105.6 t 232,805 lb	9.9 kg/cm ² 140.81 psi
120 t 264,551 lb	10.2 kg/cm ² 145.08 psi

Tab. 383: Ground pressures below counterweight carriage*

Maximum ground pressures depending on counterweight of suspended counterweight*:

Suspended counterweight weight	Maximum ground pressure
4 t 8,818 lb	0.33 kg/cm ² 4.69 psi
20 t 44,092 lb	1.66 kg/cm ² 23.61 psi
40 t 88,184 lb	3.32 kg/cm ² 47.22 psi
60 t 132,275 lb	4.99 kg/cm ² 70.97 psi
80 t 176,367 lb	6.65 kg/cm ² 94.58 psi

Suspended counterweight weight	Maximum ground pressure
100 t 220,459 lb	8.31 kg/cm ² 118.19 psi
120 t 264,551 lb	9.97 kg/cm ² 141.80 psi

Tab. 384: Ground pressures below suspended counterweight*

6.2 Tools required

We recommend the following equipment for assembling the machine:

- Wooden blocks for supporting the boom components
- Permitted grease for lubricating the pins ([For more information see: 9.2.3 Lubrication chart, page 1875](#))

6.2.1 Machine with self-assembly system

The machine is designed to be assembled without the need for an assist crane.

If there is not enough space or the ground conditions are not suitable for self assembly, an assist crane should be used for support.

All the rigging is supplied.

6.2.2 Machine without self-assembly system



WARNING

Incorrect work planning!

- ▶ Consider what aids will be necessary when assembling a machine without a self-assembly system .
 - ▶ Any questions or uncertainties must be referred to Liebherr after sales service for clarification.
-

The customer is responsible for selecting the appropriate tools.

6.3 Required length of winch1/winch2 rope

The length of the winch1/winch2 ropes depends on the following factors:

- boom pendant strap
- Boom length
- the minimum radius of the boom
- Reeving

The following formula is used to roughly calculate the rope length of winch1/winch2 needed to lower the hook or pulley block to the ground.

6.3.1 Calculating the length of winch1/winch2 rope

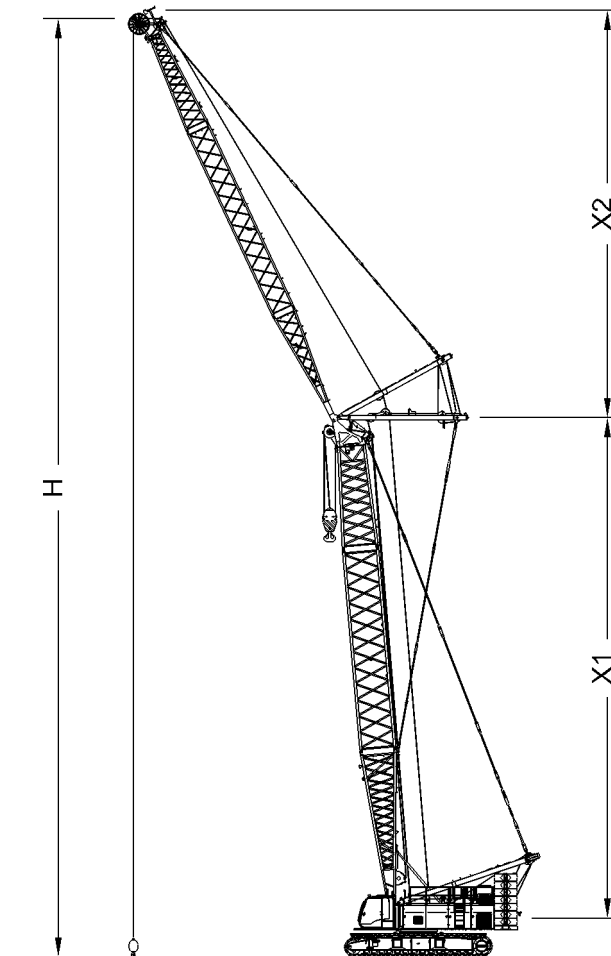


Fig. 2841: Calculating the length of winch1/winch2 rope

$$S = X1 + X2 + (n \times H) + 3_{SW} + R$$

Abbreviations	Designation
S	Length of winch1/winch2 rope
X1	Main boom length
X2	Jib length
n	Number of reevings

Abbreviations	Designation
H	Pulley height: Maximum value from the current load chart
3_{sw}	Safety windings: approx. 7 m (23' ft-in) length of rope remaining on the winch
R	Reserve: allows for the rope sag and the rope lying on the rope pulleys

*Tab. 385: Explanation of the variables for calculating the rope length of winch1/
winch2*

6.4 Choosing the correct hook or pulley block

NOTICE

Incorrect hook or pulley block selected!

Pulley blocks or hooks with too low an unladen weight cannot be lowered.

Pulley blocks or hooks with an excessively high unladen weight reduce the maximum lifting capacity.

- ▶ Select the hook and/or pulley block using the table below.
- ▶ For pulley blocks or hooks with removable counterweight slabs, the weight must be selected so that the minimum weight for the boom length is attained.

Ensure that the following conditions are fulfilled:

- The hook or pulley block is permissible for the load to be lifted.
- The groove diameter of the pulley block matches the rope diameter.
- The unladen weight of the hook or pulley block is sufficient for the boom length and reeving.

Rope reeving	1	2	3	4	5	6	7	8	9	10
Total boom length	Dead weight of the hook/pulley block									
190 m 623 ft	1150 kg 2,535 lb	2050 kg 4,519 lb								
180 m 590 ft	1100 kg 2,425 lb	1900 kg 4,189 lb	3000 kg 6,614 lb							
170 m 558 ft	1000 kg 2,205 lb	1800 kg 3,968 lb	2800 kg 6,173 lb							
150 m 492 ft	900 kg 1,984 lb	1600 kg 3,527 lb	2500 kg 5,511 lb							
130 m 426 ft	800 kg 1,764 lb	1400 kg 3,086 lb	2150 kg 4,740 lb							
120 m 393 ft	700 kg 1,543 lb	1300 kg 2,866 lb	2000 kg 4,409 lb	2750 kg 6,063 lb						
110 m 360 ft	650 kg 1,433 lb	1200 kg 2,646 lb	1800 kg 3,968 lb	2500 kg 5,511 lb						
100 m 328 ft	600 kg 1,323 lb	1050 kg 2,315 lb	1650 kg 3,638 lb	2300 kg 5,071 lb	2950 kg 6,504 lb					
90 m 295 ft	550 kg 1,213 lb	950 kg 2,094 lb	1500 kg 3,307 lb	2050 kg 4,519 lb	2650 kg 5,842 lb	3300 kg 7,275 lb				
80 m 262 ft	500 kg 1,102 lb	850 kg 1,874 lb	1350 kg 2,976 lb	1850 kg 4,078 lb	2350 kg 5,181 lb	2900 kg 6,393 lb	3500 kg 7,716 lb			
70 m 230 ft	450 kg 992 lb	750 kg 1,653 lb	1200 kg 2,646 lb	1600 kg 3,527 lb	2100 kg 4,630 lb	2550 kg 5,622 lb	3100 kg 6,834 lb	3600 kg 7,937 lb		
60 m 197 ft	350 kg 772 lb	650 kg 1,433 lb	1000 kg 2,205 lb	1400 kg 3,086 lb	1800 kg 3,968 lb	2200 kg 4,850 lb	2650 kg 5,842 lb	3100 kg 6,834 lb	3600 kg 7,937 lb	
50 m 164 ft	300 kg 661 lb	550 kg 1,213 lb	850 kg 1,874 lb	1150 kg 2,535 lb	1500 kg 3,307 lb	1850 kg 4,078 lb	2200 kg 4,850 lb	2600 kg 5,732 lb	3000 kg 6,614 lb	3450 kg 7,606 lb

Operational planning

Choosing the correct hook or pulley block

Rope reeving	1	2	3	4	5	6	7	8	9	10
Total boom length	Dead weight of the hook/pulley block									
40 m 131 ft	250 kg 551 lb	450 kg 992 lb	650 kg 1,433 lb	950 kg 2,094 lb	1200 kg 2,646 lb	1500 kg 3,307 lb	1800 kg 3,968 lb	2100 kg 4,630 lb	2400 kg 5,291 lb	2750 kg 6,063 lb
30 m 98 ft	200 kg 441 lb	350 kg 772 lb	500 kg 1,102 lb	700 kg 1,543 lb	900 kg 1,984 lb	1100 kg 2,425 lb	1350 kg 2,976 lb	1600 kg 3,527 lb	1800 kg 3,968 lb	2100 kg 4,630 lb
20 m 66 ft	150 kg 331 lb	250 kg 551 lb	350 kg 772 lb	500 kg 1,102 lb	600 kg 1,323 lb	750 kg 1,653 lb	900 kg 1,984 lb	1100 kg 2,425 lb	1250 kg 2,756 lb	1400 kg 3,086 lb

Tab. 386: Selecting the hook/pulley block for reeving 1 to 10

Rope reeving	11	12	13	14	15	16	17	18	19	20
Total boom length	Dead weight of the hook/pulley block									
50 m 164 ft	3900 kg 8,598 lb	4350 kg 9,590 lb	4800 kg 10,582 lb	5300 kg 11,684 lb						
40 m 131 ft	3100 kg 6,834 lb	3500 kg 7,716 lb	3900 kg 8,598 lb	4300 kg 9,480 lb	4700 kg 10,362 lb	5150 kg 11,354 lb				
30 m 98 ft	2350 kg 5,181 lb	2650 kg 5,842 lb	2950 kg 6,504 lb	3250 kg 7,165 lb	3550 kg 7,826 lb	3900 kg 8,598 lb	4250 kg 9,370 lb	4600 kg 10,141 lb	4950 kg 10,913 lb	5350 kg 11,795 lb
20 m 66 ft	1600 kg 3,527 lb	1800 kg 3,968 lb	2000 kg 4,409 lb	2200 kg 4,850 lb	2400 kg 5,291 lb	2650 kg 5,842 lb	2900 kg 6,393 lb	3100 kg 6,834 lb	3350 kg 7,385 lb	3600 kg 7,937 lb

Tab. 387: Selecting the hook/pulley block for reeving 11 to 20

LWNLR-x/V04.01//Auslieferung/2016-03-07/en

6.5 Positioning the hook or pulley block



DANGER

Incorrect positioning or raising of the the hook or pulley block when erecting!

- ▶ The permitted weight of the hook or pulley block is listed in the load chart.
- ▶ Only erect when the hook/pulley block is on the ground.
- ▶ Slacking of the rope must be avoided when erecting.
- ▶ Do not drag the hook or pulley block.
- ▶ Ensure that there is no diagonal pull when lifting the hook or pulley block.
- ▶ Do not raise the hook or pulley block without a valid load chart.

The positioning of the hook or pulley block is dependent in each case on their own dead weight, which can be found in the load chart.

The weight of the hook or pulley block can be found on a plate on the hook or pulley block.

6.6 Choice of correct winch in derrick operation



WARNING

Incorrect winch function(s)!
Severe injuries, damage to machine.

► Use the winches exclusively as shown.

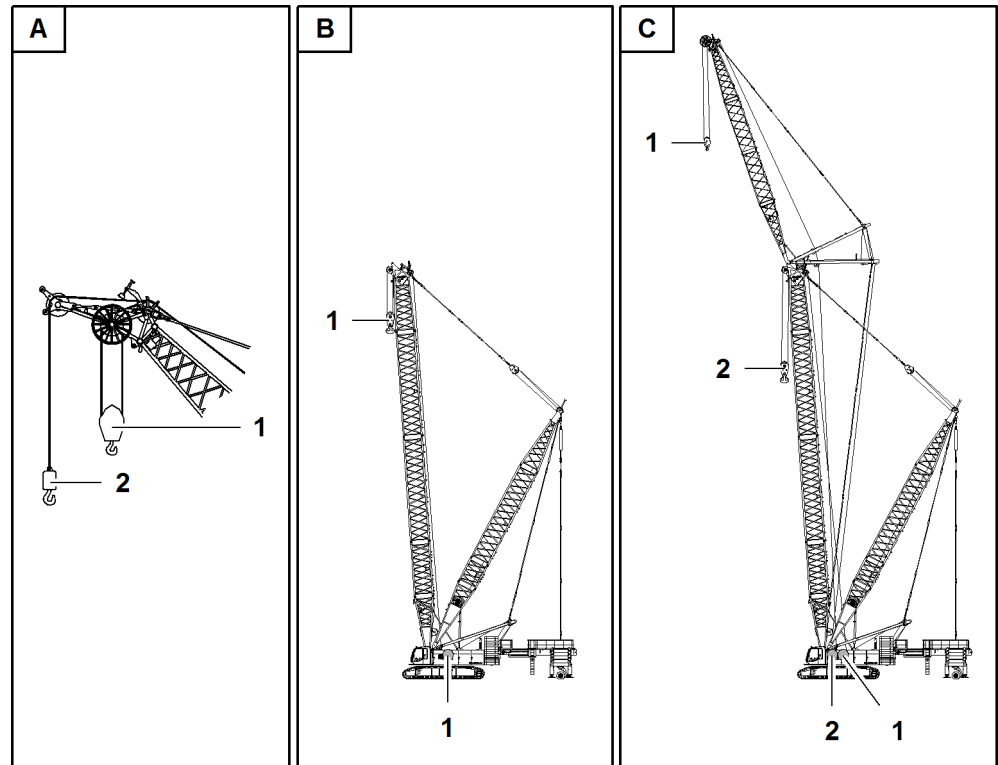


Fig. 2842: Choice of correct winch in derrick mode

- | | | | |
|----------|--|----------|-----------------|
| 1 | Winch 1 | B | Main boom |
| 2 | Winch 2 | C | Main boom + jib |
| A | Main boom + auxiliary jib or jib + auxiliary jib | | |

6.7 Restrictions due to exposure to wind



DANGER

Life-threatening exposure to wind!
Toppling of machine, structural breakdown.

- ▶ Observe general safety instructions regarding exposure to wind ([For more information see: 2.11.9 Exposure to wind, page 590](#)).

The procedure for increased wind speeds during the operation of the machine is based on the three levels described below:

- Reducing the load
- Setting boom to parked position
- Laying down the boom

6.7.1 Erecting the boom



DANGER

Excessive wind load!
Toppling of machine, structural breakdown.

If the maximum admissible wind speed according to the preface of the valid load chart is reached:

- ▶ Do not erect boom.

If the wind speeds above the maximum admissible wind speed according to the preface of the valid load chart are reached or expected, it is not permitted to erect the boom.

6.7.2 Reducing the load

With the corresponding wind speeds, the load must be reduced in accordance with the following tables. The tables show minimum values. All stated wind speeds are 3 second wind gust speeds measured at maximum boom height. The stated wind speeds are only valid in wide track operation and with all counterweights attached to the machine. In case of deviating machine configuration: Contact Liebherr customer service. The machine operator is responsible for the load reduction and for adapting the work mode.

Load reduction for a machine without derrick equipment*

Load reduction main boom 2821 (+ auxiliary jib)

Load reduction for a machine with CE load chart



CE

Main boom length	All
Wind speed	Reduction of load by
10 m/s 32.81 ft/s	0 %
12 m/s 39.37 ft/s	10 %
14 m/s 45.93 ft/s	20 %
16 m/s 52.49 ft/s	
Above 16 m/s (52.49 ft/s)	100 % = operation prohibited

Tab. 388: Load reduction main boom 2821 (+ auxiliary jib)



ANSI

Load reduction for a machine with ANSI load chart

Main boom length	All
Wind speed	Reduction of load by
7 m/s 22.97 ft/s	0 %
9 m/s 29.53 ft/s	10 %
11 m/s 36.09 ft/s	
13 m/s 42.65 ft/s	20 %
16 m/s 52.49 ft/s	30 %
Above 16 m/s (52.49 ft/s)	100 % = operation prohibited

Tab. 389: Load reduction main boom 2821 (+ auxiliary jib)

Load reduction main boom 2821 + reducing adapter 2821/2316



CE

Load reduction for a machine with CE load chart

Main boom length	All
Wind speed	Reduction of load by
10 m/s 32.81 ft/s	0 %

LWNLR-x/V04.01//Auslieferung/2016-03-07/en

Main boom length	All
Wind speed	Reduction of load by
12 m/s 39.37 ft/s	10 %
14 m/s 45.93 ft/s	
16 m/s 52.49 ft/s	20 %
Above 16 m/s (52.49 ft/s)	100 % = operation prohibited

Tab. 390: Load reduction main boom 2821 + reducing adapter 2821/2316



ANSI

Load reduction for a machine with ANSI load chart

Main boom length	All
Wind speed	Reduction of load by
7 m/s 22.97 ft/s	0 %
9 m/s 29.53 ft/s	10 %
11 m/s 36.09 ft/s	
13 m/s 42.65 ft/s	20 %
16 m/s 52.49 ft/s	
Above 16 m/s (52.49 ft/s)	100 % = operation prohibited

Tab. 391: Load reduction main boom 2821 + reducing adapter 2821/2316

Load reduction main boom 2821 + fixed jib 1713

CE

Load reduction for a machine with CE load chart

Main boom length	All
Jib length	All
Wind speed	Reduction of load by
10 m/s 32.81 ft/s	0 %
12 m/s 39.37 ft/s	10 %

Main boom length	All
Jib length	All
Wind speed	Reduction of load by
14 m/s 45.93 ft/s	20 %
16 m/s 52.49 ft/s	
Above 16 m/s (52.49 ft/s)	100 % = operation prohibited

Tab. 392: Load reduction main boom 2821 + fixed jib 1713



ANSI

Load reduction for a machine with ANSI load chart

Main boom length	All
Jib length	All
Wind speed	Reduction of load by
7 m/s 22.97 ft/s	0 %
9 m/s 29.53 ft/s	10 %
11 m/s 36.09 ft/s	
13 m/s 42.65 ft/s	20 %
16 m/s 52.49 ft/s	30 %
Above 16 m/s (52.49 ft/s)	100 % = operation prohibited

Tab. 393: Load reduction main boom 2821 + fixed jib 1713

Load reduction main boom 2821 + fixed jib 1507



CE

Load reduction for a machine with CE load chart

Main boom length	All
Jib length	All
Wind speed	Reduction of load by
10 m/s 32.81 ft/s	0 %
12 m/s 39.37 ft/s	10 %

LWNLR-x/V04.01//Auslieferung/2016-03-07/en

Main boom length	All
Jib length	All
Wind speed	Reduction of load by
14 m/s 45.93 ft/s	20 %
16 m/s 52.49 ft/s	
Above 16 m/s (52.49 ft/s)	100 % = operation prohibited

Tab. 394: Load reduction main boom 2821 + fixed jib 1507



ANSI

Load reduction for a machine with ANSI load chart

Main boom length	All
Jib length	All
Wind speed	Reduction of load by
7 m/s 22.97 ft/s	0 %
9 m/s 29.53 ft/s	10 %
11 m/s 36.09 ft/s	
13 m/s 42.65 ft/s	20 %
16 m/s 52.49 ft/s	30 %
Above 16 m/s (52.49 ft/s)	100 % = operation prohibited

Tab. 395: Load reduction main boom 2821 + fixed jib 1507

Load reduction main boom 2821 + fixed jib 1008

CE

Load reduction for a machine with CE load chart

Main boom length	All
Jib length	All
Wind speed	Reduction of load by
10 m/s 32.81 ft/s	0 %
12 m/s 39.37 ft/s	20 %
14 m/s 45.93 ft/s	

Main boom length	All
Jib length	All
Wind speed	Reduction of load by
16 m/s 52.49 ft/s	30 %
Above 16 m/s (52.49 ft/s)	100 % = operation prohibited

Tab. 396: Load reduction main boom 2821 + fixed jib 1008



Load reduction for a machine with ANSI load chart

Main boom length	All
Jib length	All
Wind speed	Reduction of load by
7 m/s 22.97 ft/s	0 %
9 m/s 29.53 ft/s	10 %
11 m/s 36.09 ft/s	
13 m/s 42.65 ft/s	20 %
16 m/s 52.49 ft/s	30 %
Above 16 m/s (52.49 ft/s)	100 % = operation prohibited

Tab. 397: Load reduction main boom 2821 + fixed jib 1008

Load reduction main boom 2821 + fixed jib 0906



Load reduction for a machine with CE load chart

Main boom length	All
Jib length	All
Wind speed	Reduction of load by
10 m/s 32.81 ft/s	0 %
12 m/s 39.37 ft/s	10 %
14 m/s 45.93 ft/s	20 %
16 m/s 52.49 ft/s	

LWNLR-x/V04.01//Auslieferung/2016-03-07/en

Main boom length	All
Jib length	All
Wind speed	Reduction of load by
Above 16 m/s (52.49 ft/s)	100 % = operation prohibited

Tab. 398: Load reduction main boom 2821 + fixed jib 0906



ANSI

Load reduction for a machine with ANSI load chart

Main boom length	All
Jib length	All
Wind speed	Reduction of load by
7 m/s 22.97 ft/s	0 %
9 m/s 29.53 ft/s	10 %
11 m/s 36.09 ft/s	
13 m/s 42.65 ft/s	20 %
16 m/s 52.49 ft/s	30 %
Above 16 m/s (52.49 ft/s)	100 % = operation prohibited

Tab. 399: Load reduction main boom 2821 + fixed jib 0906

Load reduction main boom 2821 + luffing jib 2316 (+ auxiliary jib)

CE

Load reduction for a machine with CE load chart

Main boom length	All			
Jib length	20 m (66 ft) to 26 m (85 ft)	29 m (95 ft) to 50 m (164 ft)	53 m (174 ft) to 74 m (243 ft)	77 m (253 ft) to 113 m (371 ft)
Wind speed	Reduction of load by			
10 m/s 32.81 ft/s	0 %	0 %	0 %	0 %

Main boom length	All			
Jib length	20 m (66 ft) to 26 m (85 ft)	29 m (95 ft) to 50 m (164 ft)	53 m (174 ft) to 74 m (243 ft)	77 m (253 ft) to 113 m (371 ft)
Wind speed	Reduction of load by			
12 m/s 39.37 ft/s	10 %	20 %	40 %	100 %
14 m/s 45.93 ft/s	20 %	30 %	70 %	
16 m/s 52.49 ft/s	30 %	40 %	90 %	
Above 16 m/s (52.49 ft/s)	100 % = operation prohibited			

Tab. 400: Load reduction main boom 2821 + luffing jib 2316 (+ auxiliary jib)



ANSI

Load reduction for a machine with ANSI load chart

Main boom length	All				
Jib length	20 m (66 ft) to 26 m (85 ft)	29 m (95 ft) to 50 m (164 ft)	53 m (174 ft) to 74 m (243 ft)	77 m (253 ft) to 92 m (302 ft)	95 m (312 ft) to 113 m (371 ft)
Wind speed	Reduction of load by				
7 m/s 22.97 ft/s	0 %	0 %	0 %	0 %	0 %
9 m/s 29.53 ft/s	10 %	10 %	10 %	10 %	100 %
11 m/s 36.09 ft/s	20 %	20 %	20 %	40 %	
13 m/s 42.65 ft/s		30 %	40 %	70 %	
16 m/s 52.49 ft/s	30 %	50 %	70 %	100 %	
Above 16 m/s (52.49 ft/s)	100 % = operation prohibited				

Tab. 401: Load reduction main boom 2821 + luffing jib 2316 (+ auxiliary jib)

LWNLR-x/V04.01//Auslieferung/2016-03-07/en

Load reduction main boom 2821 + luffing jib 1916 (+ auxiliary jib)



Load reduction for a machine with CE load chart

Main boom length	All			
Jib length	20 m (66 ft) to 26 m (85 ft)	29 m (95 ft) to 50 m (164 ft)	53 m (174 ft) to 74 m (243 ft)	77 m (253 ft) to 95 m (312 ft)
Wind speed	Reduction of load by			
10 m/s 32.81 ft/s	0 %	0 %	0 %	0 %
12 m/s 39.37 ft/s	10 %	20 %	30 %	70 %
14 m/s 45.93 ft/s	20 %	30 %	50 %	80 %
16 m/s 52.49 ft/s	30 %	40 %	80 %	
Above 16 m/s (52.49 ft/s)	100 % = operation prohibited			

Tab. 402: Load reduction main boom 2821 + luffing jib 1916 (+ auxiliary jib)



Load reduction for a machine with ANSI load chart

Main boom length	All		
Jib length	20 m (66 ft) to 50 m (164 ft)	53 m (174 ft) to 74 m (243 ft)	77 m (253 ft) to 95 m (312 ft)
Wind speed	Reduction of load by		
7 m/s 22.97 ft/s	0 %	0 %	0 %
9 m/s 29.53 ft/s		10 %	10 %
11 m/s 36.09 ft/s			30 %
13 m/s 42.65 ft/s		10 %	40 %
16 m/s 52.49 ft/s	20 %	50 %	90 %
Above 16 m/s (52.49 ft/s)	100 % = operation prohibited		

Tab. 403: Load reduction main boom 2821 + luffing jib 1916 (+ auxiliary jib)

Load reduction main boom 2821 + luffing jib 2316 + midfall 2316



Load reduction for a machine with CE load chart

Main boom length	All		
Jib length	38.5 m (126 ft) to 50.5 m (166 ft)	53.5 m (176 ft) to 74.5 m (244 ft)	77.5 m (254 ft) to 110.5 m (362 ft)
Wind speed	Reduction of load by		
10 m/s 32.81 ft/s	0 %	0 %	0 %
12 m/s 39.37 ft/s	20 %	40 %	100 %
14 m/s 45.93 ft/s	30 %	70 %	
16 m/s 52.49 ft/s	40 %	90 %	
Above 16 m/s (52.49 ft/s)	100 % = operation prohibited		

Tab. 404: Load reduction main boom 2821 + luffing jib 2316 + midfall 2316



Load reduction for a machine with ANSI load chart

Main boom length	All			
Jib length	38.5 m (126 ft) to 50.5 m (166 ft)	53.5 m (176 ft) to 74.5 m (244 ft)	77.5 m (254 ft) to 92.5 m (304 ft)	95.5 m (313 ft) to 110.5 m (362 ft)
Wind speed	Reduction of load by			
7 m/s 22.97 ft/s	0 %	0 %	0 %	0 %
9 m/s 29.53 ft/s	10 %	10 %	10 %	100 %
11 m/s 36.09 ft/s	20 %	20 %	40 %	
13 m/s 42.65 ft/s	30 %	40 %	70 %	
16 m/s 52.49 ft/s	50 %	70 %	100 %	
Above 16 m/s (52.49 ft/s)	100 % = operation prohibited			

Tab. 405: Load reduction main boom 2821 + luffing jib 2316 + midfall 2316

LWNLR-x/V04.01//Auslieferung/2016-03-07/en

Load reduction main boom 2821 + luffing jib 1916 + midfall 1916**Load reduction for a machine with CE load chart**

Main boom length	All		
Jib length	32.5 m (107 ft) to 50.5 m (166 ft)	53.5 m (176 ft) to 74.5 m (244 ft)	77.5 m (254 ft) to 95.5 m (313 ft)
Wind speed	Reduction of load by		
10 m/s 32.81 ft/s	0 %	0 %	0 %
12 m/s 39.37 ft/s	20 %	30 %	70 %
14 m/s 45.93 ft/s	30 %	50 %	80 %
16 m/s 52.49 ft/s	40 %	80 %	
Above 16 m/s (52.49 ft/s)	100 % = operation prohibited		

Tab. 406: Load reduction main boom 2821 + luffing jib 1916 + midfall 1916

**Load reduction for a machine with ANSI load chart**

Main boom length	All		
Jib length	32.5 m (107 ft) to 50.5 m (166 ft)	53.5 m (176 ft) to 74.5 m (244 ft)	77.5 m (254 ft) to 95.5 m (313 ft)
Wind speed	Reduction of load by		
7 m/s 22.97 ft/s	0 %	0 %	0 %
9 m/s 29.53 ft/s		10 %	10 %
11 m/s 36.09 ft/s			30 %
13 m/s 42.65 ft/s		10 %	40 %
16 m/s 52.49 ft/s	20 %	50 %	90 %
Above 16 m/s (52.49 ft/s)	100 % = operation prohibited		

Tab. 407: Load reduction main boom 2821 + luffing jib 1916 + midfall 1916

Load reduction for a machine with derrick equipment***Load reduction main boom 2821 + derrick (+ auxiliary jib)****Load reduction for a machine with CE load chart**

Main boom length	44 m (144 ft) to 65 m (213 ft)	68 m (223 ft) to 101 m (331 ft)	104 m (341 ft) to 119 m (390 ft)
Wind speed	Reduction of load by		
10 m/s 32.81 ft/s	0 %	0 %	0 %
12 m/s 39.37 ft/s ^{A)}	10 %	20 %	20 %
14 m/s 45.93 ft/s ^{A) B)}	20 %	30 %	40 %
16 m/s 52.49 ft/s ^{A) B)}	30 %	50 %	60 %
Above 16 m/s (52.49 ft/s)	100 % = operation prohibited		

Tab. 408: Load reduction main boom 2821 + derrick (+ auxiliary jib)

- A) Minimum reduction 2 t (4,409 lb).
 B) Increase "SWLmin" value by 10% when operating with suspended counterweight. In the load chart, the "SWLmin" value is shown in brackets under the load chart value. The "SWLmin" value is the load chart value required to lift the suspended counterweight off the ground.

**Load reduction for a machine with ANSI load chart**

Main boom length	44 m (144 ft) to 77 m (253 ft)	80 m (262 ft) to 101 m (331 ft)	104 m (341 ft) to 119 m (390 ft)
Wind speed	Reduction of load by		
7 m/s 22.97 ft/s	0 %	0 %	0 %
9 m/s 29.53 ft/s ^{A)}	10 %	10 %	10 %
11 m/s 36.09 ft/s ^{A)}	20 %	30 %	30 %
13 m/s 42.65 ft/s ^{A) B)}	30 %	40 %	40 %
16 m/s 52.49 ft/s ^{A) B)}	50 %	60 %	70 %

LWNLR-x/V04.01//Auslieferung/2016-03-07/en

Main boom length	44 m (144 ft) to 77 m (253 ft)	80 m (262 ft) to 101 m (331 ft)	104 m (341 ft) to 119 m (390 ft)
Wind speed	Reduction of load by		
Above 16 m/s (52.49 ft/s)	100 % = operation prohibited		

Tab. 409: Load reduction main boom 2821 + derrick (+ auxiliary jib)

- A) Minimum reduction 2 t (4,409 lb).
 B) Increase "SWLmin" value by 10% when operating with suspended counterweight. In the load chart, the "SWLmin" value is shown in brackets under the load chart value. The "SWLmin" value is the load chart value required to lift the suspended counterweight off the ground.

Load reduction main boom 2821 + fixed jib 1713 + derrick



Load reduction for a machine with CE load chart

Main boom length	50 m (164 ft) to 62 m (203 ft)	65 m (213 ft) to 98 m (322 ft)	101 m (332 ft) to 110 m (361 ft)
Jib length	All		
Wind speed	Reduction of load by		
10 m/s 32.81 ft/s	0 %	0 %	0 %
12 m/s 39.37 ft/s A) B)	10 %	10 %	10 %
14 m/s 45.93 ft/s A) B)		20 %	40 %
16 m/s 52.49 ft/s A) B)		30 %	50 %
Above 16 m/s (52.49 ft/s)	100 % = operation prohibited		

Tab. 410: Load reduction main boom 2821 + fixed jib 1713 + derrick

- A) Minimum reduction 2 t (4,409 lb).
 B) Increase "SWLmin" value by 10% when operating with suspended counterweight. In the load chart, the "SWLmin" value is shown in brackets under the load chart value. The "SWLmin" value is the load chart value required to lift the suspended counterweight off the ground.



Load reduction for a machine with ANSI load chart

Main boom length	50 m (164 ft) to 62 m (203 ft)	65 m (213 ft) to 98 m (322 ft)	101 m (331 ft) to 110 m (361 ft)
Jib length	All		
Wind speed	Reduction of load by		
7 m/s 22.97 ft/s	0 %	0 %	0 %
9 m/s 29.53 ft/s ^{A)}		10 %	10 %
11 m/s 36.09 ft/s ^{A)}	10 %	20 %	20 %
13 m/s 42.65 ft/s ^{A) B)}		30 %	40 %
16 m/s 52.49 ft/s ^{A) B)}		40 %	50 %
Above 16 m/s (52.49 ft/s)	100 % = operation prohibited		

Tab. 411: Load reduction main boom 2821 + fixed jib 1713 + derrick

- A) Minimum reduction 2 t (4,409 lb).
 B) Increase "SWLmin" value by 10% when operating with suspended counterweight. In the load chart, the "SWLmin" value is shown in brackets under the load chart value. The "SWLmin" value is the load chart value required to lift the suspended counterweight off the ground.

Load reduction main boom 2821 + fixed jib 1507 + derrick



Load reduction for a machine with CE load chart

Main boom length	44 m (144 ft) to 80 m (262 ft)	83 m (272 ft) to 113 m (371 ft)
Jib length	All	
Wind speed	Reduction of load by	
10 m/s 32.81 ft/s	0 %	0 %
12 m/s 39.37 ft/s ^{A)}	10 %	20 %
14 m/s 45.93 ft/s ^{A) B)}	20 %	30 %
16 m/s 52.49 ft/s ^{A) B)}	30 %	40 %
Above 16 m/s (52.49 ft/s)	100 % = operation prohibited	

Tab. 412: Load reduction main boom 2821 + fixed jib 1507 + derrick

- A) Minimum reduction 2 t (4,409 lb).

- B) Increase "SWLmin" value by 10% when operating with suspended counterweight. In the load chart, the "SWLmin" value is shown in brackets under the load chart value. The "SWLmin" value is the load chart value required to lift the suspended counterweight off the ground.



ANSI

Load reduction for a machine with ANSI load chart

Main boom length	All
Jib length	All
Wind speed	Reduction of load by
7 m/s 22.97 ft/s	0 %
9 m/s 29.53 ft/s ^{A)}	10 %
11 m/s 36.09 ft/s ^{A)}	20 %
13 m/s 42.65 ft/s ^{A) B)}	30 %
16 m/s 52.49 ft/s ^{A) B)}	50 %
Above 16 m/s (52.49 ft/s)	100 % = operation prohibited

Tab. 413: Load reduction main boom 2821 + fixed jib 1507 + derrick

- A) Minimum reduction 2 t (4,409 lb).
 B) Increase "SWLmin" value by 10% when operating with suspended counterweight. In the load chart, the "SWLmin" value is shown in brackets under the load chart value. The "SWLmin" value is the load chart value required to lift the suspended counterweight off the ground.

Load reduction main boom 2821 + fixed jib 0906 + derrick



CE

Load reduction for a machine with CE load chart

Main boom length	50 m (164 ft) to 62 m (203 ft)	65 m (213 ft) to 80 m (262 ft)	83 m (272 ft) to 116 m (381 ft)
Jib length	All		
Wind speed	Reduction of load by		
10 m/s 32.81 ft/s	0 %	0 %	0 %

Main boom length	50 m (164 ft) to 62 m (203 ft)	65 m (213 ft) to 80 m (262 ft)	83 m (272 ft) to 116 m (381 ft)
Jib length	All		
Wind speed	Reduction of load by		
12 m/s 39.37 ft/s ^{A)}	10 %	10 %	20 %
14 m/s 45.93 ft/s ^{A) B)}		20 %	30 %
16 m/s 52.49 ft/s ^{A) B)}		40 %	60 %
Above 16 m/s (52.49 ft/s)	100 % = operation prohibited		

Tab. 414: Load reduction main boom 2821 + fixed jib 0906 + derrick

- A) Minimum reduction 2 t (4,409 lb).
- B) Increase “SWLmin” value by 10% when operating with suspended counterweight. In the load chart, the “SWLmin” value is shown in brackets under the load chart value. The “SWLmin” value is the load chart value required to lift the suspended counterweight off the ground.



Load reduction for a machine with ANSI load chart

Main boom length	50 m (164 ft) to 62 m (203 ft)	65 m (213 ft) to 98 m (322 ft)	101 m (331 ft) to 116 m (381 ft)
Jib length	All		
Wind speed	Reduction of load by		
7 m/s 22.97 ft/s	0 %	0 %	0 %
9 m/s 29.53 ft/s ^{A)}	10 %	10 %	10 %
11 m/s 36.09 ft/s ^{A)}		20 %	30 %
13 m/s 42.65 ft/s ^{A) B)}		30 %	40 %
16 m/s 52.49 ft/s ^{A) B)}		50 %	60 %
Above 16 m/s (52.49 ft/s)	100 % = operation prohibited		

Tab. 415: Load reduction main boom 2821 + fixed jib 0906 + derrick

- A) Minimum reduction 2 t (4,409 lb).
- B) Increase “SWLmin” value by 10% when operating with suspended counterweight. In the load chart, the “SWLmin” value is shown in brackets under the load chart value. The “SWLmin” value is the load chart value required to lift the suspended counterweight off the ground.

LWNLR-x/V04.01//Auslieferung/2016-03-07/en

Load reduction main boom 2821 + luffing jib 2316 + derrick (+ auxiliary jib)



Load reduction for a machine with CE load chart

Main boom length	All			
Jib length	20 m (66 ft) to 32 m (105 ft)	35 m (115 ft) to 50 m (164 ft)	53 m (174 ft) to 68 m (223 ft)	71 m (233 ft) to 113 m (371 ft)
Wind speed	Reduction of load by			
10 m/s 32.81 ft/s	0 %	0 %	0 %	0 %
12 m/s 39.37 ft/s ^{A)}	20 %	30 %	60 %	100 %
14 m/s 45.93 ft/s ^{A) B)}	30 %	50 %	100 %	
16 m/s 52.49 ft/s ^{A) B)}	50 %	80 %		
Above 16 m/s (52.49 ft/s)	100 % = operation prohibited			

Tab. 416: Load reduction main boom 2821 + luffing jib 2316 + derrick (+ auxiliary jib)

- A) Minimum reduction 2 t (4,409 lb).
 B) Increase "SWLmin" value by 10% when operating with suspended counterweight. In the load chart, the "SWLmin" value is shown in brackets under the load chart value. The "SWLmin" value is the load chart value required to lift the suspended counterweight off the ground.



Load reduction for a machine with ANSI load chart

Main boom length	All				
Jib length	20 m (66 ft) to 32 m (105 ft)	35 m (115 ft) to 50 m (164 ft)	53 m (174 ft) to 68 m (223 ft)	71 m (233 ft) to 86 m (282 ft)	89 m (292 ft) to 113 m (371 ft)
Wind speed	Reduction of load by				
7 m/s 22.97 ft/s	0 %	0 %	0 %	0 %	0 %

Main boom length	All				
Jib length	20 m (66 ft) to 32 m (105 ft)	35 m (115 ft) to 50 m (164 ft)	53 m (174 ft) to 68 m (223 ft)	71 m (233 ft) to 86 m (282 ft)	89 m (292 ft) to 113 m (371 ft)
Wind speed	Reduction of load by				
9 m/s 29.53 ft/s ^{A)}	20 %	20 %	30 %	50 %	100 %
11 m/s 36.09 ft/s ^{A)}	30 %	40 %	60 %	90 %	
13 m/s 42.65 ft/s ^{A) B)}	50 %	60 %	90 %	100 %	
16 m/s 52.49 ft/s ^{A) B)}	70 %	90 %	100 %		
Above 16 m/s (52.49 ft/s)	100 % = operation prohibited				

Tab. 417: Load reduction main boom 2821 + luffing jib 2316 + derrick (+ auxiliary jib)

- A) Minimum reduction 2 t (4,409 lb).
- B) Increase "SWLmin" value by 10% when operating with suspended counterweight. In the load chart, the "SWLmin" value is shown in brackets under the load chart value. The "SWLmin" value is the load chart value required to lift the suspended counterweight off the ground.

Load reduction main boom 2821 + luffing jib 1916 + derrick (+ auxiliary jib)



Load reduction for a machine with CE load chart

Main boom length	All				
Jib length	20 m (66 ft) to 32 m (105 ft)	35 m (115 ft) to 44 m (144 ft)	47 m (154 ft) to 56 m (184 ft)	59 m (194 ft) to 68 m (223 ft)	71 m (233 ft) to 95 m (312 ft)
Wind speed	Reduction of load by				
10 m/s 32.81 ft/s	0 %	0 %	0 %	0 %	0 %

LWNLR-x/V04.01//Auslieferung/2016-03-07/en

Main boom length	All				
Jib length	20 m (66 ft) to 32 m (105 ft)	35 m (115 ft) to 44 m (144 ft)	47 m (154 ft) to 56 m (184 ft)	59 m (194 ft) to 68 m (223 ft)	71 m (233 ft) to 95 m (312 ft)
Wind speed	Reduction of load by				
12 m/s 39.37 ft/s ^{A)}	20 %	20 %	30 %	40 %	100 %
14 m/s 45.93 ft/s ^{A) B)}	30 %	40 %	60 %	100 %	
16 m/s 52.49 ft/s ^{A) B)}	50 %	60 %	80 %		
Above 16 m/s (52.49 ft/s)	100 % = operation prohibited				

Tab. 418: Load reduction main boom 2821 + luffing jib 1916 + derrick (+ auxiliary jib)

- A) Minimum reduction 2 t (4,409 lb).
 B) Increase "SWLmin" value by 10% when operating with suspended counterweight. In the load chart, the "SWLmin" value is shown in brackets under the load chart value. The "SWLmin" value is the load chart value required to lift the suspended counterweight off the ground.



Load reduction for a machine with ANSI load chart

Main boom length	All		
Jib length	20 m (66 ft) to 44 m (144 ft)	47 m (154 ft) to 68 m (223 ft)	71 m (233 ft) to 95 m (312 ft)
Wind speed	Reduction of load by		
7 m/s 22.97 ft/s	0 %	0 %	0 %
9 m/s 29.53 ft/s ^{A)}	10 %	20 %	30 %
11 m/s 36.09 ft/s ^{A)}	30 %	30 %	50 %
13 m/s 42.65 ft/s ^{A) B)}	40 %	50 %	100 %
16 m/s 52.49 ft/s ^{A) B)}	60 %	100 %	
Above 16 m/s (52.49 ft/s)	100 % = operation prohibited		

Tab. 419: Load reduction main boom 2821 + luffing jib 1916 + derrick (+ auxiliary jib)

- A) Minimum reduction 2 t (4,409 lb).
- B) Increase “SWLmin” value by 10% when operating with suspended counterweight. In the load chart, the “SWLmin” value is shown in brackets under the load chart value. The “SWLmin” value is the load chart value required to lift the suspended counterweight off the ground.

6.7.3 Parked positions of boom configurations



DANGER

Wind speed too high!
Toppling of machine.

- ▶ Turn boom into the wind.
- ▶ Before the maximum permitted wind speed is exceeded, place boom in specified parked position.
- ▶ Lay the suspended counterweight/counterweight carriage on the ground.
- ▶ Relieve the strain on the pendant ropes and/or pendant straps.
- ▶ Place the load on the ground.
- ▶ Pull up hook.

The parked positions of the boom configurations are valid for the specified maximum wind speeds in the following tables. If these values are exceeded, the boom must be laid down.

All stated wind speeds are 3 second wind gust speeds measured at maximum boom height. The stated wind speeds are only valid in wide track operation and with all counterweights attached to the machine. In case of deviating machine configuration: Contact Liebherr customer service.

Parked position for a machine without derrick equipment*

Parked position of main boom 2821 (+ auxiliary jib)

Description	Value
Maximum wind speed	22 m/s 72.18 ft/s
Main boom length	20 m (20 ft) to 26 m (85 ft)
Main boom angle	54° to 60°

Tab. 420: Parked position of main boom 2821 (+ auxiliary jib)

Description	Value
Maximum wind speed	22 m/s 72.18 ft/s
Main boom length	29 m (95 ft) to 104 m (341 ft)
Main boom angle	72° to 80°

Tab. 421: Parked position of main boom 2821 (+ auxiliary jib)

Parked position of main boom 2821 + reducing adapter 2821/2316

Description	Value
Maximum wind speed	22 m/s 72.18 ft/s
Main boom length	69 m (226 ft) to 114 m (374 ft)
Main boom angle	72° to 80°

Tab. 422: Parked position of main boom 2821 + reducing adapter 2821/2316

Description	Value
Maximum wind speed	20 m/s 65.62 ft/s
Main boom length	117 m (384 ft) to 123 m (404 ft)
Main boom angle	72° to 80°

Tab. 423: Parked position of main boom 2821 + reducing adapter 2821/2316

Parked position of main boom 2821 + fixed jib 1713

Description	Value
Maximum wind speed	22 m/s 72.18 ft/s
Main boom length	All
Main boom angle	72° to 78°
Jib length	All
Jib offset	15° or 30°

Tab. 424: Parked position of main boom 2821 + fixed jib 1713

Parked position of main boom 2821 + fixed jib 1507

Description	Value
Maximum wind speed	22 m/s 72.18 ft/s
Main boom length	20 m (66 ft) to 26 m (85 ft)
Main boom angle	68° to 72°
Jib offset	28°

Tab. 425: Parked position of main boom 2821 + fixed jib 1507

Description	Value
Maximum wind speed	22 m/s 72.18 ft/s

Description	Value
Main boom length	29 m (95 ft) to 86 m (282 ft)
Main boom angle	72° to 78°
Jib offset	28°

Tab. 426: Parked position of main boom 2821 + fixed jib 1507

Parked position of main boom 2821 + fixed jib 1008

Description	Value
Maximum wind speed	22 m/s 72.18 ft/s
Main boom length	20 m (66 ft) to 26 m (85 ft)
Main boom angle	68° to 72°
Jib length	All
Jib offset	15° or 30°

Tab. 427: Parked position of main boom 2821 + fixed jib 1008

Description	Value
Maximum wind speed	22 m/s 72.18 ft/s
Main boom length	29 m (95 ft) to 86 m (282 ft)
Main boom angle	72° to 78°
Jib length	All
Jib offset	15° or 30°

Tab. 428: Parked position of main boom 2821 + fixed jib 1008

Parked position of main boom 2821 + fixed jib 0906

Description	Value
Maximum wind speed	22 m/s 72.18 ft/s
Main boom length	20 m (66 ft) to 26 m (85 ft)
Main boom angle	68° to 72°
Jib offset	30°

Tab. 429: Parked position of main boom 2821 + fixed jib 0906

Description	Value
Maximum wind speed	22 m/s 72.18 ft/s
Main boom length	29 m (95 ft) to 95 m (312 ft)

Description	Value
Main boom angle	72° to 78°
Jib offset	30°

Tab. 430: Parked position of main boom 2821 + fixed jib 0906

Parked position of main boom 2821 + luffing jib 2316 (+ auxiliary jib)

Description	Value
Maximum wind speed	22 m/s 72.18 ft/s
Main boom length	20 m (66 ft) to 74 m (243 ft)
Main boom angle	80°
Jib length	20 m (66 ft) to 68 m (223 ft)
Jib angle	66° to 70°

Tab. 431: Parked position of main boom 2821 + luffing jib 2316 (+ auxiliary jib)

Description	Value
Maximum wind speed	18 m/s 59.06 ft/s
Main boom length	20 m (66 ft) to 74 m (243 ft)
Main boom angle	80°
Jib length	71 m (233 ft) to 86 m (282 ft)
Jib angle	66° to 70°

Tab. 432: Parked position of main boom 2821 + luffing jib 2316 (+ auxiliary jib)



Note

- All combinations with a jib length of 89 m (292 ft) bis 113 m (371 ft) must be laid down when the wind speed reaches a value at which work is no longer permitted (see preface of valid load chart).

Parked position of main boom 2821 + luffing jib 1916 (+ auxiliary jib)

Description	Value
Maximum wind speed	22 m/s 72.18 ft/s
Main boom length	20 m (66 ft) to 74 m (243 ft)
Main boom angle	80°

Description	Value
Jib length	20 m (66 ft) to 80 m (262 ft)
Jib angle	66° to 70°

Tab. 433: Parked position of main boom 2821 + luffing jib 1916 (+ auxiliary jib)

Description	Value
Maximum wind speed	18 m/s 59.06 ft/s
Main boom length	20 m (66 ft) to 74 m (243 ft)
Main boom angle	80°
Jib length	83 m (272 ft) to 95 m (312 ft)
Jib angle	64° to 70°

Tab. 434: Parked position of main boom 2821 + luffing jib 1916 (+ auxiliary jib)

Parked position of main boom 2821 + luffing jib 2316 + midfall 2316

Description	Value
Maximum wind speed	22 m/s 72.18 ft/s
Main boom length	20 m (66 ft) to 71 m (233 ft)
Main boom angle	80°
Jib length	38.5 m (126 ft) to 65.5 m (215 ft)
Jib angle	66° to 70°

Tab. 435: Parked position of main boom 2821 + luffing jib 2316 + midfall 2316

Description	Value
Maximum wind speed	18 m/s 59.06 ft/s
Main boom length	20 m (66 ft) to 71 m (233 ft)
Main boom angle	80°
Jib length	68.5 m (225 ft) to 83.5 m (274 ft)
Jib angle	66° to 70°

Tab. 436: Parked position of main boom 2821 + luffing jib 2316 + midfall 2316

LWNLR-x\04.01\Auslieferung\2016-03-07\en

**Note**

- ▶ All combinations above a jib length of 86.5 m (284 ft) must be laid down when the wind speed reaches a value at which work is no longer permitted (see preface of valid load chart).

Parked position of main boom 2821 + luffing jib 1916 + midfall 1916

Description	Value
Maximum wind speed	22 m/s 72.18 ft/s
Main boom length	20 m (66 ft) to 74 m (243 ft)
Main boom angle	80°
Jib length	32.5 m (107 ft) to 77.5 m (254 ft)
Jib angle	66° to 70°

Tab. 437: Parked position of main boom 2821 + luffing jib 1916 + midfall 1916

Description	Value
Maximum wind speed	18 m/s 59.06 ft/s
Main boom length	20 m (66 ft) to 74 m (243 ft)
Main boom angle	80°
Jib length	80.5 m (264 ft) to 95.5 m (313 ft)
Jib angle	64° to 70°

Tab. 438: Parked position of main boom 2821 + luffing jib 1916 + midfall 1916

Parked position for a machine with derrick equipment***Parked position main boom 2821 + derrick (+ auxiliary jib)**

Description	Value
Maximum wind speed	22 m/s 72.18 ft/s
Main boom length	44 m (144 ft) to 98 m (322 ft)
Main boom angle	74° to 78°

Tab. 439: Parked position main boom 2821 + derrick (+ auxiliary jib)

Description	Value
Maximum wind speed	20 m/s 66 ft
Main boom length	101 m (331 ft) to 119 m (390 ft)
Main boom angle	74° to 78°

Tab. 440: Parked position main boom 2821 + derrick (+ auxiliary jib)

Parked position main boom 2821 + fixed jib 1713 + derrick

Description	Value
Maximum wind speed	22 m/s 72.18 ft/s
Main boom length	50 m (164 ft) to 95 m (312 ft)
Main boom angle	78° to 80°
Jib length	All
Jib offset	15° or 30°

Tab. 441: Parked position main boom 2821 + fixed jib 1713 + derrick

Description	Value
Maximum wind speed	20 m/s 65.62 ft/s
Main boom length	98 m (322 ft) to 110 m (361 ft)
Main boom angle	78° to 80°
Jib length	All
Jib offset	15° or 30°

Tab. 442: Parked position main boom 2821 + fixed jib 1713 + derrick

Parked position main boom 2821 + fixed jib 1507 + derrick

Description	Value
Maximum wind speed	22 m/s 72.18 ft/s
Main boom length	44 m (144 ft) to 98 m (322 ft)
Main boom angle	72° to 80°
Jib offset	28°

Tab. 443: Parked position main boom 2821 + fixed jib 1507 + derrick

Description	Value
Maximum wind speed	20 m/s 65.62 ft/s
Main boom length	101 m (331 ft) to 113 m (371 ft)
Main boom angle	72° to 80°
Jib offset	28°

Tab. 444: Parked position main boom 2821 + fixed jib 1507 + derrick

Parked position main boom 2821 + fixed jib 0906 + derrick

Description	Value
Maximum wind speed	22 m/s 72.18 ft/s
Main boom length	44 m (144 ft) to 98 m (322 ft)
Main boom angle	72° to 80°
Jib offset	30°

Tab. 445: Parked position main boom 2821 + fixed jib 0906 + derrick

Description	Value
Maximum wind speed	20 m/s 65.62 ft/s
Main boom length	101 m (331 ft) to 116 m (390 ft)
Main boom angle	72° to 80°
Jib offset	30°

Tab. 446: Parked position main boom 2821 + fixed jib 0906 + derrick

Parked position main boom 2821 + luffing jib 2316 + derrick (+ auxiliary jib)

Description	Value
Maximum wind speed	22 m/s 72.18 ft/s
Main boom length	44 m (144 ft) to 86 m (282 ft)
Main boom angle	80°
Jib length	20 m (66 ft) to 50 m (164 ft)
Jib angle	66° to 70°

Tab. 447: Parked position main boom 2821 + luffing jib 2316 + derrick (+ auxiliary jib)

Description	Value
Maximum wind speed	20 m/s 65.62 ft/s
Main boom length	44 m (144 ft) to 86 m (282 ft)
Main boom angle	80°
Jib length	53 m (174 ft) to 68 m (223 ft)
Jib angle	66° to 70°

Tab. 448: Parked position main boom 2821 + luffing jib 2316 + derrick (+ auxiliary jib)

Description	Value
Maximum wind speed	18 m/s 59.06 ft/s
Main boom length	44 m (144 ft) to 86 m (282 ft)
Main boom angle	80°
Jib length	71 m (233 ft) to 104 m (341 ft)
Jib angle	66° to 70°

Tab. 449: Parked position main boom 2821 + luffing jib 2316 + derrick (+ auxiliary jib)



Note

- Lay down boom combinations as of a jib length of 107 m (351 ft) or a total boom length of 160 m (525 ft) if the wind speed reaches a value at which work is no longer permissible (see foreword to valid load chart).

Parked position main boom 2821 + luffing jib 1916 + derrick (+ auxiliary jib)

Description	Value
Maximum wind speed	22 m/s 72.18 ft/s
Main boom length	44 m (144 ft) to 92 m (302 ft)
Main boom angle	80°
Jib length	20 m (66 ft) to 56 m (184 ft)
Jib angle	66° to 70°

Tab. 450: Parked position main boom 2821 + luffing jib 1916 + derrick (+ auxiliary jib)

LWNLR-x/V04.01//Auslieferung/2016-03-07/en

Description	Value
Maximum wind speed	18 m/s 59.06 ft/s
Main boom length	44 m (144) to 92 m (302 ft)
Main boom angle	80°
Jib length	59 m (194 ft) to 80 m (262 ft)
Jib angle	66° to 70°

Tab. 451: Parked position main boom 2821 + luffing jib 1916 + derrick (+ auxiliary jib)

Description	Value
Maximum wind speed	14 m/s 45.93 ft/s
Main boom length	44 m (144) to 92 m (302 ft)
Main boom angle	80°
Jib length	83 m (272 ft) to 95 m (312 ft)
Jib angle	66° to 70°

Tab. 452: Parked position main boom 2821 + luffing jib 1916 + derrick (+ auxiliary jib)

6.7.4 Laying down the boom

The “laying-down wind speed” for the boom is reached when the maximum permissible wind speeds for the parked position are exceeded or expected to be exceeded.



DANGER

Excessive wind load!

Machine toppling over, structural breakdown.

- ▶ Lay down entire boom on the ground against the wind before the maximum permissible wind speed is reached.

If it is not possible to lay down with a boom combination including a luffing jib:

- ▶ Contact Liebherr customer service.

Observe the following safety guidelines and notes:

- Always lay down the entire main boom flat on the ground. Supporting the boom on an undulation always bears a residual danger. If the main boom is not set down completely (but only near the ground), this may lead to the destruction of the boom or the swing brake.
- Always set the main boom down so that it is facing either into or against the wind. If the main boom can only be set down crosswise to the wind direction due to limited space, then it must be set down before the wind reaches the maximum permissible speed.

- In bad weather or if a storm is forecast and work is to be interrupted for a day or more, or if the machine operator and assistants will be absent, as a rule the entire boom must be placed on the ground.
- If it turns out during planning that the boom cannot be set down completely at the site due to a lack of space and danger of a storm: contact the manufacturer in time to arrange special protective measures against storm damage.



Note

Liebherr recommends:

- ▶ The safest measure is always to lay down the boom.
-

6.8 Traveling on gradients



DANGER

Incorrect travelling of machine on gradients!
Toppling of machine.

- ▶ Take great care with every travel movement of the machine.
- ▶ Avoid dynamic travel movements.



DANGER

Inadmissible traveling with suspended counterweight on gradients!
Toppling of machine.

- ▶ Deinstall suspended counterweight.
- ▶ Leave pendant ropes on derrick boom.
- ▶ Install maximum rear counterweight and carbody counterweight.



DANGER

Improper traveling with counterweight carriage on gradients!
Toppling of machine.

- ▶ Only travel in trailer mode.
- ▶ Ensure that all wheel sets are in contact with the ground.
- ▶ Ensure that the upward tilt of the counterweight carriage is max. 45%.
- ▶ Ensure that the downward tilt of the counterweight carriage is max. 15%.
- ▶ Ensure that the lateral torsion of the counterweight carriage is max. 3.5%.
- ▶ Remove counterweight slabs from counterweight carriage.
- ▶ Install maximum rear counterweight and carbody counterweight.

The following points must be observed when travelling on gradients:

- The inclination value in % must be measured by qualified personnel and communicated to the machine operator before the machine is moved.
- Lateral gradients must not exceed 1 % when traveling.
- Machine must be fitted with maximum rear counterweight and carbody counterweight.
- Machine can be in narrow track, medium track or wide track.
- Machine may only be moved when the crawlers are in normal gear.
- Upper-carriage is parallel to crawler side frame.
- When driving on an incline, only the installed hook and/or the installed pulley block may be on the boom.
- Specified boom angles:
 - are always relative to the machine's horizontal standing area.
 - must be checked and/or adjusted before an incline is negotiated.



DANGER

Incorrect driving of machine over undulations!
Toppling of machine.

- ▶ When traveling over undulations, the entire crawler must be on the ground.

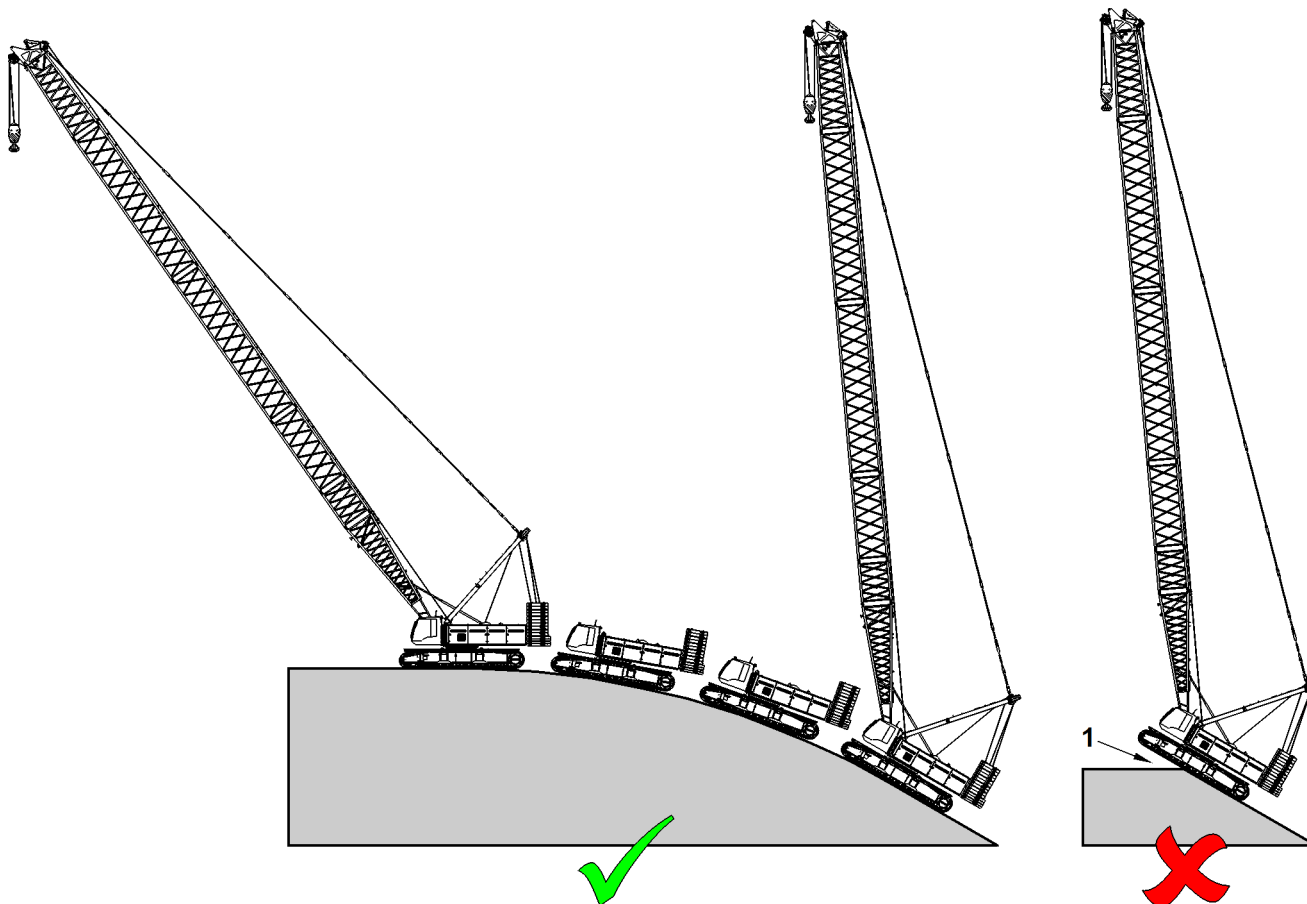


Fig. 2875: Driving over undulations (diagram)

1 Prohibited situation



Note

The following diagrams are purely to illustrate the incline! The boom angles and the inclinations shown in the diagrams do not correspond to the values in the table. All values shown in the table include maximum ballasting!

- ▶ Only use values from the table.
- ▶ If you require values for special combinations: Contact Liebherr customer service.

6.8.1 Permitted gradient for a machine without derrick equipment*

Permitted gradient main boom 2821 (+ auxiliary jib)

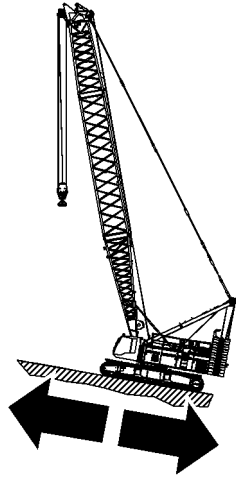


Fig. 2876: Permitted gradient main boom 2821 (+ auxiliary jib), boom travel uphill

Description	Value	
	Main boom angle	40°
Main boom length	max. gradient in %, boom travel uphill	
20 m (65' 7" ft-in) to 53 m (173' 11" ft-in)	10	-
56 m (183' 9" ft-in) to 104 m (341' 2" ft-in)	-	20

Tab. 453: Permitted gradient main boom 2821 (+ auxiliary jib), boom travel uphill

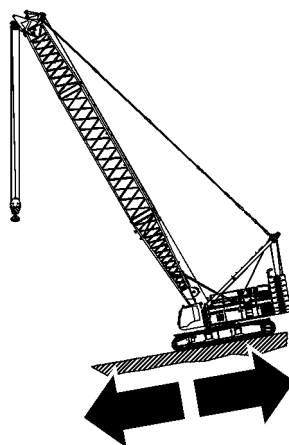


Fig. 2877: Permitted gradient for main boom 2821 (+ auxiliary jib), boom travel downhill

Description	Value	
Main boom angle	86°	60°
Main boom length	max. gradient in %, boom travel downhill	
20 m (65' 7" ft-in) to 53 m (173' 11" ft-in)	-	30
56 m (183' 9" ft-in) to 95 m (311' 8" ft-in)	30	-
98 m (321' 6" ft-in) to 104 m (341' 2" ft-in)	20	-

Tab. 454: Permitted gradient for main boom 2821 (+ auxiliary jib), boom travel downhill

Permitted gradient for main boom 2821 + reducing adapter 2821/2316

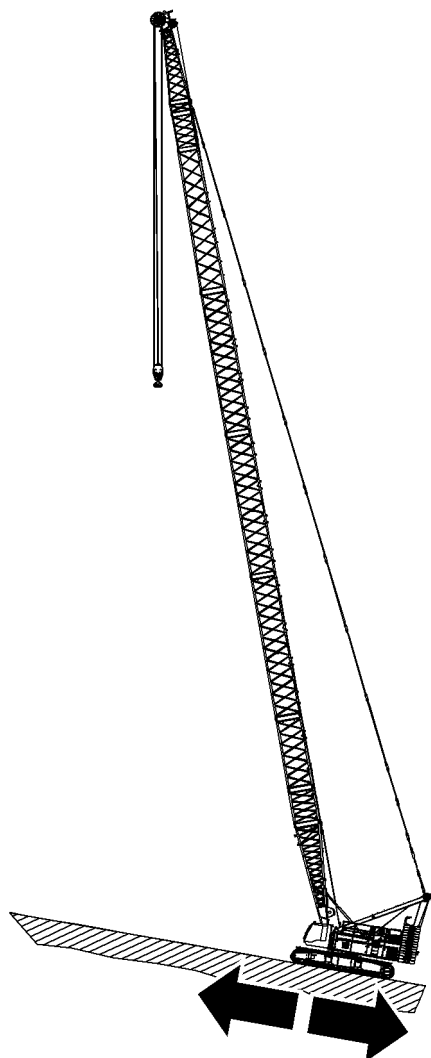


Fig. 2878: Permitted gradient for main boom 2821 + reducing adapter 2821/2316, boom travel uphill

LWN/LR-x/V04.01//Auslieferung/2016-03-07/en

Description	Value
Main boom angle	50°
Main boom length	max. gradient in %, boom travel uphill
69 m (226' 5" ft-in) to 123 m (403' 7" ft-in)	20

Tab. 455: Permitted gradient for main boom 2821 + reducing adapter 2821/2316, boom travel uphill

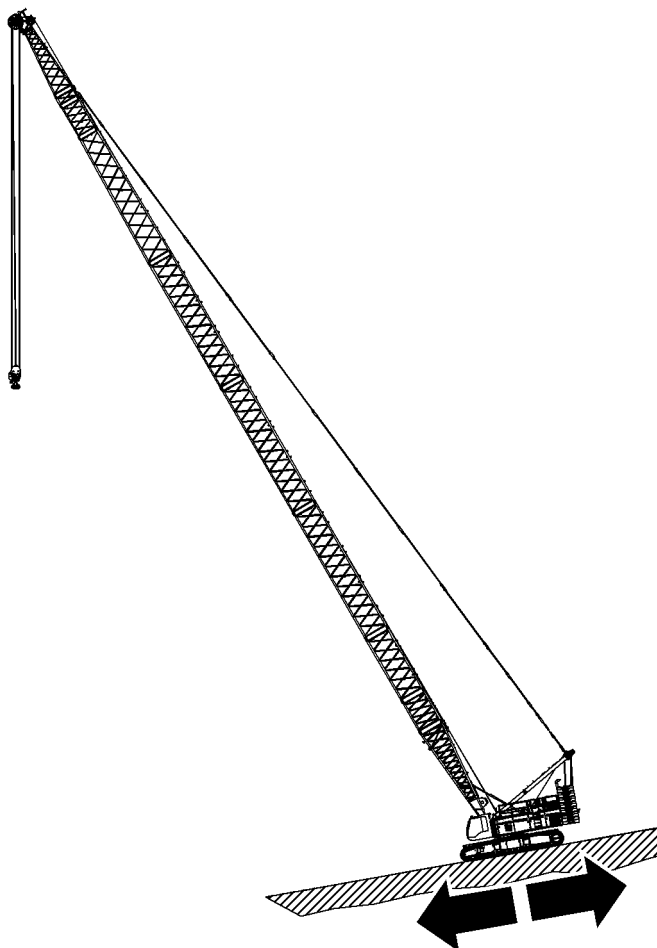


Fig. 2879: Permitted gradient for main boom 2821 + reducing adapter 2821/2316, boom travel downhill

Description	Value
Main boom angle	78°
Main boom length	max. gradient in %, boom travel downhill
69 m (226' 5" ft-in) to 78 m (255' 11" ft-in)	30
81 m (265' 9" ft-in) to 114 m (374' ft-in)	20

Description	Value
117 m (383' 10" ft-in) to 123 m (403' 7" ft-in)	10

Tab. 456: Permitted gradient for main boom 2821 + reducing adapter 2821/2316, boom travel downhill

Permitted gradient for main boom 2821 + fixed jib 1713

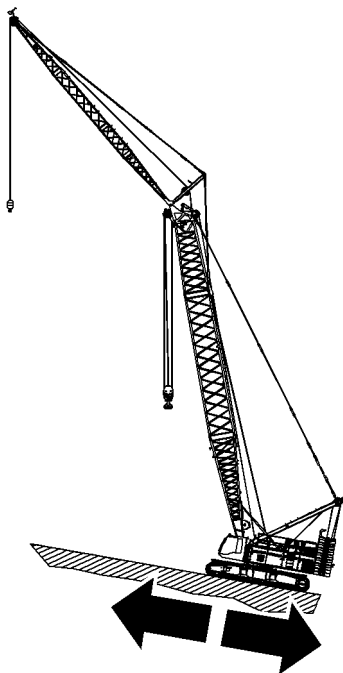


Fig. 2880: Permitted gradient for main boom 2821 + fixed jib 1713, boom travel uphill

Description	Value
Main boom angle	50°
Jib length	all
Jib offset	15° or 30°
Main boom length	max. gradient in %, boom travel uphill
20 m (65' 7" ft-in) to 83 m (272' 4" ft-in)	20

Tab. 457: Permitted gradient for main boom 2821 + fixed jib 1713, boom travel uphill

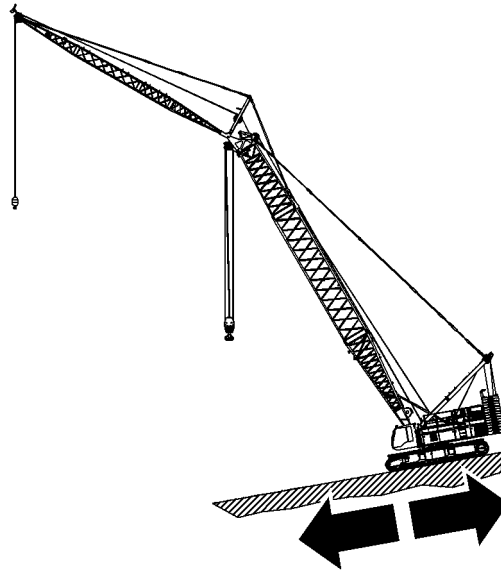


Fig. 2881: Permitted gradient for main boom 2821 + fixed jib 1713, boom travel downhill

Description	Value	
Main boom angle	80°	70°
Jib length	all	
Jib offset	15° or 30°	
Main boom length	max. gradient in %, boom travel downhill	
20 m (65' 7" ft-in) to 41 m (134' 6" ft-in)	-	30
44 m (144' 4" ft-in) to 80 m (262' 6" ft-in)	20	-
83 m 272' 4" ft-in	10	-

Tab. 458: Permitted gradient for main boom 2821 + fixed jib 1713, boom travel downhill

Permitted gradient for main boom 2821 + fixed jib 1507

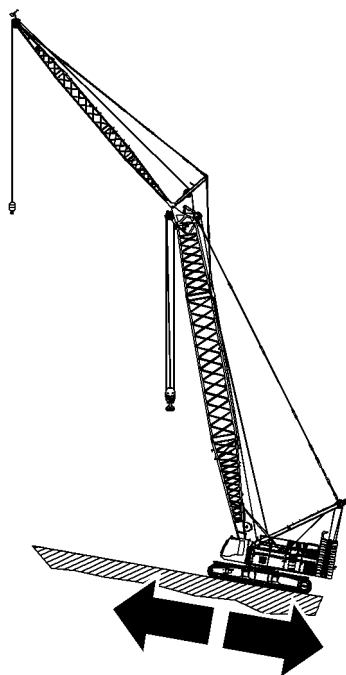


Fig. 2882: Permitted gradient for main boom 2821 + fixed jib 1507, boom travel uphill

Description	Value	
Main boom angle	40°	50°
Jib offset	28°	
Main boom length	max. gradient in %, boom travel uphill	
20 m (65' 7" ft-in) to 38 m (124' 8" ft-in)	20	-
41 m (134' 6" ft-in) to 86 m (282' 2" ft-in)	-	20

Tab. 459: Permitted gradient for main boom 2821 + fixed jib 1507, boom travel uphill

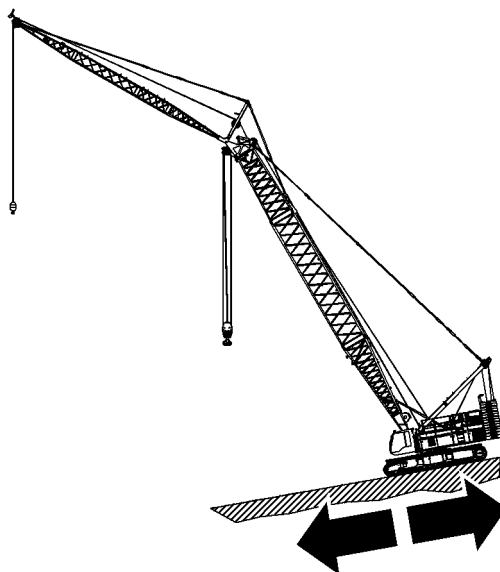


Fig. 2883: Permitted gradient for main boom 2821 + fixed jib 1507, boom travel downhill

Description	Value	
Main boom angle	80°	70°
Jib offset	28°	
Main boom length	max. gradient in %, boom travel downhill	
20 m (65' 7" ft-in) to 38 m (124' 8" ft-in)	-	30
41 m (134' 6" ft-in) to 86 m (282' 2" ft-in)	20	-

Tab. 460: Permitted gradient for main boom 2821 + fixed jib 1507, boom travel downhill

Permitted gradient for main boom 2821 + fixed jib 1008

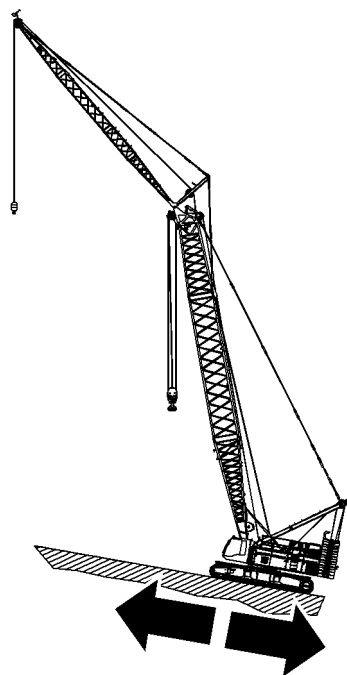


Fig. 2884: Permitted gradient for main boom 2821 + fixed jib 1008, boom travel uphill

Description	Value	
Main boom angle	40°	50°
Jib length	all	
Jib offset	15° or 30°	
Main boom length	max. gradient in %, boom travel uphill	
20 m (65' 7" ft-in) to 41 m (134' 6" ft-in)	20	-
44 m (144' 4" ft-in) to 86 m (282' 2" ft-in)	-	20

Tab. 461: Permitted gradient for main boom 2821 + fixed jib 1008, boom travel uphill

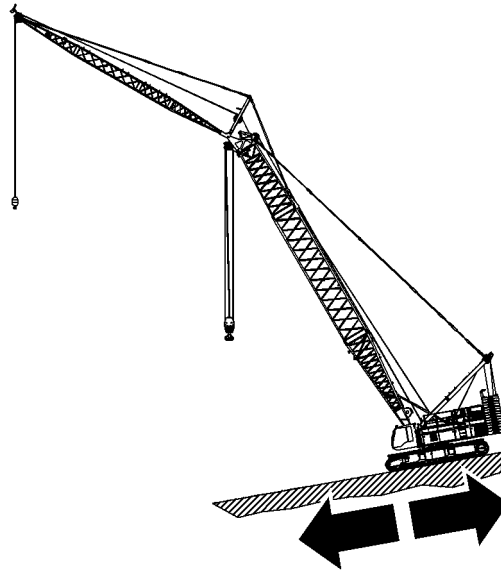


Fig. 2885: Permitted gradient for main boom 2821 + fixed jib 1008, boom travel downhill

Description	Value	
Main boom angle	80°	70°
Jib length	all	
Jib offset	15° or 30°	
Main boom length	max. gradient in %, boom travel downhill	
20 m (65' 7" ft-in) to 41 m (134' 6" ft-in)	-	30
44 m (144' 4" ft-in) to 83 m (272' 4" ft-in)	20	-
86 m 282' 2" ft-in	10	-

Tab. 462: Permitted gradient for main boom 2821 + fixed jib 1008, boom travel downhill

Permitted gradient for main boom 2821 + fixed jib 0906

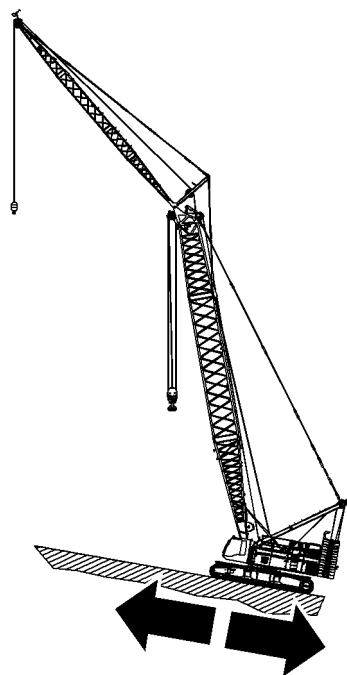


Fig. 2886: Permitted gradient for main boom 2821 + fixed jib 0906, boom travel uphill

Description	Value	
Main boom angle	40°	50°
Jib offset	30°	
Main boom length	max. gradient in %, boom travel uphill	
20 m (65' 7" ft-in) to 38 m (124' 8" ft-in)	20	-
41 m (134' 6" ft-in) to 95 m (311' 8" ft-in)	-	20

Tab. 463: Permitted gradient for main boom 2821 + fixed jib 0906, boom travel uphill

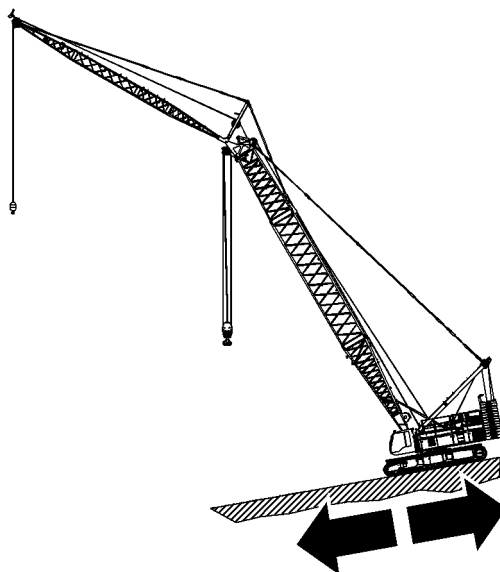


Fig. 2887: Permitted gradient for main boom 2821 + fixed jib 0906, boom travel downhill

Description	Value	
Main boom angle	80°	70°
Jib offset	30°	
Main boom length	max. gradient in %, boom travel downhill	
20 m (65' 7" ft-in) to 38 m (124' 8" ft-in)	-	30
41 m (134' 6" ft-in) to 95 m (311' 8" ft-in)	20	-

Tab. 464: Permitted gradient for main boom 2821 + fixed jib 0906, boom travel downhill

Permitted gradient for main boom 2821 + luffing jib 2316 (+ auxiliary jib)

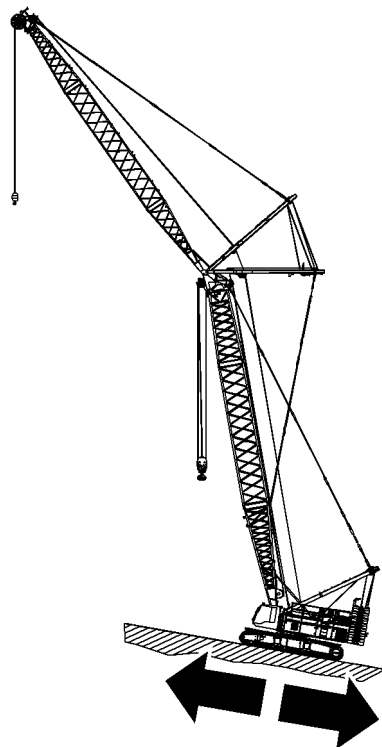


Fig. 2888: Permitted gradient for main boom 2821 + luffing jib 2316 (+ auxiliary jib), boom travel uphill

Description	Value	
Main boom angle	45°	65°
Jib angle	15°	25°
Jib length	20 m (65' 7" ft-in) to 47 m (154' 2" ft-in)	50 m (164' ft-in) to 113 m (370' 9" ft-in)
Main boom length	max. gradient in %, boom travel uphill	
20 m (65' 7" ft-in) to 71 m (232' 11" ft-in)	15	20

Tab. 465: Permitted gradient for main boom 2821 + luffing jib 2316 (+ auxiliary jib), boom travel uphill

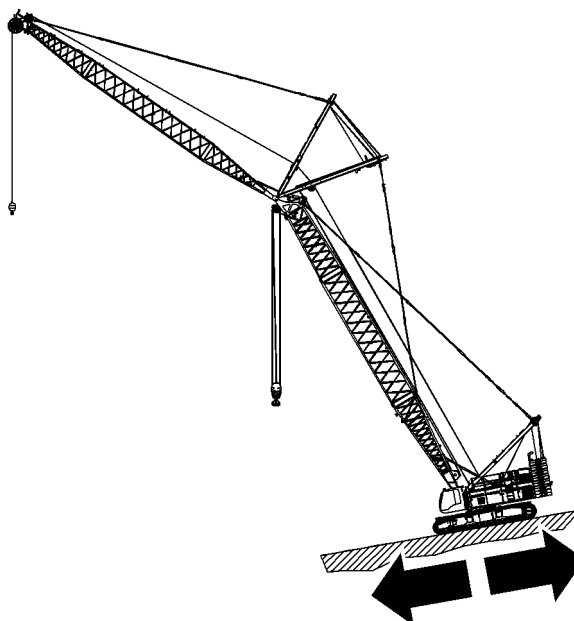


Fig. 2889: Permitted gradient for main boom 2821 + luffing jib 2316 (+ auxiliary jib), boom travel downhill

Description	Value		
Main boom angle	83°		
Jib angle	73°		
Jib length	20 m (65' 7" ft-in) to 86 m (282' 2" ft-in)	20 m (65' 7" ft-in) to 47 m (154' 2" ft-in)	50 m (164' ft-in) to 86 m (282' 2" ft-in)
Main boom length	max. gradient in %, boom travel downhill		
20 m (65' 7" ft-in) to 35 m (114' 10" ft-in)	20	-	-
38 m (124' 8" ft-in) to 71 m (232' 11" ft-in)	-	20	10

Tab. 466: Permitted gradient for main boom 2821 + luffing jib 2316 (+ auxiliary jib), boom travel downhill

Permitted gradient for main boom 2821 + luffing jib 2316 + Midfall 2316

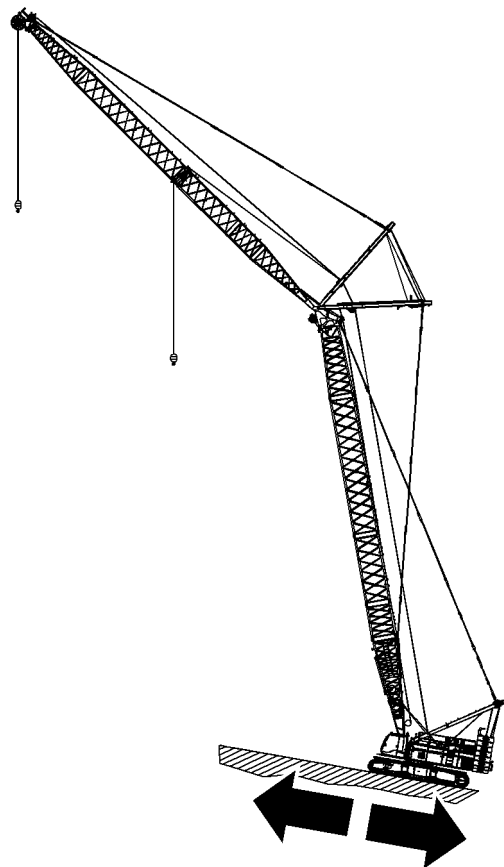


Fig. 2890: Permitted gradient for main boom 2821 + luffing jib 2316 + midfall 2316, boom travel uphill

Description	Value	
Main boom angle	45°	65°
Jib angle	15°	25°
Jib length	20 m (65' 7" ft-in) to 47 m (154' 2" ft-in)	50 m (164' ft-in) to 113 m (370' 9" ft-in)
Main boom length	max. gradient in %, boom travel uphill	
20 m (65' 7" ft-in) to 71 m (232' 11" ft-in)	15	20

Tab. 467: Permitted gradient for main boom 2821 + luffing jib 2316 + midfall 2316, boom travel uphill

LWNLR-x\04.01\Auslieferung\2016-03-07/en

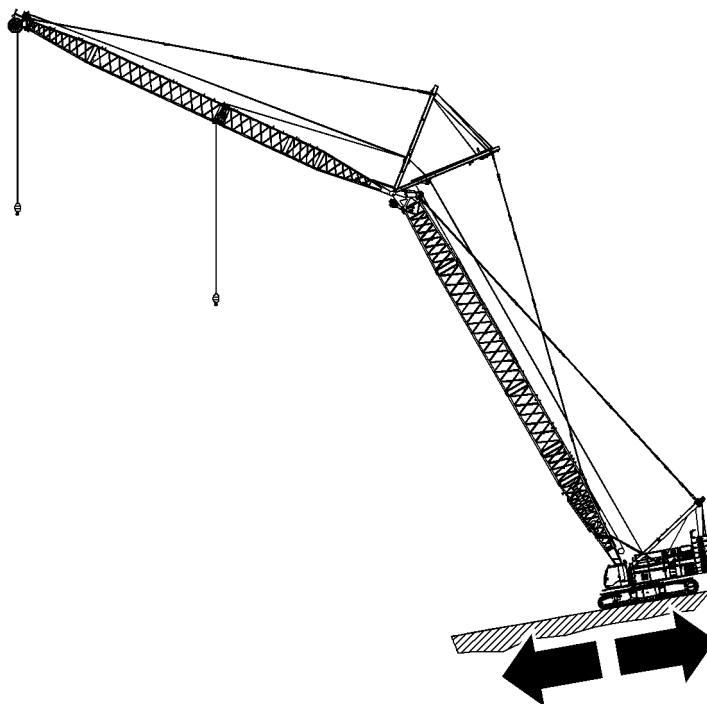


Fig. 2891: Permitted gradient for main boom 2821 + luffing jib 2316 + Midfall 2316, boom travel downhill

Description	Value		
Main boom angle	83°		
Jib angle	73°		
Jib length	20 m (65' 7" ft-in) to 86 m (282' 2" ft-in)	20 m (65' 7" ft-in) to 47 m (154' 2" ft-in)	50 m (164' ft-in) to 86 m (282' 2" ft-in)
Main boom length	max. gradient in %, boom travel downhill		
20 m (65' 7" ft-in) to 35 m (114' 10" ft-in)	20	-	-
38 m (124' 8" ft-in) to 71 m (232' 11" ft-in)	-	20	10

Tab. 468: Permitted gradient for main boom 2821 + luffing jib 2316 + Midfall 2316, boom travel downhill

Permitted gradient for main boom 2821 + luffing jib 1916 (+ auxiliary jib)

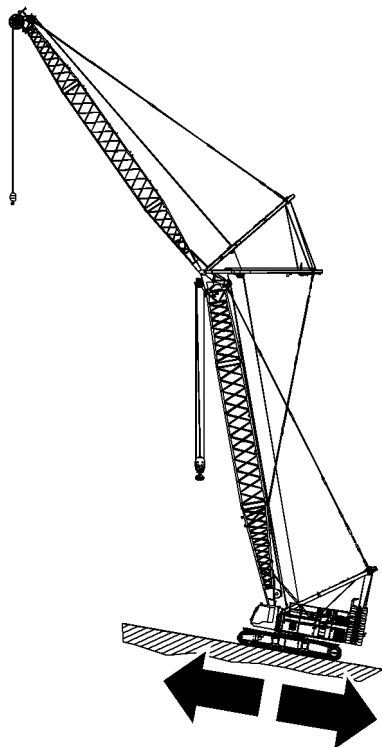


Fig. 2892: Permitted gradient for main boom 2821 + luffing jib 1916 (+ auxiliary jib), boom travel uphill

Description	Value	
Main boom angle	45°	65°
Jib angle	15°	25°
Jib length	20 m (65' 7" ft-in) to 47 m (154' 2" ft-in)	50 m (164' ft-in) to 95 m (311' 8" ft-in)
Main boom length	max. gradient in %, boom travel uphill	
29 m (95' 2" ft-in) to 74 m (242' 9" ft-in)	20	20

Tab. 469: Permitted gradient for main boom 2821 + luffing jib 1916 (+ auxiliary jib), boom travel uphill

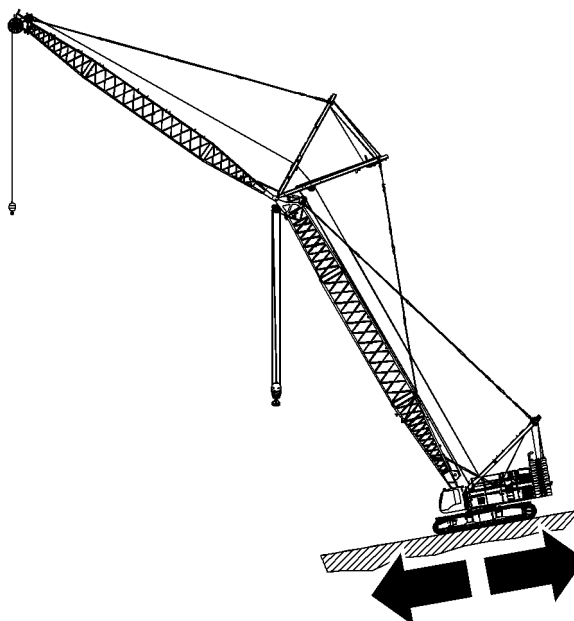


Fig. 2893: Permitted gradient for main boom 2821 + luffing jib 1916 (+ auxiliary jib), boom travel downhill

Description	Value			
Main boom angle	75°	88°	88°	88°
Jib angle	70°	78°	78°	78°
Jib length	20 m (65' 7" ft-in) to 47 m (154' 2" ft-in)	20 m (65' 7" ft-in) to 47 m (154' 2" ft-in)	50 m (164' ft-in) to 68 m (223' 1" ft-in)	71 m (232' 11" ft-in) to 95 m (311' 8" ft-in)
Main boom length	max. gradient in %, boom travel downhill			
29 m (95' 2" ft-in) to 50 m (164' ft-in)	20	-	-	-
53 m (173' 11" ft-in) to 74 m (242' 9" ft-in)	-	20	-	-
29 m (95' 2" ft-in) to 74 m (242' 9" ft-in)	-	-	20	10

Tab. 470: Permitted gradient for main boom 2821 + luffing jib 1916 (+ auxiliary jib), boom travel downhill

Permitted gradient for main boom 2821 + luffing jib 1916 + Midfall 1916

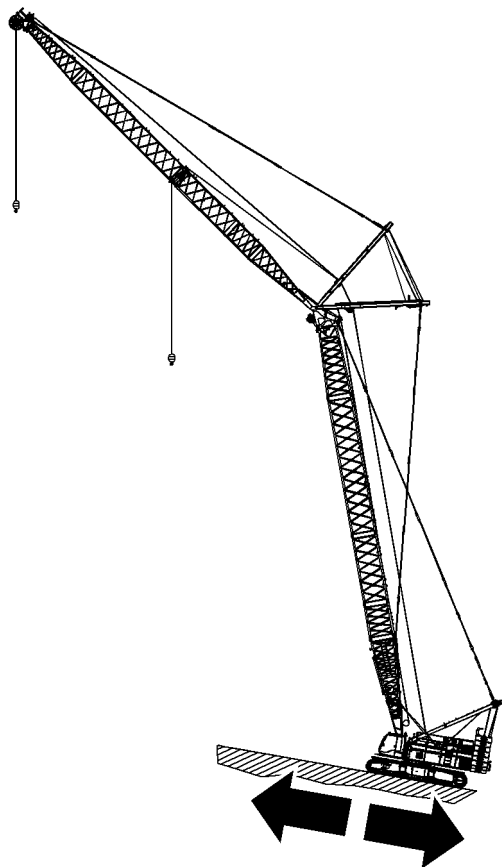


Fig. 2894: Permitted gradient for main boom 2821 + luffing jib 1916 + midfall 1916, boom travel uphill

Description	Value	
Main boom angle	45°	65°
Jib angle	15°	25°
Jib length	20 m (65' 7" ft-in) to 47 m (154' 2" ft-in)	50 m (164' ft-in) to 95 m (311' 8" ft-in)
Main boom length	max. gradient in %, boom travel uphill	
29 m (95' 2" ft-in) to 74 m (242' 9" ft-in)	20	20

Tab. 471: Permitted gradient for main boom 2821 + luffing jib 1916 + midfall 1916, boom travel uphill

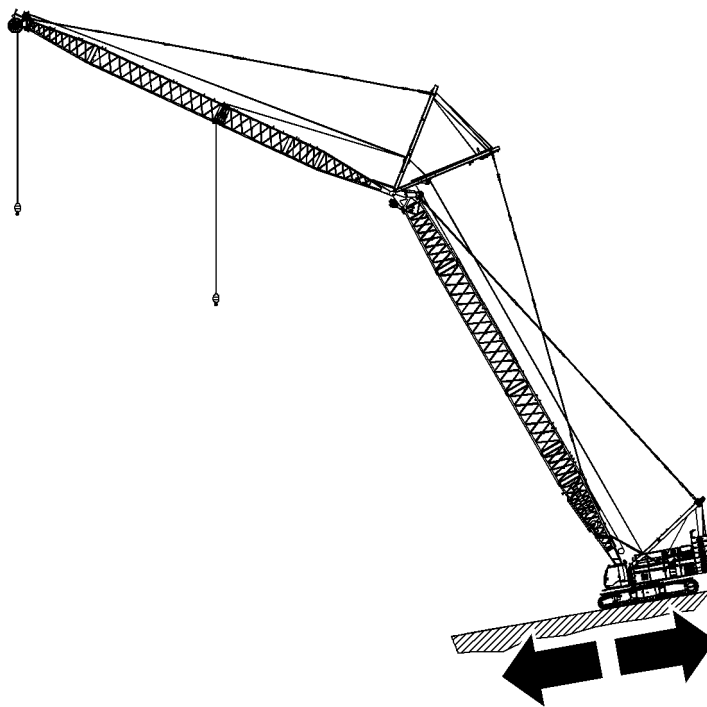


Fig. 2895: Permitted gradient for main boom 2821 + luffing jib 1916 + Midfall 1916, boom travel downhill

Description	Value			
Main boom angle	75°	88°	88°	88°
Jib angle	70°	78°	78°	78°
Jib length	20 m (65' 7" ft-in) to 47 m (154' 2" ft-in)	20 m (65' 7" ft-in) to 47 m (154' 2" ft-in)	50 m (164' ft-in) to 68 m (223' 1" ft-in)	71 m (232' 11" ft-in) to 95 m (311' 8" ft-in)
Main boom length	max. gradient in %, boom travel downhill			
29 m (95' 2" ft-in) to 50 m (164' ft-in)	20	-	-	-
53 m (173' 11" ft-in) to 74 m (242' 9" ft-in)	-	20	-	-
29 m (95' 2" ft-in) to 74 m (242' 9" ft-in)	-	-	20	10

Tab. 472: Permitted gradient for main boom 2821 + luffing jib 1916 + Midfall 1916, boom travel downhill

6.8.2 Permitted gradient for a machine with derrick equipment*

Permitted gradient for main boom 2821 + derrick (+ auxiliary jib)

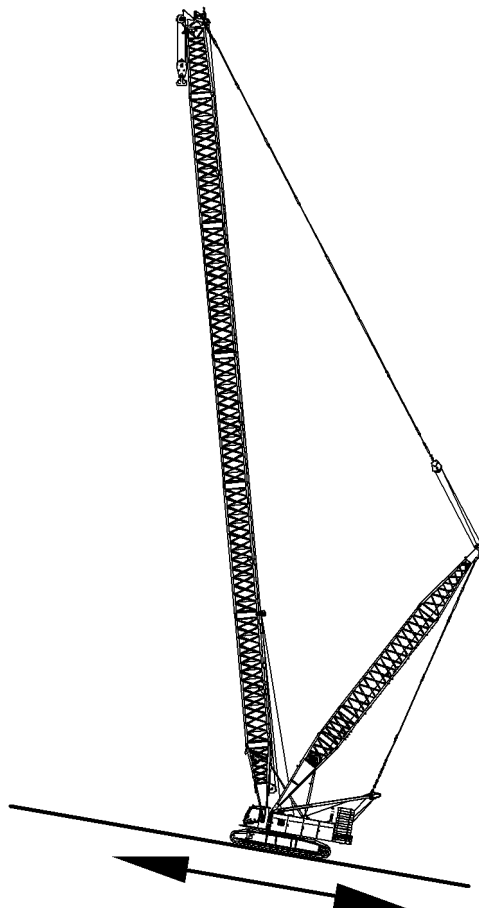


Fig. 2896: Permitted gradient - main boom 2821 + derrick (+ auxiliary jib), boom travel uphill

Description	Value
Lifting capacity (empty hook)	1.5 t (3,307 lb) to 3 t (6,614 lb)
Main boom angle	50°
Main boom length	max. gradient in %, boom travel uphill
44 m (144' 4" ft-in) to 74 m (242' 9" ft-in)	15
77 m (252' 7" ft-in) to 98 m (321' 6" ft-in)	15
101 m (331' 4" ft-in) to 119 m (390' 5" ft-in)	-

Tab. 473: Permitted gradient - main boom 2821 + derrick (+ auxiliary jib), boom travel uphill

LWNLR-x/V04.01//Auslieferung/2016-03-07/en

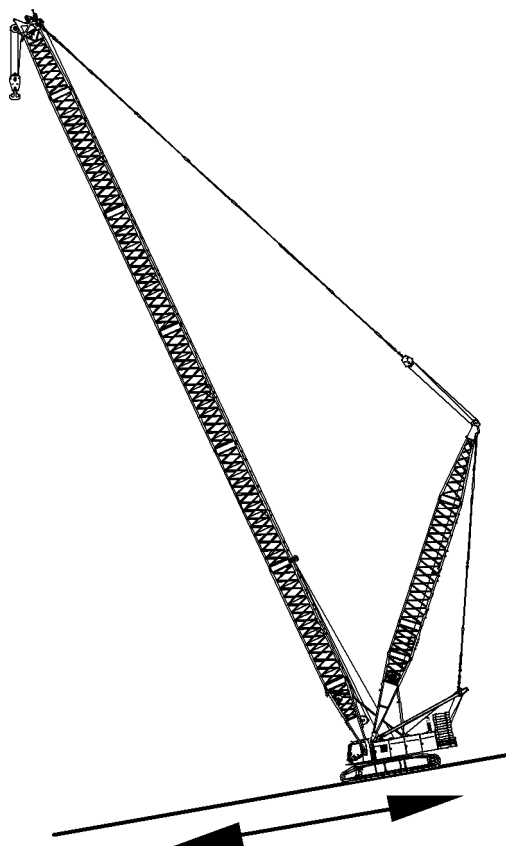


Fig. 2897: Permitted gradient for main boom 2821 + derrick (+ auxiliary jib), boom travel downhill

Description	Value
Lifting capacity (empty hook)	1.5 t (3,307 lb) to 3 t (6,614 lb)
Main boom angle	78°
Main boom length	max. gradient in %, boom travel downhill
44 m (144' 4" ft-in) to 74 m (242' 9" ft-in)	30
77 m (252' 7" ft-in) to 98 m (321' 6" ft-in)	20
101 m (331' 4" ft-in) to 119 m (390' 5" ft-in)	10

Tab. 474: Permitted gradient for main boom 2821 + derrick (+ auxiliary jib), boom travel downhill

Permitted gradient for main boom 2821 + fixed jib 0906 + derrick



Fig. 2898: Permitted gradient for main boom 2821 + fixed jib 0906 + derrick, boom travel uphill

Description	Value	
Lifting capacity (empty hook)	1.5 t (3,307 lb) to 3 t (6,614 lb)	
Main boom angle	40°	50°
Jib offset	30°	
Main boom length	max. gradient in %, boom travel uphill	
50 m (164' ft-in) to 59 m (193' 7" ft-in)	20	-
62 m (203' 5" ft-in) to 80 m (262' 6" ft-in)	-	20
83 m (272' 4" ft-in) to 116 m (380' 7" ft-in)	-	20

Tab. 475: Permitted gradient for main boom 2821 + fixed jib 0906 + derrick, boom travel uphill

LWN/LR-x/V04.01//Auslieferung/2016-03-07/en

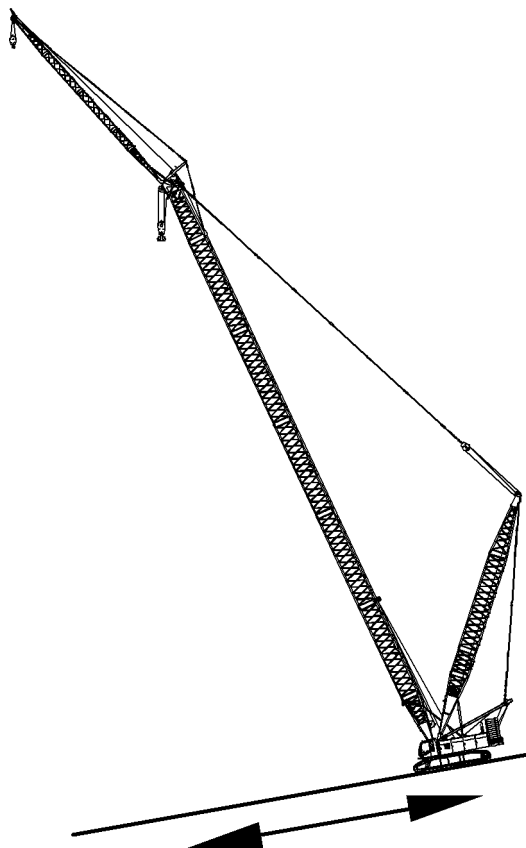


Fig. 2899: Permitted gradient for main boom 2821 + fixed jib 0906 + derrick, boom travel downhill

Description	Value	
Lifting capacity (empty hook)	1.5 t (3,307 lb) to 3 t (6,614 lb)	
Main boom angle	80°	86°
Jib offset	30°	
Main boom length	max. gradient in %, boom travel downhill	
50 m (164' ft-in) to 59 m (193' 7" ft-in)	30	-
62 m (203' 5" ft-in) to 80 m (262' 6" ft-in)	20	-
83 m (272' 4" ft-in) to 116 m (380' 7" ft-in)	-	10

Tab. 476: Permitted gradient for main boom 2821 + fixed jib 0906 + derrick, boom travel downhill

Permitted gradient for main boom 2821 + fixed jib 1507 + derrick



Fig. 2900: Permitted gradient for main boom 2821 + fixed jib 1507 + derrick, boom travel uphill

Description	Value	
Lifting capacity (empty hook)	1.5 t (3,307 lb) to 3 t (6,614 lb)	
Main boom angle	40°	50°
Jib offset	28°	
Main boom length	max. gradient in %, boom travel uphill	
44 m (144' 4" ft-in) to 80 m (262' 6" ft-in)	20	-
83 m (272' 4" ft-in) to 113 m (370' 9" ft-in)	-	20

Tab. 477: Permitted gradient for main boom 2821 + fixed jib 1507 + derrick, boom travel uphill

LWN/LR-x/V04.01//Auslieferung/2016-03-07/en

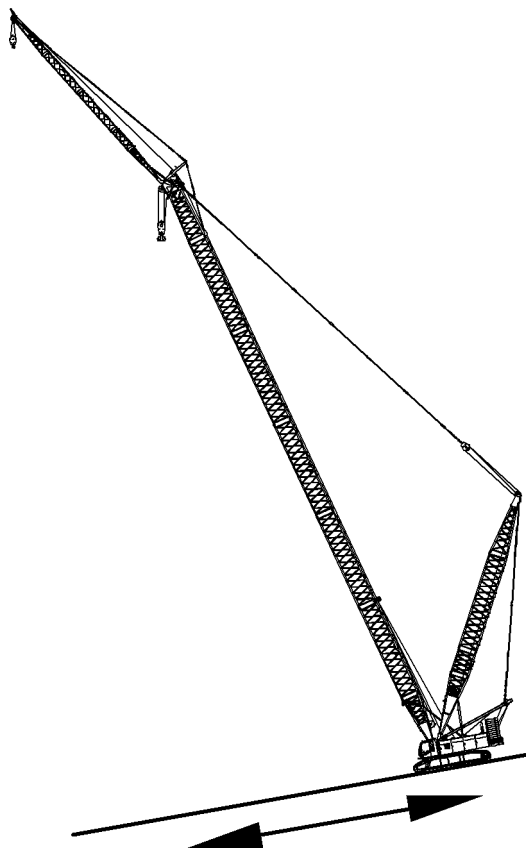


Fig. 2901: Permitted gradient for main boom 2821 + fixed jib 1507 + derrick, boom travel downhill

Description	Value	
Lifting capacity (empty hook)	1.5 t (3,307 lb) to 3 t (6,614 lb)	
Main boom angle	80°	86°
Jib offset	28°	
Main boom length	max. gradient in %, boom travel downhill	
44 m (144' 4" ft-in) to 80 m (262' 6" ft-in)	20	-
83 m (272' 4" ft-in) to 113 m (370' 9" ft-in)	-	10

Tab. 478: Permitted gradient for main boom 2821 + fixed jib 1507 + derrick, boom travel downhill

Permitted gradient for main boom 2821 + fixed jib 1713 + derrick



Fig. 2902: Permitted gradient for main boom 2821 + fixed jib 1713 + derrick, boom travel uphill

Description	Value	
Lifting capacity (empty hook)	1.5 t (3,307 lb) to 3 t (6,614 lb)	
Main boom angle	40°	50°
Jib offset	15° or 30°	
Jib length	all	
Main boom length	max. gradient in %, boom travel uphill	
50 m (164' ft-in) to 59 m (193' 7" ft-in)	20	-
62 m (203' 5" ft-in) to 95 m (311' 8" ft-in)	-	20
98 m (321' 6" ft-in) to 110 m (360' 11" ft-in)	-	20

Tab. 479: Permitted gradient for main boom 2821 + fixed jib 1713 + derrick, boom travel uphill

LWNLR-x/V04.01//Auslieferung/2016-03-07/en

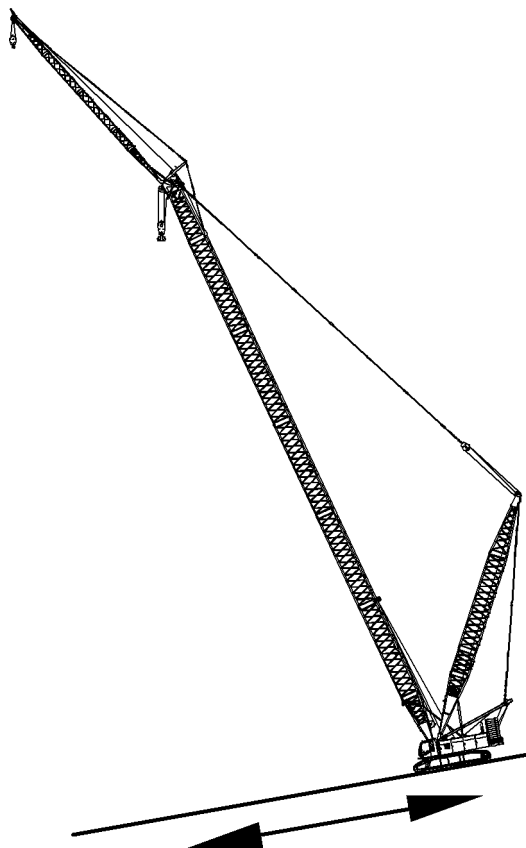


Fig. 2903: Permitted gradient for main boom 2821 + fixed jib 1713 + derrick, boom travel downhill

Description	Value	
Lifting capacity (empty hook)	1.5 t (3,307 lb) to 3 t (6,614 lb)	
Main boom angle	80°	86°
Jib offset	15° or 30°	
Jib length	all	
Main boom length	max. gradient in %, boom travel downhill	
50 m (164' ft-in) to 59 m (193' 7" ft-in)	30	-
62 m (203' 5" ft-in) to 95 m (311' 8" ft-in)	-	20
98 m (321' 6" ft-in) to 110 m (360' 11" ft-in)	-	10

Tab. 480: Permitted gradient for main boom 2821 + fixed jib 1713 + derrick, boom travel downhill

Permitted gradient for main boom 2821 + luffing jib 1916 + derrick (+ auxiliary jib)

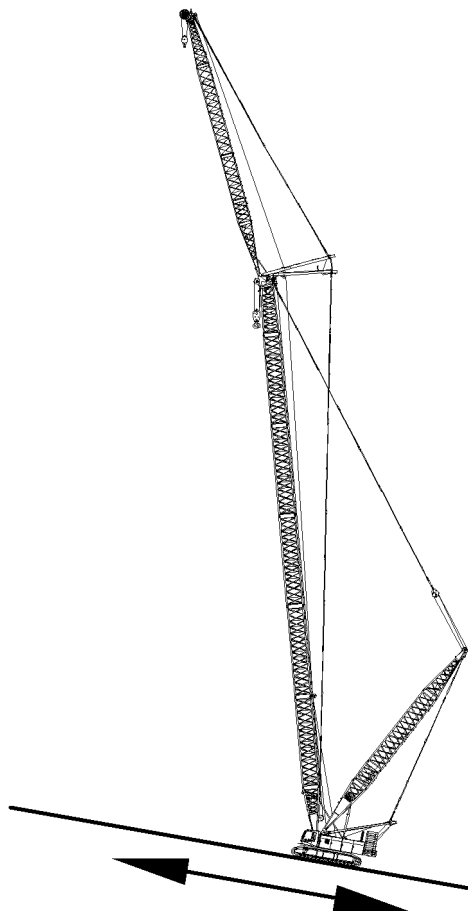


Fig. 2904: Permitted gradient for main boom 2821 + luffing jib 1916 + derrick (+ auxiliary jib), boom travel uphill

Description	Value						
Lifting capacity (empty hook)	1.5 t (3,307 lb) to 3 t (6,614 lb)						
Main boom angle	65°						
Jib angle	25°						
Jib length	20 m (65' 7" ft-in) to 32 m (105' ft-in)	35 m (114' 10" ft-in) to 44 m (144' 4" ft-in)	47 m (154' 2" ft-in) to 56 m (183' 9" ft-in)	59 m (193' 7" ft-in) to 68 m (223' 1" ft-in)	71 m (232' 11" ft-in) to 80 m (262' 6" ft-in)	83 m (272' 4" ft-in) to 95 m (311' 8" ft-in)	
Main boom length	max. gradient in %, boom travel uphill						
44 m (144' 4" ft-in) to 56 m (183' 9" ft-in)	15	15	15	15	15	-	
59 m (193' 7" ft-in) to 68 m (223' 1" ft-in)	15	15	15	-	-	-	
71 m (232' 11" ft-in) to 80 m (262' 6" ft-in)	15	15	-	-	-	-	

LWNLR-x/V04.01//Auslieferung/2016-03-07/en

Description	Value					
83 m (272' 4" ft-in) to 92 m (301' 10" ft-in)	15	-	-	-	-	-

Tab. 481: Permitted gradient for main boom 2821 + luffing jib 1916 + derrick (+ auxiliary jib), boom travel uphill

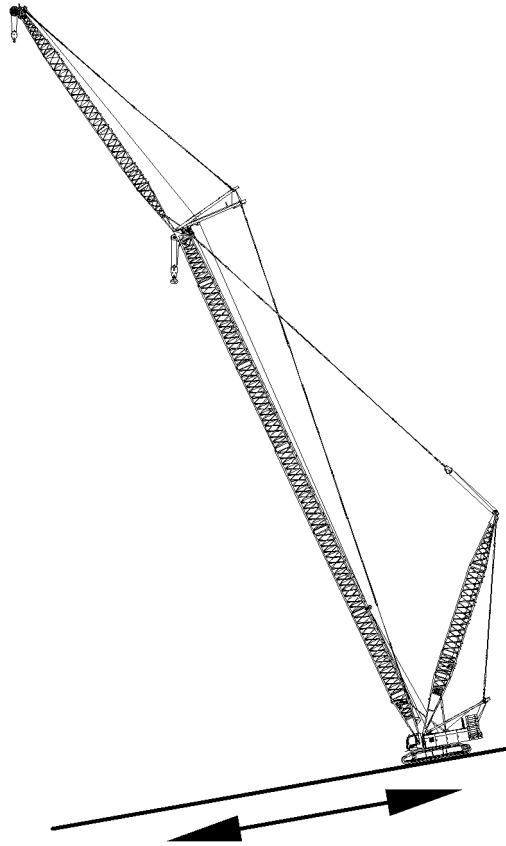


Fig. 2905: Permitted gradient for main boom 2821 + luffing jib 1916 + derrick (+ auxiliary jib), boom travel uphill

Description	Value					
Lifting capacity (empty hook)	1.5 t (3,307 lb) to 3 t (6,614 lb)					
Main boom angle	83°					
Jib angle	73°					
Jib length	20 m (65' 7" ft-in) to 32 m (105' ft-in)	35 m (114' 10" ft-in) to 44 m (144' 4" ft-in)	47 m (154' 2" ft-in) to 56 m (183' 9" ft-in)	59 m (193' 7" ft-in) to 68 m (223' 1" ft-in)	71 m (232' 11" ft-in) to 80 m (262' 6" ft-in)	83 m (272' 4" ft-in) to 95 m (311' 8" ft-in)
Main boom length	max. gradient in %, boom travel downhill					
44 m (144' 4" ft-in) to 56 m (183' 9" ft-in)	30	25	20	15	10	5
59 m (193' 7" ft-in) to 68 m (223' 1" ft-in)	25	20	15	10	5	5
71 m (232' 11" ft-in) to 80 m (262' 6" ft-in)	15	15	10	5	5	-

Description	Value					
	10	10	5	5	-	-
83 m (272' 4" ft-in) to 92 m (301' 10" ft-in)						

Tab. 482: Permitted gradient for main boom 2821 + luffing jib 1916 + derrick (+ auxiliary jib), boom travel downhill

Permitted gradient for main boom 2821 + luffing jib 2316 + derrick (+ auxiliary jib)

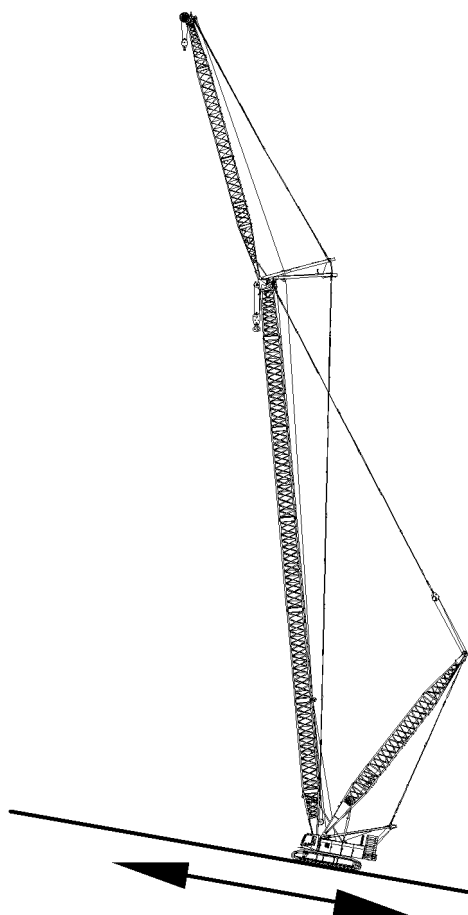


Fig. 2906: Permitted gradient for main boom 2821 + luffing jib 2316 + derrick (+ auxiliary jib), boom travel uphill

Description	Value					
Lifting capacity (empty hook)	1.5 t (3,307 lb) to 3 t (6,614 lb)					
Main boom angle	65°					
Jib angle	25°					
Jib length	20 m (65' 7" ft-in) to 32 m (105' ft-in)	35 m (114' 10" ft-in) to 50 m (164' ft-in)	53 m (173' 11" ft-in) to 68 m (223' 1" ft-in)	71 m (232' 11" ft-in) to 86 m (282' 2" ft-in)	89 m (292' ft-in) to 104 m (341' 2" ft-in)	107 m (351' 1" ft-in) to 113 m (370' 9" ft-in)
Main boom length	max. gradient in %, boom travel uphill					

LWN/LR-x/V04.01//Auslieferung/2016-03-07/en

Description	Value					
44 m (144' 4" ft-in) to 50 m (164' ft-in)	15	15	15	-	-	-
53 m (173' 11" ft-in) to 62 m (203' 5" ft-in)	15	15	-	-	-	-
65 m (213' 3" ft-in) to 74 m (242' 9" ft-in)	15	-	-	-	-	-
77 m (252' 7" ft-in) to 86 m (282' 2" ft-in)	-	-	-	-	-	-

Tab. 483: Permitted gradient for main boom 2821 + luffing jib 2316 + derrick (+ auxiliary jib), boom travel uphill

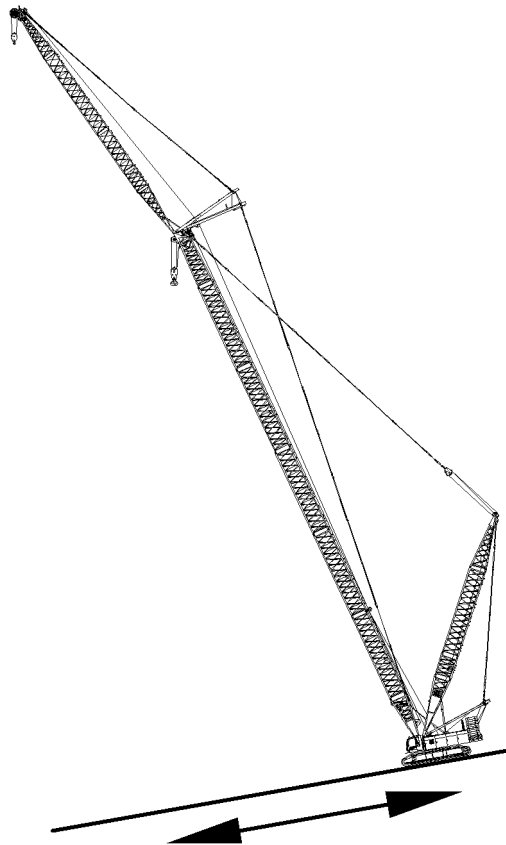


Fig. 2907: Permitted gradient for main boom 2821 + luffing jib 2316 + derrick (+ auxiliary jib), boom travel downhill

Description	Value					
Lifting capacity (empty hook)	1.5 t (3,307 lb) to 3 t (6,614 lb)					
Main boom angle	83°					
Jib angle	73°					
Jib length	20 m (65' 7" ft-in) to 32 m (105' ft-in)	35 m (114' 10" ft-in) to 50 m (164' ft-in)	53 m (173' 11" ft-in) to 68 m (223' 1" ft-in)	71 m (232' 11" ft-in) to 86 m (282' 2" ft-in)	89 m (292' ft-in) to 104 m (341' 2" ft-in)	107 m (351' 1" ft-in) to 113 m (370' 9" ft-in)
Main boom length	max. gradient in %, boom travel downhill					

Operational planning

Traveling on gradients

Description	Value					
44 m (144' 4" ft-in) to 50 m (164' ft-in)	30	25	15	10	-	-
53 m (173' 11" ft-in) to 62 m (203' 5" ft-in)	25	15	10	5	-	-
65 m (213' 3" ft-in) to 74 m (242' 9" ft-in)	15	10	5	-	-	-
77 m (252' 7" ft-in) to 86 m (282' 2" ft-in)	10	5	-	-	-	-

Tab. 484: Permitted gradient for main boom 2821 + luffing jib 2316 + derrick (+ auxiliary jib), boom travel downhill

LWNLR-x/V04.01//Auslieferung/2016-03-07/en

6.9 Rigging equipment and/or sling gear

The machine operator must make sure that the proper rigging equipment and/or sling gear is used for the load.

The rigging equipment and/or sling gear must be selected in such a way that the load can be safely lifted, held and set down again when used properly. It must be rated for the stresses occurring during proper use of the equipment.

When selecting the sling gear (e.g. shackles, round slings) make sure that these do not damage each other or other components.

The rigging equipment and/or sling gear must not be stressed beyond its load-bearing capacity.

When lifting loads with rigging with more than two strands, make sure that the load is distributed evenly to all strands.

The machine operator must know the following:

- Weight of the load to be lifted
- The center of gravity of the load to be lifted
- The dimensions of the load to be lifted

The machine operator must make sure that valid chain certificates are available when using chain weights. The chain certificates must be requested from the manufacturer on initial equipping and from the supplier when exchanging the chains.

The machine operator must make sure that valid rope certificates are available. The rope certificates must be requested from the manufacturer on initial equipping and from the supplier when replacing the ropes.

6.9.1 4-strand round sling rigging with chain shortening devices

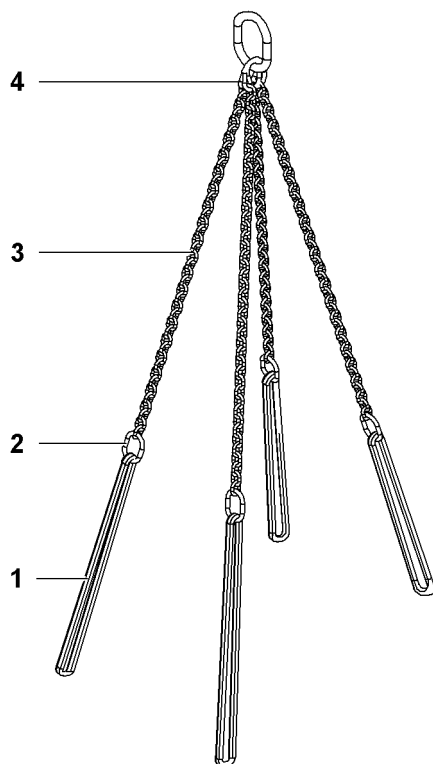


Fig. 2908: 4-strand round sling rigging with chain shortening devices

- | | | | |
|---|--|---|--|
| 1 | Round sling 10 t (22,046 lb) (4x) | 3 | Chain (4x) |
| 2 | Textile coupling 12.5 t (27,557 lb) (4x) | 4 | Suspension link with integrated chain shortening devices |

Length	Can be shortened	SWL	Application
4 m 13' 1" ft-in	from 3.6 m (11' 10" ft-in) to 1.9 m (6' 3" ft-in)	21 t 46,296 lb	Boom components
			Carbody counterweight
			Rear counterweight

Tab. 485: Technical data 4-strand round sling gear with chain shortening devices

6.9.2 4-strand round sling gear

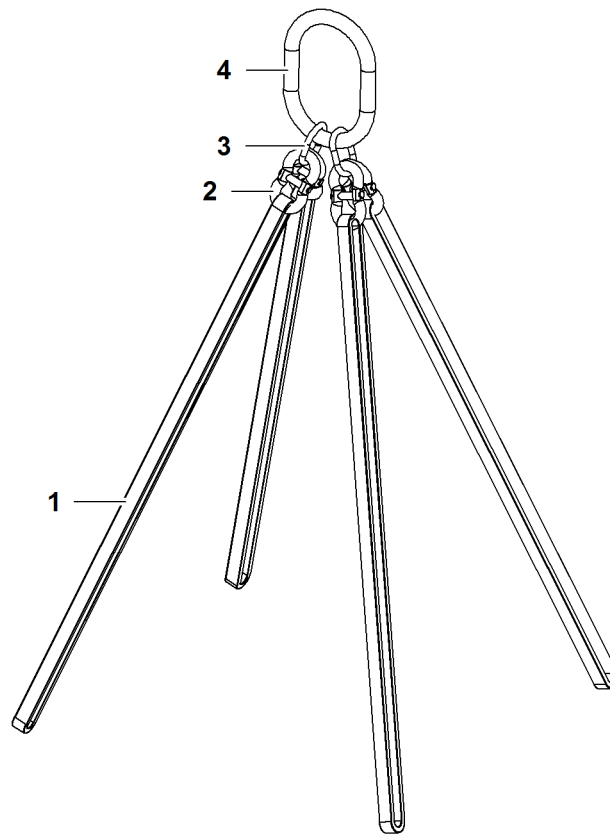


Fig. 2909: 4-strand round sling gear

1	Round sling 15 t (33,069 lb) (4x)	3	Connecting link 12.5 t (27,557 lb) (4x)
2	Textile coupling 12.5 t (27,557 lb) (4x)	4	Suspension link 26.5 t (58,422 lb)

Length	SWL	SWL single-strand	Application
6 m 19' 8" ft-in	26.5 t 58,422 lb	12.5 t 27,557 lb	Crawler side frame Rear counterweight

Tab. 486: Technical data 4-strand round sling gear

6.9.3 Other lifting devices

If a jib is delivered with the machine, round slings and shackles are included that remain fixedly installed with these components.

Number	Sling gear	Length	SWL	Component
1	Round sling	3 m 9' 10" ft-in	4 t 8,818 lb	Fixed jib
1	Round sling	2 m 6' 7" ft-in	2 t 4,409 lb	Luffing jib

Number	Sling gear	Length	SWL	Component
1	Round sling	10 m 32' 10" ft-in	15 t 33,069 lb	Luffing jib
1	Shackle		17 t 37,478 lb	Luffing jib
1	Shackle			Luffing jib

Tab. 487: Technical data other sling gear

Assembly and dismantling 7

7 Assembly and dismantling

7 Assembly and dismantling

The chapter **Assembly/disassembly** deals with the following subjects:

- Assembling the machine
- Converting the machine on site
- Disassembling the machine


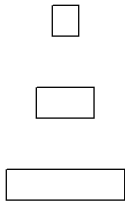
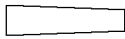



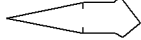
To make them simple to understand, illustrations are:


- simplified in places, as appropriate.
- not always shown with all machine components.

Directional instructions are given with reference to the position of the operator's seat.

7.1 Explanation of symbols used

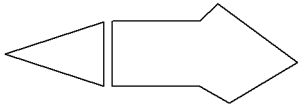
Any lengths displayed on the symbols will be quoted in metres.

Symbol	Explanation
	Boom base section
	Boom sections
	Reducing adapter
	Midfall
	Boom head
	Boom head with boom section 1 m (3 ft)
	Jib (boom base section + boom head)

Symbol	Explanation
	<p>S = Installation position of rope guide</p> <p>X1 = Installation position of mid-point suspension 1</p> <p>X2 = Installation position of mid-point suspension 2</p>

Tab. 488: Explanation of symbols used

The following symbol is used for orientation in graphics:

Symbol with explanation	
	
Position of boom base section	Position of boom head

Tab. 489: Symbol for orientation in graphics

7.2 Implementation instructions for assembly and disassembly



DANGER

Following incorrect procedures during assembly and disassembly!

- ▶ All activities for assembling and disassembling the machine must be carried out in the order described.
 - ▶ Questions or uncertainties must be resolved immediately with the assembly staff.
-



DANGER

Entering working and danger zone while machine is running!

Risk of crushing of limbs.

- ▶ Make sure that the machine operator always sits in the cabin.
- ▶ Carry out work on machine while under continuous visual and radio contact with machine operator.

When working on machine without presence of machine operator:

- ▶ Switch off the battery main switch.
-

Use only the Liebherr tool kit provided and the lifting equipment provided to assemble and disassemble the machine.

Always carry out the entire assembly and disassembly of the machine in "Assembly functions".

All movements of winches, hydraulic cylinders, crawlers and swing should be slow and take place at the lowest speed level.

7.3 Locking elements - overview

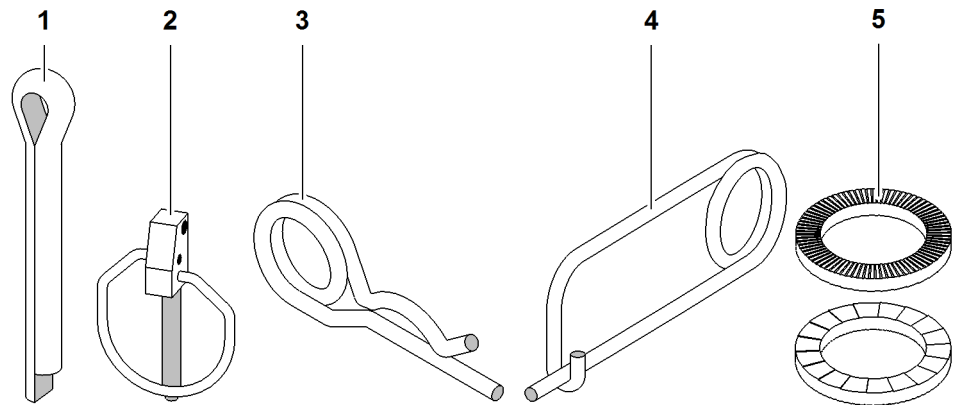


Fig. 2921: Locking elements overview

- | | | | |
|---|-------------------|---|-----------------|
| 1 | Split pin | 4 | Safety pin |
| 2 | Linchpin | 5 | Locking washers |
| 3 | Spring cotter pin | | |

7.3.1 Split pin



WARNING

Improper multiple use of a cotter pin!
Break of split pin.
Serious injury.

- ▶ Only use split pins once.

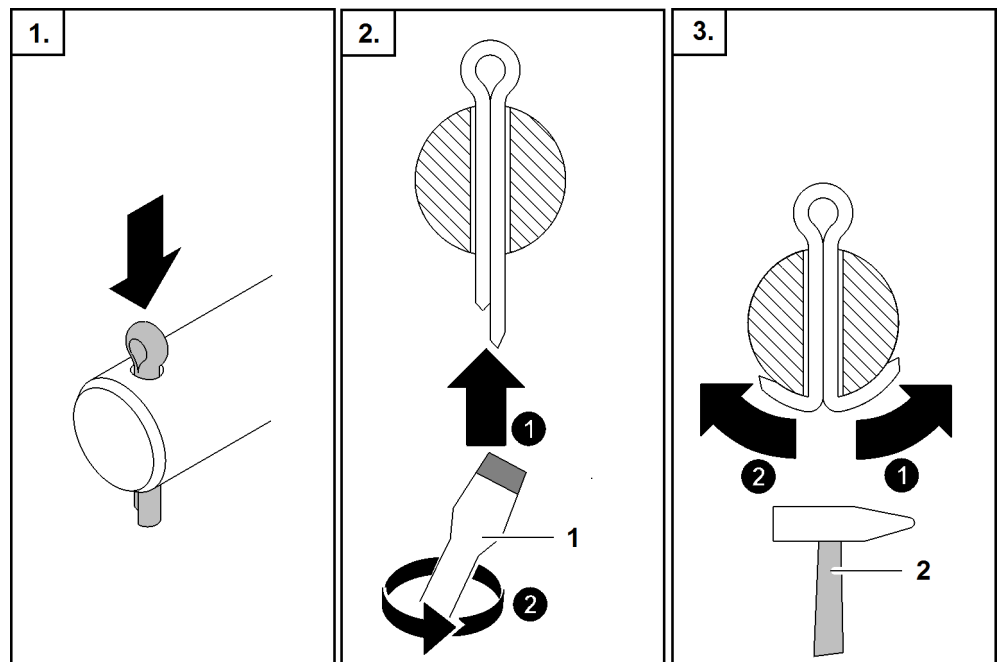


Fig. 2922: Inserting the split pin

- | | | | |
|---|-------------|---|--------|
| 1 | Screwdriver | 2 | Hammer |
|---|-------------|---|--------|

- ▶ Insert the split pin.
- ▶ Bend end of split pin outwards with screwdriver **1**.
- ▶ Bend end of split pin all the way outwards with hammer **2**.

7.3.2 Linchpin

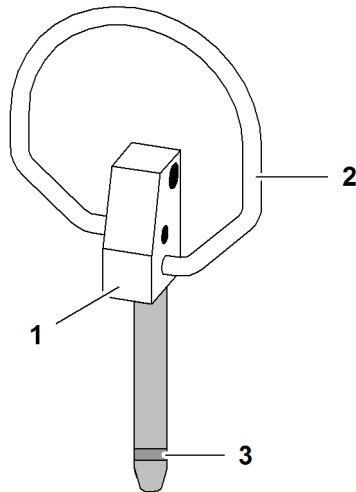


Fig. 2923: Linchpin

1 Linchpin
2 Ring

3 Notch



WARNING

Improper closing of linchpin!
Linchpin detaches unintentionally.
Serious injury.

- ▶ Snap ring **2** into notch **3**.

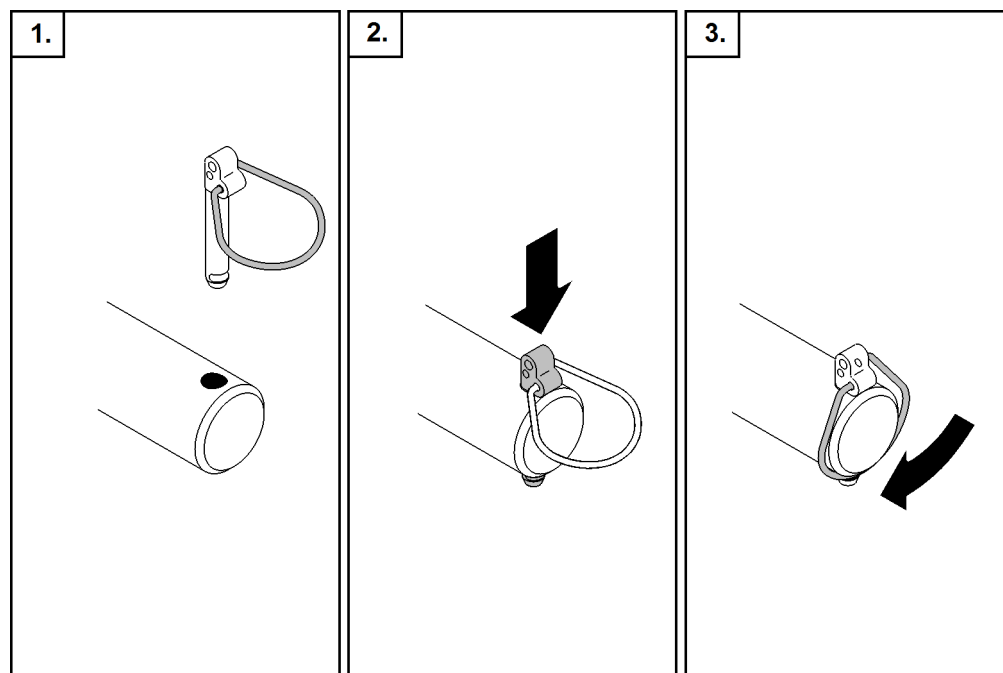


Fig. 2924: Inserting the linchpin

- ▶ Insert the linchpin.
- ▶ Snap ring into notch.

7.3.3 Spring cotter pin

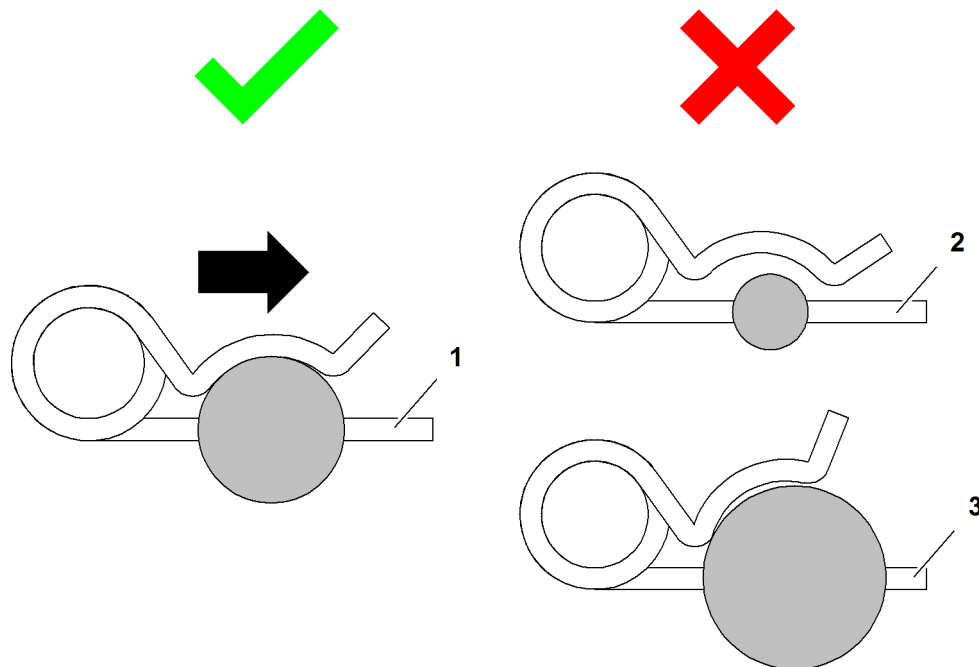


Fig. 2925: Spring cotter pin

- 1 Right spring cotter pin
- 2 Spring cotter pin too large

- 3 Spring cotter pin too small

LWN/LR-x/V04.01//Auslieferung/2016-03-07/en



WARNING

Wrong dimension of spring cotter pin!
Spring cotter pin detaches unintentionally.
Serious injury.

▶ Use proper spring cotter pin 1.

▶ Insert spring cotter pin.

7.3.4 Safety pin

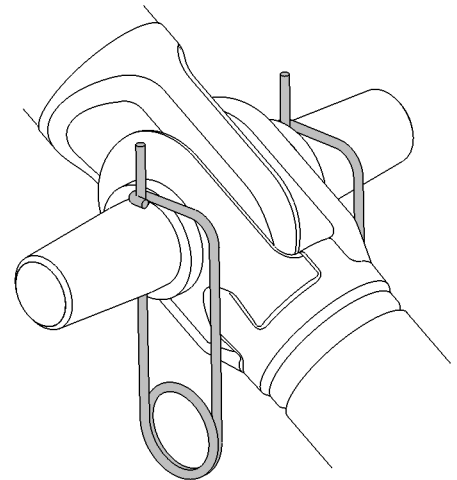
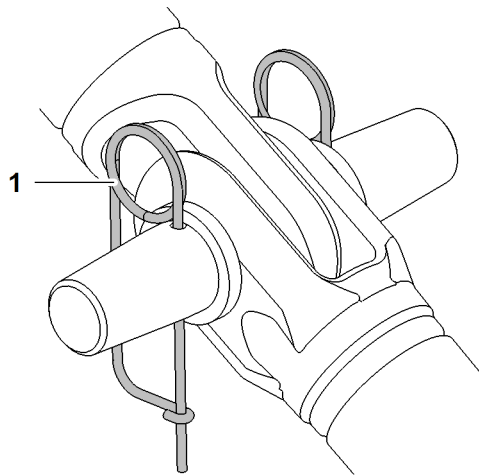


Fig. 2926: Locking spring

1 Locking spring



WARNING

Improperly installed safety pin!
Locking spring detaches unintentionally.
Serious injury.

▶ Install locking spring 1 properly.

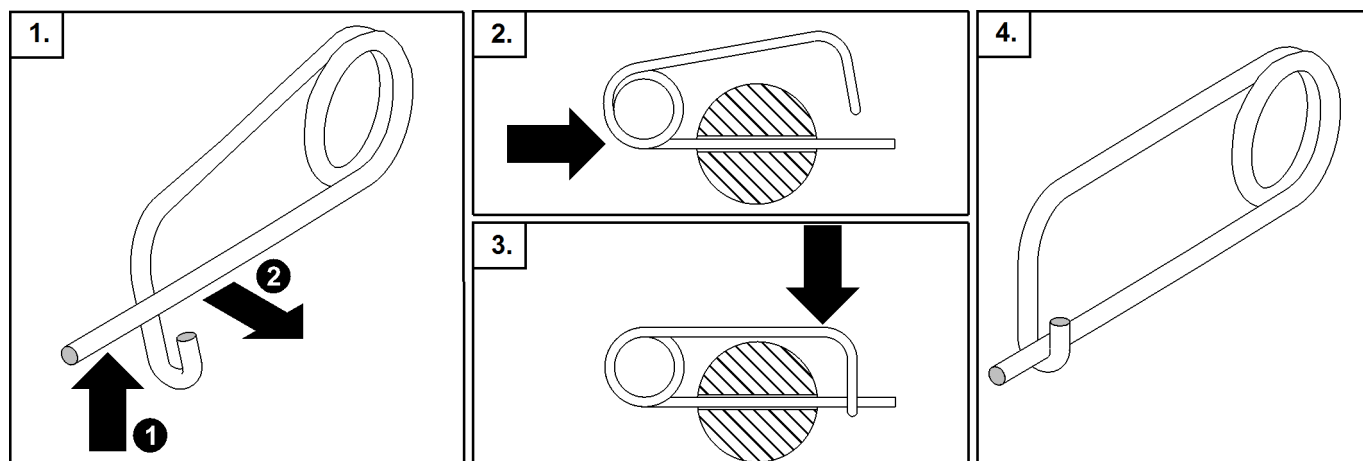


Fig. 2927: Inserting the safety pin

- ▶ Press safety pin together.
- ▶ Open safety pin.
- ▶ Insert safety pin.
- ▶ Press safety pin together.
- ▶ Close safety pin.

7.3.5 Locking washers

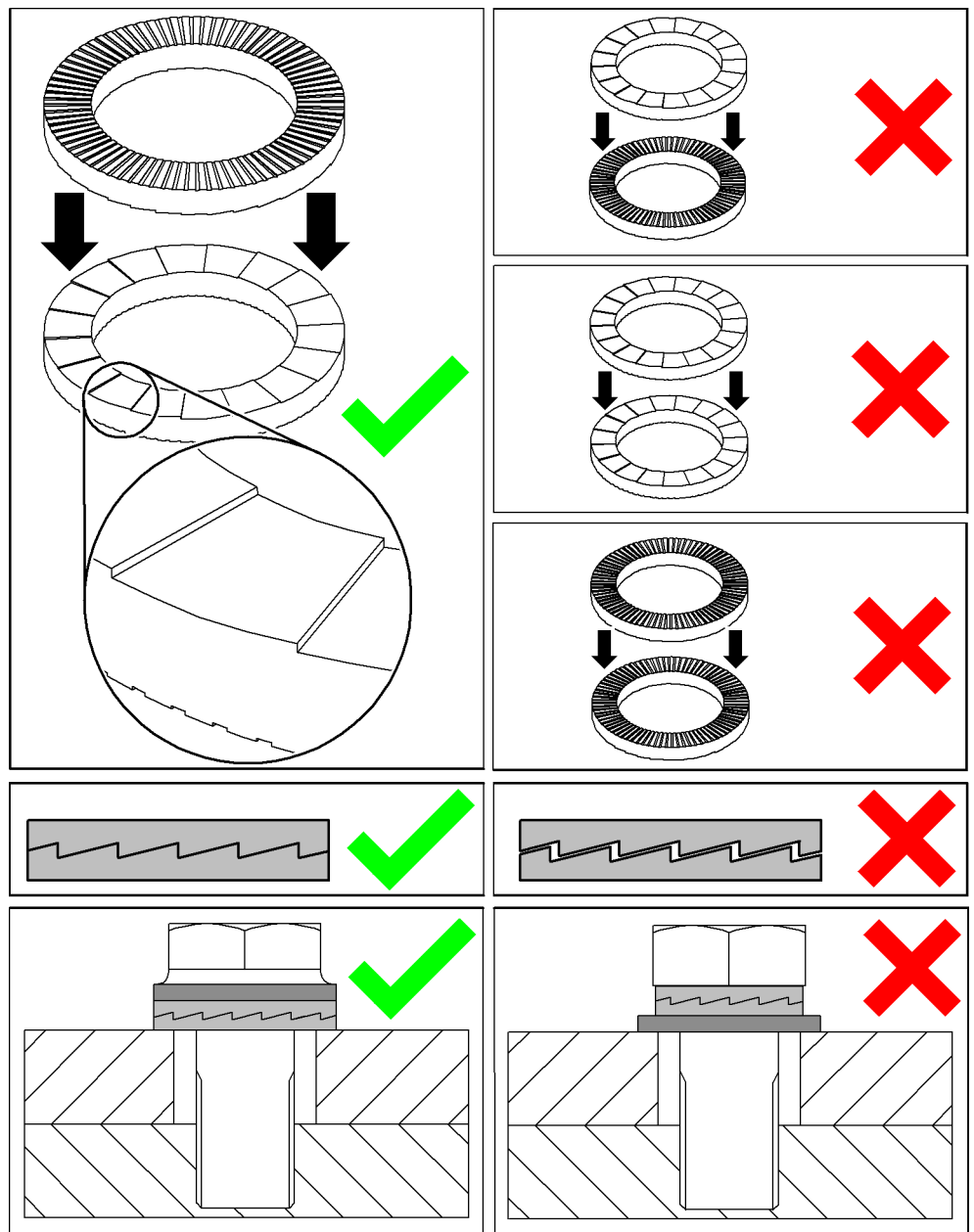


Fig. 2928: Locking washers



WARNING

Improperly installed locking washers!
Screw connection detaches unintentionally.
Serious injury.

- ▶ Install locking washers properly.
- ▶ Tighten screw with specified torque.

7.4 Assembling the basic machine

Assembly of basic machine with self-assembly system is described below.

It is not necessary to use an auxiliary crane, so this is not described.

Ensure that the following conditions are fulfilled:

- The machine has been prepared for self-assembly.
- Work plans have been drawn up.
- The number of counterweight slabs is known.
- The transport vehicles with the single components are coordinated to ensure that the procedure runs smoothly.
- Any accessories required are available.

7.4.1 Notes

The illustrations have been simplified or schematically represented for reasons of uniformity and represent the principles of assembly. They do not provide a detailed representation of the components.

7.4.2 Moving cabin platforms* into working position

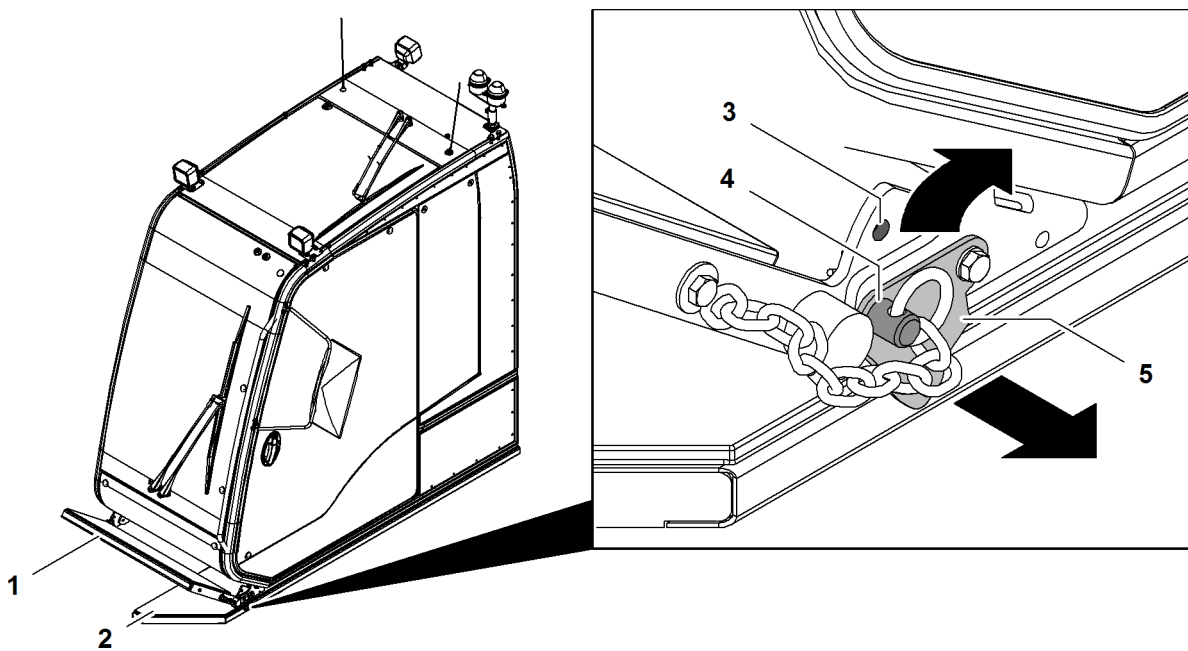


Fig. 2929: Moving cabin platforms into working position

- | | | | | | |
|---|----------------|---|--------------------------|---|-----------------|
| 1 | Front platform | 3 | Top pin connection point | 5 | Locking element |
| 2 | Side platform | 4 | Pin | | |

The pin 4 is in the bottom pin connection point.

- ▶ Remove spring cotter pin and pin 4.
- ▶ Fold up securing element 5.

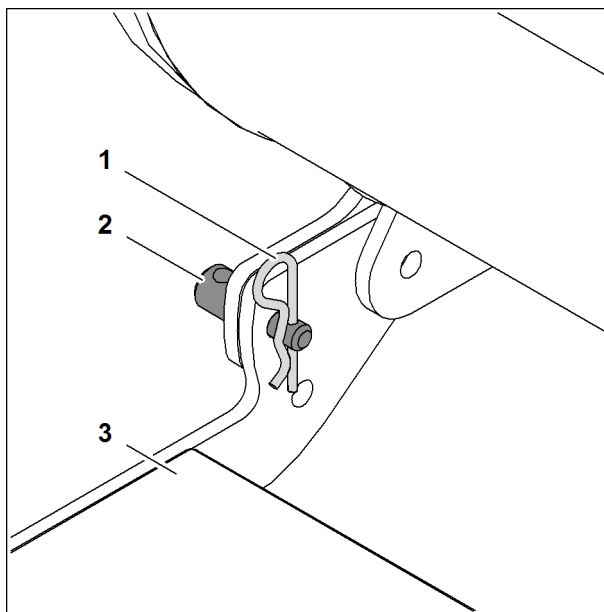


Fig. 2932: Moving the front platform into working position

- | | | | |
|---|-------------------|---|----------------|
| 1 | Spring cotter pin | 3 | Front platform |
| 2 | Pin | | |

- ▶ Repeat procedure on opposite side.
- ▶ Fold down front platform 3.

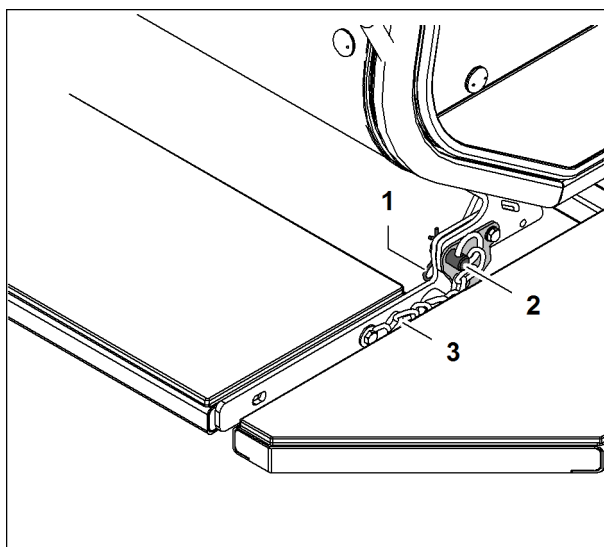


Fig. 2933: Moving the front platform into working position

- | | | | |
|---|-------------------|---|-------|
| 1 | Spring cotter pin | 3 | Chain |
| 2 | Pin | | |

- ▶ Fold down securing element.
- ▶ Insert pin 2 in top pin connection point.
- ▶ Secure pin 2 with spring cotter pin 1.



WARNING

Chain lying around!
Risk of falling off cabin.

► Ensure that no one trips over the chain **3**.

► Remove chain.

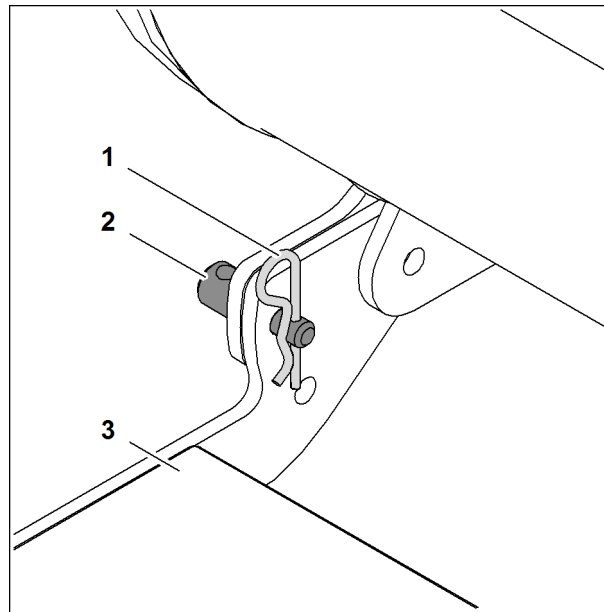


Fig. 2934: Moving the front platform into working position

1 Spring cotter pin

2 Pin

3 Front platform

► Repeat procedure on opposite side.

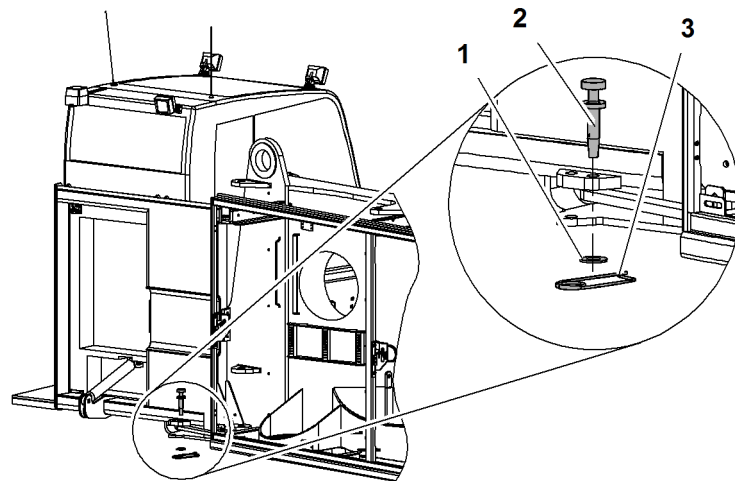


Fig. 2936: Cabin in transport position

- 1 Washer
- 2 Pin
- 3 Safety pin

► Remove safety pin 3, washer 1 and pin 2.



CAUTION

Pivoting cab!
Risk of crushing of limbs.

- Remain outside of the swing range of the cab.
- Keep all limbs well clear of moving parts.

► Swiveling the cab to the working position manually.

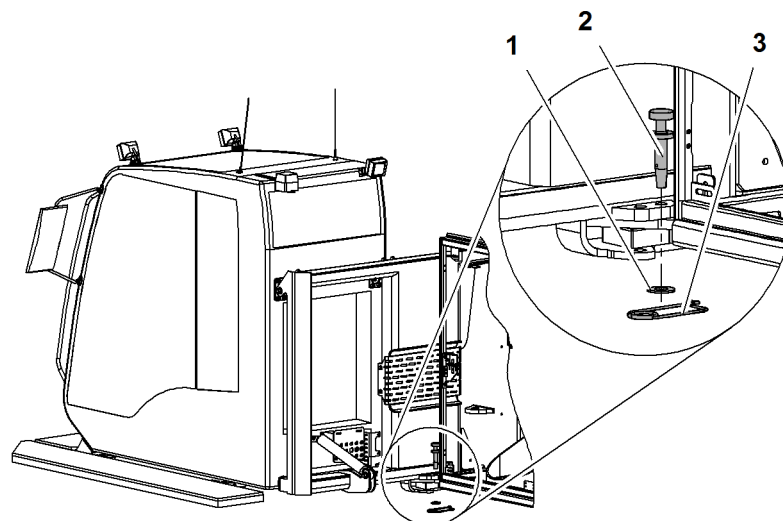


Fig. 2937: Cabin in working position

- 1 Washer
- 2 Pin
- 3 Safety pin

► Insert pin 2 and secure with washer 1 and safety pin 3.

▷ The cab is swung roughly 2° (2°) towards the boom. This swinging makes it easier to see the load (for an average radius).

7.4.4 Mounting the cabin railing*

Installing the cabin railing without platforms on the uppercarriage

If the basic machine has no platforms on the uppercarriage, this cabin railing must be installed.

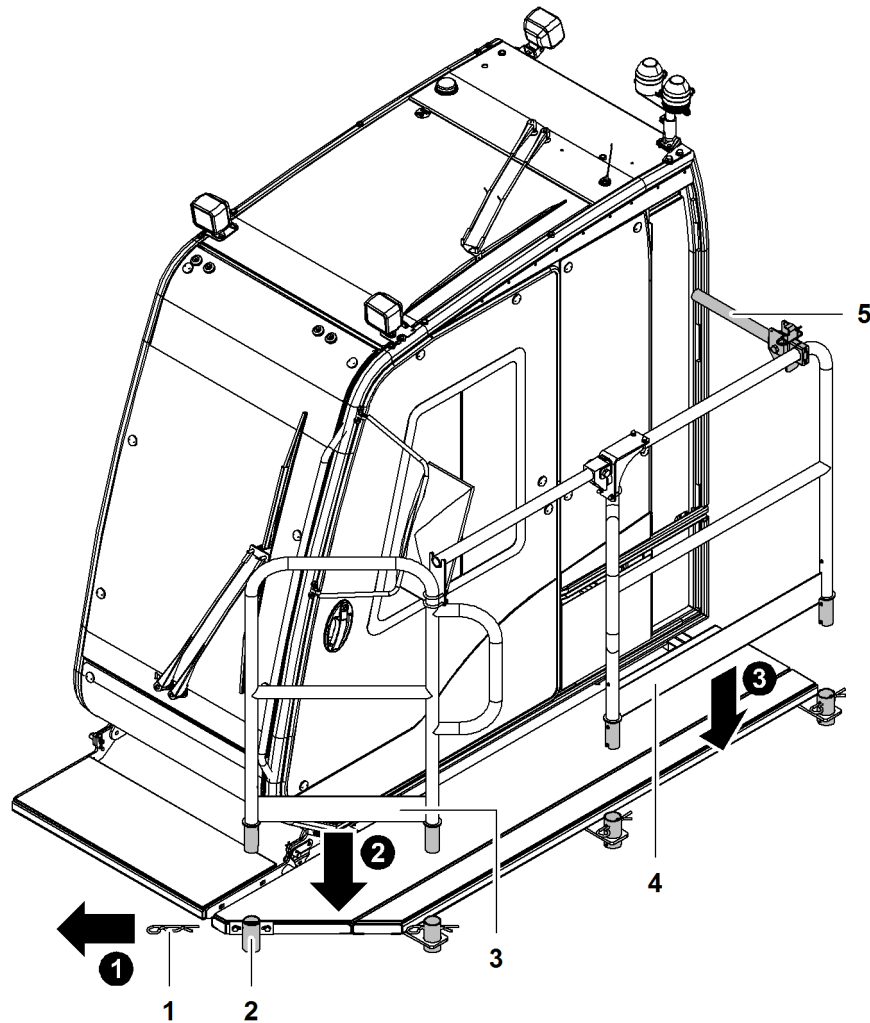


Fig. 2938: Installing the cabin railing* without platforms on the uppercarriage

- | | | | |
|---|---------------------|---|--------------------|
| 1 | Locking spring (4x) | 4 | Rear cabin railing |
| 2 | Bracket (4x) | 5 | Chopper bar |
| 3 | Front cabin railing | | |

- ▶ Remove locking springs 1.
- ▶ Push front cabin railing 3 from above into bracket 2.
- ▶ Secure front cabin railing 3 with locking springs 1.
- ▶ Push rear cabin railing 4 from above into bracket 2.
- ▶ Secure rear cabin railing 4 with locking spring 1.
- ▶ Mount chopper bar 5.

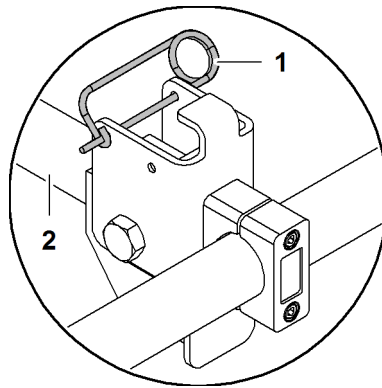


Fig. 2939: Securing the chopper bar

1 Locking spring

2 Chopper bar



WARNING

Unsecured chopper bar!
Fall from cabin platform.

- ▶ Ensure that chopper bar 2 is secured with locking spring 1 in closed position.
- ▶ Secure chopper bar 2 with locking spring 1 in closed position.

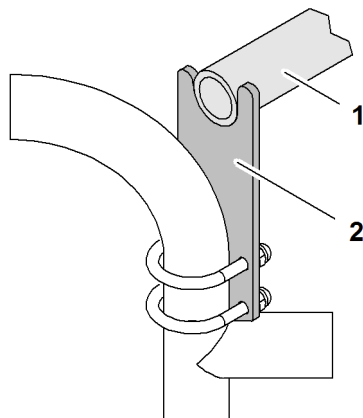


Fig. 2940: Chopper bar of cabin railing

1 Chopper bar

2 Bracket



WARNING

Unsecured chopper bar!
Fall from cabin platform.

- ▶ Ensure that chopper bar 1 engages in bracket 2.
- ▶ Check whether chopper bar 1 engages in bracket 1 by opening and closing chopper bar 2.
 - ▷ Cabin railing is mounted and secured.

Installing the cabin railing with platforms on the upper-carriage

If the basic machine has platforms on the uppercarriage, this cabin railing must be installed.

Ensure that the following conditions are fulfilled:

- Two helpers are available.

Installing the frame on the cabin

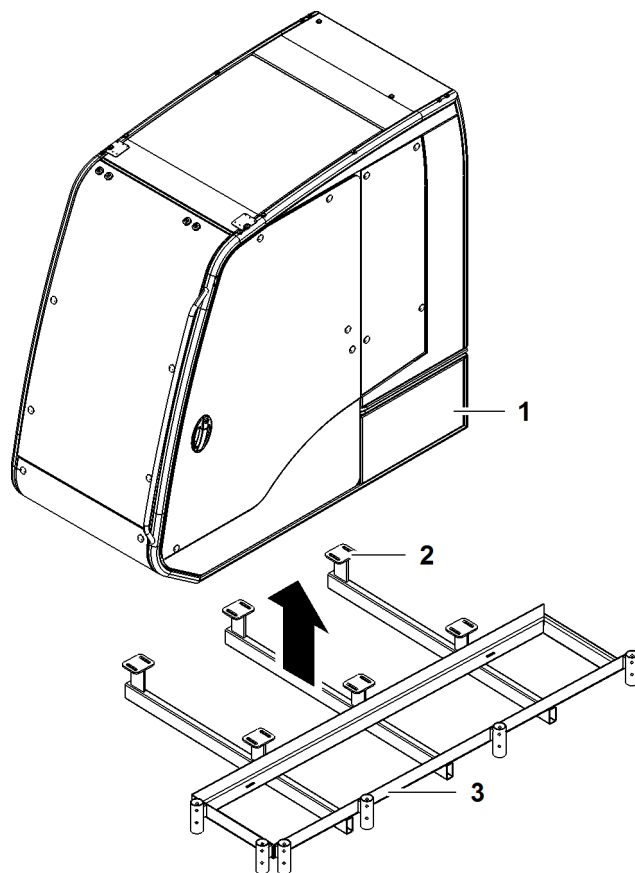


Fig. 2941: Installing the frame on the cabin

- | | | | |
|---|-----------------------|---|-------|
| 1 | Cabin | 3 | Frame |
| 2 | Attachment point (6x) | | |
- ▶ Lift frame 3 to cabin 1.
 - ▶ Install frame 3.

Installing railing parts on the frame

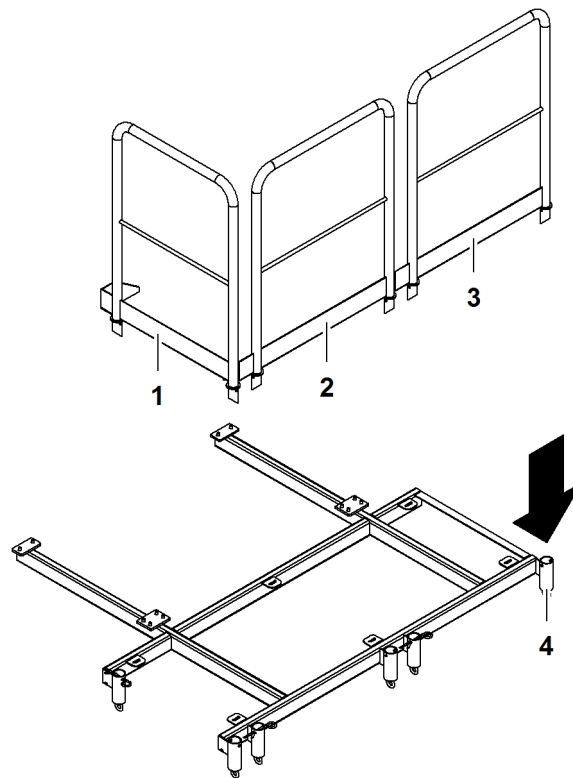


Fig. 2942: Installing railing parts on the frame

- | | | | |
|---|----------------|---|--------------------------|
| 1 | Railing part A | 3 | Railing part B |
| 2 | Railing part B | 4 | Support (6x) for railing |

- ▶ Remove locking elements of the supports 4.
- ▶ Insert railing parts A + B 1 + 2 + 3 into supports 4.

Securing the railing parts

Securing the railing parts with locking elements

There are two locking elements:

- Spring cotter pin outside
- Locking spring inside

Secure railing parts with locking spring inside

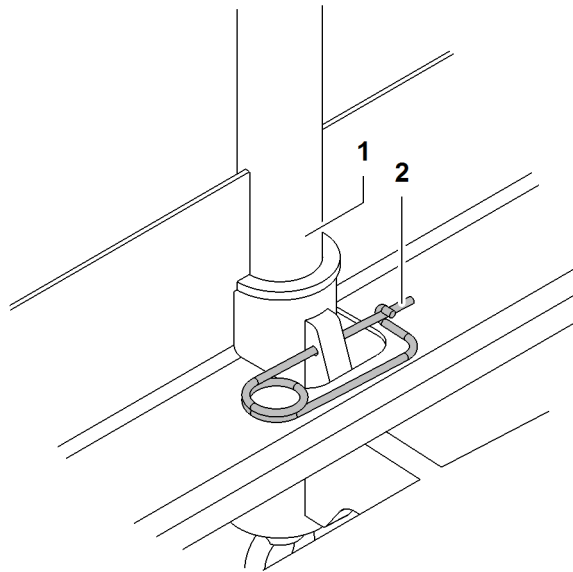


Fig. 2945: Secure railing parts with locking spring inside

- 1 Railing part
- 2 Locking spring

- ▶ Secure railing parts with locking springs 2.
- ▶ Repeat procedure with all railing parts 1.
 - ▷ Railing parts secured with locking spring inside.

Securing the railing parts with eye bolt

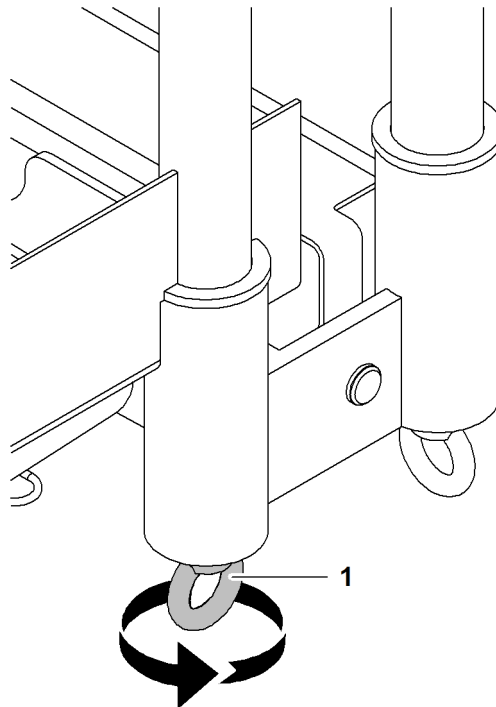


Fig. 2946: Securing the railing parts with eye bolt

- 1 Eye bolt for railing stabilization

- ▶ Tighten eye bolt 1.

LWNLR.x/V04.01//Auslieferung/2016-03-07/en

- ▷ Wedge of railing stabilization secures the railing part.
- ▶ Repeat procedure with all railing parts.

Insert catwalk grating in frame

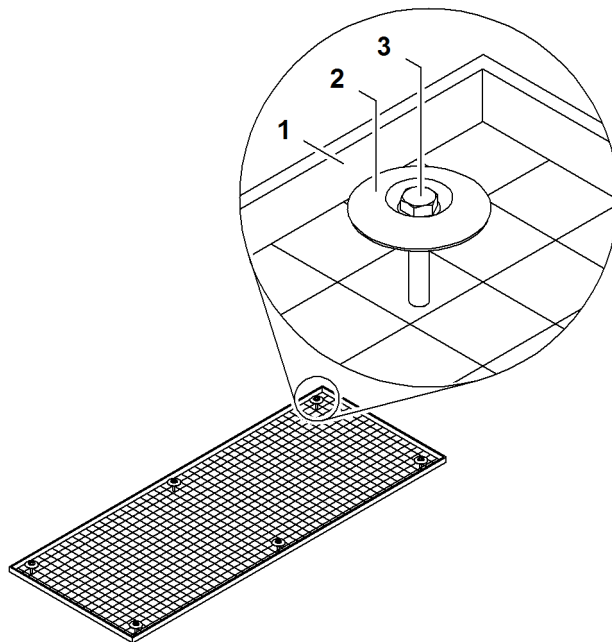


Fig. 2947: Insert catwalk grating in frame

- | | | | |
|---|-----------------|---|------------|
| 1 | Catwalk grating | 3 | Screw (6x) |
| 2 | Plate (6x) | | |

- ▶ Insert catwalk grating **1** in frame.
- ▶ Insert screw **3** with plate **2** at catwalk grating **1** and attachment point.
- ▶ Secure screw **3** with washer and nut.
 - ▷ Cabin railing is installed:

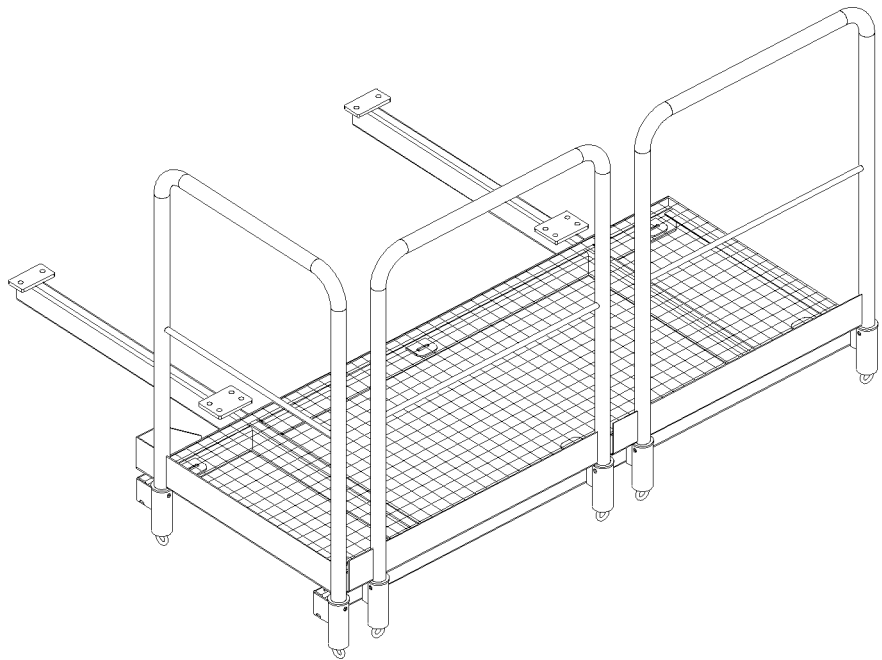


Fig. 2948: Cabin railing is installed

7.4.5 Putting the load moment limiter lamp and flashing light into working position

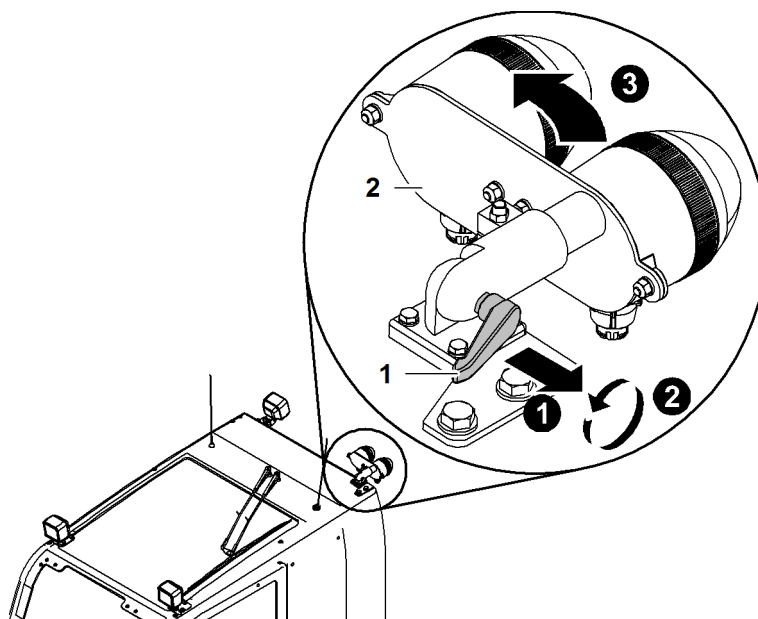


Fig. 2949: Putting the load moment limiter lamp and flashing light into working position

- | | | | |
|---|-----------------|---|---|
| 1 | Clamping device | 2 | Load moment limiter lamp and flashing light |
|---|-----------------|---|---|

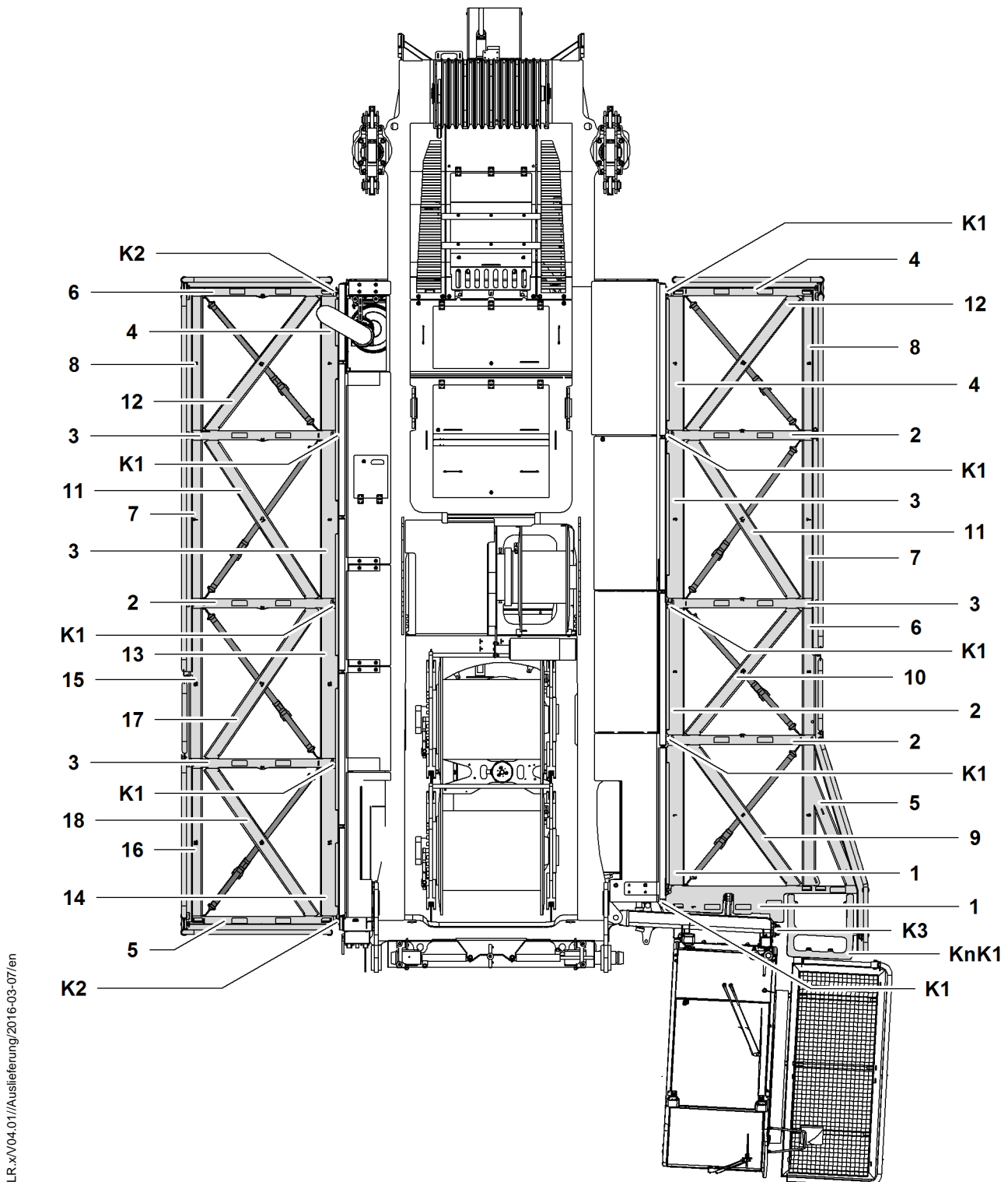
The clamping device **1** is a ratchets and can be turned into any desired position.

- ▶ Pull out clamping device.
- ▶ Turn clamping device into the desired position.
- ▶ Let go of clamping device.

- ▷ Clamping device engages.
- ▶ Twist clamping device counter-clockwise.
 - ▷ Screw fitting opens.
- ▶ Fold load moment limiter lamp and flashing light **2** upwards.
- ▶ Turn clamping device **1** clockwise.
 - ▷ Screw fitting closes.
 - ▷ Put load moment limiter lamp and flashing light into position.

7.4.6 Mounting the platforms on the uppercarriage

Sorting and positioning platform parts



LWNLR.x/V04.01//Auslieferung/2016-03-07/en

Fig. 2950: Overview of platform parts with part numbers and installation sites

The platform parts are marked with part numbers for identification.

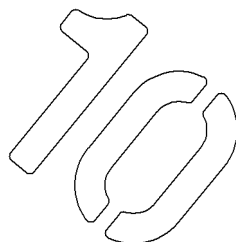


Fig. 2951: Example of a part number

Name	Part number	Number
Brackets		
Bracket	KnK1 ^{A)}	1
Bracket	1	1
Bracket	2	3
Bracket	3	3
Bracket	4	1
Bracket	5	1
Bracket	6	1
Bracket supports		
Bracket support	K1 ^{A)}	8
Bracket support	K2 ^{A)}	2
Bracket support	K3 ^{A)}	1
Plates (inside)		
Plate	1	1
Plate	2	2
Plate	3	2
Plate	4	1
Plate	13	1
Plate	14	1
Plates (outside)		
Plate	5	1
Plate	6	1
Plate	7	2
Plate	8	2
Plate	15	1
Plate	16	1
Diagonals		
Diagonal	9	1
Diagonal	10	1
Diagonal	11	2

LWN/LR-x/V04.01//Auslieferung/2016-03-07/en

Name	Part number	Number
Diagonal	12	2
Diagonal	17	1
Diagonal	18	1
Straps		
Strap	A)	8

Tab. 490: Overview of platform parts

A) No part number on platform part.



Note

Liebherr recommends:

▶ ensure that sufficient space is available.

▶ Sort platform parts.

▶ Position platform parts next to machine at the corresponding installation site.

Mounting bracket support K1 and bracket support K2

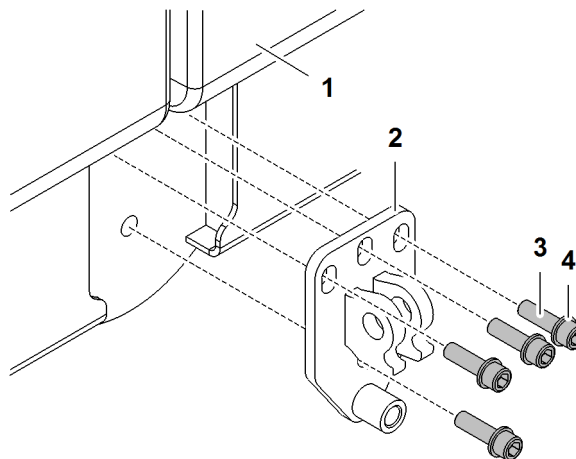


Fig. 2952: Mounting bracket support K1 and bracket support K2

1 Uppercarriage door

2 Bracket support

3 Screw (4x)

4 Washer (4x)

The bracket support **2** is defined as bracket support K1 or bracket support K2.

▶ Install bracket support **2** with screws **3** and washers **4**.

▶ Repeat procedure at all installation sites for bracket support K1 and bracket support K2.

▷ Bracket support K1 and bracket support K2 are installed.

Installing bracket1

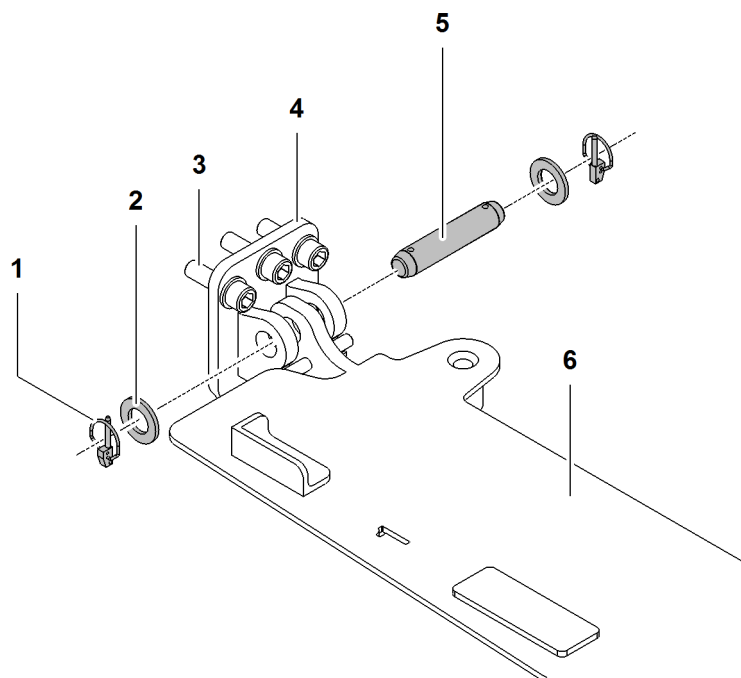


Fig. 2953: Installing bracket1

- | | | | |
|---|---------------|---|-----------------|
| 1 | Linchpin (2x) | 4 | Bracket support |
| 2 | Washer (2x) | 5 | Pin |
| 3 | Screw (4x) | 6 | Bracket1 |

- ▶ Pin bracket support **4** with bracket1 **6**.
- ▶ Secure pins **5** on both sides with washers **2** and linchpins **1**.
 - ▷ Bracket1 **6** is installed.

Installing bracket KnK1

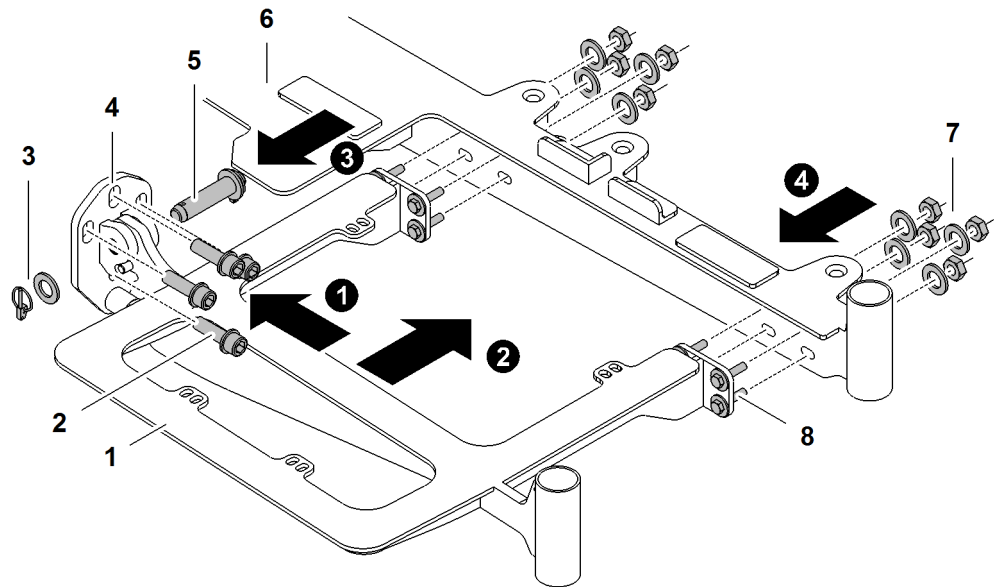


Fig. 2954: Installing bracket KnK1

1	Bracket KnK1	5	Pin
2	Screw (4x) and washer	6	Bracket1
3	Linchpin (2x) and washer	7	Nut (8x) and washer
4	Bracket support K3	8	Screw (8x) and washer

- ▶ Install bracket support K3 4 with screws 2 and washers but do not tighten all the way.
- ▶ Position bracket KnK1 1 on bracket1 6.
- ▶ Pin bracket support K3 4 with bracket KnK1 1.
- ▶ Secure pins 5 with linchpins 3 and washers.
- ▶ Insert screws 8 and washers.
- ▶ Install nuts 7 and washers but do not tighten all the way.
- ▶ Align bracket KnK1 1.
- ▶ Tighten screws 2 and screws 8.
 - ▷ Bracket KnK1 1 is installed.

Installing brackets

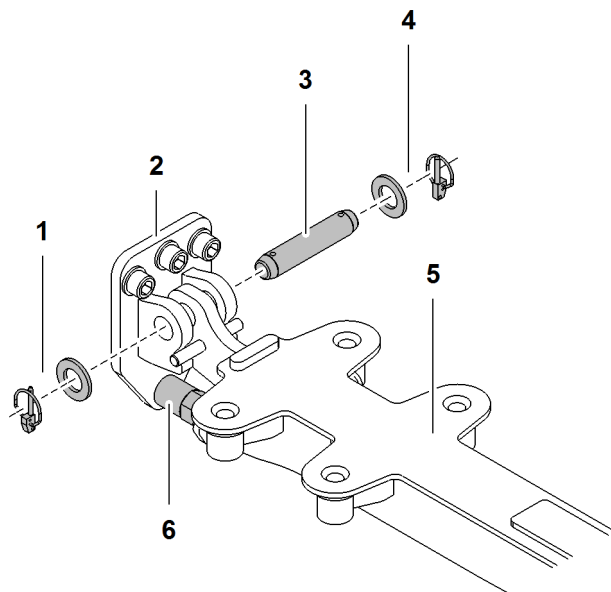


Fig. 2955: Installing brackets

- | | | | |
|---|---------------------|---|---------------------|
| 1 | Linchpin and washer | 4 | Linchpin and washer |
| 2 | Bracket support | 5 | Bracket |
| 3 | Pin | 6 | Adjusting screw |

The bracket support **2** is defined as bracket support K1 or bracket support K2.

- ▶ Pin bracket **5** with bracket support **2**.
- ▶ Secure pin **3** with linchpin **1** and washer and linchpin **4** and washer.
- ▶ Repeat the procedure for all brackets.
- ▶ Slightly lift bracket **5**.
- ▶ Level bracket **6** horizontally with adjusting screw **5**.
- ▶ Repeat the procedure for all brackets.
 - ▷ Brackets are installed.

Installing plates and diagonals

Installation of plates and diagonals is identical.

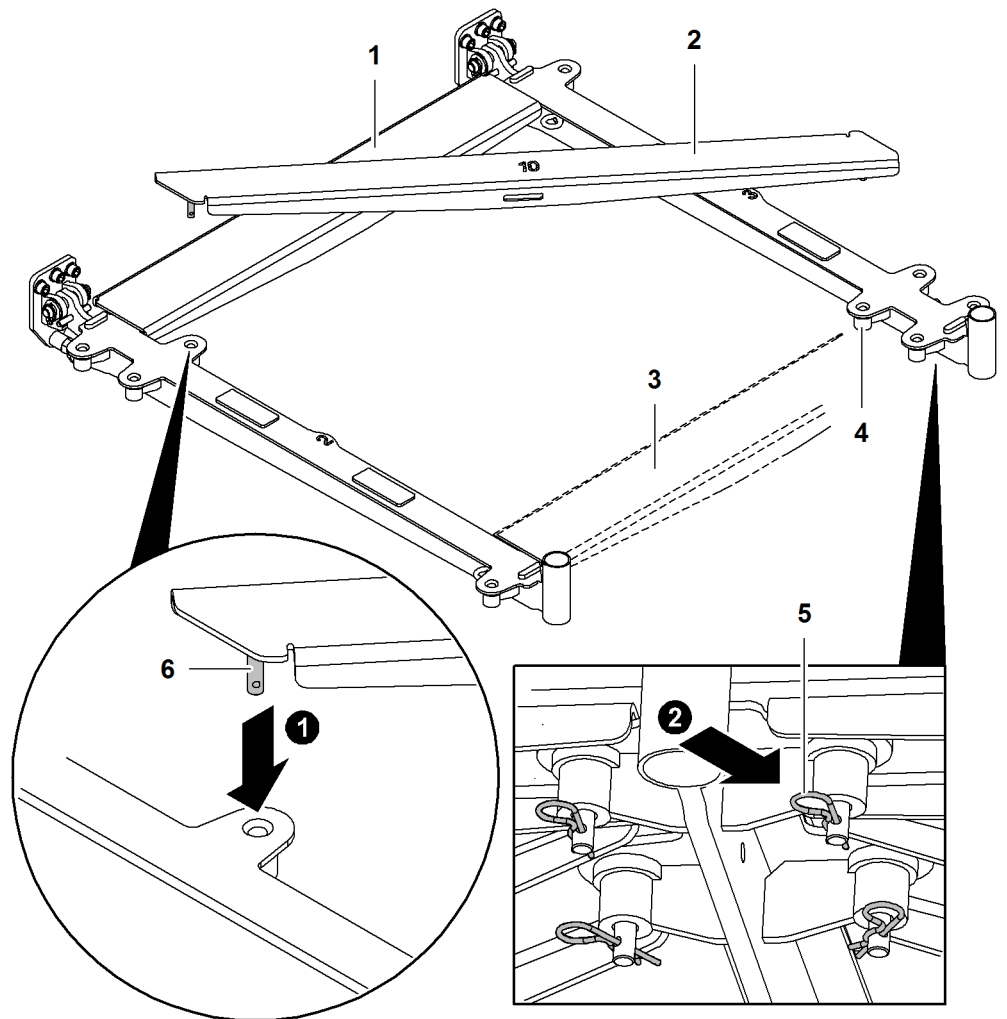


Fig. 2956: Installing plates and diagonals (illustration of principle)

- | | | | |
|---|-----------------|---|---------------------------|
| 1 | Plate (inside) | 4 | Pin connection point (6x) |
| 2 | Diagonal | 5 | Spring cotter pin (6x) |
| 3 | Plate (outside) | 6 | Pin (6x) |

Installation sequence:

- Plate 1 (inside)
 - Diagonal 2
 - Plate 3 (outside)
- ▶ Insert pin 6 at pin connection point 4.
 - ▶ Secure pin 6 with spring cotter pin 5.
 - ▶ Repeat procedure with all plates and diagonals.
 - ▷ Plates and diagonals are installed.

Sorting and positioning railing parts

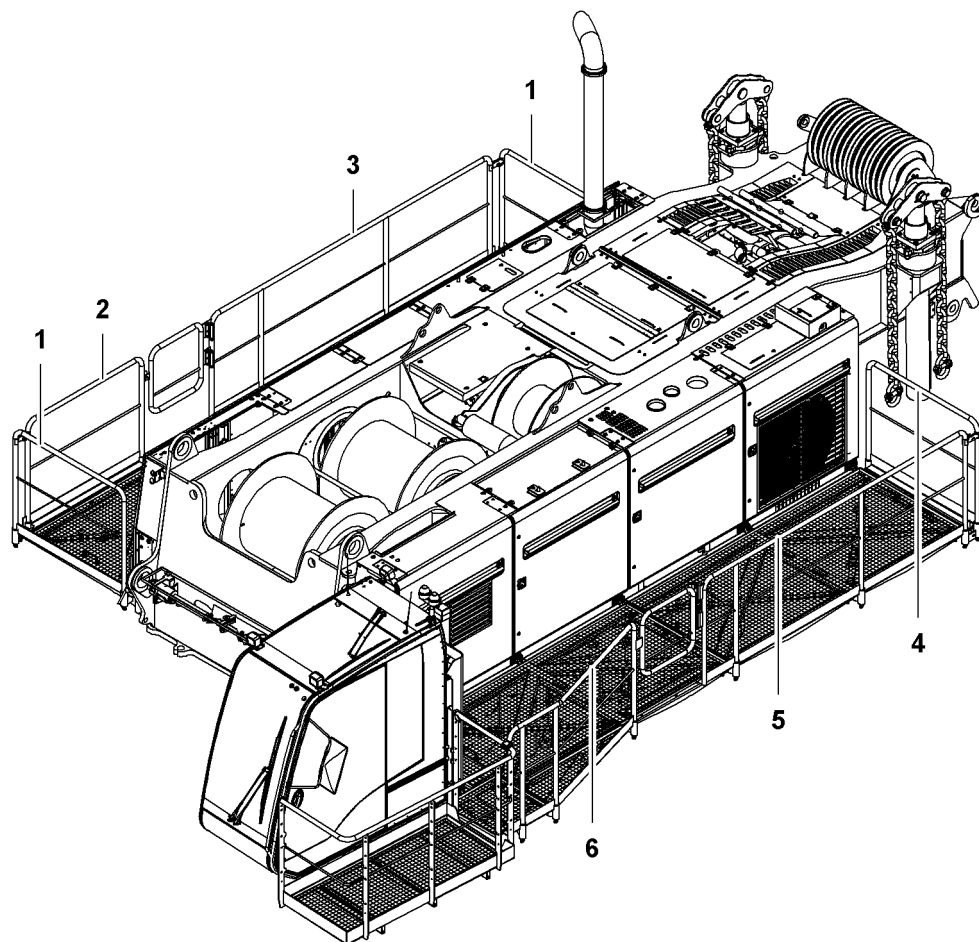


Fig. 2957: Overview of railing parts

- | | | | |
|---|---------------|---|---------------|
| 1 | Railing part1 | 4 | Railing part4 |
| 2 | Railing part2 | 5 | Railing part5 |
| 3 | Railing part3 | 6 | Railing part6 |

Name	Length	Number
Right railing		
Railing part1	1372 mm 4' 6" ft-in	2
Railing part2	1394 mm 4' 7" ft-in	1
Railing part3	3415 mm 11' 2" ft-in	1
Left railing		
Railing part6	2005 mm 6' 7" ft-in	1
Railing part5	4001 mm 13' 2" ft-in	1

LWNLR-x/V04.01//Auslieferung/2016-03-07/en

Name	Length	Number
Railing part4	1390 mm 4' 7" ft-in	1

Tab. 491: Overview of railing parts



Note

Liebherr recommends:

▶ ensure that sufficient space is available.

▶ Sort railing parts.

▶ Position railing parts next to machine at the corresponding installation site.

Installing railing parts

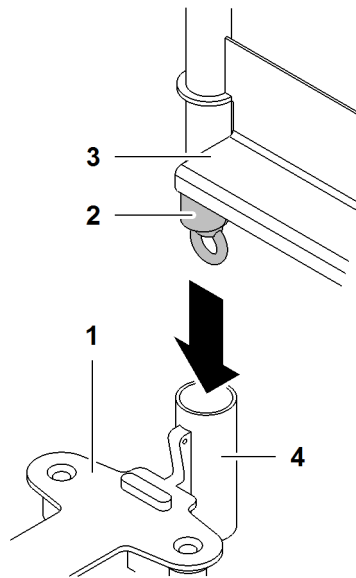


Fig. 2958: Installing railing part

- | | |
|---|-----------------------------------|
| 1 Bracket | 3 Railing part |
| 2 Eye bolt for railing stabilization | 4 Support for railing part |

▶ Undo eye bolt **2**.

▷ Wedge of railing stabilization comes undone.

▶ Insert railing part **3** at supports **4**.

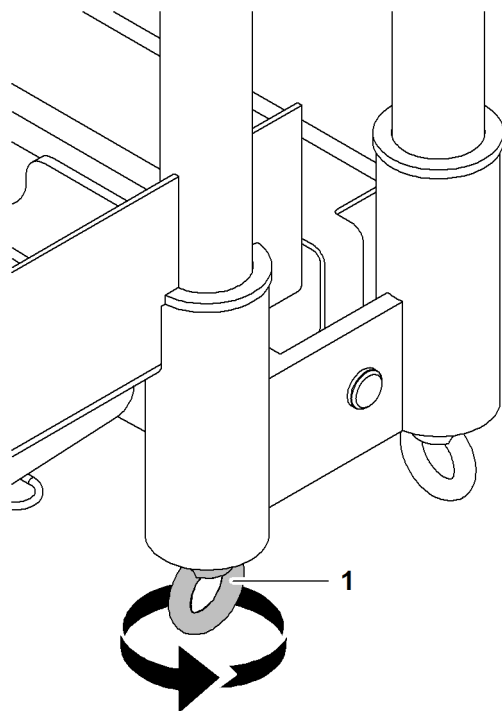


Fig. 2959: Securing the railing part

1 Eye bolt for railing stabilization



Note

Liebherr recommends:

- ▶ Grease thread of eye bolt 1.
- ▶ Tighten eye bolt 1.
 - ▷ Wedge of railing stabilization secures the railing part.
- ▶ Repeat the procedure with all railing parts.
 - ▷ Railing parts are installed.

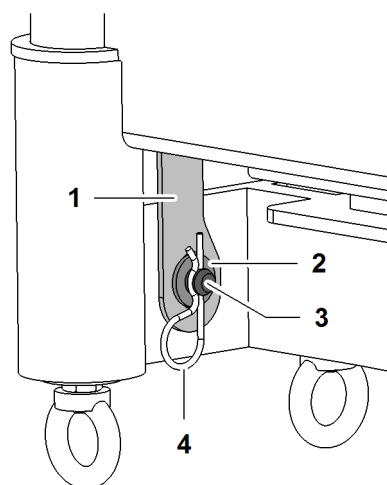


Fig. 2960: Securing the railing part with safety latch

1 Safety latch	3 Pin
2 Washer	4 Spring cotter pin

- ▶ Pin bracket with safety latch 1.

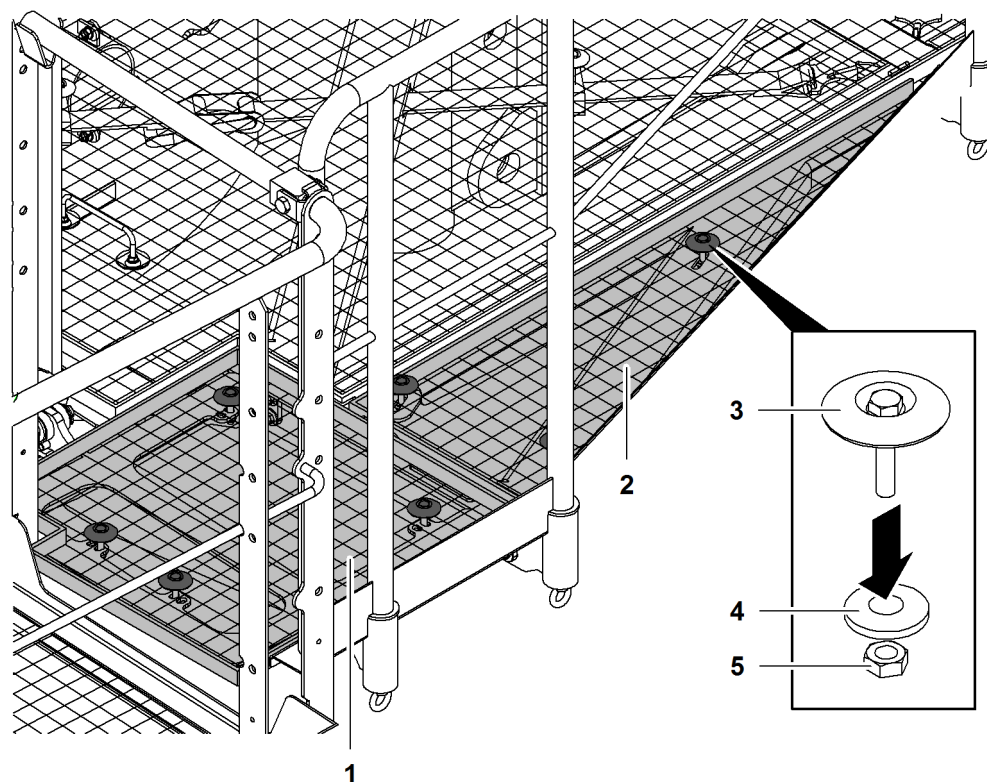


Fig. 2962: Installing grating A and grating B for left platform

- | | | | |
|---|-----------------------------|---|-------------|
| 1 | Grating A for left platform | 4 | Washer (7x) |
| 2 | Grating B for left platform | 5 | Nut (7x) |
| 3 | Screw (7x) with plate | | |

Bracket KnK1 has four attachment points for gratings.

Plate5 has three attachment points for gratings.

- ▶ Insert screw 3 with plate at grating and attachment point.
- ▶ Secure screw 3 with washer 4 and nut 5.
- ▶ Repeat procedure on all attachment points.
 - ▷ Grating A and grating B for left platform are installed.

Installing the grating

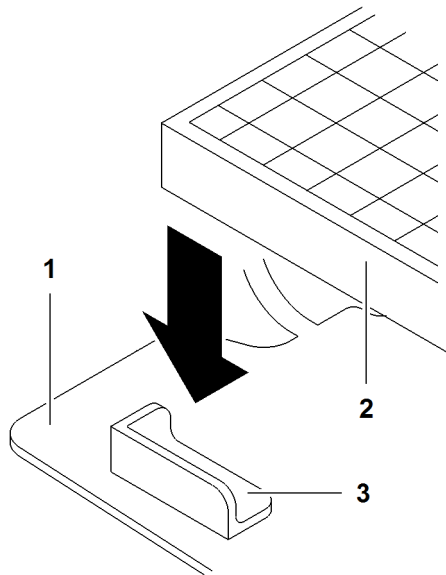


Fig. 2963: Installing the grating

- | | | | |
|---|---------|---|-------------------|
| 1 | Bracket | 3 | Guide for grating |
| 2 | Grating | | |

- ▶ Insert grating 2 in guide 3.
- ▶ Repeat procedure with all gratings 2.

Installing the strap support

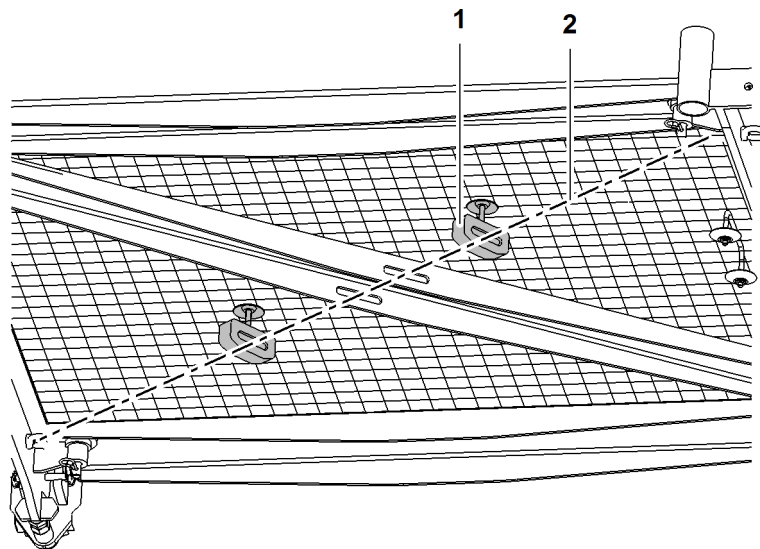


Fig. 2964: Installing the strap support

- | | | | |
|---|---------------|---|----------|
| 1 | Strap support | 2 | Diagonal |
|---|---------------|---|----------|
- ▶ Position strap support 1 with the help of the diagonal 2.
 - ▶ Insert screw with plate from above at the grating.
 - ▶ Attach Strap support 1 from below with screw.
 - ▶ Repeat procedure on all strap supports 1.

- ▷ Strap supports **1** are installed.

Installing straps

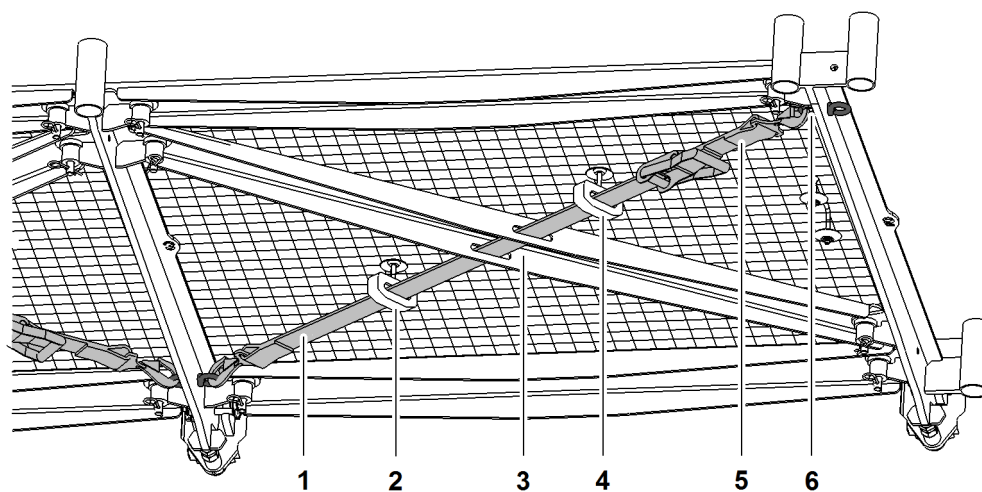


Fig. 2965: Installing straps

- | | | | |
|----------|---------------|----------|--------------------|
| 1 | Strap | 4 | Strap support |
| 2 | Strap support | 5 | Strap with ratchet |
| 3 | Diagonal | 6 | Eye bolt (2x) |

- ▶ Suspend strap **1** on eye bolt **6**.
- ▶ Pull strap **1** through strap support **2**.
- ▶ Pull strap **1** through diagonal **3**.
- ▶ Pull strap **1** through strap support **4**.
- ▶ Suspend strap **5** on eye bolt **6**.
- ▶ Pull strap **1** through ratchet.
- ▶ Tension strap **1** with ratchet.
- ▶ Repeat procedure with all straps **1 + 5**.
 - ▷ Straps **1 + 5** are installed.

Installing railing connections

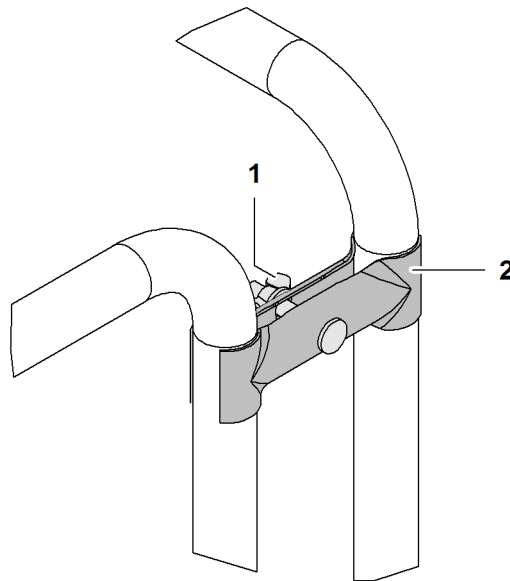


Fig. 2966: Installing railing connections

1 Wing nut **2** Railing connection

- ▶ Undo wing nut **1**.
- ▶ Insert railing connection **2** between railing parts.
- ▶ Tighten wing nut **1**.
- ▶ Repeat procedure with all railing connections **2**.
 - ▷ Railing connections **2** are installed.

Mounting uppercarriage ladder for narrow track

This ladder is only available with undercarriage* with adjustable track width.

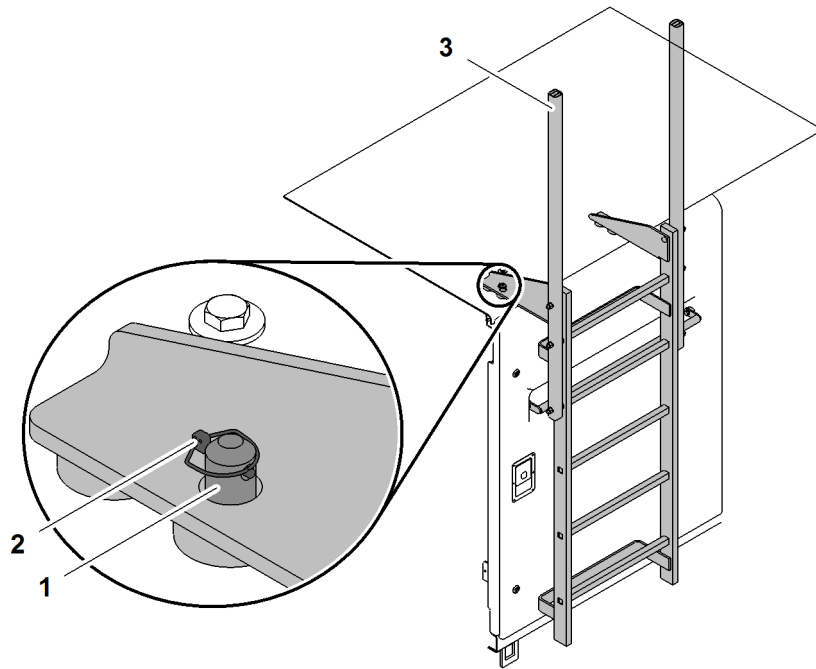


Fig. 2968: Mounting the ladder on the uppercarriage

- | | |
|----------------------------|-----------------|
| <p>1 Pin (2x)
(2x)</p> | <p>3 Ladder</p> |
|----------------------------|-----------------|

- ▶ Attach ladder 3 to pins 1.
- ▶ Secure pin 1 with linchpins 2.

7.4.8 Mounting the uppercarriage railing



WARNING

Walking on uppercarriage without appropriate safety provisions!
Risk of falling off the uppercarriage.

- ▶ A fall arrest system must be worn when working on the uppercarriage.

Uppercarriage railings must be mounted to provide a safe working environment.

If the machine is equipped with hydraulic cabin elevation*, the uppercarriage railing on the left side of the uppercarriage can only be installed after the hydraulic cabin elevation mast has been erected.

Assembly of the different uppercarriage railings is identical.

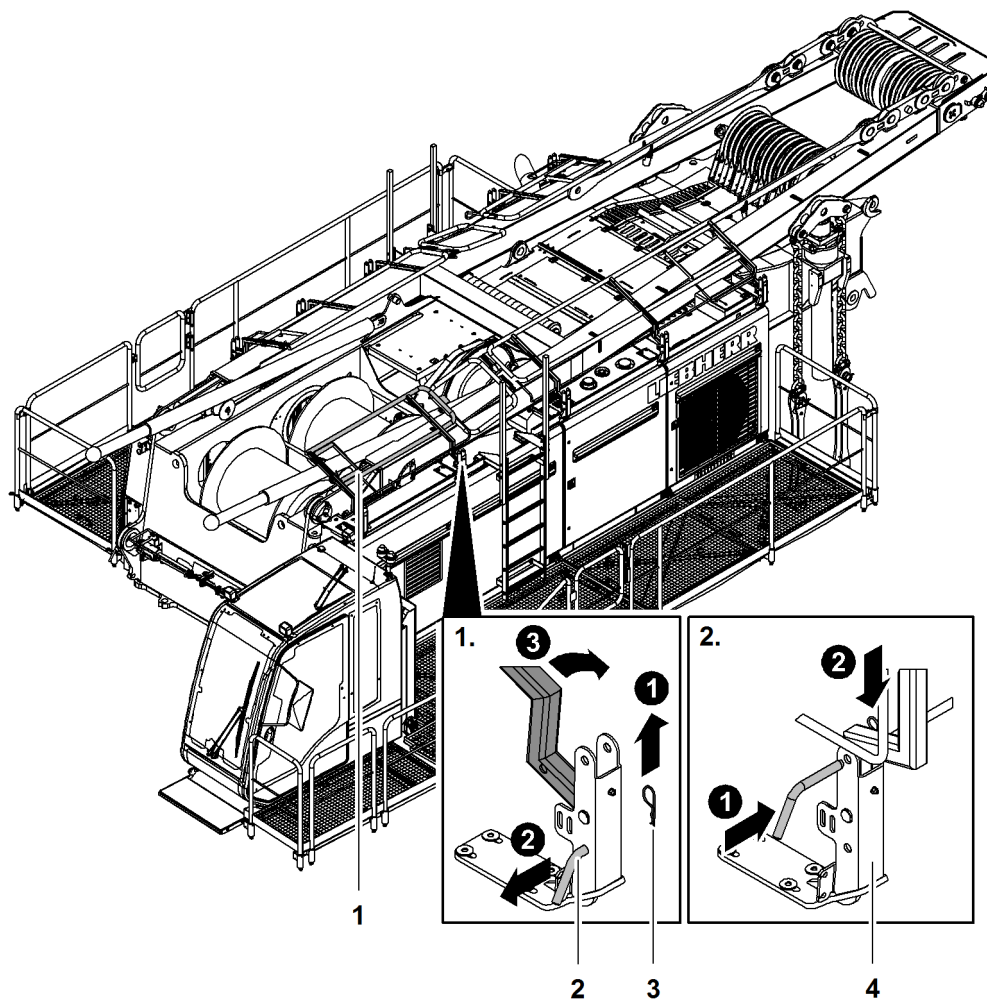


Fig. 2969: Installing the left front uppercarriage railing

- | | | | |
|---|----------------------------------|---|------------------------|
| 1 | Left front uppercarriage railing | 3 | Spring cotter pin (2x) |
| 2 | Pin (2x) | 4 | Bracket (2x) |

- ▶ Remove spring cotter pin 3 and pin 2.
- ▶ Fold up left front uppercarriage railing 1.
- ▶ Pin left front uppercarriage railing 1 with brackets 4.
- ▶ Secure pins 2 with spring cotter pins 3.

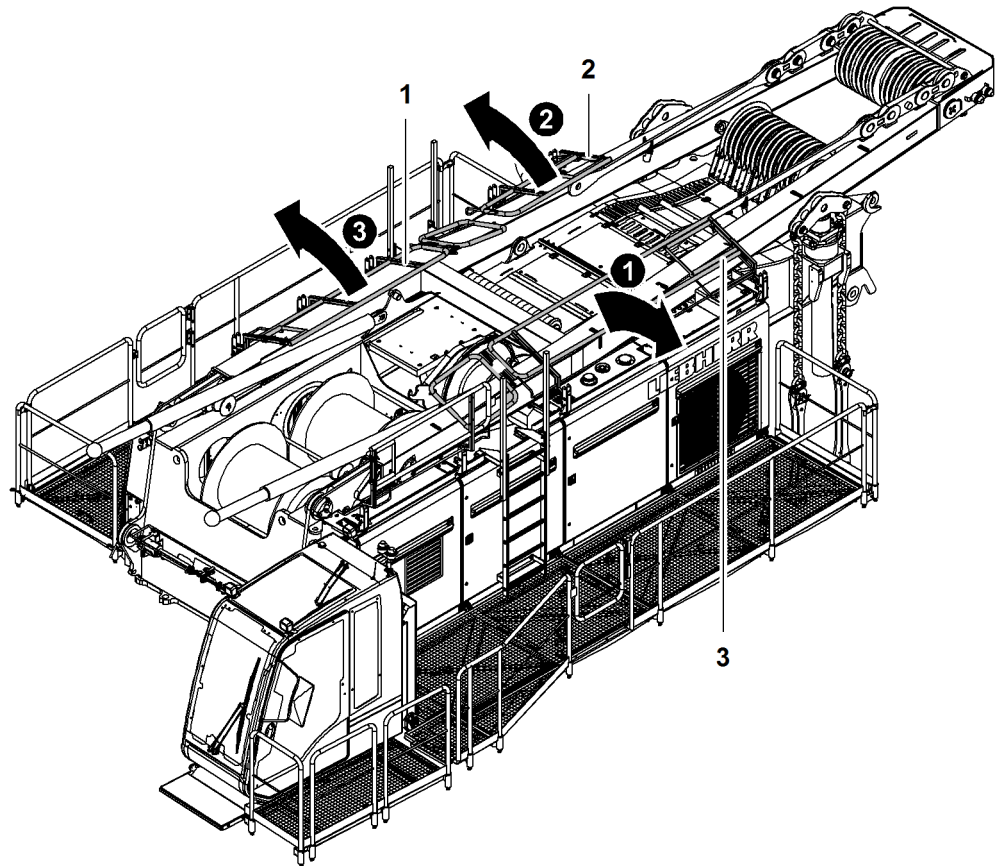


Fig. 2970: Mounting the uppercarriage railing

- | | | | |
|---|-----------------------------------|---|---------------------------------|
| 1 | Right front uppercarriage railing | 3 | Left rear uppercarriage railing |
| 2 | Right rear uppercarriage railing | | |

- ▶ Mount left rear uppercarriage railing **3** as described above.
- ▶ Mount right rear uppercarriage railing **2** as described above.
- ▶ Mount right front uppercarriage railing **1** as described above.

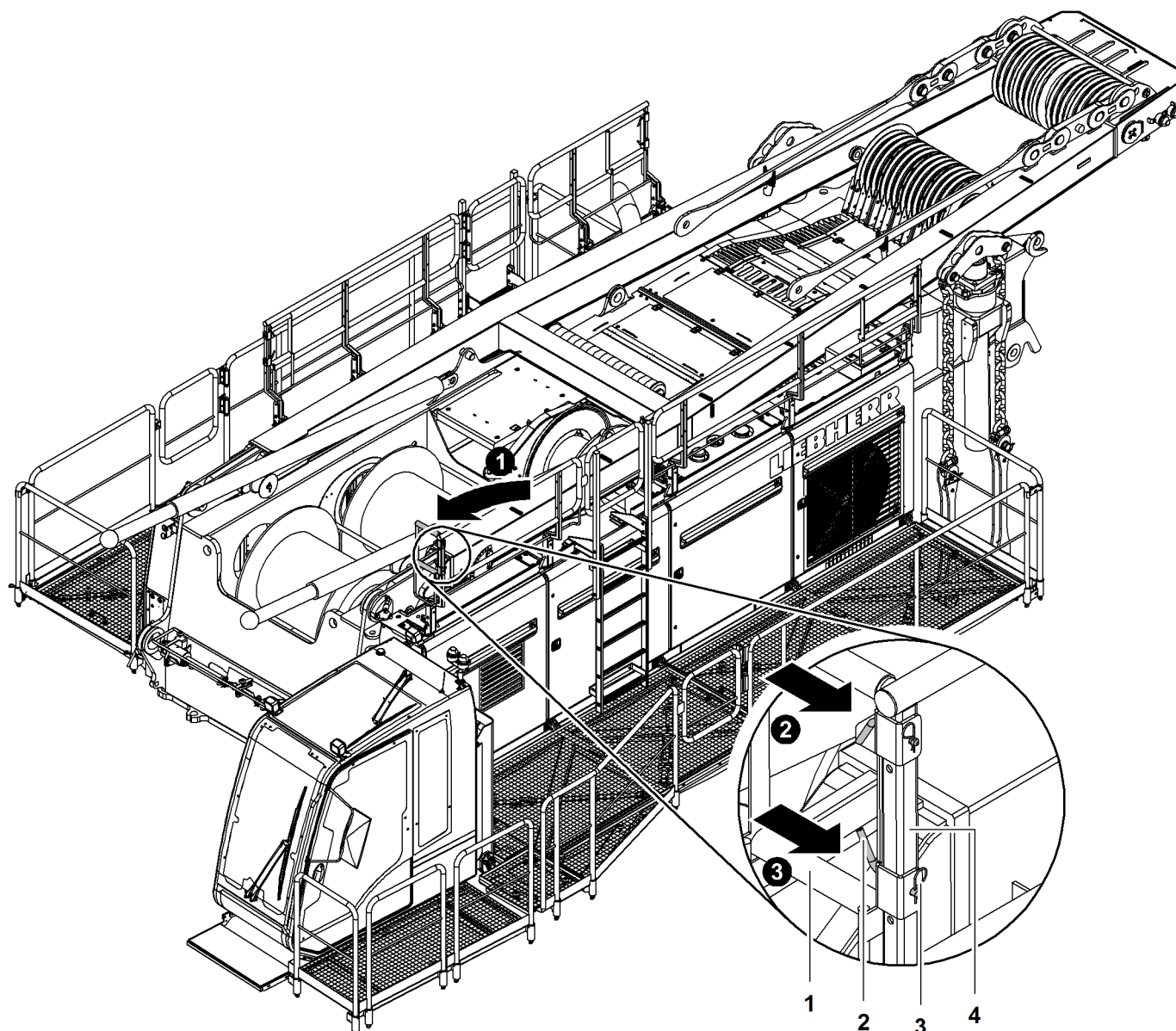


Fig. 2971: Mounting the left front uppercarriage railing part

- | | | | |
|---|---------------------------------------|---|----------------------------------|
| 1 | Left front uppercarriage railing part | 3 | Spring cotter pin (2x) |
| 2 | Pin (2x) | 4 | Left front uppercarriage railing |

- ▶ Deinstall left front uppercarriage railing part 1 on left front uppercarriage railing 4.
- ▶ Insert left front uppercarriage railing part 1 in pin connection position.
- ▶ Pin left front uppercarriage railing part 1 with left front uppercarriage railing 4.
- ▶ Secure pins 2 with spring cotter pins 3.

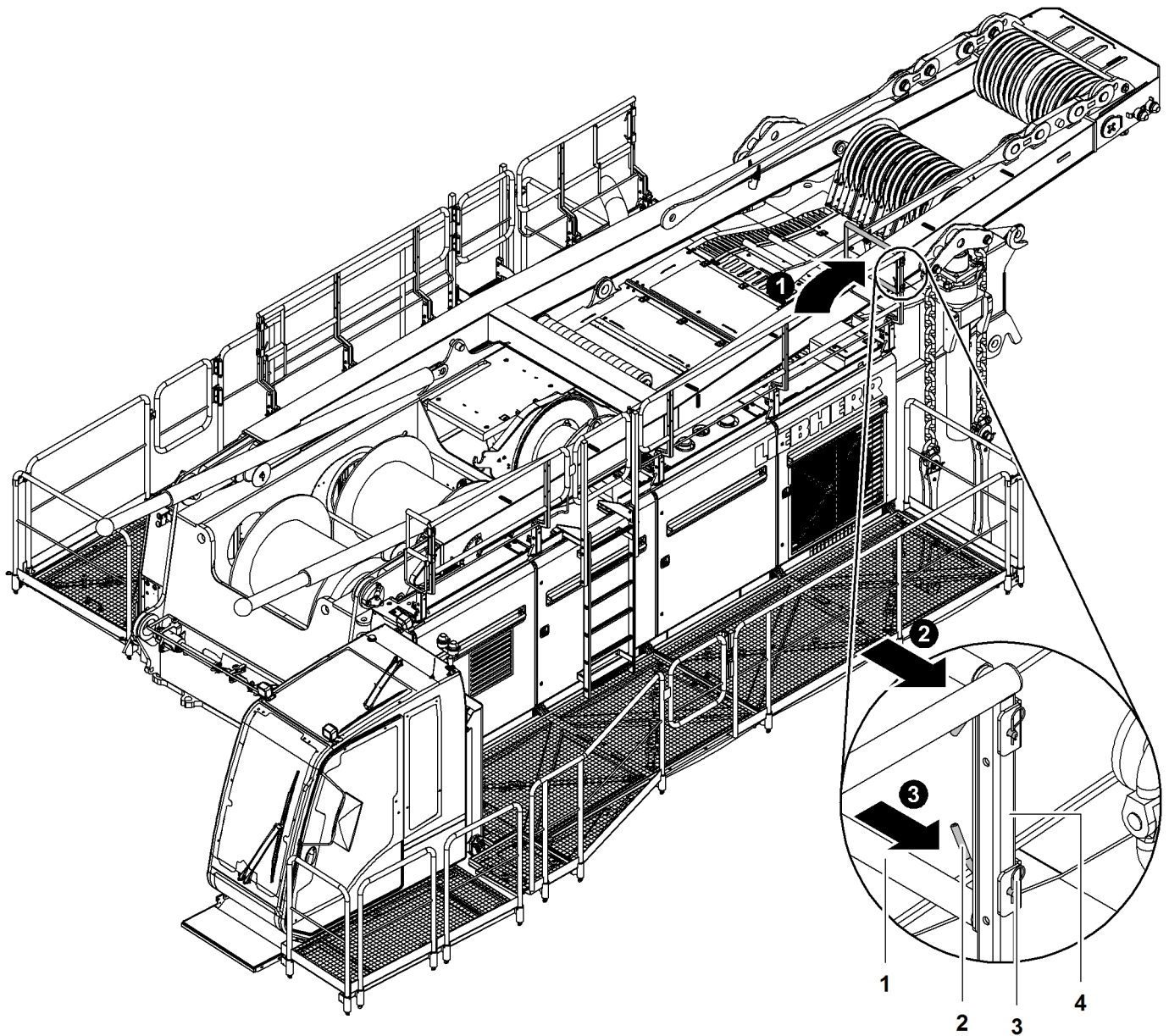


Fig. 2972: Mounting the left rear uppercarriage railing part

- | | | | |
|---|--------------------------------------|---|---------------------------------|
| 1 | Left rear uppercarriage railing part | 3 | Spring cotter pin (2x) |
| 2 | Pin (2x) | 4 | Left rear uppercarriage railing |

- ▶ Deinstall left rear uppercarriage railing part 1 on left rear uppercarriage railing 4.
- ▶ Insert left rear uppercarriage railing part 1 in pin connection position.
- ▶ Pin left rear uppercarriage railing part 1 with left rear uppercarriage railing 4.
- ▶ Secure pins 2 with spring cotter pins 3.

LWNLR.x/V04.01//Auslieferung/2016-03-07/en

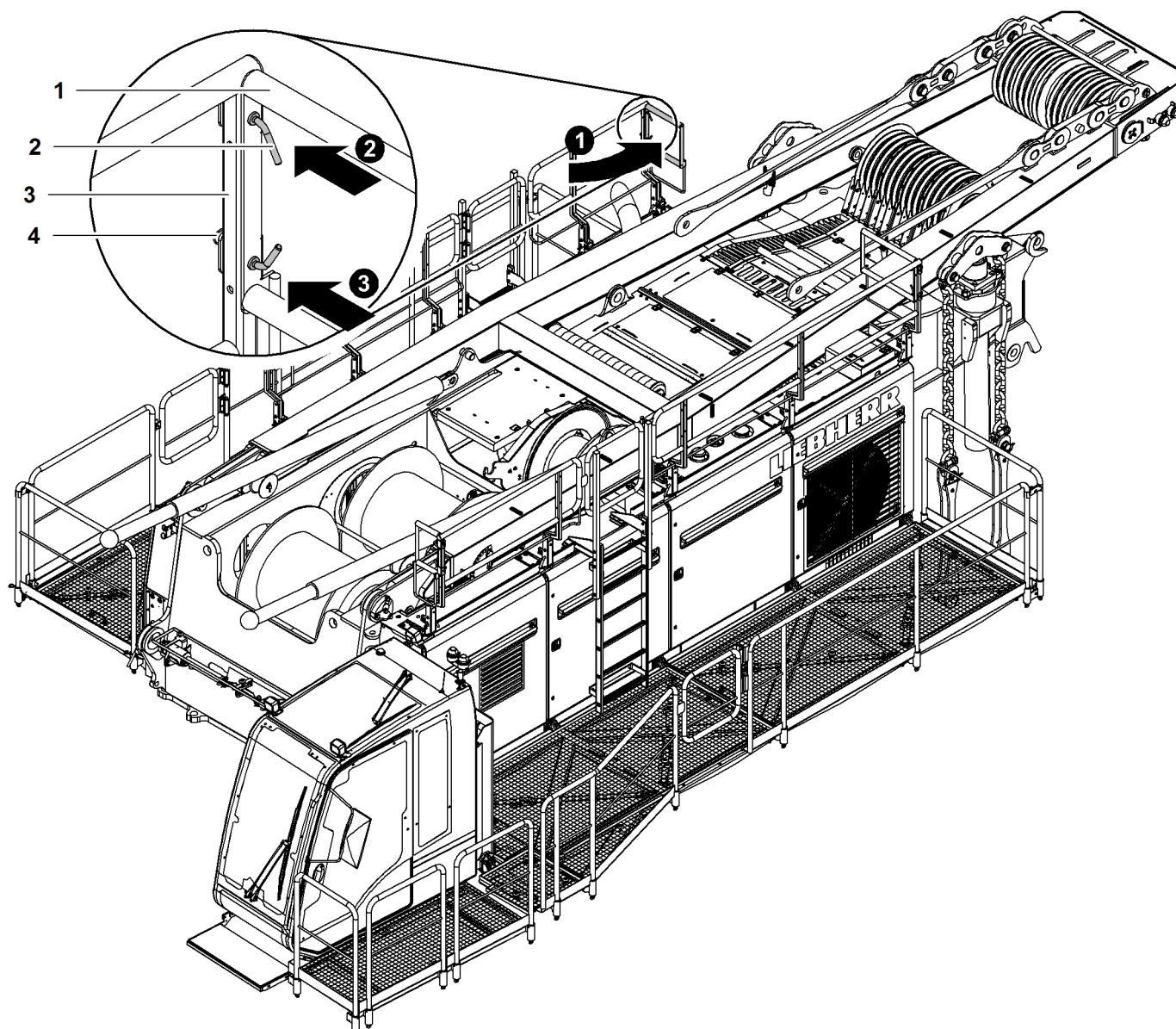


Fig. 2973: Mounting the right rear uppercarriage railing part

- | | | | |
|---|---------------------------------------|---|----------------------------------|
| 1 | Right rear uppercarriage railing part | 3 | Right rear uppercarriage railing |
| 2 | Pin (2x) | 4 | Spring cotter pin (2x) |

- ▶ Deinstall right rear uppercarriage railing part **1** on right rear uppercarriage railing **3**.
- ▶ Insert right rear uppercarriage railing part **1** in pin connection position.
- ▶ Pin right rear uppercarriage railing part **1** with right rear uppercarriage railing **3**.
- ▶ Secure pins **2** with spring cotter pins **4**.

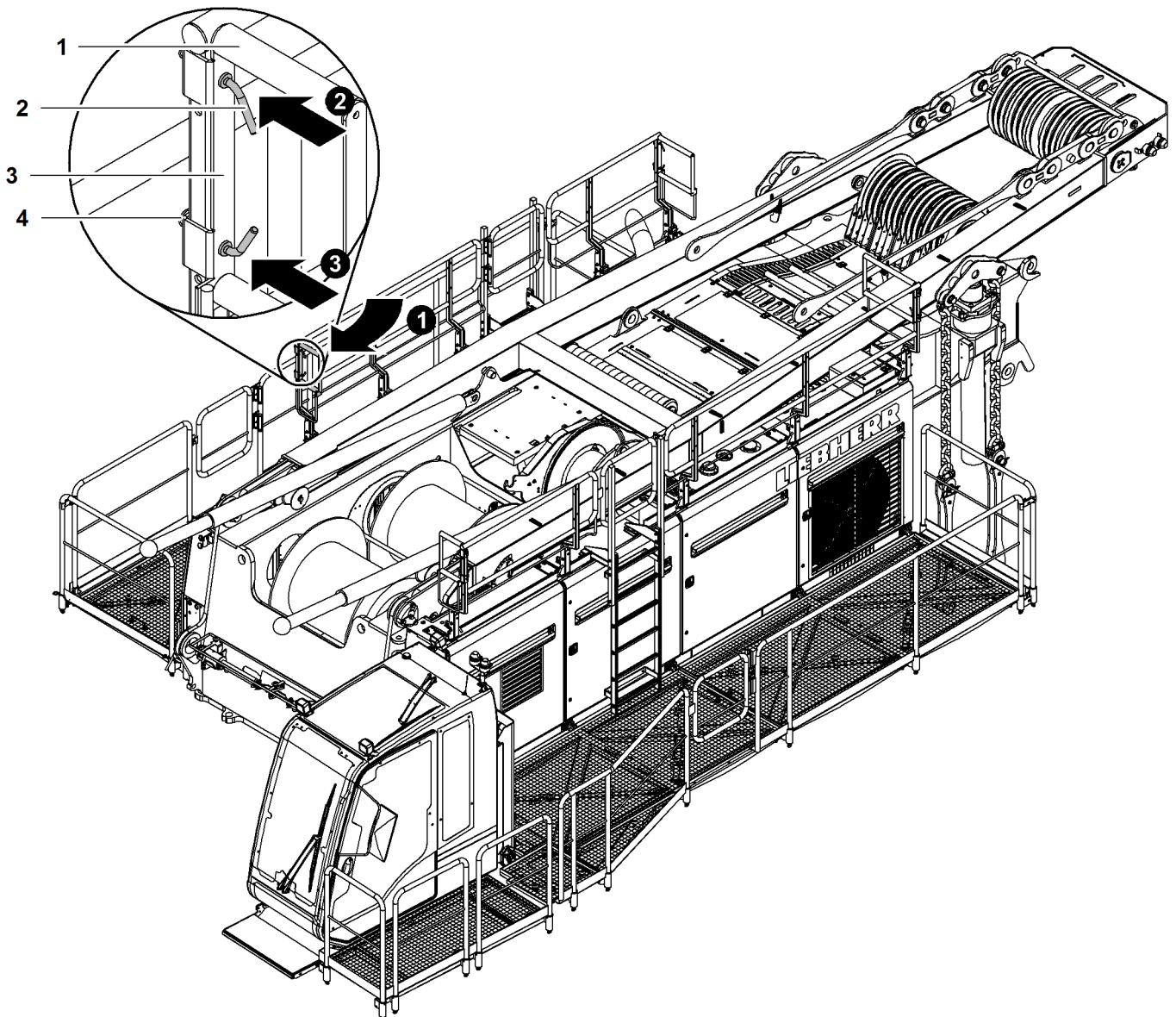


Fig. 2974: Mounting the right front uppercarriage railing part

- | | | | |
|---|--|---|-----------------------------------|
| 1 | Right front uppercarriage railing part | 3 | Right front uppercarriage railing |
| 2 | Pin (2x) | 4 | Spring cotter pin (2x) |

- ▶ Deinstall right front uppercarriage railing part 1 on right front uppercarriage railing 3.
- ▶ Insert right front uppercarriage railing part 1 in pin connection position.
- ▶ Pin right front uppercarriage railing part 1 with right front uppercarriage railing 3.
- ▶ Secure pins 2 with spring cotter pins 4.

7.4.9 Fitting the exhaust pipe

For transportation, the end pipe was removed from the exhaust pipe to reduce the transport height.



CAUTION

Exhaust pipe hot!
risk of burns to hands.

- ▶ Never touch the exhaust pipe before it has cooled down.

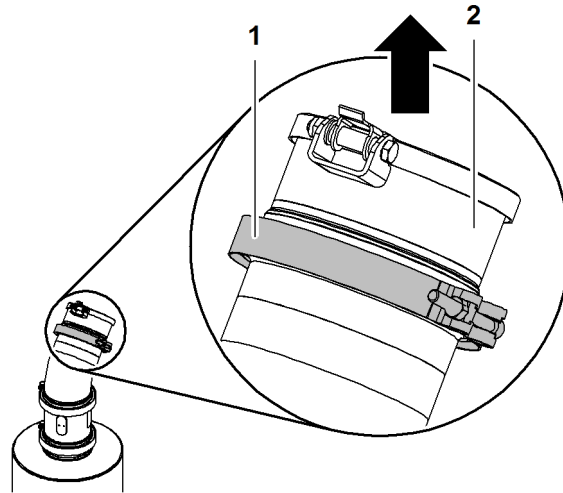


Fig. 2975: Exhaust pipe in transport position

- 1 Pipe clamp
- 2 Exhaust valve

- ▶ Undo pipe clamp 1.
- ▶ Take exhaust valve 2 off of exhaust pipe and put aside.

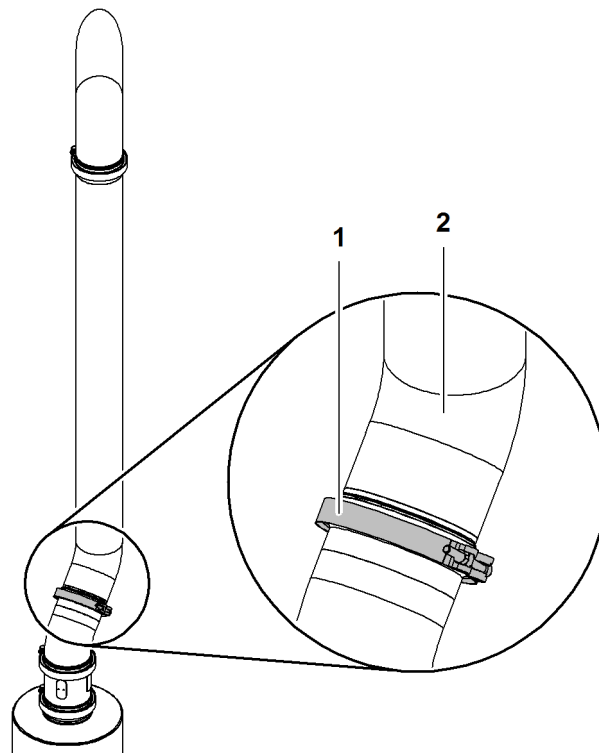


Fig. 2976: Exhaust pipe in working position

- 1 Pipe clamp
- 2 End pipe

- ▶ Put end pipe 2 onto exhaust pipe.
- ▶ Tighten pipe clamp 1.

7.4.10 Checking the position of the bypass plug

Open the front right-hand side doors on the uppercarriage to access the electric box and bypass plug.

NOTICE

Ignition is switched on!
Risk of short circuit.

- ▶ Bypass plug and electric cable must not be plugged in/unplugged unless the machine has been switched off (ignition key in position 0).

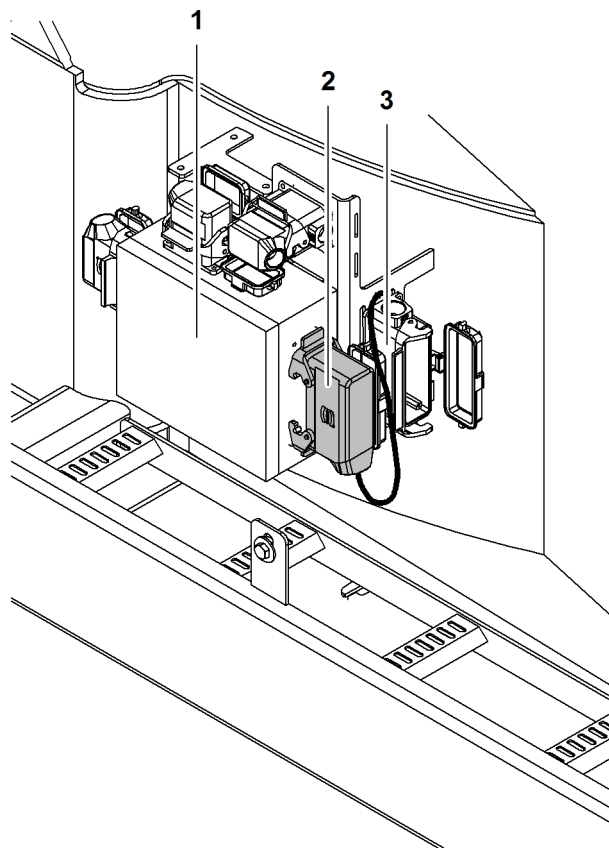


Fig. 2977: Checking the position of the bypass plug

- | | | | |
|---|--------------|---|--------------|
| 1 | Electric box | 3 | Dummy socket |
| 2 | Bypass plug | | |

The bypass plug 2 must be plugged into the electric box 1 for assembly processes.

- ▶ Check plug position.

Troubleshooting

Wrong plug position?

- ▶ Unplug/plug in bypass plug 2.

7.4.11 Putting the machine into operation

- ▶ Carry out checks before starting the machine (For more information see: [4.1 Checks before start up, page 835](#)).
- ▶ Putting the machine into operation (For more information see: [4.2 Start-up, page 837](#)).

7.4.12 Switching on assembly mode functions

When assembly mode functions are switched on, the following functions can be switched on:

- *Bypass limit switch*
- *Cylinder adjustment functions*



WARNING

Changed control lever function assignment when machine functions activated! Operating errors to the machine.

- ▶ Observe changed function assignment of control levers (For more information see: [3.5 Left control lever, page 628](#)) (For more information see: [3.6 Right control lever, page 653](#)).



Fig. 2978: Symbol Assembly functions

The *Assembly functions* symbol indicates whether assembly functions are switched on.



If the assembly functions are not switched on:

- ▶ Press the *Assembly functions* switch on control panel X12.
 - ▷ Assembly functions switched on.
 - ▷ Switch *Assembly functions* is lit.
 - ▷ Flashing light is on.
 - ▷ Symbol *Assembly functions* is displayed on the monitor:



Fig. 2980: Symbol Assembly functions

7.4.13 Switching on cylinder adjustment functions



- ▶ Press the *Cylinder adjustment functions* button on control panel X23.
 - ▷ Cylinder adjustment functions of the machine are activated.

7.4.14 Extend the tilting back support cylinders



- ▶ Press the button *Extend tilting back support cylinders* on control panel 12 until the tilting back support cylinders are extended halfway.

7.4.15 Erecting A-frame1

Ensure that the following conditions are fulfilled:

- Cylinder adjustment functions are on.



DANGER

Machine must not be lifted when A-frame1 is laid down!
Toppling of machine.

- ▶ Erect A-frame1 before raising the machine.



- ▶ Press the *Extend A-frame1 cylinder* button on control panel X23.

NOTICE

Slack rope when erecting A-frame1!
Damage to the rope of the main boom luffing winch.

- ▶ In cold weather when ropes are stiff only move A-frame1 slowly to ensure that the rope does not form any slack.
- ▶ If the rope goes slack, check the rope, the run of the rope on the pulley set, and the winding of the rope on the winch.



Note

Liebherr recommends:

- ▶ Move A-frame1 exclusively at speed level 2 of the boom adjuster and in the medium engine rpm range.
- ▶ Critical angle on instruction plate *Observe angle limitations A-frame1*.

- ▶ Unwind the main boom luffing winch.
 - ▷ A-frame1 erects itself:

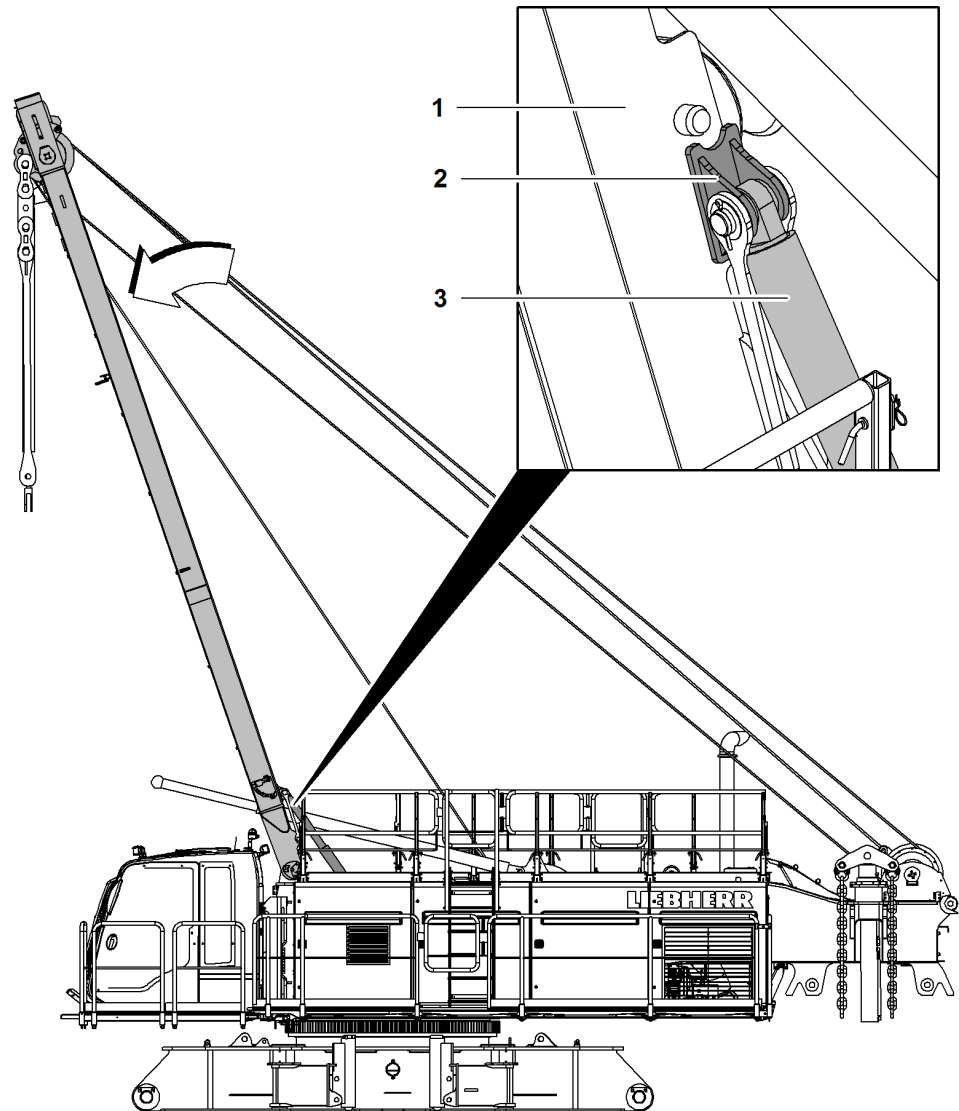


Fig. 2984: A-frame1 erects itself

- | | |
|-----------------------------------|---------------------------------|
| <p>1 A-frame1
2 Slab (2x)</p> | <p>3 A-frame1 cylinder (2x)</p> |
|-----------------------------------|---------------------------------|

► Erect A-frame1 1 until the slabs 2 of the A-frame1 cylinders 3 lift off.

7.4.16 Unloading the machine

In order to unload it from the transport vehicle and assemble the crawler side frame, the machine must be supported on the ground using jacks.

Ensure that the following conditions are satisfied:

- The machine is equipped with jacks for self-assembly.
- Checks before start-up were carried out.
- Fitters are instructed.
- All safety measures are being observed ([For more information see: 7.2 Implementation instructions for assembly and disassembly, page 1149](#)).
- Mechanical boom angle indicator is checked to ensure it is working correctly and moving freely.
- The bypass plug is connected.
- The cab is in the working position.
- The cab's boom walkways are in the working position.

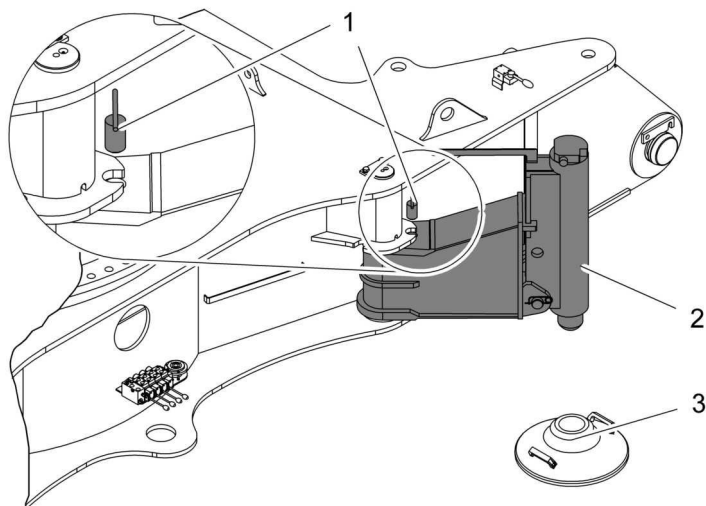


Fig. 2986: Bolting the swing brackets in the support position

- | | | | |
|---|---------------|---|-------------|
| 1 | Pin | 3 | Support pad |
| 2 | Swing bracket | | |

- ▶ Insert the pin 1.
- ▶ Repeat procedure with all slewing brackets 2.

Fitting support pads and chocks



DANGER

Incorrect use of support pads and chocks!
Machine toppling over.

- ▶ Use the support pads fixed to the undercarriage.
- ▶ Add stable material over a sufficiently wide area under the support pads if necessary.
- ▶ Chock all support pads with the same material.
- ▶ Make sure that chocks do not protrude into the transport vehicle's track.

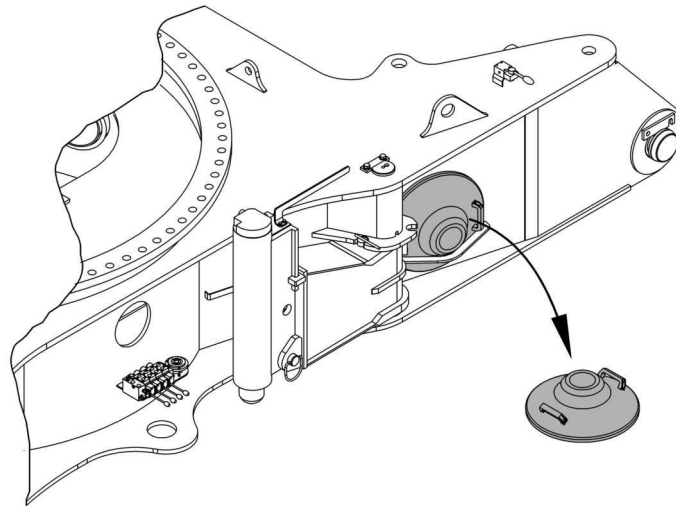


Fig. 2987: Chocking support pads

- ▶ Take support pad out of bracket.
- ▶ Place support pad below jack flat on the ground or on bedding layers.
- ▶ Repeat procedure with all jacks.

Determining the jack-up height

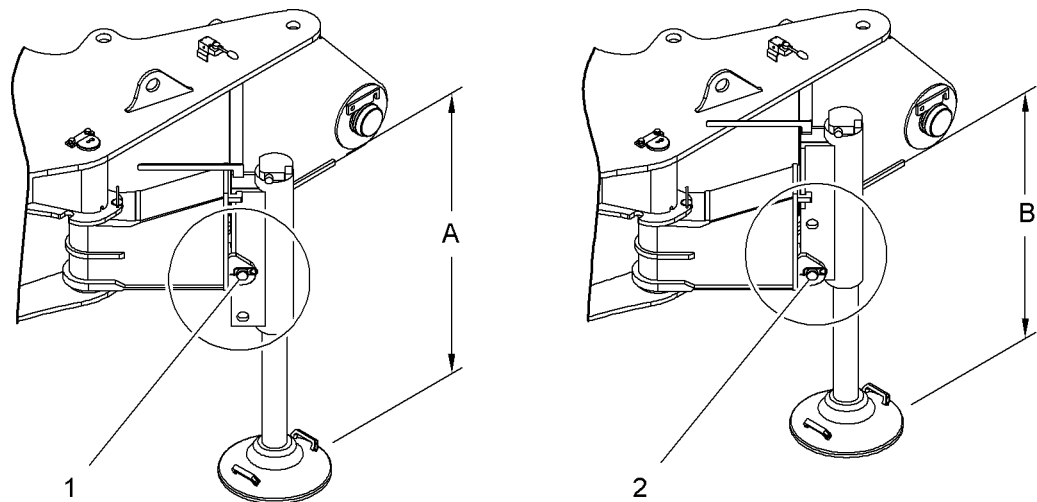


Fig. 2988: Determining the jack-up height

- 1 Jack in top pin connection position 2 Jack in bottom pin connection position

	Jack-up height A	Jack-up height B
Standard cylinder	975 mm 3' 2" ft-in	725 mm 2' 5" ft-in
Telescopic cylinder	1415 mm 4' 8" ft-in	1165 mm 3' 10" ft-in

Tab. 492: Determining the jack-up height

The jacks can be bolted to the swing brackets in two positions.

LWNLR.x/V04.01//Auslieferung/2016-03-07/en

The jack-up height needed to unload the machine depends on the:

- Height of the transport vehicle
- soil composition on the site
- version of the hydraulic jack (standard or telescopic)

Example:

- Distance from floor to loading platform of the transport vehicle: 1000 mm (3' 3" ft-in)
- Safety distance between undercarriage of basic machine and transport vehicle loading platform: 100 mm (3.94" in)
- Jack-up height of the jacks: 975 mm (3' 2" ft-in)
- Soil composition: Flat asphalt with adequate capacity

Result: place shim with thickness of 100 mm (3.94" in) underneath.

Setting the jack-up height of the jacks

When the jack-up height was determined, if it was shown that the position of the jack needed to be changed, then the following process steps should be carried out.



DANGER

Different jack-up heights!
Machine toppling over.

- ▶ Pin all jacks to same pin connection points on slewing brackets.



DANGER

Incorrect raise of the machine!
Machine toppling over.

- ▶ Extend the jack until the strain on the pin is relieved.
- ▶ Do not raise the machine.

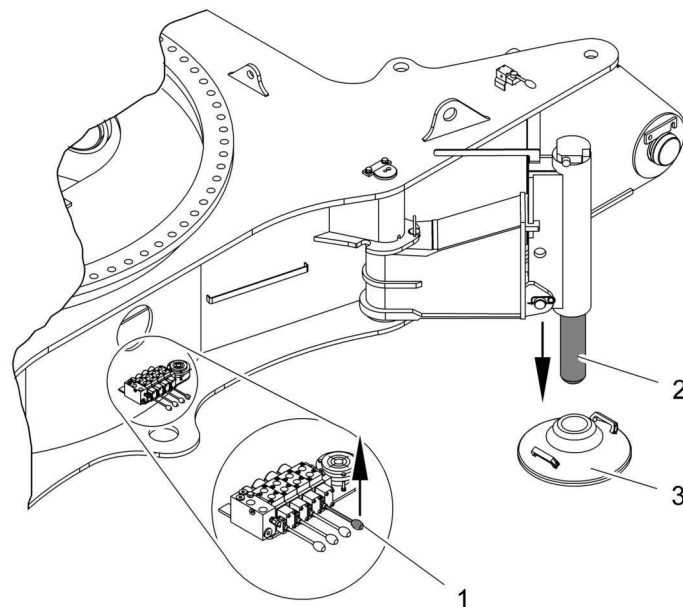


Fig. 2989: Extending the jack

- 1 Control lever
- 2 Jack

- 3 Support pads

- ▶ Extend the jack **2** using the appropriate control lever **1**.
- ▶ Align support pads **3** if necessary.
- ▶ Extend jack **2** until the pin can be turned by hand.

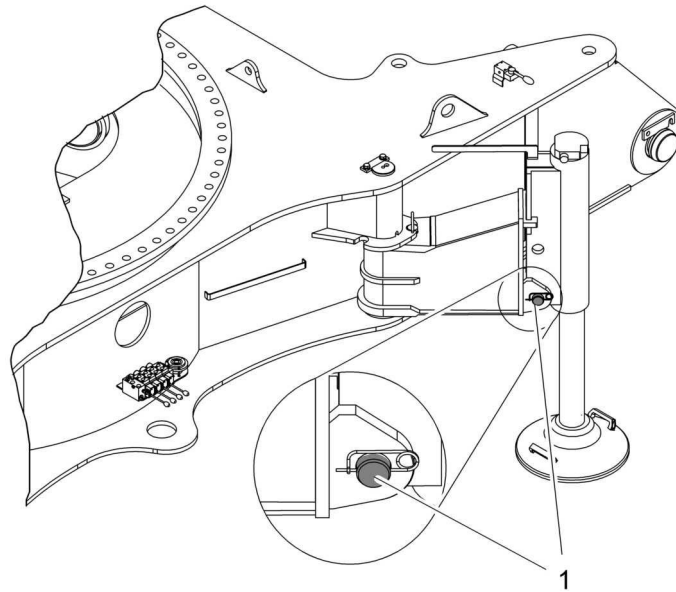


Fig. 2990: Removing pins

1 Pins

- ▶ Remove the pin **1**.



CAUTION

Moving parts!
Risk of crushing limbs.

- ▶ Keep all limbs well clear of moving parts.
- ▶ Visually check that the pin connection points are aligned.

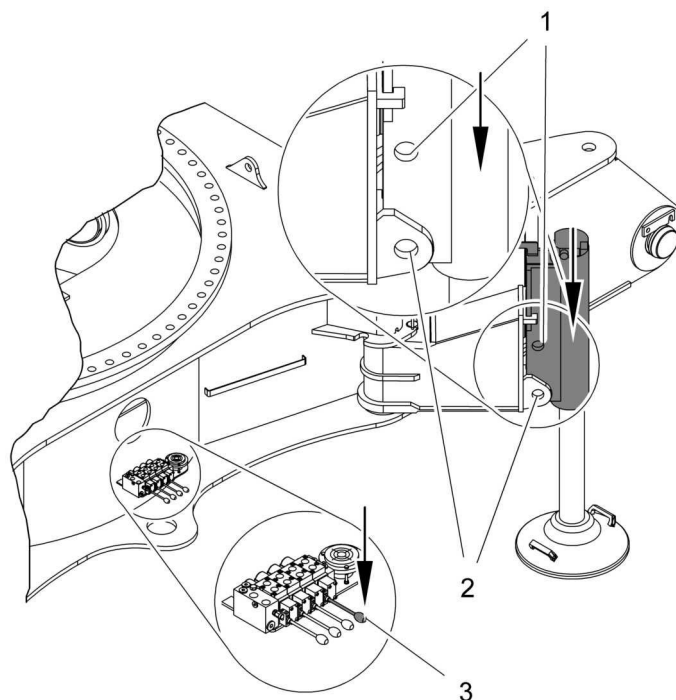


Fig. 2991: Adjusting a pin connection point

- 1 Top pin connection point
- 2 Bottom pin connection point
- 3 Control lever

- ▶ Retract jacks with the corresponding adjustment lever 3.
 - ▷ The top part of the jack moves.

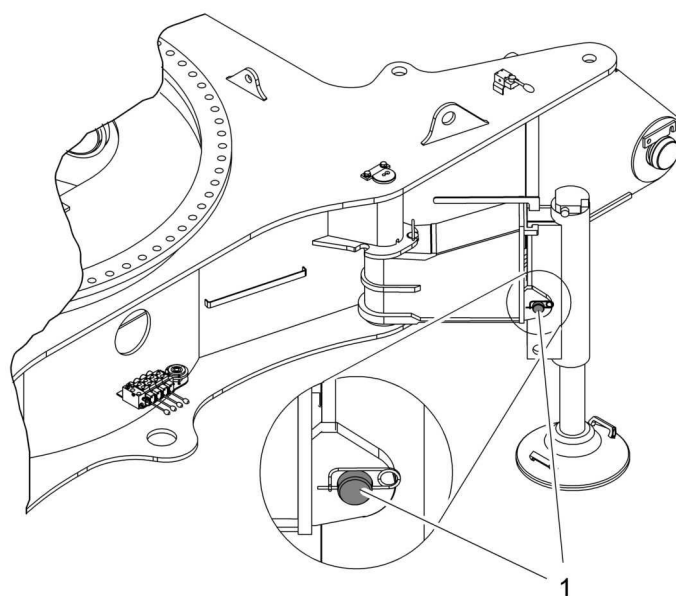


Fig. 2992: Inserting pins

- 1 Pin

When the pin connection point on the swing bracket is aligned with the upper pin connection point of the jack:

- ▶ Insert pin 1.

- ▶ Secure pin 1 with locking spring.
- ▶ Repeat procedure with all jacks.

Extending the jack



DANGER

If the jacks are extended unevenly!
Machine toppling over.

- ▶ Ensure that air bubble in spirit level does not cross outer ring.
- ▶ Make sure that one or more assistants monitor the jack-up process.

The jacks can be operated using the control levers on the undercarriage.

Several levers can be actuated at the same time.

The air bubble in the spirit level must stabilise in the innermost circle with no additional bubbles.

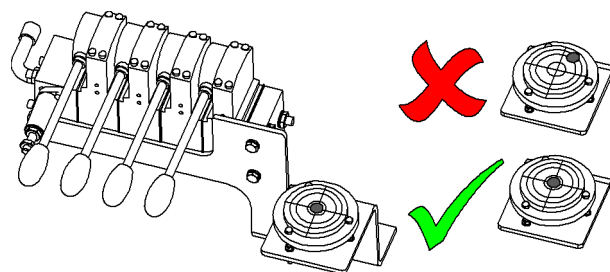


Fig. 2993: Spirit level on undercarriage



Note

Liebherr recommends:

- ▶ Always extend two support cylinders at the same time.
- ▶ Move control lever upwards.
 - ▷ The jacks extend.
 - ▷ The machine starts to rise.
- ▶ Move control lever downwards.
 - ▷ The jacks retract.
 - ▷ The machine lowers itself.
- ▶ Carefully and accurately level the machine.

Driving the transport vehicle out from underneath the machine

Ensure that the following conditions are satisfied:

- There is a clearance of at least 100 mm (3.94" in) between the transport vehicle and the machine.
- The chocks between the transport vehicle and the machine were removed.
- There are no obstacles on the ground (e.g. rocks) that might cause the transport vehicle to deviate from its track.
- The transport vehicle can drive straight out from underneath the machine.
- The steering axles on the transport vehicle are straight.
- All jacks are extended all the way to the ground.

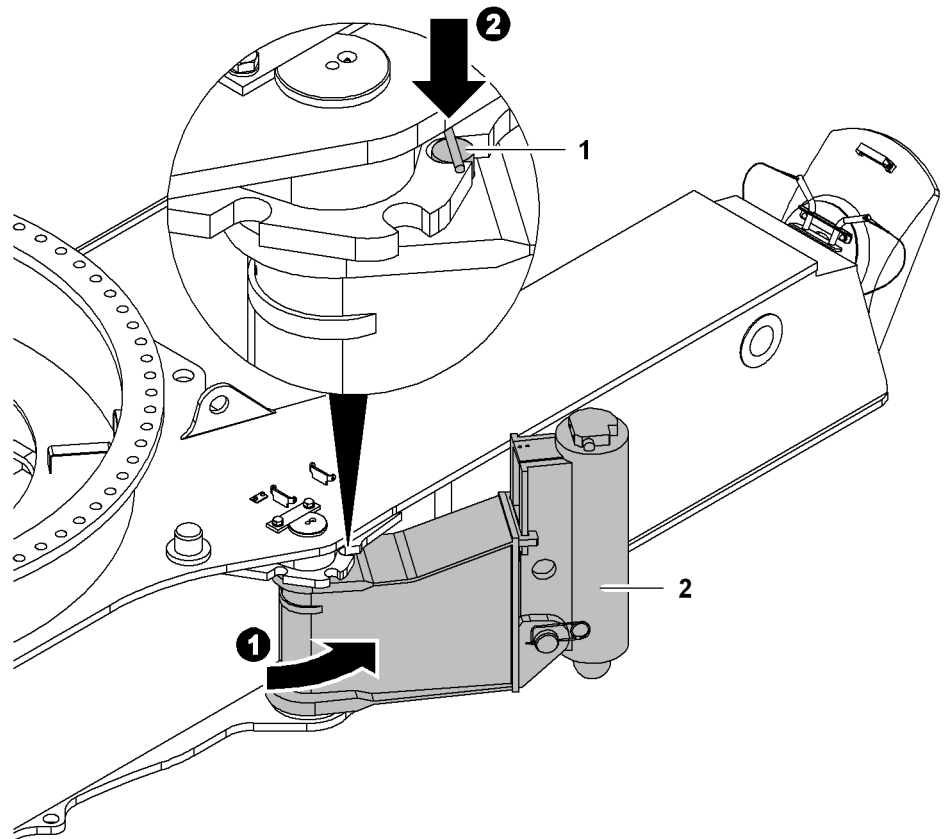


Fig. 2995: Swivel the slewing bracket and pin

1 Pin 2 Slewing bracket

► Swiveling the slewing brackets 2 into support position.



DANGER

Slewing brackets not pinned!
Toppling of machine.

► Pin slewing brackets in support position.

► Insert pin 1.

► Repeat procedure with all slewing brackets 2.

Place support pads and bedding layers underneath



DANGER

Improper application of the support pads and base plates!
Toppling of machine.

► Use support pads attached on undercarriage.

► Place stable materials with sufficient dimensions below the support pads.

► Place the same materials beneath support pads.

► Make sure that bedding layers do not protrude into the transport vehicle's track.

The support height required to unload the machine depends on:

- Height of transport vehicle
- Soil conditions at the erection site

Example:

- Distance ground to transport vehicle loading surface: 1000 mm (3' 3" ft-in)
- Safety distance between undercarriage of basic machine and low loader loading surface: 100 mm (3.94" in)
- Support height of jacks: 970 mm (3' 2" ft-in)
- Soil conditions: Level asphalt ground with sufficient load-bearing capacity

Result: Place support pads with a thickness of 100 mm (3.94" in) underneath.

Adjusting the support height of jacks

If the calculation of the support height requires a change of the jack position, perform the following steps.



DANGER

Different support heights!
Toppling of machine.

- ▶ Pin all jacks to same pin connection points on slewing brackets.
-

- ▶ Plug in the cable remote control on the undercarriage.
-



DANGER

Inadmissible lifting of machine!
Toppling of machine.

- ▶ Extend jacks until pin vents.
 - ▶ Do not lift machine.
-

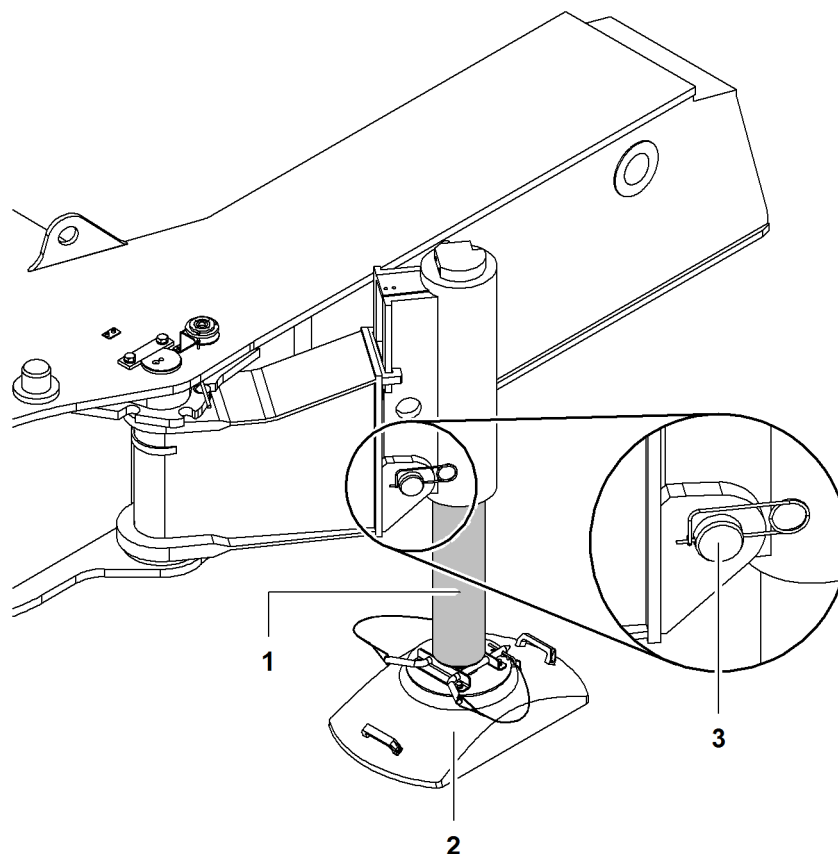


Fig. 2998: Extend jacks and remove pins

- | | | | |
|---|-------------|---|-----|
| 1 | Jack | 3 | Pin |
| 2 | Support pad | | |

The jacks **1** are operated with the toggle switches of the cable remote control (For more information see: [3.24.2 Cable remote control on undercarriage*](#), page 800) .

- ▶ Move the corresponding toggle switch on cable remote control forward.
 - ▷ Jack **1** extends.
- ▶ Align support pads **2** if necessary.
- ▶ Extend jack **1** until the pin **3** can be turned by hand.
- ▶ Remove pin **3**.



CAUTION

Movable parts!
Risk of crushing limbs.

- ▶ Keep all limbs well clear of moving parts.
- ▶ Check alignment of pin connection points visually.

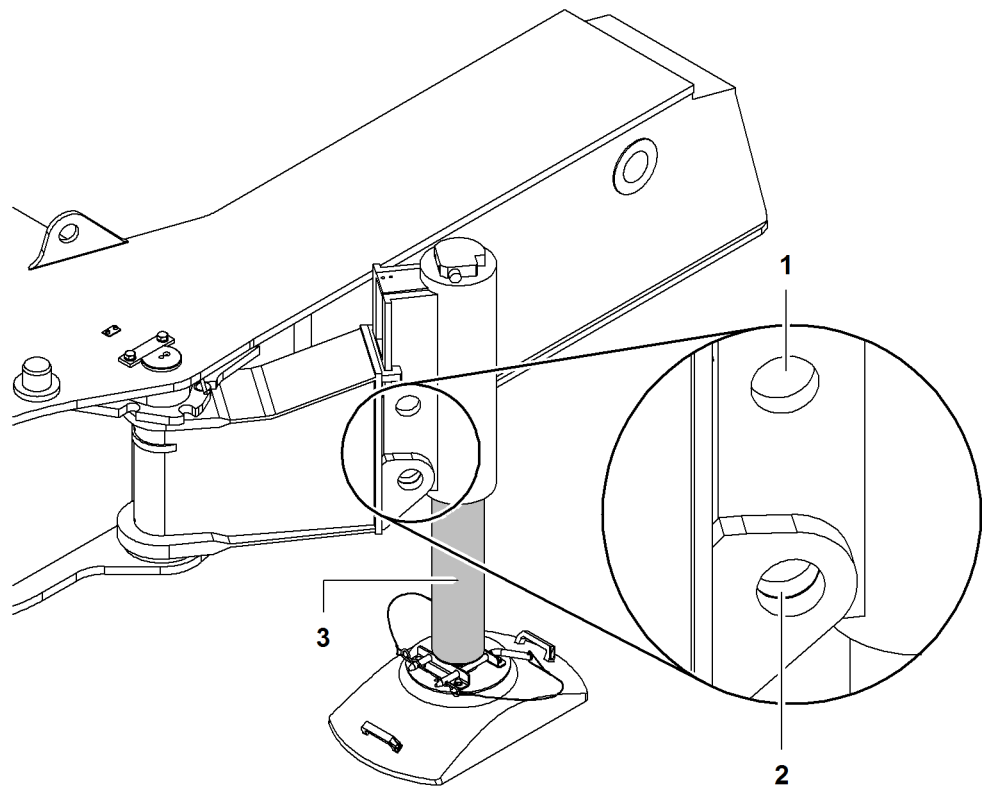


Fig. 2999: Adjusting pin connection point

- 1 Top pin connection point
- 2 Bottom pin connection point
- 3 Jack

- ▶ Move the corresponding toggle switch on cable remote control backward.
 - ▷ Top part of the jack 3 moves.

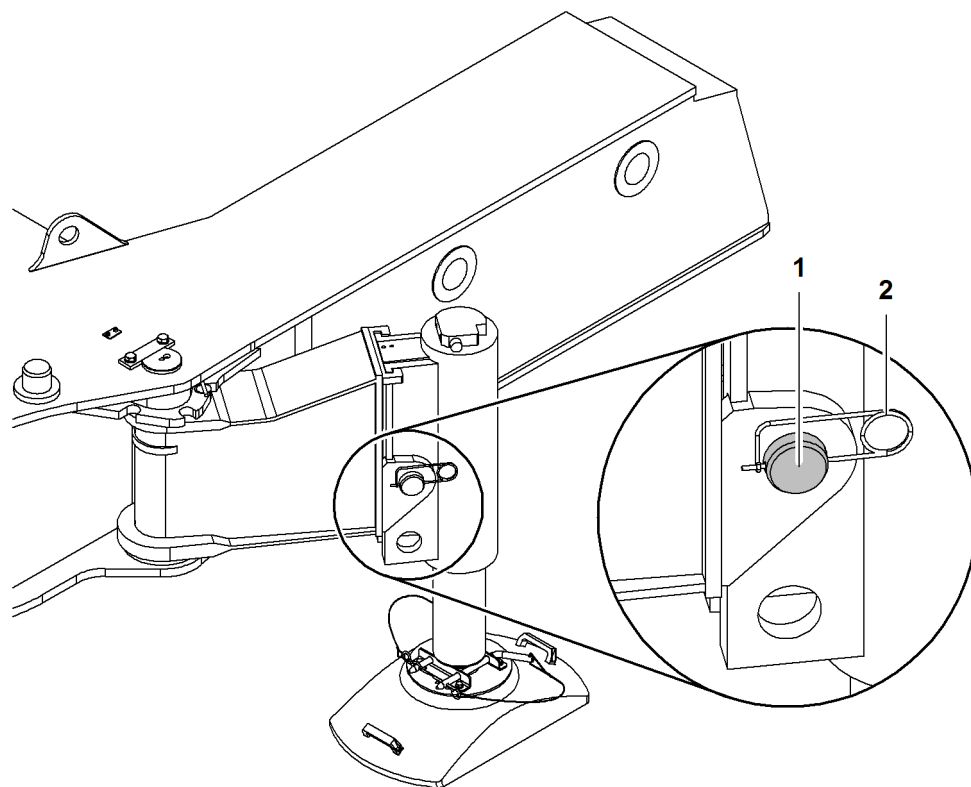


Fig. 3000: Inserting pin

1 Pin

2 Locking spring

When the pin connection point of the slewing bracket aligns with the upper pin connection point of the jack:

- ▶ Insert pin 1.
- ▶ Secure pin 1 with locking spring 2.
- ▶ Repeat procedure with all jacks.

Extend jacks



DANGER

Uneven extending of jacks!
Toppling of machine.

- ▶ Ensure that the air bubble in the spirit level does not move across the outer circle.
- ▶ Ensure that one or more assistants monitor the jack-up procedure.

The jacks are operated with the toggle switches of the cable remote control (For more information see: [3.24.2 Cable remote control on undercarriage*](#), page 800) .

Several toggle switches can be actuated at the same time.

The bubble in the spirit level must be absolutely stationary in the innermost circle without additional bubbles.

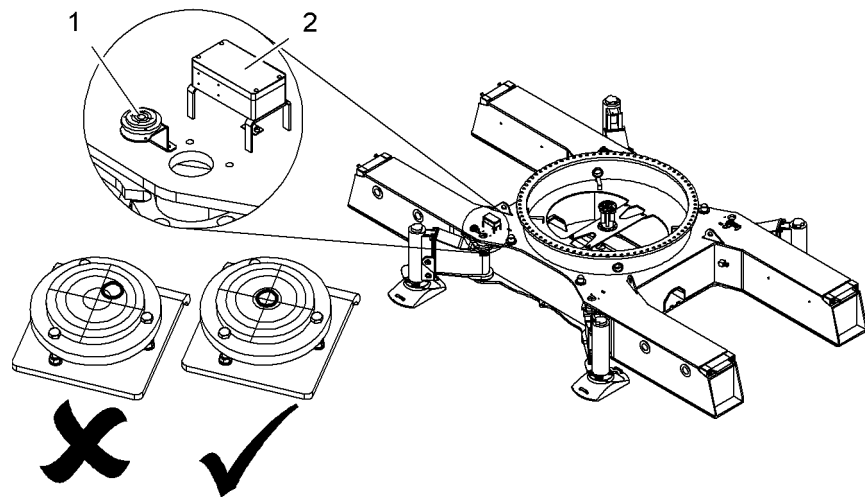


Fig. 3001: Spirit level on undercarriage

1 Spirit level

2 Connection plug of cable remote control



Note

Liebherr recommends:

▶ Always extend two jacks at the same time.

- ▶ Move the corresponding toggle switches on cable remote control forward.
 - ▷ Jacks extend.
 - ▷ Machine lifts.
- ▶ Move the corresponding toggle switches on cable remote control backward.
 - ▷ Jacks retract.
 - ▷ Machine lowers.
- ▶ Level machine carefully and precisely.

Driving the transport vehicle out from underneath the machine

Make sure the following prerequisites are met:

- There is a clearance of at least 100 mm (3.94" in) between the transport vehicle and the machine.
- The chocks between the transport vehicle and the machine were removed.
- There are no obstacles on the ground (e.g. rocks) that might cause the transport vehicle to deviate from its track.
- The transport vehicle can drive straight out from underneath the machine.
- The steering axles on the transport vehicle are straight.
- All jacks are extended all the way to the ground.



DANGER

Collision of transport vehicle with jacks!
Toppling of machine.

- ▶ Make sure that one or more assistants direct the transport vehicle.
- ▶ Drive the transport vehicle out from underneath the machine.

7.4.17 Removing the uppercarriage lock

The uppercarriage is permanently connected to the undercarriage for transportation.

This connection prevents the uppercarriage from turning during transport.

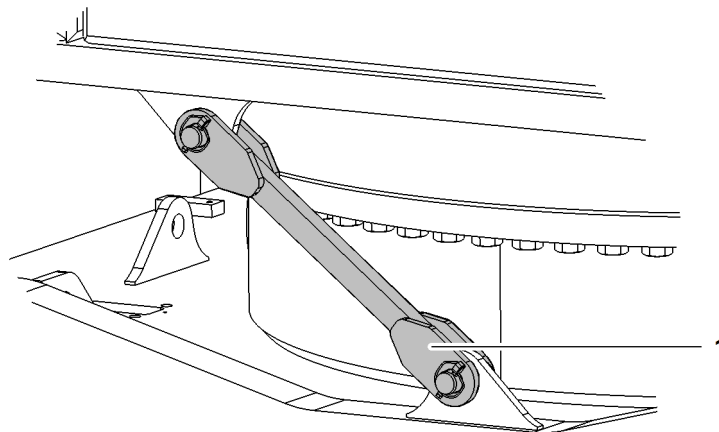


Fig. 3002: Removing the uppercarriage lock

1 Uppercarriage lock

- ▶ Remove linchpin and pin on uppercarriage.
- ▶ Place uppercarriage lock 1 on undercarriage.
- ▶ Reinsert pins and secure with linchpin.

7.4.18 Attaching the crawler side frame

The crawler side frames can be attached in any order.

Ensure that the following conditions are fulfilled:

- Approved sling gear is available ([For more information see: 6.9 Rigging equipment and/or sling gear, page 1141](#)).
- Unloading the crawler side frames from the transport vehicle on the correct side is possible.
- It is possible to approach the machine with the transport vehicle bearing the crawler side frames.
- Jacks are moved so far apart that there is sufficient ground clearance to attach the crawler side frames, and it is possible to unload from the transport vehicle.
- Machine is level.
- Cylinder adjustment functions on.

Attaching crawler side frame for undercarriage with fixed track width

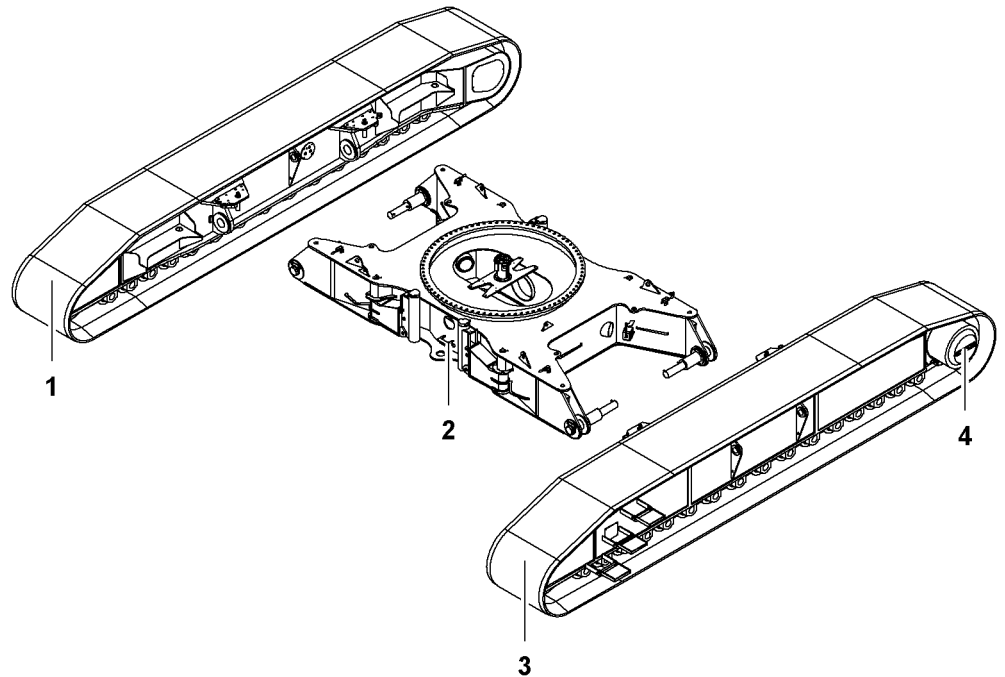


Fig. 3003: Attaching crawler side frame for undercarriage with fixed track width

- | | | | |
|---|--------------------------|---|------------------------------|
| 1 | Right crawler side frame | 3 | Left crawler side frame |
| 2 | Control lever jack | 4 | Crawler drive (tumbler) (2x) |



Note

Liebherr recommends:

- ▶ to position and align the undercarriage and/or the crawler side frames, use the jack *control levers 2*.

Preparing the undercarriage

All pin connection cylinders on the undercarriage must be retracted before the crawler side frames are attached.

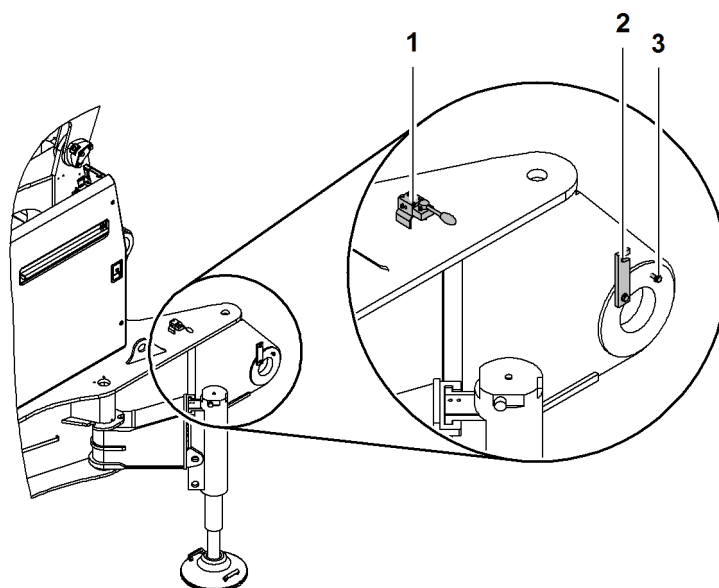


Fig. 3004: Preparing the undercarriage

- | | | | |
|---|--|---|-------|
| 1 | Control lever <i>pin connection cylinder</i> | 3 | Screw |
| 2 | Locking element | | |

- ▶ Loosen the screw **3** on the securing element **2**.
- ▶ Fold up the securing element **2**.
- ▶ Actuate pin connection cylinder *control lever 1*.
 - ▷ Pin connection cylinder retracts.
- ▶ Repeat procedure on all pin connection points.

Rigging and mounting the first crawler side frame

Rigging the transport brackets

When loading and assembling the crawler side frame, the transport brackets prevent sagging of the crawler chains.

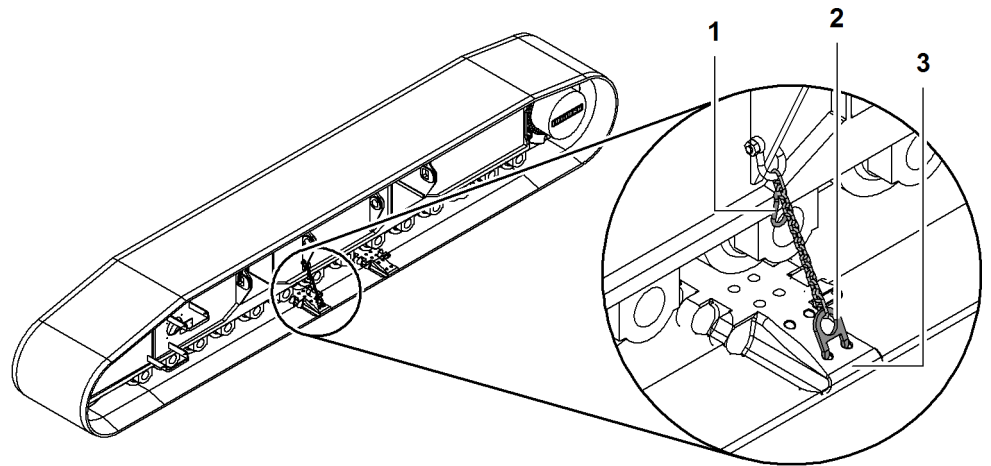


Fig. 3005: Rigging the transport brackets

- | | | | |
|---|-----------|---|------------|
| 1 | Carabiner | 3 | Base plate |
| 2 | Hook | | |

- ▶ Detach hook 2 on carabiner 1.
- ▶ Attach hook 2 at the base plate 3.
- ▶ Repeat procedure on opposite side of crawler side frame.

Rigging the first crawler side frame



DANGER

Maximum radius exceeded!
Machine toppling over.

- ▶ Do not exceed maximum radius.
- ▶ Pay attention to the mechanical boom angle indicator on A-frame 1.

The uppercarriage can be swung by 360° within the maximum radius.

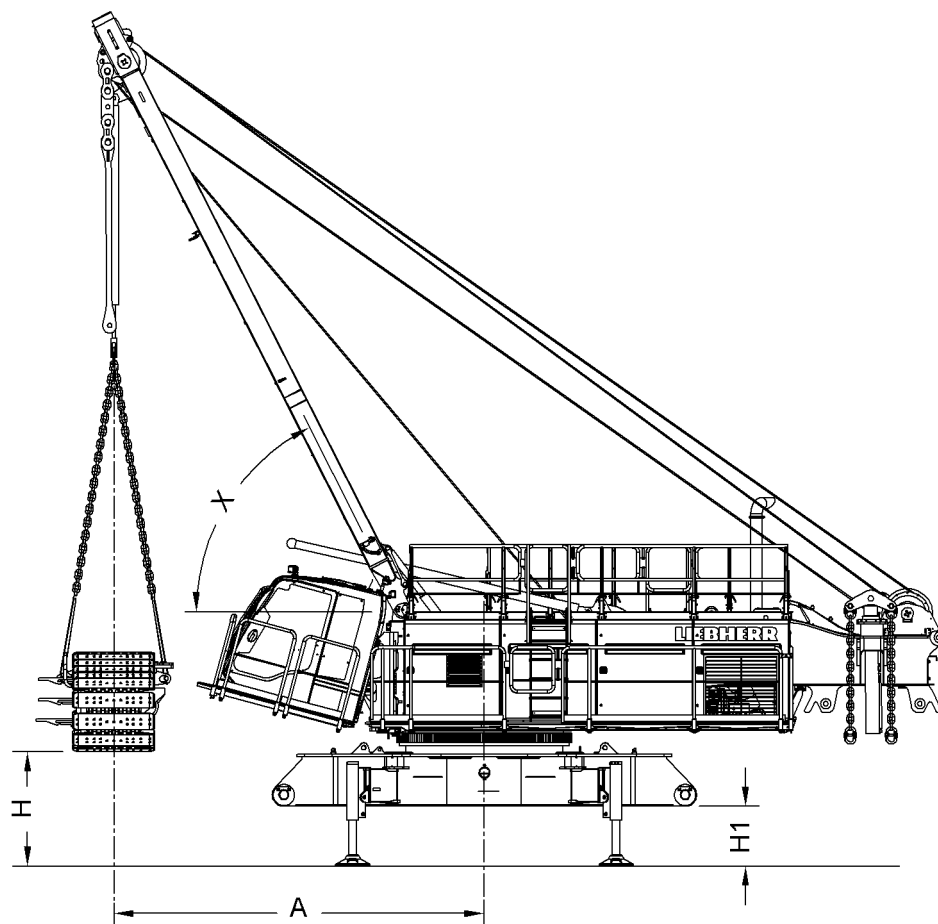


Fig. 3006: Limit values - rigging the first crawler side frame

Name	Value
A	Maximum radius 4500 mm 14' 9" ft-in
H	Maximum lifting height 1196 mm 3' 11" ft-in
H1	Maximum support height 975 mm 3' 2" ft-in
X	Minimum angle for A-frame1 70°

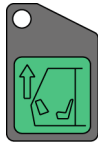
Tab. 493: Limit values - rigging the first crawler side frame

- Move the transport vehicle carrying the crawler side frame as close to the machine as possible.

NOTICE

Horizontal cab!
Damage to cab.

- The cab must be tilted upwards before the crawler side frame is attached.



- ▶ Press the *Tilt cabin up* button on control panel X11.
- ▷ The cab tilts upwards.



CAUTION

Moving folding brackets!
Risk of crushing limbs.

- ▶ Keep all limbs well clear of moving folding brackets.

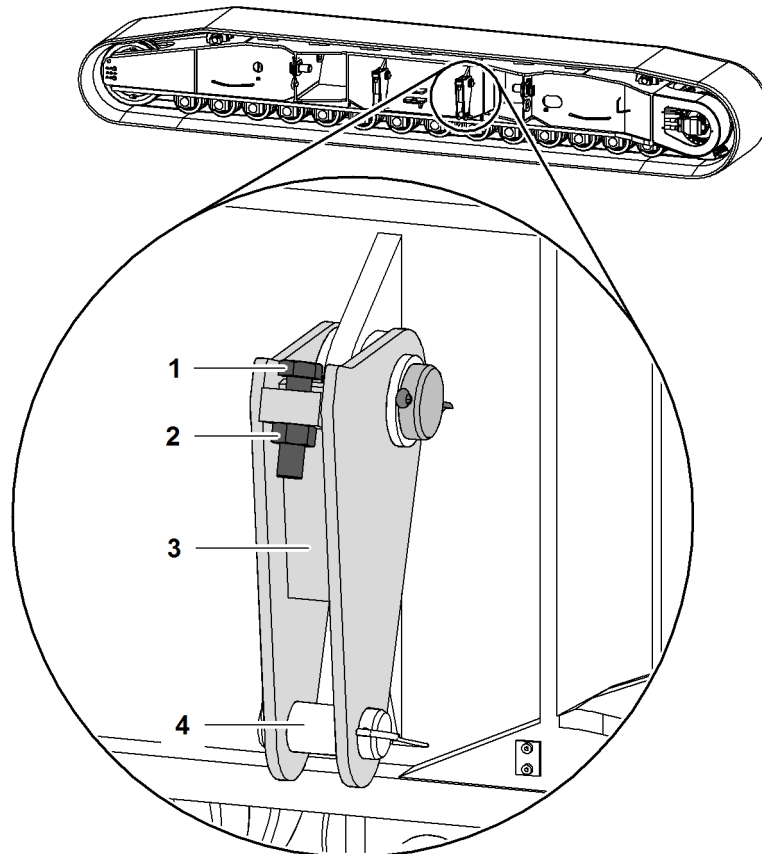


Fig. 3008: Aligning the folding brackets on the crawler side frame (illustration of principle)

- | | | | |
|---|-------|---|-----------------|
| 1 | Screw | 3 | Folding bracket |
| 2 | Nut | 4 | Pin |

Adjust angle of the folding bracket 1 by turning the screw 3.

Once all folding brackets 3 on the crawler side frame are aligned, the crawler side frame hangs level.

- ▶ Undo nut 2.
- ▶ Turn screw 1 to required position.
- ▶ Tighten nut 2.
- ▶ Remove locking spring and pin 4.
- ▶ Manually lift folding bracket 3.

The 4th round sling of the sling gear is not required for assembly.

- ▶ Rig sling gear to folding bracket 3.

- ▶ Insert pin 4.
- ▶ Secure pin 4 with locking spring.
- ▶ Repeat procedure with all folding brackets 3.
- ▶ Slightly lift crawler side frame.
 - ▷ Crawler side frame is level with undercarriage:

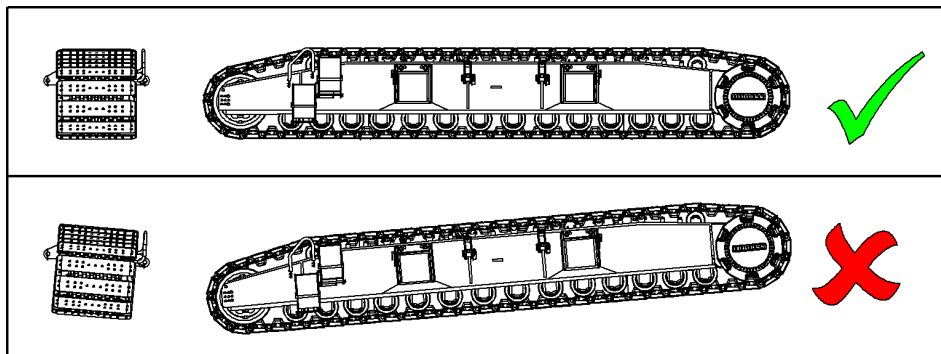


Fig. 3009: Crawler side frame is level with undercarriage (illustration of principle)

If crawler side frame is not level with undercarriage:

- ▶ Set down crawler side frame.
- ▶ Realign folding brackets 3 on crawler side frame.
- ▶ Repeat procedure until crawler side frame is level with undercarriage.

Installing the first crawler side frame

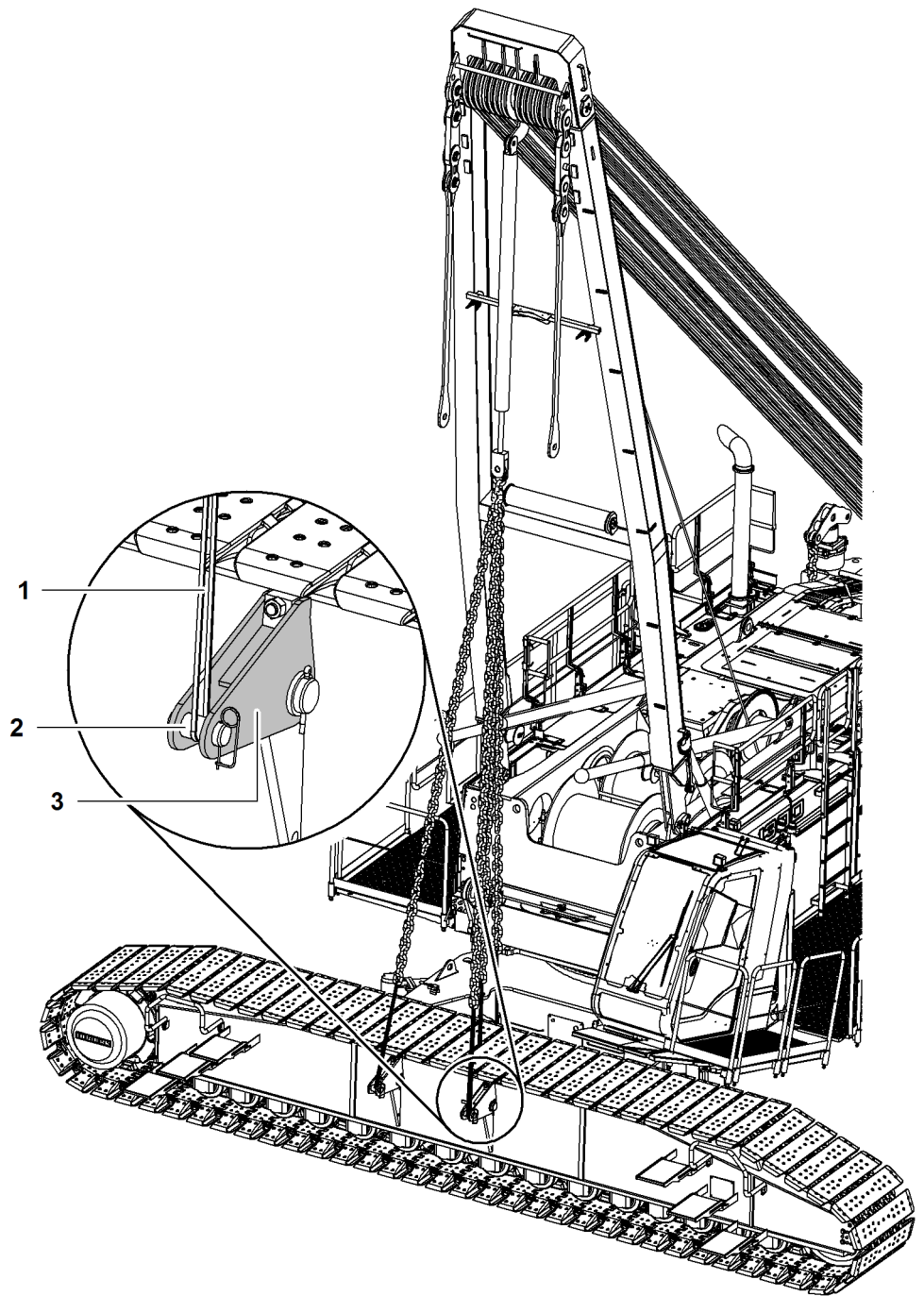


Fig. 3010: Installing the first crawler side frame

- | | | | |
|---|------------|---|-----------------|
| 1 | Sling gear | 3 | Folding bracket |
| 2 | Pin | | |



WARNING

Machine swings with a suspended load!
Crush, fatal injury.

- ▶ Make sure that no-one is standing in the danger area.
- ▶ Leave the danger area.

- ▶ Lifting the crawler side frames from the transport vehicle.
- ▶ Drive the transport vehicle away.

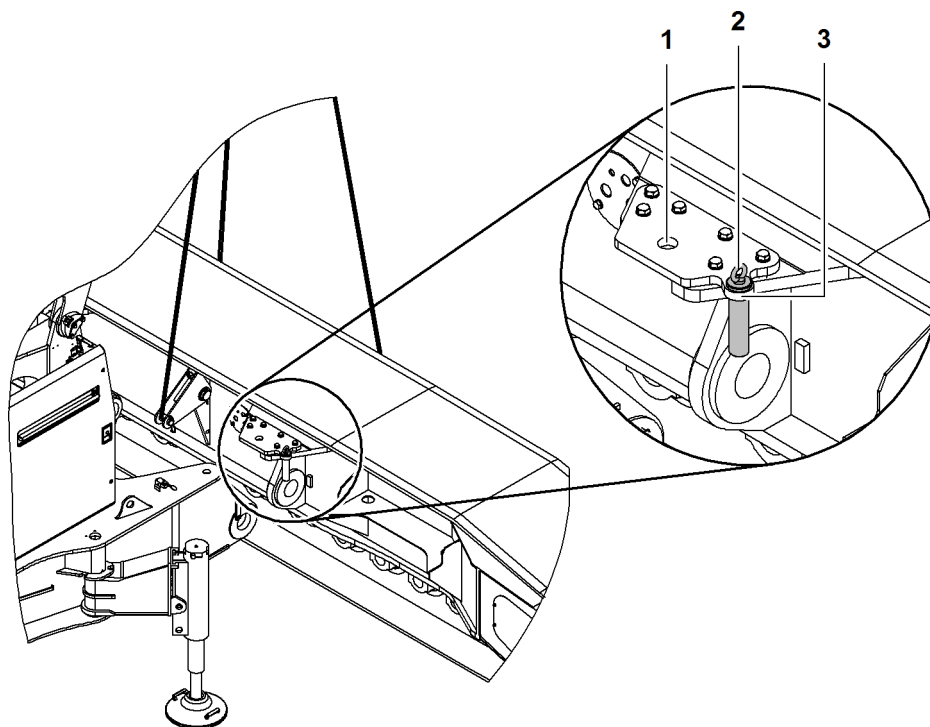


Fig. 3011: Inserting the pin in the lateral mount

- | | | | |
|---|-------------------------|---|---------------|
| 1 | Pin connection position | 3 | Lateral mount |
| 2 | Pin | | |

- ▶ Remove pin 2 from pin connection position 1.
- ▶ Insert pin 2 in lateral mount 3.
- ▶ With the assistance of the signalman, align the crawler side frame exactly with the pin connection points on the undercarriage.

NOTICE

Incorrect mounting of crawler side frames!
Damage to machine.

- ▶ Offer the crawler side frame up slowly, step-by-step and evenly.
-
- ▶ Align the crawler side frames symmetrically so they can be pinned from both sides.

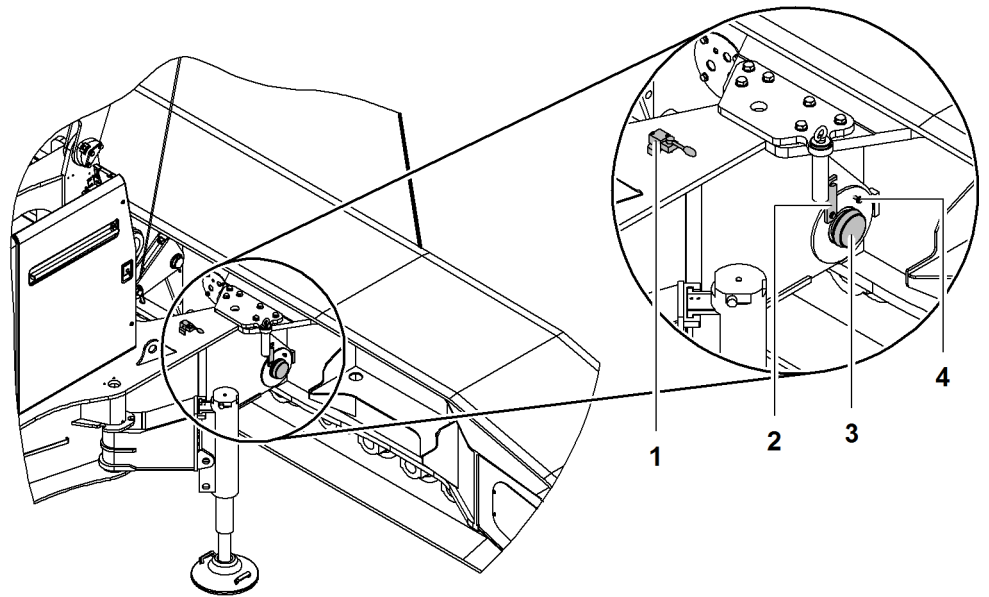


Fig. 3012: Pinning the first crawler side frame

- | | | | |
|---|---------------------------------------|---|-------------------------|
| 1 | Control lever pin connection cylinder | 3 | Pin connection cylinder |
| 2 | Locking element | 4 | Screw |

- ▶ Actuate pin connection cylinder control lever 1.
 - ▷ Pin connection cylinder 3 extends.
- ▶ Fold locking element 2 into pin connection cylinder 3 notch.
- ▶ Secure locking element 2: Tighten the screw 4.

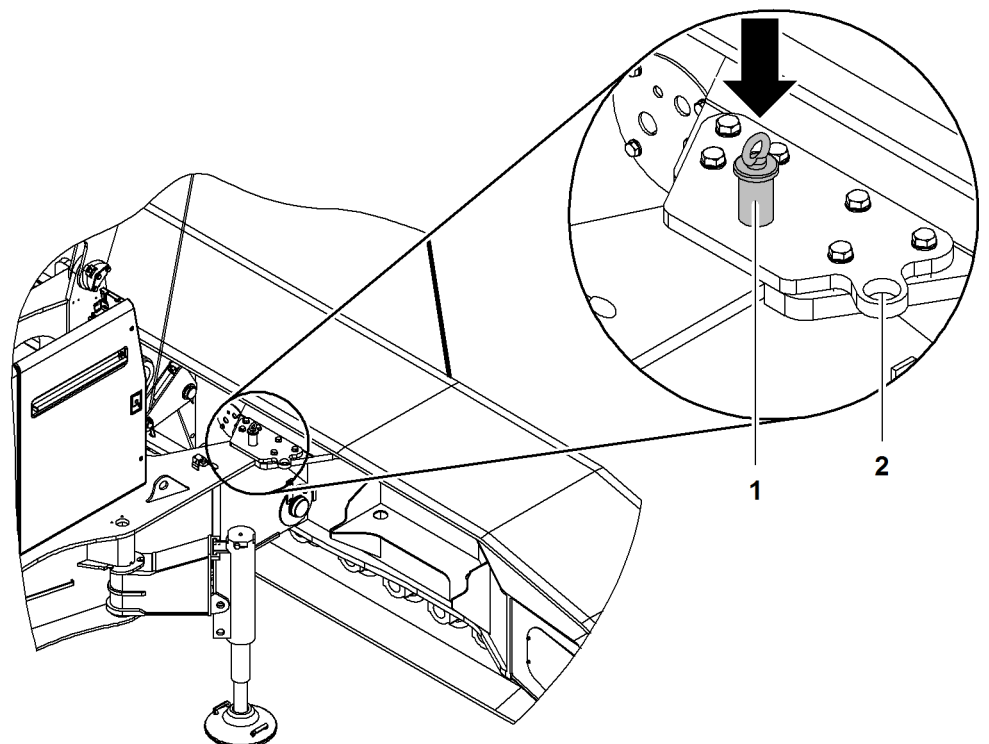


Fig. 3013: Inserting the pin into the pin connection position

- | | | | |
|---|-----|---|---------------|
| 1 | Pin | 2 | Lateral mount |
|---|-----|---|---------------|

- ▶ Remove pin **1** from lateral mount **2**.
- ▶ Insert pin **1** into the pin connection position.
- ▶ Repeat the pin insertion process on the opposite side.
- ▶ Lower assembly cylinder until sling gear slackens off.
- ▶ Detach sling gear.

Removing the transport safety

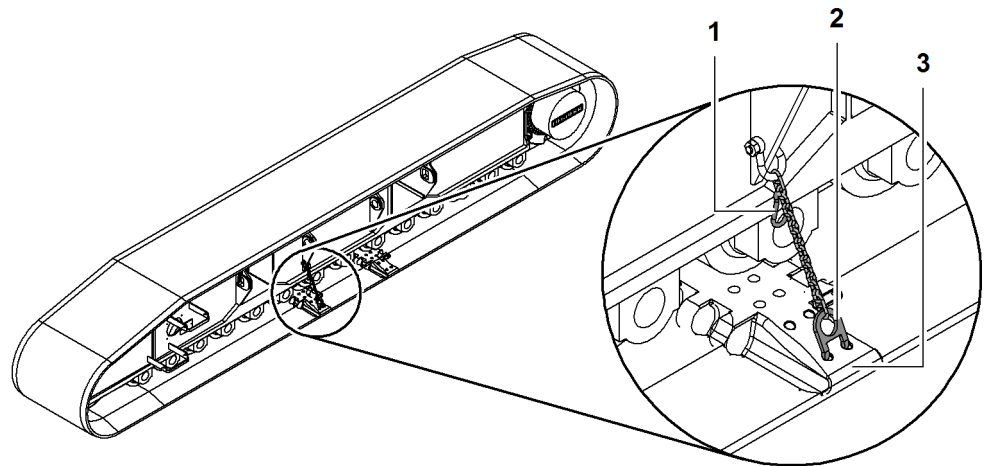


Fig. 3014: Removing the transport brackets

- | | | | |
|----------|-----------|----------|------------|
| 1 | Carabiner | 3 | Base plate |
| 2 | Hook | | |

- ▶ Detach hook **2** at base plate **3**.
- ▶ Attach hook **2** to the carabiner **1**.
- ▶ Repeat procedure on opposite side of crawler side frame.

Rigging and mounting the second crawler side frame



DANGER

Inadmissible swing angle of uppercarriage with attached crawler side frame!
Machine toppling over.

- ▶ When viewed from the mounting position of the second crawler side frame, the uppercarriage may only be swung 90° to the left or right.

- ▶ Rig, adjust and install the second crawler side frame the exact same way as the first.



DANGER

Incorrect lowering of machine!
Machine toppling over.

- ▶ Carefully lower the machine, keeping it level at all times.

- ▶ Lower the machine.
- ▶ Retract jacks.

Fitting the second crawler side frame where space is limited

If it is necessary to swing 180° from the mounting position in order to attach the second crawler side frame, then carry out the following process steps.

Ensure that the following conditions are fulfilled:

- ❑ Two support plates with a height of at least 1000 mm (3' 3" ft-in) x 1000 mm (3' 3" ft-in) and 150 mm (5.91" in) are available.

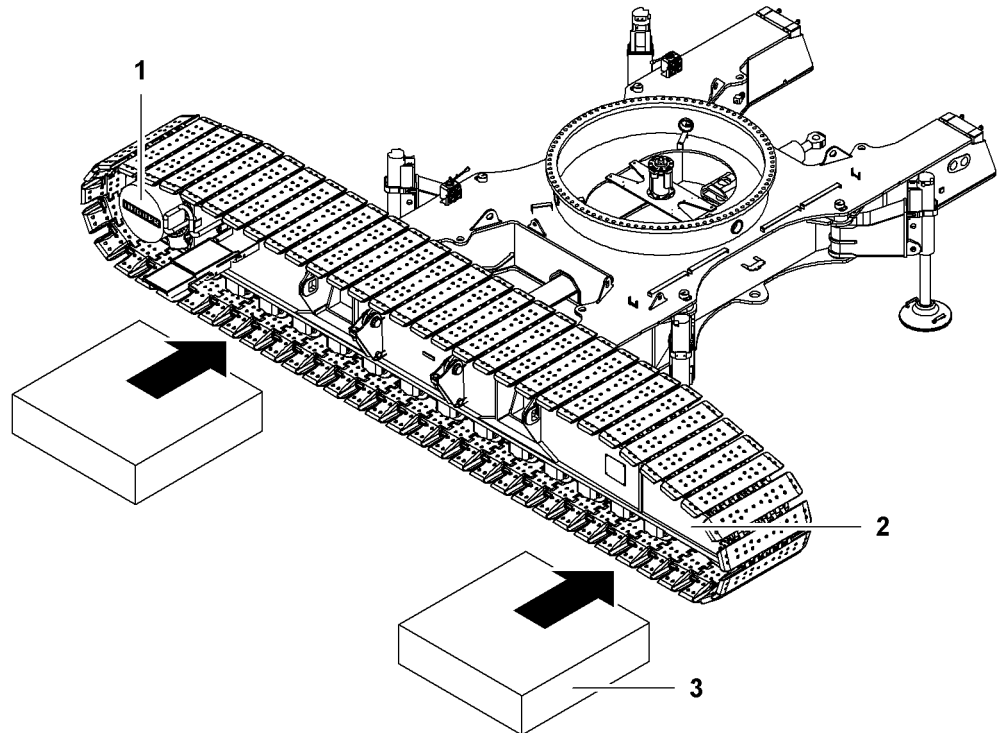


Fig. 3015: Mounting the second crawler side frame where space is limited (illustration of principle)

- 1 Crawler drive (tumbler)
- 2 Idler wheel
- 3 Support plate (2x)

- ▶ Place support plate 3 beneath crawler drive (tumbler) 1.
- ▶ Place support plate 3 beneath idler wheel 2.
- ▶ Lower crawler side frame onto support plates 3.

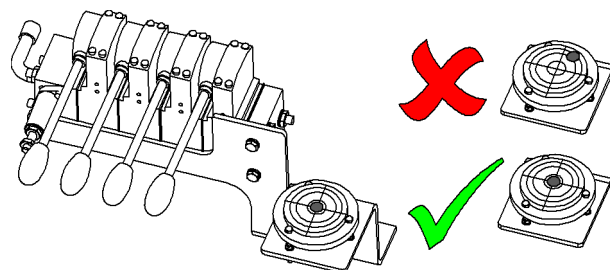


Fig. 3016: Jack control lever and spirit level on undercarriage

- ▶ Level the undercarriage.

It is not necessary to take account of a critical angle for the radius of A-frame1.

Uppercarriage can be swung as required.

- ▶ Rig, adjust and install the second crawler side frame the exact same way as the first.
- ▶ Raise the machine slightly.
- ▶ Remove base plates.



DANGER

Incorrect lowering of machine!
Machine toppling over.

- ▶ Carefully lower the machine, keeping it level at all times.

- ▶ Lower the machine.
- ▶ Retract jacks.

Connecting the hydraulic lines on the crawlers

Ensure that the following conditions are fulfilled:

- Hand lever for multi-coupling is available.
- Diesel engine is switched off.

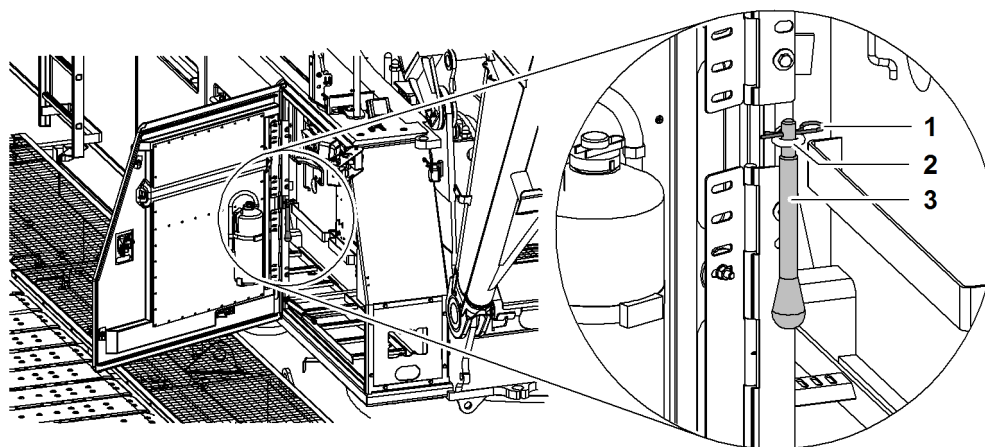


Fig. 3017: Transport bracket for hand lever of multi-coupling

- | | | | |
|---|----------------|---|------------|
| 1 | Locking spring | 3 | Hand lever |
| 2 | Ring | | |

- ▶ Lift hand lever **3** and remove locking spring **1**.
- ▶ Remove hand lever **3** downwards from ring **2**.

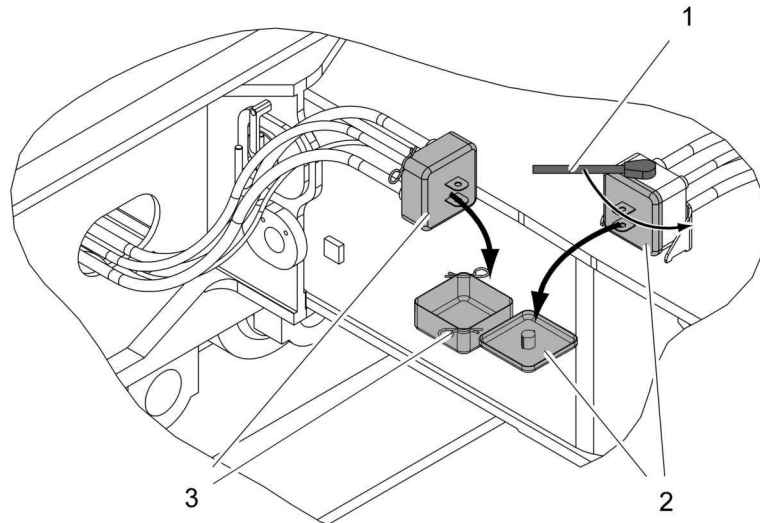


Fig. 3018: Removing the cover of the multi-couplings

- | | | | |
|---|------------|---|-------|
| 1 | Hand lever | 3 | Cover |
| 2 | Cover | | |

- ▶ Fit the hand lever 1 on the multi-coupling.
- ▶ Turn hand lever 1 in the direction indicated by the arrow.
 - ▷ Cover 2 is loose.
- ▶ Take off the cover 2 and stow it away.
- ▶ Remove locking springs on cover 3.
- ▶ Take off the cover 3 and stow it away.

NOTICE

Dirty multi-couplings!
Damage to the hydraulic system.

- ▶ Clean the multi-couplings before fitting them together.

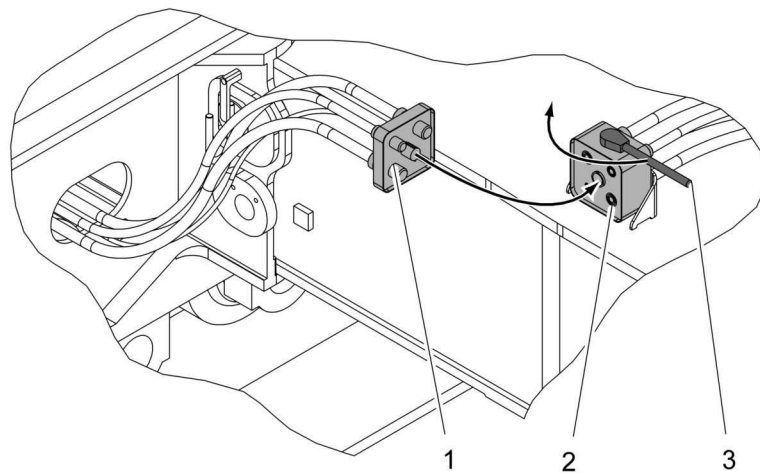


Fig. 3019: Connecting the multi-couplings

- | | | | |
|---|-------------------------------------|---|------------|
| 1 | Multi-coupling (undercarriage) | 3 | Hand lever |
| 2 | Multi-coupling (crawler side frame) | | |

- ▶ Connect the multi-couplings **1 + 2**.
- ▶ Move hand lever in direction of the arrow until latch engages.
 - ▷ Multi-couplings are visibly and audibly pulled together.
 - ▷ The multi-coupling indicating pins stick out:

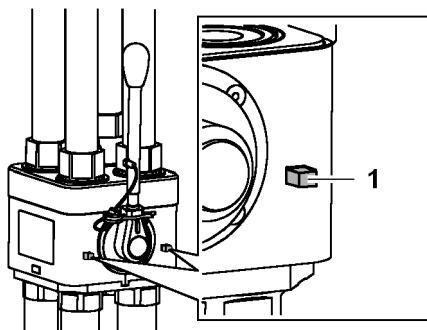


Fig. 3020: Locked multi-coupling

- 1** Indicating pin (2x)
- ▶ Disassemble the hand lever of the multi-coupling and remove.
- ▶ Repeat the procedure for the second crawler side frame.

Unfolding steps from transport position

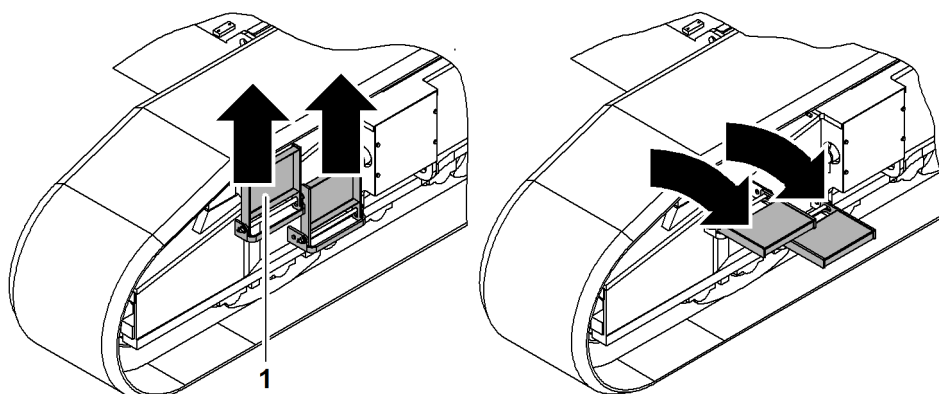


Fig. 3021: Unfolding steps from transport position

- 1** Steps (2x)
- ▶ Lift steps **1** completely.
- ▶ Fold down steps **1**.

Placing jack in transport position

In order to attach carbody counterweight to machine, jacks have to be pinned in transport position.

Make sure the following prerequisites are met:

- Installation of both crawler side frames is completed.

Adjusting the support height of jacks

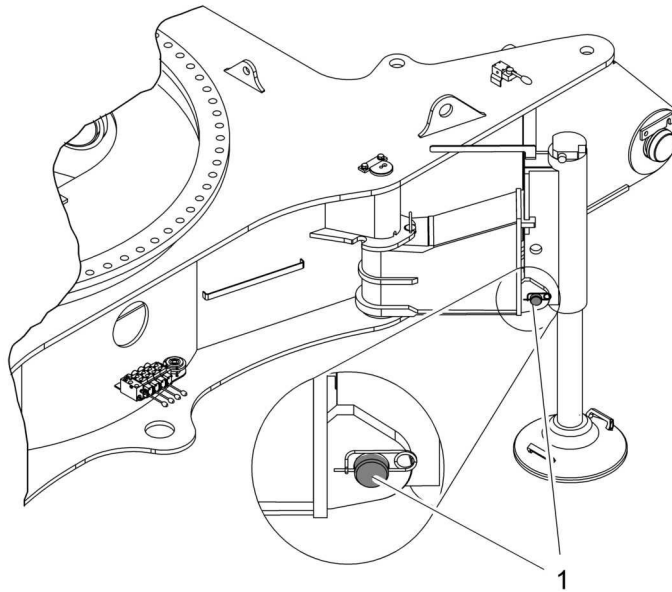


Fig. 3022: Jack in bottom pin connection position

1 Bottom pin connection position



CAUTION

Movable parts!
Risk of crushing limbs.

- ▶ Keep all limbs well clear of moving parts.
- ▶ Pin jack in bottom pin connection position **1**.
- ▶ Repeat procedure with all jacks.

Placing the slewing brackets in transport position

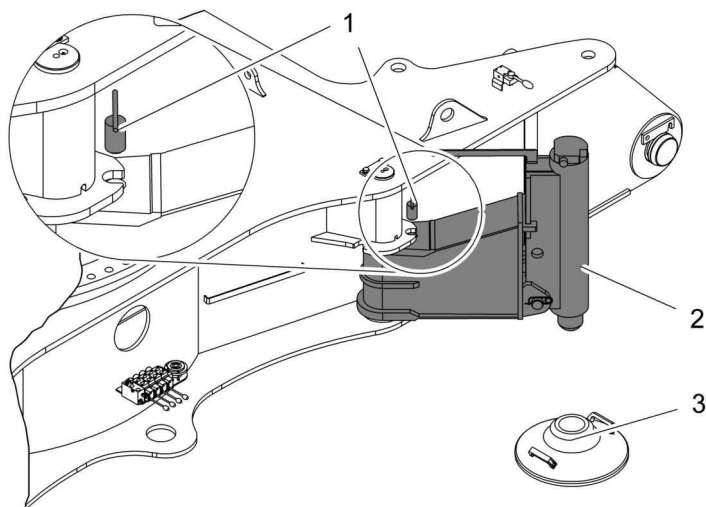


Fig. 3023: Slewing bracket in support position

- 1 Pin
- 2 Slewing bracket
- 3 Support pads

- ▶ Remove pin 1.
- ▶ Slewing the slewing brackets 2 into transport position.

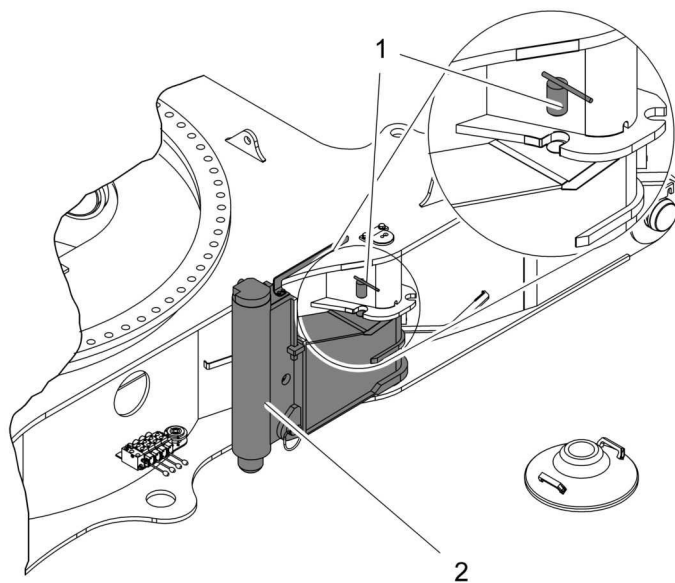


Fig. 3024: Slewing brackets in transport position

- 1 Pin
- 2 Slewing bracket

- ▶ Insert pin 1.
- ▶ Repeat procedure with all slewing brackets 2.

Removing support pads and bedding layers

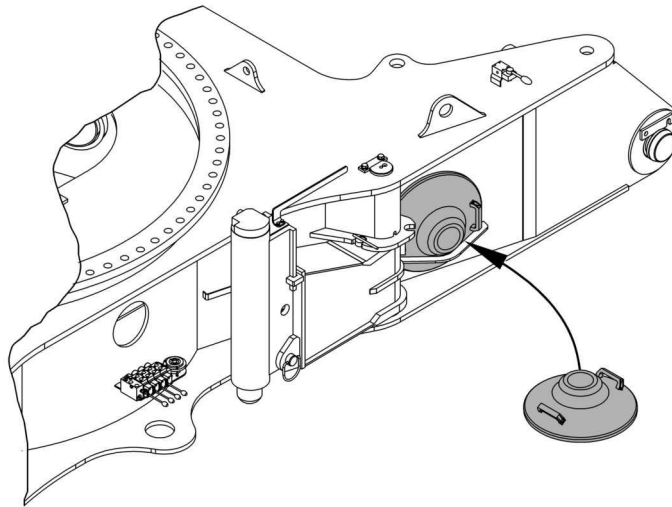


Fig. 3025: Removing support pads

► Insert support pads into brackets.

Attaching crawler side frame for undercarriage* with adjustable track width

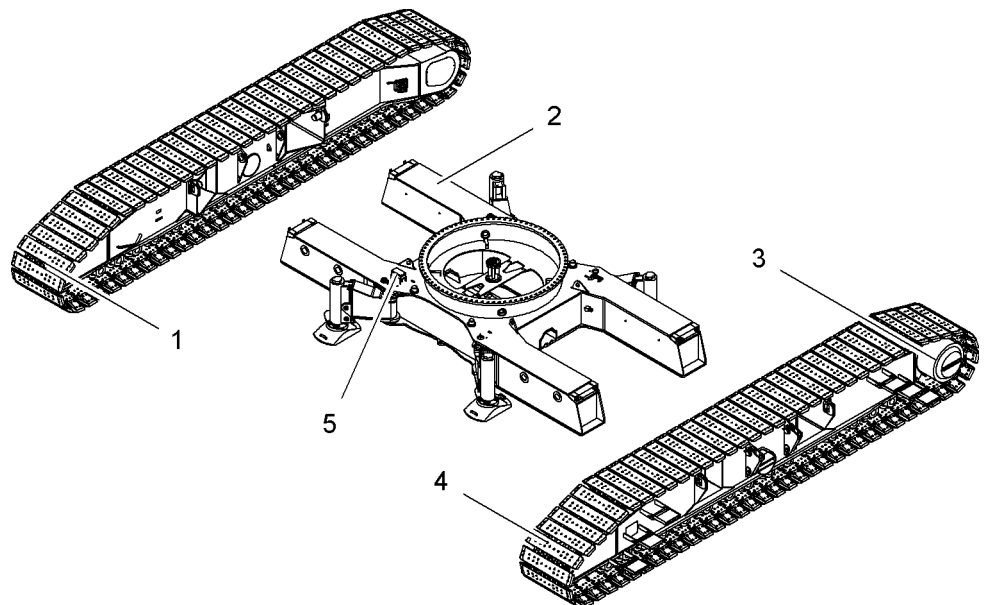


Fig. 3026: Attaching crawler side frame for undercarriage* with adjustable track width

- | | |
|---|---|
| <p>1 Right crawler side frame</p> <p>2 Undercarriage</p> <p>3 Crawler drive (tumbler) (2x)</p> | <p>4 Left crawler side frame</p> <p>5 Connection plug of cable remote control</p> |
|---|---|



Note

Liebherr recommends:

- ▶ For orientation and alignment of the undercarriage and/or crawler side frames, use the connection plug 5 of the cable remote control.

Loosening strut mountings

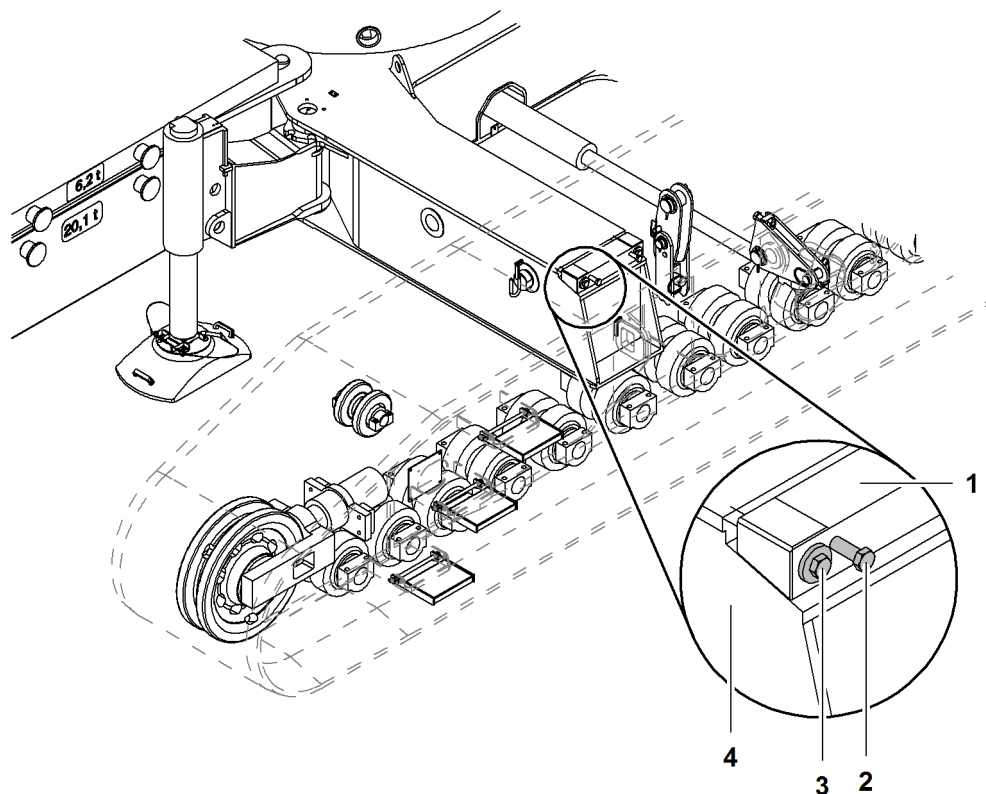


Fig. 3027: Loosening strut mountings

- | | | | |
|---|------------|---|--------------------|
| 1 | Wedge | 3 | Locking screw (2x) |
| 2 | Screw (2x) | 4 | Strut |

The two outer locking screws 3 must be turned almost completely out of the struts 4 so that the wedge 1 is located as close as possible to the end of the strut.

- ▶ Loosen screws 2 of the strut mounting.
- ▶ Loosen locking screws 3 of strut mounting and twist out almost all the way.
- ▶ Turn in screws 2 of strut mounting.
 - ▷ Wedge 1 loosens.
- ▶ Clean strut 4 and evenly grease the slide faces.
- ▶ Repeat procedure on all strut mountings.

Preparing the crawler side frame

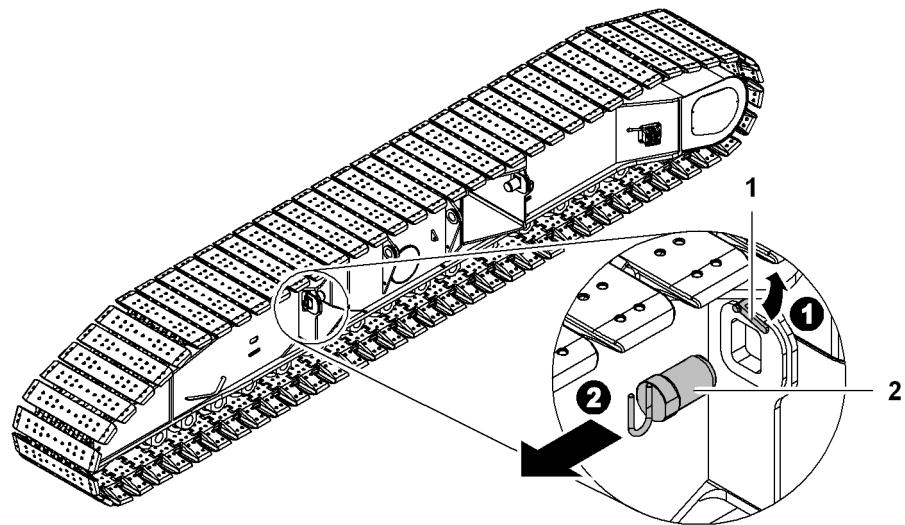


Fig. 3028: Preparing the crawler side frame

1 Safety lever

2 Pin

- ▶ Undo safety lever 1 screw.
- ▶ Fold up the safety lever 1.
- ▶ Remove pin 2.
- ▶ Repeat procedure on all crawler side frame pin connection points.

Rigging and mounting the first crawler side frame

Suspending the transport brackets

When loading and assembling the crawler side frame, the transport brackets prevent sagging of the crawler chains.

NOTICE

Improper installation of transport brackets!
 Damage to hydraulic system.
 Hydraulic oil leak.

- ▶ Ensure that the chains of the transport brackets do not damage any hydraulic oil pipes.

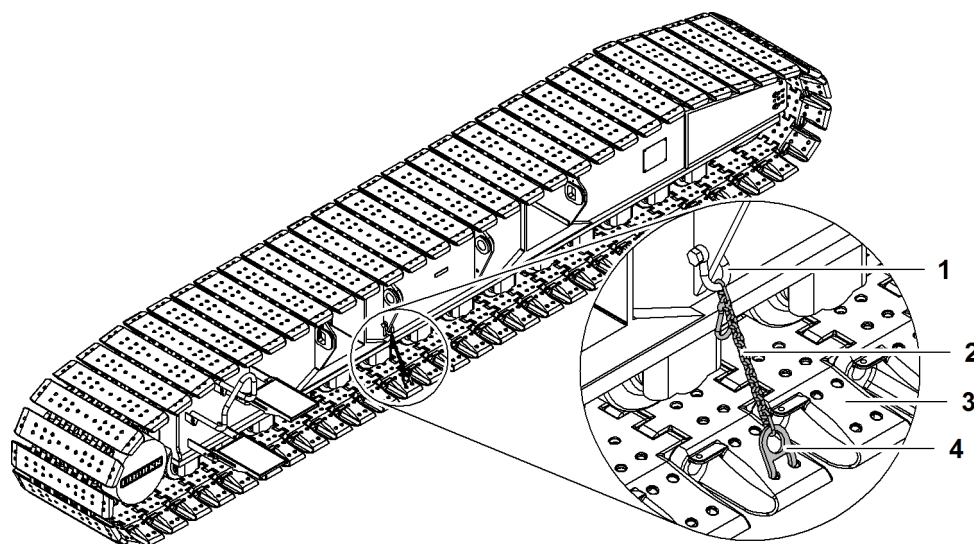


Fig. 3029: Suspending the transport brackets

- | | | | |
|---|---------|---|------------|
| 1 | Shackle | 3 | Base plate |
| 2 | Chain | 4 | Hook |

- ▶ Attach hook 4 at the base plate 3.
- ▶ Attach shackle 1 with chain 2 on a suitable spot on the crawler side frame.
- ▶ Repeat procedure on opposite side of crawler side frame.

Rigging the first crawler side frame



DANGER

Maximum radius exceeded!
Toppling of machine.

- ▶ Do not exceed maximum radius.
- ▶ Pay attention to the mechanical boom angle indicator on A-frame1.

The uppercarriage can be swung by 360° within the maximum radius.

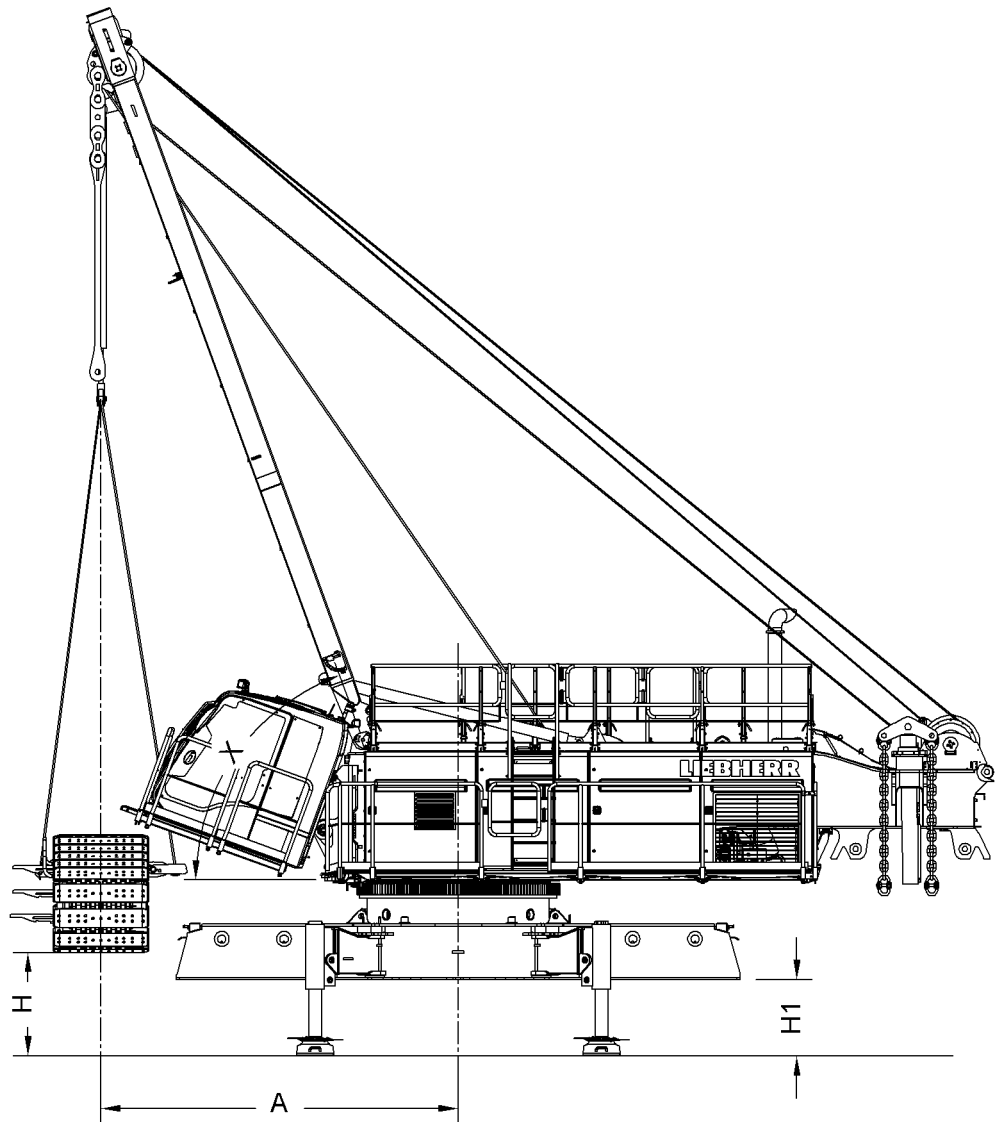


Fig. 3030: Limit values - unloading and mounting the first crawler side frame

Name	Value
A Maximum radius	4500 mm 14' 9" ft-in
H Maximum lifting height	1324 mm 4' 4" ft-in
H1 Maximum support height	970 mm 3' 2" ft-in
X Minimum angle A-frame1	70°

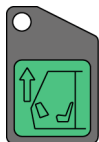
Tab. 494: Limit values - unloading and mounting the first crawler side frame

- Move the transport vehicle carrying the crawler side frame as close to the machine as possible.

NOTICE

Horizontal cabin!
Damage to cabin.

- ▶ Cabin must be tilted upward before crawler side frame is attached.



- ▶ Press the *Cabin tilt up* button on control panel X11.
 - ▷ Cabin tilts upward.



CAUTION

Moving folding brackets!
Risk of crushing limbs.

- ▶ Keep all limbs well clear of moving folding brackets.

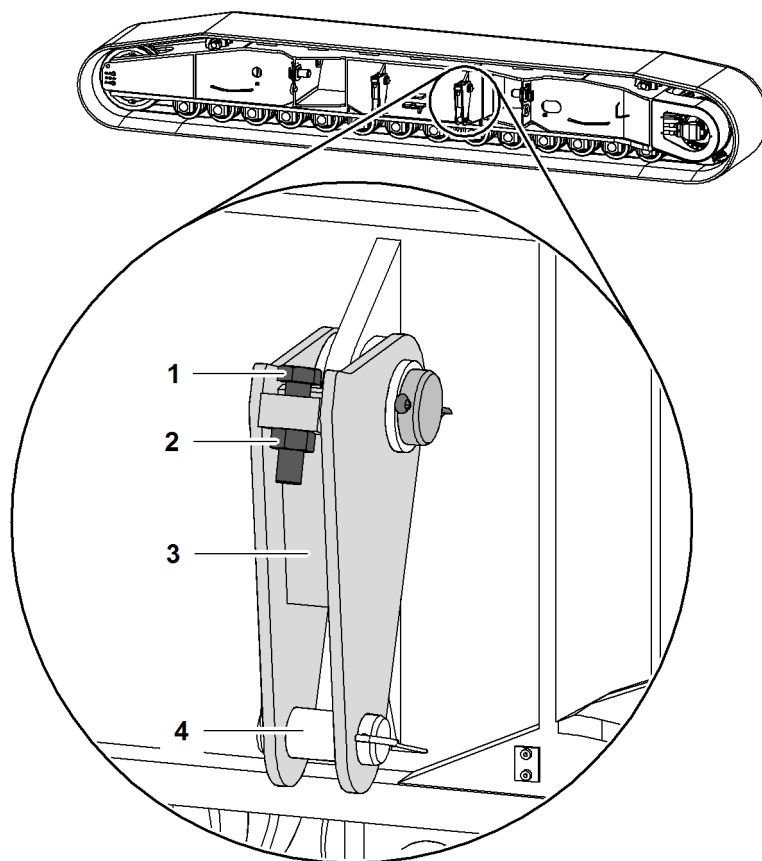


Fig. 3032: Aligning the folding brackets on the crawler side frame

- | | | | |
|---|-------|---|-----------------|
| 1 | Screw | 3 | Folding bracket |
| 2 | Nut | 4 | Pin |

Adjust angle of the folding bracket **1** by turning the screw **3**.

Once all folding brackets **3** on the crawler side frame are aligned, the crawler side frame hangs level.

- ▶ Undo nut **2**.
- ▶ Turn screw **1** to required position.
- ▶ Tighten nut **2**.

- ▶ Remove locking spring and pin **4**.
- ▶ Manually lift folding bracket **3**.
- ▶ Rig sling gear to folding bracket **3**.
- ▶ Insert pin **4**.
- ▶ Secure pin **4** with locking spring.
- ▶ Repeat procedure with all folding brackets **3**.
- ▶ Slightly lift crawler side frame.
 - ▷ Crawler side frame is level with undercarriage:

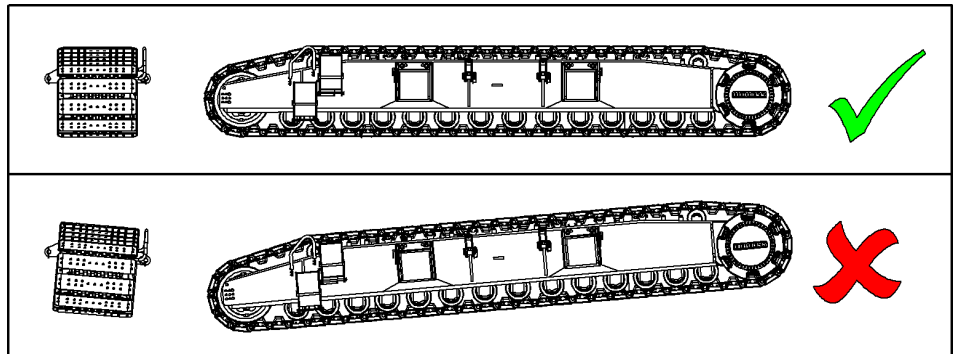


Fig. 3033: Crawler side frame is level with undercarriage

If crawler side frame is not level with undercarriage:

- ▶ Set down crawler side frame.
- ▶ Realign folding brackets **3** on crawler side frame.
- ▶ Repeat procedure until crawler side frame is level with undercarriage.

Installing the first crawler side frame

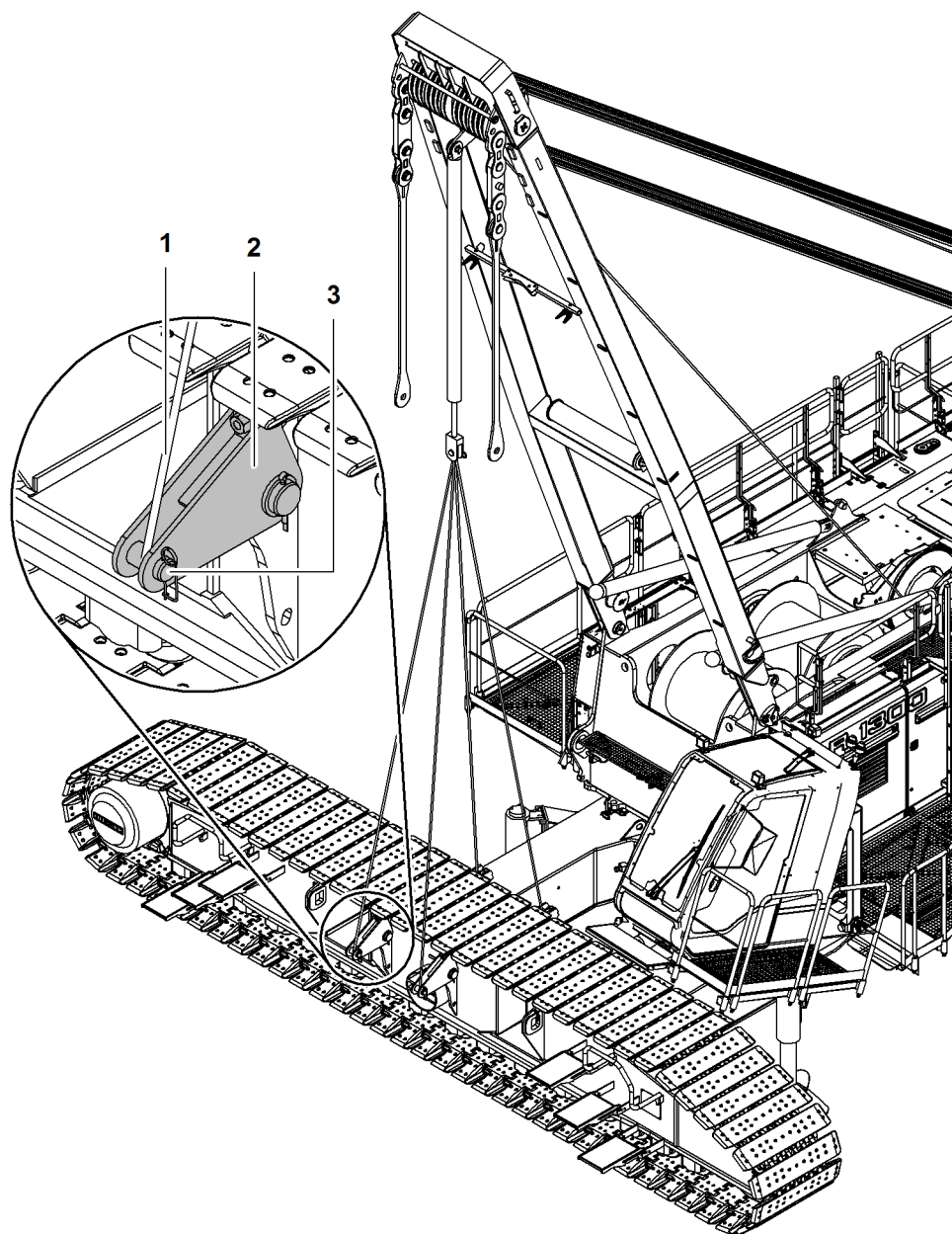


Fig. 3034: Installing the first crawler side frame

- | | | | |
|---|-----------------|---|-----|
| 1 | Sling gear | 3 | Pin |
| 2 | Folding bracket | | |



WARNING

Machine swings with a suspended load!
Death, crushing of body parts.

- ▶ Ensure that nobody is located in the danger zone.
 - ▶ Leave danger zone.
-
- ▶ Lifting the crawler side frames from the transport vehicle.
 - ▶ Remove transport vehicle.

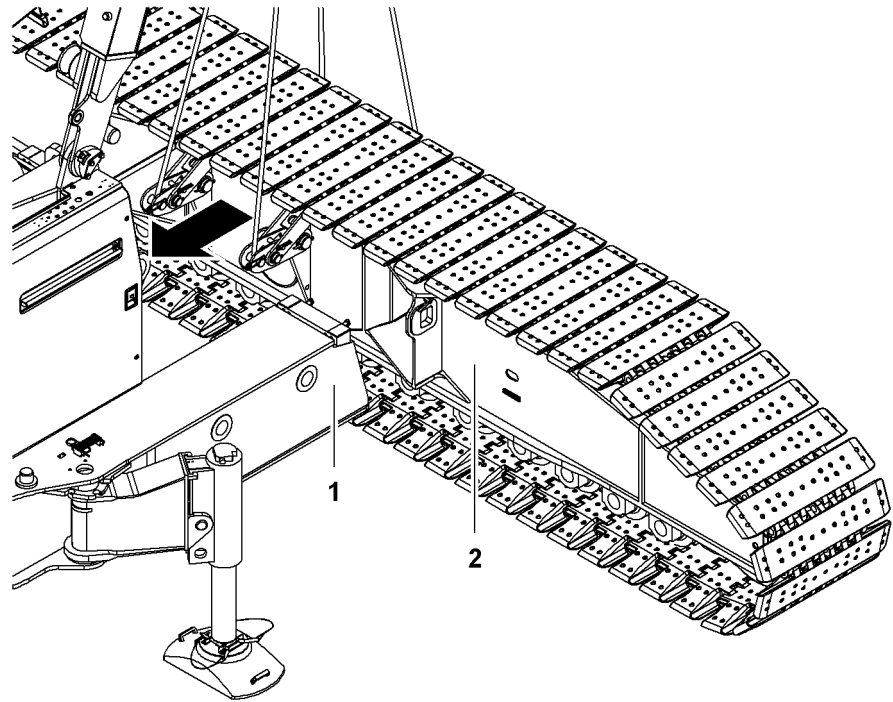


Fig. 3035: Mount first crawler side frame on struts

1 Strut (2x)

2 Crawler side frame

- ▶ Guide crawler side frame 2 to the struts 1 by lifting the main boom base section and lowering the assembly cylinder.
- ▶ With the assistance of the signalman, align the crawler side frame 2 exactly on the struts 1 of the undercarriage.

NOTICE

Incorrect mounting of crawler side frames 2!
Damage to machine.

- ▶ Mount crawler side frame 2 slowly, step by step and evenly.
-
- ▶ Align crawler side frame 2 symmetrically so it can be pinned from both sides.

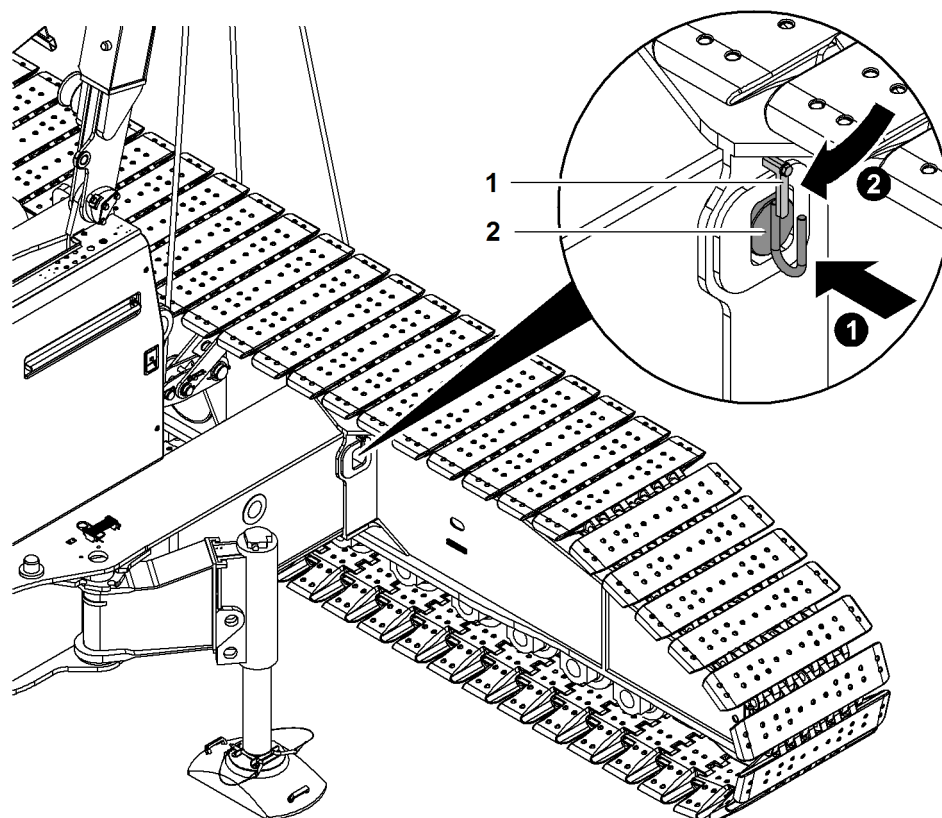


Fig. 3036: Pinning the first crawler side frame

1 Safety lever

2 Pin

- ▶ Pin crawler side frame to strut (observe installation position of pin 2).
- ▶ Undo safety lever 1 screw.
- ▶ Pull down safety lever 1.
- ▶ Tighten screw.

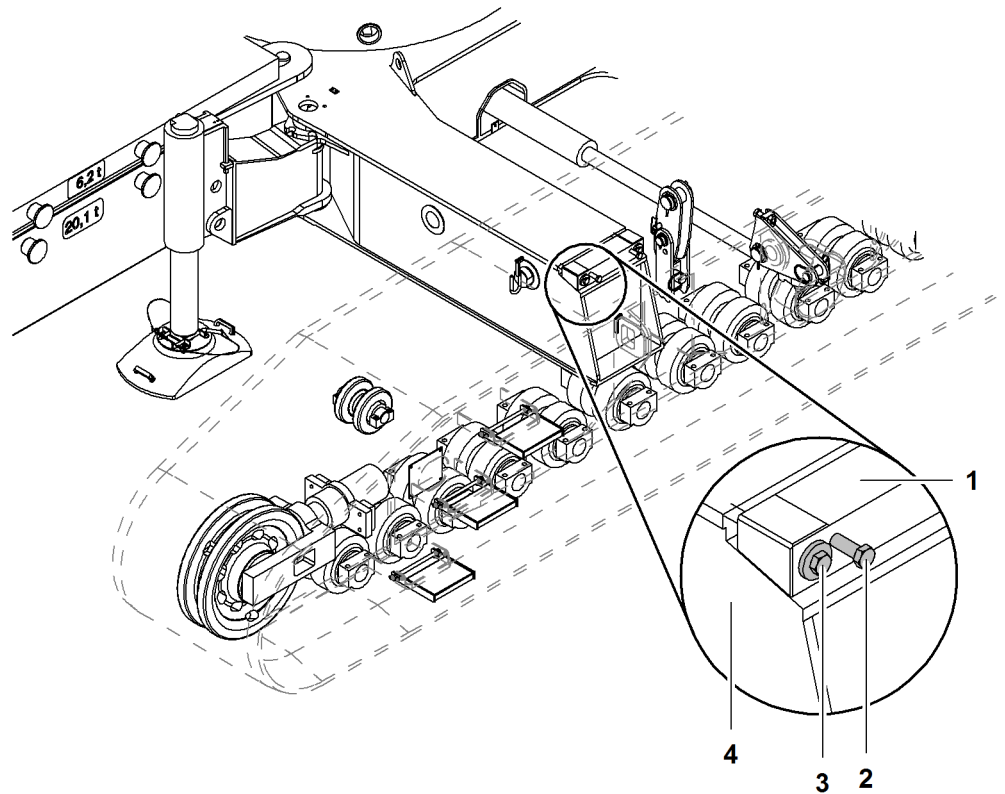


Fig. 3037: Wedging the first crawler side frame

- | | | | |
|---|------------|---|--------------------|
| 1 | Wedge | 3 | Locking screw (2x) |
| 2 | Screw (2x) | 4 | Strut |

- ▶ Undo screws **2**.
- ▶ Use locking screws **1** to clamp wedge **3** in place.
 - ▷ The crawler side frame is now wedged firmly on the struts **4**.
- ▶ Turn in screws **2** as far as they will go.
- ▶ Repeat the pinning and wedging process on the opposite side.
- ▶ Lower assembly cylinder until sling gear slackens off.
- ▶ Detach sling gear.

Removing the transport brackets

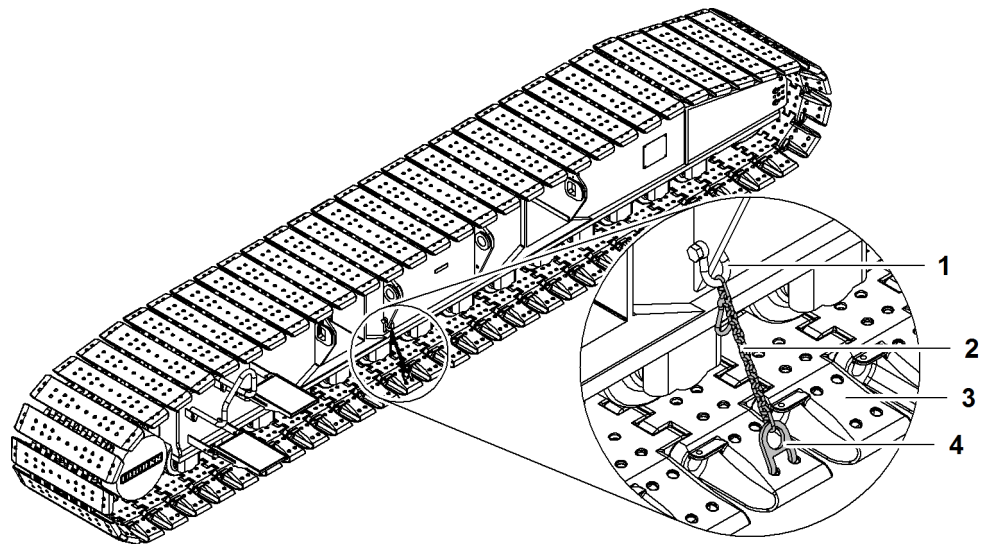


Fig. 3038: Removing the transport brackets

- | | | | |
|---|---------|---|------------|
| 1 | Shackle | 3 | Base plate |
| 2 | Chain | 4 | Hook |

- ▶ Uninstall shackle 1 and chain 2.
- ▶ Detach hook 4 at base plate 3.
- ▶ Remove transport bracket.
- ▶ Repeat procedure on opposite side of crawler side frame.

Rigging and mounting the second crawler side frame



DANGER

Inadmissible swing angle of uppercarriage with attached crawler side frame!
Toppling of machine.

- ▶ When viewed from the mounting position of the second crawler side frame, only swing uppercarriage by 90° to the left or right.
- ▶ Rig, adjust and install the second crawler side frame the same way as the first.



DANGER

Incorrect lowering of machine!
Toppling of machine.

- ▶ Lower machine carefully and leveled.
- ▶ Lower machine.
- ▶ Retract jacks.

Mounting the second crawler side frame where space is limited

If it is necessary to swing 180° from the mounting position in order to attach the second crawler side frame, then carry out the following process steps.

Make sure the following prerequisites are met:

- ❑ Two support pads with a height of at least 1000 mm (3' 3" ft-in) x 1000 mm (3' 3" ft-in) and 150 mm (5.91" in) are available.

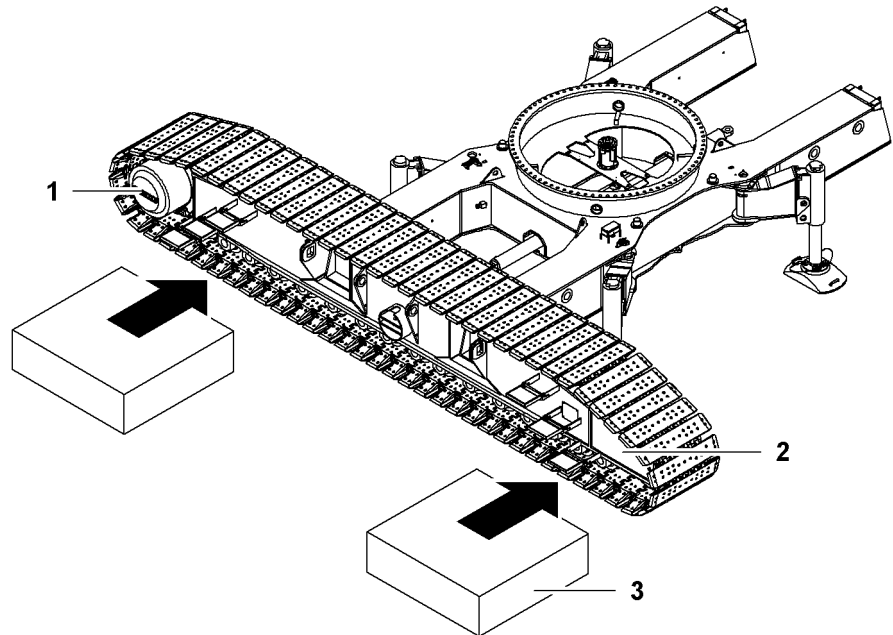


Fig. 3039: Place support plate

- 1 Crawler drive (tumbler)
- 2 Idler wheel
- 3 Support plate (2x)

- ▶ Place support plate 3 beneath crawler drive (tumbler) 1.
- ▶ Place support plate 3 beneath idler wheel 2.
- ▶ Lower crawler side frame onto support plates 3.

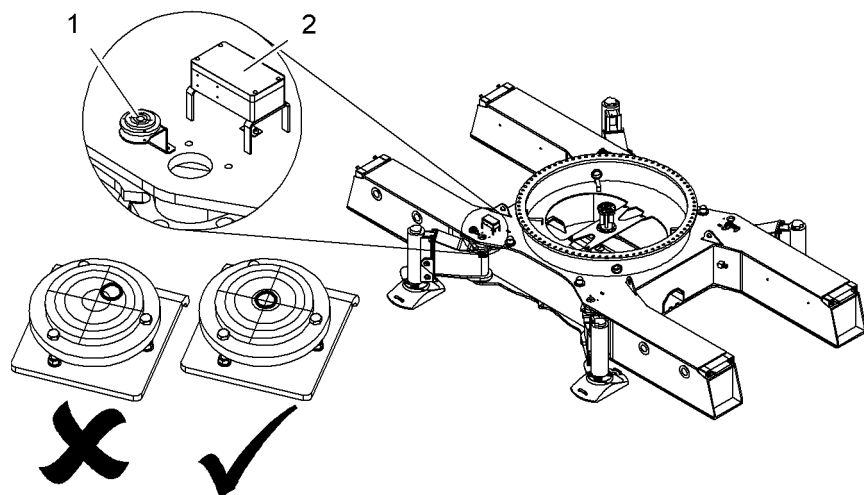


Fig. 3040: Spirit level on undercarriage

- 1 Spirit level
- 2 Connection plug of cable remote control

- ▶ Level the undercarriage.

It is not necessary to take account of a critical angle for the radius of A-frame1.

Uppercarriage can be swung as required.

- ▶ Rig, adjust and install the second crawler side frame the exact same way as the first.
- ▶ Slightly lift machine.
- ▶ Remove support plates.



DANGER

Incorrect lowering of machine!
Toppling of machine.

- ▶ Lower machine carefully and leveled.

- ▶ Lower machine.
- ▶ Retract jacks.

Connecting hydraulic lines of crawler

Make sure the following prerequisites are met:

- Hand lever for multi-coupling is available.
- Diesel engine is turned off.

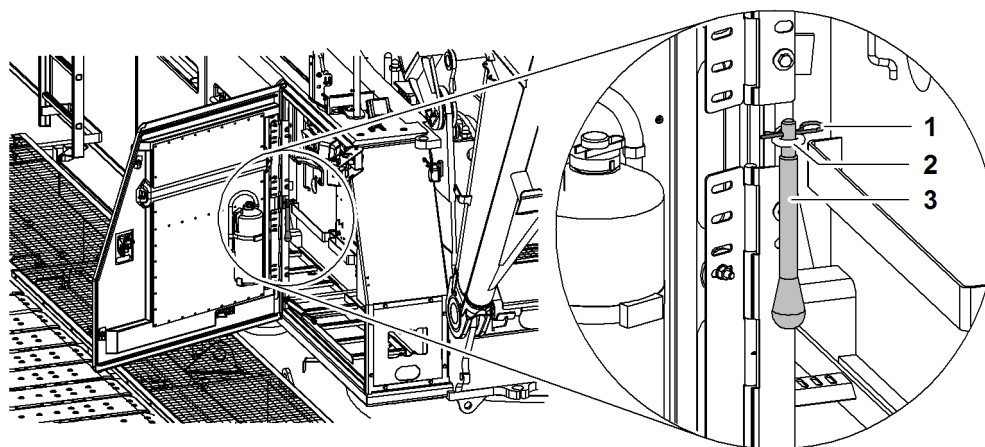


Fig. 3041: Transport bracket for hand lever of multi-coupling

- | | | | |
|---|----------------|---|------------|
| 1 | Locking spring | 3 | Hand lever |
| 2 | Ring | | |

- ▶ Lift hand lever **3** and remove locking spring **1**.
- ▶ Remove hand lever **3** downwards from ring **2**.

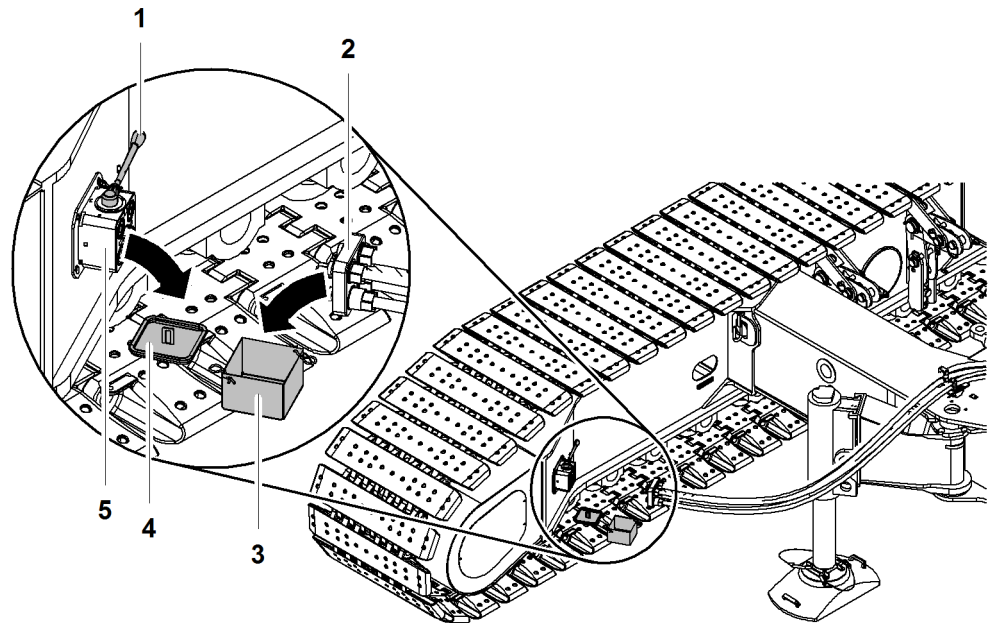


Fig. 3042: Connecting hydraulic lines of crawler

- | | | | |
|---|--------------------------------|---|-------------------------------------|
| 1 | Hand lever | 4 | Cover |
| 2 | Multi-coupling (undercarriage) | 5 | Multi-coupling (crawler side frame) |
| 3 | Cover | | |

- ▶ Fit the hand lever **1** of the multi-coupling.
- ▶ Remove locking springs on cover **3**.
- ▶ Turn hand lever **1** in the direction of the arrow.
 - ▷ Cover **4** is loose.
- ▶ Stow away cover **3 + 4**.

NOTICE

Dirty multi-couplings!
Damage to hydraulic system.

- ▶ Clean multi-couplings before connecting.
- ▶ Connect multi-couplings **2 + 5**.
- ▶ Move the hand lever until the lock engages.
 - ▷ Multi-couplings are visibly and audibly pulled together.
 - ▷ Multi-coupling indicating pins stick out:

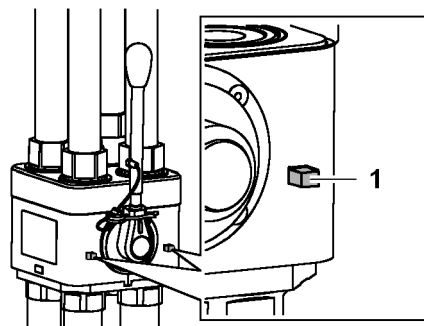


Fig. 3043: Latched multi-coupling

- | | |
|---|---------------------|
| 1 | Indicating pin (2x) |
|---|---------------------|

- ▶ Disassemble the hand lever of the multi-coupling and remove.
- ▶ Repeat procedure with second crawler side frame.

Unfolding steps from transport position

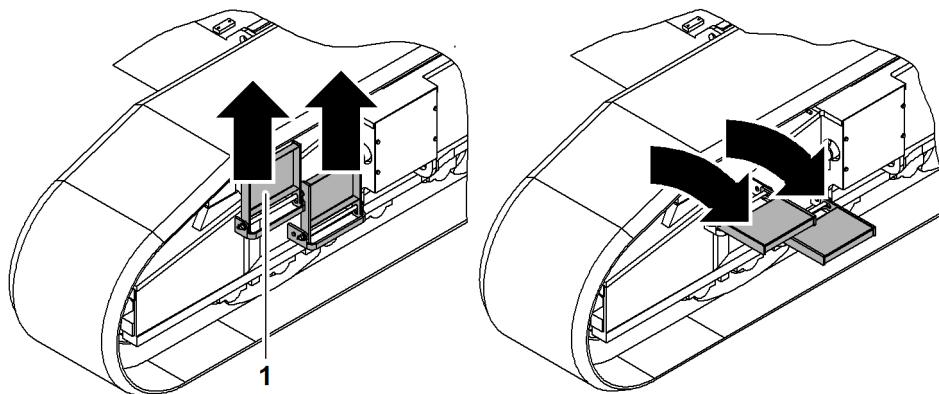


Fig. 3044: Unfolding steps from transport position

1 Steps (2x)

- ▶ Lift steps 1 completely.
- ▶ Fold down steps 1.

7.4.19 Using the machine as assembly crane

Ensure that the following conditions are fulfilled:

- Approved sling gear is available (For more information see: 6.9 Rigging equipment and/or sling gear, page 1141) .

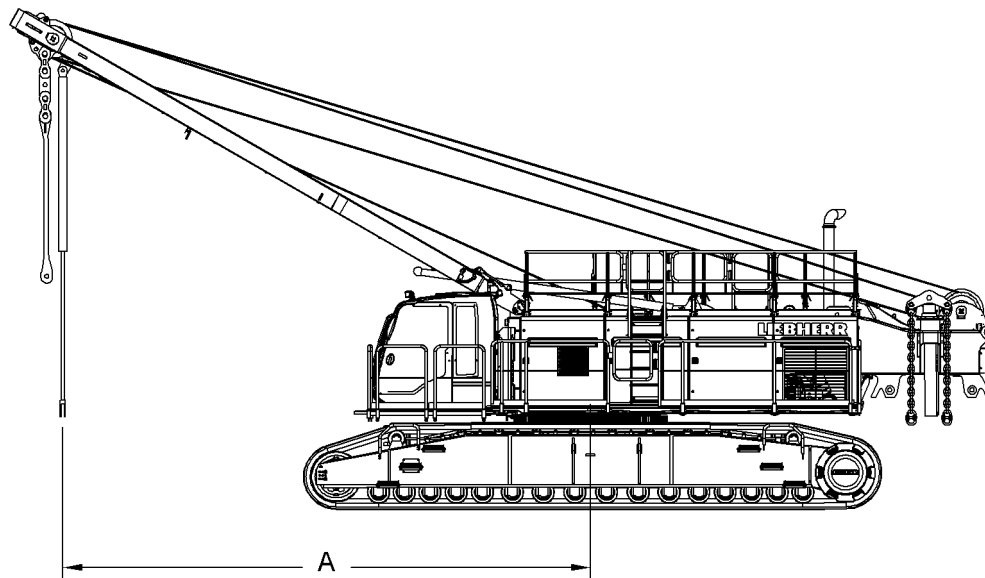


Fig. 3045: Using the machine as assembly crane

LWNLR-x/V04.01//Auslieferung/2016-03-07/en



DANGER

Maximum radius exceeded!
Machine toppling over.

- ▶ Maximum radius **A** must not exceed 9200 mm (30' 2" ft-in).



- ▶ Unwind the boom winch.
 - ▷ A-frame 1 will move forwards.
- ▶ Press the *Assembly cylinder* button on control panel X23.
 - ▷ Assembly cylinder is selected.



Procedure on a machine with two multi-directional control levers

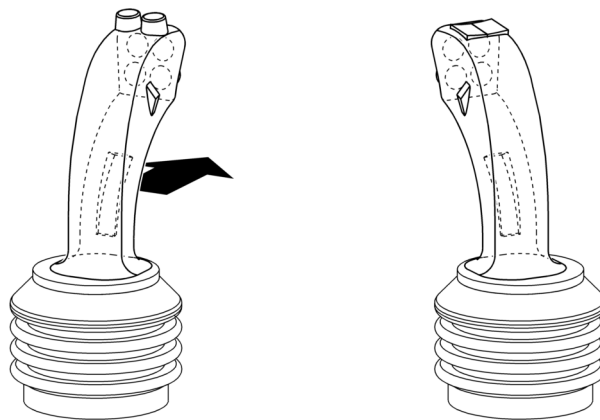
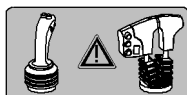


Fig. 3048: Extending the assembly cylinder with multi-directional control lever

- ▶ Push the left multi-directional control lever forwards.
 - ▷ Assembly cylinder extends.



Procedure on a machine with a multi-directional control lever and a double T-lever

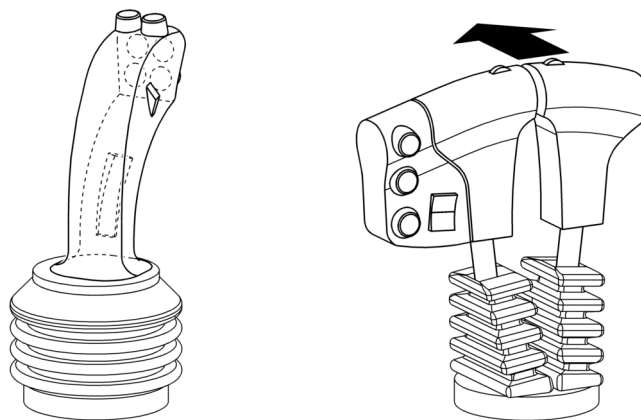


Fig. 3050: Extending the assembly cylinder using the double T-lever

- ▶ Push the outer T-control lever forwards.
 - ▷ Assembly cylinder extends.

- ▶ Remove locking spring and pin on the assembly cylinder.
- ▶ Latch sling gear.
- ▶ Insert pin into assembly cylinder and secure with locking spring.

7.4.20 Attach the carbody counterweight

The requirements, which can be found in the load chart, determine whether the machine is equipped with a carbody counterweight.



Note

The basic machine is more manoeuvrable without a carbody counterweight when used as an assembly crane.

Once all boom sections were unloaded and aligned on the ground:

- ▶ Attaching the carbody counterweight.



DANGER

Unacceptable counterweight!
Machine toppling over.

- ▶ Attaching the carbody counterweight in accordance with the load chart.

Ensure that the following conditions are fulfilled:

- Approved sling gear is available ([For more information see: 6.9 Rigging equipment and/or sling gear, page 1141](#)).
- Basic machine is ready for operation as assembly crane.
- Basic machine is on ground with sufficient load-bearing capacity.
- Cylinder adjustment functions are switched on.

Attaching carbody counterweight for undercarriage with fixed track width

Lash carbody counterweight slab 14.3 t (31,526 lb)

- ▶ Move transport vehicle carrying the carbody counterweight slab 14.3 t (31,526 lb) as close to the machine as possible.

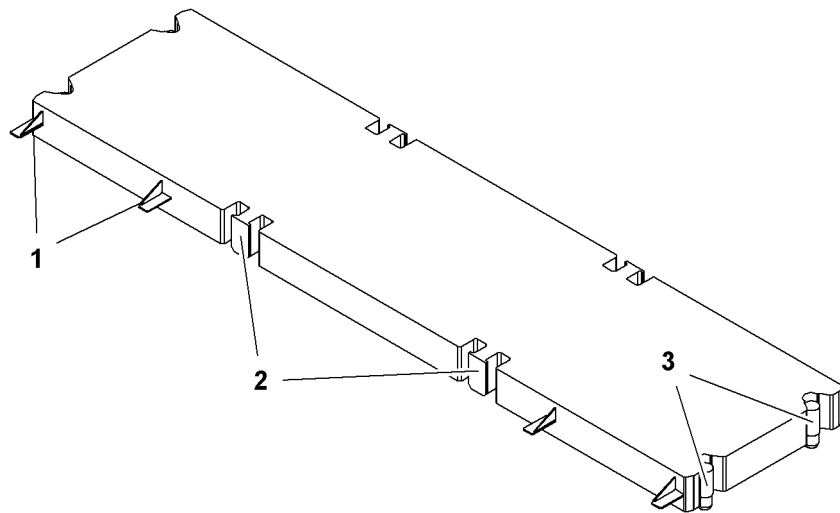


Fig. 3051: Rigging the carbody counterweight slab 14.3 t (31,526 lb)

- 1 Support for undercarriage platform 3 Locking device (4x)
 2 Lifting point (4x)

The uppercarriage can be swung by 360° without restriction.

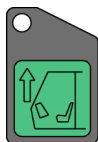
- ▶ Place assembly cylinder centrally above carbody counterweight slab 14.3 t (31,526 lb).
- ▶ Rig carbody counterweight slab 14.3 t (31,526 lb).

Installing the carbody counterweight slab 14.3 t (31,526 lb)

NOTICE

Horizontal cab!
 Damage to cab.

- ▶ Tilt cabin upwards before attaching the carbody counterweight slab 14.3 t (31,526 lb).



If the cabin is tilted down:

- ▶ Press the *Tilt cabin up* button on control panel X11.
 - ▷ The cab tilts upwards.



WARNING

Machine swings with a suspended load!
 Crush, fatal injury.

- ▶ Make sure that no-one is standing in the danger area.
 - ▶ Leave the danger area.
-
- ▶ Lift carbody counterweight slab 14.3 t (31,526 lb) off the transport vehicle.
 - ▶ Drive the transport vehicle away.

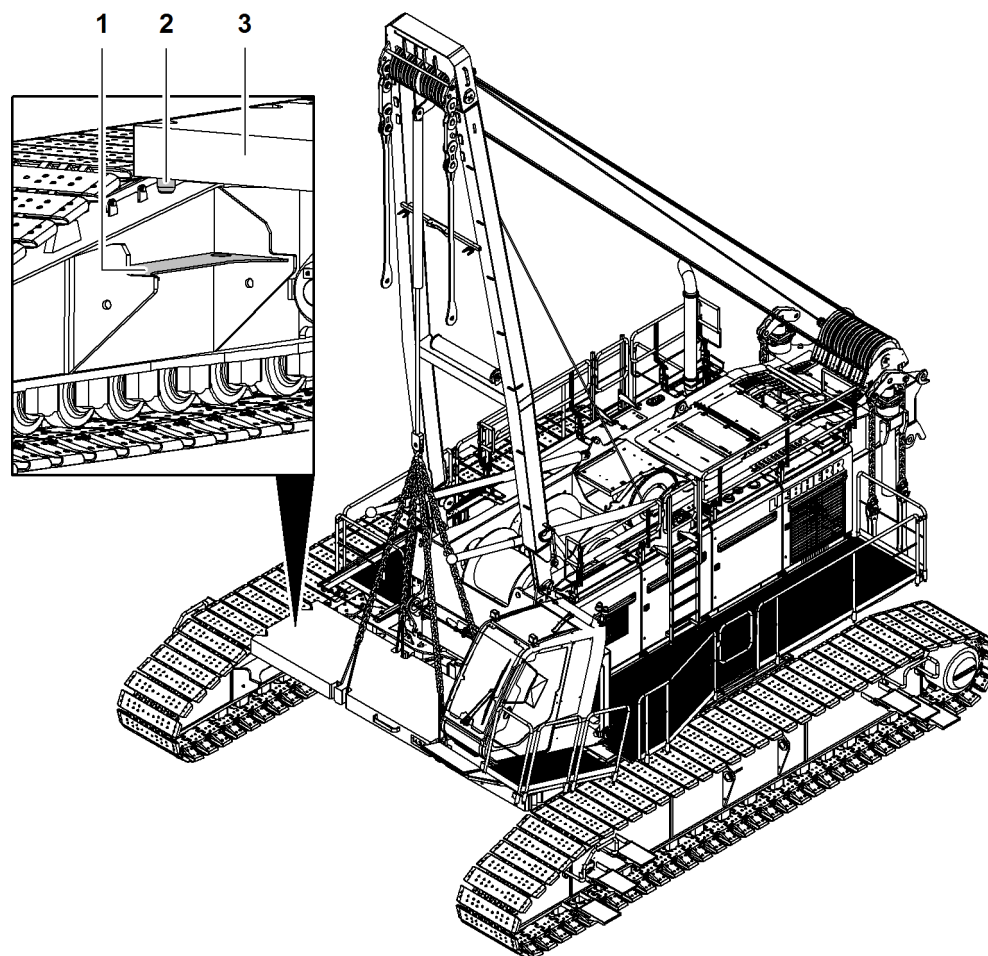


Fig. 3053: Installing the bottom carbody counterweight slab 14.3 t (31,526 lb)

- | | |
|---|--|
| <p>1 Support (2x) for bottom carbody counterweight slab
14.3 t (31,526 lb)</p> <p>2 Locking device (4x)</p> | <p>3 Bottom carbody counterweight slab 14.3 t (31,526 lb)</p> |
|---|--|

- ▶ Raise A-frame 1 and extend assembly cylinder until the bottom carbody counterweight slab 14.3 t (31,526 lb) 3 is positioned above its installation position.

NOTICE

Incorrect positioning of bottom carbody counterweight slab 14.3 t (31,526 lb)!
Damage to bottom carbody counterweight slab 14.3 t (31,526 lb).

- ▶ Place locking devices 2 for bottom carbody counterweight slab 14.3 t (31,526 lb) 3 precisely in the supports 1 of bottom carbody counterweight slab 14.3 t (31,526 lb).
- ▶ Insert bottom carbody counterweight slab 14.3 t (31,526 lb) 3 in supports 1 for bottom carbody counterweight slab 14.3 t (31,526 lb).
- ▶ Remove rigging.

NOTICE

Incorrect positioning of top carbody counterweight slab 14.3 t (31,526 lb)!
 Damage to top carbody counterweight slab 14.3 t (31,526 lb).

- ▶ Place top carbody counterweight slab 14.3 t (31,526 lb) precisely in the locking device **2** of bottom carbody counterweight slab 14.3 t (31,526 lb) **3**.
-
- ▶ Rig and mount top carbody counterweight slab 14.3 t (31,526 lb) the same way as the bottom counterweight slab 14.3 t (31,526 lb) **3**.
 - ▶ Repeat procedure on opposite side.

Installing the steps

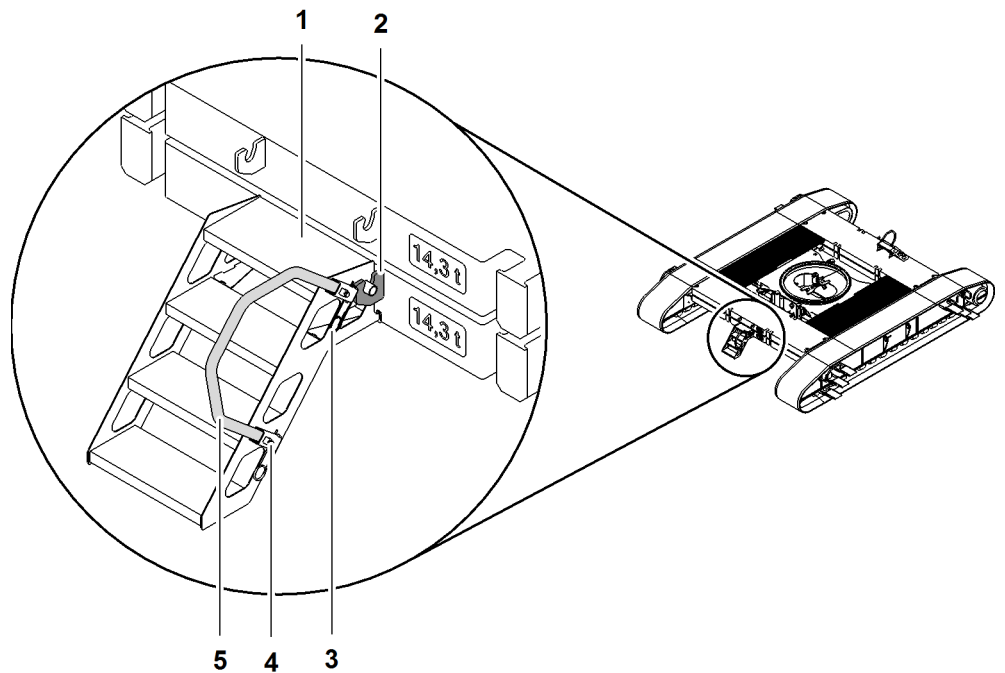


Fig. 3054: Installing the steps

- | | |
|------------------------------|-----------------------|
| 1 Steps | 4 Bracket (2x) |
| 2 Bar (2x) | 5 Handrail |
| 3 Locking spring (2x) | |

- ▶ Suspend steps **1** on bracket **2** at bottom counterweight slab.
- ▶ Insert handrail **5** in bracket **4**.
- ▶ Secure with locking springs **3**.
- ▶ Tighten screws on brackets **4**.
- ▶ Repeat procedure on opposite side.
 - ▷ Steps installed.

LWNLR.x/V04.01//Auslieferung/2016-03-07/en

Attaching carbody counterweight for undercarriage* with adjustable track width

Rigging and installing carbody counterweight slab 18.8 t (41,446 lb)

- ▶ Move transport vehicle with carbody counterweight slab 18.8 t (41,446 lb) as close to machine as possible.

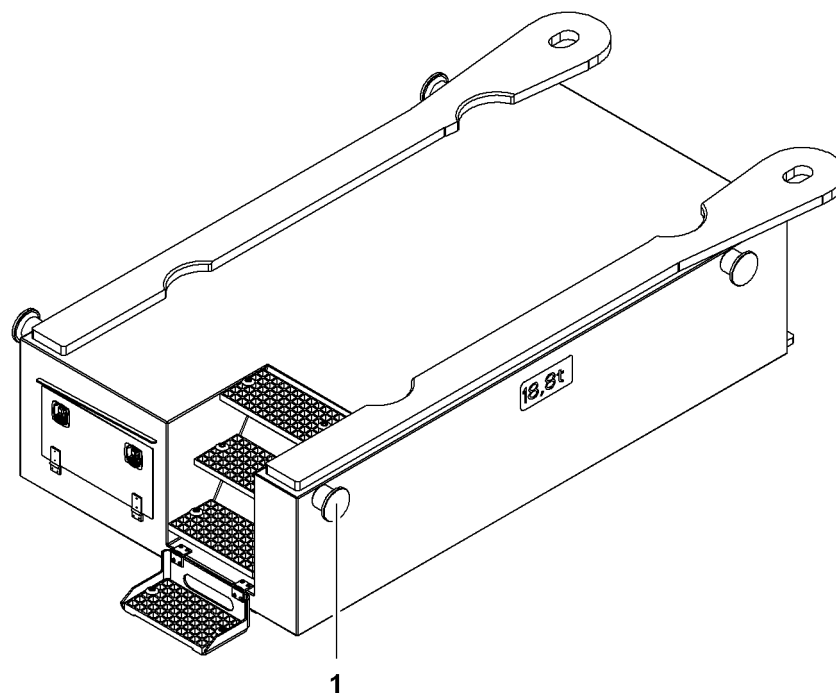


Fig. 3055: Rigging the carbody counterweight slab 18.8 t (41,446 lb)

- 1 Rigging point (4x)

The uppercarriage can be swung by 360° without restriction.

- ▶ Position assembly cylinder centrally above carbody counterweight slab 18.8 t (41,446 lb).
- ▶ Rig carbody counterweight slab 18.8 t (41,446 lb).



WARNING

Machine swings with a suspended load!
Death, crushing of body parts.

- ▶ Ensure that nobody is located in the danger zone.
 - ▶ Leave danger zone.
-
- ▶ Lift carbody counterweight slab 18.8 t (41,446 lb) off the transport vehicle.
 - ▶ Remove transport vehicle.

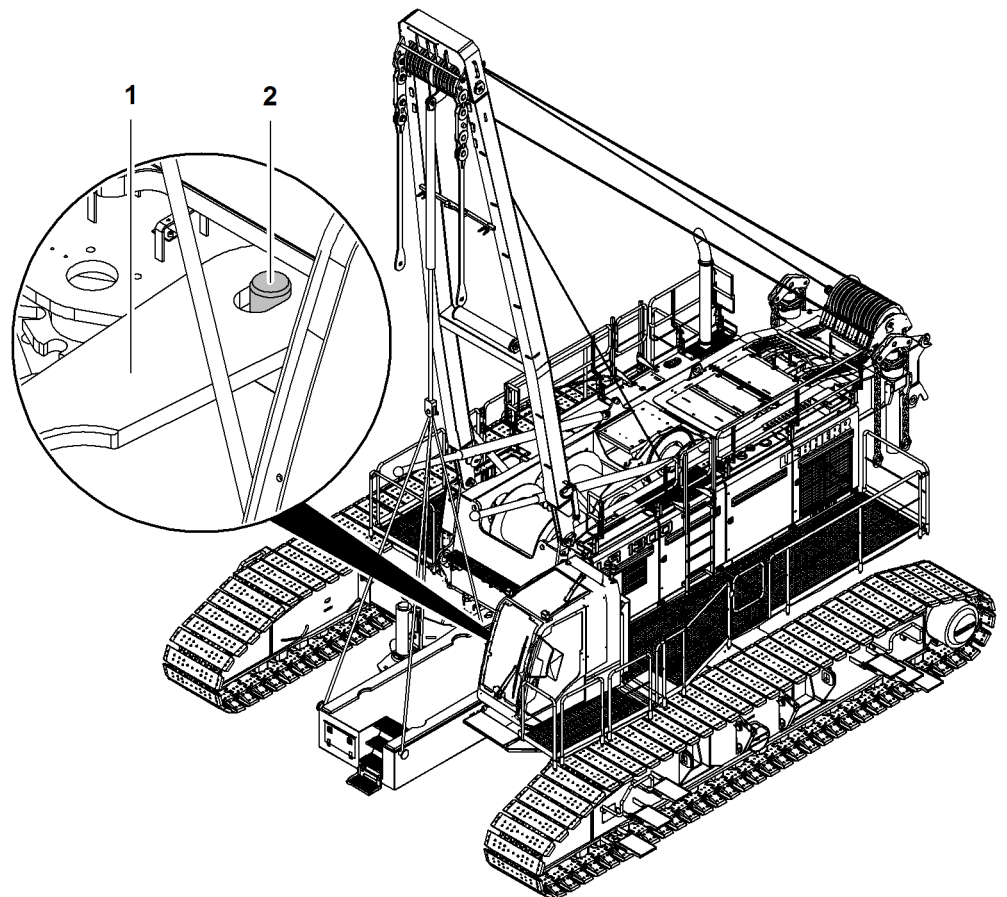


Fig. 3056: Inserting carbody counterweight slab 18.8 t (41,446 lb)

- 1** Locking device and suspension equipment **2** Pins on basic machine equipment

- ▶ Lift A-frame 1 and extend assembly cylinder until carbody counterweight slab 18.8 t (41,446 lb) is above installation position.
- ▶ Insert recess of locking device and suspension equipment **1** at pin **2**.
- ▶ Extend assembly cylinder until carbody counterweight slab 18.8 t (41,446 lb) rests completely on undercarriage.
- ▶ Remove sling gear.
- ▶ Repeat procedure on opposite side.

Rigging and installing carbody counterweight slab 7.5 t (16,534 lb)

- ▶ Move transport vehicle with carbody counterweight slab 7.5 t (16,534 lb) as close to machine as possible.

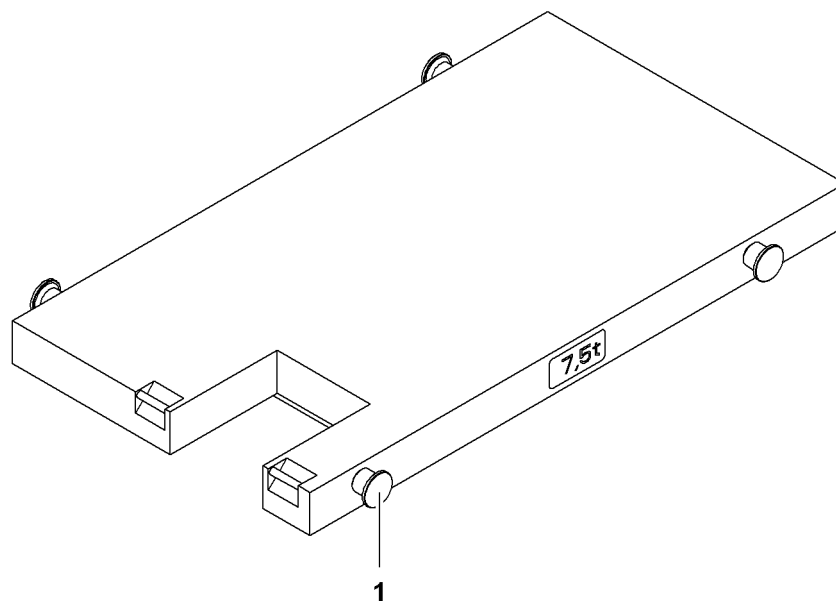


Fig. 3057: Rigging the carbody counterweight slab 7.5 t (16,534 lb)

1 Rigging point (4x)

The uppercarriage can be swung by 360° without restriction.

- ▶ Position assembly cylinder centrally above carbody counterweight slab 7.5 t (16,534 lb).
- ▶ Rig carbody counterweight slab 7.5 t (16,534 lb).



WARNING

Machine swings with a suspended load!
Death, crushing of body parts.

- ▶ Ensure that nobody is located in the danger zone.
 - ▶ Leave danger zone.
-
- ▶ Lift carbody counterweight slab 7.5 t (16,534 lb) off the transport vehicle.
 - ▶ Remove transport vehicle.

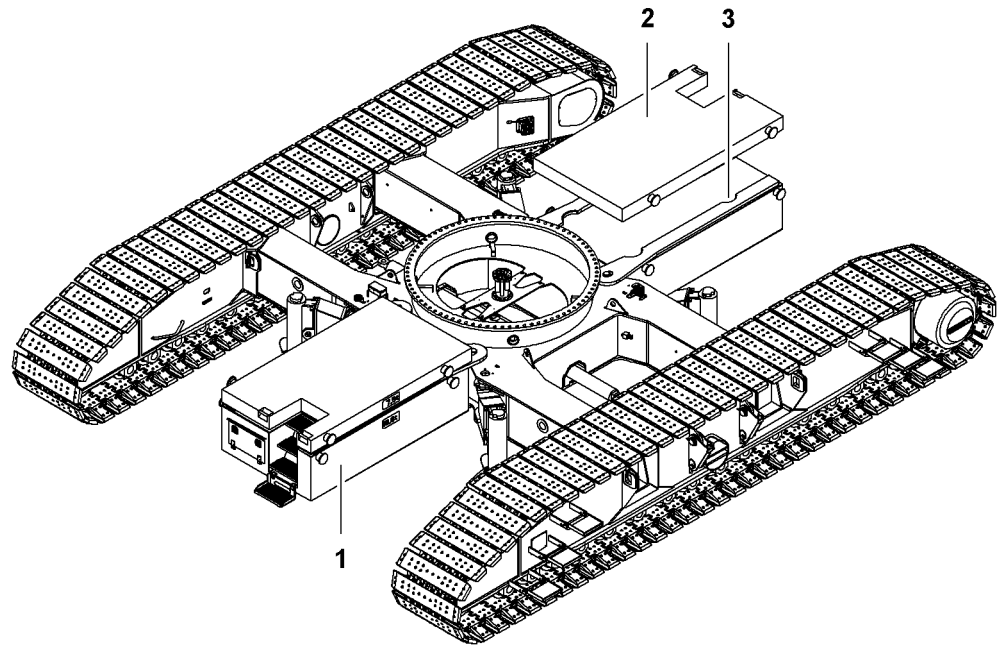


Fig. 3058: Inserting carbody counterweight slab 7.5 t (16,534 lb)

- | | |
|--|-------------------------------------|
| <p>1 Carbody counterweight slab
18.8 t (41,446 lb)</p> <p>2 Carbody counterweight slab
7.5 t (16,534 lb)</p> | <p>3 Locking device (4x)</p> |
|--|-------------------------------------|

NOTICE

Incorrect positioning of carbody counterweight slab 7.5 t (16,534 lb) **2**!
Damage to carbody counterweight slabs.

- ▶ Place carbody counterweight slab 7.5 t (16,534 lb) **2** precisely in the locking device **3** of carbody counterweight slab 18.8 t (41,446 lb) **1**.
- ▶ Place carbody counterweight slab 7.5 t (16,534 lb) **2** on carbody counterweight slab 18.8 t (41,446 lb) **1**.
- ▶ Remove sling gear.
- ▶ Repeat procedure on opposite side.

7.4.21 Installing platforms at undercarriage with fixed track width

Ensure that the following conditions are fulfilled:

- Carbody counterweight is installed.



CAUTION

No platforms at undercarriage with fixed track width!
Risk of falling off the undercarriage.

If platforms have not been installed yet:

- ▶ Step on undercarriage with utmost care.
- ▶ Align the uppercarriage parallel to the undercarriage.

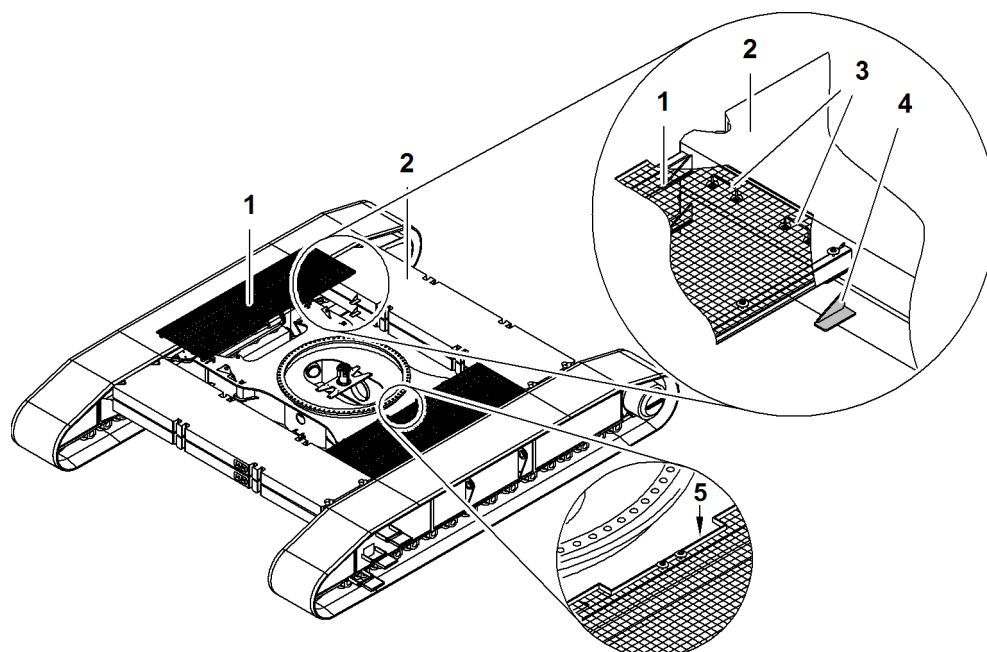


Fig. 3059: Installing platforms at undercarriage with fixed track width

- | | | | |
|---|----------------------------|---|------------------------|
| 1 | Platform (2x) | 4 | Support (8x) |
| 2 | Carbody counterweight (4x) | 5 | Recesses platform (2x) |
| 3 | Support bracket (8x) | | |

The platforms 1 on the undercarriage with fixed track width are placed on the supports 4 of the carbody counterweight 2.

On crawler side frames with 1200 mm (3' 11" ft-in) grousers, the platforms 1 have a recess 5 and are therefore asymmetrical. The recesses 5 of the platforms 1 must be located on the side of the swing ring.

On crawler side frames with 1500 mm (4' 11" ft-in) grousers, the platforms 1 are identical and symmetric.



CAUTION

Boom walkways positioned incorrectly!
Risk of crushing limbs.

- ▶ When installing the platforms 1, do not move limbs between the carbody counterweight 2 and the platform 1.
-
- ▶ Lift platform 1 using the support brackets 3 on both sides.
 - ▶ Place the platform on the supports 4 of the carbody counterweight 2.
 - ▶ Repeat the procedure on the opposite side.

7.4.22 Fitting the rear counterweight

The requirements, which can be found in the load chart, determine whether the machine is equipped with a rear counterweight.



DANGER

Incorrectly raised ballast slabs!
Machine toppling over.

- ▶ Rig and lift the counterweight slabs individually.

The uppercarriage may be turned by 360° without restriction when the rear counterweight is assembled.

Ensure that the following conditions are fulfilled:

- The requisite carbody counterweight is in place.
- The ballast slab configuration is known.
- Horizontal, sufficiently supportive subsoil is available for the rear counterweight.
- Approved sling gear is available (For more information see: 6.9 Rigging equipment and/or sling gear, page 1141) .



Note

If there is no solid ground available:

- ▶ use supports.

Positioning basic counterweight slab 14 t (30,864 lb)

- ▶ Rig basic counterweight slab 14 t (30,864 lb).
- ▶ Lift basic counterweight slab 14 t (30,864 lb).
- ▶ Lower basic counterweight slab 14 t (30,864 lb) onto ground or chocks.

Positioning the counterweight slabs 10 t (22,046 lb) and the counterweight slabs 5 t (11,023 lb)

Number of counterweight slabs 10 t (22,046 lb)	Number of counterweight slabs 5 t (11,023 lb)
Possible combination of the counterweight slabs at 124 t (273,369 lb) counterweight weight	
8	6
or	
6	10
or	
4	14
or	
2	18
Possible combination of the counterweight slabs at 114 t (251,323 lb) counterweight weight	
8	4
or	
6	8
or	
4	12
or	
2	16
Possible combination of the counterweight slabs at 104 t (229,277 lb) counterweight weight	

LWNLR.x/V04.01//Auslieferung/2016-03-07/en

Number of counterweight slabs 10 t (22,046 lb)	Number of counterweight slabs 5 t (11,023 lb)
8	2
or	
6	6
or	
4	10
or	
2	14
Possible combination of the counterweight slabs at 94 t (207,231 lb) counterweight weight	
8	0
or	
6	4
or	
4	8
or	
2	12
Possible combination of the counterweight slabs at 74 t (163,140 lb) counterweight weight	
6	0
or	
4	4
or	
2	8
Possible combination of the counterweight slabs at 54 t (119,048 lb) counterweight weight	
4	0
or	
2	4

Tab. 495: Possible combination of counterweight slabs



DANGER

Ballast slabs are stacked unevenly!
Toppling of machine during operation.

- ▶ Ballast slabs must always be stacked equally on both sides.
-
- ▶ Rig counterweight slab 10 t (22,046 lb).
 - ▶ Lift counterweight slab 10 t (22,046 lb).
 - ▶ Position 10 t (22,046 lb) counterweight slab on 14 t (30,864 lb) basic counterweight slab or on previously laid down 10 t (22,046 lb) counterweight slab.
 - ▶ Repeat procedure with all required counterweight slabs 10 t (22,046 lb).

- ▶ Rig counterweight slab 5 t (11,023 lb).
- ▶ Lift counterweight slab 5 t (11,023 lb).
- ▶ Place counterweight slab 5 t (11,023 lb) on counterweight slab 10 t (22,046 lb) or on previously set down counterweight slab 5 t (11,023 lb).
- ▶ Repeat procedure with all required counterweight slabs 5 t (11,023 lb).

Tying down the rear counterweight

The rear counterweight tie-down can be pinned in six different positions.

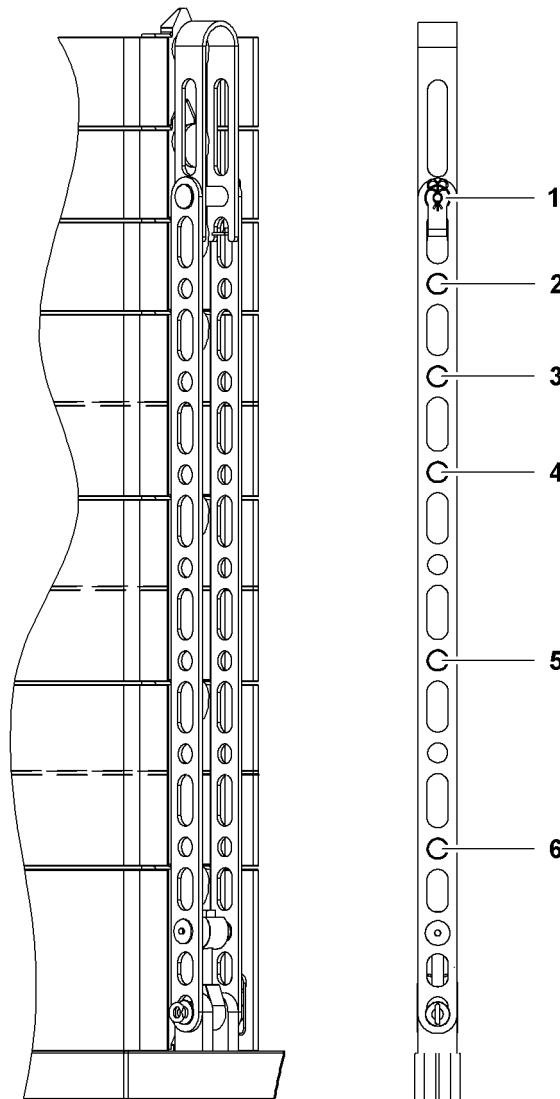


Fig. 3060: Pin connection positions of the rear counterweight tie-down

- | | |
|--|---|
| <p>1 Pin connection position of 124 t (273,369 lb) counterweight weight</p> <p>2 Pin connection position of 114 t (251,323 lb) counterweight weight</p> <p>3 Pin connection position of 104 t (229,277 lb) counterweight weight</p> | <p>4 Pin connection position of 94 t (207,231 lb) counterweight weight</p> <p>5 Pin connection position of 74 t (163,140 lb) counterweight weight</p> <p>6 Pin connection position of 54 t (119,048 lb) counterweight weight</p> |
|--|---|

- ▶ Pin counterweight tie-downs in required position.
- ▶ Secure pins with spring cotter pins.



WARNING

Incorrect lashing of rear counterweight!
Dropping counterweight slabs.

- ▶ Lash rear counterweight only as described below.

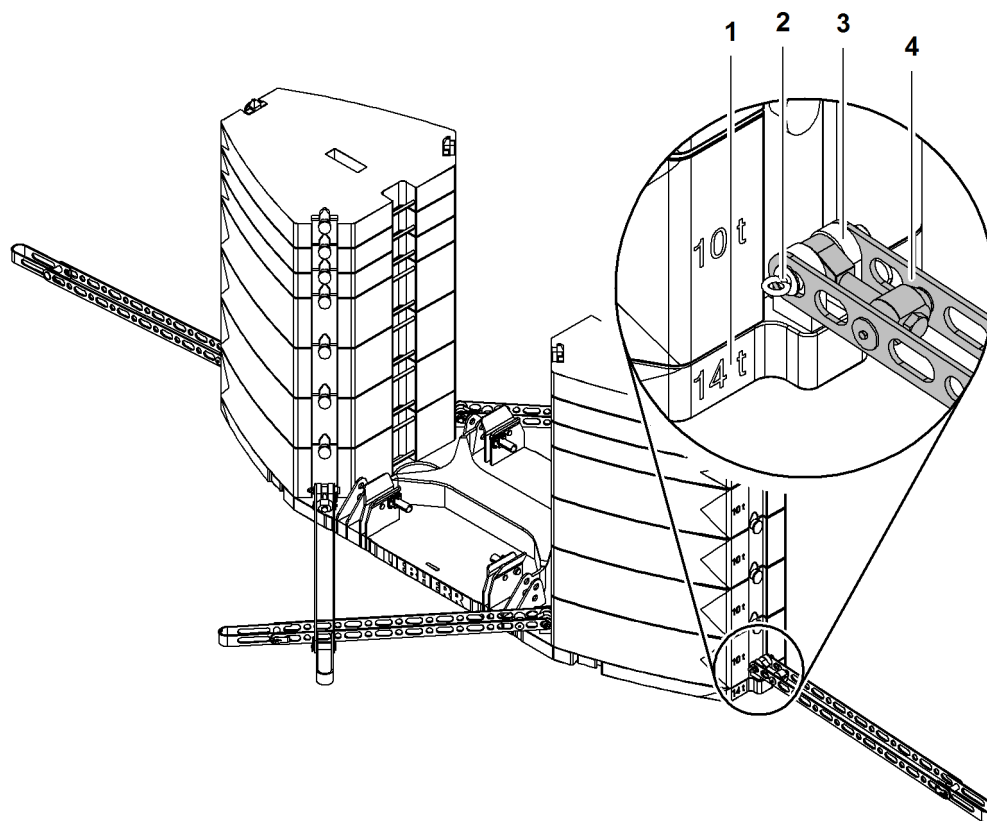


Fig. 3061: Pin counterweight tie-downs with basic counterweight slab
14 t (30,864 lb)

- | | | | |
|---|--|---|------------------------|
| 1 | Basic counterweight slab
14 t (30,864 lb) | 3 | Pin connection point |
| 2 | Pin | 4 | Counterweight tie-down |

- ▶ Pin counterweight tie-down **4** with basic counterweight slab 14 t (30,864 lb) **1**.
- ▶ Secure pin **2** with locking spring.
- ▶ Repeat procedure on all pin connection points **3**.

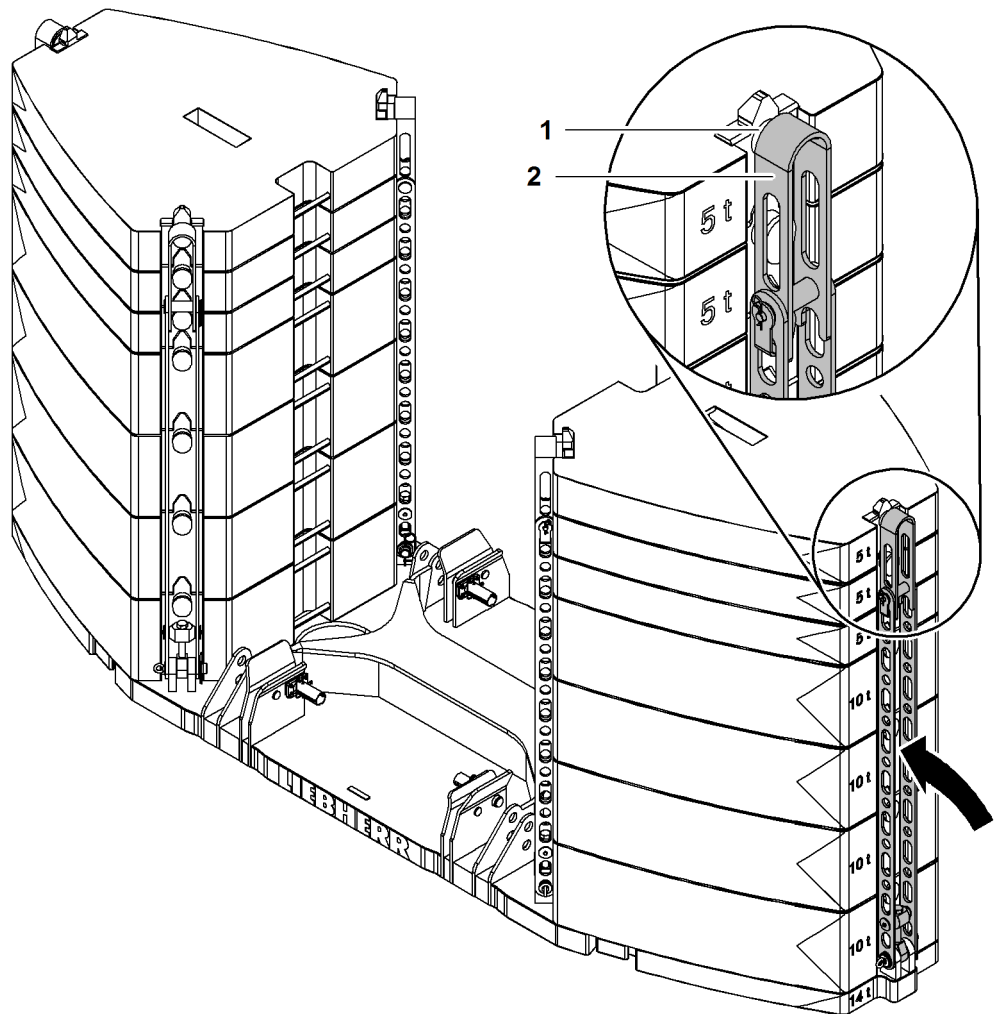


Fig. 3062: Folding up and pinning counterweight tie-downs

1 Rigging point

2 Counterweight tie-down

- ▶ Fold up counterweight tie-downs 2.
- ▶ Lift counterweight tie-down 2 above rigging point 1 of counterweight slab.
- ▶ Repeat procedure with all counterweight tie-downs 2.

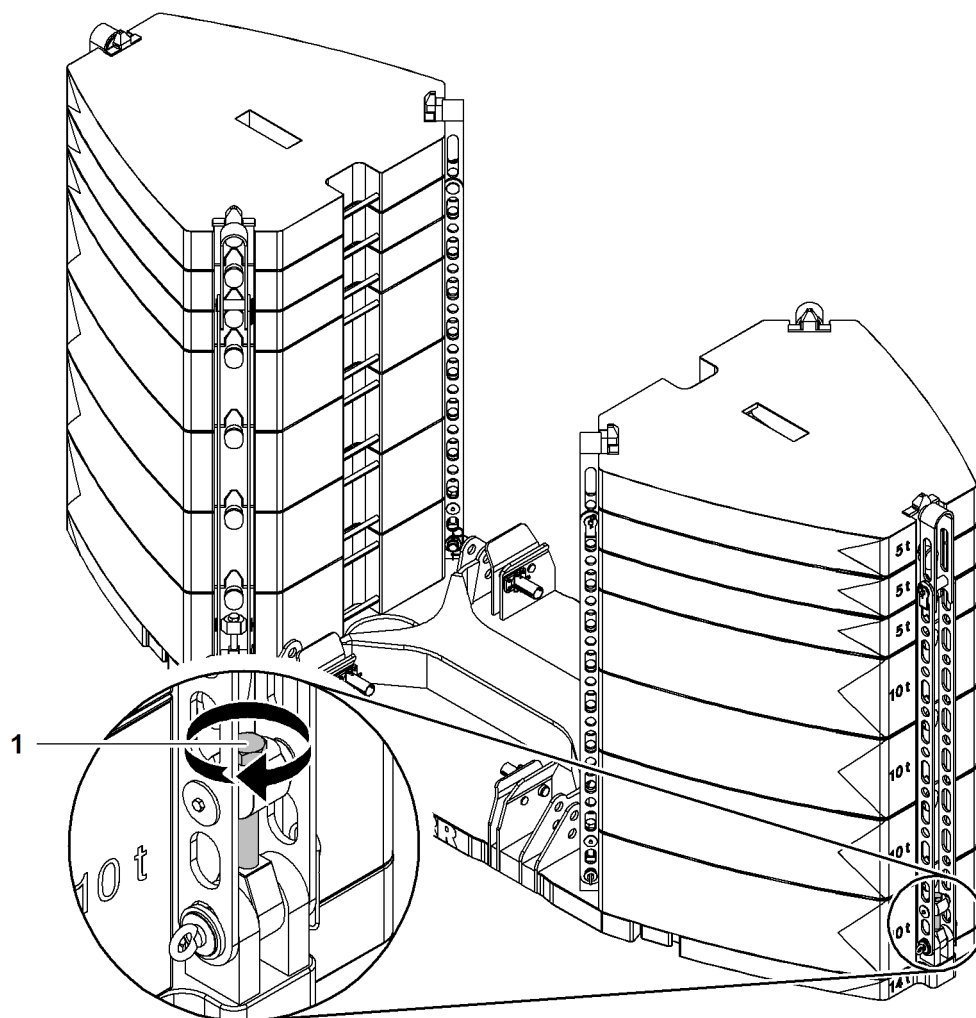


Fig. 3063: Tightening the screws of the rear counterweight tie-down

1 Screw

- ▶ Tighten the screw 1 hand-tight using a wrench.
- ▶ Repeat procedure with all counterweight tie-downs.
 - ▷ Rear counterweight is tied down.

Mount the slinging plates

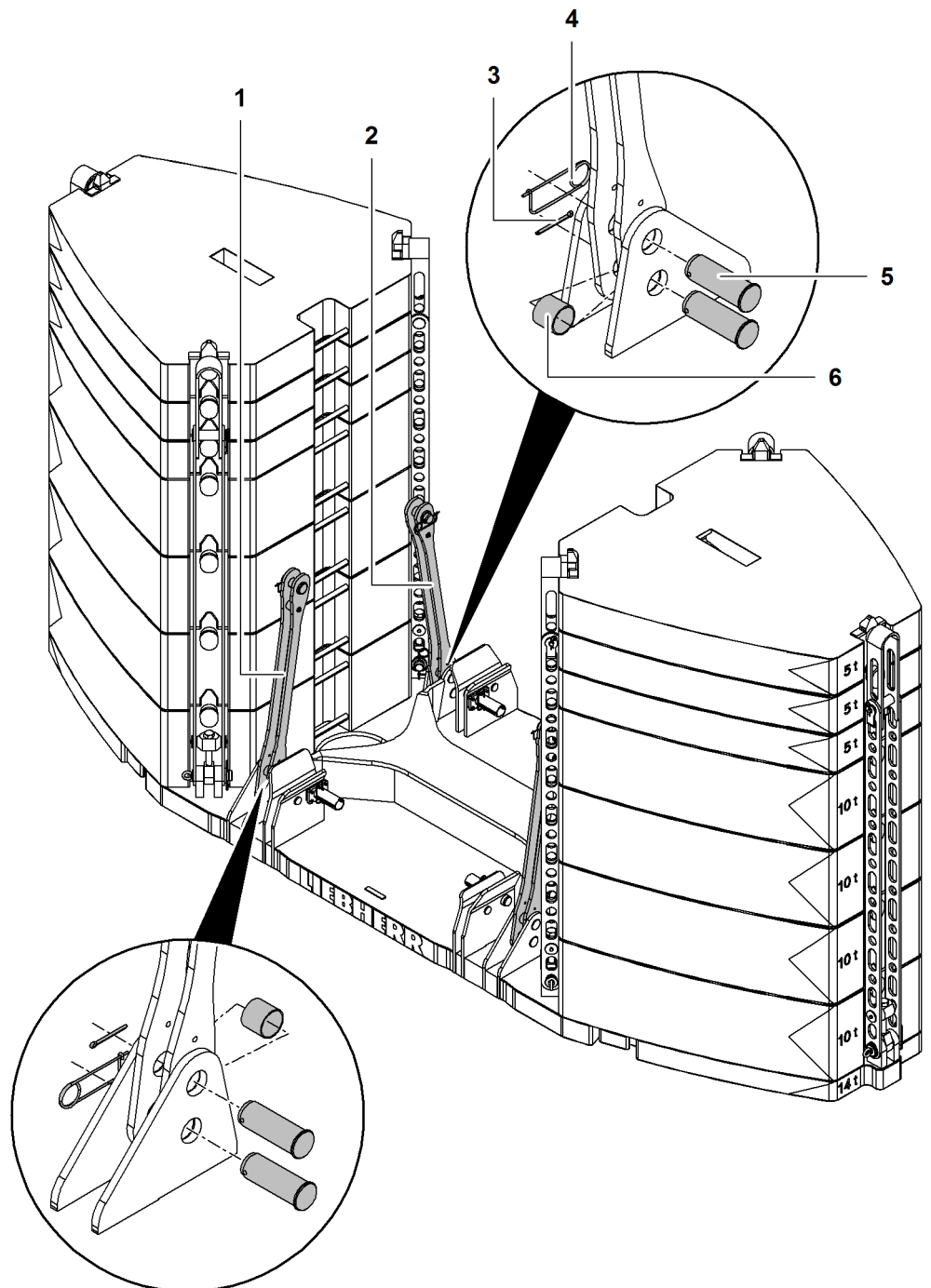


Fig. 3064: Mount the slinging plates

- | | | | |
|---|---------------------------|---|---------------------|
| 1 | Rear slinging plate (2x) | 4 | Locking spring (4x) |
| 2 | Front slinging plate (2x) | 5 | Pin (8x) |
| 3 | Split pin (4x) | 6 | Spacer ring (4x) |

Installing the front slinging plates

- ▶ Insert spacer rings **6** at bottom pin connection points.
- ▶ Pin front slinging plates **2** to basic counterweight slab 14 t (30,864 lb).
- ▶ Secure bottom pins **5** with split pins **3**.

- ▶ Secure top pins **5** with locking springs **4**.

Installing the rear slinging plates

- ▶ Insert spacer rings **6** at top pin connection points.
- ▶ Pin rear slinging plates **1** to basic counterweight slab 14 t (30,864 lb).
- ▶ Secure top pins **5** with split pins **3**.
- ▶ Secure bottom pins **5** with locking springs **4**.

Lifting and pinning the rear counterweight



DANGER

Slewing of uppercarriage with rear counterweight attached not permitted!
Machine toppling over.

- ▶ Only slew the uppercarriage according to the table ([see: tab. 496, page 1264](#)) .



DANGER

Slewing of uppercarriage with narrow track not permitted (exclusively with undercarriage with adjustable track width)!
Machine toppling over.

- ▶ Ensure that machine is set up with a wide track width.

Permitted uppercarriage turning depending on counterweight		
Initial position: Uppercarriage is parallel to crawler side frames		
Rear counterweight	Carbody counterweight	
	0 t 0.00 lb	Undercarriage with fixed track width: 57 t (125,662 lb) Undercarriage* with adjustable track width: 52.6 t (115,961 lb)
0 t 0.00 lb	360°	360°
54 t 119,048 lb	360°	360° ^{A)}
74 t 163,140 lb	±10°	360° ^{A)}
94 t 207,231 lb	-	360°
104 t 229,277 lb	-	360°
114 t 251,323 lb	-	±10° (360° ^{B)})
124 t 273,369 lb	-	±10°

Tab. 496: Permitted uppercarriage turning depending on counterweight

LWNLR-x/V04.01//Auslieferung/2016-03-07/en

- A) This counterweighting can occur during assembly of basic machine (unacceptable setup).
- B) Only permissible if A-frame1 is sufficiently far forward so that the slabs of A-frame1 cylinders lift off of A-frame1.

Ensure that the following conditions are fulfilled:

- Rear counterweight is assembled and lashed.
- Work with the assembly cylinder is completed.
- All boom sections are unloaded and in position.
- Counterweight hoisting cylinders are retracted.
- Cylinder adjustment functions on.

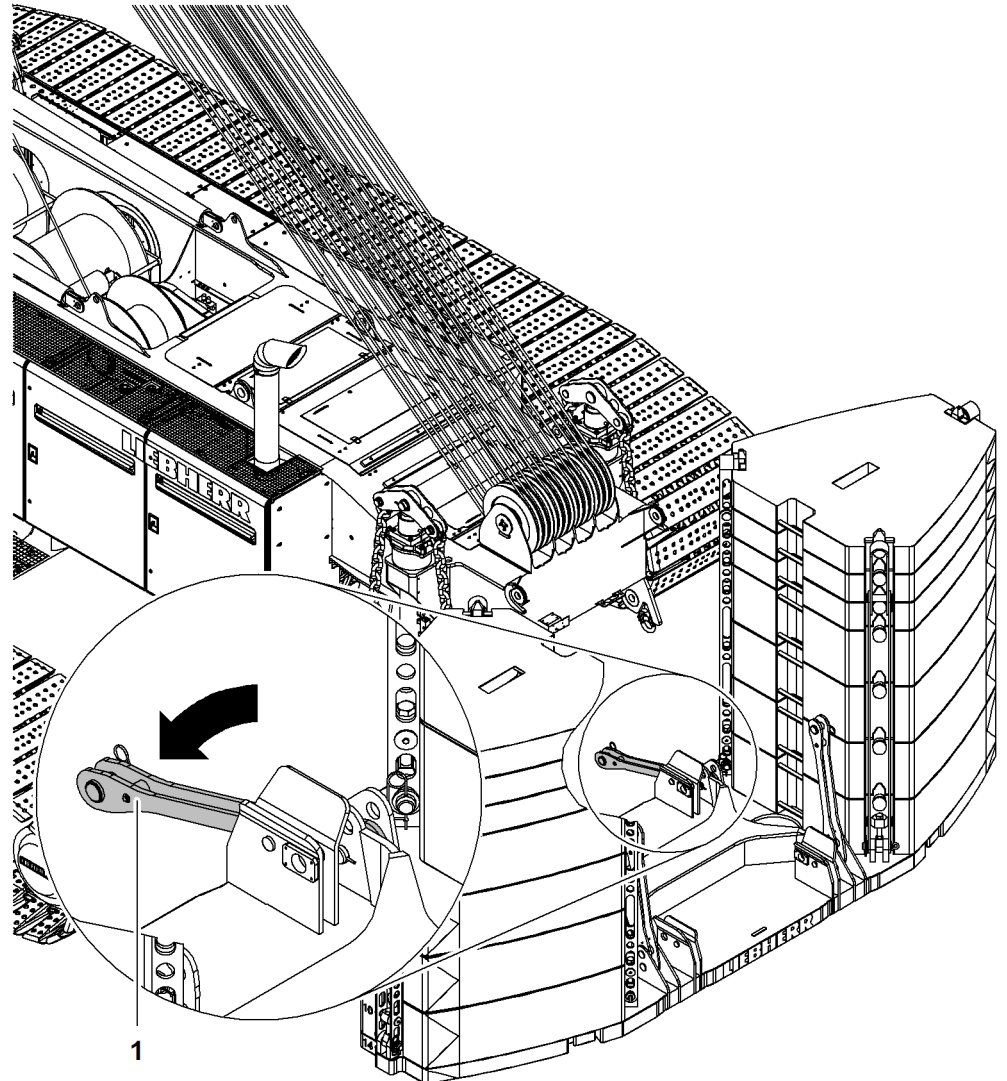


Fig. 3065: Folding the front slinging plates down

- 1 Front slinging plate (2x)

NOTICE

Improper installation of the rear counterweight!
Damage to machine.

- ▶ Fold down front slinging plates 1 prior to installing the rear counterweight.

- ▶ Remove locking springs at top pins.

- ▶ Remove top pins.
- ▶ Fold down front slinging plates 1.



DANGER

Incorrect lifting of rear counterweight!
Machine toppling over.

- ▶ Align uppercarriage parallel to undercarriage when lifting rear counterweight.
- ▶ Align uppercarriage with counterweight hoisting cylinder chains exactly above slinging plates of rear counterweight.

-
- ▶ Move basic machine backwards to rear counterweight until the chains of the counterweight hoisting cylinders are suspended exactly above the slinging plates of the rear counterweight.
 - ▶ Fold up front slinging plates 1.
 - ▶ Insert top pins.
 - ▶ Secure top pins with locking springs.
 - ▶ Open rear left uppercarriage door.
 - ▶ Plug in the cable remote control on the uppercarriage.

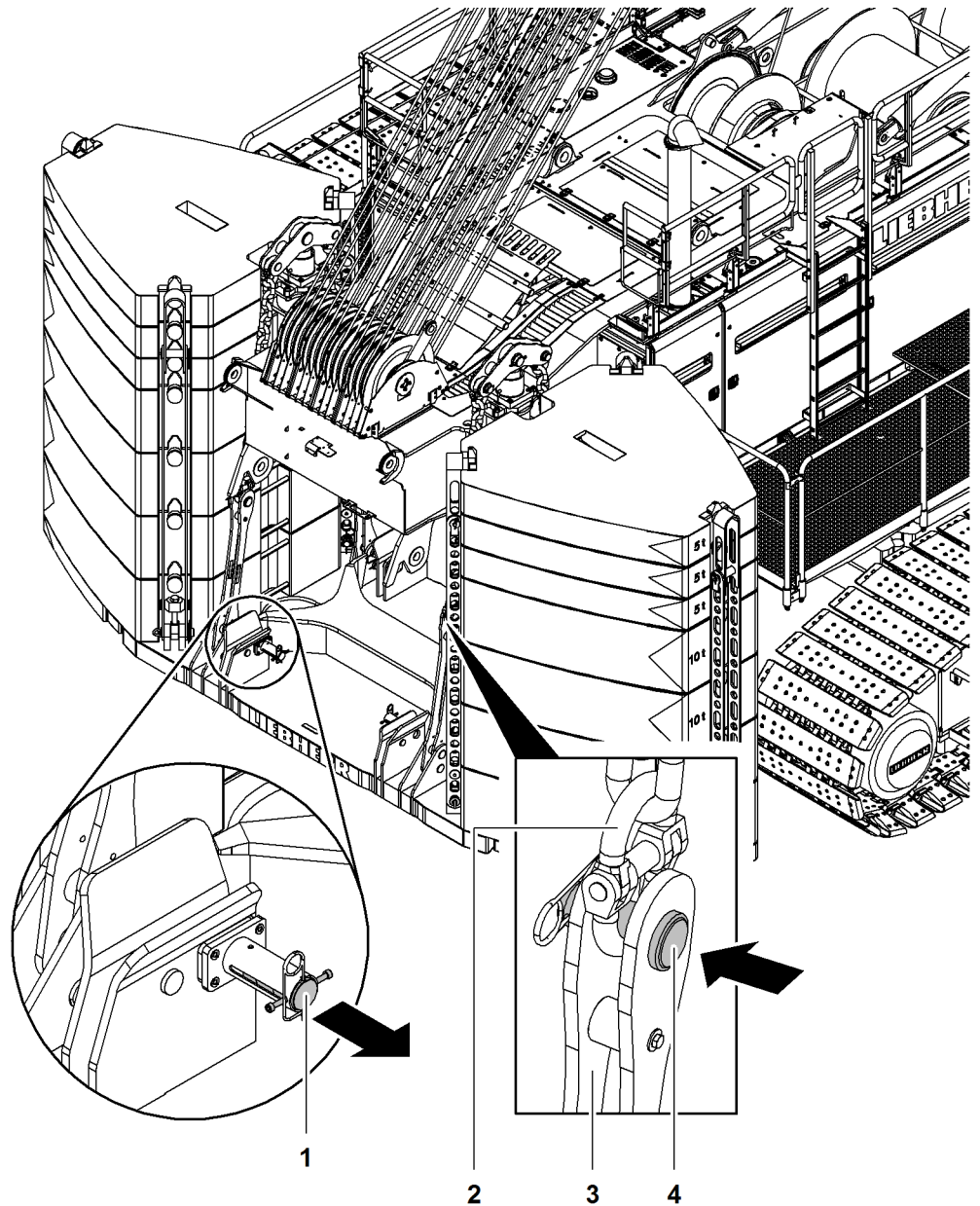


Fig. 3066: Rigging the rear counterweight

- | | | | |
|---|-------|---|----------------|
| 1 | Pin | 3 | Slinging plate |
| 2 | Chain | 4 | Pin |

- ▶ Pin chain 2 with slinging plate 3.
- ▶ Secure pin 4 with washer and locking spring.
- ▶ Pull out pin 1 until stop.
- ▶ Secure pin 1 with locking spring.
- ▶ Repeat procedure on all slinging plates 3 and pin connection points.
- ▶ Using the cable remote control, slowly extend the counterweight hoisting cylinders until the chains 2 are taut.

NOTICE

Excessive swinging of rear counterweight!

Damage to machine.

► Ensure that rear counterweight does not swing during the entire process.

► Lift rear counterweight.

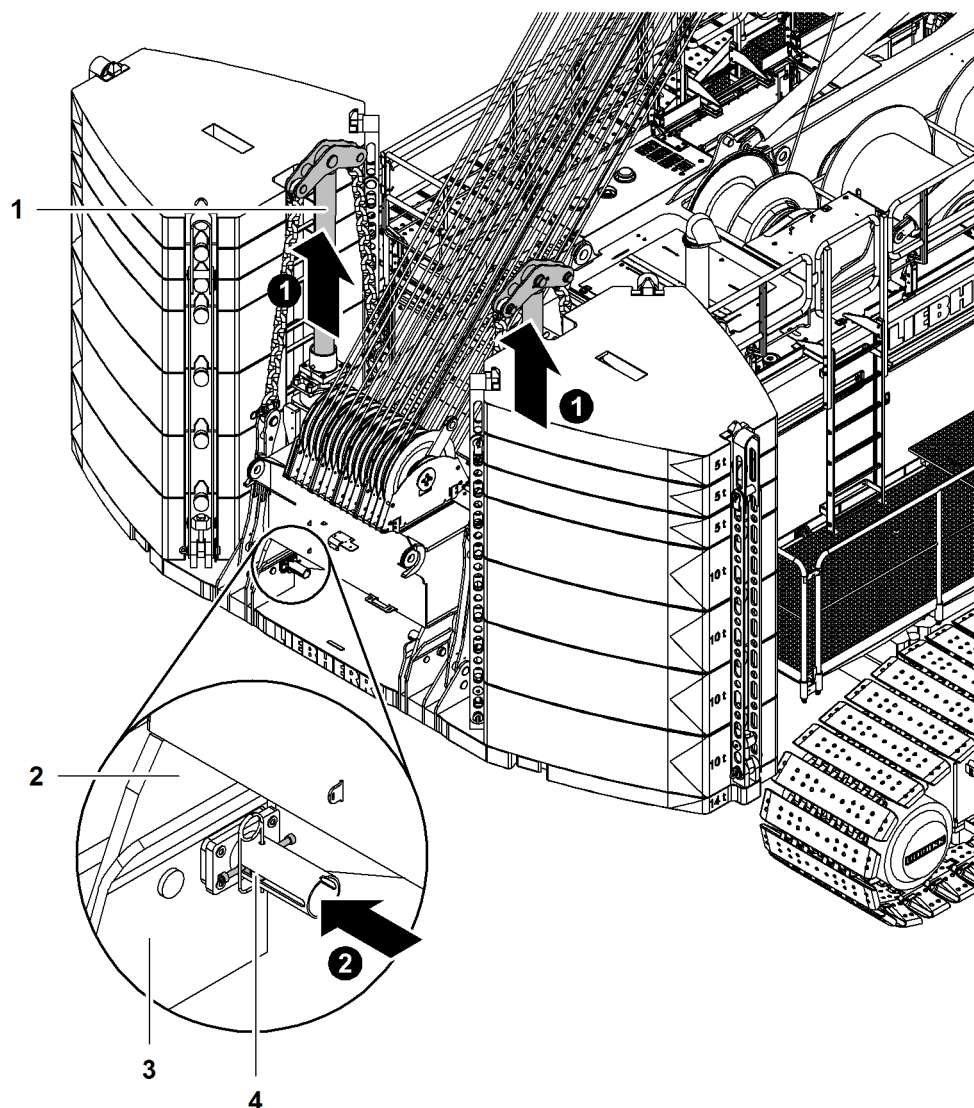


Fig. 3067: Pinning the rear counterweight

- | | | | |
|---|--|---|---|
| 1 | Counterweight hoisting cylinder (2x) | 3 | Pin connection point (4x) on rear counterweight |
| 2 | Pin connection point (4x) on uppercarriage | 4 | Pin (4x) |

► Fully extend counterweight hoisting cylinder 1.

**DANGER**

Incorrect pin connection of rear counterweight!
Machine toppling over.

- ▶ Pin rear counterweight to basic machine.
- ▶ Secure pins **4**.

If the pin connection points **2** on the uppercarriage match the pin connection points **3** on the rear counterweight:

- ▶ Push in pin **4** until stop.
- ▶ Secure pins **4** with locking springs.
 - ▷ Rear counterweight is pinned and secured.

Chains of the counterweight hoisting cylinders **1** may remain suspended.

- ▶ Fully retract the counterweight hoisting cylinders **1**.
- ▶ Unplug cable remote control on uppercarriage and stow away.
- ▶ Close rear left uppercarriage door.

7.5 Main boom 2821

System-relevant information for main boom 2821:

- Configuration of main boom
 - Installation position of rope guide (type A)
 - Mid-point suspensions installation positions
- Lengths of mid-point suspensions
- Overview of main boom 2821 steel pendant straps
- Overview of main boom 2821 CF pendant straps
- Reeving diagrams for one rope across main boom head 2821 (load position1)
- Reeving diagrams for two ropes across main boom head 2821 (load position1)
- Reeving diagrams for one rope across auxiliary jib (36 t (79300 lb)) on main boom head 2821 (load position1)
- Reeving diagrams for two ropes across auxiliary jib (36 t (79300 lb)) and main boom head 2821 (load position 1)
- Reeving diagrams jib luffing winch as auxiliary winch

7.5.1 Configuration of main boom



DANGER

Excess length of main boom!
Structural breakdown.

- ▶ Check main boom length in load chart for validity.

Main boom length	Configuration of main boom (symbolic)
20 m 66 ft	
23 m 75 ft	
26 m 85 ft	
29 m 95 ft	
32 m 105 ft	
35 m 115 ft	
38 m 125 ft	
41 m 135 ft	
44 m 144 ft	
47 m 154 ft	

LWN/LR-x/V04.01//Auslieferung/2016-03-07/en

Main boom length	Configuration of main boom (symbolic)
50 m 164 ft	
53 m 174 ft	
56 m 184 ft	
59 m 195 ft	
62 m 203 ft	
65 m 213 ft	
68 m 223 ft	
71 m 233 ft	
74 m 243 ft	
77 m 253 ft	
80 m 262 ft	
83 m 272 ft	
86 m 282 ft	
89 m 292 ft	
92 m 302 ft	
95 m 312 ft	
98 m 322 ft	
101 m 332 ft	
104 m 342 ft	

Tab. 497: Configuration of main boom 2821

S - Installation position rope guide (type A)

X1 - Installation position mid-point suspension 1

X2 - Installation position mid-point suspension 2

LWNLR-x/V04.01//Auslieferung/2016-03-07/en

7.5.2 Lengths of mid-point suspensions

Main boom length	Stay rope 1 (X1)	Stay rope 2 (X2)
	Rope length	Rope length
77 m 253 ft ^{A)}	3.7 m 12' 2" ft-in = 2.1 m (6' 11" ft-in) + 1.6 m (5' 3" ft-in)	
80 m 262 ft ^{A)}	3.2 m 10' 6" ft-in = 1.6 m (5' 3" ft-in) + 1.6 m (5' 3" ft-in)	
83 m 272 ft	3.2 m 10' 6" ft-in = 1.6 m (5' 3" ft-in) + 1.6 m (5' 3" ft-in)	
86 m 282 ft	5.6 m 18' 4" ft-in = 3 m (9' 10" ft-in) + 2.6 m (8' 6" ft-in)	2.1 m 6' 11" ft-in
89 m 292 ft	5.1 m 16' 9" ft-in = 2.1 m (6' 11" ft-in) + 3 m (9' 10" ft-in)	1.6 m 5' 3" ft-in
92 m 302 ft	5.1 m 16' 9" ft-in = 2.1 m (6' 11" ft-in) + 3 m (9' 10" ft-in)	1.6 m 5' 3" ft-in
95 m 312 ft	4.7 m 15' 5" ft-in = 2.6 m (8' 6" ft-in) + 2.1 m (6' 11" ft-in)	1.6 m 5' 3" ft-in
98 m 322 ft	4.7 m 15' 5" ft-in = 2.6 m (8' 6" ft-in) + 2.1 m (6' 11" ft-in)	1.6 m 5' 3" ft-in
101 m 332 ft	4.6 m 15' 1" ft-in = 3.0 m (9' 10" ft-in) + 1.6 m (5' 3" ft-in)	1.6 m 5' 3" ft-in
104 m 342 ft	4.2 m 13' 9" ft-in = 2.6 m (8' 6" ft-in) + 1.6 m (5' 3" ft-in)	2.1 m 6' 11" ft-in

Tab. 498: Lengths of mid-point suspensions - main boom 2821

LWN/LR-x/V04.01//Auslieferung/2016-03-07/en

A) Machine with CF pendant straps with boom configuration main boom 2821 + luffing jib 1916: Do not install any mid-point suspensions with main boom lengths 77 m (253 ft) and 80 m (262 ft).

7.5.3 Overview of main boom 2821 steel pendant straps

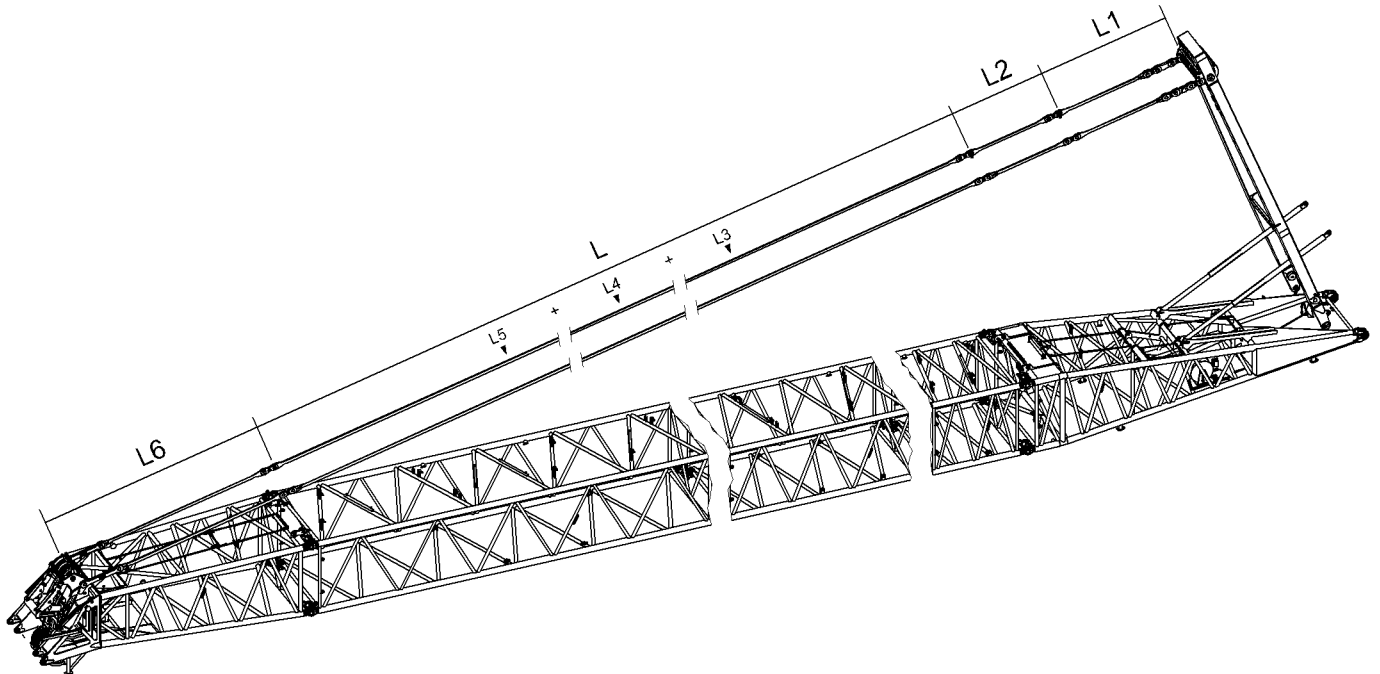


Fig. 3253: Overview of main boom 2821 steel pendant straps

Pendant straps A-frame1 to main boom head 2821

Name		Value	
L1	A-frame1 equalizer (For more information see: A-frame1 equalizer, page 77)	3730 mm 12' 3" ft-in	
L2	Main boom base section equalizer (For more information see: Equalizer of main boom base section 2821.30, page 191)	2670 mm 8' 9" ft-in	
L	Main boom pendant straps consisting of:		
	L3	Main boom pendant strap 3 m (10 ft) (For more information see: Main boom pendant strap 3 m (10 ft), page 192)	Total L3 +
	L4	Main boom pendant strap 6 m (20 ft) (For more information see: Main boom pendant strap 6 m (20 ft), page 194)	Total L4 +
L5	Main boom pendant strap 12 m (40 ft) (For more information see: Main boom pendant strap 12 m (40 ft), page 196)	Total L5	

LWNLR.x/V04.01/Auslieferung/2016-03-07/en

Name		Value
L6	Main boom pendant strap on main boom head 2821 (For more information see: Main boom pendant strap on main boom head 2821.24, page 197)	6300 mm 20' 8" ft-in

Tab. 499: Pendant straps A-frame1 to main boom head 2821

Configuration of main boom pendant straps (L):

Required number of main boom pendant straps 3 m (10 ft) (L3) corresponds to number of main boom sections 3 m (10 ft).

Required number of main boom pendant straps 6 m (20 ft) (L4) corresponds to number of main boom sections 6 m (20 ft).

Required number of main boom pendant straps 12 m (40 ft) (L5) corresponds to number of main boom sections 12 m (40 ft).



Note

► For the admissible number of main boom sections 3 m (10 ft), 6 m (20 ft), 12 m (40 ft), refer to the following table: [\(For more information see: 7.5.1 Configuration of main boom, page 1270\)](#)

7.5.4 Overview of main boom 2821 CF pendant straps

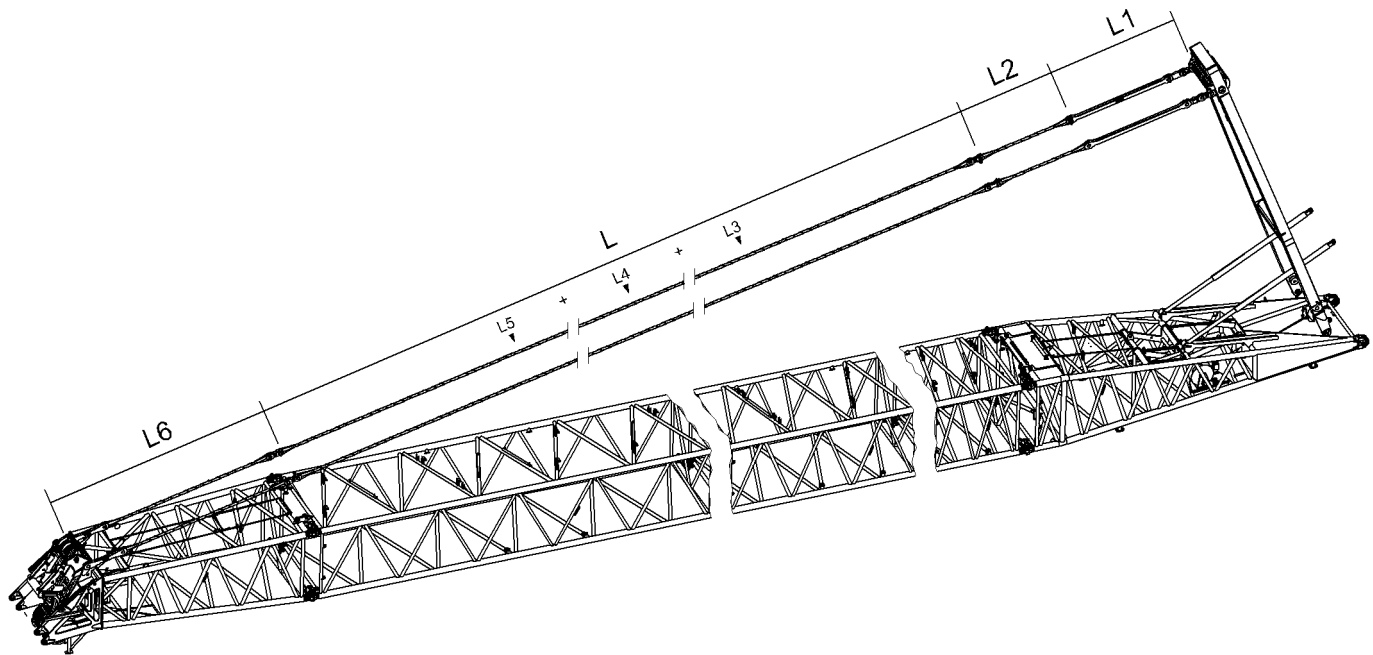


Fig. 3254: Overview of main boom 2821 CF pendant straps

Pendant straps A-frame1 to main boom head 2821

Name		Value
L1	A-frame1 equalizer (For more information see: A-frame1 equalizer, page 78)	3700 mm 12' 2" ft-in

LWNLR-x\04.01\Auslieferung\2016-03-07/en

Name		Value	
L2	Main boom base section equalizer (For more information see: Equalizer of main boom base section 2821.30, page 200)	2700 mm 8' 10" ft-in	
L	Main boom pendant straps consisting of:		
	L3	Main boom pendant strap 3 m (10 ft) (For more information see: Main boom pendant strap 3 m (10 ft), page 203)	Total L3 +
	L4	Main boom pendant strap 6 m (20 ft) (For more information see: Main boom pendant strap 6 m (20 ft), page 206)	Total L4 +
	L5	Main boom pendant strap 12 m (40 ft) (For more information see: Main boom pendant strap 12 m (40 ft), page 210)	Total L5
L6	Main boom pendant strap on main boom head 2821 (For more information see: Main boom pendant strap on main boom head 2821.24, page 214)	6300 mm 20' 8" ft-in	

Tab. 500: Pendant straps A-frame1 to main boom head 2821

Configuration of main boom pendant straps (L):

Required number of main boom pendant straps 3 m (10 ft) (L3) corresponds to number of main boom sections 3 m (10 ft).

Required number of main boom pendant straps 6 m (20 ft) (L4) corresponds to number of main boom sections 6 m (20 ft).

Required number of main boom pendant straps 12 m (40 ft) (L5) corresponds to number of main boom sections 12 m (40 ft).



Note

- For the admissible number of main boom sections 3 m (10 ft), 6 m (20 ft), 12 m (40 ft), refer to the following table: [\(For more information see: 7.5.1 Configuration of main boom, page 1270\)](#)

The main boom pendant straps (L) may consist of generation A and generation B main boom pendant straps [\(For more information see: 1.11.9 CF pendant straps on main boom 2821, page 200\)](#) . Mixing is only admissible if the number of generation B main boom pendant straps only differs by at most 1 in the left and the right strand of the main boom pendant straps.



DANGER

Inadmissible mixing of generation A and generation B main boom pendant straps! Structural breakdown.

- Ensure that the number of generation B main boom pendant straps differs by at most 1 in the left and the right strand of the main boom pendant straps.

7.5.5 Reeving diagrams for one rope across main boom head 2821 (load position1)

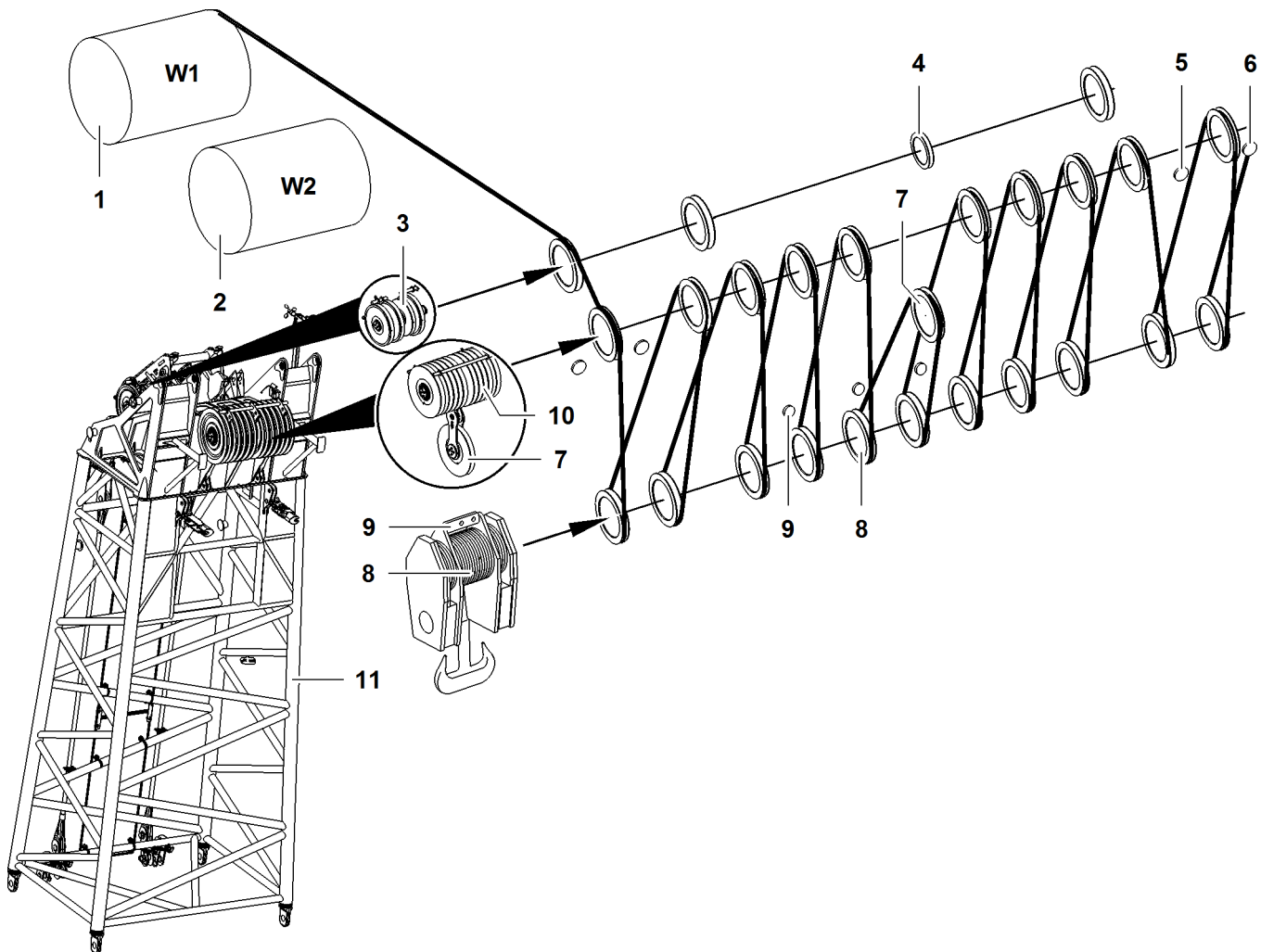


Fig. 3255: Reeving diagrams for one rope across main boom head 2821 (load position1)

- | | | | | | |
|---|--------------------------------------|---|--|----|------------------------------------|
| 1 | Winch1 | 5 | Inner rope fixing point (2x) of main boom head | 9 | Rope fixing points of pulley block |
| 2 | Winch2 | 6 | Outer rope fixing point (2x) of main boom head | 10 | Pulley (10x) of main boom head |
| 3 | Gantry pulley (3x) of main boom head | 7 | 11th pulley of main boom head | 11 | Main boom head |
| 4 | Pulley for rope of jib luffing winch | 8 | Pulley set of pulley block | | |

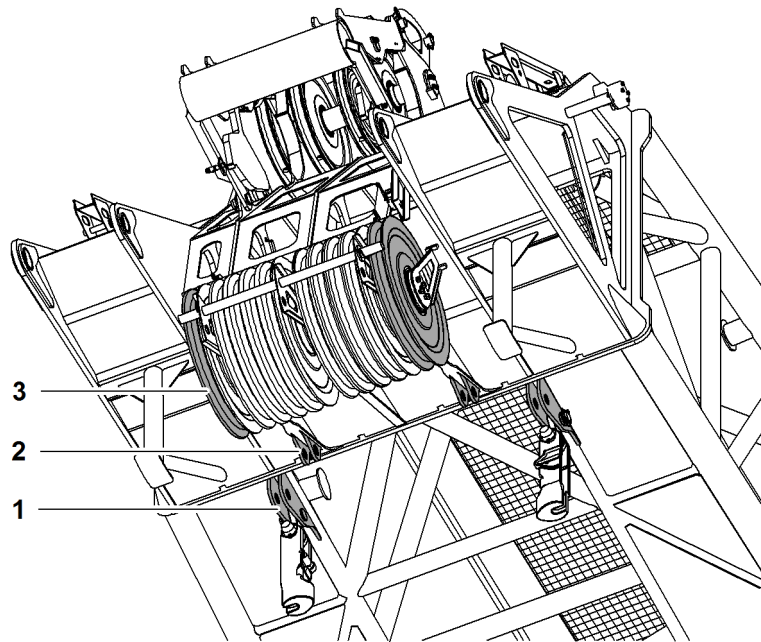


Fig. 3256: Rope fixing points main boom head 2821

- 1 Outer rope fixing point (2x)
- 2 Inner rope fixing point (2x)
- 3 Pulley (2x)

If the first or last pulley 3 on the pulley set of the main boom head is used (reeved), the outer rope fixing point 1 is to be used.

If the first or last pulley 3 on the pulley set of the main boom head is not used (not reeved), the inner rope fixing point 2 is to be used.

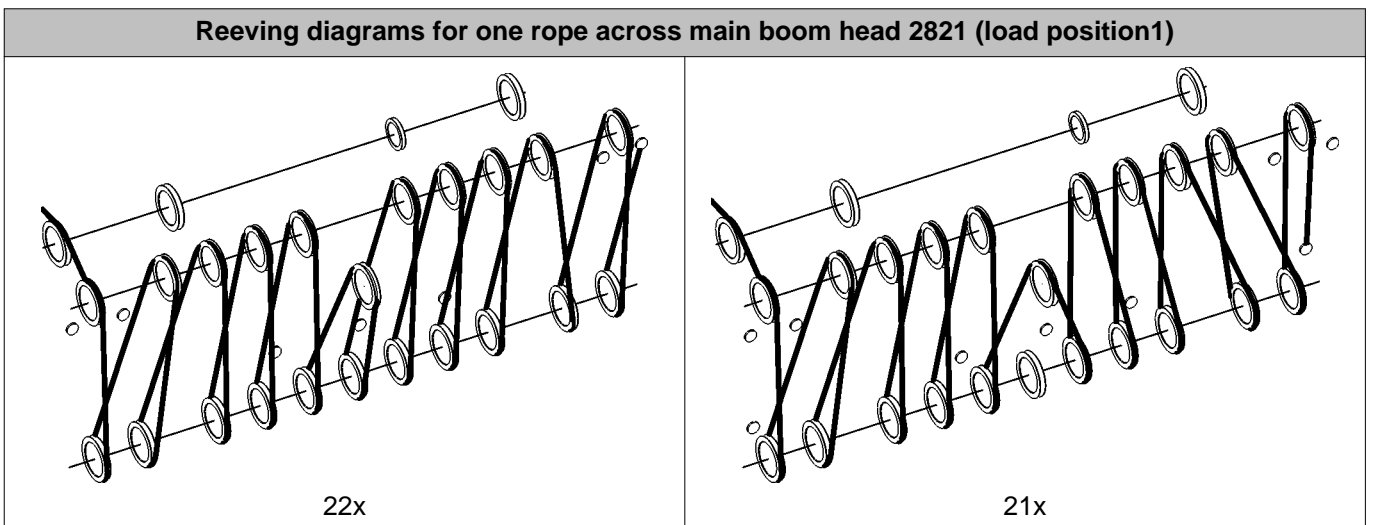


DANGER

Incorrect number of reevings!
Structural breakdown, toppling of machine.

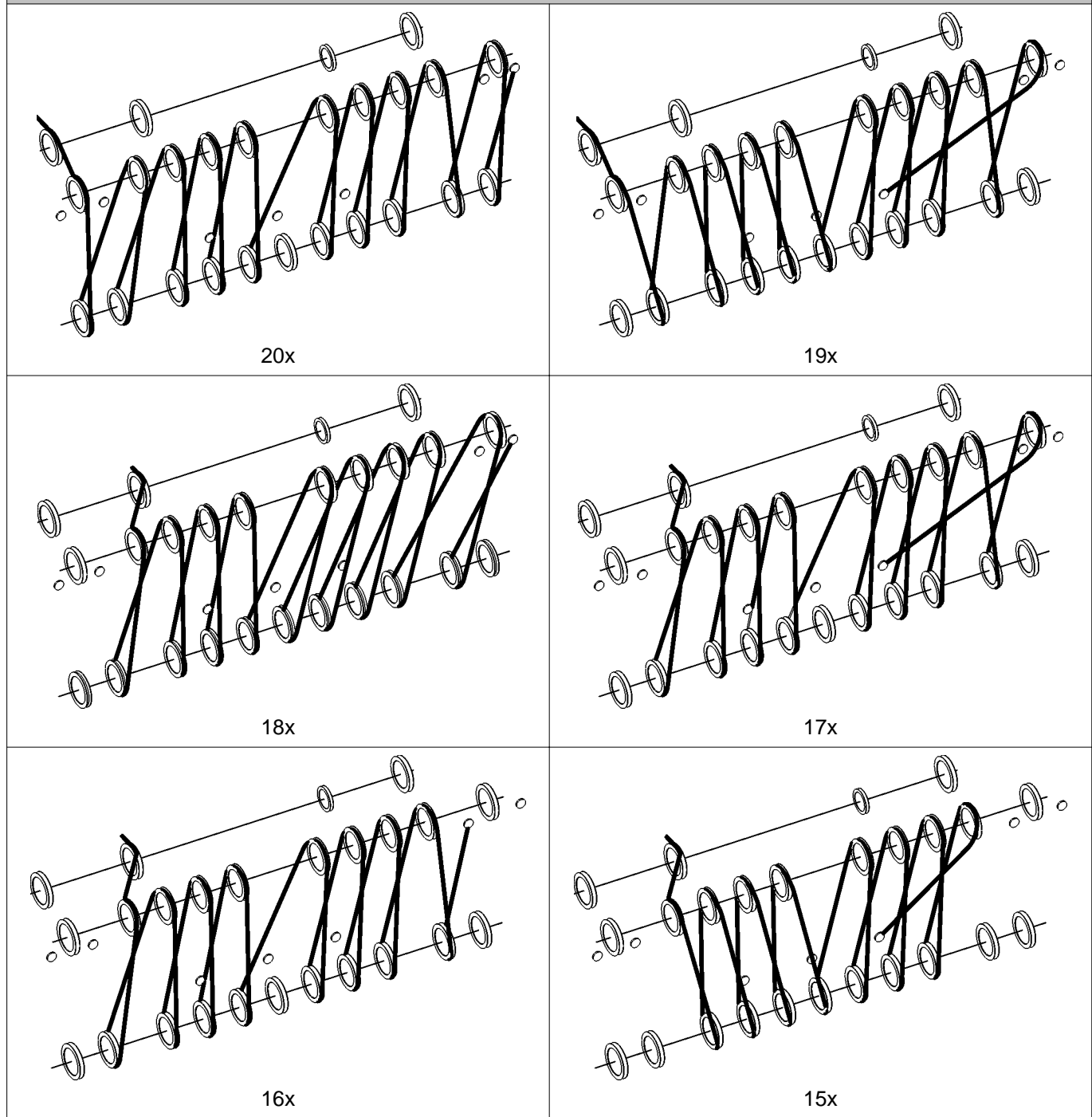
► Choose the correct number of reevings as per the load chart.

Reeving diagrams for one rope across main boom head 2821 (load position1)



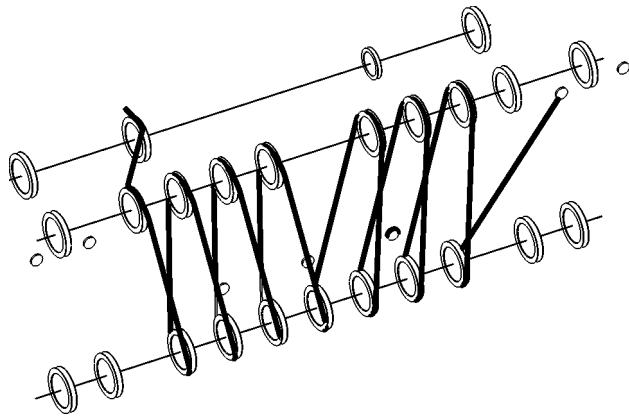
LWNLR-x/V04.01//Auslieferung/2016-03-07/en

Reeving diagrams for one rope across main boom head 2821 (load position1)

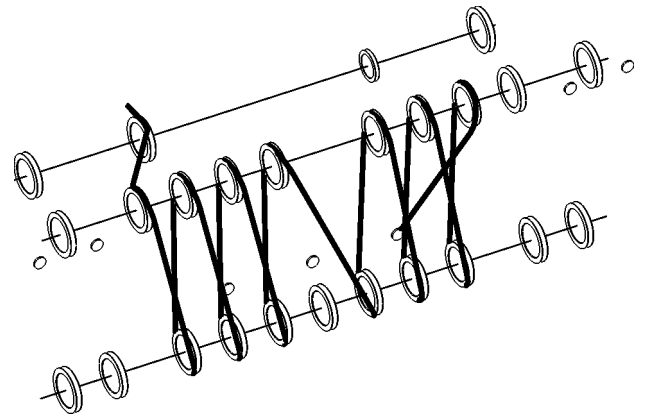


LWNLR-x\04.01\Auslieferung\2016-03-07\en

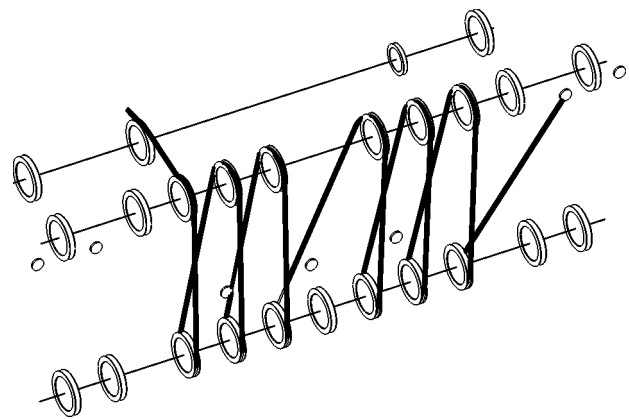
Reeving diagrams for one rope across main boom head 2821 (load position1)



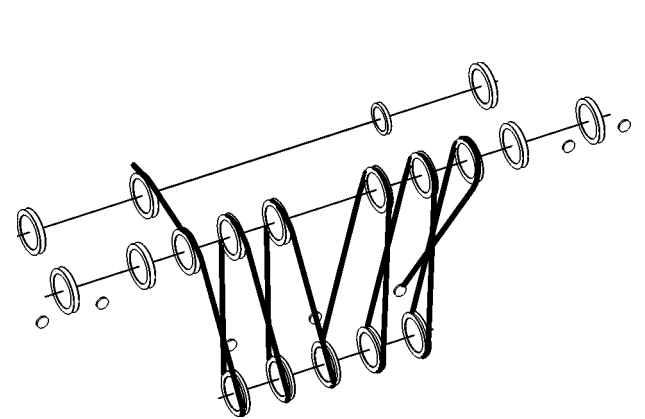
14x



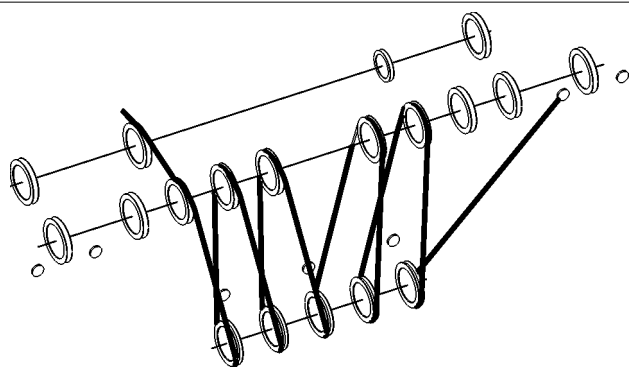
13x



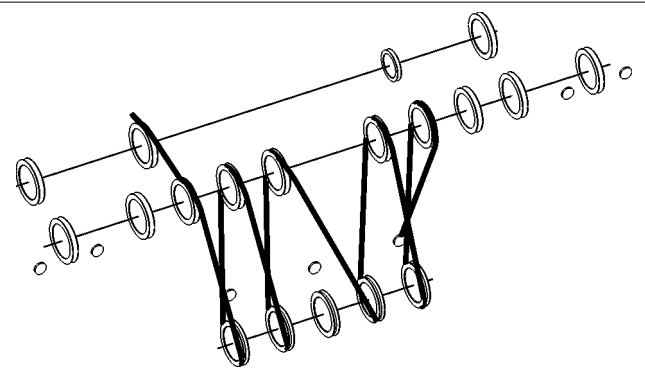
12x



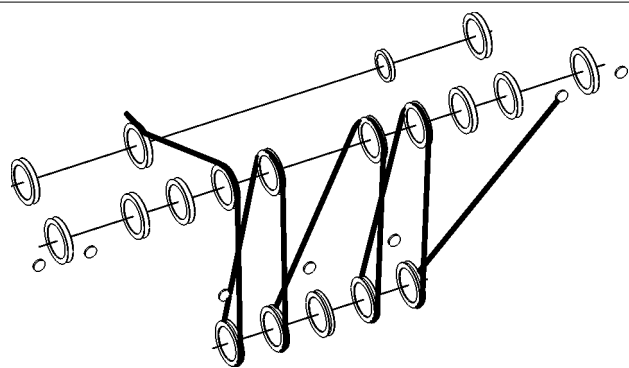
11x



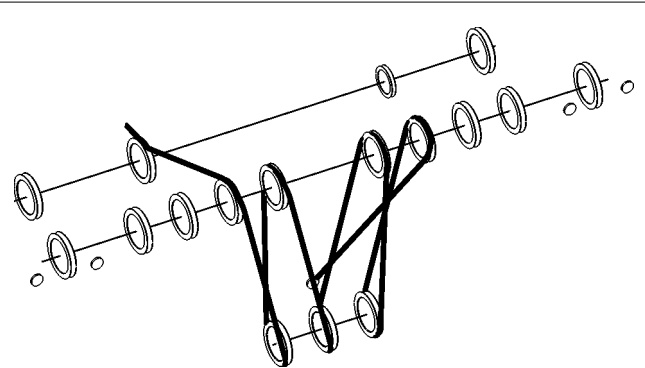
10x



9x

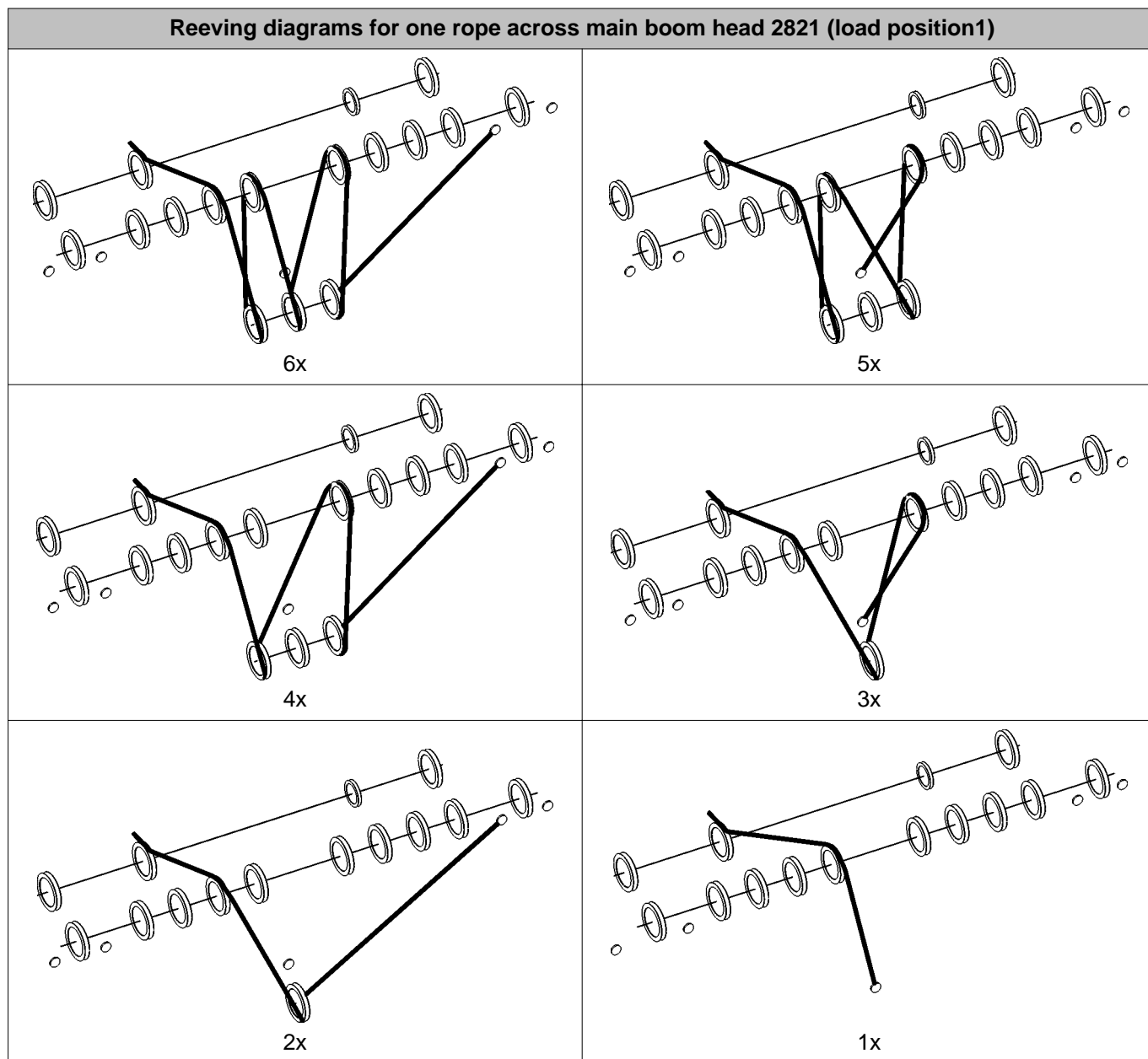


8x



7x

LWNLR.x/V04.01//Auslieferung/2016-03-07/en



Tab. 501: Reeving diagrams for one rope across main boom head 2821 (load position1)

LWNLR-x\04.01\Auslieferung\2016-03-07\en

7.5.6 Reeving diagrams for two ropes across main boom head 2821 (load position1)

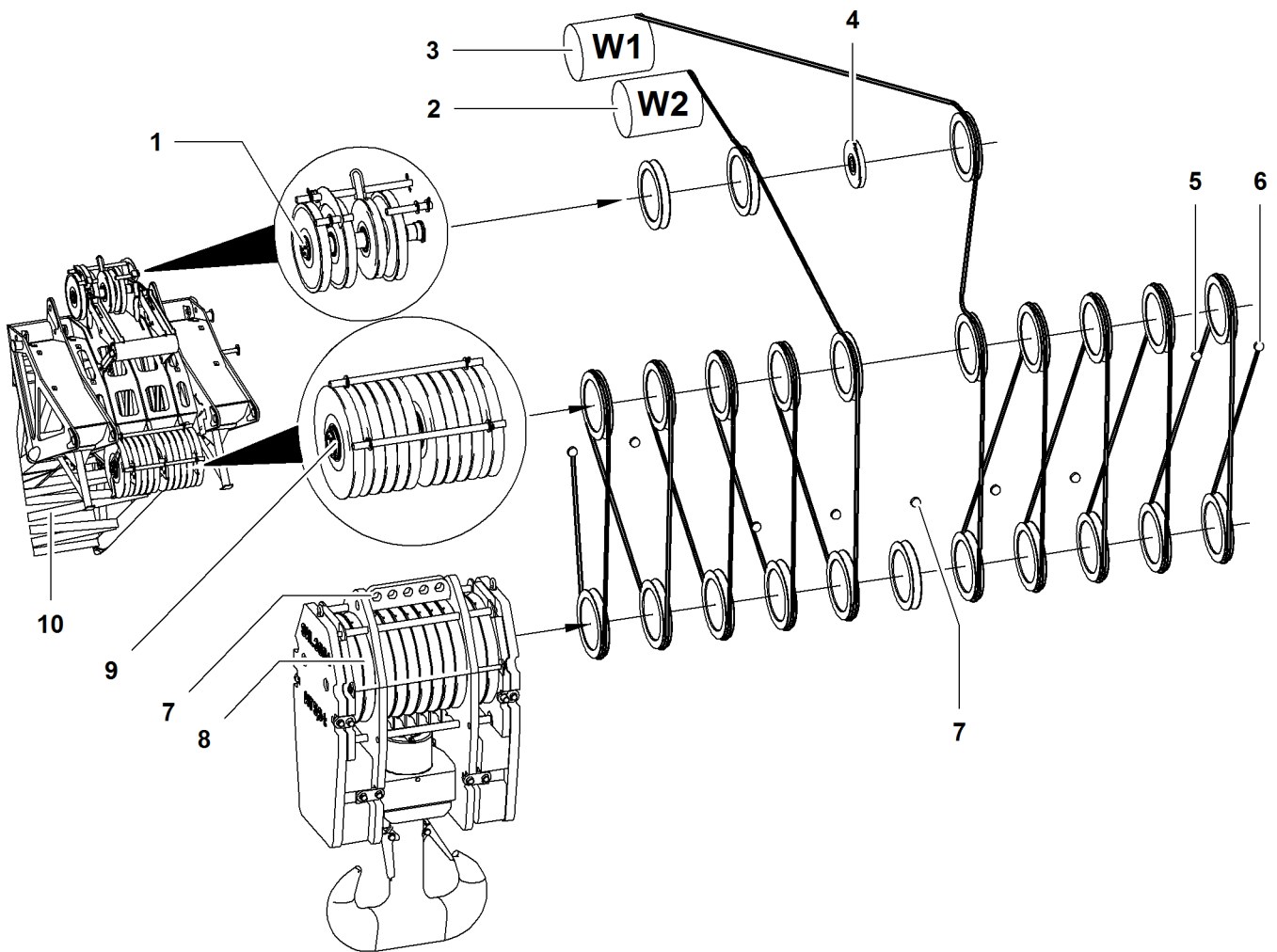


Fig. 3279: Reeving diagrams for two ropes across main boom head 2821 (load position1)

- | | | | | | |
|---|--------------------------------------|---|--|----|--------------------------------|
| 1 | Gantry pulley (3x) of main boom head | 5 | Inner rope fixing point (2x) of main boom head | 9 | Pulley (10x) of main boom head |
| 2 | Winch2 | 6 | Outer rope fixing point (2x) of main boom head | 10 | Main boom head |
| 3 | Winch1 | 7 | Rope fixing points of pulley block | | |
| 4 | Pulley for rope of jib luffing winch | 8 | Pulley set of pulley block | | |

LWNLR.x/V04.01//Auslieferung/2016-03-07/en

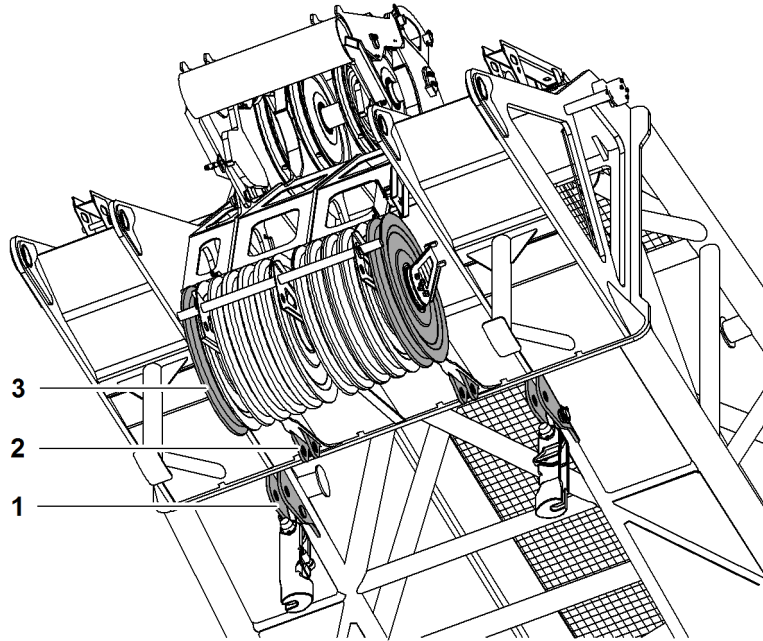


Fig. 3280: Rope fixing points main boom head 2821

- | | | | |
|---|------------------------------|---|-------------|
| 1 | Outer rope fixing point (2x) | 3 | Pulley (2x) |
| 2 | Inner rope fixing point (2x) | | |

If the first or last pulley **3** on the pulley set of the main boom head is used (reeved), the outer rope fixing point **1** is to be used.

If the first or last pulley **3** on the pulley set of the main boom head is not used (not reeved), the inner rope fixing point **2** is to be used.

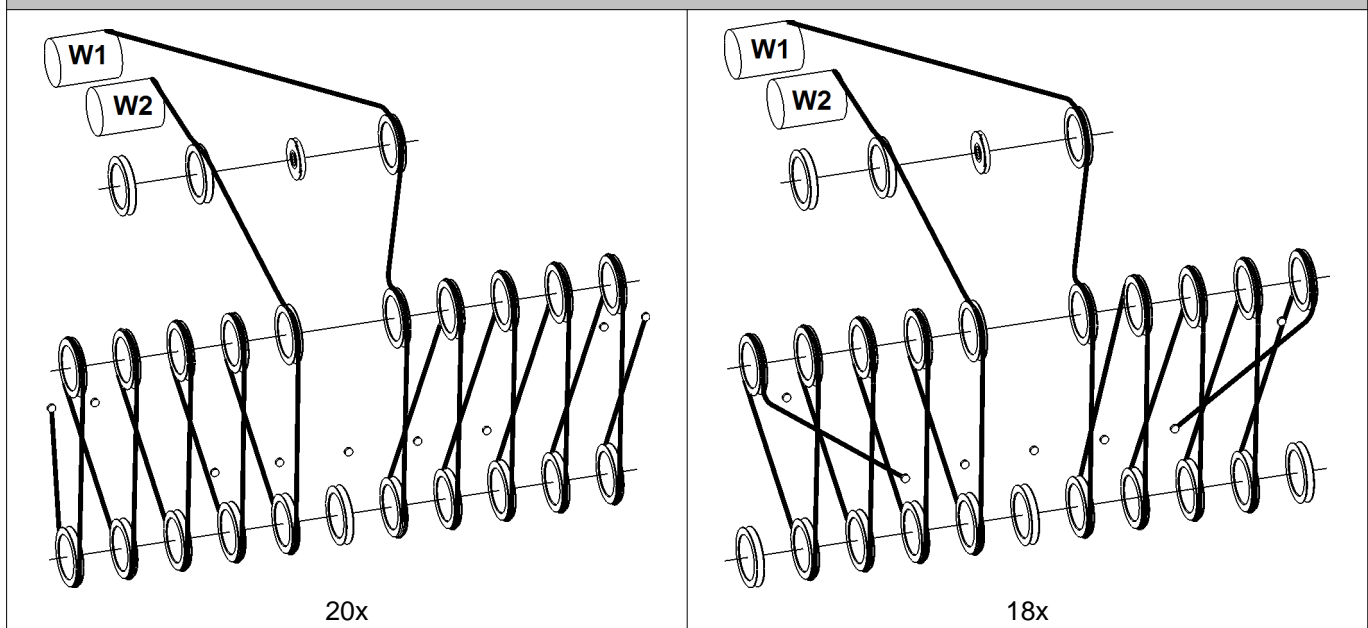


DANGER

Inadmissible number of reevings!
Structural breakdown, toppling of machine.

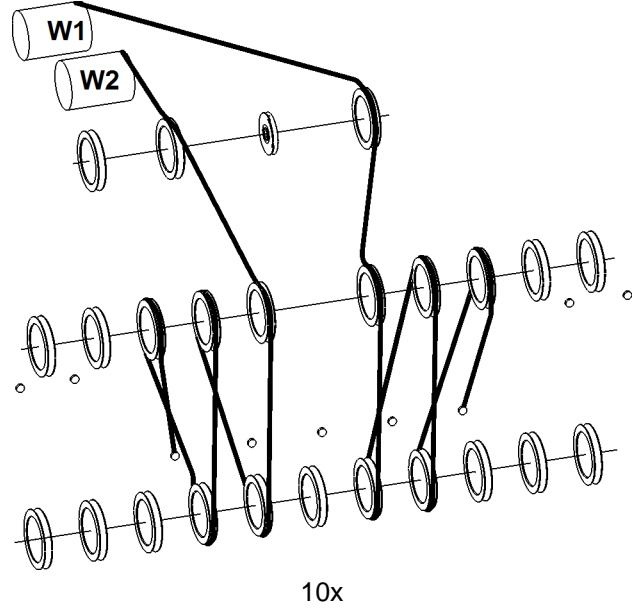
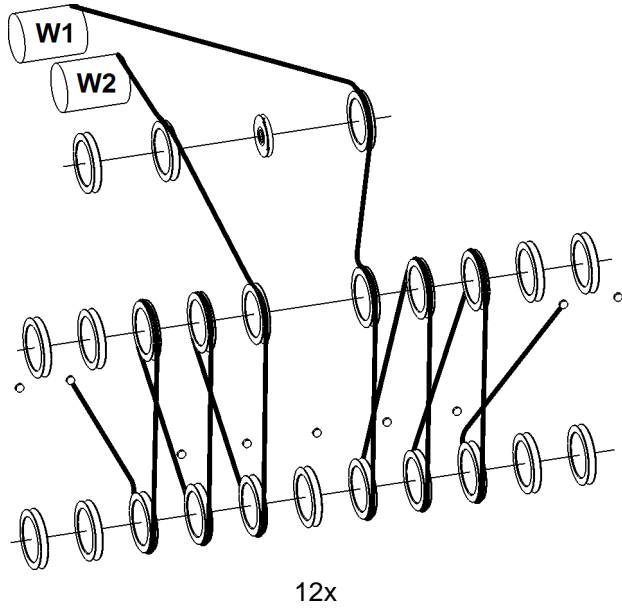
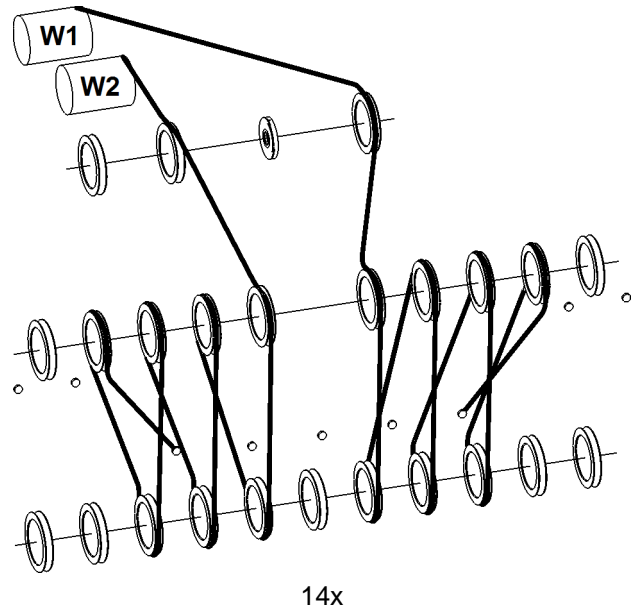
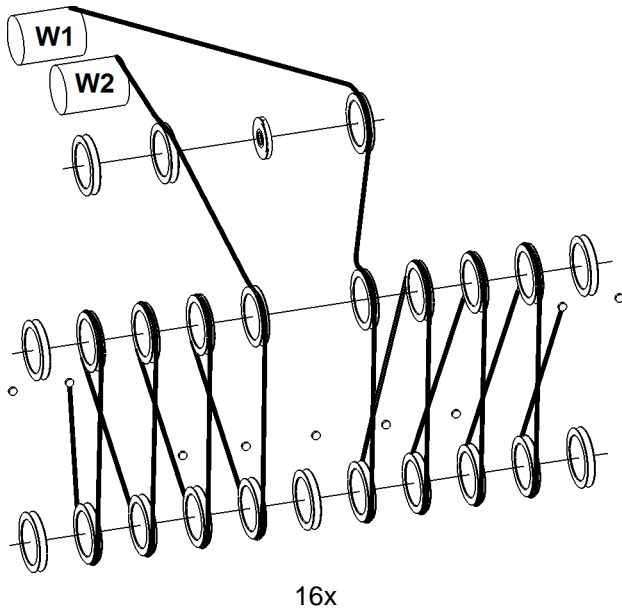
► Choose correct number of reevings as indicated in load chart.

Reeving diagrams for two ropes across main boom head 2821 (load position1)



LWNLR-x/V04.01//Auslieferung/2016-03-07/en

Reeving diagrams for two ropes across main boom head 2821 (load position1)



LWNLR.x/V04.01//Auslieferung/2016-03-07/en

7.5.7 Reeving diagrams for one rope across auxiliary jib (36 t (79300 lb)) on main boom head 2821 (load position1)

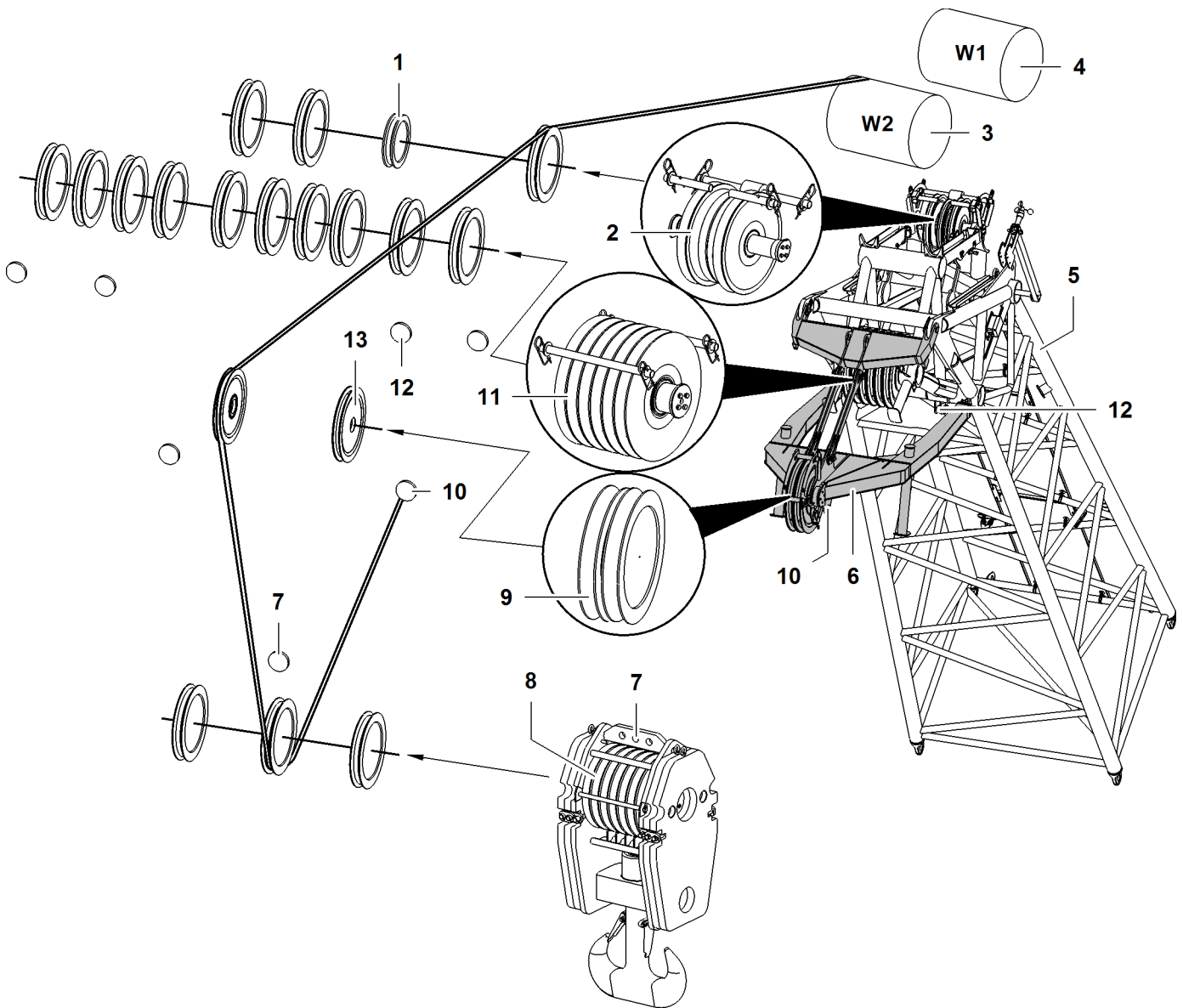


Fig. 3291: Reeving diagrams for one rope across auxiliary jib (36 t (79300 lb)) on main boom head 2821 (load position1)

- | | | | | | |
|---|--------------------------------------|----|--|----|--|
| 1 | Pulley for rope of jib luffing winch | 6 | Auxiliary jib (36 t (79300 lb)) | 11 | Pulley (10x) of main boom head |
| 2 | Gantry pulley (3x) of main boom head | 7 | Rope fixing points of pulley block | 12 | Rope fixing point (4x) of main boom head |
| 3 | Winch2 | 8 | Pulley set of pulley block | 13 | Second pulley* for triple reeving of auxiliary jib (36 t (79300 lb)) |
| 4 | Winch1 | 9 | Pulley of auxiliary jib (36 t (79300 lb)) | | |
| 5 | Main boom head | 10 | Rope fixing point of auxiliary jib (36 t (79300 lb)) | | |

LWNLR.x/V04.01//Auslieferung/2016-03-07/en

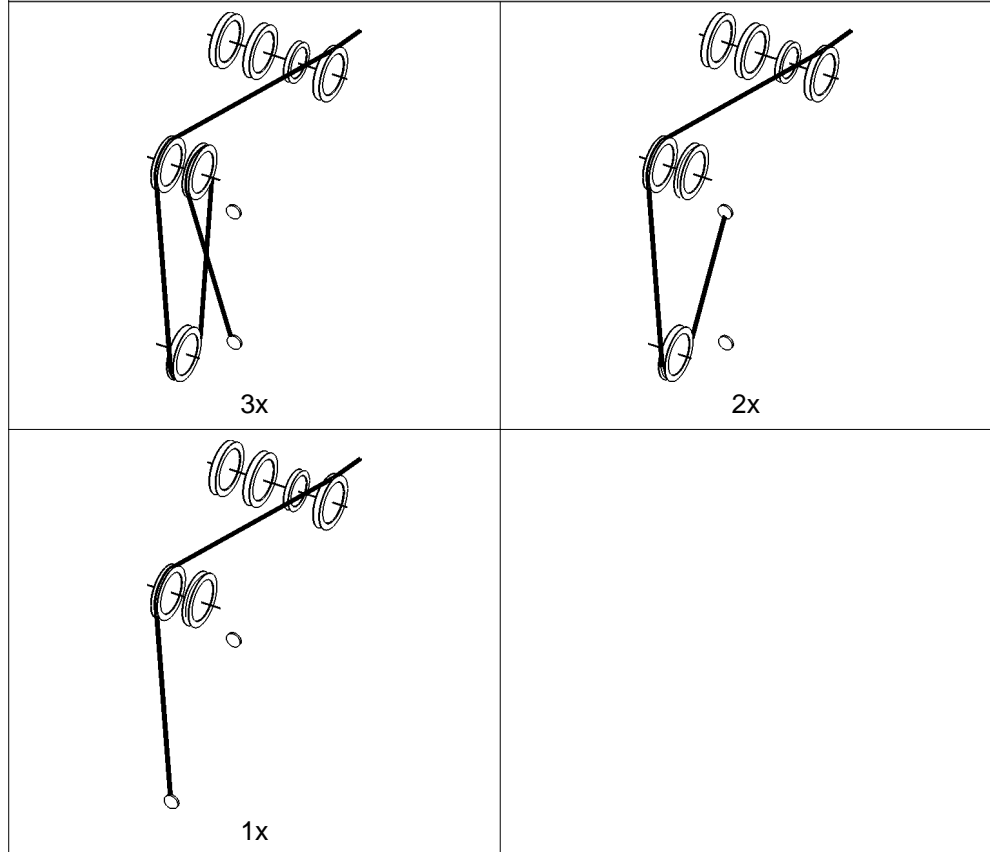


DANGER

Inadmissible number of reevings!
Structural breakdown, toppling of machine.

- ▶ Choose correct number of reevings as indicated in load chart.

Reeving diagrams for one rope across auxiliary jib (36 t (79300 lb)) on main boom head 2821 (load position1)



Tab. 503: Reeving diagrams for one rope across auxiliary jib (36 t (79300 lb)) on main boom head 2821 (load position1)

7.5.8 Reeving diagrams for two ropes across auxiliary jib (36 t (79300 lb)) and main boom head 2821 (load position 1)

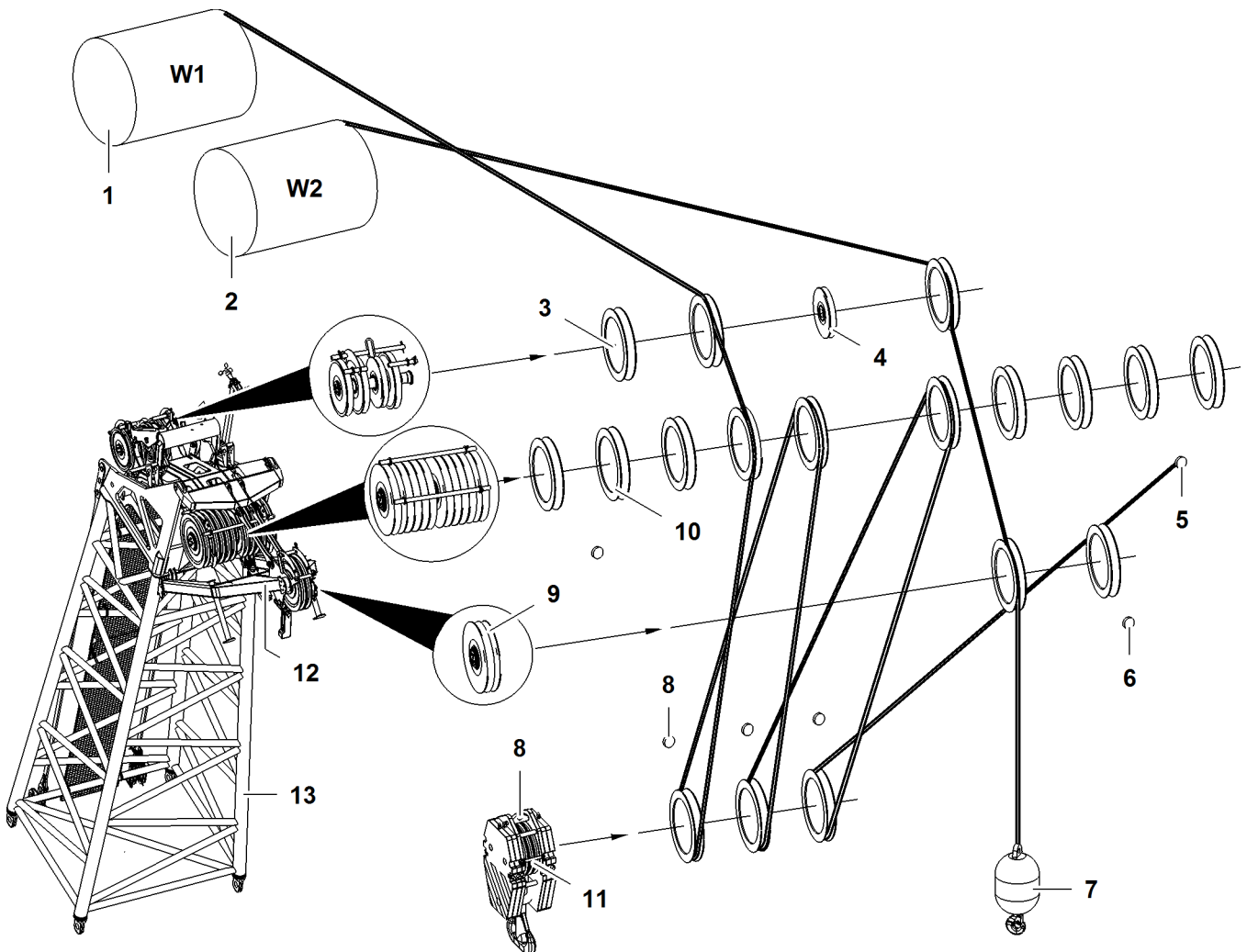


Fig. 3295: Reeving diagrams for two ropes across auxiliary jib (36 t (79300 lb)) and main boom head 2821 (load position 1)

- | | | |
|--|--|------------------------------------|
| 1 Winch1 | 6 Rope fixing point of auxiliary jib (36 t (79300 lb)) | 11 Pulley set of pulley block |
| 2 Winch2 | 7 Hook | 12 Auxiliary jib (36 t (79300 lb)) |
| 3 Gantry pulley (3x) of main boom head | 8 Rope fixing points of pulley block | 13 Main boom head |
| 4 Pulley for rope of jib luffing winch | 9 Second pulley* for triple reeving of auxiliary jib (36 t (79300 lb)) | |
| 5 Rope fixing point (4x) of main boom head | 10 Pulley (10x) of main boom head | |



DANGER

Inadmissible number of reevings!
Structural breakdown, toppling of machine.

► Choose correct number of reevings as indicated in load chart.

LWNLR.x/V04.01//Auslieferung/2016-03-07/en

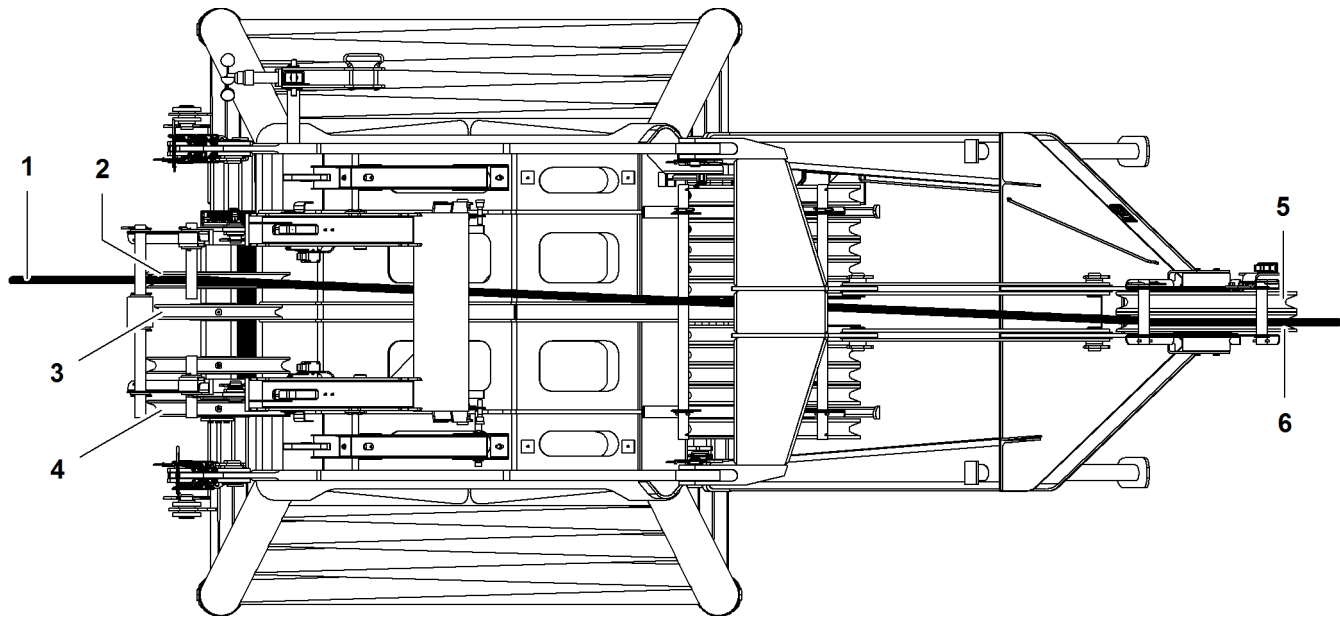


Fig. 3296: Rope run of auxiliary jib (36 t (79300 lb)) (illustration of principle)

- | | | | | | |
|---|--------------------------------------|---|--|---|--|
| 1 | Winch2 rope | 3 | Pulley for rope of jib luffing winch | 5 | Second pulley* for triple reeving of auxiliary jib (36 t (79300 lb)) |
| 2 | Left gantry pulley of main boom head | 4 | Right gantry pulley (2x) of main boom head | 6 | Pulley of auxiliary jib |

The rope of winch2 1 runs from the left gantry pulley 2 to the auxiliary jib pulley 6.

The rope of winch1 runs from one of the right gantry pulleys 4 to the required pulley on the main boom head.

7.5.9 Reeving diagram - jib luffing winch as auxiliary winch



DANGER

Incorrect number of reevings!
Structural breakdown, toppling of machine.

- ▶ Choose the correct number of reevings as per the load chart.

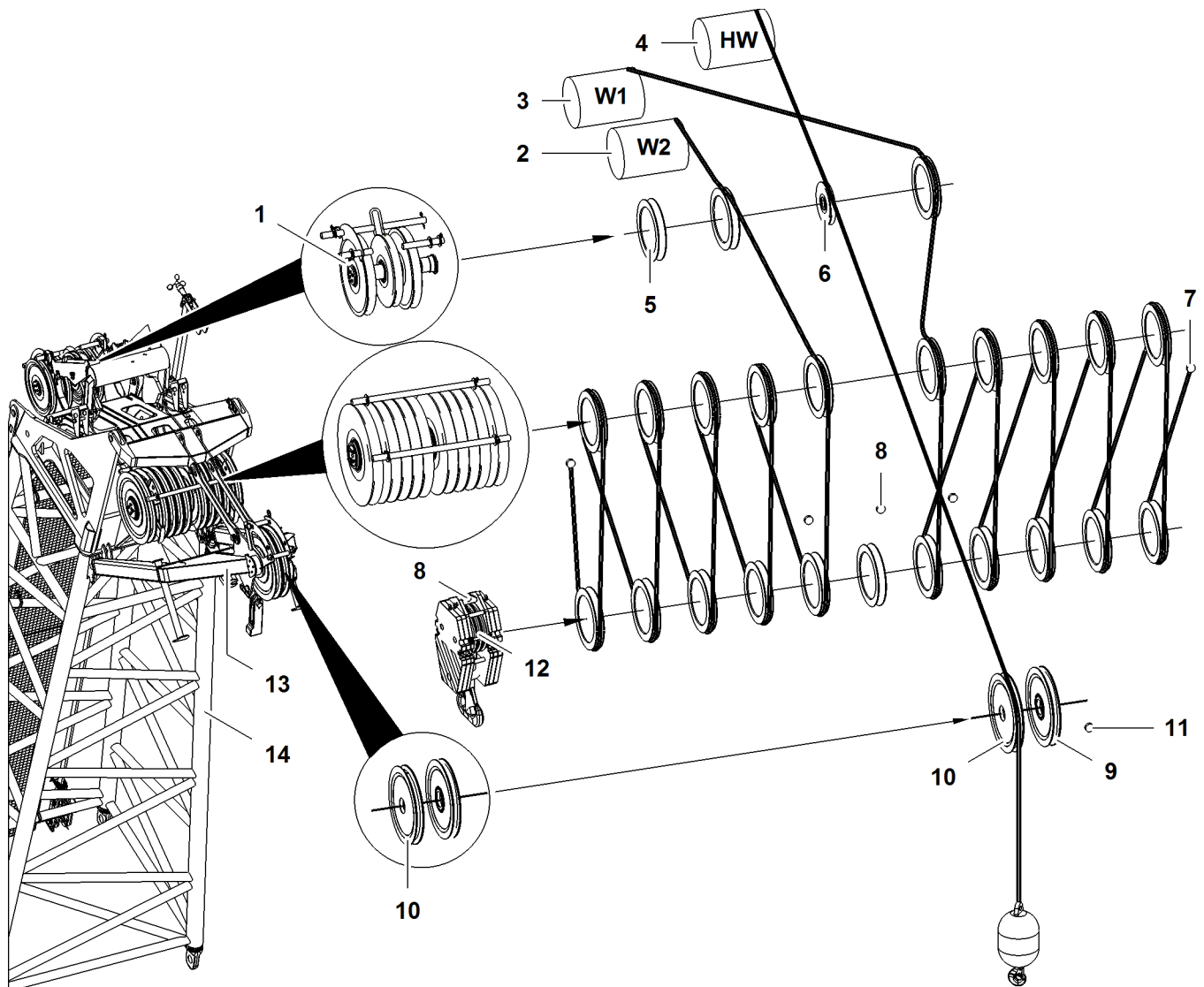


Fig. 3297: Reeving diagram - jib luffing winch as auxiliary winch (illustration of principle)

- | | | | | | |
|---|---|----|--|----|--|
| 1 | Gantry pulley (2x) of main boom head | 6 | Pulley for rope of jib luffing winch | 11 | Rope fixing point of auxiliary jib (36 t (79300 lb)) |
| 2 | Winch2 | 7 | Rope fixing points of main boom head | 12 | Pulley set of pulley block |
| 3 | Winch1 | 8 | Rope fixing points of pulley block | 13 | Auxiliary jib (36 t (79300 lb)) |
| 4 | Jib luffing winch as auxiliary winch* | 9 | Second pulley* for triple reeving of auxiliary jib (36 t (79300 lb)) | 14 | Main boom head |
| 5 | Gantry pulley (only with LR 1004 und LR 1006) | 10 | Pulley of auxiliary jib (36 t (79300 lb)) | | |

LWNLR.x/V04.01//Auslieferung/2016-03-07/en

7.6 Assembly of main boom without derrick equipment*

Make sure the following prerequisites are met:

- Assembly functions are activated.
- Machine is ready for use as assembly crane, or an assist crane is available.
- Work plans were drawn up.
- The length and the order of the main boom sections are known.
- The installation positions of the rope guide are known.
- Installation positions of the mid-point suspensions are known.
- Required accessories are available.

7.6.1 Notes

The illustrations have been simplified or schematically represented for reasons of uniformity and represent the principles of assembly. They do not provide a detailed representation of the components.

7.6.2 Programming the setup



DANGER

Unacceptable setup!

- ▶ Only program a setup on the machine that is in accordance with the load chart.
- ▶ Programming the setup on the machine ([For more information see: 4.13 Programming the setup, page 886](#)).

7.6.3 Unloading and positioning the main boom section



DANGER

Slewing of uppercarriage with rear counterweight attached not permitted!
Machine toppling over.

- ▶ Slew the uppercarriage according to the table ([For more information see: Lifting and pinning the rear counterweight, page 1264](#)) exclusively.



DANGER

Incorrect or defect parts or components!
Structural breakdown.

- ▶ Only use original Liebherr parts and original Liebherr components in perfect condition.



DANGER

Improperly assembled boom configuration!
Structural breakdown.

- ▶ Ensure that the assembled boom configuration is compatible with the programmed setup.



DANGER

Incorrect arrangement of boom sections!
Structural breakdown.

- ▶ Assemble the main boom according to the relevant system requirements.
- ▶ A boom section of 6 m (20 ft) cannot be replaced by two boom sections of 3 m (10 ft).
- ▶ A boom section of 12 m (40 ft) cannot be replaced by two boom sections of 6 m (20 ft).
- ▶ Make sure that with model LR 1300 only main boom sections with the system dimensions 2821.24 are installed (For more information see: 1.9 Distinguishing features main boom sections LR 1300 and LR 1300 SX, page 159) .
- ▶ Make sure that with model LR 1300 SX only main boom sections with the system dimensions 2821.30 are installed (For more information see: 1.9 Distinguishing features main boom sections LR 1300 and LR 1300 SX, page 159) .

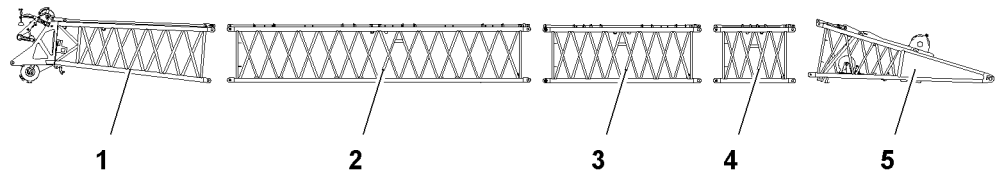


Fig. 3298: Unloading and positioning the main boom components

- | | | | |
|---|---------------------------|---|--------------------------|
| 1 | Boom head section | 4 | Boom section 3 m (10 ft) |
| 2 | Boom section 12 m (40 ft) | 5 | Boom base section |
| 3 | Boom section 6 m (20 ft) | | |

- ▶ Direct transport vehicles with boom components.
- ▶ Lash main boom sections by attaching lifting equipment to the lifting points.
- ▶ Unload main boom sections onto wooden blocks using the basic machine or assist crane and position according to the relevant system instructions.

7.6.4 Assembling the ladder* for the boom



CAUTION

Unauthorized use of ladder!
Fall from ladder.

- ▶ Only use the ladder with boom sections on which the required ladder angle of 75° to 80° can be observed.



CAUTION

The ladder must not be placed under an impermissible dynamic load!
Fall from ladder, break of ladder.

- ▶ The ladder must only be used for general assembly work on pendant straps and pin connection points on the boom sections.
- ▶ Do not stand on the ladder to knock in the boom section pins.
- ▶ The ladder must be checked for damage and cracks before it is fitted and before it is used.

LWNLR.x/V04.01//Auslieferung/2016-03-07/en



CAUTION

Take great care if walking on boom sections!
risk of falling from boom section.

- ▶ Only ever walk on boom sections if boom catwalks are fitted.
- ▶ A fall arrest system must be used when working on boom sections to prevent falling.



CAUTION

Slipping of the ladder!
Fall from ladder.

- ▶ Secure ladder against sliding.

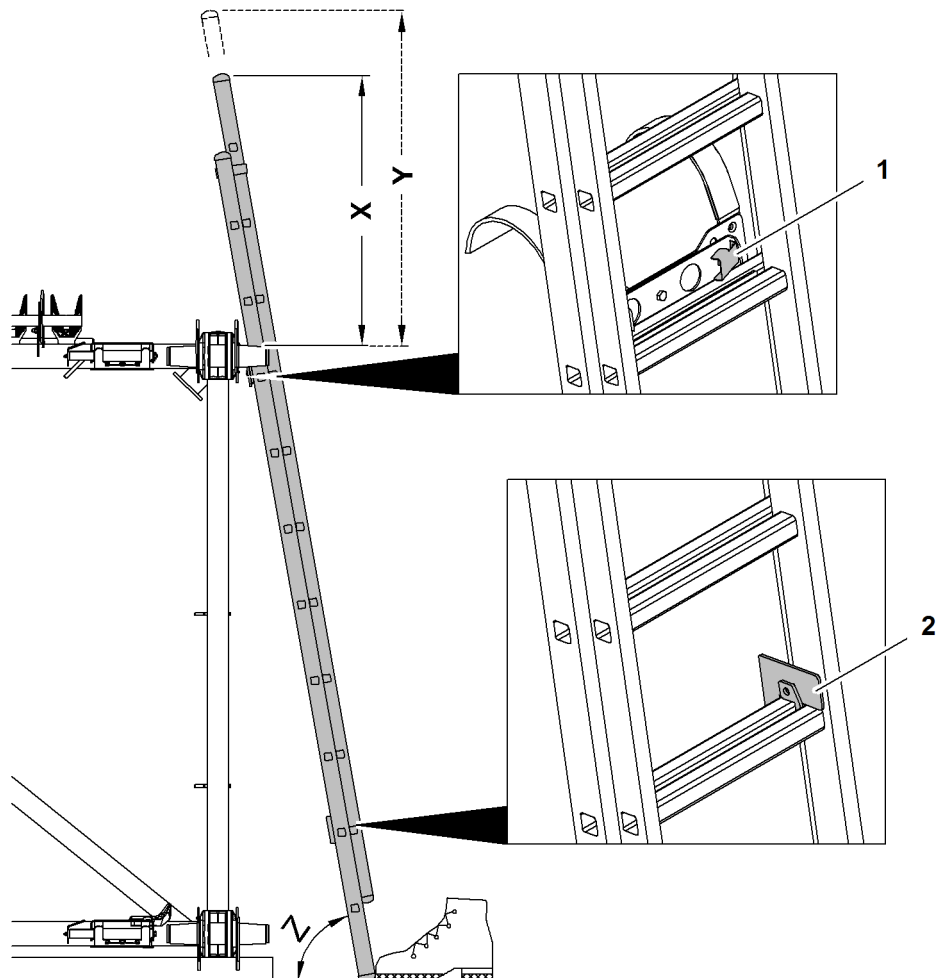


Fig. 3299: Assembling the ladder for the boom

- | | | | |
|---|------------------------|---|----------------|
| 1 | Top locking element | Y | Maximum height |
| 2 | Bottom locking element | Z | Ladder angle |
| X | Minimum height | | |

The ladder angle Z must remain between 75° and 80° .

The minimum height X must be at least 1000 mm (3' 3" ft-in).

If the maximum height Y is exceeded, the ladder topples.

- ▶ Insert ladder support at belt pipe of boom section.



CAUTION

Improperly extended ladder!
Fall from ladder.

- ▶ Observe slant angle **Z**.
- ▶ Observe minimum height **X**.
- ▶ Do not exceed maximum height **Y**.

- ▶ Extend extendable part of the ladder until minimum height **X** is exceeded.



CAUTION

Unsecured ladder!
Fall from ladder.

- ▶ Secure ladder against sliding.
- ▶ Ensure that locking elements engage.

- ▶ Check top locking element.
- ▶ Check bottom locking element.
 - ▷ Ladder for boom is installed:

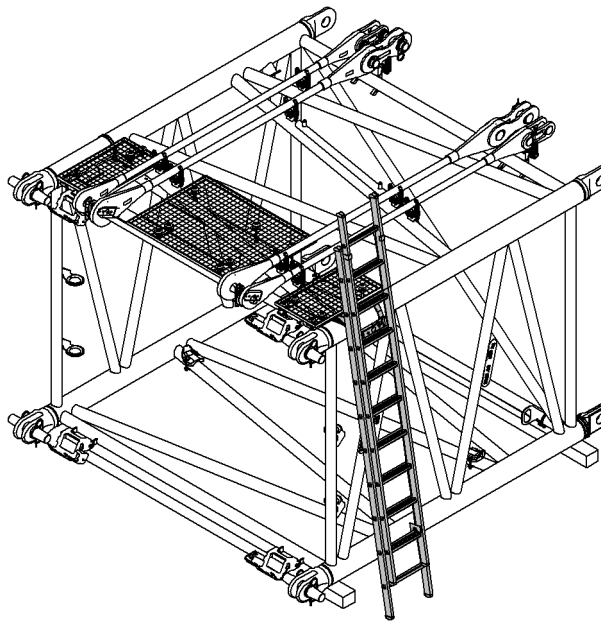


Fig. 3300: Ladder for boom is installed

7.6.5 Bolting the boom head section to the boom sections



WARNING

Never stand in the inside of the main boom sections during assembly!
Serious injury.

- ▶ Never go inside the boom sections.
- ▶ Drive in double-taper pins from the outside exclusively.



Note

If a fixed jib (excluding fixed jib 1507) is going to be added:

- ▶ Bolt the boom head section and boom section to the upper pin connection points using double-taper pins from the A-frame 2 equalizer (jib backstay strap) of the fixed jib.

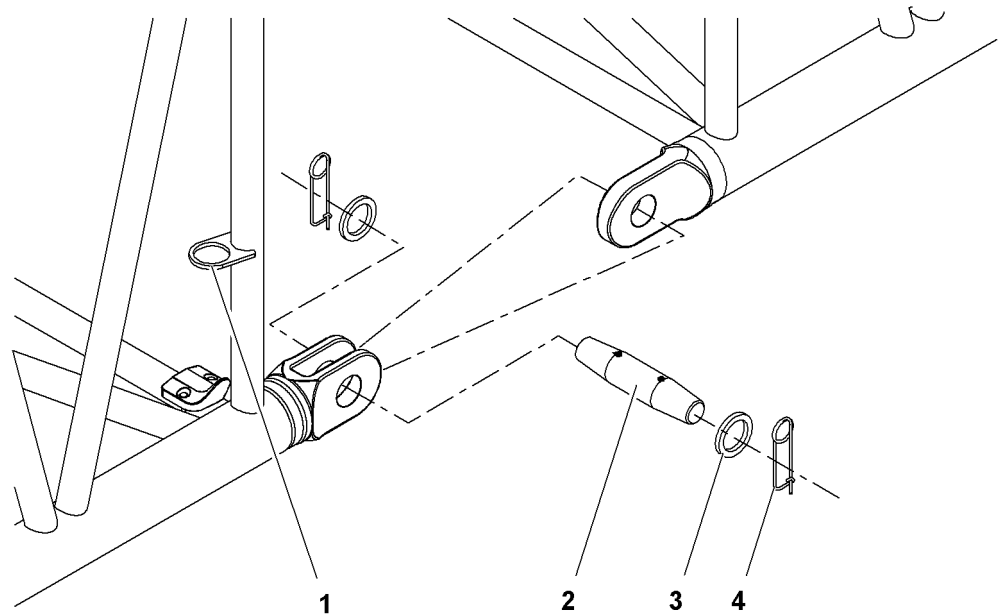


Fig. 3301: Bolting the main boom

- | | | | |
|---|--|---|-----------------|
| 1 | Transport bracket (4x) for double-taper pins | 3 | Washer (8x) |
| 2 | Double-taper pin (4x) | 4 | Safety pin (8x) |

- ▶ Remove the double-taper pins 2 from the transport brackets 1.



Note

Liebherr recommends:

- ▶ To make assembly and disassembly easier, grease the double-taper pin.

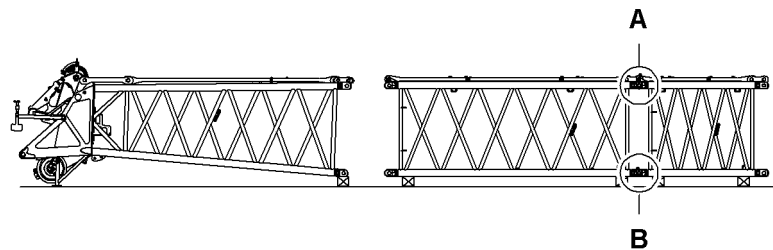


Fig. 3302: Bolting the main boom sections

- | | | | |
|---|---------------------------------|---|---------------------------------|
| A | Upper pin connection point (2x) | B | Lower pin connection point (2x) |
|---|---------------------------------|---|---------------------------------|

- ▶ Bolt all boom sections to one another on pin connection points A + B.
- ▶ Secure the double-taper pins with washers and safety pins.

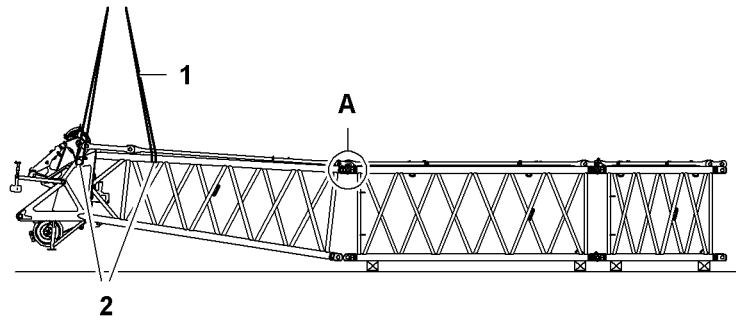


Fig. 3303: Bolting the boom head section to the boom sections at the top

- | | | | |
|---|--------------------|---|---------------------------------|
| 1 | Round sling (4x) | A | Upper pin connection point (2x) |
| 2 | Lifting point (4x) | | |

- ▶ Attach the boom head section on the lifting points **2**.
- ▶ Lift the boom head section to the boom section until the upper pin connection points **A** match.
- ▶ Bolting the boom head section to the boom sections on the upper pin connection points **A**.
- ▶ Secure the double-taper pins with washers and safety pins.

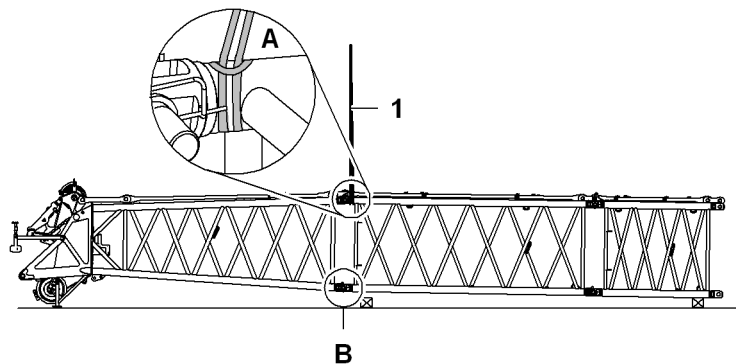


Fig. 3304: Bolting the boom head section to the boom sections at the bottom

- | | | | |
|---|------------------|---|---------------------------------|
| 1 | Round sling (2x) | B | Lower pin connection point (2x) |
| A | Chord pipe (2x) | | |

- ▶ Attach boom section to chord pipes **A**.
- ▶ Lift the boom section until the lower pin connection points **B** match.
- ▶ Bolting the boom head section to the boom sections on the lower pin connection points **B**.
- ▶ Secure the double-taper pins with washers and safety pins.

7.6.6 Connecting catwalks* for booms

Make sure the following prerequisites are met:

- Boom components are pinned to each other.

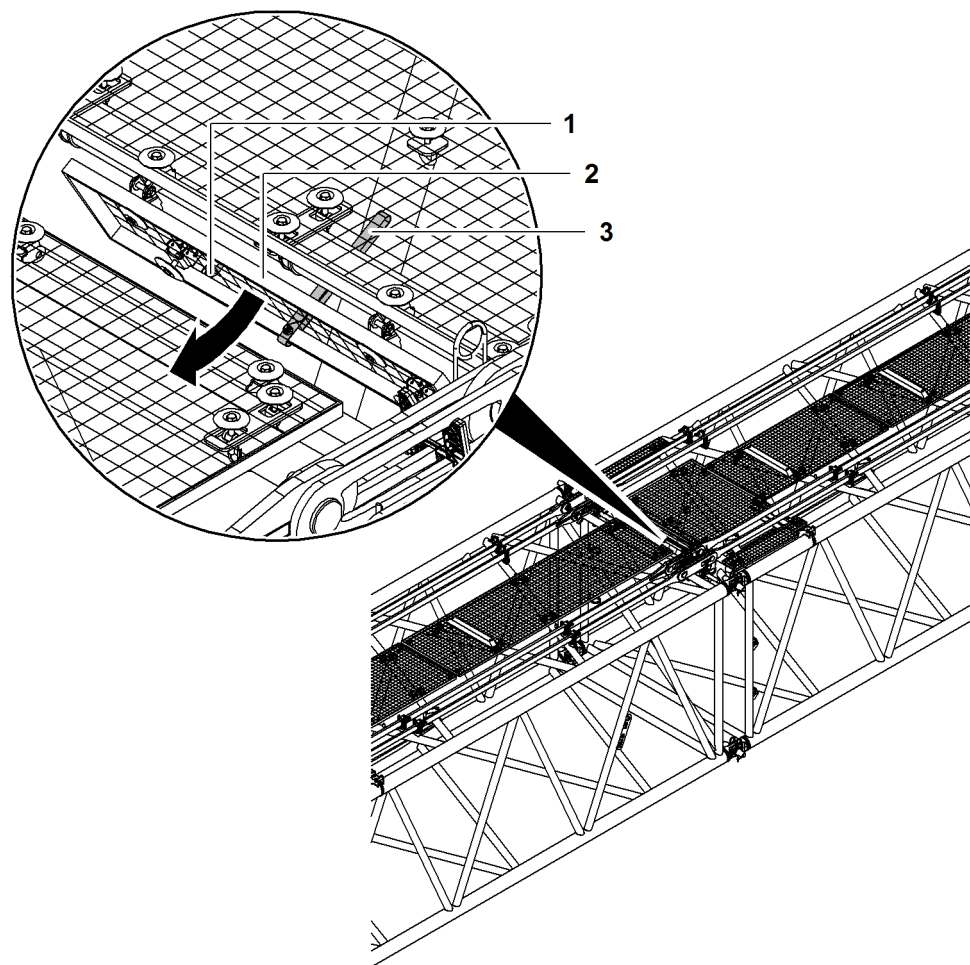


Fig. 3305: Connecting catwalks for booms (illustration of principle)

- | | | | |
|---|---------------------------------|---|---------------|
| 1 | Pin (2x) with spring cotter pin | 3 | Retainer belt |
| 2 | Catwalk (hinged) | | |

- ▶ Open retainer belt **3**.
- ▶ Remove pin **1** with spring cotter pin on both sides.
- ▶ Fold up catwalk **2**.

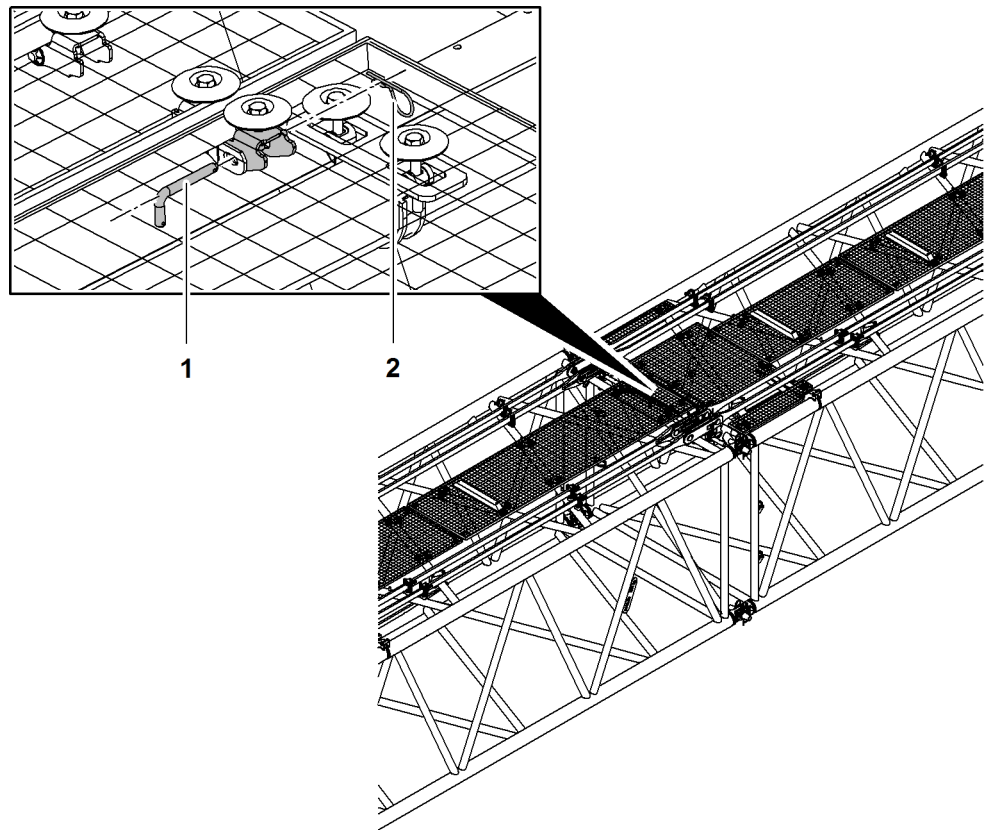


Fig. 3306: Connecting catwalks for booms (illustration of principle)

1 Pin (2x)

2 Spring cotter pin (2x)

When the pin connection points of the catwalks align:

- ▶ Insert pin 1 on both sides.
- ▶ Secure pins 1 with spring cotter pins 2.
- ▶ Repeat procedure with all boom components.

7.6.7 Connecting and checking boom fall arrest*



WARNING

Improper assembly of the boom fall arrest*!
Risk of falling off the boom.

- ▶ Ensure that the boom fall arrest* is in impeccable condition.
 - ▶ Ensure that the boom fall arrest* is connected and secured between boom sections according to the specifications.
-
- ▶ Connect and check boom fall arrest* in accordance with additional documentation LIE-TAURUS.

7.6.8 fit the rope guide

NOTICE

Incorrect assembly of the rope guide!
Risk of damage to the rope.

- ▶ Fit rope guide according to relevant system instructions.

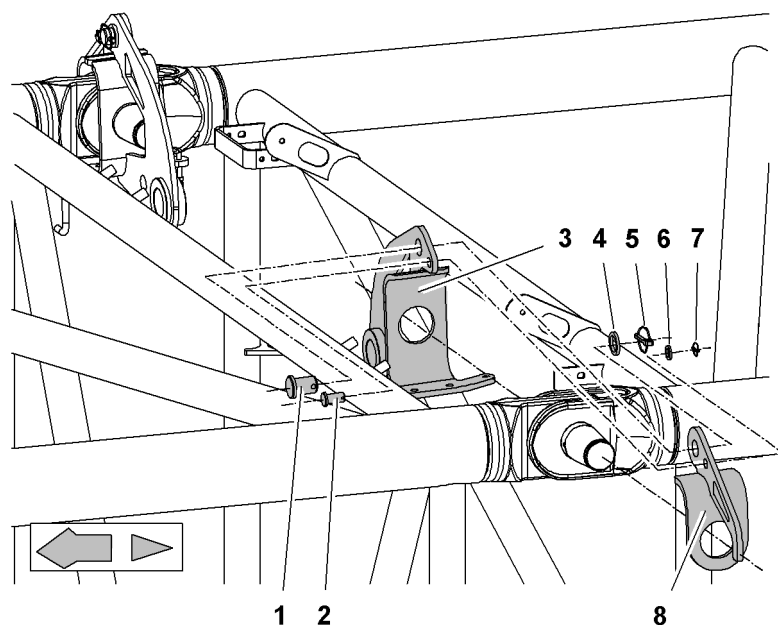


Fig. 3307: Fitting the rope guide forks

1	Pin	5	Linch pin
2	Pin	6	Washer
3	Inner section of fork	7	Linch pin
4	Washer	8	Outer section of fork

- ▶ Remove the safety pins and washers from both sides of the boom pin connection double-taper pin and stow away.
- ▶ Mount the inner and outer sections of the fork **3 + 8** on the double-taper pin.
- ▶ Pin the inner and outer sections of the **3 + 8** fork.
- ▶ Secure pin **1 + 2** with washers **4 + 6** and linch pins **5 + 7**.

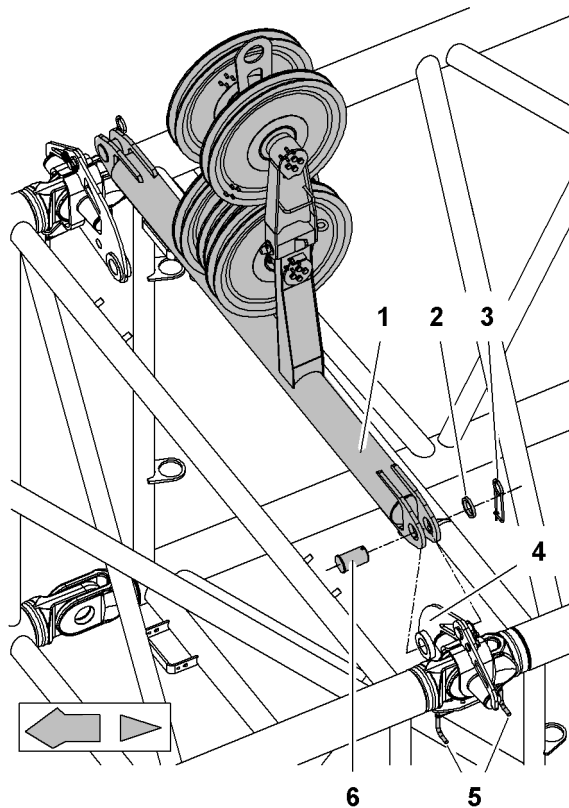


Fig. 3308: Attach rope guide

- | | | | |
|---|------------|---|------------|
| 1 | Rope guide | 4 | Fork |
| 2 | Washer | 5 | Screw (2x) |
| 3 | Safety pin | 6 | Pin |

- ▶ Pin rope guide 1 to fork 4.
- ▶ Secure the pin 6 with washer 2 and retaining spring 3.

If the assembly position of the rope guide is identical to the assembly position of the mid-point suspension:

- ▶ pin the ropes on the mid-point suspension to the rope guide forks.
- ▶ Secure the pin with a washer and safety pin.

NOTICE

The screws 5 must not be tightened before the ropes on the mid-point suspension are pinned to the rope guide forks!
Risk of damage to the components.

Once the ropes on the mid-point suspension are pinned to the rope guide forks:

- ▶ tighten screws 5.
- ▶ Use both screws 5 to vertically align the rope guide and manually fix it in place.

7.6.9 Pinning the pendant straps

- ▶ Remove safety pins from the transport brackets for pendant straps.

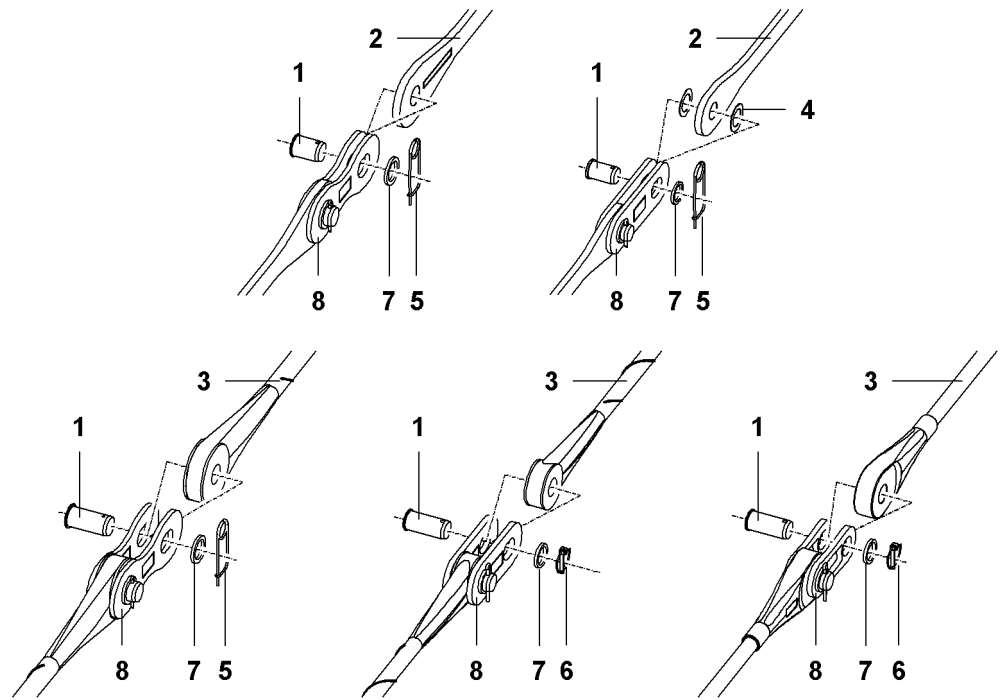


Fig. 3309: Bolt the pendant straps (schematic diagram of various pendant straps)

1	Pin	5	Safety pin
2	Steel pendant strap	6	Lynch pin
3	Carbon-fibre pendant strap	7	Washer
4	Plastic washer (2x)	8	Connecting link

- ▶ Remove the pin 1 on the connecting link 8.
- ▶ Position the pendant strap 2, 3 between the two coupling links 8.
or
- If the pendant strap has plastic washers 4:
Position the pendant strap 2 with plastic washers 4 on both sides between the two connecting links 8.
- ▶ Insert pin 1 and secure with washers 7 and safety pin 5 or lynch pin 6.

7.6.10 Removing the jib backstay straps

The jib backstay straps are transported on the boom sections. They can be removed if no jib is mounted.



Note

Higher load with deinstalled jib backstay straps!

- ▶ Refer to the foreword in the valid load capacity chart.

If the jib backstay straps are left on the main boom:

- ▶ Pin the jib backstay straps together and secure with washers and a safety pin.
- ▶ Pin the connecting links on the boom head section to the jib backstay straps and secure with washers and a safety pin.
- ▶ Pin the connecting links on the boom base section to the jib backstay straps and secure with washers and a safety pin.
- ▶ Secure the transport brackets for the jib backstay straps with safety pins.

7.6.11 Installing mid-point suspension

The lengths of the stay ropes and their assembly positions are shown in the relevant instructions for the boom.



Note

Special procedure for installing the mid-point suspension for main boom 2821 with main boom length of 80 m (262' 6" ft-in), 83 m (272' 4" ft-in) or 86 m (282' 2" ft-in) and installed jib 1507!

- ▶ Fit mid-point suspension as instructed.



DANGER

Incorrect installation of mid-point suspensions!
Structural breakdown.

- ▶ Fit mid-point suspensions according to relevant system instructions.
- ▶ Assemble required length of stay ropes in line with system-relevant details.
- ▶ Remove the safety pins and washers from both sides of the boom pin connection double-taper pin and stow away.
- ▶ Repeat procedure on opposite side.

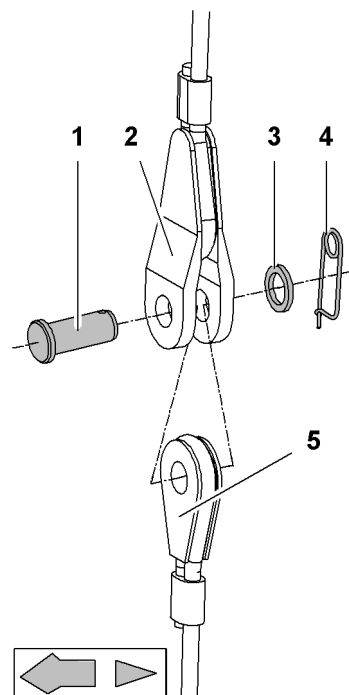


Fig. 3310: Pinning mid-point suspension stay ropes

- | | | | |
|---|---------------|---|------------------|
| 1 | Pin | 4 | Safety pin |
| 2 | Top stay rope | 5 | Bottom stay rope |
| 3 | Washer | | |

- ▶ Pin top stay rope 2 to bottom stay rope 5.
- ▶ Secure the pin 1 with washer 3 and retaining spring 4.

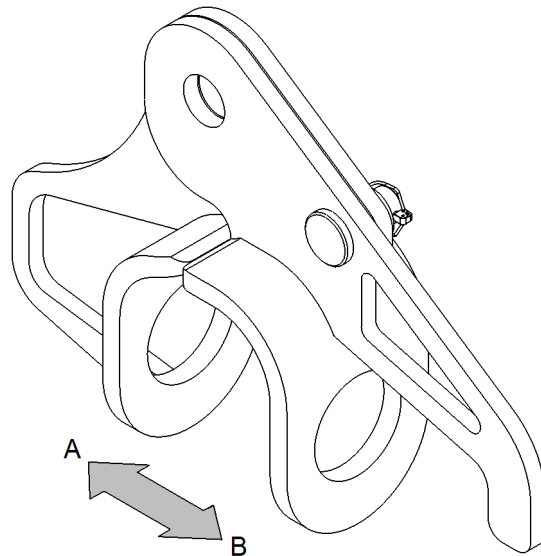


Fig. 3311: Mid-point suspension forks

A Main boom interior

B Main boom exterior

The forks may have different shapes. The permissible shape depends on the boom configuration (For more information see: 1 Product description, page 51) .

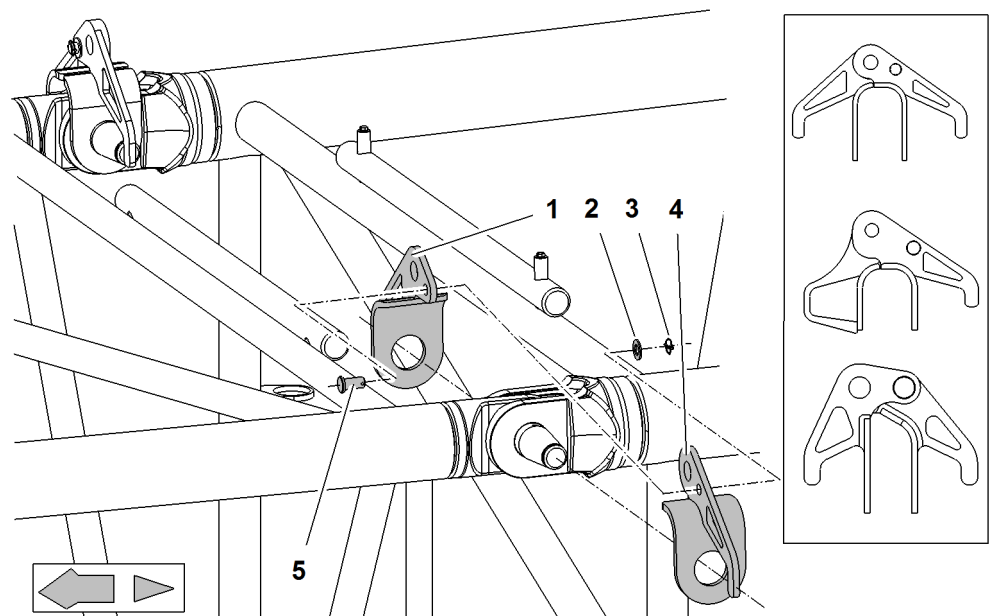


Fig. 3312: Assembling the mid-point suspension forks

1 Inner section of fork

2 Washer

3 Linch pin

4 Outer section of fork

5 Pin



Note

Special assembly procedure when the mid-point suspension and rope guide are installed in exactly the same position on the main boom!

► The rope guide forks replace the mid-point suspension forks.

► Mount inner section of fork **1** on double-taper pin.

- ▶ Mount outer section of fork **4** on double-taper pin.
- ▶ Pin inner section of fork **1** to outer section of fork **4**.
- ▶ Secure pin **5** with a washer **2** and linch pin **3**.
- ▶ Repeat procedure on opposite side.

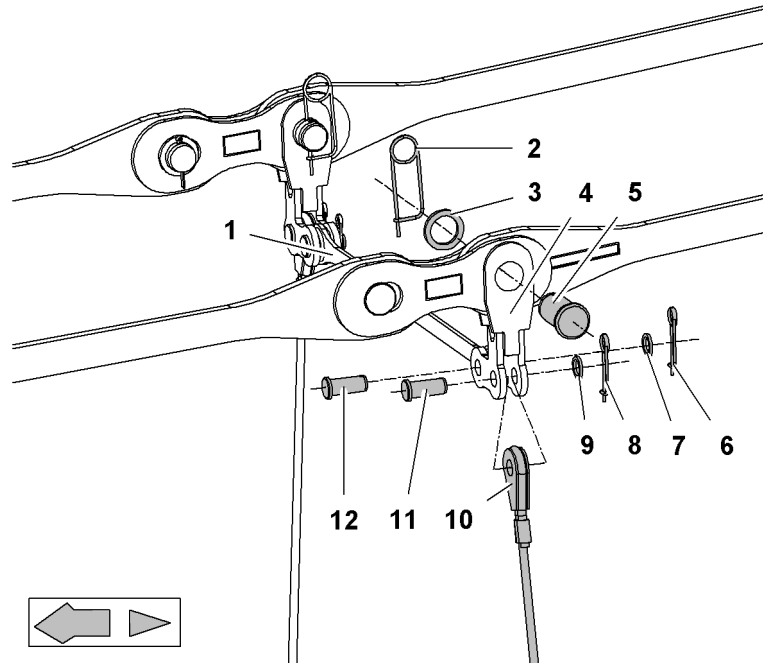


Fig. 3313: Installing the pendant straps, spacer bracket, connecting elements and mid-point suspension stay ropes

- | | | | |
|----------|------------------------|-----------|------------------------|
| 1 | Spacer bracket | 7 | Washer |
| 2 | Safety pin | 8 | Safety pin |
| 3 | Washer | 9 | Washer |
| 4 | Connecting element | 10 | Stay rope |
| 5 | Pins for pendant strap | 11 | Pin for stay rope |
| 6 | Safety pin | 12 | Pin for spacer bracket |

- ▶ Pin connecting element **4** to pendant strap.
- ▶ Secure the pin **5** with washer **3** and retaining spring **2**.
- ▶ Pin connecting element **4** to spacer bracket **1**.
- ▶ Secure the pin **12** with washer **7** and retaining spring **6**.
- ▶ Pin connecting element **4** to stay rope **10**.
- ▶ Secure the pin **11** with washer **9** and retaining spring **8**.
- ▶ Repeat procedure on opposite side.

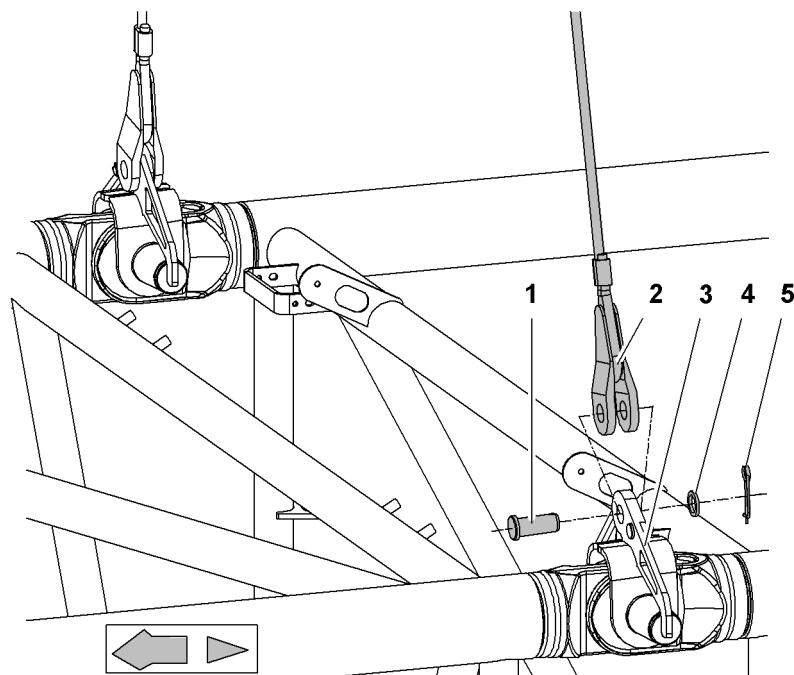


Fig. 3314: Pinning stay ropes to forks of mid-point suspension

- | | | | |
|---|-----------|---|------------|
| 1 | Pin | 4 | Washer |
| 2 | Stay rope | 5 | Safety pin |
| 3 | Fork | | |

- ▶ Pin stay rope 2 to fork 3.
- ▶ Secure the pin 1 with washer 4 and retaining spring 5.
- ▶ Repeat procedure on opposite side.

7.6.12 Installing mid-point suspension (with main boom length 80 m (262 ft), 83 m (272 ft) and 86 m (282 ft) and jib 1507 attached)

With a main boom length of 80 m (262 ft), 83 m (272 ft) and 86 m (282 ft) and 1507 fixed jib attached, installation of the mid-point suspension represents a special case.



DANGER

Incorrect installation of mid-point suspensions!
Structural failure.

- ▶ Fit mid-point suspensions according to relevant system instructions.

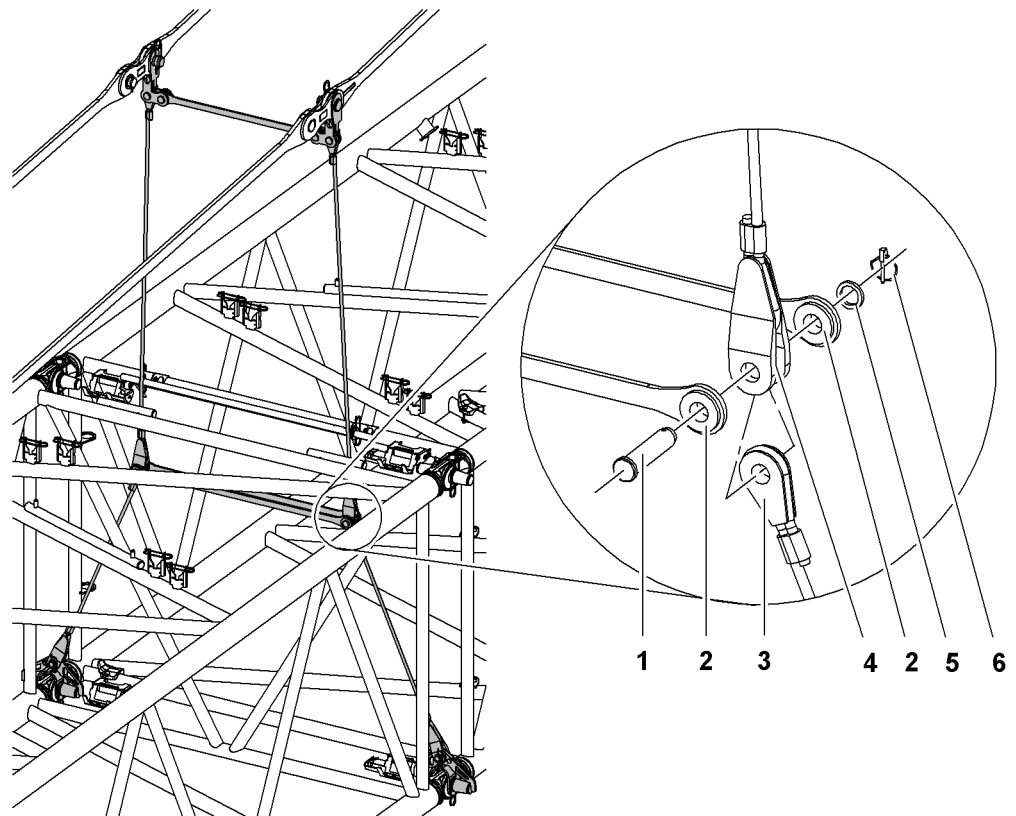


Fig. 3315: Pinning stay ropes to spacer brackets

- | | | | |
|---|------------------------|---|---------------|
| 1 | Pin for spacer bracket | 4 | Top stay rope |
| 2 | Spacer bracket (2x) | 5 | Washer |
| 3 | Bottom stay rope | 6 | Linch pin |

- ▶ Pin mid-point suspensions to pendant straps (For more information see: [7.6.11 Installing mid-point suspension, page 1301](#)) (For more information see: [Installing mid-point suspension, page 1416](#)) .
- ▶ Pin top stay rope 4 and bottom stay rope 3 to spacer bracket 2.
- ▶ Secure pin 1 with a washer 5 and linch pin 6.
- ▶ Repeat procedure on opposite side.
- ▶ Pin mid-point suspension with boom section (For more information see: [7.6.11 Installing mid-point suspension, page 1301](#)) (For more information see: [Installing mid-point suspension, page 1416](#)) .

7.6.13 Rigging and lifting the main boom base section



Note

If the jib has been attached using the self-assembly system:

- ▶ Assemble the fixed jib and attach it to the main boom before installing the main boom base section.
- ▶ Assemble the luffing jib prior to installing the main boom base section and install jib base section on main boom.



Note

Liebherr recommends:

- ▶ even if an assist crane is available, connecting the main boom base section to A-frame1 using the assembly cylinder is to be preferred.

Ensure that the following conditions are fulfilled:

- Work of the basic machine as assist crane is completed.

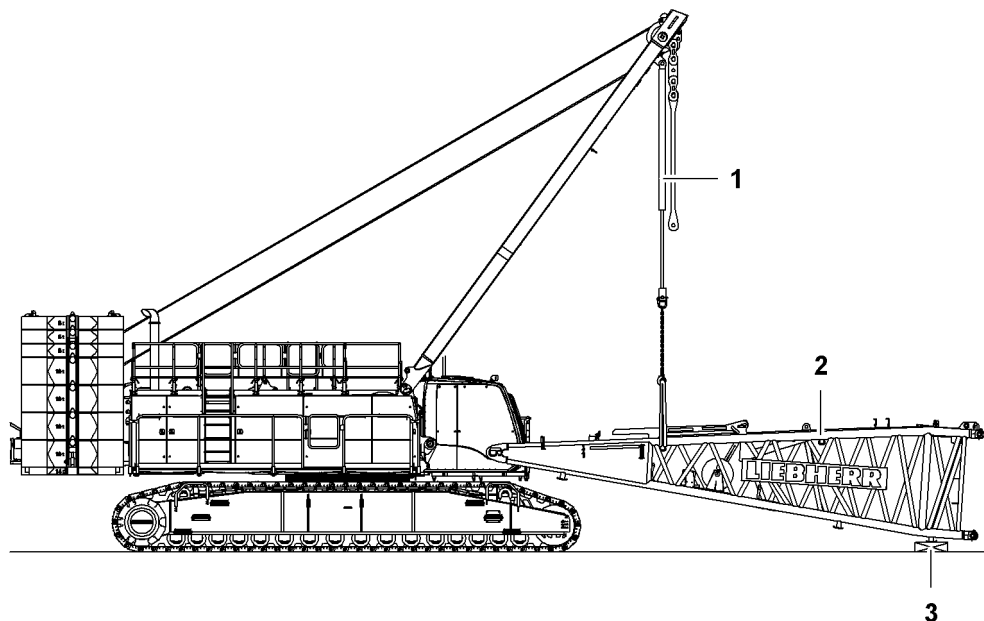


Fig. 3316: Rigging and lifting the main boom base section

- | | | | |
|---|------------------------|---|--------------|
| 1 | Assembly cylinder | 3 | Wooden block |
| 2 | Main boom base section | | |

- ▶ Support boom base section 2 front on wooden blocks 3.
- ▶ Rig main boom base section 2 to assembly cylinder 1.
- ▶ Lift main boom base section 2.

7.6.14 Attaching the boom base section to the uppercarriage



WARNING

Machine swings with a suspended load!
Crush, fatal injury.

- ▶ Make sure that no-one is standing in the danger area.
- ▶ Leave the danger area.

Ensure that the following conditions are fulfilled:

- Cylinder adjustment functions are switched on.
- ▶ Open the front right uppercarriage door.
- ▶ Plug in the cable remote control on the uppercarriage.

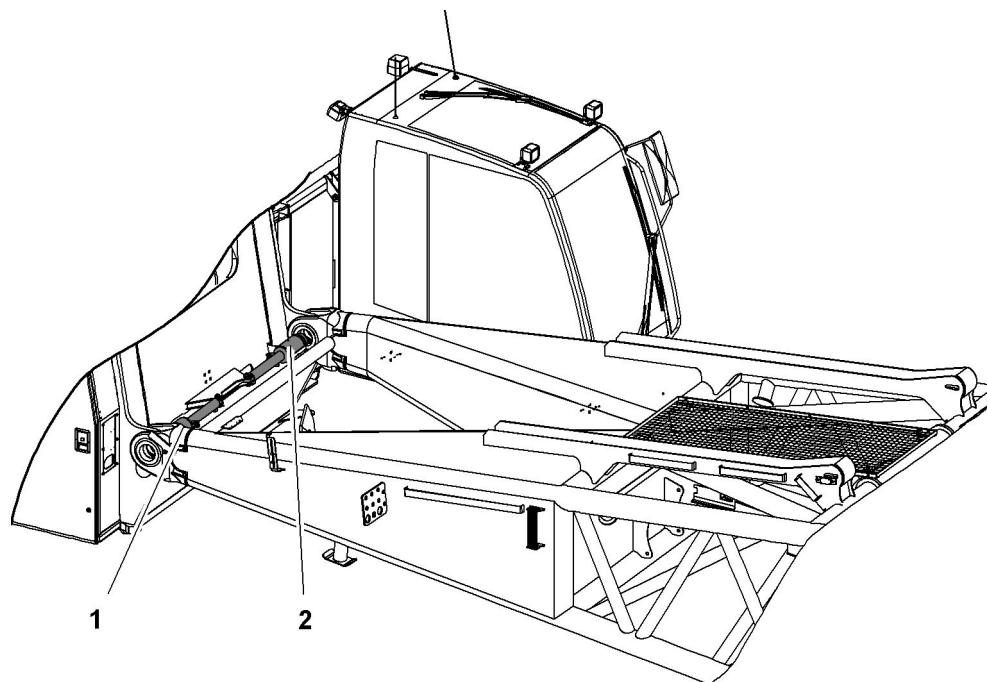


Fig. 3319: Extending the pin connection cylinder

1 Right-hand pin connection cylinder 2 Left-hand pin connection cylinder



CAUTION

Moving parts!
Crushing.

- ▶ Keep all limbs well clear of moving parts.

NOTICE

Incorrect procedure during bolting!
Pin connection cylinder and pin connection points may be damaged.

- ▶ Only extend the pin connection cylinder when the pin connection points on the boom base section and the uppercarriage are exactly aligned.

If the pin connection points of the main boom base section are flush with the pin connection points of the uppercarriage:

- ▶ Extend left pin connection cylinder **2** with cable remote control.
- ▶ Extend right pin connection cylinder **1** with cable remote control.

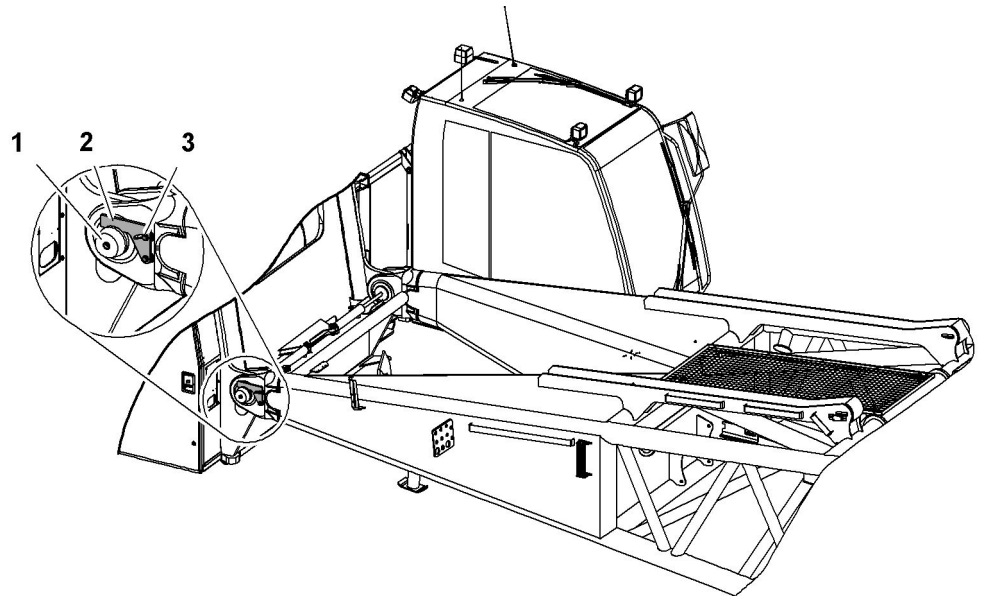


Fig. 3320: Secure pins with locking elements

- | | | | |
|----------|----------------------|----------|------------|
| 1 | Pin (2x) | 3 | Screw (2x) |
| 2 | Locking element (2x) | | |

- ▶ Fold locking element **2** into pin **1** notch.
- ▶ Securing the locking elements **2**: tighten screws **3**.
- ▶ Lower the boom base section to the ground or onto wooden blocks.
- ▶ Detach sling gear.
- ▶ Remove sling gear from assembly cylinder and stow it away.
- ▶ Unplug cable remote control on uppercarriage and stow away.
- ▶ Close the front right uppercarriage door.

7.6.15 Connecting hydraulic lines to the uppercarriage

Ensure that the following conditions are fulfilled:

- Hand lever for the multi-coupling is available.
- Diesel engine is switched off.

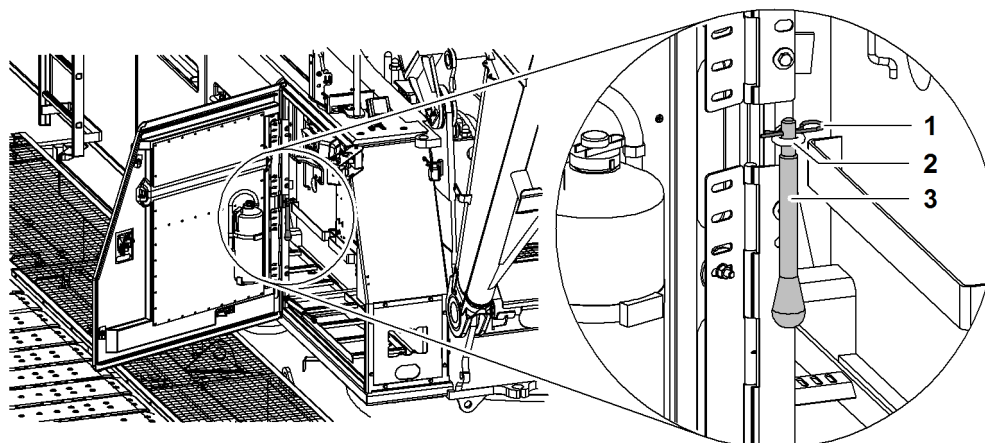


Fig. 3321: Transport mount for hand lever of multi-coupling

- | | | | |
|---|----------------|---|------------|
| 1 | Locking spring | 3 | Hand lever |
| 2 | Ring | | |

- ▶ Lift hand lever **3** and remove locking spring **1**.
- ▶ Remove hand lever **3** downwards from ring **2**.

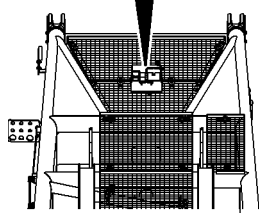
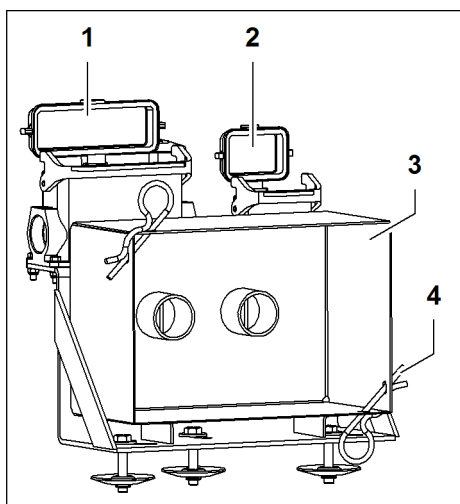


Fig. 3322: Transport position of the hydraulic pipes and electric cables on the main boom base section

- | | | | |
|---|---|---|-------------------------|
| 1 | Dummy socket for electrical system main boom base section | 3 | Cover of multi-coupling |
| 2 | Dummy receptacle for electronics rope reeving winch | 4 | Spring cotter pin |

A bracket for the cover **3** of the multi-coupling and dummy sockets for the electrical system are located on the catwalk of the main boom base section.

- ▶ Fit the hand lever of the multi-coupling.
- ▶ Remove spring cotter pin **4** on cover **3**.
- ▶ Turn hand lever in the direction of the arrow.
 - ▷ Multi-coupling can be taken out of bracket.
 - ▷ Cover **3** remains in bracket on main boom base section.

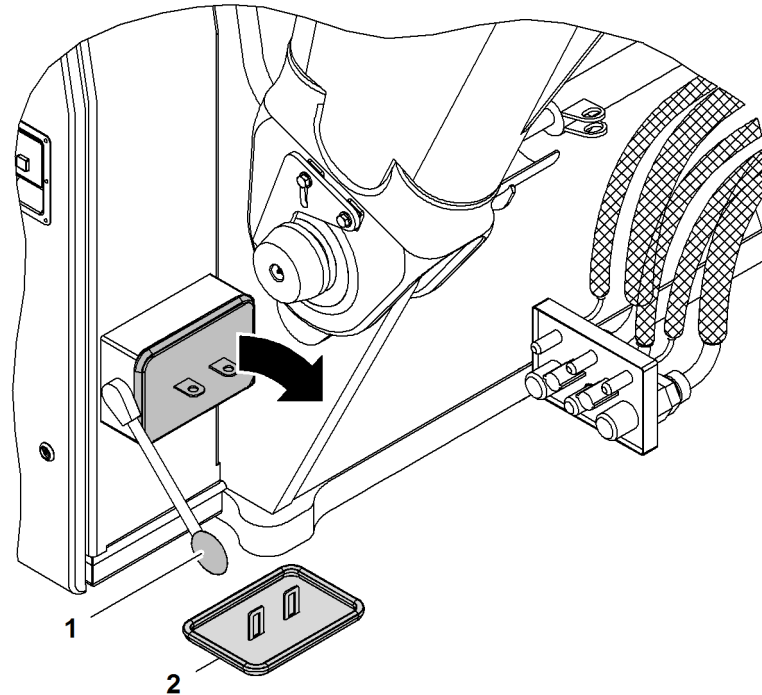


Fig. 3323: Removing the cover of the multi-couplings

- | | |
|---------------------|-------------------------|
| 1 Hand lever | 3 Cover |
| 2 Cover | 4 Locking spring |

- ▶ Fit the hand lever **1** of the multi-coupling.
- ▶ Remove the locking spring **4** on the cover **3**.
- ▶ Turn hand lever **1** in the direction of the arrow.
 - ▷ Cover **2** is loose.
- ▶ Mount cover **3** on bracket of the main boom base section and secure with locking spring.
- ▶ Remove cover **2**.

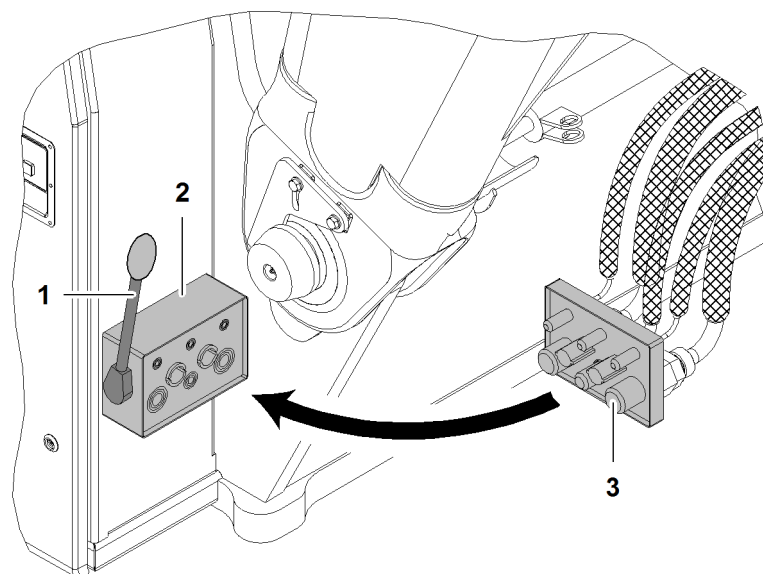


Fig. 3324: Connecting hydraulic lines to the uppercarriage

- | | |
|---|--|
| <p>1 Hand lever</p> <p>2 Multi-coupling (uppercarriage)</p> | <p>3 Multi-coupling (main boom base section)</p> |
|---|--|

NOTICE

Dirty multi-couplings!
Damage to the hydraulic system.

- ▶ Clean the multi-couplings before fitting them together.

- ▶ Connect the multi-couplings 2 + 3.
- ▶ Move hand lever 1 until latch engages.
 - ▷ The multi-couplings are visibly and audibly pulled together.
 - ▷ The multi-coupling indicating pins stick out:

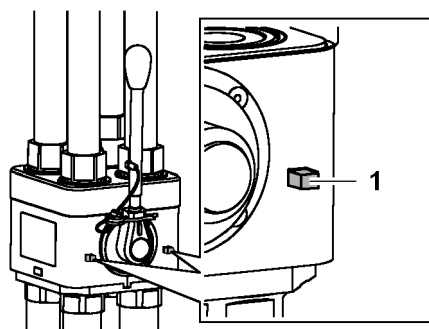


Fig. 3325: Locked multi-coupling

- | | |
|------------------------------|--|
| <p>1 Indicating pin (2x)</p> | <p>▶ Disassemble the hand lever 1 on the multi-coupling.</p> |
|------------------------------|--|

7.6.16 Connecting electric cables to the uppercarriage

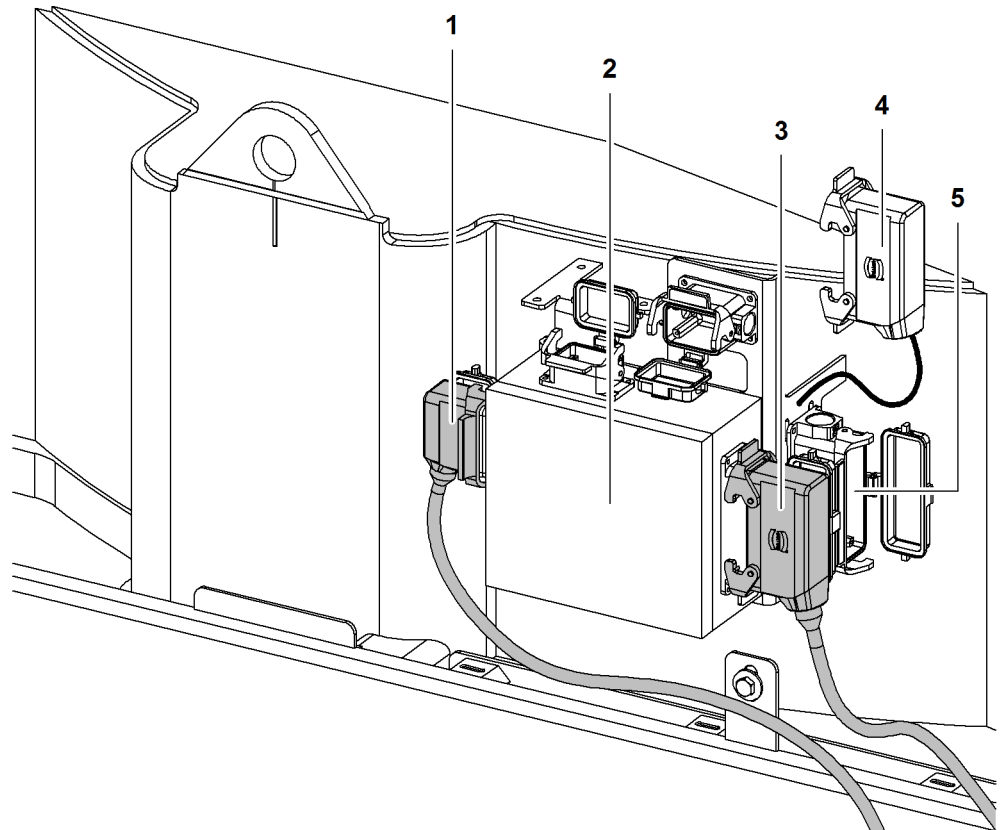


Fig. 3326: Connecting electric cables to the uppercarriage

- | | | | |
|---|--|---|------------------|
| 1 | Electric cables of the jib luffing winch and/or rope reeving winch | 4 | Bypass plug |
| 2 | Electric box | 5 | Dummy receptacle |
| 3 | Electric cables of the main boom base section | | |

- ▶ Open right front uppercarriage door.
- ▶ Plug the bypass plug 4 in the dummy receptacle 5 and secure it with the retaining clips.
- ▶ Guide the electric cables 3 of the main boom base section through the cable duct on uppercarriage.
- ▶ Plug electric line 3 into electric box 2 and lock with brackets.
- ▶ Guide the electric cables 1 of the jib luffing winch through the cable duct on uppercarriage.
- ▶ Plug electric line 1 into electric box 2 and lock with brackets.
- ▶ Close right front uppercarriage door.

7.6.17 Pinning the assembly cylinder to main boom base section

Ensure that the following conditions are fulfilled:

- Cylinder adjustment functions are switched on.

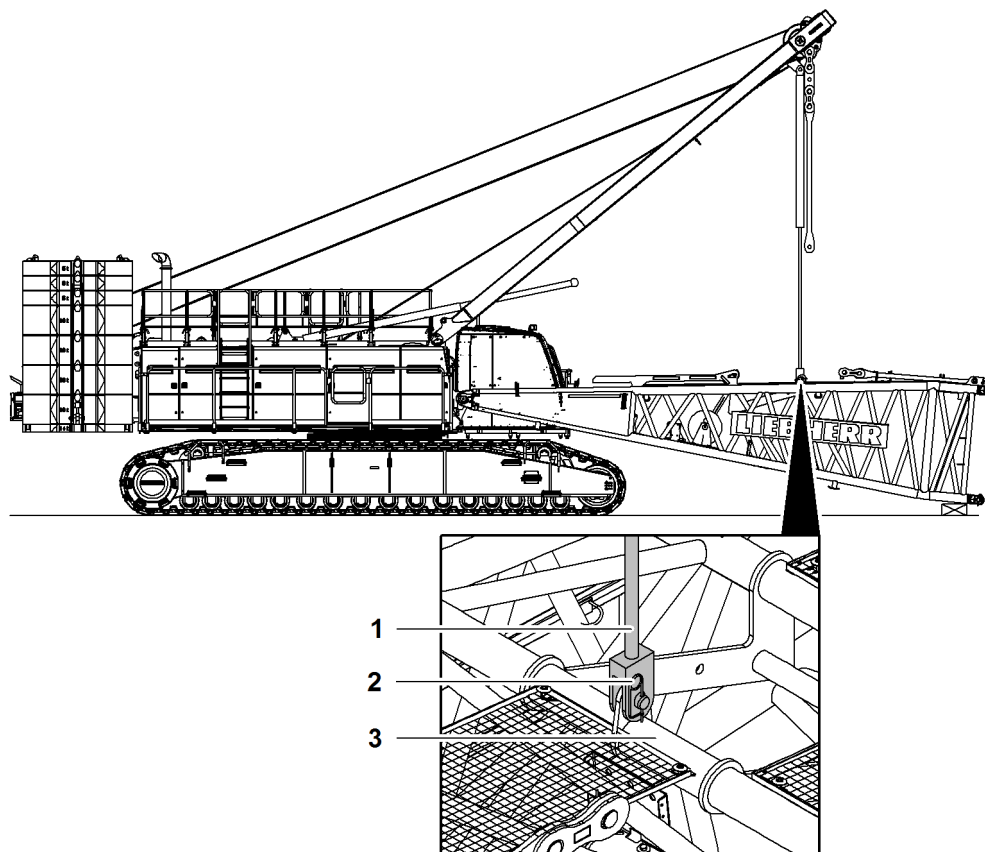


Fig. 3327: Pinning the assembly cylinder to main boom base section

- | | |
|----------------------------|---------------------------------|
| 1 Assembly cylinder | 3 Main boom base section |
| 2 Locking spring | |

- ▶ Unwind the boom winch.
 - ▷ A-frame1 lowers.
- ▶ Extend assembly cylinder 1.
- ▶ Pin assembly cylinder 1 to main boom base section 3.
- ▶ Secure pin with locking spring 2.

NOTICE

Lifting/lowering the main boom base section 3 with main boom luffing winch is not permitted!

Damage to main boom base section 3 and machine.

- ▶ Only lift or lower main boom base section 3 with assembly cylinder 1.
-
- ▶ Retract assembly cylinder 1.
 - ▷ Main boom base section 3 lifts.
 - ▶ Press the switch *Extend tilting-back support cylinders* on control panel X12 until the tilting-back support cylinders are completely extended.



7.6.18 Folding the front feet of the main boom base section upwards

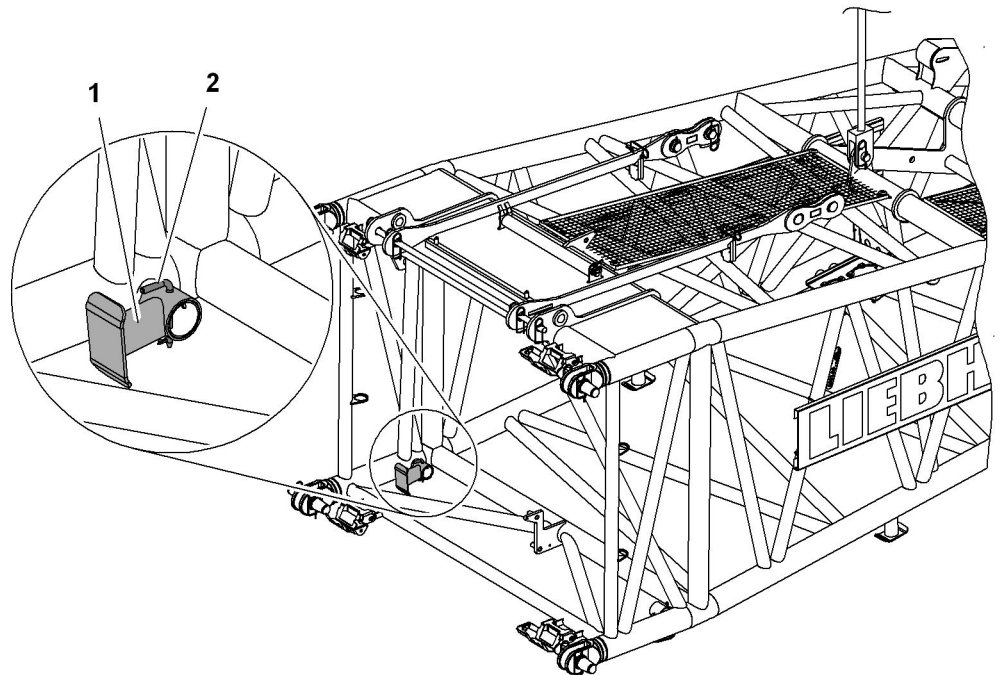


Fig. 3329: Folding the front feet of the main boom base section upwards

- | | |
|-------------------|------------------------|
| 1 Front foot (2x) | 2 Locking element (2x) |
|-------------------|------------------------|

- ▶ Fold front feet 1 up by 90°.
- ▶ Secure front feet 1 with locking elements 2.

7.6.19 Bolting the boom base section to the main boom

Ensure that the following conditions are fulfilled:

- Front feet are folded up.
- ▶ Maneuver the basic machine to the main boom.

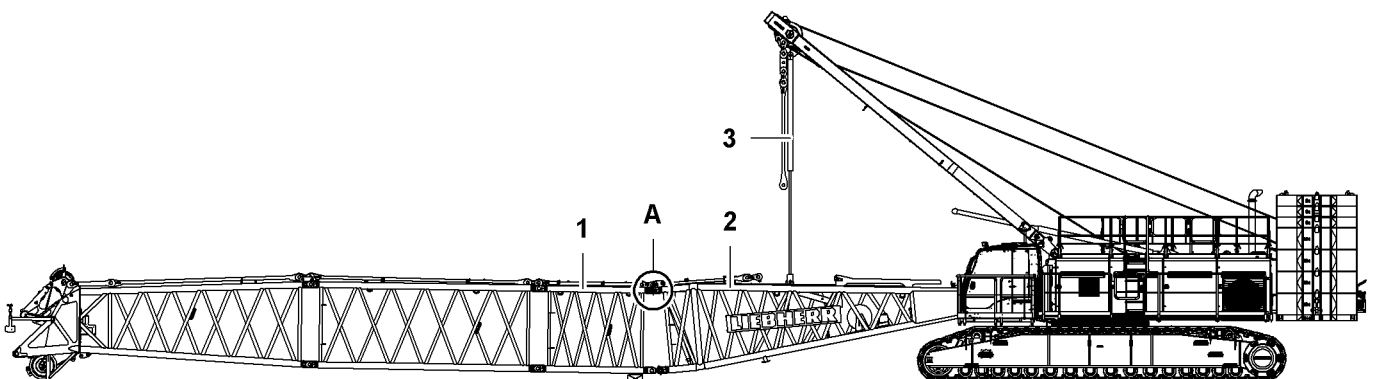


Fig. 3330: Pin main boom base section to main boom at the top

- | | |
|--------------------------|---------------------------------|
| 1 Main boom | 3 Assembly cylinder |
| 2 Main boom base section | A Top pin connection point (2x) |

- ▶ Extend or retract assembly cylinder 3 until the top pin connection points A of the main boom base section 2 and the main boom 1 are flush.

- ▶ Pin main boom base section **2** with main boom **1** to top pin connection points **A**.
- ▶ Secure the double-taper pins with washers and safety pins.

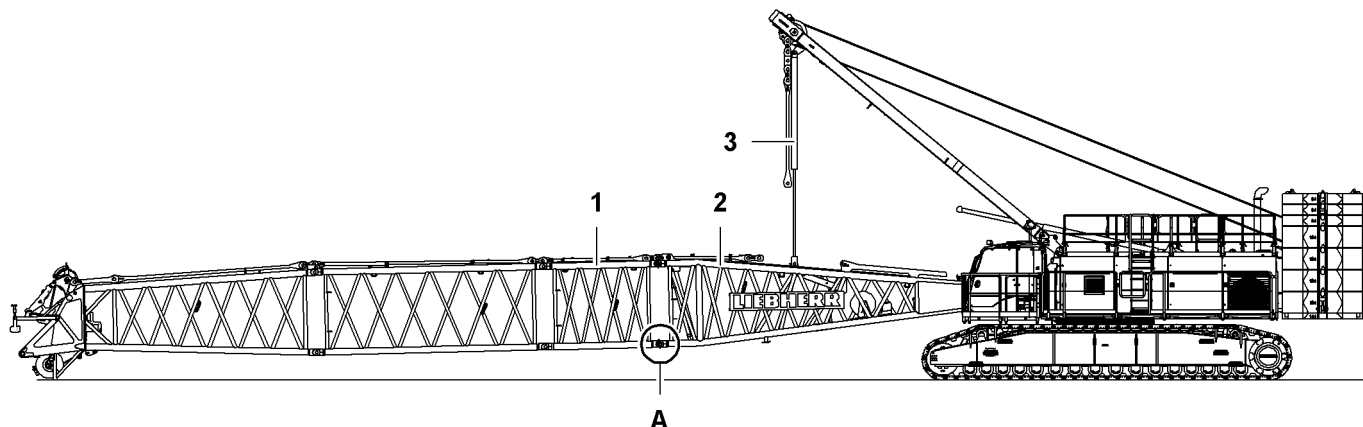


Fig. 3331: Pinning the main boom base section to the main boom at the bottom

- | | | | |
|---|------------------------|---|----------------------------------|
| 1 | Main boom | 3 | Assembly cylinder |
| 2 | Main boom base section | A | Bottom pin connection point (2x) |

NOTICE

Unauthorized raising of main boom **1** with assembly cylinder **3**!
Damage to main boom **1** and assembly cylinder **3**.

- ▶ Only retract assembly cylinder **3** so far that pinning the bottom pin connection points **A** on the main boom base section **2** is still possible.
- ▶ Retract assembly cylinder **3** until the bottom pin connection points **A** of the main boom base section **2** and the main boom **1** are flush.
- ▶ Pin main boom base section **2** with main boom **1** to bottom pin connection points **A**.
- ▶ Secure the double-taper pins with washers and safety pins.
- ▶ Detach assembly cylinder **3** from main boom base section **2**.
- ▶ Retract assembly cylinder **3**.

7.6.20 Bolting the equalizer on A-frame 1 to the main boom pendant straps

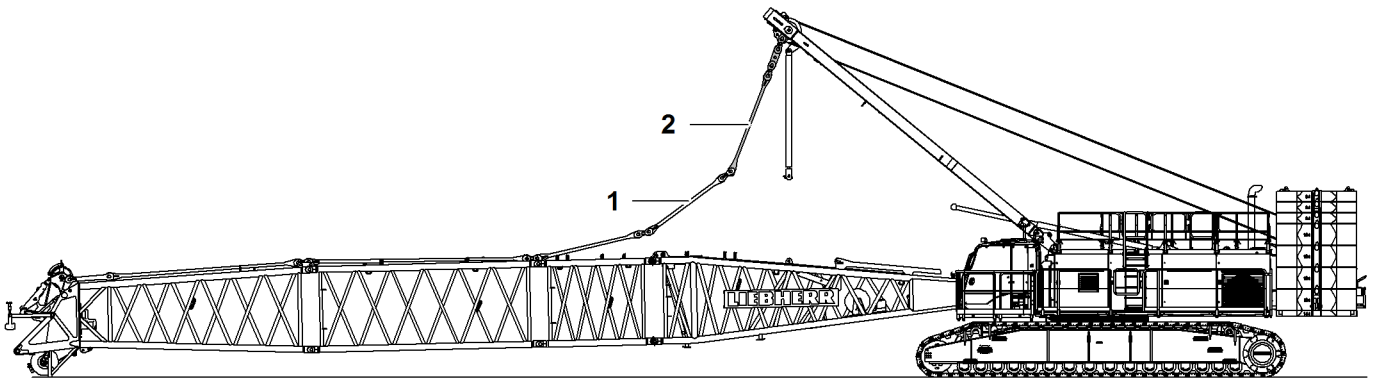


Fig. 3332: Pinning the equalizer on A-frame1 to the main boom pendant straps

- 1 Main boom pendant straps 2 A-frame1 equalizer

- ▶ Lower A-frame1 until equalizer of A-frame1 2 and main boom pendant straps 1 can be pinned together.
- ▶ Pin A-frame1 equalizer 2 to main boom pendant straps 1.
- ▶ Secure the pins with washers and safety pins.

7.6.21 Attaching the auxiliary jib (36 t (79300 lb)) to the boom head section

Make sure that the camera support (if available) on the main boom head section is detached.

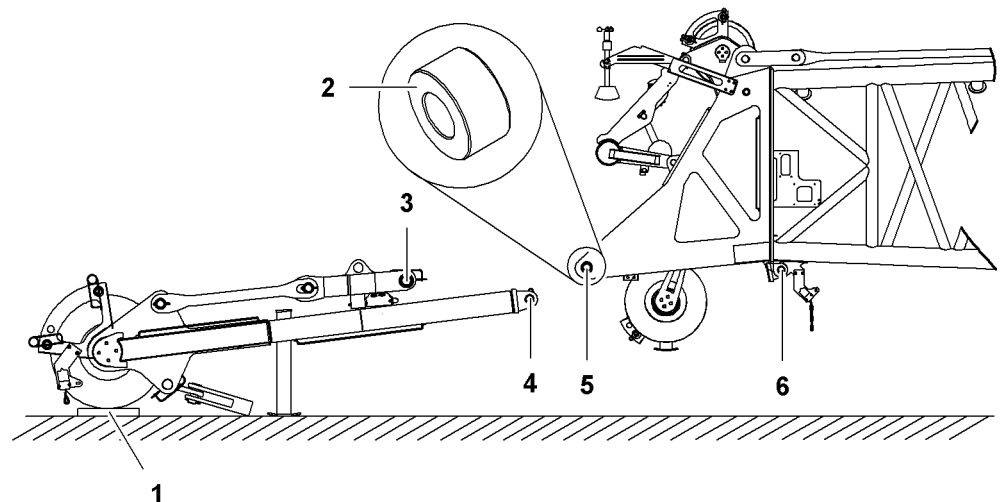


Fig. 3333: Positioning the auxiliary jib (36 t (79300 lb)) in front of the boom head section and inserting bushes

- | | | | |
|---|---|---|--|
| 1 | Wooden block | 4 | Lower pin connection point auxiliary jib (2x) |
| 2 | Bush (dia.80 mm (3.15" in) x Ø40 mm (1.57" in) x 43 mm (1.69" in)) (2x) | 5 | Upper pin connection point main boom head (2x) |

See next page for continuation of the image legend

- | | |
|--|---|
| 3 Upper pin connection point auxiliary jib (2x) | 6 Lower pin connection point main boom head (2x) |
|--|---|
- ▶ Position the auxiliary jib in front of the boom head section.
 - ▶ Protecting the pulley: Lay a wooden block **1** under the auxiliary jib pulley.
 - ▶ Insert bushes (Ø80 mm (3.15" in) x Ø40 mm (1.57" in) x 43 mm (1.69" in)) into the upper pin connection points **5** of the main boom head.
 - ▶ Lift the main boom and move it towards the auxiliary jib until the upper pin connection points **3** on the auxiliary jib match the upper connection points of the **5** main boom head.

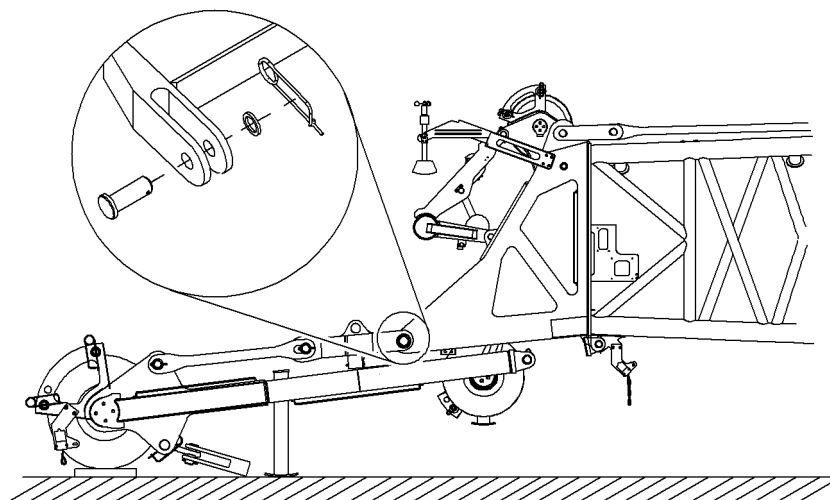


Fig. 3334: Pinning the upper pin connection points

- ▶ Pin the upper pin connection points and secure with washer and safety pin.

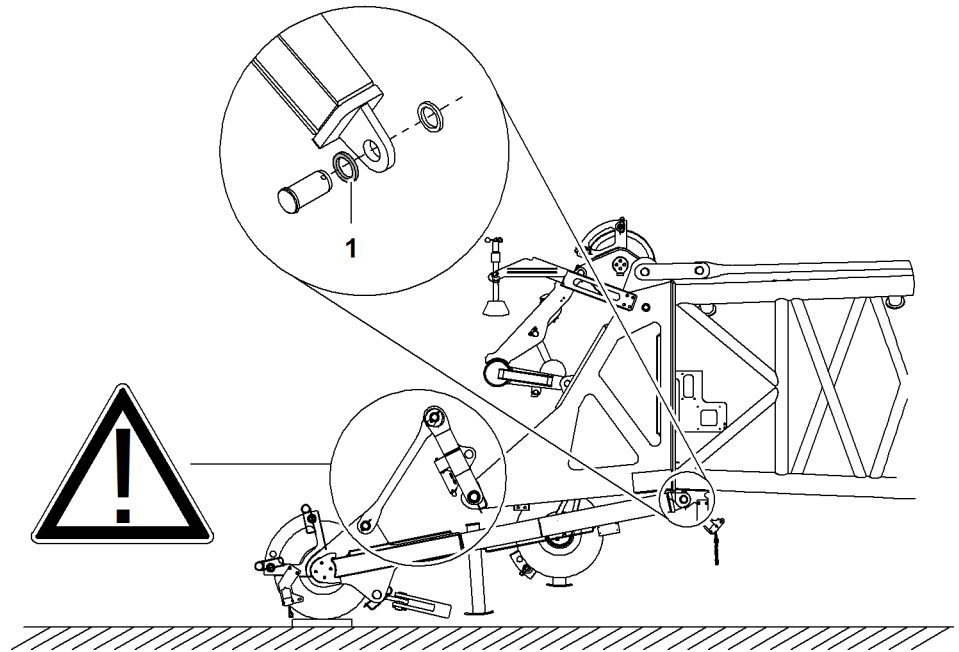


Fig. 3335: Pinning the lower pin connection points

1 Washer 8 mm (0.31" in) (2x)

The washer 8 mm (0.31" in) **1** serves to center the auxiliary jib on the main boom head.

NOTICE

Auxiliary jib pendant straps are positioned incorrectly!
Damage to auxiliary jib and pulleys on the boom head section.

- ▶ Ensure that auxiliary jib pendant straps fold up.
-
- ▶ Move the main boom towards the auxiliary jib until the bottom pin connection points **4** on the auxiliary jib match the bottom connection points of the **6** main boom head.

Assembly and dismantling

Assembly of main boom without derrick equipment*

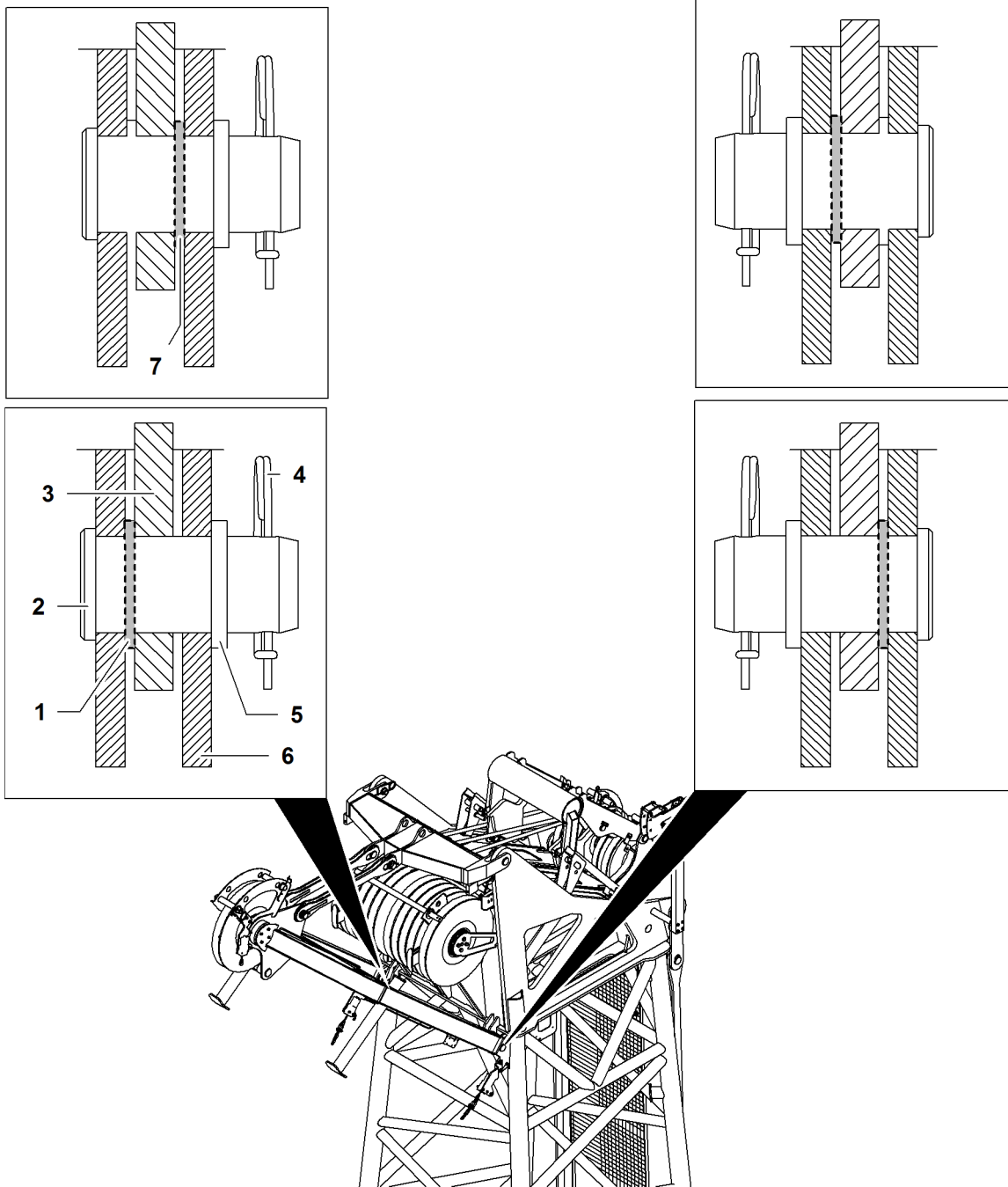


Fig. 3336: Installation notes auxiliary jib

- | | | | | | |
|----------|--|----------|---|----------|---|
| 1 | Washer 8 mm (0.31" in)
(installation site outside) (2x) | 4 | Safety pin (2x) | 7 | Washer 8 mm (0.31" in)
(installation site inside) (2x) |
| 2 | Pin (2x) | 5 | Washer (2x) | | |
| 3 | Pin connection lug auxiliary
jib (2x) | 6 | Pin connection lug main
boom head (4x) | | |

The washers 8 mm (0.31" in) must be installed both-sided on the outside (installation site outside **1**) or both-sided on the inside (installation site inside **7**).

- ▶ Push pin **2** and washer 8 mm (0.31" in) **1** through the pin connection lug **3** and the pin connection lug **6**.
- ▶ Place washer **5** on pin **2** and secure with safety pin **4**.
 - ▷ Lower pin connection points pinned and secured.

LWNLR-x/V04.01/Auslieferung/2016-03-07/en

7.6.22 Installing the hoist limit switch on auxiliary jib (36 t (79.300 lb))

Installation of the hoist limit switch on the auxiliary jib (36 t (79.300 lb)) is identical with the installation on the main boom or jib (For more information see: [7.6.31 Installing the hoist limit switch weight, page 1343](#)) (For more information see: [Installing the hoist limit switch weight, page 1461](#)) .

Connect the hoist limit switch

The electric cable to the hoist limit switch is connected for transport to a dummy receptacle on the inside of one of the two auxiliary jib support tubes.

- ▶ Disconnect the bypass plug from the terminal box on the boom head section.
- ▶ Disconnect the electric cable for the hoist limit switch from the dummy receptacle and connect it to the terminal box on the boom head section.
- ▶ Secure the electric cable to the hoist limit switch with retaining clips.
- ▶ Plug the bypass plug into the dummy receptacle and secure it with the retaining clips.

7.6.23 Folding down the link plates for the 11th pulley

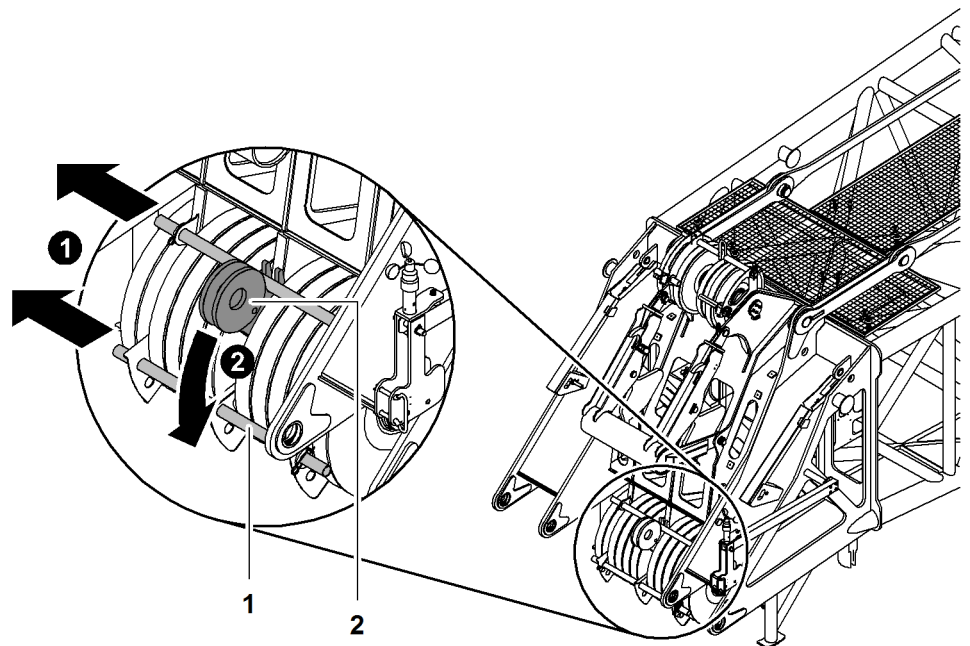


Fig. 3337: Folding down the link plates for the 11th pulley

1 Rope protection pipe (2x)

2 Link plate (2x) for 11th pulley

NOTICE

Wrong position of link plates 2 for 11th pulley on main boom head!
Risk of damage to winch2 rope.

- ▶ Fold down link plates 2 for 11th pulley.

- ▶ Remove rope protection pipes 1 on main boom head.

- ▶ Fold down link plates 2 for 11th pulley.

7.6.24 Installing second pulley to 3-fold reeve the auxiliary jib (36 t (79300 lb))

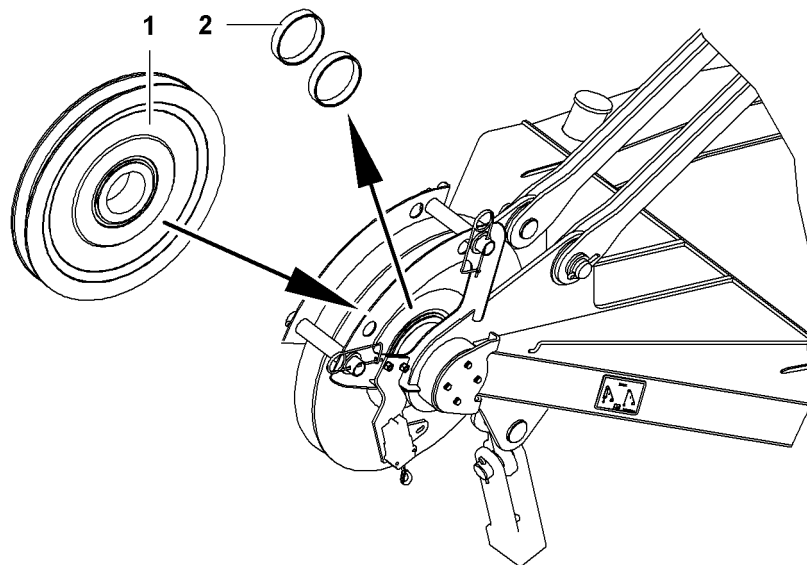


Fig. 3338: Installing second pulley to 3-fold reeve the auxiliary jib (36 t (79300 lb))

- | | | | |
|----------|---------------|----------|---|
| 1 | Second pulley | 2 | Bushes (dia.168 mm (6.61" in) x
Ø140 mm (5.51" in) x
40 mm (1.57" in)) (2x) |
|----------|---------------|----------|---|

- ▶ Remove bushes (dia.168 mm (6.61" in) x dia.140 mm (5.51" in) x 40 mm (1.57" in)) **2**
- ▶ Install second pulley

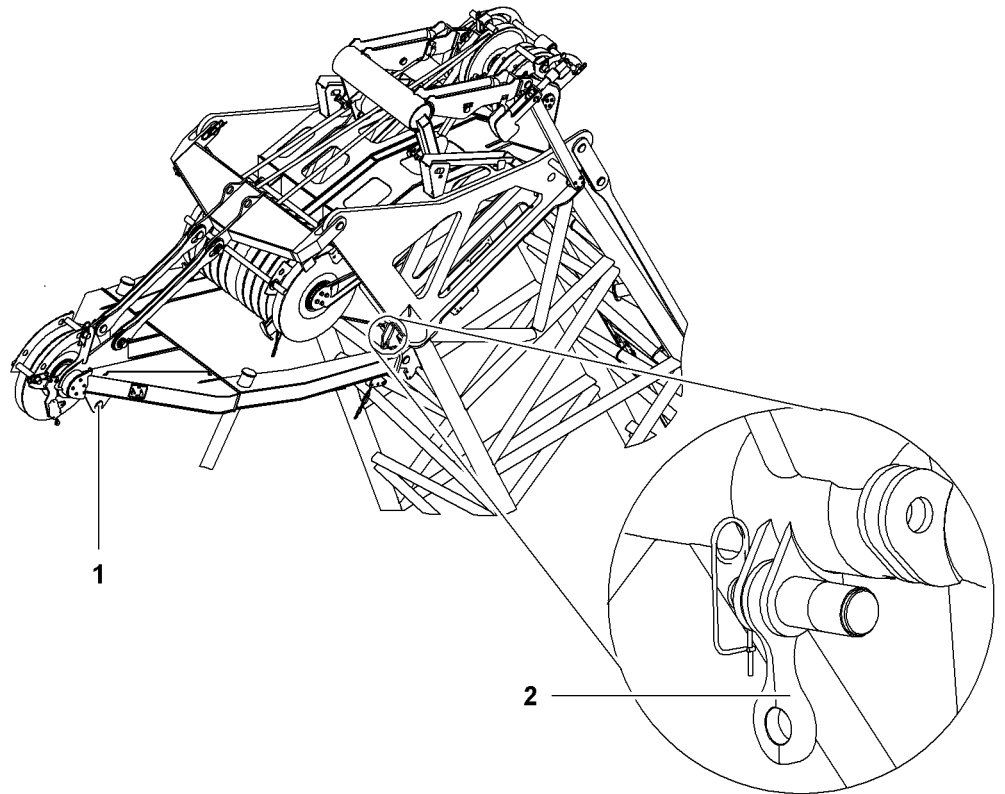


Fig. 3339: Pinning the cross strap to the boom head section

1 Auxiliary jib rope fixing point 2 Cross strap and pins

NOTICE

Cross strap and pins **2** are not positioned correctly at the rope fixing point on the auxiliary jib **1** with 3-fold reeving!
Risk of damage to winch2 rope.

- ▶ Pin the cross strap to the boom head section.
- ▶ Remove the cross strap and pins **2** from the rope fixing point of the auxiliary jib **1**.
- ▶ Pin the cross strap **2** to the boom head section.

7.6.25 Connect the electric cables

NOTICE

Electric cables have been handled incorrectly!
Damage to electric cable and plug.

- ▶ Do not pull the electric cable over sharp-edged objects.
- ▶ Do not crush or kink the electric cable.
- ▶ Keep the plug clean.
- ▶ Disconnect both electric cables from the terminal box on the boom base section.

LWNLR.x/V04.01//Auslieferung/2016-03-07/en

NOTICE

Electric cable has been unwound incorrectly!

Electric cable may be damaged.

- ▶ Push the electric cable in the cable drum into the side opening of the cable drum.

-
- ▶ Loosen the pin on the axle of the cable drum.
 - ▶ Unwind the electric cable from the cable drum and pull it inside the main boom to the boom head section.
 - ▶ Connect the electric cable to the terminal box on the boom head section and secure using retaining clips.

Two fixing holes are provided under the terminal box to relieve the strain on the plug.

- ▶ Clip both carabiners on the cable sock into the fixing holes.
- ▶ Fix the pin on the axle of the cable drum.
- ▶ Reconnect the electric cable in the cable drum to the terminal box on the boom base section.
 - ▷ The boom base section and boom head section electric cables are connected.

If an auxiliary jib is fitted:

- ▶ Plug the auxiliary jib electric cable into the boom head section.

7.6.26 Installing the obstacle warning light



Note

Use of the obstacle warning light is prescribed by national or regional regulations!

- ▶ Before using the machine, familiarise yourself with national and local regulations.

Ensure that the following conditions are fulfilled:

- Anemometer is not installed.

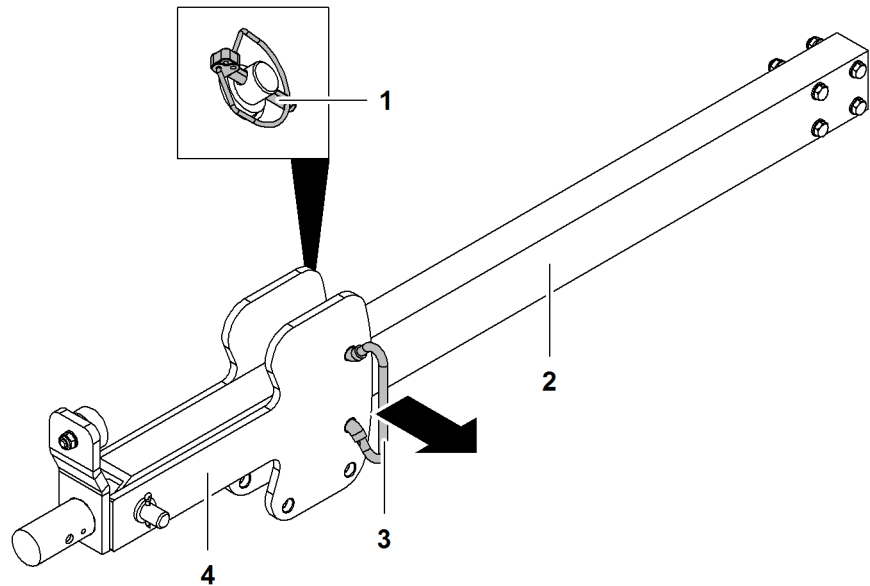


Fig. 3340: Moving the pendulum into the working position

- | | | | |
|---|----------------|---|-----------------|
| 1 | Linchpins (2x) | 3 | Locking element |
| 2 | Mount | 4 | Pendulum |

The pendulum 4 is secured on the mount 2 for machine transport.

- ▶ Remove the linchpin 1 of the locking element 3.
- ▶ Remove 3 locking element.
- ▶ Swing pendulum 4 down.
- ▶ Slide locking element 3 through pendulum 4 and secure with linchpins 1.

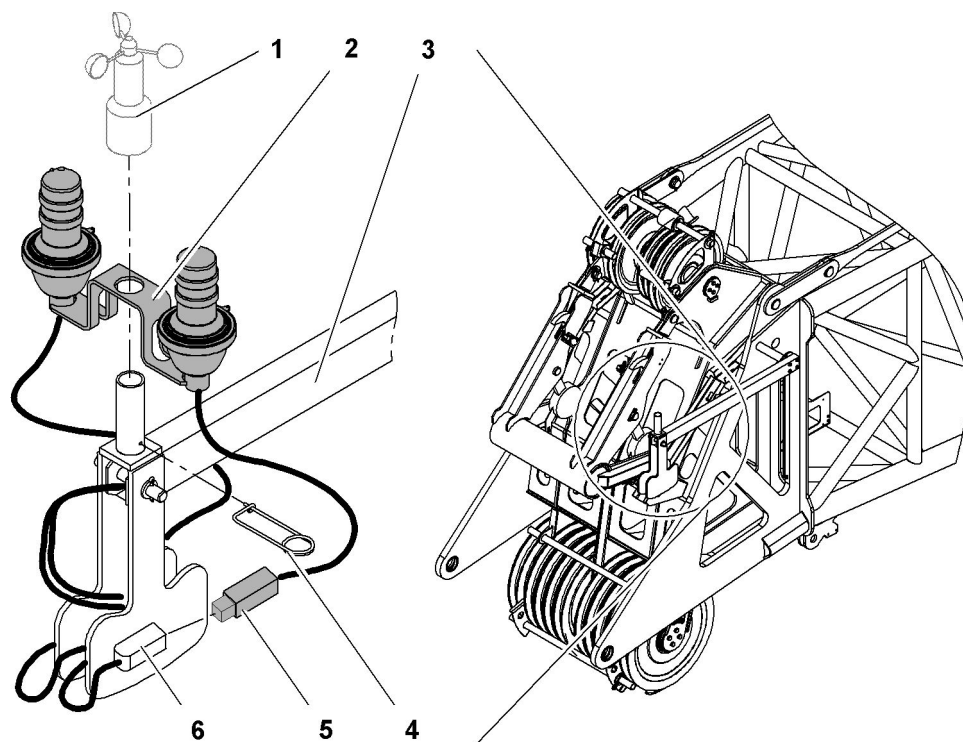


Fig. 3341: Installing the obstacle warning light

- | | | | |
|---|------------------------|---|------------|
| 1 | Anemometer | 4 | Safety pin |
| 2 | Obstacle warning light | 5 | Plug |
| 3 | Mount | 6 | Coupling |

- ▶ Place obstacle warning light 2 on pipe.
 - ▷ Obstacle warning light is secured by the pipe and axis on the bracket 3.

NOTICE

Safety pin is not fit properly!
Damage to the electric cable.

- ▶ Insert the safety pin carefully.

- ▶ Insert the safety pin 4.
 - ▷ Obstacle warning light 2 is secured.
- ▶ Connect the plug 5 to the coupling 6.
- ▶ Lock plug 5.

7.6.27 Fitting the anemometer

Ensure that the following conditions are fulfilled:

- Obstacle warning light is installed (if available).

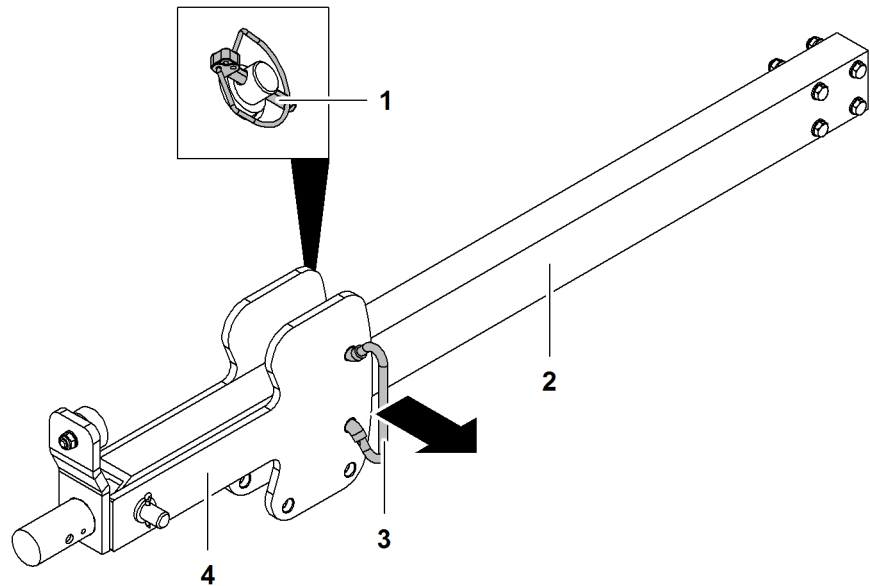


Fig. 3342: Moving the pendulum into the working position

- | | | | |
|---|----------------|---|-----------------|
| 1 | Linchpins (2x) | 3 | Locking element |
| 2 | Mount | 4 | Pendulum |

The pendulum 4 is secured on the mount 2 for machine transport.

- ▶ Remove the linchpin 1 of the locking element 3.
- ▶ Remove 3 locking element.
- ▶ Swing pendulum 4 down.
- ▶ Slide locking element 3 through pendulum 4 and secure with linchpins 1.

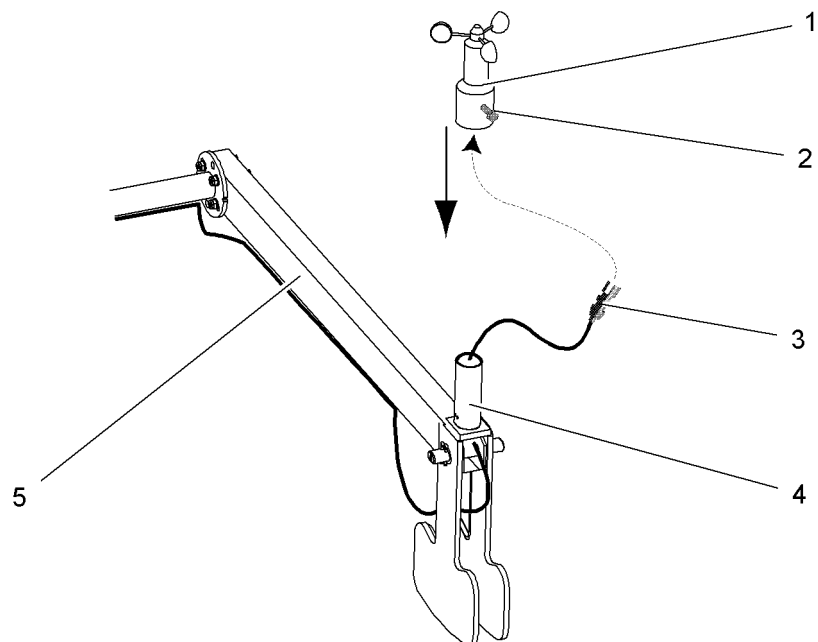


Fig. 3343: Fitting the anemometer

- | | | | |
|---|------------|---|-------|
| 1 | Anemometer | 4 | Tube |
| 2 | Screw | 5 | Mount |
| 3 | Plug | | |

- ▶ Remove cover from the plug **3**.
- ▶ Plug in the connector **3** at the bottom of the anemometer **1**.
- ▶ Secure plug **3** with nut.

NOTICE

Anemometer is not fit properly!
Damage to the electric cable.

- ▶ Pull the extended electric cable through the tube before pushing on the anemometer.

- ▶ Position the anemometer **1** on the tube **4**.
- ▶ Securing the anemometer on the mount: Tighten the screw **2**.

The rotor of the anemometer must be free to rotate slightly.

- ▶ Test the anemometer: rotate the rotor slightly and note the value on the monitor.
 - ▷ The wind speed value will increase.

7.6.28 Moving the lightning rods* into working position

Installation positions of lightning rods on main boom head

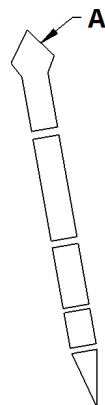


Fig. 3344: Installation positions of lightning rods on main boom head

A Main boom head

Boom configuration	Number of lightning rods	Installation positions
Main boom	1	A

Tab. 504: Installation positions and number of lightning rods on main boom head

LWNLR-x/V04.01//Auslieferung/2016-03-07/en

Moving the lightning rods* on the main boom head into working position

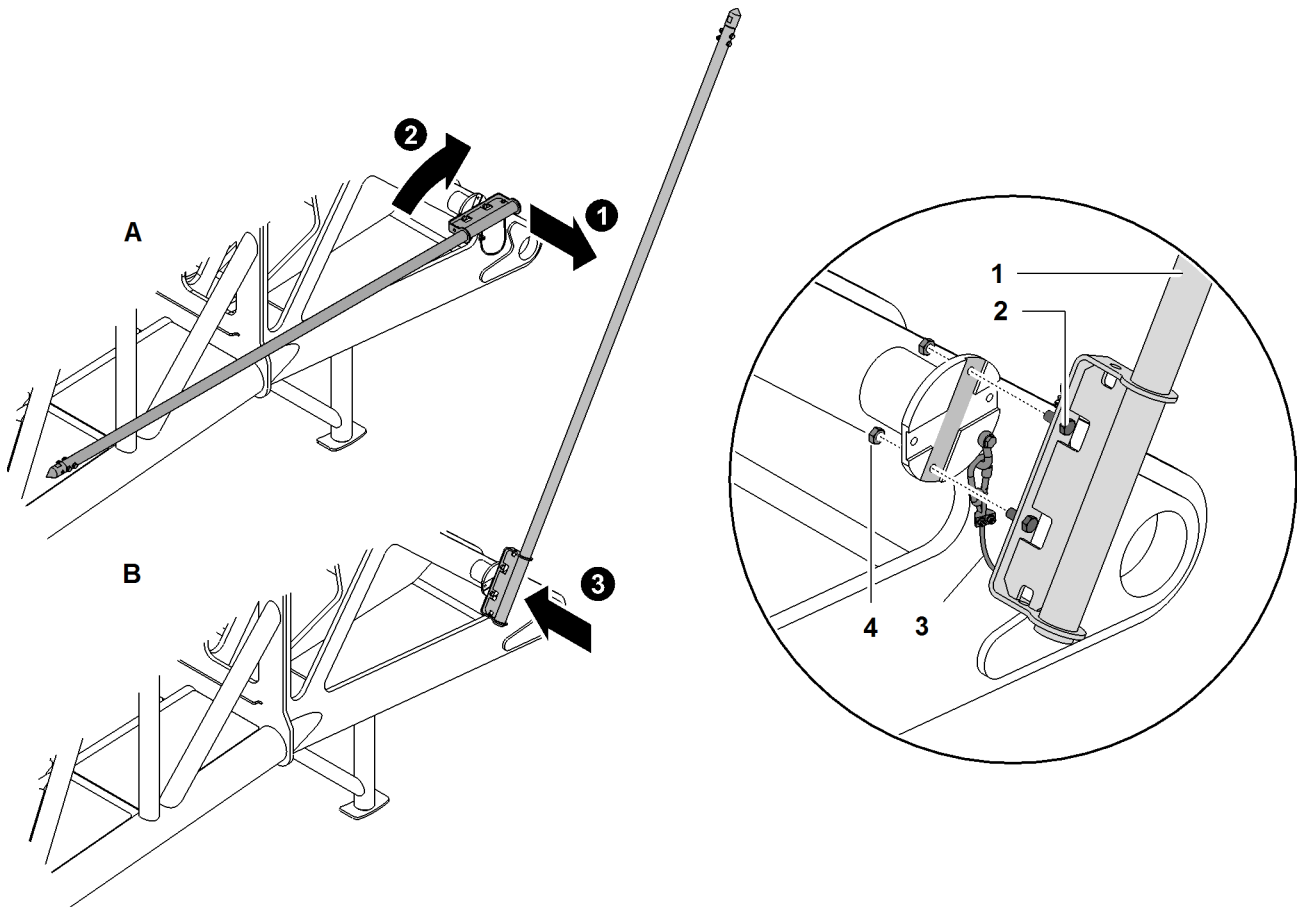


Fig. 3345: Moving the lightning rods* on the main boom head into working position (illustration of principle)

A Transport position
B Working position

1 Lightning rod
2 Screw (2x)

3 Safety rope
4 Nut (2x)

- ▶ Undo safety rope **3**.
- ▶ Undo nuts **4**.
- ▶ Undo screws **2**.
- ▶ Move lightning rod **1** from transport position **A** to working position **B**.



Note

Liebherr recommends:

- ▶ Grease threads of the screws **2**.
- ▶ Attach lightning rod **1** with screws **2**.
- ▶ Lock screws **2** with nuts **4**.

NOTICE

Safety rope not attached!
Dropping parts.

- ▶ Ensure that safety rope **3** is attached.

- ▶ Attach safety rope **3**.

NOTICE

Tip not installed!
Improperly deflected current.
Dropping parts.

- ▶ Ensure that the tip on the lightning rod **1** is installed.
- ▶ Ensure that the screws of the tip are tightened.

-
- ▶ Ensure that the tip on the lightning rod **1** is installed.
 - ▶ Ensure that the screws of the tip are tightened.

7.6.29 Reeving the rope

The rope must be reeved as specified in the rope reeving diagram according to the boom and application requirements.



WARNING

Unsecured walking on the boom!
Risk of falling off the boom.

- ▶ A fall arrest system must be worn when working on the boom to prevent falling.

Ensure that the following conditions are satisfied:

- Cylinder adjustment functions are on.

Reeving the rope using a rope reeving winch

Dismantling rope protection pipes

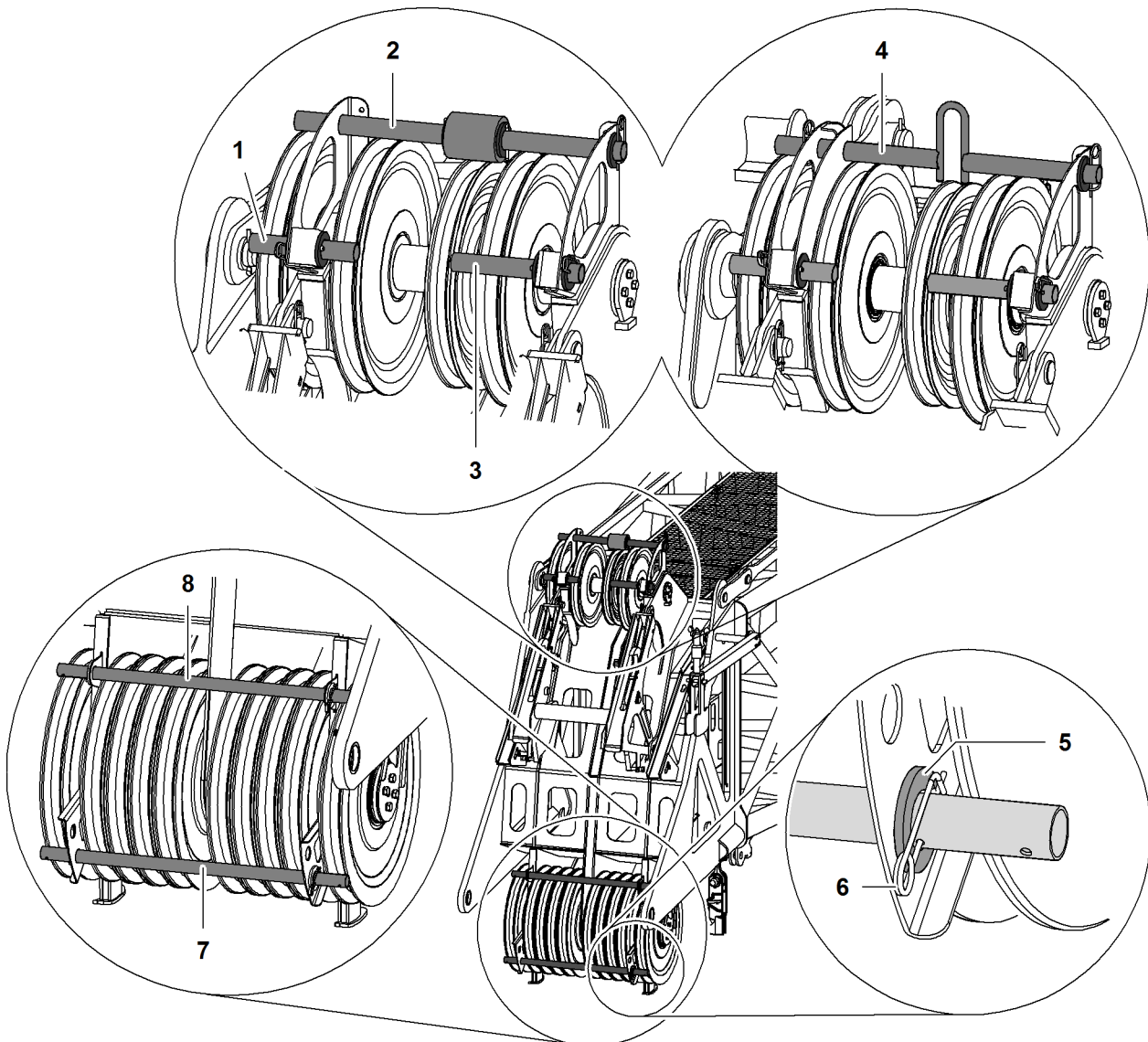


Fig. 3346: Rope protection pipes main boom head 1311, 2017, 2018, 2320, 2220, 2821

- | | | | | | |
|---|-------------------------------|---|-------------------------------|---|----------------------|
| 1 | Rope protection pipe | 4 | Rope protection pipe variant2 | 7 | Rope protection pipe |
| 2 | Rope protection pipe variant1 | 5 | Washer | 8 | Rope protection pipe |
| 3 | Rope protection pipe | 6 | Safety pin | | |

The rope protection pipes are secured with a cotter pin on one side and with a safety pin on the other side.

- ▶ Remove the safety pins 6 and the washers 5.
- ▶ Remove the rope protection pipes 1 + 2 + 3 + 4 + 7 + 8.

Removing the rope protection pipes on auxiliary jib

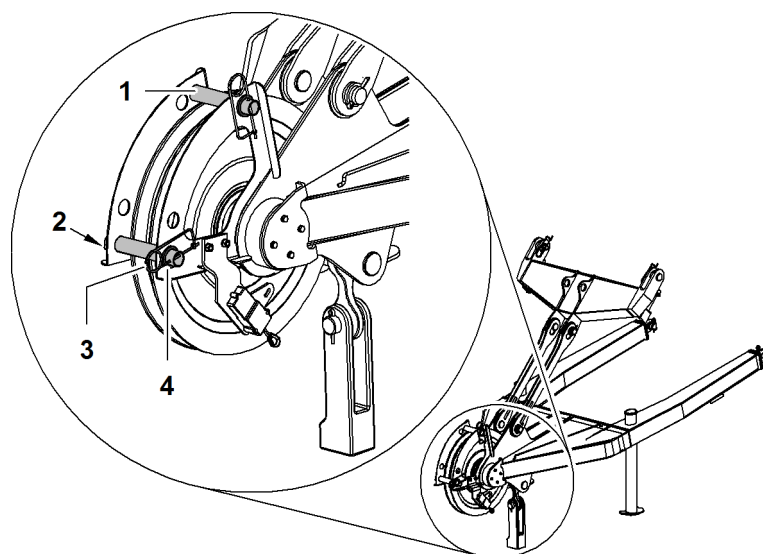


Fig. 3347: Removing the rope protection pipes on auxiliary jib

- | | | | |
|---|---------------------------|---|------------|
| 1 | Rope protection pipe (2x) | 3 | Safety pin |
| 2 | Cotter pin | 4 | Washer |

The rope protection pipes are secured with a cotter pin 2 on one side and with a safety pin 3 on the other side.

- ▶ Remove rope protection pipes 1 with attached auxiliary jib.

Reeving the rope

- ▶ Open up the rope guide (if present).

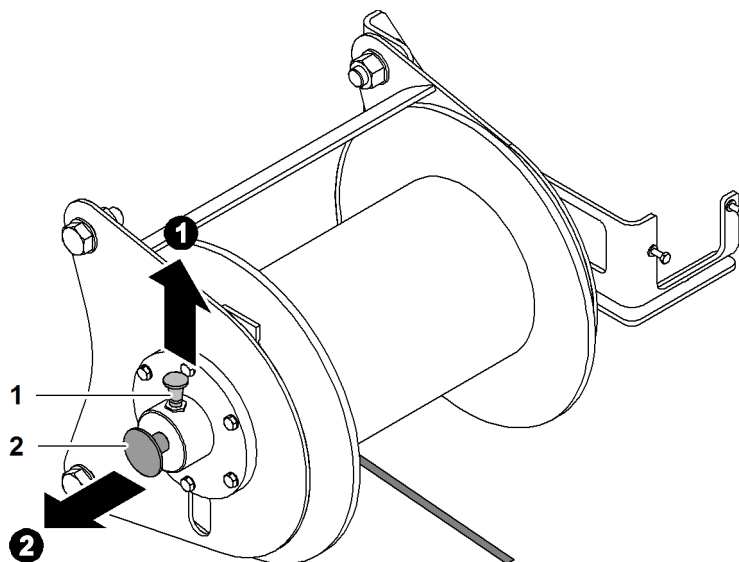


Fig. 3348: Setting the rope lug to free-wheel

- | | | | |
|---|------------------|---|-------|
| 1 | Securing element | 2 | Shaft |
|---|------------------|---|-------|



Note

Liebherr recommends:

- ▶ Making it easier to pull out the axle **2**: move the rope reeving winch manually back and forth.
-
- ▶ Pull up the locking element **1** and pull out the axle **2** at the same time.
 - ▷ Rope reeving winch is set to free-wheel.

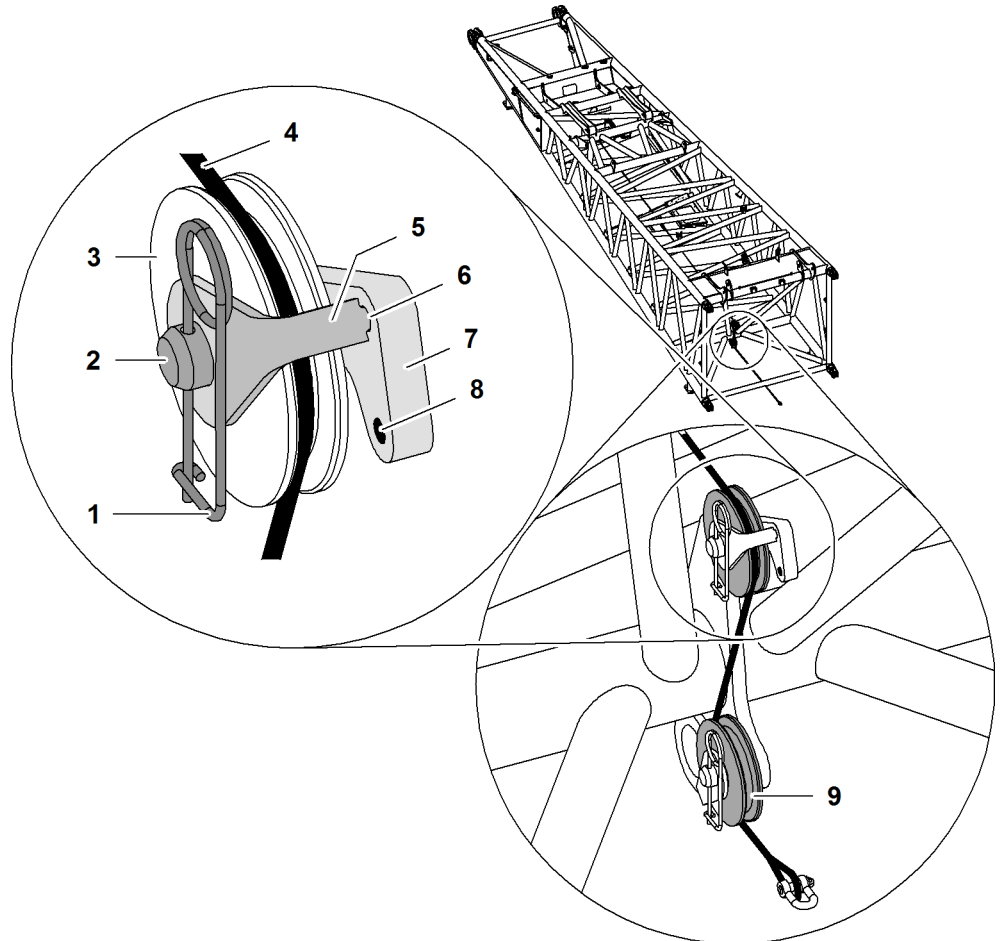


Fig. 3349: Reeving in the luffing rope of the rope reeving winch

- | | |
|---|--------------------------------|
| 1 Safety pin | 6 Recess |
| 2 Shaft | 7 Support with recesses |
| 3 Upper pulley | 8 Recess |
| 4 Rope of the rope reeving winch | 9 Lower pulley |
| 5 Locking element | |

Depending on the machine type, the mounting **7** may have one or two recesses.

- ▶ Remove safety pins **1**.
- ▶ Remove **5** securing element.
- ▶ Place rope of the rope reeving winch **4** across the top pulley **3**.

NOTICE

Wrongly mounted locking element!
Rope of the rope reeving winch jumps out of pulley.

- ▶ Make sure that the locking element **5** is mounted in recess **6**.

- ▶ Attach locking element **5** to axle **2** and guide in recess **6**.
- ▶ Attach the safety pin **1**.
- ▶ Repeat procedure on bottom pulley **9**.
 - ▷ Rope of the rope reeving winch is guided through pulleys.
- ▶ Pull the luffing rope under the boom to the boom head.
- ▶ Reeve in the rope of the rope reeving winch according to reeving plan.
- ▶ Pull the luffing rope next to the boom towards the basic machine.
- ▶ Lift luffing rope onto boom.
- ▶ Connect luffing rope with rope of winch1/winch2.

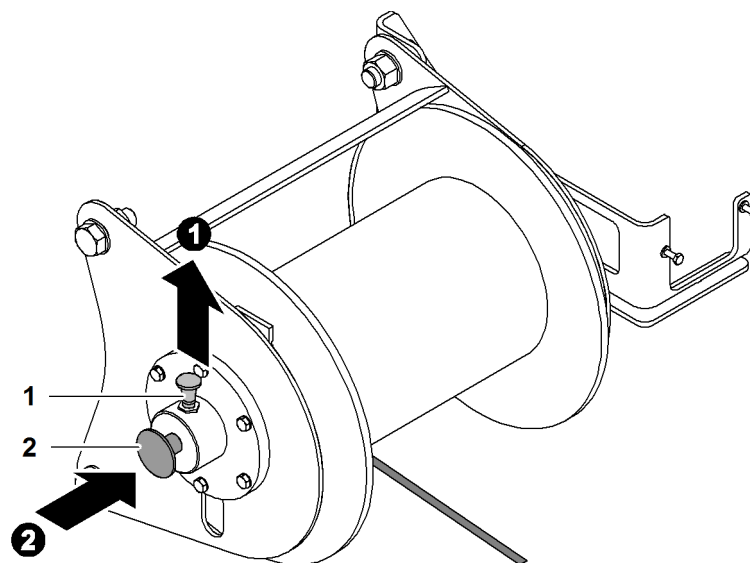


Fig. 3350: Stopping the free-wheel of the rope reeving winch

1 Locking element 2 Shaft



Note

Liebherr recommends:

- ▶ Making it easier to press in the axle **2**: move the rope reeving winch manually back and forth.

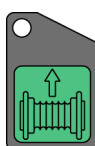
- ▶ Pull up the locking element **1** and press in the axle **2** at the same time.
 - ▷ Free-wheel of the luffing rope is deactivated.



WARNING

Never stand in the immediate vicinity of the rope reeving winch or the luffing rope!

- ▶ Make sure that no-one is standing in the danger area.
- ▶ Leave the danger area.



- ▶ Press and hold the *Rope reeving winch* button on control panel X11.
 - ▷ Rope reeving winch reeves in the rope of the rope reeving winch and tensions the rope of winch1/winch2.

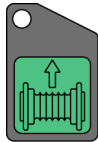


If rope of winch1/winch2 is in the 8th rope layer (only with free-fall winch 130 kN (29,230 lb_i)):

- ▶ Press the *Bypass limit switch* button on control panel X23.
 - ▷ The 3-rope windings limit switch is bypassed.

There must be no slacking of the rope when unwinding.

- ▶ Unwind the rope of winch1/winch2 up to the rope fixing point.
- ▶ Press the *Rope reeving winch* button on control panel X11.
 - ▷ Rope reeving winch switched off.
- ▶ Remove rope of the rope reeving winch from the rope of winch1/winch2.
- ▶ Press and hold the *Rope reeving winch* button on control panel X11.
 - ▷ Luffing rope is being reeved.



- ▶ Press the *Rope reeving winch* button on control panel X11.
 - ▷ Rope reeving winch switched off.
- ▶ Close and secure the rope guide (if present).

Mounting rope protection pipes on main boom head

- ▶ Mount and secure rope protection pipes.

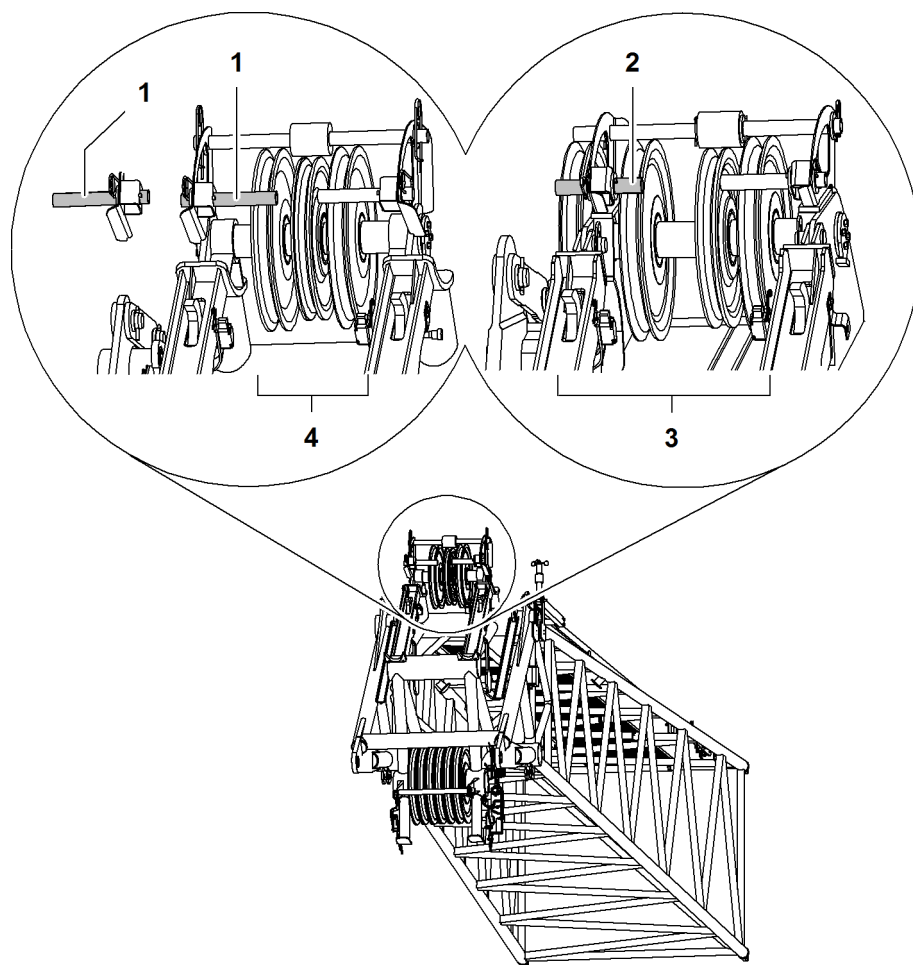


Fig. 3354: Rope protection pipe main boom head section with mounted fixed jib

- | | | | |
|---|----------------------|---|--|
| 1 | Rope protection pipe | 3 | Main boom head with four gantry pulleys |
| 2 | Rope protection pipe | 4 | Main boom head with three gantry pulleys |

NOTICE

Inadmissible rope protection pipe with mounted fixed jib!
Rope scrapes on rope protection pipe.
Damage to rope.

- ▶ Remove rope protection pipe 1 + 2.

If a fixed jib is being mounted:

- ▶ Remove rope protection pipe 2 on main boom head.
- or

Rotate rope protection pipe 1 by 180° and mount facing outwards.

Fitting the rope protection pipes to the auxiliary jib

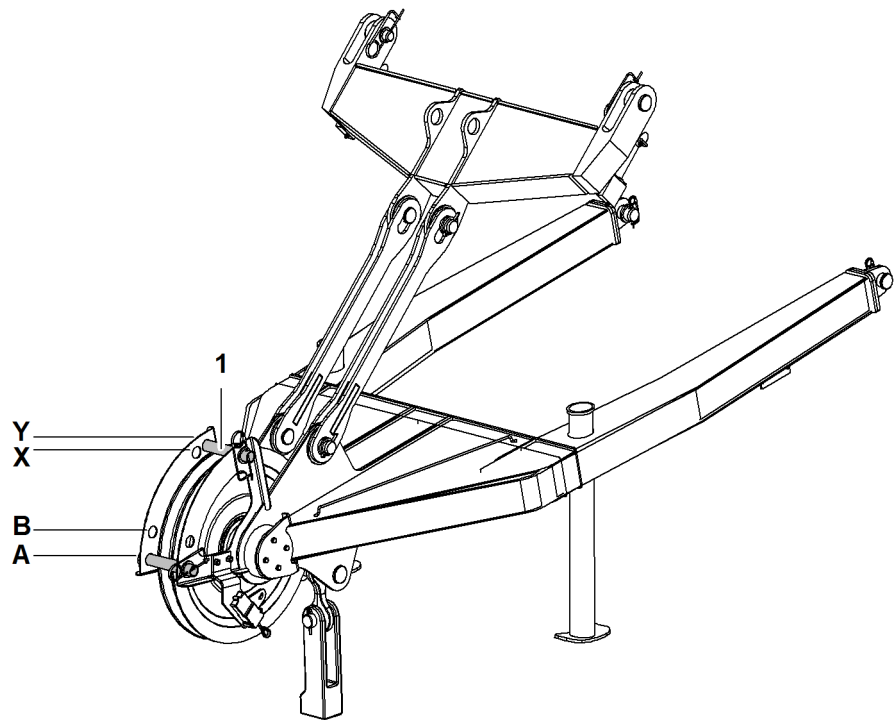


Fig. 3355: Fitting the rope protection pipes to the auxiliary jib

- 1 Rope protection pipe (2x)
- A Assembly position A for rope protection pipe
- B Assembly position B for rope protection pipe
- X Assembly position X for rope protection pipe
- Y Assembly position Y for rope protection pipe

Assembly positions of the rope protection pipes on the auxiliary jib depending on the main boom angle:

Machine type	Main boom angle		
	15° to 30°	20° to 30°	30° to 86°
LR 1001	B + X	-	A + Y
LR 1002	B + X	-	A + Y
LR 1003	B + X	-	A + Y
LR 1004	-	B + X	A + X
LR 1006	-	B + X	A + X

Tab. 505: Assembly positions for rope protection pipes on the auxiliary jib (36 t (79.300 lb)) for main boom head

- ▶ Mount rope protection pipes on auxiliary jib according to chart.

Reeving the rope without using a rope reeving winch

- ▶ Remove the rope protection pipes on the boom and the pulley block.
- ▶ Open up the rope guide (if present).

LWNLR.x/V04.01//Auslieferung/2016-03-07/en

- ▶ Connect auxiliary rope with the rope of winch1/winch2.
- ▶ Pull the auxiliary rope next to the boom as far as the boom head.
- ▶ Hoist the auxiliary rope onto the boom.
- ▶ Reeve the auxiliary rope according to the rope reeving system.



If rope of winch1/winch2 is in the 8th rope layer (only with free-fall winch 130 kN (29,230 lb,)):

- ▶ Press the *Bypass limit switch* button on control panel X23.
 - ▷ The 3-rope windings limit switch is bypassed.

There must be no slacking of the rope when unwinding.

- ▶ Unwind the rope of winch1/winch2 up to the rope fixing point.
- ▶ Remove auxiliary rope from the rope of winch1/winch2.
- ▶ Close and secure the rope guide (if present).
- ▶ Mount and secure rope protection pipes.

7.6.30 Attaching the rope fixing point



DANGER

Incorrect installation of pins and pocket lock!
Load breakaway.

- ▶ Fit pins and pocket lock as instructed.

The collar of the pins and the pocket lock openings are decisive for the installation direction of the rope fixing point.

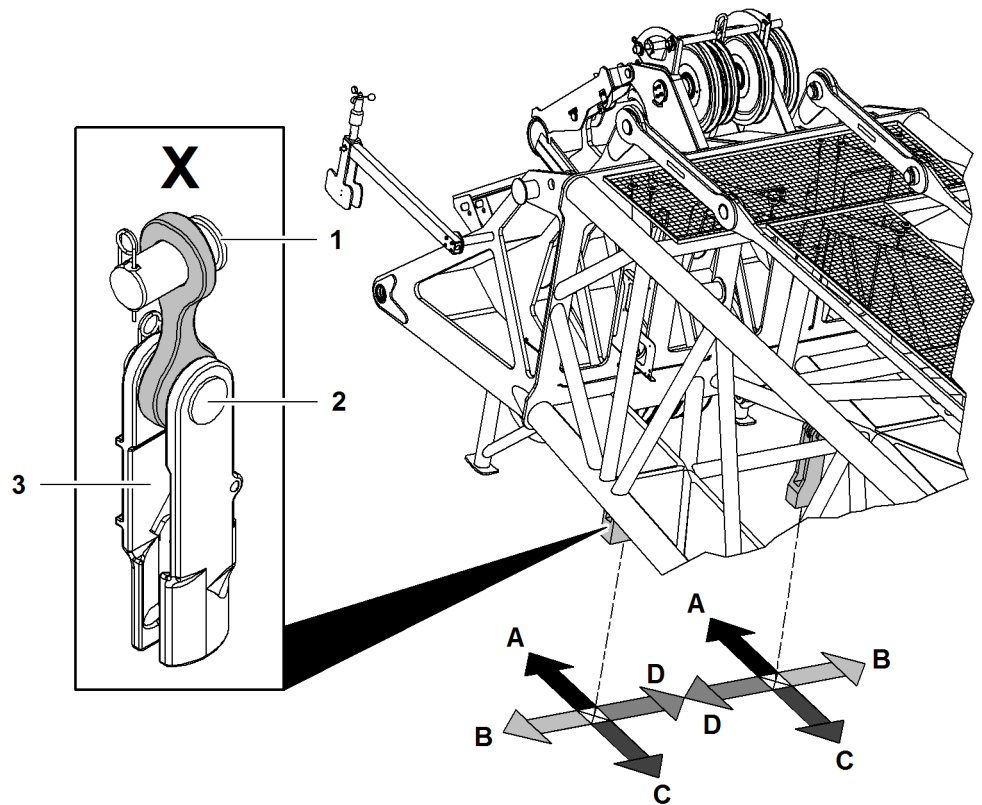


Fig. 3357: Determining the installation direction of the components of the rope fixing point of relevance for installation - main boom head (illustration of principle)

- | | | | |
|----------|------------------------------------|----------|--------------------------|
| X | Components needed for fitting | A | Direction main boom head |
| 1 | Shoulder of pin on the boom | B | Outside |
| 2 | Shoulder of pin on the pocket lock | C | Direction basic machine |
| 3 | Pocket lock opening | D | Inside |

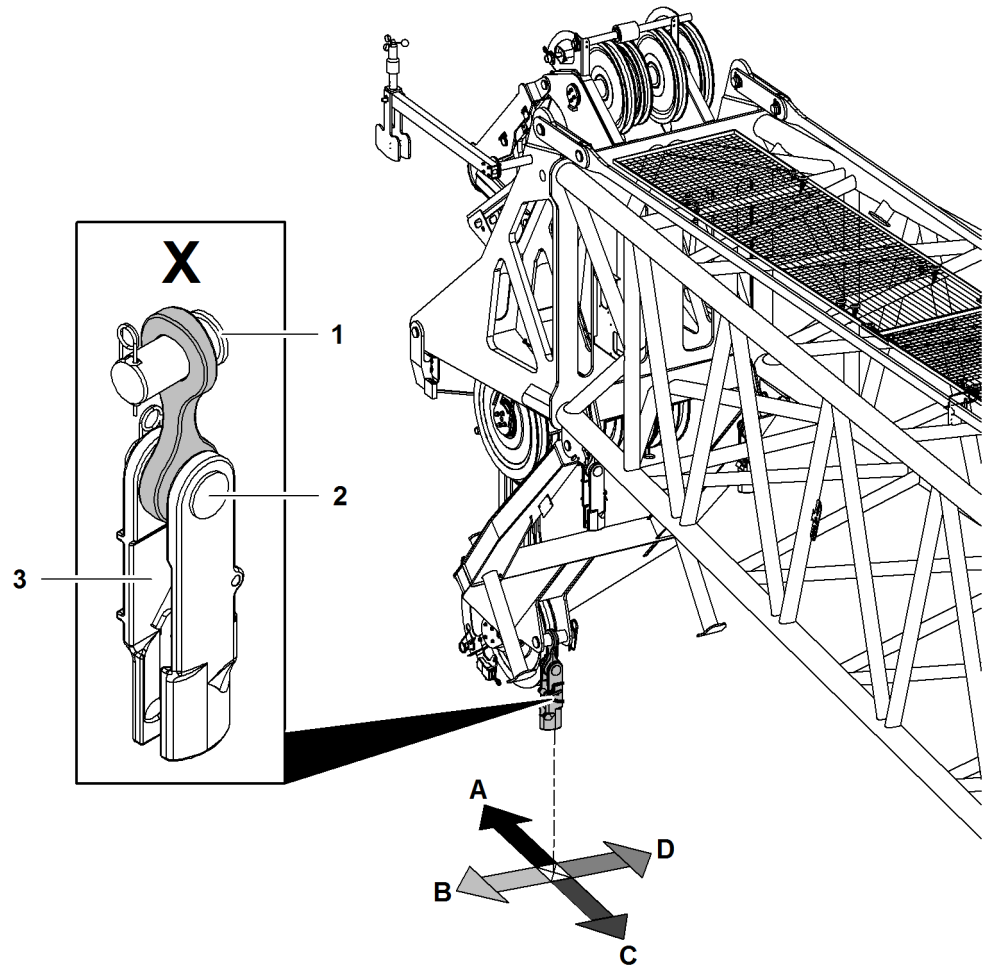


Fig. 3358: Determining the installation direction of the components of the rope fixing point of relevance for installation - auxiliary jib (illustration of principle)

- | | | | |
|----------|------------------------------------|----------|--------------------------|
| X | Components needed for fitting | A | Direction main boom head |
| 1 | Shoulder of pin on the boom | B | Outside |
| 2 | Shoulder of pin on the pocket lock | C | Direction basic machine |
| 3 | Pocket lock opening | D | Inside |

Installation direction of the rope fixing point components of relevance for installation			
	Pin collar on boom	Pin collar on pocket lock	Pocket lock opening
All rope fixing points	D	C	B
Exceptions:			
Fixed jib head 0906	B	C	B
Fixed jib head 1507	B	C	B

Tab. 506: Installation direction of the rope fixing point components of relevance for installation



WARNING

Incorrectly fit swivels!
Severe injuries, damage to machine.

- ▶ Fit rope with no twists.
- ▶ Install the rope without swivels.

LWN/LR-x/V04.01/Auslieferung/2016-03-07/en

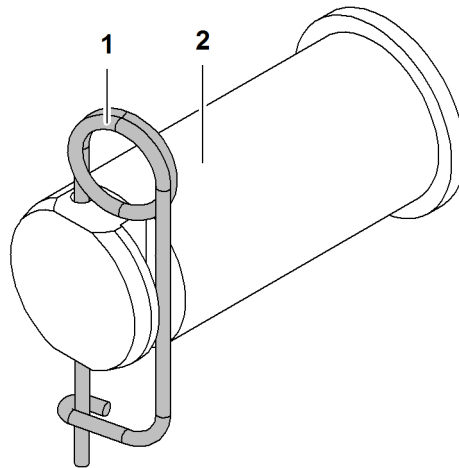


Fig. 3359: Securing the pins

1 Locking spring

2 Pin



DANGER

Pins 2 not completely secured!
Load breakaway.

- ▶ Ensure that locking spring 1 completely secures the pin 2.

Installing the rope fixing point on the boom head

- ▶ Pin cross strap with boom head.
- ▶ Secure pin with locking spring.
- ▶ Pin pocket lock with cross strap.
- ▶ Secure pin with locking spring.

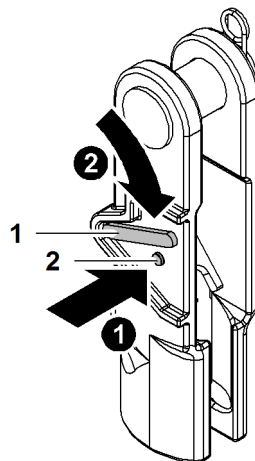


Fig. 3360: Unlocking the pocket lock

1 Safety latch

2 Locking button

- ▶ Press the locking button 2.
- ▶ Press safety latch 1 down and hold.

- ▶ Press safety latch 1 down and hold.

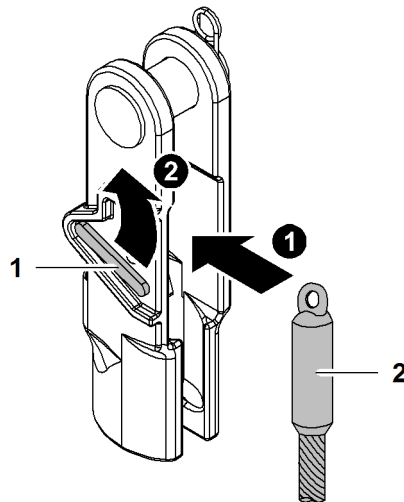


Fig. 3363: Inserting the end of rope into pocket lock and locking the pocket lock

- 1 Safety latch
- 2 End of rope

- ▶ Insert end of rope 2 in pocket lock.



DANGER

End of rope 2 not properly secured!
Load breakaway.

- ▶ Ensure that the safety latch 1 engages.

- ▶ Let go of safety latch 1.
 - ▷ Safety latch 1 engages.

7.6.31 Installing the hoist limit switch weight

NOTICE

Improper installation of the hoist limit switch weight!
Damage to the rope and hoist limit switch weight.

- ▶ Fit the hoist limit switch weight with no diagonal pull.
- ▶ Always install the hoist limit switch weight on the slack rope of winch1/winch2, except with simple reeving.

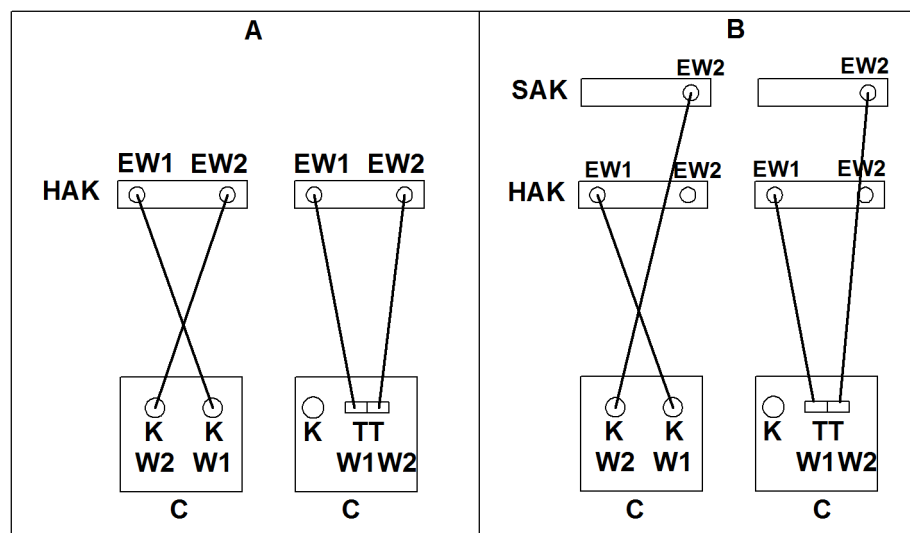


Fig. 3364: Hoist limit switch assignment in dependence on winch1/winch2

- | | |
|---|----------------------------------|
| A Boom configuration main boom | K Joystick |
| B Boom configuration main boom + jib head member | SAK Auxiliary jib |
| C Cabin | TT Double T-control lever |
| EW1 Hoist limit switch winch1 | W1 winch1 |
| EW2 Hoist limit switch winch2 | W2 winch2 |
| HAK Main boom head section | |

NOTICE

Wrong hoist limit switch!
 Hoist limit switch does not turn off.

- ▶ Make sure that the correct hoist limit switch for the correct rope of winch1/ winch2 is used.

The hoist limit switch with chain and hoist limit switch weight attached is secured to the inoperative end of the hoist rope.

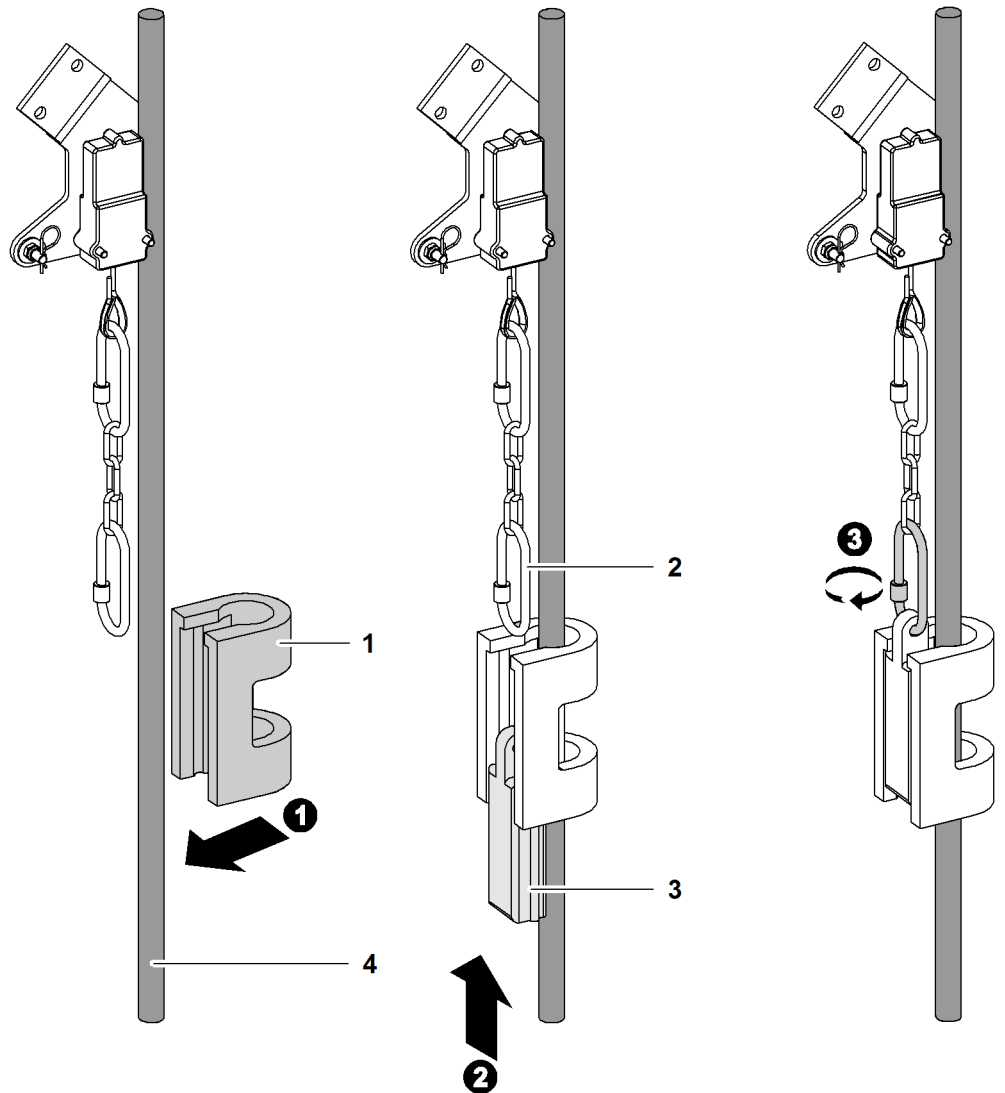


Fig. 3365: Fitting the hoist limit switch weight

- | | | | |
|---|-------------------------------------|---|-----------------------------------|
| 1 | Hoist limit switch weight (U shape) | 3 | Hoist limit switch weight (wedge) |
| 2 | Carabiner | 4 | Rope of winch1/winch2 |

► Guide the hoist limit switch weight (U shape) 1 over the rope of winch1/winch2 4.

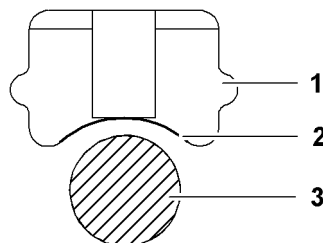


Fig. 3366: Hoist limit switch weight (wedge) view from above

- | | | | |
|---|-----------------------------------|---|-----------------------|
| 1 | Hoist limit switch weight (wedge) | 3 | Rope of winch1/winch2 |
| 2 | Curvature | | |

The hoist limit switch weight (wedge) 1 has a curvature 2 on one side.

NOTICE

Wrongly installed hoist limit switch weight (wedge)!

Hoist limit switch weight (wedge) damaged with wrong installation of rope of winch1/winch2.

- ▶ Make sure that the curvature of the hoist limit switch weight (wedge) is installed in the direction of the rope of winch1/winch2.

- ▶ Insert the hoist limit switch weight (wedge) **1** from below into the hoist limit switch weight (U shape).
- ▶ Attach the carabiner to the hoist limit switch weight (wedge) **1**.



Note

Liebherr recommends:

- ▶ visual inspection of the carabiner hook prior to installation.
- ▶ Clean dirty carabiner hook with a clean cloth and water.
- ▶ If necessary, re-clean with a slightly oily cloth.

NOTICE

Improper installation of carabiner!

Damage to machine.

- ▶ Make sure that the screw of the carabiner points downwards.
- ▶ Make sure that the securing element is twisted shut.

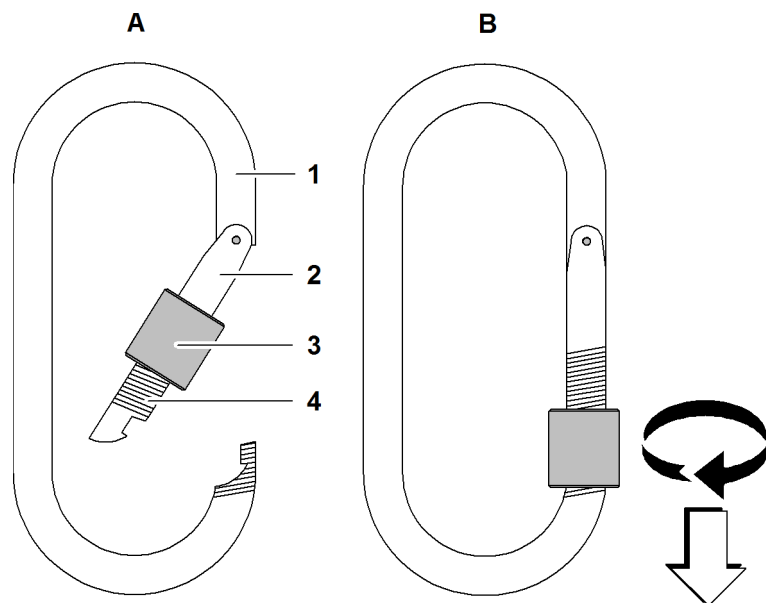


Fig. 3367: Carabiner

- | | | | |
|---|------------------|---|------------------|
| 1 | Carabiner | 4 | Thread |
| 2 | Snapper | A | Opened carabiner |
| 3 | Securing element | B | Closed carabiner |

- ▶ Secure carabiner **1** with securing element **3**.

NOTICE

The chain on the hoist limit switch weight is too short!

The hoist limit switch weight responds too late. The hook damages the boom head.

- ▶ Ensure that hoist limit switch weight chain is at least 3 m (9' 10" ft-in) and at most 4.5 m (14' 9" ft-in) long.

- ▶ Attach the chain between the hoist limit switch weight and the hoist limit switch.

7.6.32 Installing the hoist limit switch clamp* on auxiliary jib (36 t (79.300 lb))

The hoist limit switch clamp replaces the hoist limit switch weight on the auxiliary jib (36 t (79.300 lb)).

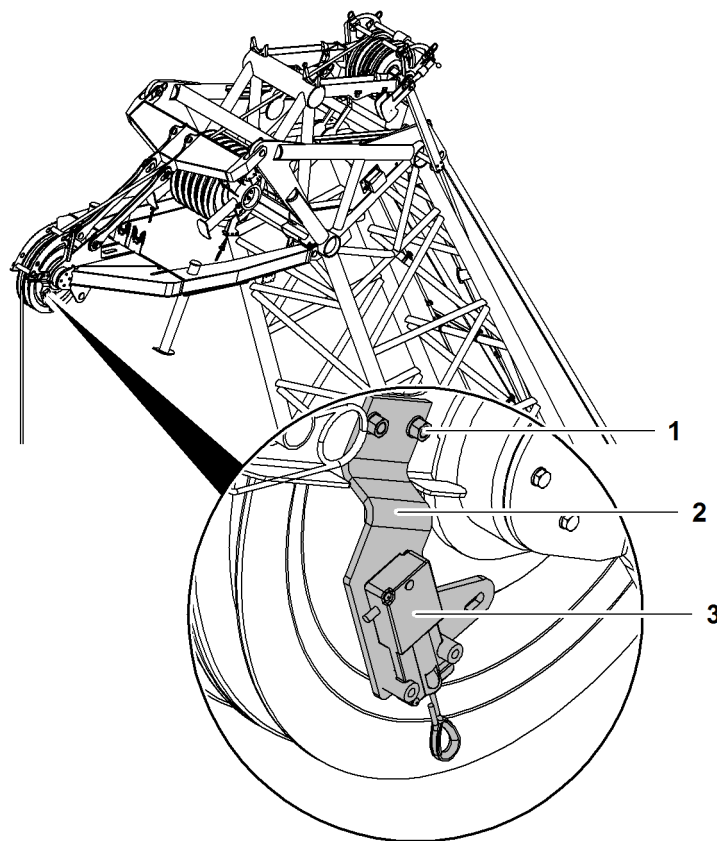


Fig. 3368: Deinstalling the installed limit switch plate

- | | | | |
|---|--------------------|---|--------------------|
| 1 | Screw (2x) | 3 | Hoist limit switch |
| 2 | Limit switch plate | | |

- ▶ Undo screws 1.
- ▶ Remove limit switch plate 2.
- ▶ Deinstall hoist limit switch 3 from limit switch plate 2.

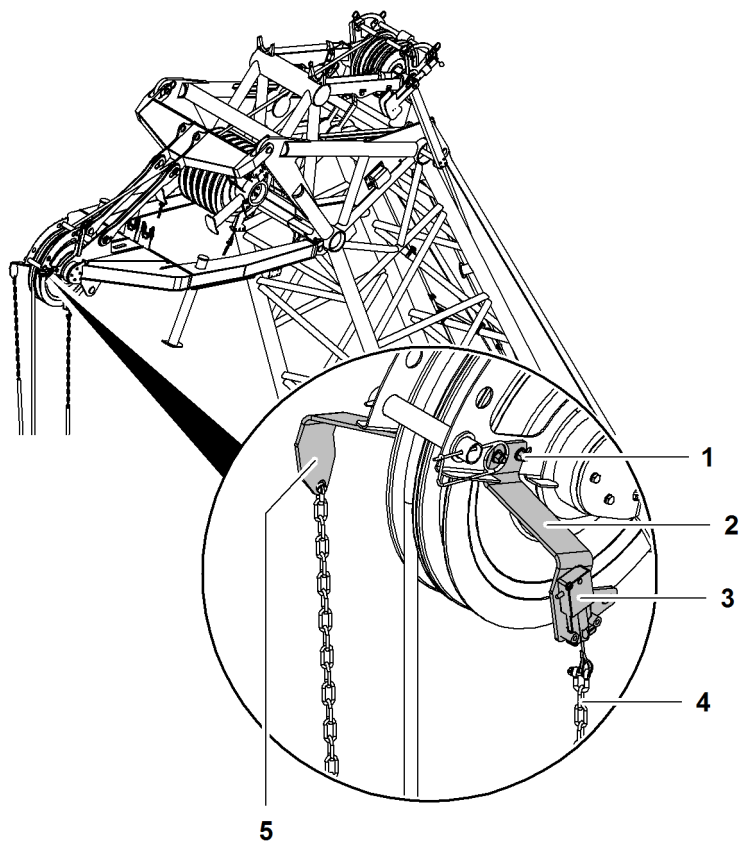


Fig. 3369: Installing the limit switch plate of the hoist limit switch clamp

- | | | | |
|---|--------------------|---|-------------|
| 1 | Screw (4x) | 4 | Chain (2x) |
| 2 | Limit switch plate | 5 | Steel plate |
| 3 | Hoist limit switch | | |

- ▶ Install available hoist limit switch **3** on limit switch plate **2**.
- ▶ Attach limit switch place **2** with screws to **1** auxiliary jib (36 t (79.300 lb)).
- ▶ Attach plate **5** on opposite side with screws.
- ▶ Attach chain **4** with shackle on hoist limit switch **3**.
- ▶ Attach chain **4** with shackle on plate **5**.

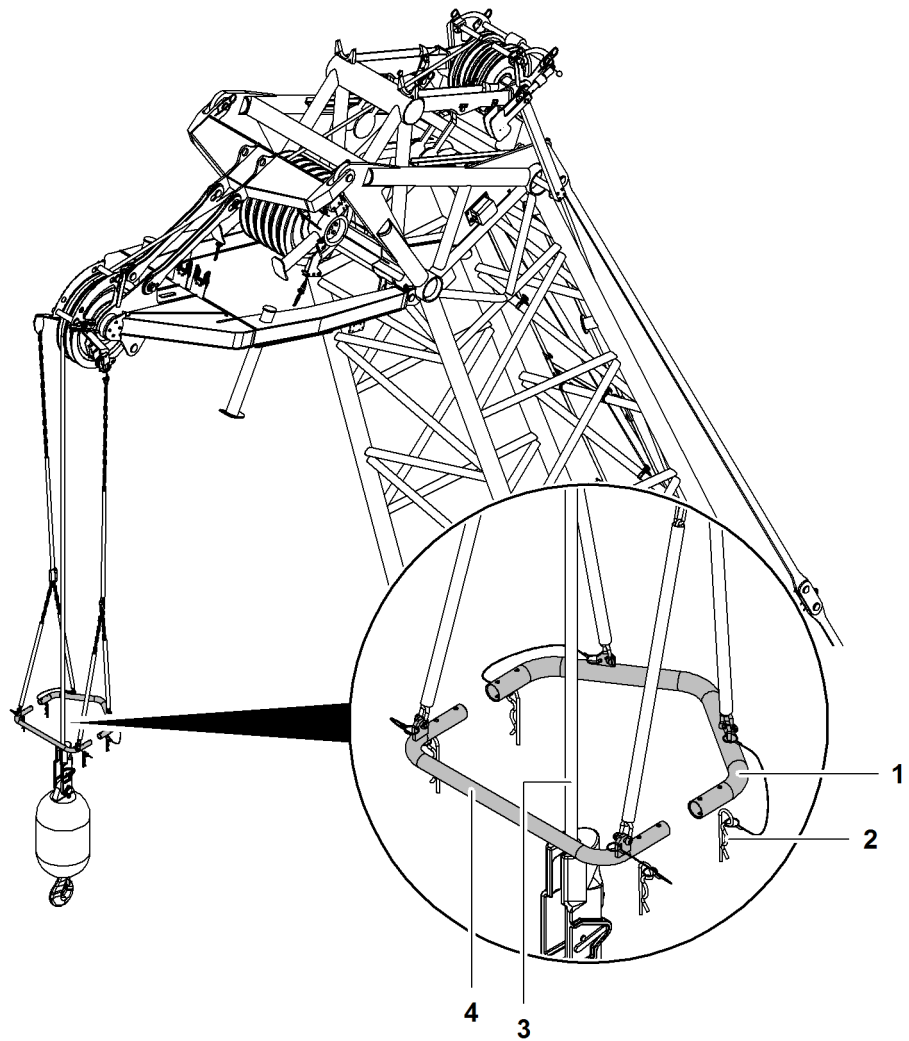


Fig. 3370: Place winch2 rope between hoist limit switch clamp

- | | | | |
|---|------------------------|---|-------------|
| 1 | Rear pipe | 3 | Winch2 rope |
| 2 | Spring cotter pin (4x) | 4 | Front pipe |

- ▶ Place winch2 rope 3 between rear pipe 1 and front pipe 4.
- ▶ Stick front pipe 4 into rear pipe 1.

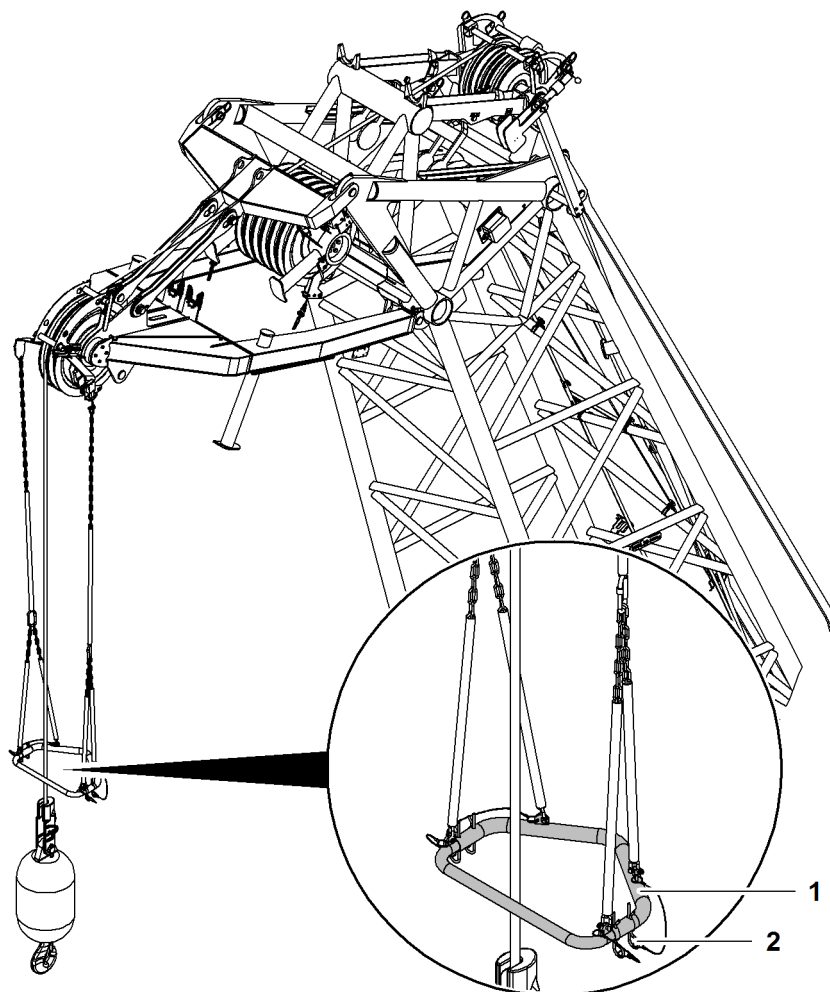


Fig. 3371: Assembling the hoist limit switch clamp

- 1 Hoist limit switch clamp 2 Spring cotter pin (4x)

► Insert spring cotter pin 2 into borings from below.

7.6.33 Bypass unused hoist limit switches.



DANGER

The hoist limit switch has been bypassed illegally!
Load breakaway.

► Only ever bypass unused hoist limit switches.

NOTICE

Wrong hoist limit switch is bypassed!
The hook damages the boom head.

- Lock winch 1 using the left hoist limit switch.
- Lock winch 2 using the right hoist limit switch.

Ensure that the following conditions are fulfilled:

- Only motion is performed with a rope of winch1/winch2. A hoist limit switch is not required.

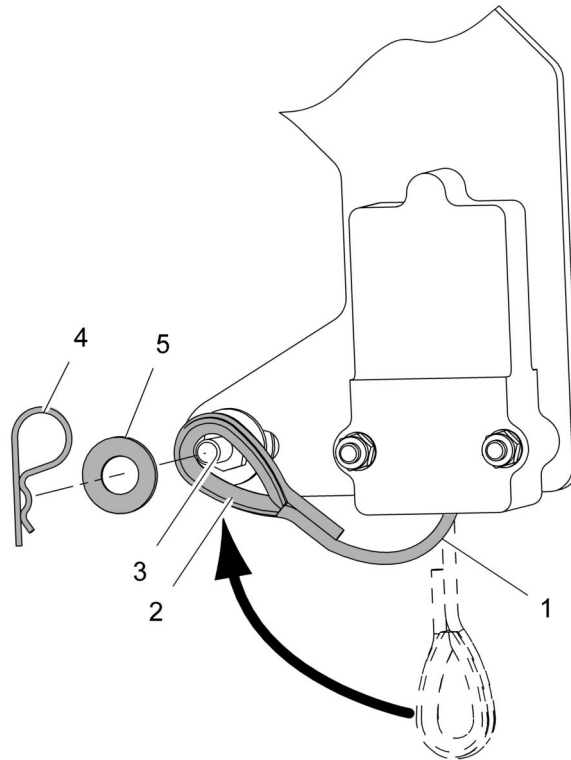


Fig. 3372: Bypassing the hoist limit switch mechanically

- | | | | |
|----------|------------|----------|------------|
| 1 | Steel rope | 4 | Safety pin |
| 2 | Loop | 5 | Washer |
| 3 | Stud bolt | | |

- ▶ Pull the steel rope **1** and place the loop **2** over the stud bolt **3**.
 - ▷ Hoist limit switch is bypassed.
- ▶ Protect the sling **2** from slipping off the stud bolt **3** by securing it with a washer **5** and a safety pin **4**.

7.7 Erecting the main boom without derrick equipment*

7.7.1 Erecting the main boom

Ensure that the following conditions are fulfilled:

- Boom configuration can be erected with counterweight.
- Signalmen and assistants are instructed.
- All work on the main boom has been completed.
- No loose parts or tools have been left on the main boom.

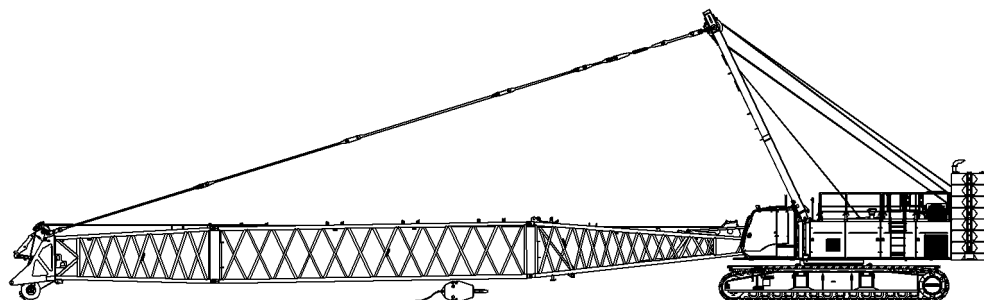


Fig. 3373: Main boom on the ground (illustration of principle)



DANGER

Hoist limit switch bypassed on control panel X23 in crane mode!
Load breakaway.

- ▶ Only bypass hoist limit switch on control panel X23 when assembling or disassembling the machine.



If hoist limit switch weight is on the ground:

- ▶ Press the *Bypass limit switch* button on control panel X23.
 - ▷ Hoist limit switches are bypassed.



- ▶ Press the *Load moment limiter assembly/self-lock* button on control panel X23.

No load chart exist for machines geometry:

- ▷ Function "load moment limiter assembly" is active.
- ▷ The LED on the button *Load moment limiter assembly/self-lock* lights up.
- ▷ Machine functions are enabled unlimited.
- ▷ Load Moment Limiter lamps flash orange.



DANGER

Erectability chart is not followed!
Machine toppling over.

- ▶ Only lift the main boom when erection is permitted according to the erectability chart.



WARNING

Falling objects!
Severe injury.

- ▶ Any loose parts and tools must be removed from the main boom.
- ▶ Make sure that nobody is located in the danger zone.
- ▶ Leave the danger area.

- ▶ Lift main boom slowly.
 - ▷ The main boom pendant straps are tensioned.



WARNING

Dangerous voltage in main boom!
Sudden sideways movement when lifting main boom off the ground.

- ▶ Make sure that no-one is standing in the danger zone.
- ▶ Leave the danger zone.

- ▶ Lift main boom further.
 - ▷ Main boom lifts off the ground.

When the auxiliary jib (36 t (79300 lb)) is attached and lifts off the ground:

- ▶ Stop main boom lift.

NOTICE

Incorrect limit stop setting for the pendant straps of the auxiliary jib!
Damage to auxiliary jib and pulleys on the main boom head when laying down.

- ▶ Ensure that the limit stop is set so that the pendant straps of the auxiliary jib fold upwards when laying down.

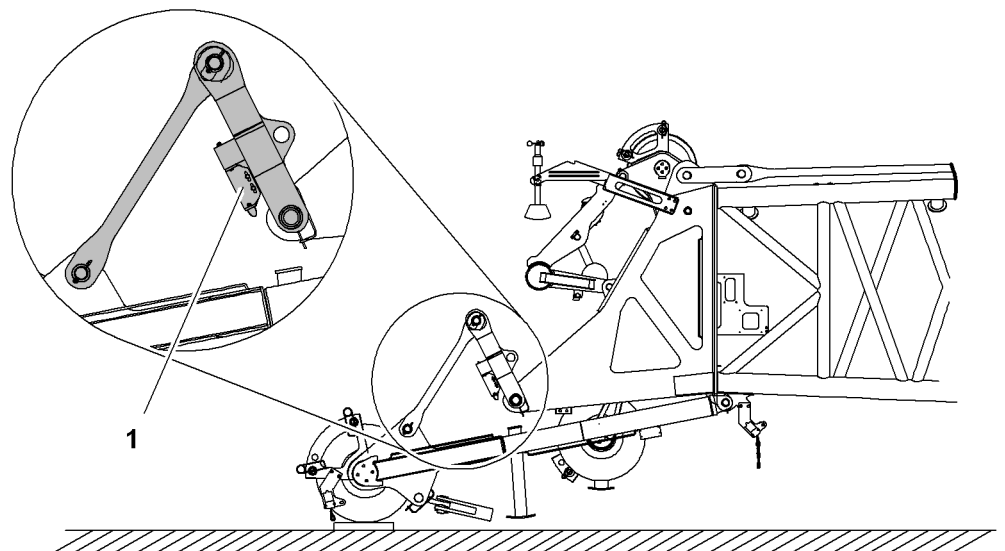


Fig. 3376: Checking the auxiliary jib limit stop

1 Limit stop

- ▶ Check the limit stop 1, if necessary lay down the main boom and set the limit stop 1.

When the limit stop 1 is set correctly:

- ▶ Lift main boom further.
- ▷ Main boom erects itself:

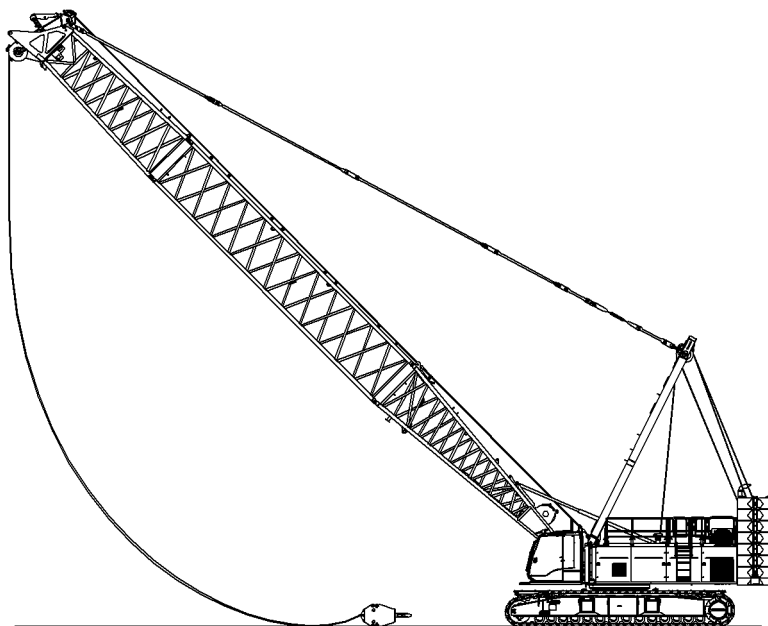


Fig. 3377: Main boom erects itself (illustration of principle)

As soon as there is a load chart for the geometry of the machine:

- ▷ Deactivate the function *Load moment limiter assembly*.
- ▷ The LED in the button *Load moment limiter assembly/self-lock* goes out.
- ▷ Load moment limiter is active.
- ▷ Load moment limiter lamps light up according to the current status of the Load Moment Limiter system.

NOTICE

Incorrect erection procedure is followed!
Damage to the equipment.

- ▶ Do not drag the hook or the pulley block along the ground.
- ▶ Do not allow any slacking of the rope.

-
- ▶ Unwind the rope of winch1/winch2 when necessary.
 - ▷ The hook/pulley block remains on the ground.

When the maximum permitted lifting capacity is at least equal to the weight of the hook and/or pulley block:

- ▶ Raise the hook/pulley block.
- ▶ Erect the main boom until it is in the desired position.
 - ▷ Main boom is erected:

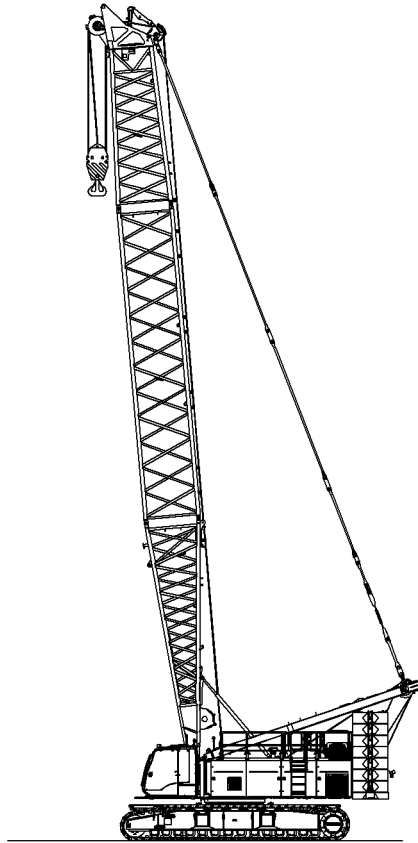


Fig. 3378: Erected main boom (illustration of principle)

7.7.2 Switching off assembly mode functions

Ensure that the following conditions are fulfilled:

- The machine is fully assembled and erected.
- All limit switches are fitted and operational.



- ▶ Press the *Assembly functions* switch on control panel X12.
 - ▷ Assembly mode functions are switched off.
 - ▷ The symbol *Assembly functions* disappears on screen.

7.7.3 Checking the main boom limit switch plate for proper adjustment

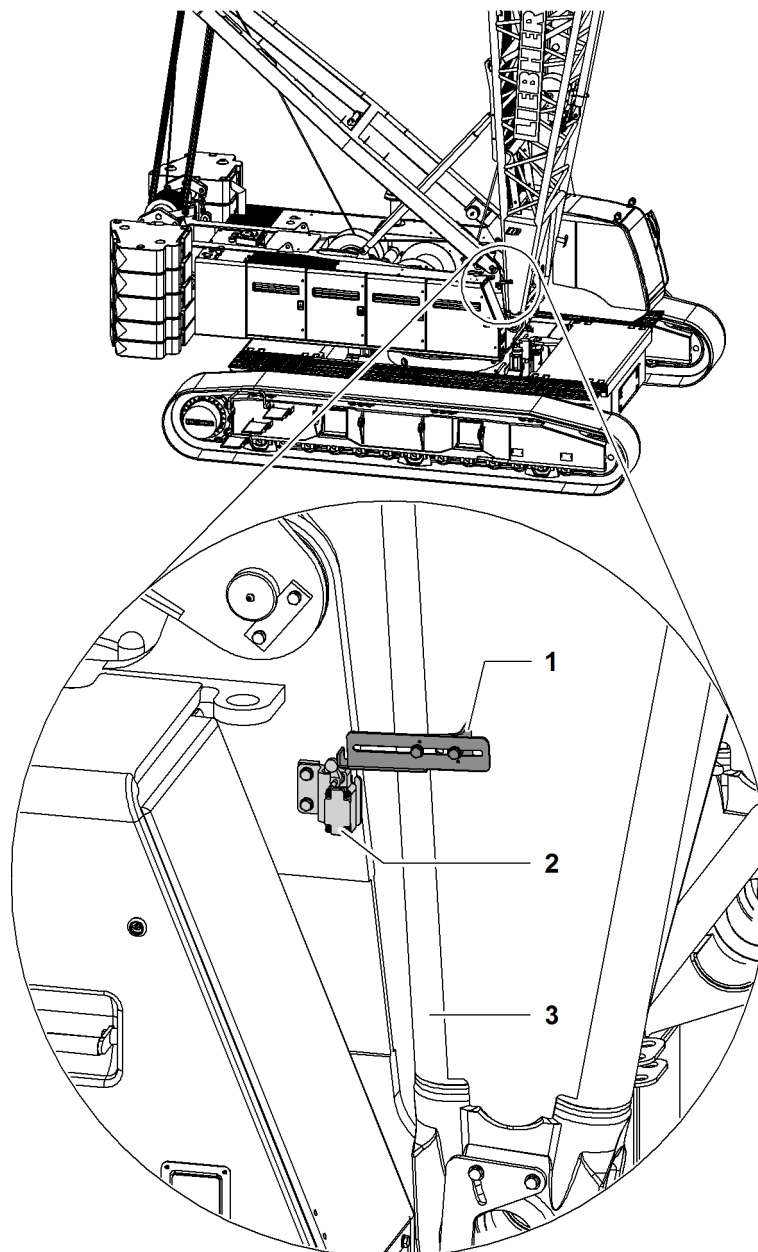


Fig. 3380: Checking the main boom limit switch plate for proper adjustment (illustration of principle)

- | | | | |
|---|--------------------|---|------------------------|
| 1 | Limit switch plate | 3 | Main boom base section |
| 2 | Limit switch | | |

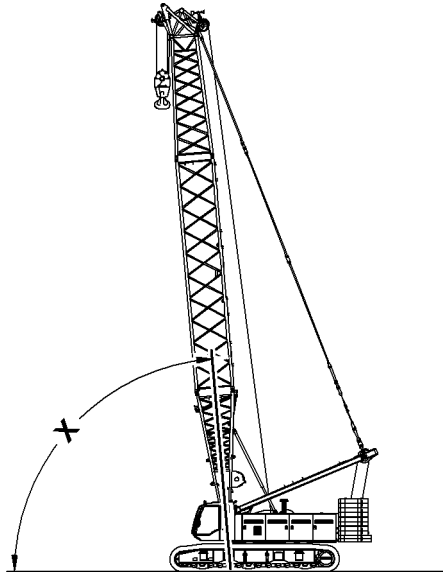


Fig. 3381: Top main boom angle (illustration of principle)

Boom configuration	Angle X
Main boom	86°
Main boom + derrick	
Main boom + reducing adapter	
Main boom + fixed jib	88°
Main boom + fixed jib + derrick	
Main boom + luffing jib	
Main boom + luffing jib + derrick	
Main boom + luffing jib + midfall	

Tab. 507: Main boom limit switch plate

NOTICE

Incorrect calibration of the main boom limit switch plate!
Damage to machine.

► Make sure that the main boom limit switch plate is properly adjusted.

- Erect the main boom until the screen *Operation* shows the angle X.
 - ▷ Limit switch triggers.
 - ▷ Lift main boom is locked.

If the limit switch triggers too early or not at all:

- Switch off machine.
- Contact Liebherr service department.

LWNLR.x/V04.01//Auslieferung/2016-03-07/en

7.8 Main boom 2821 + derrick boom 2220

System-relevant information for main boom 2821 + derrick boom 2220:

- Configuration of main boom in derrick mode
 - Rope guide installation position (type B)
 - Mid-point suspensions installation positions
- Lengths of mid-point suspensions
- Overview of main boom 2821 steel pendant straps + derrick boom 2220
- Overview of CF pendant straps of main boom 2821 + derrick boom 2220
- Reeving diagrams for one rope across main boom head 2821 (load position1)
- Reeving diagrams for two ropes across main boom head 2821 (load position1)
- Reeving diagrams for one rope across auxiliary jib (36 t (79300 lb)) on main boom head 2821 (load position1)
- Reeving diagrams for two ropes across auxiliary jib (36 t (79300 lb)) and main boom head 2821 (load position 1)
- Reeving diagrams jib luffing winch as auxiliary winch

7.8.1 Configuration of main boom in derrick mode



DANGER

Erected length of main boom excessive!
Structural breakdown.

- ▶ Check the main boom length in the load chart for validity.

Main boom length	Configuration of main boom (symbolic)
41 m 134 ft	
44 m 144 ft	
47 m 154 ft	
50 m 164 ft	
53 m 174 ft	
56 m 184 ft	
59 m 195 ft	
62 m 203 ft	
65 m 213 ft	
68 m 223 ft	

LWN/LR-x/V04.01//Auslieferung/2016-03-07/en

Main boom length	Configuration of main boom (symbolic)
71 m 233 ft	
74 m 243 ft	
77 m 253 ft	
80 m 262 ft	
83 m 272 ft	
86 m 282 ft	
89 m 292 ft	
92 m 302 ft	
95 m 312 ft	
98 m 322 ft	
101 m 332 ft	
104 m 342 ft	
107 m 351 ft	
110 m 361 ft	
113 m 371 ft	
116 m 381 ft	
119 m 390 ft	

Tab. 508: Configuration of main boom 2821 in derrick mode

S - Rope guide installation position (type B)

X1 - Assembly position of mid-point suspension 1

LWNLR-x/V04.01//Auslieferung/2016-03-07/en

7.8.2 Lengths of mid-point suspensions

Main boom length	Stay rope 1 (X1)
	Rope length
95 m 311' 8" ft-in	7.2 m 23' 7" ft-in = 2.1 m (6' 11" ft-in) + 2.1 m (6' 11" ft-in) + 3.0 m (9' 10" ft-in)
98 m 321' 6" ft-in	6.9 m 22' 8" ft-in = 1.6 m (5' 3" ft-in) + 1.6 m (5' 3" ft-in) + 1.6 m (5' 3" ft-in) + 2.1 m (6' 11" ft-in)
101 m 331' 4" ft-in	6.7 m 22' ft-in = 1.6 m (5' 3" ft-in) + 2.1 m (6' 11" ft-in) + 3.0 m (9' 10" ft-in)
104 m 341' 2" ft-in	9.2 m 30' 2" ft-in = 1.6 m (5' 3" ft-in) + 1.6 m (5' 3" ft-in) + 3.0 m (9' 10" ft-in) + 3.0 m (9' 10" ft-in)
107 m 351' 1" ft-in	8.9 m 29' 2" ft-in = 1.6 m (5' 3" ft-in) + 2.1 m (6' 11" ft-in) + 2.6 m (8' 6" ft-in) + 2.6 m (8' 6" ft-in)
110 m 360' 11" ft-in	8.8 m 28' 10" ft-in = 1.6 m (5' 3" ft-in) + 2.1 m (6' 11" ft-in) + 2.1 m (6' 11" ft-in) + 3.0 m (9' 10" ft-in)
113 m 370' 9" ft-in	8.6 m 28' 3" ft-in = 2.6 m (8' 6" ft-in) + 3.0 m (9' 10" ft-in) + 3.0 m (9' 10" ft-in)
116 m 380' 7" ft-in	8.4 m 27' 7" ft-in = 1.6 m (5' 3" ft-in) + 2.1 m (6' 11" ft-in) + 2.1 m (6' 11" ft-in) + 2.6 m (8' 6" ft-in)
119 m 390' 5" ft-in	7.9 m 25' 11" ft-in = 1.6 m (5' 3" ft-in) + 1.6 m (5' 3" ft-in) + 2.1 m (6' 11" ft-in) + 2.6 m (8' 6" ft-in)

Tab. 509: Lengths of mid-point suspensions - main boom 2821 + derrick boom 2220

LWN/LR-x/V04.01//Auslieferung/2016-03-07/en

7.8.3 Overview of main boom 2821 steel pendant straps + derrick boom 2220

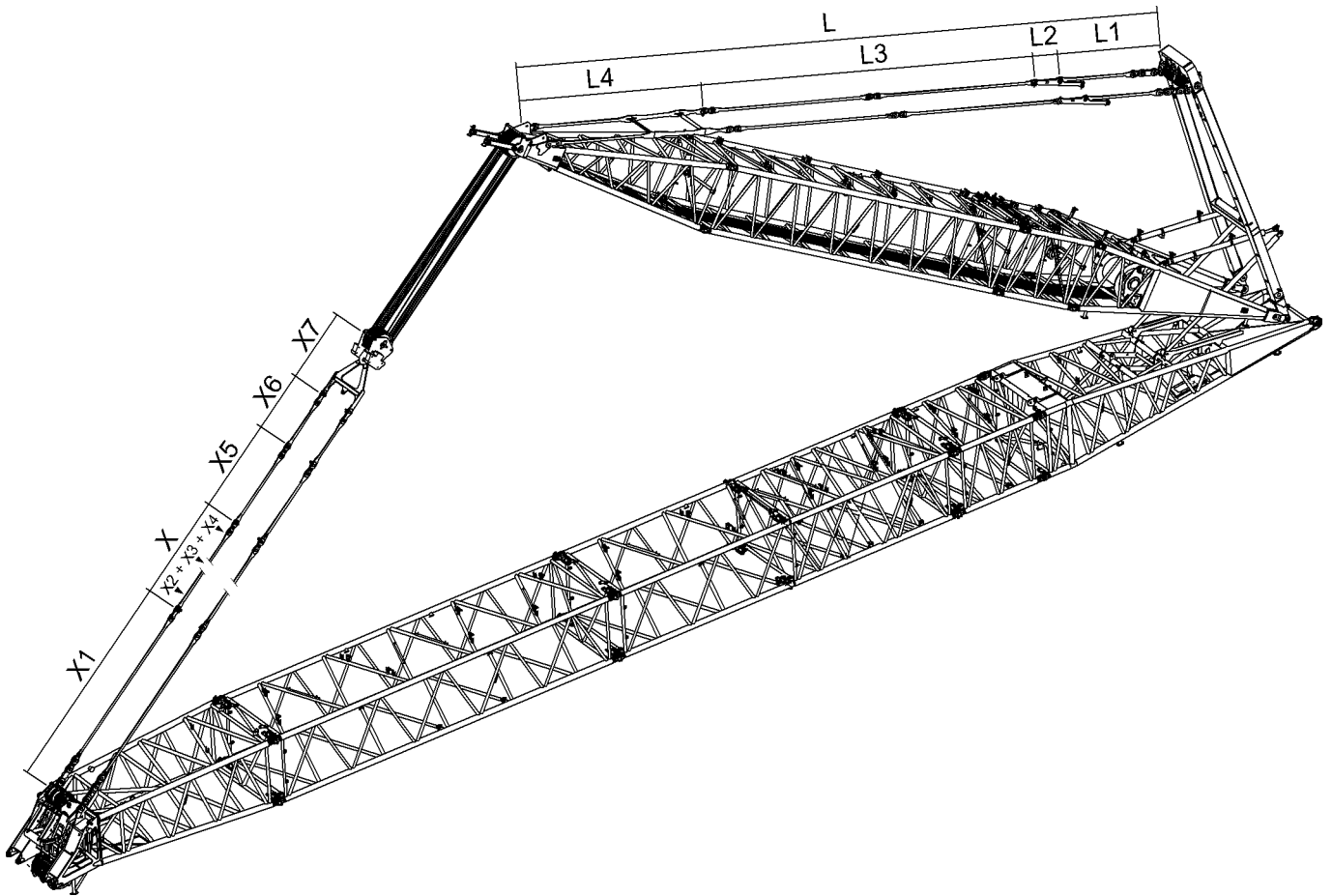


Fig. 3594: Overview of main boom 2821 steel pendant straps + derrick boom 2220

A-frame1 to 2220 derrick boom head pendant straps

Name		Value	
L	Derrick boom pendant straps consisting of:		
	L1	A-frame1 equalizer (For more information see: A-frame1 equalizer, page 77)	3730 mm 12' 3" ft-in
	L2	Adapter connecting link (For more information see: Adapter connecting link, page 390)	913 mm 3' ft-in
	L3	Derrick boom pendant strap 12 m (40 ft) (For more information see: Derrick boom pendant strap 12 m (40 ft), page 391)	12000 mm 39' 4" ft-in
	L4	Derrick boom pendant strap (crossbar) (For more information see: Derrick boom pendant strap (crossbar), page 392)	6500 mm 21' 4" ft-in

Tab. 510: A-frame1 pendant straps to derrick boom head 2220

LWNLR-x/V04.01//Auslieferung/2016-03-07/en

2821 main boom head to 2220 derrick boom head pendant straps

Name		Value
X1	Main boom pendant strap on main boom head 2821 (For more information see: Connecting links with tension load cell, page 199)	6300 mm 20' 8" ft-in
	+	
X	Main boom pendant straps consisting of:	
	X2	Main boom pendant straps 3 m (10 ft) (For more information see: Main boom pendant strap 3 m (10 ft), page 192)
	X3	Main boom pendant straps 6 m (20 ft) (For more information see: Main boom pendant strap 6 m (20 ft), page 194)
	X4	Main boom pendant straps 12 m (40 ft) (For more information see: Main boom pendant strap 12 m (40 ft), page 196)
X5	Equalizer of main boom base section 2821 (For more information see: Equalizer of main boom base section 2821.30, page 191)	2670 mm 8' 9" ft-in
X6	Main boom pendant strap (For more information see: Pendant strap with connecting link, page 199)	1855 mm 6' 1" ft-in
X7	Derrick rope rigging with crossbar (For more information see: Derrick rope rigging with crossbar, page 389)	2145 mm 7' ft-in

Tab. 511: Main boom head pendant straps 2821 for derrick boom head 2220

Composition of the pendant straps between 2821 main boom head and 2220 derrick boom head:

Main boom length	X1	Required pendant strap length X			X5	X6	X7
		X = X2 + X3 + X4					
		X2	X3	X4			
41 m 134' 6" ft-in	6300 mm 20' 8" ft-in	-	-	-	2670 mm 8' 9" ft-in	1855 mm 6' 1" ft-in	2145 mm 7' ft-in
44 m 144' 4" ft-in	6300 mm 20' 8" ft-in	-	-	1 x 3 m (10 ft)	2670 mm 8' 9" ft-in	1855 mm 6' 1" ft-in	2145 mm 7' ft-in
47 m 154' 2" ft-in	6300 mm 20' 8" ft-in	-	1 x 6 m (20 ft)	-	2670 mm 8' 9" ft-in	1855 mm 6' 1" ft-in	2145 mm 7' ft-in
50 m 164' ft-in	6300 mm 20' 8" ft-in	-	1 x 6 m (20 ft)	1 x 3 m (10 ft)	2670 mm 8' 9" ft-in	1855 mm 6' 1" ft-in	2145 mm 7' ft-in

LWNLR-x/V04.01//Auslieferung/2016-03-07/en

Main boom length	X1	Required pendant strap length X			X5	X6	X7
		X = X2 + X3 + X4					
		X2	X3	X4			
53 m 173' 11" ft-in	6300 mm 20' 8" ft-in	1 x 12 m (40 ft)	-	-	2670 mm 8' 9" ft-in	1855 mm 6' 1" ft-in	2145 mm 7' ft-in
56 m 183' 9" ft-in	6300 mm 20' 8" ft-in	1 x 12 m (40 ft)	-	1 x 3 m (10 ft)	2670 mm 8' 9" ft-in	1855 mm 6' 1" ft-in	2145 mm 7' ft-in
59 m 193' 7" ft-in	6300 mm 20' 8" ft-in	1 x 12 m (40 ft)	1 x 6 m (20 ft)	-	2670 mm 8' 9" ft-in	1855 mm 6' 1" ft-in	2145 mm 7' ft-in
62 m 203' 5" ft-in	6300 mm 20' 8" ft-in	1 x 12 m (40 ft)	1 x 6 m (20 ft)	1 x 3 m (10 ft)	2670 mm 8' 9" ft-in	1855 mm 6' 1" ft-in	2145 mm 7' ft-in
65 m 213' 3" ft-in	6300 mm 20' 8" ft-in	2 x 12 m (40 ft)	-	-	2670 mm 8' 9" ft-in	1855 mm 6' 1" ft-in	2145 mm 7' ft-in
68 m 223' 1" ft-in	6300 mm 20' 8" ft-in	2 x 12 m (40 ft)	-	1 x 3 m (10 ft)	2670 mm 8' 9" ft-in	1855 mm 6' 1" ft-in	2145 mm 7' ft-in
71 m 232' 11" ft-in	6300 mm 20' 8" ft-in	2 x 12 m (40 ft)	1 x 6 m (20 ft)	-	2670 mm 8' 9" ft-in	1855 mm 6' 1" ft-in	2145 mm 7' ft-in
74 m 242' 9" ft-in	6300 mm 20' 8" ft-in	2 x 12 m (40 ft)	1 x 6 m (20 ft)	1 x 3 m (10 ft)	2670 mm 8' 9" ft-in	1855 mm 6' 1" ft-in	2145 mm 7' ft-in
77 m 252' 7" ft-in	6300 mm 20' 8" ft-in	3 x 12 m (40 ft)	-	-	2670 mm 8' 9" ft-in	1855 mm 6' 1" ft-in	2145 mm 7' ft-in
80 m 262' 6" ft-in	6300 mm 20' 8" ft-in	3 x 12 m (40 ft)	-	1 x 3 m (10 ft)	2670 mm 8' 9" ft-in	1855 mm 6' 1" ft-in	2145 mm 7' ft-in
83 m 272' 4" ft-in	6300 mm 20' 8" ft-in	3 x 12 m (40 ft)	1 x 6 m (20 ft)	-	2670 mm 8' 9" ft-in	1855 mm 6' 1" ft-in	2145 mm 7' ft-in
86 m 282' 2" ft-in	6300 mm 20' 8" ft-in	3 x 12 m (40 ft)	1 x 6 m (20 ft)	1 x 3 m (10 ft)	2670 mm 8' 9" ft-in	1855 mm 6' 1" ft-in	2145 mm 7' ft-in
89 m 292' ft-in	6300 mm 20' 8" ft-in	4 x 12 m (40 ft)	-	-	2670 mm 8' 9" ft-in	1855 mm 6' 1" ft-in	2145 mm 7' ft-in
92 m 301' 10" ft-in	6300 mm 20' 8" ft-in	4 x 12 m (40 ft)	-	1 x 3 m (10 ft)	2670 mm 8' 9" ft-in	1855 mm 6' 1" ft-in	2145 mm 7' ft-in
95 m 311' 8" ft-in	6300 mm 20' 8" ft-in	4 x 12 m (40 ft)	1 x 6 m (20 ft)	-	2670 mm 8' 9" ft-in	1855 mm 6' 1" ft-in	2145 mm 7' ft-in
98 m 321' 6" ft-in	6300 mm 20' 8" ft-in	4 x 12 m (40 ft)	1 x 6 m (20 ft)	1 x 3 m (10 ft)	2670 mm 8' 9" ft-in	1855 mm 6' 1" ft-in	2145 mm 7' ft-in
101 m 331' 4" ft-in	6300 mm 20' 8" ft-in	5 x 12 m (40 ft)	-	-	2670 mm 8' 9" ft-in	1855 mm 6' 1" ft-in	2145 mm 7' ft-in
104 m 341' 2" ft-in	6300 mm 20' 8" ft-in	5 x 12 m (40 ft)	-	1 x 3 m (10 ft)	2670 mm 8' 9" ft-in	1855 mm 6' 1" ft-in	2145 mm 7' ft-in
107 m 351' 1" ft-in	6300 mm 20' 8" ft-in	5 x 12 m (40 ft)	1 x 6 m (20 ft)	-	2670 mm 8' 9" ft-in	1855 mm 6' 1" ft-in	2145 mm 7' ft-in
110 m 360' 11" ft-in	6300 mm 20' 8" ft-in	5 x 12 m (40 ft)	1 x 6 m (20 ft)	1 x 3 m (10 ft)	2670 mm 8' 9" ft-in	1855 mm 6' 1" ft-in	2145 mm 7' ft-in
113 m 370' 9" ft-in	6300 mm 20' 8" ft-in	6 x 12 m (40 ft)	-	-	2670 mm 8' 9" ft-in	1855 mm 6' 1" ft-in	2145 mm 7' ft-in

LWNLR.x/V04.01//Auslieferung/2016-03-07/en

Main boom length	X1	Required pendant strap length X			X5	X6	X7
		X = X2 + X3 + X4					
		X2	X3	X4			
116 m 380' 7" ft-in	6300 mm 20' 8" ft-in	6 x 12 m (40 ft)	-	1 x 3 m (10 ft)	2670 mm 8' 9" ft-in	1855 mm 6' 1" ft-in	2145 mm 7' ft-in
119 m 390' 5" ft-in	6300 mm 20' 8" ft-in	6 x 12 m (40 ft)	1 x 6 m (20 ft)	-	2670 mm 8' 9" ft-in	1855 mm 6' 1" ft-in	2145 mm 7' ft-in

Tab. 512: Configuration of main boom head 2821 pendant straps to derrick boom head 2220

7.8.4 Overview of CF pendant straps of main boom 2821 + derrick boom 2220

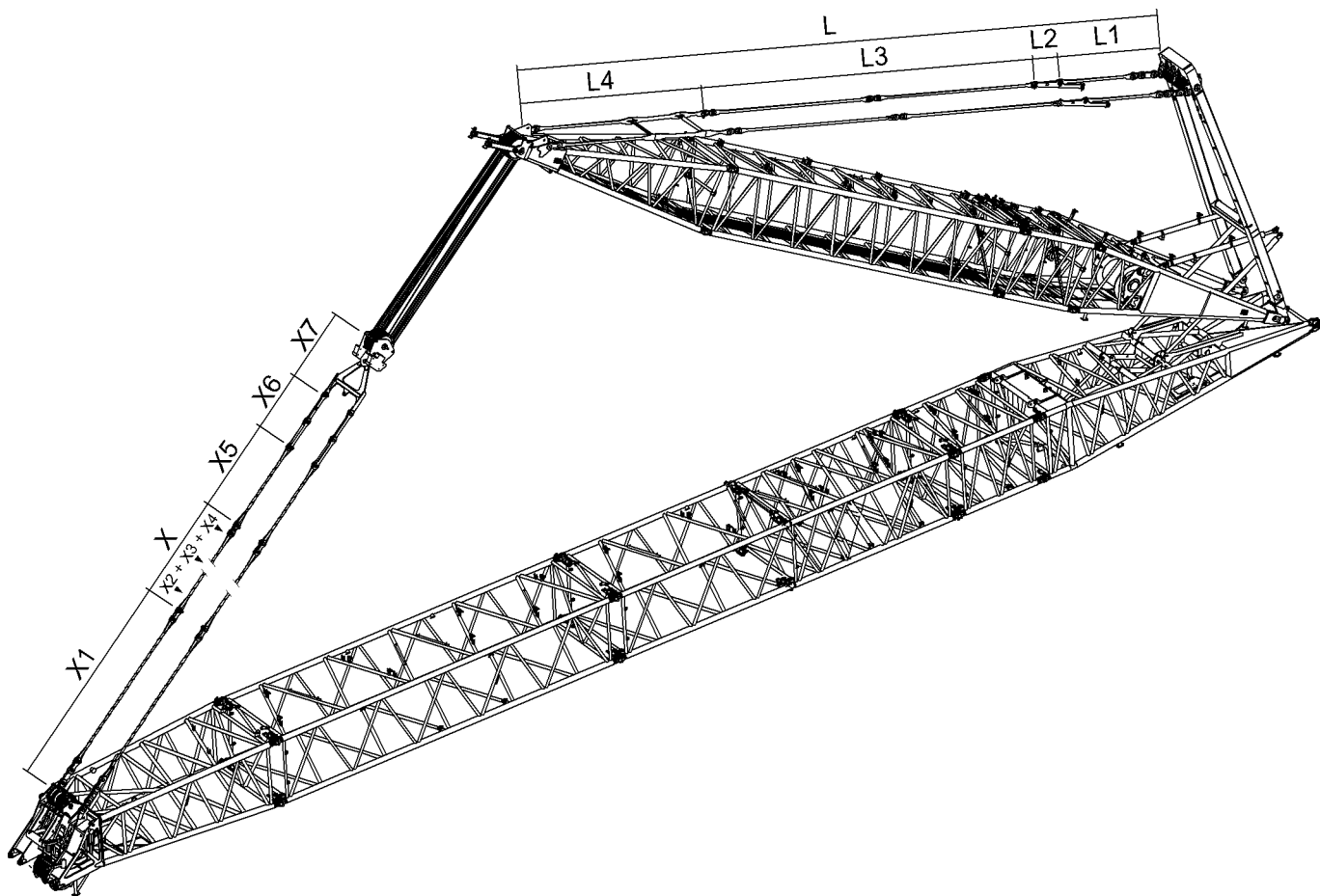


Fig. 3595: Overview of CF pendant straps of main boom 2821 + derrick boom 2220

LWN/LR-x/V04.01//Auslieferung/2016-03-07/en

A-frame1 to 2220 derrick boom head pendant straps

Name		Value	
L	Derrick boom pendant straps consisting of:		
	L1	A-frame1 equalizer (For more information see: A-frame1 equalizer, page 78)	3700 mm 12' 2" ft-in
	L2	Adapter connecting link (For more information see: Adapter connecting link, page 390)	913 mm 3' ft-in
	L3	Derrick boom pendant strap 12 m (40 ft) (For more information see: Derrick boom pendant strap 12 m (40 ft), page 391)	12000 mm 39' 4" ft-in
	L4	Derrick boom pendant strap (crossbar) (For more information see: Derrick boom pendant strap (crossbar), page 392)	6500 mm 21' 4" ft-in

Tab. 513: A-frame1 pendant straps to derrick boom head 2220

2821 main boom head to 2220 derrick boom head pendant straps

Name		Value	
X1	Main boom pendant strap on main boom head 2821 (For more information see: Connecting links with tension load cell, page 216) + (For more information see: Main boom pendant strap on main boom head 2821.24, page 214)	6300 mm 20' 8" ft-in	
X	Main boom pendant straps consisting of:		
	X2	Main boom pendant strap 3 m (10 ft) (For more information see: Main boom pendant strap 3 m (10 ft), page 203)	Total X2 +
	X3	Main boom pendant strap 6 m (20 ft) (For more information see: Main boom pendant strap 6 m (20 ft), page 206)	Total X3 +
	X4	Main boom pendant strap 12 m (40 ft) (For more information see: Main boom pendant strap 12 m (40 ft), page 210)	Total X4
X5	Equalizer of main boom base section 2821 (For more information see: Equalizer of main boom base section 2821.30, page 200)	2700 mm 8' 10" ft-in	
X6	Connecting links (For more information see: Connecting links, page 217)	1825 mm 6' ft-in	

LWNLR.x/V04.01//Auslieferung/2016-03-07/en

Name		Value
X7	Derrick rope rigging with crossbar (For more information see: Derrick rope rigging with crossbar, page 389)	2145 mm 7' ft-in

Tab. 514: Main boom head pendant straps 2821 for derrick boom head 2220

Composition of the pendant straps between 2821 main boom head and 2220 derrick boom head:

Main boom length	X1	Required pendant strap length X			X5	X6	X7
		X = X2 + X3 + X4					
		X2	X3	X4			
41 m 134' 6" ft-in	6300 mm 20' 8" ft-in	-	-	-	2700 mm 8' 10" ft-in	1825 mm 6' ft-in	2145 mm 7' ft-in
44 m 144' 4" ft-in	6300 mm 20' 8" ft-in	-	-	1 x 3 m (10 ft)	2700 mm 8' 10" ft-in	1825 mm 6' ft-in	2145 mm 7' ft-in
47 m 154' 2" ft-in	6300 mm 20' 8" ft-in	-	1 x 6 m (20 ft)	-	2700 mm 8' 10" ft-in	1825 mm 6' ft-in	2145 mm 7' ft-in
50 m 164' ft-in	6300 mm 20' 8" ft-in	-	1 x 6 m (20 ft)	1 x 3 m (10 ft)	2700 mm 8' 10" ft-in	1825 mm 6' ft-in	2145 mm 7' ft-in
53 m 173' 11" ft-in	6300 mm 20' 8" ft-in	1 x 12 m (40 ft)	-	-	2700 mm 8' 10" ft-in	1825 mm 6' ft-in	2145 mm 7' ft-in
56 m 183' 9" ft-in	6300 mm 20' 8" ft-in	1 x 12 m (40 ft)	-	1 x 3 m (10 ft)	2700 mm 8' 10" ft-in	1825 mm 6' ft-in	2145 mm 7' ft-in
59 m 193' 7" ft-in	6300 mm 20' 8" ft-in	1 x 12 m (40 ft)	1 x 6 m (20 ft)	-	2700 mm 8' 10" ft-in	1825 mm 6' ft-in	2145 mm 7' ft-in
62 m 203' 5" ft-in	6300 mm 20' 8" ft-in	1 x 12 m (40 ft)	1 x 6 m (20 ft)	1 x 3 m (10 ft)	2700 mm 8' 10" ft-in	1825 mm 6' ft-in	2145 mm 7' ft-in
65 m 213' 3" ft-in	6300 mm 20' 8" ft-in	2 x 12 m (40 ft)	-	-	2700 mm 8' 10" ft-in	1825 mm 6' ft-in	2145 mm 7' ft-in
68 m 223' 1" ft-in	6300 mm 20' 8" ft-in	2 x 12 m (40 ft)	-	1 x 3 m (10 ft)	2700 mm 8' 10" ft-in	1825 mm 6' ft-in	2145 mm 7' ft-in
71 m 232' 11" ft-in	6300 mm 20' 8" ft-in	2 x 12 m (40 ft)	1 x 6 m (20 ft)	-	2700 mm 8' 10" ft-in	1825 mm 6' ft-in	2145 mm 7' ft-in
74 m 242' 9" ft-in	6300 mm 20' 8" ft-in	2 x 12 m (40 ft)	1 x 6 m (20 ft)	1 x 3 m (10 ft)	2700 mm 8' 10" ft-in	1825 mm 6' ft-in	2145 mm 7' ft-in
77 m 252' 7" ft-in	6300 mm 20' 8" ft-in	3 x 12 m (40 ft)	-	-	2700 mm 8' 10" ft-in	1825 mm 6' ft-in	2145 mm 7' ft-in
80 m 262' 6" ft-in	6300 mm 20' 8" ft-in	3 x 12 m (40 ft)	-	1 x 3 m (10 ft)	2700 mm 8' 10" ft-in	1825 mm 6' ft-in	2145 mm 7' ft-in
83 m 272' 4" ft-in	6300 mm 20' 8" ft-in	3 x 12 m (40 ft)	1 x 6 m (20 ft)	-	2700 mm 8' 10" ft-in	1825 mm 6' ft-in	2145 mm 7' ft-in
86 m 282' 2" ft-in	6300 mm 20' 8" ft-in	3 x 12 m (40 ft)	1 x 6 m (20 ft)	1 x 3 m (10 ft)	2700 mm 8' 10" ft-in	1825 mm 6' ft-in	2145 mm 7' ft-in
89 m 292' ft-in	6300 mm 20' 8" ft-in	4 x 12 m (40 ft)	-	-	2700 mm 8' 10" ft-in	1825 mm 6' ft-in	2145 mm 7' ft-in

LWNLR-x/V04.01//Auslieferung/2016-03-07/en

Main boom length	X1	Required pendant strap length X			X5	X6	X7
		X = X2 + X3 + X4					
		X2	X3	X4			
92 m 301' 10" ft-in	6300 mm 20' 8" ft-in	4 x 12 m (40 ft)	-	1 x 3 m (10 ft)	2700 mm 8' 10" ft-in	1825 mm 6' ft-in	2145 mm 7' ft-in
95 m 311' 8" ft-in	6300 mm 20' 8" ft-in	4 x 12 m (40 ft)	1 x 6 m (20 ft)	-	2700 mm 8' 10" ft-in	1825 mm 6' ft-in	2145 mm 7' ft-in
98 m 321' 6" ft-in	6300 mm 20' 8" ft-in	4 x 12 m (40 ft)	1 x 6 m (20 ft)	1 x 3 m (10 ft)	2700 mm 8' 10" ft-in	1825 mm 6' ft-in	2145 mm 7' ft-in
101 m 331' 4" ft-in	6300 mm 20' 8" ft-in	5 x 12 m (40 ft)	-	-	2700 mm 8' 10" ft-in	1825 mm 6' ft-in	2145 mm 7' ft-in
104 m 341' 2" ft-in	6300 mm 20' 8" ft-in	5 x 12 m (40 ft)	-	1 x 3 m (10 ft)	2700 mm 8' 10" ft-in	1825 mm 6' ft-in	2145 mm 7' ft-in
107 m 351' 1" ft-in	6300 mm 20' 8" ft-in	5 x 12 m (40 ft)	1 x 6 m (20 ft)	-	2700 mm 8' 10" ft-in	1825 mm 6' ft-in	2145 mm 7' ft-in
110 m 360' 11" ft-in	6300 mm 20' 8" ft-in	5 x 12 m (40 ft)	1 x 6 m (20 ft)	1 x 3 m (10 ft)	2700 mm 8' 10" ft-in	1825 mm 6' ft-in	2145 mm 7' ft-in
113 m 370' 9" ft-in	6300 mm 20' 8" ft-in	6 x 12 m (40 ft)	-	-	2700 mm 8' 10" ft-in	1825 mm 6' ft-in	2145 mm 7' ft-in
116 m 380' 7" ft-in	6300 mm 20' 8" ft-in	6 x 12 m (40 ft)	-	1 x 3 m (10 ft)	2700 mm 8' 10" ft-in	1825 mm 6' ft-in	2145 mm 7' ft-in
119 m 390' 5" ft-in	6300 mm 20' 8" ft-in	6 x 12 m (40 ft)	1 x 6 m (20 ft)	-	2700 mm 8' 10" ft-in	1825 mm 6' ft-in	2145 mm 7' ft-in

Tab. 515: Configuration of main boom head 2821 pendant straps for derrick boom head 2220

The main boom pendant straps (**X**) may consist of generation A and generation B main boom pendant straps (For more information see: 1.11.9 CF pendant straps on main boom 2821, page 200). Mixing is only admissible if the number of generation B main boom pendant straps only differs by at most 1 in the left and the right strand of the pendant straps.



DANGER

Inadmissible mixing of generation A and generation B main boom pendant straps! Structural failure.

- ▶ Ensure that the number of generation B main boom pendant straps differs by at most 1 in the left and the right strand of the pendant straps.

7.8.5 Reeving diagrams for one rope across main boom head 2821 (load position1)

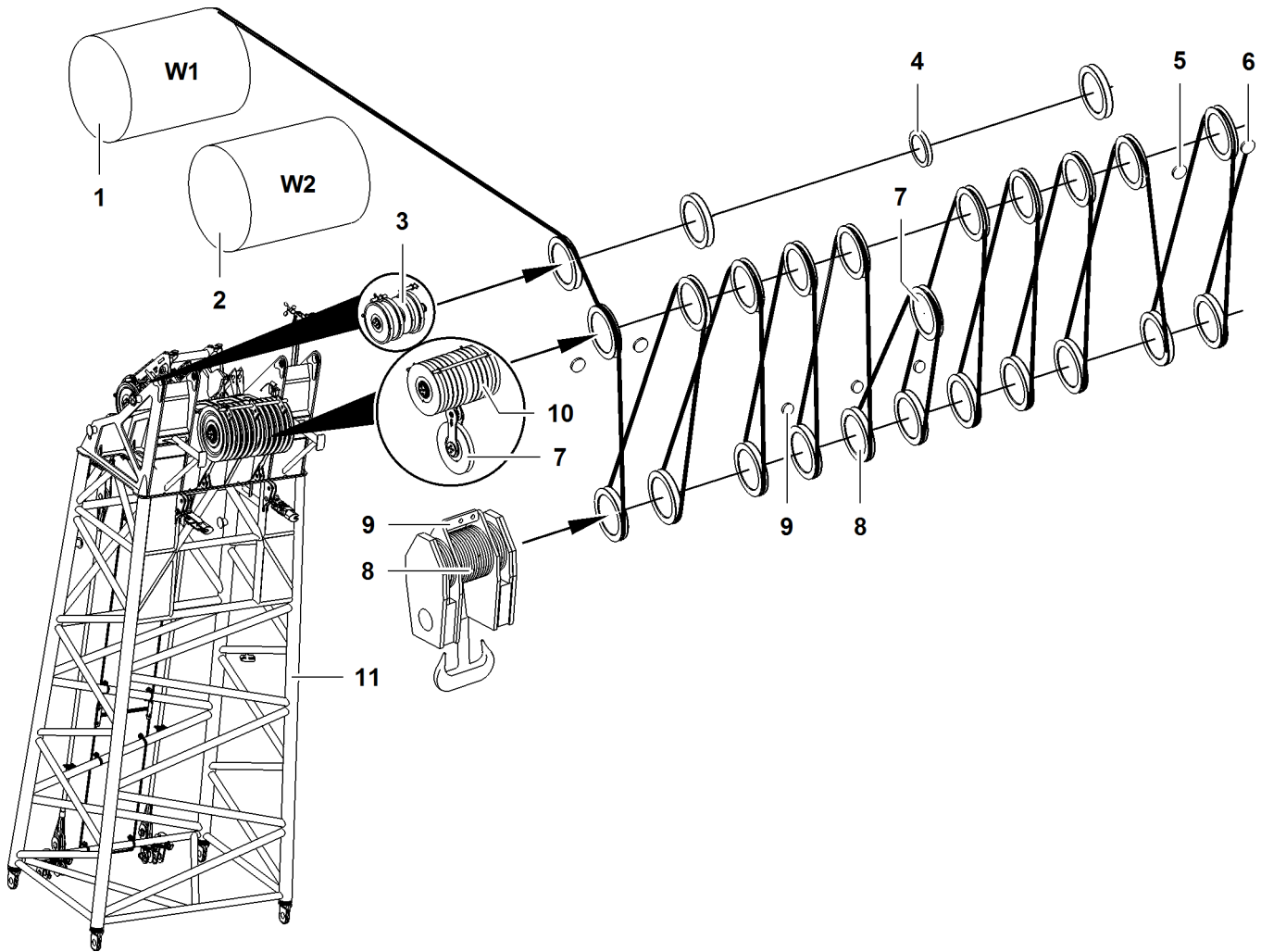


Fig. 3596: Reeving diagrams for one rope across main boom head 2821 (load position1)

- | | | | | | |
|---|--------------------------------------|---|--|----|------------------------------------|
| 1 | Winch1 | 5 | Inner rope fixing point (2x) of main boom head | 9 | Rope fixing points of pulley block |
| 2 | Winch2 | 6 | Outer rope fixing point (2x) of main boom head | 10 | Pulley (10x) of main boom head |
| 3 | Gantry pulley (3x) of main boom head | 7 | 11th pulley of main boom head | 11 | Main boom head |
| 4 | Pulley for rope of jib luffing winch | 8 | Pulley set of pulley block | | |

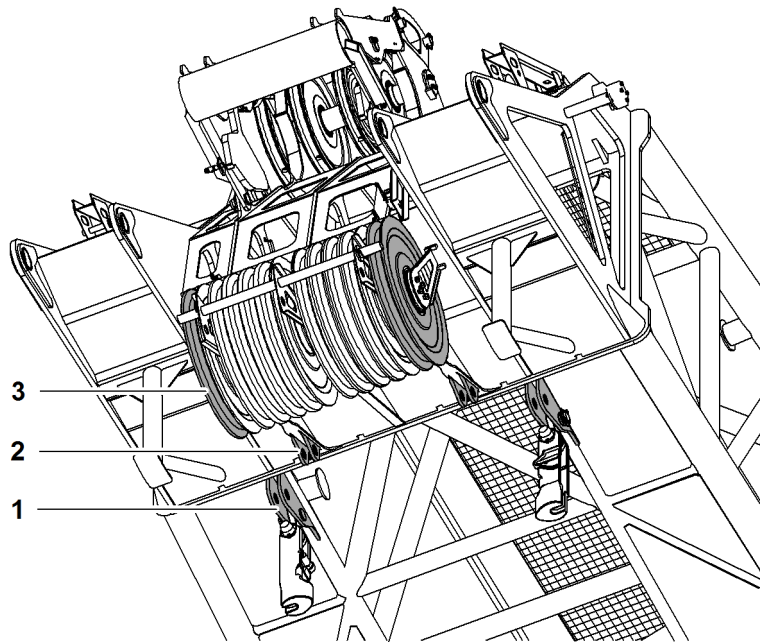


Fig. 3597: Rope fixing points main boom head 2821

- 1 Outer rope fixing point (2x)
- 2 Inner rope fixing point (2x)
- 3 Pulley (2x)

If the first or last pulley 3 on the pulley set of the main boom head is used (reeved), the outer rope fixing point 1 is to be used.

If the first or last pulley 3 on the pulley set of the main boom head is not used (not reeved), the inner rope fixing point 2 is to be used.

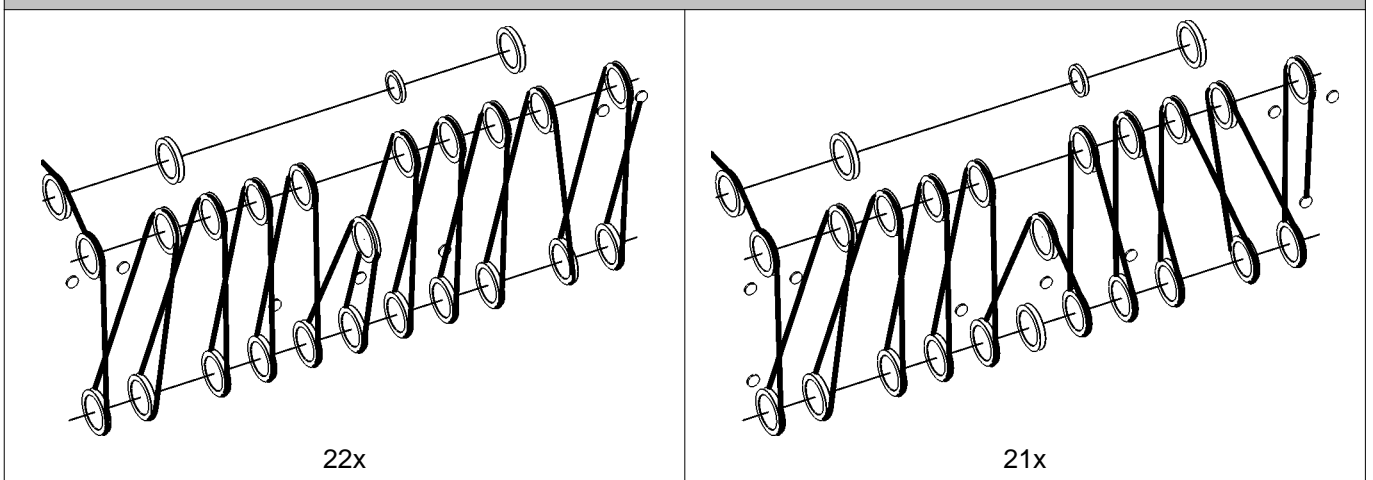


DANGER

Incorrect number of reevings!
Structural breakdown, toppling of machine.

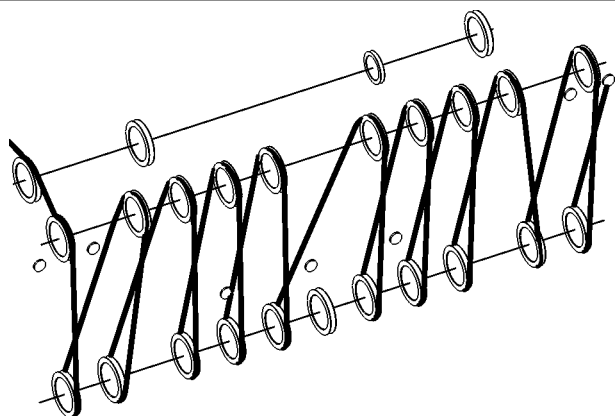
► Choose the correct number of reevings as per the load chart.

Reeving diagrams for one rope across main boom head 2821 (load position1)

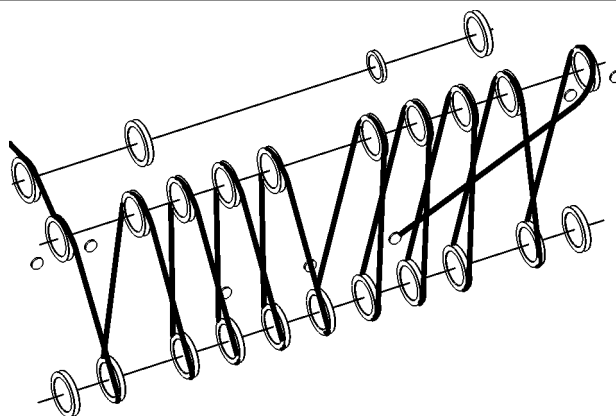


LWNLR.x/V04.01//Auslieferung/2016-03-07/en

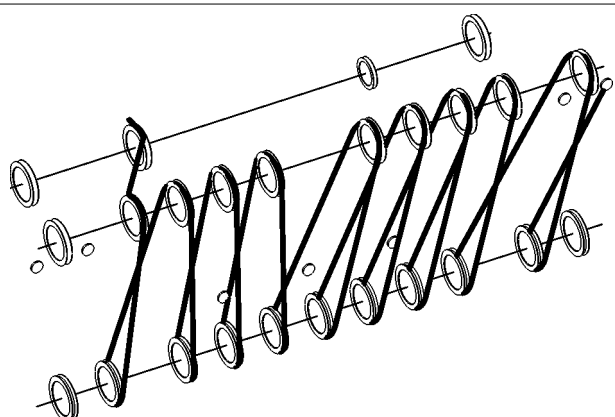
Reeving diagrams for one rope across main boom head 2821 (load position1)



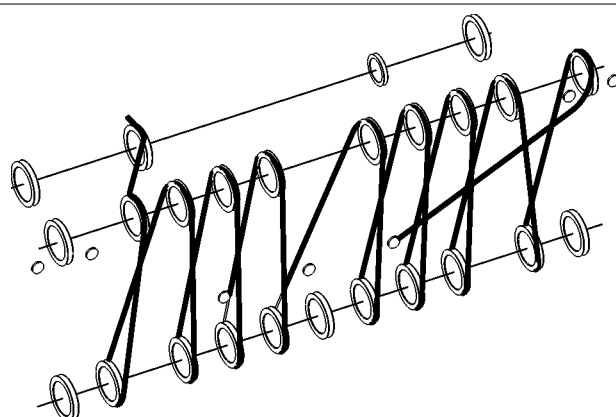
20x



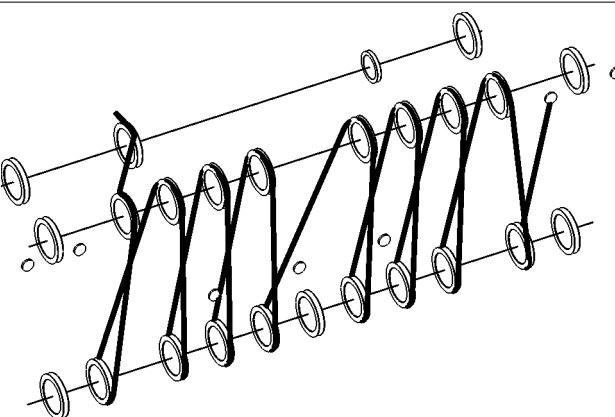
19x



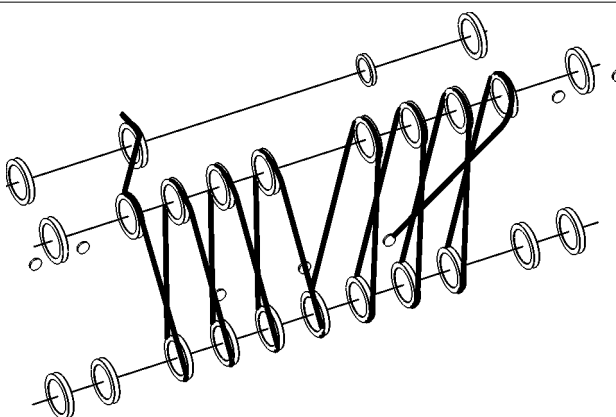
18x



17x



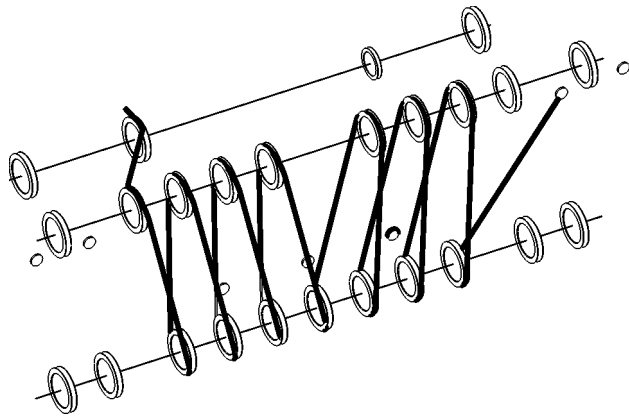
16x



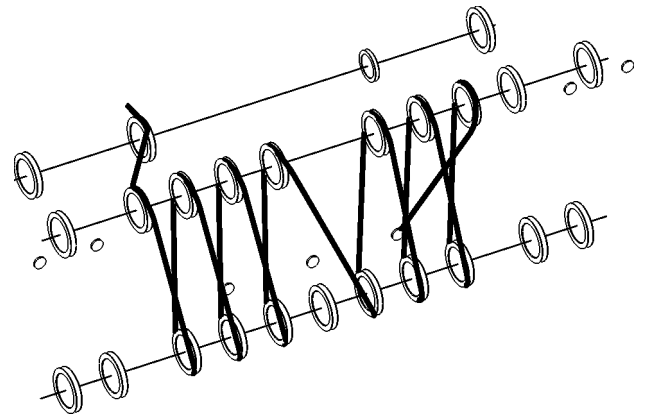
15x

LWNLR-x\04.01\Auslieferung\2016-03-07\en

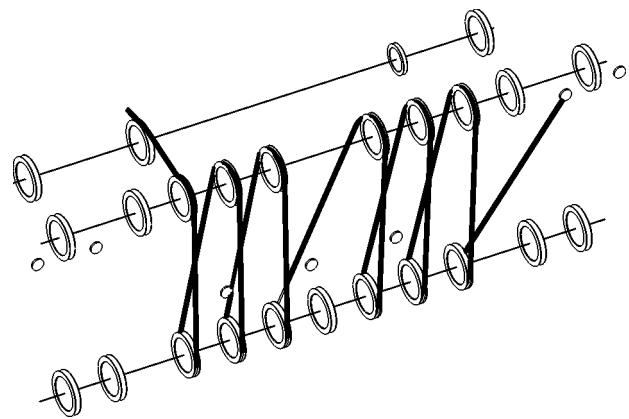
Reeving diagrams for one rope across main boom head 2821 (load position1)



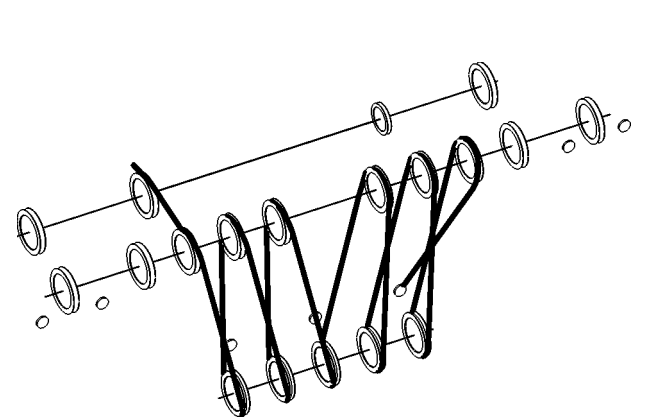
14x



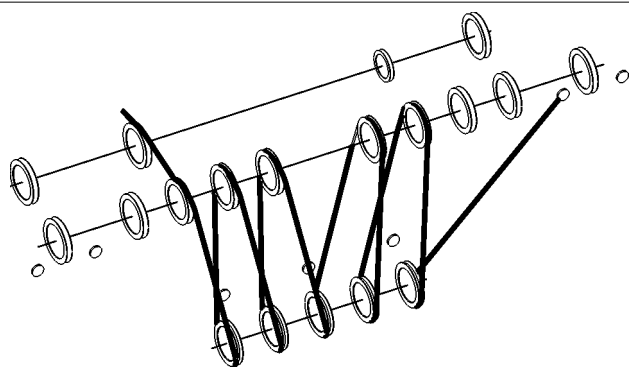
13x



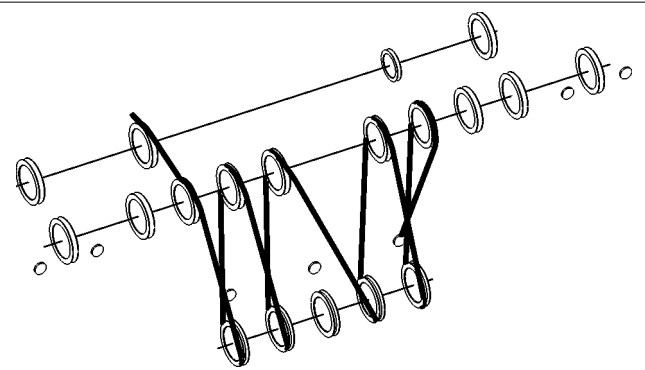
12x



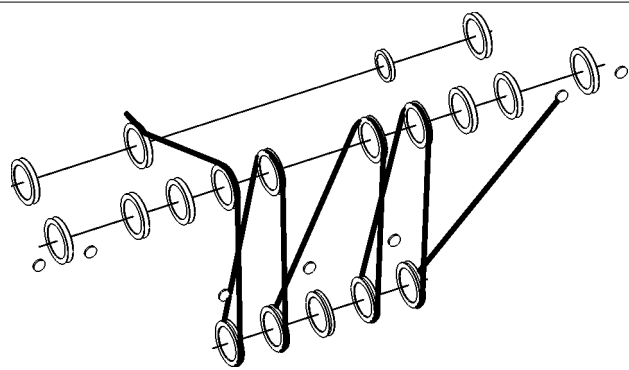
11x



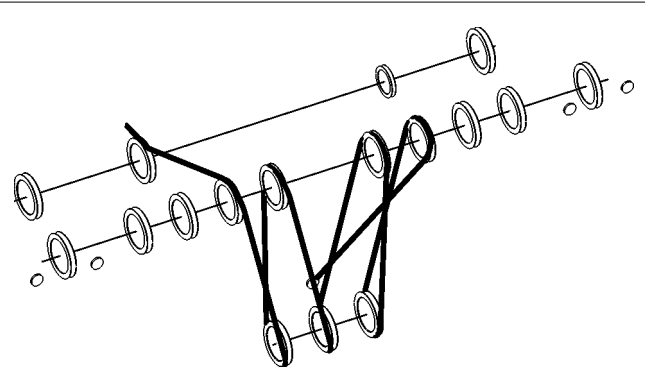
10x



9x

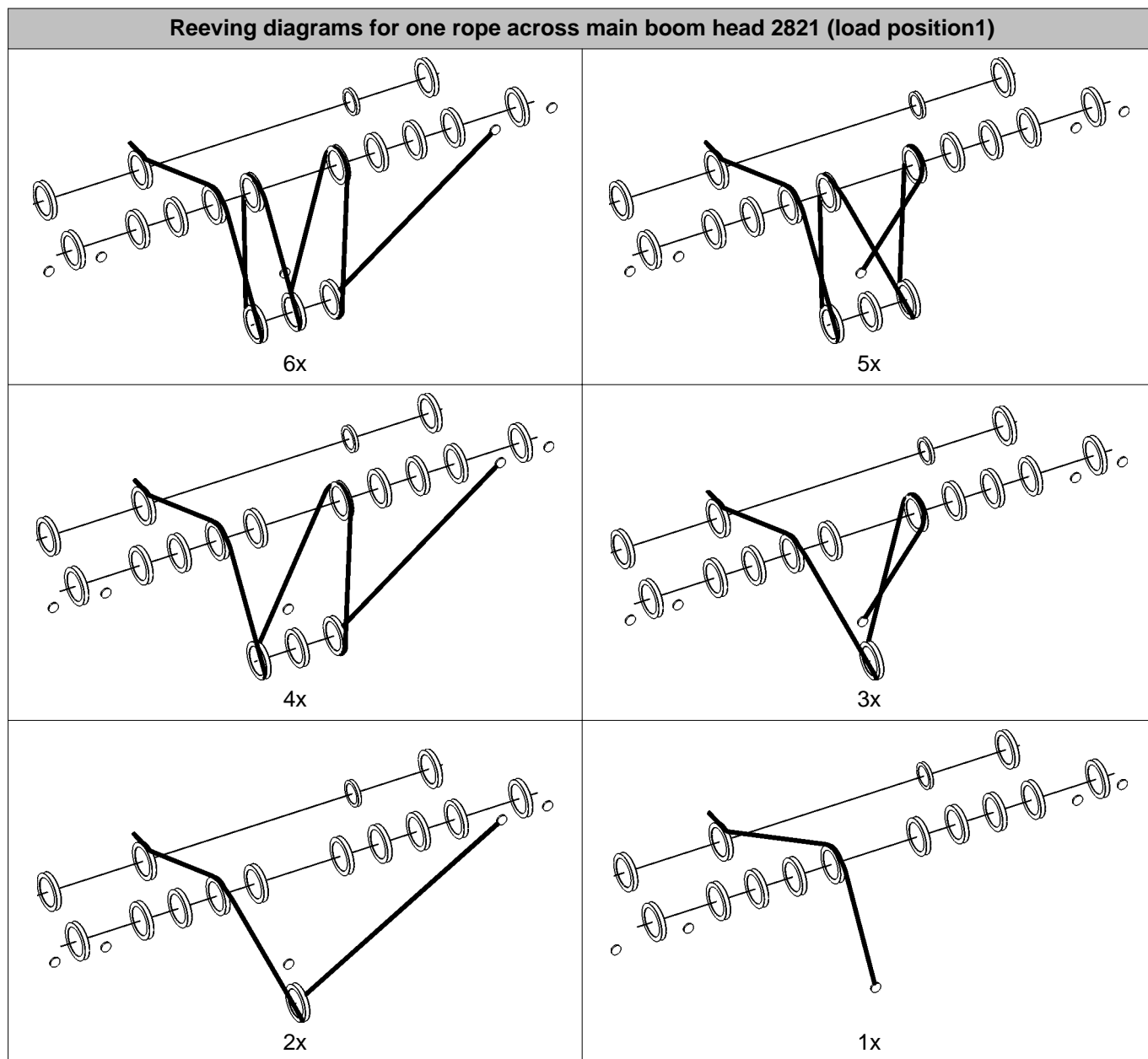


8x



7x

LWNLR.x/V04.01//Auslieferung/2016-03-07/en



Tab. 516: Reeving diagrams for one rope across main boom head 2821 (load position1)

7.8.6 Reeving diagrams for two ropes across main boom head 2821 (load position1)

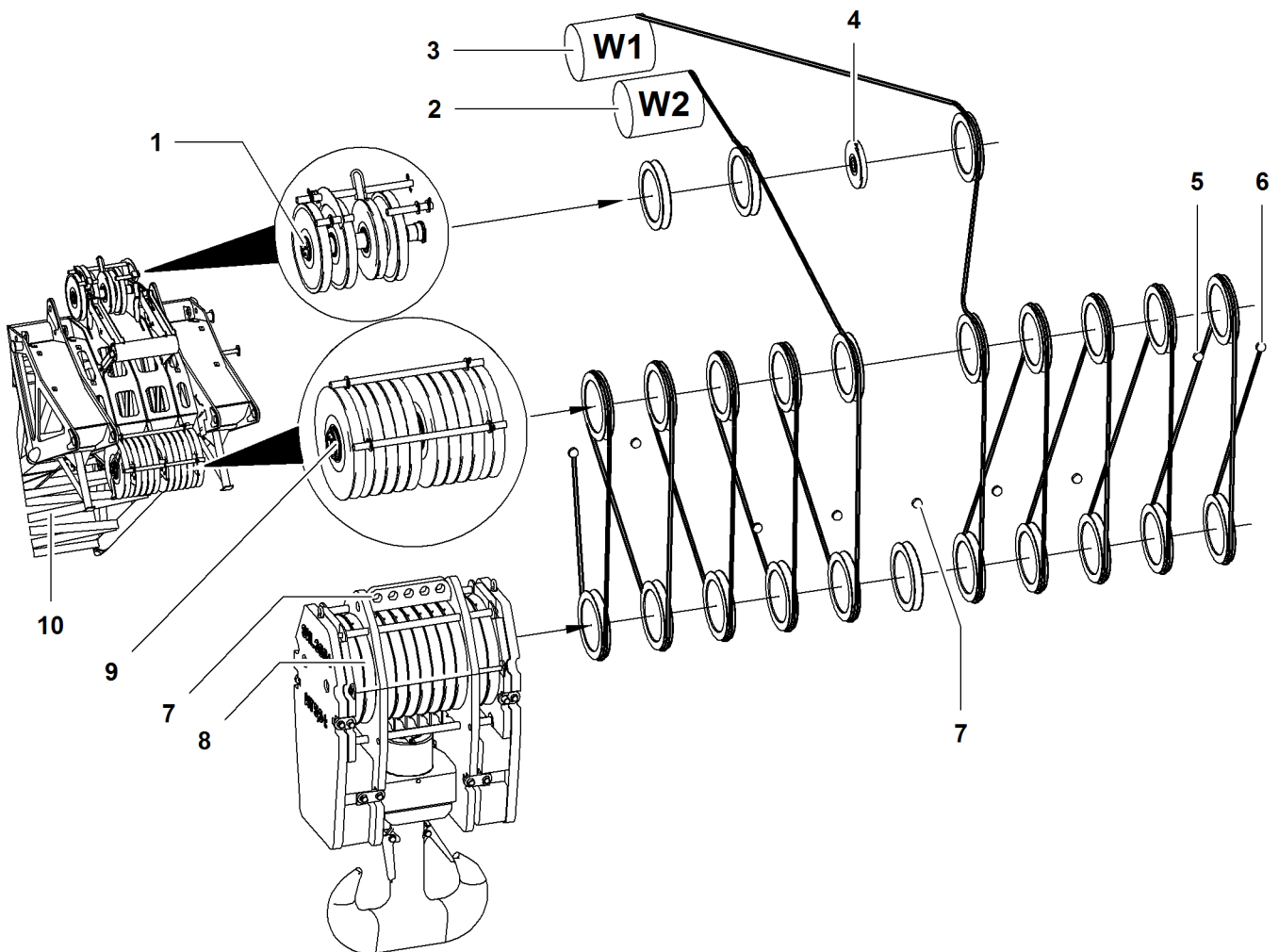


Fig. 3620: Reeving diagrams for two ropes across main boom head 2821 (load position1)

- | | | | | | |
|---|--------------------------------------|---|--|----|--------------------------------|
| 1 | Gantry pulley (3x) of main boom head | 5 | Inner rope fixing point (2x) of main boom head | 9 | Pulley (10x) of main boom head |
| 2 | Winch2 | 6 | Outer rope fixing point (2x) of main boom head | 10 | Main boom head |
| 3 | Winch1 | 7 | Rope fixing points of pulley block | | |
| 4 | Pulley for rope of jib luffing winch | 8 | Pulley set of pulley block | | |

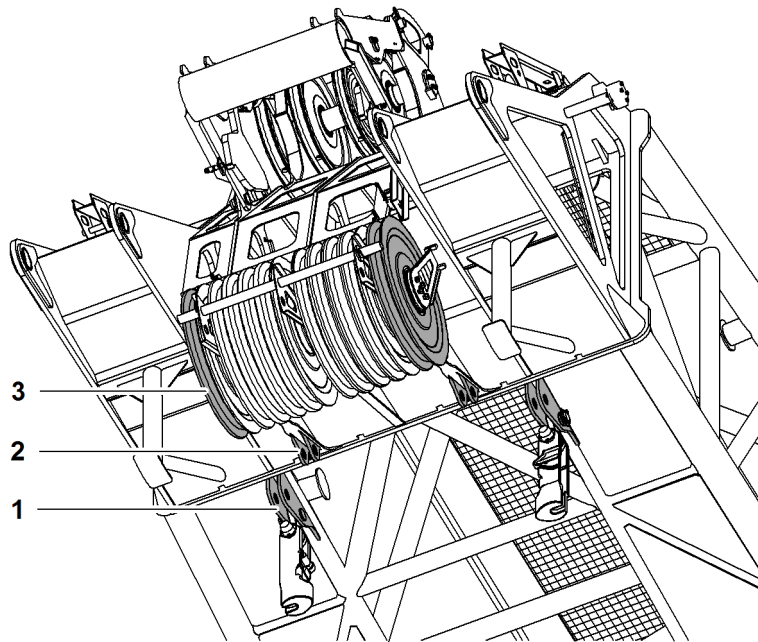


Fig. 3621: Rope fixing points main boom head 2821

- | | | | |
|---|------------------------------|---|-------------|
| 1 | Outer rope fixing point (2x) | 3 | Pulley (2x) |
| 2 | Inner rope fixing point (2x) | | |

If the first or last pulley 3 on the pulley set of the main boom head is used (reeved), the outer rope fixing point 1 is to be used.

If the first or last pulley 3 on the pulley set of the main boom head is not used (not reeved), the inner rope fixing point 2 is to be used.

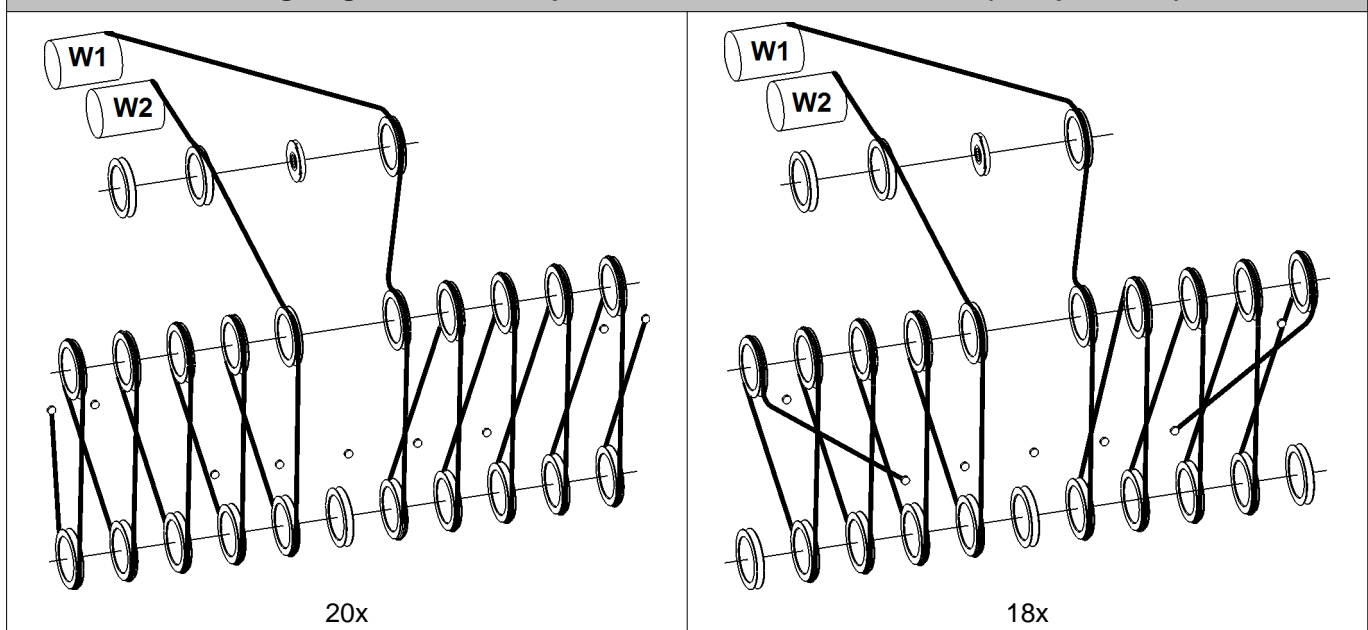


DANGER

Inadmissible number of reevings!
Structural breakdown, toppling of machine.

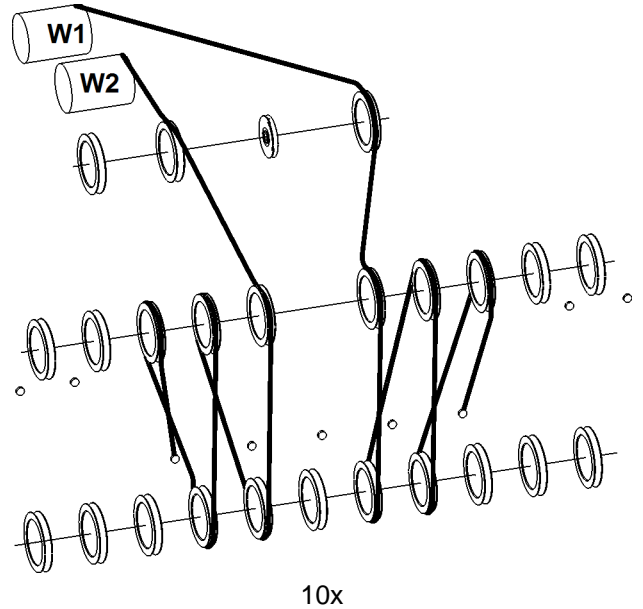
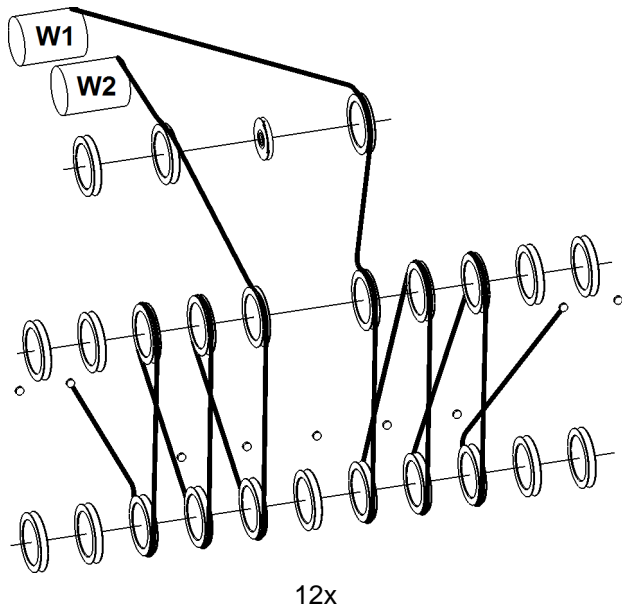
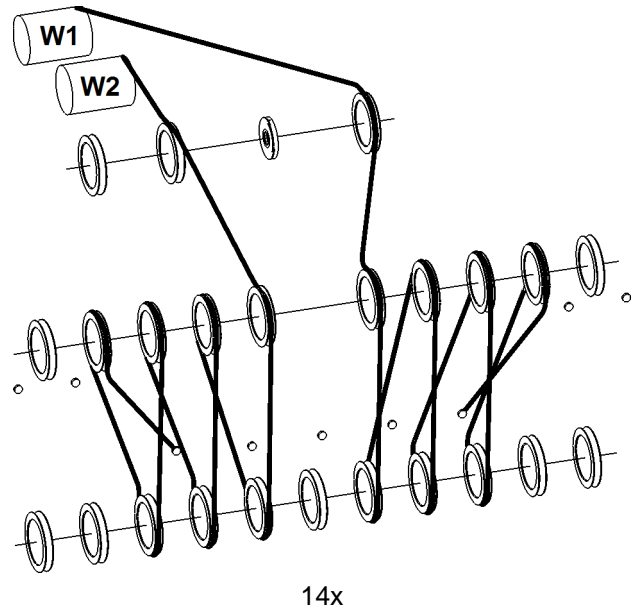
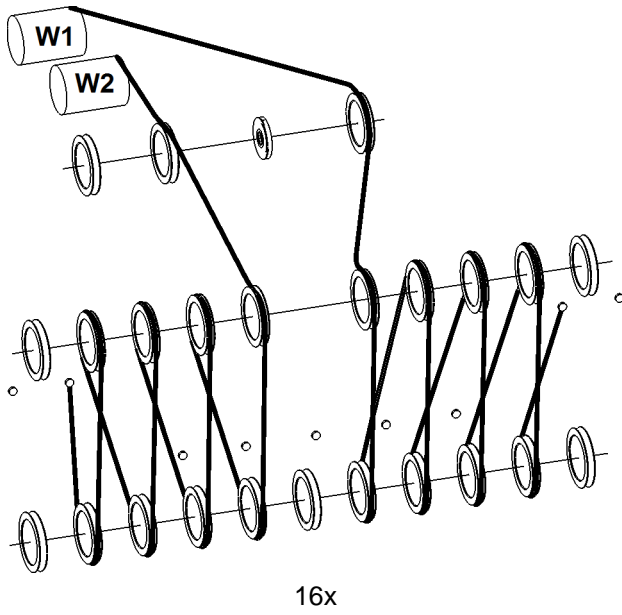
► Choose correct number of reevings as indicated in load chart.

Reeving diagrams for two ropes across main boom head 2821 (load position1)

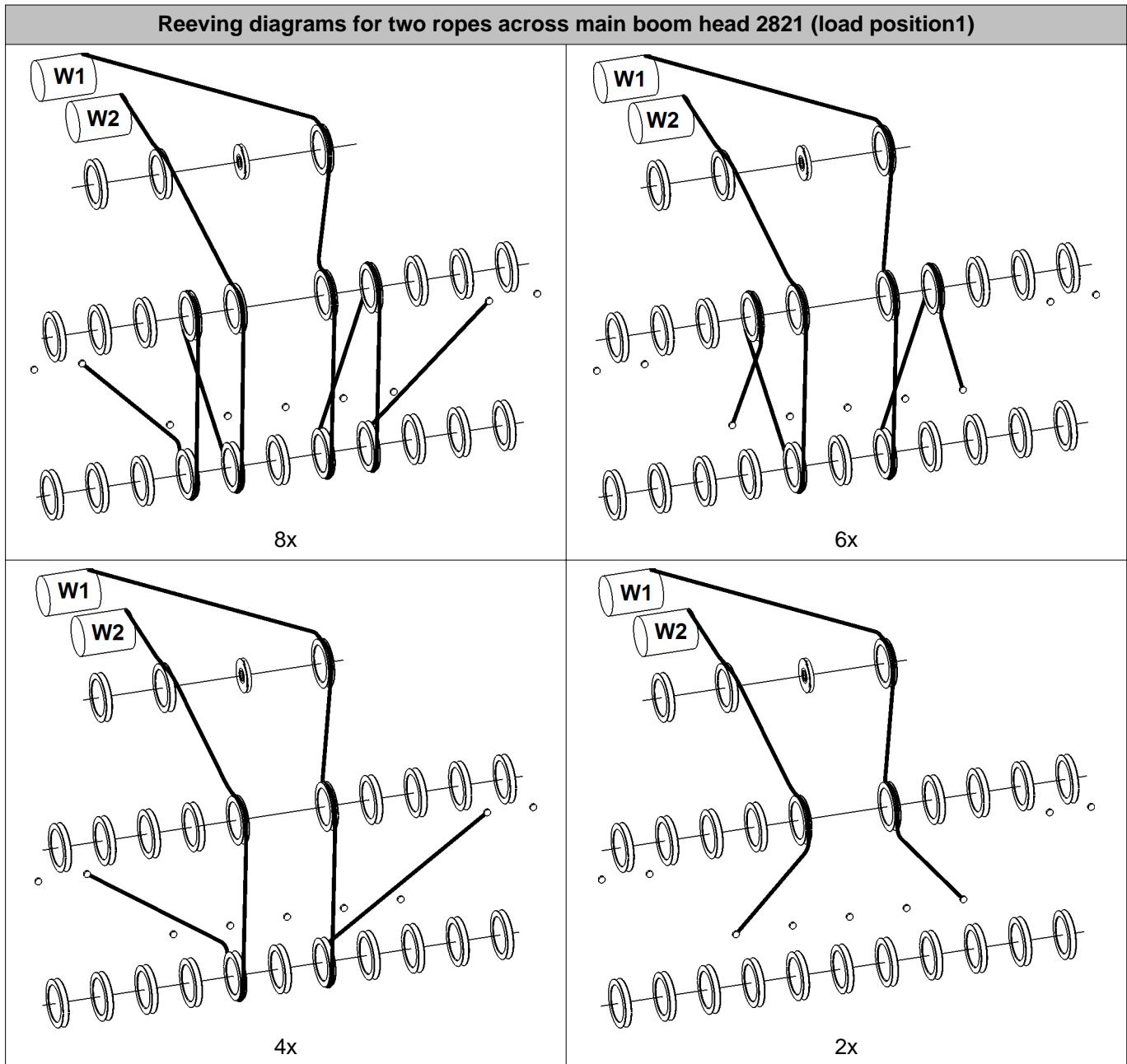


LWNLR-x/V04.01//Auslieferung/2016-03-07/en

Reeving diagrams for two ropes across main boom head 2821 (load position1)



LWNLR.x/V04.01//Auslieferung/2016-03-07/en



Tab. 517: Reeving diagrams for two ropes across main boom head 2821 (load position1)

LWNLR-x\04.01\Auslieferung\2016-03-07\en

7.8.7 Reeving diagrams for one rope across auxiliary jib (36 t (79300 lb)) on main boom head 2821 (load position1)

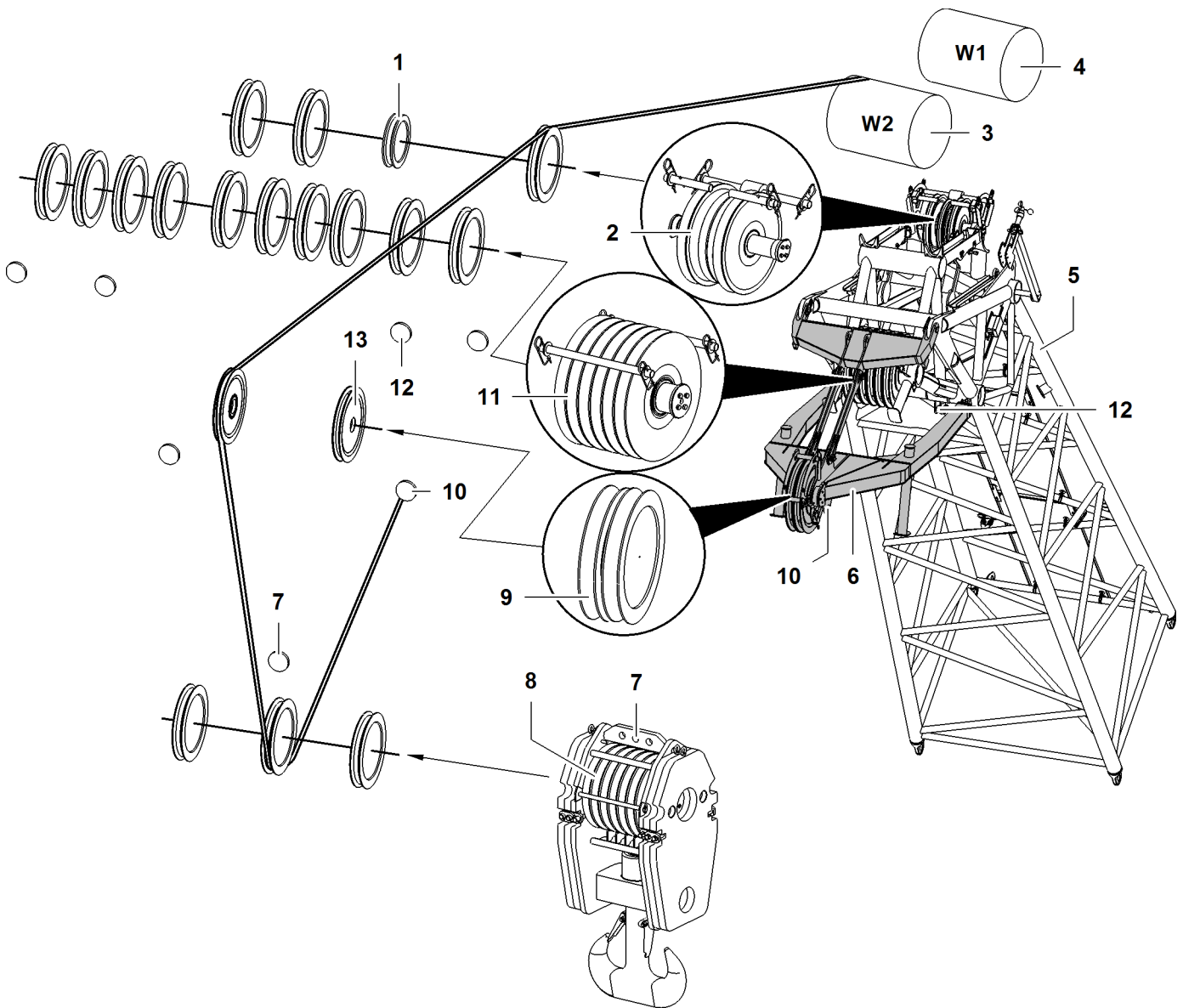


Fig. 3632: Reeving diagrams for one rope across auxiliary jib (36 t (79300 lb)) on main boom head 2821 (load position1)

- | | | | | | |
|---|--------------------------------------|----|--|----|--|
| 1 | Pulley for rope of jib luffing winch | 6 | Auxiliary jib (36 t (79300 lb)) | 11 | Pulley (10x) of main boom head |
| 2 | Gantry pulley (3x) of main boom head | 7 | Rope fixing points of pulley block | 12 | Rope fixing point (4x) of main boom head |
| 3 | Winch2 | 8 | Pulley set of pulley block | 13 | Second pulley* for triple reeving of auxiliary jib (36 t (79300 lb)) |
| 4 | Winch1 | 9 | Pulley of auxiliary jib (36 t (79300 lb)) | | |
| 5 | Main boom head | 10 | Rope fixing point of auxiliary jib (36 t (79300 lb)) | | |

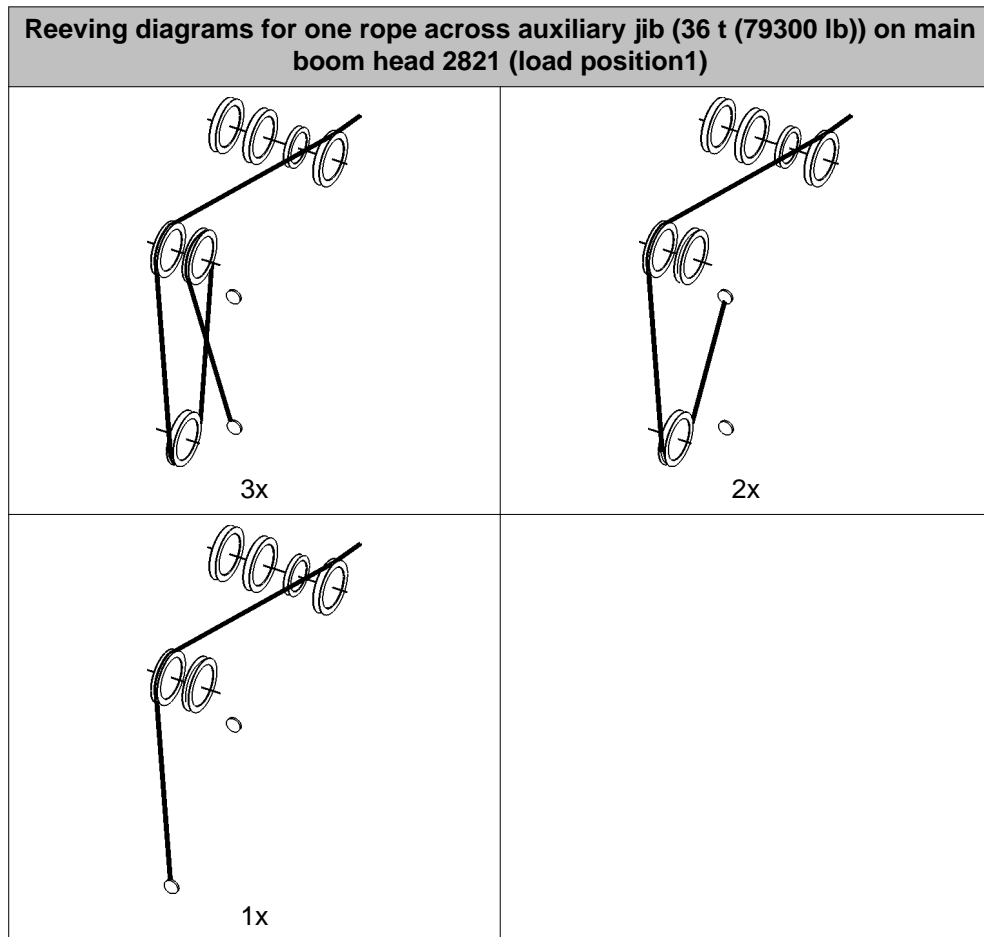
LWNLR-x/V04.01//Auslieferung/2016-03-07/en



DANGER

Inadmissible number of reevings!
Structural breakdown, toppling of machine.

- Choose correct number of reevings as indicated in load chart.



Tab. 518: Reeving diagrams for one rope across auxiliary jib (36 t (79300 lb)) on main boom head 2821 (load position1)

7.8.8 Reeving diagrams for two ropes across auxiliary jib (36 t (79300 lb)) and main boom head 2821 (load position 1)

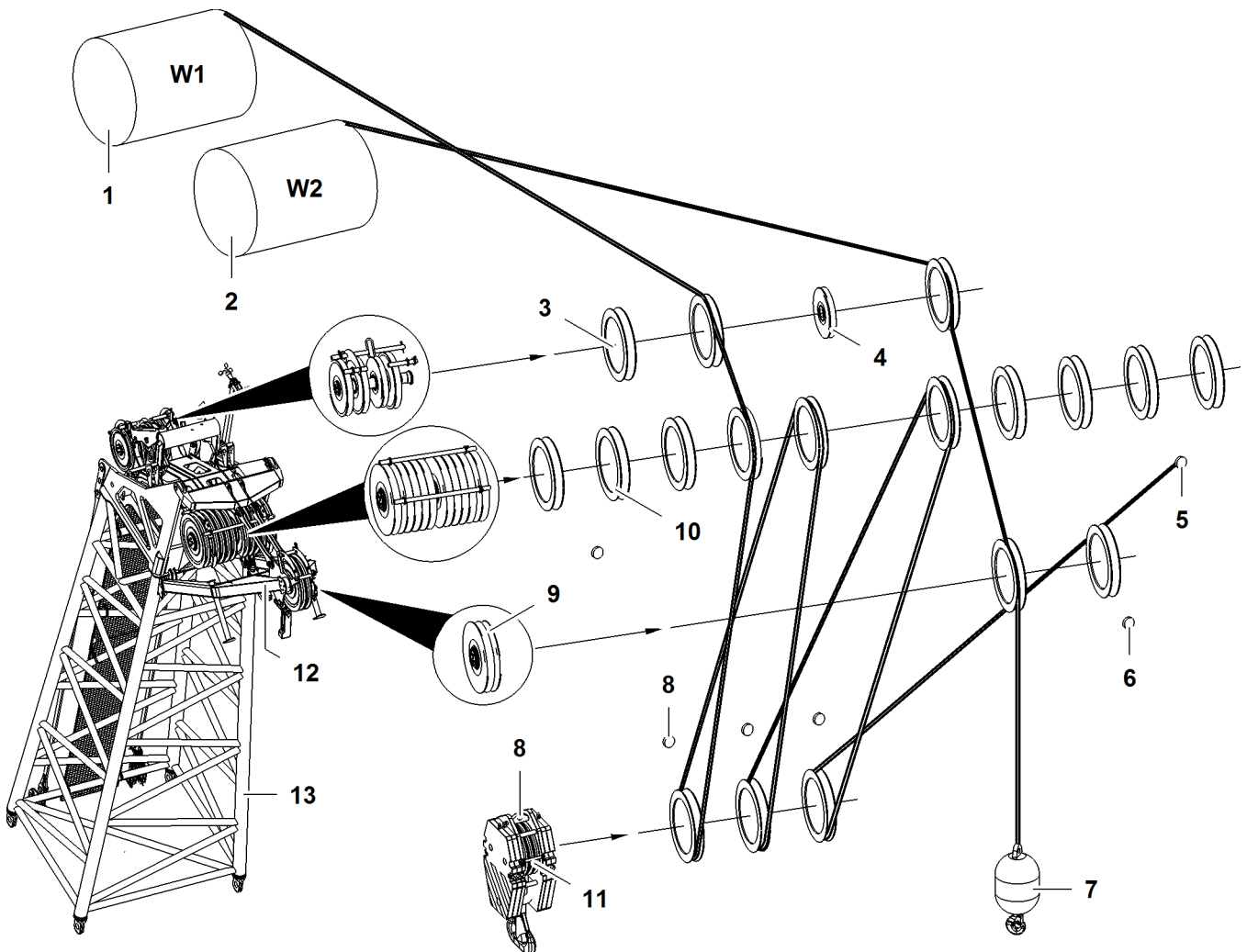


Fig. 3636: Reeving diagrams for two ropes across auxiliary jib (36 t (79300 lb)) and main boom head 2821 (load position 1)

- | | | |
|--|--|------------------------------------|
| 1 Winch1 | 6 Rope fixing point of auxiliary jib (36 t (79300 lb)) | 11 Pulley set of pulley block |
| 2 Winch2 | 7 Hook | 12 Auxiliary jib (36 t (79300 lb)) |
| 3 Gantry pulley (3x) of main boom head | 8 Rope fixing points of pulley block | 13 Main boom head |
| 4 Pulley for rope of jib luffing winch | 9 Second pulley* for triple reeving of auxiliary jib (36 t (79300 lb)) | |
| 5 Rope fixing point (4x) of main boom head | 10 Pulley (10x) of main boom head | |



DANGER

Inadmissible number of reevings!
Structural breakdown, toppling of machine.

► Choose correct number of reevings as indicated in load chart.

LWNLR.x/V04.01//Auslieferung/2016-03-07/en

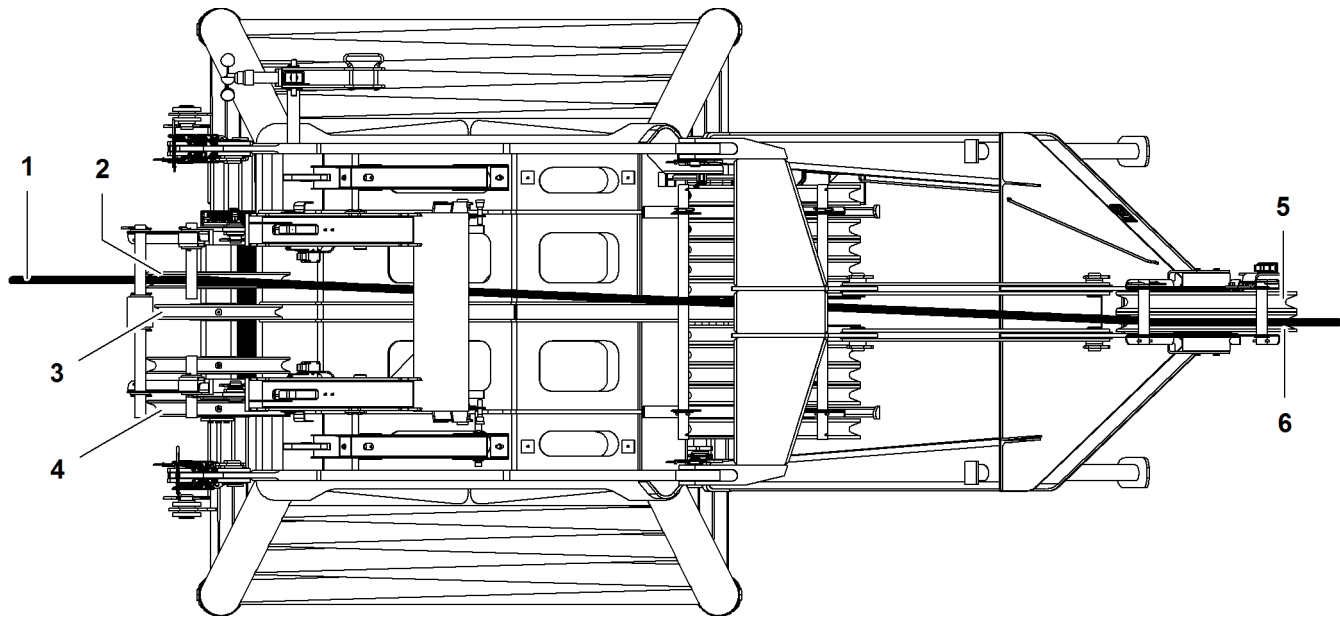


Fig. 3637: Rope run of auxiliary jib (36 t (79300 lb)) (illustration of principle)

- | | | | | | |
|---|--------------------------------------|---|--|---|--|
| 1 | Winch2 rope | 3 | Pulley for rope of jib luffing winch | 5 | Second pulley* for triple reeving of auxiliary jib (36 t (79300 lb)) |
| 2 | Left gantry pulley of main boom head | 4 | Right gantry pulley (2x) of main boom head | 6 | Pulley of auxiliary jib |

The rope of winch2 1 runs from the left gantry pulley 2 to the auxiliary jib pulley 6.

The rope of winch1 runs from one of the right gantry pulleys 4 to the required pulley on the main boom head.

7.8.9 Reeving diagram - jib luffing winch as auxiliary winch



DANGER

Incorrect number of reevings!
Structural breakdown, toppling of machine.

- ▶ Choose the correct number of reevings as per the load chart.

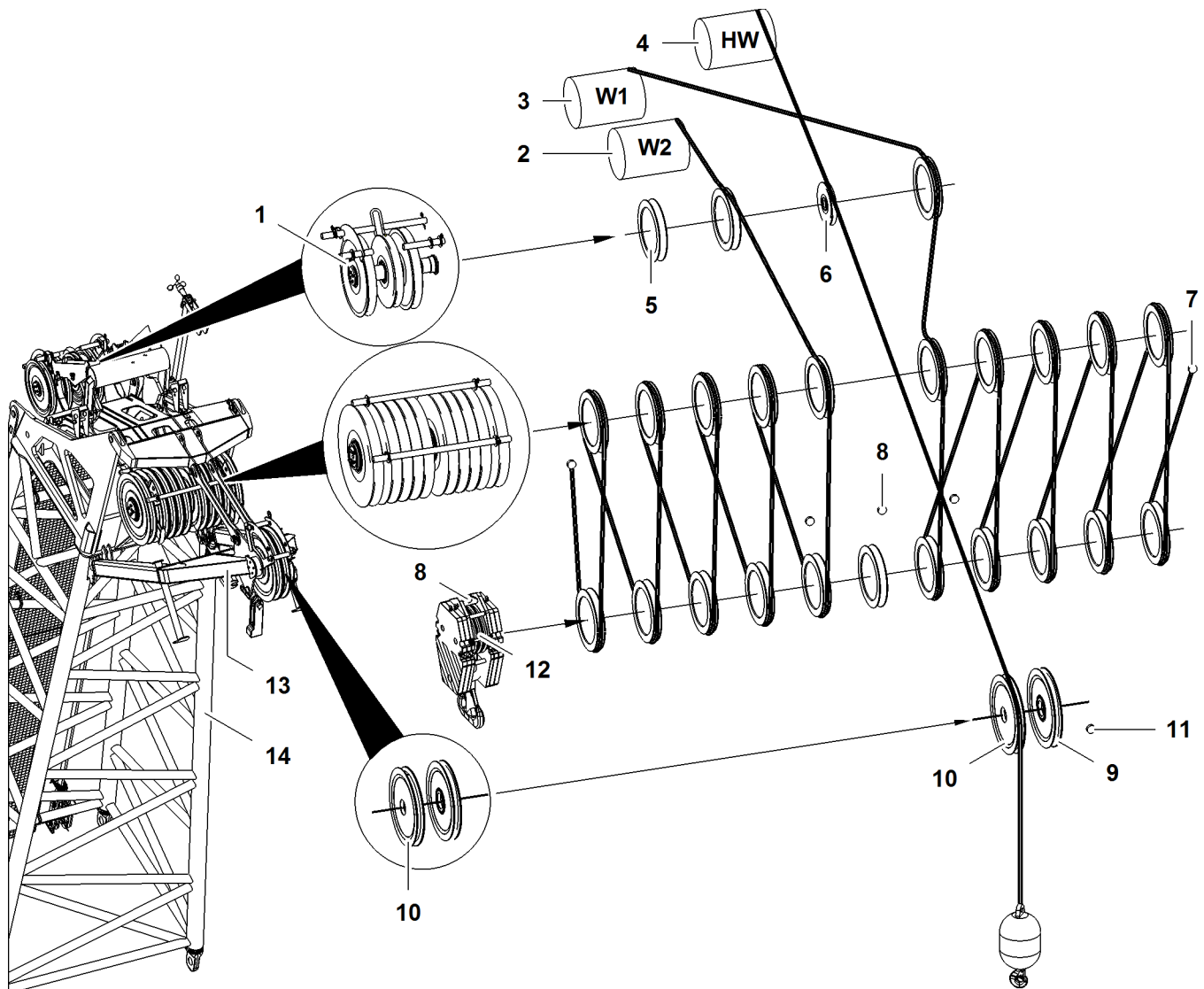


Fig. 3638: Reeving diagram - jib luffing winch as auxiliary winch (illustration of principle)

- | | | | | | |
|---|---|----|--|----|--|
| 1 | Gantry pulley (2x) of main boom head | 6 | Pulley for rope of jib luffing winch | 11 | Rope fixing point of auxiliary jib (36 t (79300 lb)) |
| 2 | Winch2 | 7 | Rope fixing points of main boom head | 12 | Pulley set of pulley block |
| 3 | Winch1 | 8 | Rope fixing points of pulley block | 13 | Auxiliary jib (36 t (79300 lb)) |
| 4 | Jib luffing winch as auxiliary winch* | 9 | Second pulley* for triple reeving of auxiliary jib (36 t (79300 lb)) | 14 | Main boom head |
| 5 | Gantry pulley (only with LR 1004 und LR 1006) | 10 | Pulley of auxiliary jib (36 t (79300 lb)) | | |

LWNLR.x/V04.01//Auslieferung/2016-03-07/en

7.9 Assembly of main boom with derrick equipment*

7.9.1 Assembly of derrick boom

Notes

The illustrations have been simplified or schematically represented for reasons of uniformity and represent the principles of assembly. They do not provide a detailed representation of the components.

Unload and position the derrick boom head components



DANGER

Derrick boom head components with differing serial numbers are assembled!
Structural breakdown.

- ▶ Note the derrick identification plate on the derrick boom components.



DANGER

Wrong or defect parts or components!
Structural breakdown.

- ▶ Only use original Liebherr parts and original Liebherr components in perfect condition.

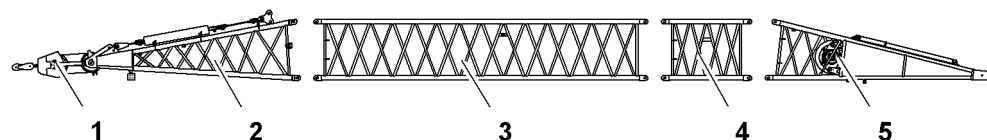


Fig. 3639: Unloading and positioning the derrick boom components

- | | | | |
|---|--|---|----------------------------------|
| 1 | Derrick pulley block | 4 | Derrick boom section 3 m (20 ft) |
| 2 | Derrick boom head | 5 | Derrick boom base section |
| 3 | Derrick boom section
11.7 m (38 ft) | | |

- ▶ Direct transport vehicles with derrick boom components.
- ▶ Rig derrick boom components with sling gear on rigging points.
- ▶ Unload derrick boom components onto wooden blocks using the basic machine or assist crane and position according to relevant system instructions.

Bolting the derrick boom



WARNING

Never stand in the inside of the derrick main boom sections during assembly!
Serious injury.

- ▶ Never go inside the derrick boom sections.
- ▶ Drive in double-taper pins from the outside exclusively.

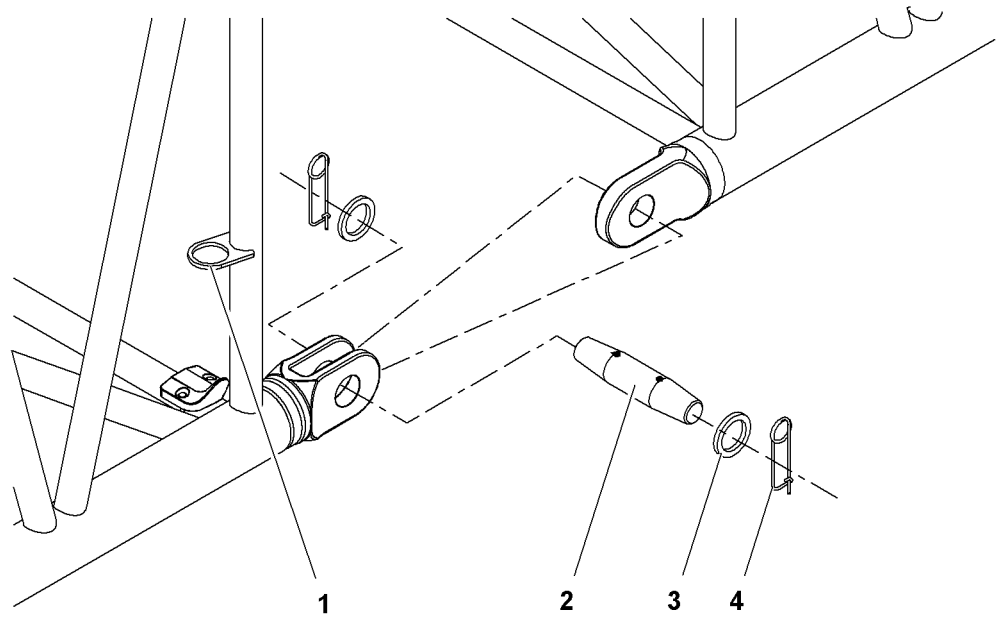


Fig. 3640: Bolting the derrick boom

- | | | | |
|---|--|---|---------------------|
| 1 | Transport bracket (4x) for double-taper pins | 3 | Washer (8x) |
| 2 | Double-taper pin (4x) | 4 | Locking spring (8x) |

- ▶ Remove the double-taper pins 2 from the transport brackets 1.



Note

Liebherr recommends:

- ▶ To make assembly and disassembly easier, grease double-taper pin.

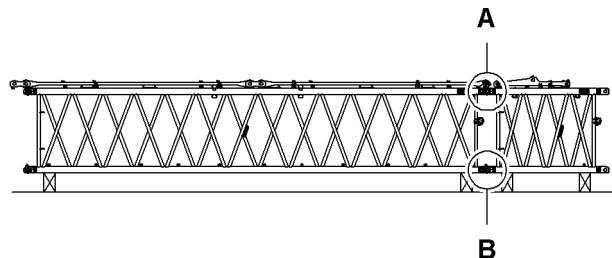


Fig. 3641: Bolt the derrick boom sections

- | | | | |
|---|-------------------------------|---|----------------------------------|
| A | Top pin connection point (2x) | B | Bottom pin connection point (2x) |
|---|-------------------------------|---|----------------------------------|

- ▶ Bolt all derrick boom sections to one another on pin connection points A + B.

- ▶ Secure the double-taper pins with washers and safety pins.

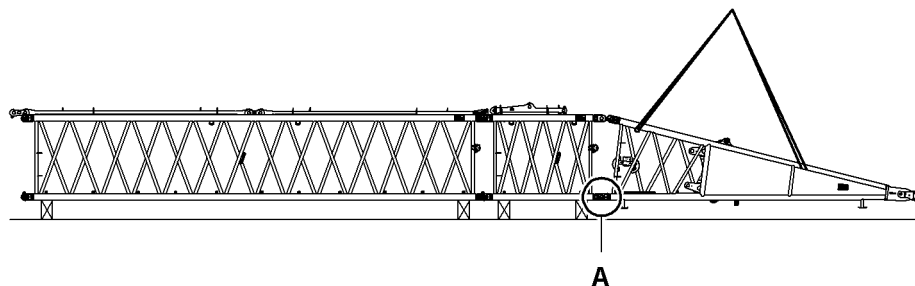


Fig. 3642: Pinning the derrick boom base section to the bottom derrick boom section

- A** Bottom pin connection point (2x)
- ▶ Rig derrick boom base section.
- ▶ Lift derrick boom base section to derrick boom section until bottom pin connection points **A** align.
- ▶ Pin derrick boom base section to the derrick boom section on bottom pin connection points **A**.
- ▶ Secure the double-taper pins with washers and safety pins.
- ▶ Place wooden blocks beneath derrick boom base section.

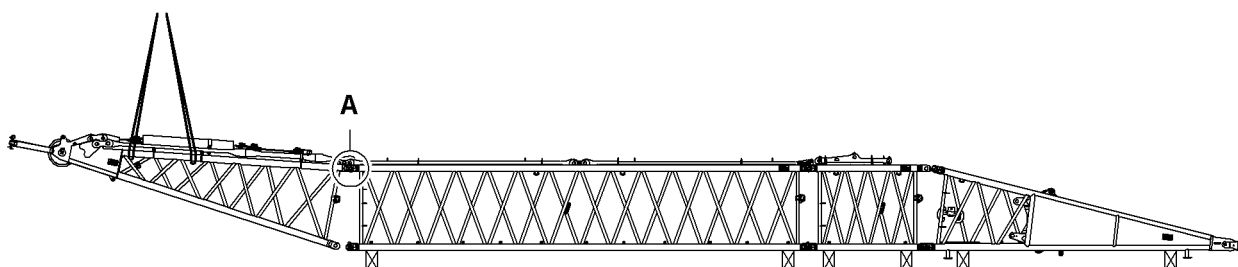


Fig. 3643: Pinning the derrick boom head to the top derrick boom section

- A** Top pin connection point (2x)
- ▶ Rig derrick boom head.
- ▶ Lift derrick boom head to derrick boom section until top pin connection points **A** align.
- ▶ Pin derrick boom head to derrick boom section on top pin connection points **A**.
- ▶ Secure double-taper pins with washers and locking springs.

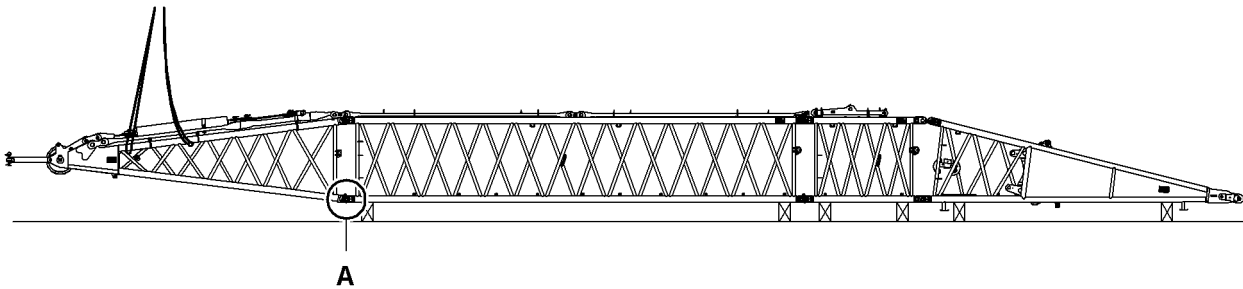


Fig. 3644: Pinning the derrick boom head to the bottom derrick boom section

A Bottom pin connection point
(2x)

- ▶ Lower the derrick boom head until the lower pin connection points **A** match.
- ▶ Bolting the derrick boom head to the derrick boom section on the lower pin connection points **A**.
- ▶ Secure the double-taper pins with washers and safety pins.

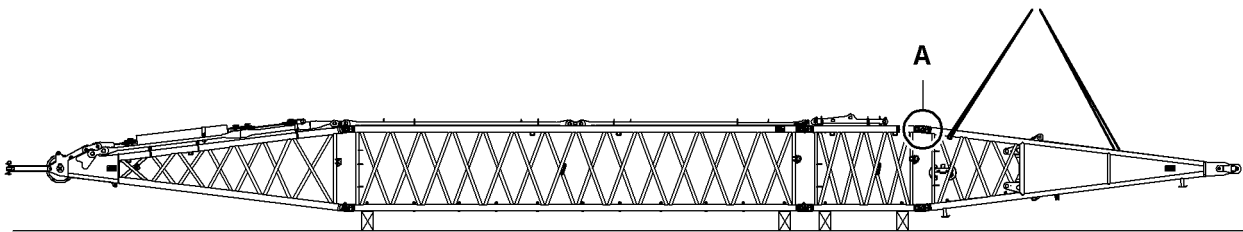


Fig. 3645: Pinning the derrick boom base section to the top derrick boom section

A Top pin connection point (2x)

- ▶ Rig derrick boom base section.
- ▶ Lift derrick boom base section until top pin connection points **A** align.
- ▶ Bolting the derrick boom base section to the derrick boom section on the upper pin connection points **A**.
- ▶ Secure the double-taper pins with washers and safety pins.

Connecting catwalks* for booms

Make sure the following prerequisites are met:

- Boom components are pinned to each other.

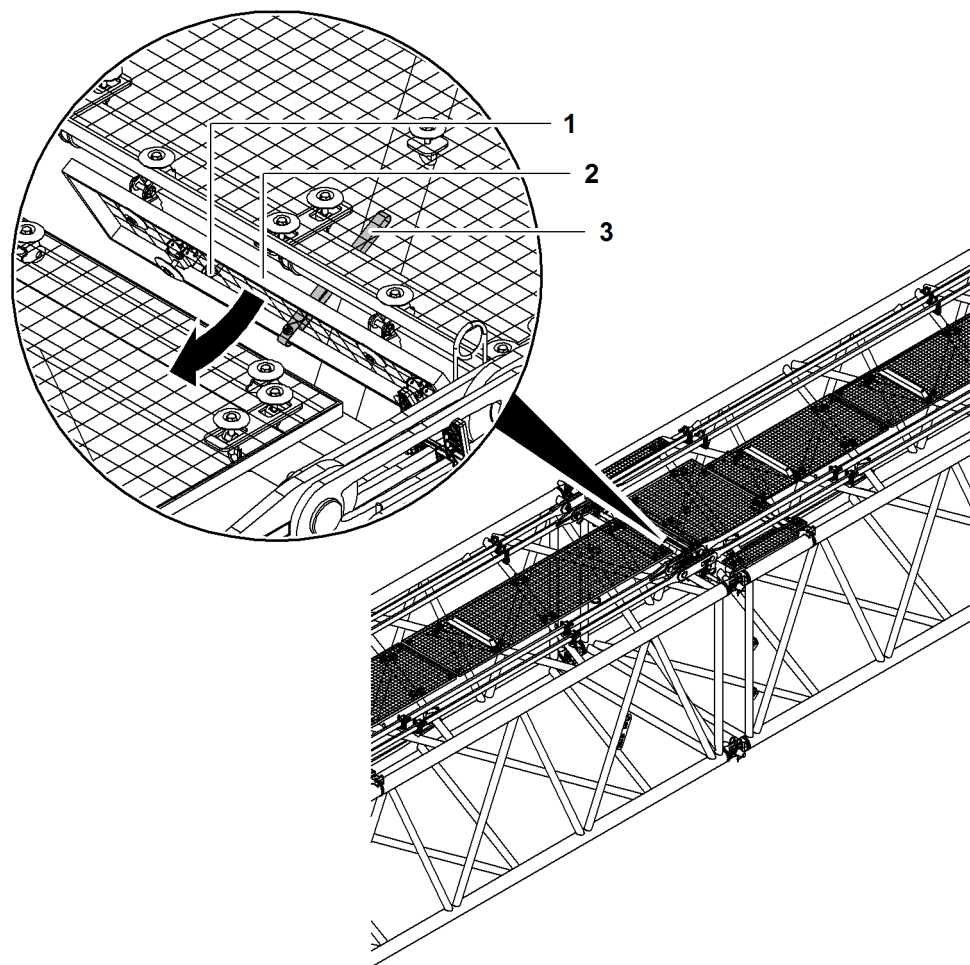


Fig. 3646: Connecting catwalks for booms (illustration of principle)

- | | | | |
|---|---------------------------------|---|---------------|
| 1 | Pin (2x) with spring cotter pin | 3 | Retainer belt |
| 2 | Catwalk (hinged) | | |

- ▶ Open retainer belt **3**.
- ▶ Remove pin **1** with spring cotter pin on both sides.
- ▶ Fold up catwalk **2**.

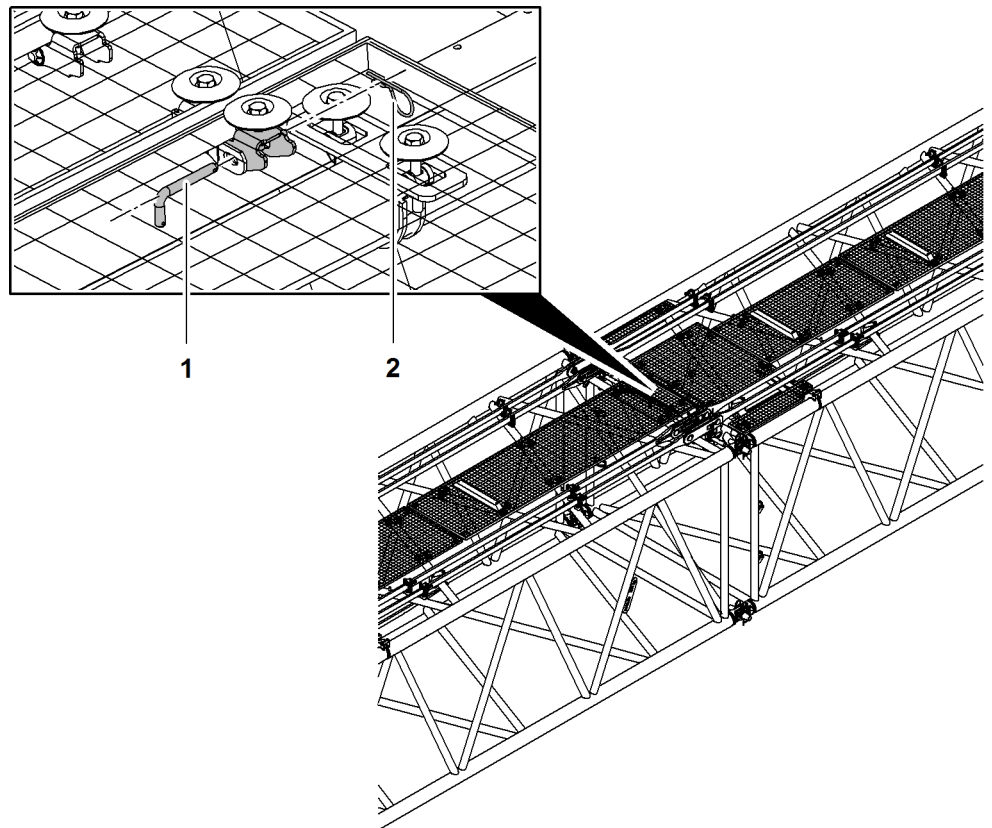


Fig. 3647: Connecting catwalks for booms (illustration of principle)

1 Pin (2x)

2 Spring cotter pin (2x)

When the pin connection points of the catwalks align:

- ▶ Insert pin 1 on both sides.
- ▶ Secure pins 1 with spring cotter pins 2.
- ▶ Repeat procedure with all boom components.

Connecting and checking boom fall arrest*



WARNING

Improper assembly of the boom fall arrest*!
Risk of falling off the boom.

- ▶ Ensure that the boom fall arrest* is in impeccable condition.
 - ▶ Ensure that the boom fall arrest* is connected and secured between boom sections according to the specifications.
-
- ▶ Connect and check boom fall arrest* in accordance with additional documentation LIE-TAURUS.

Connecting the hydraulic lines

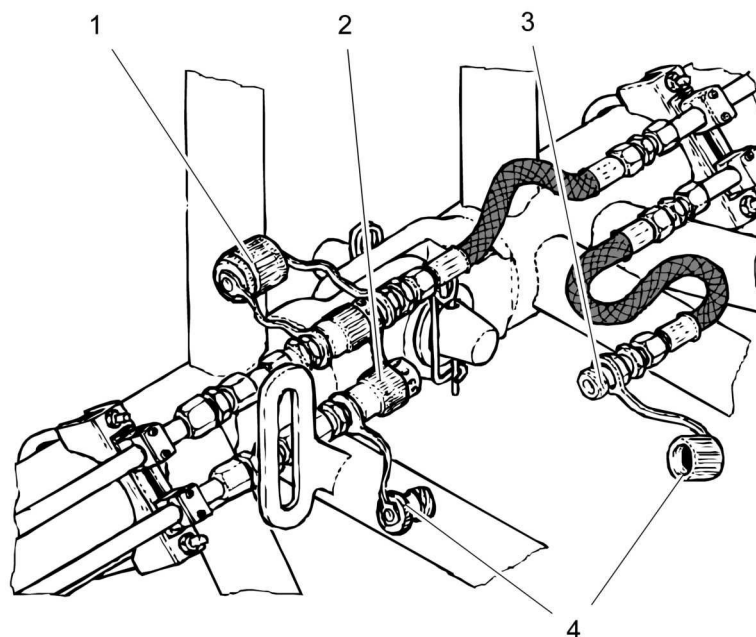


Fig. 3648: Connecting the hydraulic lines

- | | | | |
|-------|---------------------|---|---------------------|
| 1 | Protective covers | 3 | Hydraulic couplings |
| 2 + 3 | Hydraulic couplings | 4 | Protective covers |

The hydraulic lines of the individual derrick boom components must be connected.

- ▶ Remove protective covers 4 on hydraulic couplings 2 + 3.

NOTICE

Soiled hydraulic couplings 2 + 3!
Damage to the hydraulic system.

- ▶ Clean hydraulic couplings 2 + 3 before connecting.

- ▶ Connect and tighten hydraulic couplings 2 + 3.
- ▶ Screw protective covers 1 together.

Connect the electric cables

NOTICE

Electric cables have been handled incorrectly!
Damage to electric line and plug.

- ▶ Do not pull electric line over sharp-edged objects.
- ▶ Do not crush or kink electric line.
- ▶ Keep the plug clean.

- ▶ Unwind electric line from cable bracket on derrick boom base section.
- ▶ Pull electric line towards derrick boom head.
- ▶ Insert electric line on terminal box.

- ▶ Lock plug with support bracket.
- ▶ Suspend the strain relief carabiner.
- ▶ If required, rewind electric line back onto cable bracket.

Pinning the pendant straps

- ▶ Remove safety pins from the transport brackets for pendant straps.

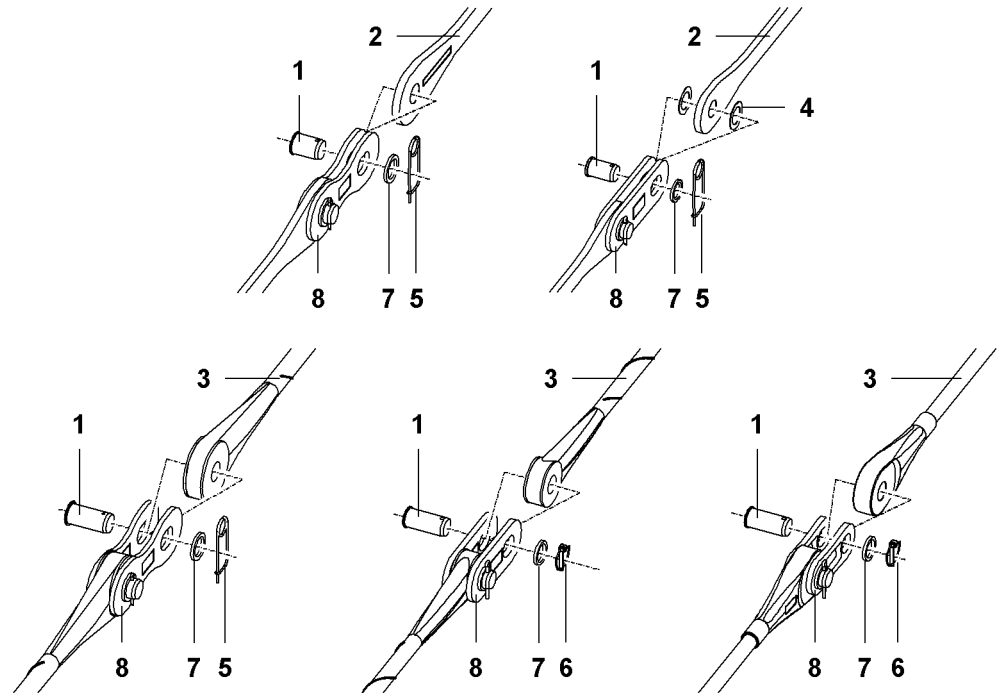


Fig. 3649: Bolt the pendant straps (schematic diagram of various pendant straps)

- | | | | |
|---|----------------------------|---|-----------------|
| 1 | Pin | 5 | Safety pin |
| 2 | Steel pendant strap | 6 | Linch pin |
| 3 | Carbon-fibre pendant strap | 7 | Washer |
| 4 | Plastic washer (2x) | 8 | Connecting link |

- ▶ Remove the pin 1 on the connecting link 8.
- ▶ Position the pendant strap 2, 3 between the two coupling links 8.
or

If the pendant strap has plastic washers 4:

Position the pendant strap 2 with plastic washers 4 on both sides between the two connecting links 8.

- ▶ Insert pin 1 and secure with washers 7 and safety pin 5 or linch pin 6.

Bolting the pendant ropes for the suspended counterweight

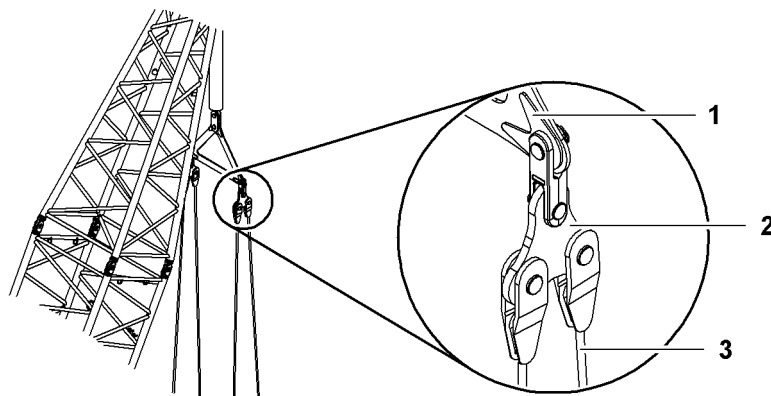


Fig. 3650: Bolting the pendant ropes for the suspended counterweight

- | | | | |
|----------|----------------------------|----------|-------------------|
| 1 | Crossbar of hoist cylinder | 3 | Pendant rope (4x) |
| 2 | Pendant rope crossbar | | |

- ▶ Place pendant ropes **3** on derrick boom.
- ▶ Pin pendant rope **2** with crossbar of hoist cylinder **1**.



CAUTION

Swinging pendant ropes **3** during assembly!
Slight injuries.

- ▶ Secure pendant ropes **3**.
- ▶ Secure pendant ropes **3** with a string or strap on the bottom part of the derrick boom.

Bolting the pendant straps for the wheeled counterweight carriage

- ▶ Place pendant straps on derrick boom.

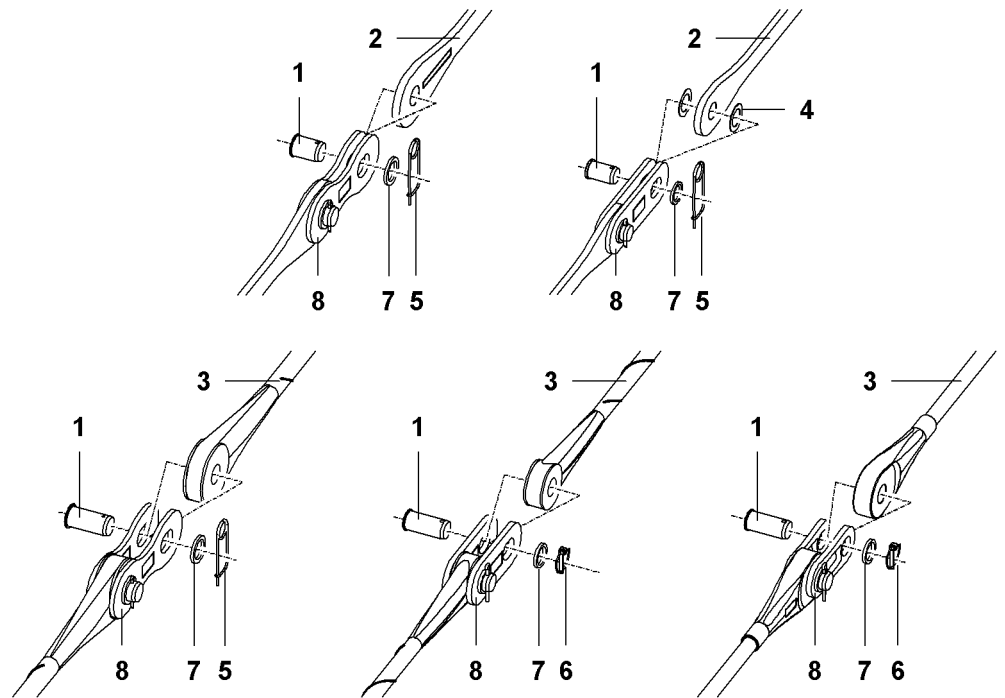


Fig. 3651: Bolt the pendant straps (schematic diagram of various pendant straps)

- | | | | |
|---|----------------------------|---|-----------------|
| 1 | Pin | 5 | Safety pin |
| 2 | Steel pendant strap | 6 | Linch pin |
| 3 | Carbon-fibre pendant strap | 7 | Washer |
| 4 | Plastic washer (2x) | 8 | Connecting link |

- ▶ Remove the pin 1 on the connecting link 8.
- ▶ Position the pendant strap 2 **bzw. 3** between the two coupling links 8.
or

If the pendant strap has plastic washers 4:

Position the pendant strap 2 with plastic washers 4 on both sides between the two connecting links 8.

- ▶ Insert pin 1 and secure with washers 7 and safety pin 5 or linch pin 6.



CAUTION

Hanging pendant straps during assembly!
Slight injuries.

- ▶ Secure pendant straps.
-
- ▶ Secure pendant straps with a string or strap on the bottom part of the derrick boom.

Installing the derrick boom on the uppercarriage

Ensure that the following conditions are fulfilled:

- Cylinder adjustment functions are activated.

The derrick boom is bolted to the same shaft as A-frame 1.

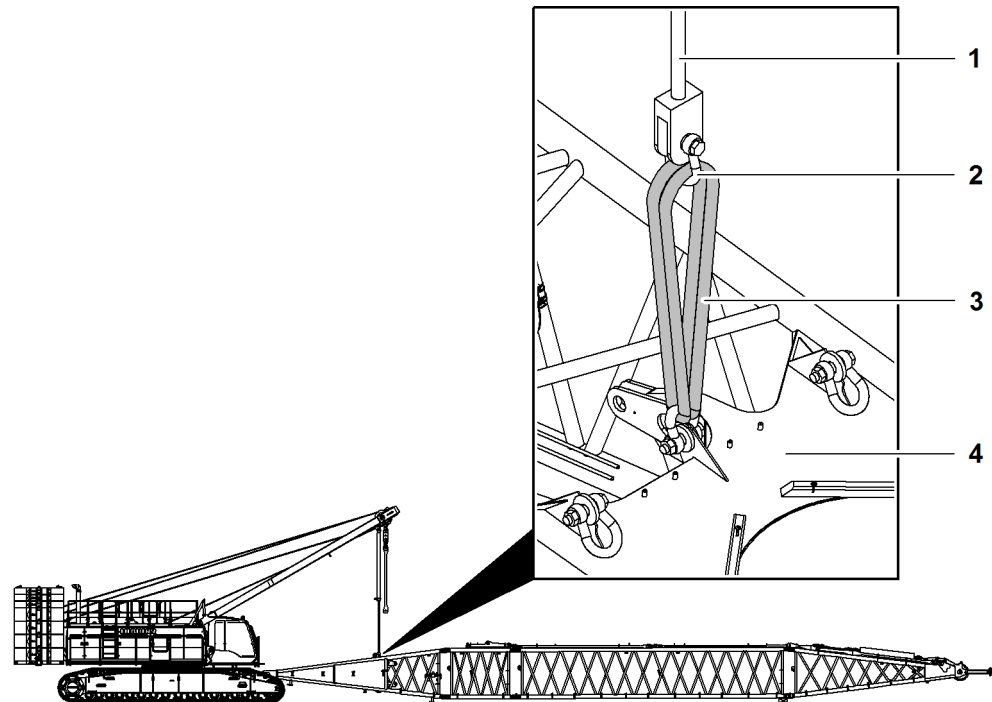


Fig. 3652: Pinning the assembly cylinder to the derrick boom base section

- | | | | |
|---|-------------------------------|---|-----------------------------|
| 1 | Assembly cylinder | 3 | Round sling 8 t (17,637 lb) |
| 2 | Shackle 25 t (55,115 lb) (2x) | 4 | Derrick boom base section |

- ▶ Unwind main boom luffing winch.
 - ▷ A-frame1 lowers.
- ▶ Extend assembly cylinder 1.
- ▶ Pin assembly cylinders 1 with shackles 2 and round sling 3 to derrick boom base section 4.

NOTICE

Dragging of the derrick boom along the ground not permitted!
Damage to derrick boom.

- ▶ Do not drag the derrick boom along the ground.

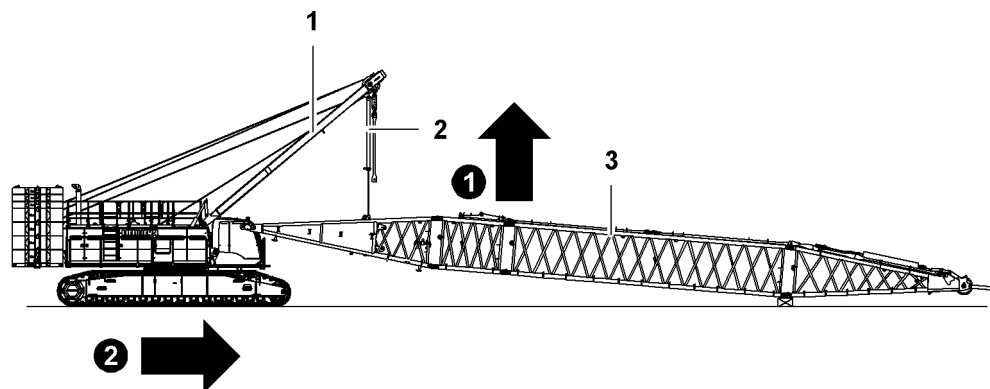


Fig. 3653: Lift derrick boom and move machine forwards

- | | | | |
|---|-------------------|---|--------------|
| 1 | A-frame1 | 3 | Derrick boom |
| 2 | Assembly cylinder | | |

- ▶ Lift derrick boom 3 with assembly cylinder 2.

- ▶ Wind up main boom luffing winch.
 - ▷ A-frame1 1 lifts.
- ▶ Move machine forward until derrick boom 3 is located in front of A-frame1 1 pivot points.

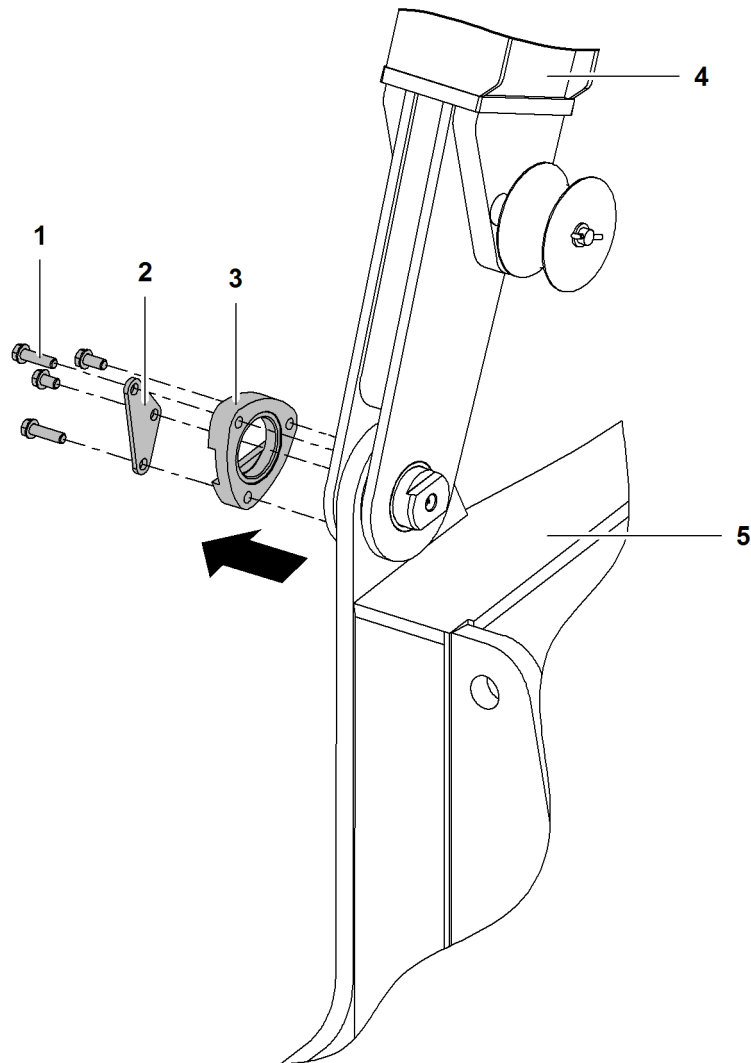


Fig. 3654: Removing A-frame1 locking elements

- | | | | |
|---|-------------------------|---|---------------|
| 1 | Screw (4x) with washers | 4 | A-frame1 |
| 2 | Plate | 5 | Uppercarriage |
| 3 | Spacer washer | | |

- ▶ Remove and store screws 1 and plate 2.
- ▶ Remove and put spacer 3 on one side.
- ▶ Repeat procedure on opposite side.

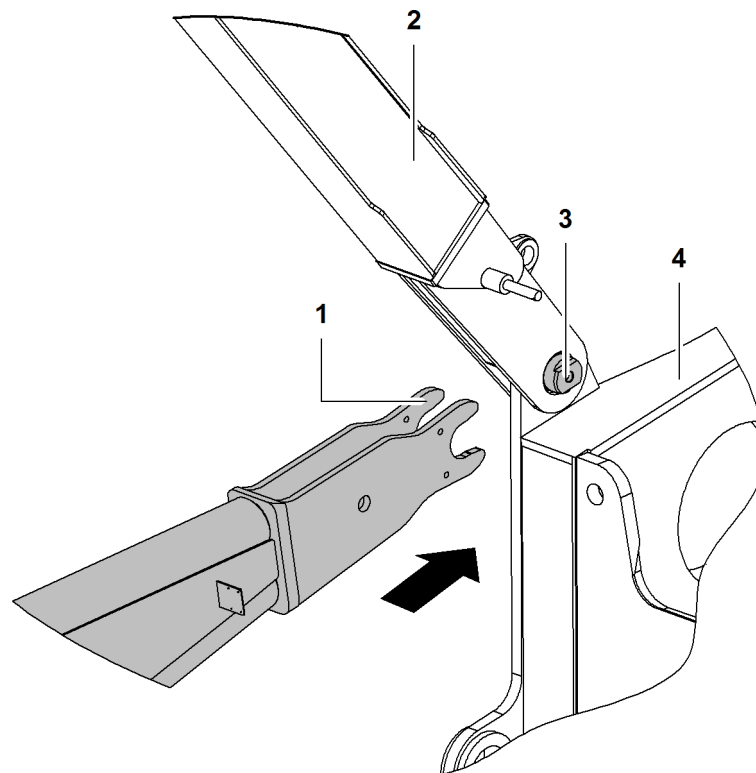


Fig. 3655: Placing the forks of the derrick boom base section on pins

1 Forks of the derrick boom base section

2 A-frame1

3 Pin

4 Uppercarriage

- ▶ Place forks 1 of the derrick boom base section both sides on pins 3 of A-frame1 2.

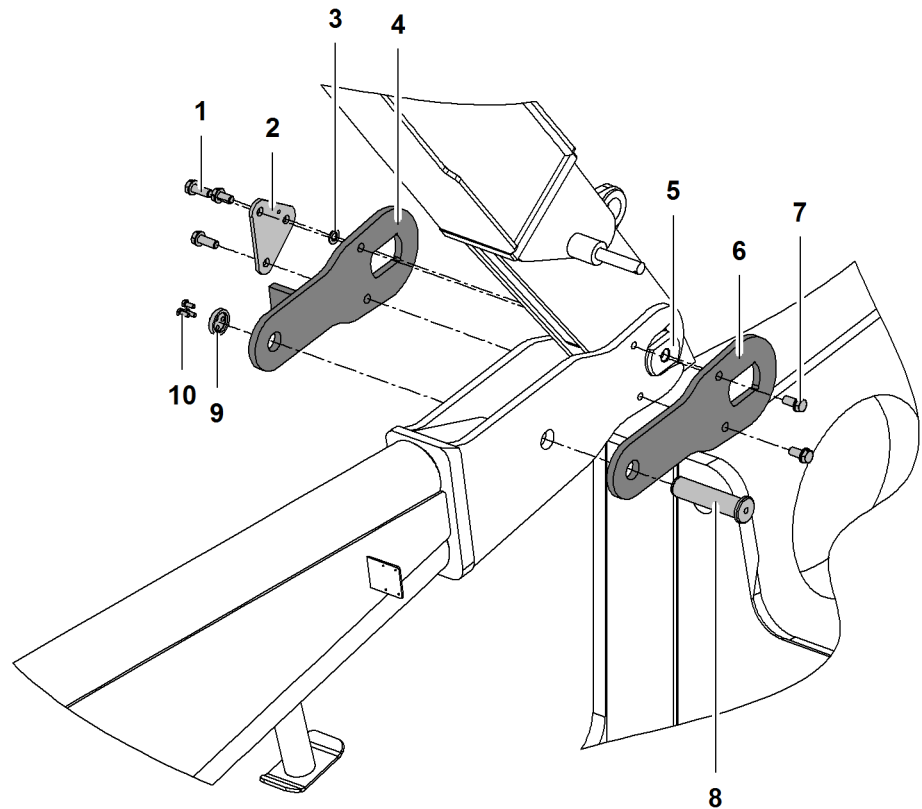


Fig. 3656: Securing the derrick boom

- | | | | |
|---|-------------------------|----|-------------------------|
| 1 | Screw (3x) with washers | 5 | Inner plate |
| 2 | Plate | 7 | Screw (2x) with washers |
| 3 | Washer | 8 | Pin |
| 4 | Pin of A-frame1 | 9 | Washer with three holes |
| 4 | Outer plate with link | 10 | Screw (3x) with washers |

- ▶ Place outer plate 4 with link on pins 4 of A-frame1.
- ▶ Place inner plate 5 on pins 4 of A-frame1.



Note

If the pin 4 of A-frame1 is not in the right position, the pin 4 must be aligned as described below!

- ▶ Put on outer plate 4 with link.
 - ▶ Secure outer plate 4 with link with washer 3, plate 2 and a screw 1 with disk.
 - ▶ Align pins 4: knock with hammer onto link of external plate 5.
-
- ▶ Secure inner plate 5 with screws 7 and washers.
 - ▶ Secure outer plate 4 with link with washer 3, plate 2 and screws 1 with disks.
 - ▶ Pin 8 must be inserted from the outside.
 - ▶ Secure pins 8 with washer 9 with three holes and screws 10 with disks.
 - ▶ Release assembly cylinder from derrick boom base section.

Connecting hydraulic lines and electric lines with the uppercarriage

NOTICE

Soiled hydraulic couplings!
Damage to the hydraulic system.

- ▶ Clean hydraulic couplings before connecting.
-
- ▶ Connect hydraulic lines with bulkhead plates on uppercarriage and tighten.
 - ▶ Screw protective covers together.

NOTICE

Incorrect handling of electric lines!
Damage to electric line and plug.

- ▶ Do not pull electric line over sharp-edged objects.
 - ▶ Do not crush or kink electric line.
 - ▶ Keep the plug clean.
-
- ▶ Insert electric line of derrick boom into connecting plug on the uppercarriage.
 - ▶ Lock plug with support bracket.

Reeve the Derrick pulley block

Ensure that the following conditions are fulfilled:

- Derrick winch is selected.
- The derrick pulley block is attached and bolted to the transport fixation on the derrick boom head.

Reeve derrick rope rigging with auxiliary rope

NOTICE

Improper reeving of derrick winch rope!
Damage to derrick winch rope.

- ▶ Install derrick winch rope without twists.
 - ▶ Do not install any swirls in derrick winch rope.
-

There must be no slacking of the rope when unwinding.

- ▶ Slowly unwind derrick winch rope.

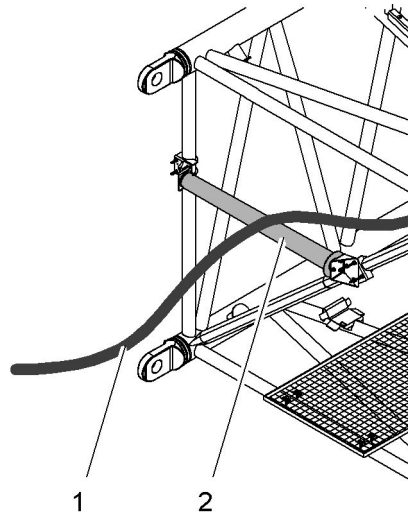


Fig. 3657: Reeve derrick rope rigging with auxiliary rope

- | | | | |
|----------|-----------------------|----------|------------------------|
| 1 | Rope of derrick winch | 2 | Rope protection roller |
|----------|-----------------------|----------|------------------------|
- ▶ Guide rope **1** of derrick winch across every rope protection roller **2**.
 - ▶ Pull rope **1** of derrick winch towards derrick boom head.
 - ▶ Connect rope **1** of derrick winch with auxiliary rope reeved between derrick boom head and derrick rope rigging.

No slack rope may form during unwinding.

- ▶ Unwind rope **1** of derrick winch up to rope fixing point.
- ▶ Remove auxiliary rope from rope **1** of derrick winch.
- ▶ Attach rope **1** of derrick winch to rope fixing point of derrick boom head.

Reeving the derrick rope rigging without auxiliary rope

NOTICE

Improper reeving of derrick winch rope!
Damage to derrick winch rope.

- ▶ Install derrick winch rope without twists.
- ▶ Do not install any swirls in derrick winch rope.

There must be no slacking of the rope when unwinding.

- ▶ Slowly unwind derrick winch rope.

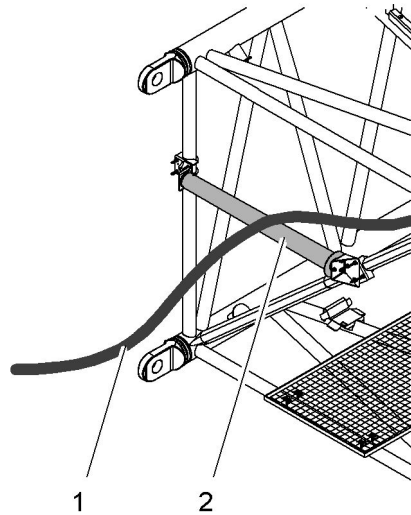


Fig. 3658: Reeving the derrick rope rigging without auxiliary rope

- 1 Rope of derrick winch
- 2 Rope protection roller
- ▶ Guide rope 1 of derrick winch across every rope protection roller 2.
- ▶ Pull rope 1 of derrick winch towards derrick boom head.

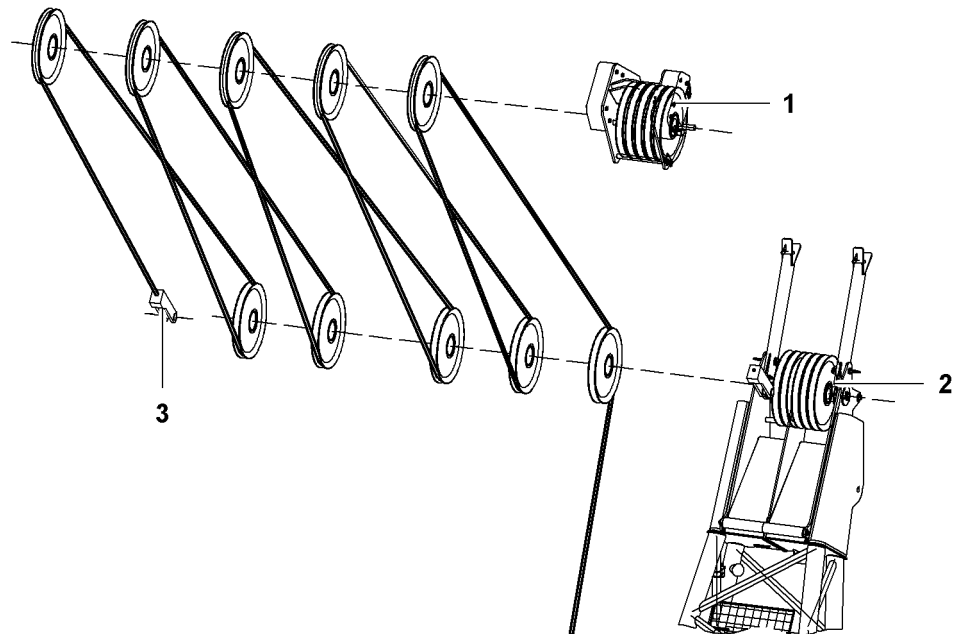


Fig. 3659: Derrick pulley block rope reeving system

- 1 Derrick pulley block
- 2 Derrick boom head
- 3 Rope fixation
- ▶ Reeve in rope of derrick winch according to reeving diagram.
- ▶ Attach rope of derrick winch on rope fixing point 3 of derrick boom head 2.

Release transport lashing from the derrick pulley block

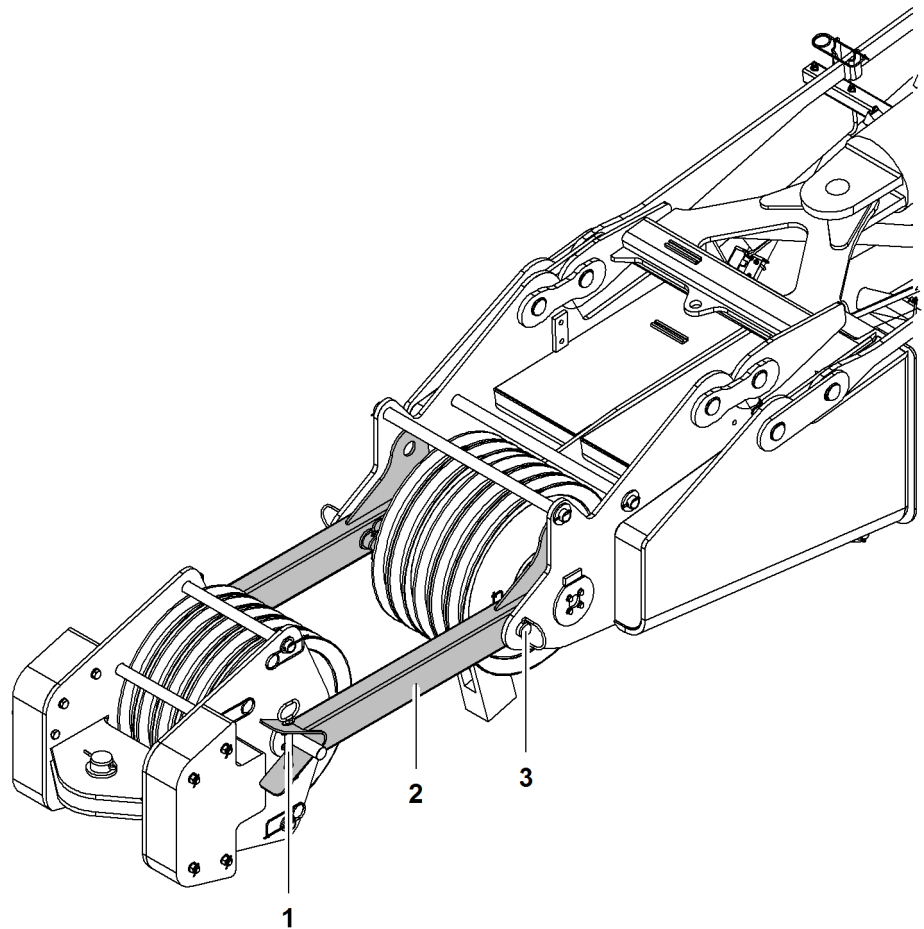


Fig. 3660: Undoing transport brackets from derrick rope rigging

- | | | | |
|---|------------------------|---|----------|
| 1 | Locking pin (2x) | 3 | Pin (2x) |
| 2 | Transport bracket (2x) | | |

► Remove locking pins 1 on transport brackets 2 and place in temporary storage.

Pinning A-frame1 equalizer to derrick boom pendant straps



WARNING

Do not stand below A-frame1!
Severe injury.

- Make sure that nobody is located in the danger zone.
- Leave the danger area.

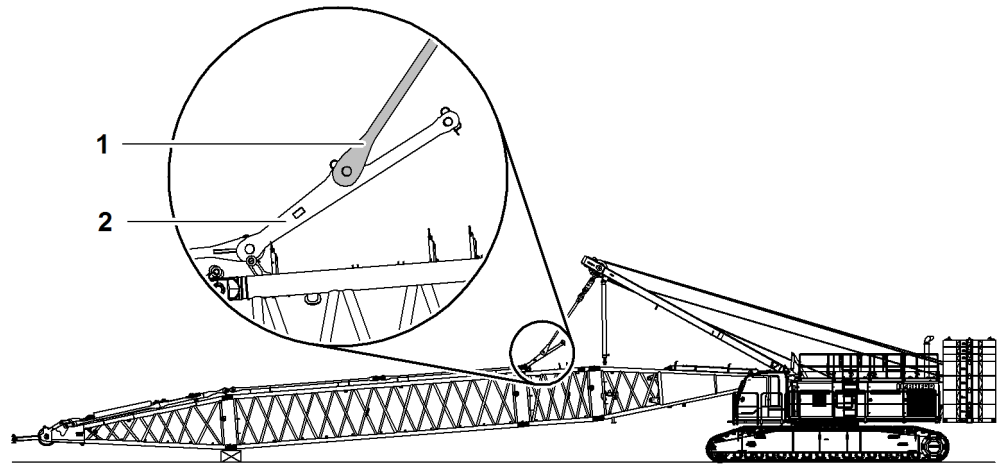


Fig. 3661: Pinning A-frame1 equalizer to derrick boom pendant straps

- 1 A-frame1 equalizer
- 2 Derrick boom pendant straps
- ▶ Lower A-frame1 until A-frame1 equalizer 1 can be pinned with derrick boom pendant straps 2.
- ▶ Pin A-frame1 equalizer 1 to derrick boom pendant straps 2.
- ▶ Secure pins with washers and locking springs.

Moving the lightning rods* into working position

Installation positions of lightning rods on derrick boom head

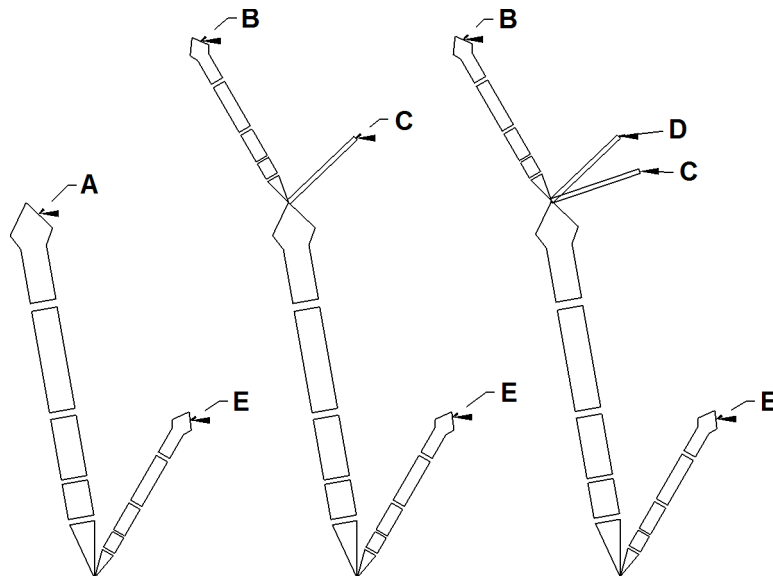


Fig. 3662: Installation positions of lightning rods on derrick boom head

- A Main boom head
- B Jib head
- C A-frame2
- D A-frame3
- E Derrick boom head

Boom configuration	Number of lightning rods	Installation positions
Main boom + derrick	2	A + E

LWN/LR-x/V04.01//Auslieferung/2016-03-07/en

Boom configuration	Number of lightning rods	Installation positions
Main boom + fixed jib + derrick	3	B + C + E
Main boom + luffing jib + derrick	4	B + C + D + E

Tab. 519: Installation positions and number of lightning rods on derrick boom head

Moving the lightning rods* on the derrick boom head into working position

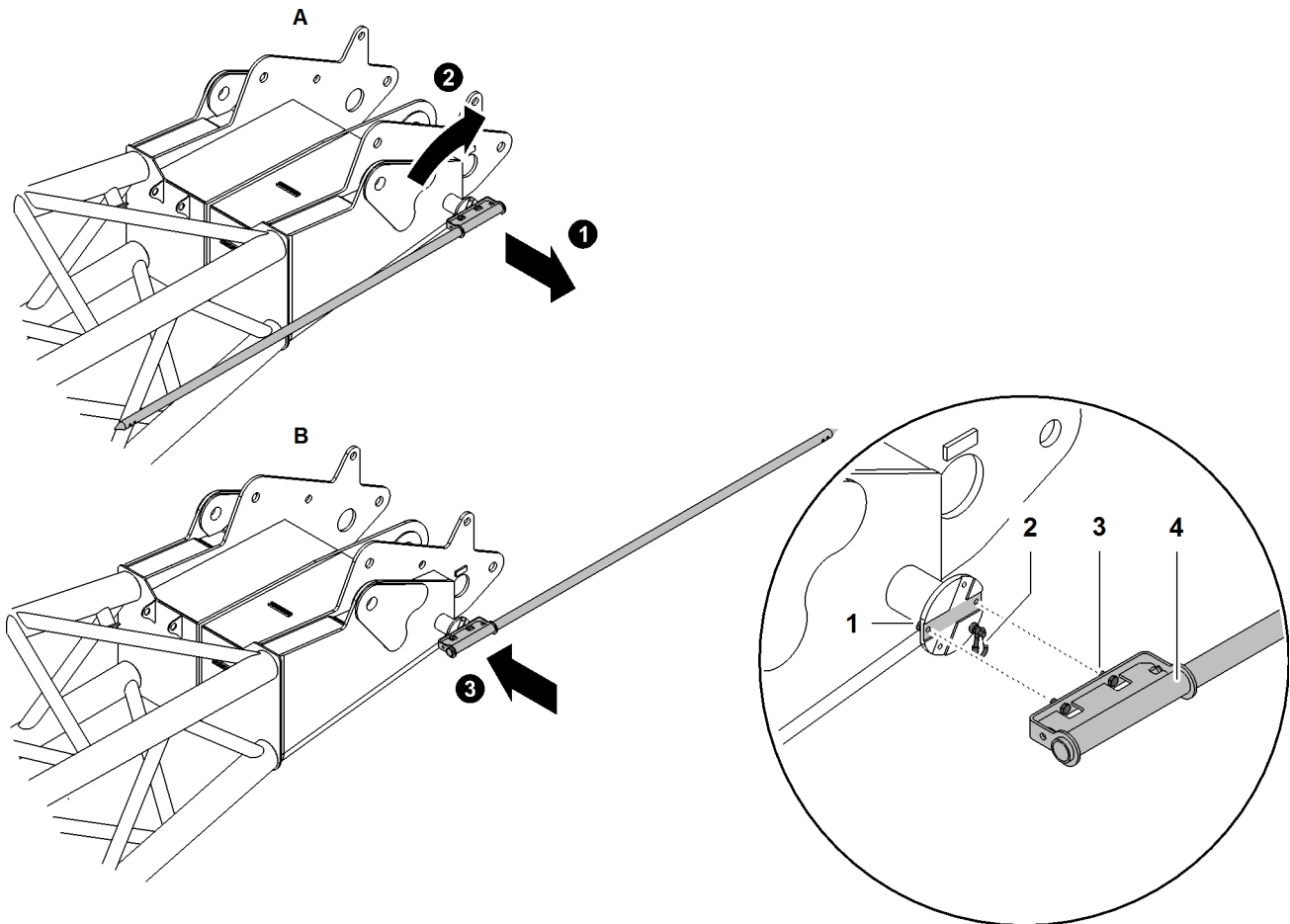


Fig. 3663: Moving the lightning rods* on the derrick boom head into working position

- A** Transport position
- B** Working position

- 1** Nut (2x)
- 2** Safety rope
- 3** Screw (2x)
- 4** Lightning rod

- ▶ Undo safety rope **2**.
- ▶ Undo nuts **1**.
- ▶ Undo screws **3**.
- ▶ Move lightning rod **4** from transport position **A** to working position **B**.



Note

Liebherr recommends:

- ▶ Grease threads of the screws **3**.
- ▶ Attach lightning rod **4** with screws **3**.

LWNLR.x/V04.01//Auslieferung/2016-03-07/en

- ▶ Lock screws **3** with nuts **1**.

NOTICE

Safety rope not attached!
Dropping parts.

- ▶ Ensure that safety rope **2** is attached.

-
- ▶ Attach safety rope **2**.

NOTICE

Tip not installed!
Improperly deflected current.
Dropping parts.

- ▶ Ensure that the tip on the lightning rod **4** is installed.
- ▶ Ensure that the screws of the tip are tightened.

-
- ▶ Ensure that the tip on the lightning rod **4** is installed.
 - ▶ Ensure that the screws of the tip are tightened.

Raise derrick boom

Ensure that the following conditions are fulfilled:

- All work on the derrick boom has been completed.
- No loose parts or tools have been left on the derrick boom.



WARNING

Falling objects!
Severe injury.

- ▶ Any loose parts and tools must be removed from the derrick boom.
- ▶ Make sure that nobody is located in the danger zone.
- ▶ Leave the danger area.

-
- ▶ Slowly reeve main boom luffing winch.
 - ▷ Derrick boom pendant straps are tensioned.
 - ▶ Wind up main boom luffing winch further.
 - ▷ Derrick boom lifts off the ground.
 - ▷ Derrick rope rigging swings downwards.

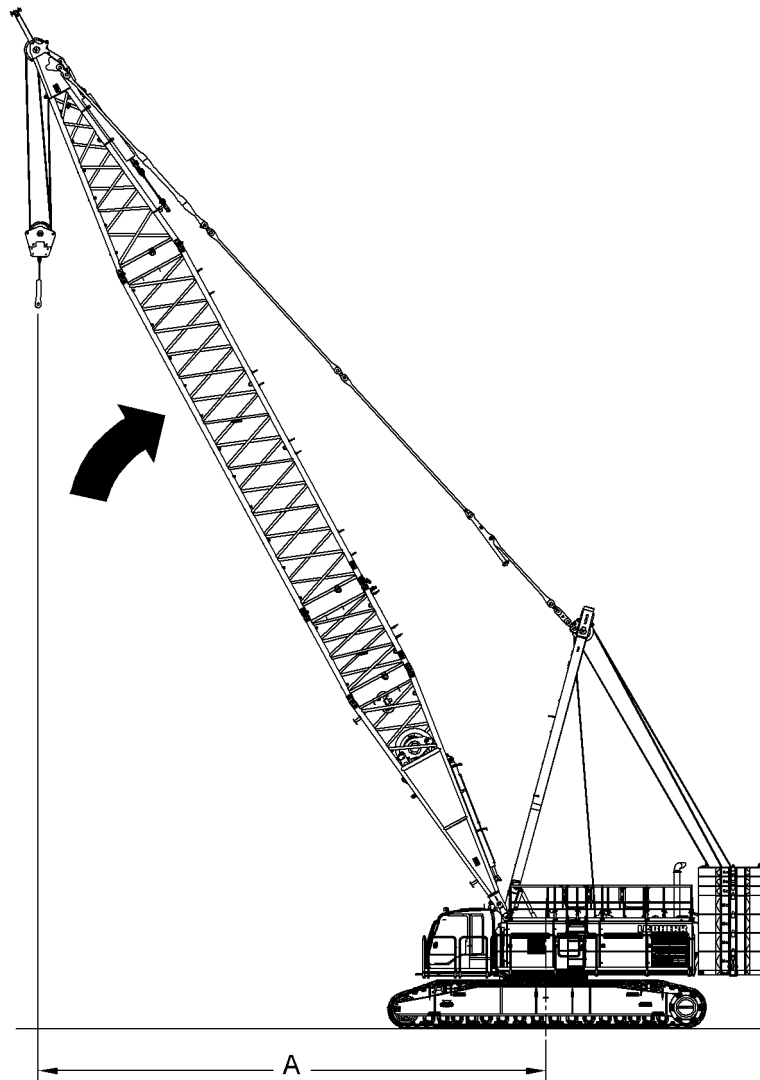


Fig. 3664: Erecting the derrick boom



DANGER

Critical angle is exceeded!
Machine toppling over.

- ▶ Do not lift derrick boom more than 70°.
 - ▶ Do not undercut minimum radius **A** of derrick boom of 11.5 m (37' 9" ft-in).
-
- ▶ Erect derrick boom until it is in the desired position.

7.9.2 Assembling the main boom

Ensure that the following conditions are fulfilled:

- Assembly functions switched on.
- The machine is ready for use as an assembly crane, or an assist crane is available.
- Work plans have been drawn up.
- The length and the order of the main boom intermediate pieces are known.
- The installation positions of the rope guide are known.
- The assembly positions of the mid-point suspensions are known.

- Any accessories required are available.

Notes

The illustrations have been simplified or schematically represented for reasons of uniformity and represent the principles of assembly. They do not provide a detailed representation of the components.

Programming the setup



DANGER

Unacceptable setup!

- ▶ Only program a setup on the machine that is in accordance with the load chart.
 - ▶ Programming the setup on the machine ([For more information see: 4.13 Programming the setup, page 886](#)).
-

Unloading and positioning the main boom section



DANGER

Slewing of uppercarriage with rear counterweight attached not permitted!
Machine toppling over.

- ▶ Slew the uppercarriage according to the table ([For more information see: Lifting and pinning the rear counterweight, page 1264](#)) exclusively.
-



DANGER

Incorrect or defect parts or components!
Structural breakdown.

- ▶ Only use original Liebherr parts and original Liebherr components in perfect condition.
-



DANGER

Improperly assembled boom configuration!
Structural breakdown.

- ▶ Ensure that the assembled boom configuration is compatible with the programmed setup.
-



DANGER

Incorrect arrangement of boom sections!
Structural breakdown.

- ▶ Assemble the main boom according to the relevant system requirements.
- ▶ A boom section of 6 m (20 ft) cannot be replaced by two boom sections of 3 m (10 ft).
- ▶ A boom section of 12 m (40 ft) cannot be replaced by two boom sections of 6 m (20 ft).
- ▶ Make sure that with model LR 1300 only main boom sections with the system dimensions 2821.24 are installed (For more information see: 1.9 Distinguishing features main boom sections LR 1300 and LR 1300 SX, page 159) .
- ▶ Make sure that with model LR 1300 SX only main boom sections with the system dimensions 2821.30 are installed (For more information see: 1.9 Distinguishing features main boom sections LR 1300 and LR 1300 SX, page 159) .

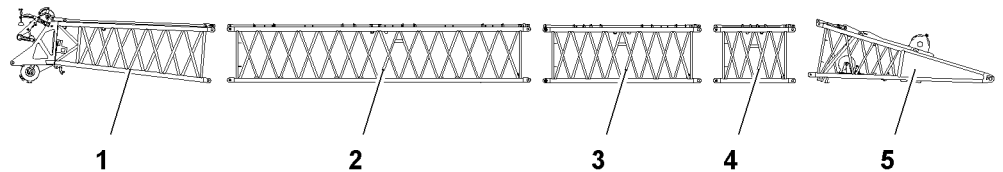


Fig. 3665: Unloading and positioning the main boom components

- | | | | |
|---|---------------------------|---|--------------------------|
| 1 | Boom head section | 4 | Boom section 3 m (10 ft) |
| 2 | Boom section 12 m (40 ft) | 5 | Boom base section |
| 3 | Boom section 6 m (20 ft) | | |

- ▶ Direct transport vehicles with boom components.
- ▶ Lash main boom sections by attaching lifting equipment to the lifting points.
- ▶ Unload main boom sections onto wooden blocks using the basic machine or assist crane and position according to the relevant system instructions.

Assembling the ladder* for the boom



CAUTION

Unauthorized use of ladder!
Fall from ladder.

- ▶ Only use the ladder with boom sections on which the required ladder angle of 75° to 80° can be observed.



CAUTION

The ladder must not be placed under an impermissible dynamic load!
Fall from ladder, break of ladder.

- ▶ The ladder must only be used for general assembly work on pendant straps and pin connection points on the boom sections.
- ▶ Do not stand on the ladder to knock in the boom section pins.
- ▶ The ladder must be checked for damage and cracks before it is fitted and before it is used.

LWNLR.x/V04.01//Auslieferung/2016-03-07/en



CAUTION

Take great care if walking on boom sections!
risk of falling from boom section.

- ▶ Only ever walk on boom sections if boom catwalks are fitted.
- ▶ A fall arrest system must be used when working on boom sections to prevent falling.



CAUTION

Slipping of the ladder!
Fall from ladder.

- ▶ Secure ladder against sliding.

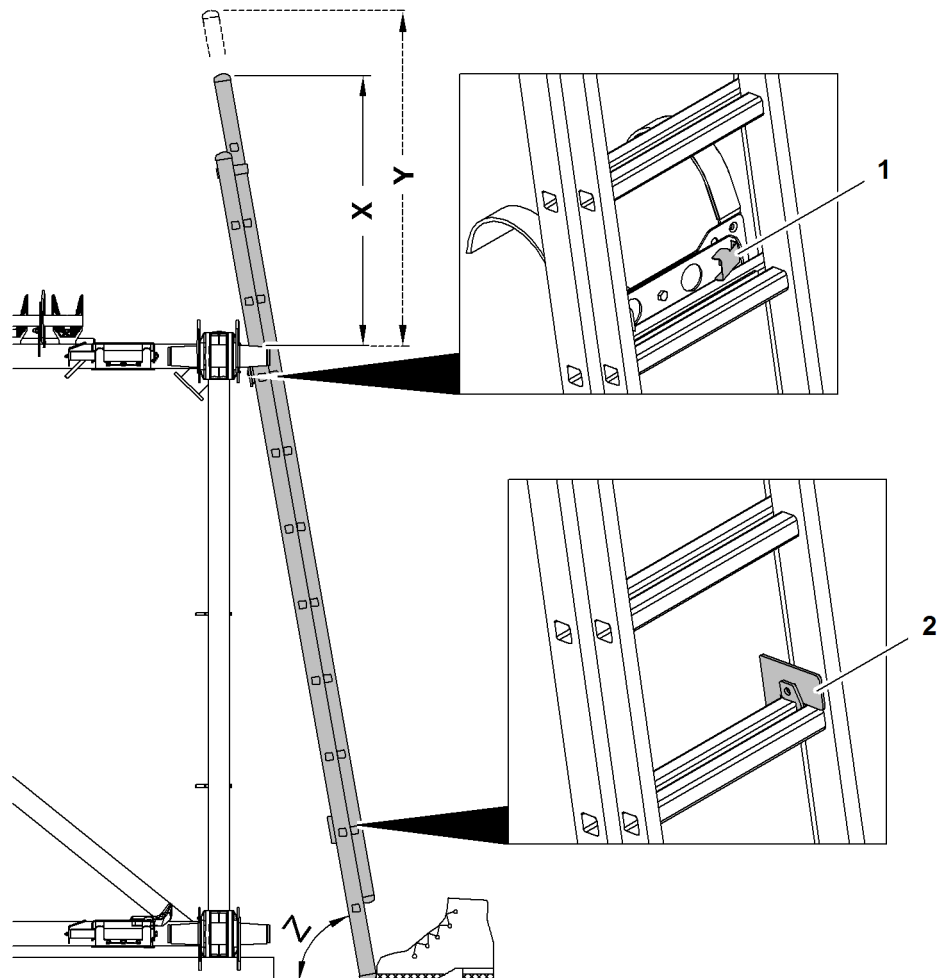


Fig. 3666: Assembling the ladder for the boom

- | | | | |
|---|------------------------|---|----------------|
| 1 | Top locking element | Y | Maximum height |
| 2 | Bottom locking element | Z | Ladder angle |
| X | Minimum height | | |

The ladder angle Z must remain between 75° and 80° .

The minimum height X must be at least 1000 mm (3' 3" ft-in).

If the maximum height Y is exceeded, the ladder topples.

- ▶ Insert ladder support at belt pipe of boom section.



CAUTION

Improperly extended ladder!
Fall from ladder.

- ▶ Observe slant angle **Z**.
- ▶ Observe minimum height **X**.
- ▶ Do not exceed maximum height **Y**.

- ▶ Extend extendable part of the ladder until minimum height **X** is exceeded.



CAUTION

Unsecured ladder!
Fall from ladder.

- ▶ Secure ladder against sliding.
- ▶ Ensure that locking elements engage.

- ▶ Check top locking element.
- ▶ Check bottom locking element.
 - ▷ Ladder for boom is installed:

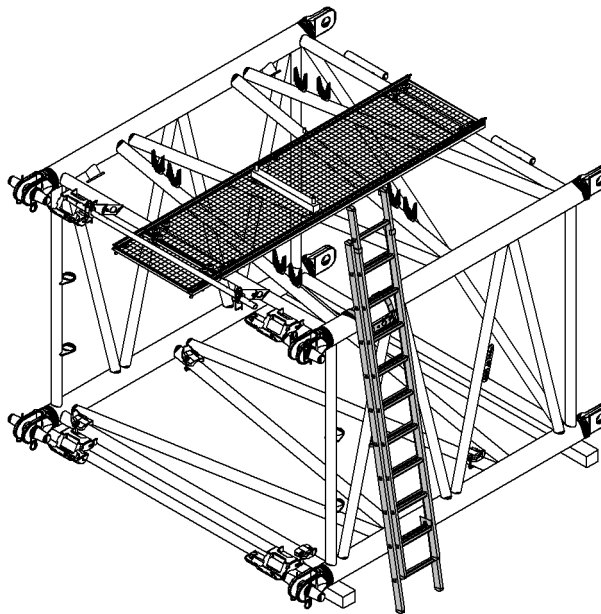


Fig. 3667: Ladder for boom is installed

Pinning together the main boom head, main boom sections and main boom base section



WARNING

Never stand in the inside of the main boom sections during assembly!
Serious injury.

- ▶ Never go inside the boom sections.
- ▶ Drive in double-taper pins from the outside exclusively.



Note

If a fixed jib (excluding fixed jib 1507) is going to be added:

- ▶ Bolt the boom head section and boom section to the upper pin connection points using double-taper pins from the A-frame 2 equalizer (jib backstay strap) of the fixed jib.

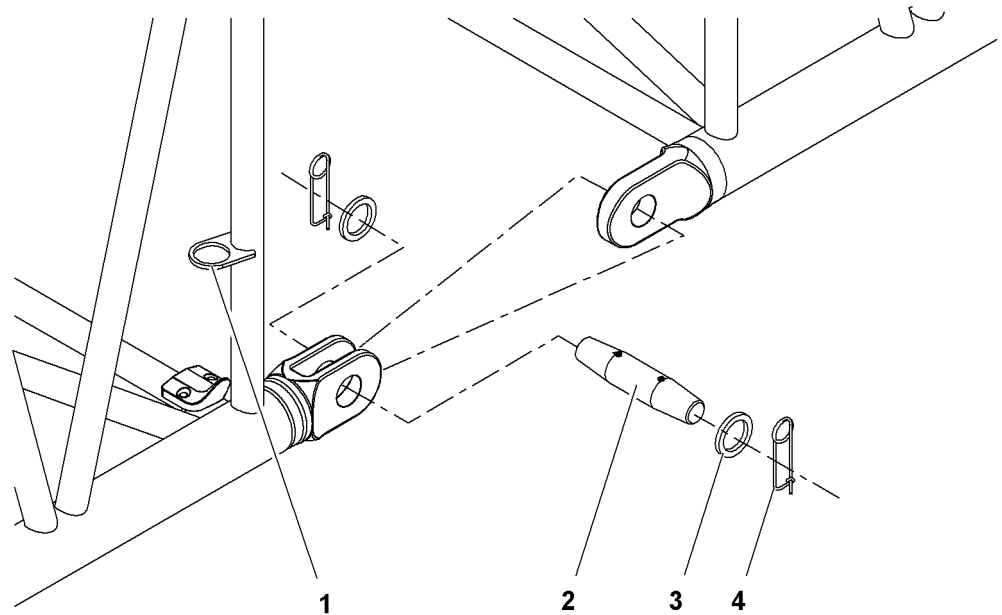


Fig. 3668: Bolting the main boom

- | | | | |
|---|--|---|---------------------|
| 1 | Transport bracket (4x) for double-taper pins | 3 | Washer (8x) |
| 2 | Double-taper pin (4x) | 4 | Locking spring (8x) |

- ▶ Remove the double-taper pins 2 from the transport brackets 1.



Note

Liebherr recommends:

- ▶ To make assembly and disassembly easier, grease double-taper pin.

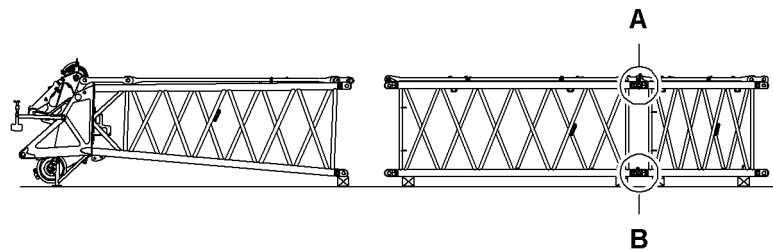


Fig. 3669: Bolting the main boom intermediate pieces

- | | | | |
|---|-------------------------------|---|----------------------------------|
| A | Top pin connection point (2x) | B | Bottom pin connection point (2x) |
|---|-------------------------------|---|----------------------------------|

- ▶ Bolt all boom sections to one another on pin connection points A + B.
- ▶ Secure the double-taper pins with washers and safety pins.

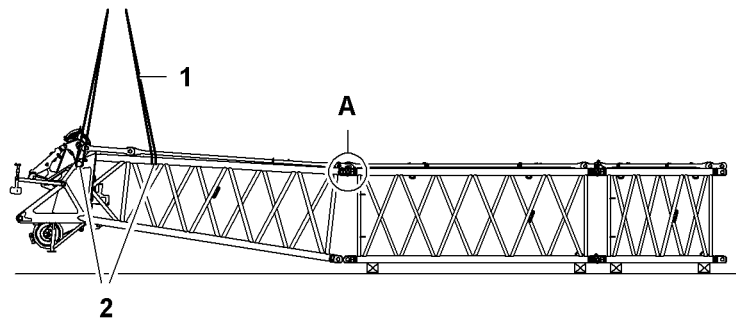


Fig. 3670: Bolting the boom head section to the boom sections at the top

- 1 Round sling (4x)
- 2 Rigging point (4x)
- A Top pin connection point (2x)

- ▶ Attach the boom head section on the lifting points 2.
- ▶ Lift the boom head section to the boom section until the upper pin connection points A match.
- ▶ Bolting the boom head section to the boom sections on the upper pin connection points A.
- ▶ Secure the double-taper pins with washers and safety pins.

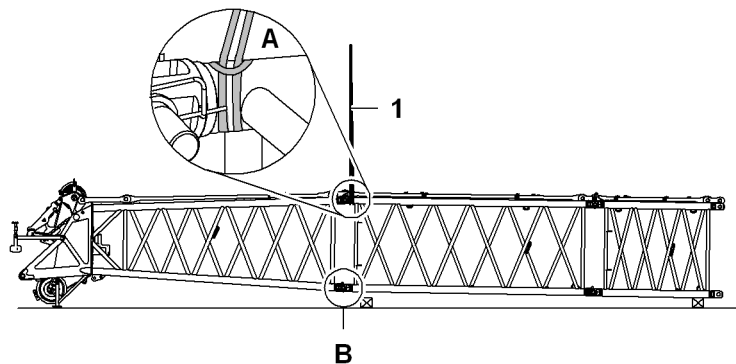


Fig. 3671: Bolting the boom head section to the boom sections at the bottom

- 1 Round sling (2x)
- A Belt pipe (2x)
- B Bottom pin connection point (2x)

- ▶ Attach boom section to chord pipes A.
- ▶ Lift the boom section until the lower pin connection points B match.
- ▶ Bolting the boom head section to the boom sections on the lower pin connection points B.
- ▶ Secure the double-taper pins with washers and safety pins.

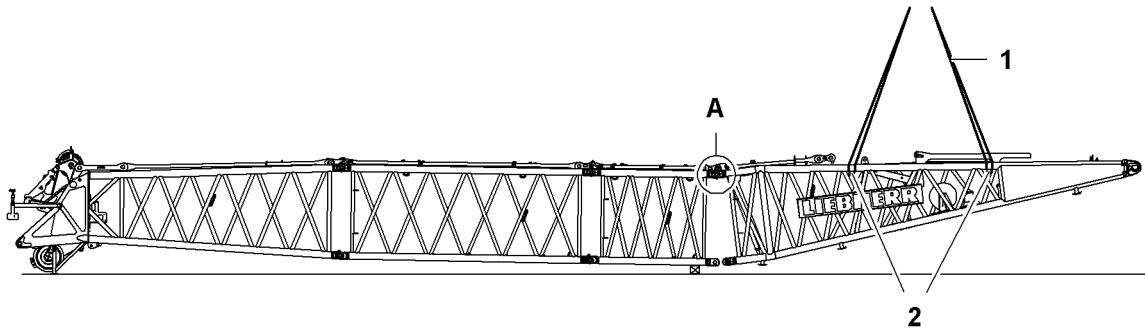


Fig. 3672: Bolting the boom base section to the boom sections at the top

- | | | | | | |
|---|------------------|---|--------------------|---|-------------------------------|
| 1 | Round sling (4x) | 2 | Rigging point (4x) | A | Top pin connection point (2x) |
|---|------------------|---|--------------------|---|-------------------------------|
- ▶ Attach the boom base section on the lifting points 2.
 - ▶ Lift the boom base section to the boom section until the upper pin connection points A match.
 - ▶ Bolting the boom base section to the boom sections on the upper pin connection points A.
 - ▶ Secure the double-taper pins with washers and safety pins.

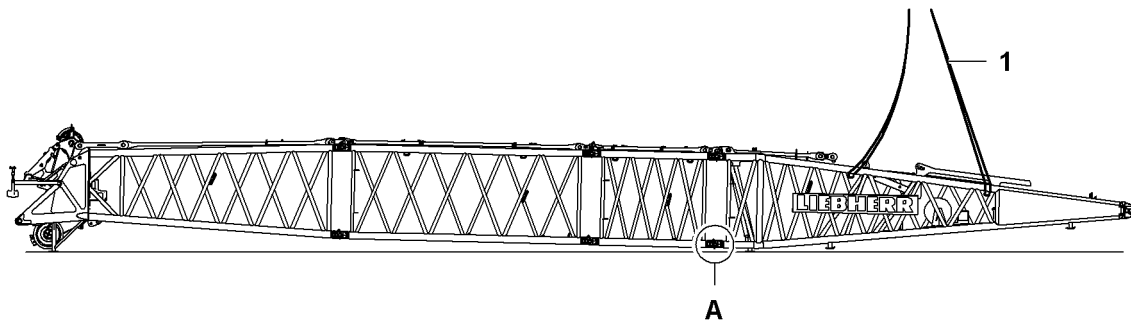


Fig. 3673: Bolting the boom base section to the boom sections at the bottom

- | | | | |
|---|------------------|---|----------------------------------|
| 1 | Round sling (4x) | A | Bottom pin connection point (2x) |
|---|------------------|---|----------------------------------|
- ▶ Lower the boom base section until the lower pin connection points A match.
 - ▶ Bolting the boom base section to the boom sections on the lower pin connection points A.
 - ▶ Secure the double-taper pins with washers and safety pins.

Connecting catwalks* for booms

Make sure the following prerequisites are met:

- Boom components are pinned to each other.

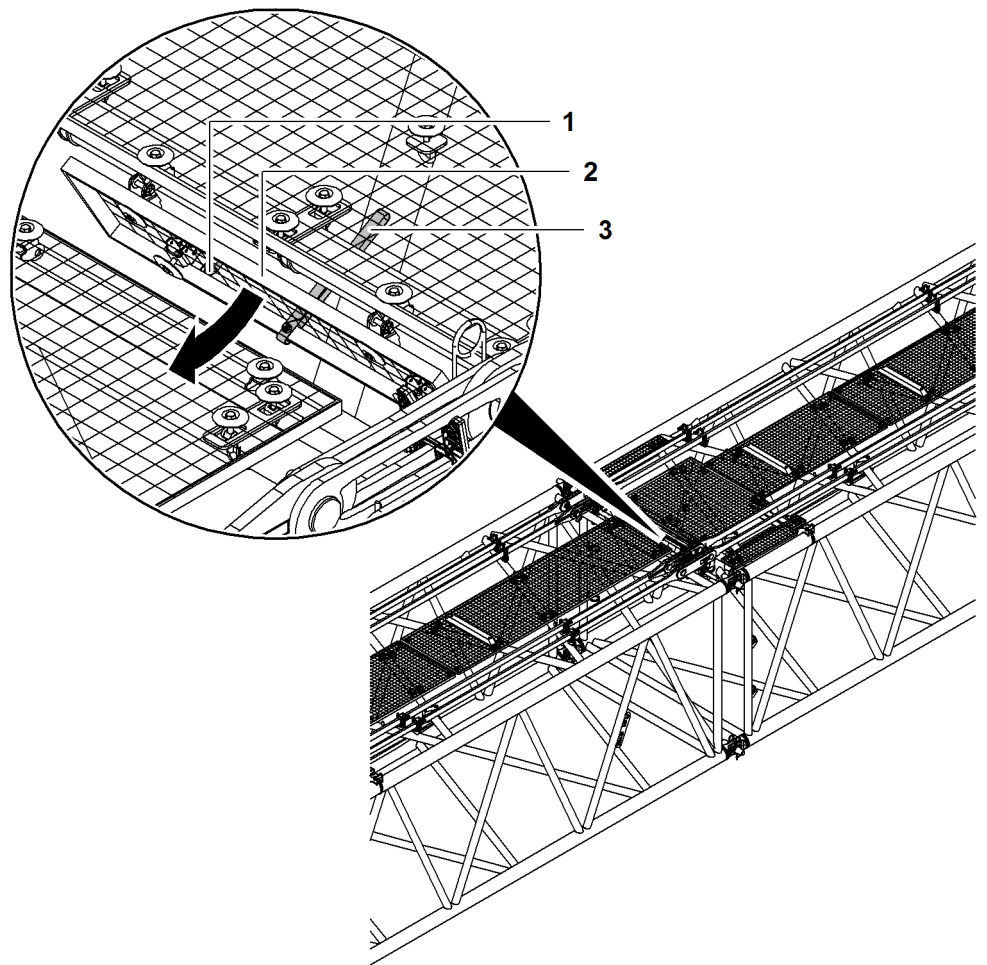


Fig. 3674: Connecting catwalks for booms (illustration of principle)

- | | | | |
|---|---------------------------------|---|---------------|
| 1 | Pin (2x) with spring cotter pin | 3 | Retainer belt |
| 2 | Catwalk (hinged) | | |

- ▶ Open retainer belt 3.
- ▶ Remove pin 1 with spring cotter pin on both sides.
- ▶ Fold up catwalk 2.

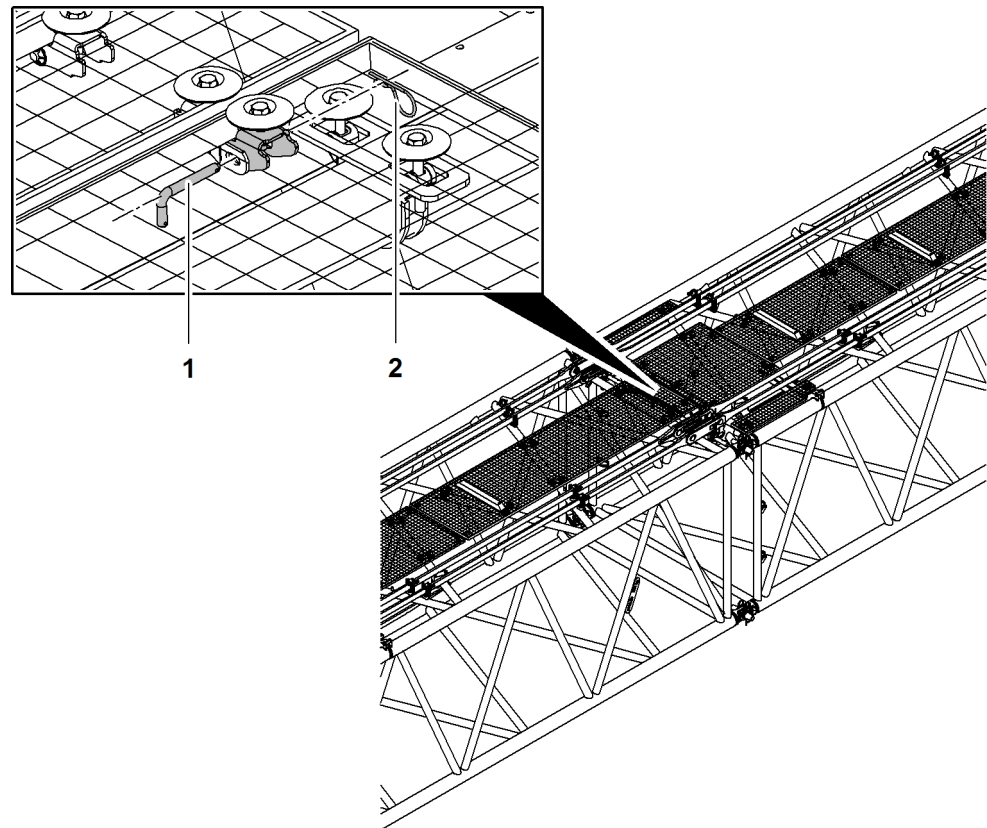


Fig. 3675: Connecting catwalks for booms (illustration of principle)

1 Pin (2x)

2 Spring cotter pin (2x)

When the pin connection points of the catwalks align:

- ▶ Insert pin **1** on both sides.
- ▶ Secure pins **1** with spring cotter pins **2**.
- ▶ Repeat procedure with all boom components.

Connecting and checking boom fall arrest*



WARNING

Improper assembly of the boom fall arrest*!
Risk of falling off the boom.

- ▶ Ensure that the boom fall arrest* is in impeccable condition.
 - ▶ Ensure that the boom fall arrest* is connected and secured between boom sections according to the specifications.
-
- ▶ Connect and check boom fall arrest* in accordance with additional documentation LIE-TAURUS.

fit the rope guide

NOTICE

Incorrect assembly of the rope guide!
Risk of damage to the rope.

- ▶ Fit rope guide according to relevant system instructions.

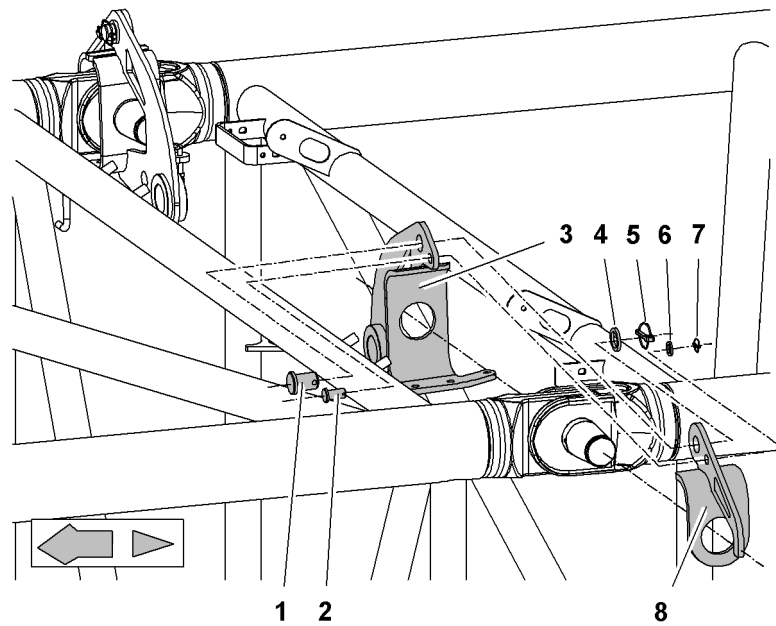


Fig. 3676: Fitting the rope guide forks

1	Pin	5	Linch pin
2	Pin	6	Washer
3	Inner section of fork	7	Linch pin
4	Washer	8	Outer section of fork

- ▶ Remove the safety pins and washers from both sides of the boom pin connection double-taper pin and stow away.
- ▶ Mount the inner and outer sections of the fork **3 + 8** on the double-taper pin.
- ▶ Pin the inner and outer sections of the **3 + 8** fork.
- ▶ Secure pin **1 + 2** with washers **4 + 6** and lynch pins **5 + 7**.

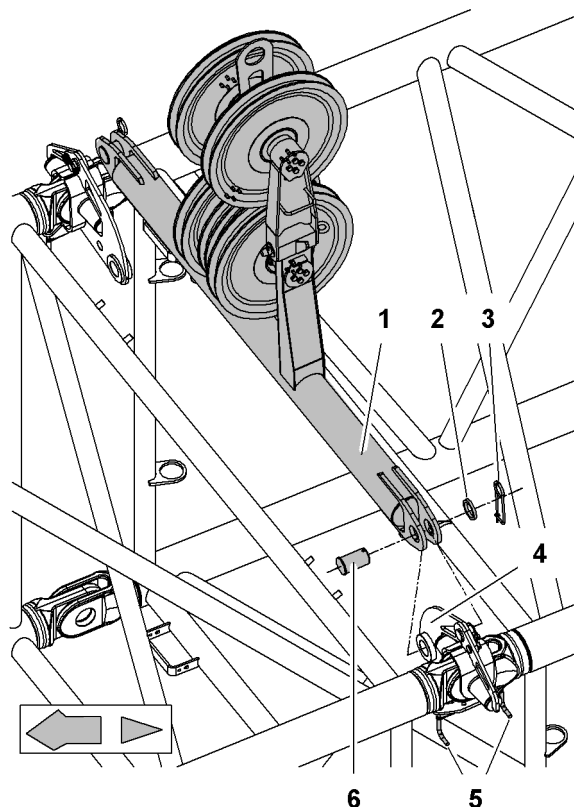


Fig. 3677: Attach rope guide

1	Rope guide	4	Fork
2	Washer	5	Screw (2x)
3	Safety pin	6	Pin

- ▶ Pin rope guide 1 to fork 4.
- ▶ Secure the pin 6 with washer 2 and retaining spring 3.

If the assembly position of the rope guide is identical to the assembly position of the mid-point suspension:

- ▶ pin the ropes on the mid-point suspension to the rope guide forks.
- ▶ Secure the pin with a washer and safety pin.

NOTICE

The screws 5 must not be tightened before the ropes on the mid-point suspension are pinned to the rope guide forks!
Risk of damage to the components.

Once the ropes on the mid-point suspension are pinned to the rope guide forks:

- ▶ tighten screws 5.

- ▶ Use both screws 5 to vertically align the rope guide and manually fix it in place.

Pinning the pendant straps

- ▶ Remove safety pins from the transport brackets for pendant straps.

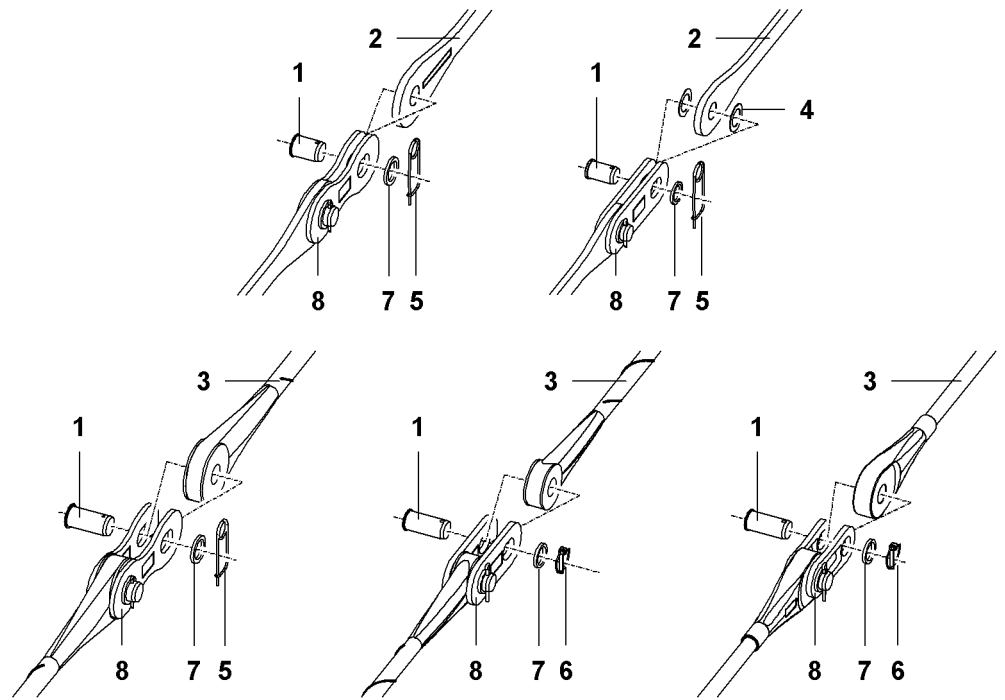


Fig. 3678: Bolt the pendant straps (schematic diagram of various pendant straps)

- | | | | |
|---|----------------------------|---|-----------------|
| 1 | Pin | 5 | Safety pin |
| 2 | Steel pendant strap | 6 | Lynch pin |
| 3 | Carbon-fibre pendant strap | 7 | Washer |
| 4 | Plastic washer (2x) | 8 | Connecting link |

- ▶ Remove the pin 1 on the connecting link 8.
- ▶ Position the pendant strap 2, 3 between the two coupling links 8.
or

If the pendant strap has plastic washers 4:

Position the pendant strap 2 with plastic washers 4 on both sides between the two connecting links 8.

- ▶ Insert pin 1 and secure with washers 7 and safety pin 5 or lynch pin 6.

Removing the jib backstay straps

The jib backstay straps are transported on the boom sections. They can be removed if no jib is mounted.



Note

Higher load with deinstalled jib backstay straps!

- ▶ Refer to the foreword in the valid load capacity chart.

If the jib backstay straps are left on the main boom:

- ▶ Pin the jib backstay straps together and secure with washers and a safety pin.
- ▶ Pin the connecting links on the boom head section to the jib backstay straps and secure with washers and a safety pin.
- ▶ Pin the connecting links on the boom base section to the jib backstay straps and secure with washers and a safety pin.
- ▶ Secure the transport brackets for the jib backstay straps with safety pins.

Installing mid-point suspension

The lengths of the stay ropes and their assembly positions are shown in the relevant instructions for the boom.



Note

Special procedure for installing the mid-point suspension for main boom 2821 with main boom length of 80 m (262' 6" ft-in), 83 m (272' 4" ft-in) or 86 m (282' 2" ft-in) and installed jib 1507!

- ▶ Fit mid-point suspension as instructed.



DANGER

Incorrect installation of mid-point suspensions!
Structural breakdown.

- ▶ Fit mid-point suspensions according to relevant system instructions.
- ▶ Assemble required length of stay ropes in line with system-relevant details.
- ▶ Remove the safety pins and washers from both sides of the boom pin connection double-taper pin and stow away.
- ▶ Repeat procedure on opposite side.

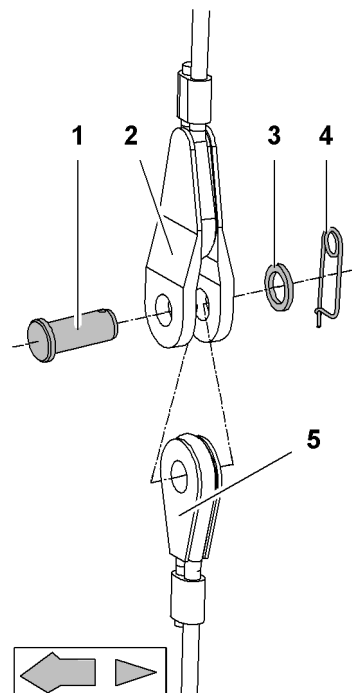


Fig. 3679: Pinning mid-point suspension stay ropes

- | | | | |
|---|---------------|---|------------------|
| 1 | Pin | 4 | Safety pin |
| 2 | Top stay rope | 5 | Bottom stay rope |
| 3 | Washer | | |

- ▶ Pin top stay rope 2 to bottom stay rope 5.
- ▶ Secure the pin 1 with washer 3 and retaining spring 4.

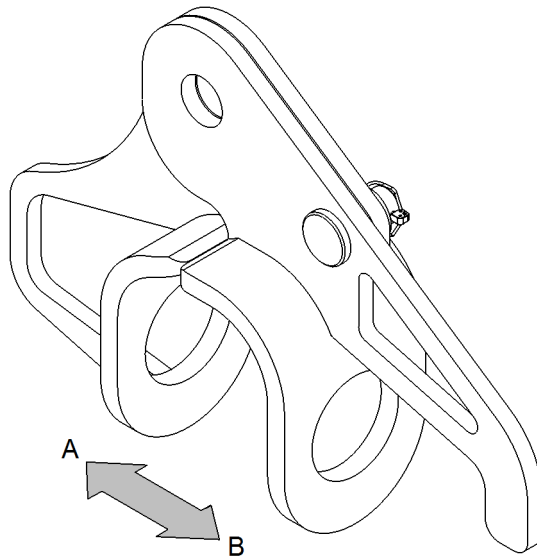


Fig. 3680: Mid-point suspension forks

A Main boom interior

B Main boom exterior

The forks may have different shapes. The permissible shape depends on the boom configuration (For more information see: 1 Product description, page 51) .

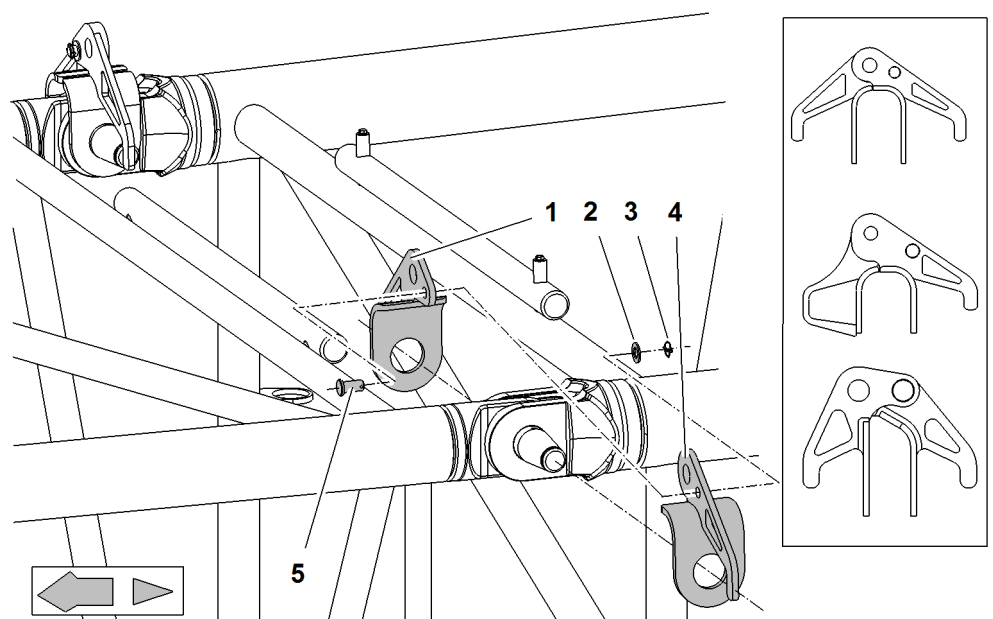


Fig. 3681: Assembling the mid-point suspension forks

1 Inner section of fork

4 Outer section of fork

2 Washer

5 Pin

3 Linch pin



Note

Special assembly procedure when the mid-point suspension and rope guide are installed in exactly the same position on the main boom!

► The rope guide forks replace the mid-point suspension forks.

► Mount inner section of fork 1 on double-taper pin.

- ▶ Mount outer section of fork **4** on double-taper pin.
- ▶ Pin inner section of fork **1** to outer section of fork **4**.
- ▶ Secure pin **5** with a washer **2** and linch pin **3**.
- ▶ Repeat procedure on opposite side.

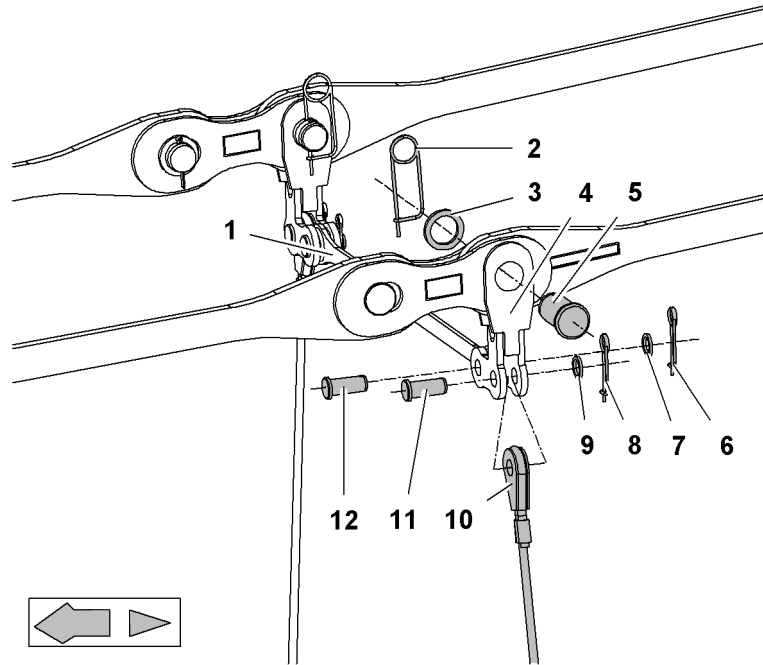


Fig. 3682: Installing the pendant straps, spacer bracket, connecting elements and mid-point suspension stay ropes

1	Spacer bracket	7	Washer
2	Safety pin	8	Safety pin
3	Washer	9	Washer
4	Connecting element	10	Stay rope
5	Pins for pendant strap	11	Pin for stay rope
6	Safety pin	12	Pin for spacer bracket

- ▶ Pin connecting element **4** to pendant strap.
- ▶ Secure the pin **5** with washer **3** and retaining spring **2**.
- ▶ Pin connecting element **4** to spacer bracket **1**.
- ▶ Secure the pin **12** with washer **7** and retaining spring **6**.
- ▶ Pin connecting element **4** to stay rope **10**.
- ▶ Secure the pin **11** with washer **9** and retaining spring **8**.
- ▶ Repeat procedure on opposite side.

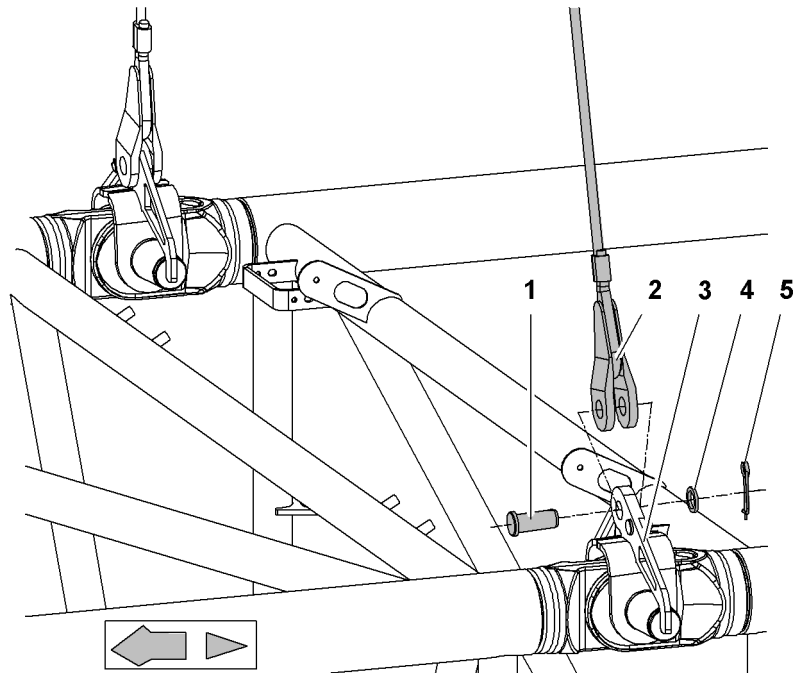


Fig. 3683: Pinning stay ropes to forks of mid-point suspension

- | | | | |
|---|-----------|---|------------|
| 1 | Pin | 4 | Washer |
| 2 | Stay rope | 5 | Safety pin |
| 3 | Fork | | |

- ▶ Pin stay rope 2 to fork 3.
- ▶ Secure the pin 1 with washer 4 and retaining spring 5.
- ▶ Repeat procedure on opposite side.

Installing mid-point suspension (with main boom length 80 m (262 ft), 83 m (272 ft) and 86 m (282 ft) and jib 1507 attached)

With a main boom length of 80 m (262 ft), 83 m (272 ft) and 86 m (282 ft) and 1507 fixed jib attached, installation of the mid-point suspension represents a special case.



DANGER

Incorrect installation of mid-point suspensions!
Structural failure.

- ▶ Fit mid-point suspensions according to relevant system instructions.

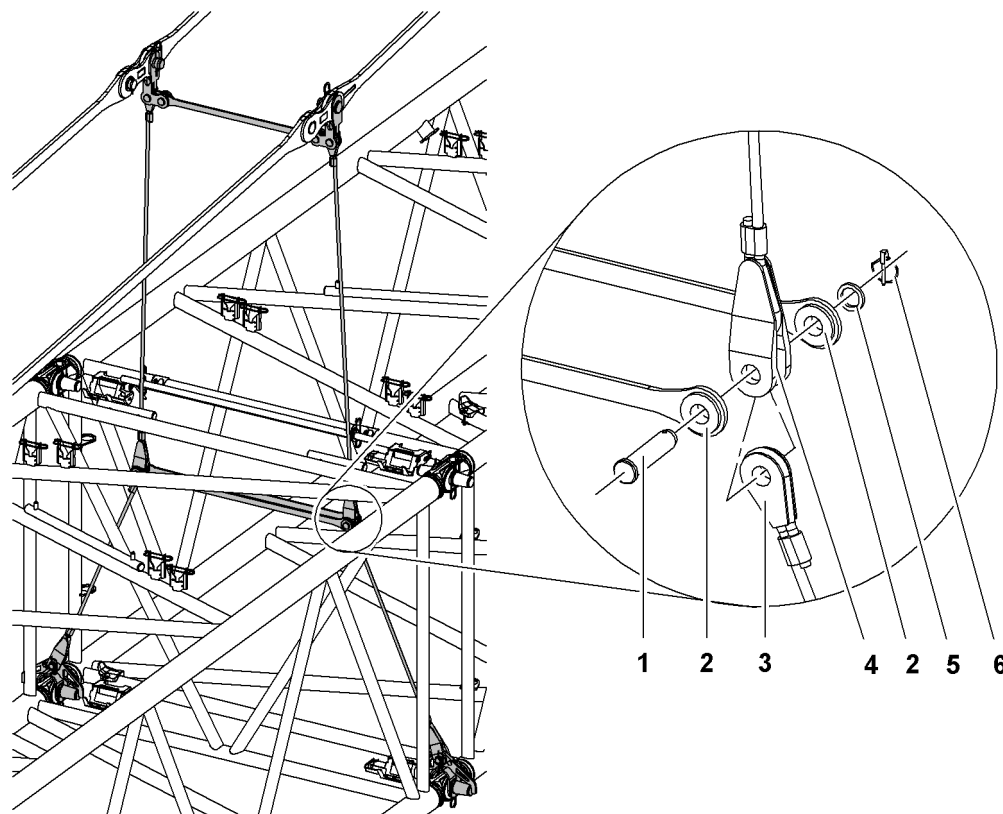


Fig. 3684: Pinning stay ropes to spacer brackets

- | | | | |
|---|------------------------|---|---------------|
| 1 | Pin for spacer bracket | 4 | Top stay rope |
| 2 | Spacer bracket (2x) | 5 | Washer |
| 3 | Bottom stay rope | 6 | Linch pin |

- ▶ Pin mid-point suspensions to pendant straps (For more information see: [7.6.11 Installing mid-point suspension, page 1301](#)) (For more information see: [Installing mid-point suspension, page 1416](#)) .
- ▶ Pin top stay rope 4 and bottom stay rope 3 to spacer bracket 2.
- ▶ Secure pin 1 with a washer 5 and lynch pin 6.
- ▶ Repeat procedure on opposite side.
- ▶ Pin mid-point suspension with boom section (For more information see: [7.6.11 Installing mid-point suspension, page 1301](#)) (For more information see: [Installing mid-point suspension, page 1416](#)) .

Connect the electric cables

NOTICE

Electric cables have been handled incorrectly!
Damage to electric cable and plug.

- ▶ Do not pull the electric cable over sharp-edged objects.
- ▶ Do not crush or kink the electric cable.
- ▶ Keep the plug clean.

- ▶ Disconnect both electric cables from the terminal box on the boom base section.

NOTICE

Electric cable has been unwound incorrectly!
Electric cable may be damaged.

- ▶ Push the electric cable in the cable drum into the side opening of the cable drum.
-
- ▶ Loosen the pin on the axle of the cable drum.
 - ▶ Unwind the electric cable from the cable drum and pull it inside the main boom to the boom head section.
 - ▶ Connect the electric cable to the terminal box on the boom head section and secure using retaining clips.

Two fixing holes are provided under the terminal box to relieve the strain on the plug.

- ▶ Clip both carabiners on the cable sock into the fixing holes.
- ▶ Fix the pin on the axle of the cable drum.
- ▶ Reconnect the electric cable in the cable drum to the terminal box on the boom base section.
 - ▷ The boom base section and boom head section electric cables are connected.

If an auxiliary jib is fitted:

- ▶ Plug the auxiliary jib electric cable into the boom head section.

Installing the obstacle warning light



Note

Use of the obstacle warning light is prescribed by national or regional regulations!

- ▶ Before using the machine, familiarise yourself with national and local regulations.

Ensure that the following conditions are fulfilled:

- Anemometer is not installed.

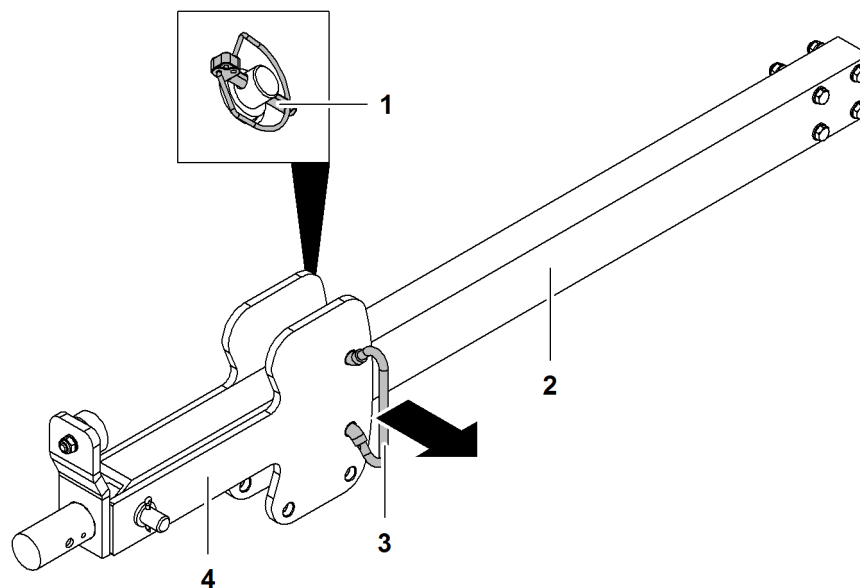


Fig. 3685: Moving the pendulum into the working position

- | | | | |
|---|----------------|---|-----------------|
| 1 | Linchpins (2x) | 3 | Locking element |
| 2 | Mount | 4 | Pendulum |

The pendulum 4 is secured on the mount 2 for machine transport.

- ▶ Remove the linchpin 1 of the locking element 3.
- ▶ Remove 3 locking element.
- ▶ Swing pendulum 4 down.
- ▶ Slide locking element 3 through pendulum 4 and secure with linchpins 1.

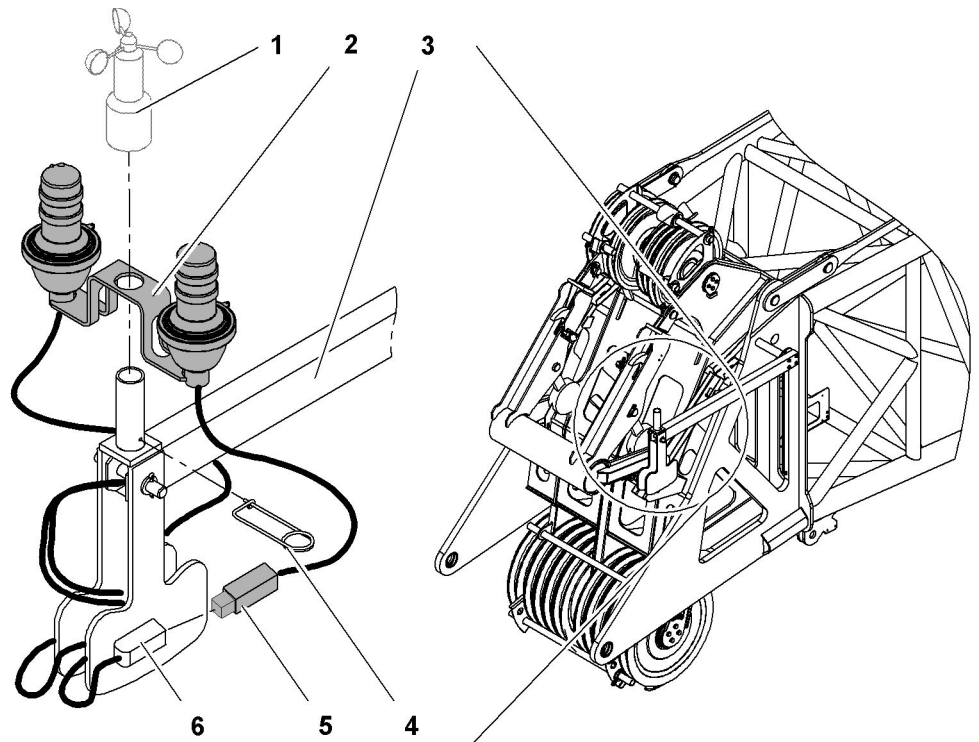


Fig. 3686: Installing the obstacle warning light

- | | | | |
|---|------------------------|---|------------|
| 1 | Anemometer | 4 | Safety pin |
| 2 | Obstacle warning light | 5 | Plug |
| 3 | Mount | 6 | Coupling |

- ▶ Place obstacle warning light 2 on pipe.
 - ▷ Obstacle warning light is secured by the pipe and axis on the bracket 3.

NOTICE

Safety pin is not fit properly!
Damage to the electric cable.

- ▶ Insert the safety pin carefully.
-
- ▶ Insert the safety pin 4.
 - ▷ Obstacle warning light 2 is secured.
 - ▶ Connect the plug 5 to the coupling 6.
 - ▶ Lock plug 5.

Fitting the anemometer

Ensure that the following conditions are fulfilled:

- Obstacle warning light is installed (if available).

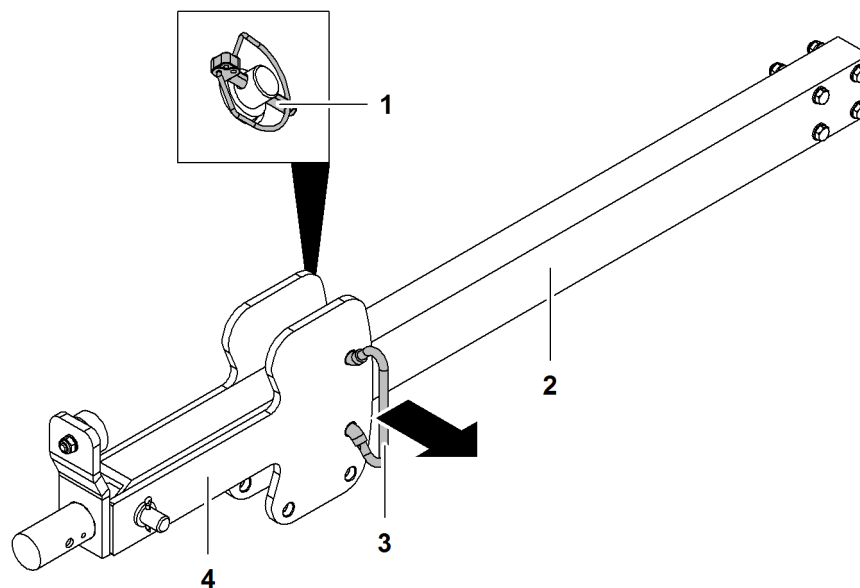


Fig. 3687: Moving the pendulum into the working position

- | | | | |
|---|----------------|---|-----------------|
| 1 | Linchpins (2x) | 3 | Locking element |
| 2 | Mount | 4 | Pendulum |

The pendulum 4 is secured on the mount 2 for machine transport.

- ▶ Remove the linchpin 1 of the locking element 3.
- ▶ Remove 3 locking element.
- ▶ Swing pendulum 4 down.
- ▶ Slide locking element 3 through pendulum 4 and secure with linchpins 1.

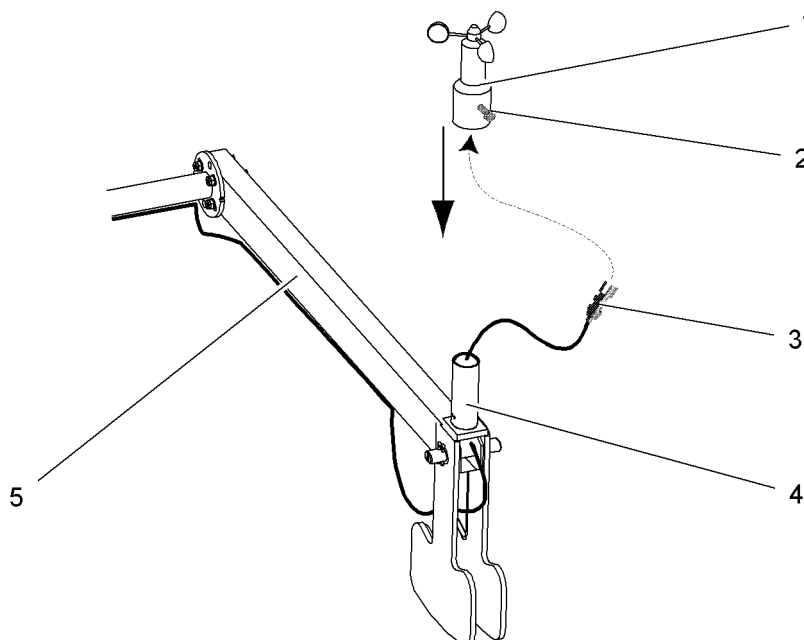


Fig. 3688: Fitting the anemometer

- | | | | |
|---|------------|---|-------|
| 1 | Anemometer | 4 | Tube |
| 2 | Screw | 5 | Mount |
| 3 | Plug | | |

- ▶ Remove cover from the plug 3.
- ▶ Plug in the connector 3 at the bottom of the anemometer 1.
- ▶ Secure plug 3 with nut.

NOTICE

Anemometer is not fit properly!
Damage to the electric cable.

- ▶ Pull the extended electric cable through the tube before pushing on the anemometer.

- ▶ Position the anemometer 1 on the tube 4.
- ▶ Securing the anemometer on the mount: Tighten the screw 2.

The rotor of the anemometer must be free to rotate slightly.

- ▶ Test the anemometer: rotate the rotor slightly and note the value on the monitor.
 - ▷ The wind speed value will increase.

Moving the lightning rods* into working position

Installation of lightning rods* on main boom head with derrick boom head

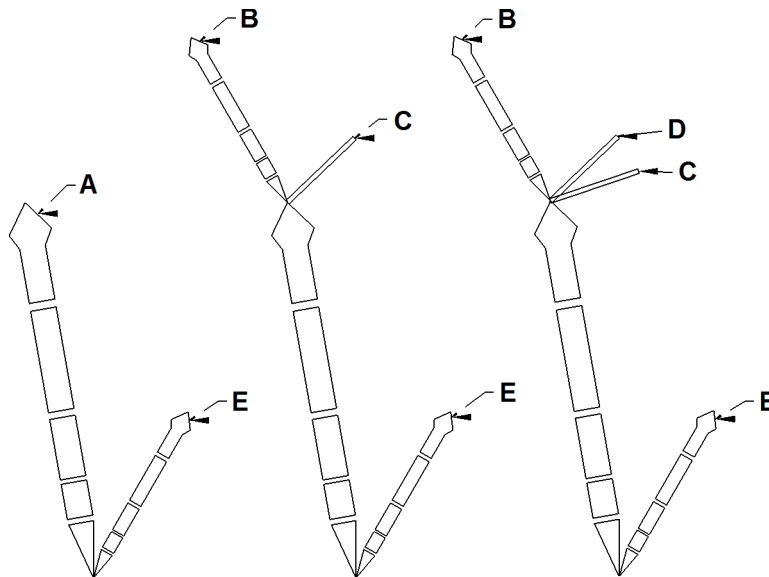


Fig. 3689: Installation of lightning rods* on main boom head with derrick boom head

- | | |
|-------------------------|----------------------------|
| A Main boom head | D A-frame3 |
| B Jib head | E Derrick boom head |
| C A-frame2 | |

Boom configuration	Number of lightning rods	Installation positions
Main boom + derrick	2	A + E
Main boom + fixed jib + derrick	3	B + C + E

LWNLR.x/V04.01//Auslieferung/2016-03-07/en

Boom configuration	Number of lightning rods	Installation positions
Main boom + luffing jib + derrick	4	B + C + D + E

Tab. 520: Installation and number of lightning rods* on main boom head with derrick boom head

Moving the lightning rods* on the main boom head into working position

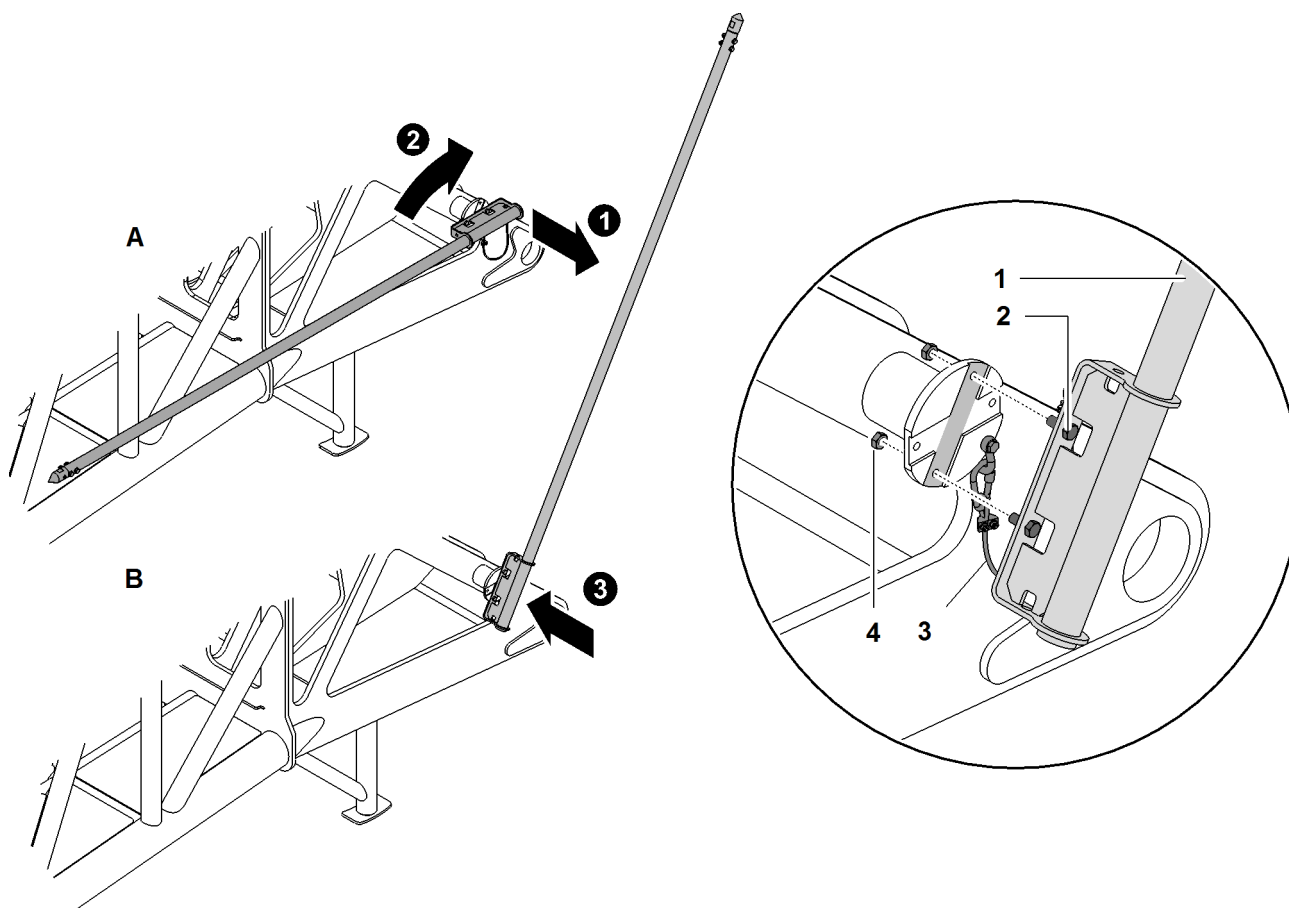


Fig. 3690: Moving the lightning rods* on the main boom head into working position (illustration of principle)

A Transport position
B Working position

1 Lightning rod
2 Screw (2x)

3 Safety rope
4 Nut (2x)

- ▶ Undo safety rope **3**.
- ▶ Undo nuts **4**.
- ▶ Undo screws **2**.
- ▶ Move lightning rod **1** from transport position **A** to working position **B**.



Note

Liebherr recommends:

- ▶ Grease threads of the screws **2**.
- ▶ Attach lightning rod **1** with screws **2**.

- ▶ Lock screws **2** with nuts **4**.

NOTICE

Safety rope not attached!
Dropping parts.

- ▶ Ensure that safety rope **3** is attached.

- ▶ Attach safety rope **3**.

NOTICE

Tip not installed!
Improperly deflected current.
Dropping parts.

- ▶ Ensure that the tip on the lightning rod **1** is installed.
- ▶ Ensure that the screws of the tip are tightened.

- ▶ Ensure that the tip on the lightning rod **1** is installed.
- ▶ Ensure that the screws of the tip are tightened.

Moving the lightning rods* on A-frame2 into working position

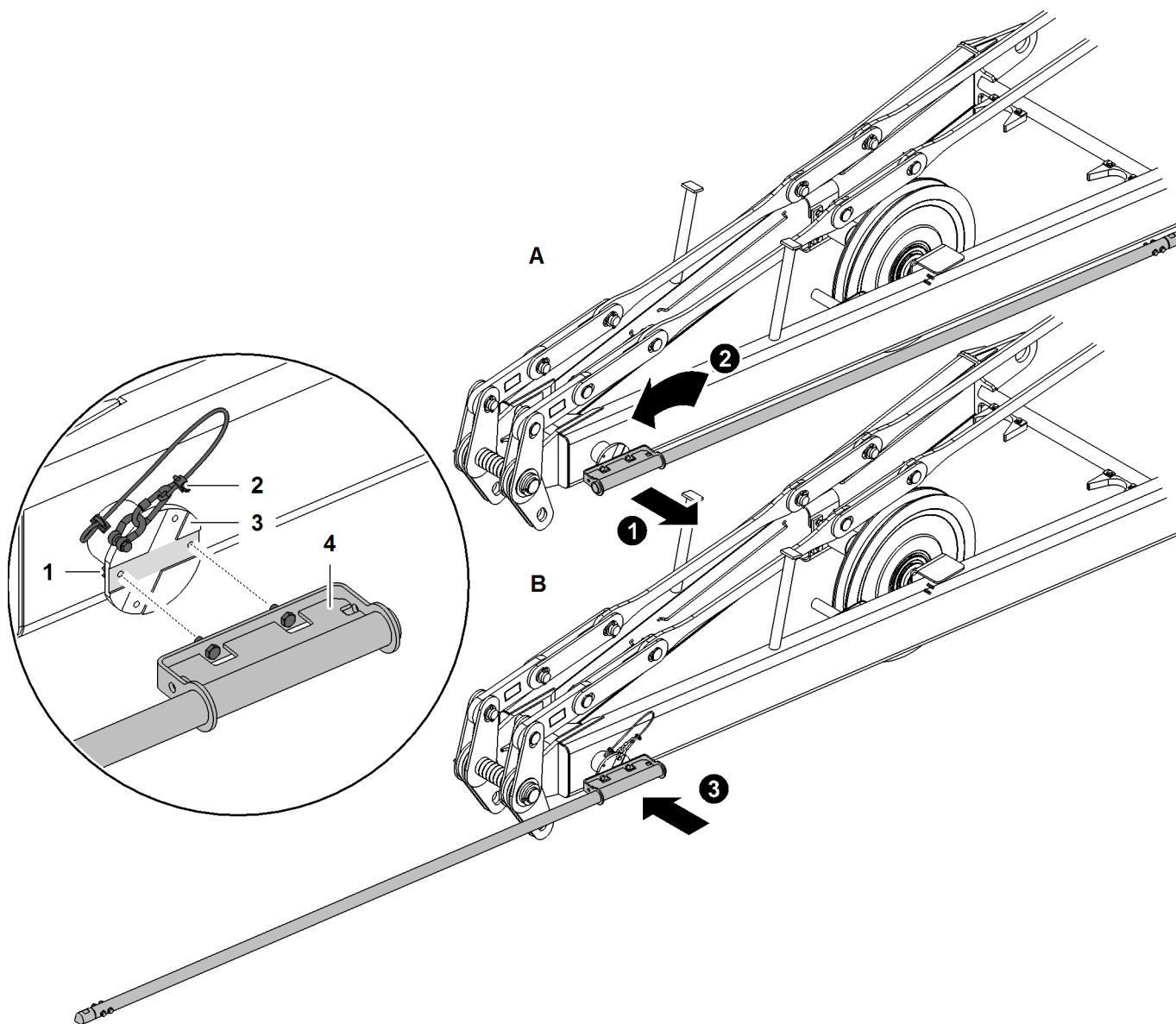


Fig. 3691: Moving the lightning rods* on A-frame2 into working position (illustration of principle)

A	Transport position	1	Nut (2x)	3	Screw (2x)
B	Working position	2	Safety rope	4	Lightning rod

- ▶ Undo safety rope **2**.
- ▶ Undo nuts **1**.
- ▶ Undo screws **3**.
- ▶ Move lightning rod **4** from transport position **A** to working position **B**.



Note

Liebherr recommends:

- ▶ Grease threads of the screws **3**.
- ▶ Attach lightning rod **4** with screws **3**.
- ▶ Lock screws **3** with nuts **1**.

NOTICE

Safety rope not attached!
Dropping parts.

- ▶ Ensure that safety rope **2** is attached.

- ▶ Attach safety rope **2**.

NOTICE

Tip not installed!
Improperly deflected current.
Dropping parts.

- ▶ Ensure that the tip on the lightning rod **4** is installed.

- ▶ Ensure that the screws of the tip are tightened.

- ▶ Ensure that the tip on the lightning rod **4** is installed.

- ▶ Ensure that the screws of the tip are tightened.

Moving the lightning rods* on A-frame2 and A-frame3 into working position

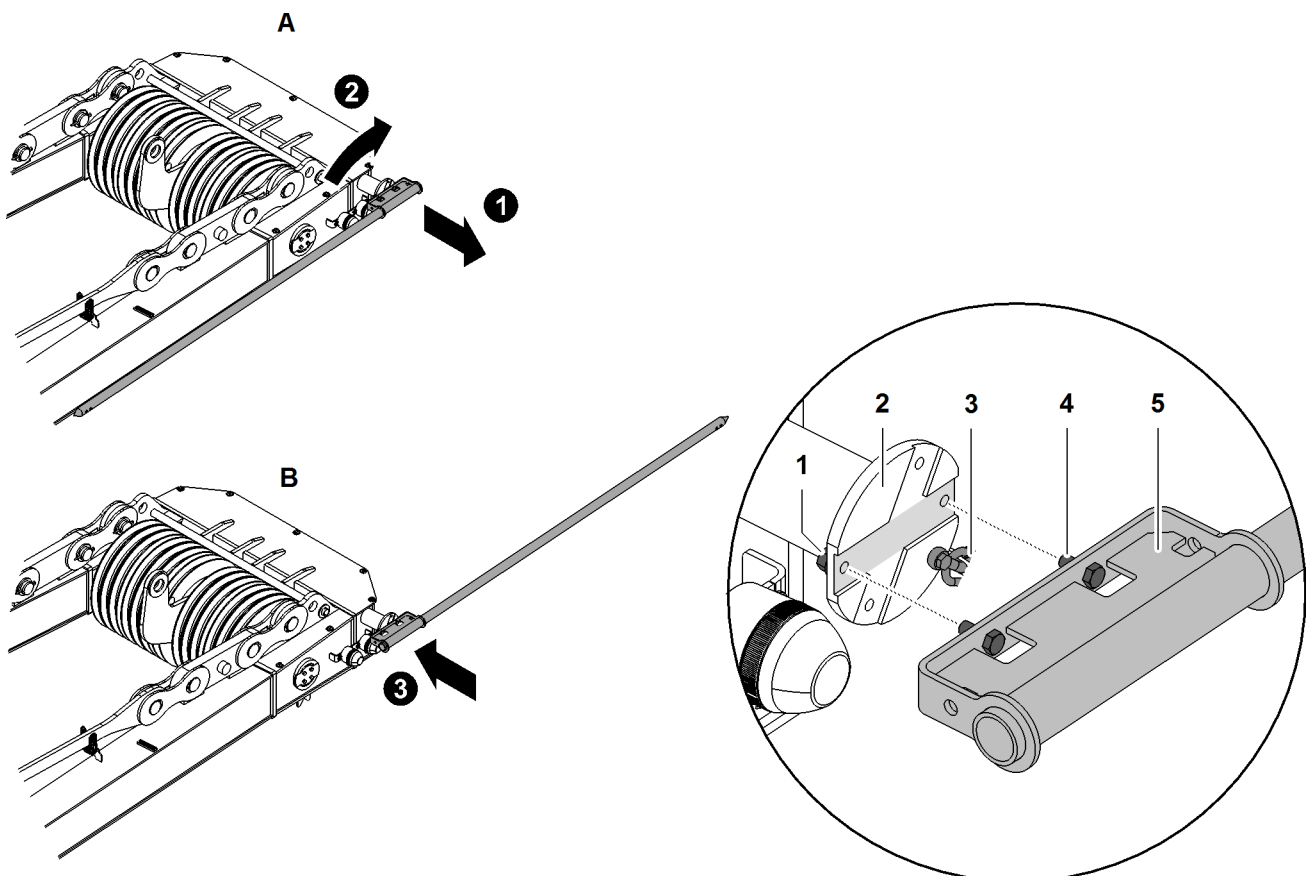


Fig. 3692: Moving the lightning rods* on A-frame2 and A-frame3 into working position (illustration of principle)

- | | | |
|-----------------------------|-------------------------|------------------------|
| A Transport position | 2 Mounting plate | 5 Lightning rod |
| B Working position | 3 Safety rope | |
| 1 Nut (2x) | 4 Screw (2x) | |

- ▶ Undo safety rope **3**.

LWNLR.x/V04.01//Auslieferung/2016-03-07/en

- ▶ Undo nuts **1**.
- ▶ Undo screws **4**.
- ▶ Move lightning rod **5** from transport position **A** to working position **B**.



Note

Liebherr recommends:

- ▶ Grease threads of the screws **4**.
-
- ▶ Attach lightning rod **5** with screws **4**.
 - ▶ Lock screws **4** with nuts **1**.

NOTICE

Safety rope not attached!

Dropping parts.

- ▶ Ensure that safety rope **3** is attached.
-
- ▶ Attach safety rope **3**.

NOTICE

Tip not installed!

Improperly deflected current.

Dropping parts.

- ▶ Ensure that the tip on the lightning rod **5** is installed.
 - ▶ Ensure that the screws of the tip are tightened.
-
- ▶ Ensure that the tip on the lightning rod **5** is installed.
 - ▶ Ensure that the screws of the tip are tightened.

Moving the lightning rods* on the fixed jib head into working position

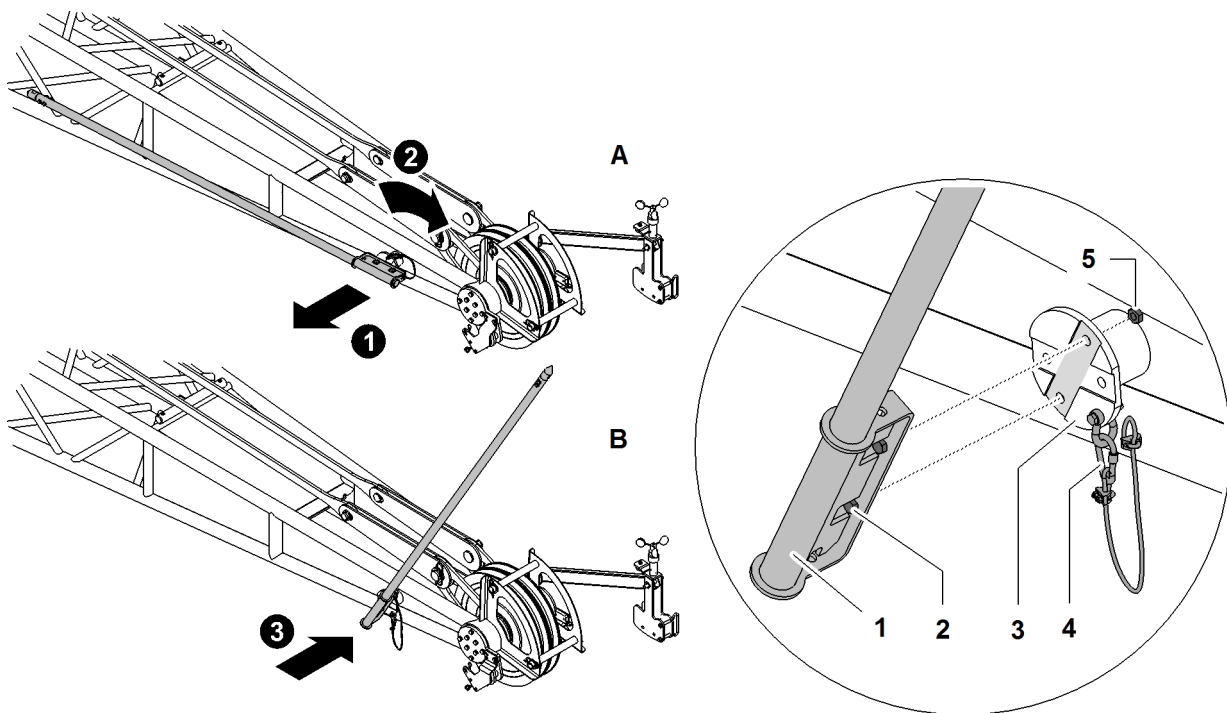


Fig. 3693: Moving the lightning rods* on the fixed jib head into working position (illustration of principle)

- | | | | | | |
|----------|--------------------|----------|----------------|----------|----------|
| A | Transport position | 2 | Screw (2x) | 5 | Nut (2x) |
| B | Working position | 3 | Mounting plate | | |
| 1 | Lightning rod | 4 | Safety rope | | |

- ▶ Undo safety rope 4.
- ▶ Undo nuts 5.
- ▶ Undo screws 2.
- ▶ Move lightning rod 1 from transport position A to working position B.



Note

Liebherr recommends:

- ▶ Grease threads of the screws 2.
- ▶ Attach lightning rod 1 with screws 2.
- ▶ Lock screws 2 with nuts 5.

NOTICE

Safety rope not attached!
Dropping parts.

- ▶ Ensure that safety rope 4 is attached.
- ▶ Attach safety rope 4.

NOTICE

Tip not installed!
Improperly deflected current.
Dropping parts.

- ▶ Ensure that the tip on the lightning rod **1** is installed.
- ▶ Ensure that the screws of the tip are tightened.

- ▶ Ensure that the tip on the lightning rod **1** is installed.
- ▶ Ensure that the screws of the tip are tightened.

Moving the lightning rods* on the luffing jib head into working position

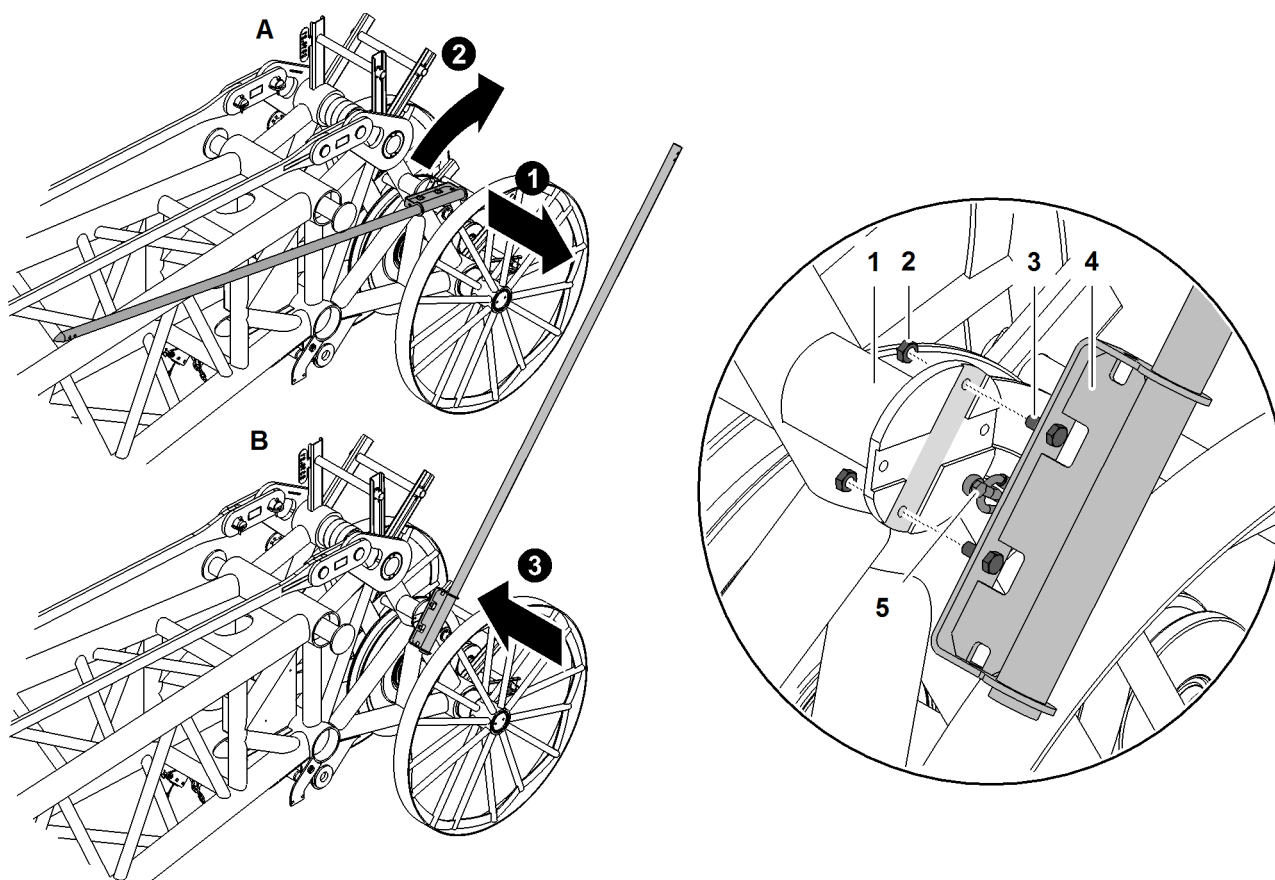


Fig. 3694: Moving the lightning rods* on the luffing jib head into working position (illustration of principle)

- A** Transport position
- B** Working position
- 1** Mounting plate

- 2** Nut (2x)
- 3** Screw (2x)
- 4** Lightning rod

- 5** Safety rope

- ▶ Undo safety rope **5**.
- ▶ Undo nuts **2**.
- ▶ Undo screws **3**.
- ▶ Move lightning rod **4** from transport position **A** to working position **B**.



Note

Liebherr recommends:

- ▶ Grease threads of the screws **3**.
- ▶ Attach lightning rod **4** with screws **3**.
- ▶ Lock screws **3** with nuts **2**.

NOTICE

Safety rope not attached!
Dropping parts.

- ▶ Ensure that safety rope **5** is attached.
- ▶ Attach safety rope **5**.

NOTICE

Tip not installed!
Improperly deflected current.
Dropping parts.

- ▶ Ensure that the tip on the lightning rod **4** is installed.
- ▶ Ensure that the screws of the tip are tightened.
- ▶ Ensure that the tip on the lightning rod **4** is installed.
- ▶ Ensure that the screws of the tip are tightened.

Rigging the main boom on derrick rope rigging

The main boom is lifted and then bolted with the help of the derrick boom and derrick pulley block.



Note

If the jib has been attached using the self-assembly system:

- ▶ Assemble the fixed jib and attach it to the main boom before installing the main boom base section.
- ▶ Assemble the luffing jib prior to installing the main boom base section and install jib base section on main boom.



Note

Liebherr recommends:

- ▶ Even if an assist crane is available, assembly of the main boom with the derrick boom is preferable.

Ensure that the following conditions are fulfilled:

- Main boom is fully assembled and ready.
- Basic machine is standing aligned precisely in front of the main boom.
- Sling gear with a load-bearing capacity of at least 16 t (35,273 lb) is available.
- ▶ Unwind the derrick winch.
 - ▷ Derrick pulley block is lowered.



DANGER

Wrong rigging points when rigging main boom!
Derrick boom tips backwards when it is mounted.

- ▶ Rig the main boom as illustrated to belt pipes of the main boom sections.
- ▶ Only lift main boom sections on both sides at the rigging points.

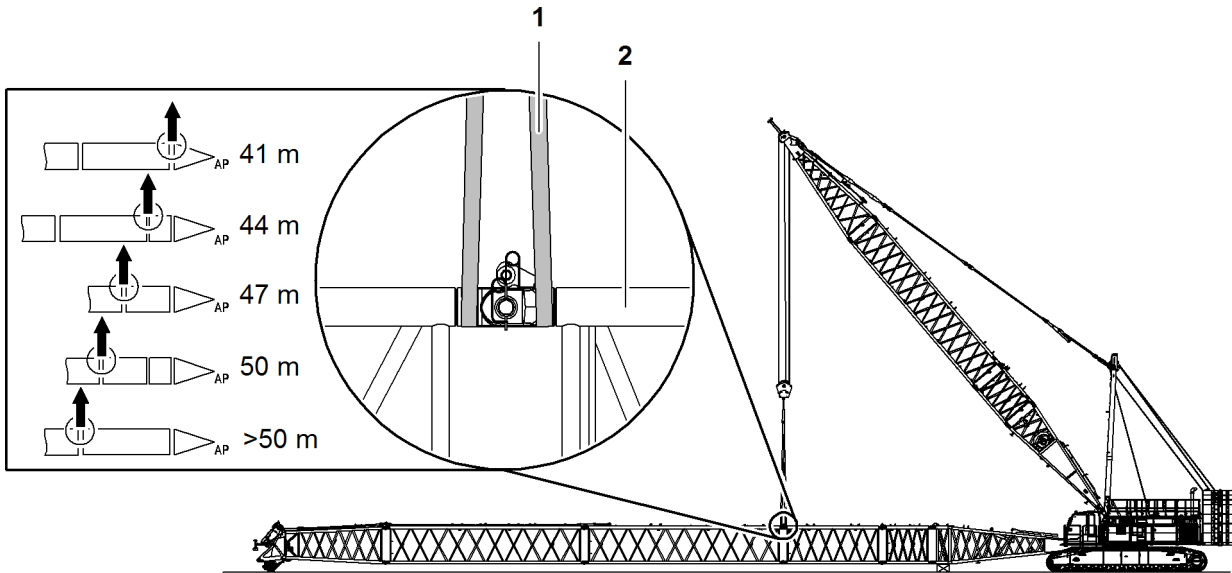


Fig. 3695: Rigging the main boom on derrick rope rigging

- 1 Sling gear
- 2 Top belt pipe of the main boom section

- ▶ Place sling gear 1 on both sides around top belt pipe 2 of main boom section.

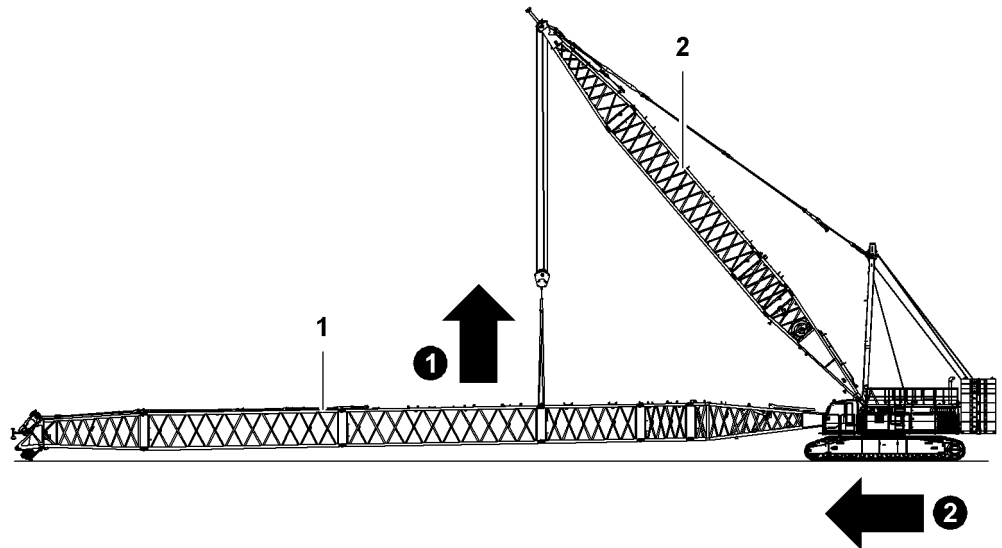


Fig. 3696: Lift main boom with derrick rope rigging

- 1 Main boom
- 2 Derrick boom

- ▶ Wind up the derrick winch.
 - ▷ Main boom 1 lifts.
- ▶ Move machine forward until main boom 1 is located in front of the uppercarriage pivot points.

LWNLR-x\04.01\Auslieferung\2016-03-07/en

Attaching the boom base section to the uppercarriage



WARNING

Machine swings with a suspended load!
Crush, fatal injury.

- ▶ Make sure that no-one is standing in the danger area.
- ▶ Leave the danger area.

Ensure that the following conditions are fulfilled:

Cylinder adjustment functions are switched on.

- ▶ Open the front right uppercarriage door.
- ▶ Plug in the cable remote control on the uppercarriage.

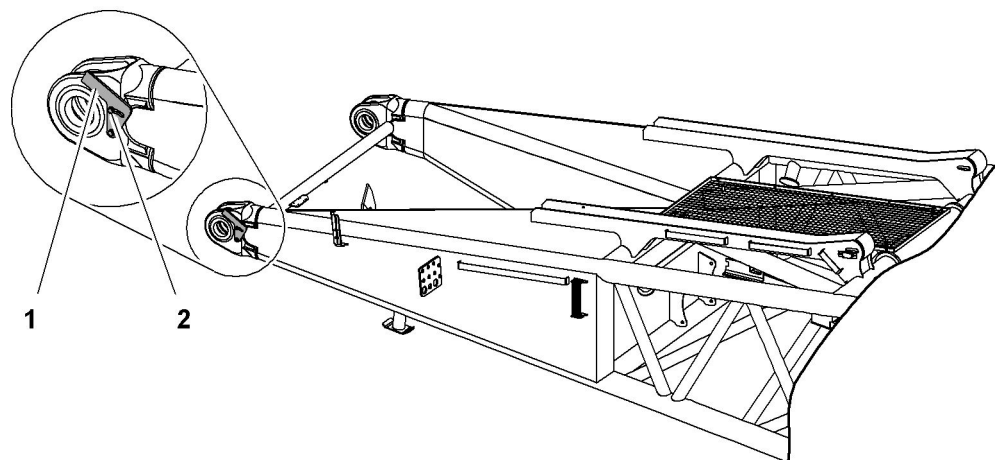


Fig. 3697: Fold up locking elements

1 Locking element (2x)

2 Screw (2x)

- ▶ Undo screws **2**.
- ▶ Fold up locking elements **1**.

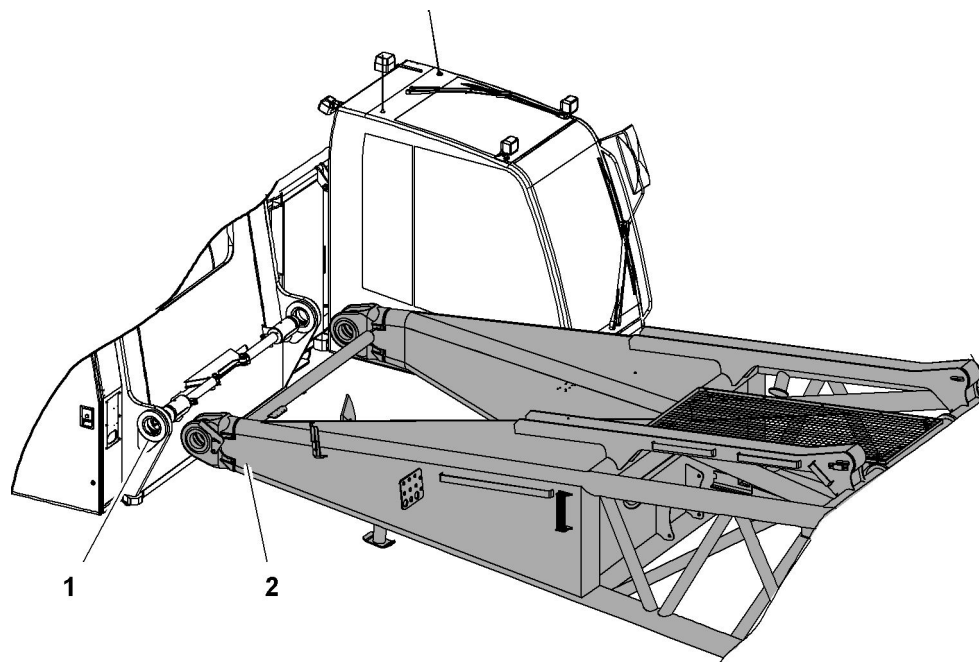


Fig. 3698: Positioning the main boom

1 Pivot point (2x)

2 Main boom

NOTICE

Main boom 2 swings!
Damage to cab.

► Ensure that an assistant guides the main boom 2 during installation.

► Align main boom 2 with pivot points 1 of uppercarriage.

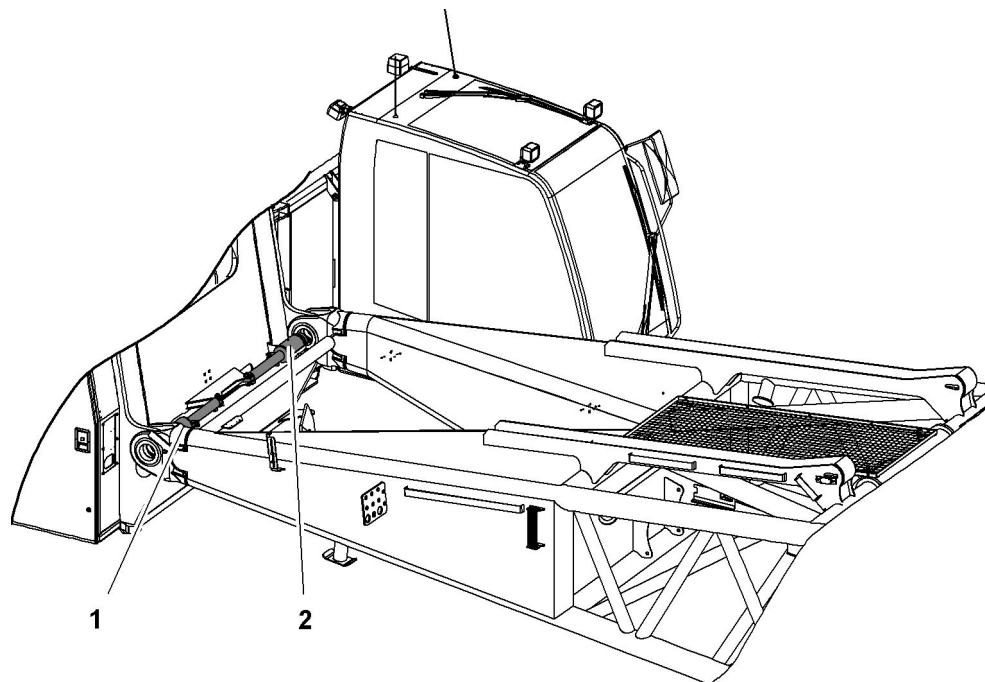


Fig. 3699: Extending the pin connection cylinder

1 Right-hand pin connection cylinder

2 Left-hand pin connection cylinder



CAUTION

Moving parts!
Crushing.

- ▶ Keep all limbs well clear of moving parts.

NOTICE

Incorrect procedure during bolting!
Pin connection cylinder and pin connection points may be damaged.

- ▶ Only extend pin connection cylinder when pin connection points of main boom and uppercarriage are aligned.

If pin connection points of main boom are aligned with the pin connection points of the uppercarriage:

- ▶ Extend left pin connection cylinder **2** with cable remote control.
- ▶ Extend right pin connection cylinder **1** with cable remote control.

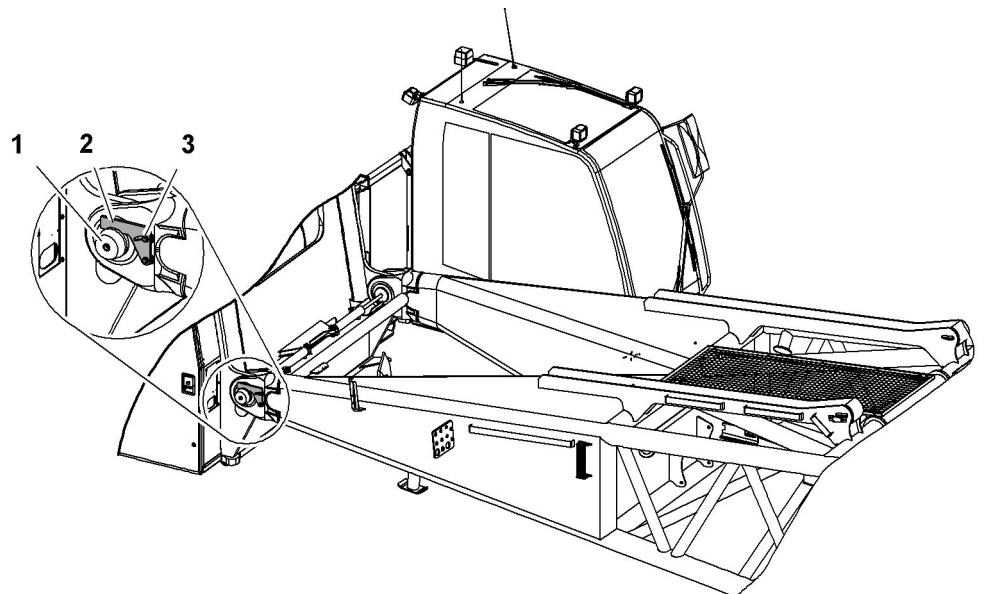


Fig. 3700: Secure pins with locking elements

- | | | | |
|----------|----------------------|----------|------------|
| 1 | Pin (2x) | 3 | Screw (2x) |
| 2 | Locking element (2x) | | |

- ▶ Fold locking element **2** into pin **1** notch.
- ▶ Securing the locking elements **2**: tighten screws **3**.
- ▶ Detach sling gear.
- ▶ Remove sling gear from derrick rope rigging and stow away.
- ▶ Remove cable remote control on basic machine and stow it away.
- ▶ Close the front right uppercarriage door.

Connecting hydraulic lines to the uppercarriage

Ensure that the following conditions are fulfilled:

- Hand lever for the multi-coupling is available.
- Diesel engine is switched off.

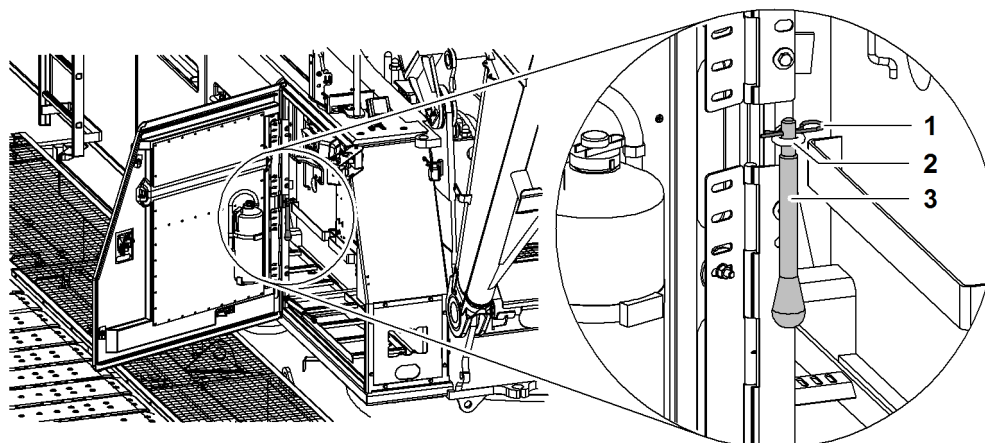


Fig. 3701: Transport mount for hand lever of multi-coupling

- | | | | |
|---|----------------|---|------------|
| 1 | Locking spring | 3 | Hand lever |
| 2 | Ring | | |

- ▶ Lift hand lever **3** and remove locking spring **1**.
- ▶ Remove hand lever **3** downwards from ring **2**.

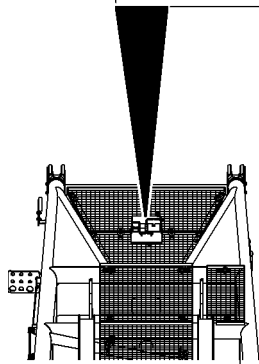
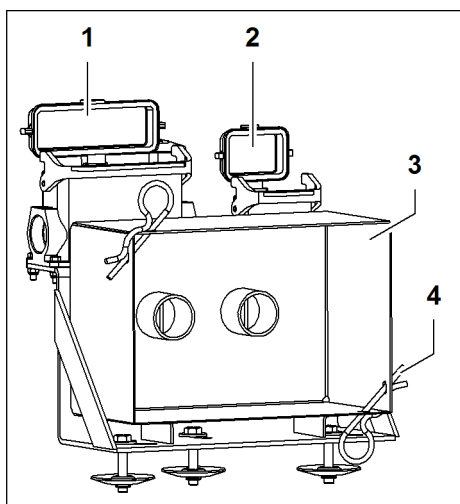


Fig. 3702: Transport position of the hydraulic pipes and electric cables on the main boom base section

- | | | | |
|---|---|---|-------------------------|
| 1 | Dummy socket for electrical system main boom base section | 3 | Cover of multi-coupling |
| 2 | Dummy receptacle for electronics rope reeving winch | 4 | Spring cotter pin |

A bracket for the cover **3** of the multi-coupling and dummy sockets for the electrical system are located on the catwalk of the main boom base section.

- ▶ Fit the hand lever of the multi-coupling.
- ▶ Remove spring cotter pin **4** on cover **3**.
- ▶ Turn hand lever in the direction of the arrow.
 - ▷ Multi-coupling can be taken out of bracket.
 - ▷ Cover **3** remains in bracket on main boom base section.

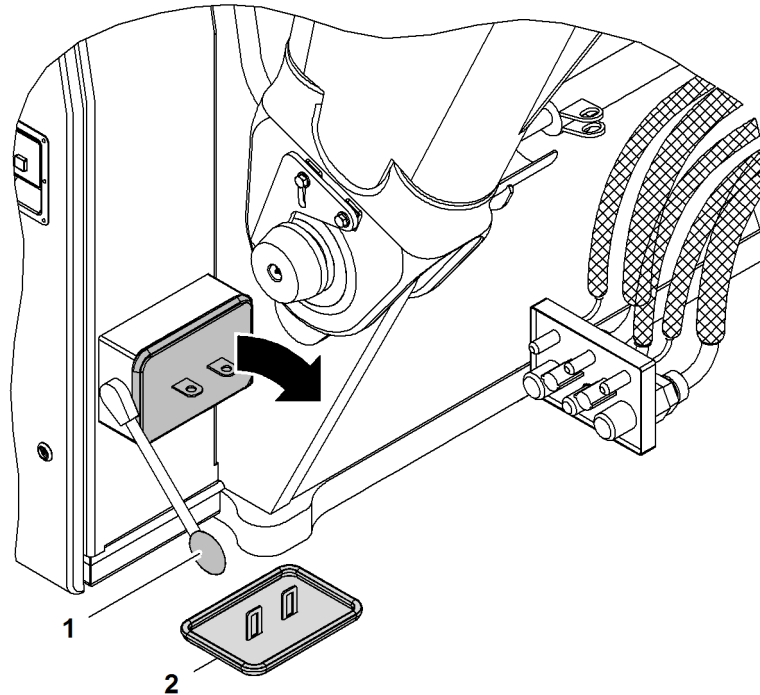


Fig. 3703: Removing the cover of the multi-couplings

- | | |
|---------------------|-------------------------|
| 1 Hand lever | 3 Cover |
| 2 Cover | 4 Locking spring |

- ▶ Fit the hand lever **1** of the multi-coupling.
- ▶ Remove the locking spring **4** on the cover **3**.
- ▶ Turn hand lever **1** in the direction of the arrow.
 - ▷ Cover **2** is loose.
- ▶ Mount cover **3** on bracket of the main boom base section and secure with locking spring.
- ▶ Remove cover **2**.

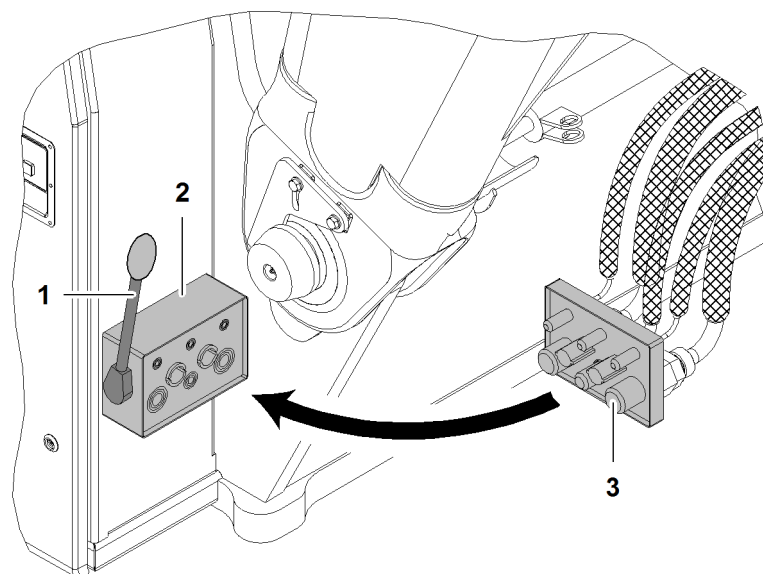


Fig. 3704: Connecting hydraulic lines to the uppercarriage

- | | | | |
|---|--------------------------------|---|---|
| 1 | Hand lever | 3 | Multi-coupling (main boom base section) |
| 2 | Multi-coupling (uppercarriage) | | |

NOTICE

Dirty multi-couplings!
Damage to the hydraulic system.

► Clean the multi-couplings before fitting them together.

- Connect the multi-couplings 2 + 3.
- Move hand lever 1 until latch engages.
 - ▷ The multi-couplings are visibly and audibly pulled together.
 - ▷ The multi-coupling indicating pins stick out:

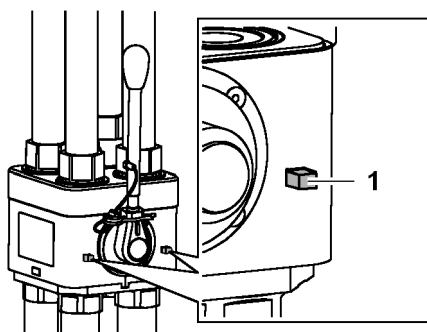


Fig. 3705: Locked multi-coupling

- | | |
|---|---------------------|
| 1 | Indicating pin (2x) |
|---|---------------------|
- Disassemble the hand lever 1 on the multi-coupling.

Connecting electric cables to the uppercarriage

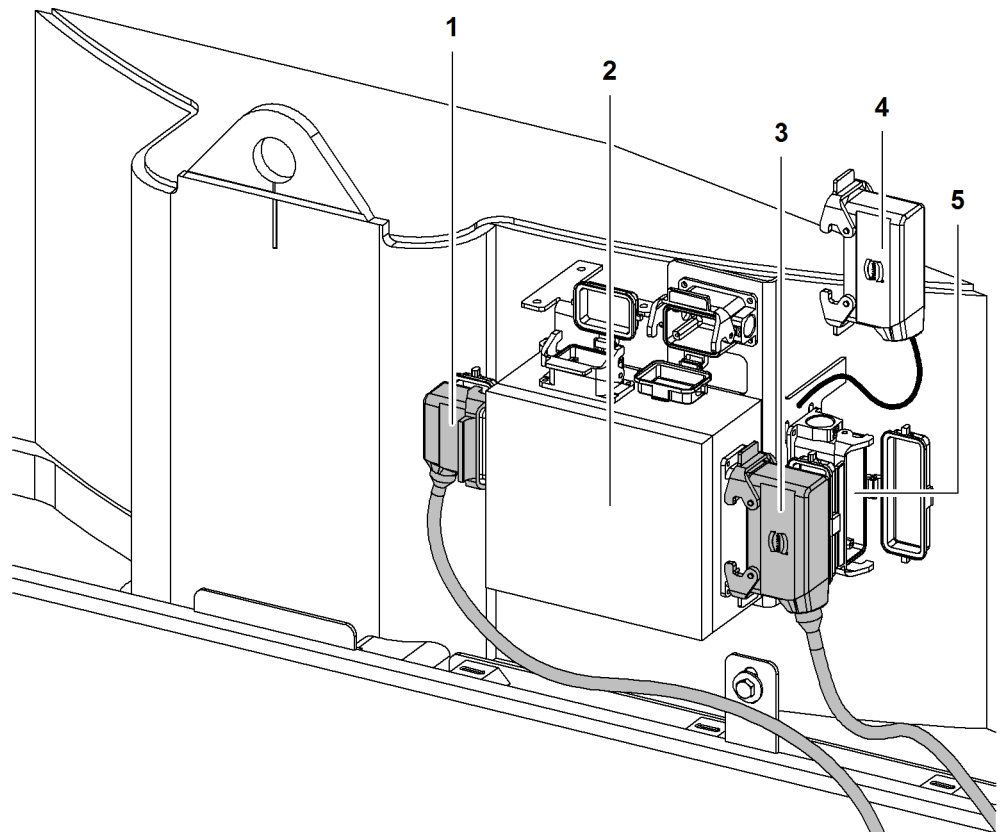


Fig. 3706: Connecting electric cables to the uppercarriage

- | | | | |
|---|--|---|------------------|
| 1 | Electric cables of the jib luffing winch and/or rope reeving winch | 4 | Bypass plug |
| 2 | Electric box | 5 | Dummy receptacle |
| 3 | Electric cables of the main boom base section | | |

- ▶ Open right front uppercarriage door.
- ▶ Plug the bypass plug 4 in the dummy receptacle 5 and secure it with the retaining clips.
- ▶ Guide the electric cables 3 of the main boom base section through the cable duct on uppercarriage.
- ▶ Plug electric line 3 into electric box 2 and lock with brackets.
- ▶ Guide the electric cables 1 of the jib luffing winch through the cable duct on uppercarriage.
- ▶ Plug electric line 1 into electric box 2 and lock with brackets.
- ▶ Close right front uppercarriage door.

Bolt the derrick pulley block with main boom pendant straps

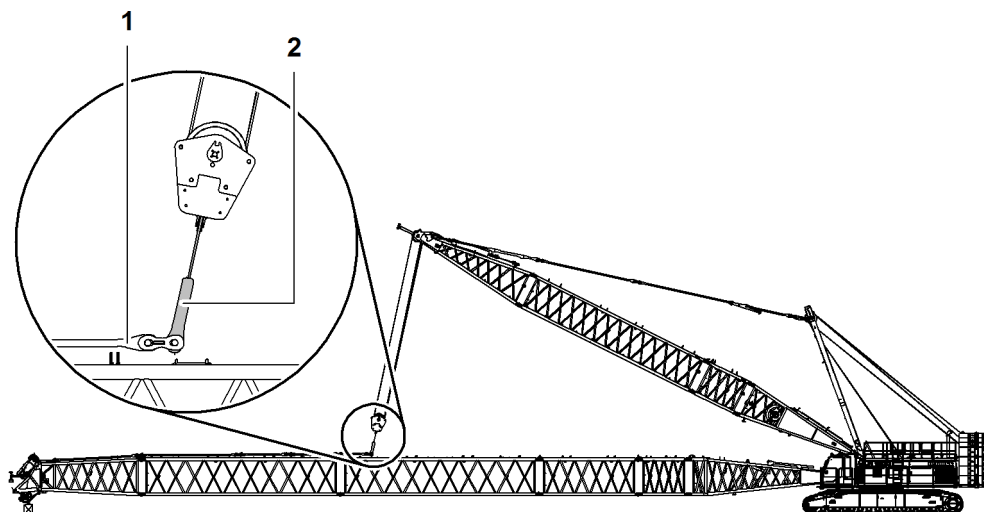


Fig. 3707: Pin derrick rope rigging with main boom pendant straps

1 Main boom pendant straps 2 Derrick rope rigging

- ▶ Unwind the boom winch.
 - ▷ Derrick boom head is lowered.
- ▶ Unwind the derrick winch.
 - ▷ Derrick rope rigging 2 lowers.
- ▶ Pin derrick rope rigging 2 with main boom pendant straps 1.
- ▶ Secure pins with washers and locking spring.

Attaching the auxiliary jib (36 t (79300 lb)) to the boom head section

Make sure that the camera support (if available) on the main boom head section is detached.

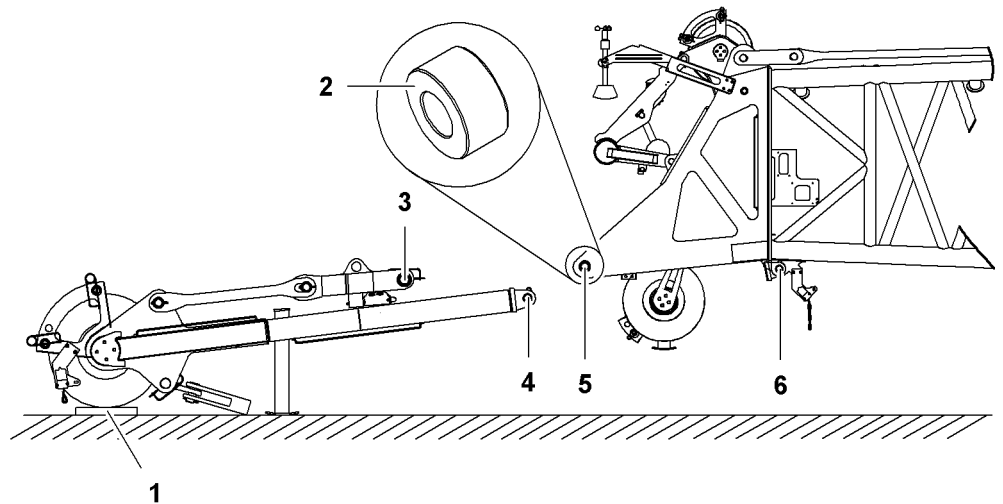


Fig. 3708: Positioning the auxiliary jib (36 t (79300 lb)) in front of the boom head section and inserting bushes

1	Wooden block	4	Lower pin connection point auxiliary jib (2x)
2	Bush (dia.80 mm (3.15" in) x Ø40 mm (1.57" in) x 43 mm (1.69" in)) (2x)	5	Upper pin connection point main boom head (2x)
3	Upper pin connection point auxiliary jib (2x)	6	Lower pin connection point main boom head (2x)

- ▶ Position the auxiliary jib in front of the boom head section.
- ▶ Protecting the pulley: Lay a wooden block **1** under the auxiliary jib pulley.
- ▶ Insert bushes (Ø80 mm (3.15" in) x Ø40 mm (1.57" in) x 43 mm (1.69" in)) into the upper pin connection points **5** of the main boom head.
- ▶ Lift the main boom and move it towards the auxiliary jib until the upper pin connection points **3** on the auxiliary jib match the upper connection points of the **5** main boom head.

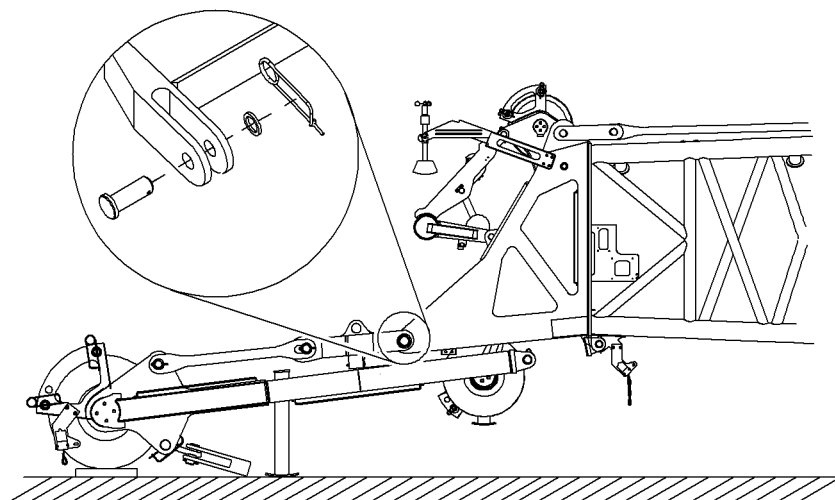


Fig. 3709: Pinning the upper pin connection points

- ▶ Pin the upper pin connection points and secure with washer and safety pin.

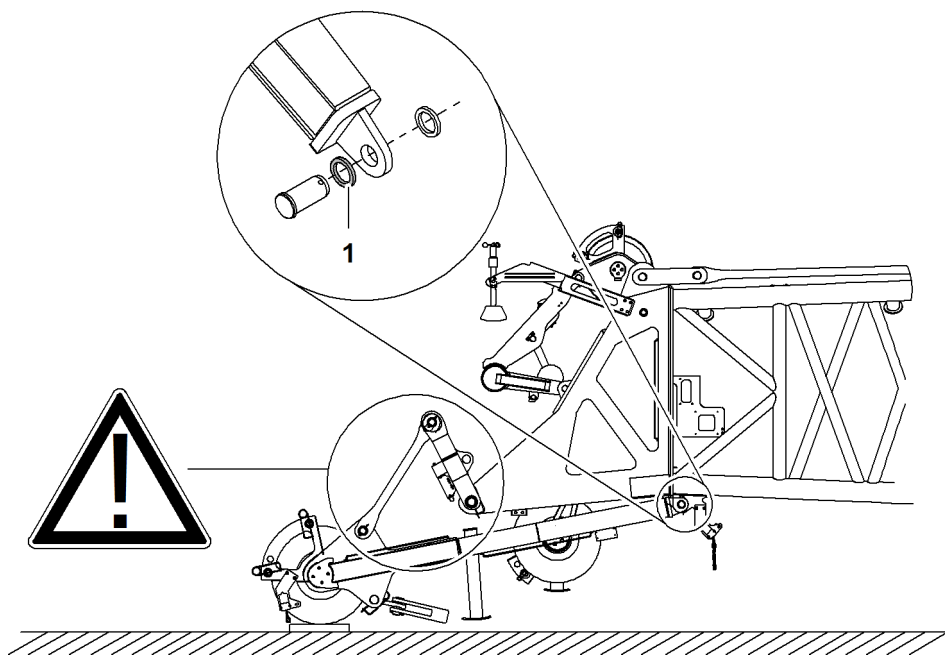


Fig. 3710: Pinning the lower pin connection points

1 Washer 8 mm (0.31" in) (2x)

The washer 8 mm (0.31" in) 1 serves to center the auxiliary jib on the main boom head.

NOTICE

Auxiliary jib pendant straps are positioned incorrectly!
Damage to auxiliary jib and pulleys on the boom head section.

- ▶ Ensure that auxiliary jib pendant straps fold up.
-
- ▶ Move the main boom towards the auxiliary jib until the bottom pin connection points 4 on the auxiliary jib match the bottom connection points of the 6 main boom head.

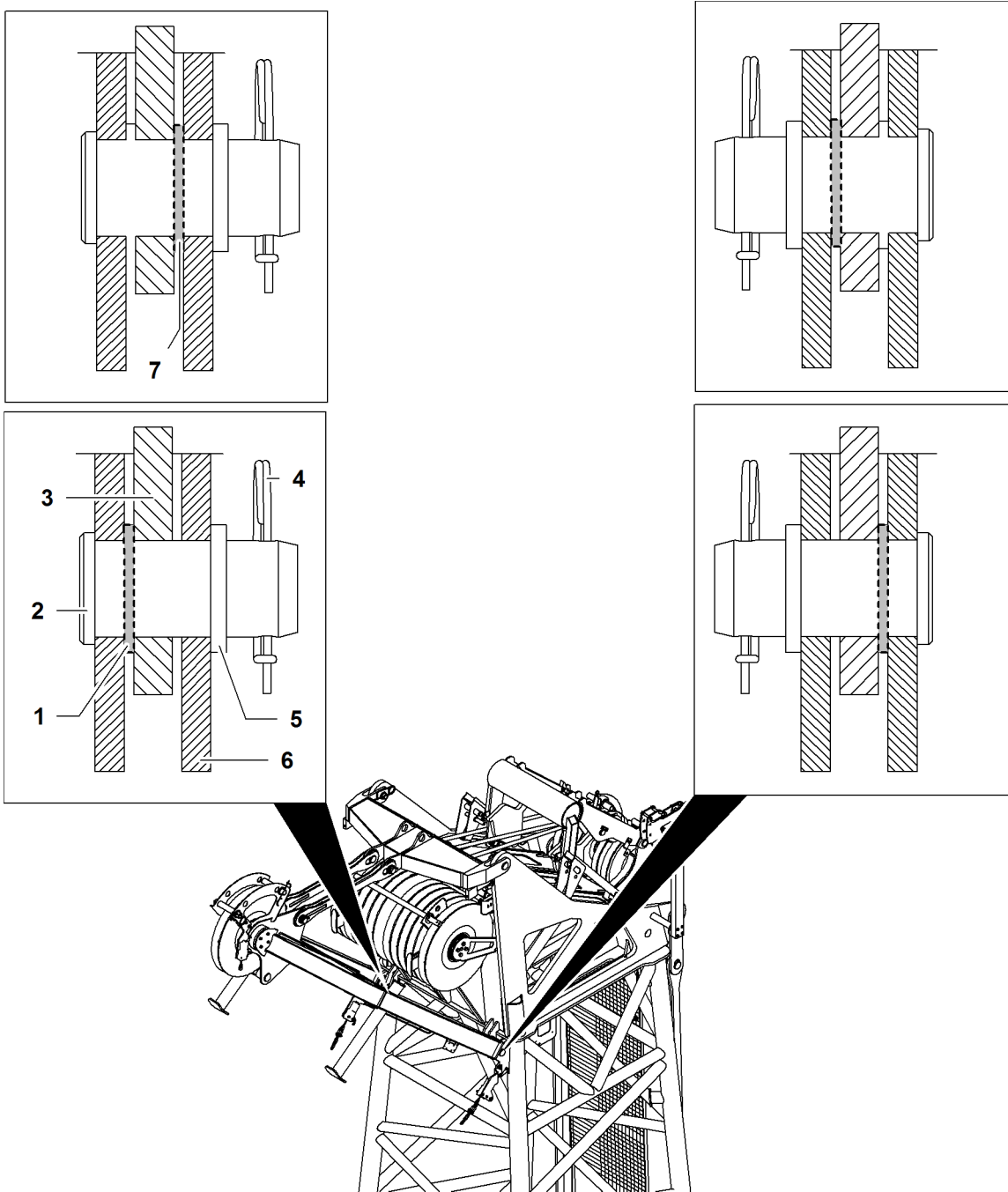


Fig. 3711: Installation notes auxiliary jib

- | | | |
|--|--|--|
| <p>1 Washer 8 mm (0.31" in)
(installation site outside) (2x)</p> <p>2 Pin (2x)</p> <p>3 Pin connection lug auxiliary
jib (2x)</p> | <p>4 Safety pin (2x)</p> <p>5 Washer (2x)</p> <p>6 Pin connection lug main
boom head (4x)</p> | <p>7 Washer 8 mm (0.31" in)
(installation site inside) (2x)</p> |
|--|--|--|

The washers 8 mm (0.31" in) must be installed both-sided on the outside (installation site outside **1**) or both-sided on the inside (installation site inside **7**).

- ▶ Push pin **2** and washer 8 mm (0.31" in) **1** through the pin connection lug **3** and the pin connection lug **6**.
- ▶ Place washer **5** on pin **2** and secure with safety pin **4**.
 - ▷ Lower pin connection points pinned and secured.

LWNLR.x/V04.01//Auslieferung/2016-03-07/en

Installing the hoist limit switch on auxiliary jib (36 t (79.300 lb))

Installation of the hoist limit switch on the auxiliary jib (36 t (79.300 lb)) is identical with the installation on the main boom or jib (For more information see: [7.6.31 Installing the hoist limit switch weight, page 1343](#)) (For more information see: [Installing the hoist limit switch weight, page 1461](#)).

Connect the hoist limit switch

The electric cable to the hoist limit switch is connected for transport to a dummy receptacle on the inside of one of the two auxiliary jib support tubes.

- ▶ Disconnect the bypass plug from the terminal box on the boom head section.
- ▶ Disconnect the electric cable for the hoist limit switch from the dummy receptacle and connect it to the terminal box on the boom head section.
- ▶ Secure the electric cable to the hoist limit switch with retaining clips.
- ▶ Plug the bypass plug into the dummy receptacle and secure it with the retaining clips.

Folding down the link plates for the 11th pulley

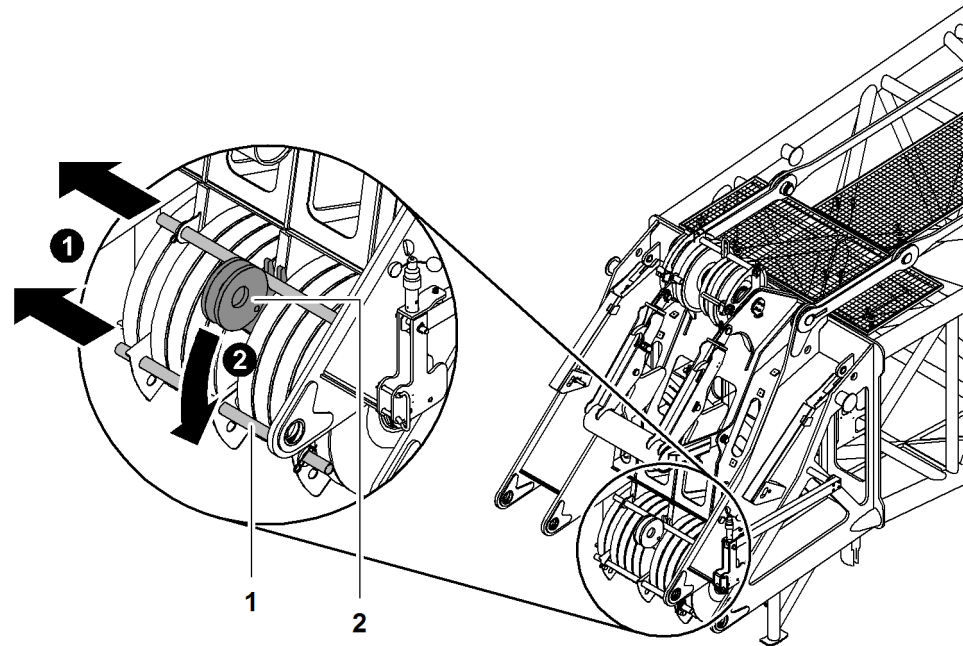


Fig. 3712: Folding down the link plates for the 11th pulley

- | | |
|-----------------------------|-----------------------------------|
| 1 Rope protection pipe (2x) | 2 Link plate (2x) for 11th pulley |
|-----------------------------|-----------------------------------|

NOTICE

Wrong position of link plates **2** for 11th pulley on main boom head!
Risk of damage to winch2 rope.

- ▶ Fold down link plates **2** for 11th pulley.
- ▶ Remove rope protection pipes **1** on main boom head.
- ▶ Fold down link plates **2** for 11th pulley.

Installing second pulley to 3-fold reeve the auxiliary jib (36 t (79300 lb))

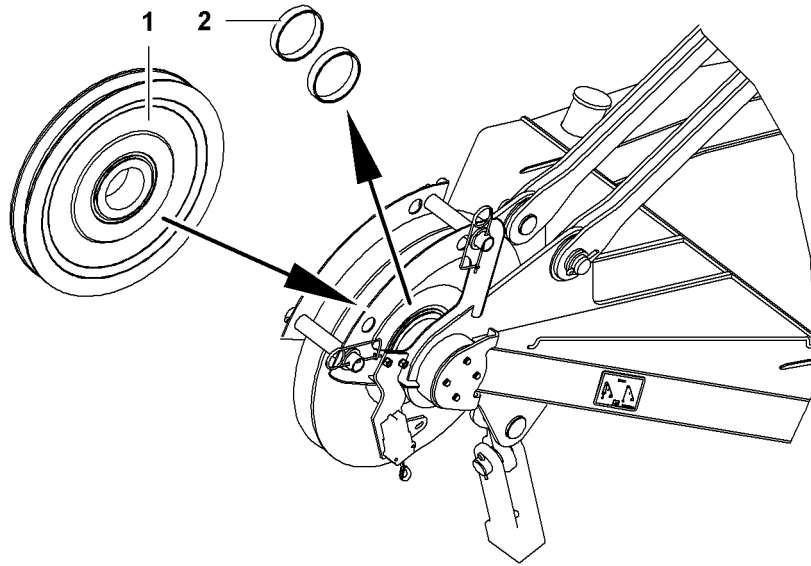


Fig. 3713: Installing second pulley to 3-fold reeve the auxiliary jib (36 t (79300 lb))

- | | | | |
|----------|---------------|----------|---|
| 1 | Second pulley | 2 | Bushes (dia.168 mm (6.61" in) x
Ø140 mm (5.51" in) x
40 mm (1.57" in)) (2x) |
|----------|---------------|----------|---|

- ▶ Remove bushes (dia.168 mm (6.61" in) x dia.140 mm (5.51" in) x 40 mm (1.57" in)) **2**
- ▶ Install second pulley

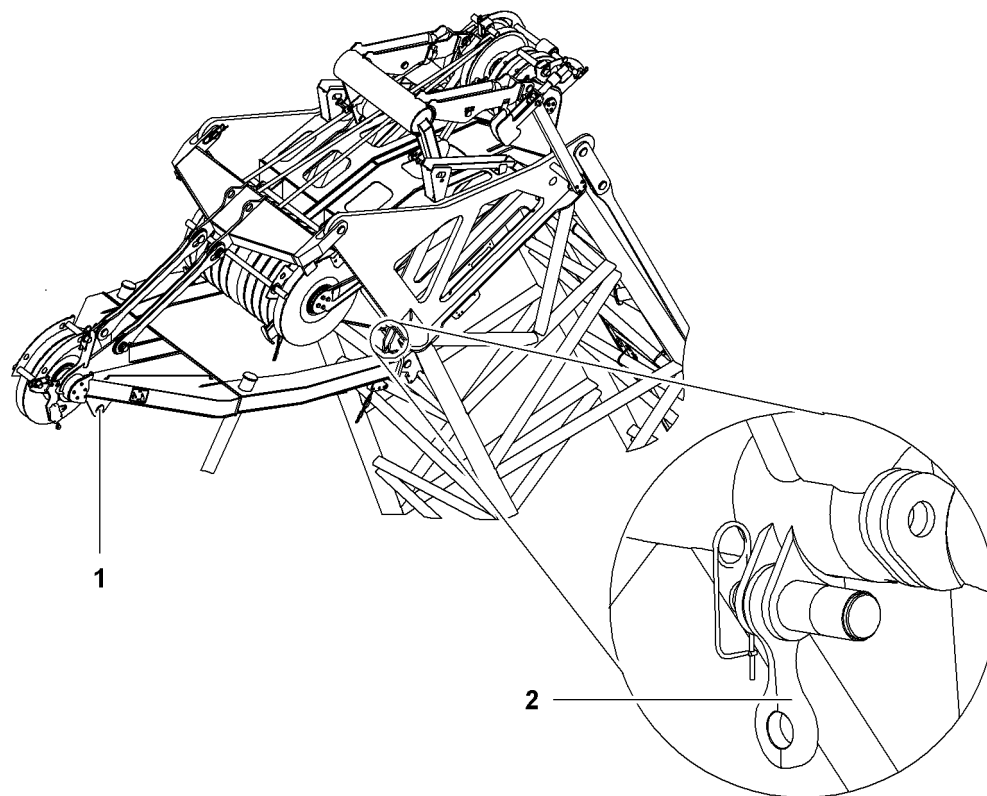


Fig. 3714: Pinning the cross strap to the boom head section

- 1 Auxiliary jib rope fixing point 2 Cross strap and pins

NOTICE

Cross strap and pins **2** are not positioned correctly at the rope fixing point on the auxiliary jib **1** with 3-fold reeving!
Risk of damage to winch2 rope.

- ▶ Pin the cross strap to the boom head section.
- ▶ Remove the cross strap and pins **2** from the rope fixing point of the auxiliary jib **1**.
- ▶ Pin the cross strap **2** to the boom head section.

Reeving the rope

The rope must be reeved as specified in the rope reeving diagram according to the boom and application requirements.



WARNING

Unsecured walking on the boom!
Risk of falling off the boom.

- ▶ A fall arrest system must be worn when working on the boom to prevent falling.

Ensure that the following conditions are satisfied:

- Cylinder adjustment functions are on.

Reeving the rope using a rope reeving winch

Dismantling rope protection pipes

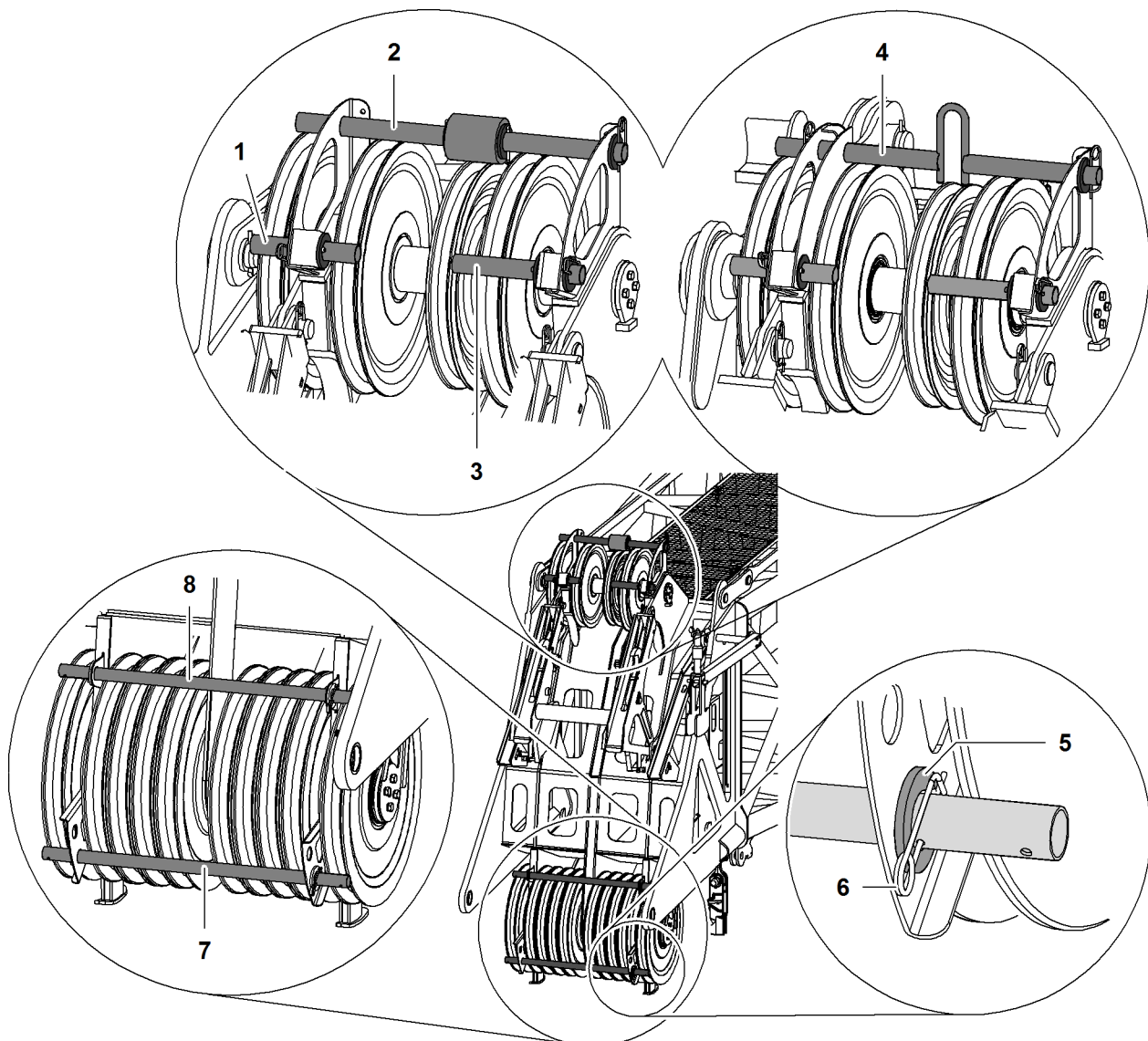


Fig. 3715: Rope protection pipes main boom head 1311, 2017, 2018, 2320, 2220, 2821

- | | | | | | |
|---|-------------------------------|---|-------------------------------|---|----------------------|
| 1 | Rope protection pipe | 4 | Rope protection pipe variant2 | 7 | Rope protection pipe |
| 2 | Rope protection pipe variant1 | 5 | Washer | 8 | Rope protection pipe |
| 3 | Rope protection pipe | 6 | Safety pin | | |

The rope protection pipes are secured with a cotter pin on one side and with a safety pin on the other side.

- ▶ Remove the safety pins 6 and the washers 5.
- ▶ Remove the rope protection pipes 1 + 2 + 3 + 4 + 7 + 8.

Removing the rope protection pipes on auxiliary jib

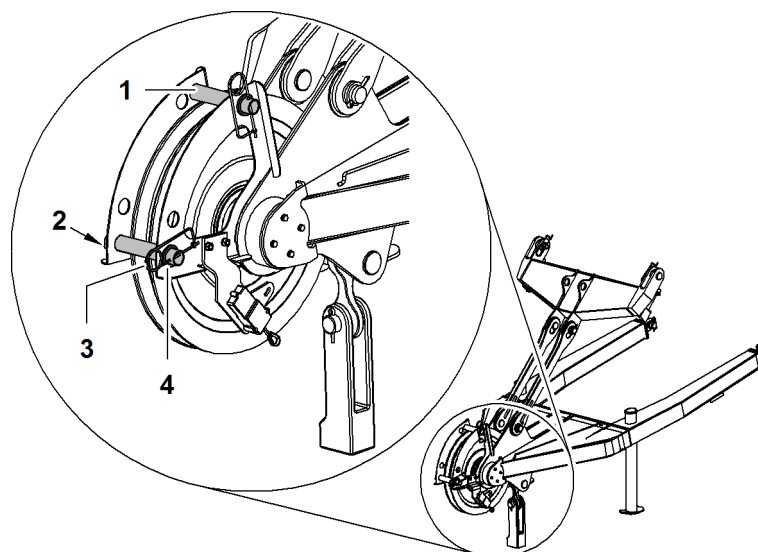


Fig. 3716: Removing the rope protection pipes on auxiliary jib

- | | | | |
|---|---------------------------|---|------------|
| 1 | Rope protection pipe (2x) | 3 | Safety pin |
| 2 | Cotter pin | 4 | Washer |

The rope protection pipes are secured with a cotter pin 2 on one side and with a safety pin 3 on the other side.

- ▶ Remove rope protection pipes 1 with attached auxiliary jib.

Reeving the rope

- ▶ Open up the rope guide (if present).

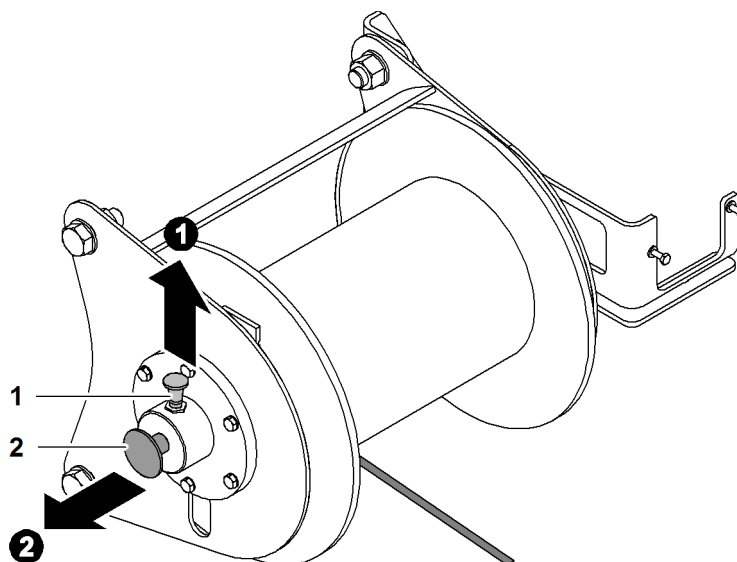


Fig. 3717: Setting the rope lug to free-wheel

- | | | | |
|---|------------------|---|-------|
| 1 | Securing element | 2 | Shaft |
|---|------------------|---|-------|



Note

Liebherr recommends:

- ▶ Making it easier to pull out the axle **2**: move the rope reeving winch manually back and forth.
-
- ▶ Pull up the locking element **1** and pull out the axle **2** at the same time.
 - ▷ Rope reeving winch is set to free-wheel.

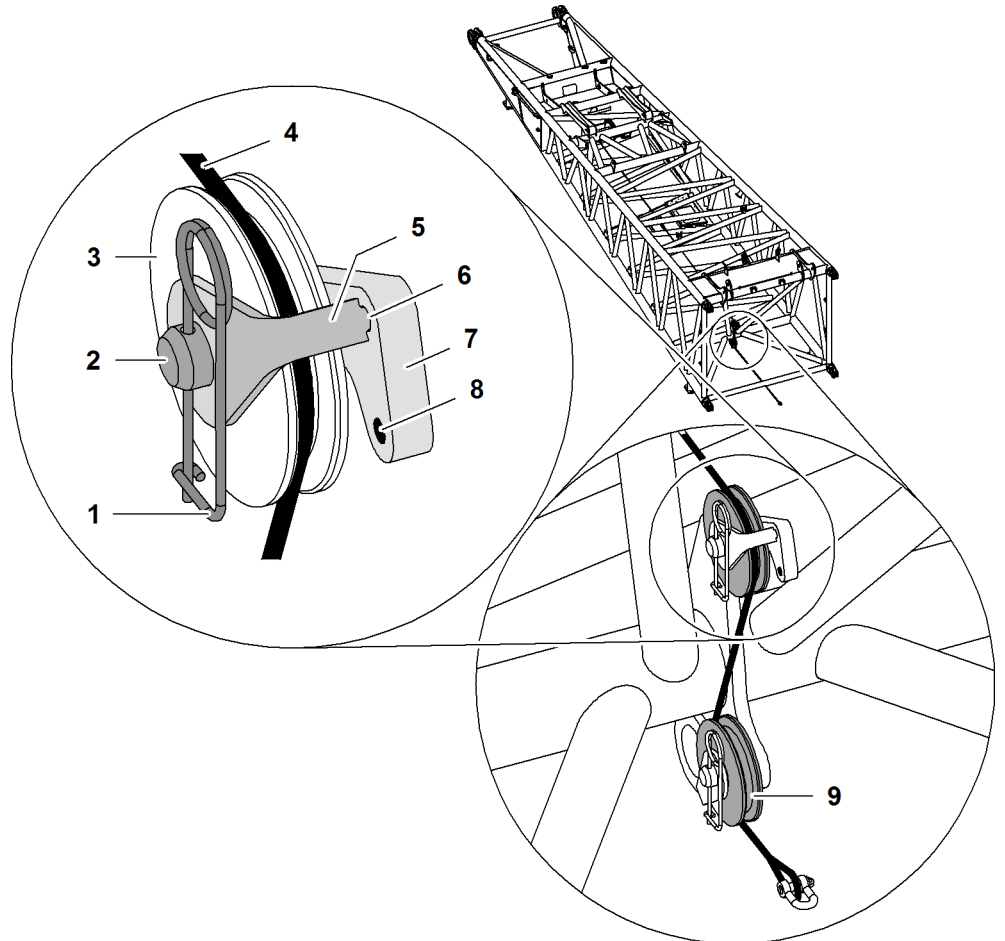


Fig. 3718: Reeving in the luffing rope of the rope reeving winch

- | | |
|---|--------------------------------|
| 1 Safety pin | 6 Recess |
| 2 Shaft | 7 Support with recesses |
| 3 Upper pulley | 8 Recess |
| 4 Rope of the rope reeving winch | 9 Lower pulley |
| 5 Locking element | |

Depending on the machine type, the mounting **7** may have one or two recesses.

- ▶ Remove safety pins **1**.
- ▶ Remove **5** securing element.
- ▶ Place rope of the rope reeving winch **4** across the top pulley **3**.

NOTICE

Wrongly mounted locking element!
Rope of the rope reeving winch jumps out of pulley.

- ▶ Make sure that the locking element **5** is mounted in recess **6**.

- ▶ Attach locking element **5** to axle **2** and guide in recess **6**.
- ▶ Attach the safety pin **1**.
- ▶ Repeat procedure on bottom pulley **9**.
 - ▷ Rope of the rope reeving winch is guided through pulleys.
- ▶ Pull the luffing rope under the boom to the boom head.
- ▶ Reeve in the rope of the rope reeving winch according to reeving plan.
- ▶ Pull the luffing rope next to the boom towards the basic machine.
- ▶ Lift luffing rope onto boom.
- ▶ Connect luffing rope with rope of winch1/winch2.

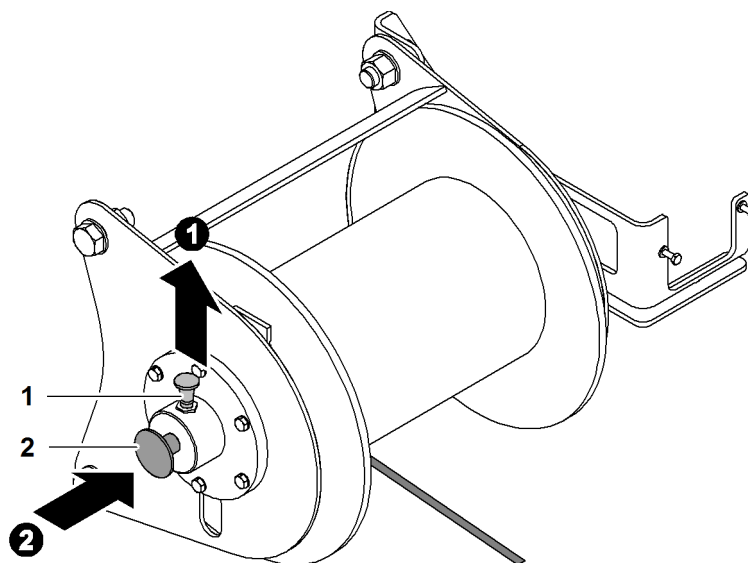


Fig. 3719: Stopping the free-wheel of the rope reeving winch

1 Locking element 2 Shaft



Note

Liebherr recommends:

- ▶ Making it easier to press in the axle **2**: move the rope reeving winch manually back and forth.

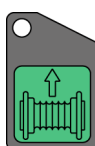
- ▶ Pull up the locking element **1** and press in the axle **2** at the same time.
 - ▷ Free-wheel of the luffing rope is deactivated.



WARNING

Never stand in the immediate vicinity of the rope reeving winch or the luffing rope!

- ▶ Make sure that no-one is standing in the danger area.
- ▶ Leave the danger area.



- ▶ Press and hold the *Rope reeving winch* button on control panel X11.
 - ▷ Rope reeving winch reeves in the rope of the rope reeving winch and tensions the rope of winch1/winch2.

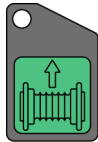


If rope of winch1/winch2 is in the 8th rope layer (only with free-fall winch 130 kN (29,230 lb_i)):

- ▶ Press the *Bypass limit switch* button on control panel X23.
 - ▷ The 3-rope windings limit switch is bypassed.

There must be no slacking of the rope when unwinding.

- ▶ Unwind the rope of winch1/winch2 up to the rope fixing point.
- ▶ Press the *Rope reeving winch* button on control panel X11.
 - ▷ Rope reeving winch switched off.
- ▶ Remove rope of the rope reeving winch from the rope of winch1/winch2.
- ▶ Press and hold the *Rope reeving winch* button on control panel X11.
 - ▷ Luffing rope is being reeved.



- ▶ Press the *Rope reeving winch* button on control panel X11.
 - ▷ Rope reeving winch switched off.
- ▶ Close and secure the rope guide (if present).

Mounting rope protection pipes on main boom head

- ▶ Mount and secure rope protection pipes.

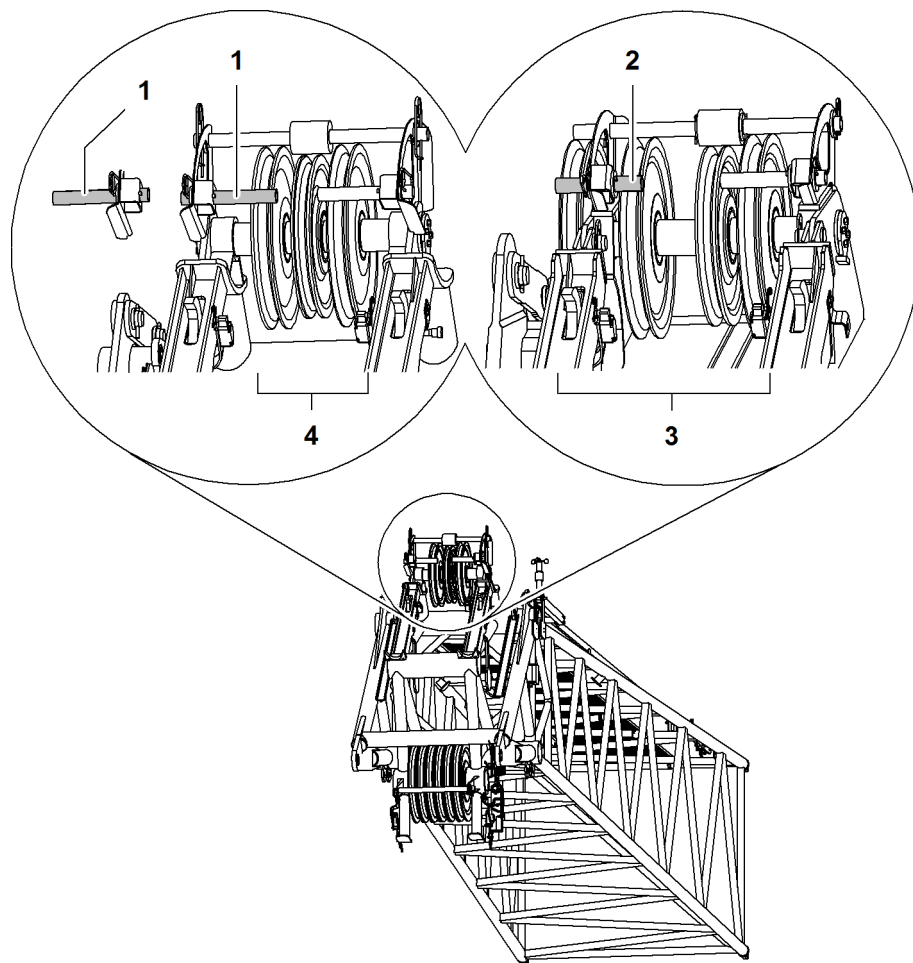


Fig. 3723: Rope protection pipe main boom head section with mounted fixed jib

- | | | | |
|---|----------------------|---|--|
| 1 | Rope protection pipe | 3 | Main boom head with four gantry pulleys |
| 2 | Rope protection pipe | 4 | Main boom head with three gantry pulleys |

NOTICE

Inadmissible rope protection pipe with mounted fixed jib!
Rope scrapes on rope protection pipe.
Damage to rope.

- ▶ Remove rope protection pipe 1 + 2.

If a fixed jib is being mounted:

- ▶ Remove rope protection pipe 2 on main boom head.
- or

Rotate rope protection pipe 1 by 180° and mount facing outwards.

Fitting the rope protection pipes to the auxiliary jib

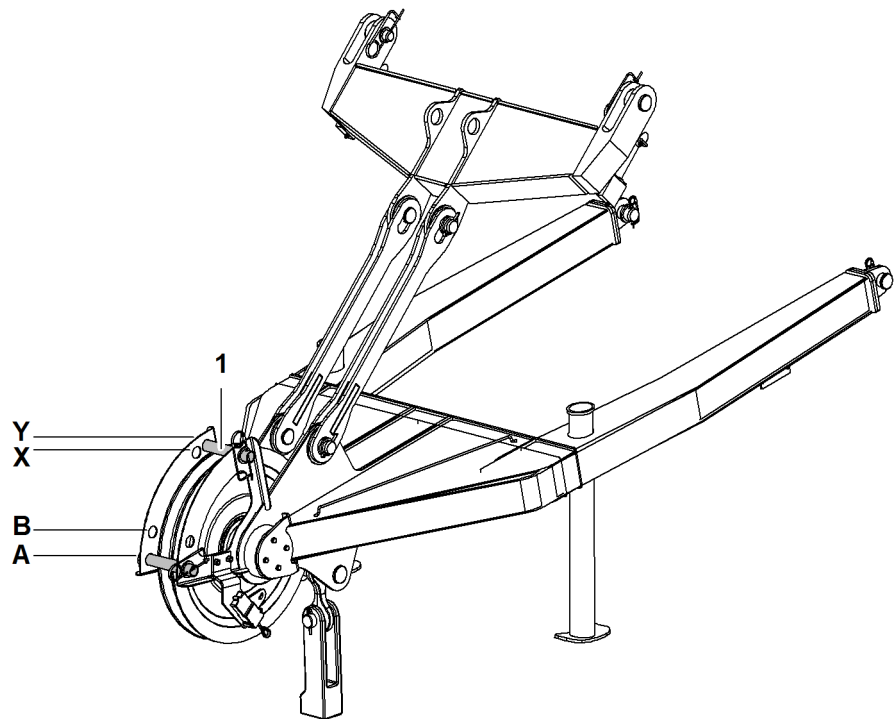


Fig. 3724: Fitting the rope protection pipes to the auxiliary jib

- 1** Rope protection pipe (2x)
- A** Assembly position A for rope protection pipe
- B** Assembly position B for rope protection pipe
- X** Assembly position X for rope protection pipe
- Y** Assembly position Y for rope protection pipe

Assembly positions of the rope protection pipes on the auxiliary jib depending on the main boom angle:

Machine type	Main boom angle		
	15° to 30°	20° to 30°	30° to 86°
LR 1001	B + X	-	A + Y
LR 1002	B + X	-	A + Y
LR 1003	B + X	-	A + Y
LR 1004	-	B + X	A + X
LR 1006	-	B + X	A + X

Tab. 521: Assembly positions for rope protection pipes on the auxiliary jib (36 t (79.300 lb)) for main boom head

- ▶ Mount rope protection pipes on auxiliary jib according to chart.

Reeving the rope without using a rope reeving winch

- ▶ Remove the rope protection pipes on the boom and the pulley block.
- ▶ Open up the rope guide (if present).

LWNLR.x/V04.01//Auslieferung/2016-03-07/en

- ▶ Connect auxiliary rope with the rope of winch1/winch2.
- ▶ Pull the auxiliary rope next to the boom as far as the boom head.
- ▶ Hoist the auxiliary rope onto the boom.
- ▶ Reeve the auxiliary rope according to the rope reeving system.



If rope of winch1/winch2 is in the 8th rope layer (only with free-fall winch 130 kN (29,230 lb,)):

- ▶ Press the *Bypass limit switch* button on control panel X23.
 - ▷ The 3-rope windings limit switch is bypassed.

There must be no slacking of the rope when unwinding.

- ▶ Unwind the rope of winch1/winch2 up to the rope fixing point.
- ▶ Remove auxiliary rope from the rope of winch1/winch2.
- ▶ Close and secure the rope guide (if present).
- ▶ Mount and secure rope protection pipes.

Attaching the rope fixing point



DANGER

Incorrect installation of pins and pocket lock!
Load breakaway.

- ▶ Fit pins and pocket lock as instructed.
-

The collar of the pins and the pocket lock openings are decisive for the installation direction of the rope fixing point.

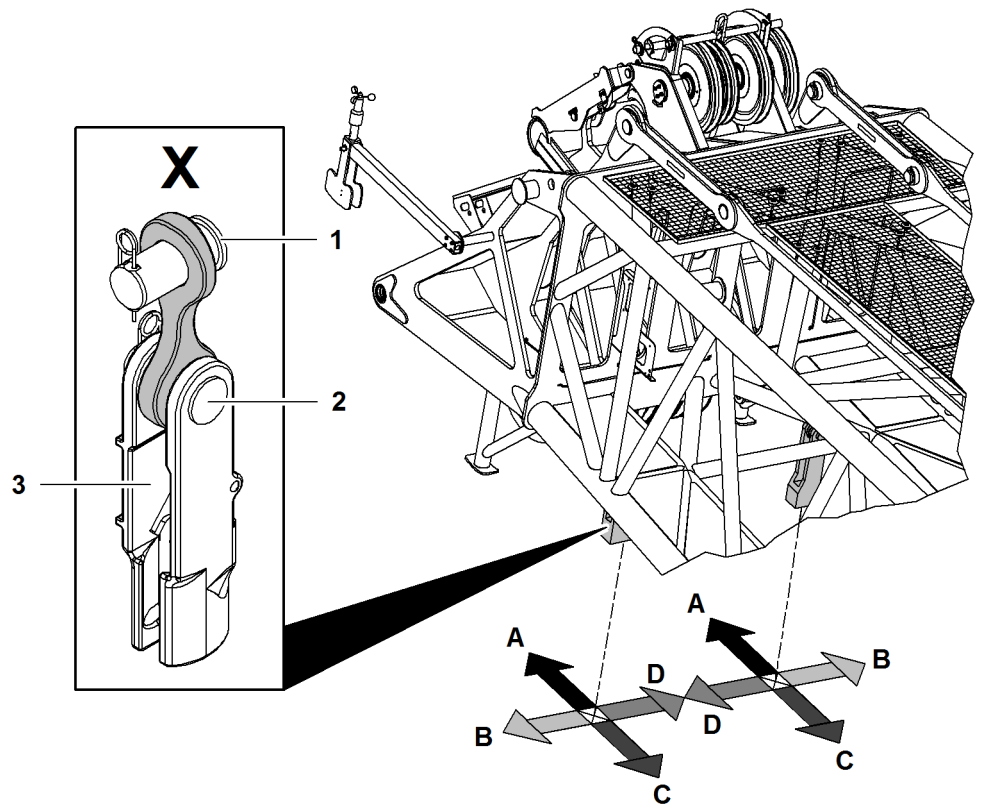


Fig. 3726: Determining the installation direction of the components of the rope fixing point of relevance for installation - main boom head (illustration of principle)

- | | | | |
|----------|------------------------------------|----------|--------------------------|
| X | Components needed for fitting | A | Direction main boom head |
| 1 | Shoulder of pin on the boom | B | Outside |
| 2 | Shoulder of pin on the pocket lock | C | Direction basic machine |
| 3 | Pocket lock opening | D | Inside |

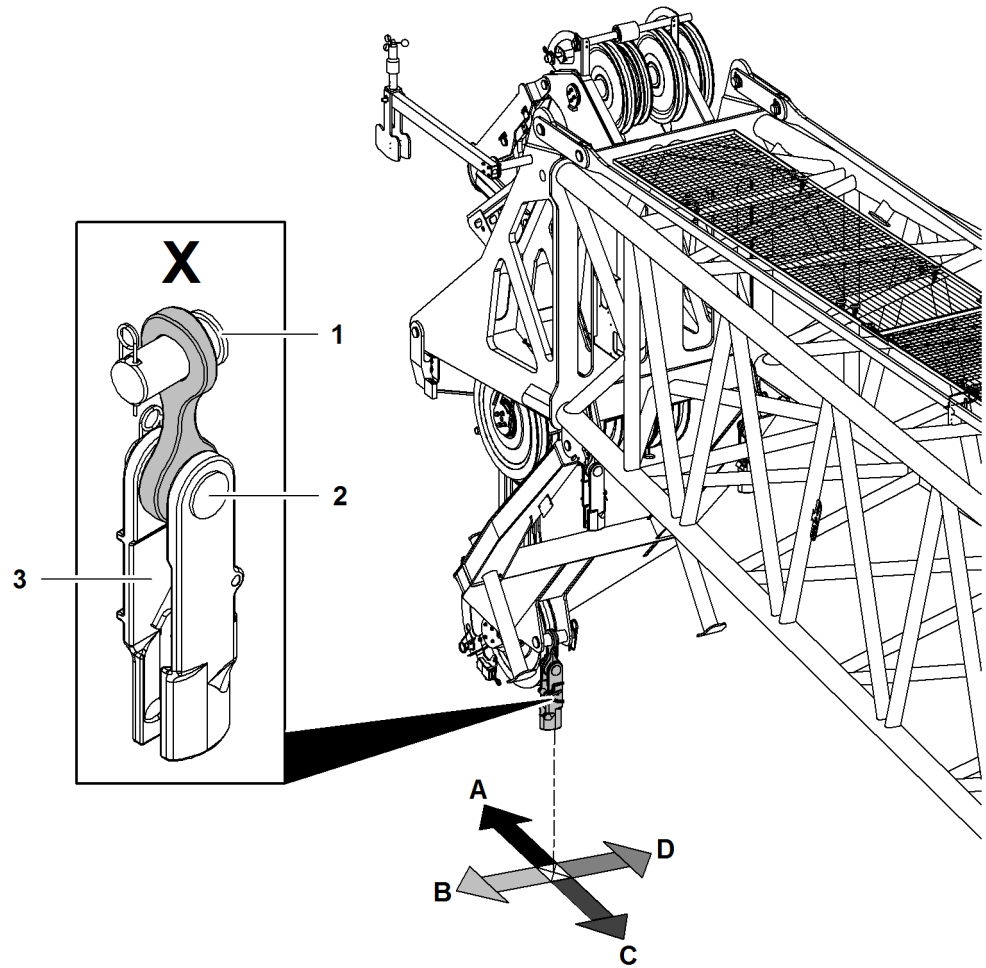


Fig. 3727: Determining the installation direction of the components of the rope fixing point of relevance for installation - auxiliary jib (illustration of principle)

- | | | | |
|----------|------------------------------------|----------|--------------------------|
| X | Components needed for fitting | A | Direction main boom head |
| 1 | Shoulder of pin on the boom | B | Outside |
| 2 | Shoulder of pin on the pocket lock | C | Direction basic machine |
| 3 | Pocket lock opening | D | Inside |

Installation direction of the rope fixing point components of relevance for installation			
	Pin collar on boom	Pin collar on pocket lock	Pocket lock opening
All rope fixing points	D	C	B
Exceptions:			
Fixed jib head 0906	B	C	B
Fixed jib head 1507	B	C	B

Tab. 522: Installation direction of the rope fixing point components of relevance for installation



WARNING

Incorrectly fit swivels!
Severe injuries, damage to machine.

- ▶ Fit rope with no twists.
- ▶ Install the rope without swivels.

LWN/LR-x/V04.01/Auslieferung/2016-03-07/en

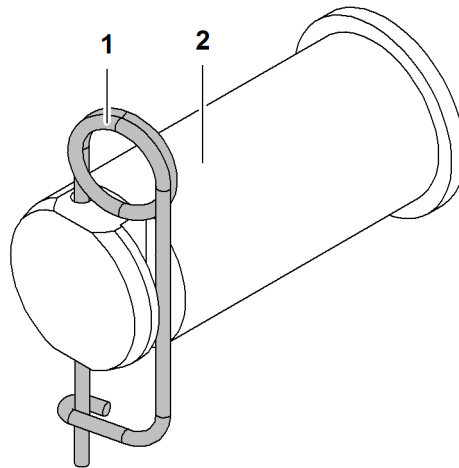


Fig. 3728: Securing the pins

1 Locking spring

2 Pin



DANGER

Pins 2 not completely secured!
Load breakaway.

- ▶ Ensure that locking spring 1 completely secures the pin 2.

Installing the rope fixing point on the boom head

- ▶ Pin cross strap with boom head.
- ▶ Secure pin with locking spring.
- ▶ Pin pocket lock with cross strap.
- ▶ Secure pin with locking spring.

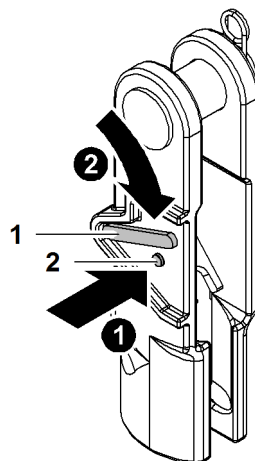


Fig. 3729: Unlocking the pocket lock

1 Safety latch

2 Locking button

- ▶ Press the locking button 2.
- ▶ Press safety latch 1 down and hold.

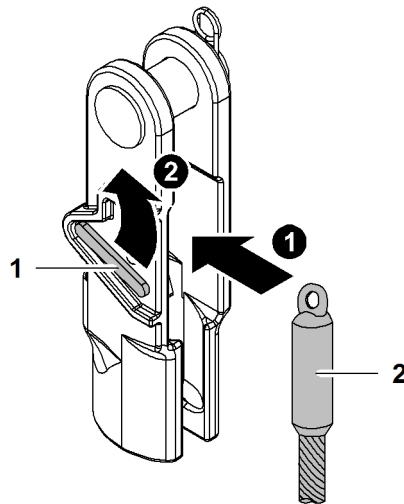


Fig. 3732: Inserting the end of rope into pocket lock and locking the pocket lock

1 Safety latch

2 End of rope

- ▶ Insert end of rope 2 in pocket lock.



DANGER

End of rope 2 not properly secured!
Load breakaway.

- ▶ Ensure that the safety latch 1 engages.
- ▶ Let go of safety latch 1.
 - ▷ Safety latch 1 engages.

Installing the hoist limit switch weight

NOTICE

Improper installation of the hoist limit switch weight!
Damage to the rope and hoist limit switch weight.

- ▶ Fit the hoist limit switch weight with no diagonal pull.
- ▶ Always install the hoist limit switch weight on the slack rope of winch1/winch2, except with simple reeving.

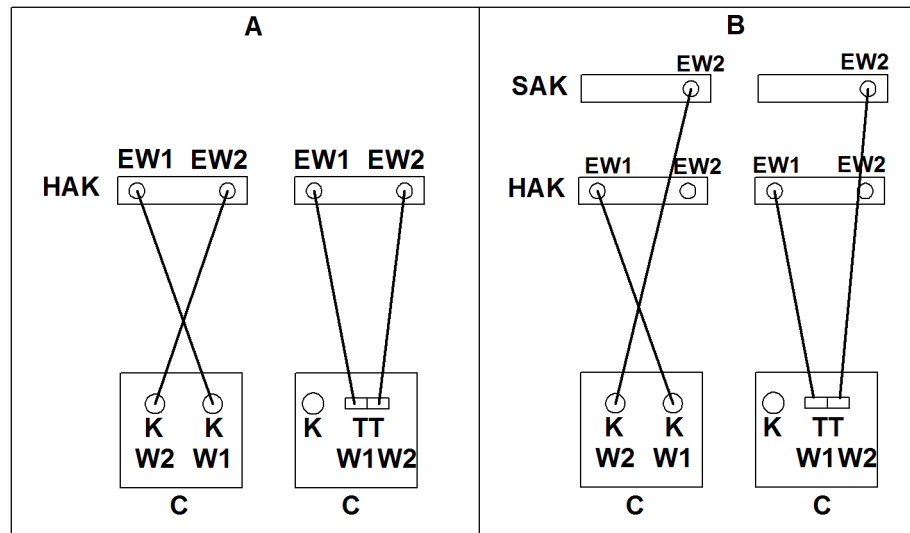


Fig. 3733: Hoist limit switch assignment in dependence on winch1/winch2

- | | |
|---|----------------------------------|
| A Boom configuration main boom | K Joystick |
| B Boom configuration main boom + jib head member | SAK Auxiliary jib |
| C Cabin | TT Double T-control lever |
| EW1 Hoist limit switch winch1 | W1 winch1 |
| EW2 Hoist limit switch winch2 | W2 winch2 |
| HAK Main boom head section | |

NOTICE

Wrong hoist limit switch!
 Hoist limit switch does not turn off.

- ▶ Make sure that the correct hoist limit switch for the correct rope of winch1/ winch2 is used.

The hoist limit switch with chain and hoist limit switch weight attached is secured to the inoperative end of the hoist rope.

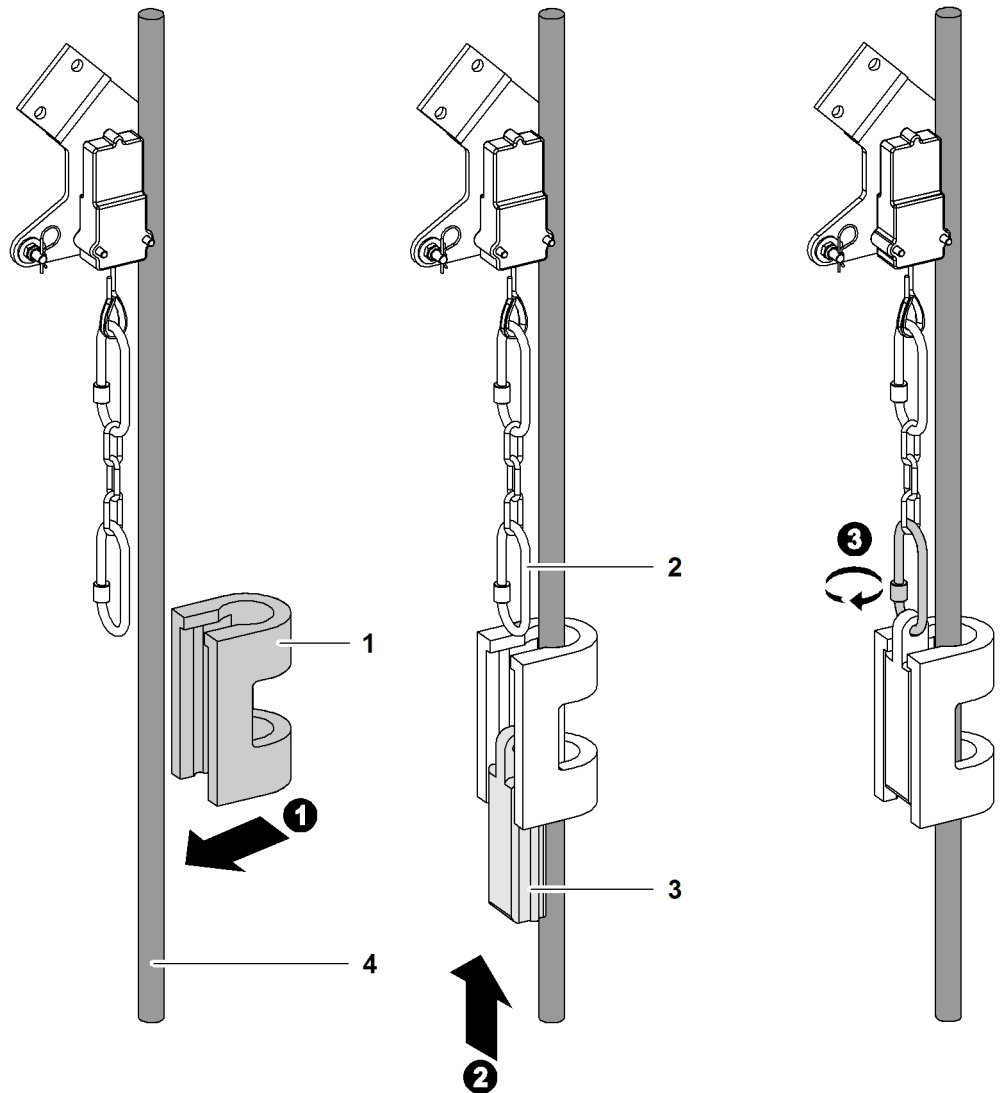


Fig. 3734: Fitting the hoist limit switch weight

- | | |
|---------------------------------------|-------------------------------------|
| 1 Hoist limit switch weight (U shape) | 3 Hoist limit switch weight (wedge) |
| 2 Carabiner | 4 Rope of winch1/winch2 |

► Guide the hoist limit switch weight (U shape) 1 over the rope of winch1/winch2 4.

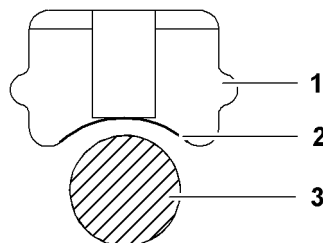


Fig. 3735: Hoist limit switch weight (wedge) view from above

- | | |
|-------------------------------------|-------------------------|
| 1 Hoist limit switch weight (wedge) | 3 Rope of winch1/winch2 |
| 2 Curvature | |

The hoist limit switch weight (wedge) 1 has a curvature 2 on one side.

NOTICE

Wrongly installed hoist limit switch weight (wedge)!

Hoist limit switch weight (wedge) damaged with wrong installation of rope of winch1/winch2.

- ▶ Make sure that the curvature of the hoist limit switch weight (wedge) is installed in the direction of the rope of winch1/winch2.

- ▶ Insert the hoist limit switch weight (wedge) **1** from below into the hoist limit switch weight (U shape).
- ▶ Attach the carabiner to the hoist limit switch weight (wedge) **1**.



Note

Liebherr recommends:

- ▶ visual inspection of the carabiner hook prior to installation.
- ▶ Clean dirty carabiner hook with a clean cloth and water.
- ▶ If necessary, re-clean with a slightly oily cloth.

NOTICE

Improper installation of carabiner!

Damage to machine.

- ▶ Make sure that the screw of the carabiner points downwards.
- ▶ Make sure that the securing element is twisted shut.

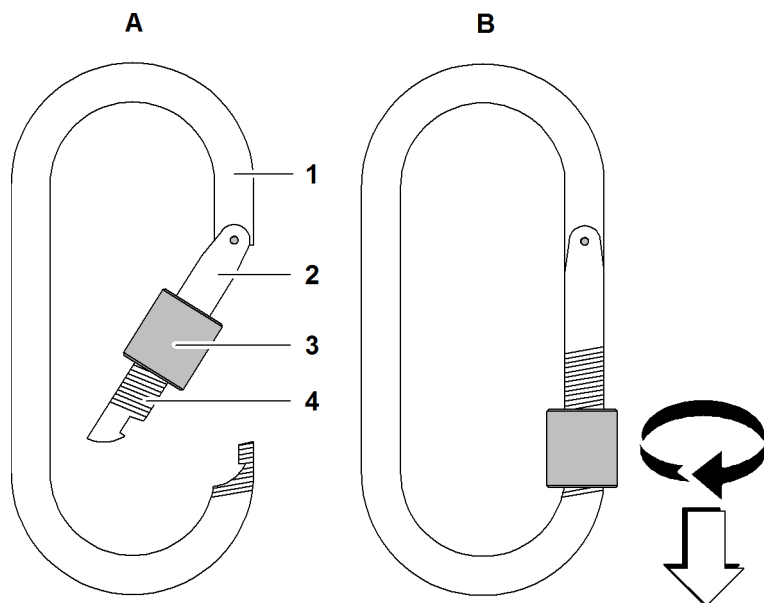


Fig. 3736: Carabiner

- | | | | |
|---|------------------|---|------------------|
| 1 | Carabiner | 4 | Thread |
| 2 | Snapper | A | Opened carabiner |
| 3 | Securing element | B | Closed carabiner |

- ▶ Secure carabiner **1** with securing element **3**.

NOTICE

The chain on the hoist limit switch weight is too short!
The hoist limit switch weight responds too late. The hook damages the boom head.

▶ Ensure that hoist limit switch weight chain is at least 3 m (9' 10" ft-in) and at most 4.5 m (14' 9" ft-in) long.

▶ Attach the chain between the hoist limit switch weight and the hoist limit switch.

Installing the hoist limit switch clamp* on auxiliary jib (36 t (79.300 lb))

The hoist limit switch clamp replaces the hoist limit switch weight on the auxiliary jib (36 t (79.300 lb)).

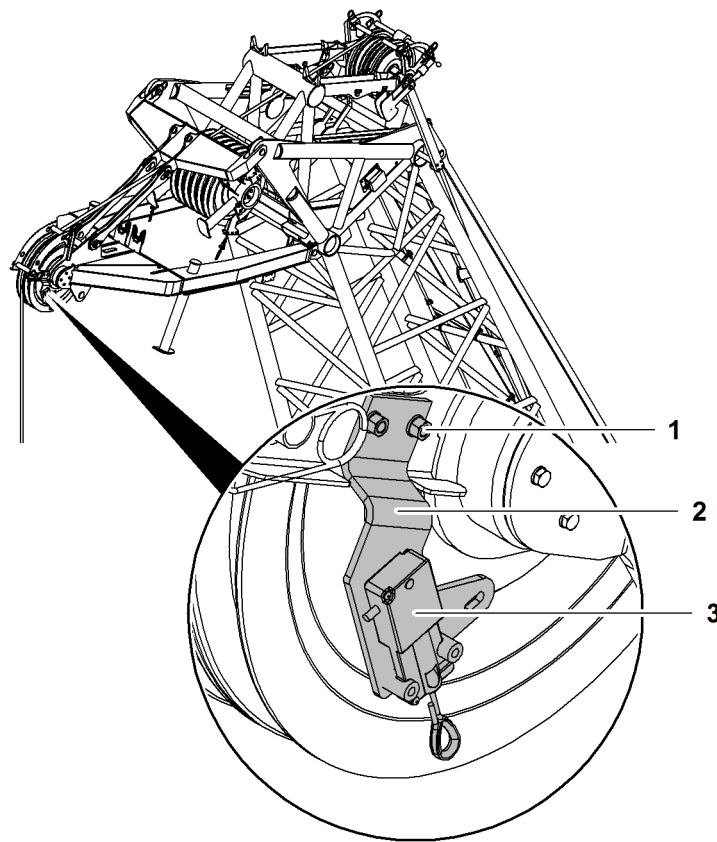


Fig. 3737: Deinstalling the installed limit switch plate

- | | | | |
|---|--------------------|---|--------------------|
| 1 | Screw (2x) | 3 | Hoist limit switch |
| 2 | Limit switch plate | | |

- ▶ Undo screws 1.
- ▶ Remove limit switch plate 2.
- ▶ Deinstall hoist limit switch 3 from limit switch plate 2.

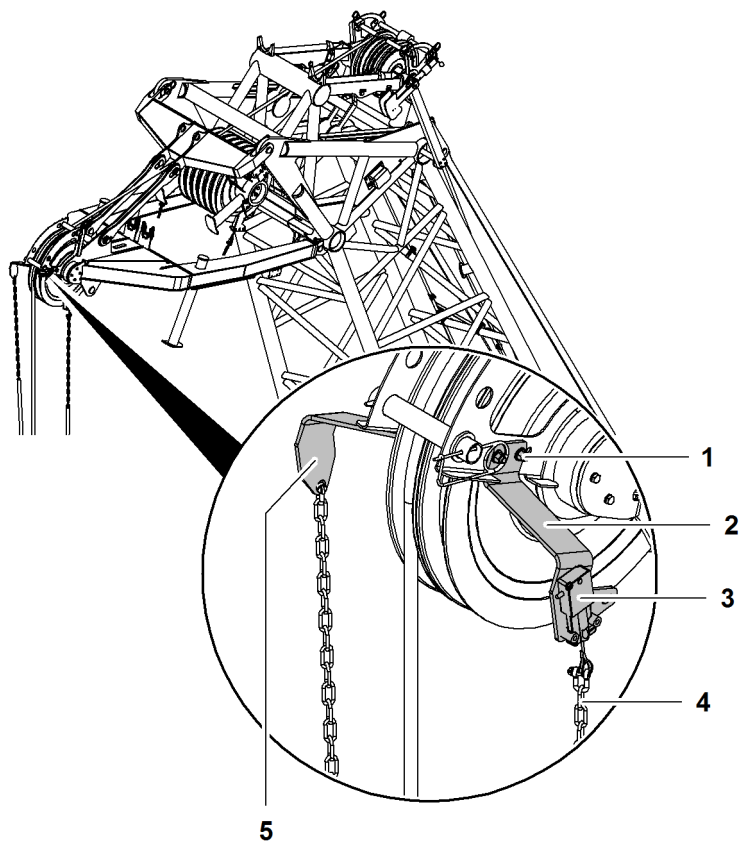


Fig. 3738: Installing the limit switch plate of the hoist limit switch clamp

- | | | | |
|---|--------------------|---|-------------|
| 1 | Screw (4x) | 4 | Chain (2x) |
| 2 | Limit switch plate | 5 | Steel plate |
| 3 | Hoist limit switch | | |

- ▶ Install available hoist limit switch **3** on limit switch plate **2**.
- ▶ Attach limit switch place **2** with screws to **1** auxiliary jib (36 t (79.300 lb)).
- ▶ Attach plate **5** on opposite side with screws.
- ▶ Attach chain **4** with shackle on hoist limit switch **3**.
- ▶ Attach chain **4** with shackle on plate **5**.

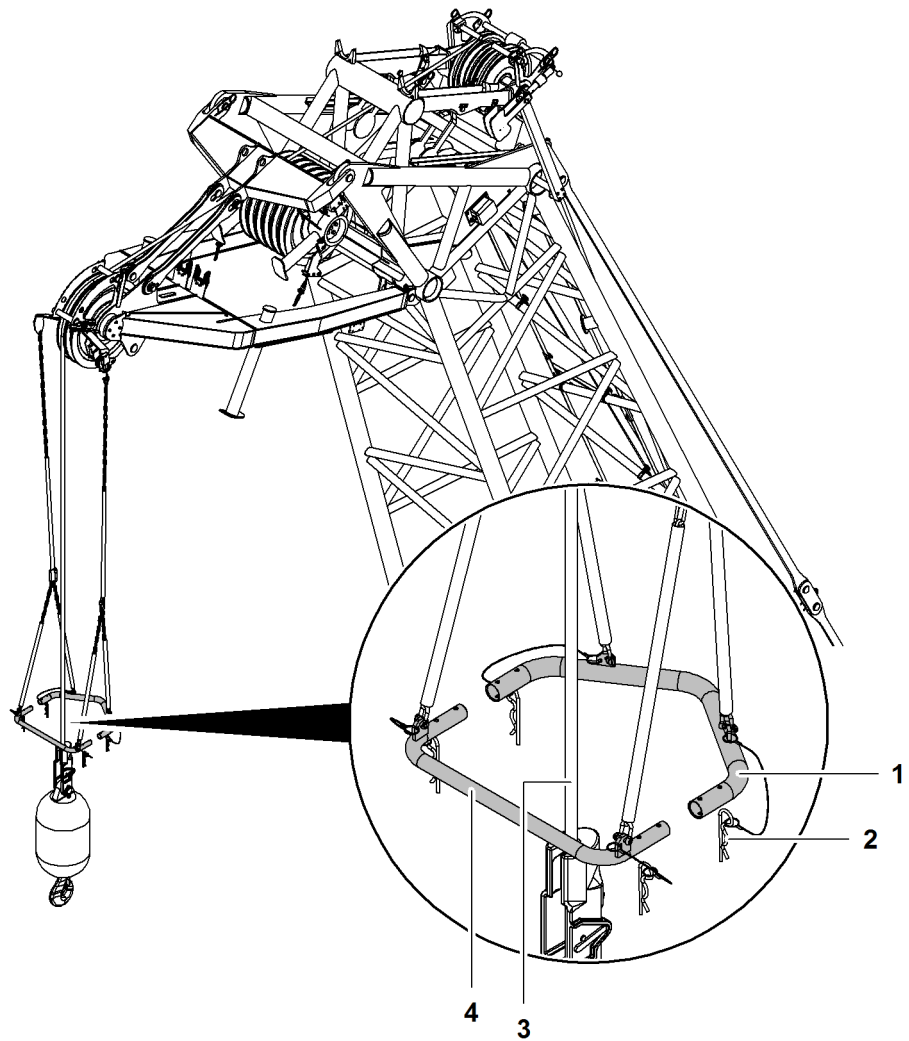


Fig. 3739: Place winch2 rope between hoist limit switch clamp

- | | | | |
|---|------------------------|---|-------------|
| 1 | Rear pipe | 3 | Winch2 rope |
| 2 | Spring cotter pin (4x) | 4 | Front pipe |

- ▶ Place winch2 rope 3 between rear pipe 1 and front pipe 4.
- ▶ Stick front pipe 4 into rear pipe 1.

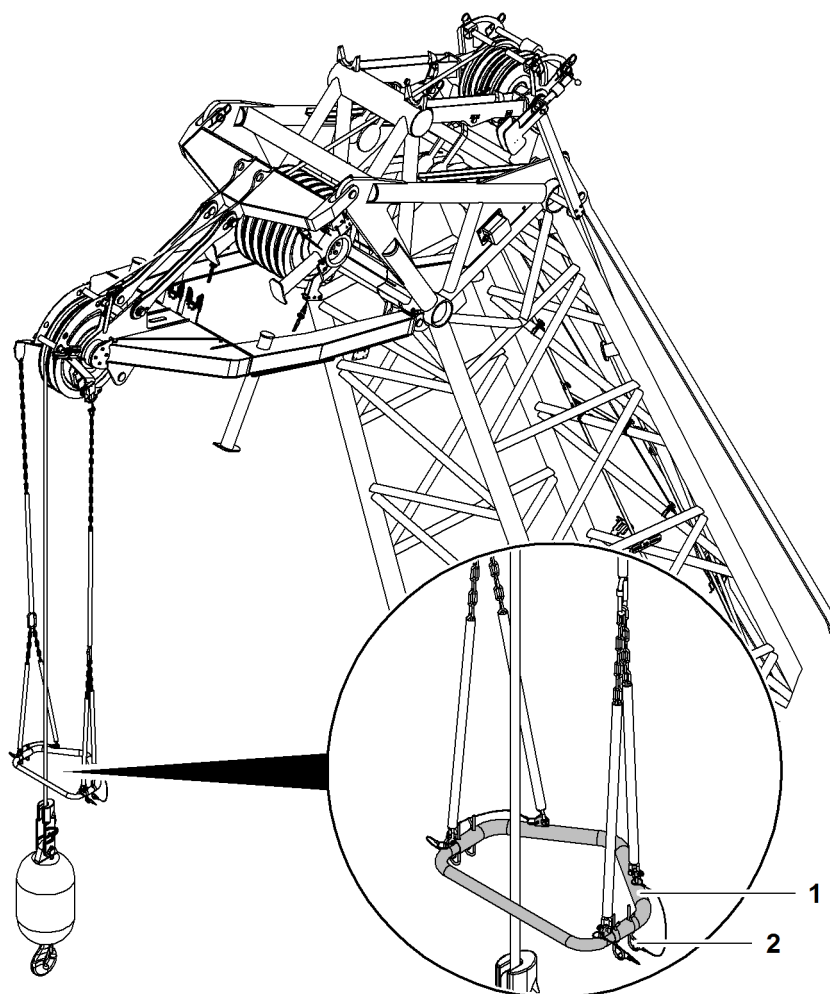


Fig. 3740: Assembling the hoist limit switch clamp

- 1 Hoist limit switch clamp 2 Spring cotter pin (4x)

► Insert spring cotter pin 2 into borings from below.

Bypass unused hoist limit switches.



DANGER

The hoist limit switch has been bypassed illegally!
Load breakaway.

► Only ever bypass unused hoist limit switches.

NOTICE

Wrong hoist limit switch is bypassed!
The hook damages the boom head.

- Lock winch 1 using the left hoist limit switch.
- Lock winch 2 using the right hoist limit switch.

Ensure that the following conditions are fulfilled:

- Only motion is performed with a rope of winch1/winch2. A hoist limit switch is not required.

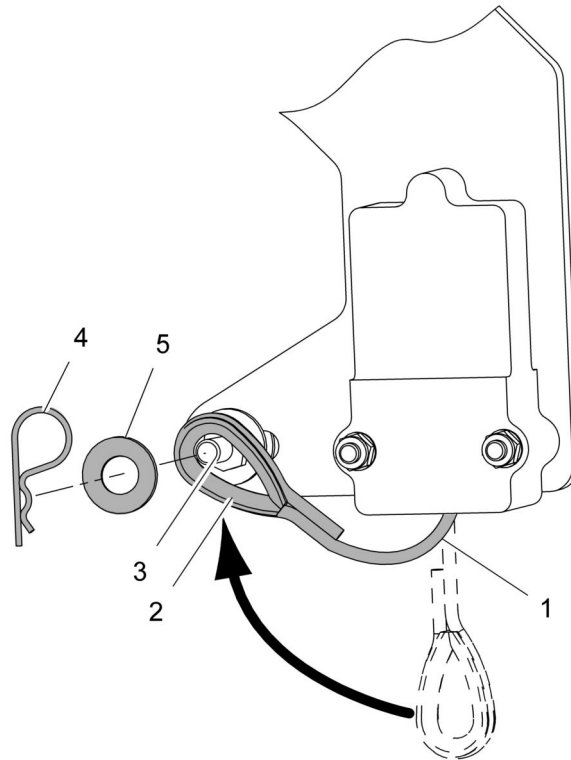


Fig. 3741: Bypassing the hoist limit switch mechanically

- | | | | |
|----------|------------|----------|------------|
| 1 | Steel rope | 4 | Safety pin |
| 2 | Loop | 5 | Washer |
| 3 | Stud bolt | | |

- ▶ Pull the steel rope **1** and place the loop **2** over the stud bolt **3**.
 - ▷ Hoist limit switch is bypassed.
- ▶ Protect the sling **2** from slipping off the stud bolt **3** by securing it with a washer **5** and a safety pin **4**.

7.10 Assembly of suspended counterweight of derrick equipment*

The suspended counterweight must be assembled before “erecting the main boom with derrick equipment*”. This makes assembly with the assist crane easier.

Make sure the following prerequisites are met:

- Assist crane is available.

7.10.1 Positioning the counterweight frame

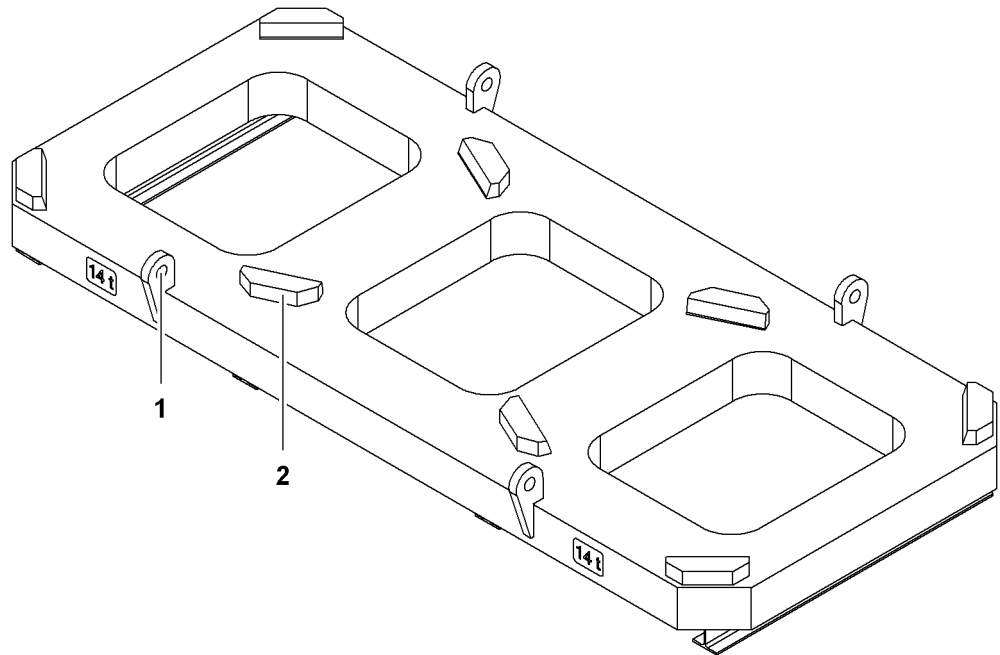


Fig. 3742: Positioning the counterweight frame

- | | |
|----------------------|-----------------------|
| 1 Rigging point (4x) | 2 Locking device (8x) |
|----------------------|-----------------------|

- ▶ Rig counterweight frame on rigging points 1.
- ▶ Lift counterweight frame.
- ▶ Center and place the counterweight frame on the ground approx. 6.5 m (21' 4" ft-in) behind the bolting points of the spacer frame.

7.10.2 Positioning the ballast slabs



DANGER

Incorrect counterweight!
Machine toppling over.

- ▶ Place ballast slabs in the center of gravity (central) on the counterweight frame.
 - ▶ Do not exceed the maximum permitted counterweight.
-
- ▶ Position ballast slabs on the counterweight frame.



DANGER

Slipping of the ballast slabs!
Machine toppling over.

- ▶ Pile of ballast slabs so that they are secured by the locking pins.

If no original ballast slabs are used:

- ▶ Secure counterweight slabs with tension chains.

- ▶ Secure counterweight slabs.

7.10.3 Release the pendant ropes from the derrick boom

Releasing the temporary attachment

The suspended counterweight pendant ropes temporarily attached to the derrick boom earlier must be released before it is erected.



WARNING

Unsecured walking on the boom!
Risk of falling.

- ▶ A fall arrest system must be worn when working on booms to prevent falling.

- ▶ Release the temporary attachment of the suspended counterweight pendant ropes on the derrick boom.

- ▶ Place the fastening materials in temporary storage.

Securing auxiliary rope

- ▶ Attach an auxiliary rope to each of the suspended counterweight pendant ropes on the left and right.
 - ▷ These enable assistants to guide the suspended counterweight pendant ropes when erecting the derrick boom.

7.11 Assembly of counterweight carriage of derrick equipment*

The counterweight carriage is delivered in two parts.

7.11.1 Positioning the wheeled counterweight carriage

Ensure that the following conditions are fulfilled:

- Wheel sets are parallel to counterweight frame.

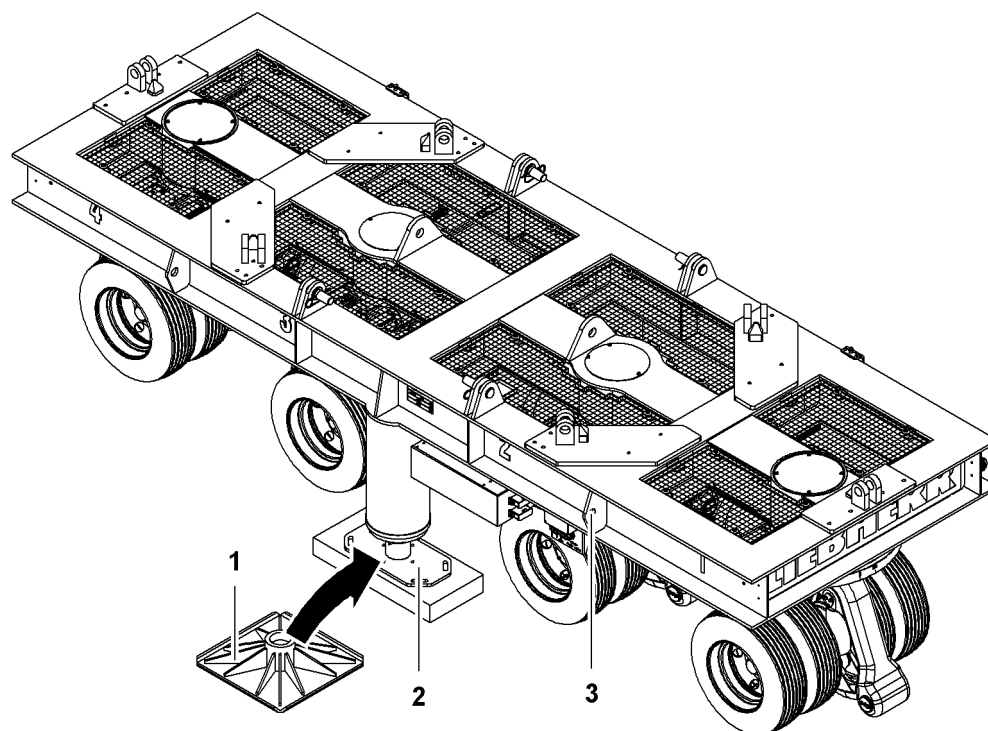


Fig. 3743: Positioning the wheeled counterweight carriage

- | | |
|------------------------------------|-----------------------------|
| 1 Working base plate (2x) | 3 Rigging point (4x) |
| 2 Transport base plate (2x) | |

- ▶ Rig counterweight carriage on rigging points **3**.
- ▶ Lift counterweight carriage.
- ▶ Lower counterweight carriage to the ground.
- ▶ Replace transport base plates **2** with working base plates **1**.

7.11.2 Attach the telescopic unit

Ensure that the following conditions are fulfilled:

- Counterweight carriage is horizontal.

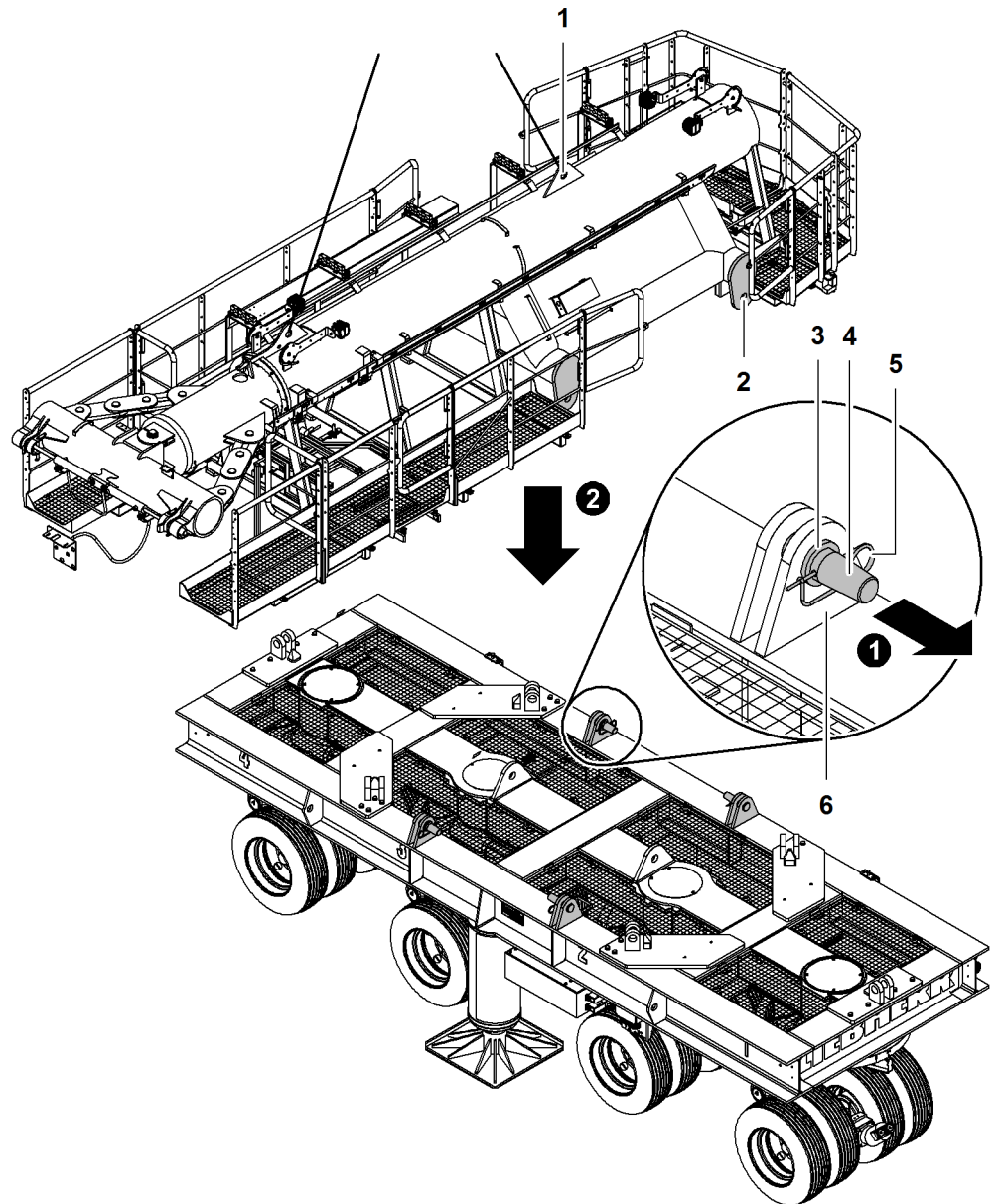


Fig. 3744: Attaching the extension device

- | | | | |
|---|--|---|---|
| 1 | Rigging point (2x) | 4 | Pin |
| 2 | Pin connection point (4x) for extension device | 5 | Locking spring |
| 3 | Washer (2x) | 6 | Pin connection point (4x) on counterweight carriage |

- ▶ Remove locking spring 5.
- ▶ Remove pins 4 and washers 3.
- ▶ Repeat procedure on all pin connection points 6 of the counterweight carriage.
- ▶ Rig extension device on rigging points 1.
- ▶ Lift extension device.

NOTICE

Improper positioning of extension device on counterweight carriage!
Damage to electric lines.

- ▶ Ensure that electric lines are not damaged when positioning the extension device on the counterweight carriage.

-
- ▶ Position extension device on counterweight carriage.

If the pin connection points **2** of the extension device aligns with the pin connection points **6** of the counterweight carriage:

- ▶ Bolt the telescopic unit to the wheeled counterweight carriage.
- ▶ Secure pin **4** with washers **3** and locking spring **5**.
- ▶ Repeat procedure on all pin connection points **6** of the counterweight carriage.

7.11.3 Connecting electric lines and hydraulic lines

- ▶ Plug electric lines of the counterweight carriage on terminal box of the extension device.
- ▶ Secure the electric plug in place.



Note

The hydraulic screw fittings are color-coded!

- ▶ Connect hydraulic lines of the same color.
-
- ▶ Screw hydraulic lines of the extension device into the back of the counterweight carriage.

7.11.4 Placing ladder and floodlight in working position

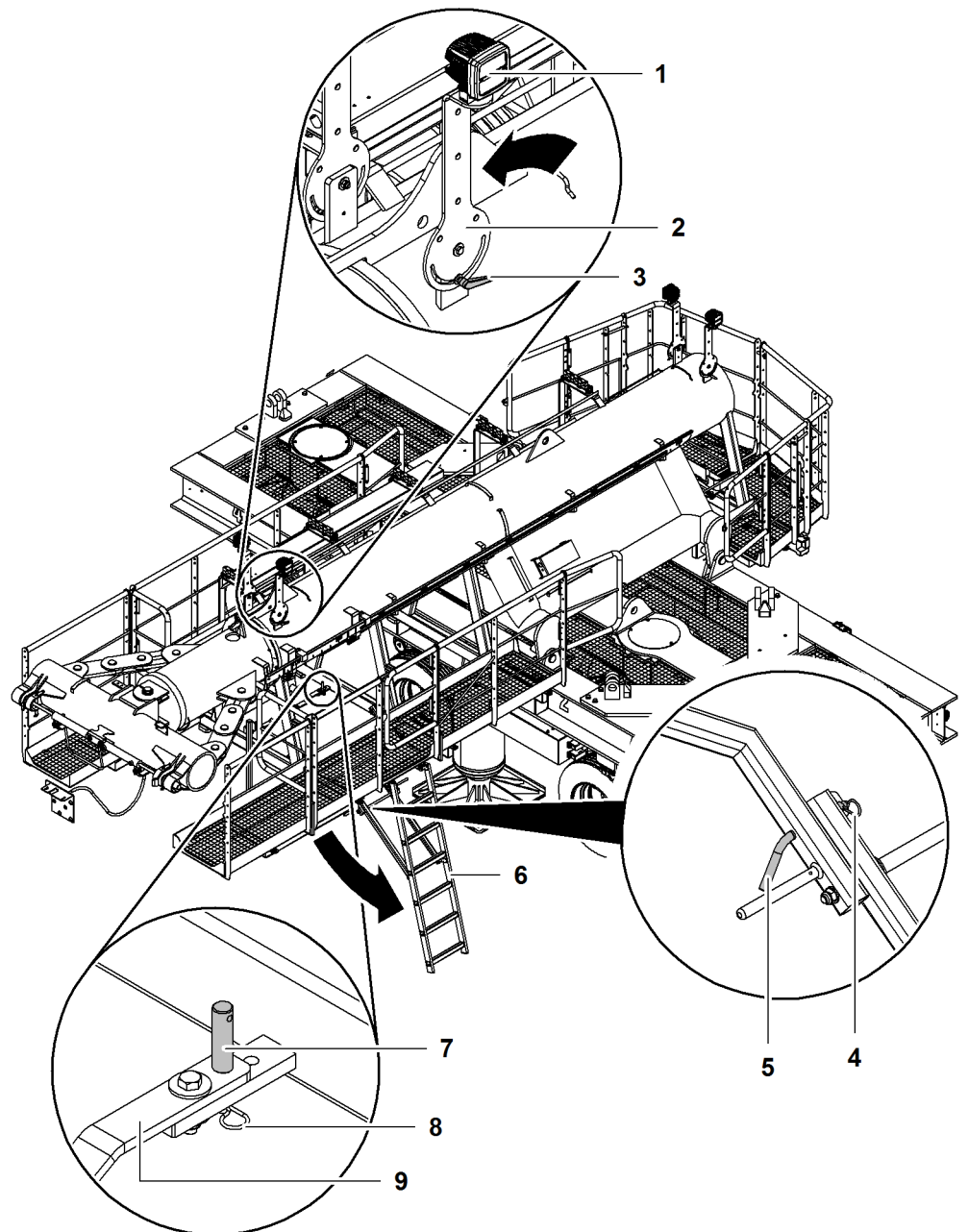


Fig. 3745: Placing ladder and floodlight in working position

- | | | | |
|---|------------------------|---|------------------------|
| 1 | Floodlight (4x) | 6 | Ladder |
| 2 | Bracket (4x) | 7 | Pin (2x) |
| 3 | Clamping device (4x) | 8 | Spring cotter pin (2x) |
| 4 | Spring cotter pin (2x) | 9 | Bar (2x) |
| 5 | Pin (2x) | | |

- ▶ Remove spring cotter pin 8.
- ▶ Remove pin 7.
- ▶ Turn bar 9 by 90°.
- ▶ Reinsert pin 7.
- ▶ Secure pin 7 with spring cotter pin 8.

- ▶ Repeat procedure on opposite side.
- ▶ Remove spring cotter pin 4.
- ▶ Remove pin 5.
- ▶ Repeat procedure on opposite side.
- ▶ Fold ladder 6 down.
- ▶ Reinsert pin 5.
- ▶ Secure pin 5 with spring cotter pin 4.
- ▶ Repeat procedure on opposite side.
 - ▷ Ladder is in working position.
- ▶ Undo clamping device 3.
- ▶ Turn bracket 2 by 90°.
- ▶ Tighten clamping device 3.
- ▶ Repeat procedure on all floodlights 1.
 - ▷ Floodlights are in working position.

7.11.5 Installing the counterweight carriage on the basic machine

Ensure that the following conditions are fulfilled:

- Counterweight carriage is assembled.

Position the basic machine in front of the wheeled counterweight carriage

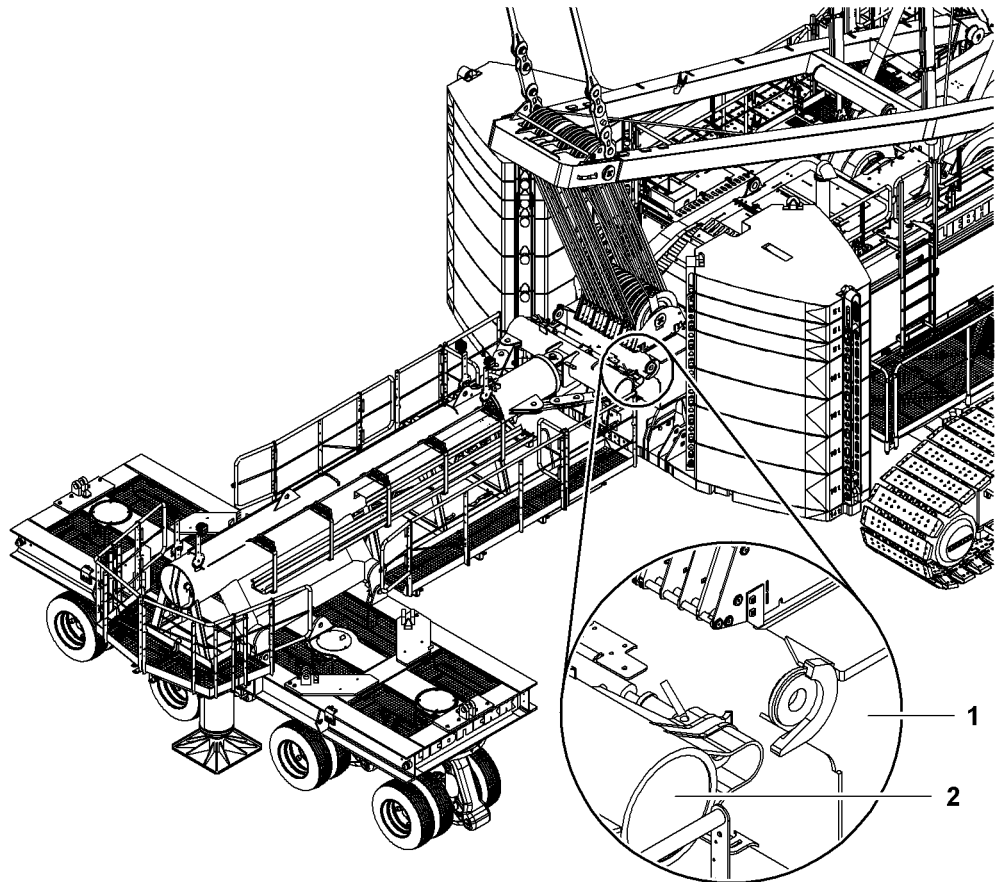


Fig. 3746: Positioning the basic machine in front of the counterweight carriage

1 Basic machine

2 Counterweight carriage

- ▶ Position rear of basic machine 1 in front of counterweight carriage 2.
- ▶ Ensure that the hydraulic lines and electric lines between the basic machine and the counterweight carriage can be connected.

Connecting electric lines and hydraulic lines with basic machine

- ▶ Plug the electric lines of the counterweight carriage into the basic machine.
- ▶ Lock electric plug.



Note

The hydraulic screw fittings are color-coded!

- ▶ Connect hydraulic lines of the same color.

- ▶ Screw hydraulic lines of the counterweight carriage onto the basic machine.

Selecting the counterweight carriage



- ▶ Press the *Mode* button on the monitor.
 - ▷ The *Mode* screen is displayed on the monitor.



If the counterweight carriage of the button *Counterweight carriage/suspended counterweight* is not lit green:

- ▶ press the *Counterweight carriage/suspended counterweight* button on the monitor.
 - ▷ Counterweight carriage of the button *Counterweight carriage/suspended counterweight* is lit blue.



- ▶ Press and hold the *Mode* button on control panel X12.



- ▶ Press the *Confirm* button on the monitor.

- ▶ Let go of the *Mode* button on control panel X12.
 - ▷ The symbol *Restart machine* is displayed on the monitor:



Fig. 3751: Symbol Restart machine

- ▶ Switch off the ignition.
- ▶ Start diesel engine after approx. 10 seconds.
 - ▷ Counterweight carriage is selected.

Aligning the counterweight carriage for mounting

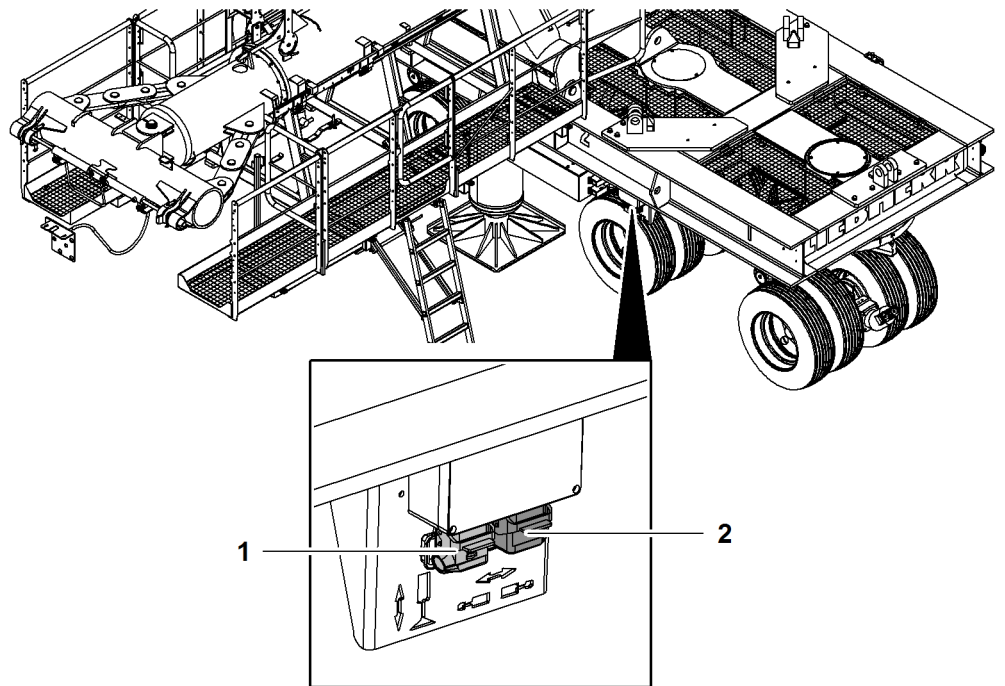


Fig. 3752: Inserting the cable remote control on the counterweight carriage

1 Plug for jack

2 Plug for pin connection cylinder

- ▶ Insert cable remote control at plug 1 for jack.

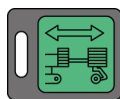


DANGER

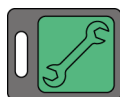
Asymmetric operation of jacks!
Wheeled counterweight carriage tipping over.

- ▶ Operate front jack and rear jack synchronously.

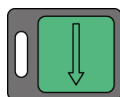
- ▶ Extend front jack and rear jack synchronously with cable remote control until pin connection points of the counterweight carriage and the pin connection points of the basic machine align.



- ▶ Press the button *Counterweight carriage radius adjustment* on control panel X26.



- ▶ Press and hold the *Counterweight carriage assembly functions* button on control panel X26.



- ▶ Press the button *Increase radius/support* on control panel X26 until the pin connection points of the counterweight carriage and the pin connection points of the basic machine align.

- ▶ Press the button *Counterweight carriage assembly functions* on control panel X26.

Pinning the counterweight carriage with the basic machine

Ensure that the following conditions are fulfilled:

- ❑ Signaller is in constant visual contact or radio contact to machine operator.

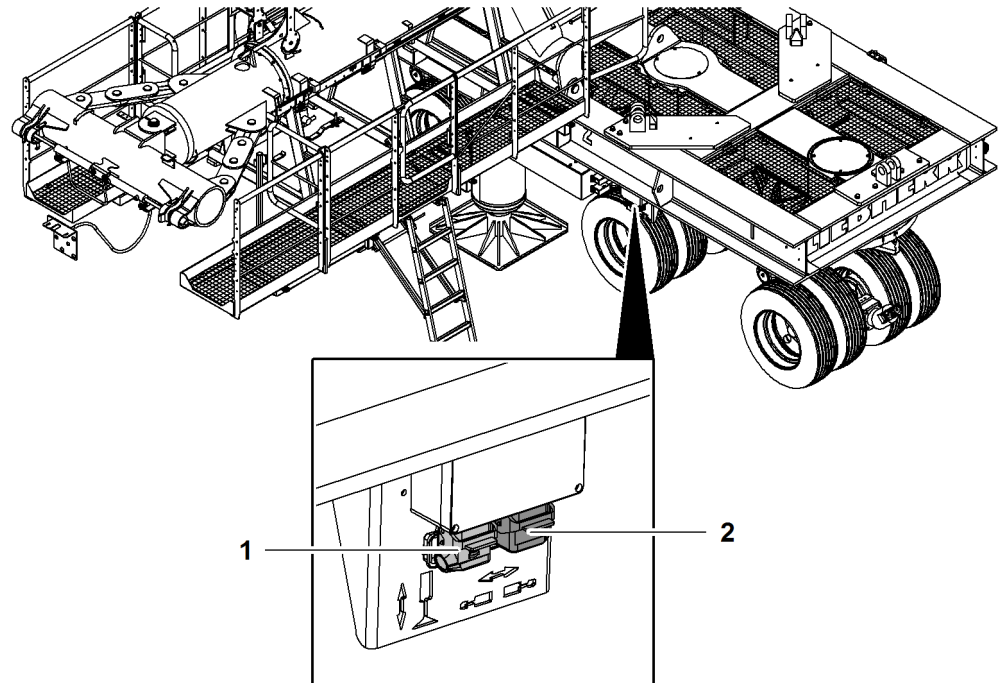


Fig. 3756: Inserting the cable remote control on the counterweight carriage

- 1 Plug for jack
- 2 Plug for pin connection cylinder
- Insert cable remote control at plug 2 for pin connection cylinder.

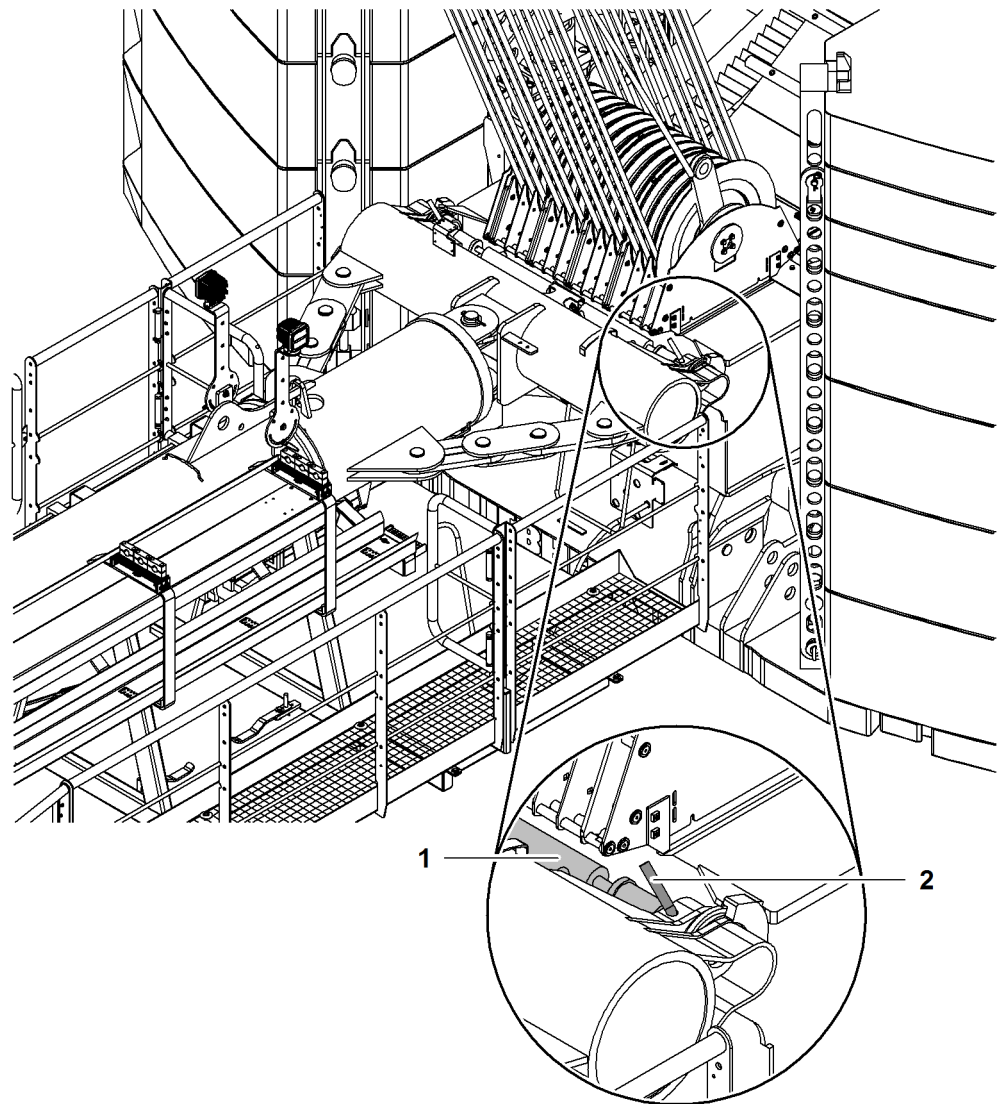


Fig. 3757: Pinning the counterweight carriage with the basic machine

1 Pin connection cylinder (2x) 2 Pin (2x)

- ▶ Remove pin 2.
- ▶ Extend pin connection cylinder 1 with cable remote control.
- ▶ Secure pin connection cylinder 1 with pins 2.

Align wheel sets

Ensure that the following conditions are fulfilled:

- Counterweight carriage is pinned to basic machine.
- Electric lines and hydraulic lines are connected to basic machine.
- Height adjusting cylinders of the wheel sets are fully retracted.

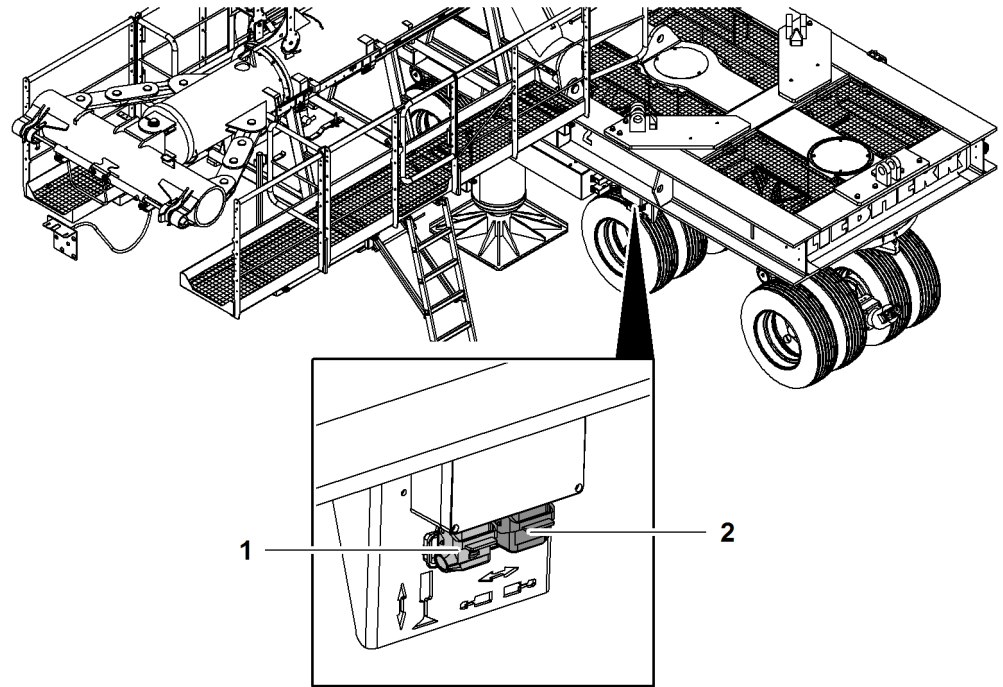
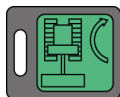
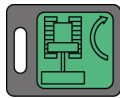


Fig. 3758: Inserting the cable remote control on the counterweight carriage

- 1 Plug for jack
- 2 Plug for pin connection cylinder

- ▶ Insert cable remote control at plug 1 for jack.
- ▶ Completely extend jacks with cable remote control.
 - ▷ The wheel sets are raised off the ground.
- ▶ Press the button *Follower mode* on control panel X26.



- ▶ Press the button *Align wheel sets* on control panel X26.
 - ▷ The wheel sets are aligned.
- ▶ Press the button *Follower mode* on control panel X26 again.

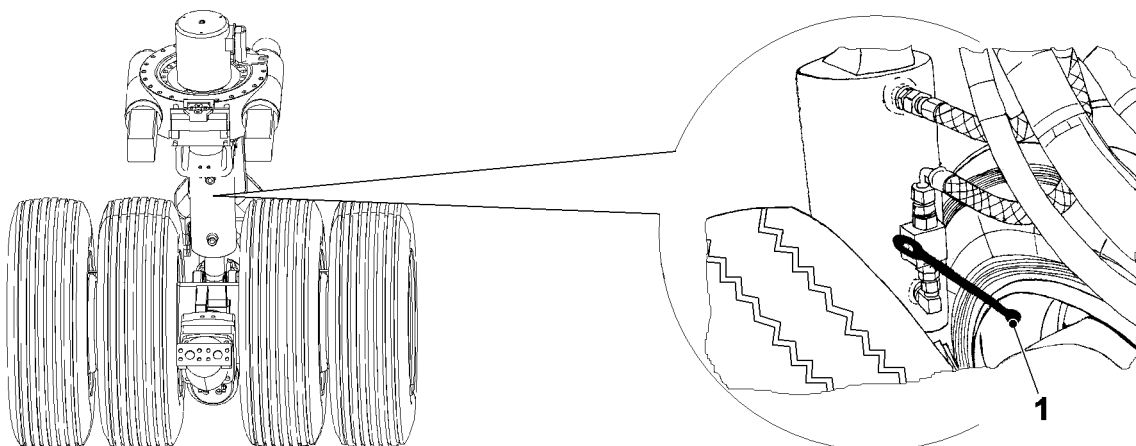


Fig. 3762: Close locking elements of external wheel sets.

- 1 Locking element (2x)

- ▶ Close locking elements 1 of the external wheel sets.

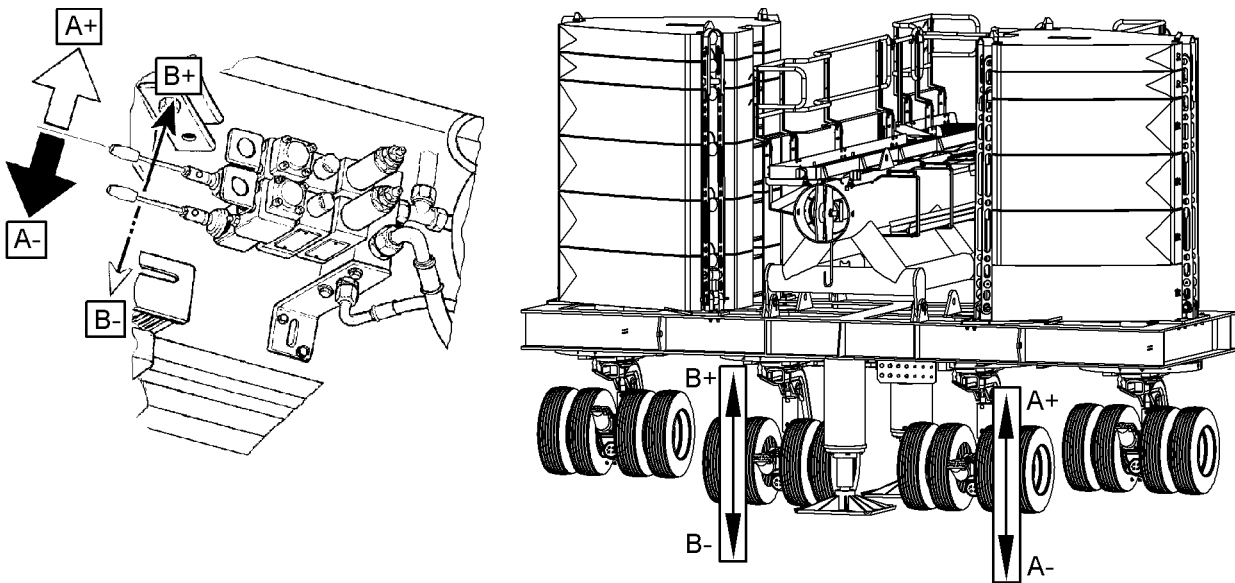


Fig. 3763: Operating the height adjusting cylinder of the inner wheel sets

The control levers of the height adjusting cylinders of the inner wheel sets are located between the jacks.

- ▶ Fully extend height adjusting cylinders of the inner wheel sets with control lever.



WARNING

Improper opening of locking element!
Wheel sets adapt automatically to height.
Crushing of body parts.

- ▶ Make sure that no persons are located beneath the wheel sets.

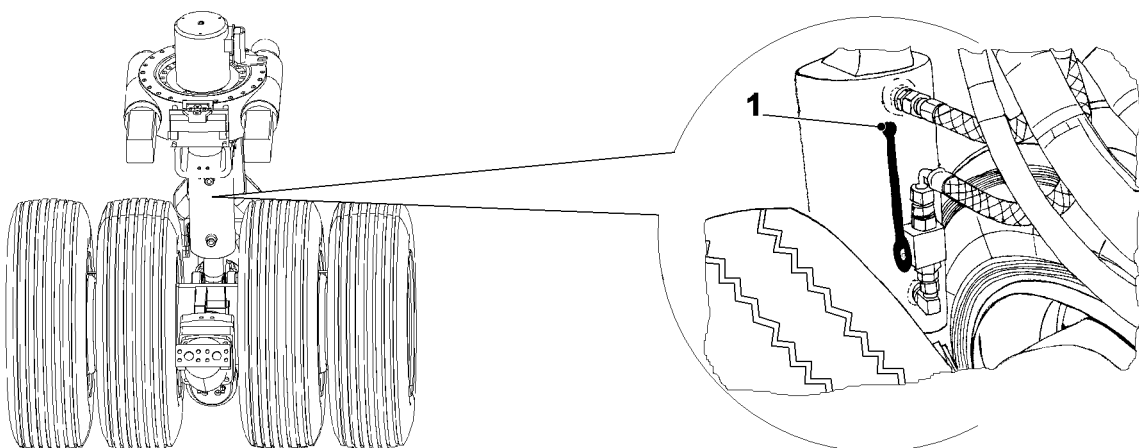


Fig. 3764: Opening the locking elements of the external wheel sets

- 1 Locking element (2x)

- ▶ Open the locking elements 1 of the external wheel sets.
 - ▷ External wheel sets adjust to the same height.
- ▶ Completely retract jacks with cable remote control.

Undoing counterweight carriages pendant straps from derrick boom

Undoing the temporary attachment of the counterweight carriage pendant straps

The wheeled counterweight carriage pendant straps temporarily attached to the derrick boom earlier must be released before it is erected.



WARNING

Unsecured walking on the boom!
Risk of falling from boom.

- ▶ A fall arrest system must be worn when working on booms to prevent falling.
-
- ▶ Release the temporary attachment of the wheeled counterweight carriage pendant straps on the derrick boom.
 - ▶ Place the fastening materials in temporary storage.

Attach auxiliary ropes and guide counterweight carriage pendant straps

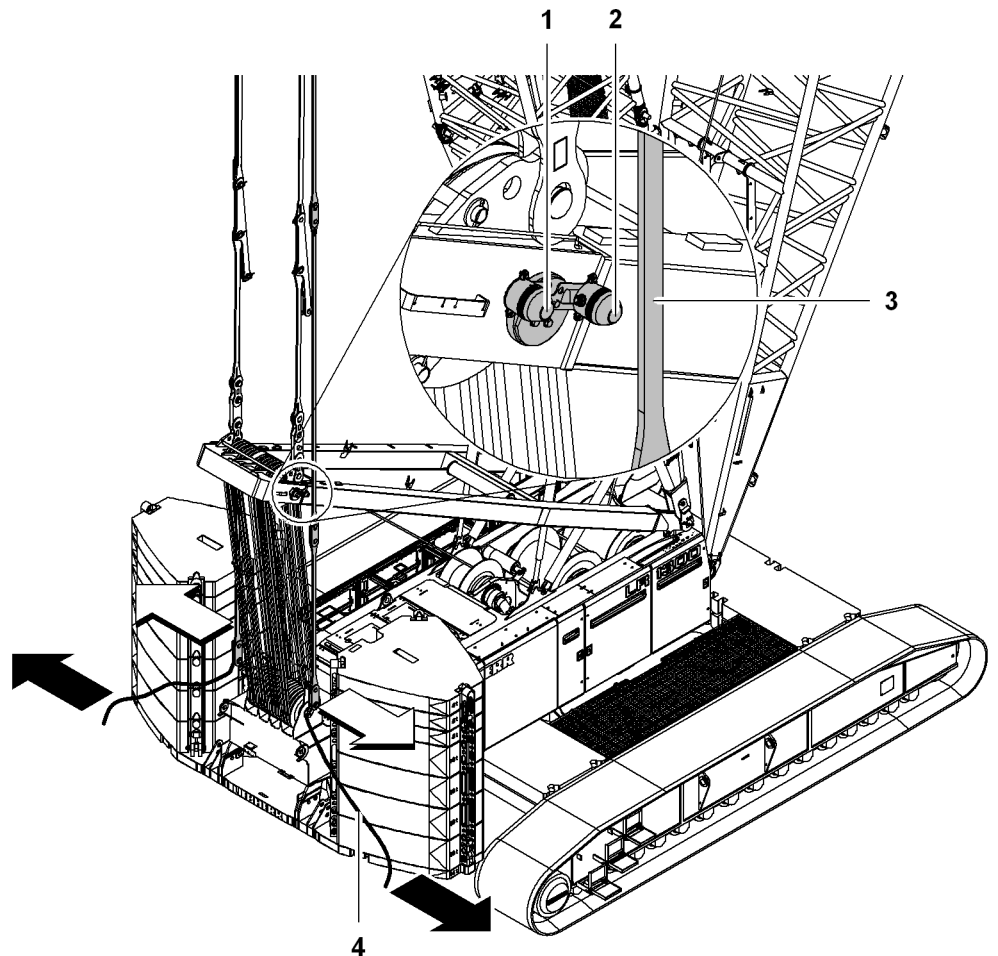


Fig. 3765: Secure auxiliary ropes and guide wheeled counterweight carriage pendant straps

- | | | | |
|---|--------------------------|---|---|
| 1 | Load Moment Limiter lamp | 3 | Wheeled counterweight carriage pendant strap (2x) |
| 2 | Flashing light | 4 | Auxiliary rope (2x) |

NOTICE

Unguided wheeled counterweight carriage pendant straps **3** while erecting derrick boom!

Damage to flashing light **2** and Load Moment Limiter lamp **1**.

- ▶ Ensure that wheeled counterweight carriage pendant straps **3** are guided using auxiliary ropes **4**.
- ▶ Attach an auxiliary rope **4** to each of the wheeled counterweight carriage pendant straps **3** on the left and right.
 - ▷ These enable assistants to guide the wheeled counterweight carriage pendant straps when erecting the derrick boom.

7.11.6 Placing and lashing counterweight slabs



DANGER

Incorrect counterweight!
Machine toppling over.

- ▶ Counterweight slabs must always be stacked equally on both sides.
- ▶ Observe the maximum permissible counterweight weight.
- ▶ Ensure that counterweight slabs are secured with locking aids.

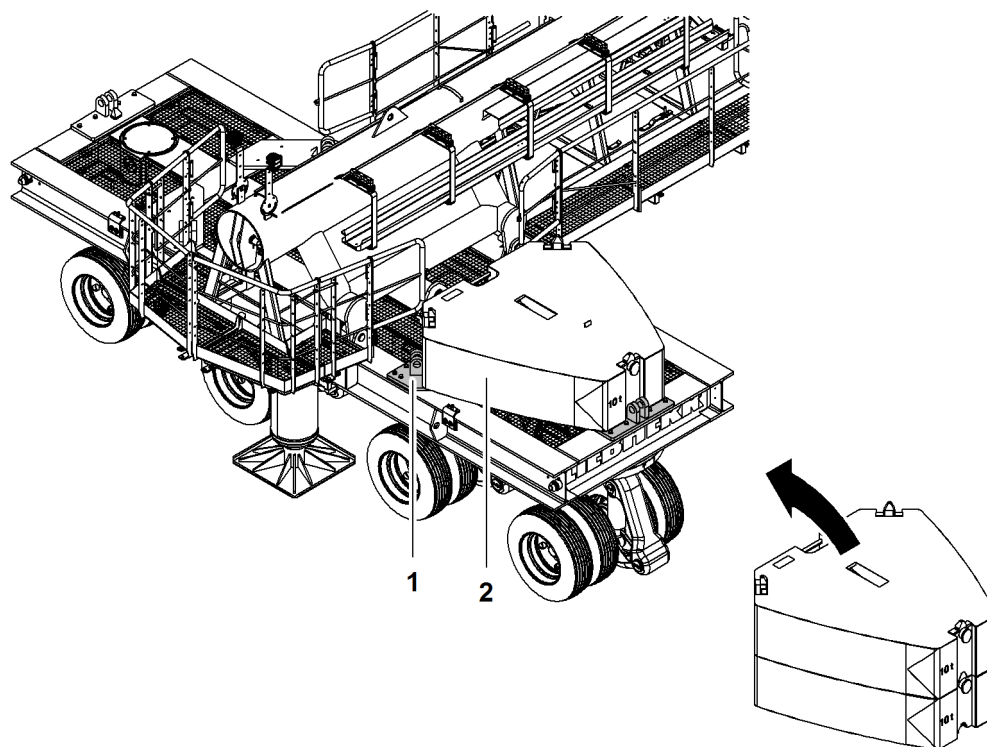


Fig. 3766: Positioning the counterweight slabs

1 Locking aid (6x)

2 Counterweight slabs

- ▶ Place counterweight slabs 2 on locking aids 1 of the counterweight carriage.



WARNING

Counterweight slabs lashed incorrectly!
Dropping counterweight slabs.

- ▶ Only lash counterweight slabs as described below.

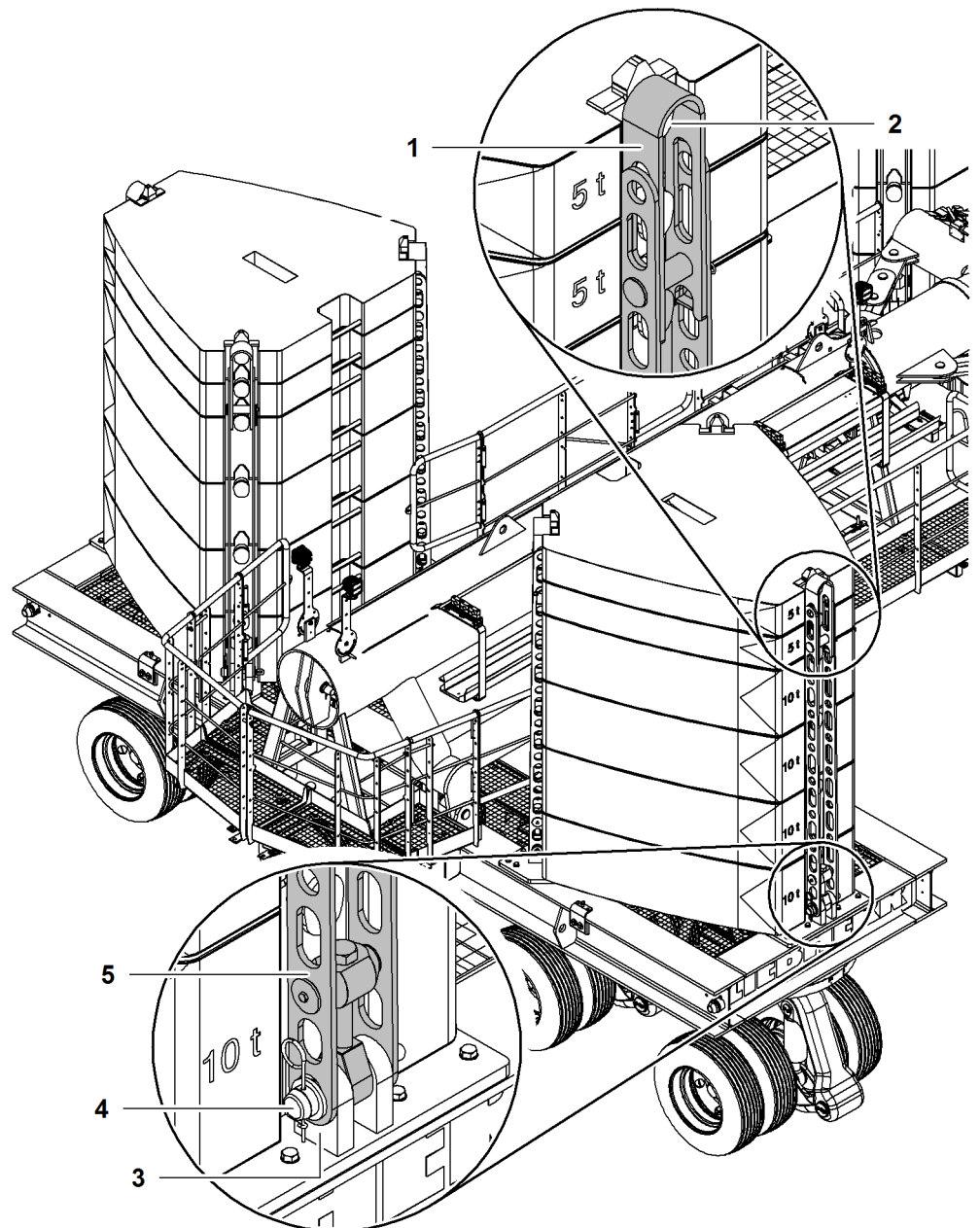


Fig. 3767: Lashing the counterweight slabs

- | | | | |
|---|--|---|--------------------------------|
| 1 | Counterweight tie-down shackle | 4 | Pin |
| 2 | Rigging point | 5 | Counterweight tie-down shackle |
| 3 | Pin connection point of the counterweight carriage | | |

- ▶ Pin counterweight tie-down shackle 5 with pin connection point 3 of the counterweight carriage.
- ▶ Secure pin 4 with washer and locking spring.
- ▶ Repeat procedure on all pin connection points 3 of the counterweight carriage.
- ▶ Fold up counterweight tie-down shackle 1.
- ▶ Lift counterweight tie-down shackle 1 over rigging point 2 of counterweight slab.
- ▶ Repeat procedure with all counterweight tie-down shackles 1.

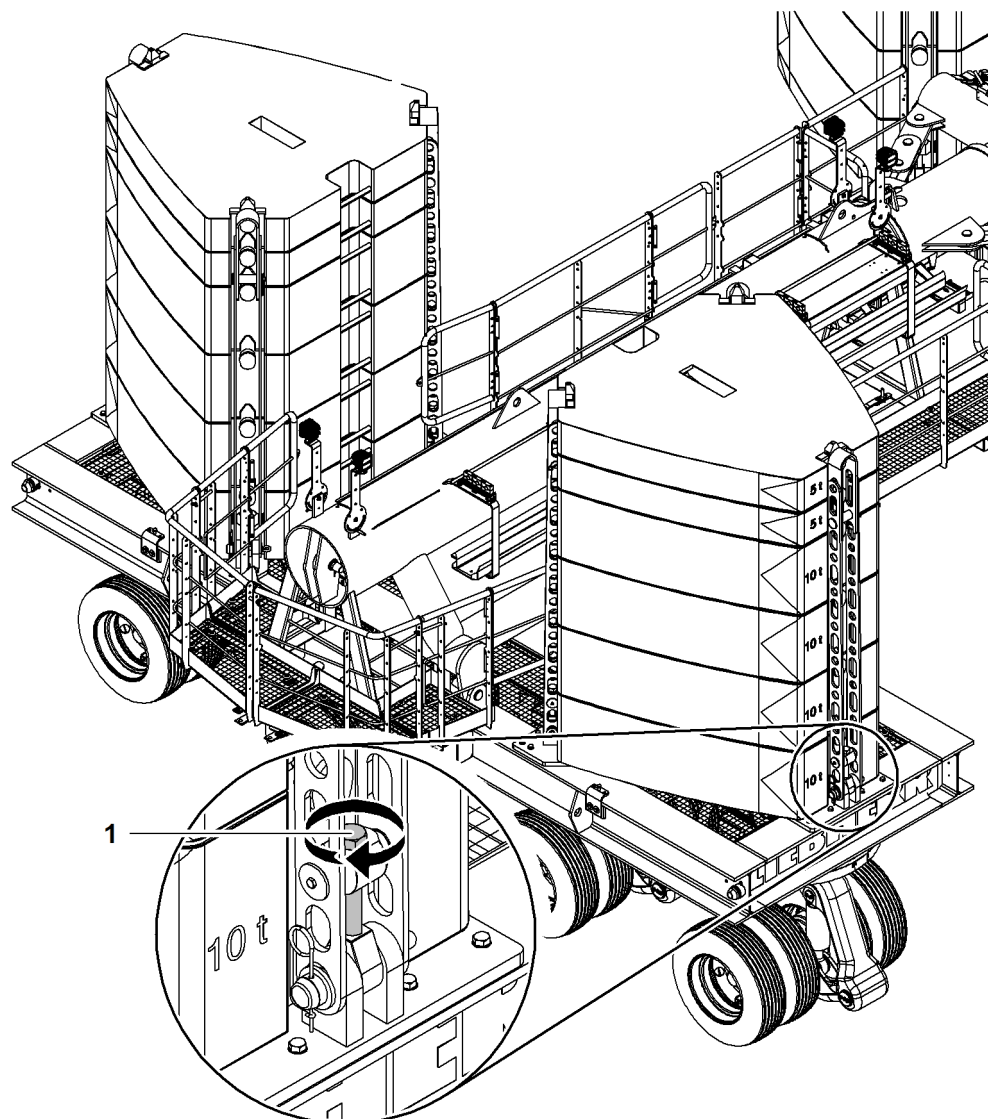


Fig. 3768: Tightening counterweight tie-down screws

1 Screw

- ▶ Tighten the screw 1 hand-tight using a wrench.
- ▶ Repeat procedure with all counterweight tie-down shackles.
 - ▷ Counterweight slabs are lashed.

7.12 Erecting the main boom with derrick equipment*

Make sure the following prerequisites are met:

- Suspended counterweight pendant ropes and/or counterweight carriage pendant straps are no longer tied to derrick boom.
- One auxiliary rope each is attached to the suspended counterweight pendant ropes and/or counterweight carriage pendant straps.
- Main boom pendant straps are connected to the derrick rope rigging.

7.12.1 Raising the derrick boom



DANGER

Inappropriate lifting of the derrick boom!
Machine toppling over.

- ▶ Leave the main boom on the ground while erecting the derrick boom.
- ▶ Ensure that the main boom pendant straps are not slack.

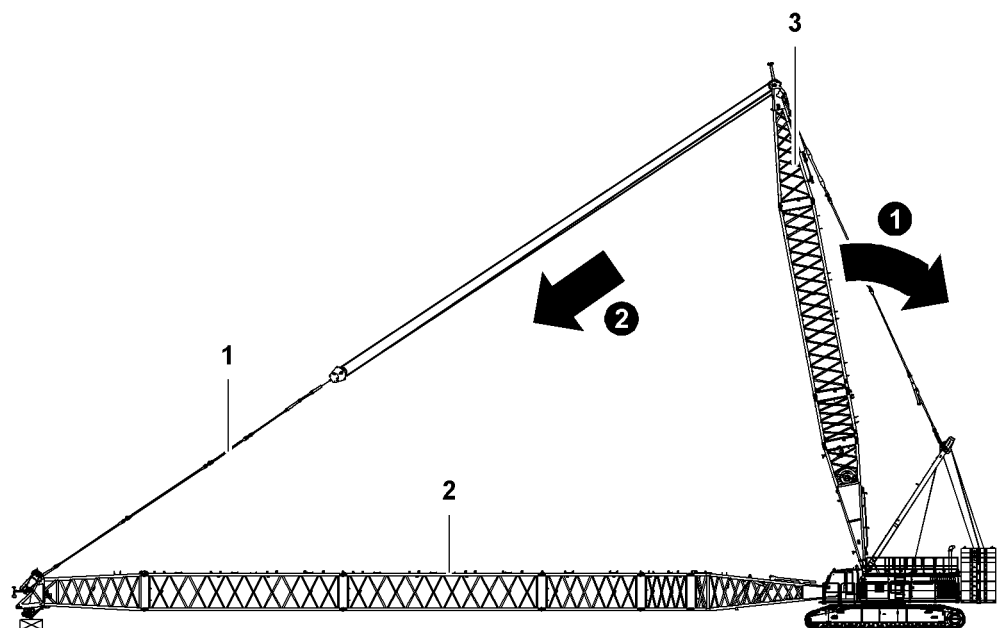


Fig. 3769: Lifting the derrick boom

- | | | | |
|---|--------------------------|---|--------------|
| 1 | Main boom pendant straps | 3 | Derrick boom |
| 2 | Main boom | | |

- ▶ Reeve derrick winch until main boom pendant straps 1 are tensioned.
- ▶ Reeve main boom luffing winch and unwind derrick winch at the same time.
 - ▷ Derrick boom 3 lifts.
 - ▷ Main boom pendant straps 1 remain pre-tensioned.
 - ▷ Main boom 2 stays on the ground.
- ▶ Erect derrick boom 3 up to 70°.
 - ▷ Limit switch triggers.
 - ▷ Main boom adjusting winch stops.



- ▶ Press the *Bypass limit switch* button on control panel X23.

NOTICE

Uncontrollable swinging of suspended counterweight pendant ropes or counterweight carriage pendant straps!
Damage to machine.

- ▶ Two assistants hold the auxiliary ropes of the suspended counterweight pendant ropes or the counterweight carriage pendant straps.
- ▶ Wind up the boom winch further.

7.12.2 Checking the derrick boom tilting-back supports

Above a derrick boom angle of 90° the derrick boom tilting-back supports swing backward.



CAUTION

Improper checking of the derrick boom tilting-back support!
Risk of crushing limbs.

- ▶ Do not place any limbs between uppercarriage and derrick boom tilting-back supports.

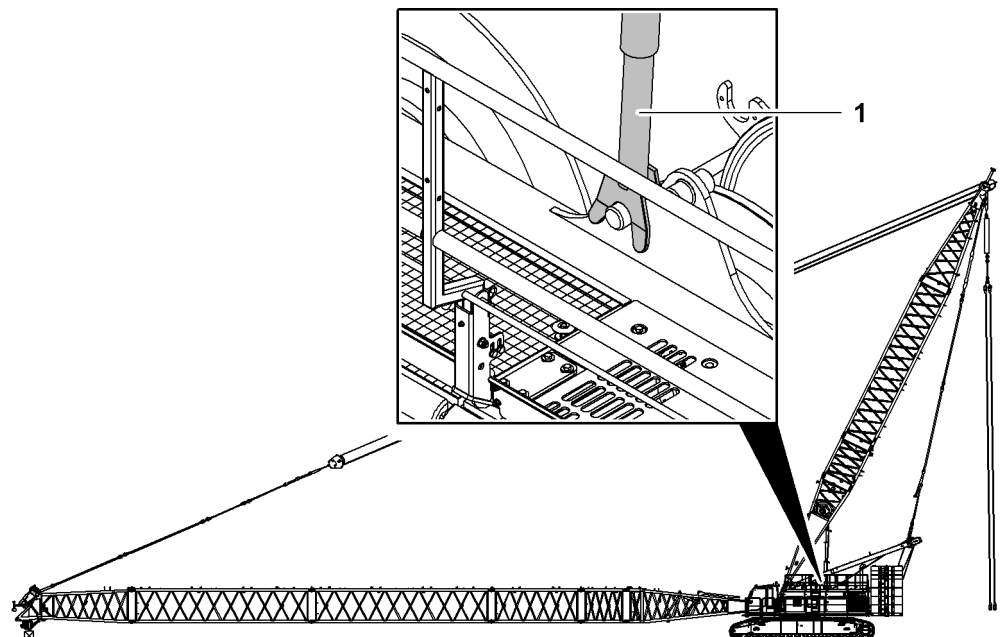


Fig. 3771: Checking the derrick boom tilting-back supports

1 Derrick tilting-back support (2x)

- ▶ Check forks of derrick boom tilting-back supports 1 for correct fit.
- ▶ If necessary, guide forks of derrick boom tilting-back supports 1.

7.12.3 Pinning the suspended counterweight pendant ropes to the counterweight frame

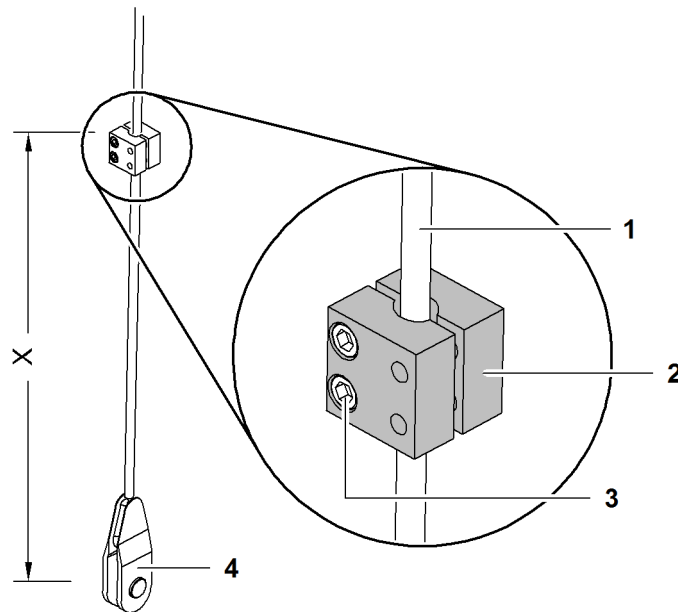


Fig. 3772: Positioning the rope clamps

- | | | | |
|---|--------------------------------------|---|------------|
| 1 | Suspended counterweight pendant rope | 3 | Screws |
| 2 | Rope clamp | 4 | Link plate |

Machine type	Distance X
LR 1005	1929 mm 6' 4" ft-in
LR 1006	1818 mm 6' ft-in

Tab. 523: Distance X depending on machine type

The rope clamps **2** must be attached at exactly the same height on the left and right.

- ▶ Attach rope clamp **2** on the front suspended counterweight pendant rope **1**.
- ▶ Position rope clamp **2** so that the top edge of the rope clamp **2** protrudes **X** over the pin connection point of the link plate **4**.
- ▶ Tighten screws **3** of the rope clamp **2**.
 - ▷ Rope clamp **2** is secured against slipping.
- ▶ Repeat procedure on opposite side.

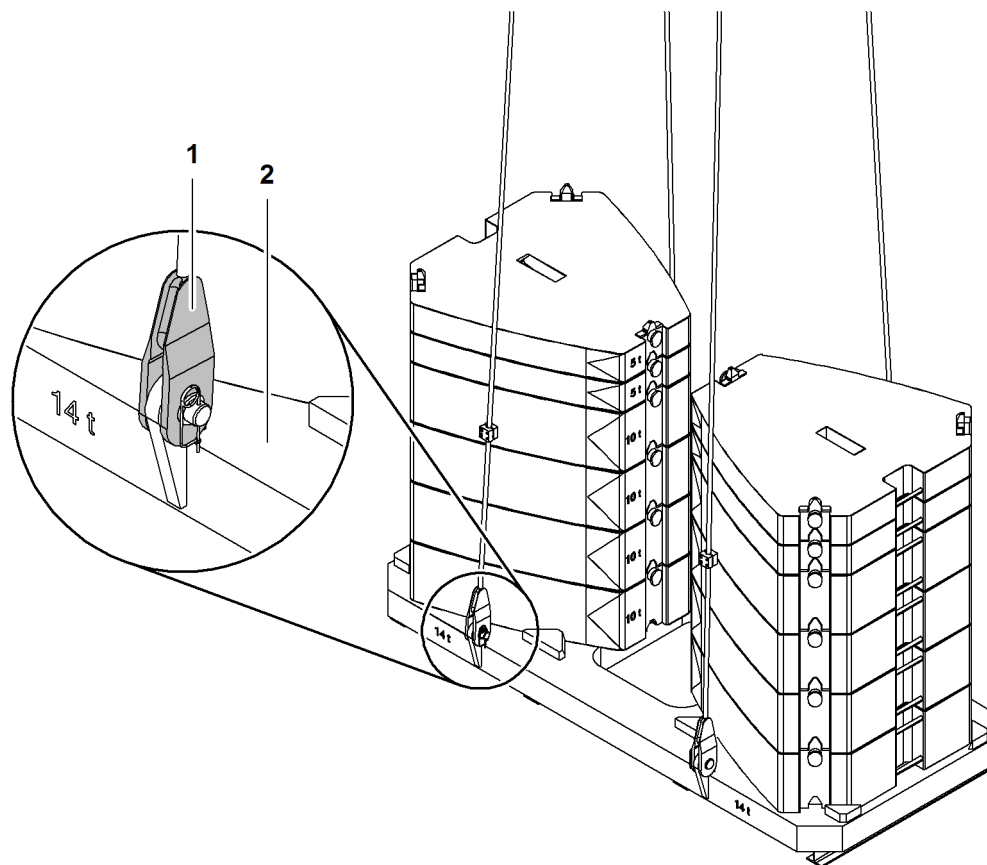


Fig. 3773: Pinning the suspended counterweight pendant ropes to the counterweight frame

- 1** Suspended counterweight pendant rope **2** Counterweight frame

- ▶ Pin the suspended counterweight pendant rope **1** to the counterweight frame **2**.
- ▶ Secure the pins with washers and safety pins.
- ▶ Repeat procedure on all pin connection points of the counterweight frame **2**.

7.12.4 Pinning the spacer frame with the uppercarriage

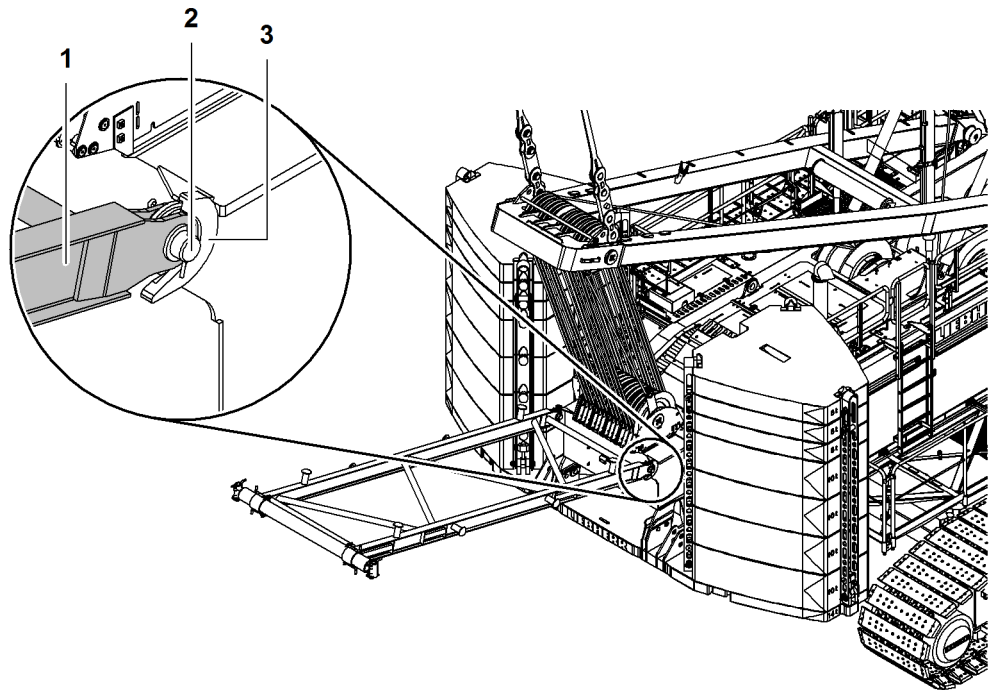


Fig. 3774: Pinning the spacer frame with the uppercarriage

- | | |
|-----------------------|------------------------|
| 1 Spacer frame | 3 Uppercarriage |
| 2 Pin (2x) | |

The spacer frame **1** can be lifted with the derrick hoist cylinder or with an assist crane.

- ▶ Rig spacer frame **1**.
- ▶ Align spacer frame **1** to pin connection points on uppercarriage **3**.
- ▶ Pin spacer frame **1** with uppercarriage **3**.
- ▶ Secure pins **2** with washers and split pins.

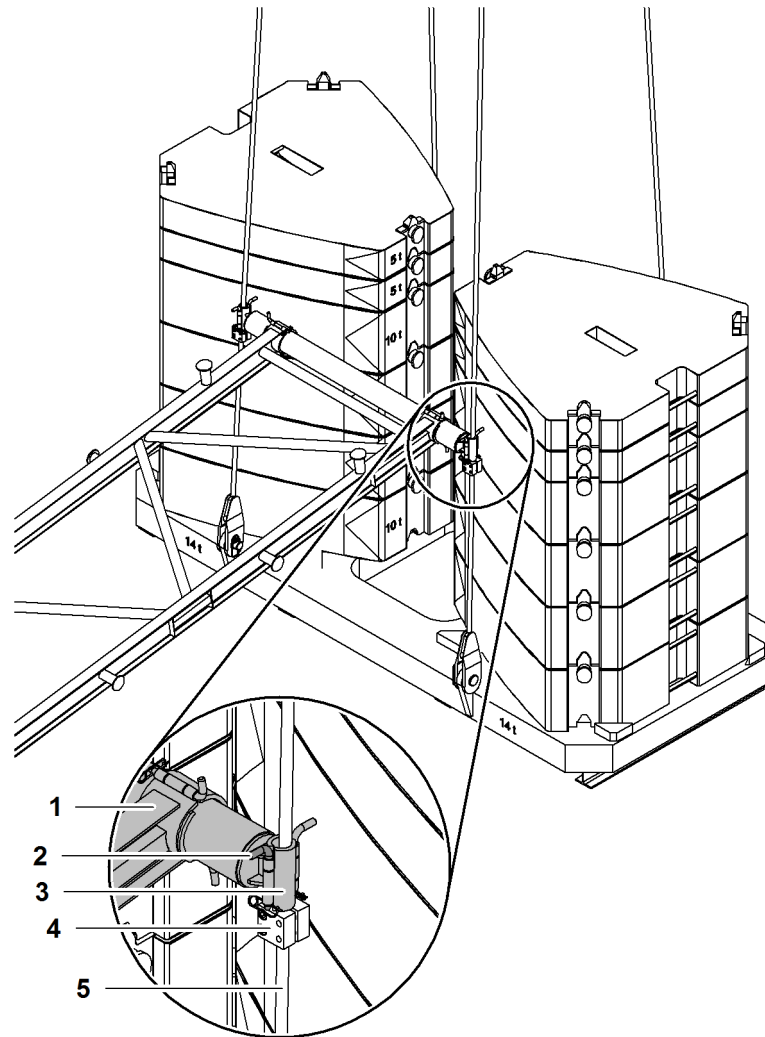


Fig. 3775: Fastening the spacer frame to the suspended counterweight pendant ropes

- | | | | |
|---|-------------------|---|---|
| 1 | Spacer frame | 4 | Rope clamp (2x) |
| 2 | Pin (2x) | 5 | Suspended counterweight pendant rope (2x) |
| 3 | Rope opening (2x) | | |

- ▶ Remove pins **2** of rope openings **3**.
- ▶ Fold open rope openings **3**.
- ▶ Lift spacer frame **1** and insert rope openings **3** on the front suspended counterweight pendant ropes **5** above the rope clamps **4**.
- ▶ Close rope openings **3**.
- ▶ Secure rope openings **3** with pins **2** and locking springs.
 - ▷ Spacer frame **1** rests on the rope clamps **4** of the suspended counterweight pendant ropes **5**.

7.12.5 Pinning the counterweight carriage pendant straps to the counterweight carriage

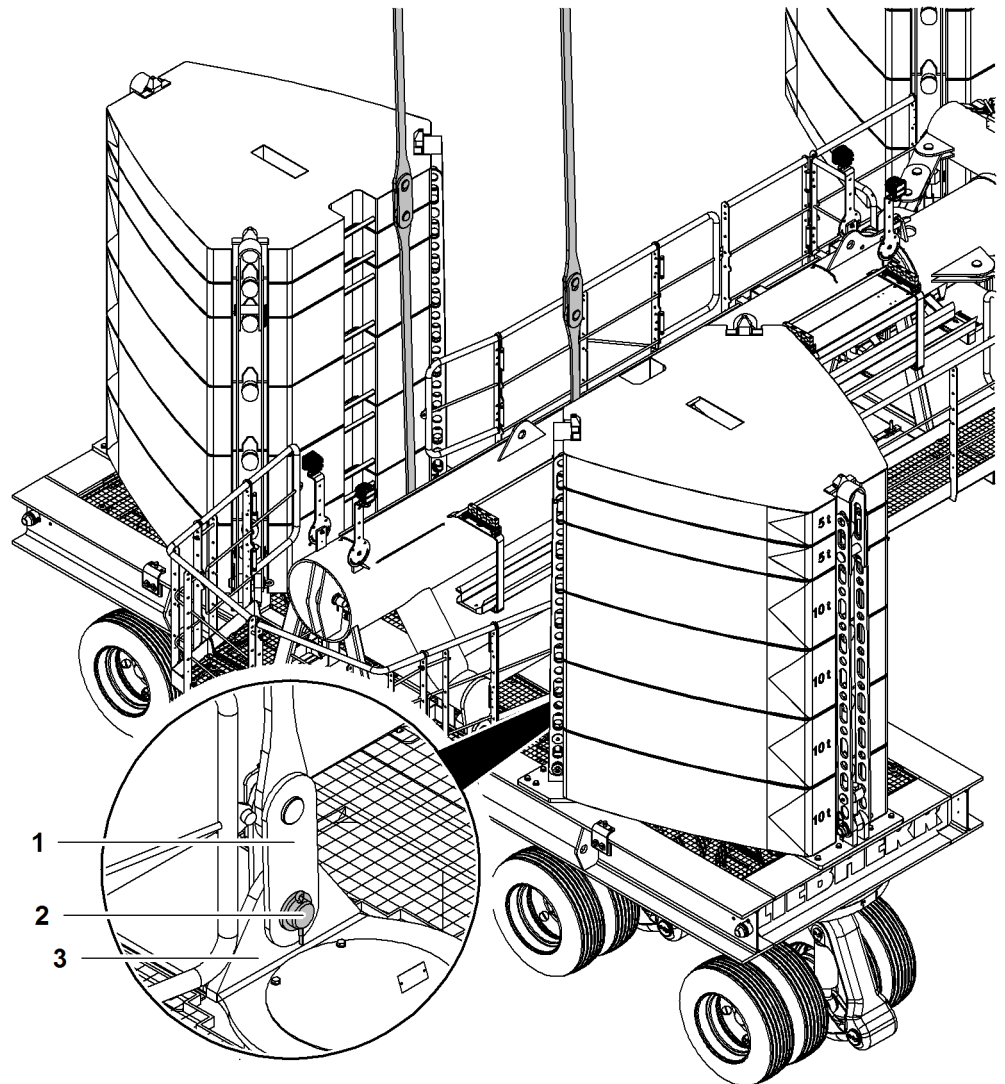


Fig. 3776: Pinning the counterweight carriage pendant straps to the counterweight carriage

- | | |
|---|---|
| <p>1 Counterweight carriage pendant straps</p> <p>2 Pin</p> | <p>3 Pin connection point on counterweight carriage</p> |
|---|---|
- ▶ Pin counterweight carriage pendant straps 1 with pin connection point on 3 counterweight carriage.
 - ▶ Secure pins 2 with washers and split pins.
 - ▶ Repeat procedure on opposite side.

7.12.6 Erecting the main boom



DANGER

Erectability chart is not followed!
Machine toppling over.

- ▶ Only lift main boom when erection is permitted according to the erectability chart.

Ensure that the following conditions are fulfilled:

- Boom configuration can be erected with counterweight.
- All work on the main boom has been completed.
- No loose parts or tools have been left on the main boom.

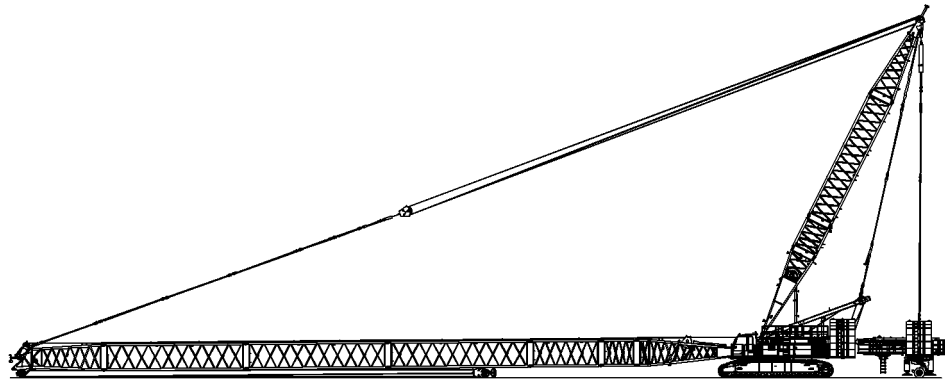


Fig. 3777: Main boom on the ground (illustration of principle)



DANGER

Hoist limit switch bypassed on control panel X23 in crane mode!
Load breakaway.

- ▶ Only bypass hoist limit switch on control panel X23 when assembling or disassembling the machine.



If hoist limit switch weight is on the ground:

- ▶ Press the *Bypass limit switch* button on control panel X23.
 - ▷ Hoist limit switches are bypassed.



- ▶ Press the *Load moment limiter assembly/self-lock* button on control panel X23.

No load chart exists for machine geometry:

- ▷ Function "load moment limiter assembly" is active.
- ▷ The LED on the button "Load moment limiter assembly/self-lock" lights up.
- ▷ Machine functions are enabled unlimited.
- ▷ Load Moment Limiter lamps flash orange.

- ▶ Pretension the counterweight on the derrick boom to approx 10 t (22,046 lb).



WARNING

Falling objects!

- ▶ Any loose parts and tools must be removed from the main boom.
- ▶ Make sure that no-one is standing in the danger area.
- ▶ Leave the danger area.

- ▶ Slowly wind up the derrick winch.
 - ▷ The main boom pendant straps are tensioned.



WARNING

Dangerous voltage in boom!
Sudden sideway movement when lifting boom from ground.

- ▶ Make sure that no-one is standing in the danger area.
- ▶ Leave the danger area.

- ▶ Continue winding up the derrick winch.
 - ▷ The main boom lifts off the ground.

When the auxiliary jib (36 t (79300 lb)) is attached and lifts off the ground:

- ▶ Stop derrick winch.

NOTICE

Incorrect limit stop setting for the pendant straps of the auxiliary jib!
Damage to auxiliary jib and pulleys on the main boom head when laying down.

- ▶ Ensure that the limit stop is set so that the pendant straps of the auxiliary jib fold upwards when laying down.

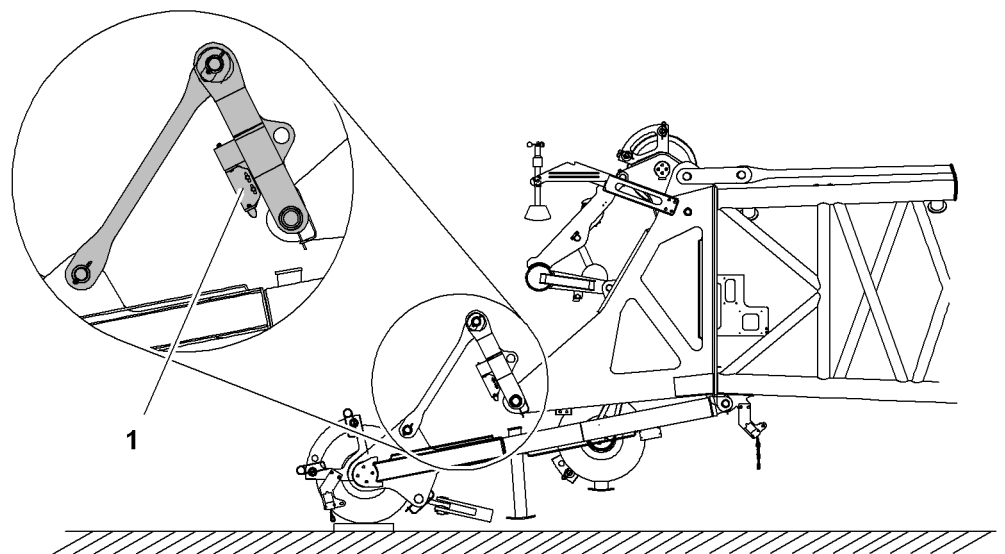


Fig. 3780: Checking the auxiliary jib limit stop

- 1 Limit stop

- ▶ Check the limit stop 1, if necessary lay down the main boom and set the limit stop 1.

When the limit stop 1 is set correctly:

- ▶ Continue winding up the derrick winch.
 - ▷ Main boom erects itself:

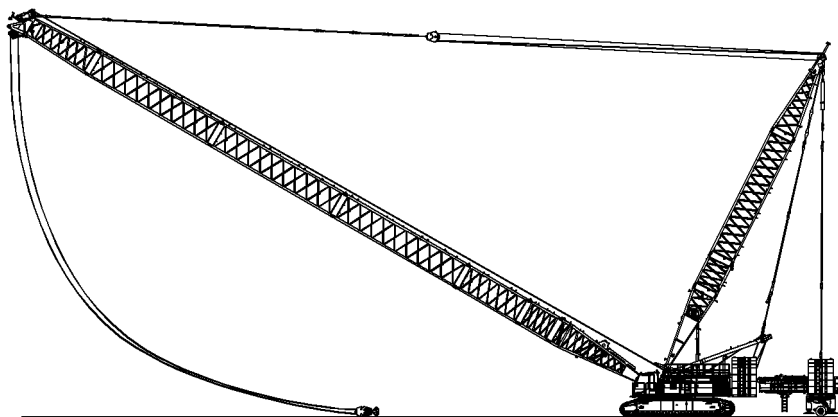


Fig. 3781: Main boom erects itself (illustration of principle)

As soon as there is a load chart for machines geometry:

- ▷ Deactivate function *load moment limiter assembly*.
- ▷ The LED on the button "Load moment limiter assembly/self-lock" goes out.
- ▷ Load moment limiter is active.
- ▷ Load moment limiter lamps light up according to the current status of the Load Moment Limiter system.

NOTICE

Incorrect erection procedure is followed!
Damage to the equipment.

- ▶ Do not drag the hook or the pulley block along the ground.
- ▶ Do not allow any slacking of the rope.

-
- ▶ Unwind the rope of winch1/winch2 when necessary.
 - ▷ The hook/pulley block remains on the ground.

When the maximum permitted lifting capacity is at least equal to the weight of the hook and/or pulley block:

- ▶ Raise the hook/pulley block.
- ▶ Erect the main boom until it is in the desired position.
 - ▷ Main boom is erected:

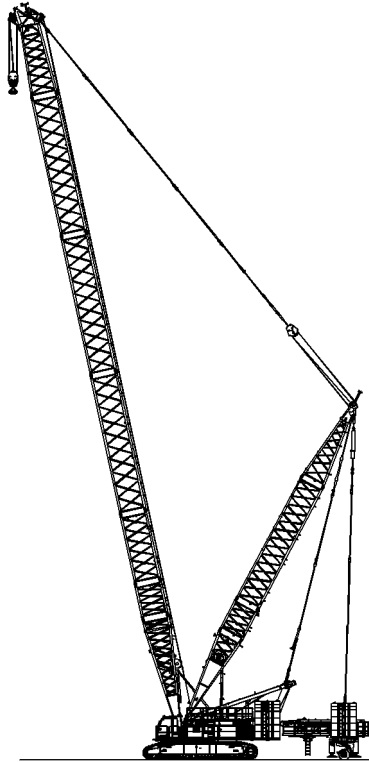


Fig. 3782: Main boom is erected

7.12.7 Switching off assembly mode functions

Ensure that the following conditions are fulfilled:

- The machine is fully assembled and erected.
- All limit switches are fitted and operational.



- ▶ Press the *Assembly functions* switch on control panel X12.
 - ▷ Assembly mode functions are switched off.
 - ▷ The symbol *Assembly functions* disappears on screen.

7.12.8 Checking the main boom limit switch plate for proper adjustment

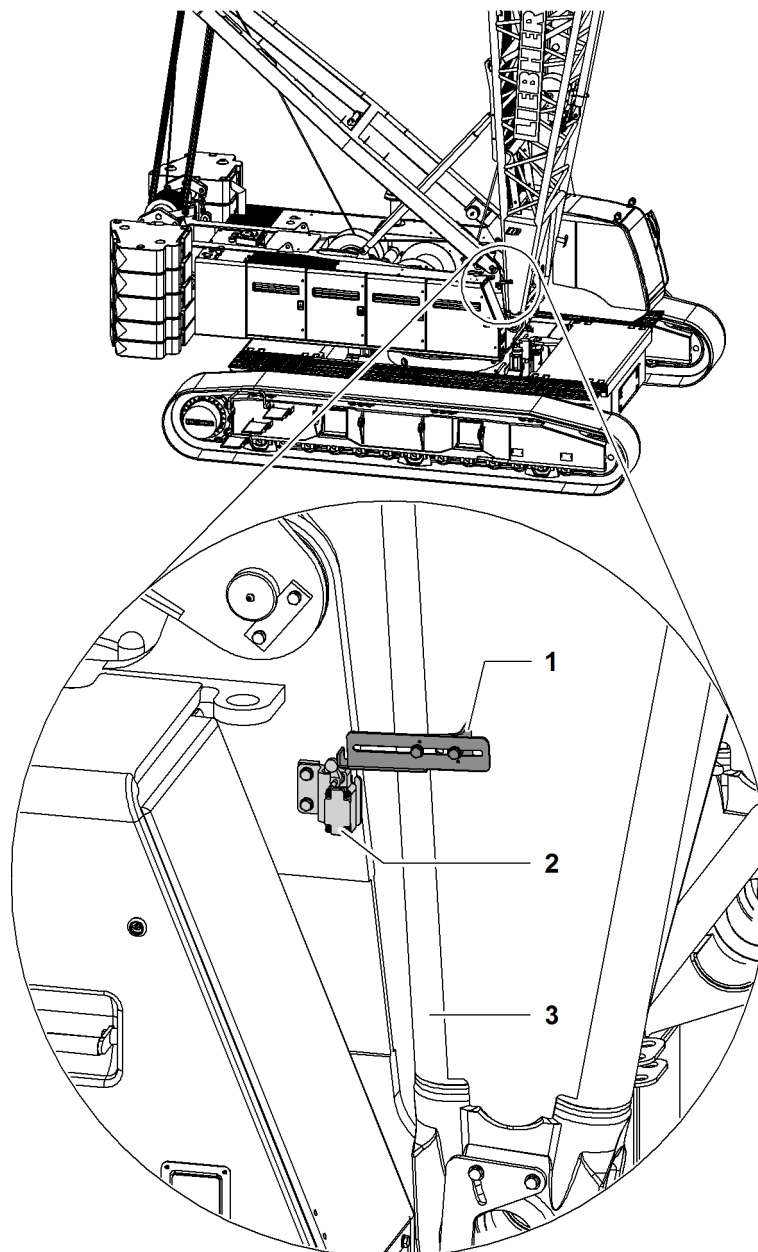


Fig. 3784: Checking the main boom limit switch plate for proper adjustment (illustration of principle)

- | | | | |
|---|--------------------|---|------------------------|
| 1 | Limit switch plate | 3 | Main boom base section |
| 2 | Limit switch | | |

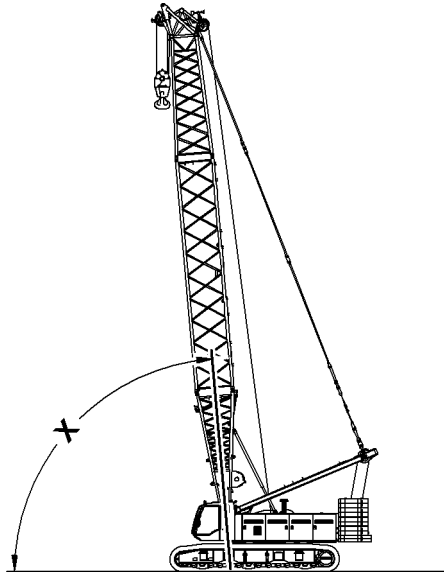


Fig. 3785: Top main boom angle (illustration of principle)

Boom configuration	Angle X
Main boom	86°
Main boom + derrick	
Main boom + reducing adapter	
Main boom + fixed jib	88°
Main boom + fixed jib + derrick	
Main boom + luffing jib	
Main boom + luffing jib + derrick	
Main boom + luffing jib + midfall	

Tab. 524: Main boom limit switch plate

NOTICE

Incorrect calibration of the main boom limit switch plate!
 Damage to machine.

► Make sure that the main boom limit switch plate is properly adjusted.

- Erect the main boom until the screen *Operation* shows the angle X.
 - ▷ Limit switch triggers.
 - ▷ Lift main boom is locked.

If the limit switch triggers too early or not at all:

- Switch off machine.
- Contact Liebherr service department.

LWNLR.x/V04.01//Auslieferung/2016-03-07/en

7.13 Main boom 2821 + reducing adapter 2821/2316

System-relevant information for main boom 2821 + reducing adapter 2821/2316:

- Configuration of main boom
 - Installation position of rope guide (type A)
 - Mid-point suspensions installation positions
- Lengths of mid-point suspensions
- Overview of main boom 2821 steel pendant straps + reducing adapter 2821/2316
- Overview of main boom 2821 CF pendant straps + reducing adapter 2821/2316
- Reeving diagrams for one rope across main boom head 2316 (load position1)
- Reeving diagrams for two ropes across main boom head 2316 (load position1)

7.13.1 Configuration of main boom



DANGER

Excess length of main boom!
Structural breakdown.

- ▶ Check main boom length in load chart for validity.



DANGER

Reducing adapter installed in wrong installation position!
Structural breakdown.

- ▶ Only install reducing adapter at 43 m (141 ft), 46 m (151 ft) or 55 m (180 ft).

Installation position reducing adapter 43 m (141 ft)	
Main boom length	Configuration of main boom (symbolic)
69 m 226 ft	
72 m 236 ft	
75 m 246 ft	
78 m 256 ft	
81 m 266 ft	
84 m 276 ft	
87 m 285 ft	
90 m 295 ft	

LWNLR-x/V04.01//Auslieferung/2016-03-07/en

Installation position reducing adapter 43 m (141 ft)	
Main boom length	Configuration of main boom (symbolic)
93 m 305 ft	
96 m 315 ft	
99 m 325 ft	
102 m 335 ft	
105 m 344 ft	
108 m 354 ft	
111 m 364 ft	
114 m 374 ft	
117 m 384 ft	
120 m 394 ft	
123 m 404 ft	

Tab. 525: Configuration of main boom 2821 + reducing adapter 2821/2316 - installation position reducing adapter 43 m (141 ft)

S - Installation position rope guide (type A)

X1 - Installation position mid-point suspension 1

X2 - Installation position mid-point suspension 2

Installation position reducing adapter 46 m (151 ft)	
Main boom length	Configuration of main boom (symbolic)
72 m 236 ft	
75 m 246 ft	
78 m 256 ft	
81 m 266 ft	
84 m 276 ft	

LWNLR.x/V04.01//Auslieferung/2016-03-07/en

Assembly and dismantling

Main boom 2821 + reducing adapter 2821/2316

Installation position reducing adapter 46 m (151 ft)	
Main boom length	Configuration of main boom (symbolic)
87 m 285 ft	
90 m 295 ft	
93 m 305 ft	
96 m 315 ft	
99 m 325 ft	
102 m 335 ft	
105 m 344 ft	
108 m 354 ft	
111 m 364 ft	
114 m 374 ft	
117 m 384 ft	
120 m 394 ft	
123 m 404 ft	

Tab. 526: Configuration of main boom 2821 + reducing adapter 2821/2316 - installation position reducing adapter 46 m (151 ft)

S - Installation position rope guide (type A)

X1 - Installation position mid-point suspension 1

X2 - Installation position mid-point suspension 2

Installation position reducing adapter 55 m (180 ft)	
Main boom length	Configuration of main boom (symbolic)
81 m 266 ft	
84 m 276 ft	
87 m 285 ft	

LWN/LR-x/V04.01//Auslieferung/2016-03-07/en

Installation position reducing adapter 55 m (180 ft)	
Main boom length	Configuration of main boom (symbolic)
90 m 295 ft	
93 m 305 ft	
96 m 315 ft	
99 m 325 ft	
102 m 335 ft	
105 m 344 ft	
108 m 354 ft	
111 m 364 ft	
114 m 374 ft	
117 m 384 ft	
120 m 394 ft	

Tab. 527: Configuration of main boom 2821 + reducing adapter 2821/2316 - installation position reducing adapter 55 m (180 ft)

S - Installation position rope guide (type A)

X1 - Installation position mid-point suspension 1

X2 - Installation position mid-point suspension 2

7.13.2 Lengths of mid-point suspensions

Assembly position of the reducing piece 43 m (141 ft)		
Main boom length	Backstay pendant (X1)	Backstay shackle (X2)
	Rope length	Shackle length
69 m 226 ft	1.3 m 4' 3" ft-in	
72 m 236 ft	1.6 m 5' 3" ft-in	
75 m 246 ft		0.74 m 2' 5" ft-in = 0.54 m (1' 9" ft-in) + 0.2 m (7.87" in)

LWNLR.x/V04.01//Auslieferung/2016-03-07/en

Assembly position of the reducing piece 43 m (141 ft)		
Main boom length	Backstay pendant (X1)	Backstay shackle (X2)
	Rope length	Shackle length
78 m 256 ft		0.93 m 3' 1" ft-in = 0.73 m (2' 5" ft-in) + 0.2 m (7.87" in)
81 m 266 ft	3.4 m 11' 2" ft-in = 2.1 m (6' 11" ft-in) + 1.3 m (4' 3" ft-in)	0.93 m 3' 1" ft-in = 0.73 m (2' 5" ft-in) + 0.2 m (7.87" in)
84 m 276 ft	3.7 m 12' 2" ft-in = 2.6 m (8' 6" ft-in) + 1.1 m (3' 7" ft-in)	0.93 m 3' 1" ft-in = 0.73 m (2' 5" ft-in) + 0.2 m (7.87" in)
87 m 285 ft	3.7 m 12' 2" ft-in = 2.6 m (8' 6" ft-in) + 1.1 m (3' 7" ft-in)	1.15 m 3' 9" ft-in = 0.95 m (3' 1" ft-in) + 0.2 m (7.87" in)
90 m 295 ft	3.7 m 12' 2" ft-in = 2.6 m (8' 6" ft-in) + 1.1 m (3' 7" ft-in)	0.74 m 2' 5" ft-in = 0.54 m (1' 9" ft-in) + 0.2 m (7.87" in)
93 m 305 ft	3.7 m 12' 2" ft-in = 2.6 m (8' 6" ft-in) + 1.1 m (3' 7" ft-in)	0.74 m 2' 5" ft-in = 0.54 m (1' 9" ft-in) + 0.2 m (7.87" in)
96 m 315 ft	2.7 m 8' 10" ft-in = 1.6 m (5' 3" ft-in) + 1.1 m (3' 7" ft-in)	0.74 m 2' 5" ft-in = 0.54 m (1' 9" ft-in) + 0.2 m (7.87" in)
99 m 325 ft	3.2 m 10' 6" ft-in = 2.1 m (6' 11" ft-in) + 1.1 m (3' 7" ft-in)	1.15 m 3' 9" ft-in = 0.95 m (3' 1" ft-in) + 0.2 m (7.87" in)
102 m 335 ft	3.9 m 12' 10" ft-in = 2.6 m (8' 6" ft-in) + 1.3 m (4' 3" ft-in)	1.15 m 3' 9" ft-in = 0.95 m (3' 1" ft-in) + 0.2 m (7.87" in)
105 m 344 ft	3.2 m 10' 6" ft-in = 2.1 m (6' 11" ft-in) + 1.1 m (3' 7" ft-in)	1.15 m 3' 9" ft-in = 0.95 m (3' 1" ft-in) + 0.2 m (7.87" in)

LWNLR-x/V04.01//Auslieferung/2016-03-07/en

Assembly position of the reducing piece 43 m (141 ft)		
Main boom length	Backstay pendant (X1)	Backstay shackle (X2)
	Rope length	Shackle length
108 m 354 ft	3.2 m 10' 6" ft-in = 2.1 m (6' 11" ft-in) + 1.1 m (3' 7" ft-in)	1.15 m 3' 9" ft-in = 0.95 m (3' 1" ft-in) + 0.2 m (7.87" in)
111 m 364 ft	3.2 m 10' 6" ft-in = 2.1 m (6' 11" ft-in) + 1.1 m (3' 7" ft-in)	1.15 m 3' 9" ft-in = 0.95 m (3' 1" ft-in) + 0.2 m (7.87" in)
114 m 374 ft	4.1 m 13' 5" ft-in = 3.0 m (9' 10" ft-in) + 1.1 m (3' 7" ft-in)	1.6 m 5' 3" ft-in ^{A)}
117 m 384 ft	3.4 m 11' 2" ft-in = 2.1 m (6' 11" ft-in) + 1.3 m (4' 3" ft-in)	0.93 m 3' 1" ft-in = 0.73 m (2' 5" ft-in) + 0.2 m (7.87" in)
120 m 394 ft	3.4 m 11' 2" ft-in = 2.1 m (6' 11" ft-in) + 1.3 m (4' 3" ft-in)	0.93 m 3' 1" ft-in = 0.73 m (2' 5" ft-in) + 0.2 m (7.87" in)
123 m 404 ft	2.9 m 9' 6" ft-in = 1.6 m (5' 3" ft-in) + 1.3 m (4' 3" ft-in)	0.74 m 2' 5" ft-in = 0.54 m (1' 9" ft-in) + 0.2 m (7.87" in)

Tab. 528: Lengths of mid-point suspensions - 2821 main boom + 2821/2316 reducing piece - assembly position of reducing piece 43 m (141 ft)

A) Backstay pendant

Assembly position of the reducing piece 46 m (151 ft)		
Main boom length	Backstay pendant (X1)	Backstay shackle (X2)
	Rope length	Shackle length
72 m 236 ft	1.3 m 4' 3" ft-in	
75 m 246 ft	1.6 m 5' 3" ft-in	
78 m 256 ft	1.6 m 5' 3" ft-in	
81 m 266 ft	1.6 m 5' 3" ft-in	

LWNLR.x/V04.01//Auslieferung/2016-03-07/en

Assembly position of the reducing piece 46 m (151 ft)		
Main boom length	Backstay pendant (X1)	Backstay shackle (X2)
	Rope length	Shackle length
84 m 276 ft	3.4 m 11' 2" ft-in = 2.1 m (6' 11" ft-in) + 1.3 m (4' 3" ft-in)	0.93 m 3' 1" ft-in = 0.73 m (2' 5" ft-in) + 0.2 m (7.87" in)
87 m 285 ft	3.2 m 10' 6" ft-in = 2.1 m (6' 11" ft-in) + 1.1 m (3' 7" ft-in)	0.74 m 2' 5" ft-in = 0.54 m (1' 9" ft-in) + 0.2 m (7.87" in)
90 m 295 ft	3.7 m 12' 2" ft-in = 2.6 m (8' 6" ft-in) + 1.1 m (3' 7" ft-in)	1.15 m 3' 9" ft-in = 0.95 m (3' 1" ft-in) + 0.2 m (7.87" in)
93 m 305 ft	3.7 m 12' 2" ft-in = 2.6 m (8' 6" ft-in) + 1.1 m (3' 7" ft-in)	0.74 m 2' 5" ft-in = 0.54 m (1' 9" ft-in) + 0.2 m (7.87" in)
96 m 315 ft	3.7 m 12' 2" ft-in = 2.6 m (8' 6" ft-in) + 1.1 m (3' 7" ft-in)	1.3 m 4' 3" ft-in ^{A)}
99 m 325 ft	2.7 m 8' 10" ft-in = 1.6 m (5' 3" ft-in) + 1.1 m (3' 7" ft-in)	0.62 m 2' ft-in = 0.42 m (1' 5" ft-in) + 0.2 m (7.87" in)
102 m 335 ft	2.7 m 8' 10" ft-in = 1.6 m (5' 3" ft-in) + 1.1 m (3' 7" ft-in)	1.15 m 3' 9" ft-in = 0.95 m (3' 1" ft-in) + 0.2 m (7.87" in)
105 m 344 ft	3 m 9' 10" ft-in	0.62 m 2' ft-in = 0.42 m (1' 5" ft-in) + 0.2 m (7.87" in)
108 m 354 ft	3.2 m 10' 6" ft-in = 2.1 m (6' 11" ft-in) + 1.1 m (3' 7" ft-in)	1.15 m 3' 9" ft-in = 0.95 m (3' 1" ft-in) + 0.2 m (7.87" in)
111 m 364 ft	3.2 m 10' 6" ft-in = 2.1 m (6' 11" ft-in) + 1.1 m (3' 7" ft-in)	1.15 m 3' 9" ft-in = 0.95 m (3' 1" ft-in) + 0.2 m (7.87" in)

LWNLR-x/V04.01//Auslieferung/2016-03-07/en

Assembly position of the reducing piece 46 m (151 ft)		
Main boom length	Backstay pendant (X1)	Backstay shackle (X2)
	Rope length	Shackle length
114 m 374 ft	3.2 m 10' 6" ft-in = 2.1 m (6' 11" ft-in) + 1.1 m (3' 7" ft-in)	0.93 m 3' 1" ft-in = 0.73 m (2' 5" ft-in) + 0.2 m (7.87" in)
117 m 384 ft	3.4 m 11' 2" ft-in = 2.1 m (6' 11" ft-in) + 1.3 m (4' 3" ft-in)	0.93 m 3' 1" ft-in = 0.73 m (2' 5" ft-in) + 0.2 m (7.87" in)
120 m 394 ft	3.2 m 10' 6" ft-in = 2.1 m (6' 11" ft-in) + 1.1 m (3' 7" ft-in)	0.74 m 2' 5" ft-in = 0.54 m (1' 9" ft-in) + 0.2 m (7.87" in)
123 m 404 ft	3.2 m 10' 6" ft-in = 2.1 m (6' 11" ft-in) + 1.1 m (3' 7" ft-in)	0.74 m 2' 5" ft-in = 0.54 m (1' 9" ft-in) + 0.2 m (7.87" in)

Tab. 529: Lengths of mid-point suspensions - 2821 main boom + 2821/2316 reducing piece - assembly position of reducing piece 46 m (151 ft)

A) Backstay pendant

Assembly position of the reducing piece 55 m (180 ft)		
Main boom length	Backstay pendant (X1)	Backstay shackle (X2)
	Rope length	Shackle length
81 m 266 ft	2.1 m 6' 11" ft-in	
84 m 276 ft	2.6 m 8' 6" ft-in	
87 m 285 ft	3.7 m 12' 2" ft-in = 2.6 m (8' 6" ft-in) + 1.1 m (3' 7" ft-in)	0.62 m 2' ft-in = 0.42 m (1' 5" ft-in) + 0.2 m (7.87" in)
90 m 295 ft	3.7 m 12' 2" ft-in = 2.6 m (8' 6" ft-in) + 1.1 m (3' 7" ft-in)	0.74 m 2' 5" ft-in = 0.54 m (1' 9" ft-in) + 0.2 m (7.87" in)
93 m 305 ft	3.7 m 12' 2" ft-in = 2.6 m (8' 6" ft-in) + 1.1 m (3' 7" ft-in)	0.74 m 2' 5" ft-in = 0.54 m (1' 9" ft-in) + 0.2 m (7.87" in)

LWNLR.x/V04.01//Auslieferung/2016-03-07/en

Assembly position of the reducing piece 55 m (180 ft)		
Main boom length	Backstay pendant (X1)	Backstay shackle (X2)
	Rope length	Shackle length
96 m 315 ft	4.1 m 13' 5" ft-in = 3.0 m (9' 10" ft-in) + 1.1 m (3' 7" ft-in)	0.74 m 2' 5" ft-in = 0.54 m (1' 9" ft-in) + 0.2 m (7.87" in)
99 m 325 ft	3.2 m 10' 6" ft-in = 2.1 m (6' 11" ft-in) + 1.1 m (3' 7" ft-in)	0.93 m 3' 1" ft-in = 0.73 m (2' 5" ft-in) + 0.2 m (7.87" in)
102 m 335 ft	4.1 m 13' 5" ft-in = 3.0 m (9' 10" ft-in) + 1.1 m (3' 7" ft-in)	1.15 m 3' 9" ft-in = 0.95 m (3' 1" ft-in) + 0.2 m (7.87" in)
105 m 344 ft	4.2 m 13' 9" ft-in = 2.1 m (6' 11" ft-in) + 2.1 m (6' 11" ft-in)	1.15 m 3' 9" ft-in = 0.95 m (3' 1" ft-in) + 0.2 m (7.87" in)
108 m 354 ft	4.2 m 13' 9" ft-in = 2.1 m (6' 11" ft-in) + 2.1 m (6' 11" ft-in)	1.15 m 3' 9" ft-in = 0.95 m (3' 1" ft-in) + 0.2 m (7.87" in)
111 m 364 ft	3.2 m 10' 6" ft-in = 2.1 m (6' 11" ft-in) + 1.1 m (3' 7" ft-in)	1.15 m 3' 9" ft-in = 0.95 m (3' 1" ft-in) + 0.2 m (7.87" in)
114 m 374 ft	3.2 m 10' 6" ft-in = 2.1 m (6' 11" ft-in) + 1.1 m (3' 7" ft-in)	0.93 m 3' 1" ft-in = 0.73 m (2' 5" ft-in) + 0.2 m (7.87" in)
117 m 384 ft	3.4 m 11' 2" ft-in = 2.1 m (6' 11" ft-in) + 1.3 m (4' 3" ft-in)	0.93 m 3' 1" ft-in = 0.73 m (2' 5" ft-in) + 0.2 m (7.87" in)
120 m 394 ft	3.4 m 11' 2" ft-in = 2.1 m (6' 11" ft-in) + 1.3 m (4' 3" ft-in)	0.93 m 3' 1" ft-in = 0.73 m (2' 5" ft-in) + 0.2 m (7.87" in)

Tab. 530: Lengths of mid-point suspensions - 2821 main boom + 2821/2316 reducing piece - assembly position of reducing piece 55 m (180 ft)

LWNLR-x/V04.01/Auslieferung/2016-03-07/en

7.13.3 Overview of main boom 2821 steel pendant straps + reducing adapter 2821/2316

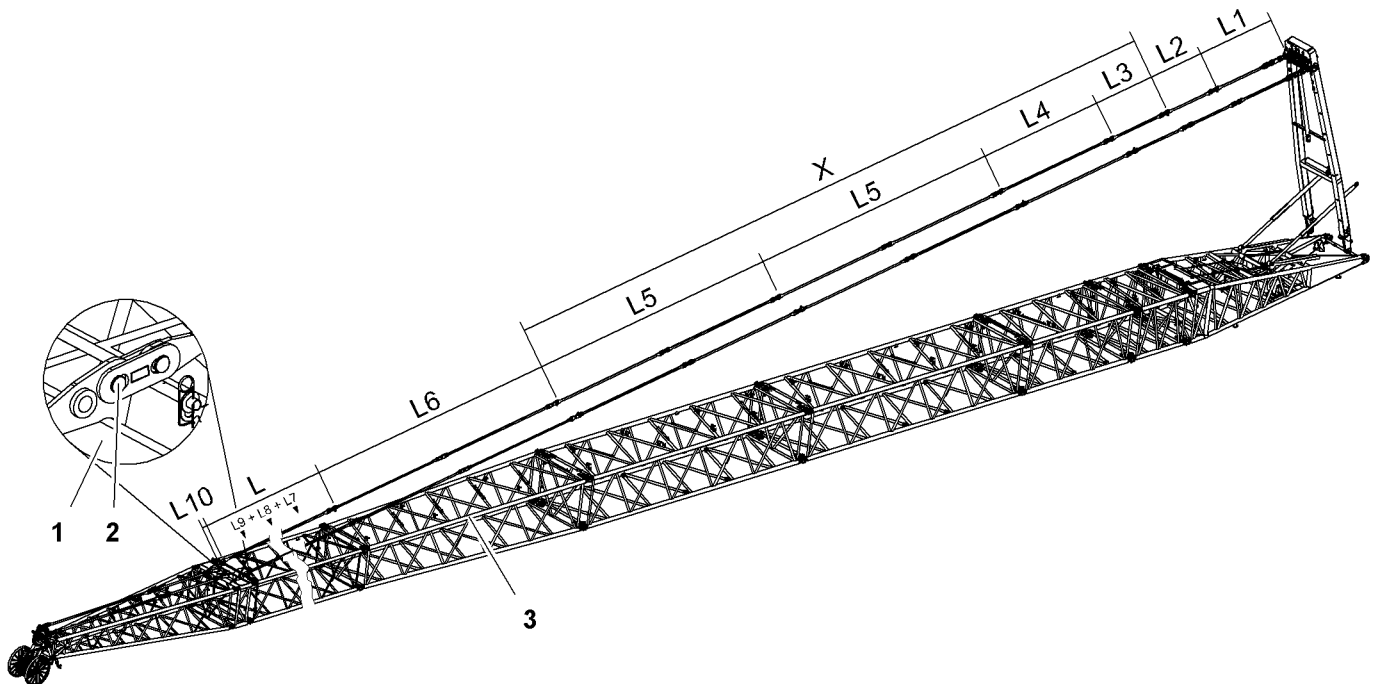


Fig. 4288: Overview of main boom 2821 steel pendant straps + reducing adapter 2821/2316

- 1 Main boom section 2316 1 m (3 ft) 2 Pin connection point main boom backstay straps 3 Reducing adapter

Pendant straps A-frame1 to main boom head 2316

Name		Value
L1	A-frame1 equalizer (For more information see: A-frame1 equalizer, page 77)	3730 mm 12' 3" ft-in
L2	Main boom base section equalizer (For more information see: Equalizer of main boom base section 2821.30, page 191)	2670 mm 8' 9" ft-in
Main boom pendant straps consisting of:		
X	L3 Main boom pendant strap 3 m (10 ft) (For more information see: Main boom pendant strap 3 m (10 ft), page 192)	Total L3 +
	L4 Main boom pendant strap 6 m (20 ft) (For more information see: Main boom pendant strap 6 m (20 ft), page 194)	Total L4 +
	L5 Main boom pendant strap 12 m (40 ft) (For more information see: Main boom pendant strap 12 m (40 ft), page 196)	Total L5

LWNLR-x/V04.01//Auslieferung/2016-03-07/en

Name		Value
L6	Reducing adapter pendant strap 12 m (40 ft) (For more information see: Reducing adapter pendant strap 12 m (40 ft), page 242)	12000 mm 39' 4" ft-in
L	Main boom pendant straps consisting of:	Total L7 + Total L8 + Total L9
	L7 Main boom pendant strap 3 m (10 ft) (For more information see: Jib pendant strap 3 m (10 ft), page 310)	
	L8 Main boom pendant strap 6 m (20 ft) (For more information see: Jib pendant strap 6 m (20 ft), page 310)	
L9 Main boom pendant strap 12 m (40 ft) (For more information see: Jib pendant strap 12 m (40 ft), page 311)		
L10	Connecting link (For more information see: Connecting link, page 243)	350 mm 1' 2" ft-in

Tab. 531: Pendant straps A-frame1 to main boom head 2316

Configuration of main boom pendant straps (X):

Reducing adapter installation position	Configuration of main boom pendant straps (X)
43 m 141' 1" ft-in	$X = L3 + L4 + L5 + L5$
46 m 150' 11" ft-in	$X = L5 + L5 + L5$
55 m 180' 5" ft-in	$X = L3 + L4 + L5 + L5 + L5$

Tab. 532: Configuration of main boom pendant straps (X) depends on the reducing adapter installation position

Configuration of main boom pendant straps (L):

Required number of main boom pendant straps 3 m (10 ft) (L7) corresponds to number of main boom sections 3 m (10 ft).

Required number of main boom pendant straps 6 m (20 ft) (L8) corresponds to number of main boom sections 6 m (20 ft).

Required number of main boom pendant straps 12 m (40 ft) (L9) corresponds to number of main boom sections 12 m (40 ft).



Note

- For admissible number of main boom sections 3 m (10 ft), 6 m (20 ft), 12 m (40 ft), refer to the following tables: ([For more information see: 7.13.1 Configuration of main boom, page 1502](#)).

7.13.4 Overview of main boom 2821 CF pendant straps + reducing adapter 2821/2316

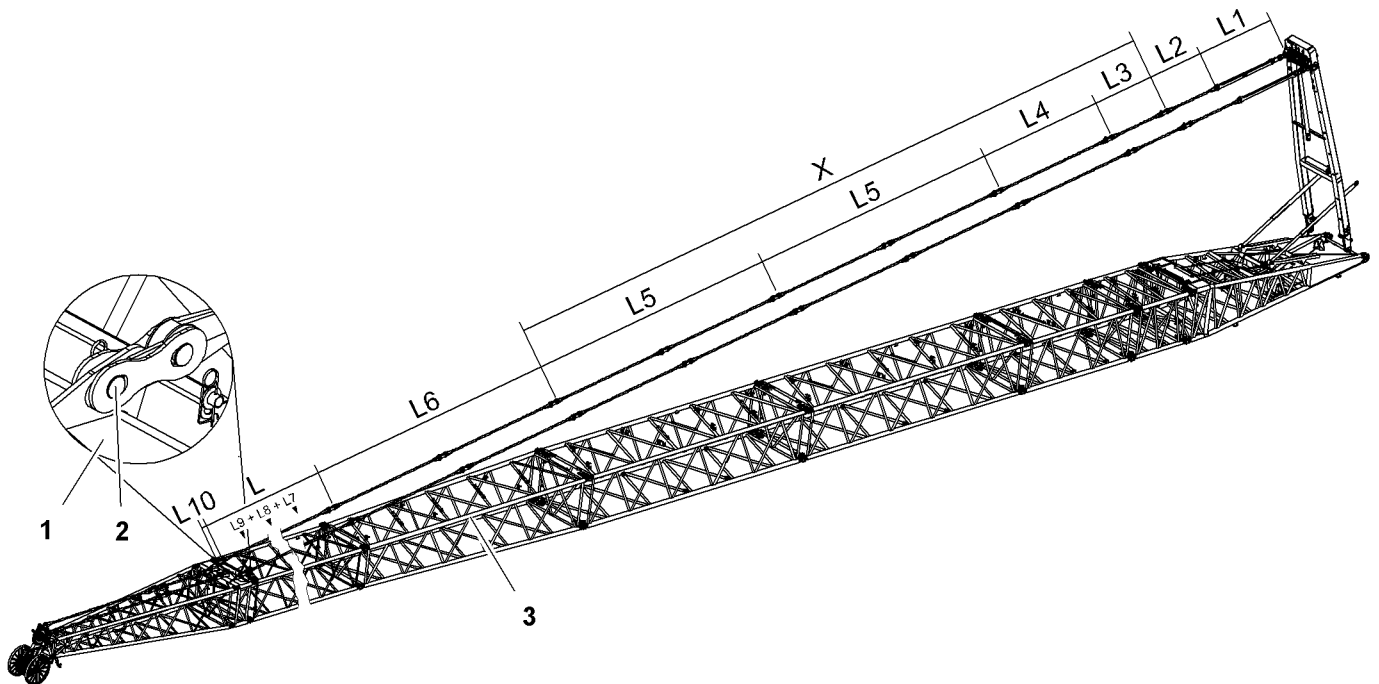


Fig. 4289: Overview of main boom 2821 CF pendant straps + reducing adapter 2821/2316

- 1 Main boom section 2316 1 m (3 ft)
- 2 Pin connection point main boom backstay straps
- 3 Reducing adapter

Pendant straps A-frame1 to main boom head 2316

Name		Value
L1	A-frame1 equalizer (For more information see: A-frame1 equalizer, page 78)	3700 mm 12' 2" ft-in
L2	Main boom base section equalizer (For more information see: Equalizer of main boom base section 2821.30, page 200)	2700 mm 8' 10" ft-in
Main boom pendant straps consisting of:		
X	L3 Main boom pendant strap 3 m (10 ft) (For more information see: Main boom pendant strap 3 m (10 ft), page 203)	Total L3 +
	L4 Main boom pendant strap 6 m (20 ft) (For more information see: Main boom pendant strap 6 m (20 ft), page 206)	Total L4 +
	L5 Main boom pendant strap 12 m (40 ft) (For more information see: Main boom pendant strap 12 m (40 ft), page 210)	Total L5

LWNLR-x/V04.01//Auslieferung/2016-03-07/en

Name		Value
L6	Reducing adapter pendant strap 12 m (40 ft) (For more information see: Reducing adapter pendant strap 12 m (40 ft) , page 244)	12000 mm 39' 4" ft-in
L	Main boom pendant straps consisting of:	
	L7 Main boom pendant strap 3 m (10 ft) (For more information see: Jib pendant strap 3 m (10 ft) , page 319)	Total L7 +
	L8 Main boom pendant strap 6 m (20 ft) (For more information see: Jib pendant strap 6 m (20 ft) , page 321)	Total L8 +
L9 Main boom pendant strap 12 m (40 ft) (For more information see: Jib pendant strap 12 m (40 ft) , page 322)	Total L9	
L10	Connecting link (For more information see: Connecting link , page 245)	350 mm 1' 2" ft-in

Tab. 533: Pendant straps A-frame1 to main boom head 2316

Configuration of main boom pendant straps (X):

Reducing adapter installation position	Configuration of main boom pendant straps (X)
43 m 141' 1" ft-in	$X = L3 + L4 + L5 + L5$
46 m 150' 11" ft-in	$X = L5 + L5 + L5$
55 m 180' 5" ft-in	$X = L3 + L4 + L5 + L5 + L5$

Tab. 534: Configuration of main boom pendant straps (X) depends on the reducing adapter installation position

Configuration of main boom pendant straps (L):

Required number of main boom pendant straps 3 m (10 ft) (L7) corresponds to number of main boom sections 3 m (10 ft).

Required number of main boom pendant straps 6 m (20 ft) (L8) corresponds to number of main boom sections 6 m (20 ft).

Required number of main boom pendant straps 12 m (40 ft) (L9) corresponds to number of main boom sections 12 m (40 ft).



Note

- For admissible number of main boom sections 3 m (10 ft), 6 m (20 ft), 12 m (40 ft), refer to the following tables: ([For more information see: 7.13.1 Configuration of main boom, page 1502](#)).

The main boom pendant straps may consist of generation A and generation B main boom pendant straps. Mixing is only admissible if the number of generation B main boom pendant straps only differs by at most 1 in the left and the right strand of the main boom pendant straps.



DANGER

Inadmissible mixing of generation A and generation B main boom pendant straps!
Structural failure.

- ▶ Ensure that the number of generation B main boom pendant straps differs by at most 1 in the left and the right strand of the main boom pendant straps.

7.13.5 Reeving diagrams for one rope across main boom head 2316 (load position1)

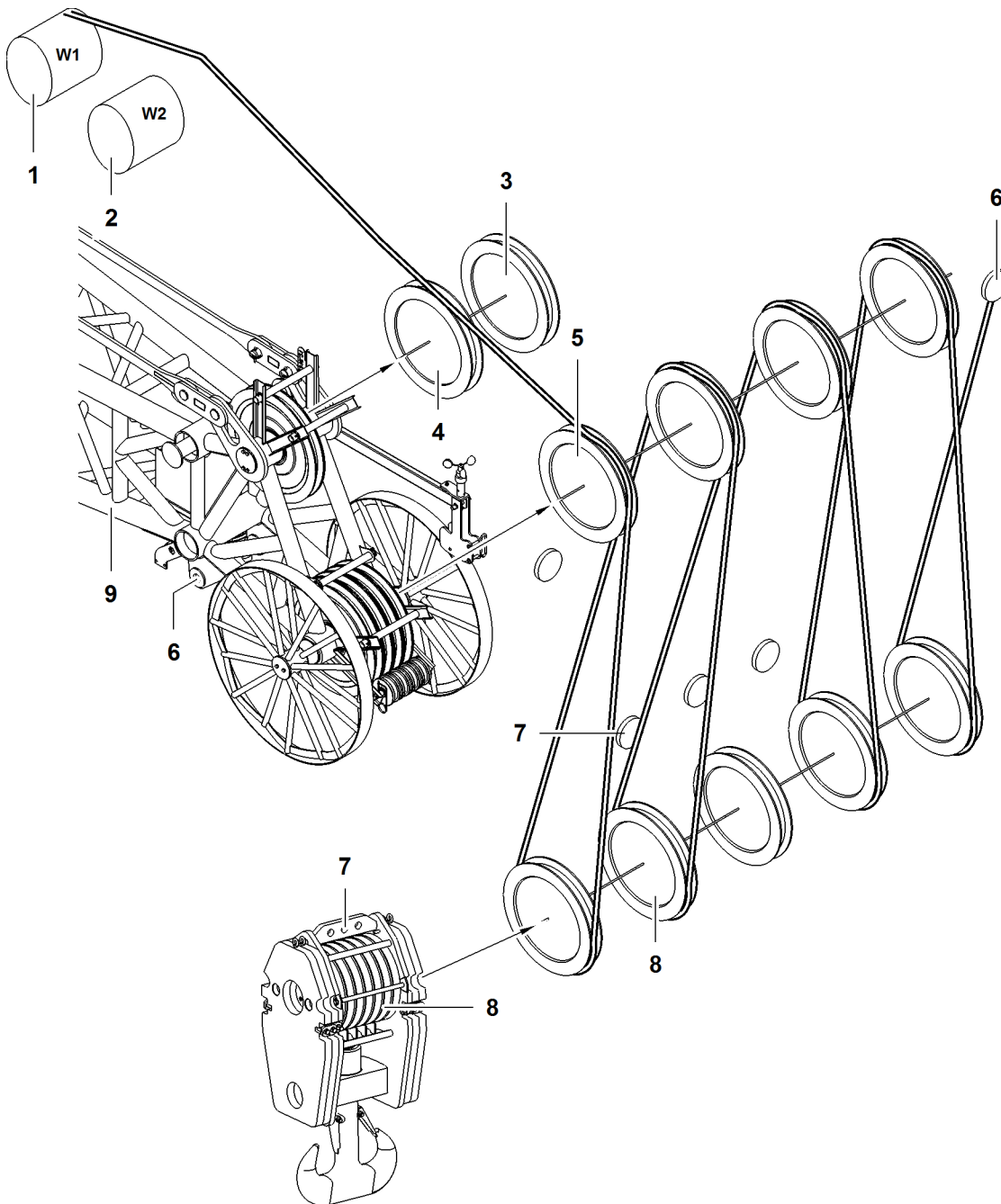


Fig. 4290: Reeving diagrams for one rope across main boom head 2316 (load position1)

- | | | |
|----------|-----------------------------------|--------------------------------------|
| 1 Winch1 | 4 Gantry pulley of main boom head | 7 Rope fixing points of pulley block |
|----------|-----------------------------------|--------------------------------------|

See next page for continuation of the image legend

LWNLR.x/V04.01//Auslieferung/2016-03-07/en

Assembly and dismantling

Main boom 2821 + reducing adapter 2821/2316

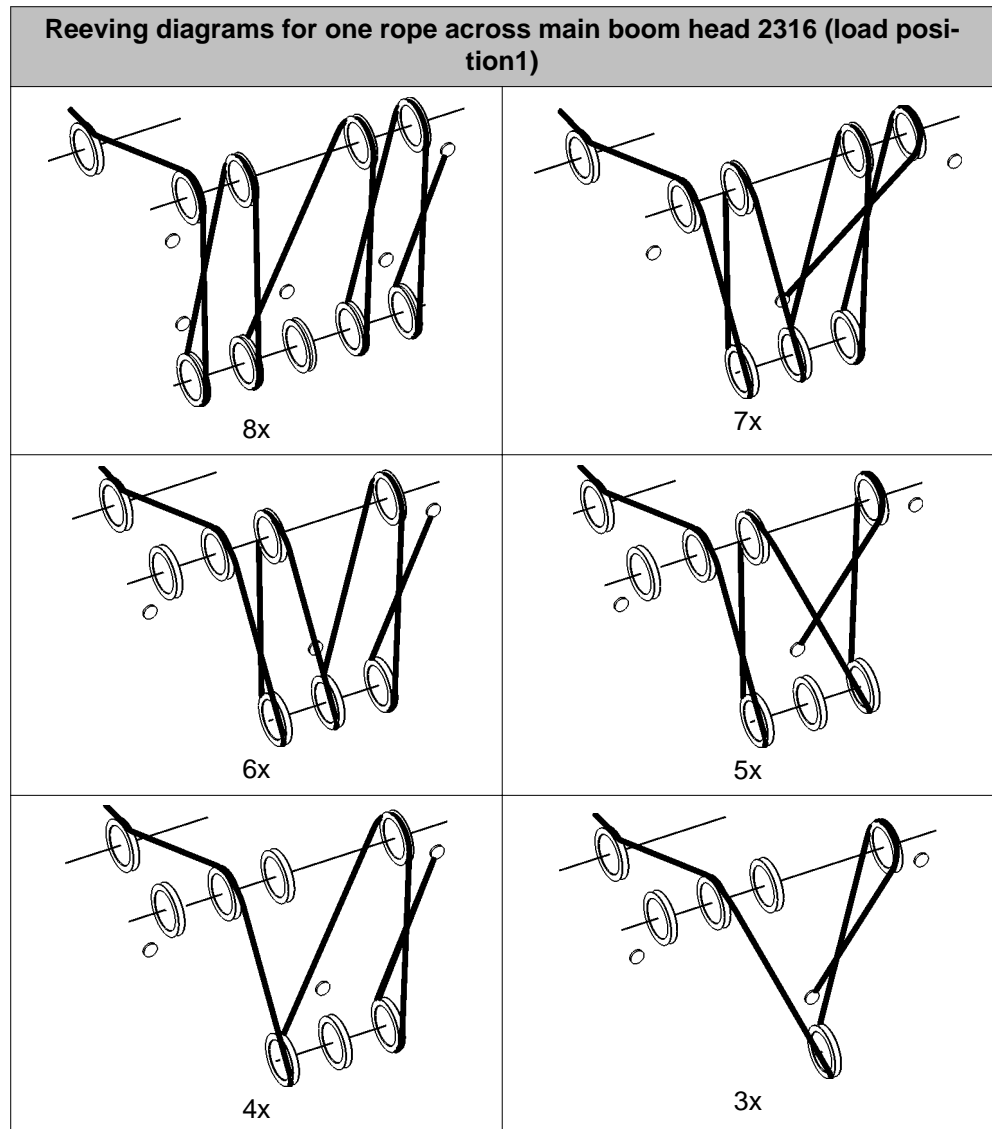
- | | | |
|---|--|---|
| <p>2 Winch2</p> <p>3 Retrofit kit* for operation with two ropes across jib head</p> | <p>5 Pulley (4x) of main boom head</p> <p>6 Rope fixing point (2x) of main boom head</p> | <p>8 Pulley set of pulley block</p> <p>9 Main boom head</p> |
|---|--|---|



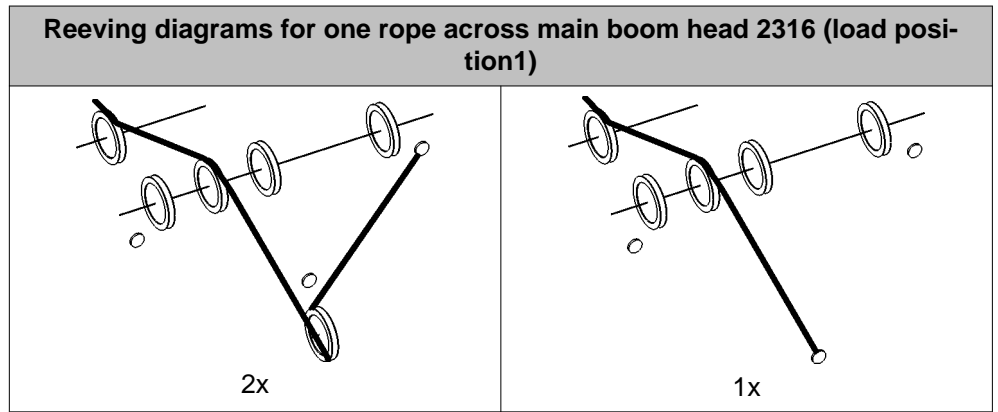
DANGER

Incorrect number of reevings!
Structural breakdown, toppling of machine.

- ▶ Choose the correct number of reevings as per the load chart.



LWNLR-x\04.01\Auslieferung\2016-03-07/en



Tab. 535: Reeving diagrams for one rope across main boom head 2316 (load position1)

7.13.6 Reeving diagrams for two ropes across main boom head 2316 (load position1)



DANGER

Inadmissible number of reevings!
Structural breakdown, toppling of machine.

- ▶ Choose correct number of reevings as indicated in load chart.

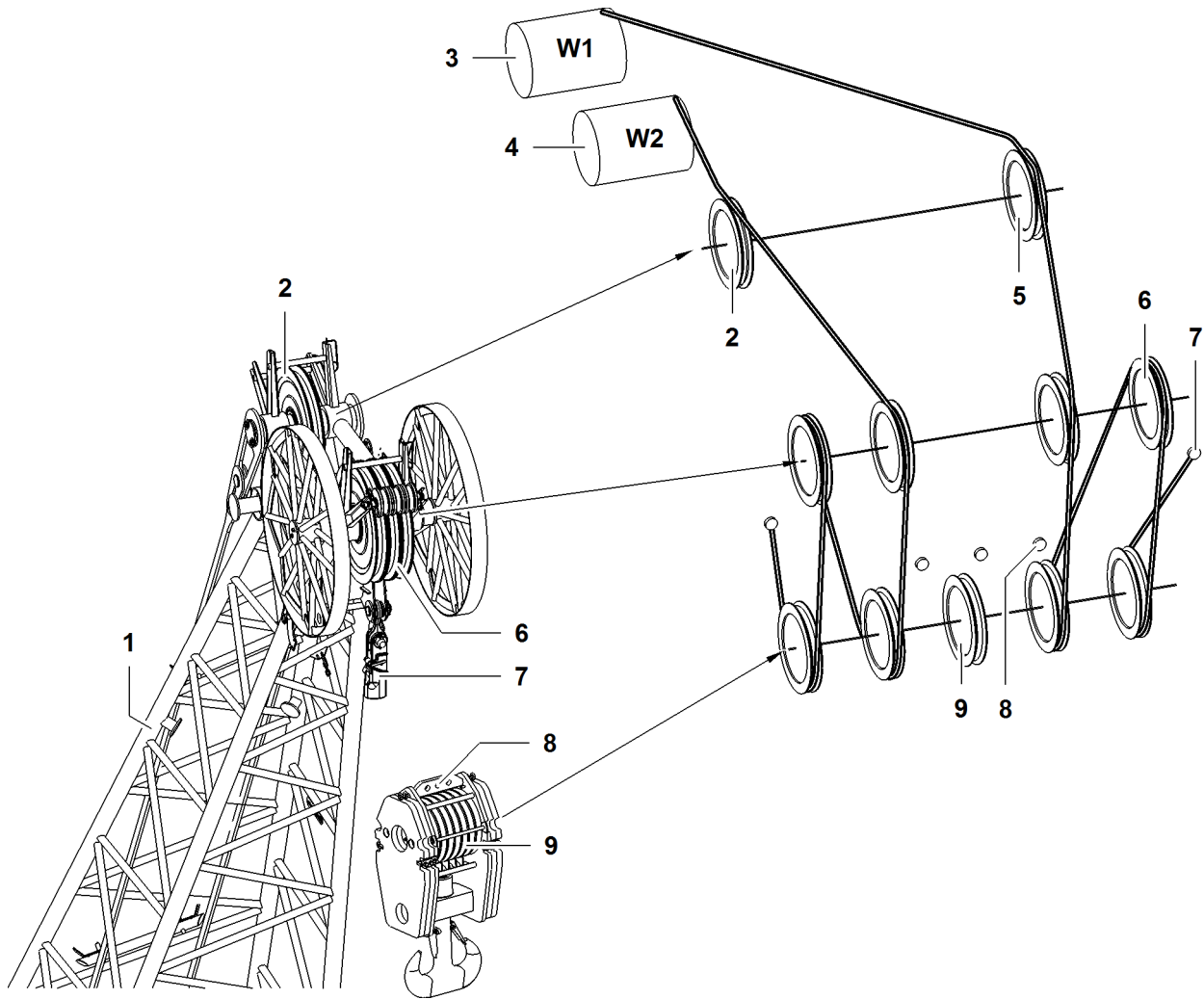


Fig. 4299: Reeving diagrams for two ropes across main boom head 2316 (load position 1)

1	Main boom head	4	Winch2	7	Rope fixing point (2x) of main boom head
2	Gantry pulley of main boom head	5	Retrofit kit* for operation with two ropes across jib head	8	Rope fixing points of pulley block
3	Winch1	6	Pulley (4x) of main boom head	9	Pulley set of pulley block

7.14 Assembling the main boom + reducing piece

Ensure that the following conditions are fulfilled:

- Assembly functions are switched on.
- The machine is ready for use as an assembly crane, or an assist crane is available.
- Work plans have been drawn up.
- The length and the order of the main boom intermediate pieces are known.
- The installation position of the reducing piece is known.
- Any accessories required are available.

7.14.1 Notes

The installation of the reducing adapter described in the following applies for all system dimensions of the reducing adapter.

The illustrations have been simplified or schematically represented for reasons of uniformity and represent the principles of assembly. They do not provide a detailed representation of the components.

7.14.2 Installing the reducing piece

The assembly stages are identical to those for the main boom without reducing piece. The following section contains information specifically for the installation of the reducing piece. The remaining operations are to be carried out as described previously in the main boom assembly section.



DANGER

Installation of the reducing piece in a wrong assembly position!
Structural breakdown.

- ▶ Fit reducing piece according to relevant system instructions exclusively.
- ▶ Install and bolt the reducing piece in the prescribed position.
- ▶ Bolt the reducing piece pendant straps to the main boom in the position of the reducing piece.



DANGER

Incorrect assembly of the main boom!
Structural breakdown.

If the 1 m (3 ft) boom section is required according to the reducing piece's system-specific information:

- ▶ Install the 1 m (3 ft) boom section between the boom head section and the last boom section.

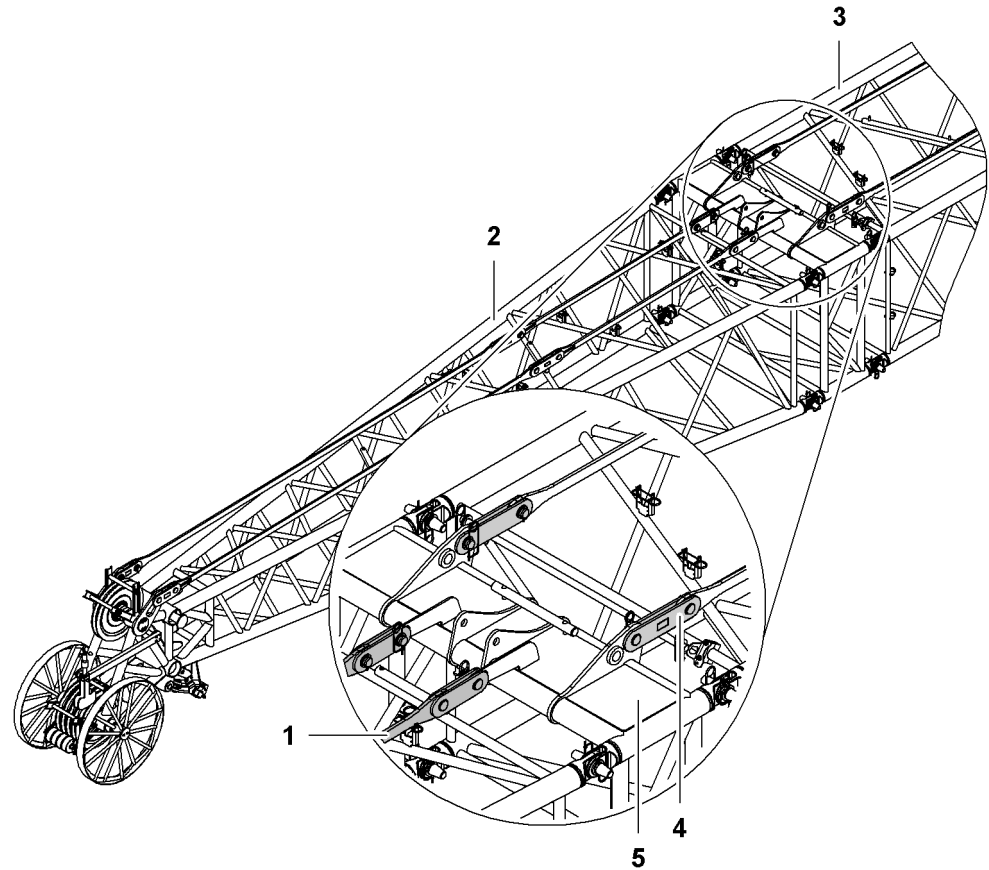


Fig. 4300: Install the 1 m (3 ft) boom section

- | | | | |
|---|---|---|------------------------------|
| 1 | Main boom pendant strap on boom head section (2x) | 4 | Main boom pendant strap (2x) |
| 2 | Main boom head section | 5 | Boom section 1 m (3 ft) |
| 3 | Main boom section | | |

If the 1 m (3 ft) boom section **5** is required according to the reducing piece's system-specific information:

- ▶ Install the 1 m (3 ft) boom section **5** between the boom head section **1** and the last boom section **2**.
- ▶ Bolt the main boom pendant straps **4** to the boom section 1 m (3 ft) **5**.
- ▶ Bolt the main boom pendant straps **3** on the boom head section to the boom section 1 m (3 ft) **5**.

7.14.3 Installing mid-point suspension

The lengths of the stay ropes and backstay shackles and their assembly positions are shown in the relevant instructions for the boom.



DANGER

Incorrect installation of mid-point suspensions!
Structural failure.

- ▶ Fit mid-point suspensions according to relevant system instructions.
- ▶ Assemble required length of backstay shackles in line with system-relevant details.

- ▶ Remove the locking springs and washers from both sides of the boom pin connection double-taper pin and stow away.
- ▶ Repeat procedure on opposite side.

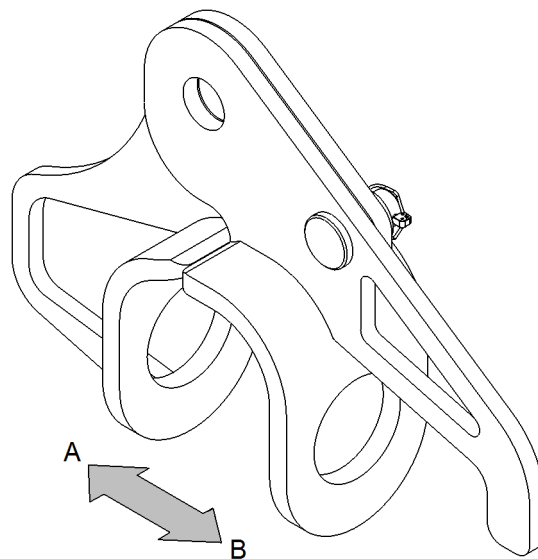


Fig. 4301: Mid-point suspension forks

A Main boom interior

B Main boom exterior

The forks may have different shapes. The permissible shape depends on the boom configuration ([For more information see: 1 Product description, page 51](#)).

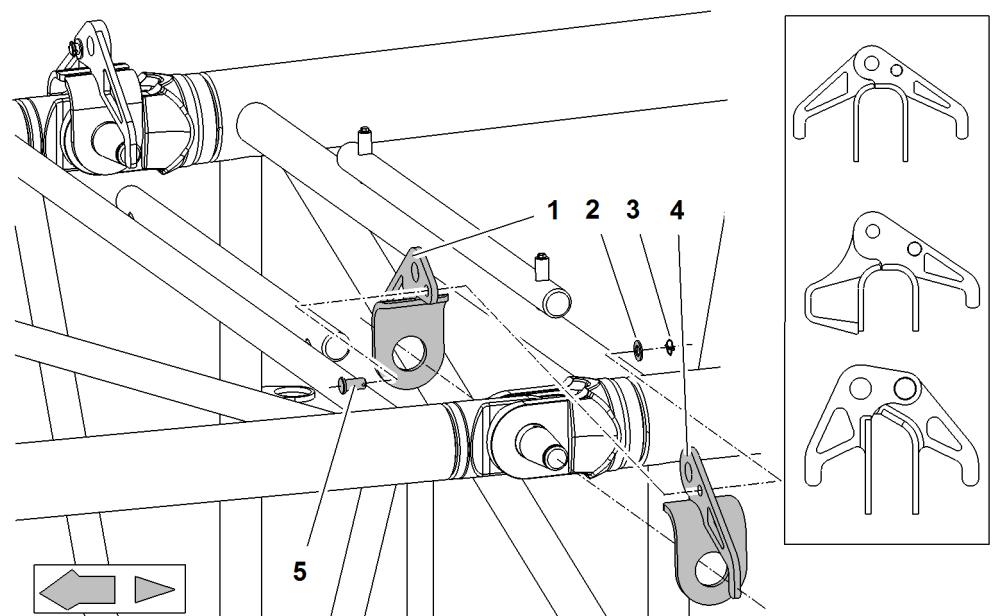


Fig. 4302: Assembling the mid-point suspension forks

- 1** Inner section of fork
- 2** Washer
- 3** Linchpin

- 4** Outer section of fork
- 5** Pin



Note

Special assembly procedure when mid-point suspension and rope guide are installed in exactly the same position on the main boom!

▶ Replace mid-point suspension forks with rope guide forks.

- ▶ Mount inner section of fork **1** on double-taper pin.
- ▶ Mount outer section of fork **4** on double-taper pin.
- ▶ Pin inner section of fork **1** to outer section of fork **4**.
- ▶ Secure pin **5** with washer **2** and linchpin **3**.
- ▶ Repeat procedure on opposite side.

The installation of the mid-point suspension in front of the reducing adapter is described in the main boom assembly instructions ([For more information see: 7.6.11 Installing mid-point suspension, page 1301](#)) ([For more information see: Installing mid-point suspension, page 1416](#)).

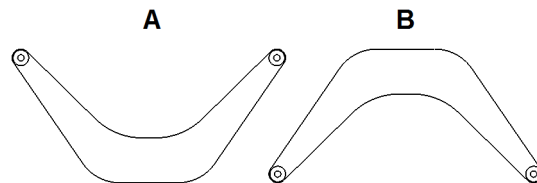


Fig. 4303: Installation direction of the spacer bracket behind the reducing adapter

A Spacer bracket down

B Spacer bracket up

Install spacer bracket behind reducing adapter in installation position spacer bracket **B up**.

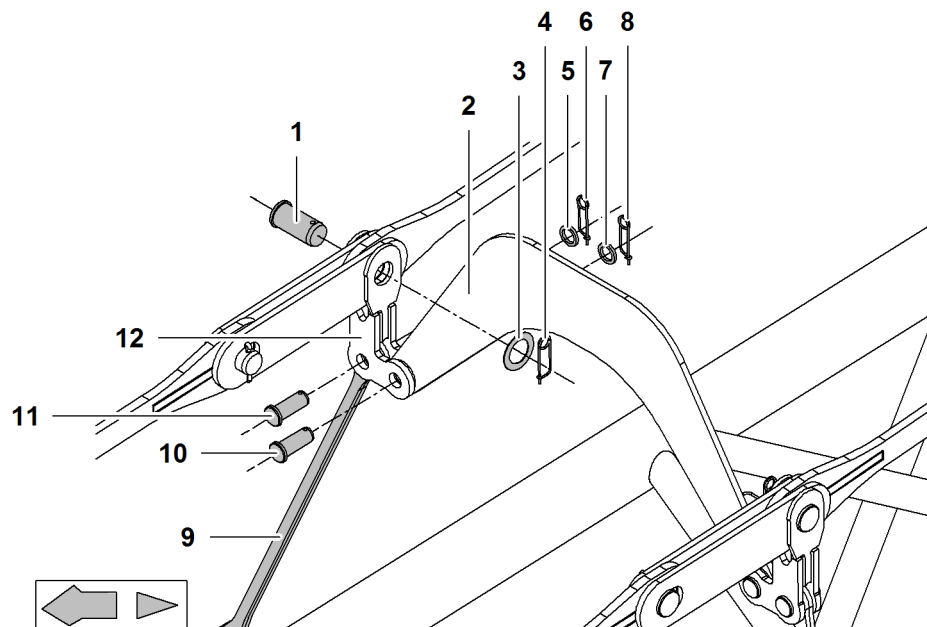


Fig. 4304: Installing pendant straps, spacer bracket, connecting elements and mid-point suspension backstay shackles behind the reducing adapter

- | | |
|---------------------------------|------------------------------------|
| 1 Pins for pendant strap | 7 Washer |
| 2 Spacer bracket | 8 Locking spring |
| 3 Washer | 9 Top backstay shackle (2x) |

See next page for continuation of the image legend

- | | | | |
|----------|----------------|-----------|--------------------------|
| 4 | Locking spring | 10 | Pin for spacer bracket |
| 5 | Washer | 11 | Pin for backstay shackle |
| 6 | Safety pin | 12 | Connecting element |

- ▶ Pin connecting element **12** to pendant strap.
- ▶ Secure pin **1** with washer **3** and locking spring **4**.

NOTICE

Inadmissible run of winch1/winch2 rope!
Damage to winch1/winch2 rope.

- ▶ Ensure that winch1/winch2 rope runs underneath spacer bracket **2**.

-
- ▶ Pin connecting element **12** to spacer bracket **2**.
 - ▶ Secure pin **10** with washer **7** and locking spring **8**.



Note

If stay ropes instead of backstay shackles must be installed according to system details:

- ▶ Install stay ropes using the same procedure as with backstay shackles.

-
- ▶ Pin connecting element **12** to top backstay shackles **9**.
 - ▶ Secure pin **11** with washer **5** and locking spring **6**.
 - ▶ Repeat procedure on opposite side.

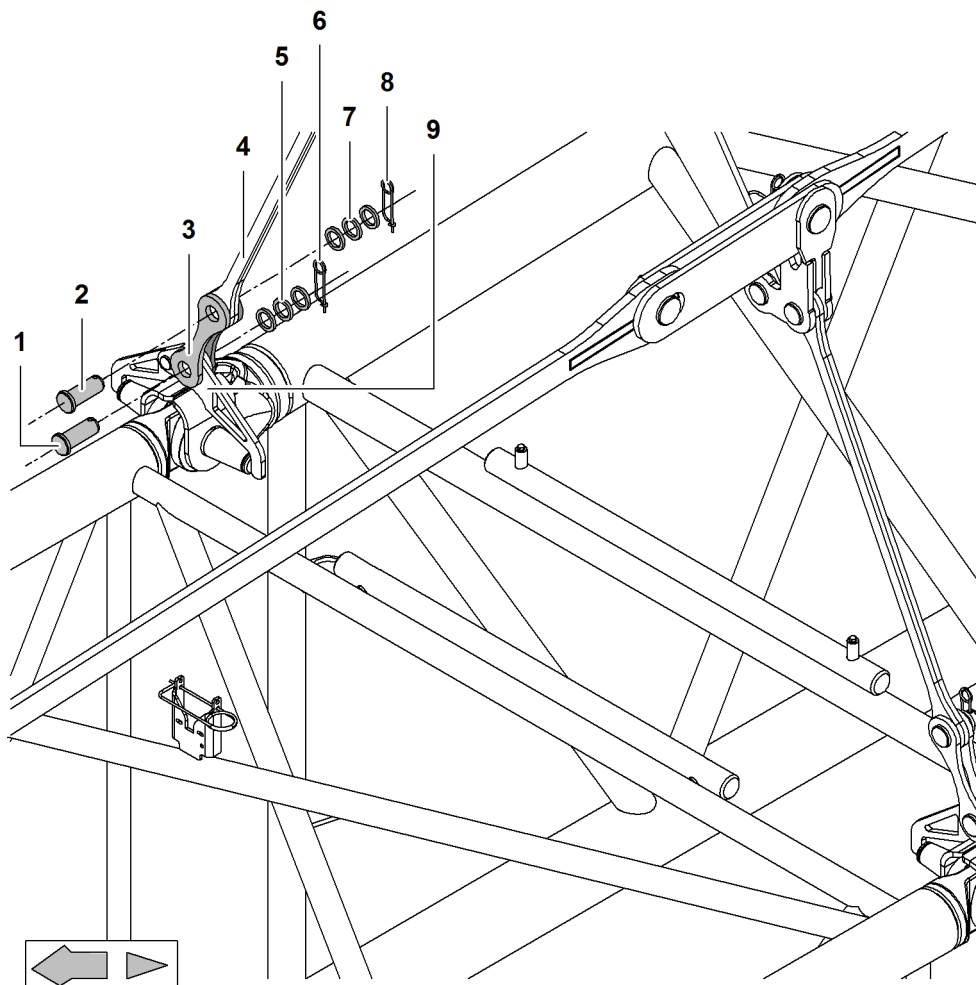


Fig. 4305: Installing bottom mid-point suspension backstay shackles behind the reducing adapter

- | | | | |
|---|------------------------------|---|----------------|
| 1 | Pin | 6 | Safety pin |
| 2 | Pin | 7 | Washers |
| 3 | Bottom backstay shackle (2x) | 8 | Locking spring |
| 4 | Top backstay shackle (2x) | 9 | Fork |
| 5 | Washers | | |



Note

- ▶ To facilitate pinning of the bottom backstay shackles **3** and fork **9**: Use A-frame1 to lift pendant straps.
- ▶ Pin bottom backstay shackles **3** to fork **9**.
As many washers **1** as possible must be inserted to keep the pin **5** from slipping.
- ▶ Secure pin **1** with washers **5** and locking spring **6**.
- ▶ Pin top backstay shackles **4** to bottom backstay shackles **3**.
As many washers **2** as possible must be inserted to keep the pin **7** from slipping.
- ▶ Secure pin **2** with washers **7** and locking spring **8**.
- ▶ Repeat procedure on opposite side.

7.14.4 Moving the lightning rods* into working position

Installation of lightning rods on jib head as main boom head

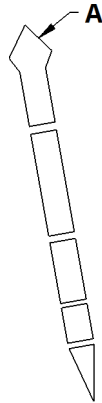


Fig. 4306: Installation of lightning rods on jib head as main boom head

A Jib head as main boom head

Boom configuration	Number of lightning rods	Installation positions
Main boom + reducing adapter	1	A

Tab. 536: Installation and number of lightning rods on jib head as main boom head

Moving the lightning rods* on the jib head as main boom head into working position

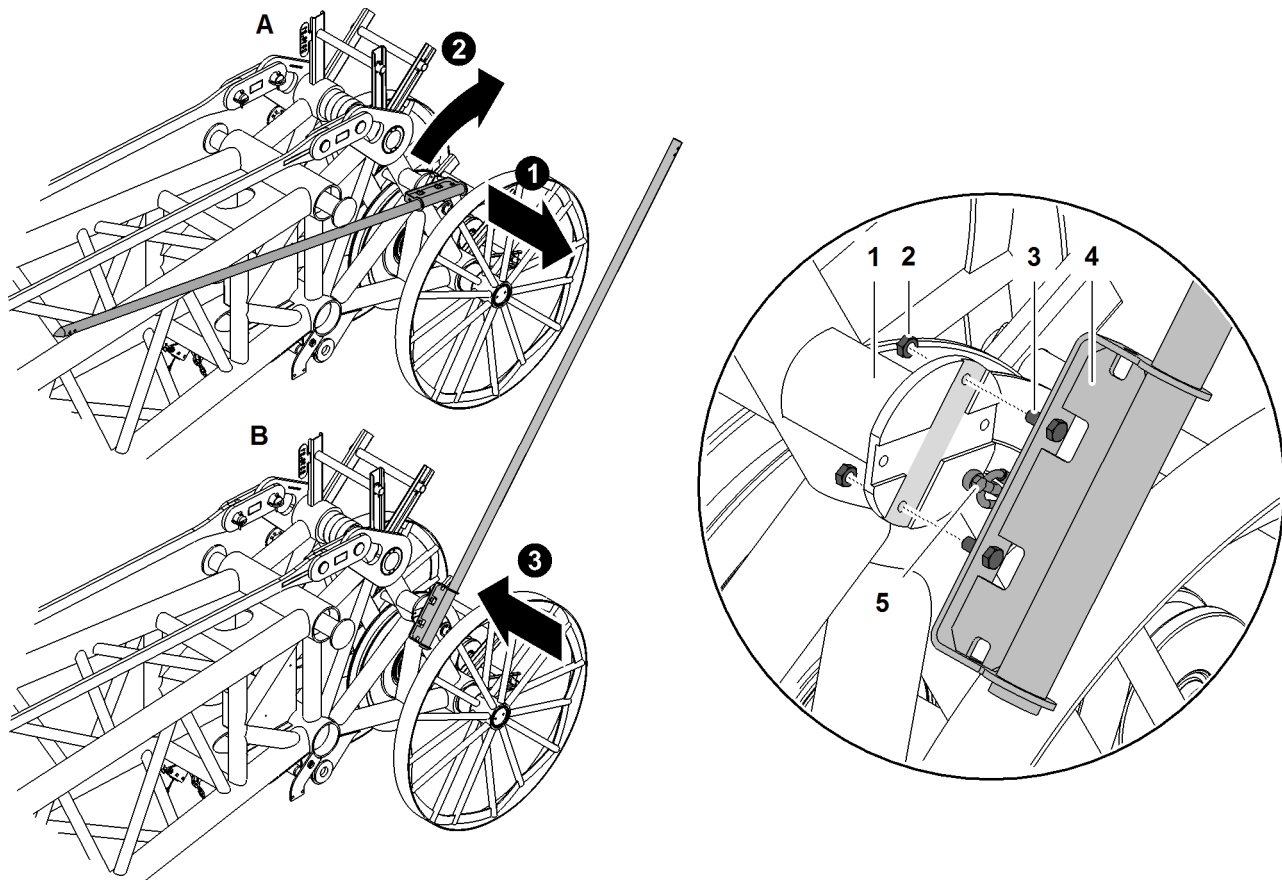


Fig. 4307: Moving the lightning rods* on the jib head as main boom head into working position (illustration of principle)

A Transport position
B Working position
1 Mounting plate

2 Nut (2x)
3 Screw (2x)
4 Lightning rod

5 Safety rope

- ▶ Undo safety rope **5**.
- ▶ Undo nuts **2**.
- ▶ Undo screws **3**.
- ▶ Move lightning rod **4** from transport position **A** to working position **B**.



Note

Liebherr recommends:

- ▶ Grease threads of the screws **3**.
- ▶ Attach lightning rod **4** with screws **3**.
- ▶ Lock screws **3** with nuts **2**.

NOTICE

Safety rope not attached!
Dropping parts.

- ▶ Ensure that safety rope **5** is attached.

- ▶ Attach safety rope **5**.
-

NOTICE

Tip not installed!
Improperly deflected current.
Dropping parts.

- ▶ Ensure that the tip on the lightning rod **4** is installed.

- ▶ Ensure that the screws of the tip are tightened.
-

- ▶ Ensure that the tip on the lightning rod **4** is installed.

- ▶ Ensure that the screws of the tip are tightened.

7.14.5 Reeving the rope

The rope must be reeved as specified in the rope reeving diagram according to the boom and application requirements.



WARNING

Unsecured walking on the boom!
Risk of falling off the boom.

- ▶ A fall arrest system must be worn when working on the boom to prevent falling.
-

Ensure that the following conditions are satisfied:

- Cylinder adjustment functions are on.

Reeving the rope using a rope reeving winch

Dismantling rope protection pipes

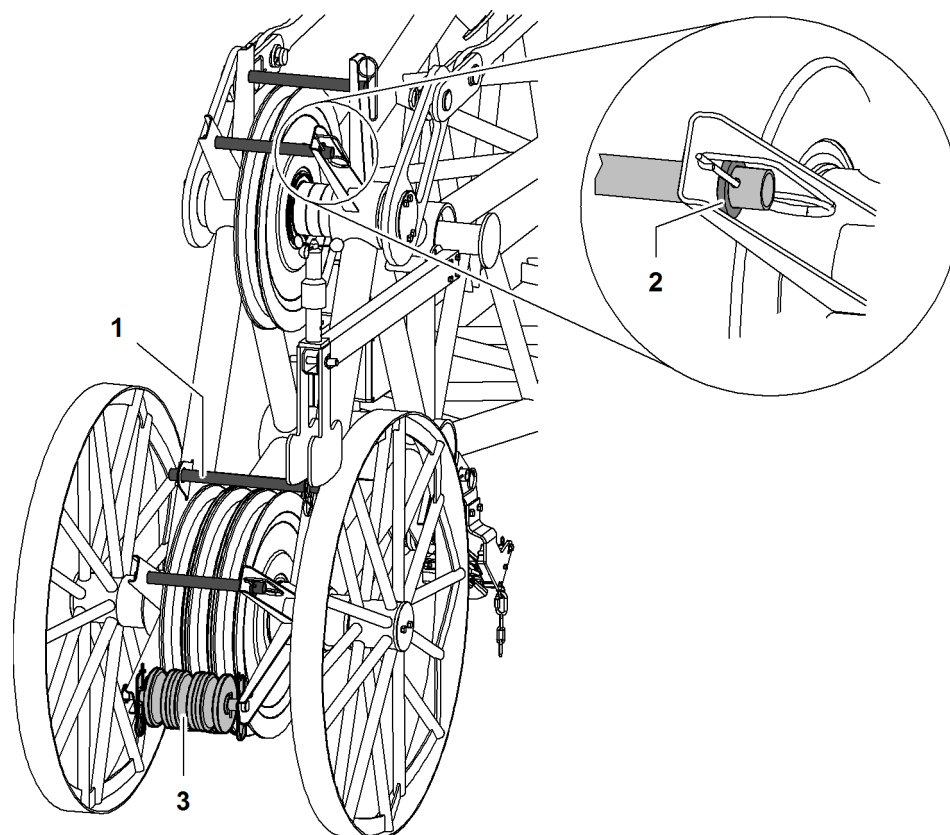


Fig. 4308: Rope protection pipes jib head section (1008, 1309, 1713, 1916, 2316)

- | | | | |
|---|----------------------|---|---------------------------------|
| 1 | Rope guard tube (4x) | 3 | Rope protection rollers package |
| 2 | Washer | | |

The rope protection pipes are secured with a cotter pin on one side and with a safety pin on the other side.

- ▶ Remove the safety pin and washer 2.
- ▶ Remove the rope protection pipes 1.

Dismantling the rope protection rollers package

The number of rope protection rollers corresponds to the number of pulleys of the jib head.

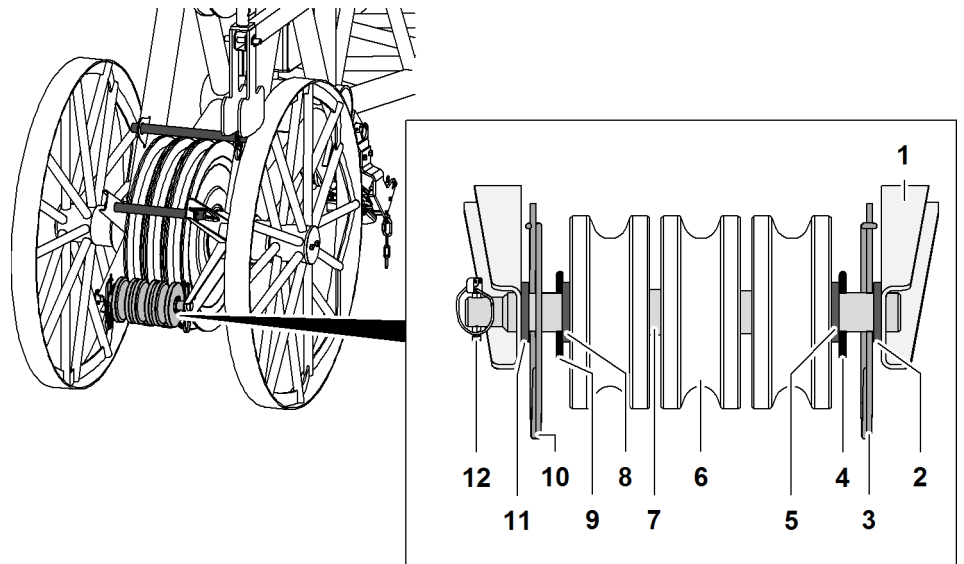


Fig. 4309: Rope protection rollers package

- | | | | |
|---|------------|----|------------|
| 1 | Mount | 7 | Shaft |
| 2 | Washer | 8 | Washer |
| 3 | Safety pin | 9 | Cotter pin |
| 4 | Cotter pin | 10 | Safety pin |
| 5 | Washer | 11 | Washer |
| 6 | Pulley | 12 | Linchpin |

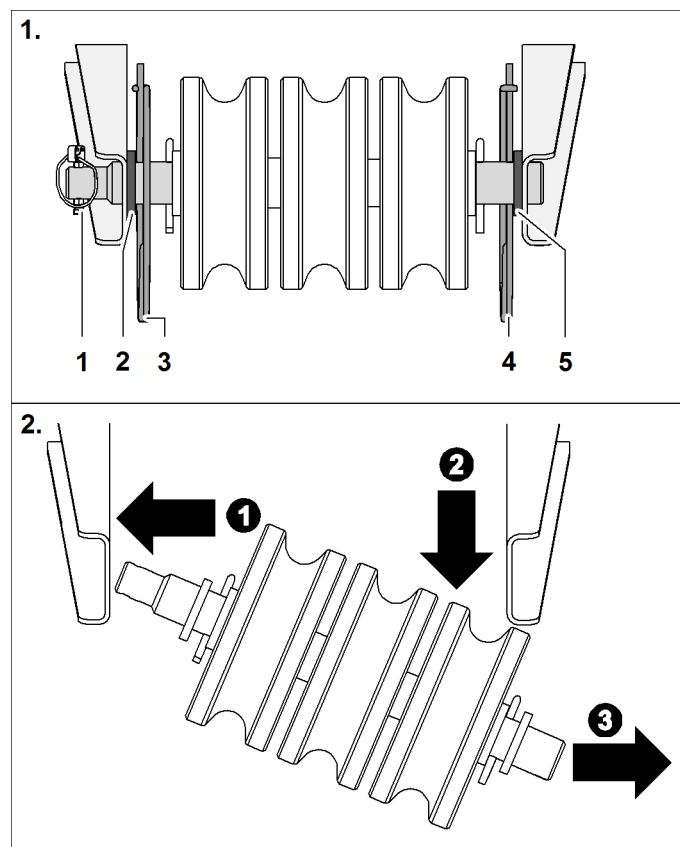


Fig. 4310: Dismantling the rope protection rollers package

- | | | | |
|---|----------|---|------------|
| 1 | Linchpin | 4 | Safety pin |
|---|----------|---|------------|

See next page for continuation of the image legend

- 2 Washer
- 3 Safety pin
- 5 Washer

- ▶ Remove the linchpin 1.
- ▶ Remove safety pin 3 + 4.
- ▶ Take rope protection rollers package off the support.
 - ▷ Rope protection rollers package is dismantled.

Reeving the rope

- ▶ Open up the rope guide (if present).

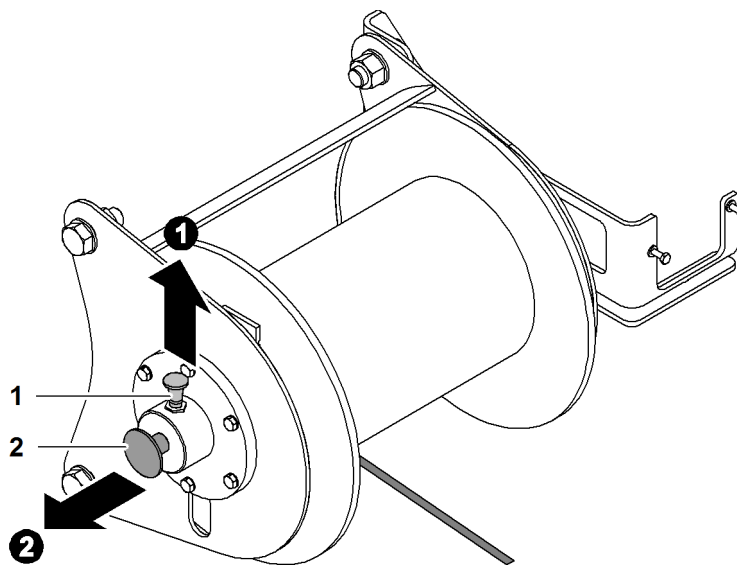


Fig. 4311: Setting the rope lug to free-wheel

- 1 Locking element
- 2 Shaft



Note

Liebherr recommends:

- ▶ Making it easier to pull out the axle 2: move the rope reeving winch manually back and forth.
- ▶ Pull up the locking element 1 and pull out the axle 2 at the same time.
 - ▷ Rope reeving winch is set to free-wheel.

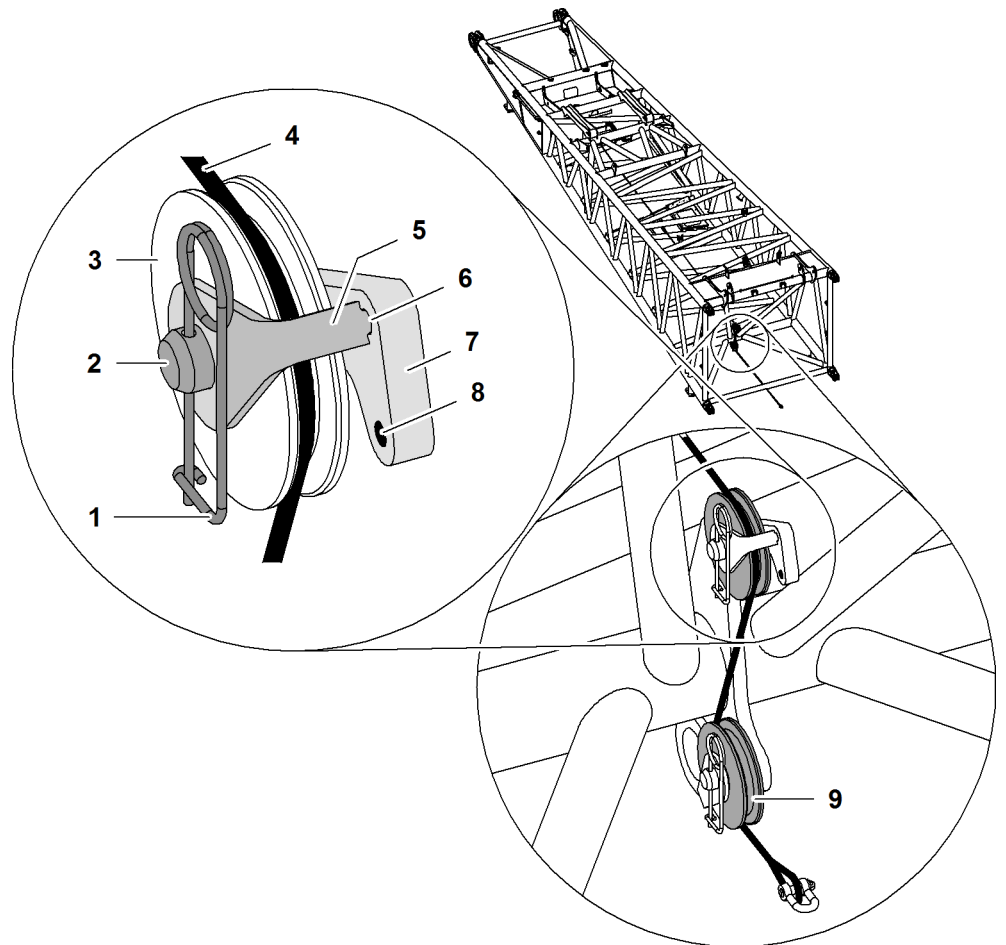


Fig. 4312: Reeving in the rope of the rope reeving winch

- | | | | |
|---|--------------------------------|---|-----------------------|
| 1 | Safety pin | 6 | Recess |
| 2 | Shaft | 7 | Support with recesses |
| 3 | Upper pulley | 8 | Recess |
| 4 | Rope of the rope reeving winch | 9 | Lower pulley |
| 5 | Locking element | | |

Depending on the machine type, the mounting **7** may have one or two recesses.

- ▶ Remove safety pins **1**.
- ▶ Remove **5** securing element.
- ▶ Place rope of the rope reeving winch **4** across the top pulley **3**.

NOTICE

Wrongly mounted locking element!

Rope of the rope reeving winch jumps out of pulley.

- ▶ Make sure that the locking element **5** is mounted in recess **6**.
- ▶ Attach locking element **5** to axle **2** and guide in recess **6**.
- ▶ Attach the safety pin **1**.
- ▶ Repeat procedure on bottom pulley **9**.
 - ▷ Rope of the rope reeving winch is guided through pulleys.
- ▶ Pull the luffing rope under the boom to the boom head.
- ▶ Reeve in the rope of the rope reeving winch according to reeving plan.

- ▶ Pull the luffing rope next to the boom towards the basic machine.
- ▶ Lift luffing rope onto boom.
- ▶ Connect luffing rope with rope of winch1/winch2.

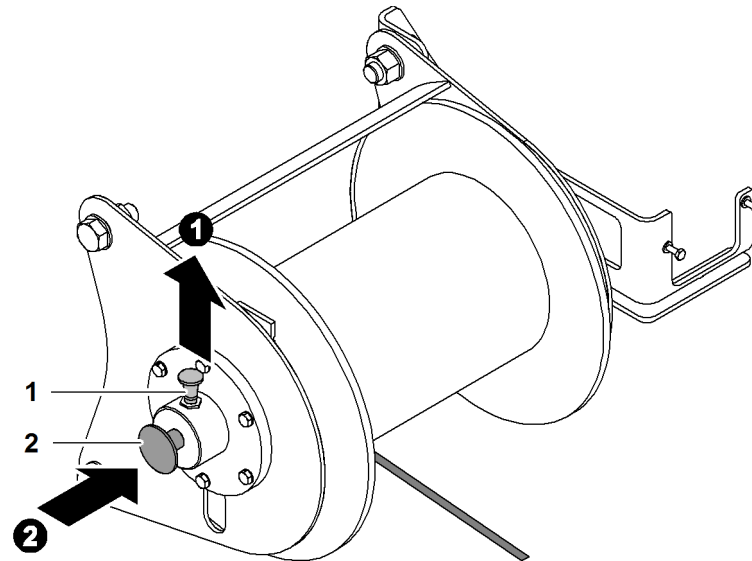


Fig. 4313: Stopping the free-wheel of the rope reeving winch

- | | | | |
|---|-----------------|---|-------|
| 1 | Locking element | 2 | Shaft |
|---|-----------------|---|-------|



Note

Liebherr recommends:

- ▶ Making it easier to press in the axle **2**: move the rope reeving winch manually back and forth.
- ▶ Pull up the locking element **1** and press in the axle **2** at the same time.
 - ▷ Free-wheel of the luffing rope is deactivated.



WARNING

Never stand in the immediate vicinity of the rope reeving winch or the luffing rope!

- ▶ Make sure that no-one is standing in the danger area.
- ▶ Leave the danger area.



- ▶ Press and hold the *Rope reeving winch* button on control panel X11.
 - ▷ Rope reeving winch reeves in the rope of the rope reeving winch and tensions the rope of winch1/winch2.

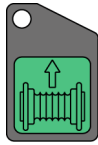


If rope of winch1/winch2 is in the 8th rope layer (only with free-fall winch 130 kN (29,230 lb.)):

- ▶ Press the *Bypass limit switch* button on control panel X23.
 - ▷ The 3-rope windings limit switch is bypassed.

There must be no slacking of the rope when unwinding.

- ▶ Unwind the rope of winch1/winch2 up to the rope fixing point.
- ▶ Press the *Rope reeving winch* button on control panel X11.
 - ▷ Rope reeving winch switched off.



- ▶ Remove rope of the rope reeving winch from the rope of winch1/winch2.
- ▶ Press and hold the *Rope reeving winch* button on control panel X11.
 - ▷ Luffing rope is being reeved.
- ▶ Press the *Rope reeving winch* button on control panel X11.
 - ▷ Rope reeving winch switched off.
- ▶ Close and secure the rope guide (if present).

Mounting the rope protection rollers package

NOTICE

Wrongly installed washers!
Rope protection rollers package falls out of the support.
Damage to jib head section.

- ▶ Ensure proper installation position of the washers.
-

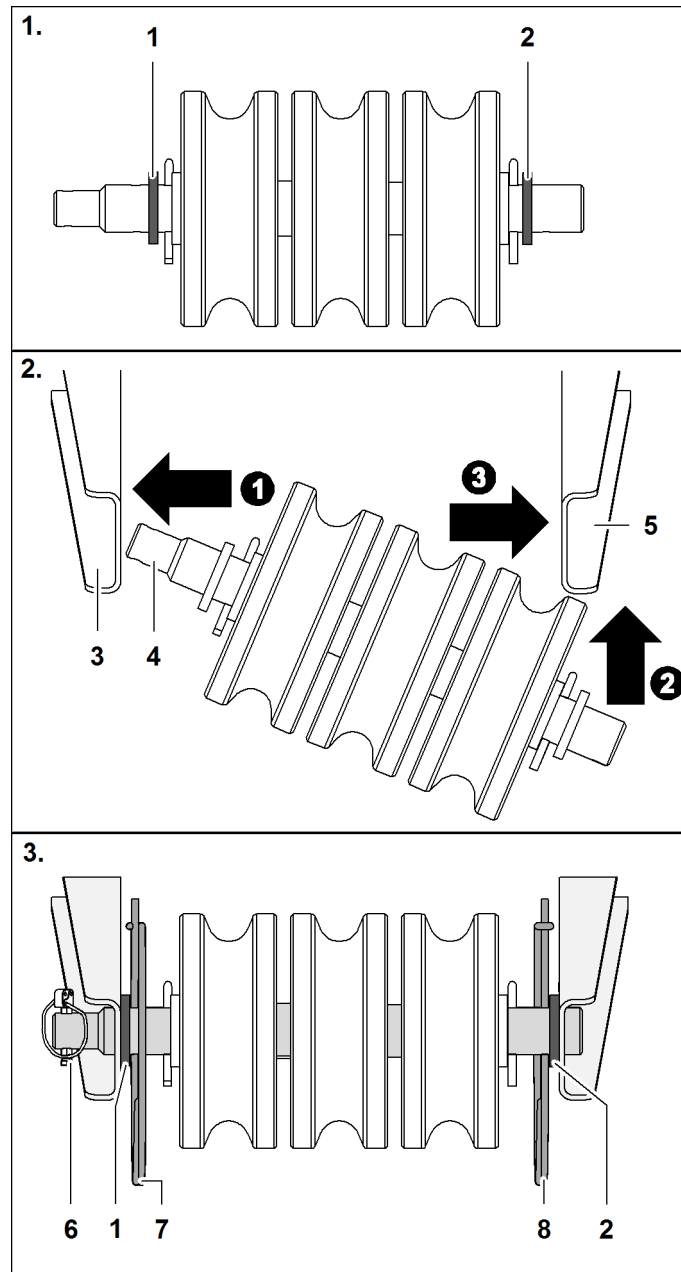


Fig. 4317: Mounting the rope protection rollers package on the jib head section

1	Washer	5	Mount
2	Washer	6	Linchpin
3	Mount	7	Safety pin
4	Shaft	8	Safety pin

- ▶ Place washers **1 + 2** on axle.
- ▶ Insert axle **4** of the rope protection rollers package into support **3**.
- ▶ Insert axle **4** into support **5**.
- ▶ Put washers **1 + 2** into position.
- ▶ Install safety pins **7 + 8**.
- ▶ Install linchpin **6**.
 - ▷ Rope protection rollers package is installed.

Installing rope protection pipes

- ▶ Mount and secure rope protection pipes.

Reeving the rope without using a rope reeving winch

- ▶ Remove the rope protection pipes on the boom and the pulley block.
- ▶ Open up the rope guide (if present).
- ▶ Connect auxiliary rope with the rope of winch1/winch2.
- ▶ Pull the auxiliary rope next to the boom as far as the boom head.
- ▶ Hoist the auxiliary rope onto the boom.
- ▶ Reeve the auxiliary rope according to the rope reeving system.



If rope of winch1/winch2 is in the 8th rope layer (only with free-fall winch 130 kN (29,230 lb_t)):

- ▶ Press the *Bypass limit switch* button on control panel X23.
 - ▷ The 3-rope windings limit switch is bypassed.

There must be no slacking of the rope when unwinding.

- ▶ Unwind the rope of winch1/winch2 up to the rope fixing point.
- ▶ Remove auxiliary rope from the rope of winch1/winch2.
- ▶ Close and secure the rope guide (if present).
- ▶ Mount and secure rope protection pipes.

7.15 Fixed jib 1713

System-relevant information for fixed jib 1713 :

- Configuration of jib
- Configuration of main boom
- Overview of pendant straps on fixed jib 1713
- Reeving diagrams for one rope across jib head 1713 (load position1)
- Reeving diagrams for two ropes across jib head 1713 (load position1)
- Reeving diagrams for one rope across main boom head 2821 (load position2)

7.15.1 Configuration of jib



DANGER

Excess length of jib!
Structural breakdown.

- ▶ Check jib length in load chart for validity.

Jib length	Configuration of jib (symbolic)
14 m 46 ft	
17 m 56 ft	
20 m 66 ft	
23 m 75 ft	
26 m 85 ft	
29 m 95 ft	
32 m 105 ft	
35 m 115 ft	

Tab. 537: Configuration of fixed jib 1713

7.15.2 Configuration of main boom



DANGER

Excess length of main boom!
Structural breakdown.

- ▶ Check main boom length in load chart for validity.

LWNLR-x/V04.01//Auslieferung/2016-03-07/en



Note

► See system-relevant data of main boom for information on main boom configuration (For more information see: [7.5.1 Configuration of main boom, page 1270](#)).

7.15.3 Overview of pendant straps on fixed jib 1713

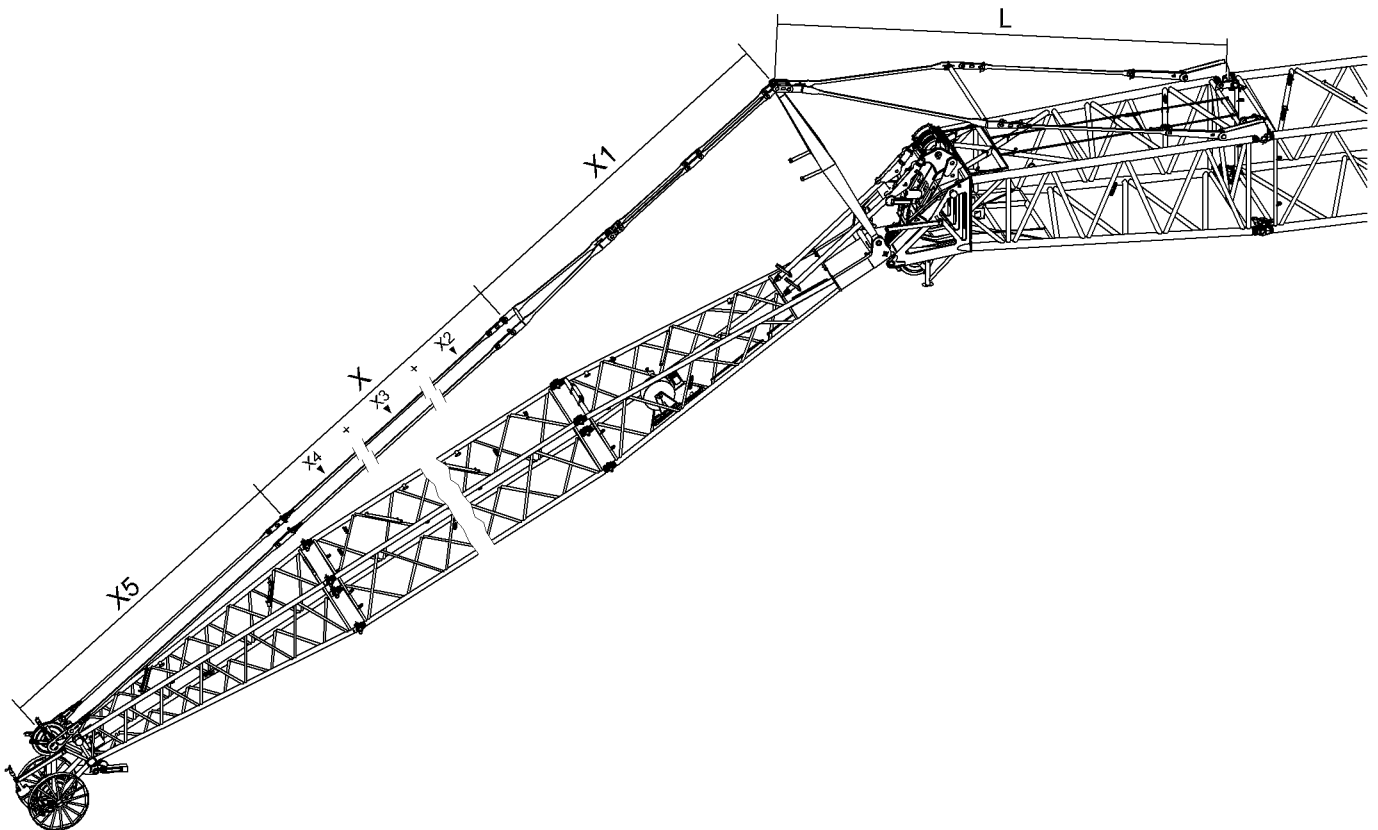


Fig. 4347: Overview of pendant straps on fixed jib 1713

Backstay straps A-frame2 to main boom head 2821

Name		Value
L	A-frame2 equalizer (jib backstay strap) (For more information see: Equalizer A-frame2 (jib backstay strap), page 255)	at 30°
		10000 mm 32' 10" ft-in
		at 15°
		9090 mm 29' 10" ft-in

Tab. 538: Backstay straps A-frame2 to main boom head 2821

LWNLR.x/V04.01//Auslieferung/2016-03-07/en

Pendant straps A-frame2 to jib head 1713

Name		Value	
X1	A-frame2 equalizer (jib pendant strap) (For more information see: Equalizer on A-frame2 (jib pendant strap), page 257)	7275 mm 23' 10" ft-in	
X	Jib pendant straps consisting of:		
	X2	Jib pendant strap 3 m (10 ft) (For more information see: Jib pendant strap 3 m (10 ft), page 258)	Total X2 +
	X3	Jib pendant strap 6 m (20 ft) (For more information see: Jib pendant strap 6 m (20 ft), page 259)	Total X3 +
	X4	Jib pendant strap 12 m (40 ft) (For more information see: Jib pendant strap 12 m (40 ft), page 260)	Total X4
X5	Jib pendant strap on jib head 1713 (For more information see: Jib pendant strap on jib head 1713.21, page 261)	6500 mm 21' 4" ft-in	

Tab. 539: Pendant straps A-frame2 to jib head 1713

Configuration of jib pendant straps (X):

Required number of jib pendant straps 3 m (10 ft) (**X2**) corresponds to number of jib sections 3 m (10 ft).

Required number of jib pendant straps 6 m (20 ft) (**X3**) corresponds to number of jib sections 6 m (20 ft).

Required number of jib pendant straps 12 m (40 ft) (**X4**) corresponds to number of jib sections 12 m (40 ft).



Note

- ▶ For the admissible number of jib sections 3 m (10 ft), 6 m (20 ft), 12 m (40 ft), refer to the following table: (For more information see: 7.15.1 Configuration of jib, page 1536)

7.15.4 Reeving diagrams for one rope across jib head 1713 (load position1)

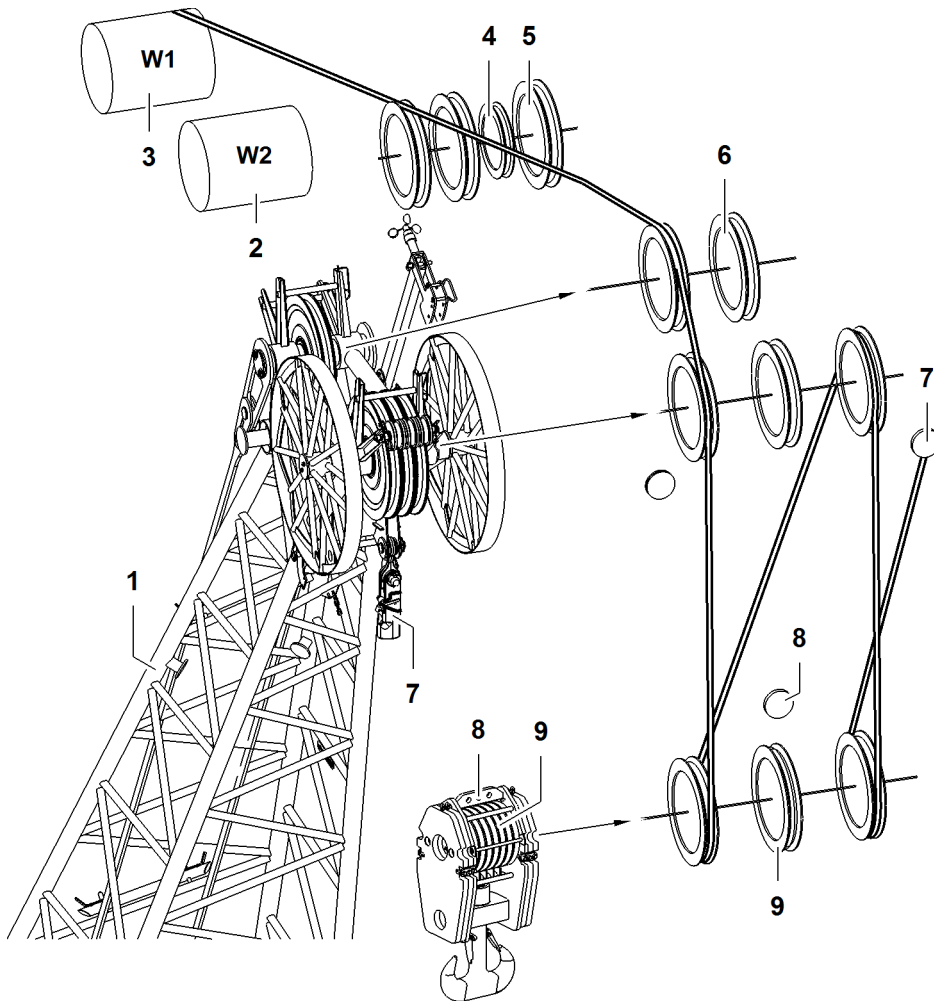


Fig. 4348: Reeving diagrams for one rope across jib head 1713 (load position1)

- | | | | | | |
|---|----------|---|--|---|------------------------------------|
| 1 | Jib head | 4 | Pulley for rope of jib luffing winch | 7 | Rope fixing point (2x) of jib head |
| 2 | Winch2 | 5 | Gantry pulley (3x) of main boom head | 8 | Rope fixing points of pulley block |
| 3 | Winch1 | 6 | Retrofit kit* for operation with two ropes across jib head | 9 | Pulley set of pulley block |

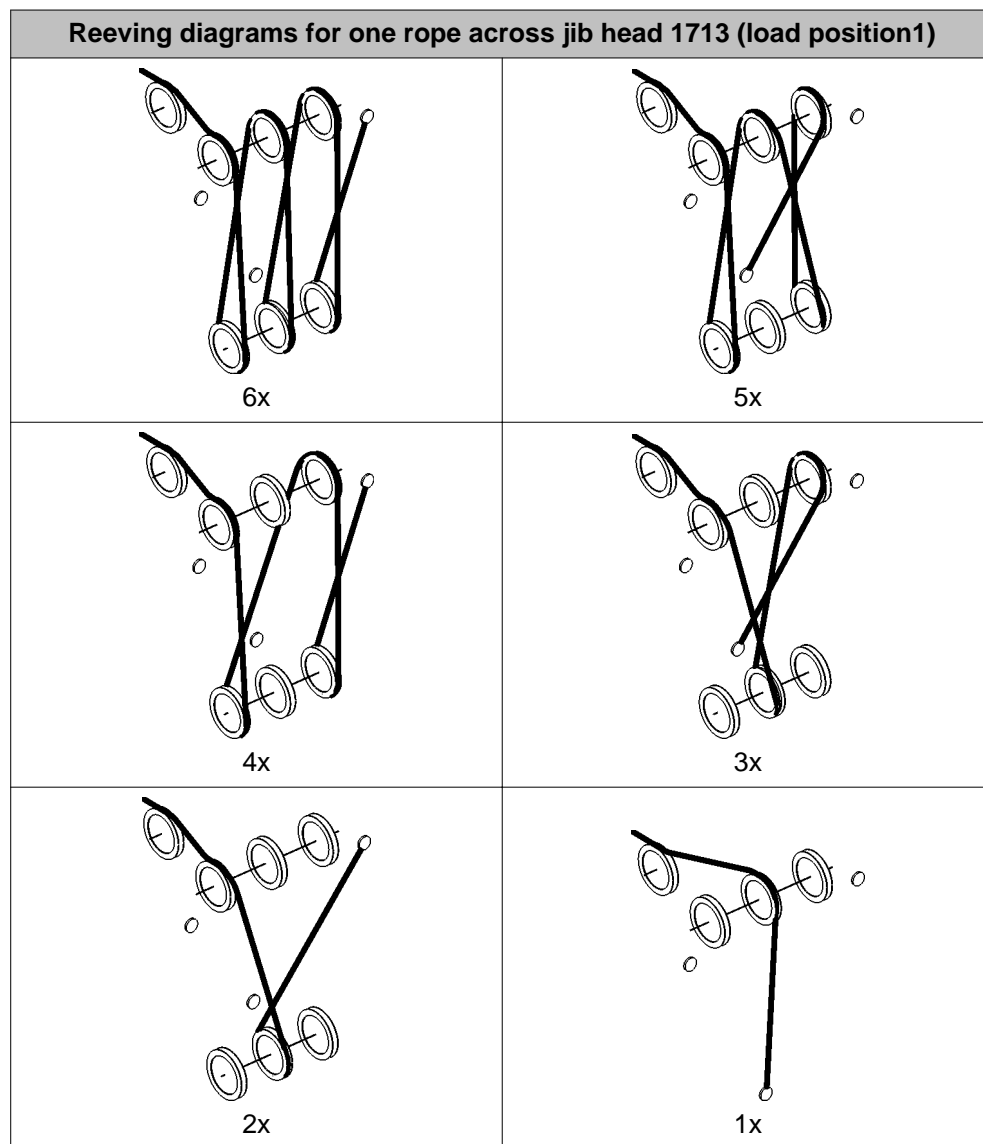


DANGER

Incorrect number of reevings!
Structural breakdown, toppling of machine.

► Choose the correct number of reevings as per the load chart.

LWNLR.x/V04.01//Auslieferung/2016-03-07/en



Tab. 540: Reeving diagrams for one rope across jib head 1713 (load position1)

7.15.5 Reeving diagrams for two ropes across jib head 1713 (load position1)



DANGER

Inadmissible number of reeving!
Structural breakdown, toppling of machine.

- Choose correct number of reeving as indicated in load chart.

LWNLR-x\04.01\Auslieferung\2016-03-07/en

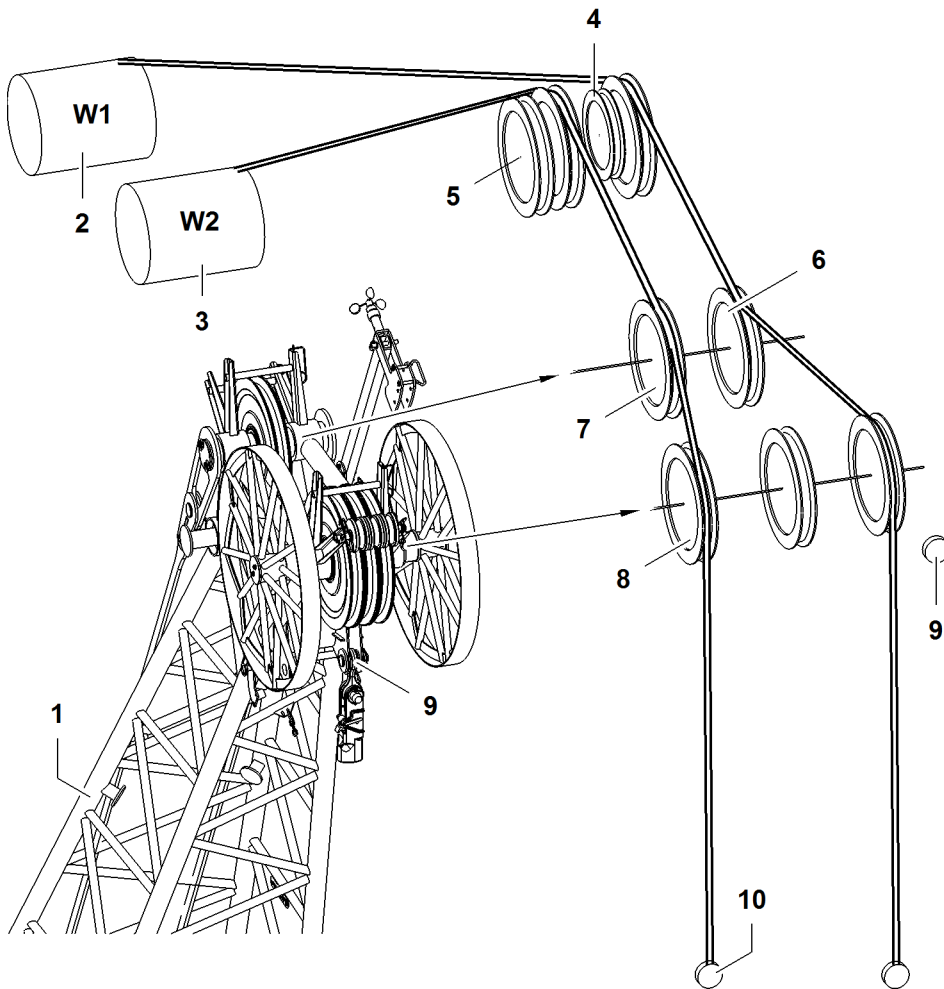


Fig. 4355: Reeving diagrams for two ropes across jib head 1713 (load position 1)

- | | | | | | |
|---|--------------------------------------|---|--|----|------------------------------------|
| 1 | Jib head | 5 | Gantry pulley (3x) of main boom head | 9 | Rope fixing point (2x) of jib head |
| 2 | Winch1 | 6 | Retrofit kit* for operation with two ropes across jib head | 10 | Rope fixing points of pulley block |
| 3 | Winch2 | 7 | Gantry pulley of jib head | | |
| 4 | Pulley for rope of jib luffing winch | 8 | Pulley (3x) of jib head | | |

7.15.6 Reeving diagrams for one rope across main boom head 2821 (load position 2)

If the main boom with jib attached is also used to lift a load, reeve main boom head 2821 as shown below.

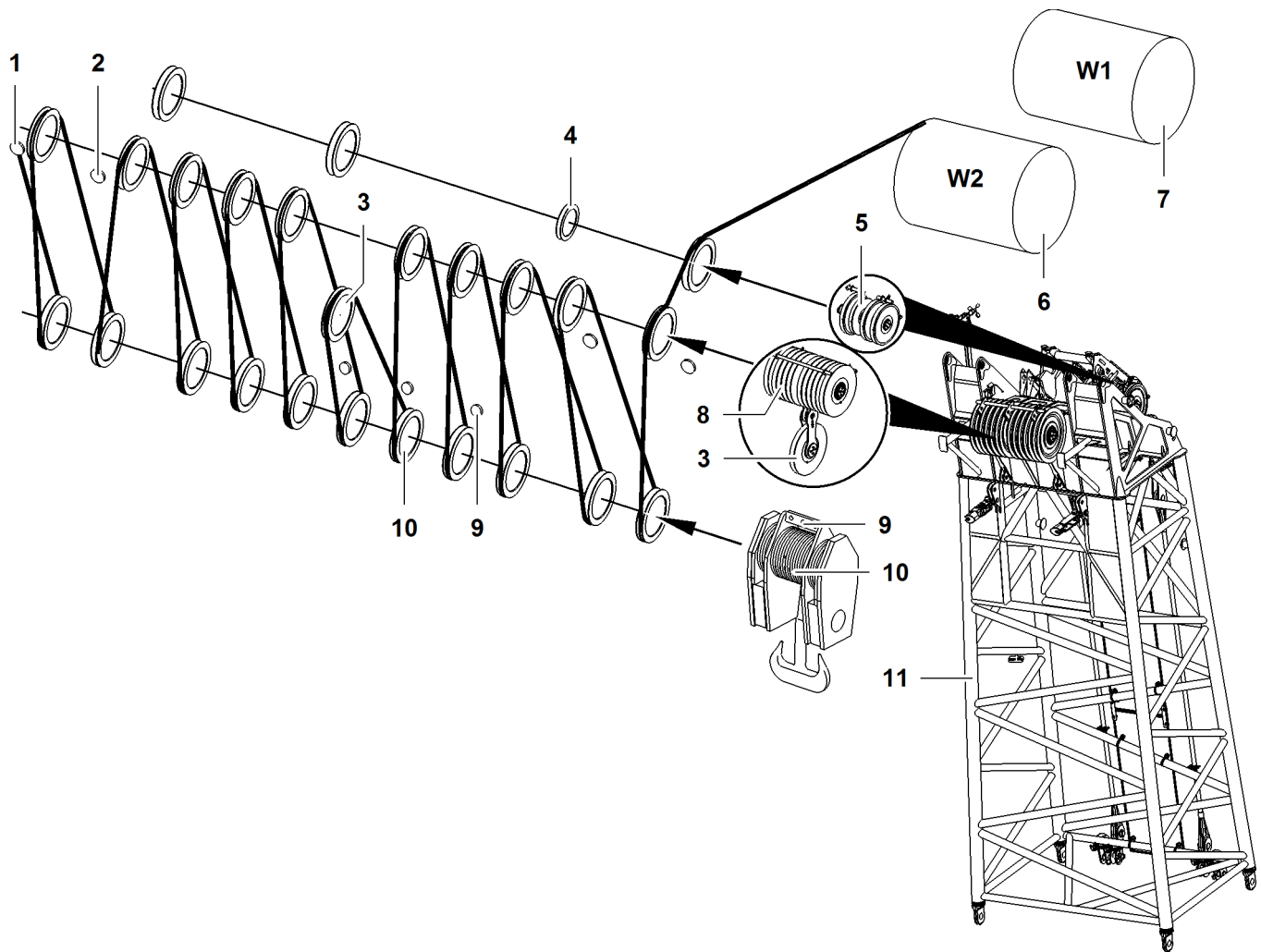


Fig. 4356: Reeving diagrams for one rope across main boom head 2821 (load position 2)

- | | | | | | |
|---|--|---|--------------------------------------|----|------------------------------------|
| 1 | Outer rope fixing point (2x) of main boom head | 5 | Gantry pulley (3x) of main boom head | 9 | Rope fixing points of pulley block |
| 2 | Inner rope fixing point (2x) of main boom head | 6 | Winch2 | 10 | Pulley set of pulley block |
| 3 | 11th pulley of main boom head | 7 | Winch1 | 11 | Main boom head |
| 4 | Pulley for rope of jib luffing winch | 8 | Pulley (10x) of main boom head | | |

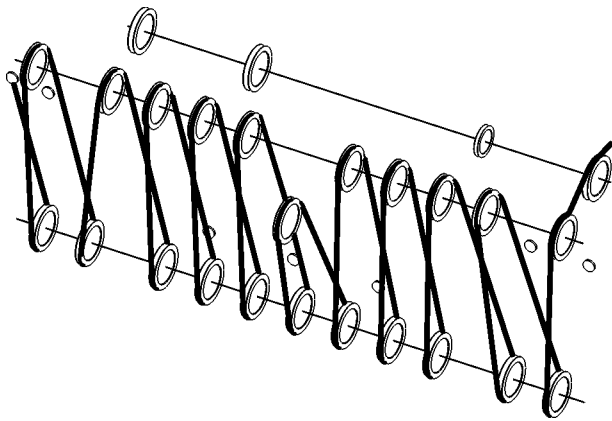


DANGER

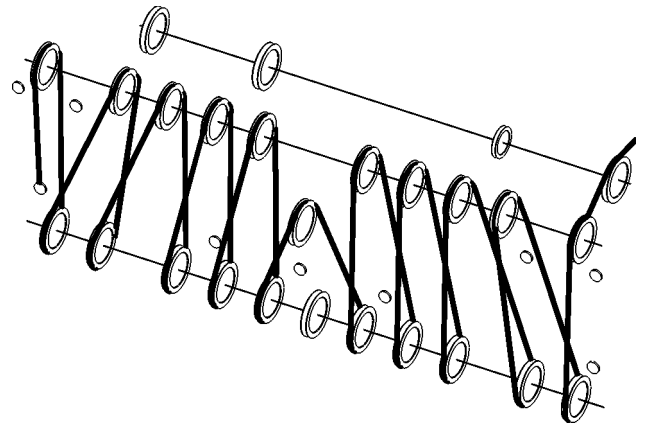
Inadmissible number of reevings!
Structural breakdown, toppling of machine.

► Choose correct number of reevings as indicated in load chart.

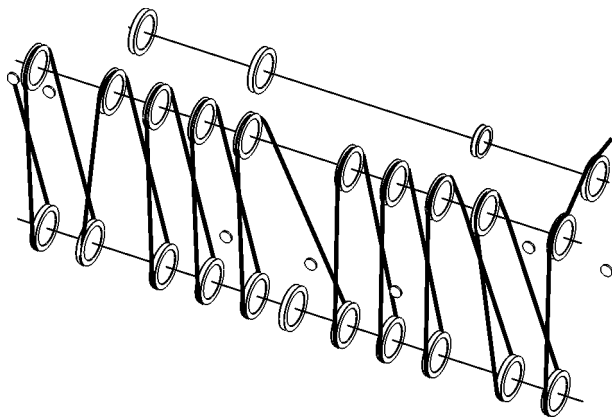
Reeving diagrams for one rope across main boom head 2821 (load position2)



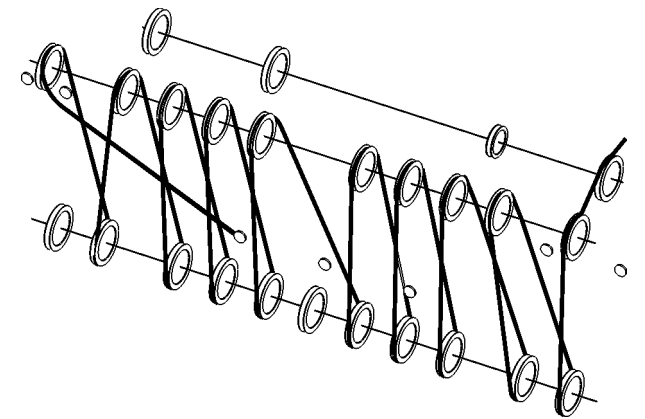
22x



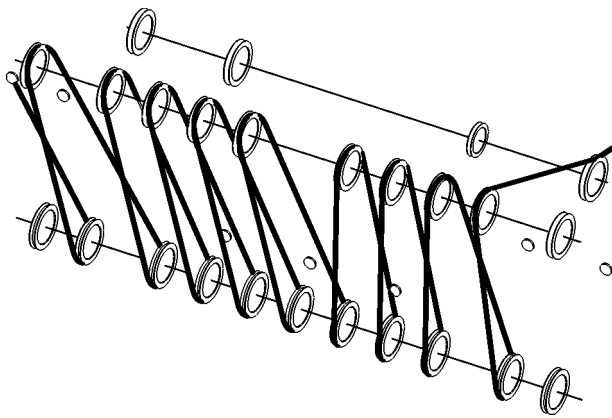
21x



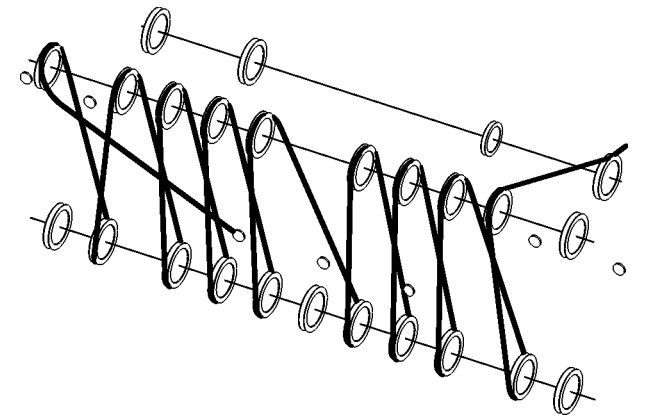
20x



19x



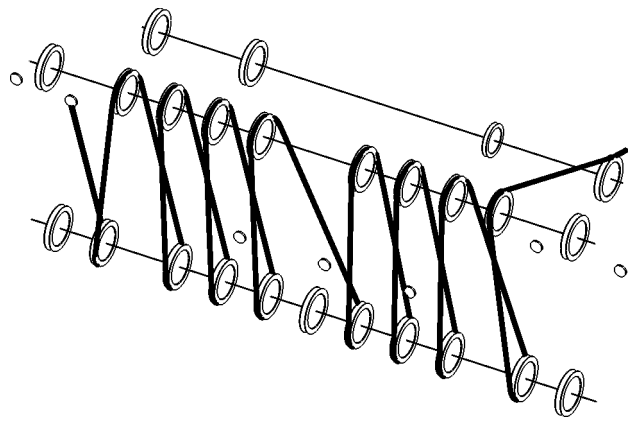
18x



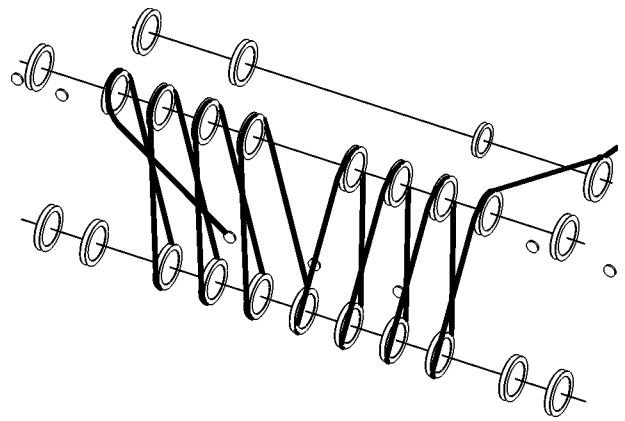
17x

LWNLR_x/V04.01//Auslieferung/2016-03-07/en

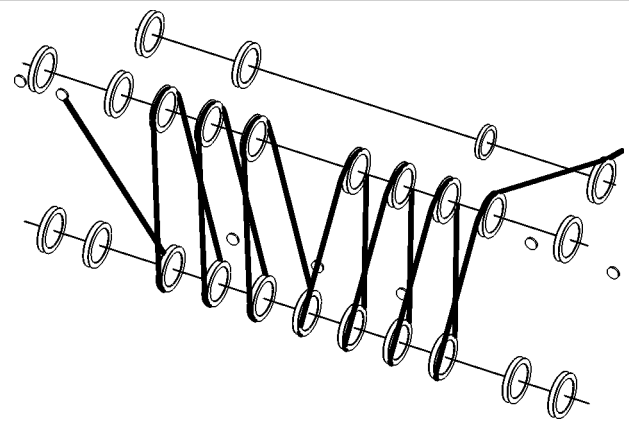
Reeving diagrams for one rope across main boom head 2821 (load position2)



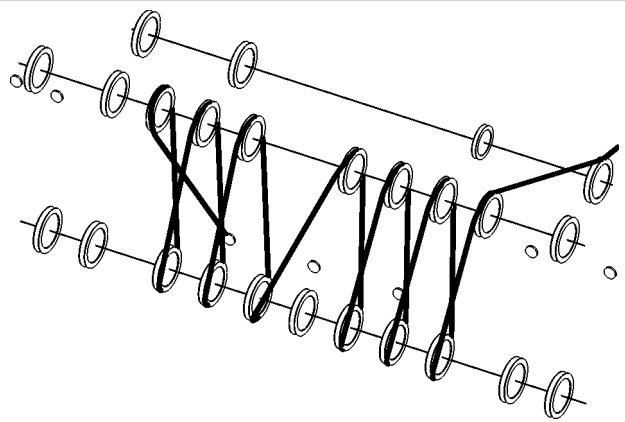
16x



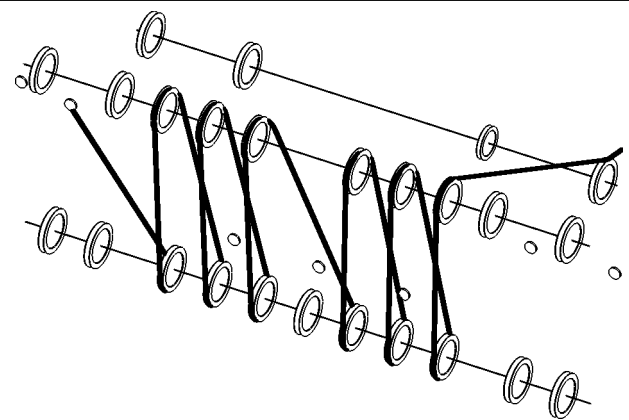
15x



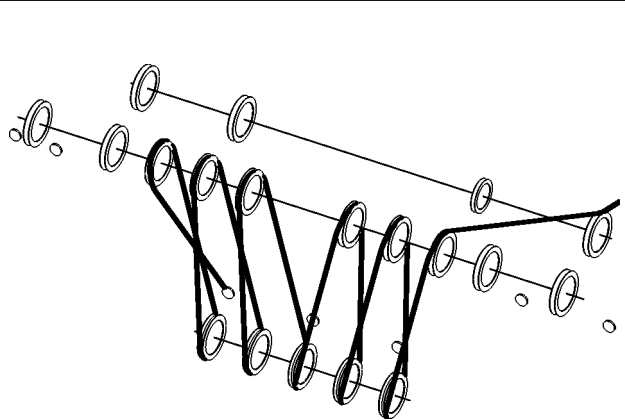
14x



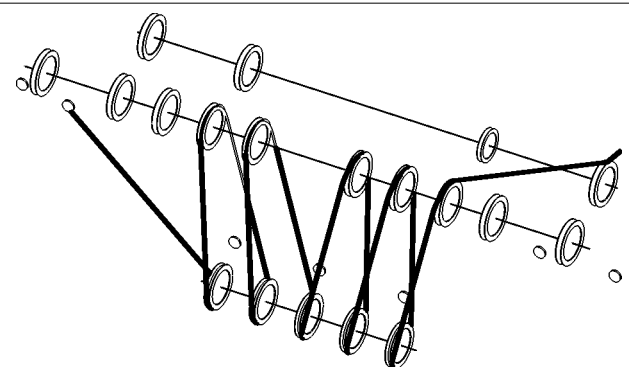
13x



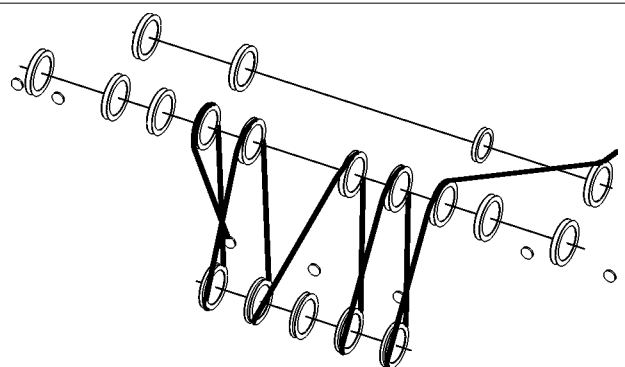
12x



11x

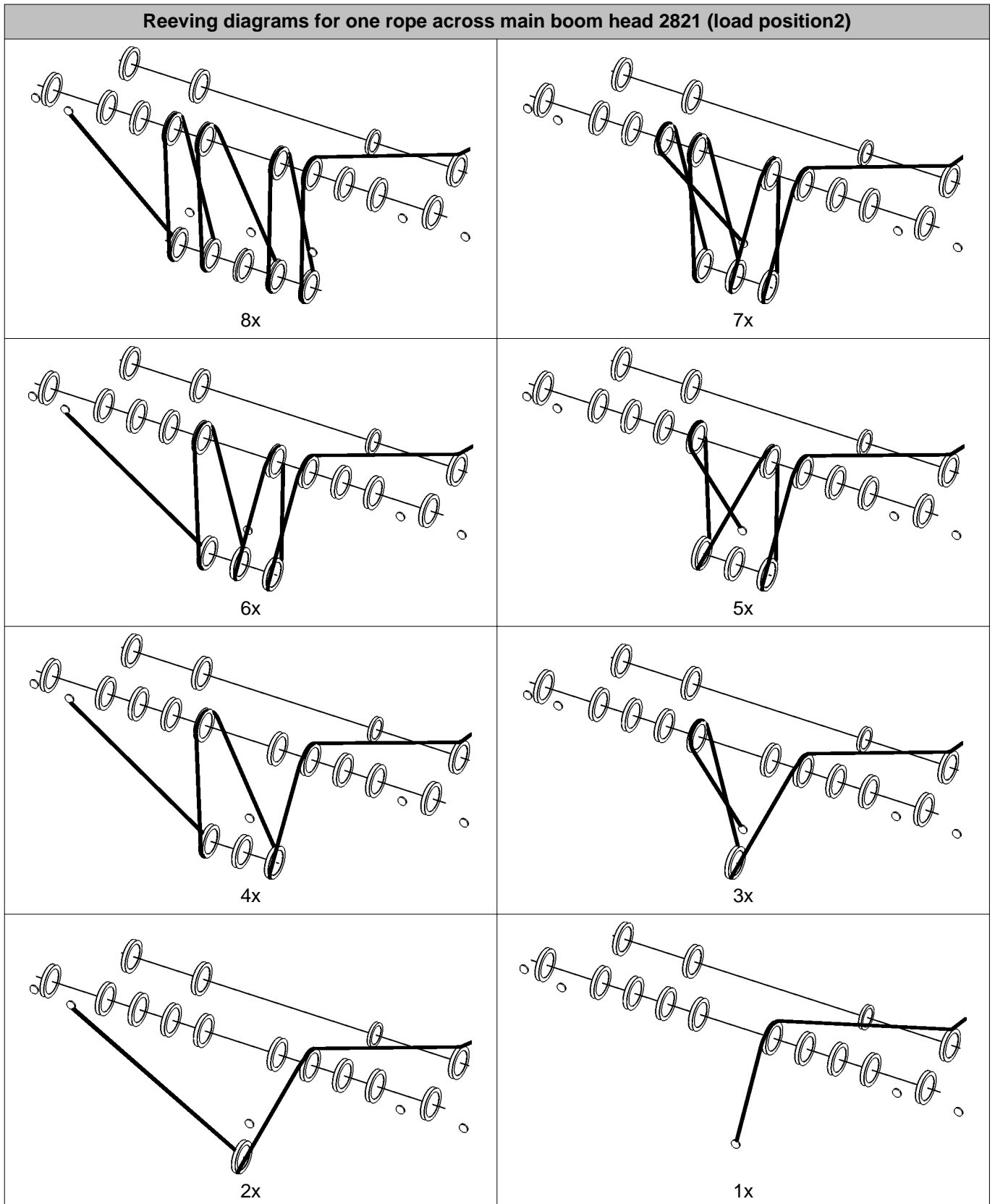


10x



9x

LWNLR-x/V04.01//Auslieferung/2016-03-07/en



LWNLR.x/V04.01//Auslieferung/2016-03-07/en

Tab. 541: Reeving diagrams for one rope across main boom head 2821 (load position2)

7.16 Fixed jib 1507

System-relevant information for fixed jib 1507:

- Configuration of jib
- Configuration of main boom
 - Rope guide installation position
 - Mid-point suspensions installation positions
 - Spacer bracket installation position
- Lengths of mid-point suspensions
- Composition of main boom in derrick mode with fixed jib 1507 attached
 - Rope guide installation position
 - Mid-point suspensions installation positions
 - Spacer bracket installation position
- Length of mid-point suspension in derrick mode with installed fixed jib 1507
- Overview of pendant straps on fixed jib 1507
- Reeving diagrams for one rope across jib head 1507 (load position1)
- Reeving diagrams for two ropes across jib head 1507 (load position1)
- Reeving diagrams for one rope across main boom head 2821 (load position2)

7.16.1 Configuration of jib

The fixed jib 1507 has a fixed length of 8 m (26 ft).

Jib length	Configuration of jib (symbolic)
8 m 26 ft	

Tab. 542: Configuration of fixed jib 1507

7.16.2 Configuration of main boom

System-relevant information for main boom 2821 with installed fixed jib 1507:

- Configuration of main boom
 - Installation position of rope guide (type A)
 - Mid-point suspensions installation positions
 - Spacer bracket installation positions
- Lengths of mid-point suspensions



DANGER

Excess length of main boom!
Structural breakdown.

- ▶ Check main boom length in load chart for validity.

Main boom length	Configuration of main boom (symbolic)
50 m 164 ft	
53 m 174 ft	

LWNLR-x/V04.01//Auslieferung/2016-03-07/en

Main boom length	Configuration of main boom (symbolic)
56 m 184 ft	
59 m 195 ft	
62 m 203 ft	
65 m 213 ft	
68 m 223 ft	
71 m 233 ft	
74 m 243 ft	
77 m 253 ft	
80 m 262 ft	
83 m 272 ft	
86 m 282 ft	

Tab. 543: Configuration of main boom 2821 with fixed jib 1507 attached

S - Installation position rope guide (type A)

X1 - Installation position mid-point suspension 1

X2 - Installation position mid-point suspension 2

Y - Installation position of spacer bracket with jib backstay straps (CF) on fixed jib 1507

7.16.3 Lengths of mid-point suspensions

Main boom length	Backstay pendant 1 (X1)	Backstay pendant 2 (X2)
	Rope length	Rope length
77 m 253 ft ^{A)}	3.7 m 12' 2" ft-in = 2.1 m (6' 11" ft-in) + 1.6 m (5' 3" ft-in)	
80 m 262 ft ^{B)}	4.2 m 13' 9" ft-in = 1.6 m (5' 3" ft-in) + 2.6 m (8' 6" ft-in)	

LWNLR.x/V04.01//Auslieferung/2016-03-07/en

Main boom length	Backstay pendant 1 (X1)	Backstay pendant 2 (X2)
	Rope length	
83 m 272 ft ^{C)}	4.2 m 13' 9" ft-in = 1.6 m (5' 3" ft-in) + 2.6 m (8' 6" ft-in)	
86 m 282 ft ^{D)}	5.6 m 18' 4" ft-in = 3.0 m (9' 10" ft-in) + 2.6 m (8' 6" ft-in)	4.2 m 13' 9" ft-in = 2.6 m (8' 6" ft-in) + 1.6 m (5' 3" ft-in)

Tab. 544: Lengths of mid-point suspensions - 2821 main boom with 1507 fixed jib attached

- A) Jib backstay straps run within the ropes of the mid-point suspension for a main boom length of 77 m (253 ft).
- B) Jib backstay straps run outside the ropes of the mid-point suspension for a main boom length of 80 m (262 ft).
- C) Jib backstay straps run outside the ropes of the mid-point suspension for a main boom length of 83 m (272 ft).
- D) Jib backstay straps run inside the ropes of the mid-point suspension with mid-point suspension 1 and outside them with mid-point suspension 2 on X2 with a main boom length of 86 m (282 ft).

7.16.4 Composition of main boom in derrick mode with fixed jib 1507 attached



DANGER

Excess length of main boom!
Structural breakdown.

► Check main boom length in load chart for validity.

Main boom length	Configuration of main boom (symbolic)
41 m 134 ft	
44 m 144 ft	
47 m 154 ft	
50 m 164 ft	
53 m 174 ft	
56 m 184 ft	
59 m 195 ft	

LWN/LR-x/V04.01//Auslieferung/2016-03-07/en

Main boom length	Configuration of main boom (symbolic)
62 m 203 ft	
65 m 213 ft	
68 m 223 ft	
71 m 233 ft	
74 m 243 ft	
77 m 253 ft	
80 m 262 ft	
83 m 272 ft	
86 m 282 ft	
89 m 292 ft	
92 m 302 ft	
95 m 312 ft	
98 m 322 ft	
101 m 332 ft	
104 m 342 ft	
107 m 351 ft	
110 m 361 ft	
113 m 371 ft	

Tab. 545: Composition of main boom 2821 in derrick mode with fixed jib 1507 attached

S - Installation position rope guide (type B)

X1 - Installation position mid-point suspension 1

Y - Installation position of spacer bracket with jib backstay straps (CF) on fixed jib 1507

LWNLR.x/V04.01//Auslieferung/2016-03-07/en

7.16.5 Length of midpoint suspension in derrick mode with installed fixed jib 1507

Main boom length	Backstay pendant 1 (X1)
	Rope length
95 m 312 ft	7.2 m 23' 7" ft-in = 2.1 m (6' 11" ft-in) + 2.1 m (6' 11" ft-in) + 3.0 m (9' 10" ft-in)
98 m 322 ft	6.9 m 22' 8" ft-in = 1.6 m (5' 3" ft-in) + 1.6 m (5' 3" ft-in) + 1.6 m (5' 3" ft-in) + 2.1 m (6' 11" ft-in)
101 m 332 ft	6.7 m 22' ft-in = 1.6 m (5' 3" ft-in) + 2.1 m (6' 11" ft-in) + 3.0 m (9' 10" ft-in)
104 m 342 ft	9.2 m 30' 2" ft-in = 1.6 m (5' 3" ft-in) + 1.6 m (5' 3" ft-in) + 3.0 m (9' 10" ft-in) + 3.0 m (9' 10" ft-in)
107 m 351 ft	8.9 m 29' 2" ft-in = 1.6 m (5' 3" ft-in) + 2.1 m (6' 11" ft-in) + 2.6 m (8' 6" ft-in) + 2.6 m (8' 6" ft-in)
110 m 361 ft	8.8 m 28' 10" ft-in = 1.6 m (5' 3" ft-in) + 2.1 m (6' 11" ft-in) + 2.1 m (6' 11" ft-in) + 3.0 m (9' 10" ft-in)
113 m 371 ft	8.6 m 28' 3" ft-in = 2.6 m (8' 6" ft-in) + 3.0 m (9' 10" ft-in) + 3.0 m (9' 10" ft-in)

Tab. 546: Lengths of mid-point suspensions - 2821 main boom in derrick operation with 1507 fixed jib attached

LWNLR-x\04.01\Auslieferung\2016-03-07/en

7.16.6 Overview of pendant straps on fixed jib 1507

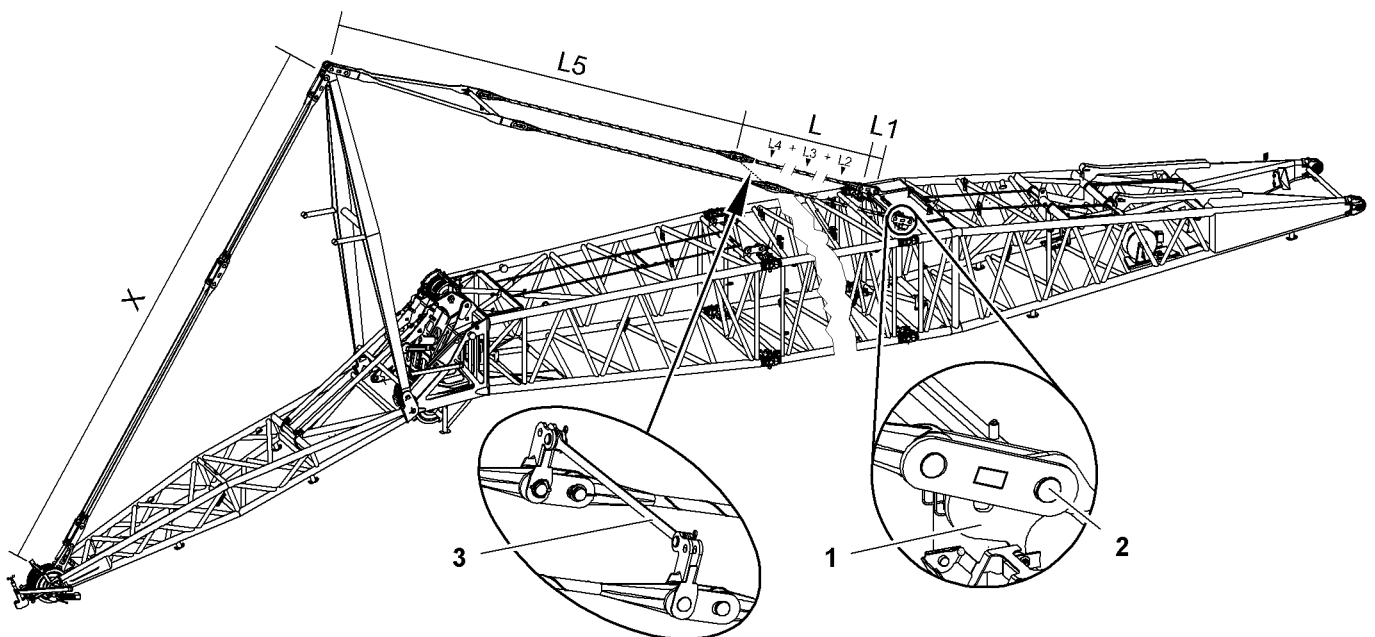


Fig. 4660: Overview of pendant straps on fixed jib 1507

- 1 Main boom base section
- 2 Pin connection point for jib backstay straps
- 3 Spacer bracket with connecting elements

Jib backstay straps A-frame2 to main boom base section 2821

Name		Value
L1	Connecting link (For more information see: Connecting link , page 202)	350 mm 1' 2" ft-in
Jib backstay straps consisting of:		
L2	Jib backstay strap 3 m (10 ft) (For more information see: Jib backstay strap 3 m (10 ft) , page 204)	Total L2 +
L3	Jib backstay strap 6 m (20 ft) (For more information see: Jib backstay strap 6 m (20 ft) , page 208)	Total L3 +
L4	Jib backstay strap 12 m (40 ft) (For more information see: Jib backstay strap 12 m (40 ft) , page 212)	Total L4
L5	A-frame2 equalizer (jib backstay strap) (For more information see: Equalizer A-frame2 (jib backstay strap) , page 264)	9980 mm 32' 9" ft-in

Tab. 547: Jib backstay straps A-frame2 to main boom base section 2821

Configuration of jib backstay straps (L):

Required number of jib backstay straps 3 m (10 ft) (L2) corresponds to number of main boom sections 3 m (10 ft).

Required number of jib backstay straps 6 m (20 ft) (L3) corresponds to number of main boom sections 6 m (20 ft).

LWNLR.x/V04.01/Auslieferung/2016-03-07/en

Required number of jib backstay straps 12 m (40 ft) (**L4**) corresponds to number of main boom sections 12 m (40 ft).



Note

- ▶ For the admissible number of main boom sections 3 m (10 ft), 6 m (20 ft), 12 m (40 ft), refer to the load chart.

The jib backstay straps (**L**) may consist of generation A and generation B jib backstay straps (For more information see: [1.16.2 Steel pendant straps on fixed jib 1507, page 264](#)) . Mixing is only admissible if the number of generation B jib backstay straps only differs by at most 1 in the left and the right strand of the backstay straps.



DANGER

Inadmissible mixing of generation A and generation B jib backstay straps!
Structural breakdown.

- ▶ Ensure that the number of generation B jib backstay straps differs by at most 1 in the left and the right strand of the backstay straps.

Pendant straps A-frame2 to jib head 1507

Name		Value
X	Jib pendant strap (A-frame2 to jib head 1507) (For more information see: Jib pendant strap (A-frame2 to jib head 1507), page 266)	11615 mm 38' 1" ft-in

Tab. 548: Pendant straps A-frame2 to jib head 1507

7.16.7 Reeving diagrams for one rope across jib head 1507 (load position1)

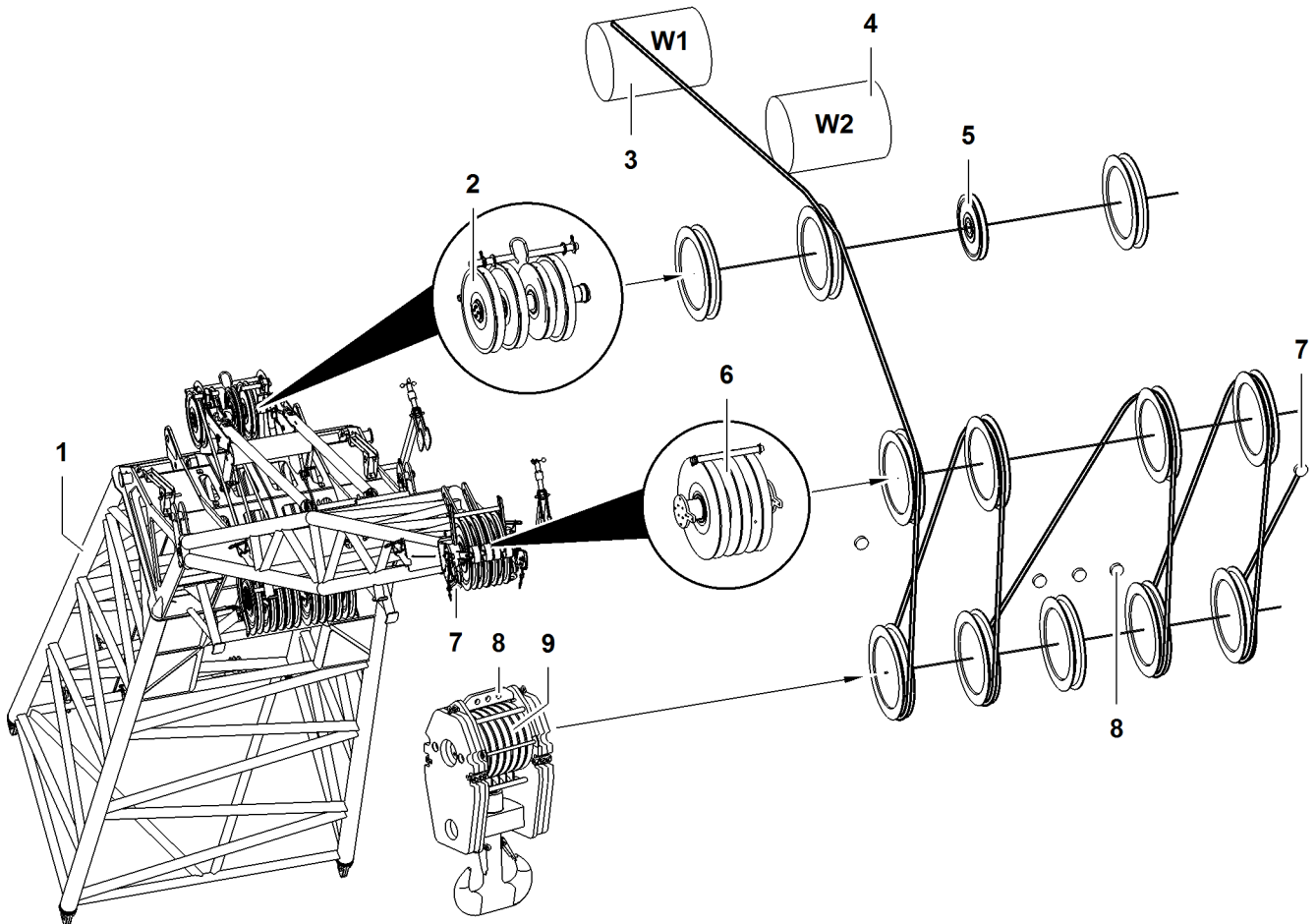


Fig. 4661: Reeving diagrams for one rope across jib head 1507 (load position1)

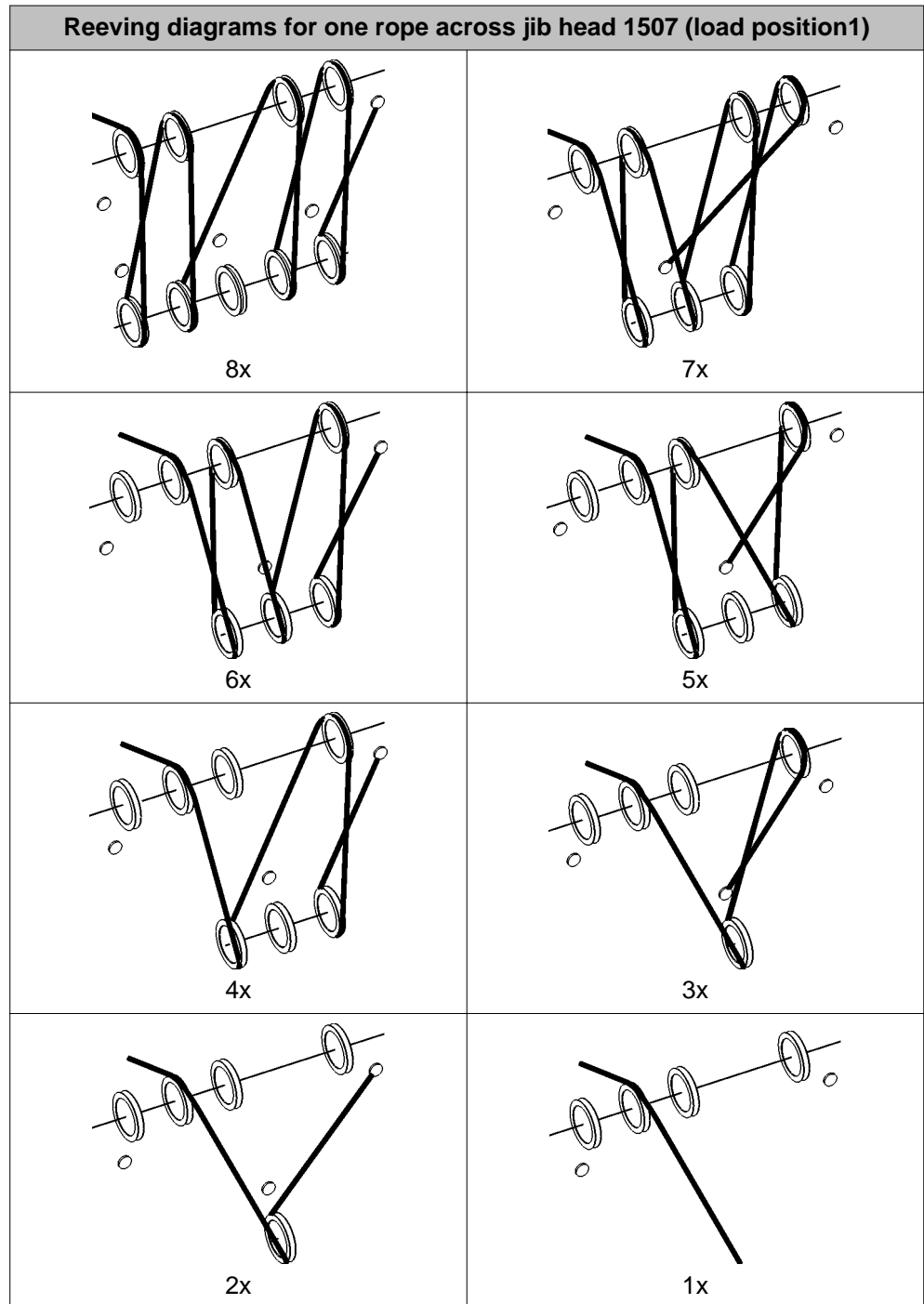
1	Main boom head	4	Winch2	7	Rope fixing point (2x) of jib head
2	Gantry pulley (3x) of main boom head	5	Pulley for rope of jib luffing winch	8	Rope fixing points of pulley block
3	Winch1	6	Pulley (4x) of jib head	9	Pulley set of pulley block



DANGER

Inadmissible number of reevings!
Structural breakdown, toppling of machine.

► Choose correct number of reevings as indicated in load chart.



Tab. 549: Reeving diagrams for one rope across jib head 1507 (load position1)

LWNLR-x/V04.01//Auslieferung/2016-03-07/en

7.16.8 Reeving diagrams for two ropes across jib head 1507 (load position1)

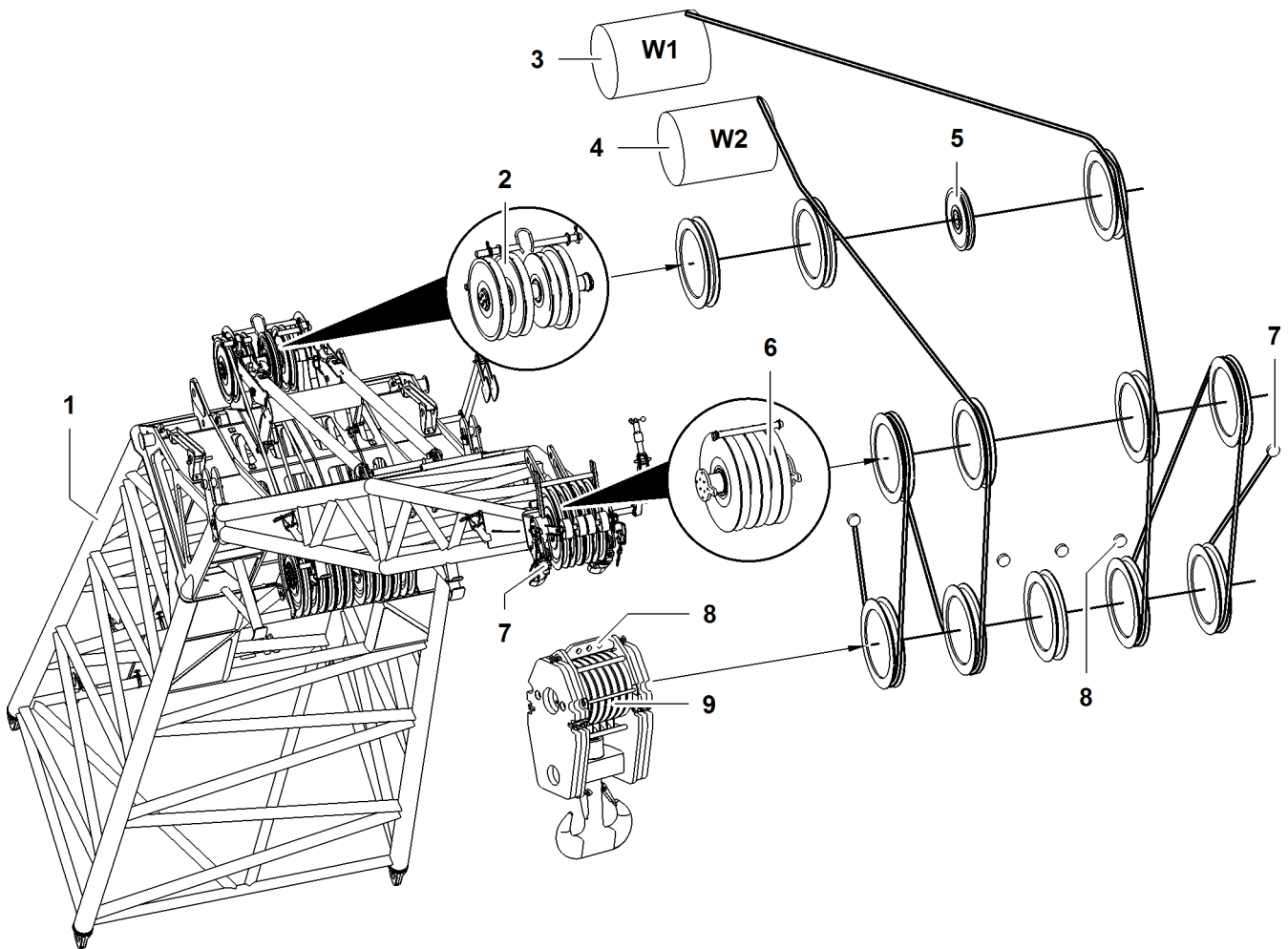
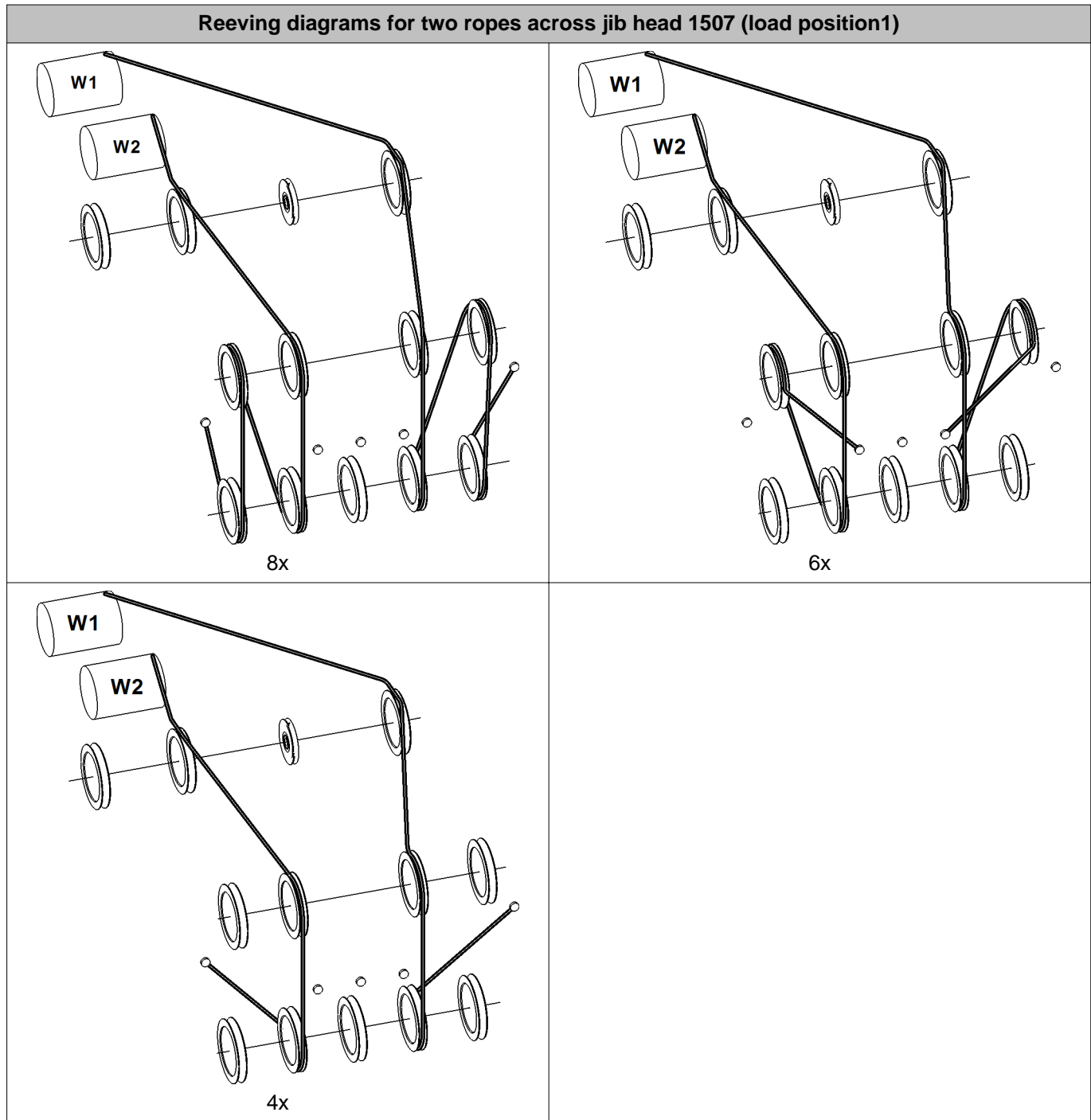


Fig. 4670: Reeving diagrams for two ropes across jib head 1507 (load position1)

1	Main boom head	4	Winch2	7	Rope fixing point (2x) of jib head
2	Gantry pulley (3x) of main boom head	5	Pulley for rope of jib luffing winch	8	Rope fixing points of pulley block
3	Winch1	6	Pulley (4x) of jib head	9	Pulley set of pulley block



Tab. 550: Reeving diagrams for two ropes across jib head 1507 (load position1)

7.16.9 Reeving diagrams for one rope across main boom head 2821 (load position2)

If the main boom with jib attached is also used to lift a load, reeve main boom head 2821 as shown below.

LWNLR-x/V04.01//Auslieferung/2016-03-07/en

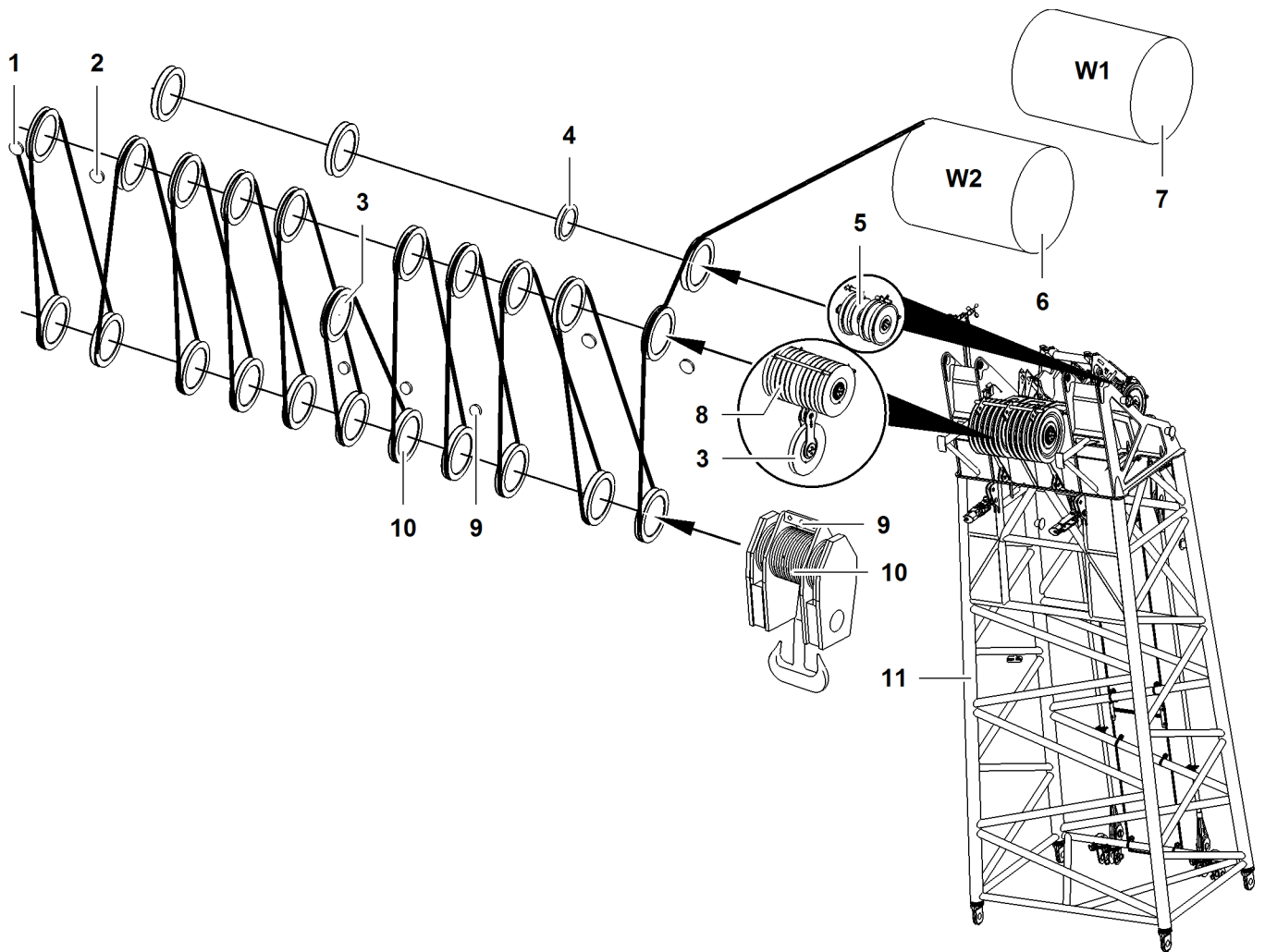


Fig. 4674: Reeving diagrams for one rope across main boom head 2821 (load position 2)

- | | | | | | |
|---|--|---|--------------------------------------|----|------------------------------------|
| 1 | Outer rope fixing point (2x) of main boom head | 5 | Gantry pulley (3x) of main boom head | 9 | Rope fixing points of pulley block |
| 2 | Inner rope fixing point (2x) of main boom head | 6 | Winch2 | 10 | Pulley set of pulley block |
| 3 | 11th pulley of main boom head | 7 | Winch1 | 11 | Main boom head |
| 4 | Pulley for rope of jib luffing winch | 8 | Pulley (10x) of main boom head | | |

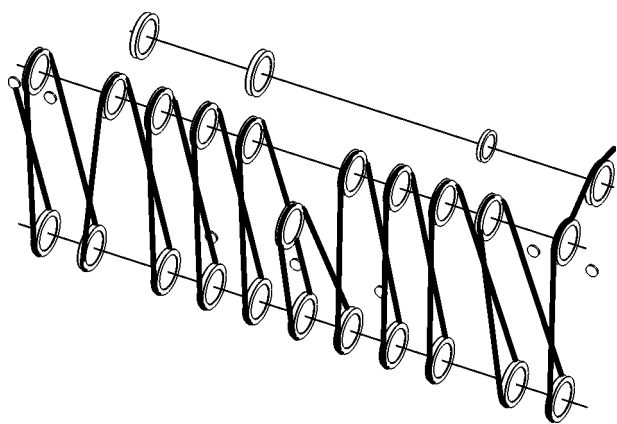


DANGER

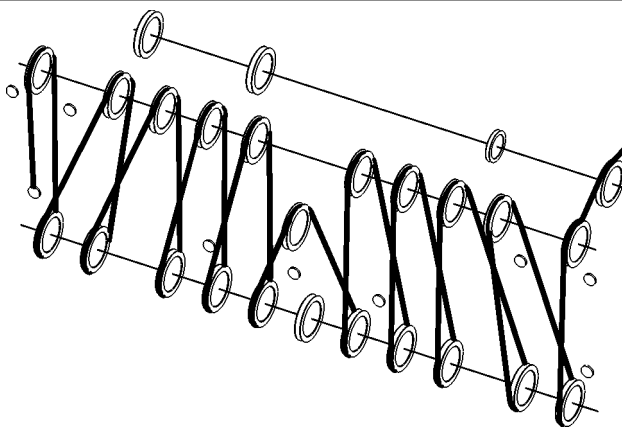
Inadmissible number of reeving!
Structural breakdown, toppling of machine.

► Choose correct number of reeving as indicated in load chart.

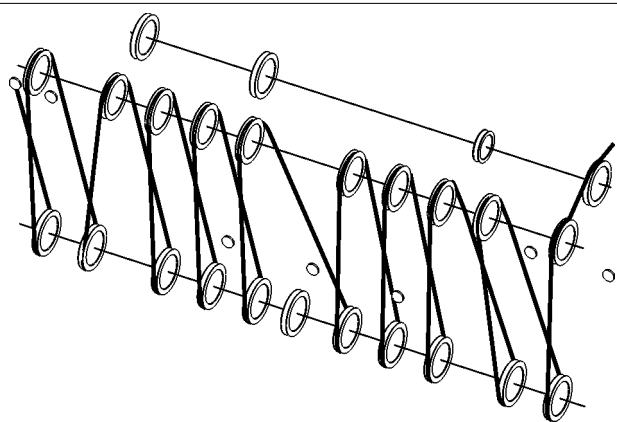
Reeving diagrams for one rope across main boom head 2821 (load position2)



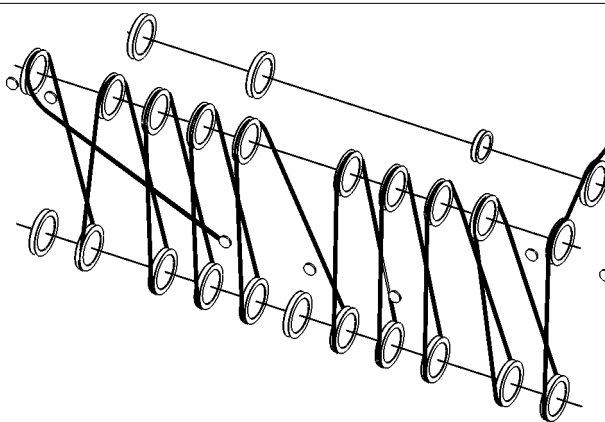
22x



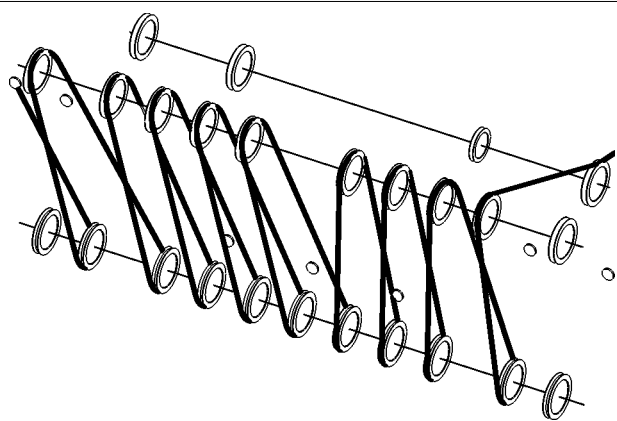
21x



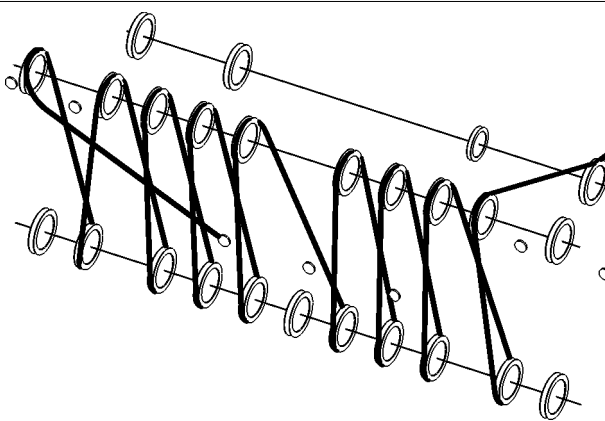
20x



19x



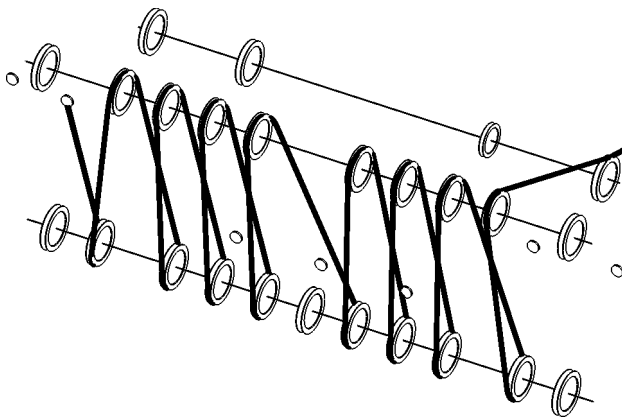
18x



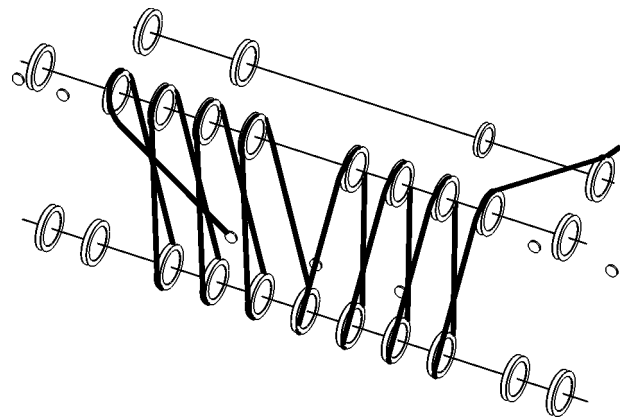
17x

LWNLR-x\04.01\Auslieferung\2016-03-07\en

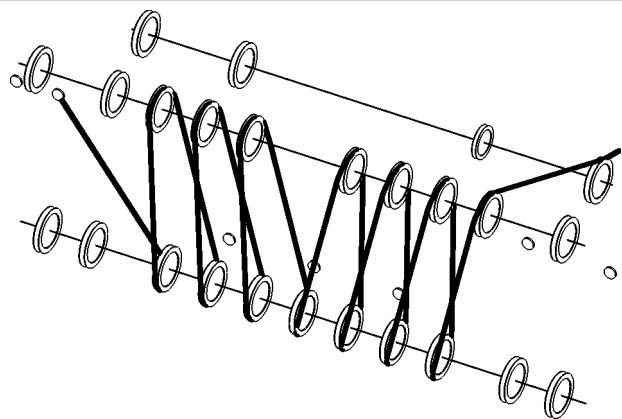
Reeving diagrams for one rope across main boom head 2821 (load position2)



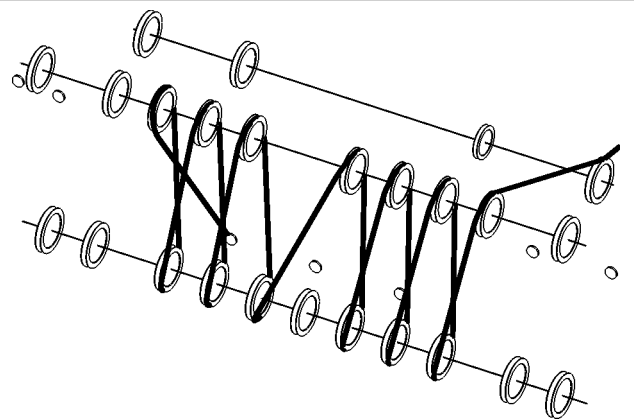
16x



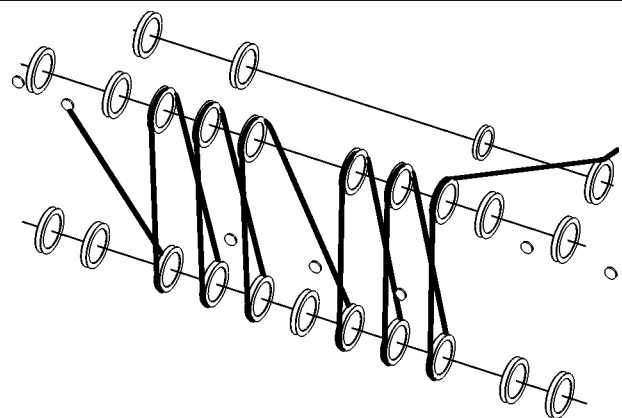
15x



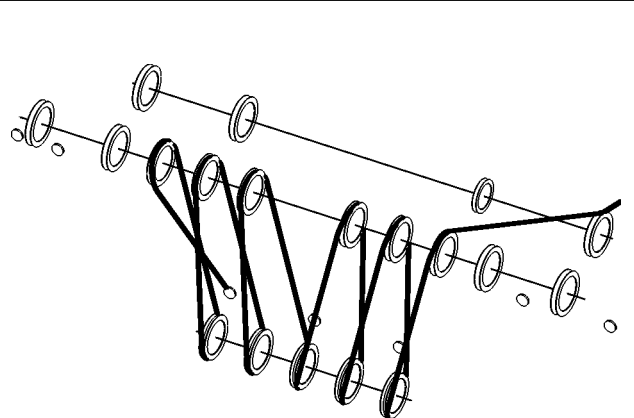
14x



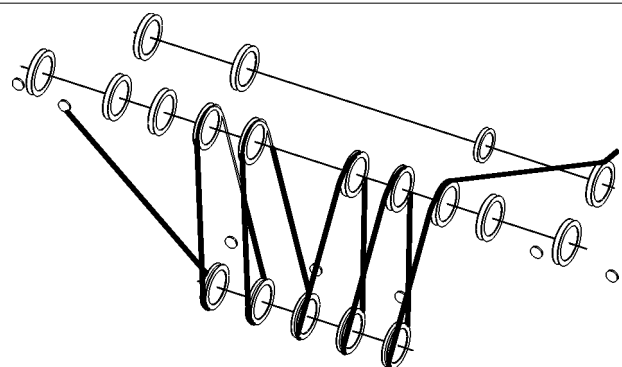
13x



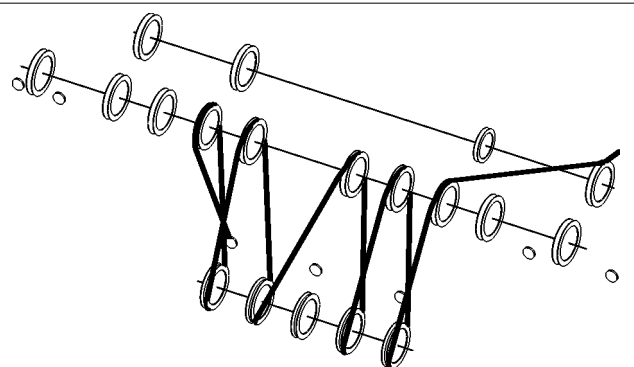
12x



11x

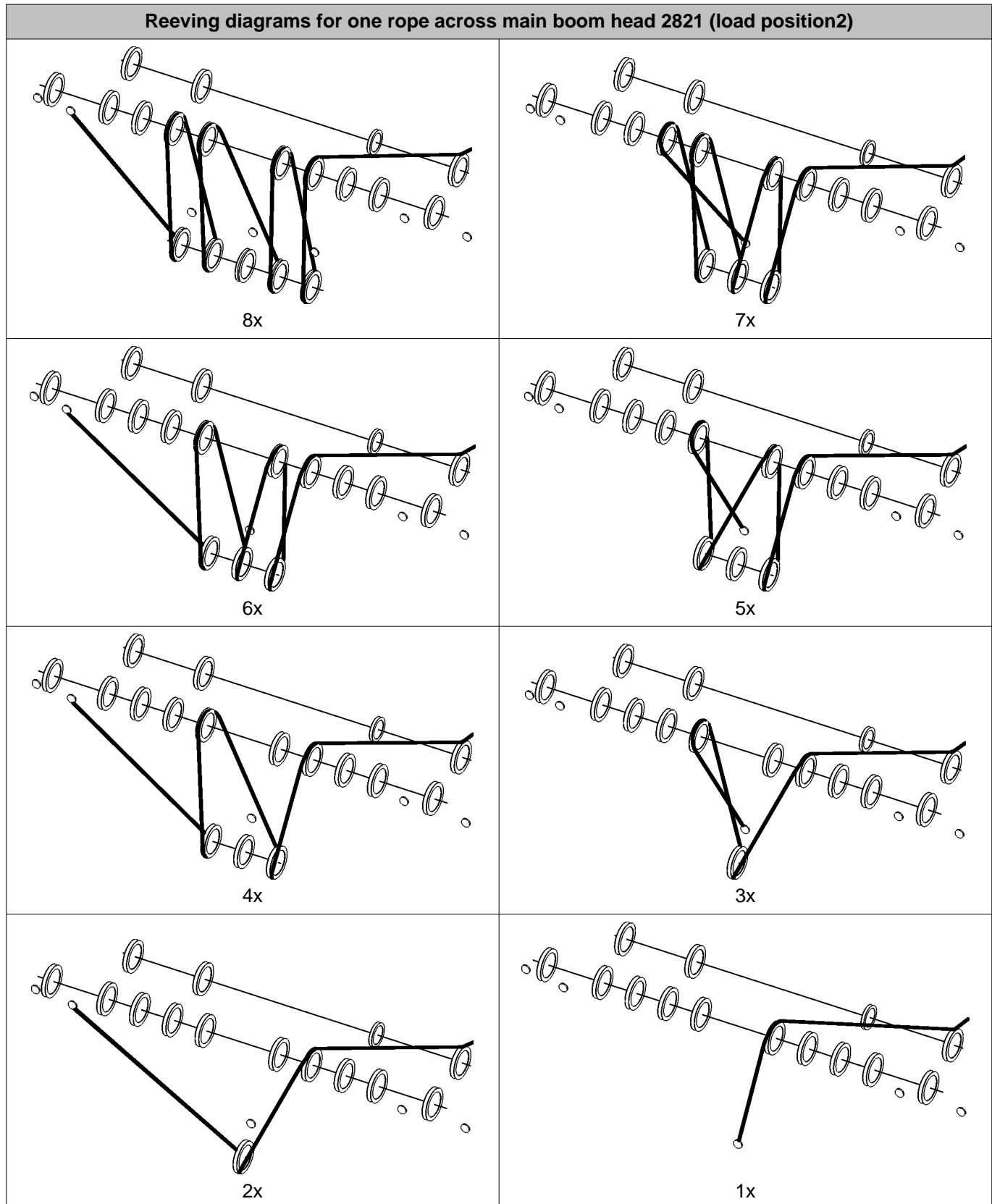


10x



9x

LWNLR-x/V04.01//Auslieferung/2016-03-07/en



Tab. 551: Reeving diagrams for one rope across main boom head 2821 (load position2)

LWNLR-x\04.01\Auslieferung\2016-03-07\en

7.17 Fixed jib 1008

System-relevant information for fixed jib 1008:

- Configuration of jib
- Configuration of main boom
- Overview of pendant straps on fixed jib 1008
- Reeving diagrams for one rope across jib head 1008 (load position1)
- Reeving diagrams for two ropes across jib head 1008 (load position1)
- Reeving diagrams for one rope across main boom head 2821 (load position2)

7.17.1 Configuration of jib



DANGER

Excess length of jib!
Structural breakdown.

- ▶ Check jib length in load chart for validity.

Jib length	Configuration of jib (symbolic)
11 m 36 ft	
14 m 46 ft	
17 m 56 ft	
20 m 66 ft	
23 m 75 ft	
26 m 85 ft	

Tab. 552: Configuration of fixed jib 1008

7.17.2 Configuration of main boom



DANGER

Excess length of main boom!
Structural breakdown.

- ▶ Check main boom length in load chart for validity.



Note

- ▶ See system-relevant data of main boom for information on main boom configuration (For more information see: [7.5.1 Configuration of main boom, page 1270](#)).

LWNLR.x/V04.01/Auslieferung/2016-03-07/en

7.17.3 Overview of pendant straps on fixed jib 1008

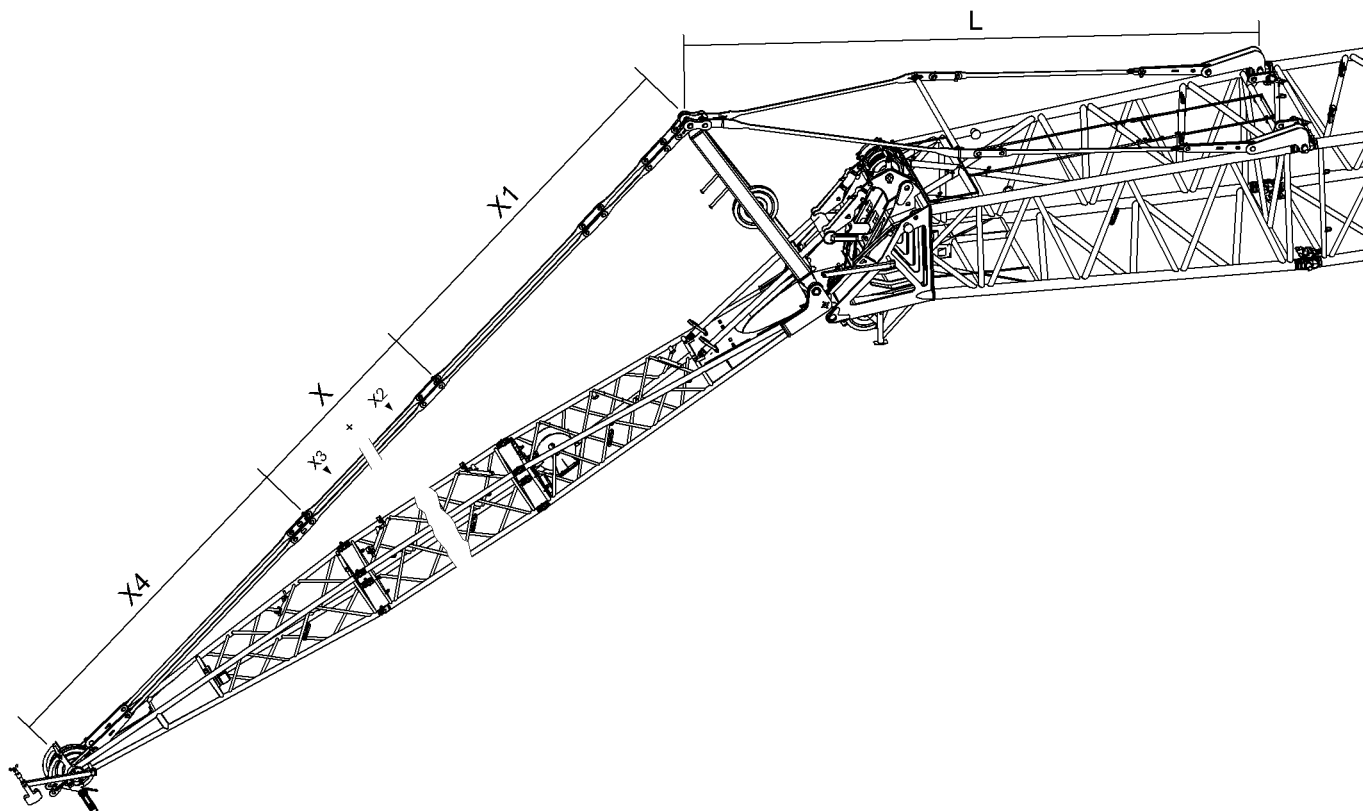


Fig. 4718: Overview of pendant straps on fixed jib 1008

Jib backstay straps A-frame2 to main boom head 2821

Name		Value
L	A-frame2 equalizer (jib backstay strap) (For more information see: Equalizer A-frame2 (jib backstay strap) , page 275)	at 30°
		9760 mm 32' ft-in
		at 15°
		8943 mm 29' 4" ft-in

Tab. 553: Jib backstay straps A-frame2 to main boom head 2821

Pendant straps A-frame2 to jib head 1008

Name		Value
X1	A-frame2 equalizer (jib pendant strap) (For more information see: Equalizer on A-frame2 (jib pendant strap) , page 277)	5785 mm 19' ft-in

LWNLR-x\04.01\Auslieferung\2016-03-07\en

Name		Value
X	Jib pendant straps consisting of:	
	X2	Jib pendant strap 3 m (10 ft) (For more information see: Jib pendant strap 3 m (10 ft), page 278)
	X3	Jib pendant strap 6 m (20 ft) (For more information see: Jib pendant strap 6 m (20 ft), page 279)
X4	Jib pendant strap on jib head 1008 (For more information see: Jib pendant strap on jib head 1008.20, page 280)	5515 mm 18' 1" ft-in

Tab. 554: Pendant straps A-frame2 to jib head 1008

Configuration of jib pendant straps (X):

Required number of jib pendant straps 3 m (10 ft) (X2) corresponds to number of jib sections 3 m (10 ft).

Required number of jib pendant straps 6 m (20 ft) (X3) corresponds to number of jib sections 6 m (20 ft).



Note

- ▶ For the admissible number of jib sections 3 m (10 ft), 6 m (20 ft), refer to the following table: (For more information see: 7.17.1 Configuration of jib, page 1561)

7.17.4 Reeving diagrams for one rope across jib head 1008 (load position1)

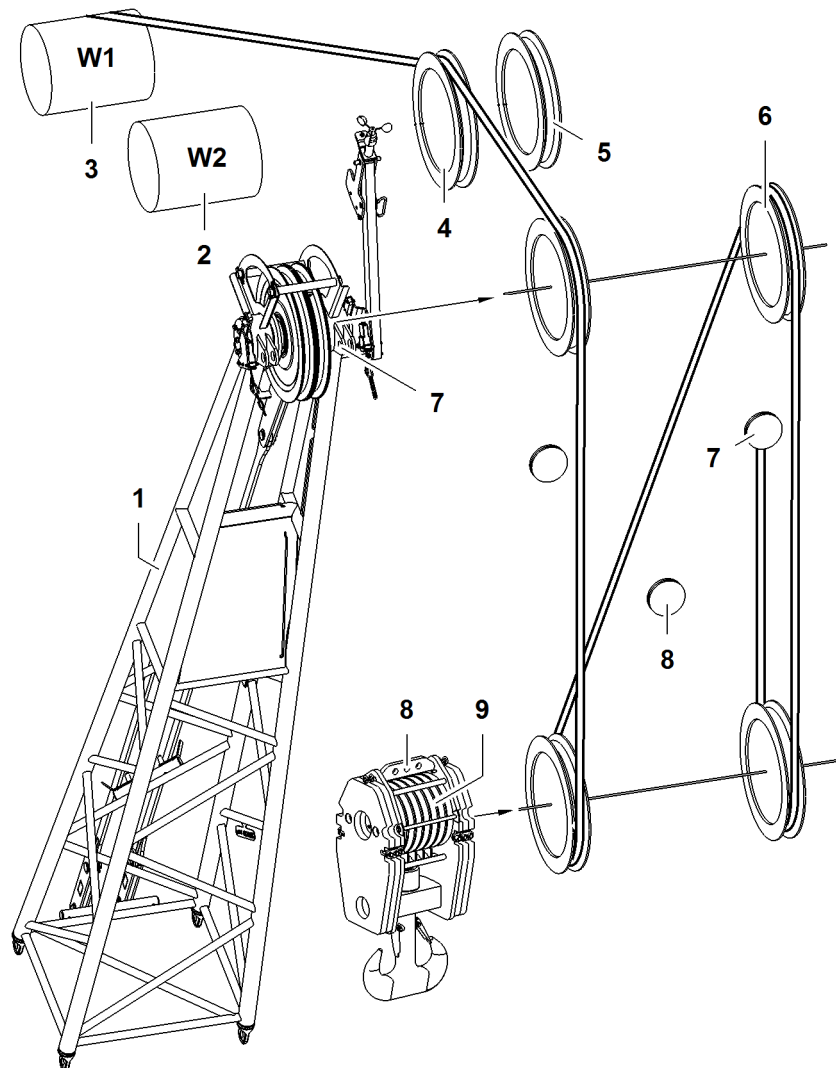


Fig. 4719: Reeving diagrams for one rope across jib head 1008 (load position1)

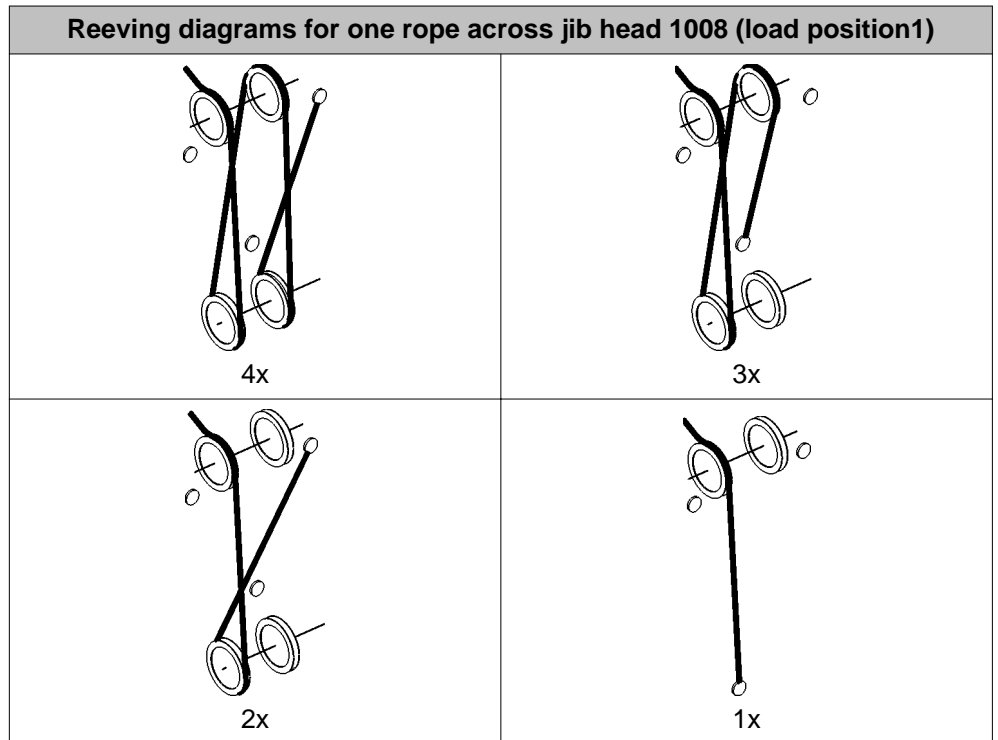
- | | | | |
|---|--|---|------------------------------------|
| 1 | Jib head | 6 | Pulley (2x) of jib head |
| 2 | Winch2 | 7 | Rope fixing point (2x) of jib head |
| 3 | Winch1 | 8 | Rope fixing points of pulley block |
| 4 | Pulley of A-frame2 | 9 | Pulley set of pulley block |
| 5 | Retrofit kit* for operation with two ropes across jib head | | |



DANGER

Incorrect number of reevings!
Structural breakdown, toppling of machine.

- ▶ Choose the correct number of reevings as per the load chart.



Tab. 555: Reeving diagrams for one rope across jib head 1008 (load position1)

7.17.5 Reeving diagrams for two ropes across jib head 1008 (load position1)



DANGER

Incorrect number of reevings!
Structural breakdown, toppling of machine.

► Choose the correct number of reevings as indicated in the load chart.

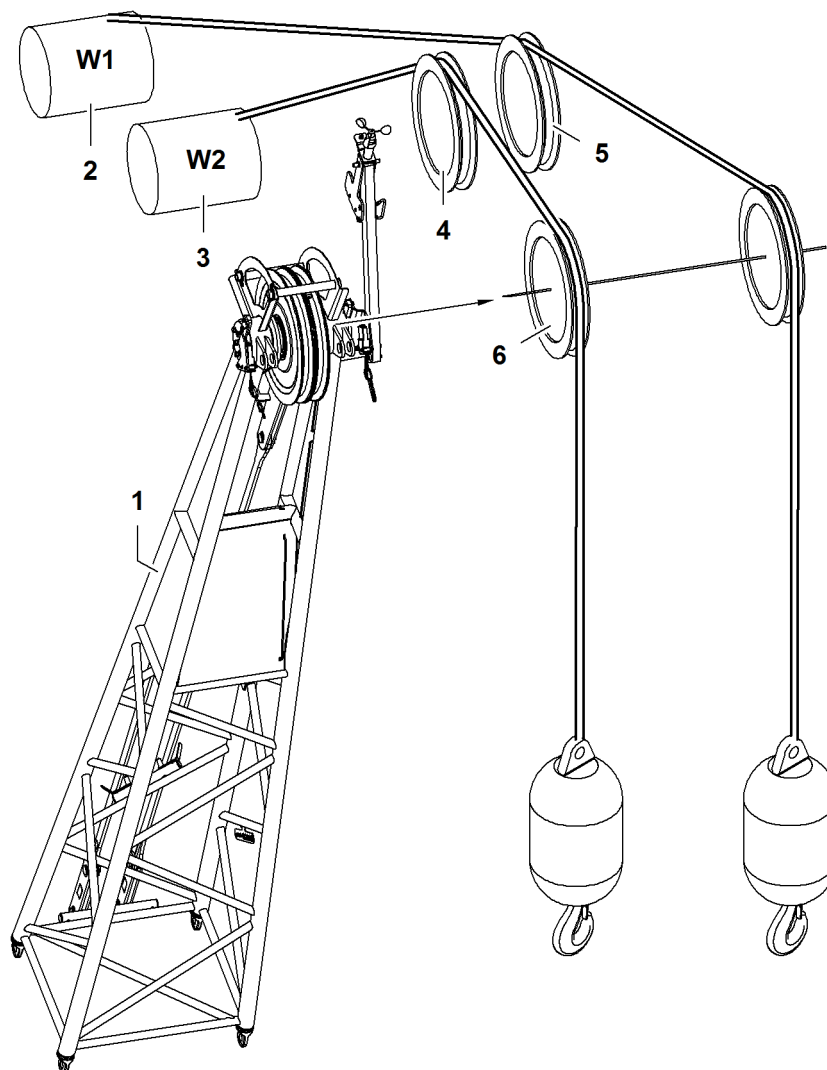


Fig. 4724: Reeving diagrams for two ropes across jib head 1008 (load position1)

- | | | | |
|---|----------|---|--|
| 1 | Jib head | 4 | Pulley of A-frame2 |
| 2 | Winch1 | 5 | Retrofit kit* for operation with two ropes across jib head |
| 3 | Winch2 | 6 | Pulley (2x) of jib head |

7.17.6 Reeving diagrams for one rope across main boom head 2821 (load position2)

If the main boom with jib attached is also used to lift a load, reeve main boom head 2821 as shown below.

LWNLR-x\04.01\Auslieferung\2016-03-07\en

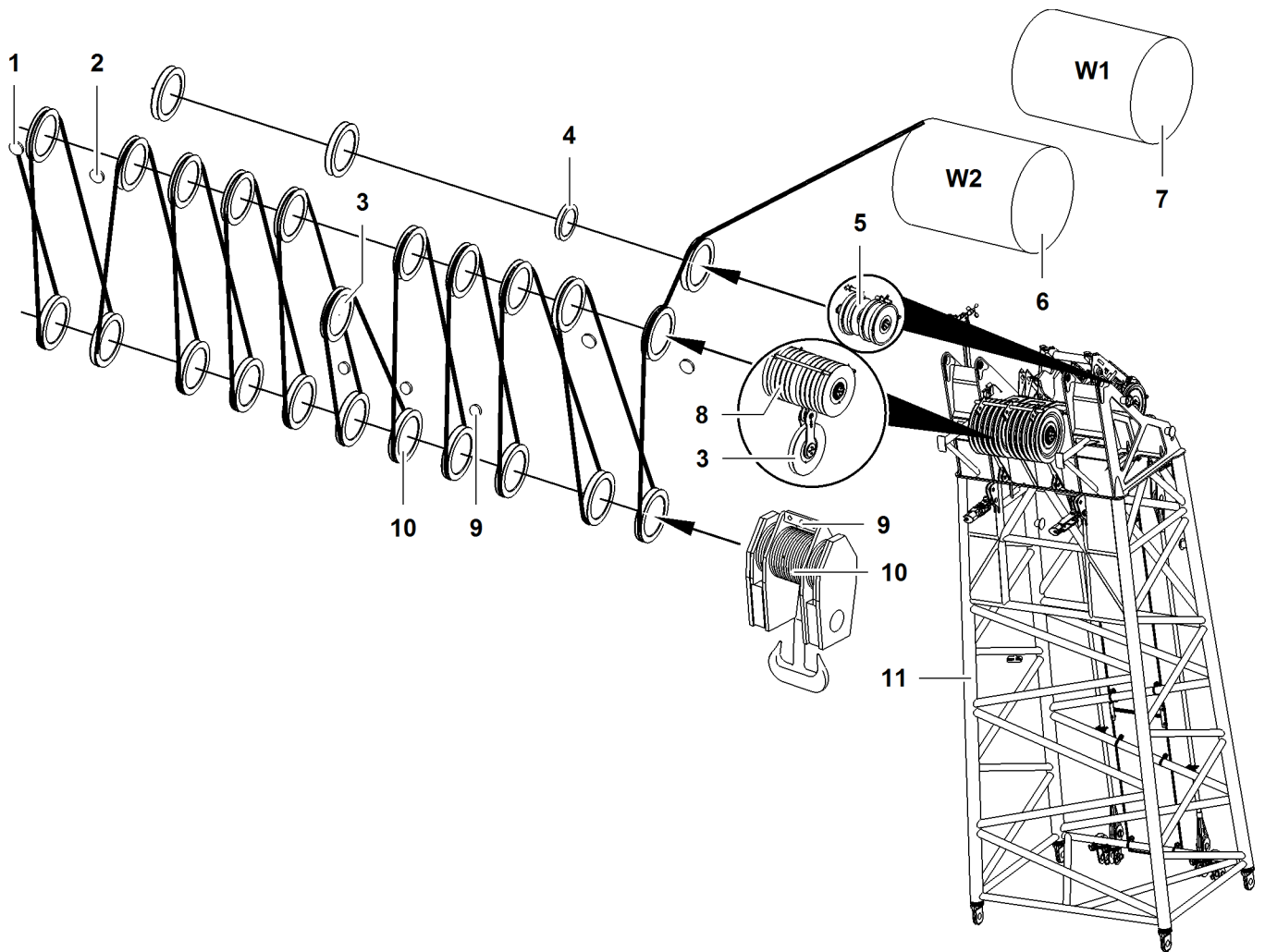


Fig. 4725: Reeving diagrams for one rope across main boom head 2821 (load position 2)

- | | | | | | |
|---|--|---|--------------------------------------|----|------------------------------------|
| 1 | Outer rope fixing point (2x) of main boom head | 5 | Gantry pulley (3x) of main boom head | 9 | Rope fixing points of pulley block |
| 2 | Inner rope fixing point (2x) of main boom head | 6 | Winch2 | 10 | Pulley set of pulley block |
| 3 | 11th pulley of main boom head | 7 | Winch1 | 11 | Main boom head |
| 4 | Pulley for rope of jib luffing winch | 8 | Pulley (10x) of main boom head | | |

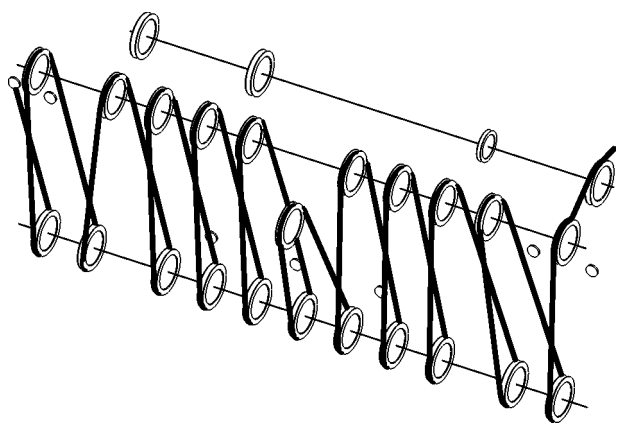


DANGER

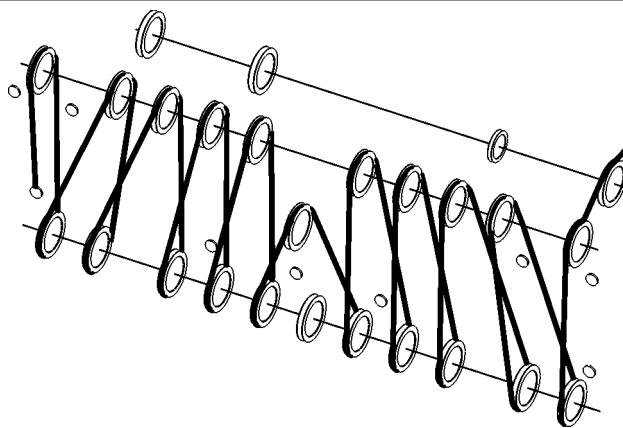
Inadmissible number of reeving!
Structural breakdown, toppling of machine.

► Choose correct number of reeving as indicated in load chart.

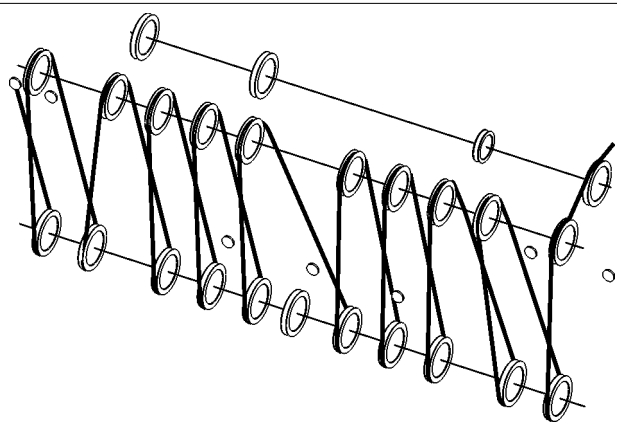
Reeving diagrams for one rope across main boom head 2821 (load position2)



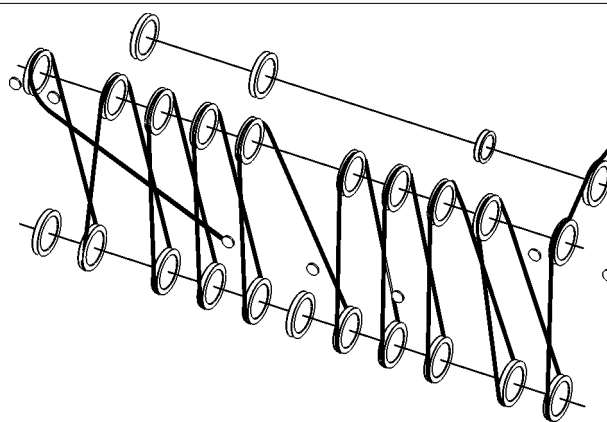
22x



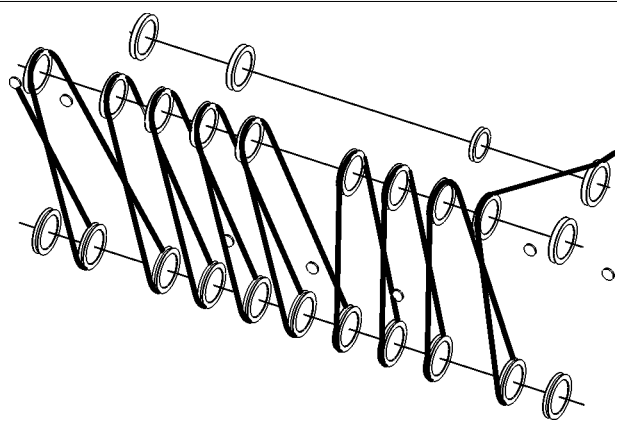
21x



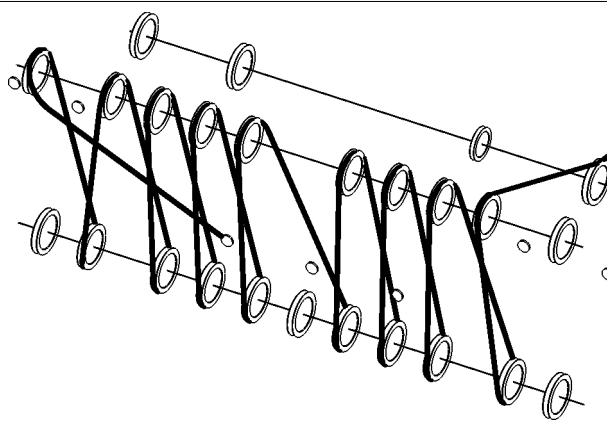
20x



19x



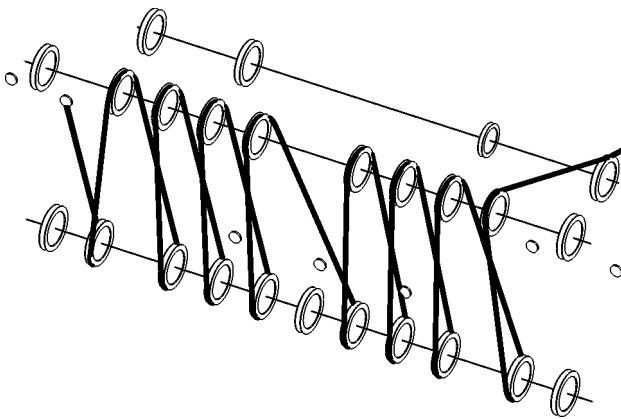
18x



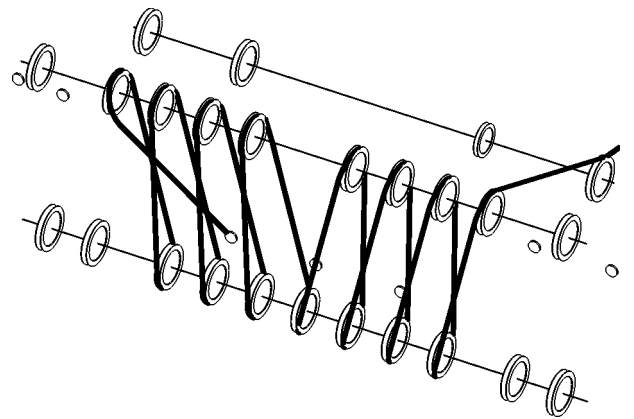
17x

LWNLR-x\04.01\Auslieferung\2016-03-07\en

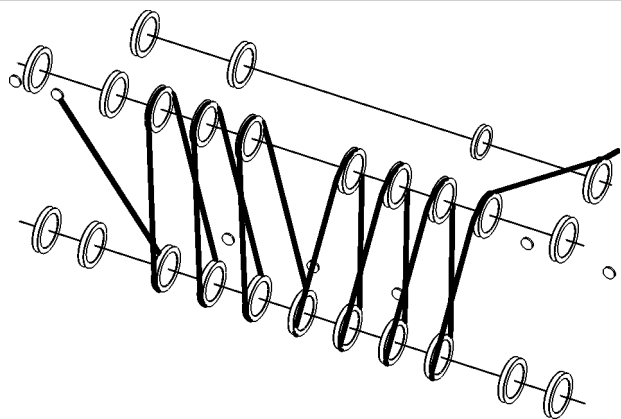
Reeving diagrams for one rope across main boom head 2821 (load position2)



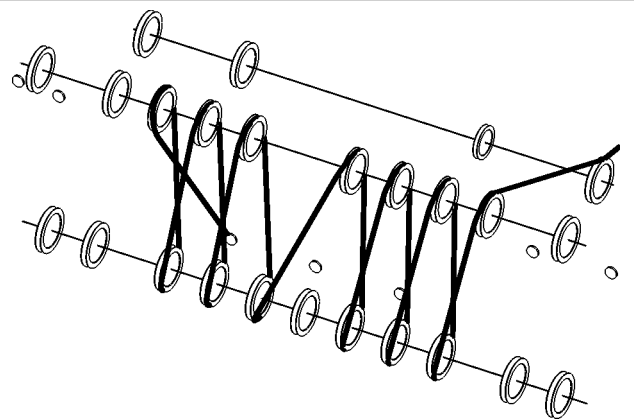
16x



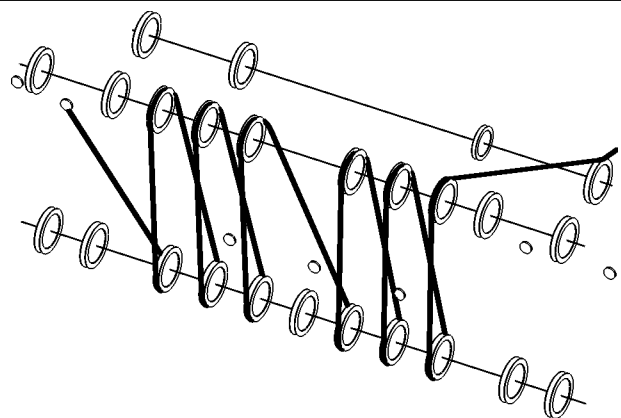
15x



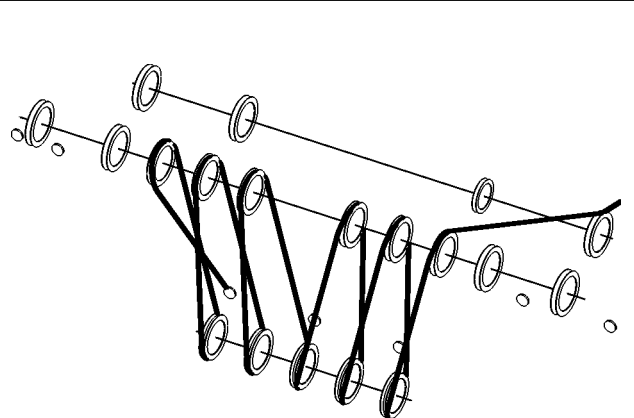
14x



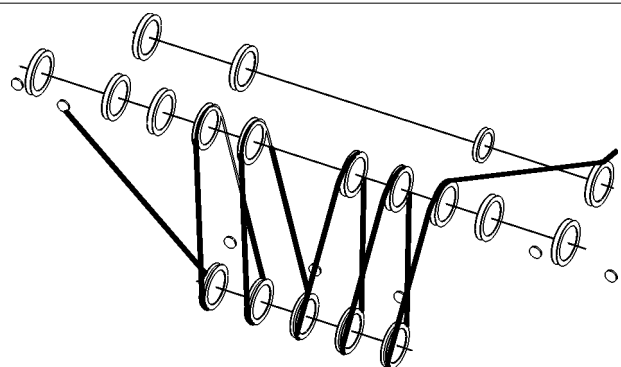
13x



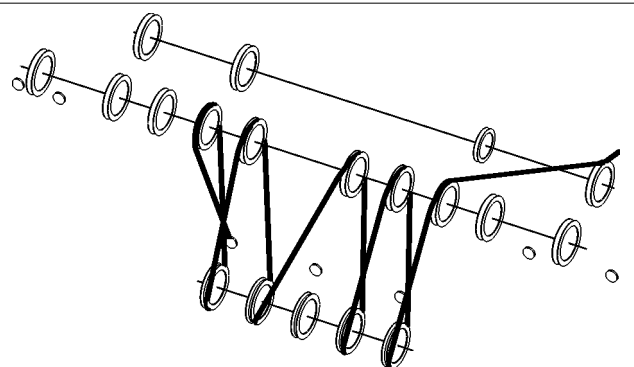
12x



11x

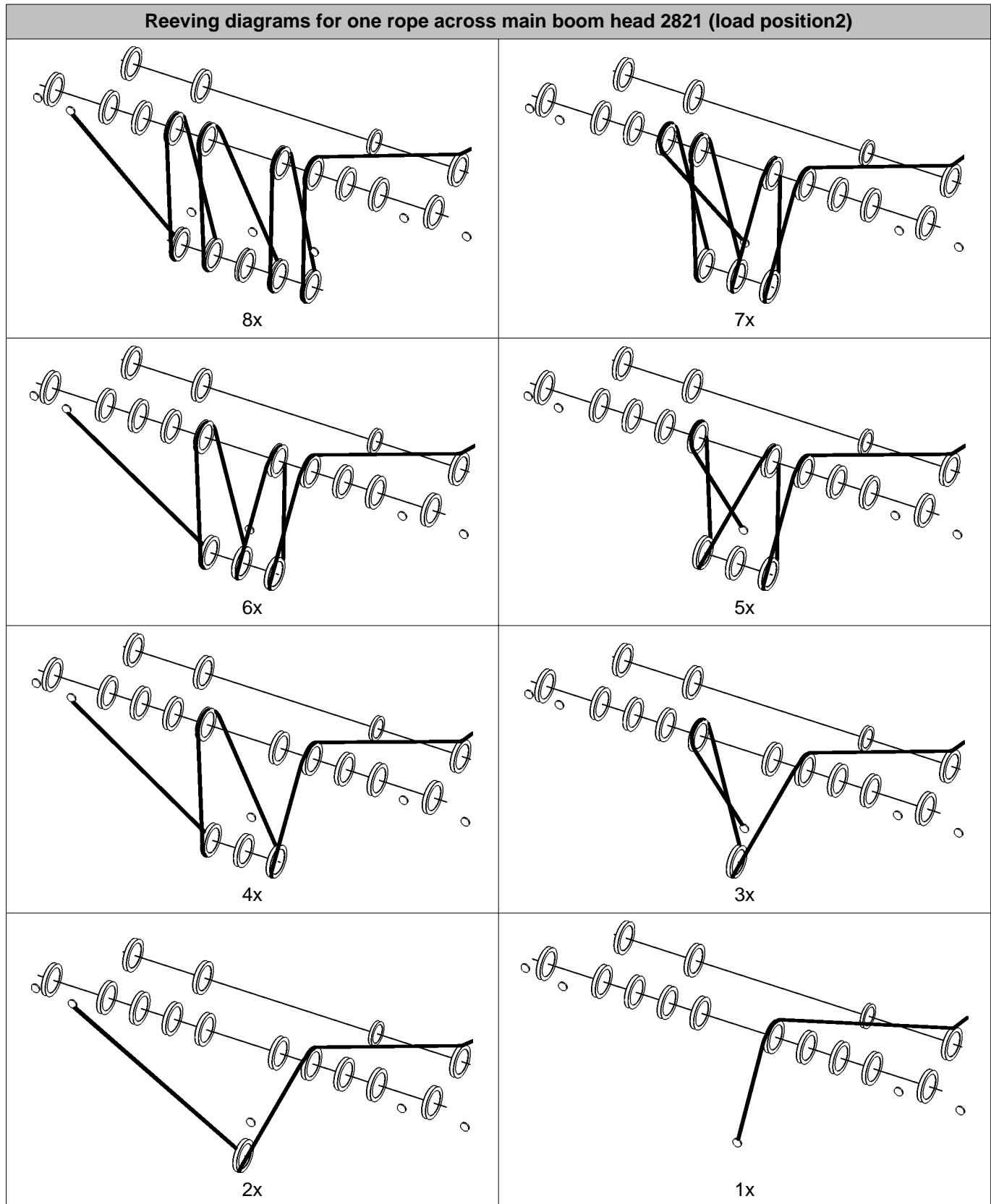


10x



9x

LWNLR-x/V04.01//Auslieferung/2016-03-07/en



Tab. 556: Reeving diagrams for one rope across main boom head 2821 (load position2)

LWNLR-x\04.01\Auslieferung\2016-03-07\en

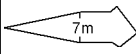
7.18 Fixed jib 0906

System-relevant information for fixed jib 0906:

- Configuration of jib
- Configuration of main boom
- Overview of pendant straps on fixed jib 0906
- Reeving diagrams for one rope across jib head 0906 (load position1)
- Reeving diagrams for two ropes across jib head 0906 (load position1)
- Reeving diagrams for one rope across main boom head 2821 (load position2)

7.18.1 Configuration of jib

The fixed jib 0906 has a fixed length of 7 m (23 ft).

Jib length	Configuration of jib (symbolic)
7 m 23 ft	

Tab. 557: Configuration of fixed jib 0906

7.18.2 Configuration of main boom



DANGER

Excess length of main boom!
Structural breakdown.

- ▶ Check main boom length in load chart for validity.



Note

- ▶ See system-relevant data of main boom for information on main boom configuration (For more information see: [7.5.1 Configuration of main boom, page 1270](#)).

7.18.3 Overview of pendant straps on fixed jib 0906

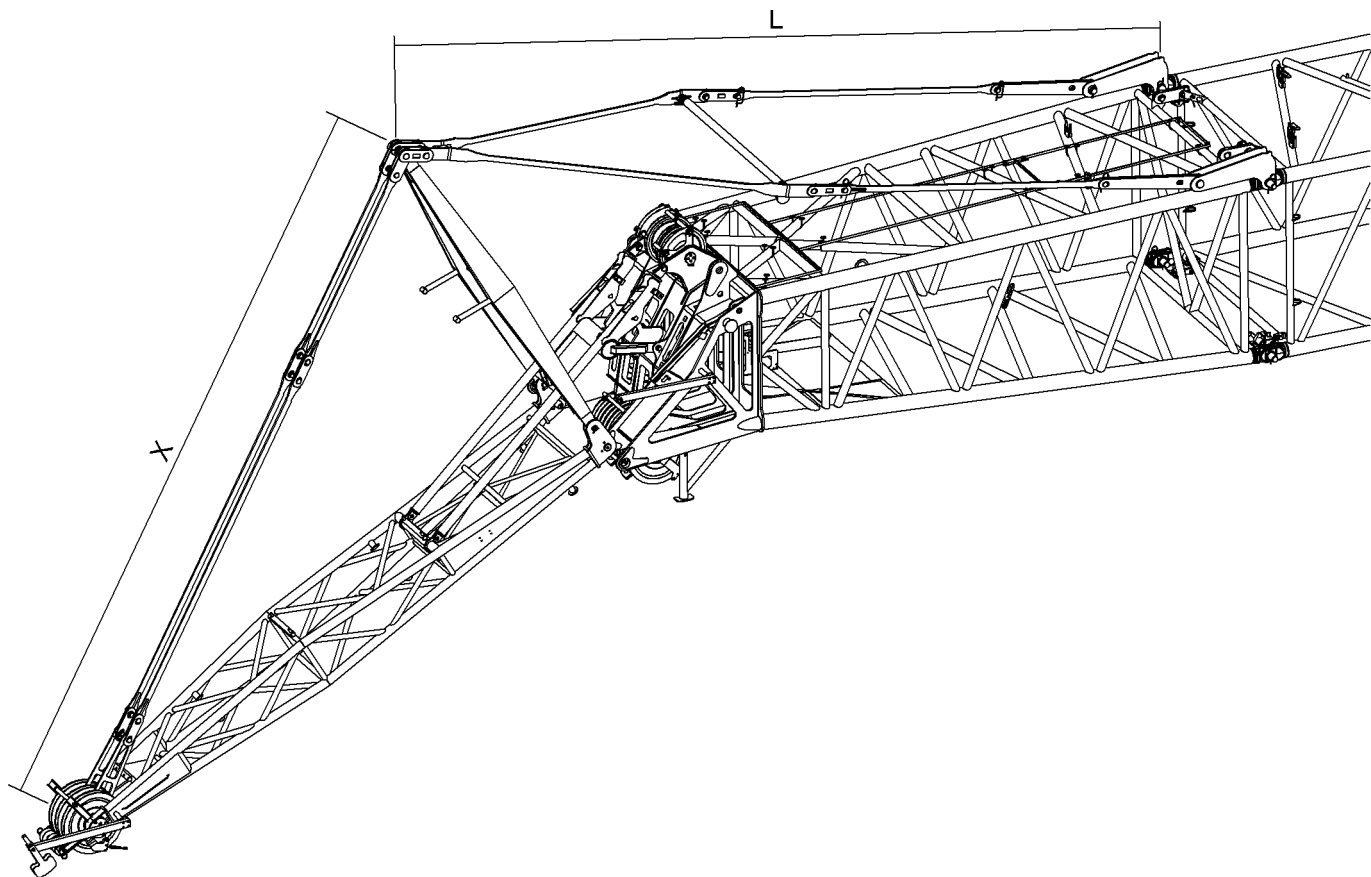


Fig. 4749: Overview of pendant straps on fixed jib 0906

Jib backstay straps A-frame2 to main boom head 2821

Name		Value
L	A-frame2 equalizer (jib backstay strap) (For more information see: Equalizer A-frame2 (jib backstay strap), page 283)	at 30° 10000 mm 32' 10" ft-in

Tab. 558: Jib backstay straps A-frame2 to main boom head 2821

Pendant straps A-frame2 to jib head 0906

Name		Value
X	Jib pendant strap (A-frame2 to jib head 0906) (For more information see: Jib pendant strap (A-frame2 to jib head 0906.21), page 285)	8235 mm 27' ft-in

Tab. 559: Pendant straps A-frame2 to jib head 0906

LWNLR-x/V04.01/Auslieferung/2016-03-07/en

7.18.4 Reeving diagrams for one rope across jib head 0906 (load position1)

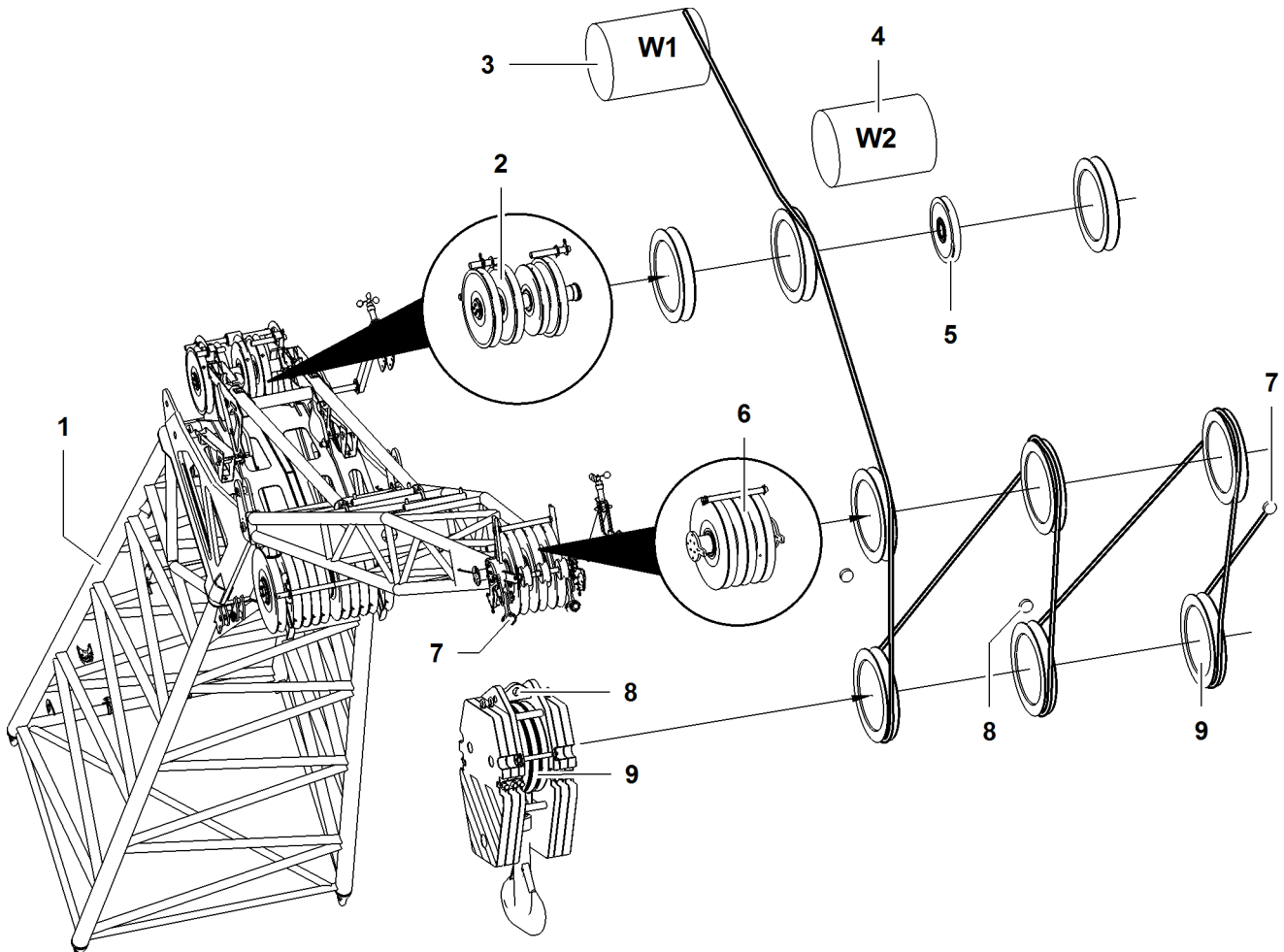


Fig. 4750: Reeving diagrams for one rope across jib head 0906 (load position1)

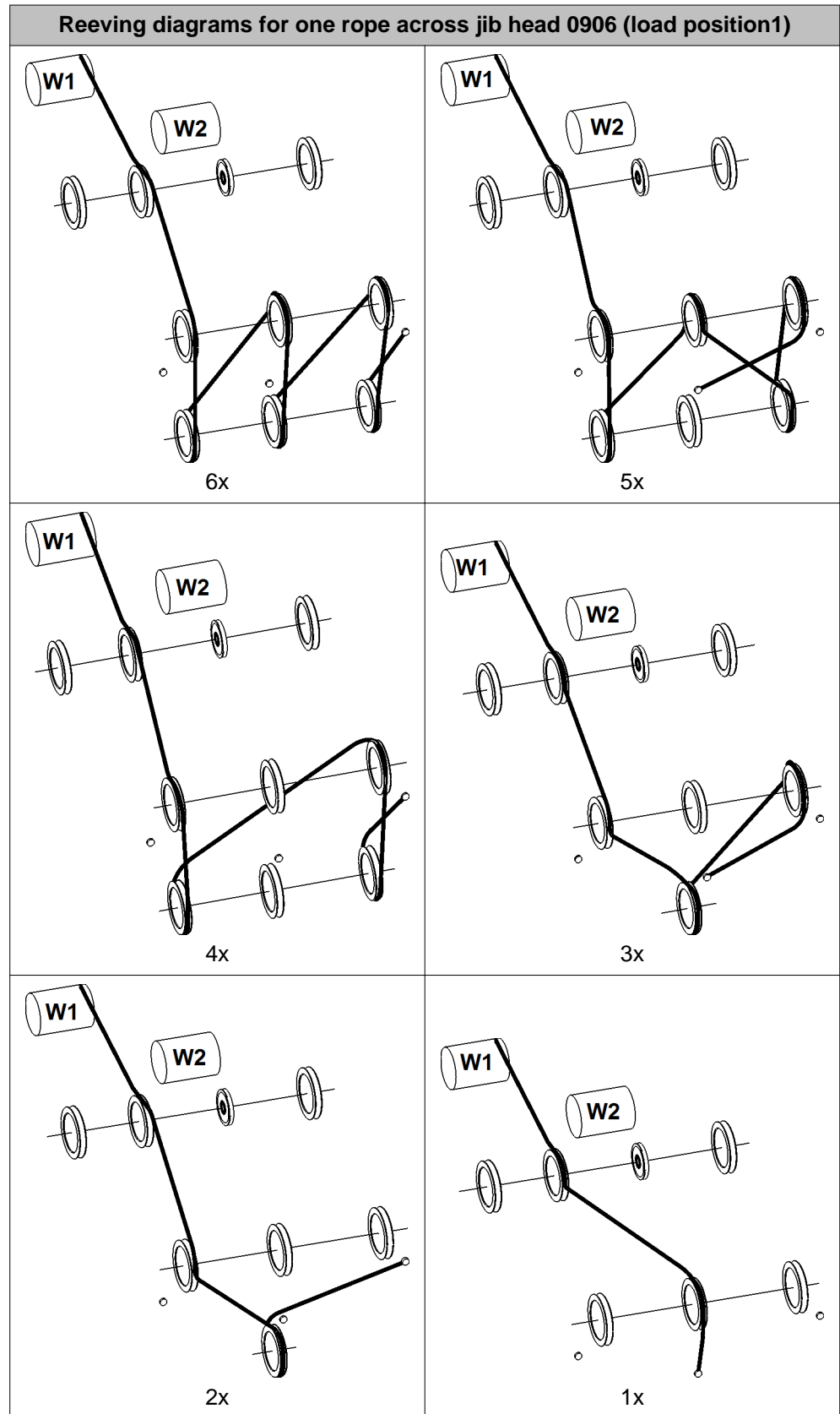
- | | | | | | |
|---|--------------------------------------|---|--------------------------------------|---|------------------------------------|
| 1 | Main boom head | 4 | Winch2 | 7 | Rope fixing point (2x) of jib head |
| 2 | Gantry pulley (3x) of main boom head | 5 | Pulley for rope of jib luffing winch | 8 | Rope fixing points of pulley block |
| 3 | Winch1 | 6 | Pulley (3x) of jib head | 9 | Pulley set of pulley block |



DANGER

Inadmissible number of reevings!
Structural breakdown, toppling of machine.

► Choose correct number of reevings as indicated in load chart.



Tab. 560: Reeving diagrams for one rope across jib head 0906 (load position1)

LWNLR-x/V04.01//Auslieferung/2016-03-07/en

7.18.5 Reeving diagrams for two ropes across jib head 0906 (load position1)



DANGER

Incorrect number of reevings!
Structural breakdown, toppling of machine.

► Choose the correct number of reevings as indicated in the load chart.

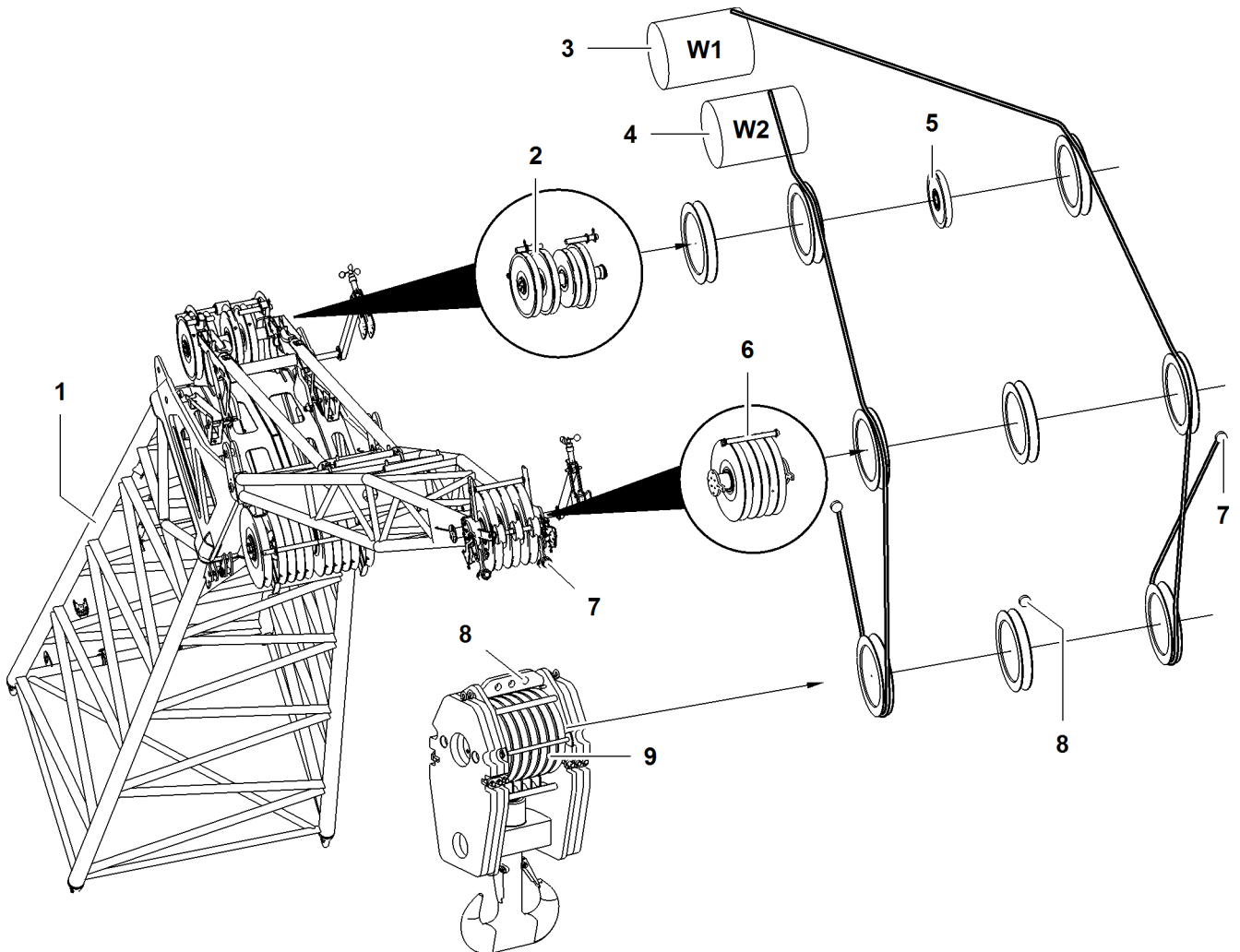


Fig. 4757: Reeving diagrams for two ropes across jib head 0906 (load position1)

- | | | |
|--|--|--------------------------------------|
| 1 Main boom head | 4 Winch2 | 7 Rope fixing point (2x) of jib head |
| 2 Gantry pulley (3x) of main boom head | 5 Pulley for rope of jib luffing winch | 8 Rope fixing points of pulley block |
| 3 Winch1 | 6 Pulley (3x) of jib head | 9 Pulley set of pulley block |

7.18.6 Reeving diagrams for one rope across main boom head 2821 (load position2)

If the main boom with jib attached is also used to lift a load, reeve main boom head 2821 as shown below.

LWNLR.x/V04.01//Auslieferung/2016-03-07/en

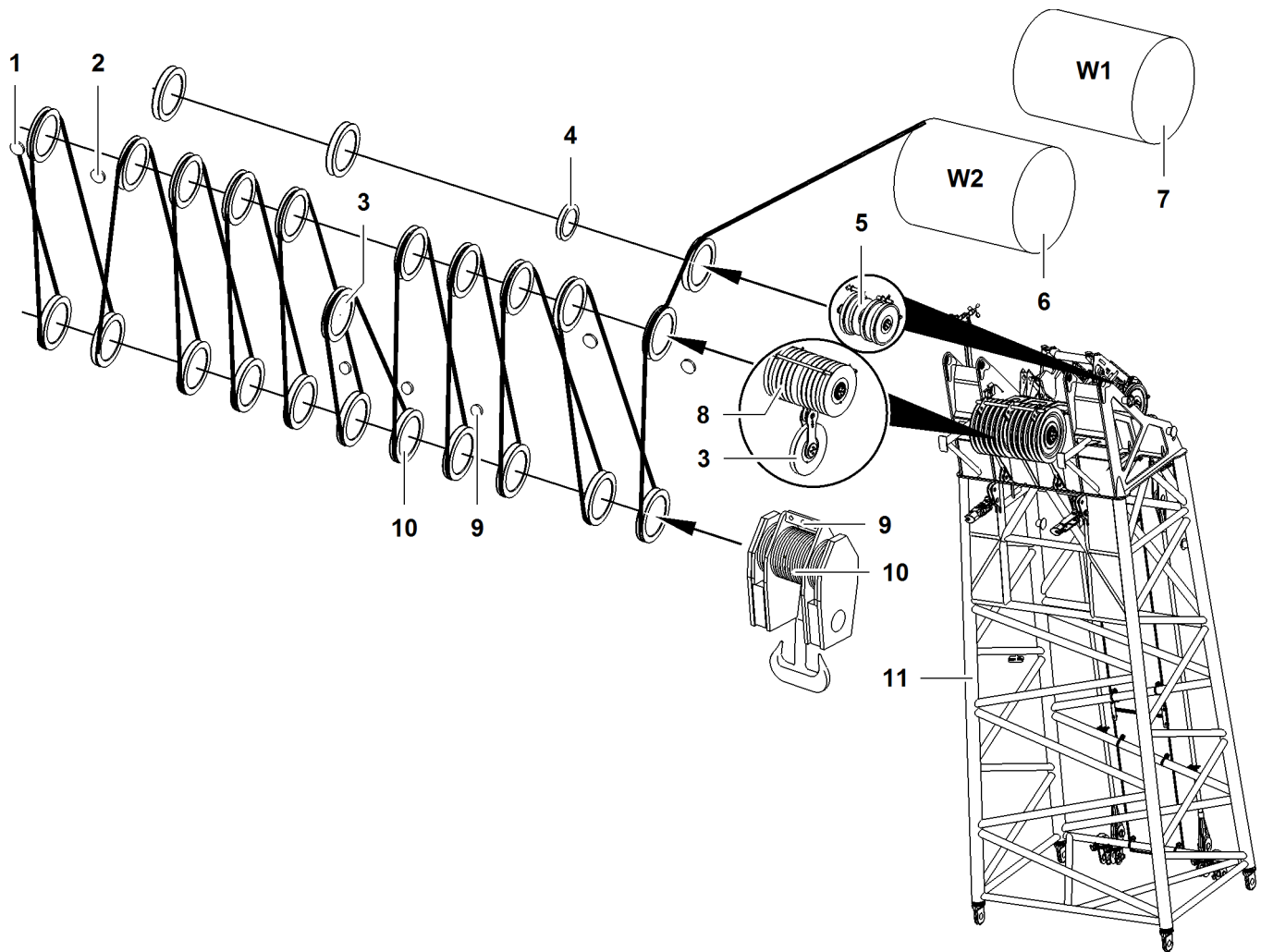


Fig. 4758: Reeving diagrams for one rope across main boom head 2821 (load position 2)

- | | | | | | |
|---|--|---|--------------------------------------|----|------------------------------------|
| 1 | Outer rope fixing point (2x) of main boom head | 5 | Gantry pulley (3x) of main boom head | 9 | Rope fixing points of pulley block |
| 2 | Inner rope fixing point (2x) of main boom head | 6 | Winch2 | 10 | Pulley set of pulley block |
| 3 | 11th pulley of main boom head | 7 | Winch1 | 11 | Main boom head |
| 4 | Pulley for rope of jib luffing winch | 8 | Pulley (10x) of main boom head | | |

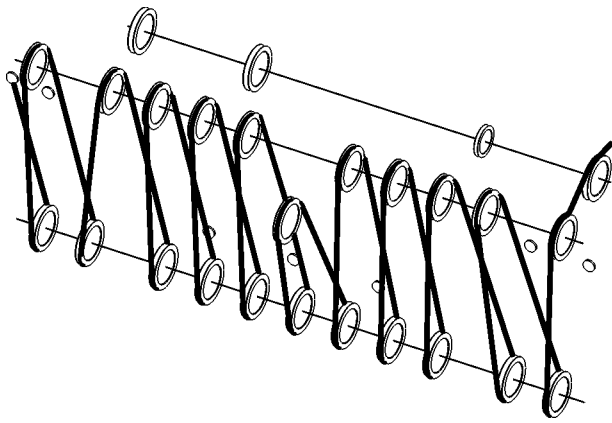


DANGER

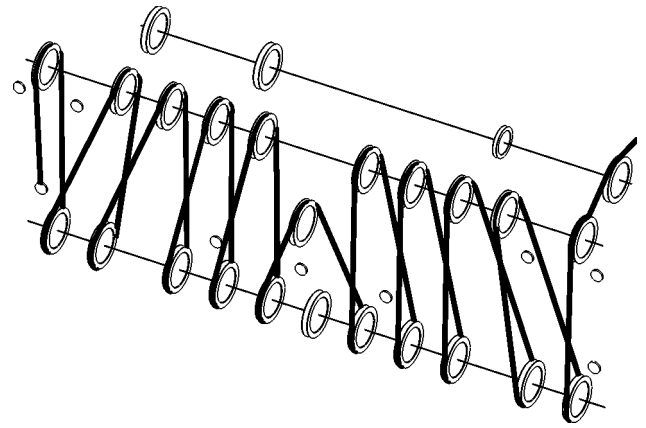
Inadmissible number of reevings!
Structural breakdown, toppling of machine.

► Choose correct number of reevings as indicated in load chart.

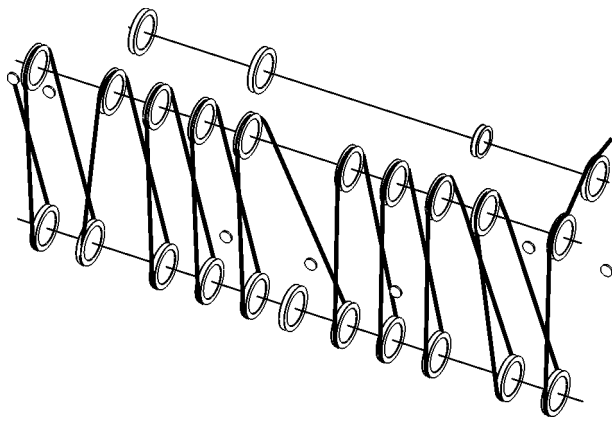
Reeving diagrams for one rope across main boom head 2821 (load position2)



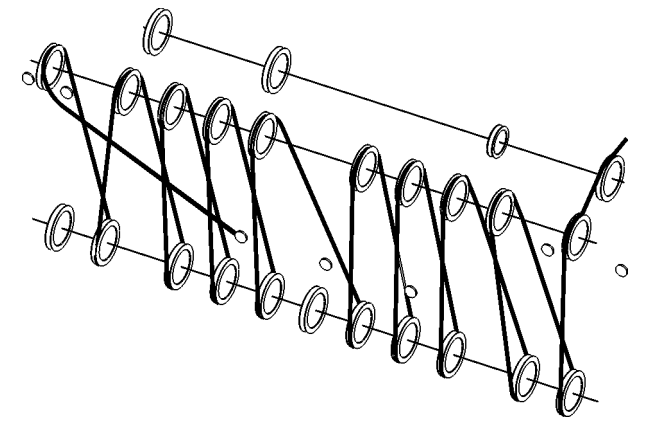
22x



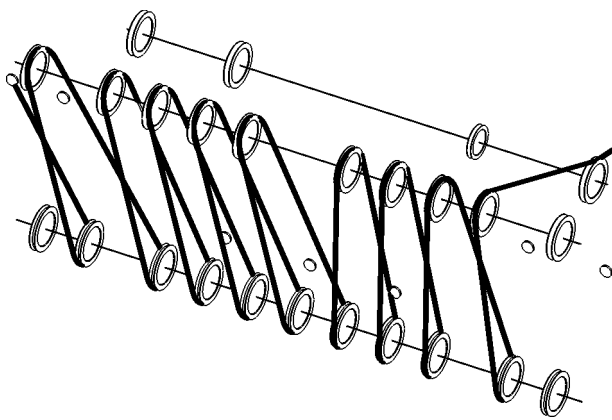
21x



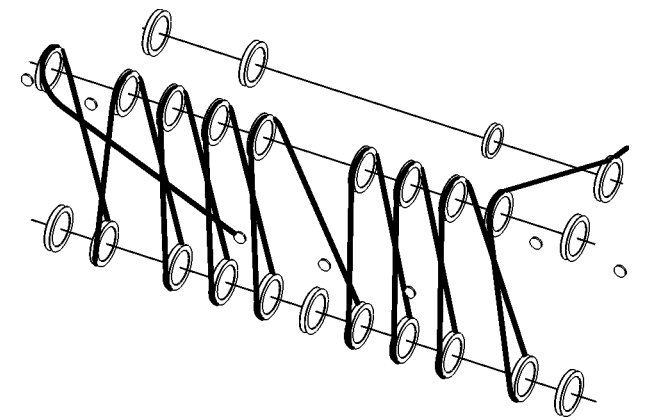
20x



19x



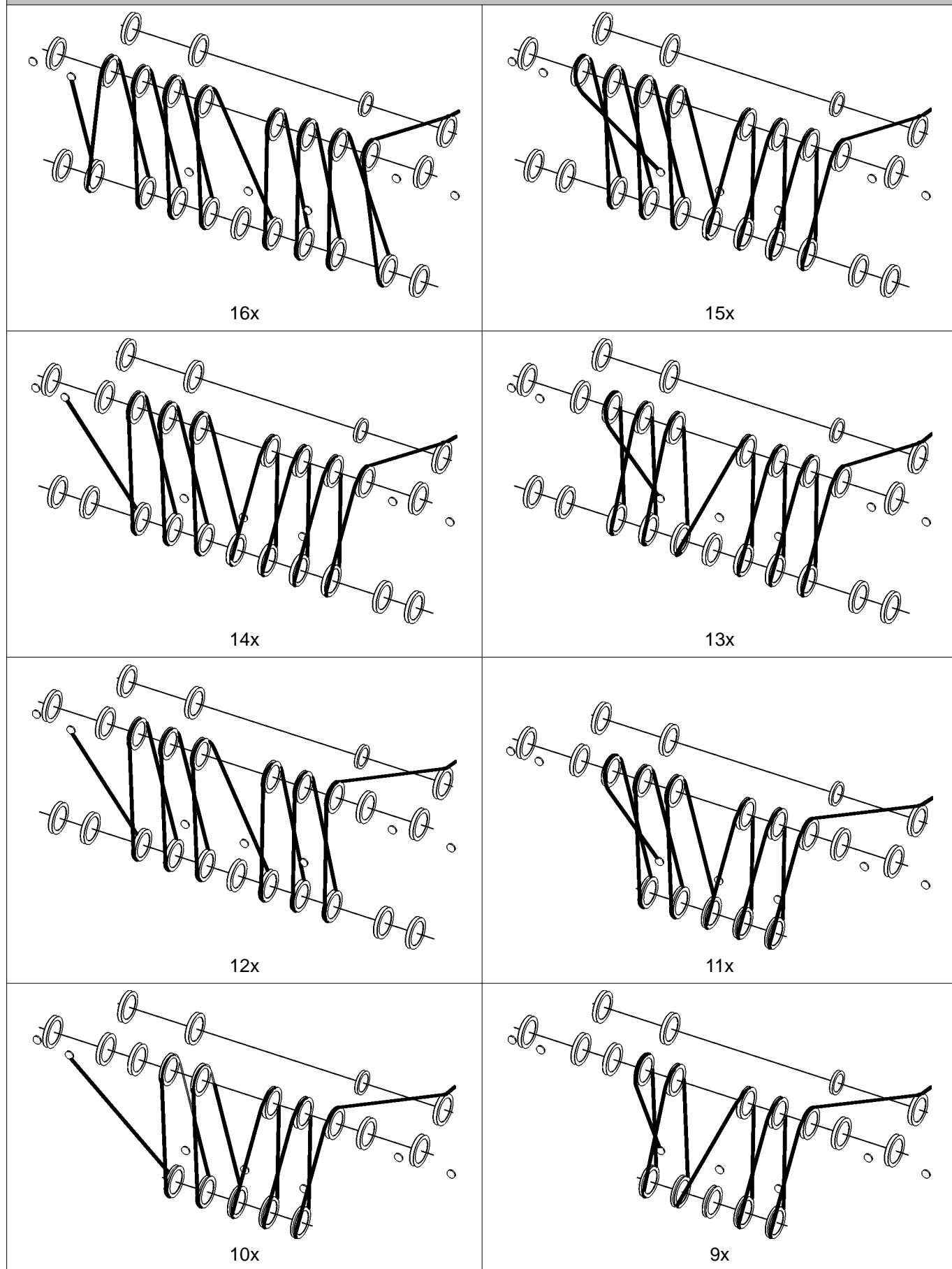
18x



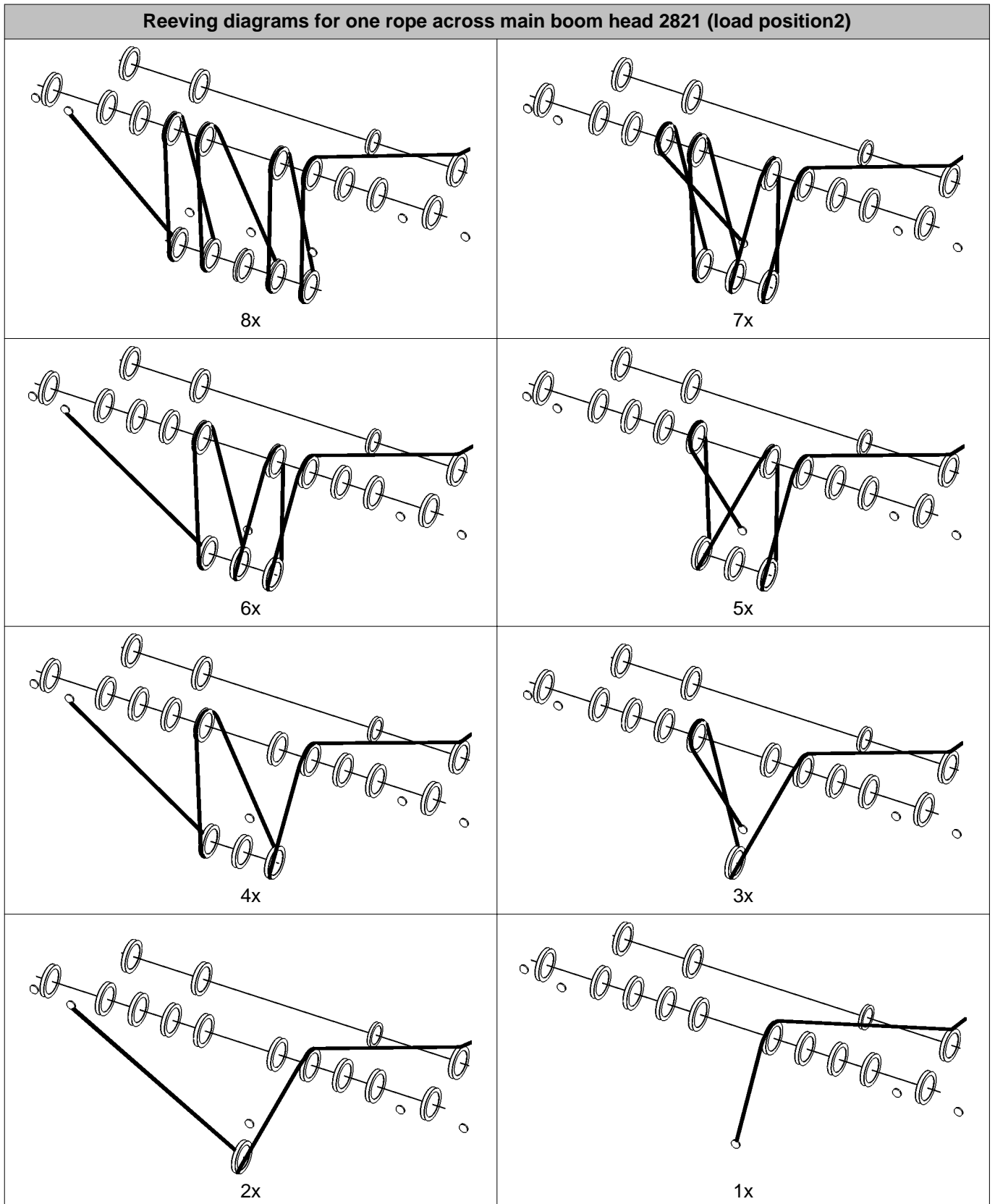
17x

LWNLR_x/V04.01//Auslieferung/2016-03-07/en

Reeving diagrams for one rope across main boom head 2821 (load position2)



LWNLR-x/V04.01//Auslieferung/2016-03-07/en



LWNLR.x/V04.01//Auslieferung/2016-03-07/en

Tab. 561: Reeving diagrams for one rope across main boom head 2821 (load position2)

7.19 Assembling the fixed jib

Ensure that the following conditions are fulfilled:

- Assembly functions are switched on.
- The machine is ready for use as an assembly crane, or an assist crane is available.
- Work plans have been drawn up.
- The length and the order of the jib sections are known.
- Any accessories required are available.

7.19.1 Notes

The assembly of the fixed jib described below applies to all system dimensions of the fixed jib.

The illustrations have been simplified or schematically represented for reasons of uniformity and represent the principles of assembly. They do not provide a detailed representation of the components.

7.19.2 Programming the setup



DANGER

Unacceptable setup!

- ▶ Only program a setup on the machine that is in accordance with the load chart.
- ▶ Programming the setup on the machine ([For more information see: 4.13 Programming the setup, page 886](#)).

7.19.3 Unloading and positioning the jib components



DANGER

Slewing of uppercarriage with rear counterweight attached not permitted!
Machine toppling over.

- ▶ Slew the uppercarriage according to the table ([For more information see: Lifting and pinning the rear counterweight, page 1264](#)) exclusively.



DANGER

Incorrect or faulty parts/components are fit!
Structural breakdown.

- ▶ Only use original Liebherr parts/components that are in perfect condition.



DANGER

Improperly assembled boom configuration!
Structural breakdown.

- ▶ Ensure that the assembled boom configuration is compatible with the programmed setup.



DANGER

Incorrect jib sections arrangement!
Structural breakdown.

- ▶ Assemble the boom according to the relevant system requirements.
- ▶ A jib section measuring 6 m (20 ft) cannot be replaced with two jib sections measuring 3 m (10 ft).
- ▶ A jib section measuring 12 m (40 ft) cannot be replaced with two jib sections measuring 6 m (20 ft).

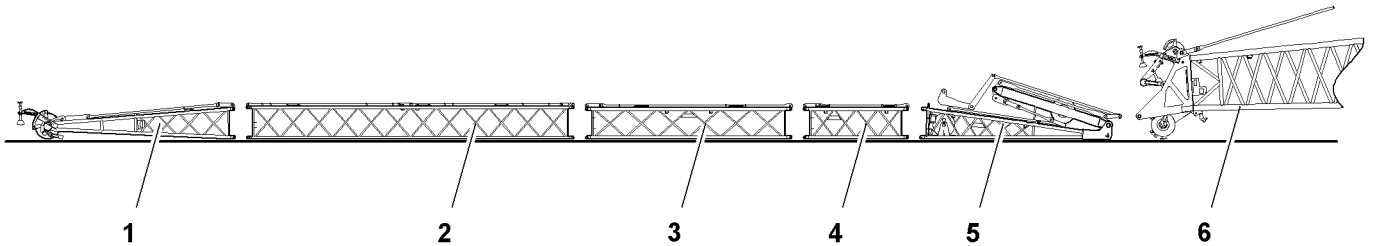


Fig. 4781: Position jib components according to relevant system instructions

- | | | | | | |
|---|---------------------------------|---|--------------------------------|---|-------------------|
| 1 | Jib head section | 3 | Jib section 6 m (19' 8" ft-in) | 5 | Jib base section |
| 2 | Jib section 12 m (39' 4" ft-in) | 4 | Jib section 3 m (9' 10" ft-in) | 6 | Boom head section |

- ▶ Direct transport vehicles with boom sections.
- ▶ Sling boom sections by attaching lifting equipment to the lifting points.
- ▶ Unload boom sections using the basic machine or assist crane and position according to the relevant system instructions.

7.19.4 Bolting the jib head section to the jib sections



WARNING

Getting caught inside the jib sections during assembly!
Serious injury.

- ▶ Never go inside the jib sections.

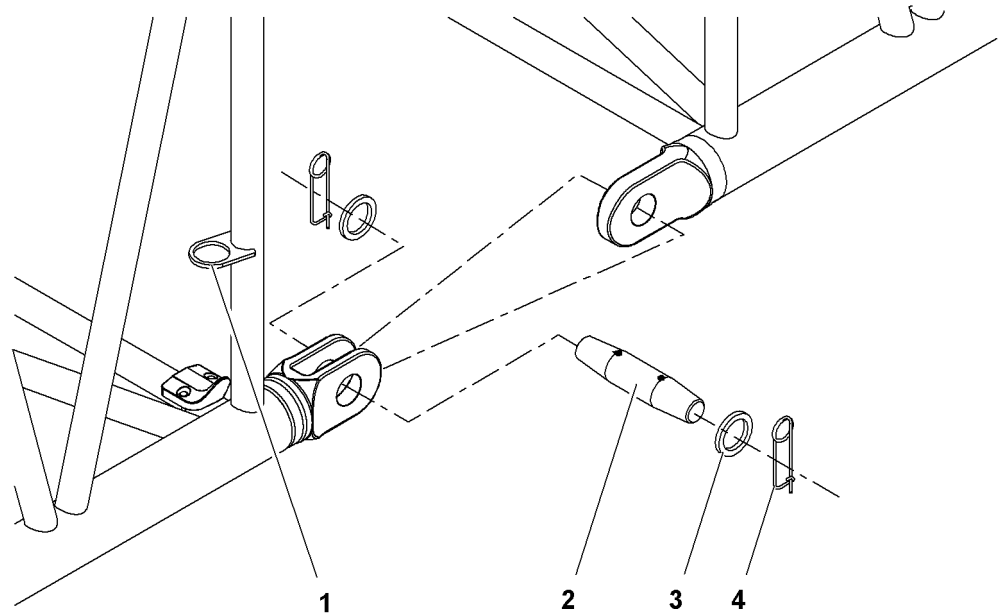


Fig. 4782: Bolting the boom

- | | | | |
|---|---|---|------------------|
| 1 | Transport brackets (4x) for double-taper pins | 3 | Washers (8x) |
| 2 | Double-taper pins (4x) | 4 | Safety pins (8x) |
- Remove the double-taper pins 2 from the transport brackets 1.



Note

- To make assembly and disassembly easier: grease the double-taper pin.
- Insert double-taper pins 2 and secure with washers 3 and safety pins 4.

7.19.5 Attaching the jib base section

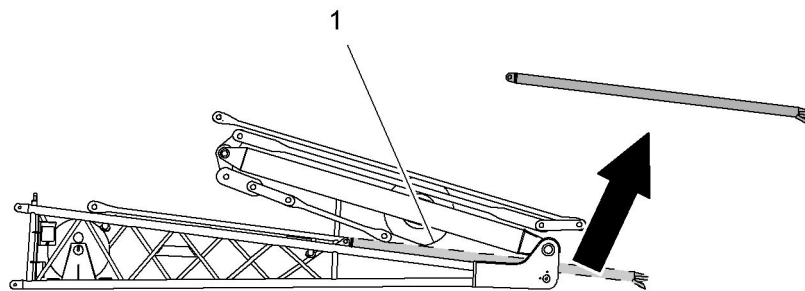


Fig. 4783: Removing rigid tilting-back supports

- | | |
|---|---------------------------------|
| 1 | Rigid tilting-back support (2x) |
|---|---------------------------------|



Note

Liebherr recommends:

- To make it easier to attach the jib base section: remove the rigid tilting-back supports 1 of the fixed jib.



Note

If the jib base section crossbar (jib backstay strap) extends a long way over the pin connection points:

- ▶ Fold the jib base section crossbar (jib backstay strap) on A-frame 2 to the front in order to make attaching the jib base section easier.

- ▶ Rig jib base section.

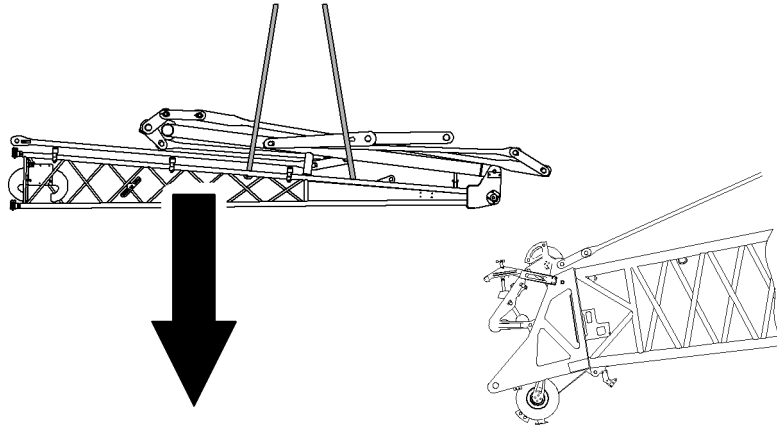


Fig. 4784: Lifting the jib base section 0806 to the boom head section

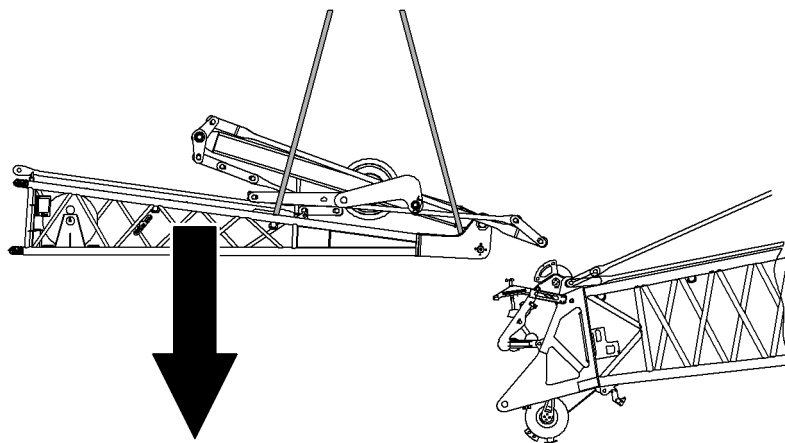


Fig. 4785: Lifting the jib base section 1008 to the boom head section

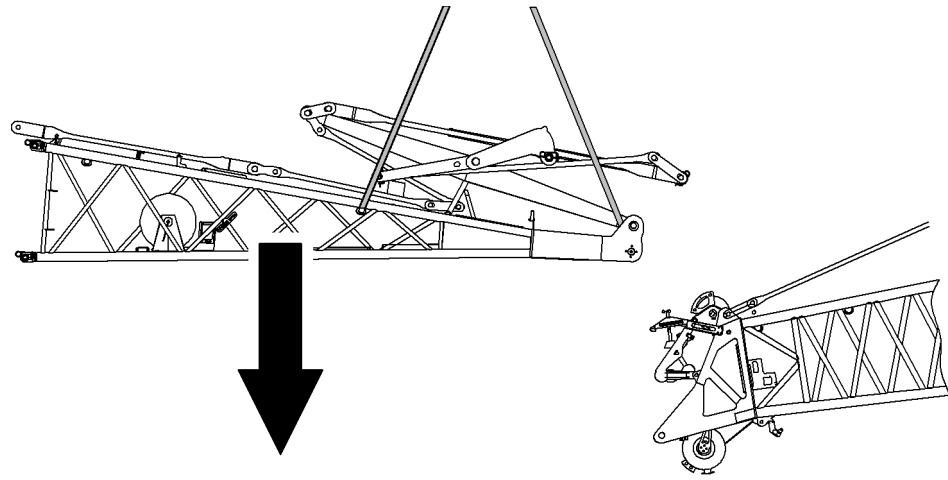


Fig. 4786: Lifting the jib base section 1713 to the boom head section

- ▶ Lift the jib base section from above onto the boom head section.
- ▶ Lower the jib base section further until the pin connection points of the jib base section and the boom head section line up.

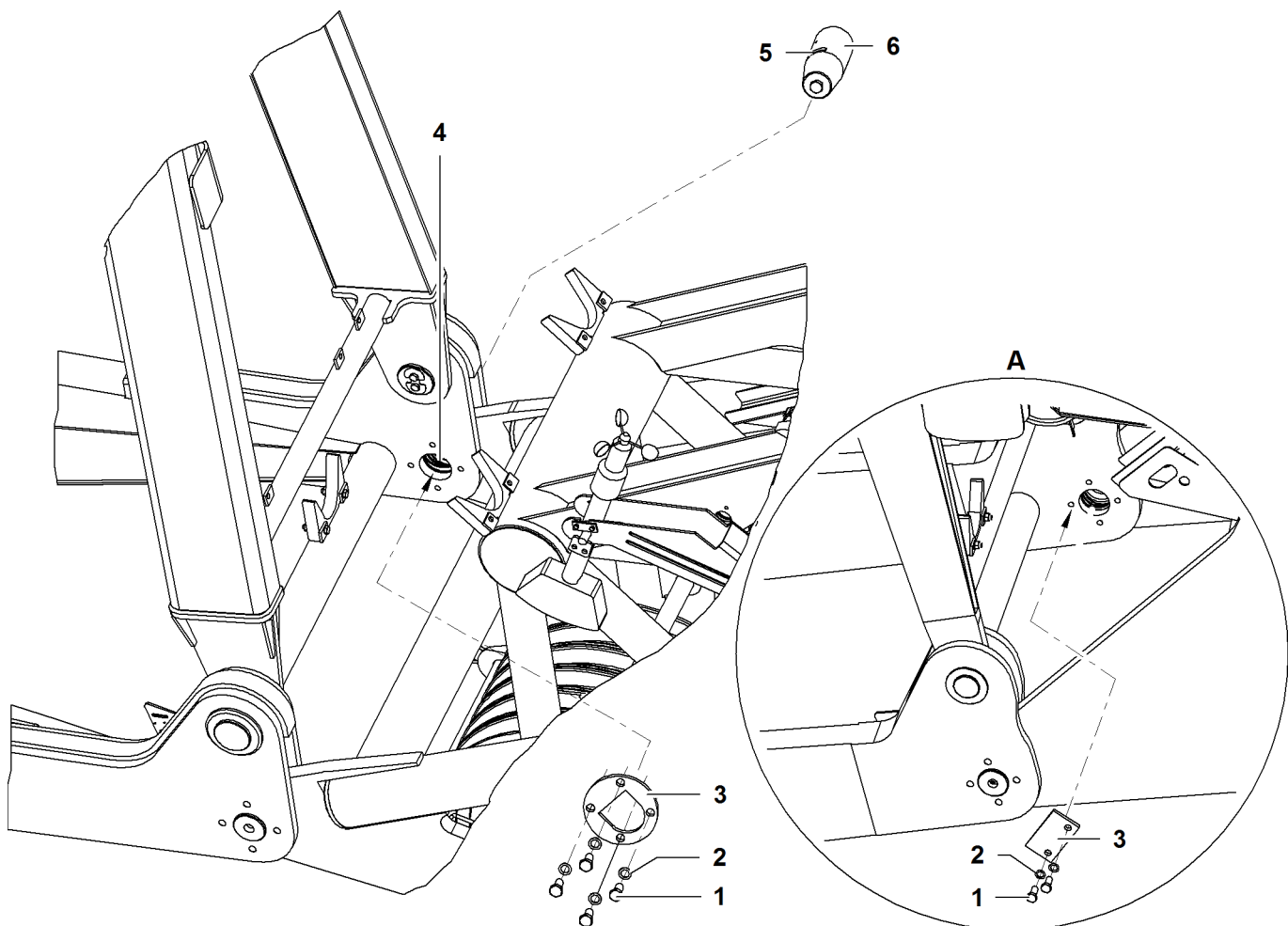


Fig. 4787: Bolting the jib base section to the boom head section

- A** Detail jib base section 0906, 1507, 1713 **3** Securing element **6** Pin

[See next page for continuation of the image legend](#)

LWNLR-x/V04.01//Auslieferung/2016-03-07/en

- 1 Screw (4x)
- 2 Washer (4x)
- 4 Pin connection point (2x)
- 5 Notch



Note

Liebherr recommends:

- ▶ To make assembly and disassembly easier, lubricate pins.

When the pin connection points **4** of the jib base section and the main boom head section line up:

- ▶ Pin **6** must be driven in from the outside.



Note

- ▶ Observe position of the notch **5** in the pin **6**.
- ▶ If necessary, use a screwdriver to turn the pin into the correct position.

- ▶ Slide locking element **3** over the pin **6** and place in notch **5**.

Type of jib	Torque	Screw treatment
0806	291 Nm 215 ft-lb	grease-free thread, treat with LOCTITE 243
0906	Nm ft-lb	grease-free thread, treat with LOCTITE 243
1008	291 Nm 215 ft-lb	grease-free thread, treat with LOCTITE 243
1507	Nm ft-lb	grease-free thread, treat with LOCTITE 243
1713	Nm ft-lb	grease-free thread, treat with LOCTITE 243

Tab. 562: Torque screws fixed jib

- ▶ Secure the locking element **3** with pins **1** and washers **2**.
- ▶ Repeat the pin insertion process on the opposite side.

7.19.6 Pinning the jib to the jib base section

- ▶ Raise the jib up to the jib base section.

When the pin connection points of the jib section and jib base section line up:

- ▶ Drive in pins from the outside in.

7.19.7 Pinning the pendant straps

- ▶ Remove safety pins from the transport brackets for pendant straps.

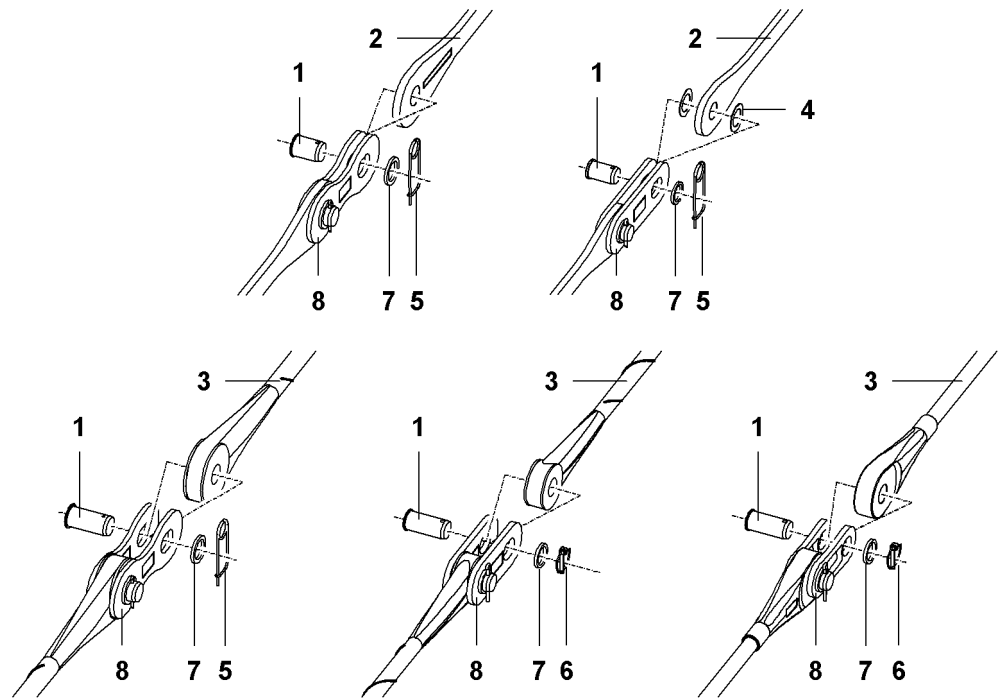


Fig. 4788: Bolt the pendant straps (schematic diagram of various pendant straps)

1	Pin	5	Safety pin
2	Steel pendant strap	6	Linch pin
3	Carbon-fibre pendant strap	7	Washer
4	Plastic washer (2x)	8	Connecting link

- ▶ Remove the pin 1 on the connecting link 8.
- ▶ Position the pendant strap 2, 3 between the two coupling links 8.
or

If the pendant strap has plastic washers 4:

Position the pendant strap 2 with plastic washers 4 on both sides between the two connecting links 8.

- ▶ Insert pin 1 and secure with washers 7 and safety pin 5 or lynch pin 6.

7.19.8 Attaching connecting links to the boom head section



WARNING

The boom will move when the upper double-taper pins on the boom head section are unpinned!
Serious injury.

- ▶ Support the main boom head section and the pinned section on wooden blocks.
 - ▶ Keep the upper double-taper pins on the boom head section free from tension.
-
- ▶ Remove the double-taper pins, safety pins and washers from the upper pin connection points on the boom head section.

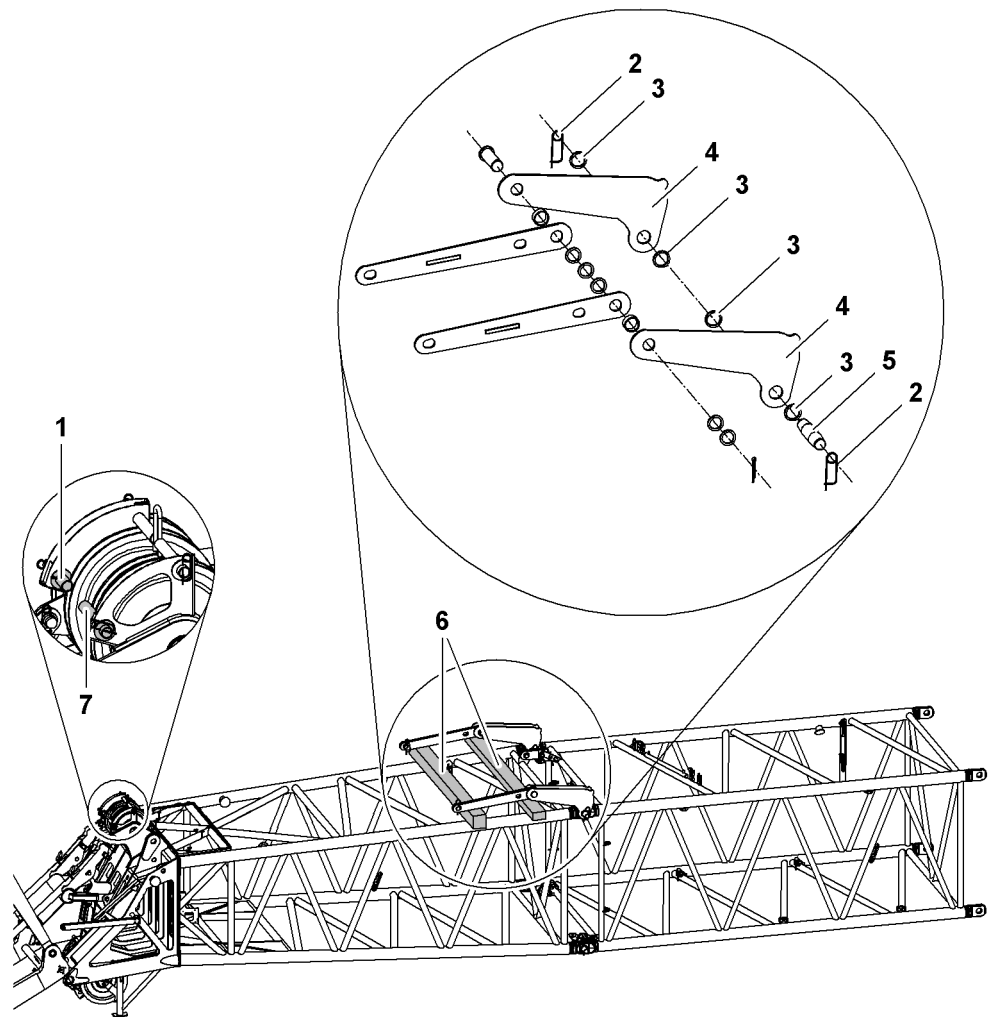


Fig. 4789: Attaching connecting links to the boom head section

- | | | | |
|---|-----------------------|---|---|
| 1 | Rope protection pipe | 5 | Double-taper pins (2x) of A-frame 2 equaliser |
| 2 | Safety pins (4x) | 6 | Wooden blocks (2x) |
| 3 | Washers (8x) | 7 | Rope protection pipe |
| 4 | Connecting links (4x) | | |

- ▶ Chock with wooden blocks **6**.
- ▶ Pin connecting links **4** with double-taper pins **5** from A-frame 2 equaliser to boom head section.
- ▶ Secure the double-taper pins with washers **3** and safety pins **2**.

NOTICE

Wrong rope protection pipe is used with a main boom + fixed jib configuration!
Damage to winch1/winch2 rope.

If the rope on winch1 is reeved over the jib head section:

- ▶ remove rope protection pipe **1**.

If the rope on winch2 is reeved over the jib head section:

- ▶ remove rope protection pipe **7**.

- ▶ remove rope protection pipes **1 + 7** if required.

7.19.9 Attaching the main boom (self-assembly system)



Note

Particular approach when using the self-assembly system!

- ▶ Attach the main boom to the basic machine.

7.19.10 Pinning the A-frame 2 equaliser to the main boom

To pin the equalizer of A-frame2 to the connecting links on the main boom, A-frame2 must be erected using the rope of winch1/winch2 as far as necessary to enable pinning.

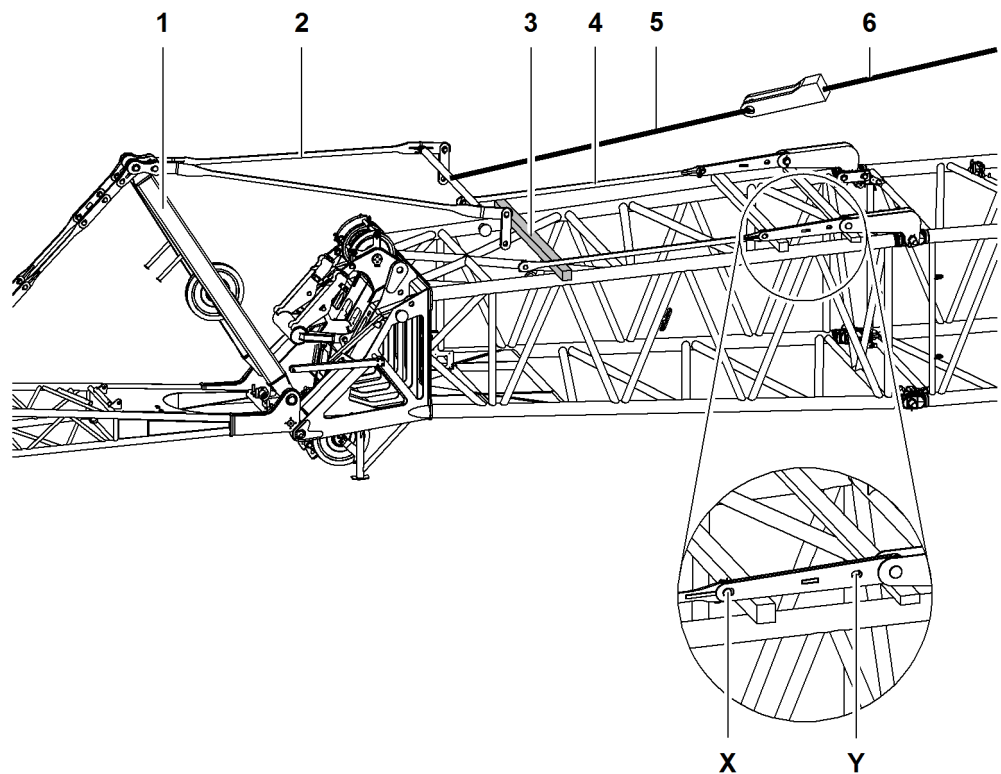


Fig. 4790: Pinning the A-frame 2 equaliser to the main boom

- | | | | |
|---|--------------------------|---|-------------------------|
| 1 | A-frame 2 | 5 | Round sling |
| 2 | A-frame 2 equaliser | 6 | Rope of winch1/winch2 |
| 3 | Wooden block | X | Tensioning position 30° |
| 4 | Jib backstay straps (2x) | Y | Tensioning position 15° |

- ▶ Separate the jib backstay straps 4 from A-frame 2 equaliser 2.



WARNING

Connecting links are bolted incorrectly on the 0906 jib!
The 0906 jib could topple backwards during crane operation.

- ▶ Only pin the connecting links at tensioning position 30° X.
- ▶ Pin jib backstay straps 4 on connecting links at tensioning position 15° Y or 30° X (jib 0906 only at 30°).
- ▶ Secure the pins with washers and safety pins.

- ▶ Attach rope of winch1/winch2 **6** with round sling **5** and pocket lock to equalizer A-frame2 **2**.
- ▶ Wind up rope of winch1/winch2.
 - ▷ A-frame 2 **1** will move backwards.
- ▶ Pin the jib backstay straps to the A-frame 2 equaliser.
- ▶ Secure the pins with washers and safety pins.



WARNING

Tilting-back supports are missing!
The jib could topple backwards during crane operation.

- ▶ Fit tilting-back supports.

- ▶ Re-fit the tilting-back supports that were removed earlier.

If the jib backstay straps are pinned:

- ▶ Unwind rope of winch1/winch2.
- ▶ Remove rope of winch1/winch2 from pocket lock.
- ▶ Remove the pocket lock from the round sling and place in temporary storage.



Note

If rope of winch1/winch2 is not subsequently reeved:

- ▶ Wind up rope of winch1/winch2.

7.19.11 Pinning the jib backstay straps (jib 1507)

- ▶ Remove locking springs of transport brackets for jib backstay straps.

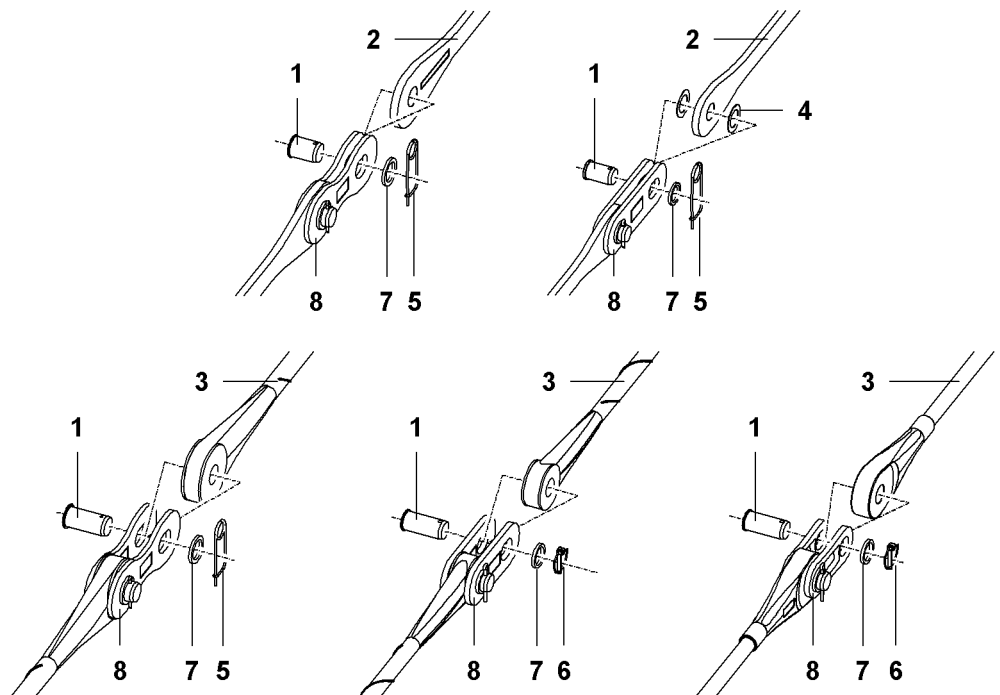


Fig. 4791: Diagram of various jib backstay straps

- 1 Pin
- 5 Locking spring

See next page for continuation of the image legend

- | | | | |
|---|----------------------------|---|-----------------|
| 2 | Jib backstay strap (steel) | 6 | Linchpin |
| 3 | Jib backstay strap (CF) | 7 | Washer |
| 4 | Plastic washers (2x) | 8 | Connecting link |

- ▶ Remove pin 1 on connecting link 8.
 - ▶ Position jib backstay strap 2, 3 between the two connecting links 8.
- If the jib backstay strap has plastic washers 4:
- ▶ Position the jib backstay strap 2 with plastic washers 4 on both sides between the two connecting links 8.
 - ▶ Insert pin 1 and secure with washers 7 and locking spring 5 or linchpin 6.

7.19.12 Installing the connecting elements and spacer brackets on jib backstay straps (jib 1507)

NOTICE

Incorrect installation positions of connecting elements and spacer brackets!
Damage to pendant straps and jib backstay straps.

- ▶ Install connecting elements and spacer brackets according to system-relevant information.

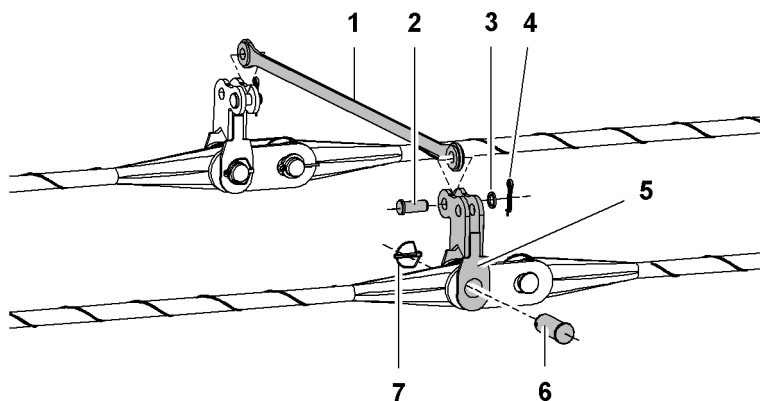


Fig. 4792: Installing connecting elements and spacer brackets on jib backstay straps

- | | | | |
|---|----------------|---|--------------------|
| 1 | Spacer bracket | 5 | Connecting element |
| 2 | Pin | 6 | Pin |
| 3 | Washer | 7 | Linchpin |
| 4 | Locking spring | | |

- ▶ Pin connecting element 5 and jib backstay strap.
- ▶ Secure pin 6 with washer and linchpin 7.
- ▶ Pin connecting element 5 and spacer bracket 1.
- ▶ Secure pin 2 with washer 3 and locking spring 4.

7.19.13 Pinning the equalizer of A-frame2 to the main boom (jib 1507)

To pin the equalizer of A-frame2 to the connecting links on the main boom, A-frame2 must be erected using the rope of winch1/winch2 as far as necessary to enable pinning.

NOTICE

Incorrect fixing of round sling to A-frame2 equalizer!
Damage to spacer bar.

- ▶ Ensure that round sling is not attached to link plate.

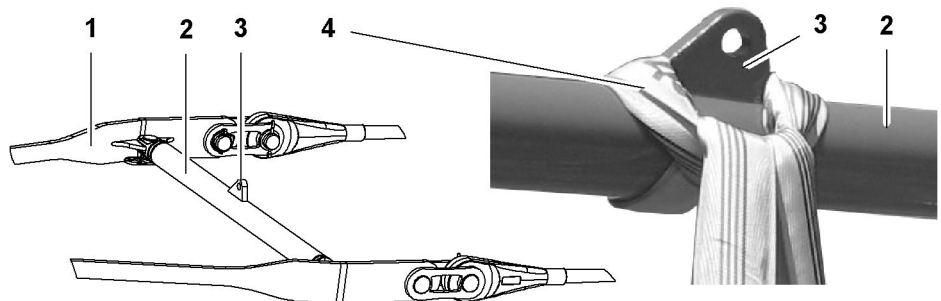


Fig. 4793: Attaching the round sling to A-frame2 equalizer

- | | |
|----------------------|---------------|
| 1 A-frame2 equalizer | 3 Link plate |
| 2 Spacer bar | 4 Round sling |

- ▶ Attach rope of winch1/winch2 with round sling and pocket lock to A-frame2 equalizer 1.
- ▶ Wind up rope of winch1/winch2.
 - ▷ A-frame2 moves backwards.

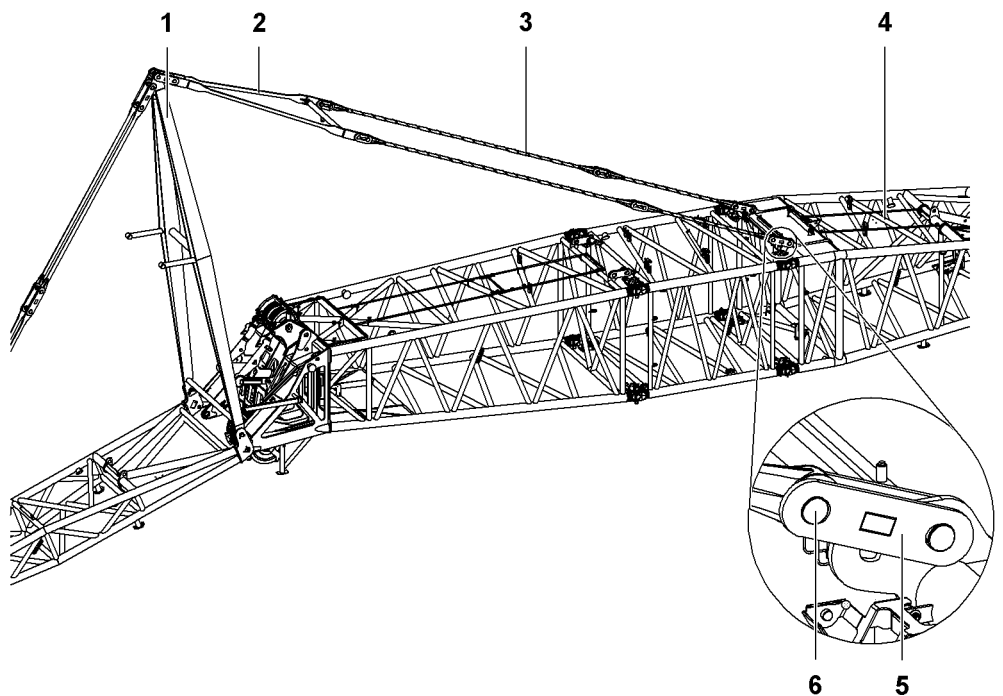


Fig. 4794: Pinning the A-frame2 equalizer with connecting links to the main boom

- | | |
|---------------------------|------------------------|
| 1 A-frame2 | 4 Jib base section |
| 2 A-frame2 equalizer | 5 Connecting link (2x) |
| 3 Jib backstay strap (2x) | 6 Pin (2x) |

- ▶ Pin jib backstay straps 3 using connecting links 5.

LWNLR.x/V04.01//Auslieferung/2016-03-07/en



WARNING

Tilting-back supports are missing!
Jib could topple backwards during crane operation.

- ▶ Install tilting-back supports.
- ▶ Secure pins **6** with washers and locking springs.

After pinning the jib backstay straps:

- ▶ Unwind rope of winch1/winch2.
- ▶ Remove rope of winch1/winch2 from rope lock.
- ▶ Remove rope lock from round sling and place in temporary storage.



Note

If winch1 or winch2 rope is not reeved subsequently:

- ▶ Wind up winch1 or winch2 rope.

7.19.14 Connect the electric cables

NOTICE

Electric cables have been handled incorrectly!
Damage to electric cable and plug.

- ▶ Do not pull the electric cable over sharp-edged objects.
- ▶ Do not crush or kink the electric cable.
- ▶ Keep the plug clean.

- ▶ Disconnect the electric cable from the dummy receptacle on the jib base section.
- ▶ Connect the electric cable to the terminal box on the main boom head section and secure using retaining clips.
 - ▷ The boom head section and jib base section electric cables are connected.

The electric cable to the jib head section is rolled on the cable drum on the jib base section.

- ▶ Disconnect both electric cables from the terminal box on the jib base section.

NOTICE

Electric cable has been unwound incorrectly!
Electric cable may be damaged.

- ▶ Push the electric cable in the cable drum into the side opening of the cable drum.
- ▶ Loosen the pin on the axle of the cable drum.
- ▶ Unwind the electric cables from the cable drum and pull it inside the jib to the jib head section.
- ▶ Connect the electric cable to the terminal box on the jib head section and secure using retaining clips.

Two fixing holes are provided under the terminal box to relieve the strain on the plug.

- ▶ Clip both carabiners on the cable sock into the fixing holes.
- ▶ Fix the pin on the axle of the cable drum.
- ▶ Reconnect the electric cable in the cable drum to the terminal box on the jib base section.
 - ▷ The jib base section and jib head section electric cables are connected.

If an auxiliary jib is fitted:

- ▶ Plug the auxiliary jib electric cable into the jib head section.

7.19.15 Installing the obstacle warning light



Note

Use of the obstacle warning light is prescribed by national or regional regulations!

- ▶ Before using the machine, familiarise yourself with national and local regulations.

Ensure that the following conditions are fulfilled:

- Anemometer is not installed.

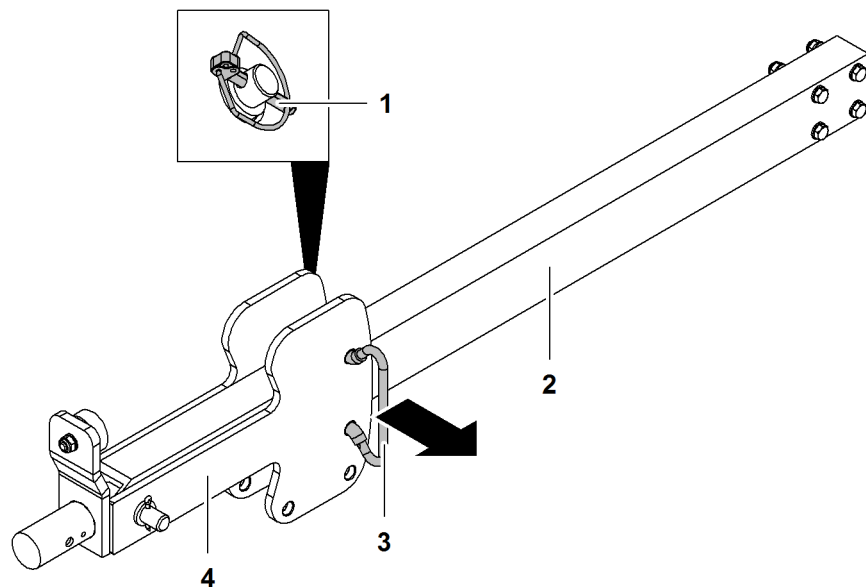


Fig. 4795: Moving the pendulum into the working position

- | | |
|------------------|-------------------|
| 1 Linchpins (2x) | 3 Locking element |
| 2 Mount | 4 Pendulum |

The pendulum 4 is secured on the mount 2 for machine transport.

- ▶ Remove the linchpin 1 of the locking element 3.
- ▶ Remove 3 locking element.
- ▶ Swing pendulum 4 down.
- ▶ Slide locking element 3 through pendulum 4 and secure with linchpins 1.

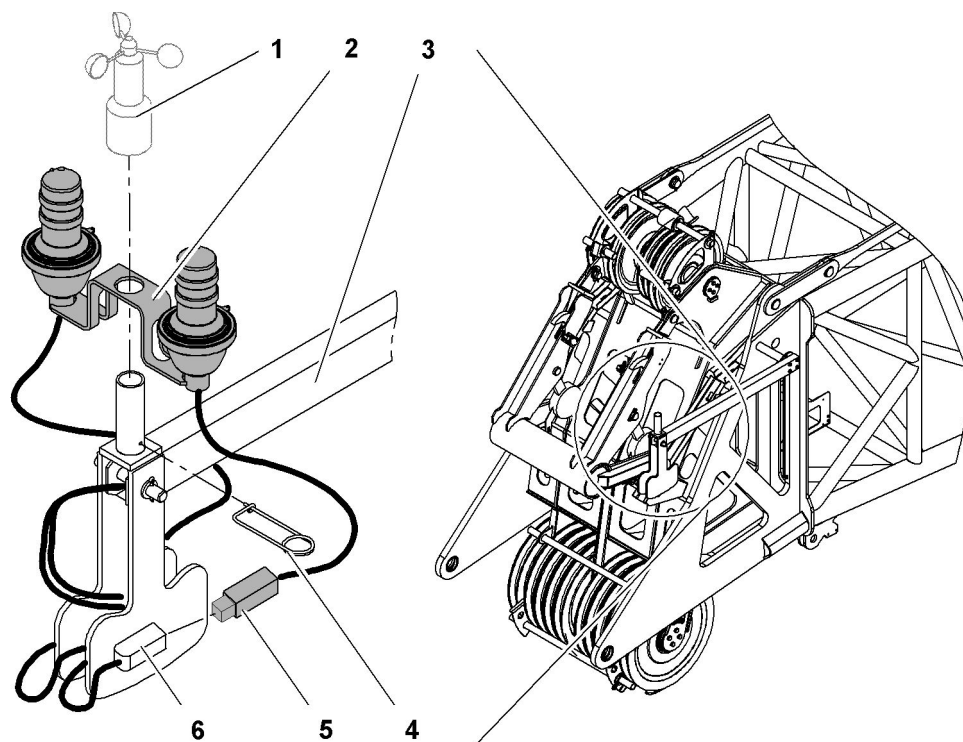


Fig. 4796: Installing the obstacle warning light

- | | | | |
|---|------------------------|---|------------|
| 1 | Anemometer | 4 | Safety pin |
| 2 | Obstacle warning light | 5 | Plug |
| 3 | Mount | 6 | Coupling |

- ▶ Place obstacle warning light 2 on pipe.
 - ▷ Obstacle warning light is secured by the pipe and axis on the bracket 3.

NOTICE

Safety pin is not fit properly!
Damage to the electric cable.

- ▶ Insert the safety pin carefully.

- ▶ Insert the safety pin 4.
 - ▷ Obstacle warning light 2 is secured.
- ▶ Connect the plug 5 to the coupling 6.
- ▶ Lock plug 5.

7.19.16 Fitting the anemometer

Ensure that the following conditions are fulfilled:

- Obstacle warning light is installed (if available).

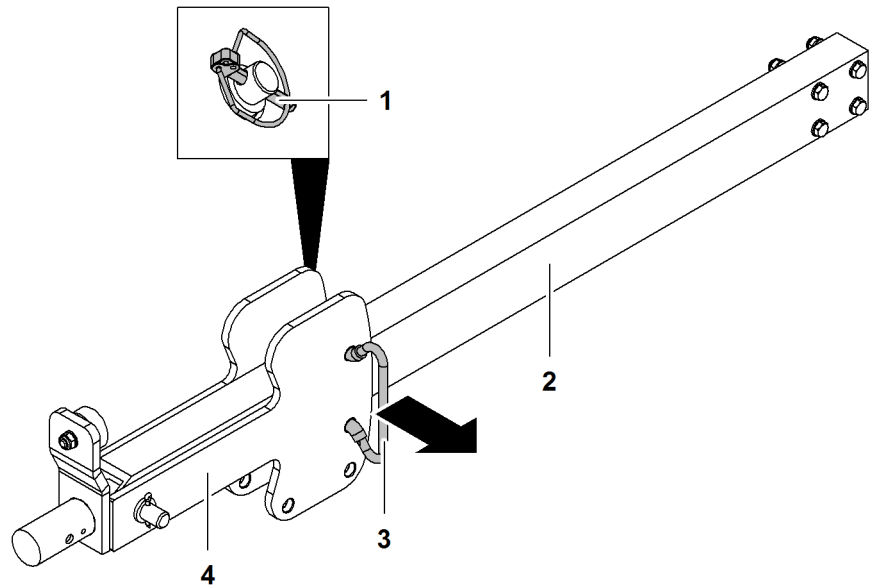


Fig. 4797: Moving the pendulum into the working position

- | | | | |
|---|----------------|---|-----------------|
| 1 | Linchpins (2x) | 3 | Locking element |
| 2 | Mount | 4 | Pendulum |

The pendulum 4 is secured on the mount 2 for machine transport.

- ▶ Remove the linchpin 1 of the locking element 3.
- ▶ Remove 3 locking element.
- ▶ Swing pendulum 4 down.
- ▶ Slide locking element 3 through pendulum 4 and secure with linchpins 1.

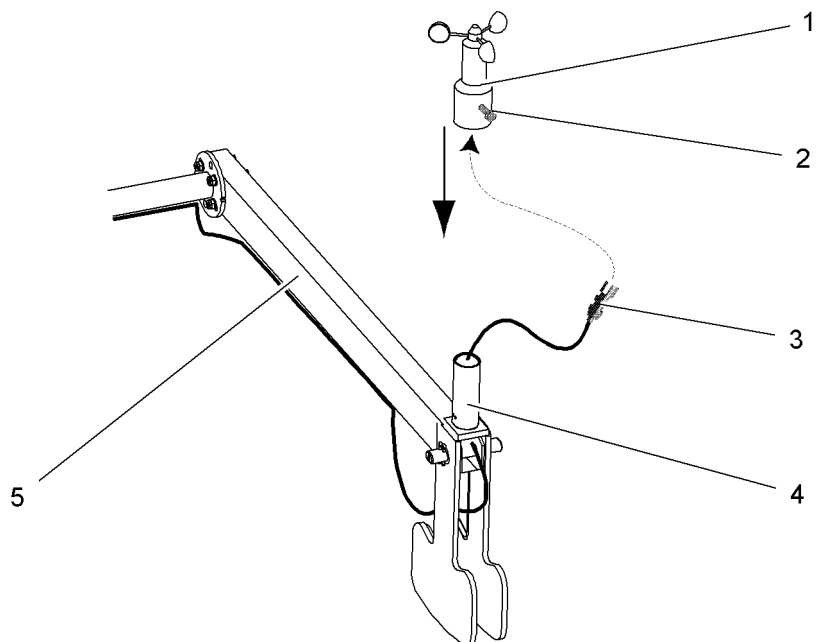


Fig. 4798: Fitting the anemometer

- | | | | |
|---|------------|---|-------|
| 1 | Anemometer | 4 | Tube |
| 2 | Screw | 5 | Mount |
| 3 | Plug | | |

Moving the lightning rods* on the fixed jib head into working position

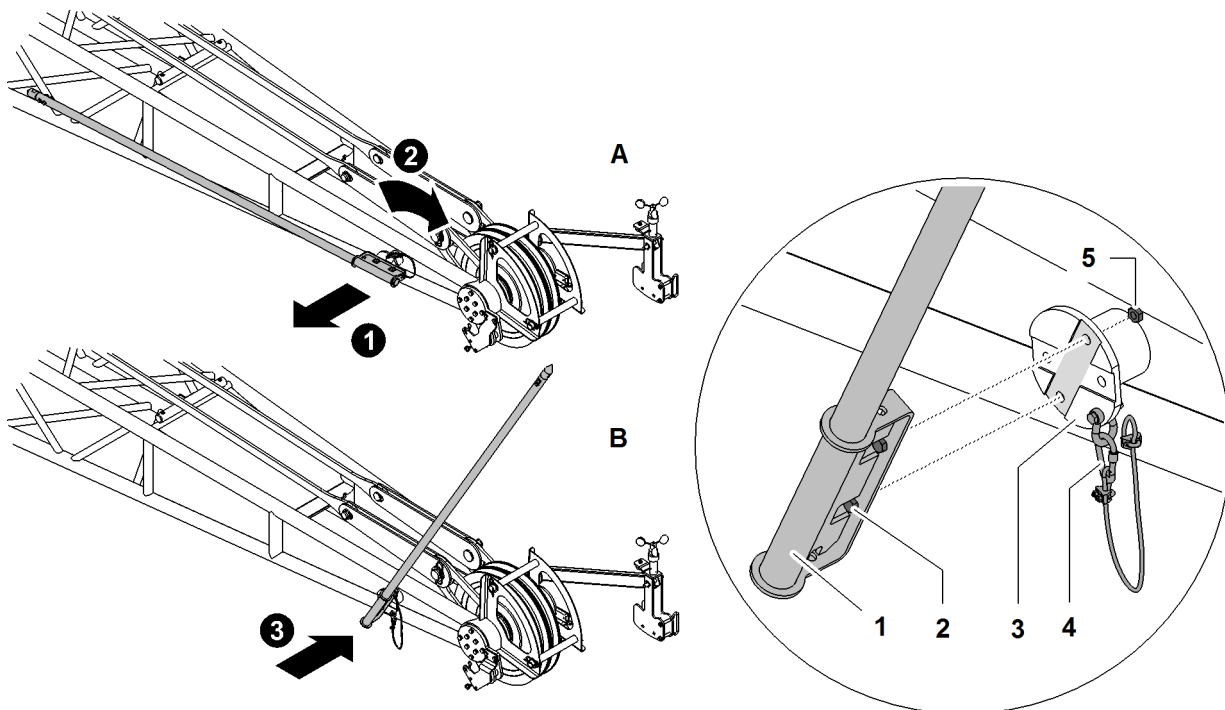


Fig. 4800: Moving the lightning rods* on the fixed jib head into working position (illustration of principle)

A	Transport position	2	Screw (2x)	5	Nut (2x)
B	Working position	3	Mounting plate	4	Safety rope
1	Lightning rod				

- ▶ Undo safety rope 4.
- ▶ Undo nuts 5.
- ▶ Undo screws 2.
- ▶ Move lightning rod 1 from transport position A to working position B.



Note

Liebherr recommends:

- ▶ Grease threads of the screws 2.
- ▶ Attach lightning rod 1 with screws 2.
- ▶ Lock screws 2 with nuts 5.

NOTICE

Safety rope not attached!
Dropping parts.

- ▶ Ensure that safety rope 4 is attached.
- ▶ Attach safety rope 4.

NOTICE

Tip not installed!
Improperly deflected current.
Dropping parts.

- ▶ Ensure that the tip on the lightning rod 1 is installed.
- ▶ Ensure that the screws of the tip are tightened.

- ▶ Ensure that the tip on the lightning rod 1 is installed.
- ▶ Ensure that the screws of the tip are tightened.

Moving the lightning rods* on A-frame2 into working position

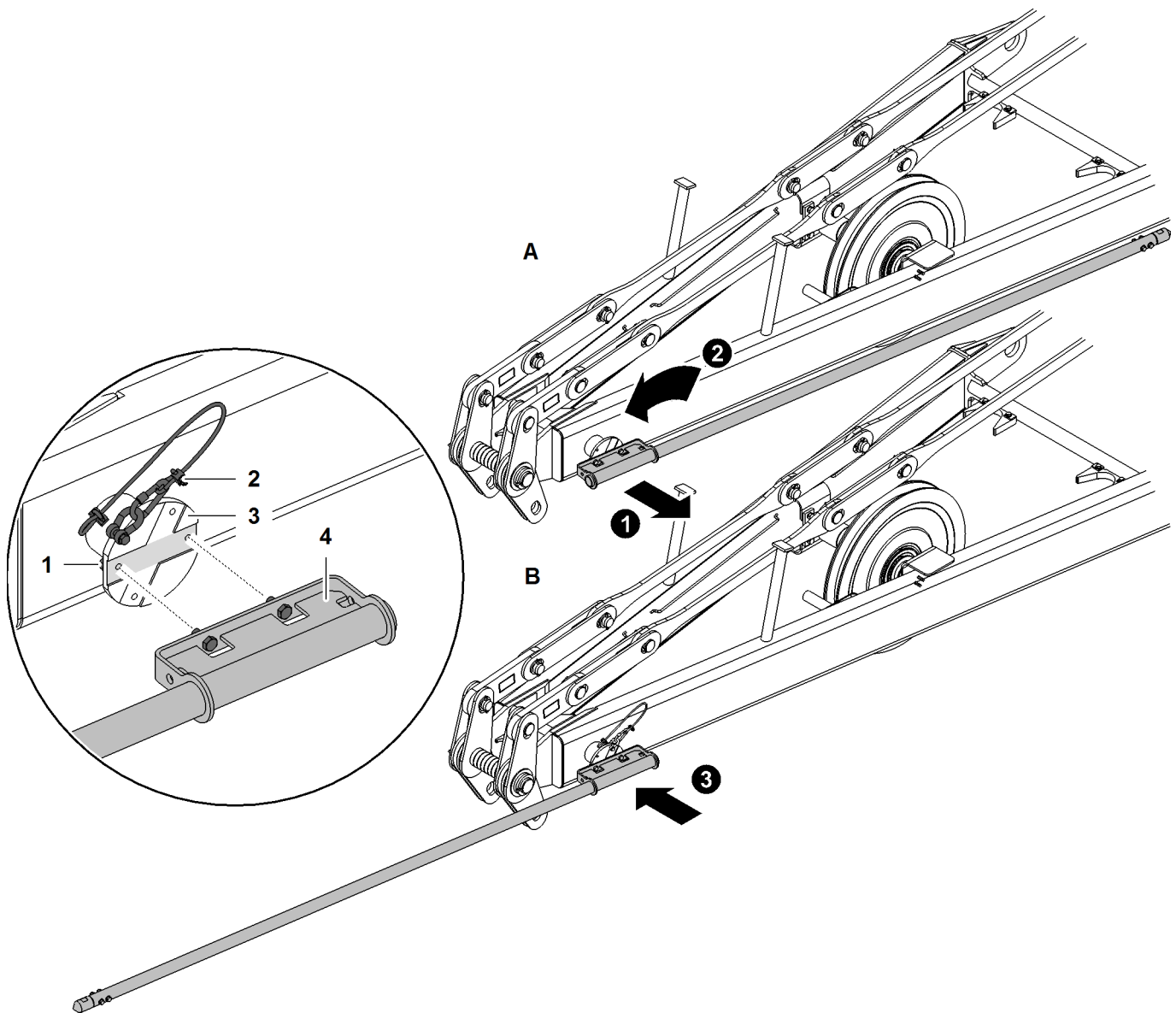


Fig. 4801: Moving the lightning rods* on A-frame2 into working position (illustration of principle)

A	Transport position	1	Nut (2x)	3	Screw (2x)
B	Working position	2	Safety rope	4	Lightning rod

LWNLR-x/V04.01//Auslieferung/2016-03-07/en

- ▶ Undo safety rope **2**.
- ▶ Undo nuts **1**.
- ▶ Undo screws **3**.
- ▶ Move lightning rod **4** from transport position **A** to working position **B**.



Note

Liebherr recommends:

- ▶ Grease threads of the screws **3**.
- ▶ Attach lightning rod **4** with screws **3**.
- ▶ Lock screws **3** with nuts **1**.

NOTICE

Safety rope not attached!
Dropping parts.

- ▶ Ensure that safety rope **2** is attached.
- ▶ Attach safety rope **2**.

NOTICE

Tip not installed!
Improperly deflected current.
Dropping parts.

- ▶ Ensure that the tip on the lightning rod **4** is installed.
- ▶ Ensure that the screws of the tip are tightened.
- ▶ Ensure that the tip on the lightning rod **4** is installed.
- ▶ Ensure that the screws of the tip are tightened.

7.19.18 Reeving the rope

The rope must be reeved as specified in the rope reeving diagram according to the boom and application requirements.



WARNING

Unsecured walking on the boom!
Risk of falling off the boom.

- ▶ A fall arrest system must be worn when working on the boom to prevent falling.

Ensure that the following conditions are satisfied:

- Cylinder adjustment functions are on.

Reeving the rope using a rope reeving winch

Dismantling rope protection pipes

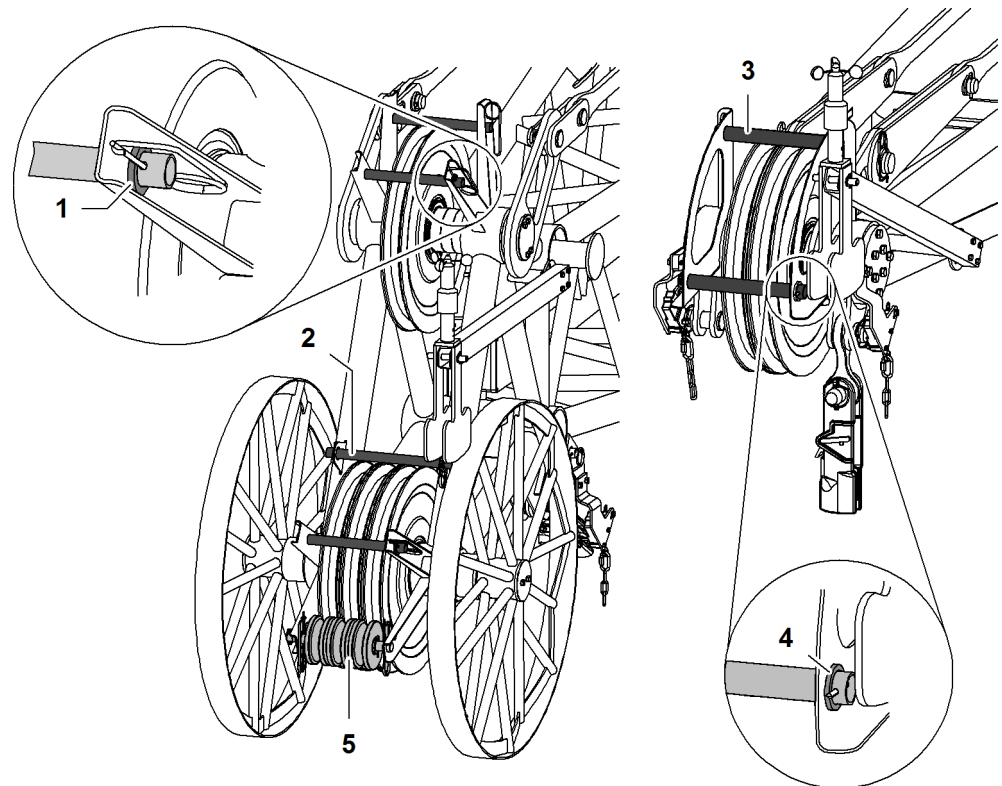


Fig. 4802: Rope protection pipes jib head section (0806, 0906, 1008, 1507, 1713)

- | | | | |
|-------|---------------------------|---|---------------------------------|
| 1 + 4 | Washer | 4 | Washer |
| 2 + 3 | Rope guard tube (4x) | 5 | Rope protection rollers package |
| 3 | Rope protection pipe (2x) | | |

The rope protection pipes are secured with a cotter pin on one side and with a safety pin on the other side.

NOTICE

Inadmissible operation of winch1/winch2 below 10° jib angle!
Damage to jib head section.

- ▶ Make sure that winch1/winch2 are not operated below 10° jib angle.

- ▶ Remove the safety pin and washer 1 + 4.
- ▶ Remove the rope protection pipes 2 + 3.

Dismantling the rope protection rollers package on the jib head section 1713

With the jib head section 1713, the rope protection rollers package must be removed as well.

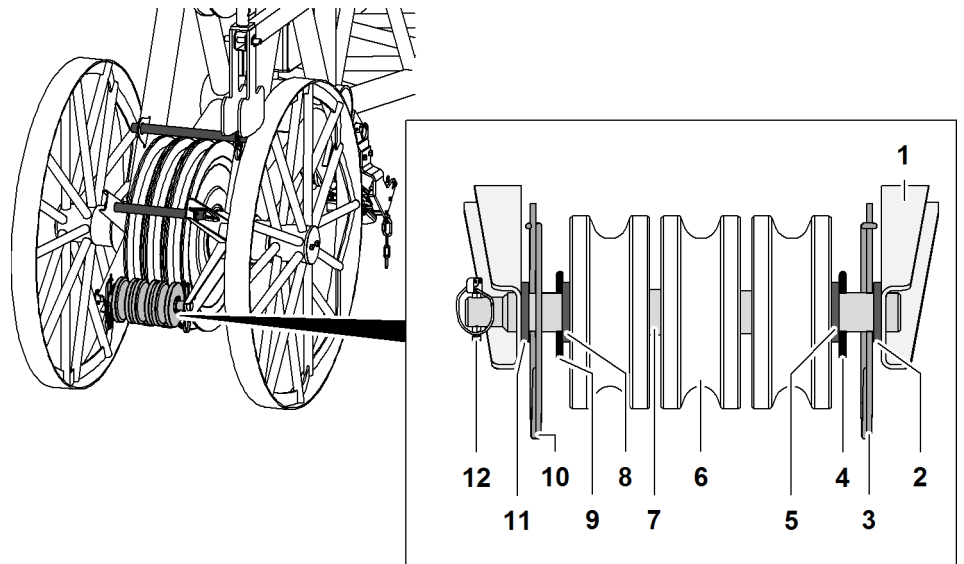


Fig. 4803: Rope protection rollers package

- | | | | |
|---|------------|----|------------|
| 1 | Mount | 7 | Shaft |
| 2 | Washer | 8 | Washer |
| 3 | Safety pin | 9 | Cotter pin |
| 4 | Cotter pin | 10 | Safety pin |
| 5 | Washer | 11 | Washer |
| 6 | Pulley | 12 | Linchpin |

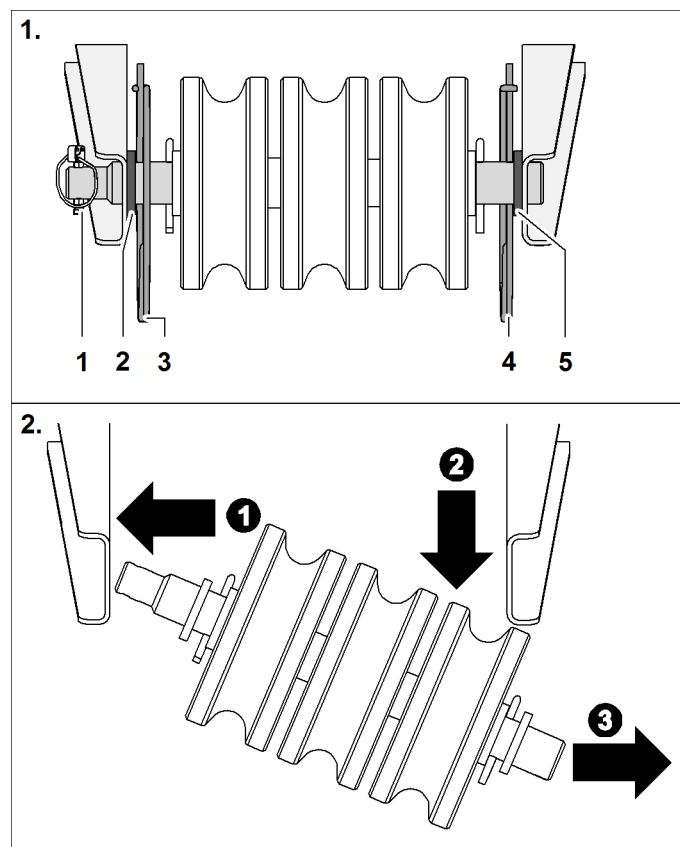


Fig. 4804: Dismantling the rope protection rollers package

- | | | | |
|---|----------|---|------------|
| 1 | Linchpin | 4 | Safety pin |
|---|----------|---|------------|

See next page for continuation of the image legend

- 2 Washer
- 3 Safety pin
- 5 Washer

- ▶ Remove the linchpin 1.
- ▶ Remove safety pin 3 + 4.
- ▶ Take rope protection rollers package off the support.
 - ▷ Rope protection rollers package is dismantled.

Reeving the rope

- ▶ Open up the rope guide (if present).

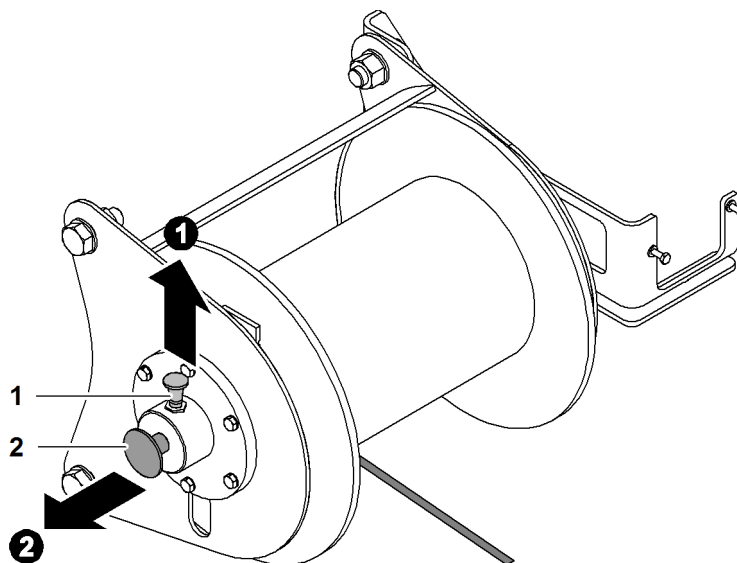


Fig. 4805: Setting the rope lug to free-wheel

- 1 Locking element
- 2 Shaft



Note

Liebherr recommends:

- ▶ Making it easier to pull out the axle 2: move the rope reeving winch manually back and forth.
- ▶ Pull up the locking element 1 and pull out the axle 2 at the same time.
 - ▷ Rope reeving winch is set to free-wheel.

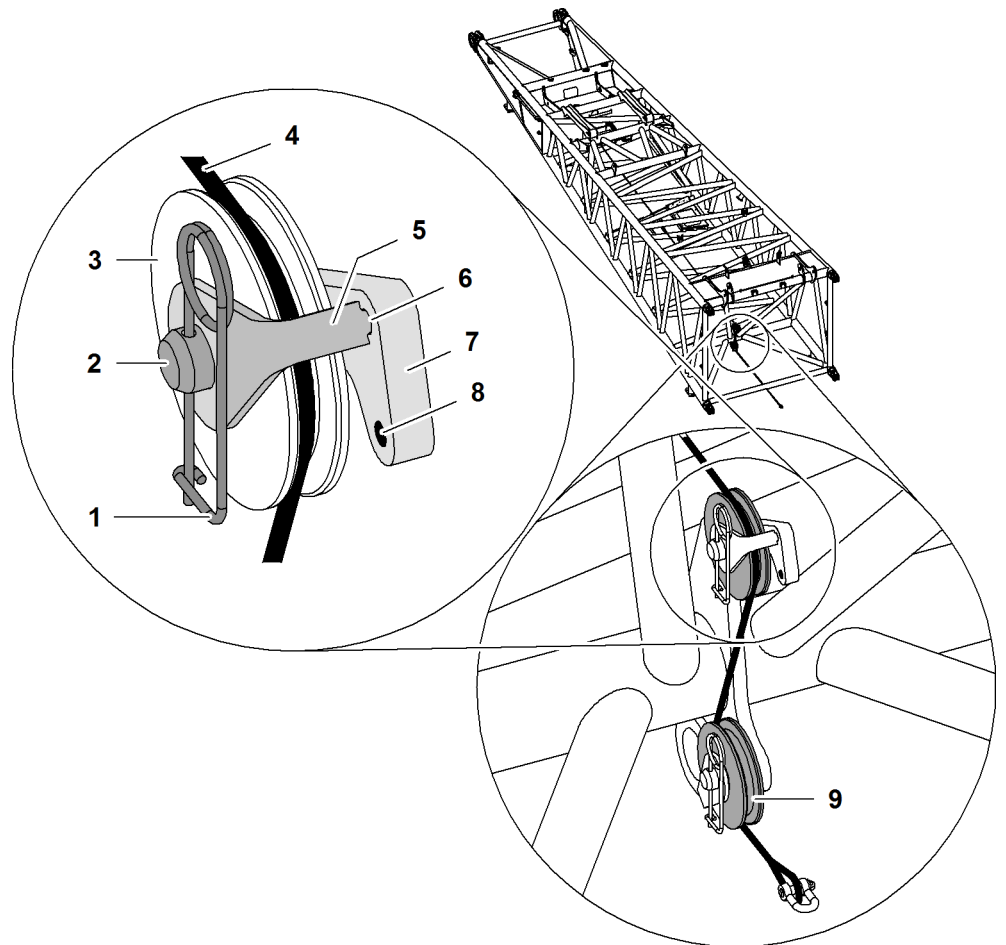


Fig. 4806: Reeving in the rope of the rope reeving winch

- | | | | |
|---|--------------------------------|---|-----------------------|
| 1 | Safety pin | 6 | Recess |
| 2 | Shaft | 7 | Support with recesses |
| 3 | Upper pulley | 8 | Recess |
| 4 | Rope of the rope reeving winch | 9 | Lower pulley |
| 5 | Locking element | | |

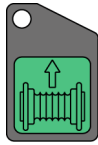
Depending on the machine type, the mounting 7 may have one or two recesses.

- ▶ Remove safety pins 1.
- ▶ Remove 5 securing element.
- ▶ Place rope of the rope reeving winch 4 across the top pulley 3.

NOTICE

Wrongly mounted locking element!
Rope of the rope reeving winch jumps out of pulley.

- ▶ Make sure that the locking element 5 is mounted in recess 6.
-
- ▶ Attach locking element 5 to axle 2 and guide in recess 6.
 - ▶ Attach the safety pin 1.
 - ▶ Repeat procedure on bottom pulley 9.
 - ▷ Rope of the rope reeving winch is guided through pulleys.
 - ▶ Pull the luffing rope under the boom to the boom head.
 - ▶ Reeve in the rope of the rope reeving winch according to reeving plan.



- ▶ Remove rope of the rope reeving winch from the rope of winch1/winch2.
- ▶ Press and hold the *Rope reeving winch* button on control panel X11.
 - ▷ Luffing rope is being reeved.
- ▶ Press the *Rope reeving winch* button on control panel X11.
 - ▷ Rope reeving winch switched off.
- ▶ Close and secure the rope guide (if present).

Mounting the rope protection rollers package on jib head section 1713

NOTICE

Wrongly installed washers!
 Rope protection rollers package falls out of the support.
 Damage to jib head section.

- ▶ Ensure proper installation position of the washers.

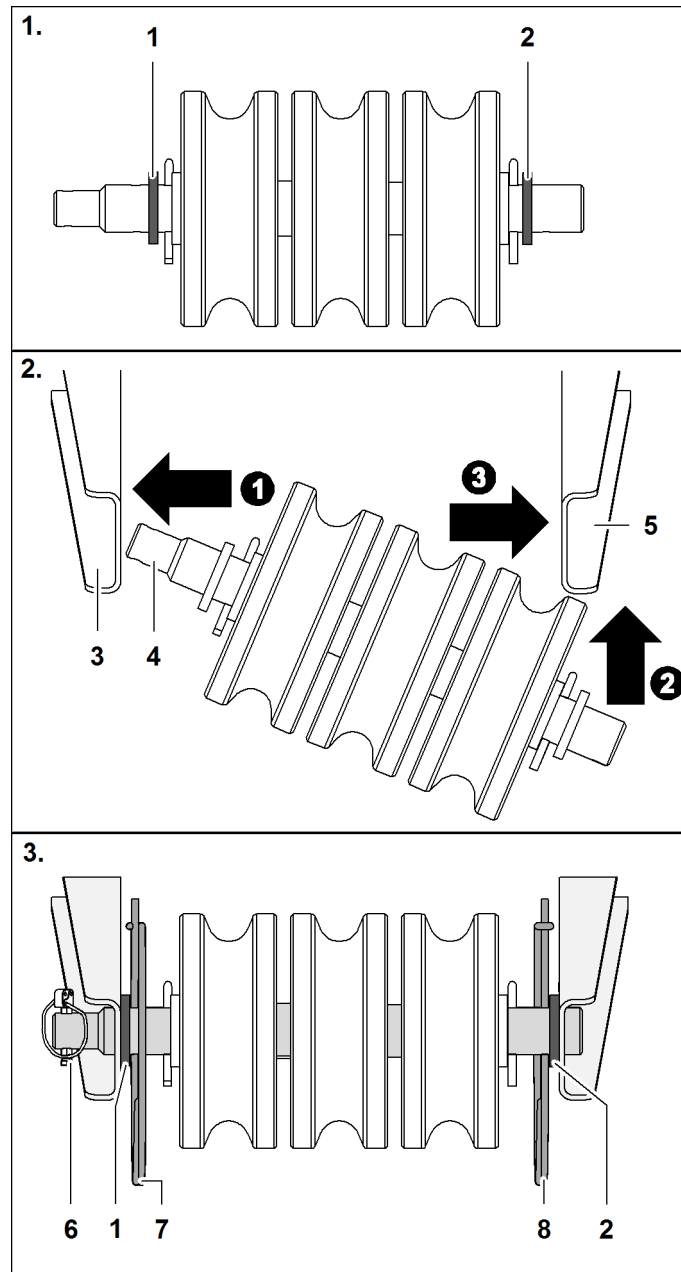


Fig. 4811: Mounting the rope protection rollers package on the jib head section

1	Washer	5	Mount
2	Washer	6	Linchpin
3	Mount	7	Safety pin
4	Shaft	8	Safety pin

- ▶ Place washers 1 + 2 on axle.
- ▶ Insert axle 4 of the rope protection rollers package into support 3.
- ▶ Insert axle 4 into support 5.
- ▶ Put washers 1 + 2 into position.
- ▶ Install safety pins 7 + 8.
- ▶ Install linchpin 6.
 - ▷ Rope protection rollers package is installed.

Installing rope protection pipes

- ▶ Mount and secure rope protection pipes.

Reeving the rope without using a rope reeving winch

- ▶ Remove the rope protection pipes on the boom and the pulley block.
- ▶ Open up the rope guide (if present).
- ▶ Connect auxiliary rope with the rope of winch1/winch2.
- ▶ Pull the auxiliary rope next to the boom as far as the boom head.
- ▶ Hoist the auxiliary rope onto the boom.
- ▶ Reeve the auxiliary rope according to the rope reeving system.



If rope of winch1/winch2 is in the 8th rope layer (only with free-fall winch 130 kN (29,230 lb_i)):

- ▶ Press the *Bypass limit switch* button on control panel X23.
 - ▷ The 3-rope windings limit switch is bypassed.

There must be no slacking of the rope when unwinding.

- ▶ Unwind the rope of winch1/winch2 up to the rope fixing point.
- ▶ Remove auxiliary rope from the rope of winch1/winch2.
- ▶ Close and secure the rope guide (if present).
- ▶ Mount and secure rope protection pipes.

7.19.19 Attaching the rope fixing point



DANGER

Incorrect installation of pins and pocket lock!
Load breakaway.

- ▶ Fit pins and pocket lock as instructed.

The collar of the pins and the pocket lock openings are decisive for the installation direction of the rope fixing point.

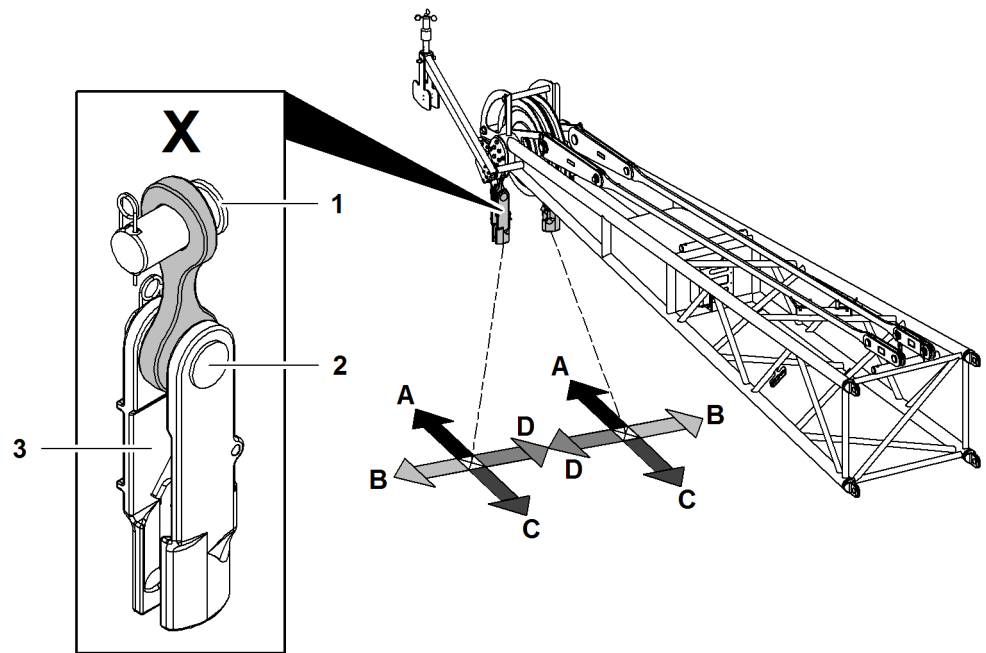


Fig. 4813: Determining the installation direction of the components of the rope fixing point of relevance for installation - fixed jib (illustration of principle)

- | | | | |
|----------|------------------------------------|----------|--------------------------|
| X | Components needed for fitting | A | Direction main boom head |
| 1 | Shoulder of pin on the boom | B | Outside |
| 2 | Shoulder of pin on the pocket lock | C | Direction basic machine |
| 3 | Pocket lock opening | D | Inside |

Installation direction of the rope fixing point components of relevance for installation			
	Pin collar on boom	Pin collar on pocket lock	Pocket lock opening
All rope fixing points	D	C	B
Exceptions:			
Fixed jib head 0906	B	C	B
Fixed jib head 1507	B	C	B

Tab. 564: Installation direction of the rope fixing point components of relevance for installation



WARNING

Incorrectly fit swivels!
Severe injuries, damage to machine.

- ▶ Fit rope with no twists.
- ▶ Install the rope without swivels.

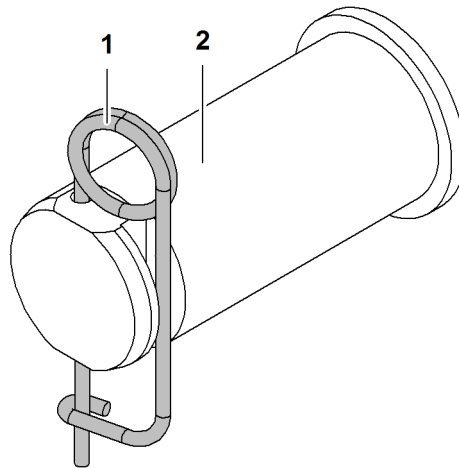


Fig. 4814: Securing the pins

1 Locking spring

2 Pin



DANGER

Pins 2 not completely secured!
Load breakaway.

- ▶ Ensure that locking spring 1 completely secures the pin 2.

Installing the rope fixing point on the boom head

- ▶ Pin cross strap with boom head.
- ▶ Secure pin with locking spring.
- ▶ Pin pocket lock with cross strap.
- ▶ Secure pin with locking spring.

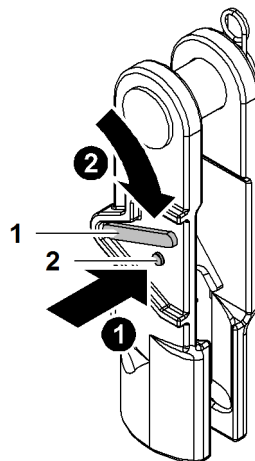


Fig. 4815: Unlocking the pocket lock

1 Safety latch

2 Locking button

- ▶ Press the locking button 2.
- ▶ Press safety latch 1 down and hold.

- ▶ Press safety latch 1 down and hold.

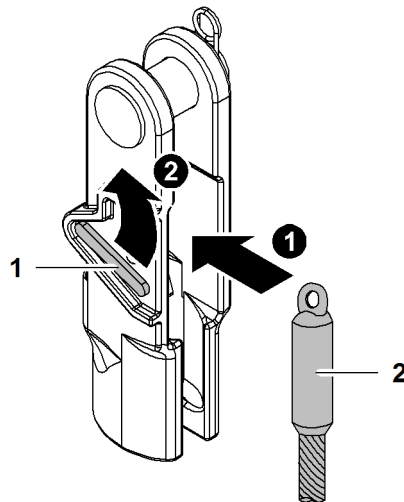


Fig. 4818: Inserting the end of rope into pocket lock and locking the pocket lock

- 1 Safety latch
- 2 End of rope

- ▶ Insert end of rope 2 in pocket lock.



DANGER

End of rope 2 not properly secured!
Load breakaway.

- ▶ Ensure that the safety latch 1 engages.

- ▶ Let go of safety latch 1.
 - ▷ Safety latch 1 engages.

7.19.20 Installing the hoist limit switch weight

NOTICE

Improper installation of the hoist limit switch weight!
Damage to the rope and hoist limit switch weight.

- ▶ Fit the hoist limit switch weight with no diagonal pull.
- ▶ Always install the hoist limit switch weight on the slack rope of winch1/winch2, except with simple reeving.

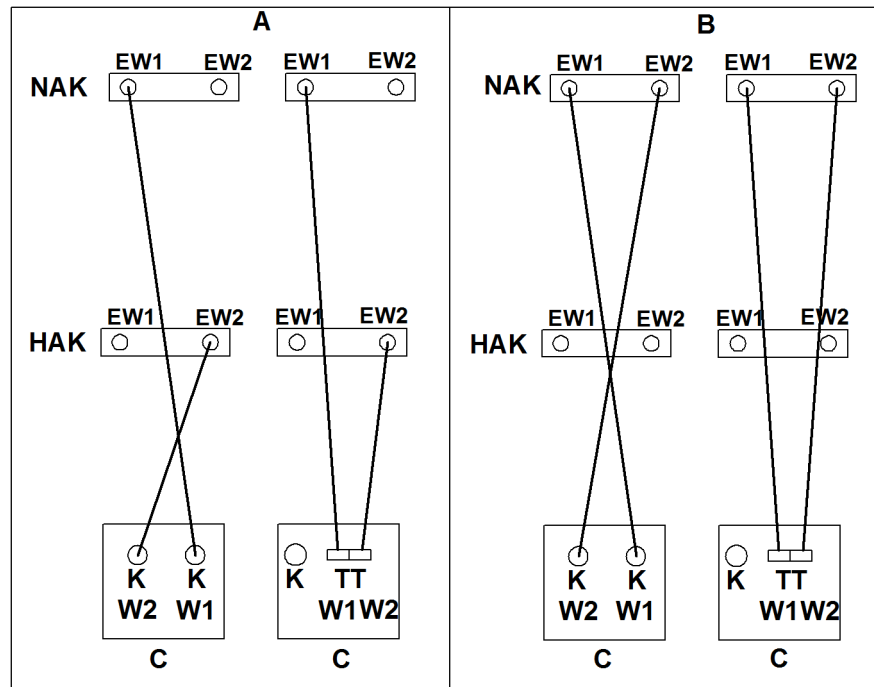


Fig. 4819: Hoist limit switch assignment in dependence on winch1/winch2

- | | | | |
|------------|---|------------|------------------------|
| A | Boom configuration main boom + fixed jib | K | Joystick |
| B | Boom configuration main boom + fixed jib with 2 ropes over jib head section | NAK | Jib head section |
| C | Cabin | TT | Double T-control lever |
| EW1 | Hoist limit switch winch1 | W1 | winch1 |
| EW2 | Hoist limit switch winch2 | W2 | winch2 |
| HAK | Main boom head section | | |

NOTICE

Wrong hoist limit switch!
Hoist limit switch does not turn off.

- ▶ Make sure that the correct hoist limit switch for the correct rope of winch1/ winch2 is used.

The hoist limit switch with chain and hoist limit switch weight attached is secured to the inoperative end of the hoist rope.

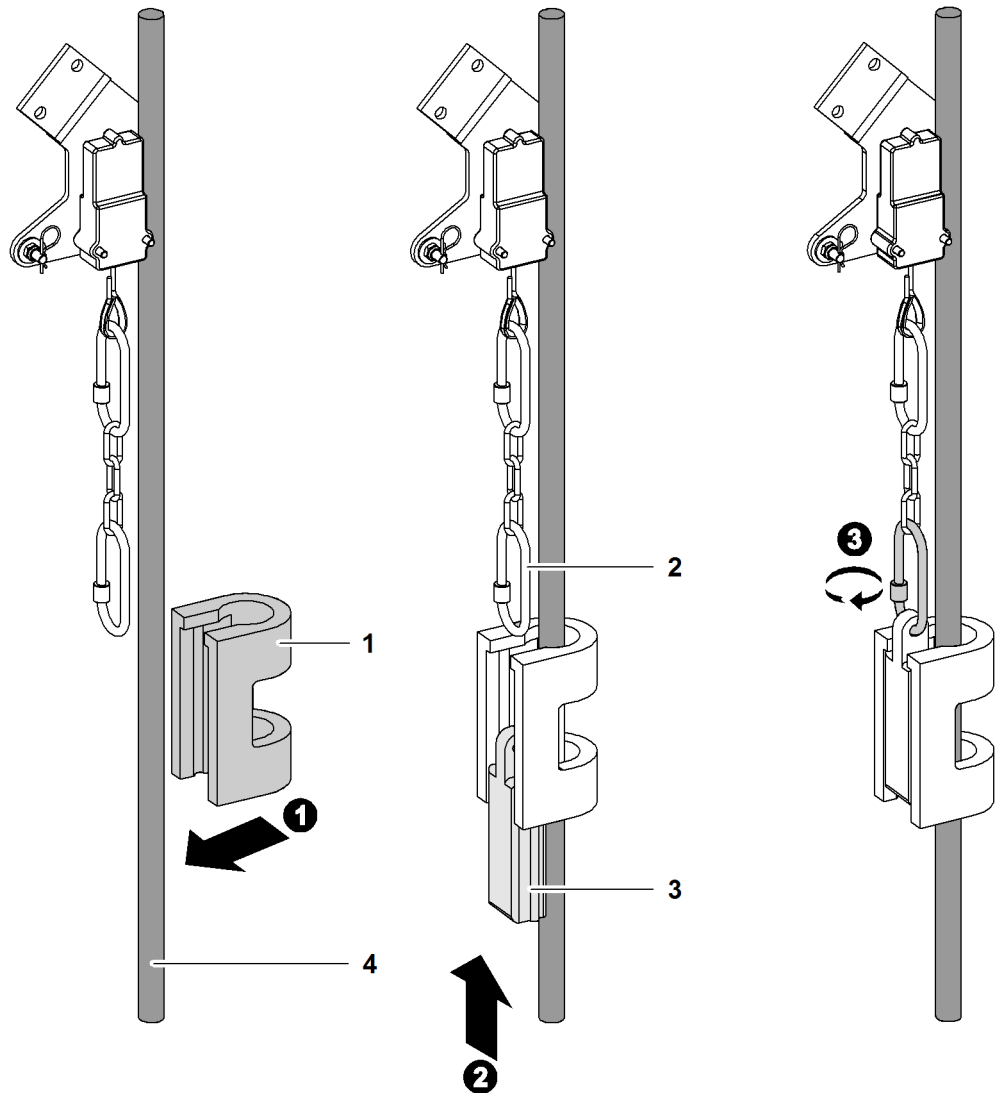


Fig. 4820: Fitting the hoist limit switch weight

- | | |
|---------------------------------------|-------------------------------------|
| 1 Hoist limit switch weight (U shape) | 3 Hoist limit switch weight (wedge) |
| 2 Carabiner | 4 Rope of winch1/winch2 |

► Guide the hoist limit switch weight (U shape) 1 over the rope of winch1/winch2 4.

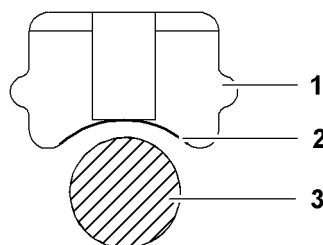


Fig. 4821: Hoist limit switch weight (wedge) view from above

- | | |
|-------------------------------------|-------------------------|
| 1 Hoist limit switch weight (wedge) | 3 Rope of winch1/winch2 |
| 2 Curvature | |

The hoist limit switch weight (wedge) 1 has a curvature 2 on one side.

NOTICE

Wrongly installed hoist limit switch weight (wedge)!
Hoist limit switch weight (wedge) damaged with wrong installation of rope of winch1/winch2.

- ▶ Make sure that the curvature of the hoist limit switch weight (wedge) is installed in the direction of the rope of winch1/winch2.
-
- ▶ Insert the hoist limit switch weight (wedge) **1** from below into the hoist limit switch weight (U shape).
 - ▶ Attach the carabiner to the hoist limit switch weight (wedge) **1**.



Note

Liebherr recommends:

- ▶ visual inspection of the carabiner hook prior to installation.
- ▶ Clean dirty carabiner hook with a clean cloth and water.
- ▶ If necessary, re-clean with a slightly oily cloth.

NOTICE

Improper installation of carabiner!
Damage to machine.

- ▶ Make sure that the screw of the carabiner points downwards.
- ▶ Make sure that the securing element is twisted shut.

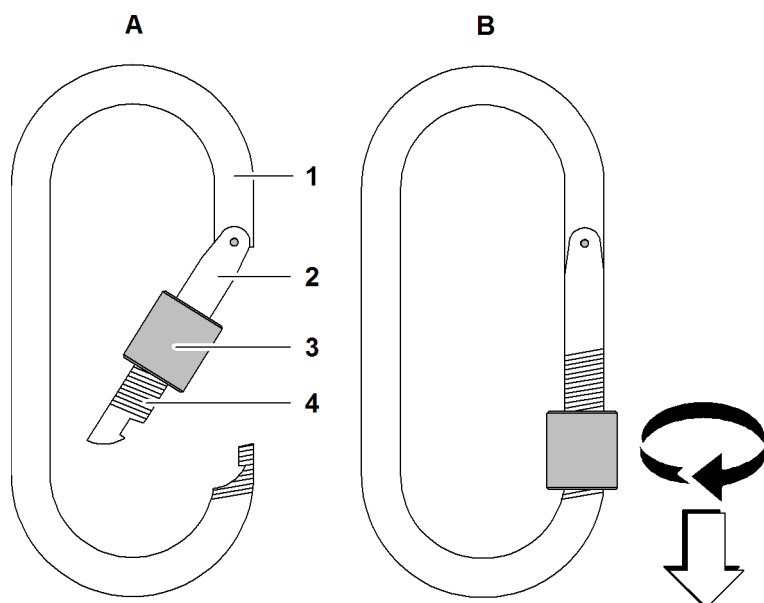


Fig. 4822: Carabiner

- | | |
|---------------------------|---------------------------|
| 1 Carabiner | 4 Thread |
| 2 Snapper | A Opened carabiner |
| 3 Securing element | B Closed carabiner |

- ▶ Secure carabiner **1** with securing element **3**.

NOTICE

The chain on the hoist limit switch weight is too short!

The hoist limit switch weight responds too late. The hook damages the boom head.

- ▶ Ensure that hoist limit switch weight chain is at least 3 m (9' 10" ft-in) and at most 4.5 m (14' 9" ft-in) long.

- ▶ Attach the chain between the hoist limit switch weight and the hoist limit switch.

7.19.21 Bypass unused hoist limit switches.



DANGER

The hoist limit switch has been bypassed illegally!

Load breakaway.

- ▶ Only ever bypass unused hoist limit switches.

NOTICE

Wrong hoist limit switch is bypassed!

The hook damages the boom head.

- ▶ Lock winch 1 using the left hoist limit switch.
- ▶ Lock winch 2 using the right hoist limit switch.

Ensure that the following conditions are fulfilled:

- Only motion is performed with a rope of winch1/winch2. A hoist limit switch is not required.

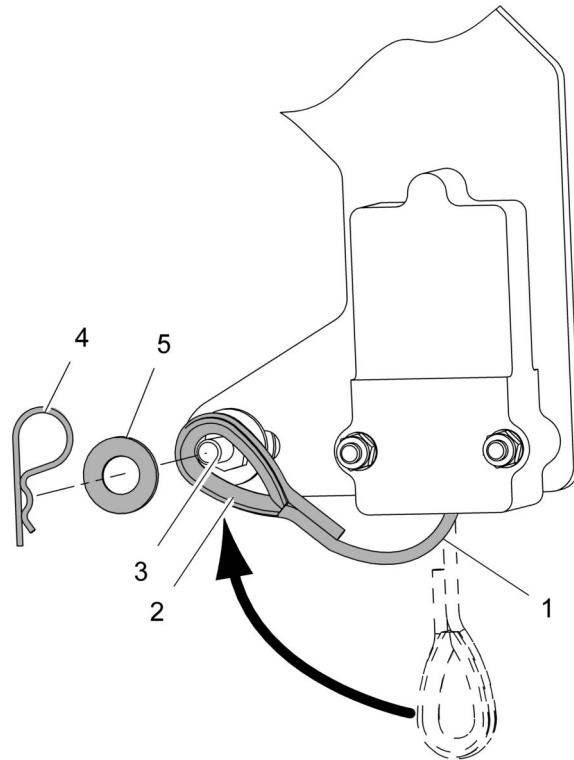


Fig. 4823: Bypassing the hoist limit switch mechanically

- | | | | |
|---|------------|---|------------|
| 1 | Steel rope | 4 | Safety pin |
| 2 | Loop | 5 | Washer |
| 3 | Stud bolt | | |

- ▶ Pull the steel rope 1 and place the loop 2 over the stud bolt 3.
 - ▷ Hoist limit switch is bypassed.
- ▶ Protect the sling 2 from slipping off the stud bolt 3 by securing it with a washer 5 and a safety pin 4.

7.19.22 Erecting a main boom + fixed jib

Ensure that the following conditions are fulfilled:

- Boom configuration can be erected with counterweight.
- Signalmen and assistants are instructed.
- All work on the boom has been completed.
- No loose parts or tools have been left on the boom.



Note

The overall center of gravity of the machine is moved beyond the first running roller!

Sudden swinging of the boom/jib when erecting.

Liebherr recommends:

- ▶ When using long main booms and short jibs, follow the procedure for “Blocked Crawlers” ([For more information see: 4.27 Blocked crawlers*, page 980](#)) .

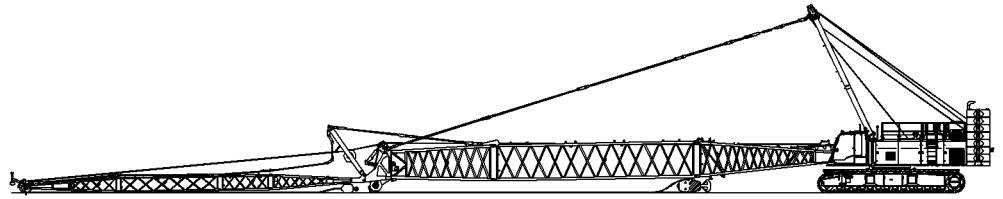


Fig. 4824: Main boom with fixed jib on the ground (illustration of principle)



DANGER

Hoist limit switch bypassed on control panel X23 in crane mode!
Load breakaway.

- ▶ Only bypass hoist limit switch on control panel X23 when assembling or disassembling the machine.



If hoist limit switch weight is on the ground:

- ▶ Press the *Bypass limit switch* button on control panel X23.
 - ▷ Hoist limit switches are bypassed.



- ▶ Press the *Load moment limiter assembly/self-lock* button on control panel X23.

No load chart exist for machines geometry:

- ▷ Function "load moment limiter assembly" is active.
- ▷ The LED on the button *Load moment limiter assembly/self-lock* lights up.
- ▷ Machine functions are enabled unlimited.
- ▷ Load Moment Limiter lamps flash orange.



DANGER

Erectability chart is not followed!
Machine toppling over.

- ▶ Only raise the boom when erection is permitted according to the erectability chart.



WARNING

Falling objects!
Severe injury.

- ▶ Any loose parts and tools must be removed from the boom.
- ▶ Make sure that no-one is standing in the danger area.
- ▶ Leave the danger area.

- ▶ Lift main boom slowly.
 - ▷ The main boom pendant straps are tensioned:

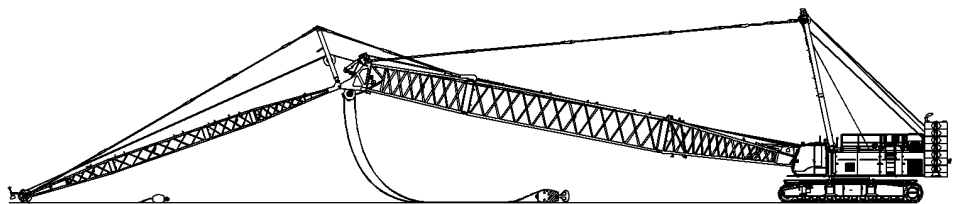


Fig. 4827: Main boom pendant straps tensioned (illustration of principle)



WARNING

Dangerous voltage in boom!
Sudden sideways movement when lifting boom from ground.

- ▶ Make sure that no-one is standing in the danger area.
- ▶ Leave the danger area.

- ▶ Lift main boom further.
 - ▷ The main boom lifts off the ground.
 - ▷ Jib head section remains on the ground and moves backwards on the pulleys.
- As soon as there is a load chart for machines geometry:
- ▷ Deactivate function *load moment limiter assembly*.
 - ▷ The LED in the button *Load moment limiter assembly/self-lock* goes out.
 - ▷ Load moment limiter is active.
 - ▷ Load moment limiter lamps light up according to the current status of the Load Moment Limiter system.

NOTICE

Incorrect erection procedure is followed!
Damage to the equipment.

- ▶ Do not drag the hook or the pulley block along the ground.
- ▶ Do not allow any slacking of the rope.

- ▶ Unwind the rope of winch1/winch2 when necessary.
 - ▷ The hook/pulley block remains on the ground.

When the maximum permitted lifting capacity is at least equal to the weight of the hook and/or pulley block:

- ▶ Raise the hook/pulley block.
- ▶ Erect the main boom until it is in the desired position.
 - ▷ Main boom with fixed jib is erected:

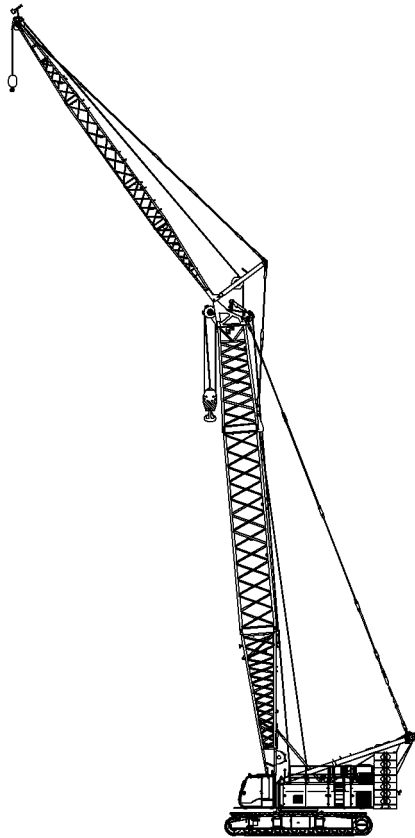


Fig. 4828: Erected main boom with fixed jib (illustration of principle)

7.19.23 Switching off assembly mode functions

Ensure that the following conditions are fulfilled:

- The machine is fully assembled and erected.
- All limit switches are fitted and operational.



- ▶ Press the *Assembly functions* switch on control panel X12.
 - ▷ Assembly mode functions are switched off.
 - ▷ The symbol *Assembly functions* disappears on screen.

7.19.24 Checking the main boom limit switch plate for proper adjustment

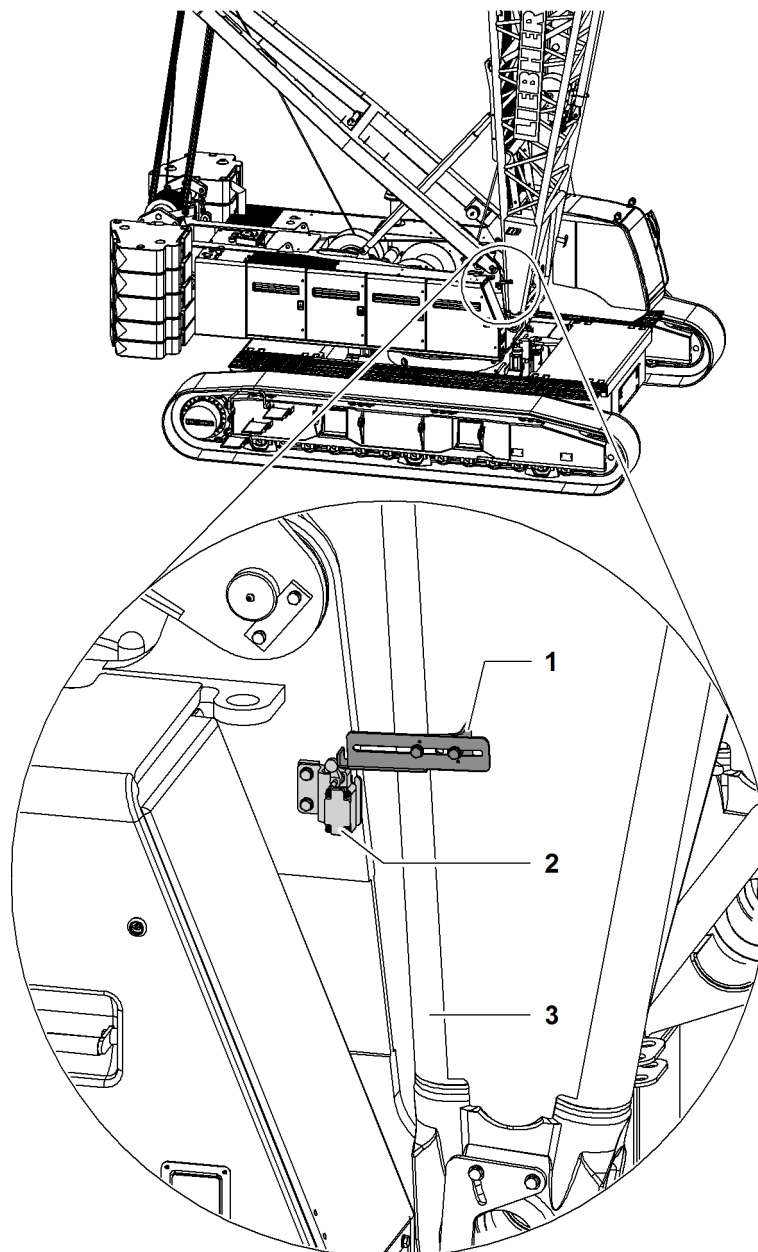


Fig. 4830: Checking the main boom limit switch plate for proper adjustment (illustration of principle)

- | | | | |
|---|--------------------|---|------------------------|
| 1 | Limit switch plate | 3 | Main boom base section |
| 2 | Limit switch | | |

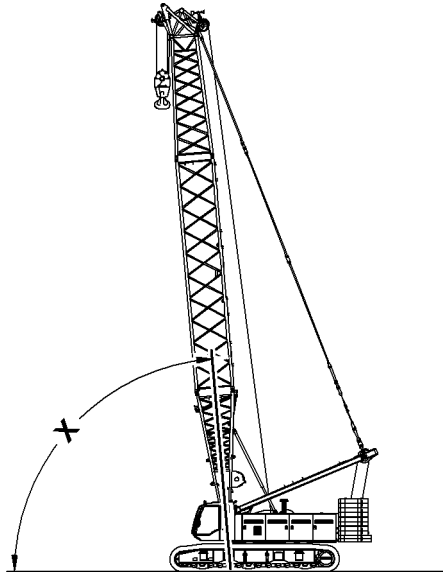


Fig. 4831: Top main boom angle (illustration of principle)

Boom configuration	Angle X
Main boom	86°
Main boom + derrick	
Main boom + reducing adapter	
Main boom + fixed jib	88°
Main boom + fixed jib + derrick	
Main boom + luffing jib	
Main boom + luffing jib + derrick	
Main boom + luffing jib + midfall	

Tab. 565: Main boom limit switch plate

NOTICE

Incorrect calibration of the main boom limit switch plate!
Damage to machine.

► Make sure that the main boom limit switch plate is properly adjusted.

- Erect the main boom until the screen *Operation* shows the angle X.
 - ▷ Limit switch triggers.
 - ▷ Lift main boom is locked.

If the limit switch triggers too early or not at all:

- Switch off machine.
- Contact Liebherr service department.

LWNLR.x/V04.01//Auslieferung/2016-03-07/en

7.20 Luffing jib 2316

System-relevant information for luffing jib 2316:

- Configuration of jib
 - Mid-point suspensions installation positions
- Lengths of jib mid-point suspensions
- Configuration of main boom
- Overview of steel pendant straps on luffing jib 2316
- Overview of CF pendant straps on luffing jib 2316
- Reeving diagram A-frame2/A-frame3
- Reeving diagrams for one rope across jib head 2316 (load position1)
- Reeving diagrams for two ropes across jib head 2316 (load position1)
- Reeving diagrams for one rope across main boom head 2821 (load position2)
- Reeving diagrams for one rope across auxiliary jib (30 t (66.000 lb)) on jib head 2316 (load position1)

7.20.1 Configuration of jib



DANGER

Excess length of jib!
Structural breakdown.

- ▶ Check jib length in load chart for validity.

Jib length	Configuration of jib (symbolic)
20 m 66 ft	
23 m 76 ft	
26 m 85 ft	
29 m 95 ft	
32 m 105 ft	
35 m 115 ft	
38 m 125 ft	
41 m 134 ft	
44 m 144 ft	
47 m 154 ft	
50 m 164 ft	

LWN/LR-x/V04.01//Auslieferung/2016-03-07/en

Jib length	Configuration of jib (symbolic)
53 m 174 ft	
56 m 184 ft	
59 m 194 ft	
62 m 203 ft	
65 m 213 ft	
68 m 223 ft	
71 m 233 ft	
74 m 243 ft	
77 m 253 ft	
80 m 262 ft	
83 m 272 ft	
86 m 282 ft	
89 m 292 ft	
92 m 302 ft	
95 m 312 ft	
98 m 322 ft	
101 m 331 ft	
104 m 341 ft	
107 m 351 ft	
110 m 361 ft	
113 m 371 ft	

Tab. 566: Configuration of luffing jib 2316

LWNLR.x/V04.01//Auslieferung/2016-03-07/en

X1 - Installation position mid-point suspension 1

X2 - Installation position mid-point suspension 2

7.20.2 Lengths of jib mid-point suspensions

Main boom length	Backstay pendant 1 (X1)	Backstay pendant 2 (X2)
	Rope length	Rope length
50 m 164 ft	3 m 9' 10" ft-in	
53 m 174 ft	3 m 9' 10" ft-in	
56 m 184 ft	2.6 m 8' 6" ft-in	
59 m 194 ft	2.6 m 8' 6" ft-in	
62 m 203 ft	2.1 m 6' 11" ft-in	
65 m 213 ft	5.6 m 18' 4" ft-in = 3.0 m (9' 10" ft-in) + 2.6 m (8' 6" ft-in)	2.1 m 6' 11" ft-in
68 m 223 ft	5.1 m 16' 9" ft-in = 3.0 m (9' 10" ft-in) + 2.1 m (6' 11" ft-in)	1.6 m 5' 3" ft-in
71 m 233 ft	5.1 m 16' 9" ft-in = 3.0 m (9' 10" ft-in) + 2.1 m (6' 11" ft-in)	1.6 m 5' 3" ft-in
74 m 243 ft	4.7 m 15' 5" ft-in = 2.1 m (6' 11" ft-in) + 2.6 m (8' 6" ft-in)	1.6 m 5' 3" ft-in
77 m 253 ft	5.6 m 18' 4" ft-in = 3.0 m (9' 10" ft-in) + 2.6 m (8' 6" ft-in)	1.6 m 5' 3" ft-in
80 m 262 ft	4.2 m 13' 9" ft-in = 2.1 m (6' 11" ft-in) + 2.1 m (6' 11" ft-in)	1.6 m 5' 3" ft-in
83 m 272 ft	4.2 m 13' 9" ft-in = 2.1 m (6' 11" ft-in) + 2.1 m (6' 11" ft-in)	2.1 m 6' 11" ft-in

LWN/LR-x/V04.01//Auslieferung/2016-03-07/en

Main boom length	Backstay pendant 1 (X1)	Backstay pendant 2 (X2)
	Rope length	Rope length
86 m 282 ft	5.1 m 16' 9" ft-in = 3.0 m (9' 10" ft-in) + 2.1 m (6' 11" ft-in)	2.1 m 6' 11" ft-in
89 m 292 ft	4.7 m 15' 5" ft-in = 2.1 m (6' 11" ft-in) + 2.6 m (8' 6" ft-in)	2.1 m 6' 11" ft-in
92 m 302 ft	4.7 m 15' 5" ft-in = 2.1 m (6' 11" ft-in) + 2.6 m (8' 6" ft-in)	2.1 m 6' 11" ft-in
95 m 312 ft	4.2 m 13' 9" ft-in = 2.1 m (6' 11" ft-in) + 2.1 m (6' 11" ft-in)	1.6 m 5' 3" ft-in
98 m 322 ft	5.6 m 18' 4" ft-in = 3.0 m (9' 10" ft-in) + 2.6 m (8' 6" ft-in)	2.1 m 6' 11" ft-in
101 m 331 ft	5.1 m 16' 9" ft-in = 3.0 m (9' 10" ft-in) + 2.1 m (6' 11" ft-in)	1.6 m 5' 3" ft-in
104 m 341 ft	5.1 m 16' 9" ft-in = 3.0 m (9' 10" ft-in) + 2.1 m (6' 11" ft-in)	2.6 m 8' 6" ft-in
107 m 351 ft	4.7 m 15' 5" ft-in = 2.1 m (6' 11" ft-in) + 2.6 m (8' 6" ft-in)	2.1 m 6' 11" ft-in
110 m 361 ft	5.6 m 18' 4" ft-in = 3.0 m (9' 10" ft-in) + 2.6 m (8' 6" ft-in)	2.6 m 8' 6" ft-in
113 m 371 ft	5.1 m 16' 9" ft-in = 3.0 m (9' 10" ft-in) + 2.1 m (6' 11" ft-in)	2.1 m 6' 11" ft-in

Tab. 567: Lengths of jib mid-point suspensions - 2316 luffing jib

LWNLR.x/V04.01//Auslieferung/2016-03-07/en

7.20.3 Configuration of main boom



DANGER

Excess length of main boom!
Structural breakdown.

- ▶ Check main boom length in load chart for validity.



Note

- ▶ See system-relevant data of main boom for information on main boom configuration (For more information see: 7.5.1 Configuration of main boom, page 1270) .

7.20.4 Overview of steel pendant straps on luffing jib 2316

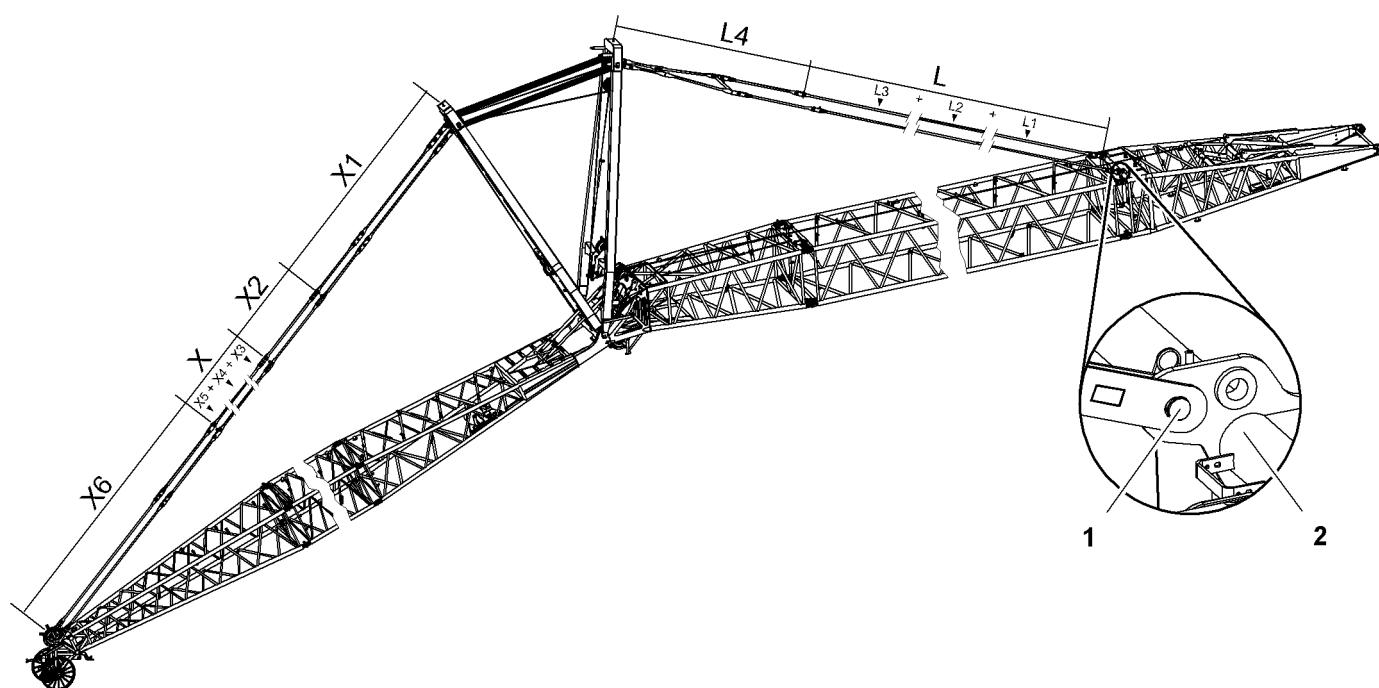


Fig. 5040: Overview of steel pendant straps on luffing jib 2316

- 1 Pin connection point for jib backstay straps
- 2 Main boom base section

LWNLR-x\04.01\Auslieferung\2016-03-07\en

Jib backstay straps A-frame2 to main boom base section 2821

Name		Value
L	Jib backstay straps consisting of:	
	L1	Jib backstay strap 3 m (10 ft) (For more information see: Jib backstay strap 3 m (10 ft), page 193)
	L2	Jib backstay strap 6 m (20 ft) (For more information see: Jib backstay strap 6 m (20 ft), page 195)
	L3	Jib backstay strap 12 m (40 ft) (For more information see: Jib backstay strap 12 m (40 ft), page 197)
L4	A-frame2 equalizer (jib backstay strap) (For more information see: Equalizer A-frame2 (jib backstay strap), page 307)	8050 mm 26' 5" ft-in

Tab. 568: Jib backstay straps A-frame2 to main boom base section 2821

Configuration of jib backstay straps (L):

Required number of jib backstay straps 3 m (10 ft) (L1) corresponds to number of main boom sections 3 m (10 ft).

Required number of jib backstay straps 6 m (20 ft) (L2) corresponds to number of main boom sections 6 m (20 ft).

Required number of jib backstay straps 12 m (40 ft) (L3) corresponds to number of main boom sections 12 m (40 ft).



Note

► For the admissible number of main boom sections 3 m (10 ft), 6 m (20 ft), 12 m (40 ft), refer to the load chart.

Pendant straps A-frame3 to jib head 2316

Name		Value
X1	A-frame3 equalizer (jib pendant strap) (For more information see: A-frame3 equalizer (jib pendant strap), page 308)	7850 mm 25' 9" ft-in
X2	Jib pendant strap (For more information see: Jib pendant strap 3 m (10 ft), page 306)	3000 mm 9' 10" ft-in
X	Jib pendant straps consisting of:	
	X3	Jib pendant strap 3 m (10 ft) (For more information see: Jib pendant strap 3 m (10 ft), page 310)
	X4	Jib pendant strap 6 m (20 ft) (For more information see: Jib pendant strap 6 m (20 ft), page 310)
	X5	Jib pendant strap 12 m (40 ft) (For more information see: Jib pendant strap 12 m (40 ft), page 311)

LWNLR-x/V04.01//Auslieferung/2016-03-07/en

Name	Value
X6 Jib pendant strap on jib head 2316 (For more information see: Jib pendant strap on jib head 2316.20, page 312)	9180 mm 30' 1" ft-in

Tab. 569: Pendant straps A-frame3 to jib head 2316

Configuration of jib pendant straps (X):

Required number of jib pendant straps 3 m (10 ft) (**X3**) corresponds to number of jib sections 3 m (10 ft).

Required number of jib pendant straps 6 m (20 ft) (**X4**) corresponds to number of jib sections 6 m (20 ft).

Required number of jib pendant straps 12 m (40 ft) (**X5**) corresponds to number of jib sections 12 m (40 ft).



Note

► For the admissible number of jib sections 3 m (10 ft), 6 m (20 ft), 12 m (40 ft), refer to the following table: ([For more information see: 7.20.1 Configuration of jib, page 1622](#))

7.20.5 Overview of CF pendant straps on luffing jib 2316

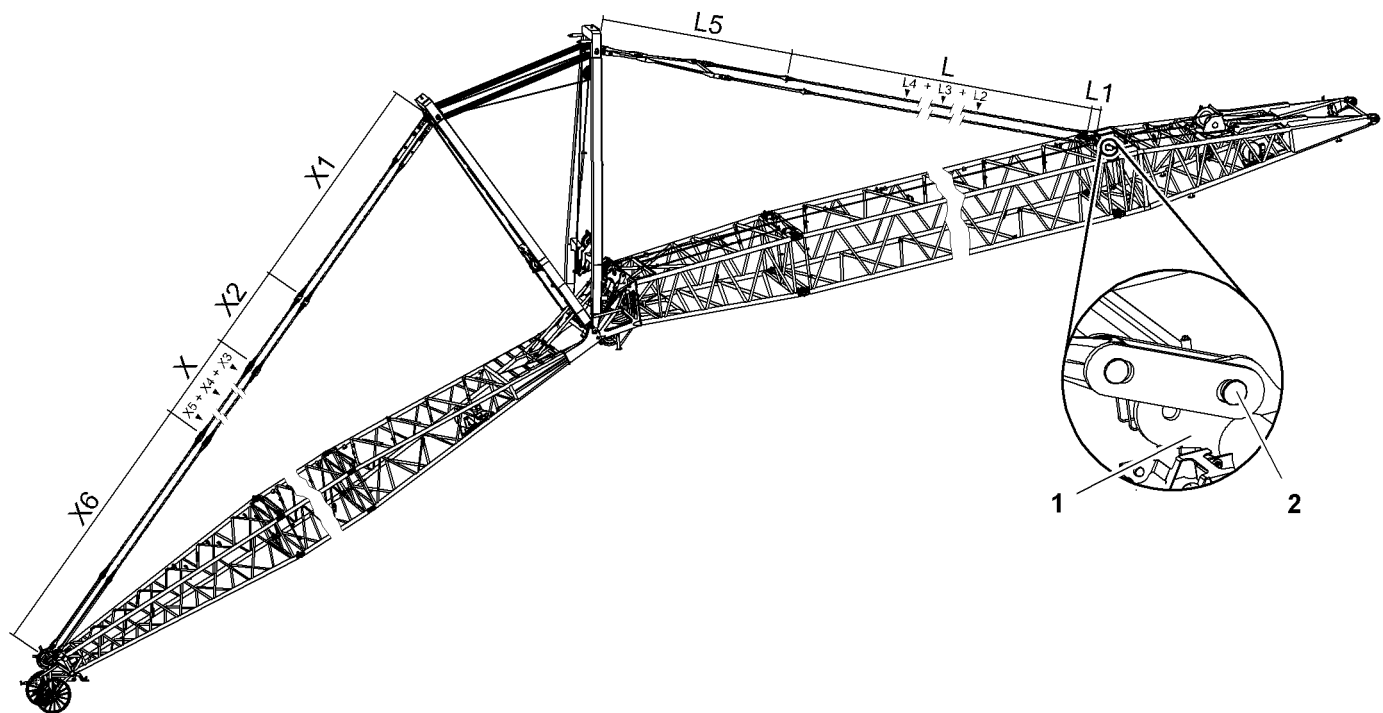


Fig. 5041: Overview of CF pendant straps on luffing jib 2316

- 1 Main boom base section
- 2 Pin connection point for jib backstay straps

LWNLR-x/V04.01//Auslieferung/2016-03-07/en

Jib backstay straps A-frame2 to main boom base section 2821

Name		Value	
L1	Connecting link (For more information see: Connecting link, page 202)	350 mm 1' 2" ft-in	
L	Jib backstay straps consisting of:		
	L2	Jib backstay strap 3 m (10 ft) (For more information see: Jib backstay strap 3 m (10 ft), page 204)	Total L2 +
	L3	Jib backstay strap 6 m (20 ft) (For more information see: Jib backstay strap 6 m (20 ft), page 208)	Total L3 +
	L4	Jib backstay strap 12 m (40 ft) (For more information see: Jib backstay strap 12 m (40 ft), page 212)	Total L4
L5	A-frame2 equalizer (jib backstay strap) (For more information see: Equalizer A-frame2 (jib backstay strap), page 315)	8050 mm 26' 5" ft-in	

Tab. 570: Jib backstay straps A-frame2 to main boom base section 2821

Configuration of jib backstay straps (L):

Required number of jib backstay straps 3 m (10 ft) (L2) corresponds to number of main boom sections 3 m (10 ft).

Required number of jib backstay straps 6 m (20 ft) (L3) corresponds to number of main boom sections 6 m (20 ft).

Required number of jib backstay straps 12 m (40 ft) (L4) corresponds to number of main boom sections 12 m (40 ft).



Note

- ▶ For the admissible number of main boom sections 3 m (10 ft), 6 m (20 ft), 12 m (40 ft), refer to the load chart.

The jib backstay straps (L) may consist of generation A and generation B jib backstay straps (For more information see: [1.11.9 CF pendant straps on main boom 2821, page 200](#)) . Mixing is only admissible if the number of generation B jib backstay straps only differs by at most 1 in the left and the right strand of the jib backstay straps.



DANGER

Inadmissible mixing of generation A and generation B jib backstay straps!
Structural failure.

- ▶ Ensure that the number of generation B jib backstay straps differs by at most 1 in the left and the right strand of the jib backstay straps.

Pendant straps A-frame3 to jib head 2316

Name		Value	
X1	A-frame3 equalizer (jib pendant strap) (For more information see: A-frame3 equalizer (jib pendant strap) , page 317)	7850 mm 25' 9" ft-in	
X2	Jib pendant strap (For more information see: Jib pendant strap 3 m (10 ft) , page 314)	3000 mm 9' 10" ft-in	
X	Jib pendant straps consisting of:		
	X3	Jib pendant straps 3 m (10 ft) (For more information see: Jib pendant strap 3 m (10 ft) , page 319)	Total X3 +
	X4	Jib pendant straps 6 m (20 ft) (For more information see: Jib pendant strap 6 m (20 ft) , page 321)	Total X4 +
	X5	Jib pendant straps 12 m (40 ft) (For more information see: Jib pendant strap 12 m (40 ft) , page 322)	Total X5
X6	Jib pendant strap on jib head 2316 (For more information see: Jib pendant strap on jib head 2316.20 , page 324)	9540 mm 31' 4" ft-in	

Tab. 571: Pendant straps A-frame3 to jib head 2316

Configuration of jib pendant straps (X):

Required number of jib pendant straps 3 m (10 ft) (**X3**) corresponds to number of jib sections 3 m (10 ft).

Required number of jib pendant straps 6 m (20 ft) (**X4**) corresponds to number of jib sections 6 m (20 ft).

Required number of jib pendant straps 12 m (40 ft) (**X5**) corresponds to number of jib sections 12 m (40 ft).



Note

- ▶ For the admissible number of jib sections 3 m (10 ft), 6 m (20 ft), 12 m (40 ft), refer to the following table: ([For more information see: 7.20.1 Configuration of jib, page 1622](#))

The jib pendant straps (**X**) may consist of generation A and generation B jib pendant straps ([For more information see: 1.20.8 CF pendant straps on luffing jib 2316, page 314](#)). Mixing is only admissible if the number of generation B jib pendant straps only differs by at most 1 in the left and the right strand of the jib pendant straps.



DANGER

Inadmissible mixing of generation A and generation B jib pendant straps!
Structural failure.

- ▶ Ensure that the number of generation B jib pendant straps differs by at most 1 in the left and the right strand of the jib pendant straps.

7.20.6 Reeving diagram A-frame2/A-frame3

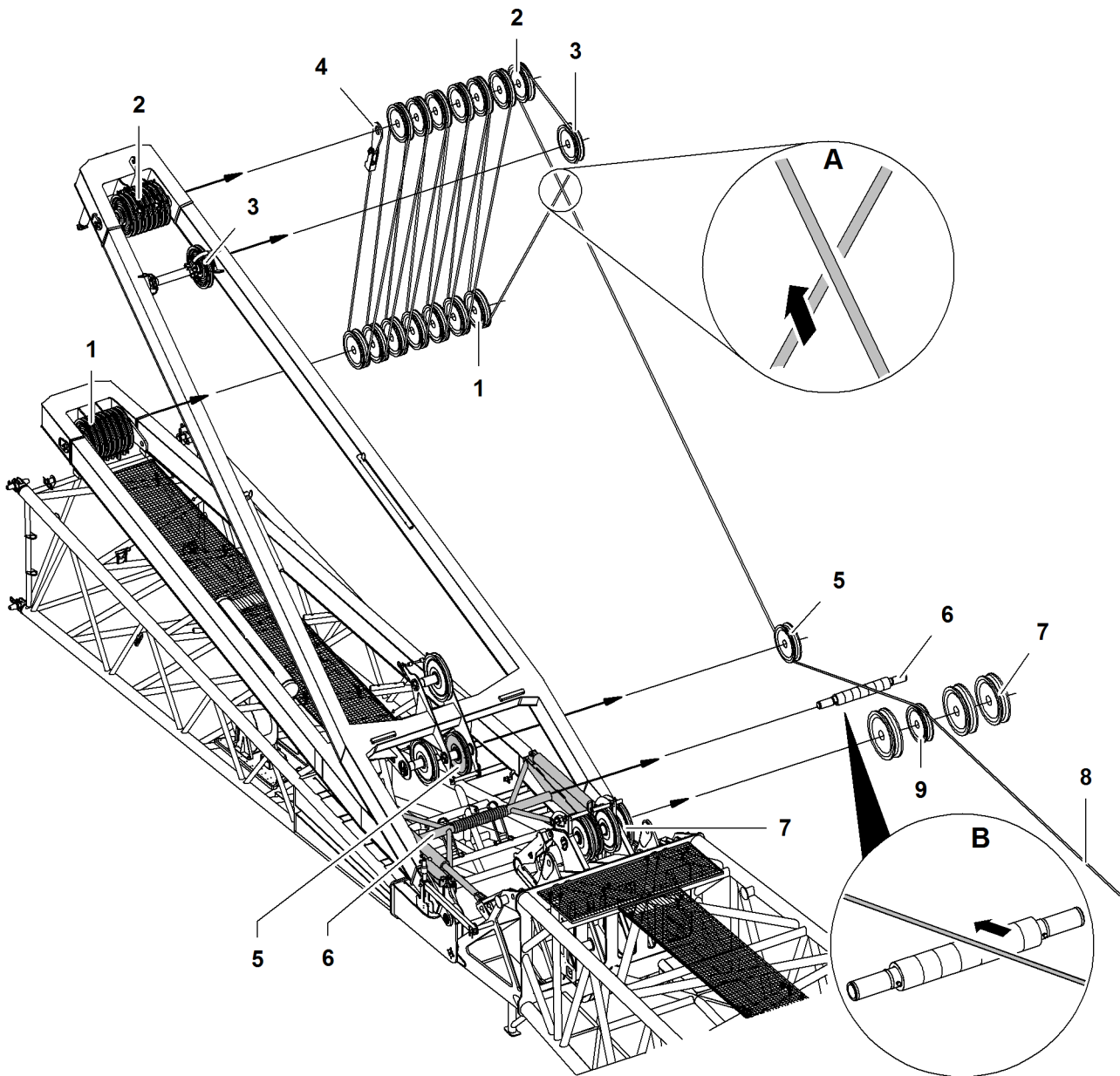


Fig. 5042: Reeving diagram A-frame2/A-frame3 - luffing jib 2316

- | | | | | | |
|---|---------------------|---|--------------------------------|---|-----------------------------------|
| 1 | Pulley set A-frame3 | 4 | Rope fixing point | 7 | Gantry pulley main boom head (3x) |
| 2 | Pulley set A-frame2 | 5 | Rope pulley in A-frame2 | 8 | Rope of jib luffing winch |
| 3 | Pulley A-frame2 | 6 | Rope protection roller support | 9 | Pulley of jib luffing winch |

Detail A:

The rope of the jib luffing winch **8** between pulley **3** and pulley set **1** runs behind the rope of the rope pulley **5** in A-frame2.

Detail B:

The rope of the jib luffing winch **8** runs over the rope protection roller **6**.

LWNLR-x/V04.01//Auslieferung/2016-03-07/en

7.20.7 Reeving diagrams for one rope across jib head 2316 (load position1)

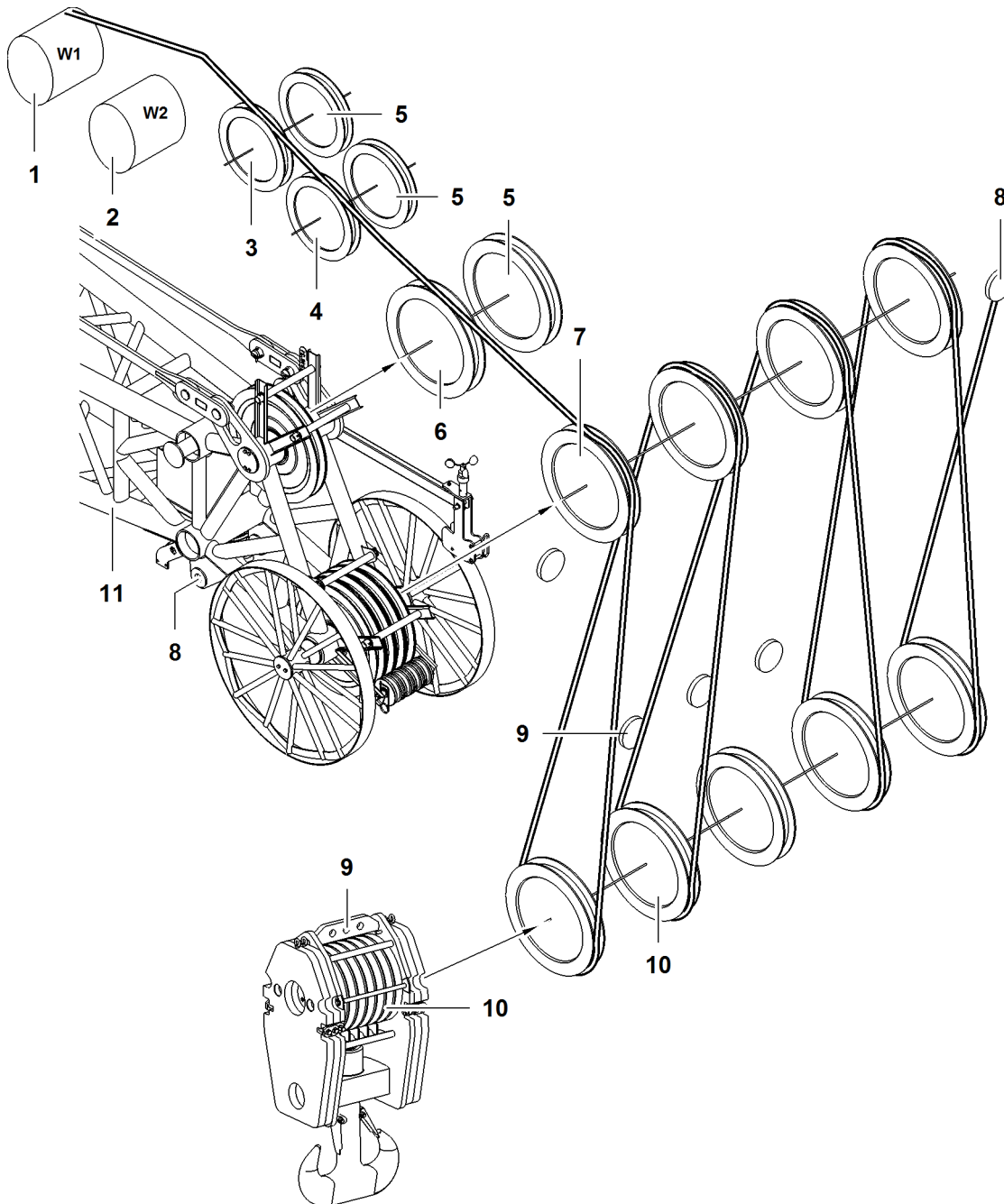


Fig. 5043: Reeving diagrams for one rope across jib head 2316 (load position1)

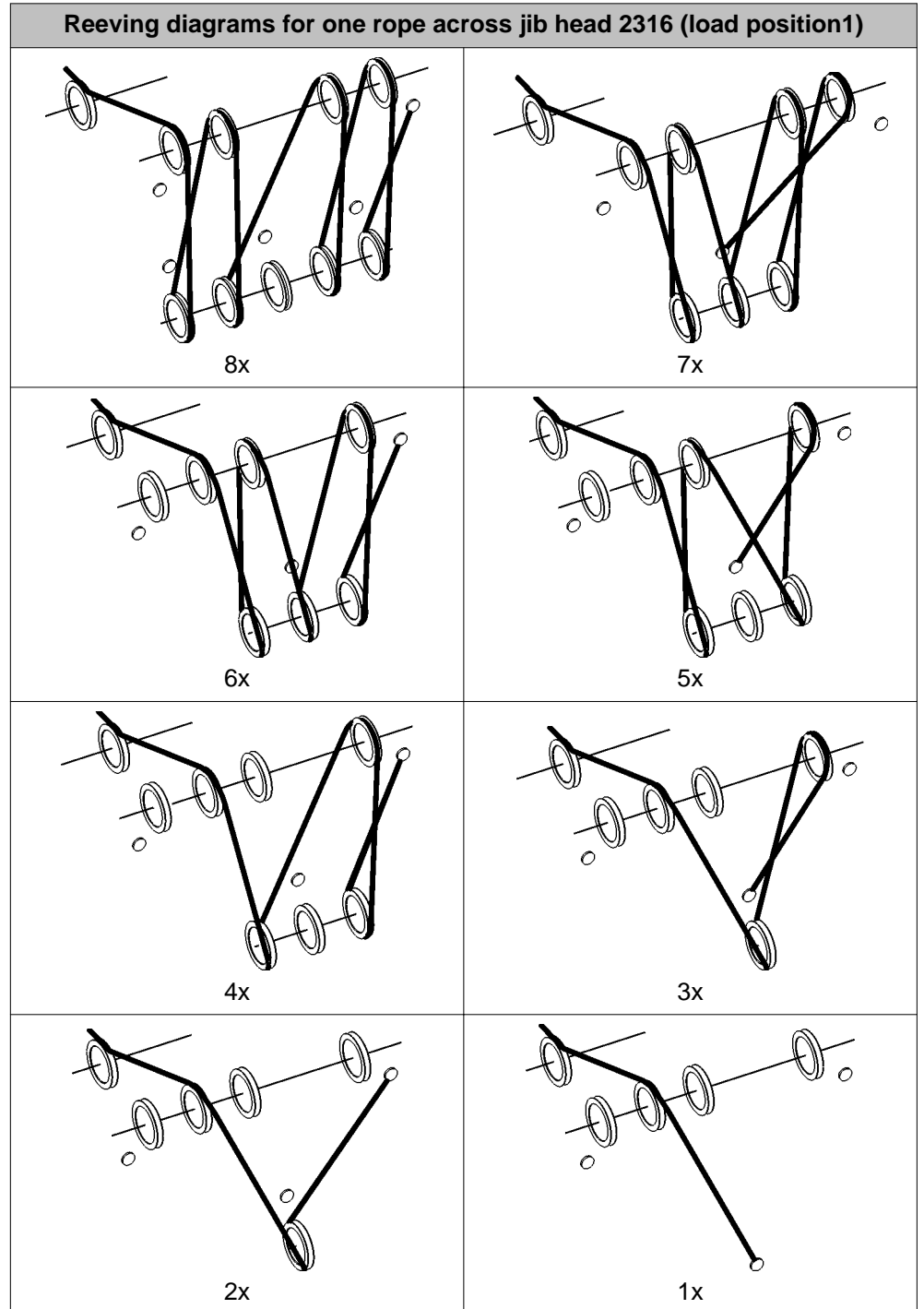
- | | | | | | |
|---|--------------------|---|--|----|------------------------------------|
| 1 | Winch1 | 5 | Retrofit kit* for operation with two ropes across jib head | 9 | Rope fixing points of pulley block |
| 2 | Winch2 | 6 | Gantry pulley of jib head | 10 | Pulley set of pulley block |
| 3 | Pulley of A-frame2 | 7 | Pulley (4x) of jib head | 11 | Jib head |
| 4 | Pulley of A-frame3 | 8 | Rope fixing point of jib head | | |



DANGER

Inadmissible number of reevings!
Structural breakdown, toppling of machine.

► Choose correct number of reevings as indicated in load chart.



Tab. 572: Reeving diagrams for one rope across jib head 2316 (load position1)

7.20.8 Reeving diagrams for two ropes across jib head 2316, 1916, 1713, 1309, 1008 (load position1)



DANGER

Inadmissible number of reevings!
Structural breakdown, toppling of machine.

► Choose correct number of reevings as indicated in load chart.

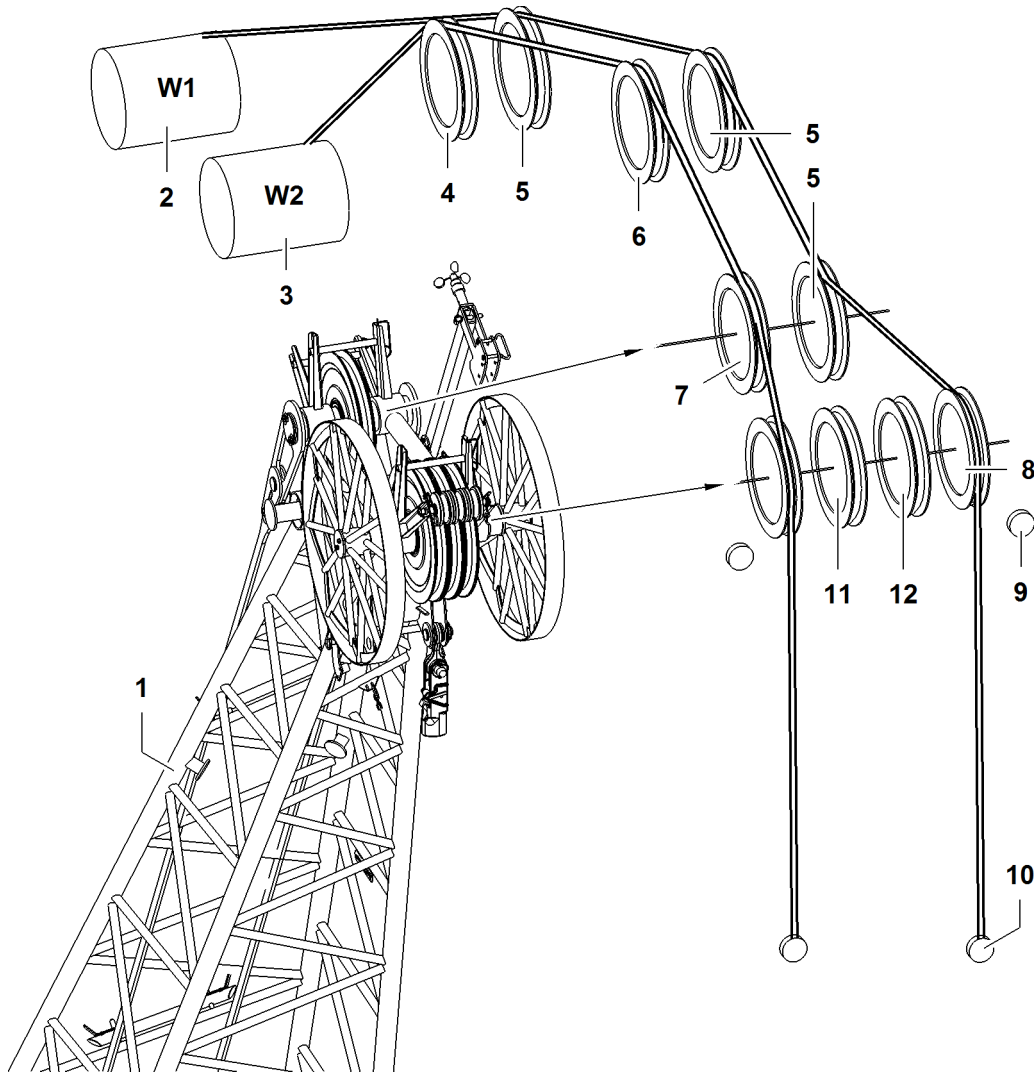


Fig. 5052: Reeving diagrams for two ropes across jib head 2316, 1916, 1713, 1309, 1008 (load position1)

1	Jib head	5	Retrofit kit* for operation with two ropes across jib head	9	Rope fixing point (2x) of jib head
2	Winch1	6	Pulley of A-frame3	10	Rope fixing points of pulley block
3	Winch2	7	Gantry pulleys of jib head	11	Pulley (only with jib head 2316)
4	Pulley of A-frame2	8	Pulleys of jib head	12	Pulley (only with jib head 2316, 1916, 1713)

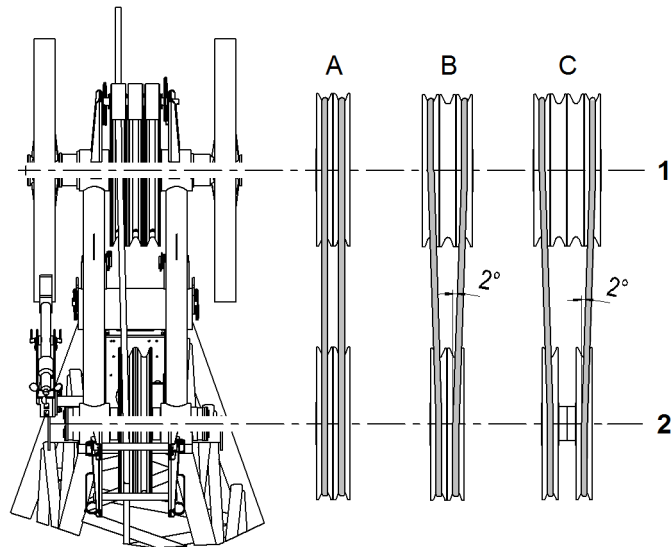


Fig. 5053: Run of the rope when two ropes pass over the jib head section

1 Pulleys of jib head

2 Gantry pulleys of jib head

Run of the rope	Type of jib
A	Luffing jib 1008
	Luffing jib 1309
B	Luffing jib 1713
	Luffing jib 1916
C	Luffing jib 2316

Tab. 573: Run of the rope when two ropes pass over the jib head

7.20.9 Reeving diagrams for one rope across main boom head 2821 (load position2)

If the main boom with jib attached is also used to lift a load, reeve main boom head 2821 as shown below.

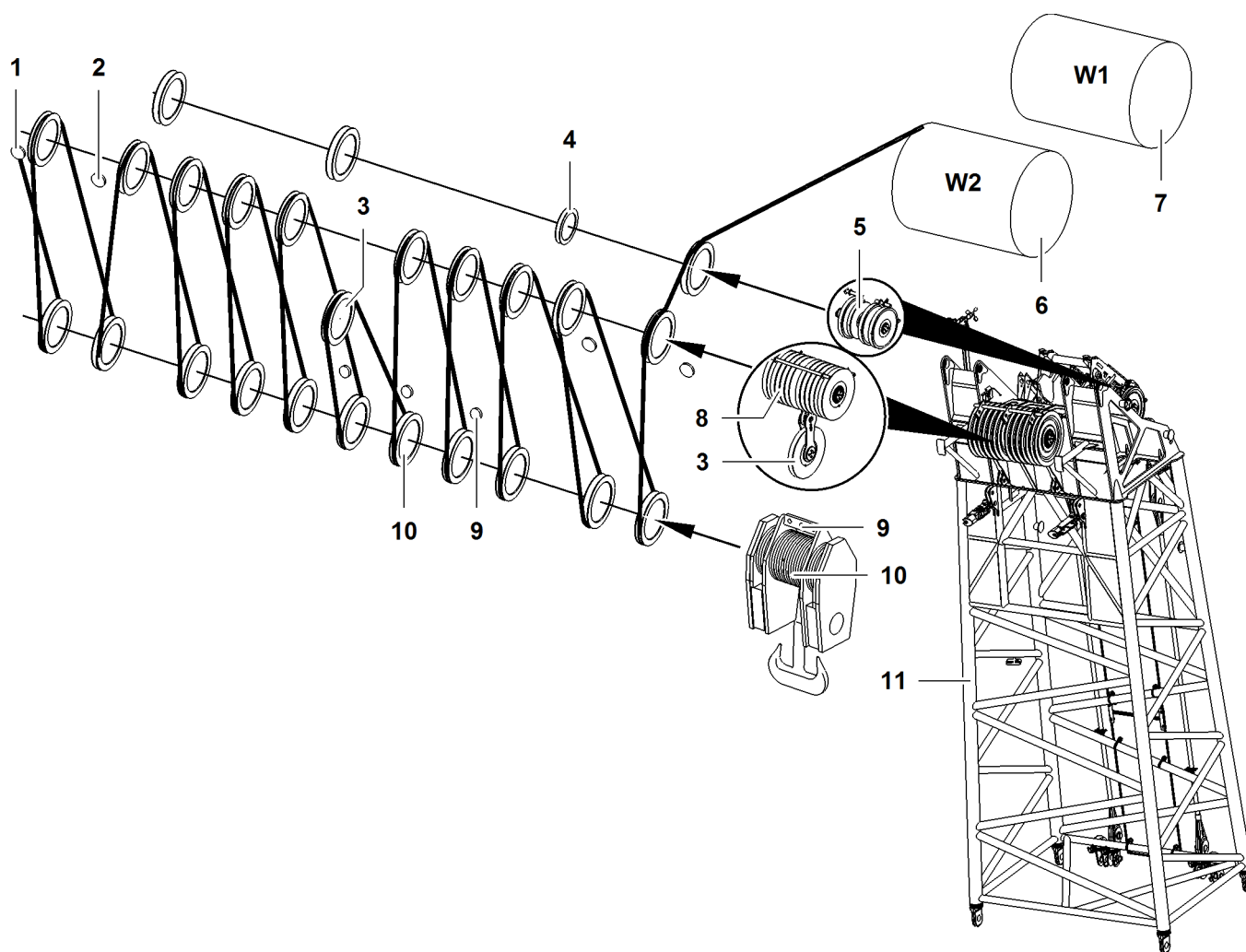


Fig. 5054: Reeving diagrams for one rope across main boom head 2821 (load position 2)

- | | | | | | |
|---|--|---|--------------------------------------|----|------------------------------------|
| 1 | Outer rope fixing point (2x) of main boom head | 5 | Gantry pulley (3x) of main boom head | 9 | Rope fixing points of pulley block |
| 2 | Inner rope fixing point (2x) of main boom head | 6 | Winch2 | 10 | Pulley set of pulley block |
| 3 | 11th pulley of main boom head | 7 | Winch1 | 11 | Main boom head |
| 4 | Pulley for rope of jib luffing winch | 8 | Pulley (10x) of main boom head | | |

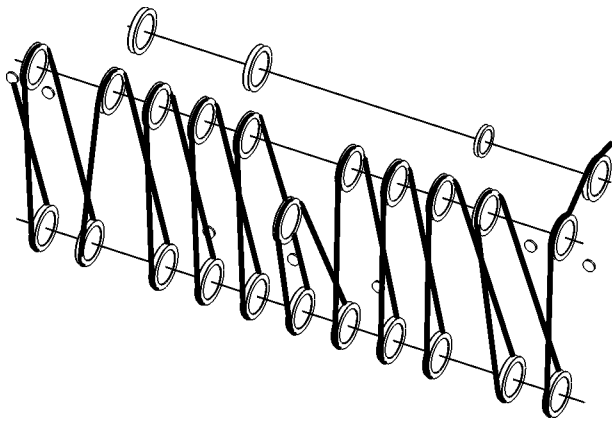


DANGER

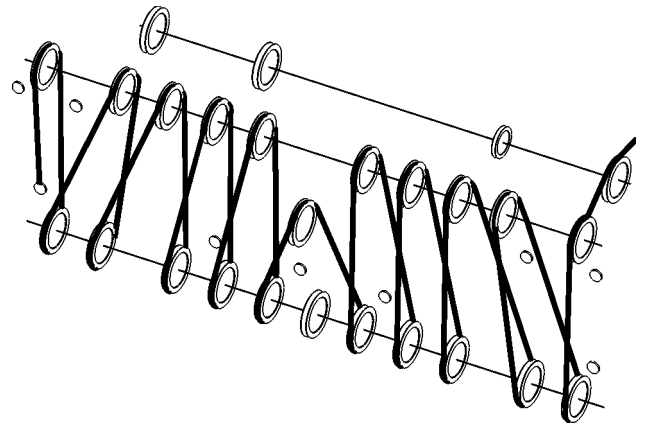
Inadmissible number of reevings!
Structural breakdown, toppling of machine.

► Choose correct number of reevings as indicated in load chart.

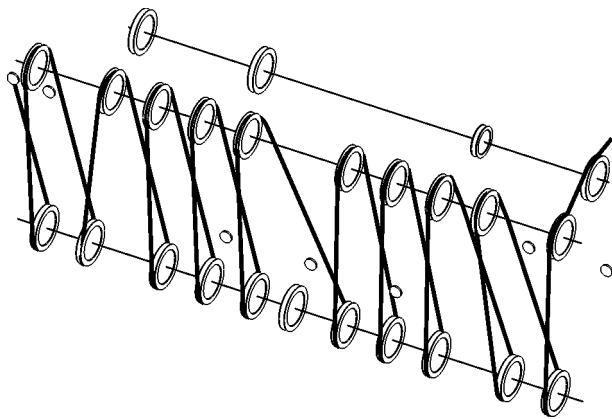
Reeving diagrams for one rope across main boom head 2821 (load position2)



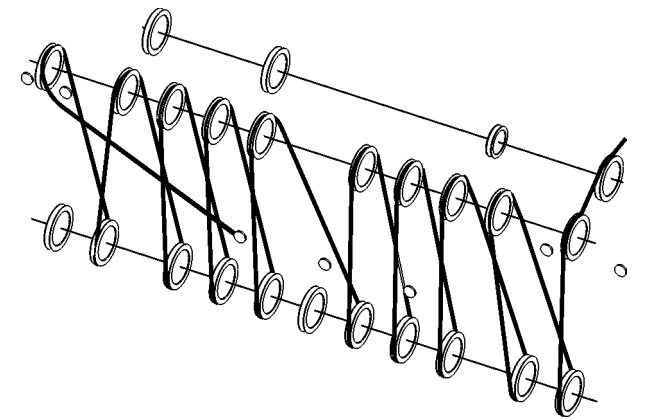
22x



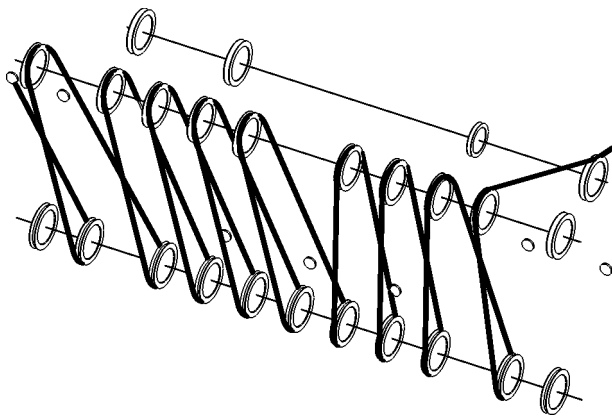
21x



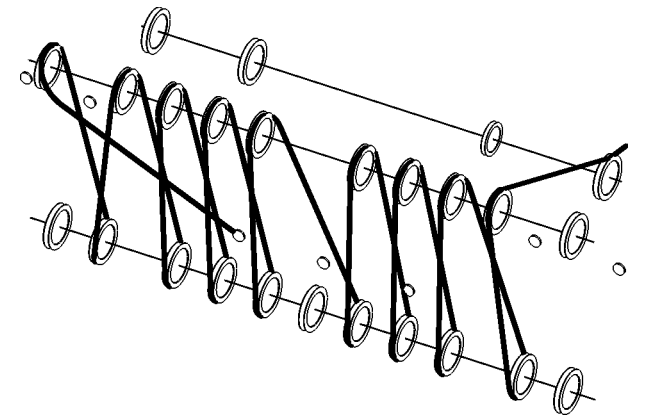
20x



19x



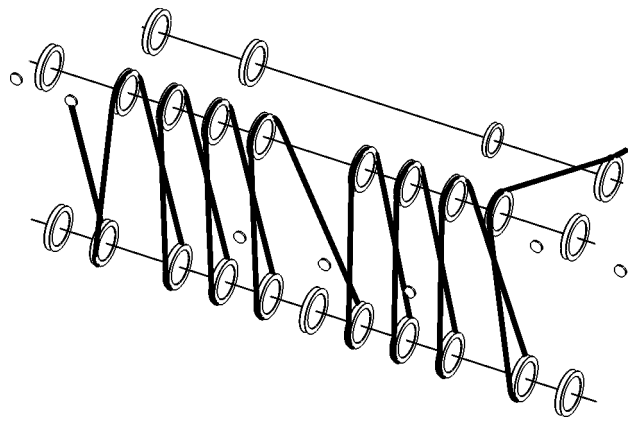
18x



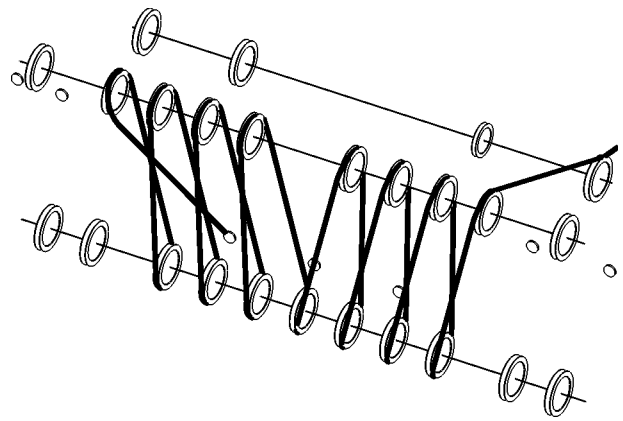
17x

LWNLR_x/V04.01//Auslieferung/2016-03-07/en

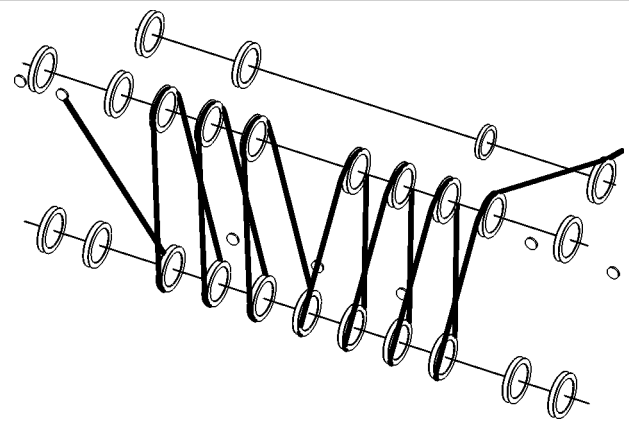
Reeving diagrams for one rope across main boom head 2821 (load position2)



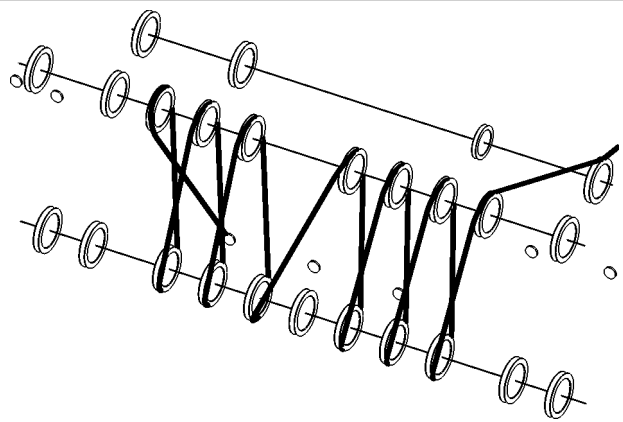
16x



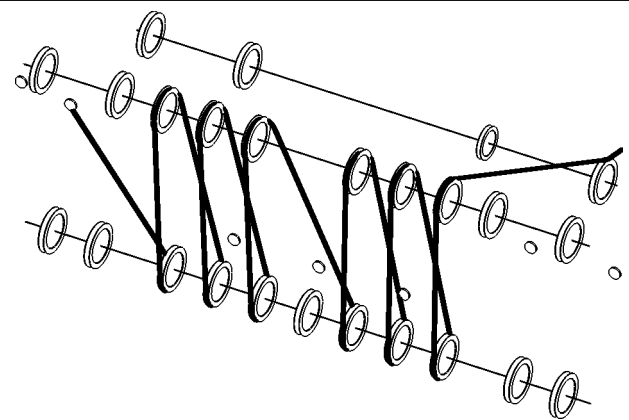
15x



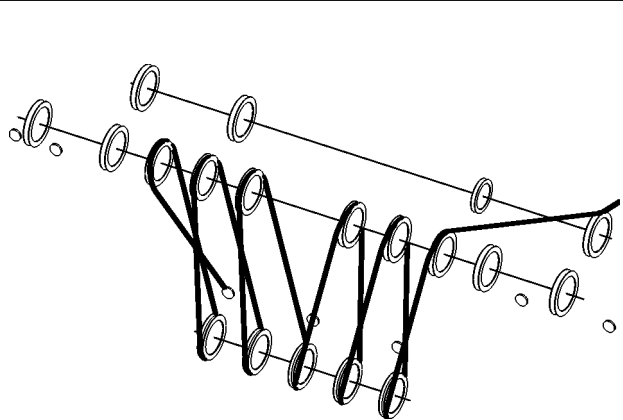
14x



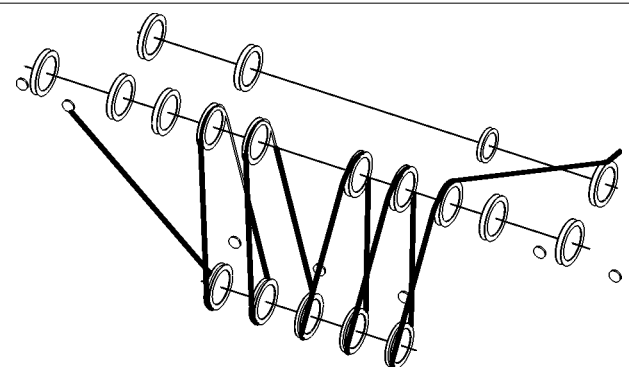
13x



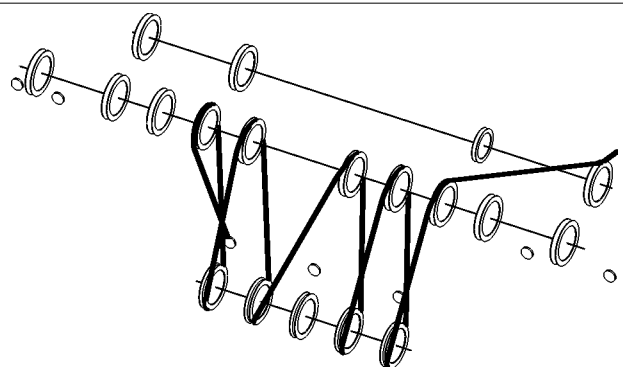
12x



11x

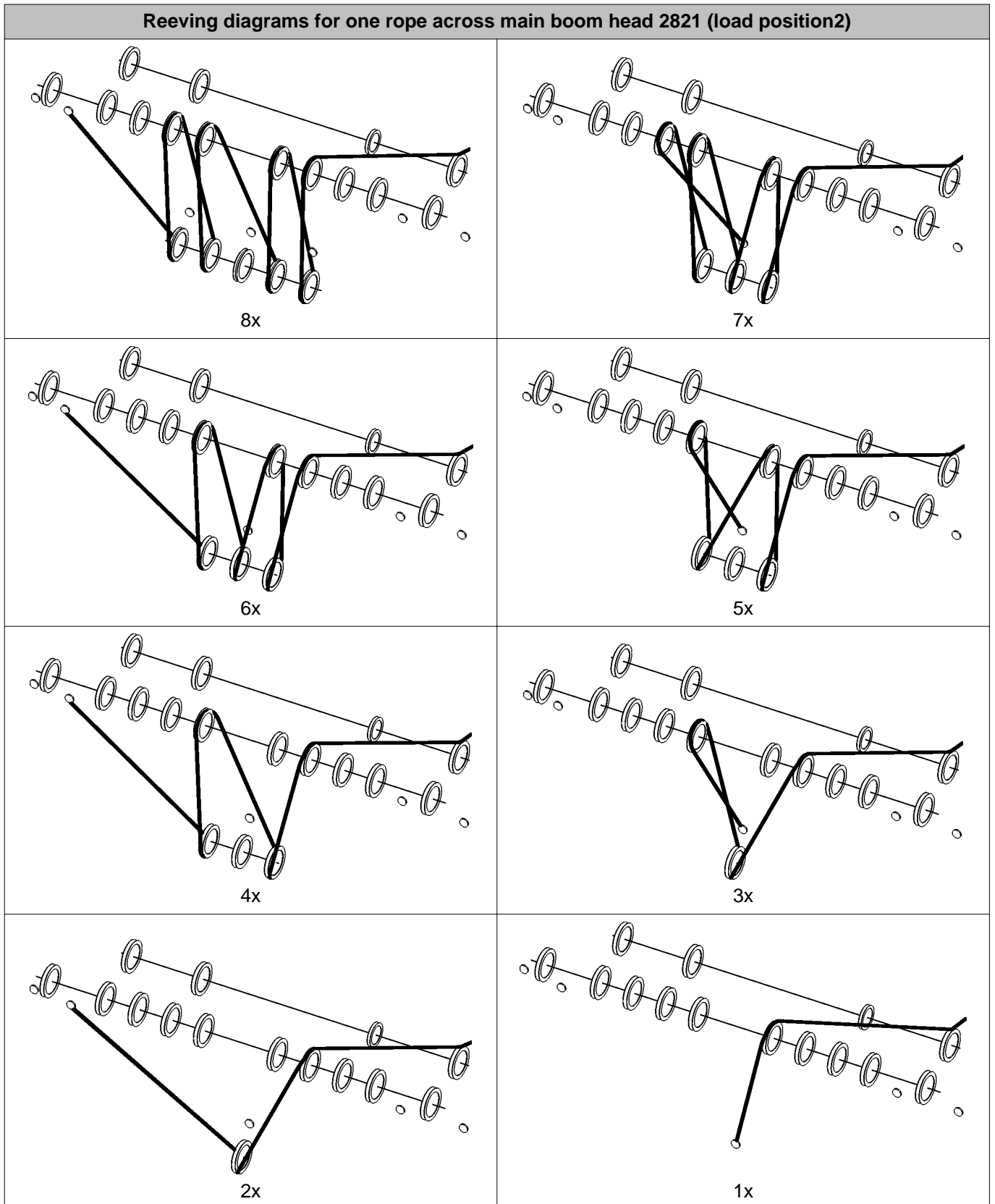


10x



9x

LWNLR-x\04.01\Auslieferung\2016-03-07\en



LWNLR.x/V04.01//Auslieferung/2016-03-07/en

Tab. 574: Reeving diagrams for one rope across main boom head 2821 (load position2)

7.20.10 Reeving diagrams for one rope across auxiliary jib (30 t (66.000 lb)) on jib head 2316 (load position1)

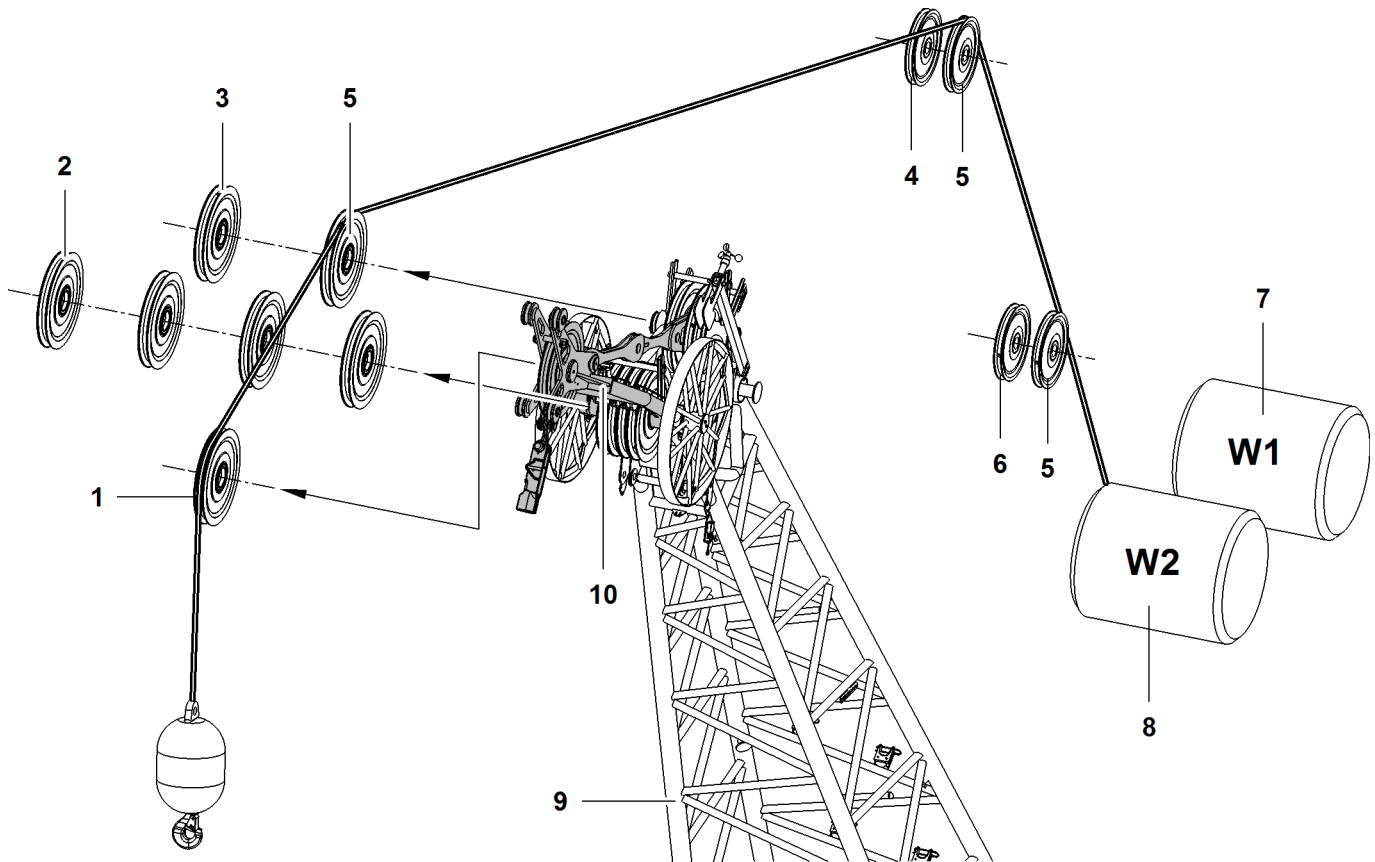


Fig. 5077: Reeving diagrams for one rope across auxiliary jib (30 t (66.000 lb)) on jib head 2316 (load position1)

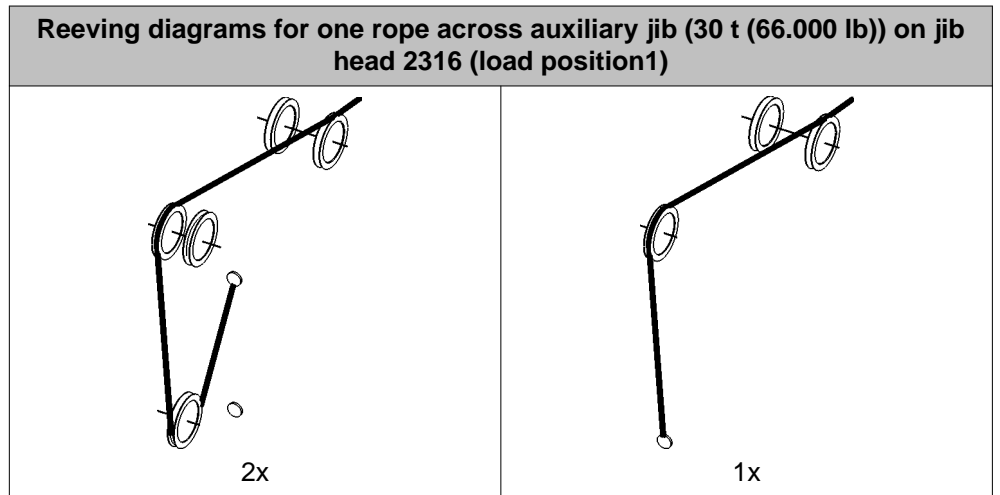
- | | | | | | |
|---|--|---|--|----|----------------------------------|
| 1 | Pulley of auxiliary jib (30 t (66.000 lb)) | 5 | Retrofit kit* for operation with two ropes across jib head | 9 | Jib head |
| 2 | Pulley (4x) of jib head | 6 | Pulley of A-frame2 | 10 | Auxiliary jib (30 t (66.000 lb)) |
| 3 | Gantry pulley of jib head | 7 | Winch1 | | |
| 4 | Pulley of A-frame3 | 8 | Winch2 | | |



DANGER

Inadmissible number of reevings!
Structural breakdown, toppling of machine.

► Choose correct number of reevings as indicated in load chart.



Tab. 575: Reeving diagrams for one rope across auxiliary jib (30 t (66.000 lb)) on jib head 2316 (load position1)

LWNLR.x/V04.01//Auslieferung/2016-03-07/en

7.21 Luffing jib 1916

System-relevant information for luffing jib 1916:

- Configuration of jib
 - Mid-point suspensions installation positions
- Lengths of jib mid-point suspensions
- Configuration of main boom
- Overview of steel pendant straps on luffing jib 1916
- Overview of CF pendant straps on luffing jib 1916
- Reeving diagram A-frame2/A-frame3
- Reeving diagrams for one rope across jib head 1916 (load position1)
- Reeving diagrams for two ropes across jib head 1916 (load position1)
- Reeving diagrams for one rope across main boom head 2821 (load position2)
- Reeving diagrams for one rope across auxiliary jib (15 t (33.000 lb)) on jib head 1916 (load position1)

7.21.1 Configuration of jib



DANGER

Excess length of jib!
Structural breakdown.

- ▶ Check jib length in load chart for validity.

Jib length	Configuration of jib (symbolic)
20 m 66 ft	
23 m 76 ft	
26 m 85 ft	
29 m 95 ft	
32 m 105 ft	
35 m 115 ft	
38 m 125 ft	
41 m 134 ft	
44 m 144 ft	
47 m 154 ft	
50 m 164 ft	

LWN/LR-x/V04.01//Auslieferung/2016-03-07/en

Jib length	Configuration of jib (symbolic)
53 m 174 ft	
56 m 184 ft	
59 m 194 ft	
62 m 203 ft	
65 m 213 ft	
68 m 223 ft	
71 m 233 ft	
74 m 243 ft	
77 m 253 ft	
80 m 262 ft	
83 m 272 ft	
86 m 282 ft	
89 m 292 ft	
92 m 302 ft	
95 m 312 ft	

Tab. 576: Configuration of luffing jib 1916

X1 - Installation position mid-point suspension 1

X2 - Installation position mid-point suspension 2

7.21.2 Lengths of jib mid-point suspensions

Jib length	Backstay pendant 1 (X1)	Backstay pendant 2 (X2)
	Rope length	Rope length
47 m 154 ft	2.1 m 6' 11" ft-in	

LWNLR-x/V04.01//Auslieferung/2016-03-07/en

Jib length	Backstay pendant 1 (X1)	Backstay pendant 2 (X2)
	Rope length	Rope length
50 m 164 ft	4.2 m 13' 9" ft-in = 2.6 m (8' 6" ft-in) + 1.6 m (5' 3" ft-in)	2.1 m 6' 11" ft-in
53 m 174 ft	6 m 19' 8" ft-in = 3.0 m (9' 10" ft-in) + 3.0 m (9' 10" ft-in)	2.1 m 6' 11" ft-in
56 m 184 ft	5.6 m 18' 4" ft-in = 3.0 m (9' 10" ft-in) + 2.6 m (8' 6" ft-in)	1.6 m 5' 3" ft-in
59 m 194 ft	5.2 m 17' 1" ft-in = 2.6 m (8' 6" ft-in) + 2.6 m (8' 6" ft-in)	1.6 m 5' 3" ft-in
62 m 203 ft	4.7 m 15' 5" ft-in = 2.6 m (8' 6" ft-in) + 2.1 m (6' 11" ft-in)	1.6 m 5' 3" ft-in
65 m 213 ft	4.6 m 15' 1" ft-in = 3.0 m (9' 10" ft-in) + 1.6 m (5' 3" ft-in)	3.0 m 9' 10" ft-in
68 m 223 ft	6 m 19' 8" ft-in = 3.0 m (9' 10" ft-in) + 3.0 m (9' 10" ft-in)	2.6 m 8' 6" ft-in
71 m 233 ft	5.2 m 17' 1" ft-in = 2.6 m (8' 6" ft-in) + 2.6 m (8' 6" ft-in)	2.1 m 6' 11" ft-in
74 m 243 ft	5.1 m 16' 9" ft-in = 3.0 m (9' 10" ft-in) + 2.1 m (6' 11" ft-in)	2.1 m 6' 11" ft-in
77 m 253 ft	4.7 m 15' 5" ft-in = 2.6 m (8' 6" ft-in) + 2.1 m (6' 11" ft-in)	2.1 m 6' 11" ft-in
80 m 262 ft	4.2 m 13' 9" ft-in = 2.1 m (6' 11" ft-in) + 2.1 m (6' 11" ft-in)	1.6 m 5' 3" ft-in

LWN/LR-x/V04.01//Auslieferung/2016-03-07/en

Jib length	Backstay pendant 1 (X1)	Backstay pendant 2 (X2)
	Rope length	Rope length
83 m 272 ft	4.2 m 13' 9" ft-in = 2.1 m (6' 11" ft-in) + 2.1 m (6' 11" ft-in)	1.6 m 5' 3" ft-in
86 m 282 ft	5.2 m 17' 1" ft-in = 2.6 m (8' 6" ft-in) + 2.6 m (8' 6" ft-in)	1.6 m 5' 3" ft-in
89 m 292 ft	4.7 m 15' 5" ft-in = 2.6 m (8' 6" ft-in) + 2.1 m (6' 11" ft-in)	1.6 m 5' 3" ft-in
92 m 302 ft	4.2 m 13' 9" ft-in = 2.1 m (6' 11" ft-in) + 2.1 m (6' 11" ft-in)	1.6 m 5' 3" ft-in
95 m 312 ft	4.2 m 13' 9" ft-in = 2.1 m (6' 11" ft-in) + 2.1 m (6' 11" ft-in)	1.6 m 5' 3" ft-in

Tab. 577: Lengths of jib mid-point suspensions - 1916 luffing jib

7.21.3 Configuration of main boom



DANGER

Excess length of main boom!
Structural breakdown.

- ▶ Check main boom length in load chart for validity.



Note

- ▶ See system-relevant data of main boom for information on main boom configuration (For more information see: [7.5.1 Configuration of main boom, page 1270](#)).

LWNLR.x/V04.01//Auslieferung/2016-03-07/en

7.21.4 Overview of steel pendant straps on luffing jib 1916

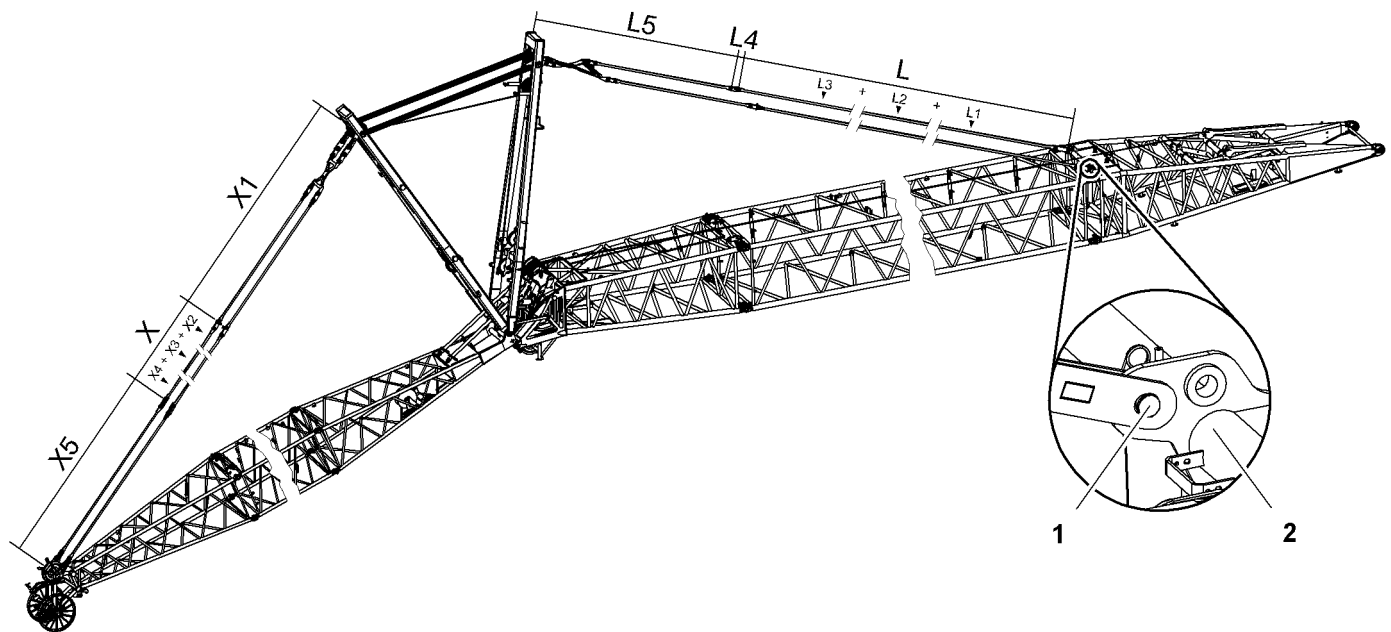


Fig. 5243: Overview of steel pendant straps on luffing jib 1916

- 1 Pin connection point for jib backstay straps
- 2 Main boom base section

Jib backstay straps A-frame2 to main boom base section 2821

Name		Value
L	Jib backstay straps consisting of:	
	L1	Jib backstay strap 3 m (10 ft) (For more information see: Jib backstay strap 3 m (10 ft) , page 193)
	L2	Jib backstay strap 6 m (20 ft) (For more information see: Jib backstay strap 6 m (20 ft) , page 195)
	L3	Jib backstay strap 12 m (40 ft) (For more information see: Jib backstay strap 12 m (40 ft) , page 197)
L4	Connecting link (conversion kit) (For more information see: Connecting link (conversion kit) , page 351)	390 mm 1' 3" ft-in
L5	A-frame2 equalizer (jib backstay strap) (For more information see: Equalizer A-frame2 (jib backstay strap) , page 345)	7769 mm 25' 6" ft-in

Tab. 578: Jib backstay straps A-frame2 to main boom base section 2821

Configuration of main boom pendant straps (L):

Required number of jib backstay straps 3 m (10 ft) (L1) corresponds to number of main boom sections 3 m (10 ft).

Required number of jib backstay straps 6 m (20 ft) (L2) corresponds to number of main boom sections 6 m (20 ft).

LWNLR-x\04.01\Auslieferung\2016-03-07/en

Required number of jib backstay straps 12 m (40 ft) (**L3**) corresponds to number of main boom sections 12 m (40 ft).



Note

► For the admissible number of main boom sections 3 m (10 ft), 6 m (20 ft), 12 m (40 ft), refer to the load chart.

Pendant straps A-frame3 to jib head 1916

Name		Value	
X1	A-frame3 equalizer (jib pendant strap) (For more information see: A-frame3 equalizer (jib pendant strap) , page 346)	7550 mm 24' 9" ft-in	
X	Jib pendant straps consisting of:		
	X2	Jib pendant strap 3 m (10 ft) (For more information see: Jib pendant strap 3 m (10 ft) , page 348)	Total X2 +
	X3	Jib pendant strap 6 m (20 ft) (For more information see: Jib pendant strap 6 m (20 ft) , page 349)	Total X3 +
	X4	Jib pendant strap 12 m (40 ft) (For more information see: Jib pendant strap 12 m (40 ft) , page 349)	Total X4
X5	Jib pendant strap on jib head 1916 (For more information see: Jib pendant strap on jib head 1916.21 , page 350)	6500 mm 21' 4" ft-in	

Tab. 579: Pendant straps A-frame3 to jib head 1916

Configuration of jib pendant straps (X):

Required number of jib pendant straps 3 m (10 ft) (**X2**) corresponds to number of jib sections 3 m (10 ft).

Required number of jib pendant straps 6 m (20 ft) (**X3**) corresponds to number of jib sections 6 m (20 ft).

Required number of jib pendant straps 12 m (40 ft) (**X4**) corresponds to number of jib sections 12 m (40 ft).



Note

► For the admissible number of jib sections 3 m (10 ft), 6 m (20 ft), 12 m (40 ft), refer to the following table: (For more information see: [7.21.1 Configuration of jib](#), page 1642)

7.21.5 Overview of CF pendant straps on luffing jib 1916

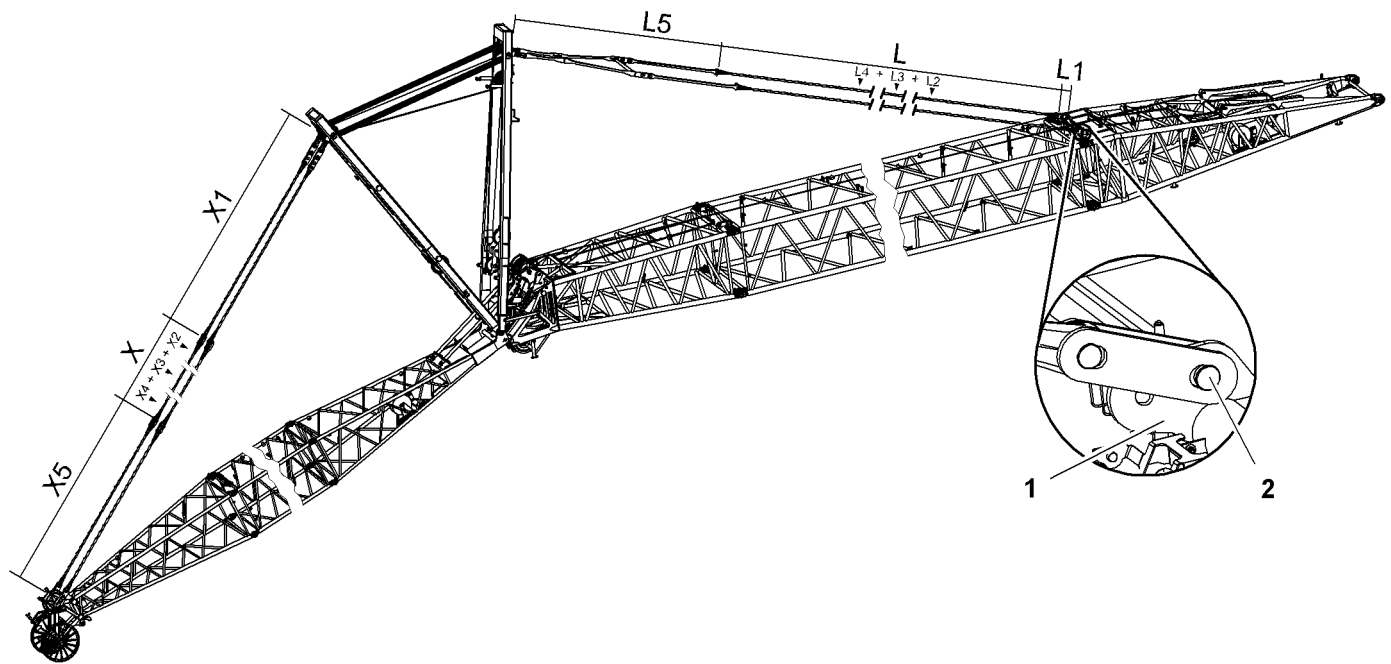


Fig. 5244: Overview of CF pendant straps on luffing jib 1916

- 1 Main boom base section
- 2 Pin connection point for jib backstay straps

Jib backstay straps A-frame2 to main boom base section 2821

Name		Value	
L1	Connecting link (For more information see: Connecting link , page 202)	350 mm 1' 2" ft-in	
L	Jib backstay straps consisting of:		
	L2	Jib backstay strap 3 m (10 ft) (For more information see: Jib backstay strap 3 m (10 ft) , page 204)	Total L2 +
	L3	Jib backstay strap 6 m (20 ft) (For more information see: Jib backstay strap 6 m (20 ft) , page 208)	Total L3 +
	L4	Jib backstay strap 12 m (40 ft) (For more information see: Jib backstay strap 12 m (40 ft) , page 212)	Total L4
L5	A-frame2 equalizer (jib backstay strap) (For more information see: Equalizer A-frame2 (jib backstay strap) , page 352)	7769 mm 25' 6" ft-in	

Tab. 580: Jib backstay straps A-frame2 to main boom base section 2821

Configuration of jib backstay straps (L):

Required number of jib backstay straps 3 m (10 ft) (L2) corresponds to number of main boom sections 3 m (10 ft).

LWN/LR-x/V04.01//Auslieferung/2016-03-07/en

Required number of jib backstay straps 6 m (20 ft) (**L3**) corresponds to number of main boom sections 6 m (20 ft).

Required number of jib backstay straps 12 m (40 ft) (**L4**) corresponds to number of main boom sections 12 m (40 ft).



Note

- ▶ For the admissible number of main boom sections 3 m (10 ft), 6 m (20 ft), 12 m (40 ft), refer to the load chart.

The jib backstay straps (**L**) may consist of generation A and generation B jib backstay straps (For more information see: 1.11.9 CF pendant straps on main boom 2821, page 200) . Mixing is only admissible if the number of generation B jib backstay straps only differs by at most 1 in the left and the right strand of the jib backstay straps.



DANGER

Inadmissible mixing of generation A and generation B jib backstay straps! Structural failure.

- ▶ Ensure that the number of generation B jib backstay straps differs by at most 1 in the left and the right strand of the jib backstay straps.

Pendant straps A-frame3 to jib head 1916

Name		Value	
X1	A-frame3 equalizer (jib pendant strap) (For more information see: A-frame3 equalizer (jib pendant strap), page 354)	7550 mm 24' 9" ft-in	
X	Jib pendant straps consisting of:		
	X2	Jib pendant strap 3 m (10 ft) (For more information see: Jib pendant strap 3 m (10 ft), page 356)	Total X2 +
	X3	Jib pendant strap 6 m (20 ft) (For more information see: Jib pendant strap 6 m (20 ft), page 358)	Total X3 +
	X4	Jib pendant strap 12 m (40 ft) (For more information see: Jib pendant strap 12 m (40 ft), page 360)	Total X4
X5	Jib pendant strap on jib head 1916 (For more information see: Jib pendant strap on jib head 1916.21, page 361)	6500 mm 21' 4" ft-in	

Tab. 581: Pendant straps A-frame3 to jib head 1916

Configuration of jib pendant straps (L):

Required number of jib pendant straps 3 m (10 ft) (**X2**) corresponds to number of jib sections 3 m (10 ft).

Required number of jib pendant straps 6 m (20 ft) (**X3**) corresponds to number of jib sections 6 m (20 ft).

Required number of jib pendant straps 12 m (40 ft) (**X4**) corresponds to number of jib sections 12 m (40 ft).

LWNLR.x/V04.01/Auslieferung/2016-03-07/en



Note

- ▶ For the admissible number of jib sections 3 m (10 ft), 6 m (20 ft), 12 m (40 ft), refer to the following table: ([For more information see: 7.21.1 Configuration of jib, page 1642](#))

The jib pendant straps (**X**) may consist of generation A and generation B jib pendant straps ([For more information see: 1.21.8 CF pendant straps on luffing jib 1916, page 352](#)). Mixing is only admissible if the number of generation B jib pendant straps only differs by at most 1 in the left and the right strand of the jib pendant straps.



DANGER

Inadmissible mixing of generation A and generation B jib pendant straps!
Structural failure.

- ▶ Ensure that the number of generation B jib pendant straps differs by at most 1 in the left and the right strand of the jib pendant straps.

7.21.6 Rope reeving system for A-frame 2/A-frame 3

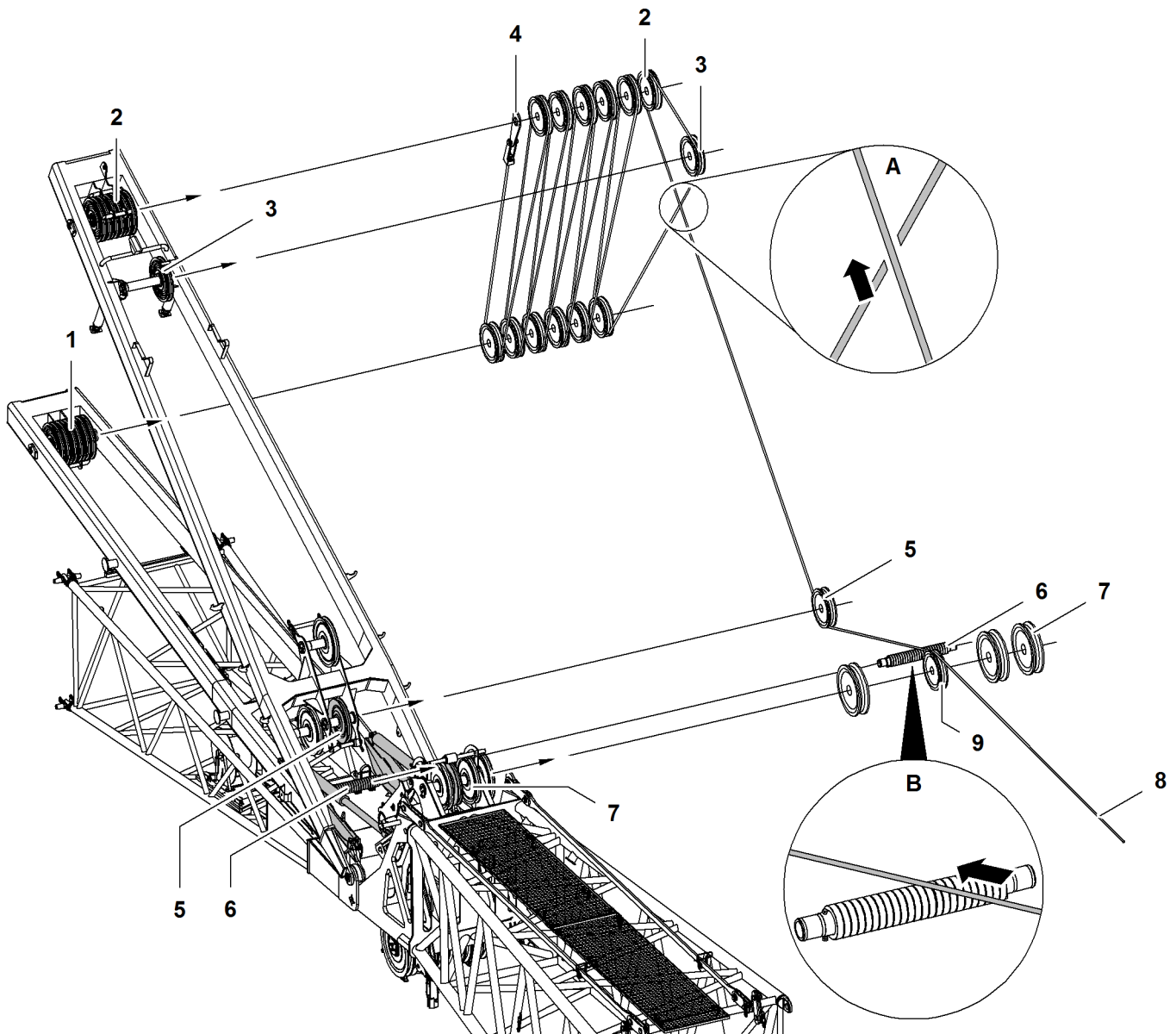


Fig. 5245: Reeving diagram for A-frame2/A-frame3 - Luffing jib 1916

- | | | | | | |
|---|---------------------|---|--------------------------------|---|-----------------------------------|
| 1 | Pulley set A-frame3 | 4 | Rope fixing point | 7 | Gantry pulley main boom head (3x) |
| 2 | Pulley set A-frame2 | 5 | Rope pulley A-frame2 | 8 | Rope of the jib luffing winch |
| 3 | Pulley A-frame2 | 6 | Rope protection roller support | 9 | Pulley of the jib luffing winch |

Detail A:

The rope of the jib luffing winch **8** between pulley **3** and pulley set **1** runs behind the rope of the rope pulley **5** in A-frame2.

Detail B:

The rope of the jib luffing winch **8** runs over the rope protection roller **6**.

LWNLR.x/V04.01//Auslieferung/2016-03-07/en

7.21.7 Reeving diagrams for one rope across jib head 1916 (load position1)

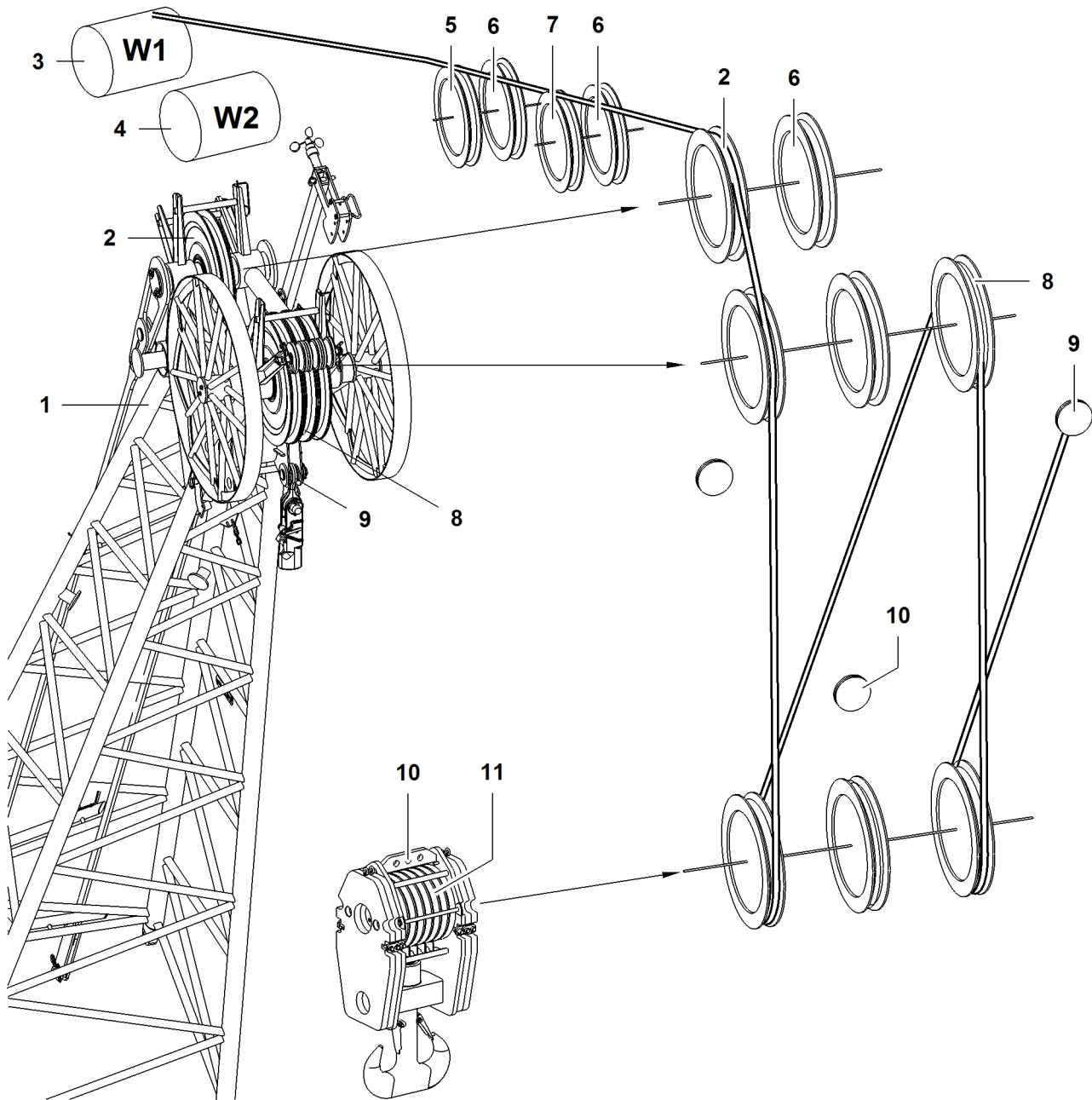


Fig. 5246: Reeving diagrams for one rope across jib head 1916 (load position1)

- | | | | | | |
|---|---------------------------|---|--|----|------------------------------------|
| 1 | Jib head | 5 | Pulley of A-frame2 | 9 | Rope fixing point of jib head |
| 2 | Gantry pulley of jib head | 6 | Retrofit kit* for operation with two ropes across jib head | 10 | Rope fixing points of pulley block |
| 3 | Winch1 | 7 | Pulley of A-frame3 | 11 | Pulley set of pulley block |
| 4 | Winch2 | 8 | Pulley (3x) of jib head | | |

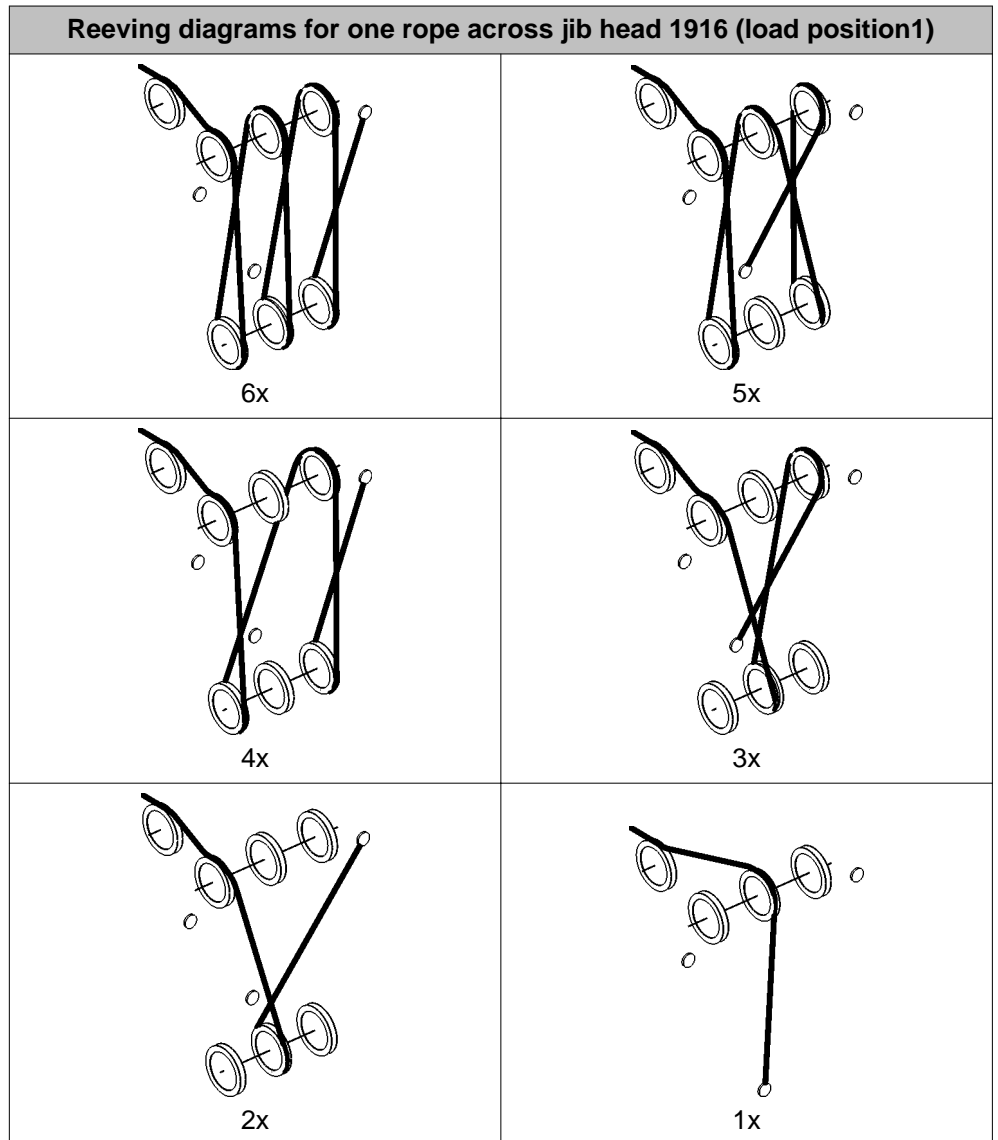


DANGER

Incorrect number of reevings!
Structural breakdown, toppling of machine.

► Choose the correct number of reevings as per the load chart.

LWNLR-x/V04.01//Auslieferung/2016-03-07/en



Tab. 582: Reeving diagrams for one rope across jib head 1916 (load position1)

7.21.8 Reeving diagrams for two ropes across jib head 2316, 1916, 1713, 1309, 1008 (load position1)



DANGER

Inadmissible number of reeving!
Structural breakdown, toppling of machine.

► Choose correct number of reeving as indicated in load chart.

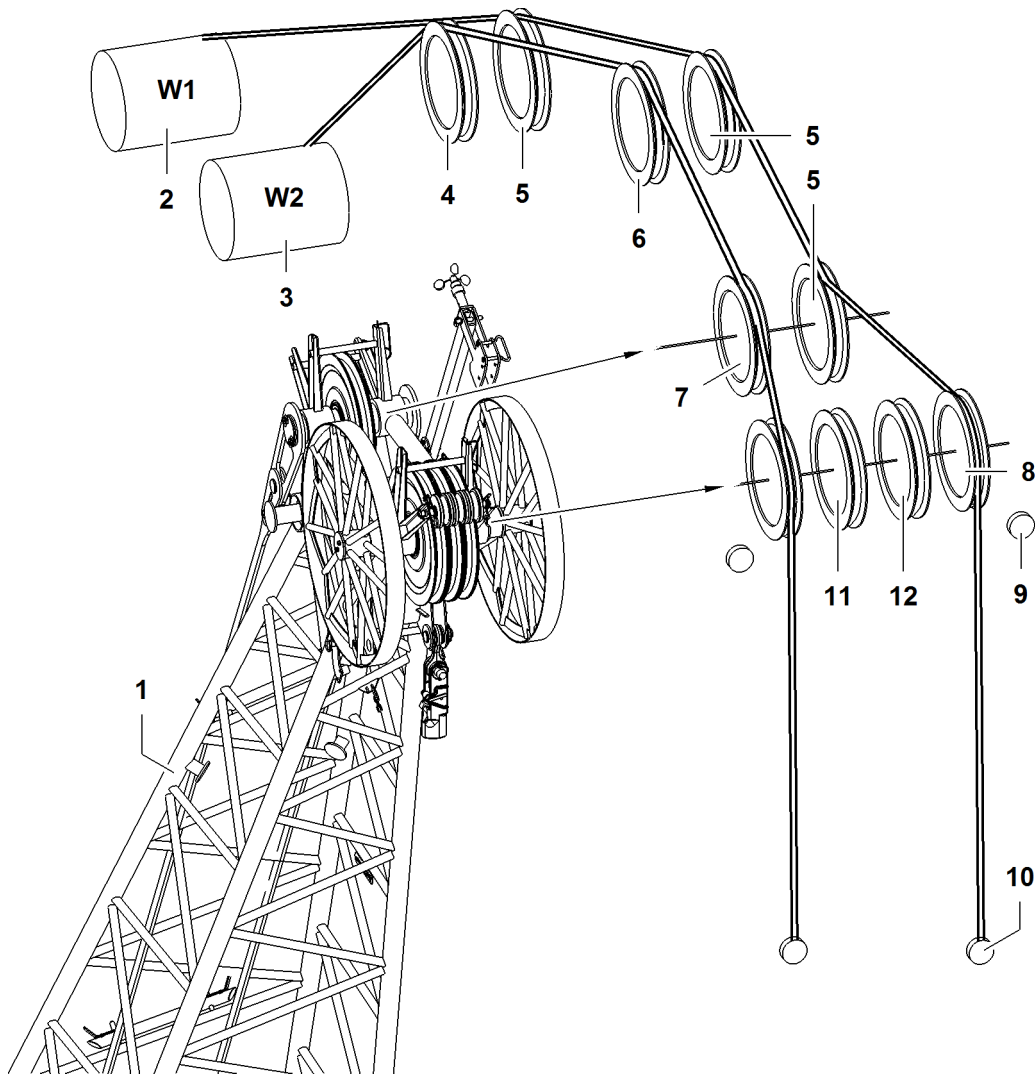


Fig. 5253: Reeving diagrams for two ropes across jib head 2316, 1916, 1713, 1309, 1008 (load position 1)

- | | | | | | |
|---|--------------------|---|--|----|--|
| 1 | Jib head | 5 | Retrofit kit* for operation with two ropes across jib head | 9 | Rope fixing point (2x) of jib head |
| 2 | Winch1 | 6 | Pulley of A-frame3 | 10 | Rope fixing points of pulley block |
| 3 | Winch2 | 7 | Gantry pulleys of jib head | 11 | Pulley (only with jib head 2316) |
| 4 | Pulley of A-frame2 | 8 | Pulleys of jib head | 12 | Pulley (only with jib head 2316, 1916, 1713) |

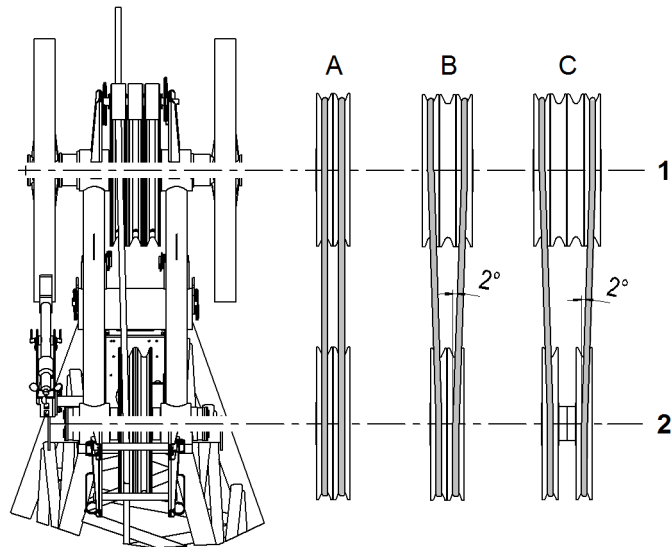


Fig. 5254: Run of the rope when two ropes pass over the jib head section

1 Pulleys of jib head

2 Gantry pulleys of jib head

Run of the rope	Type of jib
A	Luffing jib 1008
	Luffing jib 1309
B	Luffing jib 1713
	Luffing jib 1916
C	Luffing jib 2316

Tab. 583: Run of the rope when two ropes pass over the jib head

7.21.9 Reeving diagrams for one rope across main boom head 2821 (load position2)

If the main boom with jib attached is also used to lift a load, reeve main boom head 2821 as shown below.

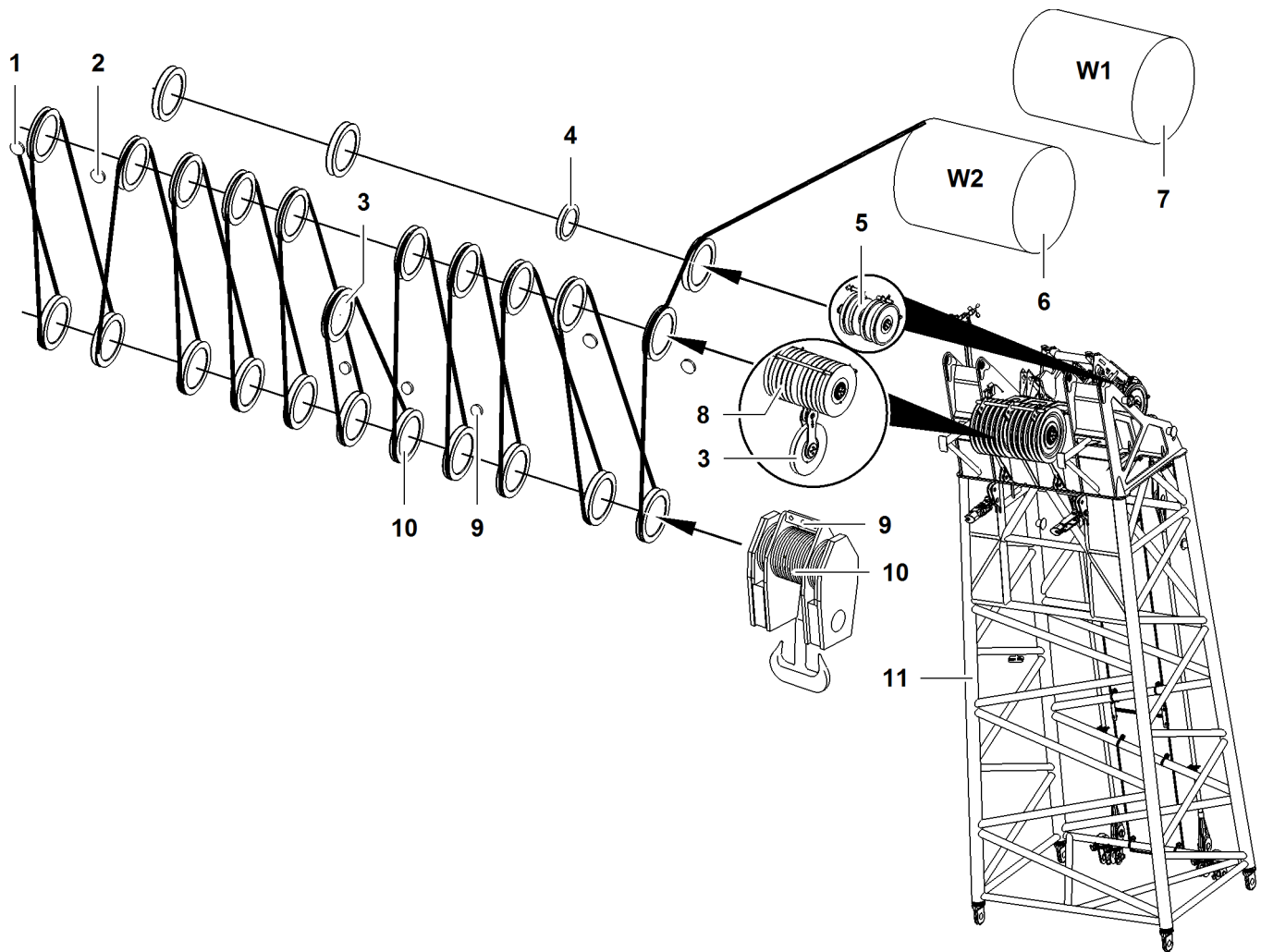


Fig. 5255: Reeving diagrams for one rope across main boom head 2821 (load position 2)

- | | | | | | |
|---|--|---|--------------------------------------|----|------------------------------------|
| 1 | Outer rope fixing point (2x) of main boom head | 5 | Gantry pulley (3x) of main boom head | 9 | Rope fixing points of pulley block |
| 2 | Inner rope fixing point (2x) of main boom head | 6 | Winch2 | 10 | Pulley set of pulley block |
| 3 | 11th pulley of main boom head | 7 | Winch1 | 11 | Main boom head |
| 4 | Pulley for rope of jib luffing winch | 8 | Pulley (10x) of main boom head | | |

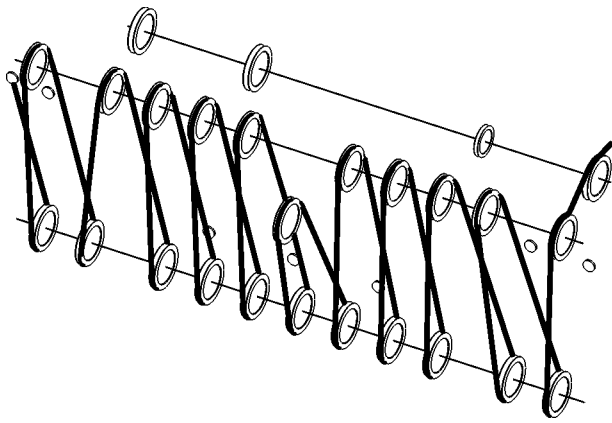


DANGER

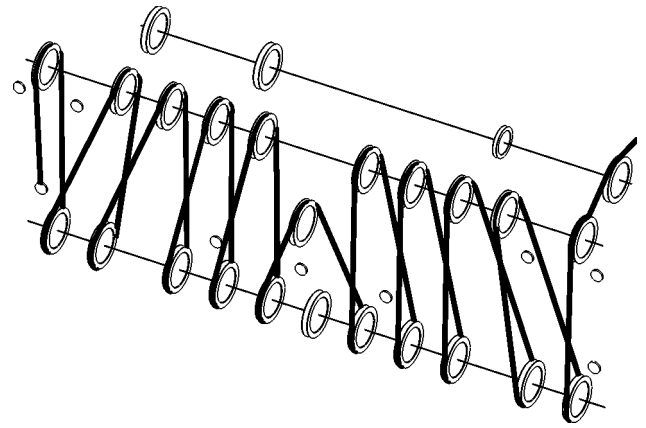
Inadmissible number of reevings!
Structural breakdown, toppling of machine.

► Choose correct number of reevings as indicated in load chart.

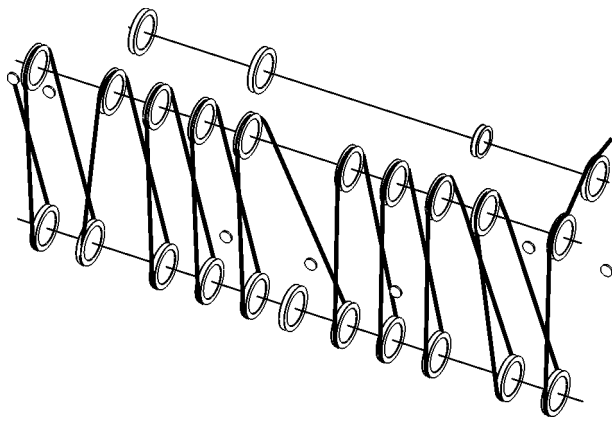
Reeving diagrams for one rope across main boom head 2821 (load position2)



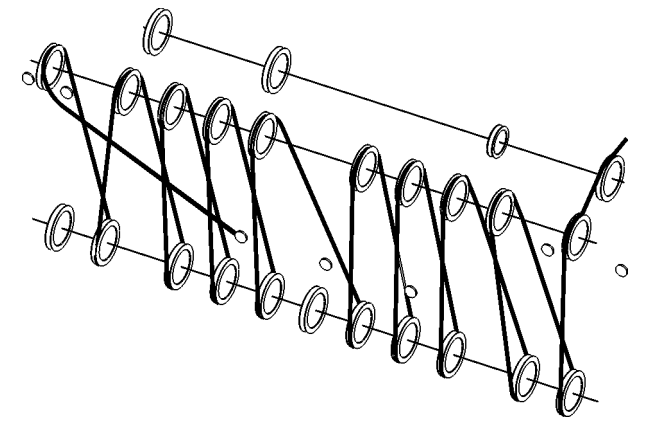
22x



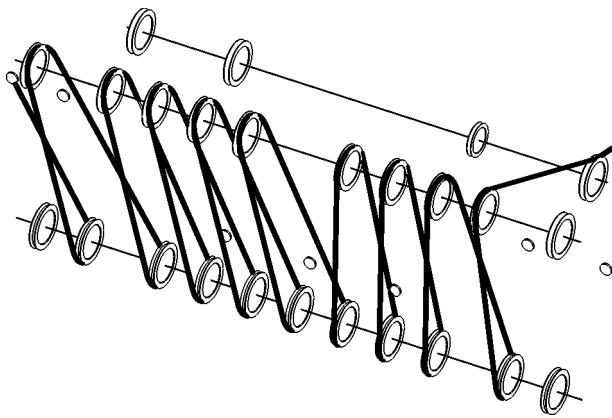
21x



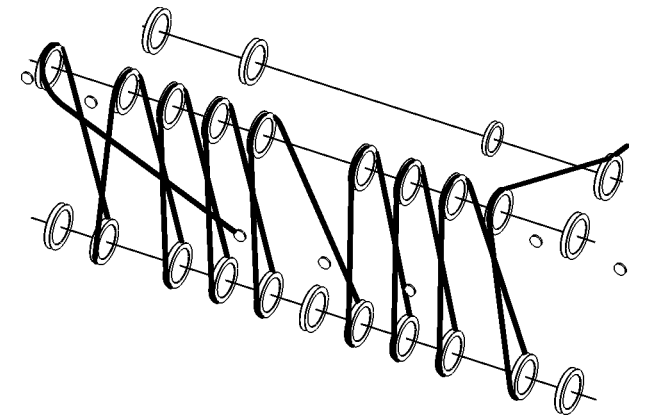
20x



19x



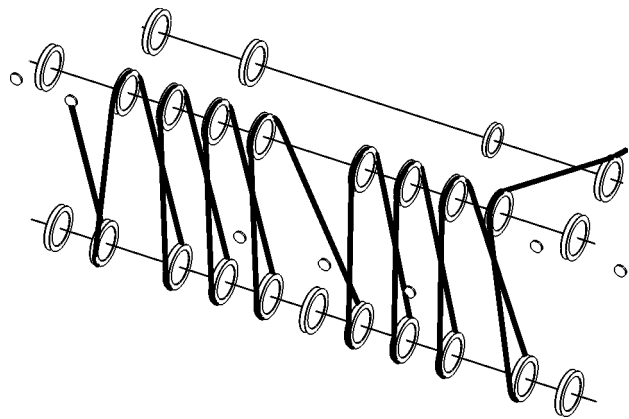
18x



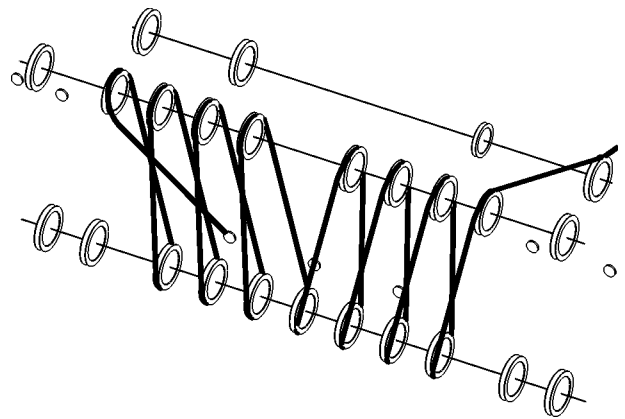
17x

LWNLR_x/V04.01//Auslieferung/2016-03-07/en

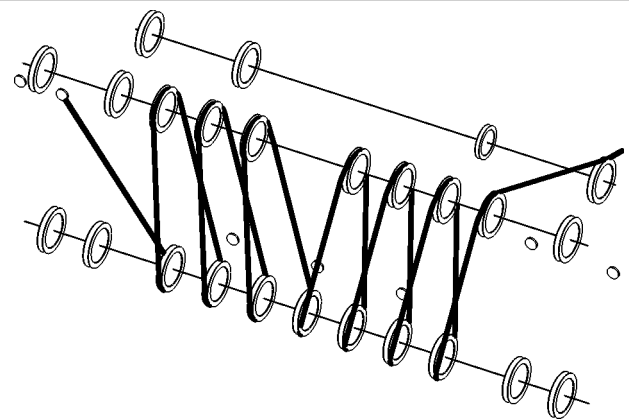
Reeving diagrams for one rope across main boom head 2821 (load position2)



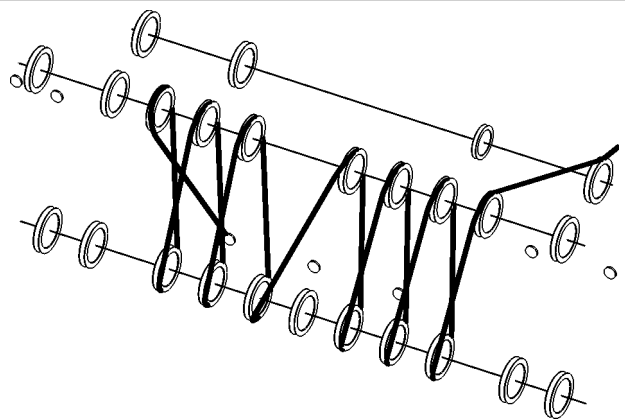
16x



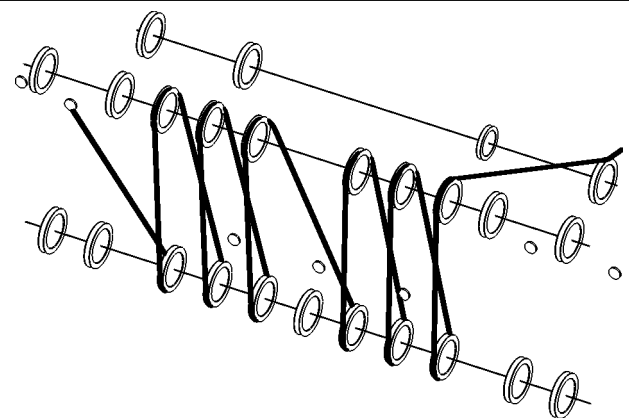
15x



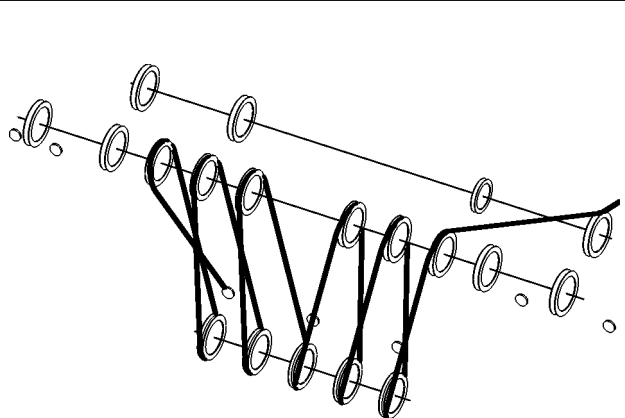
14x



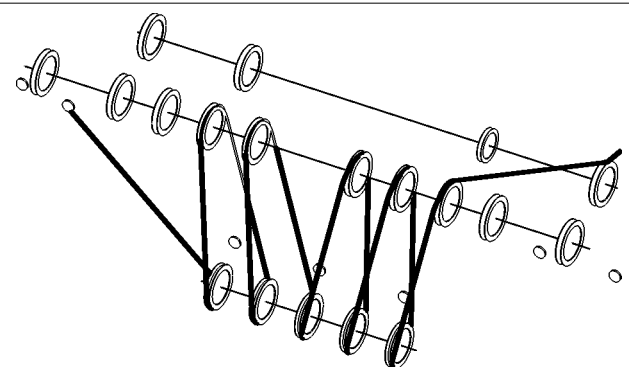
13x



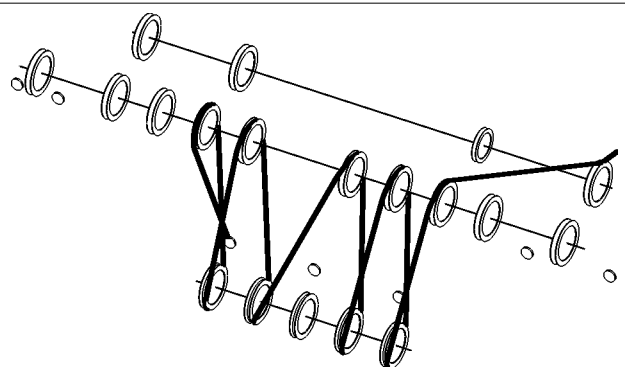
12x



11x

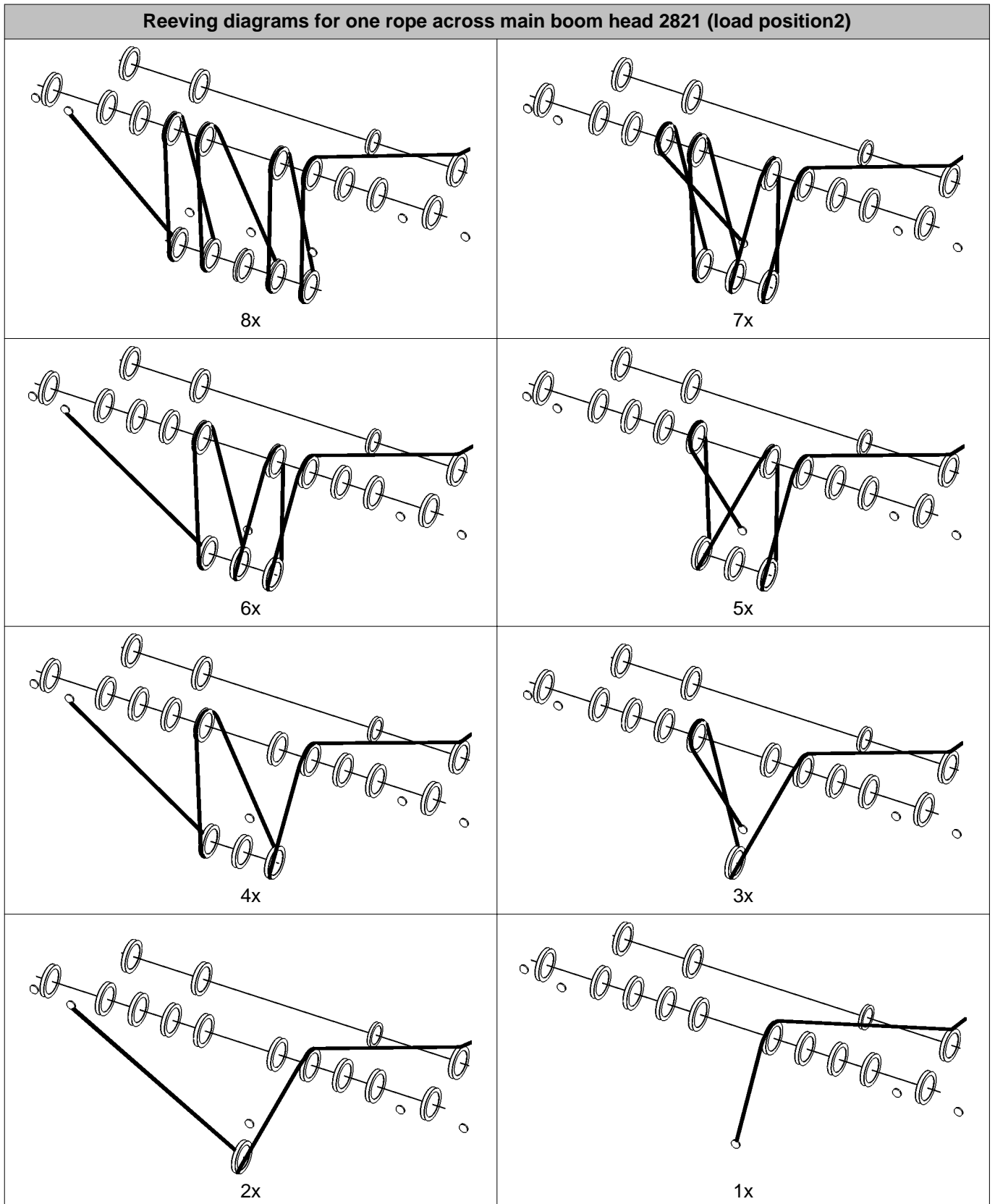


10x



9x

LWNLR-x\04.01\Auslieferung\2016-03-07\en



LWNLR.x/V04.01//Auslieferung/2016-03-07/en

Tab. 584: Reeving diagrams for one rope across main boom head 2821 (load position2)

7.21.10 Reeving diagrams for one rope across auxiliary jib (15 t (33.000 lb)) on jib head 1916, 1713, 1309, 1008 (load position1)



DANGER

Incorrect number of reevings!
Structural breakdown, toppling of machine.

► Choose the correct number of reevings as per the load chart.

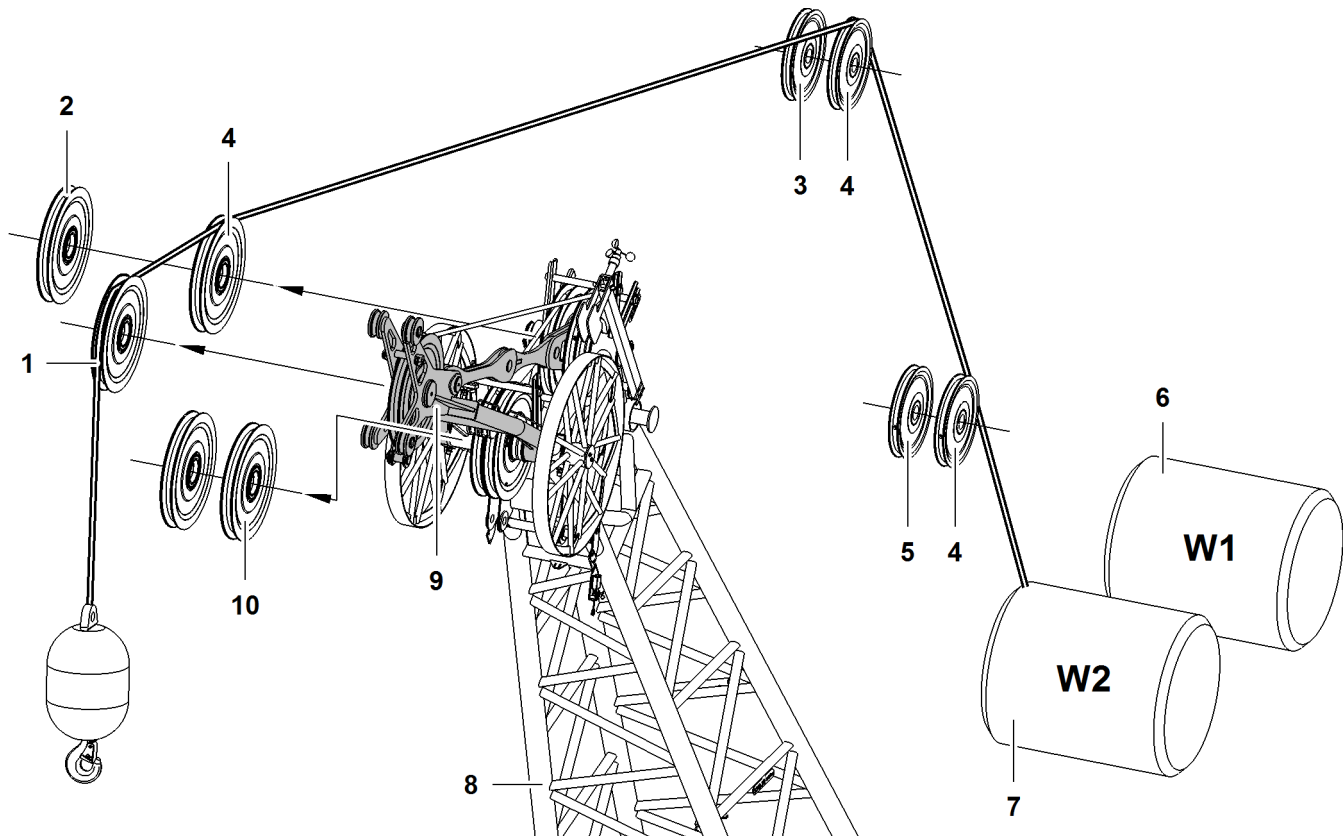


Fig. 5278: Reeving diagrams for one rope across auxiliary jib (15 t (33.000 lb)) on jib head 1916, 1713, 1309, 1008 (load position1) (illustration of principle)

- | | | | | | |
|---|--|---|--------------------|----|----------------------------------|
| 1 | Pulley of auxiliary jib (15 t (33.000 lb)) | 5 | Pulley of A-frame2 | 9 | Auxiliary jib (15 t (33.000 lb)) |
| 2 | Gantry pulley of jib head | 6 | Winch1 | 10 | Pulleys of jib head |
| 3 | Pulley of A-frame3 | 7 | Winch2 | | |
| 4 | Retrofit kit* for operation with two ropes across jib head | 8 | Jib head | | |

7.22 Assemble the luffing jib

Ensure that the following conditions are fulfilled:

- Assembly functions are switched on.
- The machine is ready for use as an assembly crane, or an assist crane is available.
- Work plans have been drawn up.
- The length and the order of the jib sections are known.
- The assembly positions of the mid-point suspensions are known.
- Any accessories required are available.

7.22.1 Notes

The assembly of the luffing jib described below applies to all system dimensions of luffing jib.

The illustrations have been simplified or schematically represented for reasons of uniformity and represent the principles of assembly. They do not provide a detailed representation of the components.

7.22.2 Programming the setup



DANGER

Unacceptable setup!

- ▶ Only program a setup on the machine that is in accordance with the load chart.
- ▶ Programming the setup on the machine ([For more information see: 4.13 Programming the setup, page 886](#)) .

7.22.3 Unloading and positioning the jib components



DANGER

Slewing of uppercarriage with rear counterweight attached not permitted!
Machine toppling over.

- ▶ Slew the uppercarriage according to the table ([For more information see: Lifting and pinning the rear counterweight, page 1264](#)) exclusively.



DANGER

Incorrect or faulty parts/components are fit!
Structural breakdown.

- ▶ Only use original Liebherr parts/components that are in perfect condition.



DANGER

Improperly assembled boom configuration!
Structural breakdown.

- ▶ Ensure that the assembled boom configuration is compatible with the programmed setup.



DANGER

Incorrect jib sections arrangement!
Structural breakdown.

- ▶ Assemble the boom according to the relevant system requirements.
- ▶ A jib section measuring 6 m (20 ft) cannot be replaced with two jib sections measuring 3 m (10 ft).
- ▶ A jib section measuring 12 m (40 ft) cannot be replaced with two jib sections measuring 6 m (20 ft).

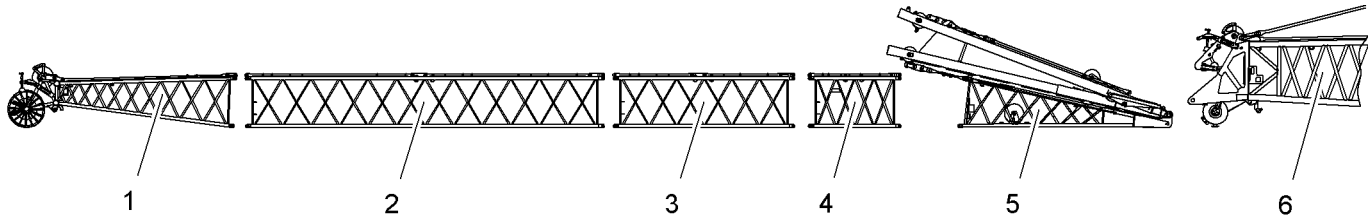


Fig. 5279: Position jib components according to relevant system instructions

1	Jib head section	3	Jib section 6 m (20 ft)	5	Jib base section
2	Jib section 11.7 m (38 ft) or 12 m (40 ft)	4	Jib section 3 m (10 ft)	6	Boom head section

- ▶ Direct transport vehicles with boom sections.
- ▶ Sling boom sections by attaching lifting equipment to the lifting points.
- ▶ Unload boom sections using the basic machine or assist crane and position according to the relevant system instructions.

7.22.4 Attaching the auxiliary jib (15 t (33.000 lb)) to the jib head section

NOTICE

Auxiliary jib is attached to an unsuitable jib head section!
Risk of damage to the components.

- ▶ Attach the auxiliary jib (15 t (33.000 lb)) to jib head 1008, 1309, 1713 or 1916 only.

Ensure that the following conditions are fulfilled:

- Second pulley by A-frame 2 is fitted.
- Second pulley by A-frame 3 is fitted.
- The second pulley (gantry pulley) and spacer rings for the jib head section are provided.

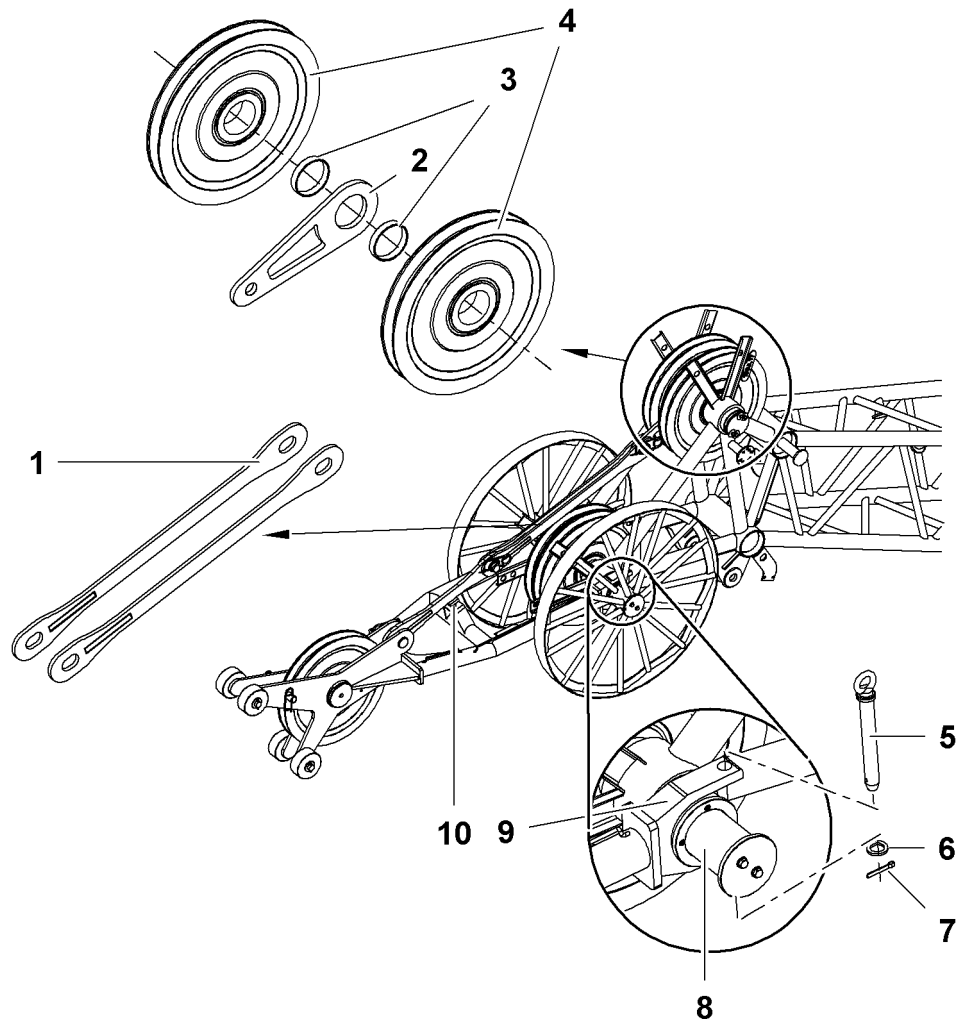


Fig. 5280: Auxiliary jib 15 t (33.000 lb)

- | | | | |
|---|---|----|-------------|
| 1 | Connecting link (2x) | 6 | Washer (2x) |
| 2 | Connecting link | 7 | Splint (2x) |
| 3 | Spacer ring (Ø152 mm (5.98" in) x Ø141 mm (5.55" in) x 29 mm (1.14" in)) (2x) | 8 | Shaft |
| 4 | Pulley (2x) | 9 | Fork (2x) |
| 5 | Pin (2x) | 10 | Limit stop |



Note

Liebherr recommends:

► To make it easier to install the auxiliary job: remove the connecting links 1.

► Remove the 4 spacer rings (Ø152 mm (5.98" in) x Ø141 mm (5.55" in) x 40 mm (1.57" in)) by the gantry pulleys from the jib head section.

► Fit the connecting link 2 and pulleys 4 with spacer rings 3.

► Lift the auxiliary jib from the front onto the jib head section.

When the forks 9 of the auxiliary jib engage the shaft 8:

► Insert pin 5 and secure with washers 6 and cotter pins 7.

- ▶ Fit the connecting links **1**.
- ▶ Set the limit stop **10** so that the connecting links **1** fold upwards when laying down the jib.

7.22.5 Attaching the auxiliary jib (30 t (66.000 lb)) to the jib head section

NOTICE

Auxiliary jib is attached to an unsuitable jib head section!
Risk of damage to the components.

- ▶ Attach the auxiliary jib (30 t (66.000 lb)) to jib head section 2316 only.
-

Ensure that the following conditions are satisfied:

- Second pulley by A-frame 2 is fitted.
- Second pulley by A-frame 3 is fitted.
- Second pulley (gantry pulley) is equipped with a spacer ring and spacer washers for the jib head section.

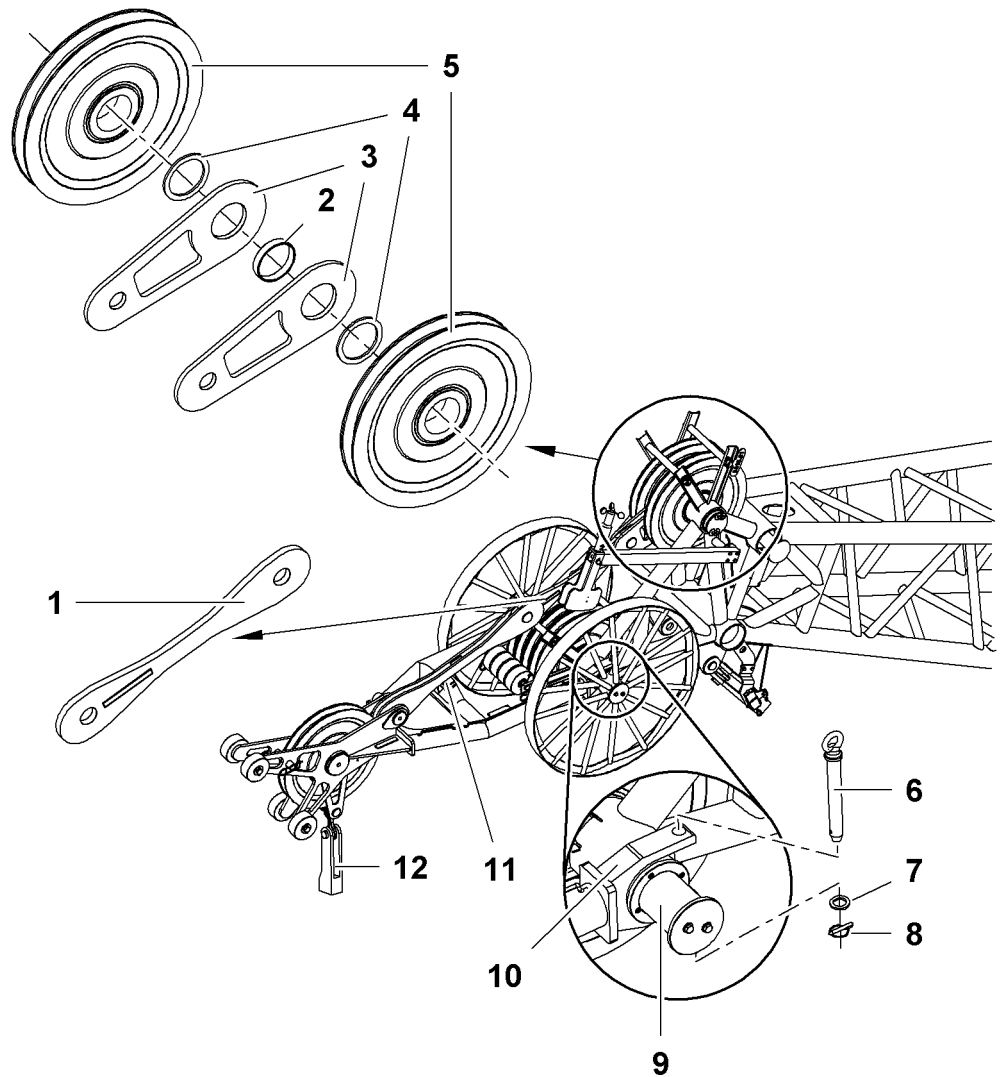


Fig. 5281: Attaching the auxiliary jib (30 t (66.000 lb)) to jib head section 2316

- | | | | |
|---|---|----|----------------|
| 1 | Pendant strap | 7 | Washers (2x) |
| 2 | Spacer ring (Ø152 mm (5.98" in) x Ø141 mm (5.55" in) x 29 mm (1.14" in)) | 8 | Linchpins (2x) |
| 3 | Connecting links (2x) | 9 | Shaft |
| 4 | Spacer washers (Ø180 mm (7.09" in) x Ø142 mm (5.59" in) x 8 mm (0.31" in)) (2x) | 10 | Forks (2x) |
| 5 | Pulleys (2x) | 11 | Limit stop |
| 6 | Pins (2x) | 12 | Rope fixation |



Note

- ▶ To make it easier to attach the auxiliary jib: remove the pendant straps 1.
- ▶ Remove the 4 spacer rings (Ø160 mm (6.30" in) x Ø140 mm (5.51" in) x 40 mm (1.57" in)) by the gantry pulleys from the jib head section.
- ▶ Fit the connecting links 3 and pulleys 5 with a spacer ring 2 and spacer washers 4.

- ▶ Lift the auxiliary jib from the front onto the jib head section.

When the forks **10** of the auxiliary jib engage the shaft **9**:

- ▶ Insert pin **6** and secure with washers **7** and linchpins **8**.
- ▶ Fit pendant strap **1**.
- ▶ Set the limit stop **11** so that the pendant strap **1** folds upwards when laying down the jib.

For 2-fold reeving of the auxiliary jib:

- ▶ Attach the rope fixing point **12**.

7.22.6 Bolting the jib head section to the jib sections



WARNING

Getting caught inside the jib sections during assembly!
Serious injury.

- ▶ Never go inside the jib sections.

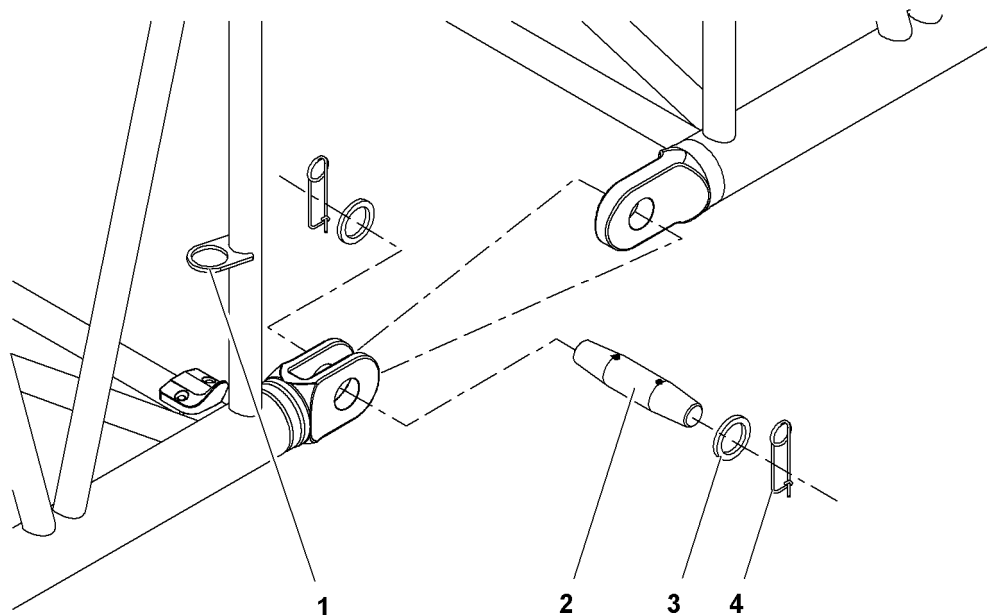


Fig. 5282: Bolting the boom

- | | |
|--|---------------------------|
| 1 Transport brackets (4x) for double-taper pins | 3 Washers (8x) |
| 2 Double-taper pins (4x) | 4 Safety pins (8x) |

- ▶ Remove the double-taper pins **2** from the transport brackets **1**.



Note

- ▶ To make assembly and disassembly easier: grease the double-taper pin.
- ▶ Insert double-taper pins **2** and secure with washers **3** and safety pins **4**.

7.22.7 Attaching the jib base section

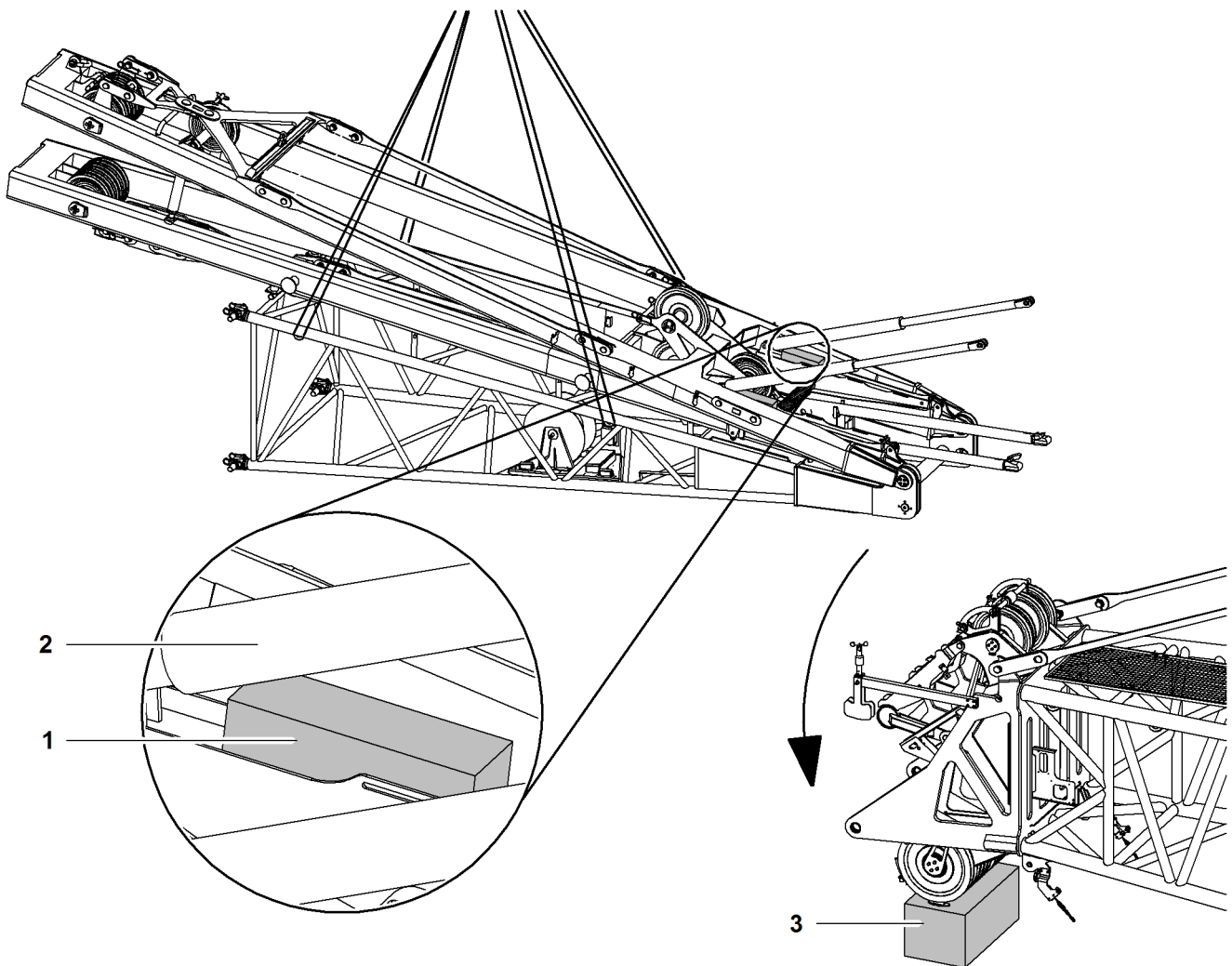


Fig. 5283: Place wooden blocks underneath and lift jib base section to main boom head

- | | | | | | |
|---|-------------------|---|-------------------------------------|---|-------------------|
| 1 | Wooden block (2x) | 2 | Hydraulic tilting-back support (2x) | 3 | Wooden block (2x) |
|---|-------------------|---|-------------------------------------|---|-------------------|



Note

Liebherr recommends:

- ▶ To facilitate installation of the jib base section: Place wooden blocks 3 beneath the feet of the main boom head.
- ▶ Chock the hydraulic tilting-back supports 2 of the luffing jib with wooden blocks 1.



Note

Special points regarding main boom head 2821.24 (LR 1006)!

- ▶ Fit the guide rails for the hydraulic tilting-back supports to the boom head section in the inner or outer position according to the jib type.
- ▶ Rig jib base section.
- ▶ Lift the jib base section from above onto the boom head section.

- ▷ Rigid and hydraulic tilting-back supports should be located in the guide rails on the boom head section.

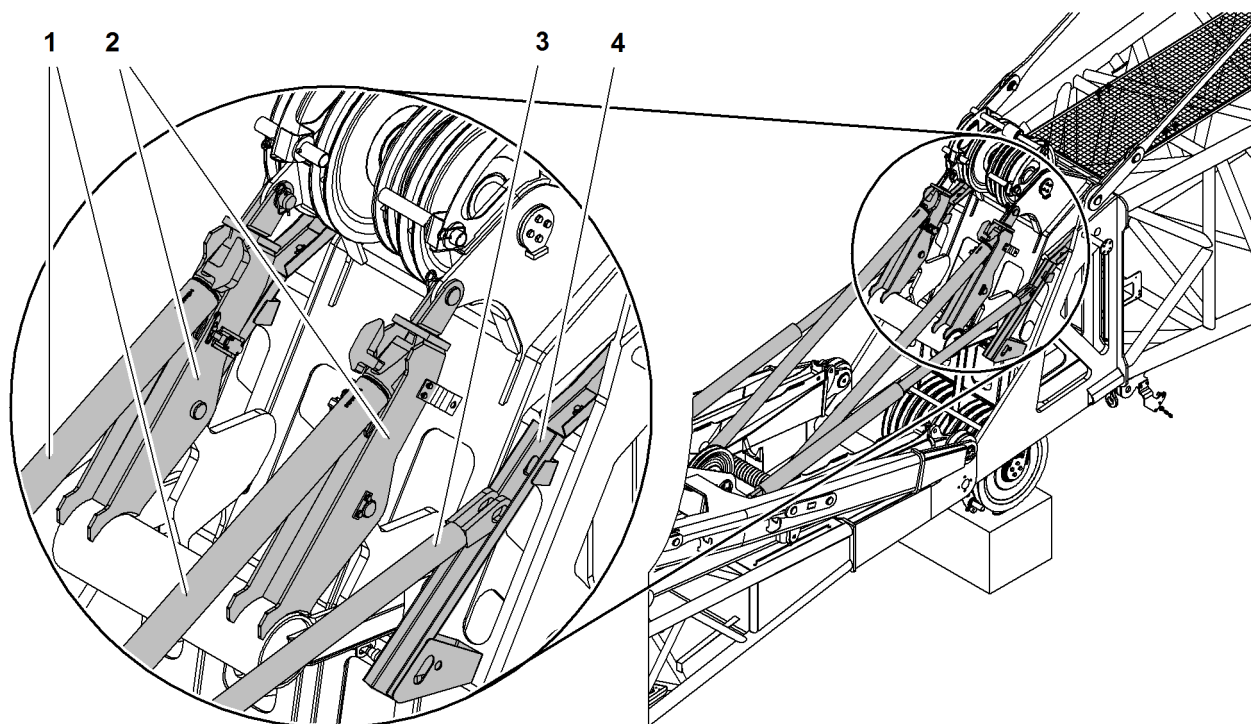


Fig. 5284: Rigid and hydraulic tilting-back supports are in the guide rails on the main boom head

- | | | | |
|---|---|---|---|
| 1 | Rigid tilting-back support (2x) | 3 | Hydraulic tilting-back support (2x) |
| 2 | Guide rail (2x) on main boom head for rigid tilting-back supports | 4 | Guide rail (2x) on main boom head for hydraulic tilting-back supports |

- ▶ Lower the jib base section further until the pin connection points of the jib base section and the boom head section line up.

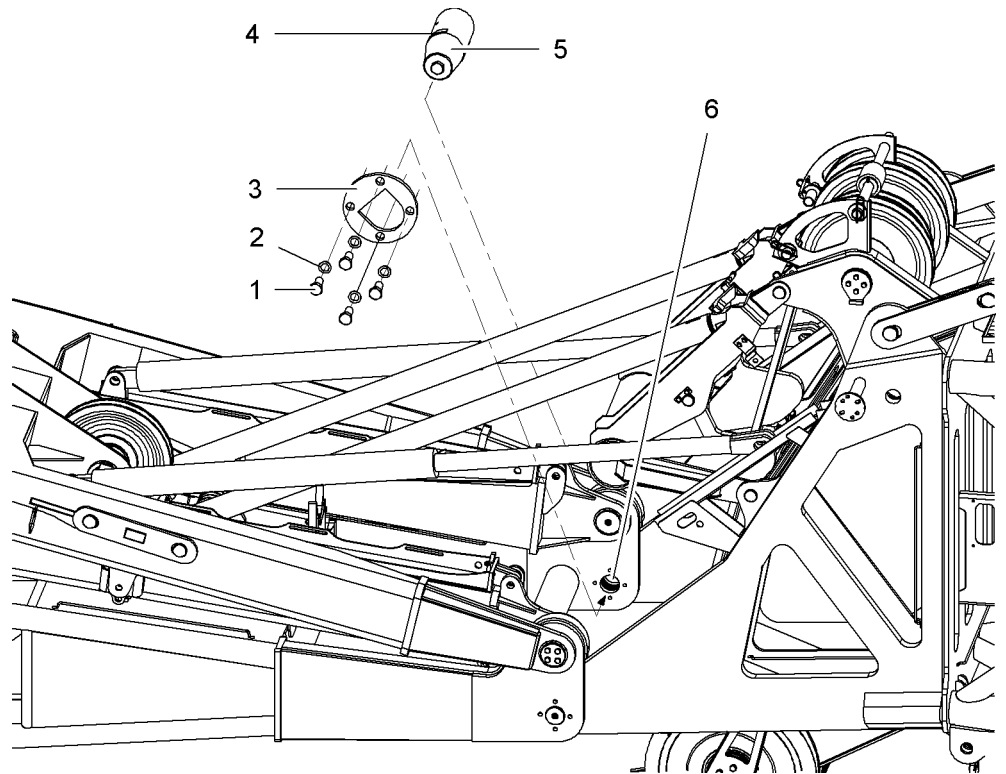


Fig. 5285: Bolting the jib base section to the boom head section

- | | | | |
|---|------------------|---|---------------------------|
| 1 | Screw (4x) | 4 | Notch |
| 2 | Washer (4x) | 5 | Pin |
| 3 | Securing element | 6 | Pin connection point (2x) |

► Lubricate pins 5.

When the pin connection points 6 of the jib base section and the boom head section line up:

► Pin 5 must be driven in from the outside in.



Note

- Pay special attention to the position of the notch 4 in the pin 5.
- If necessary, use a screwdriver to turn the pin into the correct position.

► Slide the locking element 3 over the pin 5 and place in the notch 4.

Type of jib	Torque	Screw treatment
2316	239 Nm 176 ft-lb	slightly oiled thread
1916	239 Nm 176 ft-lb	slightly oiled thread
1713	291 Nm 215 ft-lb	grease-free thread and treat with LOCTITE 243
1309	291 Nm 215 ft-lb	grease-free thread and treat with LOCTITE 243

Type of jib	Torque	Screw treatment
1008	291 Nm 215 ft-lb	grease-free thread and treat with LOCTITE 243

Tab. 585: Torque screws luffing jib

- ▶ Tighten screws 1 and disks 2 with stated torque.
- ▶ Repeat the pin insertion process on the opposite side.

7.22.8 Checking the pressure in the accumulator of the hydraulic tilting-back supports

NOTICE

Incorrect pressure in the accumulator of the hydraulic tilting-back supports!
Risk of damage to components.

- ▶ Ensure that the specified pressure for the current ambient temperature is set in the accumulator.

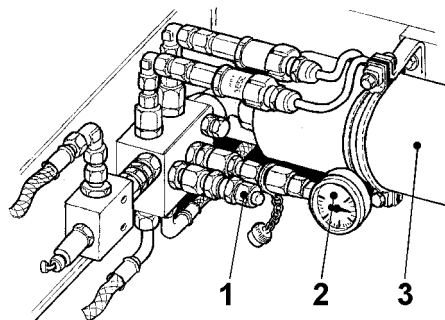


Fig. 5286: Accumulator on A-frame3

- | | | | |
|---|--|---|-------------|
| 1 | Connection for filling the accumulator | 3 | Accumulator |
| 2 | Pressure gauge | | |

The table "Specified pressure in accumulator of hydraulic tilting-back supports" is located on A-frame3.

- ▶ Check pressure in accumulator with tilting-back supports fully extended prior to each assembly.

If the pressure of the accumulator does not match that shown in the table:

- ▶ Observe ambient temperatures on site and adapt the pressure.

7.22.9 Attaching the main boom (self-assembly system)



Note

Particular approach when using the self-assembly system!

- ▶ Attach the main boom to the basic machine.

7.22.10 Connect A-frame2 with the rope of winch1/winch2.



WARNING

Unsecured walking on the boom!
risk of falling from the boom.

- ▶ A fall arrest system must be worn when working on booms to prevent falling.

On A-frame2 and on the crossbar a shackle and a round sling have been fit in the factory.

Ensure that the following conditions are fulfilled:

- The shackle and round sling are fitted to A-frame 2.
- The shackle and round sling are fitted to the crossbar.
- The round sling on A-frame 2 passes through the round sling on the crossbar.

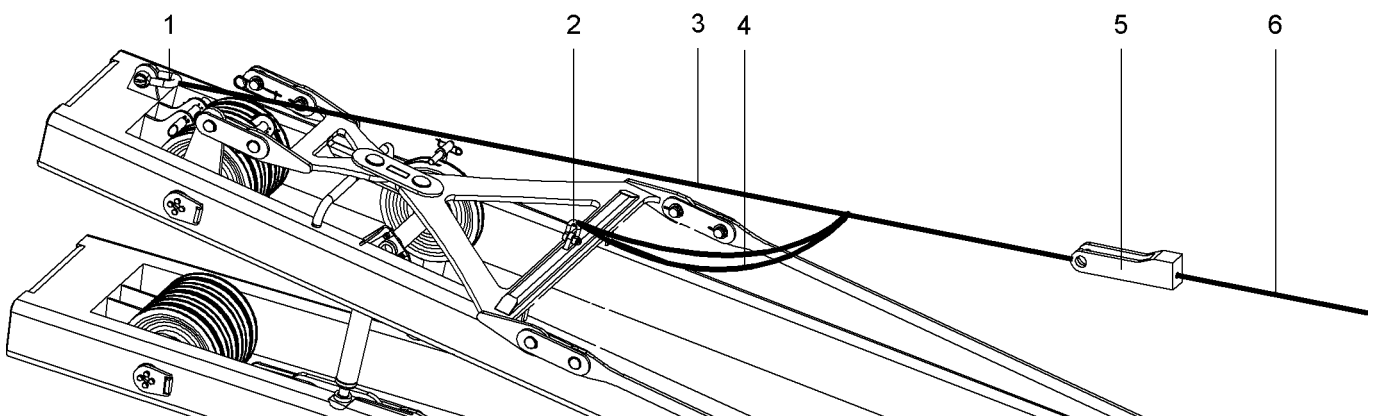


Fig. 5287: Connect A-frame2 with the rope of winch1/winch2.

- | | | | | | |
|---|----------------------|---|--------------------------|---|-----------------------|
| 1 | Shackle on A-frame 2 | 3 | Round sling on A-frame 2 | 5 | Pocket lock |
| 2 | Shackle on crossbar | 4 | Round sling on crossbar | 6 | Rope of winch1/winch2 |

To connect the rope of winch1/winch2 **6** with the round sling, use the pocket lock **5** of the main boom head.

- ▶ Attach pocket lock **5** to round sling **3** on A-frame2.
- ▶ Pull rope of winch1/winch2 **6** forward across the main boom up to the pocket lock **5**.
- ▶ Connect the rope of winch1/winch2 **6** with the pocket lock **5**.

7.22.11 Reeving A-frame 2/A-frame 3



WARNING

Unsecured walking on the boom!
risk of falling from the boom.

- ▶ A fall arrest system must be worn when working on booms to prevent falling.



WARNING

Luffing jib luffing winch is reeved incorrectly!

- ▶ Reeve in the rope of the jib luffing winch according to reeving plan.

The rope reeving plan of the jib luffing rope can be found in the relevant jib instructions.

- ▶ Open up the rope guide, if present.
- ▶ Unwind the rope of the jib luffing winch and pull forward to the jib base section.
- ▶ Connect rope of the jib luffing winch with auxiliary rope reeved in the factory.



Note

- ▶ To make reeving the rope of the jib luffing winch easier: Slightly lift A-frame2 with the rope of winch1/winch2.

- ▶ Pull out the auxiliary rope by hand and at the same time unwind the jib luffing rope.

or

Connect the auxiliary rope to the rope of the rope reeving winch and actuate the rope reeving winch.

- ▷ Rope of the jib luffing winch is being reeved.

- ▶ Remove auxiliary rope and place in temporary storage.
- ▶ Attach rope of the jib luffing winch with pocket lock to the rope fixing point of A-frame2.
- ▶ Close and secure the rope guide, if present.

7.22.12 Erecting A-frame2/A-frame3 with rope of winch1/winch2 and bolting the hydraulic tilting-back supports

NOTICE

Luffing jib luffing winch is operated incorrectly!
Damage to A-frame 2 and/or A-frame 3.

If A-frame2 is in the transport position with its feet on A-frame3:

- ▶ Only lower jib luffing winch.

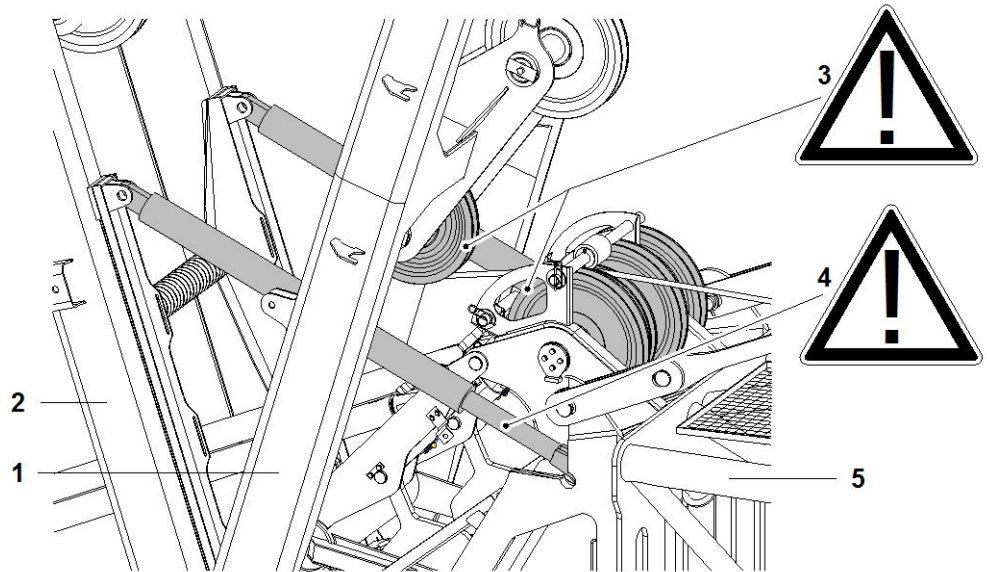


Fig. 5288: Danger points when erecting A-frame 2/A-frame 3

- | | | | |
|---|------------------------|---|---|
| 1 | A-frame 2 | 4 | Minimum dimension x of the visible piston rod of the hydraulic tilting-back supports (2x) |
| 2 | A-frame 3 | 5 | Boom head section |
| 3 | Pulley collision point | | |

NOTICE

Pulleys on A-frame2 collide with the gantry pulleys on the main boom!
Damage to machine.

- ▶ Stop the A-frame 2 erection process in good time.



Fig. 5289: Minimum dimension x of the visible piston rod of the hydraulic tilting-back supports

- x Minimum dimension
100 mm (3.94" in)

NOTICE

If the minimum dimension x of the visible piston rod of the hydraulic tilting-back supports is not achieved:
Damage to machine.

- ▶ Stop the A-frame 3 erection process in good time.
- ▶ Lower A-frame 3 forwards using the jib luffing winch.

Ensure that the following conditions are fulfilled:

- A signalman with a walkie-talkie supervises the entire procedure.

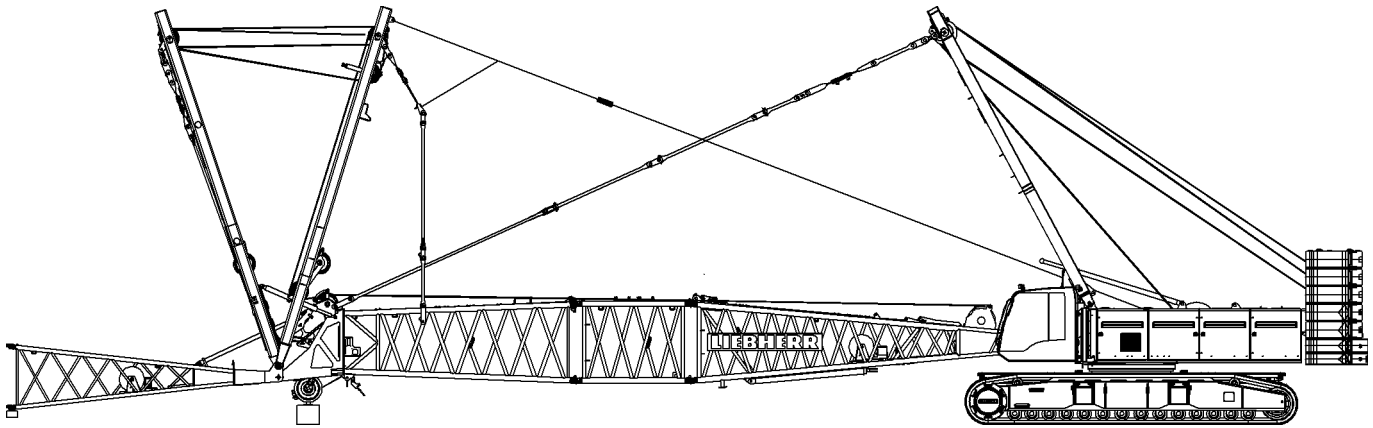


Fig. 5290: Erect A-frame 2/A-frame 3 in the bolting position of the hydraulic tilting-back supports

- ▶ Erect A-frame2 using the rope of winch1/winch2 and lower A-frame3 forwards at the same time if required.
 - ▷ The hydraulic tilting-back supports slide onto the guide rails in the direction of the pin connection points on the boom head section.

If the pin connection points on the hydraulic tilting-back supports match those on the boom head section:

- ▶ Stop the erection process.

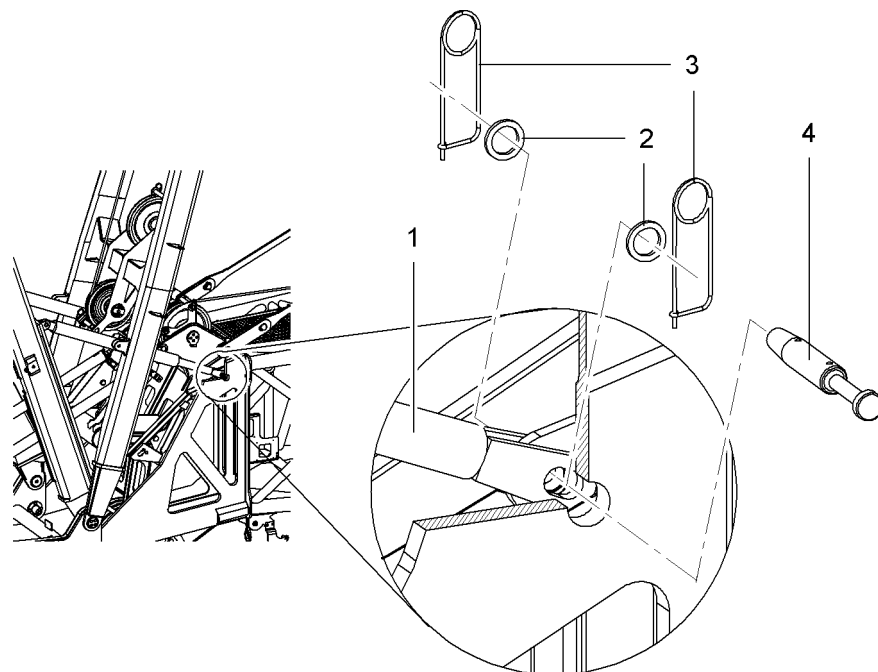


Fig. 5291: Bolting the hydraulic tilting-back supports

- | | | | |
|---|--------------------------------|---|-----------------|
| 1 | Hydraulic tilting-back support | 3 | Safety pin (2x) |
| 2 | Washer (2x) | 4 | Pin |

- ▶ Hydraulic tilting-back support 1 should be bolted with pin 4 and secured with safety pins 3 and washers 2.
- ▶ Repeat the pin insertion process on the opposite side.

7.22.13 Bolting the equaliser on A-frame 2 to the jib backstay straps



WARNING

Unsecured walking on the boom!
risk of falling from the boom.

- ▶ A fall arrest system must be worn when working on booms to prevent falling.

Ensure that the following conditions are fulfilled:

- A signalman with a walkie-talkie supervises the entire procedure.

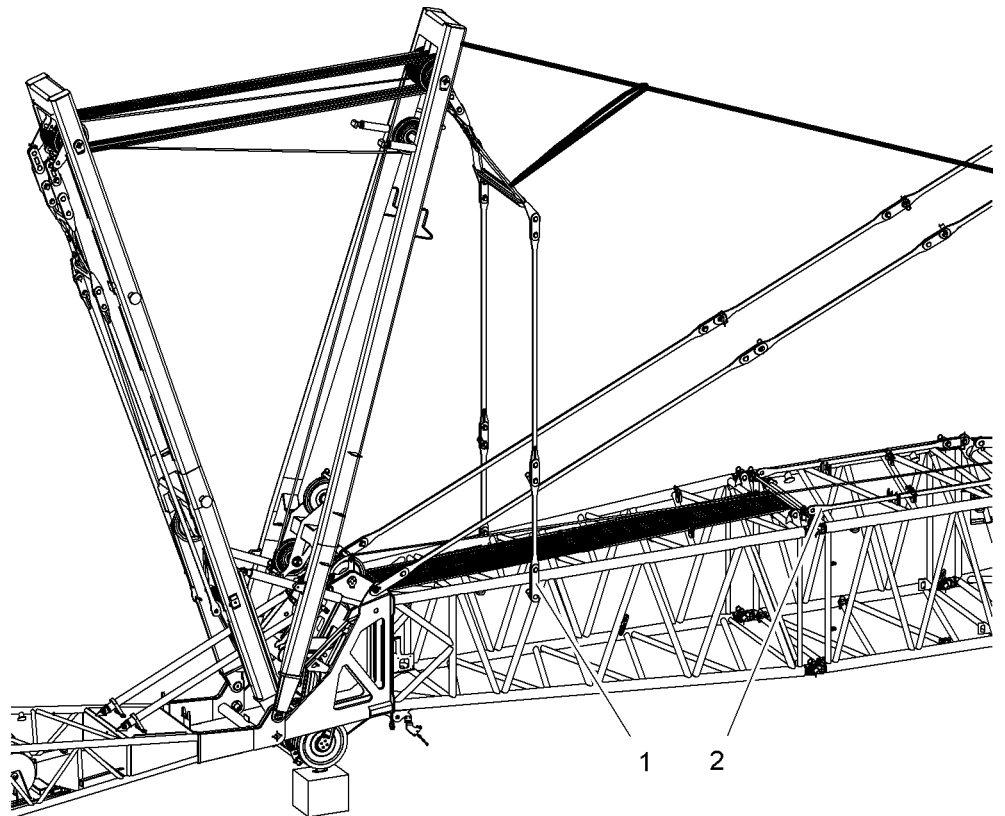


Fig. 5292: Bolting the equaliser on A-frame 2 to the jib backstay straps

1 A-frame 2 equaliser

2 Jib backstay straps on main boom

NOTICE

Not following the procedure correctly!

Damage to A-frame 2 and/or A-frame 3.

- ▶ Stop the erection process of A-frame2 in good time to avoid a collision with the pulleys on A-frame2 and the gantry pulleys on the boom head section.
- ▶ Stop the erection process of A-frame 3 in good time so as not to undercut the minimum visible dimension x of the hydraulic tilting-back supports piston rods. If required, lower A-frame 3 forwards.
- ▶ Erect A-frame2 using the rope of winch1/winch2 and lower A-frame3 forwards at the same time if required.
 - ▷ The equaliser of A-frame 2 moves towards the jib backstay straps.

Before the pulleys on A-frame2 collide with the gantry pulleys on the main boom:

- ▶ Stop the erection process.
- ▶ Bolt the equaliser on A-frame 2 to the jib backstay straps.
- ▶ Unwind rope of winch1/winch2.
- ▶ Remove rope of winch1/winch2 from pocket lock.
- ▶ Remove pocket lock from round sling.



Note

If the rope of winch1 is not reeved onto a hook or a pulley block:

- ▶ Wind up rope of winch1/winch2.

7.22.14 Connecting the equaliser on A-frame 3 to the jib base section

To bolt the jib base section to the jib, the jib base section is fastened to the equaliser of A-frame 3 with round slings. The jib base section can then be erected and moved up to the jib.



Note

Special procedure when using an assist crane!

- ▶ Lift the jib base section using an assist crane.

NOTICE

Not following the procedure correctly!

Damage to A-frame 3

- ▶ Stop the erection process of A-frame 3 in good time so as not to undercut the minimum visible dimension x of the hydraulic tilting-back supports piston rods. If required, lower A-frame 3 forwards.

Ensure that the following conditions are fulfilled:

- Approved sling gear is available ([For more information see: 6.9 Rigging equipment and/or sling gear, page 1141](#)).
- A signalman with a walkie-talkie should supervise the entire procedure.

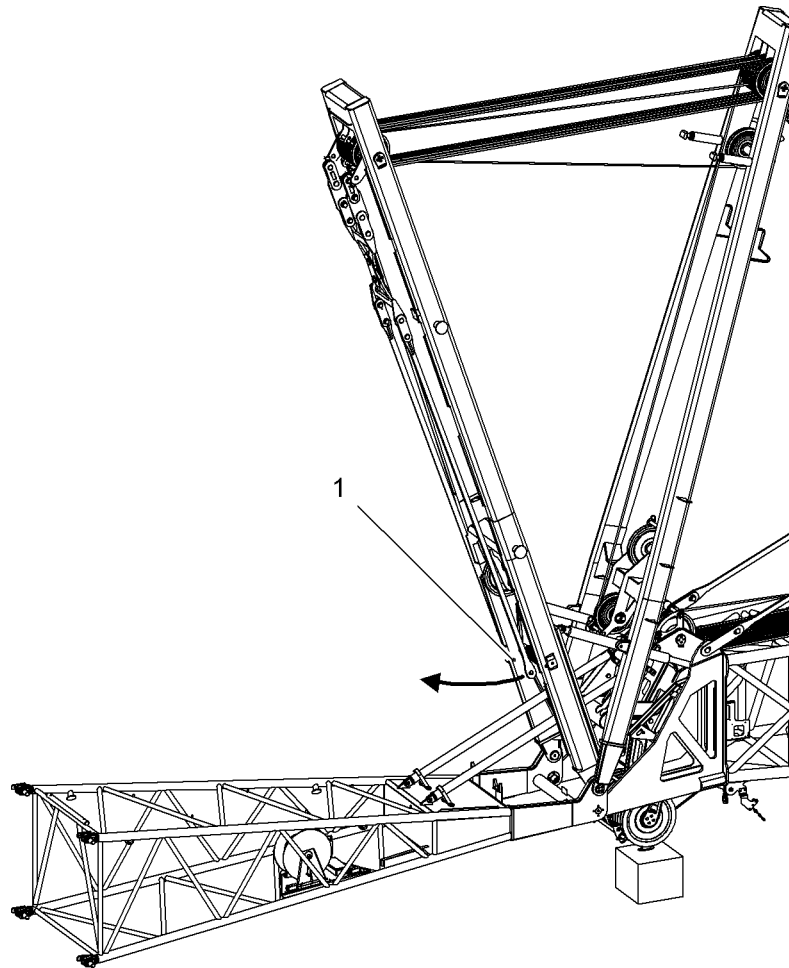


Fig. 5293: Removing the equaliser of A-frame 3 from the transport bracket

- 1 Transport brackets (2x) of the equalizer of A-frame3



CAUTION

A-frame 3 equaliser swinging down!

- ▶ Move A-frame 3 into a steep position using the jib luffing winch.
 - ▶ Leave the swing range of the equaliser of A-frame 3.
-
- ▶ Undo the safety pin and remove the equaliser of A-frame 3 from the transport bracket 1.
 - ▷ The equaliser of A-frame 3 swings downwards.

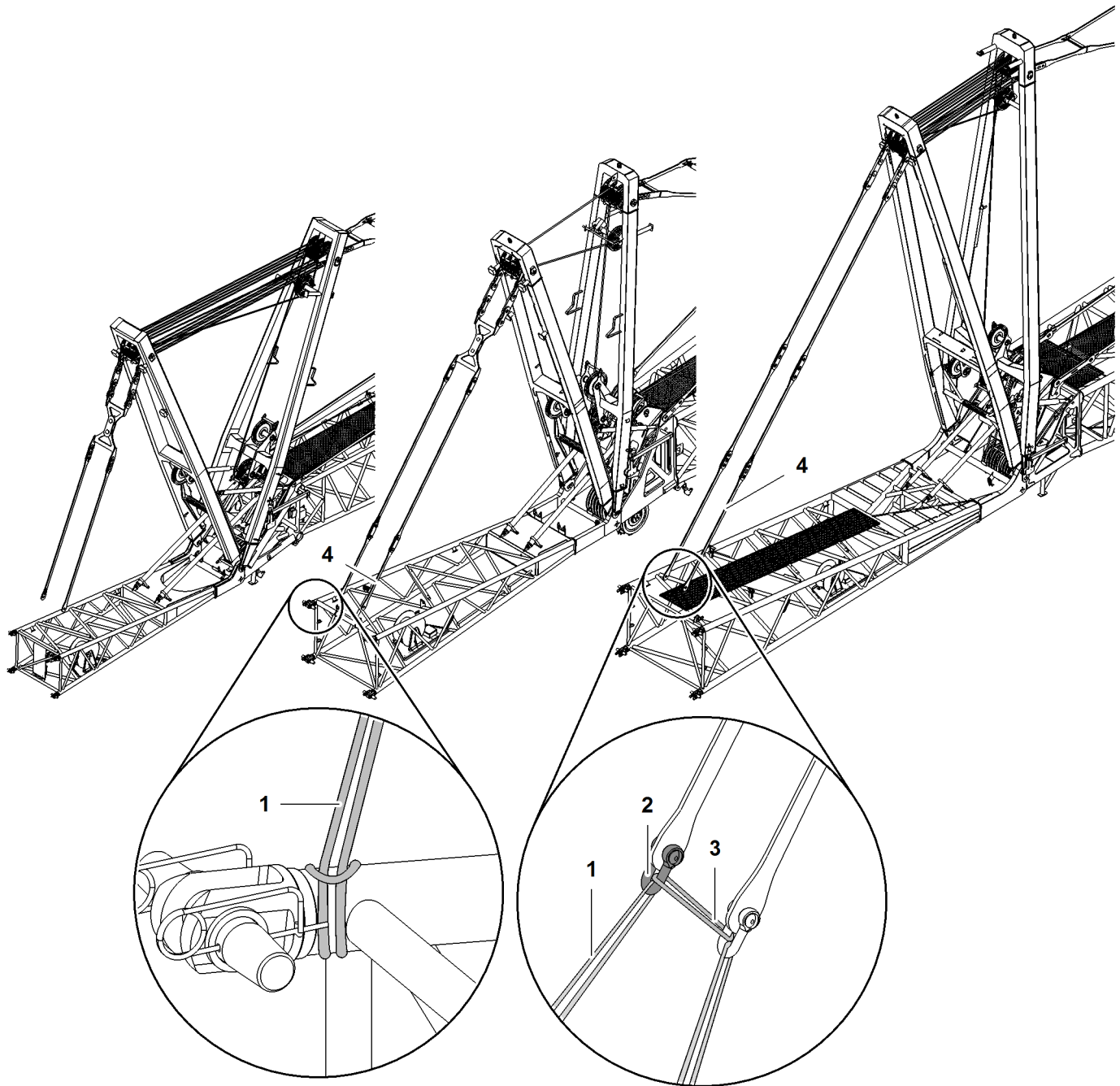


Fig. 5294: Connecting the equalizer on A-frame3 to the jib base section

- | | | | |
|---|-------------------------------------|---|---------------------------------------|
| 1 | Round sling
1.5 m (4' 11" ft-in) | 3 | Round sling 0.5 m (1' 8" ft-in) |
| 2 | Shackle (2x) | 4 | Jib pendant strap of jib base section |

Depending on the jib type, the equalizer of A-frame3 must be extended with a jib pendant strap 4 of the jib base section.

- ▶ Connect the equaliser of A-frame 3 to the jib base section as shown in the diagram.

7.22.15 Bolting the jib base section to the jib

- ▶ Wind up jib luffing winch.

- ▷ The jib base section lifts off the ground.
 - ▶ Raise the main boom with attached jib base section.
 - ▶ Move the machine forwards to enable pinning of the jib base section with the jib.
- Once the pin connection points of the jib base section and the first jib section align:
- ▶ Bolt the jib base section to the jib.

7.22.16 Bolting the equaliser on A-frame 3 to the jib pendant straps



WARNING

Unsecured walking on the boom!
risk of falling from the boom.

- ▶ A fall arrest system must be worn when working on booms to prevent falling.

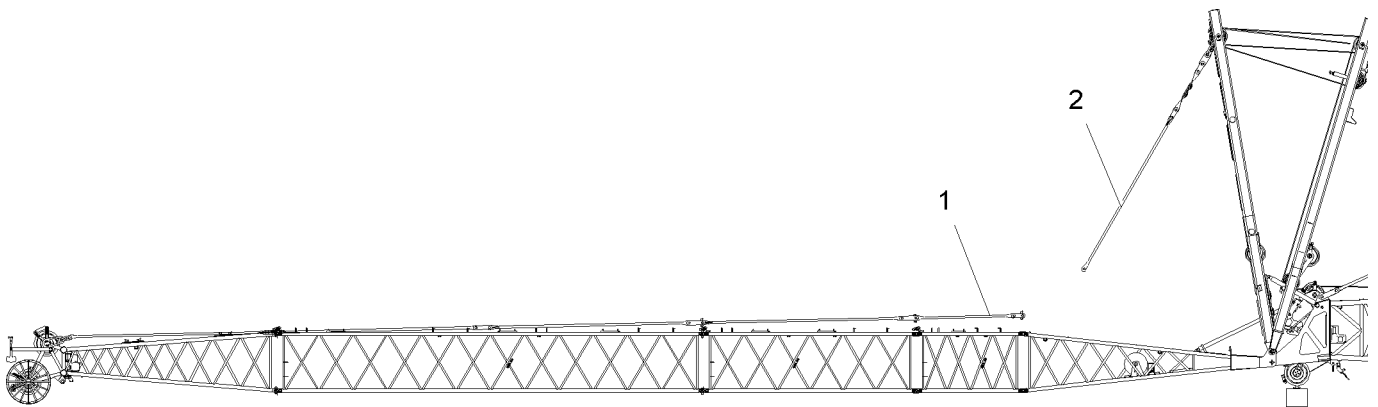


Fig. 5295: Bolting the equaliser on A-frame 3 to the jib pendant straps

1 Jib pendant straps

2 A-frame 3 equaliser

- ▶ Lower A-frame 3 forwards using the jib luffing winch.
 - ▷ The equaliser of A-frame 3 moves towards the jib.

If the shackles can be reached by hand:

- ▶ Stop the lowering process.
- ▶ Remove the shackles and round slings from the equaliser of A-frame 3 and store in a safe place.
- ▶ Continue lowering A-frame 3 forwards using the jib luffing winch.

If the equaliser of A-frame 3 can be bolted to the jib pendant straps:

- ▶ Stop the lowering process.
- ▶ Bolt the equaliser on A-frame 3 to the jib pendant straps.

7.22.17 Installing mid-point suspension

The lengths of the stay ropes and their assembly positions are shown in the relevant instructions for the boom.



DANGER

Incorrect installation of mid-point suspensions!
Structural breakdown.

- ▶ Fit mid-point suspensions according to relevant system instructions.

- ▶ Assemble required length of stay ropes in line with system-relevant details.
- ▶ Remove the safety pins and washers from both sides of the boom pin connection double-taper pin and stow away.
- ▶ Repeat procedure on opposite side.

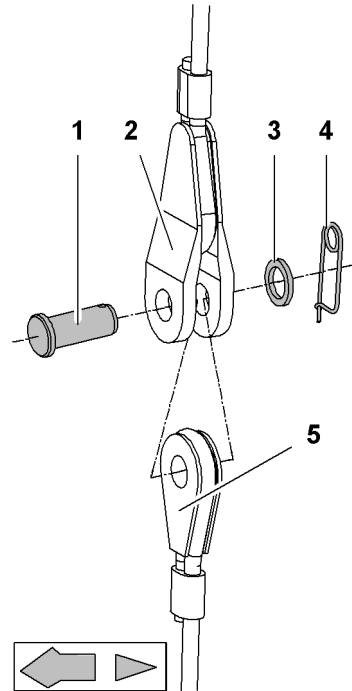


Fig. 5296: Pinning mid-point suspension stay ropes

- | | | | |
|---|---------------|---|------------------|
| 1 | Pin | 4 | Safety pin |
| 2 | Top stay rope | 5 | Bottom stay rope |
| 3 | Washer | | |

- ▶ Pin top stay rope 2 to bottom stay rope 5.
- ▶ Secure the pin 1 with washer 3 and retaining spring 4.

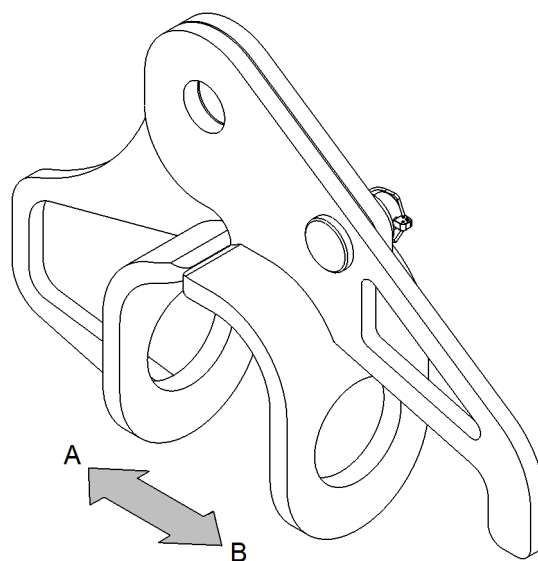


Fig. 5297: Mid-point suspension forks

- | | | | |
|---|--------------|---|--------------|
| A | Jib interior | B | Jib exterior |
|---|--------------|---|--------------|

The forks may have different shapes. The permissible shape depends on the boom configuration (For more information see: 1 Product description, page 51) .

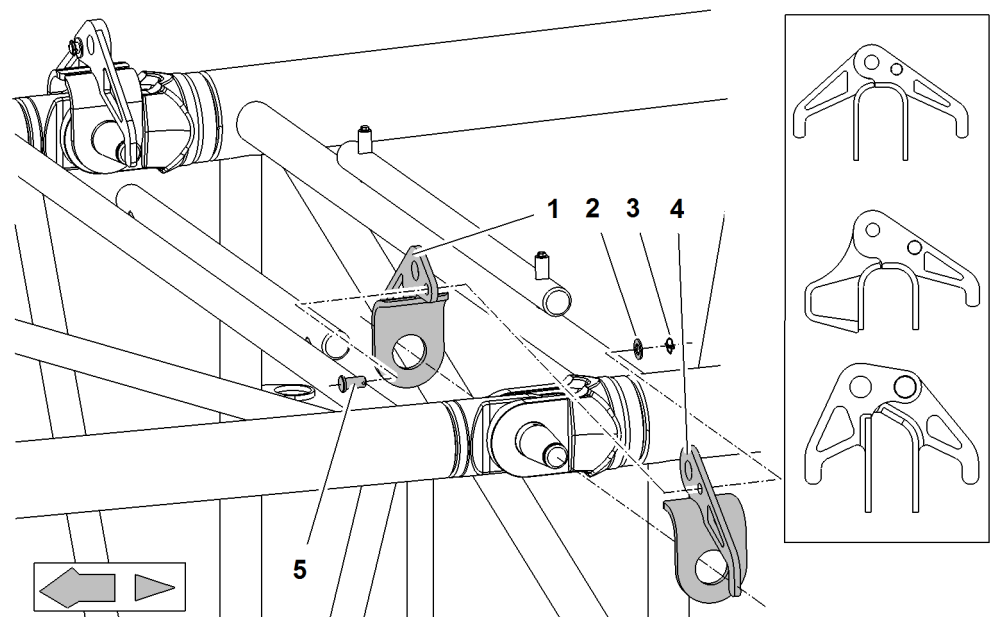


Fig. 5298: Assembling the mid-point suspension forks

- | | | | |
|---|-----------------------|---|-----------------------|
| 1 | Inner section of fork | 4 | Outer section of fork |
| 2 | Washer | 5 | Pin |
| 3 | Linch pin | | |

- ▶ Mount inner section of fork **1** on double-taper pin.
- ▶ Mount outer section of fork **4** on double-taper pin.
- ▶ Pin inner section of fork **1** to outer section of fork **4**.
- ▶ Secure pin **5** with a washer **2** and linch pin **3**.
- ▶ Repeat procedure on opposite side.

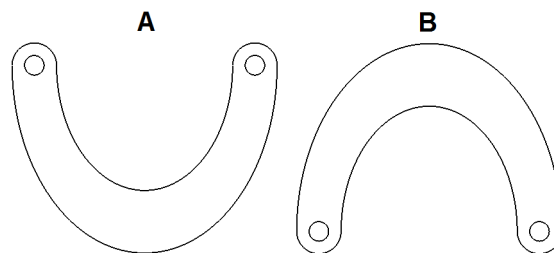


Fig. 5299: Installation position of spacer bracket with mid-point suspension on luffing jib 2316 and 1916

- | | | | |
|----------|---------------------|----------|-------------------|
| A | Spacer bracket down | B | Spacer bracket up |
|----------|---------------------|----------|-------------------|

Install spacer bracket **6** of mid-point suspension on luffing jibs 2316 and 1916 in installation position spacer bracket **B up**.

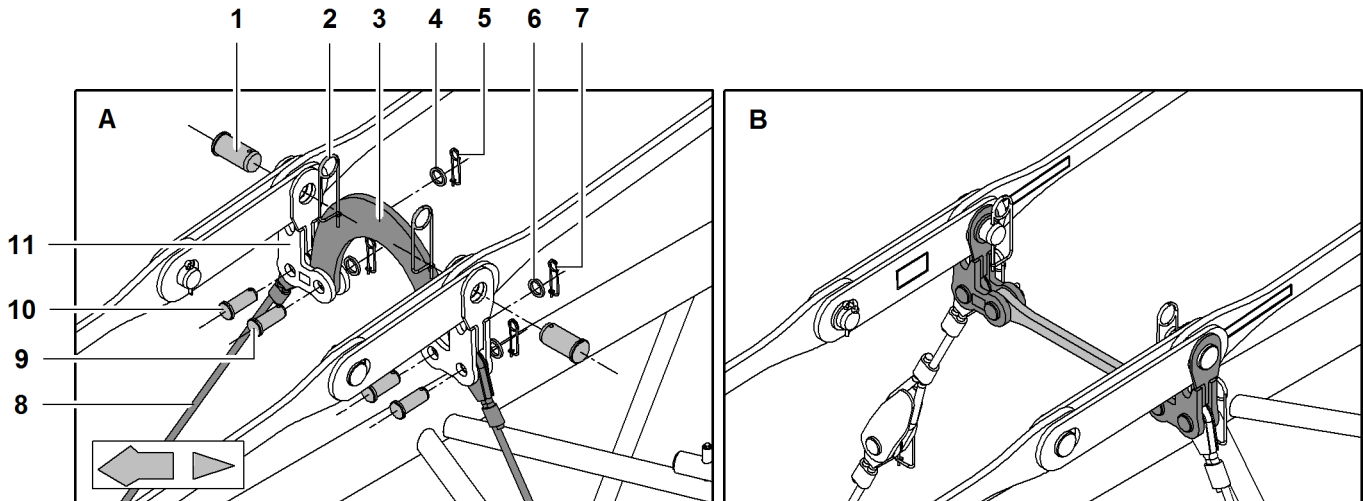


Fig. 5300: Installing the pendant straps, spacer bracket, connecting elements and mid-point suspension stay ropes

- | | | | | | |
|---|-----------------------------|----|-----------------------------|----|---|
| 1 | Pin (2x) for pendant straps | 6 | Washer (2x) | 11 | Connecting element (2x) |
| 2 | Locking spring (2x) | 7 | Locking spring (2x) | A | Mid-point suspension on luffing jib 2316 and 1916 |
| 3 | Spacer bracket | 8 | Stay ropes | B | Mid-point suspension on luffing jib 1713, 1309 and 1008 |
| 4 | Washer (2x) | 9 | Pin (2x) for spacer bracket | | |
| 5 | Locking spring (2x) | 10 | Pin (2x) for stay ropes | | |

Installation of the mid-point suspension on luffing jib 2316, 1916, 1713, 1309 and 1008 is identical. Only the spacer brackets are different.

- ▶ Pin connecting elements **11** to pendant straps.
- ▶ Secure pin **1** with locking springs **2**.

NOTICE

Inadmissible run of winch1/winch2 rope on luffing jib 2316 and 1916!
Damage to winch1/winch2 rope.

- ▶ Ensure that winch1/winch2 rope runs underneath spacer bracket **3**.

- ▶ Pin connecting elements **11** to spacer bracket **3**.
- ▶ Secure pin **9** with washers **6** and locking springs **7**.
- ▶ Pin connecting elements **11** to stay ropes **8**.
- ▶ Secure pin **10** with washers **4** and locking springs **5**.

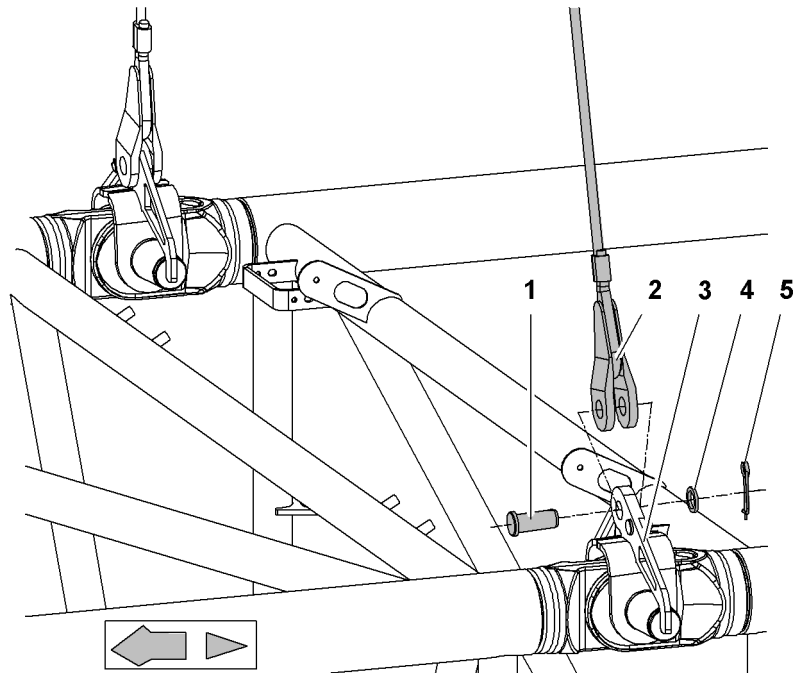


Fig. 5301: Pinning stay ropes to forks of mid-point suspension

- | | | | |
|---|-----------|---|------------|
| 1 | Pin | 4 | Washer |
| 2 | Stay rope | 5 | Safety pin |
| 3 | Fork | | |



Note

- ▶ To facilitate pinning stay ropes 2 and forks 3: Use A-frame 1 to lift pendant straps.
- ▶ Pin stay rope 2 to fork 3.
- ▶ Secure the pin 1 with washer 4 and retaining spring 5.
- ▶ Repeat procedure on opposite side.

7.22.18 Pinning the pendant straps

- ▶ Remove safety pins from the transport brackets for pendant straps.

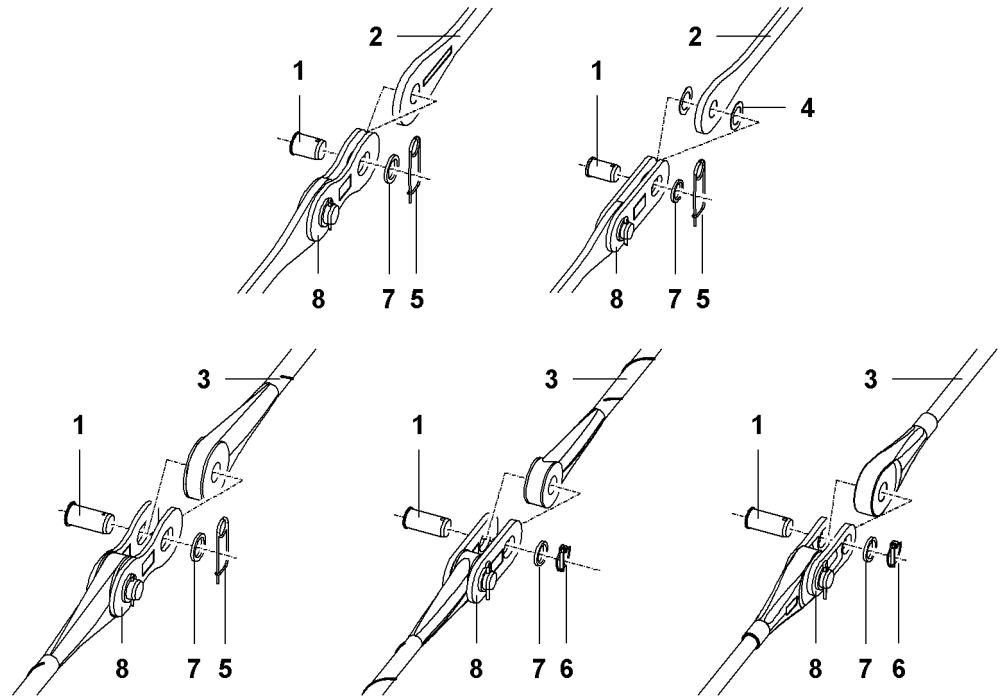


Fig. 5302: Bolt the pendant straps (schematic diagram of various pendant straps)

1	Pin	5	Safety pin
2	Steel pendant strap	6	Linch pin
3	Carbon-fibre pendant strap	7	Washer
4	Plastic washer (2x)	8	Connecting link

- ▶ Remove the pin 1 on the connecting link 8.
- ▶ Position the pendant strap 2, 3 between the two coupling links 8.
or
- If the pendant strap has plastic washers 4:
Position the pendant strap 2 with plastic washers 4 on both sides between the two connecting links 8.
- ▶ Insert pin 1 and secure with washers 7 and safety pin 5 or linch pin 6.

7.22.19 Connect the electric cables

NOTICE

Electric cables have been handled incorrectly!
Damage to electric cable and plug.

- ▶ Do not pull the electric cable over sharp-edged objects.
 - ▶ Do not crush or kink the electric cable.
 - ▶ Keep the plug clean.
-
- ▶ Disconnect the electric cable from the dummy receptacle on the jib base section.
 - ▶ Connect the electric cable to the terminal box on the main boom head section and secure using retaining clips.
 - ▷ The boom head section and jib base section electric cables are connected.

The electric cable to the jib head section is rolled on the cable drum on the jib base section.

- ▶ Disconnect both electric cables from the terminal box on the jib base section.

NOTICE

Electric cable has been unwound incorrectly!
Electric cable may be damaged.

- ▶ Push the electric cable in the cable drum into the side opening of the cable drum.

-
- ▶ Loosen the pin on the axle of the cable drum.
 - ▶ Unwind the electric cables from the cable drum and pull it inside the jib to the jib head section.
 - ▶ Connect the electric cable to the terminal box on the jib head section and secure using retaining clips.

Two fixing holes are provided under the terminal box to relieve the strain on the plug.

- ▶ Clip both carabiners on the cable sock into the fixing holes.
- ▶ Fix the pin on the axle of the cable drum.
- ▶ Reconnect the electric cable in the cable drum to the terminal box on the jib base section.
 - ▷ The jib base section and jib head section electric cables are connected.

If an auxiliary jib is fitted:

- ▶ Plug the auxiliary jib electric cable into the jib head section.

7.22.20 Installing the obstacle warning light



Note

Use of the obstacle warning light is prescribed by national or regional regulations!

- ▶ Before using the machine, familiarise yourself with national and local regulations.

Ensure that the following conditions are fulfilled:

- Anemometer is not installed.

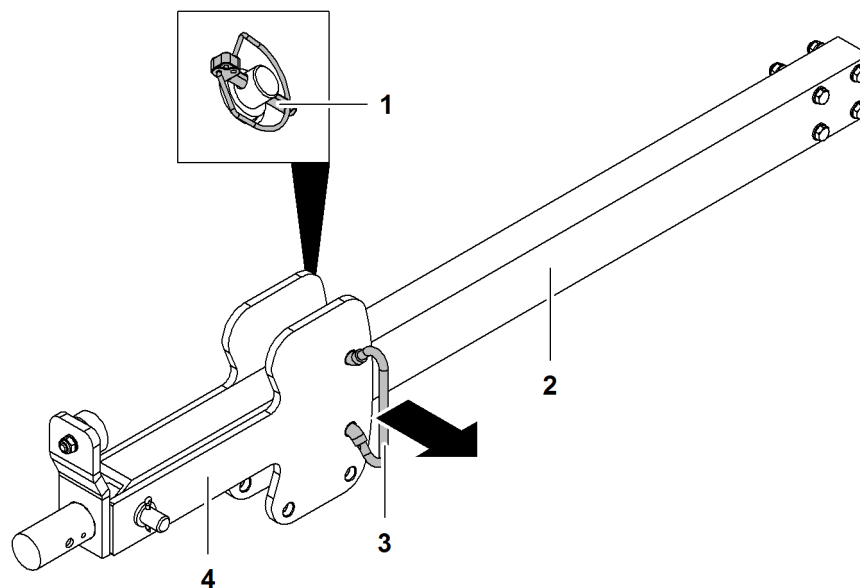


Fig. 5303: Moving the pendulum into the working position

- | | | | |
|----------|----------------|----------|-----------------|
| 1 | Linchpins (2x) | 3 | Locking element |
| 2 | Mount | 4 | Pendulum |

The pendulum **4** is secured on the mount **2** for machine transport.

- ▶ Remove the linchpin **1** of the locking element **3**.
- ▶ Remove **3** locking element.
- ▶ Swing pendulum **4** down.
- ▶ Slide locking element **3** through pendulum **4** and secure with linchpins **1**.

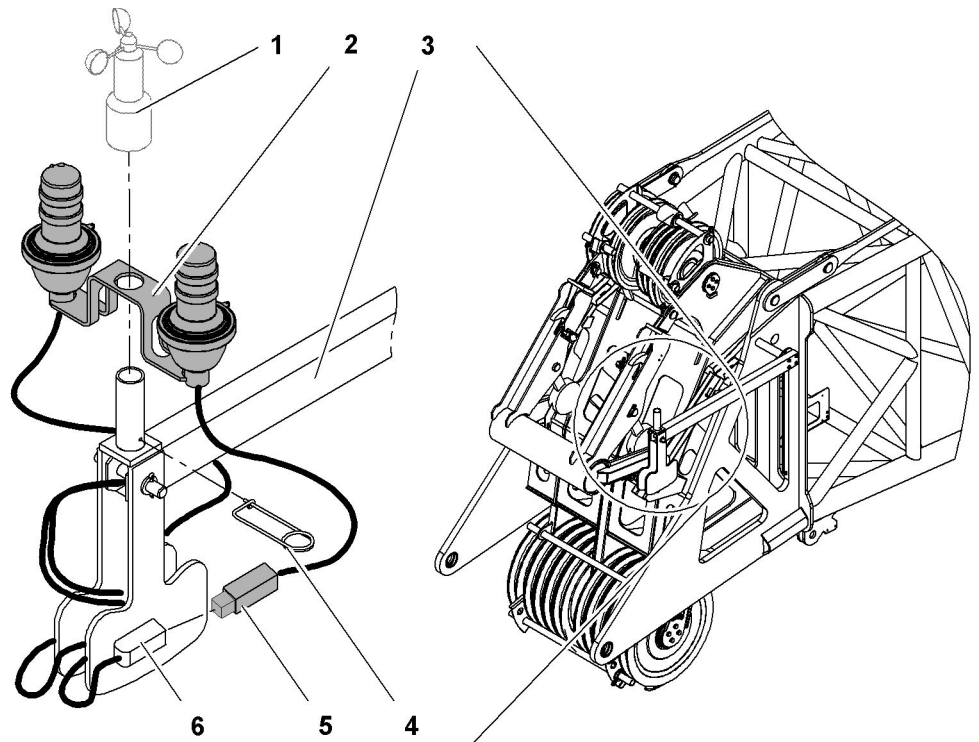


Fig. 5304: Installing the obstacle warning light

- | | | | |
|---|------------------------|---|------------|
| 1 | Anemometer | 4 | Safety pin |
| 2 | Obstacle warning light | 5 | Plug |
| 3 | Mount | 6 | Coupling |

- ▶ Place obstacle warning light 2 on pipe.
 - ▷ Obstacle warning light is secured by the pipe and axis on the bracket 3.

NOTICE

Safety pin is not fit properly!
Damage to the electric cable.

- ▶ Insert the safety pin carefully.
- ▶ Insert the safety pin 4.
 - ▷ Obstacle warning light 2 is secured.
- ▶ Connect the plug 5 to the coupling 6.
- ▶ Lock plug 5.

7.22.21 Fitting the anemometer

Ensure that the following conditions are fulfilled:

- Obstacle warning light is installed (if available).

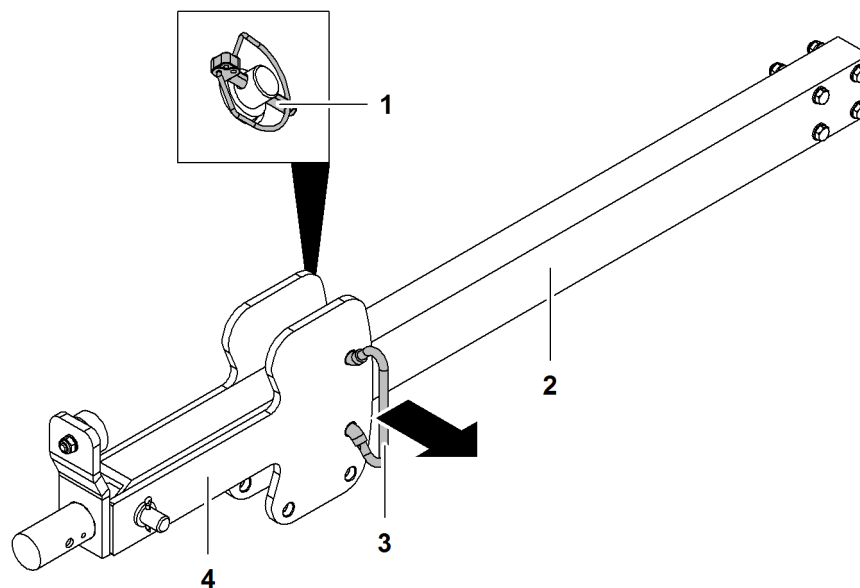


Fig. 5305: Moving the pendulum into the working position

- | | | | |
|---|----------------|---|-----------------|
| 1 | Linchpins (2x) | 3 | Locking element |
| 2 | Mount | 4 | Pendulum |

The pendulum 4 is secured on the mount 2 for machine transport.

- ▶ Remove the linchpin 1 of the locking element 3.
- ▶ Remove 3 locking element.
- ▶ Swing pendulum 4 down.
- ▶ Slide locking element 3 through pendulum 4 and secure with linchpins 1.

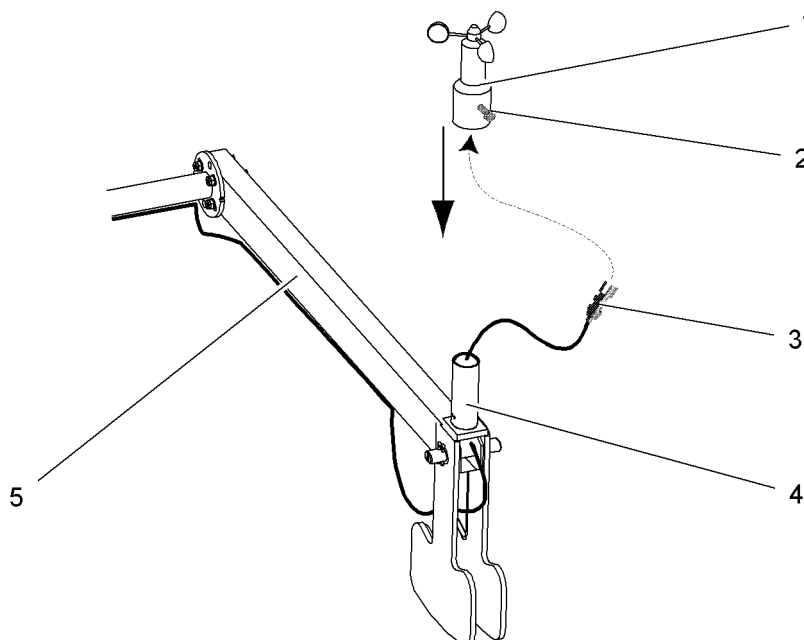


Fig. 5306: Fitting the anemometer

- | | | | |
|---|------------|---|-------|
| 1 | Anemometer | 4 | Tube |
| 2 | Screw | 5 | Mount |
| 3 | Plug | | |

- ▶ Remove cover from the plug **3**.
- ▶ Plug in the connector **3** at the bottom of the anemometer **1**.
- ▶ Secure plug **3** with nut.

NOTICE

Anemometer is not fit properly!
Damage to the electric cable.

- ▶ Pull the extended electric cable through the tube before pushing on the anemometer.

- ▶ Position the anemometer **1** on the tube **4**.
- ▶ Securing the anemometer on the mount: Tighten the screw **2**.

The rotor of the anemometer must be free to rotate slightly.

- ▶ Test the anemometer: rotate the rotor slightly and note the value on the monitor.
 - ▷ The wind speed value will increase.

7.22.22 Moving the lightning rods* into working position

Installation position of lightning rods on luffing jib

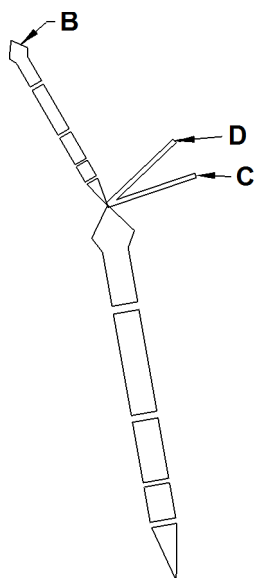


Fig. 5307: Installation position of lightning rods on luffing jib

- B** Luffing jib head
- C** A-frame2
- D** A-frame3

Boom configuration	Number of lightning rods	Installation positions
Main boom + luffing jib	3	B + C + D
Main boom + luffing jib + midfall	3	B + C + D

Tab. 586: Installation position and number of lightning rods on luffing jib

LWNLR.x/V04.01//Auslieferung/2016-03-07/en

Moving the lightning rods* on the luffing jib head into working position

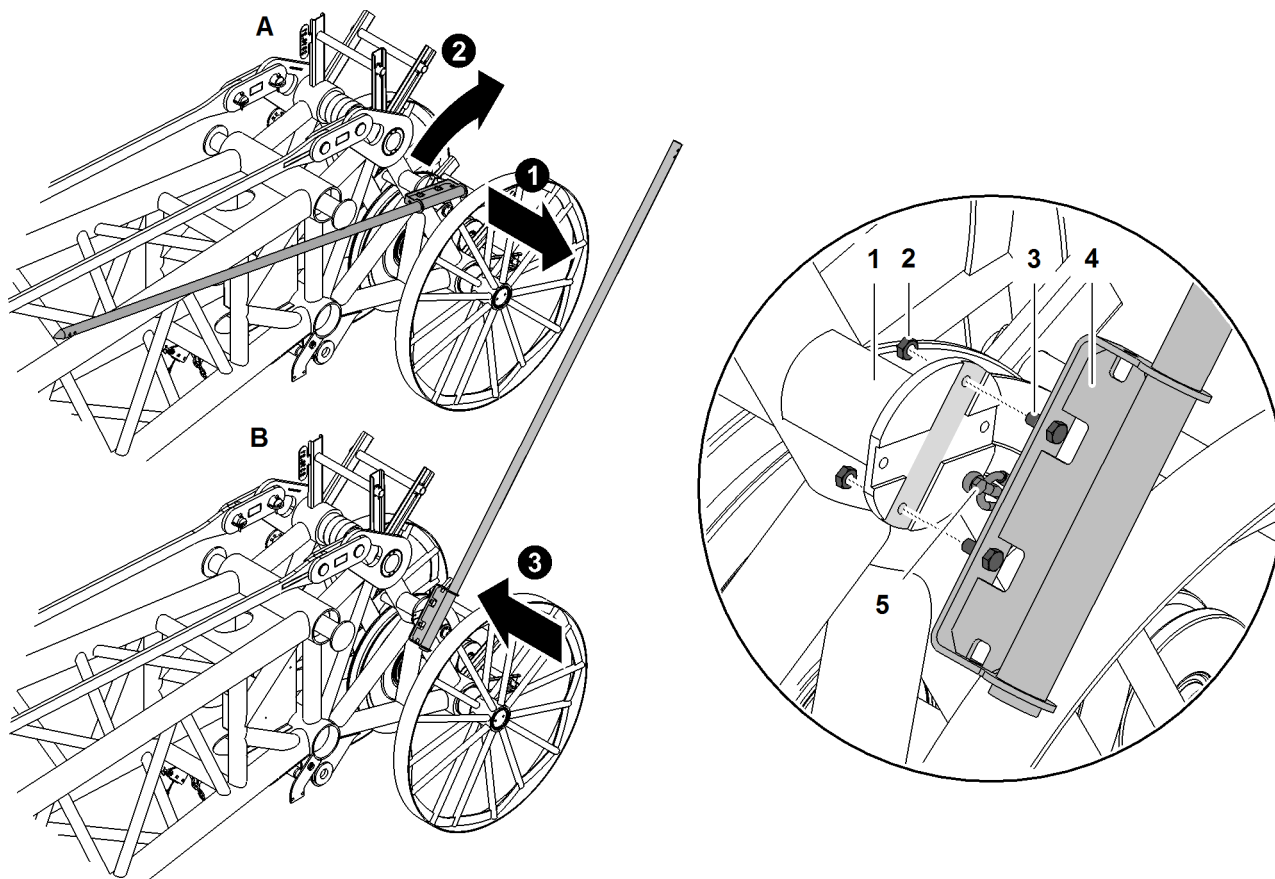


Fig. 5308: Moving the lightning rods* on the luffing jib head into working position (illustration of principle)

A Transport position
B Working position
1 Mounting plate

2 Nut (2x)
3 Screw (2x)
4 Lightning rod

5 Safety rope

- ▶ Undo safety rope 5.
- ▶ Undo nuts 2.
- ▶ Undo screws 3.
- ▶ Move lightning rod 4 from transport position A to working position B.



Note

Liebherr recommends:

- ▶ Grease threads of the screws 3.
- ▶ Attach lightning rod 4 with screws 3.
- ▶ Lock screws 3 with nuts 2.

NOTICE

Safety rope not attached!
 Dropping parts.

- ▶ Ensure that safety rope 5 is attached.

- ▶ Attach safety rope 5.

NOTICE

Tip not installed!
Improperly deflected current.
Dropping parts.

- ▶ Ensure that the tip on the lightning rod 4 is installed.
- ▶ Ensure that the screws of the tip are tightened.

- ▶ Ensure that the tip on the lightning rod 4 is installed.
- ▶ Ensure that the screws of the tip are tightened.

Moving the lightning rods* on A-frame2 and A-frame3 into working position

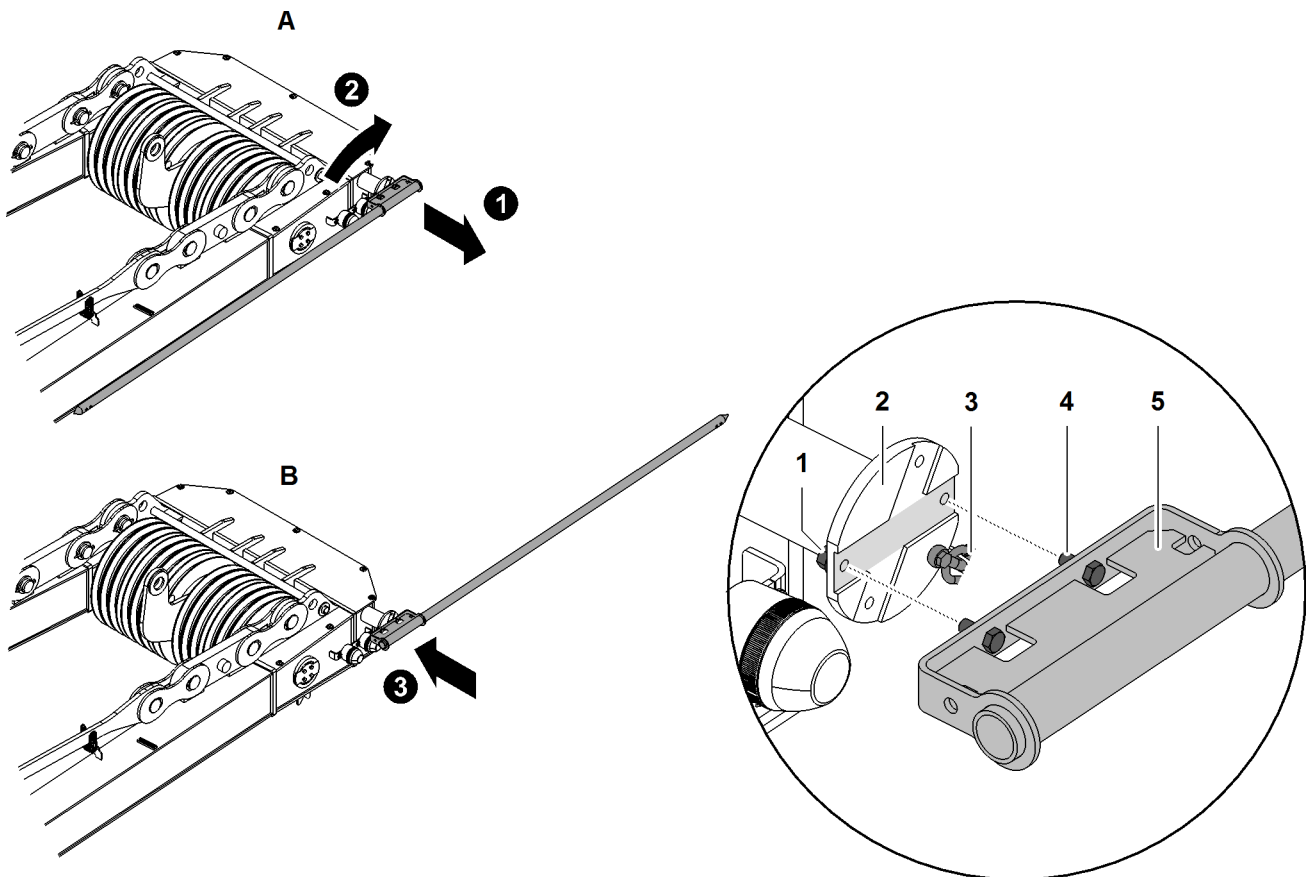


Fig. 5309: Moving the lightning rods* on A-frame2 and A-frame3 into working position (illustration of principle)

A	Transport position	2	Mounting plate	5	Lightning rod
B	Working position	3	Safety rope		
1	Nut (2x)	4	Screw (2x)		

- ▶ Undo safety rope 3.
- ▶ Undo nuts 1.
- ▶ Undo screws 4.
- ▶ Move lightning rod 5 from transport position A to working position B.

LWNLR.x/V04.01//Auslieferung/2016-03-07/en



Note

Liebherr recommends:

▶ Grease threads of the screws **4**.

▶ Attach lightning rod **5** with screws **4**.

▶ Lock screws **4** with nuts **1**.

NOTICE

Safety rope not attached!
Dropping parts.

▶ Ensure that safety rope **3** is attached.

▶ Attach safety rope **3**.

NOTICE

Tip not installed!
Improperly deflected current.
Dropping parts.

▶ Ensure that the tip on the lightning rod **5** is installed.

▶ Ensure that the screws of the tip are tightened.

▶ Ensure that the tip on the lightning rod **5** is installed.

▶ Ensure that the screws of the tip are tightened.

7.22.23 Reeving the rope

The rope must be reeved as specified in the rope reeving diagram according to the boom and application requirements.



WARNING

Unsecured walking on the boom!
Risk of falling off the boom.

▶ A fall arrest system must be worn when working on the boom to prevent falling.

Ensure that the following conditions are satisfied:

Cylinder adjustment functions are on.

Reeving the rope using a rope reeving winch

Dismantling rope protection pipes

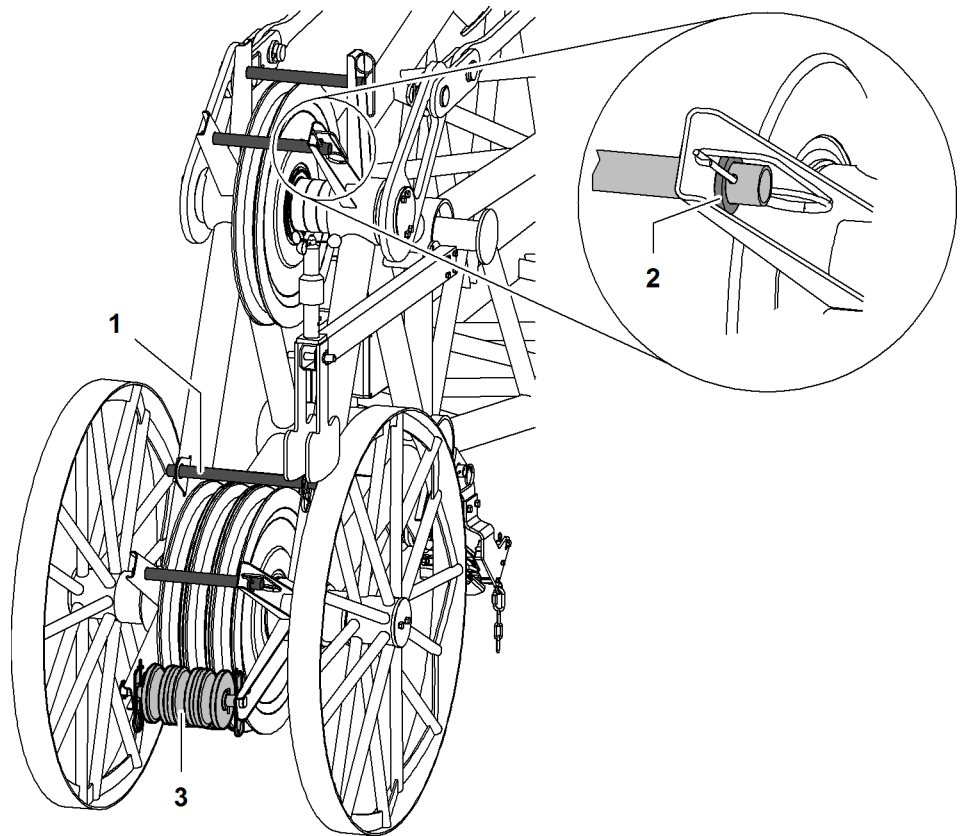


Fig. 5310: Rope protection pipes jib head section (1008, 1309, 1713, 1916, 2316)

- | | | | |
|---|----------------------|---|---------------------------------|
| 1 | Rope guard tube (4x) | 3 | Rope protection rollers package |
| 2 | Washer | | |

The rope protection pipes are secured with a cotter pin on one side and with a safety pin on the other side.

NOTICE

Inadmissible operation of winch1/winch2 below 10° jib angle!
Damage to jib head section.

- ▶ Make sure that winch1/winch2 are not operated below 10° jib angle.

- ▶ Remove the safety pin and washer 2.
- ▶ Remove the rope protection pipes 1.

Dismantling the rope protection rollers package

The number of rope protection rollers corresponds to the number of pulleys of the jib head.

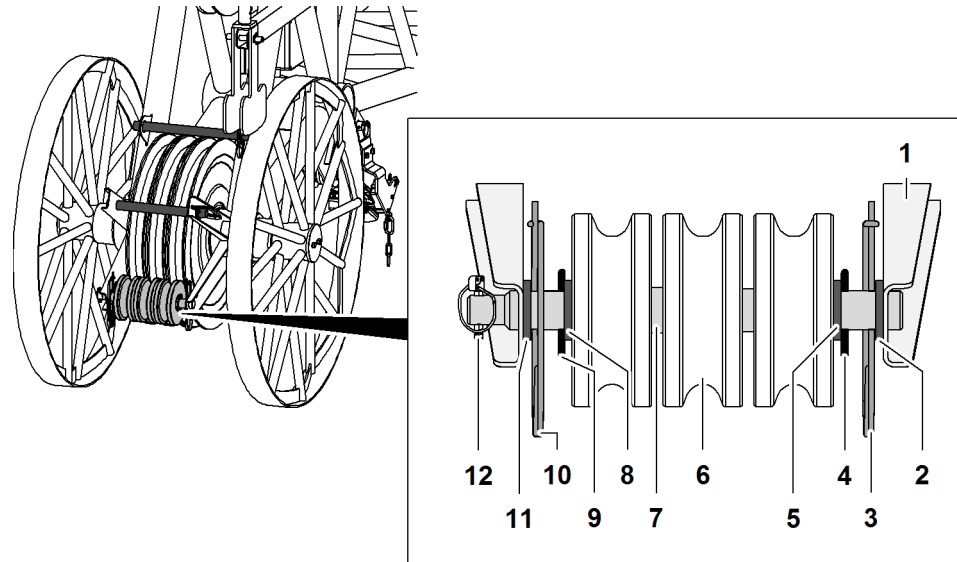


Fig. 5311: Rope protection rollers package

- | | | | |
|---|------------|----|------------|
| 1 | Mount | 7 | Shaft |
| 2 | Washer | 8 | Washer |
| 3 | Safety pin | 9 | Cotter pin |
| 4 | Cotter pin | 10 | Safety pin |
| 5 | Washer | 11 | Washer |
| 6 | Pulley | 12 | Linchpin |

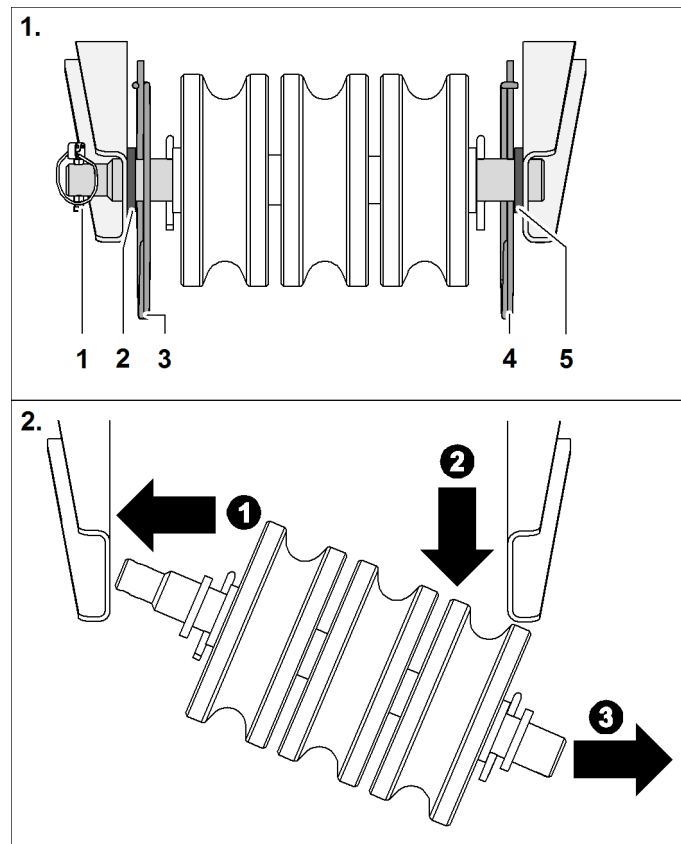


Fig. 5312: Dismantling the rope protection rollers package

- | | | | |
|---|----------|---|------------|
| 1 | Linchpin | 4 | Safety pin |
|---|----------|---|------------|

See next page for continuation of the image legend

- 2 Washer
- 3 Safety pin

- 5 Washer

- ▶ Remove the linchpin **3 + 4**.
- ▶ Remove safety pin **3 + 4**.
- ▶ Take rope protection rollers package off the support.
 - ▷ Rope protection rollers package is dismantled.

Removing the rope protection pipes on auxiliary jib

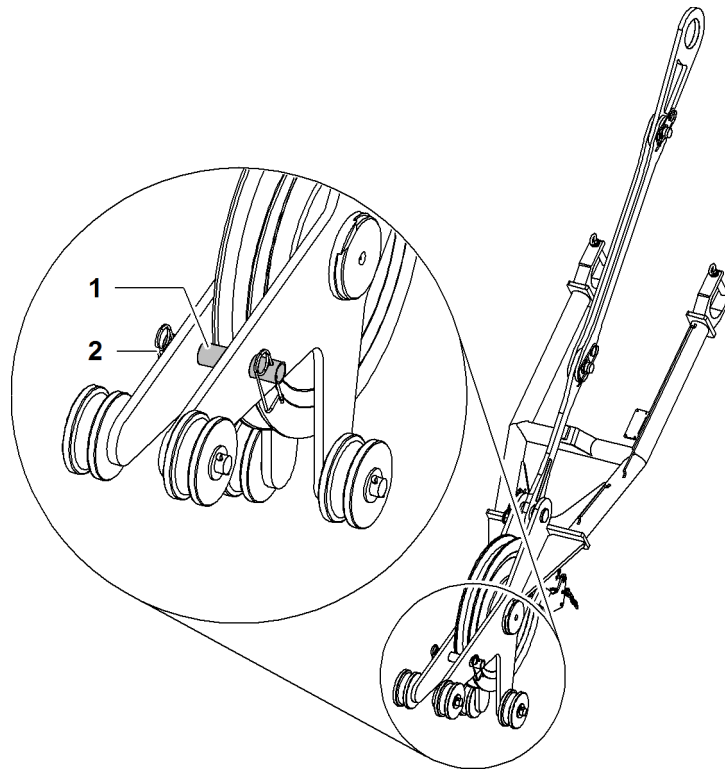


Fig. 5313: Removing the rope protection pipes on auxiliary jib

- 1 Rope protection pipe
- 2 Safety pin (2x)

- ▶ Remove rope protection pipes **1** with attached auxiliary jib.

Reeving the rope

- ▶ Open up the rope guide (if present).

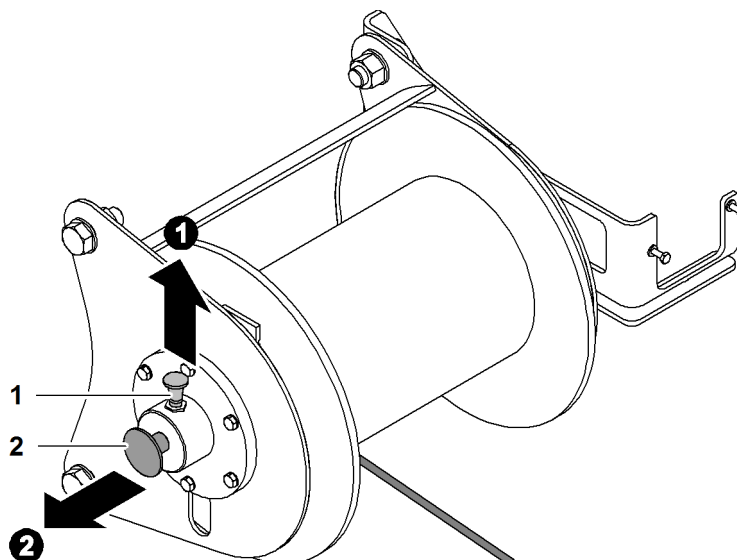


Fig. 5314: Setting the rope lug to free-wheel

1 Locking element

2 Shaft



Note

Liebherr recommends:

- ▶ Making it easier to pull out the axle 2: move the rope reeving winch manually back and forth.

- ▶ Pull up the locking element 1 and pull out the axle 2 at the same time.
 - ▷ Rope reeving winch is set to free-wheel.

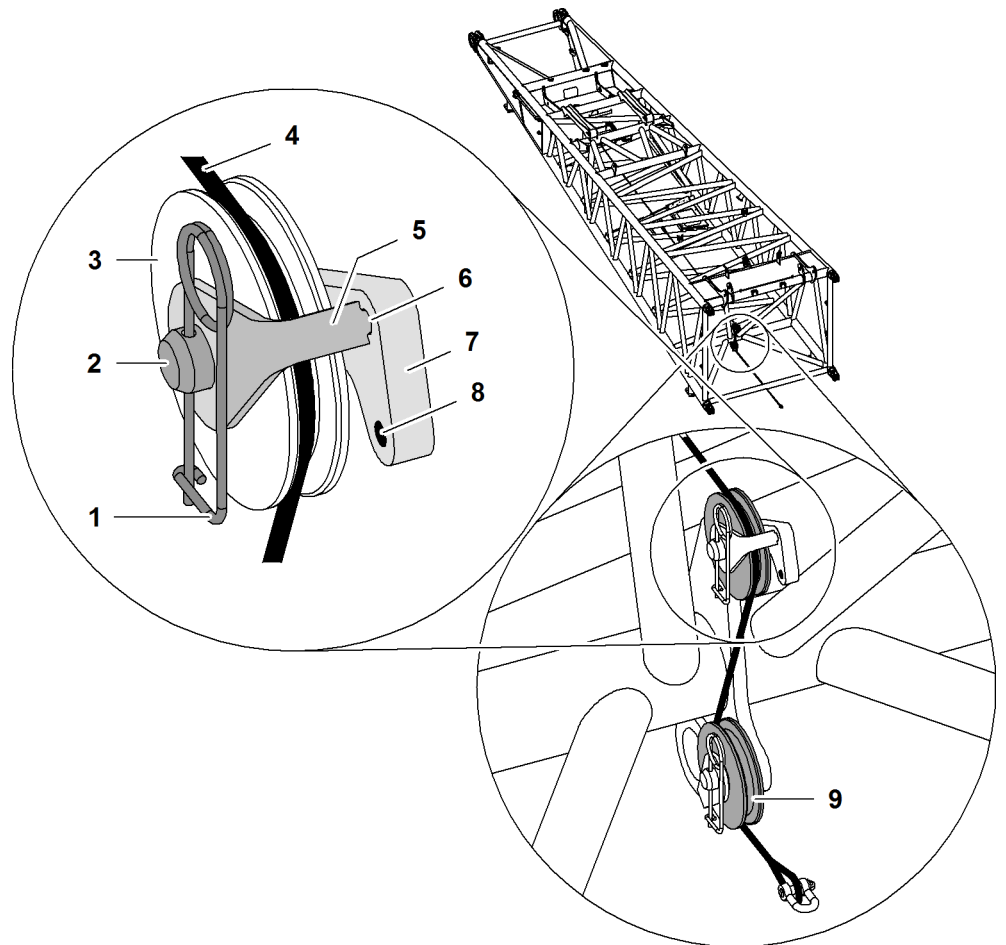


Fig. 5315: Reeving in the rope of the rope reeving winch

- | | | | |
|---|--------------------------------|---|-----------------------|
| 1 | Safety pin | 6 | Recess |
| 2 | Shaft | 7 | Support with recesses |
| 3 | Upper pulley | 8 | Recess |
| 4 | Rope of the rope reeving winch | 9 | Lower pulley |
| 5 | Locking element | | |

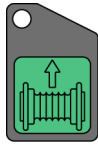
Depending on the machine type, the mounting 7 may have one or two recesses.

- ▶ Remove safety pins 1.
- ▶ Remove 5 securing element.
- ▶ Place rope of the rope reeving winch 4 across the top pulley 3.

NOTICE

Wrongly mounted locking element!
Rope of the rope reeving winch jumps out of pulley.

- ▶ Make sure that the locking element 5 is mounted in recess 6.
-
- ▶ Attach locking element 5 to axle 2 and guide in recess 6.
 - ▶ Attach the safety pin 1.
 - ▶ Repeat procedure on bottom pulley 9.
 - ▷ Rope of the rope reeving winch is guided through pulleys.
 - ▶ Pull the luffing rope under the boom to the boom head.
 - ▶ Reeve in the rope of the rope reeving winch according to reeving plan.



- ▶ Remove rope of the rope reeving winch from the rope of winch1/winch2.
- ▶ Press and hold the *Rope reeving winch* button on control panel X11.
 - ▷ Luffing rope is being reeved.
- ▶ Press the *Rope reeving winch* button on control panel X11.
 - ▷ Rope reeving winch switched off.
- ▶ Close and secure the rope guide (if present).

Mounting the rope protection rollers package

NOTICE

Wrongly installed washers!
Rope protection rollers package falls out of the support.
Damage to jib head section.

- ▶ Ensure proper installation position of the washers.
-

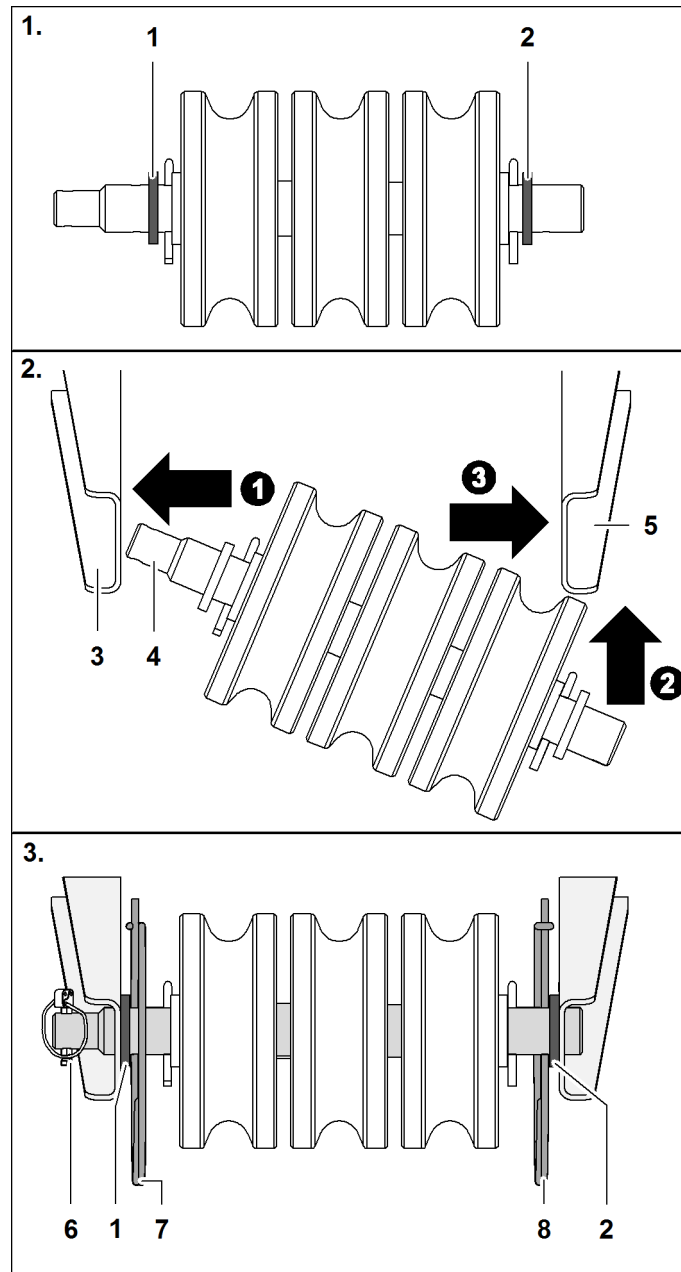


Fig. 5320: Mounting the rope protection rollers package on the jib head section

1	Washer	5	Mount
2	Washer	6	Linchpin
3	Mount	7	Safety pin
4	Shaft	8	Safety pin

- ▶ Place washers **1 + 2** on axle.
- ▶ Insert axle **4** of the rope protection rollers package into support **3**.
- ▶ Insert axle **4** into support **5**.
- ▶ Put washers **1 + 2** into position.
- ▶ Install safety pins **7 + 8**.
- ▶ Install linchpin **6**.
 - ▷ Rope protection rollers package is installed.

Installing rope protection pipes

- ▶ Mount and secure rope protection pipes on jib head section and (if available) on auxiliary jib.

Reeving the rope without using a rope reeving winch

- ▶ Remove the rope protection pipes on the boom and the pulley block.
- ▶ Open up the rope guide (if present).
- ▶ Connect auxiliary rope with the rope of winch1/winch2.
- ▶ Pull the auxiliary rope next to the boom as far as the boom head.
- ▶ Hoist the auxiliary rope onto the boom.
- ▶ Reeve the auxiliary rope according to the rope reeving system.



If rope of winch1/winch2 is in the 8th rope layer (only with free-fall winch 130 kN (29,230 lb_t)):

- ▶ Press the *Bypass limit switch* button on control panel X23.
 - ▷ The 3-rope windings limit switch is bypassed.

There must be no slacking of the rope when unwinding.

- ▶ Unwind the rope of winch1/winch2 up to the rope fixing point.
- ▶ Remove auxiliary rope from the rope of winch1/winch2.
- ▶ Close and secure the rope guide (if present).
- ▶ Mount and secure rope protection pipes.

7.22.24 Attaching the rope fixing point



DANGER

Incorrect installation of pins and pocket lock!
Load breakaway.

- ▶ Fit pins and pocket lock as instructed.

The collar of the pins and the pocket lock openings are decisive for the installation direction of the rope fixing point.

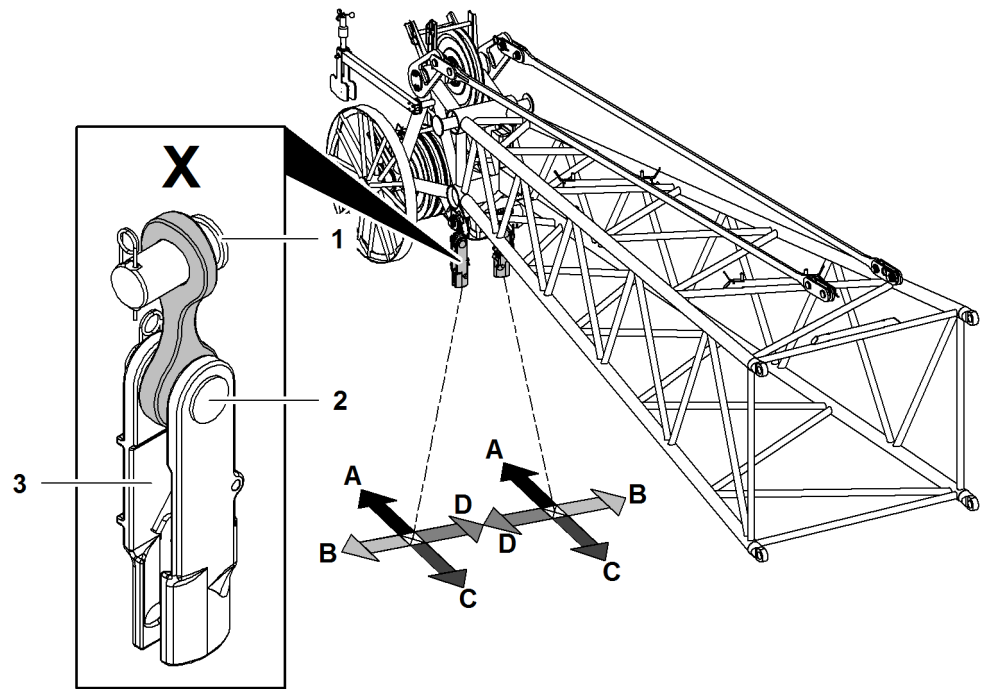


Fig. 5322: Determining the installation direction of the components of the rope fixing point of relevance for installation - luffing jib (illustration of principle)

- | | | | |
|----------|------------------------------------|----------|--------------------------|
| X | Components needed for fitting | A | Direction main boom head |
| 1 | Shoulder of pin on the boom | B | Outside |
| 2 | Shoulder of pin on the pocket lock | C | Direction basic machine |
| 3 | Pocket lock opening | D | Inside |

Installation direction of the rope fixing point components of relevance for installation			
	Pin collar on boom	Pin collar on pocket lock	Pocket lock opening
All rope fixing points	D	C	B
Exceptions:			
Fixed jib head 0906	B	C	B
Fixed jib head 1507	B	C	B

Tab. 587: Installation direction of the rope fixing point components of relevance for installation



WARNING

Incorrectly fit swivels!
Severe injuries, damage to machine.

- ▶ Fit rope with no twists.
- ▶ Install the rope without swivels.

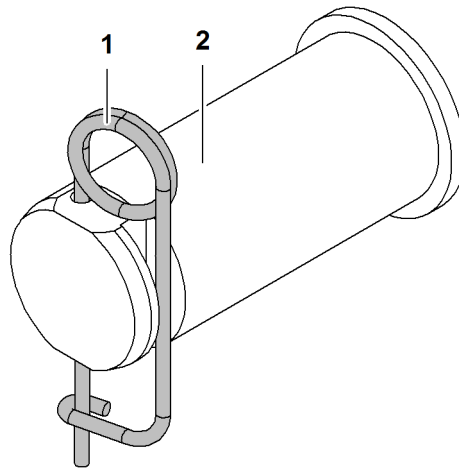


Fig. 5323: Securing the pins

1 Locking spring

2 Pin



DANGER

Pins 2 not completely secured!
Load breakaway.

- ▶ Ensure that locking spring 1 completely secures the pin 2.

Installing the rope fixing point on the boom head

- ▶ Pin cross strap with boom head.
- ▶ Secure pin with locking spring.
- ▶ Pin pocket lock with cross strap.
- ▶ Secure pin with locking spring.

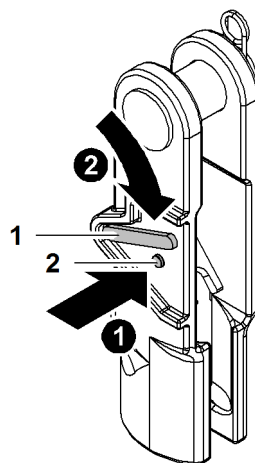


Fig. 5324: Unlocking the pocket lock

1 Safety latch

2 Locking button

- ▶ Press the locking button 2.
- ▶ Press safety latch 1 down and hold.

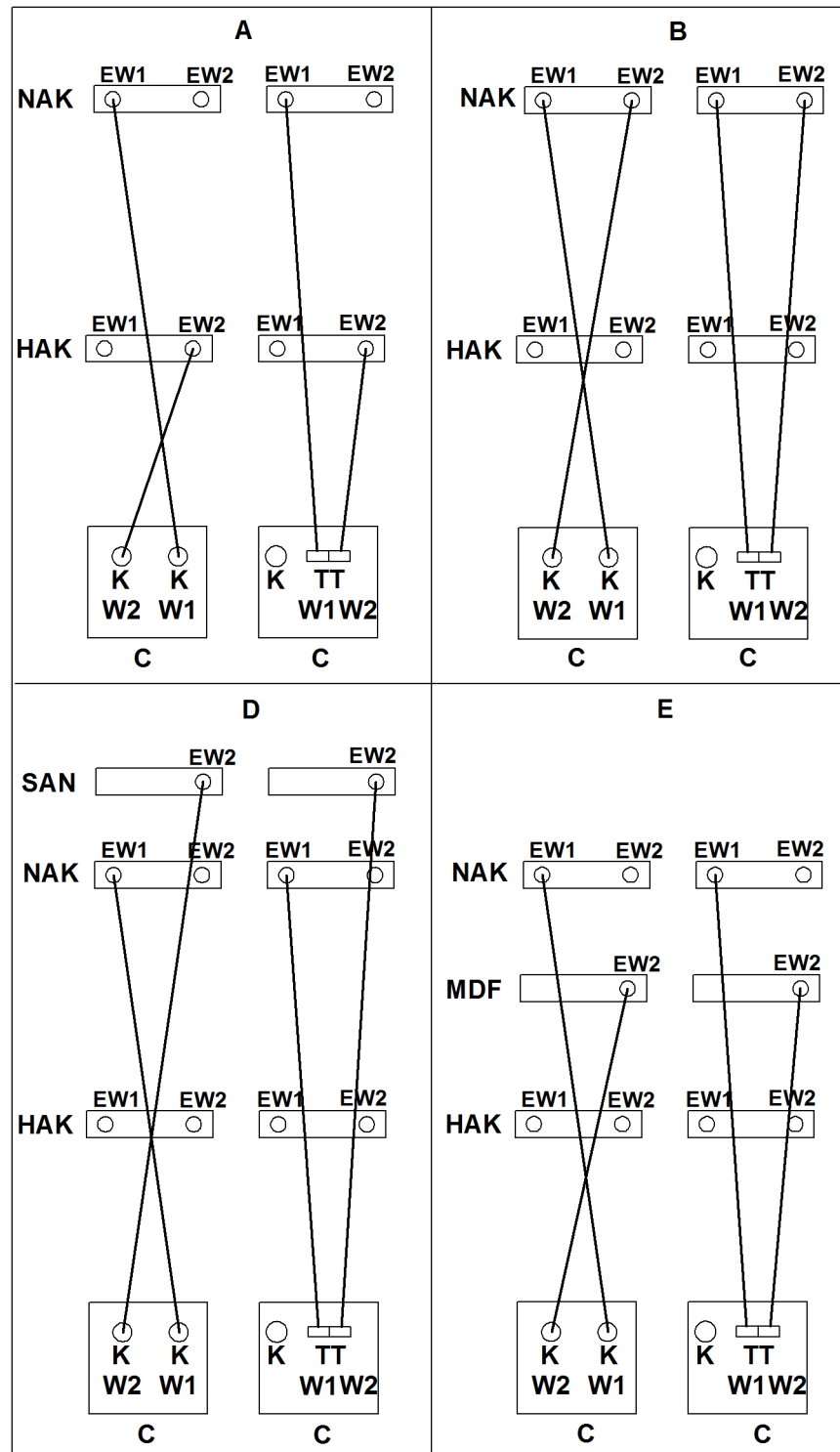


Fig. 5328: Hoist limit switch assignment in dependence on winch1/winch2

- A** Boom configuration main boom + luffing jib
- B** Boom configuration main boom + adjustable jib with 2 ropes over jib head section
- D** Boom configuration main boom + adjustable jib with jib head member on jib head section
- K** Joystick
- MDF** Midfall
- NAK** Jib head section

See next page for continuation of the image legend

- | | |
|---|--|
| E Boom configuration main boom + luffing jib + midfall | SAN Jib head member on jib head section |
| C Cabin | TT Double T-control lever |
| EW1 Hoist limit switch winch1 | W1 winch1 |
| EW2 Hoist limit switch winch2 | W2 winch2 |
| HAK Main boom head section | |

NOTICE

Wrong hoist limit switch!
Hoist limit switch does not turn off.

- ▶ Make sure that the correct hoist limit switch for the correct rope of winch1/ winch2 is used.

The hoist limit switch with chain and hoist limit switch weight attached is secured to the inoperative end of the hoist rope.

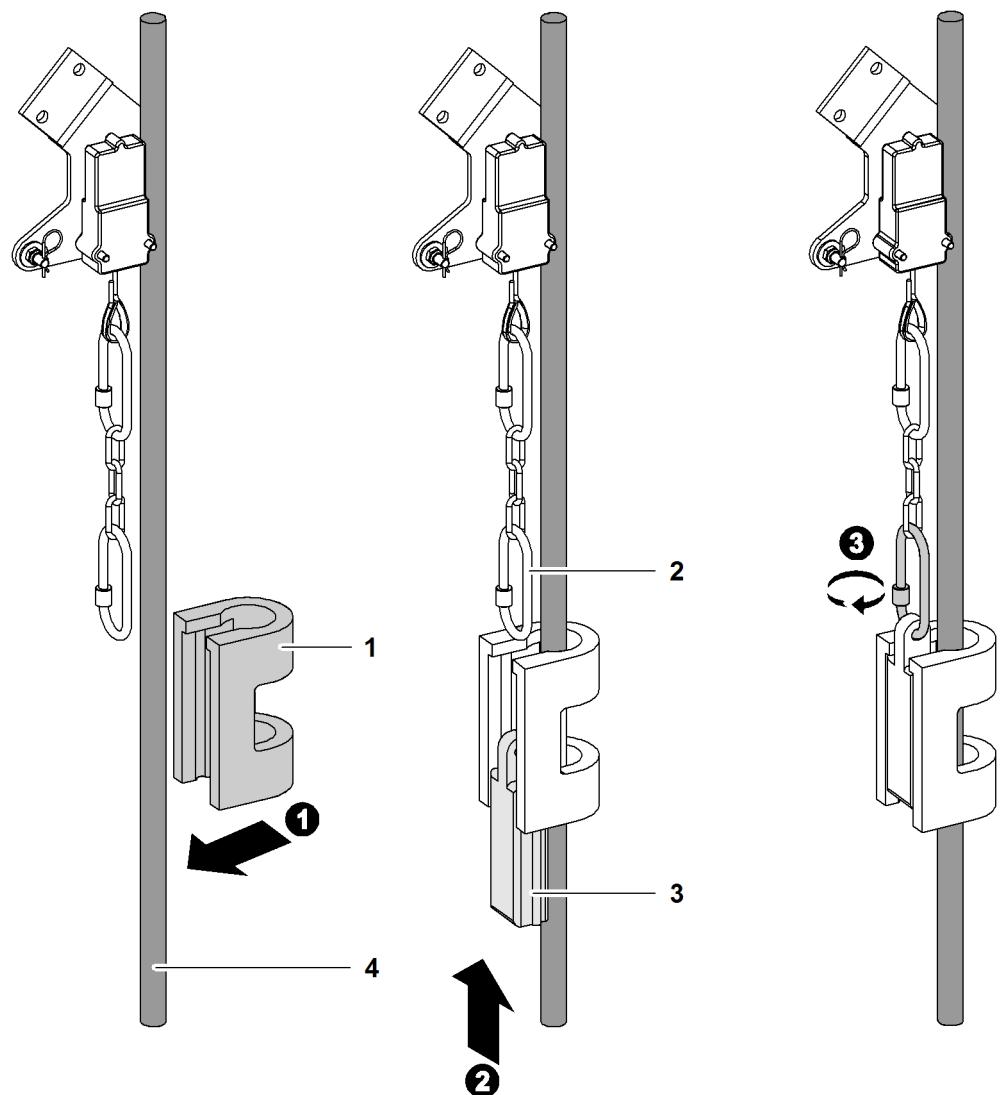


Fig. 5329: Fitting the hoist limit switch weight

- | | |
|--|--|
| 1 Hoist limit switch weight (U shape) | 3 Hoist limit switch weight (wedge) |
| 2 Carabiner | 4 Rope of winch1/winch2 |

- ▶ Guide the hoist limit switch weight (U shape) 1 over the rope of winch1/ winch2 4.

LWNLR.x/V04.01//Auslieferung/2016-03-07/en

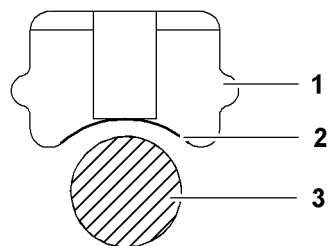


Fig. 5330: Hoist limit switch weight (wedge) view from above

- 1** Hoist limit switch weight (wedge) **3** Rope of winch1/winch2
2 Curvature

The hoist limit switch weight (wedge) **1** has a curvature **2** on one side.

NOTICE

Wrongly installed hoist limit switch weight (wedge)!
Hoist limit switch weight (wedge) damaged with wrong installation of rope of winch1/winch2.

- ▶ Make sure that the curvature of the hoist limit switch weight (wedge) is installed in the direction of the rope of winch1/winch2.
-
- ▶ Insert the hoist limit switch weight (wedge) **1** from below into the hoist limit switch weight (U shape).
 - ▶ Attach the carabiner to the hoist limit switch weight (wedge) **1**.



Note

Liebherr recommends:

- ▶ visual inspection of the carabiner hook prior to installation.
- ▶ Clean dirty carabiner hook with a clean cloth and water.
- ▶ If necessary, re-clean with a slightly oily cloth.

NOTICE

Improper installation of carabiner!
Damage to machine.

- ▶ Make sure that the screw of the carabiner points downwards.
 - ▶ Make sure that the securing element is twisted shut.
-

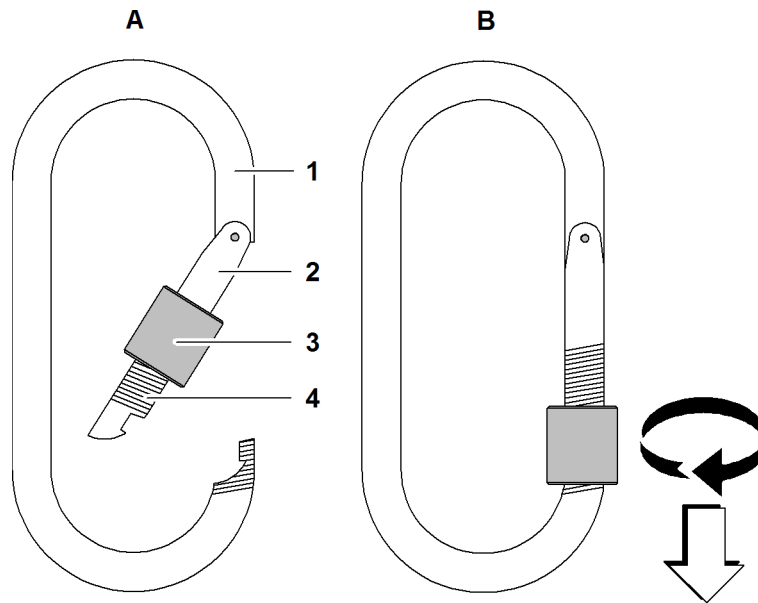


Fig. 5331: Carabiner

- | | | | |
|---|------------------|---|------------------|
| 1 | Carabiner | 4 | Thread |
| 2 | Snapper | A | Opened carabiner |
| 3 | Securing element | B | Closed carabiner |

- ▶ Secure carabiner 1 with securing element 3.

NOTICE

The chain on the hoist limit switch weight is too short!
The hoist limit switch weight responds too late. The hook damages the boom head.

- ▶ Ensure that hoist limit switch weight chain is at least 3 m (9' 10" ft-in) and at most 4.5 m (14' 9" ft-in) long.

- ▶ Attach the chain between the hoist limit switch weight and the hoist limit switch.

7.22.26 Bypass unused hoist limit switches.



DANGER

The hoist limit switch has been bypassed illegally!
Load breakaway.

- ▶ Only ever bypass unused hoist limit switches.

NOTICE

Wrong hoist limit switch is bypassed!
The hook damages the boom head.

- ▶ Lock winch 1 using the left hoist limit switch.
- ▶ Lock winch 2 using the right hoist limit switch.

Ensure that the following conditions are fulfilled:

- Only motion is performed with a rope of winch1/winch2. A hoist limit switch is not required.

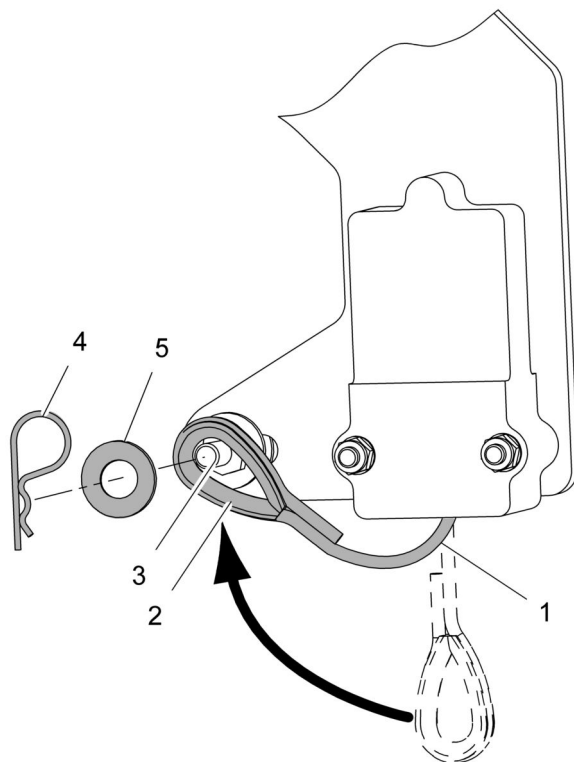


Fig. 5332: Bypassing the hoist limit switch mechanically

- | | | | |
|---|------------|---|------------|
| 1 | Steel rope | 4 | Safety pin |
| 2 | Loop | 5 | Washer |
| 3 | Stud bolt | | |

- ▶ Pull the steel rope 1 and place the loop 2 over the stud bolt 3.
 - ▷ Hoist limit switch is bypassed.
- ▶ Protect the sling 2 from slipping off the stud bolt 3 by securing it with a washer 5 and a safety pin 4.

7.22.27 Erecting the main boom + luffing jib

Ensure that the following conditions are fulfilled:

- Boom configuration can be erected with counterweight.
- Signalmen and assistants are instructed.
- All work on the boom has been completed.
- No loose parts or tools have been left on the boom.



Note

The overall center of gravity of the machine is moved beyond the first running roller!

Sudden swinging of the boom/jib when erecting.

Liebherr recommends:

- ▶ When using long main booms and short jibs, follow the procedure for "Blocked Crawlers" ([For more information see: 4.27 Blocked crawlers*](#), page 980) .

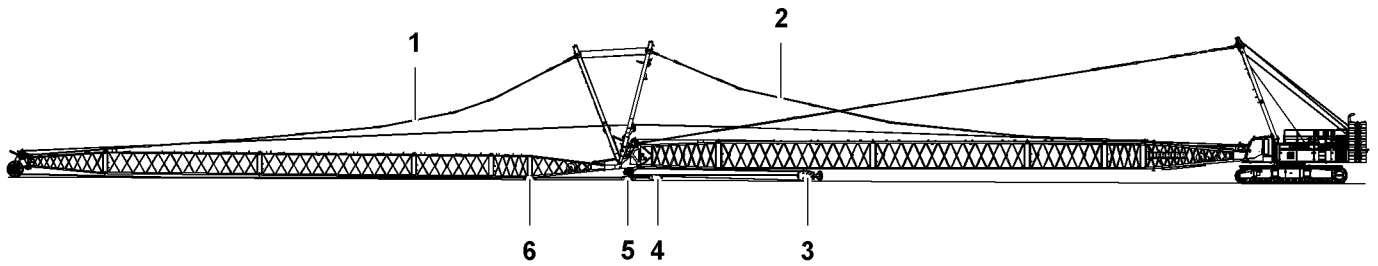


Fig. 5333: Main boom with luffing jib on the ground (illustration of principle)

- | | | | | | |
|---|---------------------|---|--------------|---|--------|
| 1 | Jib pendant straps | 3 | Pulley block | 5 | Timber |
| 2 | Jib backstay straps | 4 | Hook | 6 | Timber |



DANGER

Hoist limit switch bypassed on control panel X23 in crane mode!
Load breakaway.

- ▶ Only bypass hoist limit switch on control panel X23 when assembling or disassembling the machine.



If hoist limit switch weight is on the ground:

- ▶ Press the *Bypass limit switch* button on control panel X23.
 - ▷ Hoist limit switches are bypassed.



- ▶ Press the *Load moment limiter assembly/self-lock* button on control panel X23.

No load chart exist for machines geometry:

- ▷ Function "load moment limiter assembly" is active.
- ▷ The LED on the button *Load moment limiter assembly/self-lock* lights up.
- ▷ Machine functions are enabled unlimited.
- ▷ Load Moment Limiter lamps flash orange.



DANGER

Erectability chart is not followed!
Machine toppling over.

- ▶ Only raise the boom when erection is permitted according to the erectability chart.



WARNING

Falling objects!

- ▶ Any loose parts and tools must be removed from the boom.
- ▶ Make sure that no-one is standing in the danger area.
- ▶ Leave the danger area.

- ▶ Slowly lift main boom.
 - ▷ The main boom pendant straps are tensioned.



DANGER

Main boom and jib are lifted at the same time!
Machine toppling over.

- ▶ Do not lift jib together with main boom out of horizontal position.



WARNING

Dangerous voltage in boom!
Sudden sideways movement when lifting boom from ground.

- ▶ Make sure that no-one is standing in the danger area.
- ▶ Leave the danger area.

NOTICE

Incorrect erection procedure is followed!
Damage to the equipment.

- ▶ Do not drag the hook or the pulley block along the ground.
- ▶ Do not allow any slacking of the rope.
- ▶ Make sure that the lightning rod* on the jib head does not scrape on the ground.

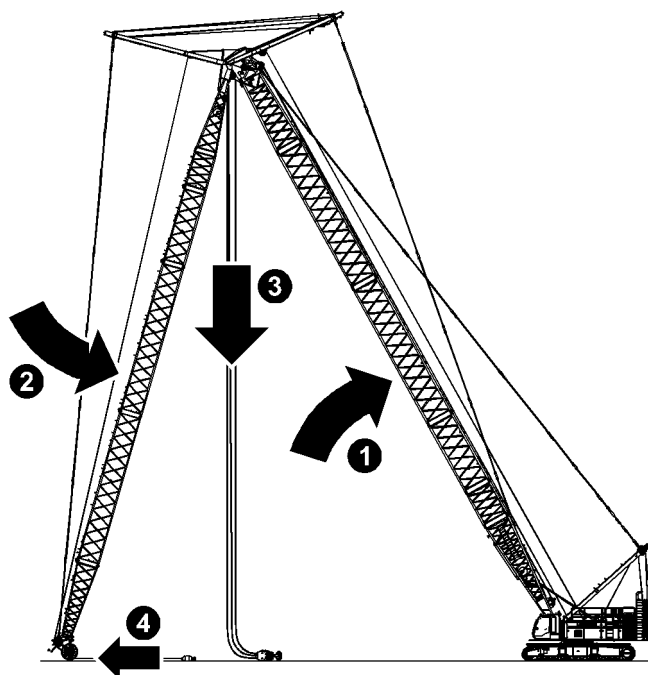


Fig. 5336: Lifting the main boom and lowering the jib at the same time (illustration of principle)

If the jib is shorter than the main boom, the lower jib limit switch triggers before the main boom reaches an angle of 85°.

If the jib is longer than the main boom, the main boom reaches an angle of 85° before the jib limit switch triggers.

The jib pendant straps must be clearly slack when erecting.

- ▶ Lift main boom and lower jib at the same time until main boom reaches an angle of 85° or the bottom jib limit switch triggers.
 - ▷ Main boom lifts off the ground.
 - ▷ Jib head runs backwards on guide rollers.
- ▶ Unwind rope of winch1/winch2 on main boom if necessary.
- ▶ Reeve rope of winch1/winch2 on jib if necessary.

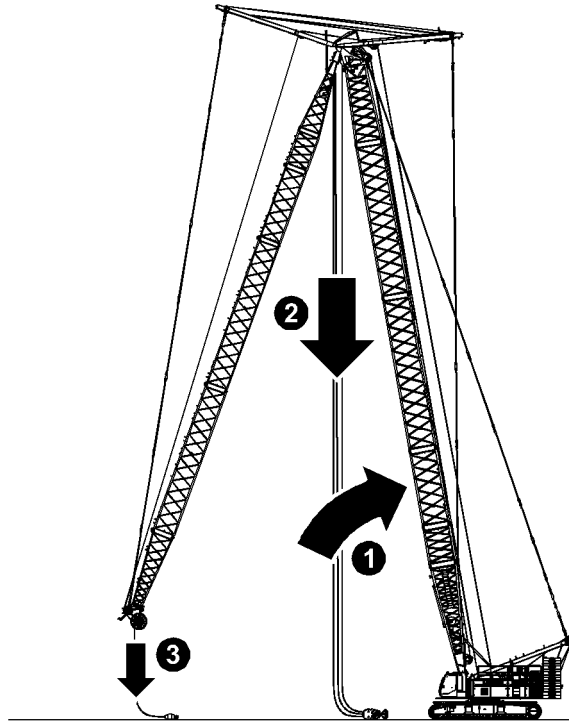


Fig. 5337: Lifting the main boom until main boom has reached an angle of 85° (illustration of principle)

When the bottom jib limit switch triggers:

- ▶ Lift main boom until main boom has reached an angle of 85°.
 - ▷ Jib head lifts off the ground.

NOTICE

Incorrect erection procedure!
Damage to equipment.

- ▶ Do not drag hook or pulley block along the ground.
- ▶ Prevent slack rope.

-
- ▶ Unwind rope of winch1/winch2 on main boom if necessary.
 - ▶ Reeve rope of winch1/winch2 on jib if necessary.

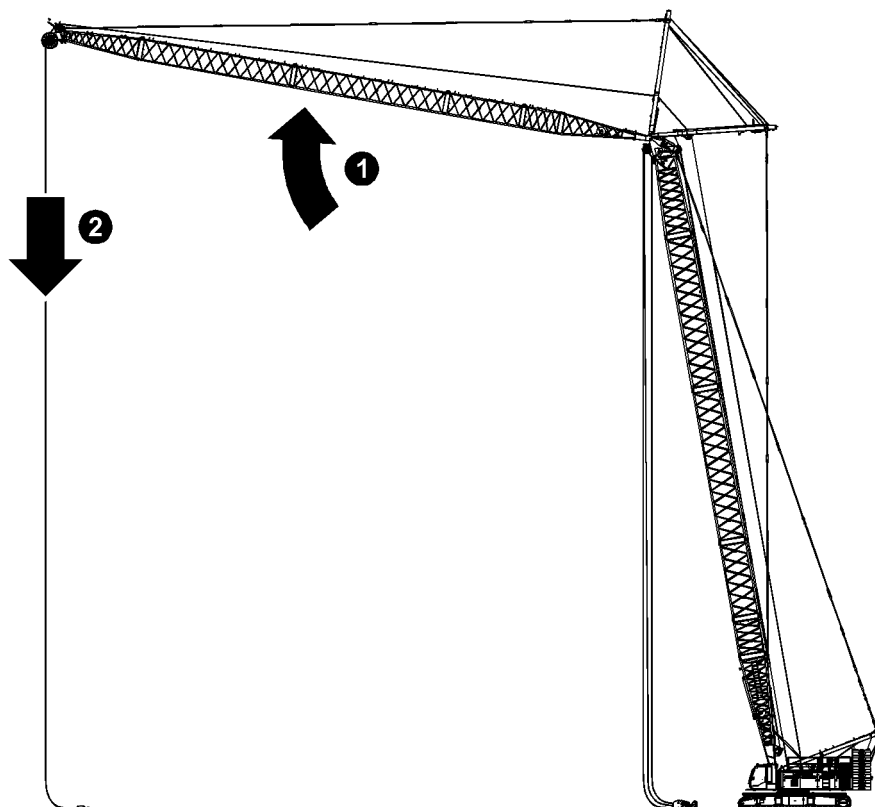


Fig. 5338: Lifting the jib

- ▶ Lift jib.
As soon as there is a load chart for machines geometry:
 - ▷ Deactivate function "load moment limiter assembly".
 - ▷ The LED on the button *Load moment limiter assembly/self-lock* goes out.
 - ▷ Load moment limiter is active.
 - ▷ Load moment limiter lamps light up according to the current status of the Load Moment Limiter system.

Troubleshooting

Jib cannot be lifted?

With boom configurations with long jibs, the line pull of the jib luffing winch is not sufficient to lift the jib.

- ▶ Lift main boom until jib head lifts off the ground.
- ▶ Lift jib.

NOTICE

Incorrect erection procedure!
Damage to equipment.

- ▶ Do not drag hook or pulley block along the ground.
- ▶ Prevent slack rope.

- ▶ Unwind rope of winch1/winch2 on jib if necessary.

When the maximum permitted lifting capacity is at least equal to the weight of the hook and/or pulley block:

- ▶ Raise the hook/pulley block.

- ▶ Erect jib until it is in the desired position.
 - ▷ Main boom with luffing jib is erected:

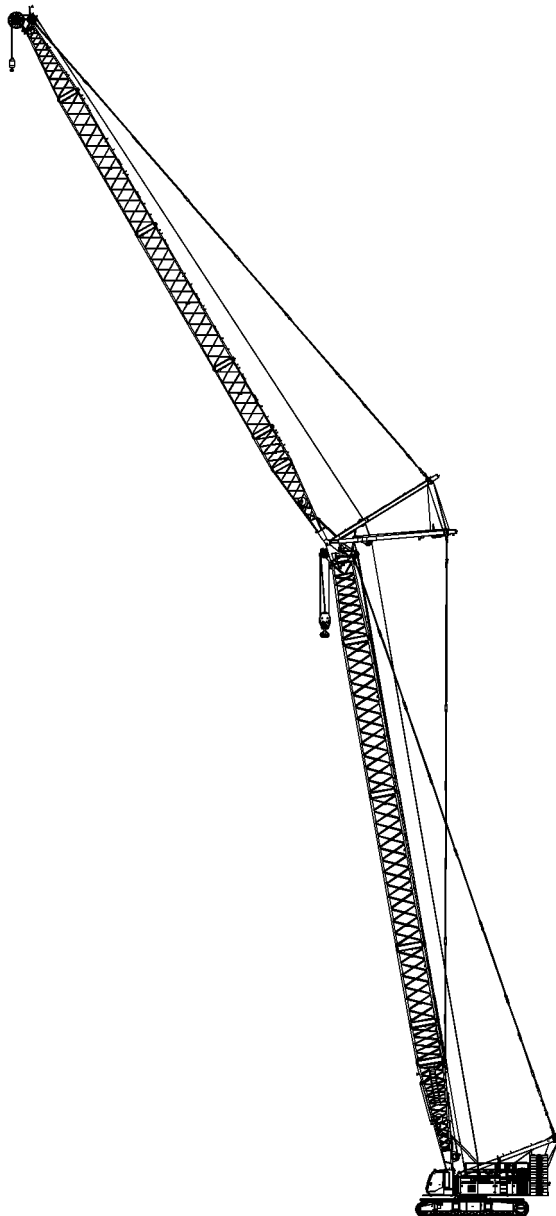


Fig. 5339: Main boom with luffing jib is erected

7.22.28 Switching off assembly mode functions

Ensure that the following conditions are fulfilled:

- The machine is fully assembled and erected.
- All limit switches are fitted and operational.



- ▶ Press the *Assembly functions* switch on control panel X12.
 - ▷ Assembly mode functions are switched off.
 - ▷ The symbol *Assembly functions* disappears on screen.

7.22.29 Checking the top jib limit switch for function

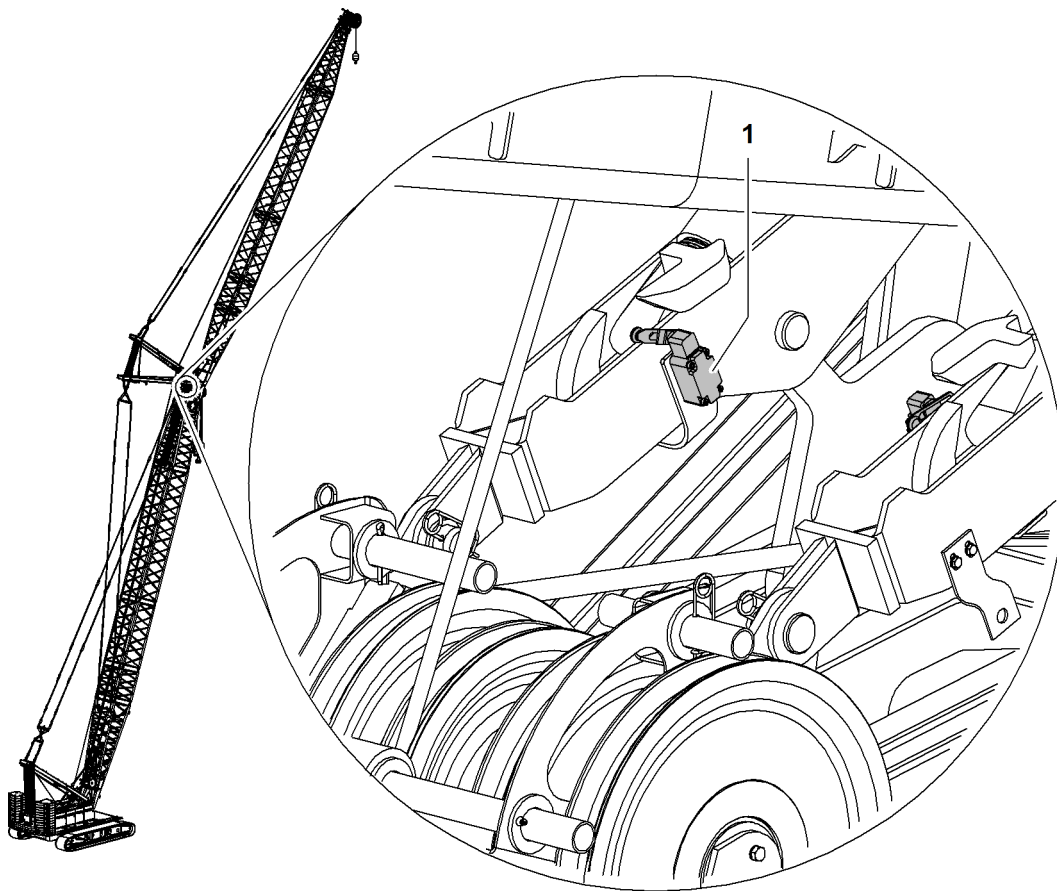


Fig. 5341: Checking the top jib limit switch for function

1 Top jib limit switch (2x)

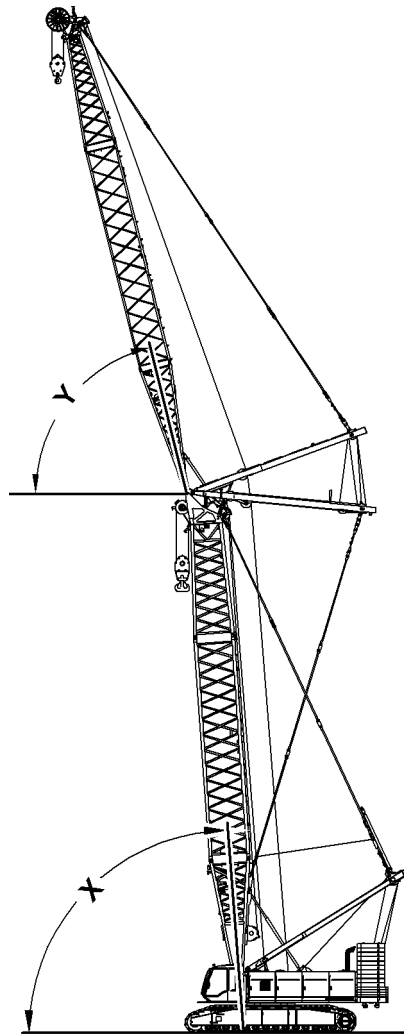


Fig. 5342: Top jib angle

Boom configuration	Angle X	Angle Y
Main boom + luffing jib	88°	78°
Main boom + luffing jib + midfall		

Tab. 588: Jib limit switch

NOTICE

Wrongly adjusted jib limit switch!
Damage to machine.

► Make sure that the jib limit switch is properly adjusted.

- Erect the jib until the screen *Operation* shows the angle **X**.
 - ▷ Limit switch triggers.
 - ▷ Lift jib is locked.

If the limit switch triggers too early or not at all:

- Switch off machine.
- Contact Liebherr service department.

7.22.30 Checking the jib limit switch plate for proper adjustment

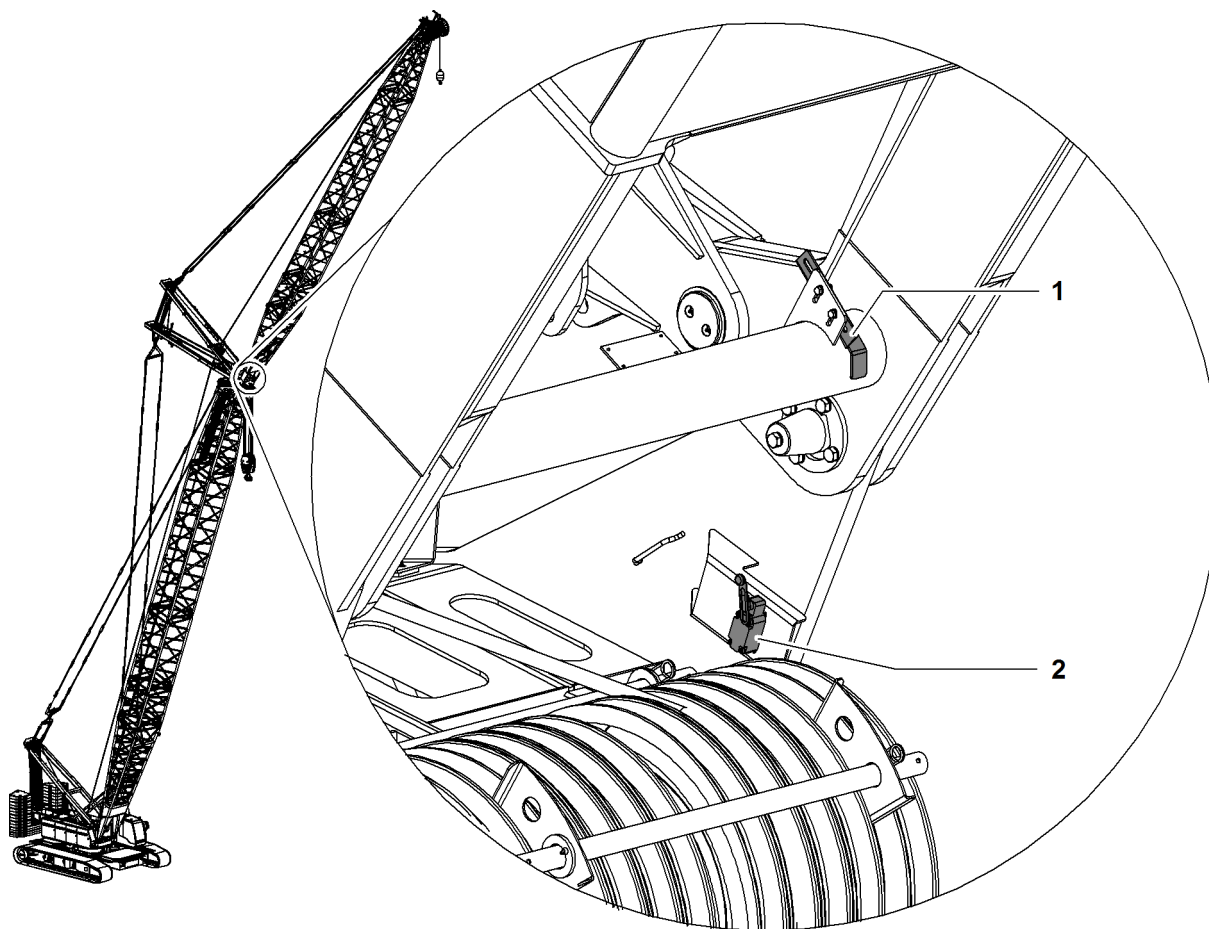


Fig. 5343: Checking the jib limit switch plate for proper adjustment

- 1 Jib limit switch plate
- 2 Jib limit switch

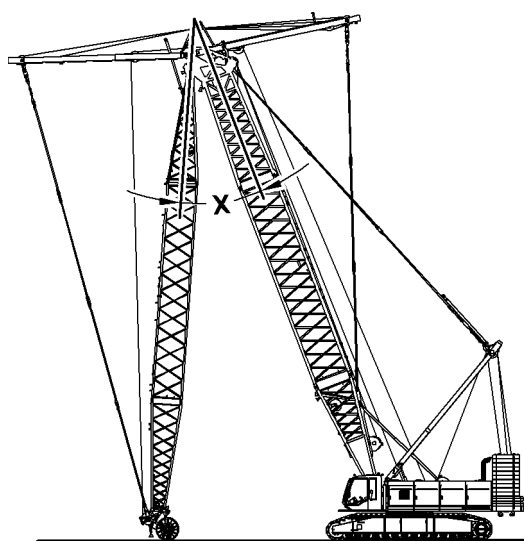


Fig. 5344: Bottom jib angle

LWNLR-x/V04.01//Auslieferung/2016-03-07/en

Boom configuration	Angle X
Main boom + luffing jib	30° difference to main boom
Main boom + luffing jib + midfall	

Tab. 589: Jib limit switch plate

NOTICE

Incorrect calibration of the jib limit switch plate!
Damage to machine.

▶ Make sure that the jib limit switch plate is properly adjusted.

- ▶ Lower the jib until the screen *Operation* shows the angle **X**.
 - ▷ Limit switch triggers.
 - ▷ Lower jib is locked.

If the limit switch triggers too early or not at all:

- ▶ Switch off machine.
- ▶ Contact Liebherr service department.

7.23 Luffing jib 2316 + midfall 2316

System-relevant information for luffing jib 2316 + midfall 2316:

- Configuration of jib
 - Mid-point suspensions installation positions
- Lengths of jib mid-point suspensions
- Configuration of main boom
- Overview of steel pendant straps on luffing jib 2316 + midfall 2316
- Overview of CF pendant straps on luffing jib 2316 + midfall 2316
- Reeving diagrams for one rope across jib head 2316 (load position1)
- Reeving diagrams for one rope across midfall 2316 (load position3)

7.23.1 Configuration of jib



DANGER

Excess length of jib!
Structural breakdown.

- ▶ Check jib length in load chart for validity.

Jib length	Position of midfall	Configuration of jib (symbolic)
38.5 m 126 ft	16 m 52' 6" ft-in	
41.5 m 136 ft	19 m 62' 4" ft-in	
44.5 m 146 ft	22 m 72' 2" ft-in	
47.5 m 156 ft	25 m 82' ft-in	
50.5 m 166 ft	28 m 91' 10" ft-in	
53.5 m 176 ft	31 m 101' 8" ft-in	
56.5 m 185 ft	22 m 72' 2" ft-in	
59.5 m 195 ft	25 m 82' ft-in	
62.5 m 205 ft	28 m 91' 10" ft-in	
65.5 m 215 ft	31 m 101' 8" ft-in	
68.5 m 225 ft	34 m 111' 7" ft-in	
71.5 m 235 ft	37 m 121' 5" ft-in	

LWN/LR-x/V04.01//Auslieferung/2016-03-07/en

Jib length	Position of midfall	Configuration of jib (symbolic)
74.5 m 244 ft	40 m 131' 3" ft-in	
77.5 m 254 ft	43 m 141' 1" ft-in	
80.5 m 264 ft	34 m 111' 7" ft-in	
83.5 m 274 ft	37 m 121' 5" ft-in	
86.5 m 284 ft	40 m 131' 3" ft-in	
89.5 m 294 ft	43 m 141' 1" ft-in	
92.5 m 304 ft	46 m 150' 11" ft-in	
95.5 m 313 ft	49 m 160' 9" ft-in	
98.5 m 323 ft	52 m 170' 7" ft-in	
101.5 m 333 ft	55 m 180' 5" ft-in	
104.5 m 343 ft	46 m 150' 11" ft-in	
107.5 m 353 ft	49 m 160' 9" ft-in	
110.5 m 363 ft	52 m 170' 7" ft-in	

Tab. 590: Configuration of luffing jib 2316 + midfall 2316

X1 - Installation position mid-point suspension 1

X2 - Installation position mid-point suspension 2

7.23.2 Lengths of jib mid-point suspensions

Main boom length	Backstay pendant 1 (X1)	Backstay pendant 2 (X2)
	Rope length	Rope length
50.5 m 166 ft	3 m 9' 10" ft-in	
53.5 m 176 ft	3 m 9' 10" ft-in	
56.5 m 185 ft	2.6 m 8' 6" ft-in	
59.5 m 195 ft	2.6 m 8' 6" ft-in	

LWNLR.x/V04.01//Auslieferung/2016-03-07/en

Main boom length	Backstay pendant 1 (X1)	Backstay pendant 2 (X2)
	Rope length	Rope length
62.5 m 205 ft	2.1 m 6' 11" ft-in	
65.5 m 215 ft	5.6 m 18' 4" ft-in = 3.0 m (9' 10" ft-in) + 2.6 m (8' 6" ft-in)	2.1 m 6' 11" ft-in
68.5 m 225 ft	5.1 m 16' 9" ft-in = 3.0 m (9' 10" ft-in) + 2.1 m (6' 11" ft-in)	1.6 m 5' 3" ft-in
71.5 m 235 ft	5.1 m 16' 9" ft-in = 3.0 m (9' 10" ft-in) + 2.1 m (6' 11" ft-in)	1.6 m 5' 3" ft-in
74.5 m 244 ft	4.7 m 15' 5" ft-in = 2.1 m (6' 11" ft-in) + 2.6 m (8' 6" ft-in)	1.6 m 5' 3" ft-in
77.5 m 254 ft	5.6 m 18' 4" ft-in = 3.0 m (9' 10" ft-in) + 2.6 m (8' 6" ft-in)	1.6 m 5' 3" ft-in
80.5 m 264 ft	4.2 m 13' 9" ft-in = 2.1 m (6' 11" ft-in) + 2.1 m (6' 11" ft-in)	1.6 m 5' 3" ft-in
83.5 m 274 ft	4.2 m 13' 9" ft-in = 2.1 m (6' 11" ft-in) + 2.1 m (6' 11" ft-in)	2.1 m 6' 11" ft-in
86.5 m 284 ft	5.1 m 16' 9" ft-in = 3.0 m (9' 10" ft-in) + 2.1 m (6' 11" ft-in)	2.1 m 6' 11" ft-in
89.5 m 294 ft	4.7 m 15' 5" ft-in = 2.1 m (6' 11" ft-in) + 2.6 m (8' 6" ft-in)	2.1 m 6' 11" ft-in
92.5 m 304 ft	4.7 m 15' 5" ft-in = 2.1 m (6' 11" ft-in) + 2.6 m (8' 6" ft-in)	2.1 m 6' 11" ft-in

LWN/LR-x/V04.01//Auslieferung/2016-03-07/en

Main boom length	Backstay pendant 1 (X1)	Backstay pendant 2 (X2)
	Rope length	Rope length
95.5 m 313 ft	4.2 m 13' 9" ft-in = 2.1 m (6' 11" ft-in) + 2.1 m (6' 11" ft-in)	1.6 m 5' 3" ft-in
98.5 m 323 ft	5.6 m 18' 4" ft-in = 3.0 m (9' 10" ft-in) + 2.6 m (8' 6" ft-in)	2.1 m 6' 11" ft-in
101.5 m 333 ft	5.1 m 16' 9" ft-in = 3.0 m (9' 10" ft-in) + 2.1 m (6' 11" ft-in)	1.6 m 5' 3" ft-in
104.5 m 343 ft	5.1 m 16' 9" ft-in = 3.0 m (9' 10" ft-in) + 2.1 m (6' 11" ft-in)	2.6 m 8' 6" ft-in
107.5 m 353 ft	4.7 m 15' 5" ft-in = 2.1 m (6' 11" ft-in) + 2.6 m (8' 6" ft-in)	2.1 m 6' 11" ft-in
110.5 m 363 ft	5.6 m 18' 4" ft-in = 3.0 m (9' 10" ft-in) + 2.6 m (8' 6" ft-in)	2.6 m 8' 6" ft-in

Tab. 591: Lengths of jib mid-point suspensions - 2316 luffing jib + 2316 Midfall

7.23.3 Configuration of main boom



DANGER

Excess length of main boom!
Structural breakdown.

- ▶ Check main boom length in load chart for validity.



Note

- ▶ See system-relevant data of main boom for information on main boom configuration (For more information see: [7.5.1 Configuration of main boom, page 1270](#)).

LWNLR.x/V04.01//Auslieferung/2016-03-07/en

7.23.4 Overview of steel pendant straps on luffing jib 2316 + midfall 2316

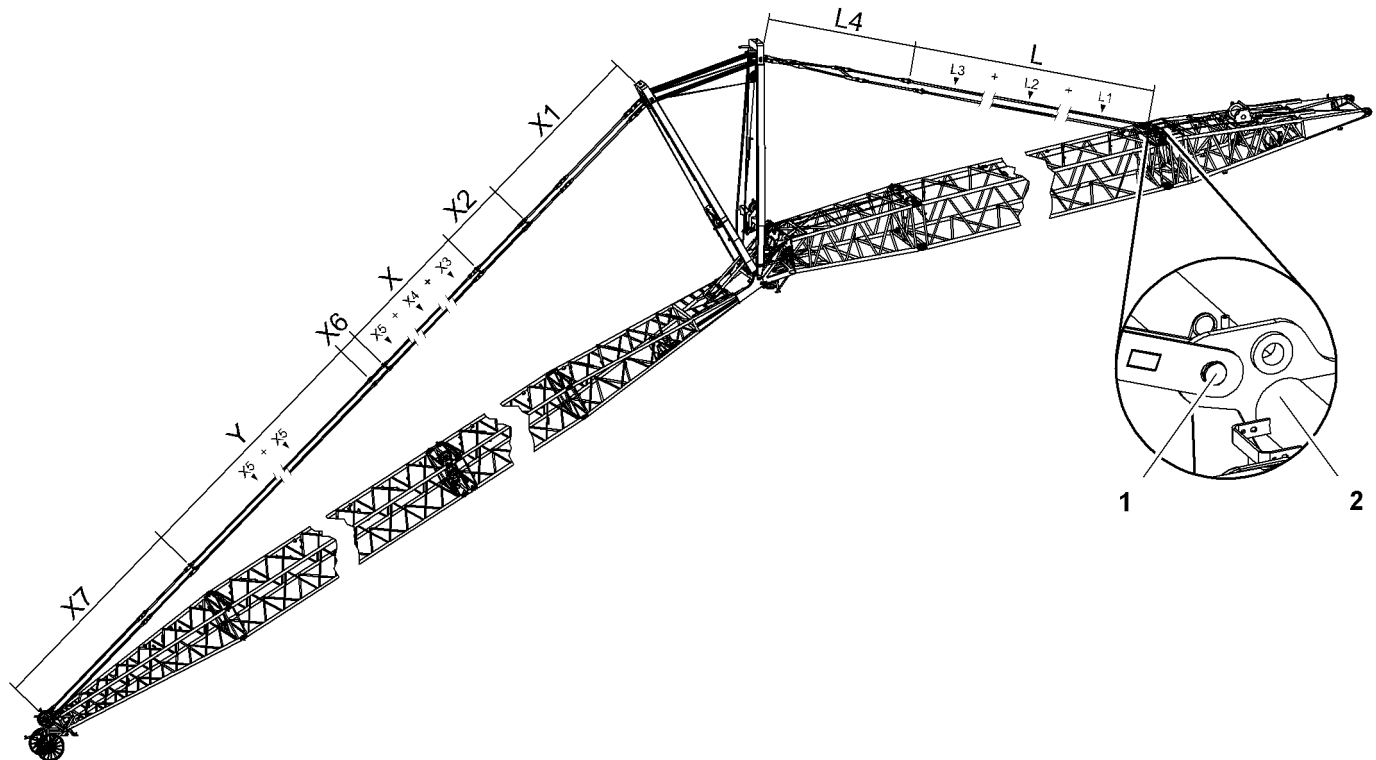


Fig. 5548: Overview of steel pendant straps on luffing jib 2316 + midfall 2316

- 1 Pin connection point for jib backstay straps
- 2 Main boom base section

Jib backstay straps A-frame2 to main boom base section 2821

Name		Value
L	Jib backstay straps consisting of:	
	L1	Jib backstay strap 3 m (10 ft) (For more information see: Jib backstay strap 3 m (10 ft), page 193)
	L2	Jib backstay strap 6 m (20 ft) (For more information see: Jib backstay strap 6 m (20 ft), page 195)
	L3	Jib backstay strap 12 m (40 ft) (For more information see: Jib backstay strap 12 m (40 ft), page 197)
L4	A-frame2 equalizer (jib backstay strap) (For more information see: Equalizer A-frame2 (jib backstay strap), page 307)	8050 mm 26' 5" ft-in

Tab. 592: Jib backstay straps A-frame2 to main boom base section 2821

Configuration of jib backstay straps (L):

Required number of jib backstay straps 3 m (10 ft) (L1) corresponds to number of main boom sections 3 m (10 ft).

LWNLR-x/V04.01//Auslieferung/2016-03-07/en

Required number of jib backstay straps 6 m (20 ft) (**L2**) corresponds to number of main boom sections 6 m (20 ft).

Required number of jib backstay straps 12 m (40 ft) (**L3**) corresponds to number of main boom sections 12 m (40 ft).



Note

► For the admissible number of main boom sections 3 m (10 ft), 6 m (20 ft), 12 m (40 ft), refer to the load chart.

Pendant straps A-frame3 to jib head 2316

Name		Value
X1	A-frame3 equalizer (jib pendant strap) (For more information see: A-frame3 equalizer (jib pendant strap) , page 308)	7850 mm 25' 9" ft-in
X2	Jib pendant strap 3 m (10 ft) (For more information see: Jib pendant strap 3 m (10 ft) , page 306)	3000 mm 9' 10" ft-in
X	Jib pendant straps consisting of:	Total X3 + Total X4 + Total X5
	X3 Jib pendant strap 3 m (10 ft) (For more information see: Jib pendant strap 3 m (10 ft) , page 310)	
	X4 Jib pendant strap 6 m (20 ft) (For more information see: Jib pendant strap 6 m (20 ft) , page 310)	
X5 Jib pendant strap 12 m (40 ft) (For more information see: Jib pendant strap 12 m (40 ft) , page 311)		
X6	Midfall connecting link (For more information see: Midfall connecting link , page 367)	920 mm 3' ft-in
Y	Jib pendant straps consisting of:	Total X5
	X5 Jib pendant strap 12 m (40 ft) (For more information see: Jib pendant strap 12 m (40 ft) , page 311)	
X7	Jib pendant strap on jib head 2316 (For more information see: Jib pendant strap on jib head 2316.20 , page 312)	9180 mm 30' 1" ft-in

Tab. 593: Pendant straps A-frame3 to jib head 2316

Configuration of jib pendant straps (X):

Required number of jib pendant straps 3 m (10 ft) (**X3**) corresponds to number of jib sections 3 m (10 ft).

Required number of jib pendant straps 6 m (20 ft) (**X4**) corresponds to number of jib sections 6 m (20 ft).

Required number of jib pendant straps 12 m (40 ft) (**X5**) corresponds to number of jib sections 12 m (40 ft).

LWNLR.x/V04.01/Auslieferung/2016-03-07/en



Note

► For the admissible number of jib sections 3 m (10 ft), 6 m (20 ft), 12 m (40 ft), refer to the following table: (For more information see: 7.23.1 Configuration of jib, page 1720)

7.23.5 Overview of CF pendant straps on luffing jib 2316 + midfall 2316

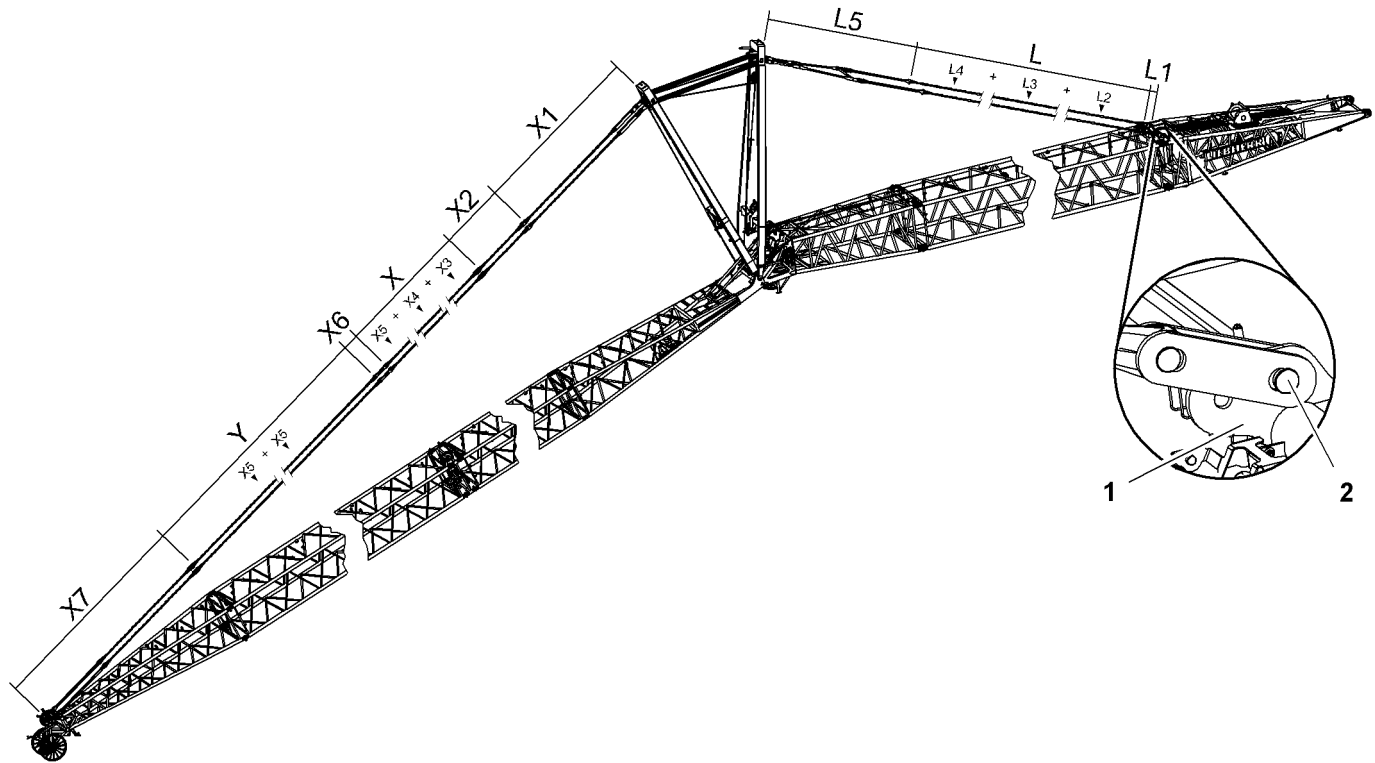


Fig. 5549: Overview of CF pendant straps on luffing jib 2316 + midfall 2316

- 1 Main boom base section
- 2 Pin connection point for jib backstay straps

Jib backstay straps A-frame2 to main boom base section 2821

Name		Value
L1	Connecting link (For more information see: Connecting link , page 202)	350 mm 1' 2" ft-in
Jib backstay straps consisting of:		
L	L2 Jib backstay strap 3 m (10 ft) (For more information see: Jib backstay strap 3 m (10 ft) , page 204)	Total L2 +
	L3 Jib backstay strap 6 m (20 ft) (For more information see: Jib backstay strap 6 m (20 ft) , page 208)	Total L3 +
	L4 Jib backstay strap 12 m (40 ft) (For more information see: Jib backstay strap 12 m (40 ft) , page 212)	Total L4

LWNLR-x/V04.01//Auslieferung/2016-03-07/en

Name		Value
L5	A-frame2 equalizer (jib backstay strap) (For more information see: Equalizer A-frame2 (jib backstay strap), page 315)	7769 mm 25' 6" ft-in

Tab. 594: Jib backstay straps A-frame2 to main boom base section 2821

Configuration of jib backstay straps (L):

Required number of jib backstay straps 3 m (10 ft) (**L2**) corresponds to number of main boom sections 3 m (10 ft).

Required number of jib backstay straps 6 m (20 ft) (**L3**) corresponds to number of main boom sections 6 m (20 ft).

Required number of jib backstay straps 12 m (40 ft) (**L4**) corresponds to number of main boom sections 12 m (40 ft).



Note

- ▶ For the admissible number of main boom sections 3 m (10 ft), 6 m (20 ft), 12 m (40 ft), refer to the load chart.

The jib backstay straps (**L**) may consist of generation A and generation B jib backstay straps (For more information see: [1.11.9 CF pendant straps on main boom 2821, page 200](#)) . Mixing is only admissible if the number of generation B jib backstay straps only differs by at most 1 in the left and the right strand of the jib backstay straps.



DANGER

Inadmissible mixing of generation A and generation B jib backstay straps!
Structural failure.

- ▶ Ensure that the number of generation B jib backstay straps differs by at most 1 in the left and the right strand of the jib backstay straps.

Pendant straps A-frame3 to jib head 2316

Name		Value	
X1	A-frame3 equalizer (jib pendant strap) (For more information see: A-frame3 equalizer (jib pendant strap), page 317)	7850 mm 25' 9" ft-in	
X2	Jib pendant strap 3 m (10 ft) (For more information see: Jib pendant strap 3 m (10 ft), page 314)	3000 mm 9' 10" ft-in	
X	Jib pendant straps consisting of:		
	X3	Jib pendant strap 3 m (10 ft) (For more information see: Jib pendant strap 3 m (10 ft), page 319)	Total X3 +
	X4	Jib pendant strap 6 m (20 ft) (For more information see: Jib pendant strap 6 m (20 ft), page 321)	Total X4 +
	X5	Jib pendant strap 12 m (40 ft) (For more information see: Jib pendant strap 12 m (40 ft), page 322)	Total X5

LWNLR.x/V04.01//Auslieferung/2016-03-07/en

Name		Value
X6	Midfall connecting link (For more information see: Midfall connecting link, page 368)	700 mm 2' 4" ft-in
Y	Jib pendant straps consisting of:	Total X5
	X5 Jib pendant strap 12 m (40 ft) (For more information see: Jib pendant strap 12 m (40 ft), page 322)	
X7	Jib pendant strap on jib head 2316 (For more information see: Jib pendant strap on jib head 2316.20, page 324)	9540 mm 31' 4" ft-in

Tab. 595: Pendant straps A-frame3 to jib head 2316

Configuration of jib pendant straps (X):

Required number of jib pendant straps 3 m (10 ft) (**X3**) corresponds to number of jib sections 3 m (10 ft).

Required number of jib pendant straps 6 m (20 ft) (**X4**) corresponds to number of jib sections 6 m (20 ft).

Required number of jib pendant straps 12 m (40 ft) (**X5**) corresponds to number of jib sections 12 m (40 ft).



Note

- For the admissible number of jib sections 3 m (10 ft), 6 m (20 ft), 12 m (40 ft), refer to the following table: ([For more information see: 7.23.1 Configuration of jib, page 1720](#))

The jib pendant straps (**X**) may consist of generation A and generation B jib pendant straps ([For more information see: 1.20.8 CF pendant straps on luffing jib 2316, page 314](#)). Mixing is only admissible if the number of generation B jib pendant straps only differs by at most 1 in the left and the right strand of the jib pendant straps.



DANGER

Inadmissible mixing of generation A and generation B jib pendant straps!
Structural failure.

- Ensure that the number of generation B jib pendant straps differs by at most 1 in the left and the right strand of the jib pendant straps.

7.23.6 Reeving diagrams for one rope across jib head 2316 (load position1)

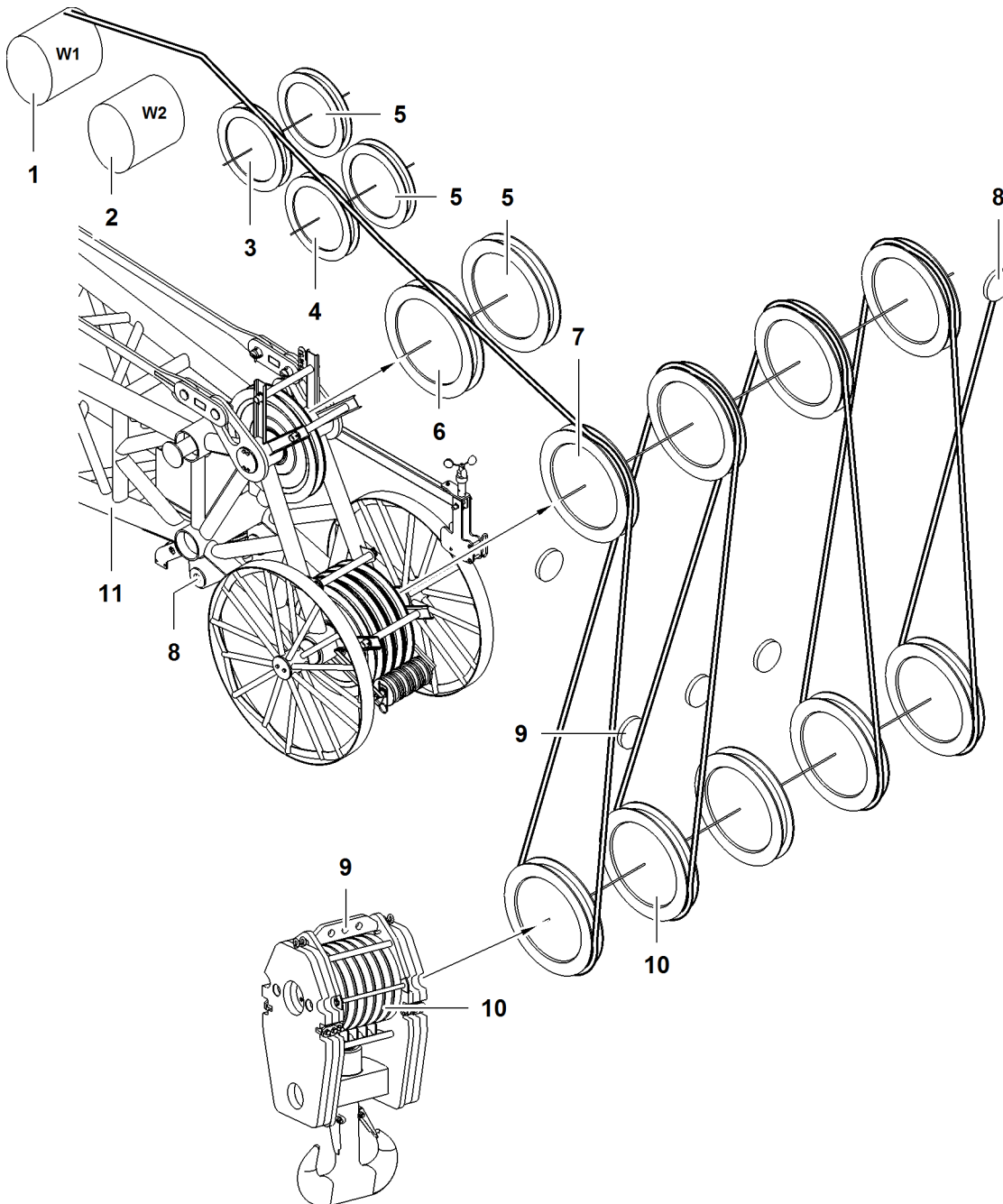


Fig. 5550: Reeving diagrams for one rope across jib head 2316 (load position1)

- | | | | | | |
|---|--------------------|---|--|----|------------------------------------|
| 1 | Winch1 | 5 | Retrofit kit* for operation with two ropes across jib head | 9 | Rope fixing points of pulley block |
| 2 | Winch2 | 6 | Gantry pulley of jib head | 10 | Pulley set of pulley block |
| 3 | Pulley of A-frame2 | 7 | Pulley (4x) of jib head | 11 | Jib head |
| 4 | Pulley of A-frame3 | 8 | Rope fixing point of jib head | | |

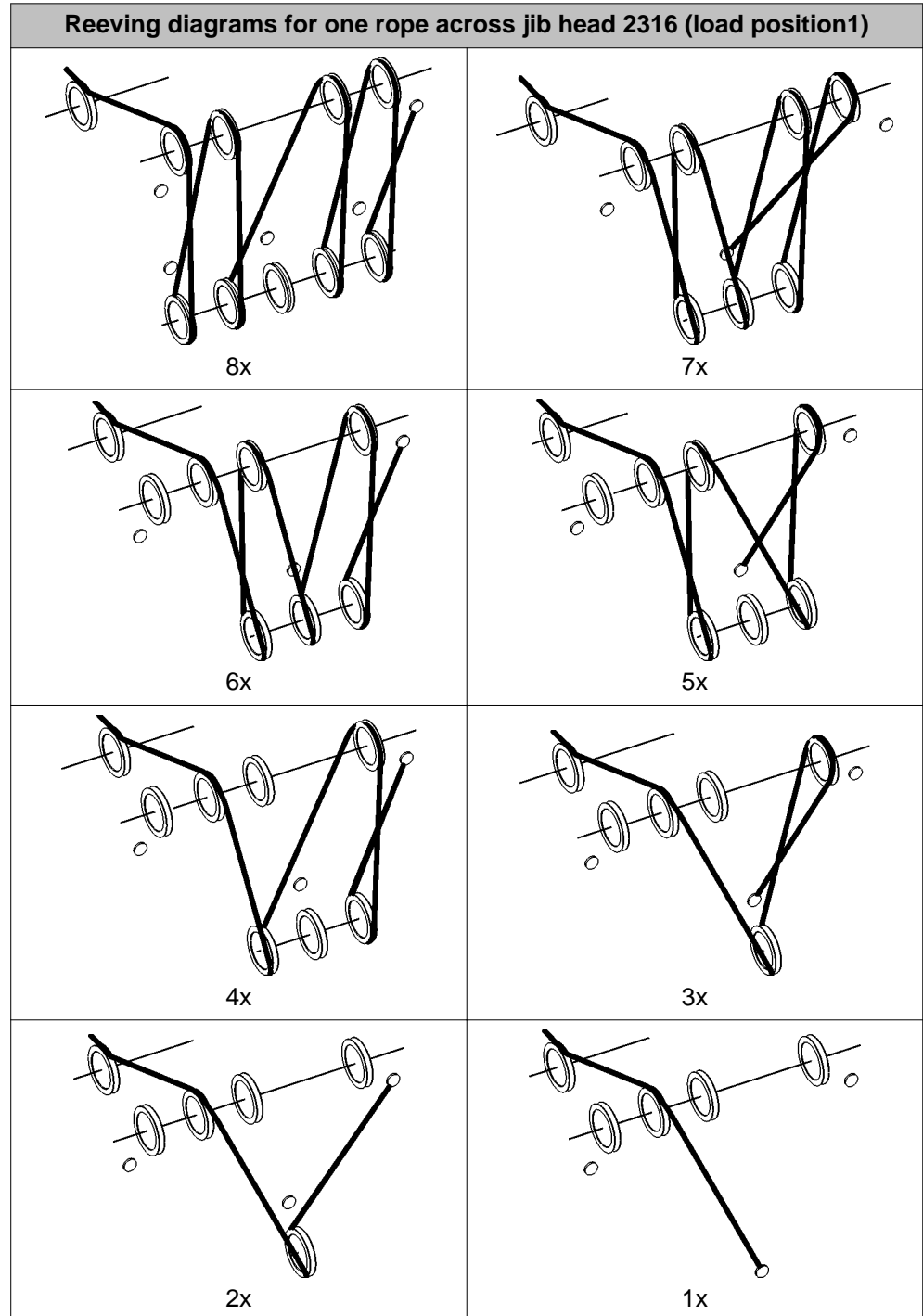
LWNLR.x/V04.01//Auslieferung/2016-03-07/en



DANGER

Inadmissible number of reevings!
Structural breakdown, toppling of machine.

- ▶ Choose correct number of reevings as indicated in load chart.



Tab. 596: Reeving diagrams for one rope across jib head 2316 (load position1)

LWNLR-x\04.01\Auslieferung\2016-03-07/en

7.23.7 Reeving diagrams for one rope across midfall 2316 (load position3)

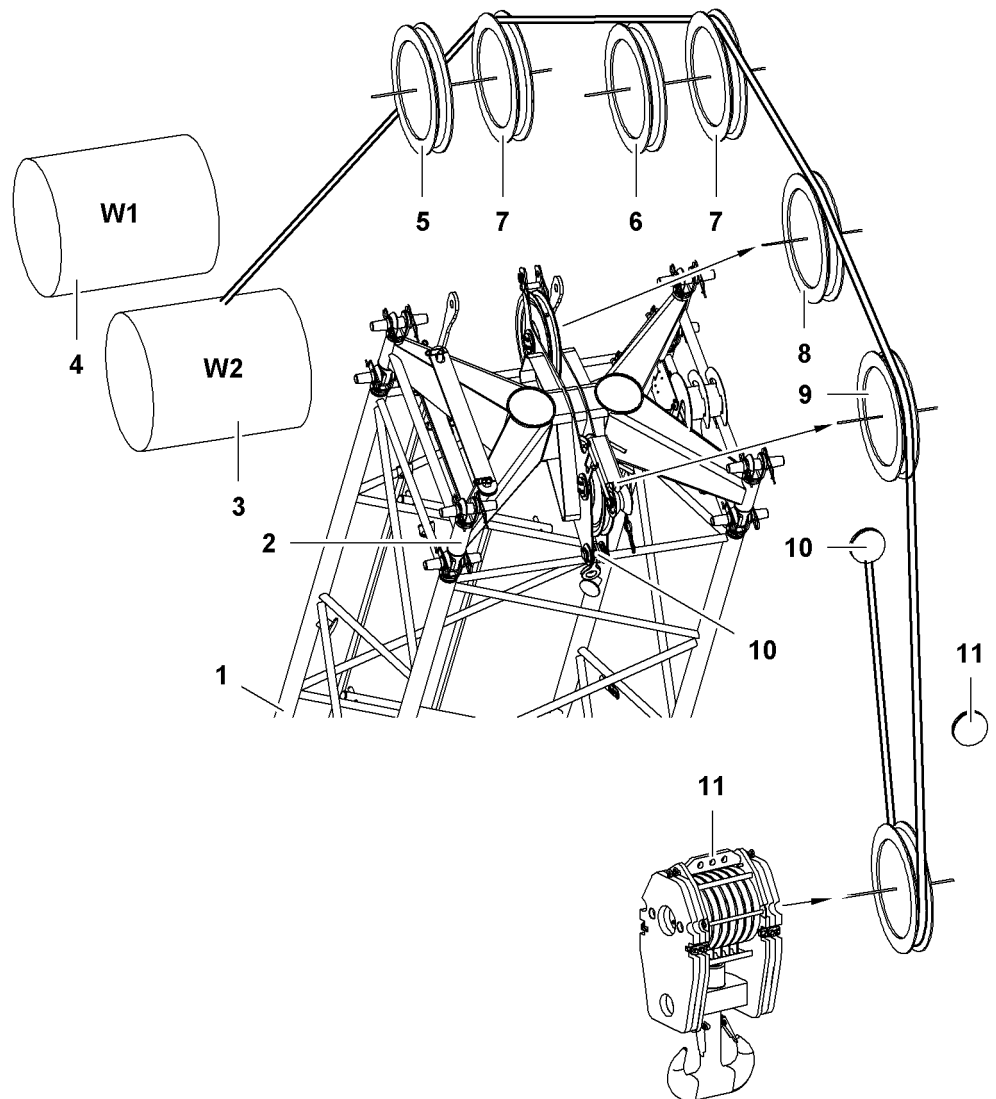


Fig. 5559: Reeving diagrams for one rope across midfall 2316 (load position3)

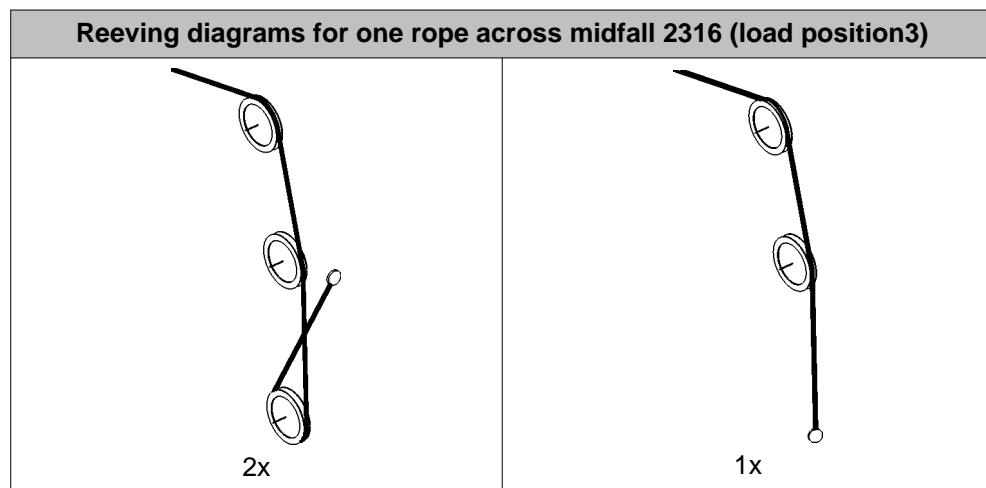
- | | | | |
|---|--------------------|----|--|
| 1 | Jib | 7 | Retrofit kit* for operation with two ropes across jib head |
| 2 | Midfall | 8 | Top pulley of midfall |
| 3 | Winch2 | 9 | Bottom pulley of midfall |
| 4 | Winch1 | 10 | Rope fixing point of midfall |
| 5 | Pulley of A-frame2 | 11 | Rope fixing points of pulley block |
| 6 | Pulley of A-frame3 | | |



DANGER

Inadmissible number of reevings!
Structural breakdown, toppling of machine.

► Choose correct number of reevings as indicated in load chart.



Tab. 597: Reeving diagrams for one rope across midfall 2316 (load position3)

7.24 Luffing jib 1916 + midfall 1916

System-relevant information for luffing jib 1916 + midfall 1916:

- Configuration of jib
 - Mid-point suspensions installation positions
- Lengths of jib mid-point suspensions
- Configuration of main boom
- Overview of steel pendant straps on luffing jib 1916 + midfall 1916
- Overview of CF pendant straps on luffing jib 1916 + midfall 1916
- Reeving diagrams for one rope across jib head 1916 (load position1)
- Reeving diagrams for one rope across midfall 1916 (load position3)

7.24.1 Configuration of jib



DANGER

Excess length of jib!
Structural breakdown.

► Check jib length in load chart for validity.

Jib length	Position of midfall	Configuration of jib (symbolic)
32.5 m 107 ft	13 m 42' 8" ft-in	
35.5 m 116 ft	16 m 52' 6" ft-in	
38.5 m 126 ft	19 m 62' 4" ft-in	
41.5 m 136 ft	22 m 72' 2" ft-in	
44.5 m 146 ft	25 m 82' ft-in	
47.5 m 156 ft	28 m 91' 10" ft-in	
50.5 m 166 ft	19 m 62' 4" ft-in	
53.5 m 176 ft	22 m 72' 2" ft-in	
56.5 m 185 ft	25 m 82' ft-in	
59.5 m 195 ft	28 m 91' 10" ft-in	
62.5 m 205 ft	31 m 101' 8" ft-in	
65.5 m 215 ft	34 m 111' 7" ft-in	

LWNLR-x/V04.01//Auslieferung/2016-03-07/en

Jib length	Position of midfall	Configuration of jib (symbolic)
68.5 m 225 ft	37 m 121' 5" ft-in	
71.5 m 235 ft	40 m 131' 3" ft-in	
74.5 m 244 ft	43 m 141' 1" ft-in	
77.5 m 254 ft	34 m 111' 7" ft-in	
80.5 m 264 ft	37 m 121' 5" ft-in	
83.5 m 274 ft	40 m 131' 3" ft-in	
86.5 m 284 ft	43 m 141' 1" ft-in	
89.5 m 294 ft	46 m 150' 11" ft-in	
92.5 m 304 ft	49 m 160' 9" ft-in	
95.5 m 313 ft	52 m 170' 7" ft-in	

Tab. 598: Configuration of luffing jib 1916 + midfall 1916

X1 - Installation position mid-point suspension 1

X2 - Installation position mid-point suspension 2

7.24.2 Lengths of jib mid-point suspensions

Jib length	Backstay pendant 1 (X1)	Backstay pendant 2 (X2)
	Rope length	Rope length
47.5 m 156 ft	2.1 m 6' 11" ft-in	
50.5 m 166 ft	4.2 m 13' 9" ft-in = 2.6 m (8' 6" ft-in) + 1.6 m (5' 3" ft-in)	2.1 m 6' 11" ft-in
53.5 m 176 ft	6.0 m 19' 8" ft-in = 3.0 m (9' 10" ft-in) + 3.0 m (9' 10" ft-in)	2.1 m 6' 11" ft-in
56.5 m 185 ft	5.6 m 18' 4" ft-in = 3.0 m (9' 10" ft-in) + 2.6 m (8' 6" ft-in)	1.6 m 5' 3" ft-in

LWNLR-x/V04.01//Auslieferung/2016-03-07/en

Jib length	Backstay pendant 1 (X1)	Backstay pendant 2 (X2)
	Rope length	Rope length
59.5 m 195 ft	5.2 m 17' 1" ft-in = 2.6 m (8' 6" ft-in) + 2.6 m (8' 6" ft-in)	1.6 m 5' 3" ft-in
62.5 m 205 ft	4.7 m 15' 5" ft-in = 2.6 m (8' 6" ft-in) + 2.1 m (6' 11" ft-in)	1.6 m 5' 3" ft-in
65.5 m 215 ft	4.6 m 15' 1" ft-in = 3.0 m (9' 10" ft-in) + 1.6 m (5' 3" ft-in)	3.0 m 9' 10" ft-in
68.5 m 225 ft	6.0 m 19' 8" ft-in = 3.0 m (9' 10" ft-in) + 3.0 m (9' 10" ft-in)	2.6 m 8' 6" ft-in
71.5 m 235 ft	5.2 m 17' 1" ft-in = 2.6 m (8' 6" ft-in) + 2.6 m (8' 6" ft-in)	2.1 m 6' 11" ft-in
74.5 m 244 ft	5.1 m 16' 9" ft-in = 3.0 m (9' 10" ft-in) + 2.1 m (6' 11" ft-in)	2.1 m 6' 11" ft-in
77.5 m 254 ft	4.7 m 15' 5" ft-in = 2.6 m (8' 6" ft-in) + 2.1 m (6' 11" ft-in)	2.1 m 6' 11" ft-in
80.5 m 264 ft	4.2 m 13' 9" ft-in = 2.1 m (6' 11" ft-in) + 2.1 m (6' 11" ft-in)	1.6 m 5' 3" ft-in
83.5 m 274 ft	4.2 m 13' 9" ft-in = 2.1 m (6' 11" ft-in) + 2.1 m (6' 11" ft-in)	1.6 m 5' 3" ft-in
86.5 m 284 ft	5.2 m 17' 1" ft-in = 2.6 m (8' 6" ft-in) + 2.6 m (8' 6" ft-in)	1.6 m 5' 3" ft-in
89.5 m 294 ft	4.7 m 15' 5" ft-in = 2.6 m (8' 6" ft-in) + 2.1 m (6' 11" ft-in)	1.6 m 5' 3" ft-in

LWNLR.x/V04.01//Auslieferung/2016-03-07/en

Jib length	Backstay pendant 1 (X1)	Backstay pendant 2 (X2)
	Rope length	Rope length
92.5 m 304 ft	4.2 m 13' 9" ft-in = 2.1 m (6' 11" ft-in) + 2.1 m (6' 11" ft-in)	1.6 m 5' 3" ft-in
95 m 312 ft	= 4.2 m (13' 9" ft-in) = 2.1 m (6' 11" ft-in) + 2.1 m (6' 11" ft-in)	1.6 m 5' 3" ft-in

Tab. 599: Lengths of jib mid-point suspensions - 1916 luffing jib + 1916 Midfall

7.24.3 Configuration of main boom



DANGER

Excess length of main boom!
Structural breakdown.

- ▶ Check main boom length in load chart for validity.



Note

- ▶ See system-relevant data of main boom for information on main boom configuration ([For more information see: 7.5.1 Configuration of main boom, page 1270](#)).

7.24.4 Overview of steel pendant straps on luffing jib 1916 + midfall 1916

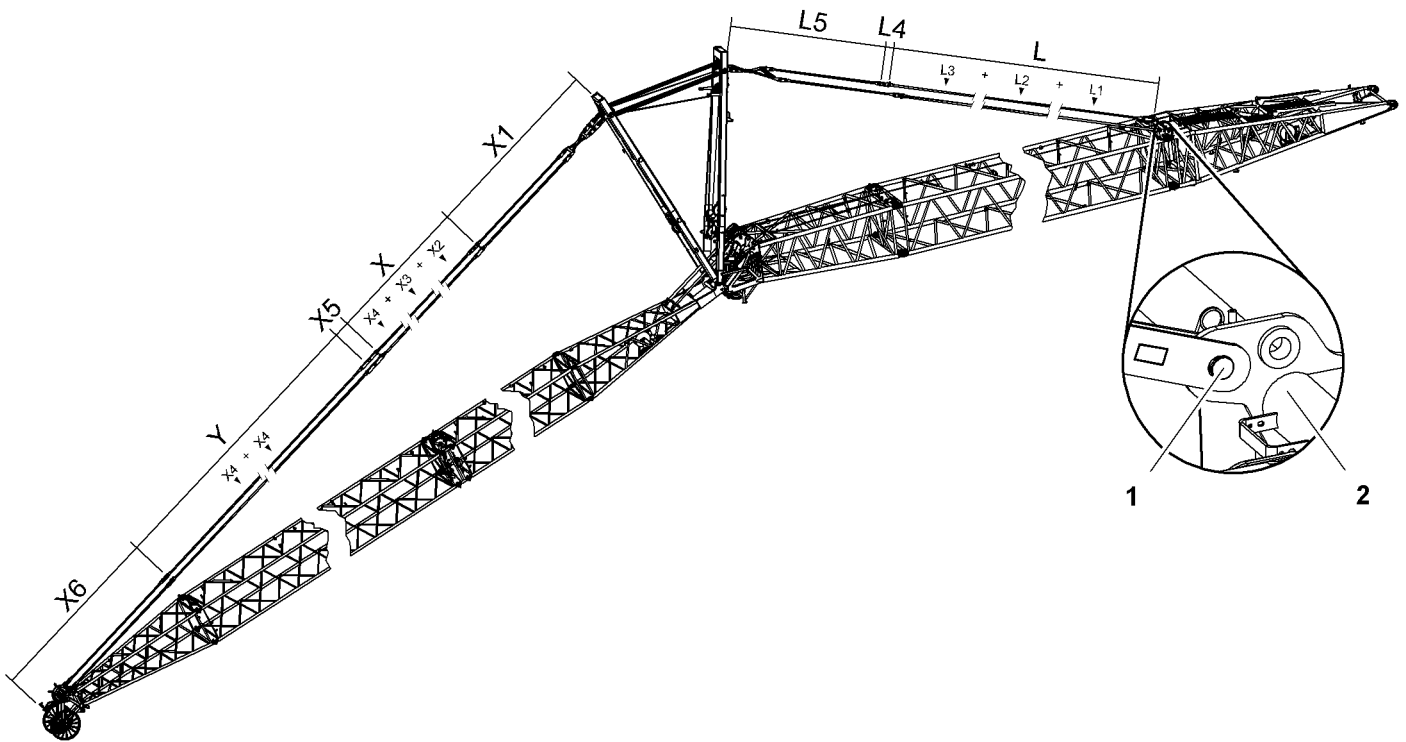


Fig. 5733: Overview of steel pendant straps on luffing jib 1916 + midfall 1916

- 1 Pin connection point for jib backstay straps
- 2 Main boom base section

Jib backstay straps A-frame2 to main boom base section 2821

Name		Value
L	Jib backstay straps consisting of:	
	L1	Jib backstay strap 3 m (10 ft) (For more information see: Jib backstay strap 3 m (10 ft), page 193)
	L2	Jib backstay strap 6 m (20 ft) (For more information see: Jib backstay strap 6 m (20 ft), page 195)
	L3	Jib backstay strap 12 m (40 ft) (For more information see: Jib backstay strap 12 m (40 ft), page 197)
L4	Connecting link (conversion kit) (For more information see: Connecting link (conversion kit), page 351)	390 mm 1' 3" ft-in
L5	A-frame2 equalizer (jib backstay strap) (For more information see: Equalizer A-frame2 (jib backstay strap), page 345)	7409 mm 24' 4" ft-in

Tab. 600: Jib backstay straps A-frame2 to main boom base section 2821

Configuration of jib backstay straps (L):

LWNLR-x/V04.01//Auslieferung/2016-03-07/en

Required number of jib backstay straps 3 m (10 ft) (**L1**) corresponds to number of main boom sections 3 m (10 ft).

Required number of jib backstay straps 6 m (20 ft) (**L2**) corresponds to number of main boom sections 6 m (20 ft).

Required number of jib backstay straps 12 m (40 ft) (**L3**) corresponds to number of main boom sections 12 m (40 ft).



Note

- For the admissible number of main boom sections 3 m (10 ft), 6 m (20 ft), 12 m (40 ft), refer to the load chart.

Pendant straps A-frame3 to jib head 1916

Name		Value	
X1	A-frame3 equalizer (jib pendant strap) (For more information see: A-frame3 equalizer (jib pendant strap), page 346)	7190 mm 23' 7" ft-in	
X	Jib pendant straps consisting of:		
	X2	Jib pendant strap 3 m (10 ft) (For more information see: Jib pendant strap 3 m (10 ft), page 348)	Total X2 +
	X3	Jib pendant strap 6 m (20 ft) (For more information see: Jib pendant strap 6 m (20 ft), page 349)	Total X3 +
	X4	Jib pendant strap 12 m (40 ft) (For more information see: Jib pendant strap 12 m (40 ft), page 349)	Total X4
X5	Midfall connecting link (For more information see: Midfall connecting link, page 372)	890 mm 2' 11" ft-in	
Y	Jib pendant straps consisting of:		Total X4
	X4	Jib pendant strap 12 m (40 ft) (For more information see: Jib pendant strap 12 m (40 ft), page 349)	
X6	Jib pendant strap on jib head 1916 (For more information see: Jib pendant strap on jib head 1916.21, page 350)	6500 mm 21' 4" ft-in	

Tab. 601: Pendant straps A-frame3 to jib head 1916

Configuration of jib pendant straps (X):

Required number of jib pendant straps 3 m (10 ft) (**X2**) corresponds to number of jib sections 3 m (10 ft).

Required number of jib pendant straps 6 m (20 ft) (**X3**) corresponds to number of jib sections 6 m (20 ft).

Required number of jib pendant straps 12 m (40 ft) (**X4**) corresponds to number of jib sections 12 m (40 ft).



Note

► For the admissible number of jib sections 3 m (10 ft), 6 m (20 ft), 12 m (40 ft), refer to the following table: (For more information see: 7.24.1 Configuration of jib, page 1733)

7.24.5 Overview of CF pendant straps on luffing jib 1916 + midfall 1916

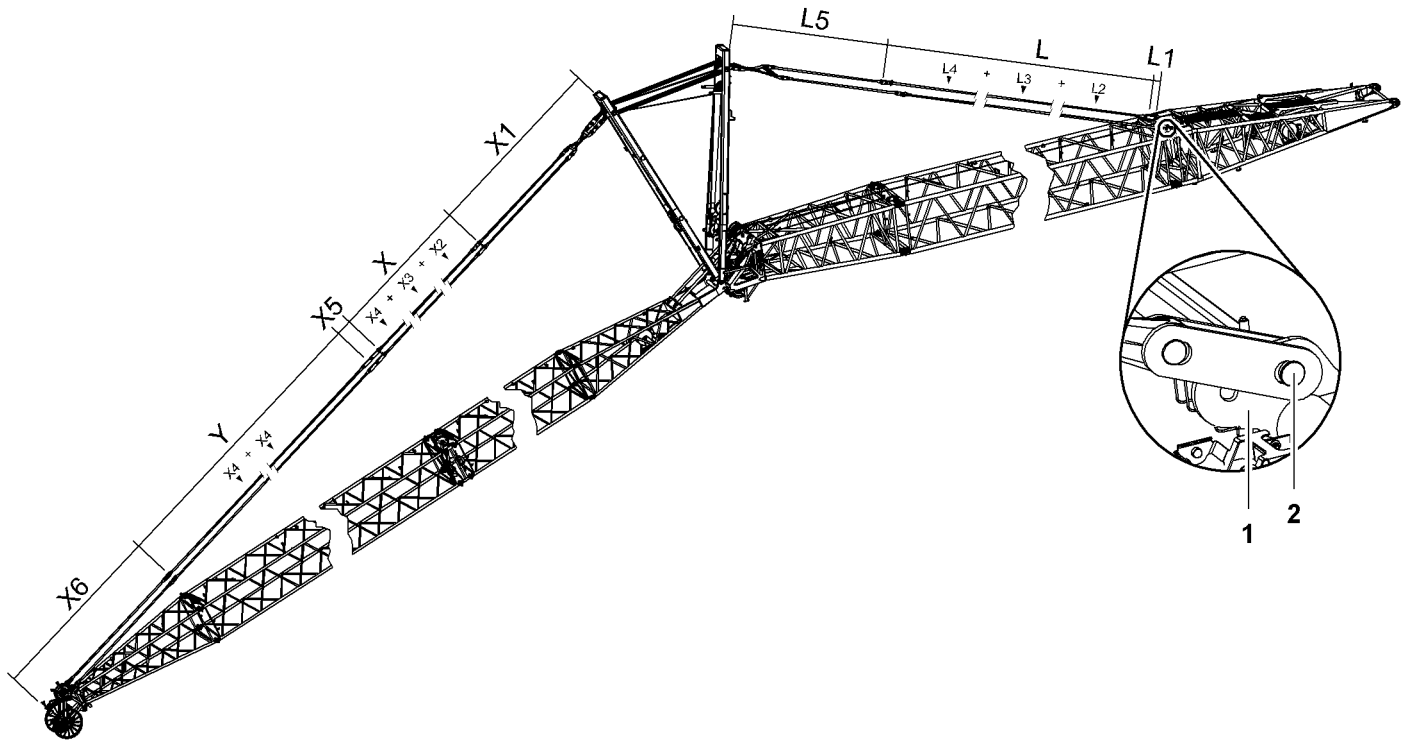


Fig. 5734: Overview of CF pendant straps on luffing jib 1916 + midfall 1916

- 1 Main boom base section
- 2 Pin connection point for jib backstay straps

Jib backstay straps A-frame2 to main boom base section 2821

Name		Value
L1	Connecting link (For more information see: Connecting link , page 202)	270 mm 10.63" in
Jib backstay straps consisting of:		
L	L2 Jib backstay strap 3 m (10 ft) (For more information see: Jib backstay strap 3 m (10 ft) , page 204)	Total L2 +
	L3 Jib backstay strap 6 m (20 ft) (For more information see: Jib backstay strap 6 m (20 ft) , page 208)	Total L3 +
	L4 Jib backstay strap 12 m (40 ft) (For more information see: Jib backstay strap 12 m (40 ft) , page 212)	Total L4

LWNLR.x/V04.01//Auslieferung/2016-03-07/en

Name		Value
L5	A-frame2 equalizer (jib backstay strap) (For more information see: Equalizer A-frame2 (jib backstay strap), page 352)	7769 mm 25' 6" ft-in

Tab. 602: Jib backstay straps A-frame2 to main boom base section 2821

Configuration of jib backstay straps (L):

Required number of jib backstay straps 3 m (10 ft) (**L2**) corresponds to number of main boom sections 3 m (10 ft).

Required number of jib backstay straps 6 m (20 ft) (**L3**) corresponds to number of main boom sections 6 m (20 ft).

Required number of jib backstay straps 12 m (40 ft) (**L4**) corresponds to number of main boom sections 12 m (40 ft).



Note

- For the admissible number of main boom sections 3 m (10 ft), 6 m (20 ft), 12 m (40 ft), refer to the load chart.

The jib backstay straps (**L**) may consist of generation A and generation B jib backstay straps (For more information see: [1.11.9 CF pendant straps on main boom 2821, page 200](#)). Mixing is only admissible if the number of generation B jib backstay straps only differs by at most 1 in the left and the right strand of the jib backstay straps.



DANGER

Inadmissible mixing of generation A and generation B jib backstay straps!
Structural failure.

- Ensure that the number of generation B jib backstay straps differs by at most 1 in the left and the right strand of the jib backstay straps.

Pendant straps A-frame3 to jib head 1916

Name		Value	
X1	A-frame3 equalizer (jib pendant strap) (For more information see: A-frame3 equalizer (jib pendant strap), page 354)	7550 mm 24' 9" ft-in	
X	Jib pendant straps consisting of:		
	X2	Jib pendant strap 3 m (10 ft) (For more information see: Jib pendant strap 3 m (10 ft), page 356)	Total X2 +
	X3	Jib pendant strap 6 m (20 ft) (For more information see: Jib pendant strap 6 m (20 ft), page 358)	Total X3 +
	X4	Jib pendant strap 12 m (40 ft) (For more information see: Jib pendant strap 12 m (40 ft), page 360)	Total X4
X5	Midfall connecting link (For more information see: Midfall connecting link, page 373)	700 mm 2' 4" ft-in	

LWNLR-x/V04.01/Auslieferung/2016-03-07/en

Name		Value
Y	Jib pendant straps consisting of:	
	X4	Jib pendant strap 12 m (40 ft) (For more information see: Jib pendant strap 12 m (40 ft), page 360)
X6	Jib pendant strap on jib head 1916 (For more information see: Jib pendant strap on jib head 1916.21, page 361)	
		Total X4 6500 mm 21' 4" ft-in

Tab. 603: Pendant straps A-frame3 to jib head 1916

Configuration of jib pendant straps (X):

Required number of jib pendant straps 3 m (10 ft) (X2) corresponds to number of jib sections 3 m (10 ft).

Required number of jib pendant straps 6 m (20 ft) (X3) corresponds to number of jib sections 6 m (20 ft).

Required number of jib pendant straps 12 m (40 ft) (X4) corresponds to number of jib sections 12 m (40 ft).



Note

- ▶ For the admissible number of jib sections 3 m (10 ft), 6 m (20 ft), 12 m (40 ft), refer to the following table: ([For more information see: 7.24.1 Configuration of jib, page 1733](#))

The jib pendant straps (X) may consist of generation A and generation B jib pendant straps ([For more information see: 1.21.8 CF pendant straps on luffing jib 1916, page 352](#)) . Mixing is only admissible if the number of generation B jib pendant straps only differs by at most 1 in the left and the right strand of the jib pendant straps.



DANGER

Inadmissible mixing of generation A and generation B jib pendant straps!
Structural failure.

- ▶ Ensure that the number of generation B jib pendant straps differs by at most 1 in the left and the right strand of the jib pendant straps.

7.24.6 Reeving diagrams for one rope across jib head 1916 (load position1)

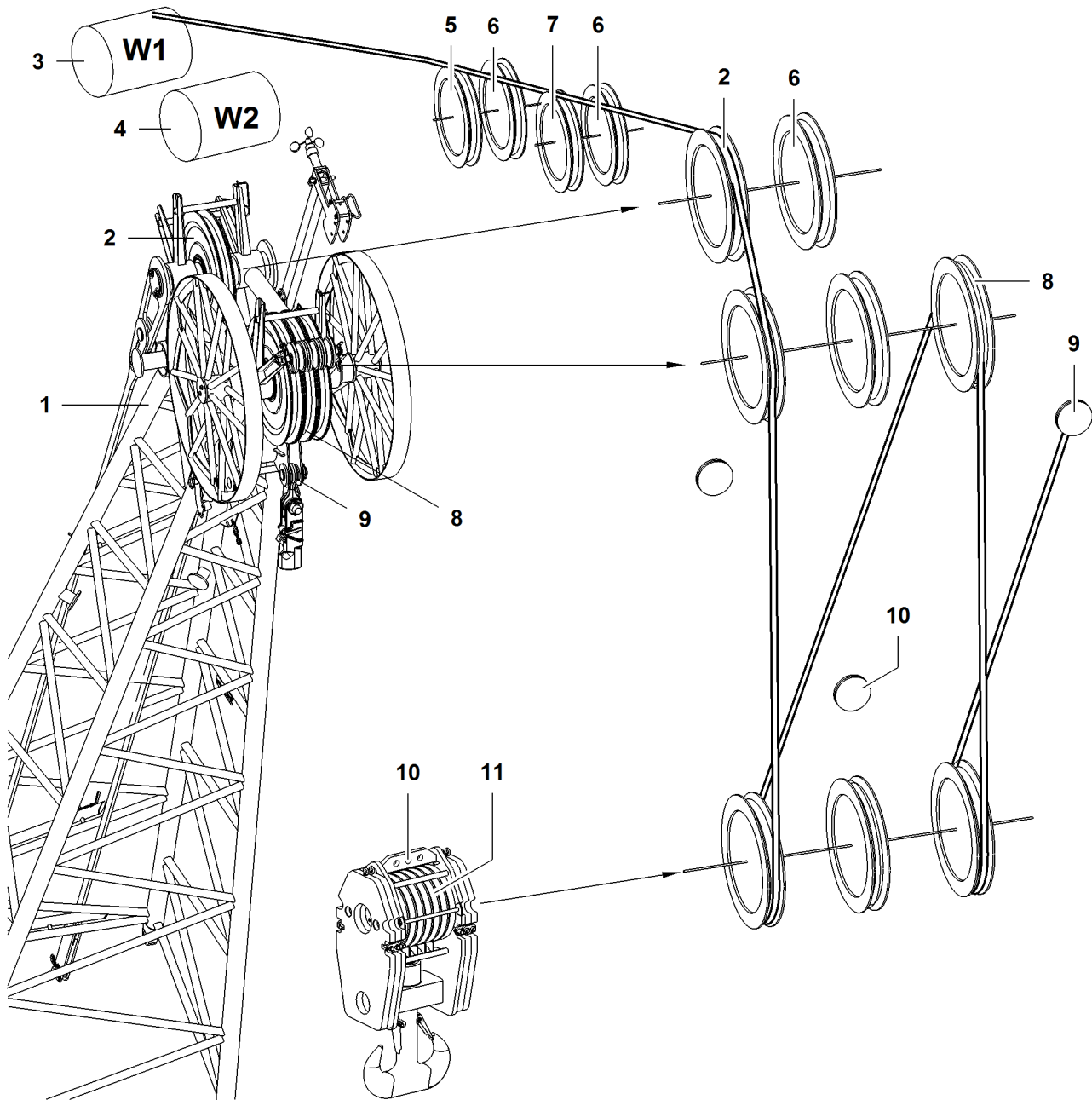


Fig. 5735: Reeving diagrams for one rope across jib head 1916 (load position1)

- | | | | | | |
|---|---------------------------|---|--|----|------------------------------------|
| 1 | Jib head | 5 | Pulley of A-frame2 | 9 | Rope fixing point of jib head |
| 2 | Gantry pulley of jib head | 6 | Retrofit kit* for operation with two ropes across jib head | 10 | Rope fixing points of pulley block |
| 3 | Winch1 | 7 | Pulley of A-frame3 | 11 | Pulley set of pulley block |
| 4 | Winch2 | 8 | Pulley (3x) of jib head | | |

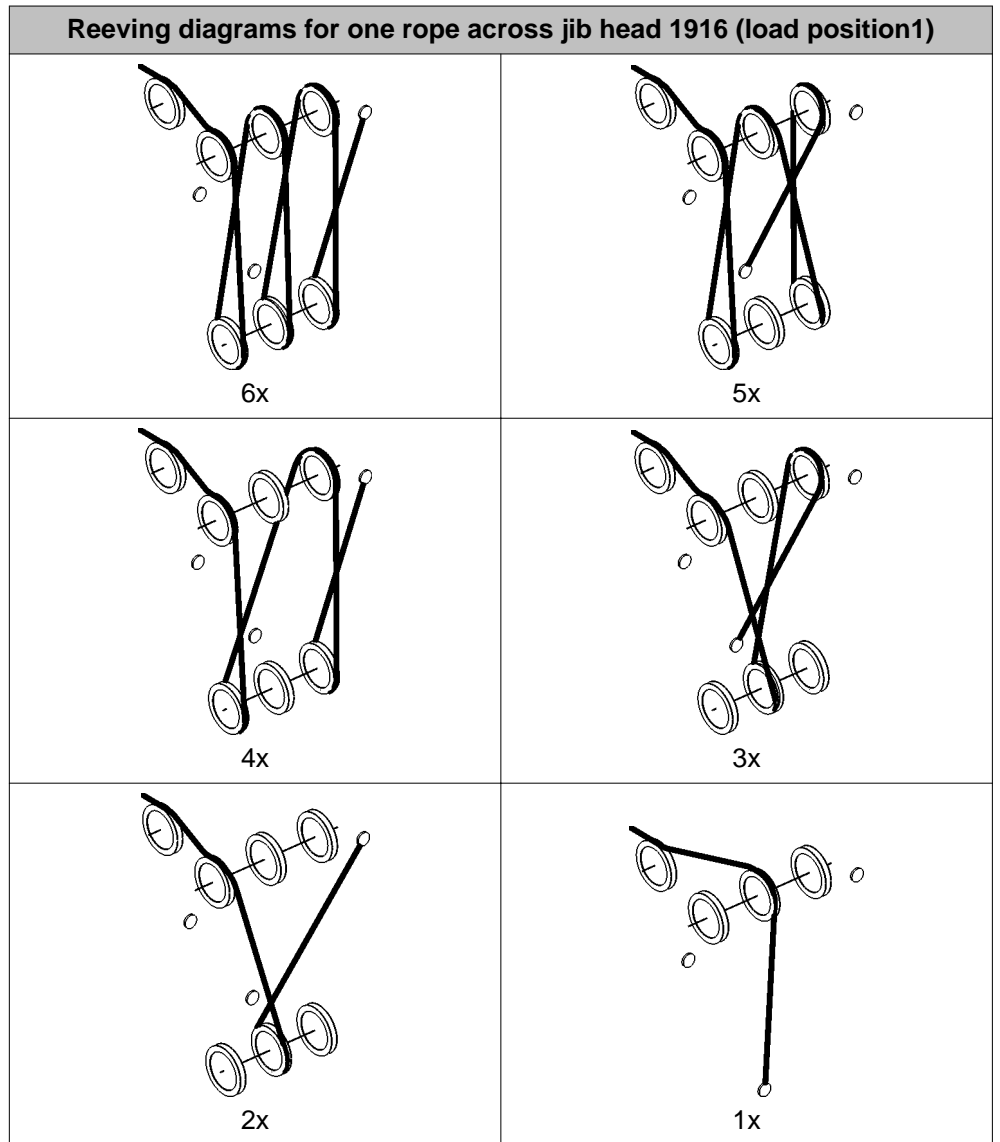


DANGER

Incorrect number of reeving!
Structural breakdown, toppling of machine.

► Choose the correct number of reeving as per the load chart.

LWNLR-x/V04.01//Auslieferung/2016-03-07/en



Tab. 604: Reeving diagrams for one rope across jib head 1916 (load position1)

LWNLR.x/V04.01//Auslieferung/2016-03-07/en

7.24.7 Reeving diagrams for one rope across midfall 1916 (load position3)

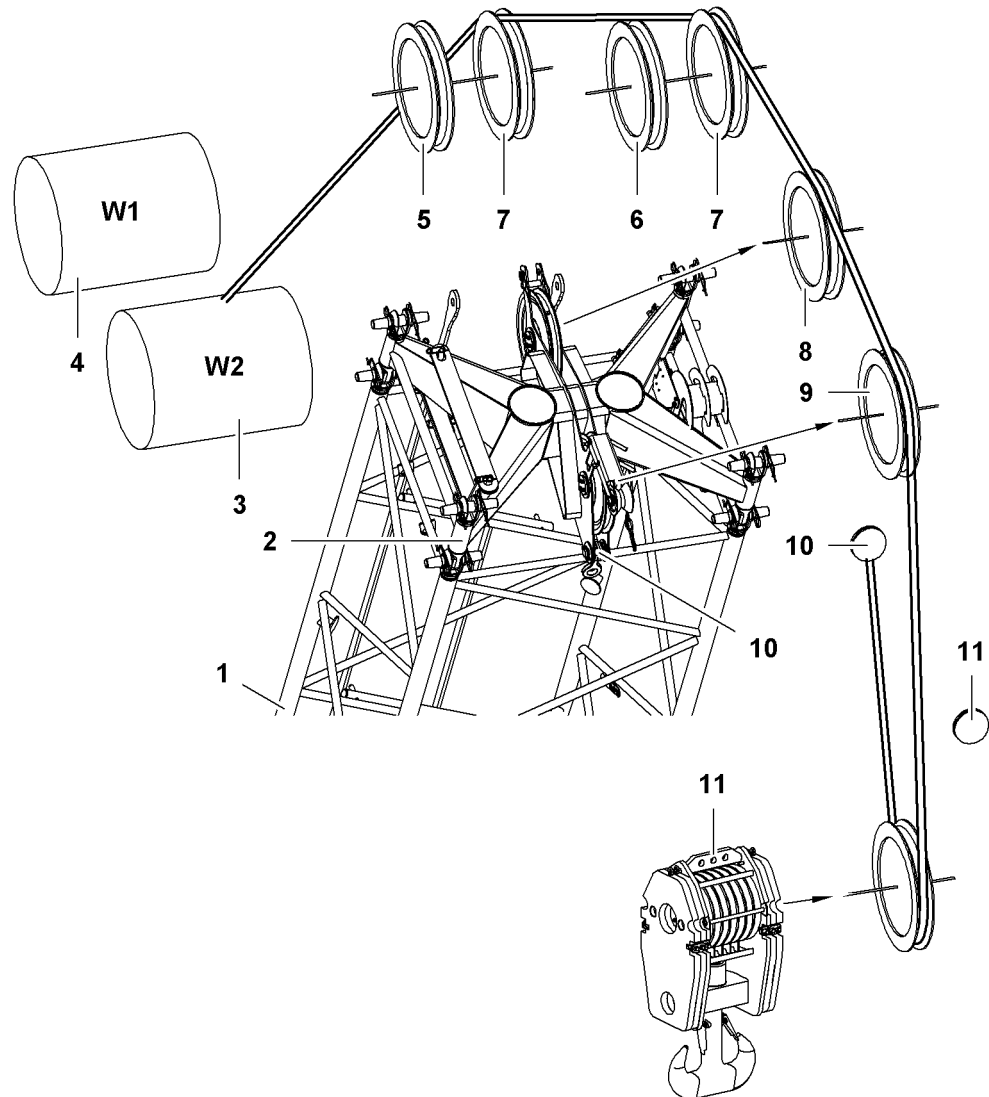


Fig. 5742: Reeving diagrams for one rope across midfall 1916 (load position3)

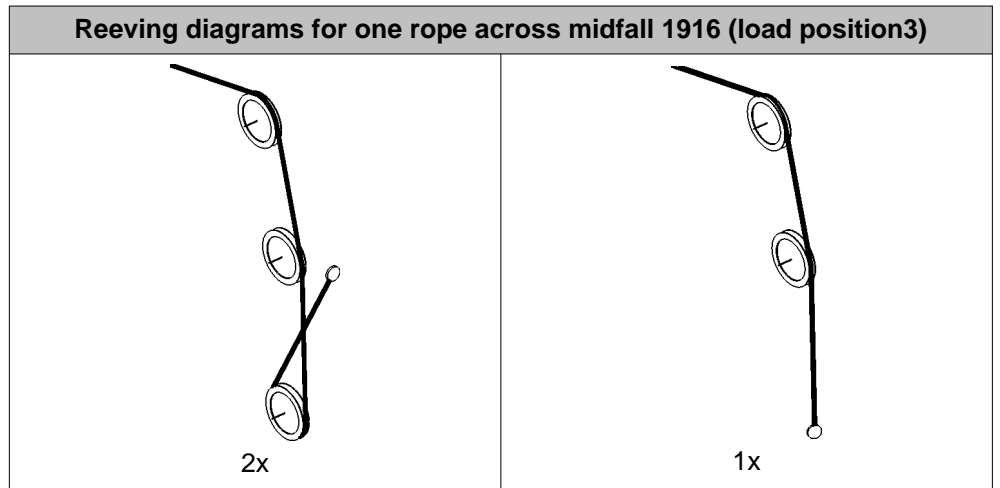
- | | | | |
|---|--------------------|----|--|
| 1 | Jib | 7 | Retrofit kit* for operation with two ropes across jib head |
| 2 | Midfall | 8 | Top pulley of midfall |
| 3 | Winch2 | 9 | Bottom pulley of midfall |
| 4 | Winch1 | 10 | Rope fixing point of midfall |
| 5 | Pulley of A-frame2 | 11 | Rope fixing points of pulley block |
| 6 | Pulley of A-frame3 | | |



DANGER

Incorrect number of reevings!
Structural breakdown, toppling of machine.

- ▶ Choose the correct number of reevings as per the load chart.



Tab. 605: Reeving diagrams for one rope across midfall 1916 (load position3)

LWNLR.x/V04.01//Auslieferung/2016-03-07/en

7.25 Assembling the luffing jib + Midfall

Ensure that the following conditions are fulfilled:

- Assembly functions are switched on.
- The machine is ready for use as an assembly crane, or an assist crane is available.
- Work plans have been drawn up.
- The assembly position of the Midfall is known.
- Any accessories required are available.

7.25.1 Notes

The installation of the Midfall described below applies to all midfall system dimensions.

The illustrations have been simplified or schematically represented for reasons of uniformity and represent the principles of assembly. They do not provide a detailed representation of the components.

7.25.2 Installing the midfall

The assembly steps are identical to those for the luffing jib without Midfall. The following section only contains information specific to the installation of the Midfall. The remaining operations are to be carried out as described previously in the luffing jib assembly section.



DANGER

Midfall installed in the wrong position!
Structural breakdown.

- ▶ The assembly position for the Midfall can be found in the load chart.
-

Replacing the connecting links

- ▶ Install and bolt the Midfall in the prescribed position.
-



WARNING

Incorrect connecting links for pendant straps!

- ▶ Replace the connecting links of the jib pendant straps with Midfall connecting links.
-

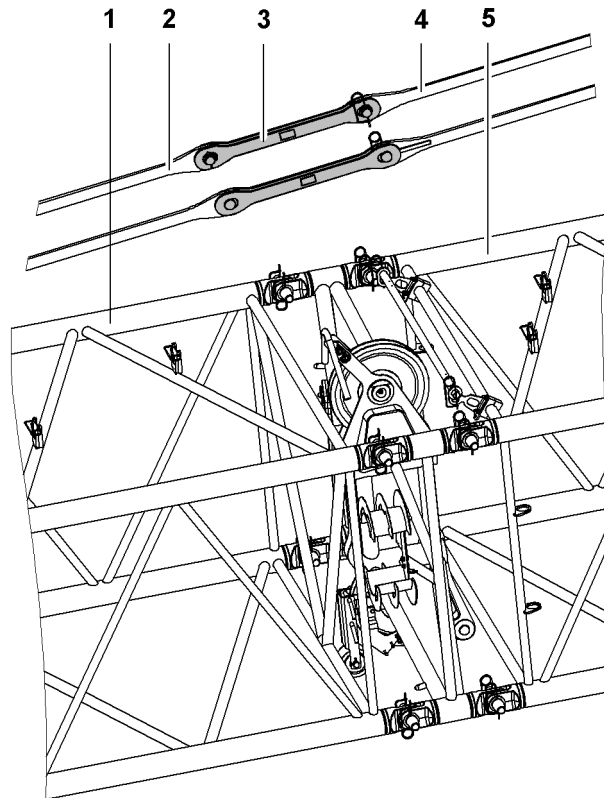


Fig. 5745: Replacing the midfall connecting links

- | | | | |
|----------|-------------------------|----------|-------------------|
| 1 | Jib section | 4 | Jib pendant strap |
| 2 | Jib pendant strap | 5 | Jib section |
| 3 | Midfall connecting link | | |

- ▶ Remove the first connecting links of the first jib pendant straps **2** after the Midfall assembly position.
- ▶ Fasten the removed connecting links in the storage position on the Midfall.
- ▶ Install the midfall connecting links **3** and pin to the jib pendant straps **2 + 4**.
- ▶ Pull the electric cable from the jib base section to the jib head section and plug it in.
- ▶ Unwind the electric cable from the wire bracket on the Midfall.
- ▶ Pull the electric cable from the Midfall to the jib head section and plug it in.

Installing the mid-point suspension

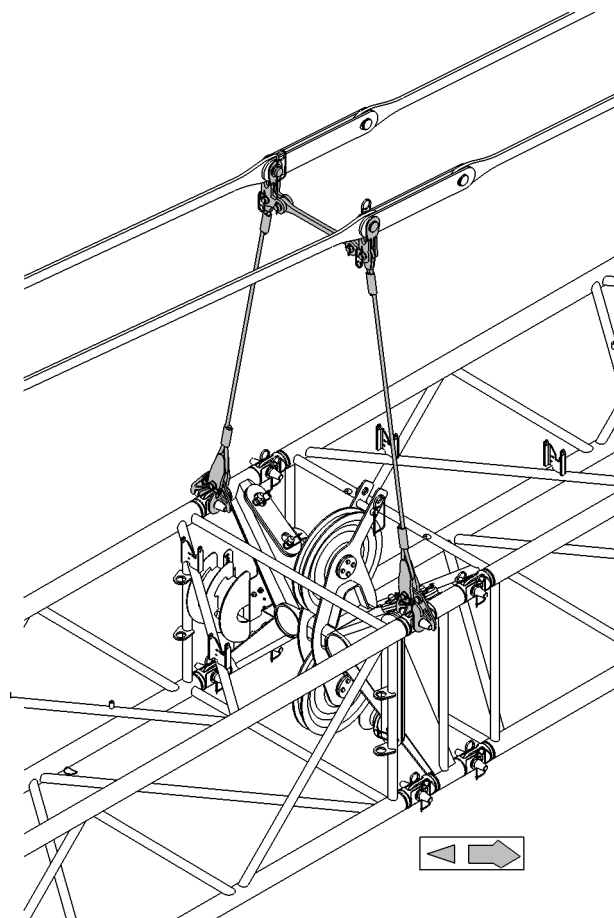


Fig. 5746: Installing the mid-point suspension (illustration of principle)

The mid-point suspension on the midfall is identical with the mid-point suspension on the luffing jib.

- ▶ Install mid-point suspension on the midfall using the same procedure as with mid-point suspension on luffing jib ([For more information see: 7.22.17 Installing mid-point suspension, page 1679](#)).

Dismantling rope protection pipes

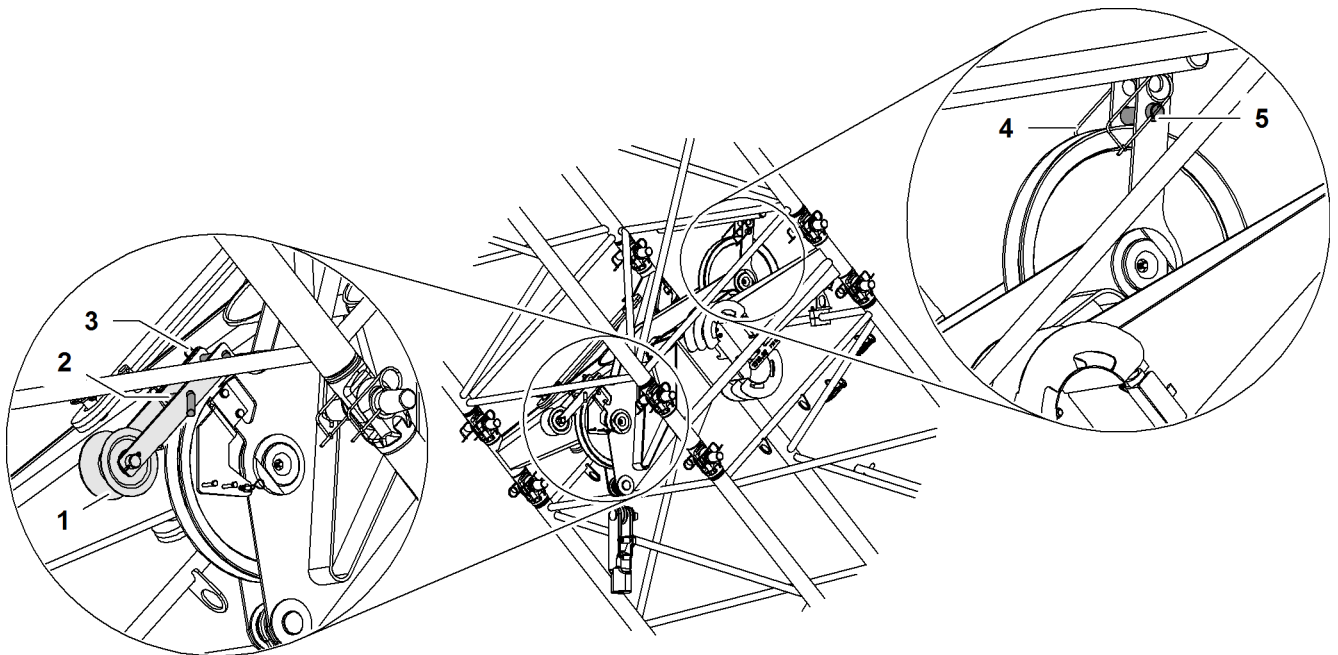


Fig. 5747: Rope pulley and rope protection pipe on midfall

- | | | | | | |
|---|-------------|---|-----------------|---|----------------------|
| 1 | Rope pulley | 3 | Safety pin (2x) | 5 | Rope protection pipe |
| 2 | Pin (2x) | 4 | Safety pin (2x) | | |

- ▶ Remove all safety pins **3 + 4**.
- ▶ Remove rope protection pipe **5**.
- ▶ Remove both pins **2**.
- ▶ Remove rope pulley **1**.
- ▶ Reeve rope over top and bottom pulley.
 - ▷ Rope reeved at midfall.
- ▶ Insert both pins **2** at the rope pulley **1**.
- ▶ Install rope protection pipe **5**.
- ▶ Install all safety pins **3 + 4**.
 - ▷ Midfall is reeved and rope protection pipes installed.

Installing the rope fixing point



DANGER

Incorrect number of reevings!
Structural breakdown, toppling of machine.

- ▶ Choose the correct number of reevings as per the load chart.



DANGER

Incorrect installation of pins for pocket lock!
Load breakaway.

- ▶ Install pins for pocket lock as instructed.

The collar of the pin for the pocket lock is decisive for the installation direction of the rope fixing point.



WARNING

Inadmissible installation of swivels!
Severe injuries, damage to machine.

- ▶ Install rope with no twists.
- ▶ Install rope without swivels.

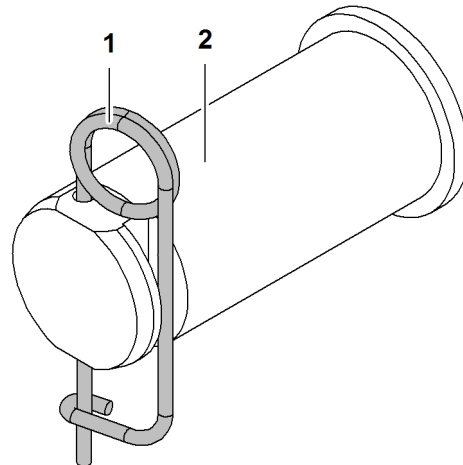


Fig. 5748: Securing the pins

1 Locking spring

2 Pin



DANGER

Pins 2 not completely secured!
Load breakaway.

- ▶ Ensure that locking spring 1 completely secures the pin 2.

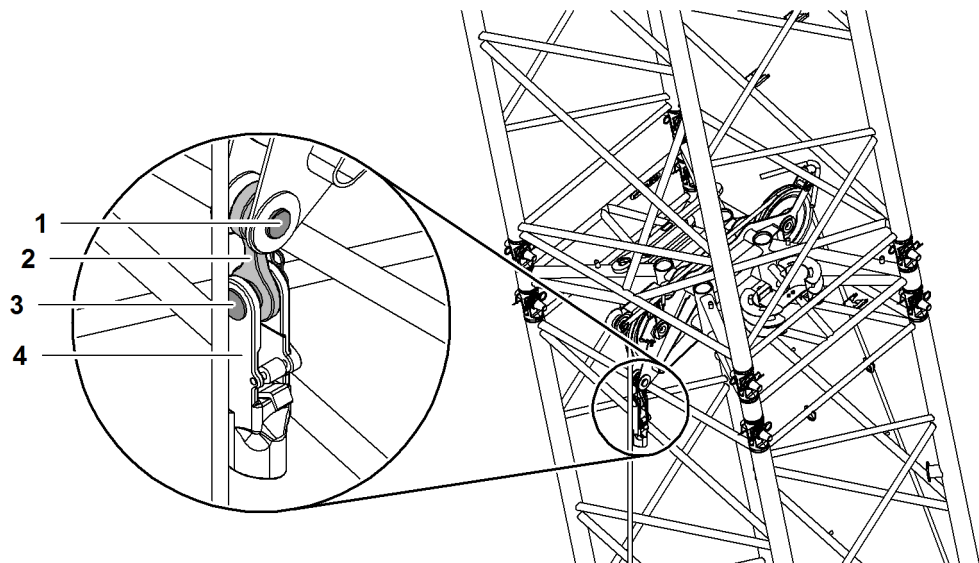


Fig. 5749: Rope fixing point on midfall

1 Pin for rope fixing point
2 Cross strap

3 Pins for pocket lock
4 Pocket lock

- ▶ Pin cross strap **2** with midfall.
- ▶ Secure pin **1** with locking spring.

The collar of the pin **3** for the pocket lock **4** must point towards the jib head.

- ▶ Pin pocket lock **4** with cross strap **2**.
- ▶ Secure pin **3** with locking spring.

7.26 Adjusting the track

Wide track is mandatory for crane operation and assembly and disassembly.

Medium and narrow track is solely intended for traveling with a lateral tilt of max. 1 % with no load on the hooks or pulley block.



DANGER

Inadmissible setup!
Toppling of machine.

- ▶ Make sure that the upgraded track width matches the track width selected on the monitor side *Setup - Basic machine*.
- ▶ Make sure that crawler side frames are pinned in the selected track width.



DANGER

Rotating the uppercarriage with medium or narrow track not permitted!
Machine toppling over.

- ▶ Ensure that the uppercarriage is parallel to the crawler side frames.



WARNING

Incorrect track width adjustment process is followed!
Bodily injuries.

- ▶ Ensure that exclusively authorized persons carry out the track width adjustment process.

Ensure that the following conditions are fulfilled:

- The subsoil is level and sufficiently supportive.
- The uppercarriage is parallel to the crawler side frames.
- The machine operator remains in the cab throughout the entire jack-up process.
- Authorized persons are available for the track width adjustment process.

7.26.1 Converting from wide track to medium or narrow track

Move machine's center of gravity to the center of the rotation axis

NOTICE

Twisting of the crawler side frames!
Damage to machine.

- ▶ Adjust the boom so that the machine's center of gravity lies in the middle of the rotation axis.
- ▶ Check the ground pressure display.

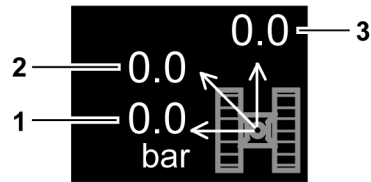


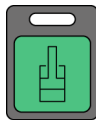
Fig. 5750: Screen section Ground pressure

- | | |
|---|--|
| <p>1 Maximum ground pressure to the side</p> <p>2 Maximum ground pressure across one edge</p> | <p>3 Maximum ground pressure forward</p> |
|---|--|

Machine's center of gravity is located at the center of the of the rotation axis when all three values of the ground pressure indicator are identical.

- ▶ Move the machine's center of gravity to the middle of the rotation axis: luff the boom.

Extending and pinning the track width adjusting cylinder



- ▶ Press the *Cylinder adjustment functions* button on control panel X23.

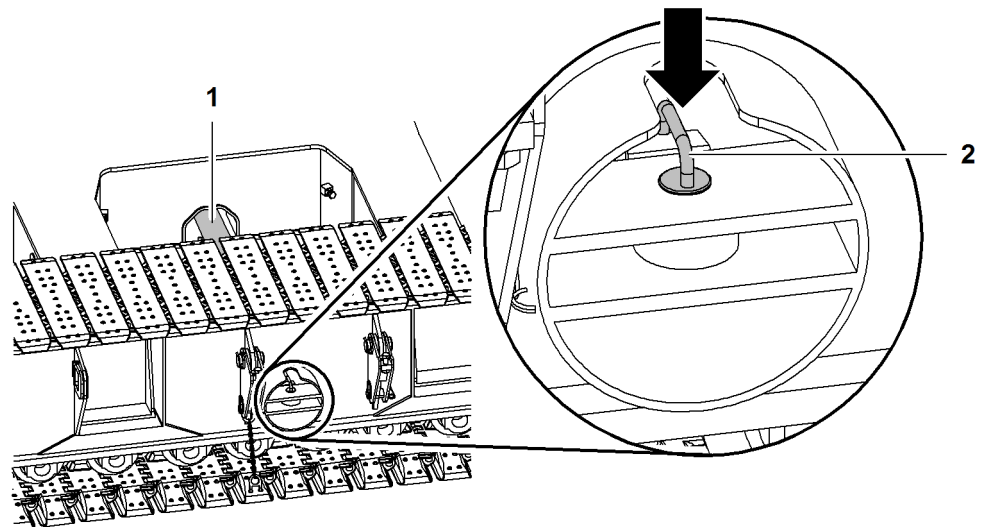


Fig. 5752: Extending and pinning the track width adjusting cylinder

- | | |
|---|--------------|
| <p>1 Track width adjusting cylinder</p> | <p>2 Pin</p> |
|---|--------------|
- ▶ Plug in the cable remote control on the undercarriage.
 - ▶ Extend track width adjusting cylinder 1 with cable remote control.
 - ▶ Pin track width adjusting cylinder 1 to crawler side frame with pins 2.
 - ▶ Repeat procedure with second track width adjusting cylinder 1.

Loosening strut mountings

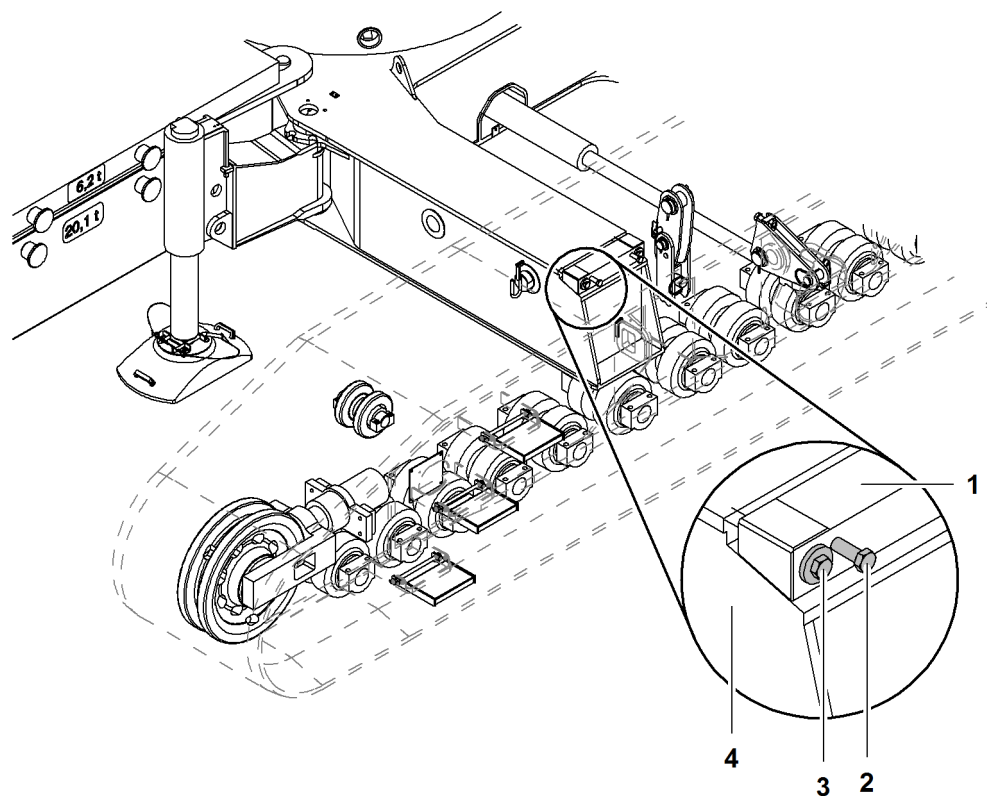


Fig. 5753: Loosening strut mountings

- | | | | |
|---|------------|---|--------------------|
| 1 | Wedge | 3 | Locking screw (2x) |
| 2 | Screw (2x) | 4 | Strut |

The two outer locking screws **3** must be turned almost completely out of the struts **4** so that the wedge **1** is located as close as possible to the end of the strut.

- ▶ Loosen screws **2** of the strut mounting.
- ▶ Loosen locking screws **3** of strut mounting and twist out almost all the way.
- ▶ Turn in screws **2** of strut mounting.
 - ▷ The wedge **1** loosens.
- ▶ Clean strut **4** and evenly grease the sliding surfaces.
- ▶ Repeat procedure on all strut mountings.

Preparing the crawler side frame

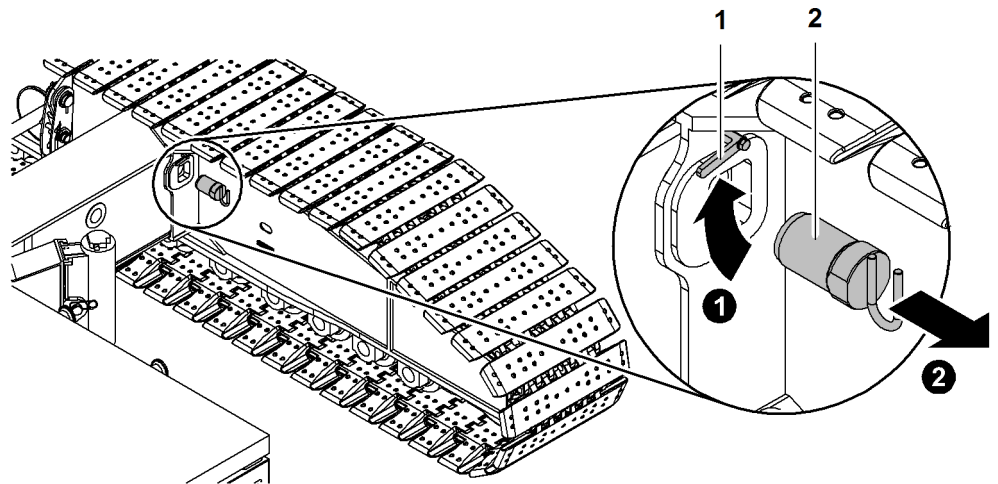


Fig. 5754: Preparing the crawler side frame

1 Safety lever

2 Pin

- ▶ Undo the safety lever 1 screw.
- ▶ Fold up the safety lever 1.
- ▶ Remove the pin 2.
- ▶ Repeat procedure on all crawler side frame pin connection points.

Supporting the machine

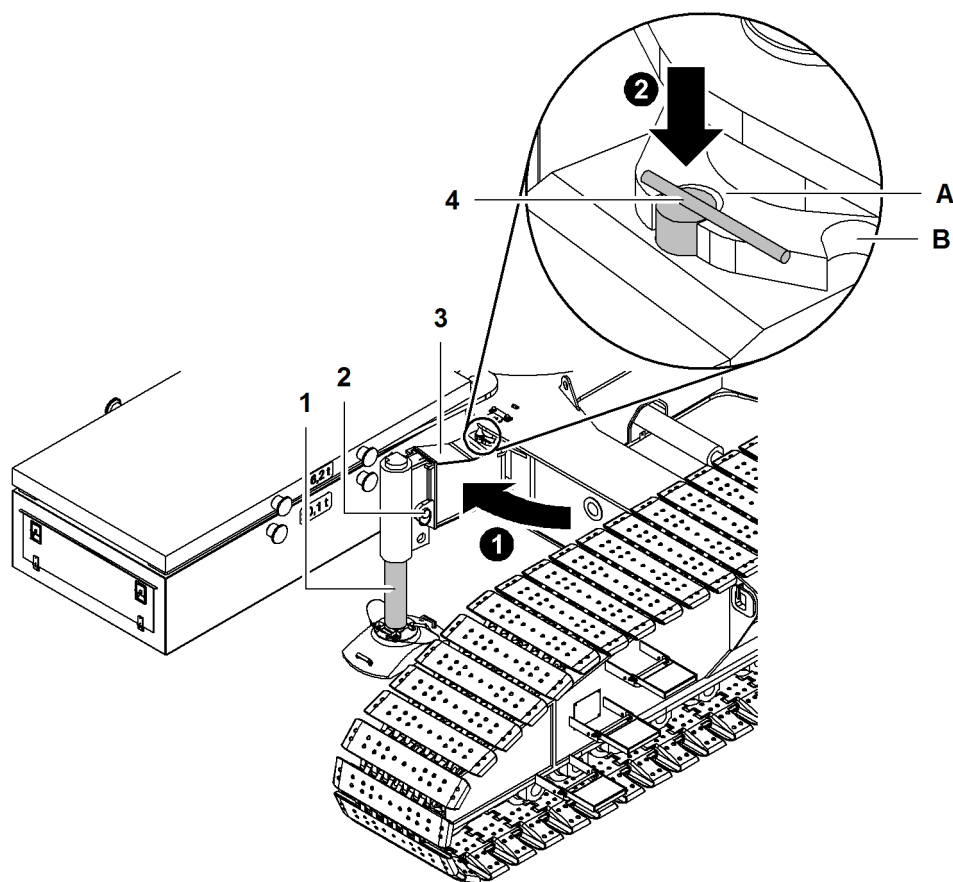


Fig. 5755: Supporting the machine

- | | | | |
|---|--------------------------|---|---|
| 1 | Jack | 4 | Pin |
| 2 | Top pin connection point | A | Pin connection point of support position for narrow track |
| 3 | Slewing bracket | B | Pin connection point of support position for wide track |

- ▶ Remove pin 4 on pin connection point B of wide track support position.
- ▶ Swing slewing bracket 3 into narrow track support position.



DANGER

Slewing brackets 3 not pinned!
Toppling of machine.

- ▶ Pin slewing brackets 3 in narrow track support position.
- ▶ Insert pin 4 at pin connection point A of narrow track support position.
- ▶ Pin jacks 1 at top pin connection point 2 (For more information see: [Adjusting the support height of jacks, page 1209](#)).
- ▶ Repeat procedure with all jacks 1.



DANGER

Incorrect jack-up process!
Machine toppling over.

- ▶ Ensure that all four jacks are always in contact with the ground.
- ▶ Extend the front and rear hydraulic jacks alternately.
- ▶ Keep an eye on the spirit level.

If guide rollers lift out of the crawler chains:

- ▶ Stop the jack-up process.

The jacks **1** are operated with the toggle switches of the cable remote control (For more information see: [3.24.2 Cable remote control on undercarriage*](#), page 800) .



Note

Liebherr recommends:

- ▶ always extend two jacks **1** at the same time.

- ▶ Move the corresponding toggle switches on cable remote control forward.
 - ▷ Jacks **1** extend.

Retracting the track width adjusting cylinders and pinning the crawler side frames

Set track width adjusting cylinder to medium track



CAUTION

Do not access adjusting range of crawler side frames!
Crushing of body parts.

- ▶ Leave danger zone.

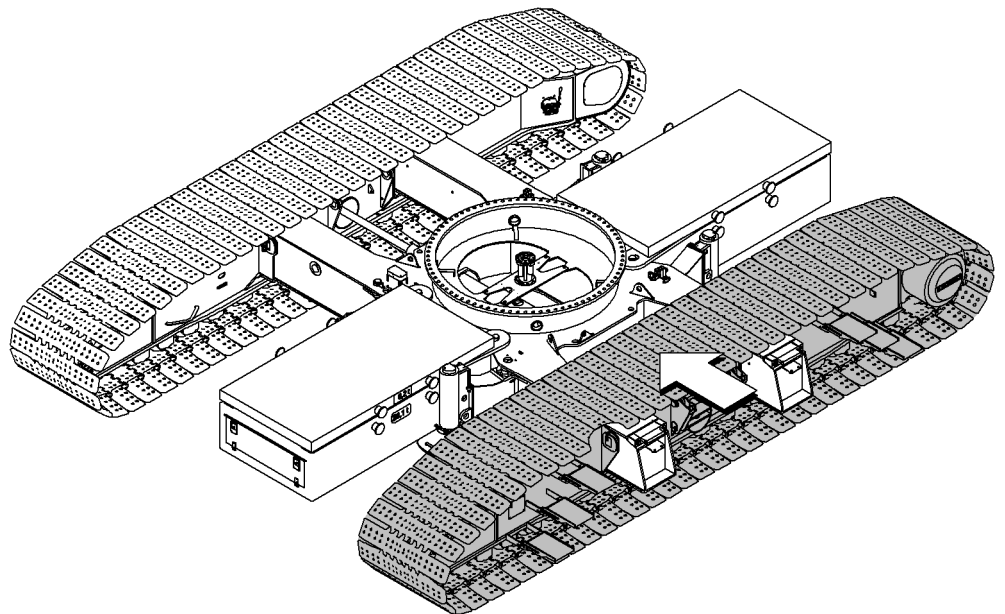


Fig. 5756: Set track width adjusting cylinder to medium track

- ▶ Retract first track width adjusting cylinder with cable remote control.
- ▶ Retract second track width adjusting cylinder with cable remote control.

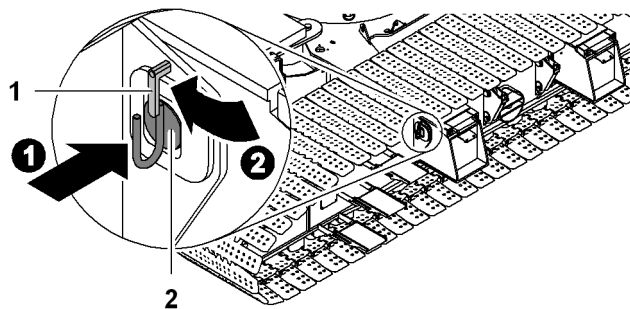


Fig. 5757: Bolting crawler side frame in medium track

1 Safety lever

2 Pin

- ▶ Insert pin 2.
- ▶ Pull down the safety lever 1.
- ▶ Tighten the safety lever 1 screw.
- ▶ Repeat procedure on all crawler side frame pin connection points.

Set track width adjusting cylinder to narrow track



CAUTION

Do not access adjusting range of crawler side frames!
Crushing of body parts.

- ▶ Leave the danger area.

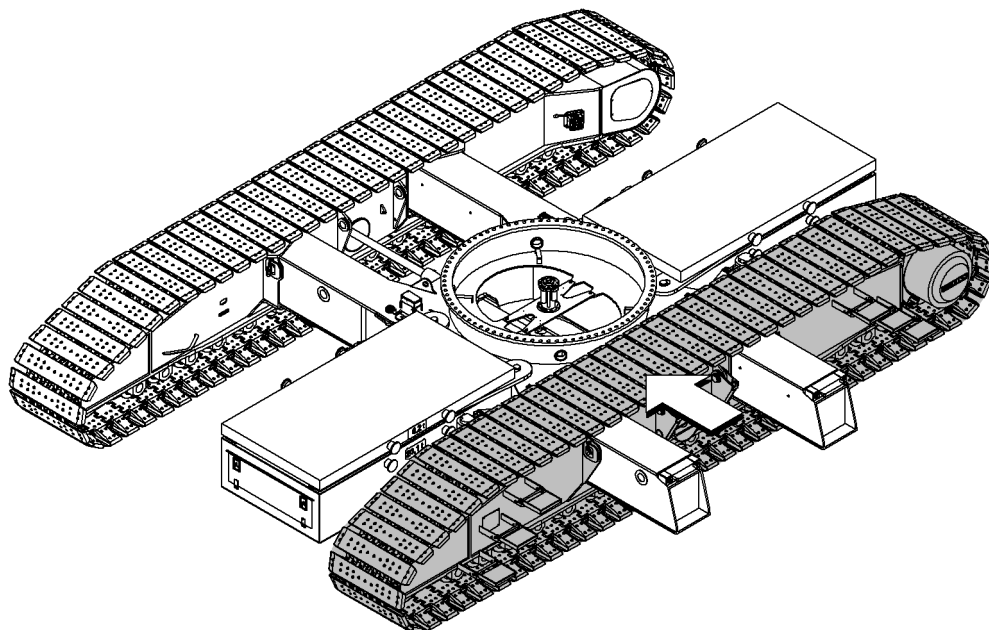


Fig. 5758: Set track width adjusting cylinder to narrow track

- ▶ Retract first track width adjusting cylinder with cable remote control.
- ▶ Retract second track width adjusting cylinder with cable remote control.

Mounting uppercarriage ladder for narrow track

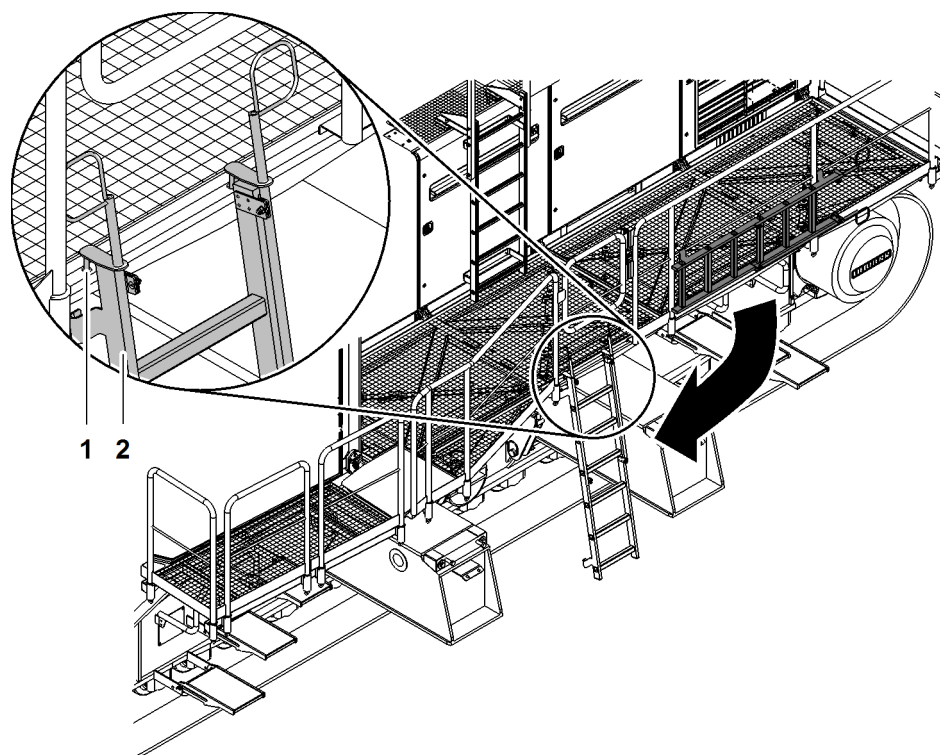


Fig. 5760: Mounting uppercarriage ladder for narrow track

1 Suspension equipment (2x) 2 Uppercarriage ladder

- ▶ Take uppercarriage ladder 2 out of bracket on railing.
- ▶ Place suspension device 1 below access in the intended openings.

7.26.2 Converting from medium or narrow track to wide track

Conversion from medium or narrow track to wide track is carried out using the same assembly procedure as the conversion from wide track to medium or narrow track (For more information see: [7.26.1 Converting from wide track to medium or narrow track, page 1752](#)).

7.27 Hydraulic cab elevation*

7.27.1 Erecting and bolting the mast



WARNING

Improper erection of the mast!
Serious injury.

- ▶ Make sure that no-one is standing in the danger area.
- ▶ Leave the danger area.
- ▶ Make sure that there are no tools and no loose objects on the mast.

Ensure that the following conditions are fulfilled:

- Diesel engine is switched on.
- Cylinder adjustment functions on.
- Cab is in transport position.

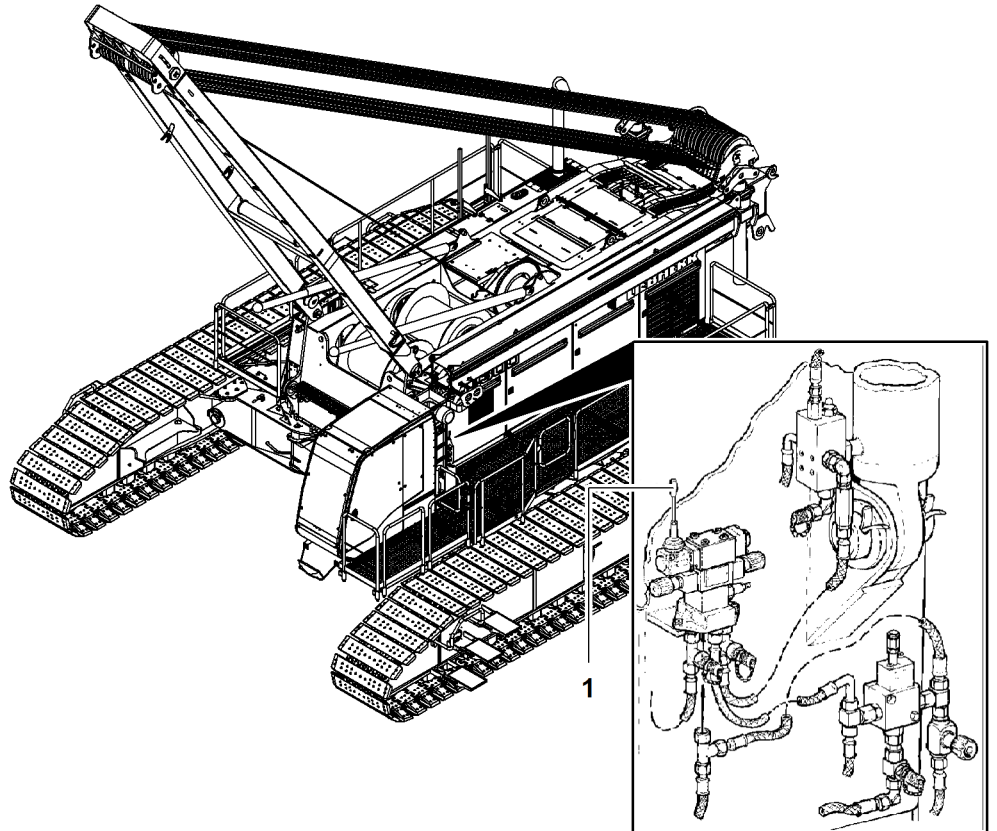


Fig. 5761: Erecting the mast

- 1 Adjustment lever
- ▶ Actuate adjustment lever 1.
 - ▷ Mast erects itself:

7.27.2 Setting the cab in the working position and bolting in place

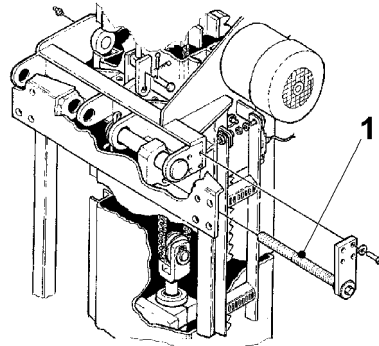


Fig. 5764: Setting the cab into the working position

1 Threaded bar

The threaded bar 1 functions as a spindle and moves the cabin in or out.

► Use the threaded bar 1 to move the cabin out as far as it will go.

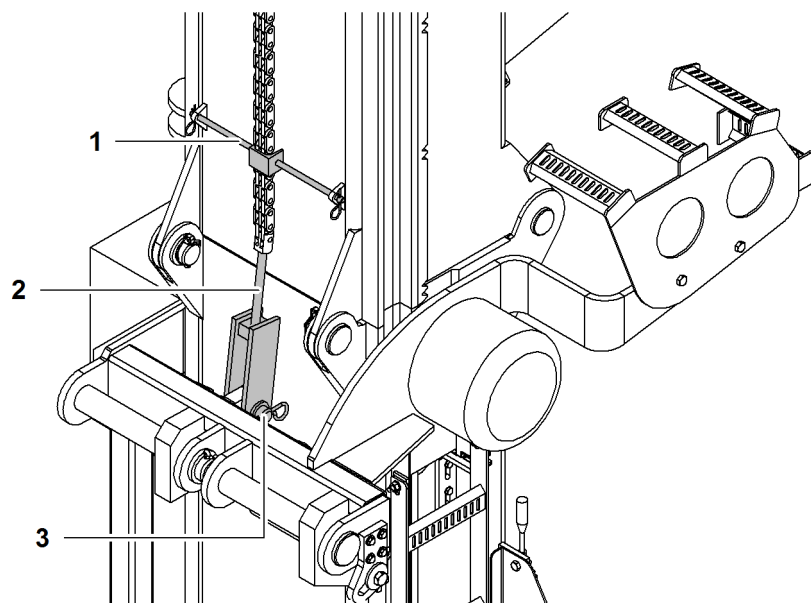


Fig. 5765: Pinning the chain

1 Chain guide

2 Chain

3 Pin

► Remove chain guide 1 and place in temporary storage.

► Pin chain 2 to cabin frame.

► Secure pin 3 with split pin.

7.27.3 Dismantling



WARNING

Improper disassembling!
Serious injury.

- ▶ Make sure that no-one is standing in the danger area.
- ▶ Leave the danger area.
- ▶ Do not remain on the uppercarriage while the mast is lowered.

NOTICE

Improper disassembling!
Damage to machine.

- ▶ Unbolt the chain from the cab.
- ▶ Attach the chain guide.
- ▶ Do not trap the hose kit.
- ▶ Dismantle the railings on the uppercarriage.
- ▶ Dismount ladder on uppercarriage.

Summary of the of disassembly steps

- ▶ Lower the cab completely.
- ▶ Unbolt the chain from the frame of the cab.
- ▶ Use a chain guide to secure the chain to the mast.
- ▶ Placing the cabin in transport position: Push all the way in with threaded bar.
- ▶ Unbolt both pins of the mast fixing.
- ▶ Lay down the mast using the control lever on the mast.

7.28 Vertical Line Finder* assistance system

7.28.1 Installing the Vertical Line Finder on the main boom head

Make sure the following prerequisites are met:

- Rope of winch1/winch2 is completely reeved on main boom head.
- Bracket of the Vertical Line Finder is installed on main boom head.
- No jib is installed on the main boom.

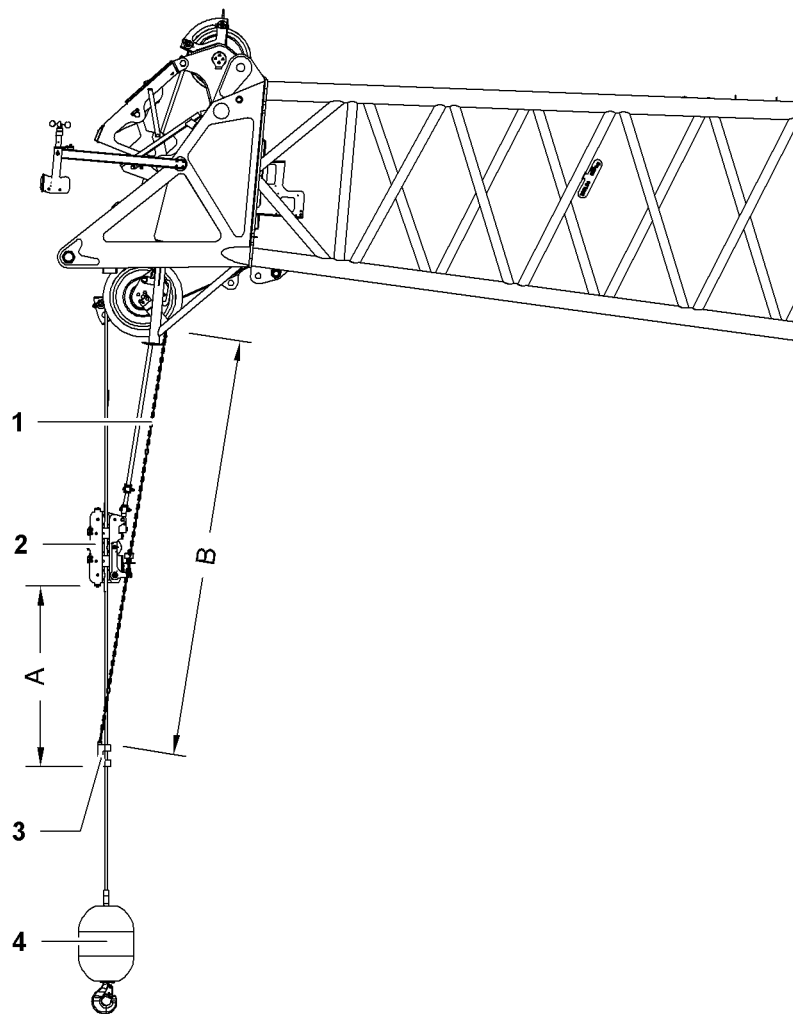


Fig. 5766: Installing the Vertical Line Finder on the main boom head

- | | | | |
|---|--------------|---|---------------------------|
| 1 | Chain | 3 | Hoist limit switch weight |
| 2 | Rope opening | 4 | Hook |

NOTICE

Improper installation of Vertical Line Finder with single or double reeving!
Damage to Vertical Line Finder and main boom head.

- ▶ Make sure that the distance between the rope opening **2** and the hoist limit switch weight **3** is at least 2000 mm (6' 7" ft-in).
- ▶ Make sure that the chain **1** of the hoist limit switch has a length of 4500 mm (14' 9" ft-in).

Name		Value
A	Minimum distance rope opening to hoist limit switch weight	2000 mm 6' 7" ft-in
B	Length of chain	4500 mm 14' 9" ft-in

Tab. 606: Installing the Vertical Line Finder with single or double reeving

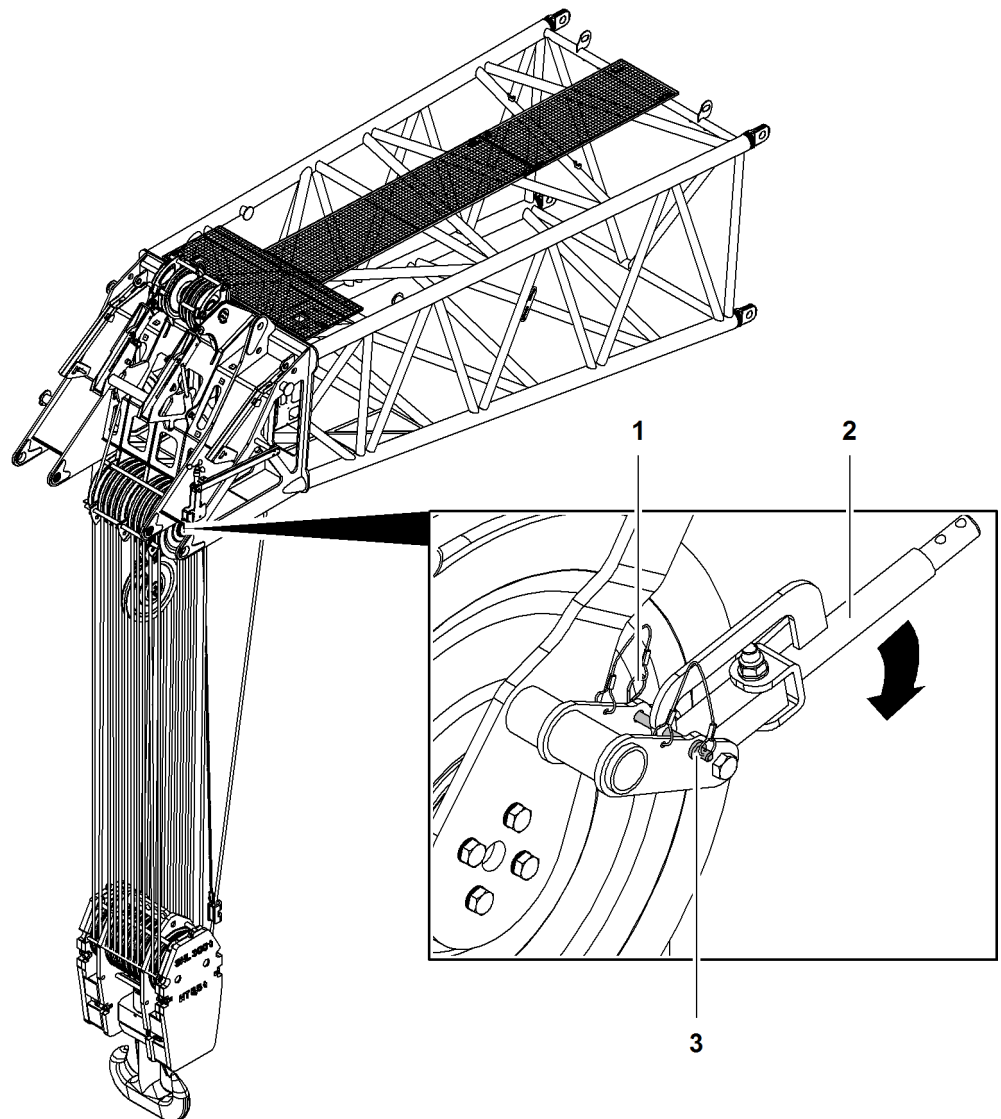


Fig. 5767: Placing the bracket of Vertical Line Finder in working position

- | | | | |
|----------|-------------------|----------|-----|
| 1 | Spring cotter pin | 3 | Pin |
| 2 | Bracket | | |

LWNLR-x/V04.01//Auslieferung/2016-03-07/en

- ▶ Remove spring cotter pin 1.
- ▶ Remove pin 3.
 - ▷ Bracket 2 folds down.
- ▶ Insert pins 3.
- ▶ Secure pin 3 with spring cotter pin 1.
- ▶ Repeat procedure on opposite side.

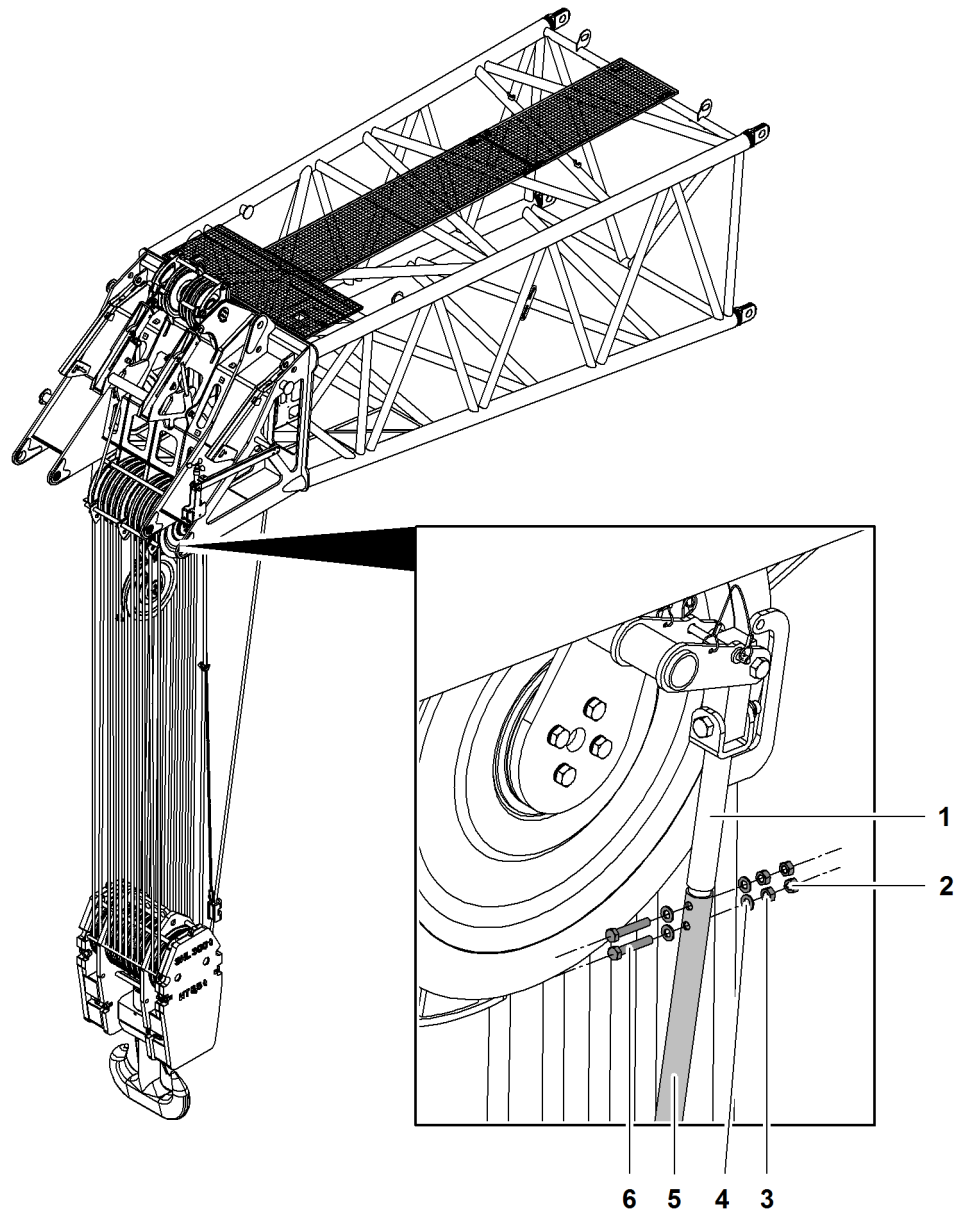


Fig. 5768: Connecting the vertical pipe with bracket

- | | | | |
|---|------------------|---|---------------|
| 1 | Bracket | 4 | Washer (4x) |
| 2 | Counter nut (2x) | 5 | Vertical pipe |
| 3 | Nut (2x) | 6 | Screw (2x) |

- ▶ Stick vertical pipe 5 on bracket 1.
- ▶ Insert screws 6 with washers 4 in borings.
- ▶ Secure screws 6 with washers 4 and nuts 3.
- ▶ Secure nuts 3 with counter nuts 2.

► Repeat procedure on opposite side.

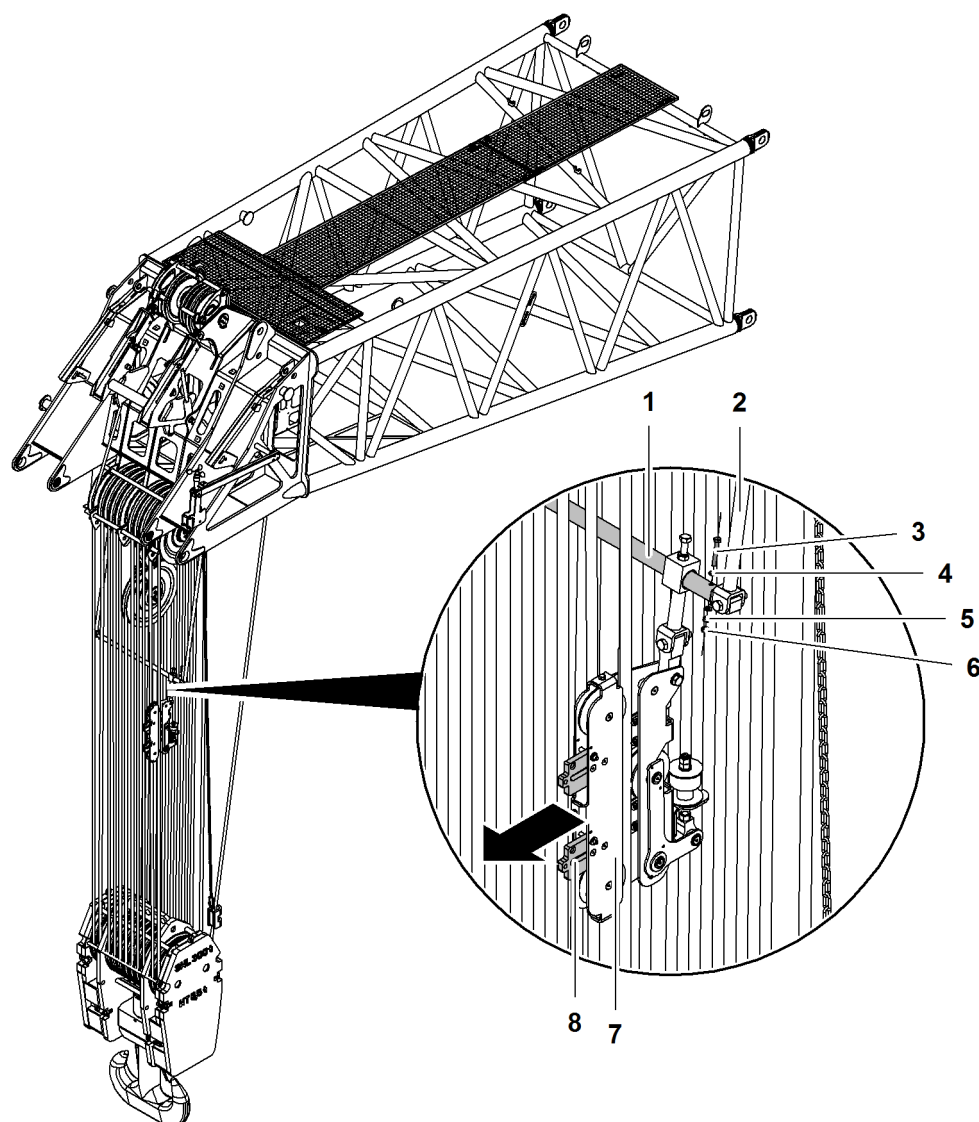


Fig. 5769: Connecting transverse pipe with vertical pipes

1	Transverse pipe	5	Nut
2	Vertical pipe (2x)	6	Counter nut
3	Screw	7	Rope opening
4	Washer (2x)	8	Rope lock (2x)

- Stick transverse pipe 1 with rope opening 7 on vertical pipes 2.
- Insert screw 3 with washer 4 in boring.
- Secure screw 3 with washer 4 and nut 5.
- Secure nut 5 with counter nut 6.
- Repeat procedure on opposite side.
- Remove pins of rope locks 8.
- Pull rope locks 8 outward.

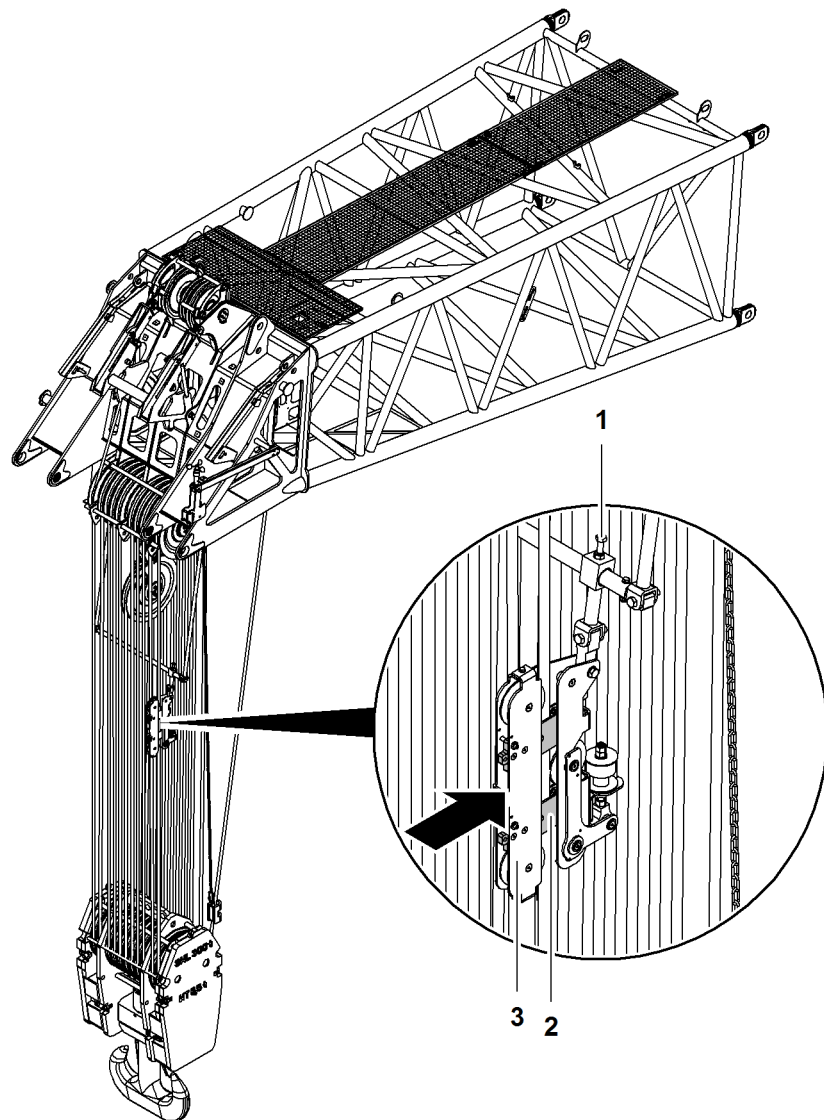


Fig. 5770: Positioning rope opening and inserting the rope

- | | | | |
|---|----------------|---|--------------|
| 1 | Screw | 3 | Rope opening |
| 2 | Rope lock (2x) | | |

The rope opening **3** must be installed on the outer rope that is closest to the rope fixing point of the main boom head.

- ▶ Position rope opening **3**.
- ▶ Secure rope opening **3** with screw **1**.
- ▶ Place rope in rope opening **3**.
- ▶ Slide rope locks **2** inward.
- ▶ Secure rope locks **2** with pins.

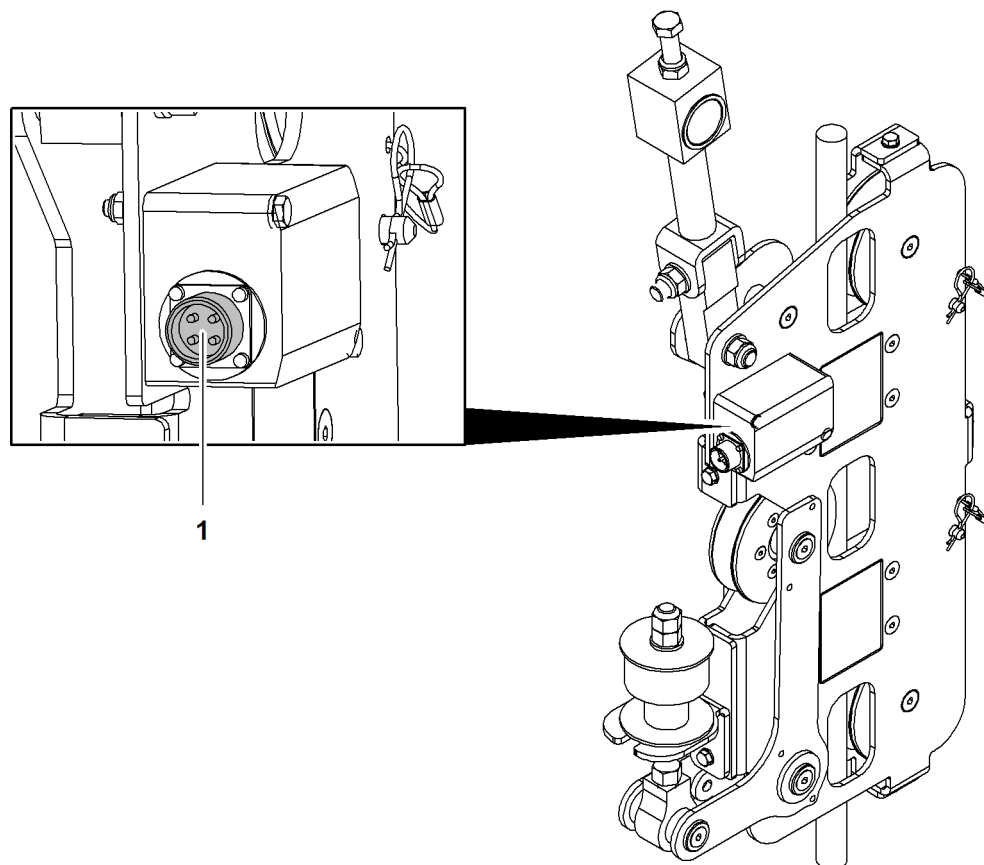


Fig. 5771: Connecting the electric line of the Vertical Line Finder

1 Bush

- ▶ Insert electric line of Vertical Line Finder at bush 1.
- ▶ Insert electric line of Vertical Line Finder on terminal box of main boom head.
 - ▷ Vertical Line Finder is ready for operation.

7.28.2 Installing the Vertical Line Finder on the jib head

Make sure the following prerequisites are met:

- Rope of winch1/winch2 is completely reeved on jib head.
- Vertical Line Finder components on the main boom head are deinstalled.
- Bracket of Vertical Line Finder on main boom head is secured in parked position.
- There is no auxiliary jib installed on the jib.

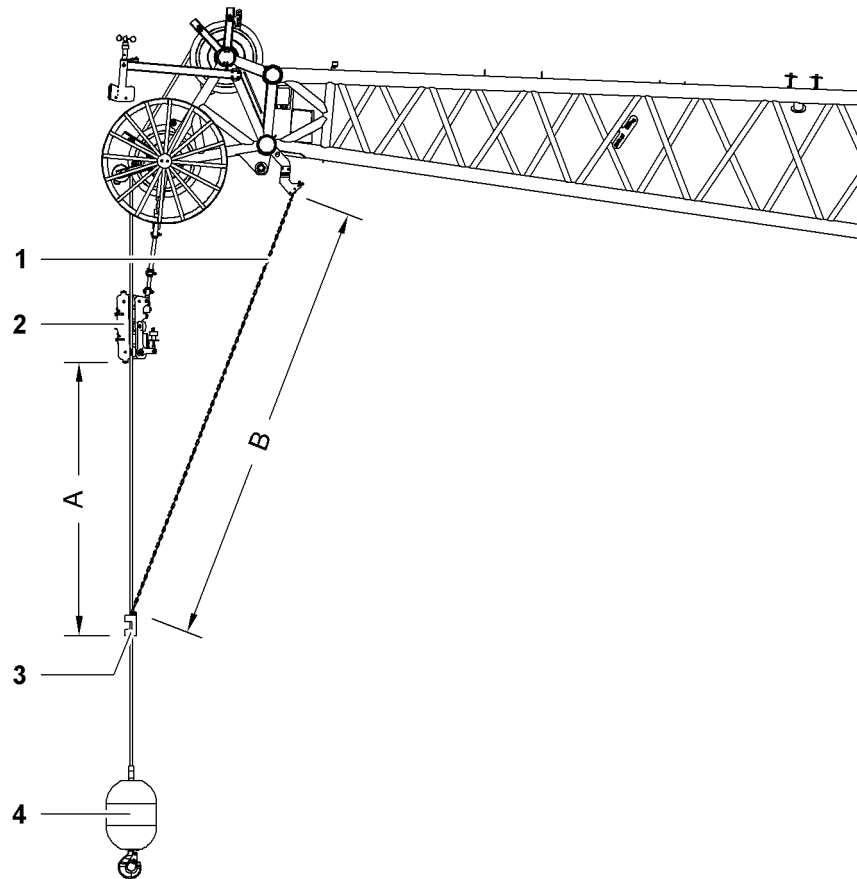


Fig. 5772: Installing the Vertical Line Finder on the jib head

- | | | | |
|---|--------------|---|---------------------------|
| 1 | Chain | 3 | Hoist limit switch weight |
| 2 | Rope opening | 4 | Hook |

NOTICE

Improper installation of Vertical Line Finder with single reeving!
 Damage to Vertical Line Finder and jib head.

- ▶ Make sure that the distance between the rope opening 2 and the hoist limit switch weight 3 is at least 2000 mm (6' 7" ft-in).
- ▶ Make sure that the chain 1 of the hoist limit switch has a length of 3250 mm (10' 8" ft-in).

Name	Value
A Minimum distance rope opening to hoist limit switch weight	2000 mm 6' 7" ft-in
B Length of chain	3250 mm 10' 8" ft-in

Tab. 607: Installation of Vertical Line Finder with single reeving!

LWNLR.x/V04.01//Auslieferung/2016-03-07/en

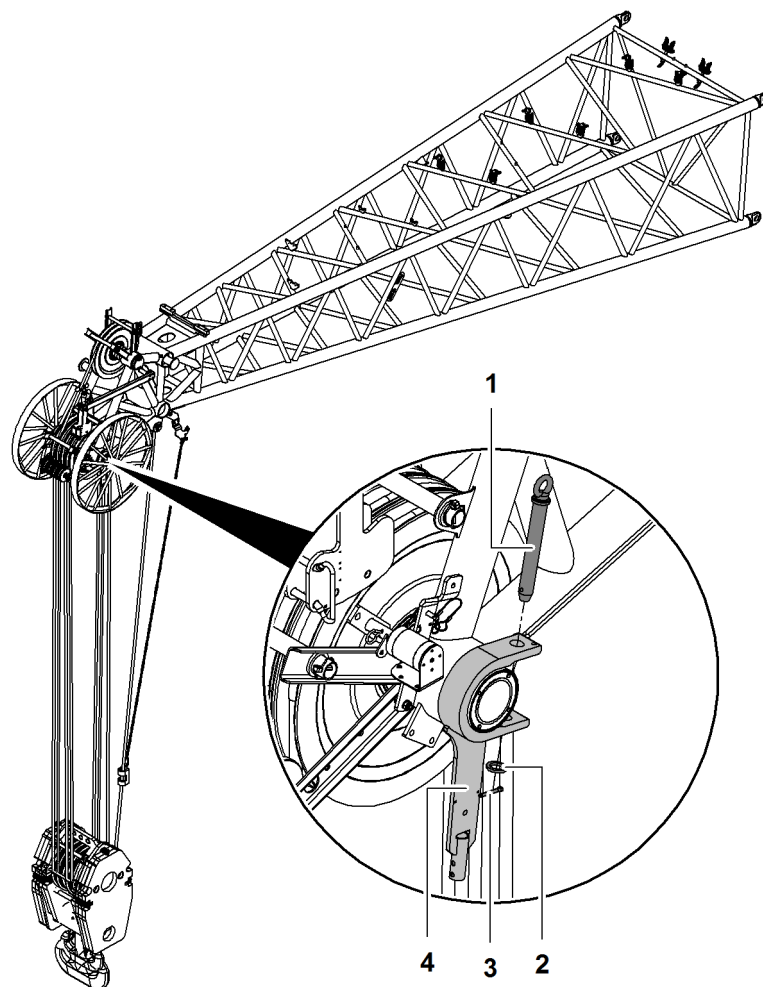


Fig. 5773: Installing the bracket of the Vertical Line Finder

- | | | | |
|---|--------|---|-----------|
| 1 | Screw | 3 | Split pin |
| 2 | Washer | 4 | Bracket |

- ▶ Position bracket 4 on jib head axis.
- ▶ Secure bracket 4 with screw 1, washer 2 and split pin 3.
- ▶ Repeat procedure on opposite side.

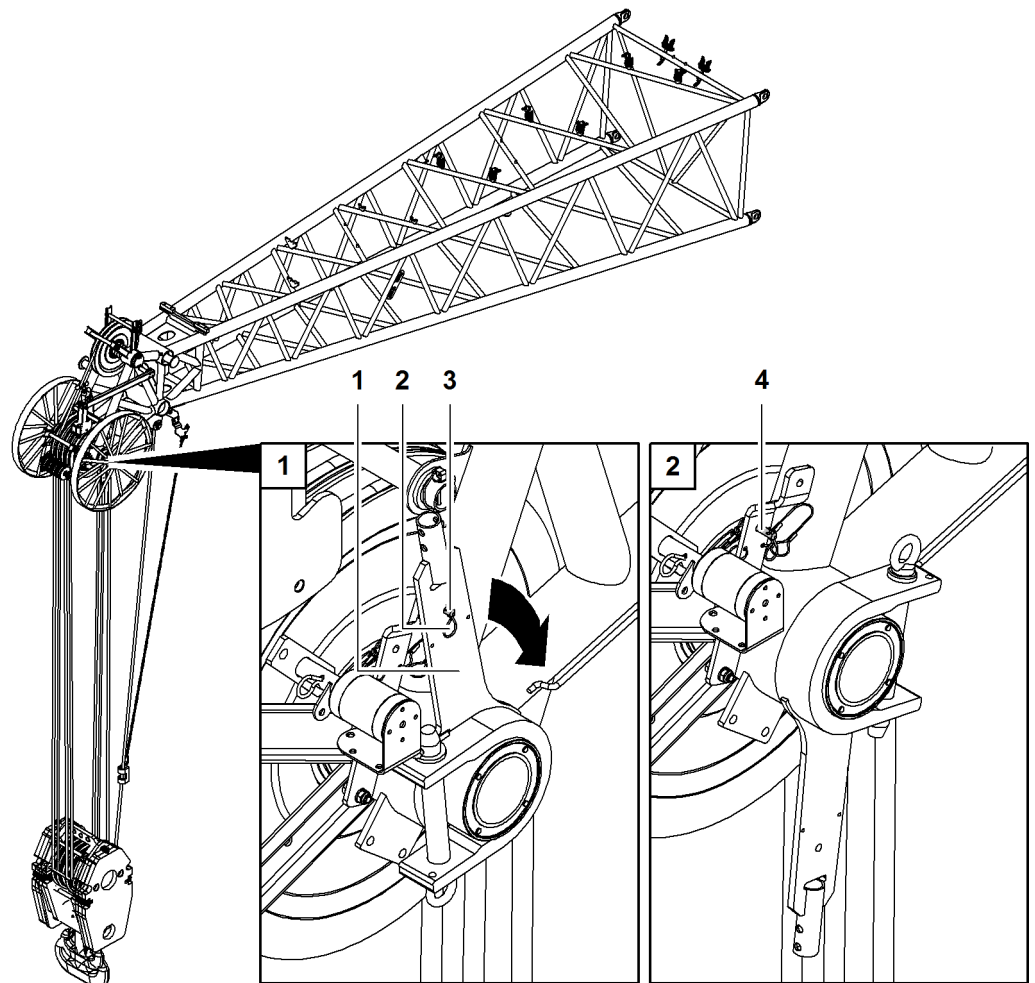


Fig. 5774: Placing the bracket of Vertical Line Finder in working position

- | | | | |
|---|-------------------|---|------------------|
| 1 | Bracket | 3 | Pin |
| 2 | Spring cotter pin | 4 | Removal position |

If the bracket of the Vertical Line Finder is already installed on the jib head, it must be put into working position for use.

- ▶ Remove spring cotter pin 2.
- ▶ Remove pin 3.
- ▶ Fold down bracket 1.
- ▶ Insert pin 3 in pinning position 4.
- ▶ Secure pin 3 with spring cotter pin 2.
- ▶ Repeat procedure on opposite side.

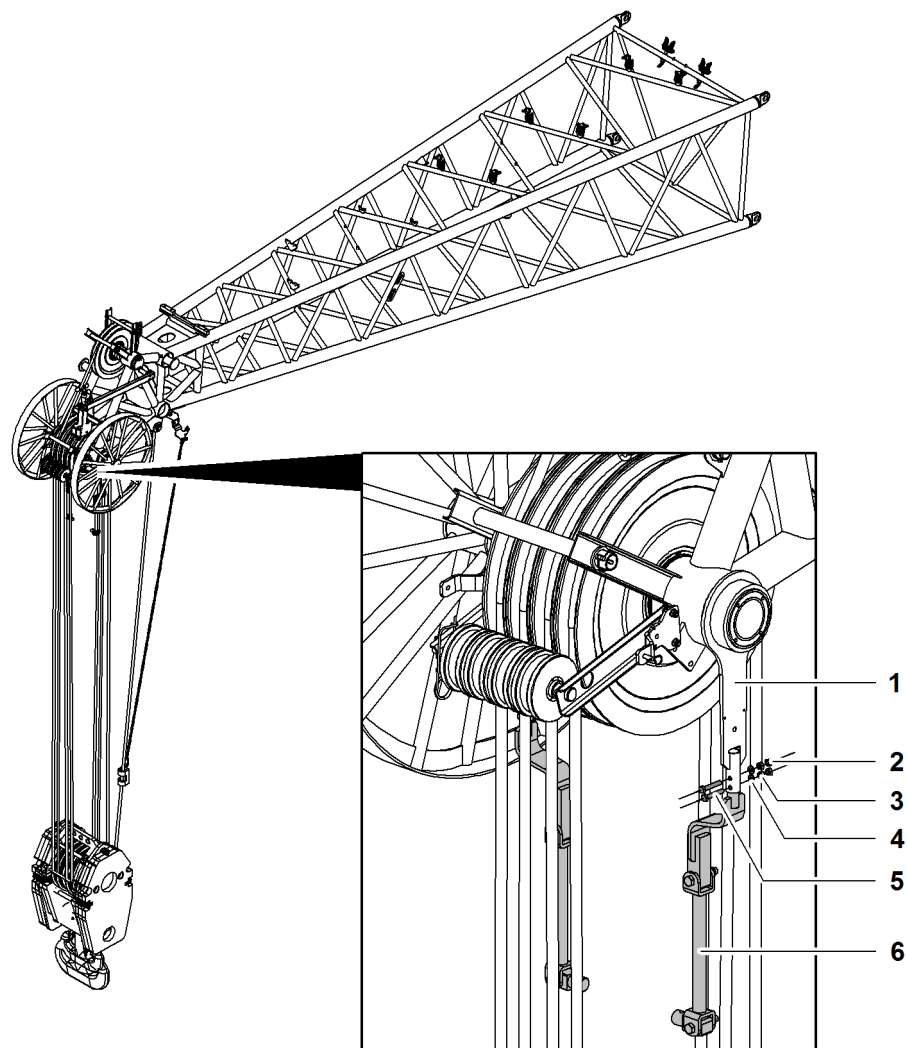


Fig. 5775: Connecting the vertical pipe with bracket

1	Bracket	4	Washer (2x)
2	Counter nut (2x)	5	Screw (2x)
3	Nut (2x)	6	Vertical pipe

- ▶ Stick vertical pipe **6** on bracket **1**.
- ▶ Insert screws **5** in borings.
- ▶ Secure screws **5** with washers **4** and nuts **3**.
- ▶ Secure nuts **3** with counter nuts **2**.
- ▶ Repeat procedure on opposite side.

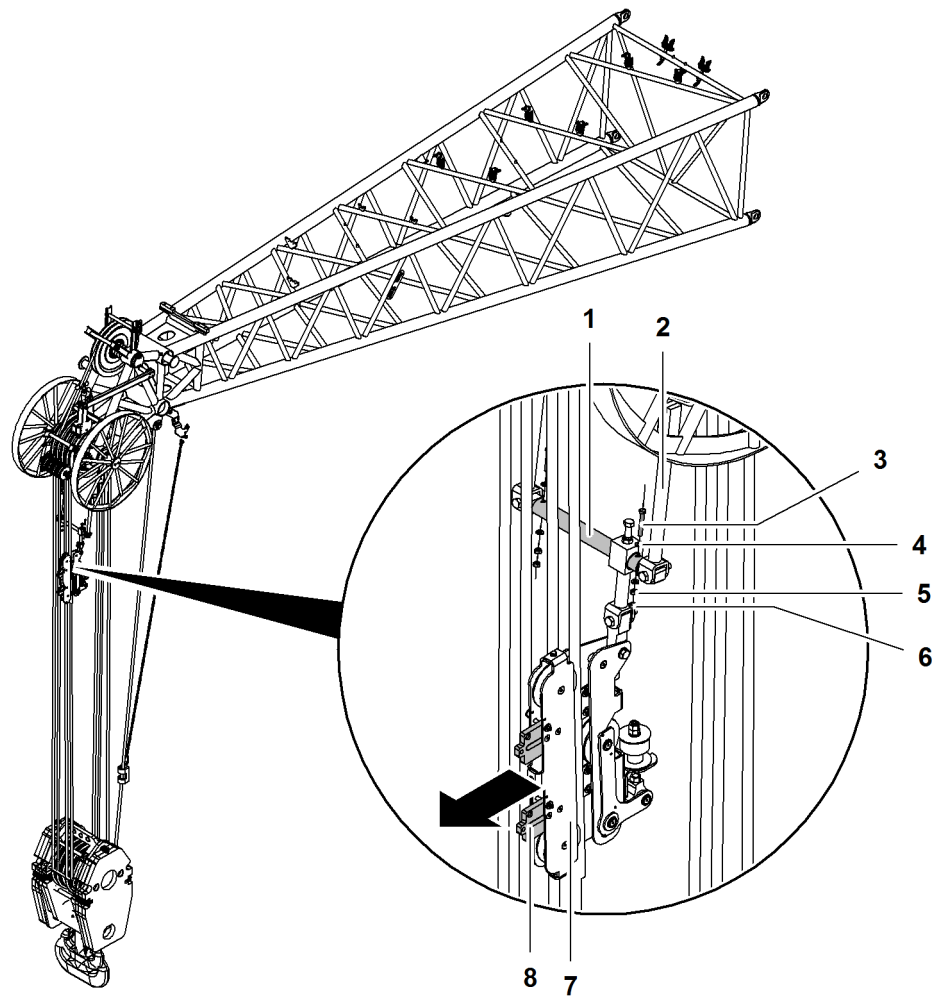


Fig. 5776: Connecting transverse pipe with vertical pipes

1	Transverse pipe	5	Nut
2	Vertical pipe (2x)	6	Counter nut
3	Screw	7	Rope opening
4	Washer (2x)	8	Rope lock (2x)

- ▶ Stick transverse pipe **1** with rope opening **7** on vertical pipes **2**.
- ▶ Insert screw **3** with washer **4** in boring.
- ▶ Secure screw **3** with washer **4** and nut **5**.
- ▶ Secure nut **5** with counter nut **6**.
- ▶ Repeat procedure on opposite side.
- ▶ Remove pins of rope locks **8**.
- ▶ Pull rope locks **8** outward.

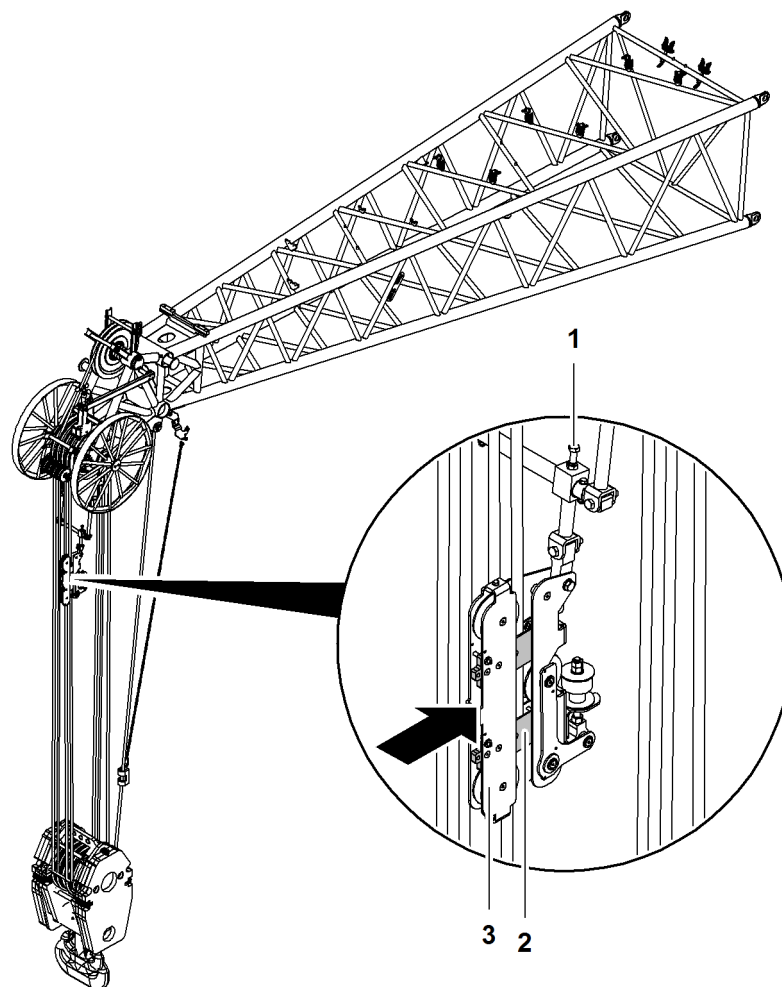


Fig. 5777: Positioning rope opening and inserting the rope

- | | | | |
|---|----------------|---|--------------|
| 1 | Screw | 3 | Rope opening |
| 2 | Rope lock (2x) | | |

The rope opening **3** must be installed on the outer rope that is closest to the rope fixing point of the jib head.

- ▶ Position rope opening **3**.
- ▶ Secure rope opening **3** with screw **1**.
- ▶ Place rope in rope opening **3**.
- ▶ Slide rope locks **2** inward.
- ▶ Secure rope locks **2** with pins.

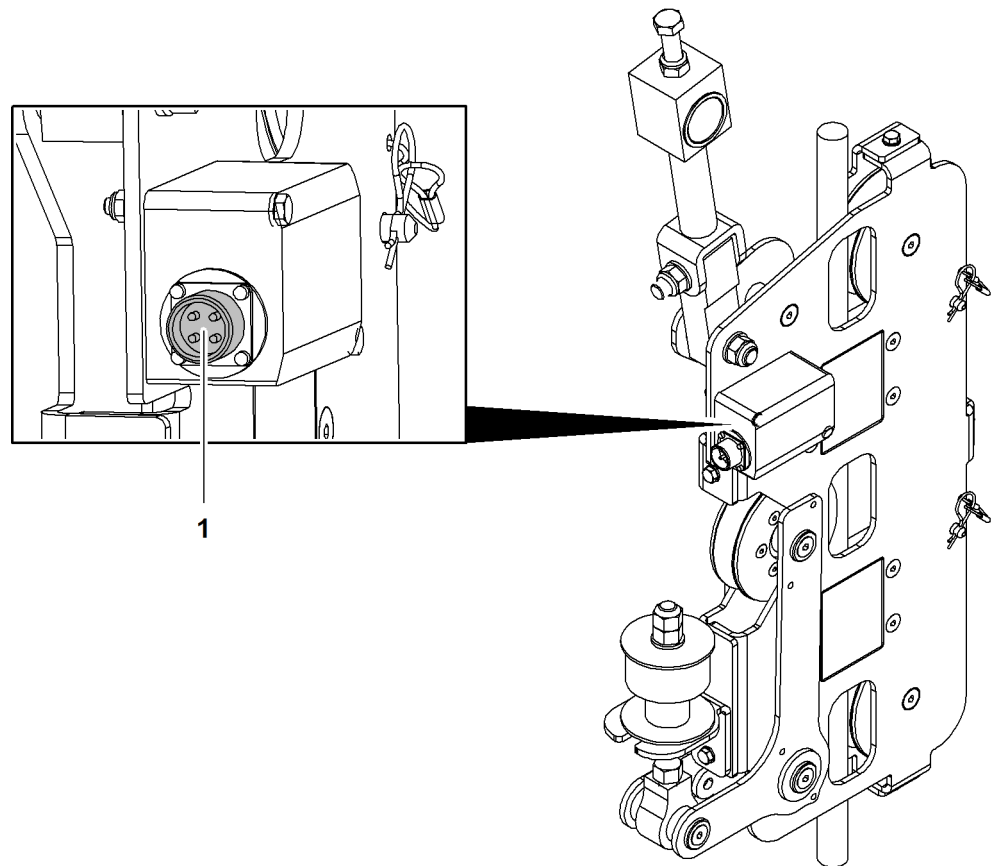


Fig. 5778: Connecting the electric line of the Vertical Line Finder

1 Bush

- ▶ Insert electric line of Vertical Line Finder at bush **1**.
- ▶ Insert electric line of Vertical Line Finder on terminal box of jib head.
 - ▷ Vertical Line Finder is ready for operation.

7.29 Vandalism protection*

7.29.1 Installing the vandalism protection

Ensure that the following conditions are fulfilled:

- Cabin is prepared for installation of the vandalism protection.

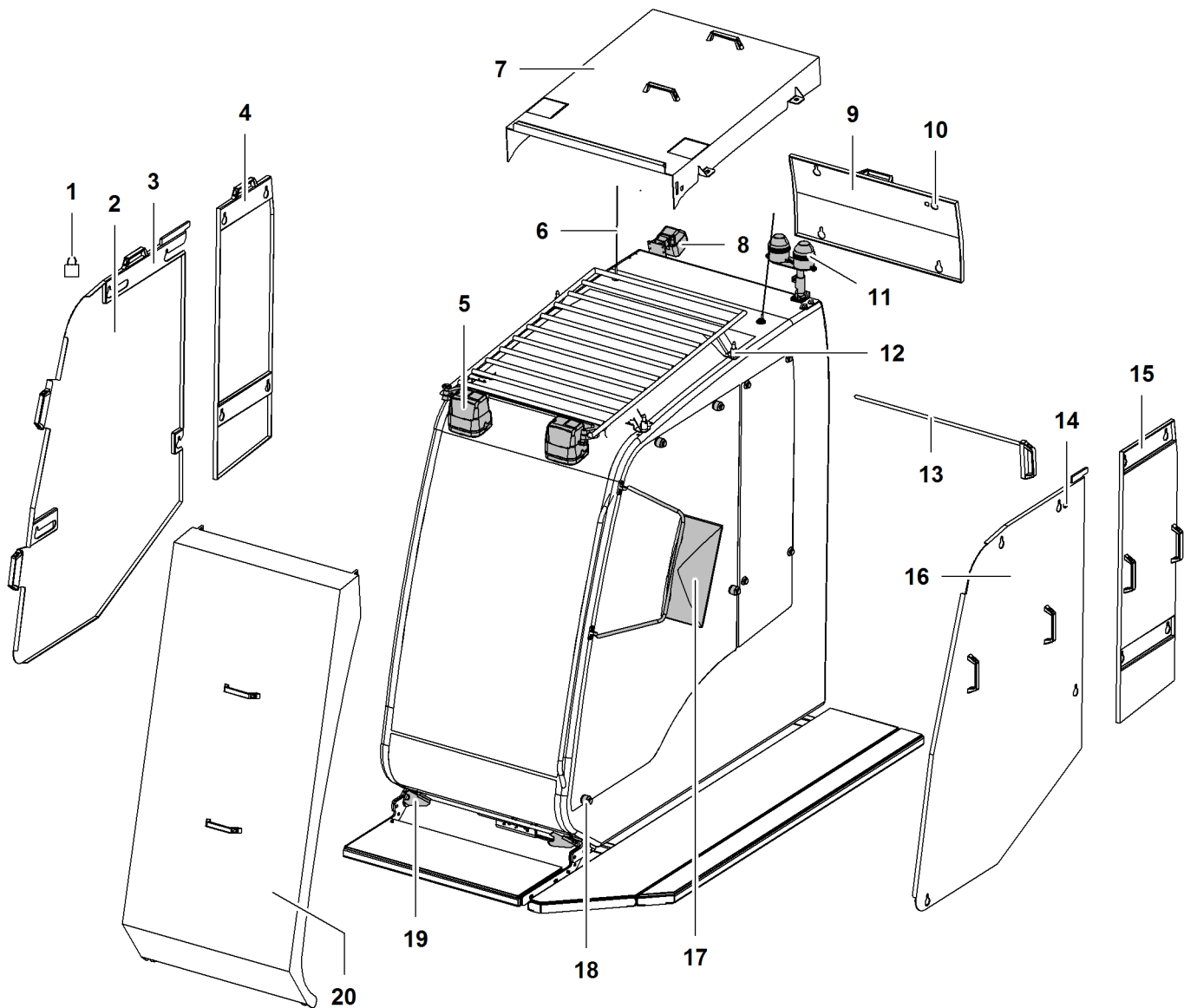


Fig. 5779: Installing the vandalism protection

- | | | | | | |
|---|-----------------------|----|---|----|------------------------------|
| 1 | Padlock | 8 | Rear floodlight | 15 | Left rear cover |
| 2 | Right front cover | 9 | Rear cover | 16 | Left front cover |
| 3 | Lock | 10 | Lock | 17 | Side mirror |
| 4 | Right rear cover | 11 | Flashing light/load moment limiter lamp | 18 | Suspension equipment (8x) |
| 5 | Front floodlight (2x) | 12 | Bracket (4x) for top cover | 19 | Bracket (2x) for front cover |
| 6 | Antenna (2x) | 13 | Barrier rod | 20 | Front cover |
| 7 | Top cover | 14 | Lock | | |

- ▶ Fold antennas 6 down.

- ▶ Fold flashing light/load moment limiter lamp **11** down.
- ▶ Deinstall side mirror **17**.
- ▶ Fold down front floodlight **5** and rear floodlight **8**.
- ▶ Insert top cover **7** at the brackets **12** of the cabin roof protection guard.
- ▶ Suspend rear cover **9** in the suspension equipment **18**.
- ▶ Close lock **10**.
 - ▷ Rear cover **9** is installed and secured.
- ▶ Suspend right rear cover **4** in the suspension equipment **18**.
- ▶ Suspend right front cover **2** in the suspension equipment **18**.
- ▶ Close lock **3**.
 - ▷ Right covers **2 + 4** are installed and secured.
- ▶ Suspend left rear cover **15** in the suspension equipment **18**.
- ▶ Suspend left front cover **16** in the suspension equipment **18**.
- ▶ Close lock **14**.
 - ▷ Left covers **15 + 16** are installed and secured.
- ▶ Insert front cover **20** at the brackets **19**.
- ▶ Fold front cover **20** back.
- ▶ Insert barrier rod **13** at the front cover **20** and top cover **7**.
- ▶ Secure barrier rod **13** with padlock **1**.
 - ▷ Vandalism protection is installed.

7.30 Jib luffing winch*

With boom configurations with fixed jibs, a jib luffing winch is required. If no jib luffing winch is installed on the main boom base section, the following steps must be performed.

Ensure that the following conditions are satisfied:

- Auxiliary crane with a working load of 1.5 t (3,307 lb) is available.
- Approved lifting equipment is available.
- Any accessories required are available.

7.30.1 Fixing rope end

To prevent the rope reeving of the jib luffing winch from coming loose, the rope end must be fixated prior to installation.

- ▶ Attach auxiliary rope to the rope end of the jib luffing winch rope.
- ▶ Wrap auxiliary rope around jib luffing winch.
- ▶ Secure auxiliary rope.

7.30.2 Lashing the jib luffing winch



WARNING

Improper lashing of the jib luffing winch!
Unforeseeable load rotation.

- ▶ Use approved rigging exclusively.
- ▶ Use prescribed lifting points.

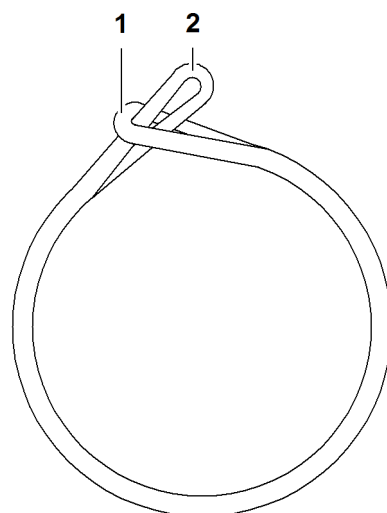


Fig. 5780: Loop

- | | |
|--|--|
| <p>1 Loop that pulls in</p> <ul style="list-style-type: none"> ▶ Form two loops from lifting equipment. ▶ Place loops left and right around rope drum of the jib luffing winch. ▶ Lash loop 2 onto auxiliary crane. | <p>2 Loop lashed to auxiliary crane</p> |
|--|--|

- ▶ Slightly tighten loop by lifting.
- ▶ By turning the loops of the jib luffing winch, align it in such a way that the jib luffing winch can be installed in the main boom base section.
 - ▷ Jib luffing winch is lashed.
- ▶ Secure hydraulic lines of the jib luffing winch with cable ties against sliding.
- ▶ Secure electric cable of the jib luffing winch with cable ties against sliding.
- ▶ If required, de-install pins of the jib luffing winch.
- ▶ Grease bolts.
- ▶ Provide securing material.
 - ▷ Jib luffing winch ready for installation.

7.30.3 Installation of jib luffing winch

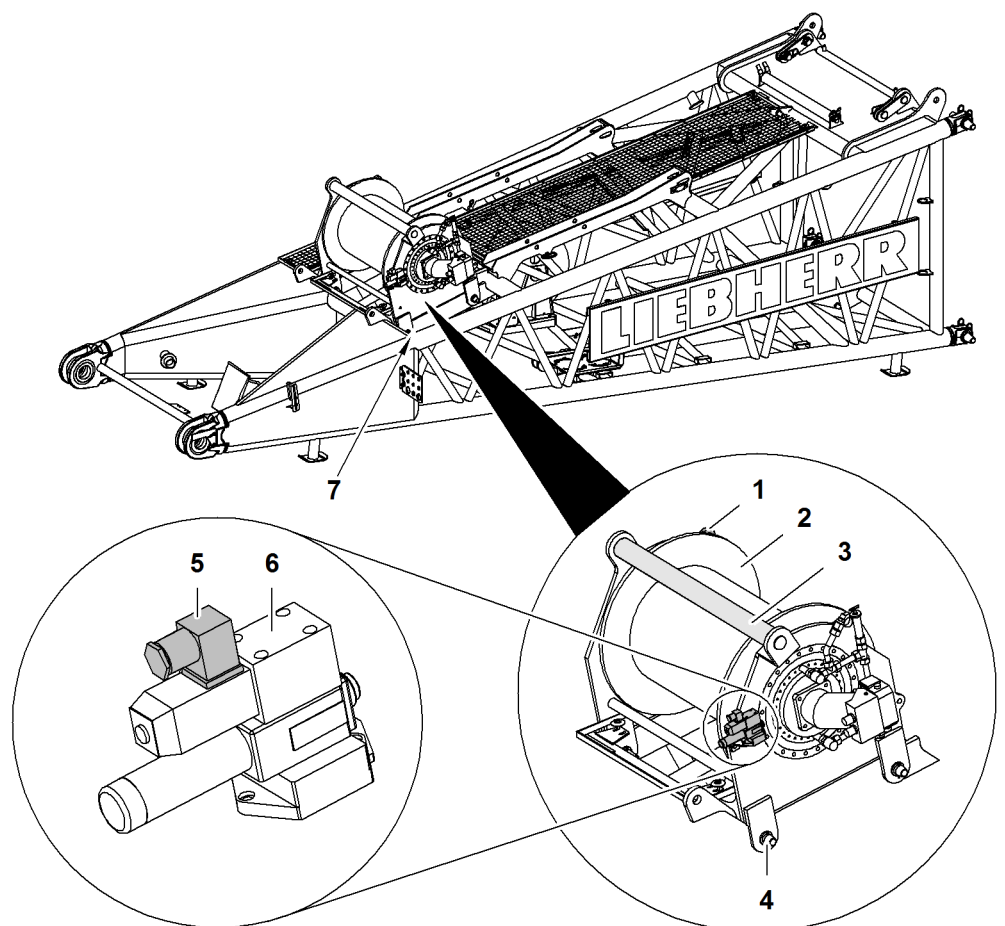


Fig. 5781: Overview installation of jib luffing winch

- | | |
|--|---|
| 1 Attachment point for rope pressure roller (2x) | 5 Electrical plug +4E-Y06 for brake valve |
| 2 Luffing jib luffing winch | 6 Brake valve |
| 3 Rope protection roller | 7 Position electrical plug |
| 4 Pin (4x) | |

- ▶ Lift jib luffing winch 2 with auxiliary crane into main boom base section.
- ▶ Bolt jib luffing winch 2 with main boom base section.
- ▶ Secure all pins 4 with cotter and washer.
 - ▷ Jib luffing winch installed in main boom base section.

7.30.4 Connect hydraulic lines

Ensure that the following conditions are satisfied:

- Hydraulic connections are clean.
- All protective covers of the hydraulic connections are in place.
- Diesel engine is turned off.

NOTICE

Dirty hydraulic connections!
Damage to the hydraulic system.

- ▶ Clean hydraulic connections prior to connection.

-
- ▶ Connect all plug-type connections.
 - ▶ Check whether plug-tape connections are completely latched.
 - ▶ Plug protective covers into each other.

NOTICE

Improper tightening of the screw connections!
Damage to thread.

- ▶ Only tighten screw connections by hand.



Note

Liebherr recommends:

- ▶ Undo screw couplings with damaged threads with filter strap wrench.
-
- ▶ Connect all screw connections.
 - ▶ Screw protective covers into each other.

7.30.5 Connect the electric cables

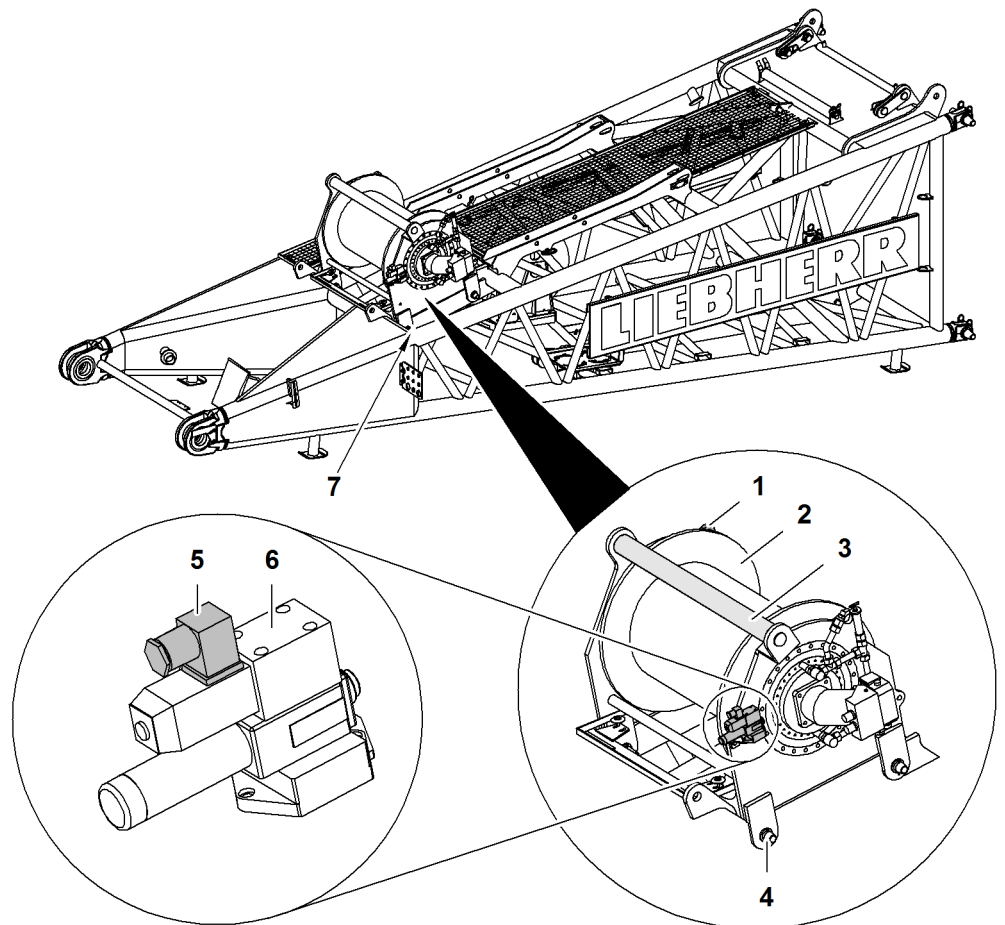


Fig. 5782: Overview installation of jib luffing winch

- | | | | |
|---|--|---|---|
| 1 | Fastening point for wire rope pressure roller (2x) | 5 | Electrical plug +4E-Y06 for brake valve |
| 2 | Luffing jib luffing winch | 6 | Brake valve |
| 3 | Rope protection roller | 7 | Position electrical plug |
| 4 | Pin (4x) | | |

The brake valve of the jib luffing winch must be supplied with power. Upon delivery of the machine without jib luffing winch, the electrical plug +4E-Y06 5 is located in the position electrical plug 6.

- ▶ Plug electrical plug +4E-Y06 5 on brake valve 6.
- ▶ Tighten screw connection.
- ▶ Attach electric line with cable tie outside of danger zone.
 - ▷ Jib luffing winch ready for operation.

7.31 Conversion to permanent auxiliary jib operation

If only auxiliary jib 36 t (79300 lb) is used on main boom head for hoisting work, the machine can be converted to permanent auxiliary jib operation. Permanent auxiliary jib operation takes strain off the pulley bearings and optimizes the diagonal rope pull.

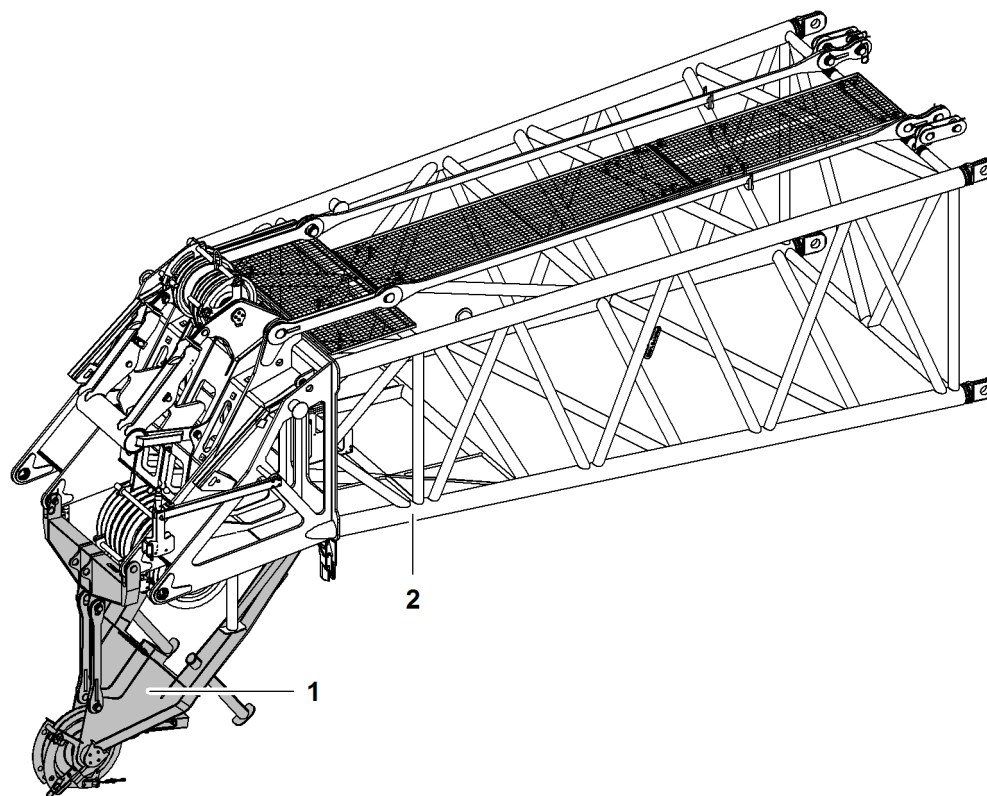


Fig. 5783: Conversion to permanent auxiliary jib operation

1 Auxiliary jib 36 t (79300 lb) 2 Main boom head

Make sure the following prerequisites are met:

- Auxiliary jib 36 t (79300 lb) is reeved at most twice.
- There is no jib installed on the main boom.

7.31.1 Converting auxiliary jib 36 t (79300 lb)

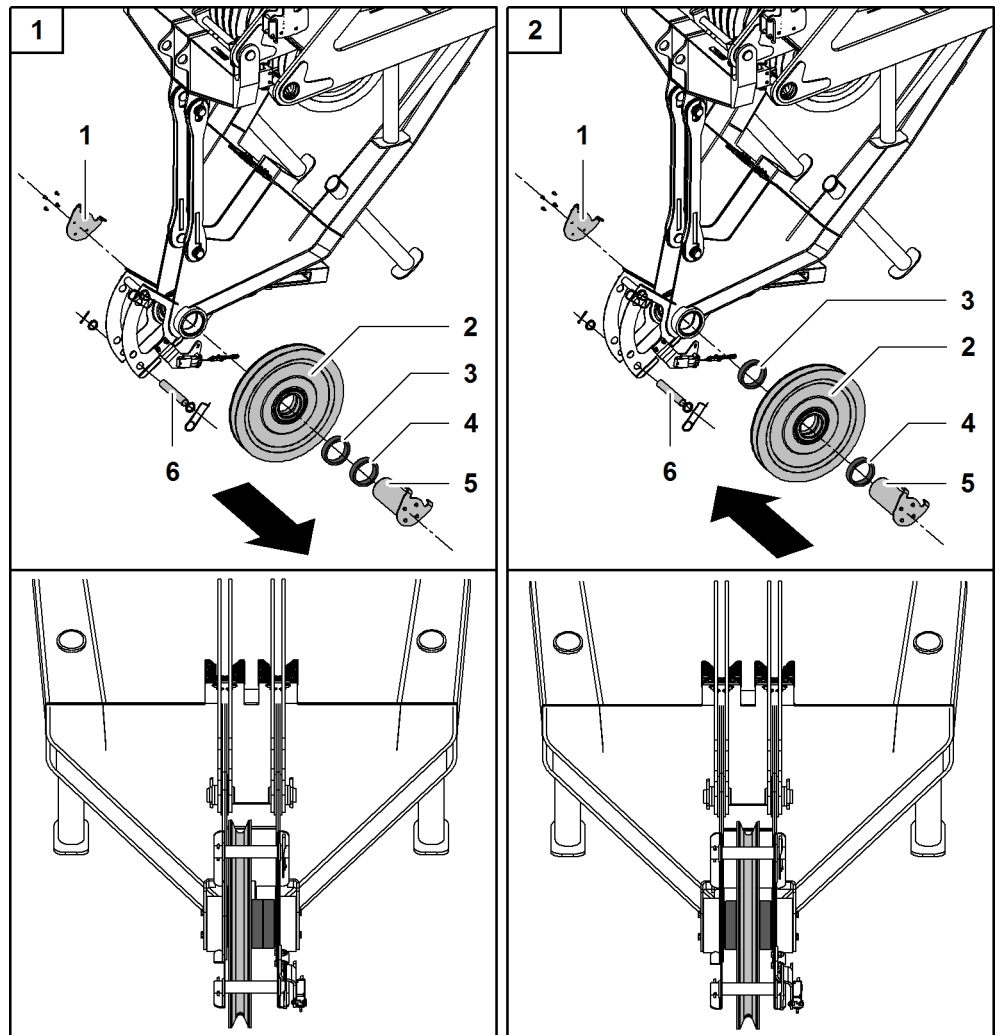


Fig. 5784: Converting auxiliary jib 36 t (79300 lb)

1	Cover plate	4	Bush
2	Pulley	5	Pin
3	Bush	6	Rope protection pipe

- ▶ Remove rope protection pipe 6.
- ▶ Loosen the screws of the cover plate 1.
- ▶ Remove cover plate 1.
- ▶ Pull pin 5 out.
- ▶ Remove pulley 2, bush 3 and bush 4.
- ▶ Reposition bush 3 so that pulley 2 is in the center.
- ▶ Insert bush 3, pulley 2 and bush 4.
- ▶ Insert pins 5.
- ▶ Insert cover plate 1 and secure with screws.
- ▶ Install and secure rope protection pipe 6.

7.31.2 Converting the main boom head

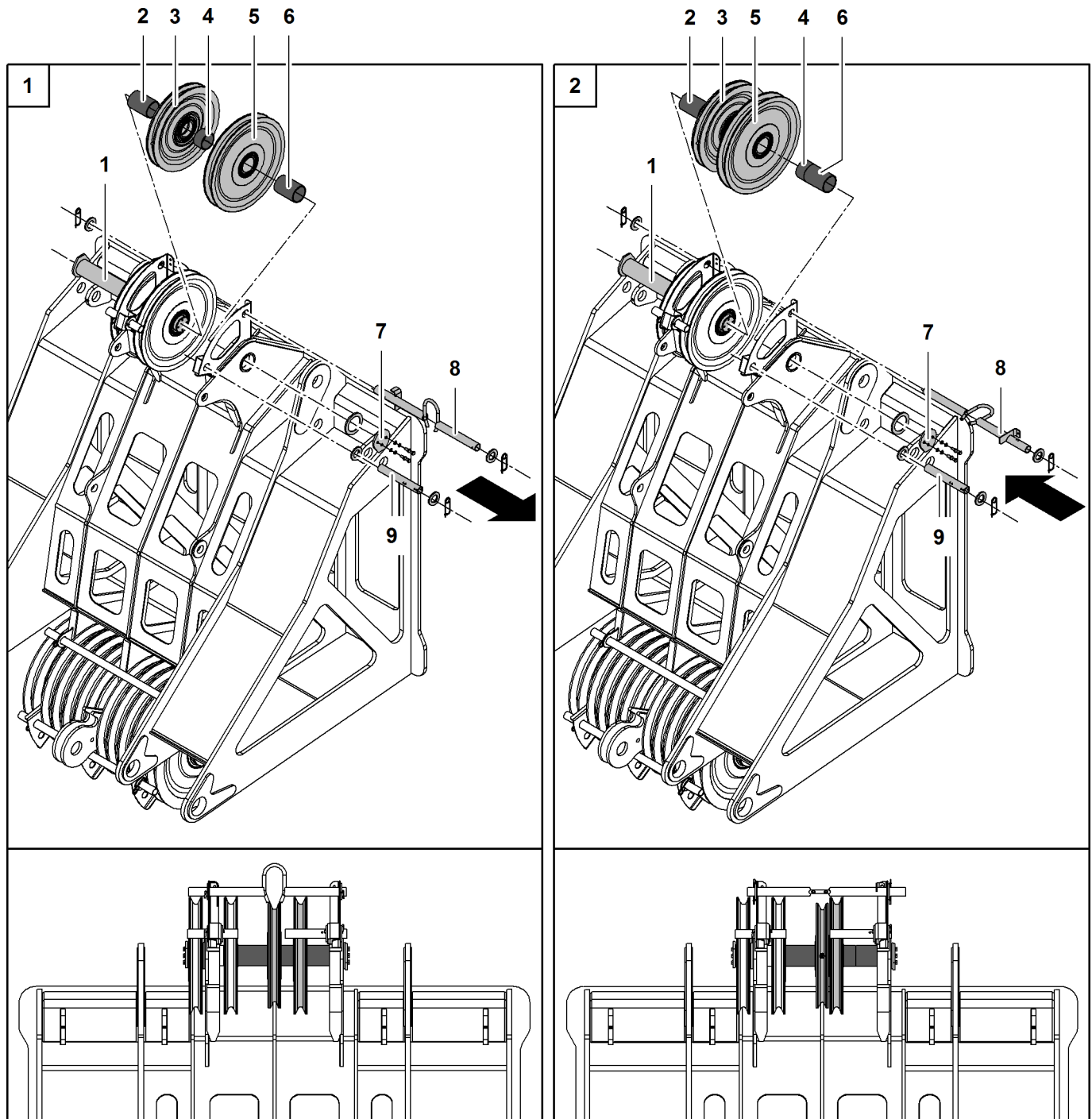


Fig. 5785: Converting the main boom head

- | | | |
|--|--|------------------------|
| 1 Pin | 4 Bush | 7 Cover plate |
| 2 Bush | 5 Pulley (500 mm (1' 8" ft-in) x 15 mm (0.59" in) x 90 mm (3.54" in) | 8 Rope protection pipe |
| 3 Pulley (450 mm (1' 6" ft-in) x 11 mm (0.43" in) x 90 mm (3.54" in) | 6 Bush | 9 Rope protection pipe |

► Remove rope protection pipe 8.

LWNLR-x/V04.01//Auslieferung/2016-03-07/en

- ▶ Remove rope protection pipe 9.
- ▶ Loosen the screws of the cover plate 7.
- ▶ Remove cover plate 7.
- ▶ Pull out pin 1 so that pulley 3 and pulley 5 can be removed.
- ▶ Remove pulley 3, bush 4, pulley 5 and bush 6.
- ▶ Place bush 4 next to bush 6.
- ▶ Insert pulley 3, pulley 5, bush 4 and bush 6.
- ▶ Insert pins 1.
- ▶ Insert cover plate 7 and secure with screws.

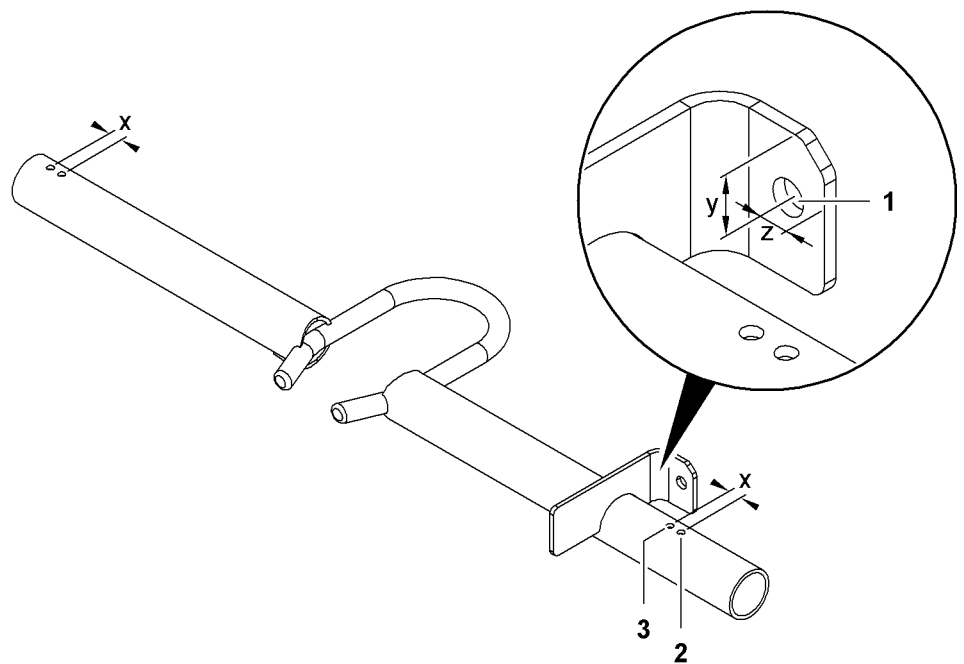


Fig. 5786: Preparing the top rope protection pipe

- | | |
|--|--|
| <p>1 Boring Ø11 mm (0.43" in) for attachment on main boom head</p> <p>2 New boring Ø6 mm (0.24" in) (2x)</p> | <p>3 Present boring Ø6 mm (0.24" in) (2x)</p> |
|--|--|

The top rope protection pipe must be prepared before installation.

Name		Value
x	Distance of borings	12 mm 0.47" in
y	Distance of boring to top edge of steel plate	20 mm 0.79" in
z	Distance of boring to side edge of steel plate	8.5 mm 0.33" in

Tab. 608: Preparing the top rope protection pipe

- ▶ Make new borings 2 with distance x to present borings 3.
- ▶ Make boring 1 for attachment on main boom head.

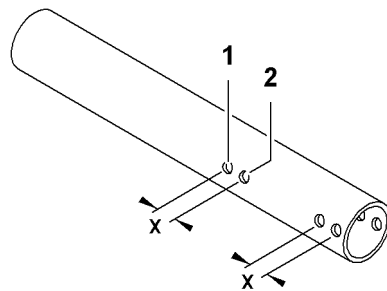


Fig. 5787: Preparing the bottom rope protection pipe

- 1 Present boring $\varnothing 6$ mm (0.24" in) (2x) 2 New boring $\varnothing 6$ mm (0.24" in) (2x)

The bottom rope protection pipe must be prepared before installation.

Name		Value
x	Distance of borings	15 mm 0.59" in

Tab. 609: Preparing the bottom rope protection pipe

- Make new borings 2 with distance x to present borings 1.

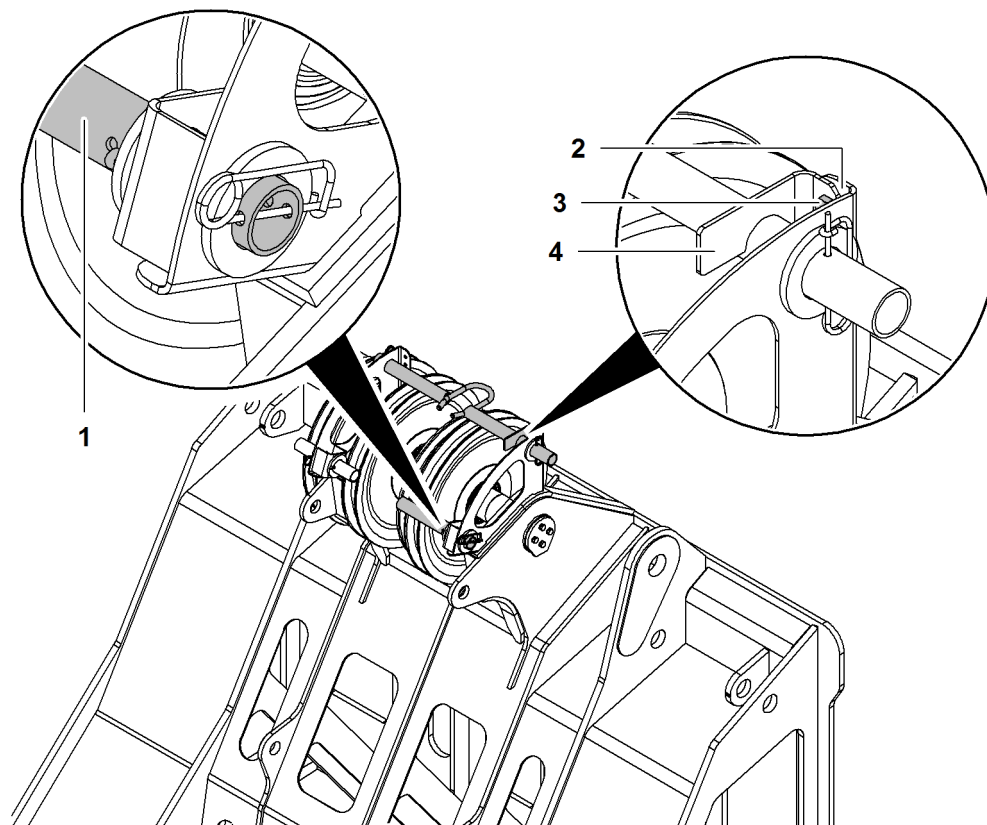


Fig. 5788: Installing rope protection pipes

- 1 Bottom rope protection pipe 3 Screw M10 with nut
2 Main boom head 4 Top rope protection pipe

- Install bottom rope protection pipe 1 and secure on new borings.
- Install top rope protection pipe 4 turned by 180° and secure on new borings.

- ▶ Turn top rope protection pipe **4** by 90° until top rope protection pipe **4** can be screwed to main boom head **2**.
- ▶ Insert M10 screw **3** and lock with nut.

7.32 Time-saving reconfiguring of the main boom

An auxiliary crane can be used to shorten or extend the main boom without having to dismantle it.

Ensure that the following conditions are fulfilled:

- Changing the main boom length is permissible.
- The applicable load chart for the new main boom length is available.
- Jib is not attached.
- Sufficient space is available for re-configuring.
- An auxiliary crane with sufficient working load is available.
- Appropriate rigging is available for the hoisting operations to be carried out by the auxiliary crane.
- Sufficient wooden blocks are available for support.
- The assembly positions of the rope guide and the mid-point suspensions are known.

7.32.1 Reconfiguring the main boom



WARNING

Laying down the main boom incorrectly!

- ▶ Follow the instructions for laying down the main boom .

NOTICE

Main boom is skewed!
Damage to the main boom.

- ▶ Set down the main boom on wooden blocks horizontally.

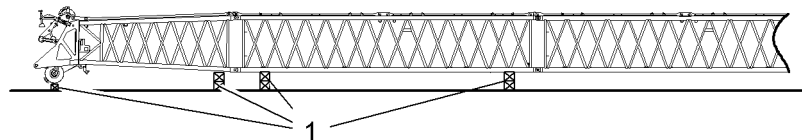


Fig. 5789: Main boom on wooden blocks

1 Wooden blocks

- ▶ Set down the main boom on wooden blocks 1.
- ▶ Lower A-frame 1 forwards until the main boom pendant straps are resting on the main boom.
- ▶ Separate the main boom pendant straps from A-frame1 equalizer.
- ▶ Bolt the assembly cylinder to the boom base section.
- ▶ Disconnect and pull back the electric cable from the terminal box on the boom head section.

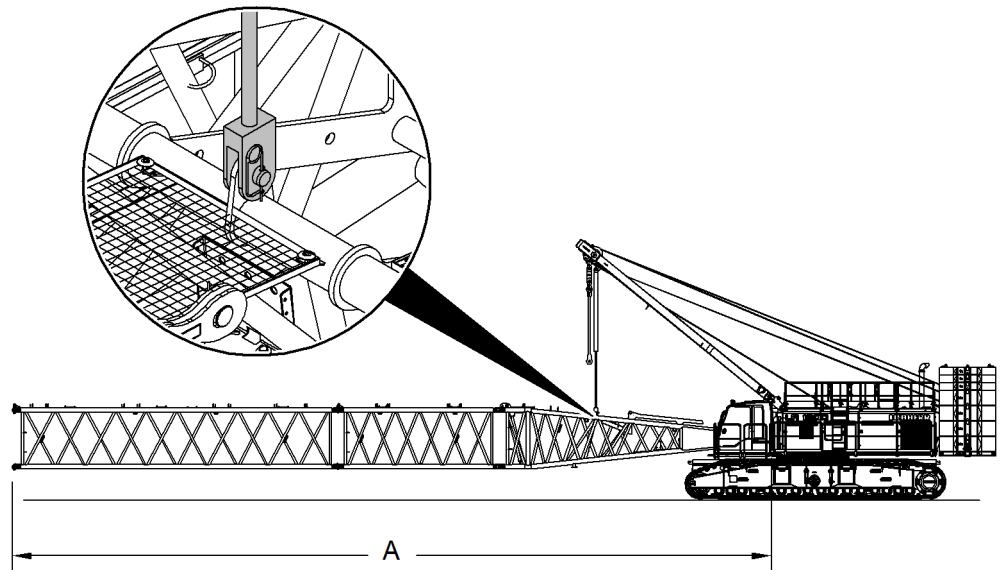


Fig. 5790: Maximum maneuverable main boom length with time-saving reconfiguration

A Maximum maneuverable main boom length

NOTICE

Maximum maneuverable main boom length **A** exceeded!
Risk of damage to the main boom and assembly cylinder.

- ▶ Maximum manoeuvrable main boom length (boom base section + boom section 6 m (20 ft) + boom section 12 m (40 ft)) must not be exceeded.
- ▶ Unbolt the main boom and main boom pendant straps at the extension point.

NOTICE

Dynamic movements when manoeuvring!
Damage to the main boom and assembly cylinder.

- ▶ Manoeuvre carefully with basic machine.
- ▶ If necessary, maneuver with the basic machine.

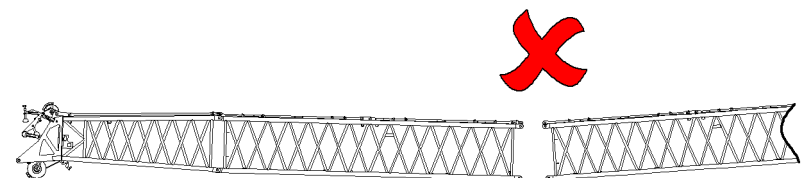


Fig. 5791: Incorrect reconfiguration

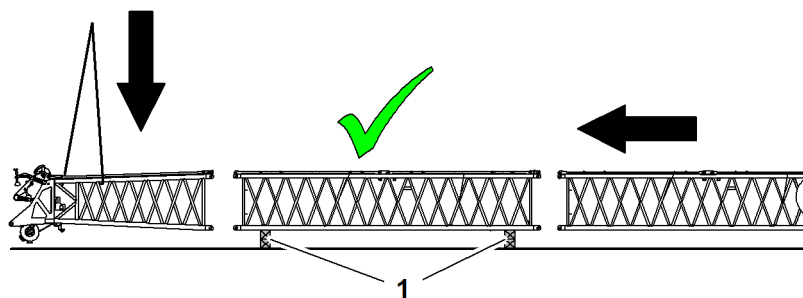


Fig. 5792: Correct reconfiguration

1 Wooden blocks

NOTICE

Boom sections lifted incorrectly!
Damage to boom sections.

- ▶ Always lift the boom sections one at a time at the lifting points provided.
- ▶ Fit and remove the boom sections using an auxiliary crane.
- ▶ Bolt on boom sections and main boom pendant straps.
- ▶ Approach the main boom carefully with the basic machine.
- ▶ Bolt on boom sections and main boom pendant straps.
- ▶ Detach assembly cylinder from main boom base section.
- ▶ Pin main boom pendant straps to A-frame1 equalizer.
- ▶ Connect the electric cable to the terminal box on the boom head section and secure using retaining clips.



DANGER

Incorrect installation of mid-point suspensions!
Structural breakdown.

- ▶ Note changes to the assembly positions and rope lengths of the mid-point suspensions.
- ▶ Check assembly positions and rope lengths of mid-point suspensions.

NOTICE

Incorrect assembly of the rope guide!
Damage to main boom and rope of winch1/winch2.

- ▶ Note changes to the assembly position of the rope guide.
- ▶ Check assembly position of rope guide.

Now proceed as follows:

7.33 Disassembling the luffing jib + Midfall



DANGER

Incorrect disassembly of the machine!

- ▶ Erectability chart, critical angles and boom radius limitations must be observed.

The luffing jib + midfall must be disassembled in the reverse order to assembly.

Ensure that the following conditions are fulfilled:

- There must be sufficient space available to lay down the assembled booms.
- The signalmen and assistants have received instructions.
- The necessary tools and approved lifting equipment is available.
- Wooden blocks are available for placement.

7.33.1 Brief summary

The luffing jib + midfall are disassembled in exactly the same way as the luffing jib
(For more information see: [7.34 Deinstalling the luffing jib, page 1794](#)) .

7.34 Deinstalling the luffing jib



DANGER

Incorrect disassembly of machine!
Toppling of machine, structural breakdown.

- ▶ Observe erectability chart, critical angles and boom radius limitations.

The luffing jib must be disassembled in the reverse order to assembly.

Ensure that the following conditions are fulfilled:

- Sufficient space is available to lay down the assembled booms.
- Signalmen and assistants are instructed.
- The necessary tools and approved lifting equipment are available.
- Wooden blocks are available for placement.

7.34.1 Preparing the machine



Note

Liebherr recommends:

- ▶ Place pulley block or hook on timber.

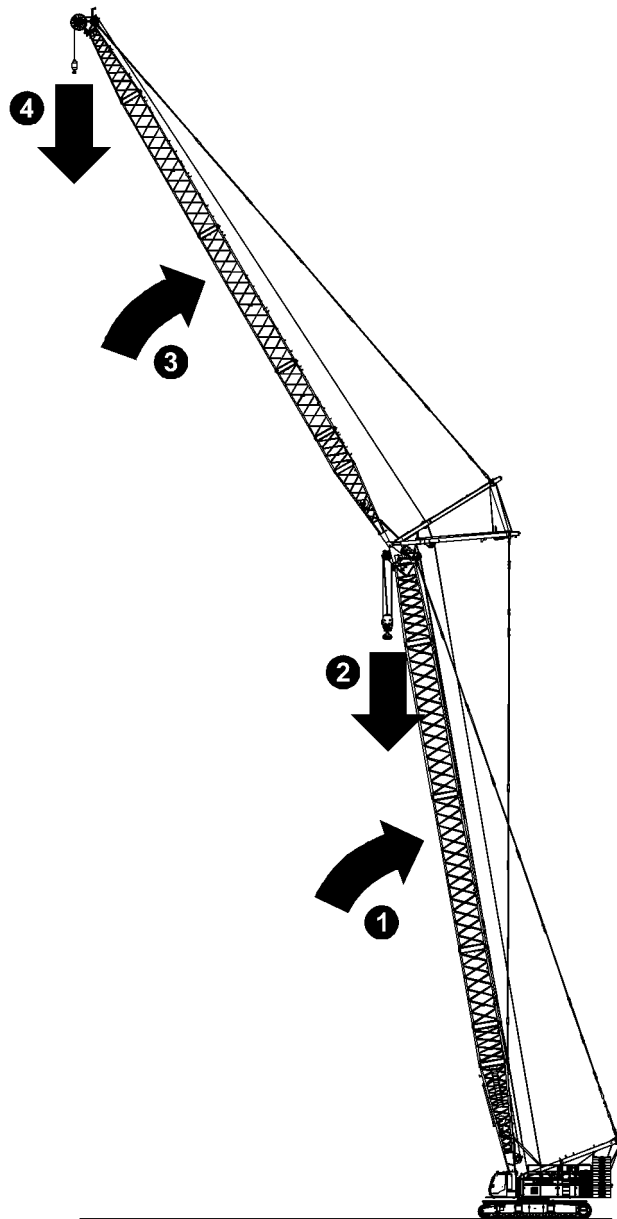


Fig. 5793: Preparing the machine (illustration of principle)



Note

The total center of gravity of the machine is moved beyond the first guide roller! Sudden swinging of the boom/jib during the laying down operation.

Liebherr recommends:

- ▶ For boom configurations with long main booms and short jibs, follow the procedure for "Blocked Crawlers" ([For more information see: 4.27 Blocked crawlers*, page 980](#)).
- ▶ Set main boom to an 85° angle.
- ▶ Lower main boom pulley block or hook to the ground and lay down.
- ▶ Set jib to an angle of 70°.
- ▶ Lower pulley block or jib hook to the ground and lay down.

7.34.2 Lowering the jib up to load moment limiter stop



DANGER

Erectability chart is not followed!
Toppling of machine.

- ▶ Only lay down boom if erection is permitted according to the erectability chart.

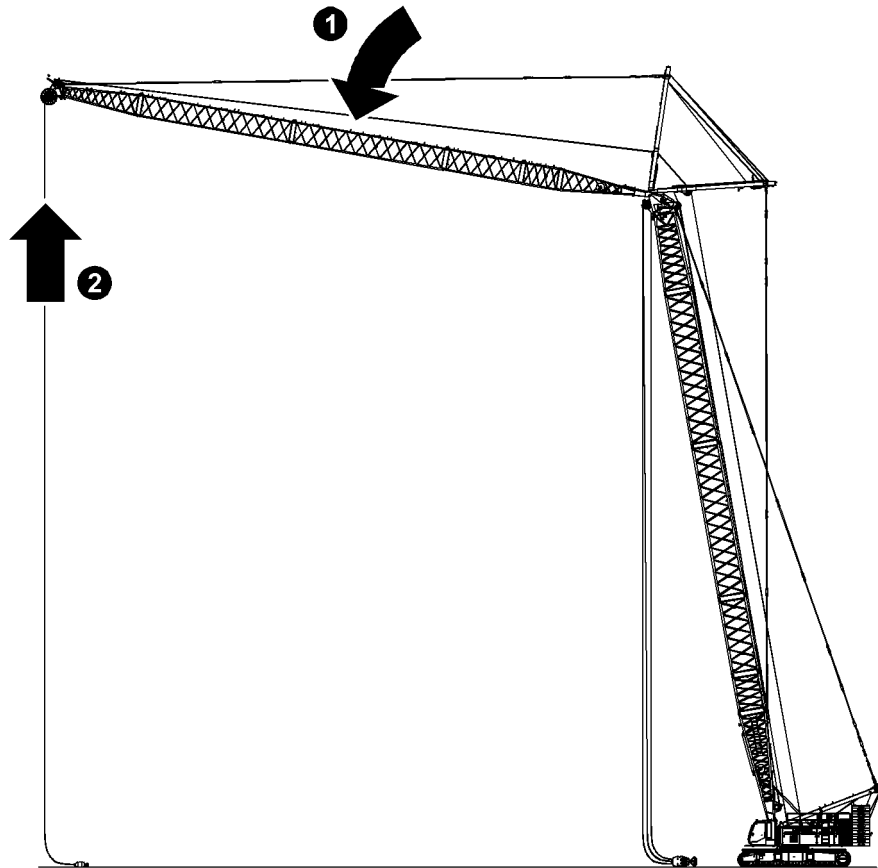


Fig. 5794: Lowering the jib up to the load moment limiter stop (illustration of principle)

- ▶ Lower jib.

NOTICE

Incorrect laying down procedure!
Damage to equipment.

- ▶ Do not drag hook or pulley block along the ground.
- ▶ Prevent slack rope.

- ▶ Reeve rope of winch1/winch2 on jib if necessary.

If a load moment limiter stop is triggered:

- ▶ Press the *Load moment limiter assembly/self-lock* button on control panel X23.



No load chart exist for machines geometry:

- ▷ Function "load moment limiter assembly" is active.
- ▷ The LED in the button *Load moment limiter assembly/self-lock* is lit.

- ▷ Machine functions are enabled without restriction.
- ▷ Load moment limiter lamps flash orange.



- ▶ Press the *Assembly functions* switch on control panel X12.

The following buttons have to be pressed additionally with machine types LR 1003, LR 1004, LR 1006:



- ▶ Press the *Cylinder adjustment functions* button on control panel X23.



- ▶ Press the *Extend A-frame1 cylinder* button on control panel X23.

7.34.3 Lowering the jib until wheels touch the ground or bottom jib limit switch is triggered

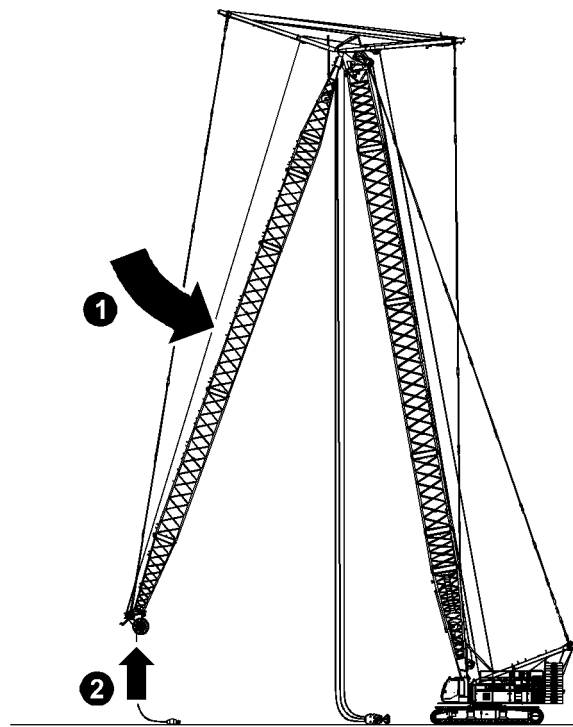


Fig. 5799: Lowering the jib until wheels touch the ground or bottom jib limit switch is triggered (illustration of principle)

If the jib is shorter than the main boom, the lower jib limit switch triggers before the wheels set down on the ground.

If the jib is longer than the main boom, the wheels set down on the ground before the jib limit switch triggers.

- ▶ Lower jib until wheels touch the ground or bottom jib limit switch is triggered.

If an attached auxiliary jib touches the ground:

- ▶ Ensure that auxiliary jib pendant straps fold up.

If the lightning rod* on the jib head touches the ground:

- ▶ Move lightning rod* on the jib head into transport position.

NOTICE

Incorrect laying down procedure!
Damage to equipment.

- ▶ Do not drag hook or pulley block along the ground.
- ▶ Prevent slack rope.

-
- ▶ Reeve rope of winch1/winch2 on jib if necessary.

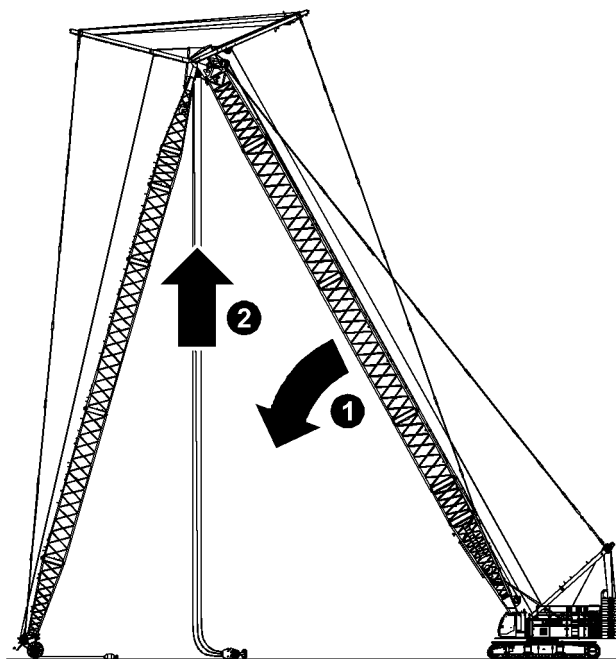


Fig. 5800: Lowering the main boom until the wheels touch the ground (illustration of principle)

NOTICE

Inadmissible jib angle!
Toppling of jib tilting-back supports.
Damage to jib.

- ▶ Make sure that jib tilting-back supports do not tilt forward.
 - ▶ Lift jib if necessary.
-

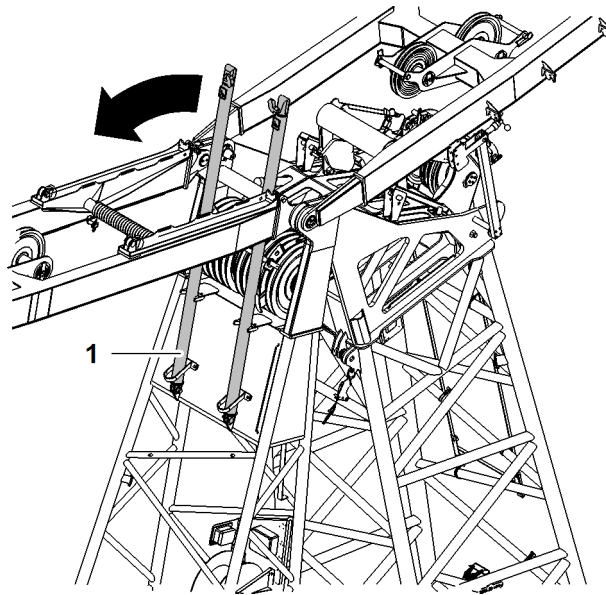


Fig. 5801: Jib tilting-back supports tilt forward

1 Jib tilting-back support (2x)

When the bottom jib limit switch triggers:

- ▶ Lower main boom and at the same time raise jib until wheels set down on the ground.

If an attached auxiliary jib touches the ground:

- ▶ Ensure that auxiliary jib pendant straps fold up.

If the lightning rod* on the jib head touches the ground:

- ▶ Move lightning rod* on the jib head into transport position.

NOTICE

Incorrect laying down procedure!
Damage to equipment.

- ▶ Do not drag hook or pulley block along the ground.
- ▶ Prevent slack rope.

- ▶ Reeve rope of winch1/winch2 on main boom if necessary.
-

7.34.4 Lowering the main boom and jib all the way to the ground



DANGER

Jib backstay straps and jib pendant straps under tension!
Toppling of machine.

- ▶ Ensure that Jib backstay straps and jib pendant straps are slightly slack.
-



DANGER

Mid-point suspension under tension!
Toppling of machine.

- ▶ Ensure that mid-point suspension ropes are slightly slack.
-

NOTICE

Obstacles when laying down jib!
Damage to boom components.

- ▶ Ensure that jib can roll forwards unhindered when it is laid down.
-

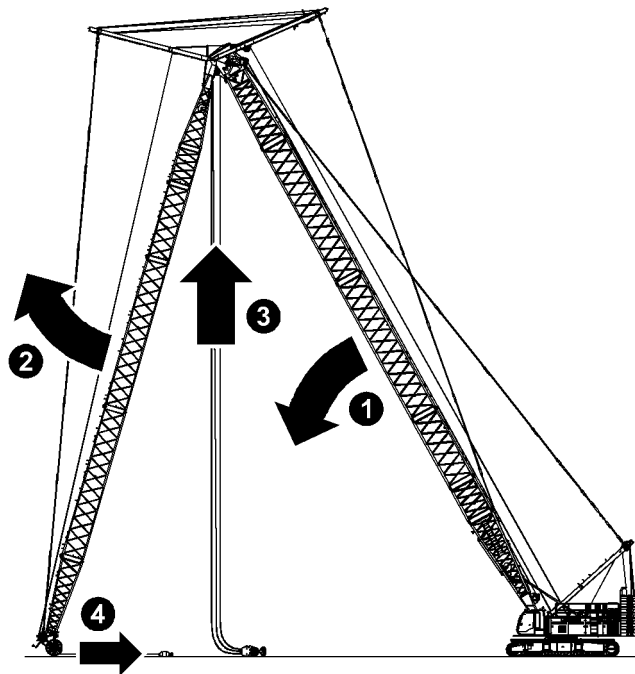


Fig. 5802: Lowering the main boom and jib all the way to the ground (illustration of principle)

NOTICE

Collision between A-frame2 and A-frame3!
Damage to A-frame2 and A-frame3.

- ▶ Do not completely move A-frame2 and A-frame3 together.
-

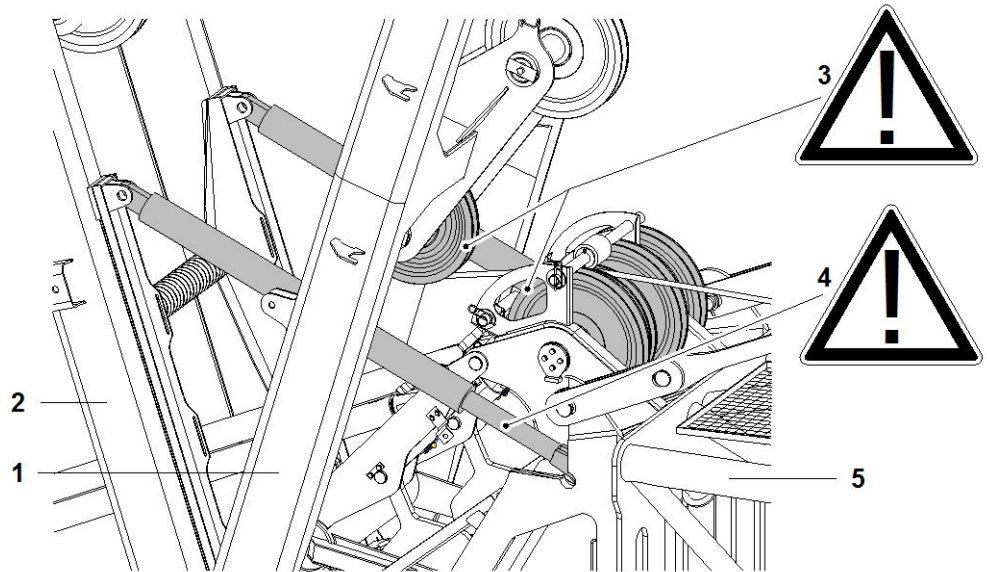


Fig. 5803: Dangers when laying down A-frame2/A-frame3

- | | | | |
|---|----------------------------|---|--|
| 1 | A-frame2 | 4 | Minimum dimension x of the visible piston rod of the hydraulic tilting-back support (2x) |
| 2 | A-frame3 | 5 | Main boom head |
| 3 | Collision point of pulleys | | |

▶ Lower main boom and lift jib at the same time.

NOTICE

Incorrect laying down procedure!
Damage to equipment.

- ▶ Do not drag hook or pulley block along the ground.
- ▶ Prevent slack rope.

- ▶ Reeve rope of winch1/winch2 on main boom if necessary.
- ▶ Reeve rope of winch1/winch2 on jib if necessary.



If hoist limit switch weight is on the ground:

- ▶ Press the *Bypass limit switch* button on control panel X23.
- ▷ Hoist limit switches are bypassed.

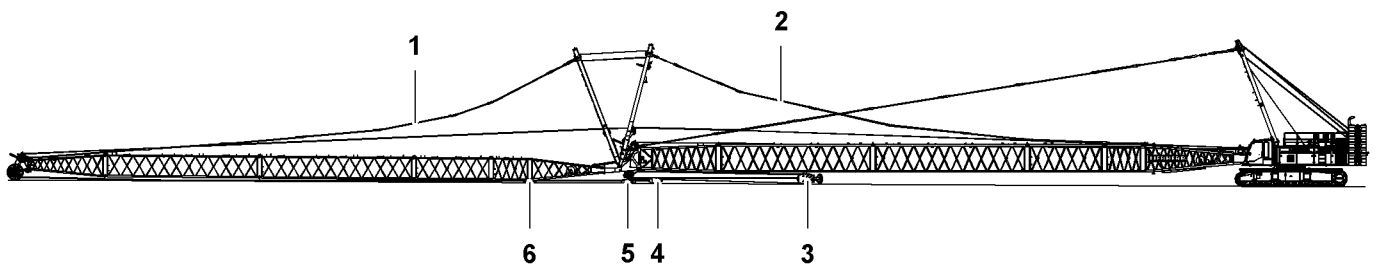


Fig. 5805: Main boom with luffing jib on the ground (illustration of principle)

- | | | | | | |
|---|---------------------|---|--------------|---|--------|
| 1 | Jib pendant straps | 3 | Pulley block | 5 | Timber |
| 2 | Jib backstay straps | 4 | Hook | 6 | Timber |

LWNLR.x/V04.01//Auslieferung/2016-03-07/en

- ▶ Remove rope protection pipes from jib head and jib base section.
- ▶ Detach rope of winch1/winch2 from jib and reeve.
- ▶ Detach rope of winch1/winch2 from main boom and pull back to main boom head.

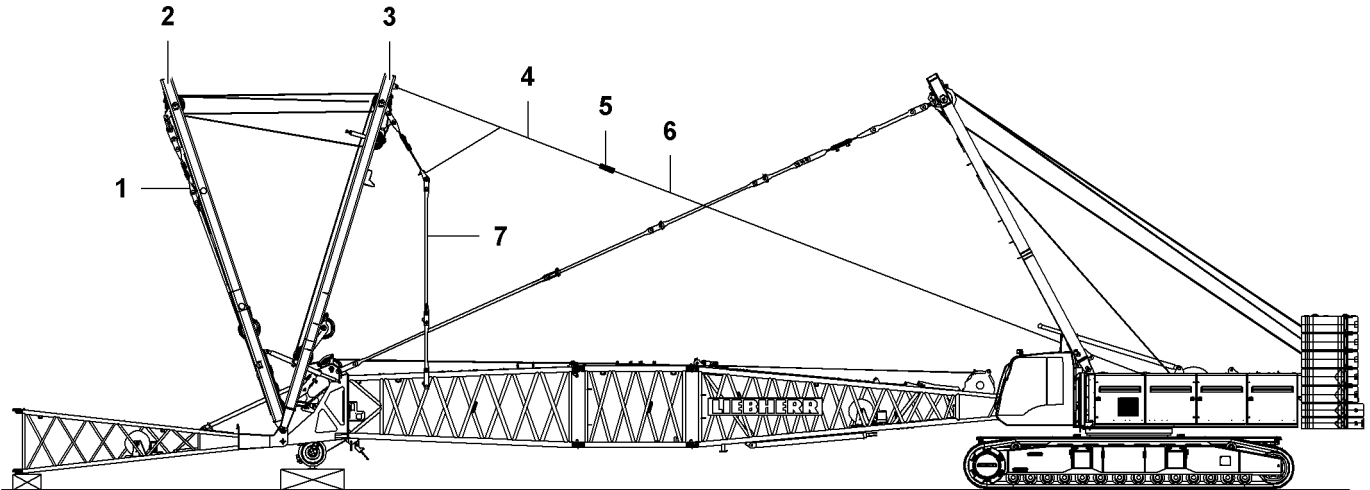


Fig. 5806: Laying down A-frame2/A-frame3 (illustration of principle)

1	A-frame3 equalizer	4	Belt	7	A-frame2 equalizer
2	A-frame3	5	Pocket lock		
3	A-frame2	6	Rope of winch1/winch2		

- ▶ Attach rope 6 of winch1/winch2 of main boom to belt 5 of A-frame2 3 with pocket lock 4.
- ▶ Tension rope 6 of winch1/winch2 from main boom.
- ▶ Lower A-frame3 2 with jib luffing winch until jib pendant straps rest on jib.
- ▶ Detach jib pendant straps from A-frame3 equalizer 1.

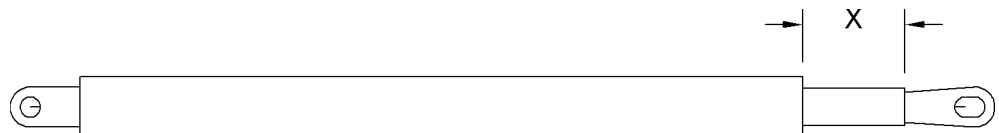


Fig. 5807: Minimum dimension x of the visible piston rod of the hydraulic tilting-back supports

x Minimum dimension
100 mm (3.94" in)

NOTICE

Inadmissible undercutting of the minimum dimension x of the visible piston rods of the hydraulic tilting-back supports!
Damage to machine.

- ▶ Stop erection process of A-frame3 in time.
- ▶ Erect A-frame3 2 with jib luffing winch.
- ▶ Secure A-frame3 equalizer 1 in transport position.
- ▶ Lower A-frame3 2 using jib luffing winch until hydraulic tilting-back support are completely extended.

NOTICE

Collision of pulleys on A-frame2 and gantry pulleys on main boom head!
Damage to machine.

- ▶ Stop erection process of A-frame2 in time.
-
- ▶ Erect A-frame2 **3** and A-frame3 **2** using the rope **6** of winch1/winch2 of the main boom until jib backstay straps rest on main boom.
 - ▶ Detach jib backstay straps from A-frame2 equalizer **7**.
 - ▶ Lower A-frame2 **3** and A-frame3 **2** using the rope **6** of winch1/winch2 of the main boom until hydraulic tilting-back supports are no longer under stress.
 - ▶ Remove pins of the hydraulic tilting-back supports from main boom head.
 - ▶ Erect A-frame2 **3** using the rope **6** of winch1/winch2 of the main boom and at the same time hold A-frame3 **2** in position with the jib luffing winch, until the feet of A-frame2 **3** are about 20 cm (7.87" in) from A-frame3 **3**.
 - ▶ Lower A-frame2 **3** and A-frame3 **2** using the rope **6** of winch1/winch2 of the main boom until A-frame3 **3** rests on jib base section.



Note

Liebherr recommends:

- ▶ Reeve supplied auxiliary rope.
-
- ▶ Remove rope protection pipes.
 - ▶ Pull out and reeve jib luffing winch rope.
 - ▶ Lower A-frame2 **3** using the rope **6** of winch1/winch2 of the main boom until A-frame2 **3** rests on A-frame3 **3**.
 - ▶ Remove rope **6** of winch1/winch2 of main boom from belt **4** of A-frame2 **3**.
 - ▶ Reinstall rope protection pipes on jib head and jib base section.
 - ▶ Remove and reeve electric lines.
 - ▶ Move lightning rods* on A-frame2 **3** and A-frame3 **3** into transport position.
 - ▶ Separate jib components and jib pendant straps.
 - ▶ Unpin jib base section and remove from main boom head.
 - ▶ Load jib components.
 - ▶ Dismantle main boom and basic machine as described below.

7.35 Dismantling the fixed jib



DANGER

Incorrect disassembly of the machine!
Toppling of machine, structural breakdown.

- ▶ Erectability chart, critical angles and boom radius limitations must be observed.

The fixed jib must be disassembled in the reverse order to assembly.

Ensure that the following conditions are fulfilled:

- There must be sufficient space available to lay down the assembled booms.
- The signalmen and assistants have received instructions.
- The necessary tools and approved lifting equipment is available.
- Wooden blocks are available for placement.

7.35.1 Brief summary

The following list provides you with a short overview of the steps to be taken when dismantling the fixed jib:

- ▶ Lay down pulley blocks/hooks.



Note

The overall center of gravity of the machine is moved beyond the first running roller!

Sudden swinging of the boom/jib during the laying down operation.

Liebherr recommends:

- ▶ When using long main booms and short jibs, follow the procedure for "Blocked Crawlers" ([For more information see: 4.27 Blocked crawlers*, page 980](#)).

- ▶ Lower main boom.



If a load moment limiter stop is triggered:

- ▶ Press the button *Load moment limiter assembly/self-lock* on control panel X23.

No load chart exist for machines geometry:

- ▷ Function "load moment limiter assembly" is active.
- ▷ The LED in the button *Load moment limiter assembly/self-lock* is lit.
- ▷ Machine functions are enabled without restriction.
- ▷ Load moment limiter lamps flash orange.



- ▶ Press the switch *Assembly functions* on control panel X12.

The following buttons have to be pressed additionally with machine types LR 1003, LR 1004, LR 1006:

- ▶ Press the *Cylinder adjustment functions* button on control panel X23.





- ▶ Press the *Extend A-frame1 cylinder* button on control panel X23.



DANGER

Obstacles in the way when laying down the jib!
Structural failure.

- ▶ Make sure that when being laid down, the jib can roll forwards unhindered.

If the lightning rod* on the jib head touches the ground:

- ▶ Move lightning rod* on the jib head into transport position.
- ▶ Lower further until main boom and jib are completely on the ground.
- ▶ Loosen rope of winch1/winch2 from jib and reeve.
- ▶ Remove the rope of winch1/winch2 from the main boom and pull it back to the boom head section.
- ▶ Attach the rope of winch1/winch2 of the main boom with pocket lock on A-frame2.
- ▶ Undo jib pendant straps from A-frame2.
- ▶ Pull A-frame 2 backwards to relieve the strain on the jib backstay straps.
- ▶ Detach the jib backstay straps from the connecting links.
- ▶ Lay down A-frame 2 forwards.
- ▶ Remove and wind up the electric cables.
- ▶ Move lightning rod* on A-frame2 into transport position.
- ▶ Disconnect jib components and jib backstay straps.
- ▶ Remove the rigid tilting-back supports.
- ▶ Unpin the jib base section and remove it from the boom head section.
- ▶ Re-fit the rigid tilting-back supports.
- ▶ Load jib components.
- ▶ Dismantle the main boom and basic machine as described below.

7.36 Disassembling main boom + reducing piece



DANGER

Incorrect disassembly of the machine!

- ▶ Erectability chart, critical angles and boom radius limitations must be observed.
-

The main boom + reducing adapter must be disassembled in the reverse order to assembly.

Ensure that the following conditions are fulfilled:

- There must be sufficient space available to lay down the assembled booms.
- The signalmen and assistants have received instructions.
- The necessary tools and approved lifting equipment is available.
- Wooden blocks are available for placement.

7.36.1 Brief summary

The main boom + reducing adapter are disassembled in exactly the same way as the main boom .

7.37 Disassembling the main boom



DANGER

The machine has been disassembled incorrectly!
Toppling of machine, structural breakdown.

- ▶ Erectability chart, critical angles and boom radius limitations must be observed.

The main boom must be disassembled in the reverse order to assembly.

Ensure that the following conditions are fulfilled:

- There must be sufficient space available to lay down the assembled booms.
- The signalmen and assistants have received instructions.
- The necessary tools and approved lifting equipment is available.
- Wooden blocks are available to place under the boom.

7.37.1 Brief summary

The following list provides you with a short overview of the steps to be taken when disassembling the main boom:

- ▶ Lay down the pulley block/load hook.
- ▶ Lower the main boom.



If a load moment limiter stop is triggered:

- ▶ Press the button *Load moment limiter assembly/self-lock* on control panel X23.

No load chart exist for machines geometry:

- ▷ Function "load moment limiter assembly" is active.
- ▷ The LED in the button *Load moment limiter assembly/self-lock* is lit.
- ▷ Machine functions are enabled without restriction.
- ▷ Load moment limiter lamps flash orange.



- ▶ Press the switch *Assembly functions* on control panel X12.

The following buttons have to be pressed additionally with machine types LR 1003, LR 1004, LR 1006:



- ▶ Press the button *cylinder adjustment functions* on control panel X23.



- ▶ Press the *Extend A-frame1 cylinder* button on control panel X23.



DANGER

Obstacles when laying down the main boom!
Structural failure.

- ▶ Make sure that the auxiliary jib (if present) can roll forwards unhindered when it is laid down.

- ▶ Continue to lower the main boom until it is just above the ground.
- If an attached auxiliary jib touches the ground:
- ▶ Ensure that auxiliary jib pendant straps fold up.

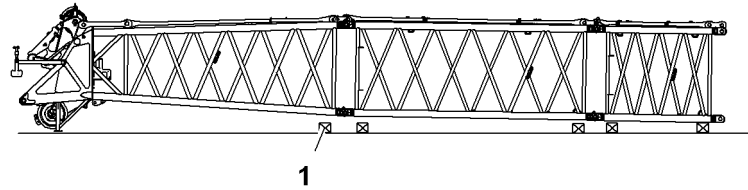


Fig. 5816: Supporting the main boom with wooden blocks (illustration of principle)

1 Wooden blocks

- ▶ Place wooden blocks to the left and right of the pin connection points underneath the chord pipe of the main boom sections.



WARNING

Impermissible voltage build-up in main boom!
Serious injury.

- ▶ Ensure that boom head section can slide in a longitudinal direction.
- ▶ If necessary install a layer of suitable support material under the feet of the main boom head section.

- ▶ Lower main boom until main boom rests on wooden blocks.
- ▶ Loosen rope of winch1/winch2 from main boom and reeve.
- ▶ Remove and wind up the electric cables from the main boom.
- ▶ Move the lightning rods* into transport position.
- ▶ Connecting the equalizer on A-frame1 to the main boom base section.



WARNING

Never stand in the inside of the main boom sections during disassembly!
Serious injury.

- ▶ Never go inside the main boom sections.



WARNING

Incorrect slacking of the rope on the main boom winch!
Main boom falls into slack rope after unpinning of the lower double-taper pins.

- ▶ Ensure that there is no slack rope on the main boom winch.
- ▶ Remove the first, bottom double-taper pin from the main boom base section.



WARNING

Impermissible voltage in main boom!
Sudden movement of main boom whilst unpinning the second, lower double-taper pin from the main boom base section.

- When the first, lower double-taper pin on the main boom base section is unpinned:
- ▶ Visually check that the pin connection points are aligned.

- ▶ Make sure that pin connection points are aligned correctly.
- ▶ Remove the second, bottom double-taper pin from the main boom base section.
- ▶ Unwind the main boom luffing winch.
 - ▷ The main boom and main boom base section fold out at the bottom pin connection point.
 - ▷ The main boom is lowered onto wooden blocks.
 - ▷ Main boom head section moves slightly forwards.
- ▶ Remove the top double-taper pins from the main boom base section.
- ▶ Drive the basic machine to the main boom head section.
- ▶ Lash rigging to main boom on the pin connection point between the main boom head section and the first main boom section with rigging.
- ▶ Remove bottom double-taper pins from main boom head.
- ▶ Lower lifting equipment.
 - ▷ Main boom and main boom head fold out at the bottom pin connection point.
 - ▷ The main boom is lowered onto wooden blocks.
- ▶ Remove the upper double-taper pins from the main boom head section.
- ▶ Load the main boom head section.
- ▶ Unpin the main boom sections.
- ▶ Load main boom sections.
- ▶ Dismantle the basic machine as described below.

7.38 Disassembling the basic machine



DANGER

Incorrect disassembly of the machine!
Toppling of machine, structural breakdown.

- ▶ Observe all critical angles and boom radius limitations as described under "Assembly".

The basic machine must be disassembled in the reverse order to assembly.

7.38.1 Brief summary

The following list provides you with a short overview of the steps to be taken when disassembling the basic machine.

- ▶ Switch on assembly mode functions.
- ▶ Switch on cylinder adjustment functions.
- ▶ Lower the rear counterweight.
- ▶ Remove the counterweight hoisting cylinder chains from the rear counterweight.
- ▶ Remove slinging plates from rear counterweight.
- ▶ Undo rear counterweight lashing links and remove.
- ▶ Disassemble rear counterweight using the specified sling gear and load the counterweight slabs.
- ▶ Remove platforms on the undercarriage.
- ▶ Remove and load the carbody counterweight slabs.
- ▶ Swing the jack swing brackets into the support position and bolt them.
- ▶ Lay the support plates under the jacks.
- ▶ Attach the transport safety with crawler side frames.
- ▶ Raise the basic machine using the jacks.
- ▶ Disconnect the hydraulic lines from the crawler side frames.
- ▶ Remove and load the crawler side frames.
- ▶ Position the transport vehicle under the basic machine.
- ▶ Place the basic machine on the transport vehicle.
- ▶ Fully retract the jack.
- ▶ Stow the support plates away.
- ▶ Swing the jack swing brackets into the transport position and bolt them.
- ▶ Lash basic machine on transport vehicle.
- ▶ Lay down A-frame1 backwards.



When A-frame1 triggers the limit switch *A-frame1, rear limit switch*:

- ▶ Press and hold the button *Retract A-frame1 cylinder* on control panel X23 until A-frame1 is in transport position.

- ▶ Retract the tilting back support cylinders.

- ▶ Switch off machine.



CAUTION

Hot exhaust components!
Risk of burns.

- ▶ Only touch the exhaust pipe when it is cold.
-
- ▶ Remove the intermediate exhaust section and put on the offset.
 - ▶ Fold the railing on the uppercarriage down.
 - ▶ Remove the ladder.
 - ▶ Remove platforms on the uppercarriage.
 - ▶ Use the uppercarriage locking device to prevent the uppercarriage from turning.
 - ▶ Move the cabin's platforms into transport position.
 - ▶ Swing the cabin into transport position and bolt it.
 - ▶ Close the cabin and secure the machine against unauthorized start-up.
 - ▶ Switch off the battery main switch.

8 Transport

8 Transport

The chapter **Transport** deals with the following subjects:

- Transporting the machine
- Transporting the components

8.1 Loading the basic machine with an assist crane

There are four different variants in which the basic machine can be loaded:

- without crawler side frame, carbody counterweight and rear counterweight
- with crawler side frame
- with crawler side frame and carbody counterweight
- with crawler side frame, carbody counterweight and rear counterweight

Ensure that the following conditions are fulfilled:

- A signalman is available.
- Equipment is secured against accidental movement.
- An adequate safety distance from electrical power lines or contact lines is maintained.
- Transport vehicle is secured against accidental movement.
- Adequate lighting is available for working in poor light.

8.1.1 Loading basic machine with undercarriage with fixed track width

Loading the basic machine without crawler side frame, carbody counterweight and rear counterweight



DANGER

Machine loaded incorrectly!
Toppling of machine, damage to machine.

- ▶ Only use lifting equipment and crossbars that meet the minimum requirements (see: [tab. 610, page 1816](#)).
-

Make sure the following prerequisites are met:

- Crawler side frame, carbody counterweight and rear counterweight are detached from the basic machine.
- Main boom base section is detached from basic machine.
- Cabin is lowered, swung into transport position and secured.
- Counterweight hoisting cylinders are retracted.
- Tilting-back supports are retracted.

- A-frame1 is folded back in transport position and A-frame1 cylinders are retracted.
- Jacks on the undercarriage are pinned in transport position and retracted.
- Additional floodlights* (if available) are deinstalled.
- All loose parts are secured to prevent slippage and falling.
- A crossbar with a suitable capacity is available.
- Lifting equipment is in good condition and approved for use.

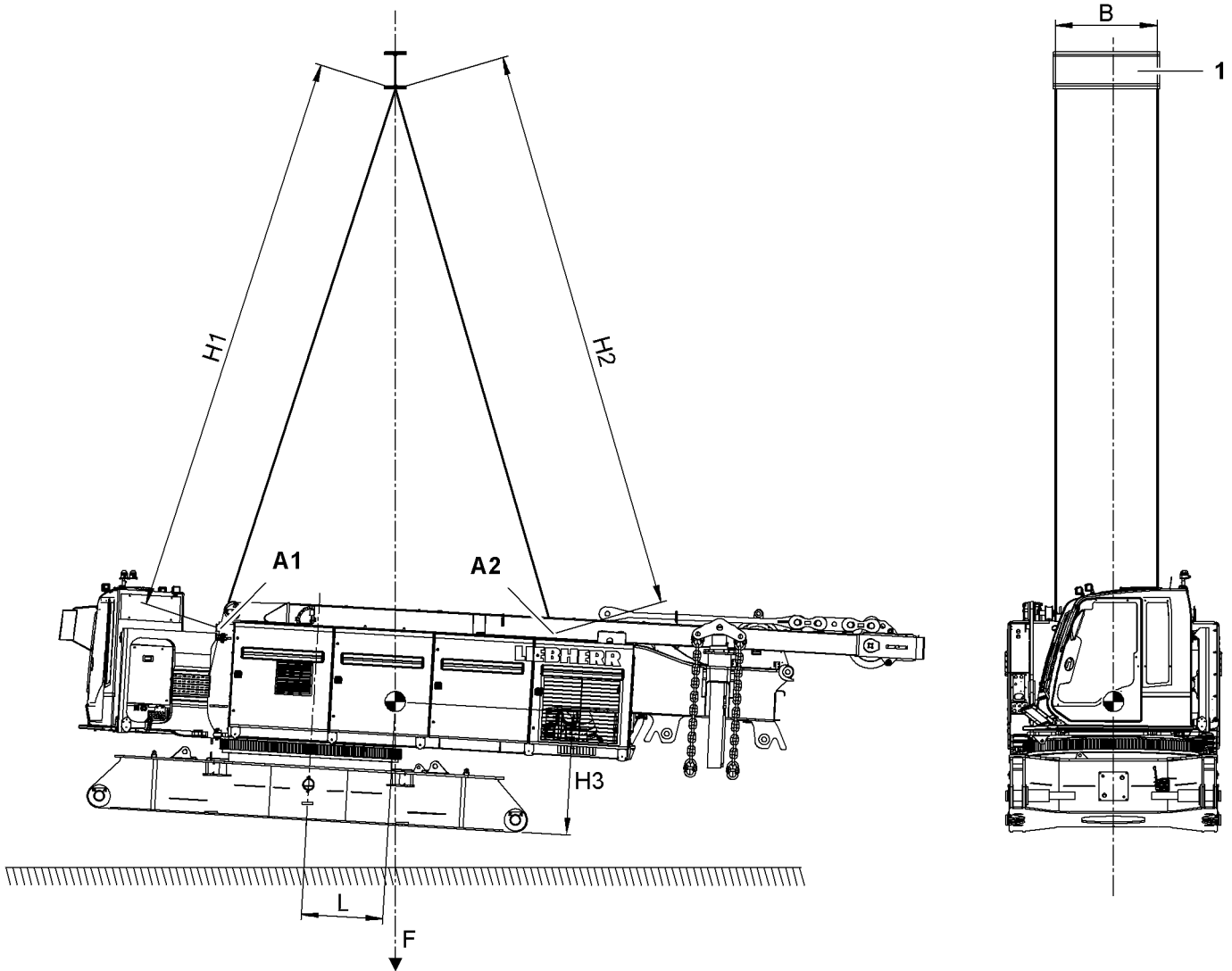


Fig. 5818: Loading the basic machine without crawler side frame, carbody counterweight and rear counterweight - overview

1 Crossbar

The mass and center of gravity may deviate from the values shown below depending on the as-delivered configuration, the liquid level in the tanks, and generally accepted tolerances.

Name		Value
H1	Length of front round slings	min. 8000 mm (26' 3" ft-in)
	Load-bearing capacity of front round slings	min. 30000 kg (66,138 lb)

LWNLR-x/V04.01//Auslieferung/2016-03-07/en

Name		Value
H2	Length of rear round slings	min. 8000 mm (26' 3" ft-in)
	Capacity of rear round slings	min. 30000 kg (66,138 lb)
A1	Load-bearing capacity of front shackles	min. 35000 kg (77,161 lb)
A2	Load-bearing capacity of rear shackles	min. 35000 kg (77,161 lb)
B	Distance from rigging points on crossbar	1360 mm (4' 6" ft-in) to 1520 mm (5' ft-in)
H3	Distance center of gravity to bottom edge of center part	1741 mm 5' 9" ft-in
L	Distance from center of gravity to rotation axis	1153 mm 3' 9" ft-in
F	Transport weight	48000 kg 105,820 lb

Tab. 610: Technical data for loading the basic machine without crawler side frame, carbody counterweight and rear counterweight

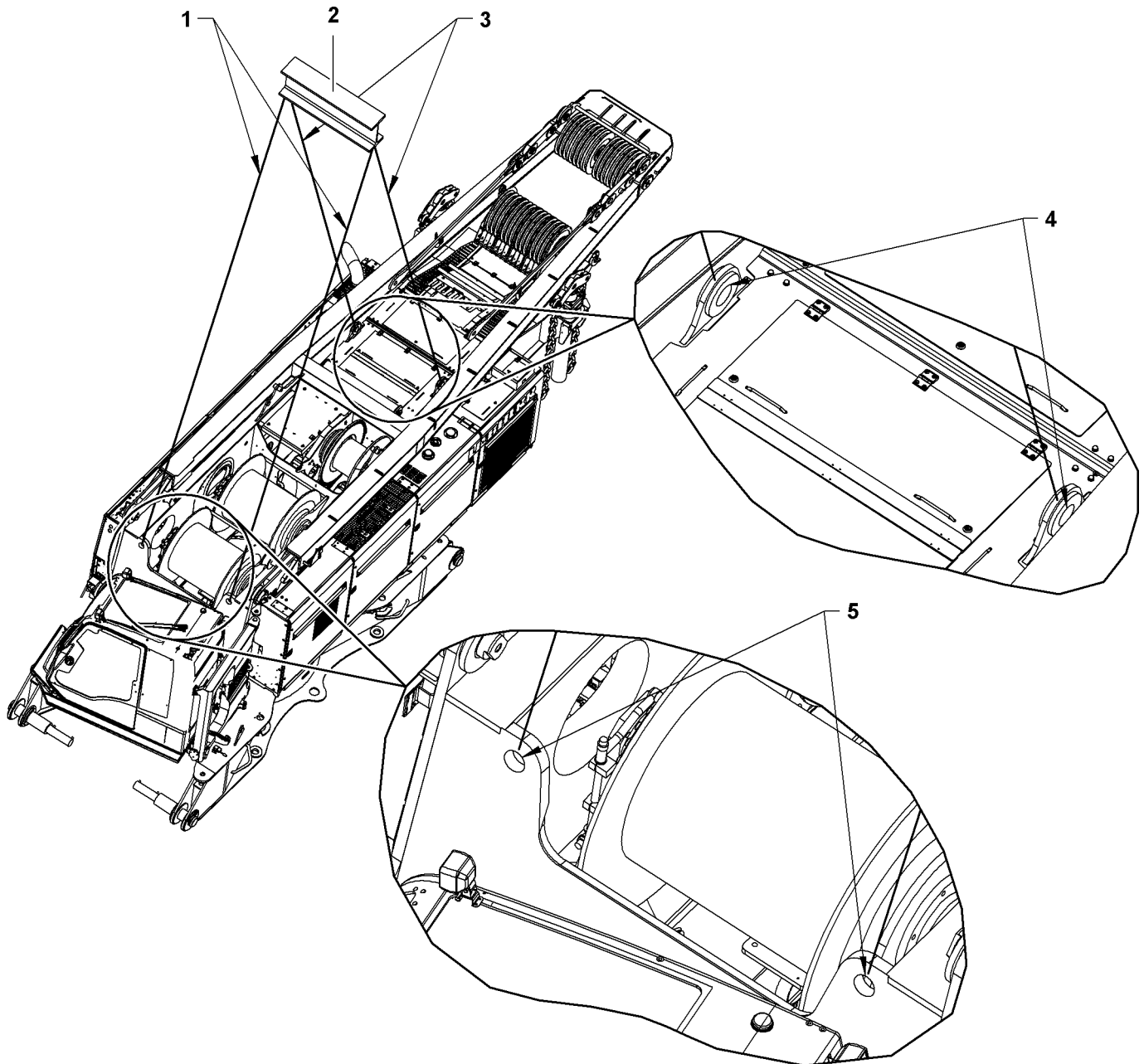


Fig. 5819: Loading the basic machine without crawler side frame, carbody counterweight and rear counterweight - rigging points

1 Front round slings
2 Crossbar

3 Rear round slings
4 Rear rigging points

5 Front rigging points

- ▶ Lash front round slings **1** to the rigging points **5** using shackles.
- ▶ Lash rear round slings **3** to the rigging points **4** using shackles.
- ▶ Carefully raise and load the basic machine.

Loading the basic machine with crawler side frame



DANGER

Machine loaded incorrectly!
Toppling of machine, damage to machine.

- ▶ Only use lifting equipment and crossbars that meet the minimum requirements (see: tab. 611, page 1820) .

Make sure the following prerequisites are met:

- Carbody counterweight and rear counterweight are detached from basic machine.
- Main boom base section is detached from basic machine.
- Cabin is lowered, swung into transport position and secured.
- Counterweight hoisting cylinders are retracted.
- Tilting-back supports are retracted.
- A-frame1 is folded back in transport position and A-frame1 cylinders are retracted.
- Jacks on the undercarriage are pinned in transport position and retracted.
- Additional floodlights* (if available) are deinstalled.
- All loose parts are secured to prevent slippage and falling.
- A crossbar with a suitable load-bearing capacity is available.
- Sling gear is in good condition and approved for use.

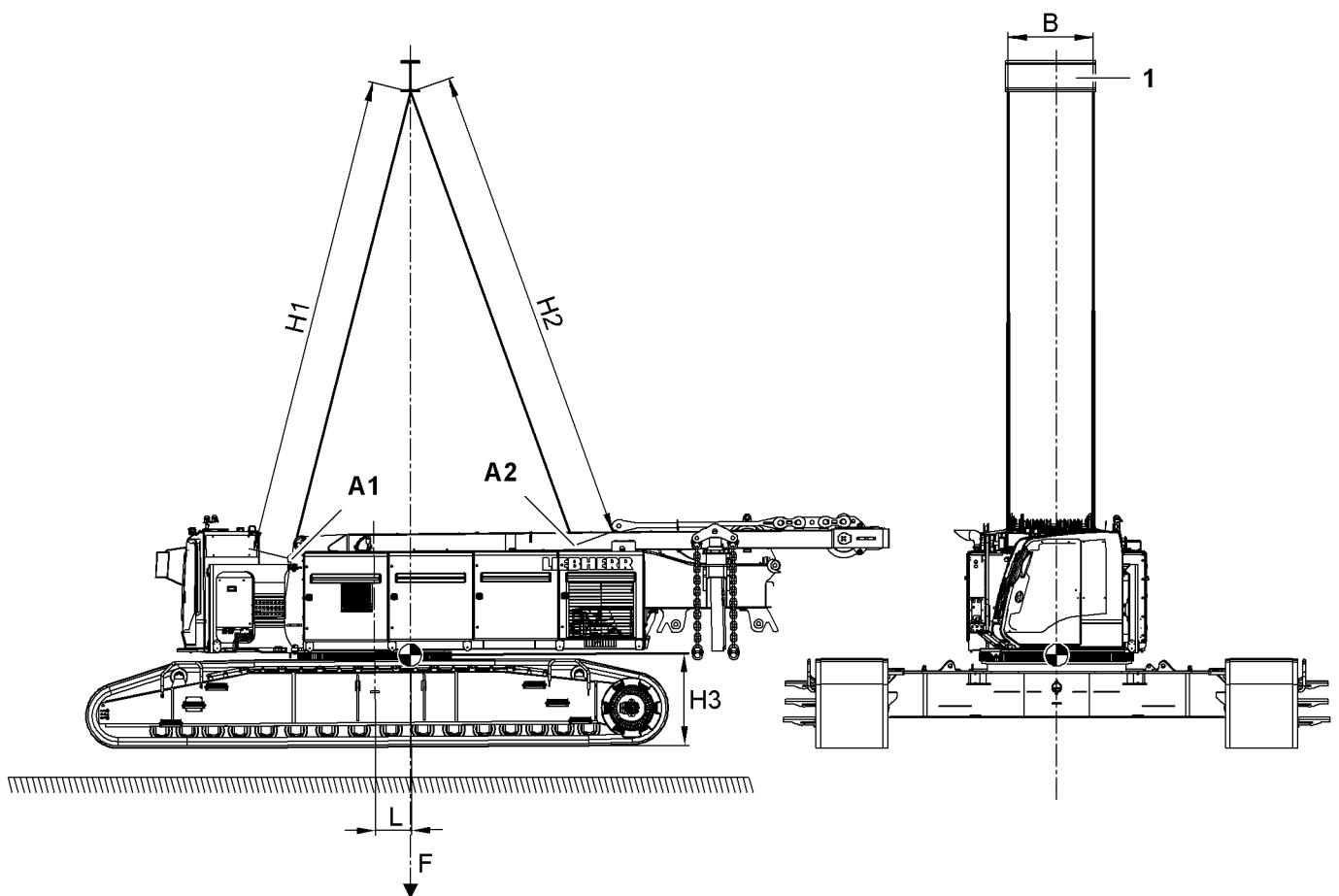


Fig. 5820: Loading the basic machine with crawler side frame - overview

1 Crossbar

The mass and center of gravity may deviate from the values shown below depending on the as-delivered configuration, the liquid level in the tanks, and generally accepted tolerances.

Name		Value
H1	Length of front round slings	min. 8000 mm (26' 3" ft-in)
	Load-bearing capacity of front round slings	min. 40000 kg (88,184 lb)
H2	Length of rear round slings	min. 8000 mm (26' 3" ft-in)
	Capacity of rear round slings	min. 40000 kg (88,184 lb)
A1	Load-bearing capacity of front shackles	min. 55000 kg (121,252 lb)
A2	Load-bearing capacity of rear shackles	min. 55000 kg (121,252 lb)
B	Distance from rigging points on crossbar	1340 mm (4' 5" ft-in) to 1500 mm (4' 11" ft-in)
H3	Distance from center of gravity to bottom edge of crawler side frame	1527 mm 5' ft-in
L	Distance from center of gravity to rotation axis	592 mm 1' 11" ft-in
F	Transport weight	92000 kg 202,822 lb

Tab. 611: Technical data for loading the basic machine with crawler side frame

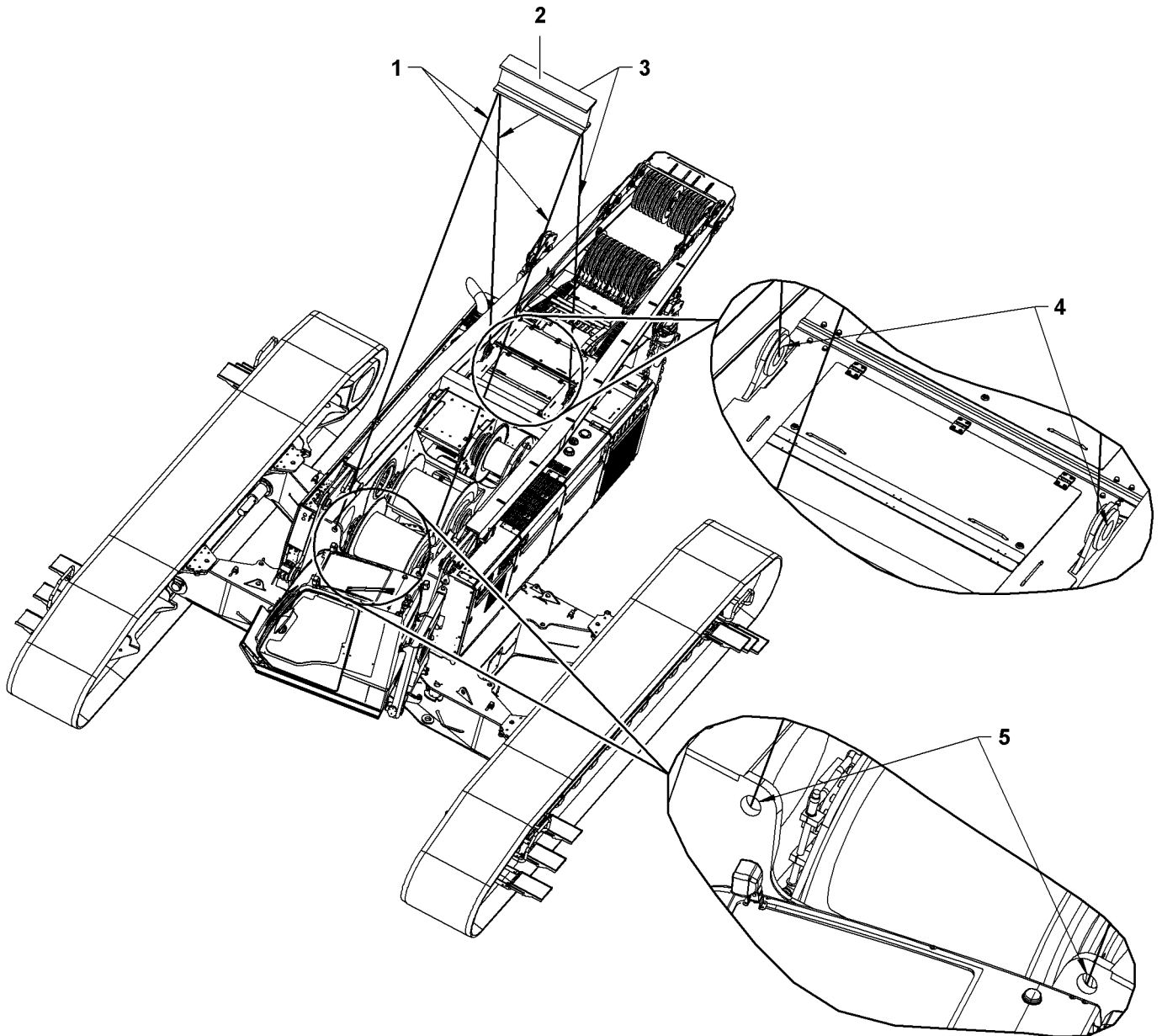


Fig. 5821: Loading the basic machine with crawler side frame - rigging points

- | | | | | | |
|---|--------------------|---|---------------------|---|----------------------|
| 1 | Front round slings | 3 | Rear round slings | 5 | Front rigging points |
| 2 | Crossbar | 4 | Rear rigging points | | |

- ▶ Lash front round slings 1 to the rigging points 5 using shackles.
- ▶ Lash rear round slings 3 to the rigging points 4 using shackles.
- ▶ Carefully raise and load the basic machine.

Loading the basic machine with crawler side frame and carbody counterweight



DANGER

Machine loaded incorrectly!
Toppling of machine, damage to machine.

- ▶ Only use lifting equipment and crossbars that meet the minimum requirements (see: tab. 612, page 1823).

Make sure the following prerequisites are met:

- The rear counterweight is removed from the basic machine.
- Main boom base section is detached from basic machine.
- Cabin is lowered, swung into transport position and secured.
- Counterweight hoisting cylinders are retracted.
- Tilting-back supports are retracted.
- A-frame¹ is folded back in transport position and A-frame¹ cylinders are retracted.
- Jacks on the undercarriage are pinned in transport position and retracted.
- Additional floodlights* (if available) are deinstalled.
- All loose parts are secured to prevent slippage and falling.
- A crossbar with a suitable load-bearing capacity is available.
- Sling gear is in good condition and approved for use.

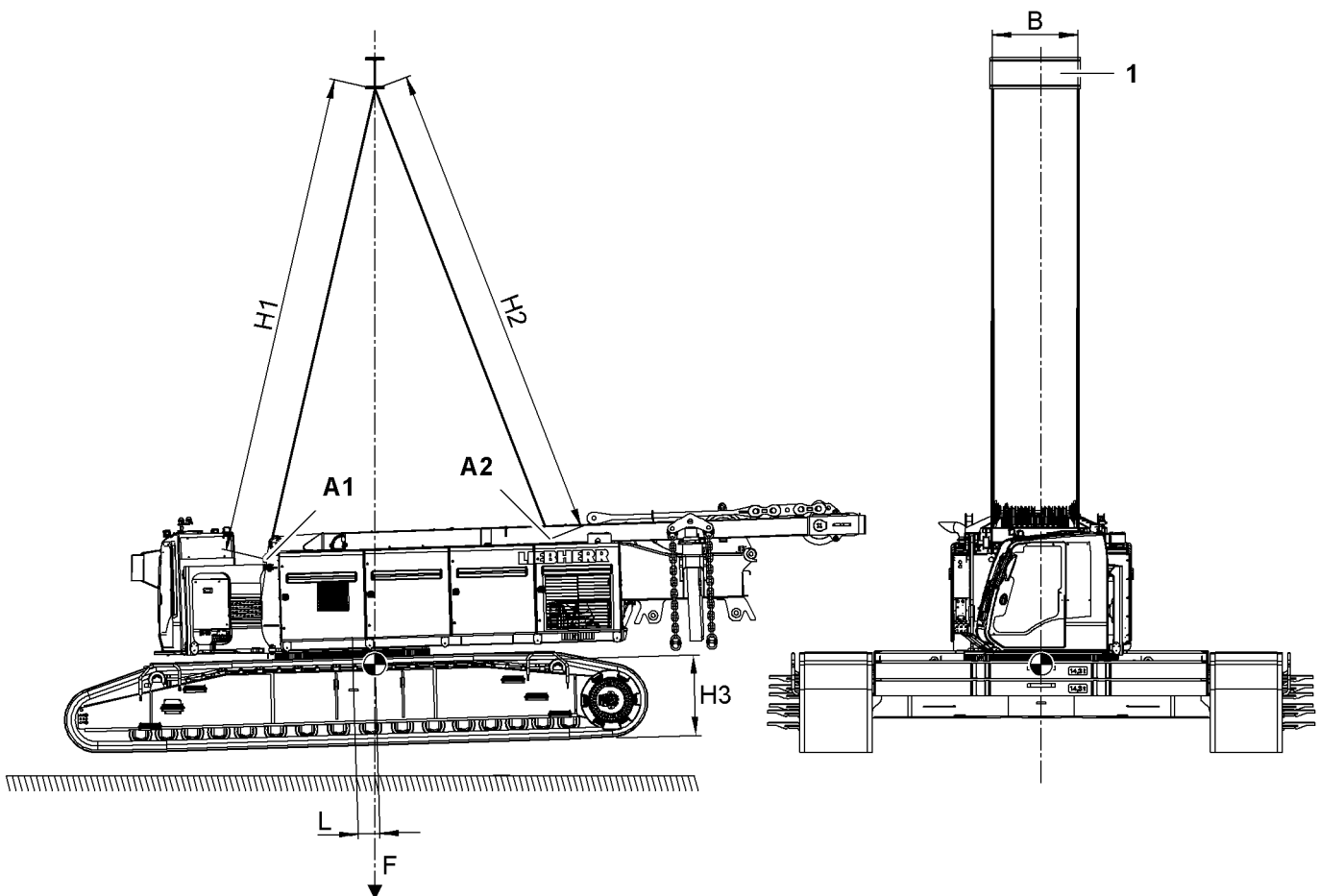


Fig. 5822: Loading the basic machine with crawler side frame and carbody counterweight - overview

1 Crossbar

LWNLR-x/V04.01//Auslieferung/2016-03-07/en

The mass and center of gravity may deviate from the values shown below depending on the as-delivered configuration, the liquid level in the tanks, and generally accepted tolerances.

Name		Value
H1	Length of front round slings	min. 8000 mm (26' 3" ft-in)
	Load-bearing capacity of front round slings	min. 80000 kg (176,367 lb)
H2	Length of rear round slings	min. 8000 mm (26' 3" ft-in)
	Capacity of rear round slings	min. 50000 kg (110,230 lb)
A1	Load-bearing capacity of front shackles	min. 85000 kg (187,390 lb)
A2	Load-bearing capacity of rear shackles	min. 55000 kg (121,252 lb)
B	Distance from rigging points on crossbar	1340 mm (4' 5" ft-in) to 1500 mm (4' 11" ft-in)
H3	Distance from center of gravity to bottom edge of crawler side frame	1335 mm 4' 5" ft-in
L	Distance from center of gravity to rotation axis	365 mm 1' 2" ft-in
F	Transport weight	150000 kg 330,688 lb

Tab. 612: Technical data for loading the basic machine with crawler side frame and carbody counterweight

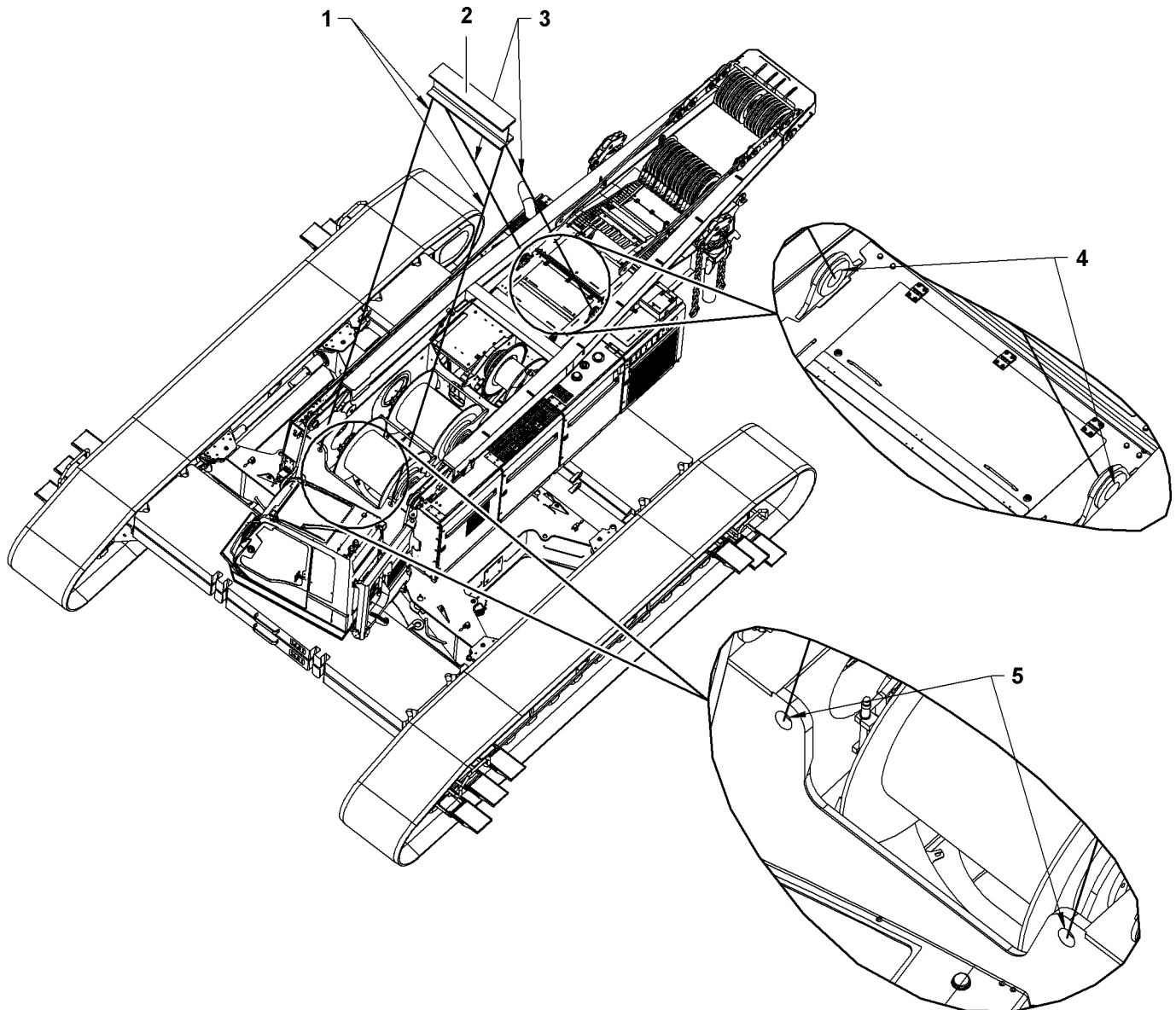


Fig. 5823: Loading the basic machine with crawler side frame and carbody counterweight - rigging points

- | | | | | | |
|---|--------------------|---|---------------------|---|----------------------|
| 1 | Front round slings | 3 | Rear round slings | 5 | Front rigging points |
| 2 | Crossbar | 4 | Rear rigging points | | |

- ▶ Lash front round slings 1 to the rigging points 5 using shackles.
- ▶ Lash rear round slings 3 to the rigging points 4 using shackles.
- ▶ Carefully raise and load the basic machine.

Loading the basic machine with crawler side frame, carbody counterweight and rear counterweight



DANGER

Machine loaded incorrectly!
Toppling of machine, damage to machine.

- ▶ Only use lifting equipment and crossbars that meet the minimum requirements (see: tab. 613, page 1825) .

Make sure the following prerequisites are met:

- Main boom base section is detached from basic machine.
- Cabin is lowered, swung into transport position and secured.
- Counterweight hoisting cylinders are retracted.
- Tilting-back supports are retracted.
- A-frame1 is folded back in transport position and A-frame1 cylinders are retracted.
- Jacks on the undercarriage are pinned in transport position and retracted.
- Additional floodlights* (if available) are deinstalled.
- All loose parts are secured to prevent slippage and falling.
- A crossbar with a suitable load-bearing capacity is available.
- Sling gear is in good condition and approved for use.

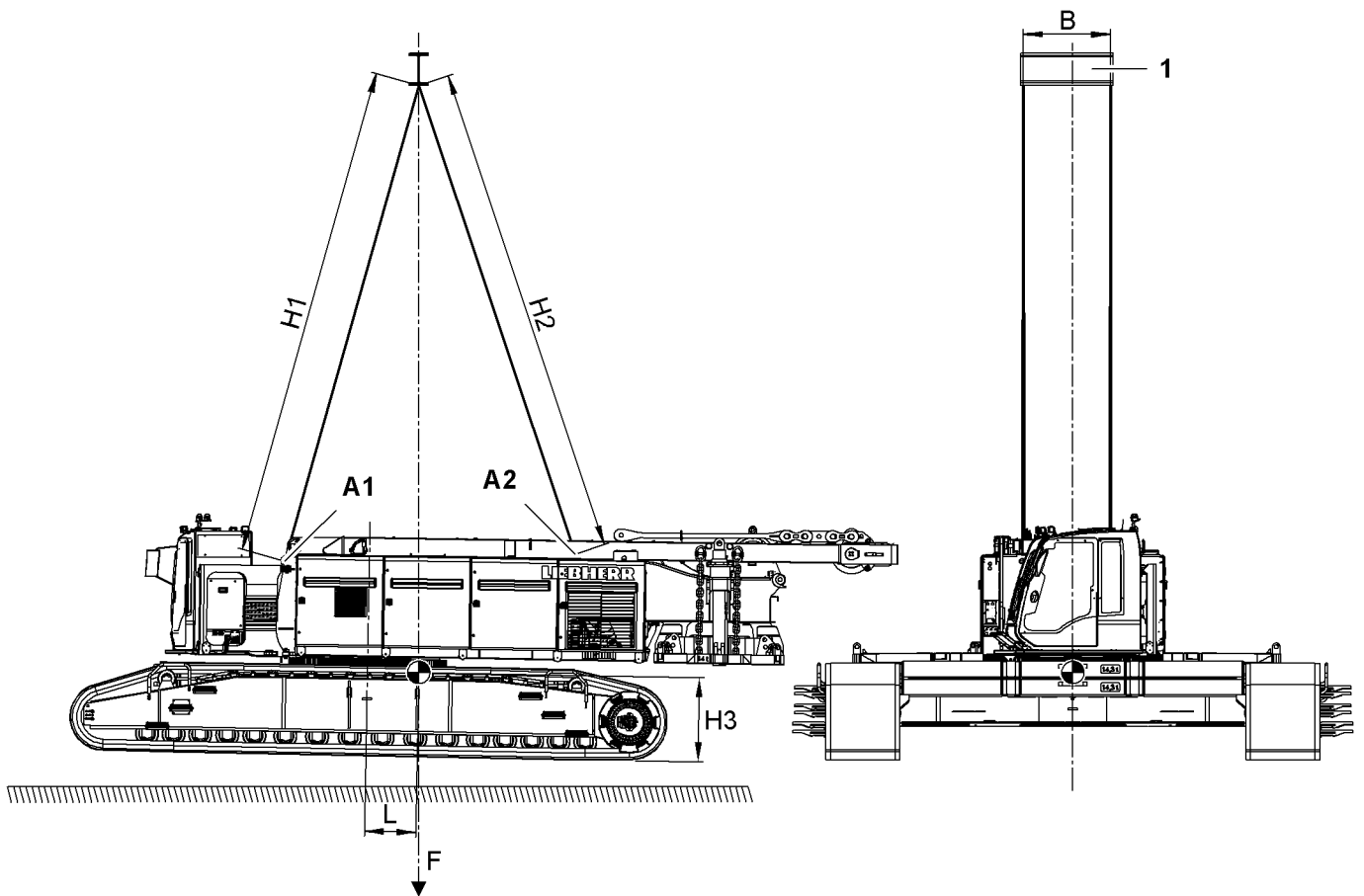


Fig. 5824: Loading the basic machine with crawler side frame, carbody counterweight and rear counterweight - overview

1 Crossbar

The mass and center of gravity may deviate from the values shown below depending on the as-delivered configuration, the liquid level in the tanks, and generally accepted tolerances.

Name		Value
H1	Length of front round slings	min. 8000 mm (26' 3" ft-in)
	Load-bearing capacity of front round slings	min. 80000 kg (176,367 lb)
H2	Length of rear round slings	min. 8000 mm (26' 3" ft-in)
	Capacity of rear round slings	min. 60000 kg (132,275 lb)

LWNLR.x/V04.01//Auslieferung/2016-03-07/en

Name		Value
A1	Load-bearing capacity of front shackles	min. 85000 kg (187,390 lb)
A2	Load-bearing capacity of rear shackles	min. 55000 kg (121,252 lb)
B	Distance from rigging points on crossbar	1340 mm (4' 5" ft-in) to 1500 mm (4' 11" ft-in)
H3	Distance from center of gravity to bottom edge of crawler side frame	1366 mm 4' 6" ft-in
L	Distance from center of gravity to rotation axis	831 mm 2' 9" ft-in
F	Transport weight	165000 kg 363,757 lb

Tab. 613: Technical data for loading the basic machine with crawler side frame, carbody counterweight and rear counterweight

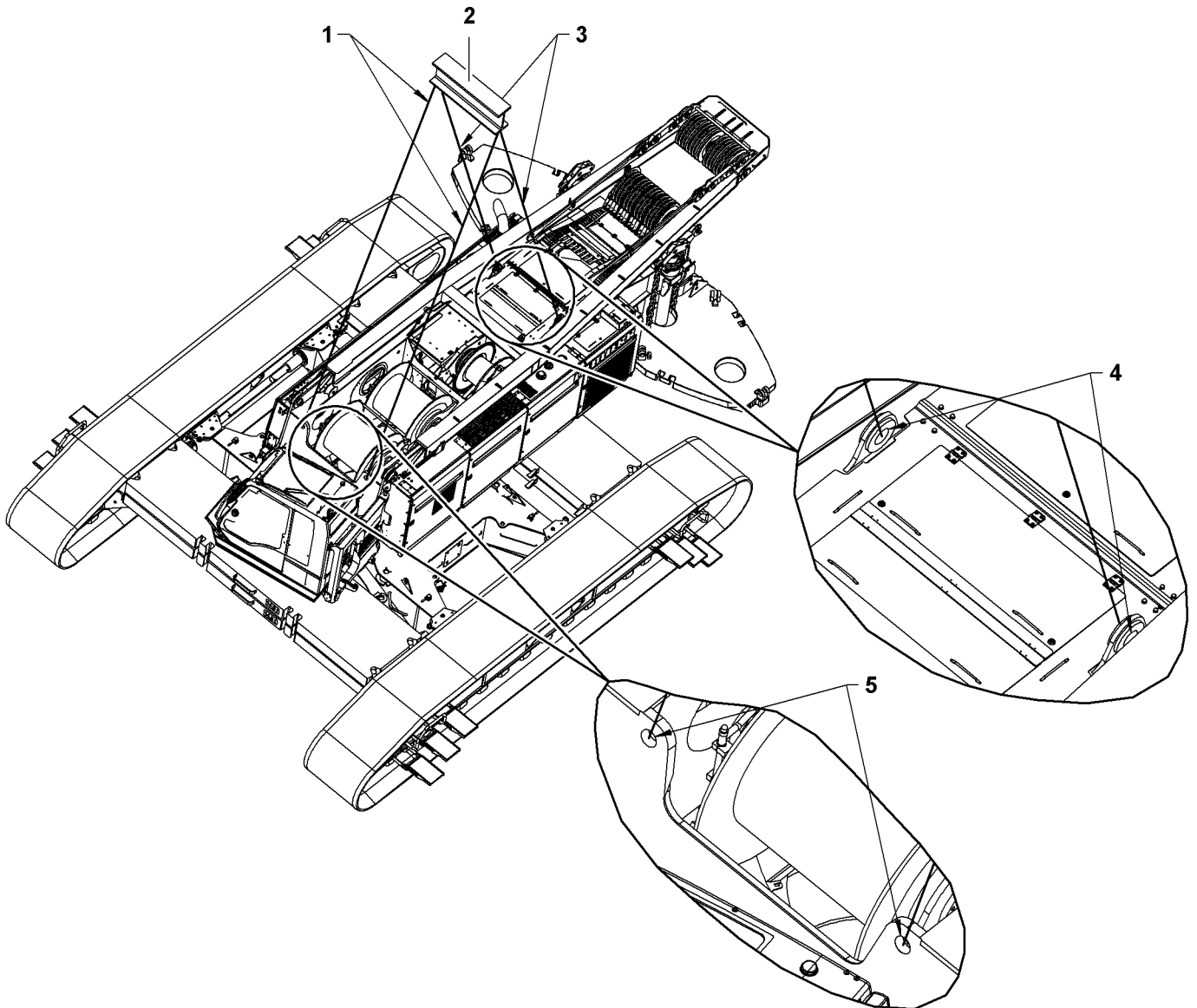


Fig. 5825: Loading the basic machine with crawler side frame, carbody counterweight and rear counterweight - rigging points

1 Front round slings
2 Crossbar

3 Rear round slings
4 Rear rigging points

5 Front rigging points

- ▶ Lash front round slings 1 to the rigging points 5 using shackles.
- ▶ Lash rear round slings 3 to the rigging points 4 using shackles.
- ▶ Carefully raise and load the basic machine.

8.1.2 Loading basic machine with undercarriage with adjustable track width

Loading basic machine without crawler side frame, carbody counterweight and rear counterweight



DANGER

Improper loading of machine!
Toppling of machine, damage to machine.

- ▶ Only use sling gear and crossbars that meet the minimum requirements (see: [tab. 614, page 1829](#)).

Make sure the following prerequisites are met:

- Crawler side frame, carbody counterweight and rear counterweight are detached from the basic machine.
- Main boom base section is detached from basic machine.
- Cabin is lowered, swung into transport position and secured.
- Counterweight hoisting cylinders are retracted.
- Tilting-back supports are retracted.
- A-frame¹ is folded back in transport position and A-frame¹ cylinders are retracted.
- Jacks on the undercarriage are pinned in transport position and retracted.
- Additional floodlights* (if available) are uninstalled.
- All loose parts are secured to prevent slippage and falling.
- A crossbar with a suitable load-bearing capacity is available.
- Sling gear is in good condition and approved for use.

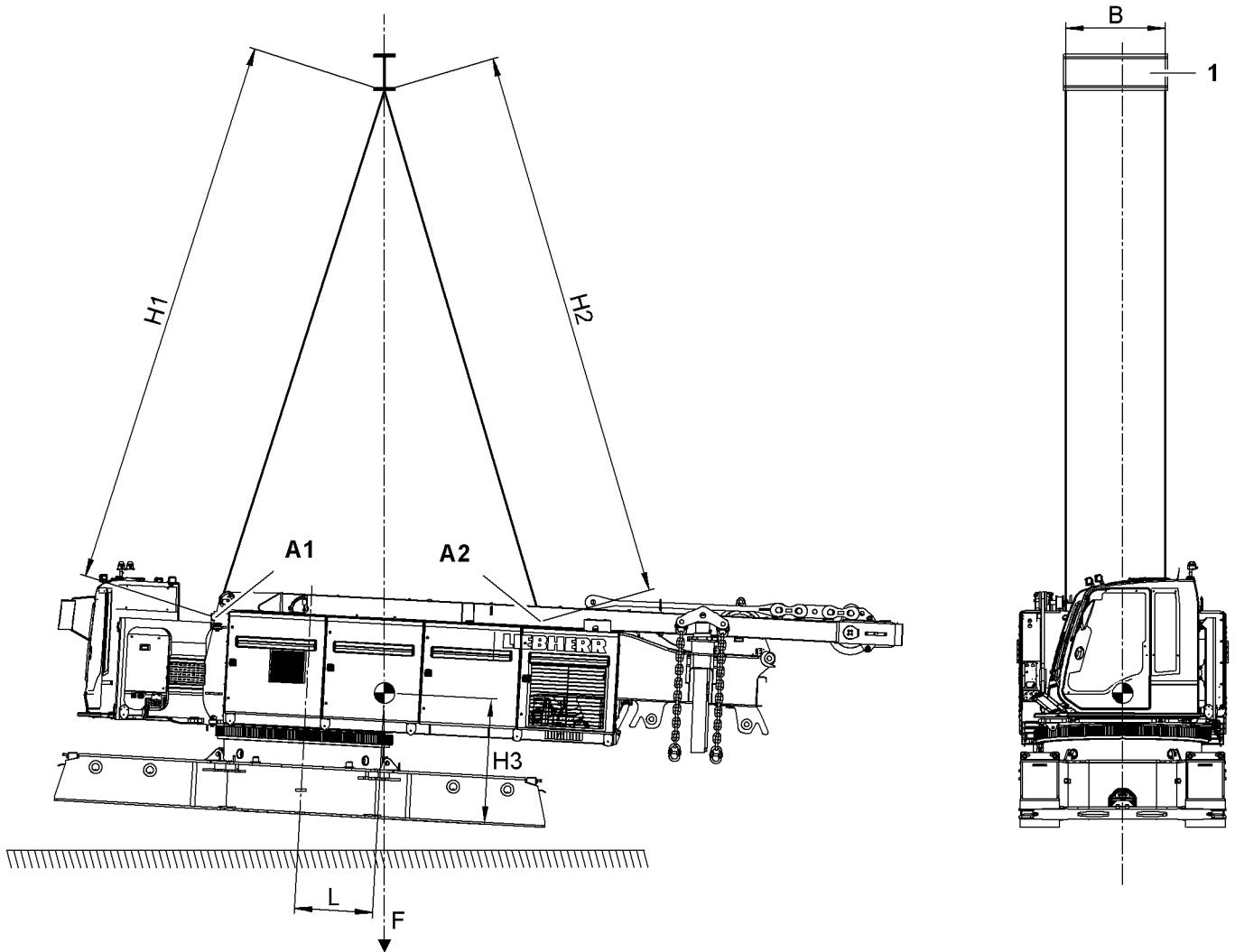


Fig. 5826: Loading basic machine without crawler side frame, carbody counterweight and rear counterweight - overview

1 Crossbar

The mass and center of gravity may deviate from the values shown below depending on the as-delivered configuration, levels in the tanks, and generally accepted tolerances.

Name		Value
H1	Length front round slings	min. 8000 mm (26' 3" ft-in)
	Load-bearing capacity front round slings	min. 30000 kg (66,138 lb)
H2	Length rear round slings	min. 8000 mm (26' 3" ft-in)
	Load-bearing capacity rear round slings	min. 30000 kg (66,138 lb)
A1	Load-bearing capacity front shackles	min. 35000 kg (77,161 lb)
A2	Load-bearing capacity rear shackles	min. 35000 kg (77,161 lb)
B	Distance rigging points on crossbar	1360 mm (4' 6" ft-in) to 1520 mm (5' ft-in)
H3	Distance center of gravity to bottom edge of center part	1814 mm 5' 11" ft-in

LWNLR.x/V04.01//Auslieferung/2016-03-07/en

Name		Value
L	Distance from center of gravity to rotation axis	1129 mm 3' 8" ft-in
F	Transport weight	46000 kg 101,411 lb

Tab. 614: Technical data loading basic machine without crawler side frame, carbody counterweight and rear counterweight

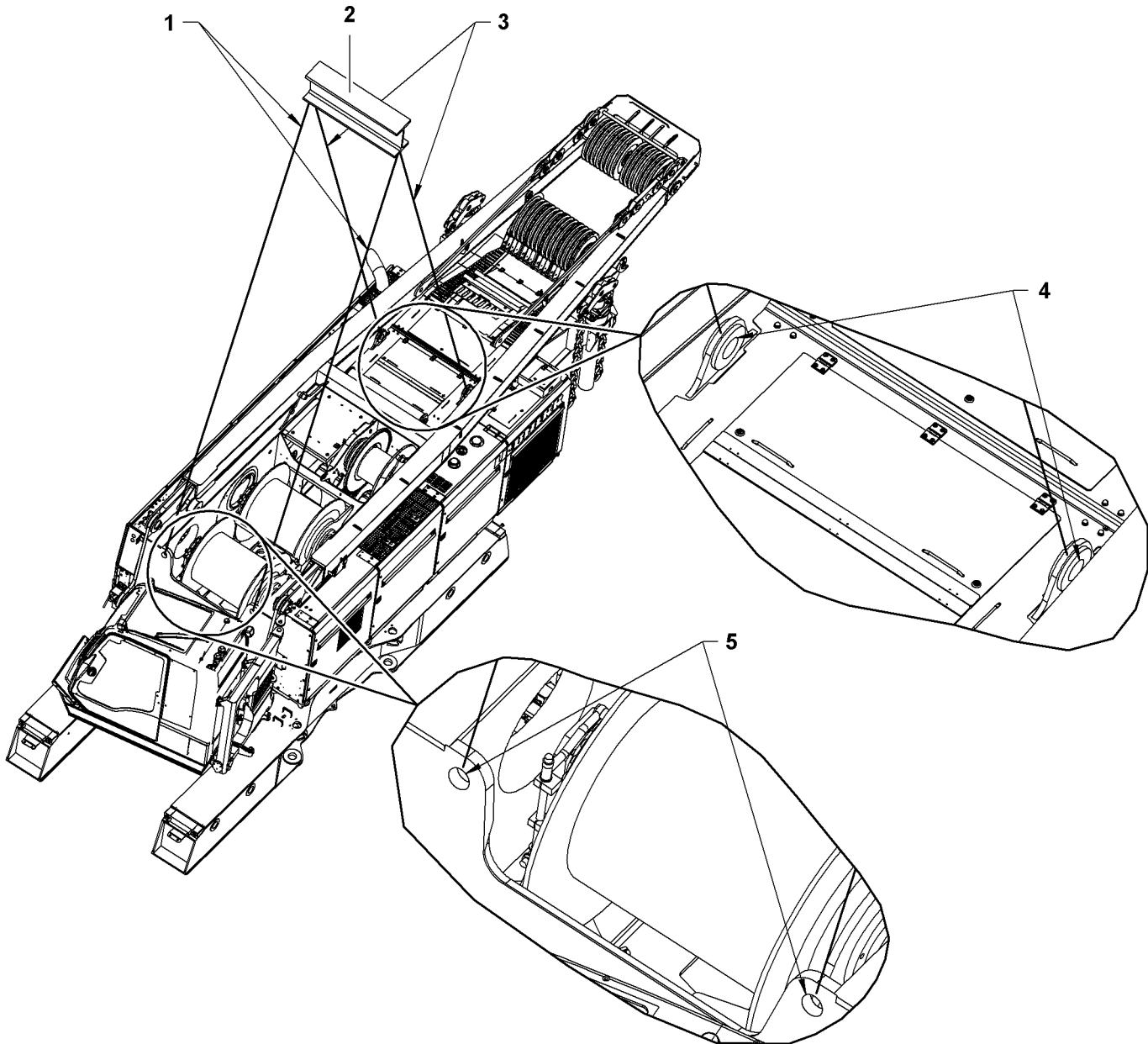


Fig. 5827: Loading basic machine without crawler side frame, carbody counterweight and rear counterweight - rigging points

- | | | | | | |
|---|--------------------|---|---------------------|---|----------------------|
| 1 | Front round slings | 3 | Rear round slings | 5 | Front rigging points |
| 2 | Crossbar | 4 | Rear rigging points | | |

▶ Lash front round slings 1 to the rigging points 5 using shackles.

LWNLR-x/V04.01//Auslieferung/2016-03-07/en

- ▶ Lash rear round slings **3** to the rigging points **4** using shackles.
- ▶ Carefully lift and load basic machine.

Loading basic machine with crawler side frame



DANGER

Improper loading of machine!
Toppling of machine, damage to machine.

- ▶ Only use sling gear and crossbars that meet the minimum requirements (see: [tab. 615, page 1832](#)).

Make sure the following prerequisites are met:

- Carbody counterweight and rear counterweight are detached from basic machine.
- Main boom base section is detached from basic machine.
- Cabin is lowered, swung into transport position and secured.
- Counterweight hoisting cylinders are retracted.
- Tilting-back supports are retracted.
- A-frame1 is folded back in transport position and A-frame1 cylinders are retracted.
- Jacks on the undercarriage are pinned in transport position and retracted.
- Additional floodlights* (if available) are uninstalled.
- All loose parts are secured to prevent slippage and falling.
- A crossbar with a suitable load-bearing capacity is available.
- Sling gear is in good condition and approved for use.

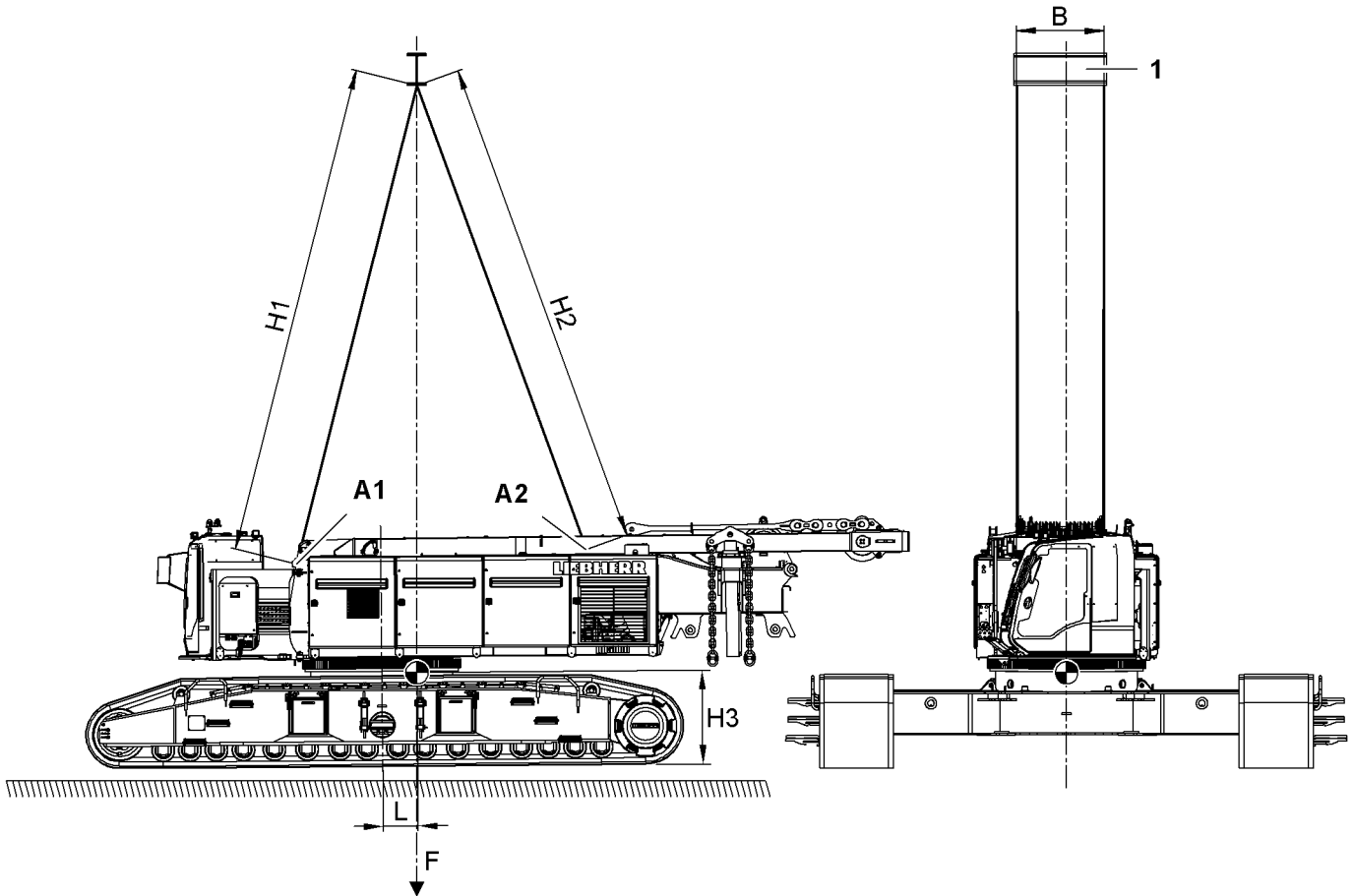


Fig. 5828: Loading basic machine with crawler side frame - overview

1 Crossbar

The mass and center of gravity may deviate from the values shown below depending on the as-delivered configuration, levels in the tanks, and generally accepted tolerances.

Name		Value
H1	Length front round slings	min. 8000 mm (26' 3" ft-in)
	Load-bearing capacity front round slings	min. 40000 kg (88,184 lb)
H2	Length rear round slings	min. 8000 mm (26' 3" ft-in)
	Load-bearing capacity rear round slings	min. 30000 kg (66,138 lb)
A1	Load-bearing capacity front shackles	min. 55000 kg (121,252 lb)
A2	Load-bearing capacity rear shackles	min. 35000 kg (77,161 lb)
B	Distance rigging points on crossbar	1340 mm (4' 5" ft-in) to 1500 mm (4' 11" ft-in)
H3	Distance from center of gravity to bottom edge of crawler side frame	1519 mm 5' ft-in
L	Distance from center of gravity to rotation axis	568 mm 1' 10" ft-in
F	Transport weight	91000 kg 200,618 lb

Tab. 615: Technical data loading basic machine with crawler side frame

LWNLR-x\04.01\Auslieferung\2016-03-07\en

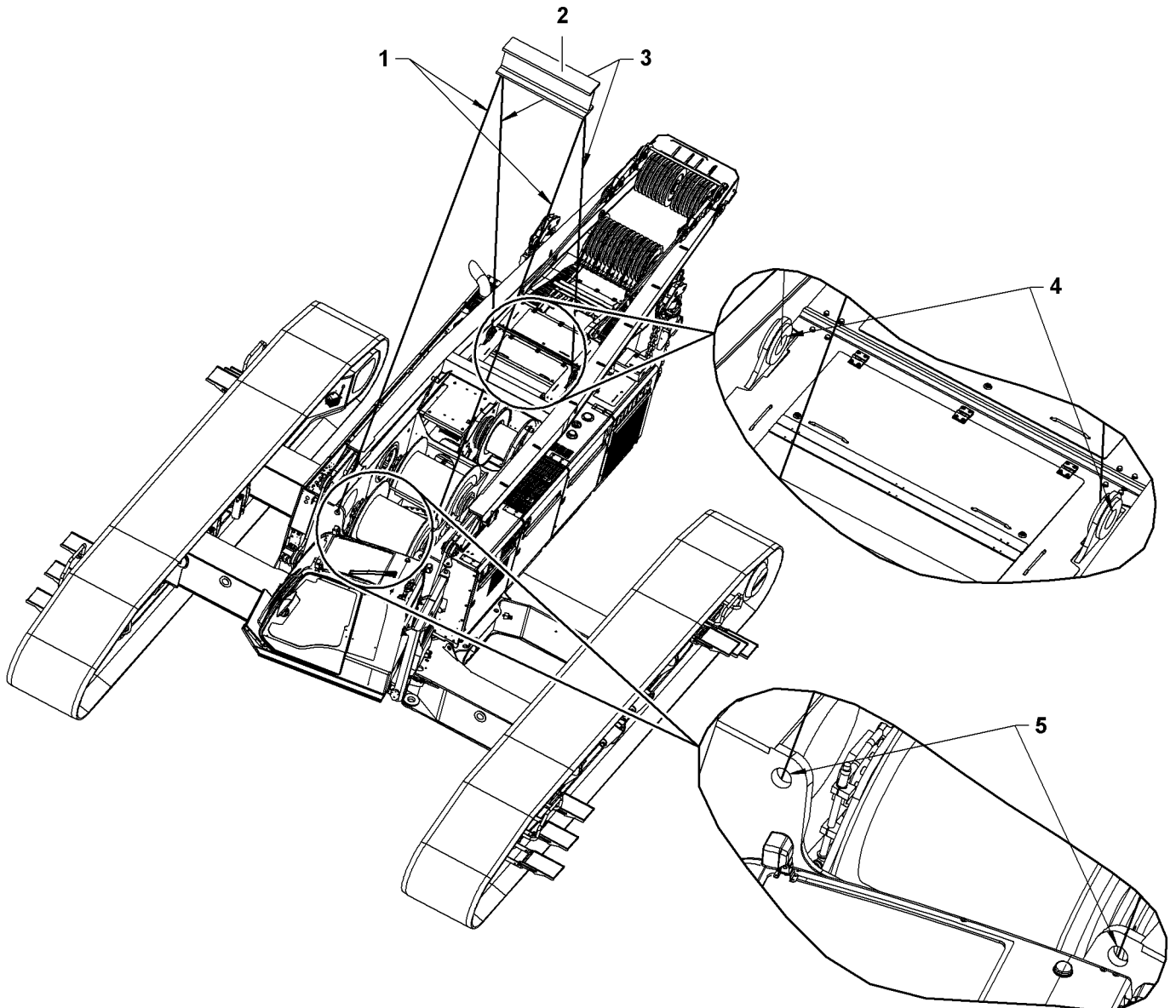


Fig. 5829: Loading basic machine with crawler side frame - rigging points

- | | | | | | |
|---|--------------------|---|---------------------|---|----------------------|
| 1 | Front round slings | 3 | Rear round slings | 5 | Front rigging points |
| 2 | Crossbar | 4 | Rear rigging points | | |

- ▶ Lash front round slings 1 to the rigging points 5 using shackles.
- ▶ Lash rear round slings 3 to the rigging points 4 using shackles.
- ▶ Carefully lift and load basic machine.

Loading basic machine with crawler side frame and carbody counterweight



DANGER

Improper loading of machine!
Topping of machine, damage to machine.

- ▶ Only use sling gear and crossbars that meet the minimum requirements (see: [tab. 616, page 1834](#)).

Make sure the following prerequisites are met:

- The rear counterweight is removed from the basic machine.
- Main boom base section is detached from basic machine.
- Cabin is lowered, swung into transport position and secured.
- Counterweight hoisting cylinders are retracted.
- Tilting-back supports are retracted.
- A-frame1 is folded back in transport position and A-frame1 cylinders are retracted.
- Jacks on the undercarriage are pinned in transport position and retracted.
- Additional floodlights* (if available) are uninstalled.
- All loose parts are secured to prevent slippage and falling.
- A crossbar with a suitable load-bearing capacity is available.
- Sling gear is in good condition and approved for use.

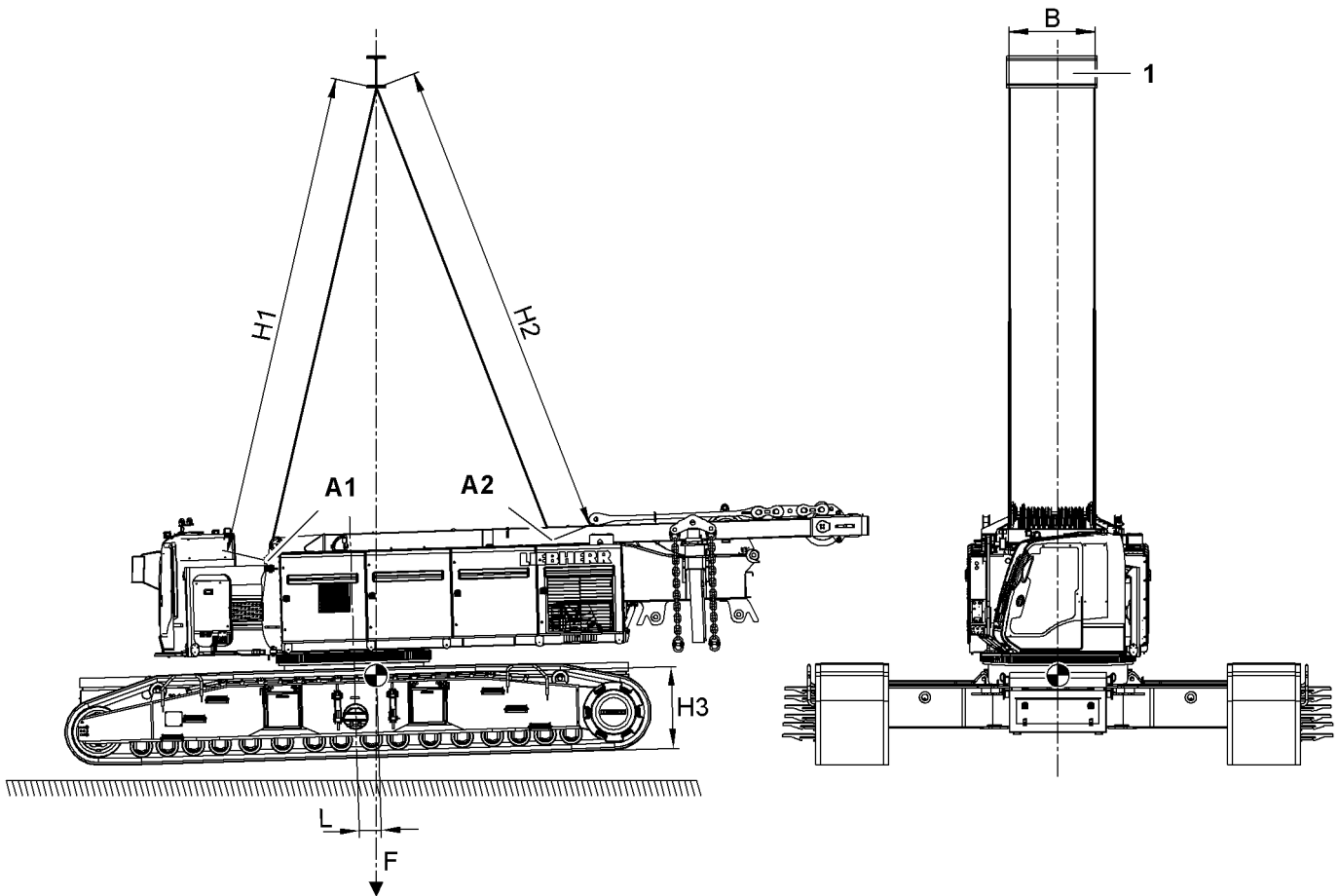


Fig. 5830: Loading basic machine with crawler side frame and carbody counterweight - overview

1 Crossbar

The mass and center of gravity may deviate from the values shown below depending on the as-delivered configuration, levels in the tanks, and generally accepted tolerances.

Name		Value
H1	Length front round slings	min. 8000 mm (26' 3" ft-in)
	Load-bearing capacity front round slings	min. 80000 kg (176,367 lb)
H2	Length rear round slings	min. 8000 mm (26' 3" ft-in)
	Load-bearing capacity rear round slings	min. 50000 kg (110,230 lb)

Name		Value
A1	Load-bearing capacity front shackles	min. 85000 kg (187,390 lb)
A2	Load-bearing capacity rear shackles	min. 55000 kg (121,252 lb)
B	Distance rigging points on crossbar	1340 mm (4' 5" ft-in) to 1500 mm (4' 11" ft-in)
H3	Distance from center of gravity to bottom edge of crawler side frame	1349 mm 4' 5" ft-in
L	Distance from center of gravity to rotation axis	359 mm 1' 2" ft-in
F	Transport weight	143500 kg 316,359 lb

Tab. 616: Technical data for loading basic machine with crawler side frame and carbody counterweight

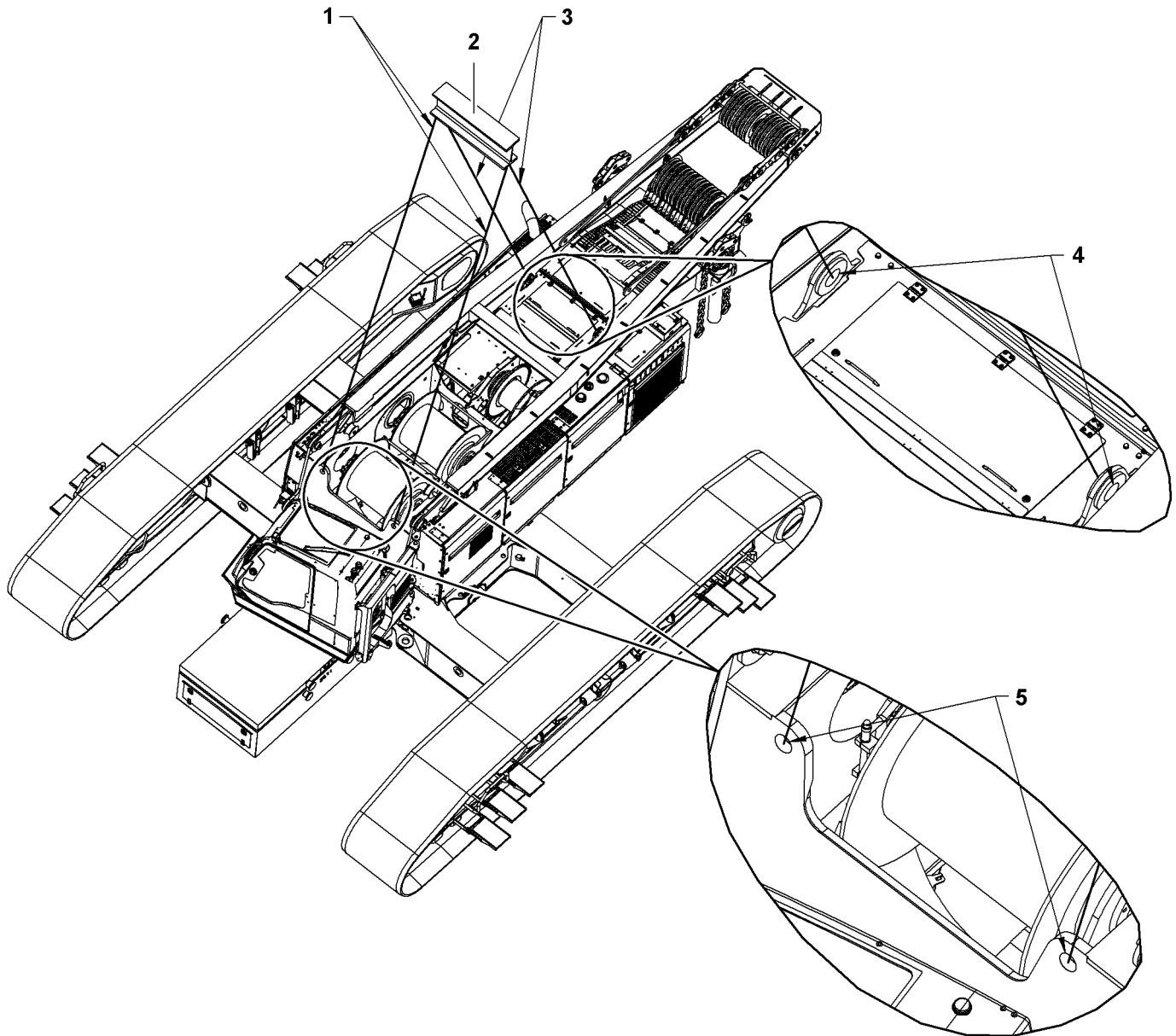


Fig. 5831: Loading basic machine with crawler side frame and carbody counterweight - rigging points

- | | | | | | |
|---|--------------------|---|---------------------|---|----------------------|
| 1 | Front round slings | 3 | Rear round slings | 5 | Front rigging points |
| 2 | Crossbar | 4 | Rear rigging points | | |

- ▶ Lash front round slings 1 to the rigging points 5 using shackles.
- ▶ Lash rear round slings 3 to the rigging points 4 using shackles.
- ▶ Carefully lift and load basic machine.

Loading basic machine with crawler side frame, carbody counterweight and rear counterweight



DANGER

Improper loading of machine!
Toppling of machine, damage to machine.

- ▶ Only use sling gear and crossbars that meet the minimum requirements (see: [tab. 617, page 1837](#)).

Make sure the following prerequisites are met:

- Main boom base section is detached from basic machine.
- Cabin is lowered, swung into transport position and secured.
- Counterweight hoisting cylinders are retracted.
- Tilting-back supports are retracted.
- A-frame1 is folded back in transport position and A-frame1 cylinders are retracted.
- Jacks on the undercarriage are pinned in transport position and retracted.
- Additional floodlights* (if available) are uninstalled.
- All loose parts are secured to prevent slippage and falling.
- A crossbar with a suitable load-bearing capacity is available.
- Sling gear is in good condition and approved for use.

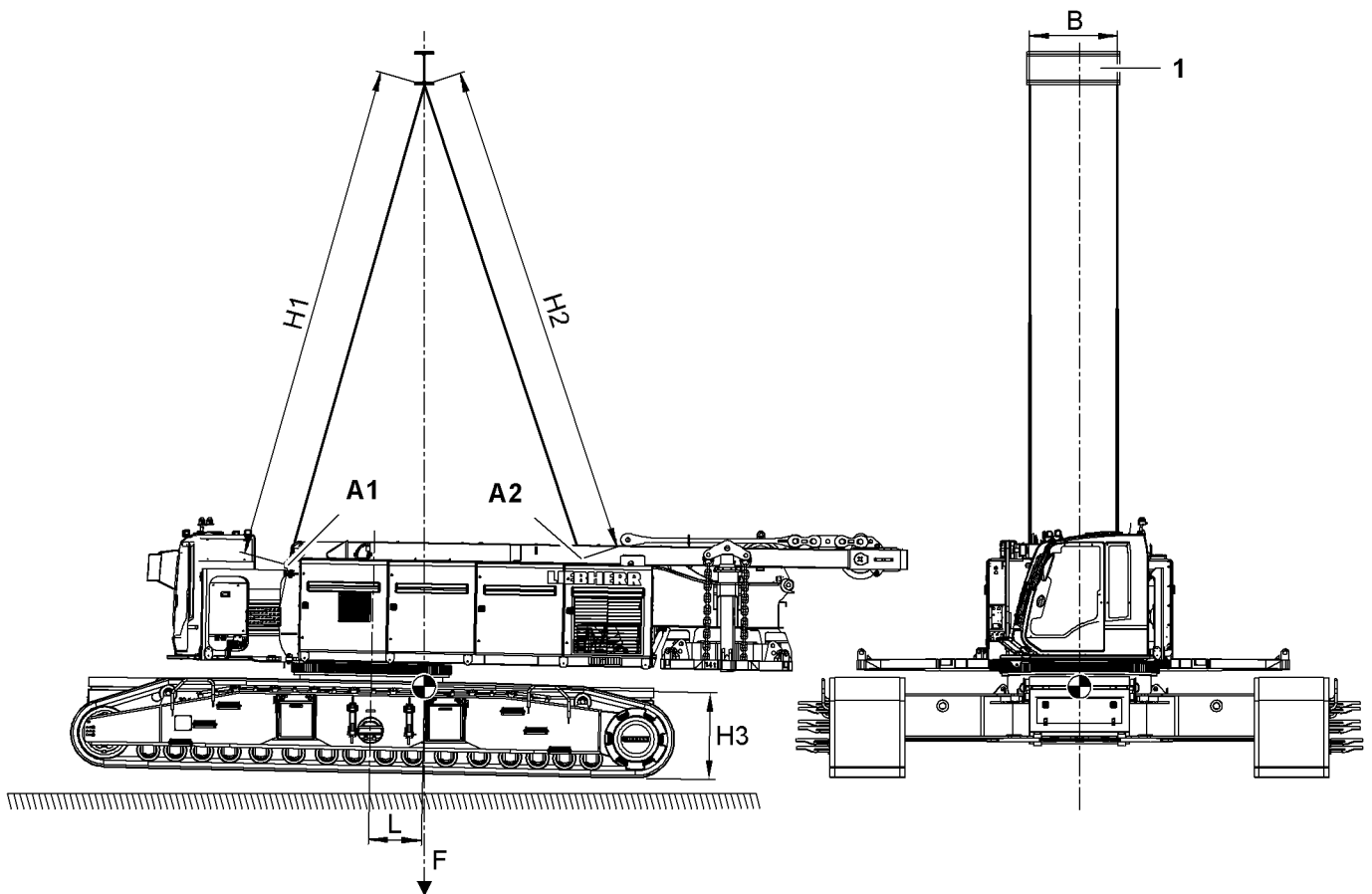


Fig. 5832: Loading basic machine with crawler side frame, carbody counterweight and rear counterweight - overview

1 Crossbar

The mass and center of gravity may deviate from the values shown below depending on the as-delivered configuration, levels in the tanks, and generally accepted tolerances.

Name		Value
H1	Length front round slings	min. 8000 mm (26' 3" ft-in)
	Load-bearing capacity front round slings	min. 80000 kg (176,367 lb)
H2	Length rear round slings	min. 8000 mm (26' 3" ft-in)
	Load-bearing capacity rear round slings	min. 60000 kg (132,275 lb)

LWNLR.x/V04.01//Auslieferung/2016-03-07/en

Name		Value
A1	Load-bearing capacity front shackles	min. 85000 kg (187,390 lb)
A2	Load-bearing capacity rear shackles	min. 55000 kg (121,252 lb)
B	Distance rigging points on crossbar	1340 mm (4' 5" ft-in) to 1500 mm (4' 11" ft-in)
H3	Distance from center of gravity to bottom edge of crawler side frame	1395 mm 4' 7" ft-in
L	Distance from center of gravity to rotation axis	850 mm 2' 9" ft-in
F	Transport weight	158000 kg 348,325 lb

Tab. 617: Technical data for loading basic machine with crawler side frame, carbody counterweight and rear counterweight

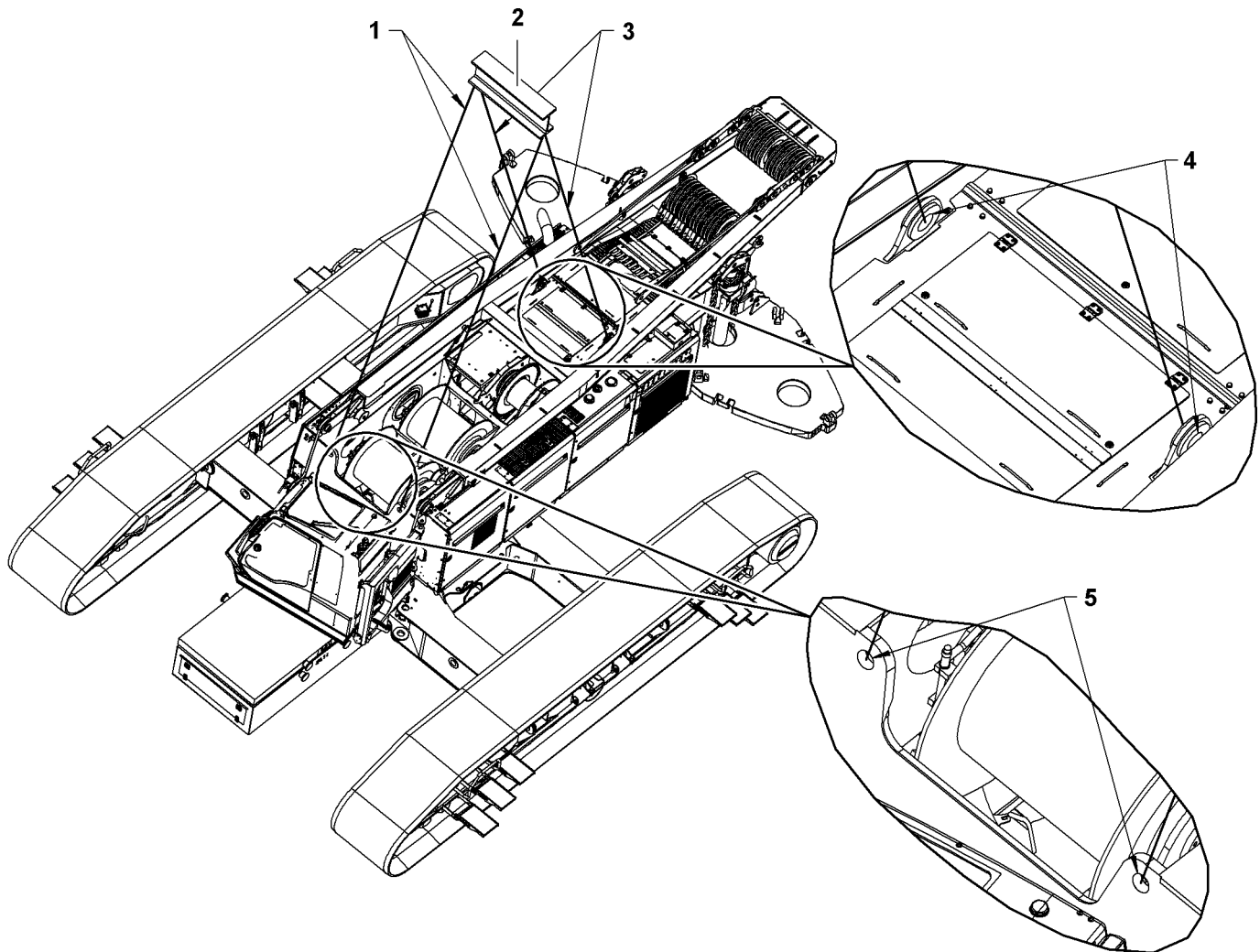


Fig. 5833: Loading basic machine with crawler side frame, carbody counterweight and rear counterweight - rigging points

- | | | |
|-----------------------------|------------------------------|-------------------------------|
| 1 Front round slings | 3 Rear round slings | 5 Front rigging points |
| 2 Crossbar | 4 Rear rigging points | |

► Lash front round slings **1** to the rigging points **5** using shackles.

LWNLR-x\04.01\Auslieferung\2016-03-07\en

- ▶ Lash rear round slings **3** to the rigging points **4** using shackles.
- ▶ Carefully lift and load basic machine.

8.2 Transporting the basic machine with a transport vehicle



Note

► Always observe national traffic regulations and local bylaws.

Ensure that the following conditions are fulfilled:

- Crawler side frame, carbody counterweight and rear counterweight are detached from the basic machine.
- Main boom base section is detached from basic machine.
- Cabin is lowered, swung into transport position and secured.
- Counterweight hoisting cylinders are retracted.
- Tilting-back supports are retracted.
- A-frame1 is folded back in transport position and A-frame1 cylinders are retracted.
- Jacks on the undercarriage are pinned in transport position and retracted.
- Additional floodlights* (if available) are deinstalled.

8.2.1 Transporting basic machine with undercarriage with fixed track width with a transport vehicle

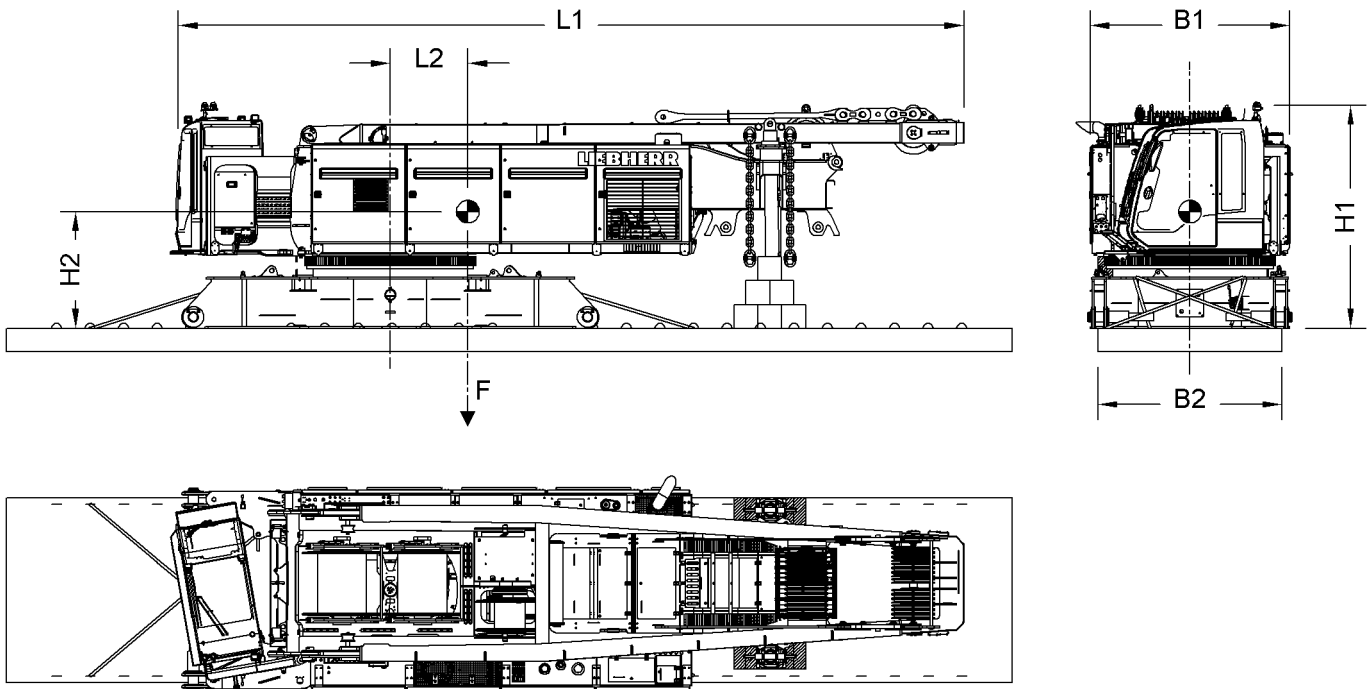


Fig. 5834: Dimensions transporting basic machine with undercarriage with fixed track width with a transport vehicle



DANGER

Machine not transported correctly!
Machine toppling over.

► Only use transport vehicle with minimum width **B2** (see: tab. 618, page 1841) .

The mass and center of gravity may deviate from the values shown below depending on the as-delivered configuration, the liquid level in the tanks, and generally accepted tolerances.

Name		Value
L1	Length basic machine	11850 mm 38' 11" ft-in
L2	Distance from center of gravity to rotation axis	1153 mm 3' 9" ft-in
B1	Width basic machine	2990 mm 9' 10" ft-in
B2	Width transport vehicle	min. 1578 mm (5' 2" ft-in)
H1	Height basic machine	3400 mm 11' 2" ft-in
H2	Distance center of gravity to bottom edge of center part	1741 mm 5' 9" ft-in
F	Transport weight	48000 kg 105,820 lb

Tab. 618: Technical data transporting basic machine with undercarriage with fixed track width with a transport vehicle



DANGER

None or wrong anti-slide mats on transport vehicle!
Basic machine slides out of position on transport vehicle.

► Never use anti-slide mats with a friction coefficient below 0.6.

► Lay out anti-slide mats on the transport vehicle.

► Loading basic machine onto transport vehicle ([For more information see: 8.1.1 Loading basic machine with undercarriage with fixed track width, page 1815](#)).

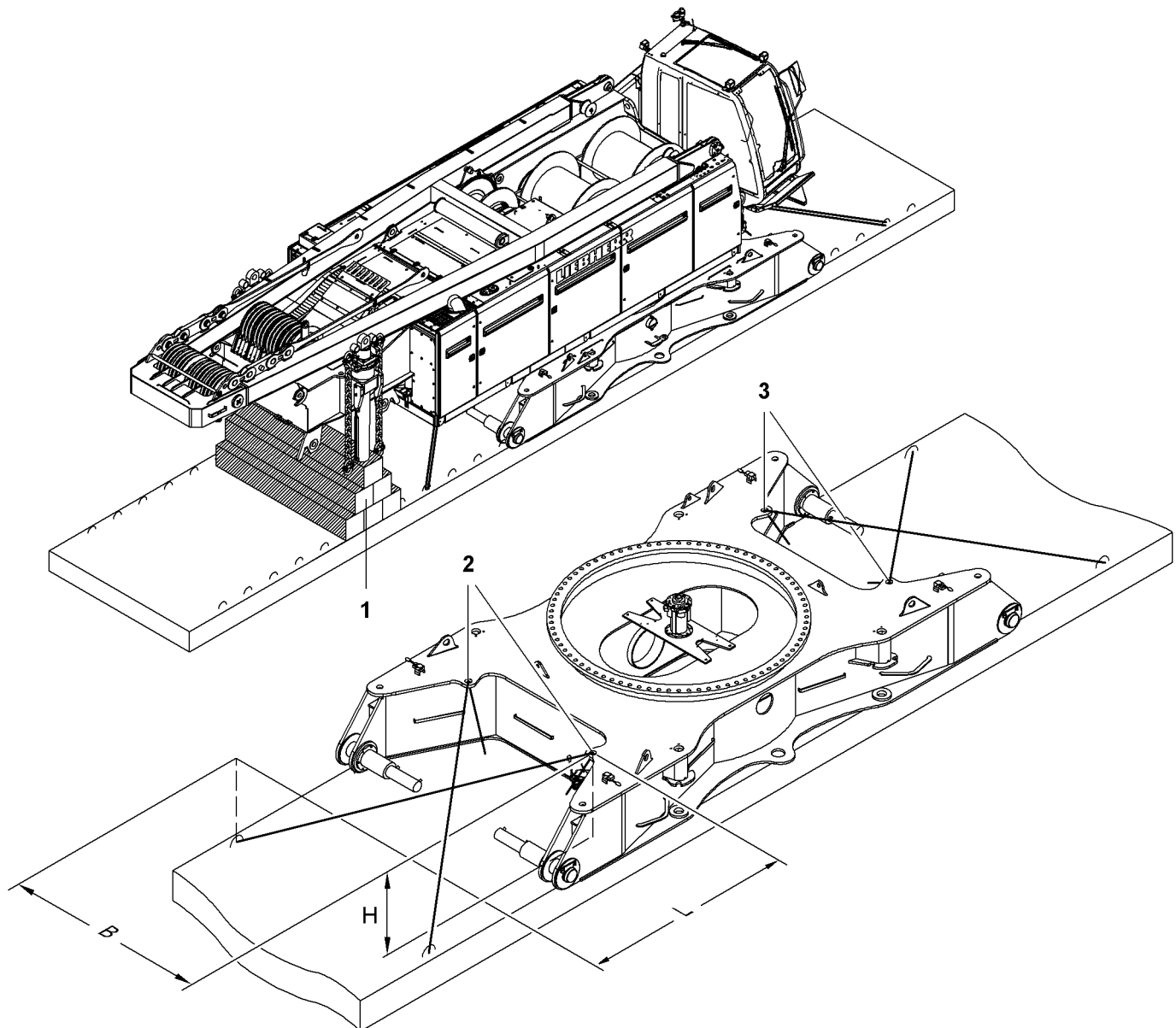


Fig. 5835: Lashing points transporting basic machine with undercarriage with fixed track width with a transport vehicle

- | | | | | | |
|---|---------------------|---|--|---|---|
| 1 | Wooden blocks | 3 | Front lashing points | B | Lateral distance between lashing points |
| 2 | Rear lashing points | L | Longitudinal distance between lashing points | H | Lashing point height |

- ▶ Underlay both counterweight hoisting cylinders with wooden blocks 1.
- ▶ Lock the operator's cab and all side doors on the uppercarriage.

**DANGER**

Incorrect lashing of machine on the transport vehicle!
Machine toppling over.

- ▶ Ensure that the lashing capacity (LC) of the chain is at least 200 kN (44,960 lb_f) (2 x 100 kN (22,480 lb_f)).
 - ▶ Make sure that chain length is at least the same as the height of the lashing point **H**.
 - ▶ Longitudinal distance between lashing points **L** must be at least 0.268 x lateral distances between lashing points **B**.
-
- ▶ Use the front **3** and rear lashing points **2** to lash the basic machine in a cross pattern on the transport vehicle.

**DANGER**

Turning of uppercarriage during transportation!
Machine toppling over.

- ▶ Secure uppercarriage to prevent it from distortion.
-
- ▶ Use the uppercarriage locking device to prevent the uppercarriage from turning.
 - ▶ The lashing should be checked continuously throughout the entire transportation process; retighten as necessary.

8.2.2 Transporting basic machine with undercarriage* with adjustable track width with a transport vehicle

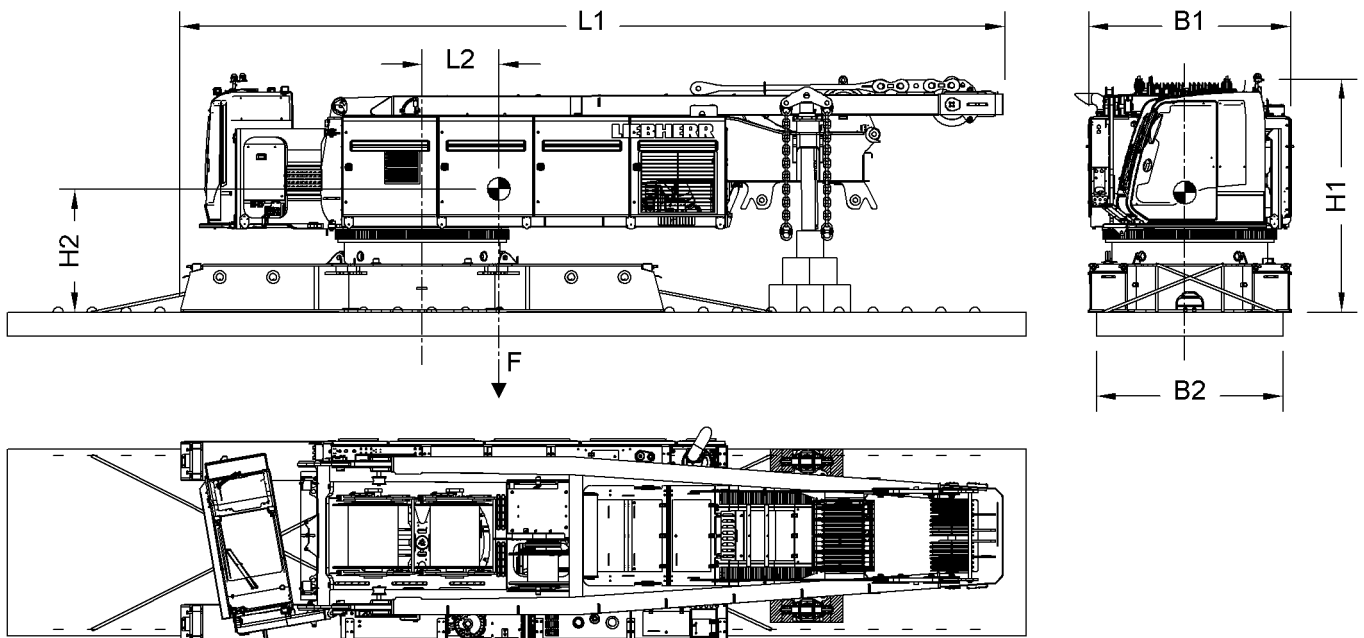


Fig. 5836: Dimensions transporting basic machine with undercarriage* with adjustable track width with a transport vehicle



DANGER

Improper transport of machine!
Toppling of machine.

- ▶ Only use transport vehicle with minimum width **B2** (see: tab. 619, page 1844) .

The mass and center of gravity may deviate from the values shown below depending on the as-delivered configuration, levels in the tanks, and generally accepted tolerances.

Name		Value
L1	Length basic machine	12300 mm 40' 4" ft-in
L2	Distance from center of gravity to rotation axis	1129 mm 3' 8" ft-in
B1	Width basic machine	3000 mm 9' 10" ft-in
B2	Width transport vehicle	min. 1714 mm (5' 7" ft-in)
H1	Height basic machine	3500 mm 11' 6" ft-in
H2	Distance center of gravity to bottom edge of center part	1814 mm 5' 11" ft-in
F	Transport weight	46000 kg 101,411 lb

Tab. 619: Technical data transporting basic machine with undercarriage* with adjustable track width with a transport vehicle



DANGER

None or wrong anti-slide mats on transport vehicle!
Basic machine slides out of position on transport vehicle.

- ▶ Never use anti-slide mats with a friction coefficient below 0.6.
- ▶ Lay out anti-slide mats on the transport vehicle.
- ▶ Load basic machine onto transport vehicle (For more information see: [8.1.2 Loading basic machine with undercarriage with adjustable track width, page 1828](#)) .

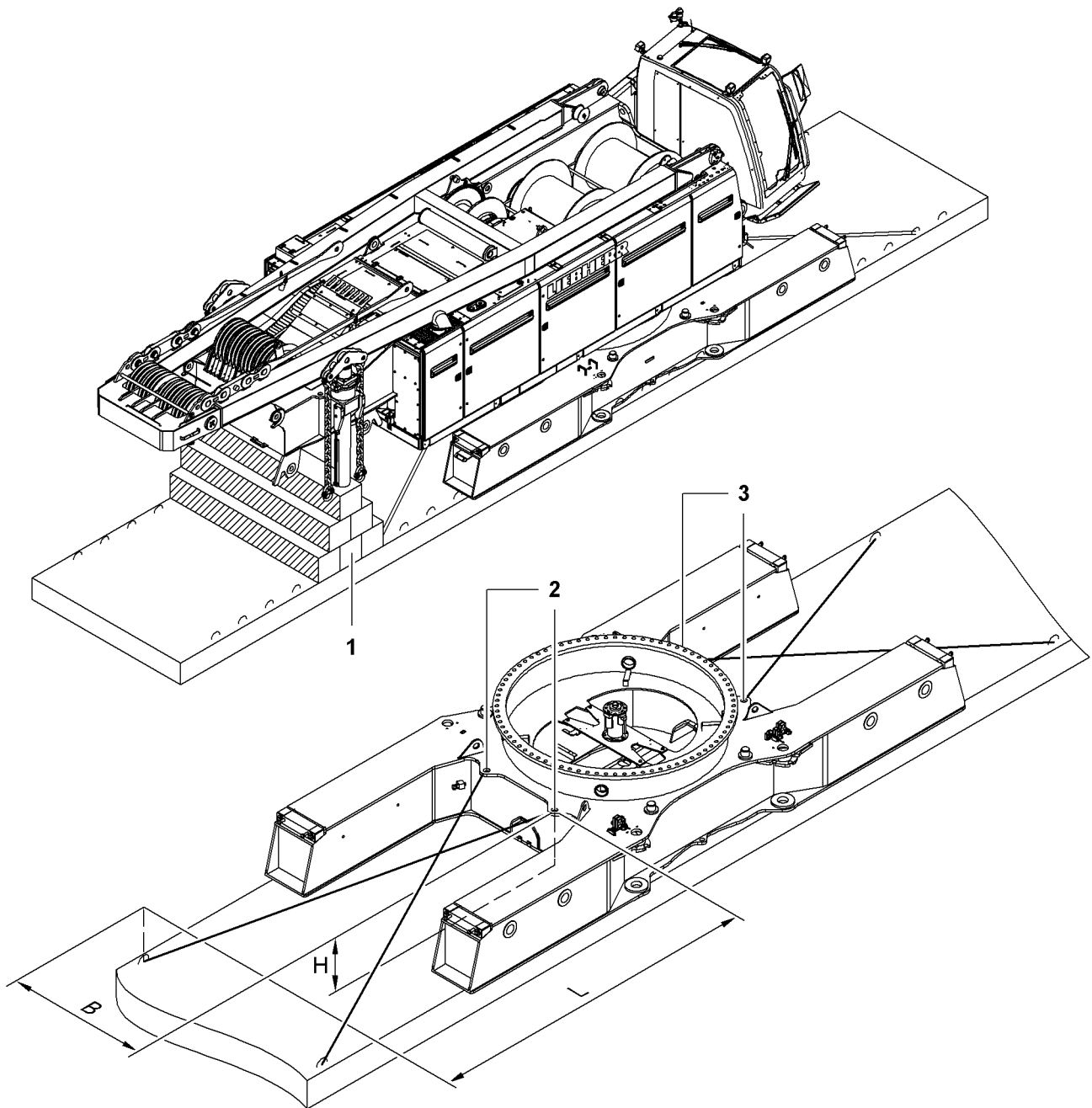


Fig. 5837: Lashing points transporting basic machine with undercarriage* with adjustable track width with a transport vehicle

- | | | | | | |
|---|---------------------|---|--|---|---|
| 1 | Wooden blocks | 3 | Front lashing points | B | Lateral distance between lashing points |
| 2 | Rear lashing points | L | Longitudinal distance between lashing points | H | Lashing point height |

- ▶ Underlay both counterweight hoisting cylinders with wooden blocks 1.
- ▶ Lock the cabin and all side doors on the uppercarriage.

LWNLR.x/V04.01//Auslieferung/2016-03-07/en



DANGER

Incorrect lashing of machine on the transport vehicle!
Toppling of machine.

- ▶ Ensure that the lashing capacity (LC) of the chain is at least 200 kN (44,960 lb_f) (2 x 100 kN (22,480 lb_f)).
 - ▶ Ensure that chain length is at least the same as the height of the lashing point **H**.
 - ▶ Longitudinal distance between lashing points **L** must be at least 0.287 x lateral distance between lashing points **B**.
-



DANGER

Turning of uppercarriage during transportation!
Toppling of machine.

- ▶ Secure uppercarriage to prevent twisting.
-
- ▶ Use the uppercarriage lock to prevent twisting of uppercarriage.
 - ▶ Lashing should be checked continuously throughout the entire transport process; retighten as necessary.

8.3 Transporting the boom sections

NOTICE

Floodlights left on the boom sections contrary to instructions!
Floodlights damaged.

► Remove the floodlights (if fitted).

The floodlight traverse may remain on the jib head during transport.

8.3.1 Adjusting and mounting the transport brackets for steel pendant straps

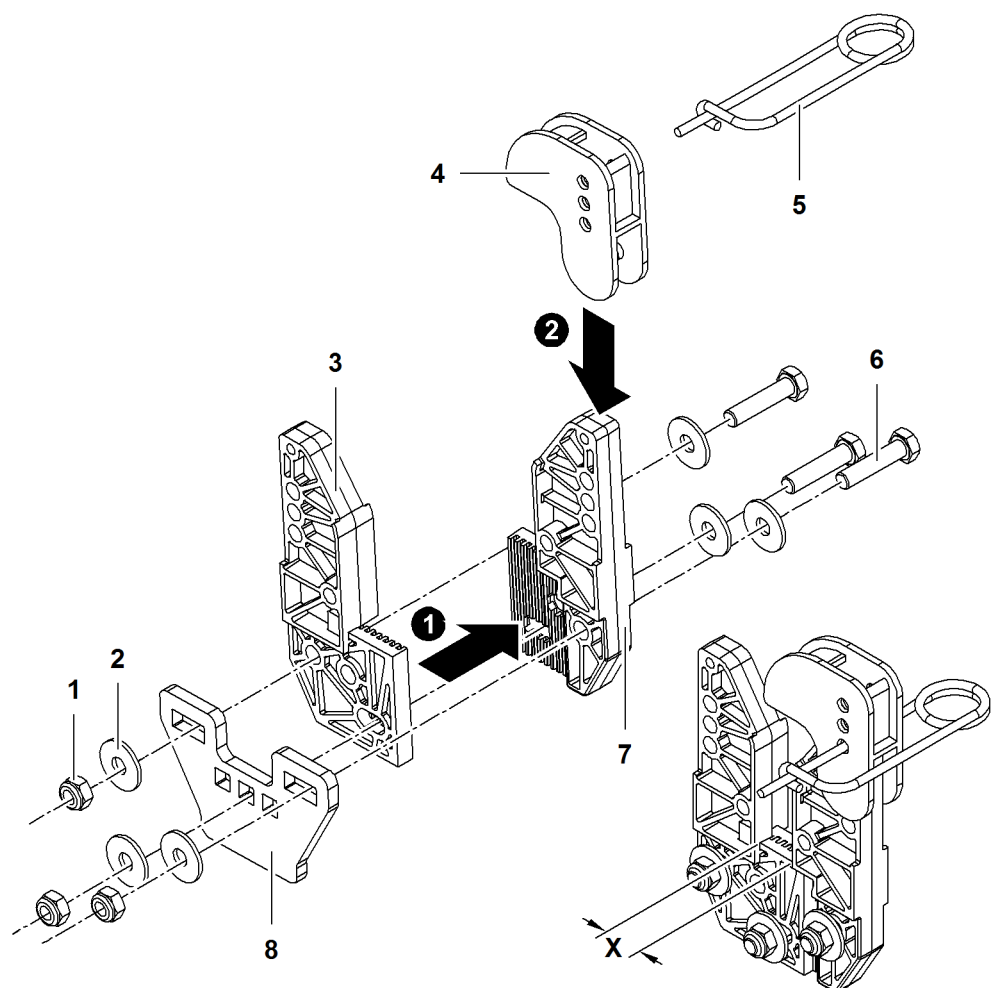


Fig. 5838: Adjusting and mounting the transport brackets for steel pendant straps

- | | | | |
|---|------------------------------|---|---|
| 1 | Nut (3x) | 6 | Screw (3x) |
| 2 | Washer (6x) | 7 | Element of transport bracket |
| 3 | Element of transport bracket | 8 | Fitting sheet |
| 4 | Securing element | X | Required width for steel pendant straps |
| 5 | Locking spring | | |
- Set required width X.

- ▶ Insert element **3** at element **7**.
- ▶ Position washers **2** on screws **6**.
- ▶ Insert screws **6** in transport bracket and fitting sheet **8**.
- ▶ Secure screws **6** with washers **2** and nuts **1**.
- ▶ Place securing element **4** onto transport bracket.
- ▶ Secure securing element **4** with locking spring **5**.

8.3.2 Installing transport brackets for CF pendant straps

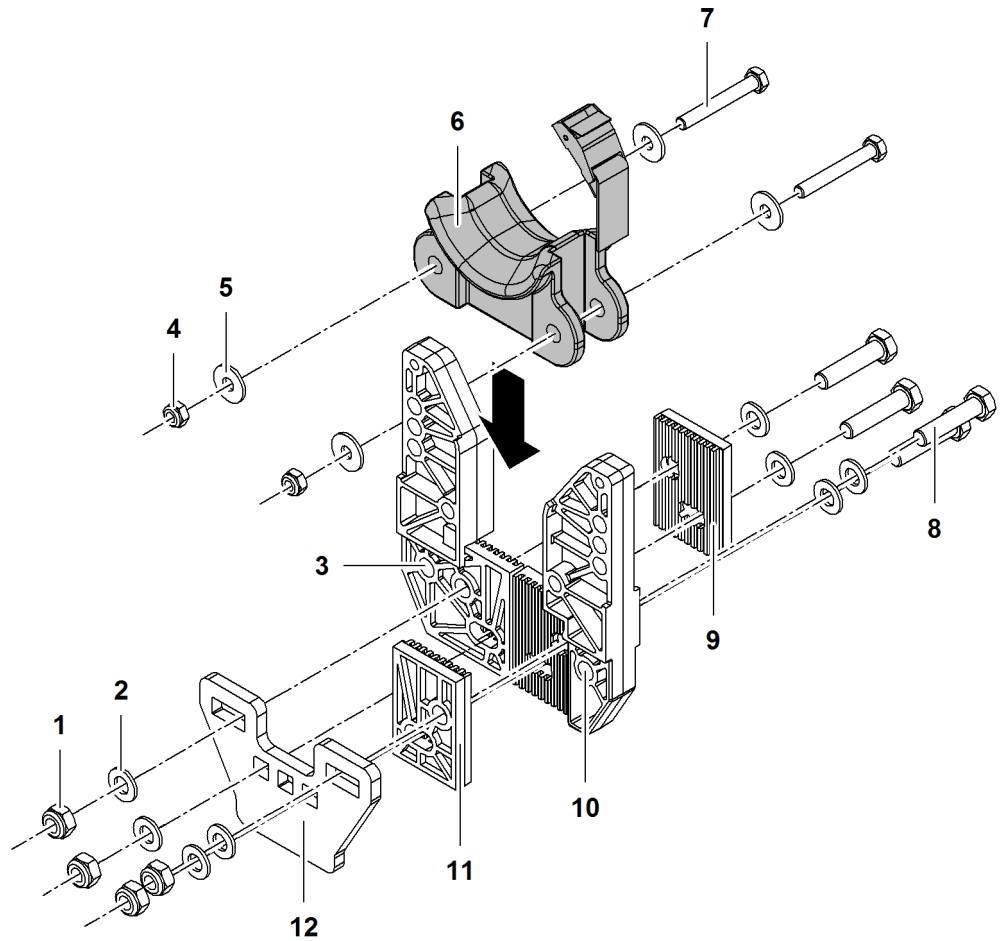


Fig. 5839: Installing transport brackets for CF pendant straps

- | | |
|--|--|
| 1 Nut (4x) | 7 Screw (2x) |
| 2 Washer (8x) | 8 Screw (4x) |
| 3 Element of transport bracket | 9 Element of transport bracket |
| 4 Nut (2x) | 10 Element of transport bracket |
| 5 Washer (4x) | 11 Element of transport bracket |
| 6 Extension element for CF pendant straps | 12 Fitting sheet |

- ▶ Insert element **11** at element **10**.
- ▶ Insert element **9** at element **3**.
- ▶ Position washers **2** on screws **8**.
- ▶ Insert screws **8** in transport bracket and fitting sheet **12**.

- ▶ Secure screws **8** with washers **2** and nuts **1**.
- ▶ Insert extension element **6** in transport bracket.
- ▶ Position washers **5** on screws **7**.
- ▶ Insert screws **7** in transport bracket and extension element **6**.
- ▶ Secure screws **7** with washers **5** and nuts **4**.

8.3.3 Adjusting and mounting transport brackets for connecting links

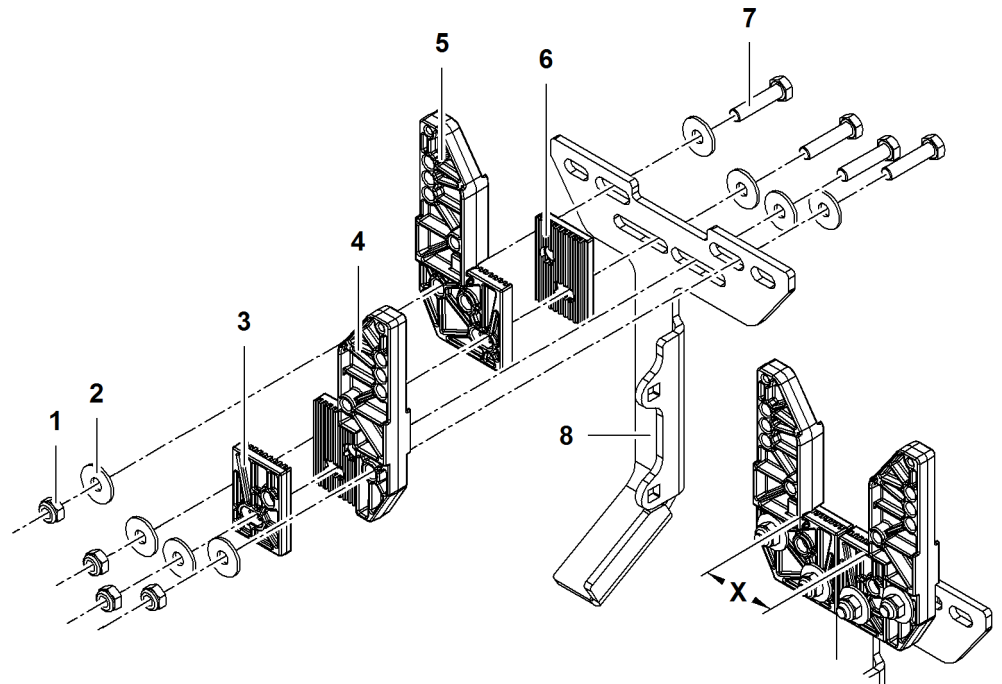


Fig. 5840: Adjusting and mounting transport brackets for connecting links

- | | |
|---------------------------------------|--|
| 1 Nut (4x) | 6 Element of transport bracket |
| 2 Washer (8x) | 7 Screw (4x) |
| 3 Element of transport bracket | 8 Fitting sheet |
| 4 Element of transport bracket | X Required width for connecting links |

5 Element of transport bracket

- ▶ Set required width **X**.
- ▶ Insert element **3** at element **4**.
- ▶ Insert element **6** at element **5**.
- ▶ Position washers **2** on screws **7**.
- ▶ Insert screws **7** in transport bracket and fitting sheet **8**.
- ▶ Secure screws **7** with washers **2** and nuts **1**.

8.3.4 Insert pendant straps in transport bracket and secure

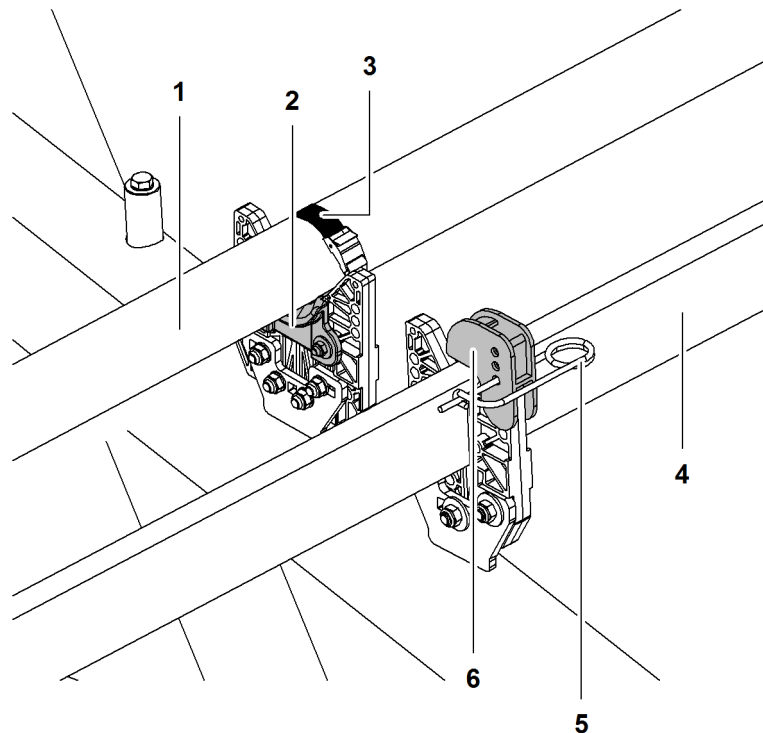


Fig. 5841: Inserting and securing pendant straps in transport bracket

- | | | | |
|---|---|---|---------------------|
| 1 | CF pendant strap | 4 | Steel pendant strap |
| 2 | Extension element for CF pendant straps | 5 | Locking spring |
| 3 | Belt | 6 | Securing element |

- ▶ Place steel pendant straps into transport brackets for steel pendant straps.
- ▶ Place securing element **6** onto transport bracket.
- ▶ Secure securing element **6** with locking spring **5**.
- ▶ Place CF pendant straps into transport brackets for CF pendant straps.
- ▶ Place belt **3** around CF pendant strap **1**.
- ▶ Tighten belt **3**.
- ▶ Repeat procedure with all main boom sections and jib sections.

8.3.5 Securing the pendant straps with transport bracket

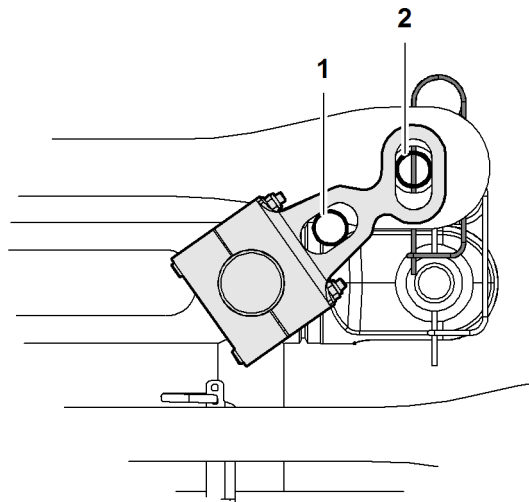


Fig. 5842: Securing the pendant straps with transport bracket

- | | | | |
|---|------------------------------------|---|--------------------------------------|
| 1 | Working position transport bracket | 2 | Transport position transport bracket |
|---|------------------------------------|---|--------------------------------------|

In crane mode, the transport bracket is located in working position 1.

- ▶ Take transport bracket out of working position 1.
- ▶ Repeat procedure with all main boom sections and jib sections.

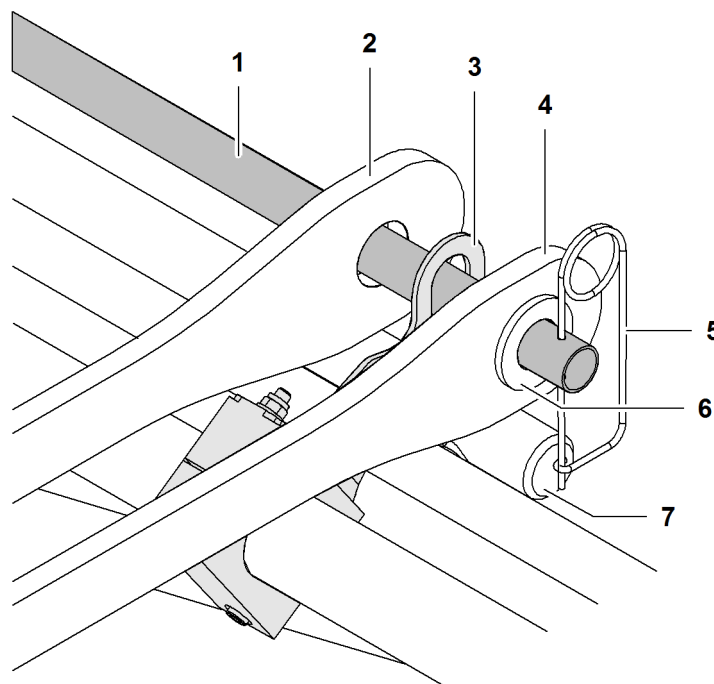


Fig. 5843: Securing the pendant straps with transport bracket

- | | | | |
|---|-------------------------|---|----------------------|
| 1 | Transport bracket | 5 | Locking spring |
| 2 | Main boom pendant strap | 6 | Washer |
| 3 | Bracket | 7 | Rope protection pipe |
| 4 | Jib backstay strap | | |

- ▶ Slide transport bracket 1 through main boom pendant strap 2, jib backstay strap 4 and bracket 3.

- ▶ Secure transport bracket **1** with washer **6** and locking spring **5**.
- ▶ Repeat procedure with all main boom sections and jib sections.
- ▶ Ensure that all loose parts are secured.

8.3.6 Preparing boom components for transport

For space-saving transport, jib sections of the same length can be pushed into main boom sections. The jib sections are pushed laterally reversed into the main boom sections.

Ensure that the following conditions are fulfilled:

- Double-taper pin is in the transport brackets.
- Locking elements are stored.
- Pins for pendant straps are secured.
- All loose parts secured.

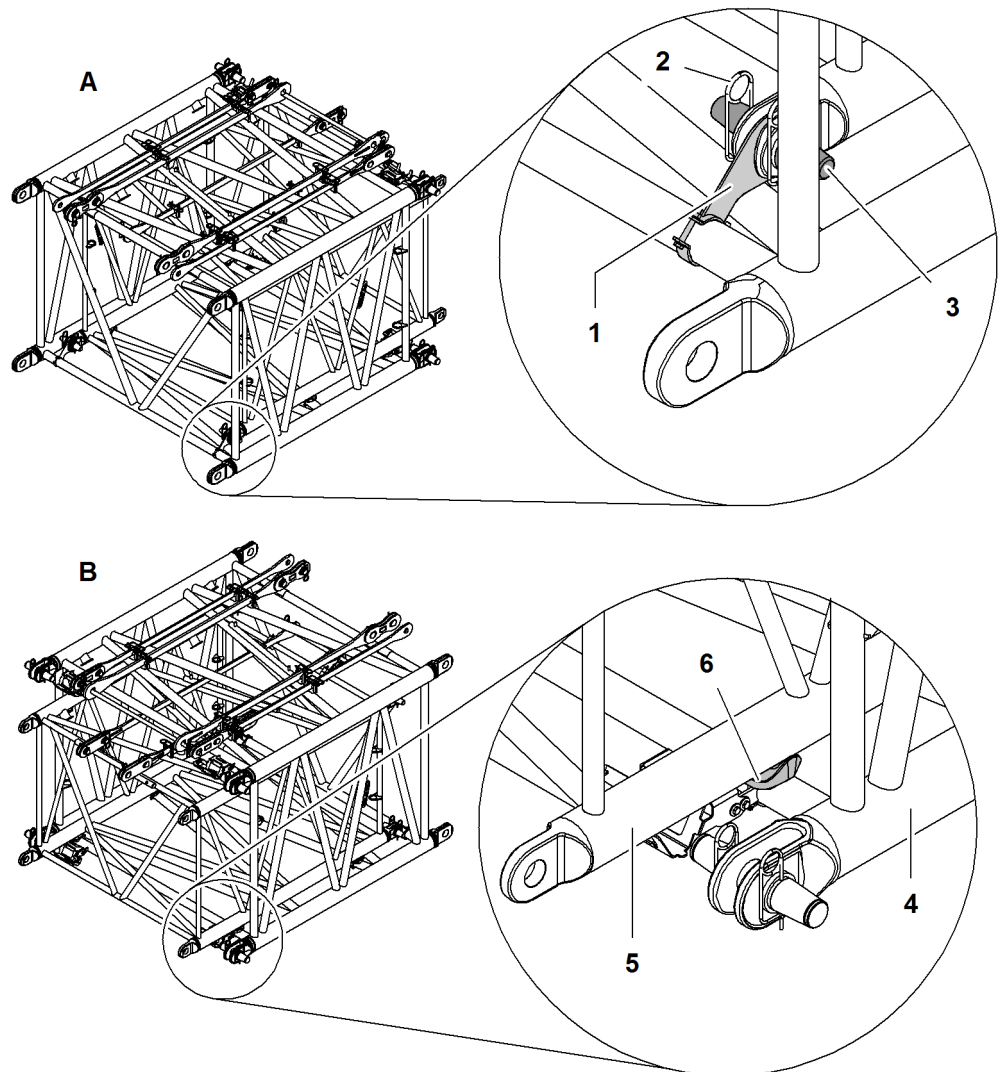


Fig. 5844: Preparing boom components for transport

- | | | | |
|----------|-----------------------|----------|---|
| 1 | Bracket (2x) | 5 | Jib section |
| 2 | Locking spring (2x) | 6 | Support (4x) for retracted jib section during transport |
| 3 | Double-taper pin (2x) | A | Rear view |
| 4 | Main boom section | B | Front view |

LWN/LR-x/V04.01//Auslieferung/2016-03-07/en

Jib system dimension	Distance between supports
2316	2440 mm 8' ft-in
1916	2063 mm 6' 9" ft-in
1713	1863 mm 6' 1" ft-in
1309	1440 mm 4' 9" ft-in
1008	1140 mm 3' 9" ft-in

Tab. 620: Distance between supports

- ▶ If necessary, adjust support **6** for jib section.
- ▶ Lift jib section **5** in main boom section **4** onto support **6**.
- ▶ Slide jib section **5** in until it is possible to pin the double-taper pin **3**.
- ▶ Bolt jib section **5** with bracket **1**.
- ▶ Secure pin with locking spring **2** and washers.
 - ▷ Boom components ready for transport:

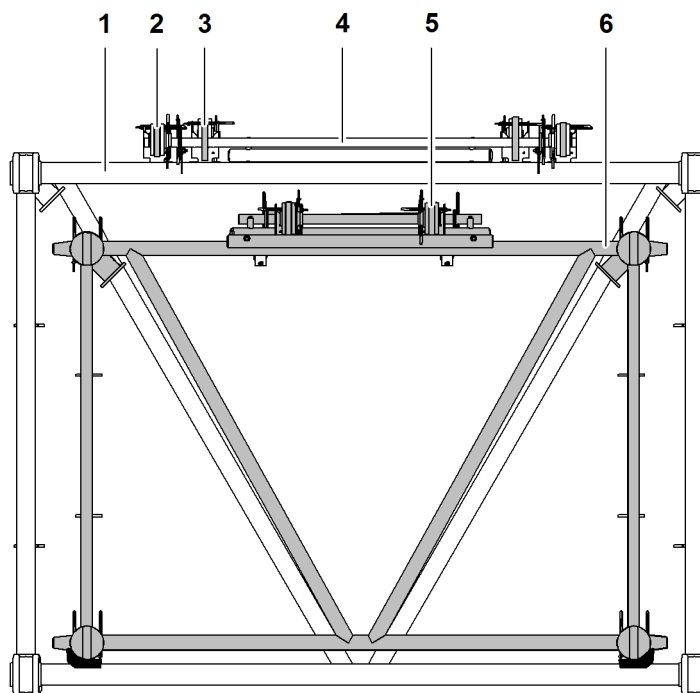


Fig. 5845: Boom components ready for transport

- | | |
|---------------------------------------|---------------------------------|
| 1 Main boom section | 4 Transport bracket |
| 2 Jib backstay strap (2x) | 5 Jib pendant strap (2x) |
| 3 Main boom pendant strap (2x) | 6 Jib section |
- ▶ Transport boom sections.

8.3.7 Transporting the pendant straps



Note

Liebherr recommends:

- ▶ Transport pendant straps on boom sections.
-

Handle pendant straps with care.

NOTICE

Pendant straps not transported correctly!
Damage to pendant straps.

If pendant straps are not transported on boom sections:

- ▶ Pack up pendant straps.
 - ▶ Store pendant straps on a soft base (e.g. wood).
-

- ▶ Transport pendant straps.

9 Maintenance

The chapter **Maintenance** deals with the following subjects:

- Maintenance and inspection of the machine
- Lubricants and consumables

9.1 Maintenance and inspection schedule

NOTICE

Improperly performed maintenance and inspection work!
Damage to machine.

- ▶ Observe the prescribed maintenance and inspection intervals according to the maintenance plan.
 - ▶ Perform all maintenance and inspection work according to specifications.
 - ▶ Observe references to manufacturer's documentation and the regulations and guidelines contained therein.
-

This chapter contains all maintenance work to be performed on the machine in table form.

The maintenance and inspection intervals are specified in operating hours and calendar times, whereby the first reached interval date is decisive.

Some maintenance work make reference to the manufacturer's documentation and must be performed in accordance with the regulations and directives of the respective manufacturer's documentation. In case of maintenance intervals and inspection intervals that diverge from the manufacturer's documentation and operation manual of the machine, however, the intervals stated in the machine's operation manual take precedence.

The maintenance work must be carried out conscientiously. The maintenance intervals must not be exceeded, but can be shortened if necessary. Shortening of intervals largely depends on the operating conditions.

The maintenance intervals must be reduced in case of the following operating conditions:

- High temperature differences on site
- Generally high temperatures
- Aggressive environment (e.g. chemical plant)
- Dirty, dusty environment (e.g. dust formation when unloading bulk goods)
- High strains during operation

Maintenance personnel

Trained personnel with the appropriate qualifications (machine operators) with specialist knowledge and experience required to carry out the respective maintenance work.

Authorized expert personnel

Specially trained personnel with extensive detailed knowledge of components or systems and were trained by Liebherr to perform this work. Mainly the Liebherr service personnel that was directly trained and authorized by the manufacturer or one of its service points.

Customer:.....Machine type:.....Serial no.:..... Operating hours:.....Date:.....

Maintenance / inspection after service hours								Tasks to be performed		
8h/Daily	40h/Weekly	500h/Quarterly	1000h/Every six months	2000h/Annually	4000h/2 years	6000h/3 years	Special intervals	By maintenance staff ■ Once-only activity ● Repeat interval † If necessary * Annually before the winter	By authorised specialist staff □ Once-only activity ○ Repeat interval † If necessary	See page
Whole machine										
				○				Checking the machine		
							◇	Visual inspection and function test of the entire machine after an exceptional situation (e.g. emergency stop, overload, collision, etc.)		
Diesel engine tier IV / Tier 4f (see operation manual of the engine manufacturer on CD)										
●								Checking the engine oil level (or according to oil level sensor in cabin)		
●								Visual inspection (no leaks, dirt or damage)		
			○					Change diesel engine oil, oil filter insert and oil separator filter insert element 1000h (with NON-Liebherr engine oil)		
							○	Change diesel engine oil, oil filter insert and oil separator filter element after 1500h (with Liebherr 5W-30 engine oil)		
		○						Check condition of belt drive, replace if necessary		
		□	○					Check intake and exhaust system for condition, attachment and leaks		
			○					Check that oil sump, engine bearing and diesel engine brackets are securely fit		
							*	Check the heating flange at the start of the cold season		
							○	Change heating flange every 10,000h		
			○					Check/adjust valve clearance		
		○						Checking the state of control device storage		
		□	○					Checking the state of sensors, actuators, cable retainers and plugs		
Diesel engine stage IV / Tier 4f (see operation manual of the engine manufacturer on CD)										
●								Checking the engine oil level (or according to oil level sensor in cabin)		
●								Performing visual inspection (no leaks, dirt or damage)		
			○					Changing diesel engine oil, oil filter insert and oil separator filter element after 1000h (with NON-Liebherr engine oil)		
							○	Changing diesel engine oil, oil filter insert and oil separator filter element after 1500h (with Liebherr 5W-30 engine oil)		
		○						Check belt drive condition and exchange if necessary		
		□	○					Check intake and exhaust system for condition, attachment and leaks		
			○					Check that oil sump, engine bearing and diesel engine brackets are securely fit		
							*	Check heating flange		
							○	Change heating flange every 10,000h		
			○					Check/adjust valve clearance		
		○						Checking the state of control device storage		
		□	○					Checking the state of sensors, actuators, cable retainers and plugs		
Fuel system (see operation manual of the engine manufacturer on CD)										
●								Check water separator on the fuel pre-filter and draining water if required		

LWNLR.x/V04.01//Auslieferung/2016-03-07/en

Maintenance

Maintenance and inspection schedule

Customer:.....Machine type:.....Serial no.:.....Operating hours:.....Date:.....

Maintenance / inspection after service hours								Tasks to be performed		
8h/Daily	40h/Weekly	500h/Quarterly	1000h/Every six months	2000h/Annually	4000h/2 years	6000h/3 years	Special intervals	By maintenance staff	By authorised specialist staff	See page
								By maintenance staff ■ Once-only activity ● Repeat interval † If necessary * Annually before the winter	By authorised specialist staff □ Once-only activity ○ Repeat interval † If necessary	
		○						Check lubricating oil system and fuel system for leaks and condition		
		○						Change fuel pre-filter (or in case of drop in performance)		
		○						Change fuel fine filter (or in case of drop in performance)		
							†	Ventilate the fuel system (injection lines may not be undone)		
Fuel tank (see operation manual of the engine manufacturer on CD)										
	●							Draining water and bottom sediments		
			○					Changing the venting filter		
Refuelling pump										
			○					Checking that the refuelling pump works properly and does not leak		
Air filter system										
	●							Checking the negative pressure indicator		1885
		●						Cleaning the air filter dust ejector		1886
							†	Exchanging the dry air filter main element (according to maintenance indicator/annually)		1886
							†	Exchanging the dry air filter safety element (with each 3rd exchange of the main element/annually)		1886
Exhaust aftertreatment system* (see operation manual of the engine manufacturer on CD)										
	●							Visual inspection of SCR system		
		■	○					Checking the profile clamp for correct tightening torque		
Cooling system (see operation manual of the engine manufacturer on CD)										
	●							Checking the coolant level		
			○					Checking cooling system and heating system for leaks and condition		
				○			*	Check anti-corrosive concentration and antifreeze concentration in coolant (at least 1 x a year)		
							○	Change coolant (anti-freeze OS mix) every 6,000 hours (at least every 4 years)		
Distributor gearbox										
	●							Checking the gearbox oil level		1888
	●							Checking the venting valve		1890
		□	○					Changing the gearbox oil		
				○				Check fastening screws for tight fit		
Swing										
	●							Checking the gearbox oil level		1891
			○					Check gearbox for leaks		
		□	○					Changing the gearbox oil		

LWNLR-x/V04.01//Auslieferung/2016-03-07/en

Customer:.....Machine type:.....Serial no.:.....Operating hours:.....Date:.....

Maintenance / inspection after service hours							Tasks to be performed			
8h/Daily	40h/Weekly	500h/Quarterly	1000h/Every six months	2000h/Annually	4000h/2 years	6000h/3 years	Special intervals	By maintenance staff ■ Once-only activity ● Repeat interval † If necessary * Annually before the winter	By authorised specialist staff □ Once-only activity ○ Repeat interval † If necessary	See page
							○	Check the fastening screws for tight fit (fastening screws may only be used for a maximum of 2 more further assembly procedures)		
			○					Visually checking the pinion and crown gear		
			○					Checking that the stopping brakes are working		
Swing connection										
		□					○	Checking the fastening screws for tight fit (exchanging fastening screws and nuts at each bearing exchange)		
●								Lubricating external teeth		1893
●								Lubricating the bearing races via the central lubrication point (preferably at the end of the shift)		1893
							◇	Measuring the bearing play		
winch1/winch2										
	●							Checking the gearbox oil level		1895
			○					Checking winch gearbox for leaks and if necessary carrying out an oil analysis		
		□		○				Changing the gearbox oil		
	●							Lubricating the counter bearing, if possible		1896
	●							Checking the rope end fastening for tight fit		1897
			○				◇	Checking 3-windings limit switch for tight fit and function (at 1,000h or when changing ropes)		
			○					Check winch for tight fit (pin clearance, pin locking)		
			○					Check fastening screws for tight fit		
				○				Performing a visual inspection		
			○					Checking that the stopping brakes are working		
			○					Checking that the free-fall brake is working (if present)		
							○	Hydraulic motor and drive planetary stage: checking the tooth profile for wear		
Boom luffing winches										
	●							Checking the gearbox oil level		1898
			○					Checking winch gearbox for leaks and if necessary carrying out an oil analysis		
		□		○				Changing the gearbox oil		
	●							Lubricating the counter bearing, if possible		1899
	●							Checking the rope end fastening for tight fit		1900
			○					Check winch for tight fit (pin clearance, pin locking)		
			○					Check fastening screws for tight fit		
				○				Performing a visual inspection		
			○					Checking that the stopping brakes are working		
							○	Hydraulic motor and drive planetary stage: checking the tooth profile for wear		

Maintenance

Maintenance and inspection schedule

Customer:.....Machine type:.....Serial no.:.....Operating hours:.....Date:.....

Maintenance / inspection after service hours							Tasks to be performed			
8h/Daily	40h/Weekly	500h/Quarterly	1000h/Every six months	2000h/Annually	4000h/2 years	6000h/3 years	Special intervals	By maintenance staff <input checked="" type="checkbox"/> Once-only activity <input checked="" type="checkbox"/> Repeat interval † If necessary * Annually before the winter	By authorised specialist staff <input type="checkbox"/> Once-only activity <input type="checkbox"/> Repeat interval † If necessary	See page
Rope reeving winch										
			<input type="checkbox"/>					Checking winch gearbox for leaks and if necessary carrying out an oil analysis		
							†	Change gearbox oil when changing ropes		
	<input checked="" type="checkbox"/>							Lubricating the counter bearing, if possible		1901
							†	Checking rope end attachment for tight fit when starting up rope reeving winch		1901
			<input type="checkbox"/>					Check winch for tight fit (pin clearance, pin locking)		
			<input type="checkbox"/>					Check fastening screws for tight fit		
Tagline winch										
	<input checked="" type="checkbox"/>							Checking the gearbox oil level		1902
			<input type="checkbox"/>					Checking winch gearbox for leaks and if necessary carrying out an oil analysis		
		<input type="checkbox"/>	<input type="checkbox"/>					Changing the gearbox oil		
	<input checked="" type="checkbox"/>							Lubricating the rope bracket on the boom base section and checking pulleys for damage		1903
	<input checked="" type="checkbox"/>							Checking the rope end fastening for tight fit		1904
			<input type="checkbox"/>					Check winch for tight fit (pin clearance, pin locking)		
			<input type="checkbox"/>					Check fastening screws for tight fit		
			<input type="checkbox"/>					Check holding brake (if available) for function		
Crawlers										
	<input checked="" type="checkbox"/>							Checking the gearbox oil level		1905
		<input type="checkbox"/>	<input type="checkbox"/>					Changing the gearbox oil		
			<input type="checkbox"/>					Check fastening screws for tight fit		
	<input checked="" type="checkbox"/>							Check gearbox and hydraulic connections for leaks		1906
			<input type="checkbox"/>					Visually inspect crawler components (carrying rollers, running rollers, idlers, track pads)		
	<input checked="" type="checkbox"/>							Clean the crawlers, earlier if necessary		1906
			<input type="checkbox"/>					Checking screws, nuts, pins for tight fit		
	<input checked="" type="checkbox"/>							Checking that the crossbeam set screws on the crawler side frames are secure on telescopic undercarriages		1907
	<input checked="" type="checkbox"/>		<input type="checkbox"/>					Check chain guides for wear and tight fit		1907
	<input checked="" type="checkbox"/>							Checking the chain tension, earlier if necessary		1908
	<input checked="" type="checkbox"/>							Checking locking screws of the track pads axes		1916
Lifting device										
	<input checked="" type="checkbox"/>		<input type="checkbox"/>					Check transport lashing and round slings for wear (according to EN 1492-2).		1917
	<input checked="" type="checkbox"/>		<input type="checkbox"/>					Check the round steel chains for wear and damage		1917

LWNLR-x/V04.01//Auslieferung/2016-03-07/en

Customer:.....Machine type:.....Serial no.:..... Operating hours:.....Date:.....

Maintenance / inspection after service hours								Tasks to be performed		
8h/Daily	40h/Weekly	500h/Quarterly	1000h/Every six months	2000h/Annually	4000h/2 years	6000h/3 years	Special intervals	By maintenance staff ■ Once-only activity ● Repeat interval † If necessary * Annually before the winter	By authorised specialist staff □ Once-only activity ○ Repeat interval ✧ If necessary	See page
Hook/pulley block										
	●			○				Checking all hooks/pulley blocks for damage, wear, corrosion and widening of the hook aperture		1918
	●			○				Lubricate bearings and axels, check rope fixing point, check for ease of movement and wear of pulleys, check that rope protection and locking elements are in place and undamaged		1918
●								Check that the safety catch is present and working properly		1919
Hydraulic system										
●								Check the hydraulic system for leaks		1920
	●							Checking the oil cooler for contamination		1920
			○					Checking that the engines and the screw fittings are tight		
Hydraulic oil tank										
							●	Carry out a hydraulic oil analysis ten hours after every oil change (reference measurement)		1921
							●	Carry out a hydraulic oil analysis after 500 hrs		1921
							●	Carry out a hydraulic oil analysis after 1000 hrs / 1 year		1921
							●	Hydraulic oil NOT supplied by LIEBHERR must be changed after 2000 hrs / 2 years		1921
							●	Change Liebherr "Hydraulik 37" oil after 4000 hrs / 4 years		1921
							●	Change Liebherr "Hydraulik Plus" and "Hydraulik Plus Arctic" oil after 6000 hrs / 6 years		1921
			○					Changing the venting filter		
	●		○					Cleaning the magnetic rod in the return filter		1922
Hydraulic oil heater										
			○					Checking that the hydraulic oil heater is working properly		
Hydraulic oil filter										
		□	○					Exchanging the hydraulic oil filter elements		1926
Accumulator										
			○					Check the accumulator		
					○			Changing the accumulator		
Hydraulic cylinders										
			○					Check that the hydraulic cylinder fits properly and does not leak		1928
	●							Protecting the piston rods of the hydraulic cylinders from corrosion		1928
							†	Preserving the piston rods of the hydraulic cylinders in case of longer periods of non-use		1928

Maintenance

Maintenance and inspection schedule

Customer:.....Machine type:.....Serial no.:.....Operating hours:.....Date:.....

Maintenance / inspection after service hours								Tasks to be performed			
8h/Daily	40h/Weekly	500h/Quarterly	1000h/Every six months	2000h/Annually	4000h/2 years	6000h/3 years	Special intervals	By maintenance staff <input checked="" type="checkbox"/> Once-only activity <input checked="" type="checkbox"/> Repeat interval † If necessary * Annually before the winter	By authorised specialist staff <input type="checkbox"/> Once-only activity <input type="checkbox"/> Repeat interval † If necessary	See page	
Hydraulic hoses											
								<input checked="" type="checkbox"/>	Checking the hydraulic hoses	1929	
								<input type="checkbox"/>	Change hydraulic hoses every 10 years; time interval dependent on imprinted date in accordance with FEM 5.020 (observe national law)		
Rotary connection											
								<input type="checkbox"/>	Checking that the rotary connection is firmly attached and does not leak		
Bypass filter system											
								<input checked="" type="checkbox"/>	Checking the bypass filter system	1930	
								<input type="checkbox"/>	Changing the filter elements	1930	
Batteries											
								<input type="checkbox"/>	Cleaning battery connections, greasing with terminal fat		
								<input type="checkbox"/>	Checking the fluid level in the cells	1933	
								<input type="checkbox"/>	Checking the battery pre-warming for correct function		
Lighting											
								<input checked="" type="checkbox"/>	Checking that the cabin lighting, floodlights and auxiliary floodlights are working properly	1935	
Rope measuring system											
								<input checked="" type="checkbox"/>	Checking the rope measuring system and height adjustment of all winches (if available) for correct function	1945	
								†	Readjusting layer change when changing ropes	1945	
GSM/GPRS/GPS modem											
								<input type="checkbox"/>	Checking GSM/GPRS/GPS modem for correct function		
Vertical Line Finder* assistance system											
								<input type="checkbox"/>	Setting the deviation of the Vertical Line Finder to zero		
PDR*											
								†	Checking correct function of PDE		
Limit switches											
								<input checked="" type="checkbox"/>	Checking hoist limit switches, boom limit switches and, if necessary, limit switches of the piling and drilling rig to ensure they are working correctly	1946	
Mechanical inclinometer											
								<input checked="" type="checkbox"/>	Checking that the mechanical inclinometer is working properly	1947	
Emergency stop											
								<input checked="" type="checkbox"/>	Checking the emergency stop	1948	

LWNLR-x/V04.01//Auslieferung/2016-03-07/en

Customer:.....Machine type:.....Serial no.:.....Operating hours:.....Date:.....

Maintenance / inspection after service hours							Tasks to be performed			
8h/Daily	40h/Weekly	500h/Quarterly	1000h/Every six months	2000h/Annually	4000h/2 years	6000h/3 years	Special intervals	By maintenance staff ■ Once-only activity ● Repeat interval † If necessary * Annually before the winter	By authorised specialist staff □ Once-only activity ○ Repeat interval † If necessary	See page
Load moment limiter (LML)										
				○				Checking that the system shuts down properly		
Obstacle warning light*										
	●							Check obstacle warning light for function and damage, check mains cable and plug (if available) for damage		1949
Emergency control system										
			○					Checking emergency control system for correct function		
Fire extinguishers										
				○				Checking the seals and inspection dates on the fire extinguishers		1950
Personal protective equipment										
	●							Checking that the personal protective gear is in place, intact and complete		1951
Safety signs										
	●							Checking that all required safety labels are mounted on the machine and are legible		1952
Access systems and railings										
	●							Checking ladders, steps, platforms, and ascents for wear, damage and anti-slip surfaces		1953
	●							Checking latches and hand rails for wear and damage		1953
	●							Checking the spring tension of railing doors		1953
	●							Checking the function of the railing stabilization		1956
Steel structure										
	●			○				Checking the machine steel structure for damage, cracks		1958
Main boom										
	●			○				Check main boom base section, main boom head and main boom sections for damage and wear (cracks, notches, corrosion, plastic deformation, wear)		1961
	●			○				Main boom base section: Check knuckle pins and locking elements for tight fit		1962
	●							Main boom base section or A-frame1: check function of the mechanical angle indicator, lubricate if necessary		1963
	●		○					Main boom head: Check screw connections and pin connections for tight fit, check rope fixing points for tears, check that rope protection and locking springs are in place and undamaged		1964
	●							Checking the anemometer for tight fit and function		1964
	●			○				Auxiliary jib: Check screw connections and pin connections for tight fit, check rope fixing points for tears, check that rope protection and locking springs are in place and undamaged		1965

LWNLR.x/V04.01//Auslieferung/2016-03-07/en

Maintenance

Maintenance and inspection schedule

Customer:.....Machine type:.....Serial no.:.....Operating hours:.....Date:.....

Maintenance / inspection after service hours								Tasks to be performed		
8h/Daily	40h/Weekly	500h/Quarterly	1000h/Every six months	2000h/Annually	4000h/2 years	6000h/3 years	Special intervals	By maintenance staff <input checked="" type="checkbox"/> Once-only activity <input checked="" type="checkbox"/> Repeat interval † If necessary * Annually before the winter	By authorised specialist staff <input type="checkbox"/> Once-only activity <input type="checkbox"/> Repeat interval † If necessary	See page
Jib										
	<input checked="" type="checkbox"/>			<input type="checkbox"/>				Check jib base section, jib head and jib sections for damage and wear (cracks, notches, corrosion, plastic deformation, wear)		1966
			<input type="checkbox"/>					Tilting-back supports: Checking the accumulator in accordance with the German Pressurized Vessel Ordinance and for tight fit		
	<input checked="" type="checkbox"/>							Check locking flaps for ease of movement, additionally during every assembly/disassembly		1972
	<input checked="" type="checkbox"/>							Jib head: Checking wheels for ease of movement		1973
	<input checked="" type="checkbox"/>							Checking the anemometer for tight fit and function		1973
			<input type="checkbox"/>					Checking hydraulic tilting-back supports of A-frame ³ and hydraulic connections for tightness		
	<input checked="" type="checkbox"/>							Jib base section: Checking screw connections and pin connections for tight fit, checking that locking springs are in place and undamaged		1974
Steel pendant straps										
	<input checked="" type="checkbox"/>			<input type="checkbox"/>				Check steel pendant straps and pins for damage and wear and check that locking springs and split pins are present (cracks, notches, corrosion, plastic deformation, wear, lubrication, etc.)		1979
		<input type="checkbox"/>						Checking the ease of movement of pin connections in the entire pendant strap strand		1980
	<input checked="" type="checkbox"/>							Protecting steel pendant straps, connecting links and pins from corrosion		1980
	<input checked="" type="checkbox"/>			<input type="checkbox"/>				Checking connecting links for damage and wear		1980
	<input checked="" type="checkbox"/>			<input type="checkbox"/>				Checking tension load cells for damage and wear, checking electricity connections for tight fit		1980
Carbon-fibre pendant straps										
	<input checked="" type="checkbox"/>			<input type="checkbox"/>				Check CF pendant straps and pins for damage and wear and check that locking springs and split pins are present (cracks, notches, corrosion, plastic deformation, wear, lubrication, etc.)		1983
		<input type="checkbox"/>						Checking the ease of movement of pin connections in the entire pendant strap strand		1985
	<input checked="" type="checkbox"/>							Protecting CF pendant strap bushes, connecting links and pins from corrosion		1985
	<input checked="" type="checkbox"/>			<input type="checkbox"/>				Checking connecting links for damage and wear		1986
	<input checked="" type="checkbox"/>			<input type="checkbox"/>				Checking tension load cells for damage and wear, checking electricity connections for tight fit		1986
Pendant ropes										
	<input checked="" type="checkbox"/>			<input type="checkbox"/>				Check pendant ropes and pins for damage and wear and check that locking springs and cotter pins are present (cracks, notches, corrosion, plastic deformation, wear, lubrication, etc.)		1987
	<input checked="" type="checkbox"/>							Protecting pendant ropes, connecting links and pins from corrosion		1987

LWNLR-x/V04.01//Auslieferung/2016-03-07/en

Customer:.....Machine type:.....Serial no.:.....Operating hours:.....Date:.....

Maintenance / inspection after service hours								Tasks to be performed		
8h/Daily	40h/Weekly	500h/Quarterly	1000h/Every six months	2000h/Annually	4000h/2 years	6000h/3 years	Special intervals	By maintenance staff ■ Once-only activity ● Repeat interval † If necessary * Annually before the winter	By authorised specialist staff □ Once-only activity ○ Repeat interval † If necessary	See page
	●			○				Checking connecting links for damage and wear		1988
						○		Changing pendant ropes		
Counterweight										
●								Checking the screws of the rear counterweight tie-down for tight fit (with exception of LR 1001.xx.xx)		1989
	●							Checking the rear counterweight, fixing lugs and round steel chains for damage, wear and secure fit		1989
	●							Checking locking elements for availability, damage, wear and tight fit		1990
	●							Checking counterweight supports (pins, shackles) for damage and wear		1990
Lubrication system										
●								Checking the function of the central lubrication system		1991
Derrick equipment*										
	●			○				Check derrick boom base section, derrick boom head and derrick boom sections for damage and wear (cracks, notches, corrosion, plastic deformation, wear)		1993
	●							Greasing the bearing of the derrick boom base section		1993
	●							Greasing the extension device of the counterweight carriage (strut, uppercarriage pin connection)		1994
●								Checking the air pressure of the counterweight carriage		1994
●								Checking the tires of the counterweight carriage for damage		1995
	●							Lubricating the axes and swing arms of the counterweight carriage's wheel sets		1995
	●							Lubricating the drive units of the counterweight carriage's wheel sets		1996
	●							Checking the gearbox oil level in the counterweight carriage's axle gearbox		1997
			○					Checking the gearbox oil in the counterweight carriage's axle gearbox		
	●							Checking the hydraulic cylinders of the counterweight carriage's wheel sets for tightness		2000
	●							Checking the hydraulic connections on the counterweight carriage for tightness		2000
●								Checking the screws of the counterweight tie-down for tight fit		2001
Ropes										
	●							Visual inspection of the ropes for deterioration or mechanical damage		2002
	●							Checking ropes for lubrication		2002
	○							Checking ropes for end of service life		2003
Drum										
	■	●						Checking rope tensioning pulleys* of drum for wear		2029
		●						Checking the groove diameter of the drum		2029

Maintenance

Maintenance and inspection schedule

Customer:.....Machine type:.....Serial no.:.....Operating hours:.....Date:.....

Maintenance / inspection after service hours								Tasks to be performed		
8h/Daily	40h/Weekly	500h/Quarterly	1000h/Every six months	2000h/Annually	4000h/2 years	6000h/3 years	Special intervals	By maintenance staff <input checked="" type="checkbox"/> Once-only activity <input checked="" type="checkbox"/> Repeat interval † If necessary * Annually before the winter	By authorised specialist staff <input type="checkbox"/> Once-only activity <input type="checkbox"/> Repeat interval † If necessary	See page
●								Checking drum for loose rope layers		2030
Rope pulleys										
	●							Checking the groove diameter of the pulley		2031
	●							Checking the bottom of groove diameter of the pulley		2032
	●							Checking the gap width of the pulley		2033
	●							Checking bottom of pulley groove for sharp edges		2034
	●							Checking pulleys for damage		2034
●								Check pulley bearings		2035
●								Check position of bearing and locking ring		2035
Rope suspension and rope fixation										
●								Checking rope suspensions (rope clamps, rope thimbles) for wire breaks, absence of corrosion and tight fit of screw fittings		2037
●								Checking the pocket locks		2038
●								Checking the rope end fittings for cracks and replacing entire rope if necessary		2039
Cab										
●								Check the windows of the cab for damage		2041
●								Checking that the cab door and the door lock work properly		2041
●								Check cabin roof protection guard for damage, locking (in case of foldable design)		2041
●								Checking outside mirrors and inside mirrors for damage		2043
●								Checking the operation of the hydraulic cab tilting device		2043
●								Hydraulic cab tilting device: check hydraulic cylinders, hydraulic hoses and connections for leaks and damage		2043
●								Hydraulic cabin elevation: Check acoustic warning signal for proper functioning, check operating elements (valves, display, etc.) for proper functioning, check safety chain is present and functioning properly, check the hydraulic hoses and connections for leaks and damage, check emergency descent equipment is present and functioning properly, check the suspension point on the cabin for damage, check emergency lowering, check pin connection for the presence of locking elements, check safety gear for damages and proper functioning		2044
				○			†	Cleaning or replacing the filter insert in the cabin		2045
Ventilation, heating and air-conditioning										
●								Checking the recirculated air filter for contamination		2047
							†	Replace recirculated air filter (at least every 200h)		2051
●								Checking the fresh air filter for contamination		2056
							†	Replace fresh air filter (at least every 200h)		2057

LWN/LR-x/V04.01//Auslieferung/2016-03-07/en

Customer:.....Machine type:.....Serial no.:..... Operating hours:.....Date:.....

Maintenance / inspection after service hours							Tasks to be performed		See page	
8h/Daily	40h/Weekly	500h/Quarterly	1000h/Every six months	2000h/Annually	4000h/2 years	6000h/3 years	Special intervals	By maintenance staff ■ Once-only activity ● Repeat interval † If necessary * Annually before the winter		By authorised specialist staff □ Once-only activity ○ Repeat interval † If necessary
							●	Check coolant level monthly in inspection glass		2061
							†	Filling in coolant		
							●	Check condenser monthly for contamination		2062
							●	Check condenser monthly for loose leads, loos screws and corrosion		2063
							●	Check fan on condenser for function, tight fit and damage monthly		2063
			○				*	Checking the function of the ventilation, heating and air conditioning system		
			○					Checking the air conditioning system for function and leaks		
							●	Check climate box for contamination every 200h		2064
			○					Heating circuit: Check hoses for leaks or damage		
							●	Check dryer monthly for damage and corrosion		2065
					○		†	Replace dryer (after 4000h or after each opening of the coolant circuit)		
			○					Check A/C compressor for tight fit		
			○					Checking the drive belts of the A/C compressor for damage		
			○					Checking the condenser and vaporizer for dirt		
			○				●	Starting the ventilation, heating, air conditioning, external air conditioning system* and auxiliary heating system* and ensuring that sufficient antifreeze has been added to the water circuit		2065
							*	Reading and analyzing the error memory of the auxiliary water heating*		
							*	Checking the electric connections of the auxiliary water heating* for contact corrosion and tight fit		
							*	Checking exhaust pipe and flue gas pipe of auxiliary water heating* for damage and free passage		
							*	Checking fuel line, coolant circuit and hoses of auxiliary water heating for leaks and tears		
							*	Replacing the fuel filter of auxiliary water heating		2068
HATZ diesel engine* (see operation manual of the engine manufacturer on CD)										
							○	Change engine oil every 250h		
							○	Check and adjust valve clearance every 250h		
							○	Clean cooling air zone every 250h		
							○	Check screw connections every 250h		
		○						Changing the fuel filter		
		○						Changing the dry air filter		
			○					Cleaning the oil filter		
							●	Checking the oil level		
							●	Checking the suction zone of the combustion air and cooling air		
							○	Check belt drive every 100h		2070

Maintenance

Maintenance and inspection schedule

Customer:.....Machine type:.....Serial no.:.....Operating hours:.....Date:.....

Maintenance / inspection after service hours								Tasks to be performed		
8h/Daily	40h/Weekly	500h/Quarterly	1000h/Every six months	2000h/Annually	4000h/2 years	6000h/3 years	Special intervals	By maintenance staff <input type="checkbox"/> Once-only activity <input checked="" type="checkbox"/> Repeat interval † If necessary * Annually before the winter	By authorised specialist staff <input type="checkbox"/> Once-only activity <input type="checkbox"/> Repeat interval † If necessary	See page
			<input type="radio"/>					Replacing the belt drive including vibration damper, deflection pulley and springs		2070
Function lock*										
			<input type="radio"/>					Checking that the function lock is working properly		
Machine care										
							<input type="radio"/>	Check the preservation protection (intervals from 6 months)		2072
							<input type="radio"/>	Reapply preservation protection (intervals from 2 months)		2072

LWN/LR-x/V04.01//Auslieferung/2016-03-07/en

9.2 Lubricants and consumables

Obeying the guidelines for lubrication and the use of fuels guarantees maximum reliability and a long machine life.

Cleanliness is important when handling lubricants and operating materials.



Note

Environmental pollution!

- ▶ Fluids such as hydraulic oil, fuel and coolant must be disposed of in accordance with national and international regulations and guidelines.
-

Lubricants have three main tasks:

- Reducing friction
- Preventing corrosion
- Removing dirt and abrasion particles

The higher the quality of the lubricant, the longer the service life of the components and the lower the wear. Higher-quality lubricants have less moisture content, which reduces consumption.

The specified lubrication intervals must not be exceeded, but can be shortened if necessary. Shortening of intervals largely depends on the operating conditions.

NOTICE

Insufficient lubrication!

Damage to machine.

- ▶ The prescribed lubrication intervals on the lubrication diagram must be observed.
-

9.2.1 Lubrication diagram

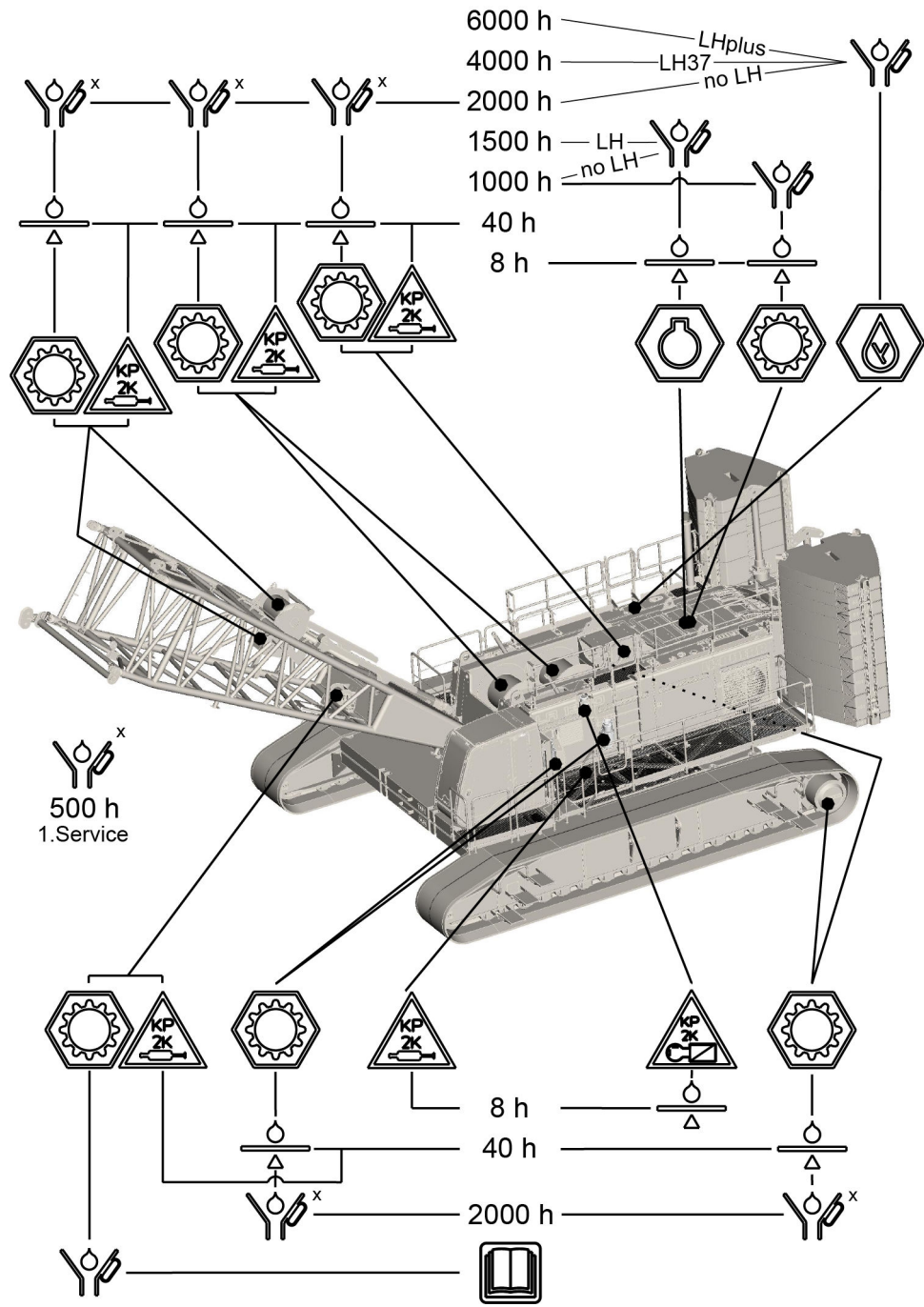


Fig. 5846: Lubrication chart

LWNLR-x\04.01\Auslieferung\2016-03-07/en

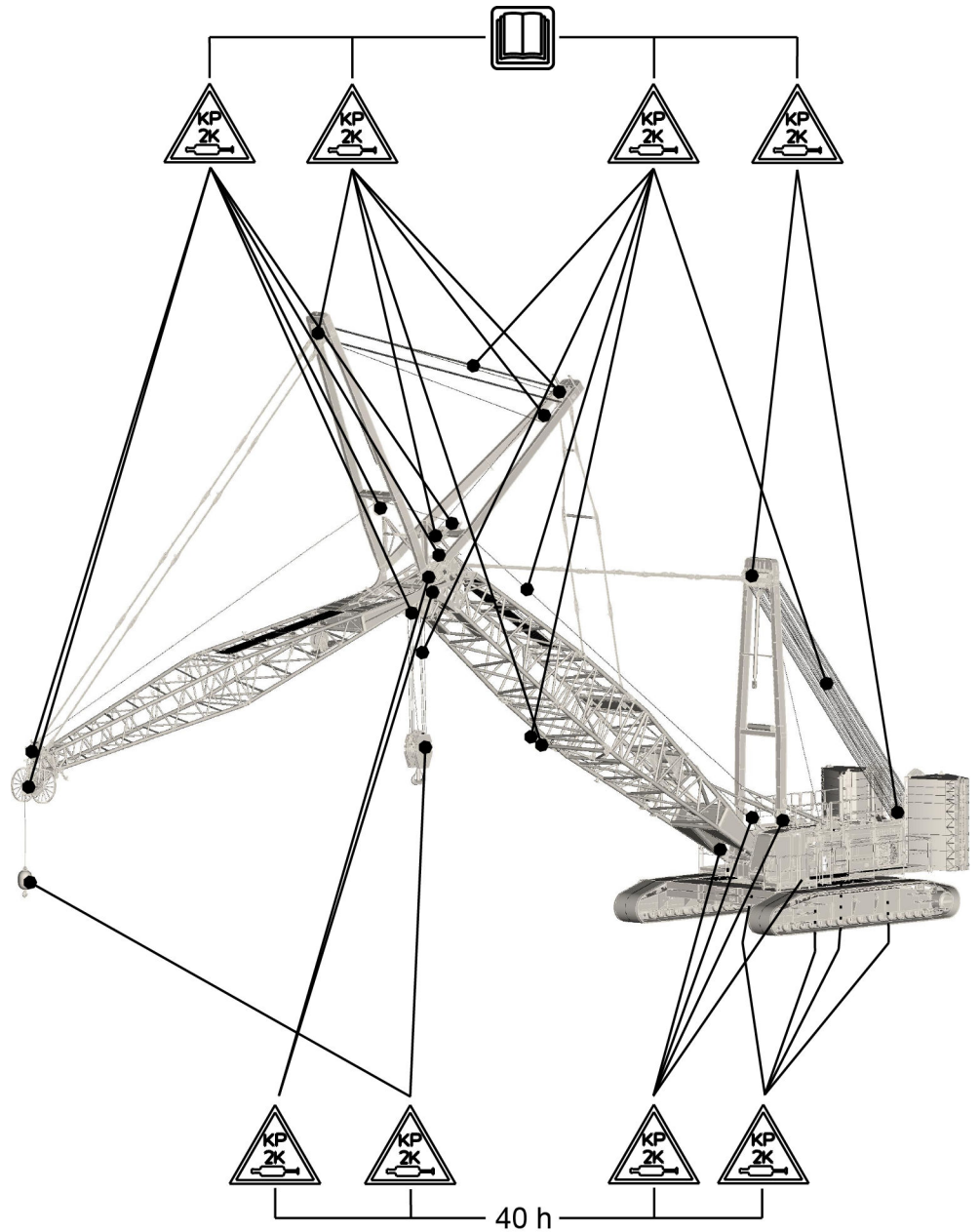


Fig. 5847: Lubrication chart

Key:



Diesel engine



gearbox



Hydraulics

LWNLR.x/V04.01//Auslieferung/2016-03-07/en



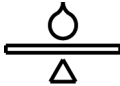
Grease



Central lubrication (optional)



Changing oil



Checking and supplementing



Observe the operation manual

9.2.2 Filling capacity table

Component	Volume	Remark
Diesel engine	see operation manual of the engine manufacturer on CD	
Distribution gearbox	7 l 1.85 gal	4 power take-offs
Crawler drive	34 l 8.98 gal	per item
Swing gear	11.2 l 2.96 gal	per item
Winch1/winch2 (crane winch)	15.5 l 4.09 gal	
Winch1/winch2 (free-fall winch)	19 l 5.02 gal	
Main boom luffing winch	7.5 l 1.98 gal	
Jib luffing winch	4.8 l 1.27 gal	
Rope reeving winch	0.4 l 13.53 oz	
Hydraulic oil tank	820 l 216.62 gal	
Fuel tank	750 l 198.13 gal	
Urea tank	78 l 20.61 gal	

Tab. 621: Filling capacity table

LWN/LR-x/V04.01//Auslieferung/2016-03-07/en

9.2.3 Lubrication chart

No.	Lubrication spots	Outside temperature	Type	Specification	Liebherr Lubricants
			ISO VG/SAE		
1	Diesel engine stage 0 to 3B/ tier 0 to 4i	all year around down to -20 °C (-4 °F) below -20 °C (-4 °F) with pre-heating	SAE 10W-40	ACEA E4 API CF	Liebherr Motoroil 10W-40
		all year around down to -20 °C (-4 °F) below -20 °C (-4 °F) with pre-heating	SAE 10W-40 low ash	ACEA E4-99 / E6 / E7 API CF-4 / CG-4 CH-4 / CI-4	Liebherr Motoroil 10W-40 low ash required when using particulate filters
	Diesel engine stage IV/tier4f	all year around down to -30 °C (-22 °F) below -30 °C (-22 °F) with pre-heating	SAE 5W-30	ACEA E4 / E7 API CF	Liebherr Motoroil 5W-30
		all year around down to -30 °C (-22 °F) below -30 °C (-22 °F) with pre-heating	SAE 5W-30 low ash	ACEA E6 / E7	Liebherr Motoroil 5W-30 low ash required when using particulate filters
2	Mechanical gearboxes, winches and drive axles	down to -25 °C (-13 °F) down to -40 °C (-40 °F)	SAE 85W-90 ISO VG 220	API GL 5 DIN51 502	Liebherr Hypoid EP 90 Liebherr Syntogear Plus 220
		to -50 °C (-58 °F) + 30 °C (86 °F)	SAE 75W-90	API GL 4; GL 5; MT 1	Liebherr Syntogear Plus 75W-90
		3	Hydrostatic drive, hydro-steer	to -25 °C (-13 °F) + 50 °C (122 °F) ^{B)}	ISO VG 32 - 46 SAE 10W-20 ATF ^{A)}
to -25 °C (-13 °F) + 50 °C (122 °F) ^{B)}	ISO VG 46 (32-68) SAE 10W-20			DIN 51 524 / T3 HVLPD HC in acc. with CEC- L-33-A-93	Liebherr Hydraulic Plus biodegradable
to -50 °C (-58 °F) + 30 °C (86 °F)	ISO VG 15 - 46 SAE 0W-20			DIN 51 524 / T3 HVLPD HC in acc. with CEC- L-33-A-93	Liebherr Hydraulic Plus Arctic biodegradable
4	Hydraulic additive for free-fall brake			DIN 51 757 DIN 51 562	Liebherr special additive NL

LWNLR.x/V04.01//Auslieferung/2016-03-07/en

No.	Lubrication spots	Outside temperature	Type ISO VG/SAE	Specification	Liebherr Lubricants
5	Roller bearings, friction bearings, ball bearing swing rings, cardan joints, other grease lubrication	to -25 °C (-13 °F) + 150 °C (302 °F) For lubrication systems	Grease, lithium saponified	DIN 51 502 KP 2 K-30 KPF 2 N-25	Liebherr Universal Grease 9900
		to -60 °C (-76 °F) + 140 °C (284 °F) For lubrication systems		DIN 51 502 KPFHC 1N-60	Liebherr Universal Grease Arctic
6	Open cogwheels and crown gears	to -25 °C (-13 °F) + 150 °C (302 °F) For lubrication systems	Lubrication and preservation	DIN 51 502 OGPF 2	Liebherr Universal Grease 9900
		to -60 °C (-76 °F) + 140 °C (284 °F) For lubrication systems		OGPF 1	Liebherr Universal Grease Arctic
		all sections		OGPF 00	Liebherr spray paste
7	Ropes	to -40 °C (-40 °F) + 50 °C (122 °F)			Liebherr WR-Lube SC
8	Telescopic boom	all sections	Special instruction	DIN 51 502 KP 2 K-30	Liebherr grease for telescopic components 9613 Plus
9	Coolant	down to -37 °C (-35 °F)		DIN 51 757/4 DIN 51 432/2	Liebherr Antifreeze OS Mix

Tab. 622: Lubrication chart

- A) The use of AFT oil is mandatory with lamella disk brakes if no Liebherr oil is being used.
 B) With activated oil pre-heating, the outside temperature may be approx. 10 °C (50 °F) lower.

**Note**

The known specifications listed in the Liebherr lubrication chart only ensure a minimum standard of oils and greases.

The high-quality Liebherr products are co-developed and co-tested. It can therefore not be guaranteed that products of a different quality perform the function of the machine to the same extent as the original products.

If the customer uses oils and grease by other manufacturers, the manufacturer and/or supplier must confirm its conformity with the required specifications to the customer. Due to the large number of lubricants and manufacturers, Liebherr is not in a position to perform this test.

The warranty is still valid if the customer uses lubricants of an equal or higher quality by a different manufacturer that meet the specifications of the Liebherr lubrication chart.

- In case of questions about Liebherr lubricants contact the Liebherr lubricant hotline +49 (0) 7354/80-6060 or lubricants@liebherr.com.

Ordering data**Engine oil**

	5 l (1.32 gal) canister	20 l (5.28 gal) canister	210 l (55.48 gal) barrel	1000 l (264.17 gal) container
Liebherr engine oil 10W-40	10 29 05 06	10 33 02 39	10 33 02 46	10 28 62 79
Liebherr engine oil 10W-40 low ash	10 32 61 13	10 32 61 12	10 32 61 11	10 32 61 10
Liebherr engine oil 5W-30	10 42 57 12	10 42 57 13	10 42 57 15	10 42 57 19
Liebherr engine oil 5W-30 low ash	11 06 60 29	11 06 60 30	11 06 60 31	11 06 60 32

Tab. 623: Order note engine oil

Gear oil

	5 l (1.32 gal) canister	20 l (5.28 gal) canister	210 l (55.48 gal) barrel	1000 l (264.17 gal) container
Liebherr Hypoid 90 EP	10 66 48 74	10 66 48 75	10 66 48 76	10 44 16 36
Liebherr Syntogear Plus 75W-90	10 33 02 85	10 33 02 87	10 33 02 88	10 29 64 77
Liebherr Syntogear Plus 220	10 19 03 87	10 19 03 88	10 19 03 89	10 19 03 90

Tab. 624: Order notice gearbox oil

Hydraulic oil

	5 l (1.32 gal) canister	20 l (5.28 gal) canister	210 l (55.48 gal) drum	1000 l (264.17 gal) container
Liebherr Hydraulic 37	10 66 48 65	10 66 48 67	10 66 47 12	10 66 48 56
Liebherr Hydraulic Plus	10 29 64 80	10 33 02 72	10 33 02 76	10 29 64 81

	5 l (1.32 gal) canister	20 l (5.28 gal) canister	210 l (55.48 gal) drum	1000 l (264.17 gal) container
Liebherr Hydraulic Plus Arctic	10 29 64 79	10 33 02 77	10 33 02 78	10 29 64 78

Tab. 625: Hydraulic oil ordering data

Oil concentrate

	5 l (1.32 gal) canister	20 l (5.28 gal) canister
Liebherr special additive NL	10 51 53 00	10 51 57 52

Tab. 626: Order notice oil concentrate

Grease

	Cartridge	5 kg (11.02 lb) bucket	10 kg (22.05 lb) bucket	25 kg (55.11 lb) bucket
Liebherr Universal Grease 9900	10 29 68 16 (400 g (0.88 lb))		10 29 68 13	10 29 68 12
Liebherr Universal Grease Arctic	10 29 68 28 (400 g (0.88 lb))		10 29 68 25	10 29 68 24
Liebherr spray paste	10 33 03 08 (950 g (2.09 lb))	10 33 03 11		
Liebherr grease for telescopic components 9613 Plus				10 33 03 15
Liebherr WR-Lube SC	10 17 33 71 (600 ml (20.29 oz) aerosol)			

Tab. 627: Order note greases

Coolant

	5 l (1.32 gal) can	20 l (5.28 gal) can	210 l (55.48 gal) barrel	1000 l (264.17 gal) container
Liebherr Antifreeze OS Mix	11 65 73 89	11 65 73 90	11 65 73 91	11 65 37 92

Tab. 628: Coolant ordering information

Oil analysis kit

88 56 018 14

9.2.4 Diesel engine lubricating oil

For further information please refer to the operation manual of the engine manufacturer on CD.

9.2.5 Fuel

For further information please refer to the operation manual of the engine manufacturer on CD.

Diesel engine tier IV / Tier 4f

The machine may be operated with diesel fuel with a maximum sulfur content of 50 mg/kg (50 ppm) under the following conditions:

- Specified diesel fuel with a sulfur content of max. 15 mg/kg (15 ppm) is not available.
- Upon receipt of the specification, Liebherr approves this diesel fuel.
- The operator is aware that components (catalyst, temperature sensor, NO_x sensor) will age faster.

9.2.6 Urea solution

The required qualification of the urea solution is NO_x reduction agent AUS 32 in accordance with DIN 70070/ISO 22241.

9.2.7 Diesel engine coolant

For further information please refer to the operation manual of the engine manufacturer on CD.

9.2.8 Hydraulic oil

Initial filling

The information sign on the hydraulic tank filler neck displays the hydraulic oil with which the machine was first filled.

If the initial filling was performed by Liebherr, the machine was initially filled with a Liebherr hydraulic oil 37 or higher as standard. In exceptional cases (low-temperature package, bio application), the machine is initially filled with a special hydraulic oil.

Mixing



Note

Mixing rapidly biodegradable third-party ester-based oils with mineral oils may result in damage to the hydraulic system!

Liebherr recommends:

- ▶ do not mix rapidly biodegradable third-party oils from different manufacturers.
- ▶ Do not mix rapidly biodegradable third-party oils with mineral oils.

Third-party oils are oils from other manufacturers.

The use of rapidly biodegradable hydraulic oil must be agreed with Liebherr.

Oils on vegetable basis are inadmissible due to the adverse temperature stability.

Using Liebherr hydraulic oils ensures that none of the disadvantages listed above will occur.

Mixing of Liebherr hydraulic oils	
Liebherr mineral oils with each other	Can be mixed at any ratio
Liebherr mineral oils with biodegradable Liebherr oils	Can be mixed at any ratio To ensure biodegradability, mixing in more than 2 % mineral oil is not permitted (in accordance with the regulations in most European countries)
Liebherr oils with oils by other manufacturers	To prevent changing the characteristics of the oils, it is not permitted to mix in more than 10 % oil made by other manufacturers

Tab. 629: Mixing of Liebherr hydraulic oils

9.2.9 Preservation medium (anti-corrosion coating)



WARNING

Incorrect use of anti-corrosion coating agents!

- ▶ When not being used, store the anti-corrosive agent in a cool, dry place (storage temperature approx. 15 °C (59 °F) to 20 °C (68 °F)).
- ▶ Keep container away from naked flames, fire, sparks and other sources of ignition.
- ▶ In the event of a fire, use CO₂ extinguishers, foam or a chemical extinguisher.
- ▶ Do not use water to extinguish the fire under any circumstances!
- ▶ When fighting a fire, wear appropriate safety apparel and breathing apparatus.



Note

Liebherr recommends:

- ▶ Use the following preservatives as anti-corrosive.

Product name	ID no. (batch)	Application	Disposal
DINITROL 3650 DINITROL 3650 is a soft, waxy protective coating with excellent creep characteristics.	890036814 (20 l (5.28 gal))	Use DINITROL 3650 for preservation of layered sheeting. Apply DINITROL 3650 by immersion, brushing or spraying. Seal the preserved parts after a drying time of 24 hours with DINITROL 4010.	Remove protective film with petroleum spirit or similar solvent-containing cleaning agents.
DINITROL 4010 DINITROL 4010 is a hard, waxy protective coating.	890036914 (20 l (5.28 gal))	Apply DINITROL 4010 by brushing or by airless spraying or airmix spraying.	Within 2 weeks of application, the DINITROL 4010 protective film can be removed with petroleum spirit. If left to dry thoroughly for 2 weeks, DINITROL 4010 will resist a high-pressure wash containing alkaline additives.

LWNLR-x\04.01\Auslieferung\2016-03-07/en

Product name	ID no. (batch)	Application	Disposal
LPS 1 LPS 1 is a non-greasy lubricant that penetrates deeply, dries quickly and is dirt repellent and dust repellent. As it repels moisture, it is ideal for drying electrical and electronic modules.	861009914 (aerosol can) 861010014 (25 l (6.6 gal))	Use LPS 1 on electrical and electronic systems and control cabinets. The grease-free protective film protects electrical and electronic components and does not cause short-circuits.	The protective film dries out and does not need to be removed.
LPS 2 LPS 2 is a highly stable lubricant that loosens rusted up and stuck components. The non-drying lubricant film provides long-term protection against corrosion.	861009714 (aerosol can) 861009814 (20 l (5.28 gal))	Use LPS 2 for door locks, hinges, joints, etc.	
LPS 3 LPS 3 has extra deep penetration capabilities and repels water. LPS 3 dries to form a transparent, soft, waxy film that provides effective protection against moisture, air, acids, alkaline vapors and other corrosive media.	861009614 (aerosol can) 861009514 (5 l (1.32 gal)) 861009414 (200 l (52.83 gal))	LPS 3 for fittings on pendant straps and back-stay straps, pin connections, etc. LPS 3 only preserves for storage. The preservation must be applied every year. Do not use in the engine compartment.	The protective film dries out and does not need to be removed.
Denso Tape Denso tape is a 1 mm (0.04" in) thick petrolatum tape. Its web is made of a non-rotting chemical fabric suitable for insulation and seals.	603231914 (roll 50 mm (1.97" in) x 10 m (32' 10" ft-in)) 693058914 (roll 100 mm (3.94" in) x 10 m (32' 10" ft-in))	Use Denso tape on exposed piston rods, valves, threaded joints of hydraulic components, etc.	Take off Denso tape and remove any residue with a degreaser or solvent-based cleaner.
CORTEC VCI 368 CORTEC VCI 368 is a drying, film-forming concentrate of highly-effective corrosion inhibitors bound in a mineral-oil based carrier substance. CORTEC VCI 368 does not contain nitrates, phosphates, chromates or heavy metals. It is also PCB and PCT-free.	861008714 (5 l (1.32 gal))	Use CORTEC VCI 368 on pins that are to be driven in again (pinning of boom sections, etc.).	Remove protective film with petroleum or petroleum spirit.

Product name	ID no. (batch)	Application	Disposal
<p>CORTEC VCI 369</p> <p>CORTEC VCI 369 is a semi-fluid grease concentrate made of highly-effective corrosion inhibitors bound in a mineral oil based carrier substance. CORTEC VCI 369 does not contain solvents, nitrites, phosphates or chromates, PCB and PCT.</p>	<p>11262917 (400 ml (13.53 oz) aerosol can)</p> <p>861008614 (5 l (1.32 gal) can)</p>	<p>Apply CORTEC VCI 369 by brushing, rolling or spraying. Use CORTEC VCI 369 for piston rods of the hydraulic cylinder.</p>	<p>Remove protective film with petroleum or petroleum spirit.</p>

Tab. 630: Preservation medium (corrosion protection)



Note

Liebherr recommends:

- ▶ Order the different preservatives directly from Liebherr using the ID number.

First-aid measures when coming into contact with DINITROL:

- Skin contact: Rinse with clear water and soap.
- Eye contact: Rinse corrosion protection medium immediately with clear water for some minutes. Contact a physician immediately.
- Ingestion: Drink milk or water. Do not induce vomiting. Contact a physician immediately.
- Inhalation: Go outside, breathe fresh air. Contact a physician immediately.

9.2.10 Liebherr oil diagnosis system



Note

- ▶ Perform the first oil change for the relevant unit as scheduled, since increased levels of contamination are to be expected during the running-in phase.

The Liebherr oil diagnosis system is a preventive maintenance system for the machine's main components.

The Liebherr oil diagnosis system is based on oil analyses and has the following tasks:

- Prevent machine breakdowns.
- Reduce standstills and downtimes.
- Minimize repair costs.
- Indicate abnormal wear.
- Detect possible causes of damage early.

Taking an oil sample

Ensure that the following conditions are fulfilled:

- Liebherr oil analysis set (ID no. 885601814) is available.
- The machine is switched off.
- The machine is secured to prevent unauthorised operation.
- The respective module or component has warmed up for 15 minutes (operating temperature).

The oil samples are taken either directly out of the housing of the respective module or component or from the draining oil when performing an oil change. Prior to sampling, drain at least 250 ml (8.45 oz) oil before filling the container with thoroughly mixed oil.

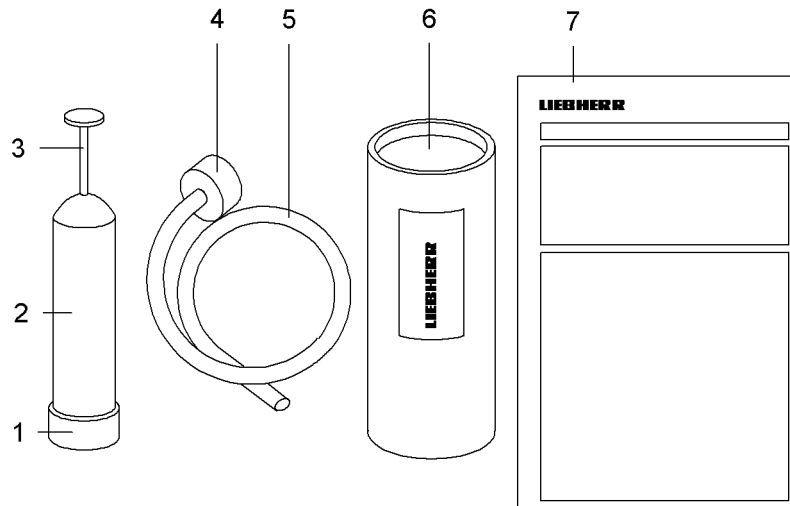


Fig. 5856: Liebherr oil analysis set (ID no. 885601814)

- | | | | |
|---|-------------------------|---|-------------------|
| 1 | Cover syringe container | 5 | Polymer hose |
| 2 | Syringe container | 6 | Shipping carton |
| 3 | Syringe neck | 7 | Sample data sheet |
| 4 | Adapter | | |

► Screw polymer hose 5 with adapter 4 onto syringe container 2.

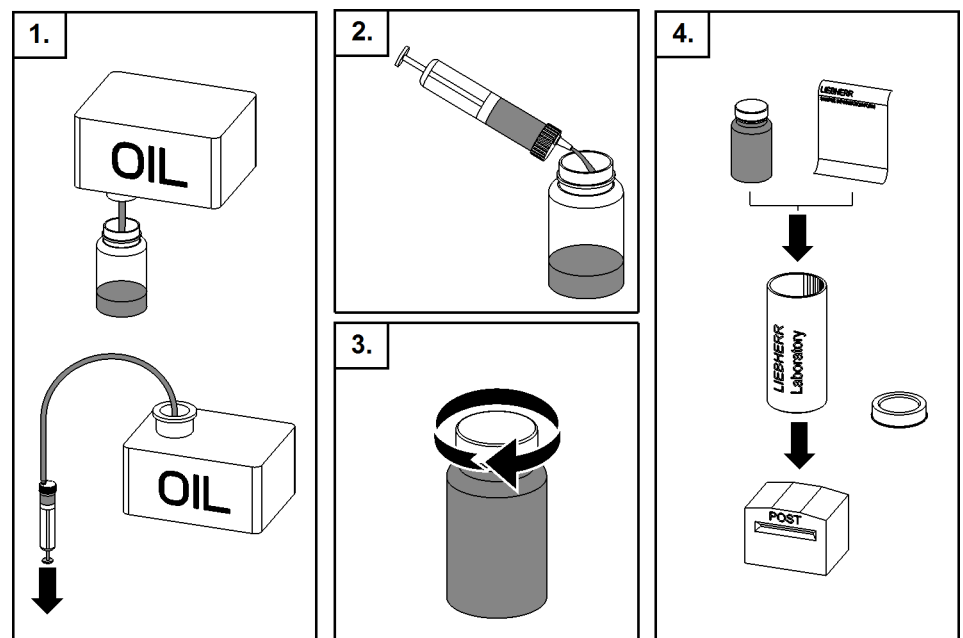






Fig. 5857: Taking an oil sample

► Take at least 200 ml (6.76 oz) of oil.

- ▶ Complete all sections of the sample data sheet.
- ▶ Place the oil sample and the sample data sheet into the shipping carton and send to the pre-printed address.

Understanding the oil diagnosis report

The oil diagnosis report shows the detailed result of the oil sample analysis and provides information about the measures to be taken. Four different symbols are used for this purpose:

Symbol	Meaning
	Normal
	High values, take second oil sample for counter-check
	Oil change required
	Repair required

Tab. 631: Oil diagnosis report

9.3 Air filter system

9.3.1 Checking the negative pressure indicator

Ensure that the following conditions are fulfilled:

- Negative pressure sensor on air intake has a tight fit.
- Negative pressure sensor on air intake is correctly connected.

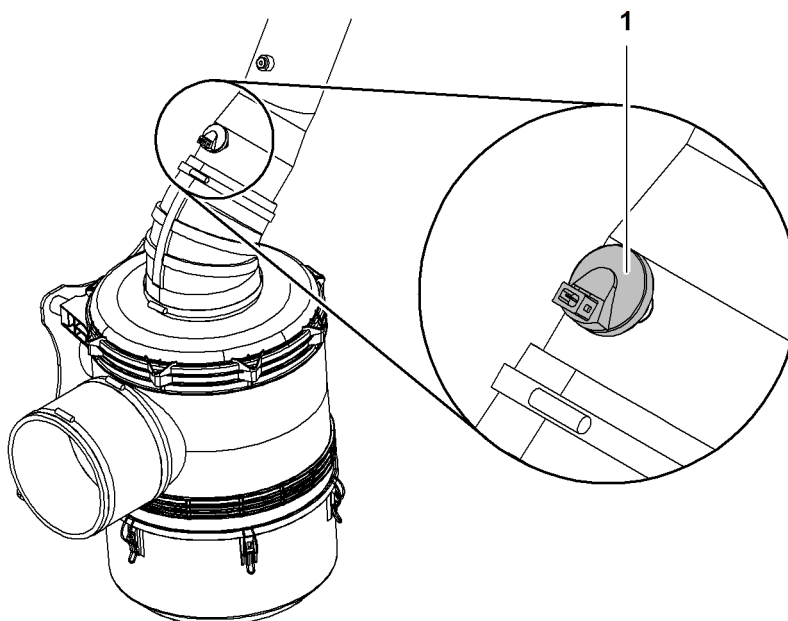


Fig. 5862: Checking the negative pressure indicator

1 Negative pressure sensor



- ▶ Press the *Error messages* button on the monitor.
 - ▷ The *Error messages* screen appears on the monitor.
- ▶ Unplug negative pressure sensor 1.
 - ▷ Error message "Air filter dirty" appears on the *Error messages* screen.

If the error message "Air filter dirty" does not appear on the screen *Error messages*:

- ▶ Contact Liebherr customer service.

9.3.2 Cleaning the air filter dust ejector

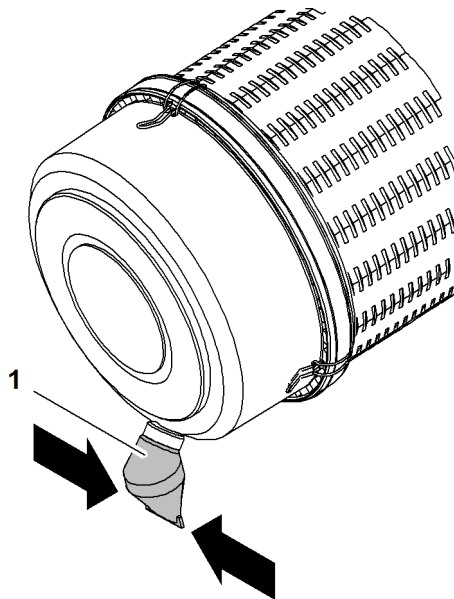


Fig. 5864: Cleaning the air filter dust ejector

1 Dust ejector

- ▶ Press the dust valve 1 together on the side.

9.3.3 Replacing the dry air filter main element and dry air filter safety element

NOTICE

Inadmissible operation without dry air filter elements!
Damage to the diesel engine.

- ▶ Only operate diesel engine with installed dry air filter main element and dry air filter safety element.
-

NOTICE

Inadmissible cleaning of dry air filter elements!
Damage to the diesel engine.

- ▶ Do not clean dry air filter main element and dry air filter safety element.
-



WARNING

Fine dust!
Risk of damage to lungs.

- ▶ To protect the respiratory tract: wear fine dust mask.
-

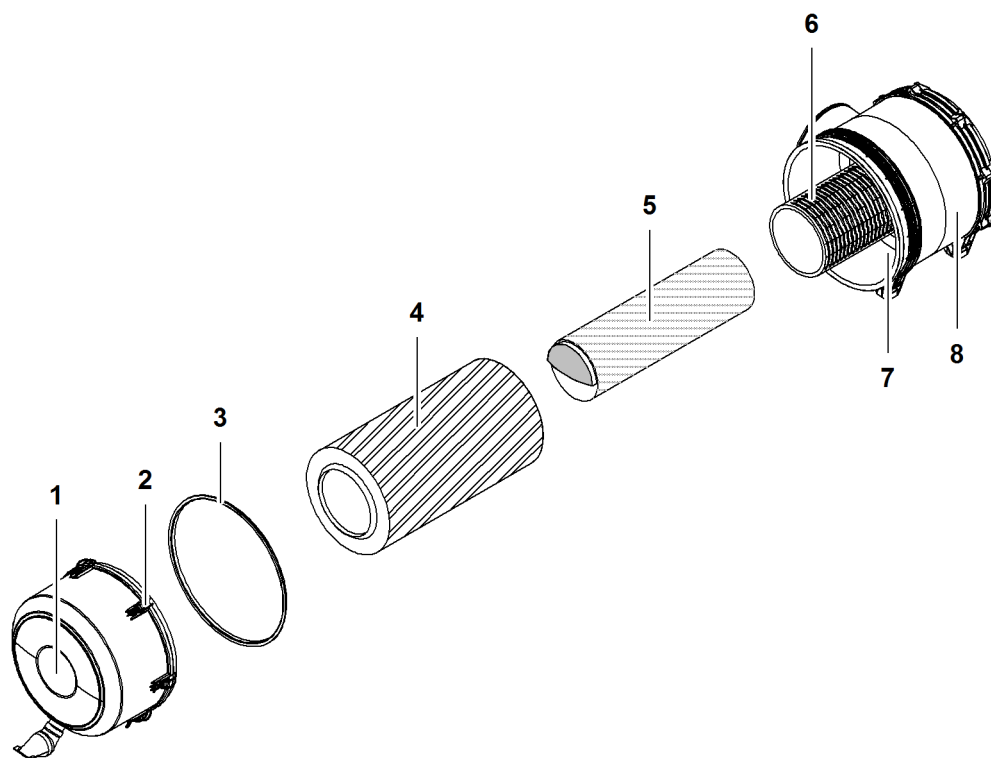


Fig. 5865: Replacing the dry air filter main element and dry air filter safety element

- | | | | |
|---|-----------------------------|---|---|
| 1 | Cover | 5 | Dry air filter safety element |
| 2 | Clamp (6x) | 6 | Bracket for dry air filter safety element |
| 3 | Seal | 7 | Bracket for dry air filter main element |
| 4 | Dry air filter main element | 8 | Air filter housing |

- ▶ Undo clamps **2** of the cover **1**.
- ▶ Remove cover **1** of air filter housing **8**.
- ▶ Turn dry air filter main element **4** and pull out at the same time.
- ▶ Pull out dry air filter safety element **5**.



Note

Environmental pollution!

- ▶ Dispose of dry air filter elements in accordance with national and international guidelines and regulations.

- ▶ Insert new dry air filter safety element **5** into bracket **6**.
- ▶ Insert new dry air filter main element **4** into bracket **7**.
- ▶ Put cover **1** on air filter housing **8**.
- ▶ Close clamps **2** of cover **1**.

9.4.2 Topping up the gearbox oil

Ensure that the following conditions are fulfilled:

- Diesel engine has been switched off for five minutes.
- The machine is level.
- The machine is secured to prevent unauthorised operation.



CAUTION

Hot gearbox components and gearbox oil!
Risk of burns.

- ▶ Maintenance work and inspection work must only be carried out when the distributor gearbox is switched off and the diesel engine has cooled down.
- ▶ Wear protective equipment.

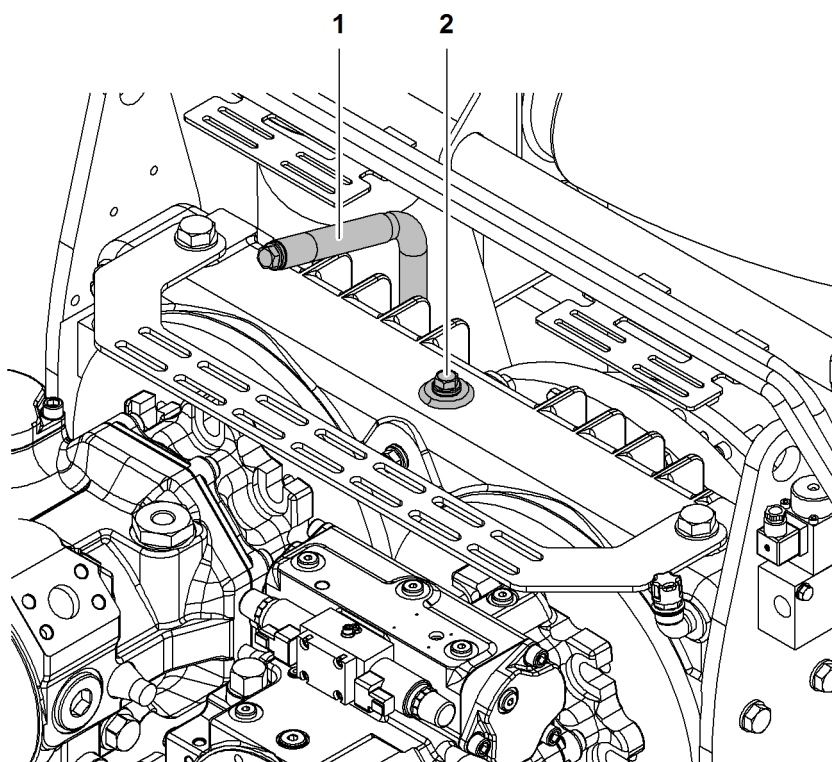


Fig. 5867: Topping up gearbox oil

1 Oil dipstick

2 Filler neck

NOTICE

Dirt and foreign bodies in the distributor gearbox!
The distributor gearbox is liable to be damaged.

- ▶ Ensure that no dirt or foreign bodies enter the filler neck 2.
- ▶ Undo the filler neck 2 screw.

NOTICE

Incorrect or contaminated gearbox oil!
The distributor gearbox is liable to be damaged.

- ▶ Top up exclusively using the appropriate gearbox oil according to the lubrication chart ([For more information see: 9.2.3 Lubrication chart, page 1875](#)).
 - ▶ Check the purity of the gearbox oil.
-

- ▶ Top up the gearbox oil until the MAX mark.
- ▶ Refit and tighten the filler neck **2** screw.
- ▶ Start the diesel engine and allow it to idle for 10 minutes.
- ▶ Switch off the diesel engine and wait 1 minute before checking the gearbox oil level again.

9.4.3 Checking the venting valve

- ▶ Check the venting valve.

If the venting valve is faulty in any way:

- ▶ Contact Liebherr after sales service.

9.5 Swing

9.5.1 Checking the gearbox oil level

Ensure that the following conditions are fulfilled:

- Diesel engine has been switched off for five minutes.
- The machine is level.
- The machine is secured to prevent unauthorised operation.

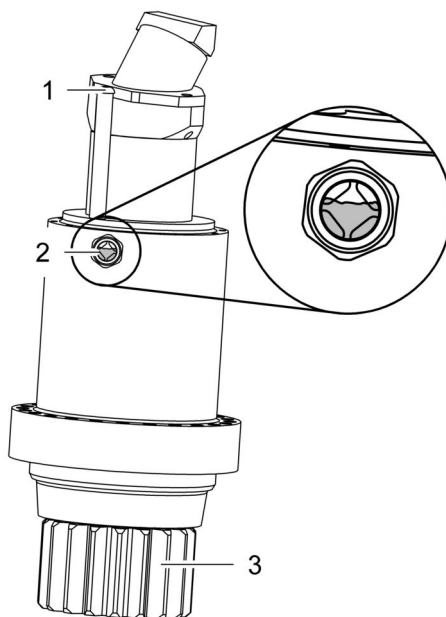


Fig. 5868: Checking the gearbox oil level

- | | | | |
|---|-------------|---|--------|
| 1 | Filler neck | 3 | Pinion |
| 2 | Sight glass | | |

- ▶ Check the gearbox oil level in the sight glass 2.

If no gearbox oil is visible in the sight glass:

- ▶ Top up using appropriate gearbox oil in accordance with the lubrication chart ([For more information see: 9.5.2 Topping up the gearbox oil, page 1891](#)).

9.5.2 Topping up the gearbox oil

Ensure that the following conditions are fulfilled:

- Diesel engine has been switched off for five minutes.
- The machine is level.
- The machine is secured to prevent unauthorised operation.

NOTICE

Dirt and foreign bodies in the swing gear!
Damage to the swing gear.

- ▶ Ensure that no dirt or foreign bodies enter the filler neck.
-

- ▶ Open the cover: turn the cover counter-clockwise.

NOTICE

Incorrect or contaminated gearbox oil!

Damage to the swing gear.

▶ Top up using only the appropriate gearbox oil according to the lubrication chart
(For more information see: [9.2.3 Lubrication chart, page 1875](#)).

▶ Check the purity of the gearbox oil.

▶ Top up the gearbox oil up to halfway on the sight glass.

▶ Close the cover: turn the cover clockwise as far as it will go.

▶ Start the diesel engine and allow it to idle for 10 minutes.

▶ Move the swing in both directions.

▶ Switch off the diesel engine and wait 1 minute before checking the gearbox oil level again.

9.6 Swing connection

9.6.1 Lubricating external teeth

Ensure that the following conditions are fulfilled:

- The grease gun from the Liebherr tool kit is present and filled with grease (For more information see: 9.2.3 Lubrication chart, page 1875) .
- The machine is secured to prevent unauthorised operation.

If the swing external teeth are not lubricated by a central lubrication:

- ▶ Lubricate the outer swing teeth using the requisite grease or alternatively apply an even coating of graphite spray (For more information see: 9.2.3 Lubrication chart, page 1875) .

9.6.2 Lubricating the bearing races via the central lubrication point

Ensure that the following conditions are fulfilled:

- The grease gun from the Liebherr tool kit is present and filled with grease (For more information see: 9.2.3 Lubrication chart, page 1875) .
- The machine is secured to prevent unauthorised operation.



CAUTION

Rotating uppercarriage!
Crushing.

- ▶ Ensure that nobody enters the danger area during the lubrication process.
- ▶ Leave the danger area.

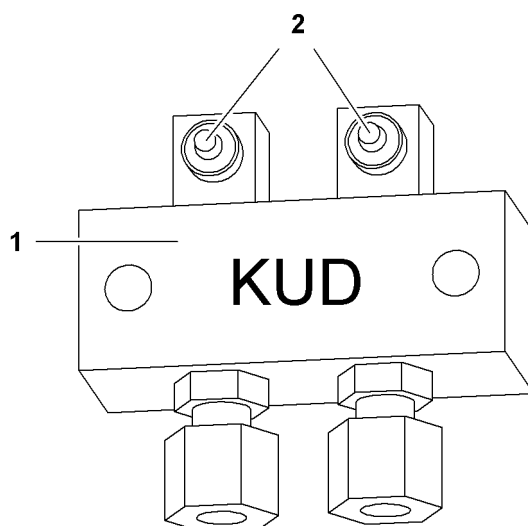


Fig. 5869: Central lubrication point

- 1 Central lubrication point 2 Grease nipple

If the swing bearing races are not lubricated by a central lubrication:

- ▶ Use the grease gun to press grease into the grease nipple 2.

- ▶ Turn the uppercarriage by 45° after each lubrication process (per grease nipple):
 - ▷ the grease distributes itself better in the swing ring.

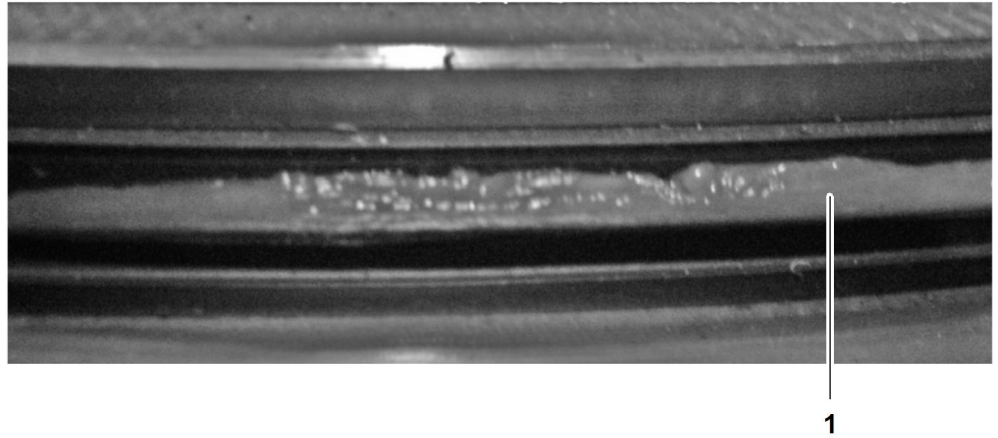


Fig. 5870: Grease collar

- ▶ Press in grease until a grease collar **1** can be seen up to the whole seal lip of the swing connection (circumference).

9.7.2 Topping up the gearbox oil

Ensure that the following conditions are fulfilled:

- Diesel engine has been switched off for five minutes.
- The machine is level.
- The machine is secured to prevent unauthorised operation.



CAUTION

Hot winch components and hot gearbox oil!
Burns and open wounds.

- ▶ Maintenance work and inspection work on the winches may only be carried out when the machine is switched off and has cooled down.
- ▶ Wear protective equipment.

NOTICE

Dirt and foreign bodies in winch gearbox!
The winch gearbox will be damaged.

- ▶ Ensure that no dirt or foreign bodies enter the filler neck.
- ▶ Pull out the oil dipstick.

NOTICE

Incorrect or contaminated gearbox oil!
The winch gearbox will be damaged.

- ▶ Top up using only the appropriate gearbox oil according to the lubrication chart ([For more information see: 9.2.3 Lubrication chart, page 1875](#)).
- ▶ Check the purity of the gearbox oil.
- ▶ Top up the gearbox oil until the MAX mark.
- ▶ Reinsert the oil dipstick as far as it will go.
- ▶ Start the diesel engine and allow it to idle for 10 minutes.
- ▶ Move the winch in both directions at low speed.
- ▶ Switch off the diesel engine and wait 1 minute before checking the gearbox oil level again.

9.7.3 Lubricating the counter bearing

Ensure that the following conditions are fulfilled:

- The grease gun from the Liebherr tool kit is present and filled with grease ([For more information see: 9.2.3 Lubrication chart, page 1875](#)).
- The machine is level.
- The machine is secured to prevent unauthorised operation.

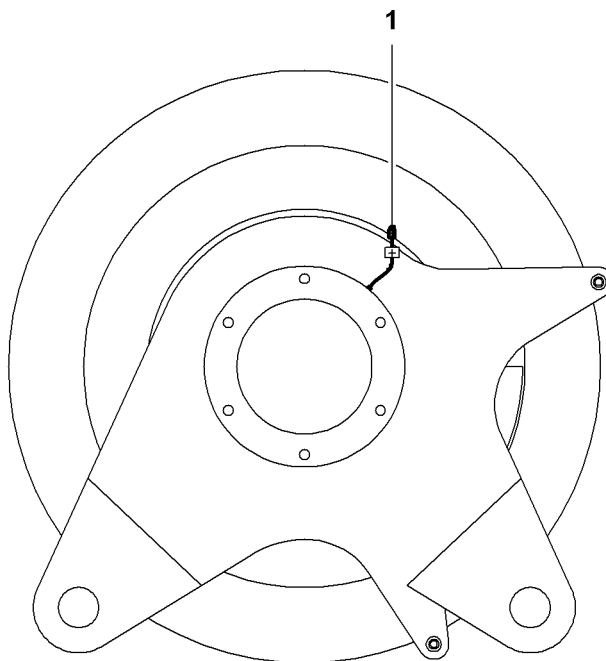


Fig. 5872: Lubricating the counter bearing

1 Grease nipple

- ▶ Use the grease gun to press grease into the grease nipple 1.
- ▶ Slowly turn the winch.
 - ▷ The grease distributes itself throughout the winch counter bearing.

9.7.4 Checking the rope end fastening for tight fit

- ▶ Check the rope end fastening for tight fit.

If the rope end fastening is loose:

- ▶ Tighten the rope end fastening.

9.8.2 Topping up the gearbox oil

Ensure that the following conditions are fulfilled:

- Diesel engine has been switched off for five minutes.
- The machine is level.
- The machine is secured to prevent unauthorised operation.



CAUTION

Hot winch components and hot gearbox oil!

Risk of burns.

- ▶ Maintenance work and inspection work on the winches may only be carried out when the machine is switched off and has cooled down.
- ▶ Wear protective equipment.

NOTICE

Dirt and foreign bodies in winch gearbox!

The winch gearbox will be damaged.

- ▶ Ensure that no dirt or foreign bodies enter the filler neck.

- ▶ Pull out the oil dipstick.

NOTICE

Incorrect or impure gearbox oil is used!

The winch gearbox will be damaged.

- ▶ Top up using only the appropriate gearbox oil according to the lubrication chart ([For more information see: 9.2.3 Lubrication chart, page 1875](#)).
- ▶ Check the purity of the gearbox oil.

- ▶ Top up the gearbox oil until the MAX mark.
- ▶ Reinsert the oil dipstick as far as it will go.
- ▶ Start the diesel engine and allow it to idle for 10 minutes.
- ▶ Move the winch in both directions at low speed.
- ▶ Switch off the diesel engine and wait 1 minute before checking the gearbox oil level again.

9.8.3 Lubricating the counter bearing

Ensure that the following conditions are fulfilled:

- The grease gun from the Liebherr tool kit is present and filled with grease ([For more information see: 9.2.3 Lubrication chart, page 1875](#)).
- The machine is level.
- The machine is secured to prevent unauthorised operation.

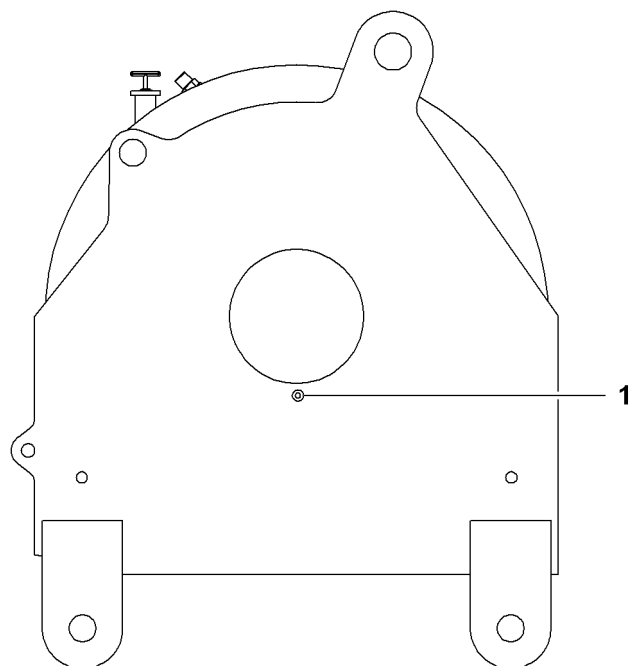


Fig. 5874: Lubricating the counter bearing

1 Grease nipple

- ▶ Use the grease gun to press grease into the grease nipple **1**.
- ▶ Slowly turn the winch.
 - ▷ The grease distributes itself throughout the winch counter bearing.

9.8.4 Checking the rope end fastening for tight fit

- ▶ Check the rope end fastening for tight fit.

If the rope end fastening is loose:

- ▶ Tighten the rope end fastening.

9.9 Rope reeving winch

9.9.1 Lubricating the counter bearing

Ensure that the following conditions are fulfilled:

- The grease gun from the Liebherr tool kit is present and filled with grease (For more information see: 9.2.3 Lubrication chart, page 1875) .
- Rope reeving winch is level.
- The machine is secured to prevent unauthorised operation.

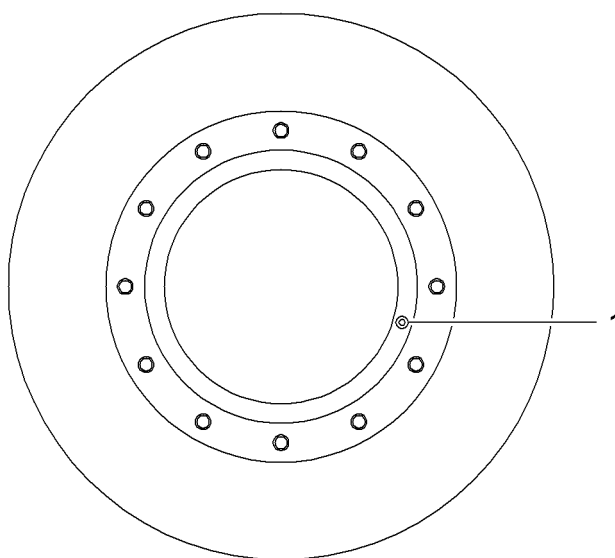


Fig. 5875: Lubricating the counter bearing

1 Grease nipple

- ▶ Use the grease gun to press grease into the grease nipple 1.
- ▶ Slowly turn the winch.
 - ▷ The grease distributes itself throughout the winch counter bearing.

9.9.2 Checking rope end attachment for tight fit when starting up rope reeving winch

- ▶ Check the rope end fastening for tight fit.

If the rope end fastening is loose:

- ▶ Tighten the rope end fastening.

9.10.2 Topping up the gearbox oil

Ensure that the following conditions are fulfilled:

- Diesel engine has been switched off for five minutes.
- The tagline winch is level.
- The machine is secured to prevent unauthorised operation.



CAUTION

Hot winch components and hot gearbox oil!
Risk of burns.

- ▶ Only perform maintenance work and inspection work on winches when the machine is switched off and has cooled down.
 - ▶ Wear protective equipment.
-

NOTICE

Dirt and foreign bodies in winch gearbox!
The winch gearbox will be damaged.

- ▶ Ensure that no dirt or foreign bodies enter the filler neck.
-

- ▶ Pull out the oil dipstick.
-

NOTICE

Incorrect or impure gearbox oil is used!
The winch gearbox will be damaged.

- ▶ Top up using only the appropriate gearbox oil according to the lubrication chart ([For more information see: 9.2.3 Lubrication chart, page 1875](#)).
 - ▶ Check the purity of the gearbox oil.
-

- ▶ Top up the gearbox oil until the MAX mark.
- ▶ Reinsert the oil dipstick as far as it will go.
- ▶ Start the diesel engine and allow it to idle for 10 minutes.
- ▶ Move the winch in both directions at low speed.
- ▶ Switch off the diesel engine and wait 1 minute before checking the gearbox oil level again.

9.10.3 Lubricating the rope bracket on the boom base section and checking pulleys for damage

Ensure that grease gun from Liebherr tool kit is available and filled with correct grease ([For more information see: 9.2.3 Lubrication chart, page 1875](#)).

9.11 Crawlers

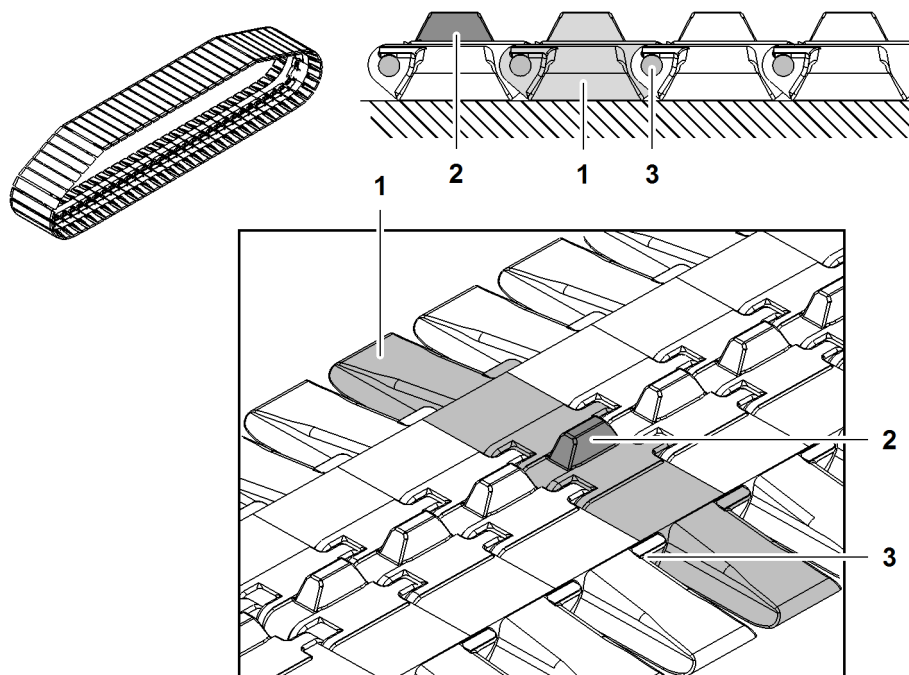


Fig. 5878: Track pad crawler

- | | | | |
|---|------------|---|----------------|
| 1 | Base plate | 3 | Pin connection |
| 2 | Guide | | |

With the track pad crawler, the individual base plates **1** of the crawler are pinned with each other. The crawler is guided with the guides **2** on the base plates.

9.11.1 Checking the gearbox oil level

Ensure that the following conditions are fulfilled:

- Inspection lamp is available.
- Allen key from the Liebherr tool kit is available.
- Torque wrench 120 Nm (89 ft-lb) is available.
- Diesel engine has been switched off for five minutes.
- The machine is level.
- The machine is secured to prevent unauthorised operation.
- The Liebherr lettering on the crawler drives is horizontally readable from left to right.



CAUTION

Hot gearbox components and hot gearbox oil!
Risk of burns.

- ▶ Maintenance work and inspection work on the crawlers must only be carried out when the machine is switched off and has cooled down.
- ▶ Wear protective equipment.

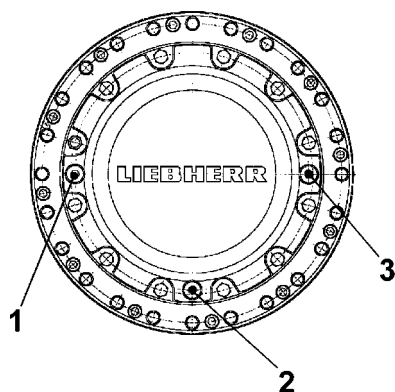


Fig. 5879: Crawler drive

- | | | | |
|---|---------------------------------|---|---------------------------------|
| 1 | Dummy socket (internal hexagon) | 3 | Dummy socket (internal hexagon) |
| 2 | Drain screw (internal hexagon) | | |

▶ Undo the dummy socket 1 using the Allen key.

▶ Check the gearbox oil level .

If the gearbox oil level does not reach the bottom edge of the opening:

▶ Top up with suitable gearbox oil.

▶ Tighten the dummy socket 1 with a torque of 120 Nm (89 ft-lb).

9.11.2 Check gearbox and hydraulic connections for leaks

▶ Check gearbox and hydraulic connections for leaks.

If the gearbox or the hydraulic connections are leaking:

▶ Do not use the crawlers.

▶ Contact Liebherr after sales service.

9.11.3 Cleaning the crawlers

NOTICE

Dirt in the crawlers!

Wear due to increased chain tension.

▶ Ensure the crawlers are kept clean.

▶ Only use authorised cleaning agents.

▶ Clean the crawlers using a high-pressure cleaner.

9.11.4 Checking that the crossbeam set screws on the crawler side frames are secure on telescopic undercarriages

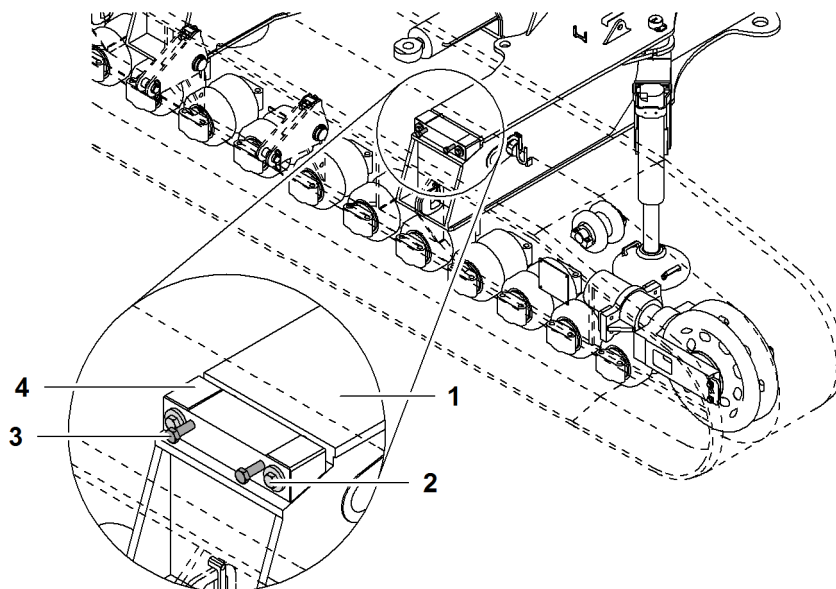


Fig. 5880: Locking screws of the struts on the crawler side frames

- | | | | |
|---|--------------------|---|------------|
| 1 | Strut | 3 | Screw (2x) |
| 2 | Locking screw (2x) | 4 | Wedge |

► Check locking screws **2** of the struts on the crawler side frames for tight fit.

If locking screws **2** of the struts on the crawler side frames are loose:

- Undo screws **3**.
- Tighten locking screw **2**.
- Tighten screws **3**.

9.11.5 Check chain guides for wear and tight fit

Chain guides are installed between chain and crawler side frame.

The chain guides consist of identical parts. The individual chain guides can be changed individually.

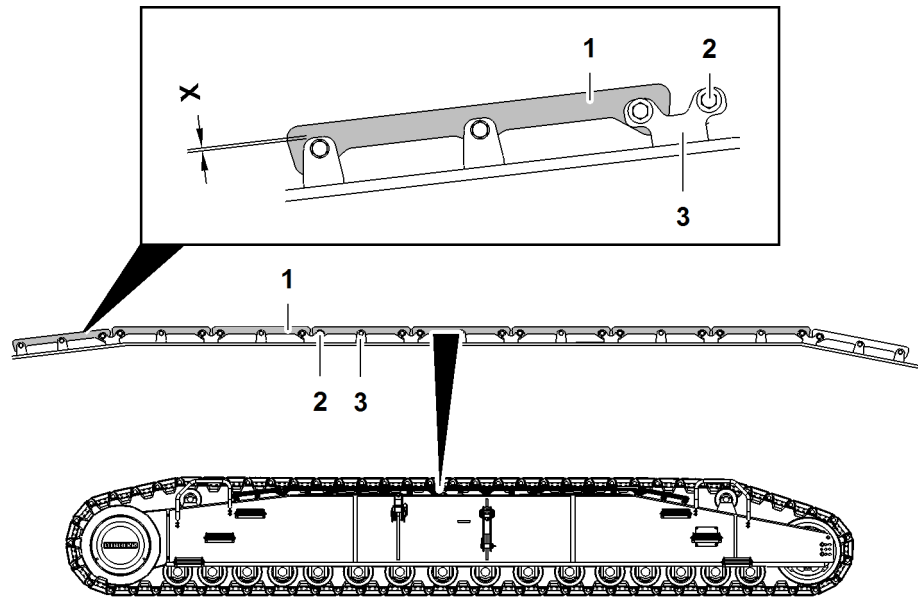


Fig. 5881: Checking the chain guides for wear and tight fit

- | | | | |
|---|------------------|---|----------------|
| 1 | Chain guide | 3 | Bracket |
| 2 | Screw connection | X | Minimum height |

The minimum height **X** of the chain guide **1** must be larger than zero.

- ▶ Measure the minimum height **X** between chain guide **1** and bracket **3**.

If the minimum height **X** is below the admissible range:

- ▶ Exchange chain guide **1**.

9.11.6 Checking the chain tension

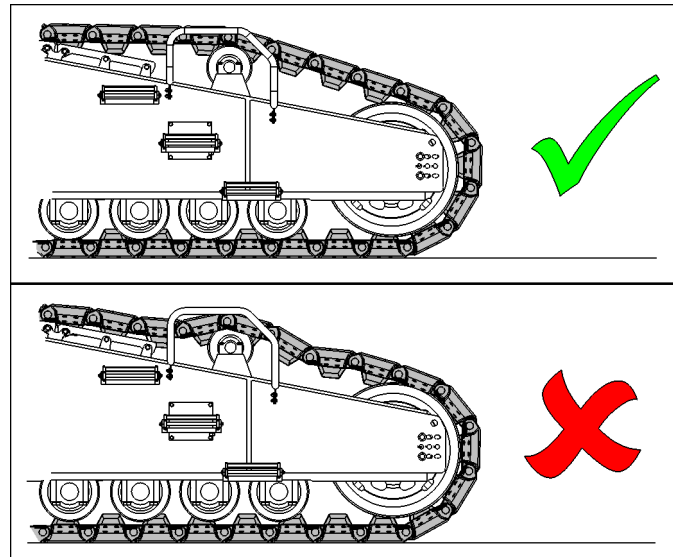


Fig. 5882: Inadmissible chain tension

NOTICE

Incorrect chain tension!
Wear or tearing of the chain.

- ▶ Make sure that no chain link scrapes on the steel construction of the crawler side frame.

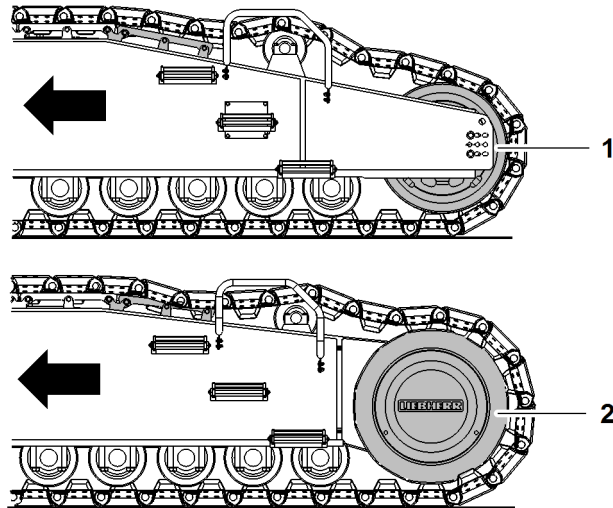


Fig. 5883: Relieving the chain

- | | | | |
|---|-------------|---|---------|
| 1 | Idler wheel | 2 | Tumbler |
|---|-------------|---|---------|

When travelling forward with the machine, the rear chain in the top section of the crawler side frame relaxes.

- ▶ Move machine one crawler side frame length forward.
 - ▷ Chain relieved.



CAUTION

Inadmissible operation of the travel gear!
Risk of crushing limbs.

- ▶ Make sure that the safety lever in the cabin is pulled up.

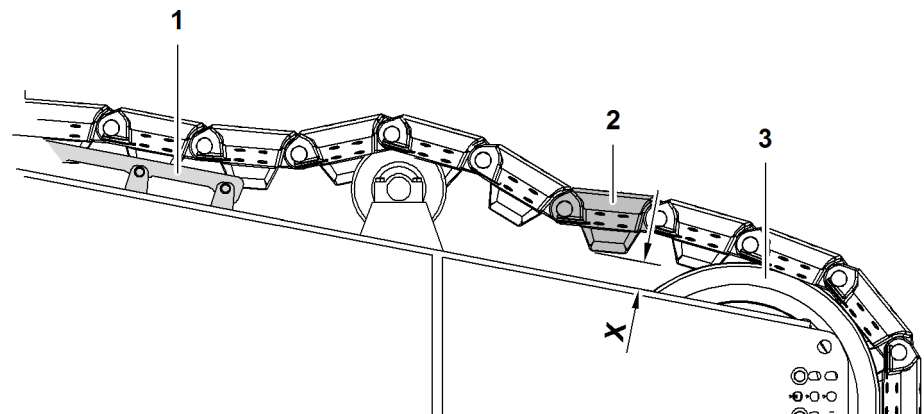


Fig. 5884: Checking the chain tension

- | | | | |
|---|---------------|---|-------------|
| 1 | Measuring rod | 4 | Idler wheel |
| 2 | Chain guide | X | Distance |
| 3 | Chain link | Y | Distance |

LWNLR.x/V04.01//Auslieferung/2016-03-07/en

The distance **X** must be at least 10 mm (0.39" in).

The distance **Y** must be at least 10 mm (0.39" in).

- ▶ Make sure that chain link **3** is free.
- ▶ Make sure that chain link **3** is guided halfway.

The distance **X** between chain link **3** and crawler side frame steel structure must be at least 10 mm (0.39" in).

- ▶ Measure distance between chain link **3** and crawler side frame steel structure.

If the distance **X** is not within the permitted range:

- ▶ Retighten chain (For more information see: [9.11.7 Retightening the chain, page 1910](#)).

9.11.7 Retightening the chain

Ensure that the following conditions are fulfilled:

- The machine is level.
- The machine is secured to prevent unauthorised operation.
- The required tools from the Liebherr tool kit are available.

NOTICE

Incorrect chain tension!

Increased wear due to excessive chain tension.

Unwinding of the crawler chain due to insufficient chain tension.

- ▶ Retension the chain according to specifications.
-

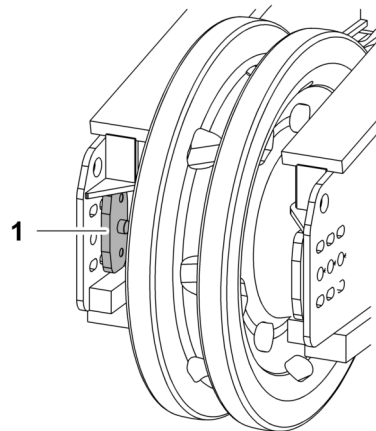


Fig. 5885: Stop hydraulic tension jack

- 1 Stop hydraulic tension jack

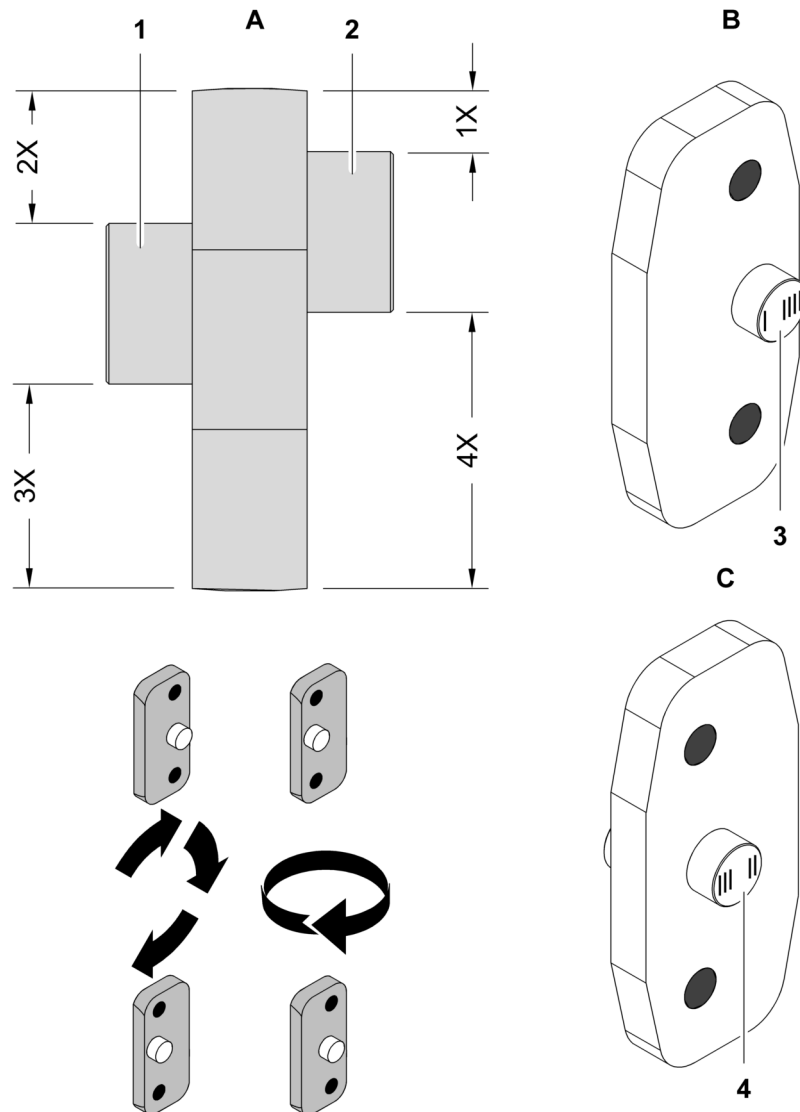


Fig. 5886: Stop hydraulic tension jack

- | | | | |
|---|-------------------------|---|---------------------|
| 1 | Left pin | A | View from top |
| 2 | Right pin | B | View from the right |
| 3 | Right pin with markings | C | View from the left |
| 4 | Left pin with markings | X | Stop path (4x) |

The stop is asymmetric. This way, the chain tension can be increased step by step by the stop path **X**. 1 to 4 lines are engraved on the pins. These lines indicate the position of the stop and the stop path **X**. If the chain is tightened, the installation position of the stop must be selected in such a way that the marking on the crawler side frame has one line more than the marking prior to dismantling the stop. Meaning one stop path **X** more. After the fourth line, move forward by one boring for pins **2** and start at the first line again.

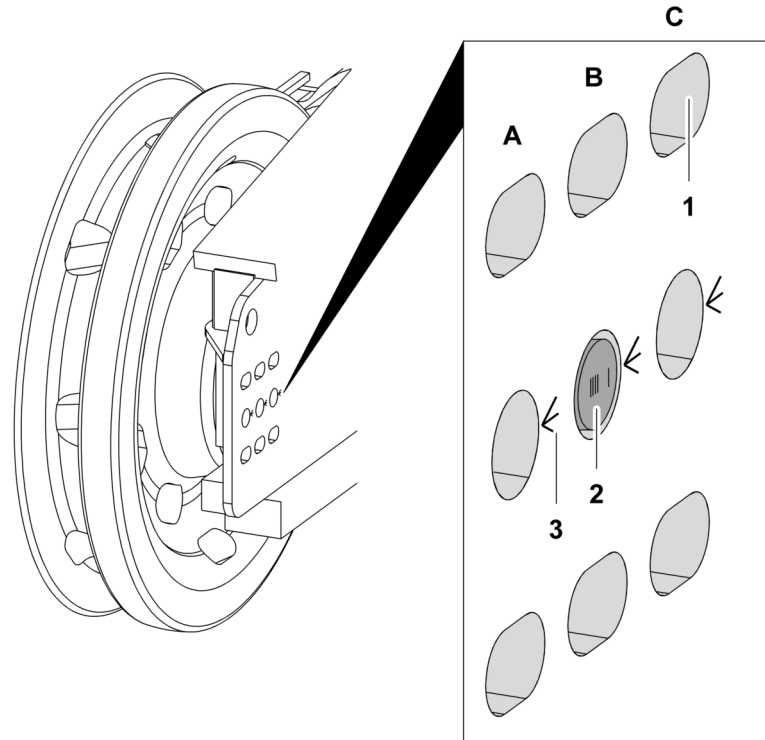


Fig. 5887: Markings on the crawler side frame

- | | | | |
|---|------------------------------------|---|-------------------------------|
| 1 | Attachment hole (6x) | A | Next larger distance to B |
| 2 | Stop pin with marking | B | Current installation position |
| 3 | Marking on crawler side frame (3x) | C | Next smaller distance to B |

The engraved markings on the stop pins 2 must point towards the marking 3. If there are no markings 3 on the crawler side frame, the valid markings on the stop pin 2 point towards the swing.

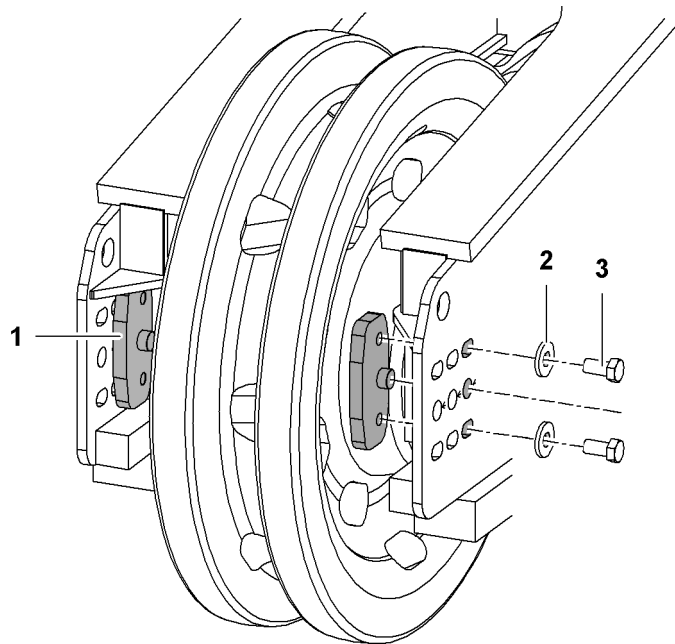


Fig. 5888: Stop crawler side frame

- | | | | |
|---|---------------------------------|---|------------|
| 1 | Installation position stop (2x) | 3 | Screw (4x) |
| 2 | Washer (4x) | | |

LWNLR-x/V04.01//Auslieferung/2016-03-07/en

Note down de-installation position of the stop.

- ▶ Dismantle stop: Undo screws **3**.
- ▶ Remove washers **2**.
- ▶ Loosen stop with punch.

If the stop cannot be de-installed:

- ▶ Release pressure on hydraulic tension jack (For more information see: [9.11.8 Release pressure on hydraulic tension jack, page 1913](#)) .
- ▶ Define new installation position of stop.

When the last position is reached:

- ▶ Remove one chain link.
- ▶ Twist and turn stop in such way that the stop path is enlarged by factor 1X (one line with the marking of the pin).

NOTICE

Incorrect installation of the stop!
Damage to chain.

- ▶ Make sure that the stop is installed in the same position on both sides of the crawler side frame and with the same marking on the pins.

-
- ▶ Install stop on both sides of the crawler side frame.
 - ▶ Insert washers **2**.
 - ▶ Tighten screws **3**.
 - ▷ Chain is taut.
 - ▶ Move machine 3 m (9' 10" ft-in) forward.
 - ▶ To compensate for chain play: move the machine back again.
 - ▶ Check chain tension (For more information see: [9.11.6 Checking the chain tension, page 1908](#)) .

Different stop installation positions may result with the two crawler side frames.

- ▶ Repeat the procedure for the second crawler side frame.

9.11.8 Release pressure on hydraulic tension jack

NOTICE

Inadmissible operation of the travel gear!
Hydraulic oil leak.

- ▶ In case of open chain, close hydraulic feed to hydraulic tension jack.
-

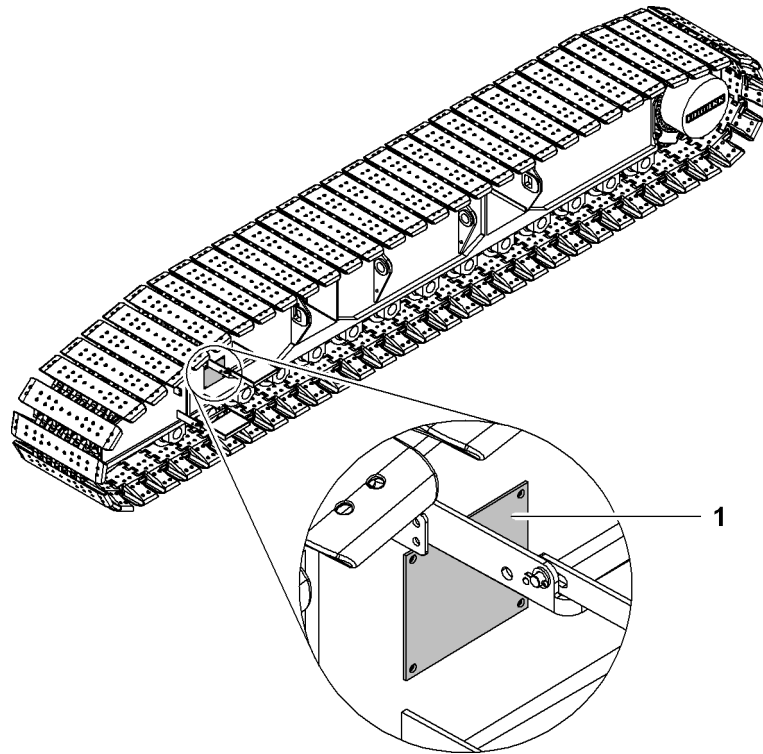


Fig. 5889: Cover crawler side frame

1 Cover

- ▶ Remove cover **1** on crawler side frame
 - ▷ Hydraulic pipes are visible.

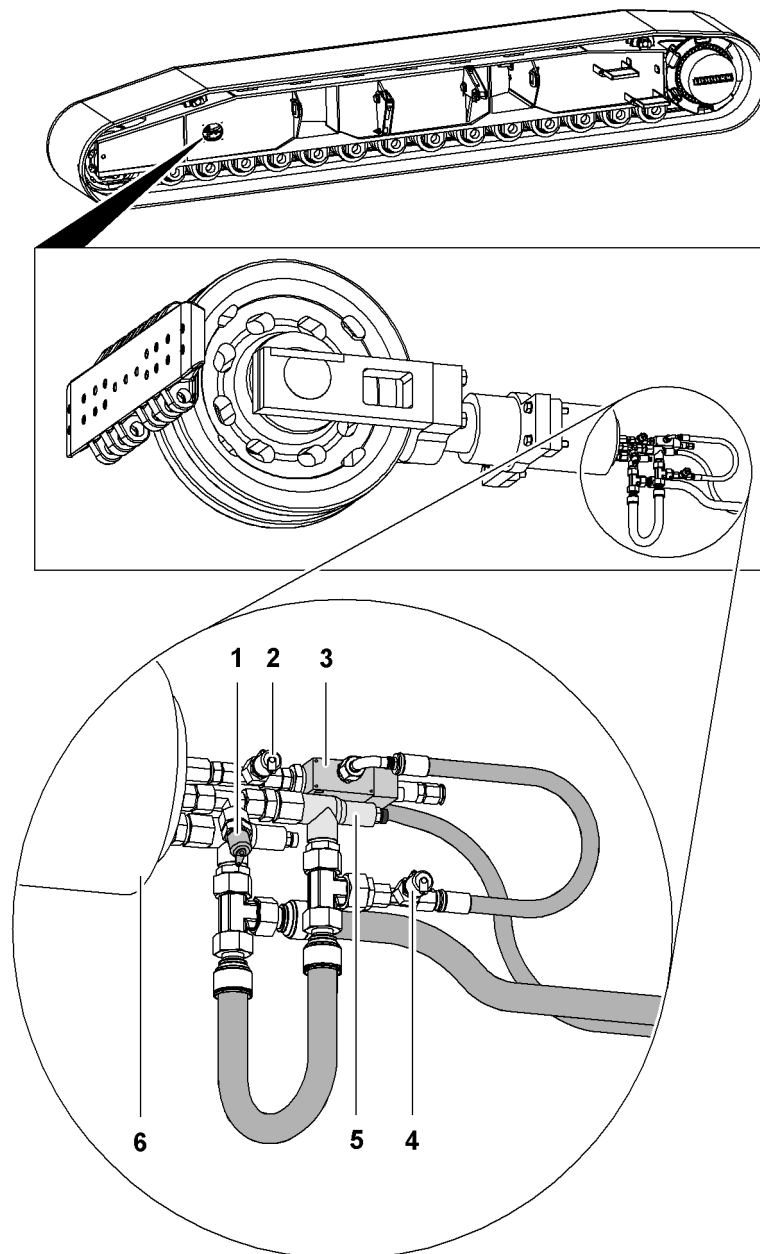


Fig. 5890: Release pressure on hydraulic tension jack

- | | | | |
|---|----------------------|---|--------------------------------|
| 1 | Measuring connection | 4 | Measuring connection |
| 2 | Measuring connection | 5 | Positive pressure relief valve |
| 3 | Pressure reducer | 6 | Hydraulic tensioner |

- ▶ Provide receptacle for hydraulic oil.
- ▶ Put one end of the miniature measuring cable into the receptacle.
- ▶ Connect other end of the miniature measuring cable with measuring connection 1.
 - ▷ Hydraulic oil emerges (approx. 0.2 l (6.76 oz)).
 - ▷ Hydraulic tension jack 6 is without pressure.
 - ▷ The hydraulic cylinder of the hydraulic tension jack 6 is pushed back through the inherent weight of the chain.
 - ▷ Clearance on stop.

- ▶ Remove miniature measuring cable from measuring connection 1.
- ▶ Dismantle stop. (For more information see: [9.11.7 Retightening the chain, page 1910](#))

9.11.9 Checking locking screws of the track pads axes

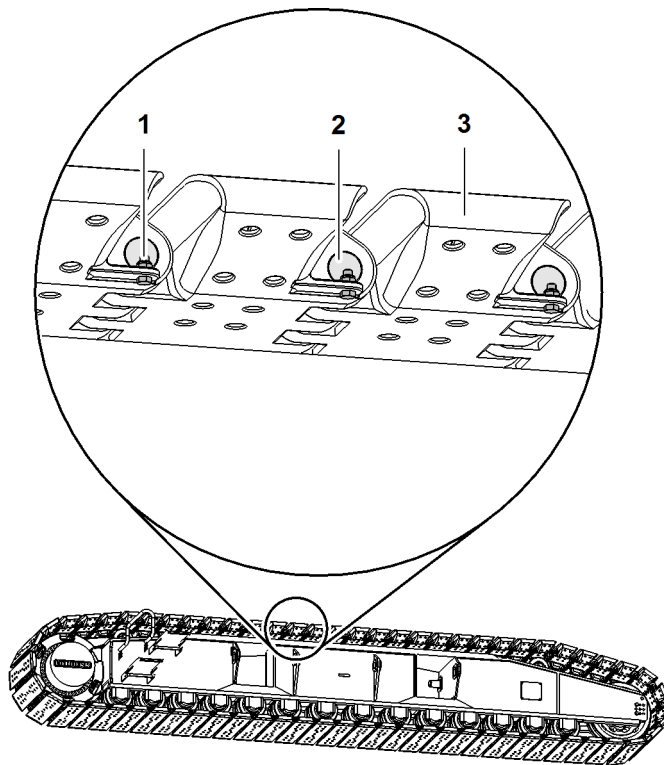


Fig. 5891: Checking locking screws of the track pads axes

- | | |
|---|---------------------------|
| <p>1 Screw (2x) with washer and counter nut</p> <p>2 Axis (2x) of the track pad</p> | <p>3 Track pad</p> |
|---|---------------------------|

Screws **1** prevent axis **2** from falling out. Because the axes is halved, the outer and inner side of the crawler side frame must be checked.

- ▶ Check availability of screws **1**.

If screws **1** are not available:

- ▶ Insert screws **1**.
- ▶ Check screws **1** for tight fit.

If the screws **1** are loose:

- ▶ Tighten screws **1**.

9.12 Lifting device

9.12.1 Check transport lashing and round slings for wear (according to EN 1492-2).

**DANGER**

Incorrectly attached rigging!
Load breakaway.

▶ Check that the transport lashing and round slings have a valid type plate.

▶ Check transport lashing and round slings for wear.

If the transport lashing or round slings show signs of wear:

▶ Replace transport lashing or round slings.

9.12.2 Check the round steel chains for wear and damage

**DANGER**

Incorrectly attached rigging!
Load breakaway.

▶ Check that the round steel chain has a valid type plate.

When visually checking the round steel chains, pay attention to the following points:

- Type plate should be legible and valid
- There should be no cracks or notches in the chain links or hooks
- Locking elements of the hooks must be present and correct
- Chain links must not be deformed

▶ Check the round steel chains for wear and damage.

If the round steel chains show signs of wear or damage:

▶ Replace round steel chains.

9.13 Hook/pulley block

9.13.1 Checking all hooks/pulley blocks for damage, wear, corrosion and widening of the hook aperture

**DANGER**

Damaged or unauthorised rigging material is used!
Load breakaway.

- ▶ Observe the national and international regulations on the use and inspection of rigging material!
 - ▶ Check all hooks/pulley blocks for signs of damage, wear, corrosion and widening of the hook aperture
- If the hooks/pulley blocks are damaged in any way:
- ▶ Contact Liebherr after sales service.

9.13.2 Lubricating bearings and axels

Ensure that grease gun from Liebherr tool kit is available and filled with correct grease (For more information see: [9.2.3 Lubrication chart, page 1875](#)).

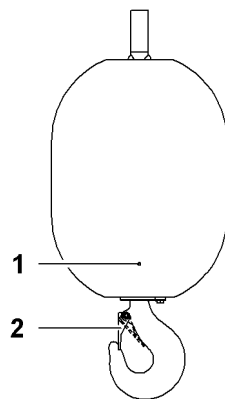


Fig. 5892: Hook

1 Grease nipple

2 Safety catch

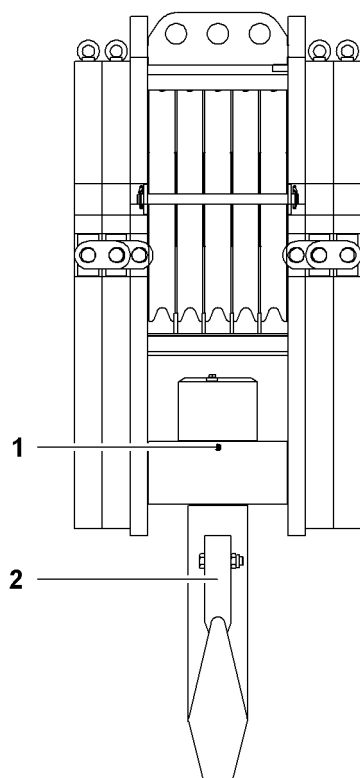


Fig. 5893: Pulley block

1 Grease nipple

2 Safety catch

- ▶ Using the grease gun, press 10 g (0.02 lb) of grease onto the grease nipple 1.
 - ▷ Optimal lubrication: During the lubrication process an even collar of fat is formed around the bearing.

9.13.3 Check that the safety catch is present and working properly



CAUTION

Self-closing safety catch!
Crushing.

- ▶ Protect your hands.

- ▶ To check the safety catch: push the safety catch back with your hand
 - ▷ The safety catch closes independently.

If the safety catch does not close by itself:

- ▶ Contact Liebherr after sales service.

9.14 Hydraulic system

9.14.1 Check the hydraulic system for leaks

Ensure that the following conditions are fulfilled:

- The machine is level.
- The machine is secured to prevent unauthorised operation.



CAUTION

Hot hydraulic oil!
Risk of burns.

- ▶ Only perform maintenance and inspection work on hydraulic system when diesel engine is switched off.
- ▶ Wear protective equipment.

-
- ▶ Check hydraulic system for leaks.

If there is a leak in the hydraulic system:

- ▶ Switch off machine.
- ▶ Contact Liebherr after sales service.

9.14.2 Checking the oil cooler for contamination

- ▶ Check oil cooler for contamination.

If oil cooler is dirty:

- ▶ clean oil cooler.

9.15 Hydraulic oil tank

9.15.1 Carrying out a hydraulic oil analysis

(For more information see: 9.2.10 Liebherr oil diagnosis system, page 1882)

9.15.2 Filling with hydraulic oil



Note

- ▶ If replacing “mineral oil-based hydraulic oil” with “synthetic oil-based hydraulic oil”, please contact Liebherr after sales service.

Ensure that the following conditions are fulfilled:

- Torque wrench 69 Nm (51 ft-lb) (width across flats 19) is available.
- The machine is level.
- The machine is secured to prevent unauthorised operation.



CAUTION

Hot engine parts and hydraulic oil!
Risk of burns.

- ▶ Do not open the cover of the return filter unless the engine is switched off and the temperature of the hydraulic oil is 40° or less.
- ▶ Wear protective equipment.

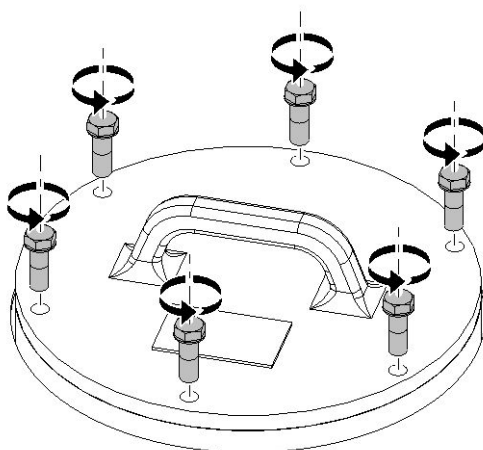


Fig. 5894: Opening the return filter

- ▶ Undo all screws.
- ▶ Remove the cover from the housing.

NOTICE

Inadmissible hydraulic oil or incorrect filling of hydraulic oil!
Damage to hydraulic system.

- ▶ Top up with suitable hydraulic oil only (For more information see: 9.2.3 Lubrication chart, page 1875) .
- ▶ Only fill in clean and water-free hydraulic oil.
- ▶ Only add approved additives or concentrates (For more information see: 9.2.3 Lubrication chart, page 1875) .
- ▶ Ensure that no dirt or foreign bodies enter the return filter.
- ▶ Only fill in pre-filtered hydraulic oil via the return filter.

- ▶ Fill with hydraulic oil.
- ▶ Replace the housing cover and align it so that the screw holes match.

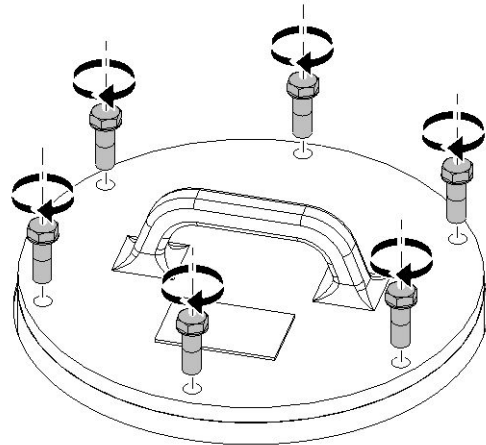


Fig. 5895: Closing the return filter

- ▶ Tighten the screws by hand.
- ▶ Tighten screws with a torque of 69 Nm (51 ft-lb).

9.15.3 Draining the hydraulic oil



Note

Environmental pollution!

- ▶ Fluids such as hydraulic oil, fuel and coolant must be disposed of in accordance with national and international regulations and guidelines.

At the bottom of the hydraulic oil tank is a drain valve.

- ▶ Remove the cover from the drain valve.
- ▶ Connect the oil drain hose from the Liebherr tool kit to the drain valve.
- ▶ Drain the hydraulic oil.

9.15.4 Cleaning the magnetic rod in the return filter

Ensure that a torque wrench 69 Nm (51 ft-lb) (width across flats 19) is available.

Opening the return filter



CAUTION

Hot engine parts and hydraulic oil!
Risk of burns.

- ▶ Do not open the cover of the return filter unless the engine is switched off and the temperature of the hydraulic oil is 40° or less.
- ▶ Wear protective equipment.

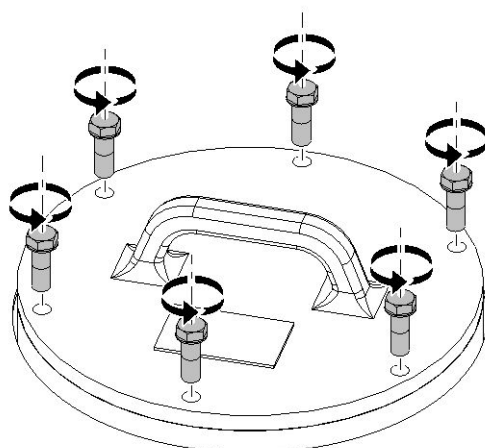


Fig. 5896: Opening the return filter

- ▶ Undo all screws.

NOTICE

Dirt and foreign bodies in return filter!
Damage to the hydraulic system.

- ▶ Ensure that no dirt or foreign bodies enter the return filter.
- ▶ Remove the cover from the housing.

Cleaning the magnetic rod

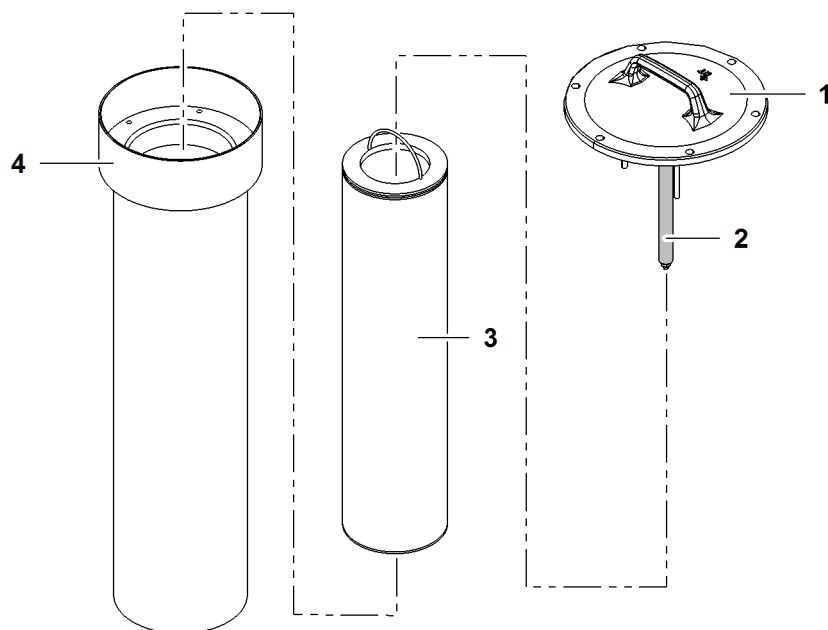


Fig. 5897: Cleaning the magnetic rod

- | | | | |
|---|--------------|---|-----------------------------------|
| 1 | Cover | 3 | Return filter |
| 2 | Magnetic rod | 4 | Housing in the hydraulic oil tank |

- ▶ Clean the magnetic rod **2** using a clean cloth.



Note

- ▶ Dispose of the oil-stained cleaning cloth according to the appropriate regulations.

Closing the return filter

- ▶ Replace the housing cover and align it so that the screw holes match.

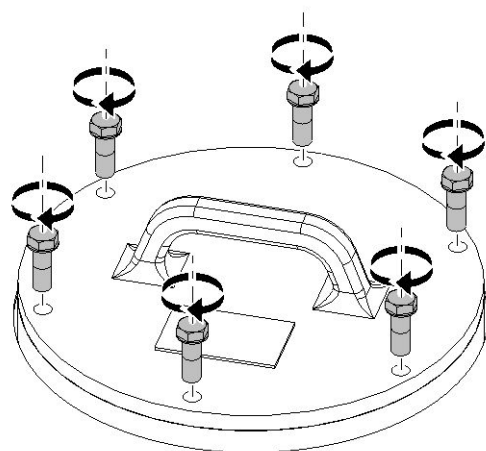


Fig. 5898: Closing the return filter

- ▶ Tighten the screws by hand.
- ▶ Torque the screws to 69 Nm (51 ft-lb).

9.16 Hydraulic oil filter

9.16.1 Exchanging the hydraulic oil filter elements

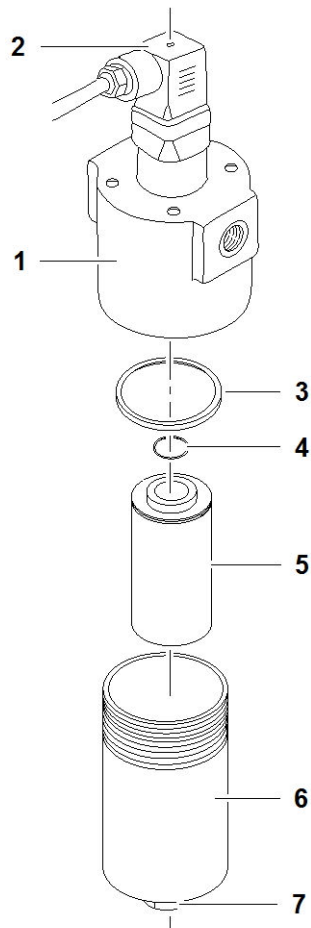


Fig. 5899: Exchanging the hydraulic oil filter elements

- | | | | |
|---|---------------------|---|------------------------|
| 1 | Top part of housing | 5 | Filter element |
| 2 | Pressure sensor | 6 | Bottom part of housing |
| 3 | Seal ring | 7 | Nut (welded on) |
| 4 | O-ring | | |

- ▶ Undo bottom part of housing **7** with nut **6** and take off.
 - ▶ Carefully remove filter element **5** and dispose of remaining oil of the bottom part of the housing **6**.
 - ▶ Clean all parts thoroughly.
 - ▶ Check O-ring **4** and seal ring **3** for damage.
- If O-ring or seal ring are damaged:
- ▶ exchange O-ring **4** or seal ring **3**.
 - ▶ Remove all dirt on the inside of the filter housing.
 - ▶ Insert new filter element **5**.

Ensure cleanliness and correct fit of the O-ring **4** and seal ring **3**.

- ▶ Reassemble parts in reverse order.
- ▶ Tighten nut **7** of the bottom part of the housing **6** all the way to the stop.
- ▶ Start diesel engine and allow it to idle for 5 minutes.
- ▶ Turn off diesel engine and again tighten nut **7** of the bottom part of the housing **6** all the way to the stop.
- ▶ Start diesel engine and allow it to idle.
- ▶ Check hydraulic system for leaks.

If hydraulic system leaks:

- ▶ contact Liebherr customer service.

9.17 Hydraulic cylinders

9.17.1 Check that the hydraulic cylinder fits properly and does not leak

- ▶ Check that the hydraulic cylinder fits properly and does not leak.

If the hydraulic cylinder is leaking or loose:

- ▶ Contact Liebherr after sales service.

9.17.2 Protecting the piston rods of the hydraulic cylinders from corrosion

The piston rods on all hydraulic cylinders are chrome-plated. Despite this, dirty and aggressive materials can still damage the chrome coating. The chrome coating only offers a certain level of protection.

- ▶ Ensure that the piston rods are in perfect condition and clean.
- ▶ Extend and retract piston rods at least once a week.

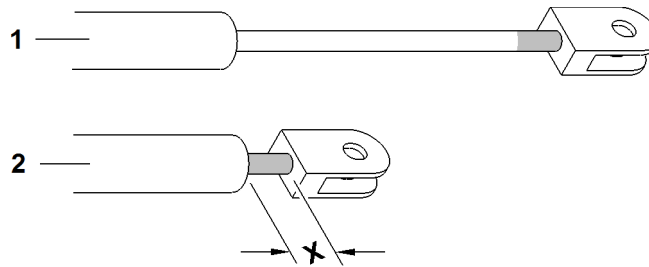


Fig. 5900: Overlap piston rod (illustration of principle)

- | | | | |
|---|----------------------|---|--------------------|
| 1 | Extended piston rod | X | Overlap piston rod |
| 2 | Retracted piston rod | | |

- ▶ Wrap overlap of piston rod X with Denso tape.

9.17.3 Preserving the piston rods of the hydraulic cylinders in case of longer periods of non-use

- ▶ Wrap piston rods with Denso tape.
or

Preserve piston rods with the protective agent CORTEC VCI 369.

9.18 Hydraulic hoses

9.18.1 Checking the hydraulic hoses

- ▶ Check hydraulic hoses for damage and tears.

If damage or tears are visible on the hydraulic hoses:

- ▶ Contact Liebherr customer service.

9.19 Bypass filter system

9.19.1 Checking the bypass filter system

Make sure the following prerequisites are met:

- Hydraulic oil is at operating temperature.
- ▶ Read dynamic pressure manometer on bypass flow filter.

If the dynamic pressure manometer of the bypass flow filter shows 1 bar (14.50 psi) above the initial value (normal value):

- ▶ change the filter elements.

9.19.2 Changing the filter elements

Ensure that the following conditions are fulfilled:

- Diesel engine has been switched off for 5 minutes.
- Machine is level.
- Machine is secured against unauthorized start-up.



Note

Liebherr recommends:

- ▶ If the machine is subjected to heavy work: halve the exchange interval.
-

The filter elements cannot be cleaned and must be disposed of in accordance with the national and international regulations and guidelines.

Removing filter elements

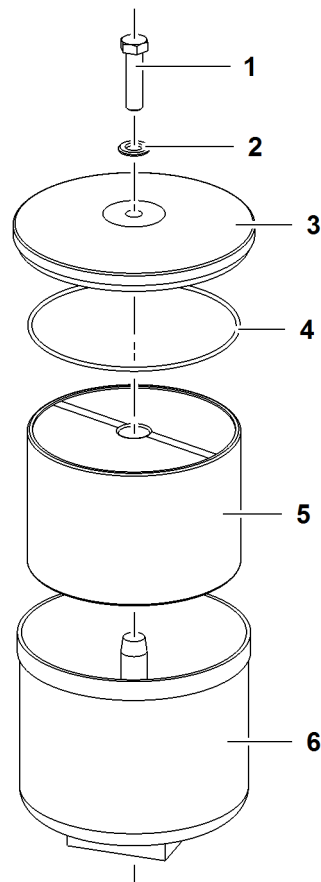


Fig. 5901: Removing filter elements

1	Screw	4	O-ring
2	Washer	5	Filter element
3	Cover	6	Filter housing



CAUTION

Hot surfaces and hot operating liquids!
Risk of burning hands.

- ▶ Only exchange filter elements **5** when the machine stands still and the hydraulic system is without pressure.
-
- ▶ Open the cover **3** of the filter housing **6**.
 - ▶ Turn filter elements **5** clockwise with the help of the carrier straps and lift at the same time.
 - ▶ Let filter element **5** drain if necessary.
 - ▶ Remove filter element **5**.
 - ▶ Check feed and discharge in the filter housing **6** for free flow.

Inserting filter elements



Note

The carton is a functional part of the filter!

▶ Do not remove carton wrap.

▶ Insert the filter element **5** in such a way that the lettering is legible and the protective polypropylene base is on the bottom.

▶ Replace O-ring **4**.

▶ Check washer **2**.

If washer **2** is defect:

▶ replace washer **2**.

▶ Tighten screw **1** with a torque of 49 Nm (36 ft-lb).

9.20 Batteries

9.20.1 Checking the fluid level in the cells

NOTICE

Contamination and moisture on the battery!
Damage to battery.

- ▶ Keep battery clean and dry.

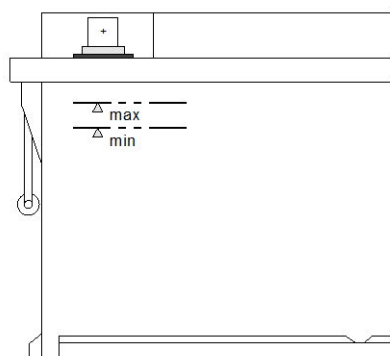


Fig. 5902: Checking the fluid level in the cells

- ▶ Check the fluid level in the cells.
- If the fluid level is below the MIN mark:
 - ▶ fill in distilled water.

9.20.2 Checking the battery fluid

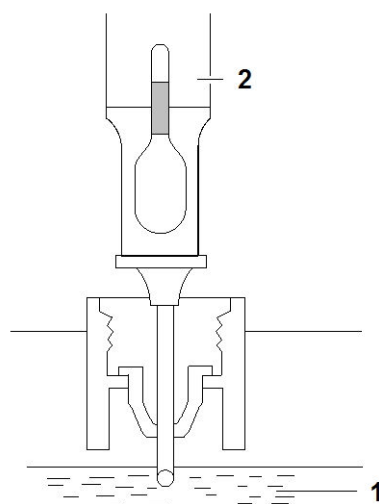


Fig. 5903: Checking the battery fluid

- 1 Battery fluid
- 2 Acid tester
- ▶ Observe operation manual of the testing devices.

- ▶ Check battery fluid **1** with refractometer or acid tester **2**.
- ▶ Top up with fluid if required or contact Liebherr customer service.

9.20.3 Exchanging the fuses on the battery

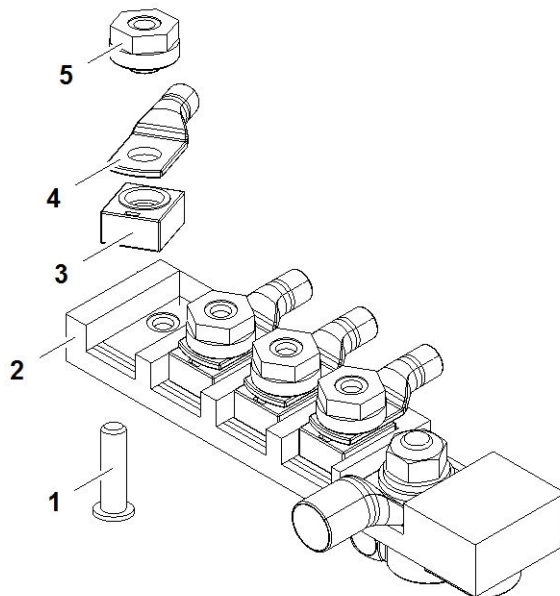


Fig. 5904: Exchanging the fuses on the battery

- | | | | |
|----------|---------------|----------|---------------------------|
| 1 | Locking screw | 4 | Electric cable (consumer) |
| 2 | Fuse block | 5 | Insulation nut |
| 3 | Fuse element | | |

Spare insulation nuts and spare fuse elements are located in the fuse box in the switch cabinet.

- ▶ Exchange insulation nuts or fuse elements when required.

9.21 Lighting

9.21.1 Checking that the cabin lighting, floodlights and auxiliary floodlights are working properly

The floodlights should illuminate if the appropriate button in the cab is pressed.

- ▶ Check that the cabin lighting, floodlights and auxiliary floodlights are working properly.

If the cabin lighting, floodlights and auxiliary floodlights do not switch on:

- ▶ Check the fuses and electric cables.
- ▶ Change the bulbs.

If the cabin lighting, floodlights and auxiliary floodlights do not switch on again:

- ▶ Contact Liebherr after sales service.

9.21.2 Changing the cab lamp light bulb

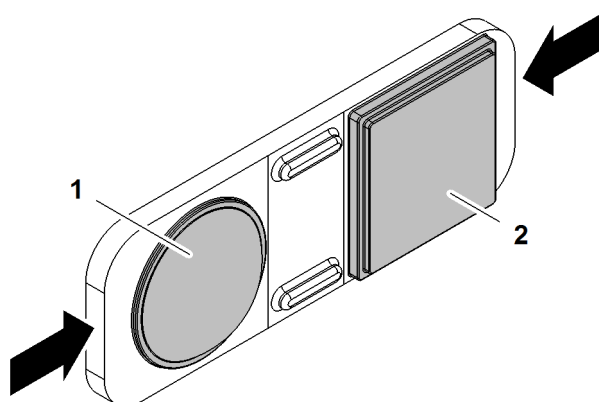


Fig. 5905: Changing the cab lamp light bulb

- | | |
|----------------|---------------|
| 1 Curved glass | 2 Clear plate |
|----------------|---------------|

Ensure that the following conditions are fulfilled:

- New bulb **R10W 24 V/10 W** is available.
- The battery main switch is switched off.
- ▶ Remove the clear plate **2** and curved glass **1** from the front by pressing on the sides.
- ▶ Remove defect bulb and dispose of properly.
- ▶ Insert new bulb.
- ▶ Refit the clear plate **2** and curved glass **1**.
 - ▷ Cabin lighting ready for operation.

9.21.3 Changing the bulbs of floodlights on the cabin and on the uppercarriage

The following floodlights are available:

- Halogen floodlights
- Xenon floodlight

- LED floodlight

Xenon and halogen floodlights

Ensure that the following conditions are fulfilled:

- The battery main switch is switched off.
- New Liebherr bulbs are available.
 - for halogen floodlights: **H3 24 V/70 W**
 - for xenon floodlights: **D2S 24 V/35 W**

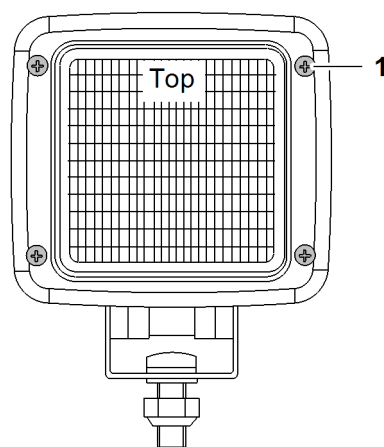


Fig. 5906: Floodlights on the cabin and on the uppercarriage

1 Screw (4x)

- ▶ Undo all screws **1**.

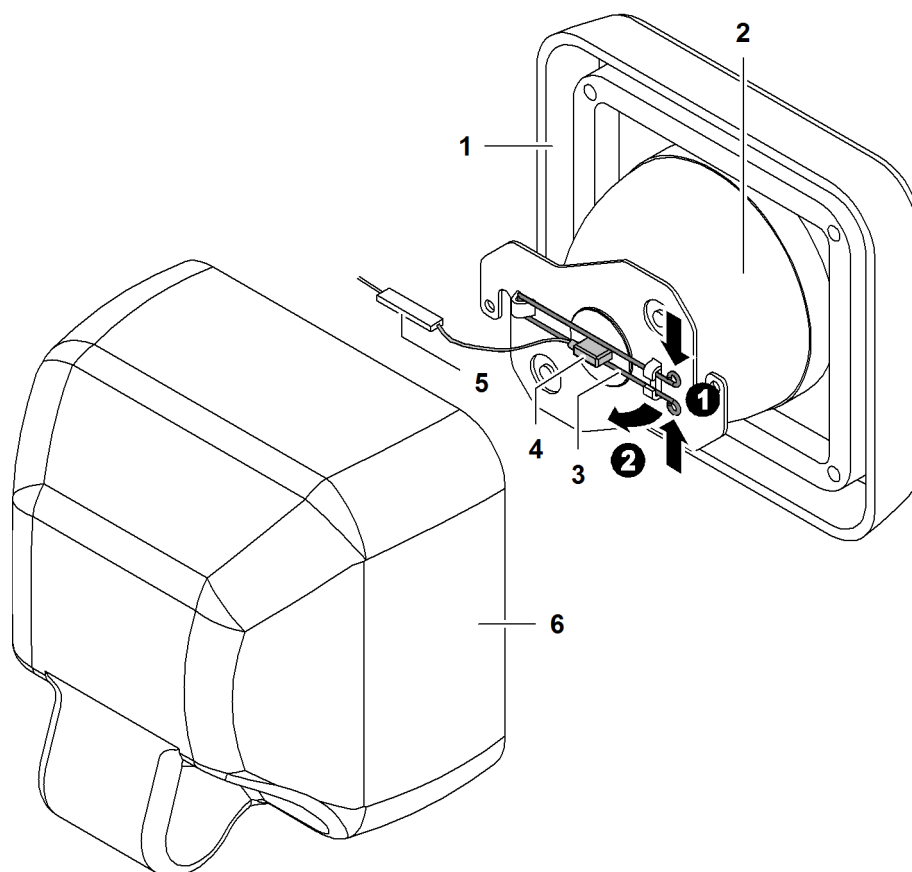


Fig. 5907: Floodlight open

- | | | | |
|---|---------------------------|---|--------------------------|
| 1 | Cover | 4 | Bulb with electric cable |
| 2 | Floodlight with reflector | 5 | Electric plug |
| 3 | Spring steel bracket | 6 | Housing |

The cover 1 has a drainage opening on the bottom.

The reflector of the floodlight 2 has a guide notch on the top.

- ▶ Take off the cover 1.
- ▶ Take out floodlight 2 with reflector.
- ▶ Press together the spring steel bracket 3 and lift.
- ▶ Unplug electric plug 5 of the bulb.
- ▶ Remove defect bulb 4 and dispose of properly.

NOTICE

Fragile bulb!
Bulb may be damaged.

- ▶ Do not touch the bulb directly with your fingers.



Note

Fingerprints on bulb!
Liebherr recommends:

- ▶ Clean bulb with a clean cloth and alcohol.
- ▶ Insert new bulb 4.

- ▶ Press together the spring steel bracket **3** and lower.
- ▶ Snap spring steel bracket **3** into mounts.
- ▶ Plug in electric cable of the bulb **4**.
- ▶ Insert floodlight **2** with reflector (observe installation direction).
- ▶ Put on cover (observe installation direction).
- ▶ Tighten all screws **1**.
 - ▷ Floodlights ready for operation.

LED floodlight

LED floodlights must be replaced completely.

9.21.4 Changing the bulbs of search floodlights

Ensure that the following conditions are fulfilled:

- New bulb **H3 24 V/70 W** is available.
- Main battery switch is switched off.

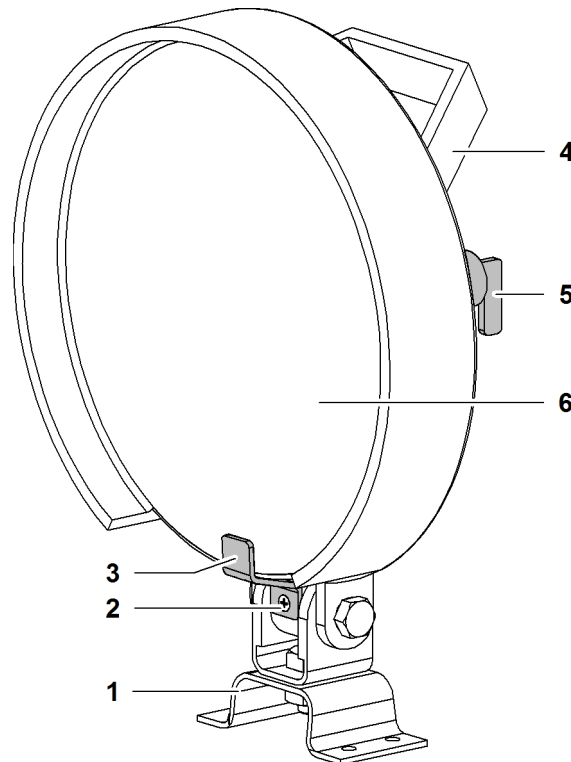


Fig. 5908: Search floodlight

- | | | | |
|----------|---------|----------|------------------|
| 1 | Mount | 4 | Handle |
| 2 | Screw | 5 | Switch |
| 3 | Bracket | 6 | Floodlight glass |

The floodlight glass **6** has an indentation below the bracket **3**. The indentation must be located in the same position again when installing.

- ▶ Undo screw **2** and remove bracket **3**.
- ▶ Lift floodlight glass **6**.
- ▶ Unplug electric cable of the bulb.

- ▶ Press together the spring steel bracket and lift.
- ▶ Remove defect bulb and dispose of properly.

NOTICE

Fragile bulb!
Bulb may be damaged.

- ▶ Do not touch the bulb directly with your fingers.

**Note**

Fingerprints on bulb!
Liebherr recommends:

- ▶ Clean bulb with a clean cloth and alcohol.
-
- ▶ Insert new bulb.
 - ▶ Press together the spring steel bracket and lower.
 - ▶ Snap spring steel bracket into mounts.
 - ▶ Plug in electric cable of the bulb.
 - ▶ Put on floodlight glass **6** (observe installation direction).
 - ▶ Tighten bracket **3** with screw **2**.
 - ▷ Floodlights ready for operation.

9.21.5 Changing the bulbs of floodlights on main boom base section

The following floodlights are available:

- Xenon floodlight
- LED floodlight

Xenon floodlight

Ensure that the following conditions are fulfilled:

- New bulb **xenon gas discharge lamp 24 V/42 W** is available.
- Main battery switch is switched off.

**CAUTION**

Hot bulb!
Risk of burning of limbs.

- ▶ Leave bulb to cool down for at least 30 minutes.

**WARNING**

Bulb breaking in a closed room!
Intoxication.

- ▶ Air room for at least 20 minutes.
- ▶ Leave room.

**WARNING**

Bulb under pressure!
Serious injury.

- ▶ Wear safety goggles and safety gloves.

**WARNING**

High-voltage control gear!
Electric shock.

- ▶ Turn main battery switch off a few minutes prior to changing the bulb.

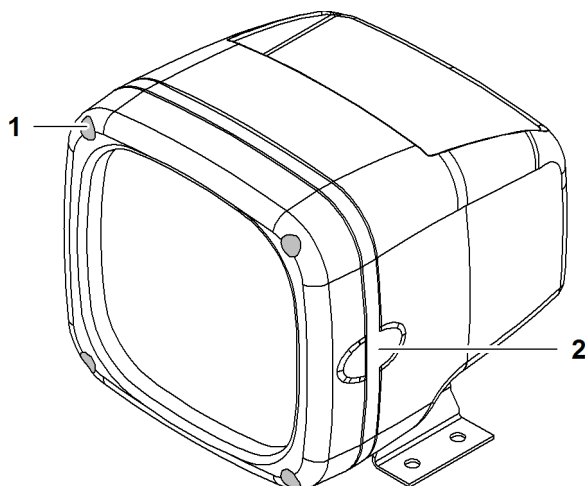


Fig. 5909: Xenon floodlights on main boom base section

1 Screw (4x)

2 Lateral marking (2x)

- ▶ Undo all screws **1**.

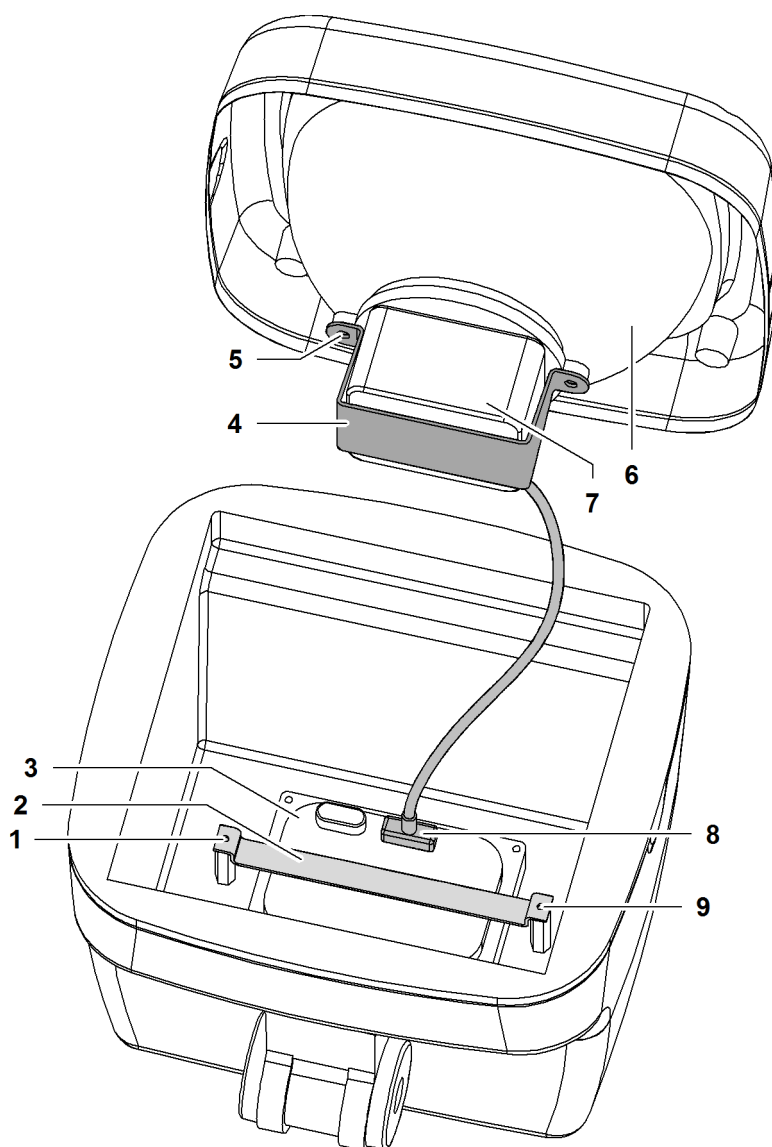


Fig. 5910: Open xenon floodlight

- | | | | |
|---|----------------------|---|---------------------------|
| 1 | Left screw | 6 | Floodlight with reflector |
| 2 | Bracket control gear | 7 | Bulb with electric cable |
| 3 | Control gear | 8 | Electric plug |
| 4 | Bracket bulb | 9 | Right screw |
| 5 | Screw (2x) | | |

The electric plug 7 is secured with a plug locking mechanism on the side of the control gear.

- ▶ Lift floodlight 6 with reflector.
- ▶ Loosen the left screw 1 of the bracket 2.
- ▶ Remove the right screw 9 of the bracket 2.
- ▶ Take off bracket 2.
- ▶ Lift control gear 3 and undo plug locking mechanism of the electric plug 8.
- ▶ Pull out electric plug 8.
- ▶ Undo both screws 5.
- ▶ Remove bracket 4.

- ▶ Remove defect bulb **7** and dispose of properly.

NOTICE

Fragile bulb!
Bulb may be damaged.

- ▶ Do not touch the bulb directly with your fingers.
-



Note

Fingerprints on bulb!
Liebherr recommends:

- ▶ Clean bulb with a clean cloth and alcohol.
-



Note

Color differences in bulbs!
Liebherr recommends:

- ▶ If there are more than one bulb, exchange all bulbs to prevent color differences.
-

- ▶ Insert new bulb **7**.
- ▶ Tighten bracket **4** over bulb **7** with screws **5**.
- ▶ Insert electric plug **8** of bulb **7** until plug locking mechanism snaps into place.
- ▶ Insert bracket **2** over control gear on left screw **1**.
- ▶ Insert and tighten right screw **9**.
- ▶ Tighten left screw **1**.
- ▶ Insert floodlight **6** with reflector (observe installation direction).
- ▶ Close floodlight housing and tighten the screws.
 - ▷ Floodlights ready for operation.

LED floodlights

LED floodlights must be replaced completely.

9.21.6 Exchanging the bulbs of floodlights on main boom or jib head

The following floodlights are available:

- High-pressure sodium vapor lamp
- LED floodlight

High-pressure sodium vapor lamp

Ensure that the following conditions are fulfilled:

- New bulb **gas discharge lamp SON-T 230 V/1000 W** is available.
- Main battery switch is switched off.

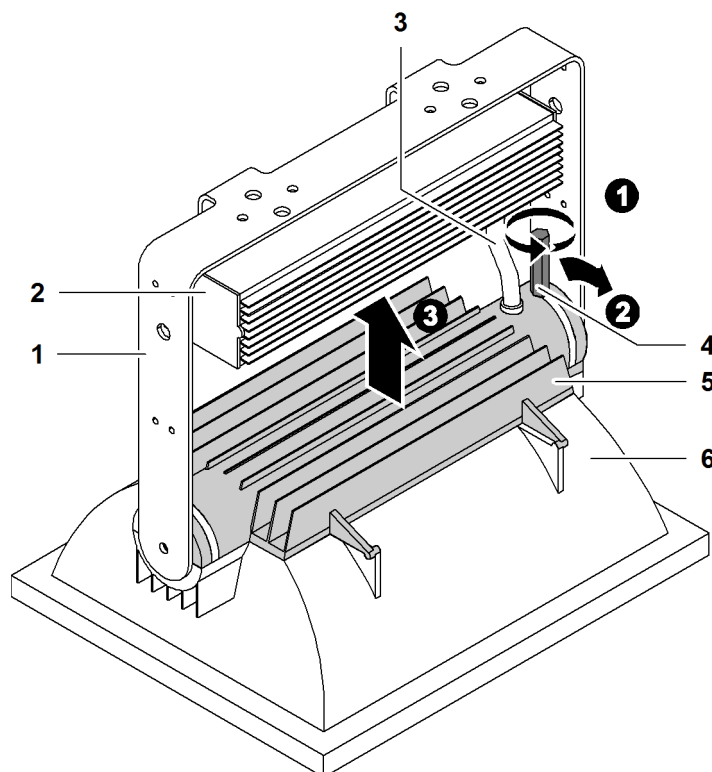


Fig. 5911: Exchanging floodlights on main boom or jib head

1	Bracket	4	Lever (2x)
2	Control gear	5	Cover
3	Electric cable	6	Main reflector

- ▶ Undo both levers 4: Turn lever 4 counter-clockwise.
- ▶ Pull down both levers 4.
- ▶ Fold the cover 5 up.
 - ▷ Bulb is visible in the cover 5.
- ▶ Twist bulb counter-clockwise.
- ▶ Dispose of defect bulb properly.

NOTICE

Fragile bulb!
Bulb may be damaged.

- ▶ Do not touch the bulb directly with your fingers.



Note

Fingerprints on bulb!
Liebherr recommends:

- ▶ Clean bulb with a clean cloth and alcohol.
- ▶ Insert new bulb.



Note

Defect electric cable!
Liebherr recommends:

▶ Ensure that the electric cable does not become pinched when assembling.

▶ Close the cover **5**.

▶ Pull up both levers **4**.

▶ Tighten both levers **4** clockwise.

▷ Floodlights ready for operation.

LED floodlight

LED floodlights must be replaced completely.

9.22 Rope measuring system

9.22.1 Checking the rope measuring system and height adjustment of all winches (if available) for correct function

Make sure the following prerequisites are met:

- There is no load on the hook.
- Diesel engine is switched on.

- ▶ Lower rope of winch1/winch2 until hook touches the ground.
- ▶ Press the *Settings* button on the monitor.



- ▶ Press the *Settings - components* button on the screen.



- ▶ Press the button *Set to zero* of winch1/winch2 on the monitor.



- ▶ Lift rope of winch1/winch2 until rope measuring system shows 1 m (3' 3" ft-in) on the monitor.
- ▶ Measure distance between hook and ground with suitable measuring instrument.

If the distance between the hook and the ground does not correspond to the rope measuring system value:

- ▶ Contact Liebherr customer service.

9.22.2 Readjusting layer change when changing ropes

(For more information see: [Programming layer change, page 997](#))

9.23 Limit switches

9.23.1 Checking hoist limit switches, boom limit switches and, if necessary, limit switches of the piling and drilling rig to ensure they are working correctly

- ▶ Check the operation of the limit switches: instruct an assistant to manually trigger the limit switches.

If the activated limit switch does not register on the monitor:

- ▶ Contact Liebherr after sales service.

9.24 Mechanical inclinometer

9.24.1 Checking that the mechanical inclinometer is working properly

- ▶ Check that the mechanical inclinometer is working properly.

If the mechanical inclinometer is faulty in any way:

- ▶ contact Liebherr service department.

9.25 Emergency stop

9.25.1 Checking the emergency stop



WARNING

Unauthorized triggering of the emergency stop!
Severe injuries, damage to machine.

- ▶ The emergency stop may only be triggered when the diesel engine is running, the machine is not moving and no load is attached.
-

- ▶ Check that all emergency stops are working.

If the diesel engine does not switch off:

- ▶ Contact Liebherr customer service.

9.26 Obstacle warning light*

9.26.1 Check obstacle warning light for function and damage, check mains cable and plug (if available) for damage

- ▶ Check obstacle warning light for function and damage.

If the obstacle warning light is damaged or does not function:

- ▶ Contact Liebherr customer service.

- ▶ Check mains cable and plug (if available) for damage.

If mains cable or plug are damaged:

- ▶ Contact Liebherr customer service.

9.27 Fire extinguishers

9.27.1 Checking the seals and inspection dates on the fire extinguishers

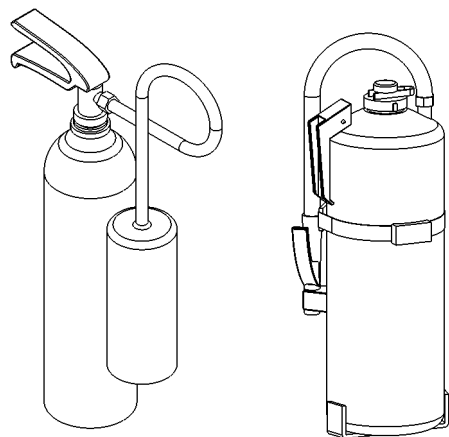


Fig. 5915: Check fire extinguishers for presence of seals and inspection due dates

NOTICE

Unsuitable or broken fire extinguishers!

- ▶ Note the type plate on the fire extinguisher.
 - ▶ Observe national regulations.
-

The guidelines for checking hand extinguishers are nationally regulated.

- ▶ Check the seals and inspection dates on the fire extinguishers.

If the fire extinguishers are missing or the inspection dates have been passed:

- ▶ Replace the fire extinguishers or have them inspected.

9.28 Personal protective equipment

9.28.1 Checking personal protective gear



WARNING

Inadequate protection!

- ▶ Observe the manufacturer's guidelines on care and maintenance of the protective gear.
 - ▶ Do not repair protective gear yourself.
-

- ▶ Check that the personal protective gear is in place, intact and complete ([For more information see: 2.4 Personal protective equipment, page 556](#)).

If the personal protective gear is not present, damaged, or incomplete:

- ▶ Complete the personal protective gear.
- ▶ Clean the personal protective gear.
- ▶ Have the personal protective gear cleaned.

9.29 Safety signs

9.29.1 Checking that all required safety labels are mounted on the machine and are legible

- ▶ Check safety labels to ensure they are complete and legible.

If safety labels are not complete or illegible:

- ▶ Complete the safety labels.
- ▶ Clean or replace safety labels.

9.30 Access systems and railings

9.30.1 Checking ladders, steps, platforms, and ascents for wear, damage and anti-slip surfaces



WARNING

Insufficient protection of machine operators and maintenance personnel!
Severe injury.

- ▶ Ensure that damaged or worn ladders, steps, platforms, or ascents are not used.
- ▶ Ensure that damaged or worn ladders, steps, platforms, or ascents are repaired immediately.

- ▶ Check ladders, steps, platforms, and ascents for wear, damage and anti-slip surfaces.

If wear or damage are visible on access systems:

- ▶ Repair access systems.

9.30.2 Checking latches and hand rails for wear and damage

- ▶ Check latches and hand rails for wear and damage.

If wear or damage are visible on latches or handrails:

- ▶ Repair latches and hand rails.

9.30.3 Checking the spring tension of railing doors

When releasing the completely opened railing door, the spring tension of the hinges must be strong enough so that the railing door closes on its own and the rubber buffer is pressed onto the stop with some force.



WARNING

Railing door does not close automatically!
Fall from machine.

- ▶ Increase spring tension of railing doors.



WARNING

Railing door closes too tight!
Fall from machine.

- ▶ Decrease spring tension of railing doors.

- ▶ Check spring tension of railing doors.

If the railing door does not close automatically:

- ▶ Increase spring tension of railing door.

If the railing door closes too tight:

- ▶ Decrease spring tension of railing door.

9.30.4 Setting the spring tension of railing doors

Ensure that the following conditions are fulfilled:

- Size 4 pin punch is available.

A pin punch is a tool for knocking through or knocking out split pins, pins or pegs.

Increasing the spring tension of the railing door

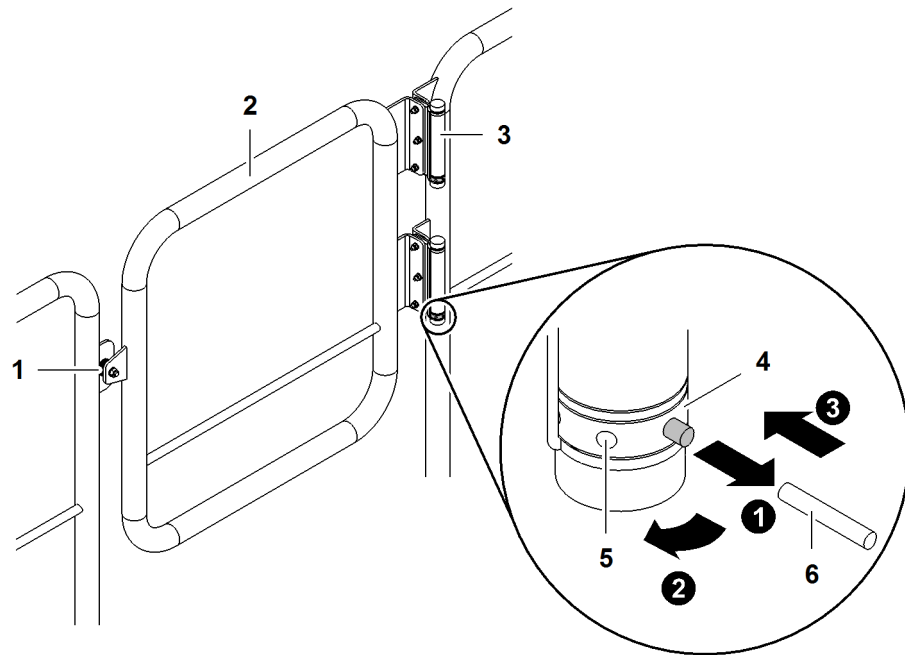


Fig. 5916: Increasing the spring tension of the railing doors

- | | | | |
|---|---------------|---|---------------------------|
| 1 | Rubber buffer | 4 | Spring adjuster ring (2x) |
| 2 | Railing door | 5 | Boring |
| 3 | Hinge (2x) | 6 | Peg |

Spring adjuster rings **3** are located on the hinges **4** and serve to adjust the spring tension.

- ▶ Insert pin punch at hinge **5** boring **3**.
- ▶ Turn spring adjuster ring **4** clockwise.
 - ▷ Peg **6** is relieved.
- ▶ Remove peg **6**.
- ▶ Turn spring adjuster ring **4** clockwise until peg **6** can be reinserted.
- ▶ Insert peg **6**.
- ▶ Remove pin punch.
- ▶ Repeat procedure on all hinges **3**.

Decreasing the spring tension of the railing door

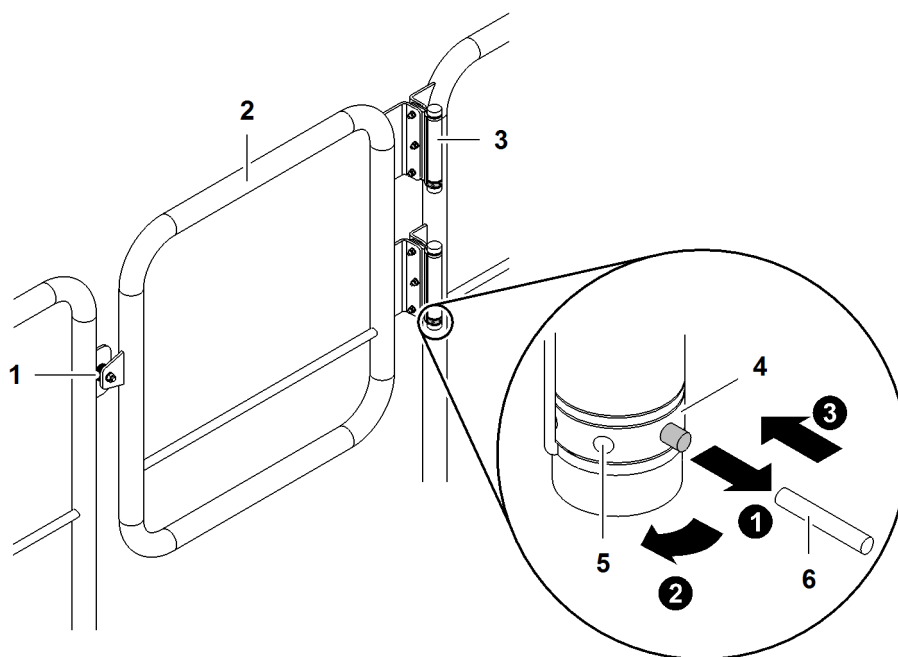


Fig. 5917: Decreasing the spring tension of the railing doors

- | | | | |
|---|---------------|---|---------------------------|
| 1 | Rubber buffer | 4 | Spring adjuster ring (2x) |
| 2 | Railing door | 5 | Boring |
| 3 | Hinge (2x) | 6 | Peg |

- ▶ Insert pin punch at hinge **5** boring **3**.
- ▶ Turn spring adjuster ring **4** clockwise.
 - ▷ Peg **6** is relieved.
- ▶ Remove peg **6**.
- ▶ Turn spring adjuster ring **4** counter-clockwise until peg **6** can be reinserted.
- ▶ Insert peg **6**.
- ▶ Remove pin punch.
- ▶ Repeat procedure on all hinges **3**.

9.30.5 Checking the function of the railing stabilization

Checking the eye bolt of the railing stabilization for tight fit

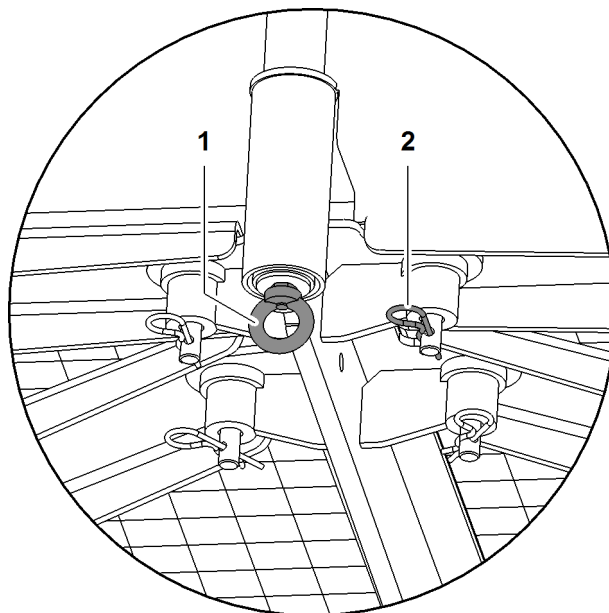


Fig. 5918: Checking the eye bolt of the railing stabilization for tight fit

1 Eye bolt for railing stabilization 2 Spring cotter pin

- ▶ Push screwdriver through eye bolt 1.
- ▶ Turn eye bolt 1 clockwise.

If the eye bolt 1 can be turned:

- ▶ Tighten eye bolt 1.
- ▶ Repeat procedure on all eye bolts 1.

Checking the availability of the spring cotter pin

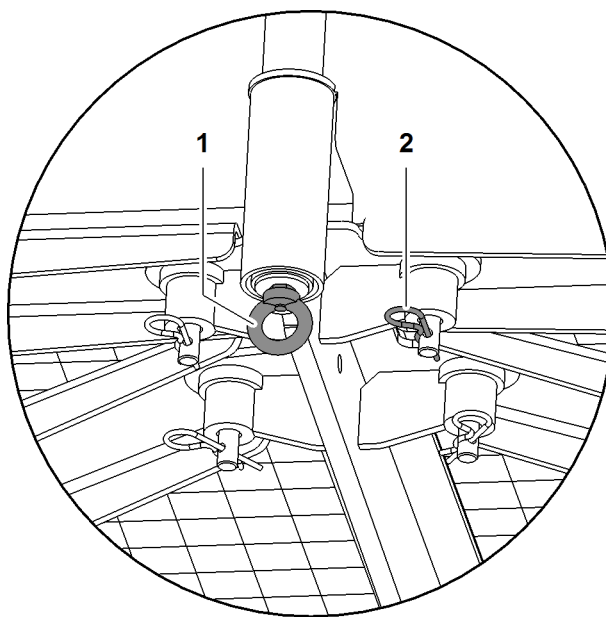


Fig. 5919: Checking the availability of the spring cotter pin

1 Eye bolt for railing stabilization 2 Spring cotter pin

▶ Checking the availability of the spring cotter pin 2.

If no spring cotter pin 2 is available:

▶ Insert spring cotter pin 2.

▶ Repeat procedure with all spring cotter pins 2.

9.31 Steel structure

9.31.1 Checking the machine steel structure for damage, cracks



DANGER

Operating the machine is not permitted if there is damage to the steel structure! Structural breakdown.

▶ Operate machine exclusively with steel structure in perfect condition.

▶ Checking the machine steel structure for damage, cracks.

If cracks or damage is visible on the steel structure of the machine:

▶ Observe instructions for repairs on steel structure ([For more information see: 9.31.2 Repairs on the steel structure, page 1959](#)).

Checking the weld seams and holes

The drawings for checking the weld seams and holes can be found in the "Technical information" volume.

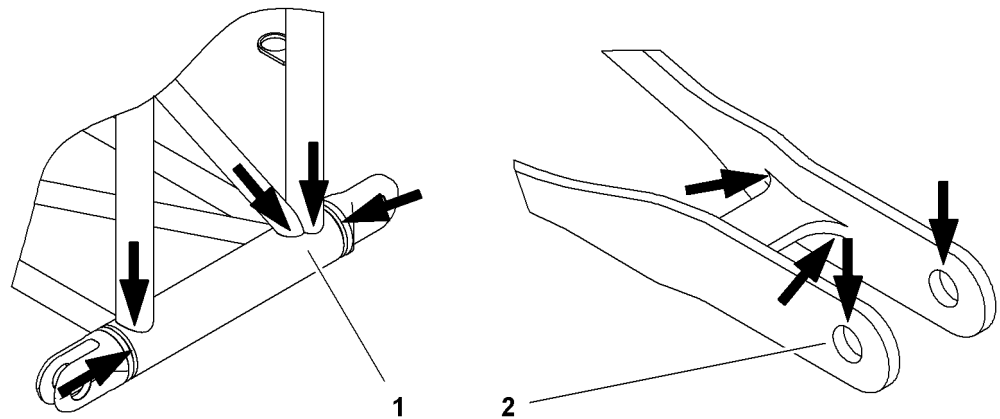


Fig. 5920: Excerpt from the drawings for checking the weld seams and holes

1 Weld seams

2 Holes

All weld seams and holes must be checked. The arrows denote the weld seams and holes that must be checked closely due to the high stresses placed on them.



DANGER

Weld seams are incorrectly or incompletely checked! Structural breakdown.

▶ Check all weld seams.

▶ Check the entire weld seam.

▶ Clean dirt from the weld seams.

▶ Visually check the weld seams for cracks.

If a crack is found:

- ▶ Observe instructions for repairs on steel structure ([For more information see: 9.31.2 Repairs on the steel structure, page 1959](#)).
- ▶ Check holes and slots (e.g. on connecting links) for wear, cracks and plastic deformations.

If a hole is damaged:

- ▶ Observe instructions for repairs on steel structure ([For more information see: 9.31.2 Repairs on the steel structure, page 1959](#)).

9.31.2 Repairs on the steel structure



DANGER

Inadmissible, improper or unauthorized repairs on the steel structure!
Structural breakdown.

- ▶ Make sure that only the Liebherr service personnel or authorized trained personnel decides whether a repair on the steel structure is admissible. If necessary, contact Liebherr after sales service.
- ▶ Make sure that the repair instructions are requested from the Liebherr customer service and observed.
- ▶ Ensure that repairs to the steel structure are performed by Liebherr service personnel or authorized trained personnel only.

The steel structure is made of high-strength fine grained steel. Each heat treatment, e.g. welding, can alter the structure of the steel and reduce the component strength.



DANGER

Steel parts are welded to the structure without authorisation!
Structural breakdown.

- ▶ Additional parts may only be welded to the steel structure after written approval has been obtained from Liebherr-Werk Nenzing GmbH.

Repair welding requirements



DANGER

Poor welding quality!
Structural breakdown.

- ▶ Observe the international and national safety and accident prevention regulations and the "Principles for the testing of cranes by specialists and experts according to the accident prevention regulations "Cranes" BGV D6 and BGG 905" (formerly: VBG 9)".
- ▶ Repair instructions, specifying the basic material and the relevant welding consumables and auxiliary agents, must be requested from Liebherr after sales service. These instructions must be observed.
- ▶ All necessary non-destructive tests must be carried out and documented.

Ensure that the following conditions are fulfilled:

- Qualified personnel are available.

- Liebherr service personnel who have passed the corresponding welding qualification tests laid down in EN 287-1 for the material and welding method in question are available.
- enterprises holding a major qualification certificate according to DIN 18800-7, DIN 15018 and DIN 4132 with the extension for cranes, crane tracks and the following high-strength and highest-strength fine-grained structural steel, have available:
 - Steel sheet S690QL1 W. No. 1.8988
 - Steel sheet S690QL W. No. 1.8928
 - Steel sheet S700MC W. No. 1.8974
 - Tubes S770QL W. No. 1.8938
 - Steel sheet S960QL W. No. 1.8933
 - Steel sheet S960MC W. No. -
- Manual arc welding certificate E (111) is available.
- experience in the repair of mobile and crawler cranes with the relevant materials and use of welding processes MAG (135).
- Repair welding must satisfy the requirements of EN 25817-B.
- ▶ Perform the repair welding in accordance with applicable regulations.



Note

- ▶ Request the necessary test loads and boom configurations from Liebherr after sales service.
-
- ▶ Subject the repaired component to a load test.
 - ▶ Document the tests performed in the crane test log.

9.32 Main boom

9.32.1 Check main boom base section, main boom head and main boom sections for damage and wear (cracks, notches, corrosion, plastic deformation, wear)



DANGER

Incorrect use of the machine with damaged main boom!
Structural breakdown.

- ▶ Exclusively use machine with main boom that is in perfect condition.
-

The steel structure of the main boom must undergo a thorough visual inspection according to the maintenance plan or as laid down in national regulations.

If the machine was subject to excess strain as the result of a severe impact or a large number of load cycles, the structural components must be examined immediately and the inspection intervals reduced.

Any cracks in the steel structure must be examined by qualified service personnel using the following testing procedures:

- magnetic powder test
- dye penetration test

The main boom base section, the main boom head and the main boom sections must also be checked for bent or damaged boom pipes of the welded structure.

- ▶ Check main boom base section, main boom head and main boom sections for damage and wear (cracks, notches, corrosion, plastic deformation, wear).

If the main boom base section, the main boom head or the main boom sections are not in perfect condition:

- ▶ Observe instructions for repairs on steel structure ([For more information see: 9.31.2 Repairs on the steel structure, page 1959](#)).

9.32.2 Boom base section: checking that the knuckle pins and locking elements fit tightly

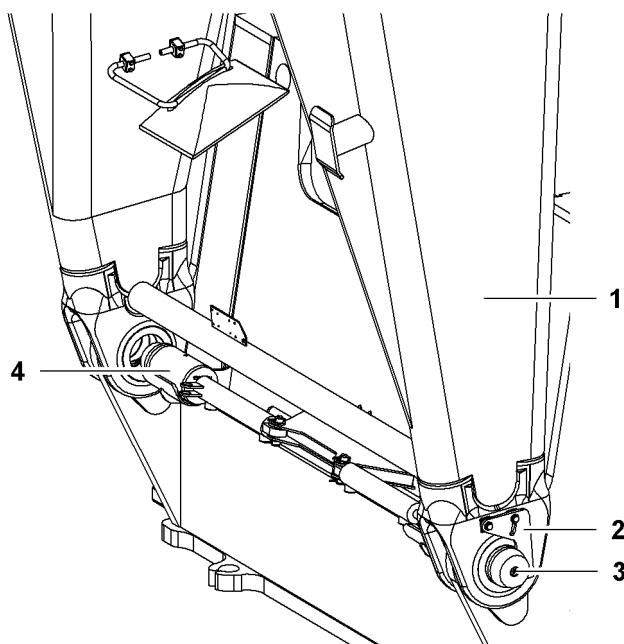


Fig. 5921: Knuckle pins and locking elements on main boom base section

- | | | | |
|---|------------------------|---|--------------------|
| 1 | Main boom base section | 3 | Grease nipple (2x) |
| 2 | Locking element (2x) | 4 | Knuckle pin (2x) |

► Check that the locking elements 2 and knuckle pins 4 fit tightly on both sides.

If the locking elements or knuckle pins are loose:

► Tighten the locking element 2 or knuckle pin 4.

9.32.3 Boom base section: lubricating knuckle pins

Ensure that the following conditions are fulfilled:

- Grease gun from Liebherr tool kit is available and filled with correct grease (For more information see: [9.2.3 Lubrication chart, page 1875](#)).

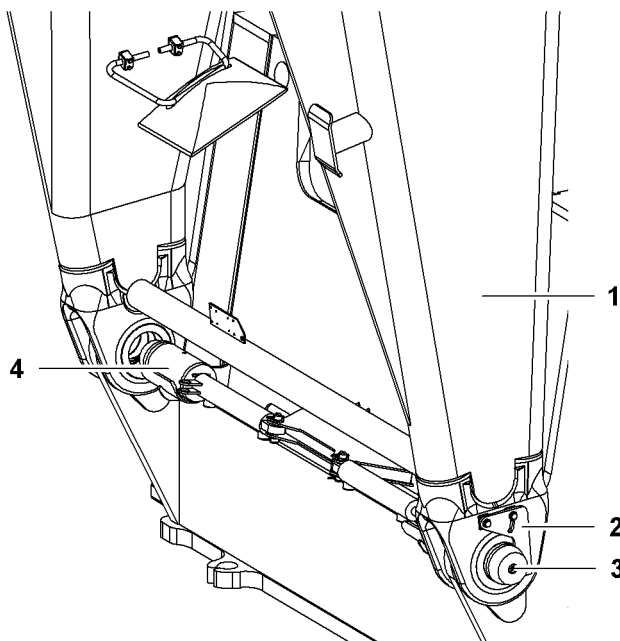


Fig. 5922: Knuckle pins and locking elements on main boom base section

- | | | | |
|---|------------------------|---|--------------------|
| 1 | Main boom base section | 3 | Grease nipple (2x) |
| 2 | Locking element (2x) | 4 | Knuckle pin (2x) |

► Use the grease gun to press grease into the grease nipple **3** on both sides.

9.32.4 Boom base section or A-frame 1: checking the operation of the mechanical boom angle indicator

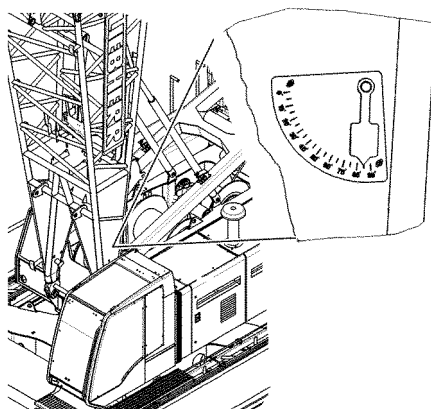


Fig. 5923: Mechanical boom angle indicator on boom base section or A-frame 1

► Checking the operation of the mechanical boom angle indicator on the boom base section or A-frame 1

If the mechanical boom angle indicator is loose:

► Secure the mechanical boom angle indicator.

If the needle cannot move easily:

► Lubricate the needle mount.

9.32.5 Checking the main boom head for function and damage

Check screw connections and pin connections for tight fit

- ▶ Check screw connections and pin connections for tight fit.

If screw connections or pin connections are loose:

- ▶ tighten screw connections and pin connections.

Checking rope fixing points for tears

- ▶ Check rope fixing points for tears.

If the rope fixing point shows tears:

- ▶ do not use main boom.
- ▶ Contact Liebherr customer service.

Checking that rope protection and locking springs are present and not damaged

- ▶ Check that rope protection and locking springs are present and not damaged.

If the rope protection or the locking springs are damaged or not in place:

- ▶ do not use main boom.
- ▶ Contact Liebherr customer service.

9.32.6 Checking the anemometer for tight fit and function

- ▶ Check anemometer for tight fit.

If anemometer is loose:

- ▶ attach anemometer.

With perfect functioning of the anemometer, the current wind speed is displayed on the *Operation* screen on the monitor.



Fig. 5924: Screen section Wind speed

- ▶ Check wind speed on the *Operation* screen on the monitor.

If a wind speed of 0 m/s (0 ft/s) is permanently displayed on the monitor:

- ▶ Check anemometer for mechanical and electronic damage.

9.32.7 Checking the auxiliary jib for function and damage

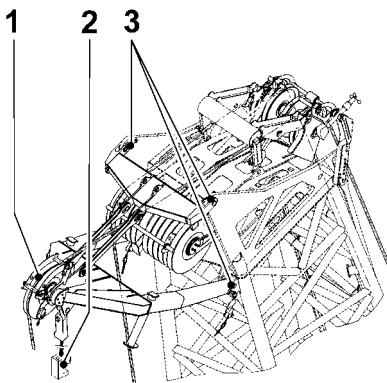


Fig. 5925: Auxiliary jib

- | | |
|---|-----------------------------------|
| <p>1 Rope pulleys</p> <p>2 Hoist limit switch</p> | <p>3 Pins and locking springs</p> |
|---|-----------------------------------|

Check screw connections and pin connections for tight fit

- ▶ Check screw connections and pin connections for tight fit.

If screw connections or pin connections are loose:

- ▶ tighten screw connections and pin connections.

Checking rope fixing points for tears

- ▶ Check rope fixing points for tears.

If the rope fixing point shows tears:

- ▶ Do not use auxiliary jib.
- ▶ Contact Liebherr customer service.

Checking that rope protection and locking springs are present and not damaged

- ▶ Check that rope protection and locking springs are present and not damaged.

If the rope protection or the locking springs are damaged or not in place:

- ▶ Do not use auxiliary jib.
- ▶ Contact Liebherr customer service.

9.33 Jib

9.33.1 Checking the jib base section, jib head and jib sections for damage and wear



DANGER

Machine operation with damaged jib is prohibited!
Structural failure.

- ▶ Operate machine exclusively with jib in perfect condition.

The steel structure of the jib must undergo a thorough visual inspection according to the maintenance plan or as laid down in national regulations.

If the machine was subject to excessive stress as the result of a severe impact or a large number of load cycles, the bearing components must be examined immediately and the inspection intervals shortened.

Any cracks in the steel structure must be examined by authorized service personnel.

This can be done using the following testing procedures:

- Magnetic particle inspection
- Dye penetrant inspection

The jib components should also be checked for bent or damaged tubing of the welded structure.

- ▶ Checking the jib base section, jib head and jib sections for damage and wear (cracks, notches, corrosion, plastic deformation, wear).

If the jib base section, the jib head or the jib sections are not in perfect condition:

- ▶ Observe instructions for repairs on steel structure ([For more information see: 9.31.2 Repairs on the steel structure, page 1959](#)).

9.33.2 Filling the accumulators for the tilting-back supports on the jib

Make sure the following prerequisites are met:

- Liebherr tool kit is available.
- The machine operator is in the cabin.
- An assistant is available.
- Cabin is tilted downwards.
- Basic machine is next to the jib base section.
- Diesel engine is turned off.

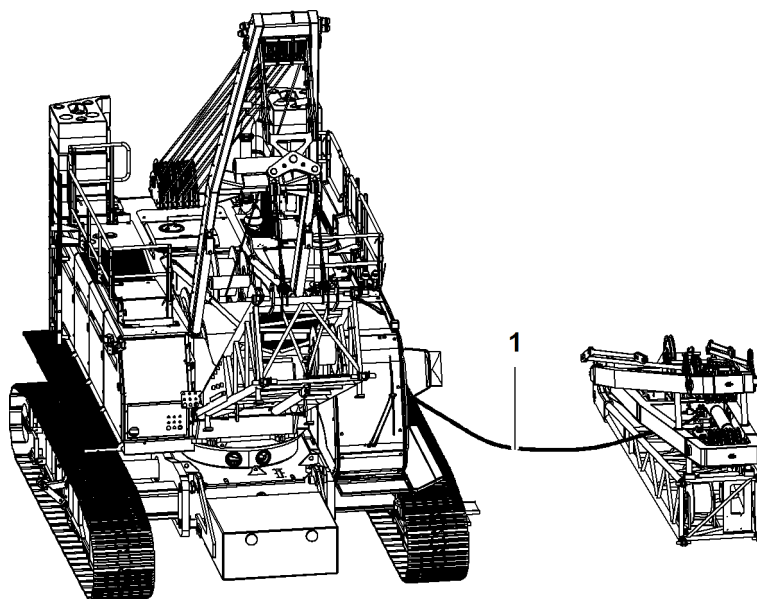


Fig. 5926: Overview filling the accumulator for the tilting-back supports on the jib

1 Hydraulic hose

Preparing the hydraulic hose

Connections of the hydraulic hose:

- Quick-action coupling
- Hydraulic connection with gate valve

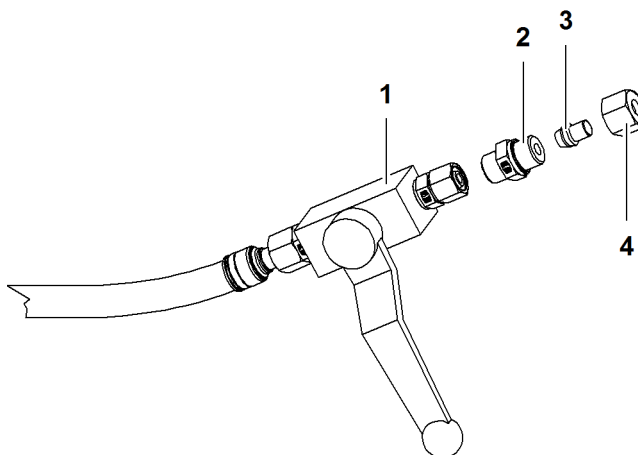


Fig. 5927: Hydraulic connection with gate valve

1	Gate valve hydraulic hose	3	Sealing element
2	Section	4	Nut

- ▶ Undo nut 4.
- ▶ Remove sealing element 3 and section 2.
 - ▷ Hydraulic hose is prepared.

Preparing the valve block of the jib base section

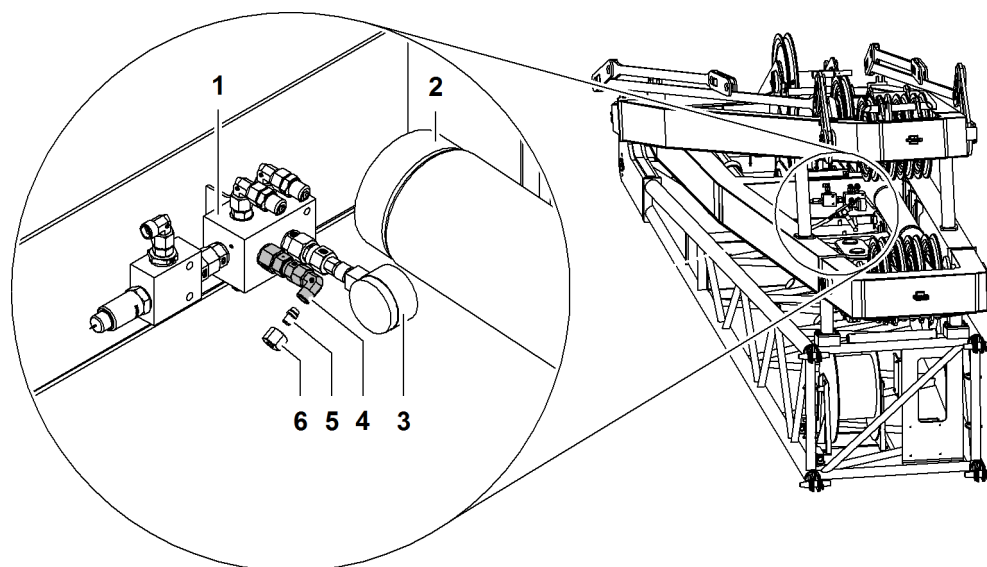


Fig. 5928: Preparing the valve block of the jib base section

- | | | | |
|---|-------------------------------------|---|-----------------|
| 1 | Valve block <i>jib base section</i> | 4 | Connection |
| 2 | Accumulator | 5 | Sealing element |
| 3 | Pressure gauge | 6 | Nut |

- ▶ Undo nut **6**.
- ▶ Remove sealing element **5**.
 - ▷ Valve block *jib base section* is prepared.

Establishing the connection between the machine and the jib base section

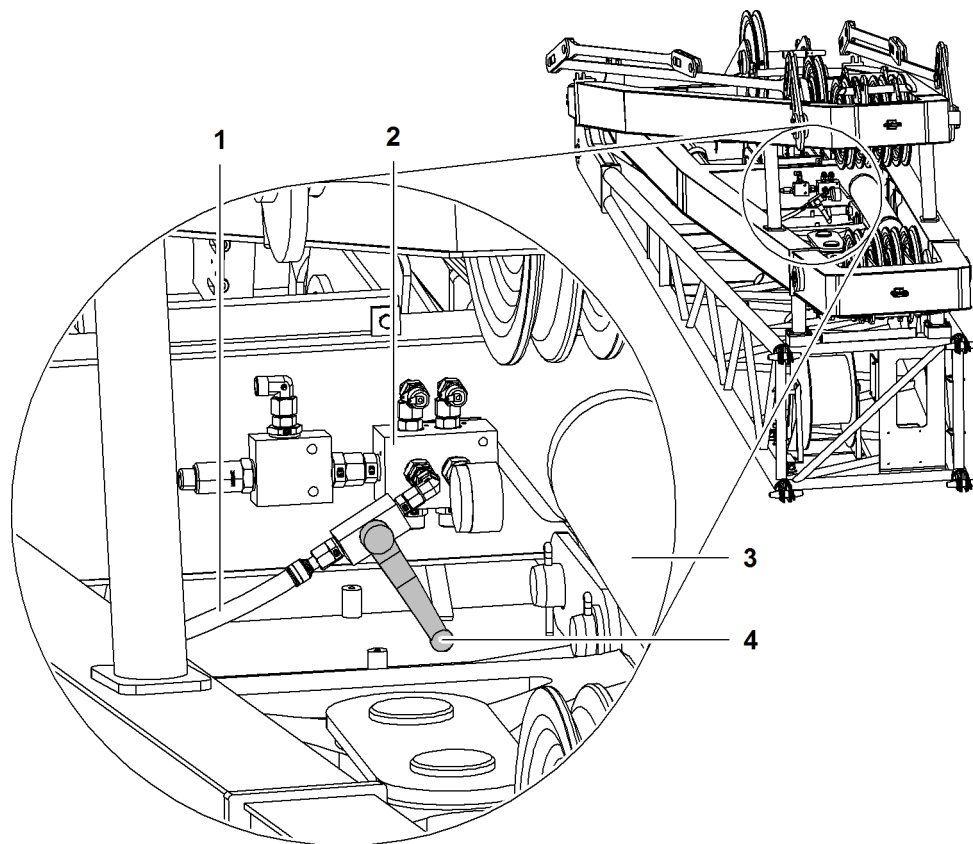


Fig. 5929: Installing the hydraulic hose on the valve block of the jib base section

- | | | | |
|---|-------------------------------------|---|----------------------------------|
| 1 | Hydraulic hose | 3 | Accumulator |
| 2 | Valve block <i>jib base section</i> | 4 | Gate valve <i>hydraulic hose</i> |

- ▶ Close gate valve *hydraulic hose* 4.
- ▶ Connect hydraulic hose 1 with valve block *jib base section* 2.

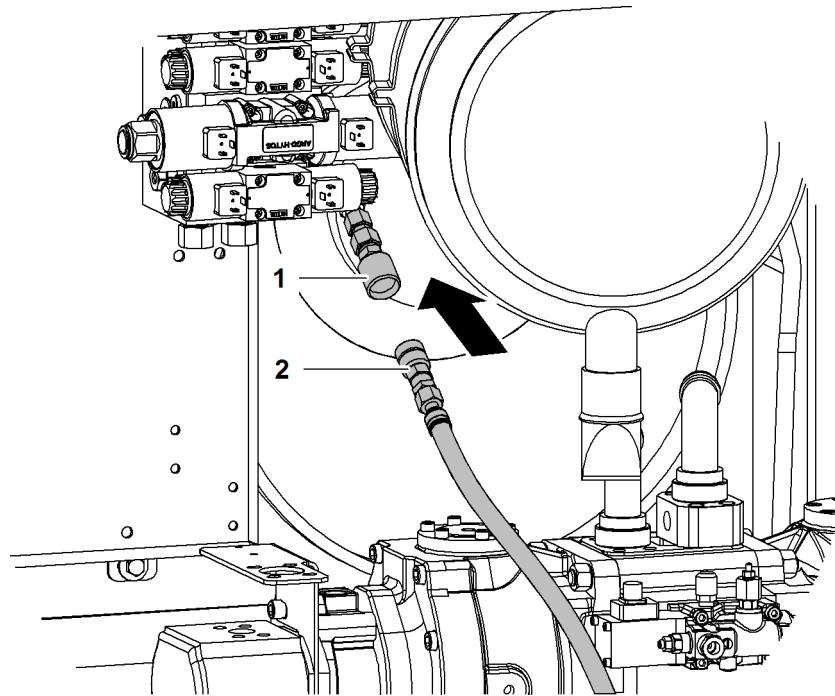
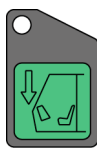


Fig. 5930: Hydraulic valve plate behind the front left uppercarriage door

- | | | | |
|---|------------|---|--------------------------------------|
| 1 | Connection | 2 | Quick-action coupling hydraulic hose |
|---|------------|---|--------------------------------------|

- ▶ Open front uppercarriage door on the left.
- ▶ Remove protective cover from connection 1.
- ▶ Remove protective cover from quick-action coupling hydraulic hose 2.
- ▶ Connect quick-action coupling hydraulic hose 2 with connection 1.
 - ▷ Connection between the machine and the jib base section established.
- ▶ Switch on the diesel engine.

Filling the accumulator



- ▶ Press and hold the button *Tilt cabin down* on control panel X11.

NOTICE

Insufficient pressure in the accumulator of the hydraulic tilting-back supports!
Risk of damage to components.

- ▶ Ensure that the specified pressure for the current ambient temperature is set in the accumulator.
-

The table “Specified pressure in accumulator of hydraulic tilting-back supports” is located on A-frame3.

- ▶ A helper carefully opens the gate valve hydraulic hose until the specified pressure is indicated on the pressure gauge of the jib base section.

When the specified pressure is reached:

- ▶ Close gate valve hydraulic hose.

- ▶ Release the *Tilt cabin down* button on control panel X11.
 - ▷ Specified pressure in the accumulator of the hydraulic tilting-back supports set.

**Note**

Displayed pressure may drop after a short while!

Liebherr recommends:

- ▶ Check the pressure in the accumulator after 1 to 2 minutes and increase the pressure again if applicable.
-

**Note**

Overpressure in the accumulator!

Liebherr recommends:

- ▶ Reduce the pressure.
 - ▶ Release the button *Tilt cabin down* on control panel X11 when the gate valve *hydraulic hose* is open.
-

**Note**

Hydraulic hose under pressure!

Liebherr recommends:

- ▶ Let go of the button *Tilt cabin down* on control panel X11 and briefly open gate valve *hydraulic hose*. The hydraulic hose is now without pressure.
-

**Note**

Hydraulic hose is filled with hydraulic oil!

Liebherr recommends:

- ▶ Place hydraulic hose with hydraulic connection with gate valve over a container and carefully open the gate valve *hydraulic hose*.
-
- ▶ Turn off diesel engine.
 - ▶ Take off hydraulic hose on both ends.
 - ▶ Dispose of hydraulic oil properly.
 - ▶ Refit the nut and sealing element on the valve block of the jib base section.
 - ▶ Refit nut, section and sealing element on the hydraulic hose.
 - ▶ Replace protective cover on quick-action coupling *hydraulic hose*.
 - ▶ Replace protective cap of the connection on the hydraulic valve plate.
 - ▶ Close uppercarriage door.

9.33.3 Checking locking flaps for ease of movement

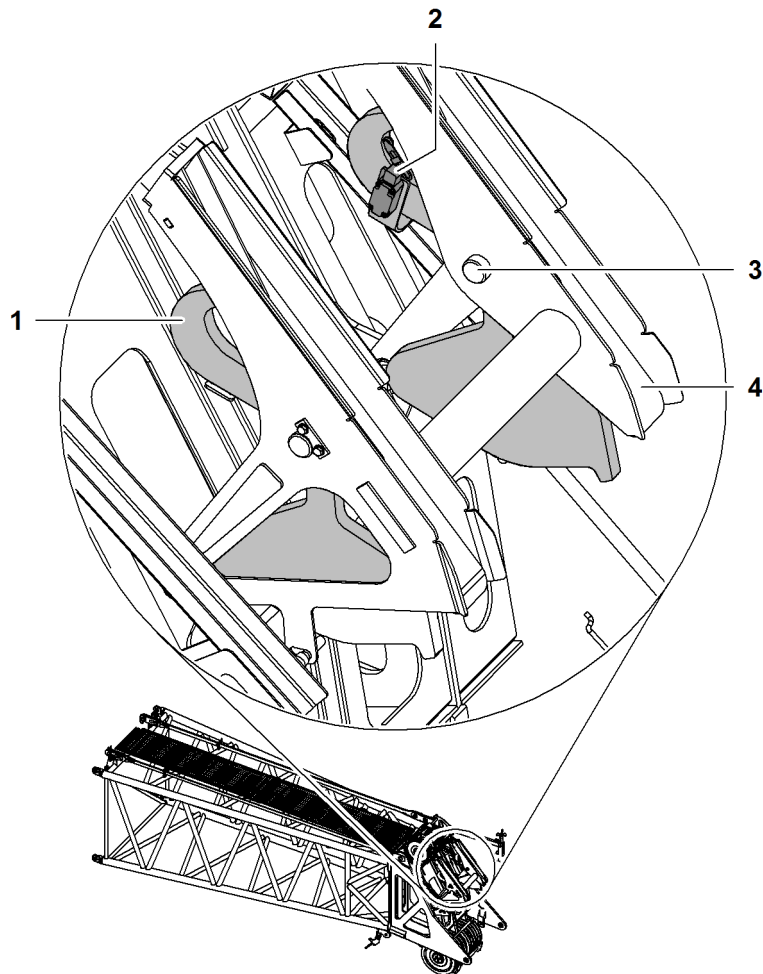


Fig. 5932: Checking locking flaps for ease of movement

- | | | | |
|---|--|---|---|
| 1 | Locking flaps (2x) for rigid jib tilting-back supports | 3 | Axis locking flap |
| 2 | Limit switch (2x) for rigid jib tilting-back supports | 4 | Guide rail (2x) for rigid jib tilting-back supports |

If the locking flaps are not adjusted by their inherent weight, erection of the main boom is not possible.

- ▶ Check locking flaps **1** for ease of movement.



Note

Locking flaps are not easy to move!

Liebherr recommends:

- ▶ Work on axis **3** with sandpaper.

If the locking flaps do not move easily:

- ▶ uninstall axis **3** and lubricate.

If anemometer is loose:

- ▶ attach anemometer.

With perfect functioning of the anemometer, the current wind speed is displayed on the *Operation* screen on the monitor.



Fig. 5934: Screen section Wind speed

- ▶ Check wind speed on the *Operation* screen on the monitor.

If a wind speed of 0 m/s (0 ft/s) is permanently displayed on the monitor:

- ▶ Check anemometer for mechanical and electronic damage.

9.33.6 Jib base section: Checking screw connections and pin connections for tight fit, checking that rope protection and locking springs are in place and undamaged

Check screw connections and pin connections for tight fit

- ▶ Check screw connections and pin connections for tight fit.

If screw connections or pin connections are loose:

- ▶ tighten screw connections and pin connections.

Checking that rope protection and locking springs are present and not damaged

- ▶ Check that rope protection and locking springs are present and not damaged.

If the rope protection or the locking springs are damaged or not in place:

- ▶ do not use jib.
- ▶ Contact Liebherr customer service.

9.34 A-frame1

A-frame 1 and its components must be checked for damage and that it is working correctly.



DANGER

Damaged A-frame 1!
Structural breakdown.

- ▶ Ensure that A-frame 1 and its components are checked by a specialist at least once a year.

As use of the machine increases, so the test cycle becomes shorter:

- ▶ Ensure that A-frame 1 and its components are checked by a specialist at more regular intervals.
- ▶ Document all results.
- ▶ Do not use the A-frame 1 under any circumstances unless it and its component parts are in perfect condition.

9.34.1 Checking A-frame 1

- ▶ Check A-frame 1 for cracks on the traverse bracings and for deformation.

If A-frame 1 shows signs of cracks on the traverse bracings or deformation:

- ▶ Switch off machine.
- ▶ Contact Liebherr after sales service.

9.34.2 Lubricating the bearings on A-frame 1

All grease nipples on A-frame 1 are present on both sides and can be accessed from the interior side.

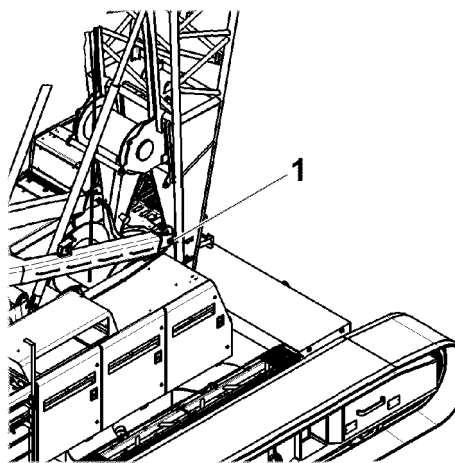


Fig. 5935: Lubricating the bearings on A-frame 1

1 Bearings on A-frame 1

Make sure the following prerequisites are met:

- Grease gun from Liebherr tool kit is available and filled with correct grease ([For more information see: 9.2.3 Lubrication chart, page 1875](#)).

- ▶ Remove protective covers.
- ▶ Use the grease gun to press grease into the grease nipple on both sides.
- ▶ Put on protective covers.

9.34.3 Lubricating the bearings on the A-frame1 cylinder

The grease nipples are present on both sides.

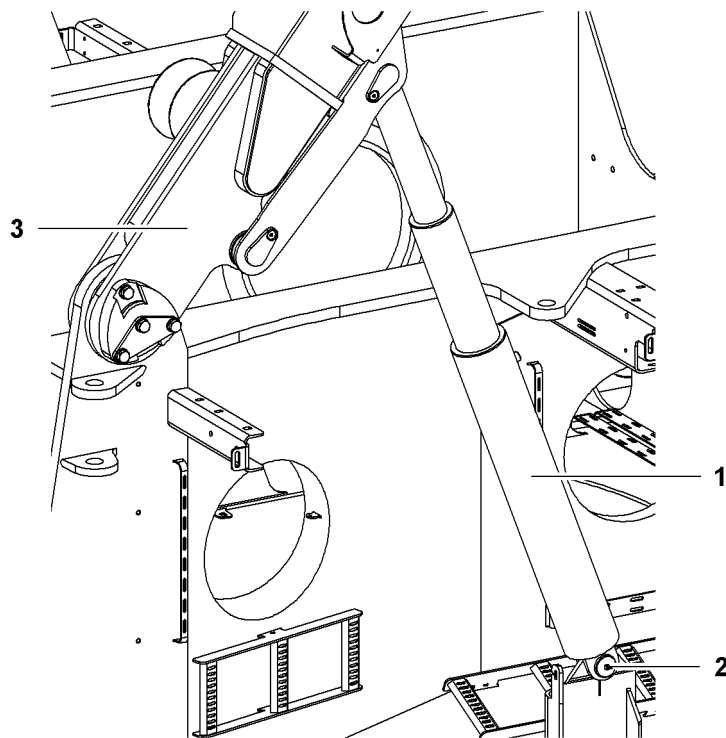


Fig. 5936: Lubricating the bearings on the A-frame1 cylinder

- | | | | |
|---|-------------------|---|----------|
| 1 | A-frame1 cylinder | 3 | A-frame1 |
| 2 | Grease nipple | | |

Make sure the following prerequisites are met:

- Grease gun from Liebherr tool kit is available and filled with correct grease ([For more information see: 9.2.3 Lubrication chart, page 1875](#)).
- ▶ Use the grease gun to press grease into the grease nipple 2 on both sides.

9.35 Tilting-back supports

9.35.1 Checking the pressure in the tilting-back support piston area

Make sure the following prerequisites are met:

- The 400 bar (5,801.48 psi) pressure gauge from the Liebherr tool kit is available.
- The machine operator is in the cab.
- The assistant is familiar with the work.
- The machine hydraulic oil is at operating temperature (approx 50 °C (122 °F) to 60 °C (140 °F)).
- The air intake hose between the filter housing and the exhaust turbocharger is in good condition.
- No load is on the hook.
- Diesel engine is switched on.
- Extend tilting-back support cylinder* switch on control panel X12 is preselected.
- The main boom is raised to approximately 75°.
- The safety lever in the cabin has been lowered.

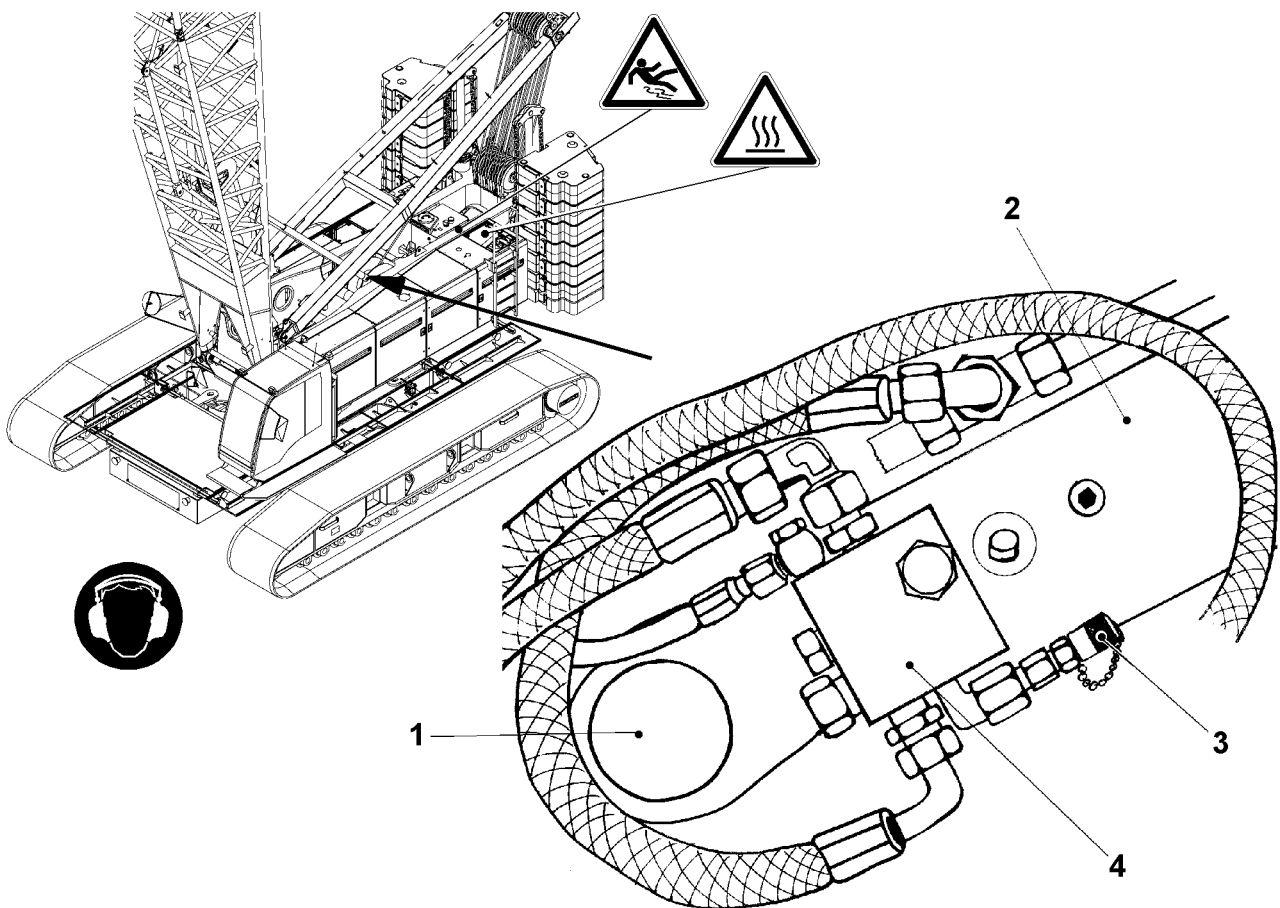


Fig. 5937: Checking the pressure in the tilting-back support piston area

- | | | | |
|---|------------------------------|---|---|
| 1 | Tilting-back support bolting | 3 | Measuring connection for pressure measurement |
| 2 | Tilting-back support | 4 | Valve block |

- ▶ To relieve the strain on the tilting-back supports **2**: lower the main boom until the tilting-back supports **2** are in the middle of the guide rails.



WARNING

Hot and slippery surfaces!
Risk of falling off the uppercarriage.

- ▶ Only touch hot surfaces with suitably protected body parts.
- ▶ Secure yourself against falling.

- ▶ Remove the protective cover on the measuring connection **3**.

The pressure in the tilting-back support piston area must correspond to the value stipulated in the chart. Maximum deviation of $\pm 20\%$ is admissible.

Machine type	Nominal value
LR 1002	90 bar 1,305.33 psi
LR 1003	90 bar 1,305.33 psi
LR 1004	150 bar 2,175.56 psi
LR 1005	132 bar 1,914.49 psi
LR 1006	132 bar 1,914.49 psi

Tab. 632: Stipulated pressure in the tilting-back support piston area

- ▶ Connect the pressure gauge to the measuring connection **3**.
 - ▷ The gauge displays the pressure.



DANGER

Tilting-back support is used with excessive/inadequate pressure in the piston area!
Wrong calculation of load moment limiter, toppling of machine, structural failure.

- ▶ Switch off machine.
- ▶ Contact Liebherr after sales service.

If the pressure displayed is outside of the permitted range:

- ▶ Switch off the machine and contact Liebherr after sales service.
- ▶ Remove the pressure gauge.
- ▶ Fit the protective cover to the measuring connection **3** again.

A measurement must be taken on each tilting-back support cylinder.

- ▶ Repeat the measurement on the opposite side.

9.36 Steel pendant straps

Steel pendant straps are sensitive components and must be checked for proper functioning and/or damage.



DANGER

Damaged steel pendant straps!
Structural breakdown.

- ▶ Make sure that a specialist checks all steel pendant straps at least once a year.

As use of the machine increases, so the test cycle becomes shorter:

- ▶ Make sure that a specialist checks all steel pendant straps additionally.
- ▶ Document all results.
- ▶ Only use perfectly functioning steel pendant straps.
- ▶ Replace damaged or faulty steel pendant straps with new Liebherr steel pendant straps.

NOTICE

Inadmissible welding on steel pendant straps!
Damage to steel pendant straps.

- ▶ Do not weld on steel pendant straps.

9.36.1 Checking steel pendant straps and pins for damage and wear and check that locking springs and split pins are present

Checking steel pendant straps for damage and wear

- ▶ Check steel pendant straps for damage and wear (cracks, notches, corrosion, deformation, etc.).

If the steel pendant straps show damage or wear:

- ▶ replace steel pendant straps.
- ▶ Contact Liebherr after sales service.

Checking the pins for wear and damage

- ▶ Check the pins for damage and wear (cracks, notches, corrosion, deformation, etc.).

If the pins are damaged or show signs of wear:

- ▶ Replace pins.
- ▶ Contact Liebherr after sales service.

Checking the locking elements for wear and damage

- ▶ Check the locking elements (washers, nuts, springs) for damage and wear (cracks, notches, corrosion, deformation, etc.).

If the locking elements (washers, nuts, springs) are damaged or show signs of wear:

- ▶ Replace locking elements.
- ▶ Contact Liebherr after sales service.

9.36.2 Checking the ease of movement of pin connections in the entire pendant strap strand

- ▶ Check ease of movement of pin connections in the entire pendant strap strand.

If pin connections no longer move easily:

- ▶ Restore ease of movement of pin connections.
- ▶ Protect steel pendant straps, connecting links and pins from corrosion ([For more information see: 9.36.3 Protecting steel pendant straps, connecting links and pins from corrosion, page 1980](#)).

9.36.3 Protecting steel pendant straps, connecting links and pins from corrosion

NOTICE

Corrosion of steel pendant straps, connecting links and pins!
Damage to steel pendant straps, connecting links and pins.

- ▶ Make sure that corrosion protection of steel pendant straps, connecting links and pins is ensured.
-

Due to high strain, pay special attention to the anticorrosive coating of the contact surfaces between steel pendant strap, pin and connecting link.

- ▶ Lubricate steel pendant straps, connecting links and pins or spray with anti-corrosion spray.

9.36.4 Checking connecting links for damage and wear

- ▶ Check the connecting links for damage and wear (cracks, notches, corrosion, deformation, etc.).

If the connecting links are damaged or show signs of wear:

- ▶ Replace connecting links.
- ▶ Contact Liebherr after sales service.

9.36.5 Checking tension load cells for damage and wear, checking electricity connections for tight fit

- ▶ Check tension load cells for damage and wear (cracks, notches, corrosion, deformation, etc.).

If tension load cells show damage or wear:

- ▶ Replace tension load cells.
- ▶ Contact Liebherr customer service.
- ▶ Check electricity connections of tension load cells for tight fit.

- If electricity connections of load tension cells are loose:
- ▶ tighten electricity connections of load tension cells.

9.37 Carbon-fibre pendant straps

CF pendant straps are sensitive components and must be checked for proper functioning and/or damage.



DANGER

Damaged CF pendant straps!
Structural breakdown.

- ▶ Ensure that a specialist checks all CF pendant straps at least once a year.

As use of the machine increases, so the test cycle becomes shorter:

- ▶ Ensure that a specialist checks all CF pendant straps additionally.
 - ▶ Document all results.
 - ▶ Only use perfectly functioning CF pendant straps.
 - ▶ Replace damaged or faulty CF pendant straps with new Liebherr CF pendant straps.
-

The permanent operating temperature of the CF pendant straps is -40 °C (-40 °F) to 80 °C (176 °F).

For short periods (around 10 minutes) temperatures up to 120 °C (248 °F) are permissible.

In a steam-saturated atmosphere a temperature of 80 °C (176 °F) should not be exceeded for a prolonged period.

NOTICE

Inadmissible welding on CF pendant straps!
Damage to CF pendant straps.

- ▶ Do not weld on CF pendant straps.
-

Since 04/2010 a new generation (Generation B) of carbon-fibre pendant straps has been available.



Fig. 5938: Generation A and generation B of the CF pedant straps

A Generation A of carbon-fibre pendant straps

B Generation B of carbon-fibre pendant straps

Maintenance of all carbon-fibre pendant straps is identical.

9.37.1 Checking CF pendant straps and pins for damage and wear and check that locking springs and split pins are present

Checking CF pendant straps for wear of the protective coating and/or wire mesh hose and checking for damage to fibers

The protective sheath or wire mesh hose may be damaged by incorrect use or by being pushed against something.



Fig. 5939: Damage to the protective sheath

The CF pendant straps may be temporarily strained.

- ▶ Check CF pendant straps for wear of the protective coating and/or wire mesh hose and check for damage to fibers.

If the underlying circumferential windings are undamaged:

- ▶ Contact Liebherr after sales service.

A repair kit is available from Liebherr after sales service if the protective sheath of carbon-fiber pendant straps needs repairing.

If the CF pendant straps show damaged fibers:

- ▶ Replace CF pendant straps.
- ▶ Contact Liebherr after sales service.

Checking the bushes of CF pendant straps



Fig. 5940: Parallel flanges

The bushes must be circular on the inside and flat on the outside.

- ▶ Before assembly bushes must always be checked with a caliper gage to ensure that the flanges are parallel.

If the flanges on the bushes are not parallel:

- ▶ Replace CF pendant straps.
- ▶ Contact Liebherr after sales service.

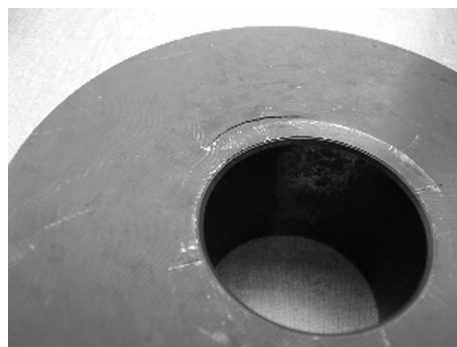


Fig. 5941: Crack on a bush

- ▶ Before assembly, bushes must always be checked for cracks, corrosion (fretting corrosion) and deformation.

If bushes are showing signs of cracks, corrosion (fretting corrosion) or deformation:

- ▶ Replace CF pendant straps.
- ▶ Contact Liebherr after sales service.

Checking pins for damage and wear

- ▶ Check pins for damage and wear (cracks, notches, corrosion, deformation, etc.).

If pins show damage or wear:

- ▶ Replace pins.
- ▶ Contact Liebherr after sales service.

Checking locking elements for damage and wear

- ▶ Check locking elements (washer, nut, spring) for damage and wear (cracks, notches, corrosion, deformation, etc.).

If the locking elements (washers, nuts, springs) are damaged or show signs of wear:

- ▶ Replace locking elements.
- ▶ Contact Liebherr after sales service.

9.37.2 Checking the ease of movement of pin connections in the entire pendant strap strand

- ▶ Check ease of movement of pin connections in the entire pendant strap strand.

If pin connections no longer move easily:

- ▶ Restore ease of movement of pin connections.
- ▶ Protect CF pendant strap bushes, connecting links and pins from corrosion ([For more information see: 9.37.3 Protecting CF pendant strap bushes, connecting links and pins from corrosion, page 1985](#)).

9.37.3 Protecting CF pendant strap bushes, connecting links and pins from corrosion

NOTICE

Corrosion of CF pendant strap bushes, connecting links and pins!
Damage to CF pendant strap bushes, connecting links and pins.

- ▶ Make sure that corrosion protection of CF pendant strap bushes, connecting links and pins is ensured.
-

Due to high strain, pay special attention to the anticorrosive coating of the contact surfaces between the bushes of the CF pendant strap, pin and connecting link.

- ▶ Lubricate CF pendant strap bushes, connecting links and pins or spray with anti-corrosion spray.

9.37.4 Checking connecting links for damage and wear

- ▶ Check connecting links for damage and wear (cracks, notches, corrosion, deformation, etc.).

If the connecting links are damaged or show signs of wear:

- ▶ Replace connecting links.
- ▶ Contact Liebherr after sales service.

9.37.5 Checking tension load cells for damage and wear, checking electricity connections for tight fit

- ▶ Check tension load cells for damage and wear (cracks, notches, corrosion, deformation, etc.).

If tension load cells show damage or wear:

- ▶ Replace tension load cells.
- ▶ Contact Liebherr customer service.
- ▶ Check electricity connections of tension load cells for tight fit.

If electricity connections of the load tension cells are loose:

- ▶ tighten electricity connections of load tension cells.

9.38 Pendant ropes

9.38.1 Check pendant ropes and pins for damage and wear and check that locking springs and cotter pins are present (cracks, notches, corrosion, plastic deformation, wear, lubrication, etc.)

Checking pendant ropes for damage and wear

- ▶ Check pendant ropes for damage and wear (cracks, notches, corrosion, deformation, etc.).

If pendant ropes show damage or wear:

- ▶ Replace pendant ropes.
- ▶ Contact Liebherr customer service.

Checking pins for damage and wear

- ▶ Check pins for damage and wear (cracks, notches, corrosion, deformation, etc.).

If pins show damage or wear:

- ▶ Replace pins.
- ▶ Contact Liebherr customer service.

Checking locking elements for damage and wear

- ▶ Check locking elements (washer, nut, spring) for damage and wear (cracks, notches, corrosion, deformation, etc.).

If locking elements (washer, nut, spring) show damage or wear:

- ▶ Replace locking elements.
- ▶ Contact Liebherr customer service.

9.38.2 Protecting pendant ropes, connecting links and pins from corrosion

NOTICE

Corrosion of pendant ropes, connecting links and pins!

Damage to pendant ropes, connecting links and pins.

- ▶ Make sure that corrosion protection of pendant ropes, connecting links and pins is ensured.
-

Due to high strain, pay special attention to the anticorrosive coating of the contact surfaces between pendant rope, pin and connecting link.

- ▶ Lubricate pendant ropes, connecting links and pins or spray with anti-corrosion spray.

9.38.3 Checking connecting links for damage and wear

- ▶ Check connecting links for damage and wear (cracks, notches, corrosion, deformation, etc.).

If connecting links show damage or wear:

- ▶ Replace connecting links.
- ▶ Contact Liebherr customer service.

9.39 Counterweight

9.39.1 Checking the screws of the rear counterweight tie-down for tight fit (with exception of LR 1001.xx.xx)

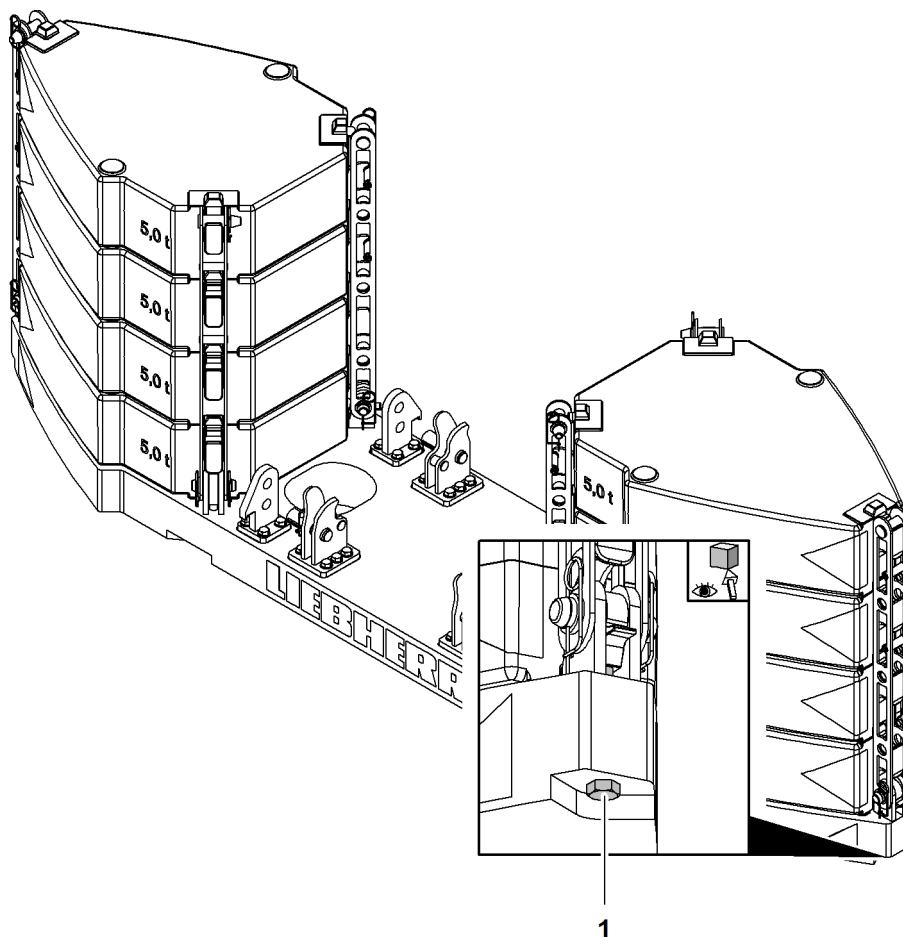


Fig. 5942: Checking the screws of the rear counterweight tie-down for tight fit (illustration of principle)

1 Screw (6x)

The screws 1 of the rear counterweight tie-down must be tightened finger-tight with a wrench.

► Check the screws 1 of the rear counterweight tie-down for tight fit.

If the screws 1 of the rear counterweight tie-down are loose:

► Tighten screws 1 hand-tight with a wrench.

9.39.2 Checking the rear counterweight, fixing lugs and round steel chains for damage, wear and secure fit

► Check rear counterweight, fixing lugs and round steel chains for damage, wear and secure fit.

If the rear counterweight, fixing lugs and round steel chains are not in perfect condition:

- ▶ Contact Liebherr customer service.

If the rear counterweight, fixing lugs and round steel chains are loose:

- ▶ Attach rear counterweight, fixing lugs and round steel chains.

9.39.3 Checking locking elements for availability, damage, wear and tight fit

- ▶ Check locking elements (washer, nut, spring) for damage and wear (cracks, notches, corrosion, deformation, etc.).

If locking elements (washer, nut, spring) show damage or wear:

- ▶ Replace locking elements.
- ▶ Contact Liebherr customer service.

9.39.4 Checking counterweight supports (pins, shackles) for damage and wear

- ▶ Check counterweight supports (pins, shackles) for damage and wear (cracks, notches, corrosion, deformation, etc.).

If counterweight supports (pins, shackles) show damage or wear:

- ▶ replace counterweight supports (pins, shackles).
- ▶ Contact Liebherr customer service.

9.40 Lubrication system

9.40.1 Checking the function of the central lubrication system

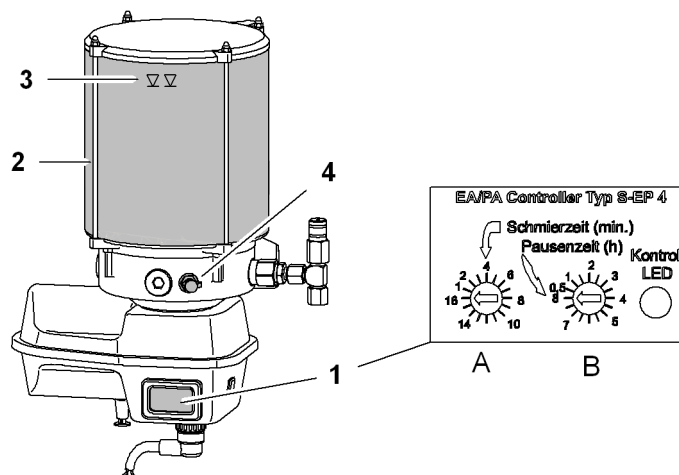


Fig. 5943: Checking the function of the central lubrication system

- | | | | |
|---|-----------------------------|---|--|
| 1 | Control unit | 4 | Filling nipple |
| 2 | Supply container | A | Set lubrication time rotary control knob |
| 3 | "Maximum fill level" marker | B | Set pause time rotary control knob |

The central lubrication system's lubricating pump is located in the uppercarriage.

Ensure that the following conditions are fulfilled:

- Safety lever is lowered.
- Free swing is switched on.

After the diesel engine is switched on, the yellow indicator light lights up for 1.5 seconds, indicating readiness for operation.

An interim lubrication at the programmed lubrication time must take place after the *Interim lubrication* button is pressed on the lubrication pump. After this lubrication time has expired, the lubrication process is switched off and the programmed pause time commences. All further lubrication processes are automatically initiated with the preset times.

- ▶ To check the operation of the central lubrication: Press the *Interim lubrication* button.

If no interim lubrication takes place after pressing the *Interim lubrication* button:

- ▶ Contact Liebherr after sales service.

9.40.2 Check fill level of the lubrication pump

Ensure that the following conditions are fulfilled:

- The grease gun from the Liebherr tool kit is present and filled with grease ([For more information see: 9.2.3 Lubrication chart, page 1875](#)).
- The machine is switched off.
- The machine is secured to prevent unauthorised operation.

NOTICE

Incorrect or impure grease!

Damage to machine.

- ▶ To prevent impurities: only fill the supply container with grease via the grease nipple.
- ▶ Ensure the purity of the grease.
- ▶ Top up using only the appropriate grease according to the lubrication chart ([For more information see: 9.2.3 Lubrication chart, page 1875](#)).

NOTICE

Empty grease supply container!

The swing ring and tooth flanks will be insufficiently lubricated and damaged.

Extensive cleaning work and venting work on central lubrication pumps.

- ▶ Ensure that supply containers are permanently topped up.

-
- ▶ Check fill level of the lubrication pump.

If the fill level lies well below the "Maximum fill level" marker:

- ▶ Top up with grease until the "Maximum fill level" marker is reached.

9.40.3 Checking the time intervals of the lubrication pump

Ensure that the following conditions are fulfilled:

- The machine is switched off.
- The machine is secured to prevent unauthorised operation.

Do not adjust the following factory-set time intervals to ensure optimum lubrication:

- Lubrication time: 2 minutes
- Break time: 1 hour

- ▶ Check time intervals of lubrication pump.

If the lubrication pump settings do not match the specifications:

- ▶ Correct the settings to match the appropriate specifications.

9.40.4 Checking the lubrication points

Ensure that the following conditions are fulfilled:

- The machine is switched off.
- The machine is secured to prevent unauthorised operation.

- ▶ Check the lubrication points for sufficient lubrication.

If no grease collars can be seen at the lubrication points:

- ▶ Check the settings of the lubrication pump.
- ▶ Check the lines for damage.
- ▶ Contact Liebherr after sales service.

9.41 Derrick equipment*

9.41.1 Check derrick boom base section, derrick boom head and derrick boom sections for damage and wear (cracks, notches, corrosion, plastic deformation, wear)



DANGER

Machine operation with damaged derrick boom is prohibited!
Structural failure.

- ▶ Operate machine exclusively with derrick boom in perfect condition.

The steel structure of the derrick boom must undergo a thorough visual inspection according to the maintenance plan or as laid down in national regulations.

If the machine was subject to excess strain as the result of a severe impact or a large number of load cycles, the structural components must be examined immediately and the inspection intervals reduced.

Any cracks in the steel structure must be examined by qualified service personnel. This can be done using the following testing procedures:

- Magnetic particle inspection
- Dye penetrant inspection

The derrick boom base section, derrick boom head and the derrick boom sections must be checked for bent or damaged boom pipes of the welded structure.

- ▶ Check derrick boom base section, derrick boom head and derrick boom sections for damage and wear (cracks, notches, corrosion, plastic deformation, wear).

If the derrick boom base section, the derrick boom head or the derrick boom sections are not in perfect condition:

- ▶ Observe instructions for repairs on steel structure ([For more information see: 9.31.2 Repairs on the steel structure, page 1959](#)).

9.41.2 Greasing the bearing of the derrick boom base section

Ensure that the following conditions are fulfilled:

- The grease gun from the Liebherr tool kit is present and filled with grease ([For more information see: 9.2.3 Lubrication chart, page 1875](#)).
- The machine is level.
- The machine is secured to prevent unauthorised operation.

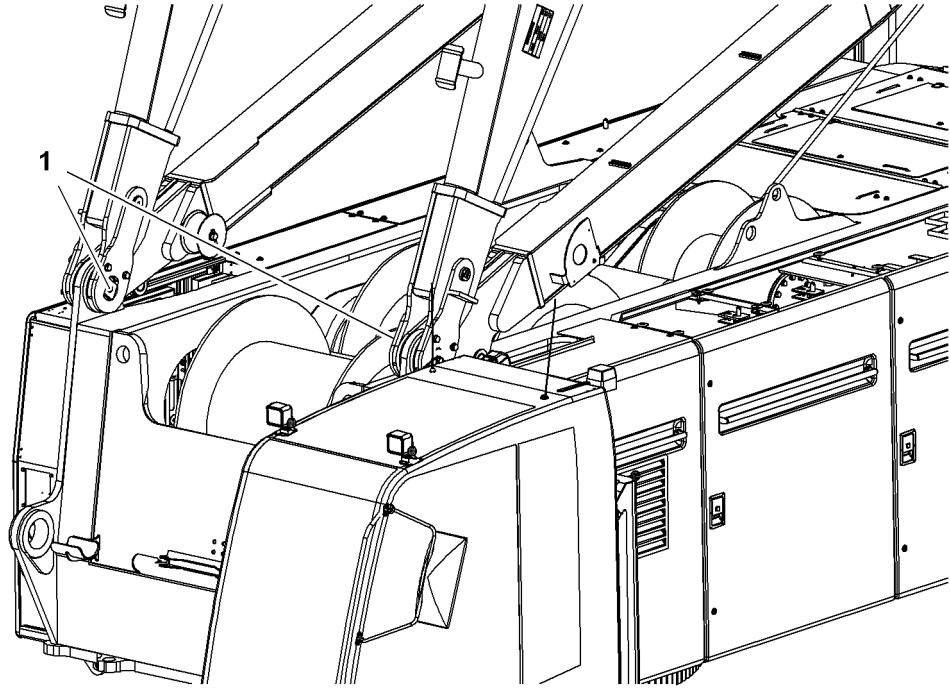


Fig. 5944: Lubricating the bearings

1 Grease nipple

► Using the grease gun, press 10 g (0.02 lb) of grease onto the grease nipple 1.

9.41.3 Greasing the extension device of the counterweight carriage (strut, uppercarriage pin connection)

Ensure that the following conditions are fulfilled:

- The grease gun from the Liebherr tool kit is present and filled with grease (For more information see: [9.2.3 Lubrication chart, page 1875](#)).
- The machine is level.
- The machine is secured to prevent unauthorised operation.
- Grease strut of extension cylinder.
- Using the grease gun, press in 10 g (0.02 lb) of grease via grease nipples (2 to 4).

9.41.4 Checking the air pressure of the counterweight carriage

Make sure the following prerequisites are met:

- Machine is level.
- Machine is secured against unauthorized start-up.

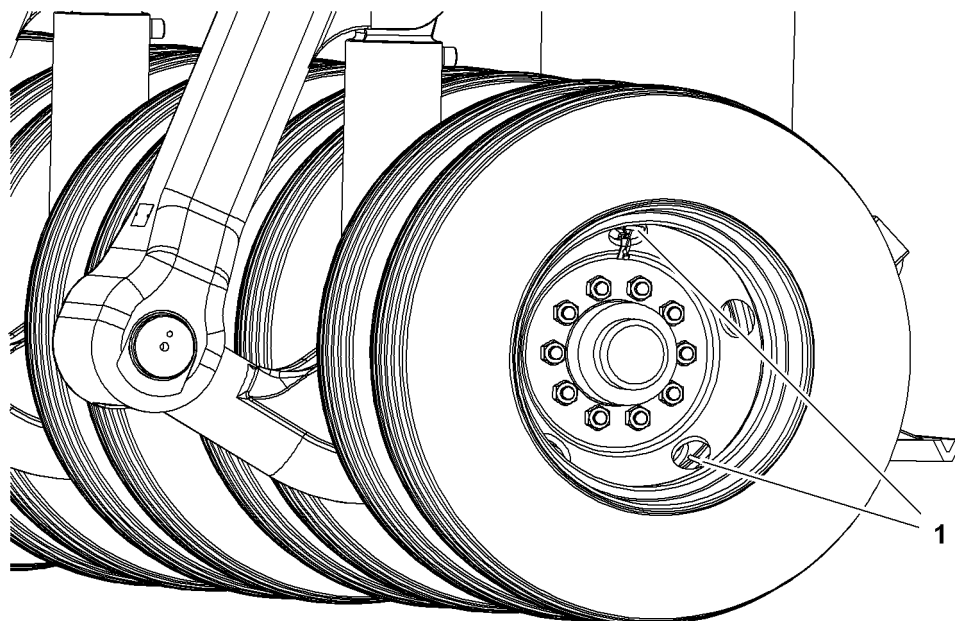


Fig. 5945: Checking the air pressure of the counterweight carriage

1 Valves

The tire pressure must be 10 bar (145.04 psi). The tire pressure stated on the tires can be ignored.

- ▶ Check air pressure with suitable compressor on the valves 1.

If the air pressure in the tires is too high:

- ▶ Reduce tire pressure.

If the air pressure in the tires is too low:

- ▶ Increase tire pressure.

9.41.5 Checking the tires of the counterweight carriage for damage

Make sure the following prerequisites are met:

- Machine is level.
- Machine is secured against unauthorized start-up.

- ▶ Check tires for tears in the side wall.
- ▶ Check running surface for penetrated foreign objects.

If the tires are not in perfect condition:

- ▶ Contact Liebherr customer service.

9.41.6 Lubricating the axes and swing arms of the counterweight carriage's wheel sets

Make sure the following prerequisites are met:

- Grease gun from Liebherr tool kit is available and filled with correct grease ([For more information see: 9.2.3 Lubrication chart, page 1875](#)).
- Machine is level.
- Machine is secured against unauthorized start-up.

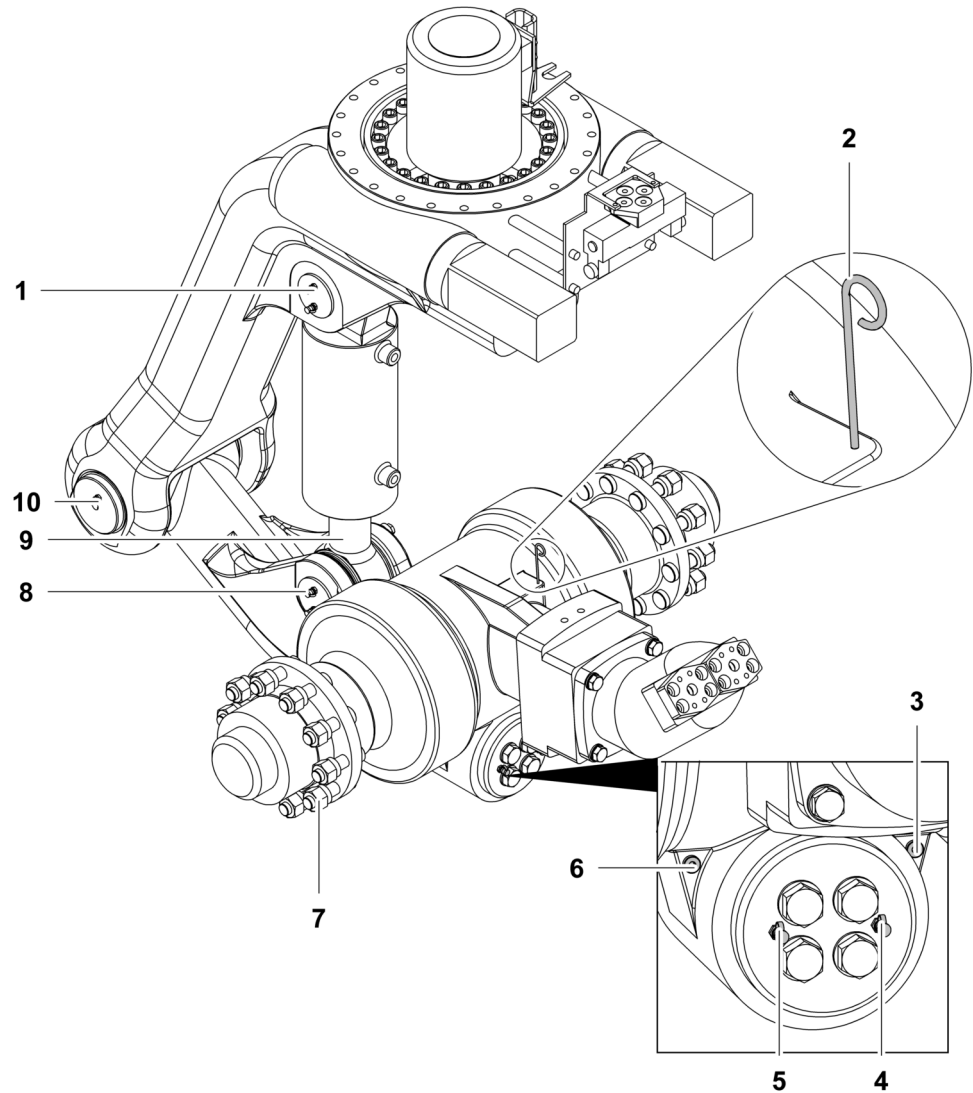


Fig. 5946: Lubricating the axes and swing arms of the counterweight carriage's wheel sets

- | | | | |
|---|--------------------|----|--------------------|
| 1 | Grease nipple (2x) | 6 | Drain screw |
| 2 | Oil dipstick | 7 | Wheel nut (20x) |
| 3 | Drain screw | 8 | Grease nipple (2x) |
| 4 | Grease nipple | 9 | Hydraulic cylinder |
| 5 | Grease nipple | 10 | Grease nipple (2x) |

► Using the grease gun, press in 10 g (0.02 lb) of grease via grease nipples **1 + 4 + 5 + 8 + 10**.

9.41.7 Lubricating the drive units of the counterweight carriage's wheel sets

Make sure the following prerequisites are met:

- Grease gun from Liebherr tool kit is available and filled with correct grease (For more information see: [9.2.3 Lubrication chart, page 1875](#)).
- Machine is level.
- Machine is secured against unauthorized start-up.

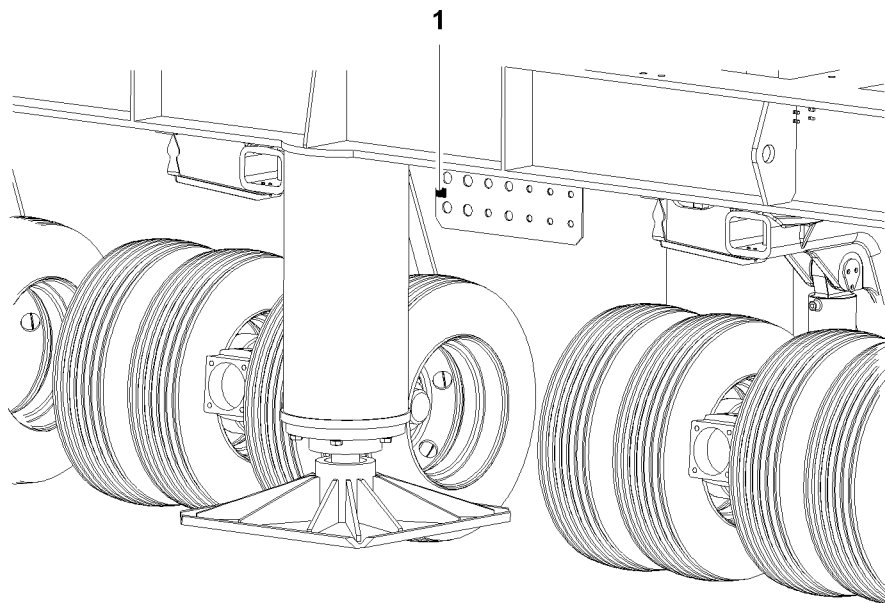


Fig. 5947: Lubricating the drive units of the counterweight carriage's wheel sets

1 Central lubrication point

- ▶ Using the grease gun, press in 10 g (0.02 lb) grease via central lubrication point 1.

9.41.8 Checking the gearbox oil level in the counterweight carriage's axle gearbox

Make sure the following prerequisites are met:

- Machine is level.
- Machine is secured against unauthorized start-up.

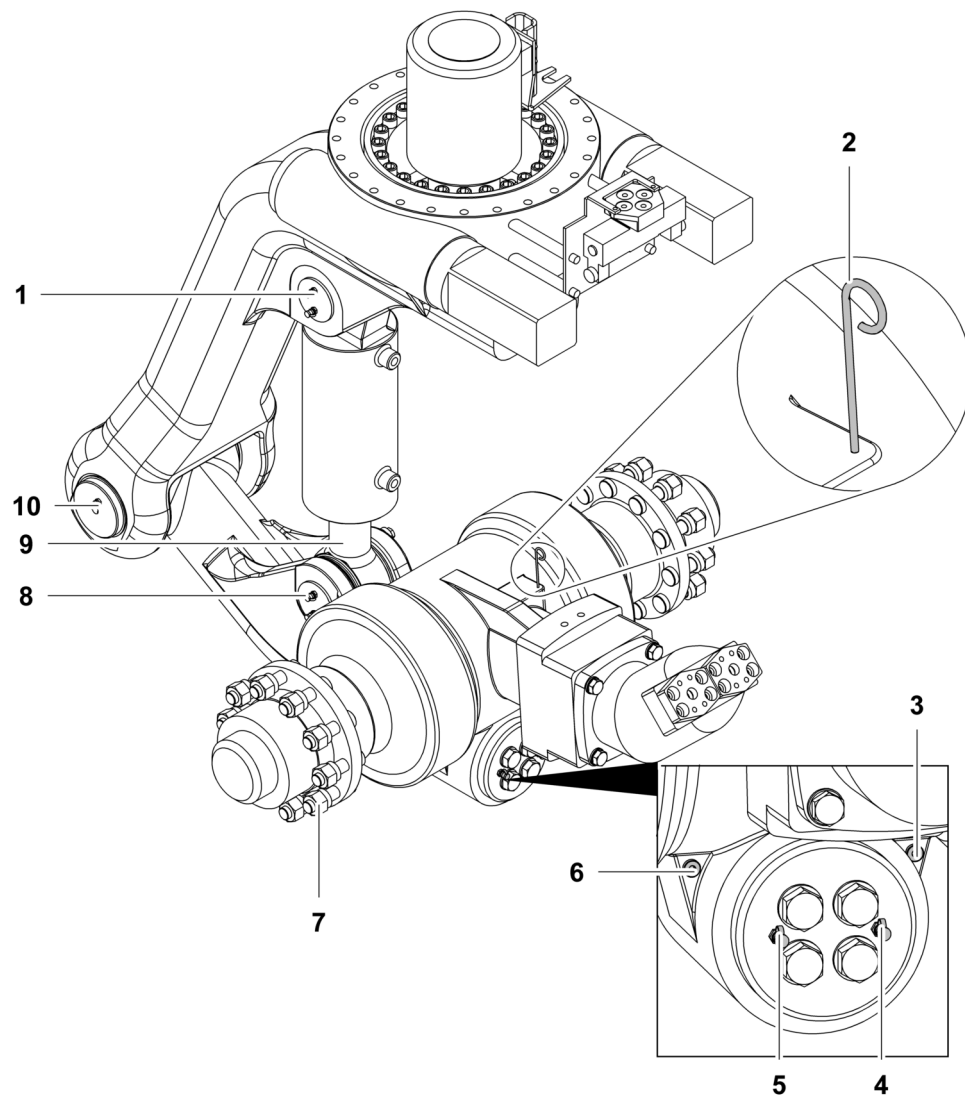


Fig. 5948: Checking the gearbox oil level in the counterweight carriage's axle gearbox

- | | | | |
|---|--------------------|----|--------------------|
| 1 | Grease nipple (2x) | 6 | Drain screw |
| 2 | Oil dipstick | 7 | Wheel nut (20x) |
| 3 | Drain screw | 8 | Grease nipple (2x) |
| 4 | Grease nipple | 9 | Hydraulic cylinder |
| 5 | Grease nipple | 10 | Grease nipple (2x) |

- ▶ Pull out oil dipstick **2**, clean, reinsert all the way.
- ▶ Pull out oil dipstick **2** again and check gearbox oil level.

If gearbox oil level is below the MIN mark:

- ▶ Top up using appropriate gearbox oil in accordance with the lubrication chart (For more information see: [9.41.9 Filling in gearbox oil at the counterweight carriage's axle gearbox, page 1999](#)).

If gearbox oil level is above the MAX mark:

- ▶ Drain gearbox oil using drain screw **3 + 6**.

9.41.9 Filling in gearbox oil at the counterweight carriage's axle gearbox

Make sure the following prerequisites are met:

- Diesel engine has been switched off for 5 minutes.
- Machine is level.
- Machine is secured against unauthorized start-up.

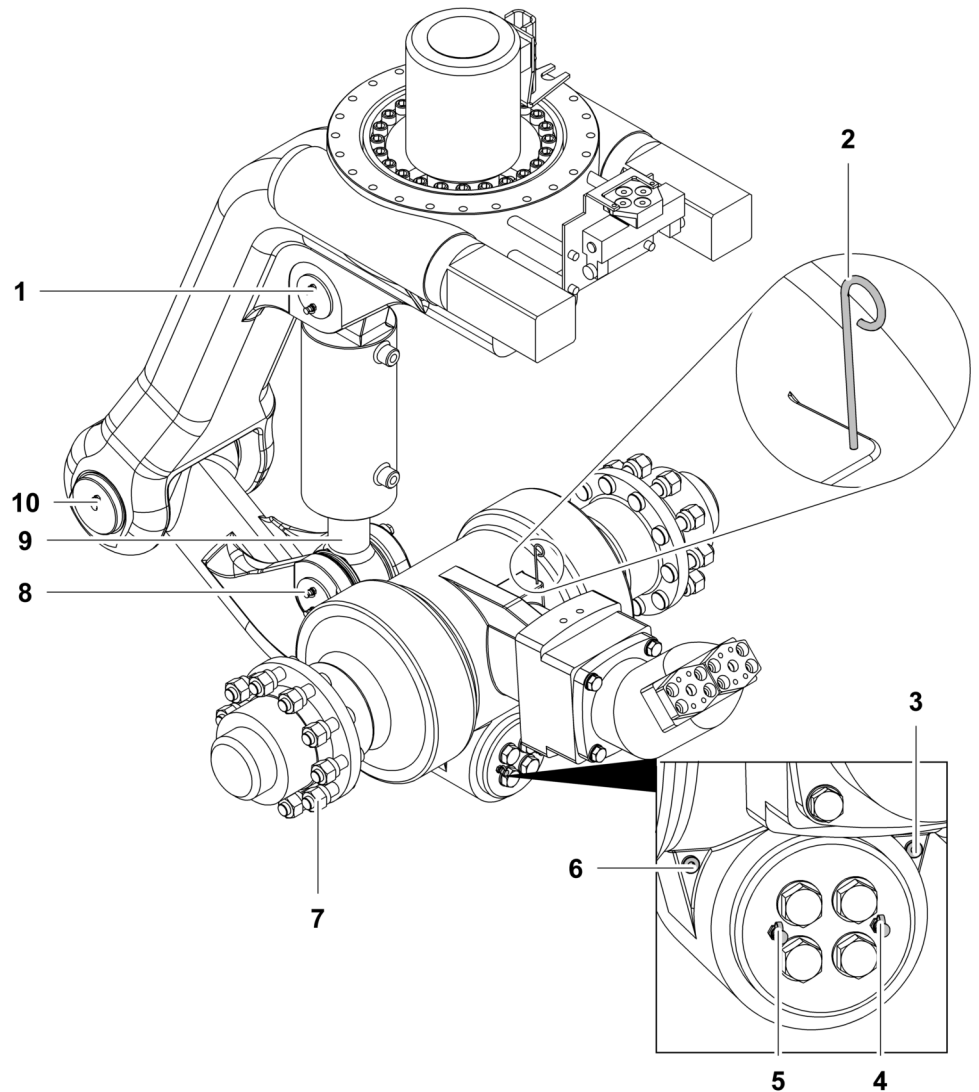


Fig. 5949: Filling in gearbox oil at the counterweight carriage's axle gearbox

- | | | | |
|----------|--------------------|-----------|--------------------|
| 1 | Grease nipple (2x) | 6 | Drain screw |
| 2 | Oil dipstick | 7 | Wheel nut (20x) |
| 3 | Drain screw | 8 | Grease nipple (2x) |
| 4 | Grease nipple | 9 | Hydraulic cylinder |
| 5 | Grease nipple | 10 | Grease nipple (2x) |



CAUTION

Hot gearbox components and gearbox oil!
Burns.

- ▶ Maintenance work and inspection work on axle gearboxes may only be carried out when the machine is switched off and has cooled down.
- ▶ Wear protective equipment.

NOTICE

Dirt and foreign bodies in axle gearbox!
Damage to axle gearbox.

- ▶ Ensure that no dirt or foreign bodies enter the filler neck.
- ▶ Pull out oil dipstick **2**.
- ▶ Pull out oil dipstick **2** again and check gearbox oil level.

NOTICE

Inadmissible or contaminated gearbox oil!
Damage to axle gearbox.

- ▶ Top up using only appropriate gearbox oil according to lubrication chart ([For more information see: 9.2.3 Lubrication chart, page 1875](#)).
- ▶ Check purity of gearbox oil.
- ▶ Top up gearbox oil up to MAX mark.
- ▶ Reinsert oil dipstick **2** all the way again.

9.41.10 Checking the hydraulic cylinders of the counterweight carriage's wheel sets for tightness

- ▶ Check hydraulic cylinders of the counterweight carriage's wheel sets for tightness.

If the hydraulic cylinders of the wheel sets are leaky:

- ▶ Do not operate counterweight carriage.
- ▶ Contact Liebherr customer service.

9.41.11 Checking the hydraulic connections on the counterweight carriage for tightness

- ▶ Check hydraulic connections on the counterweight carriage for tightness.

If the hydraulic connections on the counterweight carriage are not tight:

- ▶ Do not operate counterweight carriage.
- ▶ Contact Liebherr customer service.

9.41.12 Checking the screws of the counterweight tie-down for tight fit

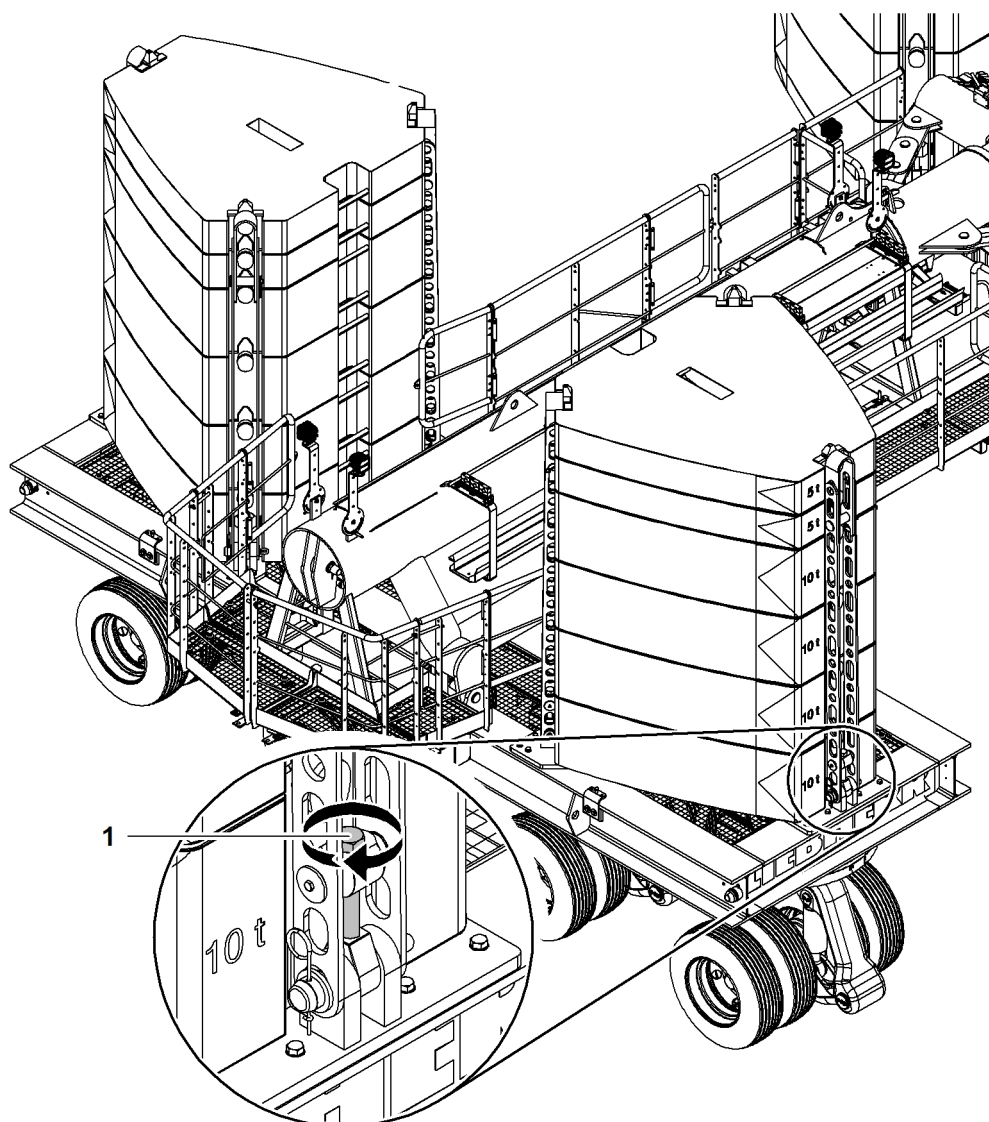


Fig. 5950: Checking the screws of the counterweight tie-down for tight fit

1 Screw (6x)

The screws **1** of the counterweight tie-down must be tightened hand-tight with a wrench.

► Check screws **1** of counterweight tie-down for tight fit.

If the screws **1** of the counterweight tie-down are loose:

► Tighten screws **1** hand-tight with a wrench.

9.42 Ropes

9.42.1 Assembly of a rope

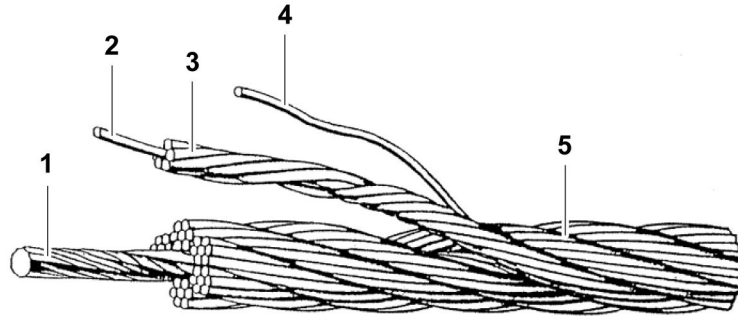


Fig. 5951: Assembly of a rope (illustration of principle)

1	Rope core	4	Wire
2	Strand core	5	Rope
3	Strand		

9.42.2 Visual inspection of the ropes for deterioration or mechanical damage

- ▶ Carry out a visual inspection of the ropes for deterioration or mechanical damage.

If you detect deterioration or mechanical damage:

- ▶ Check ropes for end of service life ([For more information see: 9.42.5 Checking ropes for end of service life, page 2003](#)).

9.42.3 Checking ropes for lubrication

Regular lubrication increases the service life of ropes. The ropes must be relubricated before they show signs of dryness or corrosion.

NOTICE

It is forbidden to operate with non-lubricated ropes!
Ropes may become damaged.

- ▶ Ensure that ropes are lubricated.
-

- ▶ Check ropes for lubrication.

If ropes are insufficiently lubricated:

- ▶ Lubricate ropes ([For more information see: 9.42.4 Rope lubrication, page 2003](#)).

9.42.4 Rope lubrication

NOTICE

Wrong lubricant!
Risk of damage to the rope.

- ▶ Only use lubricants matching the original rope lubrication (For more information see: [9.2 Lubricants and consumables, page 1871](#)).

- ▶ Lubricate ropes.
- ▶ Lubricate ropes, especially in the bending zones of the drums and pulleys.



Note

- ▶ Choose the lubrication intervals for the ropes based on the operating conditions.

9.42.5 Checking ropes for end of service life

Notes for regular inspection of the ropes

The following items are of importance for determining the inspection intervals and may shorten inspection intervals:

- National and local regulations that apply in the country of use.
- The environmental conditions to which the machine is exposed.
- The first few weeks after a rope has been put on.
- Results and experiences from previous inspections.
- The length of time the rope has already been in use



DANGER

Rope damage is not noticed!
Load breakaway.

If the machine was not operated for over three months or incidents may have caused damage to the rope:

- ▶ Check rope and end attachments.

- ▶ Check each rope over its entire length.

or

If deemed practicable by a competent person, check the working length and at least five turns on the drum.

- ▶ Create a record of the rope inspection.

Crane reference						Rope application					
Rope details..... Brand name (if known) Nominal diameter.....mm Construction..... Core ^a : IWRC FC WSC Wire finish ^a : Uncoated Zinc/Gal. Direction and type of lay ^a : (Right) sZ zZ Z (Left) zS sS S Permissible number of visible broken outer wires in 6d and..... in 30d Reference diameter.....mm Permissible decrease in diameter from reference diameter mm											
Date installed (yy/mm/dd)..... Date discarded (yy/mm/dd).....											
Visible broken outer wires				Diameter			Corrosion	Damage and/or deformation		Position in rope	Overall assessment i.e. combined severity rating ^b at position indicated
Number in length of		Severity rating ^b		Measured diameter	Actual decrease from reference	Severity rating ^b	Severity rating ^b	Nature			
6d	30d	6d	30d	mm	mm						
Other observations/comments											
Performance to date (cycles/hours/days/months/etc.)											
Date of inspection (yy/mm/dd).....											
Name (print) of competent personName (signature)											
^a Tick as applicable.											
^b Describe degree of deterioration as: slight, medium, high, very high, or discard.											

Fig. 5952: Example of an individual report

These rope changing criteria form part of ISO 4309. They describe the most commonly occurring types of rope wear.

Type of damage	Assessment method
Number of allowable wire breaks	Counting
Check reduction of the rope diameter (only with sections of rope wound as a single-layer on a drum and/or running on a steel pulley.)	Measuring
Strand break	Visual inspection
Corrosion	Visual inspection
Deformation	Visual inspection and measuring
Mechanical damage	Visual inspection
Heat induced damage	Visual inspection

Tab. 633: Discard criteria overview

Check the rope for number of permitted wire breaks

Make sure the following prerequisites are met:

- Machine is switched off.
- Machine is secured against unauthorized start-up.

The table below shows the permitted number of wire breaks relative to a defined control section of the rope.

Single-layer and parallel stranded ropes							
Rope category number (RCN)	Total number of load-bearing wires in the outer strand layers of the rope ^{A)}	Number of visible external wire breaks ^{B)}					
		Rope sections that run on steel sheaves and/or wind around a single-layer winding drum				Rope sections that wind around a multiple-layer winding drum ^{C)}	
		Class M1 to M4 or unknown class ^{D)}				All classes	
		Cross lay		Lang lay		Cross lay and lang lay	
		on a length of 6d ^{E)}	on a length of 30d ^{E)}	on a length of 6d ^{E)}	on a length of 30d ^{E)}	on a length of 6d ^{E)}	on a length of 30d ^{E)}
n							
01	$n \leq 50$	2	4	1	2	4	8
02	$51 \leq 75$	3	6	2	3	6	12
03	$76 \leq 100$	4	8	2	4	8	16
04	$101 \leq 120$	5	10	2	5	10	20
05	$121 \leq 140$	6	11	3	6	12	22
06	$141 \leq 160$	6	13	3	6	12	26
07	$161 \leq 180$	7	14	4	7	14	28
08	$181 \leq 200$	8	16	4	8	16	32
09	$201 \leq 220$	9	18	4	9	18	36

LWNLR-x/V04.01//Auslieferung/2016-03-07/en

Single-layer and parallel stranded ropes							
Rope category number (RCN)	Total number of load-bearing wires in the outer strand layers of the rope ^{A)} n	Number of visible external wire breaks ^{B)}					
		Rope sections that run on steel sheaves and/or wind around a single-layer winding drum				Rope sections that wind around a multiple-layer winding drum ^{C)}	
		Class M1 to M4 or unknown class ^{D)}				All classes	
		Cross lay		Lang lay		Cross lay and lang lay	
		on a length of 6d ^{E)}	on a length of 30d ^{E)}	on a length of 6d ^{E)}	on a length of 30d ^{E)}	on a length of 6d ^{E)}	on a length of 30d ^{E)}
10	221 ≤ 240	10	19	5	10	20	38
11	241 ≤ 260	10	21	5	10	20	42
12	261 ≤ 280	11	22	6	11	22	44
13	281 ≤ 300	12	24	6	12	24	48
	n > 300	0.04 x n	0.08 x n	0.02 x n	0.04 x n	0.08 x n	0.16 x n

PLEASE NOTE: In this table, ropes with Seale-type outer strands, which have 19 wires or less per strand (e.g. 6 □ x 19 Seale), are placed two lines above that row in which the type would normally be listed due to the number of load-bearing wires in the outer strands.

Tab. 634: Reached or exceeded number of visible wire breaks occurring in single-layer and parallel strand ropes indicating that the rope must be discarded

- A) For the purposes of this international standard, filler wires are not considered as load-bearing wires and are not contained in the value n.
- B) A broken wire has two ends (counted as one wire).
- C) The values apply for damage in the cross-over zones and overlays of windings due to deflection angles (not for rope sections that only run on pulleys and do not wind up on drums).
- D) Twice the number of broken wires listed may be applied to ropes on mechanisms of the group M5 to M8.
- E) d = nominal rope diameter.

Non-rotating ropes					
Rope category number (RCN)	Total number of load-bearing wires in the outer strands of the rope ^{A)} n	Number of visible breaks in outer wires ^{B)}			
		Rope sections that run on steel pulleys and/or wind on a single-layer winding drum (random distribution of the wire breaks)		Rope sections spooling on a multi-layer drum ^{C)}	
		over a length of 6d ^{D)}	over a length of 30d ^{D)}	over a length of 6d ^{D)}	over a length of 30d ^{D)}
21	4 strands n ≤ 100	2	4	2	4
22	3 or 4 strands n ≥ 100	2	4	4	8
	At least 11 outer strands				
23-1	71 ≤ n ≤ 100	2	4	4	8

Non-rotating ropes					
Rope category number (RCN)	Total number of load-bearing wires in the outer strands of the rope ^{A)} n	Number of visible breaks in outer wires ^{B)}			
		Rope sections that run on steel pulleys and/or wind on a single-layer winding drum (random distribution of the wire breaks)		Rope sections spooling on a multi-layer drum ^{C)}	
		over a length of 6d ^{D)}	over a length of 30d ^{D)}	over a length of 6d ^{D)}	over a length of 30d ^{D)}
23-2	$101 \leq n \leq 120$	3	5	5	10
23-3	$121 \leq n \leq 140$	3	5	6	11
24	$141 \leq n \leq 160$	3	6	6	13
25	$161 \leq n \leq 180$	4	7	7	14
26	$181 \leq n \leq 200$	4	8	8	16
27	$201 \leq n \leq 220$	4	9	9	18
28	$221 \leq n \leq 240$	5	10	10	19
29	$241 \leq n \leq 260$	5	10	10	21
30	$261 \leq n \leq 280$	6	11	11	22
31	$281 \leq n \leq 300$	6	12	12	24
	$n > 300$	6	12	12	24

PLEASE NOTE: In this table, ropes with Seale-type outer strands, which have 19 wires or less in each strand (e.g. 18 \square x 19 Seale - WSC), are placed two lines above that row in which the type would normally be listed due to the number of load-bearing wires in the outer strands.

Tab. 635: Reached or exceeded number of visible wire breaks occurring in non-rotating ropes indicating that the rope must be discarded

- A) For the purposes of this international standard, filler wires are not considered as load-bearing wires and are not contained in the value n.
- B) A broken wire has two ends (counted as one wire).
- C) The values apply for damage in the cross-over zones and overlays of windings due to deflection angles (not rope sections that only run on rope sheaves and do not wind up on drums).
- D) d = nominal rope diameter.

▶ Check the number of wire breaks with the values in the table.

If the number of wire breaks exceeds the number of permitted wire breaks:

- ▶ If possible determine cause of damage.
- ▶ Contact Liebherr customer service.
- ▶ Discard rope.

Check ropes for reduction of the nominal rope diameter

Calculate rope diameter

Make sure the following prerequisites are met:

- Caliper with wide jaws is available.
- Machine is switched off.

- Machine is secured against unauthorized start-up.

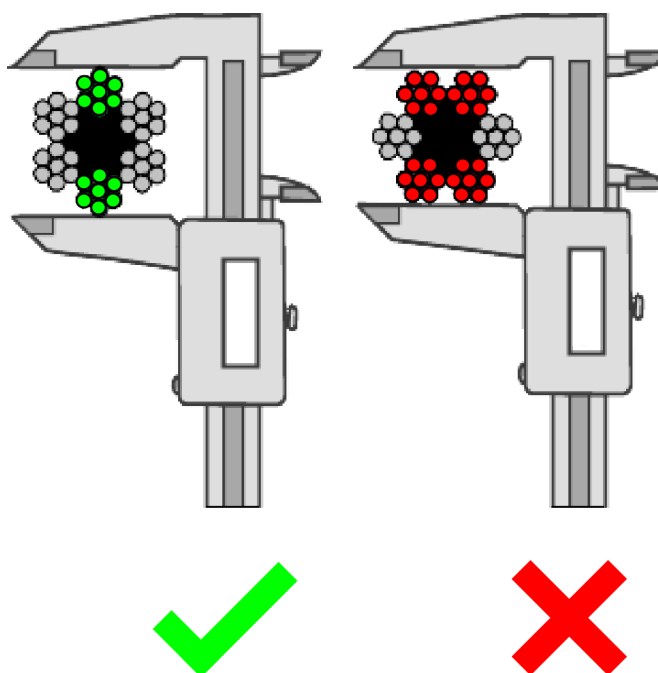


Fig. 5954: Rope diameter measured correctly (left side) and incorrectly (right side)

- ▶ Measure rope diameter between two opposite strands.
- ▶ Turn calipers by 90 ° and again measure two opposite strands in the same area.
- ▶ Measure rope diameter again in an area located at least 1 m (3' 3" ft-in) away.
- ▶ Turn calipers by 90 ° and again measure two opposite strands in the same area.

The mean value corresponds to the rope diameter.

- ▶ Calculate mean value from all four measurements.

Calculating the reduction of the rope diameter

Formula for the reduction of the rope diameter	
$\Delta d = \frac{d_{ref} - d_m}{d} \times 100 \%$	
Δd	Uniform reduction of the rope diameter.
d_{ref}	Reference diameter of the rope in new condition. Measured after laying with no load on the rope. If reference diameter is not available, then measure rope diameter before the end connection.
d_m	Measured rope diameter in used condition.
d	Nominal diameter given by the manufacturer.

Tab. 636: Calculating the reduction of the rope diameter

- ▶ Calculating the reduction of the rope diameter.

The following table describes the evaluation criteria for a uniform reduction of the rope diameter. The values apply for rope sections wound as a single-layer on a drum and/or running on a steel pulley. The values do not apply to rope sections in cross-over zones.

Rope type	Uniform decrease in diameter (expressed as % of nominal diameter)	Rating of severity	
		Description	%
Single-layer rope with fiber core	< 6	—	0
	6 to < 7	Slight	20
	7 to < 8	Medium	40
	8 to < 9	High	60
	9 to < 10	Very high	80
	> 10	Discard	100
Single-layer rope with a steel inlay or parallel stranded rope	< 3.5	—	0
	3.5 to < 4.5	Slight	20
	4.5 to < 5.5	Medium	40
	5.5 to < 6.5	High	60
	6.5 to < 7.5	Very high	80
	> 7.5	Discard	100
Non-rotating rope	< 1	—	0
	1 to < 2	Slight	20
	2 to < 3	Medium	40
	3 to < 4	High	60
	4 to < 5	Very high	80
	> 5	Discard	100

Tab. 637: Rating criteria for even reduction of the rope diameter indicating the necessity to discard the rope

If the reduction of the rope diameter has reached the “discard” degree of severity:

- ▶ Turn machine off.
- ▶ Secure the machine against unauthorized start-up.
- ▶ Contact Liebherr customer service.
- ▶ Discard rope.

Checking ropes for strand breaks

Make sure the following prerequisites are met:

- Machine is switched off.
- Machine is secured against unauthorized start-up.
- ▶ Check ropes for strand breaks.

If strand breaks are present:


- ▶ If possible determine cause of damages.

- ▶ Contact Liebherr customer service.
- ▶ Discard rope.

Check ropes for corrosion

Make sure the following prerequisites are met:

- Machine is switched off.
- Machine is secured against unauthorized start-up.

Check for:	Images of damage:
<p>Corrosion: Occurs especially due to sea air and industrial air pollution. Before evaluating, clean the rope by wiping or brushing it. Corrosion reduces the rope strength and elasticity of the rope. External and internal corrosion often occur simultaneously. An increase in diameter may be an indication of corrosion inside the rope.</p>	

Tab. 638: Checking ropes for corrosion

The following table describes the evaluation criteria for corrosion.

Corrosion type	Condition	Rating of severity
External corrosion	Signs of oxidation on the surface can be wiped off.	Superficial = 0 %
	Wire surface rough to touch.	High degree = 60% ^{A)}
	Highly corroded wire surface, sagging wires ^{B)} .	Discard = 100 %
Internal corrosion	Obvious visible signs of internal corrosion, i.e. from corrosion debris exuding from the valleys between the outer strands ^{C)} .	Discard = 100 % or examination of the internal condition of the rope, if deemed appropriate by a competent person.
Friction-induced corrosion	In the case of friction-induced corrosion, fine steel particles are abraded by the wires through the constant rubbing of dry wires and strands, which then oxidize and form corrosion deposits inside the rope; this shows up as dry powder.	Signs of this should be further investigated; if there is any uncertainty about the degree of severity, the rope must be discarded (100 %).
PLEASE NOTE: Corrosion inside the rope or friction-induced corrosion can result in an increase of diameter.		

Tab. 639: Discard criteria for corrosion and intermediate severity ratings

- A) Even in the case of oxidation of galvanized wires, the wire surface may feel rough. The overall condition is possibly not as severe as in non-galvanized wires. In such cases, the person carrying out the test may consider using a lower proportion of the combined effect of the rating given in this table.

- B) For any other intermediate conditions, an assessment should be made as to its severity rating (i.e. contribution towards the combined effect).
- C) The evaluation of the corrosion inside the rope is subjective. If there is any uncertainty regarding the severity of the corrosion inside the rope, the rope must be discarded.

- ▶ Check ropes for corrosion.

If the rope meets one of the criteria above or exhibits specific damage:

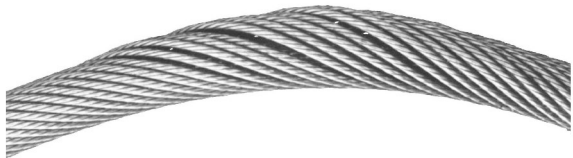

- ▶ Contact Liebherr customer service.




- ▶ Discard rope.

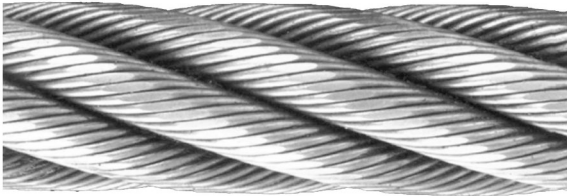
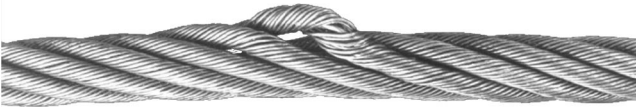


Checking rope for deformation and mechanical damage

Make sure the following prerequisites are met:

- Machine is switched off.
- Machine is secured against unauthorized start-up.

Check for:	Images of damage:
<p>Bird-caging: May occur if the outer layers of the wires have loosened or if the outer strands are longer than the inner strands. Through shifting of the outer versus the inner wire layers or strand layers, the excess length is pushed to one place.</p>	
<p>Looping: Individual wires or groups of wires penetrate out of the rope structure. In most cases, the loops are in several strands in succession.</p>	

Check for:	Images of damage:
<p>Necking: Defined as a reduction of the wire rope diameter in short stretches. Rope parts must be especially carefully checked for necking right before the final attachment. Necking is often hard to identify in these places.</p>	
<p>Knots: Are deformations of the wire rope. These are caused by pulling a loop tight which the wire rope cannot compensate by twisting its axis.</p>	
<p>Corkscrew: With this deformation, the axis of the unstrained wire rope takes on a spiral shape. This does not weaken the wire rope but may cause uneven running of the rope. Higher wear and wire brakes may be the consequences. If this deformation is more than 1/3 of the nominal rope diameter in the weakest spot, the wire rope must be exchanged.</p>	

Check for:	Images of damage:
<p>Abrasion: Abrasion may reduce both the static rope breaking force due to a reduction of the metal rope diameter, and the operational stability due to wear notches. If the rope diameter has shrunk on longer stretches by more than 10% compared to the nominal dimension, the rope must be exchanged – even if there are no wire breaks.</p>	
<p>Deformed core or strand: Core emerges between the outer strands or outer strand emerges from the rope structure.</p>	
<p>Local increase of rope diameter: Caused by deformation of the rope core or swelling of the fiber core.</p>	
<p>Flattened areas: Permanent deformation of the wire rope, caused by squeezing. The rope is damaged faster if flattened areas are present.</p>	

Tab. 640: Checking ropes for deformation

- ▶ Check rope for deformation and mechanical damage.

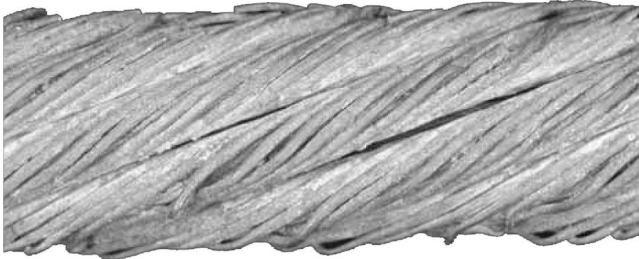
If the rope meets one of the criteria above or exhibits specific damage:

- ▶ If possible determine cause of damage.
- ▶ Contact Liebherr customer service.
- ▶ Discard rope.

Check ropes for the effects of heat

Make sure the following prerequisites are met:

- Machine is switched off.
- Machine is secured against unauthorized start-up.

Check for:	Images of damage:
<p>Heat-induced damage: Can be identified externally from respective heat discoloration on the steel wires and/or a significant loss of lubricant. A lightning strike, for example, can cause extreme heat damage.</p>	

Tab. 641: Checking ropes for heat impact



Note

- ▶ For permitted operating temperatures for ropes and end attachments, refer to EN 12385-3.

- ▶ Check ropes for significant heat damage.

If a rope shows signs of external heat damage:

- ▶ Contact Liebherr customer service.
- ▶ Discard rope.

9.42.6 Storing ropes

NOTICE

Missing label!

Confusion of ropes or rope reels.

If the label is missing or no longer clearly legible:

- ▶ Mark rope reels in accordance with the delivery documents.

- ▶ Make sure that the delivered ropes comply with the supplied material certificates and are the same as what you ordered.

- ▶ Store the material certificates.

NOTICE

Improper storage!

Damage to ropes.

- ▶ Store ropes properly.

- ▶ Wire ropes should be stored in a dry and well ventilated area.

- ▶ Protect rope and rope reel against weathering: Do not store rope and rope reel directly on the ground.

- ▶ Avoid storing outside for lengthy periods.

9.42.7 Transporting the ropes

NOTICE

Improper transport!
Damage to ropes.

► Transport ropes properly.

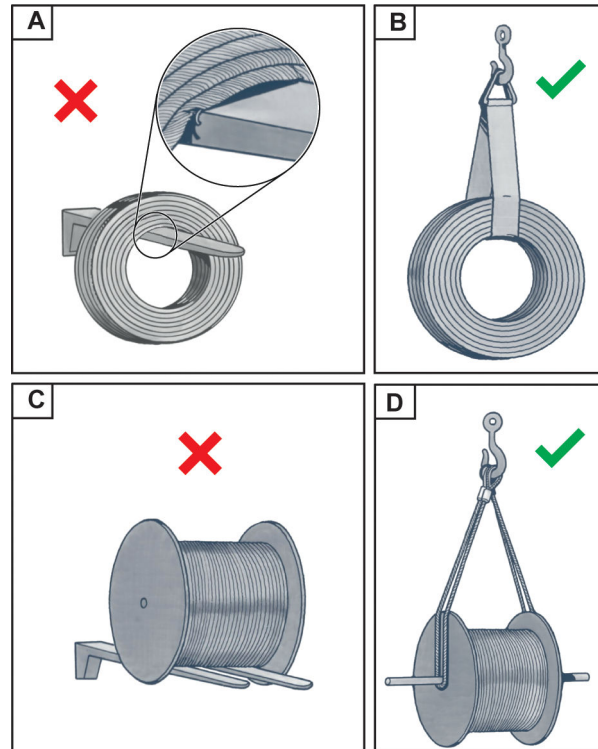


Fig. 5971: Transporting the ropes

- | | | | |
|----------|--|----------|--|
| A | Rope ring transported with metal fork | C | Rope reel transported with metal fork |
| B | Rope ring transported with lifting strap | D | Rope reel transported with shaft strap |

If the rope is wound up as a rope ring:

► Lift rope ring lift with textile sling gear (lifting straps or round slings).

If the rope is wound up on a rope reel:

► Lift the rope reel preferably from a shaft inserted in the axis hole.

9.42.8 Selecting a rope

Selection criteria for ropes

The selection of ropes depends on various criteria.

The most important selection criteria for ropes are:

- Intended use
- Torsion properties
- Minimum breaking force
- Make
- Direction of lay
- Rope inlay

- Surface finish
- Rope diameter tolerances

**DANGER**

Impermissible use of ropes that do not conform to the manufacturer's specifications!

Load breakaway.

- ▶ Only use ropes approved by Liebherr customer service.

**DANGER**

Incorrectly fit swivels!

Load breakaway.

- ▶ The fitting of swivels for any of the machine ropes is forbidden.
- ▶ For information about any exceptions: Contact Liebherr after sales service.

**WARNING**

Inadmissible combination of rotation-resistant ropes and swivels!

Life-threatening situation and damage to the machine.

- ▶ Swivels must not be used with rotation resistant (wire) ropes.

**WARNING**

Strain on rope ends of non-rotation-resistant ropes without rotation lock!
High turning moments.

- ▶ Fit anti-rotation devices.

**WARNING**

Inadmissible combination of non-rotation-resistant ropes with different lay direction!

Load breakaway.

- ▶ Only combine ropes with the same lay direction.
- ▶ Never use these rope designs with a swivel or having one or both rope ends without an anti-rotation device.

**DANGER**

Improper use of non-rotation resistant ropes for hoist winches!

Load breakaway.

- ▶ Guide load to keep it from rotating.
- ▶ Make sure that no whorls or rotating elements are installed.
- ▶ Make sure the rope does not become twisted.

- ▶ Contact Liebherr customer service.

- ▶ Select ropes.

Determining the direction of lay

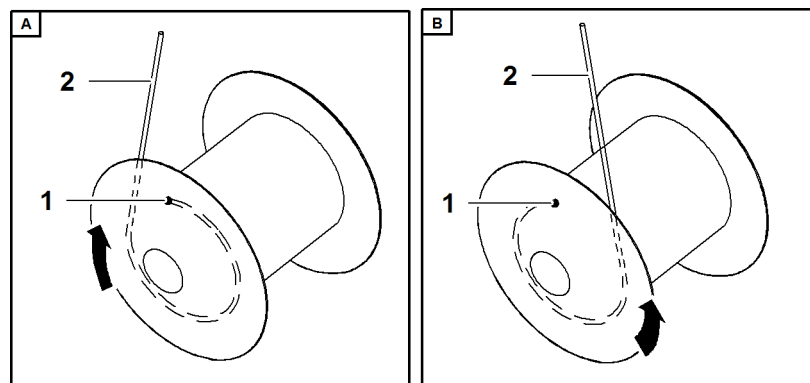


Fig. 5972: Determining the direction of lay (illustration of principle)

- | | | | |
|----------|-------------------|----------|-------------------|
| A | Left-handed rope | 1 | Rope fixing point |
| B | Right-handed rope | 2 | Unwinding rope |

- ▶ Determine on which side the rope fixing point **1** of the drum is located.
- ▶ Follow the windings of the unwinding rope **2** from the rope fixing point.

If the rope unwinds clockwise:

- ▶ Choose a left-handed rope.

If the rope unwinds counter-clockwise:

- ▶ Choose a right-handed rope.

9.42.9 Storing ropes

NOTICE

Ropes are not labelled!
Ropes/rope winders could be mixed up.

If the label is missing or is no longer clearly legible,

- ▶ Rope winders according to the delivery documents.

- ▶ Check that the labeling of supplied ropes matches the material inspection documents and the order.
- ▶ Material inspection certificates should be carefully filed away.

NOTICE

Incorrect storage!
Ropes may become damaged.

- ▶ Ropes should be stored correctly.

- ▶ Store wire ropes in a dry, well-ventilated area.
- ▶ Protect rope and rope winder from the elements: Never store rope or rope winder directly on the ground.
- ▶ Avoid storing them outdoors for prolonged periods.

9.42.10 Transporting ropes

Ropes are very sensitive to external damage.

**WARNING**

Incorrect transport (loaded, unloaded)!
Ropes may become damaged.

- ▶ Ropes should be transported correctly.

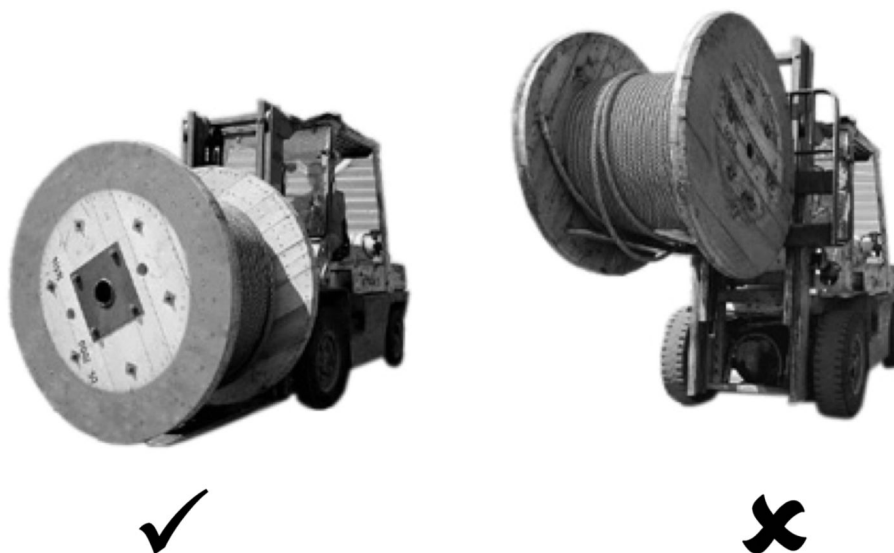


Fig. 5973: Lifting a rope winder correctly (left) and incorrectly (right) on a forklift truck

Correct procedures to avoid damage to ropes during transport:

- ▶ Lift rope winders using textile rigging (flat lifting slings or round slings).
- ▶ Ideally, rope winders should be lifted with a shaft pushed through their middle.
- ▶ Lift rope winders using forklift forks.

9.42.11 Unwind rope from rope reel

Make sure the following prerequisites are met:

- Protective equipment is worn.
- Tools and auxiliary materials are at hand.

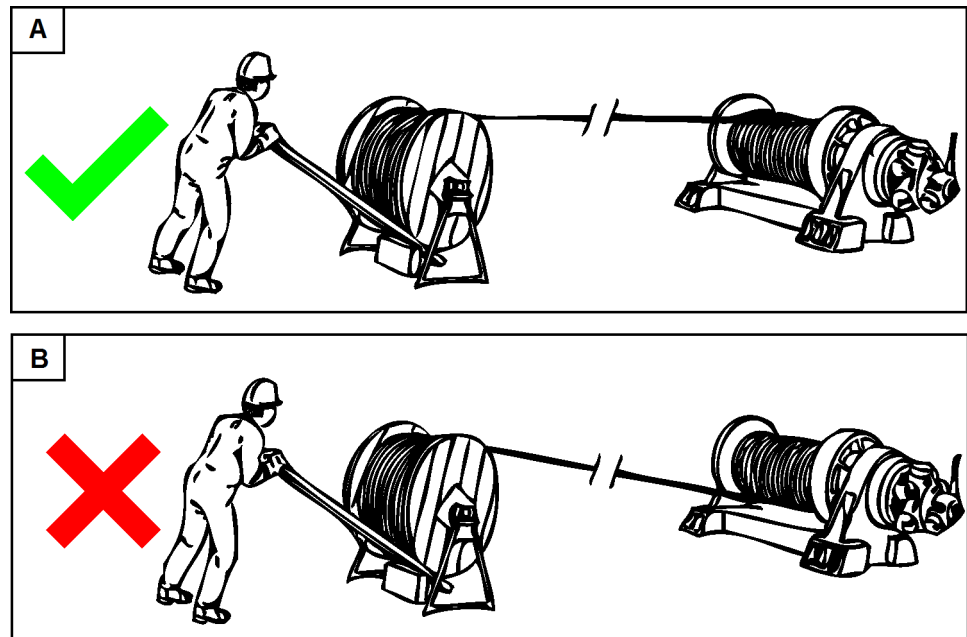


Fig. 5974: Unwind rope from rope reel

A Rope and drum with same bending direction

B Rope and drum with opposite bending direction

- ▶ Jack up rope reel.

NOTICE

Inadmissible diagonal unwinding of ropes!
Damage to rope.

- ▶ Unwind rope straight from rope reel.

NOTICE

Improper winding of rope on drum!
Damage to rope.

- ▶ Pretension rope when winding on drum. The pretension force is reached by braking the rope reel and must be 1% to 2% of the rope's minimum break force.
- ▶ Do not brake rope directly.
- ▶ Do not drag rope on ground.

- ▶ Unwind rope from braked rope reel and in the same bending direction as that of the drum.

- ▶ Check rope for damage and deformation while winding.

If the rope shows damage and deformation:

- ▶ discard rope.

9.42.12 Laying on the rope

Danger zone when luffing a rope



DANGER

Impermissible use of ropes that do not conform to the manufacturer's specifications!

- ▶ Only use ropes approved by Liebherr customer service.



DANGER

Inadmissible installation of swivels!
Load breakaway.

- ▶ Ensure that no swivels are installed on any of the ropes.
- ▶ For information about exceptions: Contact Liebherr customer service.



WARNING

Rotating winches, moving rope!
Risk of crushing of limbs, death.

- ▶ Turn off diesel engine while working on winches.
- ▶ Make sure that there is nobody in the danger zone around the winches.
- ▶ Detach/fasten ropes exclusively from the uppercarriage.
- ▶ Ensure that the machine operator is in visual contact and voice contact with the assistant.

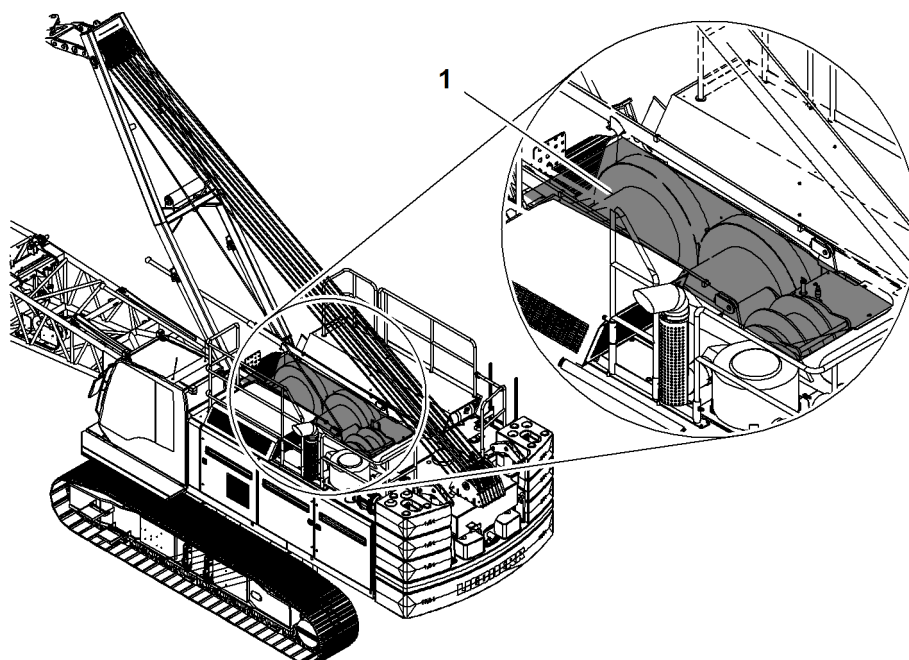


Fig. 5975: Danger zone uppercarriage (illustration of principle)

1 Danger zone

Laying on the rope of winch1 and winch2 with installed main boom

When luffing the new rope, make sure that the rope is not untwisted or twisted. The rope can be luffed using the old rope or ideally using an auxiliary rope. If an auxiliary rope is used, it must have sufficient permitted pull force (at least the weight of the rope). If the old rope is used as the luffing rope, ensure that the new rope does not become twisted.



WARNING

Impermissible changing of ropes!
Severe injury, damage to winch and rope.

- ▶ Make sure that only authorized persons change the rope.

Make sure the following prerequisites are met:

- Machine is secured against unauthorized start-up.
- Boom is laid down and/or deinstalled.
- Rope is checked before luffing for damage resulting from incorrect handling or storage.
- Protective equipment is worn.
- Two helpers assist the machine operator.
- Tools and utilities are at hand.

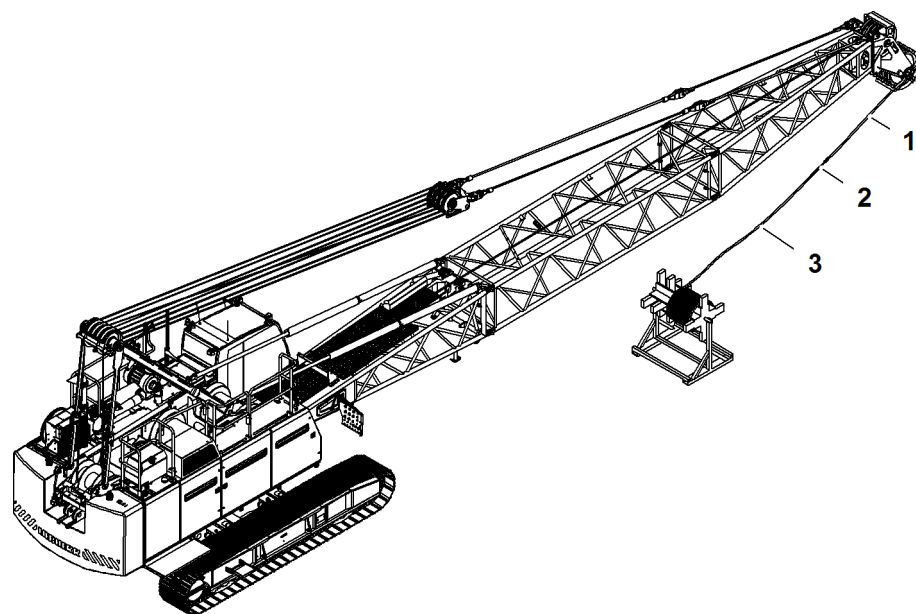


Fig. 5976: Laying on the rope of winch1 and winch2 with installed main boom (illustration of principle)

- | | | | |
|---|----------------|---|------|
| 1 | Auxiliary rope | 3 | Rope |
| 2 | Rope stocking | | |

- ▶ Positioning the reel with rope 3 laterally behind the main boom head.

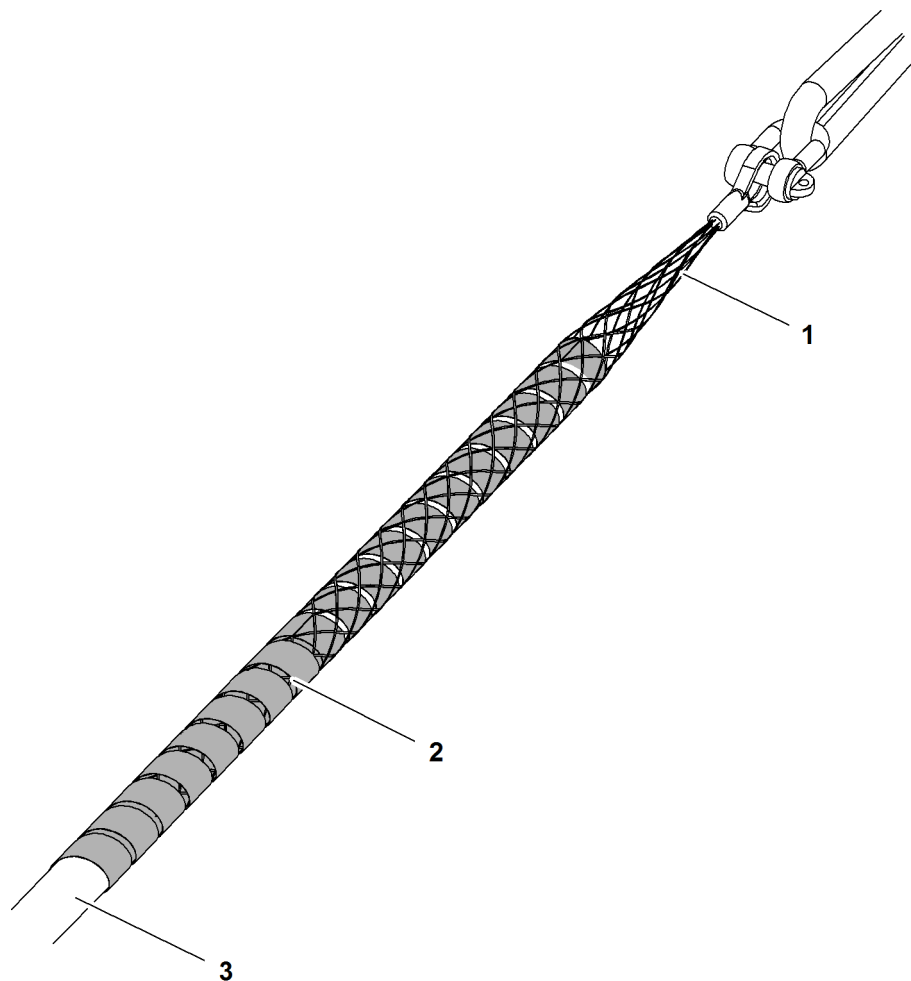


Fig. 5977: Rope stocking detail

- | | | | |
|---|---------------|---|------|
| 1 | Rope stocking | 3 | Rope |
| 2 | Textile tape | | |

- ▶ Wrap rope end (approx. 1 m (3' 3" ft-in)) with textile tape 2.
- ▶ Pull rope stocking over wrapped rope end.
- ▶ Fixate rope stocking end with textile tape 2 .
 - ▷ Rope connected with auxiliary rope.
- ▶ Reeve the auxiliary rope on the main boom head.
- ▶ Rope tensioned, guide laterally along main boom to machine.
- ▶ Throw auxiliary rope onto main boom with helper.

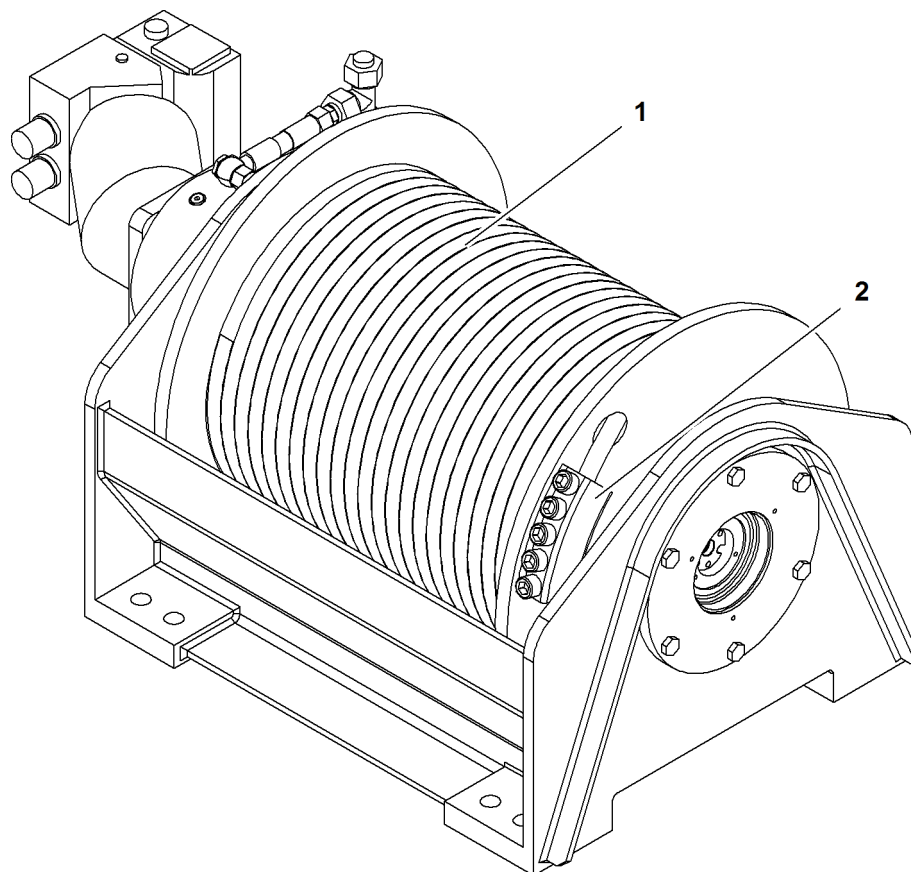


Fig. 5978: Winch on uppercarriage (illustration of principle)

1 Drum

2 Rope fixing point

- ▶ Attach auxiliary rope to drum 1 of winch1 or winch2.



WARNING

Rotating winches. Running rope.
Risk of crushing of limbs, death.

- ▶ Turn off machine while working on winches.
- ▶ Make sure that no persons are located in the danger zone.
- ▶ Make sure that the machine operator is in visual and voice contact with the assistant.



Procedure on a machine with two multi-directional control levers

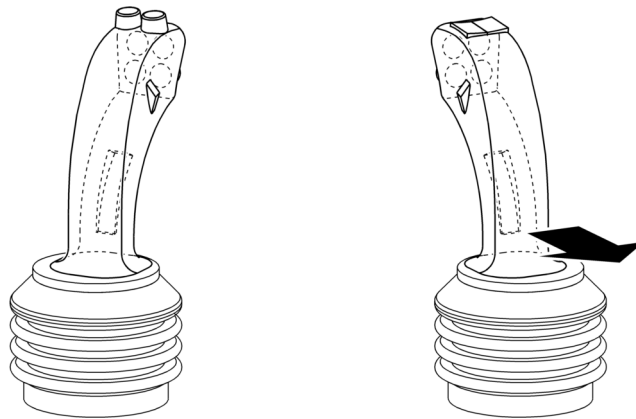
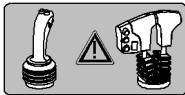


Fig. 5980: Lifting winch 1

- ▶ Push right multi-directional control lever backward.
 - ▷ Auxiliary rope is reeved on winch1.
 - ▷ Vibration button on right multi-directional control lever vibrates.



Procedure on a machine with a multi-directional control lever and a double T-lever

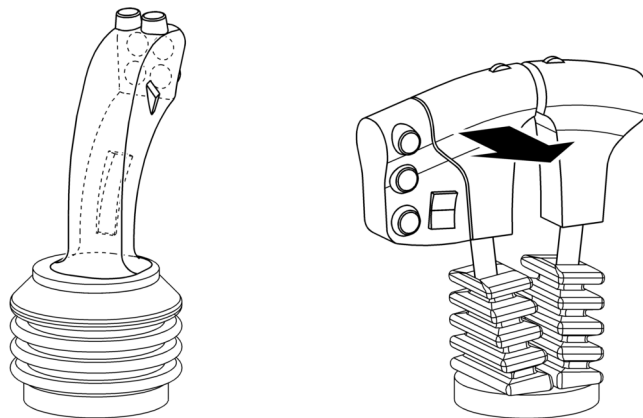


Fig. 5982: Lifting winch 1

- ▶ Push inner T-lever backward.
 - ▷ Auxiliary rope is reeved on winch1.
 - ▷ Vibration button on inner T-lever vibrates.



Procedure on a machine with two multi-directional control levers

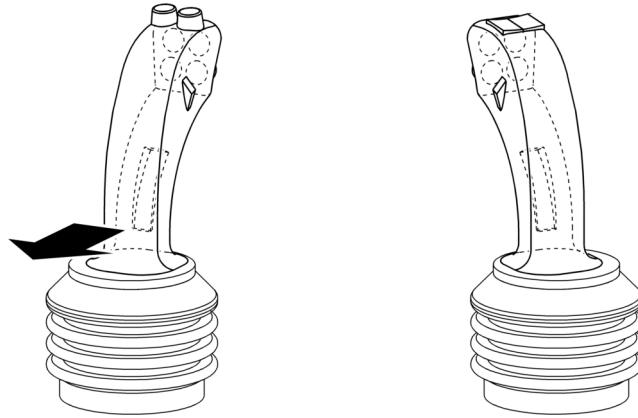
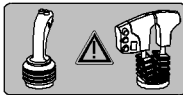


Fig. 5984: Lifting winch2

- ▶ Push left multi-directional control lever backward.
 - ▷ Auxiliary rope is reeved on winch2.
 - ▷ Vibration button on left multi-directional control lever vibrates.



Procedure on a machine with a multi-directional control lever and a double T-lever

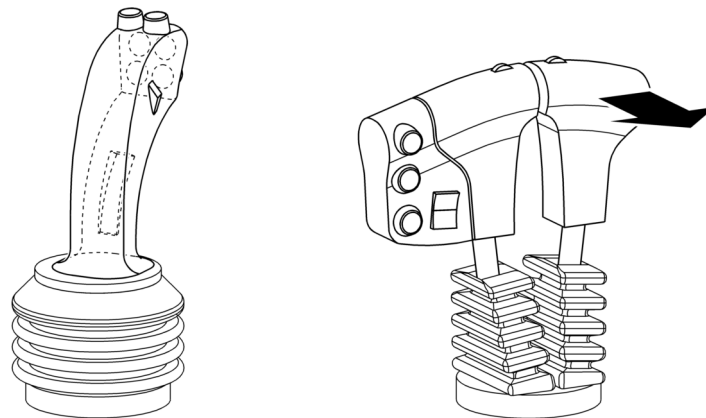


Fig. 5986: Lifting winch2

- ▶ Push outer T-lever backwards.
 - ▷ Auxiliary rope is reeved on winch2.
 - ▷ Vibration button on outer T-lever vibrates.



CAUTION

Incorrect handling!
Damage to rope.

- ▶ Rope may not scrape on rope protection on the boom head or steel structure.
- ▶ Prevent slack rope on reel.

- ▶ Reeve auxiliary rope on winch1 or winch2 until rope is located in front of winch1 or winch2.
- ▶ Loosen rope stocking and unreel auxiliary rope from winch1 or winch2.

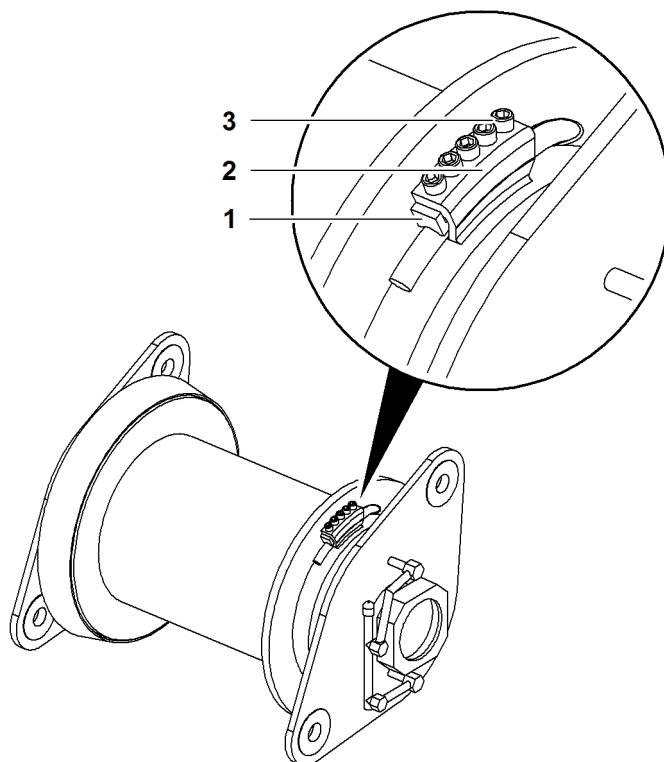


Fig. 5987: Rope fixing point (illustration of principle)

- | | | | |
|---|-------------------|---|------------|
| 1 | Rope wedge | 3 | Screw (5x) |
| 2 | Rope fixing point | | |

- ▶ Remove cover on winch1 or winch2.
- ▶ Loosen screws **3** on rope fixing point **2** of winch1 or winch2.
- ▶ Remove rope wedge **1**.



WARNING

Unsecured walking on boom sections!
Risk of falling off of boom sections.

- ▶ Only walk on boom sections with attached boom catwalks.
 - ▶ A fall arrest system must be worn when working on the boom sections.
-
- ▶ Lower winch1 or winch2 until 3-windings limit switch engages.
 - ▷ Winch1 or winch2 stops.
 - ▶ Bypass the 3-windings limit switch of winch1 or winch2 and move winch1 or winch2 three rotations lower.

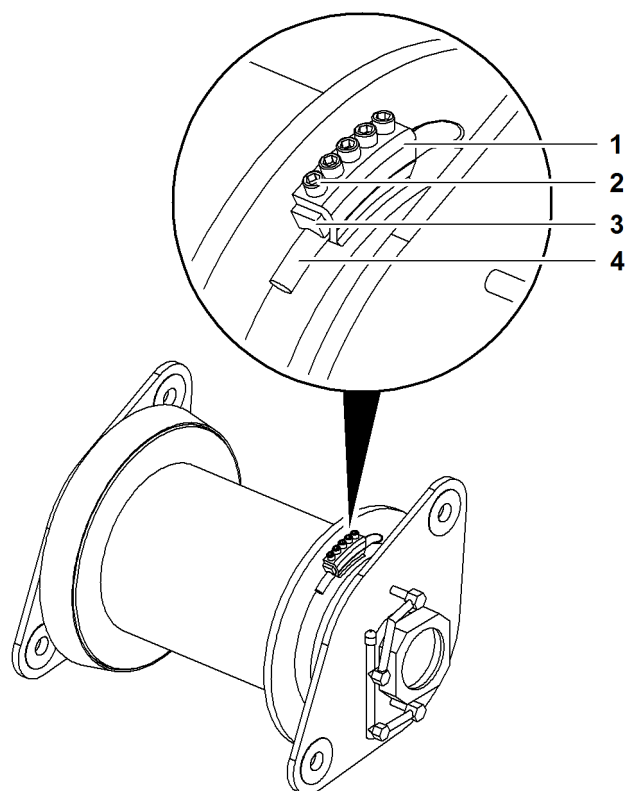


Fig. 5988: Installing the rope fixing point (illustration of principle)

- | | | | |
|----------|-------------------|----------|------------|
| 1 | Rope fixing point | 3 | Rope wedge |
| 2 | Screw | 4 | Rope |

- ▶ Slide rope **4** through rope fixing point **1** of winch1 or winch2.
- ▶ Insert rope wedge **3**.
- ▶ Tighten screw **2**.
- ▶ Reeve up one rope **4** winding on winch1 or winch2.
- ▶ Tighten all screws on rope fixing point **1**.
- ▶ Reeve rope **4** on winch1 and winch2 until 5 m (16' 5" ft-in) of rope are located in front of the main boom head.
- ▶ Install hoist limit switch and hook.
 - ▷ Main boom is ready for erecting.

9.43 Drum

9.43.1 Checking rope tensioning pulleys* of drum for wear

Make sure the following prerequisites are met:

- Machine is switched off.
- Machine is secured against unauthorized start-up.

► Check rope tensioning pulleys for wear.

If the rope tensioning pulleys are evenly worn, no further measures are required.

If the rope tensioning pulleys are not evenly worn or if rope operation does not function perfectly:

► Replace rope tension pulleys.

9.43.2 Checking the groove diameter of the drum

The grooves of the drum are checked with a groove gage for wear.

Ensure that the following conditions are fulfilled:

- Suitable groove gage is available.
- Groove is free of grease deposits.
- The machine is switched off.
- The machine is secured to prevent unauthorised operation.

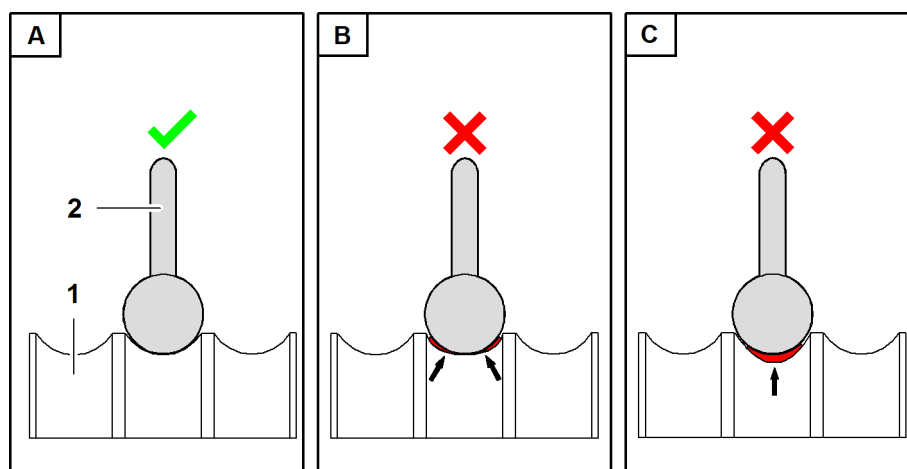


Fig. 5989: Checking the drum (illustration of principle)

- | | |
|---|--|
| <p>1 Drum</p> <p>2 Groove gage</p> <p>A Groove gage sits with no spaces</p> | <p>B Groove gage only touches bottom of groove</p> <p>C Groove gage only touches sides of groove</p> |
|---|--|

The groove gage 2 must be nearly identical to the bottom of drum 1 groove. The groove diameter of the drum 1 has to be 5 % to 10 % larger than the rope's nominal diameter.

► Use the groove gage 2 to check every single groove of the drum 1.

If the groove diameter is smaller than 5 % or greater than 10 %:

► Contact Liebherr after sales service.

9.43.3 Checking drum for loose rope layers

In the case of drums with multiple-layer windings, if the working range of the rope is in the top rope layers, the lower rope layers can become loose. The top rope layers contain gaps that degrade the winding properties and increase rope wear.

▶ Check drum for loose rope layers.

If loose rope layers are present:

▶ Unwind rope down to three windings.

▶ Wind the rope again under pre-tension (1 to 2 % of the minimum breaking force of the rope).



Note

The rope works out most economically if it is always used in its full length.

▶ Use an adequate rope length.

9.44 Rope pulleys

9.44.1 Assembly of a pulley

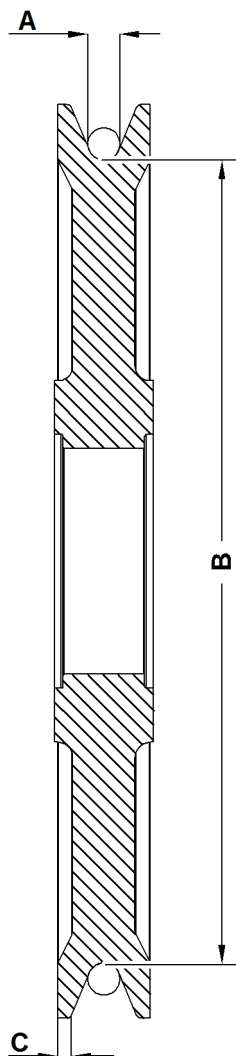


Fig. 5990: Assembly of a pulley (illustration of principle)

- | | | | |
|---|---------------------------|---|-----------|
| A | Groove diameter | C | Gap width |
| B | Bottom of groove diameter | | |

9.44.2 Checking the groove diameter of the pulley

According to ISO 16625, the groove diameter of the pulley must be between 5% and 10% greater than the nominal diameter of the rope.

Make sure the following prerequisites are met:

- Suitable groove gauge is available.
- Groove is free of grease deposits.
- Machine is switched off.
- Machine is secured against unauthorized start-up.

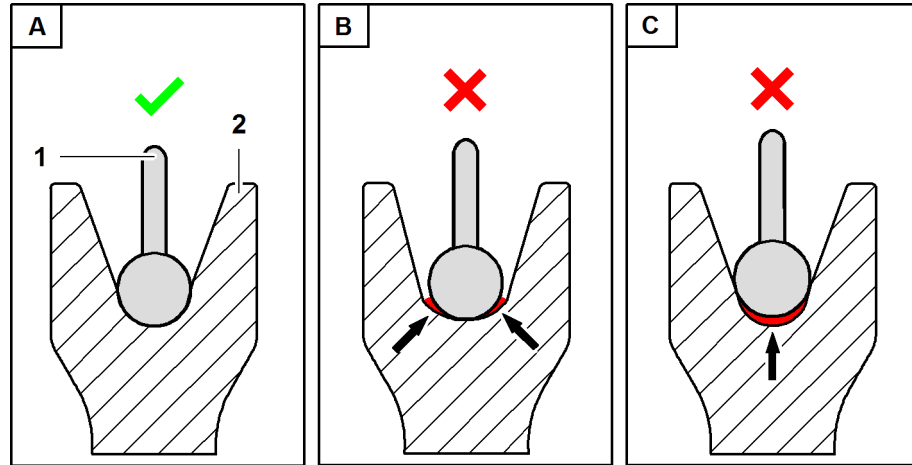


Fig. 5991: Checking the groove diameter (illustration of principle)

- | | | | |
|---|----------------------------------|---|--|
| 1 | Groove gauge | B | Groove gauge only touches bottom of groove |
| 2 | Pulley | C | Groove gauge only touches sides of groove |
| A | Groove gauge sits with no spaces | | |

The groove gauge 1 must be nearly identical to the bottom of pulley 2 groove. The groove diameter of the pulley 2 has to be 5 % to 10 % larger than the rope's nominal diameter.

► Use the groove gauge 1 to check each pulley.

If the groove diameter is smaller than 5 % or greater than 10 %:

- Contact Liebherr customer service.
- Exchange pulley.

9.44.3 Checking the bottom of groove diameter of the pulley

Ensure that the following conditions are satisfied:

- The machine is switched off.
- The machine is secured to prevent unauthorised operation.

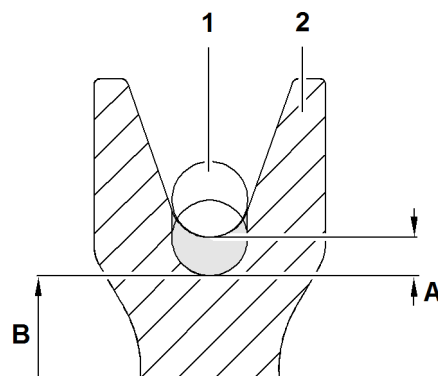


Fig. 5992: Checking the pulley for wear (illustration of principle)

- | | | | |
|---|--------|---|---------------------------|
| 1 | Rope | A | Maximum permissible wear |
| 2 | Pulley | B | Bottom of groove diameter |

Plastic pulleys: The maximum permissible wear A is 50 % of the nominal rope diameter.

Steel pulleys: The maximum permissible wear **A** is 8% of the nominal rope diameter.

▶ Measure bottom of groove diameter **B**.

If the wear exceeds the maximum permissible wear **A**:

▶ Contact Liebherr after sales service.

▶ Exchange pulley.



Note

Liebherr recommends:

▶ Measure the reference value of a comparable pulley without signs of wear.

9.44.4 Checking the gap width of the pulley

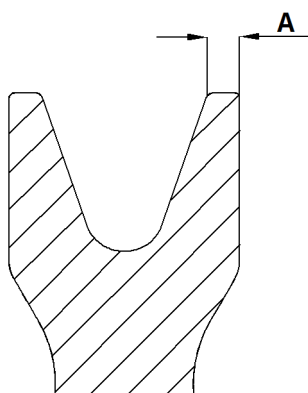


Fig. 5993: Pulley (illustration of principle)

A Gap width

▶ Check the gap width of the pulley.

If the gap width is reduced by more than 25% from the nominal dimension:

▶ Contact Liebherr customer service.

▶ Exchange pulley.



Note

Liebherr recommends:

▶ Measure the reference value of a comparable pulley without signs of wear.

9.44.5 Checking bottom of pulley groove for sharp edges

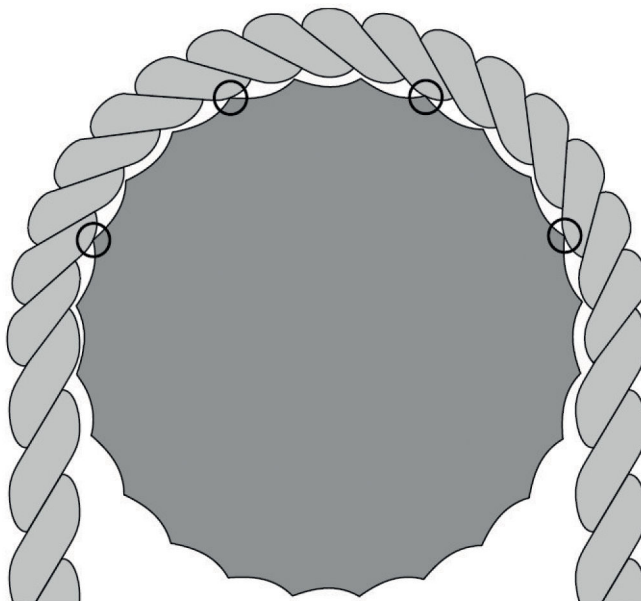


Fig. 5994: Pulley with sharp edges (illustration of principle)

- ▶ Checking bottom of groove for sharp edges.

If you can clearly see and feel any edges:

- ▶ Contact Liebherr customer service.
- ▶ Smoothen bottom of groove in the next rope change.
or
Exchange pulley.

9.44.6 Checking pulleys for damage

NOTICE

Improper laying down of pulleys on the ground!
Damage to the pulleys.

- ▶ Pulleys must only be laid on the ground with protective equipment.
-

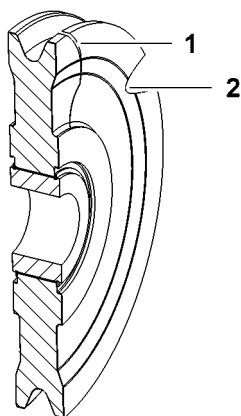


Fig. 5995: Damaged pulley

1 Crack

2 Nicks

The pulleys must align with the running direction of the rope and in perfect condition, without runouts or other damage.

- ▶ Check pulleys for damage (nicks, wobbles, cracks, notches, etc.).

If the pulley is damaged:

- ▶ Contact Liebherr after sales service.
- ▶ Replace the pulley.

9.44.7 Checking the pulley bearings

- ▶ Check bearings for smooth running.
- ▶ Check bearings for unusual sounds.
- ▶ Check lubrication of bearings.

If lubrication of bearings is not OK:

- ▶ Lubricate the pulley bearings ([For more information see: 9.44.8 Lubricating the pulley bearings, page 2035](#)).

If bearings do not function properly:

- ▶ Contact Liebherr customer service.

9.44.8 Lubricating the pulley bearings

Ensure that the following conditions are satisfied:

- Grease gun is available and filled with approved grease. ([For more information see: 9.2.3 Lubrication chart, page 1875](#)).
- The machine is switched off.
- The machine is secured to prevent unauthorised operation.
- Grease nipples are clean.
- ▶ Use the grease gun to press grease into the grease nipple.
- ▶ Press grease completely out of bearings until the new grease is visible.

9.44.9 Checking the position of bearing and locking ring

- ▶ Check the bearing for proper seating and position.

If position of bearing or locking ring are not correct:

- ▶ Correct position of bearing and locking ring.
- ▶ Contact Liebherr after sales service.

9.44.10 Cleaning plastic pulleys

NOTICE

Inadmissible operation with dirty pulleys!
Damage to the pulleys.

- ▶ Clean dirt, gum, etc. from the plastic pulleys.
-

NOTICE

Unauthorised cleaning agent!
Damage to the pulleys.

- ▶ Only clean plastic pulleys with suitable cleaning agents.
-

Plastic pulleys are resistant to:

- Mineral oil
- Petrol
- Kerosene
- Diesel

Plastic pulleys are **not** resistant or not fully resistant to:

- Concentrated mineral acids (e.g. sulphuric acid, hydrochloric acid, nitric acid)
- Concentrated organic acids (e.g. formic acid)
- Concentrated bases (e.g. sodium, caustic potash solution or corrosive potassium salts)
- Alcohol other than ethyl alcohol, methyl alcohol and propyl alcohol
- Inorganic chlorides, e.g. calcium, lithium chloride, magnesium chloride and zinc chloride

- ▶ Clean plastic pulleys with a permitted cleaning agent.

9.45 Rope suspension and rope fixation

9.45.1 Checking rope suspensions (rope clamps, rope thimbles) for wire breaks, absence of corrosion and tight fit of screw fittings

If a rope lock is being used as a rope suspension, the free rope end must be secured to prevent it being pulled through. This mechanism means that the free rope end must not be connected to the bearing rope strand in such a way that a force is transmitted.

Fitting the wire rope

The end of the new wire rope must be made up in such a way that there is absolutely no possibility of the rope structure loosening (e.g. as a result of flash-butt welding or hardening), assuming the rope structure is not separated by the type of rope fixation (e.g. splicing or casting).

NOTICE

Incorrect fitting of a new wire rope!

Risk of damage to the rope.

- ▶ No adjustments may be made, and/or attachments added, to the rope suspensions and rope fixation when laying a new wire rope.
 - ▶ The rope end should be inserted in the same way as for the original wire rope.
-
- ▶ After fitting a new wire rope, check the rope suspensions regularly for correct position of the wire rope in the fixation and to ensure that it is correctly fastened to the adjacent structure (particularly screw fastenings to the structure).
 - ▶ Check the device used to attach the rope suspension to the structure for any cracks.
 - ▶ Check the cast rope ends regularly for wire breaks and corrosion where the wire rope emerges out of the cast metal.

If the rope shows any signs of damage, deformation, wear, etc.:

- ▶ cut open the rope end and replace the cast.
- ▶ Check rope suspensions with ferrules for wire breaks near the ferrule, cracks in the ferrule material and for slippage of the wire rope.

If the rope shows any signs of damage, deformation, wear, etc.:

- ▶ Shorten the wire rope and replace the connection.
- ▶ Check detachable rope suspensions (rope lock, rope clamps, drum) for wire breaks and corrosion of the wire rope, slippage of the rope at the termination and loosening of the fastening screws.

If the rope shows sign of corrosion or wire breaks:

- ▶ shorten and refasten the rope.

If there is rope slippage at the termination and the set screws are loose:

- ▶ tighten the connection.

Checking the thimble connection

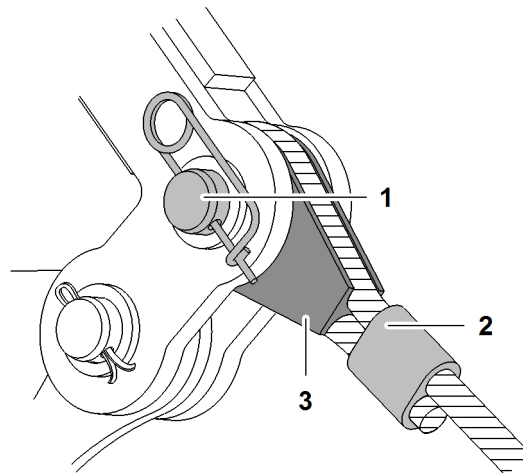


Fig. 5996: Rope thimble with ferrule

- | | | | |
|---|----------------------|---|--------------|
| 1 | Bolting | 3 | Rope thimble |
| 2 | Ferrule (wire clamp) | | |

Checking the ferrules for cracks and splitting

- ▶ Check the ferrules for cracks and splitting.
- If the ferrules show signs of cracks or splitting:
- ▶ Remove the rope.
 - ▶ Contact Liebherr after sales service.

Checking rope thimbles for corrosion, cracks and wire breaks

- ▶ Check rope thimbles for corrosion, cracks and wire breaks.
- If the rope thimbles show any signs of corrosion, cracks or wire breaks:
- ▶ Replace the rope thimble.
 - ▶ Contact Liebherr after sales service.

9.45.2 Checking the pocket locks



DANGER

Damaged pocket lock!
Load breakaway.

- ▶ Replace damaged pocket locks.
- ▶ Only use pocket locks that are in a completely flawless condition.

Immediately replace the pocket locks if the following damage is present:

- Cracks
- Corrosion
- Stiffness and sticking of the safety button
- Removability of the wire clamp or sealing sleeve

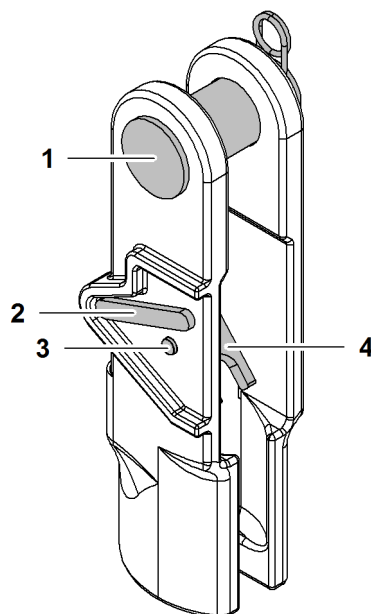


Fig. 5997: Pocket lock

- | | | | |
|---|--------------|---|----------------|
| 1 | Pin | 3 | Locking device |
| 2 | Safety latch | 4 | Safety button |

- ▶ Check the pocket lock for cracks and corrosion.
- ▶ Check the pocket lock for the correct functioning of the self-locking safety latch **2**.
- ▶ Check the ease of movement of the safety button **4** for the safety latch **2**.
- ▶ Check that the pin **1** is present.

If the pocket lock is damaged or faulty in any way:

- ▶ Replace the pocket lock.

9.45.3 Checking the rope end fittings for cracks

- ▶ Check the ferrules for cracks and splitting.

If the ferrules show signs of cracks or splitting:

- ▶ Remove the rope.
- ▶ Contact Liebherr after sales service.

9.45.4 Checking the rope fixing point

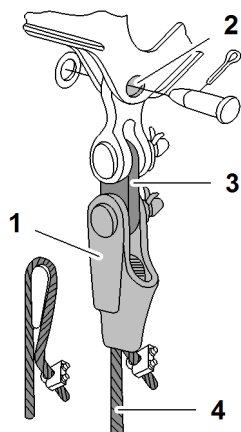


Fig. 5998: Rope lock and rope fixation

- | | | | |
|---|---------------|---|------------------------|
| 1 | Rope lock | 3 | Intermediate connector |
| 2 | Rope fixation | 4 | Hoist rope |

Checking the rope lock for damage and proper operation

- ▶ Check the rope lock for damage and proper operation.

If the rope lock is damaged or faulty in any way:

- ▶ Replace the rope lock.

Checking the rope clamp for tight fit

- ▶ Check rope clamp for tight fit.

If the rope clamp is loose:

- ▶ Remove the rope.
- ▶ Contact Liebherr after sales service.

9.46 Cab

9.46.1 Check the windows of the cab for damage

- ▶ Check the windows of the cab for damage.

If any of the cab windows are damaged:

- ▶ Change the window.
- ▶ Contact Liebherr after sales service.

9.46.2 Checking that the cab door and the door lock work properly

Checking the operation of the cab door

- ▶ Check the operation of the cab door.

If the cab door does not move freely or does not latch in the open position:

- ▶ Spray the hinges with adhesive lubricant.
- ▶ Contact Liebherr after sales service.

Checking the operation of the door lock

- ▶ Check the operation of the door lock.

If the door lock is not operating correctly:

- ▶ Spray the locks with adhesive lubricant.
- ▶ Apply frost protection to the locks in the event of low ambient temperatures.
- ▶ Contact Liebherr after sales service.

9.46.3 Check cabin roof protection guard for damage, locking (in case of foldable design)

- ▶ Check cabin roof protection guard for damage.

If cabin roof protection guard is faulty in any way:

- ▶ Contact Liebherr customer service.
- ▶ Check locking (with foldable design).

If locking does not function perfectly (with foldable design):

- ▶ Contact Liebherr customer service.

9.46.4 Changing the windscreen wipers

Ensure that the following conditions are fulfilled:

- Ring spanner with width across flats 13 is available.
- Open spanner with width across flats 13 is available.
- New Liebherr windscreen wiper is available.

Containers are located behind the operator's seat in the cabin.

- ▶ Open cover 1.

NOTICE

Unsuitable windscreen washer fluid!
Damage to the system.

- ▶ Fill the container 2 with suitable windscreen washer fluid only.
-

- ▶ Top up the windscreen washer fluid in the containers.
- ▶ Close cover 1.
- ▶ If necessary clean the windscreen wiper nozzles on the windscreen wipers with a needle.

9.46.6 Checking outside mirrors and inside mirrors for damage

- ▶ Check outside mirrors and inside mirrors for damage.

If the mirrors are damaged or do not remain fixed in position:

- ▶ Replace the mirror.
- ▶ Tighten the set screws.
- ▶ Contact Liebherr after sales service.

9.46.7 Checking the operation of the hydraulic cab tilting device and for damage

Checking the operation of the hydraulic cab tilting device

- ▶ To check the operation of the hydraulic cabin tilting device: press the appropriate button on control panel X11.

If the hydraulic cab tilting device is faulty in any way:

- ▶ Do not operate the hydraulic cab tilting device.
- ▶ Contact Liebherr after sales service.

Checking hydraulic cylinders, hydraulic hoses and connections for leaks and damage

- ▶ Check hydraulic cylinders, hydraulic hoses and connections of the hydraulic cab tilting device for leaks and damage.

If the hydraulic cylinders, hydraulic hoses and connections are leaking or damaged:

- ▶ Do not operate the hydraulic cab tilting device.
- ▶ Contact Liebherr after sales service.

9.46.8 Checking hydraulic cabin elevation for function and damage

Checking the operation of the acoustic warning signal

When the safety lever is folded up, the acoustic warning signal must sound when the cab is elevated.

- ▶ Check the operation of the acoustic warning signal.

If the acoustic warning signal is faulty in any way:

- ▶ Do not operate the hydraulic cab elevation (system).
- ▶ Contact Liebherr after sales service.

Checking the operation of the operating elements (valves, displays etc.)

- ▶ Check the operation of the operating elements (valves, displays etc.).

If the cab elevation (system) operating elements (valves, display, etc.) are faulty in any way:

- ▶ Do not operate the hydraulic cab elevation (system).
- ▶ Contact Liebherr after sales service.

Checking that the safety chain is present and working properly

The safety chain must prevent the machine operator from falling out of an open cab door.

- ▶ Check that the safety chain is present and working properly.

If the safety chain is missing, damaged or faulty in any way:

- ▶ Do not operate the hydraulic cab elevation (system).
- ▶ Contact Liebherr after sales service.

Checking hydraulic hoses and connections for leaks and damage

- ▶ Check hydraulic hoses and connections for leaks and damage.

If hydraulic hoses or connections show leaks or damage:

- ▶ do not operate hydraulic cabin elevation.
- ▶ Contact Liebherr customer service.

Checking emergency descent equipment for presence and function

- ▶ Check emergency descent equipment for presence and function.

If emergency descent equipment does not function perfectly or is missing:

- ▶ do not operate hydraulic cabin elevation.
- ▶ Contact Liebherr customer service.

Checking the cabin's suspension point for damage

- ▶ Check cabin's suspension point for damage.

If cabin's suspension point is damaged:

- ▶ do not operate hydraulic cabin elevation.
- ▶ Contact Liebherr customer service.

Checking the function of the emergency lowering system

- ▶ Check function of cabin's emergency lowering system.

If cabin's emergency lowering system is not operating correctly:

- ▶ do not operate hydraulic cabin elevation.
- ▶ Contact Liebherr customer service.

Checking pins for presence of locking elements

- ▶ Check pins for presence of locking elements.

If pin locking elements are not in place:

- ▶ do not operate hydraulic cabin elevation.
- ▶ Replace missing locking elements.

Checking the safety gear for damages and proper functioning

- ▶ Check the safety gear for damages and proper functioning in accordance with the additional documentation on CD.

If the safety gear is damaged or does not function:

- ▶ Contact Liebherr customer service.

9.46.9 Cleaning or replacing the filter insert in the cabin

The cleaning intervals of the filter insert depend on the degree of contamination of the ambient air, the frequency of use and the type of contamination. The full filter inserts can be cleaned by tapping out, blowing out or rinsing in lukewarm water. If the filter insert can no longer be cleaned, it must be replaced.

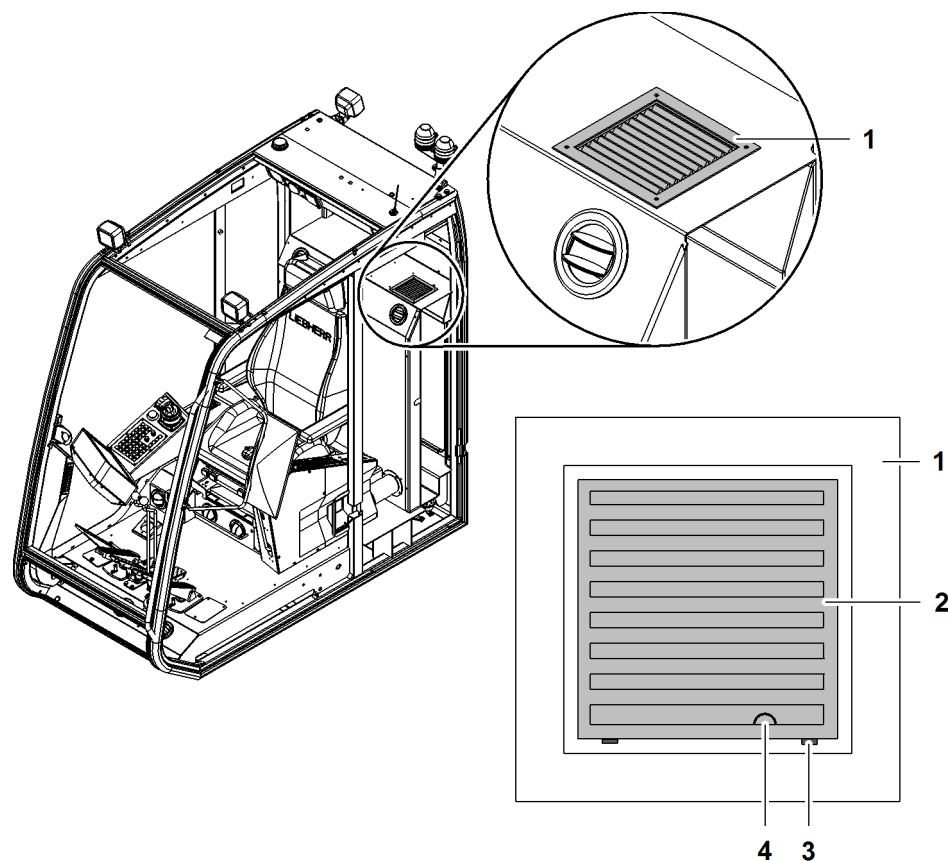


Fig. 6001: Replacing the filter insert in the cabin

- | | | | |
|---|--------------------------|---|---------|
| 1 | Fan | 3 | Recess |
| 2 | Frame with filter insert | 4 | Marking |

- ▶ Insert screwdriver into the recess **3** and lift up.

The filter insert has a smooth and a coarse side. The filter insert is installed with the coarse side **facing up**.

- ▶ Exchange the filter insert.

The frame **2** with filter insert has a marking **4**. This marking **4** must face the operator's seat when installing.

- ▶ Insert frame **2** with filter insert.

9.47 Ventilation, heating and air-conditioning



WARNING

Unauthorized maintenance on air conditioning system!
Poisoning, frostbite.

- ▶ Work on the air conditioning system may only be carried out by authorized service personnel.

9.47.1 Checking the recirculated air filter for contamination

Cleaning intervals depend on the degree of contamination of the ambient air, the frequency of use and the type of contamination.

The full filter inserts can be cleaned by tapping out, blowing out or rinsing in luke-warm water. If the filter insert can no longer be cleaned, it must be replaced.

- ▶ Fold armrests of operator's seat up.
- ▶ Fold backrest of operator's seat forward.
- ▶ Slide operator's seat forward.

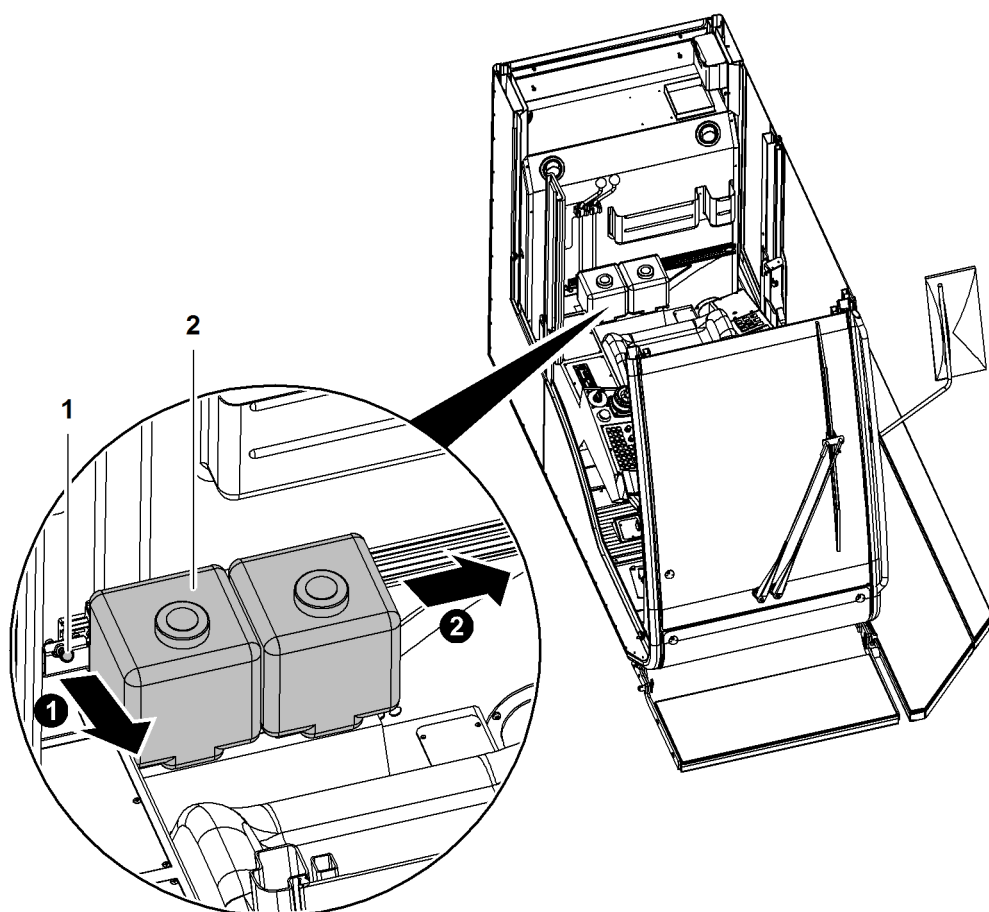


Fig. 6002: Shifting container

1 Lever

2 Container (2x) of windscreen washer system

- ▶ Pull out lever 1.
- ▶ Shift container 2 to the right.

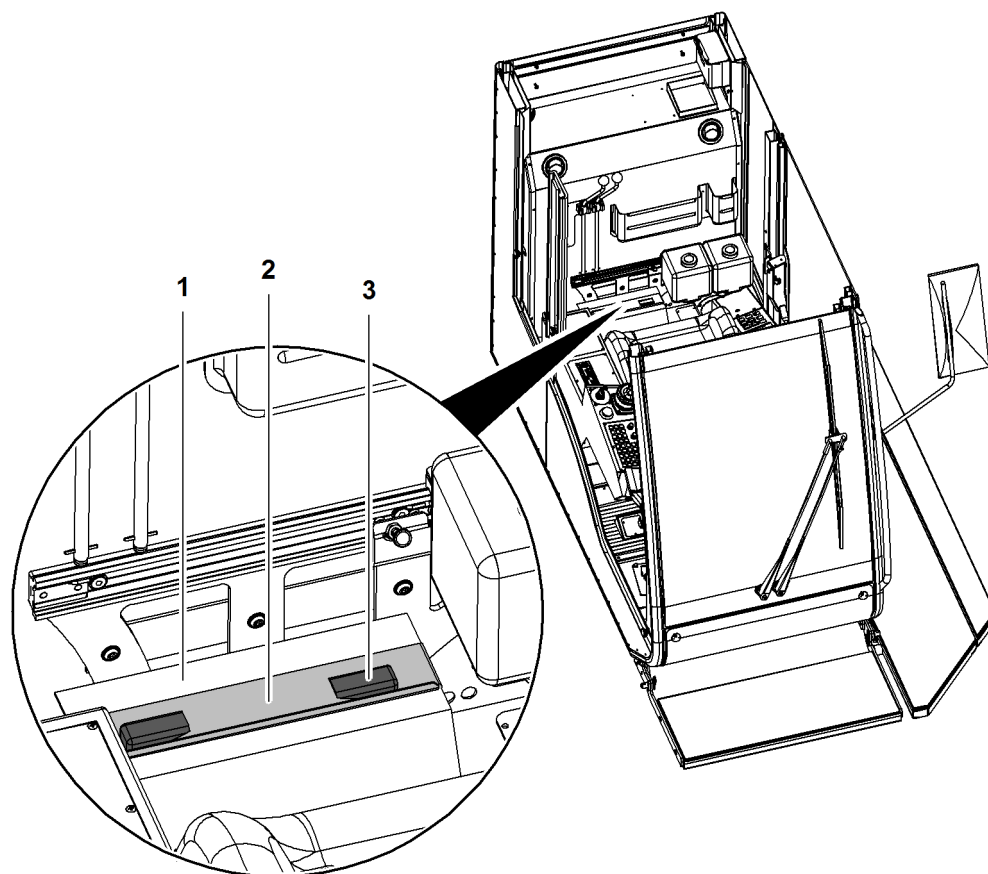


Fig. 6003: Removing cover

- | | | | |
|---|------------------------------------|---|------------|
| 1 | Housing of recirculated air filter | 3 | Clamp (2x) |
| 2 | Cover | | |

- ▶ Undo clamps 3 of cover 2.
- ▶ Remove cover 2 from housing 1.

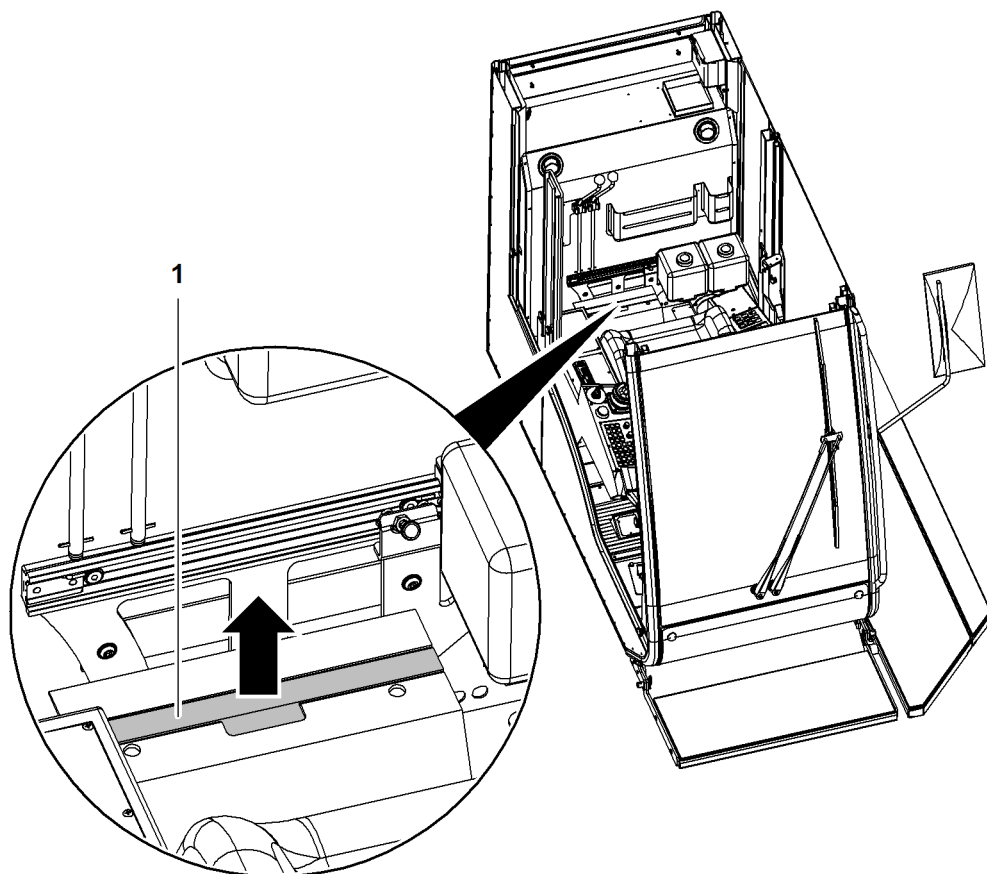


Fig. 6004: Removing recirculated air filter

1 Recirculated air filter

- ▶ Remove recirculated air filter 1.
- ▶ Check recirculated air filter 1 for contamination.



Note

Recirculated air filter 1 is wet after cleaning!

- ▶ Ensure that recirculated air filter 1 is dry before reinserting it.

If recirculated air filter 1 is dirty:

- ▶ Clean or replace recirculated air filter 1 (For more information see: [9.47.2 Replacing the recirculated air filter, page 2051](#)).

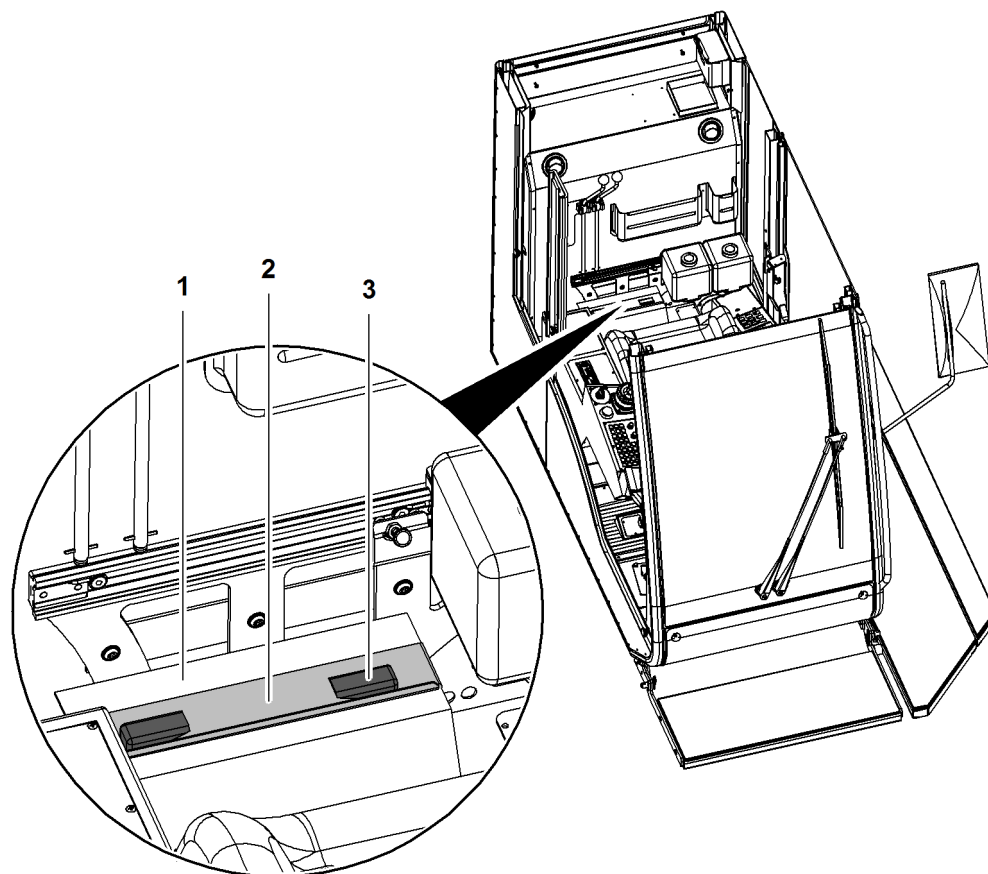


Fig. 6005: Placing cover on housing

- 1 Housing of recirculated air filter
- 2 Cover

- 3 Clamp (2x)

- ▶ Place cover 2 on housing 1.
- ▶ Close clamps 3 of cover 2.

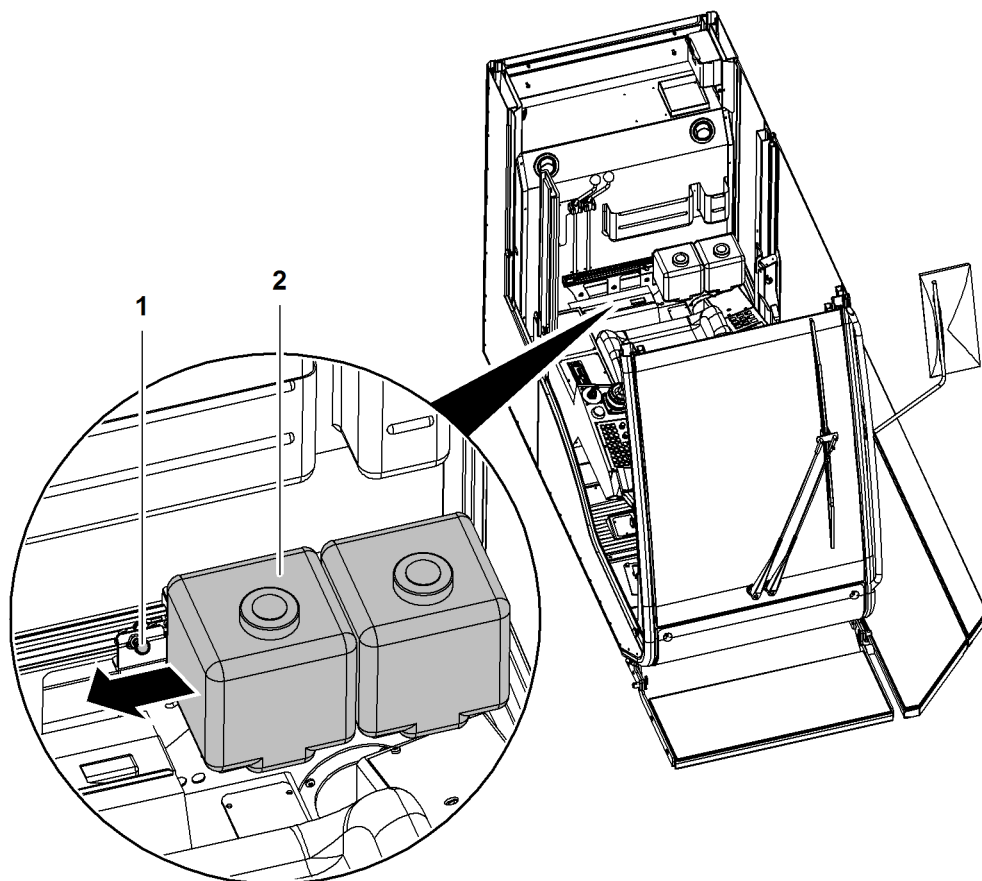


Fig. 6006: Shifting container

1 Lever

2 Container (2x) of windscreen washer system

- ▶ Shift container 2 to the left until lever 1 snaps into place.

9.47.2 Replacing the recirculated air filter

- ▶ Fold armrests of operator's seat up.
- ▶ Fold backrest of operator's seat forward.
- ▶ Slide operator's seat forward.

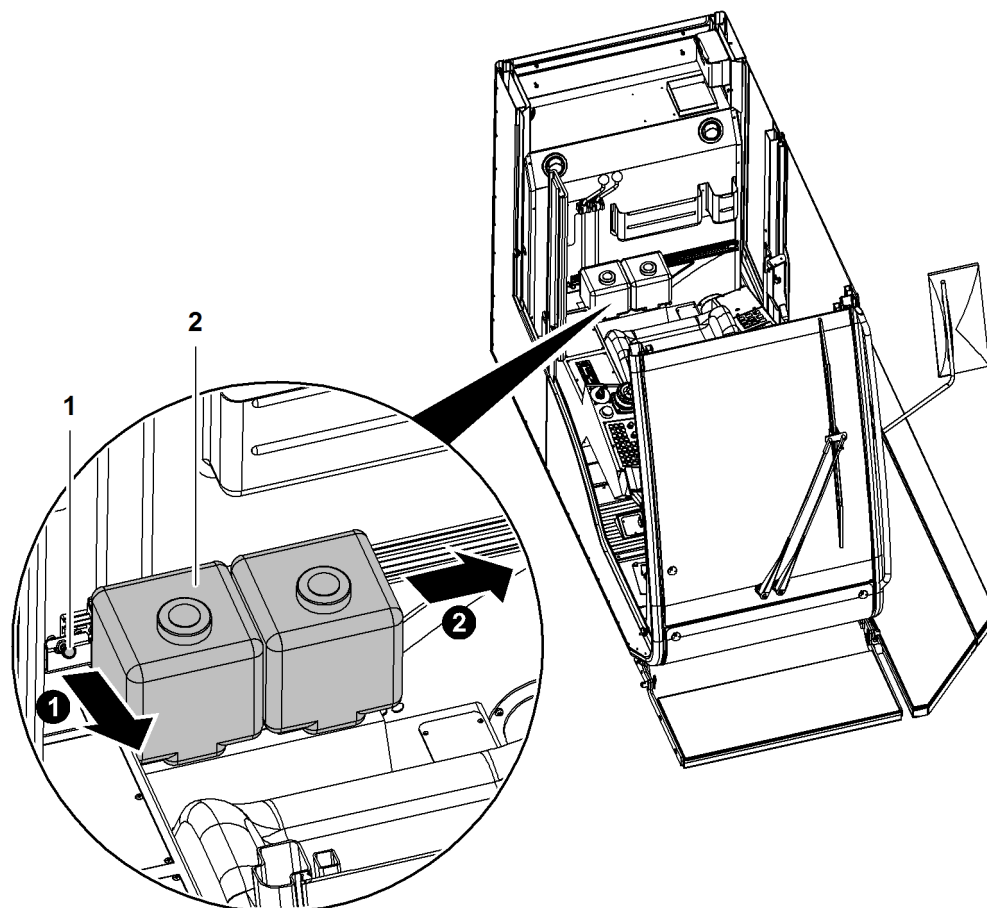


Fig. 6007: Shifting container

1 Lever

2 Container (2x) of windscreen washer system

- ▶ Pull out lever 1.
- ▶ Shift container 2 to the right.

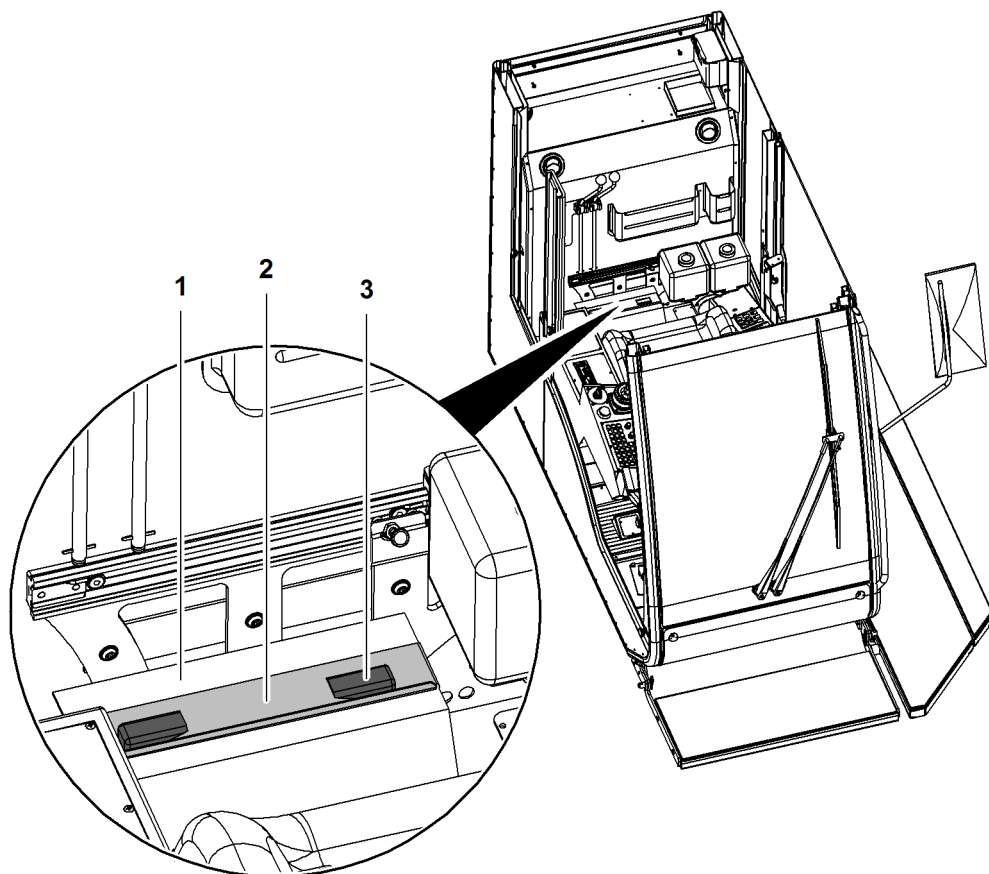


Fig. 6008: Removing cover

- | | | | |
|---|------------------------------------|---|------------|
| 1 | Housing of recirculated air filter | 3 | Clamp (2x) |
| 2 | Cover | | |
- ▶ Undo clamps 3 of cover 2.
 - ▶ Remove cover 2 from housing 1.

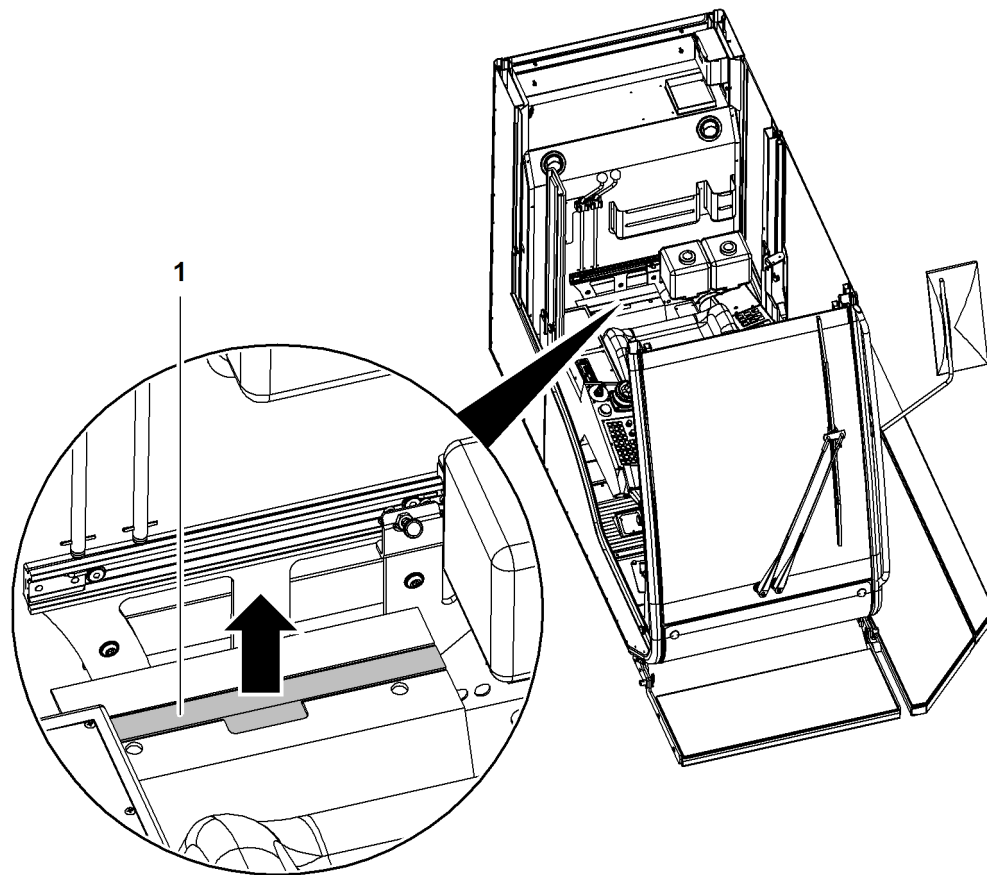


Fig. 6009: Removing recirculated air filter

1 Recirculated air filter

► Remove recirculated air filter 1.



Note

Improper installation of recirculated air filter 1!
Improperly installed recirculated air filter 1 reduces air conditioning system performance.

► Observe installation direction of recirculated air filter 1.

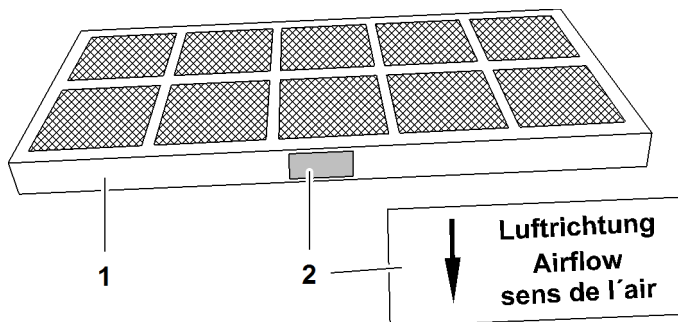


Fig. 6010: Recirculated air filter

1 Recirculated air filter

2 Sign

The arrow of the sign 2 must point toward the operator's seat when installing the recirculated air filter 1.

► Replace recirculated air filter 1.

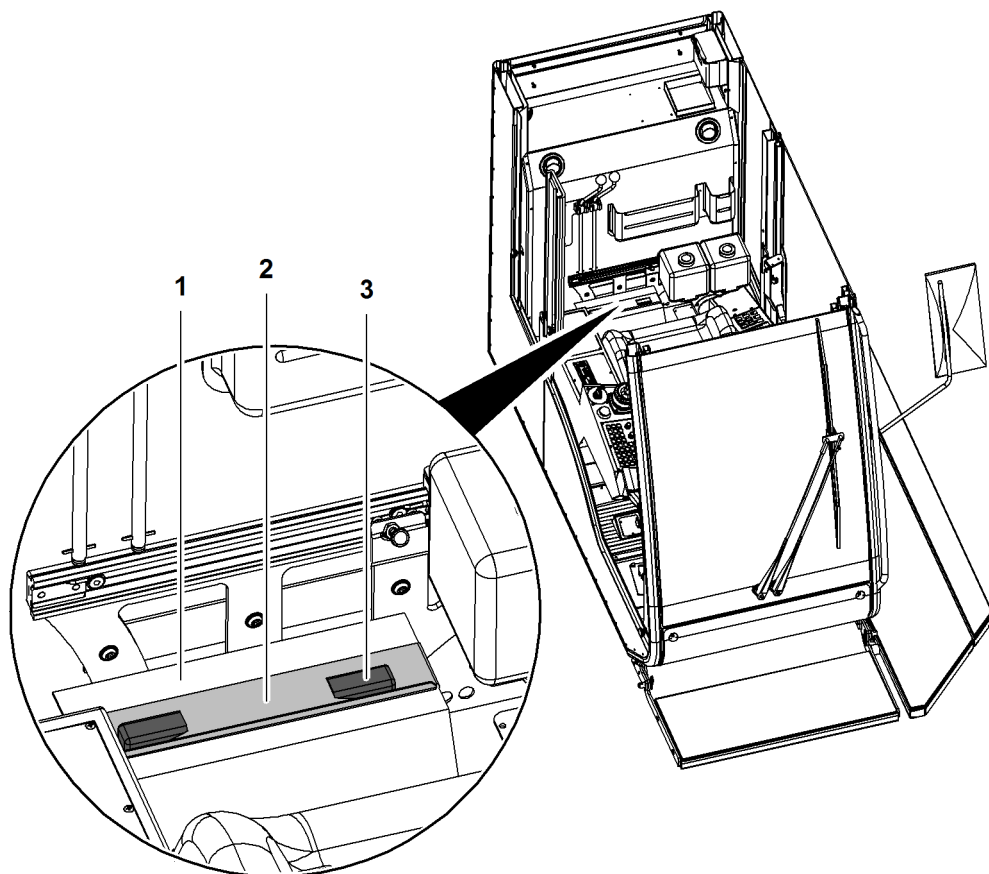


Fig. 6011: Placing cover on housing

- 1 Housing of recirculated air filter
2 Cover

- 3 Clamp (2x)

- ▶ Place cover 2 on housing 1.
- ▶ Close clamps 3 of cover 2.

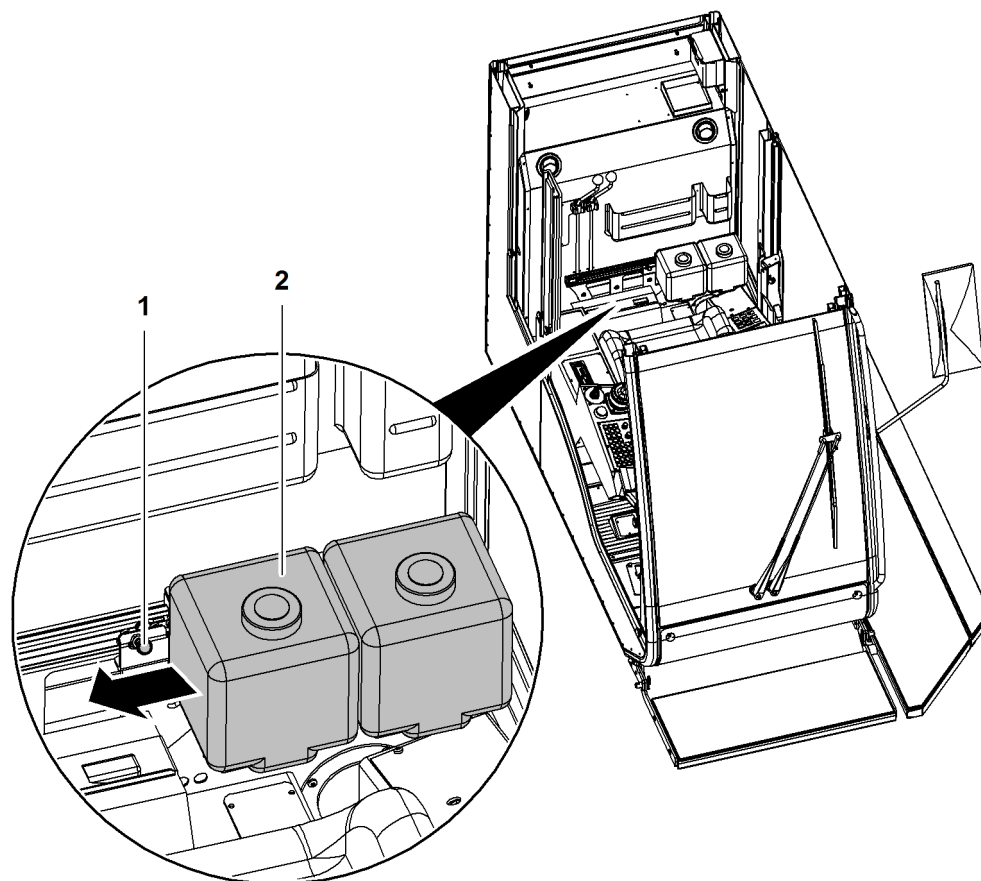


Fig. 6012: Shifting container

1 Lever

2 Container (2x) of windshield washer system

► Shift container 2 to the left until lever 1 snaps into place.

9.47.3 Checking the fresh air filter for contamination

Cleaning intervals depend on the degree of contamination of the ambient air, the frequency of use and the type of contamination.

The full filter inserts can be cleaned by tapping out, blowing out or rinsing in luke-warm water. If the filter insert can no longer be cleaned, it must be replaced.

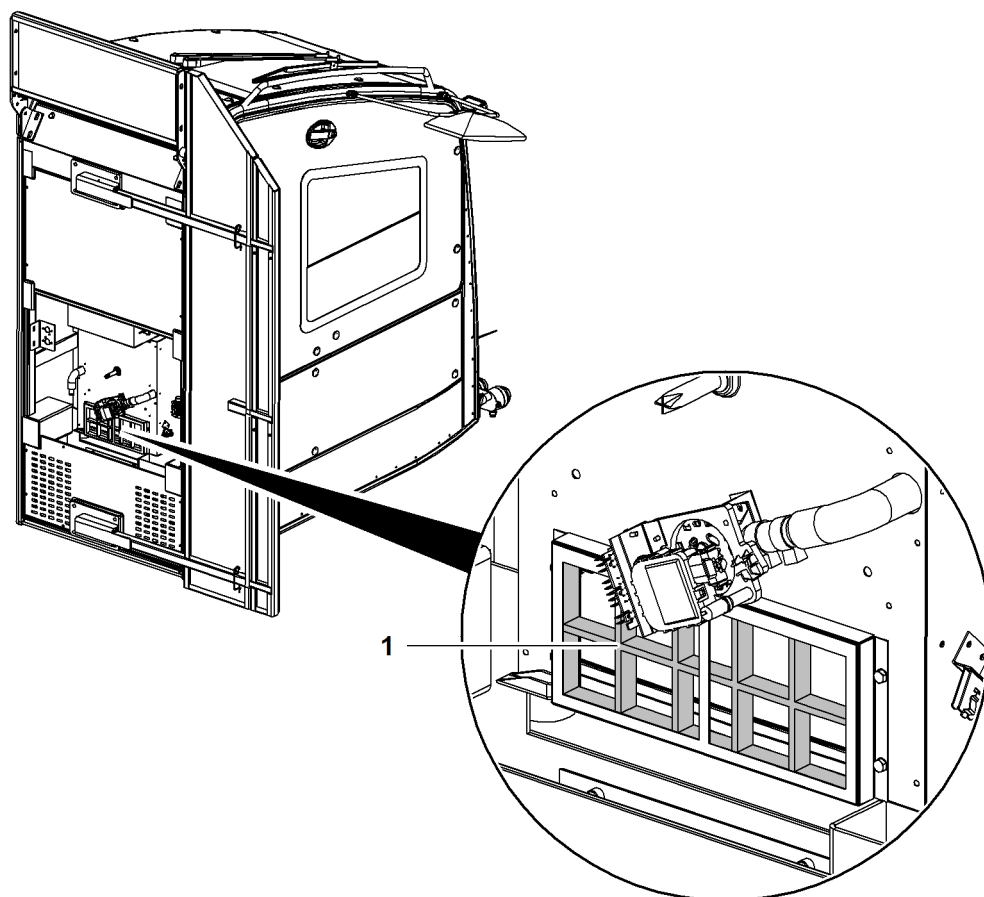


Fig. 6013: Checking fresh air filter for contamination

1 Fresh air filter

- ▶ Remove central bottom plate underneath cabin.
- ▶ Check fresh air filter 1 for contamination.



Note

Fresh air filter 1 is wet after cleaning!

- ▶ Ensure that fresh air filter 1 is dry before reinserting it.

If fresh air filter 1 is dirty:

- ▶ Clean or replace fresh air filter 1 (For more information see: [9.47.4 Replacing the fresh air filter, page 2057](#)).
- ▶ Install central bottom plate underneath cabin.

9.47.4 Replacing the fresh air filter



Note

Liebherr recommends:

- ▶ Tilting the cabin upwards.
- ▶ Turn uppercarriage.

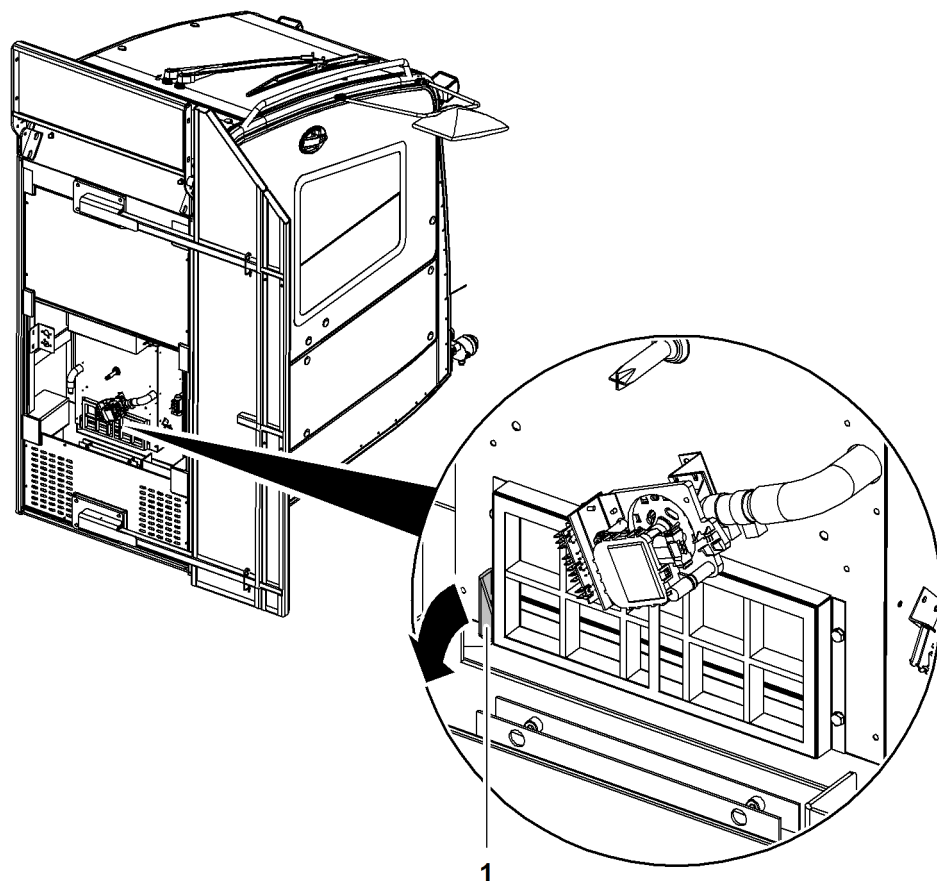


Fig. 6014: Opening housing

1 Clamp

- ▶ Remove central bottom plate underneath cabin.
- ▶ Undo clamp 1 of cover.

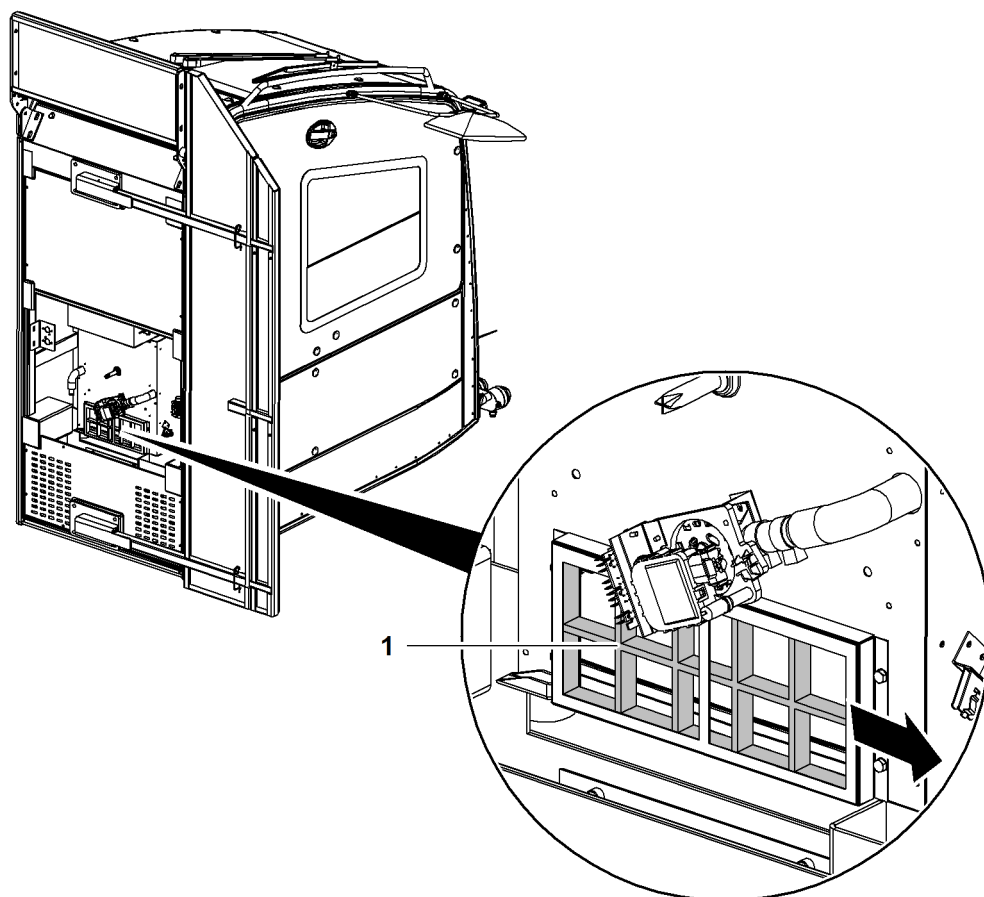


Fig. 6015: Removing fresh air filter

1 Fresh air filter



Note

Improper installation of fresh air filter 1!

Improperly installed fresh air filter 1 reduces air conditioning system performance.

► Observe installation direction of fresh air filter 1.

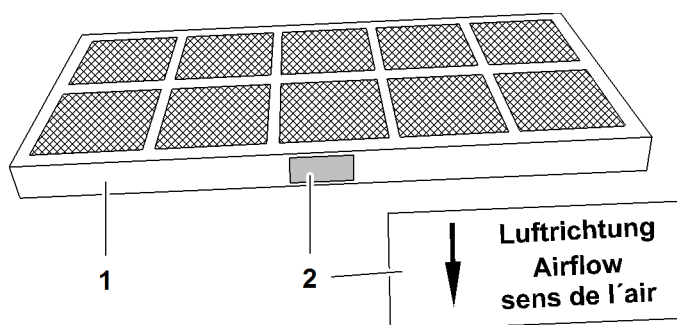


Fig. 6016: Fresh air filter

1 Fresh air filter

2 Sign

The arrow of the sign 2 must point toward the climatic box when installing the fresh air filter 1.

► Insert new fresh air filter 1 into housing.

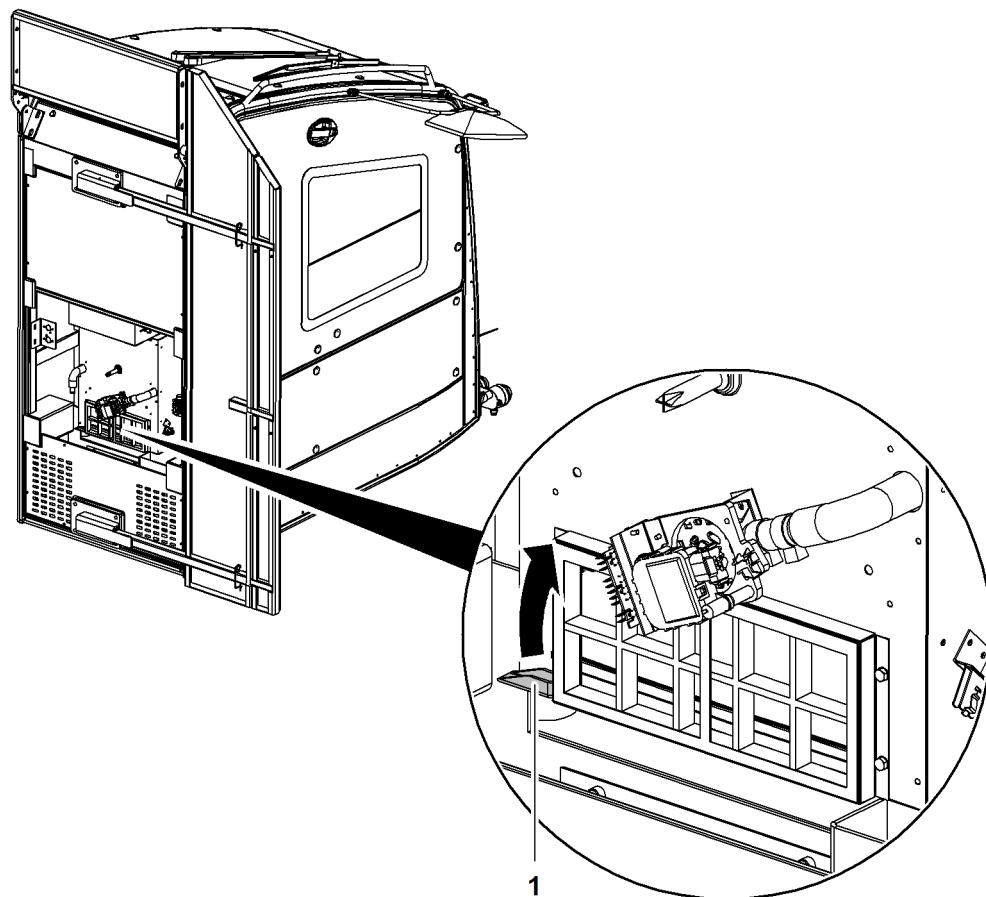


Fig. 6017: Closing housing

1 Clamp

- ▶ Close clamp 1 of housing.
- ▶ Install central bottom plate underneath cabin.

9.47.5 Checking the coolant level in the inspection glass

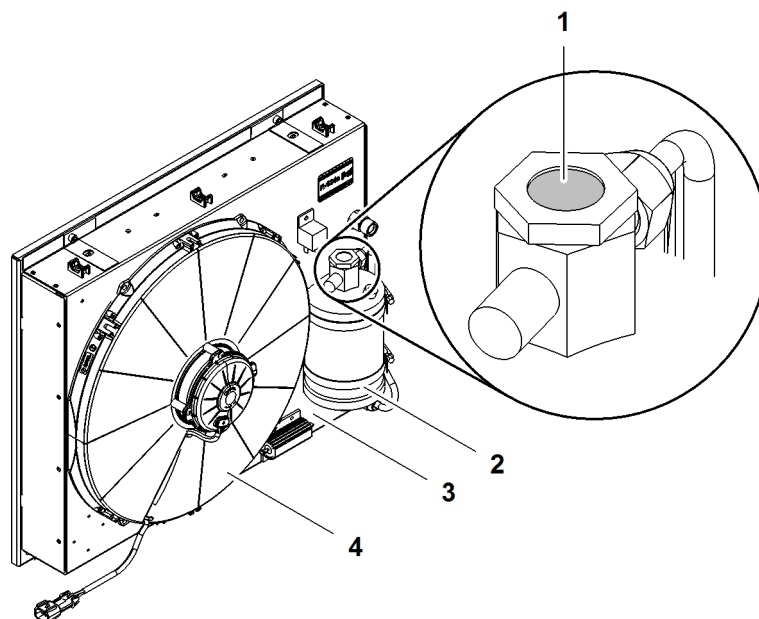


Fig. 6018: Checking the coolant level in the inspection glass

- | | | | |
|---|------------------|---|-----------|
| 1 | Inspection glass | 3 | Condenser |
| 2 | Dryer | 4 | Fan |

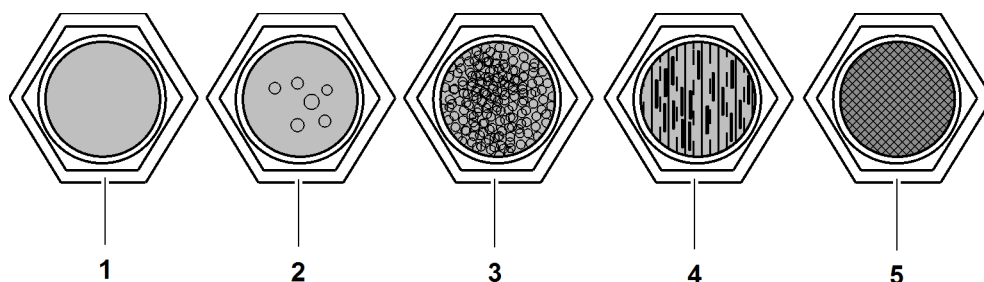


Fig. 6019: Inspection glass with different coolant levels

- | | | | |
|---|--------------------|---|-------------------|
| 1 | Clear coolant | 4 | Smears in coolant |
| 2 | Bubbles in coolant | 5 | Gray coolant |
| 3 | Froth in coolant | | |

Clear coolant 1:

- Flowing coolant
- Coolant level is OK
- System working

Bubbles in coolant 2:

- Few bubbles in flowing coolant
- Level too low
- Recommendation: Top up coolant in 50 gram intervals.

Froth in coolant 3:

- Frothing coolant and no clear fluid visible
- Level too low
- Air might be in the system
- Recommendation: Top up coolant in 100 gram intervals.

Smears in coolant 4:

- Too much oil in circuit
- Wrong oil in circuit

Gray coolant 5:

- Substantial abrasion in compressor
- Oil has changed color

- ▶ Put air conditioning system into operation for at least ten minutes.
- ▶ Watch inspection glass.

If coolant is not clear:

- ▶ Contact Liebherr customer service.

9.47.6 Checking the condenser for contamination

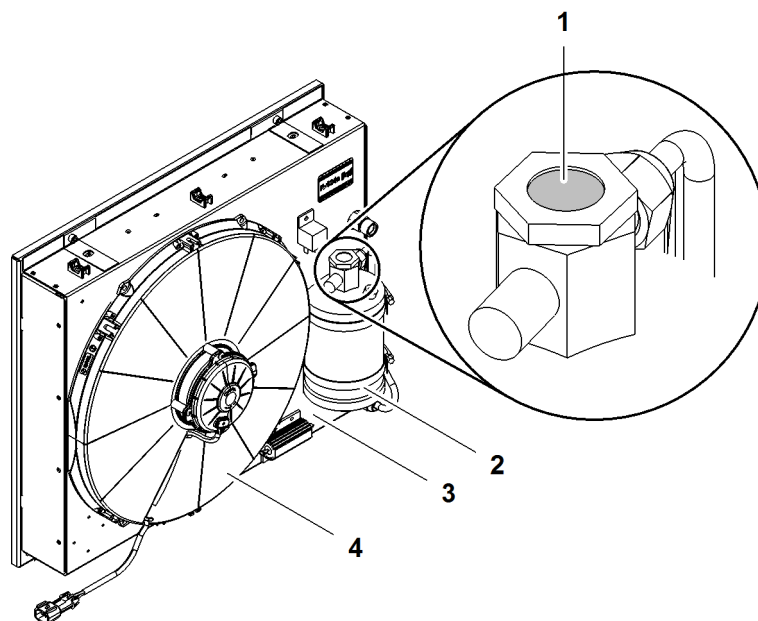


Fig. 6020: Checking the condenser for contamination

- | | | | |
|---|------------------|---|-----------|
| 1 | Inspection glass | 3 | Condenser |
| 2 | Dryer | 4 | Fan |

- ▶ Check the condenser **3** for contamination.

If condenser **3** is dirty:

- ▶ Remove fan **4**.

NOTICE

Water in electric components!
Short circuit.

- ▶ Do not clean electric components with high-pressure cleaner.

- ▶ Clean condenser **3** with high-pressure cleaner from the inside out.

**Note**

Liebherr recommends:

- ▶ Do not set pressure of high-pressure cleaner above 120 bar (1,740.44 psi).
- ▶ Keep at least 200 mm (7.87" in) distance with high-pressure cleaner from condenser.

9.47.7 Checking the condenser for loose leads, loos screws and corrosion

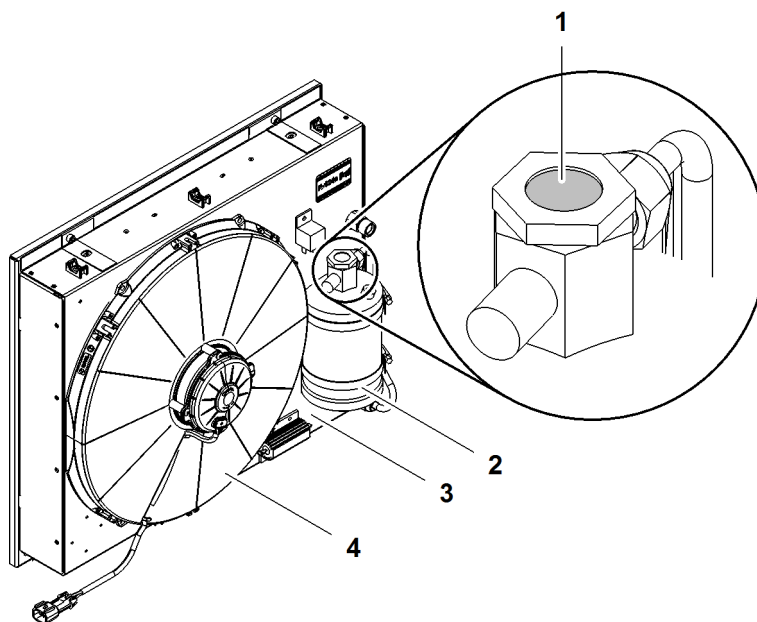


Fig. 6021: Checking the condenser for loose leads, loos screws and corrosion

1	Inspection glass	3	Condenser
2	Dryer	4	Fan

- ▶ Check coolant leads for abrasion spots.
- ▶ Check coolant leads for tight fit.
- ▶ Check electric components for corrosion.
- ▶ Check electric components for tight fit.
- ▶ Check mechanic parts for tight fit.

**Note**

Oily screw connections are a sign of leakage!

Liebherr recommends:

- ▶ Observe oily screw connections.

9.47.8 Checking the fan on condenser for function, tight fit and damage

- ▶ Check fan on condenser for tight fit.

- ▶ Check fan on condenser for damage.
- ▶ Turn on air conditioning system.

If the fan on the condenser does not turn:

- ▶ Contact Liebherr customer service.

9.47.9 Checking the climate box for contamination

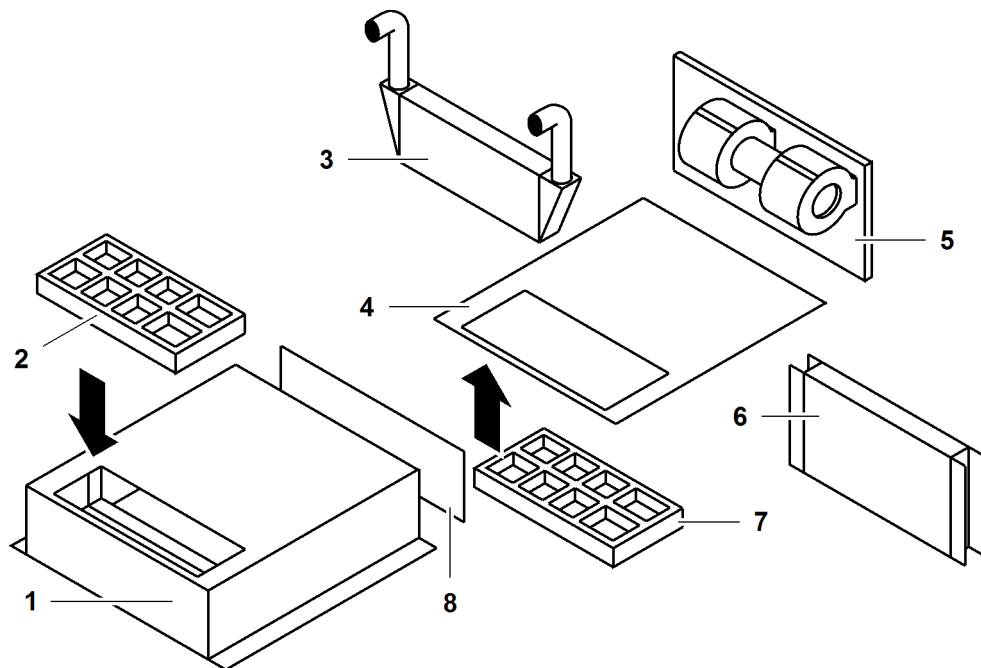


Fig. 6022: Checking the climate box for contamination (illustration of principle)

1	Climatic box	4	Bottom plate of climatic box	7	Fresh air filter
2	Recirculated air filter	5	Blower	8	Flap recirculated air/fresh air
3	Heat exchanger	6	Evaporator		

When replacing the fresh air filter **7**, it is possible to check for contamination through the opening of the heat exchangers **3**.

- ▶ Check heat exchanger **3** for contamination.

If heat exchanger **3** is dirty:

- ▶ Clean heat exchanger **3**.

When replacing the recirculated air filter **2**, it is possible to check the ease of movement of the recirculated air/fresh air flap **8**.

- ▶ Check recirculated air/fresh air flap **8** for movement.

If the recirculated air/fresh air flap **8** cannot be moved:

- ▶ Contact Liebherr customer service.

9.47.10 Checking the dryer for damage and corrosion

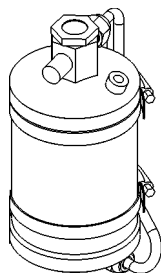


Fig. 6023: Checking the dryer for damage and corrosion

- ▶ Check dryer for damage and corrosion.

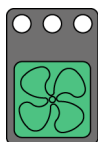
If dryer is damaged:

- ▶ Contact Liebherr customer service.

9.47.11 Starting the ventilation, heating, air conditioning, external air conditioning system* and auxiliary heating system* and ensuring that sufficient antifreeze has been added to the water circuit

Putting the ventilation system into operation

The LED of the button indicates the selected blower level. Three different fan speeds are possible.



- ▶ Press the *Heating/air conditioning fan speed* button on control panel X11.
 - ▷ The fan blows.

Putting the heating system into operation

Make sure the following prerequisites are met:

- Diesel engine is switched on.
- Ventilation is switched on.
- Cabin door and windscreen are closed.



- ▶ Turn rotary control knob *Heating/air conditioning system temperature* on control panel X11 to the right (red zone).
 - ▷ Heating is turned up.



- ▶ Turn rotary control knob *Temperature heating/air conditioning system* on control panel X11 to the left (blue zone).
 - ▷ Heating is turned down.

Activating the air conditioning system



WARNING

Leaks in air conditioning coolant circuit in an enclosed space!
Risk of suffocation.

If there is a high coolant concentration in the air:

- ▶ Immediately leave the closed room (cabin).



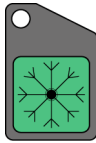
CAUTION

Rotating parts!
Risk of injury to limbs.

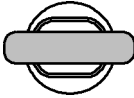
- ▶ Make sure that there are no persons in the vicinity of the fan on the condenser.

Make sure the following prerequisites are met:

- Diesel engine is switched on.
- Ventilation is switched on.
- ▶ Press the *Air conditioning system* button on control panel X11.
 - ▷ Air conditioning system is switched on.



Activating the external air conditioning system*



- ▶ Turn ignition key on control unit *External air conditioning system* to position “1”.

- ▷ Software version is displayed for two seconds on the display of control unit *External air conditioning system*:

H A T Z multiflex S 0 5 2 0 4 4 3 / 2 0 1 1
--

Fig. 6029: Software version

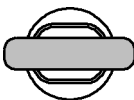
- ▷ Operating state before start is shown on the display of control unit *External air conditioning system*:

!!! OIL !!! 0,0 h 00° 0000

Fig. 6030: Operating state before start

The following parameters appear:

- Display top left: Error oil pressure indicator
- Display top right: Operating hours
- Display bottom left: Engine temperature
- Display bottom right: Diesel engine RPM



- ▶ Turn ignition key on control unit *External air conditioning system* briefly to position “2”.

- ▷ Diesel engine is switched on.
- ▷ External air conditioning system is in operation.
- ▷ Operating state after start is shown on the display of control unit *External air conditioning system*.

OIL ✓	0,0 h
25°	1000

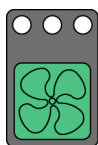
Fig. 6032: Operating state after start

The following parameters appear:

- Display top left: Oil pressure indicator OK
- Display top right: Operating hours
- Display bottom left: Engine temperature
- Display bottom right: Diesel engine RPM



- ▶ Turn rotary control knob *Temperature heating /air conditioning system* on control panel X11 to the desired temperature.



- ▶ Press the button *Fan speed heating/air conditioning system* on control panel X11 until the desired fan speed is set.
 - ▷ External air conditioning system cools down or heats up cabin to the desired temperature.

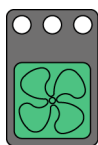
Activating auxiliary heating*

Make sure the following prerequisites are met:

- Ignition is turned on.



- ▶ Turn rotary control knob *Temperature heating/air conditioning system* on control panel X11 to the right (red zone).



- ▶ Press the button *Fan speed heating/air conditioning system* on control panel X11 until the lowest fan speed is set.



- ▶ Press the button *Instant heating* on control unit *Auxiliary heating*.

- ▶ Turn off auxiliary heating after ten minutes.

9.47.12 Replacing the fuel filter of auxiliary water heating

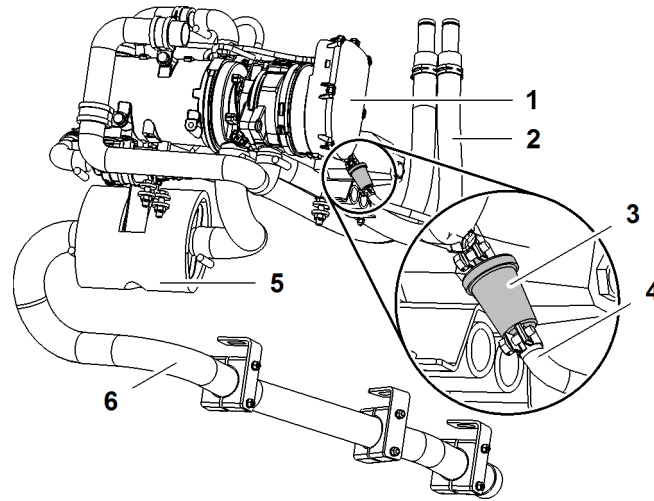


Fig. 6038: Replacing the fuel filter of auxiliary water heating (illustration of principle)

- | | | | |
|---|--------------------------|---|----------------|
| 1 | Auxiliary water heating* | 4 | Fuel line |
| 2 | Warm water pipe | 5 | Muffler |
| 3 | Fuel filter | 6 | Exhaust system |



CAUTION

Hot surface!
Risk of skin burns.

- ▶ Make sure that the exhaust system **6** of the auxiliary water heating **1** has cooled down.

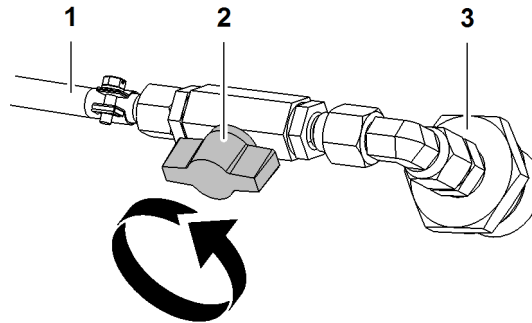


Fig. 6039: Close gate valve on fuel line

- | | | | |
|---|----------------------------|---|-------------------------|
| 1 | Fuel line | 3 | Connection of fuel tank |
| 2 | Gate valve/locking element | | |

With the fuel tank, the connection **3** of the fuel line **1** is the auxiliary water heating. A gate valve **2** is installed for each auxiliary heating system on the fuel line **1**.

- ▶ Close gate valve **2** on fuel line **1**.



Note

Seeping of fuel into the soil!
Risk of contamination to soil and groundwater.

- ▶ Collect fuel in trap.

- ▶ Put trap underneath.

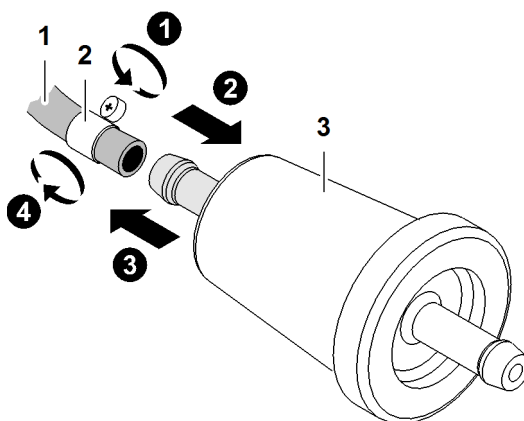


Fig. 6040: Replacing the fuel filter of auxiliary water heating

- | | | | |
|---|------------------|---|-------------|
| 1 | Fuel line | 3 | Fuel filter |
| 2 | Screw clamp (2x) | | |

- ▶ Undo screw clamps **2**.
- ▶ Remove fuel filter **3** from fuel line **1**.



Note

Environmental pollution!

- ▶ Dispose of fuel filters **3** and fuel in accordance with national and international guidelines and regulations.
- ▶ Insert new fuel filter **3** on fuel lines **1**.
- ▶ Tighten screw clamps **2**.
- ▶ Open gate valve on fuel line.

9.48 HATZ diesel engine* (see operation manual of the engine manufacturer on CD)

9.48.1 Checking the belt drive

Make sure the following prerequisites are met:

- HATZ diesel engine is protected from unauthorized start-up.
- ▶ Check belt drive for tension.
- ▶ Check belt drive for loose screws.
- ▶ Check belt drive for correct function.

9.48.2 Replacing the belt drive including vibration damper, deflection pulley and springs

The belt drive service kit consists of the following components:

- Belt drive
- Vibration damper
- Deflection pulley
- Spring (2x)
- ▶ Deinstall vibration damper.
- ▶ Unhook springs on generator.
- ▶ Fold generator up.
- ▶ Remove belts.
- ▶ Deinstall bearing support of deflection pulley.
- ▶ Replace deflection pulley.
- ▶ Reinstall bearing support.
- ▶ Insert new belts.
- ▶ Suspend new springs on generator.
- ▶ Install vibration damper.
- ▶ Check belt alignment.

9.49 Machine care

9.49.1 Cleaning the machine

Liebherr recommends that the external machine parts are cleaned regularly to maintain an even surface quality. This is strongly advised following work with highly corrosive materials.

NOTICE

Unsuitable cleaning agent is used!
The surfaces will be damaged.

- ▶ Do not use any aggressive cleaning agents.
 - ▶ Do not use any abrasive cleaning agents.
 - ▶ Do not use any phosphate cleaners.
 - ▶ Do not use and solvents or solvent-containing cleaning agents.
 - ▶ Only use cleaning agents with a pH value of ≤ 12 .
 - ▶ Ensure that the cleaning agent to water ratio does not exceed 3%.
 - ▶ Rinse with clear water (not salt water).
-

Ensure that the following conditions are fulfilled:

- The machine is switched off and secured to prevent unauthorised operation.
- The machine has cooled down.
- The battery main switch is switched off.
- The boom is laid down.



CAUTION

Hot steam and compressed air!
Risk of burns.

- ▶ Wear protective equipment.
-

The machine may only be cleaned with a maximum pressure of 150 bar (2,175.56 psi) at a distance of at least 40 cm (1' 4" ft-in). Do not exceed water temperature of 80 °C (176 °F).

The water jet must not be directed onto the following components:

- Intake manifolds for drawing air to cool the engine
 - machinery room
 - Electrical plug-in connections
 - Cab interior
- ▶ Clean the machine using a high-pressure cleaner.
-



Note

Environmental pollution!

- ▶ Dispose of the oil-stained tools and cleaning agents in accordance with national and international guidelines and regulations.
 - ▶ Cleaning water must pass through an oil separator before it enters the sewer system.
-

9.49.2 Preserving the machine

The following types of preservation are available:

- Maintaining preservation of the machine
- Preserving the machine for storage for up to 7 months
 - Preserving the machine for indoor storage
 - Preserve machine for outdoor storage
- Preserve machine for storage for more than 7 months
- Preserve machine for decommissioning
- Preserve machine for reselling

NOTICE

Insufficient or incorrect preservation agents are applied to the machine!
Damage to machine.

- ▶ Ensure that exclusively authorized qualified personnel preserve the machine.
 - ▶ Ensure that inspection and reapplication intervals are not exceeded.
-

Maintaining preservation of the machine

Climatic zones

The maintenance intervals required depend on the climatic conditions in the region where the machine is used.

The graphics below show the climatic zones. The dark markings show the regions with the climatic zone in question:

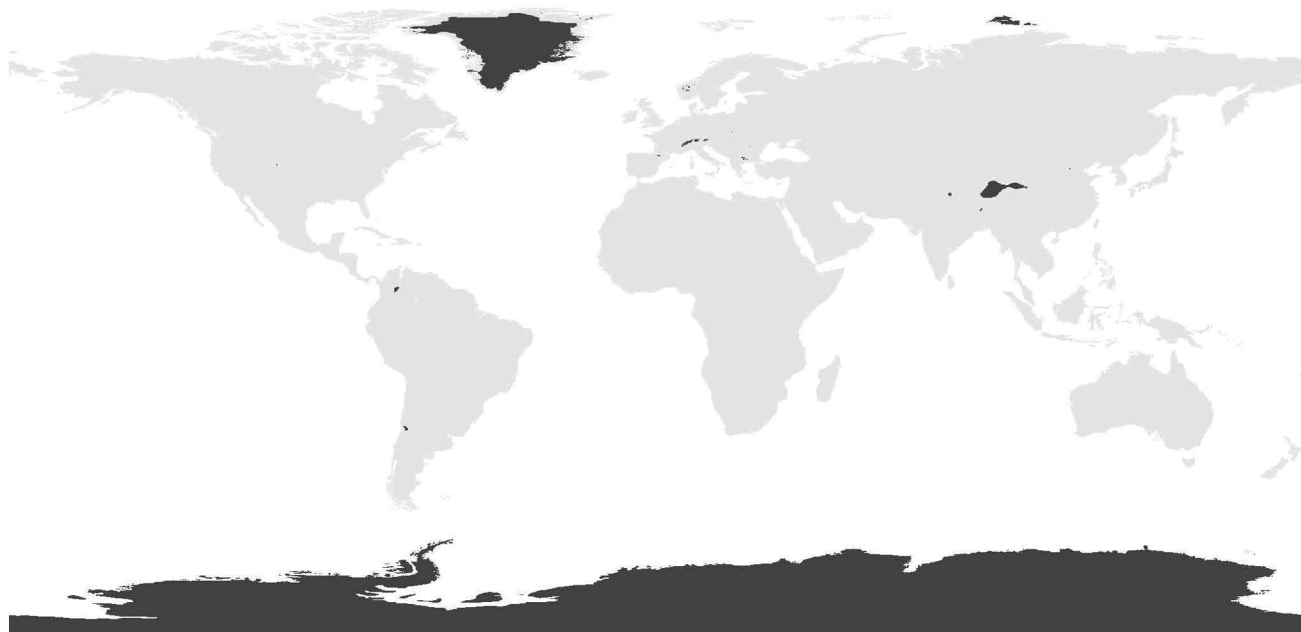


Fig. 6041: Arctic climate



Fig. 6042: Polar climate

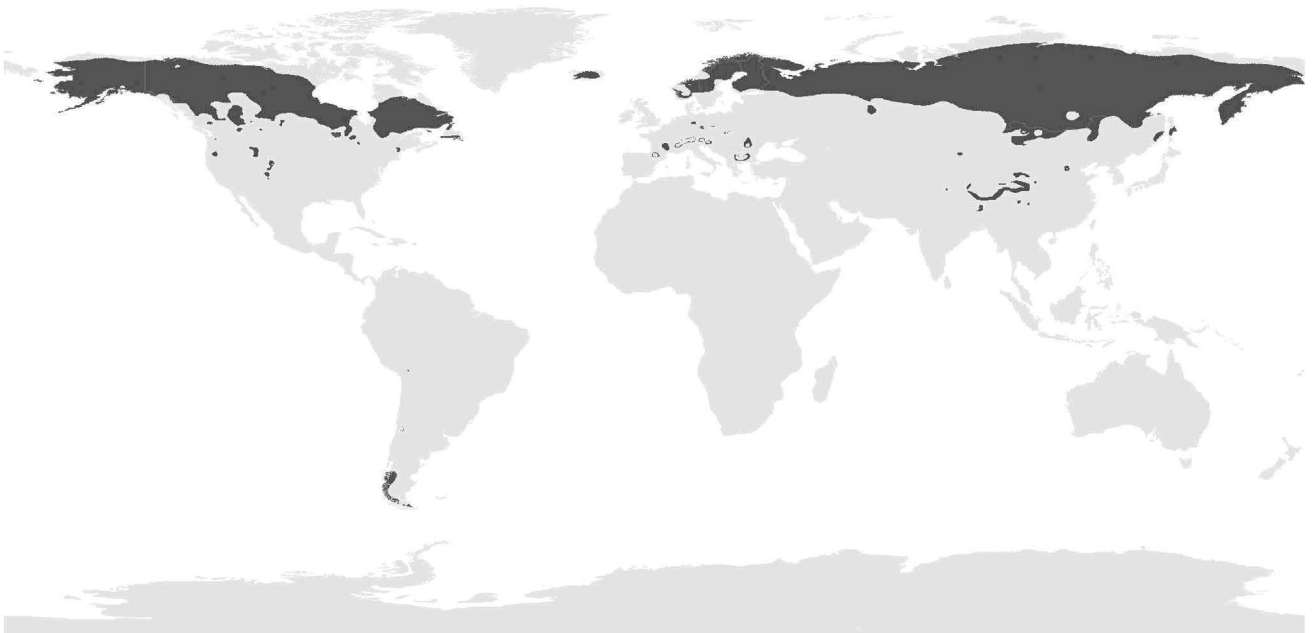


Fig. 6043: Boreal climate

LWNLR-x/V04.01//Auslieferung/2016-03-07/en

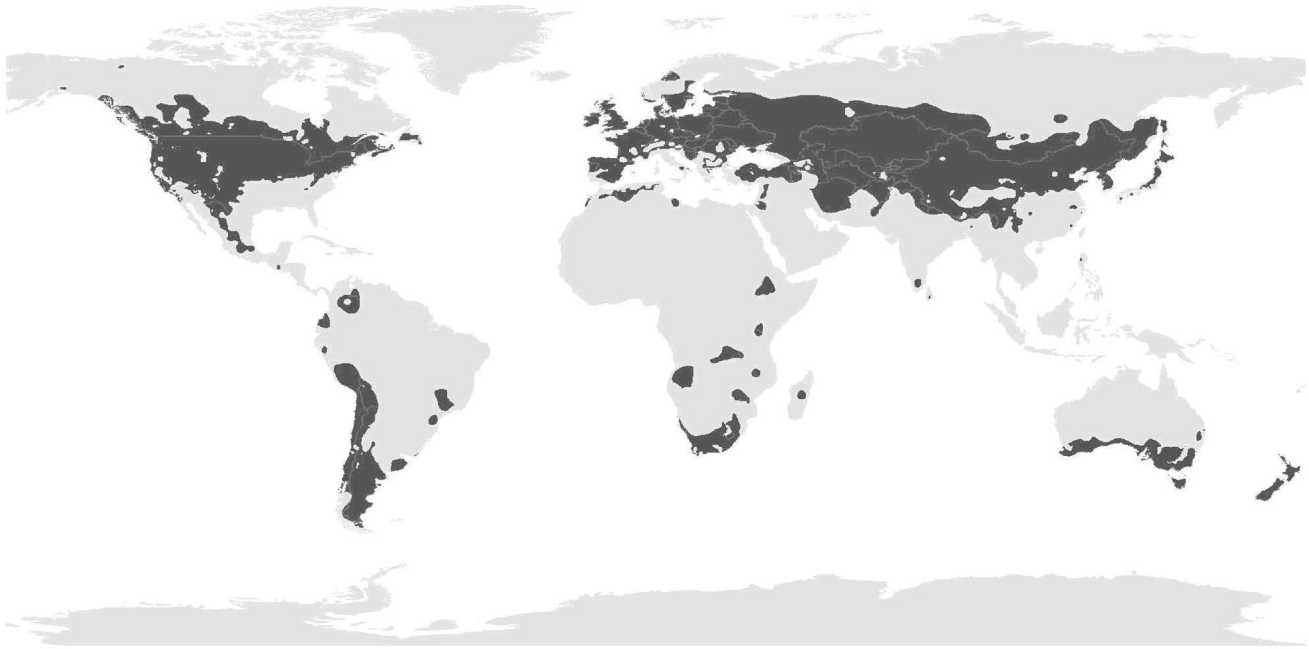


Fig. 6044: Warm temperate climate

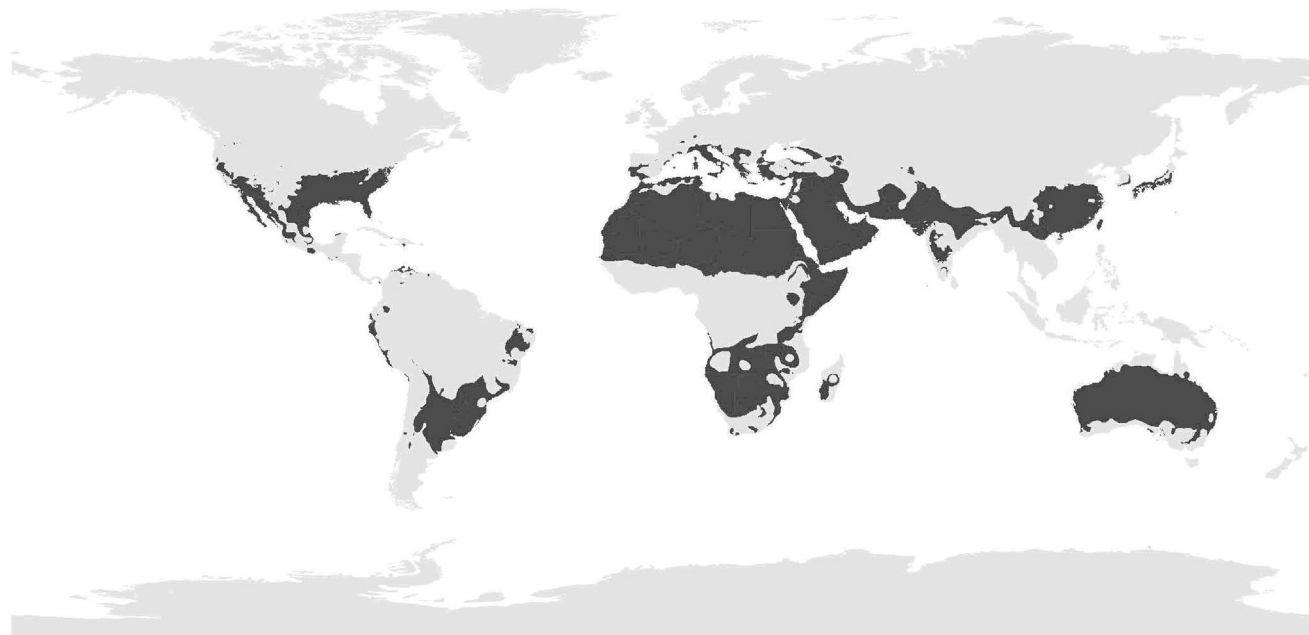


Fig. 6045: Subtropical climate

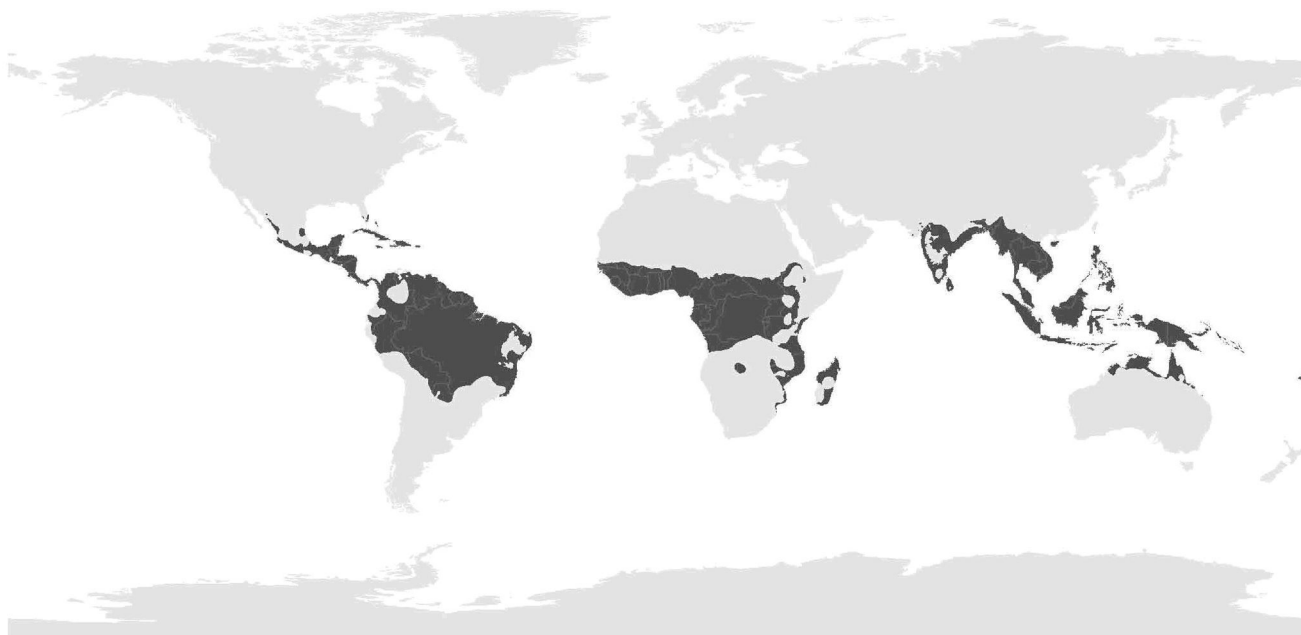


Fig. 6046: Tropical climate

Additional sub-division within climatic zones

The climatic zones are further sub-divided:

Sub-division 1

- Small fluctuations within the climatic zone
- Constant temperature
- Constant, low humidity
- High winds rare

Sub-division 2

- Moderate fluctuations within the climatic zone
- Moderate temperature differences
- Moderate humidity
- Moderate fluctuations in humidity
- Occasional high winds

Sub-division 3

- Strong fluctuations within the climatic zone
- Strong temperature differences
- Strong fluctuations in humidity
- Frequently high constant humidity
- Extreme wind speeds
- Highly contaminated wind (saline, aggressive media - chemicals, sand)
- Extreme UV radiation

Irrespective of the actual surroundings, sub-division 3 automatically applies to the following machine uses within the relevant climatic zone:

- Bulk handling with aggressive chemicals
- Offshore cranes (drilling platform cranes, ship's cranes, machines on pontoons)

Inspection intervals

The inspection intervals for the anti-corrosion coating are shown in the table below.

Rectify any faults identified by the inspection and repair mechanical damage immediately.

Anti-corrosion coating inspection intervals in months						
	Arctic climate	Polar climate	Boreal climate	Warm temperate climate	Subtropical climate	Tropical climate
Interval	6	6	9	12	9	6

Tab. 642: Anti-corrosion coating inspection intervals in months

Reapplication intervals

Assuming there is no visible damage to the protective film, the table below shows the reapplication intervals (in months) for the anti-corrosion coating.

Anti-corrosion coating reapplication intervals in months																		
Sub-division	Arctic climate			Polar climate			Boreal climate			Warm temperate climate			Subtropical climate			Tropical climate		
	1	2	3	1	2	3	1	2	3	1	2	3	1	2	3	1	2	3
Interval	-	4	2	-	4	2	9	6	3	18	12	6	6	4	2	-	4	2

Tab. 643: Anti-corrosion coating reapplication intervals in months

Ensure that the following conditions are fulfilled:

- Suitable preservation agents are available in sufficient quantities ([For more information see: 9.2.9 Preservation medium \(anti-corrosion coating\), page 1880](#)).
- The appropriate tools and accessories are available.
- The machine is switched off and secured to prevent unauthorised operation.
- The machine has cooled down.
- The battery main switch is switched off.
- Protective equipment is worn.
- ▶ Thoroughly clean the machine using a high-pressure cleaner.
- ▶ Dry if necessary with dry, oil-free air.
- ▶ Remove any areas of corrosion with sandpaper (60 – 80 grit) or a wheel sander.
- ▶ Be careful not to cause damage through mechanical removal of corrosion.
- ▶ Do not polish surfaces.



WARNING

Insufficient or incorrect preservation agents are applied to the machine!
Risk of injury to the respiratory tract, suffocation.

- ▶ Wear breath protection.

- ▶ Spray all machined, but unpainted, parts external to the machine (e.g. pins that are not removed, bearings, galvanized brackets, screws, etc.) with DINITROL 4010 or LPS 3 anti-corrosion agent.
- ▶ Spray all machined, galvanized, but unpainted, parts within the machine (e.g. flanges, pins, screws, joints, casings, contact surfaces) with anti-corrosion coating agent DINITROL 4010 or LPS 3.

- ▶ Spray the entire engine compartment with DINITROL 3650 anti-corrosion coating agent.
- ▶ Allow a drying time of 24 hours then spray the entire engine compartment with DINITROL 4010 anti-corrosion coating agent.
- ▶ Spray electrical components inside switch cabinets and terminal boxes as well as plug-in connections and limit switches with LPS 1 anti-corrosion coating agent.
- ▶ Spray screws on railings, boom walkways, steps, moving parts and floodlights with LPS 3 anti-corrosion coating agent.
- ▶ Wrap connections, threaded joints, valves of the hydraulic system with DENSO tape.
- ▶ Spray all joints (pin connections on pendant and backstay straps, equalizer, etc.) with LPS 3 anti-corrosion coating agent.
- ▶ Do not use LPS 3 anti-corrosion coating agent in the engine compartment.

Preserving the machine for storage for up to 7 months

NOTICE

Do not use a preserved machine if it has been preserved for storage for up to/more than 7 months!

Damage to machine.

- ▶ Ensure that the machine is treated with permitted lubricants.
- ▶ Ensure that all oil levels are correct.

Ensure that the following conditions are fulfilled:

- The boom is laid down.
- Rear counterweight has been removed.

Preserving the machine for indoor storage

The machine is stored in a hall or shelter and is not directly exposed to environmental influences.

Preserving the ropes

Preserve the following ropes:

- Winch 1 rope
- Winch 2 rope
- Rope of the main boom luffing winch
- Rope of the jib luffing winch
- Rope of the rope reeving winch
- ▶ Unwind ropes on first layer.
- ▶ Preserve ropes with rope grease.
- ▶ Wind up ropes correctly.

Preserving the boom

Boom intermediate pieces:

- ▶ Dismantle the boom sections.
- ▶ Repair any damage.

- ▶ Dismantle pin connection points.
- ▶ Grease pin connection points.
- ▶ Assemble pin connection points.
- ▶ Preserve all machined but unpainted parts on the boom sections with DINITROL 4010.

Boom base section/boom heads:

- ▶ Repair any damage.
- ▶ Dismantle pin connection points.
- ▶ Grease pin connection points.
- ▶ Assemble pin connection points.
- ▶ Preserve all machined but unpainted parts on the boom base sections/boom heads with DINITROL 4010.
- ▶ Retract hydraulic cylinders.
- ▶ Wrap jib tilting-back support cylinder with DENSO tape.

Pendant straps and backstay straps:

- ▶ Dismantle pin connections.
- ▶ Grease pin connections.
- ▶ Assemble pin connections.

Preserving the basic machine

A-frame 1 equalizer:

- ▶ Dismantle pin connections.
- ▶ Grease pin connections.
- ▶ Assemble pin connections.

Rear counterweight:

- ▶ Dismantle pin connections.
- ▶ Grease pin connections.
- ▶ Assemble pin connections.

Steel fabrication:

- ▶ Check the steel fabrication for damage. The drawings for checking the weld seams and holes can be found in the Technical information volume.
- ▶ Pre-preserve steel fabrication with DINITROL 3650.
- ▶ Post-preserve steel fabrication with DINITROL 4010.
- ▶ Lubricate lubrication points.

Hydraulic cylinders:

- ▶ Retract hydraulic cylinders.
- ▶ Wrap hydraulic cylinders that cannot be retracted with DENSO tape.

Swing ring:

- ▶ Apply graphite spray to tooth flanks.
- ▶ Lubricate swing ring until grease escapes from the sealing lips. This process step can also take place with the optional central lubrication.

Batteries:

- ▶ Disconnect batteries with main battery switch.
- ▶ Remove batteries.
- ▶ Charge batteries every two months (trickle charge).

Winches:

- ▶ Lubricating winches.
- ▶ Fill winch gearbox with oil.

Crawler drive:

- ▶ Lubricate crawler drive.
- ▶ Fill crawler drive with oil.

Swing gear:

- ▶ Fill swing gear with oil.

Fuel tank:

- ▶ Fill fuel tank with winter diesel.
- ▶ Drain water in the condensation trap.

Electrics:

- ▶ Apply Vaseline to all contacts on plug-in connections.

Load hook/pulley block:

- ▶ Lubricate load hook/pulley block.

Hydraulic oil tank:

- ▶ Fill hydraulic oil tank with oil.

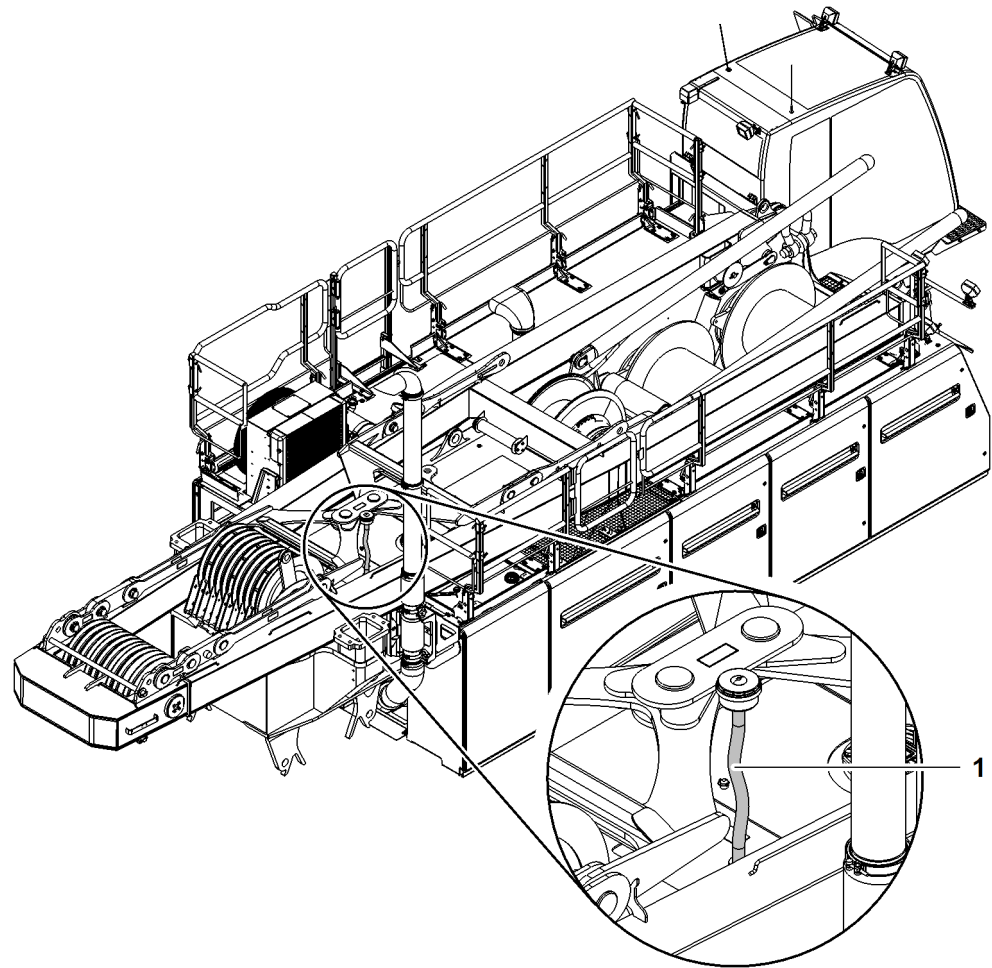


Fig. 6047: Hose on hydraulic oil tank (illustration of principle)

1 Hose with screw fittings

Because it can expand, the hose 1 prevents oil from escaping when temperature differences occur.

- ▶ Unscrew the venting filter.
- ▶ Screw on hose 1 with threaded joint.
- ▶ Screw venting valve onto hose 1.
- ▶ Fix hose 1 with venting valve in a vertical position using cable ties.
- ▶ Ensure that the connections are properly sealed.

Preserve machine for outdoor storage

The machine is stored outdoors and is directly exposed to environmental influences.

Preserving the ropes

Preserve the following ropes:

- Winch1 rope
- Winch 2 rope
- Rope of the main boom luffing winch
- Rope of the jib luffing winch
- Rope of the rope reeving winch

- ▶ Unwind ropes on first layer.
- ▶ Preserve ropes with rope grease.
- ▶ Wind up ropes correctly.

Preserving the boom

Boom intermediate pieces:

- ▶ Dismantle the boom sections.
- ▶ Remove cat walks.
- ▶ Repair any damage.
- ▶ Dismantle pin connection points.
- ▶ Grease pin connection points.
- ▶ Assemble pin connection points.
- ▶ Preserve boom sections with DINITROL 4010.

Boom base section/boom heads:

- ▶ Remove cat walks.
- ▶ Cover pulleys.
- ▶ Repair any damage.
- ▶ Dismantle pin connection points.
- ▶ Grease pin connection points.
- ▶ Assemble pin connection points.
- ▶ Preserve boom base sections/boom head with DINITROL 4010.
- ▶ Retract hydraulic cylinders.
- ▶ Wrap jib tilting-back support cylinder with DENSO tape.

Pendant straps and backstay straps:

- ▶ Dismantle pin connections.
- ▶ Grease pin connections.
- ▶ Assemble pin connections.

Preserving the basic machine

A-frame 1 equalizer:

- ▶ Dismantle pin connections.
- ▶ Grease pin connections.
- ▶ Assemble pin connections.

Rear counterweight:

- ▶ Dismantle pin connections.
- ▶ Grease pin connections.
- ▶ Assemble pin connections.

Steel fabrication:

- ▶ Check the steel fabrication for damage. The drawings for checking the weld seams and holes can be found in the Technical information volume.

- ▶ Pre-preserve steel fabrication with DINITROL 3650.
- ▶ Post-preserve steel fabrication with DINITROL 4010.
- ▶ Lubricate lubrication points.

Hydraulic cylinders:

- ▶ Retract hydraulic cylinders.
- ▶ Wrap hydraulic cylinders that cannot be retracted with DENSO tape.

Swing ring:

- ▶ Apply graphite spray to tooth flanks.
- ▶ Lubricate swing ring until grease escapes from the sealing lips. This process step can also take place with the optional central lubrication.

Batteries:

- ▶ Disconnect batteries with battery master switch.
- ▶ Remove batteries.
- ▶ Charge batteries every two months (trickle charge).

Winches:

- ▶ Lubricating winches.
- ▶ Fill winch gearbox with oil.

Crawler drive:

- ▶ Lubricate crawler drive.
- ▶ Fill crawler drive with oil.

Swing gear:

- ▶ Fill swing gear with oil.

Fuel tank:

- ▶ Fill fuel tank with winter diesel.
- ▶ Drain water in the condensation trap.

Electrics:

- ▶ Apply Vaseline to all contacts on plug-in connections.

Load hook/pulley block:

- ▶ Lubricate load hook/pulley block.

Hydraulic oil tank:

- ▶ Fill hydraulic oil tank with oil.
- ▶ Cover pulleys.

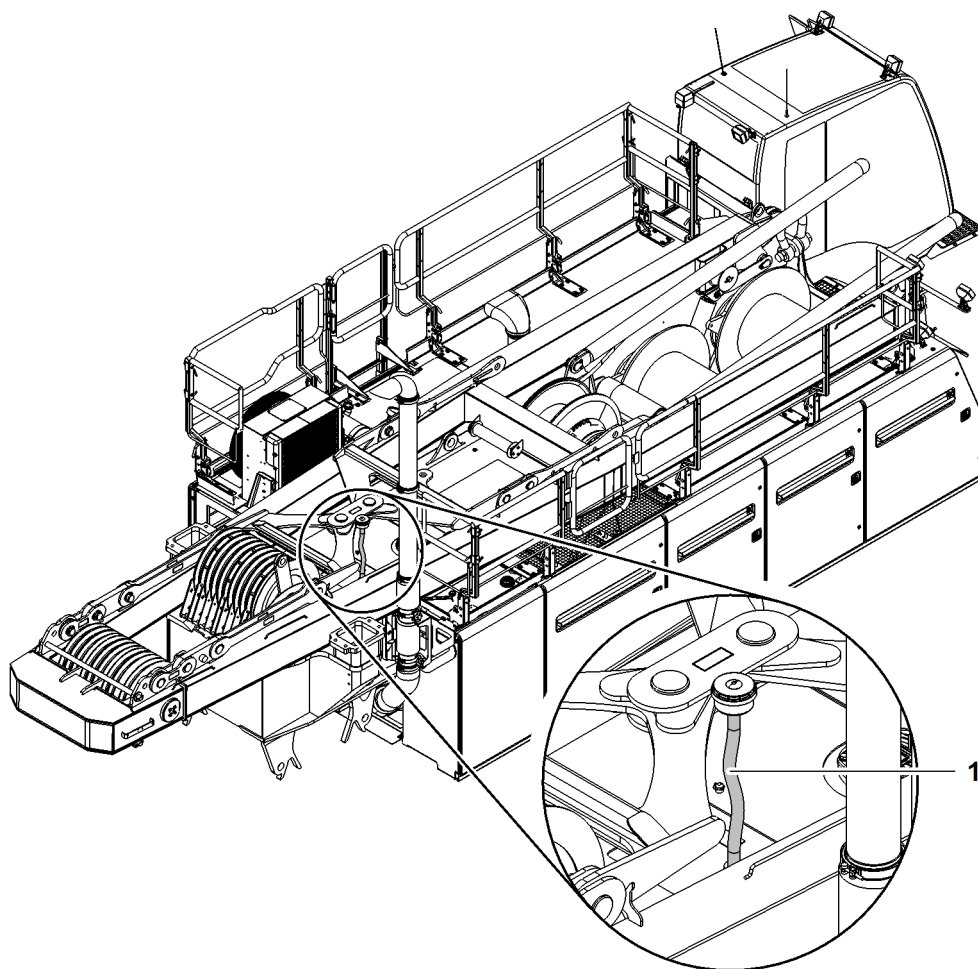


Fig. 6048: Hose on hydraulic oil tank (illustration of principle)

1 Hose with screw fittings

Because it can expand, the hose 1 prevents oil from escaping when temperature differences occur.

- ▶ Unscrew the venting filter.
- ▶ Screw on hose 1 with threaded joint.
- ▶ Screw venting valve onto hose 1.
- ▶ Fix hose 1 with venting valve in a vertical position using cable ties.
- ▶ Ensure that the connections are properly sealed.

Preserve machine for storage for more than 7 months



Note

- ▶ Contact Liebherr after sales service when storing the machine for more than 7 months.

Preserve machine for decommissioning



Note

- ▶ When decommissioning the machine, contact Liebherr after sales service.

Preserve machine for reselling



Note

- ▶ When reseling the machine, contact Liebherr after sales service.
-

Index

0

0906 fixed jib 282

1

1008 fixed jib 270
1008.17 jib section 3 m (10 ft) 272
1008.17 jib section 6 m (20 ft) 273
1008.20 jib head section 274
1507 fixed jib 263
1713 fixed jib 248
1713.18 jib section 12 m (40 ft) 253
1713.18 jib section 3 m (10 ft) 250
1713.18 jib section 6 m (20 ft) 251
1713.21 jib head section 254
1916 luffing jib 327
1916.18 jib section 12 m (40 ft) 332
1916.18 jib section 3 m (10 ft) 329
1916.18 jib section 6 m (20 ft) 330
1916.21 jib head section 334
1916.32 Midfall 370

2

2316 luffing jib 288
2316.20 jib head section 295
2316.20 jib section 12 m (40 ft) 293
2316.20 jib section 3 m (10 ft) 290
2316.20 jib section 6 m (20 ft) 291
2316.25 Midfall 365
2821 main boom 162
2821 main boom head to 2220 derrick boom head
pendant straps 1362, 1365
2821/2316 reducing piece 220
2821/2316.24 reducing piece 12 m (40 ft) 220

4

4-strand round sling gear 1143
4-strand round sling rigging with chain shortening
devices 1142

A

A/C compressor on diesel engine 463
Abseil rescue equipment* 422, 1029
Access systems and railings 1865, 1953
Accumulator 1863

Activate winch synchronization on control lever 976
Activates/deactivates continuous mode of the
windscreen wiper. 858
Activates/deactivates interval mode of the windscreen
wiper 858
Activating auxiliary heating* 2067
Activating horizontal load path 1012, 1013
Activating horizontal load path for winch1 1012
Activating horizontal load path for winch2 1013
Activating the air conditioning system 2066
Activating the external air conditioning system* 2066
Activating the positioning of the boom head above the
load's center of gravity 1016
Activating the radio remote control 992
Activating the radius adjustment of the counterweight
carriage 965
Activating the winch synchronization on control panel
X23 977
Activating winch synchronization 976
Activating/deactivating assembly functions on or
off 884
Activating/deactivating the lifting height
limitation 1010
Activating/deactivating the maximum radius radius
limitation 1007
Activating/deactivating the minimum radius radius
limitation 1006
Activating/deactivating the radius limitation 1006
Activating/deactivating the slewing range
limitation 1008
Adapter connecting link 390
Additional cab equipment 876
Additional connecting elements/spacer brackets for
fixed jib 1507 267
Additional floodlights* 831
Additional pendant straps/connecting links for luffing
jib 1916 351
Additional pendant straps/connecting links/tension
load cells 199, 216
Additional sub-division within climatic zones 2075
Adjustable floodlights on main boom base
section 542
Adjusting and mounting the transport brackets for
steel pendant straps 1847
Adjusting and mounting transport brackets for
connecting links 1849
Adjusting the cabin 881
Adjusting the control stand horizontally 848
Adjusting the dampening 852
Adjusting the ergonomics* 853
Adjusting the lamella vents 863
Adjusting the operator's seat 837, 848
Adjusting the RPM of the diesel engine 840
Adjusting the RPM of the diesel engine with the
control lever 840
Adjusting the RPM of the diesel engine with the foot
pedal 842
Adjusting the support height of jacks 1209, 1229

Adjusting the track 1752
A-frame1 76, 1975
A-frame1 equalizer 77, 78
A-frame1 to 2220 derrick boom head pendant straps 1361, 1365
A-frame3 equalizer (jib pendant strap) 308, 317, 346, 354
Aggregate screen 721
Air conditioning system 461
Air filter system 1860, 1885
Align wheel sets 1481
Aligning the counterweight carriage for mounting 1479
Ambient temperatures 60
Angle 528
Angle of view on the side 516
Angle of view rear 517
Application conditions 60
Application height 60
Application on floating devices 605
Appropriate use 53
Areas of responsibility 553
Armrests* for operator's seat 426
Assemble the luffing jib 1661
Assembling the basic machine 1156
Assembling the fixed jib 1580
Assembling the ladder* for the boom 1291, 1405
Assembling the luffing jib + Midfall 1746
Assembling the main boom 1403
Assembling the main boom + reducing piece 1519
Assembly and dismantling 1147
Assembly cylinder * 984
Assembly of a pulley 2031
Assembly of a rope 2002
Assembly of counterweight carriage of derrick equipment* 1472
Assembly of derrick boom 1382
Assembly of main boom with derrick equipment* 1382
Assembly of main boom without derrick equipment* 1290
Assembly of suspended counterweight of derrick equipment* 1470
Assembly site 1067
Assigned functions for buttons on left-hand multi-directional joystick 634
Assigned functions for movement directions on left-hand multi-directional joystick 631, 637
Assigned functions for movement directions on right-hand double T-lever 663
Assigned functions for movement directions on right-hand multi-directional joystick 656
Assistance system horizontal load path* 1012
Attach auxiliary ropes and guide counterweight carriage pendant straps 1485
Attach the carbody counterweight 1248
Attach the telescopic unit 1472

Attaching carbody counterweight for undercarriage with fixed track width 1248
Attaching carbody counterweight for undercarriage* with adjustable track width 1252
Attaching connecting links to the boom head section 1586
Attaching crawler side frame for undercarriage with fixed track width 1215
Attaching crawler side frame for undercarriage* with adjustable track width 1231
Attaching the auxiliary jib (15 t (33.000 lb)) to the jib head section 1662
Attaching the auxiliary jib (30 t (66.000 lb)) to the jib head section 1664
Attaching the auxiliary jib (36 t (79300 lb)) to the boom head section 1317, 1442
Attaching the boom base section to the uppercarriage 1306, 1435
Attaching the crawler side frame 1214
Attaching the jib base section 1582, 1667
Attaching the main boom (self-assembly system) 1588, 1670
Attaching the rope fixing point 1338, 1456, 1607, 1701
Auxiliary air heating* 469
Auxiliary floodlights* 538
Auxiliary heating altitude kit* 471
Auxiliary heating control unit 471
Auxiliary heating* 872
*Auxiliary heating** control unit 826
Auxiliary jib (15 t (33.000 lb)) on jib head 410
Auxiliary jib (36 t (79.300 lb)) on main boom head 410
Auxiliary jib* (15 t (33.000 lb)) 379
Auxiliary jib* (30 t (66.000 lb)) 377
Auxiliary jib* (36 t (79.300 lb)) 374
Auxiliary water heating* 466

B

Backstay shackles 236
Backstay straps A-frame2 to main boom head 2821 1537
Backstay straps connecting element on fixed jib 1507 267
Backstay straps spacer brackets on fixed jib 1507 268
Banksman 554, 556
Barrier rod 511
Basic counterweight slab 14 t (30,864 lb) 154
Basic machine 68
Basic machine overview 68
Basic machine with undercarriage with fixed track width 68
Basic machine with undercarriage* with adjustable track width 72
Batteries 1864, 1933
battery charger 989
Battery heating* 469

Blocked crawlers* 980
 Bolt the derrick pulley block with main boom pendant straps 1442
 Bolting the boom base section to the main boom 1315
 Bolting the boom head section to the boom sections 1293
 Bolting the derrick boom 1383
 Bolting the equaliser on A-frame 2 to the jib backstay straps 1675
 Bolting the equaliser on A-frame 3 to the jib pendant straps 1679
 Bolting the equalizer on A-frame 1 to the main boom pendant straps 1317
 Bolting the jib base section to the jib 1678
 Bolting the jib head section to the jib sections 1581, 1666
 Bolting the pendant ropes for the suspended counterweight 1390
 Bolting the pendant straps for the wheeled counterweight carriage 1390
 Boom base section or A-frame 1: checking the operation of the mechanical boom angle indicator 1963
 Boom base section: checking that the knuckle pins and locking elements fit tightly 1962
 Boom base section: lubricating knuckle pins 1962
 Boom configuration 4 - load position 1 898
 Boom configuration 4 - load position 2 899
 Boom configuration 5 - load position 1 900
 Boom configuration 5 - load position 3 901
 Boom configuration 6 - load position 2 902
 Boom configuration 8 - load position 1 903
 Boom configuration 8 - load position 2 904
 Boom configuration 9 - load position 1 905
 Boom configuration 9 - load position 2 906
 Boom luffing winches 1861, 1898
 Bottom backstay shackle 237
 Bracket KnK1 107
 Bracket support K1 132
 Bracket support K2 133
 Bracket support K3 134
 Bracket1 106
 Bracket2 109
 Bracket3 110
 Bracket4 111
 Bracket5 112
 Bracket6 113
 Brackets for front cover 511
 Brief summary 1793, 1804, 1806, 1807, 1810
 Burns 586
 Buttons 694
 Buttons on the side 809
 Bypass filter system 1864, 1930
 By-pass flow filter system* 489
 Bypass unused hoist limit switches. 1350, 1468, 1615, 1709

C

Cab 1868, 2041
 Cab roof protection guard* 435
 Cab tilting device* 880
 Cabin 82, 627, 831
 Cabin overview 513
 Cabin railing* 456
 Cable remote control 458, 800
 Cable remote control on undercarriage* 800
 Cable remote control on uppercarriage 800
 Calculate rope diameter 2008
 Calculating load charts 897
 Calculating load charts online 897
 Calculating the length of winch1/winch2 rope 1071
 Calculating the reduction of the rope diameter 2009
 Calculating the revised set-up 887
 Calibrating the rope measuring system 997
 Call up the *Setup* screen 886
 Calling up time and day 873
 Camera 520
 Camera cable in main boom base section 529
 Cancelling the stop after crawler operation 1011
 Carbody counterweight 148
 Carbody counterweight for undercarriage with fixed track width 148
 Carbody counterweight for undercarriage* with adjustable track width 150
 Carbody counterweight slab 13.4 t (29,542 lb)* 149
 Carbody counterweight slab 14.3 t (31,526 lb) 148
 Carbody counterweight slab 18.8 t (41,446 lb) 151
 Carbody counterweight slab 7.5 t (16,534 lb) 152
 Carbon-fibre pendant straps 1866, 1982
 Carrying out a hydraulic oil analysis 1921
 Catwalk grating 90
 Catwalks* for boom 476
 Central lubrication system 537
 Central lubrication* 830, 883
 Central power unit 83
 CF pendant straps on A-frame1 78
 CF pendant straps on A-frame2 315, 352
 CF pendant straps on A-frame3 317, 354
 CF pendant straps on fixed jib 0906 286
 CF pendant straps on fixed jib 1008 281
 CF pendant straps on fixed jib 1507 269
 CF pendant straps on fixed jib 1713 262
 CF pendant straps on jib base section 2316.22 314
 CF pendant straps on jib head 1916.21 361
 CF pendant straps on jib head 2316.20 324
 CF pendant straps on jib section 1916.18
 12 m (40 ft) 360
 CF pendant straps on jib section 1916.18
 3 m (10 ft) 356
 CF pendant straps on jib section 1916.18
 6 m (20 ft) 358
 CF pendant straps on jib section 2316.20
 12 m (40 ft) 322

- CF pendant straps on jib section 2316.20
 - 3 m (10 ft) 319
- CF pendant straps on jib section 2316.20
 - 6 m (20 ft) 321
- CF pendant straps on luffing jib 1916 352
- CF pendant straps on luffing jib 2316 314
- CF pendant straps on main boom 2821 200
- CF pendant straps on main boom base section 2821.30 200
- CF pendant straps on main boom head 2821.24 214
- CF pendant straps on main boom section 2316.25
 - 1 m (3 ft) 245
- CF pendant straps on main boom section 2821.30
 - 12 m (40 ft) 210
- CF pendant straps on main boom section 2821.30
 - 3 m (10 ft) 203
- CF pendant straps on main boom section 2821.30
 - 6 m (20 ft) 206
- CF pendant straps on midfall 1916.32 373
- CF pendant straps on midfall 2316.25 368
- CF pendant straps on reducing adapter 2821/2316 244
- CF pendant straps on reducing adapter 2821/2316.24
 - 12 m (40 ft) 244
- Changing the bulbs of floodlights on main boom base section 1939
- Changing the bulbs of floodlights on the cabin and on the uppercarriage 1935
- Changing the bulbs of search floodlights 1938
- Changing the cab lamp light bulb 1935
- Changing the filter elements 1930
- Changing the windscreen wipers 2041
- Charger 439, 441
- Charging the rechargeable battery with a battery charger 989
- Check cabin roof protection guard for damage, locking (in case of foldable design) 2041
- Check chain guides for wear and tight fit 1907
- Check derrick boom base section, derrick boom head and derrick boom sections for damage and wear (cracks, notches, corrosion, plastic deformation, wear) 1993
- Check fill level of the lubrication pump 1991
- Check gearbox and hydraulic connections for leaks 1906
- Check main boom base section, main boom head and main boom sections for damage and wear (cracks, notches, corrosion, plastic deformation, wear) 1961
- Check obstacle warning light for function and damage, check mains cable and plug (if available) for damage 1949
- Check pendant ropes and pins for damage and wear and check that locking springs and cotter pins are present (cracks, notches, corrosion, plastic deformation, wear, lubrication, etc.) 1987
- Check ropes for corrosion 2011
- Check ropes for reduction of the nominal rope diameter 2008
- Check ropes for the effects of heat 2014
- Check screw connections and pin connections for tight fit 1964, 1965, 1974
- Check that the hydraulic cylinder fits properly and does not leak 1928
- Check that the safety catch is present and working properly 1919
- Check the hydraulic system for leaks 1920
- Check the rope for number of permitted wire breaks 2006
- Check the round steel chains for wear and damage 1917
- Check the windows of the cab for damage 2041
- Check transport lashing and round slings for wear (according to EN 1492-2). 1917
- Checking A-frame 1 1975
- Checking all hooks/pulley blocks for damage, wear, corrosion and widening of the hook aperture 1918
- Checking bottom of pulley groove for sharp edges 2034
- Checking CF pendant straps and pins for damage and wear and check that locking springs and split pins are present 1983
- Checking CF pendant straps for wear of the protective coating and/or wire mesh hose and checking for damage to fibers 1983
- Checking connecting links for damage and wear 1980, 1986, 1988
- Checking counterweight supports (pins, shackles) for damage and wear 1990
- Checking drum for loose rope layers 2030
- Checking emergency descent equipment for presence and function 2044
- Checking hoist limit switches, boom limit switches and, if necessary, limit switches of the piling and drilling rig to ensure they are working correctly 1946
- Checking hydraulic cabin elevation for function and damage 2044
- Checking hydraulic cylinders, hydraulic hoses and connections for leaks and damage 2043
- Checking hydraulic hoses and connections for leaks and damage 2044
- Checking ladders, steps, platforms, and ascents for wear, damage and anti-slip surfaces 1953
- Checking latches and hand rails for wear and damage 1953
- Checking locking elements for availability, damage, wear and tight fit 1990
- Checking locking elements for damage and wear 1985, 1987
- Checking locking flaps for ease of movement 1972
- Checking locking screws of the track pads axes 1916
- Checking outside mirrors and inside mirrors for damage 2043
- Checking pendant ropes for damage and wear 1987
- Checking personal protective gear 1951
- Checking pins for damage and wear 1985, 1987
- Checking pins for presence of locking elements 2045

- Checking position of main battery switch 836
 Checking pulleys for damage 2034
 Checking rope end attachment for tight fit when starting up rope reeving winch 1901
 Checking rope fixing points for tears 1964, 1965
 Checking rope for deformation and mechanical damage 2012
 Checking rope suspensions (rope clamps, rope thimbles) for wire breaks, absence of corrosion and tight fit of screw fittings 2037
 Checking rope tensioning pulleys* of drum for wear 2029
 Checking rope thimbles for corrosion, cracks and wire breaks 2038
 Checking ropes for end of service life 2003
 Checking ropes for lubrication 2002
 Checking ropes for strand breaks 2010
 Checking steel pendant straps and pins for damage and wear and check that locking springs and split pins are present 1979
 Checking steel pendant straps for damage and wear 1979
 Checking tension load cells for damage and wear, checking electricity connections for tight fit 1980, 1986
 Checking that all required safety labels are mounted on the machine and are legible 1952
 Checking that rope protection and locking springs are present and not damaged 1964, 1965, 1974
 Checking that the cab door and the door lock work properly 2041
 Checking that the cabin lighting, floodlights and auxiliary floodlights are working properly 1935
 Checking that the crossbeam set screws on the crawler side frames are secure on telescopic undercarriages 1907
 Checking that the mechanical inclinometer is working properly 1947
 Checking that the safety chain is present and working properly 2044
 Checking the air pressure of the counterweight carriage 1994
 Checking the anemometer for tight fit and function 1964, 1973
 Checking the auxiliary jib for function and damage 1965
 Checking the availability of the spring cotter pin 1957
 Checking the battery fluid 1933
 Checking the belt drive 2070
 Checking the bottom of groove diameter of the pulley 2032
 Checking the bushes of CF pendant straps 1984
 Checking the bypass filter system 1930
 Checking the cabin's suspension point for damage 2045
 Checking the chain tension 1908
 Checking the climate box for contamination 2064
 Checking the condenser for contamination 2062
 Checking the condenser for loose leads, loos screws and corrosion 2063
 Checking the coolant level in the inspection glass 2061
 Checking the derrick boom tilting-back supports 1490
 Checking the dryer for damage and corrosion 2065
 Checking the ease of movement of pin connections in the entire pendant strap strand 1980, 1985
 Checking the emergency stop 1948
 Checking the eye bolt of the railing stabilization for tight fit 1956
 Checking the fan on condenser for function, tight fit and damage 2063
 Checking the ferrules for cracks and splitting 2038
 Checking the fluid level in the cells 1933
 Checking the fresh air filter for contamination 2056
 Checking the fuel fill level 838
 Checking the function of the central lubrication system 1991
 Checking the function of the emergency lowering system 2045
 Checking the function of the railing stabilization 1956
 Checking the fuses 1062
 Checking the gap width of the pulley 2033
 Checking the gearbox oil level 1888, 1891, 1895, 1898, 1902, 1905
 Checking the gearbox oil level in the counterweight carriage's axle gearbox 1997
 Checking the groove diameter of the drum 2029
 Checking the groove diameter of the pulley 2031
 Checking the hydraulic connections on the counterweight carriage for tightness 2000
 Checking the hydraulic cylinders of the counterweight carriage's wheel sets for tightness 2000
 Checking the hydraulic hoses 1929
 Checking the hydraulic oil tank gate valve 838
 Checking the jib base section, jib head and jib sections for damage and wear 1966
 Checking the jib limit switch plate for proper adjustment 1718
 Checking the locking elements for wear and damage 1979
 Checking the lubrication points 1992
 Checking the machine steel structure for damage, cracks 1958
 Checking the main boom head for function and damage 1964
 Checking the main boom limit switch plate for proper adjustment 1356, 1500, 1620
 Checking the negative pressure indicator 1885
 Checking the oil cooler for contamination 1920
 Checking the operation of the acoustic warning signal 2044
 Checking the operation of the cab door 2041
 Checking the operation of the door lock 2041
 Checking the operation of the hydraulic cab tilting device 2043

- Checking the operation of the hydraulic cab tilting device and for damage 2043
- Checking the operation of the operating elements (valves, displays etc.) 2044
- Checking the pins for wear and damage 1979
- Checking the pocket locks 2038
- Checking the position of bearing and locking ring 2035
- Checking the position of the bypass plug 1195
- Checking the pressure in the accumulator of the hydraulic tilting-back supports 1670
- Checking the pressure in the tilting-back support piston area 1977
- Checking the programmed setup 888
- Checking the pulley bearings 2035
- Checking the rear counterweight, fixing lugs and round steel chains for damage, wear and secure fit 1989
- Checking the recirculated air filter for contamination 2047
- Checking the rope clamp for tight fit 2040
- Checking the rope end fastening for tight fit 1897, 1900, 1904
- Checking the rope end fittings for cracks 2039
- Checking the rope fixing point 2040
- Checking the rope lock for damage and proper operation 2040
- Checking the rope measuring system and height adjustment of all winches (if available) for correct function 1945
- Checking the safety gear for damages and proper functioning 2045
- Checking the screws of the counterweight tie-down for tight fit 2001
- Checking the screws of the rear counterweight tie-down for tight fit (with exception of LR 1001.xx.xx) 1989
- Checking the seals and inspection dates on the fire extinguishers 1950
- Checking the spring tension of railing doors 1953
- Checking the thimble connection 2038
- Checking the tilting-back support cylinder 844
- Checking the time intervals of the lubrication pump 1992
- Checking the tires of the counterweight carriage for damage 1995
- Checking the top jib limit switch for function 1716
- Checking the urea solution fill level 838
- Checking the venting valve 1890
- Checks before start up 835
- Chemical burns 587
- Choice of correct winch in derrick operation 1076
- Choosing the correct hook or pulley block 1073
- Clamping devices 845
- Cleaning or replacing the filter insert in the cabin 2045
- Cleaning plastic pulleys 2036
- Cleaning the air filter dust ejector 1886
- Cleaning the crawlers 1906
- Cleaning the machine 2071
- Cleaning the magnetic rod 1924
- Cleaning the magnetic rod in the return filter 1922
- Climatic box beneath cabin 463
- Climatic zones 2072
- Closing the return filter 1924
- Composition of main boom in derrick mode with fixed jib 1507 attached 1548
- Condenser on uppercarriage door/dryer on condenser 462
- Configuration of jib 1536, 1546, 1561, 1571, 1622, 1642, 1720, 1733
- Configuration of main boom 1270, 1502, 1536, 1546, 1561, 1571, 1626, 1645, 1723, 1736
- Configuration of main boom in derrick mode 1358
- Confirming the existing setup 837
- Connect A-frame2 with the rope of winch1/ winch2. 1671
- Connect hydraulic lines 1782
- Connect the electric cables 1323, 1388, 1420, 1592, 1684, 1783
- Connecting and checking boom fall arrest* 1297, 1387, 1412
- Connecting catwalks* for booms 1295, 1385, 1410
- Connecting electric cables to the uppercarriage 1313, 1441
- Connecting electric lines and hydraulic lines 1474
- Connecting electric lines and hydraulic lines with basic machine 1477
- Connecting elements for CF pendant straps 185, 299, 338
- Connecting elements for CF pendant straps behind reducing adapter 229
- Connecting elements for CF pendant straps in front of reducing adapter 226
- Connecting elements for steel pendant straps 184, 298, 337
- Connecting elements for steel pendant straps behind reducing adapter 228
- Connecting elements for steel pendant straps in front of reducing adapter 225
- Connecting hydraulic lines and electric lines with the uppercarriage 1396
- Connecting hydraulic lines of crawler 1244
- Connecting hydraulic lines to the uppercarriage 1309, 1437
- Connecting link 202, 243, 245
- Connecting link (conversion kit) 351
- Connecting links 217
- Connecting links with tension load cell 199, 216
- Connecting the equaliser on A-frame 3 to the jib base section 1676
- Connecting the hydraulic lines 1388
- Connecting the hydraulic lines on the crawlers 1226
- Connection interruptions 995
- Control and operating elements 623
- Control panel X11 686

- Control panel X12 688
Control panel X23 690
Control panel X26 and mount 431
Control panel X26 for counterweight carriage* 693
Control panel zoom camera 521, 828
Control panels 845
Control unit *external air conditioning system* 466
Control unit *external air conditioning system** 824
Conversion to permanent auxiliary jib operation 1784
Converting auxiliary jib 36 t (79300 lb) 1785
Converting from medium or narrow track to wide track 1760
Converting from wide track to medium or narrow track 1752
Converting the main boom head 1786
Coolant 1878
Cooling circuit 461
Cooling system (see operation manual of the engine manufacturer on CD) 1860
Counterweight 1867, 1989
Counterweight carriage 400, 403
Counterweight carriage preparation unit* 430
Counterweight carriage* radius adjustment 965
Counterweight frame 396
Counterweight slab 10 t (22,046 lb) 155, 397, 405
Counterweight slab 5 t (11,023 lb) 156, 398, 406
Crawler 64
Crawler side frame 139
Crawler side frame for undercarriage with fixed track width 139
Crawler side frame for undercarriage* with adjustable track width 141
Crawlers 925, 1862, 1905
Cross strap 413
- ## D
- Danger zone 558
Danger zone when luffing a rope 2021
Deactivate winch synchronization on control lever 979
Deactivating horizontal load path 1015
Deactivating horizontal load path for winch1 1015
Deactivating horizontal load path for winch2 1015
Deactivating rope reeving winch free-fall 1019
Deactivating the positioning of the boom head above the load's center of gravity 1017
Deactivating the radius adjustment of the counterweight carriage 967
Deactivating the winch synchronization on control panel X23 979
Deactivating winch synchronization 979
Declaration of conformity 52
Decreasing the pull force of the tagline winch 1023
Decreasing the radius of the counterweight carriage 966
Decreasing the spring tension of the railing door 1955
Deinstalling the luffing jib 1794
Derrick boom 2220 382
Derrick boom base section 2220.24 382
Derrick boom head 2220.22 388
Derrick boom pendant strap (crossbar) 392
Derrick boom pendant strap 12 m (40 ft) 391
Derrick boom section 2220.22 11.7 m (38 ft) 386
Derrick boom section 2220.24 3 m (10 ft) 384
Derrick equipment* 381, 1867, 1993
Derrick hoist cylinder* 968
Derrick preparation unit 436
Derrick rope rigging with crossbar 389
Determining the direction of lay 2018
Determining the jack-up height 1201
Determining the support height 1208
Diagonal10 127
Diagonal11 128
Diagonal12 129
Diagonal17 130
Diagonal18 131
Diagonal9 126
Diesel engine 61
Diesel engine automatic stop system* 1027
Diesel engine coolant 1879
Diesel engine coolant heating* 473
Diesel engine lubricating oil 1878
Diesel engine lubrication oil heating* 474
Diesel engine stage IV / Tier 4f (see operation manual of the engine manufacturer on CD) 1859
Diesel engine tier IV / Tier 4f 1879
Diesel engine tier IV / Tier 4f (see operation manual of the engine manufacturer on CD) 1859
Disassembling main boom + reducing piece 1806
Disassembling the basic machine 1810
Disassembling the luffing jib + Midfall 1793
Disassembling the main boom 1807
Discard criteria overview 2005
Dismantling 1764
Dismantling rope protection pipes 1331, 1449, 1528, 1600, 1693, 1749
Dismantling the fixed jib 1804
Dismantling the rope protection rollers package 1528, 1693
Dismantling the rope protection rollers package on the jib head section 1713 1600
Display area 815
Display section 704
Displaying error messages 870
Displaying or deleting alarm times 875
Displaying or deleting start of heating 874
Distinguishing features main boom sections LR 1300 and LR 1300 SX 159
Distributor gearbox 1860, 1888
Draining the hydraulic oil 1922
Drive unit 465
Driving onto the support plates 981
Driving the transport vehicle out from underneath the machine 1205, 1213
Drum 1867, 2029

E

Electric components 471
 Electrical energy 584
 Electromagnetic influence 589
 Emergency control system 1865
 Emergency operation control* 490, 819, 1041
 Emergency stop 1031, 1864, 1948
 Emissions 60
 Engine oil 1877
 Environment 600
 Equalizer A-frame2 (jib backstay strap) 255, 264, 275, 283, 307, 315, 345, 352
 Equalizer of main boom base section 2821.30 191, 200
 Equalizer on A-frame2 (jib pendant strap) 257, 277
 Erecting a main boom + fixed jib 1616
 Erecting A-frame1 1197
 Erecting A-frame2/A-frame3 with rope of winch1/ winch2 and bolting the hydraulic tilting-back supports 1672
 Erecting and bolting the mast 1761
 Erecting the boom 1077
 Erecting the main boom 1352, 1496
 Erecting the main boom + luffing jib 1710
 Erecting the main boom with derrick equipment* 1489
 Erecting the main boom without derrick equipment* 1352
 Error displays on monitor 1045
Error messages screen 798
 Establishing the connection between the machine and the jib base section 1969
 Exchanging the bulbs of floodlights on main boom or jib head 1942
 Exchanging the fuses on the battery 1934
 Exchanging the hydraulic oil filter elements 1926
 Exhaust aftertreatment system* (see operation manual of the engine manufacturer on CD) 1860
 Explanation of symbols used 1147
 Exposure to wind 590
 Extend assembly cylinder 984
 Extend jacks 1212
 Extend the tilting back support cylinders 1197
 Extending and pinning the track width adjusting cylinder 1753
 Extending the derrick hoist cylinder 968
 Extending the jack 1205
 Extension device 401
 External air conditioning system* 464
 External power supply low temperature package* 61
 External power supply obstacle warning light 438
 External power supply obstacle warning light* 61
 External power supply* 438
 External supply low temperature package 440

F

Falling object protection* for cabin 500

Filling capacity table 1874
 Filling in gearbox oil at the counterweight carriage's axle gearbox 1999
 Filling machine with fuel 987
 Filling the accumulator 1970
 Filling the accumulators for the tilting-back supports on the jib 1966
 Filling the fuel tank 987
 Filling the windscreen cleaning system 2042
 Filling up with urea solution* 988
 Filling with hydraulic oil 1921
 Fire and explosion 587
 Fire classes 603
 Fire extinguishers 1865, 1950
 Fire protection signs 578
 Firefighting 603
 First response to a current transfer 602
 fit the rope guide 1297, 1412
 Fitting support pads and chocks 1200
 Fitting the anemometer 1326, 1423, 1594, 1687
 Fitting the exhaust pipe 1193
 Fitting the rear counterweight 1256
 Fitting the rope protection pipes to the auxiliary jib 1337, 1455
 Fitting the second crawler side frame where space is limited 1225
 Fitting the wire rope 2037
 Fixed jib - overview 247
 Fixed jib 0906 1571
 Fixed jib 1008 1561
 Fixed jib 1507 1546
 Fixed jib 1713 1536
 Fixed jib head 408
 Fixed jib head 0906 and 1507 532
 Fixed jib head 1008 531
 Fixing rope end 1780
 Floodlights on cabin 541
 Floodlights on jib head 548
 Floodlights on main boom 543
 Floodlights on uppercarriage 538
 Folding down the link plates for the 11th pulley 1321, 1446
 Folding the front feet of the main boom base section upwards 1315
 Foot pedal adjuster* 446
 Foot pedal* for zoom camera 536
 Foot pedals and hand levers 684
 Fork 187
 Forks 301, 340
 Forks behind reducing adapter 232
 Forks in front of reducing adapter 231
 Frame 87
 Free-fall operation* 970
 Front and rear platform 144
 Front cover 505
 Fuel 1879
 Fuel pre-filter heating 475

Fuel system (see operation manual of the engine manufacturer on CD) 1859
 Fuel tank (see operation manual of the engine manufacturer on CD) 1860
 Function assignment buttons of right control lever 805
 Function assignment for movement directions on left linear control lever 808
 Function assignment for movement directions on left multi-directional control lever 641, 649
 Function assignment for movement directions on right double T-lever 678
 Function assignment movement direction of left control lever 803
 Function assignment movement direction of right control lever 806
 Function assignment of buttons on left multi-directional control lever 628, 639, 646
 Function assignment of buttons on right double T-lever 661, 676
 Function assignment of buttons on right multi-directional control lever 653, 668
 Function assignment of movement directions on right linear control lever 809
 Function assignment of movement directions on right multi-directional control lever 671
 Function assignment of the left control lever on machine with derrick equipment* 638
 Function assignment of the left control lever on machine without derrick equipment* 628
 Function assignment of the right control lever on machine with derrick equipment* 668
 Function assignment of the right control lever on machine without derrick equipment* 653
 Function lock* 1870
 Fuses 1060

G

Gear oil 1877
 General 889
 General hand signals in accordance with BGV A8 610
 Generation A of A-frame3 equalizer (jib pendant strap) 317, 354
 Generation A of equalizer for main boom base section 2821.30 201
 Generation A of jib backstay strap 12 m (40 ft) 212
 Generation A of jib backstay strap 3 m (10 ft) 205
 Generation A of jib backstay strap 6 m (20 ft) 209
 Generation A of jib pendant strap 12 m (40 ft) 323, 360
 Generation A of jib pendant strap 3 m (10 ft) 314, 319, 357
 Generation A of jib pendant strap 6 m (20 ft) 321, 358
 Generation A of jib pendant strap on jib head 1916.21 362
 Generation A of jib pendant strap on jib head 2316.20 325

Generation A of main boom pendant strap 12 m (40 ft) 210
 Generation A of main boom pendant strap 3 m (10 ft) 203
 Generation A of main boom pendant strap 6 m (20 ft) 207
 Generation A of main boom pendant strap on main boom head 2821.24 214
 Generation A of reducing adapter pendant strap 12 m (40 ft) 244
 Generation B of A-frame3 equalizer (jib pendant strap) 318, 355
 Generation B of equalizer for main boom base section 2821.30 201
 Generation B of jib backstay strap 12 m (40 ft) 213
 Generation B of jib backstay strap 3 m (10 ft) 206
 Generation B of jib backstay strap 6 m (20 ft) 209
 Generation B of jib pendant strap 12 m (40 ft) 324, 361
 Generation B of jib pendant strap 3 m (10 ft) 315, 320, 357
 Generation B of jib pendant strap 6 m (20 ft) 322, 359
 Generation B of jib pendant strap on jib head 1916.21 363
 Generation B of jib pendant strap on jib head 2316.20 326
 Generation B of main boom pendant strap 12 m (40 ft) 211
 Generation B of main boom pendant strap 3 m (10 ft) 204
 Generation B of main boom pendant strap 6 m (20 ft) 208
 Generation B of main boom pendant strap on main boom head 2821.24 215
 Generation B of reducing adapter pendant strap 12 m (40 ft) 245
 Grating A for left platform 103
 Grating A for right platform 96
 Grating B for left platform 103
 Grating B for right platform 97
 Grating C for left platform 104
 Grating D for left platform 105
 Grease 1878
 Greasing the bearing of the derrick boom base section 1993
 Greasing the extension device of the counterweight carriage (strut, uppercarriage pin connection) 1994
 Ground bearing strength 596
 Ground pressure display* 999
 GSM/GPRS/GPS modem 447, 1864
 Guideline values for safe distances from overhead power lines 599

H

Hand signals 609
 Hand signals for lifting gear application in accordance with ASME/ANSI B30.5 615

Handrail* / wide steps* 450
HATZ diesel engine* (see operation manual of the engine manufacturer on CD) 1869, 2070
Hazards 583
Heating circuit 466
Higher risk of machine corrosion on floating devices 607
High-pressure sodium vapor lamp 544, 1942
Hoist limit switch clamp* for auxiliary jib (36 t (79.300 lb)) 453
Hook (16 t (35,273 lb)) 420
Hook fixing point * 448
Hook/pulley block 1863, 1918
How to respond in the event of a current transfer 601
How to respond in the event of a fire 602
Hydraulic cab elevation* 454, 821, 1761
Hydraulic cabin elevation* 881
Hydraulic connections and electricity connections for the counterweight carriage 430
Hydraulic connections and electricity connections for the derrick 436
Hydraulic cylinders 1863, 1928
Hydraulic emergency mode* 1035
Hydraulic energy 585
Hydraulic hoses 1864, 1929
Hydraulic oil 1877, 1879
Hydraulic oil filter 1863, 1926
Hydraulic oil heater 1863
Hydraulic oil heater* 475
Hydraulic oil tank 1863, 1921
Hydraulic oil tank heater* 472
Hydraulic system 1863, 1920

I
Identifying faults 1045
Implementation instructions for assembly and disassembly 1149
Inappropriate use 56
Inclination display* 1000
Increasing the constant pull of the tagline winch 1021
Increasing the pull force of the tagline winch 1022
Increasing the radius of the counterweight carriage 966
Increasing the spring tension of the railing door 1954
Information about boom designation 157
Initial filling 1879
Insert catwalk grating in frame 1168
Insert pendant straps in transport bracket and secure 1850
Inspecting the machine 835
Inspection intervals 2075
Installation of jib luffing winch 1781
Installation of lightning rods on jib head as main boom head 1525
Installation of lightning rods* on main boom head with derrick boom head 1425

Installation position of lightning rods on luffing jib 1689
Installation position of lightning rods with fixed jib 1596
Installation positions of lightning rods on derrick boom head 1400
Installation positions of lightning rods on main boom head 1328
Installing bracket KnK1 1175
Installing bracket1 1174
Installing brackets 1176
Installing grating A and grating B for left platform 1181
Installing mid-point suspension 1301, 1416, 1520, 1679
Installing mid-point suspension (with main boom length 80 m (262 ft), 83 m (272 ft) and 86 m (282 ft) and jib 1507 attached) 1304, 1419
Installing plates and diagonals 1176
Installing platforms at undercarriage with fixed track width 1255
Installing railing connections 1185
Installing railing parts 1179
Installing railing parts on the frame 1165
Installing rope protection pipes 1535, 1607, 1701
Installing second pulley to 3-fold reeve the auxiliary jib (36 t (79300 lb)) 1322, 1447
Installing straps 1184
Installing the cabin railing with platforms on the uppercarriage 1163
Installing the cabin railing without platforms on the uppercarriage 1162
Installing the carbody counterweight slab 14.3 t (31,526 lb) 1249
Installing the connecting elements and spacer brackets on jib backstay straps (jib 1507) 1590
Installing the counterweight carriage on the basic machine 1476
Installing the derrick boom on the uppercarriage 1391
Installing the first crawler side frame 1221, 1238
Installing the frame on the cabin 1164
Installing the grating 1183
Installing the hoist limit switch clamp* on auxiliary jib (36 t (79.300 lb)) 1347, 1465
Installing the hoist limit switch on auxiliary jib (36 t (79.300 lb)) 1321, 1446
Installing the hoist limit switch weight 1343, 1461, 1611, 1705
Installing the midfall 1746
Installing the mid-point suspension 1748
Installing the obstacle warning light 1324, 1421, 1593, 1685
Installing the reducing piece 1519
Installing the rope fixing point 1749
Installing the rope fixing point on the boom head 1341, 1459, 1609, 1703
Installing the rope fixing point on the hook or pulley block 1342, 1460, 1610, 1704

Installing the steps 1251
 Installing the strap support 1183
 Installing the vandalism protection 1778
 Installing the Vertical Line Finder on the jib head 1770
 Installing the Vertical Line Finder on the main boom head 1765
 Installing transport brackets for CF pendant straps 1848
 Interfaces 61
 Interim lubrication 883

J

Jib 949, 1866, 1966
 Jib 0906.21 282
 Jib 1507.20 263
 Jib backstay strap 12 m (40 ft) 197, 212
 Jib backstay strap 3 m (10 ft) 193, 204
 Jib backstay strap 6 m (20 ft) 195, 208
 Jib backstay straps A-frame2 to main boom base section 2821 1551, 1627, 1629, 1646, 1648, 1724, 1726, 1737, 1739
 Jib backstay straps A-frame2 to main boom head 2821 1562, 1572
 Jib base section 1008.20 270
 Jib base section 1713.22 248
 Jib base section 1916.22 327
 Jib base section 2316.22 288
 Jib base section: Checking screw connections and pin connections for tight fit, checking that rope protection and locking springs are in place and undamaged 1974
 Jib head: Checking wheels for ease of movement 1973
 Jib luffing winch 63
 Jib luffing winch* 1780
 Jib pendant strap (A-frame2 to jib head 0906.21) 285
 Jib pendant strap (A-frame2 to jib head 1507) 266
 Jib pendant strap 12 m (40 ft) 260, 311, 322, 349, 360
 Jib pendant strap 3 m (10 ft) 258, 278, 306, 310, 314, 319, 348, 356
 Jib pendant strap 6 m (20 ft) 259, 279, 310, 321, 349, 358
 Jib pendant strap on jib head 1008.20 280
 Jib pendant strap on jib head 1713.21 261
 Jib pendant strap on jib head 1916.21 350, 361
 Jib pendant strap on jib head 2316.20 312, 324

K

Keyboard menu 795

L

Ladder* for boom 479
 Ladder* for uppercarriage 481

Lash carbody counterweight slab 14.3 t (31,526 lb) 1248
 Lashing the jib luffing winch 1780
 Laying down the boom 1105
 Laying on the rope 2021
 Laying on the rope of winch1 and winch2 with installed main boom 2022
 Leak oil return* 478
 Leaving the machine in event of current transfer with fire 602
 LED floodlight 545, 1938, 1944
 LED floodlights 1942
 Left control lever 628, 803
 Left corner platform 146
 Left front cover 509
 Left linear control lever 808
 Left multi-directional control lever 628, 633, 638, 645
 Left platform on uppercarriage 98
 Left rear cover 510
 Left steel plate 147
 Length of midpoint suspension in derrick mode with installed fixed jib 1507 1550
 Lengths of jib mid-point suspensions 1624, 1643, 1721, 1734
 Lengths of mid-point suspensions 1272, 1360, 1505, 1547
 Liebherr oil diagnosis system 1882
 Lift jib 950
 Lifting and pinning the rear counterweight 1264
 Lifting device 1862, 1917
 Lifting the empty hook in free-fall operation 974
 Lifting the load on winch1 955
 Lifting the load on winch2 959
 Lifting the main boom 944
 Lighting 856, 1864, 1935
 Lightning rods* 437
 Lightning strike 597
 Limit switches 822, 1864, 1946
 Linchpin 1151
 List of fuses 1060
 Litronic control system 484
 Litronic testing system 1051
 Litronic testing system overview 1051
 Load moment limiter (LML) 889, 1865
 Load moment limiter self-lock 892
 Load moment limiter shut down (ANSI load chart) 895
 Load moment limiter shut down (CE load chart) 894
 Load reduction for a machine with derrick equipment* 1088
 Load reduction for a machine without derrick equipment* 1077
 Load reduction main boom 2821 (+ auxiliary jib) 1077
 Load reduction main boom 2821 + derrick (+ auxiliary jib) 1088
 Load reduction main boom 2821 + fixed jib 0906 1082
 Load reduction main boom 2821 + fixed jib 0906 + derrick 1091

Load reduction main boom 2821 + fixed jib
1008 1081
Load reduction main boom 2821 + fixed jib
1507 1080
Load reduction main boom 2821 + fixed jib 1507 +
derrick 1090
Load reduction main boom 2821 + fixed jib
1713 1079
Load reduction main boom 2821 + fixed jib 1713 +
derrick 1089
Load reduction main boom 2821 + luffing jib 1916 (+
auxiliary jib) 1085
Load reduction main boom 2821 + luffing jib 1916 +
derrick (+ auxiliary jib) 1094
Load reduction main boom 2821 + luffing jib 1916 +
midfall 1916 1087
Load reduction main boom 2821 + luffing jib 2316 (+
auxiliary jib) 1083
Load reduction main boom 2821 + luffing jib 2316 +
derrick (+ auxiliary jib) 1093
Load reduction main boom 2821 + luffing jib 2316 +
midfall 2316 1086
Load reduction main boom 2821 + reducing adapter
2821/2316 1078
Loading basic machine with crawler side frame 1831
Loading basic machine with crawler side frame and
carbody counterweight 1833
Loading basic machine with crawler side frame,
carbody counterweight and rear counterweight 1836
Loading basic machine with undercarriage with
adjustable track width 1828
Loading basic machine with undercarriage with fixed
track width 1815
Loading basic machine without crawler side frame,
carbody counterweight and rear counterweight 1828
Loading the basic machine with an assist crane 1815
Loading the basic machine with crawler side
frame 1819
Loading the basic machine with crawler side frame
and carbody counterweight 1822
Loading the basic machine with crawler side frame,
carbody counterweight and rear counterweight 1824
Loading the basic machine without crawler side frame,
carbody counterweight and rear counterweight 1815
Locking elements - overview 1150
Locking or unlocking the crawler 934
Locking or unlocking the main boom 948
Locking or unlocking the swing 943
Locking or unlocking winch1/winch2 963
Locking washers 1155
Long work interruption 1033
Loosening strut mountings 1232, 1754
Low temperature function lock* 475
Lower jib 952
Lowering the empty hook in free-fall operation 974
Lowering the jib until wheels touch the ground or
bottom jib limit switch is triggered 1797
Lowering the jib up to load moment limiter stop 1796

Lowering the load on winch1 957
Lowering the load on winch2 961
Lowering the main boom 946
Lowering the main boom and jib all the way to the
ground 1799
Lowering the safety lever 844
Lubricants and consumables 62, 1871
Lubricating bearings and axels 1918
Lubricating external teeth 1893
Lubricating the axes and swing arms of the
counterweight carriage's wheel sets 1995
Lubricating the bearing races via the central
lubrication point 1893
Lubricating the bearings on A-frame 1 1975
Lubricating the bearings on the A-frame1
cylinder 1976
Lubricating the counter bearing 1896, 1899, 1901
Lubricating the drive units of the counterweight
carriage's wheel sets 1996
Lubricating the pulley bearings 2035
Lubricating the rope bracket on the boom base
section and checking pulleys for damage 1903
Lubrication chart 1875
Lubrication diagram 1872
Lubrication system 1867, 1991
Luffing jib - overview 287
Luffing jib 1916 1642
Luffing jib 1916 + midfall 1916 1733
Luffing jib 2316 1622
Luffing jib 2316 + midfall 2316 1720
Luffing jib head 409
Luffing jib luffing winch as auxiliary winch* 488, 1025

M

Machine 58
Machine care 1870, 2071
Machine operator 554, 555
Machine overview 58, 514
Machine with derrick equipment* 59
Machine with self-assembly system 1070
Machine without derrick equipment* 58
Machine without self-assembly system 1070
Main boom 910, 913, 919, 922, 944, 1865, 1961
Main boom - overview 161
Main boom + fixed jib 911, 915, 920, 923
Main boom + luffing jib 911, 916, 920, 923
Main boom + luffing jib + Midfall 912, 918
Main boom + reducing piece 911, 915, 919, 923
Main boom 2821 1270
Main boom 2821 + derrick boom 2220 1358
Main boom 2821 + reducing adapter 2821/2316 1502
Main boom adjusting winch emergency mode 1037
Main boom base section 2821.30 162
Main boom head 407
Main boom head section 2821.24 176
Main boom luffing winch 63
Main boom pendant strap 12 m (40 ft) 196, 210

Main boom pendant strap 3 m (10 ft) 192, 203
 Main boom pendant strap 6 m (20 ft) 194, 206
 Main boom pendant strap on main boom head
 2821.24 197, 214
 Main boom section 2316.25 1 m (3 ft) 222
 Main boom section 2821 12 m (40 ft) 172
 Main boom section 2821 3 m (10 ft) 164
 Main boom section 2821 6 m (20 ft) 168
 Main boom section 2821.24 12 m (40 ft) for LR
 1300 174
 Main boom section 2821.24 3 m (10 ft) for LR
 1300 166
 Main boom section 2821.24 6 m (20 ft) for LR
 1300 170
 Main boom section 2821.30 12 m (40 ft) for LR 1300
 SX 172
 Main boom section 2821.30 3 m (10 ft) for LR 1300
 SX 164
 Main boom section 2821.30 6 m (20 ft) for LR 1300
 SX 168
 Main screen page 1052
 Mains cable 442
 Maintaining preservation of the machine 2072
 Maintenance 1857
 Maintenance and inspection schedule 1857
 Maintenance and service personnel 554
 Maintenance personnel 556
 Malfunctions 1045
 Mandatory signs 573
 Manufacturer 553
 Meaning of machine-specific signs 578
 Meaning of the safety signs 573
 Mechanic components 475
 Mechanical action 583
 Mechanical inclinometer 1864, 1947
 Menu bar 704, 794
 Midfall 411
 Midfall 1916.32 370
 Midfall 2316.25 365
 Midfall connecting link 367, 368, 372, 373
 Midfall overview 364
 Mid-point suspension on luffing jib 1916 335
 Mid-point suspension on luffing jib 2316 296
 Mid-point suspension on main boom 2821 182
 Mid-point suspension on midfall 1916.32 371
 Mid-point suspension on midfall 2316.25 366
 Mid-point suspension on reducing adapter
 2821/2316 223
 Mixing 1879
 Mode 884
Mode screen 708, 785, 815
 Monitor 696, 811
 Monitor buttons 817
 Monitoring installations 66
 Mount 846
 Mount A 524
 Mount B 525
 Mount C 526

Mount the slinging plates 1263
 Mounting bracket support K1 and bracket support
 K2 1173
 Mounting rope protection pipes on main boom
 head 1335, 1453
 Mounting the cabin railing* 1162
 Mounting the ladder on the uppercarriage 1186
 Mounting the platforms on the uppercarriage 1171
 Mounting the rope protection rollers package 1533,
 1699
 Mounting the rope protection rollers package on jib
 head section 1713 1605
 Mounting the second crawler side frame where space
 is limited 1242
 Mounting the uppercarriage railing 1187
 Mounting uppercarriage ladder for narrow track 1185,
 1760
 Mounts 523
 Move machine's center of gravity to the center of the
 rotation axis 1752
 Moving cabin platforms* into working position 1156
 Moving the lightning rods* into working position 1328,
 1400, 1425, 1525, 1596, 1689
 Moving the lightning rods* on A-frame2 and A-frame3
 into working position 1429, 1691
 Moving the lightning rods* on A-frame2 into working
 position 1428, 1598
 Moving the lightning rods* on the derrick boom head
 into working position 1401
 Moving the lightning rods* on the fixed jib head into
 working position 1431, 1597
 Moving the lightning rods* on the jib head as main
 boom head into working position 1526
 Moving the lightning rods* on the luffing jib head into
 working position 1432, 1690
 Moving the lightning rods* on the main boom head
 into working position 1329, 1426
 Moving the machine backwards 927
 Moving the machine forward 926
 Moving the machine in crab mode 933
 Moving the machine in follower mode 932
 Moving the machine in trailer mode 930

N

Noise measurement data 60
 Notes 1156, 1290, 1382, 1404, 1519, 1580, 1661,
 1746
 Notes for regular inspection of the ropes 2003
 Notice signs 579

O

Obstacle warning light* 451, 1865, 1949
 Oil analysis kit 1878
 Oil concentrate 1878
 Opening the return filter 1923
 Operating elements 802

Operating elements at undercarriage with fixed track width 623
 Operating elements at undercarriage* with adjustable track width 624
 Operating elements in the cab 821
 Operating elements on counterweight carriage* 626
 Operating elements on mast 822
 Operating elements on the undercarriage 623
 Operating elements on the uppercarriage 625
 Operating free-fall operation 972
Operating hours screen 728
 Operating sensitive hoisting 1028
 Operating the additional floodlights 856
 Operating the assembly cylinder 984
 Operating the cab lighting 857
 Operating the crawler with counterweight carriage* 929
 Operating the derrick hoist cylinder 968
 Operating the edge limitation 1001
 Operating the emergency control 1041
 Operating the engine compartment lighting 857
 Operating the external air conditioning system* 865
 Operating the floodlights on the uppercarriage 856
 Operating the ground pressure display 999
 Operating the inclinometer 1000
 Operating the jib 950
 Operating the lifting height limitation 1009
 Operating the main boom 944
 Operating the menu 868
 Operating the radio 877
 Operating the radius limitation 1005
 Operating the safety lever 876
 Operating the sector limitation 1003
 Operating the slewing range limitation 1008
 Operating the swing 937
 Operating the swing with counterweight carriage* 942
 Operating the swing with suspended counterweight* 941
 Operating the travel gear 925
 Operating the ventilation 863
 Operating the winch synchronization 977
 Operating the windscreen washer system 859
 Operating the windscreen wipers 858
 Operating units 694
 Operating winch 1 955
 Operating winch 2 959
 Operation 835
 Operation of the machine down to -20 °C (-4 °F) (standard) 608
 Operation of the machine down to -25 °C (-13 °F)* 609
 Operation of the machine down to -40 °C (-40 °F)* 609
 Operation of the machine on floating devices 606
 Operational faults, diagnosis 1045
 Operational planning 1067
 Operator's seat 847
 Ordering data 1877

Other lifting devices 1143
 Outside mirror* 429
 Overhead power lines 598
 Overview of CF pendant straps of main boom 2821 + derrick boom 2220 1364
 Overview of CF pendant straps on luffing jib 1916 1648
 Overview of CF pendant straps on luffing jib 1916 + midfall 1916 1739
 Overview of CF pendant straps on luffing jib 2316 1628
 Overview of CF pendant straps on luffing jib 2316 + midfall 2316 1726
 Overview of derrick equipment 381
 Overview of main boom 2821 CF pendant straps 1274
 Overview of main boom 2821 CF pendant straps + reducing adapter 2821/2316 1513
 Overview of main boom 2821 steel pendant straps 1273
 Overview of main boom 2821 steel pendant straps + derrick boom 2220 1361
 Overview of main boom 2821 steel pendant straps + reducing adapter 2821/2316 1511
 Overview of pendant straps on fixed jib 0906 1572
 Overview of pendant straps on fixed jib 1008 1562
 Overview of pendant straps on fixed jib 1507 1551
 Overview of pendant straps on fixed jib 1713 1537
 Overview of steel pendant straps on luffing jib 1916 1646
 Overview of steel pendant straps on luffing jib 1916 + midfall 1916 1737
 Overview of steel pendant straps on luffing jib 2316 1626
 Overview of steel pendant straps on luffing jib 2316 + midfall 2316 1724
 Owner 553

P

Parked position for a machine with derrick equipment* 1101
 Parked position for a machine without derrick equipment* 1096
 Parked position main boom 2821 + derrick (+ auxiliary jib) 1101
 Parked position main boom 2821 + fixed jib 0906 + derrick 1103
 Parked position main boom 2821 + fixed jib 1507 + derrick 1102
 Parked position main boom 2821 + fixed jib 1713 + derrick 1102
 Parked position main boom 2821 + luffing jib 1916 + derrick (+ auxiliary jib) 1104
 Parked position main boom 2821 + luffing jib 2316 + derrick (+ auxiliary jib) 1103
 Parked position of main boom 2821 (+ auxiliary jib) 1096

- Parked position of main boom 2821 + fixed jib 0906 1098
- Parked position of main boom 2821 + fixed jib 1008 1098
- Parked position of main boom 2821 + fixed jib 1507 1097
- Parked position of main boom 2821 + fixed jib 1713 1097
- Parked position of main boom 2821 + luffing jib 1916 (+ auxiliary jib) 1099
- Parked position of main boom 2821 + luffing jib 1916 + midfall 1916 1101
- Parked position of main boom 2821 + luffing jib 2316 (+ auxiliary jib) 1099
- Parked position of main boom 2821 + luffing jib 2316 + midfall 2316 1100
- Parked position of main boom 2821 + reducing adapter 2821/2316 1097
- Parked positions of boom configurations PDR* 1864
- Pendant ropes 1866, 1987
- Pendant strap with connecting link 199
- Pendant straps A-frame1 to main boom head 2316 1511, 1513
- Pendant straps A-frame1 to main boom head 2821 1273, 1274
- Pendant straps A-frame2 to jib head 0906 1572
- Pendant straps A-frame2 to jib head 1008 1562
- Pendant straps A-frame2 to jib head 1507 1552
- Pendant straps A-frame2 to jib head 1713 1538
- Pendant straps A-frame3 to jib head 1916 1647, 1649, 1738, 1740
- Pendant straps A-frame3 to jib head 2316 1627, 1630, 1725, 1727
- Pendant straps on derrick boom 2220 390
- Pendant straps on derrick boom head 2220.22 392
- Pendant straps on derrick boom section 2220.22 11.7 m (38 ft) 391
- Pendant straps on derrick boom section 2220.24 3 m (10 ft) 390
- Permitted gradient for a machine with derrick equipment* 1128
- Permitted gradient for a machine without derrick equipment* 1109
- Permitted gradient for main boom 2821 + derrick (+ auxiliary jib) 1128
- Permitted gradient for main boom 2821 + fixed jib 0906 1118
- Permitted gradient for main boom 2821 + fixed jib 0906 + derrick 1130
- Permitted gradient for main boom 2821 + fixed jib 1008 1116
- Permitted gradient for main boom 2821 + fixed jib 1507 1114
- Permitted gradient for main boom 2821 + fixed jib 1507 + derrick 1132
- Permitted gradient for main boom 2821 + fixed jib 1713 1112
- Permitted gradient for main boom 2821 + fixed jib 1713 + derrick 1134
- Permitted gradient for main boom 2821 + luffing jib 1916 (+ auxiliary jib) 1124
- Permitted gradient for main boom 2821 + luffing jib 1916 + derrick (+ auxiliary jib) 1136
- Permitted gradient for main boom 2821 + luffing jib 1916 + Midfall 1916 1126
- Permitted gradient for main boom 2821 + luffing jib 2316 (+ auxiliary jib) 1120
- Permitted gradient for main boom 2821 + luffing jib 2316 + derrick (+ auxiliary jib) 1138
- Permitted gradient for main boom 2821 + luffing jib 2316 + Midfall 2316 1122
- Permitted gradient for main boom 2821 + reducing adapter 2821/2316 1110
- Permitted gradient main boom 2821 (+ auxiliary jib) 1109
- Personal protective equipment 556, 1865, 1951
- Pinning A-frame1 equalizer to derrick boom pendant straps 1399
- Pinning the A-frame 2 equaliser to the main boom 1588
- Pinning the assembly cylinder to main boom base section 1313
- Pinning the counterweight carriage pendant straps to the counterweight carriage 1495
- Pinning the counterweight carriage with the basic machine 1480
- Pinning the equalizer of A-frame2 to the main boom (jib 1507) 1590
- Pinning the jib backstay straps (jib 1507) 1589
- Pinning the jib to the jib base section 1585
- Pinning the pendant straps 1299, 1389, 1414, 1585, 1683
- Pinning the spacer frame with the uppercarriage 1493
- Pinning the suspended counterweight pendant ropes to the counterweight frame 1491
- Pinning together the main boom head, main boom sections and main boom base section 1407
- Pins for CF pendant straps 190, 305, 344
- Pins for CF pendant straps behind reducing adapter 241
- Pins for CF pendant straps in front of reducing adapter 239
- Pins for steel pendant straps 189, 304, 343
- Pins for steel pendant straps behind reducing adapter 240
- Pins for steel pendant straps in front of reducing adapter 239
- Pins for the rope fixing point 414
- Place support pads and bedding layers underneath 1207
- Placing and lashing counterweight slabs 1486
- Placing jack in transport position 1228
- Placing ladder and floodlight in working position 1475
- Placing the slewing bracket in support position 1206

- Placing the slewing brackets in transport position 1230
- Placing the swing brackets in the support position 1199
- Plate 528
- Plate1 114
- Plate13 122
- Plate14 123
- Plate15 124
- Plate16 125
- Plate2 115
- Plate3 116
- Plate4 117
- Plate5 118
- Plate6 119
- Plate7 120
- Plate8 121
- Platform 145
- Platform on cabin 86
- Platforms at undercarriage with fixed track width 143
- Platforms on uppercarriage 85
- Pocket lock 411
- Poisoning and suffocation 589
- Position 1 696, 704, 811
- Position 10 701, 705
- Position 11 701, 706
- Position 12 701, 706
- Position 13 702
- Position 2 697, 704, 812
- Position 3 697, 705, 812
- Position 4 697, 705, 813
- Position 5 698, 705, 814
- Position 6 698, 814
- Position 7 699
- Position 8 700, 705
- Position 9 700, 705
- Position the basic machine in front of the wheeled counterweight carriage 1477
- Positioning basic counterweight slab 14 t (30,864 lb) 1257
- Positioning the ballast slabs 1470
- Positioning the boom head above load's center of gravity 1016
- Positioning the counterweight frame 1470
- Positioning the counterweight slabs 10 t (22,046 lb) and the counterweight slabs 5 t (11,023 lb) 1257
- Positioning the hook or pulley block 1075
- Positioning the wheeled counterweight carriage 1472
- Power cable 440
- Preparing boom components for transport 1852
- Preparing the crawler side frame 1233, 1755
- Preparing the hydraulic hose 1967
- Preparing the machine 1794
- Preparing the machine with the radio remote control 991
- Preparing the operating of the external air conditioning system 865
- Preparing the undercarriage 1215
- Preparing the valve block of the jib base section 1968
- Preservation medium (anti-corrosion coating) 1880
- Preserve machine for decommissioning 2083
- Preserve machine for outdoor storage 2080
- Preserve machine for reselling 2084
- Preserve machine for storage for more than 7 months 2083
- Preserving the basic machine 2078, 2081
- Preserving the boom 2077, 2081
- Preserving the machine 2072
- Preserving the machine for indoor storage 2077
- Preserving the machine for storage for up to 7 months 2077
- Preserving the piston rods of the hydraulic cylinders in case of longer periods of non-use 1928
- Preserving the ropes 2077, 2080
- Priority Level* screen (for Liebherr service personnel only) 1057
- Process data recording (PDR)* 493
- Process data report (PDR)* 494
- Product description 51
- Programing rope layer change 1-2 997
- Programing rope layer change 3-4 998
- Programing rope layer change 5-6 998
- Programing the jib radius limitation 1005
- Programing the main boom radius limitation 1005
- Programing the sector limitation 1003
- Programing the slewing range limitation 1008
- Programming layer change 997
- Programming the edge limitation 1001
- Programming the lifting height limitation 1009
- Programming the setup 886, 1290, 1404, 1580, 1661
- Prohibition signs 574
- Protecting CF pendant strap bushes, connecting links and pins from corrosion 1985
- Protecting pendant ropes, connecting links and pins from corrosion 1987
- Protecting steel pendant straps, connecting links and pins from corrosion 1980
- Protecting the piston rods of the hydraulic cylinders from corrosion 1928
- Pulley block (100 t (220,459 lb)) 418
- Pulley block (160 t (352,734 lb)) 416
- Pulley block (300 t (661,377 lb)) 415
- Pulley block (50 t (110,230 lb)) 419
- Pulley block/hook* 415
- Pump wear indicator* 495
- Putting on safety belt 855
- Putting the heating system into operation 2065
- Putting the load moment limiter lamp and flashing light into working position 1169
- Putting the machine into operation 1196
- Putting the tagline winch into operation 1020
- Putting the ventilation system into operation 2065

Q

- Quad monitor 518, 827

Quick latch couplings* on jib luffing winch 497

R

Radio remote control* 443, 802, 989

Railing connection 135

Railing part A 88

Railing part B 89

Railing part1 for right platform 92

Railing part2 for right platform 94

Railing part3 for right platform 95

Railing part4 for left platform 102

Railing part5 for left platform 101

Railing part6 for left platform 99

Raise derrick boom 1402

Raising the derrick boom 1489

Reading light* for cabin 483

Readjusting layer change when changing ropes 1945

Reapplication intervals 2076

Rear counterweight 153

Rear cover 504

rechargeable battery 989

Reconfiguring the main boom 1790

Rectifying general engine error messages 1050

Rectifying grave engine error message 1050

Reducing adapter pendant strap 12 m (40 ft) 242, 244

Reducing piece overview 219

Reducing the constant pull of the tagline winch 1022

Reducing the load 1077

Reeve derrick rope rigging with auxiliary rope 1396

Reeve the Derrick pulley block 1396

Reeving A-frame 2/A-frame 3 1671

Reeving diagram - jib luffing winch as auxiliary winch 1288, 1380

Reeving diagram A-frame2/A-frame3 1631

Reeving diagrams for one rope across auxiliary jib (15 t (33.000 lb)) on jib head 1916, 1713, 1309, 1008 (load position1) 1660

Reeving diagrams for one rope across auxiliary jib (30 t (66.000 lb)) on jib head 2316 (load position1) 1640

Reeving diagrams for one rope across auxiliary jib (36 t (79300 lb)) on main boom head 2821 (load position1) 1285, 1377

Reeving diagrams for one rope across jib head 0906 (load position1) 1573

Reeving diagrams for one rope across jib head 1008 (load position1) 1564

Reeving diagrams for one rope across jib head 1507 (load position1) 1553

Reeving diagrams for one rope across jib head 1713 (load position1) 1539

Reeving diagrams for one rope across jib head 1916 (load position1) 1652, 1742

Reeving diagrams for one rope across jib head 2316 (load position1) 1632, 1729

Reeving diagrams for one rope across main boom head 2316 (load position1) 1515

Reeving diagrams for one rope across main boom head 2821 (load position1) 1276, 1368

Reeving diagrams for one rope across main boom head 2821 (load position2) 1541, 1556, 1566, 1575, 1635, 1655

Reeving diagrams for one rope across midfall 1916 (load position3) 1744

Reeving diagrams for one rope across midfall 2316 (load position3) 1731

Reeving diagrams for two ropes across auxiliary jib (36 t (79300 lb)) and main boom head 2821 (load position 1) 1287, 1379

Reeving diagrams for two ropes across jib head 0906 (load position1) 1575

Reeving diagrams for two ropes across jib head 1008 (load position1) 1565

Reeving diagrams for two ropes across jib head 1507 (load position1) 1555

Reeving diagrams for two ropes across jib head 1713 (load position1) 1540

Reeving diagrams for two ropes across jib head 2316, 1916, 1713, 1309, 1008 (load position1) 1634, 1653

Reeving diagrams for two ropes across main boom head 2316 (load position1) 1517

Reeving diagrams for two ropes across main boom head 2821 (load position1) 1281, 1373

Reeving the derrick rope rigging without auxiliary rope 1397

Reeving the rope 1330, 1332, 1448, 1450, 1527, 1530, 1599, 1602, 1692, 1695

Reeving the rope of the rope reeving winch 1019

Reeving the rope using a rope reeving winch 1331, 1449, 1528, 1600, 1693

Reeving the rope without using a rope reeving winch 1337, 1455, 1535, 1607, 1701

Refueling pump* 434

Refuelling pump 1860

Release pressure on hydraulic tension jack 1913

Release the pendant ropes from the derrick boom 1471

Release transport lashing from the derrick pulley block 1399

Releasing safety belt 855

Remedying radio transmission interruptions longer than 8 seconds 995

Remedying radio transmission interruptions of less than 8 seconds 995

Removing support pads and bedding layers 1231

Removing the jib backstay straps 1300, 1415

Removing the rope protection pipes on auxiliary jib 1332, 1450, 1695

Removing the transport brackets 1242

Removing the transport safety 1224

Removing the uppercarriage lock 1214

Repair welding requirements 1959

Repairs on the steel structure 1959

Replacing fuses 1064
Replacing the belt drive including vibration damper, deflection pulley and springs 2070
Replacing the connecting links 1746
Replacing the dry air filter main element and dry air filter safety element 1886
Replacing the fresh air filter 2057
Replacing the fuel filter of auxiliary water heating 2068
Replacing the recirculated air filter 2051
Requesting the operating hours 867
Required length of winch1/winch2 rope 1071
Requirements to personnel 555
Rescue signs 577
Resetting daily operating hours 869
Resetting limitations 1011
Resistance area, step voltage 601
Restrictions due to exposure to wind 1077
Retightening the chain 1910
Retract assembly cylinder 985
Retracting jacks and track width adjusting cylinders 1759
Retracting the derrick hoist cylinder 969
Retracting the track width adjusting cylinders and pinning the crawler side frames 1757
Retrofit kit for 0806 fixed jib 487
Retrofit kit for 1008 fixed jib 486
Retrofit kit for luffing jibs 1008 / 1309 / 1713 / 1916 / 2316 485
Retrofit kits* for operation with two ropes over the jib head section 485
Rigger 554, 555
Rigging and installing carbody counterweight slab 18.8 t (41,446 lb) 1252
Rigging and installing carbody counterweight slab 7.5 t (16,534 lb) 1253
Rigging and lifting the main boom base section 1305
Rigging and mounting the first crawler side frame 1216, 1233
Rigging and mounting the second crawler side frame 1224, 1242
Rigging equipment and/or sling gear 1141
Rigging the first crawler side frame 1217, 1234
Rigging the main boom on derrick rope rigging 1433
Rigging the transport brackets 1216
Right and left platform 143
Right control lever 653, 805
Right corner platform 145
Right double T-lever 660, 676
Right front cover 506
Right linear control lever 809
Right multi-directional control lever 653, 668
Right platform on uppercarriage 90
Right rear cover 508
Right steel plate 147
Rope fixation 407
Rope guide (type A) 180
Rope guide (type A/B) on main boom 2821 179

Rope guide (type B) 181
Rope lubrication 2003
Rope measuring system 1864, 1945
Rope measuring system* 997
Rope pulleys 1868, 2031
Rope reeving system for A-frame 2/A-frame 3 1651
Rope reeving winch 1018, 1862, 1901
Rope reeving winch* 63
Rope suspension and rope fixation 1868, 2037
Ropes 1867, 2002
Rotary connection 1864

S

Safety barrier* 423
Safety belt* 855
Safety equipment 65
Safety instructions 553
Safety pin 1153
Safety signs 578, 1865, 1952
Safety signs on the machine 559
Safety signs on the machine (US market) 566
Screen *Access control* 780
Screen *Add Selection* 1054
Screen *CAN Configuration* 1057
Screen *CAN Line Information* 1057
Screen *Clients* 1058
Screen *Confirm connection* 817
Screen *CORRECTION* 1055
Screen *Display Configuration* 1057
Screen *Drive Function* 1056
Screen *INPUT/OUTPUT* 1052
Screen *Language Selection* 1056
Screen *MDE/PDE* 1058
Screen *MEMORY* 1053
Screen *MESSAGES* 1055
Screen *Modem Function* 1056
Screen *Operation* in derrick mode 716
Screen *Operation* with activated assembly functions 816
Screen pages 1052
Screen *Sampling Trace* 1058
Screen *SELECT* 1053
Screen *Select File Load* 1054
Screen *Select File Save* 1054
Screen *Settings - components* 787
Screen *Settings - Litronic testing system* 793
Screen *Setup - basic machine* 758, 763
Screen *Setup - main boom* 760, 765
Screen *SPECIAL FUNCTIONS* 1056
Screen *Start* 707
Screen *System Language Selection* 1057
Screen *System Status* 1058
Screen *Time Function* 1056
Screen *Working range limitation* 770
Screen *Working range limitation - lifting height limitation* 777

- Screen *Working range limitation - working range limitation* 770
- Search floodlight 832
- Securing the pendant straps with transport bracket 1851
- Securing the railing parts 1165
- Securing the railing parts with eye bolt 1167
- Securing the railing parts with locking elements 1165
- Select assembly cylinder 984
- Select maximum pull force of the tagline winch 1023
- Selecting a rope 2016
- Selecting and changing settings 887
- Selecting free-fall mode 971
- Selecting free-fall operation for winch1 973
- Selecting free-fall operation for winch2 973
- Selecting jib on control lever 949
- Selecting secured free-fall operation 971
- Selecting the counterweight carriage 1478
- Selecting the derrick hoist cylinder 968
- Selecting the jib 949
- Selecting the jib on control panel X23 950
- Selecting the mode 884
- Selecting unsecured free-fall operation 972
- Selection criteria for ropes 2016
- Sensitive hoisting* 1028
- Set lubrication time 883
- Set pause time 883
- Set the constant tension of the tagline winch 1021
- Set the load capacity display to zero (taring) 907
- Set track width adjusting cylinder to medium track 1757
- Set track width adjusting cylinder to narrow track 1758
- Setting control panel X25* or control panel X26* 845
- Setting deviations of the Vertical Line Finder to zero 1016
- Setting manual start or automatic start 866
- Setting recirculated air or fresh air 863
- Setting remaining operating time 874
- Setting start of heating 873
- Setting the activation time 874
- Setting the air vent 862
- Setting the alarm 874
- Setting the cab in the working position and bolting in place 1763
- Setting the constant engine RPM 842
- Setting the crawler speed 925
- Setting the jack-up height of the jacks 1202
- Setting the load display of winch1 or winch2 to zero 907
- Setting the pull force of the tagline winch 1022
- Setting the rope length of winch1 to zero 997
- Setting the rope length of winch2 to zero 997
- Setting the rope length to 15 windings 998
- Setting the rope length to zero 997
- Setting the rope reeving winch to free-wheel 1018
- Setting the spring tension of railing doors 1954
- Setting the swing speed 935
- Setting the time and day 873
- Settings - units screen 790
- Settings* screen 787
- Setup - basic machine screen 735, 738, 741, 746, 750, 755
- Setup - boom configuration 1 screen 735
- Setup - boom configuration 2 screen 738
- Setup - boom configuration 3 screen 741
- Setup - boom configuration 4 screen 746
- Setup - boom configuration 5 screen 750
- Setup - boom configuration screen 733
- Setup - jib screen 744, 748, 753, 761, 766
- Setup - load chart screen 768
- Setup - main boom screen 736, 739, 743, 747, 752, 757
- Setup screen 731
- Setup screen - boom configuration 6 755
- Setup screen - boom configuration 8 758
- Setup screen - boom configuration 9 763
- Short work interruption 1032
- Shutdown 1032
- Single hook operation/two-hook operation 908
- Single-hook mode with one winch on one hook 910
- Single-hook mode with two winches on one hook 912
- Single-hook mode with two winches on two hooks 913
- Slings plates on uppercarriage* 424
- Snow and ice loads 595
- Socket* in cab 499
- Sorting and positioning platform parts 1171
- Sorting and positioning railing parts 1178
- Spacer bracket 188, 302, 341
- Spacer bracket behind reducing adapter 235
- Spacer bracket in front of reducing adapter 234
- Spacer frame 395
- Special hand signals for sling gear application 612
- Special modes of operation 55
- Split pin 1150
- Spring cotter pin 1152
- Starting the diesel engine 839
- Starting the Litronic® testing system 1059
- Starting the machine with the radio remote control 991
- Starting the ventilation, heating, air conditioning, external air conditioning system* and auxiliary heating system* and ensuring that sufficient antifreeze has been added to the water circuit 2065
- Start-up 837
- Status bar 696, 811
- Stay ropes 189, 238, 303, 342
- Steel pendant straps 1866, 1979
- Steel pendant straps on A-frame1 77
- Steel pendant straps on A-frame2 255, 264, 275, 283, 307, 345
- Steel pendant straps on A-frame3 308, 346
- Steel pendant straps on fixed jib 0906 283
- Steel pendant straps on fixed jib 1008 275
- Steel pendant straps on fixed jib 1507 264

Steel pendant straps on fixed jib 1713 255
Steel pendant straps on jib base section 2316.20 306
Steel pendant straps on jib head 1008.20 280
Steel pendant straps on jib head 1713.21 261
Steel pendant straps on jib head 1916.21 350
Steel pendant straps on jib head 2316.20 312
Steel pendant straps on jib section 1008.17
3 m (10 ft) 278
Steel pendant straps on jib section 1008.17
6 m (20 ft) 279
Steel pendant straps on jib section 1713.18
12 m (40 ft) 260
Steel pendant straps on jib section 1713.18
3 m (10 ft) 258
Steel pendant straps on jib section 1713.18
6 m (20 ft) 259
Steel pendant straps on jib section 1916.18
12 m (40 ft) 349
Steel pendant straps on jib section 1916.18
3 m (10 ft) 348
Steel pendant straps on jib section 1916.18
6 m (20 ft) 349
Steel pendant straps on jib section 2316.20
12 m (40 ft) 311
Steel pendant straps on jib section 2316.20
3 m (10 ft) 310
Steel pendant straps on jib section 2316.20
6 m (20 ft) 310
Steel pendant straps on luffing jib 1916 345
Steel pendant straps on luffing jib 2316 306
Steel pendant straps on main boom 2821 191
Steel pendant straps on main boom base section
2821.30 191
Steel pendant straps on main boom head
2821.24 197
Steel pendant straps on main boom section 2316.25
1 m (3 ft) 243
Steel pendant straps on main boom section 2821.30
12 m (40 ft) 196
Steel pendant straps on main boom section 2821.30
3 m (10 ft) 192
Steel pendant straps on main boom section 2821.30
6 m (20 ft) 194
Steel pendant straps on midfall 1916.32 372
Steel pendant straps on midfall 2316.25 367
Steel pendant straps on reducing adapter
2821/2316 242
Steel pendant straps on reducing adapter
2821/2316.24 12 m (40 ft) 242
Steel plates 146
Steel structure 1865, 1958
Stop screen 816
Stopping the empty hook in free-fall operation 974
Storing ropes 2015, 2018
Strap 135
Strap support 136
Submenu bar 706
Suction flap* 425

Supply 439, 441
Supporting the machine 1756
Suspended counterweight 394
Suspending the transport brackets 1233
Swing 64, 935, 1860, 1891
Swing connection 1861, 1893
Swing emergency mode 1038
Swinging the load when load is on different boom
heads/load positions 922
Swinging the machine to the left 928
Swinging the machine to the right 929
Swinging the uppercarriage to the left 940, 941
Swinging the uppercarriage to the right 940, 941
Switching off assembly mode functions 1355, 1499,
1619, 1715
Switching off auxiliary heating 873
Switching off battery main switch 1034
Switching off free-fall operation 975
Switching on assembly mode functions 1196
Switching on auxiliary heating 872
Switching on cylinder adjustment functions 1196
Switching on free-fall operation 970
Switching on the ignition 837
Switching swing free-wheel on/off using the control
lever 937
Switching the diesel engine automatic stop system on
or off 1027
Swivel the cab to the working position 1160

T

Tagline winch 1862, 1902
Tagline winch* 432, 1020
Take/cede control 993
Take/cede control to/from radio remote control 993
Taking an oil sample 1882
Taking/ceding control in cabin 994
Technical condition of the machine 553
Technical data 60
Third hoist limit switch* 452
Tilting the cabin 880
Tilting-back supports 1977
Time-saving reconfiguring of the main boom 1790
Toggle switch 810
Tools required 1070
Top backstay shackle 236
Top cover 503
Topping up the gearbox oil 1889, 1891, 1896, 1899,
1903
Transport 1815
Transport of the machine on floating devices 607
Transporting basic machine with undercarriage with
fixed track width with a transport vehicle 1840
Transporting basic machine with undercarriage* with
adjustable track width with a transport vehicle 1843
Transporting ropes 2018
Transporting the basic machine with a transport
vehicle 1840

Transporting the boom sections 1847
 Transporting the pendant straps 1854
 Transporting the ropes 2016
 Traveling on gradients 1107
 Troubleshooting 1050
 Turn the tagline winch on or off 1021
 Turning swing free-wheel on/off on control panel X23 936
 Turning tagline winch free-wheel on or off 1023
 Turning the air conditioning system on or off 864
 Turning the diesel engine on or off 993
 Turning the edge limitation on or off 1002
 Turning the external air conditioning system off 866
 Turning the external air conditioning system on 865
 Turning the external air conditioning system* on or off 865
 Turning the function sensitive lift on or off 1028
 Turning the sector limitation on or off 1004
 Turning the swing free-wheel on or off 936
 Twin-hook mode with two hooks on one load 921
 Twin-hook mode with two hooks on two loads 919
 Tying down the rear counterweight 1259
 Type plate 51

U

Undercarriage 137
 Undercarriage with fixed track width 137
 Undercarriage* with adjustable track width 138
 Understanding the oil diagnosis report 1884
 Undoing counterweight carriages pendant straps from derrick boom 1484
 Undoing the temporary attachment of the counterweight carriage pendant straps 1484
 Unfolding steps from transport position 1228, 1246
 Unload and position the derrick boom head components 1382
 Unloading and positioning the jib components 1580, 1661
 Unloading and positioning the main boom section 1290, 1404
 Unloading machine with undercarriage with fixed track width 1199
 Unloading machine with undercarriage* with adjustable track width 1206
 Unloading the machine 1198
 Unwind rope from rope reel 2019
 Upper carriage 80
 Urea solution 1879
 Use as auxiliary winch 1026
 Use as jib luffing winch 1025
 Use as leader height adjusting winch 1026
 Use at low temperatures 608
 Use of the fire extinguisher 603
 Using abseil rescue equipment 1029
 Using emergency stop 1031
 Using the ashtray 878
 Using the cigarette lighter 879

Using the heater 864
 Using the horn 876
 Using the machine as assembly crane 1246

V

Vandalism protection* 502, 1778
 Ventilation, heating and air-conditioning 460, 860, 1868, 2047
 Vertical Line Finder* assistance system 427, 1016, 1765, 1864
 Vibrations 61
 Video monitoring system* 513, 827
 Video surveillance - basic device 515
 Video surveillance - boom 517
 Visual inspection of the ropes for deterioration or mechanical damage 2002
 Visual motion warning device* 491

W

Warning signs 575
 What to do in dangerous situations 601
 Whole machine 1859
 Winch 1/Winch 2 955
 Winch 2 emergency mode 1035
 Winch synchronization* 976
 winch1/winch2 62, 1861, 1895
 Winches 62
 Windscreen wiper system 858
 With retrofit kit access control (red and blue ignition keys)* 782
 Without retrofit kit access control (black ignition keys) 780
 Without retrofit kit access control (blue ignition keys) 781
 Work area 557
 Working at heights 605
 Working range limitation* 1001
 Working with Blocked Crawlers 982

X

Xenon and halogen floodlights 1936
 Xenon floodlight 1939

Z

Zoom camera 522
 Zoom camera in auxiliary jib 15 t (33000 lb) 534
 Zoom camera in auxiliary jib 36 t (79300 lb) 534
 Zoom camera in fixed jib head 531
 Zoom camera in luffing jib head 533
 Zoom camera in main boom head 530

